

NAVAL POSTGRADUATE SCHOOL Monterey, California



THESIS

DEVELOPMENT OF SHROUDED TURBOJET TO FORM A
TURBORAMJET FOR FUTURE MISSILE APPLICATIONS

by

Suleiman M. al-Namani

June 2000

Thesis Advisor:
Thesis Co-Advisor:

Garth V. Hobson
K.E. Woehler

Approved for public release; distribution is unlimited

DTIC QUALITY INSPECTED 4

20000620 007

REPORT DOCUMENTATION PAGE

Form Approved
OMB No. 0704-0188

Public reporting burden for this collection of information is estimated to average 1 hour per response, including the time for reviewing instruction, searching existing data sources, gathering and maintaining the data needed, and completing and reviewing the collection of information. Send comments regarding this burden estimate or any other aspect of this collection of information, including suggestions for reducing this burden, to Washington headquarters Services, Directorate for Information Operations and Reports, 1215 Jefferson Davis Highway, Suite 1204, Arlington, VA 22202-4302, and to the Office of Management and Budget, Paperwork Reduction Project (0704-0188) Washington DC 20503.

1. AGENCY USE ONLY (Leave blank)

2. REPORT DATE
June 2000

3. REPORT TYPE AND DATES COVERED
Master's Thesis

4. TITLE AND SUBTITLE Development of Shrouded Turbojet to Form a Turboramjet For Future Missile Applications

5. FUNDING NUMBERS

6. AUTHOR(S)
Suleiman. M. al-Namani

7. PERFORMING ORGANIZATION NAME(S) AND ADDRESS(ES)
Naval Postgraduate School
Monterey, CA 93943-5000

8. PERFORMING ORGANIZATION
REPORT NUMBER

9. SPONSORING / MONITORING AGENCY NAME(S) AND ADDRESS(ES)

10. SPONSORING / MONITORING
AGENCY REPORT NUMBER

11. SUPPLEMENTARY NOTES

The views expressed in this thesis are those of the author and do not reflect the official policy or position of the Department of Defense or the U.S. Government.

12a. DISTRIBUTION / AVAILABILITY STATEMENT

Approved for public release; distribution is unlimited.

12b. DISTRIBUTION CODE

13. ABSTRACT (maximum 200 words) Development of shroud to form part of an afterburner for a turbo-ramjet engine which has a possible application for high speed long range missile applications. Research has been conducted on scram-jet engines with little or no emphasis on a turbojet/ramjet combined cycle engines. With the possibility of the turbojet providing the thrust at subsonic conditions and the ramjet providing the thrust at supersonic conditions. A small turbojet engine, the Sophia J450 was evaluated experimentally and the results were compared to the prediction using an industry standard program with a perfect comparison over a wide operating range. In order to study possible turbo-ramjet configurations, a Sophia J450 turbojet engine was used with varying shroud configurations, to compare static thrust and specific fuel consumption measured in a test rig. Shroud pressures were also recorded to determine the entrainment rate of the ducts. The short shroud results were found to produce the best performance of the three configurations tested, which were more significant at lower engine spool speed that produced a sharp increase in secondary entrainment pressure. A conical supersonic intake was designed for combined cycle engine at a Mach 2 flight condition resulting in a near optimum cone angle of 15 (deg) to be tested in the new free jet facility. The flight envelope of the baseline engine was also determined over a wide range of flight speeds and operating altitudes.

14. SUBJECT TERMS

Micro-turbojet, GASTURB, Engine shroud, Turboramjet, Sophia J450, Microturbine Performance

15. NUMBER OF PAGES
101

16. PRICE CODE

17. SECURITY CLASSIFICATION OF REPORT
Unclassified

18. SECURITY CLASSIFICATION OF THIS PAGE
Unclassified

19. SECURITY CLASSIFICATION OF ABSTRACT
Unclassified

20. LIMITATION OF ABSTRACT
UL

THIS PAGE IS INTENTIONALLY LEFT BLANK

Approved for public release; distribution is unlimited

**DEVELOPMENT OF SHROUDED TURBOJET TO FORM A TURBORAMJET
FOR FUTURE MISSILE APPLICATIONS**

Suleiman M. al-Namani
Captain, Royal Army of Oman
B.Eng Electronics(Hons) Staffordshire University UK, 1992
B/Tec National Diploma (Elec/Elctrn) Bradford Colledge UK, 1989
O'Level Mathmatics London University UK, 1986
O'Level Physics London University UK, 1986

Submitted in partial fulfillment of the
requirements for the degree of

MASTER OF SCIENCE IN APPLIED PHYSICS

from the

**NAVAL POSTGRADUATE SCHOOL
June 2000**

Author:



Suleiman M. al-Namani

Approved by:

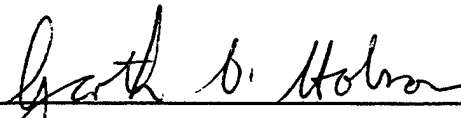

Garth V. Hobson, Thesis Advisor



K.E. Woehler, Co-Advisor

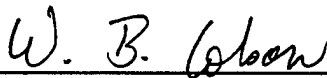

William B. Maier, Chair
Department of Combat System and Physics

THIS PAGE IS INTENTIONALLY LEFT BLANK

ABSTRACT

Development of a shroud to form part of an afterburner for a turbo-ramjet engine which has a possible application for high speed long range missile applications. Research has been conducted on scram-jet engines with little or no emphasis on turbojet/ramjet combined cycle engines. With the possibility of the turbojet providing the thrust at subsonic conditions and the ramjet providing the thrust at supersonic conditions. A small turbojet engine, the Sophia J450, was evaluated experimentally and the results were compared to the prediction using an industry standard program with a perfect comparison over a wide operating range. In order to study possible turbo-ramjet configurations, a Sophia J450 turbojet engine was used with various shroud configurations, to compare static thrust and specific fuel consumption measured in a test rig. Shroud pressures were also recorded to determine the entrainment rate of the ducts. The short shroud results were found to produce the best performance of the three configurations tested. The performance improvements were more significant at lower engine spool speeds that produced a sharp increase in secondary entrainment pressure.

A conical supersonic intake was designed for combined cycle engine at a Mach 2 flight condition resulting in a near optimum cone angle of 15 (deg) to be tested in the new free jet facility. The flight envelope of the baseline engine was also determined over a wide range of flight speeds and operating altitudes.

THIS PAGE IS INTENTIONALLY LEFT BLANK

TABLE OF CONTENTS

I.	INTRODUCTION.....	1
II.	SOPHIA J450-2 ENGINE TEST PROGRAM.....	5
	A. EXPERIMENTAL SETUP.....	5
	1. Overview.....	5
	2. Engine Test Rig.....	6
	B. DATA ACQUISITION AND REDUCTION.....	7
	1. Overview.....	7
	2. Instrumentation and Control.....	9
	a. Thrust Measurements.....	9
	b. Fuel Flow Rate Measurements.....	10
	c. Shroud Pressure Measurements.....	11
	C. RESULTS OF SOPHIA J450-2 ENGINE TEST PROGRAM.....	12
	1. Sophia J450-2 Test Results.....	12
	2. Cycle Analysis Procedure.....	14
	D. RESULTS OF SOPHIA J450-1 ENGINE TEST PROGRAM.....	18
	1. Long Shroud Pressure Distribution.....	18
	2. Medium Shroud Pressure Distribution.....	22
	3. Short Shroud Pressure Distribution.....	27
	E. SUMMARY AND COMPARISON OF RESULTS.....	32
	1. Comparison of Shrouds Pressure Distribution.....	32
	2. Comparison of SFC, Thrust and Spool Speed.....	33

F.	SUPERSONIC INTAKE (CONICAL) DESIGNS.....	36
G.	J450 FLIGHT ENVELOPE PREDICTIONS.....	45
III.	CONCLUSIONS AND RECOMMENDATIONS.....	47
A.	CONCLUSIONS.....	47
B.	RECOMMENDATIONS.....	47
	APPENDIX A. GASTURB (OFF-DESIGN PERFORMANCE).....	49
	APPENDIX B. SOPHIA J450-2 CALIBRATION DATA.....	51
	APPENDIX C. SOPHIA J450-2 THRUST RESULTS.....	53
	APPENDIX D. ACQUISITION PROGRAM MODIFICATION.....	55
	APPENDIX E. SOPHIA J450-1 CALIBRATION DATA	57
	APPENDIX F. SOPHIA J450-1 TEST DATA FOR SHROUDS.....	59
	APPENDIX G. COMPARSION BETWEEN J450-1 BASELINE, LONG, MEDIUM AND SHORT SHROUD CONFIGURATIONS.....	67
	APPENDIX H. STARTING THE SOPHIA J450-2 ENGINE.....	69
	APPENDIX I. SETTING THE TRANSMITTER OF SOPHIA J450-2.....	71
	APPENDIX J. FEATURES OF SOPHIA J450-2.....	73
	APPENDIX K.SOPHIA J450 TEST PROGRM CHECKLIST.....	75
K1.	FUEL WEIGHT AND THRUST BEAM CALIBRATION.....	75
K2.	DATA ACQUISITION SYSTEM SETUP.....	76
K3.	DATA ACQUISITION SYSTEM	77
K4.	DATA FILE PURGE	78
	APPENDIX L. SAMPLE CALCULATIONS CONICAL FLOW	81
	LISTS OF REFERANCES.....	83

INITIAL DISTRIBUTION LIST.....85

THIS PAGE IS INTENTIONALLY LEFT BLANK

LIST OF FIGURES

Figure 1. Engine Test Rig.....	6
Figure 2. Data Acquisition.	7
Figure 3. A Photograph of Data Aquisition.	8
Figure 4. A Photograph of the Thrust Measurement System and its Calibration.....	9
Figure 5. A Photograph of the Fuel Weight Measurement.	10
Figure 6. A Photograph of the Pressure Taps and Manometer.	11
Figure 7. Thrust vs Spool Speed.	12
Figure 8. SFC vs Spool Speed.....	13
Figure 9. SFC vs Thrust.....	13
Figure 10. a and b Compressor Map and Turbine Maps respectively... ..	16
Figure 11. Prediction of SFC vs Thrust.....	17
Figure 12. Thrust vs Spool Speed.	18
Figure 13. SFC vs Spool Speed.....	19
Figure 14. SFC vs Thrust.....	19
Figure 15. Long Shroud With Nozzle and Elliptic Intake.....	20
Figure 16. Long Shroud Pressure Destribution.	21
Figure 17. Thrust vs Spool Speed.	22
Figure 18. SFC vs Spool Speed.....	23
Figure 19. SFC vs Thrust.....	23
Figure 20. A Photograph of Medium Shroud.	24
Figure 21. Medium Shroud With Nozzle and Elliptic Intake.	25
Figure 22. A Plot of Medium Shroud Pressure Distribution.....	26
Figure 23. Thrust vs Spool Speed	27
Figure 24. SFC vs Spool Speed.....	28
Figure 25. SFC vs Thrust.....	28
Figure 26. A Photograph of Short Shroud.....	29
Figure 27. Short Shroud With Nozzle and Elliptic Intake.	30
Figure 28. A Plot of Short Shroud Pressure Distribution.....	31

Figure 29. Pressure Distribution Comparison between shrouds	32
Figure 30. Thrust vs Spool Speed	34
Figure 31. SFC vs Spool Speed.....	34
Figure 32. SFC vs Thrust.....	35
Figure 33. Inlet Flow Field Features.....	38
Figure 34. Intake Pressure Ratio at Mach 2 with a Different Cone Angles.....	39
Figure 35. Intake Pressure Ratio at Mach 4 For a Different Cone Angles	40
Figure 36. Intake Pressure Ratio at Cone Angle 15 deg For a Different Mach Numbers	41
Figure 37. Schematic of Engine in Shroud with a Supersonic Intake.....	42
Figure 38. Conical Supersonic Intake Design Detailed Drawing.....	43
Figure 39. Conical Supersonic Intake Design Support Struts Detailed Drawing.....	44
Figure 40. Prediction Subsonic Thrust performance of Sophia J450.....	46
Figure 41. Predicted subsonic and Supersonic performance of Sophia J450.....	46
Figure 42. Fuel Cell Calibration of J450-2.....	52
Figure 43. Thrust beam Calibration of J450-2... ..	52

LIST OF TABLES

Table 1.	Sophia J450 Specification After Ref [1] and[5].	5
Table 2.	Sohia J450-2 Test Program Results.	12
Table 3.	Gasturb J450-2 Design Point Input Data.	15
Table 4.	Gasturb Predicted Design P.T Performance.	15
Table 5.	Sophia J450-1 Test Program.	18
Table 6.	Sophia J450-1 Test Program.	22
Table7.	Sophia J450-1 Test Program.	27
Table 8.	Intake Design at Mach 2 with a Different Cone Angles	39
Table 9.	Intake Design at Mach 4 with a Different Cone Angles.	40
Table 10.	Intake Design at Cone Angle 15 (deg) with a Different Mach Number.	41
Table 11.	Fuel Cell Calibration.	51
Table 12.	Thrust Beam Calibration.	51
Table 13.	Sophia J450-2 Thrust Result 105% Spool Speed.	53
Table 14.	Sophia J450-2 Thrust Resul 100% Spool Speed.	53
Table 15.	Sophia J450-2 Thrust Result 90% Spool Speed.	53
Table 16.	Sophia J450-2 Thrust Result 80% Spool Speed.	54
Table 17.	Sophia J450-2 Thrust Result 50% Spool Speed	54
Table 18.	Fuel Weight Calibration Between J450-1 Baseline,Long,Medium and Short	57
Table 19.	Thrust beam Calibration Between J450-1 Baseline,Long,Medium and Short.	57
Table 20.	Sophia J450-1 Test Data for Long Shroud at 105% Spool Speed.	59
Table 21.	Sophia J450-1 Test Data for Long Shroud at 100% Spool Speed	59
Table 22.	Sophia J450-1 Test Data for Long Shroud at 90% Spool Speed.	59
Table 23.	Sophia J450-1 Test Data for Long Shroud at 80% Spool Speed.	59
Table 24.	Test Data for Long Shroud with Nozzle Pressure Distrubition.	60
Table 25.	Test Data for Medium Shroud at 105% Spool Speed.	61
Table 26.	Test Data for Medium Shroud at 100% Spool Speed	61
Table 27.	Test Data for Medium Shroud at 90% Spool Speed.	61
Table 28.	Test Data for Medium Shroud at 80% Spool Speed.	61

Table 29. Test Data for Medium Shroud with Nozzle Pressure Distribution.	62
Table 30. Sophia J450-1 Test Data for Short Shroud at 105% Spool Speed.	63
Table 31. Sophia J450-1 Test Data for Short Shroud at 100% Spool Speed	63
Table 32. Sophia J450-1 Test Data for Short Shroud at 90% Spool Speed.	63
Table 33. Sophia J450-1 Test Data for Short Shroud at 80% Spool Speed.	63
Table 34. Test Data for Short Shroud with Nozzle Pressure Distribution.	64
Table 35. Pressure Distribution Comparison between Long, Medium and Short for 100%. 65	
Table 36. SFC vs Thrust Comparison Between J450-1, Long, Medium and Short	67
Table 37. SFC vs Spool Speed Comparison Between J450-1, Long, Medium and Short Shroud.....	67
Table 38. Thrust vs Spool Speed Comparison between J450-1, Long, Medium and Short.....	67

ACKNOWLEDGEMENT

I extended my sincere appreciation in acknowledging several persons whose efforts greatly contributed towards the development of this thesis.

I would like to thank Mr. Rick Still, Mr. John Gibson, and Mr. Doug Seivwright of the Department of Aeronautics and Astronautics.

I greatly appreciate the efforts of most useful discussions with my supervisor Dr. Garth Hobson of the Department of Aeronautics and Astronautics in providing the opportunity to pursue this thesis. Without his guidance, patience, and dedicated support, this research would never have been completed.

I would also like to express my thanks to my co-advisor Dr. K.E. Woehler of the Physics Department for his technical support to pursue this thesis

I. INTRODUCTION

Missile technology is running on both evolutionary and revolutionary tracks. Evolution will be the path for the near to mid-term, but revolutionary changes in high-speed propulsion could emerge in a decade if tests in the next several years prove successful.

Raytheon's Meteor design employs a liquid fuel ramjet developed by Aerospatiale Missiles, drawing on its years of experience in developing the (ASMP). Meteor is to employ a solid fuel; variable flow ducted ramjet developed by Deutsche Aerospace (DASA) a subsidiary Bayern - Chemie. Under a separate but parallel technology demonstration program for the German air force, DASA (LFK) has been working on a Beyond Visual Range Air-to-Air Missile (BVRAAM) missile called Euraam, which it would also employ a ramjet system developed by Bayern Chemie. Ramjet propulsion is also a key ingredient of a new technology anti-radar missile being worked on by Bodenswerk (BGT) of Germany, called Armiger. It would employ a Mach 3 ram-rocket propulsion system for increased range and reduced time to target. The proposed ram-rocket motor would feature four air inlets in the center of the missile body and high boron content in the sustainer propellant for high specific impulse with low volume. After being boosted to the required operating speed, the air breathing ramjet sustainer would take over for the rest of the flight, mixing fuel-rich gas from a boron gas generator.

The hypersonic transport propulsion system research (HYPR) project was launched in 1989 as a ten-year project. The program is the first large-scale international collaboration research sponsored by Japan's Ministry of International Trade and Industry

(MITI). The participants are three Japanese Aero-engine companies (IHI, KHI and MHI), four foreign companies (GE, PWA, RR, and SNECMA) and four Japanese national laboratories (NAL MEL, NRLM and ONRI). The purpose of this project is to develop technologies for a Mach 5 propulsion system for a high speed transport (HST) airplane of the early 21 century, which could be environmentally acceptable and economically viable. The combined cycle engine, composed of a variable cycle engine (VCE) and a ramjet engine, is being studied. Three types of demonstrator engines were developed to demonstrate the system integration technologies of the combined cycle engine, that is, a high temperature core engine (HTCE), turbojet engine (HYPR 90-T) and combined cycle engine (HYPR90-C). The combined cycle engine demonstrator (HYPR90-C) was designed and manufactured reflecting these outcomes from the turbojet engine and ramjet research. The first sea-level engine tests have been carried out successfully, where the system function, mechanical integrity, ram ignition and zoning were validated at (IHI) Mizuho test cell in February 1998. The (HYPR90-C) altitude tests were scheduled to begin in Dec 1998 at GEAE.

In 1998, Rivera (Ref.1), began testing the compressor performance of a Garrett T1.5 turbocharger. This turbocharger was similar to the rotor used in Sophia J450 turbojet engine. He also bench tested the Sophia J450, and compared the results to the previously documented tests conducted on another small turbojet engine tested by Lobik (Ref.2), the JPX-240. Rivera also investigated the on - and off -design performance of the Sophia J450 turbojet engine using a cycle analysis program GASTURB (Ref.3), incorporating the experimentally determined Garrett T1.5 compressor map. The performance predictions were favorably compared to off-design tests of the Sophia J450

In March 1999, Hackaday (Ref.4) performed a study of the static performance of the Sophia J450 with an constant area ejector. These results were compared to baseline engine measurements obtained by Rivera to evaluate thrust augmentation. The results were also compared to theoretical predictions obtained using a one-dimensional analysis of the ejector flow. The compressor map for the actual rotor within the J450 was obtained and used with GASTURB to better predict the off-design performance. An engine shroud was manufactured and measurements were made as an initial setup in the consideration of a combined cycle engine.

In September 1999, Andreou (Ref.5), tested the Sophia J450 inside a shroud of varying configurations, to compare the performance of different duct lengths. Pressure measurements were also performed along the length of the various duct configurations to determine the amount of secondary flow entrainment into the shroud. An elliptical engine intake was designed and tested with two of the shroud configurations.

In the present thesis the continued development of a ducted turbojet engine was considered . The static performance was repeated and verified under prolonged testing at different engine speeds. The prolonged running of the engine was determined with an instrumented version capable of being remotely controlled. This version of the engine (denoted J450-2) allowed the accurate measurement of engine shaft rotational speed and exhaust gas temperature through a ground support unit (GSU) and engine control unit (ECU). The continuous engine runs allowed efficient evaluation of the performance and shroud pressures of the uninstrumented engine (J450-1). With the aim to future free-jet engine tests the design of a supersonic intake was initiated and completed.

THIS PAGE INTENTIONALLY LEFT BLANK

II. SOPHIA J450 ENGINE TEST PROGRAMS

A. EXPERIMENTAL SETUP

1. Overview

The Sophia J450 is a small turbojet engine manufactured in Japan. Although small in size, the J450 design and principle of operation is very much the same as full-scale jet engine. The J450 used heavy fuels which were either jet fuel or kerosene/Coleman lantern fuel mixture as described in Appendix J. Pertinent performance specifications are listed below as Table 1.

SOPHIA J450 ENGINE SPESIFICATION	
Length / Diameter	13.19 / 4.72 [in]
Total weight	4 [lb]
Fuel	Jet fuel or Coleman/Kerosene
Starting System	Compressed air
Ignition system	Spark plug (J450-2)or glow plug (J450-1)
Lubrication	6V pulsed oil pump
Fuel feed system	12V turbine fuel pump
Compressor	Single stage centrifugal
Thrust	11[lbf] at 123000 [RPM]
Fuel consumption	19.98 [lbm/hr]
Throttle system	Remote control

Table 1. Sophia J450 Specifications After Refs [1] and [2]

2. Engine Test Rig

The engine test rig used for the Sophia J450 was located in the Gas Dynamics Laboratory (Building 216) at the Naval Postgraduate School. It was the same apparatus that was designed in 1995 (Ref.2) for the JPX-240 test program with several minor modifications such as engine control unit (ECU) which consisted of a fuel pump, oil pump and remote control transmitter. Schematics of the test rig components are shown below in Figure 1.

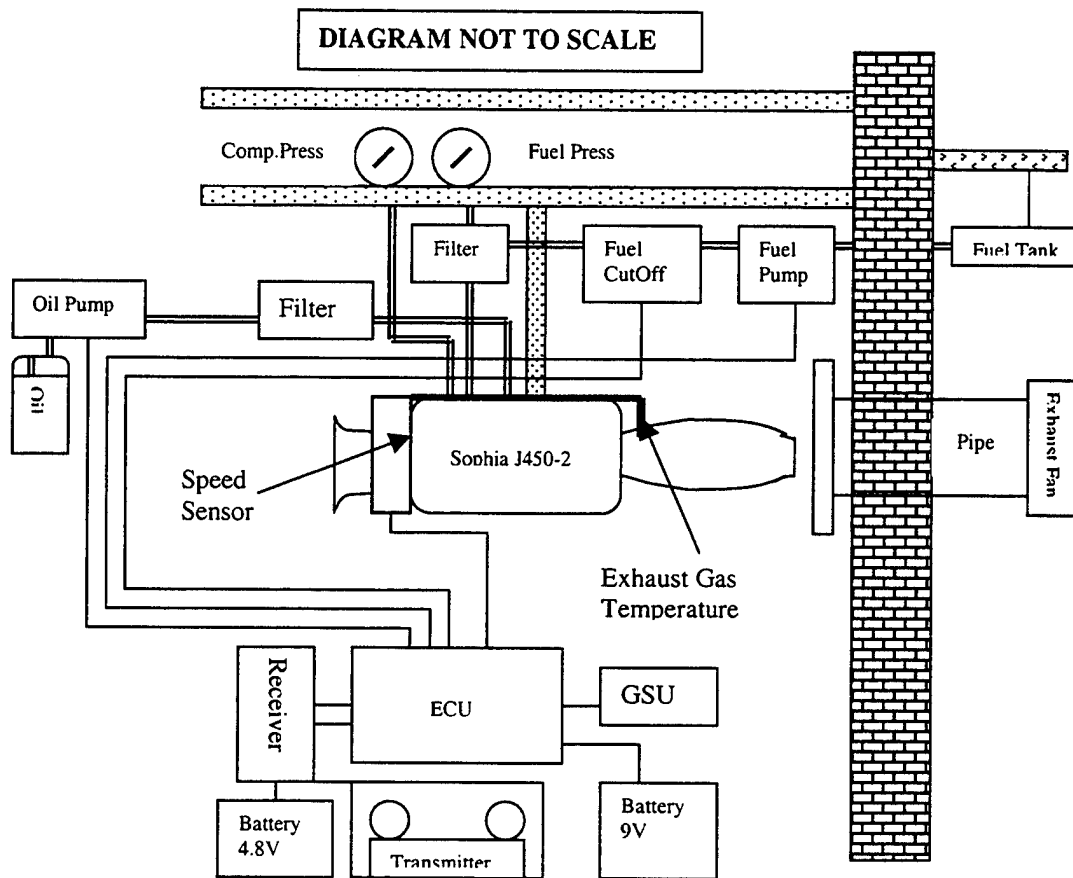

Figure 1. Engine Test Rig

B. DATA ACQUISITION AND REDUCTION

1. Overview

A schematic and photograph of the data acquisition are shown in Figures 2 and 3 respectively. The HP9000 Series 300 workstation was used to control the data acquisition system and to store and process the data. The primary instruments used for data acquisition were strain gages. The strain readings were obtained using a [HP6944A] Data Acquisition Control Unit [DACU] in conjunction with a HP digital voltmeter [DVM], which received signals through a signal conditioner.

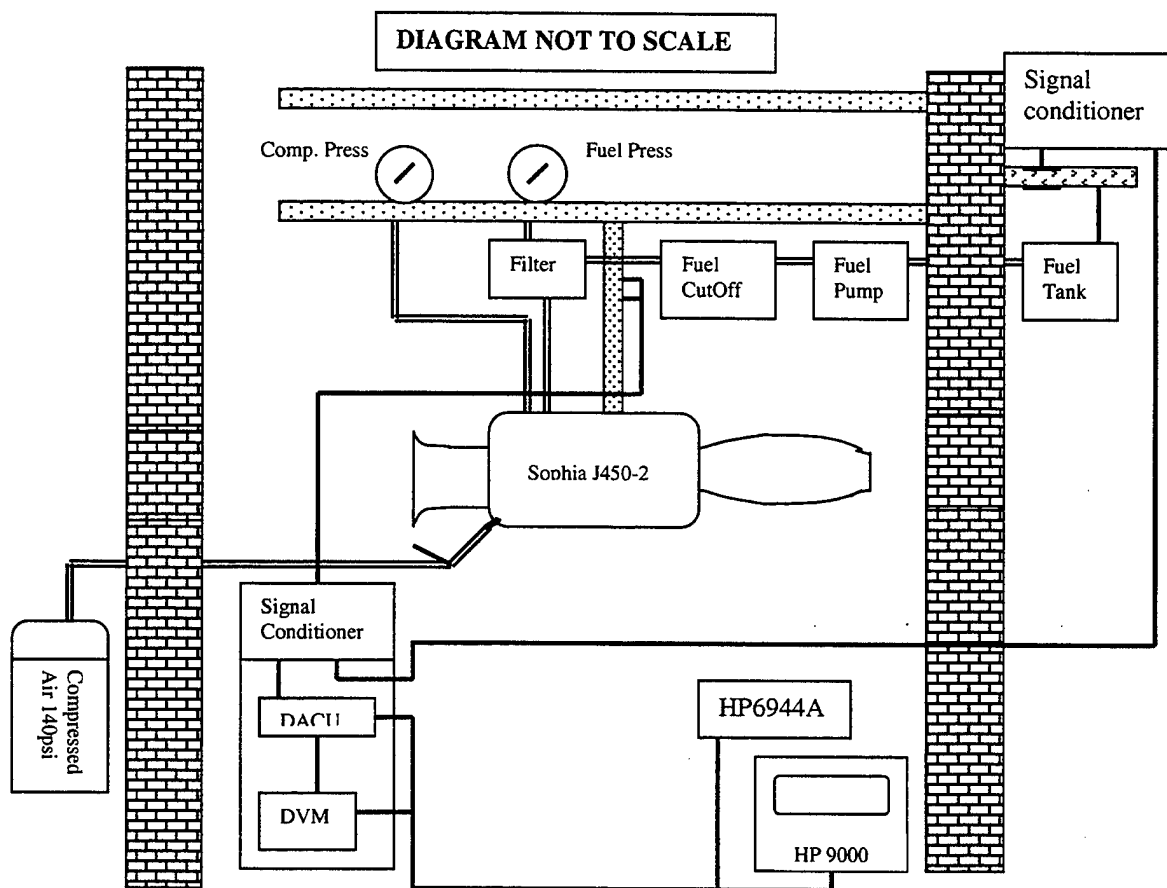

Figure 2. Data Acquisition

The DACU, DVM, and multiprogrammer were connected to the workstation via a HP-IB [IEEE-488] bus. A listing of the THRUST-SFC is given in Appendix C.

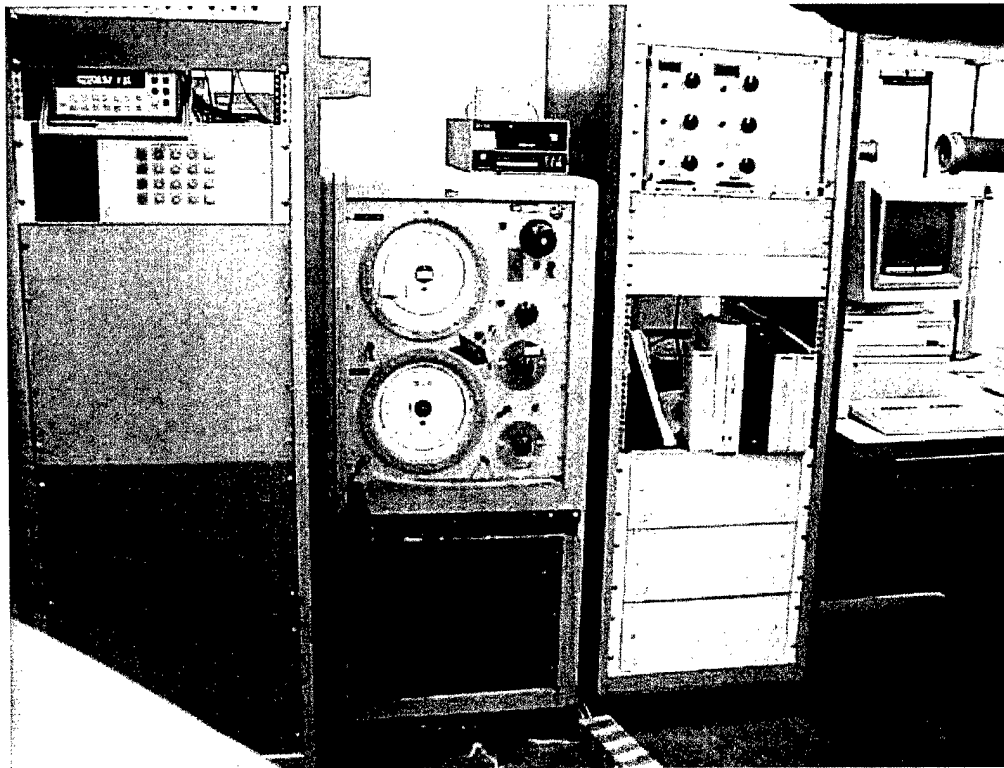

Figure 3. A Photograph of Data Acquisition

2. Instrumentation and Control

a. Thrust Measurements

The engine thrust was determined by using the beam from which the engine was suspended as a thrust-measuring device. The arrangement is shown in Figure 4. The beam contained four strain-gages [two on each side], which were configured in a full Whetstone bridge with the leads providing an output through a signal conditioner to the data acquisition system. The Digital Voltmeter was used to zero out the bridge prior to performing the calibration through channel six on the front panel of the signal conditioner panel. Prior to engine testing, the beam was calibrated with different weights hung off the front of the engine (as shown below in Figure 4) using HP Basic program "MICROJET CAL". The calibration results are provided in Appendix B as Table 12.

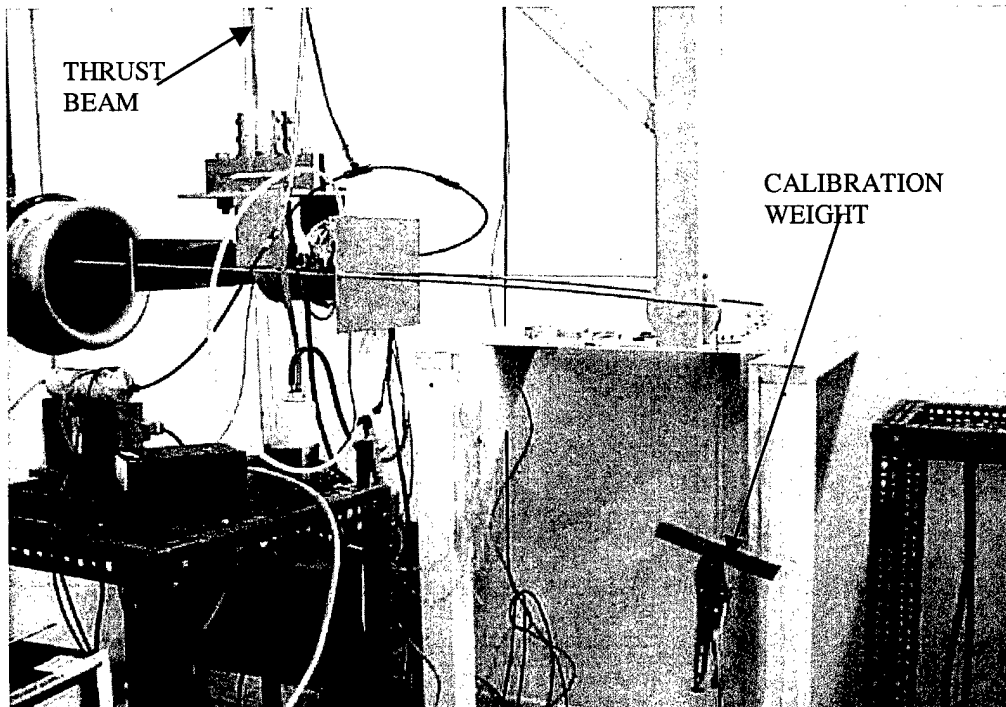

Figure 4. A Photograph of the Thrust Measurement System and its Calibration Arrangement

b. Fuel Flow Rate Measurements

The fuel flow rate was determined by using a cantilevered beam as a weighing device to calculate the change in fuel weight over given periods of time. The arrangement is shown in Figure 5. The beam used two strain-gages configured in a half Whetstone bridge to provide an output through a signal conditioner to the data acquisition system. Prior to engine testing, the beam was calibrated with known different weights, again using the program "MICROJET_CAL". The calibration results are provided in Appendix B as Table 11.

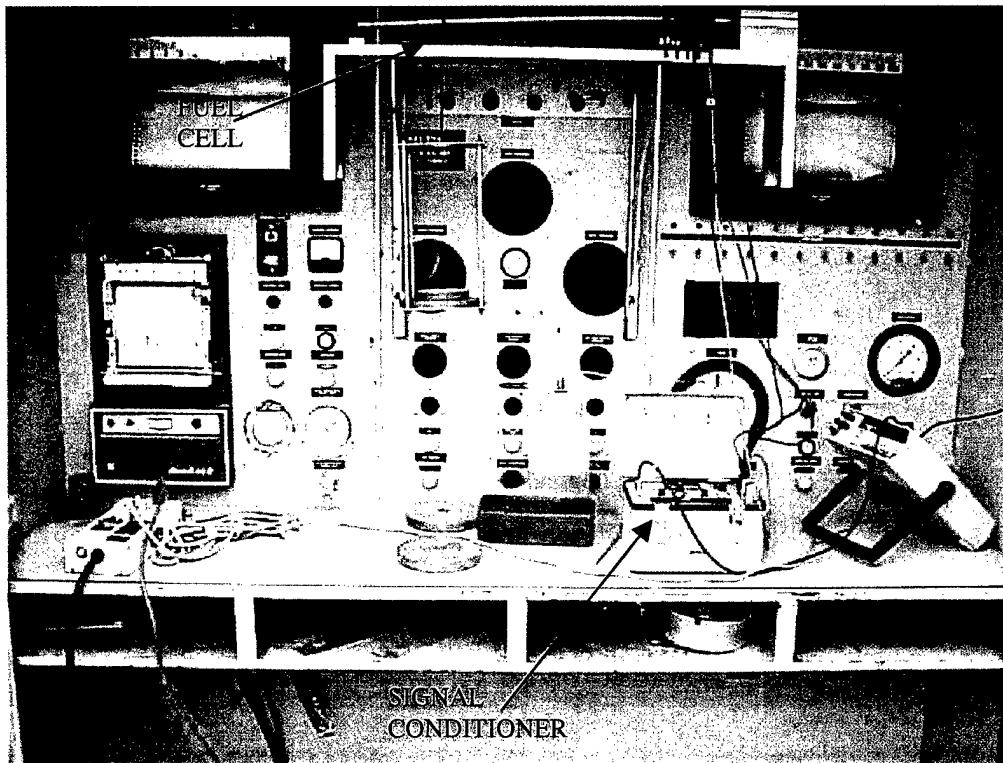

Figure 5. A Photograph of Fuel Weight Measurement

c. Shroud Pressure Measurements

These were recorded with a bank of eleven water manometers. The location of the pressure taps can be seen in Figure 6.

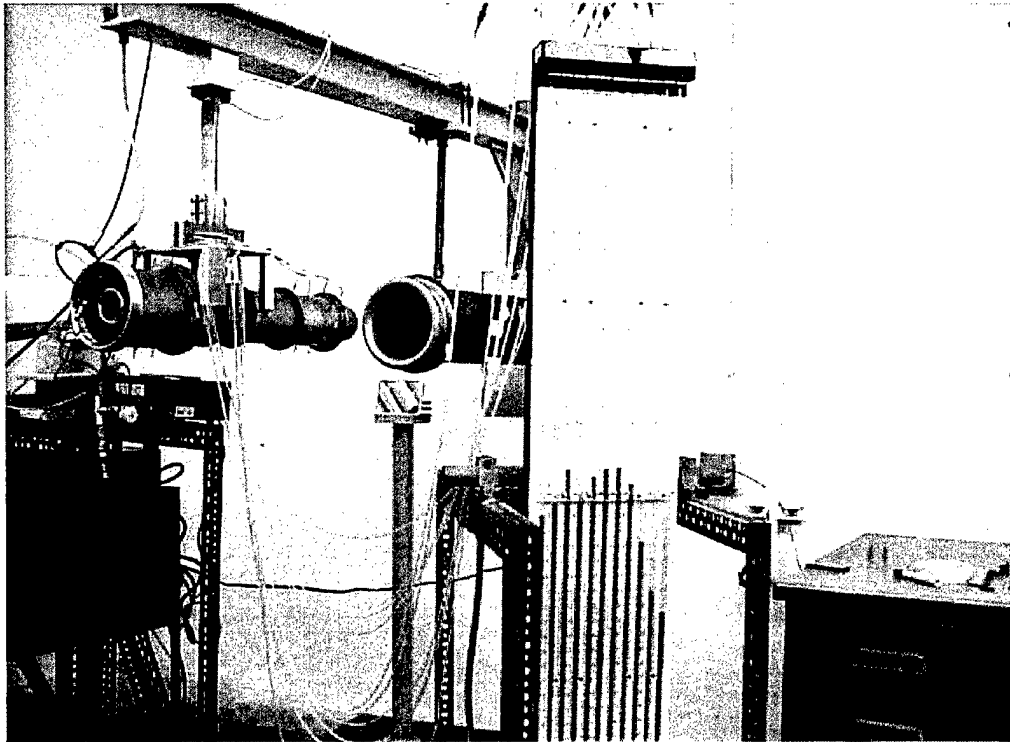

Figure 6. A Photograph of Pressure Taps and Manometer

C. RESULTS OF SOPHIA J450-2 ENGINE TEST PROGRAM

1. Sophia J450-2 Test Results

Four speed runs were conducted on the Sophia J450-2 engine at 105%, 100%, 90%, 80 % and 55% (IDLE). Each data run was performed from a maximum spool speed of 125000-rpm to a minimum spool speed of 62000 rpm. The plots and data are provided below in Figures 7, 8 and 9. Each data point was an average of five measurements taken with the data acquisition system the summary of which is presented in Table 2. For each run the Thrust, Specific Fuel Consumption (SFC) and spool speed is listed. The complete data listing is provided in Appendix C.

RUN	Thrust(lbs.)	SFC(lbm/lb/hr)	Spool Speed (RPM)
1	11.0935	1.585	125000 (105%)
2	9.8379	1.581	120000 (100%)
3	4.4752	1.673	109000 (90%)
4	4.7125	2.0724	93000 (80%)
5	1.5262	4.4096	62000 (IDLE)

Table 2. Sophia J450-2 Test Program Results

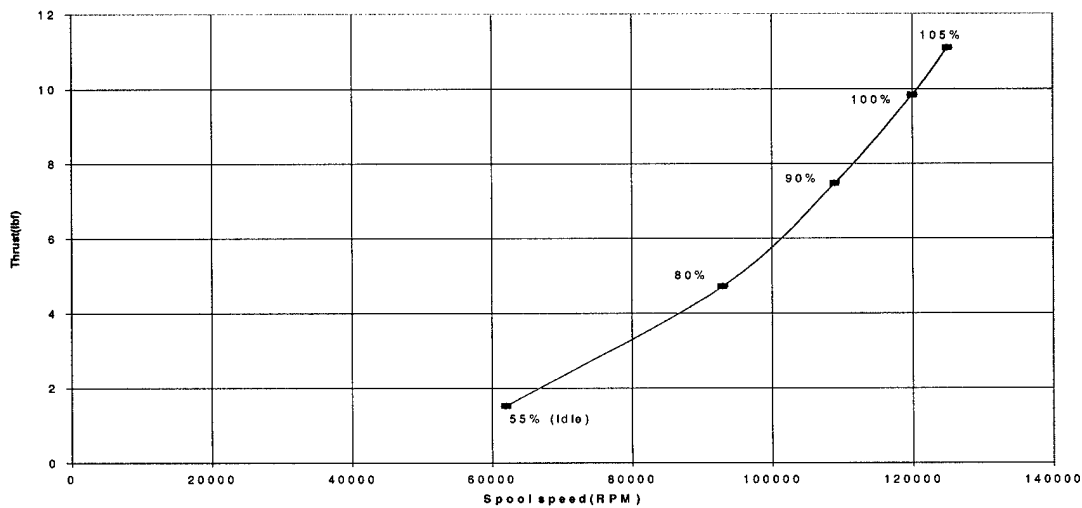

Figure 7. Thrust vs Spool Speed

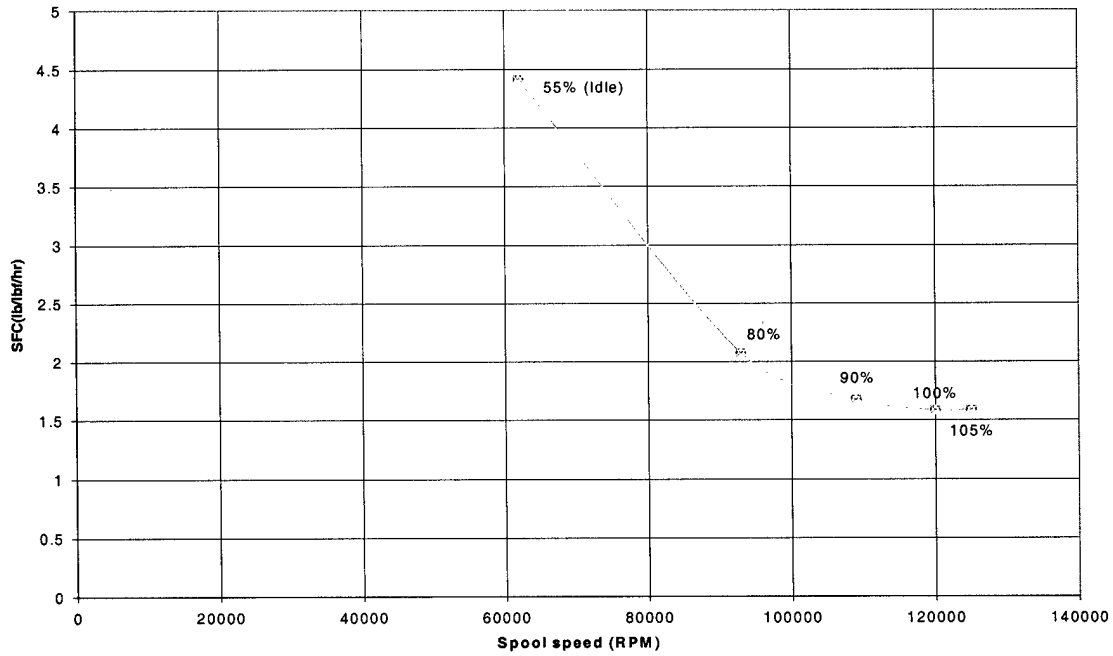

Figure 8. SFC vs Spool Speed

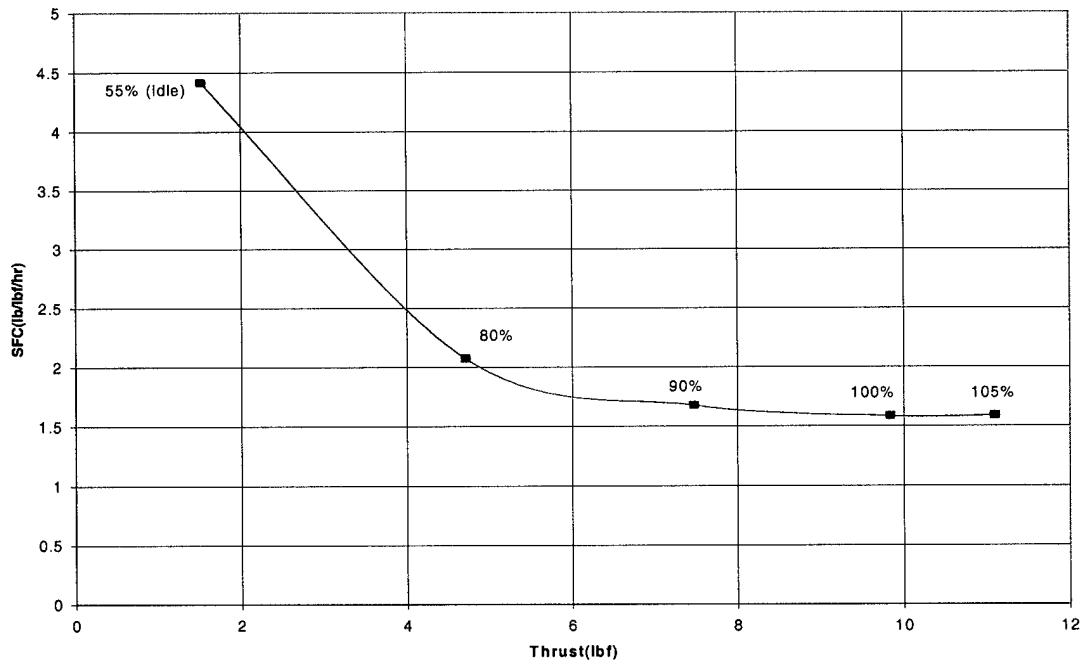

Figure 9. SFC vs Thrust

2. Cycle Analysis Procedure

The single spool turbojet design point analysis was selected once the GASTURB program was executed. The design point condition inputs to the program are provided below as a Table 3. The design point speed being 115000rpm.

The burner exit temperature was determined to be 1860 deg. R by using the iteration option of the software. Selecting the burner exit temperature as the iteration variable, and setting the net thrust determined from the J450-2 test program, 9.89 lbf, as the value to achieve, allowed the iteration algorithm of GASTURB to determine the necessary burner exit temperature. The design point calculated results are provided below as a Table 4.

The off-design performance prediction involved the evaluation of the J450-2 at different spool speeds. The first step was to select the off-design option of GASTURB, then select the special map option. The SMOOTHC formatted compressor map for the Garrett T2 turbocharger (used in the J450-2) was selected during this analysis as was the default radial turbine map (RADTUR). The procedure for the use of GASTURB is provided in Appendix A.

The Garrett compressor map used in the GASTURB analysis is shown in Figure 10a and the RADTUR turbine map is shown in Figure 10b. The speed lines were represented as fractions of the design speed [115000RPM]. Additionally, the figure has the predicted operating line of the engine displayed as squares while the circle on the [+0.994] speed line denoted the engine design point.

File: C:\PROGRA~1\OASTURB7\J450_2.CYJ
 Date: Dec2799
 Time: 12:01

Turbojet SL static, ISA

Basic Data		
Altitude	ft	0
Delta T from ISA	R	0
Mach Number		0
Inlet Corr. Flow W2Rstd	lb/s.....	0.256
Intake Pressure Ratio		1
Pressure Ratio		2.15
Burner Exit Temperature	R.....	1950
Burner Efficiency		1
Fuel Heating Value	BTU/lb.....	18.5
Rel. Handling Bleed		0
Overboard Bleed	lb/s	0
Rel. Overboard Bleed W_Bld/w2		0
Rel. Enthalpy of Overb. Bleed		0
Turbine Cooling Air W_CI/W2		0
NOV Cooling Air W_CI-NGV/w2		0
Power Of takes	hp	0
Mechanical Efficiency		1
Burner Pressure Ratio		1
Turbine Exit Duct Press Ratio		1
Nozzle Thrust Coefficient		1
Comp Efficiency		
Isentr. Compr Efficiency		0.653
Turb Efficiency		
Isentr.Turbine Efficiency		0.68

Table 3. GASTURB J450-2 Design Point Input Data

File: C:\PROGSA~1\CAsTURB7\J450_2.CYJ - modified
 Date: Jan2000
 Time: 10:57

Turbojet EL static, ISA

Station	W	T	P	WRstd	FN	9.89	
amb		518.67	14.696		TSFC	1.5703	
2	0.256	518.67	14.696	0.256	FN/W2	1243.48	
3	0.256	699.62	31.596	0.138	Prop Eff	0.0000	
4	0.260	1860.00	31.596	0.229	Core Eff	0.0974	
41	0.260	1860.00		0.229	WF	0.0043	
5	0.260	1707.10	19.129	0.363	WFRH	0.0000	
6	0.260	1707.10	19.129		A8	1.2356	
8	0.260	1707.10	19.129		P8/Pamb	1.3016	
P2/Pi	= 1.0000	P4/P3 = 1.0000	P6/PS	= 1.0000	Pwx	0	
Efficiencies:		isent	polytr	RNI	P/P	W~NGV/W2	0.00000
Compressor		0.7000	0.7301	1.00	2.150	WC1/W2	0.00000
Turbine		0.7100	0.6912	0.25	1.652	WBld/W2	0.00000
Spool mech		1.0000					

Composed Values:

1: xM8 = 0.639225

Table 4. GASTURB Predicted Design PT. Performance

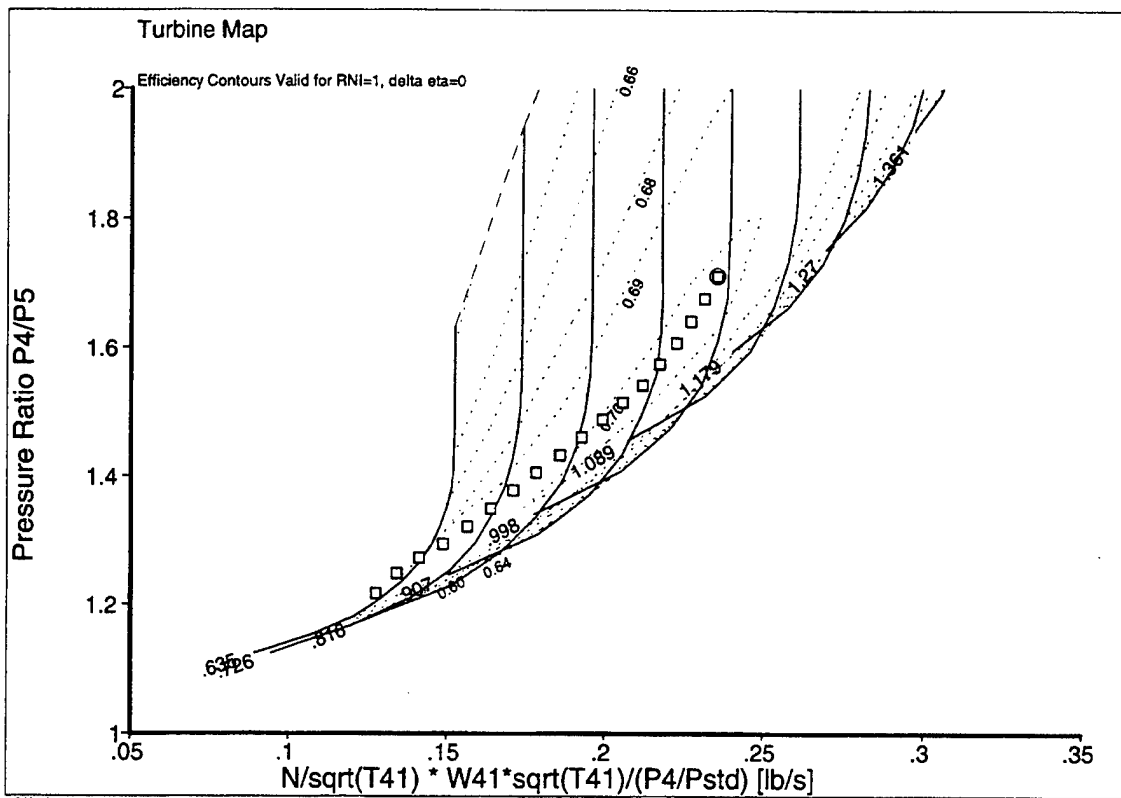
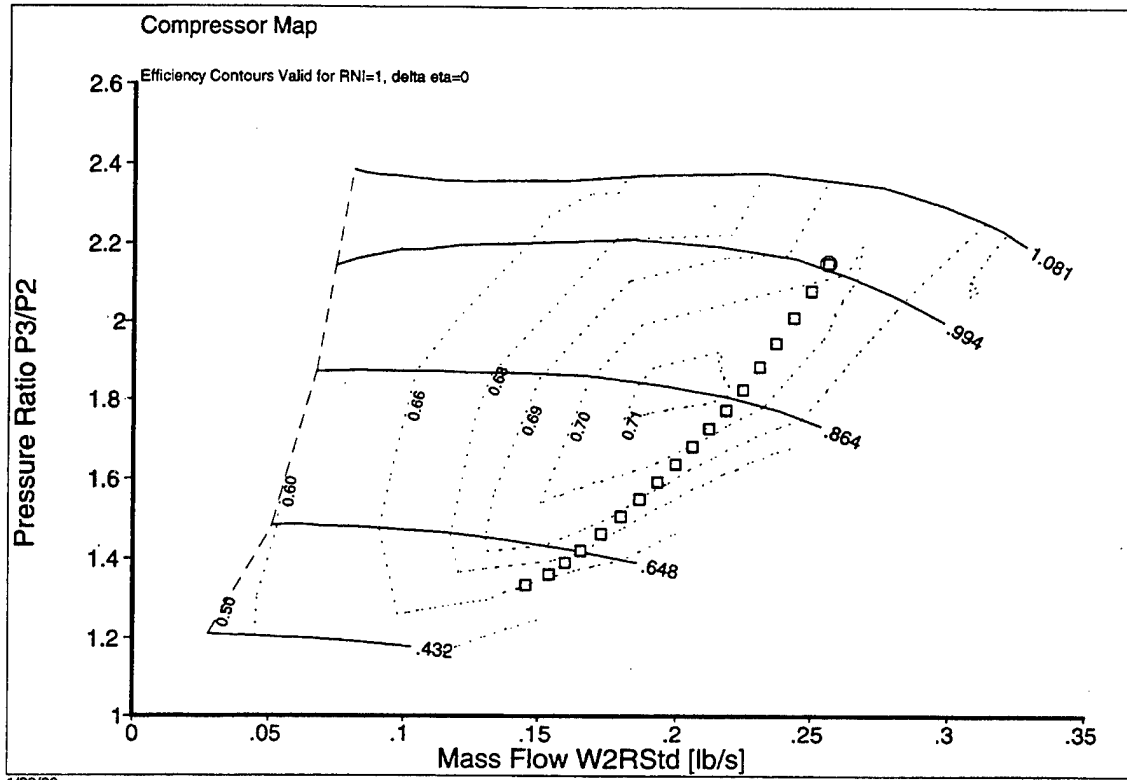

Figure 10a and 10b Compressor and Turbine Maps Respectively

The performance predictions of SFC vs Thrust were matched to the experimentally measured performance data of the J450-2 at the [115000 RPM] design condition. At off-design the GASTURB results become a prediction since these relied on matching of the compressor and turbine maps. The comparison between experiment and measurement are shown in Figure 11 below. As can be seen the comparison over the speed range from approximately 70% to 104% spool speed was excellent.

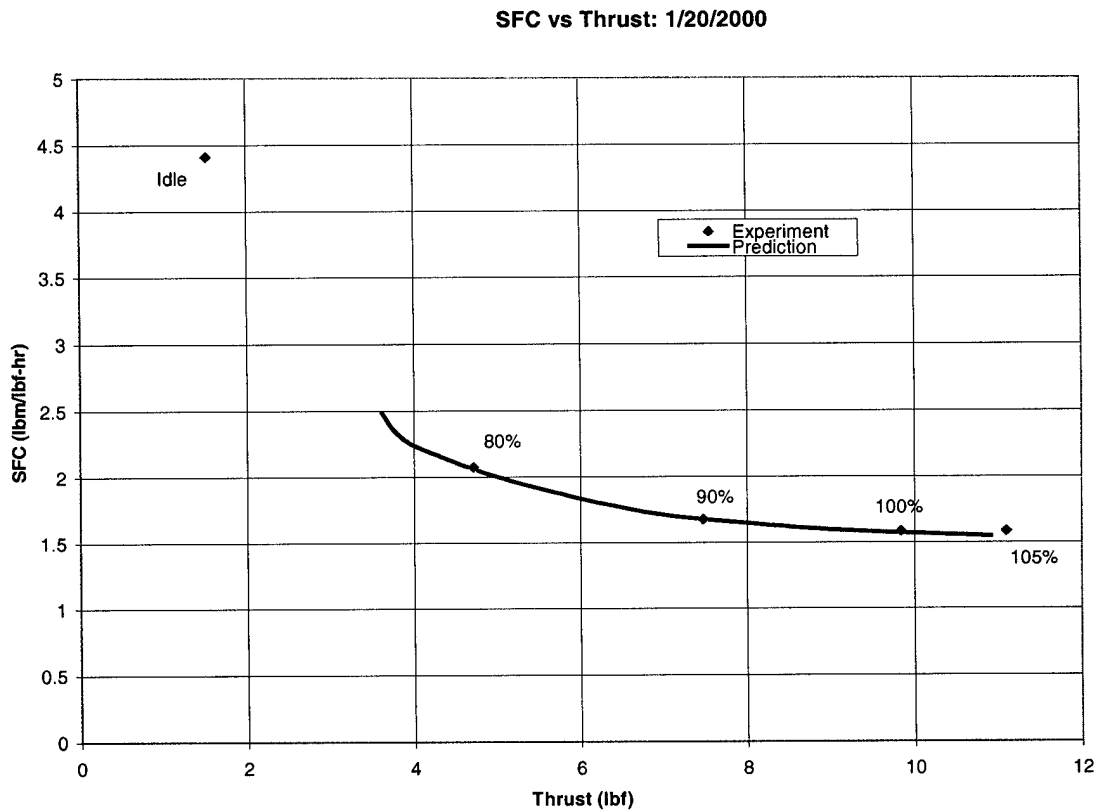

Figure 11. Prediction of SFC vs Thrust

D. RESULTS OF SOPHIA J 450-1 ENGINE TEST PROGRAM

1. Long Shroud Pressure Distribution

Four speed runs were conducted on the Long Shroud at 105%, 100%, 90% and 80% spool speed respectively. For each run data were recorded for SFC, spool speed and Thrust which are provided in Appendix F. Figures 12, 13 and 14 are of Thrust vs spool speed, SFC vs spool speed and SFC vs Thrust respectively, the results are averaged and summarized in Table 5 below. A schematic of the engine in the shroud is shown in Figure 15 with the location of the shroud pressure taps.

RUN	Thrust(lbs.)	SFC(lbm/lb./hr)	Spool Speed (RPM)
1	8.788	2.1193	125000(105%)
2	7.9046	2.0996	120000(100%)
3	6.0434	2.2426	109000(90%)
4	3.998	2.6476	93000(80%)

Table 5. Sophia J450-1 Test Program

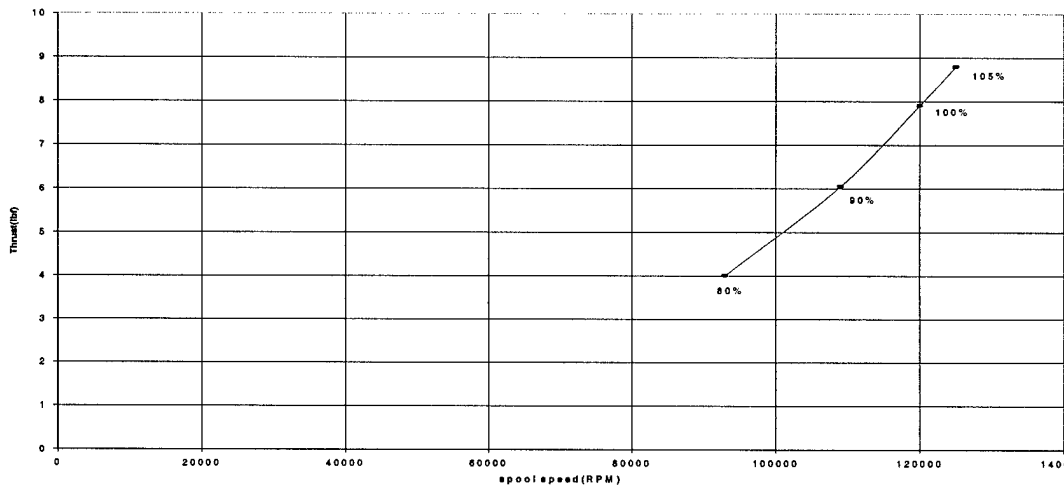

Figure. 12 Thrust vs Spool Speed

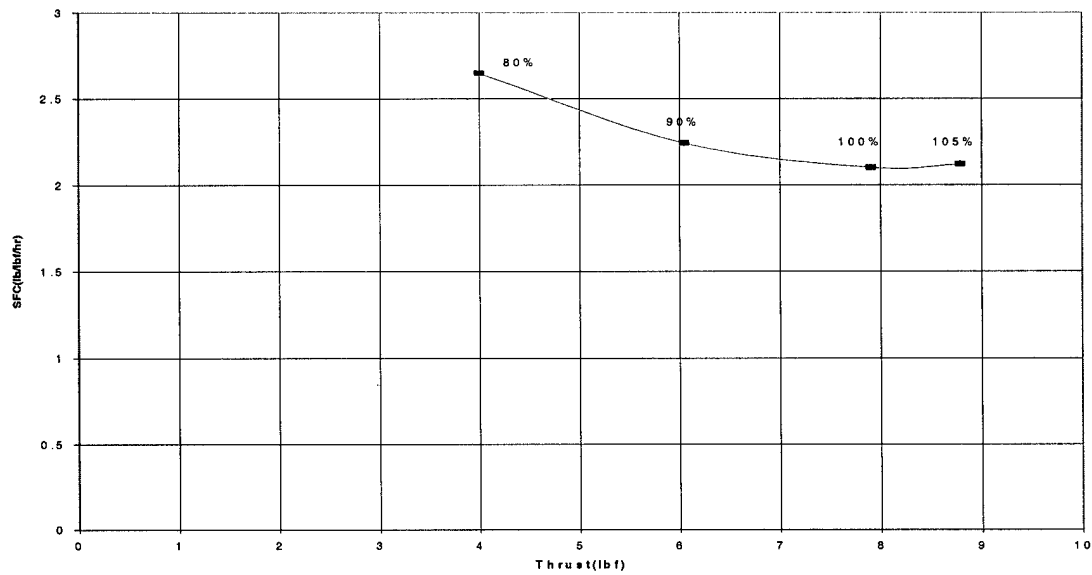

Figure 13. SFC vs Spool Speed

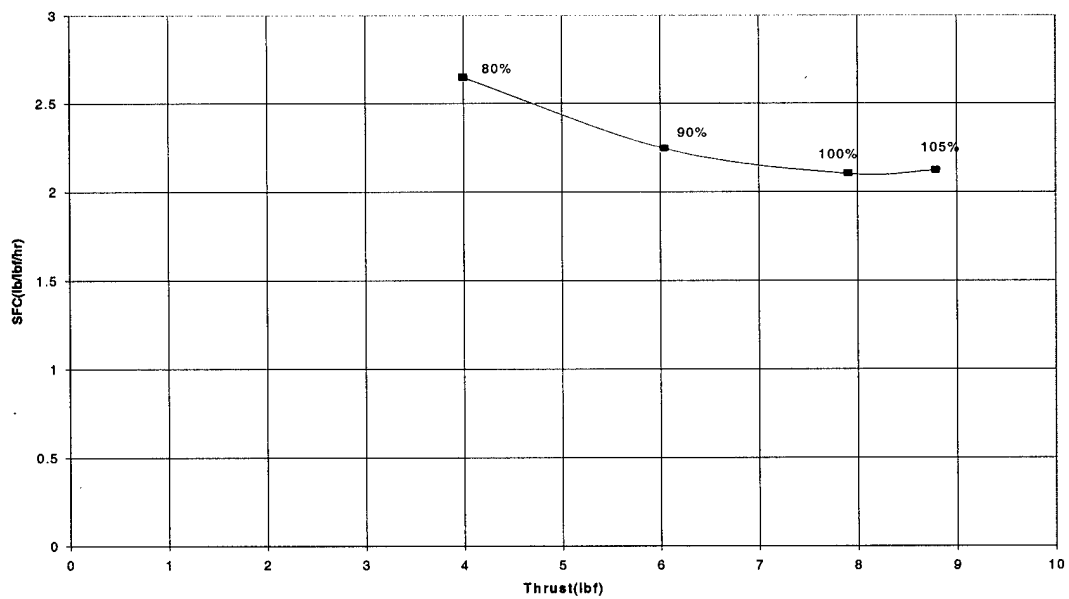

Figure 14. SFC vs Thrust

From Figure 16 below for the Long Shroud pressure distribution versus distance in inches along the shroud at four different spool speeds, it can be seen that the minimum entrainment pressure recorded on shroud were -3.3" water at 105%, -3.2' water at 100%, -2.5" water at 90% and -1.8" water at 80% respectively. Note that there were high positive pressures at the three final pressure taps on the nozzle, which indicated that the final duct was at a significantly higher pressure than atmospheric pressure, which limited the amount of secondary flow entrainment.

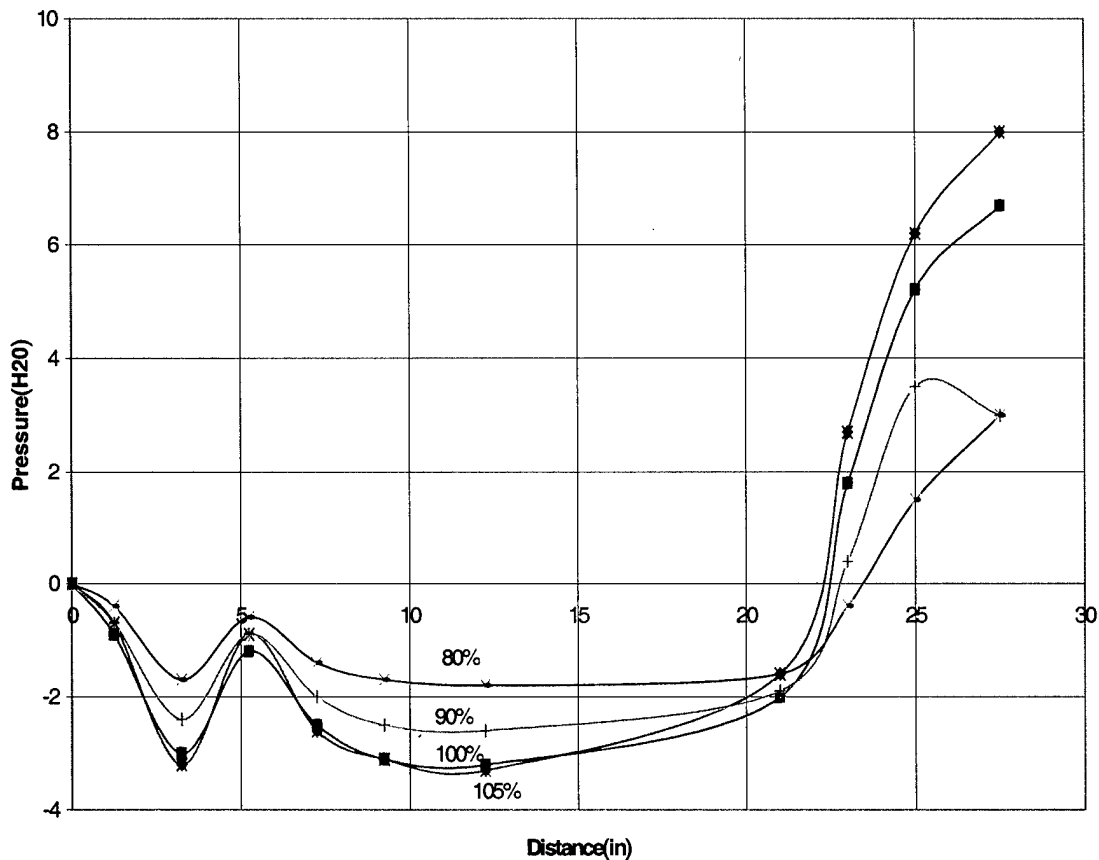

Figure 16. Long Shroud Pressure Distribution

2. Medium Shroud Pressure Distribution

Four design speed runs were conducted on Medium Shroud at 105%, 100%, 90% and 80% spool speed respectively. For each run data were recorded for SFC, spool speed and Thrust which are provided in Appendix F. Figures 17, 18 and 19 are of Thrust vs spool speed, SFC vs spool speed and SFC vs Thrust respectively, the results are averaged and summarized in Table 6 as below. A photograph of Medium Shroud installation in the stand is shown in Figure 20. A schematic of the engine in the shroud is shown in Figure 21 with the location of the shroud pressure taps.

RUN	Thrust(lbs.)	SFC(lbm/lb./hr)	Spool Speed (RPM)
	9.4191	1.9382	125000(105%)
2	8.423	1.949	120000(100%)
3	6.53374	2.049	109000(90%)
4	4.2406	2.4728	93000(80%)

Table 6. Sophia J450-1 Test Program Medium Shroud

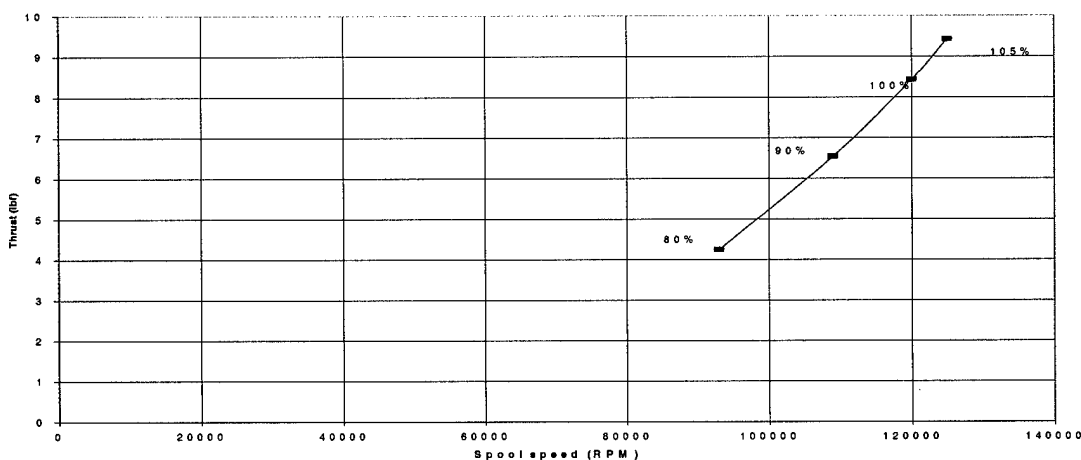

Figure 17. Thrust vs Spool Speed

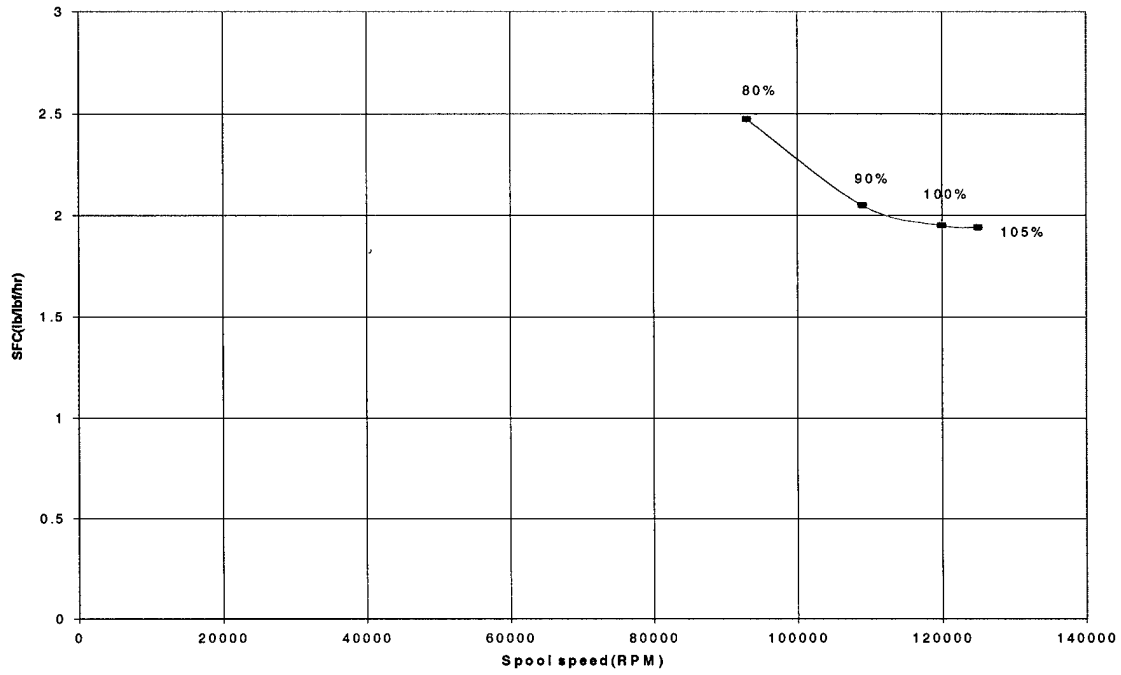

Figure 18. SFC vs Spool Speed

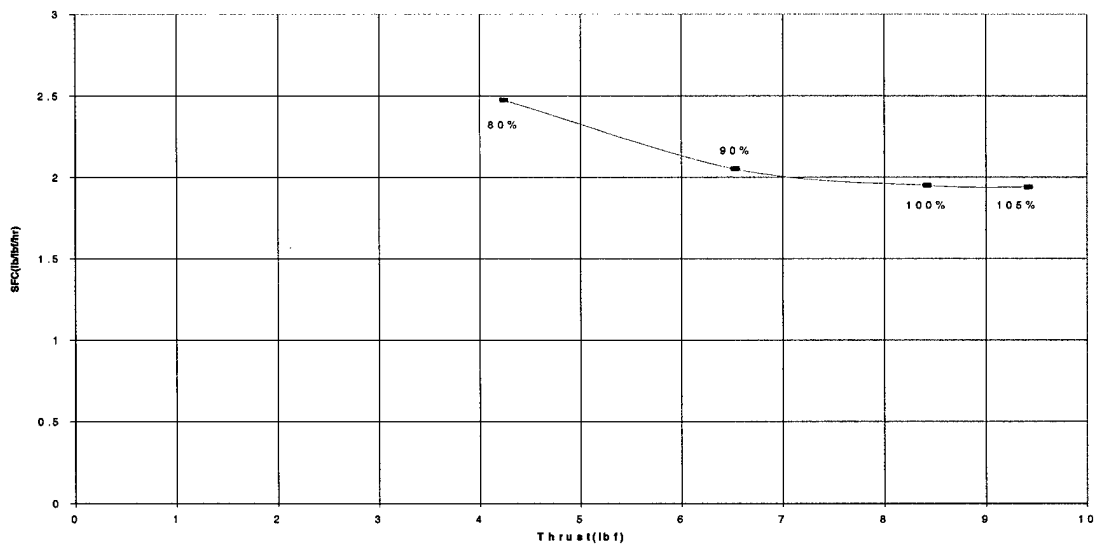

Figure 19. SFC vs Thrust

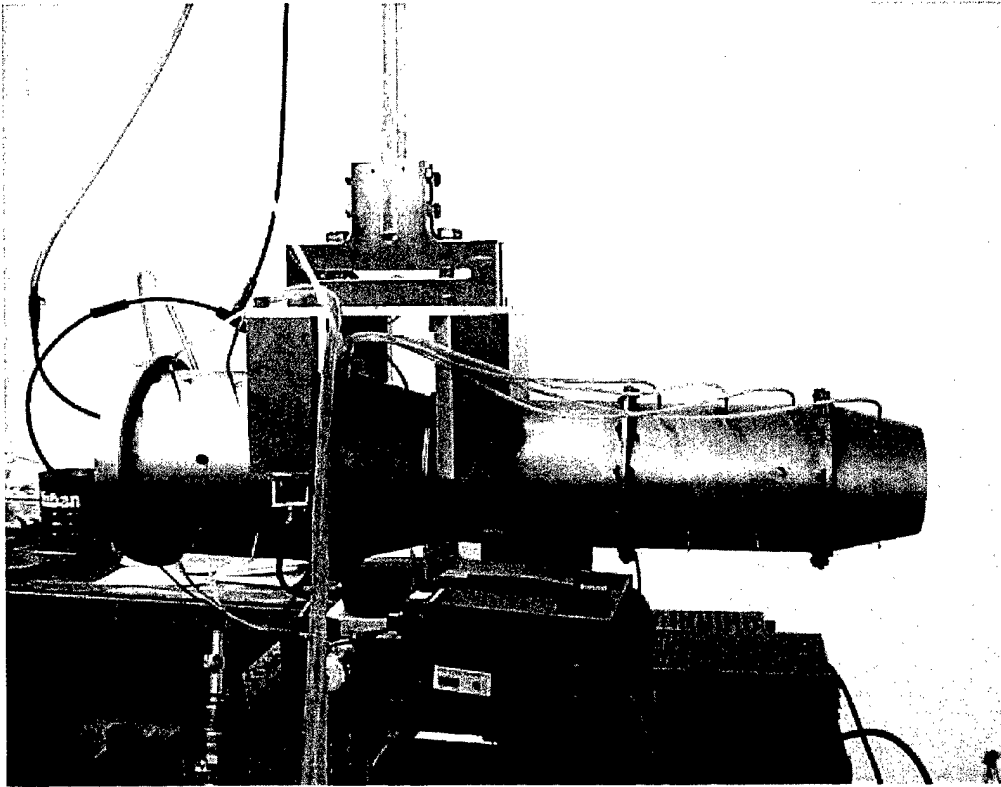

Figure 20. A Photograph of Medium Shroud

From Figure 22 below for the Medium Shroud pressure distribution versus distance in inches along the shroud at four different spool speeds, it can be seen that the minimum entrainment pressure recorded on shroud were -3.7" water at 105%, -3.4" water at 100%, -2.9" water at 90% and -1.9" water at 80% respectively. Note that there were positive pressures at the final pressure taps on the nozzle, which indicated that the final duct was at a higher pressure than atmospheric pressure, which limited the amount of secondary flow entrainment.

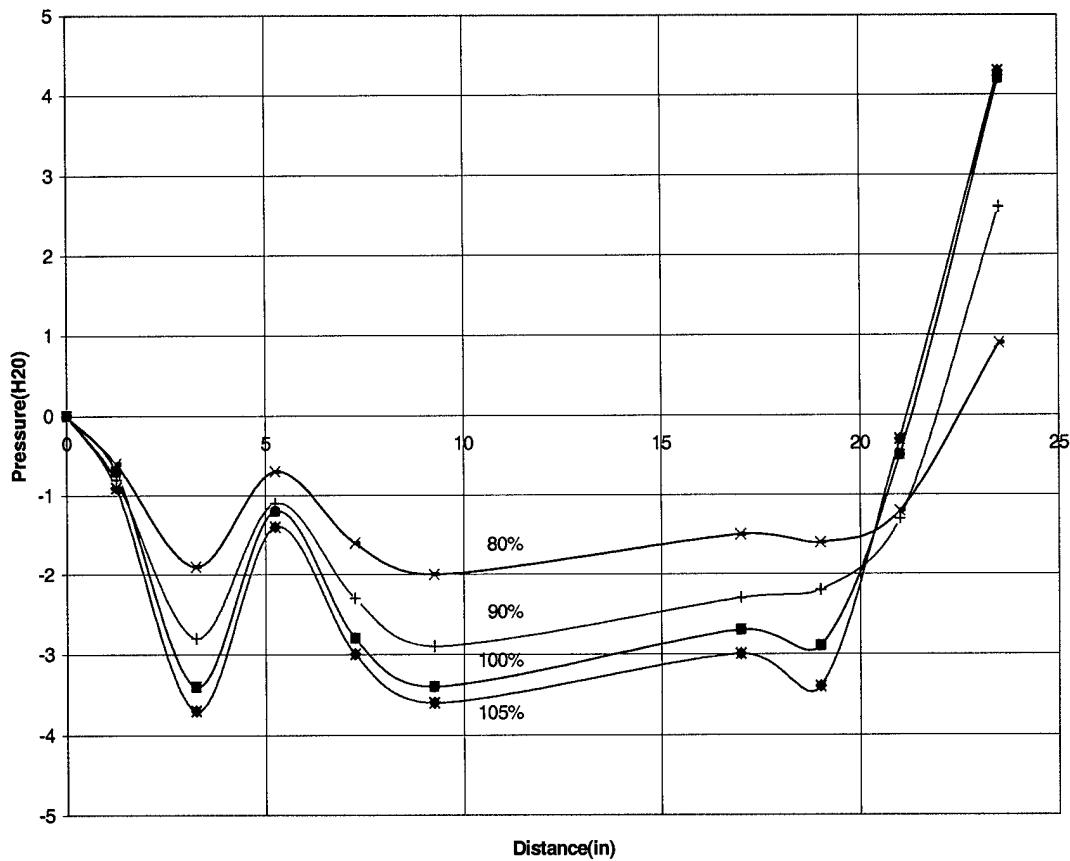

Figure 22. A plot of Medium Shroud Pressure Distribution

3. Short Shroud Pressure Distribution

Four design speed runs were conducted on Short Shroud at 105%, 100%, 90% and 80% spool speed respectively. For each run data were recorded for SFC, spool speed and Thrust which are provided in Appendix F. Figures 23, 24 and 25 are of Thrust vs spool speed, SFC vs spool speed and SFC vs Thrust respectively, the results are averaged and summarized in Table 7 as below. A photograph of Short Shroud installation in the stand is shown in Figure 26. A schematic of the engine in the shroud is shown in Figure 27 with the location of the shroud pressure taps.

RUN	Thrust(lbs.)	SFC(lbm/lb./hr)	Spool Speed (RPM)
1	9.5206	1.921	125000(105%)
2	8.626	1.912	120000(100%)
3	6.599	2.021	109000(90%)
4	4.509	2.358	93000(80%)

Table 7. Sophia J450-1 Test Program

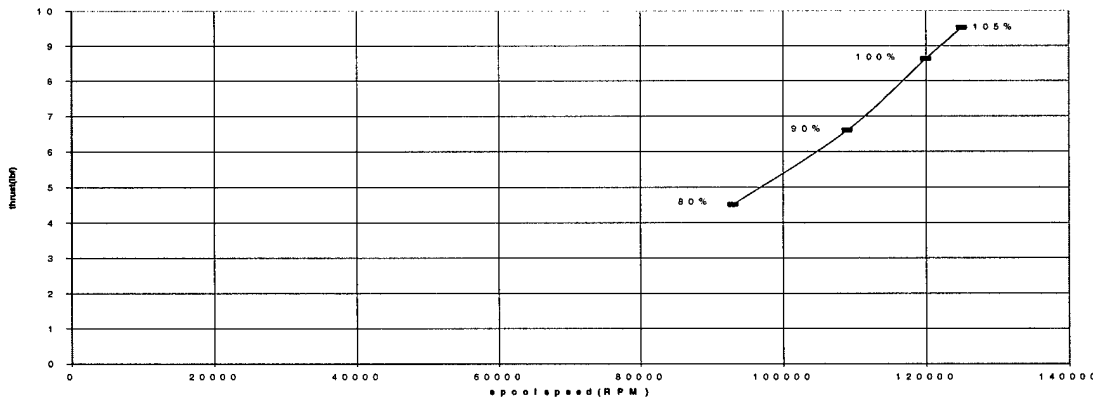

Figure 23. Thrust vs Spool Speed

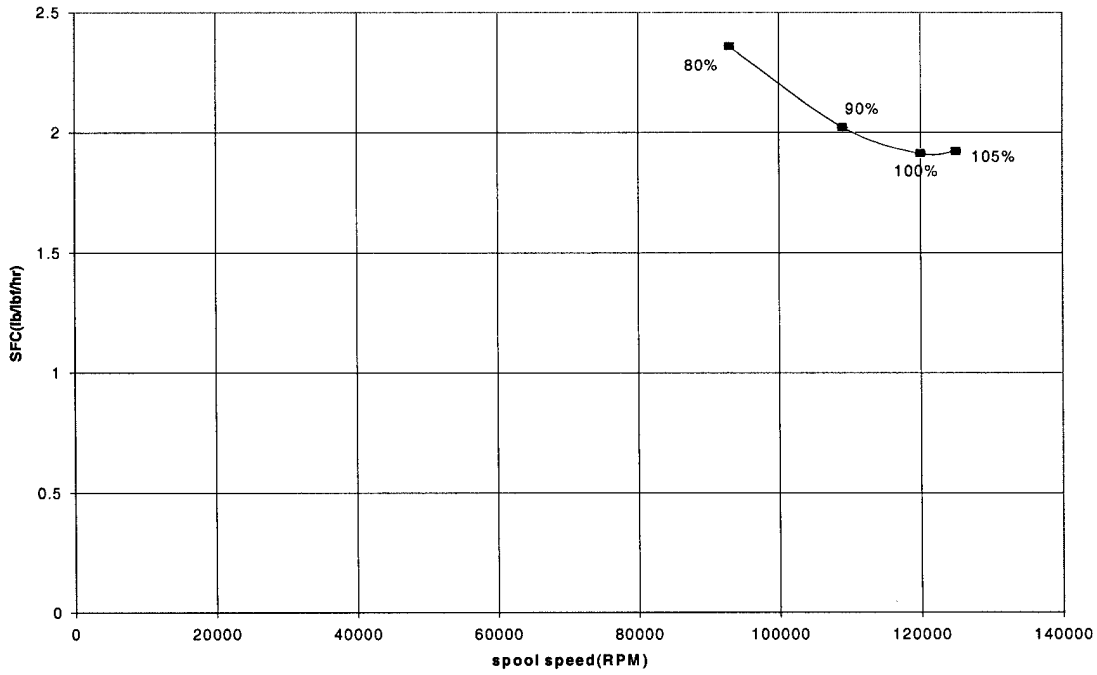

Figure 24. SFC vs Spool Speed

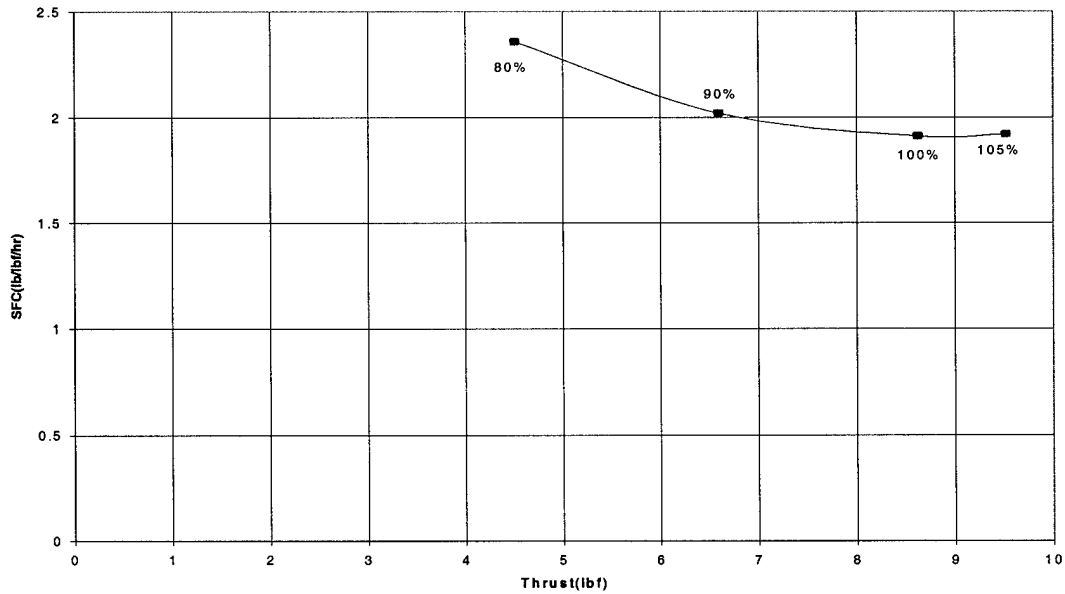

Figure 25. SFC vs Thrust

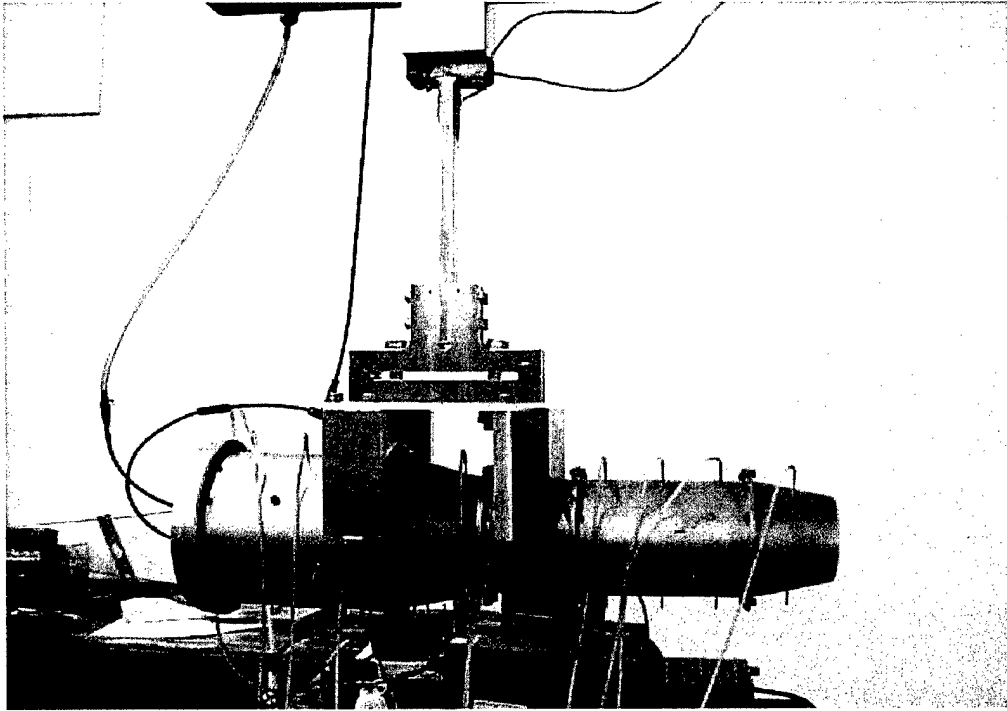

Figure 26. A Photograph of Short Shroud

From Figure 28 below for the Short Shroud pressure distribution versus distance in inches along the shroud at four different pool speeds, it can be seen that the minimum entrainment pressure recorded on shroud were -4.1" water at 105%, -3.8" water at 100%, -2.9" water at 90% and -2" water at 80% respectively. Note that there were high positive pressures at the final pressure taps on the nozzle, only for the two highest speed case.

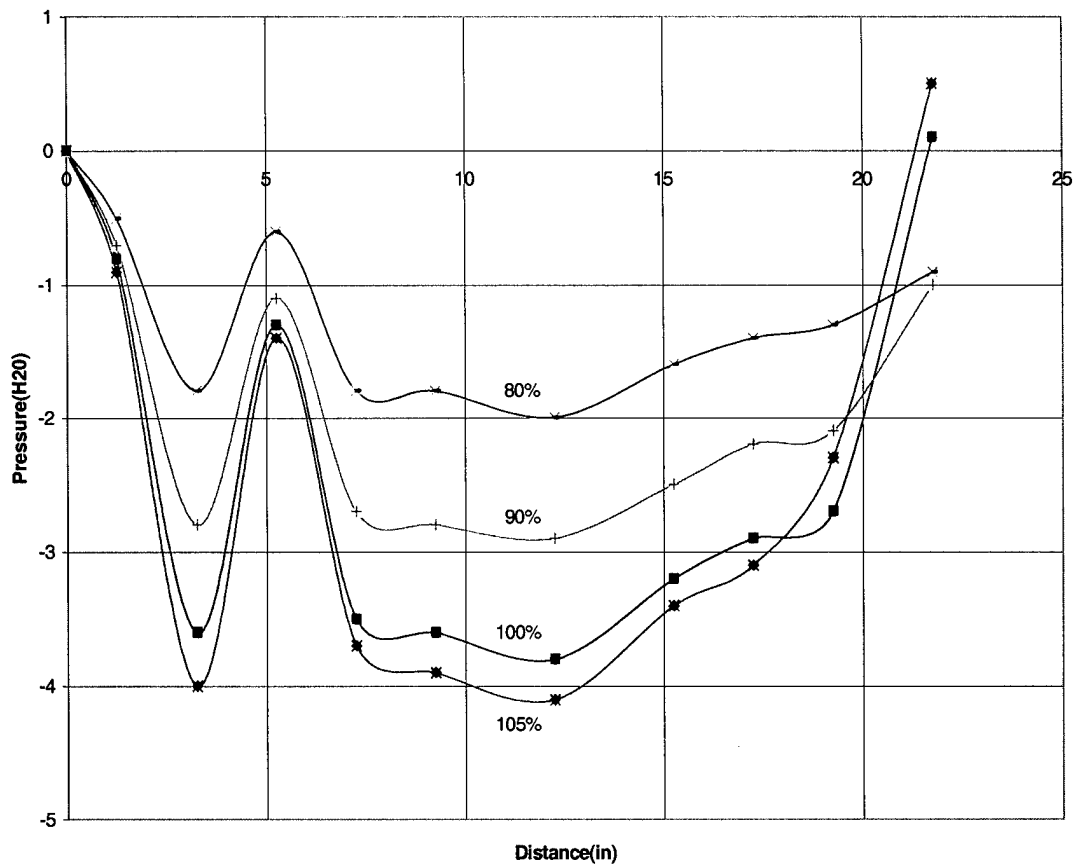

Figure 28. A plot of Short Shroud Pressure Distribution

E. SUMMARY AND COMPARISON OF RESULTS

1. Comparison of Shroud Pressure Distribution

Figure 29 shows the comparison, at 100% spool speed, of the pressure distributions for the Long, Medium and Short Shrouds. As can be seen the minimum entrainment (or suction) pressures for each configuration were -3.2, -3.4 and -3.8 inches of water respectively. Overall the shape of the pressure distribution over the front of the shroud remained unchanged. The Medium Shroud experienced the minimum suction pressure at a distance of 3.25 inches from the shroud inlet. The Long Shroud also experienced the minimum suction pressure at 3.25 inches from the inlet. And The Short Shroud experienced the minimum suction pressure at a distance of 12.25 inches from the inlet or at the exhaust nozzle of the J450-1.

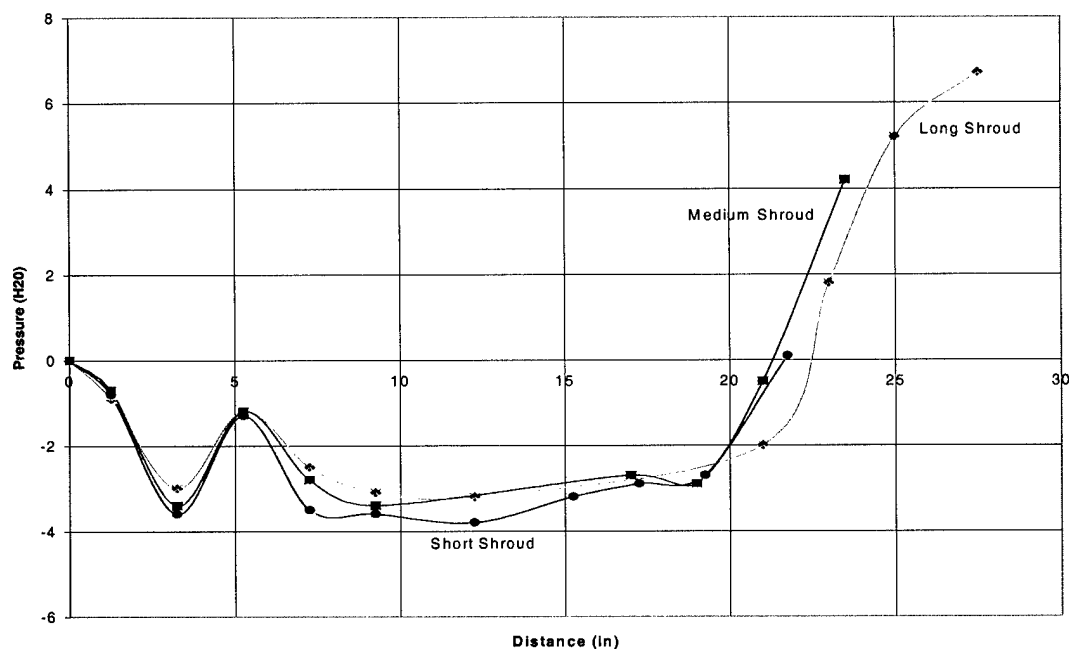

Figure 29. Pressure Distribution Between Shrouds

Also of note was that as the duct length increased, the final positive pressure in the nozzle increased. This positive pressure was probably a significant factor in controlling the overall entrainment rate into the shroud. The Short Shroud with nozzle displayed a higher level of secondary flow entrainment, indicated by the lower pressure distribution throughout the shroud.

2. Comparison of SFC, Thrust and Spool Speed

From Figure 30 Thrust vs Spool speed, Figure 31 SFC vs spool speed and Figure 32 SFC vs Thrust of Long, Medium and Short Shroud comparison respectively.

The Thrust vs spool speed comparison of Short Shroud results showed that at 105% spool speed the thrust is (9.52 lbf), with lower spool speed 80% the Thrust is at (4.509 lbf). Which had a better performance than either of Long and Medium Shrouds. In general comparisons of the above shroud results can be concluded that the Short Shroud is the best in performance with a sharp increase in secondary flow entrainments.

The SFC vs spool speed comparison of Short Shroud results showed that at 105% spool speed the SFC is (1.921 lb/lbf/hr), with lower spool speed 80% the SFC is at (2.358 lb/lbf/hr). Which had a better performance than either of Long and Medium Shrouds.

The SFC vs Thrust comparison of Short Shroud results showed that at 105% spool speed the thrust is (9.52 lbf) and SFC at (1.921 lb/lbf/hr), with lower spool speed 80% the thrust is at (4.509 lbf) and SFC is at (2.358 lb/lbf/hr). Which had a better performance than either of Long and Medium Shrouds.

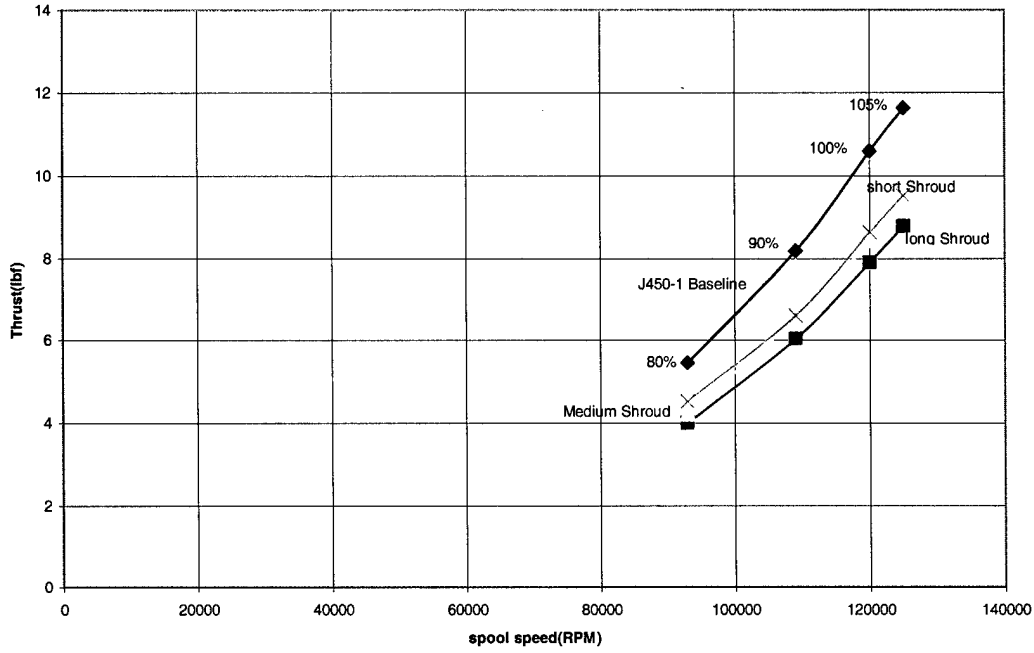

Figure 30. Thrust vs Spool Speed

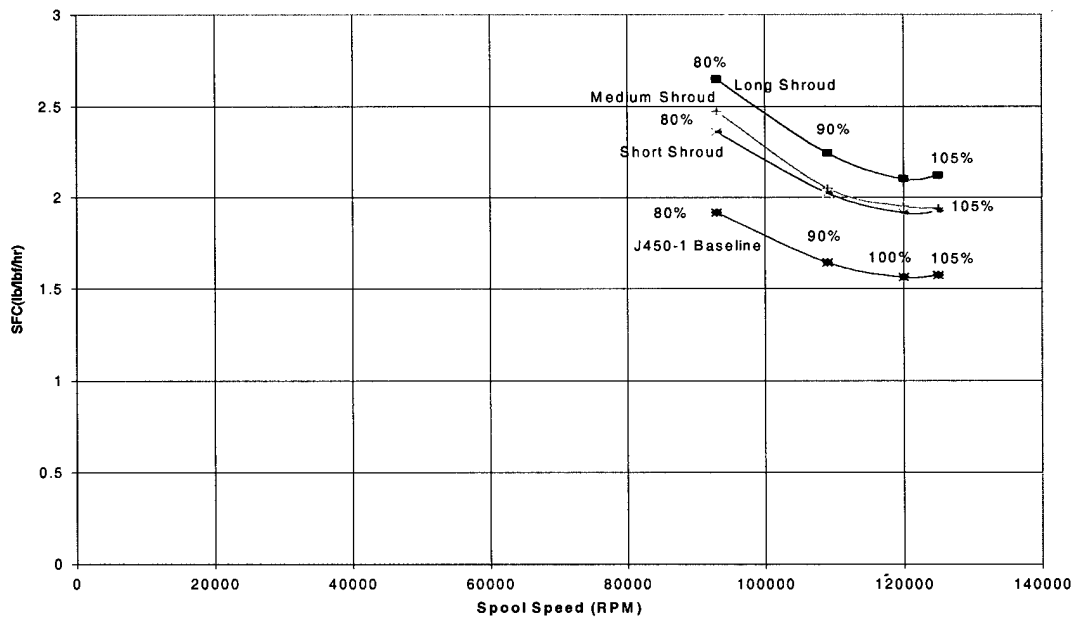

Figure 31. SFC vs Spool Speed

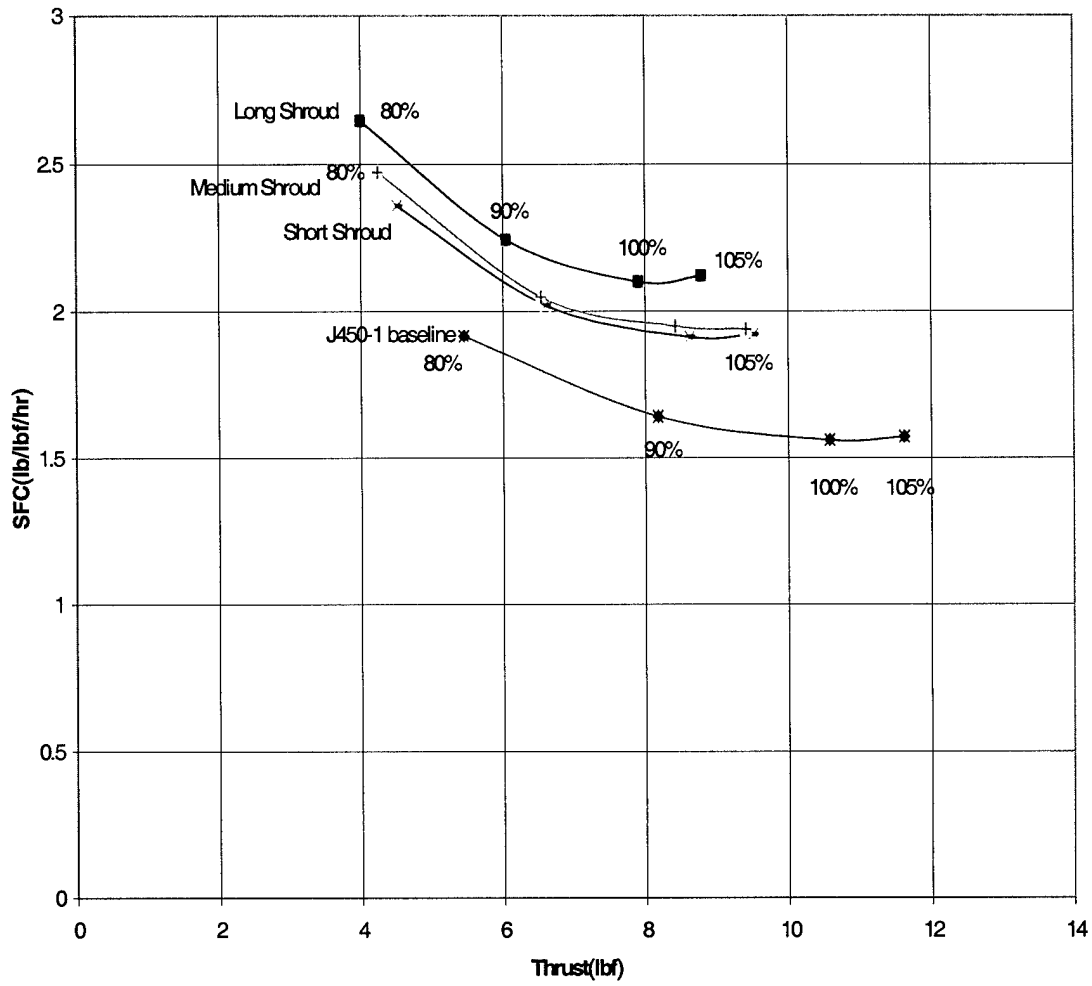

Figure 32. SFC vs Thrust

F. SUPERSONIC INTAKE (CONICAL) DESIGNS

Purpose: Design a single fixed inlet suitable for a Missile at a freestream Mach number of $M=2$ at 10,000 feet on a standard day. The engine is a Turbojet/Ramjet combined cycle engine, at the design Mach number.

Discussion: Designing an inlet for Turbojet/Ramjet combined cycle engine of several objectives, such as performance, manufacturing complexity and weight. ultimately, the inlet design should bring the freestream Mach number down to a velocity of approximately $M=0.5$, in order to maximize engine performance. The optimum way to achieve this is either by using a variable ramp or several ramps, which would generate several oblique shocks and a final normal shock. The greater the number of oblique shocks (theoretically), the greater the total pressure recovery. However, variable ramp inlets are heavy and therefore not ideal for most Missile designs. The designer must evaluate the weight and complexity of the ramp(s) and performance tradeoffs. The inlet geometric shape can also be optimized for a specific flight condition, but again performance trade-offs must be made depending on the expected performance envelope of the Missile.

Procedure: The inlet flowfield features are shown in Figure 33 whereby the inlet design was to include one oblique shock and one normal shock to decelerate the flow from Mach 2 to subsonic conditions at station 2. At the design condition of Mach 2 five different inlet cone angles were considered namely 10, 12.5, 15, 17.5 and 20 degrees. The 15 degree cone angle gave the nearly optimum stagnation pressure ratio as shown in Figure 34 and tabulated in Table 8. A sample calculation of the stagnation pressure drop across the shock system for 15 degrees is presented in Appendix L.

A similar parametric study was done at Mach 4 whereby the inlet cone angle was varied from 5 degrees to 27.5 degrees. Where the optimum was found to be approximately 10 degrees as shown in Figure 35 and Table 9. Because of size constraints the inlet cone angle of 15 degrees was chosen in the final design. Then a off- design study

was conducted with the 15 degrees cone angle inlet at various supersonic free-stream Mach numbers from 1.5 to 4. The predicted performance of the inlet for these conditions is shown in Figure 36 and Table 10. Where the stagnation pressure ratio varied from 0.98 to 0.66.

Finally the schematic of the engine in the shroud with the supersonic intake are presented in Figure 38, and the engineering drawing of the inlet spike and struts are presented in Figure 39 and 40 respectively.

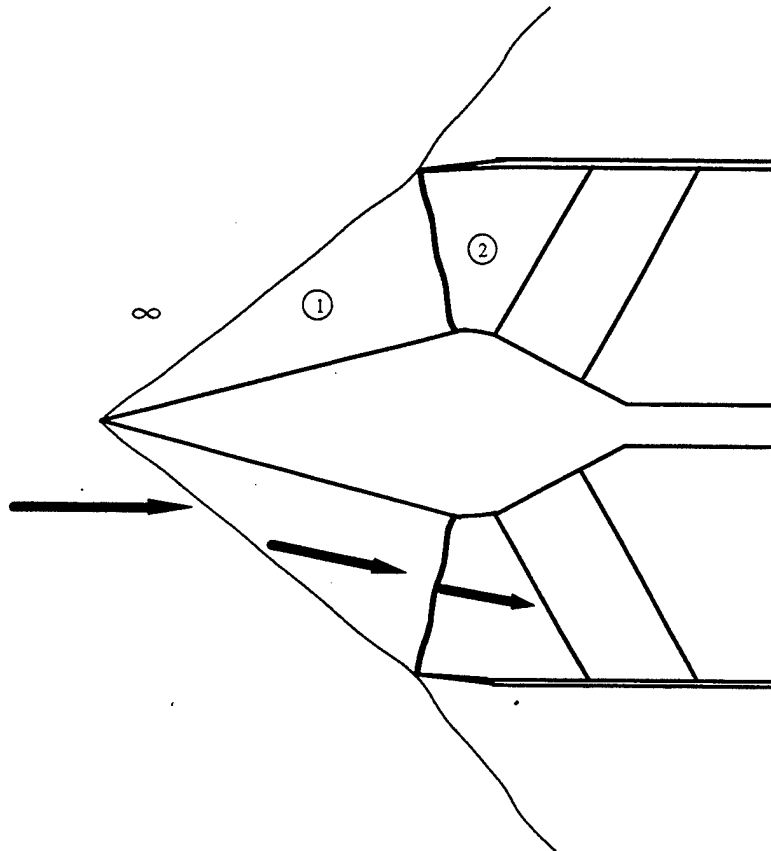

Figure 33. Inlet Flowfield Features

Mach Number 2	
Cone Angle (deg)	Pt2/Pt_inf
10	.903
12.5	.909
15	.909
17.5	.8956
20	.858

Table 8. Intake Design at Mach 2 With a Different Cone Angles

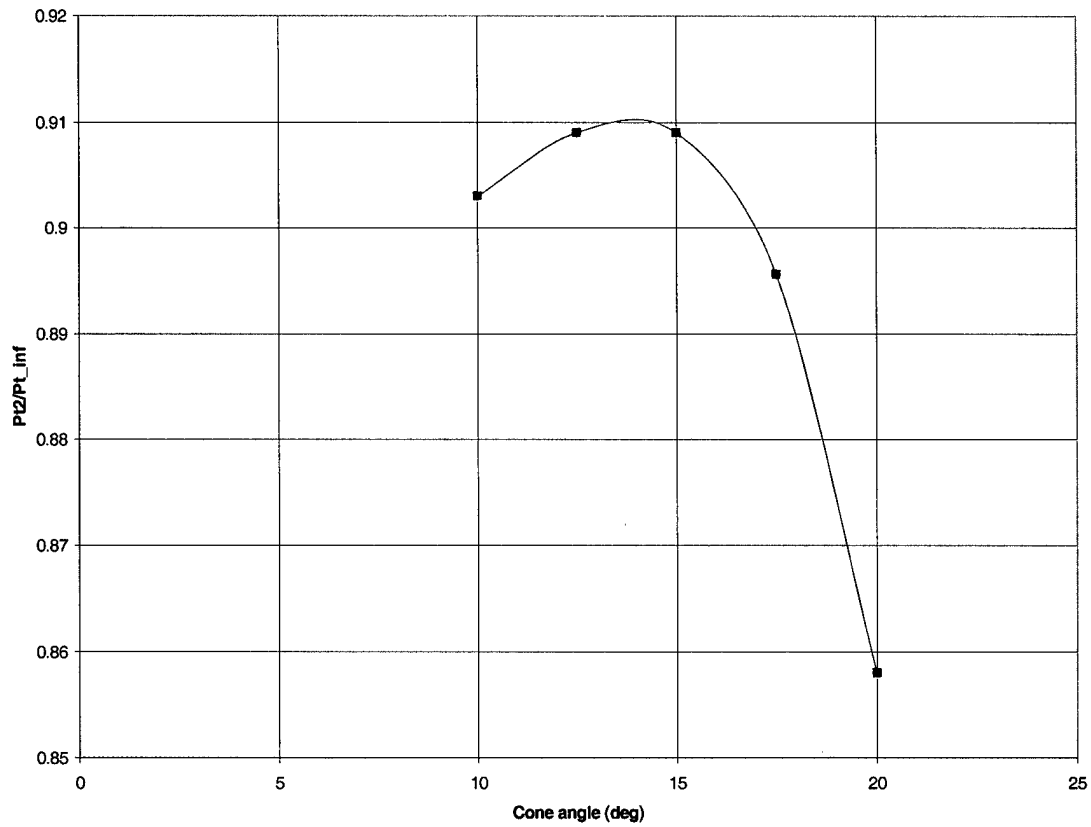

Figure 34. Intake Pressure Ratio at Mach 2 For a Different Cone Angles

Mach Number 4	
Cone Angle (deg)	Pt2/Pt_inf
5	.664
10	.677
15	.6649
17.5	.644
20	.609
22.5	.57
25	.535
27.5	.409

Table 9. Intake Design at Mach 4 With a Different Cone Angles

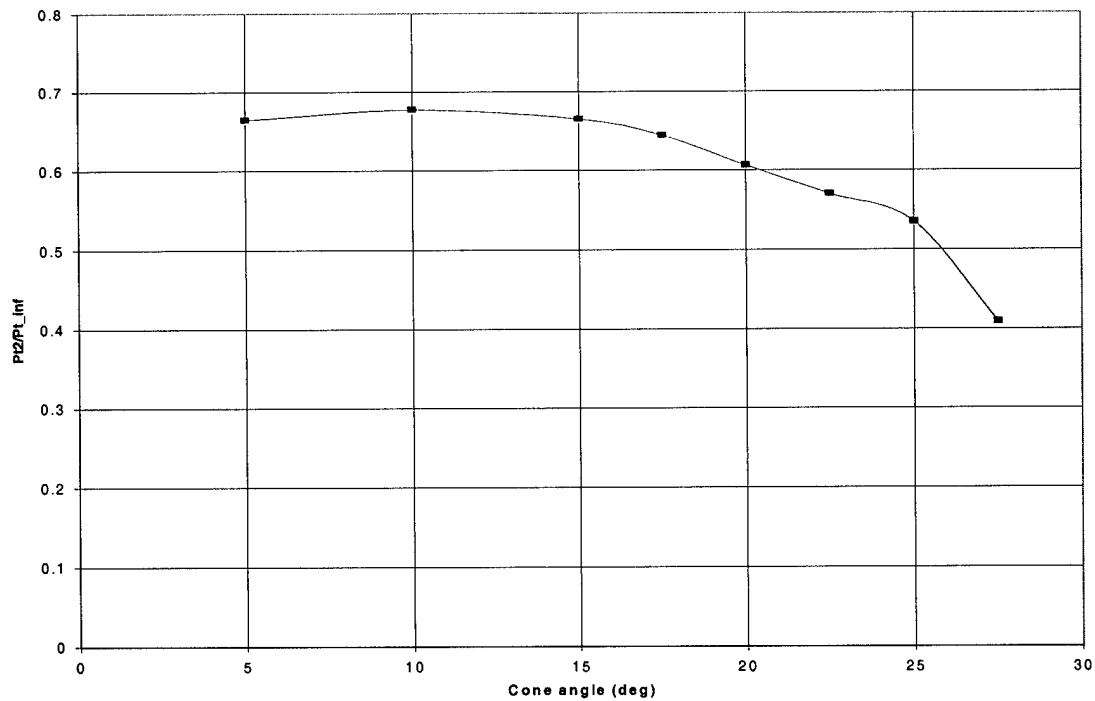

Figure 35. Intake Pressure Ratio at Mach 4 For a Different Cone Angles

Cone Angle 15 (deg)	
Mach Number	Pt2/Pt_inf
1.5	.9829
2	.909
2.5	.8005
3	.6672
4	.6649

Table 10. Intake Design at Cone Angle 15 (deg) With a Different Mach Numbers

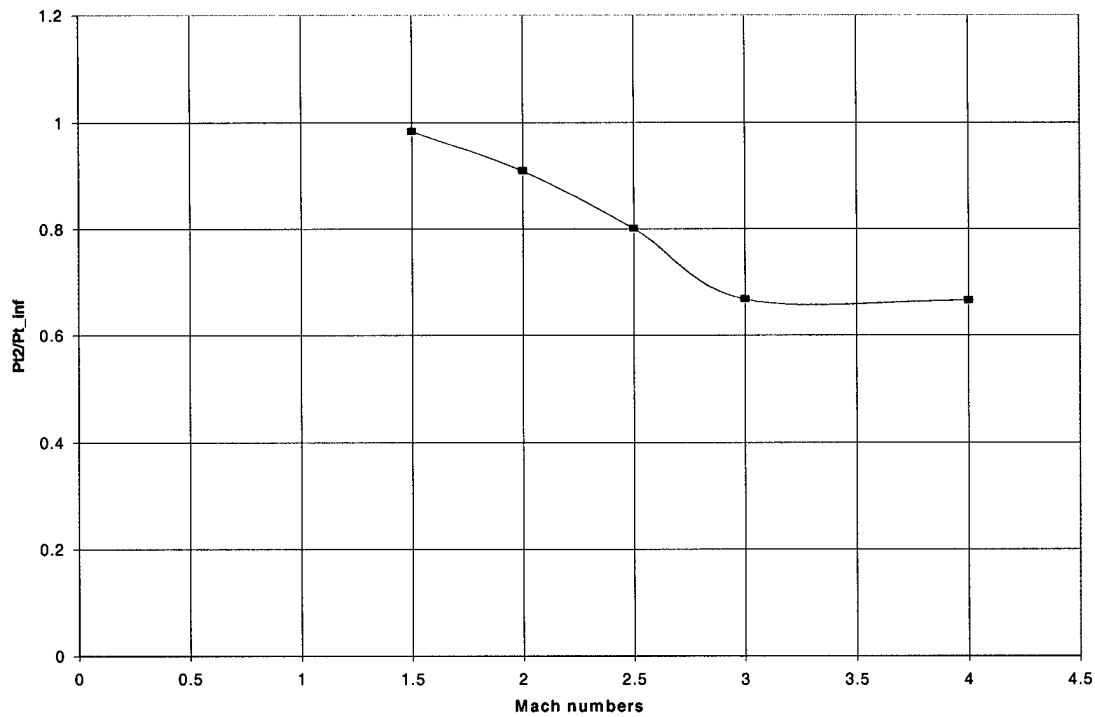

Figure 36. Intake Pressure Ratio at Cone Angle 15 deg For a Different Mach Numbers

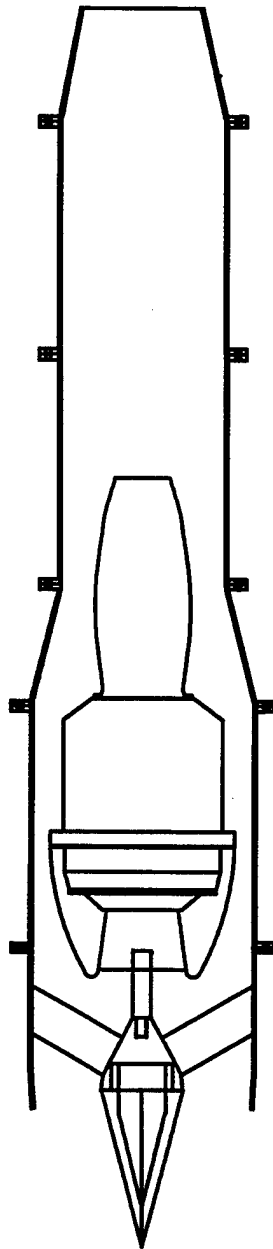

Figure 37. Schematic of Engine in Shroud With a Supersonic Intake

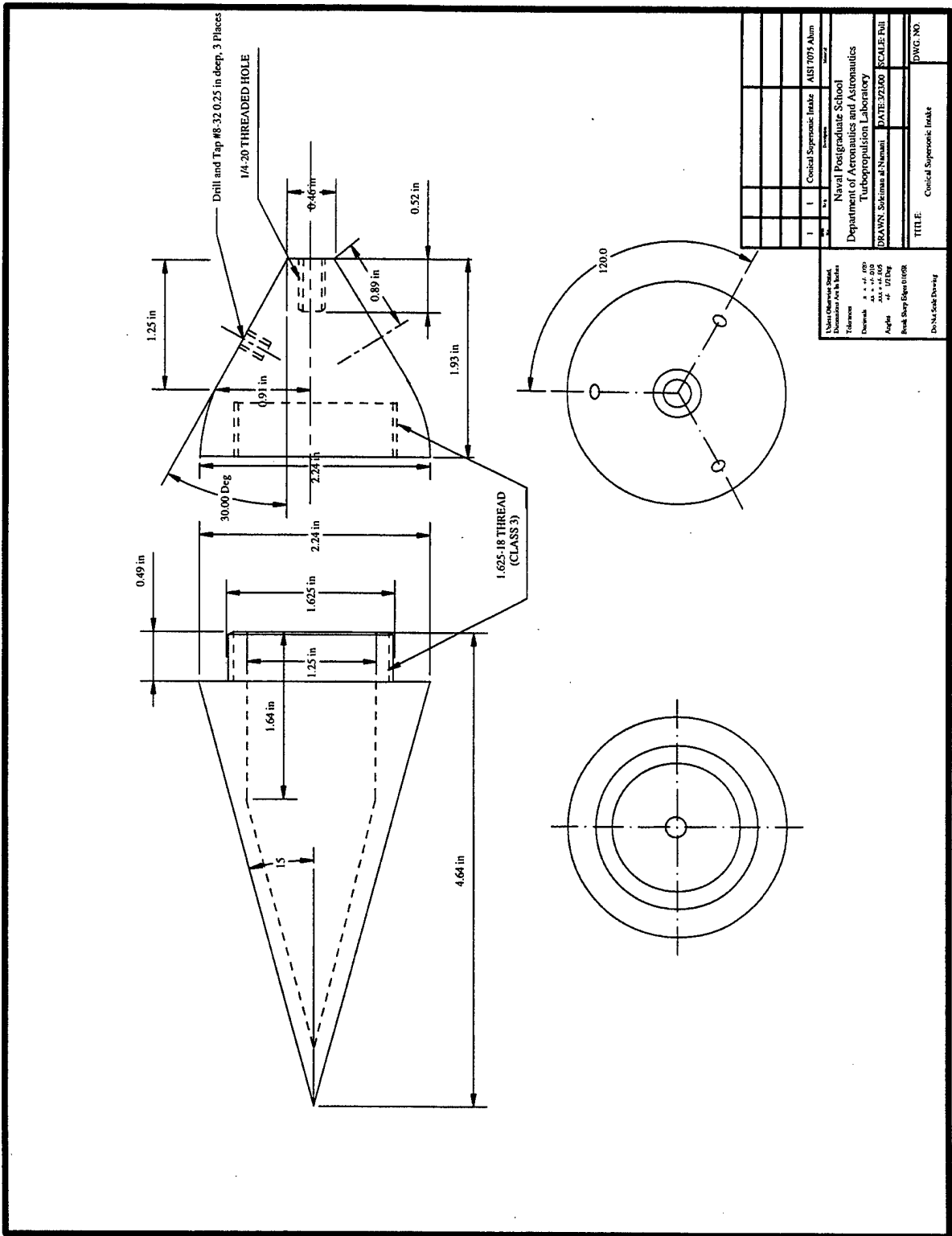
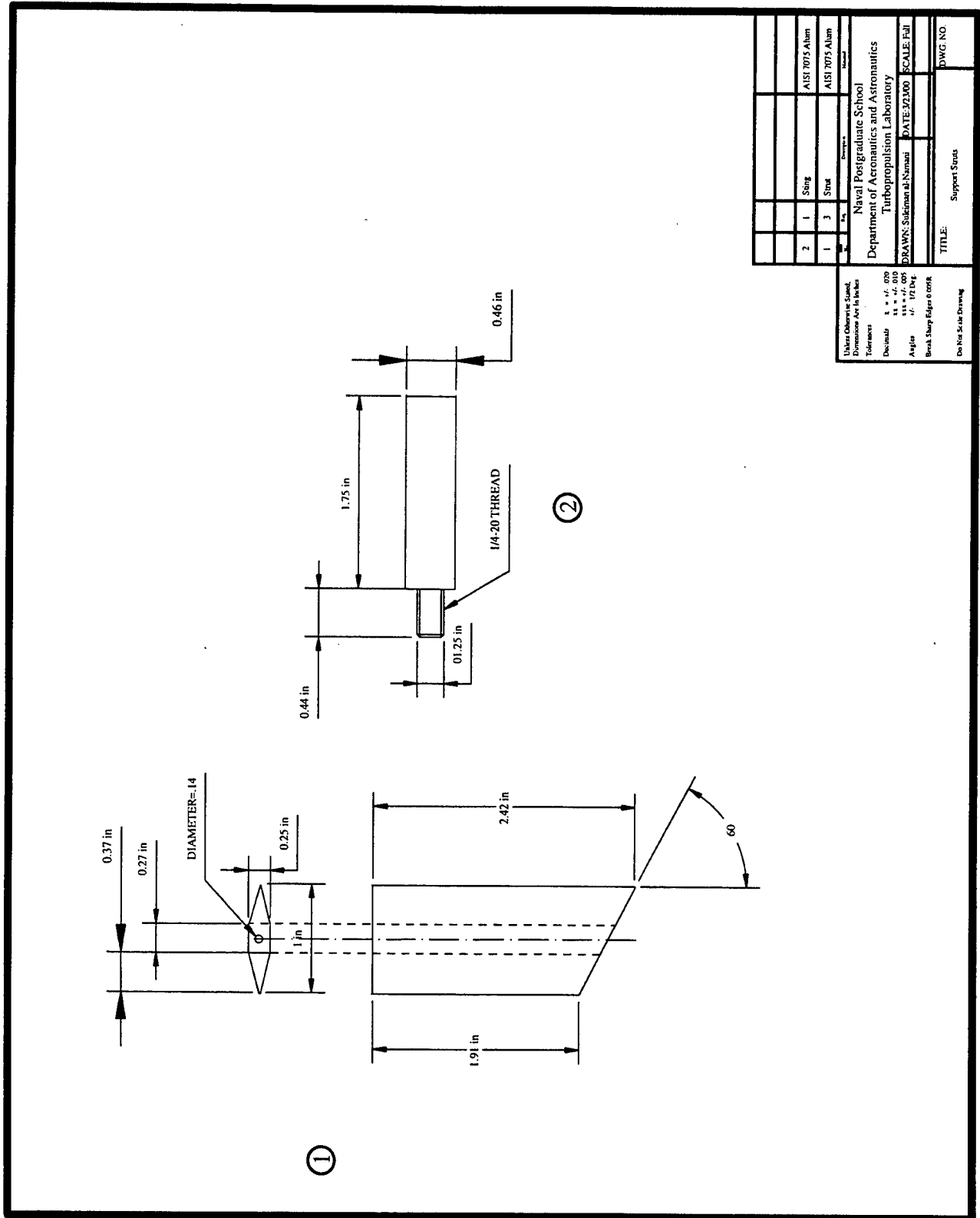

Figure 38. Conical Supersonic Intake Design Detailed Drawing



2	1	String	AISI 7075 Alum
1	3	String	AISI 7075 Alum
Naval Postgraduate School Department of Aeronautics and Astronautics Turbopropulsion Laboratory			
DRAWN: Sultanat al-Naimat		DATE: 02/10/00	SCALE: Full
TITLE: Support Struts			DWG. NO.

Unless Otherwise Specified,
 Dimensions Are in Inches
 Tolerances
 Decimals ± .010
 Fractions ± .005
 Angles ± 1/16 Deg
 Break Sharp Edges 0.008
 Do Not Scale Drawing

Figure 39. Conical Supersonic Intake Design Support Struts Detailed Drawing

G. J450 FLIGHT ENVELOPE PREDICTIONS

The Mach number dependent relationship in GASTURB was used to determine the intake performance by using the equation $[P_{t2}/P_{t_{inf}} = 1 - 0.057(M_{inf} - 1)^{1.35}]$ as presented by Hesse (Ref. 9).

Then compressor and turbine maps were used as follows: First, to predict the subsonic performance by using different Mach numbers starting from Mach number 0 to 0.8 at altitudes from 0 ft to 1000 ft. The 3-D plot of Thrust vs Mach number and altitude is presented in Figure 40.

Second, to predict the subsonic and supersonic performance by using different Mach numbers starting from Mach number 0 to 2 at altitudes from 0 ft to 1000 ft. The 3-D performance plot is presented in Figure 41. As it can be seen from the plot the Thrust increased from Mach number 1 to 1.5. However at Mach 2 the sea level thrust was less than the thrust at 10000 ft indicating that the engine will perform better at altitude in the supersonic range.

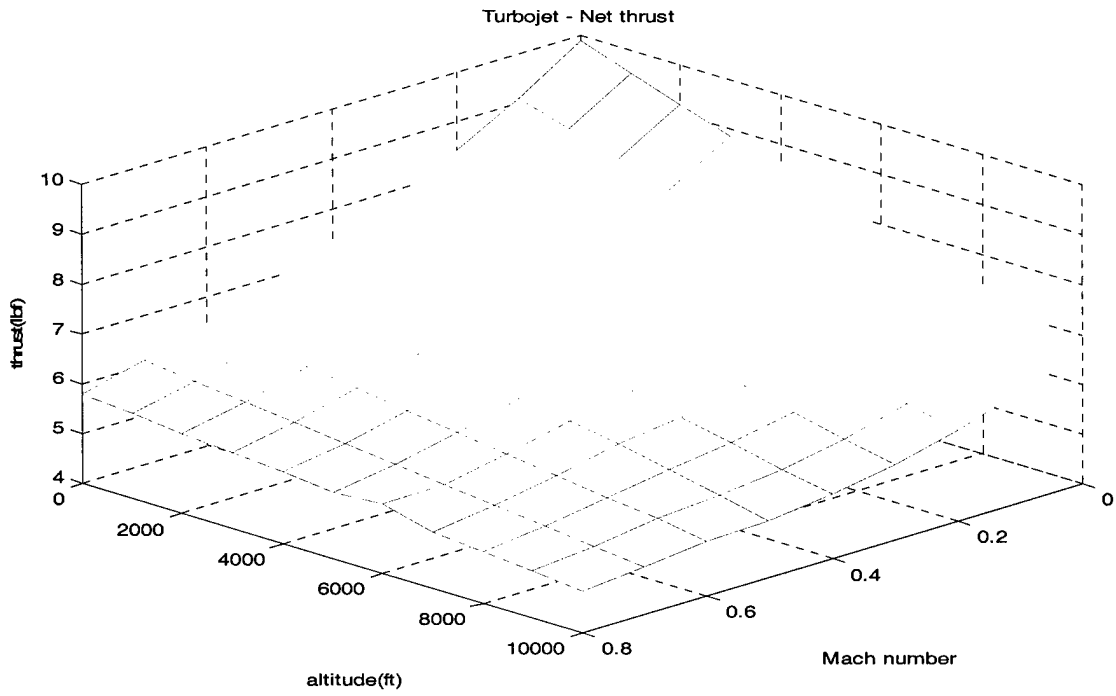

Figure 40. Prediction Subsonic Thrust Performance of the Sophia J450

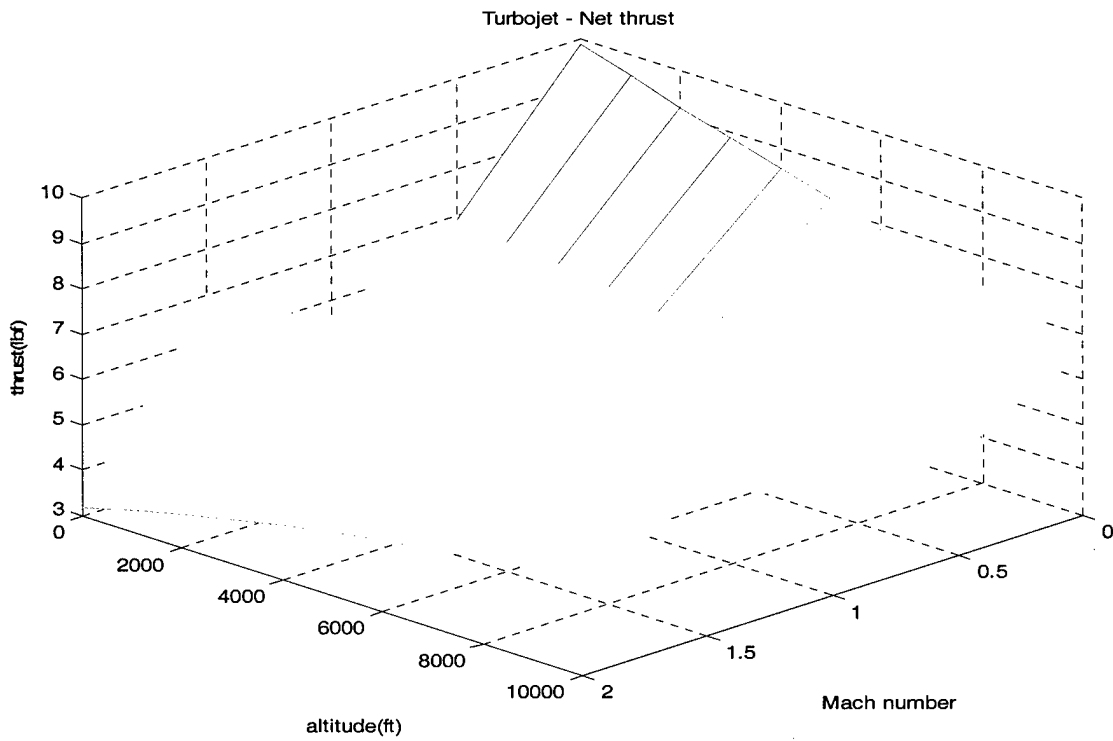

Figure 41. Predicted Subsonic and Supersonic Performance of Sophia J450

III. CONCLUSIONS AND RECOMMENDATIONS

A. CONCLUSIONS

A remotely controlled microjet engine, the Sophia J450-2 was setup and statically tested in an instrumented test stand. Performance parameters such as thrust, specific fuel consumption and engine spool speed were recorded. An engine performance program, GASTURB, was used with component maps for the compressor and the turbine to predict the off-design performance of the engine. Excellent comparisons between the experiment and prediction were realised over a wide operating range of the engine. Several shroud configurations were tested with an uninstrumented engine, the Sophia J450-1, to determine the performance penalty of the engine in the various duct lengths. Shroud pressures were also recorded to determine the amount of entrainment of secondary air into the shroud. These measurements indicated that the short shroud configuration experienced the best entrainment of secondary air.

The design of a supersonic spike inlet was completed with the view to future non-static tests of the engine in a free jet facility. The design flight condition was chosen to be Mach 2 resulting in a near optimum inlet cone angle of 15 degrees for the two shock (one oblique and one normal) system. The flight envelope of the Sophia J450 was determined for both subsonic and supersonic flight ($M=0.0$ to $M=2.0$) and at altitudes up to 10000 ft. The thrust of the engine at altitude and at high Mach number falling to around 4 lbf from the static sea-level value of 10 lbf.

B. RECOMMENDATIONS

The supersonic cone intake needs to be tested using the newly installed free-jet facility.

A ramjet combustion chamber (afterburner) needs to be designed and tested for the shroud assembly to fully test a turbo-ramjet combination.

A nozzle needs to be designed and tested for the different shroud lengths with different spool speeds.

The data acquisition system needs to be up graded to a personal computer based system.

APPENDIX A. GASTURB (OFF-DESIGN PERFORMANCE)

Process: Perform a single cycle calculation for a single spool turbojet by selecting **[calculate Signal Cycle]** and press **[Go On]**. For the initial calculation you must enter the engine type, at the prompt select **[Sophia]** or select the **[demo-jet.cyj]** and enter the data contained in at the end of this process as Table 3, into the Design Point Input menu. When complete selected **[Go On]**, the design Turbojet SL and static performance should appear as indicated in Table 4. Press **[Close]** twice to perform off design calculations. Once at the introduction screen, select [Off Design] and then select **[Go On]**. At this point select **[Maps]**, to read in special compressor and or turbine maps. Select **[Maps]** then **[Special]**, the special component map screen will appear. Select **[Read]** to read special compressor or turbine into the current file. **[Compr or Turb]** must be selected after the map is read into the current file to view and select the design point with the small yellow square. By placing the pointer over the yellow square (design point) and press the right mouse button to move the design point to coincide with experimental data. Once both the compressor and turbine maps are selected and the design points verified **[Close]** the component map window.

To create an operating line selects **[Task]** and choose **[Line] operating** and **[Go On]** Increase the number of points in the operation line to **[20]**. Select the down arrow for decreasing load and select **[go on]** once computed, select no for another operation line. You can now elect to view pressure ratio Vs mass flow rate or a variety of many other combinations. Or you can select to view operation line of the **[Compressor or Turbine]** once complete Select **[Close]** once to return to the off-design-input screen. If you wish to

Compare other turbine map combination select Maps and repeat the steps from that point to continue analysis. If you finished with comparisons continue to select [**Close**] until the startup screen to exit.

APPENDIX B. SOPHIA J450-2 CALIBRATION DATA

FUEL CELL CALIBRATION

DATE: 1/14/2000

VOLTS(v)	WEIGHT(lbs.)
0	0
.00927	.5
.02788	1.5
.046	2.5
.0553	3
.0646	3.5
.0737	4
.092	5

Table 11. fuel cell calibration

THRUST BEAM CALIBRATION

VOLTS(v)	WEIGHT(lbs.)
0	0
.503	3.25
.9	5.73
1.288	8.23
1.686	10.73
2.069	13.23

Table 12. Thrust beam calibration of J450-2

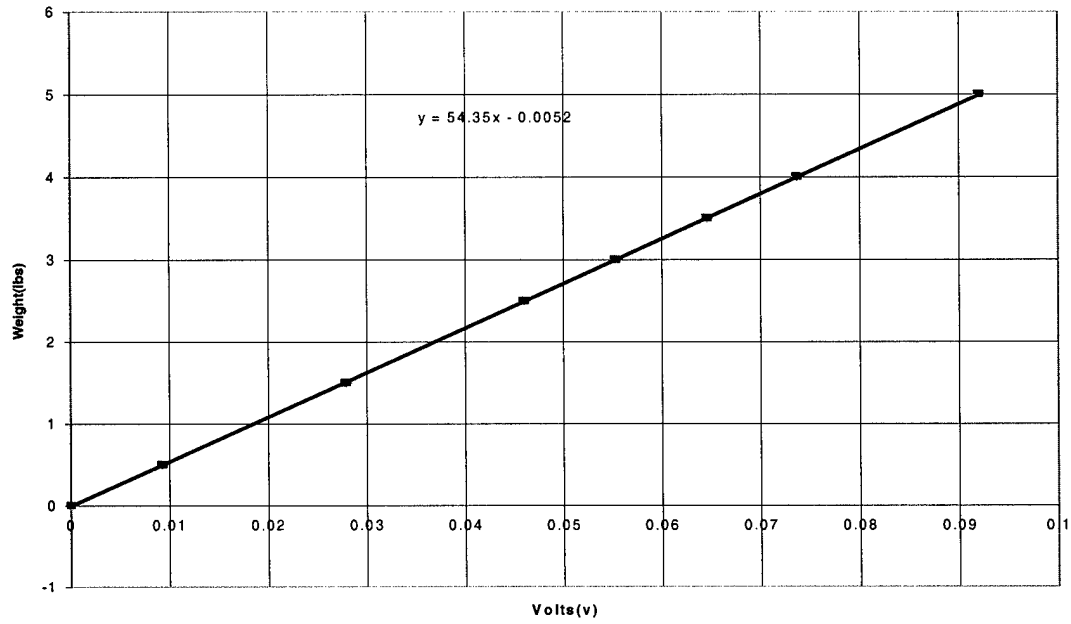

Figure 42. Fuel Cell Calibration of J450-2

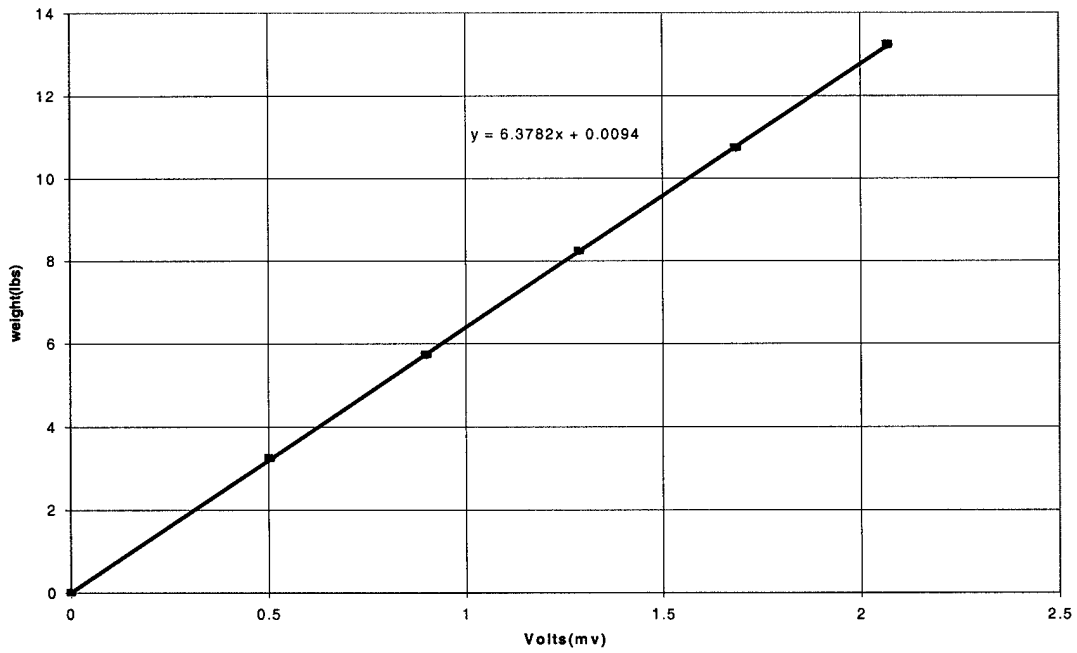

Figure 43. Thrust Beam Calibration

APPENDIX C. SOPHIA J450-2 THRUST RESULTS

DATE: 1/18/2000

Table 13		105% Spool Speed	
RUN	Thrust(lbs.)	Fuel flow(lbs./sec)	SFC(lbm/lb/hr)
1	11.15629552	.00495867495125	1.6
2	11.06697804	.00495050184182	1.6103
3	11.060013264	.00480133670639	1.562819
4	11.082310026002	.00482310026002	1.5659
AVERAGE	11.0935	-	1.585

Table.14		100% Spool Speed	
RUN	Thrust(lbs.)	Fuel Flow(lbs./sec)	SFC(lbm/lb/hr)
1	9.843881836	.00433343208017	1.5877
2	9.90189412	.00426616291441	1.5509
3	9.88979058	.00430435512459	1.5668
4	9.715939056	.00436493505959	1.6173
AVERAGE	9.8379	-	1.581

Table.15		90% Spool Speed	
RUN	Thrust(lbs.)	Fuel Flow(lbs./sec)	SFC(lbm/lb/hr)
1	7.496152692	.00349082348	1.65048
2	7.46932968	.00349082348	1.6508
3	7.439082348	.003557552546	1.7216
4	7.496152692	.00347940102925	1.6709
AVERAGE	7.4752	-	1.673

Table.16

80% Spool Speed

RUN	Thrust(lbs.)	Fuel Flow(lbs./sec)	SFC(lbm/lb/hr)
1	4.705676338	.00274322056338	2.0986
2	4.730192676	.00267533900325	2.0361
3	4.710484656	.00267820076923	2.0466
4	4.70383878	.00275480894908	2.108
AVERAGE	4.7125	-	2.0724

Table.17

50% Spool Speed

RUN	Thrust(lbs.)	Fuel Flow(lbs./sec)	SFC(lbm/lb/hr)
1	1.485028008	.00176176437703	4.2708
2	1.5272121	.00187198358613	4.412699
3	1.539470616	.00190923365114	4.4646
4	1.553259852	.00193755689057	4.49068
AVERAGE	1.5262	-	4.4096

APPENDIX D. ACQUISITION PROGRAM MODIFICATION

```
1      !
2      ! PROGRAM TO MEASURE THE THRUST AND SFC OF A TURBOJET ENGINE
3
4      !
5      Xtime=0
6      lbs_=0
7      For I=1 TO 5
10     Dacu=709
20     Dvm=722
40     ASSIGN @Dacu TO Dacu
50     ASSIGN @Gages TO Dacu
60     ASSIGN @Dvm TO Dvm
80     CLEAR @Gages
100    CLEAR @ SCREEN
110    CLEAR @ Dacu
120    Ac$="AC"
130    Id$=VAL$(0)
140    OUTPUT @Dacu;Ac$&Id$
150    Total=0
180    FOR J=1 TO 5
190    OUTPUT @Dvm;"MEASURE:VOLT:DC? 1V"
200    ENTER @Dvm;lbs_fuel
210    Total=Total+lbs_fuel*70.02
220    NEXT J
230    CLEAR @gages
240    Lbs_fuel=Total/5
250    M_dot_fuel=(Lbs_fuel-Lbs_fuel_1)/(Xtime+9.23)
260    Lbs_fuel_1=Lbs_fuel
270    CLEAR @Dacu
280    CLEAR @Dvm
320    Id$=VAL$(5)
330    OUTPUT @Dacu;Ac$&Id$
331    Total=0
340    FOR J=1 TO 5
350    OUTPUT @Dvm;"MEASURE:VOLT:DC? 1V"
360    ENTER @Dvm;Thrust
370    Total=Total+Thrust*(-6242)
380    NEXT J
381    Thrust=Total/5
382    PRIN "THRUST IS ",TAB(27);Thrust;"LBS"
383    PRINT "FUEL FLOW RATE IS ",TAB(25);M_dot_fuel;"LBS/SEC"
400    CLEAR @Dacu
420    CLEAR @Gages
430    ASSIGN @Dacu TO *
450    ASSIGN @Dvm TO *
460    ASSIGN @Gages TO *
461    BEEP
462    PRINT "XTIME =",Xtime,"ITER=";I
463    WAIT Xtime
464    NEXT I
470    END
```

THIS PAGE IS INTENTIONALLY LEFT BLANK

APPENDIX E. SOPHIA J450-1 CALIBRATION DATA

DATE: 2/25/2000

J450-1 Baseline		Long shroud		Medium shroud		Short shroud	
Volts(v)	Weight (lbs)	Volts(v)	Weight (lbs)	Volts(v)	Weight (lbs)	Volts(v)	Weight (lbs)
0	0	0	0	0	0	0	0
.00513	.5	.00507	.5	.00566	.5	.00796	.5
.01509	1.5	.01523	1.5	.01701	1.5	.0245	1.5
.02576	2.5	.02568	2.5	.02831	2.5	.0399	2.5
.0309	3	.0308	3	.0342	3	.0478	3
.03619	3.5	.036	3.5	.0396	3.5	.0557	3.5
.0413	4	.041	4	.0454	4	.0636	4
.05164	5	.0514	5	.0569	5	.0796	5

Table 18. Fuel Weight calibration Comparison between (J450-1 Baseline, Long shroud, Medium shroud and Short shroud)

J450-1 Baseline		Long shroud		Medium shroud		Short shroud	
Volts(v)	Weight (lbs)	Volts(v)	Weight (lbs)	Volts(v)	Weight (lbs)	Volts(v)	Weight (lbs)
0	0	0	0	0	0	0	0
.505	3.25	.571	3.25	.555	3.25	.601	3.25
.901	5.73	1.01	5.73	.978	5.73	1.059	5.73
1.282	8.23	1.441	8.23	1.402	8.23	1.513	8.23
1.658	10.73	1.87	10.73	1.822	10.73	1.967	10.73
2.048	13.23	2.295	13.23	2.233	13.23	2.417	13.23

Table 19. Thrust beam calibration Comparison between (J450-1 Baseline, Long shroud, Medium shroud and Short shroud)

THIS PAGE IS INTENTIONALLY LEFT BLA

APPENDIX F. SOPHIA J450-1 TEST DATA FOR SHROUDS

TEST DATA FOR LONG SHROUD WITH NOZZLE

DATE: 2/8/2000

TABLE 20 105% SPOOL SPEED (RPM) at 125K,120K,109K and 93K respectively			
RUN	THRUST(lbf)	Fuel flow(lbm/se)	SFC (lbm/lb/hr)
1	8.7294	.005234	2.1587
2	8.7472	.005122	2.1081
3	8.8282	.005176	2.1108
4	8.85166	.005165	2.0996
AVEREGE	8.788	-	2.1193

TABLE 21 100% SPOOL SPEED (RPM) at 125K,120K,109K and 93K respectively			
RUN	THRUST(lbf)	Fuel flow(lbm/sec)	SFC(lbm/lb/hr)
1	7.91342	.004596	2.0909
2	7.8860	.0046292	2.1132
3	7.9344	.0046446	2.1073
4	7.8848	.004574	2.0884
AVERAGE	7.9046	-	2.0996

TABLE 22 90% SPOOL SPEED (RPM) at 125K,120K,109K and 93K respectively			
RUN	THRUST(lbf)	Fuel flow(lbm/sec)	SFC(lbm/lb/hr)
1	6.06619	.003772	2.2387
2	6.04531	.0036994	2.2030
3	6.00749	.0037655	2.2565
4	6.05470	.0038220	2.272
AVEREGE	6.0434	-	2.2426

TABLE 23 80% SPOOL SPEED (RPM) at 125K,120K,109K and 93K respectively			
RUN	THRUST(lbf)	Fuel flow (lbm/sec)	SFC(lbm/lb/hr)
1	4.023823	.0029422	2.6323
2	3.99132	.002944	2.6553
3	4.00462	.002908	2.6150
4	3.97226	.0029658	2.6878
AVEREGE	3.998	-	2.6476

TEST DATA FOR LONG SHROUD WITH NOZZLE PRESSURE DISTRIBUTION

DATE: 2/8/2000

TABLE 24.

RUN	125000,120000,109000 and 93000 (RPM) SPOOL SPEED Respectively			
Distance between Ports (in)	105% Pressure(H2O) P2 to P11	100% Pressure(H2O) P2 to P11	90% Pressure (H2O) P2 to P11	80% Pressure (H2O) P2 to P11
0	0	0	0	0
1.25	-.7	-.9	-.7	-.4
3.25	-3.2	-3	-2.4	-1.7
5.25	-.9	-1.2	-.9	-.6
7.25	-2.6	-2.5	-2	-1.4
9.25	-3.1	-3.1	-2.5	-1.7
12.25	-3.3	-3.2	-2.6	-1.8
21	-1.6	-2	-1.9	-1.6
23	2.7	1.8	.4	-.4
25	6.2	5.2	3.5	1.5
27.5	8	6.7	3	3

TEST DATA FOR MEDIUM SHROUD WITH THE NOZZLE

DATE: 2/18/2000

TABLE 25 105% SPOOL SPEED (RPM) at 125K,120K,109K and 93K respectively			
RUN	THRUST (lbf)	Fuel flow(lbm/sec)	SFC(lbm/lb/hr)
1	9.405	.00513	1.965
2	9.384	.00503	1.929
3	9.414	.00511	1.954
4	9.472	.00501	1.904
AVEREGE	9.419	-	1.938

TABLE 26 100% SPOOL SPEED (RPM) at 125K,120K,109K and 93K respectively			
RUN	THRUST(lbf)	Fuel flow (lbm/sec)	SFC(lbm/lb/hr)
1	8.420	.00453	1.939
2	8.422	.00455	1.944
3	8.450	.00456	1.945
4	8.401	.00459	1.969
AVEREGE	8.423	-	1.949

TABLE 27 90% SPOOL SPEED (RPM) at 125K,120K,109K and 93K respectively			
RUN	THRUST (lbf)	Fuel flow(lbm/sec)	SFC(lbm/lb/hr)
1	6.551	.00368	2.026
2	6.531	.00368	2.028
3	6.516	.00380	2.103
4	6.535	.00370	2.039
AVEREGE	6.533	-	2.049

TABLE 28 80% SPOOL SPEED (RPM) at 125K, 120K, 109K and 93K respectively			
RUN	THRUST(lbf)	Fuel flow(lbm/sec)	SFC(lbm/lb/hr)
1	4.257	.00287	2.434
2	4.216	.00289	2.470
3	4.250	.00289	2.449
4	4.237	.00298	2.536
AVEREGE	4.240	-	2.472

TEST DATA FOR MEDIUM SHROUD WITH NOZZLE PRESSURE DISTRIBUTION

DATE: 2/18/2000

TABLE .29

RUN	125000,120000,109000 and 93000(RPM) SPOOL SPEED Respectively			
Distance between ports (in)	105% Pressure (H2O) P2 to P11	100% Pressure (H2O) P2 to P11	90% Pressure (H2O) P2 to P11	80% Pressure (H2O) P2 to P11
0	0	0	0	0
1.25	-.9	-.7	-.8	-.6
3.25	-3.7	-3.4	-2.8	-1.9
5.25	-1.4	-1.2	-1.1	-.7
7.25	-3	-2.8	-2.3	-1.6
9.25	-3.6	-3.4	-2.9	-2
17	-3	-2.7	-2.3	-1.5
19	-3.4	-2.9	-2.2	-1.6
21	-.3	-.5	-1.3	-1.2
23.5	4.3	4.2	2.6	.9

SOPHIA J450-1 TEST DATA FOR SHORT SHROUD WITH THE NOZZLE

DATE: 2/16/2000

TABLE 30 105% SPOOL SPEED (RPM) at 125K,120K,109K and 93K respectively			
RUN	THRUST(lbf)	Fuel flow(lbm/sec)	SFC(lbm/lb/hr)
1	9.478	.00514	1.954
2	9.498	.00507	1.924
3	9.521	.00507	1.919
4	9.583	.00502	1.887
AVEREGE	9.520	-	1.921

TABLE 31 100% SPOOL SPEED (RPM) at 125K,120K,109K and 93K respectively			
RUN	THRUST(lbf)	Fuel flow(lbm/sec)	SFC(lbm/lb/hr)
1	8.6226	.00456	1.907
2	8.6227	.00461	1.925
3	8.6301	.00452	1.887
4	8.6313	.00462	1.930
AVEREGE	8.626	-	1.912

TABLE 32 90% SPOOL SPEED (RPM) at 125K,120K,109K and 93K respectively			
RUN	THRUST(lbf)	Fuel flow(lbm/sec)	SFC(lbm/lb/hr)
1	6.6130	.00372	2.027
2	6.5587	.00365	2.007
3	6.6038	.00372	2.030
4	6.6242	.00371	2.019
AVEREGE	6.5999	-	2.021

TABLE33 80% SPOOL SPEED (RPM) at 125K,120K,109K and 93K respectively			
RUN	THRUST(lbf)	Fuel flow(lbm/sec)	SFC(lbm/lb/hr)
1	4.489	.00292	2.341
2	4.512	.00288	2.300
3	4.523	.00304	2.420
4	4.510	.00297	2.370
AVEREGE	4.509	-	2.358

TEST DATA FOR SHORT SHROUD WITH NOZZLE PRESSURE DISTRIBUTION

DATE: 2/16/2000

TABLE 34

RUN	125000,120000,109000 and 93000 (RPM) SPOOL SPEED Respectively			
Distance between Ports (in)	105% Pressure (H2O) P2 to P11	100% Pressure (H2O) P2 to P11	90% Pressure (H2O) P2 to P11	80% Pressure (H2O) P2 to P11
0	0	0	0	0
1.25	-9	-8	-7	-5
3.25	-4	-3.6	-2.8	-1.8
5.25	-1.4	-1.3	-1.1	-.6
7.25	-3.7	-3.5	-2.7	-1.8
9.25	-3.9	-3.6	-2.8	-1.8
12.25	-4.1	-3.8	-2.9	-2
15.25	-3.4	-3.2	-2.5	-1.6
17.25	-3.1	-2.9	-2.2	-1.4
19.25	-2.3	-2.7	-2.1	-1.3
21.75	.5	.1	-1	-.9

Pressure Distribution Comparison between long shroud, Medium shroud and Short shroud for 100% Spool speed

DATE: 2/25/2000

TABLE 35

100% Spool speed at 115K(RPM) for Long shroud, Medium shroud and Short shroud Respectively					
Distance between Ports (in)	Long shroud Pressure H20) P2 to P11	Distance between Ports (in)	Medium shroud Pressure. H20	Distance between Ports (in)	Short shroud Pressure H20 P2 to P11
0	0	0	0	0	0
1.25	-.9	1.25	-.7	1.25	-.8
3.25	-3	3.25	-3.4	3.25	-3.6
5.25	-1.2	5.25	-1.2	5.25	-1.3
7.25	-2.5	7.25	-2.8	7.25	-3.5
9.25	-3.1	9.25	-3.4	9.25	-3.6
12.25	-3.2	17	-2.7	12.25	-3.8
21	-2	19	-2.9	15.25	-3.2
23	1.8	21	-.5	17.25	-2.9
25	5.2	23.5	4.2	19.25	-2.7
27.5	6.7	-	-	21.75	.1

THIS PAGE IS INTENTIONALLY LEFT BLANK

**APPENDIX G. COMPARISON BETWEEN J450-1 BASELINE, LONG,
MEDIUM AND SHORT SHROUD CONFIGURATIONS**

DATE: 2/25/2000

93K(80%),109K(90%),120K(100%) and 125K(105%)(RPM) Spool speed for Long,Medium and Short shroud Respectively							
J450-1 Baseline		Long shroud		Medium shroud		Short shroud	
Thrust (lbf)	SFC (lb/lbf/hr)	Thrust (lbf)	SFC (lb/lbf/hr)	Thrust (lbf)	SFC (lbf)	Thrust (lbf)	SFC (lb/lbf/hr)
5.447	1.915	3.998	2.6476	4.2406	2.4728	4.509	2.358
8.17944	1.6406	6.0434	2.2426	6.5337	2.049	6.599	2.021
10.5828	1.5598	7.9046	2.0996	8.423	1.949	8.626	1.912
11.6215	1.5709	8.788	2.1193	9.4191	1.938	9.52	1.921

Table 36. SFC Vs Thrust Comparison between (J450-1 Baseline, Long shroud, Medium and Short shroud)

93K(80%),109K(90%),120K(100%) and 125K(105%)(RPM) Spool speed for Long Medium and Short shroud Respectively							
J450-1 Baseline		Long shroud		Medium shroud		Short shroud	
RPM	SFC (lb/lbf/hr)	RPM	SFC (lb/lbf/hr)	RPM	SFC (lbf)	RPM	SFC (lb/lbf/hr)
93000	1.915	93000	2.6476	93000	2.4728	93000	2.358
109000	1.6406	109000	2.2426	109000	2.049	109000	2.021
120000	1.5598	120000	2.0996	120000	1.949	120000	1.912
125000	1.5709	125000	2.1193	125000	1.938	125000	1.921

Table 37. SFC Vs Spool speed Comparison between (J450-1 Baseline, Long shroud, Medium shroud and Short shroud)

93K(80%),109K(90%),120K(100%) and 125K(105%)(RPM) Spool speed for Long Medium and Short shroud Respectively							
J450-1 Baseline		Long shroud		Medium shroud		Short shroud	
RPM	Thrust (lbf)	RPM	Thrust (lbf)	RPM	Thrust (lbf)	RPM	Thrust (lbf)
93000	5.447	93000	3.998	93000	4.2406	93000	4.509
109000	8.17944	109000	6.0434	109000	6.5337	109000	6.599
120000	10.5828	120000	7.9046	120000	8.423	120000	8.626
125000	11.6215	125000	8.788	125000	9.4191	125000	9.52

Table 38. Thrust Vs Spool speed Comparison between (J450-1 Baseline, Long shroud, Medium shroud and Short shroud)

THIS PAGE IS INTENTIONALLY LEFT BLANK

APPENDIX H. STARTING THE SOPHIA J450-2 ENGINE

1. Think safety!
2. Ensure that only people who are necessary to the operating are within **25** feet.
3. Ensure all the connections are made as per the instructions, the fuel and oil tanks are full, and all batteries are fully charged.
4. Make sure the engine test stand is secure.
5. Have your assistance ready with a fire extinguisher (with safety pin removed).
6. Ensure that all wires and tubes are away from the exhaust and intake.
7. Switch **ON** the transmitter and then the receiver . (you should have programmed your system).
8. Move the switch on your transmitter to the “**stand-by**” (**ready/run**) position. Ensure the “Throttle stick” is set to **minimum** and “Trim” to **maximum**.
9. The yellow “stand-by” light should be lit. Or the display will indicate “stand-by”. If the yellow light is not lit, flick the switch on the transmitter to “**Emergency off**” and back to “stand-by”.
10. Double-check and connect air to inlet connection.
11. Blow air gently and places hand around connection to check for leaks. (it is not acceptable to have any leaks whatsoever).
12. Clear the area . Check to make sure that there are no obstructions near the inlet or tailpipe and that nothing can be sucked into the engine.
13. When ready, compress the air trigger fully. (you will hear the engine start to whirl).
14. If using the **GSU**, look at the RPM reading, and when the figure is approximately **9,000RPM**, release the air.
15. When the air is released, the RPM will drop down.
16. Assuming all is well, when the engine spin down, ignition will take place. You will hear a “pop”, and this is your signal to supply full air pressure again.
17. If you do not hear a “pop”, apply another burst of air up to **9,000 RPM**; as soon as the yellow LED goes on again, release the air. If you still get no ignition, cease

operations, wait for the engine to spin down, reset your 3-position switch to “stop” and then switch to “stand-by” (ready/run) position. Then reapply the air and repeat the start sequence.

18. The engine should now be accelerating under the control of the ECU. Do not release the air until the yellow LED goes off. This will be at least **50,000 RPM**.
19. The turbine will now accelerate to **85,000 RPM** and stabilize. At this time, disconnect the air.
20. During the star-up sequence, the ECU is monitoring all the systems. Only when it has completed all of its diagnostic checks will it turn over the operation of the throttle to the pilot. This indicated by the engine decelerating to **50,000RPM** (low throttle), and the green light will show on your display panel. It will NOT come in if your throttle stick is not at “idle” is in maximum position. You now have throttle control. All acceleration rates and protections are taken care of by the ECU, so you can operate the throttle as you wish.
21. If anything is wrong , the engine will either fail to start or will be aborted by the ECU.

APPENDIX I. SETTING THE TRANSMITTER OF SOPHIA J450-2

1. Make sure that all electrical connection are connected properly (battery to ECU, fuel pump to ECU, fuel cut-off valve to ECU, oil pump to ECU, glow driver from engine to ECU, and the control cable from engine to **ECU**).
2. Switch the transmitter to "**ON**". Set the throttle and auxiliary channel to 100% throw. Make sure that there are no mixers activated.
3. Press the small button on the status display board or "**Menu select**" on the optional GSU. Keep it pressed and switch **ON** receiver. The GSU will show "learning **RC**".
4. Now move the throttle stick to "**IDLE**" and the throttle trim to "**Minimum**", then press the button (or "**Menu select**" on the GSU).
5. Move the throttle trim to "**Maximum**". Then press the **button** on GSU.
6. Move the throttle stick to "**Maximum**". Then press the **button** on GSU.
7. Ensure that the "Auxiliary" switch is in position[**1**] (emergency stop). Then press the **button** on GSU.
8. Move the "Auxiliary" switch to position [**2**] (run/ready). Then press the **button** on GSU.
9. Move the "Auxiliary" switch to position [**3**] (auto-stop). The press the **button** on GSU.
10. Now the status display board should flash **again** , the transmitter and ECU are set.
11. Move the "Auxiliary" switch to position [**1**]and then to position [**2**] (center). The yellow LED will be lit. If it fail to do so, please go back to #1 and make sure that all the connection are correct. Then re-program the transmitter and ECU.
12. Ready to start the engine. **SEE APPENDIX.... STARTING THE ENGINE SOPHIA J450-2 procedures.**

THIS PAGE IS INTENTIONALLY LEFT BLANK

APPENDIX J. FEATURES OF SOPHIA J450-2

J1. FUEL

J2. ELECTRONIC CIRCUIT

J3. CONNECTING THE ECU TO THE RECEIVER

J1. FUEL. The J450-2 runs on a mixture of kerosene and Coleman. The optimum mixture ratio depends on the ambient air temperature. The cold the ambient air temperature, the more white gasoline (Coleman) should be used. Sophia J450-2 recommends that the following mixture ratio:

Fuel Mix Ratios: (*kerosene/Coleman* fuel):

COLD CLIMATE	WARM CLIMATE
75 % / 25 % [1 bottle / 3 bottle]	80 % / 20 % [1 bottle / 4 bottle]

Because of the variability in the quality of white gasoline(Coleman) and kerosene on market, Sophia recommends that only the highest quality fuels be used, such as Coleman fuel and jet A1(kerosene).

J2. The Electronic Circuits. Be sure to examine both sides of the ECU to ensure that is connecting the wires in the correct locations. There are two main connections to the turbine that are used by the ECU to monitor and control its operation:

1. The control cable (black, ribbon-type cable with Rj-11 telephone jacks), Which connects the RPM and Temperature sensors to ECU.
2. The glow cable (two wire which connects the ECU-controlled glow power to the Engine).

J3.Connecting the ECU to the Receiver. There are two connections that must be made from the ECU to the receiver:

- 1.Connect the throttle connector of the ECU to the throttle socket on the receiver.
- 2.Connect the auxiliary connector of the ECU to the auxiliary socket on the receiver that corresponds to the 3-position switch on the transmitter.

THIS PAGE IS INTENTIONALLY LEFT BLANK

APPENDIX K. SOPHIA J450 TEST PROGRAM CHECKLIST

K1. FUEL WEIGHT AND THRUST BEAM CHECKLIST

K2. DATA ACQUISITION SYSTEM SETUP CHECKLIST

K3. DATA ACQUISITION SYSTEM CHECKLIST

K4. DATA PUE PURGE CHECKLIST

K1. FUEL WEIGHT AND THRUST BEAM CALIBRATION

1. Ensure that the test rig is configured in accordance with Figures # and # of [Ref. 1] and that all devices are properly energized.

2. The-fuel pump power supply should be [OFF] with the voltage knob turned counter clockwise until slight resistance is felt.

3. Zero the thrust beams by connecting the CHANNEL [6] output of the signal conditioner to the DVM front panel. Once properly connected, adjust the ZERO KNOB accordingly until the DVM reads 0 mV. Once zeroed, restore the signal conditioner and DVM to their initial configuration (REAR position)

4. Calibrate the fuel flow beam in the following manner.

4.1 Connect the strain gages [1 and 2] in a half Wheatstone bridge configuration as shown on the inside cover of the P3500.

4.2 Set the bridge push button to **half-bridge** position.

4.3 Depress AMP ZERO and adjust thumb wheel until [±000] is displayed.

4.4 Depress GAGE FACTOR and ensure the range is set on [1 7-2 5].

4.5 Adjust GAGE FACTOR knob until [2.080] is displayed.

- 4.6 Depress RUN and set the BALANCE Control for a reading of [± 000].
- 4.7 With a DVM connected to the P3500 output, adjust the OUTPUT thumb wheel until the DVM reads [**0 mV**].
- 4.8 Disconnect the external **DVM**.
- 4.9 Perform a calibration of Fuel weight.
5. Place Fuel bottle on carriage and connect fuel line to engine.
6. Prime fuel pump by disconnecting the fuel line forward of the check valve.

K2. DATA ACQUISITION SYSTEM SETUP

- 1 Energize the HP9000 computer system.
- 2 The first screen is the HP9000 Series 300 Computer Data Acquisition /Reduction System introduction.
- 3 Select [**F7**] and set the current time and date The format is **HH: MM: SS** for the time, then select [**F2**] and set the date **DD MMM YYYY**, (i.e. **10:20:00,08 Jan 2000**)
- 4 Press **Shift** and **Reset** at same time .
- 5 Type **CAT** and then return.
- 6 Type **MSI "HP6944AOLD"** then return.

- 7 Press [F5] then type "Thrust_SFC" then return.
- 8.Type LIST then return.
- 9 Press [F1] then return.
- 10 Go to line [210] then change the value of the Fuel weight calculated then return.
- 11 Go to line [370] then change the value of the thrust calculated then return.
- 12 Press Shift and Reset at same time.
- 13.Press [F8] then type "Thrust_SFC" then return.
- 14.Press [F3] to RUN the program.
- 15.Type printer is [702] for using the printer.
- 16.Type printer is CRT to go back to the screen.

The program is attached at appendix [D].

K3. DATA ACQUISITION SYSTEM

- 1.Energize the Nitrogen system and select [F4].
- 2.Once the engine is operating at the desired speed and stabilized, select [F5] to begin data acquisition sequence.
- 3 Manually record the Thrust and Fuel Flow rate for each of the data runs as displayed on the screen.
- 4 Once the data collection sequence is completed, secure the engine
- 5 Secure Nitrogen once post calibration is complete
- 6 Select [F6] to begin data reduction.
- 7 Select [F8] to exit once data reduction is complete.

- 8 Select [**STOP**] to display the reduced data.
 - 9 Select [**F5**] and type "READ-MJ-ZOC".
 - 10 Select [**F3**] to RUN.
 - 11 Enter 1, date (YMMDD), Run number (i.e. for run 1 on 10 Jan 2000, type:1,90308,1).
 - 12 Select [**1**] for printer option.
 - 13 Select [**0**] to Exit.
- NOTE: Selecting exit does not exit the program but displays the average of the port readings for the selected data run.
14. Select [**STOP**] to exit the program.
 - 15 Repeat steps 10-13 for the remaining data **runs**.
 - 16 If ejector data was measured select [**STOP**].
 17. Select [**F5**] and type "EJ_ZOC"
 18. Select [**F3**] to run.
 19. Data files are presented in the same manner as above.
 20. When complete viewing data select [**STOP**].
 - 21 Type [**RINTER IS CRT**].

K4. DATA FILE PURGE

1.The raw data files are stored on the "HP9000":,700" hard drive as ZW190381

(example for

10 Jan 2000, run number 1) through ZW19038X for X data runs.

2. The reduced data files are stored as ZRXXXXXX and the calibration data is stored as

ZCXXXXXX.

3. Select [F5] and type "ZOC_MENU".
4. Select [F3] to Run.
5. Select [F8] to exit menu.
- 6 Type [MSI";,700"].
- 7 Type [PURGE"FILENAME"]. (eg PURGE "ZW190381").
8. Ensure deletion of each files. If all created files are not deleted an error will be encountered if obtaining additional data.
9. Cycle the power switch on the lower left corner **of the HP9000 CPU to reset the computer.**

THIS PAGE IS INTENTIONALLY LEFT BLANK

APPENDIX L. SAMPLE CALCULATIONS CONICAL FLOW

$$M_{\infty} = 2.0$$

$$\theta_s = 15^\circ \text{ cone angle}$$

$$\theta_w = 33.9^\circ \text{ oblique shock angle}$$

used conic shock tables (Ref. 7) to determine Mach numbers at the cone and intake lip.

at cone: $M1^* = 1.486$ use normal shock tables (NST), (Ref. 8) where $M2 = .708$,

$$Pt2/Pt1 = .93600$$

at lip: $M1^* = 1.555$ use N.S.T, where $M2 = .6841$, $Pt2/Pt1 = .913119$

$$\Psi1 = .0799 \text{ rad} = 4.6^\circ \text{ flow angle}$$

$$\Delta s/R = \ln (Pt1/Pt_{\infty}) \text{ therefore } Pt1/Pt_{\infty} = e^{-.0162} = .984$$

$$\text{average of } Pt2/Pt1 = .9246$$

$$\text{average of } Pt2/Pt_{\infty} = (Pt1/Pt_{\infty})(Pt2/Pt1) = .909$$

$M2 = .708$, use Isentropic flow table (IFT), (Ref. 8), $A2/A2^* = 1.09$

where $A2 = 1.8125$ inch squared, therefore $A2^* = 1.875/1.09 = 1.662 = A3^*$

Choose $M3 = .5$ then use I.F.T, $A3/A3^* = 1.33984$, therefore $A3 = (1.662)(1.33984) = 2.22$

inch squared.

THIS PAGE IS INTENTIONALLY LEFT BLANK

LIST OF REFERENCES

1. Rivera, G., *Turbochargers to Small Turbojet Engine for Uninhabited Aerial Vehicles*, Engineer's Thesis, Department of Aeronautics and Astronautics, US. Naval Postgraduate School, Monterey, CA, June 1998
2. Lobik, L.P. *Unmanned Aerial Vehicles: A Study of Gas Turbine Application*, Master's Thesis, Department of Aeronautics and Astronautics, US. Naval Postgraduate School, Monterey, CA, September 1995
3. Kurzke, J., *GASTURB 7.0 for Windows A Program to Calculate Design and Off Design Performance Of Gas Turbines*, 1996
4. Hackaday, G. L. *Thrust Augmentation For a Small Turbojet Engine*, Master's Thesis, Department of Aeronautics and Astronautics, US. Naval Postgraduate School, Monterey, CA, June 1998
5. Andreou, L. *Performance of a Ducted Micro Turbojet Engine*, Master Thesis Department of Aeronautics and Astronautics, US. Naval Postgraduate School Monterey, CA, September 1999
6. Sophia USA, *Sophia J450 Turbine Engine Instruction Manual and Owner's Guide*
7. Joseph L.Sims, *Tables For Supersonic Flow Around Right Circular Cones at Zero Angle of Attack*, NASA SP-3004, 1964
8. Robert D.Zucker, *Fundamentals of Gas Daynamics*, Martix publishers ,INC., 1977
9. Walter J. Hesse, *Jet Propulsion for Aerospace Applications*, Pitman Publishing corp., 1958

THIS PAGE IS INTENTIONALLY LEFT BLANK

INITIAL DISTRIBUTION LIST

- 1 Defense Technical Information center.....2
 8725 John J. Kingman Rd., Suite 0944
 Ft Belvoir, VA 22060-6218
- 2 Dudley Knox Library.....2
 Naval Postgraduate School
 411 Dyer Rd
 Monterey, CA 93943-5101
- 3 Prof William B. Maier.....1
 Chairman, Department of Physics
 Naval Postgraduate School
 699 Dyer Road, Room 203
 Monterey, CA 93943-5106
- 4 Prof Garth V Hobson, Code Aa/Hg..... 5
 Department of Aeronautics and Astronautics
 Naval Postgraduate School
 699 Dyer Road, Room 137
 Monterey, CA 93943-5106
- 5 Prof K.E. Woehler, code Ph/Wh.....1
 Department of Physics
 Naval Postgraduate School
 699 Dyer Road, Room 206B
 Monterey, CA 93943-5106
- 6 Naval Air Warfare Center Aircraft Division.....1
 Propulsion and Power Engineering
 22195 Elmer Road
 Patuxent River, MD 20670-5305
 ATTN: J Carroll, Code 4.4.3.2, BLDG 1461
- 7 Naval Air Warfare Center Aircraft Division.....1
 Propulsion and Power Engineering
 22195 Elmer Road
 Patuxent River, MD 20670-5305
 ATTN: C. Georgio, Code 4.4
- 8 Suleiman al-Namani.....2
 Royal Army of Oman
 P.O.Box 721, P.C.111.Seeb. Sultanate of Oman