

# NAVAL POSTGRADUATE SCHOOL Monterey, California



## THESIS

THRUST AUGMENTATION FOR A  
SMALL TURBOJET ENGINE

by

Gary L. Hackaday

March 1999

Thesis Advisor:  
Second Reader:

Garth V. Hobson  
Raymond P. Shreeve

19990512 034

Approved for public release; distribution is unlimited.

# REPORT DOCUMENTATION PAGE

Form Approved OMB No. 0704-0188

Public reporting burden for this collection of information is estimated to average 1 hour per response, including the time for reviewing instruction, searching existing data sources, gathering and maintaining the data needed, and completing and reviewing the collection of information. Send comments regarding this burden estimate or any other aspect of this collection of information, including suggestions for reducing this burden, to Washington headquarters Services, Directorate for Information Operations and Reports, 1215 Jefferson Davis Highway, Suite 1204, Arlington, VA 22202-4302, and to the Office of Management and Budget, Paperwork Reduction Project (0704-0188) Washington DC 20503.

1. AGENCY USE ONLY (Leave blank)		2. REPORT DATE March 1999	3. REPORT TYPE AND DATES COVERED Master's Thesis	
4. TITLE AND SUBTITLE THRUST AUGMENTATION FOR A SMALL TURBOJET ENGINE			5. FUNDING NUMBERS	
6. AUTHOR(S) Hackaday, Gary L.				
7. PERFORMING ORGANIZATION NAME(S) AND ADDRESS(ES) Naval Postgraduate School Monterey, CA 93943-5000			8. PERFORMING ORGANIZATION REPORT NUMBER	
9. SPONSORING / MONITORING AGENCY NAME(S) AND ADDRESS(ES)			10. SPONSORING / MONITORING AGENCY REPORT NUMBER	
11. SUPPLEMENTARY NOTES The views expressed in this thesis are those of the author and do not reflect the official policy or position of the Department of Defense or the U.S. Government.				
12a. DISTRIBUTION / AVAILABILITY STATEMENT Approved for public release; distribution is unlimited.			12b. DISTRIBUTION CODE	
13. ABSTRACT (maximum 200 words) A Sophia J450 (nine pounds of thrust) gas turbine engine was used first to examine the thrust augmentation generated using an ejector shroud. Experimental results obtained with and without the ejector were compared with performance predicted using an engine code and a one-dimensional ejector analysis. The engine code was revised to incorporate a radial turbine and the correct compressor map. Thrust augmentation of 3-10 % was measured and the trends were correctly predicted. Second, an engine shroud was designed and installed around the engine and flow measurements were conducted to determine the entrainment rate in the shroud. The engine shroud was the initial step toward designing a turboramjet.				
14. SUBJECT TERMS Micro-Turbojet, Ejectors, Micro Turbomachinery, GASTURB, SMOOTHC, Engine Shroud, Turboramjet, Sophia J450, Combined cycle, Microturbine Performance			15. NUMBER OF PAGES 91	
			16. PRICE CODE	
17. SECURITY CLASSIFICATION OF REPORT Unclassified	18. SECURITY CLASSIFICATION OF THIS PAGE Unclassified	19. SECURITY CLASSIFICATION OF ABSTRACT Unclassified	20. LIMITATION OF ABSTRACT UL	

NSN 7540-01-280-5500

Standard Form 298 (Rev. 2-89)  
Prescribed by ANSI Std. Z39-18



Approved for public release; distribution is unlimited

**THRUST AUGMENTATION FOR A SMALL TURBOJET ENGINE**

Gary L. Hackaday  
Lieutenant, United States Navy  
B.S.E.E., Hampton University, 1990

Submitted in partial fulfillment of the requirements for the degree of

**MASTER OF SCIENCE IN AERONAUTICAL ENGINEERING**

From the

**NAVAL POSTGRADUATE SCHOOL  
March 1999**

Author:

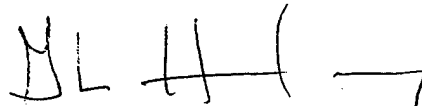

Gary L. Hackaday

Approved by:

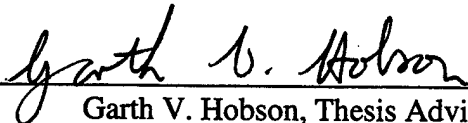

Garth V. Hobson, Thesis Advisor



Raymond P. Shreeve, Second Reader

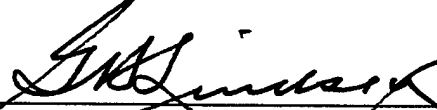

Gerald H. Lindsey, Chairman, Department of  
Aeronautics and Astronautics



## ABSTRACT

A Sophia J450 (nine pounds of thrust) gas turbine engine was used first to examine the thrust augmentation generated using an ejector shroud. Experimental results obtained with and without the ejector were compared with performance predicted using an engine code and a one-dimensional ejector analysis. The engine code was revised to incorporate a radial turbine and the correct compressor map. Thrust augmentation of three to ten percent was measured and the trends were correctly predicted. Second, an engine shroud was designed and installed around the engine and flow measurements were conducted to determine the entrainment rate in the shroud. The engine shroud was the initial step toward designing a turboramjet.



## TABLE OF CONTENTS

I.	INTRODUCTION.....	1
II.	ENGINE PERFORMANCE MODELING .....	3
	A.    RADIAL TURBINE MAP.....	3
	B.    CENTRIFUGAL COMPRESSOR MAPS.....	4
III.	EJECTOR PERFORMANCE PREDICTION .....	9
IV.	EJECTOR TEST PROGRAM .....	15
	A.    EXPERIMENTAL SETUP .....	15
	B.    DATA ACQUISITION PROCESS.....	19
	C.    RESULTS.....	22
V.	COMBINED CYCLE ANALYSIS.....	25
	A.    OVERVIEW.....	25
	B.    ENGINE TEST RIG.....	27
	C.    DATA ACQUISITION PROCESS.....	27
	D.    RESULTS.....	28
VI.	CONCLUSIONS AND RECOMMENDATIONS.....	31
	A.    CONCLUSIONS .....	31
	B.    RECOMMENDATIONS .....	32
	APPENDIX A. RADIAL TURBINE MAP .....	33
	APPENDIX B. COMPRESSOR MAPS .....	35
	APPENDIX C. ENGINE PERFORMANCE PREDICTION .....	37
	APPENDIX D. SMOOTHC OPERATIONS.....	39
	APPENDIX E. GASTURB (OFF-DESIGN PERFORMANCE) .....	47
	APPENDIX F. SOPHIA J450 TEST PROGRAM CHECKLIST.....	49
	F1. FUEL CELL AND THRUST BEAM CHECKLIST .....	49
	F2. DATA ACQUISITION SYSTEM SETUP CHECKLIST.....	50
	F3. ENGINE STARTUP AND OPERATION CHECKLIST.....	51
	F4. DATA ACQUISITION SYSTEM CHECKLIST .....	52
	F5. DATA FILE PURGE CHECKLIST .....	53
	F6. QUICK REFERENCE CHECKLIST.....	55
	APPENDIX G. SOPHIA J450 TEST RESULTS .....	57



APPENDIX H. EJECTOR PERFORMANCE PREDICTION PROGRAM .....	65
APPENDIX I: SHROUD DRAWINGS.....	67
APPENDIX J. SHROUD TEST RESULTS .....	73
LIST OF REFERENCES .....	75
INITIAL DISTRIBUTION LIST .....	77

## LIST OF FIGURES

Figure 1 Predicted Thrust vs Spool Speed (RADIAL vs DEFAULT Turbine).....	4
Figure 2 Predicted SFC vs Spool Speed (RADIAL vs DEFAULT Turbine) .....	4
Figure 3 Predicted and Measured Engine Thrust.....	5
Figure 4 Predicted and Measure Engine SFC .....	6
Figure 5 Thrust Comparison (T2 vs. T3 and Measured).....	7
Figure 6 SFC Comparison (T2 vs. T3 and Measured) .....	7
Figure 7 Ejector Analysis Control Volume.....	9
Figure 8 Theoretical Secondary Velocity and Predicted Augmentation.....	13
Figure 9 Sophia J450 Exterior Dimensions .....	16
Figure 10 Sophia J450 with Bellmouth and Ejector .....	16
Figure 11 Engine Test Rig .....	18
Figure 12 Sophia as Tested with Ejector.....	18
Figure 13 Ejector Tested .....	19
Figure 14 Ejector Performance.....	24
Figure 15 HYPR90 Combined Cycle Engine Demonstrator [from Ref. 9] .....	25
Figure 16 Shroud with Sophia J450 Installed .....	26
Figure 17 Shroud Pressure Tap Line Numbers .....	30
Figure 18 Shroud Pressure vs. Distance (100 percent spool speed).....	30
Figure A1 RADTUR (Inflow Radial Turbine).....	33
Figure B1 T3 Compressor Map.....	35
Figure B2 T2 Compressor Map.....	35

Figure C1 Predicted Thrust Comparison.....	38
Figure C2 Predicted SFC Comparison.....	38
Figure G1 Thrust Beam Calibration.....	64
Figure G2 Fuel Weight Measurement Calibration.....	64
Figure I1 Complete Engine Shroud with Exhaust Cone .....	67
Figure I2 Shroud (Section 1) Front .....	68
Figure I3 Shroud (Section 2) Center Cone.....	69
Figure I4 Shroud (Section 3) Rear .....	70
Figure I5 Shroud (Section 4 & 5) Mixer and Combustor .....	71
Figure I6 Shroud (Section 6) Exhaust Cone.....	72

## LIST OF TABLES

Table 1 Sophia J450 Engine Specifications .....	15
Table 2 Non-Ejector Results .....	22
Table 3 Ejector Results .....	22
Table 4 Comparison of Non-Ejector to Ejector Thrust .....	23
Table 5 Baseline Shroud Results.....	28
Table 6 Shroud with Extension .....	28
Table 7 Comparison of Baseline to Extension Thrust.....	28
Table C1 Predicted SFC and Thrust with RADTUR Turbine Map .....	28
Table D1 Garrett T3 SMOOTHC Speedline Data.....	41
Table E1 Sophia Design Point Input (115000 RPM).....	48
Table E2 Predicted Design Point Values (115000 RPM-GASTURB).....	48
Table G1 Non-Ejector Test Results (8 Mar 99, Run 1).....	57
Table G2 Non-Ejector Test Results (8 Mar 99, Run 2).....	58
Table G3 Ejector Test Results (8 Mar 99, Run 1).....	59
Table G4 Ejector Test Results (8 Mar 99, Run 2).....	60
Table G5 Ejector Test Results (5 Mar 99).....	62
Table G6 Miscellaneous Data Runs (5 Mar 99).....	62
Table G7 Miscellaneous Data Runs (8 Mar 99).....	63
Table J1 Shroud Test Results (15 Mar 99).....	73

## I. INTRODUCTION

Many advances over the years have led to more efficient and more reliable turbojet engines for flight at subsonic and supersonic speeds. One milestone that has not yet been achieved is an efficient engine to power a vehicle from take-off to speeds above Mach 3. One possible solution is a combined-cycle turboramjet hybrid, which was demonstrated in the early fifties by the Nord-Aviation Company in France through the creation of the Griffon II. The engine in the Griffon II was the first operational combined-cycle turboramjet.

The combined-cycle engine has the advantages of both engine types; turbojets are efficient at static through low supersonic conditions, while ramjets are efficient at higher Mach numbers. Ramjets can operate at flight conditions as low as Mach 0.2, but high thrust specific fuel consumption (TSFC) make this a highly undesirable range of speed. In the Griffon II, the thrust provided by the ramjet was varied between zero to as much as eighty percent of the required thrust to reach Mach two.

With new mission need statements for higher speed missiles, speeds in excess of Mach 3 and ranges up to 600 nautical miles are called for. Conventional solid propellant missiles are unable to meet these requirements. Ramjets are the best choice for airbreathing propulsion engines in the Mach three to six range. The turboramjet is a potential solution.

In order to develop understanding and to examine the ability to predict augmented and ducted performance, a small gas turbine engine, the Sophia J450, was used in the

present study. A study of the static performance of the Sophia J450 with a non-optimized constant area ejector was conducted first. The results were compared to baseline engine measurements obtained by Rivera [Ref. 1] to evaluate thrust augmentation. The results were also compared to theoretical predictions obtained using a simple 1-D analysis based on mass, momentum and energy conservation equations. Rivera developed a simulation of the J450 by experimentally determining the compressor performance map of a similar, but smaller, centrifugal compressor, and incorporating the map into an engine code, GASTURB [Ref. 2]. The experimental results were scaled up to the engine design point conditions, and the code was used to predict the off-design performance. During the present study, the actual map for the engine's compressor was obtained and incorporated into GASTURB to improve the off-design performance predictions. In reporting the work, the improved engine simulation is described in section II. In section III an analysis of the constant area ejector is given, and in the section IV the program of tests is reported.

In the second phase of the study, an engine shroud was constructed and measurements were made as an initial step in the consideration of a combined cycle engine. The shroud acted as an ejector at static conditions. Under flight conditions, when ram effect becomes important, the mass flow through the shroud will be determined by the forward speed of the engine or aircraft. The combined-cycle engine, and the results obtained using the Sophia J450 in a ducted configuration at static conditions, are discussed in section V. Conclusions and recommendations from both phases are given in section VI.

## II. ENGINE PERFORMANCE MODELING

In the previous analysis performed by Rivera [Ref. 1], the default turbine map, in combination with the experimentally determined map of the Garrett T2 turbocharger compressor, was used to predict the performance of the Sophia J450 turbojet engine [Ref. 3] using GASTURB [Ref. 2]. The first step in the present study was to explore the possibility of finding a compressor/turbine map combination that would more closely match the test data of the operating engine obtained by Rivera.

### A. RADIAL TURBINE MAP

GASTURB provided several centrifugal compressor maps and one radial turbine map, namely RADTUR, a NASA generated turbine shown in Figure A1, [Appendix A]. The predicted performance of the engine with the RADTUR turbine map was compared to that presented by Rivera [Ref. 1] using the default axial turbine map. The comparison of the predicted Thrust vs. Spool Speed is plotted below in Figure 1, which shows that there was very little difference in the predicted thrust when using the radial in-flow (RADTUR) turbine map or the default axial map. There was a slight difference in the predicted performance at the lower engine spool speeds, which can be more easily seen in the plot of SFC vs spool speed in Figure 2.

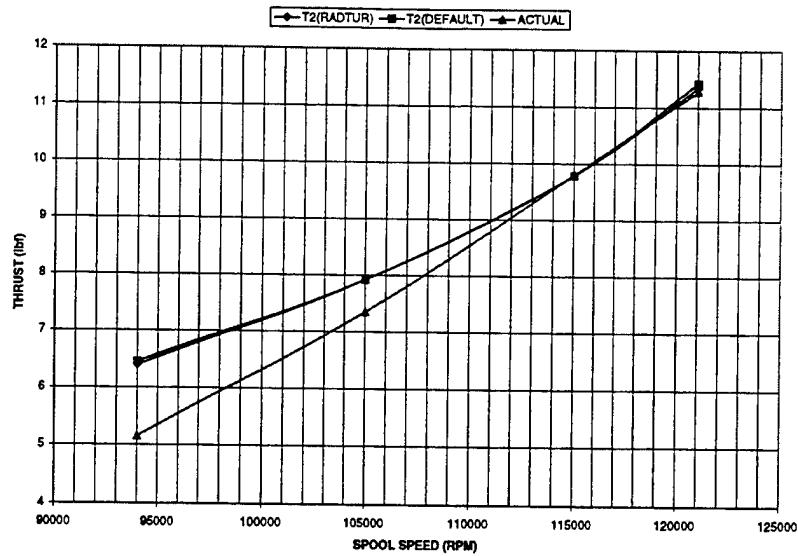

Figure 1 Predicted Thrust vs Spool Speed (RADIAL vs DEFAULT Turbine)

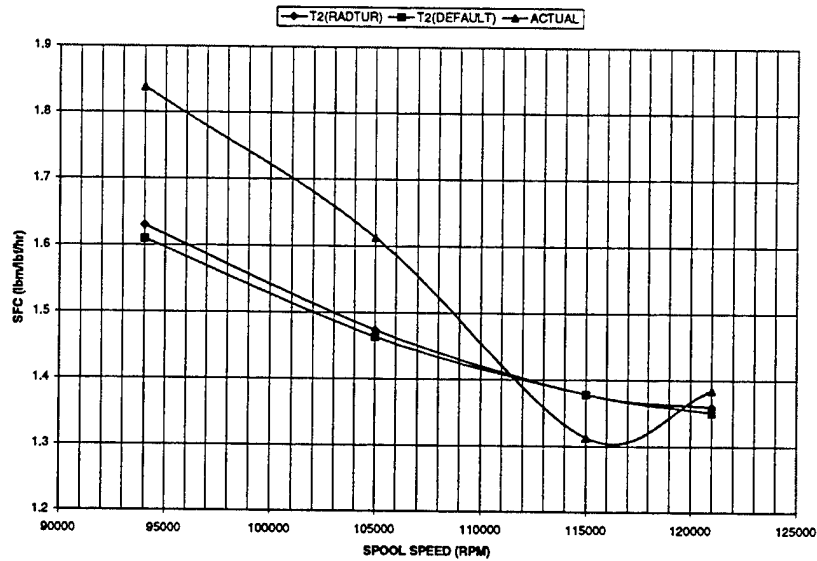

Figure 2 Predicted SFC vs Spool Speed (RADIAL vs DEFAULT Turbine)

## B. CENTRIFUGAL COMPRESSOR MAPS

It was determined from Sophia [Ref. 4] that the compressor in the Sophia J450 was the Garrett T3. The compressor map for the Garrett T3 was obtained [Ref. 5], digitized and entered into SMOOTHC [Ref. 6]. The map for T3 is shown in Figure B1



[Appendix B]. The map obtained by Rivera for T2 is shown as Figure B2 [Appendix B]. Five other maps that were single stage centrifugal compressors were obtained from [Ref. 7]. Engine performance calculations were carried out with the seven different compressor maps and the results are presented in Appendix C together with measured [Actual] data. The results that most closely matched the actual experimental data were obtained with compressors RAD1KG and T100RAD, and these are presented below as Figure 3 and Figure 4 respectively.

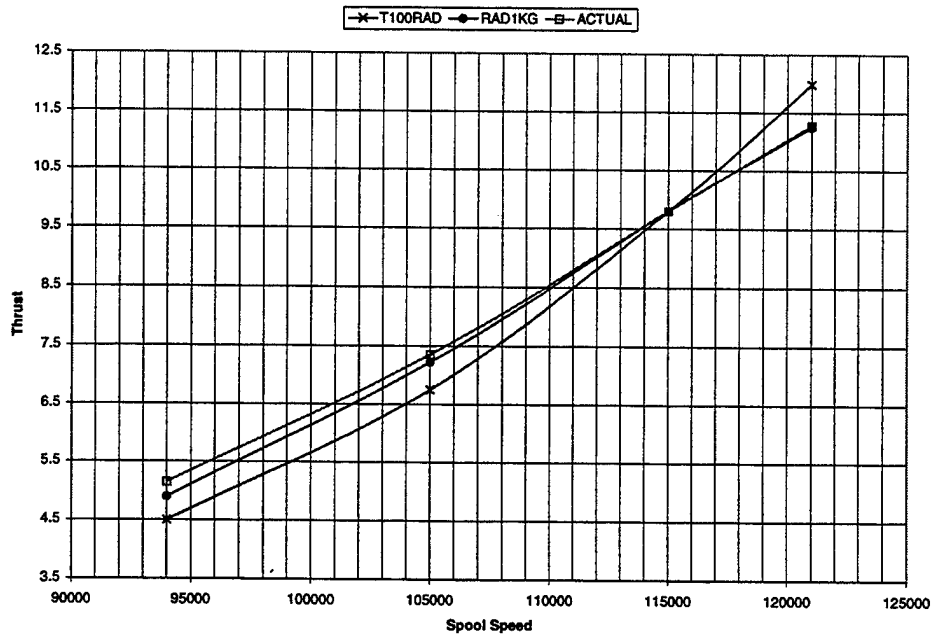

Figure 3 Predicted and Measured Engine Thrust

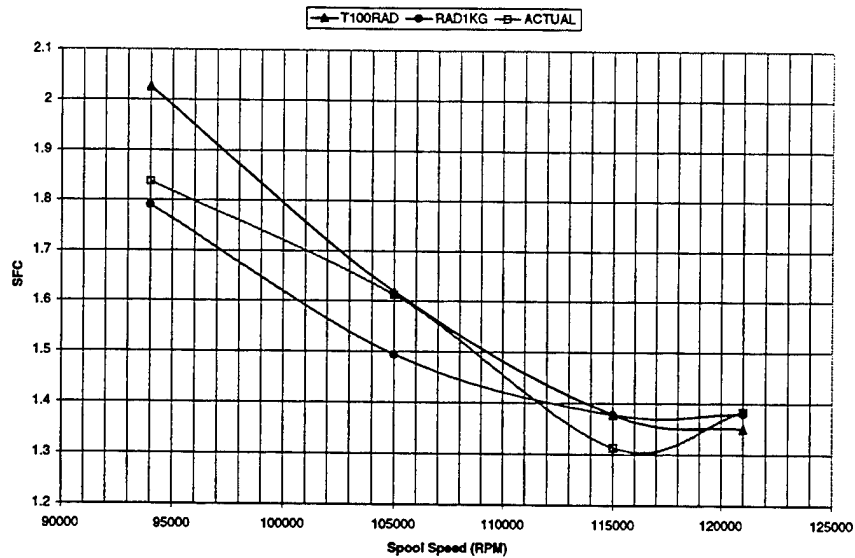

Figure 4 Predicted and Measured Engine SFC

The results obtained with T3 are compared with the those obtained with a scaled up version of T2 in Figure 5 and Figure 6. As expected, the T3 more closely matched the actual performance in both the thrust and SFC. Consequently, the radial inflow turbine (RADTUR) in combination with the T3 was used throughout the remainder of the study to obtain predicted stagnation temperatures and pressures for the ejector analysis.

The procedures followed and data used to obtain maps using SMOOTHC are given in Appendix D. Procedures followed using GASTURB, and input parameters used for the performance predictions are given in Appendix E.

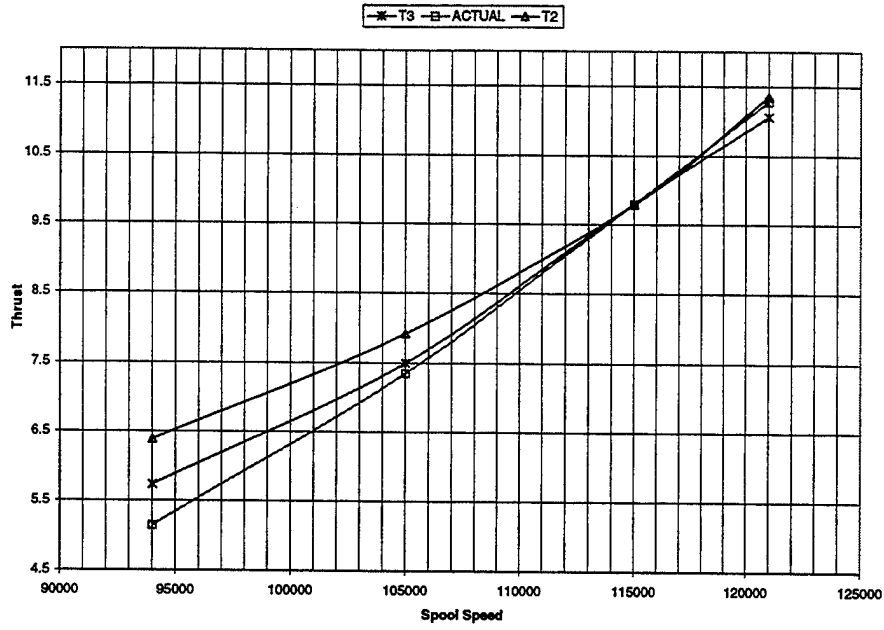

Figure 5 Thrust Comparison (T2 vs. T3 and Measured)

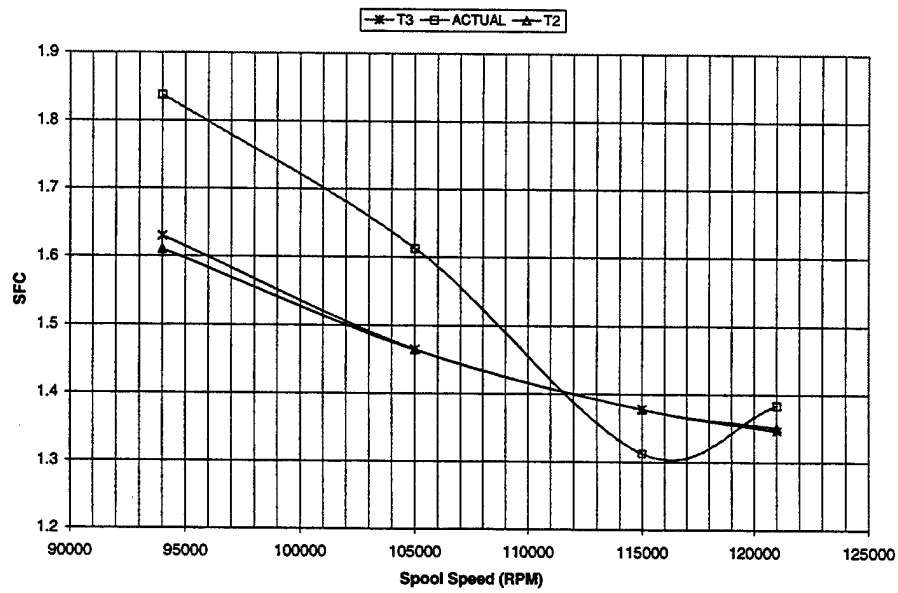

Figure 6 SFC Comparison (T2 vs. T3 and Measured)





In the following simplified 1-D flow analysis, [Ref. 8] the two streams of fluid were assumed to be completely mixed, at a constant cross sectional area, before exiting the ejector.

Considering the control volume above in Figure 7, where  $\dot{m}$  = mass flow rate,  $A$  = area,  $\rho$  = density,  $V$  = velocity,  $p$  = pressure,  $h$  = enthalpy,  $T$  = temperature,  $R$ =Gas constant and  $\gamma$ = ratio of specific heats

Mass conservation:

$$\dot{m}_s + \dot{m}_p = \dot{m}_2 \Rightarrow \rho_s A_s V_s + \rho_p A_p V_p = \rho_2 A_2 V_2$$

$$\frac{p_1}{T_s} V_s + a \frac{p_1}{T_p} V_p = (a+1) \frac{p_a}{T_2} V_2 \dots\dots\dots \text{eq.1}$$

Momentum: Neglecting skin friction.

$$p_p A_p + p_s A_s - p_2 A_2 = \dot{m}_2 V_2 - \dot{m}_p V_p - \dot{m}_s V_s$$

$$(a+1)(p_1 - p_a) = (a+1) \frac{p_a}{RT_2} V_2^2 - a \frac{p_1}{RT_p} V_p^2 - \frac{p_a}{RT_s} V_s^2 \dots\dots\dots \text{eq. 2}$$

where  $a = \frac{A_p}{A_s}$ ,  $R = 287 \text{ Nm/kg K}$  and  $\gamma = 1.4$

Energy equation: Adiabatic flow

$$\dot{m}_p \left( h_p + \frac{V_p^2}{2} \right) + \dot{m}_s \left( h_s + \frac{V_s^2}{2} \right) = \dot{m}_2 \left( h_2 + \frac{V_2^2}{2} \right)$$

$$a \frac{p_1 V_p}{RT_p} \left( \frac{\gamma R}{(\gamma - 1)} T_p + \frac{V_p^2}{2} \right) + \frac{p_1 V_s}{RT_s} \left( \frac{\gamma R}{(\gamma - 1)} T_s + \frac{V_s^2}{2} \right) = (a + 1) \frac{p_2 V_2}{RT_2} \left( \frac{\gamma R}{(\gamma - 1)} T_2 + \frac{V_2^2}{2} \right)$$

.....eq.3

The above three equations have seven unknowns which are:

$$p_1, V_s, T_s, V_p, T_p, T_2, V_2$$

Since there are seven unknowns and only three equations, four more equations are required to solve for the unknowns. Assuming isentropic flow in the nozzles leads to the following in terms of temperature:

$$\frac{T_0}{T} = 1 + \frac{V^2}{2C_p T} \Rightarrow \frac{T_0}{T} = 1 + \frac{\gamma - 1}{2\gamma R} \frac{V^2}{T} \Rightarrow T_0 = T + \frac{\gamma - 1}{2\gamma R} V^2$$

for primary and secondary nozzle respectively;

$$T_{o_p} = T_p + \frac{\gamma - 1}{2\gamma R} V_p^2 \dots\dots\dots \text{eq. 4}$$

$$T_{o_s} = T_a = T_s + \frac{\gamma - 1}{2\gamma R} V_s^2 \dots\dots\dots \text{eq. 5}$$

for primary and secondary nozzle respectively in terms of pressure:

$$\frac{p_o}{p} = \left( 1 + \frac{\gamma - 1}{2} M^2 \right)^{\frac{\gamma}{\gamma - 1}} \Rightarrow \left( \frac{p_o}{p} \right)^{\frac{\gamma - 1}{\gamma}} = 1 + \frac{\gamma - 1}{2\gamma R} \frac{V^2}{T}$$

$$\left(\frac{P_{o_p}}{P_1}\right)^{\frac{\gamma-1}{\gamma}} = 1 + \frac{\gamma-1}{2\gamma R} \frac{V_p^2}{T_p} \dots\dots\dots\text{eq. 6}$$

$$\left(\frac{P_{o_s}}{P_1}\right)^{\frac{\gamma-1}{\gamma}} = \left(\frac{P_a}{P_1}\right)^{\frac{\gamma-1}{\gamma}} = 1 + \frac{\gamma-1}{2\gamma R} \frac{V_s^2}{T_s} \dots\dots\dots\text{eq. 7}$$

With seven equations it is now possible to solve the system of equations. This was accomplished by an iterative process.

The following method was used to predict the ejector performance. The primary nozzle total values were obtained from GASTURB design point calculations. The value of the secondary velocity ( $V_s$ ) was initially guessed to start the solution procedure.

The above seven equations were used to iterate until the initially guessed value was converged upon, as follows;

1. Guess the value for  $V_s$  and use to solve for  $T_s$  in equation 5.
2. With  $T_s$  and  $V_s$  solve for  $p_1$  using equation 7.
3. With  $p_1$  solve for  $V_p$  using equation 4 and equation 6.
4. Then solve for  $T_p$  with equation 4.
5. With  $T_p$  and  $V_p$  solve for  $V_2$  using equations 1 and 3.
6. With  $V_2$  solve for  $T_2$  with equation 3.
7. Use equation 2 to calculate an updated  $V_s$ . If different values are obtained, calculate a new value for  $V_s$  and repeat steps one through six.

A Matlab ejector prediction program was written and is included as Appendix H and the solutions are presented as Figure 8.



For design point, the primary nozzle temperature of ( $T_{op}=877$  deg. Kelvin) and pressure ( $P_{op}=134.58$  kPa) were used to conduct a study of the effect of area ratio  $a$  ( $=A_p/A_s$ ) on predicted thrust augmentation. When the area ratio was varied from 1 down to 0.05 ( $A_s=200A_p$ ), the predicted thrust augmentation varied from 13 to 80 percent.

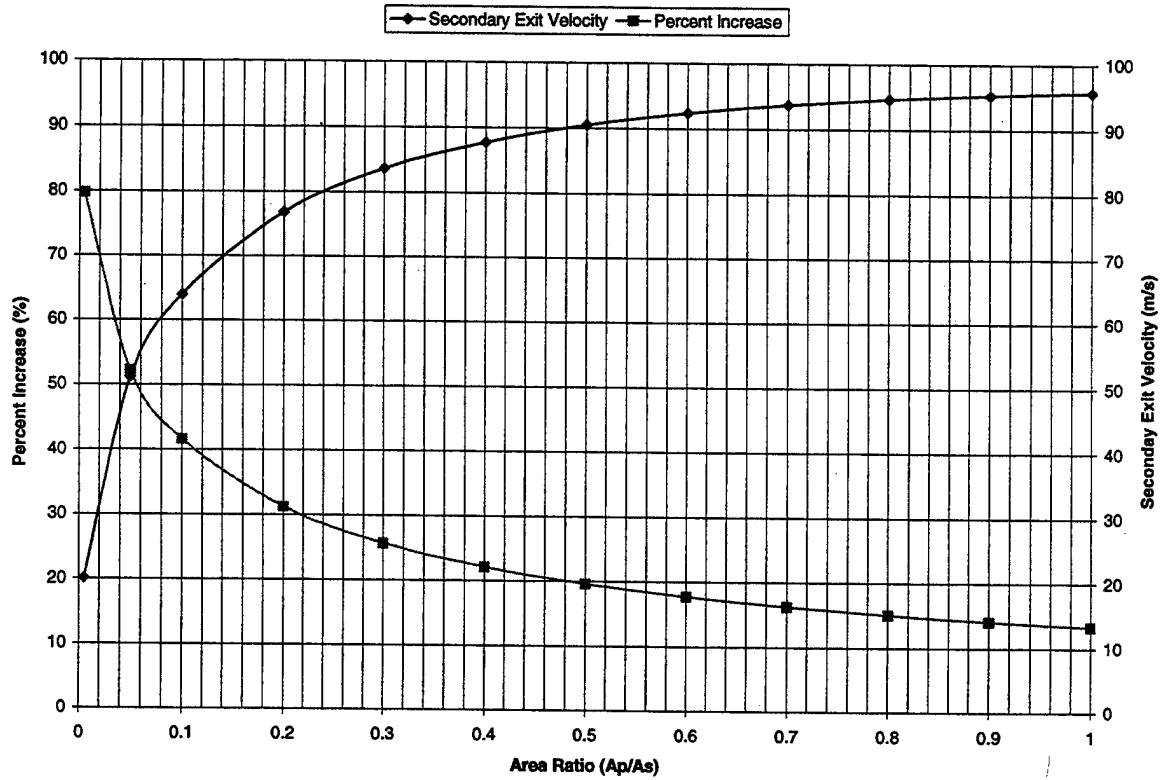

Figure 8 Theoretical Secondary Velocity and Predicted Augmentation



## IV. EJECTOR TEST PROGRAM

### A. EXPERIMENTAL SETUP

#### 1. Overview

The Sophia J450 turbojet engine, Figure 9, is a small turbojet engine manufactured in Japan. Although small in design, the J450's design and principle of operation are very much the same as a full scale jet engine. Pertinent performance specifications are listed below as Table 1.

<b>Engine Specification</b>	
Total Weight	4 lbs.
Dimensions	4.72 in x 13.19 in
Thrust	11 lbf @ 123,000 RPM
EGT	1300 deg. F (max)
Fuel Consumption	3.17 gallon/hr
Fuel Feed System	12V turbine fuel pump
Throttle System	Manual
Lubrication System	Total loss oil mist
Starting System	Compressed air
Ignition System	Spark plug and Igniter
Fuel	Coleman & Kerosene
Lubrication	MIL-L-23669C

Table 1 Sophia J450 Engine Specifications

The engine was tested without the ejector to obtain the baseline performance. The bellmouth in Figure 10 was used in both ejector and non-ejector configurations to measure the engine airflow rate. A detailed drawing of the bellmouth can be found in

[Ref. 9]. With the average engine inlet pressure obtained using four pressure taps, a mass flow rate through the engine was calculated.

Two pressure gauges were used to monitor and control engine operations [Ref. 3]. The engine lubrication system was pressurized by tapping off air at the pressure take-off of the compressor's impeller while the engine was running; which produced a gauge

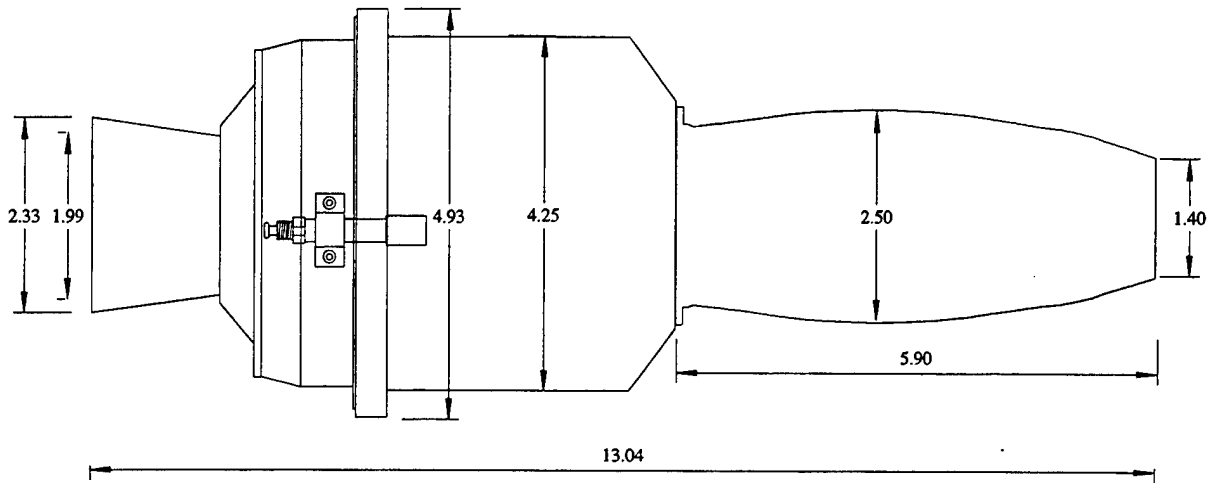

Figure 9 Sophia J450 Exterior Dimensions

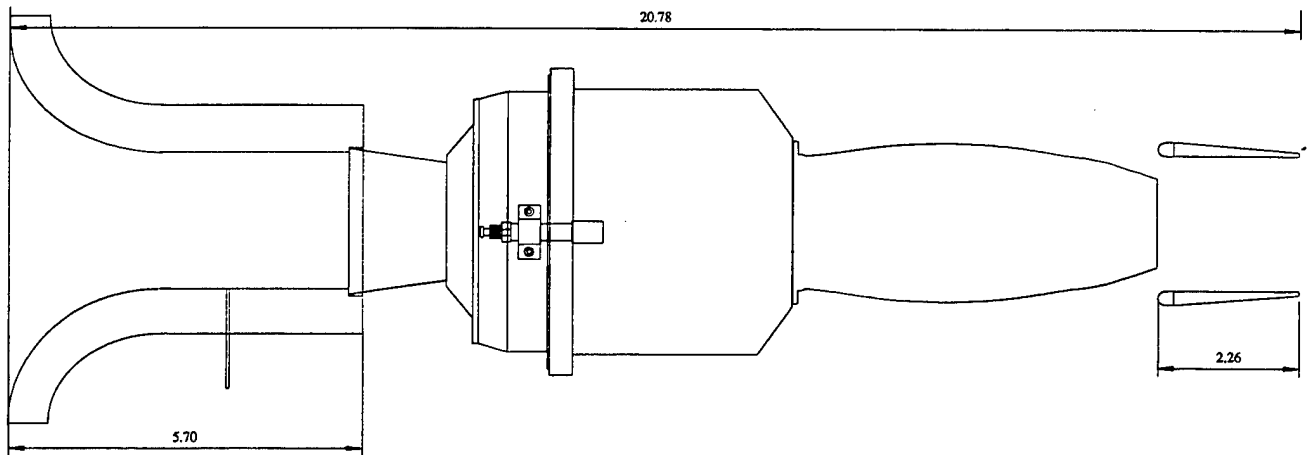

Figure 10 Sophia J450 with Bellmouth and Ejector

pressure between zero and 1.6 bars. The synthetic lubrication oil was fed to the engine bearings via an orifice valve that regulated oil flow rate. The initial production J450 used a needle valve to control the rate of oil consumption to the engine. This lubrication metering system resulted in a consumption of about four ounces of oil in approximately two minutes at full throttle. This was twice the manufacturer's specified consumption! As the engine was a total-loss oil-mist system, excessive oil consumption affects fuel consumption. Since the same engine was used in different configurations, this effect was consistent for all tests.

By regulating the fuel flow to the engine, the compressor pressure and hence the speed were controlled. Initially on startup, the fuel pressure was twice that required for idle operation to start combustion. After the pressure built up in the compressor, the fuel pressure was used as a reference for engine operation. Detailed instruction for engine operations can be found in [Ref. 3].

## **2. Engine Test Rig**

The engine test rig used for the J450 was located in the Gas Dynamics Laboratory at Naval Postgraduate School. It was the same apparatus used by Rivera [Ref. 1] and Lobik [Ref. 9]. The only modification on the test cell was the placement of the fuel measuring device in an enclosed space to shield it from the weather. A detailed engineering drawing of the test rig can be found in [Ref. 9]. A photo of the Sophia J450 mounted in the test rig is illustrated in Figure 11 and one of the engine with an ejector mounted as tested is shown in Figure 12.

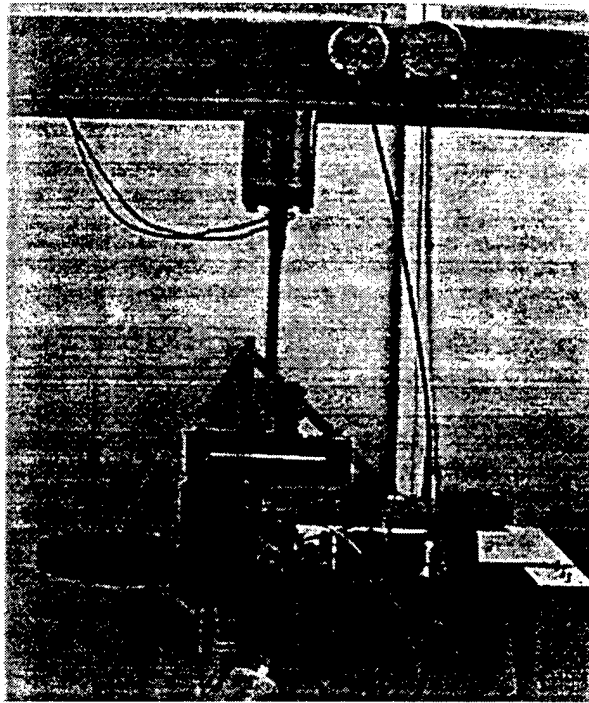

Figure 11 Engine Test Rig

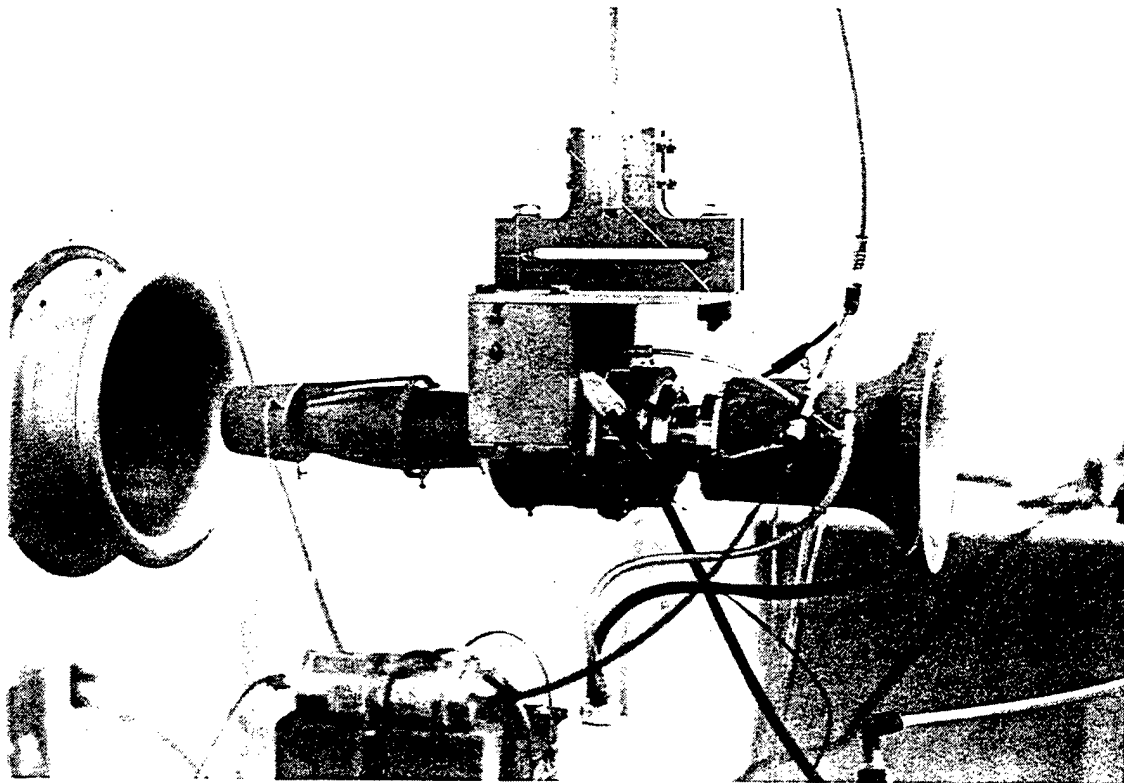

Figure 12 Sophia as tested with ejector

### 3. Ejector Geometry

The ejector geometry that was tested is shown below as Figure 13.

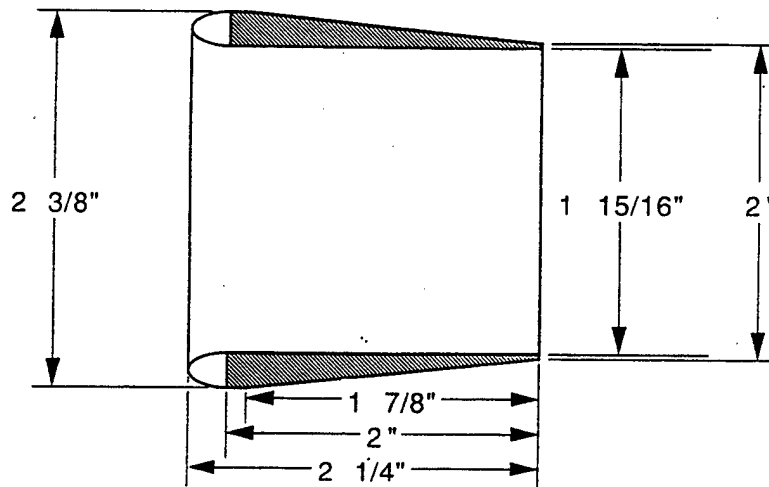

Figure 13 Ejector tested

## B. DATA ACQUISITION PROCESS

### 1. Overview

A Hewlett Packard 9000 workstation was used to control the data acquisition of three primary instruments used to measure the performance of the Sophia turbojet. The three instruments used were the strain gauges for the thrust beam, the Scanivalve Zero-Operate-Calibrate (ZOC-14) system for the pressure measurements and a strain-gauged cantilever beam/Vishay P-3500 Strain Indicator for fuel flow rate measurements. The equations for the best linear fits to calibration data were manually inserted into both the thrust beam and fuel weight subroutines in the "MICROJET" program. The procedures for the two steps above are included as Appendix F.

## 2. Instrumentation and Control

### *a. Thrust Measurements*

Thrust measurements were obtained using strain gauges placed on the suspension beam used to support the engine. The strain gauges were arranged in a full Wheatstone bridge configuration that was input through a signal conditioner to the HP3497A Data Acquisition Control Unit (DACU). The thrust beam was calibrated by hanging weights. The results of the calibration performed is given in Appendix G as Figure G1.

### *b. Fuel Flow Rate Measurements*

The fuel flow was determined by using a cantilevered beam as a weighing device to measure the change in fuel weight over a given period of time. The output of the Vishay P-3500 Strain Indicator was fed to channel zero of the signal conditioner. The beam was calibrated by hanging weights and the results are given in Appendix G as Figure G2. An enclosure was added to shield the fuel weight apparatus (which was outside the building) from the winds, which greatly improved the accuracy of the measurements.

### *c. Mass Flow Rate Measurements*

Pressure measurements were taken from the four pressure taps placed ninety degrees from one another on the bellmouth. The pressures were recorded using



the Scanivalve ZOC system. With the ambient and average bellmouth static pressure known, the mass flow rate into the engine was estimated using equation 10 in [Ref. 1].

**d. *Entrainment Pressures (Ejector Only)***

Pressure measurements were taken from three pressure taps located on the inside surface of the ejector spaced 120 degrees peripherally apart, (Figure 13). The pressures were recorded at the location of maximum thickness and using the Scanivalve ZOC system. With the average ejector pressure known, the entrainment pressure could be compared to the predicted by the ejector program.

**3. Software**

**a) *MICROJET, MICROJET\_CAL, and READ\_MJ\_ZOC***

The above mentioned programs are explained in detail in [Ref. 1].

**b) *EJ\_ZOC***

This program was used to obtain the pressures on the three pressure taps located on the ejector. The pressure at each tap was measured and an average of the three was tabulated.

**4. Data collection**

Step-by-step instructions for complete setup, including calibration of the fuel weighing device, load cell, engine setup and the operation of the HP9000 data acquisition system are given in Appendix F.

### C. RESULTS

Three individual data runs were conducted at 94,000, 105,000 and 115,000 RPM which corresponded to 83, 91 and 100 percent of design spool speed, respectively. The test data are given in Appendix G. The test results for runs on 08 March 1999 are summarized in Table 2.

NON-EJECTOR DATA			
Spool Speed (RPM)	115000	105000	94000
Pressure (BARS)	1.15	0.90	0.66
Thrust (lbf)	9.7134	7.4139	5.2395
Flow rate (lb/sec)	0.28350	0.24903	0.21090
Bellmouth press (inHg)	-0.32314	-0.25743	-0.19671
Fuel Flow (lbm/sec)	0.003613	0.003133	0.002635
SFC (lbm/lbf/hr)	1.33924	1.52155	1.81049

Table 2 Non-Ejector Results

The engine conditions as above were used for the ejector tests. The test data are given in Appendix G. The test results are summarized below in Table 3.

EJECTOR DATA			
Spool Speed (RPM)	115000	105000	94000
Pressure (Bars)	1.15	0.90	0.66
Thrust Ejector (lbf)	10.05	7.84	5.77
Flow rate (lb/sec)	0.28328	0.25270	0.21418
Bellmouth press (inHg)	-0.35356	-0.27680	-0.8993
Ejector press (inHg)	-0.7358	-0.5227	-0.3945
Fuel Flow (lbm/sec)	0.003536	0.003066	0.002638
SFC (lbm/lbf/hr)	1.274079	1.40791	1.645334

Table 3 Ejector Results

In Table 4 below, a comparison is made at the three speeds between the baseline engine and the ejector-augmented engine. As can be seen, the ejector increased the thrust by approximately 10 percent at 83 percent of design speed and approximately three percent at design speed.

SPOOL SPEED	NON-EJECTOR	EJECTOR	INCREASE
RPM	lbf	lbf	%
115000	9.7134	10.0449	3.41
105000	7.4139	7.8397	5.74
94000	5.2395	5.77148	10.15

Table 4 Comparison of Non-Ejector to Ejector Thrust

The ejector prediction program calculated a thrust increase of over 13 percent at design conditions. The large increase in augmented thrust at the lower spool speeds was of interest since the pressure in the ejector also decreased as the velocity of the exit stream decreased at the lower engine speeds. The difference between the primary and secondary flow velocities was less, resulting in more thrust augmentation, i.e. relatively more entrainment. The results in Table 4 are plotted in Figure 14, which also includes the predicted thrust from the ejector program. The engine exhaust stagnation temperature and pressure were obtained from the GASTURB off-design performance prediction. The results were repeatable, as shown in Appendix G, Table G2 and G4 respectively.

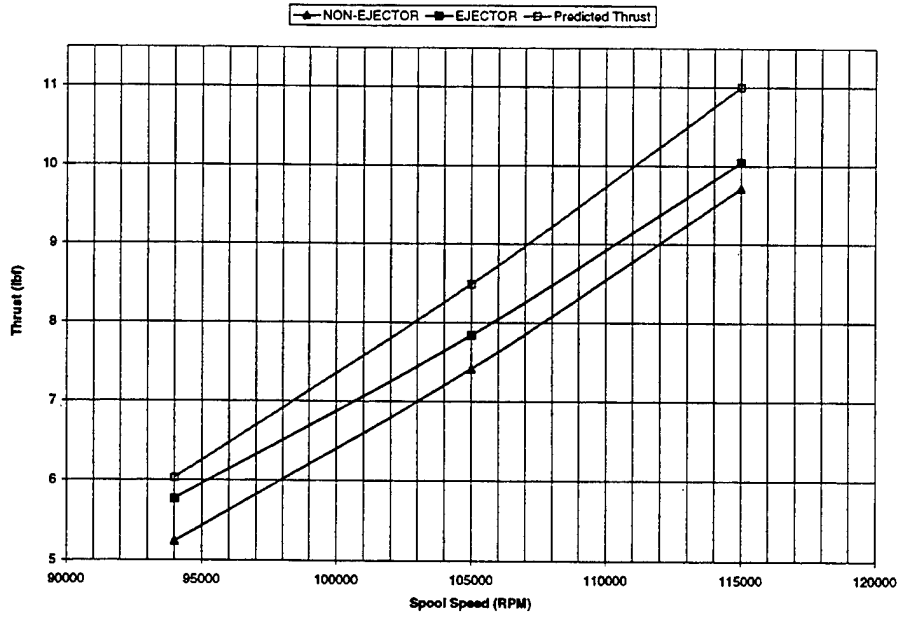

Figure 14 Ejector Performance

## V. COMBINED CYCLE ANALYSIS

### A. OVERVIEW

Several Japanese aero-engine companies and four Japanese national laboratories are participating in a project to design a Mach 5-capable airplane. The focus of the research is a combined-cycle engine that consists of a variable cycle turbo-engine and a ramjet engine. The simplest of the engines being tested is included below in Figure 15 to show the similarities between it and the shrouded geometry tested in the present study.

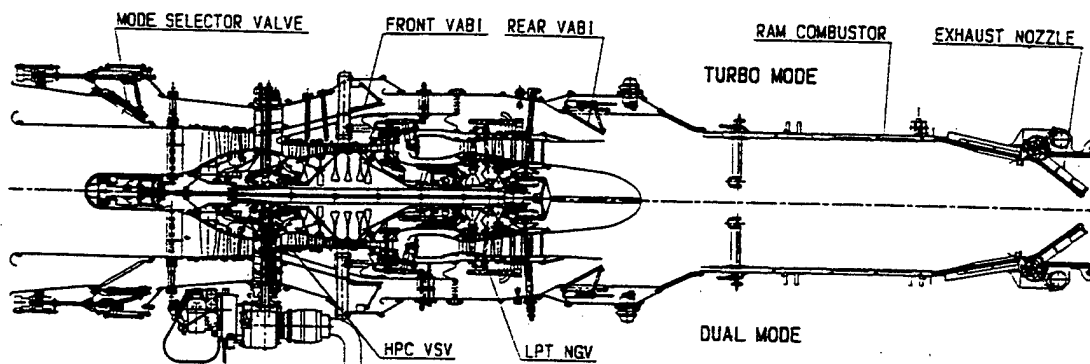

Figure 15 HYPR90 Combined Cycle Engine Demonstrator [from Ref. 9]

The purpose was to explore if thrust augmentation or degradation was obtained by placing the Sophia J450 in a non-optimized, simple geometry shroud; which is shown in Figure 16. If successful, the shroud would later serve as a baseline for a combined cycle turboramjet engine. Initially, pressure measurements were taken to ensure that the proper distribution existed within the shroud. First, measurements were made with the shroud equal in length to the engine. Then a six inch extension (mixer) was added, and the measurements repeated with pressure taps on the shroud connected to a bank of water

manometers. Thrust and SFC performance were also recorded and compared with baseline engine data.

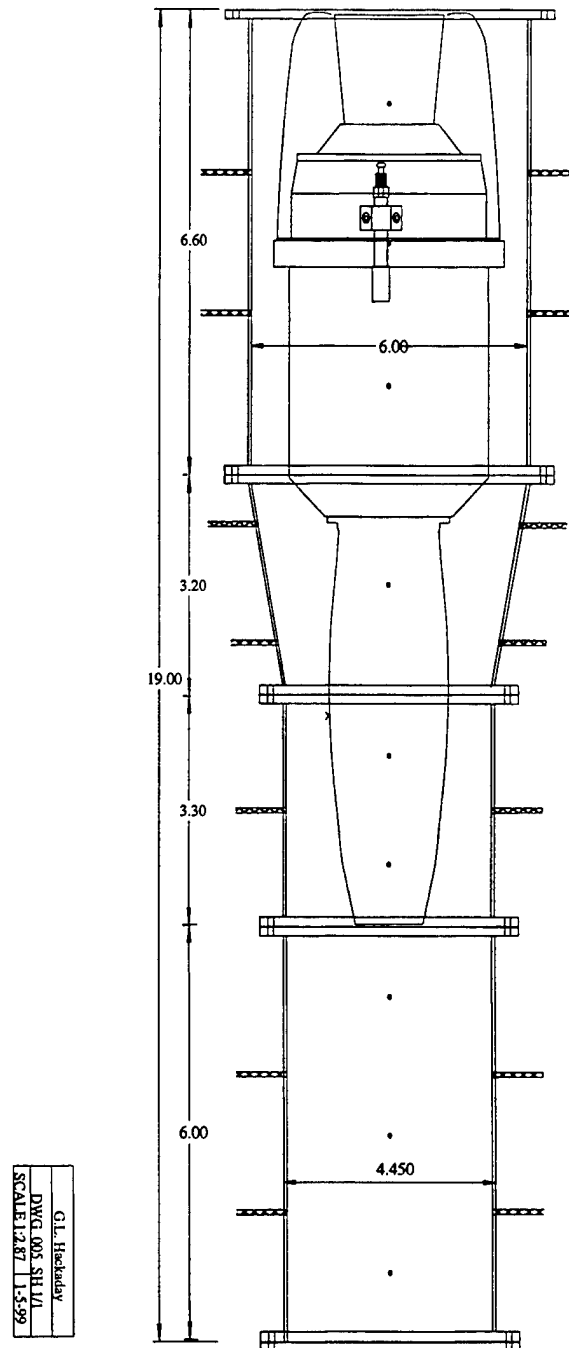

Figure 16 Shroud with Sophia J450 Installed

## **B. ENGINE TEST RIG**

The engine test rig used for the shrouded engine was the same as was used for the baseline engine with the exception of modified blocks and cradle to support the engine.

Drawings of the shroud and support system are given in Appendix I.

## **C. DATA ACQUISITION PROCESS**

### **1. Overview**

The same acquisition system was used for the shrouded engine test with the addition of 22 pressure lines that were used to measure the static pressure within the shroud. The bellmouth was also removed, which eliminated the engine mass flow rate measurement. The engine manufacturer-furnished inlet cowling was installed on the engine in an attempt to streamline the outside of the engine and minimize flow losses within the shroud.

### **2. Instrumentation and Control**

#### *a. Thrust Measurements*

Thrust measurements were accomplished in the same manner as the ejector. The center of gravity shift due to the shroud was not properly accounted for which meant that the non-operational thrust had to be subtracted from the thrust measured during operation.

*b. Fuel Flow Rate Measurements*

Fuel flow was measured as previously described in chapter IV.

*c. Entrainment Pressures*

Pressure measurements were taken from ports 19 to 28 (Figure 17), which were connected to a bank of water manometers.

**D. RESULTS**

Two runs were conducted at 83 and 100 percent spool speed on the baseline shroud, which ended at the engine exhaust (Figure 16). The test results are provided in Appendix J and are summarized below in Table 5.

BASELINE SHROUD		
Spool Speed (RPM)	115000	94000
Pressure (BARS)	1.15	0.65
Thrust (lbf)	9.4819	5.1296
Fuel Flow (lbm/sec)	0.003789	0.002640
SFC (lbm/lbf/hr)	1.4387	1.852687

Table 5 Baseline Shroud Results

The same conditions as above were used for tests with the shroud with the six inch mixer. The test data are provided in Appendix J and summarized in Table 6.

SHROUD w\Extension		
Spool Speed (RPM)	115000	94000
Pressure (BARS)	1.15	0.65
Thrust (lbf)	9.0501	5.0404
Fuel Flow (lbm/sec)	0.003765	0.002703
SFC (lbm/lbf/hr)	1.494019	1.930571

Table 6 Shroud with Extension



The results of the two data sets are compared in Table 7.

SPOOL SPEED	BASELINE	EXTENSION	INCREASE
RPM	lbf	lbf	%
115000	9.4819	9.0501	-4.55
94000	5.1296	5.0404	-1.74

Table 7 Comparison of Baseline to Extension Thrust

The slight decrease in thrust, compared to the unshrouded engine (Table G1), could have been the result of removing the bellmouth and degrading the smooth entrance of air into the compressor.

Shown below in Figure 17 and Figure 18 respectively are the shroud with the pressure line locations, and the pressure measured there with a water manometer. The minimum entrainment (gauge) pressure of -1.65 inches of water was recorded at the smallest passage area, which occurred approximately four inches axially into the shroud. Along much of the shroud the gauge pressure was constant at -1.5 inches of water.

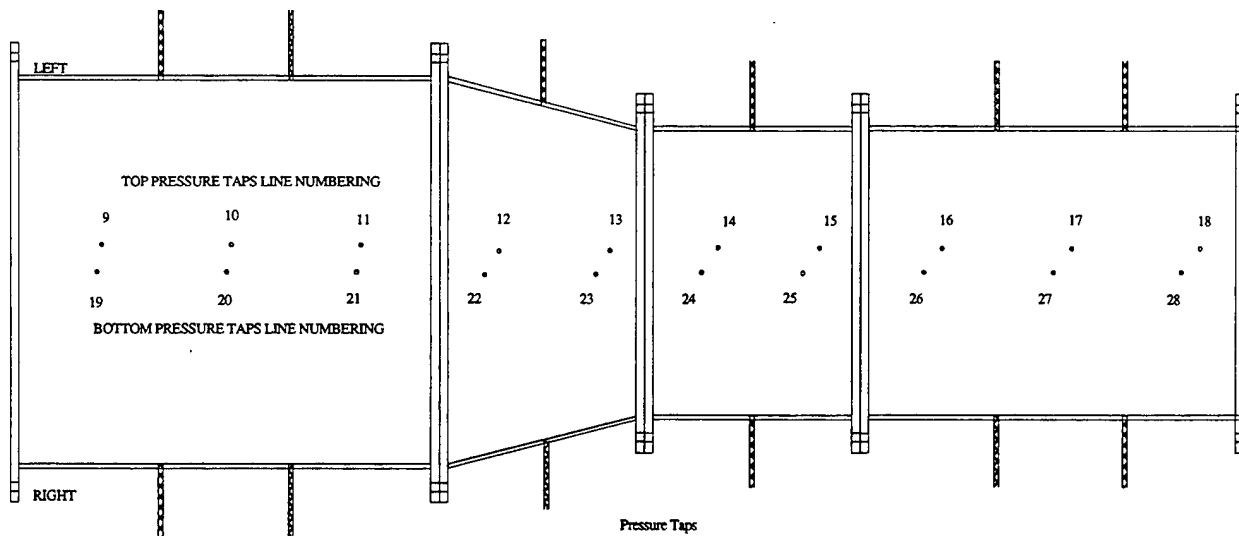

Figure 17 Shroud Pressure Tap Line Numbers

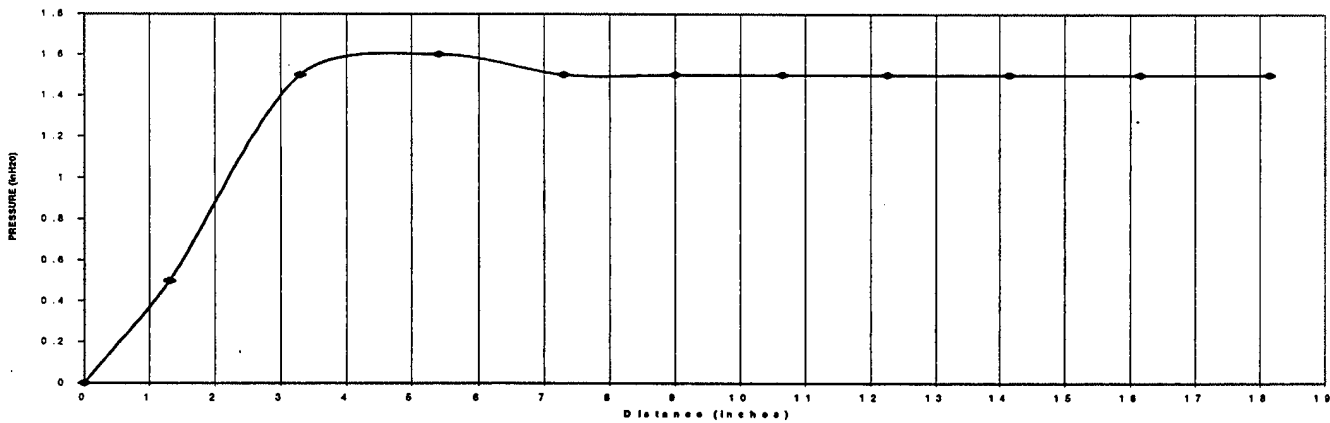

Figure 18 Shroud Pressure vs. Distance (100 Percent Spool Speed)

## VI. CONCLUSIONS AND RECOMMENDATIONS

### A. CONCLUSIONS

A more realistic engine performance prediction program that includes the compressor map of the Garrett T3 and RADTUR radial inflow turbine was developed.

The Garrett T2 closely matched the Garrett T3 suggesting that scaling up compressor maps is acceptable.

The ejector worked as expected and the performance prediction program predicted the correct off-design trend of the ejector's performance. Thrust augmentation of approximately three percent at design condition, and over ten percent at 65 percent spool speed, was measured.

The engine shroud affected only slightly the engine performance at static conditions. The slight decrease in engine performance may be a the result of the bellmouth being removed, degrading the smooth transition of incoming air to the engine.

The extended shroud, with the six-inch mixer, did produce a secondary flow of approximately -1.5 inches of water (gauge). The baseline performance of the engine at static conditions was reduced by almost five percent at design spool speed and less than two percent at 65 percent spool speed.

## **B. RECOMMENDATIONS**

An investigation of ejectors with various lengths and area ratios should be conducted to study the effect of changing these parameters. This may show a trend as to which parameter has the greatest influence on ejector performance.

The ongoing study of the combined-cycle engine dictates the need for a control room to ensure the safety of personnel.

The data acquisition system which is currently in use should be upgraded. Although the HP9000 has been reliable over the past decade, a faster more flexible PC-based system will greatly reduce the time required between data runs.

An Electronic Control Unit for start-up of the engine would reduce the likelihood of hot-starts, and increase the engine operation life.

The use of a speed pick-up would confirm engine operation speed and ensure that the engine was operating at the same point on the operating line for different augmentation configurations.

The effects of extended length shrouds, including a final nozzle as shown in Appendix I, Figure I6, should be studied to determine whether a longer shroud will yield a more completely mixed flow at the exit, and give enhanced thrust augmentation.

# APPENDIX A. RADIAL TURBINE MAP

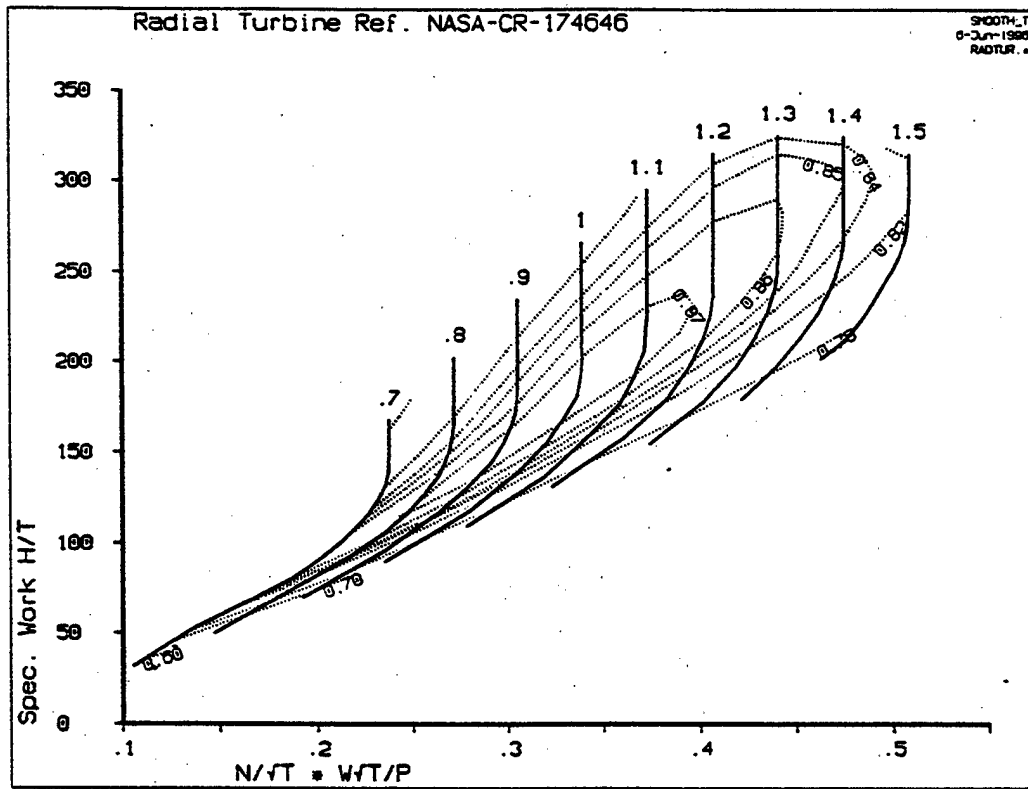

Figure A1 RADTUR (Inflow Radial Turbine)



## APPENDIX B. COMPRESSOR MAPS

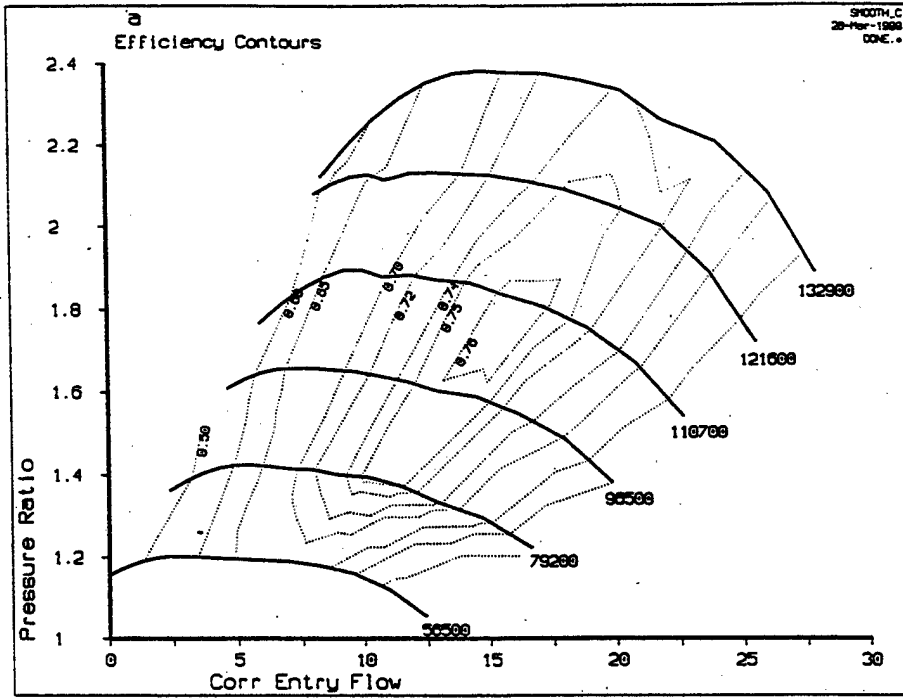

Figure B1 T3 Compressor Map

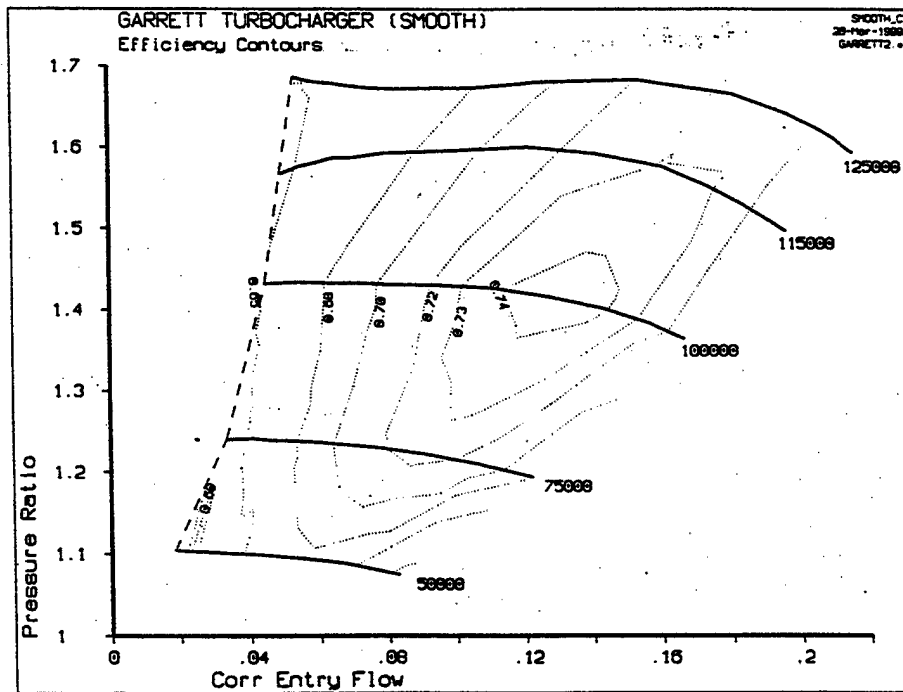

Figure B2 T2 Compressor Map





## APPENDIX C. ENGINE PERFORMANCE PREDICTION

RADTUR TURBINE				SFC				
RPM	DLRRAD57	SSCENT	PEP82R12	T100RAD	T3	RAD1KG	ACTUAL	T2
94000	1.588	1.485	2.079	2.026	1.63	1.79	1.838	1.63
105000	1.455	1.4	1.53	1.619	1.465	1.495	1.613	1.474
115000	1.378	1.378	1.378	1.378	1.378	1.378	1.313	1.378
121000	1.352	1.398	1.318	1.35	1.347	1.38	1.384	1.359
THRUST								
RPM	DLRRAD57	SSCENT	PEP82R12	T100RAD	T3	RAD1KG	ACTUAL	T2
94000	5.49	5.787	3.78	4.5	5.735	4.9	5.15	6.39
105000	7.5	7.73	6.57	6.75	7.5	7.22	7.35	7.92
115000	9.8	9.8	9.8	9.8	9.8	9.8	9.8	9.79
121000	11.34	10.98	12.42	11.99	11.06	11.25	11.28	11.35

Table C1 Predicted SFC and Thrust with RADTUR Turbine Map

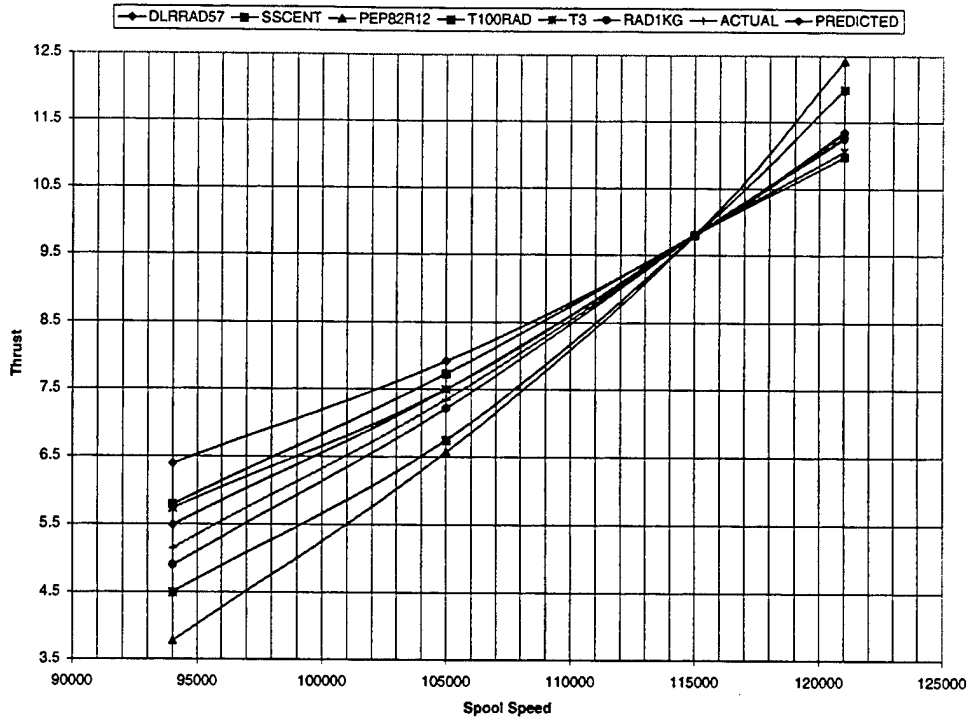

Figure C1 Predicted Thrust Comparison

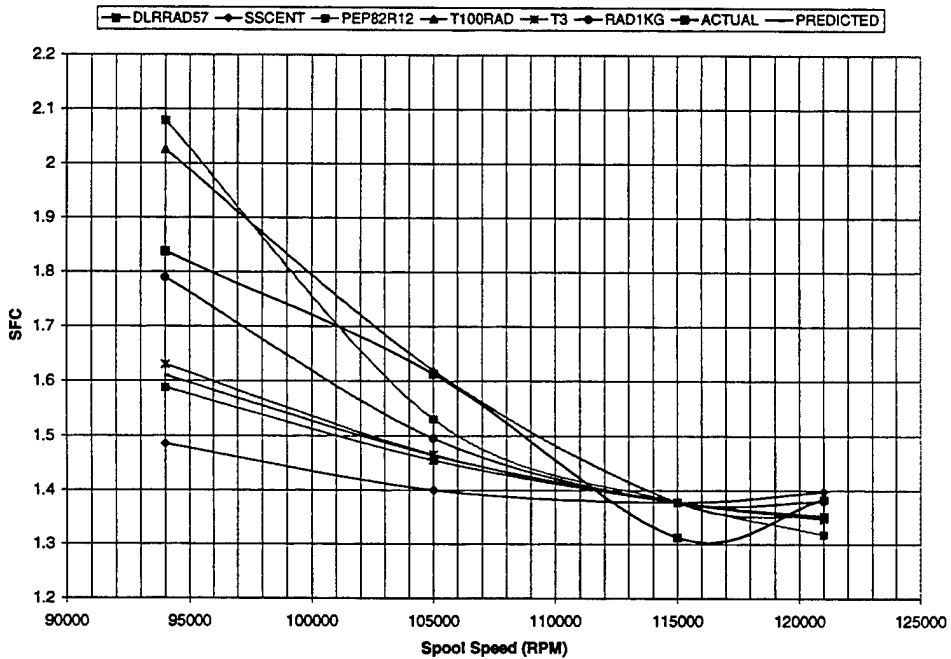

Figure C2 Predicted SFC Comparison

## APPENDIX D. SMOOTHC OPERATIONS

SMOOTHC is a computer program used to generate high quality compressor maps from measured data. The use of SMOOTHC is straightforward until you reach the print command or attempt to read the output file into a performance synthesis program such as GASTURB.

The output file can only be printed on a Hewlett Packard printer or a HP compatible printer that recognizes the Hewlett Packard graphics language. The output option of "store synthesis table to disk" does not provide a complete input file required by GASTURB. Additional inputs to the file must first be accomplished prior to successful reading into the GASTURB program. Unfortunately this information was not included in the SMOOTHC User's Manual, it can be found in the GASTURB 7.0 User's Manual, chapter four, section two, Component Map format for off-design.

The modification of the data file can be accomplished using Microsoft Notepad to add the following information in the first two lines. On the first line of the map data file there must be the number 99 followed by a space. After the space on the first line any text may follow (i.e. Map title). On the second line the Reynolds number correction factor on efficiency are given as follows: Reynolds:  $RNI=x_1$   $f=y_1$   $RNI=x_2$   $f=y_2$

Where the Reynolds Number Index is  $RNI = \frac{P/P_{ref}}{T/T_{ref}} \frac{\mu_{T_{ref}}}{\mu_T}$  with  $\mu$  for dynamic viscosity.

Reference conditions are  $P_{ref} = 101325$  kPa and  $T_{ref} = 288.15$ . An example of the format of the synthesis table generated by SMOOTHC was provided in the previous section with the

actual data used for the T3 compressor map. An output file of the compressor map with efficiency island was also provided as Figure B1 in Appendix B.

With the above data correctly entered into the SMOOTHC data you are now ready to read the compressor map into GASTURB and begin performance predictions. The speedline data for the Garrett T3 is included as Table D1 along with the output data generated by SMOOTHC.

Speed: 0.452				Speed: 0.634			
Point	Pressure Ratio	Mass Flow	Efficiency	Point	Pressure Ratio	Mass Flow	Efficiency
1	1.2	2	0.54	1	1.42	4.5	0.58
2	1.2	3	0.57	2	1.42	6	0.65
3	1.198	4	0.63	3	1.415	7	0.69
4	1.195	5	0.65	4	1.4	8.75	0.73
5	1.19	6.1	0.67	5	1.38	11	0.75
6	1.18	8	0.67	6	1.33	13	0.72
7	1.17	9	0.64	7	1.27	15.5	0.63
Speed: 0.772				Speed: 0.886			
Point	Pressure Ratio	Mass Flow	Efficiency	Point	Pressure Ratio	Mass Flow	Efficiency
1	1.65	6.1	0.62	1	1.88	7.6	0.62
2	1.655	7.5	0.67	2	1.89	9	0.67
3	1.65	9	0.69	3	1.88	11	0.7
4	1.63	11	0.73	4	1.87	13	0.73
5	1.6	13	0.76	5	1.82	16	0.76
6	1.55	16	0.73	6	1.75	19	0.74
7	1.45	18.7	0.67	7	1.59	22	0.66
Speed: 0.973				Speed: 1.06			
Point	Pressure Ratio	Mass Flow	Efficiency	Point	Pressure Ratio	Mass Flow	Efficiency
1	2.11	9	0.62	1	2.35	12.5	0.65
2	2.12	11.2	0.66	2	2.38	14.5	0.68
3	2.125	13.5	0.69	3	2.37	16.3	0.71
4	2.11	16	0.73	4	2.35	19	0.73
5	2.06	19	0.75	5	2.25	22.5	0.74
6	1.97	22.5	0.73	6	2.16	25	0.73
7	1.77	25	0.65	7	1.93	27.5	0.65

Table D1 Garrett T3 SMOOTHC Speedline Data

99 Garrett T3 Compressor Map

Reynolds: RNI=0.100 f=0.950 RNI=1.000 f=1.000

Mass Flow

8.01600	0.00000	0.07143	0.14286	0.21429
0.28571	0.35714	0.42857	0.50000	0.57143
0.64286	0.71429	0.78571	0.85714	0.92857
1.00000				
0.45200	11.83210	10.25510	8.86364	7.28664
5.89518	4.82839	3.90074	3.11224	2.41651
1.81354	1.30334	0.79314	0.28293	-0.18089
-0.59833				
0.63400	16.50693	14.38173	12.46326	10.92897
9.56491	8.34440	7.34504	6.46278	5.64226
5.01307	4.32578	3.63850	2.95122	2.26393
1.57665				
0.77200	20.00000	17.72727	15.77922	13.96104
12.40260	11.16883	10.06494	9.09091	8.24675
7.46753	6.75325	6.10390	5.51948	4.93506
4.35065				
0.88600	22.82004	20.59369	18.58998	16.64193
15.08349	13.63636	12.46753	11.35436	10.40816
9.57328	8.79406	8.07050	7.40260	6.79035
6.23377				
0.97300	25.65863	23.59926	21.59555	19.31354
17.47681	15.97403	14.63822	13.41373	12.30056
11.35436	10.51948	9.74026	9.07236	8.34879
7.68089				
1.00000	26.37755	24.31818	22.25881	20.03247
18.19573	16.63729	15.24583	14.02134	12.90816
11.90631	10.96011	10.12523	9.29035	8.56679
7.67625				
1.06000	28.00586	25.92786	23.70466	21.61515
19.79171	18.13727	16.61252	15.35037	14.18333
13.08402	11.98472	10.88541	9.78611	8.68680
7.58750				

Efficiency

8.01600	0.00000	0.07143	0.14286	0.21429
0.28571	0.35714	0.42857	0.50000	0.57143
0.64286	0.71429	0.78571	0.85714	0.92857

1.00000				
0.45200	0.45439	0.57544	0.64474	0.68860
0.66842	0.64737	0.62807	0.57456	0.55351
0.53684	0.51930	0.49649	0.47544	0.46140
0.45263				
0.63400	0.54900	0.68741	0.73808	0.74942
0.74780	0.72618	0.70224	0.67047	0.63227
0.60728	0.57015	0.52900	0.48521	0.43989
0.39397				
0.77200	0.64298	0.69474	0.73246	0.75877
0.75965	0.73596	0.71579	0.69298	0.67895
0.66930	0.64825	0.62105	0.59649	0.56579
0.50877				
0.88600	0.63684	0.69474	0.74737	0.75877
0.75877	0.73860	0.72105	0.70439	0.68947
0.67632	0.66579	0.64386	0.61228	0.57544
0.51754				
0.97300	0.63070	0.68947	0.74474	0.75000
0.74649	0.72895	0.70789	0.68860	0.67281
0.66140	0.65088	0.63509	0.62018	0.59298
0.54035				
1.00000	0.62807	0.69649	0.74298	0.74825
0.74298	0.72982	0.70877	0.69211	0.67368
0.66053	0.64737	0.62807	0.60789	0.57632
0.52982				
1.06000	0.62350	0.72018	0.74019	0.74514
0.73872	0.72368	0.71437	0.69648	0.67679
0.66103	0.63888	0.61122	0.57884	0.54242
0.50260				

Pressure Ratio

8.01600	0.00000	0.07143	0.14286	0.21429
0.28571	0.35714	0.42857	0.50000	0.57143
0.64286	0.71429	0.78571	0.85714	0.92857
1.00000				
0.45200	1.06512	1.12896	1.17280	1.18645
1.18999	1.19532	1.19730	1.19845	1.19813
1.19773	1.19835	1.19532	1.18911	1.18302
1.17748				
0.63400	1.22754	1.30437	1.34826	1.38091
1.39925	1.40731	1.41530	1.41956	1.41828
1.42401	1.41778	1.40512	1.38692	1.36404
1.33736				
0.77200	1.38617	1.48691	1.55395	1.58790

1.60790	1.62853	1.64028	1.64734	1.65322
1.65414	1.65197	1.64830	1.64451	1.63430
1.61830				
0.88600	1.53748	1.67204	1.76138	1.80504
1.84254	1.85893	1.87780	1.88182	1.88699
1.89070	1.88882	1.88315	1.87527	1.86656
1.85823				
0.97300	1.71077	1.89464	2.01678	2.05330
2.08281	2.10915	2.12368	2.12594	2.12055
2.11898	2.11753	2.11102	2.10952	2.08987
2.06965				
1.00000	1.75800	1.95220	2.07781	2.12554
2.16066	2.18580	2.19783	2.20357	2.20127
2.19497	2.18012	2.16726	2.14216	2.12317
2.06893				
1.06000	1.86996	2.08714	2.21672	2.29269
2.34285	2.36839	2.37310	2.38228	2.37970
2.36541	2.33224	2.28241	2.21816	2.14171
2.05530				

Specific Work dH/T

8.01600	0.00000	0.07143	0.14286	0.21429
0.28571	0.35714	0.42857	0.50000	0.57143
0.64286	0.71429	0.78571	0.85714	0.92857
1.00000				
0.45200	0.00961	0.01471	0.01735	0.01745
0.01830	0.01939	0.02018	0.02218	0.02299
0.02366	0.02453	0.02529	0.02562	0.02559
0.02535				
0.63400	0.02638	0.02755	0.02899	0.03094
0.03234	0.03390	0.03567	0.03770	0.03987
0.04201	0.04416	0.04632	0.04847	0.05062
0.05277				
0.77200	0.03651	0.04147	0.04399	0.04469
0.04593	0.04877	0.05094	0.05310	0.05462
0.05547	0.05711	0.05933	0.06147	0.06393
0.06957				
0.88600	0.04930	0.05467	0.05639	0.05816
0.06036	0.06299	0.06567	0.06748	0.06926
0.07085	0.07185	0.07391	0.07716	0.08144
0.08984				
0.97300	0.06311	0.06975	0.07154	0.07305
0.07500	0.07827	0.08142	0.08384	0.08548
0.08686	0.08818	0.08996	0.09202	0.09490



0.10263				
1.00000	0.06686	0.07260	0.07509	0.07713
0.07956	0.08235	0.08546	0.08784	0.09011
0.09153	0.09249	0.09453	0.09603	0.09998
0.10461				
1.06000	0.07540	0.07799	0.08283	0.08619
0.08949	0.09267	0.09412	0.09702	0.09970
0.10128	0.10286	0.10444	0.10601	0.10759
0.10917				

Surge Line

1.00800	1.97542	4.49187	6.08742	7.58303
8.98220	9.60858	12.44245		
1.00000	1.19784	1.41928	1.64819	1.87740
2.10708	2.15173	2.34605		



## APPENDIX E. GASTURB (OFF-DESIGN PERFORMANCE)

Process: Perform a single cycle calculation for a single spool turbojet by selecting **Calculate Single Cycle** and press **Go On**. For the initial calculation you must enter the engine type, at the prompt select **sophia.cyj** or select the **demo\_jet.cyj** and enter the data contained in at the end of this process as Table E1 into the Design Point Input menu. When complete selected **Go On**, the design Turbojet SL and static performance should appear as indicated in Table E1. Press **Close** twice to perform off design calculations. Once at the introduction screen, select **Off Design** and then select **Go On**. At this point select **Maps** to read in special compressor and or turbine maps. Select **Maps** then **Special**, the special component map screen will appear. Select **Read** to read special compressor or turbine into the current file. **Compr or Turb** must be selected after the map is read into the current file to view and select the design point with the small yellow square. By placing the pointer over the yellow square (design point) and press the right mouse button to move the design point to coincide with experimental data. Once both the compressor and turbine maps are selected and the design points verified **Close** the component map window.

To create an operating line select **Task** and choose **Operating Line** and **Go On**. Increase the number of points in the operation line to 20. Select the down arrow for decreasing load and select **Go On**. Once computed, select no for another operation line. You can now elect to view pressure ratio vs mass flow rate or a variety of many other combinations. Or you can select to view operation line of the **Compressor or Turbine**. Once complete Select **Close** once to return to the off-design input screen. If you wish to

compare other turbine map combination select Maps and repeat the steps from that point to continue analysis. If you are finished with comparisons continue to select **Close** until the startup screen to exit.

Parameter	Value
Input Corr. Floww2Rstd (lb/s)	0.256
Intake Pressure Ratio	1
Pressure Ratio	2.15
Burner Exit Temperature (R)	1715
Burner Efficiency	1
Fuel Heating Value (BTU/lb)	18.5
Mechanical Efficiency	1
Burner Pressure Ratio	1
Turbine Exit Duct Press Ratio	1
Nozzle Thrust Coefficient	1
Compressor Efficiency	0.73
Turb Efficiency	0.77
All others	0

Table E1 Sophia Design Point Input (115000 RPM)

Sophia Design Calculation (115,000 RPM -GASTURB)

Station	W	T	P	WRstd	FN	=	9.79
amb		518.67	14.696		TSFC	=	1.3783
2	0.256	518.67	14.696	0.256	FN/W2	=	1230.97
3	0.256	692.21	31.596	0.138	Prop Eff	=	0.0000
4	0.260	1715.00	31.596	0.220	Core Eff	=	0.1101
41	0.260	1715.00		0.220	WF	=	0.0038
5	0.260	1565.32	19.520	0.340	WFRH	=	0.0000
6	0.260	1565.32	19.520		A8	=	1.1322
8	0.260	1565.32	19.520		P8/Pamb	=	1.3282
P2/P1 = 1.0000		P4/P3 = 1.0000		P6/P5 = 1.0000	PWX	=	0
Efficiencies:	isent	polytr	RNI	P/P	W_NGV/W2	=	0.00000
Compressor	0.7300	0.7572	1.00	2.150	WC1/W2	=	0.00000
Turbine	0.7700	0.7555	0.29	1.619	WB1d/W2	=	0.00000
Spool mech	1.0000						

Table E2 Predicted Design Point Values (115000 RPM - GASTURB)

## APPENDIX F. SOPHIA J450 TEST PROGRAM CHECKLIST

- F1. FUEL WEIGHT AND THRUST BEAM CHECKLIST
- F2. DATA ACQUISITION SYSTEM SETUP CHECKLIST
- F3. ENGINE STARTUP AND OPERATION CHECKLIST
- F4. DATA ACQUISITION SYSTEM CHECKLIST
- F5. DATA FILE PURGE CHECKLIST
- F6. QUICK REFERENCE CHECK LIST

### F1. FUEL WEIGHT AND THRUST BEAM CHECKLIST

1. Ensure that the test rig is configured in accordance with Figures 7 and 8 of [Ref. 1] and that all devices are properly energized.
2. The fuel pump power supply should be OFF with the voltage knob turned counter clockwise until slight resistance is felt.
3. Zero the thrust beam by connecting the CHANNEL 5 output of the signal conditioner to the DVM front panel. Once properly connected, adjust the ZERO KNOB accordingly until the DVM reads 0 mV. Once zeroed, restore the signal conditioner and DVM to their initial configuration.
4. Calibrate the fuel flow beam in the following manner
  - 5.1. Connect the strain gauges (1 and 2) in a half Wheatstone bridge configuration as shown on the inside cover of the P-3500.
  - 5.2. Set the bridge push button to half-bridge position.
  - 5.3. Depress AMP ZERO and adjust thumbwheel until  $\pm 0000$  is displayed.
  - 5.4. Depress GAGE FACTOR and ensure the range is set on 1.7-2.5.
  - 5.5. Adjust GAGE FACTOR knob until 2.08 is displayed.
  - 5.6. Depress RUN and set the BALANCE Control for a reading of +0000.

- 5.6. With a DVM connected to the P-3500 output, adjust the OUTPUT thumbwheel until the DVM reads 0 mV.
- 5.7. Perform a calibration of Fuel Cell.
5. Place Fuel bottle on carriage and connect fuel line to engine.
6. Prime fuel pump by disconnecting the fuel line forward of the check valve.

## **F2. DATA ACQUISITION SYSTEM SETUP CHECKLIST**

1. Energize the HP9000 computer system.
2. The first screen is the HP9000 Series 300 Computer Data Acquisition/Reduction System introduction.
3. Select **F7** and set the current time and date. The format is HH: MM: SS for the time and DD MMM YYYY, (i.e. 10:20:00, 08 Jan 1999).
4. Select **F3**, Old HP6944A Directory.
5. Select **F1**, ZOC-14 Module Menu.
6. Open the Nitrogen bottle valve and adjust the pressure reducer at the bottle so that 110 psi is displayed. The pressure reducer on the rear of the CALSYS 2000 should read 90 psi when Nitrogen bottle is energized.
7. Ensure the CALSYS 2000 pressure range on CALMOD 2 are set at 20, 10 and 0 inHg respectively.
8. Select **F4**, Read CALSYS 2000 Calibration Pressures.
9. Select **2** to scan CALMOD.
10. Select **1**, for printer.
10. Select **F2** to continue, if the high, middle, and low pressures displayed are correct, continue on to the next step. If the calibration pressures are not correct, repeat steps 8 and 9 until correct.

11. Select **F1** to Scan 1-3 ZOC-14 Modules (32 ports each). The default program "SCAN-ZOC-08" will initialize.
12. Once "SCAN-ZOC-08" introduction screen is displayed, select the **STOP** key.
13. Select **F5** to LOAD and type "MICROJET".
14. Once "MICROJET" is loaded, select **F3** to RUN.
15. Once "MICROJET" introduction screen is displayed select **F3** for system setup.
16. Select **0** for hard drive "1,700" storage.
17. Select **1000** Hz for sampling rate.
18. Select **10** for samples per port.
19. Select **1** ZOC connected to Multi-programmer.
20. Select **3** for the number of desired runs.
21. Select **5** for the time interval (in seconds) between data runs.
22. Select **2** for CALMOD set for ZOC # 2.
- 23 Do not Select **F4** unless nitrogen system is energized.

### **F3. ENGINE STARTUP AND OPERATION CHECKLIST**

1. Connect the air-trigger to the J450. Ensure that the air compressor is fully charged before attempting start.
2. Ensure the spark plug is installed correctly. (Gap facing forward)
3. Pre-lube the engine bearings before start.
4. Pre-spin engine to ensure freedom of movement.
5. Engine is now ready for start
6. Apply start air and once the rotor sound level has increased, push the igniter button.

7. Slowly increase the voltage to the fuel pump by turning the knob in the clockwise direction.
8. Fuel pressure should not exceed 1.0 bar on start up.
9. Continue to supply start air until a pressure of at least 0.3 bars in the compressor. Adjusting the fuel pump pressure to 0.4 bars should correspond to a compressor pressure of approximately 0.4 bar.

**NOTE:** If engine does not start within 10 seconds, turn off fuel pump and spark while continuing start air. Once excess fuel and oil is drained attempt restart.

**NOTE:** If hot start occurs (Tail Pipe Glows red-hot) cut the power to fuel pump immediately but continue ignition and start air. After 5 seconds reenergize fuel pump.

**NOTE:** If extremely cold, extra Coleman will ensure combustion. Do not exceed recommended ratios.

10. Confirm the flow of lubrication oil immediately after start.
11. The safe operating range is below 1.3 bars. **NEVER EXCEED 1.3 bar compressor pressure.**
12. To cease engine operation, reduce power to 0.7 bars and secure power to the fuel pump.

#### **F4. DATA ACQUISITION SYSTEM CHECKLIST**

1. Energize the Nitrogen system and select **F4**
2. Once the engine is operating at the desired speed and stabilized, select **F5** to begin data acquisition sequence.
3. Manually record the Thrust and Fuel Flow rate for each of the data runs as displayed on the screen.
4. Once the data collection sequence is completed, secure the engine.
5. Secure Nitrogen once post calibration is complete.



6. Select **F6** to begin data reduction.
7. Select **F8** to exit once data reduction is complete.
8. Select **STOP** to display the reduced data.
9. Select **F5** and type "READ-MJ-ZOC".
10. Select **F3** to RUN.
11. Enter 1, date (YMMDD), Run number. (i.e. for run 1 on 08 March 1999, type: **1,90308,1**)
12. Select **1** for printer option.
13. Select **0** to Exit.

**NOTE:** Selecting exit does not exit the program but displays the average of the port readings for the selected data run.

14. Select **STOP** to exit the program.
15. Repeat steps 10-13 for the remaining data runs.
16. If ejector data was measured select **STOP**.
17. Select **F5** and type "EJ\_ZOC".
18. Select **F3** to run.
19. Data files are presented in the same manner as above.
20. When complete viewing data select **STOP**.
21. Type **PRINTER IS CRT**.

#### **F5. DATA FILE PURGE CHECKLIST**

1. The raw data files are stored on the "HP9000 ",700" hard drive as ZW190381 (example for 08 March 1999, run number 1) through ZW19038X for X data runs.

2. The reduced data files are stored as ZRXXXXXX and the calibrations data is stored as ZCXXXXXX.
3. Select **F5** and type "ZOC\_MENU".
4. Select **F3** to Run.
5. Select **F8** to exit menu.
6. Type **MSI ":",700"**.
7. Type **PURGE "FILENAME"**. (ex. PURGE "ZW190381").
8. Ensure deletion of each files. If all created files are not deleted an error will be encountered if obtaining additional data.
9. Cycle the power switch on the lower left corner of the HP9000 CPU to reset the computer.

## F6. QUICK REFERENCE CHECKLIST

This checklist guide is provided for convenience and to ensure all systems have been properly configured.

- |   |       |       |
|---|-------|-------|
| 1. Power up: HP9000   | _____ | _____ |
| SCANIVALVES (1 & 2)   | _____ | _____ |
| ZOC Systems   | _____ | _____ |
| 2. Perform a visual inspection of engine and test stand                                       | _____ | _____ |
| 3. Enter correct date into computer   | _____ | _____ |
| 4. Place fire bottle within 10 feet of test rig   | _____ | _____ |
| 5. Perform Calibration of the Thrust Beam   | _____ | _____ |
| 6. Perform calibration of the Fuel Cell   | _____ | _____ |
| 7. Load "MICROJET_CAL" to ensure data Acquisition working correctly                           | _____ | _____ |
| 8. Enter corrected slope in "MICROJET" Fuel-line 2450 & Thrust-line 2660)                     | _____ | _____ |
| 9. Place exhaust fan on exhaust duct  | _____ | _____ |
| 10. Place fuel container on carriage (ensure siphon is down)                                  | _____ | _____ |
| 11. Disconnect fuel line aft of check-valve and purge line (Do not run pump > 60 seconds dry) | _____ | _____ |
| 12. Check all lines for proper connection   | _____ | _____ |
| 13. Connect air start line (Ensure water purged from tank)                                    | _____ | _____ |
| 14. Pre-lube engine bearings  | _____ | _____ |
| 15. Pre-spin engine to ensure freedom of movement   | _____ | _____ |

- |  |       |       |
|--|-------|-------|
| 16. Perform a system pressure calibration<br>(Secure nitrogen after calibration)   | _____ | _____ |
| 17. Load "MICROJET" and input parameters<br>(Press F4 after nitrogen re-energized) | _____ | _____ |
| 18. Power supply energized for: Spark Igniter<br>Fuel Pump<br>Exhaust Fan          | _____ | _____ |
| 19. Start Engine and stabilize<br>(Press F5 after stabilized)                      | _____ | _____ |
| 20. Manually record Thrust and Fuel Flow   | _____ | _____ |
| 21. Secure engine and fuel pump power  | _____ | _____ |
| 22. Secure nitrogen after post calibration complete                                | _____ | _____ |
| 23. Reduce data and view output files<br>(As desired)                              | _____ | _____ |
| 24. Purge Data Files   | _____ | _____ |
| 25. For additional data runs repeat step 12 through 22                             | _____ | _____ |

## APPENDIX G. SOPHIA J450 TEST RESULTS

Sophia J450 Test Data (Non Ejector)

Date: 08 March 1999

Pamb: 14.80835 psi

Temperature: 58 F

				1.15 Bars				
Mass Flow Rate Calculations					Thrust and Fuel Flow Rate Calculations			
Run	Pamb-Port (in-Hg)	Mass Flow (lbm/sec)	Mass Flow (Ref.) (lbm/sec)		Run	Thrust (lbf)	Fuel Flow (lbm/sec)	SFC (lbm/lb/hr)
1	0.325976	0.280946	0.281596		1	9.6825	---	---
2	0.298237	0.283338	0.283730		2	9.7838	0.003606	1.326846
3	0.345217	0.286220	0.287067		3	9.6739	0.003621	1.347502
Average	0.323143	0.283501	0.284131	Average	9.7134	0.0036135	1.339243	
				0.90 Bars				
Mass Flow Rate Calculations					Thrust and Fuel Flow Rate Calculations			
Run	Pamb-Port (in-Hg)	Mass Flow (lbm/sec)	Mass Flow (Ref.) (lbm/sec)		Run	Thrust (lbf)	Fuel Flow (lbm/sec)	SFC (lbm/lb/hr)
1	0.254476	0.249793	0.249772		1	7.393	---	---
2	0.256508	0.247189	0.247185		2	7.399	0.003128	1.521935
3	0.255301	0.250186	0.250172		3	7.4497	0.003139	1.516893
Average	0.255428	0.249056	0.249043	Average	7.4139	0.0031335	1.521547	
				0.66 Bars				
Mass Flow Rate Calculations					Thrust and Fuel Flow Rate Calculations			
Run	Pamb-Port (in-Hg)	Mass Flow (lbm/sec)	Mass Flow (Ref.) (lbm/sec)		Run	Thrust (lbf)	Fuel Flow (lbm/sec)	SFC (lbm/lb/hr)
1	0.176104	0.208025	0.207464		1	5.2278	---	---
2	0.213985	0.214323	0.214015		2	5.2407	0.002604	1.788769
3	0.200040	0.210246	0.209847		3	5.2499	0.002666	1.828149
Average	0.196709384	0.210865	0.210442	Average	5.2395	0.002635	1.810490	

Table G1 Non-Ejector Test Results (8 Mar 99, Run1)

Sophia J450 Test Data (Non Ejector)

Date: 08 March 1999

Pamb: 14.793849 psi

				1.15 Bars			
Mass Flow Rate Calculations				Thrust and Fuel Flow Rate Calculations			
Run	Pamb-Port (in-Hg)	Mass Flow (lbm/sec)	Mass Flow (Ref.) (lbm/sec)	Run	Thrust (lbf)	Fuel Flow (lbm/sec)	SFC (lbm/lb/hr)
1	0.338689	0.279920	0.280688	1	9.6579	---	---
2	0.285827	0.274440	0.274706	2	9.6293	0.00368268	1.376807
3	0.324219	0.279452	0.280082	3	9.6241	0.0036252	1.356043
Average	0.316245	0.277937	0.278491	Average	9.6371	0.00365394	1.364953
				0.90 Bars			
Mass Flow Rate Calculations				Thrust and Fuel Flow Rate Calculations			
Run	Pamb-Port (in-Hg)	Mass Flow (lbm/sec)	Mass Flow (Ref.) (lbm/sec)	Run	Thrust (lbf)	Fuel Flow (lbm/sec)	SFC (lbm/lb/hr)
1	0.277432	0.246356	0.246525	1	7.4558	---	---
2	0.291859	0.250075	0.250368	2	7.4821	0.00312851	1.505268
3	0.266559	0.250740	0.250820	3	7.4531	0.00312166	1.507831
Average	0.278617	0.249057	0.249238	Average	7.4637	0.00312508	1.507341
				0.66 Bars			
Mass Flow Rate Calculations				Thrust and Fuel Flow Rate Calculations			
Run	Pamb-Port (in-Hg)	Mass Flow (lbm/sec)	Mass Flow (Ref.) (lbm/sec)	Run	Thrust (lbf)	Fuel Flow (lbm/sec)	SFC (lbm/lb/hr)
1	---	---	---	1	5.2230	---	---
2	---	---	---	2	5.2545	0.002652	1.816962
3	---	---	---	3	5.2649	0.00263392	1.801001
Average	---	---	---	Average	5.2475	0.00264296	1.813197

Table G2 Non-Ejector Test Results (8 Mar 99, Run 2)

Sophia J450 Test Data (Ejector)

Date: 08 March 1999

Pamb: 14.793849 psi

Temperature: 58 F

					1.15 Bars				
Mass Flow Rate Calculations						Thrust and Fuel Flow Rate Calculations			
Run	Pamb-Port (in-Hg)	Pamb-Peject (in-Hg)	Mass Flow (lbm/sec)	Mass Flow (Ref.) (lbm/sec)		Run	Thrust (lbf)	Fuel Flow (lbm/sec)	SFC (lbm/lb/hr)
1	0.357519	0.647183	0.284014	0.284972		1	10.0660	---	---
2	0.358713	0.599559	0.281709	0.282670		2	10.0520	0.003554	1.27282133
3	0.344438	0.634126	0.284123	0.284957		3	10.0167	0.003556	1.2780257
Average	0.353557	0.626956	0.283282	0.284200		Average	10.0449	0.003555	1.27407938
					0.90 Bars				
Mass Flow Rate Calculations						Thrust and Fuel Flow Rate Calculations			
Run	Pamb-Port (in-Hg)	Pamb-Peject (in-Hg)	Mass Flow (lbm/sec)	Mass Flow (Ref.) (lbm/sec)		Run	Thrust (lbf)	Fuel Flow (lbm/sec)	SFC (lbm/lb/hr)
1	0.279689	0.468683	0.253008	0.253200		1	7.8459	---	---
2	0.275225	0.511918	0.250898	0.251051		2	7.8793	0.00305	1.39352481
3	0.275491	0.466535	0.254179	0.254336		3	7.7940	0.003082	1.42355914
Average	0.276801	0.482379	0.252695	0.252863		Average	7.8397	0.003066	1.40790587
					0.66 Bars				
Mass Flow Rate Calculations						Thrust and Fuel Flow Rate Calculations			
Run	Pamb-Port (in-Hg)	Pamb-Peject (in-Hg)	Mass Flow (lbm/sec)	Mass Flow (Ref.) (lbm/sec)		Run	Thrust (lbf)	Fuel Flow (lbm/sec)	SFC (lbm/lb/hr)
1	0.182812	0.411389	0.212696	0.2121690		1	5.7556	---	---
2	0.196078	0.411378	0.216355	0.215915		2	5.7796	0.00261561	1.629210
3	0.19090	0.407030	0.213483	0.213012		3	5.7792	0.00265997	1.656950
Average	0.189929	0.409933	0.214178	0.213698		Average	5.7715	0.00263779	1.645338

Table G3 Ejector Test Results (8 Mar 99, Run 1)

Sophia J450 Test Data (Ejector)

Date: 08 March 1999

Pamb: 14.793849

Temperature: 59 F

					0.90 Bars			
Mass Flow Rate Calculations					Thrust and Fuel Flow Rate Calculations			
Run	Pamb-Port (in-Hg)	Pamb-Peject (in-Hg)	Mass Flow (lbm/sec)	Mass Flow (Ref.) (lbm/sec)	Run	Thrust (lbf)	Fuel Flow (lbm/sec)	SFC (lbm/lb/hr)
1	0.267549	0.500616	0.250337	0.250425	1	7.8931	---	---
2	0.274930	0.489867	0.250673	0.250823	2	7.9400	0.00307838	1.395745
3	0.273464	0.489882	0.249975	0.250113	3	7.9272	0.00310625	1.410644
Average	0.271981	0.493455	0.250328	0.250454	Average	7.9201	0.00309231	1.405580

					0.66 Bars			
Mass Flow Rate Calculations					Thrust and Fuel Flow Rate Calculations			
Run	Pamb-Port (in-Hg)	Pamb-Peject (in-Hg)	Mass Flow (lbm/sec)	Mass Flow (Ref.) (lbm/sec)	Run	Thrust (lbf)	Fuel Flow (lbm/sec)	SFC (lbm/lb/hr)
1	0.159006	0.396333	0.207511	0.206833	1	5.7324	---	---
2	0.183394	---	0.209993	0.209478	2	5.8044	0.0026527	1.645255
3	---	---	---	---	3	5.8138	0.00266061	1.647493
Average	0.171200	0.396333	0.208752	0.208156	Average	5.7835	0.00265666	1.653653

Table G4 Ejector Test Results (8 Mar 99, Run 2)



Sophia J450 Test Data (Ejector)

Date: 05 March 1999

Pamb: 14.7938492 psi

Temperature: 62 F

					1.15 Bars				
Mass Flow Rate Calculations						Thrust and Fuel Flow Rate Calculations			
Run	Pamb-Port (in-Hg)	Mass Flow (lbm/sec)	Pamb-Peject (in-Hg)	Mass Flow (Ref.) (lbm/sec)		Run	Thrust (lbf)	Fuel Flow (lbm/sec)	SFC (lbm/lb/hr)
1	0.358147	0.284968	0.699836	0.285936		1	9.7800	---	---
2	0.334788	0.283566	0.676152	0.284306		2	9.8000	0.00342	1.256327
3	0.328470	0.280902	0.678185	0.281575		3	9.9270	0.00367	1.330916
Average	0.340468	0.283145	0.684724	0.283939	Average	9.8357	0.003545	1.297523	
					0.90 Bars				
Mass Flow Rate Calculations						Thrust and Fuel Flow Rate Calculations			
Run	Pamb-Port (in-Hg)	Mass Flow (lbm/sec)	Pamb-Peject (in-Hg)	Mass Flow (Ref.) (lbm/sec)		Run	Thrust (lbf)	Fuel Flow (lbm/sec)	SFC (lbm/lb/hr)
1	0.271459	0.256629	0.540838	0.256754		1	7.6400	---	---
2	0.274585	0.254967	0.514733	0.255117		2	7.5700	0.00299	1.421929
3	0.294808	0.255027	0.512547	0.255351		3	7.6500	0.003016	1.419294
Average	0.280284	0.255541	0.522706	0.255740	Average	7.6200	0.003003	1.418740	
					0.65 Bars				
Mass Flow Rate Calculations						Thrust and Fuel Flow Rate Calculations			
Run	Pamb-Port (in-Hg)	Mass Flow (lbm/sec)	Pamb-Peject (in-Hg)	Mass Flow (Ref.) (lbm/sec)		Run	Thrust (lbf)	Fuel Flow (lbm/sec)	SFC (lbm/lb/hr)
1	0.192959	0.210167	0.384309	0.209718		1	5.2260	---	---
2	0.188396	0.215107	0.397353	0.214615		2	5.2980	0.002579	1.752435
3	0.198828	0.213466	0.401711	0.213052		3	5.3420	0.002624	1.768326
Average	0.193394	0.212913	0.394458	0.212462	Average	5.2887	0.0026015	1.770843	

Table G5 Ejector Test Results (5 Mar 99)

Sophia J450 Test Data

Date: 05 March 1999

Pamb: 14.7938492 psi

Temperature: 62 F

					1.15 Bars				
Mass Flow Rate Calculations					Ejector	Thrust and Fuel Flow Rate Calculations			
Run	Pamb-Port (in-Hg)	Mass Flow (lbm/sec)	Pamb-Peject (in-Hg)	Mass Flow (Ref.) (lbm/sec)		Run	Thrust (lbf)	Fuel Flow (lbm/sec)	SFC (lbm/lb/hr)
1	0.351530	0.288460	0.701121	0.289375		1	9.9618	---	---
2	0.346057	0.286191	0.740270	0.287046		2	10.0560	0.0036725	1.314737
3	0.353810	0.289399	0.735951	0.290340		3	10.1624	0.003735	1.323113
Average	0.350466	0.288017	0.725781	0.288920		Average	10.0601	0.00370375	1.325389
					1.30 Bars				
Mass Flow Rate Calculations					Ejector	Thrust and Fuel Flow Rate Calculations			
Run	Pamb-Port (in-Hg)	Mass Flow (lbm/sec)	Pamb-Peject (in-Hg)	Mass Flow (Ref.) (lbm/sec)		Run	Thrust (lbf)	Fuel Flow (lbm/sec)	SFC (lbm/lb/hr)
1	0.420187	0.304356	0.865714	0.306027		1	11.5350	---	---
2	0.392285	0.303908	0.831047	0.305290		2	11.6320	0.00384	1.188446
3	0.427045	0.301793	0.848486	0.303520		3	11.6650	0.003872	1.194959
Average	0.413172	0.303353	0.848416	0.304946		Average	11.6107	0.003856	1.195590
					1.15 Bars				
Mass Flow Rate Calculations					Non-Ejector	Thrust and Fuel Flow Rate Calculations			
Run	Pamb-Port (in-Hg)	Mass Flow (lbm/sec)	Pamb-Peject (in-Hg)	Mass Flow (Ref.) (lbm/sec)		Run	Thrust (lbf)	Fuel Flow (lbm/sec)	SFC (lbm/lb/hr)
1	0.317912	0.277511	---	0.278078		1	9.4470	---	---
2	0.350511	0.280034	---	0.280913		2	9.5300	0.00387	1.461910
3	0.298749	0.277879	---	0.278268		3	9.5700	0.00375	1.410658
Average	0.322391	0.278474	---	0.279086		Average	9.5157	0.00381	1.441412

Table G6 Miscellaneous Data Runs (5 Mar 99)

**Sophia J450 Test Data (Non Ejector)**

**Date: 08 March 1999**

**Pamb: 14.79825 psi**

**1.3 Bars (Ejector)**

<b>Thrust and Fuel Flow Rate Calculations</b>			
<b>Run</b>	<b>Thrust (lbf)</b>	<b>Fuel Flow (lbm/sec)</b>	<b>SFC (lbm/lb/hr)</b>
<b>1</b>	11.5350	---	---
<b>2</b>	11.6320	0.00384	1.18844567
<b>3</b>	11.6650	0.003872	1.19495928
<b>Average</b>	11.6107	0.003856	1.19559026

**1.15 Bars (Ejector)**

<b>Thrust and Fuel Flow Rate Calculations</b>			
<b>Run</b>	<b>Thrust (lbf)</b>	<b>Fuel Flow (lbm/sec)</b>	<b>SFC (lbm/lb/hr)</b>
<b>1</b>	9.9618	---	---
<b>2</b>	10.0560	0.0036725	1.31473747
<b>3</b>	10.1624	0.003735	1.32311265
<b>Average</b>	10.0601	0.00370375	1.32538883

**0.65 Bars (Ejector)**

<b>Thrust and Fuel Flow Rate Calculations</b>			
<b>Run</b>	<b>Thrust (lbf)</b>	<b>Fuel Flow (lbm/sec)</b>	<b>SFC (lbm/lb/hr)</b>
<b>1</b>	5.2260	---	---
<b>2</b>	5.2980	0.002579	1.75243488
<b>3</b>	5.3420	0.002624	1.76832647
<b>Average</b>	5.2887	0.0026015	1.77084331

**Table G7 Miscellaneous Data Runs (8 Mar 99)**

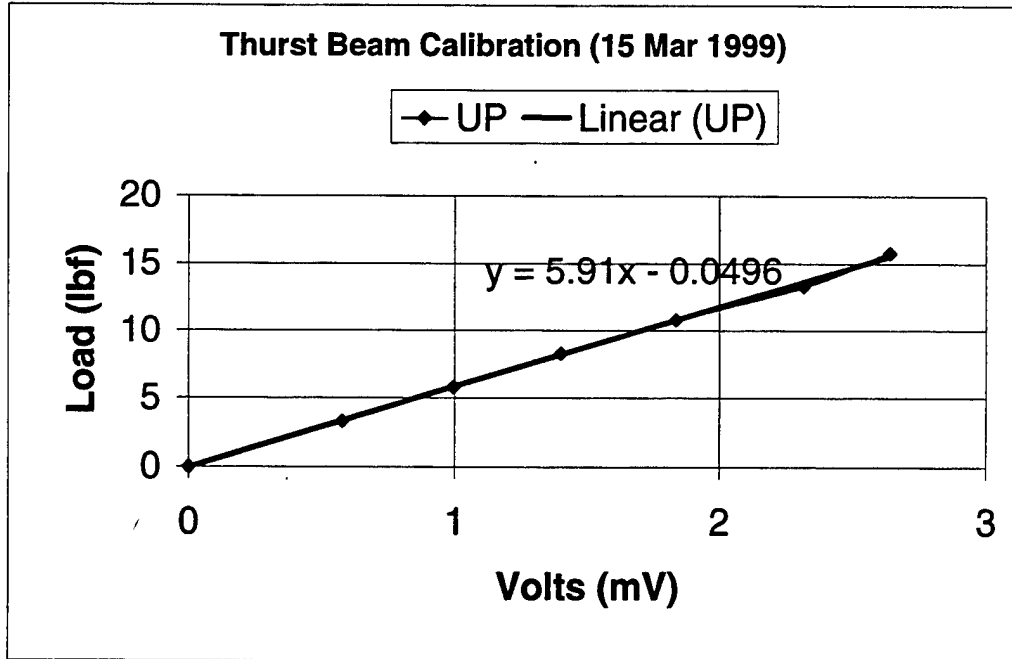

Figure G1 Thrust Beam Calibration

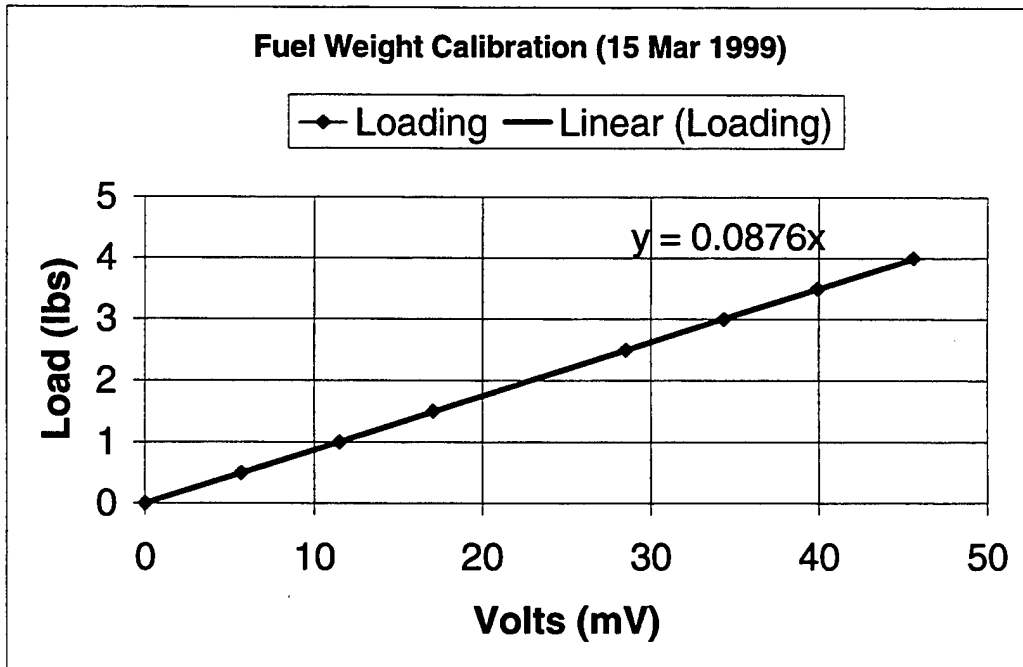

Figure G2 Fuel Weight Measurement Calibration

## APPENDIX H. EJECTOR PERFORMANCE PREDICTION PROGRAM

```
% Simple 1-D Steady Flow Perfect gas analysis
% Ejector theoretical performance prediction calculations
% using continuity, energy and momentum equations
clear
format bank
r=287; gamma=1.4; pa=101325;
eps=.0001;
tOp=input('Enter primary temperature (C): ');
pOp=input('Enter primary pressure (Pa): ');
vs=input('Enter secondary flow velocity (m/s): ');
pOs=input('Enter secondary pressure (Pa): ');
tOs=input('Enter secondary exit temperature (C): ');
a=input('Enter ejector area ratio: ');

gm1=gamma-1;
term1=gm1/(2.*gamma*r);
term2=gamma*r/gm1;
term3=gamma/gm1;
term4=gm1/gamma;

for kount=1:70                                % loop
    ts=tOs-term1*vs^2;
    p1=pOs/((1+term1*vs^2/ts)^term3);

    prat=pOp/p1;                               % primary flow velocity
    prat1=prat^term4;
    vp=sqrt(tOp*(prat1-1.)/(term1*prat1));
    tp=tOp-term1*vp^2;

% continuity eqn. into energy eqn-- solve for exit velocity

    c1=a*p1*vp*(term2*tp+vp^2/2)/(r*tp);
    c2=p1*vs*(term2*ts+vs^2/2)/(r*ts);
    c3=(p1*vs/ts+a*p1*vp/tp)/r;
    c=-(c1+c2)/c3;
    b=term2*(a+1.)*pa/(p1*vs/ts+a*p1*vp/tp);
    v2=-b+sqrt(b^2-2.*c);

% exit plane temp from energy eqn.

    t2=(a+1)*pa*v2/(p1*vs/ts+a*p1*vp/tp);

% secondary flow velocity from momentum eqn.

    xvs=abs(sqrt(r*ts*((a+1)*(pa-p1)+(a+1)*pa*v2^2/(r*t2)-
a*p1*vp^2/(r*tp))/p1));

    if abs(xvs-vs)>eps
        vs=vs-((xvs-vs)-abs(xvs-xvs)/2.);
    end
end
```

```

    else
    end
end
fprintf(' \n');
fprintf('Secondary exit velocity is %4.2f \n\n', vs);

% primary mass flowrate

amdotp=(p1/r/tp)*vp;
fprintf('Primary mass flowrate is %4.2f \n\n', amdotp);

% secondary mass flowrate

amdots=(p1/r/ts)*vs/a;
fprintf('Secondary mass flowrate is %4.2f \n\n', amdots);

% total mass flow

amtot=amdotp+amdots;
fprintf('Total mass flowrate is %4.2f \n\n', amtot);

% thrust

t=amtot*v2;
fprintf('Jet thrust is %4.2f \n\n', t);

% non ejector thrust

amp=sqrt(((pOp/pa)^term4-1)*2/gm1);
fprintf('Nozzle Mach number is %4.2f \n\n', amp);

ttp=tOp/(1+(gm1/2)*amp^2);
fprintf('Temperature is %4.2f \n\n', ttp);

vvp=amp*sqrt(gamma*r*ttp);
fprintf('Velocity is %4.2f \n\n', vvp);

amassp=(pa/r/ttp)*vvp;
fprintf('Mass flowrat is %4.2f \n\n', amassp);

thrust=amassp*vvp;
fprintf('Non-ejector thrust is %4.2f \n\n', thrust);

incr=(t/thrust-1)*100;
fprintf('Net increase in thrust is %4.2f percent\n\n',incr);

```

# APPENDIX I: SHROUD DRAWINGS

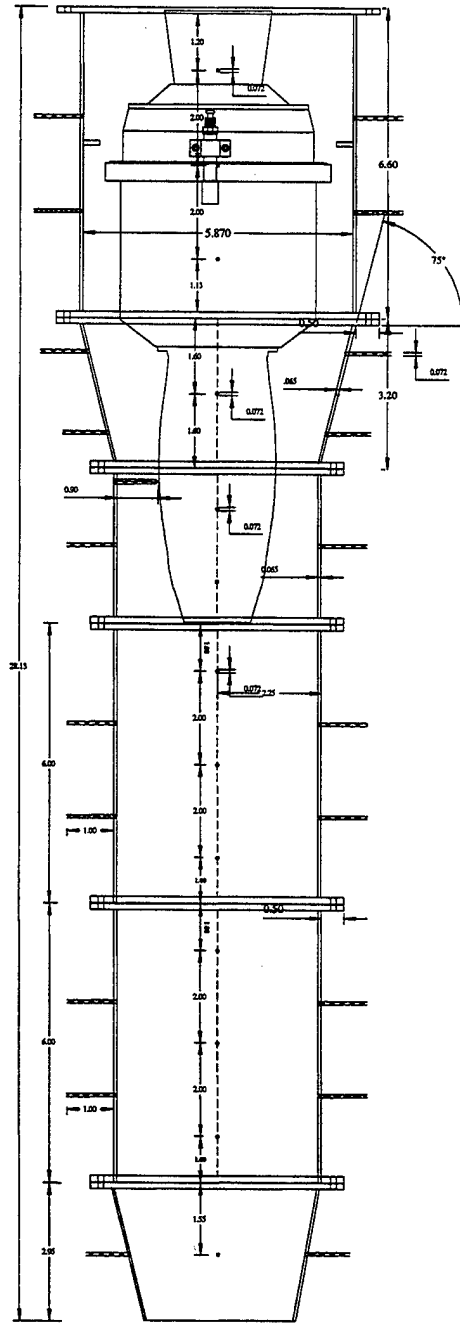

O.L. Haddock
DWG 005 SH U1
SCALE 1:2.57 1:3.99

Figure I1 Complete Engine Shroud with Exhaust Cone

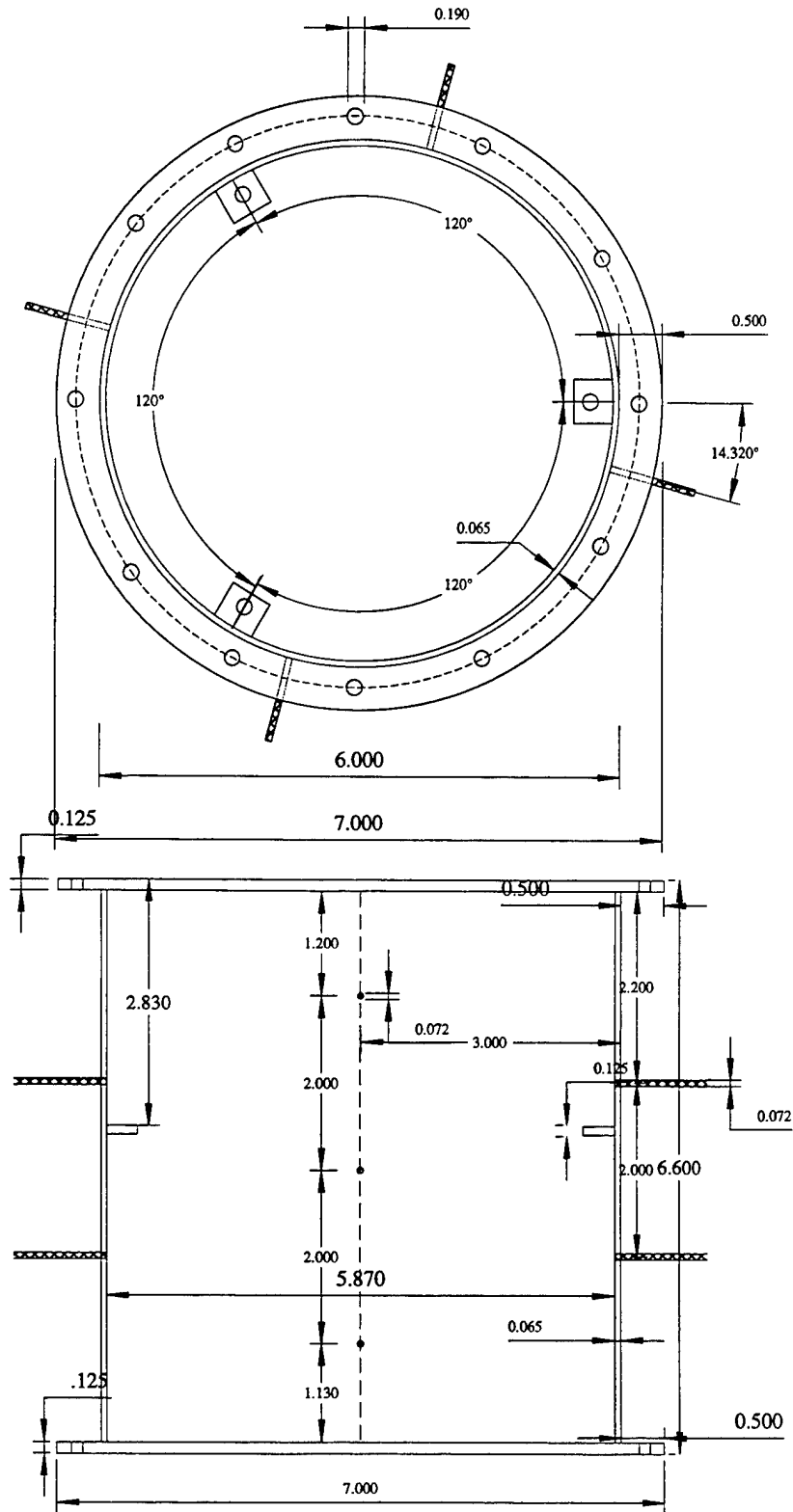

Figure I2 Shroud (Section 1) Front









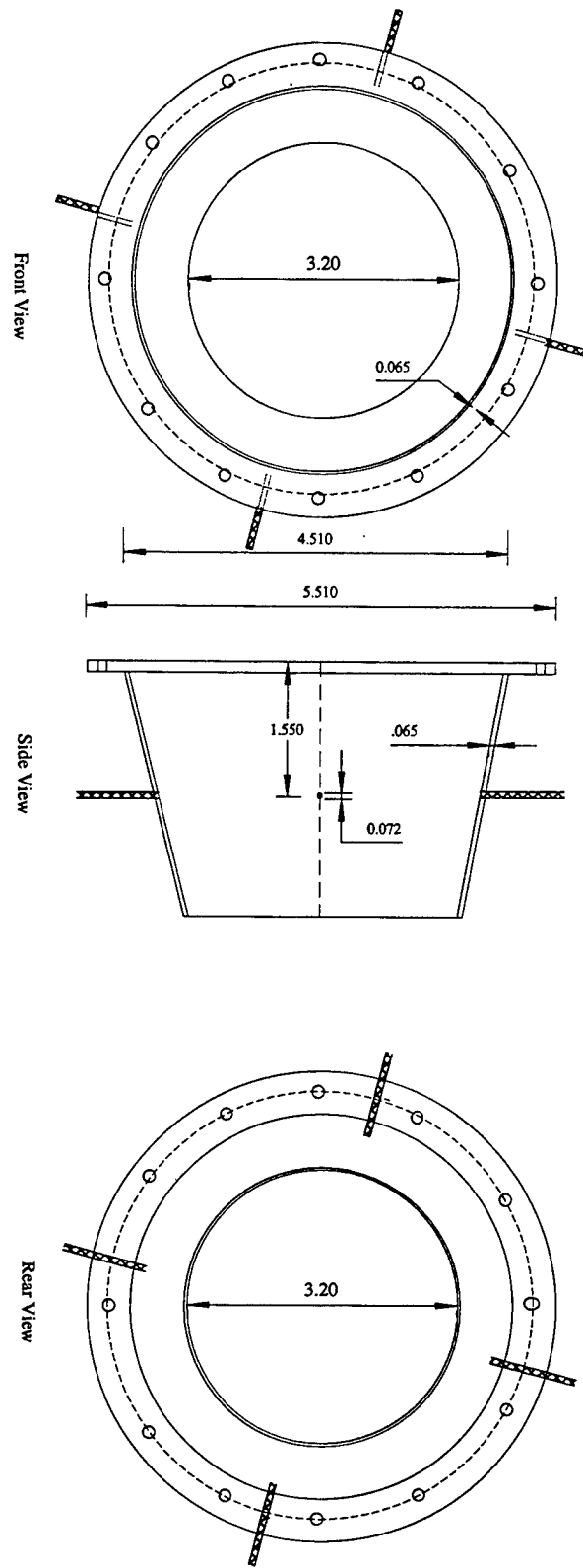

Figure I6 Shroud (Section 6) Exhaust Cone

## APPENDIX J. SHROUD TEST RESULTS

Sophia J450 Shroud Test Data

Date: 15 March 1999

Pamb: 14.64881152 psi

Temperature: 59 F

Thrust and Fuel Flow Rate Calculations				Baseline	Thrust and Fuel Flow Rate Calculations			
Run 1 1.15 bars	Thrust (lbf)	Fuel Flow (lbm/sec)	SFC (lbm/lb/hr)	Shroud	Run 1 0.65 bars	Thrust (lbf)	Fuel Flow (lbm/sec)	SFC (lbm/lb/hr)
1	9.3841	---	---		1	5.0849	---	---
2	9.5608	0.003701	1.393560		2	5.1522	0.002662	1.859671
3	9.5009	0.003878	1.469339		3	5.1518	0.002618	1.829613
<b>Average</b>	<b>9.4819</b>	<b>0.003789</b>	<b>1.438715</b>		<b>Average</b>	<b>5.1296</b>	<b>0.002640</b>	<b>1.852687</b>

Thrust and Fuel Flow Rate Calculations				Shroud	Thrust and Fuel Flow Rate Calculations			
Run 1 1.15 bars	Thrust (lbf)	Fuel Flow (lbm/sec)	SFC (lbm/lb/hr)	6 in ext.	Run 1 0.65 bars	Thrust (lbf)	Fuel Flow (lbm/sec)	SFC (lbm/lb/hr)
1	9.0161	---	---		1	5.0335	---	---
2	9.0569	0.003698	1.470062		2	5.0283	0.002771	1.983581
3	9.0774	0.003813	1.512315		3	5.0595	0.002635	1.875242
<b>Average</b>	<b>9.0501</b>	<b>0.003756</b>	<b>1.494019</b>		<b>Average</b>	<b>5.0404</b>	<b>0.002703</b>	<b>1.930571</b>

Thrust and Fuel Flow Rate Calculations				Shroud
Run 1 1.15 bars	Thrust (lbf)	Fuel Flow (lbm/sec)	SFC (lbm/lb/hr)	6 in ext.
1	8.9077	---	---	
2	9.0845	0.003409	1.350958	
3	9.1334	0.003507	1.382151	
<b>Average</b>	<b>9.0419</b>	<b>0.003458</b>	<b>1.376739</b>	

Table J1 Shroud Test Results (15 March 1999)



## LIST OF REFERENCES

1. Rivera, G., *Turbochargers to Small Turbojet Engines for Uninhabited Aerial vehicles*, Engineer's Thesis, Department of Aeronautics and Astronautics, U.S. Naval Postgraduate School, Monterey, CA, June, 1998
2. Kurzke, J., *GASTURB 7.0 for Windows, A Program to Calculate Design and Off-Design Performance of Gas Turbines*, 1996
3. Sophia USA, *Sophia J450 Turbine Engine Instruction Manual and Owner's guide*
4. Hoya, Hiroshi, Private communication, 1998
5. [www.turbonetics.com](http://www.turbonetics.com)
6. Kurzke, J., *SMOOTH User's Manual, Preparing Turbomachinery Maps for Performance Computer Programs*, 1993
7. Kurzke, J., *Turbomachinery Maps for Gas Turbine Performance Computer Programs*, 1996
8. Hill, P.G., and Peterson, C.R., *The Mechanics and Thermodynamics of Propulsion*, Addison-Wesley Publishing Company, Inc., June 1992
9. Lobik, L.P., *Unmanned Aerial Vehicles: A Study of Gas Turbine Application*, Master's Thesis, Department of Aeronautics and Astronautics, U.S. Naval Postgraduate School, Monterey, CA, September 1995
10. Hiroshi, Miyagawa, *Aircraft Gas Turbines*, Bulletin of Gas Turbine Society of Japan, 1998, [ISSN 1341-6618]





## INITIAL DISTRIBUTION LIST

1. Defense Technical Information Center ..... 2  
8725 John J. Kingman Rd., Suite 0944  
Ft. Belvoir, VA 22060-6218
2. Dudley Knox Library ..... 2  
Naval Postgraduate School  
411 Dyer Rd.  
Monterey, CA 93943-5101
3. Prof. Gerald H. Lindsey, Code AA/Li ..... 1  
Chairman, Department of Aeronautics and Astronautics  
Naval Postgraduate School  
Monterey, CA 93943-5106
4. Prof. Garth V. Hobson, Code AA/Hf ..... 5  
Department of Aeronautics and Astronautics  
Naval Postgraduate School  
Monterey, CA 93943-5106
5. Prof. Raymond P. Shreeve, Code AA/Sf ..... 1  
Department of Aeronautics and Astronautics  
Naval Postgraduate School  
Monterey, CA 93943-5106
6. Associate Prof. Knox Millsaps, Code ME/Mi ..... 1  
Department of Mechanical Engineering  
Naval Postgraduate School  
Monterey, CA 93943-5106
7. Glenn Madert, Program Manager..... 1  
Defense Airborne Reconnaissance Office  
Office of the Under Secretary of Defense, Acquisition & Technology  
Washington, DC 20301
8. Joint Projects and Demonstrations Directorate ..... 1  
Attn: Ms Malinda Pagett (UPR1)  
Washington, DC 20261-1014

- 9. Naval Air Warfare Center – Aircraft Division  
 Propulsion and Power Engineering  
 22195 Elmer Road  
 Patuxent River, MD 20670-5305  
     ATTN: C. Gorton, Code 4.4.T, BLDG 106 ..... 1  
           J. Carroll, Code 4.4.3.2, BLDG 1461.....1  
           C. Georgio, Code 4.4.....1
  
- 10. LT Gary L. Hackaday .....2  
 45557 Longfields Boulevard  
 Great Mills, MD 20634