

UNCLASSIFIED

Defense Technical Information Center  
Compilation Part Notice

ADP011109

TITLE: Thrust Vectoring Nozzle for Modern Military Aircraft

DISTRIBUTION: Approved for public release, distribution unlimited

This paper is part of the following report:

TITLE: Active Control Technology for Enhanced Performance Operational Capabilities of Military Aircraft, Land Vehicles and Sea Vehicles  
[Technologies des systemes a commandes actives pour l'amelioration des performances operationnelles des aeronefs militaires, des vehicules terrestres et des vehicules maritimes]

To order the complete compilation report, use: ADA395700

The component part is provided here to allow users access to individually authored sections of proceedings, annals, symposia, etc. However, the component should be considered within the context of the overall compilation report and not as a stand-alone technical report.

The following component part numbers comprise the compilation report:

ADP011101 thru ADP011178

UNCLASSIFIED



Industria de Turbo Propulsores, S.A.

## Thrust Vectoring Nozzle for Modern Military Aircraft

Daniel Ikaza

**Industria de Turbo Propulsores S.A. (ITP)**  
Parque Tecnológico, edificio 300  
48170 Zamudio, Spain  
daniel.ikaza@itp.es

presented at  
**NATO R&T ORGANIZATION Symposium**  
on

### ACTIVE CONTROL TECHNOLOGY FOR ENHANCED PERFORMANCE OPERATIONAL CAPABILITIES OF MILITARY AIRCRAFT, LAND VEHICLES AND SEA VEHICLES

Braunschweig, Germany  
8<sup>th</sup>-11<sup>th</sup> May 2000

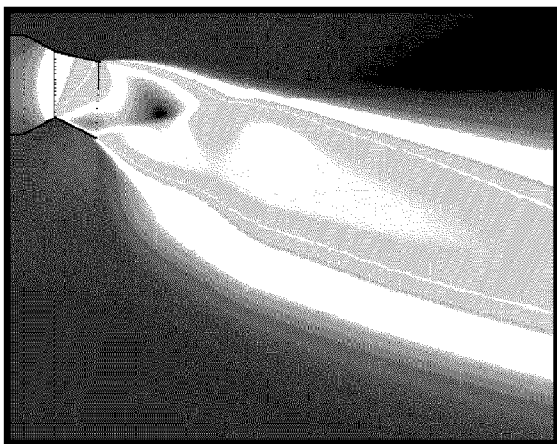

Fig. 1.- CFD Model of a TVN

#### ABSTRACT

This paper describes the technical features of the Thrust Vectoring Nozzle (TVN) developed by ITP and its advantages for modern military aircraft. It is presented in conjunction with two other papers by DASA (Thrust Vectoring for Advanced Fighter Aircraft High Angle of Attack Intake Investigations) and MTU-München (Integrated Thrust Vector Jet Engine Control) respectively.

#### Thrust Vectoring: advantages and technology

Thrust Vectoring is a relatively new technology which has been talked about for some time, and it can provide modern military aircraft with a number of advantages regarding performance (improved manoeuvrability, shorter take-off and landing runs, extended flight envelope, etc...) and survivability (control possible in post-stall condition, faster reaction in combat, etc...).

Additionally, as a byproduct of Thrust Vectoring, there is also the capacity to independently control the exit area of the nozzle, which allows to have always an "adapted" nozzle to every flight condition and engine power setting. This means an improvement in thrust which in cases can be as high as 7%.

There are several types of Thrust Vectoring Nozzles. For example, there are 2-D (or single-axis; or Pitch-only) Thrust Vectoring Nozzles, and there are 3-D (or multi-axis; or Pitch and Yaw) Thrust Vectoring Nozzles. The ITP Nozzle is a full 3-D Vectoring Nozzle. Also, there are different ways to achieve the deflection of the gas jet: the most efficient one is by mechanically deflecting the divergent section only, hence minimizing the effect on the engine upstream of the throat (sonic) section.

The major aerodynamic aspects of the design of a Thrust Vectoring Nozzle include the correct dimensioning of the vectoring envelope, accounting for the difference between "geometrical" and "effective" vectoring; as well as the sealing pattern of the master and slave petals at and around the throat section.

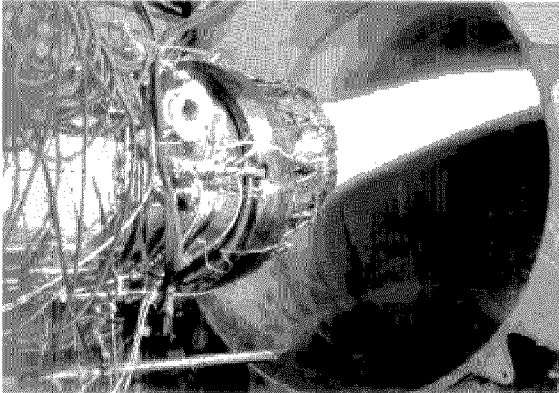

Fig. 2.- TVN ground tests at ITP

### ITP Design

The ITP concept consists of a patented design featuring the so-called “Three-Ring-System”, which allows all nozzle functions (Throat Area, Exit Area, Pitch Vectoring and Yaw Vectoring) to be performed with a minimum number of actuators, which, in turn, leads to an optimized mass and overall engine efficiency.

The nozzle is controlled by four independent hydraulic actuators, each one with its own servovalve and position transducer. The level of redundancy will depend on the exact application.

There is also, only at design level, a simplified variant of the nozzle, with three actuators only, which has basically the same functions of the 4-actuator one, except the independent exit area control. This variant would be a little lighter, but it misses the thrust improvement capability.

The reaction bars of the ITP nozzle present an arrangement which allows for high deflection angles, without the risk of petal overlapping and/or disengagement. The present prototype has demonstrated deflections up to 23°, but studies have been performed of variants of the nozzle with deflection angles of up to 30-35°.

Finally, the ITP design makes use of a partial “Balance-Beam” effect, which takes advantage of the energy of the gas stream, on one hand to help close the nozzle under high pressures, hence reducing the maximum load required from the actuators; on the other hand to allow self-closing of the nozzle in case of hydraulic loss under low pressure conditions, specially interesting to retain thrust for take-off.

### ITP TVN programme - Past, Present and Future

ITP has dedicated a research programme on Thrust Vectoring technology which started back in 1991, and which met an important milestone as is the ground testing of a prototype nozzle at the ITP facilities in Ajalvir, near Madrid, in 1998. Altitude testing is scheduled for 2000.

The next major goal will be the realisation of a flight programme, in order to validate the system in flight, and evaluate the capabilities and performance of the system as a means of flight control.

The design used for the ground prototype has been a simple one, for short life and limited safety. For the flight standard, a number of changes will be introduced, in order to comply

with the very demanding aircraft requirements in terms of weight, life, safety, etc...

The experience acquired during the ground test phase has helped ITP learn a lot about the behaviour of the nozzle, showing areas in which the design has to be modified, providing data for the integration of nozzle and engine controls, etc... The main outcome of the tests has been the confirmation that the concept designed is valid and it works smoothly.

A decisive contribution is being done by ITP's partner company MTU of Munich, Germany, by developing the electronic Control System.

This programme is making the Thrust Vectoring technology available in Europe for existing military aircraft such as Eurofighter, in which the introduction of Thrust Vectoring could be carried out with a relatively small number of changes to the aircraft and to the engine, and could provide it with an improved performance.

## CONTENTS

- 1.- DEFINITIONS AND ABBREVIATIONS
- 2.- BACKGROUND
- 3.- BENEFITS OF THRUST VECTORING AND NOZZLE EXIT AREA CONTROL
- 4.- TYPES OF THRUST VECTORING
- 5.- ITP DESIGN: BASELINE AND OPTIONS
- 6.- ITP THRUST VECTOR PROGRAMME
- 7.- CONCLUSIONS
- 8.- ACKNOWLEDGEMENTS

### 1. - DEFINITIONS AND ABBREVIATIONS

|        |                                      |
|--------|--------------------------------------|
| A8     | Nozzle throat area                   |
| A9     | Nozzle exit area                     |
| ATF    | Altitude Test Facility               |
| CFD    | Computational Fluid Dynamics         |
| Con-Di | Convergent-Divergent                 |
| DECU   | Digital Engine Control Unit          |
| DOF    | Degree of freedom                    |
| ESTOL  | Extremely Short Take-Off and Landing |
| FCS    | Flight Control System                |
| R&D    | Research and Development             |
| RCS    | Radar Cross Section                  |
| SFC    | Specific Fuel Consumption            |
| SLS    | Sea Level Static                     |
| TVN    | Thrust Vectoring Nozzle              |

## 2.- BACKGROUND

The Thrust Vectoring Nozzle developed by ITP was initially designed to fit and be compatible with an EJ200 engine, which powers the European Fighter Aircraft EF2000. This aircraft is developed by the European consortium Eurofighter, constituted by the companies British Aerospace (UK), DASA (Germany), Alenia (Italy) and CASA (Spain). Similarly, the above engine EJ200 is developed by the European consortium Eurojet, constituted by the companies Rolls-Royce (UK), MTU (Germany), Fiat Avio (Italy) and ITP (Spain).

The current EJ200 engine is equipped with a variable-geometry Convergent-Divergent (Con-Di) Nozzle, developed by ITP. This nozzle can modify the area to match the engine running point and afterburner setting, but it has no vectoring capability.

Through a dedicated R&D programme, ITP have now introduced a new Thrust Vectoring Nozzle which could be applied to EJ200 to significantly enhance the capabilities of EF2000 Aircraft.

### Introduction to Military Aircraft Nozzles

In a military aircraft engine with reheat (also called afterburner or augmentor), the nozzle presents a convergent section, which has the task to accelerate the gas jet in order to generate thrust, yet with the characteristic that it must be capable of varying the throat area according to the requirement of the engine running point. These are called “variable geometry convergent” nozzles.

Some nozzles, additionally, comprise a divergent section downstream of the convergent section, which overexpands the jet between the throat area and the exit area in order to extract yet some extra thrust. These are called “Variable geometry convergent-divergent” (or Con-Di) nozzles.

Depending on the level of control upon this divergent section, variable geometry Con-Di nozzles can be of two types:

- One-parameter Nozzles: also called 1-DOF nozzles; the Convergent section (hence Throat Area) is fully controlled, and Divergent section (hence Exit Area) follows a pre-defined relationship to the convergent section behaviour (throat area). The current EJ200 nozzle is of this type.
- Two-parameter Nozzles: also called 2-DOF nozzles; the Convergent section (Throat Area) and Divergent section (Exit area) are fully controlled independently. This type can match the Divergent section to the exact flight condition in order to obtain an optimised thrust.

Also there are some intermediate solutions such as “floating” and some other “passive” means of exit area control, which are outside the scope of this paper.

One solution or the other is chosen according to the particular requirements of each case, in terms of weight, cost, reliability, thrust, priority missions, etc...

In the case of Thrust Vectoring Nozzles, they also have the task to direct the jet to generate side thrust to transmit it to the aircraft structure, so that the aircraft can make use of it as a means of flight and manoeuvre control.

## 3.- BENEFITS OF THRUST VECTORING AND NOZZLE EXIT AREA CONTROL

Although the description of benefits of Thrust Vectoring and nozzle exit area control for modern military aircraft is in fact the subject of a separate paper by DASA, a brief description of some of them is given here for reference.

They can be basically grouped in four categories:

- Enhanced performance in conventional flight
- Post-Stall flight
- Increased Safety
- Reduction of aero controls

### Enhanced performance in conventional flight

The concept of Thrust Vectoring is often associated with spectacular loop-type manoeuvres performed by small aircraft in airshow demonstrations or combat simulations, and the operational use of these capabilities is often regarded with a lot of skepticism, due to the trends of modern air combat. However, there is a lot more to Thrust Vectoring than these funny manoeuvres, and in fact the greatest argument in favour of Thrust Vectoring is not found in combat characteristics but rather in conventional performance, as described in more detail below:

#### Stationary Flight Trimming

The use of the Nozzles as a complementary control surface allows the aircraft to better optimize its angle of attack in stationary level flight for a given flight point and load configuration, hence reducing the drag, which in turn leads to strong benefits in SFC, and therefore range.

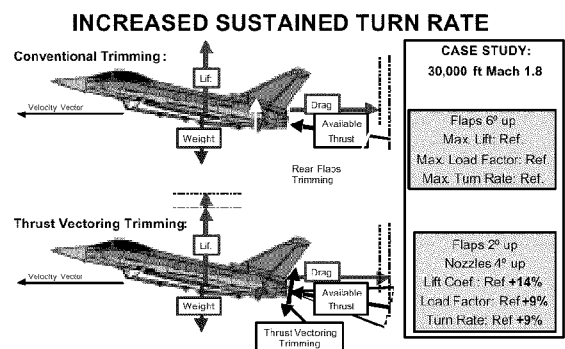

Fig. 3.- Increased Sustained Turn Rate with TVNs

### Stationary and Transient Manoeuvres

Similarly to the above case, the nozzles can be used to increase the maximum load factor that is achievable under certain circumstances while maintaining the aircraft trimmed. This applies both for stationary manoeuvres (sustained turn rate) and for transient manoeuvres (rapid deceleration).

### Nozzle Exit Area Control

As described in the Introduction to military aircraft nozzles, in one-parameter Con-Di nozzles the divergent section (hence A9) follows a pre-defined relationship to the

convergent section (hence A8). This relationship is optimised for an average of all missions, which normally means low A9/A8 Ratio for dry operations (without reheat) and high A9/A8 Ratio for operations with reheat.

In rough terms, this is reasonably optimised for low speed dry operations (cruise, climb, etc...) and for high speed reheat operations (high speed strike, etc...), but is not optimised for low speed reheat operations (take-off) and high speed dry operations (supersonic cruise).

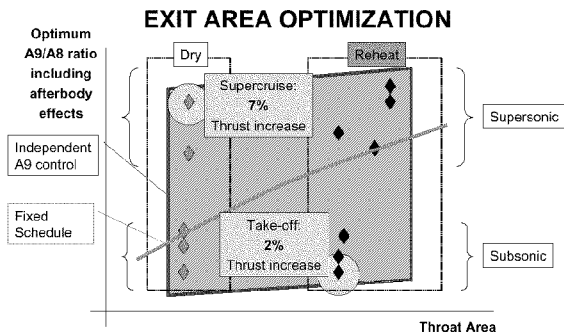

Fig. 4.- Optimization of Nozzle Exit Area

The use of an independently controlled divergent section allows A9 to be optimised for any engine running condition at any flight point, and has an improvement especially in those conditions where one-parameter A9/A8 Ratio is not optimized.

For example, for a supersonic cruise case (Mach 1.2, altitude 36,000 ft, engine at Max Dry condition) of EJ200 engine on Eurofighter, the use of independent A9 control could lead to an improvement of up to 7% in installed net thrust relative to the current performance. This is due to the combination of two effects: increase of nozzle internal thrust; and reduction of nozzle external drag.

In addition to thrust increase, independent A9 control also permits reduction in SFC for certain flight points.

Reduction of take-off and landing runs

The rotation of the aircraft for take-off and landing can be accelerated by using Thrust Vectoring. Also, Thrust Vectoring can be used to increase angle of attack, hence lift, while maintaining a trimmed aircraft. The combination of all these effects gives an important reduction in the take-off and landing runs for an aircraft such as Eurofighter.

Global mission performance

The combined effect of all the above items across a typical combat mission could add up to some 3% Fuel saving by using Thrust Vectoring.

Post-Stall Flight

The most spectacular benefit of Thrust Vectoring, although possibly not the most important, is the fact that it can exert an active control of an aircraft while the main aerodynamic surfaces are stalled, hence not suitable for control, and this opens a whole new domain of flight conditions where flight used to be unthinkable.

Extension of flight envelope

The use of Thrust Vectoring permits the aircraft to hold stationary flight in an area of the envelope where conventional controls are not sufficient.

In the Altitude/Mach-number envelope, Thrust Vectoring permits an extension of the envelope in the low speed-medium height region. In the Altitude/Mach-number/Angle-of-attack envelope, Thrust Vectoring permits operation at much higher values of Angle of attack.

Air superiority

A better control of the aircraft is achieved with Thrust Vectoring, especially at low speed conditions, where conventional aerodynamic controls are not effective, and where a good number of combat scenarios are to take place.

ESTOL

The ESTOL concept (Extremely Short Take-Off and Landing) is becoming more and more appealing to military aircraft operators, and it consists of performing the Take-off and Landing manoeuvres with the aircraft stalled. It reduces take-off and landing runs by a large amount.

This is only possible with Thrust Vectoring Nozzles, that operate when the aerodynamic controls are no longer useful.

Increased safety

This is probably one of the strongest arguments in favour of Thrust Vectoring. The existence of redundant means of aircraft control allows for a better survivability.

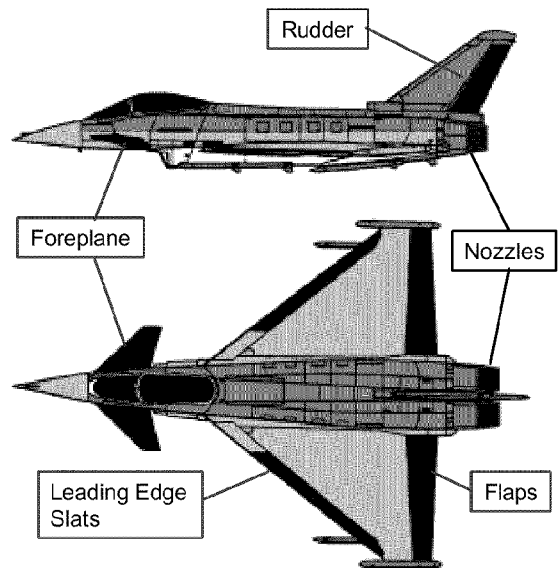

Fig. 5.- Redundant Flight Controls with TVNs

In peace time, an aircraft crash by loss of aerodynamic control could be avoided by the use of Thrust Vectoring.

In war time, damage to aerodynamic control surfaces can be compensated with Thrust Vectoring.

Next Step: reduction of aero controls

Once the Thrust Vectoring system has been sufficiently validated, it will be a primary control for the aircraft. This

means that it will allow a gradual reduction of existing conventional aerodynamic control surfaces such as horizontal and vertical stabilizers. This will have an impact, and there will be a reduction in:

- Mass
- Drag
- Radar Cross Section (RCS)

The extent of these impact could only be properly assessed in the future, and it will probably not be fully exploited until the next generation of combat aircraft, but mass reductions of 15%-20% of the total aircraft are conceivable.

#### **4.- TYPES OF VECTORING NOZZLES**

From the point of view of the type of actuation means, TVNs can be classified:

- Fluidic Actuation: The deflection of the gas flow is achieved by injection of secondary airflows. This type is specially suitable for fixed-area high expansion nozzles, such as those used in rockets and missiles.
- Mechanical Actuation: The deflection of the gas flow is achieved by mechanical movement of the nozzle, which is powered by hydraulic or pneumatic actuators. This type is specially suitable for variable geometry military aircraft nozzles.

\* \* \*

From the point of view of the direction of vectoring, TVNs can be classified:

- Single-Axis TVNs: (also called 2-D or Pitch-only) The deflection of the gas flow is achieved in vertical direction only. They replace and/or complement horizontal control surfaces. This type is suitable for all types of variable geometry military aircraft nozzles.
- Multi-Axis TVNs: (also called 3-D or Pitch and Yaw) The deflection of the gas flow is achieved in any direction. They replace and/or complement horizontal and vertical control surfaces. This type is specially suitable for round nozzles.

\* \* \*

If we focus on 3-D, Con-Di military aircraft TVNs with mechanical actuation, there are several ways to materialise the vectoring:

- Deflect whole nozzle. The disadvantages are: a large mass has to be moved; and there is a big impact on performance upstream of the nozzle.
- External Flaps. The disadvantages are: there is a need for additional mass; and the efficiency of vectoring is very low.
- Deflect Divergent section. This is the preferred solution. the size of the nozzle is optimised and the effect on performance is negligible. The ITP Nozzle is of this third type.

#### **EXISTING 3-D THRUST VECTORING SYSTEMS**

*Mechanical Actuation, Con-Di Military Nozzles*

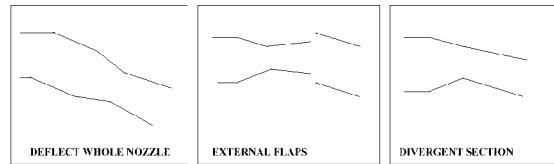

Fig. 6.- Existing types of 3-D TVNs

Regarding the nozzles of the third type, that is, those that deflect the flow by orienting the divergent section only, they generally need actuation means for:

- Controlling convergent section (hence A8)
- Controlling divergent section (hence vectoring and A9)

Where other designs make use of two separate actuation systems, the ITP design has a unified actuation system with a minimum total number of actuators.

#### **5.- ITP DESIGN: BASELINE AND OPTIONS**

One of the biggest problems encountered when designing a Thrust Vectoring Nozzle is how to find a mechanical configuration comprising casing, rings, etc..., which must be compatible with both functions of the nozzle: on one hand, open and close the convergent section to control throat area (optionally open and close the divergent section to control exit area); and on the other hand to direct the nozzle in directions different to axial, to obtain the jet deflection that provides vectored thrust.

The other big problem of a Thrust Vectoring Nozzle is how to find an actuation system (hydraulic, pneumatic, electro-mechanical, mixed, etc..) capable of generating the movements required in the nozzle, to accomplish all the above functions, and reasonably limited under criteria such as weight, size, etc...

Many different configurations have been studied at ITP for TVNs, the result being a "baseline" configuration, plus a series of options available for every particular application.

The main option is the A9 modulation capability, aimed at optimising the thrust as described above in the chapter "Benefits of Thrust Vectoring and nozzle area control".

#### **Baseline**

The baseline ITP TVN design is a Convergent-divergent axisymmetric (round) nozzle with multi-axis Thrust Vectoring, mechanically actuated, and where the deflection of the gas flow is achieved by orienting the divergent section only. This way the moving mass is minimized, and the distortion to the engine turbomachinery upstream of the nozzle is negligible.

It has three degrees of freedom (DOFs), namely: Throat area (A8), Pitch vectoring and Yaw vectoring. Any oblique vectoring is made of a combination of pitch and yaw. Exit area (A9) follows a certain relationship to A8.

The actuation system consists of only three independent hydraulic actuators, a fact which is made possible by the basic feature of the design: the "Three-Ring-System".

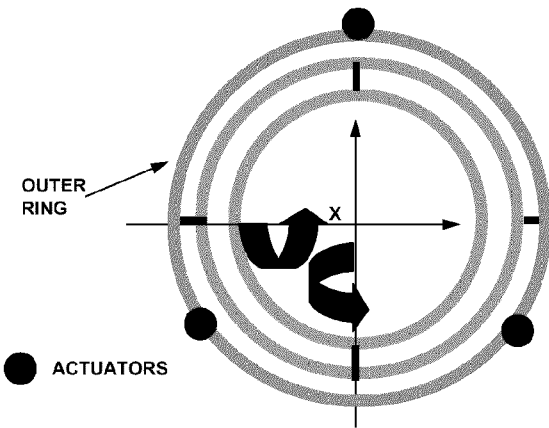

Fig. 7.- Three Ring System (3 actuators)

This system consists of three concentric rings which are linked by pins and form a universal (or “cardan”) joint. The inner ring is linked to the convergent section of the nozzle, the outer ring is linked to the divergent section through the reaction bars, and the intermediate ring acts as the crossbar between the inner and outer rings. The actuators are linked to the outer ring only. The design of the rings and reaction bars is such that a small tilt angle on the ring is amplified to a large deflection angle on the divergent section.

The outer ring can be tilted in any direction while the inner ring can only keep a normal orientation to the engine centreline, but they both are forced to keep the same axial position along the engine. This is the key factor that permits a full control of the nozzle by acting on the outer ring only, hence minimizing the total number of actuators.

For pure throat area movements, all three actuators move in parallel, hence all three rings follow axially, and A8 is set to the appropriate value. A9 follows a pre-defined relationship to A8 according to the dimensions of the mechanism.

For Pitch and/or Yaw vectoring movements, the three actuators move differently, hence defining a tilt plane of the outer ring. The divergent section will deflect in the direction of that plane. Throat area (A8) is not affected unless this movement is combined with a throat area movement.

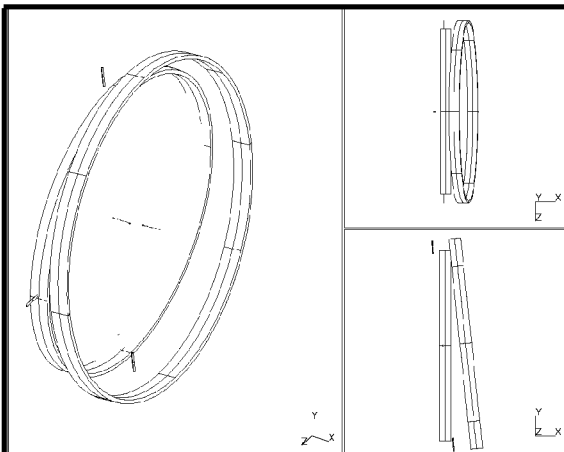

Fig. 8.- Ring Movement in vectoring

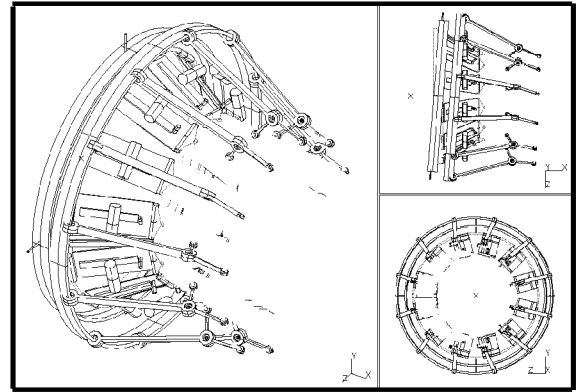

Fig. 9.- Nozzle Movement in vectoring

**A9 Control option: optimised thrust**

This option consists basically of the baseline design, except for the fact that the outer ring is split in two halves, forming a “hinged” outer ring.

It has four degrees of freedom (DOFs), namely Throat Area (A8), Exit Area (A9), Pitch vectoring and Yaw vectoring. Again, any oblique vectoring is achieved by combination of pitch and yaw.

The actuation system consists of four independent actuators, also linked to the outer ring only.

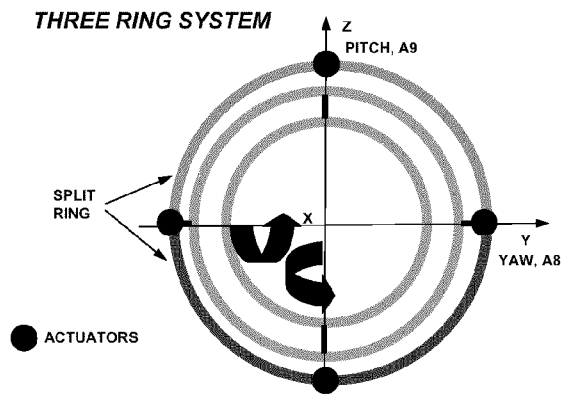

Fig. 10.- Three Ring System (4 actuators)

The same Three Ring principle is used as in the three actuator version, and A8 and vectoring movements are operated in a similar way, yet this time with four instead of three actuators.

Additionally, pure A9 control movements are performed by moving top and bottom actuators in parallel while the other two stay static, hence “hinging” the outer ring open or close. The divergent section opens or closes relative to the nominal position, acquiring an “oval” shape. Hence this movement is sometimes referred to as “ovalization”. Of course, A9 movements can be combined with A8 movements and/or vectoring movements.

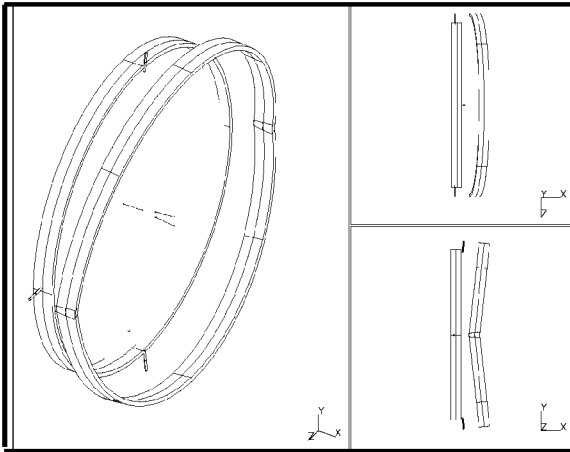

Fig. 11.- Ring Movement in A9 control

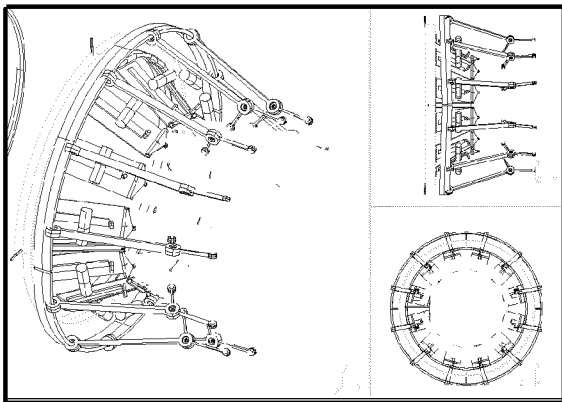

Fig. 12.- Nozzle Movement in A9 control

With this configuration there could be an improvement in installed net thrust of up to 7% in certain conditions.

In fact, this A9 option could well be considered as the baseline, leaving the non-A9 configuration as a “simplified option”.

**Third Member of the Family: "Two-Ring" Pitch-only Nozzle**

This is a simplified version of the ITP Nozzle where the intermediate Ring is deleted, hence reducing some weight and complexity. Outer Ring is split in two as in previous version.

It retains the four actuators and it has three DOFs (A8, A9, Pitch Vectoring).

It is suitable for application in aircraft with no Post-Stall capability, but where the benefits in conventional flight are important.

**SIMPLIFIED TWO-RING SYSTEM FOR PITCH-ONLY APPLICATIONS**

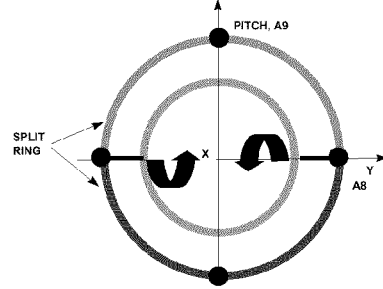

Fig. 13.- "Two-Ring" Pitch-only Nozzle

**Other features: "hinged" Reaction Bars**

The design of the reaction bars presents “hinged struts” which allow an optimised smooth movement of petals. Where other designs are limited to about 20° geometric deflection by the disengagement and/or interference between petals, the ITP design allows for growth if required, and studies have been carried out for deflections up to 30°-35°.

**SIMPLE REACTION STRUTS**

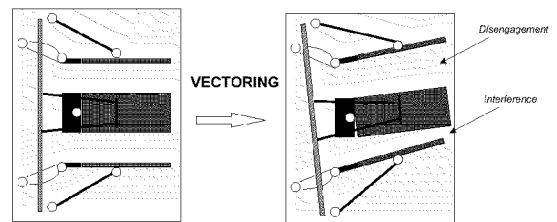

Fig. 14a.- Vectoring with simple reaction bars

**HINGED REACTION STRUTS**

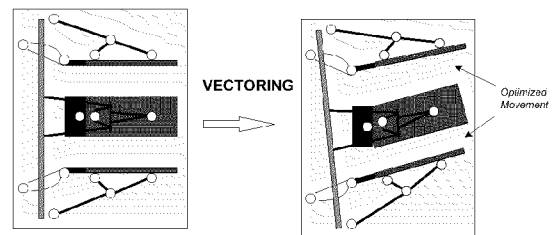

Fig. 14b.- Vectoring with hinged reaction bars

**Balance-Beam**

The ITP TVN makes use of a partial balance-beam effect, which consists of taking advantage of the energy of the gas stream to help close the nozzle in high pressure conditions.

The closing movement of the nozzle is accompanied by an axial displacement of the throat, so that the volume swept against the gas pressure is modified, in particular more volume is swept in the low pressure region of the nozzle, and less volume in the high pressure region.



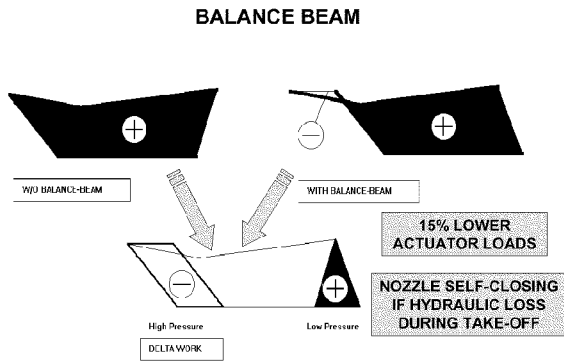

Fig. 15.- Balance Beam effect

This has two beneficial effects:

- On one hand, in high pressure conditions, the total work performed by the actuation system upon the gas stream is reduced by as much as 15%, which results in smaller actuator dimensions and better engine efficiency.
- On the other hand, in case of hydraulic loss in low pressure conditions, the nozzle self-closes, which is particularly interesting to retain thrust during take-off.

**Actuation and Control System**

The control system of the nozzle consists of three (baseline design) or four (A9 option) independent actuators, each with its own servovalve and position transducer. The servovalves are powered by the engine hydraulic pump; the electronic control loops and safety logic between servovalves and transducers are performed by the TVN Control Unit, which is built into the engine DECU, which, in turn, is connected to the aircraft Flight Control System (FCS).

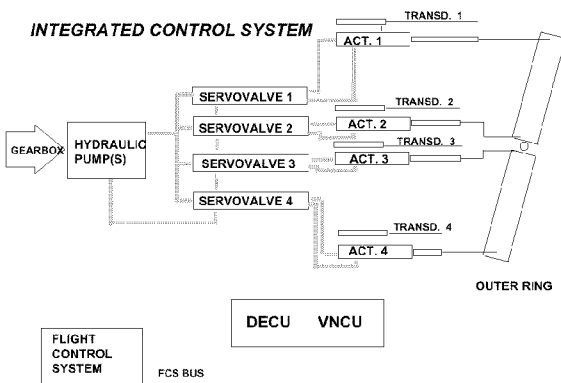

Fig. 16.- TVN Control System

For a twin-engine application such as Eurofighter, a simple hydraulic system and dual electrical system provide enough safety for a primary control.

On the other hand, for a single-engine application, there will probably be a need for duplex hydraulic system and triplex electrical system.

**Changes to EJ200 engine**

Relative to current EJ200 engine, the introduction of a TVN with "full capability" implies a number of changes:

- Nozzle
- Nozzle actuators, including Servovalves and transducers
- Bigger Hydraulic Pump
- DECU, including Thrust Vectoring functions
- Casing reinforcement
- Slight modification to engine mounts
- Reheat Liner, especially rear attachment
- Dressings (pipes and harnesses)

However, a reduced-capability TVN version of EJ200 is feasible with very minor changes.

In any case, these changes are small if compared with the advantages obtained by introducing Thrust Vectoring.

**Advantages of ITP design**

In summary, the ITP design presents a number of advantages relative to other designs, such as:

- **Minimum number of actuators**, which leads to lower weight and better overall engine efficiency.
- Unique reaction bar design for **high deflection angles**.
- Partial **Balance-Beam** effect for lower actuator loads.
- Nozzle **self-closing** in case of hydraulic loss during take-off allows thrust retention
- It is the only **proved example** of 3-D TVN for 20,000 lbf thrust engine class.

**6.- ITP TVN PROGRAMME**

ITP's R&D programme on Thrust Vectoring technology started in 1991, and within this programme a good number of general studies have been performed, including:

- CFD analyses
- Performance studies
- Concept design: Baseline plus options
- Trade-off studies with side loads, number of petals, etc...
- Patents
- Mechanical / Kinematic simulations
- Mock-ups
- etc...

\* \* \*

Additionally, a feasibility study has been carried out together with DASA regarding the application of TVN for Eurofighter. The outcome of this study includes the definition of the requirements for the TVN on the

Eurofighter, and some of the operational benefits expected for Eurofighter.

An initial study was done in 1994-95, and an update study is being conducted now 1998-2000, this time with MTU also taking part.

\* \* \*

ITP and MTU have a special co-operation agreement under which MTU has developed the electronic Control System that controls the ITP TVN and actuators.

**Prototype Nozzle**

In 1995 ITP launched what is called a “Technology Demonstration Phase” within the Thrust Vectoring technology R&D programme. This phase includes the design, construction and test of a prototype Thrust Vectoring Nozzle. The design of the prototype started in early 1996 and the first run took place in July 1998, becoming the key milestone in ITP Thrust Vectoring programme so far.

This prototype nozzle was aimed at demonstrating as much as possible, even if some things were not necessarily required from the aircraft point of view. Therefore it was designed for high vector loads (30 kN) even if the aircraft requirement will be not higher than 15 kN. Similarly, it incorporated the A9 option to optimise thrust. A deflection of 20° was specified for any engine running condition.

The prototype nozzle was constructed for an EJ200 engine vehicle, but maintaining a minimum impact on current EJ200, both regarding the hardware changes, as well as regarding the development programme.

In principle, only Sea Level Static (SLS) tests were scheduled, namely the ITP testbed in Ajalvir, near Madrid. However, the nozzle was specified to take the loads of the full flight envelope, and real flight standard materials were used in its construction, so that the mechanism could be validated as far as possible.

Most of the components were manufactured in ITP, hence keeping a high degree of flexibility to introduce quick changes in the design.

As part of the work associated to the tests of the prototype nozzle, a new detuner (exhaust duct) had to be installed in the ITP testbed (Cell No.2) at Ajalvir. The need for this new detuner was motivated both by the different flow pattern in the cell, and also by the need for cooling.

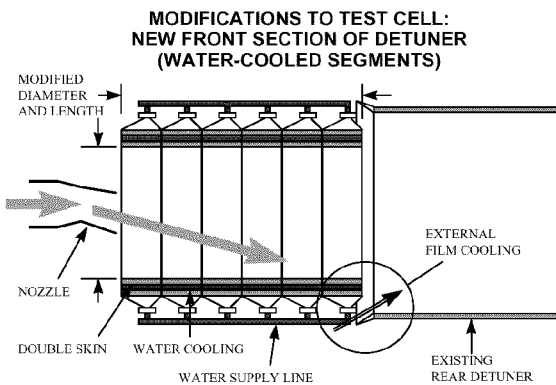

Fig. 17.- Modifications to Test Cell

\* \* \*

The test results obtained during the running of the prototype include the following highlights:

- 80 running hours, including 15 with reheat
- Vectoring in all 360° directions, both dry and reheat
- 23,5° maximum vector angle
- 110°/sec maximum slew rate
- 20 kN maximum lateral force
- Programmed ramps and Joystick control
- Thermal case: sustained 20° vector in reheat for 5 minutes
- Rapid transients Idle-Dry-Reheat while vectoring
- 100+ performance points run
- Exit area control: 2% thrust improvement
- Endurance: 6700+ vectoring cycles
- Endurance: 600+ throttle cycles (with sustained 20° vector)

The nozzle performed smoothly and free of mechanical failures

\* \* \*

The conclusion of the ground tests in Ajalvir represents the fulfilment of the Technology Demonstration Phase. From this point onwards, the next steps to be taken include a continuation of the general studies on Thrust Vectoring, as well as the continuation of the feasibility study with DASA and MTU.

Additionally, altitude tests with the prototype nozzle are scheduled for the second quarter of 2000 at the Altitude Test Facility (ATF) in Stuttgart.

The next big milestone in the Thrust Vectoring programme will necessarily be a flight programme, in order to validate the TVN in flight condition. Consequently, ITP as well as all ITP’s partners are strongly pursuing this possibility.

**ITP THRUST VECTORING NOZZLE PROGRAMME**

| ITP THRUST VECTORING NOZZLE PROGRAMME     | 1990 04        | 1995 | 1996 | 1997 | 1998 | 1999 2002 |
|---|----------------|------|------|------|------|-----------|
| Concept Design, Patents, Mock-ups         | [Timeline bar] |      |      |      |      |           |
| Preliminary and Aerodynamic Design        | [Timeline bar] |      |      |      |      |           |
| Demonstrator Nozzle Design                | [Timeline bar] |      |      |      |      |           |
| Advanced Material Orderings               | [Timeline bar] |      |      |      |      |           |
| Component Manufacture                     | [Timeline bar] |      |      |      |      |           |
| Manufacture of Actuators                  | [Timeline bar] |      |      |      |      |           |
| Design of Control System (MTU)            | [Timeline bar] |      |      |      |      |           |
| Component Testing                         | [Timeline bar] |      |      |      |      |           |
| Manufacture of Control System (MTU)       | [Timeline bar] |      |      |      |      |           |
| Actuator and Control System Testing (MTU) | [Timeline bar] |      |      |      |      |           |
| Test Bed Modification                     | [Timeline bar] |      |      |      |      |           |
| Prototype Assembly and Instrumentation    | [Timeline bar] |      |      |      |      |           |
| Integration in EJ200 Engine               | [Timeline bar] |      |      |      |      |           |
| Ground Testing                            | [Timeline bar] |      |      |      |      |           |
| Extensive Instrumentation Results         | [Timeline bar] |      |      |      |      |           |
| Flight Programme                          | [Timeline bar] |      |      |      |      |           |

Fig. 18.- ITP Thrust Vectoring programme

**7.- CONCLUSIONS**

- Thrust Vectoring offers great advantages for modern military aircraft, in return for relatively small changes in the aircraft, and is clearly the way to go for the future.

- Thrust Vectoring technology has become available in Europe, helped by the R&D programme conducted by ITP, especially after the ground test of the prototype nozzle.
- The ITP design presents some advantages relative to other designs, which may prove vital on the long term.
- The aerospace community in Europe is actively in favour of this technology, and the institutions are willing to support this.
- With a very small number of changes to EF2000, a demonstration flight programme would be possible and produce a very important stepping stone for the introduction of this technology into service.

## **8.- ACKNOWLEDGEMENTS**

The success of ITP's programme has only been possible with the contribution of partners and organizations, namely:

**Spanish Ministries of Industry and Defence**, with funding through an R&D programme

**MTU**, of Munich, Germany, developed the electronic control system under a dedicated agreement with ITP.

**Eurojet** and the Partner Companies (**Rolls-Royce**, **MTU** and **Fiat-Avio**), as ITP's partners in the EJ200 development programme for Eurofighter, gave support to ITP.

**CESA**, of Getafe, Spain, designed the hydraulic actuators for the TVN.

**Sener**, of Las Arenas, Spain, who started in the programme many years ago, also contributed to the engineering work of the programme.

**DASA**, of Munich, Germany, as partner in the Eurofighter feasibility study, provided the assessment of requirements and benefits for EF2000 with TVN.

Paper#A11

Q, by P. M. Lodge: What is the level of redundancy of the nozzle actuation?

A. (D. Ikaza) Simplex for the ground tests. Simplex will also be taken to flight for EF2000

**This page has been deliberately left blank**



**Page intentionnellement blanche**