

DEC 23 1946

ARR No. 4B08

~~Report~~
~~_____~~
~~_____~~

NATIONAL ADVISORY COMMITTEE FOR AERONAUTICS

WARTIME REPORT

ORIGINALLY ISSUED
February 1944 as
Advance Restricted Report 4B08

FLAME-VISIBILITY TESTS WITH INDIVIDUAL EXHAUST STACKS

By L. Richard Turner and Leroy V. Humble

Aircraft Engine Research Laboratory
Cleveland, Ohio

NACA

WASHINGTON

NACA LIBRARY
LANGLEY MEMORIAL AERONAUTICAL
LABORATORY
Langley Field, Va.

NACA WARTIME REPORTS are reprints of papers originally issued to provide rapid distribution of advance research results to an authorized group requiring them for the war effort. They were previously held under a security status but are now unclassified. Some of these reports were not technically edited. All have been reproduced without change in order to expedite general distribution.

NATIONAL ADVISORY COMMITTEE FOR AERONAUTICS

ADVANCED RESEARCH REPORT

FLAME-VISIBILITY TESTS WITH INDIVIDUAL EXHAUST STACKS

By L. Richard Turner and Leroy V. Humble

SUMMARY

Tests were made on a Wright 1820-G single-cylinder engine to determine the effect of operating variables and the effect of shape and size of the exhaust stack on the visibility of the exhaust gases for individual-stack installations. Estimates of the relative brightness of the exhaust flames were made by photographic means.

Flame damping was improved by decrease in nozzle-exit area, by increase in stack length, and by reduction in hydraulic diameter of the exhaust jets. When the throat section of the nozzle was lengthened and a bend introduced in this section to prevent view of the interior of the stack, a large decrease in exhaust visibility occurred.

A simulated acceptance test was set up. None of the experimental stacks met the imposed visibility test under all conditions. The background conditions in these tests were thought to be more severe than would be obtained in flight. Until a quantitative specification of the limit of flame luminosity or background brightness and uniformity is made, the effectiveness of a flame-damping stack must be determined by flight test. The limitations of photographic techniques and simulated visibility tests are discussed.

INTRODUCTION

The use of military aircraft at night in regions defended by hostile fighters requires that the flame produced by the engine exhaust be reduced in visibility to the point where the airplane cannot be detected by its exhaust flame before it can be more easily detected by other visual means. The present Army and Navy specifications for the limit of range of visibility are set at 300 feet for airplanes intended for flight over water and at 150 feet for airplanes intended for flight over land under all conditions of flight on a dark, moonless night.

Exhaust systems with collector dampers that reduce flame visibility have been built, but they sacrificed the considerable performance increment made available by use of individual jet stacks. The flame produced with single-cylinder jet stacks is less bright than

that produced with a collector but, in most cases, the flame luminosity is objectionably high. Individual stacks produce useful thrust because of the high exhaust-gas efflux velocities; making extreme changes in the stack geometry to achieve flame damping is not desirable; these changes may either reduce the thrust or involve a loss in engine power, or both.

Preliminary tests with individual stacks showed that considerable flame damping could be simply achieved, although none of the simplest forms used in the earliest experiments was entirely satisfactory. In the present series of tests the effect on flame intensity of several factors in stack design was investigated with the aim of developing a satisfactory stack design.

These tests were conducted at the Langley Memorial Aeronautical Laboratory from April to October 1942.

METHODS AND TESTS

The only strict test of flame visibility is direct visual observation, for the eye has a sensitivity which depends upon the color and size as well as the intensity of the source in a way that no other radiation detector does. Measurement of low intensity by visual devices is, unfortunately, not very convenient and requires extreme care to obtain reliable objective results.

Photographic measurement of flame intensities. - If flames of the same color are to be compared, their visible intensity, except for the effect of object size, will vary in the same way as the photographic intensity. A photographic method, therefore, provides a means of comparing the performance of exhaust stacks of different design to determine whether or not a given change in design has resulted in an improvement in flame damping. The brightness of the flame "end on" could not be measured photographically because optical surfaces were fouled by the exhaust-gas jet.

The intensity of the flames as observed from the side was measured by photographing each test flame and a graded reference standard of intensity in front of a photographically black background. All photographs were taken at a distance of about 3 feet. An Eastman Kodak Co. Ektra camera with an Ektar f 1.9 lens 50 mm was used with Eastman Kodak Co. Tri-X Aero Safety film. Negatives were developed to high contrast for 12 minutes in D-19 developer at 70° F.

The construction of the comparison light source is shown in figure 1. The lamp was operated at constant voltage by use of a regulator in order to insure a constant light intensity. The lamp illuminates a square piece of opal glass to make a white surface of

uniform brightness. In front of the glass is a pair of neutral filters, each consisting of three strips of graded density. The two filters are crossed to make the source an array of nine squares of graded-intensity. The series of intensities were measured by use of a Weston illumination meter; they are listed in the following table:

INTENSITY OF THE COMPARISON SOURCE

| Square | Brightness, B (millilamberts ^a) | Log B |
|--------|--|--------|
| 1 | 0.505 | -0.297 |
| 2 | .188 | -.727 |
| 3 | .0593 | -1.227 |
| 4 | .0188 | -1.727 |
| 5 | .00665 | -2.177 |
| 6 | .00210 | -2.677 |
| 7 | .000593 | -3.227 |
| 8 | .000210 | -3.677 |
| 9 | .0000665 | -4.177 |

^aOne millilambert = 10^{-3} lambert. A surface has a brightness of 1 lambert when 1 lumen of light flux is diffusely emitted per square centimeter, according to Lambert's cosine law. Alternately, a surface that has an apparent brightness of 1 lambert emits $1/\pi$ lumens per square centimeter of surface normal to the direction of observation.

The intensity of the exhaust flame was determined by measurement of photographic densities with a photometer. The photometer is essentially a photoelectric cell upon which light falls from a light source of constant intensity through a hole in a diaphragm. If a photographic film is interposed between the source and the cell at the position of the diaphragm, the density of the film is defined as the logarithm of the ratio of the photometer deflection with film interposed to that with the film removed.

Each photograph was made by a simultaneous exposure of the exhaust flame and the comparison source on the same film. On each negative the image of the comparison source provided a series of densities, which were plotted against the log of the intensities as measured in the initial light-source calibration. The relative intensity of the flame could then be found from the density of a chosen portion of the flame image by use of the curve. Relative intensities of various flames of constant spectral distribution are accurately measured by the procedure

described, regardless of the exposure time, if the effect of intermittency of the flame may be neglected. A calibration of the photographic film is shown in figure 2.

Simulated acceptance-test method of estimating flame visibility. - A second method used to estimate exhaust-flame visibility simulates flight conditions. The primary purpose of these tests was to indicate whether the stacks developed would meet the severe service requirements. A background as nearly black as possible was provided for a visual observation of the flame at the effective standard distance. The background was blacker than the night sky on clear, moonless nights; hence, the simulated test was believed to be more severe than the standard test.

In the tests conducted at LMAL, space limitations made it necessary to view the flames in a mirror. The actual distance was 277 feet and the reflection coefficient of the mirror was found to be 0.84; the effective distance was therefore 303 feet. A diagrammatic sketch of the visibility test setup is shown in figure 3.

The flames were viewed end on through a tube 6 feet long, equipped with three stops of dull-black paper, each with a 1-inch hole at its center. The tube was 5 inches square inside, had a $2\frac{1}{2}$ -inch-diameter hole at each end, and was painted dull black inside and outside. (See fig. 4.) A black-velveteen backdrop was placed behind the mirror. All engine parts in the field of view were painted black. No external lights were used in the test room during visibility tests except a small light located near the test object or flame and adjusted to be barely visible to the observer. This light, which could be turned on at will by the observer, was used to make certain that, in reporting a given flame as invisible, the observer was actually looking at the flame and had not accidentally moved his eye to a position from which the flame could not be seen. All tests of this type were conducted using monocular vision.

The brightness of the velveteen backdrop and of the surrounding field was estimated to be less than 1 percent of that of the night sky on a clear, moonless night. The backdrop was of sufficiently low brightness that it was never visible through the sighting tube even after prolonged dark adaptation of the observer.

In order to make sure that the two observers had eyes of normal sensitivity to dim light sources, they were tested with the apparatus and a small, calibrated source. A series of black paper masks were used to control the illumination. The order of presentation of the test signals was completely random, and a small number of tests at each intensity level were made; the results are shown in figure 5. The fraction of the times a test source was visible is plotted against

the logarithm of the mean illumination at the observer's eye. The dotted curves of figure 5 were faired through the data; the theoretical curve for seven quanta of reference 1 was used. When the ordinate value is 0.5, the abscissa value is $10^{-6.5}$ microphot, which corresponds to the threshold of vision for a dark-adapted eye as given in reference 2. The phot, a unit of illumination of a surface, is 1 lumen incident per square centimeter of surface.

All flame tests were run on a Wright 1820-G single-cylinder test engine. All photographic measurements were made at an engine speed of 1500 rpm, at an intake-air pressure of 30 inches of mercury absolute, using Army 100-octane fuel with a hydrogen-carbon ratio of 0.188. A few qualitative tests were made with isooctane (S-1 reference fuel); isooctane with tetraethyl lead up to 8 milliliters per gallon; and various aromatic blends, including pure benzol.

RESULTS AND DISCUSSION

Characteristics of Exhaust Flames

Effect of fuel-air ratio. - Photographs of the so-called undamped flame produced with an unrestricted stack 5 inches long, area 4.20 square inches, are shown in figure 6. The variable-density mosaic in each photograph is the comparison source. The three brightest squares were covered with a metal mask lined with dull-black paper because they were found to be too bright to be used in an evaluation of intensity of the flame bases. Since the mosaic and the flame were at the same distance from the camera, the mosaic serves as a scale for estimating the flame size. Each small square is 2 inches on an edge.

The flame had a dull-gray color at fuel-air ratios between 0.116 and 0.1015 (fig. 6). As the mixture was leaned below 0.1015, an orange base surrounded by a pale-blue plume appeared. At mixtures leaner than 0.066 the orange base disappeared and the flame took on a dull-white appearance with a trace of yellow or blue. In the fuel-air range from 0.1015 to 0.066 the pale-blue plume was surrounded by a feathery edge of a much more intense blue, sometimes called electric blue. The blue flame had a maximum intensity at a fuel-air ratio of about 0.08. This intense-blue fringe is at present attributed to burning on contact with air at the flame boundaries, because it could be caused to disappear completely by increasing the exhaust-jet velocity by means of a reduction of nozzle-exit area. This burning is seen in the photographs as a feathery edge on the flame. As the mixture was enriched above a fuel-air ratio of 0.11, the color changed from dull gray to bright red at a fuel-air ratio of approximately 0.125. At this condition the flame was smoky, the engine misfired, and intermittent bright-blue explosions were seen. Two prints, given different treatment

in reproduction, are shown for a fuel-air ratio of 0.1015 to indicate the variability of the flame and the extremes of light in the base.

Effect of fuel composition. - With fuels having some aromatic constituents, afterburning occurs at higher fuel-air ratios than the limiting fuel-air ratio for isooctane. With 40 percent aromatics, hydrogen-carbon ratio of 0.145, afterburning occurs for fuel-air ratios up to about 0.110. With pure benzol, hydrogen-carbon ratio of 0.084, afterburning occurs for fuel-air ratios up to about 0.130 to 0.140, when the flame becomes sooty. These effects occur only when no flame damping is attempted, for example, with the stub comparison stack. In all tests with fuels containing aromatics, the flames at a given numerical fuel-air ratio had a slightly "leaner" appearance than flames with isooctane or other fuels with high hydrogen-carbon ratios. The presence of tetraethyl lead in concentrations up to 8 milliliters per gallon had no noticeable effect on the flame characteristics or intensity.

Effect of ignition and oil consumption. - Cutting off one of the two spark plugs reduced the intensity of the orange glow in the flame base and increased the tendency to afterburning; the tendency to afterburning was apparently increased because of an increase in temperature of the gas. Cutting off one spark plug also decreased the fuel-air ratio at which a red and sooty flame was formed. Placing a large series resistor in the high-tension ignition line caused a red, sooty flame at still lower fuel-air ratios.

The following fuel-air ratios at which a red, smoky flame was just noticed were measured for a fuel with a hydrogen-carbon ratio of 0.188:

| Number of spark plugs | Series resistor (megohms) | Fuel-air ratio |
|-----------------------|---------------------------|----------------|
| 2 | 0 | 0.125 |
| 1 | 0 | .120 |
| 1 | .4 | .118 |
| 1 | .75 | .116 |
| 1 | 1.5 | .114 |

Excessive oil consumption may produce a smoky flame at almost any fuel-air ratio. The flame in this case is similar to the red, smoky flame formed with very rich mixtures. No quantitative data have been obtained on this subject.

Source of flame light. - The exhaust flame was too dim to make possible an accurate spectrographic identification of the sources of the visible light. The spectrum of the flame could, however, be observed by use of a spectroscope. The following conclusions, based on such observations, are somewhat speculative at present.

The blue light associated with afterburning is supposedly caused by the combustion of carbon monoxide with oxygen from the atmosphere. The spectrum consisted of a nearly continuous band structure in the blue and violet. The blue light emitted by exhaust gas in the absence of air is also called afterburning in some cases. Afterburning, as used in this report, refers only to actual combustion of the residual carbon monoxide and hydrogen.

The red light seen in the sooty flame with very rich mixtures and with excessive oil consumption is supposedly due to hot carbon aggregates, because the spectrum is continuous in the red.

The nearly white light seen in the leaner-than-stoichiometric mixtures seems to be a mixture of the blue light previously mentioned with some yellow light. Visual spectroscopic examination of this flame using a broad slit, revealed a yellow band with a wave length of approximately 0.58 micron; no red or orange light was apparent. A study of the reported band systems of diatomic molecules suggests that this band might be due to nitrogen.

In the fuel-air-ratio range near 0.070, the orange light appeared to consist of the yellow band observed for lean mixtures and an orange-red band near 0.61 micron. The cyanogen spectrum, which has a band near this wave length, should be observed whenever carbon monoxide is mixed with the active nitrogen that is assumed to cause the yellow band. The appearance of the cyanogen spectrum is a delicate spectroscopic test for carbon monoxide. (See reference 3.)

In reference 4, activation of nitrogen was reported in explosions of carbon monoxide and air at high pressure. The flame in these combustions is a bright-orange color and is followed by a persistent red glow. It is believed that the light in exhaust-flame bases may be similar to that obtained in these high-pressure explosions.

Some light is undoubtedly emitted by carbon and lead-oxide particles under all conditions. Chemical analyses of exhaust gas have shown very little evidence of solid carbon in the gas for fuel-air ratios lower than 0.110.

Damping of Exhaust Flame

Effect of exhaust-stack length and nozzle area on afterburning. - Both reduction in nozzle area and increase in stack length reduce the tendency toward afterburning. A series of flame photographs, taken during the measurements of flame-base intensities, are shown in figures 7 and 8. With an unrestricted stack, area 4.20 square inches, afterburning occurred with all but the 48-inch stack (see fig. 7); whereas, with a nozzle having an area of 1.39 square inches, afterburning occurred only with a very short stack (over-all length of 5 in.). With the 5-inch stack afterburning occurred with all nozzle sizes but was much less prominent for the nozzles smaller than 2.85 square inches. With a total stack-and-nozzle length of 20 inches, afterburning occurred only with an unrestricted exhaust stack. The unit of base intensities in figures 6 to 8 is the millilambert.

The extinction of afterburning with fuels containing aromatics has not proved to be appreciably more difficult than with fuels having higher hydrogen-carbon ratios. With aromatic fuels, the same methods are effective and the reductions in afterburning are more striking.

The effect of exhaust-stack length and nozzle area on the intensities of base sections of the external flame. - The lateral intensity of the bases of flames produced with straight stacks that end in simple convergent nozzles was measured by the procedure previously described. Figure 9 shows the log (to the base 10) of the intensity for several stacks and nozzle areas plotted against fuel-air ratio. Data for the 5-inch unrestricted stack were taken over the complete range of fuel-air ratio; for the other stacks it was taken at fuel-air ratios of approximately 0.066, 0.08, and 0.11. The data for only a few of the stack arrangements are shown in figure 9. The curve for the 5-inch unrestricted stack indicates that the maximum intensity occurred at a fuel-air ratio between 0.07 and 0.08. According to figure 9 the flame intensity at a fuel-air ratio of 0.07 was $10^{0.75}$ or 5.6 times that at a ratio of 0.05, and $10^{2.25}$ or 178 times that at a ratio of 0.115.

The comparison of the intensity of the flame at different fuel-air ratios is probably not very accurate because of the change in color of the flame with fuel-air ratio and the variation of the response of the film to different colors. At any given fuel-air ratio, however, the exhaust flames for the different stack arrangements are of substantially the same color; therefore, their relative flame intensities are probably accurately given by the values of the flame intensities measured by the procedure described in this report. The following expedient is used for comparing the flame intensity of the various stack arrangements: The flame intensities of the unrestricted 5-inch stack are taken as a standard of reference and the intensities of the other stack-and-nozzle combinations are presented in terms of the logarithm of the ratio of

the intensities for the given combination to the intensities for the 5-inch unrestricted stack at the same fuel-air ratio. Figures 10 and 11 show these data.

Both reduction in nozzle area and increase in stack length reduced the flame intensity (see figs. 10 and 11). In the rich-mixture range (fuel-air ratio, 0.110), where the reference flame intensity was already low, the improvement obtained by increasing the stack length or decreasing the nozzle area was small; whereas, at the other mixture ratios where the flame intensity was considerably higher the improvement provided by the increase in stack length and decrease in nozzle area was large. It also appears that the nozzle was more effective as a flame damper when used in conjunction with a long stack than with a short stack.

The general trend of damping of the flame bases suggests that not all of the damping was produced by cooling since the heat loss in a short stack is small, and yet small increases in stack length produced appreciable decreases in flame-base intensity for constant nozzle size. Measurements of exhaust-gas jet velocity (references 5 and 6) have shown that the mean gas efflux velocity is determined mainly by the nozzle size and the mass rate of flow of gas at constant fuel-air ratio. As the stack length is changed, the only additional cooling possible must take place by heat transfer to the exhaust stack or by additional heat transfer in the cylinder. Tests on the cylinder, used for the current tests at the same engine speed and boost, showed that no increase in head temperature was caused by constriction of the exhaust stack except for the smallest nozzle used. (See fig. 13(b) of reference 5.) Thus, some effects other than cooling contribute to the flame damping provided by long stacks.

The total external flame luminosity (intensity times extent) decreased faster than is indicated by the decrements shown in figures 10 and 11 because the flame size decreased as the stack length was increased and as the nozzle area was decreased. Figures 7 and 8 show the relative sizes of several flames produced with representative sizes of exhaust stack and nozzle area.

Some large discrepancies are noted in figures 10 and 11. No attempt has been made to check the measurements because flaming characteristics were found to be variable. It is believed that oil consumption probably influences the amount of flame and that other engine factors, particularly conditions of ignition, have some effect.

The important result of these tests is that the flame-base intensity and the tendency toward afterburning were reduced by the use of longer stacks and restricted nozzles. As will be shown later, a similar nozzle effect may be achieved by the use of nozzles having a small hydraulic mean diameter.

Use of a bend to reduce the intensity of light from within stack. - The maximum total light flux from an exhaust flame is always seen when looking directly into the end of the exhaust stack. Not only is light from the external plume effective, but also light from the long column of glowing gas inside the stack and possibly light from glowing metal surfaces in the exhaust system.

When the glow in the gas at the base of the external flame is reduced in intensity by a nozzle at the end of the stack, the glow of the gas in the stack is not similarly damped; gas at high pressure glows quite brightly. It is believed that the glow of the gas inside the stack is made brighter if the static pressure of the gas is appreciably raised by the presence of the nozzle. For the nozzles that had a short, constant-area throat section, the bright-orange glow of the gas decreased just before the gas reached the throat to about the same intensity as that of the external flame bases.

The light omitted in the stack appeared to be identical with the light omitted in the external flame bases. It was reddish for extremely rich mixtures, when the flame was sooty, orange for fuel-air ratios from 0.025 to 0.100, and a dilute yellow white or blue white for fuel-air ratios from 0.050 to 0.020.

The visibility of exhaust flames caused by light emitted from inside the stack may be reduced by placing a bend in the stack to hide from view part of the gas column and the glowing metal surfaces. Because of the lower luminosity of the gas in the throat of the nozzle, a more effective damping of the flame within the stack can be achieved by lengthening the nozzle throat and placing a bend in this section. By this means the entire high-pressure region of the stack is hidden. A few stacks with long bent throats were tested. The bends were observed to appreciably reduce the intensity of the light issuing from within the stack but had no great effect on the light intensity of the external plume.

Effect of nozzle hydraulic diameter on flame intensity. - Considerations of dynamic similarity suggested that, if the hydraulic diameter of the flame jets was reduced, the length of flame would likewise be reduced with a reduction in flame visibility. A stack was constructed of 61 tubes that provided a total exit area of 3.2 square inches; each of these tubes was 3 inches in length. (See fig. 12.) The flame of this stack was compared with that of a 20-inch stack, which had the same total surface area and the same nozzle area. The flame from the "porcupine" stack was much dimmer and shorter than that on the 20-inch stack, although there was a tendency toward intermittent afterburning with the porcupine stack owing to poor cooling. The tubes were red hot where they entered the hood and, although the temperature decreased toward the discharge end of the tubes, they were still sufficiently hot to start combustion of the exhaust gases. (The afterburning was

nearly eliminated by increasing the tube lengths to 6 in.) The improvement is, therefore, entirely due to a reduction in the hydraulic diameter of the jets.

The time that the exhaust gases were contained within the exhaust stack might have been an important factor, because more of the radiating particles associated with approach to equilibrium of the gases would be contained within the exhaust stack for the longer time. The factor of time favored the 20-inch stack; its effect is apparently small however, compared with the effect of hydraulic diameter of the jets because the hydraulic diameter controlled the flame intensity. The porcupine nozzle almost completely eliminated the orange flame base in the rich-mixture range. Photographs of the two porcupine nozzles are shown in figures 12 and 13; the flames produced by these nozzles are shown in figure 14. Afterburning with the 3-inch tubes and the lack of afterburning for the 6-inch tubes for Army 100-octane fuel and a blend of 40 percent aromatics with 60 percent Army 100-octane fuel are observable.

Qualitative tests with flattened nozzles, such as those shown in figure 13, confirmed the importance of small hydraulic diameter for an effective flame damper.

Effect of cooling on exhaust-flame luminosity. - A stack 20 inches long was equipped with a water jacket 18 inches long and tested with and without water cooling. Without cooling, the stack was a bright red, but only a slight reduction in flame-base intensity was noted with water cooling. A slight reduction in the tendency to afterburning was also noted with water cooling, but the difference was unimpressive. No further tests on the effect of cooling were conducted. The cooling achievable with the small amount of heat-transfer area of the conventional short stack would probably not produce an appreciable reduction of the flame visibility, although cooling with extremely large amounts of heat-transfer area will certainly prevent flaming and gas glow.

Effect of external obstacles on afterburning. - An obstacle that extends into a high-velocity jet may induce afterburning in a range of fuel-air ratios where afterburning might ordinarily occur only if the jet separated from the obstacle in such a way that air was entrained. Tests with a round tube $1/4$ inch in diameter showed that the reduction in tube temperature effected by cooling the tube with water had some effect on the tendency to afterburning. Photographs of the flame with and without the $1/4$ -inch tube in place are shown in figure 15. (The vertical break in the flame near the tip is the shadow of a rod used to support the test rod.) Afterburning is evidenced by the larger plume formed to the right of the small break. A $1/4$ -inch streamline strut, when symmetrically placed, caused afterburning on both sides, just beyond the maximum thickness. With a sufficiently large

angle of attack, afterburning occurred only on the upper, or lifting, surface. A 20-percent-thick, $1\frac{1}{4}$ -inch-chord strut, sharpened symmetrically fore and aft, did not cause afterburning except at high angles of attack.

Introducing a blunt obstruction into the jet caused the intensity of the orange or yellow glow in the gas to increase in the region of compression at the stagnation point or in any subsequent compression waves. The first compression glow may be seen in figure 15. An orange glow may also be produced by an obstacle in the gas stream beyond the visible flame. In this case, afterburning was not induced.

The fact that afterburning may be easily induced in high-speed jets makes it clear that afterburning is not suppressed by cooling the entire gas stream. Instead, the manner of mixing the exhaust gas with air is of principal importance.

Suggested design of flame-damping exhaust stacks. - The results of the accumulated evidence indicate that a flame-damping stack should have a fairly short, unstricted pipe, perhaps 8 or 10 inches long. This section should be connected by a smooth transition with a section of reduced area of as small a hydraulic mean diameter as can be afforded when the limits of stack area and space are considered. A series of bands or lips to direct the gas toward the rear should be provided and shaped in such a way that it is impossible to see into the unstricted section of the stack. The gas jet should not come in contact with projections from the airplane.

This type of stack design first produces damping of the gas flow as the gas passes into the restricted section of the pipe or the section of small hydraulic mean diameter. The band in the damping section prevents the brightly glowing gas in the stack from being seen. The lip or extended throat then hides or eliminates the external bluish plume. Following engineering practice of duct design, the radii of curvature of the throat or any external lip should be roughly four or more times the radial depth of the throat.

The nozzle section of the stack is designed to obtain high jet thrust consistent with no appreciable loss in engine power.

The exhaust stack, as described, may not satisfy the present extremely severe service requirement. Additional design features may be required to hide the residual column of glowing gas in the stack and to hide the external plume. This result may be accomplished by a duct surrounding the plume through which sufficient air is passed to reduce the final temperature of the mixture of exhaust gas and air below the ignition point.

Sample flame-damping stacks. - Three sample stacks were built on the basis of the experience gained in this research and are shown in figure 16. Stack A consists of a header smoothly faired into four tubes having an internal diameter of 1.009 inches each. The total exit area of the tubes is 3.20 square inches. Stack B is similar in design to stack A except that one flattened tube is used in place of the four round tubes. The exit area is also 3.20 square inches. The area of the stack ahead of the constriction is 4.20 square inches. Stack C is similar to stack B except that the exit area is 2.50 square inches.

Flames produced with the two types of sample stack, at about 0.080 fuel-air ratio, are shown in figure 17. The photograph shows some afterburning with the large-area "paddle" stack. An extension of 9 inches in unstricted-stack length very nearly eliminated this effect, as shown in figure 17(c).

The flame from the four-tube stack at 0.11 fuel-air ratio was so faint that the photographic image with 3-minute exposure could be seen only by looking through the film at a very oblique angle.

Simulated acceptance tests of flame visibility. - The three sample stacks and the following series of other stack types were tested with the simulated acceptance test setup diagrammed in figure 5:

- (a) Straight stack, 14 inches long, exit area 4.20 square inches
- (b) Straight stack, 14 inches long, exit area 2.24 square inches
- (c) Porcupine stack with 6-inch tubes, preceded by 9 inches of straight stack
- (d) Multiple-flat-tube nozzle, exit area 3.20 square inches, total stack length 20 inches, cooled with a compressed-air blast and uncooled. The nozzle is shown in figure 13.

Results of the tests are summarized in figures 18, 19, and 20. In all tests the observer reported whether he saw each test flame. In figures 18 and 19 the results of each test are individually shown. In figure 20 the average number of times that all flames within a range of 0.005 fuel-air ratio were seen is plotted against the fuel-air ratio at the middle of the range. The number of tests in each range is indicated on this figure.

In the test with straight stacks and nozzles (fig. 13), most of the responses, except in tests at very high fuel-air ratios, were definite; considerable hesitancy in giving responses was experienced in tests with the other stacks. Flames produced with the straight stack, and particularly those with the 2.24-square-inch nozzle, were reported to have color.

In the case of the porcupine-type nozzle and the multiple-flat-tube nozzle, a red glow, attributed to the hot metal, was usually seen. Cooling the multiple-flat-tube nozzle with a compressed-air blast somewhat reduced the visibility. The porcupine stack could not be appreciably cooled.

These tests indicate that the straight stack, 14 inches long, is unsatisfactory with either nozzle. Use of the porcupine-type or the multiple-flat-tube nozzle somewhat reduces the luminosity of the flame, but the combined visibility of the flame and hot metal of the stack is excessive except at very rich mixtures.

The damping achieved with the larger exit area, paddle-type stack (fig. 19) appears to be insufficient. As was previously stated, some afterburning occurred with this stack. The visibility of flame with the paddle stack of smaller exit area seems to be satisfactory for fuel-air ratios higher than about 0.085. It is seen in figure 16 that the unstricted section with the larger exit area is very short; this feature may be partly responsible for the poorer performance of this stack.

The visibility of flame with the four-tube stack (fig. 20) at an engine speed of 1500 rpm appears to be satisfactory for all fuel-air ratios higher than about 0.065. At 2000 rpm the visibility appears to be satisfactory for fuel-air ratios higher than about 0.085.

In general, the damping of flame was least successful for low fuel-air ratios. Maximum visibility of the exhaust flame from the four-tube stack occurs at a fuel-air ratio of 0.060, whereas maximum flame-base intensity with no flame damping is apparently found at a fuel-air ratio of about 0.070. (See fig. 9.) Fortunately, the maximum visibility of the damped flame occurs at a fuel-air ratio ordinarily used only for cruising at low outputs.

On the basis of these tests it cannot be concluded that the flame from any stack completely fulfilled the service requirement of invisibility under all conditions. In general, engines will be operated at higher outputs than the test conditions used, and the flames from several cylinders will be discharged within a small area. The light flux from all flames visible in one direction tends to determine the range of visibility. On the other hand, the test conditions used are known to be more severe than required to meet the desired limits for aircraft flying over water.

GENERAL PROBLEMS ASSOCIATED WITH EXHAUST-FLAME VISIBILITY

The principal difficulties involved in setting up laboratory tests of exhaust-flame visibility are those associated with the visual

function. The relative sensitivity of the human eye to light of different wave lengths depends on the intensity of the light and on the level of adaptation of the eye. No simple objective method of photometry that takes this second phenomenon into account is known. Use of subjective methods to estimate flame visibility, therefore, seems necessary.

In the process of seeing a small source, the eye or the brain tends to integrate the light received within a fairly large, solid angle. For subtended angles up to about 1° of arc, this accumulation is nearly complete for faint sources. Light just outside the limits of this arc will also contribute to the visibility of the light within this arc, but the effect of this outside flux decreases as the angular distance of the light from the limits of the arc increases. Thus, the distance from which the exhaust is visible depends not only on the intensity of the individual plumes but also on the number of plumes that are visible at one time and the distance between them.

The quantity of light required for visibility of an exhaust flame depends upon the surrounding illumination. Very little data on the way in which the quantity varies with background illumination for continuously exposed sources are available. If background illumination is used in a simulated test, the background must be considerably larger than the light in order that it not be confused with the test light.

Since the sensitivity of the eye is much greater for indirect vision than for direct vision, the observer must allow his eye to roam or must have a small fixation light provided near the edge of the surrounding field. With such a fixation light, means of occulting the test source or flame for several seconds at a time must be provided since objects viewed at a fixed spot in the periphery of the eye tend to disappear if viewed for a long period of time.

The accuracy of a single visual test may be very poor. It has been shown in reference 1 that, because of the quantum structure of light, methods of probability must be used to determine the chance of receiving a sufficient signal in a short flash. Whether this variability of the stimulus need be taken into account in visual phenomena with continuous exposures is not known. Tests reported in references 7 and 8 showed that the distribution of response for threshold tests using continuous exposures was the same as the distribution using short flashes. This result suggests that the same effect appears in all tests.

The root-mean-square error in the range of visibility of an exhaust flame, corresponding to the results of references 7 and 8, is about ± 5 percent. It seems possible and the tests shown in figures 18 and 19 indicate that exhaust flames may occasionally be seen at much greater than average range.

In the setting up of a simulated test system, or in the evaluation of the data obtained, account must be taken of the fact that the minimum perceptible light intensity is from 20 to 40 percent lower for binocular vision than for monocular vision. At very low levels of illumination, the value reported in reference 7 is 40 percent. This difference corresponds to a difference in range between monocular and binocular vision of about 20 percent.

Some reports from present theaters of action suggest that only flames bright enough to appear colored can lead to the detection of an enemy airplane. If so, the area of accumulation will be somewhat smaller than previously indicated and the presence of adjacent flames will be slightly less troublesome. In any case, the design of an exhaust-stack installation that will permit an observer to look directly into as few stacks as possible from one position is desirable.

If interest in simulated flame-visibility tests continues, a standard value of limiting glare luminosity or a standard value of background intensity should be specified. Until such objective specifications are set up, a test in actual flight provides the only sure means of judging the acceptability of a flame-damping stack.

CONCLUSIONS

On the basis of these tests, the following conclusions have been drawn:

1. With no damping, light emitted by afterburning of exhaust gases discharged from individual stacks was brightest at a fuel-air ratio of about 0.08. The intensity of the orange light near the stack exit was greatest at a fuel-air ratio of 0.070.
2. Aromatic constituents in fuels increased the tendency toward afterburning when no damping was attempted. Reduction of afterburning to an acceptable level of intensity was only slightly more difficult with aromatic fuels than with nonaromatic fuels.
3. Excessive oil consumption may cause a red, sooty exhaust flame.
4. A decrease in the number of operating spark plugs or the introduction of a large series resistor in the ignition line increased the tendency toward afterburning and might cause rich mixtures to burn with a red, sooty exhaust flame.
5. An increase in exhaust-stack length reduced exhaust-flame visibility.

6. Reductions in exhaust-nozzle area reduced exhaust-flame visibility. This effect was greater with long stacks than with short ones.

7. Reduction of the hydraulic mean diameter of the flame decreased the exhaust-flame visibility.

8. Water jacketing an 18-inch length of a 20-inch stack had only a small effect on flame visibility.

9. An obstacle in the luminous part of the flame may produce afterburning that would otherwise be absent.

10. The glow of exhaust gas inside an exhaust stack was not appreciably reduced in intensity by the use of longer stacks or constricted nozzles when the entire gas column was visible. This glow was most easily reduced by providing an optical screen. This screen could be provided by placing suitable bends in the nozzle throat or by adding external lips.

Aircraft Engine Research Laboratory,
National Advisory Committee for Aeronautics,
Cleveland, Ohio.

REFERENCES

1. Hecht, Selig: The Quantum Relations of Vision. Jour. Optical Soc. Am., vol. 32, no. 1, Jan. 1942, pp. 42-49.
2. National Research Council: International Critical Tables. Vol. I. McGraw-Hill Book Co., Inc., 1926, p. 92.
3. Rayleigh, Lord: Further Studies on Active Nitrogen: III. Experiments to Show that Traces of Oxygen or other Impurity Affect Primarily the Walls of the Vessel, and not the Phenomena in the Gas Space. Proc. Roy. Soc. (London), ser. A, vol. 180, no. 981, June 5, 1942, pp. 123-139.
4. Bone, William A., Newitt, Dudley M., and Townend, Donald T. A.: Gaseous Combustion at High Pressures. Longmans, Green & Co., Ltd. (London), 1929.
5. Pinkel, Benjamin, Turner, L. Richard, and Voss, Fred: Design of Nozzles for the Individual Cylinder Exhaust Jet Propulsion System. NACA ACR, April 1941.

18.

6. Turner, L. Richard, and Humble, Leroy V.: The Effect of Exhaust-Stack Shape on the Design and Performance of the Individual Cylinder Exhaust-Gas Jet-Propulsion System. NACA ARR, Nov. 1942.
7. Crozier, W. J., and Holway, A. H.: Theory and Measurement of Visual Mechanisms. Jour. Gen. Physiology, vol. 22, no. 3, Jan. 20, 1939, pp. 341-364.
8. Holway, Alfred H.: On the Precision of Photometric Observations. Jour. Optical Soc. Am., vol. 27, no. 3, March 1937, pp. 120-123.

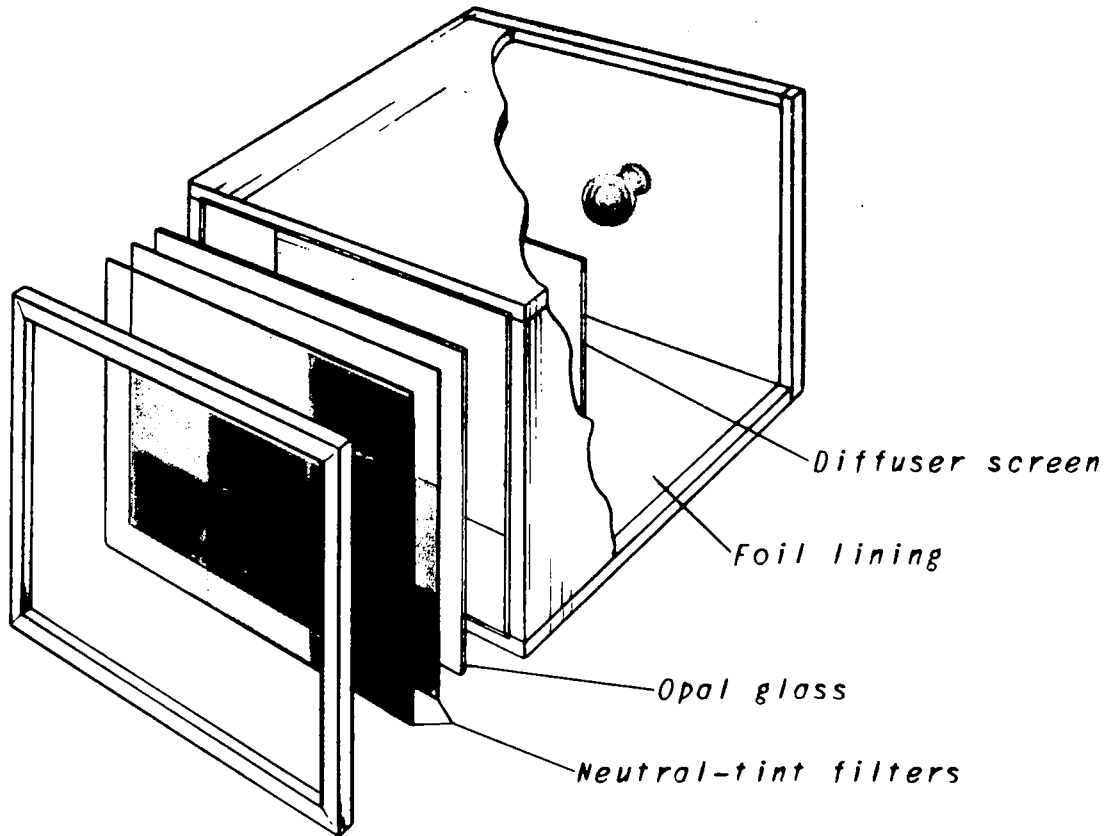

NATIONAL ADVISORY
COMMITTEE FOR AERONAUTICS

Figure 1. - Construction of comparison light source.

NATIONAL ADVISORY
COMMITTEE FOR AERONAUTICS

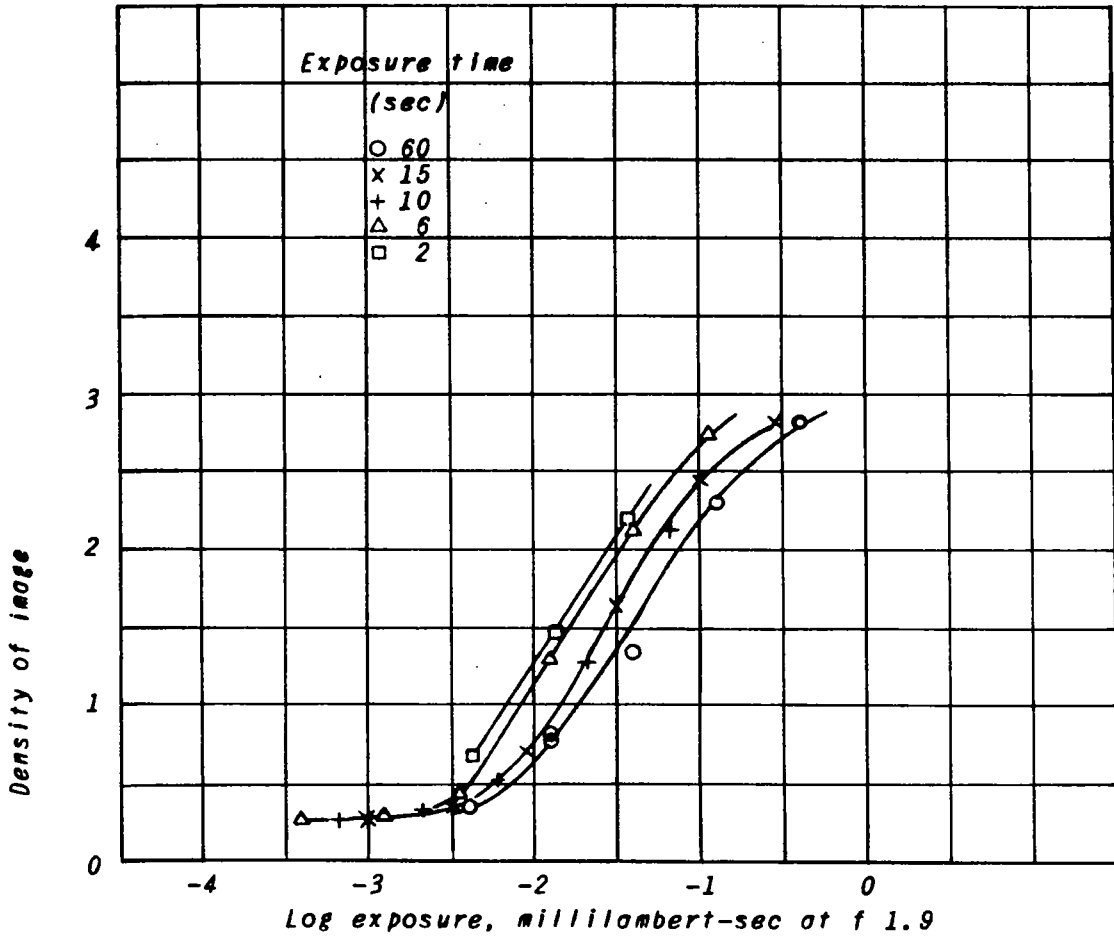

Figure 2. - Sample densitometric curves for Tri-X Aero Safety film.

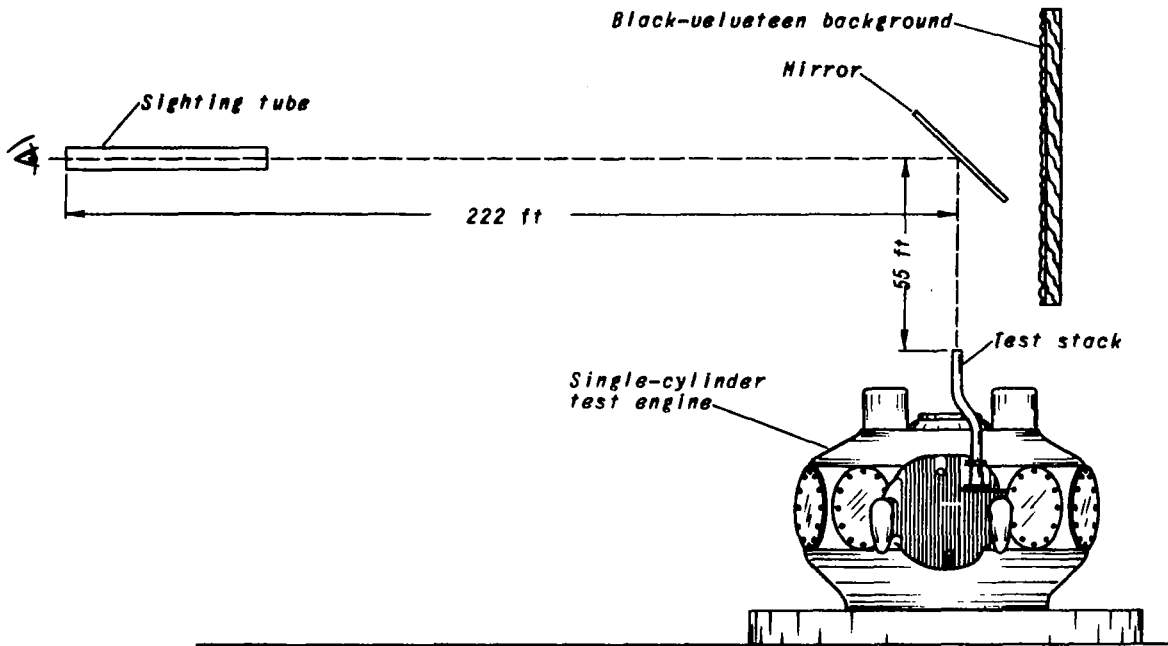

Figure 3. - Visibility-test setup.

NATIONAL ADVISORY
COMMITTEE FOR AERONAUTICS

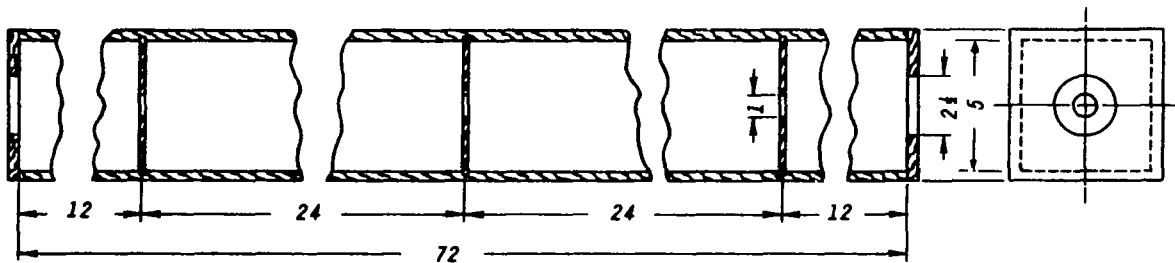

Figure 4. - Construction of sighting tube. All dimensions in inches.

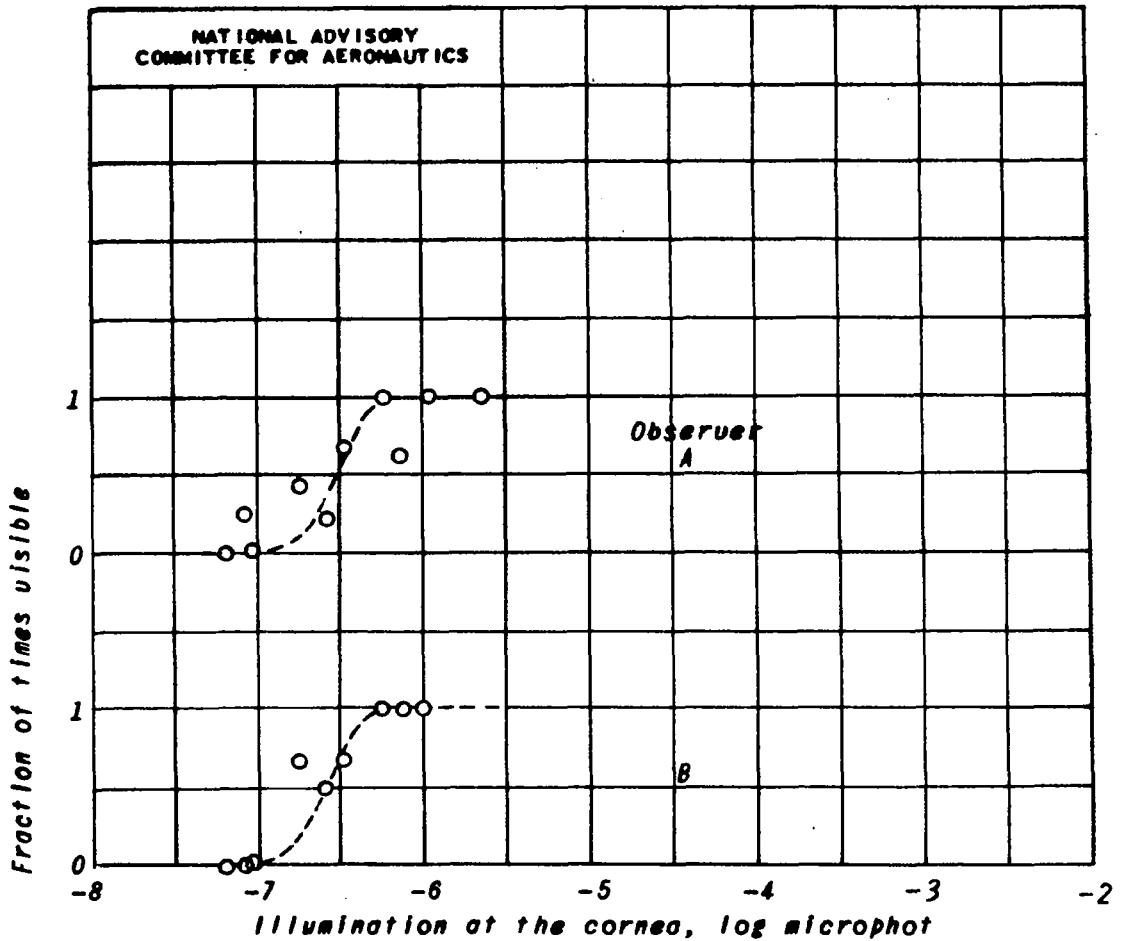
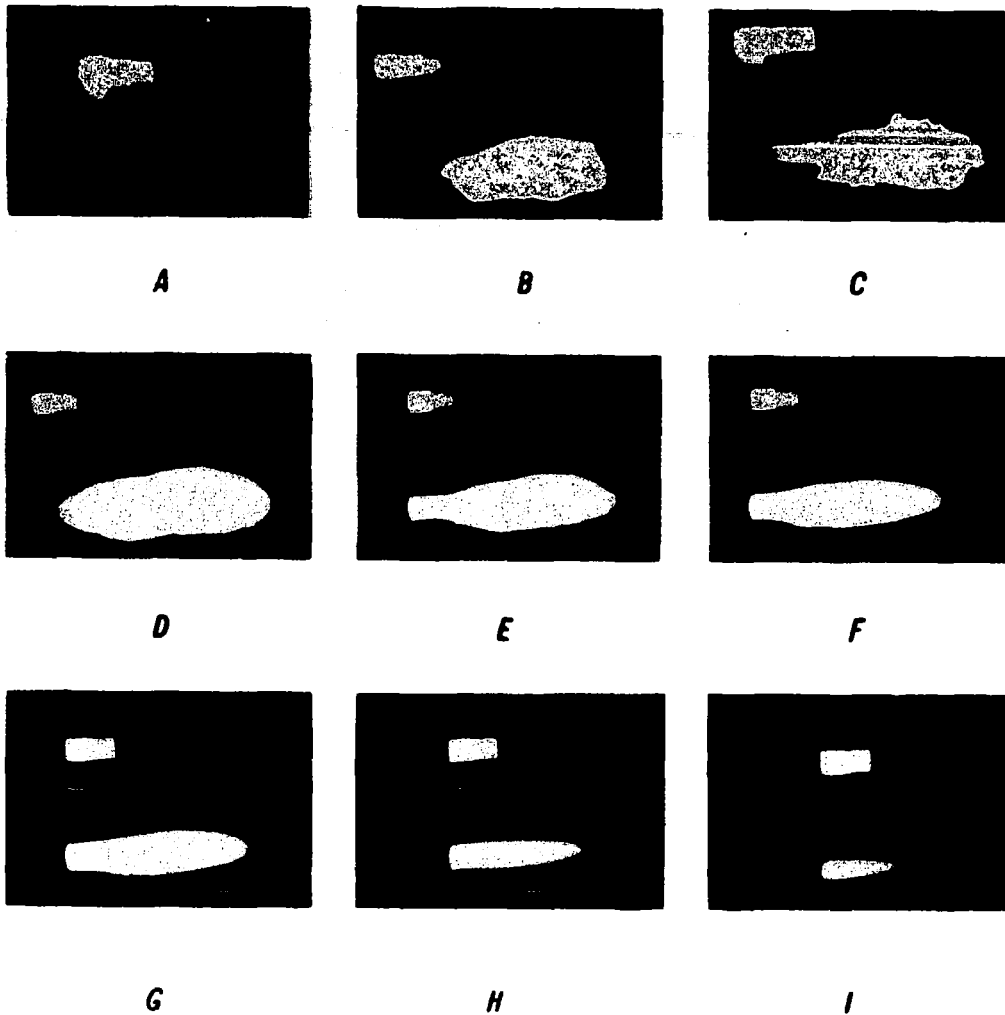

Figure 5. - Sensitivity of the observers under test conditions. Monocular vision, natural pupil, no fixation. Curves faired from theory of reference 1.



LMAL
30269

Figure 6. - Undamped flame of the 1820-G engine.
 Fuel, leaded; fuel-air ratio, variable;
 hydrogen-carbon ratio, 0.189.

| | Fuel-air ratio | Base intensity (millilamberts) | Exposure (sec) |
|---|-------------------|-----------------------------------|-------------------|
| A | 0.116 | 0.00020 | 60 |
| B | .1015 | .00048 | 15 |
| C | .1015 | .00047 | 6 |
| D | .0898 | .0023 | 2 |
| E | .0792 | .0155 | 2 |
| F | .0705 | .037 | 2 |
| G | .0662 | .026 | 2 |
| H | .0603 | .0135 | 5 |
| I | .0496 | .0062 | 5 |

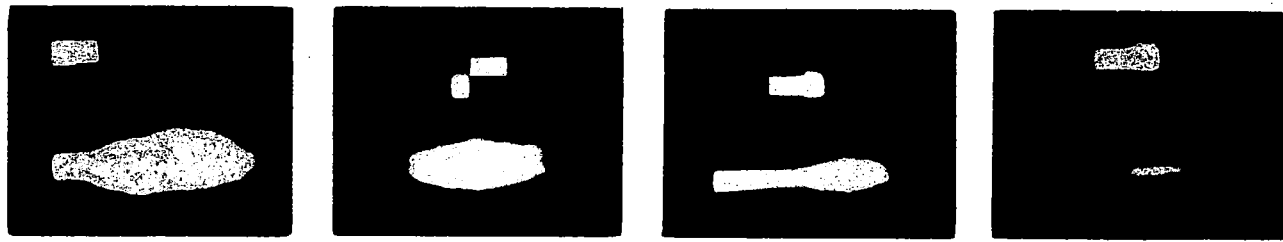

A **B** **C** **D**
 (a) Nozzle area, 4.20 square inches.



E **F** **G** **H**
 (b) Nozzle area, 1.39 square inches.

LMAL
 30271

Figure 7. - The effect of pipe length on exhaust flame for two nozzle areas.

| | Stack length (in.) | Fuel-air ratio | Base intensity (millilamberts) | Exposure (sec) |
|---|-----------------------|-------------------|-----------------------------------|-------------------|
| A | 5 | 0.0792 | 0.0155 | 2 |
| B | 14 | .0800 | .0014 | 1 |
| C | 20 | .0804 | .0036 | 5 |
| D | 48 | .0812 | .00105 | 15 |
| E | 5 | .0800 | .0091 | 2 |
| F | 14 | .0796 | .00055 | 30 |
| G | 20 | .0796 | .00065 | 15 |
| H | 48 | .0804 | .00034 | 60 |

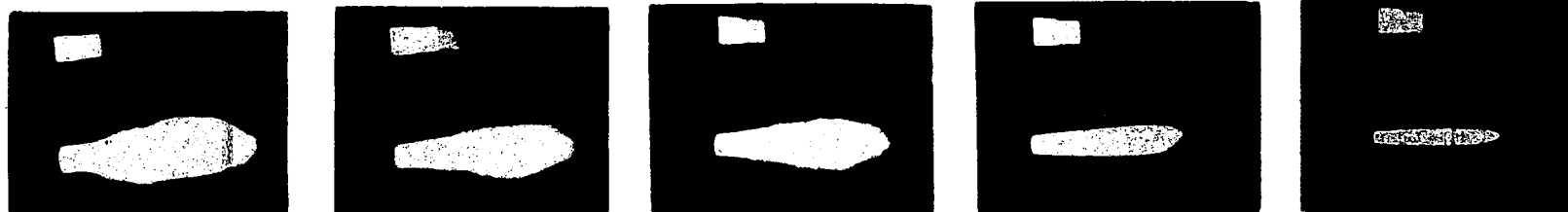

A B
(a) Stack length, 5 inches.

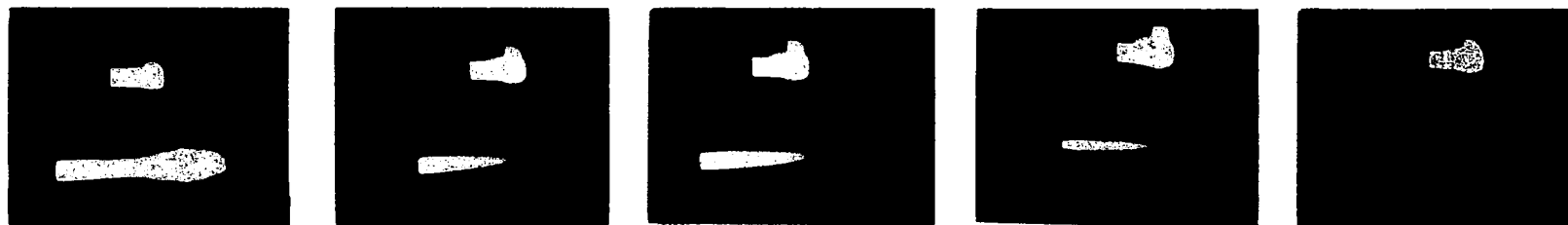

F G H I J
(b) Stack length, 20 inches.

LMAL
30272

Figure 8. - The effect of nozzle area on exhaust flame for two stack lengths.

| | Nozzle area (sq in.) | Fuel-air ratio | Base intensity (millilamberts) | Exposure (sec) |
|---|-------------------------|-------------------|-----------------------------------|-------------------|
| A | 4.20 | 0.0792 | 0.0155 | 2 |
| B | 3.20 | .0799 | .0141 | 2 |
| C | 2.85 | .0800 | .015 | 2 |
| D | 2.24 | .0800 | .0105 | 2 |
| E | 1.39 | .0800 | .0091 | 2 |
| F | 4.20 | .0804 | .0036 | 5 |
| G | 3.20 | .0798 | .0054 | 15 |
| H | 2.85 | .0803 | .0027 | 15 |
| I | 2.24 | .0794 | .00076 | 30 |
| J | 1.39 | .0796 | .00065 | 15 |

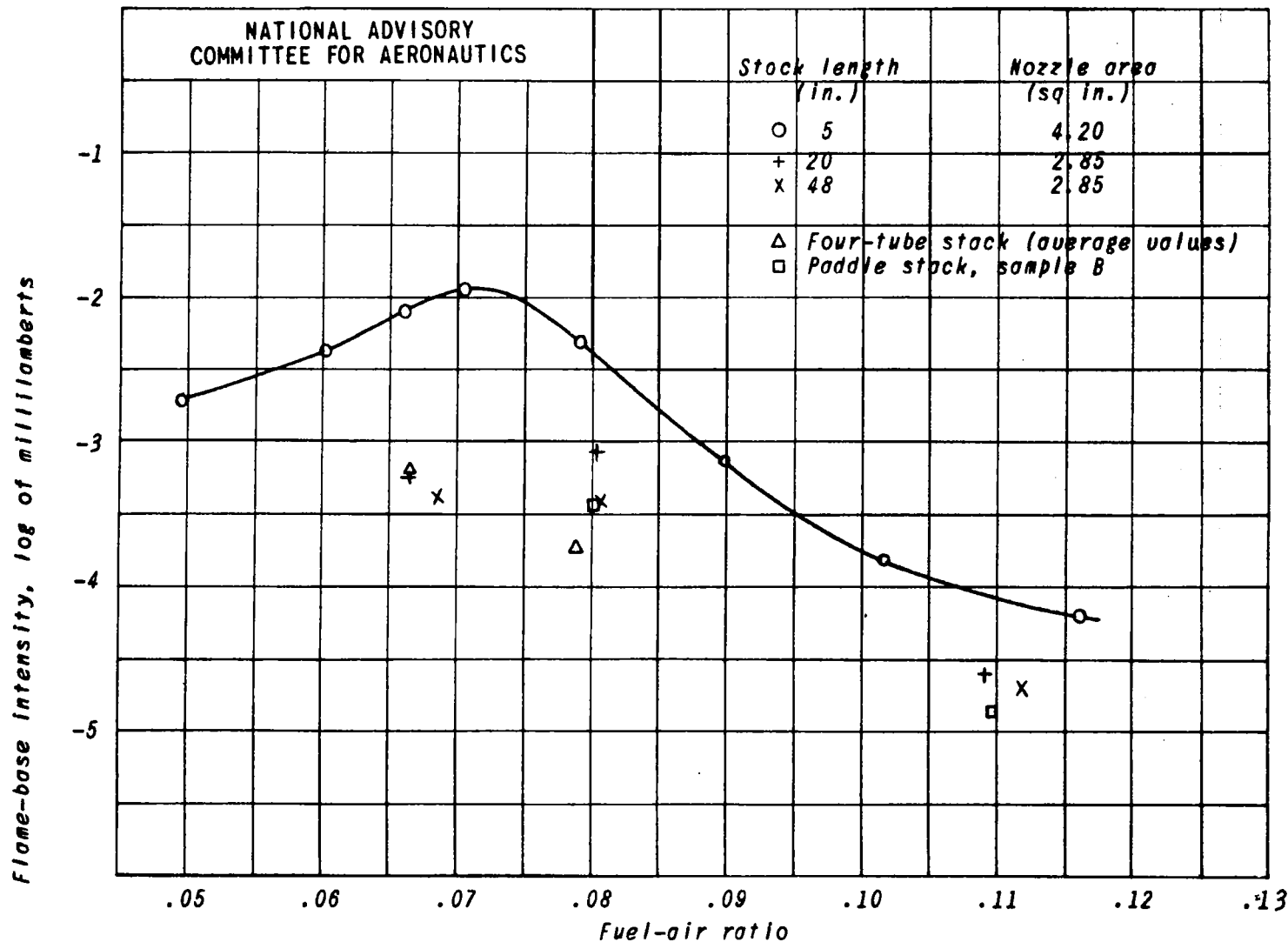

Figure 9. - Intensity of flame base for 5-inch unrestricted stack and other stacks and nozzles. Intake-manifold pressure, 30 inches Hg absolute; engine speed, 1500 rpm.

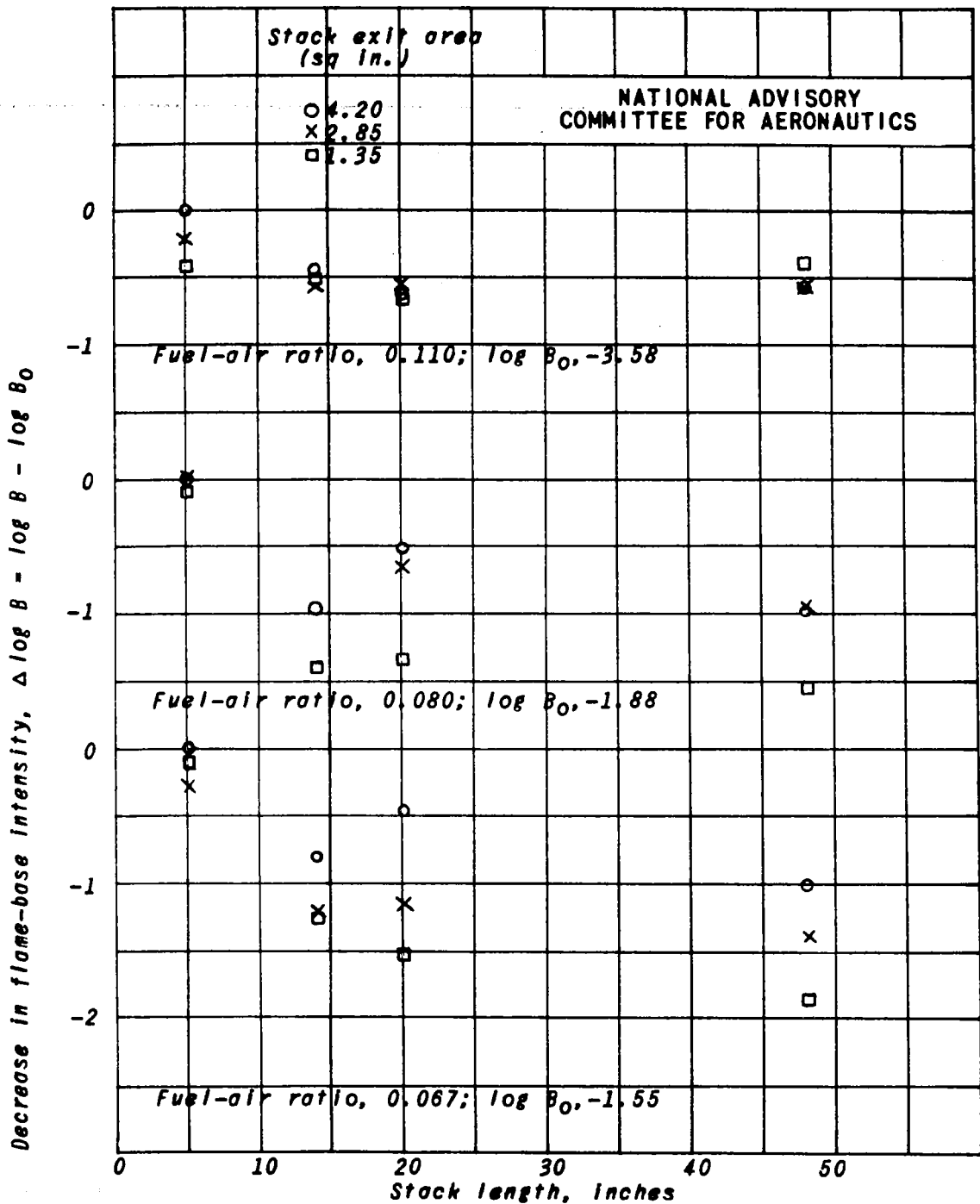

Figure 10. - Effect of stack length on external flame-base intensity. B_0 is the intensity of undamped flame base in millilamberts.

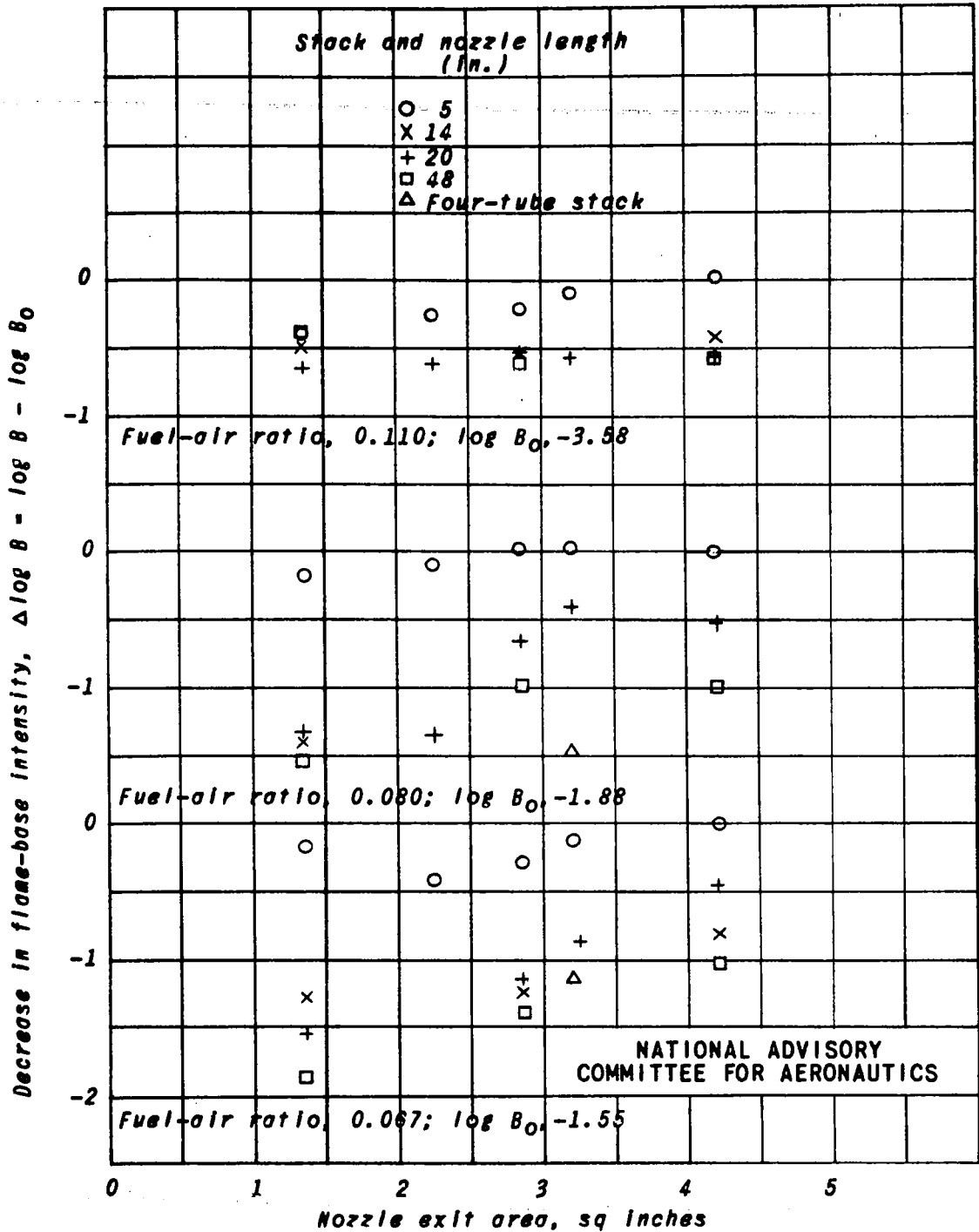

Figure 11. - Effect of stack exit area on external flame-base intensity. B_0 is the intensity of undamped flame base in millilamberts.

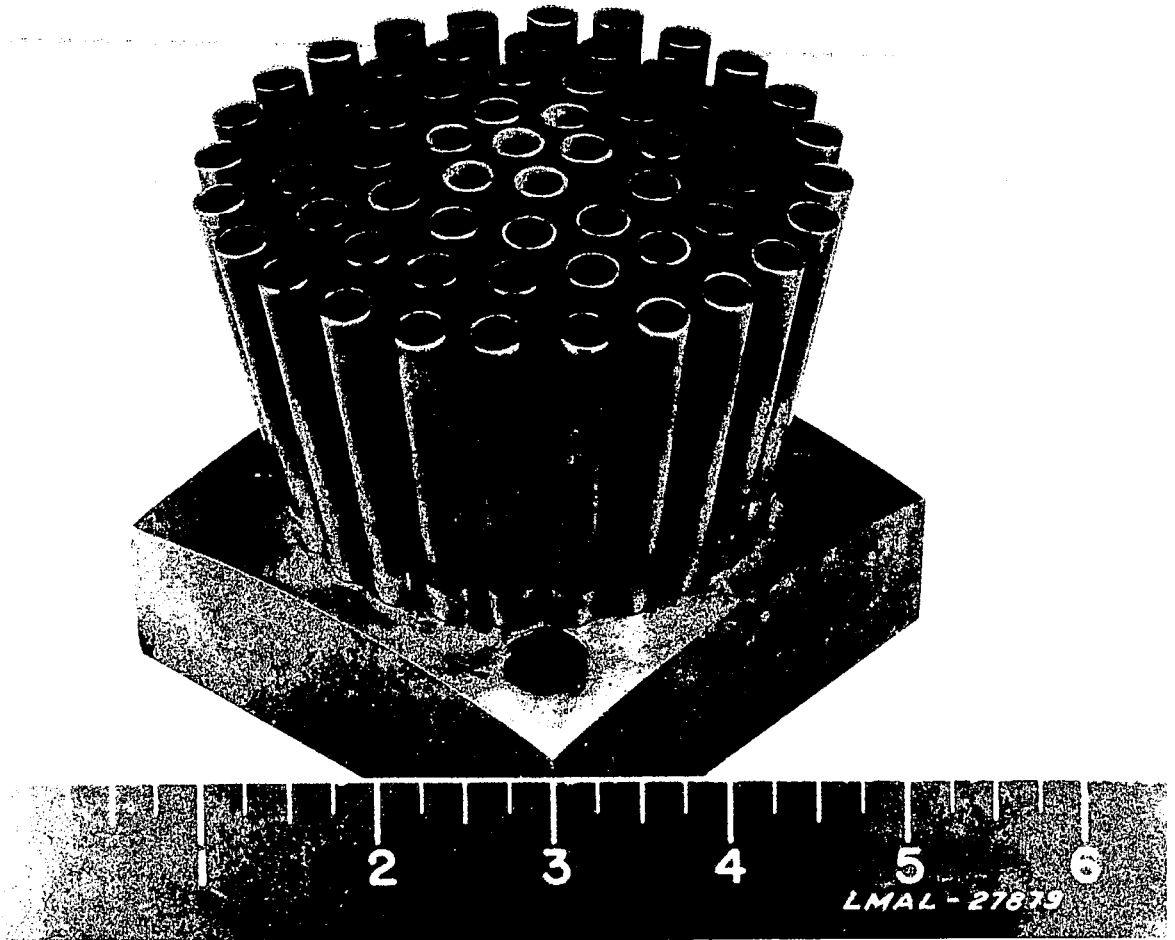

Figure 12. - The 3-inch porcupine nozzle.

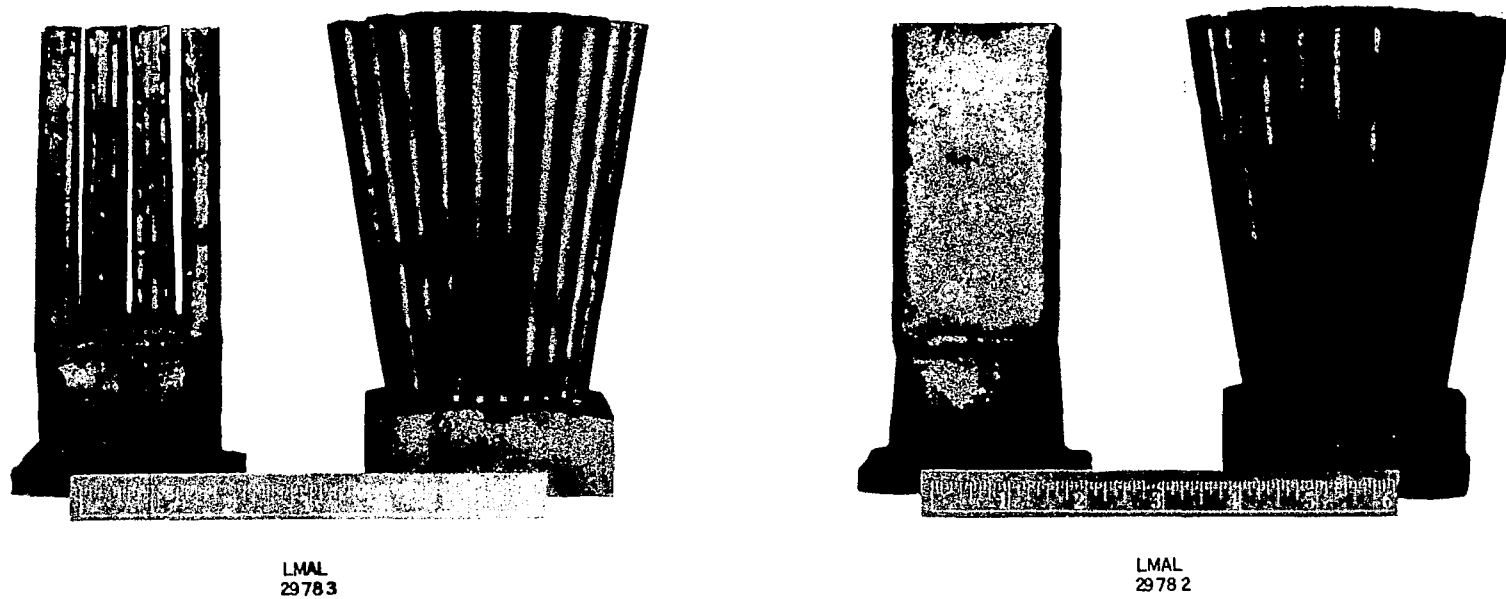
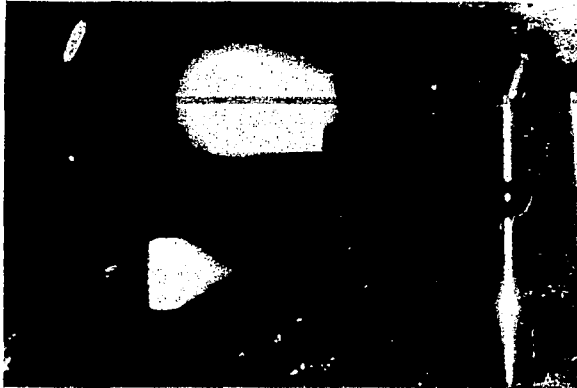

Figure 13. - Multiple-flat-tube nozzle and 6-inch porcupine nozzle.



(a) *The 3-inch porcupine nozzle. Stack length, 15 inches; fuel, Army 100 octane; fuel-air ratio, 0.0799; exposure, 15 seconds.*



(b) *The 6-inch porcupine nozzle. Fuel, Army 100 octane; fuel-air ratio, 0.0799; exposure, 15 seconds.*



(c) *The 6-inch porcupine nozzle. Fuel, mixture of 60 percent 100 octane and 40 percent aromatics; fuel-air ratio, 0.0809; exposure, 15 seconds.*

NACA
C-16065
10-21-46

Figure 14. - Flames from porcupine stacks.

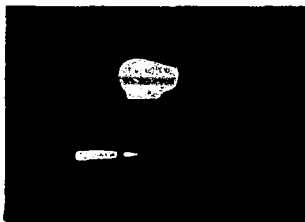

Flame with no disturber rod

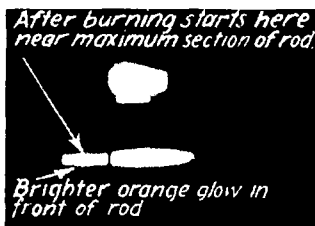

Flame with uncooled 1/4-inch rod



Flame with water-cooled 1/4-inch rod

LMAL
30270

Figure 15. - Ignition of an exhaust-gas jet by a 1/4-inch rod. Engine, Wright 1820-G; fuel-air ratio, 0.074; exposure, 15 seconds.

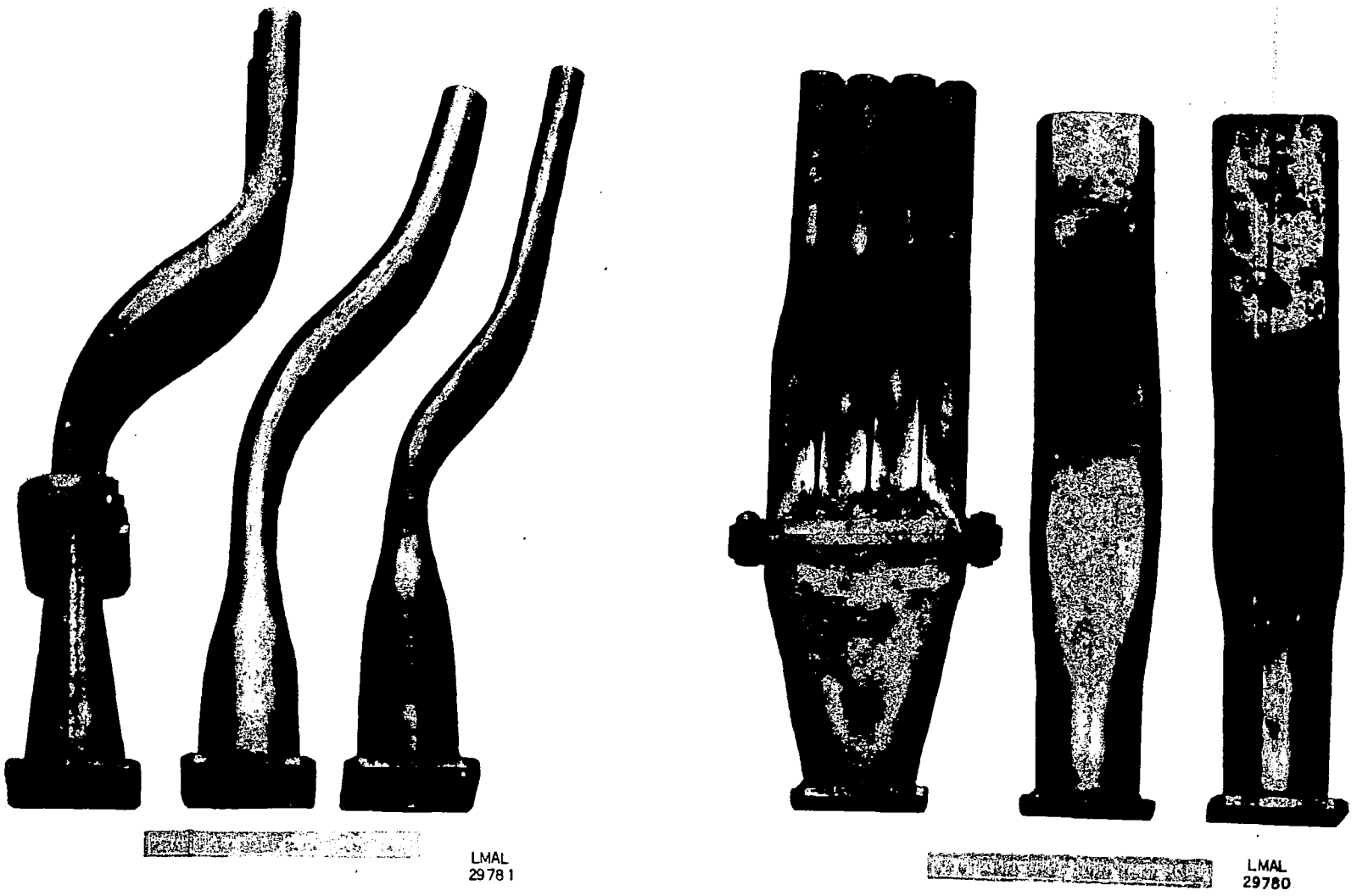
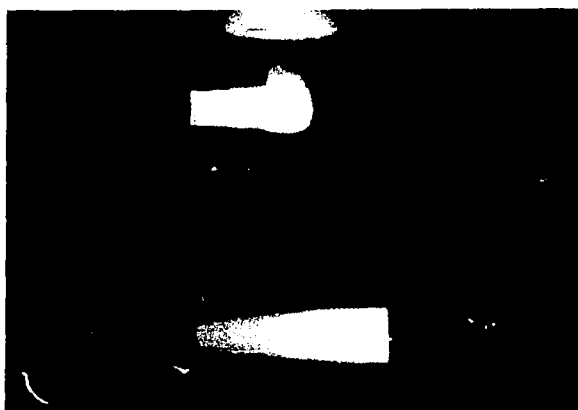

Figure 16. - Sample flame-damping stacks A, B, and C.



(a) Four-tube stack. Fuel-air ratio, 0.0789; exposure, 30 second



(b) Sample stack B. Fuel-air ratio, 0.0801; exposure, 15 seconds.

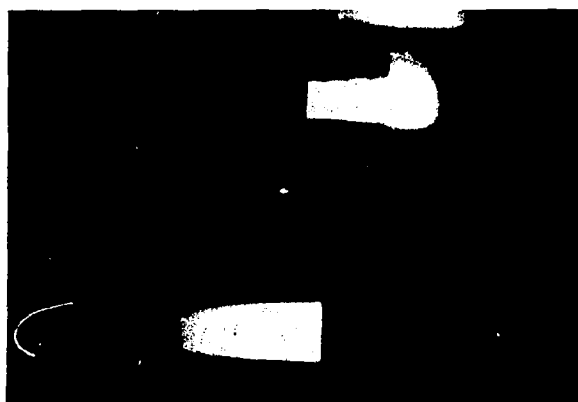

NACA
C-16066
10-21-46

(c) Sample stack B with added unstricted stack 9 inches long. Fuel-air ratio, 0.0778; exposure, 15 seconds.

Figure 17. - Flames from sample stacks.

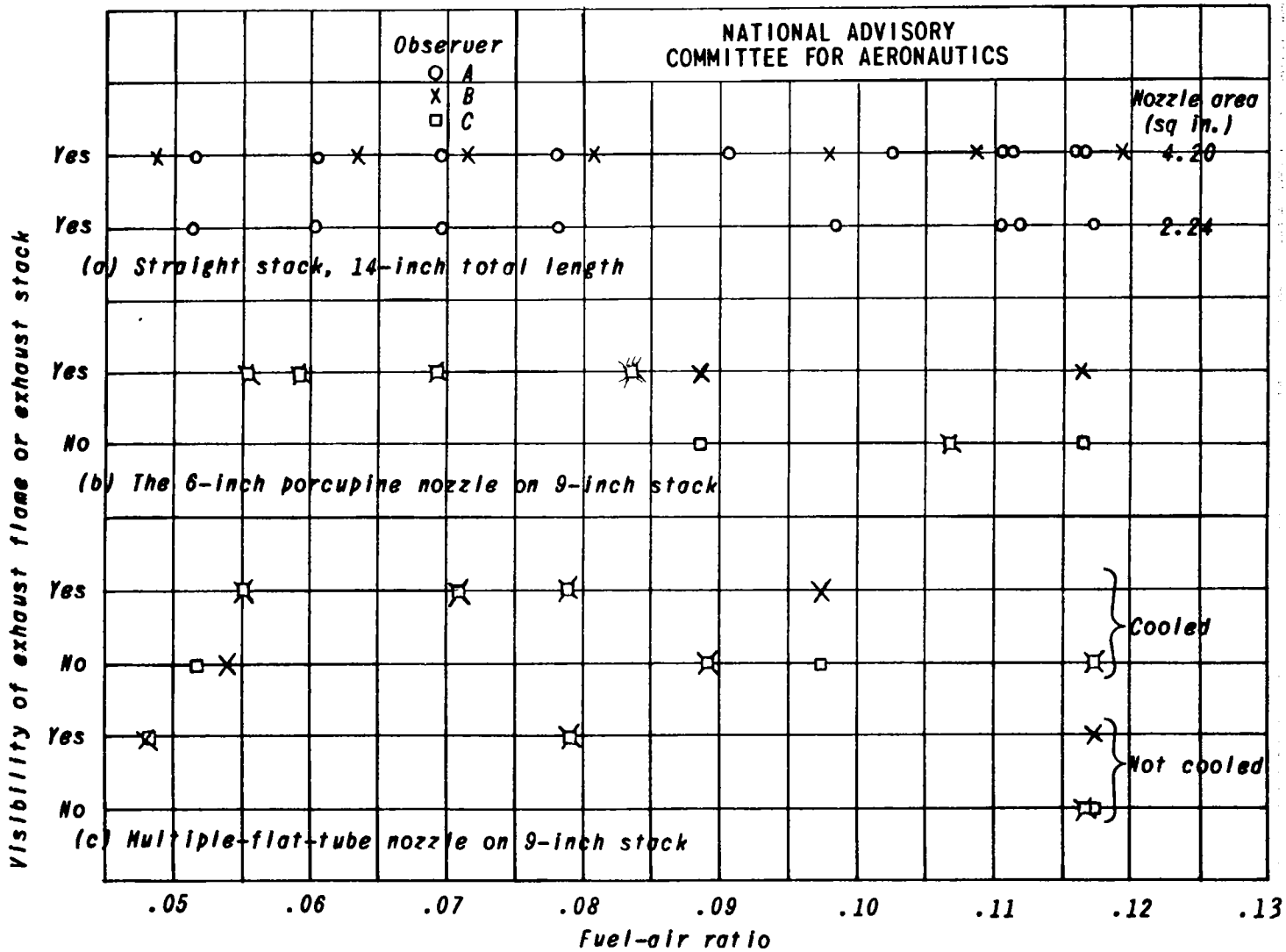

Figure 18. - Visibility of exhaust flame or exhaust stack with miscellaneous nozzles.

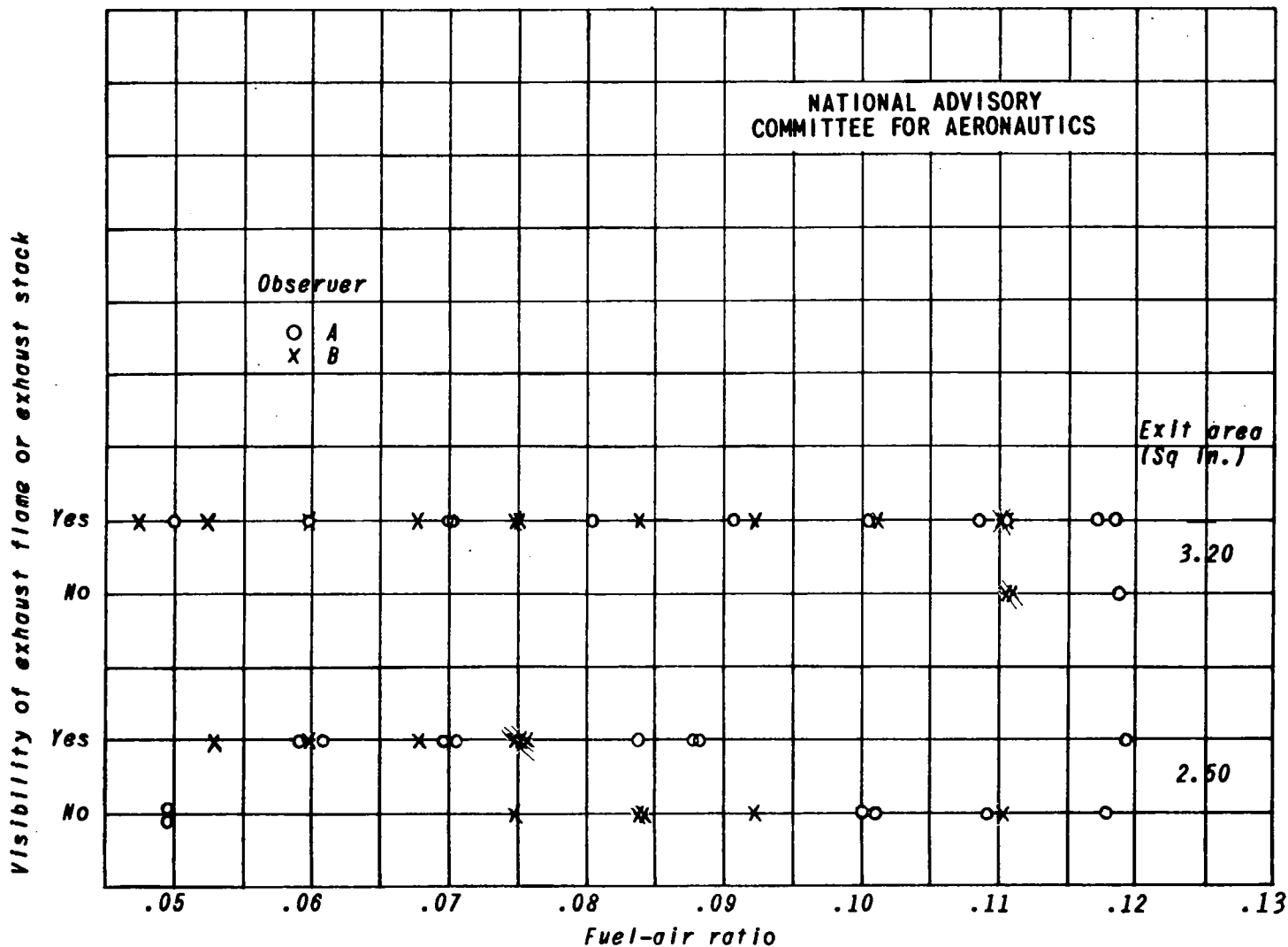

Figure 19. - Visibility of exhaust flames from paddle-type stacks, samples B and C.

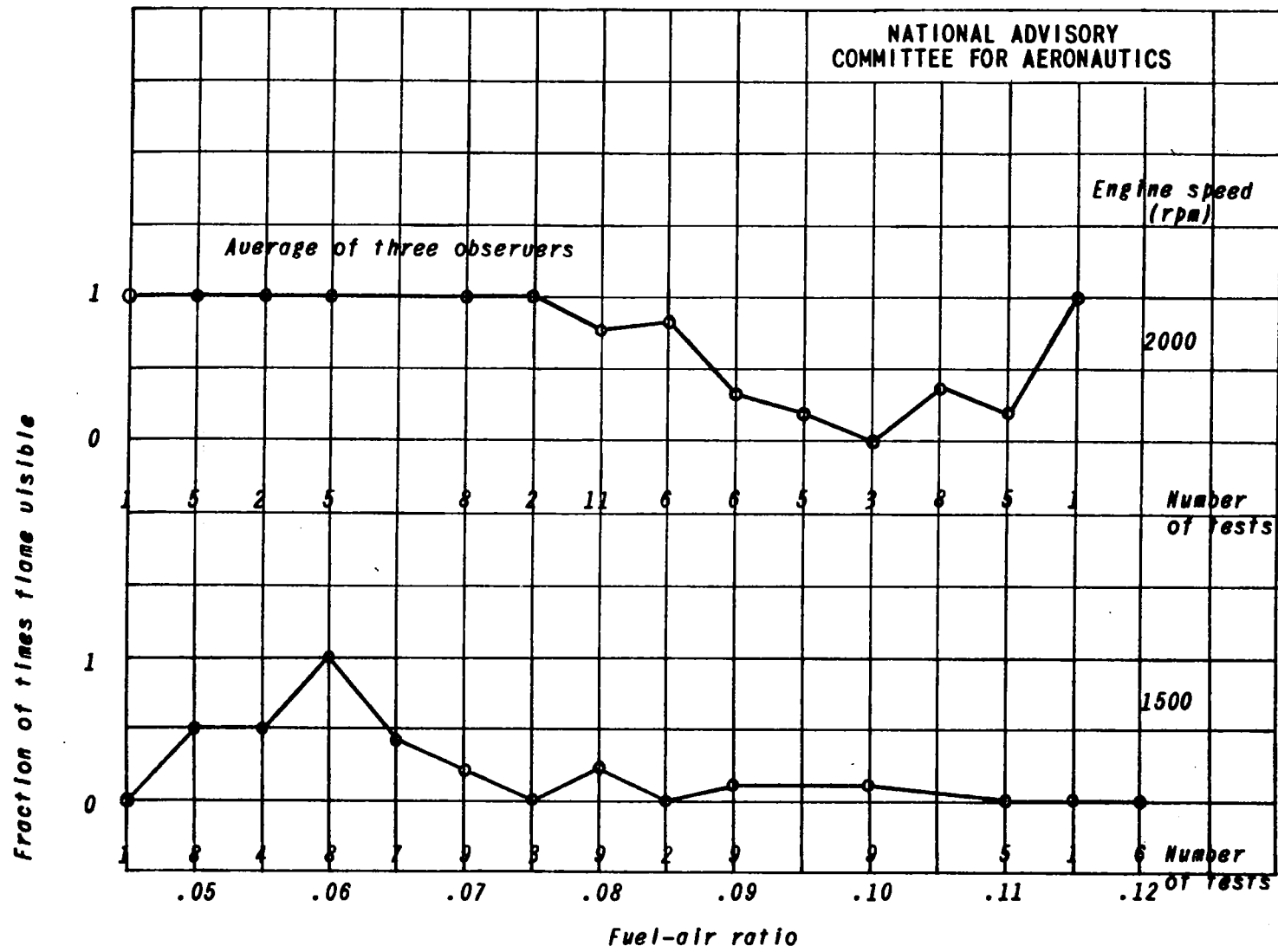

Figure 20. - Visibility of exhaust flame from the four-tube stack, sample A.

Confidential

DISTRIBUTION:

ATI: 7383

TITLE:

FOREIGN TITLE:

AUTHOR(S):

ORIGINATING AGENCY:

P.A. NO.:

PUBLISHING AGENCY:

P.A. NO.:

TRANSLATING AGENCY:

T.A. NO.:

DATE:

COUNTRY:

LANGUAGE:

PAGES:

REMARKS:

SUBJECT

DIV.

SECT.

SUBJECT HEADINGS:

*Type of 8377**Cancelled 20 May '48*

TITLE: Flame-Visibility Tests with Individual Exhaust Stacks

AUTHOR(S): Turner, L. Richard; Humble, Leroy V.

ORIGINATING AGENCY: National Advisory Committee for Aeronautics, Washington, D. C.

PUBLISHED BY: (Same)

ATI- 8377

REVISION (None)

ORIG. AGENCY NO.
ARR-4B08

PUBLISHING AGENCY NO.

| DATE | DOC. CLASS. | COUNTRY | LANGUAGE | PAGES | ILLUSTRATIONS |
|---------|-------------|---------|----------|-------|--------------------------|
| Feb '44 | Unclass. | U.S. | Eng. | 38 | photos, graphs, drawings |

ABSTRACT:

Investigation was made on the development of an exhaust stack that would satisfactorily dampen flame intensity of engine exhaust. Effects of fuel-air ratio, fuel composition, ignition, and oil consumption are explained. Flame damping was improved by decreasing nozzle exit area, increasing stack length, and reducing hydraulic diameter of exhaust jets. Estimates of relative brightness of exhaust flames were made by photographic means. Limitations of photographic techniques and simulated visibility tests are discussed.

DISTRIBUTION: Request copies of this report only from Originating Agency

DIVISION: Power Plants, Reciprocating (6)

SECTION: Exhaust System (5)

SUBJECT HEADINGS: Exhaust stacks - Flame damping (34413); Exhaust systems - Design (34414.05)

ATI SHEET NO.: R-6-5-3