

UNCLASSIFIED

AD NUMBER

ADB805407

CLASSIFICATION CHANGES

TO: unclassified

FROM: restricted

LIMITATION CHANGES

TO:
Approved for public release; distribution is unlimited.

FROM:
Distribution authorized to DoD only; Administrative/Operational Use; OCT 1941. Other requests shall be referred to National Aeronautics and Space Administration, Washington, DC. Pre-dates formal DoD distribution statements. Treat as DoD only.

AUTHORITY

NACA list dtd 28 Sep 1945; NASA TR Server website

THIS PAGE IS UNCLASSIFIED

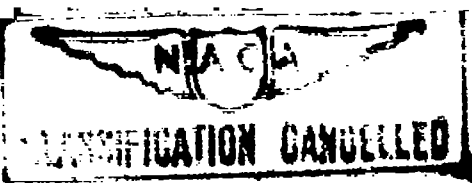

RESTRICTED 270

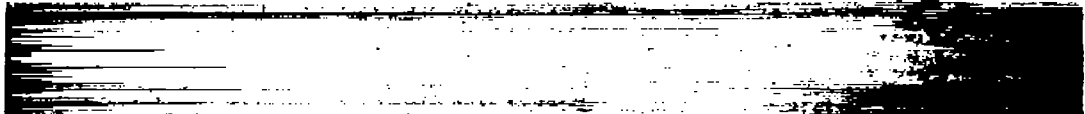

TECHNICAL NOTES

NATIONAL ADVISORY COMMITTEE FOR AERONAUTICS

MAR 2 1945

No. 830

DAMPING CHARACTERISTICS OF DASHPOTS

By John B. Peterson
National Bureau of Standards

CLASSIFIED DOCUMENT

This document contains classified information affecting the National Defense of the United States within the meaning of the Espionage Act, USC 50:31 and 32. The transmission or the revelation of its contents in any manner to an unauthorized person is prohibited by law. Information so classified may be imparted only to persons in the military and naval Services of the United States, appropriate civilian officers and employees of the Federal Government who have a legitimate interest therein, and to United States citizens of known loyalty and discretion who of necessity must be informed thereof.

Washington
October 1941

NATIONAL ADVISORY COMMITTEE FOR AERONAUTICS

TECHNICAL NOTE NO. 830

DAMPING CHARACTERISTICS OF DASHPOTS

By John B. Peterson

SUMMARY

An investigation of the damping characteristics of dashpots was carried out combining theory and experiment. Laminar flow was assumed and three equations for the steady velocity of a piston moving in a cylinder filled with liquid were derived. In the first equation, the piston was assumed coaxial in the cylinder and, in the second equation, the piston was assumed eccentric in the cylinder with an element of the piston in contact with the cylinder wall. The third equation is for a piston of circular cross section in an elliptical cylinder. Experiments showed that the piston is normally eccentric in the cylinder. The pistons tested were 1.25 and 2 inches in diameter, 0.062 to 1.00 inch long, and the clearances varied from 1.38 to 5.16×10^{-3} inch. The difference in pressure on the two sides of the piston varied from about 2 to 65 pounds per square inch. The piston velocities for each assembly were measured with damping liquids of three different viscosities.

At high piston velocities, when turbulent flow exists, the observed velocities were much lower than the velocities calculated on the basis of laminar flow. Results for a wide range of Reynolds numbers are presented in graphical form.

INTRODUCTION

The simple dashpot, which is a piston in a cylinder filled with liquid that must pass through the clearance when there is relative motion between the piston and the cylinder, has apparently been neglected in technical literature. Data on the damping coefficient in the common differential equation for damped vibrations of a system including a dashpot are singularly lacking. The need for these data, in order to design dashpots intelligently,

prompted the National Advisory Committee for Aeronautics to request an investigation and to furnish financial assistance to carry it out. The investigation was conducted at the National Bureau of Standards. The assistance of Mr. Starr Truscott in planning the investigation is acknowledged. Credit for the solution of case 3, a piston of circular cross section in an elliptical cylinder, is due to Dr. G. H. Keulegan.

THEORETICAL ANALYSIS

The general notation used in the analysis of the steady relative velocity of the piston and cylinder in terms of the clearance and other design constants is as follows:

R	one-half the sum of the radii of cylinder and piston
C	radial clearance between piston and cylinder wall
C_0	base clearance (fig. 1)
L	length of piston
V	velocity of cylinder relative to piston
V_0	observed velocity
V_c	calculated velocity
v'	velocity of fluid (relative to piston) at distance x from piston
v	average velocity of fluid (relative to piston)
P	difference in fluid pressure on two sides of piston
W_g	force exerted on piston
Q	volume flow per unit of circumference
F	total volume flow
μ	coefficient of absolute viscosity

In the theoretical treatment, it is assumed that the piston is held stationary and the cylinder is moving up. Thus, in figure 1 the velocity of the liquid is shown relative to the piston.

For steady motion

$$\frac{d^2 v'}{dx^2} = \frac{-P}{\mu L} = A \quad (1)$$

$$\frac{dv'}{dx} = A (x + B) \quad (2)$$

$$v' = A \left(\frac{x^2}{2} + Bx + D \right) \quad (3)$$

If $v' = 0$ when $x = 0$, $D = 0$

and if

$v' = V$ when $x = C$

$$V = A \left(\frac{C^2}{2} + BC \right) \quad (4)$$

$$B = \frac{V}{AC} - \frac{C}{2} \quad (5)$$

After substitution of this value in (3)

$$v' = \frac{Ax^2}{2} + \frac{Vx}{C} - \frac{ACx}{2} \quad (6)$$

The volume flow per unit circumference is

$$Q = \int_0^C v' dx \quad (7)$$

$$= \int_0^C \left(\frac{A}{2} x^2 dx + \frac{V}{C} x dx - \frac{A}{2} Cx dx \right) \quad (8)$$

$$= \frac{A}{2} \frac{C^3}{3} + \frac{VC}{2} - \frac{A}{2} \frac{C^3}{2} \quad (9)$$

$$= -\frac{AC^3}{12} + \frac{VC}{2} \quad (10)$$

and the average velocity across the clearance,

$$v = - \frac{AC^2}{12} + \frac{V}{2} \quad (11)$$

$$= \frac{PC^2}{12\mu L} + \frac{V}{2} \quad (12)$$

Solutions for the three cases shown in figure 2 will be given.

Case 1: A circular piston travels coaxially in a circular cylinder.

Case 2: A circular piston touches the wall of a circular cylinder, except for a thin film of liquid.

Case 3: A circular piston touches the wall of an elliptical cylinder at the point of intersection of the major axis, except for a thin film of liquid.

For case 1, since the average velocity of the liquid in the clearance times the area of the clearance equals the velocity of the piston times the cross-sectional area of the cylinder,

$$\frac{V}{v} = \frac{2\pi R C}{\pi R^2} = \frac{2C}{R} \quad (13)$$

From equations (12) and (13)

$$V = \frac{PC^3}{6R\mu L} + \frac{VC}{R} \quad (14)$$

where the uniform value of the clearance is designated C .

Now

$$P = \frac{W_g}{\pi R^2} \quad (15)$$

where W_g is the force exerted on the piston and πR^2 is the area of the piston. Substitute this value for P in equation (14),

$$V = \frac{W_g}{6\pi\mu L} \left(\frac{C}{R}\right)^3 \left(1 + \frac{C}{R}\right) \quad (16)$$

For most calculations the $\left(\frac{C}{R}\right)$ term may be omitted and there is obtained as the final equation for case 1

$$v = \frac{Wg}{6\pi\mu L} \left(\frac{C}{R}\right)^3 \quad (17)$$

For case 2, where the piston touches one side of the cylinder wall, the notation is given in figure 1(b). The base radial clearance C_0 is equal to the radius of the cylinder minus the radius of the piston. If the clearance is small in comparison to the cylinder radius, it can be shown that, approximately,

$$C = C_0 (1 + \cos \phi) \quad (18)$$

From equation (11), neglecting the second term and remembering that C in this equation is the actual clearance,

$$v = - \frac{AC^2}{12} \quad (19)$$

$$= - \frac{AC_0^2}{12} (1 + \cos \phi)^2 \quad (20)$$

The volume flow past the piston

$$F = \int_0^{2\pi} vCRd\phi \quad (21)$$

$$= - \frac{ARC_0^3}{12} \int_0^{2\pi} (1 + \cos \phi)^2 \quad (22)$$

$$= - \frac{ARC_0^3}{12} \int_0^{2\pi} (1 + 3 \cos \phi + 3 \cos^2 \phi + \cos^3 \phi) d\phi \quad (23)$$

$$= - \frac{5\pi ARC_0^3}{12} \quad (24)$$

If equation (24) is divided by $2\pi RC_0$ to get the average velocity, and for A is substituted the value given in equation (1)

$$v_0 = \frac{5AC_0^2}{24} = \frac{5PC_0^2}{24\mu L} \quad (25)$$

The equation for case 2 follows from equation (25) by treatment as in equations (13) to (17),

$$V = \frac{5Wg}{12\pi\mu L} \left(\frac{C_0}{R}\right)^3 \quad (26)$$

The equation for case 3 is

$$V = \frac{Wg}{12\pi\mu L} \left(\frac{C_1}{R}\right)^3 \left(5 + \frac{45k}{4C_1} + \frac{39k^2}{4C_1^2}\right) \quad (27)$$

In this equation, C_1 and k have the values specified in figure 2.

Because of its limited application in practice, the derivation of equation (27) is not given. One of the cylinders used in the tests was slightly elliptical in shape, and the theoretical velocities calculated by the equation for case 3 showed much better agreement with observed values than the theoretical velocities calculated by the equations for case 2.

The equations for these three cases have been developed on the assumption that there is no turbulence. An empirical equation for use in the turbulent range is given in the latter part of this report. (See equation (29).)

EXPERIMENTAL INVESTIGATION

The apparatus shown in figure 3 was used to determine experimentally the relation between applied force and velocity of the pistons. A downward force was applied to the piston by hanging weights at W . The weight of the frame, in the liquid, was measured by a spring balance.

Although a travel of 16 inches is possible, it was in

no case found advisable to time the piston for a distance greater than 6 inches. The center section of the cylinder was always timed. The piston was allowed to come to a constant speed before the timing interval started, so as to eliminate any inertia effects. Lower speeds were timed by a hand-operated stop watch; higher speeds were timed by a contact-operated electric clock.

In order to get consistent results the axes of the cylinder and the piston were kept parallel by adjusting the top of the cylinder, in two horizontal directions, by means of screws provided for the purpose. (See fig. 3.) The cylinder position was adjusted to obtain maximum velocity of the piston for a given load. It was found that one-quarter turn on one of these screws made an appreciable difference in the velocity, especially for the longer pistons.

CYLINDERS AND PISTONS

Hard-drawn brass tubing, purchased from the Chase Brass and Copper Company and selected for uniformity of inside diameter, was used for cylinders. Tubes of inside diameter $1\frac{1}{2}$, 2, and 3 inches were purchased, but no experiments were conducted on the 3-inch tubes because of excessive variation in the inside diameter.

Some of the pistons were constructed of cast iron and others of brass. The final finishing operation on the cast-iron pistons was performed on a cylindrical grinder. The nominal dimensions of the pistons and the radial clearances are given in table I.

MEASUREMENT OF CYLINDER AND PISTON DIAMETERS

A modification of the pneumatic method described in reference 1 was used to measure the inside diameters of the tubes. Figure 4(a) shows schematically the pneumatic head together with the pressure regulator P and a water manometer. The pressure regulator serves to maintain a constant pressure in chamber A. The volume of air passing from this chamber through the capillary restriction C is a function of the clearance between the nozzle N and the inside wall of the tube. Therefore the clearance is a function of the reading of the water manometer.

A ring micrometer was used as shown in figure 4(b) to calibrate this pneumatic-tube gage. A change in clearance of 0.001 inch caused a change in the differential pressure across the capillary restriction of approximately 5 inches of water.

This same tube gage was used as shown in figure 4(c) to measure the diameter of each piston. The clearance between the tube and the piston is then equal to the micrometer reading corresponding to the tube diameter minus the micrometer reading on the piston. A direct and accurate measurement of the clearance is believed to have been obtained by this method.

Although the diameter of each tube was measured along its entire length and on each of six diameters, these values are not included in this report, because only the 6-inch center section was used in the dashpot experiments. As shown in table I, the maximum variation in radial clearance caused by variation in tube diameter was $\pm 0.05 \times 10^{-3}$ inch for the 1.25-inch tube and $\pm 0.22 \times 10^{-3}$ inch for the 2.00-inch tube. This variation was caused almost entirely by the ellipticity of the cylinders; the taper was negligible in comparison. The clearance values of table I are arithmetical averages. It was found that taking the average values of C^3 gave velocities differing by not more than 2 percent from the velocities calculated on the basis of arithmetical averages.

DAMPING LIQUIDS

Four damping liquids were used. They were highly refined, water-white mineral oils known commercially as Vacuum oil, Bayol D, and two lots of Marcol. The kinematic viscosities of these liquids were measured in the viscosimeters described in reference 2. The densities were determined by the pycnometer method. The absolute viscosities and the densities at temperatures of 24° C and 27° C are given in table II. In the experiments, when the temperature varied slightly from these temperatures, viscosities and densities for the actual temperatures were linearly interpolated.

COAXIAL OR ECCENTRIC PISTON

At the start of the investigation it was assumed that the pistons would be slightly stable in the center of the cylinder, making the radial clearance uniform all around the circumference, provided that the cylinder was vertical and that all parts of the apparatus were properly aligned. All the experimental data, however, indicated that the pistons were traveling on the side of the cylinder. Theoretically, the piston velocity is 2.5 times greater in the eccentric position than in the coaxial position.

As an additional check, in order to determine whether the piston was coaxial or eccentric, the piston was adjusted for maximum velocity near the top of the cylinder and a horizontal side pull of 8 pounds was applied to the piston rod. This side pull flexed the rod so that the piston axis was no longer parallel to the cylinder axis, and the velocity decreased. After adjustment of the cylinder for parallelism with the piston, the rate was the same as without the side pull. This result indicates that the piston is normally eccentric in the cylinder. Otherwise a change from the coaxial to the eccentric position, caused by the side pull, would have increased the velocity.

RESULTS OF TESTS

The test results are all plotted in figure 5. The ratio of the observed velocity to the calculated velocity (case 2) is plotted against the logarithm of the dimensionless Reynolds number. The Reynolds number, designated N to avoid confusion with radius R , is given by

$$N = C_0 \frac{\rho}{\mu} v_0 = 4R \frac{\rho}{\mu} V_c$$

where

C_0 average radial clearance between piston
and cylinder

ρ density of liquid

μ absolute viscosity of liquid

- v_o average calculated velocity of liquid in clearance
- R one-half the sum of the radii of cylinder and piston
- V_c piston velocity, calculated for case 2
- and
- V_o observed piston velocity

At low Reynolds numbers, most of the observed velocities agree fairly well with the eccentric-piston theory (case 2). The largest discrepancies are encountered in the values for piston B. It appears here that the elliptical shape of the cylinder should be taken into consideration. For piston B, the average of the factors obtained by dividing each observed velocity by the corresponding velocity calculated by the equation for case 2 is 1.24. If the equation for case 3 is used in these calculations, this factor is reduced to 1.04. The effect of the elliptical cylinder will be much less for any other cylinder and piston combination.

The average of the individual curves of figure 5 is shown as a heavy dashed line. Several attempts to explain the rather large variations of the individual curves from the average curve were made without success. Several of the tests giving curves of most questionable shape (L1N, K1B, and K2B) were repeated four times; each time the tests gave practically the same result. These pistons were tested with sharp edges and with edges rounded to a radius of 0.005 inch. The results were practically the same. These repeat tests also indicated that the variation was not due to any chance adjustment or relative alignment of cylinder and piston.

The general equation for calculating the velocity of a piston, arrived at empirically from the test results, is

$$v = \frac{5W\xi}{12\pi\mu L} \left(\frac{C_o}{R}\right)^3 4R \left[\frac{\rho}{\mu} \frac{5W\xi}{12\pi\mu L} \left(\frac{C_o}{R}\right)^3 \right] \quad (29)$$

where the Reynolds number factor,

$$\phi \left[4R \frac{\rho}{\mu} \frac{5W\xi}{12\pi\mu L} \left(\frac{C_o}{R}\right)^3 \right] = \phi \left(4R \frac{\rho}{\mu} v_c \right) = \frac{v_o}{v_c}$$

is taken from the heavy dotted line of figure 5.

According to equation (29), the force necessary to cause a given velocity varies directly as the length of the piston and inversely as the cube of the radial clearance. The tests indicate that, except for errors of observation, these relations hold for both the laminar and the turbulent ranges, for any piston in the series tested. They would not hold for very thin pistons. In the laminar range the force, for a given velocity, varies directly as the cube of the radius of the piston. In the turbulent range this relation is more complicated.

DISCUSSION

The results presented in this report indicate that dashpots should be designed on the assumption that the piston will travel against the side wall of the cylinder rather than concentric with the cylinder.

In order to attain consistent damping, the dashpot should be designed so that the axis of the piston will remain parallel to the axis of the cylinder. This requirement can be attained by guiding a rigid piston rod or by the use of a double piston, as shown in figure 6.

It is believed that the best method for positively eliminating variation of the coefficient of a dashpot with temperature is to hold the dashpot at a constant temperature by means of a thermostatically controlled electrical heater.

A temperature-compensated dashpot with an aluminum alloy or bronze piston and a cast-iron cylinder appears to be theoretically feasible. The design has the advantage of simplicity. The disadvantage lies in the difficulty of adjusting the coefficient after the dashpot has been constructed. It will have been designed for a liquid of a specified viscosity and the substitution of a liquid of a different viscosity will upset the temperature compensation. Likewise, the use of an adjustable bypass valve is not practicable because the temperature compensation would be effective for only one setting of the bypass valve. One rather awkward method of controlling the damping coefficient would be to adjust the length of one or more lever arms between the mechanism and the dashpot. For some applications this method might be warranted.

The designer should remember that the percentage change in viscosity for a given change in temperature is usually less for low-viscosity liquids than for high-viscosity liquids.

National Bureau of Standards,
Washington, D. C., August 15, 1941.

REFERENCES

1. Houseman, M. R., and Keulegan, G. H.: Investigation of Damping Liquids for Aircraft Instruments - II. Rep. No. 398, NACA, 1931.
2. Wattebot, M. Louis: L'amplification pneumatique. Principe. Theorie. Mécanique, Bull. Société Française des Mécaniciens, vol. 21, no. 271, 1937, pp. 70-72.

TABLE I

Data on Pistons and Clearances

Piston	Material (C.I., cast iron; B, brass)	Nominal diameter (in.)	Length (in.)	Radial clearance (in.)	
				Average value	Maximum variation
B-4	C.I.	2	0.25	2.08×10^{-3}	$\pm 0.22 \times 10^{-3}$
B-8	C.I.	2	.50	2.04	$\pm .22$
B-16	C.I.	2	1.00	2.18	$\pm .22$
C-4	C.I.	2	.25	5.09	$\pm .22$
C-8	C.I.	2	.50	5.09	$\pm .22$
C-16	C.I.	2	1.00	5.16	$\pm .22$
K-1	B	1.25	.054	1.38	$\pm .05$
K-2	B	1.25	.116	1.38	$\pm .05$
K-4	C.I.	1.25	.25	1.38	$\pm .05$
K-8	C.I.	1.25	.50	1.38	$\pm .05$
K-16	C.I.	1.25	1.00	1.38	$\pm .05$
L-1	B	1.25	.057	4.33	$\pm .05$
L-2	B	1.25	.113	4.33	$\pm .05$
L-4	C.I.	1.25	.25	4.33	$\pm .05$
L-8	C.I.	1.25	.50	4.33	$\pm .05$
L-16	C.I.	1.25	1.00	4.33	$\pm .05$

TABLE II

VISCOSITIES AND DENSITIES
OF FOUR DAMPING LIQUIDS TESTED

(Poises can be converted to lb/sq in. by multiplying by 5.6×10^{-3} ; densities can be converted to lb/cu in. by multiplying by 0.03613)

Damping liquid		Viscosity (poise)		Density (gram/cc)	
Trade name	Designation in this paper	at 24° C	at 27° C	at 24° C	at 27° C
Vacuum oil	V	0.00830	0.00794	0.773	0.770
Bayol D	B	.0174	.0165	.784	.782
Marcol	M	.245	.215	.847	.841
Marcol	N	.215	.188	.836	.831

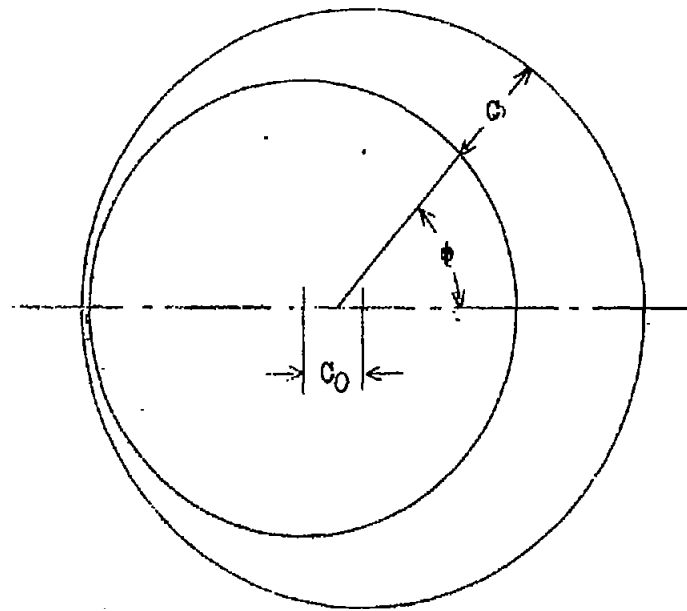
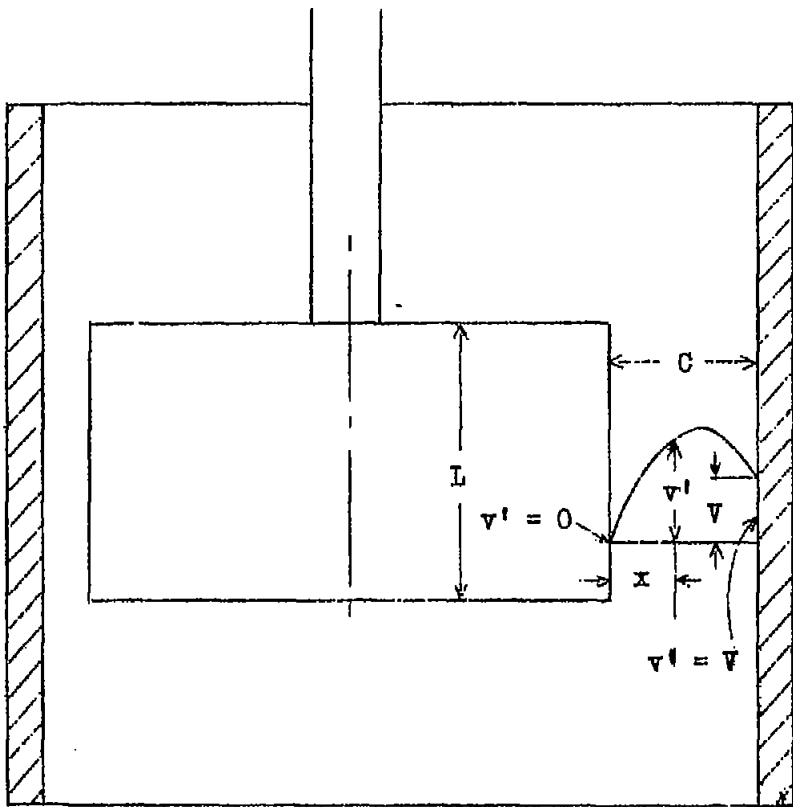
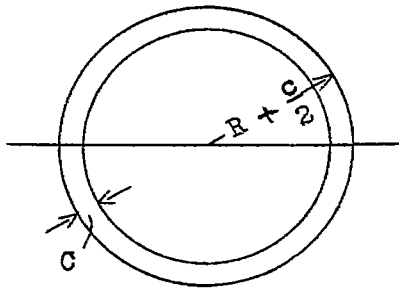
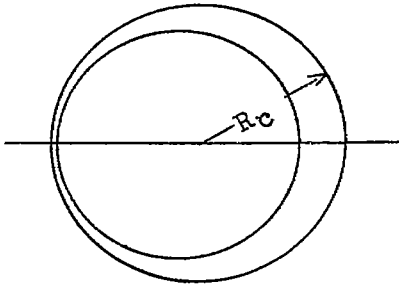

Figure 1.- Notation for piston and cylinder.



$$v = \frac{Wg}{8\pi\mu L} \left(\frac{c}{R}\right)^3$$

Case 1, Coaxial.



$$v = \frac{5Wg}{12\pi\mu L} \left(\frac{c_0}{R}\right)^3$$

Case 2, Eccentric.

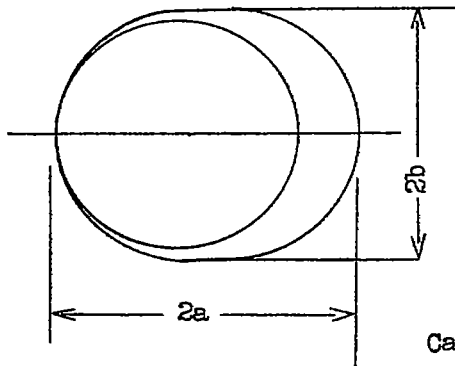

$$v = \frac{Wg}{12\pi\mu L} \left(\frac{c}{R}\right)^3 \left(5 + \frac{45k}{4C_1} + \frac{39k^2}{4C_1^2}\right)$$

$$k = a - b \quad C_1 = C_0 - \frac{a - b}{2}$$

Case 3, Elliptical cylinder.

Figure 2.- Summary of derived equations for calculating the velocity of pistons on the basis of laminar flow.

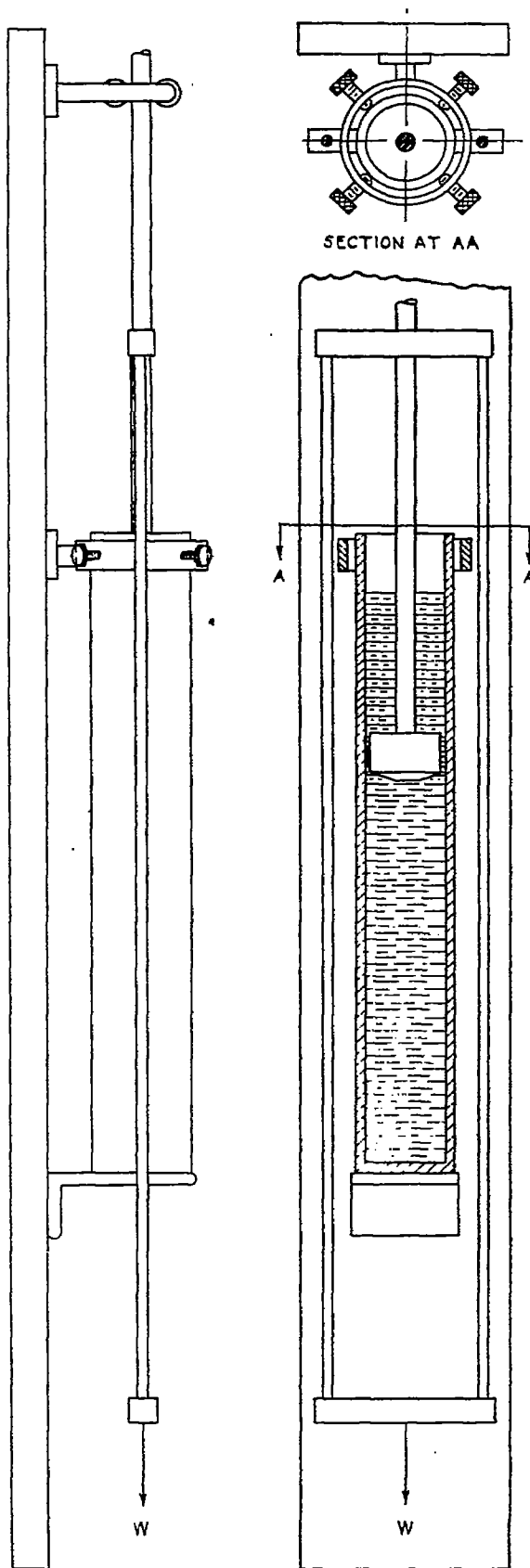

Figure 3.- Schematic diagram of an experimental dashpot.

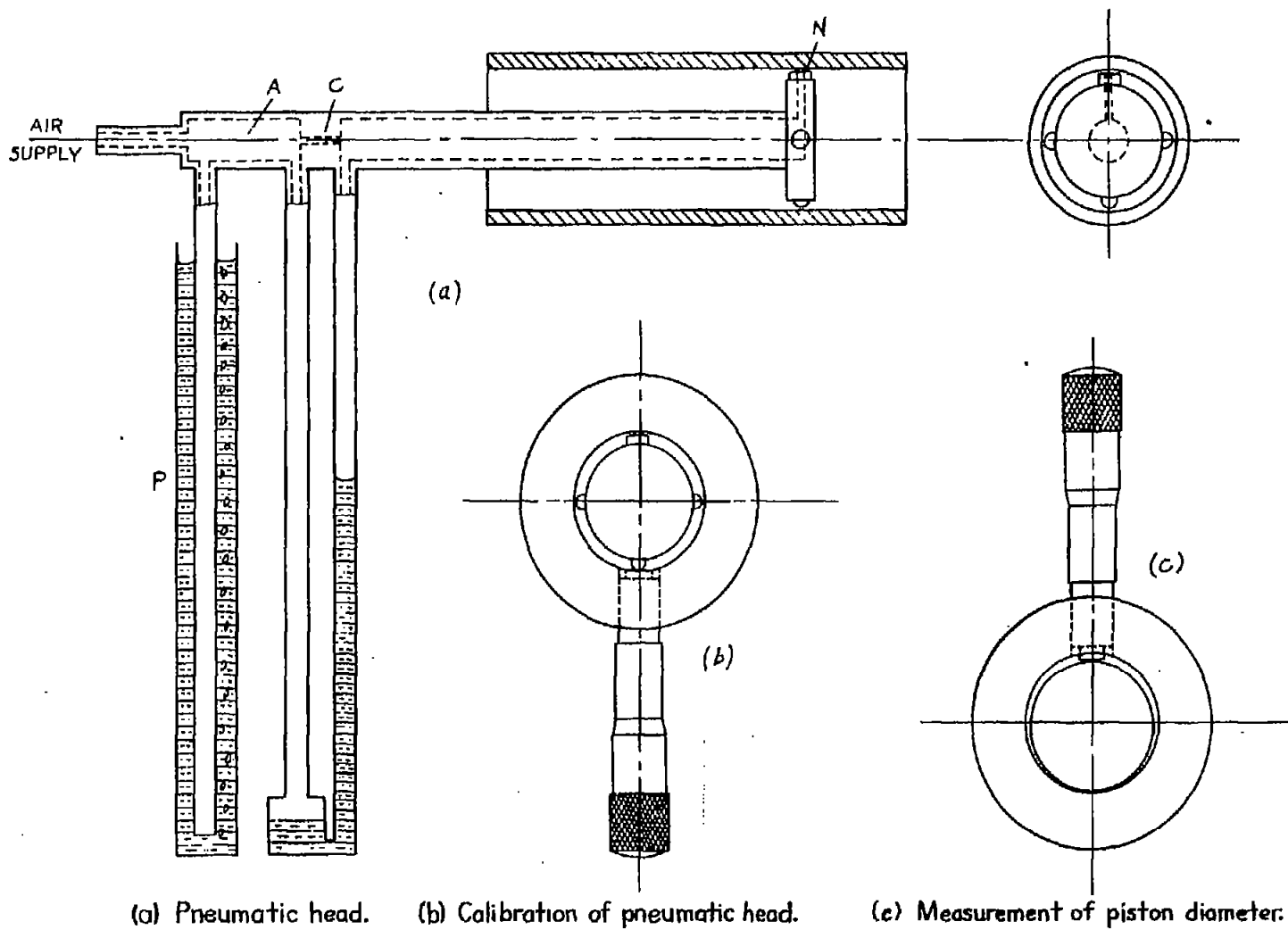
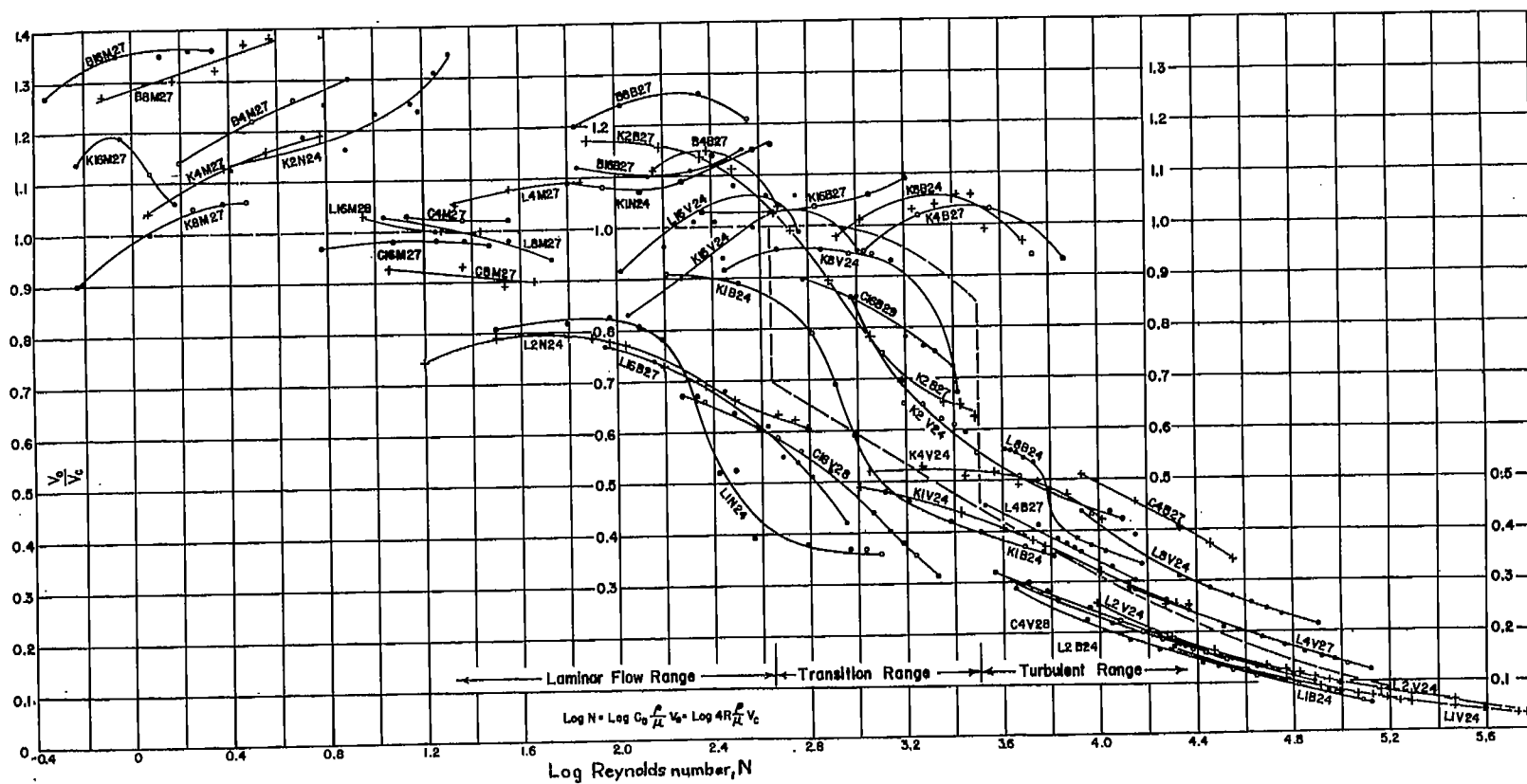

Figure 4.—Pneumatic gage for measurement of pistons and cylinders.



The first letter of the curve designation is the piston diameter: B and C, 2 inches; K and H, 1.25 inches; the first number, the length of the piston in sixteenths of an inch; the second letter, the liquid, (see table II); the second number, the temperature in °C.

Figure 5.-- Ratio of observed to calculated velocity to logarithm of the Reynolds number. (All logarithms are to the base 10.)

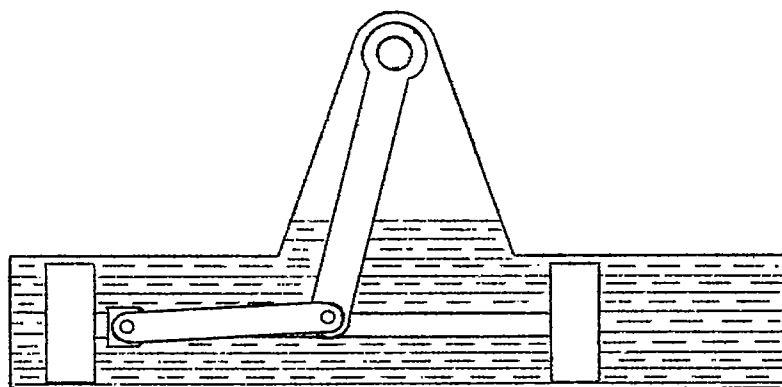

Figure 6.- Use of a double piston to assure parallelism of piston and cylinder.

TITLE: Damping Characteristics of Dashpots

AUTHOR(S): Peterson, John B.

ORIGINATING AGENCY: National Advisory Committee for Aeronautics, Washington, D. C.

PUBLISHED BY: (Same)

micro only DF 1 Aug 69
~~RESTRICTED~~

ATI- 8573

DIVISION (None)

ORIG. AGENCY NO.

TN-830

PUBLISHING AGENCY NO.

(Same)

DATE	DOC. CLASS.	COUNTRY	LANGUAGE	PAGES	ILLUSTRATIONS
Oct '41	Restr.	U.S.	Eng.	19	tables, diagrs, graph, drwgs (OVER)

ABSTRACT:

Laminar flow was assumed and three equations for the steady velocity of a piston moving in a cylinder filled with liquid were derived. Pistons tested were 1.25 and 2 in. in diameter; 0.062 to 1.00 in. long, and the clearances varied from 1.38 to 5.16×10^{-4} in. Difference in pressure varied from about 2 to 65 lb per square in. At high piston velocities when turbulent flow exists, the observed velocities were much lower than calculated on laminar flow. Results for a wide range of Reynolds numbers are presented in graphical form.

Proll Dash pots

DISTRIBUTION: Request copies of this report only from Originating Agency

240 400

DIVISION: Hydraulic & Pneumatic Equipment
SECTION: Components and Accessories (7) (20)

SUBJECT HEADINGS: Dashpots (28770)

ATI CREST NO. D-20 7 1

AD-B805 407

CAL INDEX

Wright-Patterson Air Force Base
Dayton, Ohio

CLASSIFICATION CHANGED

TO UNCLASSIFIED

AUTH *List-NACA-etc 28 Sept 1945*

BY *George R. Jordan*, USCO

DATE *29 APRIL 49*

RESTRICTED

TITLE: Damping Characteristics of Dashpots

ATI- 8573

AUTHOR(S): Peterson, John B.

DIVISION:

(None)

ORIGINATING AGENCY: National Advisory Committee for Aeronautics, Washington, D. C.

ORIG. AGENCY NO.

TN-830

PUBLISHED BY: (Same)

PUBLISHING AGENCY NO.

(Same)

DATE	SEC. CLASS.	COUNTRY	LANGUAGE	PAGES	ILLUSTRATIONS
Oct '41	Restr.	U.S.	Eng.	19	tables, diagrs, graph, drugs

ABSTRACT:

Laminar flow was assumed and three equations for the steady velocity of a piston moving in a cylinder filled with liquid were derived. Pistons tested were 1.25 and 2 in. in diameter; 0.082 to 1.00 in. long, and the clearances varied from 1.38 to 5.16×10^{-4} in. Difference in pressure varied from about 2 to 65 lb per square in. At high piston velocities when turbulent flow exists, the observed velocities were much lower than calculated on laminar flow. Results for a wide range of Reynolds numbers are presented in graphical form.

DISTRIBUTION: Request copies of this report only from Originating Agency

DIVISION: Hydraulic & Pneumatic Equipment
SECTION: Components and Accessories (7) (20)

SUBJECT HEADINGS: Dashpots (28770)

ATI SHEET NO.: R-20-7-1