

UNCLASSIFIED

AD NUMBER

ADB010926

LIMITATION CHANGES

TO:

Approved for public release; distribution is unlimited.

FROM:

Distribution authorized to U.S. Gov't. agencies only; Test and Evaluation; APR 1976. Other requests shall be referred to Rome Air Development Center, Attn: OCDR, Griffiss Air Force Base, NY 13441.

AUTHORITY

RADC ltr, 23 Oct 1978

THIS PAGE IS UNCLASSIFIED

THIS REPORT HAS BEEN DELIMITED  
AND CLEARED FOR PUBLIC RELEASE  
UNDER DOD DIRECTIVE 5200.20 AND  
NO RESTRICTIONS ARE IMPOSED UPON  
ITS USE AND DISCLOSURE.

DISTRIBUTION STATEMENT A

APPROVED FOR PUBLIC RELEASE;  
DISTRIBUTION UNLIMITED.

✓

✓ (2)

RADC-TR-75-320, Volume II  
In-House Report  
April 1976



AD B 010926

PROJECT SEEK SCREEN  
Tactical Air Control System

Joseph T. Massoud

Distribution limited to U.S. Gov't agencies only;  
test and evaluation; April 1976. Other requests  
for this document must be referred to RADC (OCDR),  
Griffiss AFB, NY 13441.

AD NO. \_\_\_\_\_  
DDC FILE COPY

DDC  
RECEIVED  
MAY 13 1976  
REGULATED

Rome Air Development Center  
Air Force Systems Command  
Griffiss Air Force Base, New York 13441

✓ JTB B

This report has been reviewed and is approved for publication.

APPROVED: *Thomas Maggic*

THOMAS MAGGIC, Chief  
Surveillance Equipment Development Branch  
Surveillance Division

APPROVED: *Moses A. Diab*

MOSES A. DIAB, Chief  
Space Surveillance and Instrumentation Branch/OC  
Surveillance Division

FOR THE COMMANDER:

*John P. Huss*

JOHN P. HUSS  
Acting Chief, Plans Office

|                                 |  |
|---------------------------------|--|
| ACCESSION for                   |  |
| NTIS                            | White Section <input type="checkbox"/>           |
| DOC                             | Bull Section <input checked="" type="checkbox"/> |
| UNANNOUNCED                     | <input type="checkbox"/>                         |
| JUSTIFICATION.....              |  |
| BY.....                         |  |
| DISTRIBUTION/AVAILABILITY CODES |  |
| Dist.                           | AVAIL. and/or SPECIAL                            |
| B                               |  |

Do not return this copy.  
Retain or destroy.

*MISSION  
of  
Rome Air Development Center*

RADC is the principal AFSC organization charged with planning and executing the USAF exploratory and advanced development programs for information sciences, intelligence, command, control and communications technology, products and services oriented to the needs of the USAF. Primary RADC mission areas are communications, electromagnetic guidance and control, surveillance of ground and aerospace objects, intelligence data collection and handling, information system technology, and electronic reliability, maintainability and compatibility. RADC has mission responsibility as assigned by AFSC for demonstration and acquisition of selected subsystems and systems in the intelligence, mapping, charting, command, control and communications areas.



UNCLASSIFIED

SECURITY CLASSIFICATION OF THIS PAGE (When Data Entered)

| REPORT DOCUMENTATION PAGE   |                           | READ INSTRUCTIONS<br>BEFORE COMPLETING FORM  |
|---|---------------------------|--|
| 1. REPORT NUMBER<br>RADC-TR-75-320 - Vol <del>1</del> - 2   | 2. GOVT ACCESSION NO. (9) | 3. REPORT'S CATALOG NUMBER<br>Repl. for  |
| 4. TITLE (and Subtitle)<br>PROJECT SEEK SCREEN, Volume II,<br>Tactical Air Control System   |                           | 5. TYPE OF REPORT & PERIOD COVERED<br>In-House Report<br>January <del>1975</del> - July 75                       |
| 6. AUTHOR(S)<br>Joseph T. Massoud   |                           | 7. PERFORMING ORG. REPORT NUMBER<br>N/A  |
|   |                           | 8. CONTRACT OR GRANT NUMBER(s)<br>N/A  |
| 9. PERFORMING ORGANIZATION NAME AND ADDRESS<br>Rome Air Development Center (OCDR)<br>Griffiss Air Force Base, New York 13441  |                           | 10. PROGRAM ELEMENT, PROJECT, TASK<br>AREA & WORK UNIT NUMBERS<br>Program Element 921A<br>Job Order No. R2126101 |
| 11. CONTROLLING OFFICE NAME AND ADDRESS<br>Rome Air Development Center (OCDR)<br>Griffiss Air Force Base, New York 13441  | (11)                      | 12. REPORT DATE<br>Apr 1976 (12/68p)   |
|   |                           | 13. NUMBER OF PAGES<br>60  |
| 14. MONITORING AGENCY NAME & ADDRESS (if different from Controlling Office)<br>Same   |                           | 15. SECURITY CLASS. (of this report)<br>UNCLASSIFIED   |
|   |                           | 15a. DECLASSIFICATION/DOWNGRADING<br>SCHEDULE<br>N/A   |
| 16. DISTRIBUTION STATEMENT (of this Report)<br>Distribution limited to U.S. Gov't agencies only; test and evaluation;<br>April 1976. Other requests for this document must be referred to<br>RADC (OCDR), Griffiss AFB, NY 13441.   |                           |  |
| 17. DISTRIBUTION STATEMENT (of the abstract entered in Block 20, if different from Report)<br>Same  |                           |  |
| 18. SUPPLEMENTARY NOTES<br>This is Volume II of eight volumes.  |                           |  |
| 19. KEY WORDS (Continue on reverse side if necessary and identify by block number)<br>Tactical Air Control System (TACS)<br>407L<br>485L  |                           |  |
| 20. ABSTRACT (Continue on reverse side if necessary and identify by block number)<br>The mission of the Tactical Air Force component of the Joint Task Force<br>(JTF) is to plan, direct, control and coordinate the resources assigned or<br>attached for the conduct of Tactical Air Operations. These operations<br>include:<br>Close Air Support<br>Air Interdiction<br>Counter Air (Offensive and Defensive) |                           |  |

309050 ✓

Handwritten mark

UNCLASSIFIED

SECURITY CLASSIFICATION OF THIS PAGE(When Data Entered)

20. Abstract (Cont'd)

→ Air Reconnaissance  
Tactical Airlift  
Air Refueling  
Air Rescue  
Special Operations

The Tactical Air Force Component Commander is assisted in the accomplishment of these missions by the Tactical Air Control System (TACS). The TACS development program is an evolutionary effort. The initial system development was performed under the 407L TACS program. The 407L TACS then formed the baseline system for the 485L TACS improvement effort. The Tactical Air Control System is that system comprised of facilities, personnel, procedures and equipment through which the Tactical Air Force (TAF) Component Commander plans, directs, controls and coordinates the resources assigned or attached to him for the conduct of Tactical Air Command's Contingency Operations on a world-wide basis and in a wide range of operational and environmental situations. The TACS must be capable of unilateral, joint or combined air/ground operations; must be modular and deployable; must provide support to all levels of conflict; and must provide centralized control for decentralized execution. In this context, the TACS will interface with a broad range of Tactical Air Force units and tactically deployed elements of the Army, Navy, and Marines.

→ The TACS is composed of four basic subsystems. Aircraft Control and Warning Subsystem (AC&W); Tactical Air Support Subsystem (TAS); Air Traffic Control Subsystem (ATC); Command Communications Subsystem. These four subsystems and their respective functional elements are discussed in this report.

and

UNCLASSIFIED

SECURITY CLASSIFICATION OF THIS PAGE(When Data Entered)

## TABLE OF CONTENTS

| Contents   | Page |
|--|------|
| Introduction   | 1    |
| System Descriptions  | 1    |
| 1. Subsystem and Elements  | 1    |
| 2. Communications Links  | 3    |
| 3. Deployment Configurations   | 3    |
| Element/Equipment Descriptions   | 3    |
| 1. Air Force Component Headquarters TAC Central Center Element (AFCH/TACC)                 | 3    |
| 2. Control Reporting Center/Air Traffic Regulation Center Element (CRC/ATRC)               | 15   |
| 3. Control and Reporting Post Element (CRP)  | 27   |
| 4. Forward Air Control Post Element (FACP)   | 30   |
| 5. Direct Air Support Center Element (DASC)  | 39   |
| 6. Tactical Air Control Party Element (TACP)   | 45   |
| 7. Tactical Air Base Communications/Terminal Air Traffic Control Facility (TAB/Comm/TATCF) | 46   |
| 8. Support Equipment   | 50   |
| 9. Other TACS Facilities   | 50   |
| 10. 485L Tactical Air Control Systems (TACSI) Descriptions                                 | 52   |
| 11. TACS Improvements  | 53   |



## LIST OF ILLUSTRATIONS

| Figure |  | Page |
|--------|--|------|
| 1.     | 407L Tactical Air Control System   | 2    |
| 2.     | AFCH/TACC Typical Field Deployment   | 8    |
| 3.     | AFCH/TACC Block Diagram (Typical)  | 8    |
| 4.     | TACC/CRC/CRP Operations Center - Assembly Sequence                                   | 9    |
| 5a.    | TACC (Minimum) Operations Center   | 11   |
| 5b.    | TACC (Minimum) Operations Center - Current Operations and Current Plans              | 11   |
| 6.     | TACC Operations Center - Field Deployed  | 14   |
| 7a.    | TACC (Maximum) Operations Center - Current Operations                                | 14   |
| 7b.    | TACC (Maximum) Operations Center - Current Plans                                     | 14   |
| 8.     | CRC/ATRC Typical Field Deployment  | 17   |
| 9.     | CRC/ATRC Block Diagram (Typical)   | 17   |
| 10.    | CRC/CRP Two-Cell Inflated Shelter (including Group Display and Console Modules Only) | 18   |
| 11a.   | CRC/CRP (Medium) Operations Center   | 19   |
| 11b.   | CRC/CRP (Medium) Operations Center - Interior  | 19   |
| 11c.   | Radar Set AN/TPS-43  | 23   |
| 12.    | CRP Typical Field Deployment   | 29   |
| 13.    | CRP Block Diagram (Typical)  | 29   |
| 14.    | FACP Typical Field Deployment  | 31   |
| 15.    | FACP Block Diagram (Typical)   | 32   |
| 15a.   | Radar Set AN/TPS-44  | 32   |
| 16.    | DASC Typical Field Deployment  | 41   |
| 17.    | DASC Block Diagram (Typical)   | 41   |
| 18.    | DASC Operations Center - Assembly Sequence   | 42   |
| 19.    | DASC (Alternate) One-Cell Module Operations Shelter                                  | 42   |
| 20.    | DASC (Alternate) Operations Center Internal Layout                                   | 43   |

**LIST OF ILLUSTRATIONS**  
(continued)

| <b>Figure</b> |  | <b>Page</b> |
|---------------|--|-------------|
| 21a.          | DASC (Minimum) Operations Center                   | 43          |
| 21b.          | DASC (Minimum) Operations Center - Mudle Expansion | 44          |
| 22.           | TACP Typical Field Deployment                      | 46          |
| 23.           | TACP Block Diagram (Typical)                       | 46          |
| 24.           | TAB Comm/TATCF Typical Field Deployment            | 47          |
| 25.           | TAB Comm/TATCF Block Diagram (Typical)             | 49          |
| 26.           | SEEK FLEX I/II                                     | 55          |
| 27.           | AFCH/TACC Typical Field Deployment                 | 57          |
| 28.           | CRC - Typical Field Deployment                     | 57          |
| 29.           | CRP Typical Field Deployment                       | 58          |
| 30.           | DASC Typical Field Deployment                      | 58          |
| 31.           | TAB Comm/TATCF Typical Field Deployment            | 59          |
| 32.           | FACP Tactical Field Deployment                     | 59          |

## TACTICAL AIR CONTROL SYSTEM

### INTRODUCTION

The mission of the Tactical Air Force Component of the Joint Task Force (JTF) is to plan, direct, control and coordinate the resources assigned or attached for the conduct of Tactical Air Operations. These operations include:

- Close air support
- Air interdiction
- Counter air (offensive and defensive)
- Air reconnaissance
- Tactical air lift
- Air refueling
- Air rescue
- Special operations

The Tactical Air Force Component Commander is assisted in the accomplishment of these missions by the Tactical Air Control System (TACS). The TACS development program is an evolutionary effort. The initial system development was performed under the 407L TACS program. The 407L TACS then formed the baseline system for the 485L TACS improvement effort. The current TACS will be discussed in the sections to follow.

### SYSTEM DESCRIPTION

#### 1. Subsystems and Elements

The TACS is the system comprised of facilities, personnel, procedures and equipment through which the Tactical Air Force (TAF) Component Commander plans, directs, controls and coordinates the resources assigned or attached to him to conduct Tactical Air Operations with ground and naval forces. TACS is to be deployed by each USAF Tactical Command, i.e., TAC, USAFE, PACAF, and will be utilized in the manner of the Tactical Air Command's Contingency Plan.

To provide the required support and direction to these operations on a worldwide basis and in a wide range of operational and environmental situations, the TACS must be capable of unilateral, joint or combined air/ground operations; must be modular and deployable; must provide support to all levels of conflict; and must provide centralized control for decentralized execution. In this context, the TACS will interface with a broad range of Tactical Air Force units and tactically deployed elements of the ARMY, NAVY, and Marines.

The TACS is composed of four basic subsystems. The four subsystems and their respective functional elements (Fig. 1) are discussed in this section.

##### a. Aircraft Control and Warning Subsystem (AC&W)

The AC&W subsystem performs planning and coordination of the air effort, coordinates surveillance (detection and tracking), displays and disseminates air intelligence information, and controls tactical aircraft missions. The elements which comprise this subsystem are the Air Force Component Headquarters/Tactical Air Control Center (AFCH/TACC), Control and Reporting Centers (CRC), Control and Reporting Posts (CRP), and the Forward Air Control Posts (FACP). These elements are discussed in Section 3.



## 2. Communications Links

All elements of the TACS include HF/SSB links for ground-to-ground communications. For maximum flexibility, reliability, and capacity, these links are supplemented (as soon as base establishment is complete) with direct microwave or troposcatter communication links between most of the elements. Thereafter, the HF links are used for backup communications and, in addition, to expand networks that will be established between the TACC, CRC, CRP, DASC, and the air bases for scramble information exchange, air traffic control, and air support. Likewise, the elements possess ground-to-air capabilities (UHF and VHF) as an integral part of the respective networks.

## 3. Deployment Configurations

The deployment configurations of the TACS equipments are a function of the tactical capacity required by the Tactical Air Force Component Commander in his support of deployed tactical forces and the Army tactical field missions. The three main configurations are minimum, medium, and maximum. These nominally support an Army Division, Corps, and Field Army, respectively.

Each of the configurations employs different combinations of elements and, within each element, different mixes of equipments. Tables 1, 2, and 3 depict the equipments utilized for the respective element/location configuration. It should be noted that the equipment quantities defined are nominal and merely represent a typical tactical situation. In an actual operational environment, elements could be added, deleted, or utilized in another level configuration. Likewise, the quantities of equipments assigned to the elements could vary, thereby providing flexibility to the element functional capacity.

At the conclusion of the text will be found a "Ready-Reference" of Operations Center Module Configuration Quantities and a standard military listing of "Joint Electronic Type Designation System."

## ELEMENT/EQUIPMENT DESCRIPTIONS

### 1. Air Force Component Headquarters/Tactical Air Control Center Element (AFCH/TACC)

#### a. General

The AFCH is the headquarters facility for the Air Force component of a joint command and is the operating location where general planning, command, administrative, and logistics supervision operations are conducted. It includes the command section and key staff agencies representing operations, intelligence, logistics, communications, weather, and field support activities.

The TACC shelter complex is the operations center of the AFCH and the focal point for all air activity within the TACS.

The TACC plans and coordinates the employment of tactical air effort and air control functions in the area of operations. It is composed of two distinct and separate agencies: (1) Combat Operations Weapons Employment, normally referred to as Current Operations, and (2) Combat Operations Plans, normally referred to as Current Plans. The TACC will

- Provide centralized control of the Air Force effort.
- Recommend allocation of air effort for close air support, tactical reconnaissance, and

air defense.

- Allocate sorties to the Direct Air Support Center (DASC) to satisfy Army requirements for immediate close air support.
- Plan and commit aircraft for preplanned close air support and reconnaissance missions based on Army requirements.
- Plan counter-air, air interdiction, airlift, and air rescue operations.
- Plan tactical air reconnaissance operations.
- Exercise operational control of all elements of the Tactical Air Control System.

#### **b. Configuration Concepts**

The TACC is designed with sufficient flexibility and modularity to operate in conjunction with the highest ground force field command responsible for planning and directing daily combat operations. Normally, this may be expected to range from division (and smaller size forces) up to a field army.

The functions of the TACC at any of the force levels are essentially the same; however, the scope and volume of required activities vary to a considerable extent. In a situation where enemy air is a major concern or in which the military/political objectives are attainable through decisive or predominate air actions alone, the TACC functional requirements are much more extensive. Thus, the TACC deployment configuration must be compatible to plan and direct the entire spectrum of offensive and defensive air operations. This represents a necessary variable to associate the TACC position configuration to "force level" alone, i.e., minimum, medium, or maximum.

#### **c. Functional Configuration**

A typical field deployment is shown in Figure 2, typical block diagram in Figure 3.

#### **d. AFCH/TACC Equipment Description**

##### **(1) TACC Operations Center (TSQ-92)**

**Mission.** The Operations Center shall provide the facilities to perform the Current Operations and Current Plans functions of the AFCH/TACC. The center shall contain desk positions, manually posted displays, and communications equipment necessary to support operators in the accomplishment of the tactical air central mission.

**Configuration.** The Operations Center has the option of deploying in incremental modules (inflatable shelters, i.e., a one-cell assembly sequence is shown in Figure 4) ranging from a minimum to a maximum configuration. The number and types of modules for each deployment configuration are listed in Table 4. A typical Operations Center (plan view and internal layout) is shown in Figures 5a and 5b. A field layout of a typical TACC Operations Center (medium and maximum configurations) is shown in Figures 6, 7a, and 7b.

**Table 1. Minimum Configuration\***

| Equipment                           | Element                 |                        |                 |                         |                 |                            |
|-------------------------------------|-------------------------|------------------------|-----------------|-------------------------|-----------------|----------------------------|
|                                     | TACC<br>(Min)<br>1-Site | CRC<br>(Min)<br>1-Site | FACP<br>2-Sites | DASC<br>(Min)<br>1-Site | TACP<br>N-Sites | TAB Comm**<br>(Partial)*** |
| TSQ-92                              | X                       |                        |                 |                         |                 |                            |
| TSQ-91                              |                         | X                      |                 |                         |                 |                            |
| 3-D Radar                           |                         | X                      |                 |                         |                 | X                          |
| Communications Central              | X                       |                        |                 |                         |                 |                            |
| Communications Center Teletype (I)  | X                       |                        |                 |                         |                 | X                          |
| Communications Center Teletype (II) | X                       | X                      |                 |                         |                 | X                          |
| Electronic Telephone Central Office | X                       | X                      |                 |                         |                 | X                          |
| Communications Central              | X                       |                        |                 |                         |                 |                            |
| FACP Operations Center              |                         |                        | X               |                         |                 |                            |
| 2-D Radar                           |                         |                        | X               |                         |                 |                            |
| Communications Central              |                         |                        | X               |                         |                 |                            |
| UHF G/A Radio                       | X                       | X                      | X               |                         |                 | X(2)                       |
| Troposcatter Radio                  | X(3)***                 | X(5)                   |                 | X(2)                    |                 |                            |
| HF/SSB Radio (1 KW)                 | X                       | X(3)                   |                 | X                       |                 | X                          |
| HF/SSB Radio (2.5 KW)               | X                       |                        |                 |                         |                 | X( )                       |
| HF/SSB Radio (10 KW)                | X                       |                        |                 |                         |                 | X( )                       |
| Mobile Communications Central       | X                       |                        |                 |                         |                 | X( )                       |
| Manpack Radio                       |                         |                        |                 |                         |                 | X( )                       |
| Manpack Radio                       |                         |                        |                 |                         |                 | X( )                       |
| DASC Operations Center (Min)        |                         |                        |                 | X                       |                 |                            |
| Landing Control Center              |                         |                        |                 |                         |                 | X                          |
| Control Tower                       |                         |                        |                 |                         |                 | X                          |

\*See Section 2.3.

\*\*This is additional equipment provided to an existing airbase (civil or otherwise) which has its own control tower and runway landing system. The TSW-7 is optional, depending upon "bare bones" requirements.

\*\*\*Depicts nominal quantities per element or site — see Section 2.3.

Communications Center Teletype (I)

**Table 2. Medium Configuration\***

| Equipment   | Element                 |                        |                         |                 |                         |                 |                            |
|-------------|-------------------------|------------------------|-------------------------|-----------------|-------------------------|-----------------|----------------------------|
|             | TACC<br>(Med)<br>1-Site | CRC<br>(Med)<br>1-Site | CRP<br>(Min)<br>2-Sites | FACP<br>4-Sites | DASC<br>(Med)<br>1-Site | TACP<br>N-Sites | TAB Comm**<br>(Partial)*** |
| TSQ-92      | X                       |                        |                         |                 |                         |                 |                            |
| TSQ-91      |                         | X                      | X                       |                 |                         |                 |                            |
| TSQ-91      |                         |                        | X                       |                 |                         |                 |                            |
| TPS-43      |                         |                        |                         |                 |                         |                 | X                          |
| TGC-26      | X                       |                        |                         |                 |                         |                 |                            |
| TGC-27      | X(2)**                  |                        |                         |                 |                         |                 |                            |
| TGC-28      |                         | X                      | X                       |                 |                         |                 | X                          |
| TTC-30      | X                       | X                      | X                       |                 |                         |                 | X                          |
| TSC-62      | X                       | X                      | X                       |                 |                         |                 | X                          |
| TSQ-61      |                         |                        |                         | X               |                         |                 |                            |
| TPS-44      |                         |                        |                         | X               |                         |                 |                            |
| TSC-53      |                         |                        |                         | X               |                         |                 |                            |
| TRC-87      |                         |                        |                         |                 |                         |                 |                            |
| TRC-97A     | X                       | X(2)                   | X                       | X               | X(2)                    |                 | X                          |
| TSC-60      | X(3)                    | X(6)                   | X(4)                    |                 | X                       |                 | ****                       |
| TSC-60A     | X                       | X(3)                   | X(2)                    |                 |                         |                 | X(3)                       |
| TSC-60B     | X                       |                        |                         |                 |                         |                 |                            |
| MRC-107/108 |                         |                        |                         |                 |                         | X( )            | X( )                       |
| PRC-41/66   |                         |                        |                         |                 |                         | X( )            | X( )                       |
| PRC-47/74   |                         |                        |                         |                 |                         | X( )            | X( )                       |
| TSQ-93      |                         |                        |                         |                 | X                       |                 |                            |
| TPN-19      |                         |                        |                         |                 |                         |                 | X                          |
| TSW-7       |                         |                        |                         |                 |                         |                 | X                          |

\*See Section 2.3.

\*\*This is additional equipment provided to an existent (civilian or otherwise) air base which has its own control tower and runway landing system. The TSW-7 is optional, depending upon "bare bones" requirements.

\*\*\*Depicts nominal quantities per element or site.

\*\*\*\*1-Site (2) TRC-97-A, 1-Site (3) TRC-97A.

TGC-26



**Table 3. Maximum Configuration\***

| Equipment   | Element           |                  |                  |                  |                  |              |                   |              |                   |                    |                    |
|-------------|-------------------|------------------|------------------|------------------|------------------|--------------|-------------------|--------------|-------------------|--------------------|--------------------|
|             | TACC (Max) 1-Site | CRC (Max) 1-Site | CRC (Med) 1-Site | CRP (Med) 1-Site | CRP (Min) 1-Site | FACP 6-Sites | DASC (Max) 1-Site | TACP N-Sites | TAB Comm** 1-Site | TAB Comm** 2-Sites | TAB Comm** 2-Sites |
| TSQ-92      | X                 |                  |                  |                  |                  |              |                   |              |                   |                    |                    |
| TSQ-91      |                   | X                |                  |                  |                  |              |                   |              |                   |                    |                    |
| TSQ-91      |                   |                  | X                |                  | X                |              |                   |              |                   |                    |                    |
| TSQ-91      |                   |                  |                  | X                |                  |              |                   |              |                   |                    |                    |
| TPS-43      |                   |                  | X                |                  | X                |              |                   |              |                   |                    | X                  |
| TGC-26      |                   |                  |                  |                  |                  |              |                   |              |                   |                    |                    |
| TGC-27      | X(2)***           |                  |                  |                  |                  |              |                   |              |                   |                    | X                  |
| TGC-28      |                   | X                | X                | X                | X                |              |                   |              |                   |                    | X                  |
| TTC-30      | X                 | X                | X                | X                | X                |              |                   |              |                   |                    | X                  |
| TSC-62      | X                 | X                | X                | X                | X                |              |                   |              |                   |                    | X                  |
| TSQ-61      |                   |                  |                  |                  |                  | X            |                   |              |                   |                    |                    |
| TPS-44      |                   |                  |                  |                  |                  | X            |                   |              |                   |                    |                    |
| TSC-53      |                   |                  |                  |                  |                  | X            |                   |              |                   |                    |                    |
| TRC-87      |                   |                  |                  |                  |                  |              |                   |              |                   |                    |                    |
| TRC-97A     | X(2)              | X(3)             | X(3)             | X(3)             | X(2)             | X            | X(2)              |              |                   |                    | X(2)               |
| TSC-60      | X                 | X(3)             | X(2)             | X(5)             | X(5)             |              | X                 |              |                   |                    |                    |
| TSC-60A     | X                 | X(4)             | X                | X(3)             | X(3)             |              |                   |              |                   |                    | X(3)               |
| TSC-60B     | X                 |                  |                  |                  |                  |              |                   |              |                   |                    |                    |
| MRC-107/108 |                   |                  |                  |                  |                  |              |                   |              | X( )              | X( )               | X( )               |
| PRC-41/66   |                   |                  |                  |                  |                  |              |                   |              | X( )              | X( )               | X( )               |
| PRC-47/74   |                   |                  |                  |                  |                  |              |                   |              | X( )              | X( )               | X( )               |
| TSQ-93      |                   |                  |                  |                  |                  |              | X                 |              |                   |                    |                    |
| TPN-19      |                   |                  |                  |                  |                  |              |                   |              |                   |                    | X                  |
| TSW-7       |                   |                  |                  |                  |                  |              |                   |              |                   |                    | X                  |

\*See Section 2.3.  
 \*\*This is additional equipment provided to an existent (civilian or otherwise) air base which has its own control tower and runway landing system. The TSW-7 is optional, depending upon "bare bones" requirements.  
 \*\*\*Depicts nominal quantities per element or site.

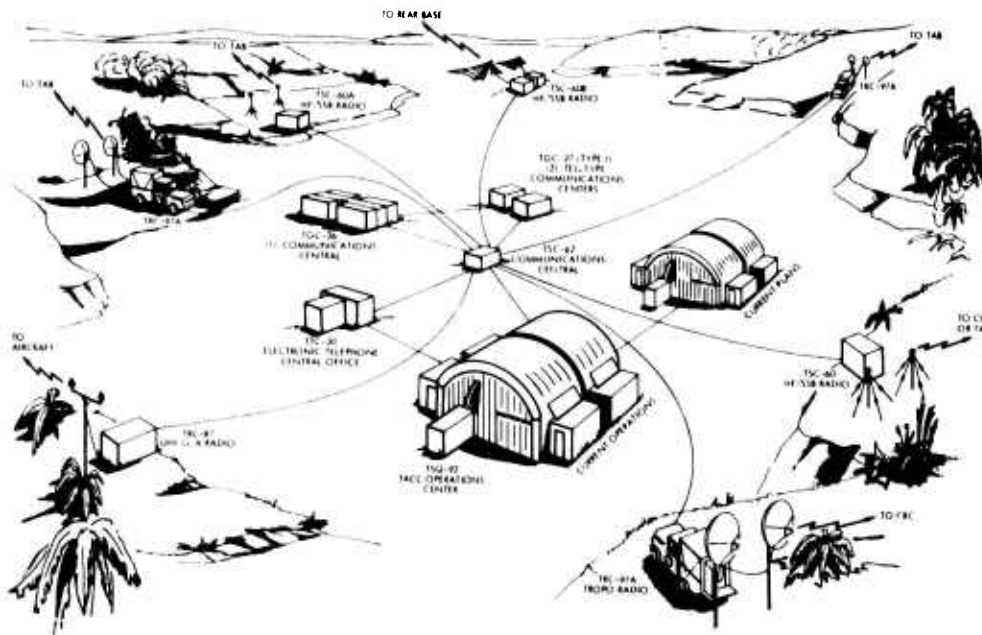

Figure 2. AFCH/TACC Typical Field Deployment

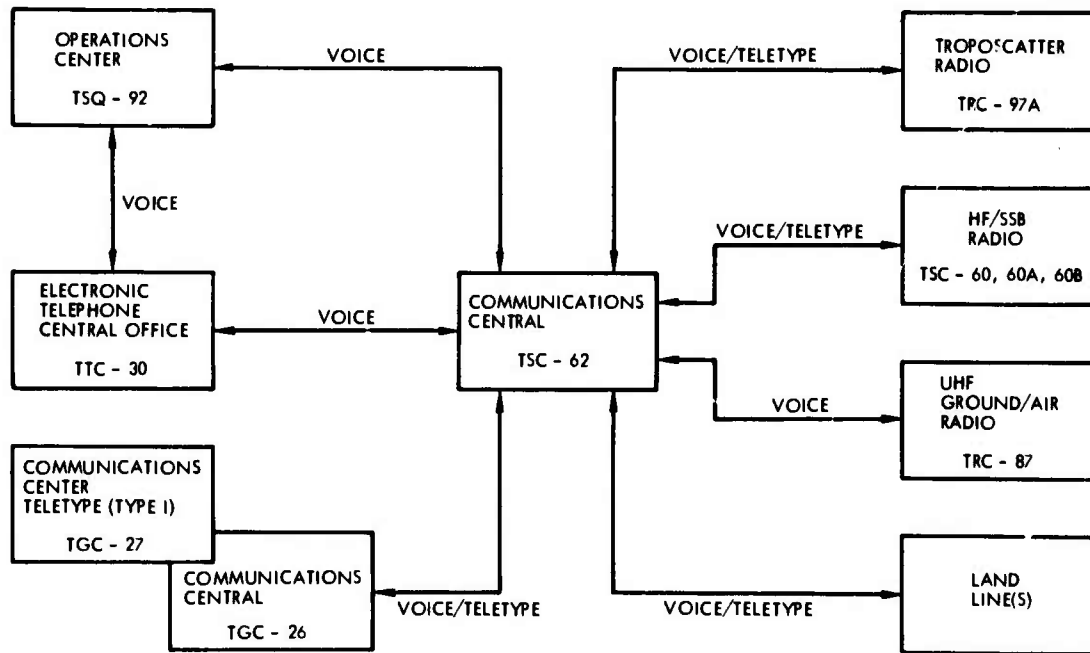

Figure 3. AFCH/TACC Block Diagram (Typical)

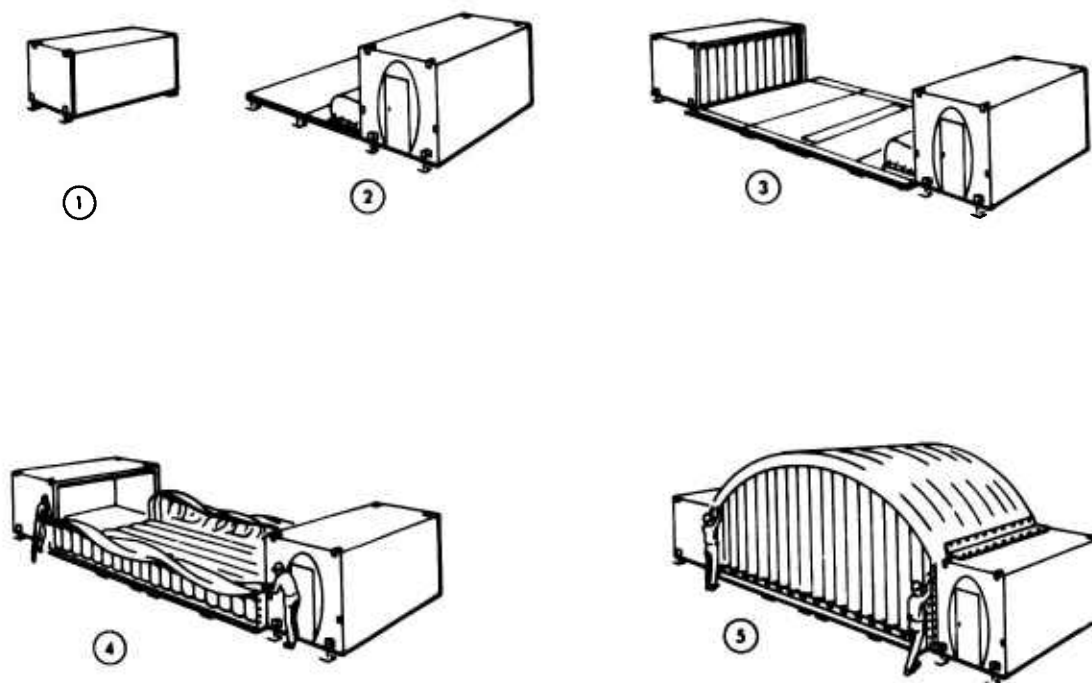

Figure 4. TACC/CRC/CRP Operations Center – Assembly Sequence

Table 4. TACC Modules/Equipment Quantities

| Item                    | Equipment Quantities |     |     |
|-------------------------|----------------------|-----|-----|
|                         | Min                  | Med | Max |
| Group Display Module    | 2                    | 4   | 4   |
| Furnishings Module      | 1                    | 4   | 4   |
| Air Conditioning Module | 1                    | 2   | 2   |
| Total                   | 5                    | 10  | 10  |

**Equipment and Staffing.** The minimum configuration shall contain 40 desk positions, group displays, communication end instruments, and associated support equipment. Positions for a minimum of 47 operational personnel and one guard shall be provided.

The medium configuration shall contain 64 desk positions, group displays, communication end instruments, and associated support equipment. Positions for a minimum of 73 operational personnel and two guards shall be provided.

The maximum configuration shall contain 68 desk positions, group displays, communication end instruments, and associated support equipment. Positions for a minimum of 80 operational personnel and two guards shall be provided.

Functional Characteristics. The Operations Center shall employ a manual method of operation and no automatic data processing facilities shall be required. This method shall consist of the use of manual plotting techniques on display (Air Situation, Mission Schedule, Status and May) boards, voice communications and written records for coordination and bookkeeping functions, and manually operated fragmentary order preparation devices. The communication equipment will include secure and nonsecure telephone equipment as well as teletypewriter equipment.

**(2) Communications Central (TSC-62)**

The Communications Central (TSC-62) serves as the focal point for the dispersion and interface of most intra- and intersite communications lines in the field deployment. The central is capable of quick operation after arrival on site and is provided with quick make/break connections to all other onsite communications facilities such as switchboards, telephone switching centers, operation centers, teletype centers, radio sets, and long-line wire circuits. In addition to the patching capability, the central exercises a continuous supervision of the operating condition of the communication equipments and is used to perform circuit and channel tests on these equipments.

**(3) Electronic Telephone Central Office (TTC-30)**

The Electronic Telephone Central Office (TTC-30) has the capability of performing switching functions (local and long distance) for inter- and intrasite communications within the TACS environment. The TTC-30 shall consist of interconnected shelters which are mechanically and electrically joined to form a complete shelter group.

The TTC-30 will provide the capabilities of intrasite telephone communications, direct long distance dialing (without the use of an operator), automatic alternate routing of calls according to traffic load at that instant, preemption of nonessential calls by priority marking, and special interface links to manual and foreign switchboards.

**(4) Troposcatter Radio (TRC-97A)**

The Troposcatter Radio (TRC-97A) is a tactical two-way (ground-to-ground) communication terminal used in conjunction with a similar terminal in the 4400-to 5000-MHz (SHF) band by means of tropospheric scatter, line of sight (LOS) and obstacle gain diffraction propagation. The power output is 1 KW, and the nominal range is 100 nautical miles. When utilized in conjunction with automatic switchboards, the combination will permit direct or alternate routing of voice communication among the deployed TACS operating locations. The TRC-97A is a complete radio unit coupled with an antenna and power generation equipment. The radio provides simultaneous two-directional communications on all information channels (full duplex, multichannel) using telephone and teletype. There are 24 voice channels available for telephone and FSK data. The teletype multiplex equipment can multiplex 16 teletype channels into any one of the 24 voice frequency channels to provide a capability of 16 teletype channels along with 23 voice and/or FSK data channels.

**(5) UHF Ground-To-Air Radio (TRC-87)**

The TRC-87 UHF Radio provides the primary ground-to-air voice communications at the AFCH/TACC. The radio is a transportable militarized set, housed in a single shelter, which

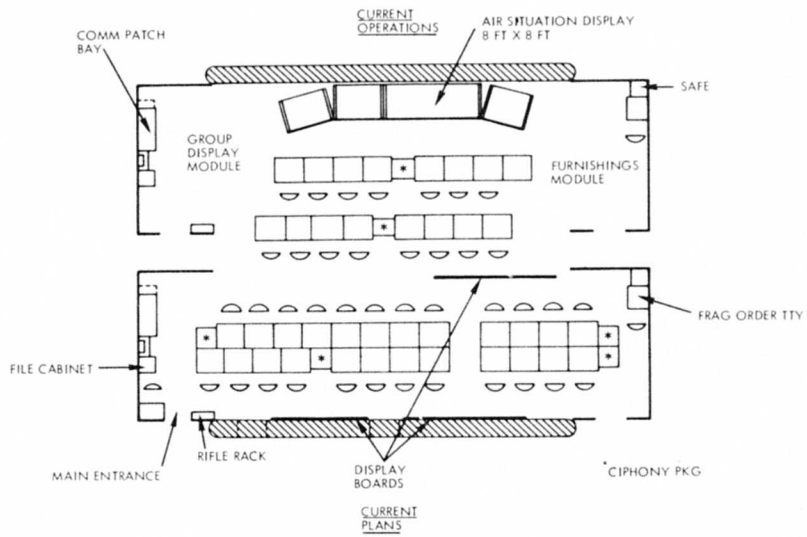

Figure 5a. TACC (Minimum) Operations Center

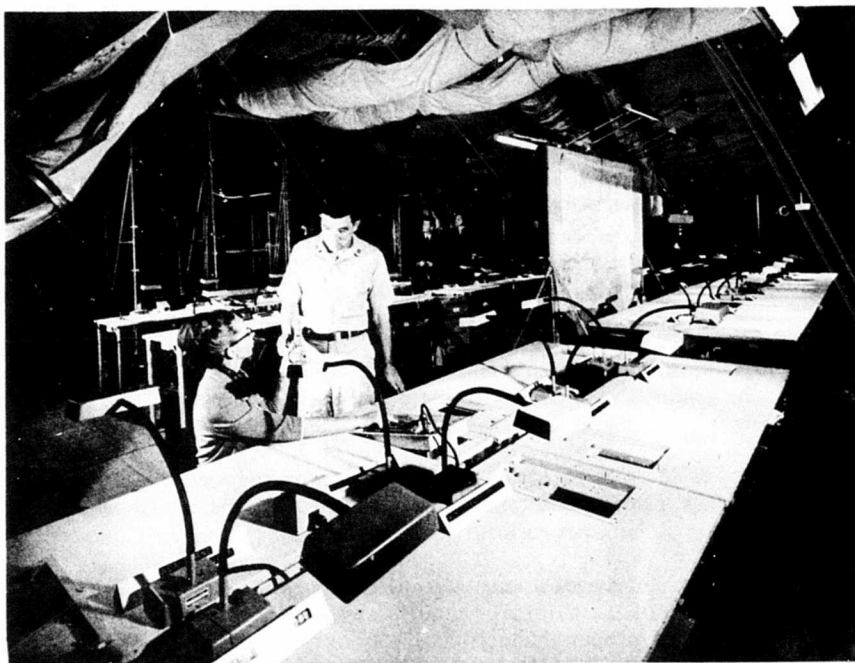

Figure 5b. TACC (Minimum) Operations Center - Current Operations and Current Plans

provides two-way communications between the operations center and airborne aircraft. Its nominal range is 200 statute miles. The set contains five simplex channels of UHF/AM in the 225-to 400 MHz range at a 100-watt power output.

The set can be operated through a remote control system. Four of the five channels are manually tuned (at the shelter) to any of 3500 frequencies. These preselected fixed-frequency voice channels are then available at the remote operating site. The fifth channel is automatic. It can be preset (at the shelter) to 21 of the 3500 frequencies. At the remote site, these 21 channels can then be automatically selected. Thus, a total of 25 channels is available to the operator (who can be located up to 5 miles away from the transceiver).

#### (6) Communications Central (TGC-26)

The TGC-26 Communications Central is a telegraph facility providing torn tape equipment to terminate 24 full duplex teletype circuits; 18 of these cryptographically secured, 4 nonsecure, and 2 spare. The Communications Central is normally collocated with the AFCH/TACC and provides the facilities to receive and relay teletype messages within the TACS and other military and commercial systems. The central is divided into two modules, each module designed for 12 full duplex lines; 9 of these secure, 2 nonsecure, and 1 spare. The modules are capable of marriage, electrically and mechanically, and are capable of operation as a single unit when any two modules are deployed together. The central provides the following functional capabilities.

Message Reception and Routing. Message reception takes place in the receiving section. This section consists of 24 typing reperforators, each assigned to a particular teletype circuit. Incoming traffic that is to be relayed is manually placed at the proper message transmission location. Messages to be routed to more than one location are reproduced at the multiple address processor (MAP).

Message Transmission. The message transmission section consists of 24 transmitter-distributors. Each channel has a printing reperforator as a monitoring device, and an automatic channel numbering device is provided for each transmitting channel.

#### (7) Communications Center Teletype (TGC-27( (Type I)

The TGC-27 Teletype Center is designed to perform the message preparation, acceptance, and delivery functions for the AFCH/TACC and the Tactical Air Bases. The center is capable of quick operation immediately after arrival on site and is provided with quick make/break connectors to other onsite facilities. The TGC-27 will terminate four full duplex teletype circuits and cryptographically secure these circuits with either four KG-13's or eight KW-7's or a mixture of both. The center is capable of off-line preparation of teletype tapes; monitoring, patching, and testing of equipment and circuits; and limited relay of incoming messages.

Message Reception. Message reception shall take place in the receiving section which shall consist of a group of page printers and reperforators assigned to a particular teletype circuit through the appropriate patching network.

Message Transmission. Messages originating in the immediate compound of the TACS area shall be prepared by means of the automatic send/receive (ASR) equipment. These messages shall be transmitted over the proper channels via the transmitter distributors (TD). Each transmitter distributor shall have an automatic numbering capability. The Type I center shall also have monitoring capabilities.

Limited Relaying Capabilities. Messages to be routed shall be reproduced on tape and routed to the proper destination.

**(8) HF/SSB Radio [AN/TSC-60V(1,2,3)]**

The HF/SSB Communications Centrals provide for point-to-point and ground-to-air HF communications. The centrals may be used to establish long haul communications to a DCS entry point or rear main operating base; medium range communications between Tactical Air Bases or from the AFCH/TACC to remote operating locations; and short range communications between operating sites of the TACS where broadband links cannot be established due to terrain or distance. The radio sets in the centrals are capable of operation with either voice operated transmission (VOX) or Push-to-Talk and are capable of operating in the following operator selectable modes:

- Upper Side Band (USB)
- Lower Side Band (LSB)
- Independent Side Bands (ISB)
- Compatible AM
- Continuous Wave Telegraphy (CW)
- Duplex

Each TSC-60V Radio has the capability to provide ground-to-ground and ground-to-air communications in the 2-to 30 MHz region. Each TSC-60V(1) (1-KW Peak Envelope Power) and TSC-60V(2) (2.5-KW Peak Envelope Power) contains two complete radio sets capable of simultaneous operation or one set operating on-line and the other set operating into a dummy load on "Hot Standby." Each has the following capabilities:

- Simplex or duplex operation
- Up to a maximum of four speech channels in each radio set
- Up to a maximum of four speech plus duplex telegraph channels in each radio set
- Three channels of voice and multiplexes telegraph in the fourth voice channel
- Digital data rates up to 2400 bits per second (BPS)
- Provision for control and monitoring of each radio set from a remote location at distances up to 1/4 mile
- Provisions for signaling conversion and termination for eight 2-wire or 4-wire circuits with 20-CPS and 1600-CPS signaling
- Provisions for interfacing with terminal teletype equipment utilizing neutral or polar DC or VF tone signals
- Patching facilities for interconnecting the radio and telephone/telegraph equipments to the external lines and to connect and radio input and output line to any signaling converter or telegraph/telephone terminal.

The TSC-60V(3) radio is used for tactical communications when there is a need for

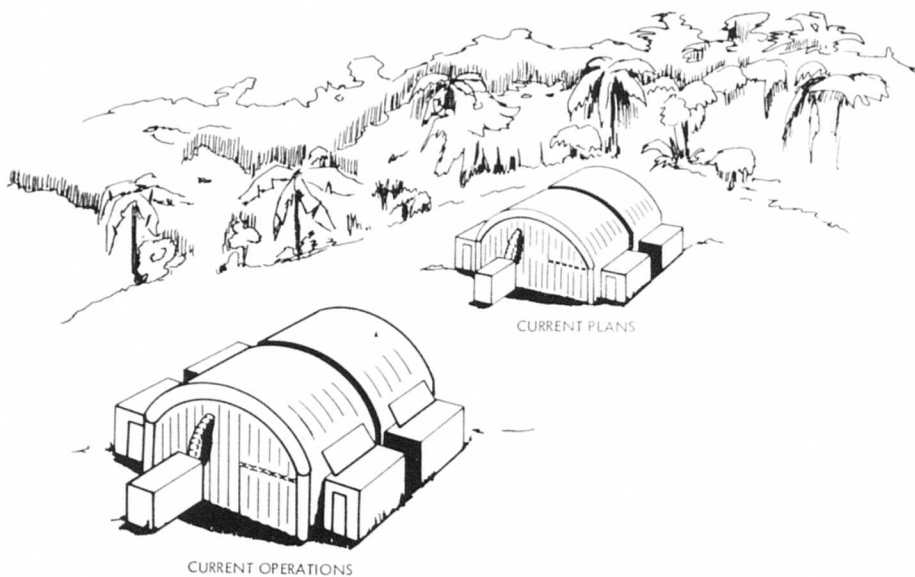

Figure 6. TACC Operations Center - Field Deployed

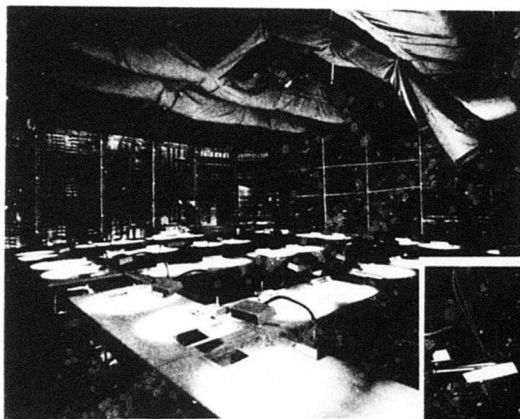
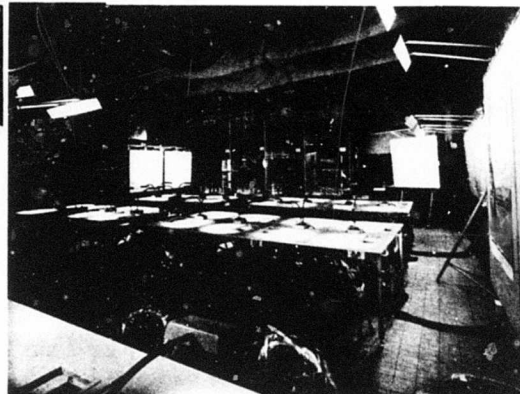

Figure 7a. TACC (Maximum) Operations Center - Current Operations

Figure 7b. TACC (Maximum) Operations Center - Current Plans





10-KW PEP power output. The central consists of the TSC-60V(2) and a second independent shelter housing a 10-KW PEP Amplifier. The excitation and modes of operation are generated and controlled by either of the radio sets in the TSC-60V(2), except that the amplifier power supply in the TSC-60V(2) is bypassed. The remaining radio set in the TSC-60V(2) will function independently and either operate into its own antenna or remain in hot standby as a 2.5-KW PEP backup. The TSC-60V(3) has the same functional capabilities as the TSC-60V(2).

## **2. Control Reporting Center/Air Traffic Regulation Center Element (CRC/ATRC)**

### **a. General**

The CRC/ATRC is subordinate to the TACC. It utilizes radar to control in-flight aircraft and perform surveillance within its assigned area of a combat zone.

The CRC coordinates and controls the TACS Aircraft Control and Warning Radar networks of the CRC's subordinates, i.e., CRP and FACP and furnishes air situation information to the TACC. As such, it is the focal point of the AC&W capability. In addition, it has the capability to collect, display, evaluate, and distribute information on air activity within its sphere of influence.

The ATRC portion of the CRC provides coordination of area Air Force air traffic with the Army, Navy, Marines, Civil, and Allied Forces.

### **b. Configuration Concepts**

The size of a CRC deployment is dependent primarily upon the force level supported. Usually the functions of the element do not change with a change in the force level. The capacity of work is proportional to the deployment configuration, i.e., minimum, medium, maximum, or alternate TACC.

### **c. Functional Configuration**

A typical field deployment is shown in Figure 8, typical block diagram in Figure 9.

### **d. CRC/ATRC Equipment Description**

#### **(1) CRC Operations Center (TSQ-91)**

**Mission.** The Operations Center consists of shelters which have operational personnel, data processing and display equipment, and telephone terminal equipment. In a field deployment situation, the equipment configurations may vary since the CRC shall perform the management function for the aircraft control and warning network and provide the ATRC for the network. Under certain tactical situations, the CRC will possess the capability of operating as an alternate TACC.

**Configuration.** The Operations Center has the option of deploying in incremental modules (inflatable shelters) ranging from a minimum to a medium to a maximum configuration. The number and types of modules for each configuration are listed in Table 5. A typical Medium Operation Center (inflatable shelter, group and console modules only) is shown in Figure 10. A plan view of a typical Medium CRC/CRP Operation Center configuration is shown in Figure 11a. A typical internal view is shown in Figure 11b.

**Table 5. CRC/CRP Modules/Equipment Quantities**

| <u>Equipment</u>           | <u>Min</u> | <u>Med</u> | <u>Max</u> |
|----------------------------|------------|------------|------------|
| Group Display Module       | 1          | 2          | 3          |
| Console Module             | 1          | 2          | 3          |
| Air Conditioning Module    | 1          | 2          | 2          |
| Ancillary Equipment Module | 1          | 1          | 1          |
| Data Processing Module     | 1          | 1          | 1          |
| Total                      | 5          | 8          | 10         |

Equipment and Personnel. The minimum configuration that may be employed shall contain six multipurpose display stations, group displays, three video mappers, SIF processor, communication equipments, and data processing and associated support equipment. Operational positions for a minimum of 15 personnel shall be provided.

The medium configuration shall contain ten multipurpose display stations, group displays, three video mappers, SIF processor, communication equipments, and data processing and associated support equipment. Operational positions for a minimum of 27 personnel shall be provided.

The maximum configuration shall contain 14 multipurpose display stations, group displays, three video mappers, SIF processor, communication equipments, and data processing and associated support equipment. Operational positions for a minimum of 44 personnel shall be provided.

Functional Description:

Console Module. The console module provides highly mobile man-machine interface for the display and control of air situations as required by the center to which it is related. The console module contains radio and telephone equipment so that the duty stations are provided secure and nonsecure telephone service and nonsecure ground-to-air radio service.

Group Display Module. The Group Display Module provides a communications capability by the use of communications equipment, auxiliary map, and wall displays.

The Group Display Module contains radio and telephone equipment so that the duty stations are provided secure (desk only) and nonsecure (all positions) telephone services as well as nonsecure ground-to-air radio service (desk positions only). Also, the status clerk is provided weather teletype service.

Data Processing Module. The Data Processing Module provides video maps to the operations center's display console and a data processing facility which includes a computer and associated peripheral equipment. The data processing module also provides for nonsecure

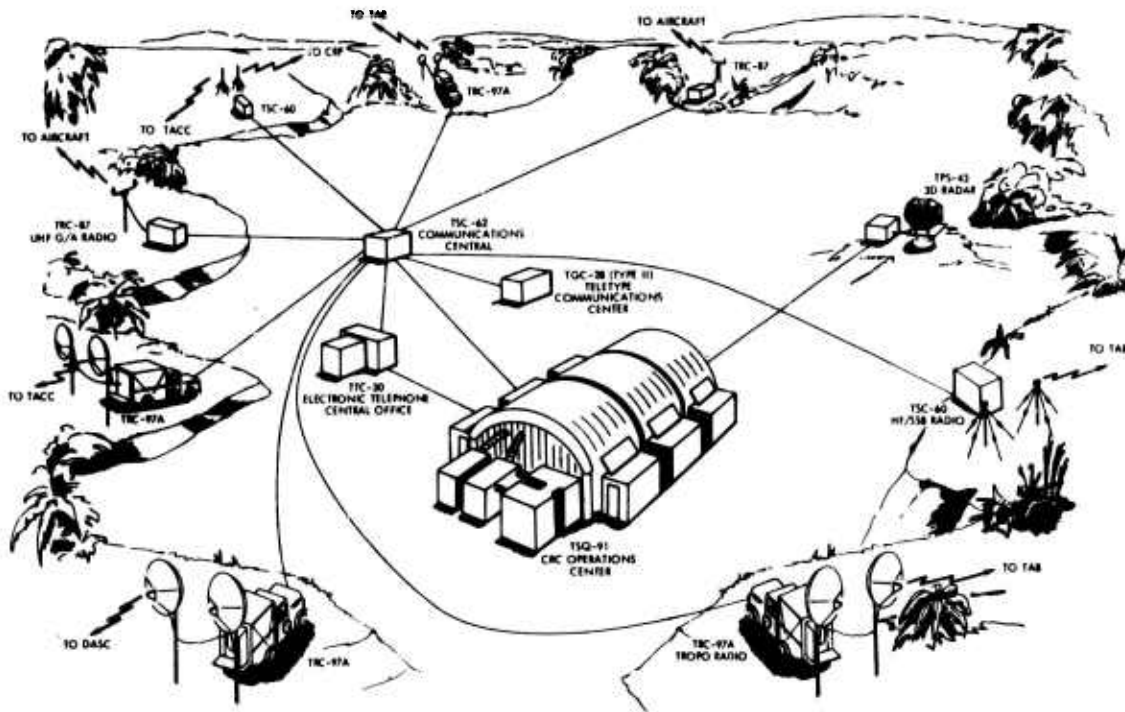

Figure 8. CRC/ATRC Typical Field Deployment

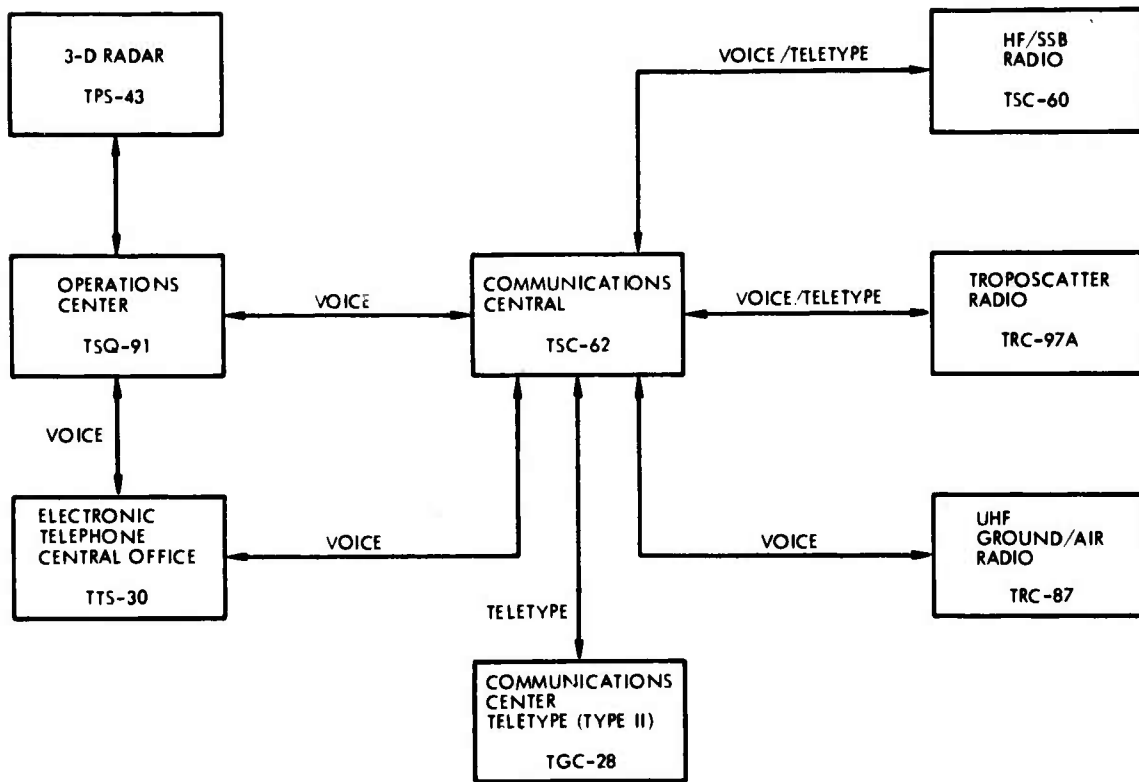

Figure 9. CRC/ATRC Block Diagram (Typical)



Figure 10. CRC/CRP Two-Cell Inflated Shelter (Including Group Display and Console Modules Only)

telephone communications and voice recording provisions.

Ancillary Equipment Module. The Ancillary Equipment Module provides display/computer data buffering, symbol generation, video mapper sweep and unblinking generation, and two operational display positions.

Also, the Ancillary Equipment Module provides for the following functional capabilities: nonsecure telephone communications, nonsecure ground-to-air radio communications, and voice recording.

(2) 3-D Radar (AN/TPS-43)

(a) Purpose

The AN/TPS-43 radar set is a transportable radar set designed for simultaneous long range search and height finding (3-D). This radar set is a self-contained data gathering system for the CRC/CRP Operation Centers. (Figure 11c).

(b) General

The design of the AN/TPS-43 represents a classic example of performance trade-offs versus externally imposed limitations. For example, there are basic conflicts between low PRF for long unambiguous range, high PRF for good clutter rejection and high operating frequency for good angular resolution. Similarly, there are basic conflicts between physically/electrically small reflector type antennas, multiple stacked beams and good sidelobe control. However, within the framework of these basic limitations, the radar has a relatively high degree of sophistication, especially in the areas of signal modulation and frequency control. The principal

Figure 11a. CRC/CRP (Medium Operations Center)

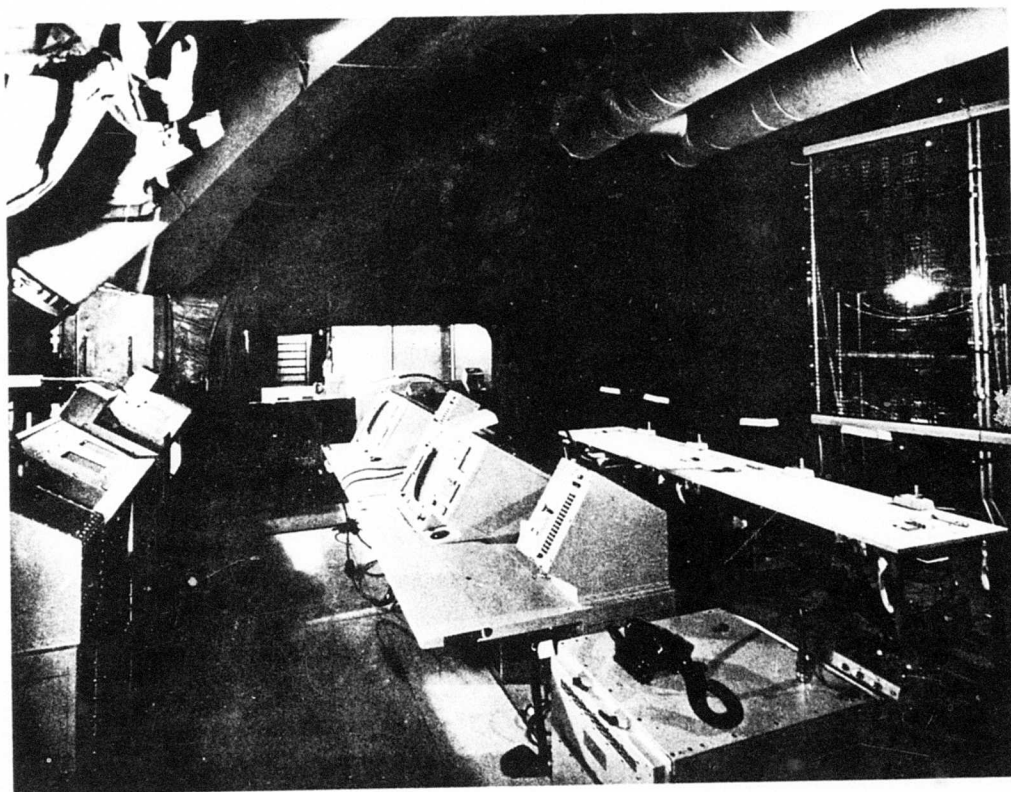
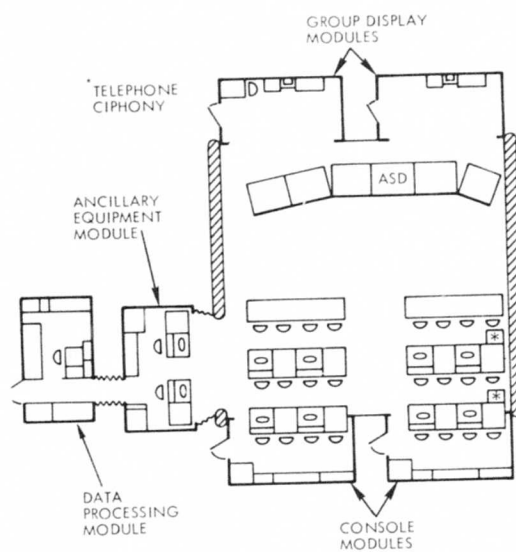

Figure 11b. CRC/CRP (Medium) Operations Center - Interior

electrical characteristics are discussed in the next paragraph. Table 6 lists the logistic characteristics and Table 7 lists the radar features. A discussion of the presently available ECCM features is contained in section d. It is readily apparent that its ECCM capability is derived principally in the two areas of signal and frequency control as well as its relatively high average transmitter power.

(c) Description

Radar Set AN/TPS-43 utilizes a stacked beam antenna as a means of providing simultaneous range and height information on a target over a wide range of elevation angles. A parabolic reflector forms the reflecting surface for the feed array which uses multiple horns and horn aperture sharing to effect the stacked-beam radiation pattern. Antenna coverage can be altered by a tilt adjustment that varies the angle of the antenna rotating beam relative to the pedestal. All microwave components are located in a box beam with the exception of the IFF antennas and the sidelobe reference antenna. The IFF antennas are located on either side of the feed array and the sidelobe reference antenna is located on the back of the feed array.

**Table 6 Logistic Characteristics**

**PRIMARY POWER REQUIREMENTS:**

|             |   |
|-------------|---|
| Voltage     | 120/208 volts $\pm$ 5 percent, three phase, four wire |
| Frequency   | 400 Hz $\pm$ 5 percent                                |
| Total Power | 80 KW (includes the air conditioner)                  |

**TRANSPORTABILITY:**

Transportable via helicopter, C-130 aircraft, M-35 truck or M-720 wheeled transporters. Each package is capable of being loaded or unloaded by manpower and light ground handling equipment. The maximum individual package weight is 4000 lbs.

**ERECTION TIME:**

The radar set, including all ancillary equipment, can be field assembled from the transport condition and put into operation by a trained crew of six men within one hour in daylight and with a trained crew of nine men in 90 minutes at night. Disassembly can be performed by the same personnel within the same time.

**TOTAL SHIPPING WEIGHT:**

Shelter - 4000 lb (approximate) Antenna pallet - 4000 lb (approximate).

**TOTAL SHIPPING VOLUME:**

Shelter - 410 cu ft (approximate) Antenna pallet - 606 cu ft (approximate).

Table 7. Features

|                                   |   |
|-----------------------------------|---|
| TRANSMITTING FREQUENCY:           | Three modes: fixed frequency, frequency agility, or MTI frequency agility selection of 16 frequencies in the 2900 MHz to 3100 MHz range (S band). |
| PRF (PULSE REPETITION FREQUENCY): |   |
| Fixed PRF                         | 250 ±0.5 Hz   |
| Staggered PRF                     | 280 ±0.5 Hz, 227 ±0.5 Hz, 267 ±0.5 Hz, 235 ±0.5 Hz, 256 ±0.5 Hz, and 245 ±0.5 Hz.   |
| TRANSMITTER CHARACTERISTICS:      |   |
| Peak power                        | 2.8 megw nominal  |
| Average power                     | 4.7 KW nominal  |
| Pulse width                       | 6.7 ±0.15 sec   |
| Output tube                       | Twystron – Type VA-145E   |
| V <sub>swr</sub>                  | 1.5:1 maximum   |
| FALSE ALARM RATE:                 | 1 part in 10 <sup>-6</sup> ± 10%  |
| INTERMEDIATE FREQUENCY:           | 30 MHz  |
| MDS (MINIMUM DISCERNIBLE SIGNAL): | -109 dbm  |
| RECEIVER NOISE FIGURE:            | 6.5 db  |
| THREE-DIMENSIONAL COVERAGE:       |   |
| Azimuth                           | 360 degrees   |
| Elevation angles                  | 0 5 degree to 20 degrees above the radar horizontal   |
| Maximum altitude                  | 75,000 ft   |
| Range                             | From a minimum of 1 nautical mile to a maximum of 200 nautical miles  |
| SECTOR BLANKING:                  | Maximum sector of 357.2 degrees in 2.8 degrees' steps   |

Table 7. (con't)

|                              |  |
|------------------------------|--|
| RANGE RESOLUTION:            | 3,400 ft in slant range                                |
| AZIMUTH RESOLUTION:          | 3 degrees  |
| HEIGHT ACCURACY:             | $\pm$ 2000 ft in 100 nautical miles up to 30,000 ft    |
| SCV (SUBCLUTTER VISIBILITY): | 20 db  |
| ANTENNA CHARACTERISTICS:     |  |
| Scanning rate                | 6 rpm (10 seconds per scan)                            |
| Reflector aperture           | 14 ft high by 21 ft 4 in. wide                         |
| Polarization                 | Vertical   |
| Tilt angle                   | Adjustable from +3 to -1.5 degrees in 0.5 degree steps |
| Gain                         |  |
| Receive                      | 39.0 db (0.8 degree elevation)                         |
| Transmit                     | 35.7 db (0.8 degree elevation)                         |
| Beamwidth                    |  |
| Horizontal                   | 1.1 degrees  |
| Vertical                     | 1.55 degrees to 8.1 degrees                            |
| IFF                          |  |
| Beamwidth                    | 4 degrees  |
| Sidelobes                    | 25 db  |
| Interrogations per scan      | 28   |
| Noise figure                 | 5 db   |



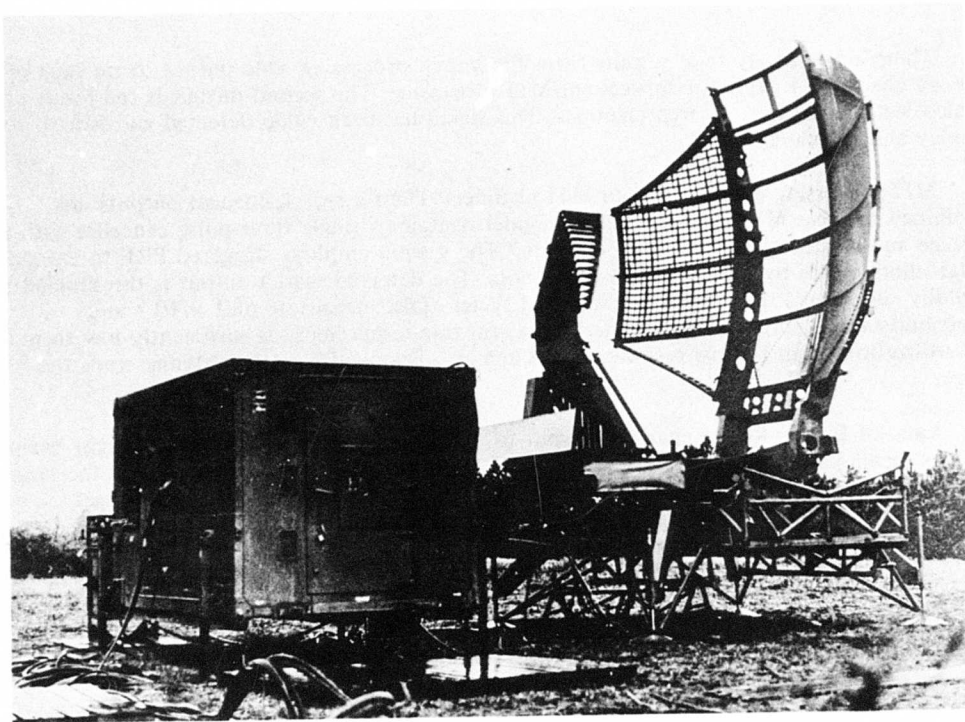

Figure 11c. 1 et AN/TPS-43

The transmitter section of the radar set, with the exception of the driver, is located in an enclosed area at the back of the shelter. With an input of -5 dbm from the frequency generator and an output of 2.0 megawatts minimum, 2.8 megawatts nominal, at the shelter, the transmitter provides 100.4 db of gain. This is accomplished in successive stages of amplification through the driver, modulator and twystron, (Master Oscillator Power Amplifier or M.O.P.A.). The driver is a separate unit and is located near the frequency generator. The high voltage power supply and modulator are enclosed in an SF<sub>6</sub> tank in the transmitter compartment. Three kilowatts of heat are dissipated within the tank. At room temperature, the tank is pressurized at 30 psig. The output of the SF<sub>6</sub> tank is supplied through an oil tank assembly to the twystron. The oil tank holds 5.5 gallons of oil and dissipates 250 watts of heat. A focus coil mounts on top of the oil tank and the twystron fits within the focus coil and seats in its socket in the tank. X-ray protection is maintained by lining the inside of the oil tank, focus coil, and twystron collector with lead. The output of the twystron is supplied through waveguide to the antenna for radiation. Waveguide pressure is maintained at 30 psi by a waveguide compressor. In addition, a remoted heat exchanger provides cooling air for components mounted in the transmitter area and cooling water to the twystron body and collector, the focus coil, pulse-forming network, and the SF<sub>6</sub> tank.

Processing of target returns from the antenna is accomplished in the radar receiver, the MTI and the signal processor. Each of the six receive channels, one for each elevation beam, is split for subsequent search and height processing. The search channels offer pulse compression of the phase coded pulses through the use of CPACS (Coded Pulse Anti-Clutter System) processing. The search channels also include hard limiting and provide CFAR (Constant False Alarm Rate) characteristics. The height channels perform pulse compression with CPACS processing, but utilize linear processing for beam interpolation.

There are basically two outputs from the search processing. One output, from each of the six channels at i-f, is for subsequent MTI processing. The second output is the result of peak-selection of the six search channels. This signal has been video detected and is used for display and thresholding.

MTI processing consists of four MTI channels. The six search channel outputs are combined in these MTI channels. Each channel contains a single three-pulse canceller with the storage and cancellation performed digitally. The system employs staggered PRF to extend the radar blind speeds to approximately 575 knots. The detected search output is thresholded and digitally integrated to produce the required system false alarm rate of  $1 \times 10^{-6}$  and probability of detection of 0.75. The false alarm rate requirement is sufficiently low to require the utilization of all returns received in the azimuth beamwidth as the antenna scans the target.

Each of the six height channels is split to obtain the beam-pair sums of adjacent beams and the beam-pair difference. Peak selection among the five beam-pair sums yields the target base height angle. The beam-pair difference of the peak selected pair yields the target interpolation angle. This technique is typically referred to as beam-splitting or amplitude monopulsing. Since the height channels do not hard limit, they will exhibit no CFAR characteristics. Therefore, to obtain a CFAR characteristic in the height channels, the height computations will be enabled by the search first threshold. The false alarm rate of the first threshold and the operation of the height evaluator provide a combined false alarm rate in the height channel approximately equal to that in the search channel.

The base angle and interpolation angle are supplied to the height computer for height computation. Other inputs to the computer include target range and antenna tilt. Stored in the height computer are corrections for earth's curvature and atmospheric bending of the radar beam. The hit-by-hit target height computations are supplied to the height evaluator. The height evaluator selects the three most consistent height computations obtained as the antenna beam scans the target, and averages these three computations to provide a height answer.

Target height data is supplied from the radar in digital form. The digital output is available at the radar output on every target producing an evaluated height answer. Display of the digital target height is provided in the shelter in the form of a numeric read-out with a least significant bit of 500 feet. The digital read-out is enabled by placing range and azimuth strobes over the target displayed on the PPI.

A seventh receive channel processes receptions made by the sidelobe reference antenna. The outputs from the sidelobe reference channel and the height channel are compared to determine whether the detection occurred in the azimuth sidelobes. Sidelobe detections can be blanked from the search video at the operator's discretion.

Search video and height data are displayed at the PPI. The search videos available at the PPI are: gated MTI, pulse compressed search and synthetic search. The gated MTI search output is produced by combining the MTI channel and the normal search output. MTI video is supplied when detections are made in a designated MTI sector with normal search video supplied at all other ranges and azimuths. The normal search output to be combined with the MTI output can be either raw unthresholded video or integrated synthetic search, at the operator's discretion. The pulse compressed search video is simply the raw unthresholded search output. The synthetic search output can be supplied by either the integrated search output or after first thresholding, at the operator's discretion. This is controlled by the integrator switch on the signal processor.

The transmit and stalo frequencies are produced at the frequency generator. At the frequency generator, one of sixteen possible frequencies is selected by a gate from the frequency programmer. A solid-state varactor multiplier chain multiplies this frequency to the final stalo frequency. The transmit frequency is obtained by offsetting the stalo by 30 MHz.

Built-in automatic self-test features and on-line monitoring provide a continuous survey of essential subsystem parameters. Built-in manual self-test and calibration features provide capabilities for selective confidence checking and gross fault isolation. A comprehensive test point placement scheme and a built-in monitor scope are provided to permit rapid fault isolation to the replaceable subassembly.

#### **(d) Electronic Counter-Countermeasures (ECCM)**

##### Frequency Agility

In this mode, the frequency of the transmit pulse is randomly selected among 16 frequencies within the frequency band of 2900 MHz to 3100 MHz on a pulse-to-pulse basis. In the MTI frequency agility mode, there are twelve transmissions on any one of the 16 frequencies, with random frequency selection between groups of twelve transmissions.

##### Jamming Analysis and Transmission Selection (JATS)

In the presence of active jamming, the JATS mode can be selected by the operator. The JATS circuitry examines the jamming interference and then inhibits the transmit frequency or frequencies that are being jammed. The remaining uninhibited frequencies are then randomly selected for transmission among the holes in the jamming spectrum.

##### Coded Pulse Anti-Clutter System (CPACS)

The search video channel develops and processes six channels of hard limited, pulse compressed, peak selected search video for display. Also, within the circuit, six channels of 30 MHz IF are used in the development of the MTI video channels. The search video channels consist of IF limiters, CPACS decoders, IF amplifiers and detectors, and a diode peak selector. For CPACS operation, the limited amplified 30 MHz log IF signals from the IF amplifiers are coupled through the CPACS decoders which decode the phase-coded pulse returns by applying pulse compression techniques. The signal-to-noise ratio is improved by 11 db. This technique is used to enhance the rejection of clutter by decreasing the clutter cell volume in the range dimension.

##### Constant False Alarm Rate (CFAR) Receivers

The search channels also include hard limiting and provide CFAR characteristics. That is, limiting of amplification following a logarithmic function provides for CFAR operation, whereby the average noise pulses are maintained at a constant level. Subsequent amplification of the 30 MHz IF insures a minimum signal-to-noise ratio. This operation maintains constant false alarm output in the presence of jamming or other interference to prevent overloading of the target track processing system.

##### Three Pulse Canceller Digital MTI

The MTI is used to eliminate signals from ground clutter and other near zero radial velocity clutter and passes signal returns from moving targets. The principle of MTI operation is the pulse repetition period (PRT) to pulse repetition period (PRT) phase shift between returns on the same target. When a signal is reflected from a moving target, the frequency (or rate of phase variation) of the target signal is shifted by an amount that is proportional to the speed of the moving target. This phenomenon is known as the Doppler effect. As a result of the Doppler effect, the phase of signals returned from moving targets varies continuously while the phase shift of signal returned from stationary targets does not vary. Since returns from land masses and other stationary objects have the same phase each

PRT, comparison of phase shifts from PRT to PRT can be used to eliminate stationary targets. One measure of the ability of an MTI System to discriminate between fixed and moving targets is subclutter visibility (SCV). This stacked beam 3-D radar obtains signal returns from antenna receive beams 1 through 6, converts them to 30 MHz IF which is amplified by the receiver and supplied to the MTI. The returns are split into two paths for use by the receiver and by the MTI circuits. Returns supplied to the MTI are grouped into four channels and supplied to four phase detectors. Phase angle data is stored in shift register memory for later use. Data from two PRTs is stored for each of the four channels. This data is compared with the incoming data by a three-pulse canceller. Returns from stationary targets are eliminated by the canceller. The channel with the largest canceller output is selected for display as MTI video. This output is integrated and converted to an analog voltage. The analog output is supplied to the video selection circuits for display.

#### Staggered Pulse Repetition Frequency or Period (PRF or PRT)

Certain radial velocities of the target with respect to the antenna prohibit MTI detection of the target regardless of the clutter level. This situation occurs when the PRT to PRT phase shift of the target is a whole number of wavelengths of the transmitted frequency. The lowest target velocity for which this occurs is called the first blind speed. Other blind speeds occur at multiples of the first blind speed. Staggered PRT is employed in the AN/TPS-43 to extend the first blind speed to 575 knots; in fixed PRT it is 24 knots. This mode of operation removes the lower velocity MTI blind speeds and prevents synchronous interference.

#### Sidelobe Blanking (SLB)

SLB is used to reject low duty cycle (pulse type) interference or jamming via the antenna sidelobes. A sidelobe reference channel is employed with the operation of the height video channels, whereby a target return in the main beams resulting from sidelobe beam detection can be inhibited from video display. A target return in the sidelobe reference channel is processed to develop a detected video pulse. This pulse, together with the six height video channel outputs, is applied to a peak selector. If the target in the sidelobe reference channel is of greater signal strength than in the main channels and the receiver SLB switch is in the ON position, a sidelobe blanking gate is supplied to the MTI and height evaluator. (The sidelobe reference antenna has patterns tailored to overlap the mainbeam azimuth sidelobes. The seventh receive channel from the sidelobe reference antenna undergoes amplification and mixing similar to that which takes place with the six IF receive channels.)

#### Azimuth Resolution

The narrow (1.1 degree) azimuth beamwidth aids in reducing the clutter cell volume and in making the escort jammer less effective. For example, at 50 n mi., the separation in azimuth between the escort jamming aircraft and the attacking aircraft must not be more than approximately 5000 feet in order that it effectively jam in the main beam and screen the attacker.

#### Sensitivity Time Control (STC)

Ring around interference is displayed on PPI display as circular range rings. This occurs when a target is close enough in range to give returns not only to the mainbeam, but also to the sidelobes. This type of interference is minimized by the use of STC which starts the receiver at low sensitivity at zero range and increases the sensitivity as a function of range. The sensitivity of the receiver is thereby lowered for strong (close-in range) returns and raised for weaker (far-out range) returns. The receiver dynamic range is increased by STC.

#### Video Integration

Provided by a non-coherent integration of the radar pulses per beam dwell interval. This signal processing operation acts to further increase the radar's effectiveness against receiver noise, external interference or jamming.

### **(3) Communications Center Teletype (TGC-28) (Type II)**

The TGC-28 Teletype Center is designed to perform the message preparation, acceptance, and delivery functions for the CRC. The center is capable of quick operation immediately after arrival on site and provided with quick make/break connections to other onsite facilities. The center is capable of receiving, originating, transmitting, and limited relay of teletype messages. It is also capable of off-line preparation of teletype types, monitoring, patching and testing of equipment and circuits. All lines, except one to and from the center, are cryptographically secure using KW-7 for five duplex circuits.

Message Reception. The message reception shall take place in the receiving section which shall consist of a group of page printers and reperforators assigned to a particular teletype circuit through the appropriate patching network.

Message Transmission. Messages originating in the immediate compound of the TACS area shall be prepared by means of the automatic send/receive (ASR) equipment. These messages shall be transmitted over the proper channels via the transmitter distributors (TD). Each transmitter distributor shall have an automatic numbering capability.

Limited Relaying Capabilities. Messages to be routed shall be reproduced on tape and routed to the proper destination.

### **(4) Electronic Telephone Central Office (TTC-30)**

This is discussed in the TACC Element section.

### **(5) Communications Central (TSC-62)**

This is discussed in the TACC Element section.

### **(6) HF/SSB Radio (TSC-60V)**

This is discussed in the TACC Element section.

### **(7) Troposcatter Radio (TRC-97A)**

This is discussed in the TACC Element section.

### **(8) UHF Ground-to-Air Radio (TRC-87)**

This is discussed in the TACC Element section.

## **3. Control and Reporting Post Element (CRP)**

### **a. General**

The Control and Reporting Post is an element/operating location which is subordinate to the CRC and provides radar control and surveillance within an assigned area forward of the CRC. Thus, it extends the control and surveillance/warning area coverage of the CRC. The element has the capability of assuming CRC functional responsibilities in an emergency. One or more CRPs may be utilized depending upon area size, terrain conditions, and anticipated level of air operations. In its assigned capacity, it provides the operational link between the CRC and the FACP elements. Its functions (except for identification and weapon assignment activities which are centralized in the CRC) are similar to those assigned in the CRC except on

a more limited capacity.

The CRP will normally forward-tell filtered track information developed internally and from subordinate FACPs to the CRC. Internally, the CRP provides navigational assistance and direction to aircraft on offensive and defensive missions. To perform these functions, the CRP maintains communications with the CRC, adjacent CRPs subordinate FACPs, and the TABs for which it has been authorized scramble authority. Normally, the CRP contains sufficient air movement/identification and IFF/SIF (Identification-Friend-Foe/Selected Identification Features) capability to assume the CRC "manager" functions of the Aircraft Control and Warning Network, if tactically required.

#### **b. Configuration Concepts**

The size of a CRP deployment is dependent primarily upon the force level supported. Usually the functions of the element do not change with a change in the force level. The capacity of work is proportional to the deployment configuration.

#### **c. Functional Configuration**

A typical field deployment is shown in Figure 12, a typical block diagram in Figure 13.

#### **d. CRP Equipment Description**

##### **(1) CRP Operations Center (TSQ-91)**

The center is described under the CRC Operations Center.

##### **(2) 3-D Radar (TPS-43)**

This is discussed in the CRC Element section.

##### **(3) Communications Center Teletype (TGC-28) (Type II)**

This is discussed in the CRC Element section.

##### **(4) Electronic Telephone Central Office (TTC-30)**

This is discussed in the TACC Element section.

##### **(5) Communications Central (TSC-62)**

This is discussed in the TACC Element section.

##### **(6) HF/SSB Radio (TSC-60V)**

This is discussed in the TACC Element section.

##### **(7) Troposcatter Radio (TRC-97A)**

This is discussed in the TACC Element section.

##### **(8) UHF Ground-to-Air Radio (TRC-87)**

This is discussed in the TACC Element section.

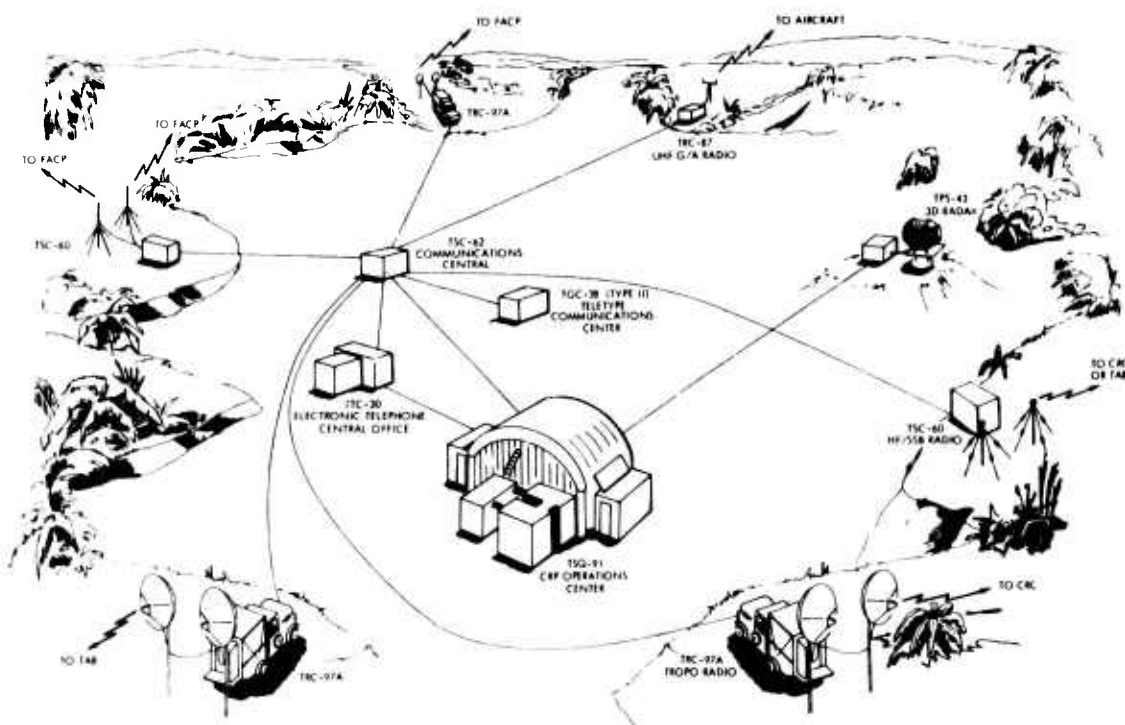

Figure 12. CRP Typical Field Deployment

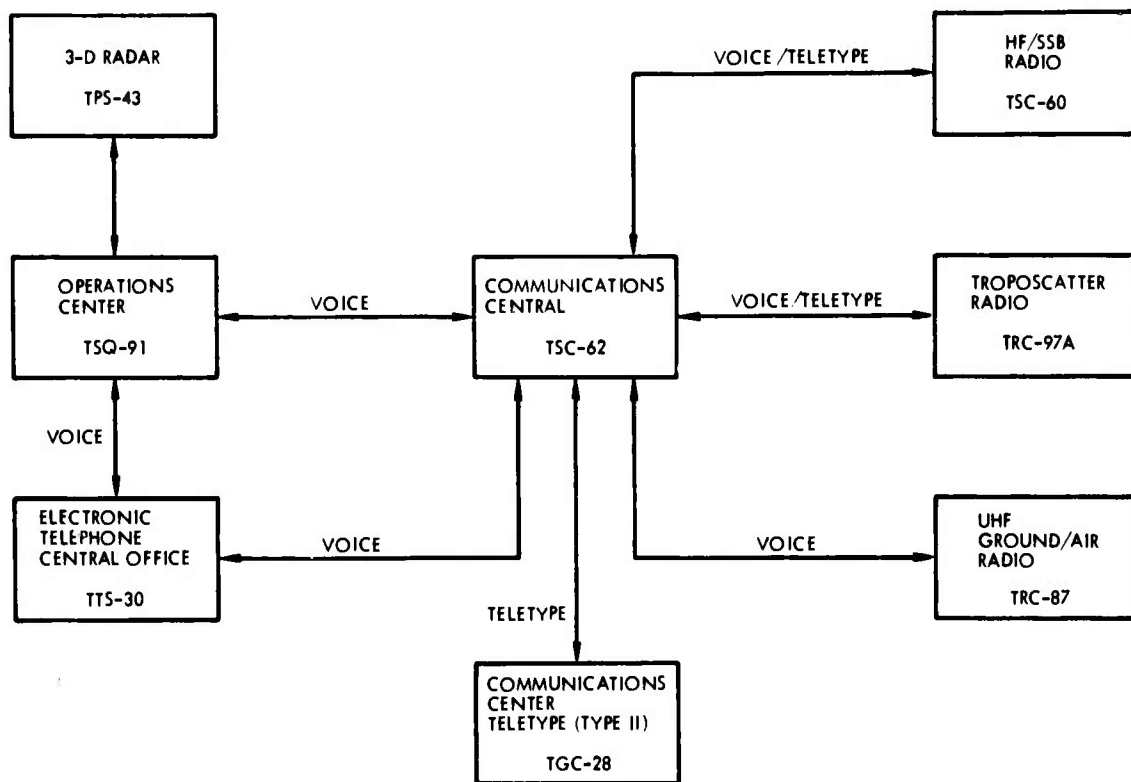

Figure 13. CRP Block Diagram (Typical)

#### **4. Forward Air Control Post Element (FACP)**

##### **a. General**

The FACP is a mobile radar and communication (control) element normally subordinate to a CRP. It augments the CRC and CRP surveillance coverage within the forward combat area. The FACP is primarily responsible for radar control of missions to and from designated control points for hand off to Forward Air Controllers (FAC) directing Direct Air Support Missions. It operates in the forward battle area and is capable of positive control of tactical missions during marginal and Instrument Flight Rules (IFR) weather conditions down to an altitude of 1000 feet (above ground level) within a radius of 30 miles.

It may function alone, in the initial phase of a TACS deployment, to provide the preliminary air control and surveillance capability pending follow-on positioning of CRCs and CRPs. A part of a more complete deployment, the FACP provides low altitude or gap filler coverage and control and/or navigational assistance to aircraft on offensive and defensive missions.

The element is self-contained and does not require the large communications centers provided for other elements. The FACP is provided an integrated communications center, an operations center, and associated radar and radio sets.

##### **b. Configuration Concepts**

The numbers and the configurations of the respective equipment in a FACP element are constant and independent of the Force Level Deployment (minimum, medium, or maximum). What does vary is the number of FACP elements employed for a given Force Level Deployment.

##### **c. Functional Configuration**

A typical field deployment is shown in Figure 14, a typical block diagram in Figure 15.

##### **d. FACP Equipment Description**

###### **(1) Communications Central (TSC-53)**

The Communications Central is provided at the FACP for voice and teletype communication terminations. The central provides an inter- and intrasite telephone facility, required radio sets for point-to-point and ground-to-air communications (with other sites and airborne aircraft) and a facility for monitoring, testing, and patching all equipment and circuits. To accomplish its mission, the central contains the following:

- Telephone Switchboard
- Radio Group
- Secure Teletype Facilities
- Technical Control Facility

###### **(2) Operations Center (TSQ-61)**

The Operations Center, when integrated with the other equipment (i.e., radar, IFF/SIF, and communications equipment) performs the functions of surveillance, identification, control of air, and inform. The Operations Center is a one-shelter module which provides space and facilities for four operator positions, i.e., Weapons Director, Weapons Director Technician, Surveillance Operator, and Plotter Teller. The center contains two.



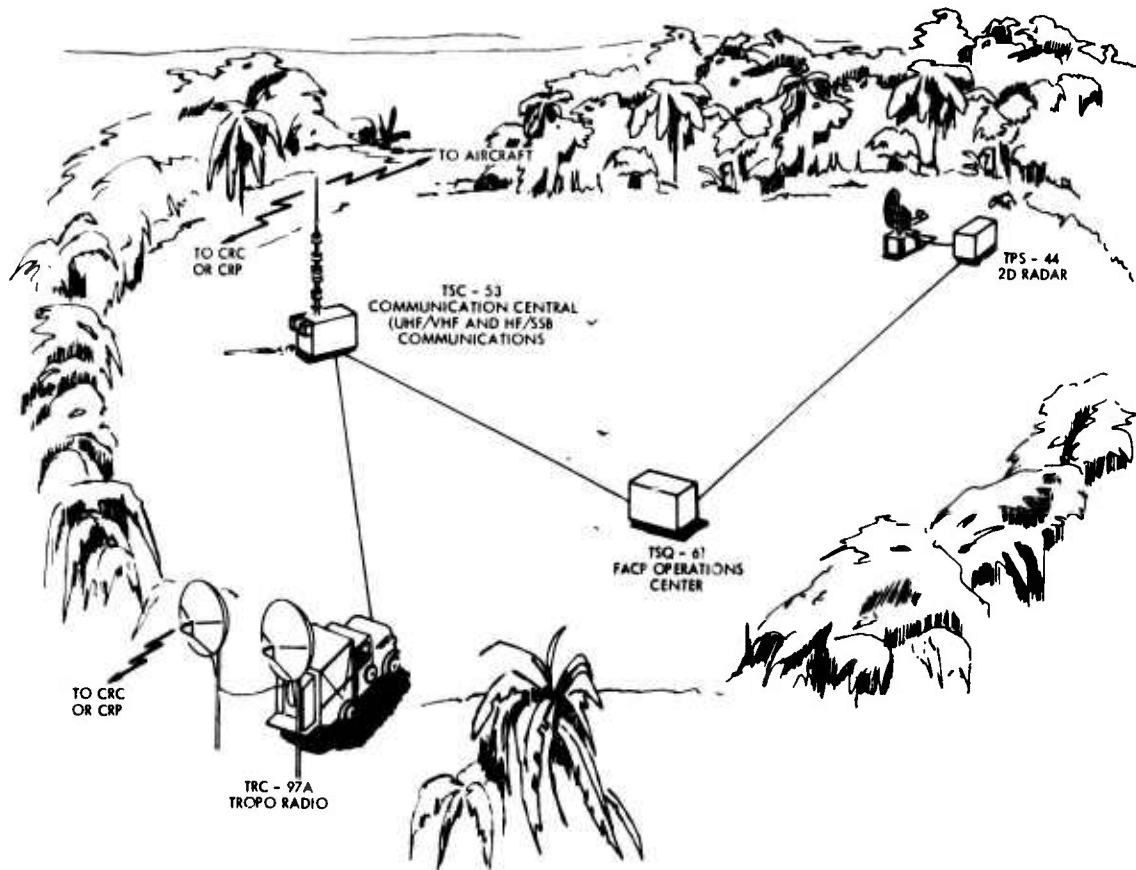

Figure 14. FACP Typical Field Deployment

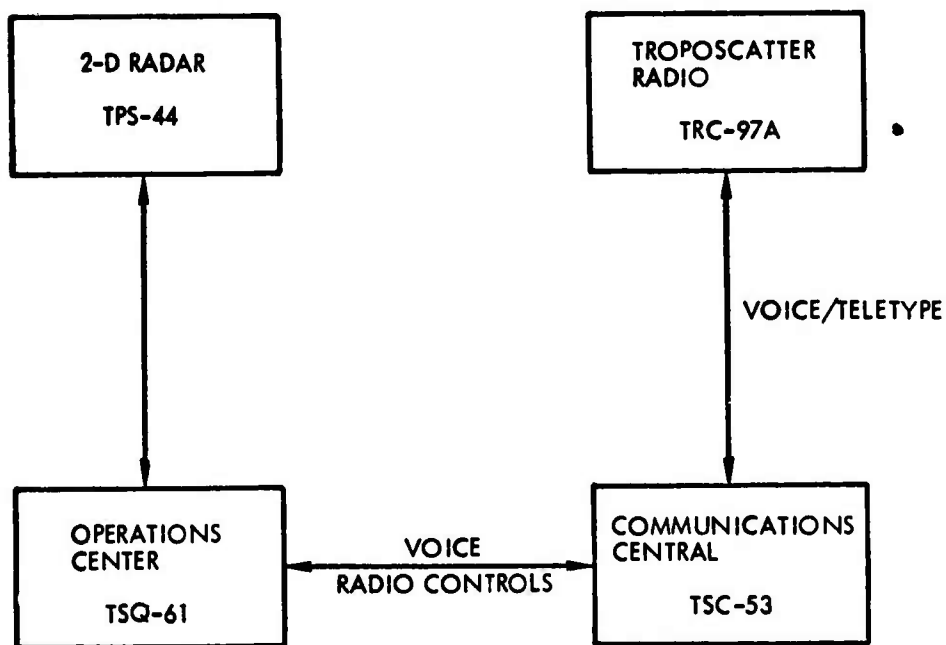

Figure 15. FACP Block Diagram (Typical)

tracking and aircraft control display consoles, plotting boards, remote control equipment, IFF/SIF, decode and control equipment, secure telephone and associated ciphony equipment, and non-secure telephone and interconsole communication equipment.

### (3) 2-D Radar (AN/TPS-44)

#### (a) Purpose

The AN/TPS-44 is a transportable surveillance radar designed to locate and identify airborne targets. This set is primarily deployed as a part of the Forward Air Control Post (FACP). (Figure 15a).

#### (b) General

The AN/TPS-44 employs a conventional shaped (CSC<sup>2</sup>) fan beam in the vertical dimension for extended high angle, close-in range coverage. This radar suffers from three basic limitations when required to operate in a hostile ECM environment. First, it has, for purposes of mobility, a physically/electrically small antenna for its operating frequency. This results in poor angular resolution against both active and passive ECM. Second, it has a pulsed oscillator transmitter rather than a master oscillator-power amplifier (MOPA) type. This limits its frequency agility and signal control flexibility. Thirdly, it is limited in average power for "burn through" capability. The principal electrical characteristics are discussed in section (3). Table 8 lists the logistic characteristics and Table 9 lists the radar features. A discussion of the presently available ECCM features is contained in section (d).

#### (c) Description

The AN/TPS-44 radar set utilizes a search radar that includes two indicator displays: A PPI and a range indicator. MTI (Moving Target Indication) is provided to achieve extra clarity

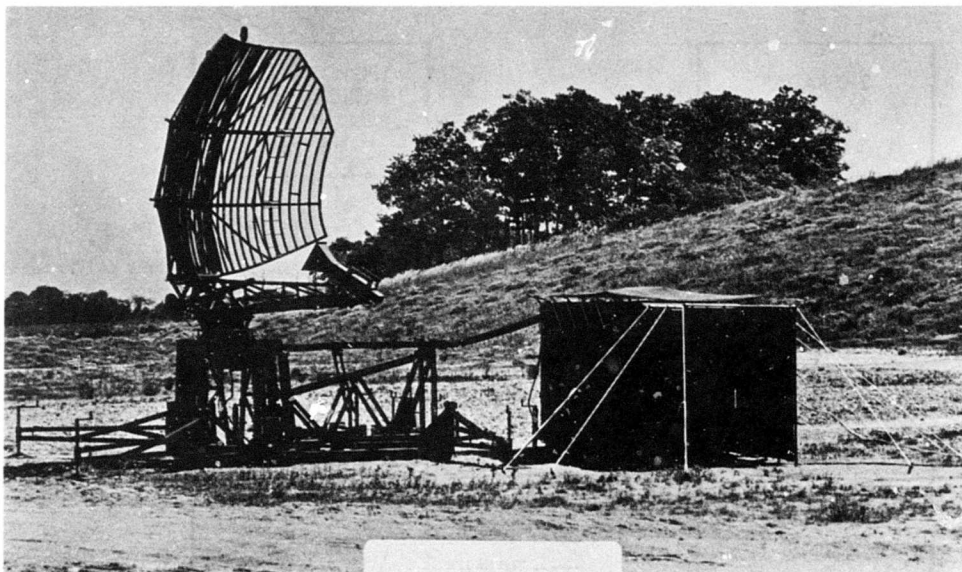

Figure 15a. Radar Set AN/TPS-44

in high foliage or other fixed clutter areas; VSI (Video Sweep Integration) is provided to enhance the system-target-detection capability for long-range operation. The set has remoting capabilities for: antenna-azimuth position, normal MTI and MTI/Normal Videos, system triggers, and communications. In addition, a remote control capability of system performance is provided via a remote control panel that is supplied as a part of the set. The range indicator doubles as a test monitor scope for troubleshooting the equipment. The set also includes IFF (Identification, Friend or Foe) to automatically identify aircraft.

The receiver utilizes a parametric amplifier to improve the radar performance via an improvement in the receiver MDS (Minimum Discernible Signal).

The equipment shelter houses the indicators, receiver, transmitter, antenna drive servo amplifier and the IFF interrogator and decoder. The units are rack mounted on slides and they can be slid out and tilted for convenient servicing. Extensive use of plug-in modules, monitoring of power circuits, and accessible test points provide a high degree of maintainability. The equipment shelter is provided with an air conditioning unit that can either cool or heat the shelter.

The foldable palletized antenna contains the antenna, antenna-pedestal, antenna elevating mechanism, and stabilization outriggers. The antenna is a dual surveillance-IFF type that provides superior air coverage for both the air-traffic control radar and the IFF subsystem. The antenna folds onto the pallet to a compact, transportable package.

The basic operational configuration of the set consists of a shelter group and palletized antenna. The shelter group with its sunroof and entryway awning is connected via 50-foot power cables to the external power source. After energizing the power source, the equipment in the shelter can be turned on to allow for magnetron heater warmup and STALO stabilization. The foldable palletized antenna is then erected, the outriggers placed, the unit leveled, and the power cables and waveguide section connected to the equipment shelter. The system is then essentially ready for the transmission of high power; antenna rotation can be turned on and the system operated.

The set can be operated in a variety of configurations. In addition to ground installation for each of the two packages, the antenna can be operated off an M-35 2-1/2 ton type cargo truck with the shelter package on a transporter. The set also can be operated with the antenna and shelter on trucks.

**Table 8. Logistic Characteristics**

| <u>Functional Power Requirements</u>   |   |   |
|--|---|---|
| Search Radar . . . . .                 | 9460 watts, 9890 va   | Total system<br>17 KW<br>22,100 va<br>including<br>air<br>conditioner |
| IFF/SIF Interrogator-Decoder . . . . . | 1000 watts, 1250 va   |   |
| Air Conditioner . . . . .              | 11,000 watts, 145<br>amp (locked rotor),<br>28 amp (running<br>rotor) |   |
| Utility Outlets . . . . .              | 1200 watts max,<br>1200 va  |   |
| Shelter Lights . . . . .               | 200 watts, 200 va   |   |

Overall Dimension and Weight

|   | <u>Length<br/>(inches)</u> | <u>Width<br/>(inches)</u> | <u>Height<br/>(inches)</u> | <u>Weight<br/>(pounds)</u> |
|---|----------------------------|---------------------------|----------------------------|----------------------------|
| Shelter   | 121                        | 84                        | 83                         | 4000                       |
| Antenna (folded)                                | 145                        | 87                        | 91                         | 4140                       |
| Antenna (operation with<br>outriggers extended) | 228                        | 258                       | 222                        | -                          |

Transportable Packages

|                 |   |
|-----------------|---|
| Shelter Package | Shelter housed electronic components and air conditioner; leveling jacks stored inside shelter. |
| Antenna Pallet  | Antenna folded down; outriggers folded in on pallet, waveguide also on pallet.                  |

Transportation Methods

|                |   |
|----------------|---|
| Cargo Aircraft | C-130A aircraft or equivalent.  |
| Helicopter     | Shelter and antenna pallet package each in lifting slings and lifted by helicopter. |
| Trucks         | Shelter and antenna pallet each secured on type M-35 truck or equivalent.           |
| Transporters   | Shelter and pallet mounted on transporters and pulled by truck.                     |

Table 9. Features

| <u>Features</u>        | <u>Radar</u>   | <u>IFF</u>   |
|------------------------|--|--|
| Transmission Frequency | 1250 to 1350 mc (tunable)  | 1030 mc  |
| Transmitter Pulse      | 1.4 $\mu$ sec at 800 pps or<br>1.4 $\mu$ sec at 553 pps or<br>4.2 $\mu$ sec at 267 pps | 0.7 to 0.9 $\mu$ sec<br>at 400 pps max<br>(modes 1, 2, 3) 1% max. duty<br>cycle (mode 4) |
| Transmitter Power      | 1 megawatt peak minimum  | 1.5 Kilowatts<br>peak, minimum, 2 Kilowatts<br>peak, max.                                |
| Reception Frequency    | 1250 to 1350 mc (tunable)  | 1090 mc  |
| Receiver Sensitivity   | -109 dbm MDS with<br>1.4 $\mu$ sec pulse or -113 dbm<br>MDS with 4.2 $\mu$ sec pulse   | -95 dbm MDS  |
| Range (unambiguous)    | To 275 M   | To 275 NM  |
| Accuracy               | 1° in azimuth  | 1° in azimuth  |

Table 9. (con't)

|   |  |   |
|---|--|---|
| MTI Cancellation<br>Radio               | 35 db  | — |
| VSI S/N<br>Improvement                  | 10 db typical  | — |
| <u>PWD Pulse Acceptance Range</u> ..... | $1\mu\text{sec} < \text{Pulse Width} < 2.0\mu\text{sec}$ or                                |   |
|   | $1\mu\text{sec} < \text{Pulse Width} < 3.0\mu\text{sec}$ or                                |   |
|   | $1\mu\text{sec} < \text{Pulse Width} < 4.0\mu\text{sec}$                                   |   |
| <u>Antenna Pattern</u>                  |  |   |
| Vertical .....                          | Csc <sup>2</sup> from 7 to 27 elevation, 3 db beamwidth 7° Fan beam from 0 to 7° elevation |   |
| Horizontal .....                        | 3 db beamwidth 4°  |   |
| Antenna Rotation .....                  | 0 to 15 rpm, variable  |   |
| <u>Ambient Temperatures</u>             |  |   |
| Non-Operating .....                     | -62°C to +71°C (-80°F to +160°F)   |   |
| (with solar radiation)                  |  |   |
| Operating .....                         | -40°C to +51°C (-40°F to +125°F)   |   |
| <u>Wind and Ice</u>                     |  |   |
| Non-Operating .....                     | 100 knots with 2 inches radial ice   |   |
| Operating .....                         | Antenna rotation 14 rpm at 25 knots with 0.5 inches radial ice                             |   |
|   | Antenna rotation 6 rpm at 52 knots with 0.5 inches radial ice                              |   |
| Humidity .....                          | Up to 95 percent   |   |
| <u>Altitude</u>                         |  |   |
| Operating .....                         | 10,000 feet  |   |
| Non-Operating .....                     | 50,000 feet  |   |
| <u>Rain and Snow</u>                    |  |   |
| Rain .....                              | 4 inches per hour  |   |
| Snow .....                              | 2 inches per hour, windblown   |   |
| Set-Up Time .....                       | 2 hours or less with 4-man crew  |   |
| Take-down Time .....                    | 2 hours or less with 4-man crew  |   |
| Warm-up Time .....                      | Off to operate, 15 minutes   |   |

(d) Functional Description

System Functions

The search radar of the AN/TPS-44 is a long range type which is designed for air search. It provides azimuth and range data on large and small cross-section aircraft at ranges up to 275 miles. Targets are displayed on a 10-inch PPI scope and a 3-inch A-scope. The IFF radar

includes an IFF interrogator and a decoder. In addition, remoting provisions are provided to enable transmission of video azimuth and range data on targets to a remote control center via a microwave link or land lines.

An MTI (Moving Target Indication) system is incorporated on the 40 and 80 mile ranges (gated MTI). In the MTI mode, the clutter of fixed objects on the indicator displays is greatly reduced, thereby effectively increasing the ability of the system to detect a moving target in an area of fixed objects. In the normal or VSI (Video Sweep Integration) modes, the MTI feature is removed.

The antenna can be rotated in azimuth either by an adjustable constant speed circuit for continuous operation, or by a manually positioned servo circuit for searchlight operation. In continuous search operation, the antenna can be driven in a clockwise direction only. In the searchlight operation, the antenna can be rotated in either direction.

Operational control of the entire equipment can be performed at the front panel of the indicator rack. Provisions are made for switching operational control of the equipment to a remote location.

#### Major Groups of the Radar Set

##### Antenna Group

The antenna group consists of a foldable parabolic reflector and feedhorn assembly, an azimuth scanning antenna pedestal, a pedestal leveling assembly and a manually adjustable elevation mechanism.

Radar and IFF r-f signals are conducted through a waveguide and an r-f cable, respectively. These signals are applied to and from the same antenna by a rotary joint coupler to the feedhorn of the antenna. The FAA warning light and the antenna feedhorn heater receive a-c power through the pedestal rotary joint.

A manual antenna tilt control enables -3 to +6 degree elevation adjustment of the reflector-feed assembly. In addition, a leveler assembly enables manual adjustment of the pedestal to a level position when the pallet is within 6 degrees of being level.

##### Receiver Group

The receiver group consists of a parametric amplifier, a frequency converter, an i-f amplifier, a signal comparator, a delay line, an electrical synchronizer, and a power supply.

Received signals through from the antenna are coupled through a directional coupler, a duplexer and a coaxial switch to the receiver front end. The parametric amplifier, located in the front-end amplifier, receives signals. This is a very low-noise amplifier. Also, this amplifier can be bypassed, by a self-contained circuit, if the tactical condition requires such an operation. The amplified or passed r-f signal is applied to the frequency converter.

The frequency converter receives the r-f signal from the parametric amplifier and a sample of the transmitted signal from the transmitter. By the mixing action of the received r-f and an injection from an internal stabilized local oscillator, an i-f signal results. The transmitter sample is mixed with an injection from the internal stabilized local oscillator in the AFC (automatic frequency control) mixer. The AFC signals stabilize the mixing conversion of the converter. The system trigger signal from the electrical synchronizer is used to initiate AFC (automatic frequency control) action within the transmitter sample. The AFC mixer output is further processed to generate a lock pulse signal for the COHO and test pulses for MTI.

The i-f signals are amplified and processed by the i-f amplifier to produce an MTI i-f

signal and normal video signal. Trigger and pretrigger inputs to the i-f amplifier initiate the operation of the STC (sensitivity time-control) circuits. A noise-feedback circuit is available to desensitize the linear i-f amplifier during clutter blocks. If selected by the operator, these circuits vary the gain of the linear i-f amplifier so that at short ranges the gain is reduced. The two output signals are applied to the signal comparator.

The signal comparator has two modes of operation: VSI and MTI. In VSI, integration is performed by summing incoming video with video that has been delayed by one prf period (the delay period of the delay line). Thus, any signals that are coincident will be enhanced; any that are not will not be enhanced. In MTI, the incoming video signal is compared with a video signal that has been delayed one prf period. Coincident video signals with equal amplitude are cancelled in the MTI mode. Normal, VSI or MTI video is sent to electrical synchronizer. The VSI, MTI, and pretrigger sync carrier is sent through the delay line to the electrical synchronizer.

The electrical synchronizer provides the following:

- System triggers and pretriggers for master timing of the radar set.
- Pulse width discrimination of video inputs to eliminate pulses that are wider than the width of the transmitted pulse or less than  $1\mu$  sec pulse width.
- Delayed trigger sync carrier provides a video delay of one prf during MTI or VSI operation.
- Delayed VSI carrier provides a means of power amplification for the VSI signal.

#### Transmitter Group

The transmitter group consists of a transmitter control, a radar modulator, and a magnetron oscillator. Associated components are a tuning drive unit (used to adjust the frequency output of the magnetron) and a video dummy load (used as a test load during testing of the modulator).

The transmitter control receives the radar trigger from the electrical synchronizer of the receiver group. This trigger is passed through the transmitter control chassis to the radar modulator as an interlocked signal. Control of the pulse width is accomplished by processing the pulse-width signal from the azimuth-range indicator (PPI). A mechanical tuning drive determines the frequency of the magnetron. Either high or low power operation of the transmitter is manually selected by the control. In automatic operation, the modulator is automatically placed in a low-power output mode at the end of the fifteen minute warmup period. The transmitter may then be placed in high power at the operator's convenience. Various monitoring of the modulator operation is accomplished at the control unit.

The modulation trigger fires the modulator thyratron, which in turn energizes the magnetron oscillator. All control and monitoring of the modulator operation is performed by the transmitter control, including high and low power output. The magnetron output is fed through a duplexer, a directional coupler and waveguide to the antenna.

#### Video Indicator Group

The video indicator consists of an indicator group monitor (A-scope), a local receiver control, an azimuth range indicator (PPI), a power supply, and an electronic control amplifier. In addition, an intercommunications unit, a telephone set, and a jack patch are mounted in the indicator rack.

The A-scope can monitor the range signals or various internal operating waveforms of the radar set. As shown in the block diagram, system triggers and pretriggers, normal or VSI video, and MTI video are received from the electrical synchronizer of the receiver. Range markers, received from the PPI, are displayed on the A-scope when it is used as a range monitor.

System trigger, normal video, and MTI video signal are interlocked by the A-scope to the PPI. Control of the STALO frequency and selection of automatic or manual frequency control of the receiver is facilitated at the A-scope. In addition, the A-scope panel can monitor and control the magnetron frequency of the transmitter.

Azimuth and range data are displayed on the PPI scope. This unit includes most of the radar set operating controls. The displayed azimuth position is synchronized with the position of the antenna by the synchro data received from the antenna group. Automatic clockwise scanning, up to 15 rpm, or manual searchlight scanning in either direction is facilitated by an antenna speed circuit. Normal, VSI or MTI video, and IFF video returns are displayed as intensified areas or spots. Remote signals are sent to the operations central panel from the PPI.

Electrical power to drive the antenna is supplied by the electronic control amplifier, which is the servo amplifier in the antenna servo system. The tachometer feedback signal completes the servo loop to this amplifier.

#### Interrogator Group

This group consists of an interrogator set and a decoder unit; the decoder is mounted on the video indicator rack. The interrogator basically transmits IFF interrogations and receives airborne transponder replies, which are analyzed by the decoder to determine whether the target is a friend or foe. In addition to its function as an identifying equipment, the interrogator can be used for tracking a friendly aircraft. Both radar and IFF signals are received and transmitted from a common antenna. The circuits that comprise the interrogator are as follows:

- Antenna circuits that include directional coupler, duplexer and preselector stages.
- Transmitting circuits that include a pulse shaper, modulator, and power output stages.
- Receiving circuits that amplify IFF replies.
- Trigger generating circuits that are synchronized with the radar search signals. These circuits time and control the operation of the interrogator.
- Coding circuits that determine the transmission modes.
- Indicating and control circuits that monitor and are used to manually control the operation of the interrogator.

#### Power Distribution Group

The a-c power from either generator of the power pallet can be selected by the GEN SELECT switch. This switch has an AUTO position which enables automatic switchover to the standby generator. The generators also supply d-c power for emergency shelter lighting.

The main a-c circuit breaker can shut down the entire system; group circuit breakers and miscellaneous breakers are used to energize and deenergize individual groups and miscellaneous functions.

#### **(e) Electronic Counter-Countermeasures (ECCM)**

##### Video Sweep Integrator (VSI)

By VSI, integration is performed by summing incoming video with video that has been delayed by one prf period. Thus any signals that are coincident will be enhanced; any that are not will not be enhanced. Non-synchronous interference, (such as caused by a nearby radar, the prf of which may or may not be constant) and its carrier frequency which may or may not correspond to that of the desired signal will not be integrated and, therefore, will be removed from the display. This type of interference has a fence-like appearance on the A-scope and a spoke-like appearance on the PPI display.



#### Sensitivity Time Control (STC)

Sensitivity time control provides low sensitivity at zero range and increases the sensitivity at 12 db per octave (in-range). The sensitivity of the receiver is thereby lowered for strong (close-in range) returns and raised for weaker (far-out range) returns. STC is a feature which prevents Ring Around interference from being displayed on the PPI (appears as circular range rings). This interference occurs when a strong target is close enough in range to give returns not only in the mainlobe, but also in the sidelobes.

#### Pulse Width Discriminator (PWD)

The PWD is used to select only video pulses which are between a lower and an upper blanking limit. The lower blanking limit is fixed at 1.0 sec; the upper blanking limit can be set to 2.0, 3.0, or 4.0 microsec. Video pulses less than the lower blanking limit or above the upper blanking limit are rejected. Video pulses within the blanking limits are displayed. This circuit is an effective method of rejecting interference or false target (synchronous jamming) which falls outside of the radar's pulse width.

#### Logarithmic Fast Time Constant (Log FTC-CFAR)

This is a standard method of obtaining wide dynamic range and constant false alarm rate (CFAR) against noise jamming. (The characteristic effect of noise jamming on a linear amplifier is that the PPI goes black in the jammed areas. The noise jamming drives the amplifier beyond its dynamic range and permits no output signal even though they may be stronger than the jammer.) In LOG FTC operation, wide signals, such as clutter, returns are differentiated to produce super-clutter visibility.

The LOG-CFAR operation, with a narrow band video filter, and a smooth and symmetrical impulse response, averages the number of resolution cells of interference, and its output is a reasonable average containing little fluctuation compared to its input. The CFAR characteristic is obtained by the ability of the filter to follow any changes in the average interference power. In both cases, signals stronger than the interference can be observed on the PPI (super-clutter, super-jamming visibility).

#### **(4) Troposcatter Radio (TRC-97A)**

This is discussed in the TACC Element section.

#### **5. Direct Air Support Center Element (DASC)**

##### **a. General**

The DASC is a highly mobile air transportable facility designed to operate with the Army Tactical Operation Center (TOC). It is subordinate (a forward element) to the TACC and receives plans and coordinates Army requests for immediate close air support, tactical air reconnaissance, and assault airlift. It directs the employment of the air effort allocated for these missions and acts as advisory agency to the Army Commander on the feasibility of requests for air support. The DASC also provides overall supervision for the activities of the Tactical Air Control Parties (TACP's). It must be capable of rapid deployment and must have mobility sufficient to permit operation under field conditions including the ability to split its facilities and personnel in a "leap-frog" fashion to insure continuous operation when changing location.

##### **b. Configuration Concepts**

The size of a DASC deployment is dependent primarily upon the force level supported.

The highest ground force level conducting daily combat operations will be provided a DASC. Since this can vary from a single division (or smaller operation) to a field army, the size can vary considerably. Usually the functions of the element do not change with a change in the force level supported. The capacity of work is proportional to the deployment configurations, i.e., minimum, medium, maximum, or alternate.

**c. Functional Configuration**

A typical field deployment is shown in Figure 16, a typical block diagram in Figure 17.

**d. DASC Equipment Description**

**(1) DASC Operations Center (TSQ-93)**

**Mission.** The center is the operations/communications portion of the DASC which integrates with the Army Tactical Operations Center to provide fast reaction to ground requirements for immediate close air support and tactical reconnaissance.

**Configuration.** The communications/operations modules (inflatable shelters, i.e., one cell assembly sequence shown in Figure 18) are capable of expanding from an alternate through a maximum configuration. The number and types of modules for each deployment configuration are listed in Table 10. A typical DASC Operations Center (inflatable shelter) is shown in Figures 19 and 20. A plan view and modular expansion of a typical DASC Operations Center (minimum configuration) are shown in Figures 21a and 21b.

**Functional Characteristics**

**Communications Module.** The module is used to accomplish interconnection of the transmission media to the Operations Module (Center). It handles teletype and voice communications and also includes technical control (analogous to TSC-62) equipment. The equipment provides the following functional capabilities: telephone switching, secure and non-secure teletype and telephone, communications, and as mentioned earlier, technical control capability.

**Table 10. DASC Modules/Equipment Quantities**

| Equipment                           | Equipment Quantities |     |     |     |
|-------------------------------------|----------------------|-----|-----|-----|
|                                     | Alt                  | Min | Med | Max |
| DASC Operations Module              | 1                    | 1   | 2   | 3   |
| DASC Communications Module          | 0                    | 1   | 1   | 1   |
| Prime Power/Air Conditioning Module | 1                    | 2   | 3   | 4   |
| Total                               | 2                    | 4   | 6   | 8   |

**Equipment and Staffing.** All deployment levels shall be provided with desk positions, communications equipment, and support equipment for operating personnel in the quantities shown:

| Deployment | Personnel |
|------------|-----------|
| Minimum    | 10        |
| Alternate  | 12        |
| Medium     | 24        |
| Maximum    | 36        |

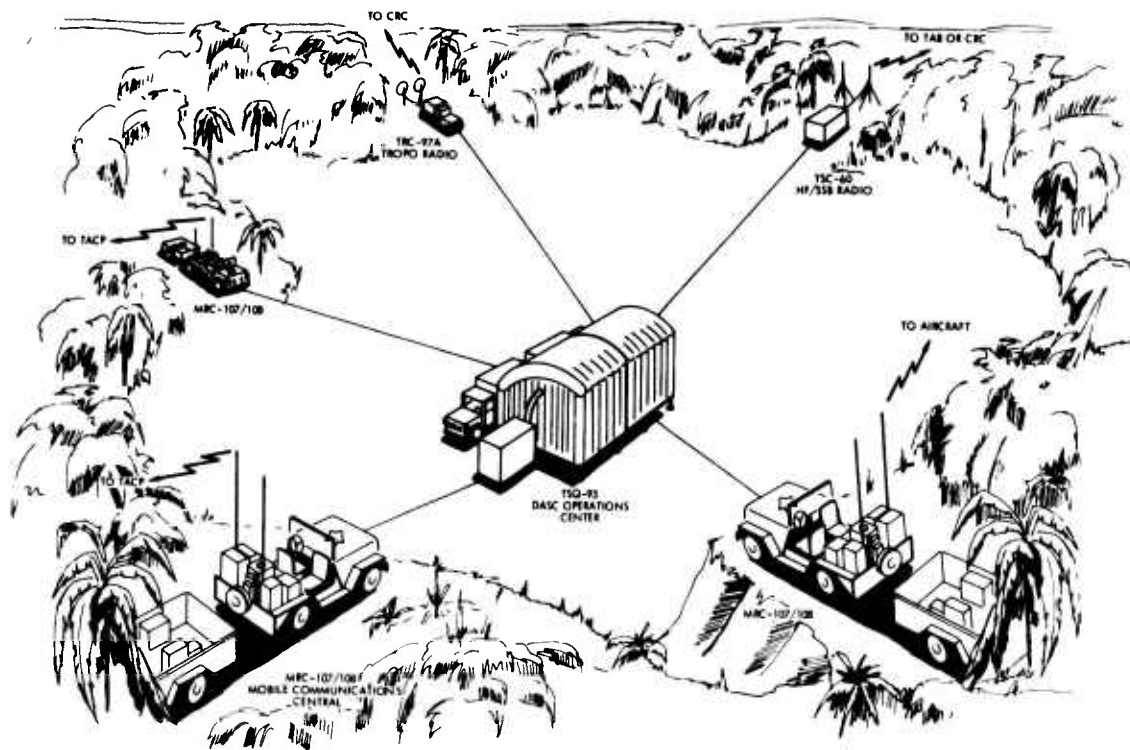

Figure 16. DASC Typical Field Deployment

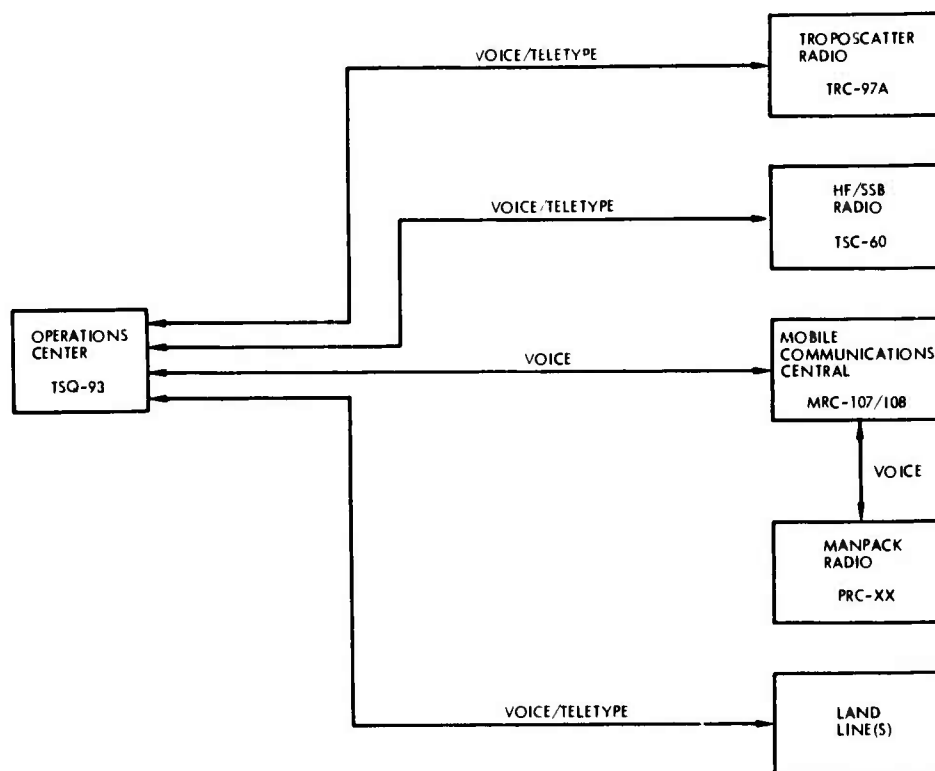

Figure 17. DASC Block Diagram (Typical)

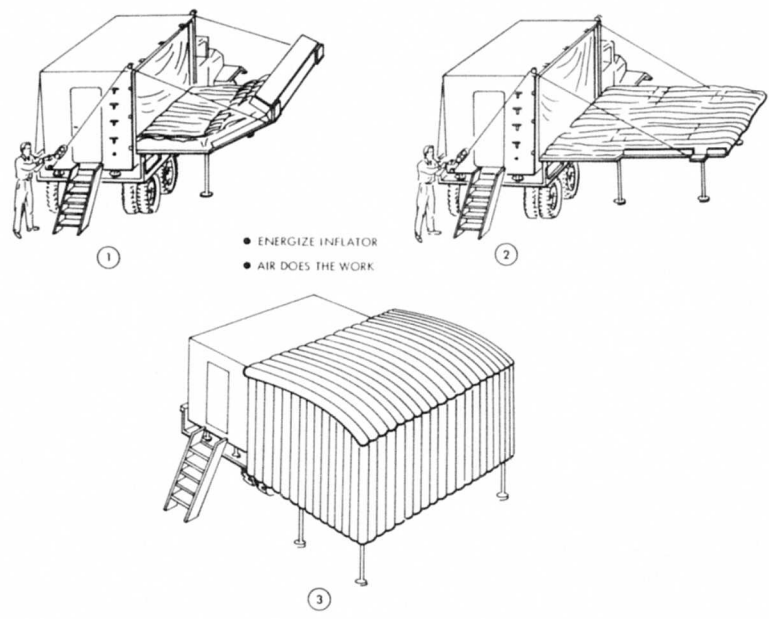

Figure 18. DASC Operations Center – Assembly Sequence

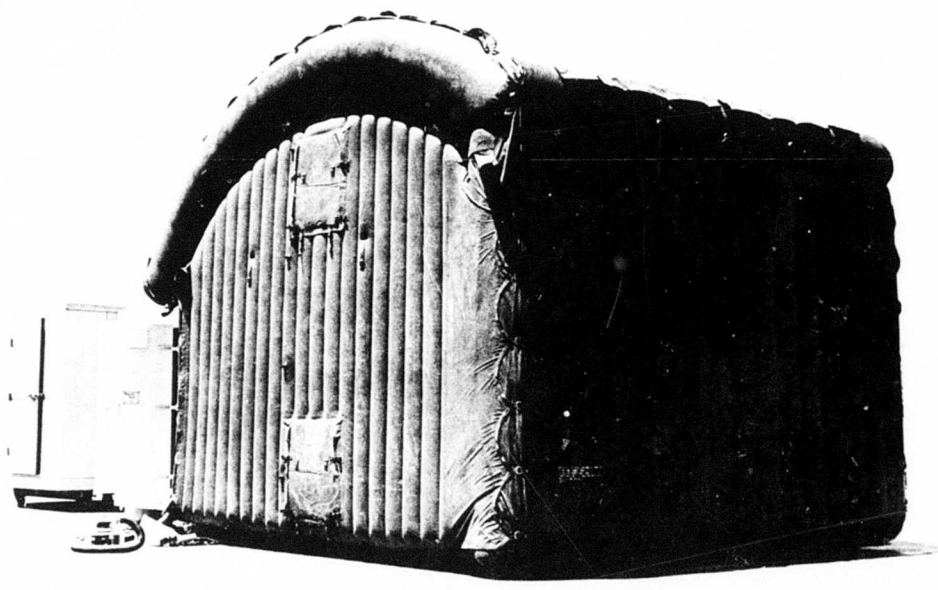

Figure 19. DASC (Alternate) One-Cell Module Operations Shelter

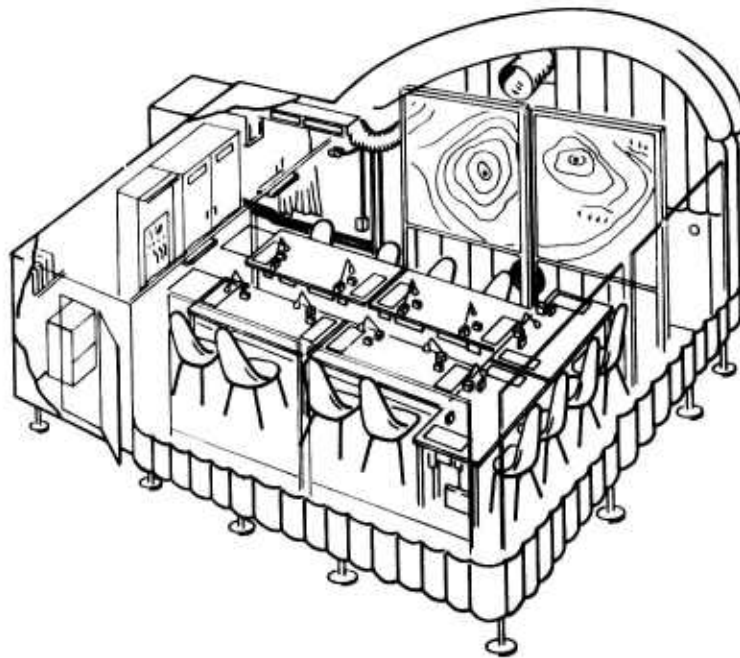

Figure 20. DASC (Alternate) Operations Center Internal Layout

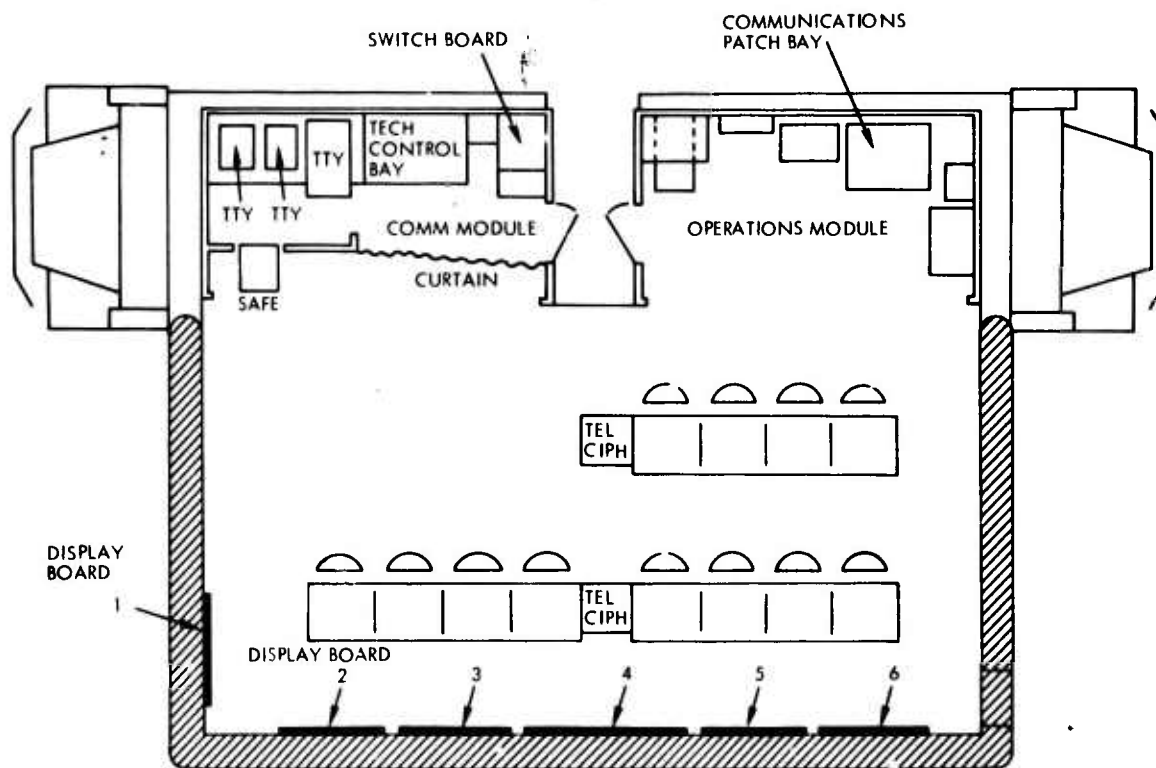

Figure 21a. DASC (Minimum) Operations Center

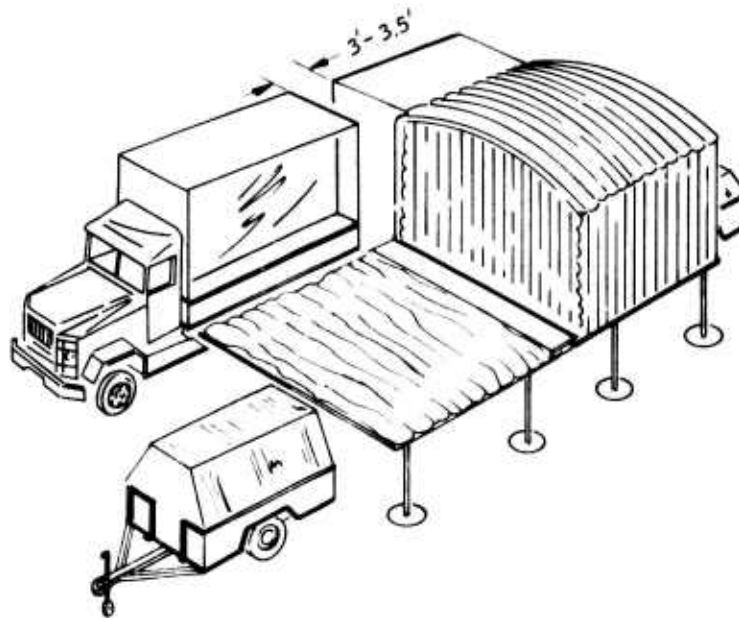

Figure 21b. DASC (Minimum) Operations Center – Module Expansion

Operations Module. The operations module will normally be mated (electrically, mechanically, and physically) to the Communications Module. The Operations shelter will contain radio and telephone patching equipment through which the operational positions are provided secure and nonsecure telephone and ground-to-air radio service. The module will also be provided with display boards for plotting and posting tactical situations.

**(2) Mobile Communications Central (MRC-107/108)**

The radio centrals are "Jeeps" containing vehicle-mounted and manpack radio communications equipment which operate in the HF, VHF, and UHF ranges. The centrals are used to communicate between

- (a) The DASC Operation Center and aircraft via UHF/VHF
- (b) The DASC Operation Center and the TACP (Forward Air Controller) via HF
- (c) The TACP (Forward Air Controller) and the aircraft via UHF/VHF

The MRC-107 and MRC-108 Radio Centrals are functionally interchangeable.

**(3) VHF/FM Manpack Radio (PRC-25/PRC-77)**

This is discussed in the TACP Element section.

**(4) UHF/AM Manpack Radio (PRC-41/PRC-66)**

This is discussed in the TACP Element section.

**(5) HF/SSB Manpack Radio (PRC-47/PRC-104)**

This is discussed in the TACP Element section.

**(6) Troposcatter Radio (TRC-97A)**

This is discussed in the TACC Element section.

**(7) HF/SSB Radio (TSC-60V)**

This is discussed in the TACC Element section.

**6. Tactical Air Control Party Element (TACP)**

**a. General**

The TACP consists of Air Force personnel and mobile communications equipment. The personnel are "attached" to Army command posts (CP) as an Air Liaison Officer (ALO) and in the front lines as a Forward Air Controller (FAC). The FAC visually directs tactical air strikes on ground targets close to friendly lines. The ALO serving at the CP normally serves to advise the Battalion Commander of Air Force capabilities and also transmits mission requests to the DASC. The equipments comprising the element are the Communication Central (MRC-107 and MRC-108) and the Portable Manpack Radios (PRC-25/PRC-77 VHF/FM, PRC-41/PRC-66 UHF/AM, and the PRC-47/PRC-104 HF/SSB).

**b. Functional Configurations**

A typical field deployment is shown in Figure 22; a typical block diagram in Figure 23.

**c. TACP Equipment Description**

**(1) Mobile Communications Central (MRC-107/108)**

This is discussed in the DASC Element section.

**(2) VHF/FM Manpack Radio (PRC-25/PRC-77)**

This is a portable manpack transceiver of approximately 5 miles range. It operates between 30 and 76 MHz with an output power of 1.5 to 2.0 watts and is used for ground-to-air (G/A) communications.

**(3) UHF/AM Manpack Radio (PRC-41/PRC-66)**

This is a portable manpack transceiver of approximately 25 miles (line-of-sight) range and communicates with aircraft and operates between 225.0 and 399.9 MHz with an output of 3.0 watts.

**(4) HF/SSB Manpack Radio (PRC-47/PRC-104)**

This is a portable two-manpack upper sideband transceiver possessing CW capability. It operates between 2.0 and 11.999 MHz with an output power of 100 watts (high power) and 20 watts (low power) and is used to communicate between the Forward Air Controller and the DASC Operation Center.

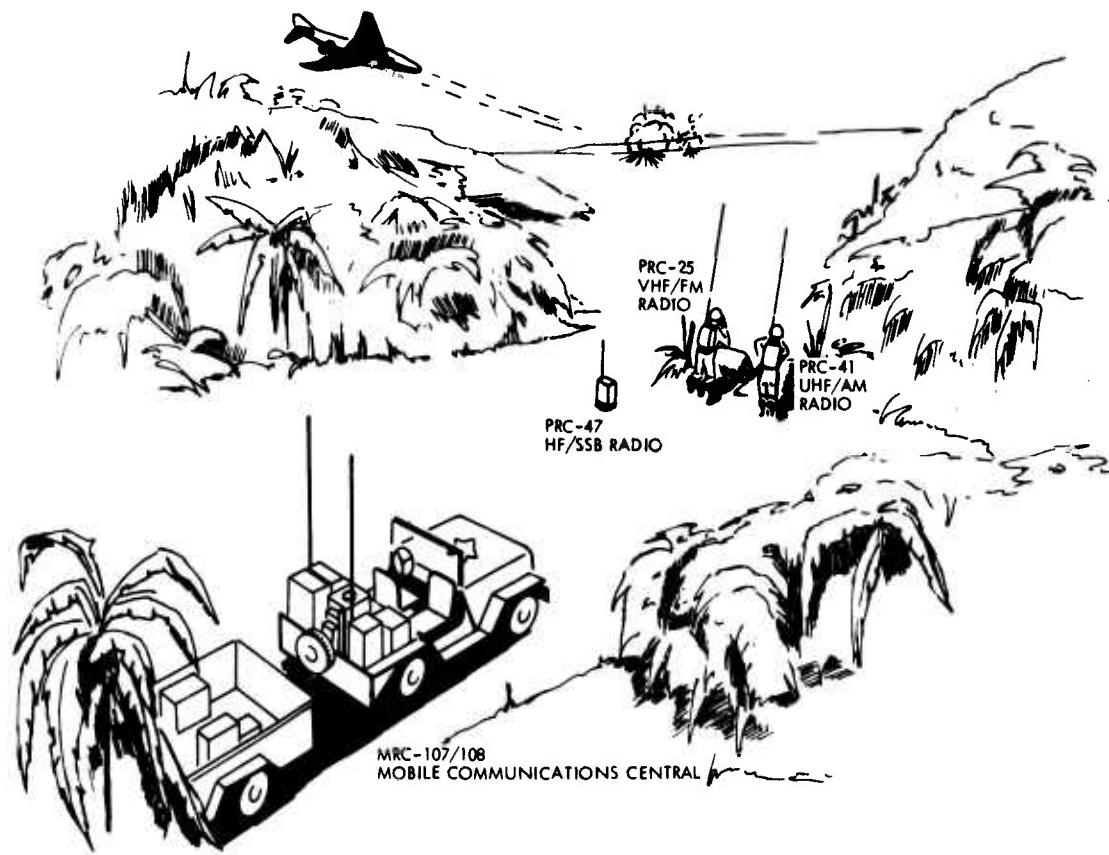

Figure 22. TACP Typical Field Deployment

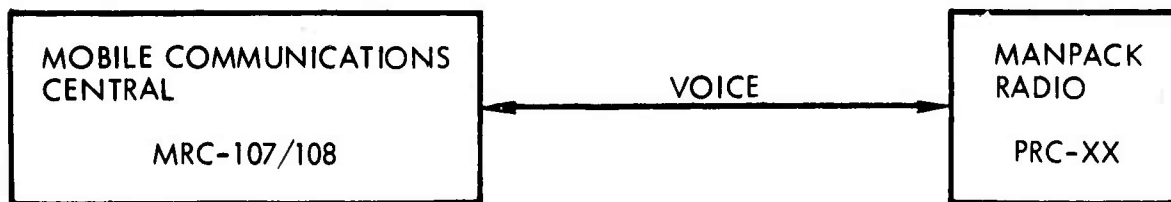

Figure 23. TACP Block Diagram (Typical)

**7. Tactical Air Base Communications/Terminal Air Traffic Control Facility (TAB Comm/TATCF)**

**a. General**

The air base is the operating location from which the Tactical Air Force Units react in support of the Air Force Component Commander's requirements for interdiction, troop ground support, airlift, reconnaissance, etc.





#### **d. TAB/TATCF Equipment Description**

##### **(1) Landing Control Central (TPN-19)**

The Landing Control Central, normally referred to as the Transportable Ground Controlled Approach (TGCA) facility, shall be a self-contained modular three-shelter complex whose shelters are linked via microwave and multiplex remoting equipment or cable. The facility shall consist of

Operations Shelter (RAPCON)

Air Surveillance Radar (ASR) Shelter, including Air Traffic Control Radar

Beacon System (ATCRBS) capability

Precision Approach Radar (PAR) Shelter

It shall include radar equipment, radio communications, microwave links, environmental control units, primary power generators, furnishings, and spares.

The deployment configurations can utilize the TGCA capability of simultaneously performing surveillance and precision GCA guidance assistance for aircraft at the designated air base. It should be emphasized that the ASR and PAR shelters also have the capability of autonomous operation, while collocated or separated, for independent performance of the surveillance or precision GCA functions. There may be deployment situations where a complete TGCA facility is located at one air base and, due to the proximity of another air base, all that will be required is a PAR shelter or a PAR shelter and an Operations shelter.

##### **(2) Air Traffic Control Central (TSW-7)**

The TSW-7 Central is used to provide visual air traffic control over aircraft on the ground and in the air within a designated control zone where fixed air traffic control is accomplished through the use of radio communications and, to a lesser degree, by light signalling (light gun). A limited capacity for approach control service is available through the use of the radio equipment and flight data strips. The TSW-7 has the following capabilities:

- (a) Acquires data by voice which is derived from
  - Incoming search radar
  - Incoming navigational aids
  - UHF/VHF direction finding equipment and visual observation
- (b) Provides holding patterns, approach and landing guidance to aircraft pilots via
  - UHF/VHF radio systems
  - Light gun
- (c) Provides the aircraft commander with
  - Taxi information
  - Parking information
- (d) Under emergency conditions the TSW-7 tower alerts
  - Fire fighting trucks
  - Crash trucks

##### **(3) Instrument Landing System (AN/TRN-27 TALAR)**

The AN/TRN-27 TALAR is a lightweight, portable Instrument Landing System supplied to combat control teams and for use on bare bases.

**(4) Tactical Air Navigation (AN/TRN-26 TACAN)**

The AN/TRN-26 TACAN is a lightweight mobile TACAN for use by the Air Force Communication Squadron (AFCS) mobile Communications Groups in support of tactical operations.

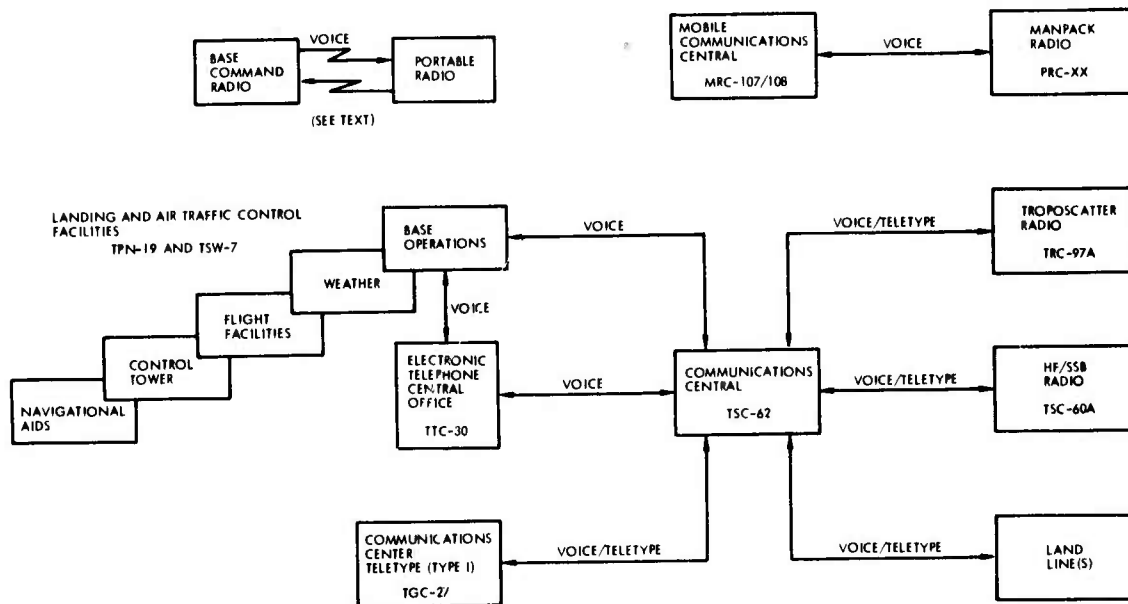

**Figure 25. TAB Comm/TATCF Block Diagram (Typical)**

**(5) Tactical Air Base Weather Station (TABWS)**

The TABWS provides a capability for observation of local weather conditions, weather analysis and limited local short term forecasting, and interfacing with external weather elements.

**(6) Communications Center Teletype (TGC-27) (TYPE 1)**

This is discussed in the TACC Element section.

**(7) Troposcatter Radio (TRC-97A)**

This is discussed in the TACC Element section.

**(8) HF/SSB Radio (TSC-60V)**

This is discussed in the TACC Element section.

**(9) Communications Central (TSC-62)**

This is discussed in the TACC Element section.

**(10) Mobile Communications Central (MRC-107/108)**

This is discussed in the DASC Element section.

**(11) VHF/FM Manpack Radio (PRC-25/PRC-77)**

This is discussed in the TACP Element section.

(12) UHF/AM Manpack Radio (PRC-41/PRC-66)  
This is discussed in the TACP Element section.

(13) HF/SSB Manpack Radio (PRC-47/PRC-104)  
This is discussed in the TACP Element section.

(14) Electronic Telephone Central Office (TTC-30)  
This is discussed in the TACC Element section.

## 8. Support Equipment

(a) In addition to the radar, data processing, display, and communications equipments identified and which provide the basic operational equipment for the TACS elements, numerous ancilliary items have been procured which are required for the support of the deployed elements. These include, but are not limited, to:

Demountable dolly sets to facilitate the movement of TACS shelters and pallets;

Electronic maintenance shops and electrical equipment shelters for the maintenance and supply of deployed equipment;

Pallet and shelter loading kits to facilitate the transport of equipment;

Gas turbine and diesel power generating equipment;

Environmental control units; and

Fuel handling system.

## 9. Other TACS Facilities

### a. Airlift Control Center (ALCC)

The airlift control function at minimum force level is normally performed within the TACC. When the size and planning load of the airlift missions increases, the airlift control function may exceed the physical capabilities of the space allocated in the TACC. In this case, a separate ALCC facility is established with its own shelter, furnishings and communications equipment.

### b. Airlift Control Element (ALCE)

The ALCE is an element of the TACS through which the ALCC maintains control of assigned airlift forces and ensures their effective employment and utilization. The ALCE contains limited ground-to-ground and ground-to-air communications equipment for communicating with airlift aircraft, other TAB units, and other elements of the TACS and manual display equipment for mission monitoring, resource status monitoring and performance monitoring.

### c. Combat Control Team (CCT)

The CCT is the TACS element which provides for the initial air traffic control in the objective area of an airborne assault. It provides and operates the terminal navigational aids required to ensure that the airlift forces reach the objective area. Equipment includes air deployable ground-to-ground and point-to-point radio equipment, navigational and identification aids to mark landing/drop points, and weather observation equipment.



d. Air Support Radar Team (ASRT)

The ASRT is a mobile facility for providing accurate, all-weather terminal navigation for strike, reconnaissance and airlift aircraft. The ASRT equipment includes point-to-point radios for communicating with other elements of the TACS, primarily CRCS, CRPS, TACPS, and DASCs; ground-to-air radios for controlling mission aircraft; and specialized radar and computational equipment for aircraft guidance.

e. Sensor Reporting Post (SRP)

The SRP provides the TACS with information on ground targets obtained by surveillance sensors implanted in either friendly or enemy territory. The facility, which has been constructed from basic TACS equipment, receives ground surveillance sensor information via relay aircraft. This information is processed and correlated to identify potential ground targets. Information on these is then forwarded to the appropriate TACS element for allocation of strike resources and interdiction of the targets.

f. Airborne Tactical Air Coordination Center (ATACC)

The ATACC provides an airborne extension of the TACC Current Operations Division. It provides for direct on-the-scene control of airborne units performing tactical missions.

g. Airborne Battlefield Command Control Center (ABCCC)

The ABCCC is a modular command and control center capable of being carried in a C-130 aircraft. It provides the Commander with an immediate accessible command center which can be utilized as a Joint Operations Center, an Airborne Command Post, a TACC or a DASC during the initial stages of a deployment.

h. Airborne Warning and Control System (AWACS)

Provides tactical commanders with an airborne command and control platform which will function independently or as an integral element of the Tactical Air Control System. It will provide an airborne surveillance capability and the associated command, control and communications functions required to support or to supplement ground TACS elements in any given contingency operation. AWACS will be employed to enhance the deployment, initial employment and maintained operations of tactical forces engaged in all phases of tactical warfare, i.e., counter air, interdiction, close air support, reconnaissance, airlift, special as well as support operations.

**10. 485L Tactical Air Control Systems Improvements (TACSI) Descriptions**

The 485L Program is defined by SMD-1-406-485L-(1) as being "... established to manage and provide material improvements to the Tactical Air Control System (TACS)." It is the intent of the Program to provide evolutionary improvements to the TACS in the areas of Tactical Air Control (including TACC, ALCC, CRC, ALCE, CCT, CRP and FACP), Tactical Air Support (including DASC and TACP), and Communications (including facilities for the TAF HW, between the TAF HQ and the TABS, and inter- and intra-base). The basic TACS was characterized by limitations in particular areas. Of major import is the lack of data automation capability at the TACC/ALCC level to aid the Tactical Air Force Commander in performing the planning and operational functions.

A second major area which has been recognized as requiring an improved capability is the CRC/CRP. While many of the CRC/CRP functions were automated, the AMS (Air Movements System) function remains essentially manual. This limits severely the number of aircraft for which the available operators can provide appropriate direction. Additionally, within the CRC/CRP the radar tracking function on non-SIF returns is essentially manual; continuous attention by the operator is required for the system to track any non-SIF maneuvering aircraft. This also limits the ability of the operators to follow and manage the entire air situation.

Thirdly, RADs 9-15-(2) and 9-15-(2A) require the development, exercise, and evaluation of a capability to digitally exchange air surveillance (and other) information with the Tactical Data Systems of the Navy, Marine Corps, Army, and other deployed systems such that the capability to conduct joint operations can be established/demonstrated. This requirement results in the necessity to make significant changes in the TACS, primarily the CRC

In addition to the above, various communications improvements are planned for the current system. These involve the ability to remote communications/radars from the associated operations centers, and improvements in transportability and reliability of other communication equipments.

## 11. TACS Improvements

The TACS improvements developed under the 485L Program and authorized by SMD-1-406-485L-(1) are described below.

### a. Automatic Skin Tracking

The existing CRC/CRP capability provides automatic beacon tracking of friendly cooperative traffic; tracking by skin radar returns is rate-aided only. Automatic skin tracking can significantly enhance the total number of aircraft that can be updated and tracked simultaneously by a given number of operators. It also provides better quality track data for intercept vectoring and cross-telling to tracking systems associated with other defense weapons (surface-to-air missiles).

Since the 407L TACS CRC/CRP already includes automatic beacon tracking for cooperative IFF/SIF equipped aircraft, the class of targets to be automatically skin tracked are presumed to be either hostile or otherwise uncooperative.

The overall tracking improvement, however, is dependent on the quality of the radar data. There will be circumstances when automatic skin tracking may not be possible due to excessive clutter and/or jamming and, in such cases, it will be necessary to resort to manual or rate-aided tracking.

### b. Air Traffic Regulation

Within the CRC, there are current limitations in the air traffic regulation function. The limitations are primarily due to the manual tasks involved in the accomplishment of flight plan entry, maintenance and display; flight plan correlation and conformance checking; and aircraft position reporting, status reporting and communications. Automation of these functions requires a new CRC computer program in addition to the hardware items listed below.

### c. Flight Plan Entry, Maintenance and Display

The CRC must have information about all flights that are scheduled to operate in its area of responsibility. Flight plans enter the system from various sources and in varying degrees of completeness. They are currently manually checked and edited, and flight strips are handwritten from them. Flight strip modification is also a manual process for there is no provision for flight plans in the data base. Thus flight plan processing is time consuming and error prone with too much time spent on bookkeeping tasks.

To alleviate these weaknesses in the system, it is planned to develop an Enroute Air Traffic control capability for the CRC. This capability will be compatible with the FAA System.

### d. Tactical Air Control System (TACC) Automation

TACC Automation will provide the data processing required to reducing the data handling time within the selected lower echelon elements and the TACC and to expedite the flow of tactical operations data between these elements (Figure 26). The acquisition program will include hardware and software for these elements and their interface with the TACS communications capabilities provided under Program 407L. Maximum use will be made of 407L TACS communications, shelters, power plants, environmental control units and transporters.

The primary use of input data from the lower echelon elements to the TACC is for planning, monitoring and adjusting tactical air operations. The initial capabilities to be provided at the TACC will serve as the basic structure for further augmentation in subsequent phases of SEEK FLEX. Common to all phases is the need to exchange data with external sources, to provide for the centralized receipt and storage of data and the retrieval of data for presentation to the decision makers who support the basic TACC functions. The majority of the tactical data used for the Current Plans and Current Operations functions is received from the CRC, ALCE, DASC, TUOC/TUCP/TAB and other subordinate TACS elements. These usually are defined, structured messages with strict rules for reporting frequency, format and content. Provision will be made to accommodate the digital flow of information between the TACC element and the CRC, ALCE, TUOD/TUCP/TAB, and DASC, in addition to the existing communications with other interfacing elements.

Voice and teletype capabilities will continue to exist. In addition, a digital message processing capability will be acquired at the TACC to accommodate the exchange of operational information with the TUOC/TUCP/TAB, ALCE, DASC and CRC. This capability will be of modular design to allow for changes in the number of reporting elements, and to accommodate changes in formats and communication techniques.

### e. TACS/TADS System Description

The objective of the TACS/TADS Interface Program is to establish the technical compatibility, interoperability, and joint operational effectiveness in the interface among the several systems comprising the TACS/TADS environment. These systems include the AN/TSQ-73, NTDS/ATDS, AN/TSQ-91, MACCS, and SIS. The interface among these systems will provide for intersystem data exchange by digital means and will insure that such exchange is secure and can be accomplished on a real time or near real time basis during joint military operations.



## SEEK FLEX I/II

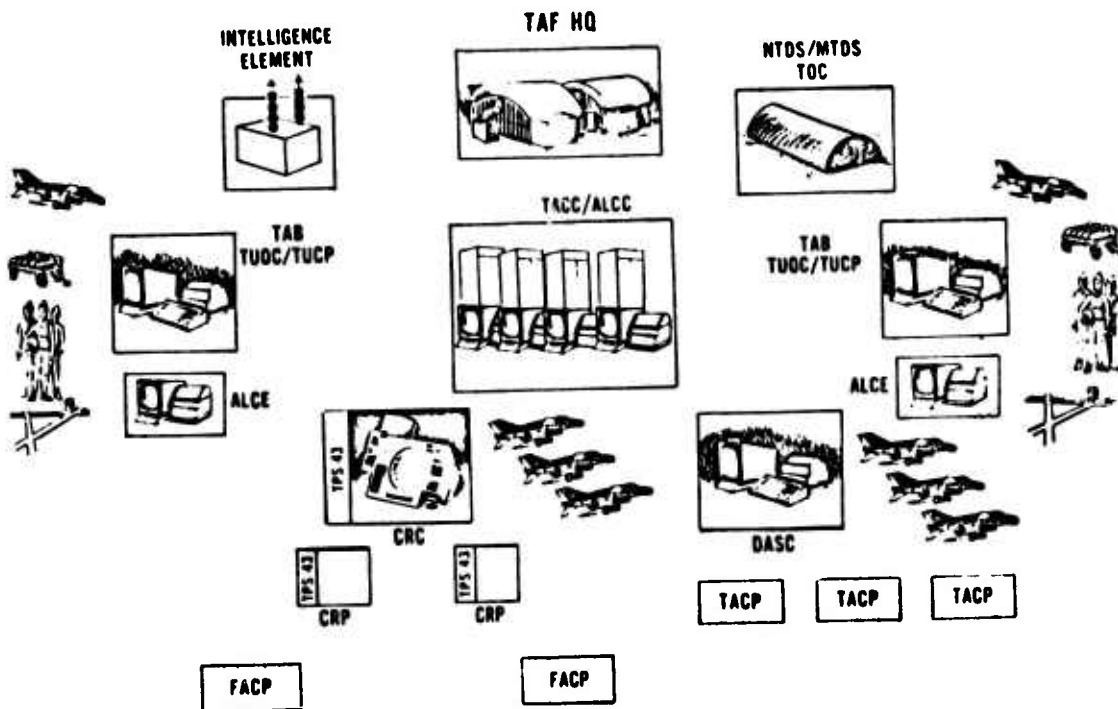

FIGURE 26

Each of the participating services will be responsible for the procurement, modification, installation, and checkout of its own test unit. Following this, intersite testing will proceed on a phased basis. Both simulated and live inputs will be introduced at each test unit and mutual exchange of information will be induced by appropriate actions and preconditions. As the tests progress, an attempt will be made to exercise all significant functional capabilities and load areas.

The Major Air Force design effort for TACS/TADS was the development of Message Processor Module. The Message Processor Module (MPM) includes a TADIL-A link, approximately five TADIL-B links and a data processor. The MPM will function to provide a secure digital data interface with external or remote TADIL-B systems, and with the joint MTDS/NTDS/ATDS TADIL-A net. Internal or local interfaces with other Air Force units (CRPs, CRCs, SRPs, and TACC), add on occasion with the Army AN/TSQ-73, will continue to be provided via the CRC Ancillary Equipment Module (AEM). It is currently planned that the MPM will be constructed by modifying an existing Data Processing Module (DPM).

### f. Microwave Relay

The TACS, and particularly the operations centers, are, by design, mobile and transportable. This capability allows deployment to tactically convenient locations which will often be selected to utilize natural terrain features, such as valleys or heavy canopy, for protection by concealment. However, such a philosophy is in distinct contradiction to the utilization of surveillance or communications equipment, thus necessitating the pro-

vision of a remoting capability. This microwave relay capability is intended to fill this requirement and will also provide a capability for short range, line-of-sight communications between elements (see Figures 27-32 and paras below).

Each of the data transfer systems employs the AN/GRC-199 radio set.

**(1) AN/GSQ-119 (V) Communications Data Transfer Central (CDTC)**

This device is an assembly of several physically discrete man-portable components for use in remoting intersite communications equipment and for transmission of reliable intersite 2W/4W telephone, teletype, facsimile and digital data traffic. The CDTC is a completely solid state design and provides full duplex-multichannel frequency division multiplexed microwave communication links operating up to 15 nautical miles line-of-sight in the 4.4 to 5.0 and 7.125 to 8.4 GHz frequency bands. The modular design of the CDTC allows for its expansion from an initial minimum capacity of 12 voice frequency (VF) channels to a fully implemented capability of 132 VF channels (or 16 teletype/control signals per voice channel). The microwave radio component of the CDTC has been designed to transmit up to 600 VF channels, although additional multiplexing and combining equipment would be required for this purpose. A baseband operating and diversity combining capability is inherent in the design of the CDTC; however, the equipment necessary to implement these features has not been provided. Each unique component is transit-case packaged and a pallet is provided for transporting a complete microwave terminal. All CDTC communications equipment is compatible with the requirements of DCA Circular 330-175-1, Notices 1 through 8.

**(2) AN/GSQ-120 (A) and (B) Radar Data Transfer Central (RDTC)**

The "A" version of the AN/GSQ-120 is capable of microwave remoting the inputs/outputs of the AN/TPS-43 Radar set to both the AN/TSQ-91 and AN/TSQ-61 Operation Centrals of TACS. The "B" version is capable of microwave remoting the inputs/outputs of the AN/TPS-44 Radar set to the AN/TSQ-61 Operation Central of the Forward Air Control Post. RDTC (A) and (B) each consists of two complete self-contained functional terminals; one located at the radar site and the second at the operations site. Each terminal of RDTC (A) and (B) is housed in a type S-141 shelter and is capable of transmitting and receiving the respective radar inputs/outputs over a 15 nautical mile path in either the 4.4 to 5.0 or 7.125 to 8.4 GHz frequency bands. The microwave radio used in the AN/GSQ-120 is the same as that used in the AN/GSQ-119.

**g. Lightweight Manpack Radios**

A need has long been recognized for a family of lightweight, manpack radio sets to provide the communications capabilities required by Tactical Air Control Parties (and Combat Control Teams). This requirement has been documented in TAC ROC 52-67 as amended 25 May 1970. Sets provided will weigh approximately ten pounds each, including an interoperable battery, and are generally intended to replace and upgrade current equipment.

**(1) HF-SSB Manpack Radio Set AN/PRC-100**

The HF-SSB radio will provide communication capability between the TACP and the DASC (Air Request Net) and coordination with Army/Artillery Nets. The frequency range will be from 2.000 MHz to 29.999 MHz with frequency control provided by a 1 KHz step synthesizer. This is a Marine Corps Development.

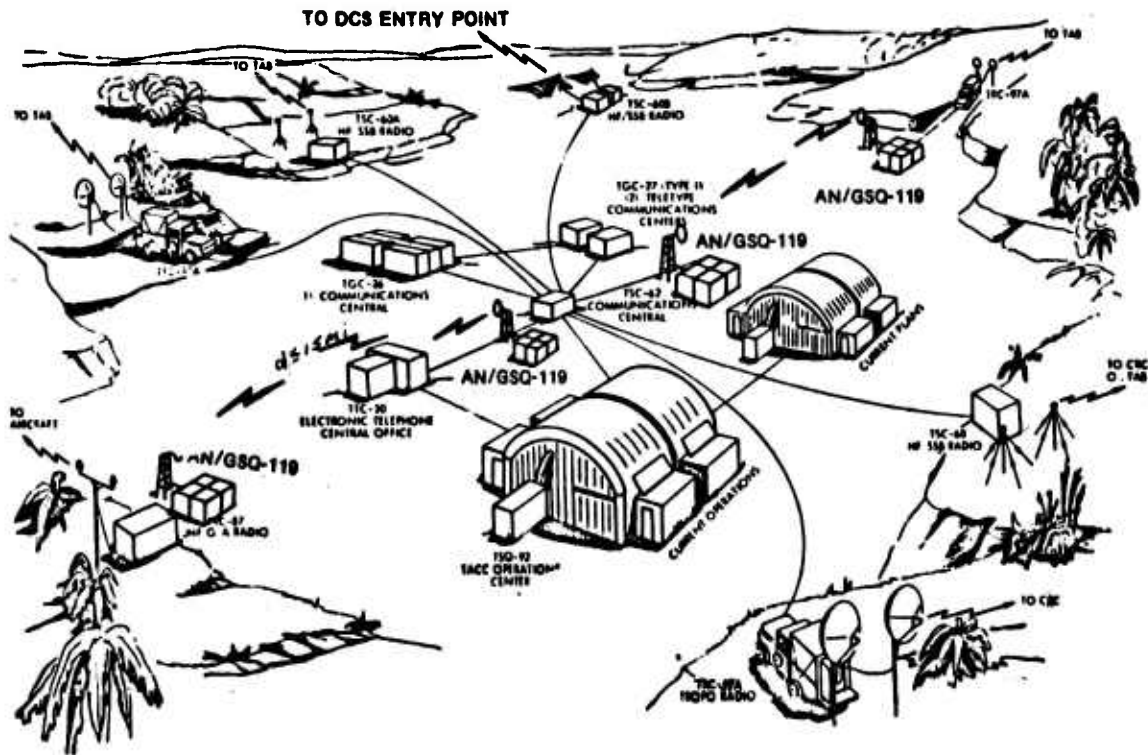

Figure 27 AFCH/TACC Typical Field Deployment

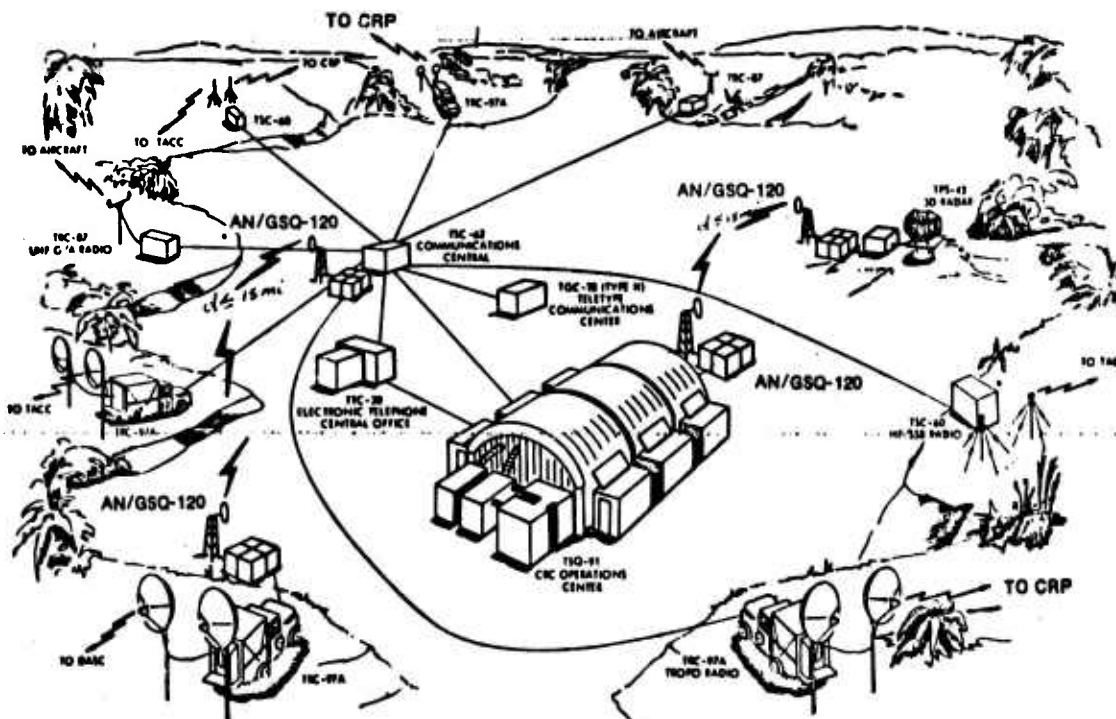

Figure 28 CRC - Typical Field Deployment

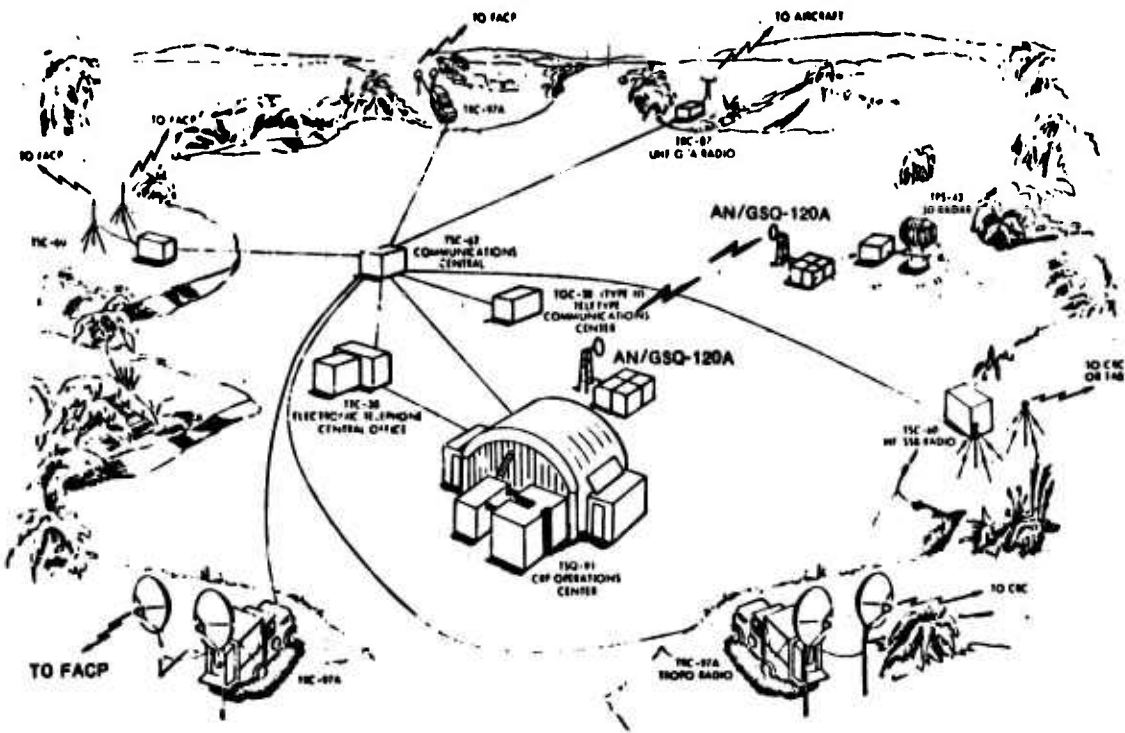

Figure 29 CRP Typical Field Deployment

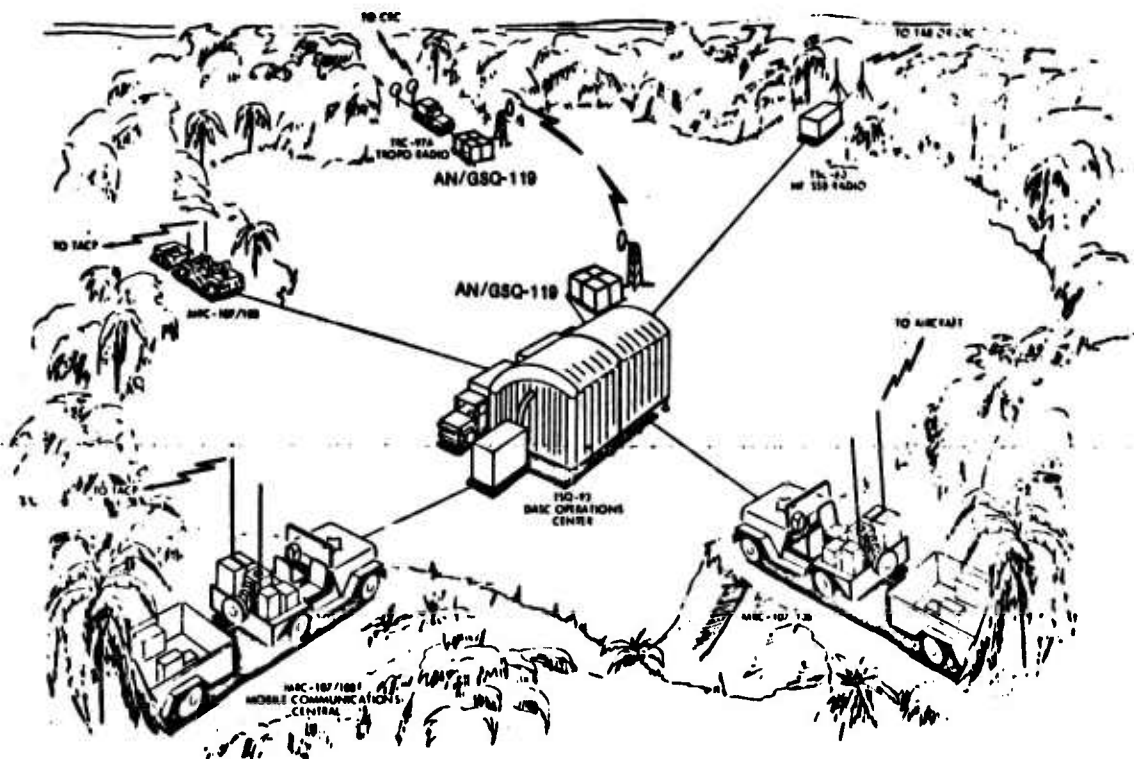

Figure 30 - DASC Typical Field Deployment

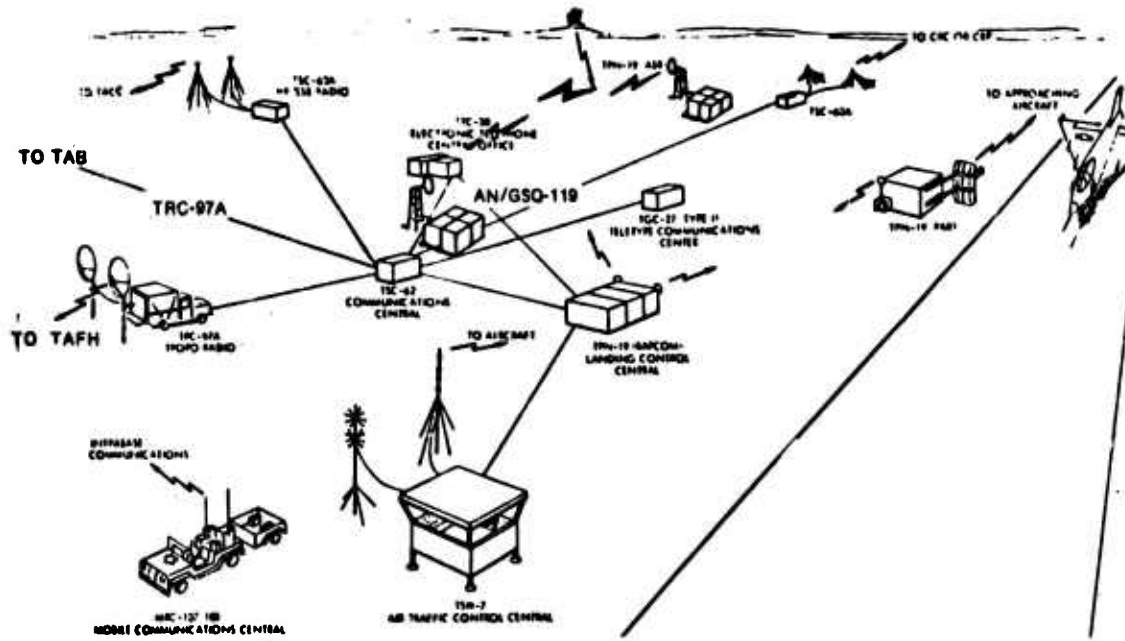

Figure 31 TAB Comm/TATCF Typical Field Deployment

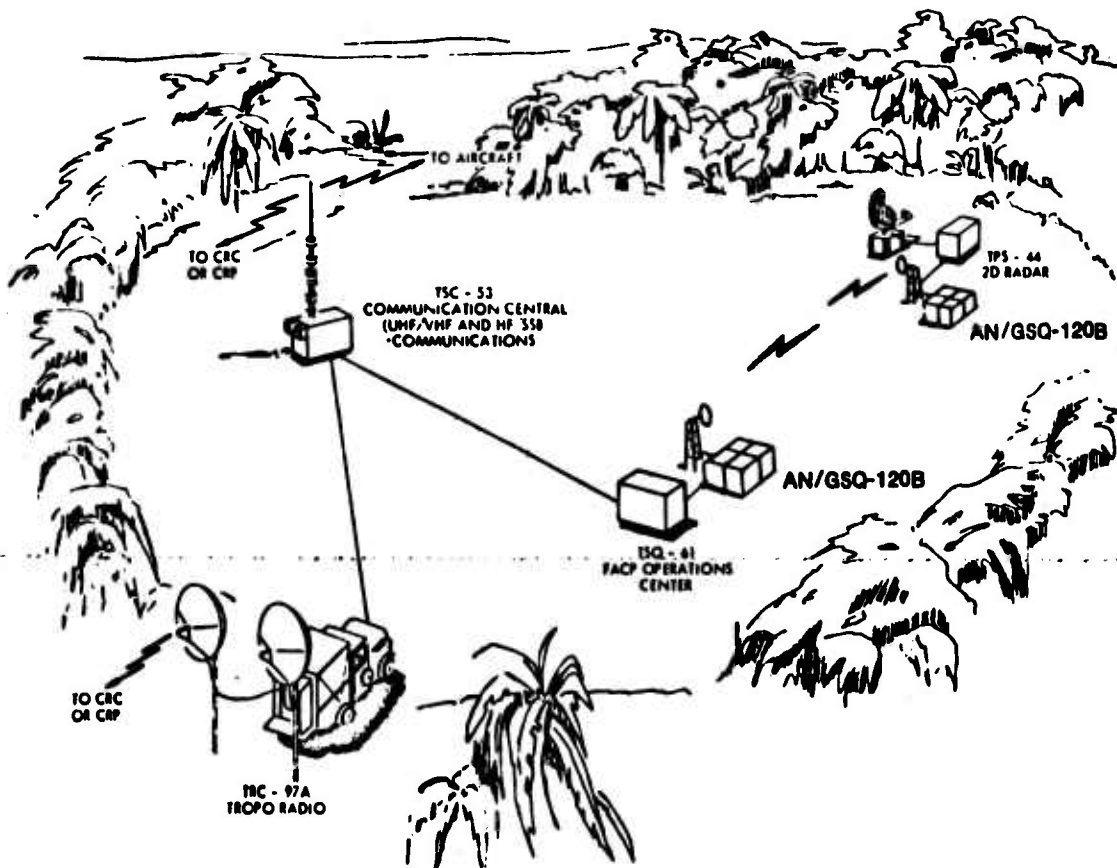

Figure 32 FACP Tactical Field Deployment

**(2) VHF-FM Manpack Radio Set, AN/PRC-77**

The VHF-FM radio will provide for secure communications between the TACP (or CCT) and Army units. The frequency range will be from 30 to 75.95 MHz with frequency control provided by a 50 KHz synthesizer. This is an Army Development.

**(3) UHF-AM Manpack Radio Set, AN/PRC-66**

The AN/PRC-66 provides ground-to-air communications between USAF aircraft and the TACP (or CCT). The frequency range is 225 MHz to 399.95 MHz with frequency control provided by a 50-KHz step synthesizer. A guard channel receiver will be added to the AN/PRC-66 to permit reception of emergency broadcasts while monitoring any assigned channel.

**Joint Electronics Type Designation System**

| <u>Installation</u>               | <u>Equipment</u>       | <u>Purpose</u>                       |
|-----------------------------------|------------------------|--------------------------------------|
| A - Airborne                      | A - Infrared           | A - Auxiliary                        |
| B - Underwater                    | B - Pigeon             | B - Bombing                          |
| C - Air Transportable             | C - Carrier (wire)     | C - Communications                   |
| D - Pilotless carrier             | D - Radiac             | D - Direction finding/reconnaissance |
| F - Fixed                         | E - Nupac              | E - Ejection/release                 |
| G - Ground                        | F - Photographic       | G - Fire control                     |
| K - Amphibious                    | G - Telegraph-teletype | H - Record-reproduce                 |
| M - Ground, mobile                | I - Interphone/PA      | L - Searchlight control              |
| P - Pack or portable              | J - Electro-mechanical | M - Maintenance/test                 |
| S - Surface craft                 | K - Telemetering       | N - Navigation aids                  |
| T - Ground, transportable         | L - Countermeasure     | P - Reproducing                      |
| U - General utility               | M - Meteorological     | Q - Special purposes                 |
| V - Ground, vehicular             | N - Sound in air       | R - Receiving                        |
| W - Water, surface and underwater | P - Radar              | S - Detect/range/bearing             |
|                                   | Q - Sonar              | T - Transmitting                     |
|                                   | R - Radio              | W - Control                          |
|                                   | S - Special types      | X - Identification and recognition   |
|                                   | T - Telephone (wire)   |                                      |
|                                   | V - Visible light      |                                      |
|                                   | W - Armament           |                                      |
|                                   | X - Facsimile or TV    |                                      |
|                                   | Y - Data processing    |                                      |

Example

