

UNCLASSIFIED

AD NUMBER

ADB002275

LIMITATION CHANGES

TO:

Approved for public release; distribution is unlimited. Document partially illegible.

FROM:

Distribution authorized to U.S. Gov't. agencies only; Test and Evaluation; AUG 1974. Other requests shall be referred to Naval Surface Weapons Center, Dahlgren Laboratory, Attn: Code FVR, Dahlgren, VA 22448. Document partially illegible.

AUTHORITY

usnswc ltr, 26 mar 1984

THIS PAGE IS UNCLASSIFIED

**Best
Available
Copy**

AD B002 275

AUTHORITY: USNSWC
1tr, 26 MAR 84



MDC E1099

ADB002275

AD No.
DDC FILE COPY

1-0

INTEGRATED CIRCUIT ELECTROMAGNETIC SUSCEPTIBILITY INVESTIGATION - PHASE II

TEST AND MEASUREMENT SYSTEMS

BEST AVAILABLE COPY

DDC
RECEIVED
MAR 11 1975
RECEIVED
E

MCDONNELL DOUGLAS ASTRONAUTICS COMPANY - EAST

MCDONNELL DOUGLAS
CORPORATION

Distribution limited to U.S. Government agencies and selected recipients only; test and evaluation (August 1974). Other requests for this document must be referred to OIC and Asst. Commander, Naval Surface Weapons Center, Dahlgren Laboratory, Dahlgren, Virginia 22448, Attn: Code FVR.

DDC
RECEIVED
MAR 10 1975
B

**INTEGRATED CIRCUIT
ELECTROMAGNETIC
SUSCEPTIBILITY INVESTIGATION
PHASE II**

11 12 JUL 74

14 MDC-E1099

TEST AND MEASUREMENT SYSTEMS.

13 155p

SUBMITTED TO:
CONTRACTING OFFICER
U.S. NAVAL WEAPONS LABORATORY
DAHLGREN, VA. 22448
CONTRACT NO. N00178-73-C-0362

DDC
RECEIVED
MAR 11 1975
E

MCDONNELL DOUGLAS ASTRONAUTICS COMPANY - EAST
Saint Louis, Missouri 63166 (314) 232-0232

MCDONNELL DOUGLAS CORPORATION

Distribution limited to U.S. Gov't. agencies only!
Test and Evaluation; AUG 1974 Other requests
for this document must be referred to

Naval Surface Weapon Center
Code FVR Dahlgren Lab.
Dahlgren, Va. 22448

BEST AVAILABLE COPY
403 930 ✓

PREFACE

This document is one of eight task-oriented reports prepared under Contract No. N00178-73-C-0362 for the U. S. Naval Weapons Laboratory, Dahlgren, Virginia 22448.

The McDonnell Douglas Astronautics Company Personnel involved were:

J. M. Roe, Study Manager

J. R. Chott

C. E. Clous

V. R. Ditton

T. A. Niemeier

G. W. Renken

R. D. Von Rohr

J. A. Waite

This report was reviewed by J. R. Cummings.

TABLE OF CONTENTS

<u>Title</u>	<u>Page</u>
1. INTRODUCTION AND SUMMARY	1
2. TEST FIXTURES	2
2.1 Flat Pack Test Fixture	3
2.2 Dual In-Line Package Test Fixture	3
2.3 TO-5 Package Test Fixture	4
2.4 Bias Unit	5
3. SEMI-AUTOMATED TEST SYSTEM	7
3.1 Crystal Detector Calibration	7
3.2 RF Test Fixture Calibration	8
3.3 Interference Testing Using the Semi-Automatic Test System	10
3.3.1 7400 NAND Gate Interference Testing	11
3.3.2 741 Operational Amplifier Interference Testing	11
3.3.3 MOS 4011 Interference Testing	12
3.3.4 2002 Hybrid Interference Testing	12
3.3.5 Extra Digital Device Interference Testing	12
3.4 Special Circuits.	13
3.4.1 Digital Control Box	13
3.4.2 Operational Amplifier Control Box	13
3.4.3 MOS Control Box	13
3.4.4 Comparator Box	14
3.4.5 Comparator Control Box	14
3.4.6 Voltage Regulator Control Box	14
4. CATASTROPHIC FAILURE TESTING	15
DISTRIBUTION LIST.	152

LIST OF PAGES

Title

i - ii

1 through 156

1. INTRODUCTION AND SUMMARY

This report describes the RF test fixture and the semi-automatic test set up developed on contract number N00178-73-C-0362 to investigate the susceptibility of integrated circuits to high power RF signals. Some of the material contained herein has appeared in previous reports, but is also included here to provide a complete testing document.

Test fixtures were fabricated to permit testing of integrated circuits with up to 16 leads on three different package styles (flat-pack, dual in-line, and T0-5 can) while fully biased and operational. The semi-automatic test system was developed to facilitate collecting the enormous amount of data needed for the integrated circuit susceptibility investigation. The heart of the system is an HP9810A programmable calculator and a 50-channel scanning digital voltmeter; however, several circuits had to be designed and fabricated to aid in biasing and loading the IC and to interface with the computer.

To facilitate reading, figures start on page 16 and tables start on page 74.

2. TEST FIXTURES

Development of suitable test fixtures and a semi-automatic test system to assist in collection and recording of data was a key achievement of this program. This section describes the test fixtures and the principles used in their design. Design of the test fixtures incorporated the following requirements:

- (1) interface the IC with conventional RF transmission lines
- (2) provide operational conditioning for biased testing of ICs
- (3) permit determination of dissipated RF power within the IC to an absolute accuracy of 10%
- (4) exhibit a bandwidth of 100 MHz to 12.4 GHz
- (5) permit repeatable measurements.

A test fixture for each of the three package styles (flat-pack, dual in-line, and T0-5 can) is now available. In an earlier report we had indicated an approach involving a universal base module containing the RF input lines and having bias units incorporated into each line to separate the video and RF frequencies. After further consideration, we decided that the advantages associated with having more than one complete test fixture available outweighs the small cost savings associated with the universal base module concept. Consequently, a complete test fixture is available for each package style.

Each fixture features stripline technology to interface between the IC package and conventional RF transmission line. Stripline launchers accomplish the transition from coaxial transmission line to the stripline paths on the board. Type N connectors provide standard, reliable, well shielded RF connections. Such connection ease expedites measurements at all ports. The video inputs to the test fixture are through type BNC connectors. Paragraphs 2.1, 2.2, and 2.3 describe the test fixtures for the flat-pack, dual in-line, and T0-5 can packages, respectively. The bias units are the same for all the test fixtures and are described in paragraph 2.4

A

2.1 Flat Pack Test Fixture - Figure 1 is an exploded view of the test fixture which will accommodate flat pack ICs having up to 16 leads. Items (19) and (20) form the stripline feed system (consisting of two copper clad, low loss tangent, dielectric boards). The bottom board has the stripline paths etched upon it. Installation holes in the centers of the top dielectric board and cover plate permit the IC to be placed within the fixture. An IC lead locator plug, item (15), taken from an integrated circuit test socket is press fitted into the center of the bottom dielectric board. It holds the device in a consistent orientation which assures proper alignment of the leads.

A cover plug, item (12), fits snugly into the installation hole enclosing the IC within the stripline feed system. The cover plug also provides dielectric continuity above the device and RF shielding integrity for the top aluminum cover plate. By applying pressure upon the IC leads which lay atop the stripline feed system in the fixture, the cover plug connects the IC to the stripline. Rubber pads, item (13), evenly distribute the pressure to all IC leads. A toggle clamp, item (4), provides an adjustable pressure to enable a reliable connection.

Structural rigidity is required of the fixture to permit repeatable data. Consequently, the stripline boards are enclosed in an aluminum housing which keeps the dielectric boards from flexing or moving. Screws shorting the two ground planes together are located at intervals of less than one-half wavelength at the highest frequency of interest to prevent propagation of higher order modes.

The bias units, item (27), are connected to the stripline type N launchers and are held in place by the test fixture skirt, item (22). The lower connector on each bias unit is the RF input (or output) and is DC isolated from the IC. DC bias and video pulses can be applied or measured using the upper connector on each bias unit.

2.2 Dual In-Line Package Test Fixture - Figure 2 is an exploded view of the test fixture which will accommodate dual in-line packaged ICs having up to 16 pins.

Items (10) and (11) form the stripline feed system. The top board has the stripline paths etched upon it. A 16 pin dual in-line socket, item (8), is used to assure a consistent orientation of the IC under test. The copper on the ground plane side of the top board has been removed from under the socket and holes drilled through the dielectric board for the 16 pins from the socket. Each pin is soldered to the appropriate stripline center conductor. The socket is held securely in place by small tabs, item (6), bolted to the top plate of the aluminum housing. The cover plug, item (1), and spring loaded hold down, item (2), assures RF shielding integrity for the top plate. Removal of the IC is facilitated by a lever, item (18), and two small teflon rods, item (19).

Structural rigidity is obtained in the same manner as for the flat pack package test fixture. Bias units are connected and used in the same way as for the flat pack package test fixture.

2.3 T0-5 Package Test Fixture - The T0-5 package test fixture was designed to accommodate T0-5 cans having 8 or 10 pins. Figure 3 is an exploded view of the test fixture. Items (9) and (10) from the stripline feed system. The top board has the stripline paths etched upon it. Two interchangeable top boards are required; one for 8-pin T0-5 packages, another for 10-pin packages. A socket, item (7), is used to assure a consistent orientation of the IC under test. A test cap, item (6), provides alignment guides for the pins to facilitate placement of the IC into the socket. The copper on the ground plane side of the top board has been removed from under the socket and holes drilled through the dielectric board for the socket pins. Each pin is soldered to the appropriate stripline center conductor. The test cap and socket are held securely in place by the aluminum housing, with the top plate contacting the lip around the bottom of the test cap. The cover plug, item (1), and spring loaded hold down, item (2), assures RF shielding integrity for the top plate. Removal of the IC is facilitated by a lever, item (21), and a small teflon rod, item (13).

Structural rigidity is obtained in the same manner as for the flat pack package test fixture. Bias units are also connected and used in the same way.

2.4 Bias Unit - The function of the bias insertion unit is to provide a low-pass path for the video signals while providing high-pass characteristics for the RF signal. The problem is complicated by the wide RF frequency band (100 MHz to 10 GHz) over which the unit must perform. Desirable video section performance is free passage of video signals up to approximately 10 MHz while rejecting RF signals by approximately 20 dB. The RF section must provide RF transmission properties with no large reflections due to mismatches in the line, especially near the video section connection. The basic design requires a capacitor (DC block) in the RF line to reject low frequency signals and an inductor (RF choke) in the video line to reject high frequency signals. Achieving a good RF choke in the microwave region is difficult across a wide band due to resonances in interwinding capacitances or distributed parameters. The use of ferrite material as a core offered the best chance for success.

After considerable development, success was achieved with the design diagrammed in figure 4. A 2 1/2 turn choke on a ferrite core provided the RF choke while a commercial DC block (coaxial) is used in the RF line to isolate low frequency signals. Figure 5 is a cutaway drawing of the assembled bias unit.

This bias unit provides a nominal 20 dB isolation from the RF path to the bias input port, passes a one microsecond, one ampere pulse with an 80 nanosecond rise-time from the bias port to the test IC, and has an RF path insertion loss of 3.5 dB or less. Figure 6 shows the measured insertion loss from the RF path to the bias input port. Figure 7 shows the measured RF insertion loss through the RF path.

Figure 8 shows the setup used to measure the video path response to short, high current pulses. Figure 9 compares the open circuit voltage available from the pulse generator to the received pulse at the test device port. At current levels up to

one ampere, no ferrite saturation effects are seen, and the risetime is shown to be approximately 80 nanoseconds. Protection offered to the RF generator by the DC block is shown in figure 10. Table 1 lists the data for loss calibration for the 16 bias units used for the interference testing.

3. SEMI-AUTOMATED TEST SYSTEM

To facilitate collecting the enormous amount of data needed for the integrated circuit susceptibility investigation, MDAC-E developed a semi-automatic test system specifically for use on this contract. The heart of the system is an HP9810A programmable calculator and a 50-channel scanning digital voltmeter. Data is recorded on a digital tape cassette for later processing in an HP9830A computer. The following paragraphs describe the test set ups, test procedures, computer programs, and peripheral equipment designed and fabricated to aid in testing the various types of integrated circuits.

3.1 Crystal Detector Calibration - One of the critical tasks in setting up the semi-automatic test system was the calibration of the crystal detectors to permit determination of RF power level at each port of the test fixture during a test. A test requires monitoring the power entering one port and exiting from as many as 16 ports (the other 15 pins on the IC plus the reflected power from the input port). Seventeen HP423A crystal detectors were calibrated by subjecting them to sequential steps of RF power while monitoring the detected voltages. Each crystal detector was terminated in a 10K ohm resistor. This value was chosen as a compromise for obtaining adequate detected output voltage while not appreciably affecting rise and fall times during testing for pulsed conditions.

Calibrations were performed at all five test frequencies (.22, .91, 3.0, 5.6 and 9.1 GHz). The data was processed to obtain a least squares fit to the equation:

$$y = B_0 + B_1x + B_2x^2 + B_3x^3$$

where: $y = \log_{10}$ (RF power)

$x = \log_{10}$ (detected voltage)

and B_0 , B_1 , B_2 , and B_3 are the calculated coefficients. The cubic-order power-series-fit proved to be quite adequate over the power range of .01 to 100 milliwatts required

for testing after accounting for the various coupling and attenuation factors associated with each port. Table 2 shows a typical data tabulation where the actual and calculated values are compared. Figure 11 shows a graph of a typical calculated function and the measured data points. Tables 3 through 7 show the values of the coefficients which are used by the HP9810A calculator to compute the various power levels as the detected voltages are measured.

Figure 12 shows the data acquisition and recording set up for the crystal detector calibration. Figures 13 through 17 are block diagrams of the RF portions of the crystal calibration test set ups for each of the five test frequencies. The HP9810A program used to acquire and record the crystal detector calibration data is shown in table 8. The recorded data at this stage is not in array format. To change the data to an array format, which is desirable for data reduction by the HP9830A, and to obtain a hard copy of the data, the recorded data was then processed on the HP9830A computer calculator, using the program shown in table 9, and recorded. The program shown in table 10 was then used in calculating the calibration coefficients on the HP 9830A.

3.2 RF Test Fixture Calibration - Each test fixture was characterized for dissipation loss without bias units. Dissipation loss is a measure of the fraction of RF power lost from a given path within the fixture. That fraction of power not dissipated in the fixture or coupled out of the ports must be delivered to the IC. Fixture dissipation had to be determined accurately, since a knowledge of power dissipation within the device to an absolute accuracy of $\pm 10\%$ was desired.

Dissipation losses are primarily due to characteristics of the stripline paths within the fixture. The dissipative loss per stripe, L, is defined as the ratio:

$$L = \frac{P_{in}}{P_{out}} > 1$$

where P_{out} is the power delivered at the end of the stripe for an input power P_{in} .

Since each stripe is the same length and shape, L is assumed to be the same value for each of the i stripes. This assumption was verified experimentally.

Referring to figure 18, the power which comes out of each port must be L times greater at the center of the fixture. Hence, P_{dist} , the total power distributed from the center, is given by:

$$P_{dist} = \sum_{j=1}^i LP_j$$

P_a is the amount of power available for distribution from the center of the fixture and is given by:

$$P_a = \frac{P_{incident}}{L}$$

Conservation of energy requires that these two quantities be equal. Hence:

$$P_a = P_{dist}$$

and,
$$L^2 = \frac{P_{incident}}{\sum P_j} \quad (j = 1 \rightarrow i)$$

It is not possible to measure directly the loss per stripe because of lack of connectors at the IC end of each stripe. A dummy IC was made for each test fixture which shorted stripes together so that a continuous path was provided between ports.

By using each port for power input to the fixture at each given frequency, i different values of L were measured for each fixture. Statistical analyses were performed on this group of loss factors to compute the average loss and the standard error. The test fixture calibration was performed using the semi-automatic test system. In operating the system for test fixture calibration, the operator initiates the data cycle by pressing the CONTINUE button on the HP9810A calculator. The system sequentially samples the RF power level of the required number of ports by means of the calibrated crystal detectors and records the data. The operator then changes the input ports, presses the CONTINUE button again, and more data is acquired and recorded. This process is repeated until all ports have been used as

input ports. The HP9810A then calculates and prints out (on a typewriter) the calculated loss when using each port as an input, the mean loss and the standard error (all in dB).

Figure 19 shows the data acquisition and recording set up for test fixture calibration. Figures 20 through 24 are block diagrams of the RF portions of the test set ups. Table 11 is a listing of the HP9810A program for the test fixture calibration and table 12 lists the data register allocations for that program. Tables 13 through 17 show the data resulting from the measurements and calculations for the 16 pin dual in-line package test fixture. Tables 18 through 22 are the results for the 8 pin T0-5 package test fixture.

3.3 Interference Testing Using the Semi-Automatic Test System - The semi-automatic test system is illustrated in figure 25. Acquisition and storage of the data in the laboratory is controlled by an HP9810A calculator. It also directs the data recording on digital tape cassettes. Analysis of this data is performed using an HP9830A computer. A hard copy of the data, an example of which is shown in table 23 is prepared to verify successful data runs and as insurance against mishap with the tape. The computer is also used to prepare curves such as shown in figure 26, thus providing a pictorial representation of the data to aid in analysis.

In operating the semi-automatic test set-up for interference testing, the operator selects an input power level to be applied to the device and initiates the data cycle by pressing the CONTINUE button on the HP9810A calculator. The system sequentially samples the RF power level of the required number of ports by means of the calibrated crystal detectors, computes the ratio of power delivered to the device to the input power (the calibration factor) using a stored program and constants, then measures various device voltages and currents. Selected device voltages and currents and the calibration factor are stored along with the corrected power dissipated in the chip (which is the independent variable) on the digital tape cassette. A photograph of the system in operation is shown in figure 27.

The test set ups and computer programs used are very similar for all the device types tested. There are some differences due to the number of ports to be monitored, bias and loading requirements, test equipment availability, and improvements in programming techniques over the term of the contract.

3.3.1 7400 NAND Gate Interference Testing - The 7400 NAND gate contains four 2-input NAND gates in a 14 pin flat pack. Nondestructive measurements were made with the device in active bias states using the RF test fixture described previously. Figure 28 shows the data acquisition and recording set up for interference testing of the 7400. Figures 29 through 33 are block diagrams of the RF portions of the 7400 interference test set ups for each of the five test frequencies. Figure 34 shows the interference test flow diagram for the 7400 device and table 24 is the program for the HP9810A used to incorporate this procedure. To keep track of the data, each device was given a pre-test sample number which encoded all the pertinent data about its test configuration (frequency, port, bias state, and device number from 0 to 9). This sample number is entered into the measurement system manually and becomes a part of each file of data on the magnetic tape.

Table 25 is a listing of the program for the HP9830A to change the data acquired by the HP9810A to an array format, which can be used more efficiently by the HP9830A during later data reduction. Table 26 is a listing of the program for the HP9830A to plot the 7400 data after conversion to the array format.

3.3.2 741 Operational Amplifier Interference Testing - Interference testing on the 741 operational amplifier was conducted in a manner similar to that for the 7400. Figure 35 shows the data acquisition and recording test set up for the testing. Figures 36 through 40 are block diagrams of the RF portions of the test set ups. Table 27 is the program for the HP9810A used to acquire and record the data and table 28 is a list of the data register locations required for the program. The test frequency, port, and device number were encoded and entered into the measurement

system manually. Table 29 is a listing of the program for the HP9830A to change the data acquired by the HP9810A to an array format. Table 30 is a listing of the program for the HP9830A to plot the 741 data.

3.3.3 MOS 4011 Interference Testing - The MOS 4011 contains four 2-input NAND gates utilizing CMOS fabrication techniques in a 14 pin flat pack. Figure 41 shows the data acquisition and recording test set up for interference testing of this device. Figures 42 through 45 are block diagrams of the RF portions of the test set ups. Figure 46 shows the interference test flow diagram and table 31 is the program for the HP9810A used to incorporate this procedure. Table 32 is a list of the data register locations required by the program. The test frequency, port, and device number were encoded and entered into the measurement system manually. Table 33 is a listing of the program for the HP9830A to change the data acquired by the HP9810A to an array format and table 34 is a listing of the program for the HP9830A to plot the MOS 4011 data.

3.3.4 2002 Hybrid Interference Testing - Figure 47 shows the data acquisition and recording test set up for interference testing of the 2002 hybrid. Figures 48 through 51 are block diagrams of the RF portions of the test set ups. Table 35 is a listing of the program for the HP9810A used for the interference testing and table 36 lists the data register locations required by the programs. Again the test frequency, port, and device numbers were encoded and entered. Table 37 is a listing of the program for the HP9830A to print the 2002 data.

3.3.5 Extra Digital Devices Interference Testing - The following digital devices received more limited interference testing than the devices discussed above: 3021, 7432, 7402, 7404, 7405, 7450, 7473, and 7479. This testing was performed to verify the MDAC-E 7400 susceptibility model for other devices. These devices were tested using only four input power levels (vs 20 for the others): (1) no input power, (2) power which would cause a previously set interference threshold to be crossed,

(3) maximum power the crystal detectors could safely stand, and (4) a point approximately half-way between the interference threshold and the crystal detector maximum. As shown in figure 52 the interference threshold level was determined using a comparator box, which compared the output from the device under test to a previously determined level. RF power with a pulse width of 500 microsecond was applied to the device when setting up the interference threshold level, to reduce heating effect contributions, but the data was obtained with CW input at that level. Block diagrams of the RF test set ups are the same as for the 2002 (Figures 48 through 51). Table 38 is a listing of the HP9810A program. The data register locations are the same as for the 2002 (table 36). Table 39 is a listing of the program for the HP9830A to reduce the data from the HP9810A.

3.4 Special Circuits - Design and fabrication of several special circuits were required to bias, load, and test the various types of ICs whose susceptibility was evaluated. These circuits were shown in block diagrams in preceding paragraphs where applicable. The following paragraphs give a short description of the function of each circuit along with a schematic.

3.4.1 Digital Control Box - The digital control box supplies worst case loading to the digital device under test while providing voltage and current monitoring of all device terminals. A schematic of the digital control box is shown in figure 53.

3.4.2 Operational Amplifier Control Box - The operational amplifier control box supplies loading to the operational amplifiers contained in the linear test devices and provides voltage and current monitoring of all device terminals. A schematic of this control box is shown in figure 54.

3.4.3 MOS Control Box - This circuit provides biasing and loading for the MOS digital devices and also provides for voltage and current monitoring of the devices. The schematic is shown in figure 55.

3.4.4 Comparator Box - The Comparator Box is used to monitor the output(s) of the devices during the Extra Digital Devices Interference Testing and to indicate when an interference threshold is exceeded. A schematic of the comparator is shown in figure 56.

3.4.5 Comparator Control Box - The comparator control box supplies loading to the comparator linear test device and provides voltage and current monitoring of all device terminals. A schematic of this control box is shown in figure 57.

3.4.6 Voltage Regulator Control Box - The voltage regulator control box supplies loading to the positive and negative voltage regulators contained in the linear test devices and provides voltage and current monitoring of all device terminals. A schematic of this control box is shown in figure 58.

4. CATASTROPHIC FAILURE TESTS

Tests were performed to determine the power levels at which catastrophic failure occur for the 7400 and the 741 operational amplifier. 800 7400's were tested: 20 in each of two states, at each of four input ports, at each of five frequencies. 560 741's were tested: 20 with input power at each of seven ports, at each of four frequencies (9.1 GHz was not included). Figures 59 through 63 shows block diagrams of the test setups for the catastrophic failure testing.

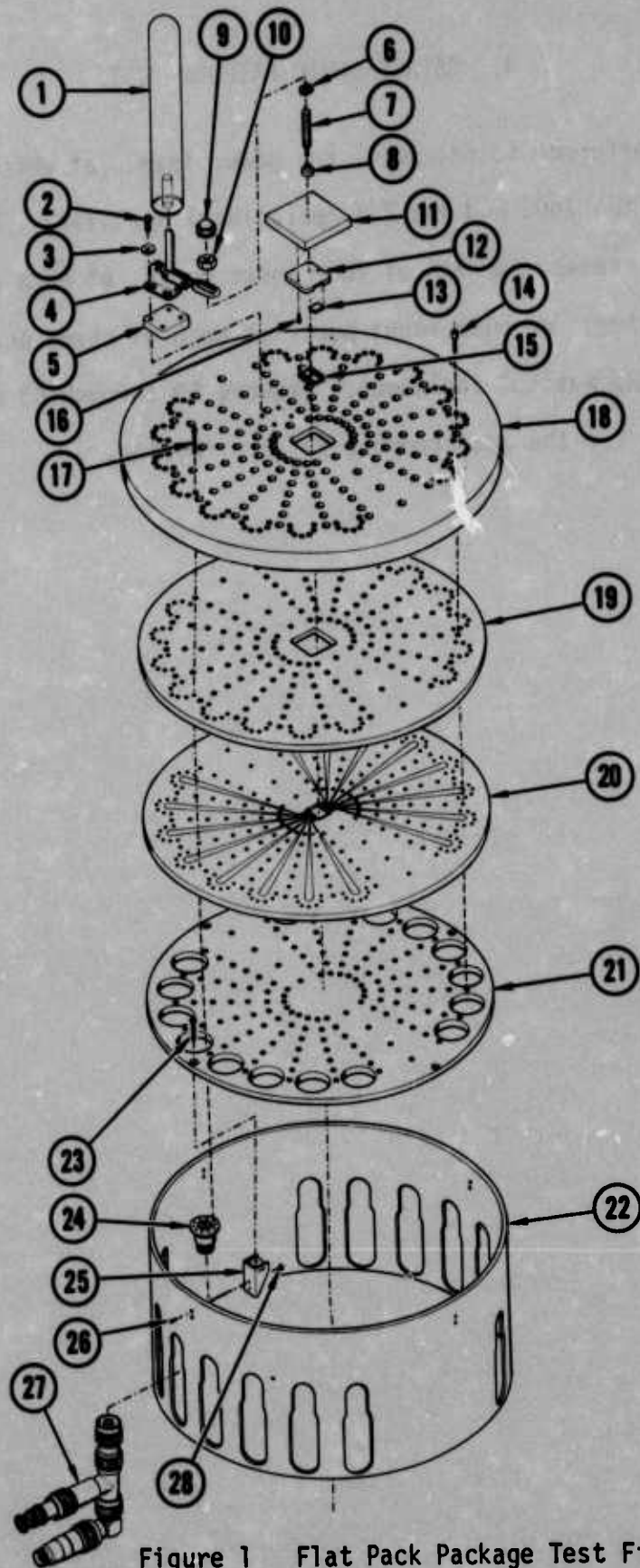

Figure 1 Flat Pack Package Test Fixture - Exploded View

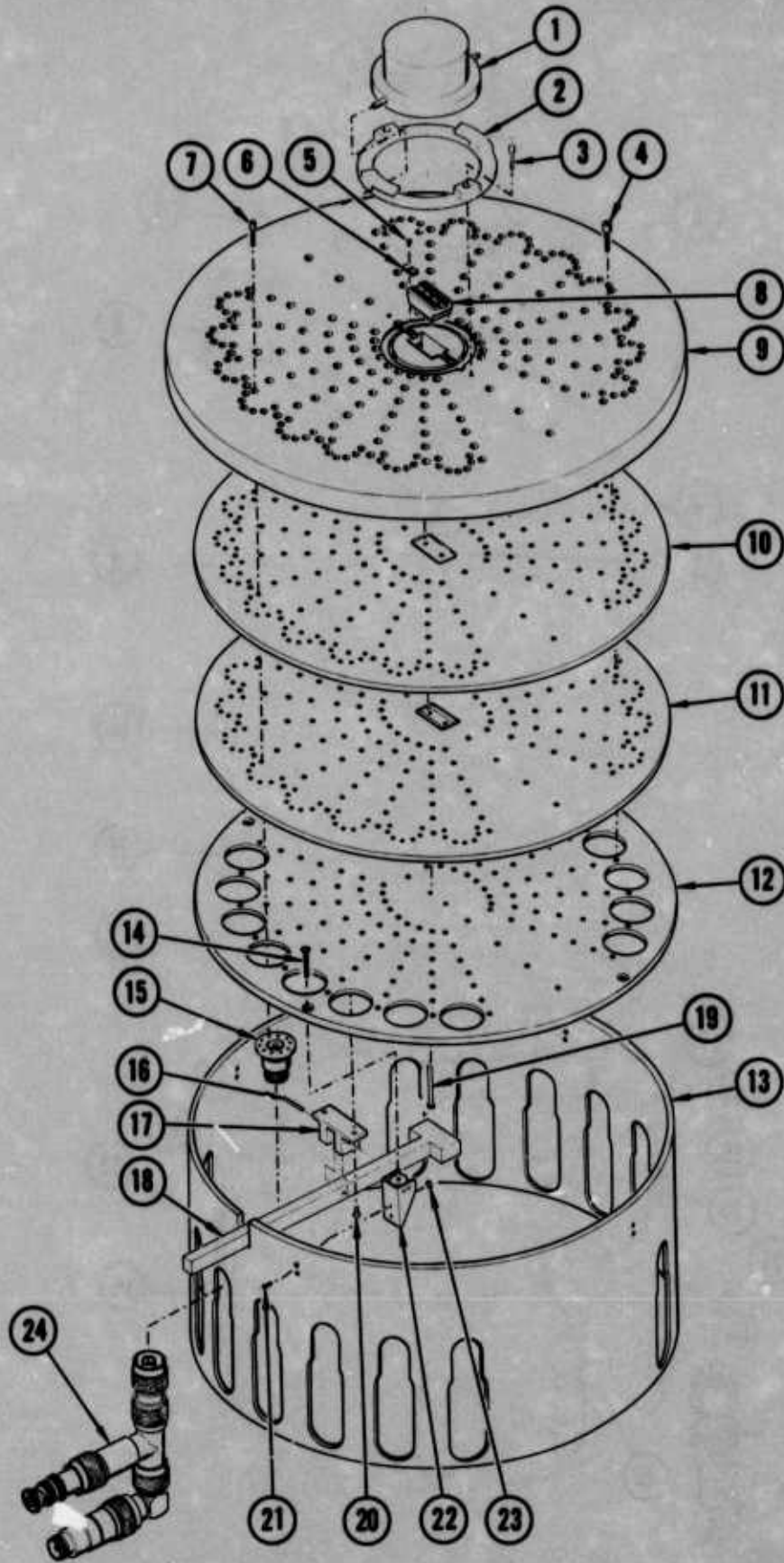

Figure 2 Dual In-Line Package Test Fixture - Exploded View

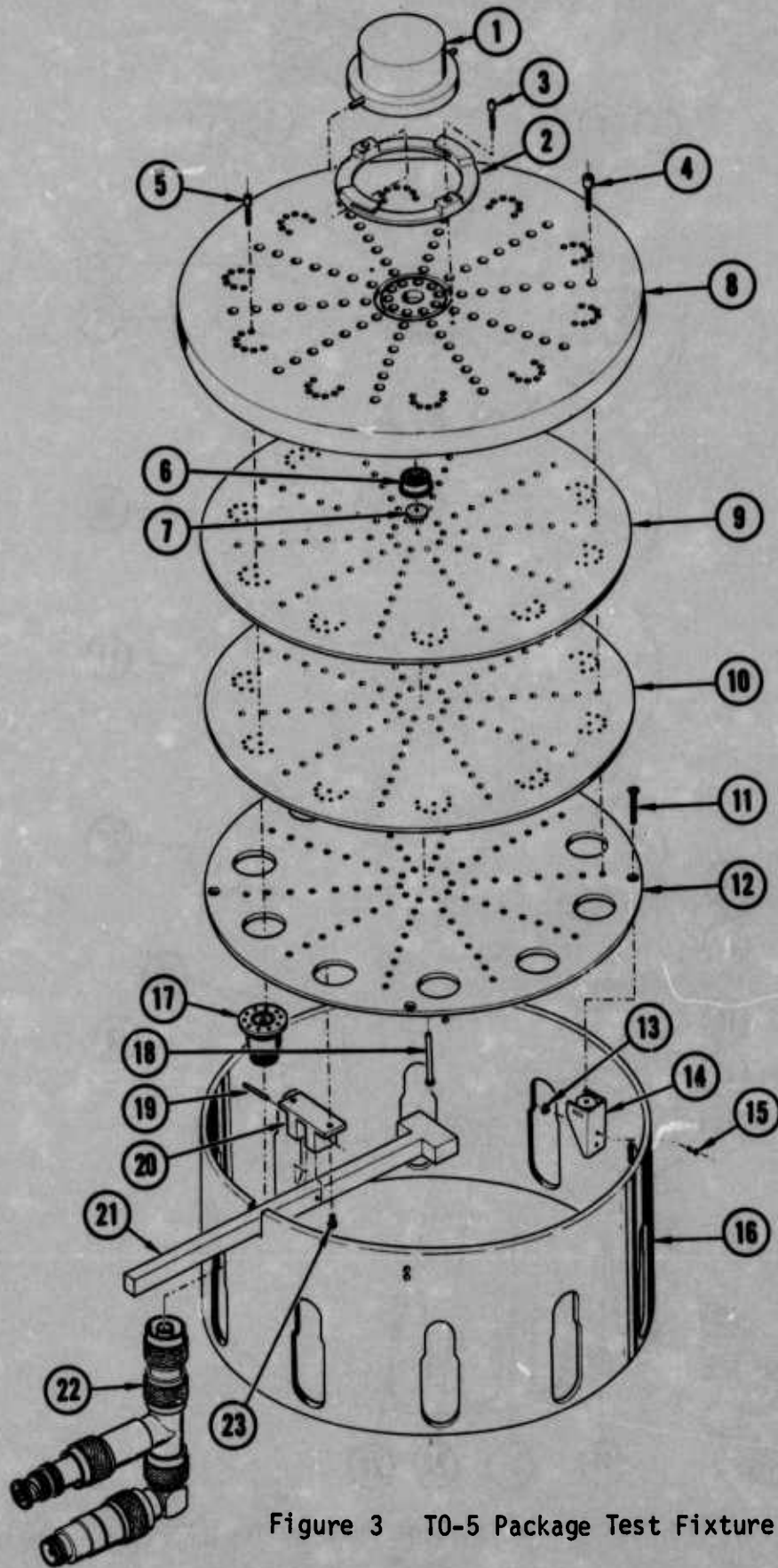

Figure 3 T0-5 Package Test Fixture - Exploded View

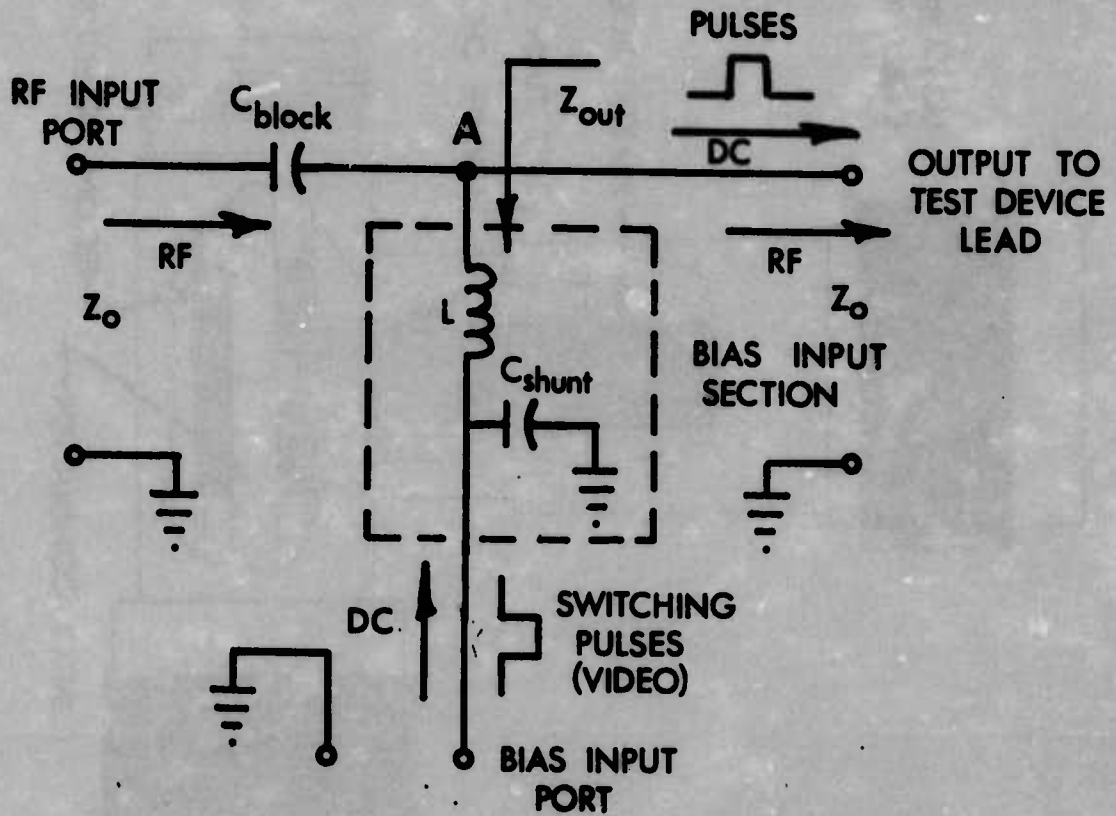

Figure 4 Bias Unit With 2 1/2 Turn Ferrite Choke

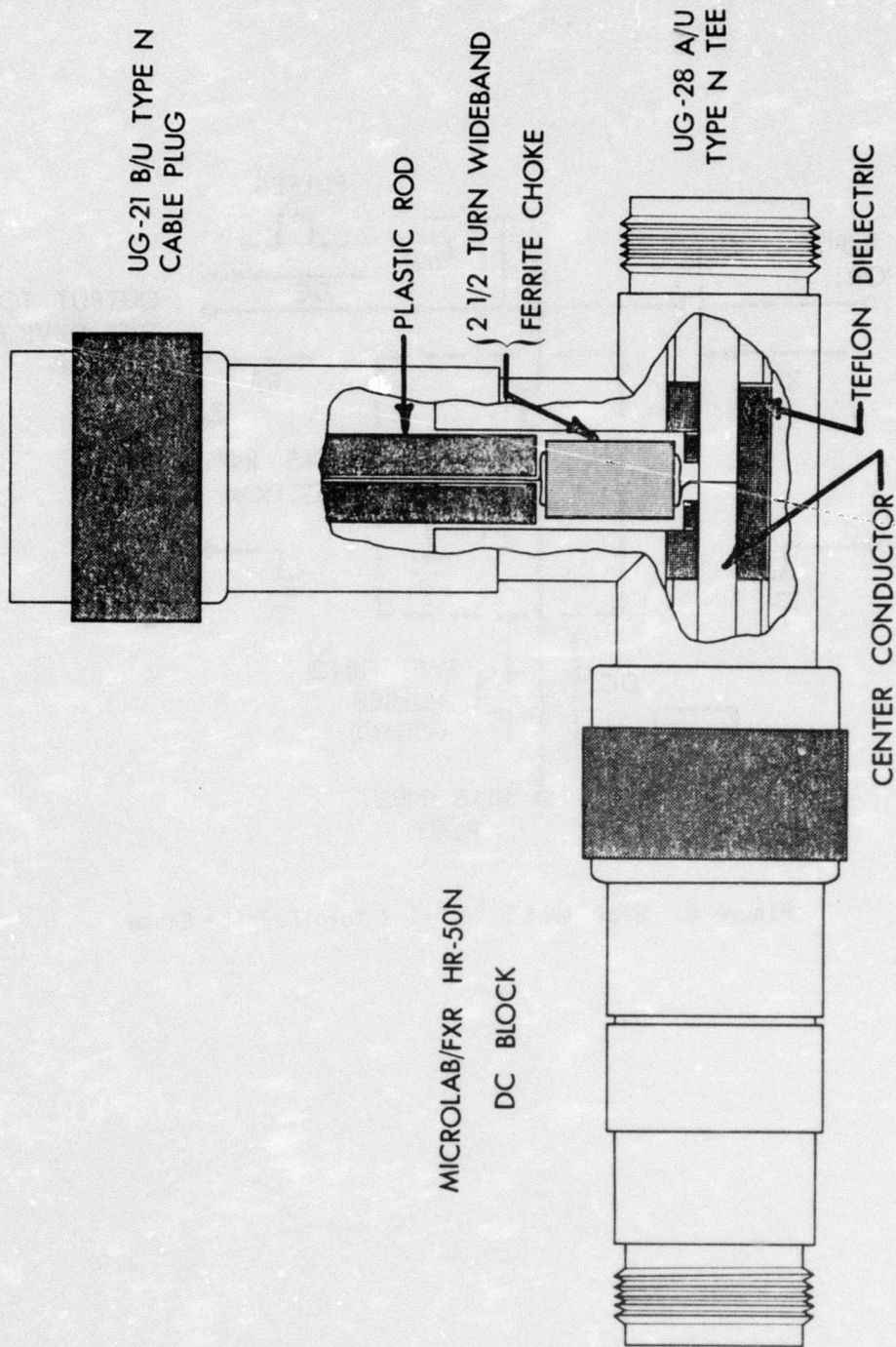
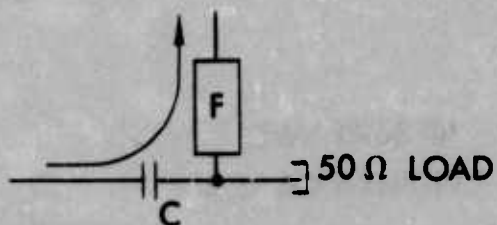

FIGURE 5 CUTAWAY DRAWING OF THE ASSEMBLED BIAS UNIT



C: FXR HR-50 N

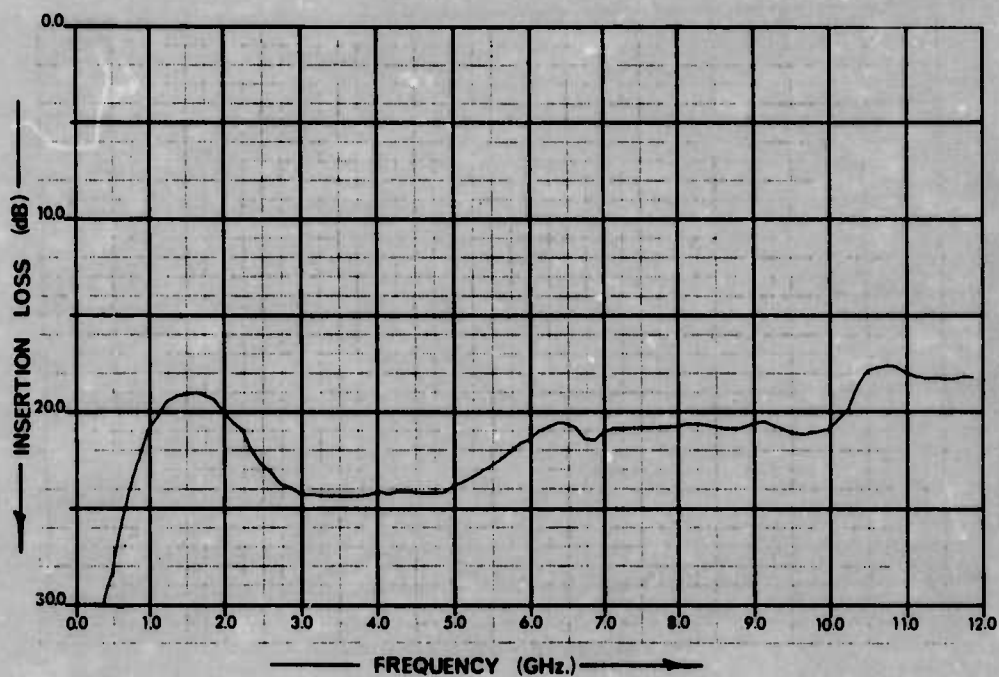

FIGURE 6 RF ISOLATION FROM RF PATH TO BIAS INPUT PORT

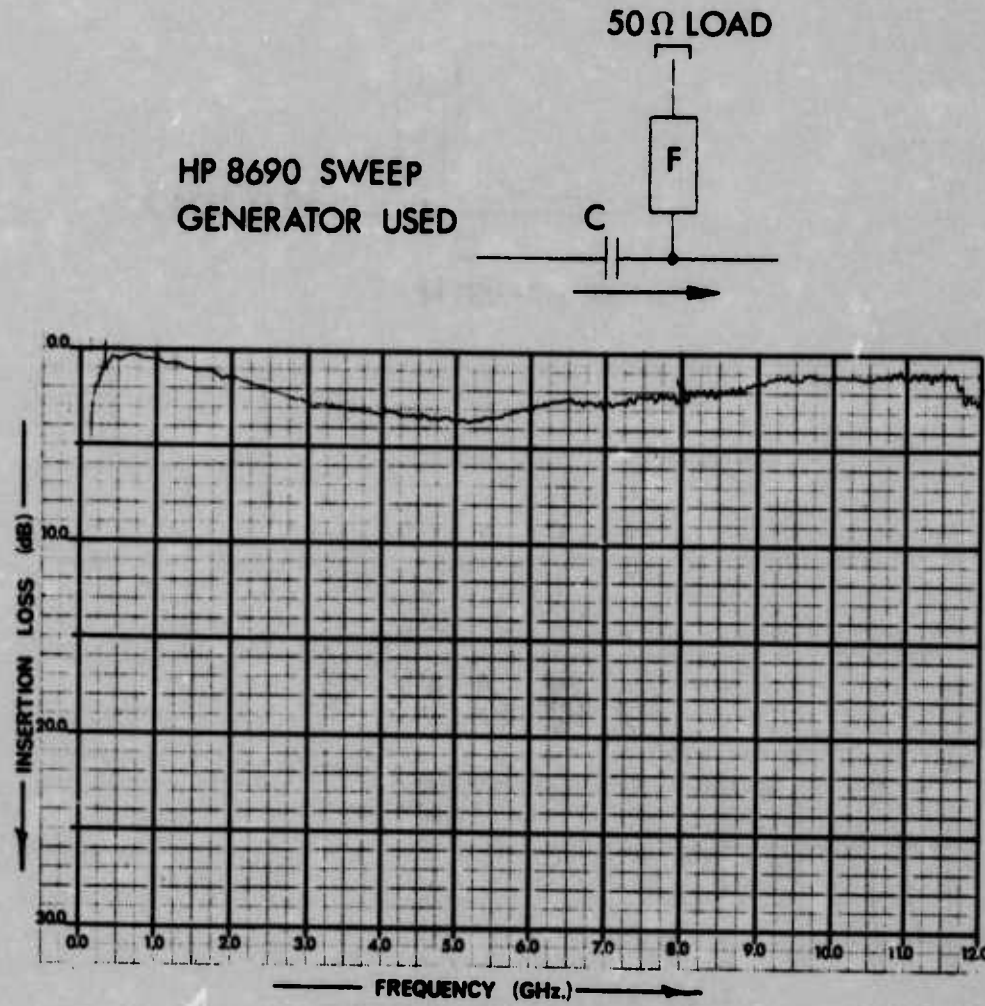

FIGURE 7 BIAS UNIT RF PATH INSERTION LOSS

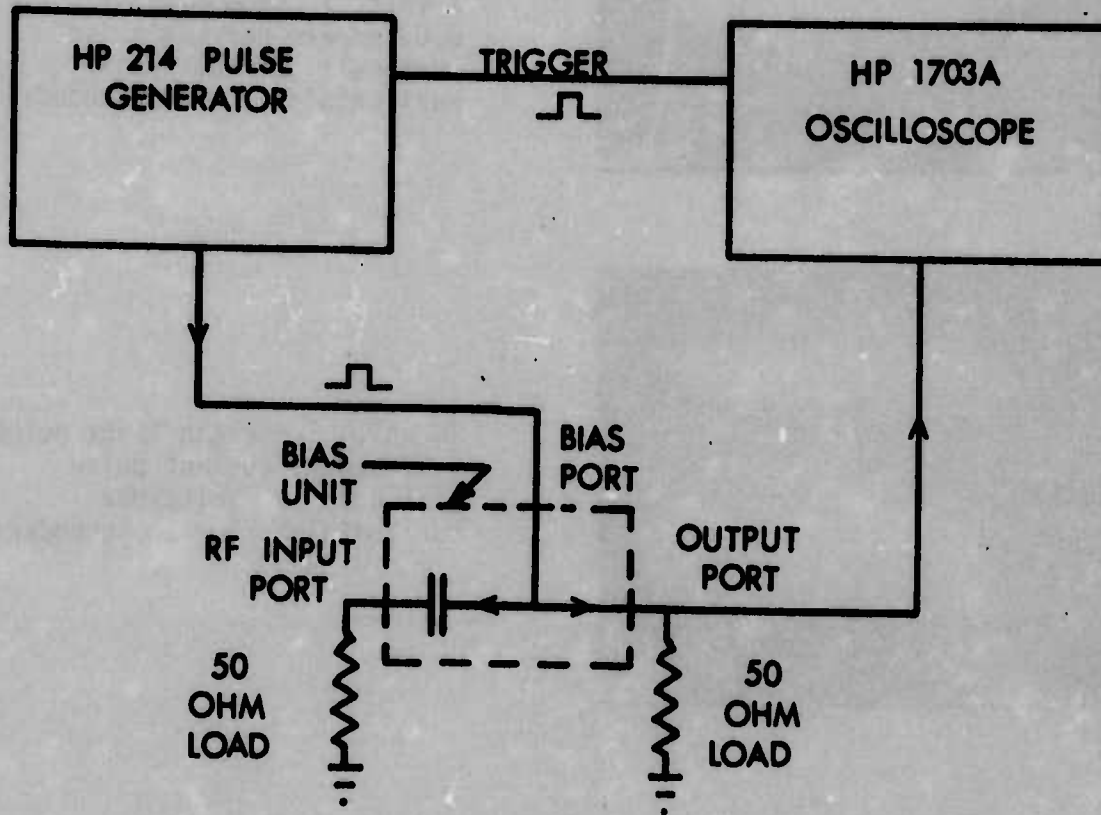
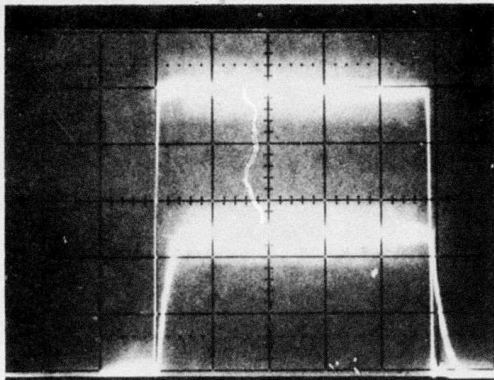
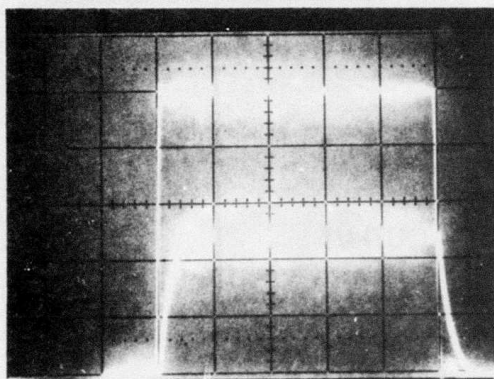

FIGURE 8 SETUP USED TO MEASURE CURRENT SATURATION EFFECTS UPON THE 2 1/2 TURN FERRITE CHOKE



Top pulses in each photograph are input pulses to the bias unit. The bottom pulses are the output pulses from the bias unit's output port. All pulses are delivered to a 25 ohm load.

1 volt, 1 μ second input pulse
0.01 ampere current pulse
vertical: .20 volts/div
horizontal: 200 nanoseconds/div



10 volt, 1 μ second input pulse
0.10 ampere current pulse
vertical: 2 volts/div
horizontal: 200 nanoseconds/div

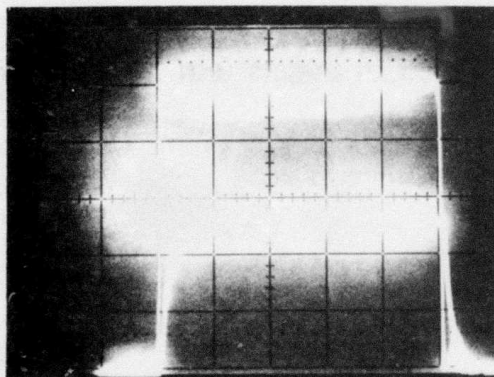

100 volt, 1 μ second input pulse
1.0 ampere current pulse
vertical: 20 volts/div
horizontal: 200 nanoseconds/div.

FIGURE 9 SATURATION EFFECTS FROM HIGH CURRENT LEVELS UPON THE FERRITE CHOKE

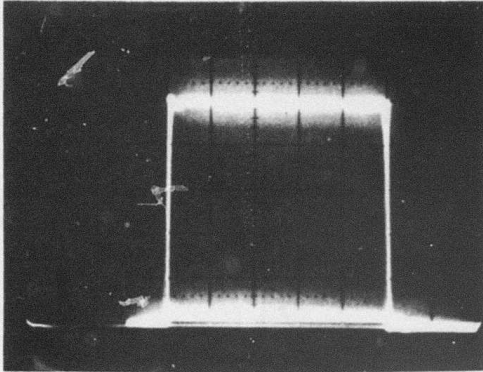

Vertical: 2 Volts/div
0.08 amp/div

Horizontal: 200 nanosecond
per div.

Upper trace: open circuit voltage
available from
generator

Lower trace: voltage delivered
to RF generator

FIGURE 10 ISOLATION OF THE RF GENERATOR FROM INPUT PULSES DUE TO THE
MICROLAB/FXR DC BLOCKS CAPACITIVE REACTANCE

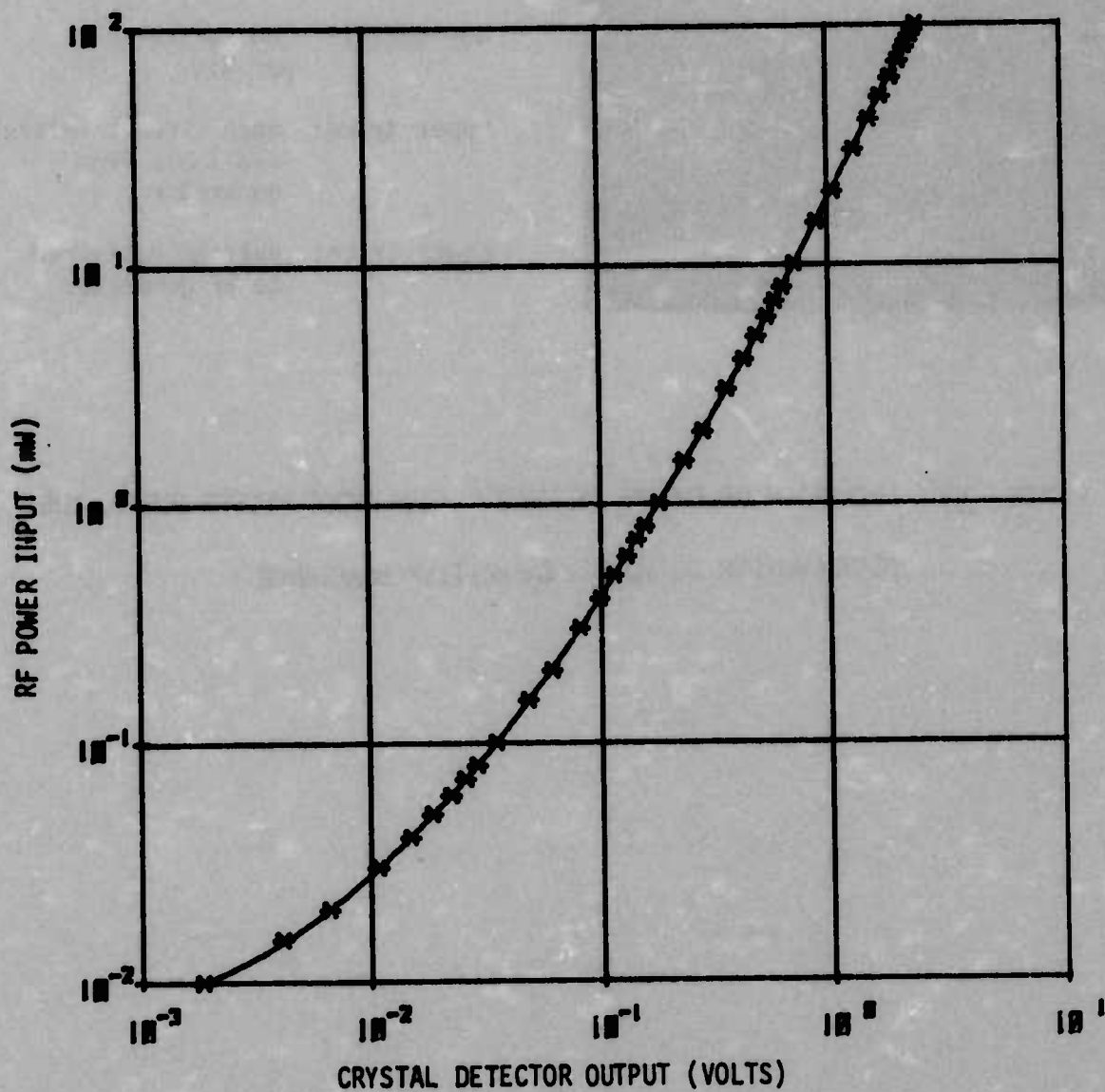

FIGURE 11 TYPICAL CRYSTAL CALIBRATION CURVE

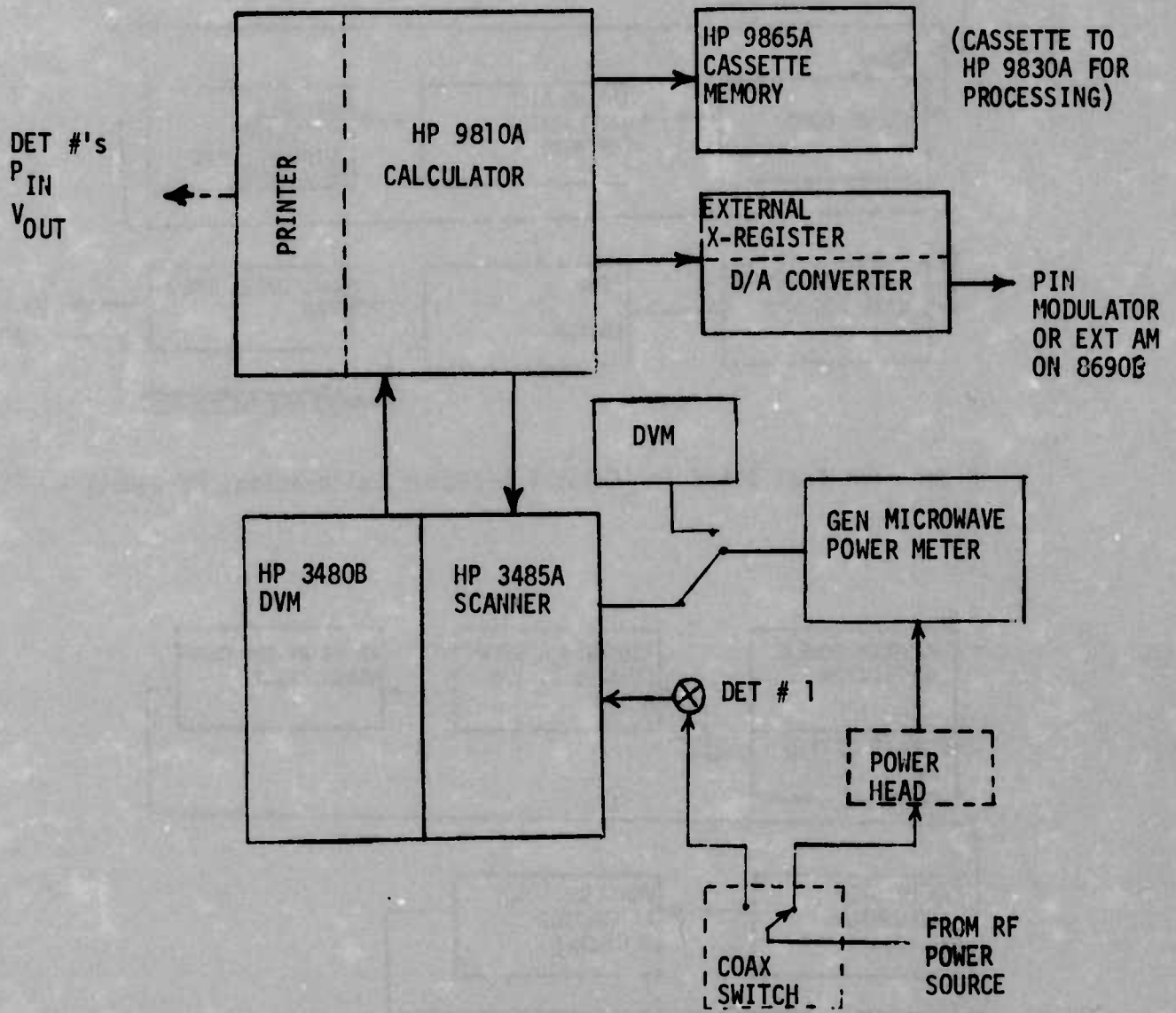

Figure 12 GENERAL TEST SETUP FOR CRYSTAL DETECTOR CALIBRATION

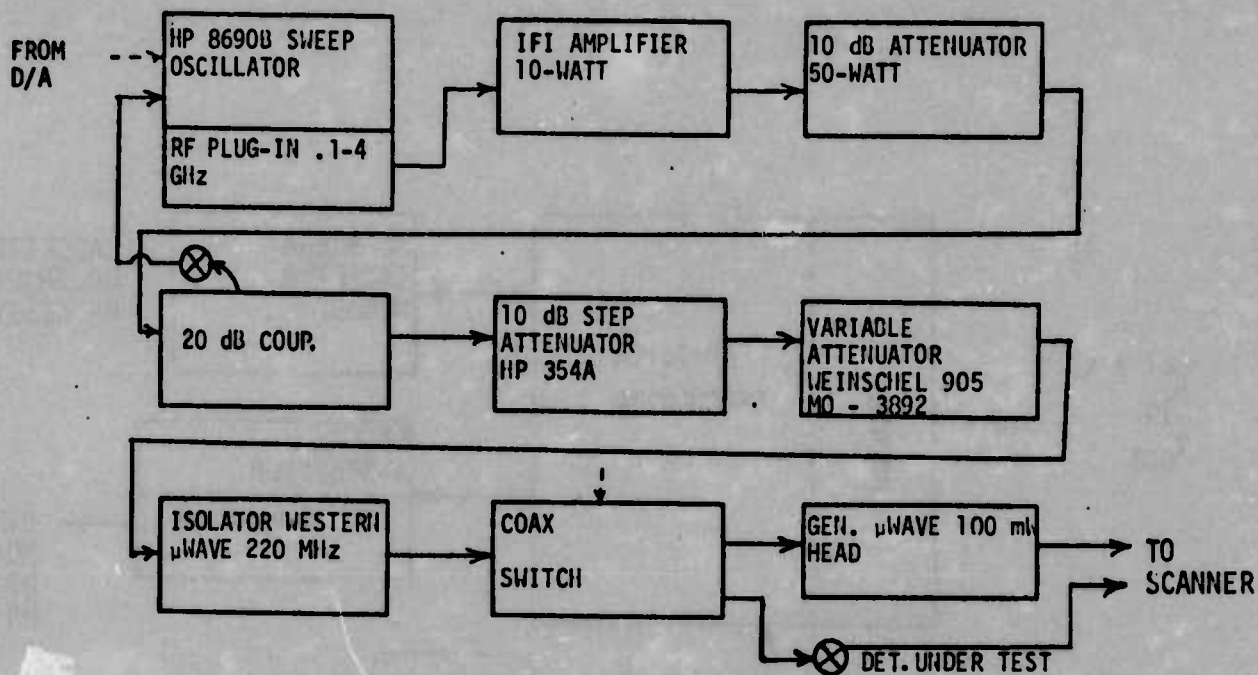

Figure 13 Test Setup for Crystal Detector Calibration, Frequency = .22 GHz

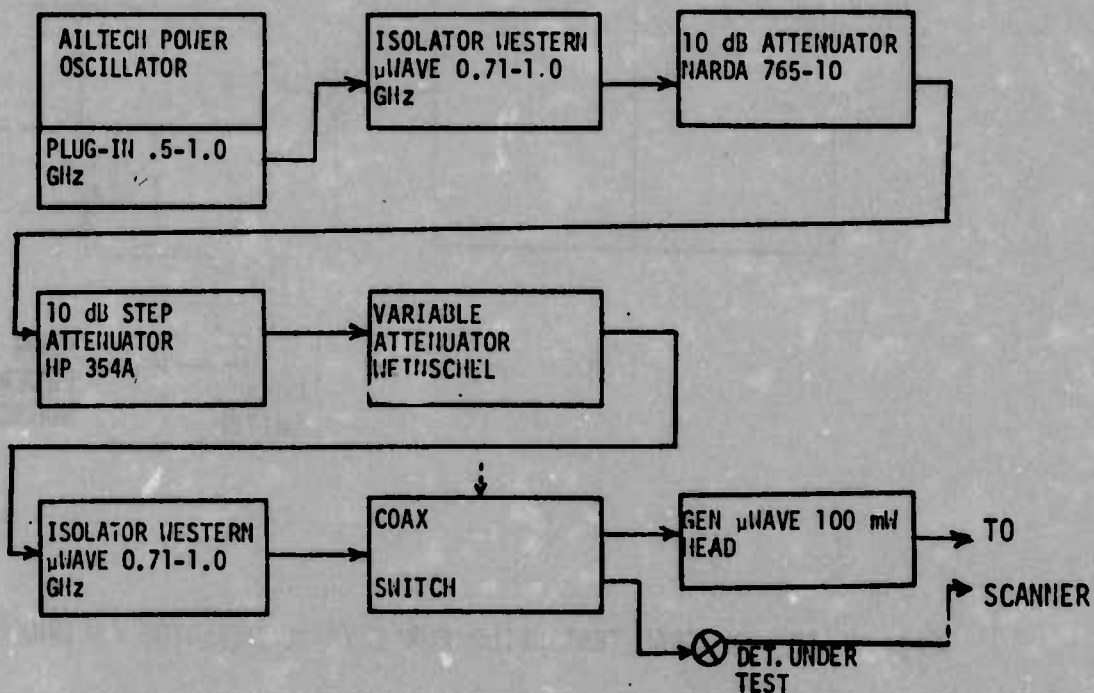

Figure 14 Test Setup for Crystal Detector Calibration, Frequency = 0.91 GHz

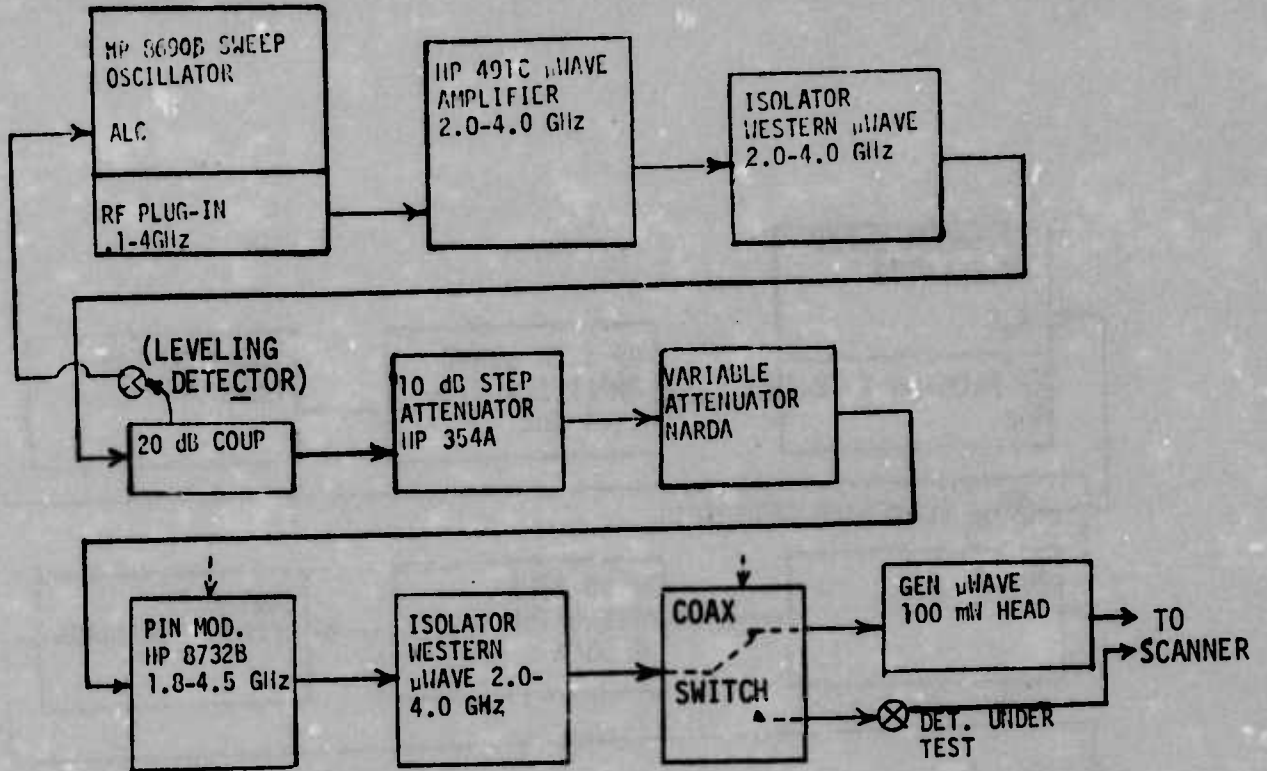

Figure 15 Test Setup for Crystal Detector Calibration, Frequency = 3 GHz

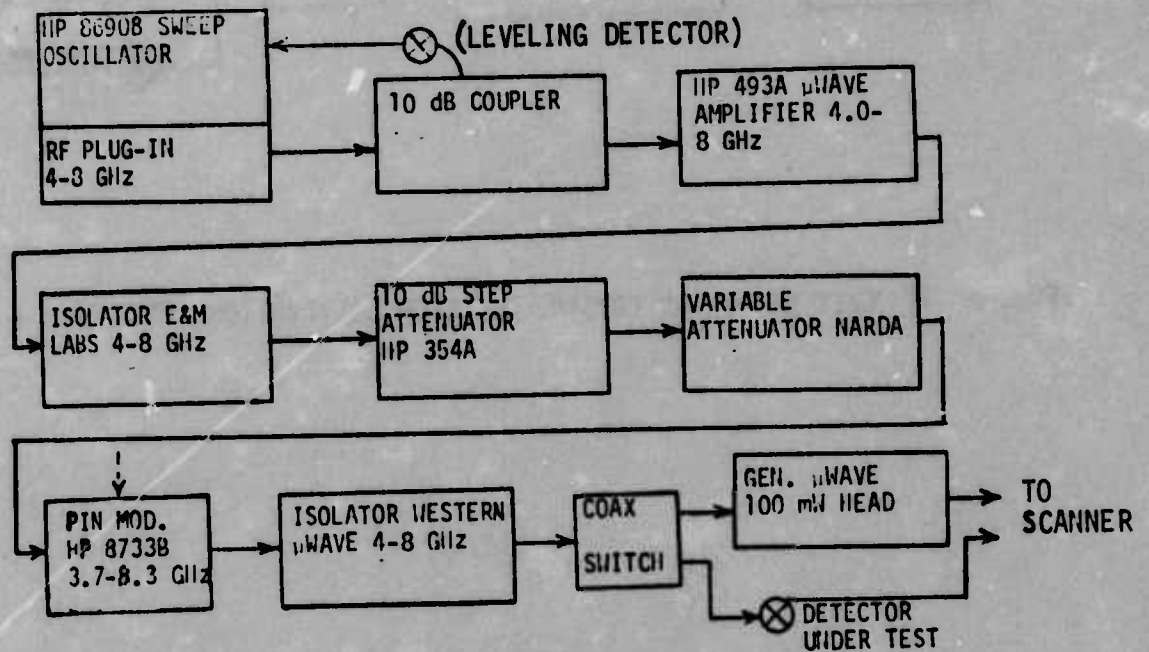

Figure 16 Test Setup for Crystal Detector Calibration, Frequency = 5.6 GHz

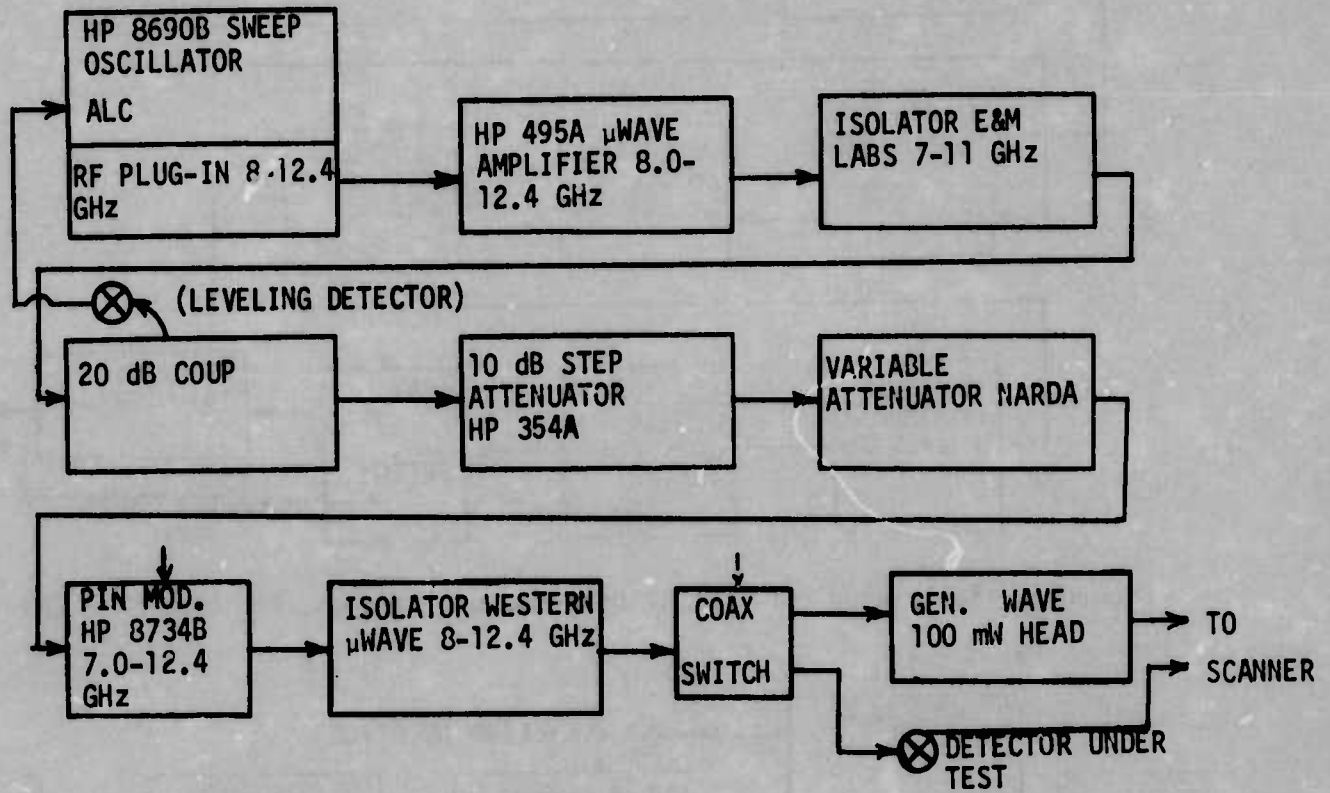
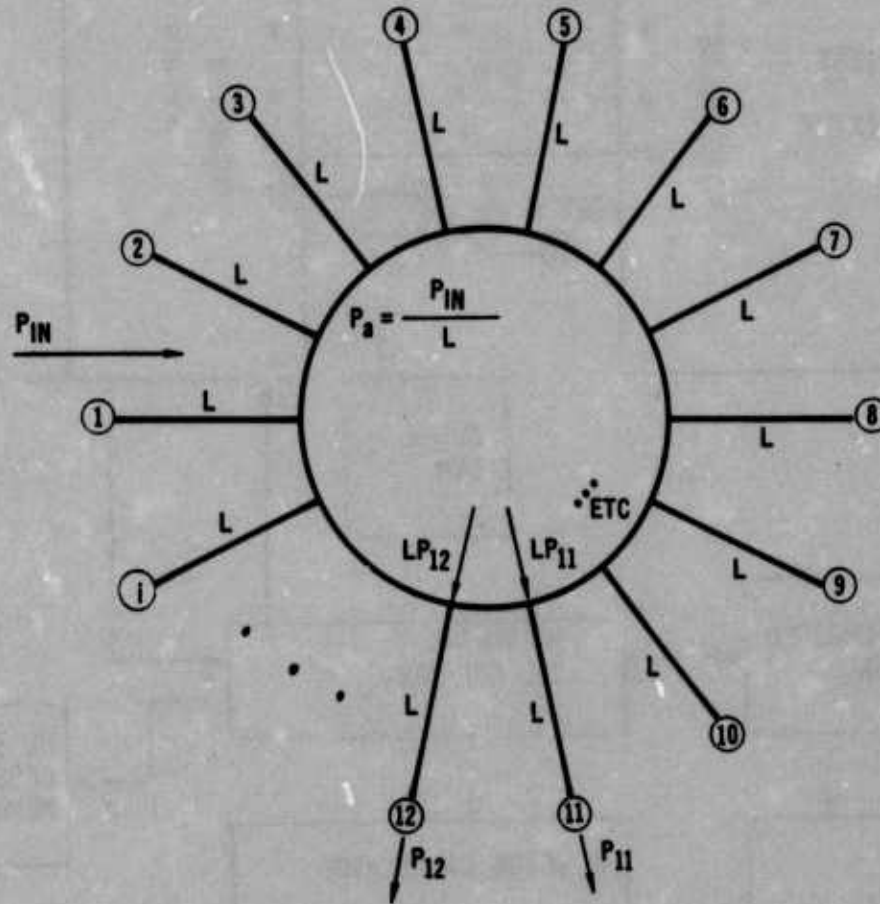

Figure 17 TEST SETUP FOR CRYSTAL DETECTOR CALIBRATION, FREQUENCY = 9.1 GHz



P_a - POWER AVAILABLE FOR DISTRIBUTION TO OUTPUT PORTS
 P_j - POWER MEASURED OUT OF J'TH PORT

$$P_a = \frac{P_{IN}}{L} = \frac{1}{\sum_{j=1}^i LP_j} \text{ HENCE, } L^2 = \frac{P_{IN}}{\sum_{j=1}^i P_j}$$

FIGURE 18 DETERMINATION OF FIXTURE DISSIPATION LOSS

A

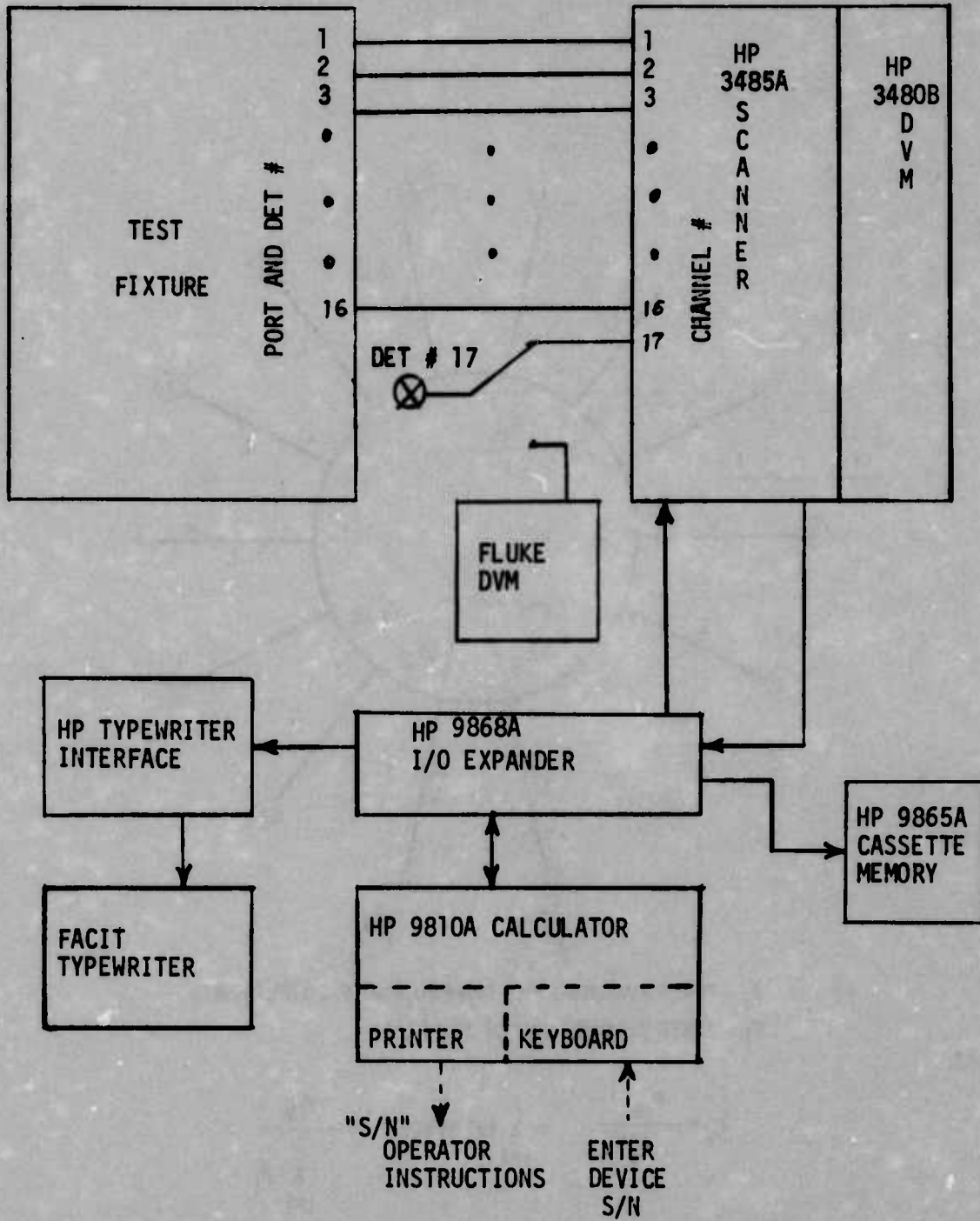

Figure 19 HP 9810A DATA SYSTEM FOR ALL FREQUENCIES FOR FIXTURE CALIBRATION

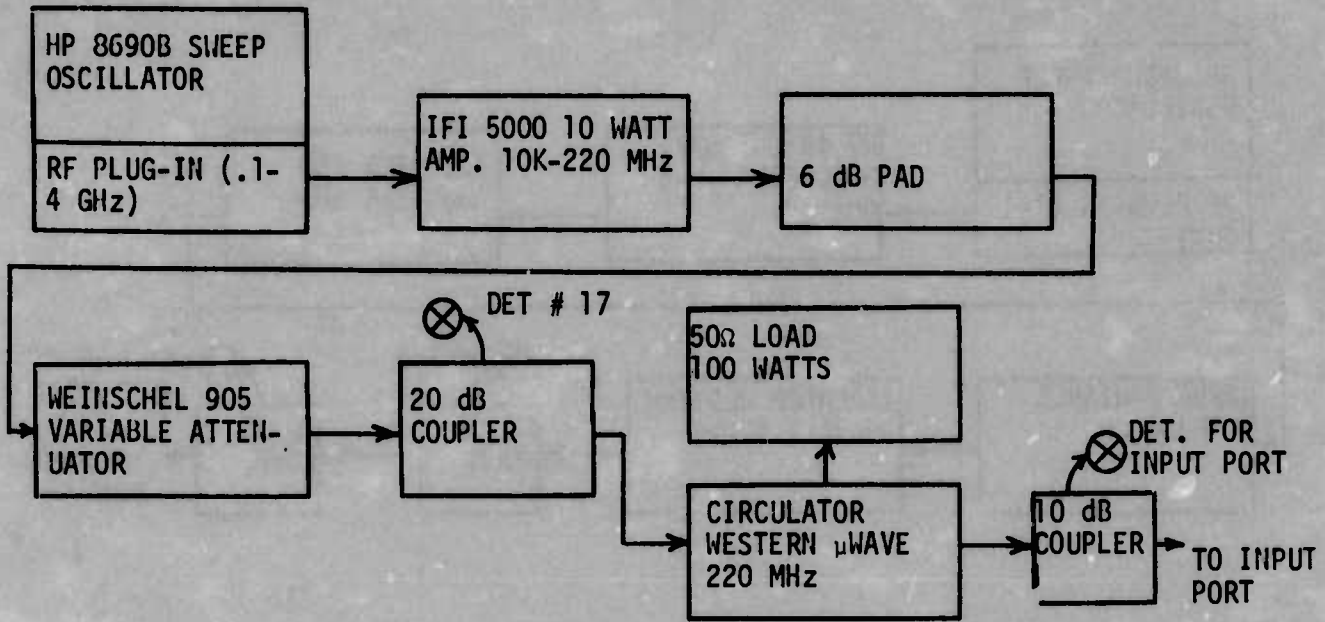

Figure 20 RF SETUP FOR FIXTURE CALIBRATION $f = 0.22$ GHz

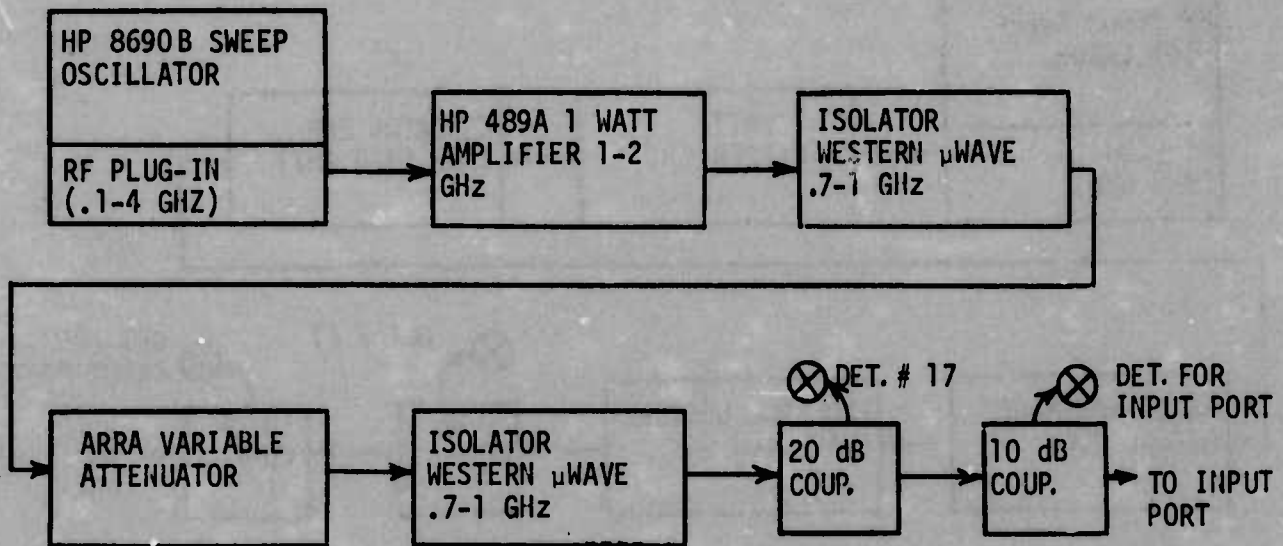

Figure 21 RF SETUP FOR FIXTURE CALIBRATION $f = 0.91$ GHz

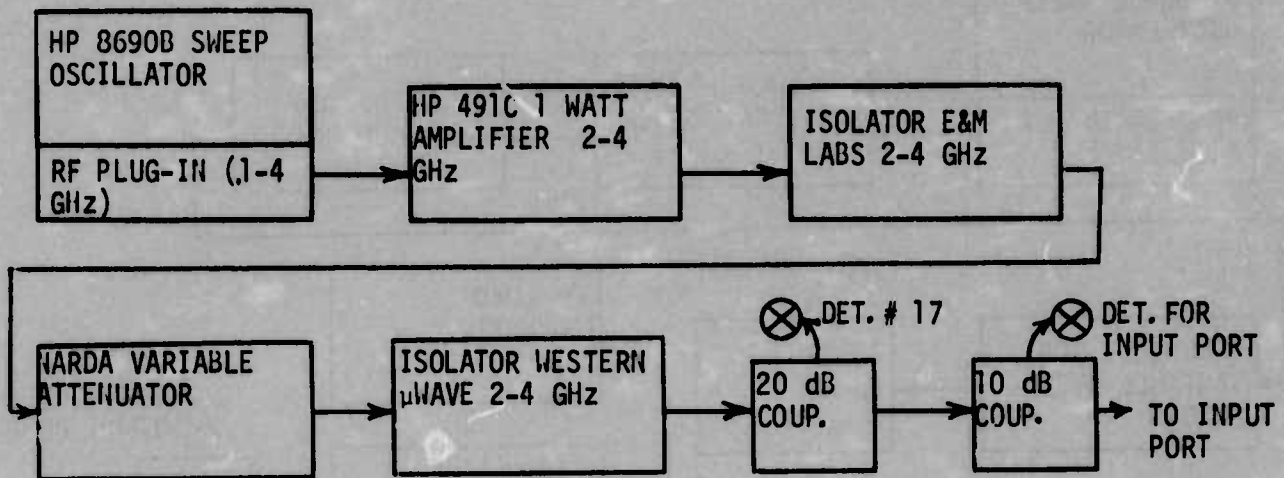

Figure 22 RF SETUP FOR FIXTURE CALIBRATION $f = 3.0$ GHz

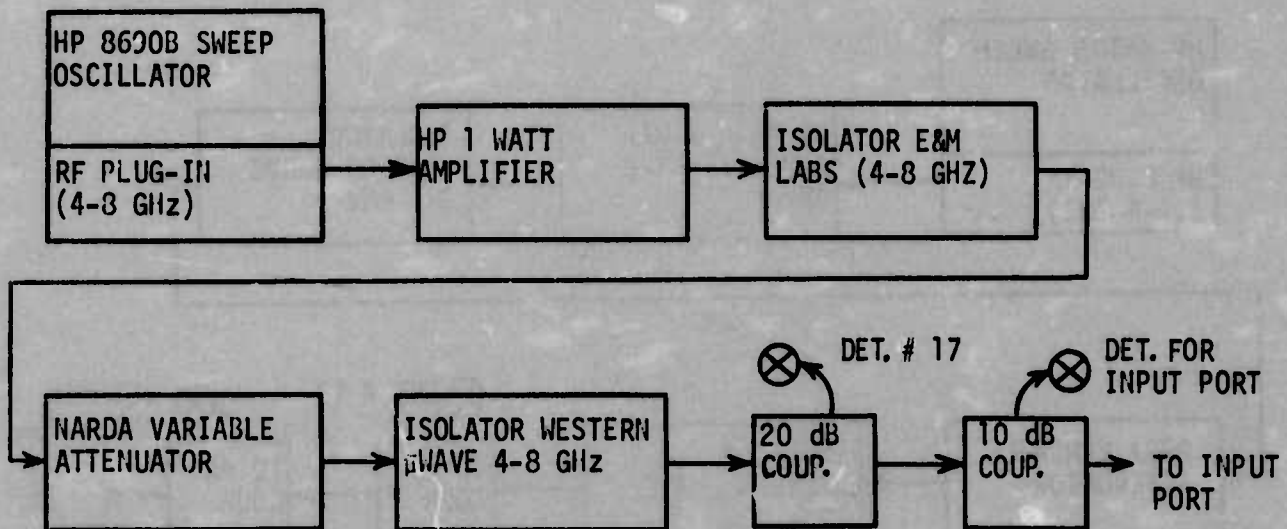

Figure 23 RF SETUP FOR FIXTURE CALIBRATION $f = 5.6$ GHz

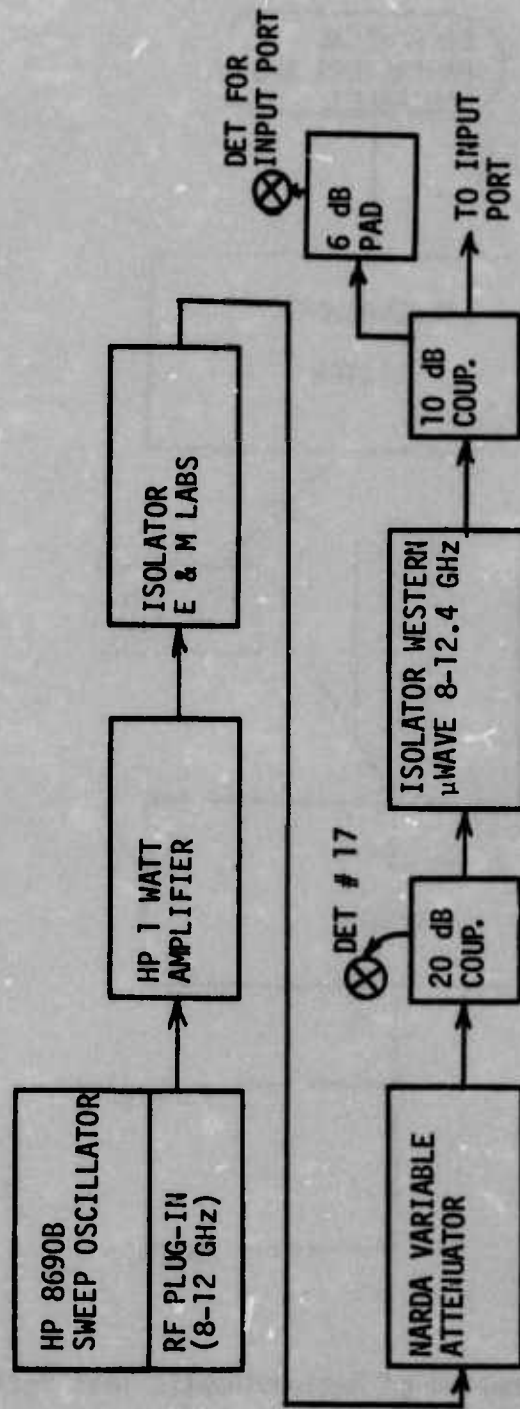

Figure 24 RF SETUP FOR FIXTURE CALIBRATION $f = 9.1$ GHz

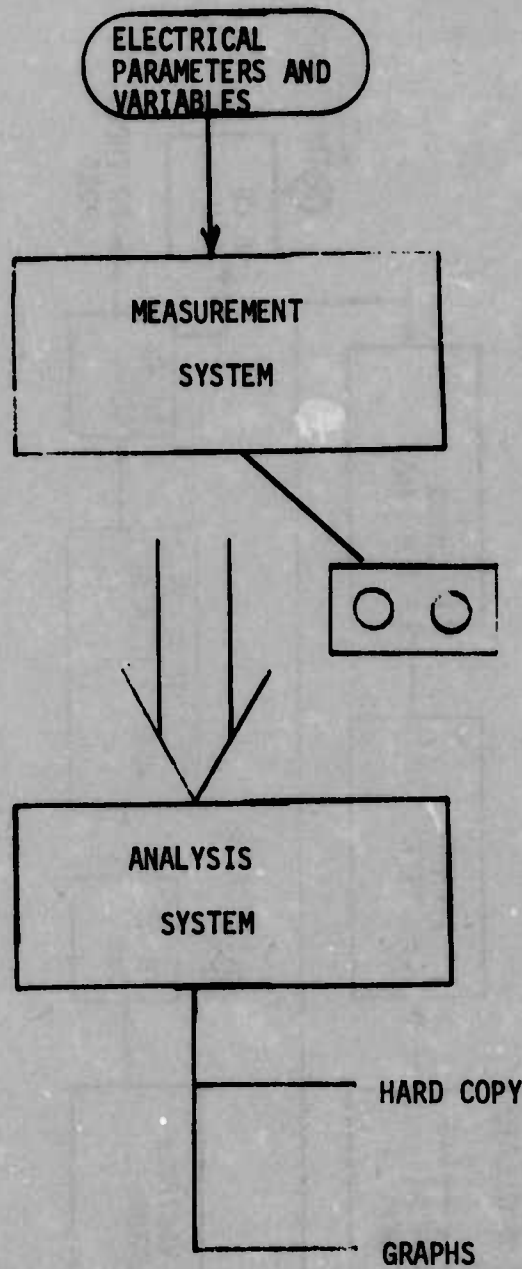

Figure 25 Illustration of Semi-Automatic Test System Measurement and Analysis

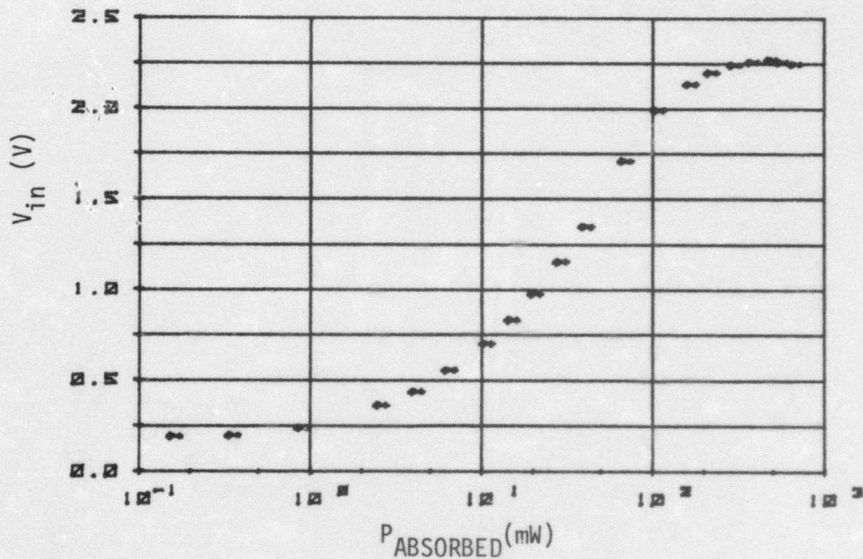
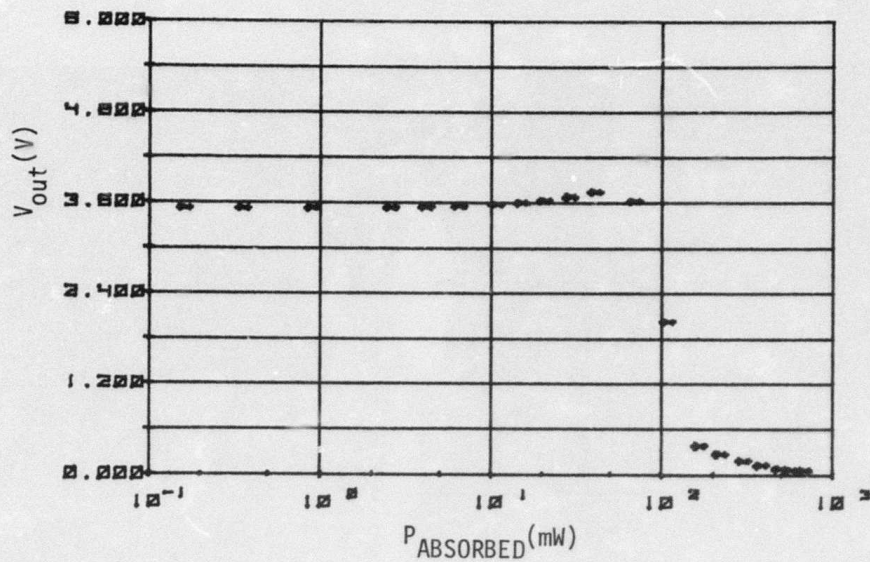

FIGURE 26 EXAMPLES OF V_{OUT} AND V_{IN} VS $P_{ABSORBED}$
RF INJECTED INTO INPUT PORT OF 7400 DEVICE,
INPUT LOW, OUTPUT HIGH BIAS STATE, 220 MHz

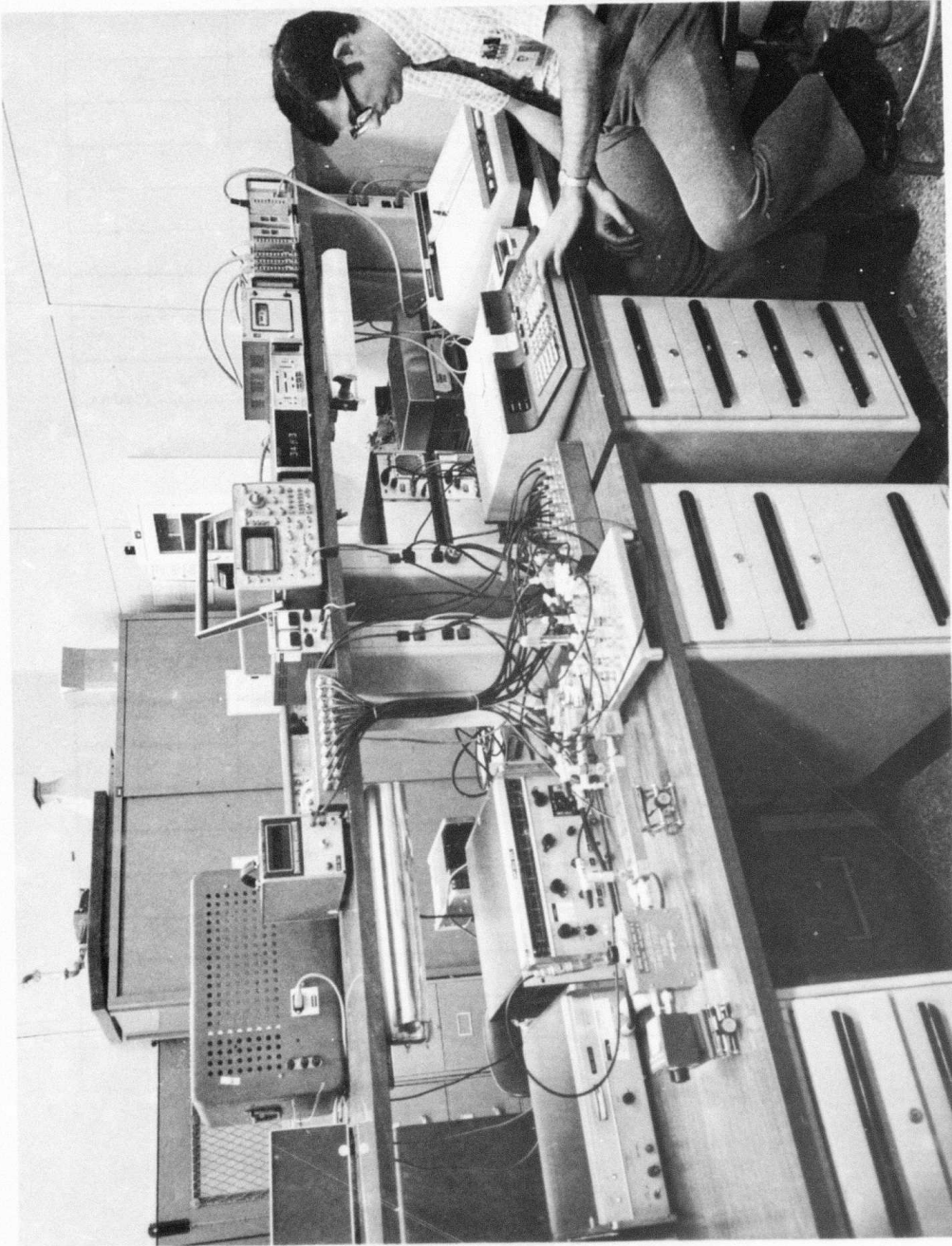

FIGURE 27 SET II - AUTOMATED MEASUREMENT TEST SETUP

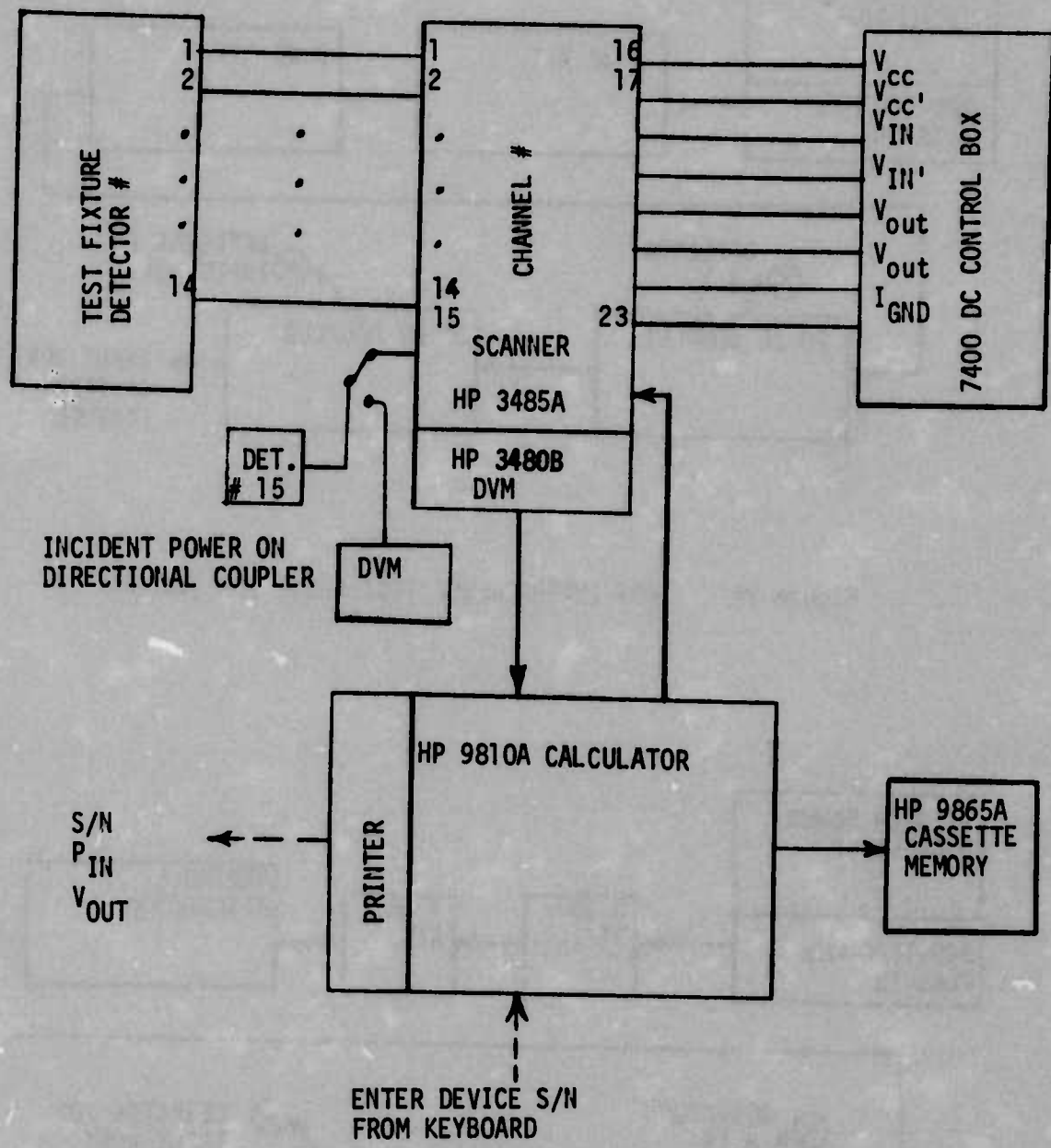

Figure 28 GENERAL TEST SETUP FOR 7400 INTERFERENCE TESTING

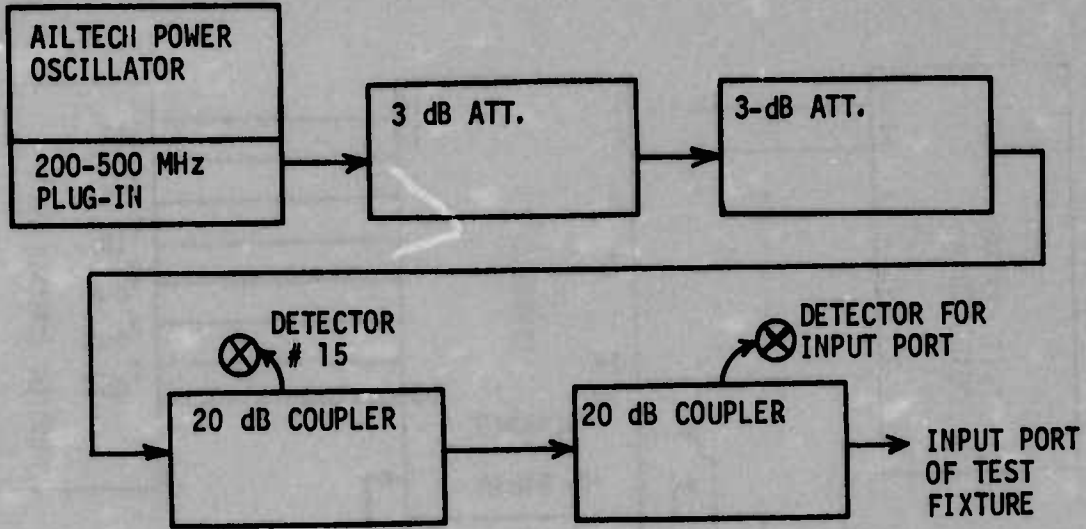

Figure 29 7400 INTERFERENCE TEST SETUP FOR .22 GHz

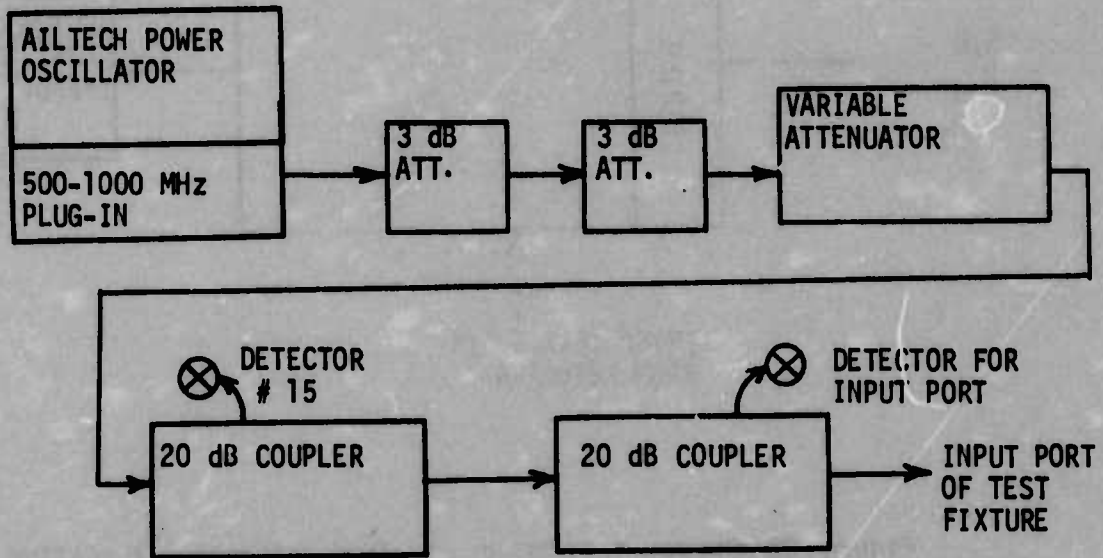

Figure 30 7400 INTERFERENCE TEST SETUP FOR .91 GHz

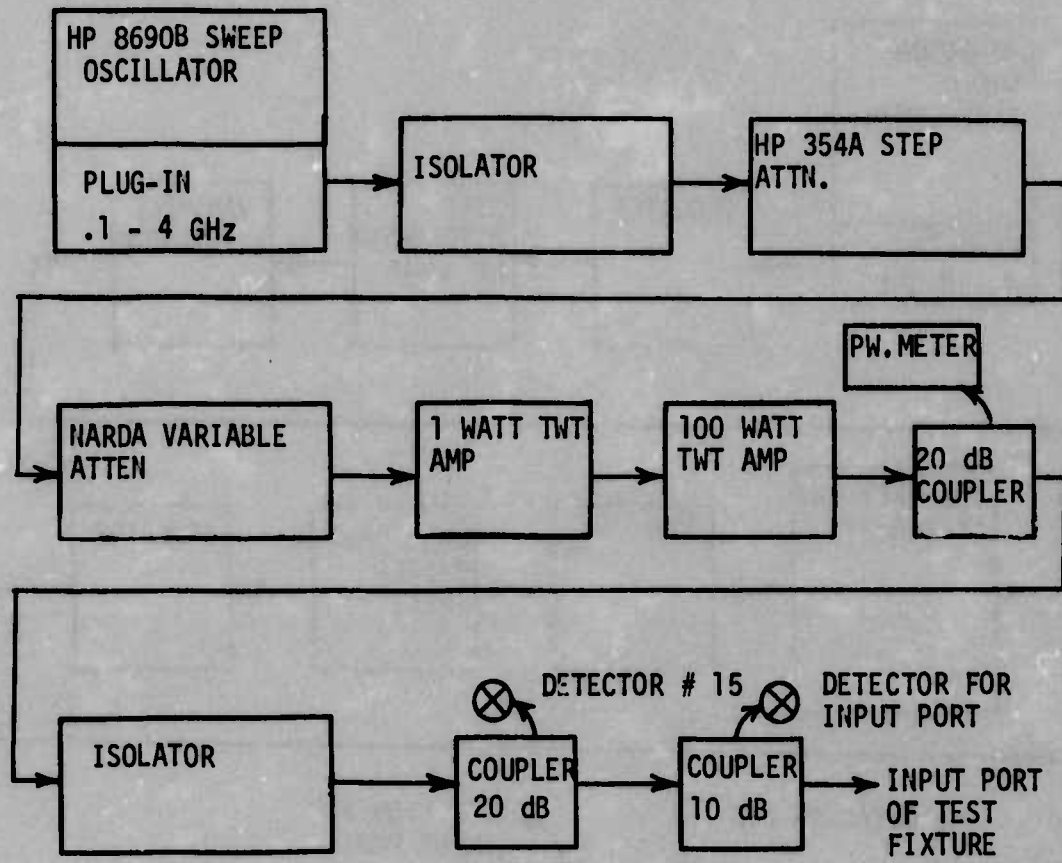

Figure 31 7400 INTERFERENCE TEST SETUP FOR 3.0 GHz

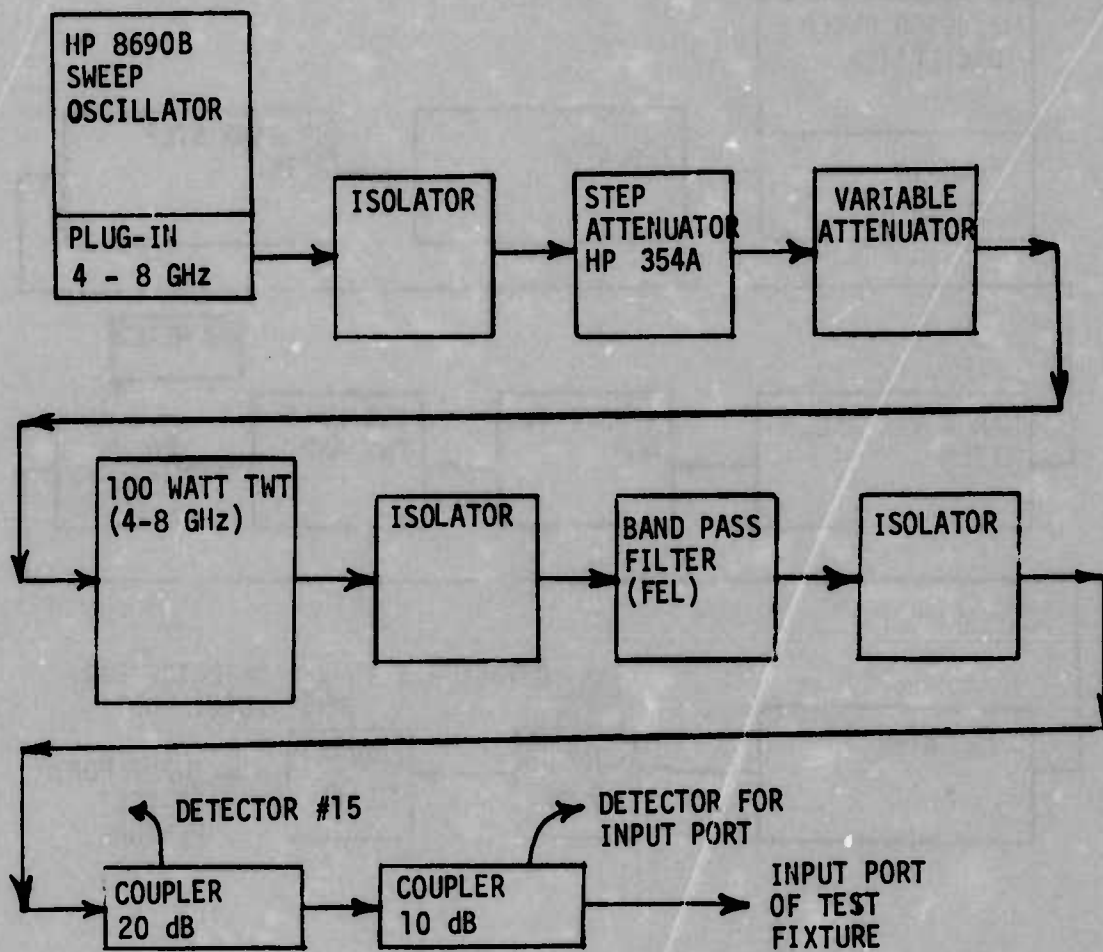
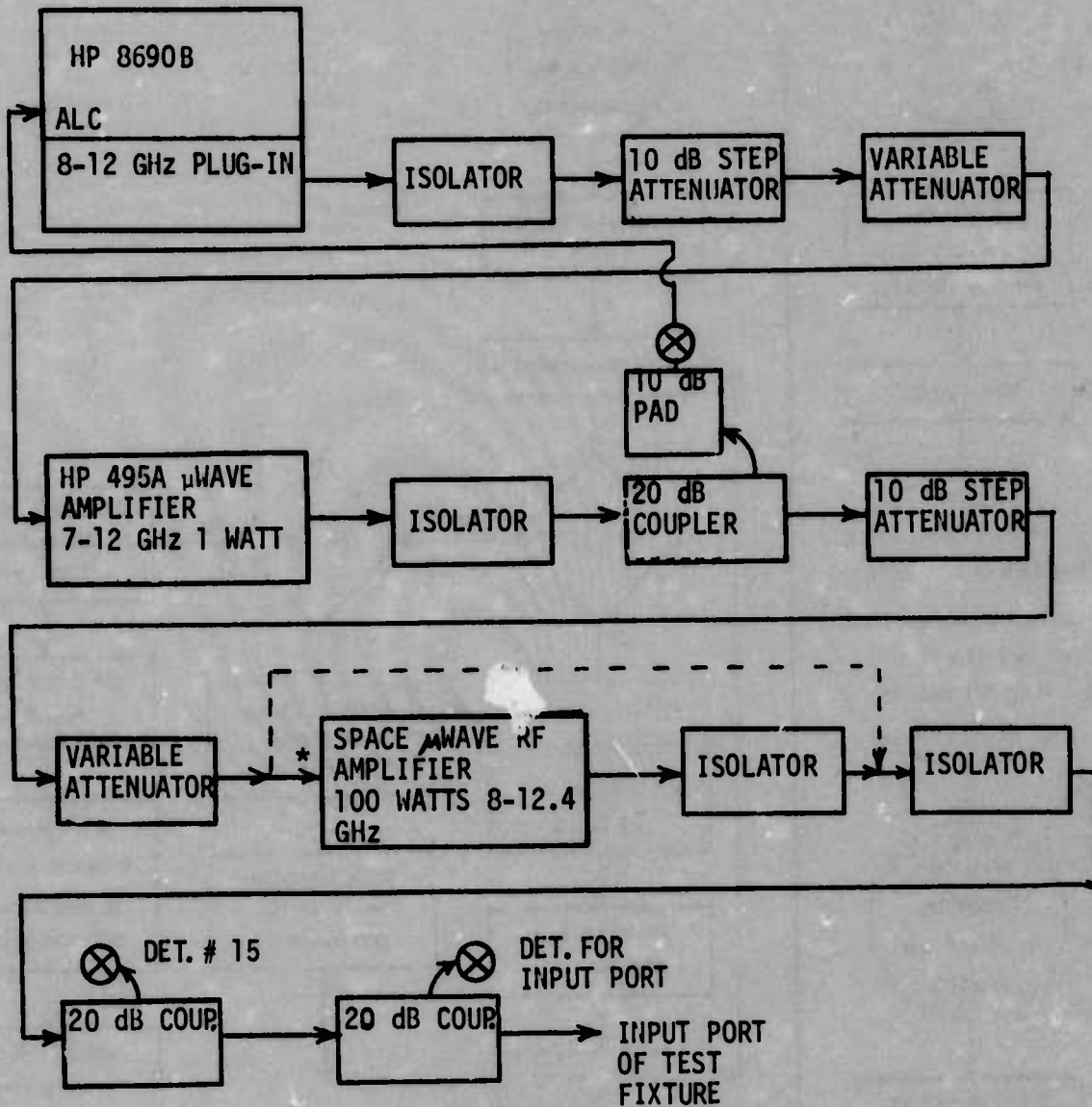

Figure 32 7400 Interference Test Setup for 5.6 GHz



* USE 100-WATT AMPLIFIER AND ISOLATOR COMBINATION ONLY AS NEEDED

Figure 33 7400 INTERFERENCE TEST SEJUP FOR 9.1 GHz

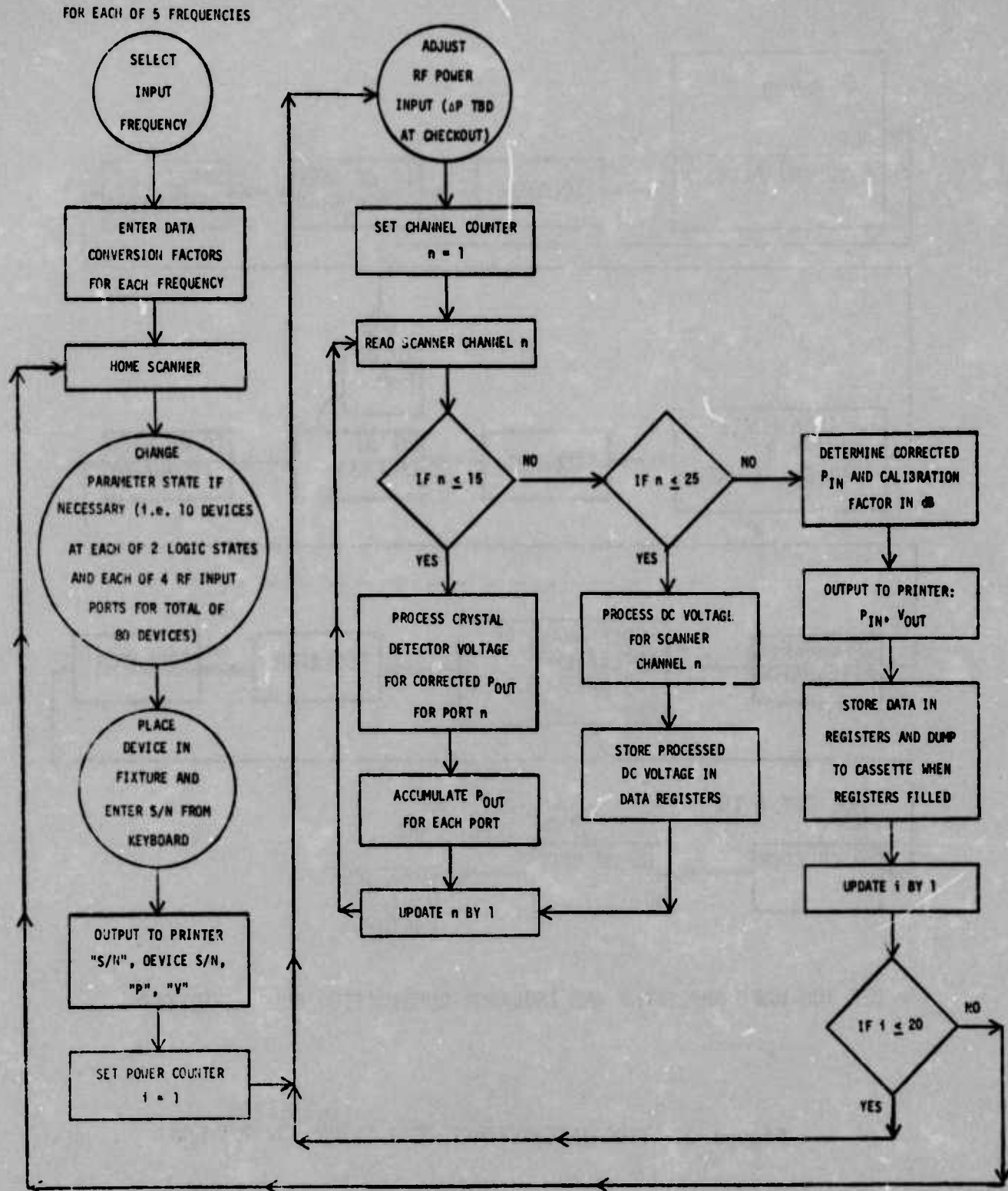

FIGURE 34 7400 INTERFERENCE TEST FLOW DIAGRAM

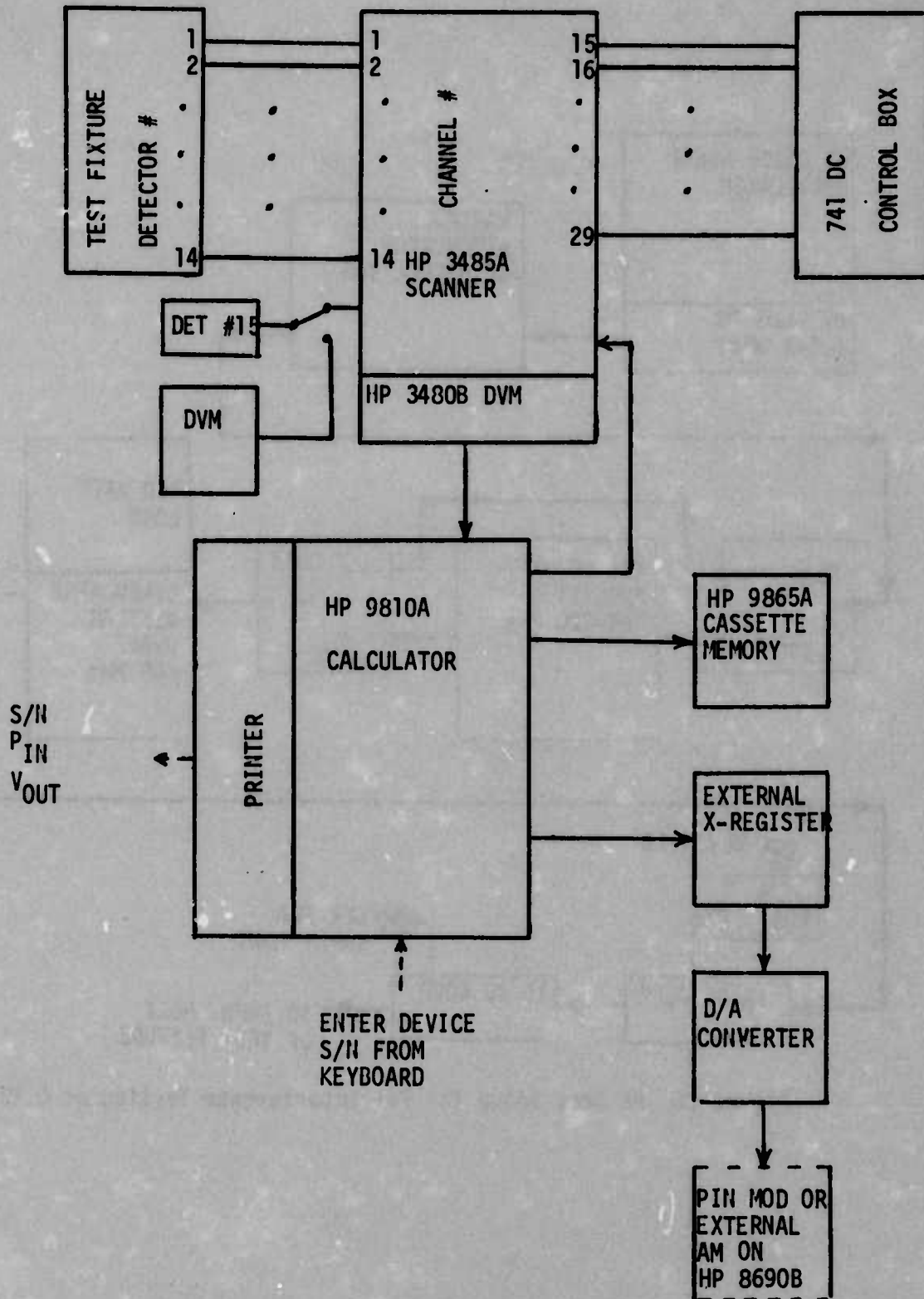

Figure 35 General Test Setup for 741 Interference Testing

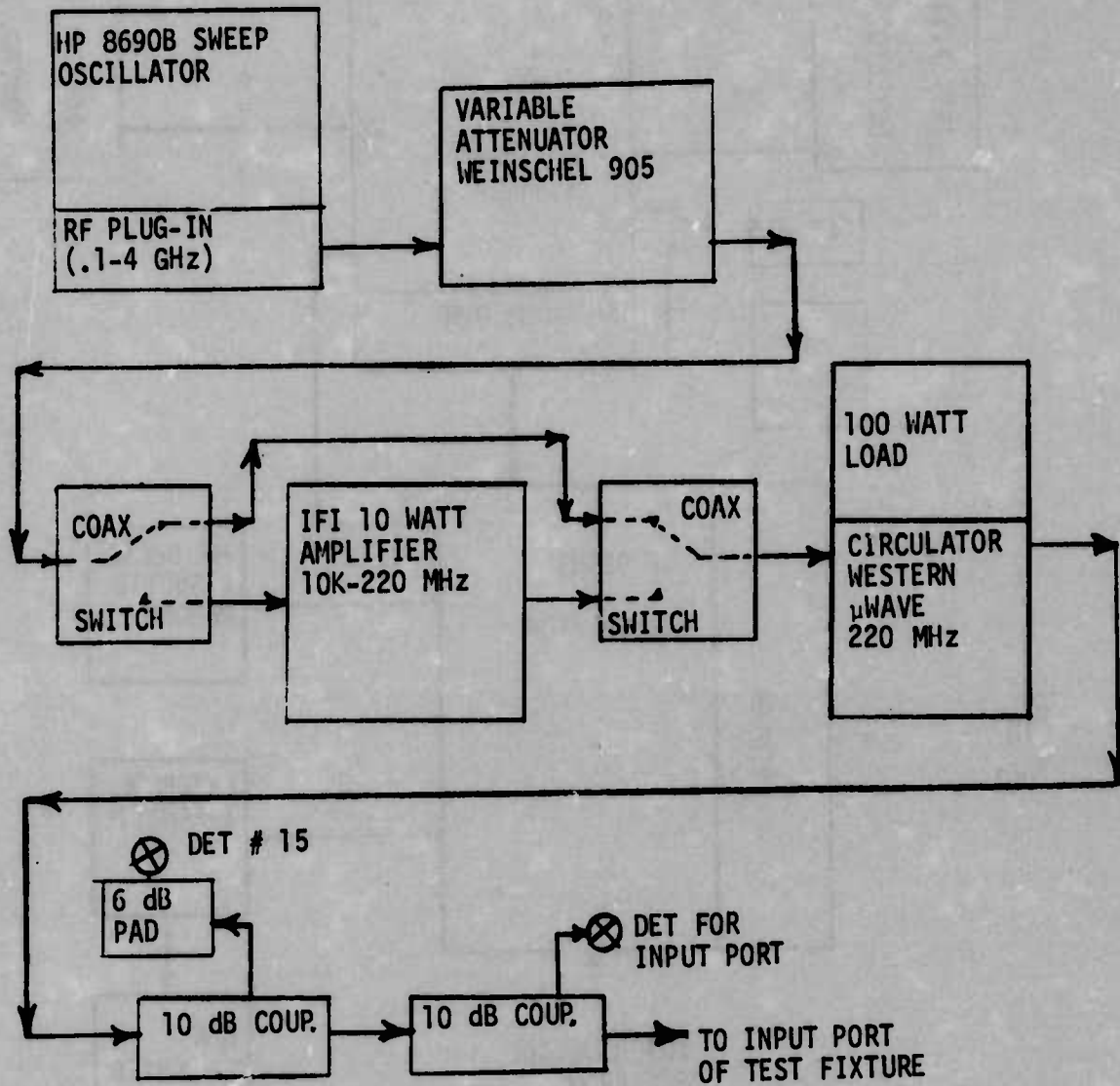

Figure 36 RF Test Setup for 741 Interference Testing at 0.22 GHz

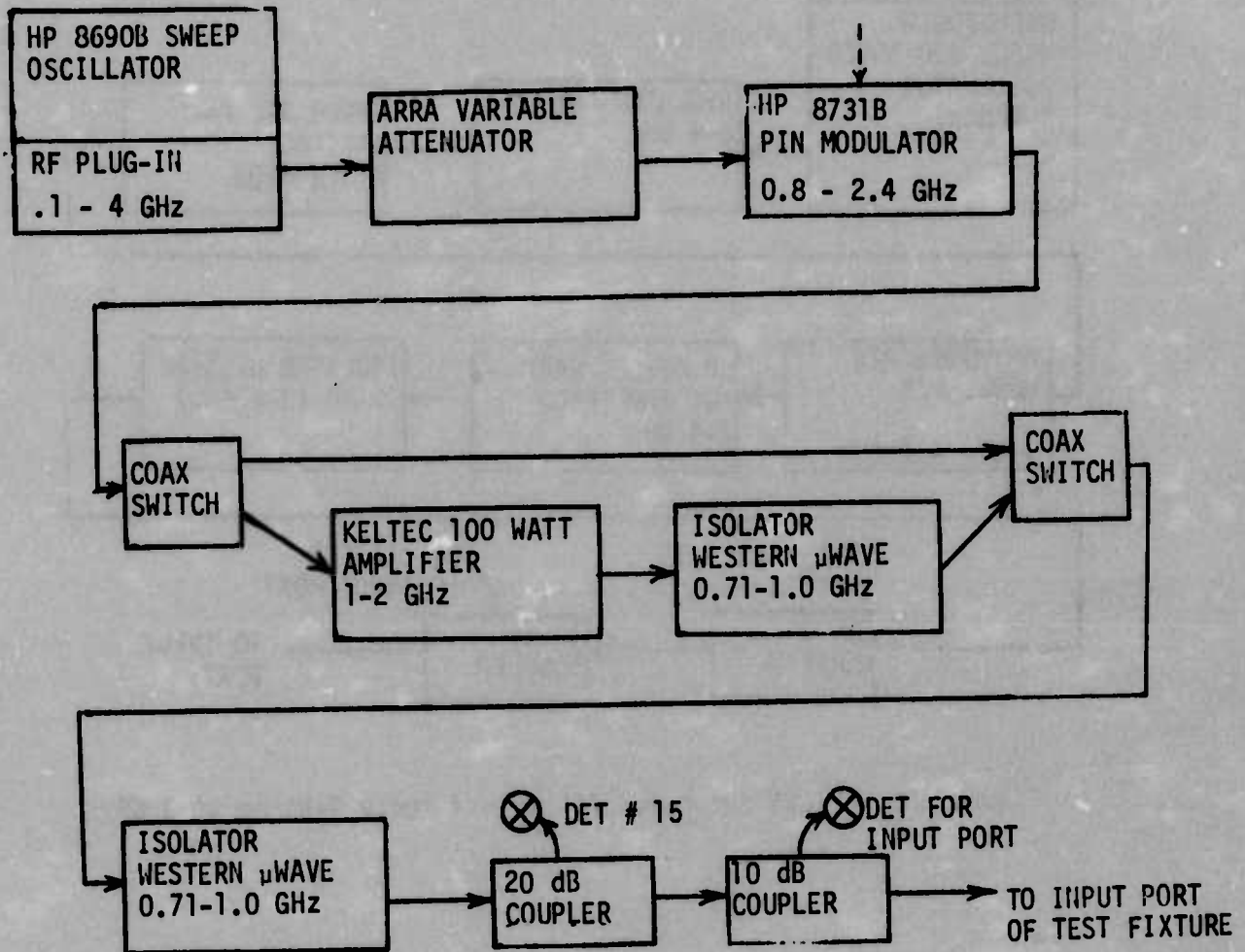

Figure 37 RF Test Setup for 741 Interference Testing at 0.91 GHz

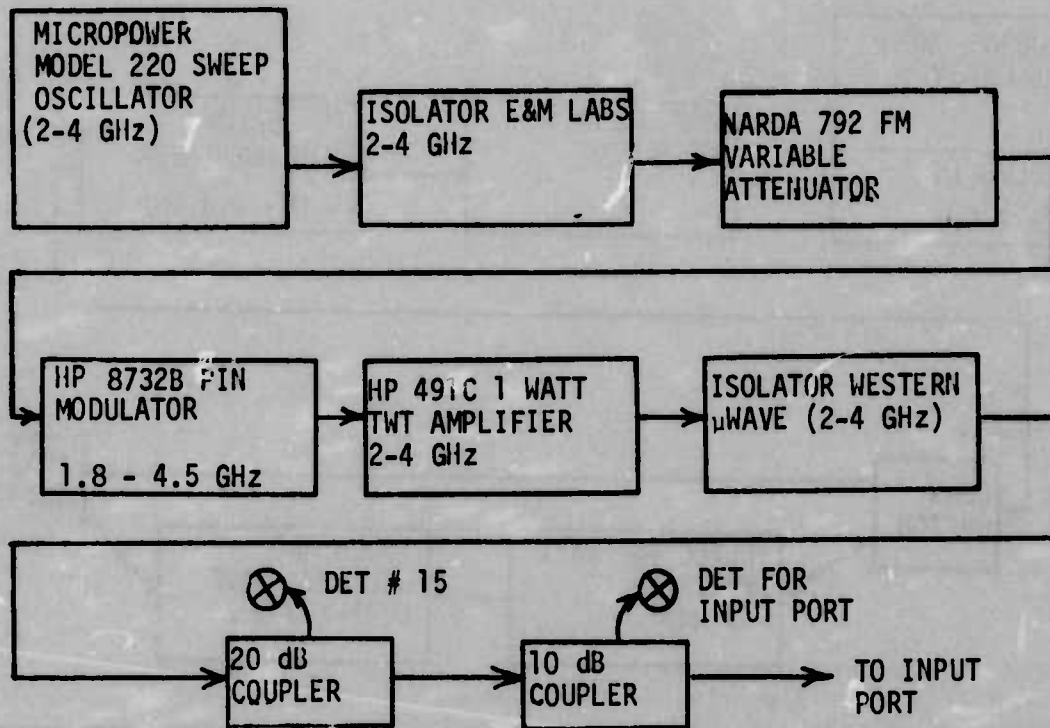

Figure 38 RF Test Setup for 741 Interference Testing at 3 GHz

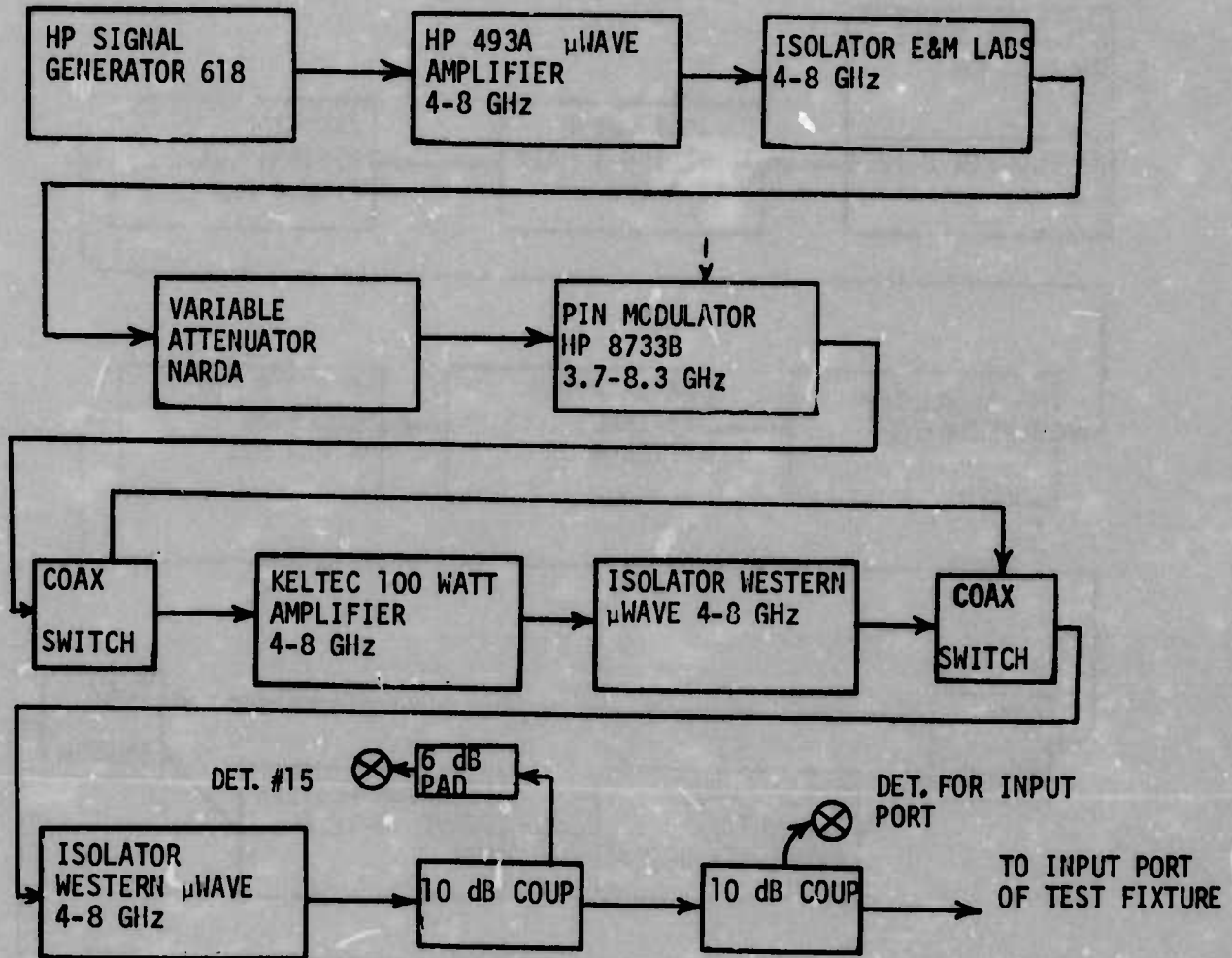

Figure 39 RF Test Setup for 741 Interference Testing at 5.6 GHz

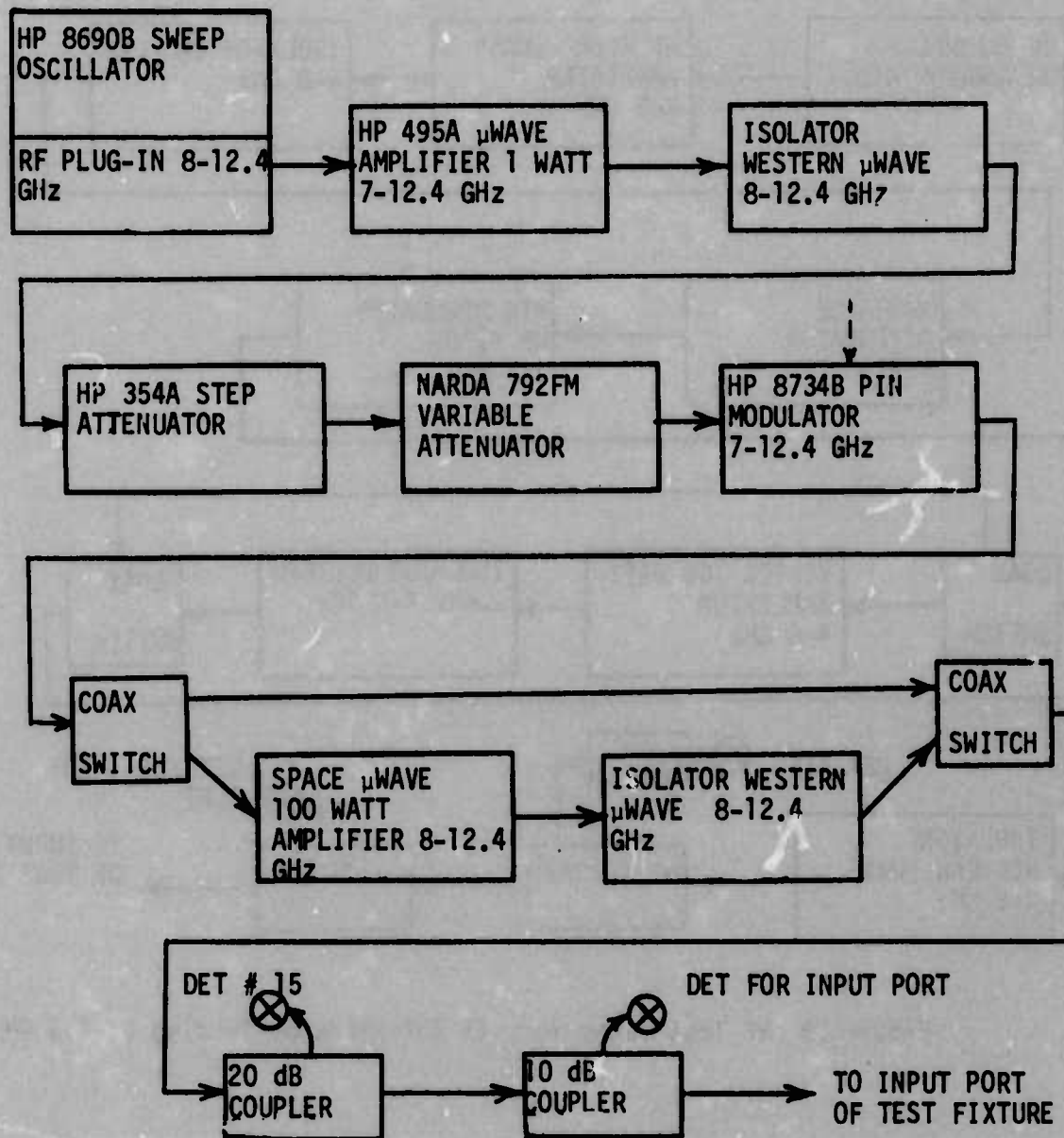

Figure 40 741 Interference Test Setup for $f = 9.1$ GHz

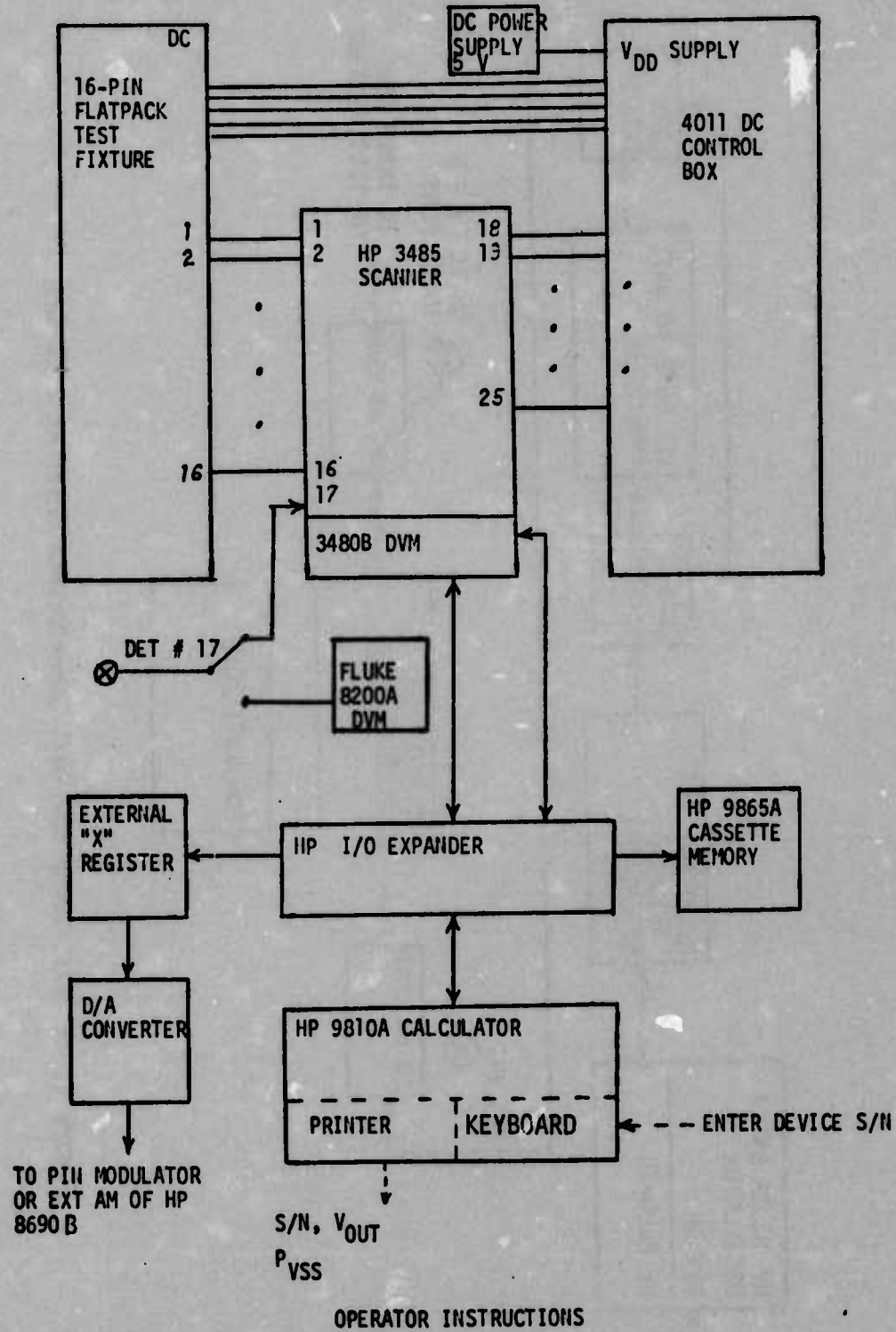

Figure 41 General Test Setup for MOS 4011 Interference Testing

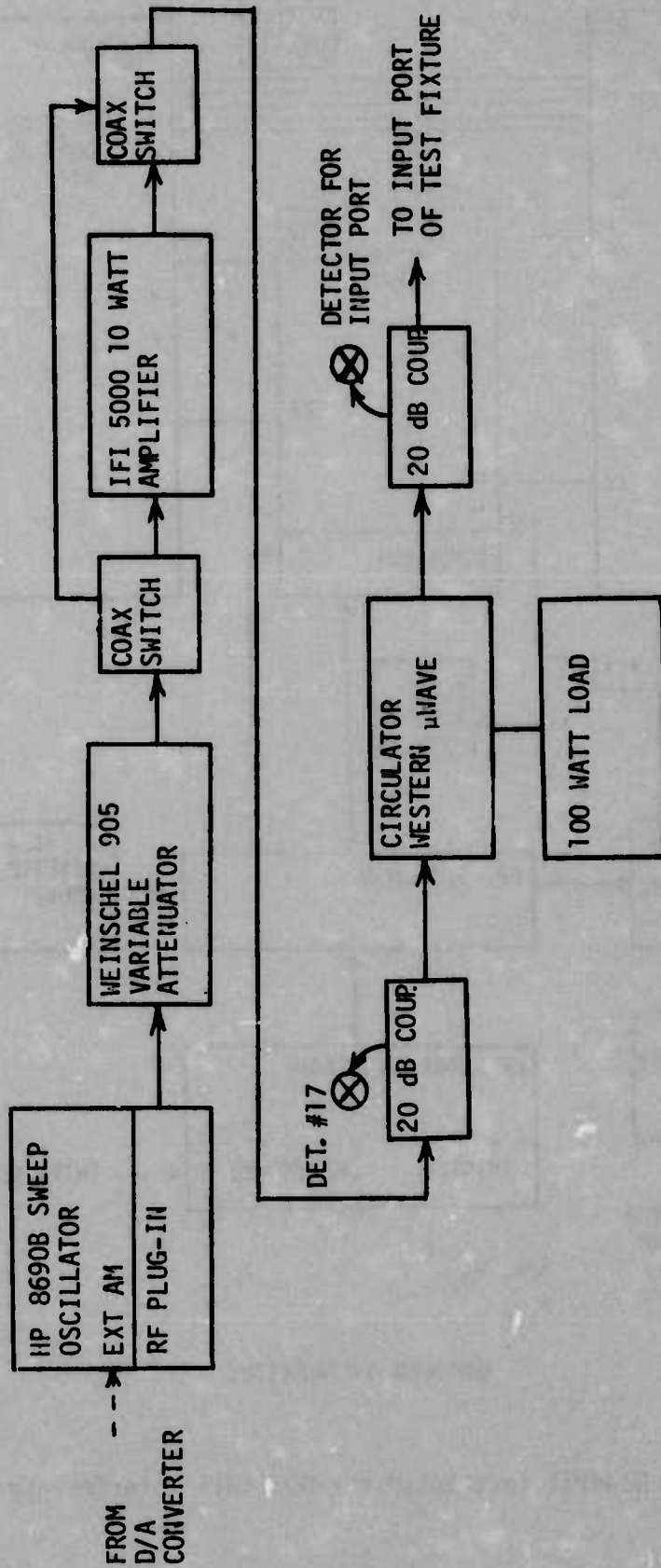

Figure 42 RF Test Setup for 4011 Interference Tests at 0.22 GHz

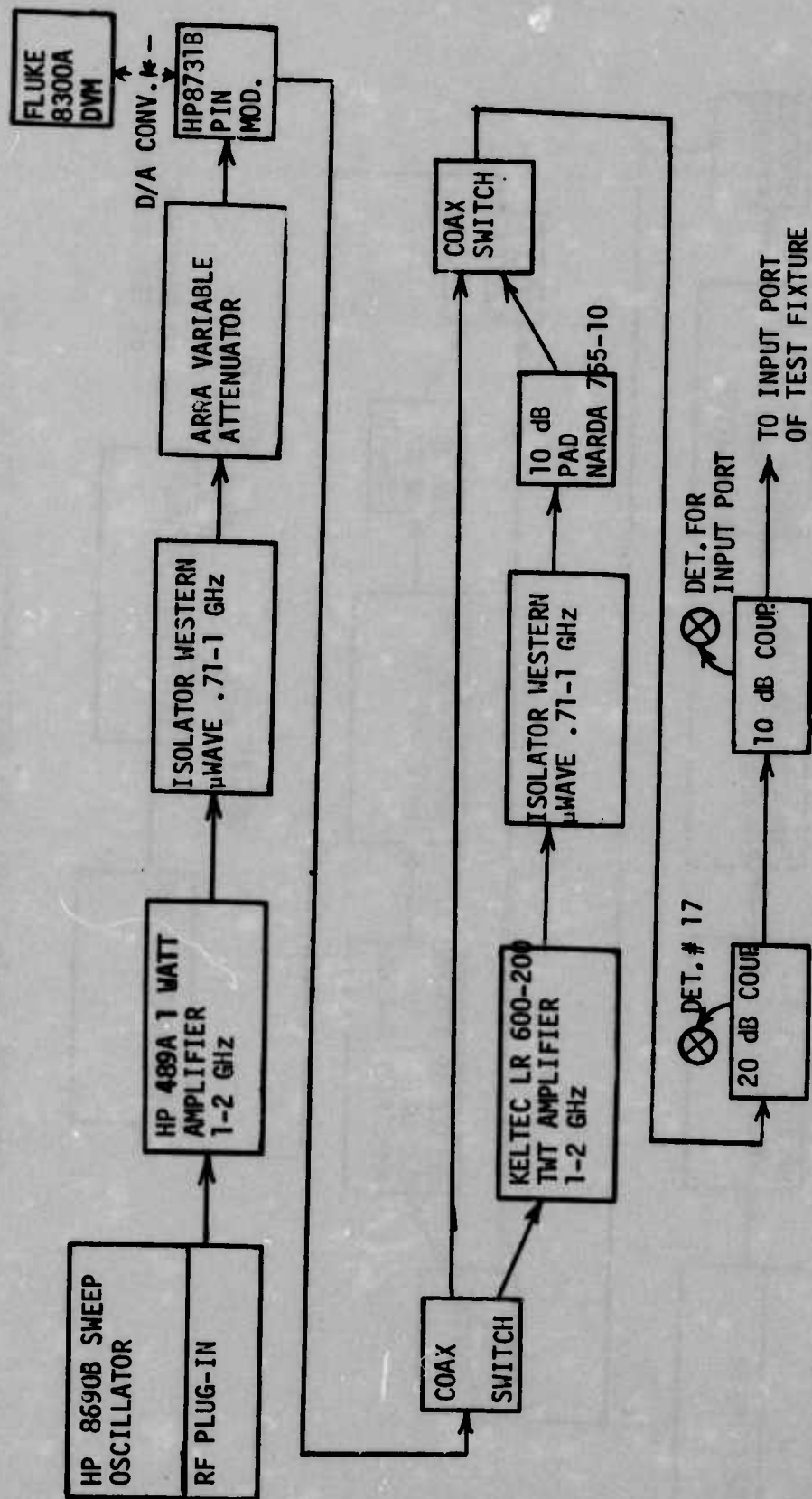

Figure 43 RF Test Setup for 4011 Interference Tests at 0.91 GHz

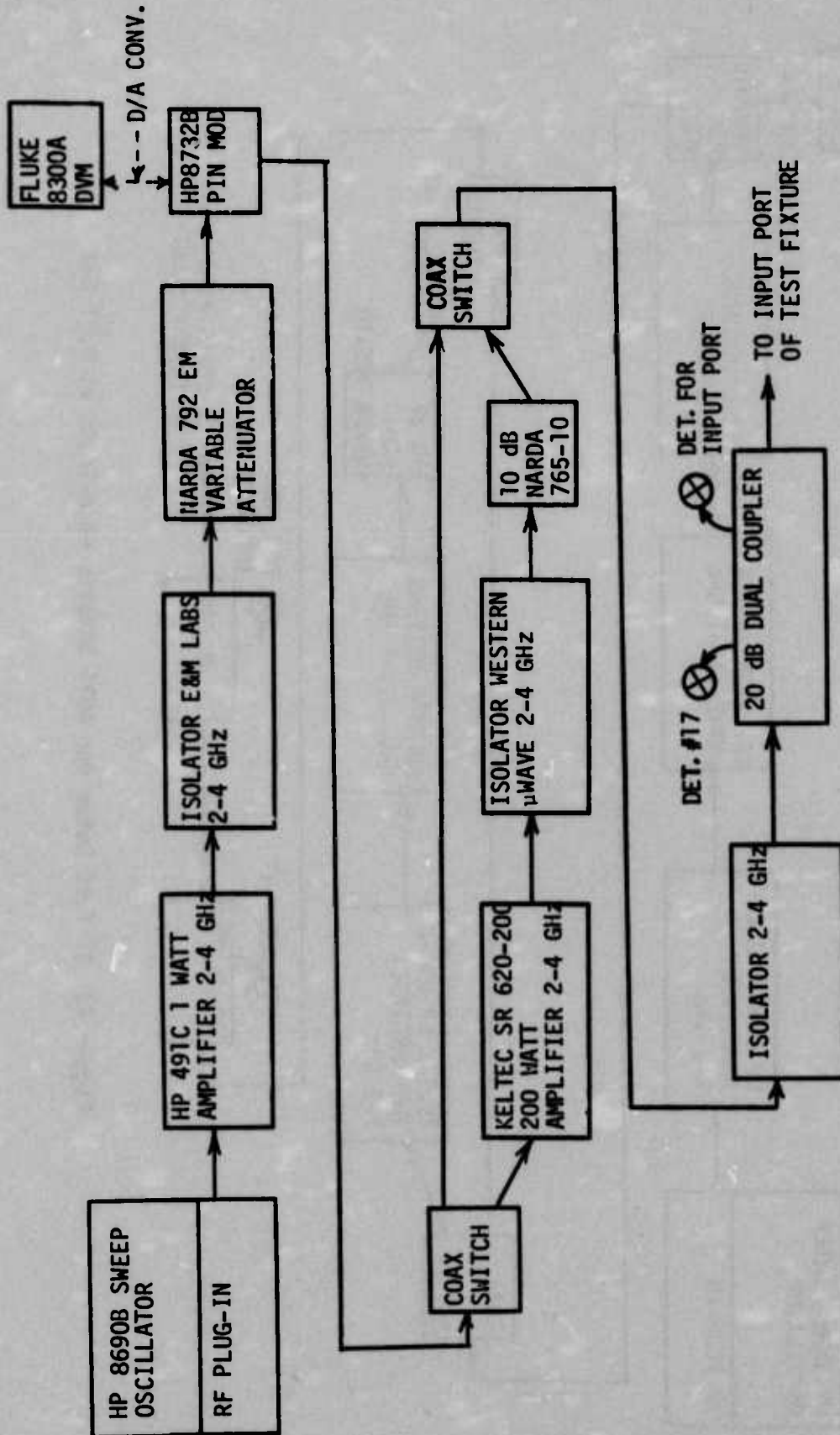

Figure 44 RF Test Setup for 4011 Interference Tests at 3 GHz

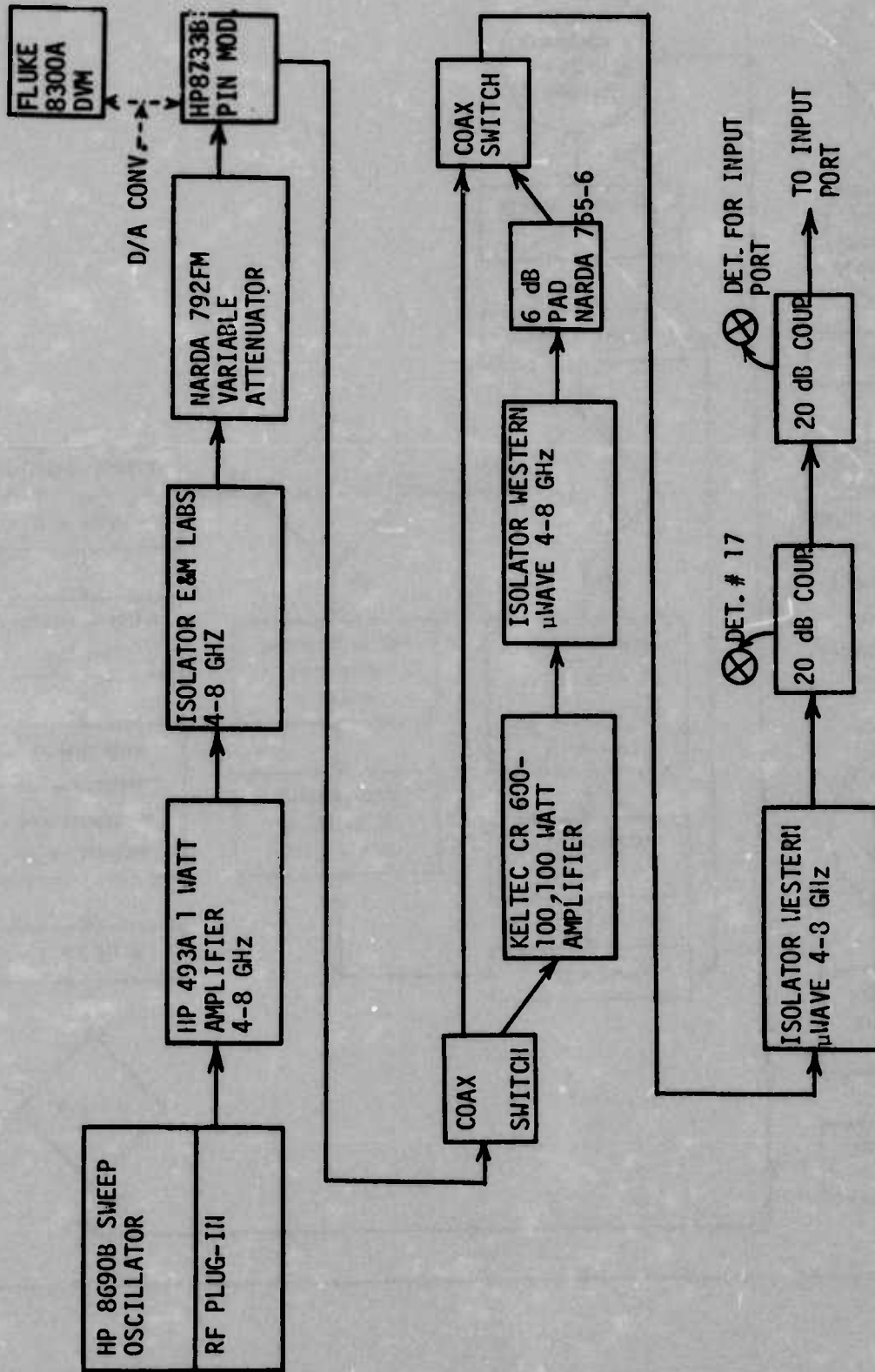

Figure 45 RF Test Setup for 4011 Interference Tests at 5.6 GHz

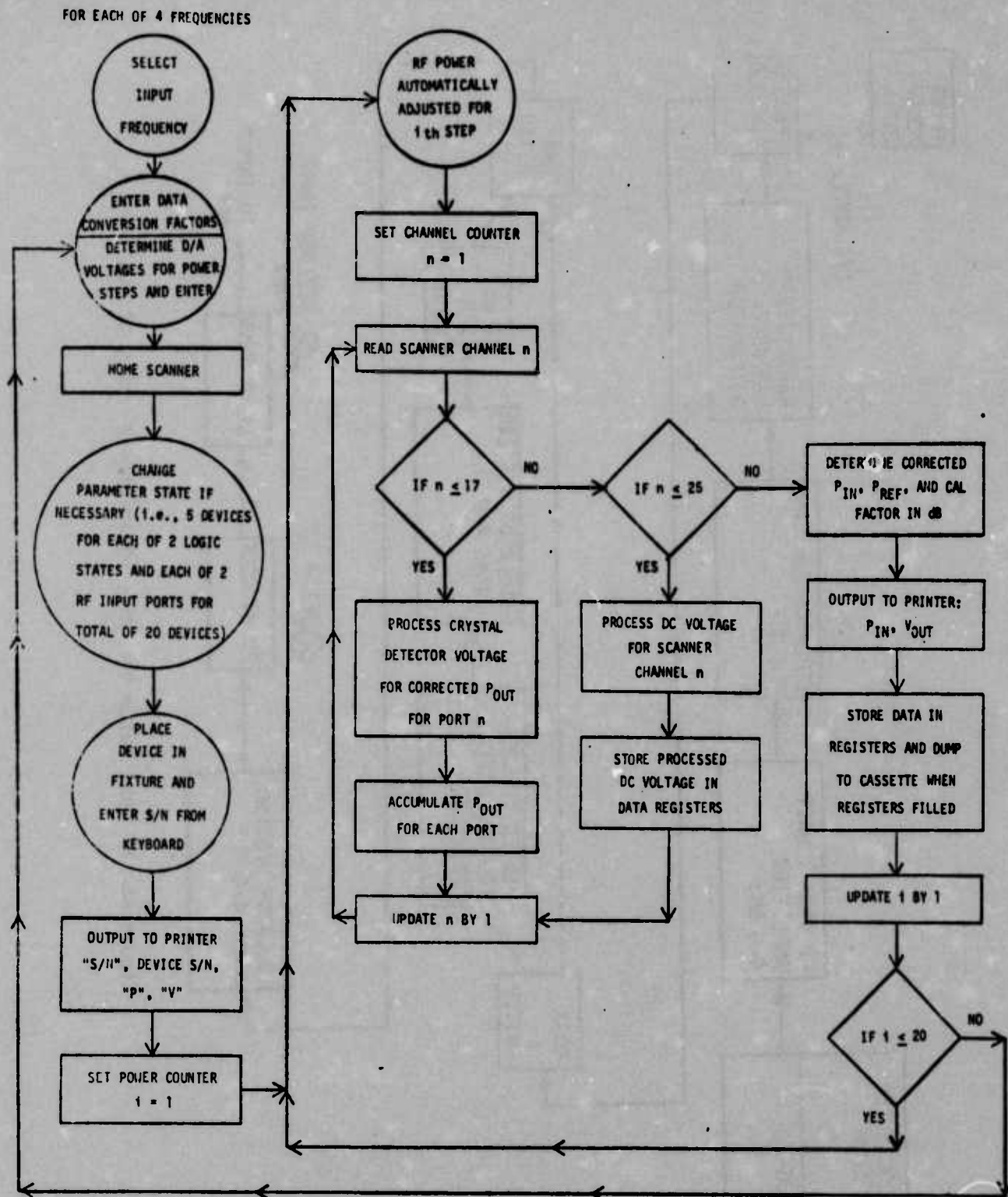

Figure 46 4011 Interference Test Flow Diagram

A

INTEGRATED CIRCUIT SUSCEPTIBILITY

MDC E1099
12 JULY 1974

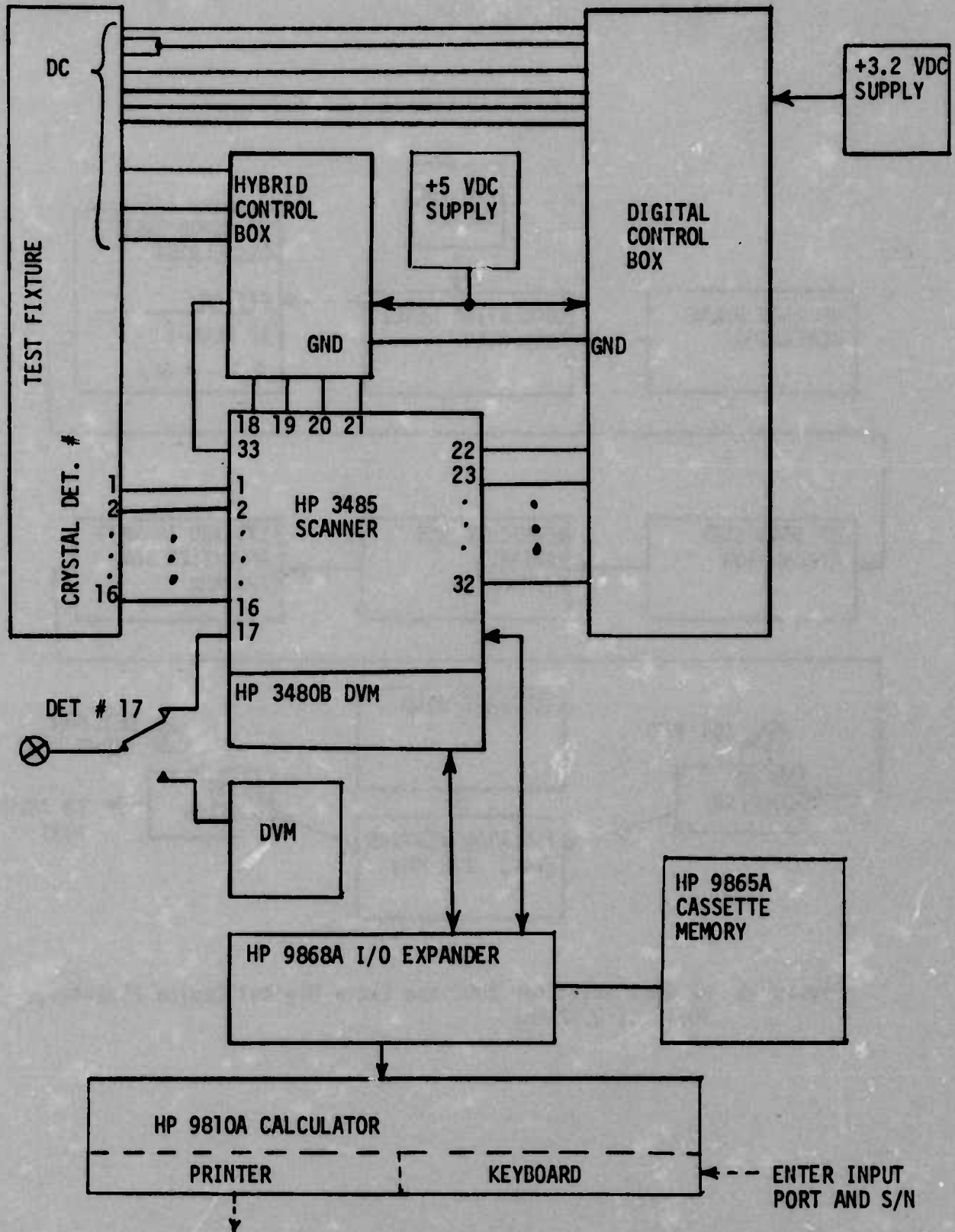

Figure 47 General Test Setup for 2002 Hybrid Interference Test

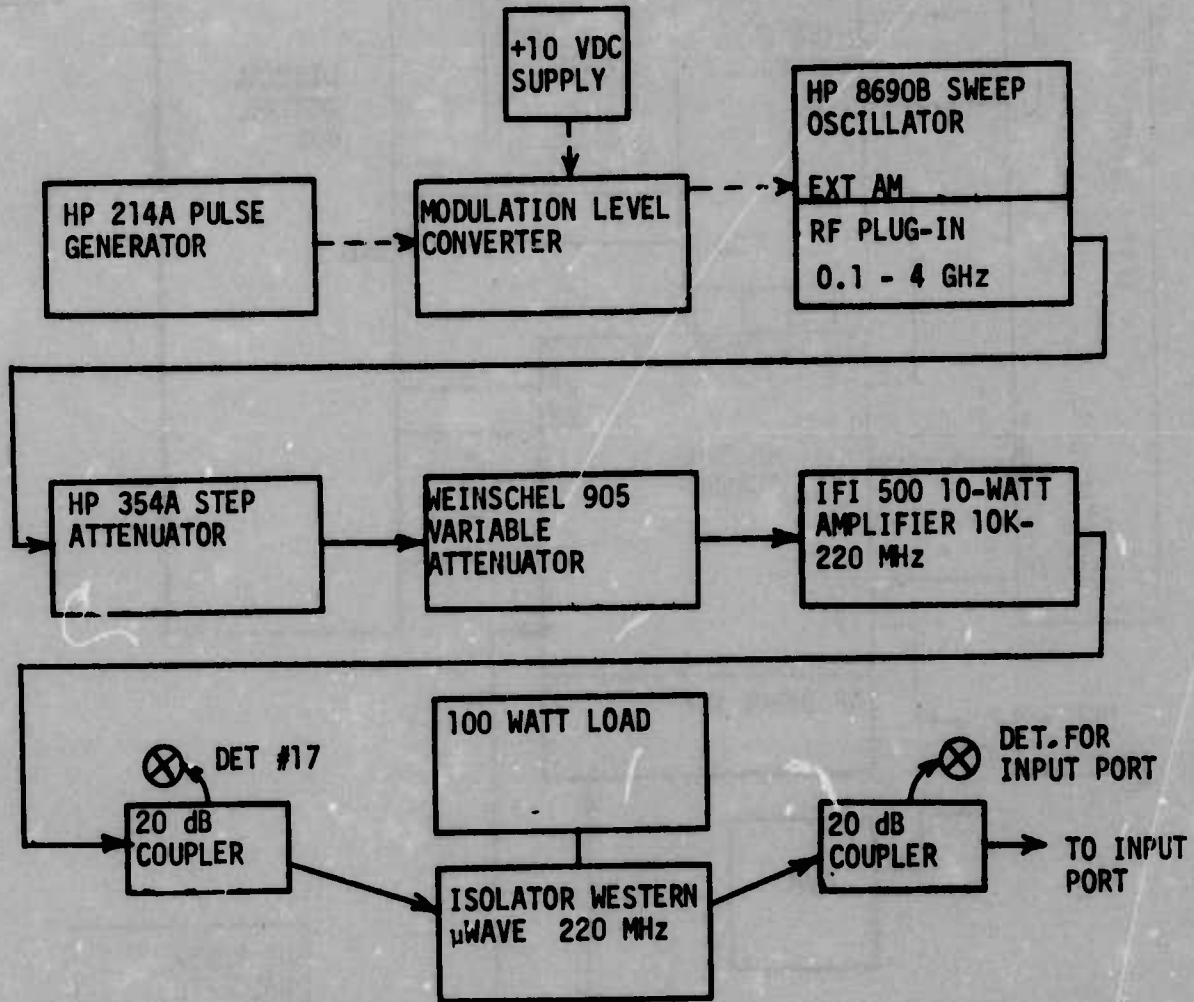

Figure 48 RF Test Setup for 2002 and Extra Digital Device Interference Tests at 0.22 GHz

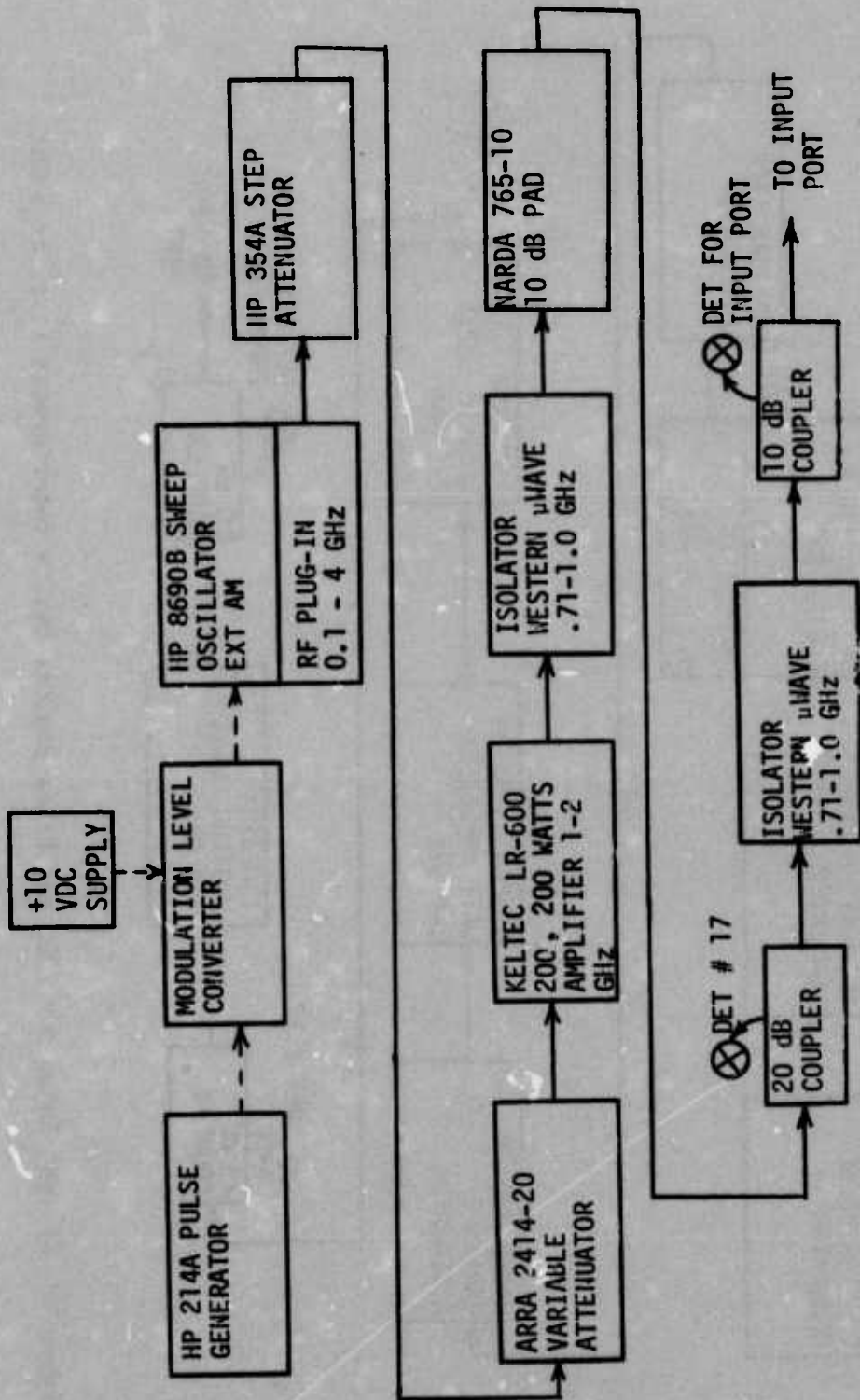

Figure 49 RF Test Setup for 2002 and Extra Digital Device Interference Tests at 0.91 GHz

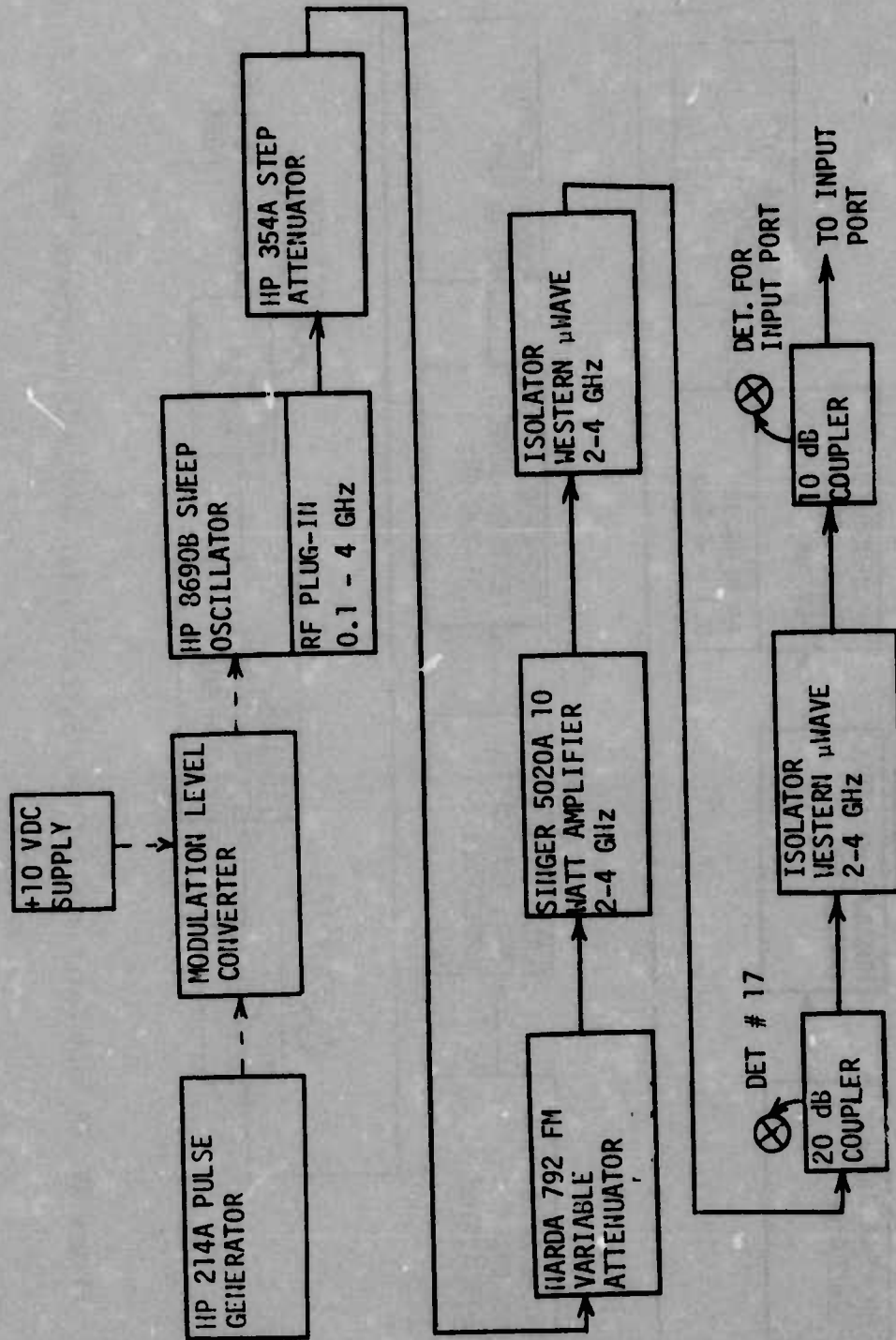

Figure 50 RF Test Setup for 2002 and Extra Digital Device Interference Tests at 3 GHz

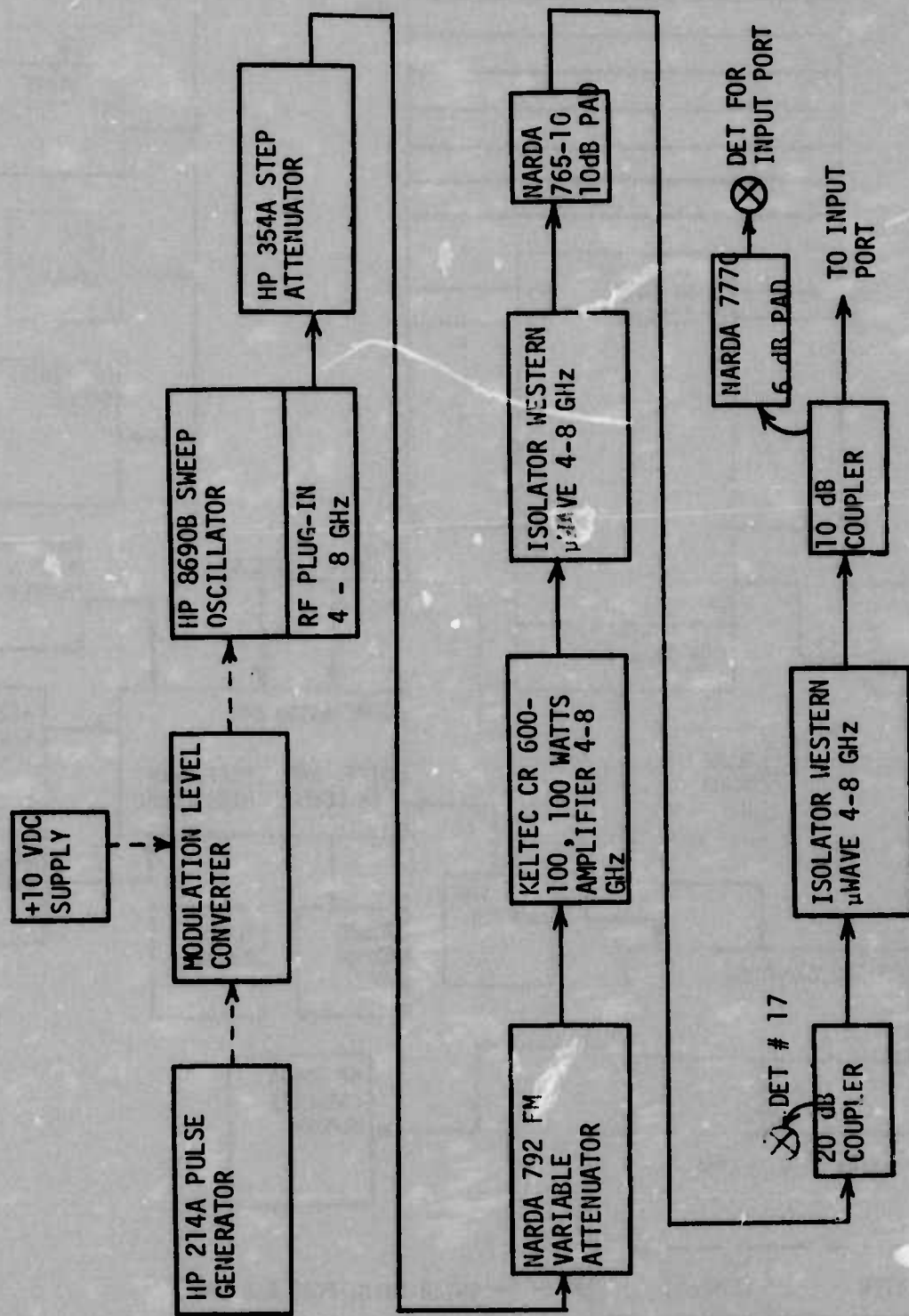

Figure 51 RF Test Setup for 2002 and Extra Digital Device Tests at 5.6 GHz

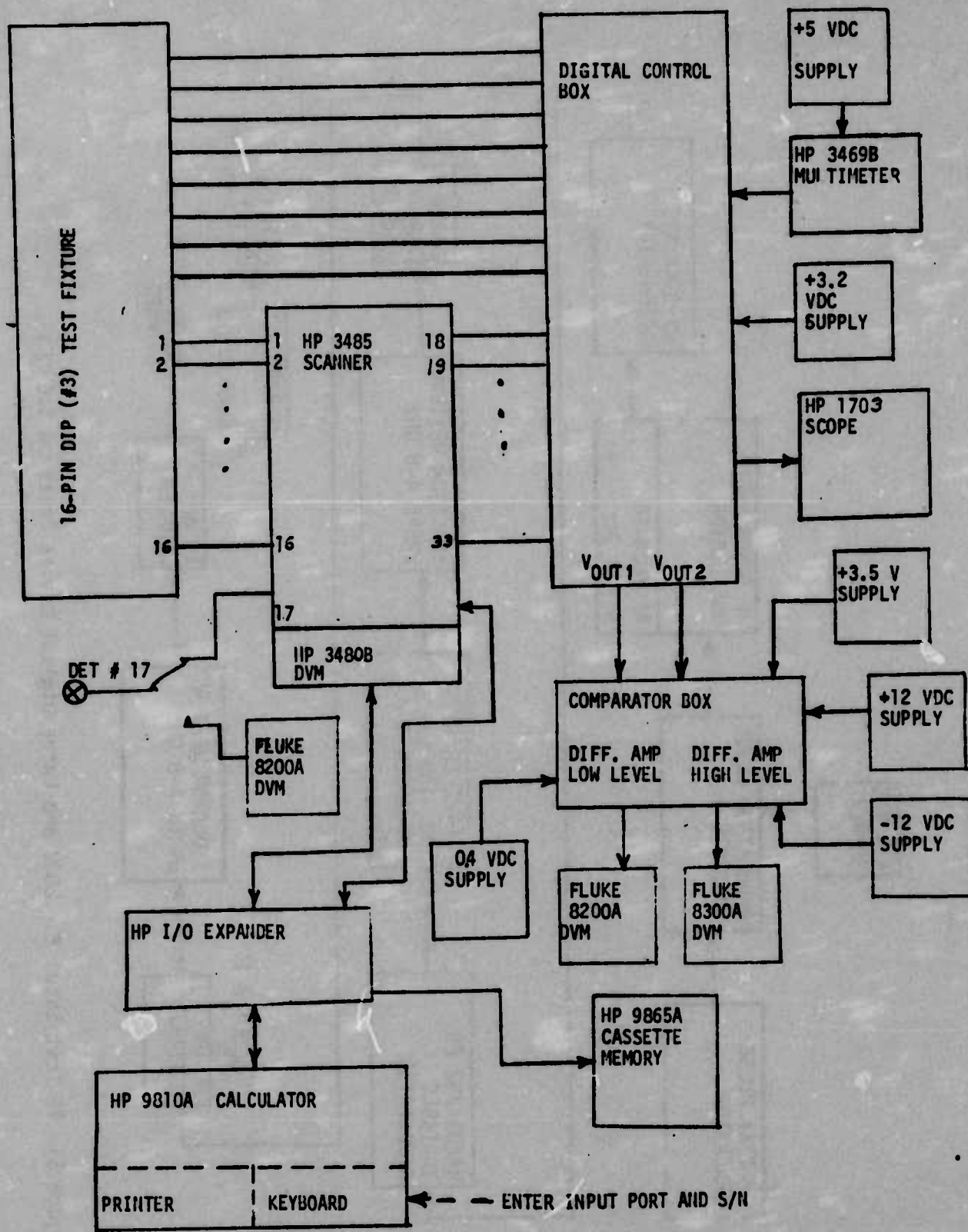

Figure 52 General Test Setup for Extra Digital Device Interference Testing

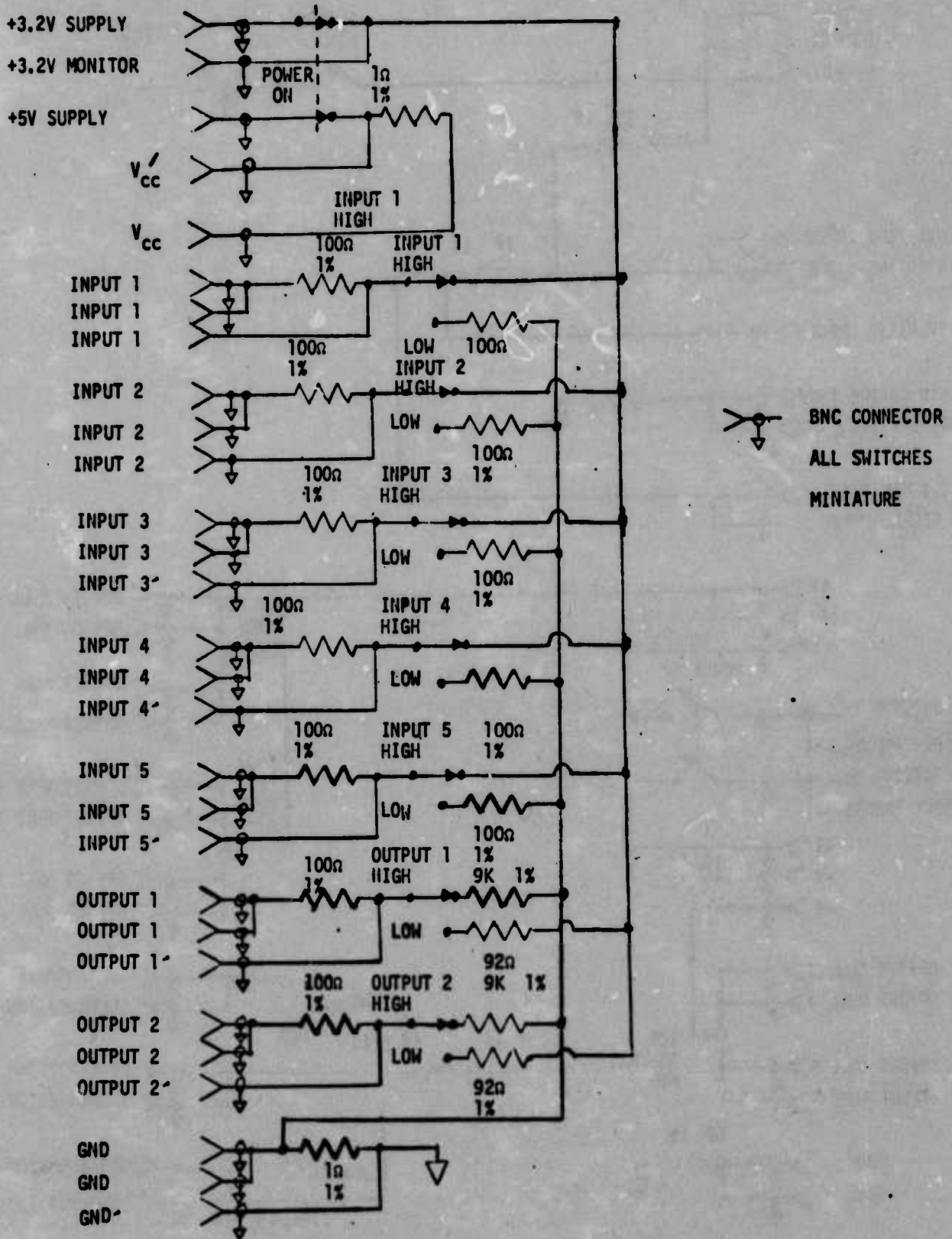

Figure 53 Schematic: Digital Control Box

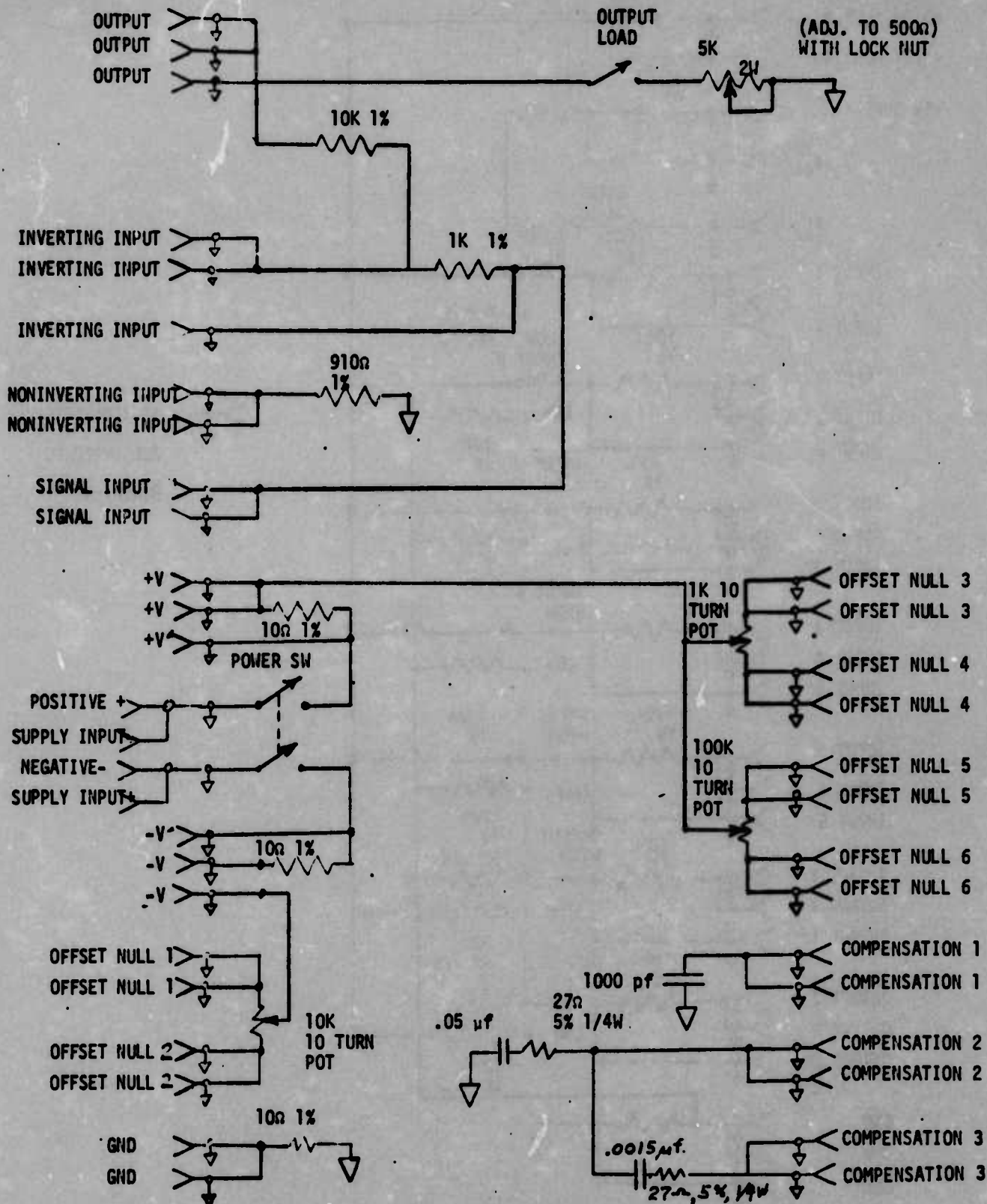

Figure 54 Schematic: Op-Amp Control Box

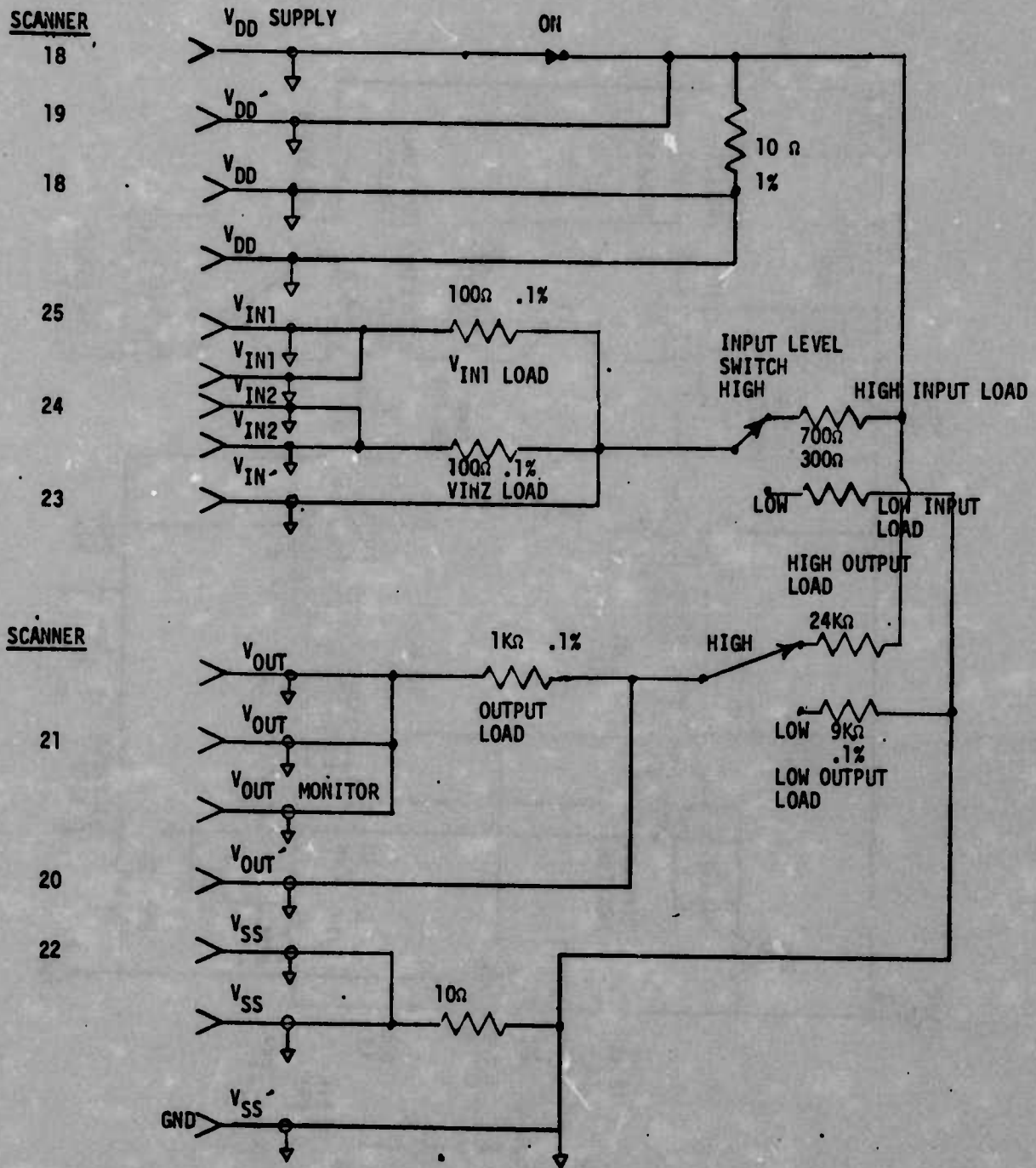

Figure 55 Schematic: MOS Control Box

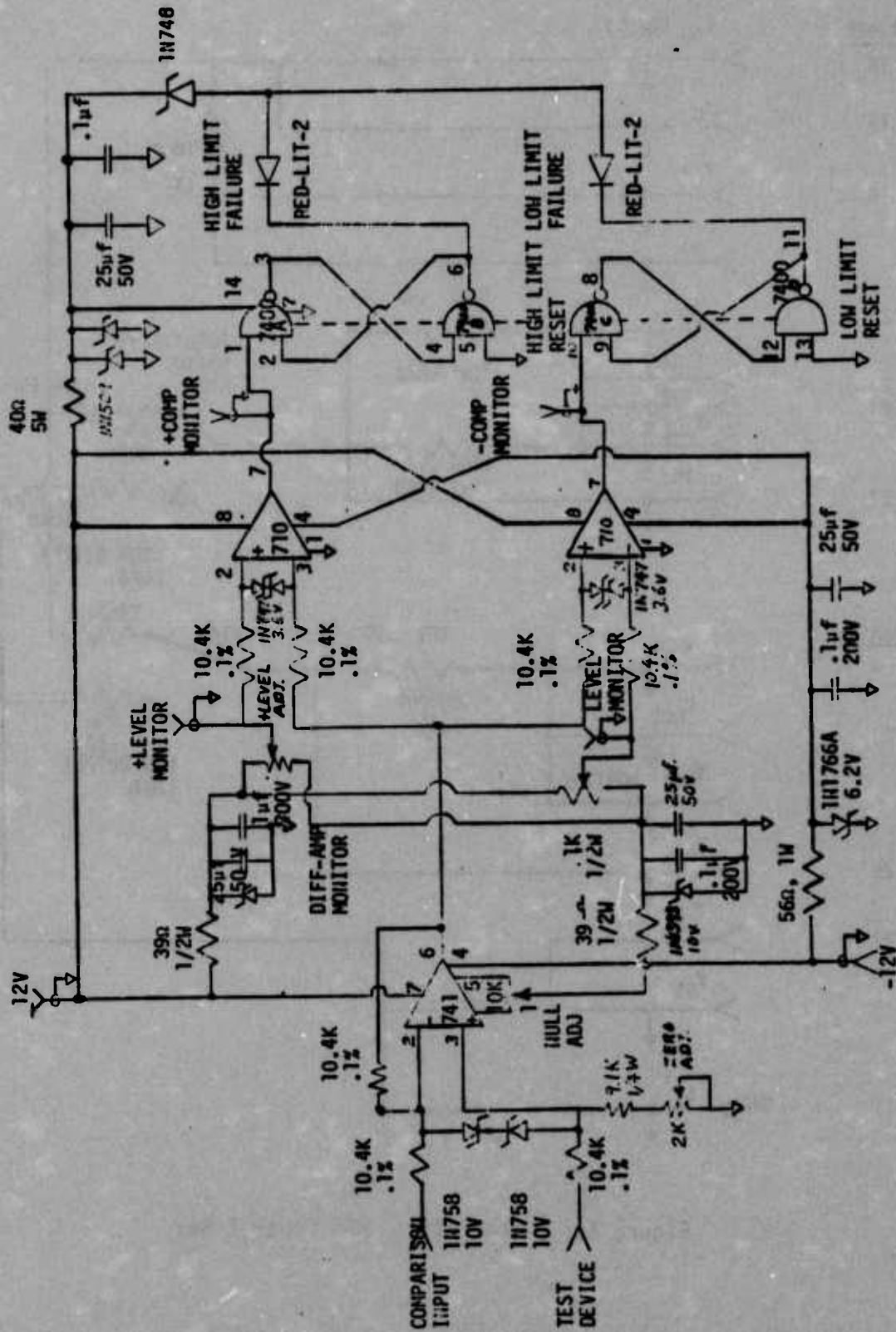

Figure 56 Schematic-Comparator

A

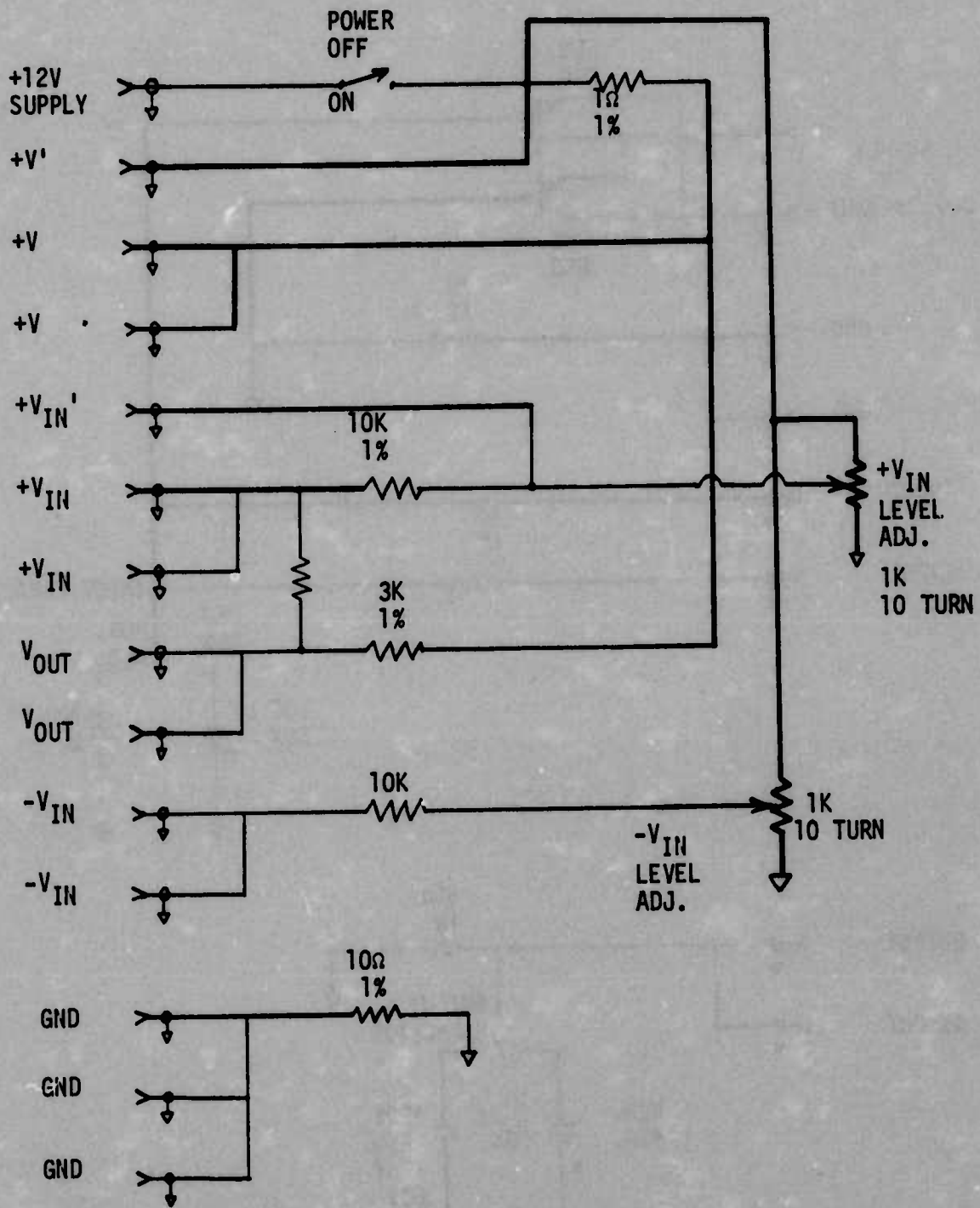

Figure 57 Schematic: Comparator Control Box

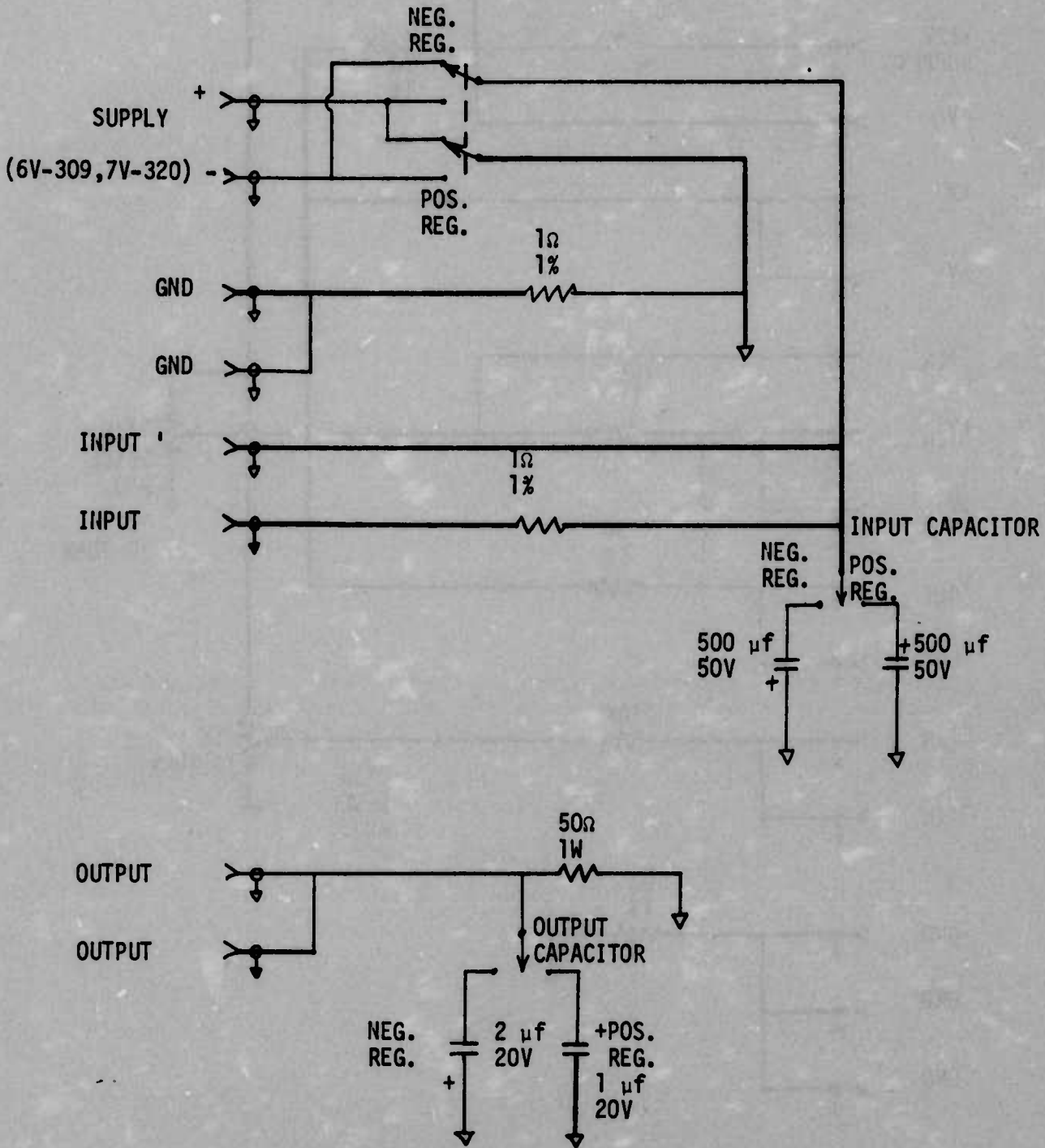

Figure 58 Schematic: Voltage Regulator Control Box

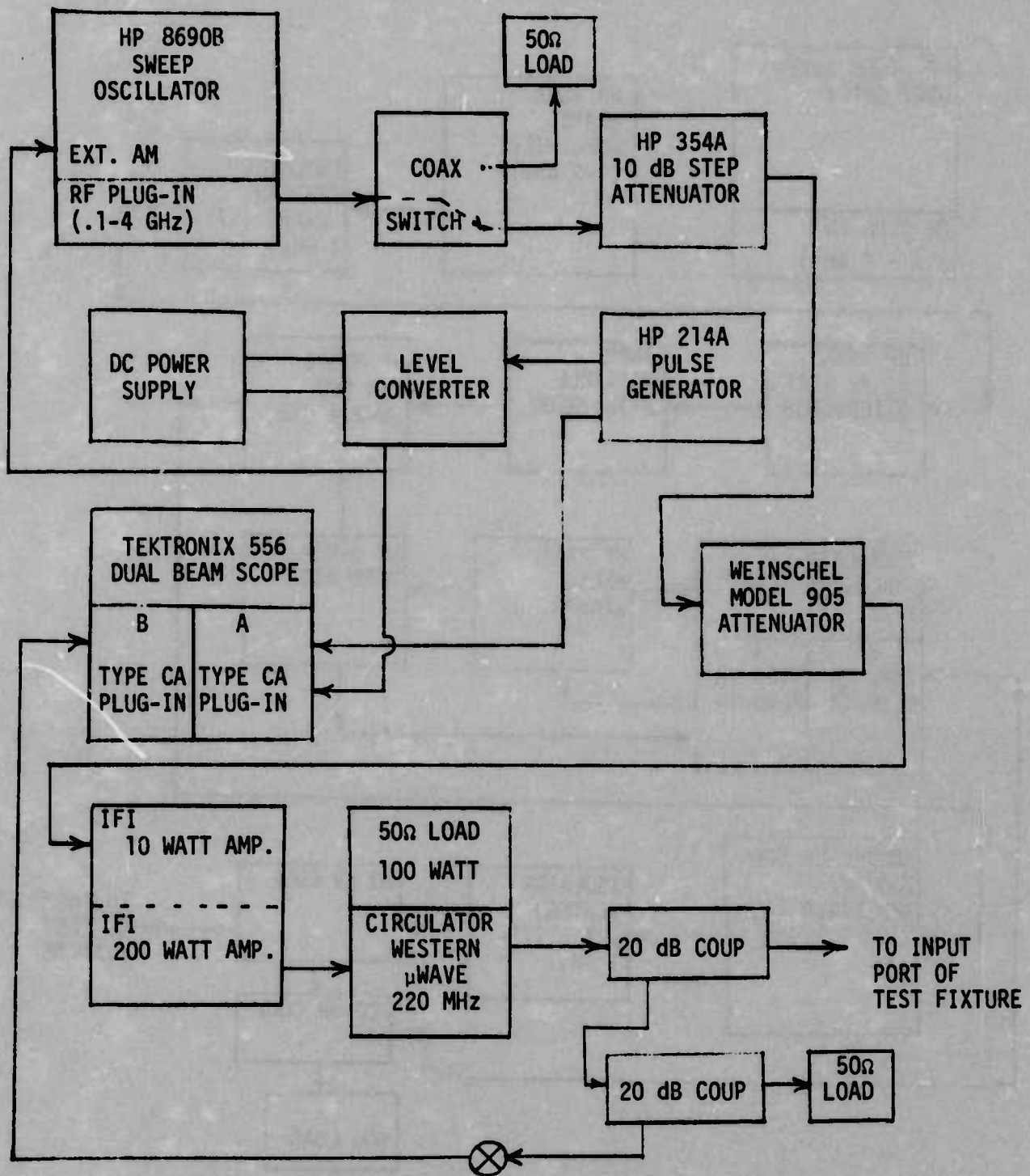

FIGURE 59 TEST SETUP FOR CATASTROPHIC FAILURE TESTING OF 7400 AND 741 AT C.22 GHz

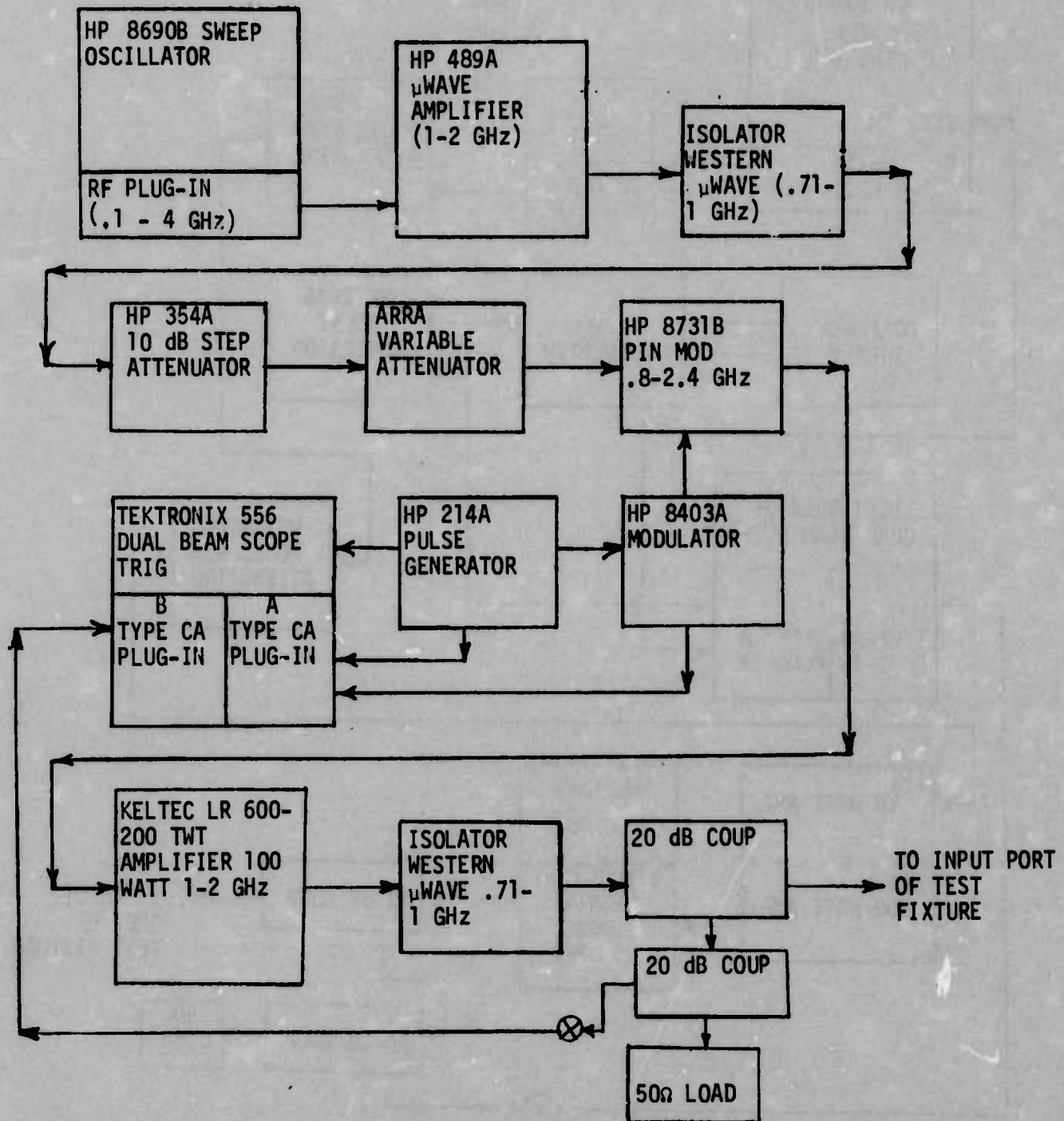

Figure 60 Test Setup for Catastrophic Failure Testing of 7400 and 741 at 0.91 GHz

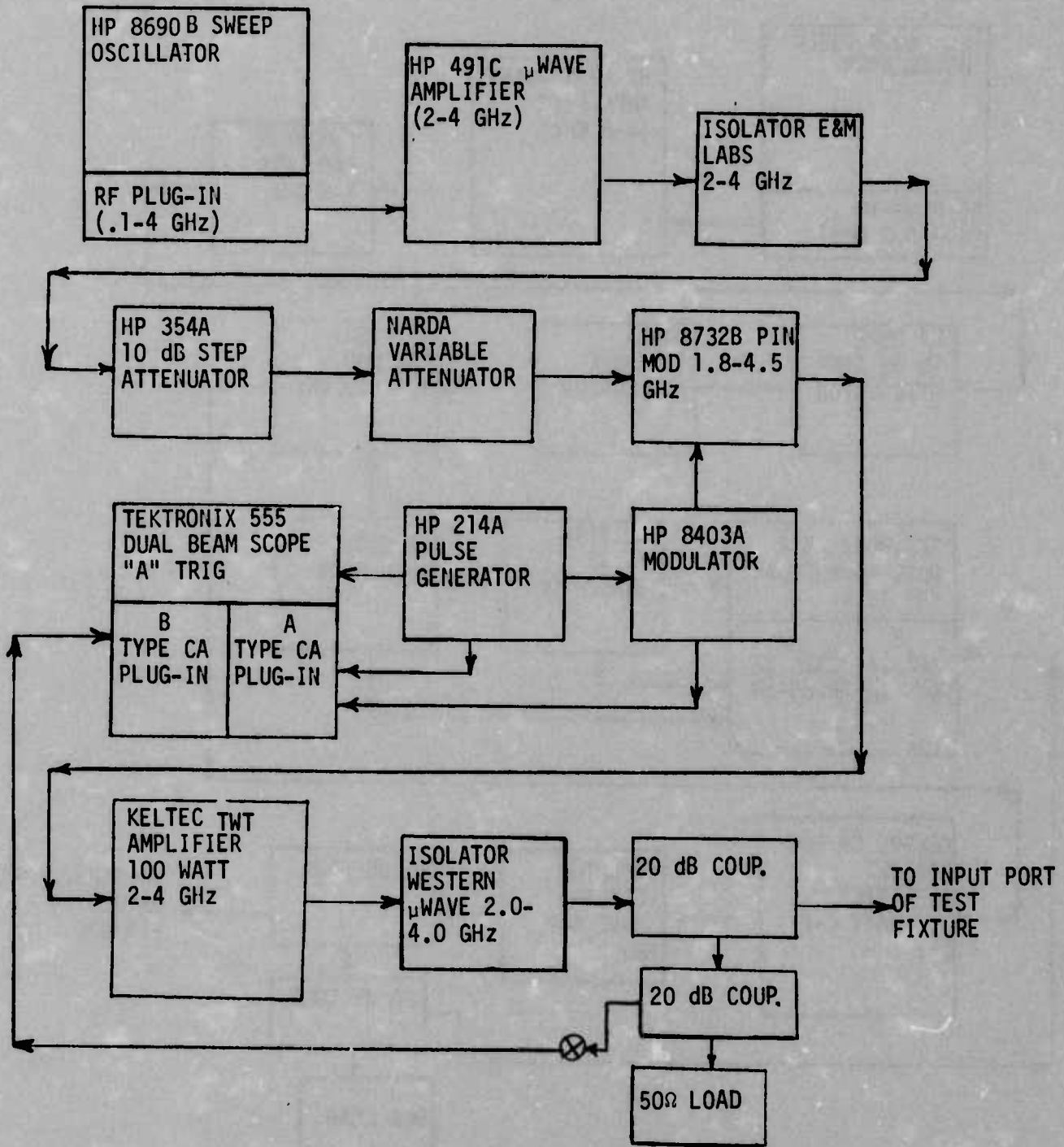

Figure 61 Test Setup for Catastrophic Failure Testing of 7400 and 741 at 3 GHz

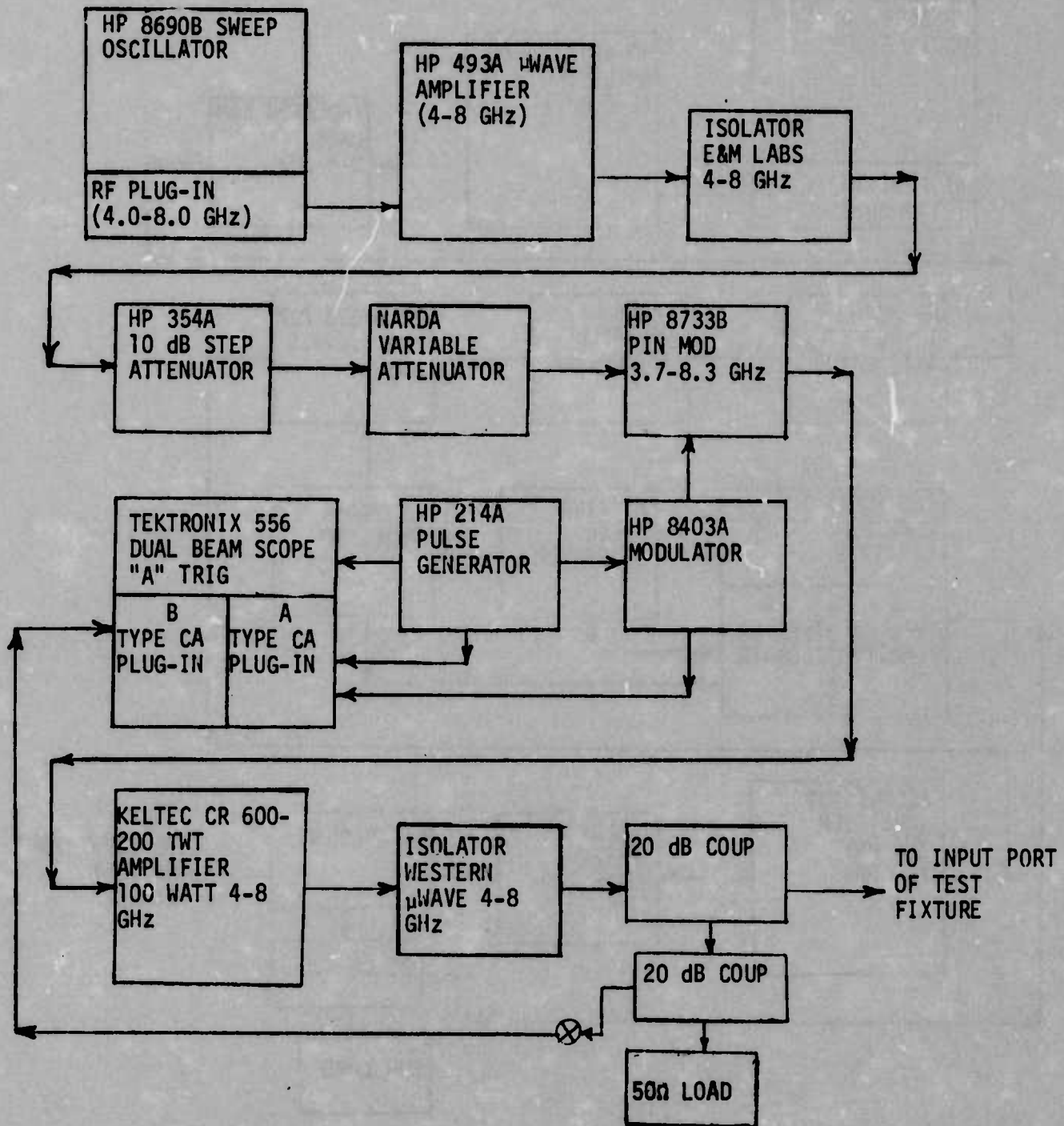

Figure 62 Test Setup for Catastrophic Failure Testing of 7400 and 741 at 5.6 GHz

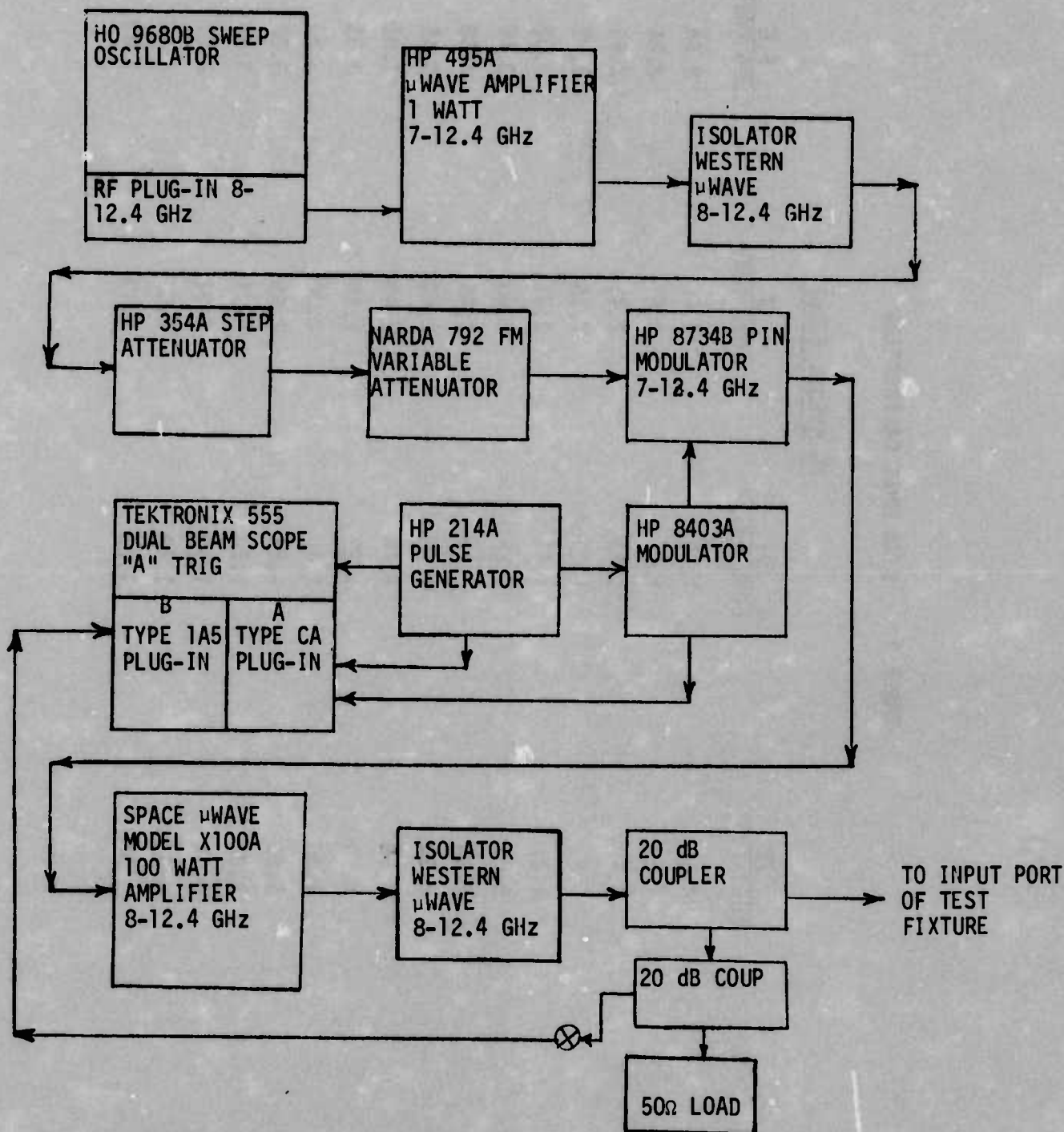

Figure 63 Test Setup for Catastrophic Failure Testing of 7400 9.1 GHz

TABLE 1 BIAS UNIT CALIBRATION

<u>UNIT NO.</u>	<u>FREQUENCY (GHz)</u>		
	<u>.22</u> <u>LOSS (dB)</u>	<u>.91</u> <u>LOSS (dB)</u>	<u>3</u> <u>LOSS (dB)</u>
1	4.00	1.19	2.84
2	4.27	1.18	2.85
3	4.52	1.14	2.90
4	5.02	1.29	2.82
5	4.27	1.15	3.06
6	5.02	1.25	3.15
7	4.34	1.13	3.08
8	4.34	1.18	3.42
9	5.59	1.28	2.82
10	4.70	1.22	2.93
11	4.90	1.19	3.57
12	4.90	1.23	3.28
13	4.30	1.20	3.01
14	4.48	1.13	2.87
15	4.63	1.13	3.48
17	3.94	1.05	3.43

TABLE 2 TYPICAL CRYSTAL CALIBRATION DATA

S/N = 2.91000

COEFFICIENTS

B(0) = 1.2707600
 B(1) = 1.8522600
 B(2) = 0.1669000
 B(3) = -0.0268600

VOLTS	MILLIWATTS	Y'	ERROR (%)
0.00184	0.01000	0.01006	-0.63063
0.00410	0.01500	0.01464	2.39674
0.00659	0.02000	0.02011	-0.56073
0.01075	0.03000	0.02993	0.22854
0.01483	0.04000	0.04034	-0.85928
0.01832	0.05000	0.04985	0.30539
0.02198	0.06000	0.06039	-0.65043
0.02530	0.07000	0.07045	-0.64706
0.02840	0.08000	0.08027	-0.33626
0.03432	0.10000	0.10012	-0.11734
0.04746	0.15000	0.14917	0.55004
0.06032	0.20000	0.20361	-1.80563
0.08012	0.30000	0.29934	0.21924
0.09868	0.40000	0.40176	-0.44087
0.11443	0.50000	0.49805	0.38929
0.13050	0.60000	0.60501	-0.83448
0.14400	0.70000	0.70156	-0.22314
0.15710	0.80000	0.80105	-0.13118
0.18170	1.00000	1.00314	-0.31351
0.23200	1.50000	1.47753	1.49824
0.28080	2.00000	2.01529	-0.76460
0.35440	3.00000	2.96917	1.02781
0.42100	4.00000	3.97940	0.51500
0.47730	5.00000	4.94206	1.15874
0.53070	6.00000	5.94709	0.88191
0.57730	7.00000	6.89731	1.46695
0.62370	8.00000	7.91132	1.10851
0.70580	10.00000	9.87174	1.28260
0.88600	15.00000	14.92309	0.51275
1.05200	20.00000	20.49366	-2.46829
1.29600	30.00000	30.29784	-0.99280
1.51000	40.00000	40.50085	-1.25212
1.68900	50.00000	50.20193	-0.40387
1.86300	60.00000	60.66256	-1.10427
2.00900	70.00000	70.23142	-0.33060
2.14900	80.00000	80.09138	-0.11423
2.27600	90.00000	89.61976	0.42249
2.38900	100.00000	98.56803	1.43197

RMS ERROR = 0.98765 PERCENT

Table 3 Crystal Detector Calibration for .22 GHz

CRYSTAL	B(0)	B(1)	B(2)	B(3)
1	1.21158	1.81590	0.291131	0.0350609
2	1.24074	1.79556	0.297538	0.0373098
3	1.23564	1.81008	0.322782	0.0424489
4	1.20574	1.86404	0.314155	0.0384294
5	1.19481	1.85190	0.197600	0.0000358
6	1.24345	1.83651	0.276008	0.0322073
7	1.18596	1.85907	0.241479	0.0201003
8	1.20217	1.83820	0.214148	0.0081422
9	1.24621	1.87547	0.226720	0.0109330
10	1.18101	1.88188	0.290815	0.0348513
11	1.26691	1.86180	0.249975	0.0214213
12	1.24609	1.81700	0.256647	0.0257495
13	1.28168	1.87127	0.311244	0.0386666
14	1.26642	1.79186	0.212334	0.0139630
15	1.25083	1.84017	0.235486	0.0199060
16	1.27627	1.99836	0.345040	0.0421244
17	1.22667	1.79601	0.235048	0.0192368

Table 4 Crystal Detector Calibration Coefficients for .91 GHz

CRYSTAL	B(0)	B(1)	B(2)	B(3)
1	1.26608	1.80527	0.259396	0.0271789
2	1.27636	1.77042	0.239902	0.0204803
3	1.28785	1.76456	0.284451	0.0353526
4	1.25658	1.83276	0.261251	0.0262011
5	1.19111	1.84995	0.195178	0.0018103
6	1.23989	1.82310	0.261538	0.0256129
7	1.18055	1.85284	0.233946	0.0147341
8	1.22359	1.83593	0.194614	0.0014644
9	1.24661	1.86559	0.219143	0.0094050
10	1.17248	1.87113	0.280579	0.0299600
11	1.28972	1.84059	0.234094	0.0162157
12	1.24014	1.82607	0.276245	0.0304371
13	1.27212	1.85121	0.295265	0.0335471
14	1.27301	1.79602	0.249553	0.0256183
15	1.24890	1.83210	0.220251	0.0115535
16	1.26884	1.96376	0.302778	0.0292455
17	1.22657	1.80361	0.254249	0.0250931

Table 5 Crystal Detector Calibration Coefficients for 3 GHz

CRYSTAL	B(0)	B(1)	B(2)	B(3)
1	1.27763	1.81892	0.263690	0.0251775
2	1.28302	1.78576	0.253112	0.0248788
3	1.29163	1.77227	0.280223	0.0334609
4	1.26470	1.84092	0.261317	0.0244254
5	1.19930	1.86181	0.198932	0.0000000
6	1.23358	1.83813	0.272475	0.0270827
7	1.18078	1.86341	0.238082	0.0131825
8	1.21794	1.84851	0.202025	0.0012353
9	1.24672	1.88003	0.233851	0.0126360
10	1.17681	1.88742	0.284124	0.0272287
11	1.26364	1.85084	0.233118	0.0130534
12	1.23927	1.83673	0.272627	0.0261232
13	1.26724	1.88329	0.329327	0.0421188
14	1.27187	1.78476	0.251192	0.0200216
15	1.24135	1.84327	0.223890	0.0098869
16	1.27151	1.98515	0.307480	0.0270774
17	1.21854	1.81764	0.280198	0.0333236

Table 6 Crystal Detector Calibration Coefficients for 5.6 GHz

CRYSTAL	B(0)	B(1)	B(2)	B(3)
1	1.29461	1.79075	0.223596	0.0153620
2	1.28414	1.77989	0.242594	0.0209951
3	1.29507	1.77151	0.274308	0.0317389
4	1.27982	1.84971	0.265698	0.0261293
5	1.22245	1.85525	0.188531	0.0000001
6	1.23468	1.83720	0.262285	0.0241400
7	1.19720	1.86466	0.229990	0.0130577
8	1.22201	1.84760	0.190717	0.0000001
9	1.24856	1.88552	0.227181	0.0100407
10	1.18795	1.88286	0.278124	0.0295213
11	1.27018	1.85684	0.236416	0.0184783
12	1.24434	1.84279	0.273079	0.0290070
13	1.27030	1.89418	0.329192	0.0426467
14	1.26289	1.78335	0.263753	0.0272889
15	1.24186	1.84348	0.214324	0.0087737
16	1.27460	2.00459	0.316760	0.0334410
17	1.20244	1.81554	0.264836	0.0260548

Table 7 Crystal Detector Calibration Coefficients for
9.1 GHz

CRYSTAL	B(0)	B(1)	B(2)	B(3)
1	1.32402	1.82107	0.241207	0.0190506
2	1.30934	1.80303	0.257192	0.0243327
3	1.31229	1.79759	0.285859	0.0328200
4	1.32211	1.84600	0.239467	0.0163895
5	1.28484	1.89469	0.209176	0.0000000
6	1.25896	1.86727	0.278290	0.0262121
7	1.24194	1.88356	0.236714	0.0142114
8	1.23284	1.87247	0.202222	0.0000000
9	1.26049	1.90474	0.230906	0.0061021
10	1.22897	1.90423	0.271844	0.0235726
11	1.30727	1.86117	0.210239	0.0034527
12	1.27749	1.83829	0.236720	0.0124962
13	1.28878	1.90109	0.308784	0.0341583
14	1.25911	1.79075	0.287093	0.0347386
15	1.24244	1.84655	0.200972	0.0041398
16	1.30114	2.05071	0.353879	0.0426360
17	1.22237	1.82678	0.288599	0.0331120

Table 8 HP 9810A Program for Crystal Detector Calibration

0000	.	20	0051	L	40	0101	GTO	44
0001	.	55	0052	IND	31	0102	LBL	51
0002	CLX	37	0053	I	65	0103	E	60
0003	LBL	51	0054	XTO	23	0104	CNT	47
0004	A	62	0055	C	61	0105	XEY	30
0005	FMT	42	0056	H	74	0106	0	00
0006	FMT	42	0057	-	34	0107	I	01
0007	D	63	0058	M	70	0108	XLY	50
0008	E	60	0059	E	60	0109	XCY	52
0009	XTO	23	0060	XTO	23	0110	GTO	44
0010	.	21	0061	E	60	0111	LBL	51
0011	CNT	47	0062	a	13	0112	C	61
0012	GTO	44	0063	FMT	42	0113	CNT	47
0013	FMT	42	0064	I	01	0114	DN	25
0014	STP	41	0065	0	00	0115	I	01
0015	XTO	23	0066	UP	27	0116	0	00
0016	0	00	0067	b	14	0117	0	00
0017	PNT	45	0068	X>Y	53	0118	X	36
0018	I	01	0069	GTO	44	0119	GTO	44
0019	XTO	23	0070	S/R	77	0120	LBL	51
0020	a	13	0071	LBL	51	0121	D	63
0021	XTO	23	0072	F	16	0122	LBL	51
0022	b	14	0073	STP	41	0123	C	61
0023	LBL	51	0074	FMT	42	0124	DN	25
0024	B	66	0075	4	04	0125	I	01
0025	FMT	42	0076	1	01	0126	0	00
0026	4	04	0077	FMT	42	0127	X	36
0027	1	01	0078	1	01	0128	GTO	44
0028	FMT	42	0079	FMT	42	0129	LBL	51
0029	SFL	54	0080	PSE	57	0130	D	63
0030	FMT	42	0081	PSE	57	0131	LBL	51
0031	CNT	47	0082	FMT	42	0132	E	60
0032	5	05	0083	3	03	0133	XEY	30
0033	0	00	0084	3	03	0134	I	01
0034	UP	27	0085	.	21	0135	0	00
0035	a	13	0086	UP	27	0136	XEY	30
0036	+	33	0087	CNT	47	0137	X>Y	53
0037	XTO	40	0088	CNT	47	0138	DN	25
0038	5	05	0089	FMT	42	0139	GTO	44
0039	0	00	0090	4	04	0140	LBL	51
0040	XFR	67	0091	1	01	0141	D	63
0041	IND	31	0092	FMT	42	0142	DN	25
0042	5	05	0093	1	01	0143	.	21
0043	0	00	0094	FMT	42	0144	I	01
0044	FMT	42	0095	UP	27	0145	X	36
0045	4	04	0096	2	02	0146	LBL	51
0046	2	02	0097	1	01	0147	D	63
0047	XTO	23	0098	UP	27	0148	G	15
0048	CNT	47	0099	a	13	0149	FLX	26
0049	FMT	42	0100	X>Y	52	0150	0	00
0050	FMT	42						

Table 8 HP 9810A Program for Crystal Detector Calibration (Cont)

0151--		--36	0201--		--36	0251--		--04
0152--	DN	--25	0202--	DI	--25	0252--	DP	--27
0153--	INT	--64	0203--	XEY	--30	0253--	0	--08
0154--	XTO	--23	0204--	FMT	--42	0254--	FMT	--42
0155--	IND	--31	0205--	FMT	--42	0255--	5	--05
0156--	a	--13	0206--	n	--56	0256--	XTO	--23
0157--	CNT	--47	0207--	XCY	--52	0257--	GTO	--44
0158--	CNT	--47	0208--	M	--70	0258--	LBL	--51
0159--	FMT	--42	0209--	IND	--31	0259--	A	--62
0160--	FMT	--42	0210--	PSE	--57	0260--	LBL	--51
0161--	YTO	--40	0211--	CLR	--20	0261--	F	--10
0162--	IND	--31	0212--	INT	--64	0262--	FMT	--42
0163--	I	--65	0213--	XCY	--52	0263--	FMT	--42
0164--	XTO	--23	0214--	INT	--64	0264--	C	--61
0165--	C	--61	0215--	0	--71	0265--	H	--74
0166--	H	--74	0216--	L	--72	0266--	A	--62
0167--	-	--34	0217--	XTO	--23	0267--	N	--70
0168--	D	--63	0218--	YTO	--40	0268--	u	--10
0169--	E	--60	0219--	PSE	--57	0269--	E	--60
0170--	XTO	--23	0220--	FMT	--42	0270--	CNT	--47
0171--	.	--21	0221--	FMT	--42	0271--	a	--13
0172--	FMT	--42	0222--	XEY	--30	0272--	A	--62
0173--	STP	--41	0223--	PNT	--45	0273--	N	--70
0174--	FMT	--42	0224--	1	--01	0274--	G	--15
0175--	3	--03	0225--	UP	--27	0275--	E	--61
0176--	3	--03	0226--	E	--60	0276--	FMT	--42
0177--	.	--21	0227--	4	--04	0277--	1	--01
0178--	UP	--27	0228--	1	--01	0278--	XTO	--23
0179--	G	--15	0229--	UP	--27	0279--	b	--10
0180--	1	--01	0230--	a	--13	0280--	S/R	--70
0181--	0	--00	0231--	XCY	--52	0281--	END	--40
0182--	DIV	--35	0232--	GTO	--44			
0183--	YTO	--40	0233--	LBL	--51			
0184--	IND	--31	0234--	B	--66			
0185--	+	--33	0235--	CNT	--47			
0186--	a	--13	0236--	FMT	--42			
0187--	XFR	--67	0237--	5	--05			
0188--	IND	--31	0238--	EEX	--26			
0189--	a	--13	0239--	FMT	--42			
0190--	UP	--27	0240--	FMT	--42			
0191--	INT	--64	0241--	a	--13			
0192--	-	--34	0242--	E	--60			
0193--	UP	--27	0243--	C	--61			
0194--	EEX	--26	0244--	D	--71			
0195--	3	--03	0245--	a	--13			
0196--	DIV	--35	0246--	D	--63			
0197--	RUP	--22	0247--	IFG	--43			
0198--	XCY	--30	0248--	FMT	--42			
0199--	J	--01	0249--	XTP	--41			
0200--	0	--00	0250--	0	--10			

Table 9 HP 9830A Program to Convert Data to Matrix Format for 1 Crystal

```
10 DISP "FIRST FILE #";
20 REM PROGRAM TO CONVERT FROM DATA TO MATRIX FORMAT FOR 1 CRYSTAL
30 INPUT N
40 DISP "FIRST MATRIX FILE#";
50 INPUT M
60 DIM A[84,1],CS[8,41]
70 REDIM A[84,1]
80 LOAD DATA N,A
90 C[1,1]=C[2,1]=A[1,1]
100 GOTO 180
110 C[5,1]=C[6,1]=A[43,1]
120 C[7,1]=C[8,1]=A[64,1]
130 GOTO 160
140 IF A[22,1]#C[1,1] THEN 560
150 IF A[1,1]#C[3,1] THEN 560
160 IF I=1 THEN 260
170 FOR J=0 TO 1
180 FOR K=2 TO 41
190 V=A[K,1]
200 P=INT(V)/1000
210 V=10*(V-INT(V))
220 C[1,K]=P
230 C[2,K]=V
240 NEXT K
250 GOTO 400
260 FOR J=0 TO 1
270 FOR K=2 TO 21
280 V=A[J*21+K,1]
290 P=INT(V)/1000
300 V=10*(V-INT(V))
310 IF J>0 THEN 350
320 C[2*J+3,K]=P
330 C[2*J+4,K]=V
340 GOTO 370
350 C[2*J-1,K+20]=P
360 C[2*J,K+20]=V
370 NEXT K
380 NEXT J
390 NEXT I
400 FOR I=1 TO 41
410 WRITE (15,430)C[1,I],C[2,I]
420 NEXT I
430 FORMAT 4F10.5
440 REDIM A[2,42]
460 FOR K=1 TO 41
470 A[1,K]=C[1,K]
```

Table 9 HP 9830A Program to Convert Data to Matrix Format for 1 Crystal (cont)

```
480 A[2,K]=C[2,K]
490 NEXT K
500 A[1,42]=A[2,42]=A[1,1]
510 STORE DATA #5,M,A
520 N=N+1
530 M=M+1
550 GOTO 70
560 DISP "S/N NOT =";
570 END
```

Table 10 HP 9830A Program to Calculate Coefficients for Crystal Detectors -
Degree = 3

```
10 DIM CS[36],B[8],A[2,42]
20 REM PROGRAM TO CALCULATE CRYSTAL DETECTOR COEFFICIENTS
30 DISP "FIRST FILE #, # OF FILES";
40 INPUT N1,N2
50 FOR L=0 TO N2-1
60 MAT C=ZER
70 MAT B=ZER
80 B[1]=1
90 W=N=S1=S2=S3=S4=S5=0
100 D1=D2=3
110 LOAD DATA N1+L,A
120 FIXED 6
130 FOR H=2 TO 4:
140 B[2]=LGT(A[2,H])
150 Y=LGT(A[1,H])
160 FOR I=2 TO D2
170 B[I+1]=B[I]*B[2]
180 NEXT I
190 B[D2+2]=Y
200 R=0
210 FOR I=1 TO D2+2
220 FOR J=I TO D2+2
230 R=R+1
240 C[R]=C[R]+E[I]*B[J]
250 NEXT J
260 NEXT I
270 S1=S1+B[2]
280 S2=S2+B[2]^2
290 S3=S3+Y
300 S4=S4+Y^2
310 S5=S5+B[2]*Y
320 N=N+1
330 NEXT H
340 D1=3
350 IF W=0 THEN 830
360 T=0
370 FOR I=1 TO D1+1
380 B[I]=0
390 FOR J=1 TO D1-I+2
400 R=(I+J-1)*(D2+2-0.5*(I+J))
410 B[I]=B[I]+C[T+J]*C[R]
420 NEXT J
430 T=I*(D2+(3-I)/2)
440 NEXT I
450 R1=0
460 FOR I=2 TO D1+1
470 R1=R1+C[I*(D2+(3-I)/2)]^2
```

Table 10 HP 9830A Program to Calculate Coefficients for Crystal Detector -
Degree = 3 (cont)

```
480 NEXT I
490 TO=C[(D2+1)*(D2+2)/2]
500 TO=TO-C[D2+1]^2
510 FOR I=1 TO 3
520 PRINT
530 NEXT I
540 PRINT " ", "S/N ="A[1,1];"SECOND CALIBRATION"
550 PRINT
560 PRINT
570 PRINT " ", "COEFFICIENTS"
580 PRINT
590 FORMAT 12X,F2.0,F12.7
600 FOR I=1 TO D1+1
610 WRITE (15,590)"B("I-1")="B[I]
620 NEXT I
630 PRINT
640 PRINT
650 PRINT " ", "R SQUARE ="R1/TO
660 PRINT
670 PRINT " ", " VOLTS", "MILLIWATTS", " Y' ", " ERROR(%)"
680 Q=0
690 FOR I=2 TO 41
700 X1=A[2,I]
710 Y1=A[1,I]
720 Y2=10^(B[1]+B[2]*LGT(X1)+B[3]*(LGT(X1))^2+B[4]*(LGT(X1))^3)
730 Q=Q+((Y1-Y2)/Y1)^2
740 PRINT " ", X1, Y1, Y2, 100*(Y1-Y2)/Y1
750 NEXT I
760 PRINT
770 PRINT
780 PRINT " ", "RMS ERROR ="100*SQR(Q/40)"PERCENT"
790 FOR J=1 TO 6
800 PRINT
810 NEXT J
820 GOTO 1210
830 P=W=1
840 D2=D2+1
850 FOR J=1 TO D2
860 C[P]=SQRC[P]
870 FOR I=1 TO D2-J+1
880 C[P+I]=C[P+I]/C[P]
890 NEXT I
900 R=P+I
910 S=R
920 FOR I=1 TO D2-J
930 P=P+1
940 FOR M=1 TO D2+2-J-I
```

Table 10 HP 9830A Program to Calculate Coefficients for Crystal Detectors -
Degree = 3 (cont)

```
950 C[R+M-1]=C[R+M-1]-C[P]*C[P+M-1]
960 NEXT M
970 R=R+M-1
980 NEXT I
990 P=S
1000 NEXT J
1010 T=(D2+1)*(D2+2)/2
1020 FOR I=1 TO D2-1
1030 T=T-1-I
1040 C[T]=1/C[T]
1050 FOR J=1 TO D2-I
1060 P=D2+1-I-J
1070 P=P*(D2+1-(P-1)/2)-I
1080 R=P-J
1090 S=0
1100 U=I+J+1
1110 V=P
1120 FOR K=1 TO J
1130 V=V+U-K
1140 S=S-C[R+K]*C[V]
1150 NEXT K
1160 C[P]=S/C[R]
1170 NEXT J
1180 NEXT I
1190 C[1]=1/C[1]
1200 GOTO 360
1210 NEXT L
1220 END
```

Table 11 General Fixture Calibration Program (HP 9810A)- 16 Pins

0000--CLX---20		
0001--K---55	0051--710---40	0101--π---56
0002--CLX---37	0052--DIV---35	0102--L---60
0003--FMT---42	0053--N---73	0103--α---13
0004--FMT---42	0054--FMT---42	0104--FMT---42
0005--E---60	0055--STP---41	0105--STP---41
0006--N---73	0056--XTO---23	0106--1---01
0007--XTO---23	0057--1---01	0107--XTO---23
0008--E---60	0058--0---00	0108--α---13
0009--α---13	0059--8---10	0109--FMT---42
0010--CNT---47	0060--PNT---45	0110--4---04
0011--D---63	0061--INT---64	0111--1---01
0012--A---62	0062--UP---27	0112--FMT---42
0013--XTO---23	0063--EEX---26	0113--1---01
0014--A---62	0064--2---02	0114--FMT---42
0015--CNT---47	0065--DIV---35	0115--PSE---57
0016--C---61	0066--DN---25	0116--PSE---57
0017--A---62	0067--UP---27	0117--PSE---57
0018--α---13	0068--INT---64	0118--CNT---47
0019--D---63	0069-- - ---34	0119--CNT---47
0020--FMT---42	0070--EEX---26	0120--LBL---51
0021--CNT---47	0071--2---02	0121--C---61
0022--FMT---42	0072--X---36	0122--FMT---42
0023--XFR---67	0073--YTO---40	0123--3---03
0024--FMT---42	0074--8---10	0124--3---03
0025--FMT---42	0075--9---11	0125-- . ---21
0026--F---16	0076--FMT---42	0126--UP---27
0027--α---13	0077--4---04	0127--FMT---42
0028--E---60	0078--1---01	0128--4---04
0029--b---14	0079--FMT---42	0129--1---01
0030-- . ---21	0080--SFL---54	0130--FMT---42
0031--CNT---47	0081--FMT---42	0131--1---01
0032--SFL---54	0082--CNT---47	0132--FMT---42
0033--FMT---42	0083--FMT---42	0133--α---13
0034--XFR---67	0084--FMT---42	0134--UP---27
0035--0---00	0085--YTO---40	0135--XFR---67
0036--PNT---45	0086--E---60	0136--8---10
0037--1---01	0087--XTO---23	0137--9---11
0038--XTO---23	0088--CNT---47	0138--X=Y---50
0039--0---00	0089--π---56	0139--DN---25
0040--CLX---37	0090--0---71	0140--GTO---44
0041--XTO---23	0091--IND---31	0141--LBL---51
0042--1---01	0092--E---60	0142--D---63
0043--9---11	0093--α---13	0143--1---01
0044--XTO---23	0094--CNT---47	0144--7---07
0045--2---02	0095--A---62	0145--X=Y---50
0046--0---00	0096--N---73	0146--DN---25
0047--LBL---51	0097--D---63	0147--GTO---44
0048--B---66	0098--CLR---20	0148--LBL---51
0049--FMT---42	0099--π---56	0149--D---63
0050--FMT---42	0100--A---62	0150--DN---25

INTEGRATED CIRCUIT SUSCEPTIBILITY

MDC E1099
12 JULY 1974

Table 11 General Fixture Calibration Program (HP 9810A)- 16 Pins
(cont)

0151	-15	0201	-07	0251	-CNT---47
0152	--LLA---26	0202	--CNT---47	0252	--CNT---47
0153	--CHS---32	0203	-- 1 ---01	0253	-- 1 ---01
0154	-- 3 ---03	0204	--XTO---23	0254	-- 8 ---10
0155	--X>Y---53	0205	-- + ---33	0255	-- UP---27
0156	--CLX---37	0206	-- b ---14	0256	-- a ---13
0157	--XEY---30	0207	--XFR---67	0257	--X<Y---52
0158	--CNT---47	0208	--IND---31	0258	--PSE---57
0159	--CNT---47	0209	-- b ---14	0259	--GTO---44
0160	--LBL---51	0210	-- UP---27	0260	--LBL---51
0161	-- D ---63	0211	--INT---64	0261	-- C ---61
0162	--DN---25	0212	-- - ---34	0262	--XFR---67
0163	-- K ---55	0213	-- UP---27	0263	-- 1 ---01
0164	-- 4 ---04	0214	--EEX---26	0264	-- 7 ---07
0165	--XTO---23	0215	-- 7 ---07	0265	--XTO---23
0166	-- 8 ---10	0216	--DIV---35	0266	--DIV---35
0167	-- 8 ---10	0217	--RUP---22	0267	-- 1 ---01
0168	-- a ---13	0218	--XEY---30	0268	-- 0 ---00
0169	-- UP---27	0219	--XFR---67	0269	-- 6 ---06
0170	-- 2 ---02	0220	-- 8 ---10	0270	--CNT---47
0171	-- X ---36	0221	-- 8 ---10	0271	-- 8 ---10
0172	-- 1 ---01	0222	-- X ---36	0272	-- 9 ---11
0173	-- 9 ---11	0223	-- X ---36	0273	--XFR---67
0174	-- + ---33	0224	--RUP---22	0274	-- + ---33
0175	--YTO---40	0225	--XEY---30	0275	-- 8 ---10
0176	-- b ---14	0226	-- X ---36	0276	-- 9 ---11
0177	--XFR---67	0227	-- X ---36	0277	--XTO---23
0178	--IND---31	0228	-- X ---36	0278	-- b ---14
0179	-- b ---14	0229	--DN---25	0279	--XFR---67
0180	-- UP---27	0230	-- + ---33	0280	-- 1 ---01
0181	--INT---64	0231	--YE---24	0281	-- 8 ---10
0182	-- - ---34	0232	-- + ---33	0282	--XTO---23
0183	-- UP---27	0233	-- 8 ---10	0283	--IND---31
0184	--EEX---26	0234	-- 7 ---07	0284	--DIV---35
0185	-- 5 ---05	0235	--DN---25	0285	-- b ---14
0186	--DIV---35	0236	-- K ---55	0286	-- 9 ---11
0187	--DN---25	0237	-- 5 ---05	0287	-- 0 ---00
0188	--XEY---30	0238	-- UP---27	0288	--XTO---23
0189	-- UP---27	0239	-- 8 ---10	0289	-- a ---13
0190	-- 1 ---01	0240	-- 9 ---11	0290	--CLX---37
0191	-- 0 ---00	0241	--XFR---67	0291	-- UP---27
0192	-- X ---36	0242	-- + ---33	0292	--LBL---51
0193	--XFR---67	0243	-- a ---13	0293	-- E ---60
0194	-- 8 ---10	0244	--XTO---23	0294	--XFR---67
0195	-- 8 ---10	0245	-- b ---14	0295	--IND---31
0196	-- X ---36	0246	--YTO---40	0296	-- a ---13
0197	--DN---25	0247	--IND---31	0297	-- + ---33
0198	-- + ---33	0248	-- b ---14	0298	-- 1 ---01
0199	--YTO---40	0249	-- 1 ---01	0299	-- 2 ---60
0200	-- 8 ---10	0250	-- E ---60	0300	-- 1 ---01

Table 11 General Fixture Calibration Program (HP 9810A)- 16 Pins
(cont)

0301-- 0 ---00	0351-- CNT ---47	0401-- 1 ---01
0302-- 0 ---06	0352-- FMT ---42	0402-- YTO ---23
0303-- UP ---27	0353-- 4 ---04	0403-- 6 ---14
0304-- a ---13	0354-- 8 ---10	0404-- LBL ---51
0305-- XKY ---52	0355-- FMT ---42	0405-- F ---16
0306-- DN ---25	0356-- YTO ---40	0406-- FMT ---42
0307-- GTO ---44	0357-- DIV ---35	0407-- 4 ---04
0308-- LBL ---51	0358-- N ---73	0408-- . ---21
0309-- E ---60	0359-- CNT ---47	0409-- 4 ---04
0310-- DN ---25	0360-- UP ---27	0410-- . ---21
0311-- YTO ---40	0361-- - ---34	0411-- 0 ---00
0312-- 1 ---01	0362-- UP ---27	0412-- 6 ---14
0313-- 0 ---00	0363-- FMT ---45	0413-- FMT ---42
0314-- 7 ---07	0364-- CLR ---20	0414-- 4 ---04
0315-- FMT ---42	0365-- SFL ---54	0415-- 8 ---10
0316-- 4 ---04	0366-- XEY ---30	0416-- FMT ---45
0317-- 8 ---10	0367-- CLR ---20	0417-- CNT ---47
0318-- FMT ---42	0368-- r ---56	0418-- FMT ---42
0319-- CLR ---20	0369-- 0 ---71	0419-- 4 ---04
0320-- SFL ---54	0370-- a ---13	0420-- . ---21
0321-- UP ---27	0371-- XTO ---23	0421-- 1 ---01
0322-- DN ---25	0372-- CNT ---47	0422-- 7 ---07
0323-- CLR ---20	0373-- CNT ---47	0423-- . ---21
0324-- UP ---27	0374-- CNT ---47	0424-- 4 ---04
0325-- CNT ---47	0375-- CNT ---47	0425-- XFR ---67
0326-- CNT ---47	0376-- CNT ---47	0426-- IND ---31
0327-- CNT ---47	0377-- CNT ---47	0427-- a ---13
0328-- CNT ---47	0378-- CNT ---47	0428-- FMT ---42
0329-- CNT ---47	0379-- M ---70	0429-- 4 ---04
0330-- CNT ---47	0380-- I ---65	0430-- 8 ---10
0331-- CNT ---47	0381-- L ---72	0431-- FMT ---42
0332-- CNT ---47	0382-- L ---72	0432-- FMT ---45
0333-- CNT ---47	0383-- I ---65	0433-- CLR ---20
0334-- CNT ---47	0384-- IND ---31	0434-- SFL ---54
0335-- UP ---27	0385-- A ---62	0435-- XEY ---30
0336-- IFG ---43	0386-- XTO ---23	0436-- FMT ---42
0337-- FMT ---42	0387-- XTO ---23	0437-- 1 ---01
0338-- CNT ---47	0388-- YTO ---40	0438-- UP ---27
0339-- FMT ---42	0389-- CNT ---47	0439-- E ---60
0340-- 4 ---04	0390-- 0 ---71	0440-- 1 ---01
0341-- . ---21	0391-- 1/X ---17	0441-- 7 ---07
0342-- 1 ---01	0392-- XTO ---23	0442-- UP ---27
0343-- 0 ---00	0393-- CLR ---20	0443-- 6 ---14
0344-- . ---21	0394-- SFL ---54	0444-- XKY ---52
0345-- 3 ---03	0395-- XEY ---30	0445-- GTO ---44
0346-- CNT ---47	0396-- FMT ---42	0446-- LBL ---51
0347-- XFR ---67	0397-- 9 ---11	0447-- F ---16
0348-- 1 ---01	0398-- 0 ---60	0448-- CNT ---47
0349-- 0 ---00	0399-- XTO ---23	0449-- XFR ---67
0350-- 8 ---10	0400-- a ---13	0450-- 1 ---01

Table 11

General Fixture Calibration Program (HP 9810A) - 16 Pins
(cont)

0451-- 0 ---00	0501-- 0 ---71	0551-- 0 ---64
0452-- 6 ---06	0502-- IND---31	0552-- 0 ---10
0453-- FMI---42	0503-- E ---60	0553-- FMT---42
0454-- 4 ---04	0504-- a ---13	0554-- CNT---47
0455-- . ---21	0505-- CNT---47	0555-- UP---27
0456-- 1 ---01	0506-- 0 ---71	0556-- N ---70
0457-- 0 ---00	0507-- 1/X---17	0557-- UP---27
0458-- . ---21	0508-- XTO---23	0558-- IND---31
0459-- 4 ---04	0509-- CNT---47	0559-- CLR---20
0460-- FMT---42	0510-- UP---27	0560-- SFL---54
0461-- 4 ---04	0511-- - ---34	0561-- CLR---20
0462-- 8 ---10	0512-- UP---27	0562-- XEY---30
0463-- FMT---42	0513-- FMT---42	0563-- L ---70
0464-- CLR---20	0514-- XFR---67	0564-- 0 ---71
0465-- 1 ---65	0515-- 1 ---01	0565-- YTO---13
0466-- N ---73	0516-- 0 ---00	0566-- YTO---40
0467-- C ---61	0517-- 6 ---06	0567-- UP---27
0468-- I ---65	0518-- UP---27	0568-- 8 ---10
0469-- D ---63	0519-- XFR---67	0569-- D ---63
0470-- E ---60	0520-- 1 ---01	0570-- UP---27
0471-- N ---73	0521-- 0 ---00	0571-- B ---66
0472-- XTO---23	0522-- 7 ---07	0572-- UP---27
0473-- CNT---47	0523-- DIV---35	0573-- 9 ---11
0474-- π ---56	0524-- XEY---30	0574-- UP---27
0475-- 0 ---71	0525-- K ---55	0575-- CNT---47
0476-- IND---31	0526-- 4 ---04	0576-- UP---27
0477-- E ---60	0527-- UP---27	0577-- - ---34
0478-- a ---13	0528-- 5 ---05	0578-- FMT---42
0479-- CNT---47	0529-- X ---36	0579-- XFR---67
0480-- UP---27	0530-- YTO---40	0580-- IND---31
0481-- - ---34	0531-- IND---31	0581-- 0 ---00
0482-- UP---27	0532-- 0 ---00	0582-- FMT---42
0483-- CNT---47	0533-- YTO---40	0583-- 4 ---04
0484-- PNT---45	0534-- + ---33	0584-- 8 ---10
0485-- CNT---47	0535-- 1 ---01	0585-- PNT---45
0486-- UP---27	0536-- 9 ---11	0586-- CNT---47
0487-- M ---70	0537-- DN---25	0587-- FMT---42
0488-- UP---27	0538-- UP---27	0588-- 5 ---05
0489-- IND---31	0539-- XSO---12	0589-- EEX---26
0490-- CLR---20	0540-- XTO---23	0590-- FMT---42
0491-- SFL---54	0541-- + ---33	0591-- FMT---42
0492-- XEY---30	0542-- 2 ---02	0592-- a ---13
0493-- CLR---20	0543-- 0 ---00	0593-- E ---60
0494-- XTO---23	0544-- RUP---22	0594-- C ---61
0495-- 0 ---71	0545-- FMT---42	0595-- 0 ---71
0496-- XTO---23	0546-- 4 ---04	0596-- a ---13
0497-- R ---62	0547-- 8 ---10	0597-- D ---63
0498-- L ---72	0548-- PNT---45	0598-- IFG---43
0499-- CNT---47	0549-- CNT---47	0599-- FMT---42
0500-- π ---56	0550-- FMT---42	0600-- SIF---41

Table 11

General Fixture Calibration Program (HP 9810A)- 16 Pins
(cont)

0601-- 1 ---01	0651-- E ---60	0701-- 4 ---04
0602-- 2 ---11	0652-- IND---31	0702-- . ---21
0603-- UP---27	0653-- CNT---47	0703-- 4 ---04
0604-- 9 ---11	0654-- π ---56	0704-- . ---21
0605-- 0 ---00	0655-- R ---62	0705-- 0 ---00
0606-- FMT---42	0656-- π ---56	0706-- α ---10
0607-- 5 ---05	0657-- E ---60	0707-- FMT---42
0608-- XTO---23	0658-- α ---13	0708-- 1 ---04
0609-- 1 ---01	0659-- FMT---42	0709-- 8 ---10
0610-- XTO---23	0660-- STP---41	0710-- PNT---45
0611-- + ---33	0661-- FMT---42	0711-- CNT---47
0612-- 0 ---00	0662-- 4 ---04	0712-- FMT---42
0613-- CNT---47	0663-- 8 ---10	0713-- 4 ---04
0614-- 1 ---01	0664-- FMT---42	0714-- . ---21
0615-- 7 ---07	0665-- CLR---20	0715-- 1 ---01
0616-- UP---27	0666-- SFL---54	0716-- 4 ---04
0617-- XFR---67	0667-- XEY---30	0717-- . ---21
0618-- 0 ---00	0668-- π ---56	0718-- 4 ---04
0619-- XCY---52	0669-- 0 ---71	0719-- XFR---67
0620-- GTO---44	0670-- α ---13	0720-- IND---31
0621-- LBL---51	0671-- XTO---23	0721-- α ---10
0622-- B ---66	0672-- CNT---47	0722-- FMT---42
0623-- CNT---47	0673-- CNT---47	0723-- 4 ---04
0624-- XFR---67	0674-- CNT---47	0724-- 8 ---10
0625-- 1 ---01	0675-- CNT---47	0725-- FMT---42
0626-- 9 ---11	0676-- CNT---47	0726-- PNT---45
0627-- UP---27	0677-- CNT---47	0727-- CLR---20
0628-- 1 ---01	0678-- CNT---47	0728-- SFL---54
0629-- 6 ---06	0679-- L ---70	0729-- XEY---30
0630-- DIV---35	0680-- 0 ---71	0730-- FMT---42
0631-- YTO---40	0681-- YTO---40	0731-- 1 ---01
0632-- 1 ---01	0682-- YTO---40	0732-- E ---60
0633-- 9 ---11	0683-- UP---27	0733-- 1 ---01
0634-- YE---24	0684-- 8 ---10	0734-- 7 ---07
0635-- 2 ---02	0685-- D ---63	0735-- UP---27
0636-- 0 ---00	0686-- UP---27	0736-- α ---10
0637-- DIV---35	0687-- B ---66	0737-- XCY---52
0638-- XFR---67	0688-- UP---27	0738-- GTO---44
0639-- 1 ---01	0689-- 9 ---11	0739-- LBL---51
0640-- 9 ---11	0690-- UP---27	0740-- G ---15
0641-- XSQ---12	0691-- CLR---20	0741-- CNT---47
0642-- - ---34	0692-- SFL---54	0742-- FMT---42
0643-- DN---25	0693-- XEY---30	0743-- 4 ---04
0644-- J ---76	0694-- FMT---42	0744-- . ---21
0645-- XTO---23	0695-- 1 ---01	0745-- 9 ---11
0646-- 2 ---02	0696-- XTO---23	0746-- . ---21
0647-- 0 ---00	0697-- α ---13	0747-- 4 ---04
0648-- FMT---42	0698-- LBL---51	0748-- CNT---47
0649-- FMT---42	0699-- G ---15	0749-- FMT---42
0650-- H ---73	0700-- FMT---42	0750-- 4 ---04

Table 11 General Fixture Calibration Program (HP9810A)- 16 Pins (cont)

0751-- a ---10	0801--PNT---45	0851--CH---47
0752--PNT---42	0802--CLR---20	0852-- F ---16
0753--CLR---20	0803--SFL---54	0853-- a ---10
0754-- M ---70	0804--XEY---30	0854-- E ---60
0755-- E ---60	0805--CLR---20	0855-- b ---14
0756-- A ---62	0806-- A ---62	0856-- . ---21
0757-- N ---73	0807-- B ---66	0857--FMT---42
0758--CNT---47	0808--YTO---40	0858--STP---41
0759-- UP---27	0809-- O ---71	0859--END---46
0760-- - ---34	0810-- L ---72	
0761--FMT---42	0811--1/X---17	
0762--CNT---47	0812--XTO---23	
0763--XFR---67	0813-- E ---60	
0764-- 1 ---01	0814--CNT---47	
0765-- 9 ---11	0815-- L ---72	
0766--FMT---42	0816-- O ---71	
0767-- 4 ---04	0817--YTO---40	
0768-- 8 ---10	0818--YTO---40	
0769--FMT---42	0819--CNT---47	
0770--PNT---45	0820-- F ---16	
0771--CLR---20	0821-- A ---62	
0772--SFL---54	0822-- C ---61	
0773--XEY---30	0823--XTO---23	
0774--CLR---20	0824-- O ---71	
0775--YTO---40	0825-- a ---13	
0776--XTO---23	0826--CNT---47	
0777-- A ---62	0827-- UP---27	
0778-- N ---73	0828-- - ---34	
0779-- D ---63	0829--FMT---42	
0780-- A ---62	0830--XFR---67	
0781-- a ---13	0831-- 1 ---01	
0782-- D ---63	0832-- 9 ---11	
0783--CNT---47	0833-- UP---27	
0784-- E ---60	0834-- 1 ---01	
0785-- a ---13	0835-- 0 ---00	
0786-- a ---13	0836--DIV---35	
0787-- O ---71	0837-- DN---25	
0788-- a ---13	0838-- K ---55	
0789--CNT---47	0839-- 5 ---05	
0790-- UP---27	0840--FMT---42	
0791-- - ---34	0841-- 4 ---04	
0792--FMT---42	0842-- 8 ---10	
0793--CNT---47	0843--PNT---45	
0794--XFR---67	0844--CNT---47	
0795-- 2 ---02	0845--FMT---42	
0796-- 0 ---00	0846--FMT---42	
0797--FMT---42	0847-- N ---73	
0798-- 4 ---04	0848-- E ---60	
0799-- 8 ---10	0849-- YE---24	
0800--FMT---42	0850--XTO---23	

Table 12 General Fixture Calibration Program Data Register Allocation

a	CHANNEL COUNTER	
b	INDIRECT AND SCRATCH	
0	FREQUENCY, PORT COUNTER	
1	LOSS IN dB WITH INPUT PORT #	1
2		2
3		3
4		4
5		5
6		6
7		7
8		8
9		9
10		10
11		11
12		12
13		13
14		14
15		15
16		16
17	INCIDENT POWER COUPLER FACTOR	
18	REFLECTED POWER COUPLER FACTOR	
19	M	
20	E	
21	DETECTOR COEFFICIENTS - B_0 & B_1 - DETECTOR #	1
22		B_2 & B_3 1
23		B_0 & B_1 2

Table 12 (Continued)

24	DETECTOR COEFFICIENTS B_2 & B_3 - DETECTOR #	2
25	B_0 & B_1	3
26	B_2 & B_3	3
27	B_0 & B_1	4
28	B_2 & B_3	4
29	B_0 & B_1	5
30	B_2 & B_3	5
31	B_0 & B_1	6
32	B_2 & B_3	6
33	B_0 & B_1	7
34	B_2 & B_3	7
35	B_0 & B_1	8
36	B_2 & B_3	8
37	B_0 & B_1	9
38	B_2 & B_3	9
39	B_0 & B_1	10
40	B_2 & B_3	10
41	B_0 & B_1	11
42	B_2 & B_3	11
43	B_0 & B_1	12
44	B_2 & B_3	12
45	B_0 & B_1	13
46	B_2 & B_3	13
47	B_0 & B_1	14
48	B_2 & B_3	14
49	B_0 & B_1	15

Table 12 (Continued)

50	DETECTOR COEFFICIENTS - B_2 & B_3	DETECTOR # 15
51	B_0 & B_1	16
52	B_2 & B_3	16
53	B_0 & B_1	17
54	B_2 & B_3	17
55	SPARE	
56	SPARE	
57	SPARE	
58	SPARE	
59	SPARE	
60	SPARE	
61	SPARE	
62	SPARE	
63	SPARE	
64	SPARE	
65	SPARE	
66	SPARE	
67	SPARE	
68	SPARE	
69	SPARE	
70	SPARE	
71	SPARE	
72	SPARE	
73	SPARE	
74	SPARE	
75	SPARE	

INTEGRATED CIRCUIT SUSCEPTIBILITY

MDC E1099
12 JULY 1974

Table 12 (Continued)

76	SPAKE	
77	SPARE	
78	SPARE	
79	SPARE	
80	SPARE	
81	SPARE	
82	SPARE	
83	SPARE	
84	SPARE	
85	SPARE	
86	SPARE	
87	TEMPORARY STORAGE FOR CALCULATING P	
88	LOG V	
89	INPUT PORT	
90	POWER OUT OF PORT # 1	
91		2
92		3
93		4
94		5
95		6
96		7
97		8
98		9
99		10
100		11
101		12

INTEGRATED CIRCUIT SUSCEPTIBILITY

MDC E1099
12 JULY 1974

Table 12 (Continued)

102	POWER OUT OF PORT 13	
103		14
104		15
105		16
106	INCIDENT POWER	
107	TOTAL POWER OUT	
108	S/N	

Table 13

Dissipation Loss Data for
16 Pin DIP Test Fixture at
0.22 GHz

PORT	LOSS (dB)
1	0.1369
2	0.1790
3	0.1715
4	0.1532
5	0.1626
6	0.0748
7	0.1650
8	0.1698
9	0.1833
10	0.1625
11	0.1764
12	0.1557
13	0.1333
14	0.1734
15	0.1814
16	0.1738

MEAN = 0.1596

STANDARD ERROR = 0.0262

ABSOLUTE LOSS FACTOR = 1.0374

Table 14

Dissipation Loss Data
for 16 Pin DIP Test Fixture
at 0.91 GHz

PORT	LOSS (dB)
1	0.3517
2	0.4721
3	0.4837
4	0.5139
5	0.4787
6	0.4157
7	0.3713
8	0.4804
9	0.5095
10	0.3941
11	0.4221
12	0.4409
13	0.5746
14	0.6120
15	0.5008
16	0.6633

MEAN = 0.4791

STANDARD ERROR = 0.0839

ABSOLUTE LOSS FACTOR = 1.1166

Table 16
Dissipation Loss Data for
16 Pin DIP Test Fixture at
5.6 GHz

PORT	LOSS (dB)
1	1.0181
2	0.7169
3	1.0751
4	0.5275
5	0.5637
6	1.2343
7	0.6952
8	0.9124
9	0.9274
10	0.7600
11	1.2159
12	0.8551
13	0.6707
14	1.4796
15	0.7602
16	1.0528

MEAN = 0.9044

STANDARD ERROR = 0.2542

ABSOLUTE LOSS FACTOR = 1.2315

Table 15
Dissipation Loss Data for
16 Pin DIP Test Fixture at
3 GHz

PORT	LOSS (dB)
1	0.1611
2	0.2371
3	0.2189
4	0.1635
5	0.1733
6	0.1989
7	0.2347
8	0.1972
9	0.2017
10	0.2070
11	0.2376
12	0.1697
13	0.1321
14	0.1882
15	0.2496
16	0.1815

MEAN = 0.1970

STANDARD ERROR = 0.0319

ABSOLUTE LOSS FACTOR = 1.0464

Table 18
Dissipation Loss Data for
8 Pin TO-5 Test Fixture at
0.22 GHz

PORT	LOSS (dB)
1	0.1519
2	0.8181
3	0.1392
4	0.0000
5	0.1938
6	0.3123
7	0.3386
8	0.2383

MEAN = 0.3079

STANDARD ERROR = 0.2255

ABSOLUTE LOSS FACTOR = 1.0735

Table 17
Dissipation Loss Data for
16 Pin DIP Test Fixture at
9.1 GHz

PORT	LOSS (dB)
1	0.9107
2	0.5559
3	0.4131
4	0.7084
5	0.5642
6	0.6113
7	0.7256
8	1.3006
9	1.1167
10	0.6015
11	0.4773
12	0.4697
13	0.4818
14	0.5247
15	0.6945
16	1.1751

MEAN = 0.7089

STANDARD ERROR = 0.2661

ABSOLUTE LOSS FACTOR = 1.1773

Table 19
Dissipation Loss
Data for 8 Pin
T0-5 Test Fixture
at 0.91 GHz

PORT	LOSS(dB)
1	0.4150
2	1.0125
3	0.5663
4	0.4030
5	0.3797
6	0.4132
7	0.4316
8	0.4331

MEAN = 0.5068

STANDARD ERROR = 0.1983

ABSOLUTE LOSS FACTOR = 1.1238

Table 20
Dissipation Loss Data
for 8 Pin T0-5 Test
Fixture at 3 GHz

PORT	LOSS(dB)
1	0.3019
2	0.6478
3	0.3319
4	0.2966
5	0.2757
6	0.3976
7	0.4162
8	0.3973

MEAN = 0.3831

STANDARD ERROR = 0.1117

ABSOLUTE LOSS FACTOR = 1.0922

Table 21
Dissipation Loss
Data for 8 Pin
T0-5 Test Fixture
at 5.6 GHz

PORT	LOSS(dB)
1	0.6941
2	1.1559
3	0.8308
4	0.9468
5	0.8308
6	1.1359
7	0.9228
8	0.9321

MEAN = 0.9311

STANDARD ERROR = 0.1454

ABSOLUTE LOSS FACTOR = 1.2391

Table 22
Dissipation Loss Data
for 8 Pin T0-5 Test
Fixture at 9.1 GHz

PORT	LOSS(dB)
1	2.3016
2	1.7793
3	1.8985
4	2.0717
5	2.1899
6	2.6554
7	2.4368
8	2.6065

MEAN = 2.2425

STANDARD ERROR = 0.2977

ABSOLUTE LOSS FACTOR = 1.6759

TABLE 23 EXAMPLE OF 741 INTERFERENCE SUSCEPTIBILITY DATA

S/N = 330

P(mW)	C.F.(dB)	VOUT	IOUT	VNI	INI	VON2	ION2	VON6
-0.0001	0.000	-4.927	9.85	0.00	-0.0106	-11.82	-0.0278	-11.82
0.0384	2.253	-4.988	9.98	0.00	-0.0110	-11.82	-0.0280	-11.82
0.0596	2.229	-5.019	10.04	0.00	-0.0110	-11.82	-0.0282	-11.82
0.0851	2.493	-5.068	10.14	-0.00	-0.0112	-11.82	-0.0284	-11.81
0.2514	2.519	-5.380	10.76	0.00	-0.0110	-11.81	-0.0300	-11.81
0.4498	2.530	-5.772	11.54	0.00	-0.0111	-11.80	-0.0314	-11.80
0.9689	2.508	-6.652	13.30	-0.00	-0.0112	-11.78	-0.0354	-11.78
1.6265	2.512	-7.564	15.13	-0.00	-0.0112	-11.75	-0.0394	-11.75
3.0516	2.496	-8.912	17.82	-0.00	-0.0111	-11.72	-0.0444	-11.72
10.5494	2.446	-8.993	17.99	-0.00	-0.0109	-11.72	-0.0446	-11.72
18.5502	2.419	-8.972	17.94	0.00	-0.0108	-11.72	-0.0442	-11.72
34.0799	2.383	-8.922	17.84	-0.00	-0.0108	-11.73	-0.0442	-11.72
54.5367	2.354	-8.843	17.69	0.00	-0.0108	-11.73	-0.0438	-11.72
103.4030	2.453	9.829	-19.66	0.00	-0.0081	-11.94	-0.0054	-11.95
134.7200	2.355	9.732	-19.46	0.00	-0.0099	-11.94	-0.0054	-11.94
198.5100	2.209	9.506	-19.01	0.00	-0.0107	-11.94	-0.0056	-11.94
277.1050	2.085	9.195	-18.39	0.00	-0.0107	-11.94	-0.0060	-11.94
396.2030	1.961	8.721	-17.44	0.00	-0.0110	-11.94	-0.0064	-11.94
521.0260	1.867	8.186	-16.37	0.00	-0.0109	-11.93	-0.0068	-11.94
760.4520	1.713	7.254	-14.51	0.00	-0.0105	-11.86	-0.0222	-11.93

P(mW)	ION6	VCC+	ICC+	VCC-	ICC-	VII	III
-0.0001	-0.0278	11.93	0.80	-11.84	-11.50	0.0032	0.4940
0.0384	-0.0280	11.93	0.80	-11.84	-11.80	-0.0024	0.4996
0.0596	-0.0284	11.93	0.90	-11.84	-11.70	-0.0052	0.5024
0.0851	-0.0286	11.93	0.90	-11.84	-11.80	-0.0097	0.5068
0.2514	-0.0298	11.93	0.90	-11.83	-12.50	-0.0381	0.5353
0.4498	-0.0316	11.93	0.80	-11.82	-13.40	-0.0737	0.5708
0.9689	-0.0356	11.93	0.90	-11.80	-15.40	-0.1539	0.6510
1.6265	-0.0396	11.93	1.30	-11.77	-17.70	-0.2366	0.7338
3.0516	-0.0446	11.93	0.90	-11.74	-20.30	-0.3596	0.8568
10.5494	-0.0454	11.93	1.00	-11.74	-20.50	-0.3666	0.8638
18.5502	-0.0452	11.93	0.90	-11.74	-20.50	-0.3647	0.8618
34.0799	-0.0448	11.93	1.00	-11.74	-20.30	-0.3598	0.8569
54.5367	-0.0444	11.93	0.90	-11.74	-20.10	-0.3516	0.8487
103.4030	-0.0052	11.71	22.00	-11.97	-0.50	1.4130	-0.9157
134.7200	-0.0054	11.71	21.90	-11.96	-0.60	1.5130	-1.0157
198.5100	-0.0054	11.71	21.70	-11.96	-0.70	1.7090	-1.2117
277.1050	-0.0058	11.72	21.40	-11.96	-0.90	1.9090	-1.4117
396.2030	-0.0062	11.72	20.70	-11.96	-1.00	2.1450	-1.6477
521.0260	-0.0064	11.73	19.80	-11.96	-1.10	2.3260	-1.8287
760.4520	-0.0066	11.75	18.20	-11.96	-1.10	2.5610	-2.0636

ALL VOLTAGES IN VOLTS
ALL CURRENTS IN MILLIAMPS

Table 24 7400 Interference Test Program (HP9810A)

0000--CLR---20		
0001--FMT---42	0051-- 2 ---02	0101--XFR---67
0002--XFR---67	0052-- 4 ---04	0102-- 1 ---01
0003--XFR---67	0053--CLX---37	0103-- 6 ---06
0004-- 2 ---02	0054--XTO---23	0104-- UP---27
0005-- 4 ---04	0055-- 3 ---03	0105--INT---64
0006--PNT---45	0056-- 2 ---02	0106-- - ---34
0007--LBL---51	0057--XTO---23	0107-- UP---27
0008-- A ---62	0058-- 4 ---04	0108--EEX---26
0009--FMT---42	0059-- 1 ---01	0109-- 5 ---05
0010-- 4 ---04	0060--LBL---51	0110--DIV---35
0011-- 1 ---01	0061-- B ---66	0111--RUP---22
0012--FMT---42	0062--FMT---42	0112--XEY---30
0013--SFL---54	0063-- 4 ---04	0113-- 1 ---01
0014--FMT---42	0064-- 1 ---01	0114-- 0 ---00
0015--PSE---57	0065--FMT---42	0115-- X ---36
0016--FMT---42	0066-- 1 ---01	0116-- DN---25
0017--FMT---42	0067--FMT---42	0117--XTO---23
0018--YTO---40	0068--STP---41	0118-- 4 ---04
0019--DIV---35	0069-- 1 ---01	0119-- 6 ---06
0020-- H ---73	0070--XTO---23	0120--YTO---40
0021--FMT---42	0071-- a ---13	0121-- 4 ---04
0022--STP---41	0072--SFL---54	0122-- 5 ---05
0023--XTO---23	0073--LBL---51	0123--XFR---67
0024-- 3 ---03	0074-- C ---61	0124-- 1 ---01
0025-- 0 ---00	0075--FMT---42	0125-- 7 ---07
0026--PNT---45	0076-- 3 ---03	0126-- UP---27
0027-- UP---27	0077-- 3 ---03	0127--INT---64
0028--EEX---26	0078-- . ---21	0128-- - ---34
0029-- 3 ---03	0079-- UP---27	0129-- UP---27
0030--DIV---35	0080--FMT---42	0130--EEX---26
0031-- DN---25	0081-- 4 ---04	0131-- 7 ---07
0032-- UP---27	0082-- 1 ---01	0132--DIV---35
0033--INT---64	0083--FMT---42	0133-- DN---25
0034-- - ---34	0084-- 1 ---01	0134--CHS---32
0035-- 1 ---01	0085--FMT---42	0135--XTO---23
0036-- 0 ---00	0086-- 1 ---01	0136-- 4 ---04
0037-- X ---36	0087-- 5 ---05	0137-- 6 ---10
0038-- DN---25	0088-- UP---27	0138--YTO---40
0039--INT---64	0089-- a ---13	0139-- 4 ---04
0040-- UP---27	0090--X>Y---53	0140-- 7 ---07
0041-- 1 ---01	0091--GTO---44	0141--XFR---67
0042--XTO---23	0092--LBL---51	0142--IND---31
0043-- 2 ---02	0093-- I ---65	0143-- a ---13
0044-- 3 ---03	0094--CNT---47	0144-- UP---27
0045--X=Y---50	0095--RUP---22	0145-- 4 ---04
0046--CNT---47	0096-- K ---55	0146-- 5 ---05
0047-- 1 ---01	0097-- 4 ---04	0147--XTO---23
0048-- 0 ---00	0098--XTO---23	0148-- 6 ---14
0049-- + ---33	0099-- 2 ---02	0149--LBL---51
0050--YTO---40	0100-- 6 ---06	0150-- D ---63

Table 24 7400 Interference Test Program (HP 9810A)
(cont)

0151--G O---44	0201-- 5 ---10	0251-- L ---14
0152--D R---77	0202-- - ---34	0252-- DN---29
0153--LBL---51	0203-- DN---25	0253--YTO---40
0154-- H ---74	0204-- K ---55	0254--IND---31
0155--XTO---23	0205-- 5 ---05	0255-- b ---14
0156--IND---31	0206-- UP---27	0256--GTO---44
0157-- - ---34	0207-- 1 ---01	0257--LBL---51
0158-- b ---14	0208-- 5 ---05	0258-- J ---75
0159-- 1 ---01	0209-- UP---27	0259--LBL---51
0160--XTO---23	0210-- a ---13	0260-- E ---60
0161-- + ---33	0211--XKY---52	0261-- 2 ---02
0162-- b ---14	0212--GTO---44	0262-- 3 ---03
0163-- 4 ---04	0213--LBL---51	0263--XEY---30
0164-- 9 ---11	0214-- E ---60	0264-- 9 ---11
0165-- UP---27	0215--CHT---47	0265--XFR---67
0166-- b ---14	0216--XFF---67	0266-- X ---36
0167--XKY---52	0217-- 0 ---00	0267-- 2 ---02
0168-- DN---25	0218--INT---64	0268-- 3 ---03
0169--GTO---44	0219--XEY---30	0269-- + ---33
0170--LBL---51	0220--EEX---26	0270--YTO---40
0171-- D ---63	0221-- 6 ---06	0271-- 2 ---02
0172--XFR---67	0222--DIV---35	0272-- 5 ---05
0173-- 2 ---02	0223-- DN---25	0273-- DN---25
0174-- 6 ---06	0224--DIV---35	0274--XFR---67
0175--XTO---23	0225-- 1 ---01	0275-- 1 ---01
0176-- b ---14	0226-- 8 ---10	0276-- 8 ---16
0177--XFR---67	0227--XFR---67	0277-- X ---36
0178-- X ---36	0228-- + ---33	0278-- 5 ---05
0179-- 4 ---04	0229-- 2 ---02	0279-- UP---27
0180-- 6 ---06	0230-- 4 ---04	0280-- a ---13
0181--XFR---67	0231--XTO---23	0281--XKY---52
0182-- + ---33	0232-- b ---14	0282--GTO---44
0183-- 4 ---04	0233-- YE---24	0283--LBL---51
0184-- 5 ---05	0234--IND---31	0284-- G ---15
0185-- UP---27	0235--DIV---35	0285--CHT---47
0186-- b ---14	0236-- b ---14	0286--XEY---30
0187--XSO---12	0237-- YE---24	0287-- 1 ---01
0188--XFR---67	0238--DIV---35	0288-- 1 ---01
0189-- X ---36	0239-- 1 ---01	0289--X=Y---50
0190-- 4 ---04	0240-- 8 ---10	0290--GTO---44
0191-- 7 ---07	0241--XFR---67	0291--LBL---51
0192-- + ---33	0242-- 2 ---02	0292-- G ---15
0193-- b ---14	0243-- 3 ---03	0293--CHT---47
0194--XSO---12	0244-- UP---27	0294-- DN---25
0195--XFR---67	0245-- 9 ---11	0295--YTO---40
0196-- X ---36	0246-- X ---36	0296--IND---31
0197-- b ---14	0247-- 2 ---02	0297-- + ---33
0198--XFR---67	0248-- 2 ---02	0298-- 2 ---02
0199-- X ---36	0249-- + ---33	0299-- 5 ---05
0200-- 4 ---04	0250--YTO---40	0300--GTO---44

Table 24 7400 Interference Test Program (HP 9810A) (cont)

0301--LBL---51	0351-- J ---75	0401--FMT---42
0302-- J ---75	0352-- 1 ---01	0402--SFL---54
0303--LBL---51	0353-- E ---60	0403--FMT---42
0304-- G ---15	0354--GTO---44	0404-- 2 ---02
0305-- 1 ---01	0355--LBL---51	0405-- 3 ---03
0306-- 8 ---10	0356-- C ---61	0406-- UP---27
0307--XFR---67	0357--LBL---51	0407-- 9 ---11
0308-- + ---33	0358-- 1 ---65	0408--XFR---67
0309-- a ---13	0359-- 2 ---02	0409-- X ---36
0310--XTO---23	0360-- 2 ---02	0410-- 2 ---02
0311-- b ---14	0361--XEY---30	0411-- 3 ---03
0312-- DH---25	0362-- a ---13	0412-- + ---33
0313-- YE---24	0363--X>Y---53	0413--YTO---40
0314--IND---31	0364--GTO---44	0414-- a ---13
0315-- X ---36	0365--LBL---51	0415--XFR---67
0316-- b ---14	0366-- a ---13	0416--IND---31
0317--XFR---67	0367--CNT---47	0417-- a ---13
0318-- 2 ---02	0368--PSE---57	0418--CHS---32
0319-- 4 ---04	0369--PSE---57	0419-- UP---27
0320-- UP---27	0370--JFG---43	0420-- 1 ---01
0321-- a ---13	0371-- DH---25	0421--CHS---32
0322--X=Y---50	0372--GTO---44	0422-- L ---60
0323-- DN---25	0373--LBL---51	0423--XFR---67
0324--GTO---44	0374-- L ---72	0424--IND---31
0325--LBL---51	0375--SFL---54	0425-- a ---13
0326-- F ---16	0376-- DH---25	0426-- + ---33
0327-- DN---25	0377-- YE---24	0427--YTO---40
0328--YTO---40	0378--IND---31	0428--IND---31
0329--IND---31	0379-- - ---34	0429-- a ---13
0330-- + ---33	0380-- 2 ---02	0430--XEY---30
0331-- 2 ---02	0381-- 5 ---05	0431--DIV---35
0332-- 5 ---05	0382--LBL---51	0432--FMT---42
0333--GTO---44	0383-- L ---72	0433--FMT---42
0334--LBL---51	0384-- 1 ---01	0434-- a ---56
0335-- J ---75	0385--XTO---23	0435--CLR---20
0336--LBL---51	0386-- + ---33	0436--INT---64
0337-- F ---16	0387-- 2 ---02	0437--FMT---42
0338--XFR---67	0388-- 5 ---05	0438--PNT---45
0339-- 0 ---00	0389--YTO---40	0439-- DH---25
0340-- UP---27	0390--IND---31	0440-- K ---55
0341--INT---64	0391-- 2 ---02	0441-- 4 ---04
0342-- - ---34	0392-- 5 ---05	0442-- UP---27
0343-- DH---25	0393--GTO---44	0443-- 1 ---01
0344--DIV---35	0394--LBL---51	0444-- 0 ---00
0345--YTO---40	0395-- J ---75	0445-- X ---36
0346--IND---31	0396--LBL---51	0446-- 1 ---01
0347-- + ---33	0397-- a ---13	0447-- E ---60
0348-- 2 ---02	0398--FMT---42	0448--YTO---40
0349-- 5 ---05	0399-- 4 ---04	0449--IND---31
0350--LBL---51	0400-- 1 ---01	0450-- a ---13

Table 24 7400 Interference Test Program (HP 9810A)(cont)

0451-- 5 ---05
0452-- E ---60
0453--XFR---67
0454--IND---31
0455-- o ---13
0456--PNT---45
0457-- 1 ---01
0458--XTO---23
0459-- + ---33
0460-- 2 ---02
0461-- 3 ---03
0462--XFR---67
0463-- 2 ---02
0464-- 3 ---03
0465-- UP---27
0466-- 3 ---03
0467--X>Y---53
0468--GTO---44
0469--LBL---51
0470-- B ---66
0471--CNT---47
0472-- 1 ---01
0473-- 9 ---11
0474-- UP---27
0475-- 3 ---03
0476-- 0 ---00
0477--FMT---42
0478-- 5 ---05
0479--XTO---23
0480--GTO---44
0481--LBL---51
0482-- A ---62
0483--LBL---51
0484-- H ---74
0485--EEX---26
0486-- 3 ---03
0487-- X ---36
0488-- DN---25
0489-- UP---27
0490--INT---64
0491-- - ---34
0492-- UP---27
0493--EEX---26
0494-- 4 ---04
0495--DIV---35
0496-- DN---25
0497--S/R---77
0498--END---46

Table 25 7400 Data Tape to Matrix Tape Conversion Program for HP 9830A

```

10 COM FS[20,9],A
20 DISP "FIRST MATRIX TAPE FILE#";
30 INPUT Q
40 DIM C[19]
50 DISP "FIRST FILE #, # OF FILES";
60 INPUT M,N
70 FOR I=0 TO N-1
80 LOAD DATA H+I,C
90 IF I>0 THEN 110
100 A=C[1]
110 IF A#C[1] THEN 490
120 FOR J=1 TO 2
130 FOR K=1 TO 9
140 T[J+2*I,K]=C[K+1+9*(J-1)]
150 NEXT K
160 NEXT J
170 NEXT I
180 FOR I=1 TO 20
190 F[I,4]=1000*F[I,4]
200 F[I,6]=10*F[I,6]
210 F[I,8]=10*F[I,8]
220 F[I,9]=1000*F[I,9]
230 NEXT I
240 PRINT
250 PRINT
260 PRINT
270 WRITE (15,280)A
280 FORMAT 30X,"S/N =",F7.0
290 PRINT
300 PRINT
310 FORMAT " "
320 WRITE (15,310)"
330 FOR I=1 TO 20

```

III",F4.0

YII

ICC

VCC
ICLD"

C.F.(dB)
ICUT

P(mW)
VOUT

(15,280)A
30X,"S/N =",F7.0

"
(15,310)"

FOR I=1 TO 20

Table 25 7400 Data Tape to Matrix Tape Conversion Program (cont)

```

340 WRITE (15, 350) F[I, 1], F[I, 2], F[I, 3], F[I, 4], F[I, 5], F[I, 6], F[I, 7], F[I, 8], F[I, 9]
350 FORMAT 5X, F10.4, 2F8.4, 4F8.3, 4F8.4, 4F8.3
360 NEXT I
370 PRINT
380 PRINT
390 PRINT
400 PRINT
410 PRINT
420 PRINT
430 PRINT
440 STORE DATA #5, Q
450 Q=Q+1
460 M=M+10
470 GOTO 70
480 END
490 DISP "S/N NOT ="A;C[1]
500 STOP
    
```

Table 26 General Plot Program from Matrix Tapes for 7400 for HP 9830A

```
10 COM FS[20,9],A
20 DIM C[19]
30 DISP "FIRST FILE #";
40 INPUT P
60 LOAD DATA P
70 SCALE 0,8.5,0,10
80 OFFSET 2,1.5
90 XAXIS 0,1.5,0,6
100 YAXIS 0,0.7,0,7
110 FOR J=0 TO 3
120 PLOT (LGT(2)+J)*1.5,0,1
130 LABEL (*,1,3.4,PI/2,7/6)
140 CPLOT 0,-0.3
150 LABEL (*)"-";
160 PLOT (LGT(5)+J)*1.5,0,1
170 CPLOT 0,-0.3
180 LABEL (*)"-";
190 NEXT J
200 DISP "YMIN,YMAX";
210 INPUT N,M
220 SCALE -7/3,10/3,N-1.5*(M-N)/7,N+8.5*(M-N)/7
230 FOR I=-1 TO 3
240 LABEL (*,1.5,1.7,0,7/6)
250 PLOT I,N,1
260 CPLOT -2,-2
270 LABEL (310,1.5,1.7,0,7/6)10;
280 CPLOT 0,0.6
290 LABEL (320,1.125,1.7,0,7/6)I;
300 NEXT I
310 FORMAT F3.0
320 FORMAT F2.0
330 LABEL (*,1.5,1.7,0,7/6)
340 A=(M-N)/5
350 FOR I=0 TO 5
360 PLOT -1,N+A*I,1
370 CPLOT -7,-0.3
380 LABEL (400)N+A*I;
390 NEXT I
400 FORMAT F7.3
410 LABEL (*,1,0.8,0,7/6)
420 FOR I=1 TO 20
430 PLOT LGT(F[I,1]),ABS(F[I,7]),1
440 CPLOT -0.3,-0.3
450 LABEL (*)"*"
460 IPLOT 0,0,1
470 NEXT I
```

Table 26 General Plot Program from Matrix Tapes for 7400 for HP 9830A

```
480 PEN  
490 SCALE 0,8.5,0,10  
500 OFFSET 2,1.5  
510 FOR I=1 TO 4  
520 PLOT I*1.5,0,1  
530 PLOT I*1.5,7,2  
540 NEXT I  
550 FOR I=1 TO 10  
560 PLOT 0,I*0.7,1  
570 PLOT 6,I*0.7,2  
580 NEXT I  
590 PEN  
600 SCALE -7/3,10/3,N-1.5*(M-N)/7,N+8.5*(M-N)/7  
610 FOR Q=P+1 TO P+9  
620 LOAD DATA Q  
630 FOR I=1 TO 20  
640 PLOT LGT(F[I,1]),ABS(F[I,7]),1  
650 CPLOT -0.3,-0.3  
660 LABEL (*) "*" "  
670 NEXT I  
680 NEXT Q  
690 PLOT 0.15,7.5,1  
700 LABEL (*) A  
710 END
```

Table 27 HP 9810A 741 Interference Program

0000--FLI---42	0019--DU---25	0098-- 2 ---02
0001--XFR---67	0050--XTO---23	0099-- 0 ---00
0002--XFR---67	0051-- 1 ---01	0100--XTO---23
0003-- 0 ---00	0052-- 7 ---07	0101-- 6 ---14
0004--PNT---45	0053--LBL---51	0102--XFR---67
0005--LBL---51	0054-- A ---62	0103--IND---31
0006-- 1 ---56	0055--FMT---42	0104-- 6 ---14
0007-- 1 ---01	0056-- 4 ---04	0105--FMT---42
0008--XTO---23	0057-- 1 ---01	0106-- 4 ---04
0009-- 2 ---02	0058--FMT---42	0107-- 2 ---02
0010-- 0 ---00	0059--SFL---54	0108--XTO---23
0011--XFR---67	0060--FMT---42	0109--PSE---57
0012-- 5 ---05	0061--PSE---57	0110--PSE---57
0013-- 1 ---01	0062--PSE---57	0111--PSE---57
0014--FMT---42	0063--CLX---37	0112-- 1 ---01
0015-- 4 ---04	0064--XTO---23	0113--XTO---23
0016-- 2 ---02	0065-- 7 ---07	0114-- 0 ---10
0017--XTO---23	0066-- 8 ---10	0115--SFL---54
0018--FMT---42	0067--XTO---23	0116--LBL---51
0019--FMT---42	0068-- 9 ---11	0117-- 0 ---60
0020--YTO---40	0069-- 4 ---04	0118--FMT---42
0021--DIV---35	0070--CHT---47	0119-- 3 ---03
0022-- M ---73	0071-- 1 ---01	0120-- 3 ---03
0023--FMT---42	0072--XTO---23	0121-- . ---21
0024--STP---41	0073-- 0 ---00	0122--UP---27
0025--XTO---23	0074--LBL---51	0123--FMT---42
0026-- 7 ---07	0075-- C ---61	0124-- 4 ---04
0027-- 6 ---06	0076--FMT---42	0125-- 1 ---01
0028--PNT---45	0077-- 4 ---04	0126--FMT---42
0029--UP---27	0078-- 1 ---01	0127-- 1 ---01
0030--EEX---26	0079--FMT---42	0128--FMT---42
0031-- 2 ---02	0080-- 1 ---01	0129-- 0 ---10
0032--DIV---35	0081--FMT---42	0130--UP---27
0033--DN---25	0082--XFR---67	0131--XFR---67
0034--UP---27	0083-- 7 ---07	0132-- 1 ---01
0035--INT---64	0084-- 3 ---03	0133-- 7 ---07
0036-- - ---34	0085--UP---27	0134--X=Y---56
0037-- 1 ---01	0086--XFR---67	0135--DN---25
0038-- 0 ---00	0087-- 2 ---02	0136--GTO---44
0039-- X ---36	0088-- 0 ---00	0137--LBL---51
0040--DN---25	0089--X=Y---50	0138-- M ---70
0041--INT---64	0090--GTO---44	0139-- 1 ---01
0042--UP---27	0091--S/R---77	0140-- 5 ---05
0043-- 5 ---05	0092--LBL---51	0141--KEY---30
0044--KEY---30	0093-- 0 ---10	0142--X>Y---53
0045--X>Y---53	0094-- 5 ---05	0143--GTO---44
0046--UP---27	0095-- 0 ---00	0144--LBL---51
0047-- 4 ---04	0096--XFR---67	0145-- 1 ---65
0048-- + ---35	0097-- 1 ---10	0146--CHT---47

Table 27 HP 9810A 741 Interference Program (cont)

0141-- M ---25	0196-- TQ ---40	0245-- DN ---25
0142-- 2 ---15	0197-- 7 ---07	0246-- XFR ---67
0149-- EEX ---26	0198-- 1 ---01	0247-- 1 ---01
0150-- CHS ---32	0199-- PSE ---57	0248-- 5 ---05
0151-- 3 ---03	0200-- 1 ---01	0249-- DIV ---35
0152-- X>Y ---53	0201-- XTQ ---23	0250-- YE ---24
0153-- CLX ---37	0202-- + ---33	0251-- IND ---31
0154-- KEY ---30	0203-- b ---14	0252-- DIV ---35
0155-- CNT ---47	0204-- XFR ---67	0253-- 1 ---01
0156-- CNT ---47	0205-- IND ---31	0254-- 7 ---07
0157-- LBL ---51	0206-- b ---14	0255-- XFR ---67
0158-- M ---70	0207-- UP ---27	0256-- 0 ---00
0159-- DN ---25	0208-- INT ---64	0257-- UP ---27
0160-- K ---55	0209-- - ---34	0258-- 1 ---01
0161-- 4 ---04	0210-- UP ---27	0259-- 6 ---06
0162-- XTQ ---23	0211-- EEX ---26	0260-- X ---36
0163-- 1 ---01	0212-- 7 ---07	0261-- 6 ---06
0164-- 8 ---10	0213-- DIV ---35	0262-- 1 ---01
0165-- a ---13	0214-- RUP ---22	0263-- + ---33
0166-- UP ---27	0215-- KEY ---30	0264-- YTO ---40
0167-- 2 ---02	0216-- XFR ---67	0265-- b ---14
0168-- X ---36	0217-- 1 ---01	0266-- DN ---25
0169-- 1 ---01	0218-- 8 ---10	0267-- YTO ---40
0170-- 9 ---11	0219-- X ---36	0268-- IND ---31
0171-- + ---33	0220-- X ---36	0269-- b ---14
0172-- YTO ---40	0221-- RUP ---22	0270-- GTO ---44
0173-- L ---14	0222-- KEY ---30	0271-- LBL ---51
0174-- XFR ---67	0223-- X ---36	0272-- H ---74
0175-- IND ---31	0224-- X ---36	0273-- LBL ---51
0176-- b ---14	0225-- X ---36	0274-- F ---16
0177-- UP ---27	0226-- DN ---25	0275-- 6 ---06
0178-- INT ---64	0227-- + ---33	0276-- 2 ---02
0179-- - ---34	0228-- YE ---24	0277-- KEY ---30
0180-- UP ---27	0229-- + ---33	0278-- 1 ---01
0181-- EEX ---26	0230-- 7 ---07	0279-- 6 ---06
0182-- 5 ---05	0231-- 1 ---01	0280-- XFR ---67
0183-- DIV ---35	0232-- DN ---25	0281-- X ---36
0184-- DN ---25	0233-- K ---55	0282-- 0 ---00
0185-- KEY ---30	0234-- 5 ---05	0283-- + ---33
0186-- UP ---27	0235-- UP ---27	0284-- YTO ---40
0187-- 1 ---01	0236-- 1 ---01	0285-- 1 ---01
0188-- 0 ---00	0237-- 5 ---05	0286-- 9 ---11
0189-- X ---36	0238-- UP ---27	0287-- DN ---25
0190-- XFR ---67	0239-- a ---13	0288-- YE ---24
0191-- 1 ---01	0240-- X>Y ---52	0289-- IND ---31
0192-- 8 ---10	0241-- GTO ---44	0290-- X ---36
0193-- X ---36	0242-- LBL ---51	0291-- a ---13
0194-- DN ---25	0243-- F ---16	0292-- XFR ---67
0195-- + ---33	0244-- CNT ---47	0293-- 1 ---01

Table 27 HP 9810A 741 Interference Program (cont)

0294-- 7 ---07	0343-- 1 ---75	0392-- INT---31
0295-- UP---27	0344-- SFL---54	0393-- a ---13
0296-- a ---13	0345-- DN---25	0394-- CHS---32
0297-- X=Y---50	0346-- YE---24	0395-- UP---27
0298-- RUP---22	0347-- IND---31	0396-- 1 ---01
0299-- GTO---44	0348-- - ---34	0397-- D ---63
0300-- LBL---51	0349-- 1 ---01	0398-- XFR---67
0301-- G ---15	0350-- 9 ---11	0399-- INT---31
0302-- RUP---22	0351-- LBL---51	0400-- a ---13
0303-- GTO---44	0352-- J ---75	0401-- - ---33
0304-- LBL---51	0353-- 1 ---01	0402-- - ---40
0305-- N ---73	0354-- XTO---23	0403-- INT---31
0306-- LBL---51	0355-- + ---33	0404-- a ---13
0307-- G ---15	0356-- 1 ---01	0405-- XEY---30
0308-- XFR---67	0357-- 9 ---11	0406-- DIV---35
0309-- DIV---35	0358-- YTO---40	0407-- FMT---42
0310-- 1 ---01	0359-- IND---31	0408-- FMT---42
0311-- 6 ---06	0360-- 1 ---01	0409-- a ---56
0312-- LBL---51	0361-- 9 ---11	0410-- CLR---20
0313-- N ---73	0362-- GTO---44	0411-- INT---64
0314-- XTO---23	0363-- LBL---51	0412-- FMT---42
0315-- IND---31	0364-- H ---74	0413-- PNT---45
0316-- + ---33	0365-- LBL---51	0414-- DN---25
0317-- 1 ---01	0366-- K ---55	0415-- K ---55
0318-- 9 ---11	0367-- XFR---67	0416-- 4 ---04
0319-- LBL---51	0368-- 5 ---05	0417-- UP---27
0320-- H ---74	0369-- 1 ---01	0418-- 1 ---01
0321-- 1 ---01	0370-- FMT---42	0419-- 0 ---00
0322-- E ---60	0371-- 4 ---04	0420-- X ---36
0323-- GTO---44	0372-- 2 ---02	0421-- 1 ---01
0324-- LBL---51	0373-- XTO---23	0422-- E ---60
0325-- D ---63	0374-- FMT---42	0423-- YTO---40
0326-- LBL---51	0375-- 4 ---04	0424-- IND---31
0327-- I ---65	0376-- 1 ---01	0425-- a ---13
0328-- 2 ---02	0377-- FMT---42	0426-- 1 ---01
0329-- 9 ---11	0378-- SFL---54	0427-- E ---60
0330-- XEY---30	0379-- FMT---42	0428-- XFR---67
0331-- a ---13	0380-- 1 ---01	0429-- IND---31
0332-- X>Y---53	0381-- 6 ---06	0430-- a ---13
0333-- GTO---44	0382-- UP---27	0431-- PNT---45
0334-- LBL---51	0383-- XFR---67	0432-- 1 ---01
0335-- K ---55	0384-- 0 ---00	0433-- XTO---23
0336-- CNT---47	0385-- X ---36	0434-- + ---31
0337-- PSE---57	0386-- 6 ---06	0435-- 0 ---00
0338-- PSE---57	0387-- 2 ---02	0436-- XTO---23
0339-- IFG---43	0388-- + ---33	0437-- + ---33
0340-- DN---25	0389-- YTO---40	0438-- 2 ---02
0341-- GTO---44	0390-- a ---13	0439-- 1 ---00
0342-- LBL---51	0391-- XFR---67	0440-- - ---67

Table 27 HP 9810A 741 Interference Program (cont)

0441-- 0 ---00	0471-- --02
0442-- UP---27	0472-- 0 --00
0443-- 3 ---03	0473--X=Y---50
0444--X>Y---53	0474--GTO---44
0445--GTO---44	0475--LBL---51
0446--LBL---51	0476-- 0 ---56
0447-- C. ---61	0477--CNT---47
0448--CNT---47	0478--GTO---44
0449--FMT---42	0479--LBL---51
0450-- 5 ---05	0480-- R ---62
0451--EEX---26	0481--LBL---51
0452--FMT---42	0482-- 0 ---13
0453--FMT---42	0483--XFR---67
0454-- 0 ---13	0484-- 5 ---05
0455-- E ---60	0485-- 1 ---01
0456-- C ---61	0486--FMT---42
0457--FMT---42	0487-- 4 ---04
0458--STP---41	0488-- 2 ---00
0459-- 3 ---03	0489--XTO---23
0460-- 3 ---03	0490--FMT---42
0461-- UP---27	0491--FMT---42
0462-- 7 ---07	0492-- R ---62
0463-- 6 ---06	0493-- N ---70
0464--FMT---42	0494-- 0 ---50
0465-- 5 ---05	0495--FMT---42
0466--XTO---23	0496--STP---41
0467-- 2 ---02	0497--S/R---77
0468-- 1 ---01	0498--END---46
0469-- UP---27	
0470--XFR---67	

Table 28 Register Allocation For Revised 741 HP 9810A Program

a	CHANNEL COUNTER	
b	SCRATCH AND INDIRECT	
0	FREQUENCY, POWER COUNTER FOR DUMPING TO CASSETTE	
1	LOSS FOR PORT 1	
2		2
3		3
4		4
5		5
6		6
7		7
8		8
9		9
10		10
11		11
12		12
13		13
14		14
15	INCIDENT POWER COUPLER COEFFICIENT	
16	REFLECTED POWER COUPLER COEFFICIENT	
17	INPUT PORT	
18	LOG V	
19	CAL. FACTOR ADDRESS, V & I ADDRESSES	
20	POWER COUNTER FOR PIN MODULATOR	
21	DETECTOR COEFFICIENTS - B_0 & B_1 - DETECTOR # 1	
22	B_2 & B_3 DETECTOR 1	
23	B_0 & B_1 DETECTOR 2	
24	B_2 & B_3 DETECTOR 2	

Table 28 (cont)

25	DETECTOR COEFFICIENTS - B_0 & B_1 -	DETECTOR #
26	B_2 & B_3	3
27	B_0 & B_1	4
28	B_2 & B_3	4
29	B_0 & B_1	5
30	B_2 & B_3	5
31	B_0 & B_1	6
32	B_2 & B_3	6
33	B_0 & B_1	7
34	B_2 & B_3	7
35	B_0 & B_1	8
36	B_2 & B_3	8
37	B_0 & B_1	9
38	B_2 & B_3	9
39	B_0 & B_1	10
40	B_2 & B_3	10
41	B_0 & B_1	11
42	B_2 & B_3	11
43	B_0 & B_1	12
44	B_2 & B_3	12
45	B_0 & B_1	13
46	B_2 & B_3	13
47	B_0 & B_1	14
48	B_2 & B_3	14
49	B_0 & B_1	15

INTEGRATED CIRCUIT SUSCEPTIBILITY

Table 28 (cont)

50	DETECTOR COEFFICIENTS - B_2 & B_3 - DETECTOR # 15
51	VOLTAGE FOR PIN MODULATOR FOR POWER STEP # 1
52	2
53	3
54	4
55	5
56	6
57	7
58	8
59	9
60	10
61	11
62	12
63	13
64	14
65	15
66	16
67	17
68	18
69	19
70	20
71	TEMPORARY STORAGE FOR CALCULATING P
72	SPARE
73	POWER STEP TO ADD LARGE AMPLIFIER
74	SPARE
75	SPARE
76	S/N
77	P_{IN}
78	CAL FACTOR
79	V_{OUT}
80	$V_{OUT} - V'_{OUT}$
81	V_{NI}
82	$V_{NI} - V'_{NI}$
83	$V_{ON \#2}$
84	$V_{ON \#2} - V'_{ON \#2}$
85	$V_{ON \#6}$

INTEGRATED CIRCUIT SUSCEPTIBILITY

MDC E1099
12 JULY 1974

Table 28 (cont)

86	$V_{ON \#6} - V'_{ON \#6}$
87	V_{CC+}
88	$V_{CC+} - V'_{CC+}$
89	V_{CC-}
90	$V_{CC-} - V'_{CC-}$
91	V_{II}
92	$V_{II} - V'_{II}$
93	P_{IN}
94	CAL FACTOR
95	V_{OUT}
96	$V_{OUT} - V'_{OUT}$
97	V_{NI}
98	$V_{NI} - V'_{NI}$
99	$V_{ON \#2}$
100	$V_{ON \#2} - V'_{ON \#2}$
101	$V_{ON \#6}$
102	$V_{ON \#6} - V'_{ON \#6}$
103	V_{CC+}
104	$V_{CC+} - V'_{CC+}$
105	V_{CC-}
106	$V_{CC-} - V'_{CC-}$
107	V_{II}
108	$V_{II} - V'_{II}$

Table 29 HP 9830A Program to Convert from Data to Matrix Tapes for 741

```

10 COM FS[20,16],A
20 REM REV. PROG. TO CONVERT FROM DATA TO MATRIX TAPE FOR 741
30 DIM C[37]
40 DISP "FIRST MATRIX TAPE FILE #";
50 INPUT Q
60 DISP "FIRST FILE #";
70 INPUT M
80 FOR I=0 TO 9
90 LOAD DATA M+I,C
100 IF I>0 THEN 120
110 A=C[1]
120 IF A#C[1] THEN 630
130 FOR J=1 TO 2
140 FOR K=1 TO 16
150 IF J+2*I#1 THEN 170
160 IF K=2 THEN 190
170 F[J+2*I,K]=C[K+1+16*(J-1)]
180 GO TO 200
190 F[J+2*I,2]=0
200 NEXT K
210 NEXT J
220 NEXT I
230 R2=5000
240 FOR I=1 TO 20
250 F[I,4]=F[I,4]*2
260 F[I,6]=F[I,6]*10/9.1
270 F[I,8]=F[I,8]*1000/R2
280 F[I,10]=F[I,10]*1000/R2
290 F[I,12]=F[I,12]*100
300 F[I,14]=F[I,14]*100
310 NEXT I
320 PRINT
330 PRINT

```

Table 29 HP 9830A Program to Convert from Data to Matrix Tape for 741 (cont)

```

340 PRINT
350 PRINT
360 WRITE (15,370)A
370 FORMAT 30X,"S/N =",F7.0
380 PRINT
390 PRINT
400 FORMAT " P(MW) C.F.(DB) VNI INI",F4.0
410 WRITE (15,400)" VON2 ION2 WOUT IOUT VNI INI",F4.0
420 FOR I=1 TO 20
430 WRITE (15,440)F[I,1],F[I,2],F[I,3],F[I,4],F[I,5],F[I,6],F[I,7],F[I,8],F[I,9]
440 FORMAT 5X,F9.4,F9.3,F8.3,F8.2,F7.2,F8.4,F8.2,F8.4,F8.2
450 NEXT I
460 PRINT
470 PRINT
480 PRINT
490 PRINT
500 FORMAT " P(MW) ION6 VCC+ IOC+ VCC-",F4.0
510 WRITE (15,500)" IOC- VII III"
520 FOR I=1 TO 20
530 WRITE (15,550)F[I,1],F[I,10],F[I,11],F[I,12],F[I,13],F[I,14],F[I,15],F[I,16]
540 NEXT I
550 FORMAT 5X,2F9.4,F7.2,3F8.2,F9.4,F8.4
560 FOR I=1 TO 12
570 PRINT
580 NEXT I
590 STORE DATA #5,Q
600 Q=Q+1
610 M=M+10
620 GO TO 80
630 DISP "S/N NOT ="A;C[1]
640 STOP
650 END

```

Table 30 741 Interference Data Plot Program from Matrix Tape (HP 9830A)

```
10 COM FS[20,16],A
20 REM PROGRAM TO PLOT 741 DATA FROM MATRIX TAPE
30 DISP "DATA COLUMN #";
40 INPUT Y
50 DISP "FIRST MATRIX FILE #";
60 INPUT X
70 DISP "YMIN,YMAX";
80 INPUT N,M
90 DISP "PLACE PAPER-PLATEN; CONT & EXEC"
100 STOP
110 SCALE 0,11,0,7.5
120 OFFSET 2.5,1.5
130 XAXIS 0,1.4,0,7
140 YAXIS 0,0.5,0,5
150 LABEL (*,2,3.4,PI/2,5/7)
160 FOR J=0 TO 4
170 PLOT (LGT(2)+J)*1.4,0,1
180 CPLOT 0,-0.3
190 LABEL (*)"-";
200 PLOT (LGT(5)+J)*1.4,0,1
210 CPLOT 0,-0.3
220 LABEL (*)"-";
230 NEXT J
240 FOR I=1 TO 5
250 PLOT I*1.4,0,1
260 PLOT I*1.4,5,2
270 NEXT I
280 FOR I=1 TO 10
290 PLOT 0,I*0.5,1
300 PLOT 7,I*0.5,2
310 NEXT I
320 SCALE -53/14,57/14,N-1.5*(M-N)/5,N+6*(M-N)/5
330 FOR I=-2 TO 3
340 LABEL (*,1.5,1.7,0,5/7)
350 PLOT I,N,1
360 CPLOT -2,-2
370 LABEL (410,1.5,1.7,0,5/7)10;
380 CPLOT 0,0.6
390 LABEL (420,1.125,1.7,0,5/7)I;
400 NEXT I
410 FORMAT F3.0
420 FORMAT F2.0
430 LABEL (*,1.5,1.7,0,5/7)
440 J=(M-N)/5
450 FOR I=0 TO 5
460 PLOT -2,N+J*I,1
470 CPLOT -9,-0.3
480 LABEL (500)N+J*I;
```

Table 30

741 Interference Data Plot Program from Matrix Tape (HP 9830A)
(cont)

```
490 NEXT I
500 FORMAT F6.2
510 FOR K=1 TO 10
520 LOAD DATA X
530 LABEL (*,1,0.8,0.5/7)
540 PLOT -2.07,F[1,Y],1
550 CPLOT -0.3,-0.3
560 LABEL (*)"X"
570 FOR I=2 TO 20
580 IF LGT(F[I,1])>-2 THEN 600
590 F[I,1]=0.01
600 PLOT LGT(F[I,1]),F[I,Y],1
610 CPLOT -0.3,-0.3
620 LABEL (*)"*";
630 NEXT I
640 X=X+1
650 NEXT K
660 PLOT 0.2,M-1.7*(M-N)/10,1
670 LABEL (*)A
680 GOTO 90
690 END
```

Table 31

4011 Interference Test Program (HP 9810A)

0000--FMT---42		
0001--XFR---67		
0002--XFR---67		
0003-- 0 ---00		
0004--PNT---45		
0005--LBL---51		
0006-- A ---62		
0007-- 1 ---01		
0008--XTO---23		
0009-- 2 ---02		
0010-- 0 ---00		
0011--XFR---67		
0012-- 5 ---05		
0013-- 5 ---05		
0014--FMT---42		
0015-- 4 ---04		
0016-- 2 ---02		
0017--XTO---23		
0018--FMT---42		
0019--FMT---42		
0020--YTO---40		
0021--DIV---35		
0022-- N ---73		
0023--FMT---42		
0024--STP---41		
0025--XTO---23		
0026-- 8 ---10		
0027-- 6 ---06		
0028--PNT---45		
0029-- UP---27		
0030--EEX---26		
0031-- 3 ---03		
0032--DIV---35		
0033-- DN---25		
0034-- UP---27		
0035--INT---64		
0036-- - ---34		
0037-- 1 ---01		
0038-- 0 ---00		
0039-- X ---36		
0040-- DN---25		
0041--INT---64		
0042-- UP---27		
0043-- 4 ---04		
0044--X=Y---50		
0045-- 1 ---01		
0046-- 6 ---06		
0047-- UP---27		
0048--CNT---47		
0049--YTO---40		
0050-- 1 ---01		
0051-- 3 ---11		
0052--LBL---51		
0053-- B ---66		
0054--FMT---42		
0055-- 4 ---04		
0056-- 1 ---01		
0057--FMT---42		
0058--SFL---54		
0059--FMT---42		
0060--PSE---57		
0061--CLX---37		
0062--XTO---23		
0063-- 8 ---10		
0064-- 9 ---11		
0065--XTO---23		
0066-- 1 ---01		
0067-- 0 ---00		
0068-- 0 ---00		
0069--PSE---57		
0070-- 1 ---01		
0071--XTO---23		
0072-- 0 ---00		
0073--LBL---51		
0074-- C ---61		
0075--FMT---42		
0076-- 4 ---04		
0077-- 1 ---01		
0078--FMT---42		
0079-- 1 ---01		
0080--FMT---42		
0081--XFR---67		
0082-- 7 ---07		
0083-- 5 ---05		
0084-- UP---27		
0085--XFR---67		
0086-- 2 ---02		
0087-- 0 ---00		
0088--X=Y---50		
0089--GTO---44		
0090--S/R---77		
0091--LBL---51		
0092-- L ---72		
0093-- 5 ---05		
0094-- 4 ---04		
0095--XFR---67		
0096-- + ---33		
0097-- 2 ---02		
0098-- 0 ---00		
0099--XTO---23		
0100-- 6 ---14		
0101--XFR---67		
0102--IND---31		
0103-- b ---14		
0104--FMT---42		
0105-- 4 ---04		
0106-- 2 ---02		
0107--XTO---23		
0108--PSE---57		
0109--PSE---57		
0110--PSE---57		
0111-- 1 ---01		
0112--XTO---23		
0113-- a ---13		
0114--LBL---51		
0115-- D ---63		
0116--FMT---42		
0117-- 3 ---03		
0118-- 3 ---03		
0119-- . ---21		
0120-- UP---27		
0121--FMT---42		
0122-- 4 ---04		
0123-- 1 ---01		
0124--FMT---42		
0125-- 1 ---01		
0126--FMT---42		
0127-- a ---13		
0128-- UP---27		
0129--XFR---67		
0130-- 1 ---01		
0131-- 9 ---11		
0132--X=Y---50		
0133-- DN---25		
0134--GTO---44		
0135--LBL---51		
0136-- E ---60		
0137-- 1 ---01		
0138-- 7 ---07		
0139--XEY---30		
0140--X>Y---53		
0141--GTO---44		
0142--LBL---51		
0143-- J ---75		
0144--CNT---47		
0145-- DN---25		
0146-- G ---15		
0147--EEX---26		
0148--CHS---32		
0149-- 3 ---03		
0150--X>Y---53		

Table 31 4011 Interference Test Program (HP 9810A)(cont)

0151--CLX---37	0201-- b ---14	0251-- 1 ---01
0152--XEY---30	0202--XFR---67	0252-- 9 ---11
0153--CNT---47	0203--IND---31	0253--XFR---67
0154--CNT---47	0204-- b ---14	0254-- 0 ---00
0155--LBL---51	0205-- UP---27	0255-- UP---27
0156-- E ---60	0206--INT---64	0256-- 1 ---01
0157-- DN---25	0207-- - ---34	0257-- 1 ---01
0158-- K ---55	0208-- UP---27	0258-- X ---36
0159-- 4 ---04	0209--EEX---26	0259-- 7 ---07
0160--XTO---23	0210-- 7 ---07	0260-- 6 ---06
0161-- 7 ---07	0211--DIV---35	0261-- + ---33
0162-- 7 ---07	0212--RUP---22	0262--YTO---40
0163-- a ---13	0213--XEY---30	0263-- b ---14
0164-- UP---27	0214--XFR---67	0264-- DN---25
0165-- 2 ---02	0215-- 7 ---07	0265--YTO---40
0166-- X ---36	0216-- 7 ---07	0266--IND---31
0167-- 1 ---01	0217-- X ---36	0267-- b ---14
0168-- 9 ---11	0218-- X ---36	0268--GTO---44
0169-- + ---33	0219--RUP---22	0269--LBL---51
0170--YTO---40	0220--XEY---30	0270-- I ---65
0171-- b ---14	0221-- X ---36	0271--LBL---51
0172--XFR---67	0222-- X ---36	0272-- F ---16
0173--IND---31	0223-- X ---36	0273-- 7 ---07
0174-- b ---14	0224-- DN---25	0274-- 8 ---10
0175-- UP---27	0225-- + ---33	0275--XEY---30
0176--INT---64	0226-- YE---24	0276-- 1 ---01
0177-- - ---34	0227-- + ---33	0277-- 1 ---01
0178-- UP---27	0228-- 7 ---07	0278--XFR---67
0179--EEX---26	0229-- 8 ---10	0279-- X ---36
0180-- 5 ---05	0230-- DN---25	0280-- 0 ---00
0181--DIV---35	0231-- K ---55	0281-- + ---33
0182-- DN---25	0232-- 5 ---05	0282--YTO---40
0183--XEY---30	0233-- UP---27	0283-- 7 ---07
0184-- UP---27	0234-- 1 ---01	0284-- 6 ---06
0185-- 1 ---01	0235-- 7 ---07	0285-- DN---25
0186-- 0 ---00	0236-- UP---27	0286-- YE---24
0187-- X ---36	0237-- a ---13	0287--IND---31
0188--XFR---67	0238--X<Y---52	0288-- X ---36
0189-- 7 ---07	0239--GTO---44	0289-- a ---13
0190-- 7 ---07	0240--LBL---51	0290--XFR---67
0191-- X ---36	0241-- F ---16	0291-- 1 ---01
0192-- DN---25	0242--CNT---47	0292-- 9 ---11
0193-- + ---33	0243-- DN---25	0293-- UP---27
0194--YTO---40	0244--XFR---67	0294-- a ---13
0195-- 7 ---07	0245-- 1 ---01	0295--X=Y---50
0196-- 8 ---10	0246-- 7 ---07	0296--RUP---22
0197--PSE---57	0247--DIV---35	0297--GTO---44
0198-- 1 ---01	0248-- YE---24	0298--LBL---51
0199--XTO---23	0249--IND---31	0299-- G ---15
0200-- + ---33	0250--DIV---35	0300--RUP---22

Table 21 4011 Interference Test Program (HP 9810A)(cont)

0301--GTO---44	0351--XTO---23	0401--IND---31
0302--LBL---51	0352-- + ---33	0402-- u ---13
0303-- H ---74	0353-- 7 ---07	0403--XEY---30
0304--LBL---51	0354-- 6 ---06	0404--DIV---35
0305-- G ---15	0355-- DN---25	0405--FMT---42
0306--XFR---67	0356--YTO---40	0406--FMT---42
0307--DIV---35	0357--IND---31	0407-- n ---56
0308-- 1 ---01	0358-- 7 ---07	0408--CLX---37
0309-- 8 ---10	0359-- 6 ---06	0409--INT---64
0310-- UP---27	0360--GTO---44	0410--FMT---42
0311-- 1 ---01	0361--LBL---51	0411--PNT---45
0312--CHS---32	0362-- I ---65	0412-- DN---25
0313--XFR---67	0363--LBL---51	0413-- K ---55
0314-- + ---33	0364-- K ---55	0414-- 4 ---04
0315-- 7 ---07	0365--XFR---67	0415-- UP---27
0316-- 6 ---06	0366-- 5 ---05	0416-- 1 ---01
0317--XTO---23	0367-- 5 ---05	0417-- 0 ---00
0318-- b ---14	0368--FMT---42	0418-- X ---36
0319-- DN---25	0369-- 4 ---04	0419-- 2 ---02
0320--XTO---23	0370-- 2 ---02	0420-- E ---60
0321--IND---31	0371--XTO---23	0421--YTO---40
0322-- b ---14	0372--FMT---42	0422--IND---31
0323--LBL---51	0373-- 4 ---04	0423-- a ---13
0324-- H ---74	0374-- 1 ---01	0424-- 4 ---04
0325--XTO---23	0375--FMT---42	0425-- E ---60
0326--IND---31	0376--SFL---54	0426--XFR---67
0327-- + ---33	0377--FMT---42	0427--IND---31
0328-- 7 ---07	0378-- 1 ---01	0428-- a ---13
0329-- 6 ---06	0379-- 1 ---01	0429--PNT---45
0330--LBL---51	0380-- UP---27	0430-- 1 ---01
0331-- I ---65	0381--XFR---67	0431--XTO---23
0332-- 1 ---01	0382-- 0 ---00	0432-- + ---33
0333-- E ---60	0383-- X ---36	0433-- 0 ---00
0334--GTO---44	0384-- 7 ---07	0434--XTO---23
0335--LBL---51	0385-- 8 ---10	0435-- + ---33
0336-- D ---63	0386-- + ---33	0436-- 2 ---02
0337--LBL---51	0387--YTO---40	0437-- 0 ---00
0338-- J ---75	0388-- a ---13	0438--XFR---67
0339-- 2 ---02	0389--XFR---67	0439-- 0 ---00
0340-- 5 ---05	0390--IND---31	0440-- UP---27
0341--XEY---30	0391-- a ---13	0441-- 3 ---03
0342-- a ---13	0392--CHS---32	0442--X>Y---53
0343--X>Y---53	0393-- UP---27	0443--GTO---44
0344--GTO---44	0394-- 2 ---02	0444--LBL---51
0345--LBL---51	0395-- D ---63	0445-- C ---61
0346-- K ---55	0396--XFR---67	0446--CNT---47
0347--CNT---47	0397--IND---31	0447--FMT---42
0348--PSE---57	0398-- a ---13	0448-- 5 ---05
0349--PSE---57	0399-- + ---33	0449--EEX---26
0350-- 1 ---01	0400--YTO---40	0450--FMT---42

Table 31 4011 Interference Test Program (HP 9810A)(cont)

0451--FMT---42
0452-- a ---13
0453-- E ---60
0454-- C ---61
0455--IFG---43
0456--FMT---42
0457--STP---41
0458-- 2 ---02
0459-- 3 ---03
0460-- UP---27
0461-- 8 ---10
0462-- 6 ---06
0463--FMT---42
0464-- 5 ---05
0465--XTO---23
0466-- 2 ---02
0467-- 1 ---01
0468-- UP---27
0469--XFR---67
0470-- 2 ---02
0471-- 0 ---00
0472--X=Y---50
0473--GTO---44
0474--LBL---51
0475-- R ---62
0476--CNT---47
0477--GTO---44
0478--LBL---51
0479-- B ---66
0480--LBL---51
0481-- L ---72
0482--XFR---67
0483-- 5 ---05
0484-- 5 ---05
0485--FMT---42
0486-- 4 ---04
0487-- 2 ---02
0488--XTO---23
0489--FMT---42
0490--FMT---42
0491-- R ---62
0492-- M ---70
0493-- n ---56
0494--FMT---42
0495--STP---41
0496--S/R---77
0497--END---46

Table 32 4011 Interference Test Program Register Allocations

a	CHANNEL COUNTER	
b	SCRATCH & INDIRECT	
0	FREQUENCY (GHz), COUNTER FOR DUMPING TO CASSETTE	
1	LOSS FOR PORT 1	
2		2
3		3
4		4
5		5
6		6
7		7
8		8
9		9
10		10
11		11
12		12
13		13
14		14
15		15
16		16
17	INCIDENT POWER COUPLER COEFFICIENT	
18	REFLECTED POWER COUPLER COEFFICIENT	
19	INPUT PORT	
20	POWER COUNTER FOR PIN MODULATOR	
21	DETECTOR COEFFICIENTS - B_0 & B_1 - DETECTOR # 1	
22	B_2 & B_3	1
23	B_0 & B_1	2
24	B_2 & B_3	2

Table 32 (cont)

25	DETECTOR COEFFICIENTS - B_0 & B_1 - DETECTOR # 3	
26	B_2 & B_3	3
27	B_0 & B_1	4
28	B_2 & B_3	4
29	B_0 & B_1	5
30	B_2 & B_3	5
31	B_0 & B_1	6
32	B_2 & B_3	6
33	B_0 & B_1	7
34	B_2 & B_3	7
35	B_0 & B_1	8
36	B_2 & B_3	8
37	B_0 & B_1	9
38	B_2 & B_3	9
39	B_0 & B_1	10
40	B_2 & B_3	10
41	B_0 & B_1	11
42	B_2 & B_3	11
43	B_0 & B_1	12
44	B_2 & B_3	12
45	B_0 & B_1	13
46	B_2 & B_3	13
47	B_0 & B_1	14
48	B_2 & B_3	14
49	B_0 & B_1	15
50	B_2 & B_3	15

Table 32 (cont)

51	DETECTOR COEFFICIENTS - B_0 & B_1 - DETECTOR #	16
52	B_2 & B_3	16
53	B_0 & B_1	17
54	B_2 & B_3	17
55	VOLTAGE FOR PIN MODULATOR STEP #	1 (No RF)
56		2
57		3
58		4
59		5
60		6
61		7
62		8
63		9
64		10
65		11
66		12
67		13
68		14
69		15
70		16
71		17
72		18
73		19
74		20
75	POWER STEP TO ADD LARGE AMPLIFIER	
76	CAL. FACTOR ADDRESS, V ADDRESSES	
77	LOG V	

Table 32 (cont)

78	TEMPORARY STORAGE FOR CALCULATING P
79	BIAS UNIT REFLECTION LOSS COEFFICIENT
80	SPARE
81	SPARE
82	SPARE
83	SPARE
84	SPARE
85	SPARE
86	S/H
87	P_{DISS}
88	P_{REF}
89	CAL. FACTOR
90	V_{DD}
91	V'_{DD}
92	V'_{OUT}
93	V_{OUT}
94	V_{SS}
95	V'_{IN}
96	V_{IN2}
97	V_{IN1}
98	P_{DISS}
99	P_{REF}
100	CAL. FACTOR
101	V_{DD}
102	V'_{DD}
103	V'_{OUT}

Table 32 (cont)

- 104 V_{OUT}
- 105 V_{SS}
- 106 V'_{IN}
- 107 V_{IN2}
- 108 V_{IN1}

Table 33 4011 Data Tape to Matrix Tape Conversion Program (HP 9830A)

```

10 COM FS[23,11],A
20 DIM C[23]
30 MAT F=ZER
40 DISP "FIRST FILE #, # OF FILES";
50 INPUT M,N
60 DISP "FIRST MATRIX FILE #";
70 INPUT Q
80 FOR I=0 TO N-1
90 LOAD DATA M+I,C
100 IF I>Q THEN 120
110 A=C[1]
120 IF A#C[1] THEN 480
130 FOR J=1 TO 2
140 FOR K=1 TO 11
150 IF C[K+1+9*(J-1)]<-1E+60 THEN 170
160 F[J+2*I,K]=C[K+1+11*(J-1)]
170 NEXT K
180 NEXT J
190 NEXT I
200 FOR I=1 TO 20
210 F[I,5]=(F[I,5]-F[I,4])*100
220 F[I,8]=(F[I,8])*(-100)
230 F[I,6]=F[I,6]-F[I,7]
240 F[I,9]=(F[I,9]-F[I,10])*2.5
250 NEXT I
260 PRINT
270 PRINT
280 PRINT
290 WRITE (15,300)A
300 FORMAT 30X,"S/N=",F7.0
310 PRINT
320 PRINT
330 FORMAT " PD(M) PR(M) CF(DB) VDD IDD IOUF VOUT ISS "

```

Table 33 4011 Data Tape to Matrix Tape Conversion Program (HP 9830A)(cont)

```

340 WRITE (15, 330) " IINRF VIN2 VIN1"
350 FOR I=1 TO 20
360 WRITE (15, 450) F[I, 1], F[I, 2], F[I, 3], F[I, 4], F[I, 5], F[I, 6], F[I, 7], F[I, 8],
370 WRITE (15, 460) F[I, 9], F[I, 10], F[I, 11]
380 NEXT I
390 PRINT
400 PRINT
410 PRINT
420 PRINT
430 PRINT
440 PRINT
450 FORMAT F9.3, F8.3, F6.2, 2F6.3, F7.3, F6.3, F6.2
460 FORMAT 3F7.3
470 GOTO 500
480 DISP "S/N NOT = "A;C[1]
490 STOP
500 DISP "CHANGE TO MATRIX TAPE";
510 STOP
520 STORE DATA Q
530 M=M+10
540 Q=Q+1
550 DISP "CHANGE TO DATA TAPE";
560 STOP
570 GOTO 80

```

Table 34 General Plot Program from Matrix Tape For 4011

```

10 COM FS[23,11],A
20 MAT F=ZER
30 DISP "FOR PLOT,WRITE COL# & PRESS EXEC";
40 INPUT K
50 DISP "FIRST MATRIX FILE NO.";
60 INPUT Q
70 SCALE 0,8.5,0,10
80 OFFSET 2,1.5
90 XAXIS 0,1.5,0,6
100 YAXIS 0,0.7,0,7
110 FOR J=0 TO 3
120 PLOT (LGT(2)+J)*1.5,0,1
130 LABEL (*,1,3.4,PI/2,7/6)
140 CPLOT 0,-0.3
150 LABEL (*)"-";
160 PLOT (LGT(5)+J)*1.5,0,1
170 CPLOT 0,-0.3
180 LABEL (*)"-";
190 NEXT J
200 DISP "YMIN,YMAX";
210 INPUT N,M
220 SCALE -7/3,10/3,N-1.5*(M-N)/7,N+8.5*(M-N)/7
230 FOR I=-1 TO 3
240 LABEL (*,1.5,1.7,0,7/6)
250 PLOT I,N,1
260 CPLOT -2,-2
270 LABEL (310,1.5,1.7,0,7/6)10;
280 CPLOT 0,0.6
290 LABEL (320,1.125,1.7,0,7/6)I;
300 NEXT I
310 FORMAT F3.0
320 FORMAT F2.0
330 LABEL (*,1.5,1.7,0,7/6)
340 A=(M-N)/5
350 FOR I=0 TO 5
360 PLOT -1,N+A*I,1
370 CPLOT -7,-0.3
380 LABEL (400)N+A*I;
390 NEXT I
400 FORMAT F7.3
410 LABEL (*,1,0.8,0,7/6)
420 FOR G=Q TO Q+4
430 LOAD DATA G
440 FOR I=1 TO 20
450 F[1,1]=0.1
460 PLOT LGT(F[I,1]),ABS(F[I,K]),1
470 CPLOT 0.3,-0.3

```

Table 34 General Plot Program from Matrix Tape for 4011 (cont)

```
480 LABEL (*) "*"
490 IPLOT 0,0,1
500 NEXT I
510 NEXT G
520 PEN
530 SCALE 0,8.5,0,10
540 OFFSET 2,1.5
550 FOR I=1 TO 4
560 PLOT I*1.5,0,1
570 PLOT I*1.5,7,2
580 NEXT I
590 FOR I=1 TO 10
600 PLOT 0,I*0.7,1
610 PLOT 6,I*0.7,2
620 NEXT I
630 PEN
640 GOTO 30
```

Table 35 2002 Hybrid Interference Test Program (HP 9810A)

0000--LLP---20	0051--FMT---42	0101--INT---42
0001--K---55	0052--4---04	0102--a---13
0002--CLX---37	0053--1---01	0103--UP---27
0003--FMT---42	0054--FMT---42	0104--XFR---67
0004--XFR---67	0055--SFL---54	0105--1---01
0005--XFR---67	0056--FMT---42	0106--9---11
0006--0---00	0057--CNT---47	0107--X=Y---50
0007--PNT---45	0058--FMT---42	0108--DN---25
0008--LBL---51	0059--FMT---42	0109--GTO---44
0009--R---62	0060--YTO---40	0110--LBL---51
0010--CNT---47	0061--E---60	0111--E---60
0011--1---01	0062--XTO---23	0112--1---01
0012--6---06	0063--CNT---47	0113--7---07
0013--XTO---23	0064--π---56	0114--XEY---30
0014--2---02	0065--0---71	0115--X>Y---53
0015--0---00	0066--IND---31	0116--GTO---44
0016--CNT---47	0067--E---60	0117--LBL---51
0017--1---01	0068--a---13	0118--J---75
0018--XTO---23	0069--FMT---42	0119--CNT---47
0019--0---00	0070--CNT---47	0120--DN---25
0020--FMT---42	0071--STP---41	0121--G---15
0021--FMT---42	0072--CLX---37	0122--EEX---26
0022--1---65	0073--XTO---23	0123--CHS---32
0023--N---73	0074--7---07	0124--3---03
0024--π---56	0075--5---05	0125--X>Y---53
0025--1/X---17	0076--PSE---57	0126--CLX---37
0026--XTO---23	0077--FMT---42	0127--XEY---30
0027--CNT---47	0078--4---04	0128--CNT---47
0028--π---56	0079--1---01	0129--CNT---47
0029--0---71	0080--FMT---42	0130--LBL---51
0030--a---13	0081--1---01	0131--E---60
0031--XTO---23	0082--FMT---42	0132--DN---25
0032--FMT---42	0083--PSE---57	0133--K---55
0033--STP---41	0084--PSE---57	0134--4---04
0034--XTO---23	0085--PSE---57	0135--XTO---23
0035--1---01	0086--1---01	0136--5---05
0036--9---11	0087--XTO---23	0137--7---07
0037--PNT---45	0088--a---13	0138--a---13
0038--FMT---42	0089--LBL---51	0139--UP---27
0039--FMT---42	0090--D---63	0140--2---02
0040--YTO---40	0091--FMT---42	0141--X---36
0041--DIV---35	0092--3---03	0142--1---01
0042--N---73	0093--3---03	0143--9---11
0043--FMT---42	0094--·---21	0144--+---33
0044--STP---41	0095--UP---27	0145--YTO---40
0045--XTO---23	0096--FMT---42	0146--b---14
0046--7---07	0097--4---04	0147--XFR---67
0047--3---03	0098--1---01	0148--IND---31
0048--PNT---45	0099--FMT---42	0149--b---14
0049--LBL---51	0100--1---01	0150--UP---27
0050--B---66		

Table 35 2002 Hybrid Interference Test Program (HP 9810A)(cont)

0151--INT---64	0201--YE---24	0251--RUP---22
0152-- - ---34	0202-- + ---33	0252--GTO---44
0153--UP---27	0203--5 ---05	0253--LBL---51
0154--EEX---26	0204--8 ---10	0254--H ---74
0155--5 ---05	0205--DN---25	0255--LBL---51
0156--DIV---35	0206--K ---55	0256--G ---15
0157--DN---25	0207--5 ---05	0257--XFR---67
0158--XEY---30	0208--UP---27	0258--DIV---35
0159--UP---27	0209--1 ---01	0259--1 ---01
0160--1 ---01	0210--7 ---07	0260--8 ---10
0161--0 ---00	0211--UP---27	0261--LBL---51
0162--X ---36	0212--a ---13	0262--H ---74
0163--XFR---67	0213--XKY---52	0263--UP---27
0164--5 ---05	0214--GTO---44	0264--7 ---07
0165--7 ---07	0215--LBL---51	0265--5 ---05
0166--X ---36	0216--F ---16	0266--XFR---67
0167--DN---25	0217--CNT---47	0267-- + ---33
0168-- + ---33	0218--DN---25	0268--a ---13
0169--YTO---40	0219--XFR---67	0269--XTO---23
0170--5 ---05	0220--1 ---01	0270--b ---14
0171--8 ---10	0221--7 ---07	0271--YTO---40
0172--PSE---57	0222--DIV---35	0272--IND---31
0173--1 ---01	0223--YE---24	0273--b ---14
0174--XTO---23	0224--IND---31	0274--YTO---40
0175-- + ---33	0225--DIV---35	0275-- + ---33
0176--b ---14	0226--1 ---01	0276--7 ---07
0177--XFR---67	0227--9 ---11	0277--5 ---05
0178--IND---31	0228--YTO---40	0278--LBL---51
0179--b ---14	0229--9 ---11	0279--I ---65
0180--UP---27	0230--2 ---02	0280--1 ---01
0181--INT---64	0231--GTO---44	0281--E ---60
0182-- - ---34	0232--LBL---51	0282--GTO---44
0183--UP---27	0233--I ---65	0283--LBL---51
0184--EEX---26	0234--LBL---51	0284--D ---60
0185--7 ---07	0235--F ---16	0285--LBL---51
0186--DIV---35	0236--DN---25	0286--J ---75
0187--RUP---22	0237--YE---24	0287--1 ---01
0188--XEY---30	0238--IND---31	0288--7 ---07
0189--XFR---67	0239--X ---36	0289--XFR---67
0190--5 ---05	0240--a ---13	0290-- + ---33
0191--7 ---07	0241--XFR---67	0291--2 ---02
0192--X ---36	0242--1 ---01	0292--0 ---00
0193--X ---36	0243--9 ---11	0293--XEY---30
0194--RUP---22	0244--UP---27	0294--a ---13
0195--XEY---30	0245--a ---13	0295--X>Y---52
0196--X ---36	0246--X=Y---50	0296--GTO---44
0197--X ---36	0247--RUP---22	0297--LBL---51
0198--X ---36	0248--GTO---44	0298--K ---55
0199--DN---25	0249--LBL---51	0299--CNT---47
0200-- + ---33	0250--G ---15	0300--PSE---57

Table 35 2002 Hybrid Interference Test Program (HP 9810A)(cont)

0301--PSE---57	0351-- 9 ---11	0401--EEX---26
0302-- 7 ---07	0352-- 6 ---06	0402-- 3 ---03
0303-- 5 ---05	0353--CNT---47	0403-- X ---36
0304--KEY---30	0354-- 9 ---11	0404--YTO---40
0305-- a ---13	0355-- 7 ---07	0405--IND---31
0306-- + ---33	0356--XTO---23	0406-- a ---13
0307--YTO---40	0357-- a ---13	0407-- 1 ---01
0308-- 6 ---14	0358--LBL---51	0408-- E ---60
0309-- DN---25	0359-- L ---72	0409-- YE---24
0310--YTO---40	0360--XFR---67	0410--IND---31
0311--IND---31	0361--IND---31	0411-- a ---13
0312-- 6 ---14	0362-- a ---13	0412--EEX---26
0313--GTO---44	0363-- UP---27	0413-- 3 ---03
0314--LBL---51	0364-- 1 ---01	0414-- X ---36
0315-- I ---65	0365-- E ---60	0415--YTO---40
0316--LBL---51	0366--XFR---67	0416--IND---31
0317-- K ---55	0367--IND---31	0417-- a ---13
0318--FMT---42	0368-- a ---13	0418-- 1 ---01
0319-- 4 ---04	0369--CNT---47	0419-- E ---60
0320-- 1 ---01	0370-- - ---34	0420-- YE---24
0321--FMT---42	0371-- 1 ---01	0421--IND---31
0322--SFL---54	0372-- 0 ---00	0422-- a ---13
0323--FMT---42	0373-- X ---36	0423--EEX---26
0324--XFR---67	0374--YTO---40	0424-- 3 ---03
0325-- 9 ---11	0375--IND---31	0425-- X ---36
0326-- 3 ---03	0376-- a ---13	0426--YTO---40
0327-- UP---27	0377-- 1 ---01	0427--IND---31
0328--XFR---67	0378-- E ---60	0428-- a ---13
0329-- 9 ---11	0379-- 1 ---01	0429--XFR---67
0330-- 4 ---04	0380-- 0 ---00	0430-- 7 ---07
0331-- - ---34	0381-- 5 ---05	0431-- 5 ---05
0332-- 2 ---02	0382-- UP---27	0432--CHS---32
0333-- 0 ---00	0383-- a ---13	0433-- UP---27
0334-- X ---36	0384--XKY---52	0434--XFR---67
0335--YTO---40	0385--GTO---44	0435-- 9 ---11
0336-- 9 ---11	0386--LBL---51	0436-- 2 ---02
0337-- 4 ---04	0387-- L ---72	0437-- + ---33
0338--XFR---67	0388--CNT---47	0438--YTO---40
0339-- 9 ---11	0389--CNT---47	0439-- 7 ---07
0340-- 5 ---05	0390--XFR---67	0440-- 4 ---04
0341-- UP---27	0391--IND---31	0441--KEY---30
0342--XFR---67	0392-- a ---13	0442--DIV---35
0343-- 9 ---11	0393-- UP---27	0443--FMT---42
0344-- 6 ---06	0394-- 1 ---01	0444--FMT---42
0345-- - ---34	0395-- E ---60	0445-- a ---56
0346-- 1 ---01	0396--XFR---67	0446--CLX---37
0347-- 0 ---00	0397--IND---31	0447--INT---64
0348-- 0 ---00	0398-- a ---13	0448--FMT---42
0349-- X ---36	0399--CNT---47	0449--PNT---45
0350--YTO---40	0400-- - ---34	0450-- DN---25

Table 35 2002 Hybrid Interference Test Program (HP 9810A)(cont)

0451--	H	---	55	0480--	UP	---	47
0452--	4	---	04	0481--	FMT	---	42
0453--	UP	---	27	0482--	STP	---	41
0454--	1	---	01	0483--	3	---	03
0455--	0	---	00	0484--	6	---	06
0456--	X	---	36	0485--	UP	---	27
0457--	YTO	---	40	0486--	7	---	07
0458--	7	---	07	0487--	3	---	03
0459--	5	---	05	0488--	FMT	---	42
0460--	XFR	---	67	0489--	5	---	05
0461--	9	---	11	0490--	XTO	---	23
0462--	3	---	03	0491--	1	---	01
0463--	PNT	---	45	0492--	XTO	---	23
0464--	XFR	---	67	0493--	+	---	33
0465--	1	---	01	0494--	0	---	00
0466--	0	---	00	0495--	XFR	---	67
0467--	6	---	06	0496--	0	---	00
0468--	UP	---	27	0497--	UP	---	27
0469--	FMT	---	42	0498--	9	---	11
0470--	5	---	05	0499--	X>Y	---	53
0471--	EEX	---	26	0500--	GTO	---	44
0472--	FMT	---	42	0501--	LBL	---	51
0473--	FMT	---	42	0502--	B	---	66
0474--	a	---	13	0503--	CNT	---	47
0475--	E	---	60	0504--	GTO	---	44
0476--	C	---	61	0505--	LBL	---	51
0477--	0	---	71	0506--	A	---	62
0478--	a	---	13	0507--	STP	---	41
0479--	D	---	63	0508--	END	---	46

Table 36 General Device and 2002 Interference Test Register Allocations

a	CHANNEL COUNTER	
b	SCRATCH AND INDIRECT	
0	FREQUENCY (GHz), INTERFERENCE LEVEL COUNTER	
1	LOSS FOR PORT 1	
2		2
3		3
4		4
5		5
6		6
7		7
8		8
9		9
10		10
11		11
12		12
13		13
14		14
15		15
16		16
17	INCIDENT POWER COUPLER COEFFICIENT	
18	REFLECTED POWER COUPLER COEFFICIENT	
19	INPUT PORT	
20	NUMBER OF DC PARAMETERS TO BE MONITORED	
21	DETECTOR COEFFICIENTS - B_0 & B_1 - DETECTOR #	1
22		B_2 & B_3 1
23		B_0 & B_1 2

Table 36 (cont)

24	DETECTOR COEFFICIENTS - B_2 & B_3 - DETECTOR #	2
25	B_0 & B_1	3
26	B_2 & B_3	3
27	B_0 & B_1	4
28	B_2 & B_3	4
29	B_0 & B_1	5
30	B_2 & B_3	5
31	B_0 & B_1	6
32	B_2 & B_3	6
33	B_0 & B_1	7
34	B_2 & B_3	7
35	B_0 & B_1	8
36	B_2 & B_3	8
37	B_0 & B_1	9
38	B_2 & B_3	9
39	B_0 & B_1	10
40	B_2 & B_3	10
41	B_0 & B_1	11
42	B_2 & B_3	11
43	B_0 & B_1	12
44	B_2 & B_3	12
45	B_0 & B_1	13
46	B_2 & B_3	13
47	B_0 & B_1	14
48	B_2 & B_3	14
49	B_0 & B_1	15

Table 36 (cont)

50	DETECTOR COEFFICIENTS - B_2 & B_3 - DETECTOR # 15	
51	B_0 & B_1	16
52	B_2 & B_3	16
53	B_0 & B_1	17
54	B_2 & B_3	17
55	LOSS WITH OLD HP BIAS UNIT A/D FIXTURE	
56	SPARE	
57	LOG V	
58	TEMPORARY STORAGE FOR CALCULATING P	
59	SPARE	
60	SPARE	
61	SPARE	
62	SPARE	
63	SPARE	
64	SPARE	
65	SPARE	
66	SPARE	
67	SPARE	
68	SPARE	
69	SPARE	
70	SPARE	
71	SPARE	
72	SPARE	
73	S/N	
74	P_{DISS}	
75	CAL. FACTOR	

Table 36 (cont)

76	P
	1
77	P
	2
78	P
	3
79	P
	4
80	P
	5
81	P
	6
82	P
	7
83	P
	8
84	P
	9
85	P
	10
86	P
	11
87	P
	12
88	P
	13
89	P
	14
90	P
	15
91	P
	16
92	P _{INC}
93	V _{OUT 1} (VOLTAGE MONITORED ON PRINTER) (V _{COLL} - 2002)
94	I _{OUT 1} (I _{COLL} - 2002)
95	V _{OUT 2} (V _{BASE} - 2002)
96	I _{OUT 2} (NOTHING - 2002)
97	V _{IN 1} (V _{IN 9} - 2002)
98	I _{IN 1} (I _{IN 1 + 2})
99	V _{IN 2} (V _{IN 1 + 2})
100	I _{IN 2} (I _{IN 1 + 2})
101	V _{IN 3}

INTEGRATED CIRCUIT SUSCEPTIBILITY

MDC E1099
12 JULY 1974

Table 36 (cont)

102	$I_{IN\ 3}$
103	$V_{IN\ 4}$
104	$I_{IN\ 4}$
105	V_{CC}
106	I_{CC}
107	I_{GND}
108	SPARE (I_{EMIT} ON 2002)

Table 37 2002 Hybrid Data Reduction Program (HP 9830A)

```

10 DIM A[8,36], C[36]
20 DISP "FILE #";
30 INPUT M
40 FOR K=0 TO 7
50 I=0
60 LOAD DATA M+K C
70 IF K#0 THEN 110
80 C[3]=0
90 S=C[1]
100 I=1
110 IF K#1 THEN 130
120 I=7
130 IF S#C[1] THEN 650
140 IF S#C[1] THEN 650
150 FOR J=1 TO 36
160 A[X+I, J]=C[J]
170 NEXT J
180 NEXT K
190 FOR J=1 TO 8
200 PRINT
210 NEXT J
220 WRITE (15,230)S
230 FORMAT 35X, "S/N =", F5.0
240 PRINT
250 FORMAT 4F13.4, F1.1
260 FOR I=0 TO 4 STEP 4
270 FORMAT F3.0, "RF LEVEL " F3.0, "RF LEVEL " F3.0, "RF LEVEL " F3.0, "RF LEVEL "
280 WRITE (15,270)"
290 PRINT
300 WRITE (15,250)"
310 WRITE (15,250)"
320 WRITE (15,250)"
330 PRINT
    P INC. " ,A[I+1,20],A[I+2,20],A[I+3,20],A[I+4,20]
    P DIS. " ,A[I+1,2],A[I+2,2],A[I+3,2],A[I+4,2]
    C.F. " ,A[I+1,3],A[I+2,3],A[I+3,3],A[I+4,3]
    PARAMETER " ,I+0,I+1,I+2,I+3

```

Table 37 2002 Hybrid Data Reduction Program (cont)

```

340 GOTO 410
350 FOR K=1 TO 16
360 FORMAT F5.0, 1X, 4F13.4, F1.1
370 WRITE (15, 360) "P", K, A[1, K+3], A[2, K+3], A[3, K+3], A[4, K+3]
380 NEXT K
390 WRITE (15, 250) "P INC. ", A[1, 20], A[2, 20], A[3, 20], A[4, 20]
400 PRINT
410 WRITE (15, 250) "V COLL ", A[1+1, 21], A[1+2, 21], A[1+3, 21], A[1+4, 21]
420 WRITE (15, 250) "I COLL ", A[1+1, 22], A[1+2, 22], A[1+3, 22], A[1+4, 22]
430 WRITE (15, 250) "V BASE ", A[1+1, 23], A[1+2, 23], A[1+3, 23], A[1+4, 23]
440 WRITE (15, 250) "I IN 9 ", A[1+1, 25], A[1+2, 25], A[1+3, 25], A[1+4, 25]
450 WRITE (15, 250) "I IN 9 ", A[1+1, 26], A[1+2, 26], A[1+3, 26], A[1+4, 26]
460 WRITE (15, 250) "I IN 1&2 ", A[1+1, 27], A[1+2, 27], A[1+3, 27], A[1+4, 27]
470 WRITE (15, 250) "I IN 1&2 ", A[1+1, 28], A[1+2, 28], A[1+3, 28], A[1+4, 28]
480 WRITE (15, 250) "I IN 3 ", A[1+1, 29], A[1+2, 29], A[1+3, 29], A[1+4, 29]
490 WRITE (15, 250) "I IN 3 ", A[1+1, 30], A[1+2, 30], A[1+3, 30], A[1+4, 30]
500 WRITE (15, 250) "I IN 4 ", A[1+1, 31], A[1+2, 31], A[1+3, 31], A[1+4, 31]
510 WRITE (15, 250) "I IN 4 ", A[1+1, 32], A[1+2, 32], A[1+3, 32], A[1+4, 32]
520 WRITE (15, 250) "I CC ", A[1+1, 33], A[1+2, 33], A[1+3, 33], A[1+4, 33]
530 WRITE (15, 250) "I CC ", A[1+1, 34], A[1+2, 34], A[1+3, 34], A[1+4, 34]
540 WRITE (15, 250) "I GND ", A[1+1, 35], A[1+2, 35], A[1+3, 35], A[1+4, 35]
550 WRITE (15, 250) "I ENIT ", A[1+1, 36], A[1+2, 36], A[1+3, 36], A[1+4, 36]
560 FOR K=1 TO 4
570 PRINT
580 NEXT K
590 NEXT I
600 FOR K=1 TO 8
610 PRINT
620 NEXT K
630 M=M+8
640 GOTO 40
650 DISP "S/N NOT =" ; S ; C[1]
660 STOP
670 END

```

Table 38 Extra Digital Device Interference Test Program (HP 9810A)

0000--CLP---20		
0001-- K ---55		
0002--CLX---37		
0003--FMT---42		
0004--XFR---67		
0005--XFR---67		
0006-- 0 ---00		
0007--PNT---45		
0008--LBL---51		
0009-- A ---62		
0010--CNT---47		
0011--CNT---47		
0012--CNT---47		
0013--CNT---47		
0014--CNT---47		
0015--CNT---47		
0016--CNT---47		
0017--CNT---47		
0018--CNT---47		
0019--CNT---47		
0020--CNT---47		
0021--CNT---47		
0022--CNT---47		
0023--CNT---47		
0024--CNT---47		
0025--CNT---47		
0026--CNT---47		
0027-- 1 ---01		
0028-- 6 ---06		
0029--XTO---23		
0030-- 2 ---02		
0031-- 0 ---00		
0032--CNT---47		
0033-- 1 ---01		
0034--XTO---23		
0035-- 0 ---00		
0036--FMT---42		
0037--FMT---42		
0038-- I ---65		
0039-- N ---73		
0040-- π ---56		
0041--1/X---17		
0042--XTO---23		
0043--CNT---47		
0044-- π ---56		
0045-- 0 ---71		
0046-- α ---13		
0047--XTO---23		
0048--FMT---42		
0049--STP---41		
0050--XTO---23		
0051-- 1 ---01		
0052-- 9 ---11		
0053--PNT---45		
0054--FMT---42		
0055--FMT---42		
0056--YTO---40		
0057--DIV---35		
0058-- N ---73		
0059--FMT---42		
0060--STP---41		
0061--XTO---23		
0062-- 7 ---07		
0063-- 3 ---03		
0064--PNT---45		
0065--LBL---51		
0066-- B ---66		
0067--FMT---42		
0068-- 4 ---04		
0069-- 1 ---01		
0070--FMT---42		
0071--SFL---54		
0072--FMT---42		
0073--CNT---47		
0074--FMT---42		
0075--FMT---42		
0076--YTO---40		
0077-- E ---60		
0078--XTO---23		
0079--CNT---47		
0080-- π ---56		
0081-- 0 ---71		
0082--IND---31		
0083-- E ---60		
0084-- α ---13		
0085--FMT---42		
0086--CNT---47		
0087--STP---41		
0088--CLX---37		
0089--XTO---23		
0090-- 7 ---07		
0091-- 5 ---05		
0092--PSE---57		
0093--FMT---42		
0094-- 4 ---04		
0095-- 1 ---01		
0096--FMT---42		
0097-- 1 ---01		
0098--FMT---42		
0099--PSE---57		
0100--PSE---57		
0101--PSE---57		
0102-- 1 ---01		
0103--XTO---23		
0104-- α ---13		
0105--LBL---51		
0106-- D ---63		
0107--FMT---42		
0108-- 3 ---03		
0109-- 3 ---03		
0110-- . ---21		
0111-- UP---27		
0112--FMT---42		
0113-- 4 ---04		
0114-- 1 ---01		
0115--FMT---42		
0116-- 1 ---01		
0117--FMT---42		
0118-- α ---13		
0119-- UP---27		
0120--XFR---67		
0121-- 1 ---01		
0122-- 9 ---11		
0123--X=Y---50		
0124-- DN---25		
0125--GTO---44		
0126--LBL---51		
0127-- E ---60		
0128-- 1 ---01		
0129-- 7 ---07		
0130--XEY---30		
0131--X>Y---53		
0132--GTO---44		
0133--LBL---51		
0134-- J ---75		
0135--CNT---47		
0136-- DN---25		
0137-- G ---15		
0138--EEX---26		
0139--CHS---32		
0140-- 3 ---03		
0141--X>Y---53		
0142--CLX---37		
0143--XEY---30		
0144--CNT---47		
0145--CNT---47		
0146--LBL---51		
0147-- E ---60		
0148-- DN---25		
0149-- K ---55		
0150-- 4 ---04		

Table 38 Extra Digital Device Interference Test Program (HP 9810A)(cont)

0151--XTO---23	0201-- 7 ---07	0251-- F ---16
0152-- 5 ---05	0202--DIV---35	0252-- DI---25
0153-- 7 ---07	0203--RUP---22	0253-- YE---24
0154-- a ---13	0204--XEY---30	0254--IND---31
0155-- UP---27	0205--XFR---67	0255-- X ---36
0156-- 2 ---02	0206-- 5 ---05	0256-- a ---13
0157-- X ---36	0207-- 7 ---07	0257--XFR---67
0158-- 1 ---01	0208-- X ---36	0258-- 1 ---01
0159-- 9 ---11	0209-- X ---36	0259-- 9 ---11
0160-- + ---33	0210--RUP---22	0260-- UP---27
0161--YTO---40	0211--XEY---30	0261-- a ---13
0162-- b ---14	0212-- X ---36	0262--X=Y---50
0163--XFR---67	0213-- X ---36	0263--RUP---22
0164--IND---31	0214-- X ---36	0264--GTO---44
0165-- b ---14	0215-- DN---25	0265--LBL---51
0166-- UP---27	0216-- + ---33	0266-- G ---15
0167--INT---64	0217-- YE---24	0267--RUP---22
0168-- - ---34	0218-- + ---33	0268--GTO---44
0169-- UP---27	0219-- 5 ---05	0269--LBL---51
0170--EEX---26	0220-- 8 ---10	0270-- H ---74
0171-- 5 ---05	0221-- DN---25	0271--LBL---51
0172--DIV---35	0222-- K ---55	0272-- G ---15
0173-- DN---25	0223-- 5 ---05	0273--XFR---67
0174--XEY---30	0224-- UP---27	0274--DIV---35
0175-- UP---27	0225-- 1 ---01	0275-- 1 ---01
0176-- 1 ---01	0226-- 7 ---07	0276-- 8 ---10
0177-- 0 ---00	0227-- UP---27	0277--LBL---51
0178-- X ---36	0228-- a ---13	0278-- H ---74
0179--XFR---67	0229--XKY---52	0279-- UP---27
0180-- 5 ---05	0230--GTO---44	0280-- 7 ---07
0181-- 7 ---07	0231--LBL---51	0281-- 5 ---05
0182-- X ---36	0232-- F ---16	0282--XFR---67
0183-- DN---25	0233--CNT---47	0283-- + ---33
0184-- + ---33	0234-- DN---25	0284-- a ---13
0185--YTO---40	0235--XFR---67	0285--XTO---23
0186-- 5 ---05	0236-- 1 ---01	0286-- b ---14
0187-- 8 ---10	0237-- 7 ---07	0287--YTO---40
0188--PSE---57	0238--DIV---35	0288--IND---31
0189-- 1 ---01	0239-- YE---24	0289-- b ---14
0190--XTO---23	0240--IND---31	0290--YTO---40
0191-- + ---33	0241--DIV---35	0291-- + ---33
0192-- b ---14	0242-- 1 ---01	0292-- 7 ---07
0193--XFR---67	0243-- 9 ---11	0293-- 5 ---05
0194--IND---31	0244--YTO---40	0294--LBL---51
0195-- b ---14	0245-- 9 ---11	0295-- I ---65
0196-- UP---27	0246-- 2 ---02	0296-- 1 ---01
0197--INT---64	0247--GTO---44	0297-- E ---60
0198-- - ---34	0248--LBL---51	0298--GTO---44
0199-- UP---27	0249-- I ---65	0299--LBL---51
0200--EEX---26	0250--LBL---51	0300-- D ---63

Table 38 Extra Digital Device Interference Test Program (HP 9810A)(cont)

0301--LDL---51	0351--E---60	0401--IND---40
0302--J---75	0352--YFF---67	0402--IND---31
0303--1---01	0353--IND---31	0403--a---13
0304--7---07	0354--a---13	0404--XFR---67
0305--XFR---67	0355--CNT,---47	0405--7---07
0306--+---33	0356-- - ---34	0406--5---05
0307--2---02	0357--1---01	0407--CHS---32
0308--0---00	0358--0---00	0408--UP---27
0309--XEY---30	0359--X---36	0409--XFR---67
0310--a---13	0360--YTO---40	0410--9---11
0311--X>Y---53	0361--IND---31	0411--2---02
0312--GTO---44	0362--a---13	0412--+---33
0313--LBL---51	0363--1---01	0413--YTO---40
0314--K---55	0364--E---60	0414--7---07
0315--CNT---47	0365--1---01	0415--4---04
0316--PSE---57	0366--0---00	0416--XEY---30
0317--PSE---57	0367--5---05	0417--DIV---35
0318--7---07	0368--UP---27	0418--FMT---42
0319--5---05	0369--a---13	0419--FMT---42
0320--XEY---30	0370--XCY---52	0420--n---56
0321--a---13	0371--GTO---44	0421--CLX---37
0322--+---33	0372--LBL---51	0422--INT---64
0323--YTO---40	0373--L---72	0423--FMT---42
0324--b---14	0374--CNT---47	0424--PNT---45
0325--DN---25	0375--CNT---47	0425--DN---25
0326--YTO---40	0376--XFR---67	0426--K---55
0327--IND---31	0377--IND---31	0427--4---04
0328--b---14	0378--a---13	0428--UP---27
0329--GTO---44	0379--UP---27	0429--1---01
0330--LBL---51	0380--1---01	0430--0---00
0331--I---65	0381--E---60	0431--X---36
0332--LBL---51	0382--XFR---67	0432--YTO---40
0333--K---55	0383--IND---31	0433--7---07
0334--FMT---42	0384--a---13	0434--5---05
0335--4---04	0385--CNT---47	0435--XFR---67
0336--1---01	0386-- - ---34	0436--9---11
0337--FMT---42	0387--EEX---26	0437--3---03
0338--SFL---54	0388--3---03	0438--PNT---45
0339--FMT---42	0389--X---36	0439--XFR---67
0340--9---11	0390--YTO---40	0440--1---01
0341--3---03	0391--IND---31	0441--0---00
0342--XTO---23	0392--a---13	0442--6---06
0343--a---13	0393--1---01	0443--UP---27
0344--LBL---51	0394--E---60	0444--FMT---42
0345--L---72	0395--YE---24	0445--5---05
0346--XFR---67	0396--IND---31	0446--EEX---26
0347--IND---31	0397--a---13	0447--FMT---42
0348--a---13	0398--EEX---26	0448--FMT---42
0349--UP---27	0399--3---03	0449--a---13
0350--1---01	0400--X---36	0450--E---60

Table 38 Extra Digital Device Interference Test Program (HP 9810A) (cont)

0451-- C ---61
0452-- 0 ---71
0453-- a ---13
0454-- D ---63
0455--CNT---47
0456--FMT---42
0457--STP---41
0458-- 3 ---03
0459-- 6 ---06
0460-- UP---27
0461-- 7 ---07
0462-- 3 ---03
0463--FMT---42
0464-- 5 ---05
0465--XTO---23
0466-- 1 ---01
0467--XTO---23
0468-- + ---33
0469-- 0 ---00
0470--XFR---67
0471-- 0 ---00
0472-- UP---27
0473-- 5 ---05
0474--X>Y---53
0475--GTO---44
0476--LBL---51
0477-- B ---66
0478--CNT---47
0479--GTO---44
0480--LBL---51
0481-- A ---62
0482--STP---41
0483--END ---46

Table 39 Extra Digital Device Data Reduction and Print

Line	Code	0 RF LEVEL	1 RF LEVEL	2 RF LEVEL	3 RF LEVEL
10	DIM	A[4,36], C[36]			
20	DISP	"FILE #";			
30	INPUT	I			
40	FOR	K=0 TO 3			
50	LOAD	DATA M+K, C			
60	FOR	J=1 TO 36			
70	IF	K#0 THEN 90			
80	C	[3]=0			
90	A	[K+1, J]=C[J]			
100	NEXT	J			
110	NEXT	K			
120	FOR	J=1 TO 12			
130	PRINT				
140	NEXT	J			
150	FORMAT	4F13.4, F1.1			
160	FORMAT	6X, "PARAMETER			
170	WRITE	(15, 160)			
180	PRINT				
190	WRITE	{15, 150} "			
200	WRITE	{15, 150} "			
210	WRITE	{15, 150} "			
220	PRINT				
230	FOR	K=1 TO 16			
240	FORMAT	F5.0, 1X, 4F13.4, F1.1			
250	WRITE	(15, 240) "			
260	NEXT	K			
270	WRITE	(15, 150) "			
280	PRINT				
290	WRITE	{15, 150} "			
300	WRITE	{15, 150} "			
310	WRITE	{15, 150} "			
320	WRITE	{15, 150} "			
330	WRITE	{15, 150} "			

S.N. "A[1,1], A[2,1], A[3,1], A[4,1]
P DIS. "A[1,2], A[2,2], A[3,2], A[4,2]
C.F. "A[1,3], A[2,3], A[3,3], A[4,3]

P INC. "A[1,20], A[2,20], A[3,20], A[4,20]

V OUT 1 "A[1,21], A[2,21], A[3,21], A[4,21]
I OUT 1 "A[1,22], A[2,22], A[3,22], A[4,22]
V OUT 2 "A[1,23], A[2,23], A[3,23], A[4,23]
I OUT 2 "A[1,24], A[2,24], A[3,24], A[4,24]
V IN 1 "A[1,25], A[2,25], A[3,25], A[4,25]

Table 39 Extra Digital Device Data Reduction and Print (cont)

I	IN	1	"	A	1,	26	,	A	2,	26	,	A	3,	26	,	A	4,	26
V	IN	2	"	A	1,	27	,	A	2,	27	,	A	3,	27	,	A	4,	27
I	IN	2	"	A	1,	28	,	A	2,	28	,	A	3,	28	,	A	4,	28
V	IN	3	"	A	1,	29	,	A	2,	29	,	A	3,	29	,	A	4,	29
I	IN	3	"	A	1,	30	,	A	2,	30	,	A	3,	30	,	A	4,	30
V	IN	4	"	A	1,	31	,	A	2,	31	,	A	3,	31	,	A	4,	31
I	IN	4	"	A	1,	32	,	A	2,	32	,	A	3,	32	,	A	4,	32
V	CC		"	A	1,	33	,	A	2,	33	,	A	3,	33	,	A	4,	33
I	CC		"	A	1,	34	,	A	2,	34	,	A	3,	34	,	A	4,	34
I	GND		"	A	1,	35	,	A	2,	35	,	A	3,	35	,	A	4,	35

```

340 WRITE (15,150)
350 WRITE (15,150)
360 WRITE (15,150)
370 WRITE (15,150)
380 WRITE (15,150)
390 WRITE (15,150)
400 WRITE (15,150)
410 WRITE (15,150)
420 WRITE (15,150)
430 WRITE (15,150)
440 FOR K=1 TO 17
450 PRINT
460 NEXT K
470 M=M+4
480 GOTO 40
490 END
    
```

DISTRIBUTION

Executive Office of the President
Office of Telecommunications Policy
Washington, D. C. 20504

ODDR&E
Assistant Director (E&PS)
Attn: Dr. George H. Heilmeier
Pentagon, Room 3D1079
Washington, D. C. 20301

Director, Defense Nuclear Agency
Attn: RAEV (Maj. W. Adams)
Washington, D. C. 20305

Chief of Naval Operations
Attn: OP-932
OP-932C
Washington, D. C. 20350

Chief of Naval Material
Attn: MAT-03423 (Lt. R. Birchfield)
PM7T
Washington, D. C. 20360

Headquarters, U. S. Air Force (RDPE)
Attn: Lt. Col. A. J. Bills
The Pentagon, Room 4D267
Washington, D. C. 20330

Commanding General, U. S. Army Electronics Command
Attn: AMSEL-TL-I (R. A. Gerhold)
NL-C (J. O'Neil)
Ft. Monmouth, New Jersey 07703

Commander, Naval Air Systems Command
Attn: AIR-360G (A. D. Klein)
Washington, D. C. 20360

Commander, Naval Electronic Systems Command
Attn: NAVELEX-095
NAVELEX-3041 (J. A. Cauffman)
NAVELEX-3044 (Navy Member: Advisory Group on Electron Devices,
Working Group on Low Power Devices)
NAVELEX-3108 (D. G. Sweet)
NAVELEX-5032 (C. W. Neill)
Washington, D. C. 20360

Commander, Naval Sea Systems Command
Attn: SEA-034
SEA-0341
SEA-06G
Washington, D. C. 20360

INTEGRATED CIRCUIT SUSCEPTIBILITY

MDC E1099
12 JULY 1974

Department of the Navy
Attn: Code 7624 (J. Ramsey)
Naval Ammunition Depot
Crane, Indiana 47522

Commander, Naval Electronics System Test and
Evaluation Facility
Attn: M. Gullberg
Webster Field
St. Inigoes, Maryland 20684

Naval Post Graduate School
Attn: Code AB (Dr. R. Adler)
Monterey, California 93940

National Bureau of Standards
Attn: J. French
H. Schafft
Washington, D. C. 20234

Dr. James Whalen, Room 2B
4232 Ridge Lea Road
State University of New York at Buffalo
Amherst, New York 14226

The Rand Corporation
Attn: A. L. Hiebert
1700 Main St.
Santa Monica, California 90406

Fairchild Research and Development
Attn: Dr. J. M. Early
M/S 30-0200
4001 Miranda Ave.
Palo Alto, California 94303

RCA Laboratories
Director, Solid State Technology Center
Attn: Dr. G. B. Herzog
Princeton, New Jersey 08540

Mr. J. S. Kilby
5924 Royal Lane
Suite 150
Dallas, Texas 75230

Dr. Gordon E. Moore, V.P.
Intel Corp.
3065 Bowers Road
Santa Clara, California 95051

INTEGRATED CIRCUIT SUSCEPTIBILITY

MDC E1099
12 JULY 1974

Commander, Rome Air Development Center
Attn: RB (J. Scherer)
RBC1 (J. Smith)
RCCT (H. Hewitt)
Griffiss Air Force Base
New York 13440

Commander, Air Force Avionics Laboratory
Attn: AFAL/TEA (H. H. Steenbergen)
Wright-Patterson A.F.B., Ohio 45433

Director, Avionics Engineering
Attn: EA (C. Seth)
Wright-Patterson A.F.B.
Dayton, Ohio 45433

Commander, Kirtland Air Force Base
Attn: AFWL/DYX (Dr. D. C. Wunsch)
New Mexico 87117

Commanding Officer, Harry Diamond Laboratory
Attn: J. Sweton
W. L. Vault
H. Dropkin
Washington, D. C. 20438

Commander, Naval Electronics Laboratory Center
Attn: Code 4800 (Dr. D. W. McQuitty)
(A. R. Hart)
San Diego, California 92152

Commander, Naval Ordnance Laboratory
Attn: Code 431 (Dr. M. Petree)
(Dr. J. Malloy)
(R. Haislmaier)

White Oak
Silver Spring, Maryland 20910

Commander, Naval Weapons Center
Attn: Code 5531 (D. Cobb)
Code 5535 (H. R. Blecha)
China Lake, California 93555

Reliability Analysis Center
Rome Air Development Center
Attn: RBRAC (I. Krulac)
Griffiss Air Force Base, New York 13441

Commanding Officer, Electromagnetic Compatibility
Analysis Center (ECAC)
Attn: CDR Case
J. Atkinson
North Severn
Annapolis, Maryland 21402

INTEGRATED CIRCUIT SUSCEPTIBILITY

**MDC E1099
12 JULY 1974**

Bell Telephone Laboratories
Attn: Dr. G. E. Smith
Unipolar Design Department
600 Mountain Avenue
Murray Hill, New Jersey 07974

Automation Industries
Vitro Laboratories Division
Attn: T. H. Miller
14000 Georgia Ave.
Silver Springs, Maryland 20910

Braddock, Dunn, and McDonald, Inc.
Attn: J. Schwartz
First National Bank-East (17th Floor)
Albuquerque, New Mexico 87108

R&D Associates
Attn: Dr. W. Graham
P. O. Box 3480
Santa Monica, California 90406

Illinois Institute of Technology Research Institute
Attn: Dr. Weber
10 West 35th St.
Chicago, Illinois 60616

Research Triangle Institute
Attn: Dr. M. Simons
Dr. Burger
Research Triangle Park,
North Carolina 27709

Defense Documentation Center
Cameron Station
Alexandria, Virginia 22314

Secretariat, Advisory Group on Electron Devices
Attn: W. Kramer, Working Group B
201 Varick St.
New York, New York 10014

LOCAL DISTRIBUTION

C

D

E

EPA/Hooker

F

FC

FE

FG

FV

FVE

FVN

FVR

G

GB

GBP

GBR

MIL

MIM

RELATED DOCUMENTS

1. MDC E0595, "Integrated Circuit Electromagnetic Susceptibility Investigation - Study Phase Report " dated 5 May 1972.
2. MDC E0690, "Integrated Circuit Electromagnetic Susceptibility Investigation - Development Phase Report" dated 19 October 1972.
3. MDC E0883, "Integrated Circuit Electromagnetic Susceptibility Investigation - Interim Report No. 1" dated 24 August 1973.
4. MDC E0981, "Integrated Circuit Electromagnetic Susceptibility Investigation - Interim Report No. 2" dated 28 December 1973.
5. MDC E1099, "Integrated Circuit Electromagnetic Susceptibility Investigation - Test and Measurement Systems" dated 12 July 1974.
6. MDC E1101, "Integrated Circuit Electromagnetic Susceptibility Investigation - MOS NAND Gate Study" dated 26 July 1974.
7. MDC E1102, "Integrated Circuit Electromagnetic Susceptibility Investigation - Pulse Interference Study" dated 12 July 1974.
8. MDC E1103, "Integrated Circuit Electromagnetic Susceptibility Investigation - Package Effects Study" dated 12 July 1974.
9. MDC E1123, "Integrated Circuit Electromagnetic Susceptibility Investigation - Bipolar NAND Gate Study" dated 26 July 1974.
10. MDC E1124, "Integrated Circuit Electromagnetic Susceptibility Investigation - Bipolar Op Amp Study" dated 9 August 1974.
11. MDC E1125, "Integrated Circuit Electromagnetic Susceptibility Investigation - MOS/Hybrid Study" dated 9 August 1974.
12. MDC E1126, "Integrated Circuit Electromagnetic Susceptibility Investigation - Susceptibility Survey Study" dated 9 August 1974.

MCDONNELL DOUGLAS ASTRONAUTICS COMPANY - EAST

Saint Louis, Missouri 63166 (314) 232-0232

MCDONNELL DOUGLAS

CORPORATION

THIS REPORT HAS BEEN DELIMITED
AND CLEARED FOR PUBLIC RELEASE
UNDER DOD DIRECTIVE 5200.20 AND
NO RESTRICTIONS ARE IMPOSED UPON
ITS USE AND DISCLOSURE.

DISTRIBUTION STATEMENT A

APPROVED FOR PUBLIC RELEASE;
DISTRIBUTION UNLIMITED.