

233
DTIC FILE COPY

2

ORIGINAL

AD-A955 270

AIRFRAME AND EQUIPMENT ENGINEERING

REPORT NO. 45

SIMPLIFIED FLUTTER PREVENTION CRITERIA
FOR PERSONAL TYPE AIRCRAFT

1955

DTIC
SELECTED
JUL 23 1987
S E D

FAA - WASHINGTON DC 20591

Prepared by:

Robert Rosenbaum
Robert Rosenbaum
Chief, Dynamics Section

Approved by:

A. A. Vollmecke
A. A. Vollmecke
Chief, Airframe and
Equipment Engineering
Branch

This report has been approved
for release and sale; its
distribution is unlimited.

This report is a continuation of the series of reports which previously
appeared as Aircraft Airworthiness Reports and Engineering Section Reports.

SIMPLIFIED FLUTTER PREVENTION CRITERIA
FOR PERSONAL TYPE AIRCRAFT

This report is intended to serve as a guide to the small plane designer in the presentation of design criteria for the prevention of such aeroelastic phenomena as flutter, aileron reversal and wing divergence. It should also serve as a guide to recommended and acceptable practice for the design of non-structural, mass balance weights and attachments. The criteria developed in this report include: wing torsional rigidity; aileron, elevator and rudder mass balance; reversible tab and balance weight attachment criteria.

Introduction

The simplified criteria appearing in CAM 04 were developed at a time when rational methods of flutter analysis were not available. Because of the lack of available methods of analysis various attempts were made to set up empirical formulae which, if complied with, would reasonably assure freedom from flutter. The sources of material for these studies were three-fold:

1. A statistical study of the geometric, inertia and elastic properties of those airplanes which had experienced flutter in flight, and the methods used to eliminate the flutter.
2. Limited wind tunnel tests conducted with semi-rigid models. These models were solid models of high rigidity so that effectively the model was non-deformable. The motion of the models was controlled by attaching springs at the root and at the control surface to simulate wing bending, torsion and control surface rotation.
3. Analytic studies based on the two dimensional study of a representative section of an airfoil.

For the most part these studies indicated that for a conventional airfoil in which the center of gravity of the airfoil section is not too far back, that wing flutter could be prevented by designing for a certain degree of wing torsional rigidity and by control surface dynamic balance, whereas empennage flutter could be prevented by providing a degree of control surface dynamic balance. The limitations were based on the design dive speed of the airplane and within certain ranges were functions of the ratio of control surface natural frequency to fixed surface frequency.

Satisfactory rational analytic methods have been available for a number of years which would permit an engineer to carry through computations to determine the flutter stability of a specific design. In view of the fact that flutter is an aeroelastic phenomenon which is caused by a combination of aerodynamic, inertia and elastic effects, any criteria which

does not consider all three effects is bound to have severe limitations. That this is so, is evidenced by the fact that in almost all cases where rational analyses have been carried thru for specific designs it has been found that the balance requirements specified by the simple criteria have been too severe. In some special cases the criteria in CAM 04 appear to have been unconservative, i.e. flutter has been encountered in some airplanes which complied with these criteria. In spite of the fact that the old flutter prevention criteria for the most part yield over-conservative results most small aircraft companies in the personal plane field prefer to comply with these criteria rather than perform complex flutter analyses. In order to aid the small manufacturer the CAA in October 1948 issued Airframe and Equipment Engineering Report No. 43, entitled, "Outline of An Acceptable Method of Vibration and Flutter Analysis for a Conventional Airplane". The purpose of that report was to present to the inexperienced flutter analyst an acceptable, three dimensional method of analysis by presenting in detail a step-by-step tabular technique of analysis. Although a number of aircraft companies are using the methods outlined in the report, others are of the opinion that this method entails too much time and expense and are therefore seeking other means of complying with those regulations which require them to show freedom from flutter.

Although a rational flutter analysis is to be preferred to the use of the simplified criteria contained herein (since in most cases a better design may be achieved by reducing or eliminating the need for non-structural balance weights), the application of these criteria to conventional aircraft of the personal plane type is believed to be adequate to insure freedom from flutter.

The criteria contained in the present report have been developed after an exhaustive study of the American and British literature as well as independent investigations. For the most part the criteria contained in this report are new, however, some have been taken with little or no modification from other sources.

It should be noted that the empennage criteria developed in this report, have been developed on the basis of a single representative (conservative) value of the empennage mass moment of inertia about the bending axes. The value was chosen as a result of a study of the mass parameters of a number of airplanes of the personal plane type. Therefore, for larger .03 aircraft than those usually classified as personal planes the criteria may not be applicable. The wing criteria on the other hand should be applicable to all conventional .03 airplanes which do not have large mass concentrations on the wings.

Distribution/	
Availability Codes	
Dist	Avail and/or Special
UNCLASSIFIED	
A-1	

The criteria developed in this report are of a preliminary nature, and although considered to represent current thinking on acceptable and recommended practices regarding flutter prevention measures for personal type airplanes, these criteria should not be construed as required procedure to meet the flutter prevention requirements of the Civil Air Regulations.

Definitions

Flutter: Flutter is the unstable self-excited oscillation of an airfoil and its associated structure, caused by a combination of aerodynamic, inertia and elastic effects in such manner as to extract energy from the airstream. The amplitude of oscillation, (at the critical flutter speed) following an initial disturbance will be maintained. At a higher speed these amplitudes will increase.

Divergence: Divergence is the static instability of an airfoil in torsion which occurs when the torsional rigidity of the structure is exceeded by aerodynamic twisting moments. If the elastic axis of a wing is aft of the aerodynamic center then the torsional moment about the elastic axis due to the lift at the aerodynamic center tends to increase the angle of attack, which further increases the lift and therefore further increases the torsional moment. For speeds below some critical speed (the divergence speed), the additional increments of twist and moment become smaller so that at each speed below the divergent speed an equilibrium position is finally attained (i.e. the process of moment increasing angle and thereby increasing moment etc. is convergent); above this critical speed the process is non-convergent.

Control Surface Reversal: This is the reversal in direction of the net normal force induced by the deflected control surface, due to aerodynamic moments twisting the elastic "fixed" surface. This phenomenon can best be illustrated by considering the case of aileron reversal. Normally the lift over the wing with down aileron is increased by the aileron deflection, while the lift over the wing with up aileron is decreased by the aileron deflection, thus a rolling moment results from an aileron deflection. However, since the center of pressure for the lift due to the deflected aileron is usually aft of the elastic axis, deflecting the aileron downward tends to reduce the wing angle of attack thus reducing the increment of lift. For the wing with up aileron the torsional moment due to up aileron tends to increase the wing angle of attack. It can thus be seen that the rolling moment for an elastic wing is less than for a rigid wing. Since the wing torsional rigidity is constant while the twisting moment due to aileron deflection increases with the square of the velocity it is obvious that at some critical speed the rolling moment due to aileron deflection will be zero. Above this speed the rolling moment will be opposite to that normally expected at speeds below this critical speed. The critical speed so defined is the aileron reversal speed.

Summary of Criteria

Wing Torsional Stiffness

The wing torsional flexibility factor F defined below should be equal to or less than $\frac{200}{V_d^2}$

Where: $F = \int \theta_i C_i^2 ds$

θ_i = Wing twist at station i, per unit torsional moment applied at a wing station outboard of the end of the aileron. (radians/ft - lb)

C_i = Wing chord length at station i, (ft)

ds = Increment of span (ft)

V_d = Design dive speed (IAS) of the airplane

Integration to extend over the aileron span only. The value of the above integral can be obtained either by dividing the wing into a finite number of spanwise increments ΔS over the aileron span and summing the values of $\theta_i C_i^2 \Delta S$ or by plotting the variation of $\theta_i C_i^2$ over the aileron span and determining the area under the resulting curve.

In order to determine the wing flexibility factor F, a pure torsional couple should be applied near the wing tip (outboard of the end of the aileron span) and the resulting angular deflection at selected intervals along the span measured. The test can best be performed by applying simultaneously equal and opposite torques on each side of the airplane and measuring the torsional deflection with respect to the airplane centerline. The twist in radians per unit torsional moment in ft-lbs should then be determined. If the aileron portion of the wing is divided into four spanwise elements and the deflection determined at the midpoint of each element the flexibility factor F can be determined by completing a table similar to Table I below. Figure 1 illustrates a typical setup for the determination of the parameters C and ΔS

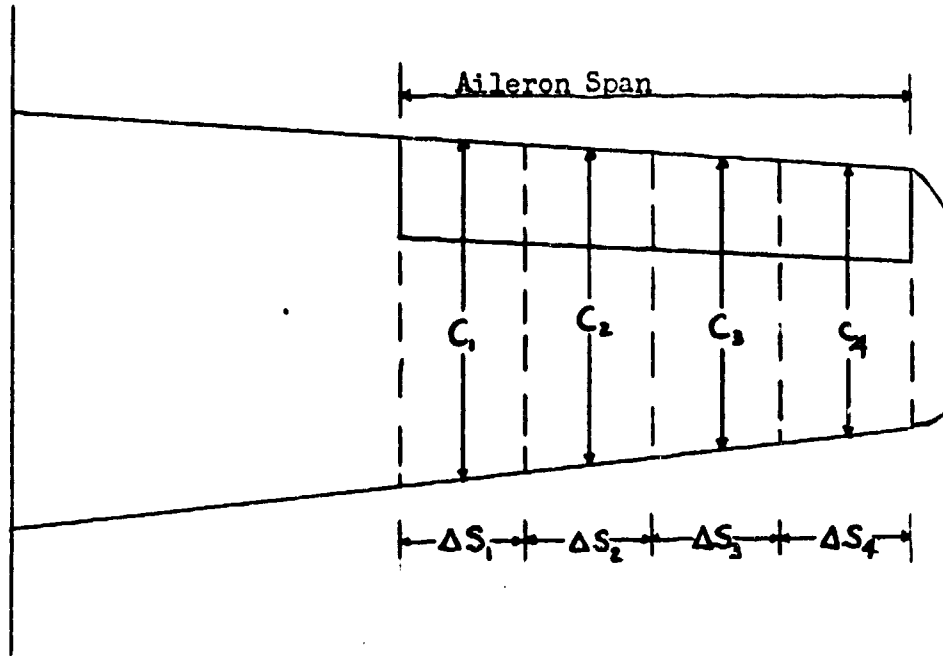

Fig. 1

TABLE I

(1)	(2)	(3)	(4)	(5)	(6)
STATION	ΔS	c	c^2	e	$e_c 2\Delta S$
	ft	ft	ft ²	$\frac{\text{rad}}{\text{ft lb}}$	
1					
2					
3					
4					

$$F = \sum \text{column (6)}$$

Aileron Balance Criterion

The dynamic balance co-efficient K/I should not be greater than the value obtained from figure 2 wherein K/I is referred to the wing fundamental bending node line and the aileron hinge line. If no knowledge exists of the location of the bending node line the axis parallel to the fuselage center line at the juncture of the wing and fuselage can be used.

Wherein: K = product of inertia

I = mass moment of inertia of aileron about its hinge line

Free Play of Ailerons

The total free play at the aileron edge of each aileron, when the other aileron is clamped to the wing should not exceed 2.5 percent of the aileron chord aft of the hinge line at the station where the free play is measured.

Elevator Balance

Each elevator should be dynamically balanced to preclude the parallel axis flutter (fuselage vertical bending-symmetric elevator rotation) as well as perpendicular axis flutter (fuselage torsion - antisymmetric elevator rotation). If, however, the antisymmetric elevator frequency is greater than 1.5 times the fuselage torsional frequency the perpendicular axis criterion need not apply.

Parallel Axis Criterion

The balance parameter γ as obtained from Figure 3 should not be exceeded. In Figure 3 the balance parameter γ and the flutter speed parameter V_f are defined as:

$$\gamma = \frac{bS_p}{I}$$

$$V_f = \frac{V_d}{bf_h}$$

Where: S_p = Elevator Static Balance about hinge line (ft - lbs)

I = Elevator mass moment of inertia about the hinge line (lb - ft²)

b = Semichord of the horizontal tail measured at the mid-span station (ft)

V_d = Design dive speed of the airplane (mph)

f_h = Fuselage vertical bending frequency (cpm)

Perpendicular Axis Criterion

For each elevator the balance parameter λ as obtained from Figure 4 should not be exceeded. In Figure 4 the balance parameter λ and the flutter speed parameter V_f are defined as:

$$\lambda = \frac{bK}{SI}$$

$$V_f = \frac{V_d}{bf_\alpha}$$

Where: S = Semispan of horizontal tail (ft)

b = Semichord of horizontal tail at midspan station (ft)

K = Elevator product of inertia referred to stabilizer center line and elevator hinge line (lb - ft²)

I = Elevator mass moment of inertia about the elevator hinge (lb - ft²)

f_α = Fuselage torsional frequency (cpm)

Rudder Balance

The value of γ as obtained from Figure 3 and the value λ as obtained from Figure 4 should not be exceeded; where in Figures 3 and 4, $\gamma = \frac{bS_A}{I}$, $\lambda = \frac{bK}{SI}$ and:

S = Distance from fuselage torsion axis to tip of fin (ft)

b = Semichord of vertical tail measured at the seventy percent span position (ft)

K = Product of inertia of rudder referred to the fuselage torsion axis and the rudder hinge line (lb - ft²)

f_α = Fuselage torsional frequency (cpm)

f_h = Fuselage side bending frequency (cpm)

S_r = Rudder static balance about hinge line (lb - ft)

I = Mass moment of inertia of the rudder about hinge line (lb - ft²)

Tab Criteria

All reversible tabs should be 100% statically mass balanced about the tab hinge line. Tabs are considered to be irreversible and need not be mass balanced if they meet the following criteria:

1. For any position of the control surface and tab no appreciable deflection of the tab can be produced by means of a moment applied directly to the tab, when the control surface is held in a fixed position and the pilots tab controls are restrained.

2. The total free play at the tab trailing edge should be less than 2.5% of the tab chord aft of the hinge line, at the station where the play is measured.
3. The tab natural frequency should be equal to or exceed the value given by the lower of the following two criteria

$$(a) f_t = 63 \frac{V_d}{C_l} \frac{S_t}{S_c} \text{ cpm}$$

or

- (b) $f_t = 2000$ cpm for airplanes having a design dive speed of less than 200 mph. For airplanes with a design dive speed greater than 200 mph the frequency in cpm should exceed the value given by 10 times the design dive speed in miles per hour.

Thus for an airplane with a design dive speed less than 200 mph if (a) above gave a value in excess of 2000 cpm it would only be necessary to show a frequency of 2000 cpm for the frequency criterion.

Where: f_t = lowest natural frequency of the tab as installed in the airplane (cpm) — either tab rotation about the hinge line or tab torsion whichever is lower.

C_l = chord of moveable control surface aft of the hinge line, at the tab midspan position (ft)

S_t = Span of tab (ft)

S_c = Span of moveable control surface to which tab is attached (both sides of elevator, each aileron and rudder)(ft)

Particular care should be taken in the detail design to minimize the possibility of fatigue failures which might allow the tab to become free and flutter violently.

Balance Weight Attachment Criteria

Balance weights should be distributed along the span of the control surface so that the static unbalance of each spanwise element is approximately uniform. However, where a single external concentrated balance weight is attached to a control surface of high torsional rigidity the natural frequency of the balance weight attachment should be at least

50 percent above the highest frequency of the fixed surface with which the control surface may couple in a flutter mode. For example the aileron balance weight frequency should be at least 50% above the wing fundamental torsional frequency. The balance weight supporting structure should be designed for a limit load of $24g$ normal to the plane of the surface and $12g$ in the other mutually perpendicular directions.

It should be noted that the dynamic balance coefficient K/I can be reduced by (1) reducing K , (2) increasing I or (3) reducing K and increasing I . Since an increase in I results in a reduced control surface natural frequency with possible adverse flutter effects, the primary purpose of ballast weights used to reduce K/I , should be to decrease the product of inertia K and not to increase the mass moment of inertia I .

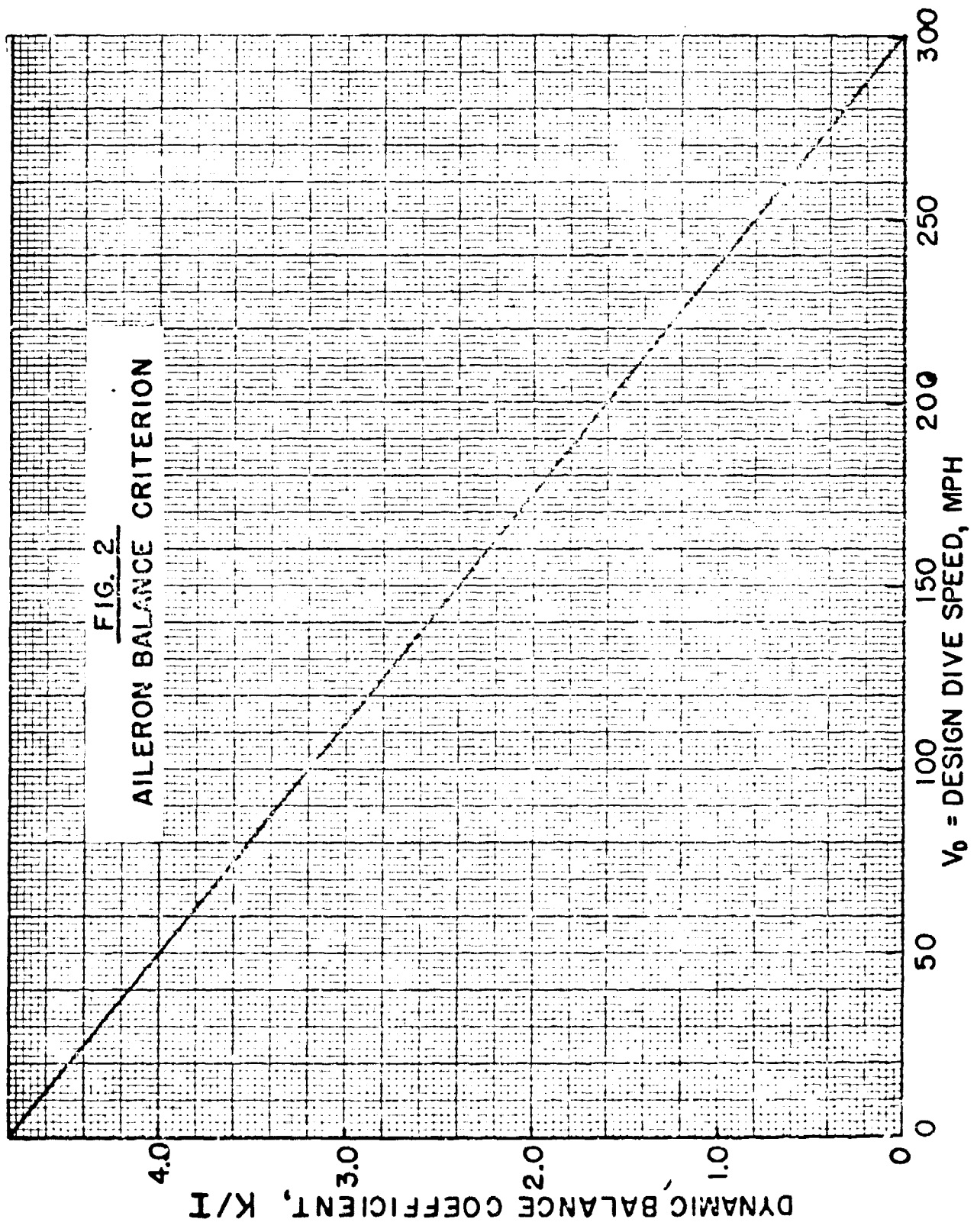

23177

FIG. 3
ELEVATOR AND RUDDER BALANCE CRITERIA
PARALLEL AXES
(FUSELAGE BENDING - CONTROL SURFACE)

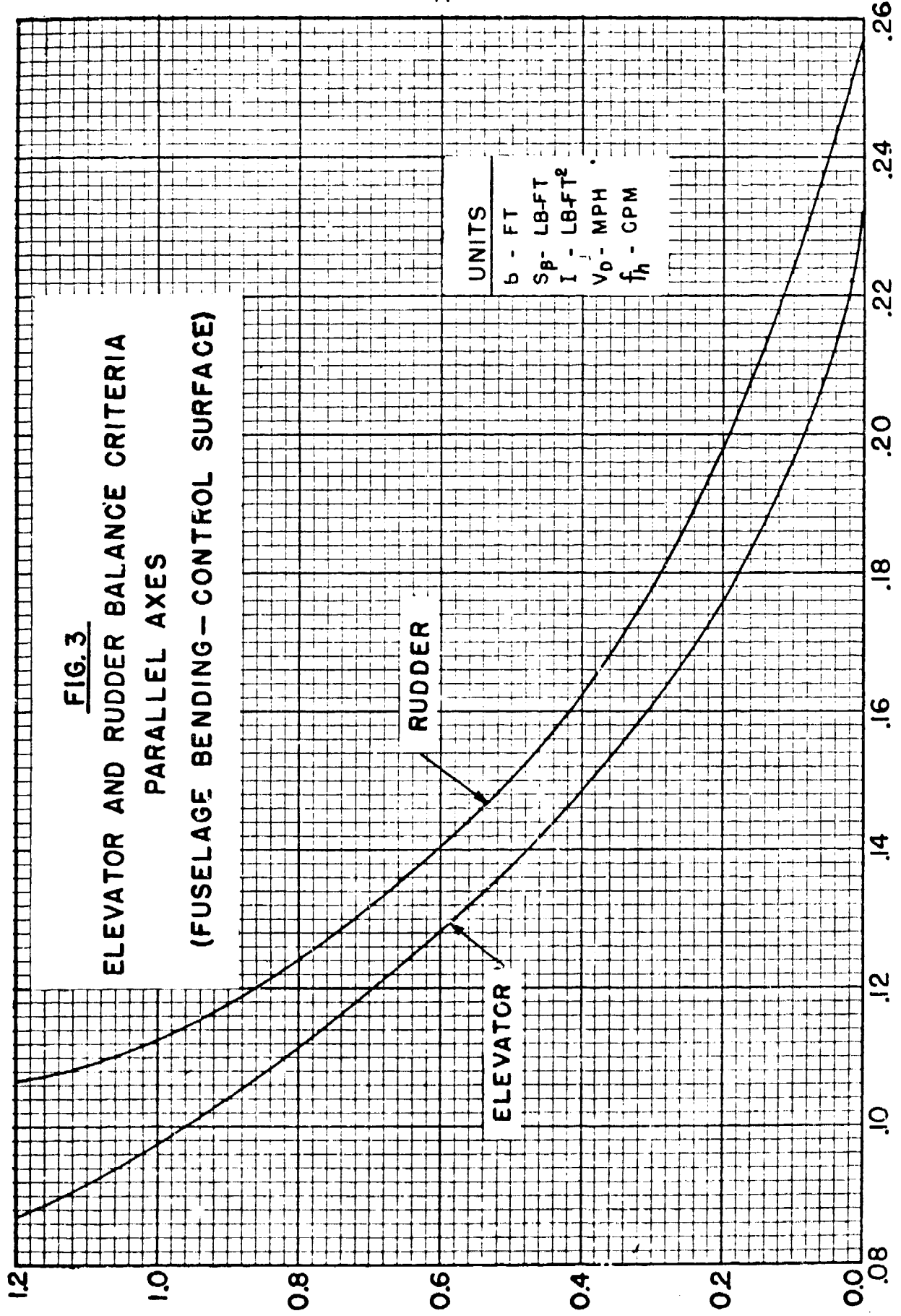

FLUTTER SPEED FACTOR, $V = \frac{V_0}{\sqrt{\dots}}$

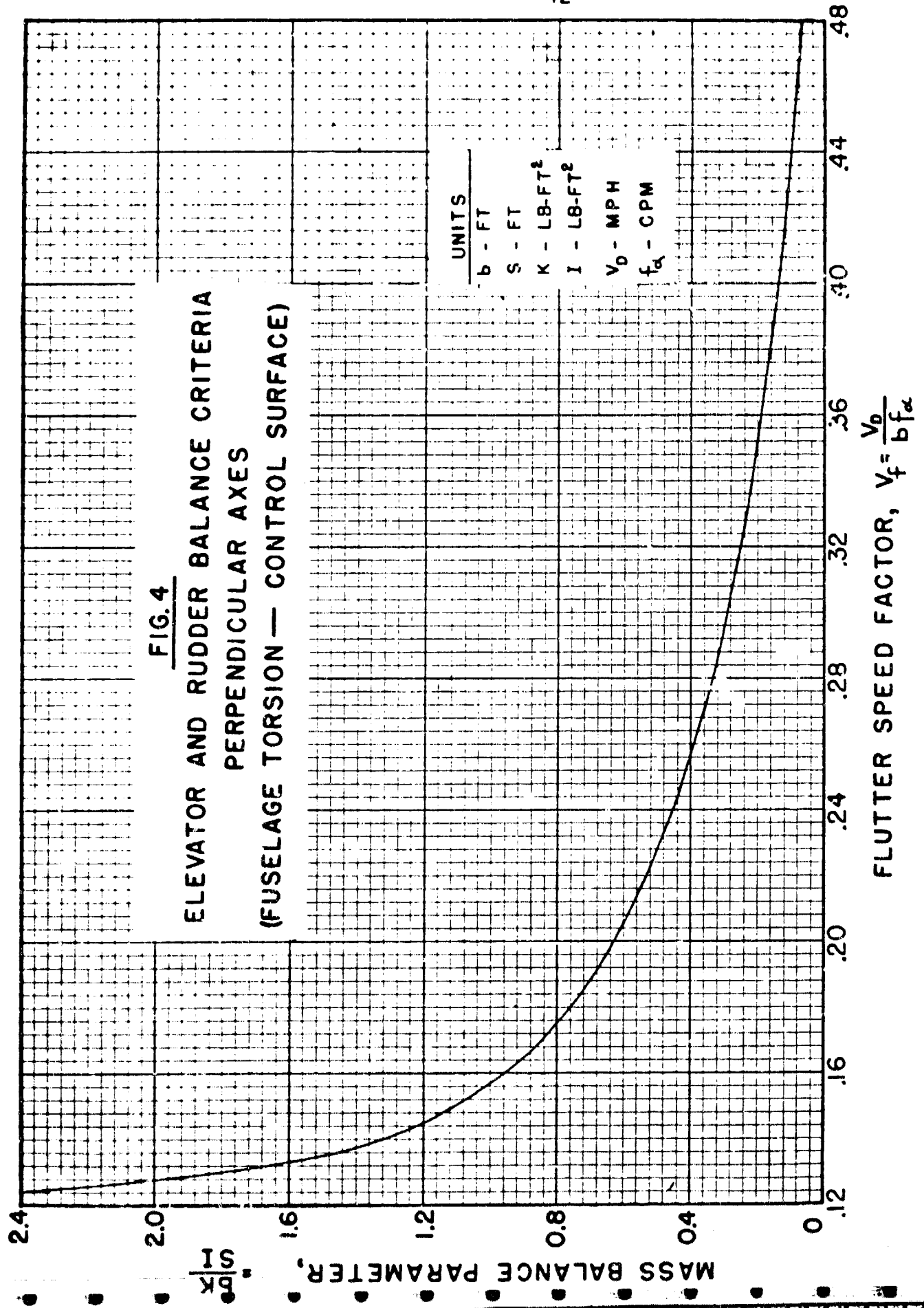

Dynamic and Static Balance of Moveable
Control Surfaces

Definitions

Static Balance: Complete static balance of a moveable control surface is obtained when the center of gravity of the control surface lies on the hinge line i.e. the resultant moment of the mass of the surface about the hinge line is zero. If the center of gravity of a surface lies aft of the hinge surface it is called statically unbalanced, whereas if the center of gravity lies forward of the hinge line the surface is called statically over-balanced.

Dynamic Balance: A moveable surface is dynamically balanced with respect to a given axis if an angular acceleration about that axis does not tend to cause the surface to rotate about its own hinge line. The dynamic balance coefficient K/I is a measure of the dynamics balance condition of the moveable control surface, wherein K is the product of inertia of the surface (including balance weights) about the hinge and oscillation axes and I is the mass moment of inertia of the control surface (including balance weights) about the hinge axis. Physically the dynamic balance coefficient K/I may be interpreted to represent:

$$\frac{\text{Exciting Torque}}{\text{Resisting Torque}}$$

Mass Balance Computations

Assume the X axis coincident with the oscillation axis and the Y axis coincident with the control surface hinge line. After the reference axes have been determined the surface should be divided into relatively small parts and the weight of each part W and the distance from its c.g. to each axis tabulated. See Figure 5 and Table II. Referring to Figure 5 the static moment of the element ΔW is ΔWx , the moment of inertia about the hinge line is ΔWx^2 and the product of inertia is ΔWxy . The static unbalance of the total surface S_p is then $\sum \Delta Wx$; the moment of inertia of the surface is $\sum \Delta Wx^2$ and the product of inertia is $K = \sum \Delta Wxy$

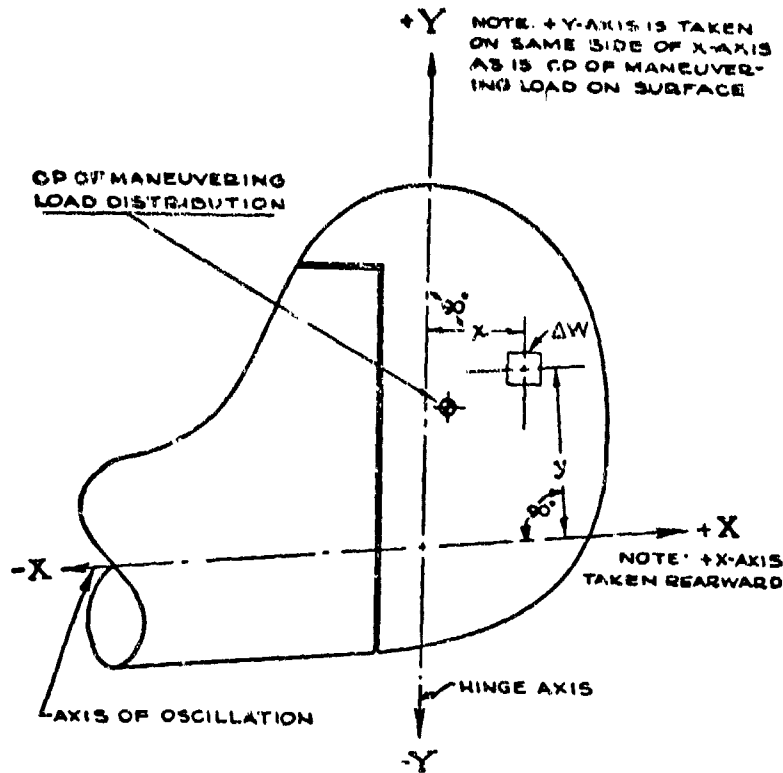

Fig. 5

TABLE II

Item No.	Part No.	Description	Weight w lbs.	Dist. from hinge \bar{x} inches	\bar{y}	Moment = $w\bar{r}$		$I_{\bar{y}\bar{y}} = w\bar{r}^2$ lb.-ins. ²	Dist. from oscillation axis = y in.	$K = w\bar{r}y$	
						- inch.-lbs.	+ inch.-lbs.			-	+
			(1)	(2)	(3)	(4)	(5)	(6)	(7)	(8)	(9)
1 2 etc.											

Product of Inertia with respect to Other Axes

Having determined the product of inertia with respect to one oscillation axis it may be desirable or necessary to determine the product of inertia with respect to some other oscillation axis. If the product of inertia was originally calculated for an oscillation axis which was perpendicular to the hinge axis then the product of inertia with respect to inclined

axes O-O and Y-Y can be determined from the perpendicular axes product of inertia (X-X and Y-Y) by use of the following equation:

$$K_{OY} = K_{XY} \sin \phi - I_{YY} \cos \phi$$

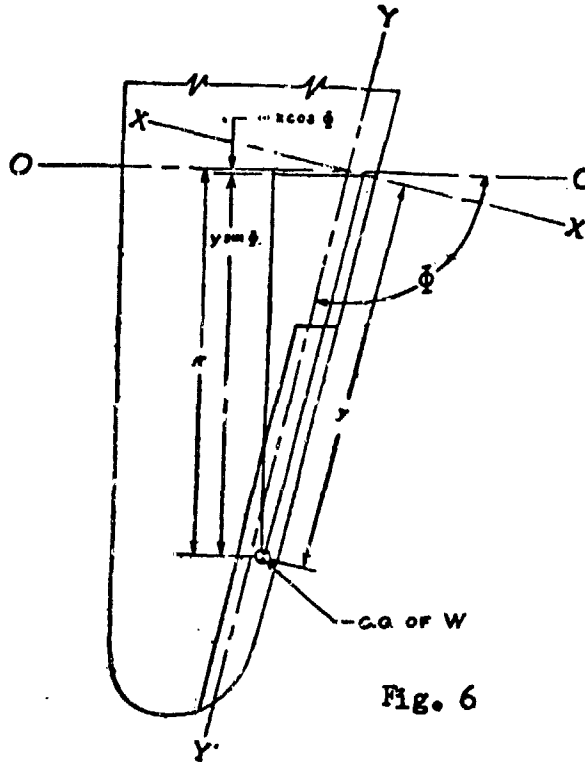

Fig. 6

where: ϕ is the angle between O-O and Y-Y in the quadrant where the center of gravity of the surface is located.

If the product of inertia was originally calculated for one set of axes and it is desired to determine the product of inertia for another set of axes parallel to the original set, then the new product of inertia K_2 can be determined from the equation:

$$K_2 = K_1 + x_0^2 W + y_0^2 W - x_0 y_0 W$$

Where: W = total weight in pounds of the moveable surface

K_1 = product of inertia with respect to axes X_1-Y_1

x_0 = distance between X_1 and X_2 axes

y_0 = distance between Y_1 and Y_2 axes

\bar{x} = distance from C.G. of surface to X_1 axis

\bar{y} = distance from C.G. of surface to Y_1 axis

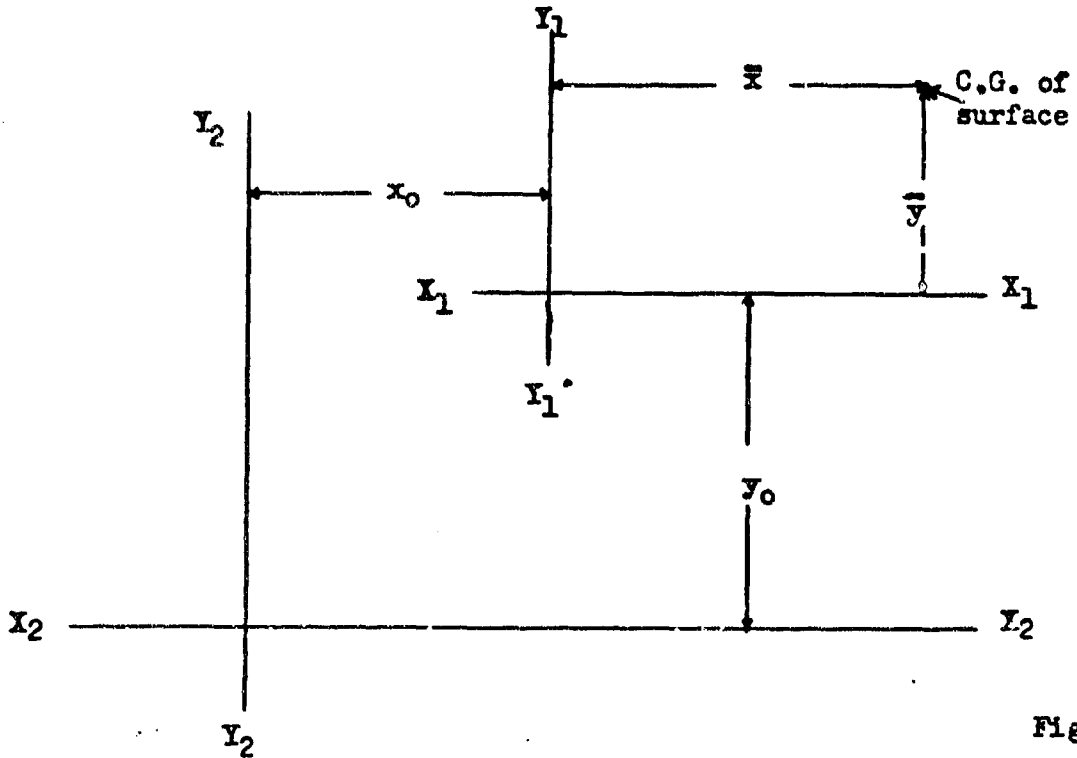
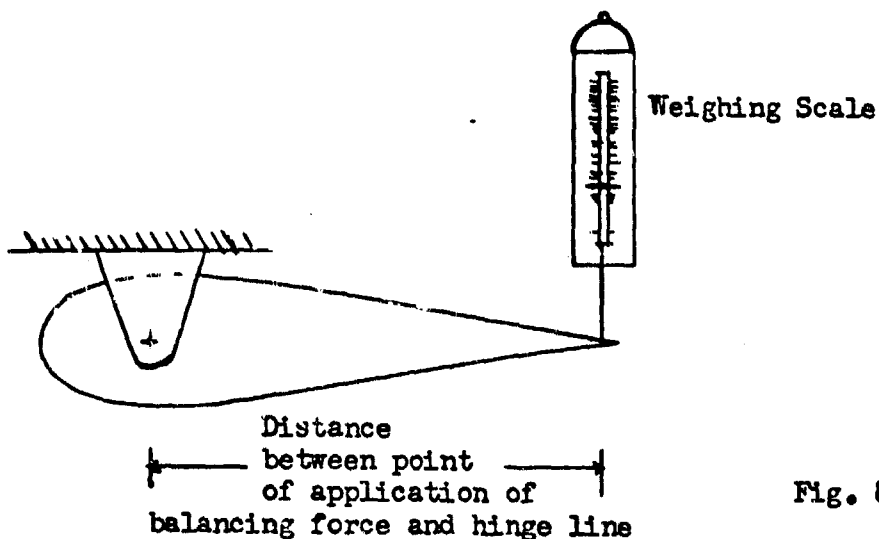

Fig. 7

Experimental Determination of Static Unbalance, Moment of Inertia and Product of Inertia

(a) Static Unbalance

The moveable control surface should be carefully supported at its hinge line on knife edges or in a jig with a minimum of friction. The force necessary to balance the control surface, when applied to a given point, is then measured by an accurate weighing scale. The net force times the distance between the hinge line and the point of application of the force is equal to the static unbalance



(b) Moment of Inertia

The experimental determination of the mass moment of inertia consists of supporting the surface or tab at the hinge line with a minimum of friction in a jig in an attitude similar to that described above and maintaining it in this attitude by means of one or two springs, as shown in Figure IX. One spring is sufficient for control surfaces with large static unbalances, while two are generally used for surfaces which are fairly well statically balanced. The natural frequency of the surface (for small oscillations) under the restraining action of the springs is then measured by means of a stop watch by determining the time necessary for a given number of cycles. In order to reduce experimental errors to a minimum, the time for a large number of cycles (about 30) is measured.

The spring stiffnesses are dynamically determined by placing a weight W_1 on spring 1 which will deflect it an amount approximately equal to the average spring deflection during the moment of inertia test and then determining the natural frequency of the spring with W_1 attached by determining with a stop watch the time necessary for a given number of cycles; a similar test is conducted for the determination of the spring stiffness of spring 2, using a weight W_2 .

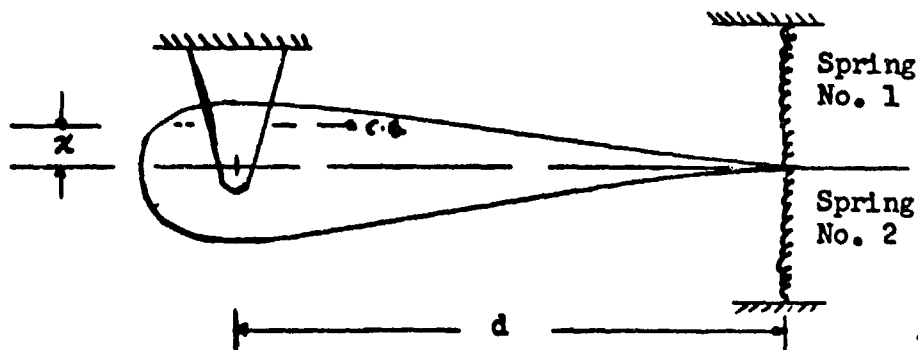

Fig. 9

The moment of inertia can then be calculated by substituting the test results in either equation 1 or 2, depending on whether the control surface center of gravity is above or below the hinge axis.

If control surface center of gravity is below hinge axis:

$$I = \frac{d^2}{f_0^2} (W_1 f_1^2 + W_2 f_2^2) + 9.788 \frac{W_0 x}{f_0^2} \text{ LB.-IN}^2 \quad (1)$$

If control surface center of gravity is above hinge axis:

$$I = \frac{d^2}{f_0^2} (W_1 f_1^2 + W_2 f_2^2) - 9.788 \frac{W_0 x}{f_0^2} \quad (2)$$

Where: I = Moment of inertia of surface about hinge axis (pound-inches²)

W_0 = Weight of surface (pounds); W_1, W_2 Spring calibration weights (pounds)

x = Distance of surface C.G. above or below hinge axis (inches)

d = Distance from hinge axis to springs (inches)

f_0 = Frequency of surface when restrained by springs (c.p.s.)

f_1 = Calibration frequency of spring K_1 under weight W_1 (c.p.s.)

f_2 = Calibration frequency of spring K_2 under weight W_2 (c.p.s.)

(c) Product of Inertia

The product of inertia K_{xy} of a moveable control surface can be calculated from three experimentally determined moments of inertia. If the control surface moments of inertia are obtained by oscillating about each of the axes X-X, Y-Y and then about a third axis O-O lying in the XY plane and making an angle α with the X-X axis, then the product of inertia K_{xy} is obtained from:

$$K_{xy} = \frac{I_{xx} \cos^2 \alpha + I_{yy} \sin^2 \alpha - I_{oo}}{2 \sin \alpha \cos \alpha}$$

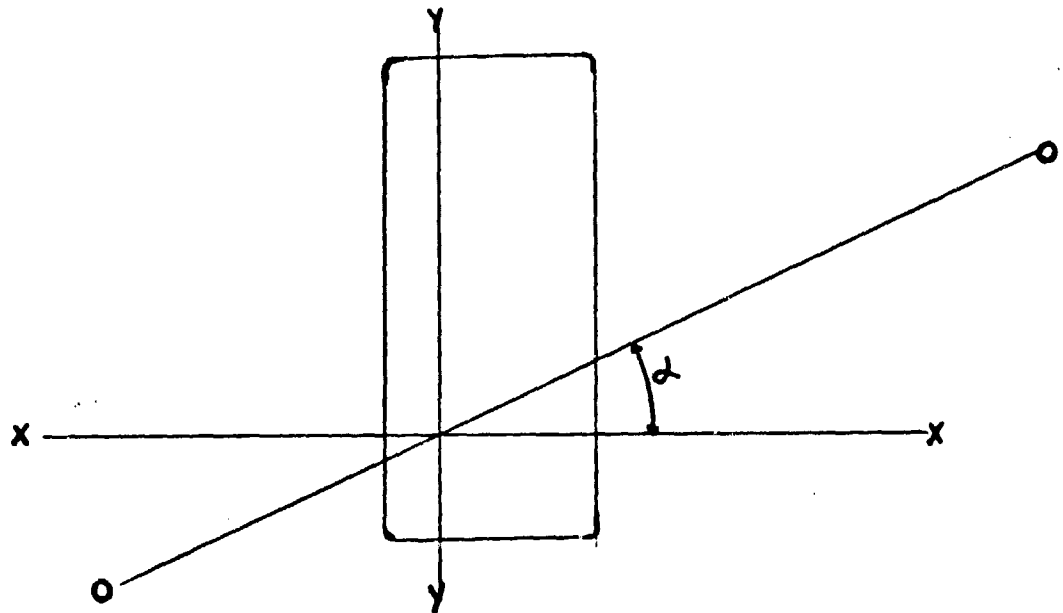

Fig. 10

Since this method of determining the product of inertia involves small differences between large quantities a small experimental error in the determination of the moments of inertia may result in large errors in the product of inertia. It can be shown (ACIC No. 711 "The Determination of the Product of Inertia of Aircraft Control Surfaces"), that the error can be reduced to acceptable levels by the proper choice of the angle α . The proper value of α can be determined after having determined I_{xx} and I_{yy} ; this value is given by the relationship:

$$\alpha = \tan^{-1} \sqrt{\frac{I_{xx}}{I_{yy}}}$$

Appendix I -- Discussion of Empennage Flutter Criteria

Studies made by the Air Material Command the Civil Aeronautics Administration and many independent investigators have shown that for the most part empennage flutter modes can be closely associated with control surface unbalance and the appropriate fuselage natural frequency with which the control surface will couple. Thus, in the case of elevator coupling, for the most part, the fuselage vertical bending mode enters into the motion of the system whereas for the rudder either fuselage side bending or torsion will couple. Although it is fully realized that any analysis based on this type of simplification would of necessity be only approximate, it should be noted that the results obtained are usually highly conservative, since other modes which generally enter into the motion of the complete system tend to damp the motion with a resultant higher flutter speed. Thus, the fuselage vertical bending mode is generally damped by coupling with wing symmetric bending and stabilizer bending whereas fuselage side bending motion is usually damped by coupling with fuselage torsion the anti-symmetric bending of the stabilizer and bending of the fin.

Based on these considerations the Air Material Command prepared a report Army Air Forces Technical Report No. 5107 entitled "Charts for Fuselage Bending vs Control Surface Flutter". It has been found that these charts are applicable to larger aircraft than those considered in the personal plane field. Each chart in AAFTR 5107 shows the variation of $\mu V_x^2 g_x$ with $\sqrt{b}\omega$ for various values of μV_x^2 . Unfortunately the limits of the values of the parameter $\mu V_x^2 g_x$ used, are such that for most airplanes in the personal plane field these curves cannot be read with any degree of accuracy, without doubtful extrapolation. Furthermore, it was considered that for simplicity a single curve would be more suitable in treating the relatively low performance personal plane field, than a family of curves.

Fuselage Bending - Control Surface Rotation *

The following assumptions were made in the determination of the fuselage bending control surface rotation flutter criterion (Figure 3):

(1) $\omega = \omega_x$

(2) $\omega_\beta = 0$

(3) $c-e = 0$

(4) $a = -3$

(5) $\mu V_x^2 g_x = 5$

for elevator rotation vs fuselage vertical bending

= 8

for rudder rotation vs fuselage side bending

*The notation used in this section is similar to that appearing in CAA Airframe and Equipment Engineering Report No. 43

The above assumptions are believed to be rational and valid for most aircraft in the field under consideration. Justification for each of the above assumptions is given below.

- (1) The flutter frequency ω is equal to the fuselage bending frequency ω_b . Experience has shown that because of the relatively large inertia of the tail the aerodynamic and inertia coupling terms are comparatively small. The flutter frequency is therefore very close to the fuselage bending frequency.
- (2) For conventional aircraft with no springs in the control system the natural frequency of the empennage control surfaces is zero. For the most part conventional tail control systems are so rigged that elastic deformation in the control system takes place only if the controls are locked in the cockpit. Since under actual flight conditions the pilot restraint in the cockpit is small, the assumption of $\omega_p = 0$ is considered to be valid.
- (3) In the low performance field it has been found that most control surfaces are not aerodynamically balanced. Since in general an increase in aerodynamic balance will tend to increase the critical flutter speed this assumption will yield conservative results for aircraft with aerodynamically balanced surfaces and yield correct results for those aircraft with no aerodynamic balance.
- (4) The flutter mode involving fuselage bending and control surface rotation is analogous to the wing torsion-aileron rotation case with the effective fuselage bending axis corresponding to the wing elastic axis. This axis of rotation is the effective point about which the airfoil section (stabilizer-elevator or fin-rudder) rotates when the fuselage bends and is not the nodal line of the fuselage in bending. A study made by the Air Material Command from vibration measurements of a large number of airplanes indicates that the effective fuselage bending axis is located approximately 1.5 tail surface chord lengths ahead of the tail surface mid-chord (i.e. $a = -3.0$).
- (5) An examination of the values of the parameter $\mu \zeta^2$ for the empennage of a number of small airplanes of the .03 type indicates that this parameter is small varying approximately between 4 and 8 at low altitudes (based on $g = .03$). For the case of fuselage side bending it has been found that the effective increase in mass moment of inertia of the

fuselage due to wing yawing is approximately 75% of the empennage mass moment of inertia. By assuming $u \dot{q}_\alpha$ constant, one curve of allowable mass balance parameter versus flutter speed parameter can be calculated for each value of α thus simplifying the problem. The values of $u \dot{q}_\alpha = 5$ for fuselage vertical bending and $u \dot{q}_\alpha = 8.75$ for fuselage side bending are believed to be representative, conservative values for .03 airplanes.

Derivation of Criterion:

The two degree, three dimensional flutter stability equations used in the development of the criteria are:

$$\begin{aligned} & \{ I_\alpha + \pi \rho A_{\alpha\alpha} - I_\alpha (1 + j g_\alpha) \left(\frac{u}{\omega} \right)^2 \} \alpha + \{ P_{\alpha\beta} + \pi \rho A_{\alpha\beta} \} \beta = 0 \\ & \{ P_{\alpha\beta} + \pi \rho A_{\beta\alpha} \} \alpha + \{ I_\beta + \pi \rho A_{\beta\beta} - I_\beta (1 + j g_\beta) \left(\frac{u}{\omega} \right)^2 \} \beta = 0 \end{aligned} \tag{1}$$

Where: I_α = mass moment of inertia of the entire empennage about the effective fuselage bending axis

I_β = mass moment of inertia of control surface about its hinge line (both sides of elevator for fuselage vertical bending flutter and complete rudder for side bending flutter)

$P_{\alpha\beta}$ = mass product of inertia about effective bending axis and hinge line = $(c-a)b \dot{S}_\beta + I_\beta$

A_{ij} = Aerodynamic terms of the form

$$A_{\alpha\alpha} = \left[M_\alpha - \left(\frac{1}{2} + a \right) (L_\alpha + M_h) + \left(\frac{1}{2} + a \right)^2 L_h \right] \int b^4 dx$$

Setting the determinant of the coefficients of equation (1) equal to zero and making the appropriate substitutions for the assumptions the following equation is obtained:

$$\begin{vmatrix} \pi \rho A_{\alpha\alpha} - I_\alpha g_\alpha j & P_{\alpha\beta} + \pi \rho A_{\alpha\beta} \\ P_{\alpha\beta} + \pi \rho A_{\beta\alpha} & I_\beta + \pi \rho A_{\beta\beta} \end{vmatrix} = 0 \tag{2}$$

If $\pi \rho A_{ij} = \pi \rho b^4 S A'_{ij}$ where A'_{ij} is the aerodynamic portion of A_{ij} , i.e. $A'_{\alpha\alpha} = [M_{\alpha\alpha} - (\frac{1}{2} + e)(L_{\alpha\alpha} + M_{\alpha\alpha}) + (\frac{1}{2} + e)^2 L_{\alpha\alpha}]$, then dividing thru equation (2) by $\pi \rho b^4 S$ and substituting $I_{\alpha\alpha} g_{\alpha} / \pi \rho b^4 S = 5$ the following equation is obtained:

$$\begin{vmatrix} A'_{\alpha\alpha} - 5j & P + A'_{\alpha\beta} \\ P + A'_{\beta\alpha} & I + A'_{\beta\beta} \end{vmatrix} = 0 \quad (3)$$

Where: $P = P_{\alpha\alpha} / \pi \rho b^4 S$

$I = I_{\alpha\alpha} / \pi \rho b^4 S$

$S =$ Total span of surface (ft)

$b =$ Semi-chord (ft)

$S_{\rho} =$ Total static mass unbalance of control surface about hinge (Slug-ft)

Equation (3) when expanded can be expressed in the following form:

$$P^2 + (A'_{\alpha\beta} + A'_{\beta\alpha})P + A'_{\beta\alpha}A'_{\alpha\beta} - A'_{\alpha\alpha}A'_{\beta\beta} + 5A'_{\beta\beta}j + (5j - A'_{\alpha\alpha})I = 0 \quad (4)$$

For a fixed value of e and $1/2$ equation (4) when expanded results in two real equations, in P and I , one a quadratic equation in P and the other a linear equation in P . From the linear equation a value of I is obtained as a function of P . When this value of I is substituted into the quadratic equation of P , an equation in P is obtained which does not contain I . The resulting quadratic in P can be solved and from the roots of this equation the associated values of I can be obtained. The ratio of $P/I = 1 / 3b^5 / I_{\alpha}$ as a function of $V/b\omega$ can then be used as the flutter prevention criterion. One curve of $b^5 S_{\rho} / I_{\alpha}$ vs $V/b\omega$ can be obtained for each value of e , where eb is the distance from the airfoil midchord to the control surface leading edge. Solutions were obtained for $e = -.1, 0, 1,$ and $.2$ and it was found that the variation in allowable $b^5 S_{\rho} / I_{\alpha}$ for any $V/b\omega$ value was small. Figure 3 was then chosen as a reasonable curve to represent the envelope of curves, thus simplifying the problem by setting up a single curve applicable to conventional small aircraft.

Fuselage Torsion - Control Surface Rotation

An approach to this problem was used which in essence is similar to that for the fuselage bending-control surface case. The case involving fuselage torsion is analogous to the wing bending-aileron case. If the horizontal and vertical tail do not deflect elastically then for an angular deflection θ radians of the fuselage, an airfoil section located x feet from the torsion axis will have a linear (bending) deflection of magnitude $x\theta$. It should be noted that in the three dimensional analysis integrals of the form.

$$M = \int m(x) [f(x)]^2 dx \qquad A_{nn} = \int b^2 L_n [f(x)]^2 dx$$

$$S_p = \int S_p(x) f(x) dx \qquad A_{np} = \int b^2 L_p f(x) dx$$

appear in the equations. If $f(x) = \frac{x}{S}$ where S is the distance from the torsion axis to the tip of the fin then the mass and geometric parameters may be considered to be "weighted" parameters. In a three dimensional analysis the integration for the M and A_{nn} terms must be taken over the complete horizontal and vertical tail surfaces whereas the other terms involve integration over the rudder span only.

Although data was available for the evaluation of $\mu r^2 g_\alpha$ in the case of fuselage bending vs control surface rotation similar data was not available for the evaluation of $M g_{n\delta}$ (which bears a similar relationship to the fuselage torsion case). For the analysis then g_n was assumed to be zero and a curve obtained for $\frac{p}{q} - \frac{r}{q}$ versus \sqrt{bw} . Since the assumption of $g_n = 0$ is known to be highly conservative the resulting curve obtained from the above analysis was raised by an amount which experience indicates is reasonable. Table III below gives a comparison of the K/I determined by the proposed criterion with the allowable K/I as given by CAM 04 and ANC 12, as well as the actual K/I of the rudder on the airplane in service. It should be noted that since $\frac{w}{b}$ is less than one, the allowable K/I as given in CAM 04 is limited to a maximum value of unity.

TABLE III

Airplane	V_D	f cpm	b	New K/I	Actual K/I on Air- plane	CAM OL	ANC 12
(1) All American 10A	183	860	1.083	3.16	3.6	1.0	.90
(2) Bellanca 14-13	240	510	1.458	.69	.708	.96	.69
(3) Cessna 190	259	685	1.917	1.53	.994	.65	.61
(4) Howard 18	250	250	1.40	0	0	.79	.64
(5) Luscombe 8A	176	870	1.583	4.8	1.225	1.000	.92
(6) Navion	210	480	1.208	.655	1.00	1.00	.81
(7) Rawdon T-1	200	450	1.625	.886	1.59	1.00	.84
(8) Thorpe T-11	164	950	1.183	4.06	4.08	1.00	.96

Appendix II — Discussion of Wing and Tab Criteria

In the case of empennage flutter prevention criteria the problem could be treated analytically. This was due to the simplification of the problem by a number of rational assumptions, which experience indicated to be valid. Thus, because of the structural elements involved, the problem could be reduced to a two degree of freedom flutter system with but one elastic restraint. However, in the case of the wing no such simplification is available. An adequate analytic treatment of the problem requires a minimum three degree of freedom consideration (with three elastic restraints). It is true that if the ailerons are completely statically and dynamically mass balanced the system can be reduced to a two degree case. However, since most light aircraft do not have completely mass balanced control surfaces, the problem must be treated as a three degree of freedom one.

Because of the large number of parameters involved the development of criteria based on an analytic approach is not feasible. However, experience to date indicates that for a conventional wing, where there are no large mass concentration located far aft of the elastic axis and for which the ailerons are adequately mass balanced the aileron reversal phenomenon will probably be the most critical of the aeroelastic phenomena of flutter, divergence and reversal. Since the critical reversal speed is a function of the geometry and torsional rigidity of the wing the problem of flutter prevention for a conventional wing can be resolved by providing adequate torsional rigidity to preclude aileron reversal and by a criterion for aileron balance.

Wing Torsional Rigidity Criterion

The C_{TR} criterion given in CAM 04 requires that at certain specified distances from the wing tip the torsional rigidity of the wing exceed a value which is a function only of the design dive speed of the airplane. This criterion was considered to be adequate to preclude wing bending-torsion flutter as well as divergence and reversal. Since the reversal speed is a function not only of the torsional rigidity and design dive speed this criterion was reviewed and a new one developed which is a function of the dive speed, the torsional rigidity of the wing over the aileron portion of the span, the wing chord and the aileron span. The criterion developed for the torsional rigidity is in essence similar to the criterion developed by the Air Material Command in TSFAL 2-4595-1-11 "A Simplified Criterion for Wing Torsional Stiffness" dated June 1945. The basic difference in forms between the two criteria is that in the Army criterion the wing rigidity and chord length is chosen at one station only, whereas in the criterion proposed herein the variation of torsional rigidity and chord length over the aileron span of the wing is used. For conventional wings both criteria should yield approximately the same results.

This criterion was checked on a number of light aircraft and it was found that in all cases calculated reversal speed by the proposed method resulted in a slightly more conservative answer than that predicted by the Army criterion.

Aileron Balance

Experience to date indicates that the aileron balance criterion in CAM 04 is conservative. In some cases recently checked by analytic means, allowable values of K/I of approximately five times that permitted by the criteria were obtained. However, since the wing flutter prevention criteria are based almost completely on empirical methods and since the success of the torsional rigidity requirement as a flutter prevention method is dependent on a well balanced control surface, any major change in existing criteria is believed to be unwarranted. It should be noted that in a recent check on several light aircraft the allowable value of aileron unbalance was much higher than that given by any existing balance criteria. However, in every case checked, the wing torsional rigidity was higher than the minimum permissible rigidity.

Tab Criterion

The tab criteria proposed herein are essentially the same as those in ANC 12. A recent study of tab frequency criteria indicated that the ANC 12 criterion although very conservative was the most satisfactory, consistent criterion available. However, the use of the second of the two frequency criteria as applied to small, low performance aircraft has in the past yielded satisfactory results. It is therefore suggested that in any particular case the less conservative of the two criteria (the one permitting the lowest frequency) be used.