

UNCLASSIFIED

AD NUMBER

ADA801405

CLASSIFICATION CHANGES

TO: unclassified

FROM: restricted

LIMITATION CHANGES

TO:

Approved for public release; distribution is unlimited.

FROM:

Distribution authorized to DoD only; Administrative/Operational Use; 28 JAN 1947. Other requests shall be referred to National Aeronautics and Space Administration, Washington, DC. Pre-dates formal DoD distribution statements. Treat as DoD only.

AUTHORITY

E.O. 10501 dtd 5 Nov 1953; NASA TR Server website

THIS PAGE IS UNCLASSIFIED

UNCLASSIFIED

COPY NO. 84

RM No. E7A28a

Source of Acquisition
CASI Acquired



RESEARCH MEMORANDUM

AN ANALYSIS OF THE FULL-FLOATING JOURNAL BEARING

By M. C. Shaw and T. J. Nussdorfer, Jr.

Aircraft Engine Research Laboratory
Cleveland, Ohio

TECHNICAL LIBRARY
MANUFACTURING INFORMATION
SECTION
UNIVERSITY OF MICHIGAN
ANN ARBOR, MICHIGAN

MAR 26 1947

Restriction/Classification
Cancelled

CLASSIFIED DOCUMENT

Classified information affecting the United States within the meaning of the Espionage Act, USC 50:91 and 32. Its transmission or the revelation of its contents in any manner to an unauthorized person is prohibited by law. Information so classified may be imparted only to persons in the military and naval Services of the United States, appropriate civilian officers and employees of the Federal Government who have a legitimate interest therein, and to United States citizens of known loyalty and discretion who of necessity must be informed thereof.

NATIONAL ADVISORY COMMITTEE FOR AERONAUTICS

WASHINGTON

January 28, 1947

UNCLASSIFIED

E7A28a

E7A28a

NATIONAL ADVISORY COMMITTEE FOR AERONAUTICS

RESEARCH MEMORANDUM

AN ANALYSIS OF THE FULL-FLOATING JOURNAL BEARING

By M. C. Shaw and T. J. Nussdorfer, Jr.

SUMMARY

An analysis of the operating characteristics of a full-floating bearing - a bearing in which a floating sleeve is located between the journal and bearing surfaces - is presented together with charts from which the performance of such bearings may be predicted. Examples are presented to illustrate the use of these charts and a limited number of experiments conducted upon a glass full-floating bearing to verify some results of the analysis are reported.

The floating sleeve can operate over a wide range of speeds for a given shaft speed, the exact value depending principally upon the ratio of clearances and upon the ratio of radii of the bearing. Lower operating temperatures at high rotative speeds are to be expected by using a full-floating bearing. This lower operating temperature would be obtained at the expense of the load-carrying capacity of the bearing if, for comparison, the clearances remain the same in both bearings. A full-floating bearing having the same load capacity as a conventional journal bearing may be designed if decreased clearances are allowable.

INTRODUCTION

The recent use of high-speed turbines and compressors has caused much interest in bearings and other machine elements that are suitable for high-speed use. Overheating of journal bearings, which is often encountered in high-speed operation, is generally alleviated by increasing the clearance to induce a greater oil flow. An increase in clearance, however, may have objectionable effects such as a decrease in load-carrying capacity or an increase in the tendency for oil-film whirl (references 1 and 2).

The full-floating bearing (fig. 1) offers a means of increasing the oil flow without increasing the clearance between adjacent mating surfaces. A floating sleeve between the shaft and the bearing surface provides two channels through which the oil may flow.

In figure 2 a conventional journal bearing and a full-floating bearing are schematically shown with greatly exaggerated clearances. It is evident that the full-floating bearing is capable of much greater oil flow and hence should have better cooling characteristics for the same clearance between sliding surfaces. The total allowable deflection of the journal relative to the outer bearing housing will be greater, however, for a full-floating bearing than for an "equivalent" journal bearing. An equivalent journal bearing denotes a conventional journal bearing having the same shaft diameter and the same clearance as the inner clearance of the full-floating bearing except as noted elsewhere. The viscosity of the oil and the unit bearing load are also assumed equal.

The origin of the full-floating bearing is not known. Stodola (reference 3) mentions the use of a multisleeve bearing on a Parsons steam turbine; the function of this construction was to dampen the vibration from an unbalanced rotor. From 1920 to 1930 full-floating bearings were used extensively by the British in the connecting rods of Bristol aircraft engines. Orloff (reference 4) has discussed the temperature characteristics of the full-floating bearing. Floating-type multiple-oil-film bearings are described in references 5 and 6. Experiments by Ferretti (reference 7) indicate that under light loads a needle bearing functions as a full-floating bearing, the needles tending to rotate as a unit rather than to roll.

Published information on the operating characteristics of the full-floating bearing is incomplete and in some cases misleading. An analytical study of the full-floating bearing was therefore made at the NACA Cleveland laboratory to determine better the operating characteristics of this type of bearing. A full-floating bearing may be used with two general types of load: a unidirectional load and a rotating load. The theory is developed for a bearing subjected to a unidirectional load and charts are presented for use in the design of such bearings. The manner in which these charts may be used for bearings subjected to a rotating load is also presented. Experiments using a glass bearing were included in this investigation to check some of the general results of the analysis.

SYMBOLS

The following symbols were used in the computations of the theoretical and the experimental analyses:

c_p	specific heat of oil at constant pressure
c	radial clearance between journal and bearing surfaces, (in.)
E	total work done per unit time in shearing oil film, (in.-lb/sec)
e	eccentricity of journal relative to bearing, (in.)
H	heat generated per unit time in shearing oil film, (Btu/sec)
h	film thickness at any point in the oil film, (in.)
L	axial length of bearing, (in.)
N	speed, (rpm)
n	attitude, $\left(\frac{e}{c}\right)$
P	unit bearing load on the projected area, (lb/sq in.)
p	pressure at any point in oil film, (lb/sq in.)
Q	oil flow, (cu in./sec)
r	radius, (in.)
S	Sommerfeld number
s	shear stress at any point in the oil film, (lb/sq in.)
T	friction torque, (in.-lb)
Δt	temperature rise in oil film, ($^{\circ}$ F)
U	boundary velocity in the positive-x direction, (in./sec)
u	velocity of particle of oil in positive-x direction, (in./sec)
W	bearing load, (lb)
x, y, z	axes of rectangular system of coordinates
γ	temperature criterion, $\left[\frac{Q_f}{Q_e}\right] / \left[\frac{H_f}{H_e}\right]$
θ, r, z	cylindrical coordinates (See appendix.)

- ϕ attitude angle (See appendix.)
 μ viscosity of lubrication, reyns (lb-sec/sq in.)

Subscripts:

- f full-floating journal bearing
f' full-floating journal bearing with restrained sleeve
e equivalent journal bearing

For conventional journal bearing

- b bearing
j journal

For full-floating bearing with unidirectional load

- 0 shaft surface
1 inner surface of floating sleeve
2 outer surface of floating sleeve
3 stationary bearing surface

For full-floating bearing with rotating load

- 0 outer bearing surface
1 outer surface of floating sleeve
2 inner surface of floating sleeve
3 shaft surface

THEORY

Two load-carrying oil films are associated with a full-floating journal bearing subjected to a unidirectional load: one in contact with the inner surface of the floating sleeve, the other in contact with the outer surface. Viscous shear in the inner oil film tends

to make the floating sleeve rotate with the journal, whereas shear in the outer oil film tends to retard this rotation. The floating sleeve is thus subjected to two torques of opposite sense, which cause this sleeve to rotate at an equilibrium velocity between the velocity of the journal and that of the stationary bearing.

Floating sleeve speed. - The charts of figure 3 are constructed from equations (A-25), (A-27), and (A-28) derived in the appendix. From these charts the ratio of the speed of the floating sleeve to that of the journal N_1/N_0 may be determined for any ratio of clearances c_2/c_1 , ratio of radii r_2/r_1 , and Sommerfeld number S_0 (reference 8, pp. 23-26, 119-121)

where

$$S_0 = \left(\frac{r_1}{c_1} \right)^2 \frac{\mu N_0}{P_1} \quad (1)$$

S_0 is the Sommerfeld number when the sleeve is assumed fixed.

Heat generated in full-floating bearing. - Energy is dissipated as heat in overcoming the viscous resistance to shear in any hydrodynamic bearing. In normal operation most of the heat thus developed is carried away by the oil as it flows from the ends of the bearing. In high-speed operation, a high equilibrium temperature generally results. It is therefore desirable to compare the amount of heat generated in a full-floating bearing with that produced in an equivalent journal bearing.

All work done in shearing the two oil films of a full-floating bearing must be supplied by the rotating shaft. The total work E_f that is absorbed by the two oil films per unit time is therefore equal to the product of the friction force acting on the inner journal and the velocity of this journal. From equation (A-17),

$$E_f = \left[\frac{n_1 c_1}{2r_0} W \sin \phi + \frac{2\pi\mu r_0 L}{c_1 \sqrt{1-n_1^2}} \left(\frac{2\pi r_0 N_0}{60} - \frac{2\pi r_1 N_1}{60} \right) \right] \left(\frac{2\pi r_0 N_0}{60} \right) \quad (2)$$

The corresponding quantity for an equivalent journal bearing is

$$E_e = \left[\frac{n_e c_e}{2r_e} W \sin \phi_e + \frac{2\pi\mu r_e L}{c_e \sqrt{1-n_e^2}} \left(\frac{2\pi r_e N_e}{60} \right) \right] \left(\frac{2\pi r_e N_e}{60} \right) \quad (3)$$

The ratio of the total heat generated in the full-floating bearing to that developed in an equivalent journal bearing is then

$$\frac{H_f}{H_e} = \frac{E_f}{E_e} = \frac{\left[\frac{n_1 c_1}{2r_0} W \sin \phi_1 + \frac{4\pi^2 \mu r_0 L (r_0 N_0 - r_1 N_1)}{60 c_1 \sqrt{1-n_1^2}} \right] r_0 N_0}{\left(\frac{n_e c_e}{2r_e} W \sin \phi_e + \frac{4\pi^2 \mu r_e^2 L N_e}{60 c_e \sqrt{1-n_e^2}} \right) r_e N_e} \quad (4)$$

Equation (5) is computed by making $N_e = N_0$, $c_e = c_0$, and $r_e = r_0 \cong r_1$ and applying equations (A-24), (A-26), and (A-27) of the appendix to equation (4).

$$\frac{H_f}{H_e} = \frac{15n_1 (1-n_1^2) + \pi^2 (2S_e - S_1)}{15n_e (1-n_e^2) + \pi^2 S_e} \sqrt{\frac{1-n_e^2}{1-n_1^2}} \quad (5)$$

A number of curves showing the variation of the ratio of heat generated H_f/H_e with the Sommerfeld number S_e are given in figure 4. These curves were obtained by use of equation (5) and the speed-ratio curves of figure 3.

Flow of lubricant through full-floating bearing. - In general, the two oil films in a full-floating bearing together permit more oil to flow than the single film in an equivalent bearing. In order to evaluate the relative flow through these two bearings, it is first necessary to obtain an expression for the flow between two close-fitting cylinders with parallel axes.

Orloff (reference 4) gives the following expression for the flow between two parallel eccentric cylinders (with a change of notation and units):

$$Q = \frac{\pi}{6} \frac{rc^3 p}{\mu L} (1 + 1.5n^2) \quad (6)$$

In this equation the supply pressure p is assumed to be constant along the periphery of the bearing. In an actual bearing the

pressure changes from point to point around the bearing; for this case p is a function of θ and equation (6) does not strictly apply. If the variation of pressure around the equivalent and full-floating oil films is assumed to be the same, however, then to a good approximation the pressure may be cancelled from the numerator and denominator of the expression for the ratio of flow through the two bearings. Thus,

$$\frac{Q_f}{Q_e} = \frac{\frac{\pi}{6} \frac{r_0 c_1^3 p}{\mu L} (1 + 1.5n_1^2) + \frac{\pi}{6} \frac{r_2 c_2^3 p}{\mu L} (1 + 1.5n_2^2)}{\frac{\pi}{6} \frac{r_1 c_1^3 p}{\mu L} (1 + 1.5n_e^2)} \quad (7)$$

$$= \frac{(1 + 1.5n_1^2) + \left(\frac{r_2}{r_1}\right) \left(\frac{c_2}{c_1}\right)^3 (1 + 1.5n_2^2)}{1 + 1.5n_e^2} \quad (8)$$

A number of curves showing the variation of oil-flow ratio Q_f/Q_e with Sommerfeld number S_e are given in figure 5. These curves were obtained by use of equation (8) and the speed-ratio curves of figure 3.

Temperature criterion for full-floating bearing. - The operating temperature of a bearing is, in general, dependent upon two quantities: the amount of heat generated in the bearing and the quantity of lubricant flowing through the bearing to carry this heat away. Several other factors such as the specific heat of the lubricant and the temperature difference between the oil and the bearing surfaces also influence the resulting bearing temperature but to a lesser degree.

The operating temperature of a full-floating bearing can be compared to that of an equivalent journal bearing by means of a factor called the temperature criterion. In any bearing problem it is approximately correct to assume that the heat generated is equal to the heat removed because most of the heat is carried away by the oil. The following equations may therefore be written:

$$H_e = Q_e c_p \Delta t_e$$

$$H_f = Q_f c_p \Delta t_f$$

where the oil-temperature rise Δt is proportional to the bearing-temperature rise. Therefore,

$$\frac{\Delta t_e}{\Delta t_f} = \gamma = \frac{\frac{Q_f}{H_f}}{\frac{Q_e}{H_e}} \quad (9)$$

From equations (5) and (3)

$$\gamma = \frac{15n_e (1-n_e^2) + \pi^2 S_e}{15n_1 (1-n_1^2) + \pi^2 (2S_e - S_1)} \left[\frac{(1 + 1.5n_1^2) + \left(\frac{r_2}{r_1}\right) \left(\frac{c_2}{c_1}\right)^3 (1 + 1.5n_2^2)}{1 + 1.5n_e^2} \right] \sqrt{\frac{1-n_1^2}{1-n_e^2}} \quad (10)$$

The operating temperature of the equivalent bearing will be γ times the operating temperature of the full-floating bearing under the same conditions. Curves showing the variation of the temperature criterion with Sommerfeld number are given in figure 6.

Operating characteristics of lightly loaded bearings. - The operating characteristics of the full-floating bearing are of particular interest at very high values of Sommerfeld number, inasmuch as such bearings are generally used at high speeds. Values of speed ratio and temperature criterion are therefore given in figure 7 for an unloaded bearing, which is equivalent to a bearing operating with a high value of S_e .

APPARATUS AND PROCEDURE

A photograph of the apparatus used to check part of the foregoing analysis of the full-floating bearing is shown in figure 8. The test shaft was supported by two standard, self-aligning, ball-bearing pillow blocks with the journal midway between these supporting bearings. The brass floating sleeve had a central circumferential oil groove $\frac{9}{32}$ -inch wide by $\frac{1}{64}$ -inch deep on the inside and outside surfaces. Six symmetrically spaced radial holes connected the outer

and inner oil grooves. The outer bearing was made of precision-bore glass tubing ground to a close tolerance; an inspection of the extent and condition of the oil film could therefore be made under operating conditions. In all experiments the pressure of the inlet oil supplied to the groove through a hole in the glass bearing was maintained constant at 15 pounds per square inch.

Three full-floating bearings of the following dimensions were used:

	Bearing		
	A	B	C
Journal diameter, (in.)	1.5286	1.5242	1.5242
Diameter of floating sleeve, (in.)			
Inside	1.5325	1.5266	1.5325
Outside	1.9975	1.9973	1.9975
Diameter of glass bearing, (in.)			
Inside	2.0013	2.0013	2.0013
Radial bearing clearance, (in.)			
Inner, (c_1)	0.0019	0.0012	0.0042
Outer, (c_2)	0.0019	0.0020	0.0018
Ratio of clearances, (c_2/c_1)	1.00	1.67	0.43
Ratio of radii, (r_2/r_1)	1.30	1.30	1.30
Bearing length, (L), (in.)	1.705	1.750	1.705
Ratio of bearing length to journal diameter	1.12	1.15	1.12

Inasmuch as glass was used as one the bearing materials, it was thought advisable to limit the applied load to relatively low values. Failure of the bearing as indicated by stoppage of the floating sleeve could, however, be caused at any value of load by gradually reducing the speed of the shaft. The bearing was always loaded unidirectionally by means of a lever as shown in figure 8; the range of load was from 0 to 50 pounds. The test shaft was driven at speeds ranging from 150 to 5000 rpm. The speed of the floating sleeve was determined by inspection under a stroboscopic light of variable frequency. A few runs were made to check the

effect of ratio of clearances upon speed ratio for an unloaded bearing and also to check the effect of bearing load upon speed ratio. In all runs the effective viscosity of the lubricant was maintained at 3×10^{-6} reyns (SAE 10 oil at 125° F).

RESULTS AND DISCUSSION

Full-Floating Bearing with Unidirectional Load

Floating-sleeve speed. - The floating sleeve of a full-floating bearing can operate over a wide range of speeds for a given shaft speed, the exact value depending principally upon the ratio of clearances and upon the ratio of radii of the bearing. It is evident from figure 4 that except for low values of Sommerfeld number, which are avoided in practice, the speed ratio N_1/N_0 is independent of Sommerfeld number. Figure 7 may therefore be used for lightly loaded bearings as well as for bearings operating without load. The three data points shown in figure 7 were obtained using three unloaded full-floating bearings, each having a ratio of radii of 1.3. Two of these points are seen to fall very close to the analytically determined solid curve, but the one corresponding to the larger ratio of clearances is somewhat below the theoretical curve.

Experimentally determined values of speed ratio are shown in figure 9 plotted against sommerfeld number for full-floating bearings A and C, having ratios of clearances of 1.00 and 0.43, respectively. The experimental points lie close to the analytically determined solid curve over a wide range of loads in the case of the bearing C having a ratio of clearances of 0.43. The points for the bearing A, having a ratio of clearances of 1.00, however, deviate from the theoretical curve at low values of Sommerfeld number. Similar runs were made on bearing B having a ratio of clearances of 1.67, but these points were irreproducible unless the bearing was operating completely unloaded. The experimental results indicate that the analytically determined curves approximately represent the performance to be expected from a lightly loaded full-floating bearing. The bearings with a large ratio of clearances tend to be unstable when operated under load.

Extent of oil film. - Observation of the outer oil film through the glass bearing under operating conditions corresponding to those of the foregoing experiments showed the oil film to be continuous at all points when the bearing was unloaded. As load was gradually

applied, however, the film became progressively discontinuous in the region beyond the point of closest approach in the direction of rotation. The rupture of the oil film, when the journal moves eccentrically, is due to the tendency for high negative pressures to be formed in the region where the surfaces are diverging. Because a film cannot withstand tension, it will break when a negative pressure develops. Inasmuch as the analysis assumed a complete oil film to exist at all times, failure of this assumption to be completely realized could account for the limited discrepancy existing between the experimental and the calculated data.

Temperature characteristics. - Less total heat is generated in the two oil films of a full-floating bearing than is generated in the single oil film of an equivalent journal bearing. This fact is evident from the curves of figure 4. In addition, figure 5 shows that the total oil flow through the two clearance spaces of a full-floating bearing is always greater than that through the single clearance space of the conventional bearing. These two characteristics of the full-floating bearing make its use of particular interest in high-speed applications where the operating temperature is an important consideration. The temperature criterion offers a convenient means of evaluating the combined influence of an increase in flow and a decrease in bearing friction upon the operating temperature of the bearing. From figure 6 the temperature criterion is seen to be always greater than 1 and hence the full-floating bearing is an advantageous design under all operating conditions so far as bearing temperature is concerned.

Load capacity. - The full-floating bearing is considered to fail when the speed ratio N_1/N_0 is either 0 or 1. This condition of failure does not mean that the full-floating bearing as a unit has seized to the housing because the unit may continue to operate as a conventional journal bearing, with seizure existing between only one of the pairs of mating surfaces. The full-floating bearing failed at the outer surface before it failed at the inner surface in all cases. A comparison of the Sommerfeld numbers for the two oil films should indicate which surface failed first.

From equations (A-27) and (A-28)

$$\frac{S_1}{S_2} = \left(\frac{r_1}{r_2}\right)^3 \left(\frac{c_2}{c_1}\right)^2 \left(1 + \frac{N_0}{N_1}\right) \quad (11)$$

If this ratio is greater than 1, the outer bearing surface should fail before the inner surface. For bearings A and B the value of the ratio S_1/S_2 was greater than 1. The value of this ratio for bearing C was 0.63 but it also failed on the outside surface. This inconsistency between the theoretical and the experimental results may be explained by consideration of several unknown variables not taken into account, namely, deflection of the floating sleeve, dirt in oil, different viscosity of the oil in each oil film, and difference in coefficients of friction of the bearing materials. Equation (11) shows that, if the floating sleeve is thick (r_2/r_1 large) and the outer clearance c_2 is small relative to the inner clearance, the bearing may be made to fail on the inner surface first. Bearings of practical proportions, however, should fail first on the outer surface.

Inasmuch as the floating sleeve of a full-floating bearing is actuated by a fluid drive rather than by a positive mechanical linkage, it may fail to rotate under certain circumstances. When the shaft starts to rotate, the floating sleeve will fail to rotate if the boundary friction between the inner bearing surfaces is considerably less than that between the outer bearing surfaces. In general, the starting friction between these two sets of surfaces will be about the same, but the presence of a small amount of dirt between the outer bearing surfaces may increase the starting friction in this region to a value high enough to prevent the floating sleeve from rotating. If metal-to-metal contact exists between the outer bearing surfaces at the same time that a hydrodynamic film exists between the inner surfaces, the hydrodynamic film will be incapable of transmitting sufficient torque to the floating sleeve to overcome the high starting friction between the outer surfaces. This difficulty should be considered particularly when the bearing is subjected to a unidirectional load. In order to achieve normal operation of the bearing, it is necessary to remove the load and to allow sufficient time for an oil film to be established. A mechanical disturbance such as vibration will shorten the time required to establish this oil film.

The failure of the full-floating bearing to function properly at all times when started from rest is a decided disadvantage. However, the choice of proper bearing materials to be used on inner and outer bearing surfaces can mitigate this difficulty. The materials for the outer mating surfaces should offer low friction under boundary conditions of lubrication and also have good embeddability. The bearing materials of the inner mating surfaces should offer high frictional resistance under boundary conditions and should not have as good embeddability inasmuch as the presence of dirt between these

surfaces will augment the frictional resistance, which causes the floating sleeve to rotate. For example, aluminum might be used against steel for the inner bearing surfaces and lead against steel for the outer bearing surfaces.

Failure of the floating sleeve may also be caused by starving one of the oil films. Proper bearing design and sufficient oil pressure will prevent failure of this nature.

When load capacities are compared, the basis of the comparison is the equivalent journal bearing as previously defined. The low operating temperature of the full-floating bearing may, however, allow smaller clearances between adjacent surfaces than were necessary for the conventional journal bearing. In this case it would be possible to replace the conventional bearing with a full-floating bearing having a load capacity equal to or greater than the conventional journal bearing.

Floating-sleeve whirl. - Oil-film whirl or shaft whirl is generally caused by the action of the oil when the bearing is supporting light loads at speeds above the critical speed of the shaft. It is undesirable because severe vibration and bearing failures often result. The floating sleeve was observed to whirl in the direction of journal rotation at shaft speeds as low as 50 rpm when unloaded. The circumferential movement of the point of closest approach between the floating sleeve and the glass bearing was quite distinct when the fluorescent lubricant was observed by means of "black light." With bearing B, the rotative speed of the point of closest approach was found to vary from 0.329 to 0.717 times the floating-sleeve speed as the floating-sleeve speed varied from 217 to 630 rpm. The whirl speed is not one-half the critical speed of the mechanical system as it has been reported (references 1 and 2) to be in conventional high-speed bearings. The whirling characteristics of the floating sleeve of a full-floating bearing should be thoroughly investigated. The proper choice of grooving in the surfaces of a full-floating bearing may prevent this phenomenon.

Use of full-floating-bearing charts. - An example is presented to illustrate the use of the full-floating-bearing charts presented in figures 3 to 6. In order to illustrate the importance of the relation between the inner and outer clearances of a full-floating bearing, five bearings of various arrangements of clearances are analyzed. Representative operating characteristics of these five full-floating bearings as applied to a rotor of a compressor-turbine power plant are presented in table I.

The results presented in table I demonstrate the wide difference in performance that can be caused by relatively slight changes in the inner and outer clearances. Such clearances must be controlled to very close tolerances if the performance of a full-floating bearing is to be predicted. By changing only the clearances, the speed ratio in the table varied from 0.21 to 0.54.

The decrease in the total heat generated in the two films of a full-floating bearing over that generated in the single film of an equivalent bearing is illustrated by the data in table I. Evidently, the total heat generated in a full-floating bearing may be as little as one-half that generated in an equivalent journal bearing. By the proper adjustment of clearances, the combined effect of increased oil flow and decreased heat generation may yield a temperature criterion that is greater than 20. Bearings 2 and 4 illustrate the manner in which the clearances may be chosen to cause the inner bearing to fail first.

The load capacity of a bearing is directly proportional to the Sommerfeld number. Comparison of the Sommerfeld numbers of bearings 1 and 5 (each having the same inner clearance) shows that the load capacity of the inner bearing is somewhat improved by increasing the ratio of clearances from 1 to 2 but at the same time the load capacity of the outer bearing is considerably reduced. The clearance combinations of bearings 3 and 5, in which the ratio of clearances is equal to 2, are advantageous from a consideration of the operating temperature of the bearing (γ is approximately 23). This increased cooling capacity, however, is obtained at the expense of a decrease in load capacity. This effect is found to be generally the case.

note The best combination of clearances to be used depends upon the conditions under which the bearing must operate. If the speed of the journal is high and the load is relatively light, cooling the bearing is the paramount problem; under such circumstances a ratio of clearances greater than 1 might be employed. It should be noted, however, that the measured speed ratio of the full-floating bearing became less reproducible as the ratio of clearances was increased. From an over-all consideration of bearing operation, including reproducibility, load capacity, and cooling capacity, a ratio of clearances of a little less than 1 would be desirable for most full-floating bearings. This bearing will be stable and will have approximately equal load capacities in the inner and outer oil films. Whereas this bearing will not have the maximum temperature criterion, its cooling capacity will be about twice that of an equivalent journal bearing.

Full-Floating Bearing with Rotating Load

Free sleeve. - The foregoing discussion pertains to a full-floating bearing under a unidirectional load, as diagrammatically shown in figure 10(a). The operating characteristics are significantly changed when a bearing of this type is subjected to a rotating load. The most common case, in which the load rotates at the same speed as the shaft, will be considered in the following discussion. (See fig. 10(b).) Inasmuch as it is difficult to visualize the effective motion between the bearing surfaces when the load is rotating, it is advantageous to employ an equivalent diagram oriented with respect to a fixed point on the load vector (fig. 10(c)). Comparison of this diagram with figure 10(a) indicates that the rotating and stationary elements are interchanged. The equations and charts of the foregoing analysis may therefore be made applicable to a bearing operating under a rotating load by simply changing the notation, that is, by numbering the successive surfaces inward from the outer surface rather than outward from the inner surface. (See symbol list.)

The ratio of radii is less than 1 for a bearing operating under a rotating load whereas this ratio was always greater than 1 with a unidirectional load. Inasmuch as the curves of figures 3 and 6 are relatively flat for high values of Sommerfeld number, where the full-floating bearing is of most interest, curves for values of ratio of radii less than 1 are included only in figure 7. The speed ratio will evidently be greater for a bearing subjected to a rotating load than for a bearing supporting a unidirectional load; the temperature criterion is also slightly greater. It should be noted that the equivalent journal bearing used in the comparison with a full-floating bearing subjected to a rotating load had a diameter and clearance equal to that for the outer bearing. On the other hand, the equivalent journal bearing used in the comparison with a unidirectionally loaded full-floating bearing had a diameter and clearance equal to that of the inner bearing.

Restrained sleeve. - In order to improve the over-all load capacity of a floating bearing, Stone and Underwood (reference 9) proposed a bearing with a nonrotating sleeve (fig. 10(d)). Rotation of the floating element is prevented by loosely pinning it to the outer bearing surface in such a way that curvilinear translation (irrotational motion) is permitted. The equivalent diagram with respect to the load vector is given in figure 10(e). The load capacity of the inner bearing is then equal to the capacity of the equivalent journal bearing for which $c_e = c_2$ and $r_e = r_2 \approx r_1$,

whereas the load capacity of the outer bearing is twice the capacity of the equivalent journal bearing. The heat generated, however, in the floating bearing is always greater than that developed in the equivalent journal bearing as is evident from the following equation, which may be developed by a sequence of steps similar to those used in deriving equation (5):

$$\frac{H_{F1}}{H_e} = 1 + \left(\frac{c_1}{c_2}\right) \left[\frac{30n_1 \sqrt{1-n_1^2} \sqrt{1-n_e^2}}{15n_e (1-n_e^2) + \pi^2 S_e} \right] \quad (12)$$

where H_{F1} is the total heat generated per unit time in the bearing of figure 10(e), and the subscripts 1 and 2 refer to the outer and inner oil films, respectively, of the floating bearing.

The quantity H_{F1}/H_e is shown in figure 11 plotted against S_e , which is the Sommerfeld number for a conventional bearing having a diameter the same as that of the inner journal of the floating bearing. Whereas the additional heat generated in the floating bearing over the heat developed in a similar equivalent bearing is small for lightly loaded bearings, this additional heat may be as much as 100 percent greater than the heat generated in the equivalent bearing under heavy load. A bearing having similar properties under a unidirectional load is obtained by loosely pinning the floating element to the shaft.

Other Design Considerations

The full-floating bearings shown in figures 10(a) and 10(c) will operate at a lower temperature than an equivalent journal bearing of $c_1 = c_2 = c_e$ but the load capacity will be reduced by a factor equal to the speed ratio. This lower operating temperature is due to the combined effects of decreased heat generated in the oil film and increased oil flow through the bearing. The floating bearing, which has a nonrotating sleeve (fig. 10(d)), will have a load capacity equal to the capacity of the equivalent journal bearing but will operate at a temperature intermediate between the temperature of the equivalent journal bearing and that of the full-floating bearing with rotating sleeve. The decision to restrain the floating sleeve depends upon whether bearing temperature or load capacity is the critical factor.

SUMMARY OF RESULTS

An analysis of full-floating bearings operating under either a unidirectional or a rotating load has been made and a design chart is presented from which the important operating characteristics of such bearings may be obtained. This analysis enabled the following observations to be made:

1. The floating sleeve operated over a wide range of speeds for a given shaft speed, the exact speed of the element depending principally upon the ratio of clearances and the ratio of radii.
2. The speed ratio of the full-floating bearing became increasingly irreproducible as the ratio of clearances is increased above 1.
3. Less total heat was generated in the two oil films of a full-floating bearing than was generated in the single oil film of an equivalent journal bearing (if the floating sleeve was not restrained from rotating).
4. The over-all cooling capacity of a full-floating bearing was always greater than that of an equivalent journal bearing.
5. The failure of the floating sleeve of a full-floating bearing to start always from rest, when under load, would be an important consideration in the design of this bearing.
6. The floating sleeve was observed to whirl at rotative speeds of this element as low as 50 rpm under light load. The speed of the whirl was observed to vary from 0.329 to 0.717 times the floating sleeve speed as the speed of the sleeve varied from 217 to 630 rpm.
7. The load capacity of a full-floating bearing was less than that of an equivalent journal bearing if the clearances between all mating surfaces were the same. By adjusting the clearances for a full-floating bearing, the load capacity would be greater or less than that of a conventional journal bearing of the same shaft diameter.

Aircraft Engine Research Laboratory,
National Advisory Committee for Aeronautics,
Cleveland, Ohio.

APPENDIX - DERIVATION OF EQUATIONS FOR SPEED OF FLOATING SLEEVE

Expressions are first derived for the friction torques acting on the journal and bearing surfaces of a conventional journal bearing. These expressions may then be used to obtain the friction torques, which act at the inner and outer surfaces of a full-floating bearing. The following assumptions are involved in the derivation:

- (1) Lubricant is Newtonian
- (2) Flow is laminar
- (3) There is no slip between fluid and wall
- (4) Inertia effects of fluid may be neglected
- (5) Weight of fluid may be neglected
- (6) Fluid is incompressible
- (7) Film pressure is constant with depth of film
- (8) Curvature of film may be neglected
- (9) Films are so thin that they may be unwrapped
- (10) Slopes of unwrapped films are so small that cosine of angle is unity and the sine of the angle is equal to the angle in radians
- (11) Viscosity of the fluid is uniform throughout the film

Derivation of General Friction Torque Equations

A conventional journal bearing is shown operating under load in Figure 12. In the system of coordinates employed, the x-axis extends along the surface of the bearing but is not attached to this surface. Consider the free-body diagram of a particle of lubricant with all forces acting upon it parallel to the x-axis. The sum of all these forces must be zero; that is,

$$\begin{aligned}
 p dy dz - \left(p + \frac{\partial p}{\partial x} dx \right) dy dz + \left(s + \frac{\partial s}{\partial y} dy \right) dx dz - s dx dz \\
 + \left(s + \frac{\partial s}{\partial z} dz \right) dx dy - s dx dy = 0
 \end{aligned}
 \tag{A-1}$$

or

$$\frac{\partial p}{\partial x} = \frac{\partial s}{\partial y} + \frac{\partial s}{\partial z} \quad (\text{A-2})$$

By Newton's law of viscous flow

$$s = \mu \left(\frac{\partial u}{\partial y} + \frac{\partial u}{\partial z} \right) \quad (\text{A-3})$$

From equations (A-2) and (A-3), noting that $\frac{\partial u}{\partial z} \ll \frac{\partial u}{\partial y}$ because the lubricant film is thin

$$\frac{\partial^2 u}{\partial y^2} = \frac{1}{\mu} \frac{\partial p}{\partial x} \quad (\text{A-4})$$

The following equation is obtained by integrating twice with respect to y and evaluating the constants of integration from the following conditions: $u = U_b$ when $y = 0$, and $u = U_j$ when $y = h$.

$$u = \frac{1}{2\mu} \frac{\partial p}{\partial x} y(y-h) + \frac{y}{h} (U_j - U_b) + U_b \quad (\text{A-5})$$

From equations (A-3) and (A-5)

$$s = \frac{1}{2} \frac{\partial p}{\partial x} (2y-h) + \frac{\mu}{h} (U_j - U_b) \quad (\text{A-6})$$

Assuming a continuous oil film to extend around the bearing (a full journal bearing) the friction torque acting upon the bearing surface is

$$T_b = r \int_0^L \int_0^{2\pi r} s(y=0) \, dx dz \quad (\text{A-7})$$

Because $dx = r d\theta$, (A-8)

$$T_b = r^2 \int_0^L \int_0^{2\pi} s(y=0) \, d\theta dz \quad (\text{A-9})$$

and therefore

$$T_b = -\frac{r}{2} \int_0^L \int_0^{2\pi} h \frac{\partial p}{\partial \theta} d\theta dz + \mu r^2 (U_j - U_b) \int_0^L \int_0^{2\pi} \frac{d\theta dz}{h} \quad (\text{A-10})$$

The following integration may be performed by parts:

$$\int_0^{2\pi} h \frac{\partial p}{\partial \theta} d\theta = ph \Big|_{\theta=0}^{2\pi} - \int_0^{2\pi} p \frac{dh}{d\theta} d\theta \quad (\text{A-11})$$

The first right-hand term is 0 and hence from equations (A-10) and (A-11)

$$T_b = \frac{r}{2} \int_0^L \int_0^{2\pi} p \frac{dh}{d\theta} d\theta dz + \mu r^2 L (U_j - U_b) \int_0^{2\pi} \frac{d\theta}{h} \quad (\text{A-12})$$

The film thickness at any point in the oil film (fig. 12) can be expressed to a good approximation as

$$h = c(1 + n \cos \theta) \quad (\text{A-13})$$

where bearing attitude $n = \frac{e}{c}$

From equations (A-12) and (A-13)

$$T_b = -\frac{ncr}{2} \int_0^L \int_0^{2\pi} p \sin \theta d\theta dz + \mu r^2 L (U_j - U_b) \frac{2}{c\sqrt{1-n^2}} \quad (\text{A-14})$$

Inasmuch as all forces acting on the bearing in a direction perpendicular to the line of centers OO' (fig. 12) must be zero for equilibrium

$$r \int_0^L \int_0^{2\pi} p \sin \theta d\theta dz = W \sin \phi \quad (\text{A-15})$$

From equations (A-14) and (A-15)

$$T_b = -\frac{nc}{2} W \sin \phi + \frac{2\pi\mu r^2 L}{c \sqrt{1-n^2}} (U_j - U_b) \quad (A-16)$$

The following expression for the torque acting upon the journal surface may be similarly derived:

$$T_j = \frac{nc}{2} W \sin \phi + \frac{2\pi\mu r^2 L}{c \sqrt{1-n^2}} (U_j - U_b) \quad (A-17)$$

Application of Friction Torque Equations

A full-floating bearing is diagrammatically shown in figure 13. The torques T_1 and T_2 , which act upon the inner and outer surfaces, respectively, of the floating bearing, must be equal in accordance with static equilibrium. Expressions for T_1 and T_2 may be obtained by substituting the proper dimensions from figure 13 in equations (A-16) and (A-17), respectively.

$$T_1 = -\frac{n_1 c_1}{2} W \sin \phi_1 + \frac{2\pi\mu r_1^2 L \left(\frac{2\pi r_0 N_0}{60} - \frac{2\pi r_1 N_1}{60} \right)}{c_1 \sqrt{1-n_1^2}} \quad (A-18)$$

$$T_1 = -\frac{n_1 c_1}{2} W \sin \phi_1 + \frac{\pi^2 \mu r_1^2 L (r_0 N_0 - r_1 N_1)}{15 c_1 \sqrt{1-n_1^2}} \quad (A-19)$$

$$T_2 = \frac{n_2 c_2}{2} W \sin \phi_2 + \frac{\pi^2 \mu r_2^3 L N_1}{15 c_2 \sqrt{1-n_2^2}} \quad (A-20)$$

Equating (A-19) and (A-20) and noting that $r_0 N_0 - r_1 N_1 = r_1 (N_0 - N_1)$ to a very good approximation

$$N_0 = \left(1 + \frac{c_1 r_2^3 \sqrt{1-n_1^2}}{c_2 r_1^3 \sqrt{1-n_1^2}} \right) N_1 + \frac{15c_1 \sqrt{1-n_1^2} W}{2\pi^2 \mu L r_1^3} (c_2 n_2 \sin \phi_2 + c_1 n_1 \sin \phi_1) \quad (\text{A-21})$$

The following equation is obtained by replacing W in equation (A-21) with its equivalent $2Lr_1 P_1$, where P_1 is the unit bearing load acting on the projected area of the inner bearing:

$$N_0 = \left(1 + \frac{c_1 r_2^3 \sqrt{1-n_1^2}}{c_2 r_1^3 \sqrt{1-n_2^2}} \right) N_1 + \frac{15c_1 \sqrt{1-n_1^2} P_1}{\pi^2 \mu r_1^2} (c_2 n_2 \sin \phi_2 + c_1 n_1 \sin \phi_1) \quad (\text{A-22})$$

The viscosities of the inner and outer oil films have been considered equal in the foregoing derivation.

The attitude angle ϕ (fig. 12) has a value of 90° when a load of any magnitude is imposed upon a full journal bearing of infinite length (reference 8, p. 107). The significant end flow associated with bearings of finite length causes this attitude angle to vary with load. The manner in which the attitude angle for this bearing varies with load cannot be analytically expressed inasmuch as the differential equation for the pressure distribution in the load-carrying oil film of a full journal bearing of finite length has not been solved in closed form. Published results of several experimental investigations of this problem are available, as well as approximate solutions for partial bearings. (See references 10 to 14.) This work indicates that, as the bearing is loaded, the journal center moves along a path similar to the one shown in figure 14. It will therefore be assumed in this

investigation that, as load is applied, the journal center moves along a Circular arc in accordance with the following expression:

c = dia of circle

$$e = c \cos \phi \tag{A-23}$$

$$\sin \phi = \sqrt{1-n^2} \tag{A-24}$$

From equations (A-22) and (A-24)

$$N_0 = \left(1 + \frac{c_1 r_2^3 \sqrt{1-n_1^2}}{c_2 r_1^3 \sqrt{1-n_2^2}} \right) N_1 + \frac{15c_1 \sqrt{1-n_1^2} P_1}{\pi^2 \mu r_1^2} \left(c_2 n_2 \sqrt{1-n_2^2} + c_1 n_1 \sqrt{1-n_1^2} \right) \tag{A-25}$$

Further simplification of this equation requires a relation between the load acting on the bearing and the resulting attitude. Whereas this expression is not available for a bearing of finite length, the equation for a full journal bearing of infinite length (reference 8, p. 120)

$$S = \left(\frac{r}{c} \right)^2 \frac{\mu N}{P} = \frac{5(2+n^2)(1-n^2)^{1/2}}{\pi^2 n} \tag{A-26}$$

Sommerfeld number is, in general, only of qualitative value. Strictly used, it should be applied only to bearings of infinite length but when employed for the purpose of comparing two bearings of the same finite length, the errors introduced by ignoring end leakage tend to cancel each other.

Swift (reference 15) has analytically shown that the load capacity of a unidirectionally loaded bearing in which both journal and bearing rotate in the same direction (as in fig. 12) is the same as though the journal alone were to rotate at a speed equal to the sum of the actual journal and bearing speeds. Stone and Underwood (reference 9) have experimentally verified Swift's analytical results. Therefore, in applying equation (A-26) to the inner oil film of a full-floating bearing, the speed to be used is $N_0 + N_1$ and equation (A-26) then becomes

$$S_1 = \left(\frac{r_1}{c_1}\right)^2 \frac{\mu(N_0 + N_1)}{P_1} = \frac{5(2 + n_1^2)(1 - n_1^2)^{1/2}}{\pi^2 n_1} \quad (\text{A-27})$$

For the outer oil film equation (A-26) becomes

$$S_2 = \left(\frac{r_2}{c_2}\right)^2 \frac{\mu N_1}{P_2} = \frac{5(2 + n_2^2)(1 - n_2^2)^{1/2}}{\pi^2 n_2} \quad (\text{A-28})$$

Equations (A-25), (A-27), and (A-28) may be combined to give

$$\frac{N_1}{N_0} = \left[\left(\frac{c_1}{c_2}\right)^2 \left(\frac{r_2}{r_1}\right)^3 \left(\frac{n_2}{n_1}\right) \frac{2 + n_1^2}{2 + n_2^2} \sqrt{\frac{1 - n_1^2}{1 - n_2^2}} + 1 \right]^{-1} \quad (\text{A-29})$$

and

$$\begin{aligned} \left(\frac{c_2}{c_1}\right)^2 \left(\frac{n_1}{n_2}\right) (2 + n_2^2) \left[2 \left(\frac{r_1}{r_2}\right)^3 \sqrt{\frac{1 - n_2^2}{1 - n_1^2}} + \frac{c_1}{c_2} \right] &= 2 + n_1^2 \\ - 3n_1 \left(n_1 \sqrt{1 - n_1^2} + \frac{c_2}{c_1} n_2 \sqrt{1 - n_2^2} \right) & \quad (\text{A-30}) \end{aligned}$$

Method of Constructing Charts

Equations (A-27), (A-29), and (A-30) may be used to construct charts from which values of the speed ratio N_1/N_0 may be determined for any value of the Sommerfeld number for given values of ratio of clearances c_2/c_1 and ratio of radii r_2/r_1 . The sequence of operations to be followed in obtaining such charts is summarized as follows:

- (a) Choose values for c_2/c_1 and r_2/r_1
- (b) For the values of (a), plot n_2 against n_1 with equation (A-30)
- (c) Plot S_1 against n_1 by use of equation (A-27)
- (d) For a given value of S_1 , find the corresponding values of n_1 (from curve of (c)) and n_2 (from curve of (b))

- (e) Substitute these values of n_1 and n_2 in equation (A-29) and determine the corresponding value of the speed ratio N_1/N_0
- (f) Repeat this procedure using other values of S_1 to obtain data for a curve of N_1/N_0 against S_1 corresponding to the chosen values of c_2/c_1 and r_2/r_1

In practice S_1 (equation (A-27)) is not a convenient variable to use because it is necessary to know the speed N_1 of the floating sleeve as well as the shaft speed N_0 before S_1 may be determined. A more convenient variable is

$$S_0 = \left(\frac{r_1}{c_1}\right)^2 \frac{\mu N_0}{P_1} \quad (\text{A-31})$$

The quantity S_1 may be expressed in terms of S_0 from equations (A-27) and (A-31) as follows:

$$S_1 = \left(\frac{r_1}{c_1}\right)^2 \frac{\mu}{P_1} N_0 \left(1 + \frac{N_1}{N_0}\right) = S_0 \left(1 + \frac{N_1}{N_0}\right) \quad (\text{A-32})$$

This equation may be used to replot speed-ratio curves against the Sommerfeld number S_0 instead of S_1 . A number of speed-ratio curves obtained in this manner are shown in figure 3.

REFERENCES

1. Newkirk, B. L., and Taylor, H. D.: Shaft Whipping Due to Oil Action in Journal Bearings. Gen. Electric Rev., vol. 28, no. 8, Aug. 1925, pp. 559-568.
2. Newkirk, Burt L., and Grobel, Lloyd P.: Oil-Film Whirl — A Non-Whirling Bearing. A.S.M.E. Trans., vol. 56, no. 8, Aug. 1934, pp. 607-615.
3. Stodola, A.: Steam and Gas Turbines. Vol. I. McGraw-Hill Book Co., Inc., 1927, pp. 483-496.
4. Orloff, P. I.: Coefficient of Friction, Oil Flow, and Heat Balance of a Full-Journal Bearing. Aero. Eng. (Moscow), 9th year, Jan. 1935, pp. 25-56.

5. Shebat, Herbert V.: Bearing. U. S. Patent Office No. 2,076,254, April 6, 1937.
6. Michell, Anthony G. M., and Seggel, August J.: Improvements in Bearings. Australian Patent No. 101,857, Aug. 17, 1937.
7. Ferretti, Pericle: Experiments with Needle Bearings. NACA TM No. 707, 1933.
8. Norton, Arthur Edwin: Lubrication. J. R. Munger, ed., McGraw-Hill Book Co., Inc., 1942.
9. Stone, J. M., and Underwood, A. F.: Load-Carrying Capacity of Journal Bearings. SAE Trans., vol. 1, no. 1, Jan. 1947, pp. 56-67; discussion, pp. 67-70.
10. Falz, Erich: Der Einfluss des Lagerspieles. Ch. II, sec. 8 of Grundzüge der Schmiertechnik, 2d ed., Julius Springer (Berlin), 1931, pp. 42-48. (Reprinted, Edwards Bros., Inc. (Ann Arbor), 1943.)
11. Bradford, Louis J., and Davenport, Charles C.: Characteristic Curves for Fluid Film Lubricated Journal Bearings. Refrigerating Eng., vol. 24, no. 6, Dec. 1932, pp. 343-347.
12. Stone, M.: Film Lubrication in Sleeve Bearings. Jour. Appl. Mech., vol. 2, no. 2, June 1935, pp. A-59-A-64.
13. Clayton, D., and Jakeman, C.: The Measurement of Attitude and Eccentricity in Complete Clearance Bearings. Proc. Inst. Mech. Eng., vol. 134, Nov.-Dec. 1936, pp. 437-506.
14. Swift, Herbert Walker: The Stability of Lubricating Films in Journal Bearings. Paper No. 4909, Proc. Inst. Civil Eng. (Minutes), vol. 233, Jan. 12, 1932, pp. 267-288; discussion, pp. 289-309; correspondence, pp. 310-322.
15. Swift, Herbert Walker: Fluctuating Loads in Sleeve Bearings. Paper No. 5070, Jour. Inst. Civil Eng., vol. 5, no. 4, Feb. 1937, pp. 161-195.

TABLE I - REPRESENTATIVE OPERATING CHARACTERISTICS OF FULL-FLOATING BEARINGS

	Bearing				
	1	2	3	4	5
Assumptions:					
Journal speed, N_0 , (rpm)	20,000	20,000	20,000	20,000	20,000
Viscosity, μ , (reyns)	5 centipoises = 0.72×10^{-6} reyns				
Unit bearing load, P_1 , (lb/sq in.)	100	100	100	100	100
Bearing length, L , (in.)	2	2	2	2	2
Journal radius, r_0 , (in.)	1	1	1	1	1
Outer radius of floating bearing, r_2 , (in.)	1.2	1.2	1.2	1.2	1.2
Clearance of inner bearing, c_1 , (in.)	0.002	0.004	0.001	0.002	0.002
Clearance of outer bearing, c_2 , (in.)	0.002	0.002	0.002	0.001	0.004
Clearance ratio, c_2/c_1	1	0.5	2.0	0.5	2.0
Ratio of radii, r_2/r_1	1.2	1.2	1.2	1.2	1.2
Calculated operating characteristics:					
Sommerfeld number					
Equivalent journal bearing, S_0	36	9	144	36	36
Inner bearing, S_1	49.1	10.9	222	44.1	55.5
Outer bearing, S_2	22.7	13.1	33.6	56	8.4
Speed ratio, N_1/N_0	0.37	0.21	0.54	0.23	0.54
Speed of floating sleeve, N_1 , (rpm)	7300	4200	10,800	4500	10,800
Flow ratio, Q_f/Q_e	2.2	1.2	10.6	1.2	10.6
Ratio of heat generated, H_f/H_e	0.64	0.78	0.46	0.78	0.46
Temperature criterion, γ	3.5	1.5	22.9	1.5	22.9

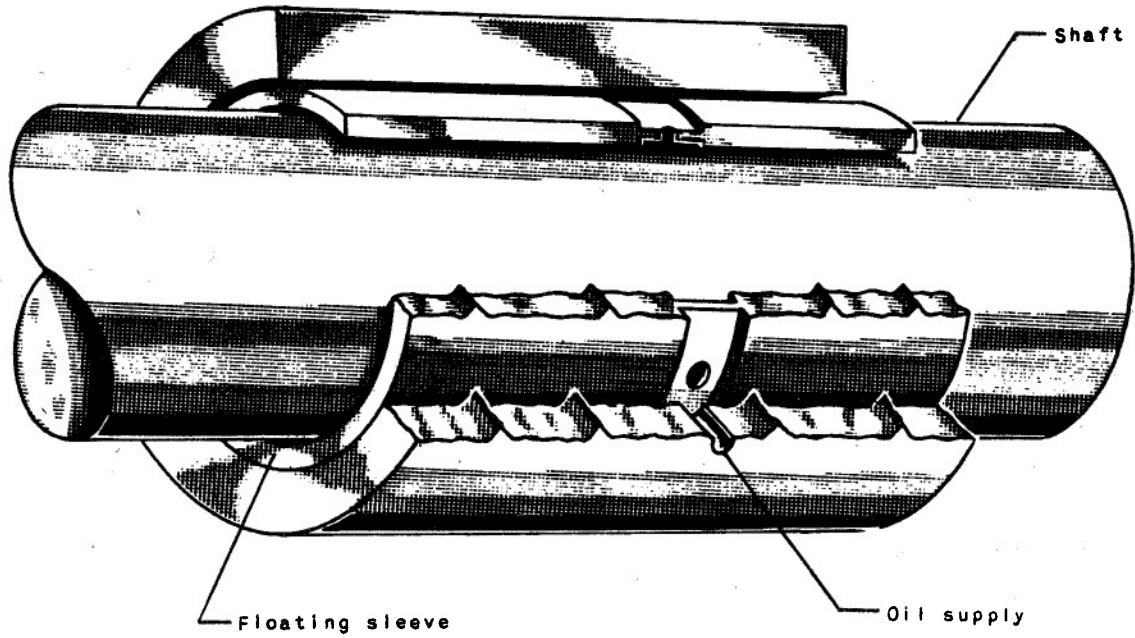

NATIONAL ADVISORY
COMMITTEE FOR AERONAUTICS

Figure 1. - Full-floating bearing.

1011 171

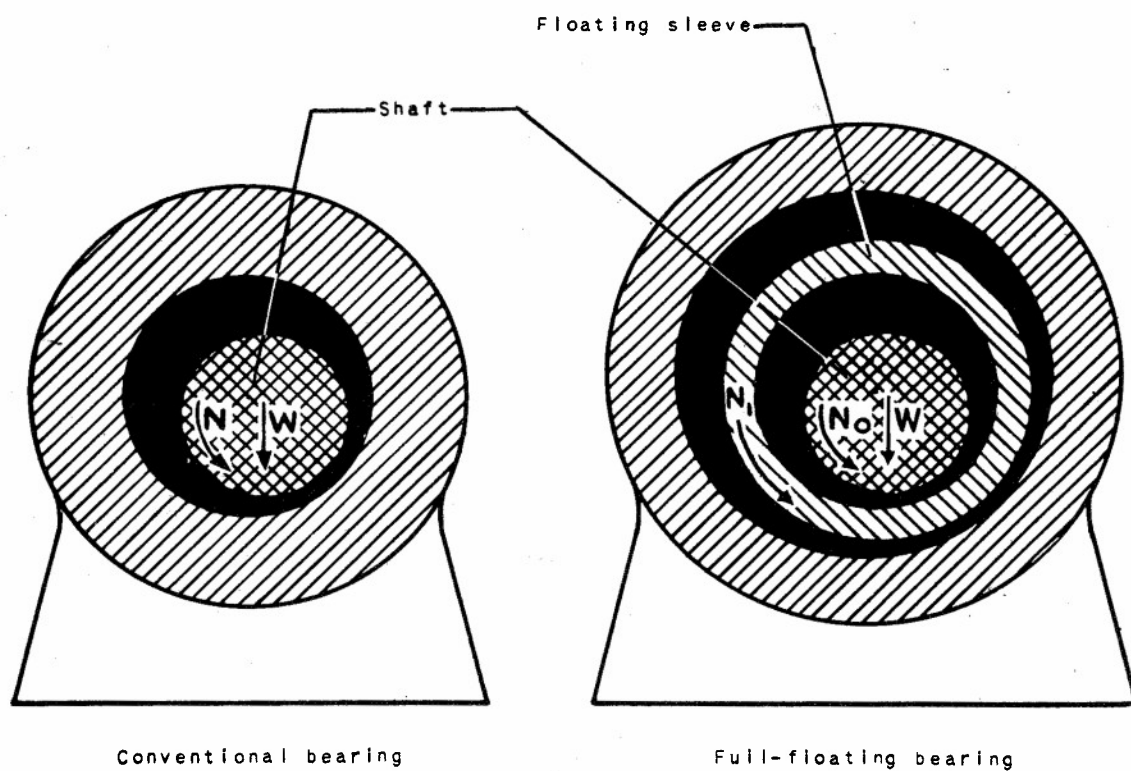

Figure 2. - Diagrammatic representation of conventional and full-floating journal bearings operating under load.

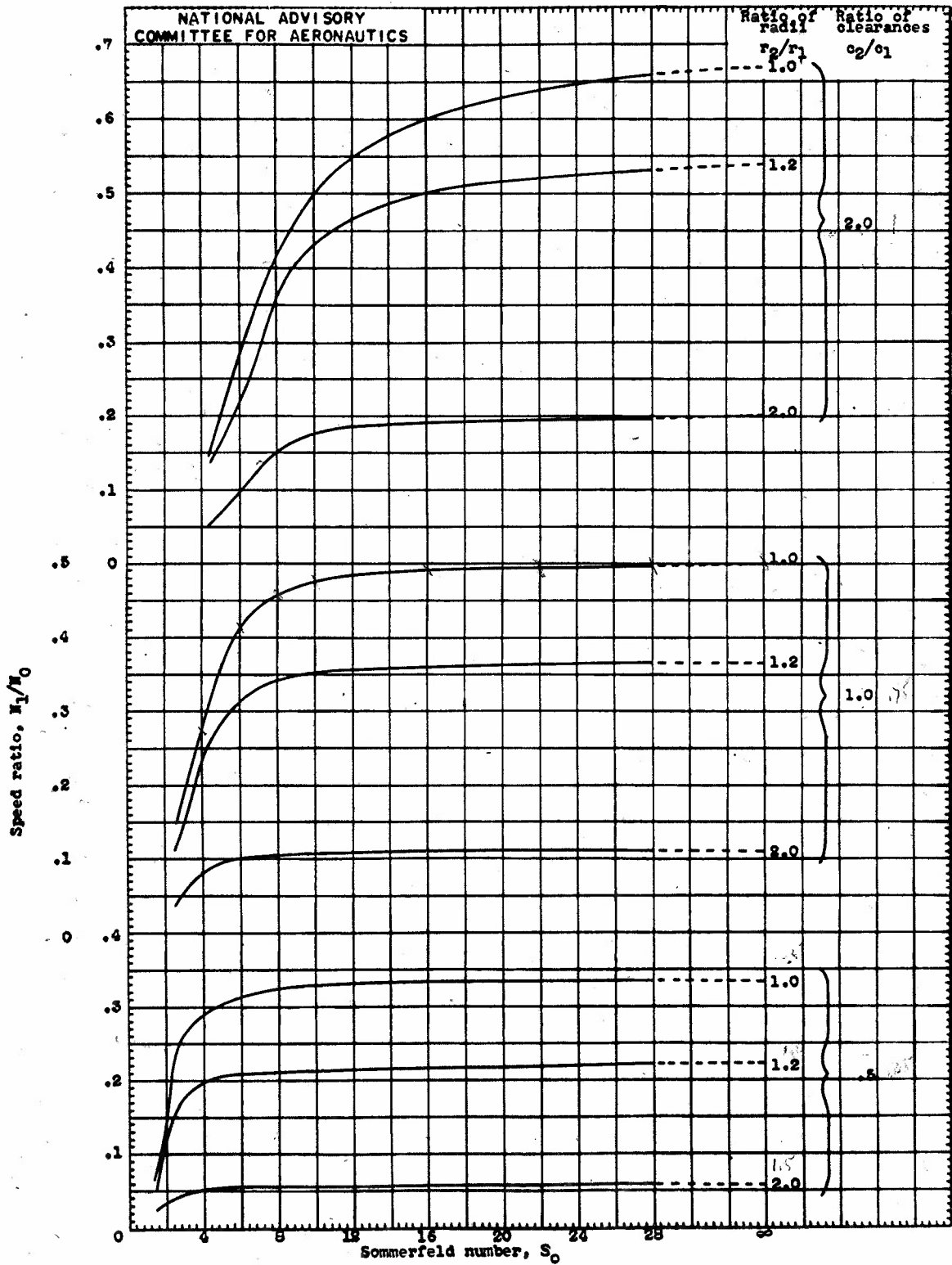

Figure 3. - Variation of speed ratio with Sommerfeld number for full-floating bearing.

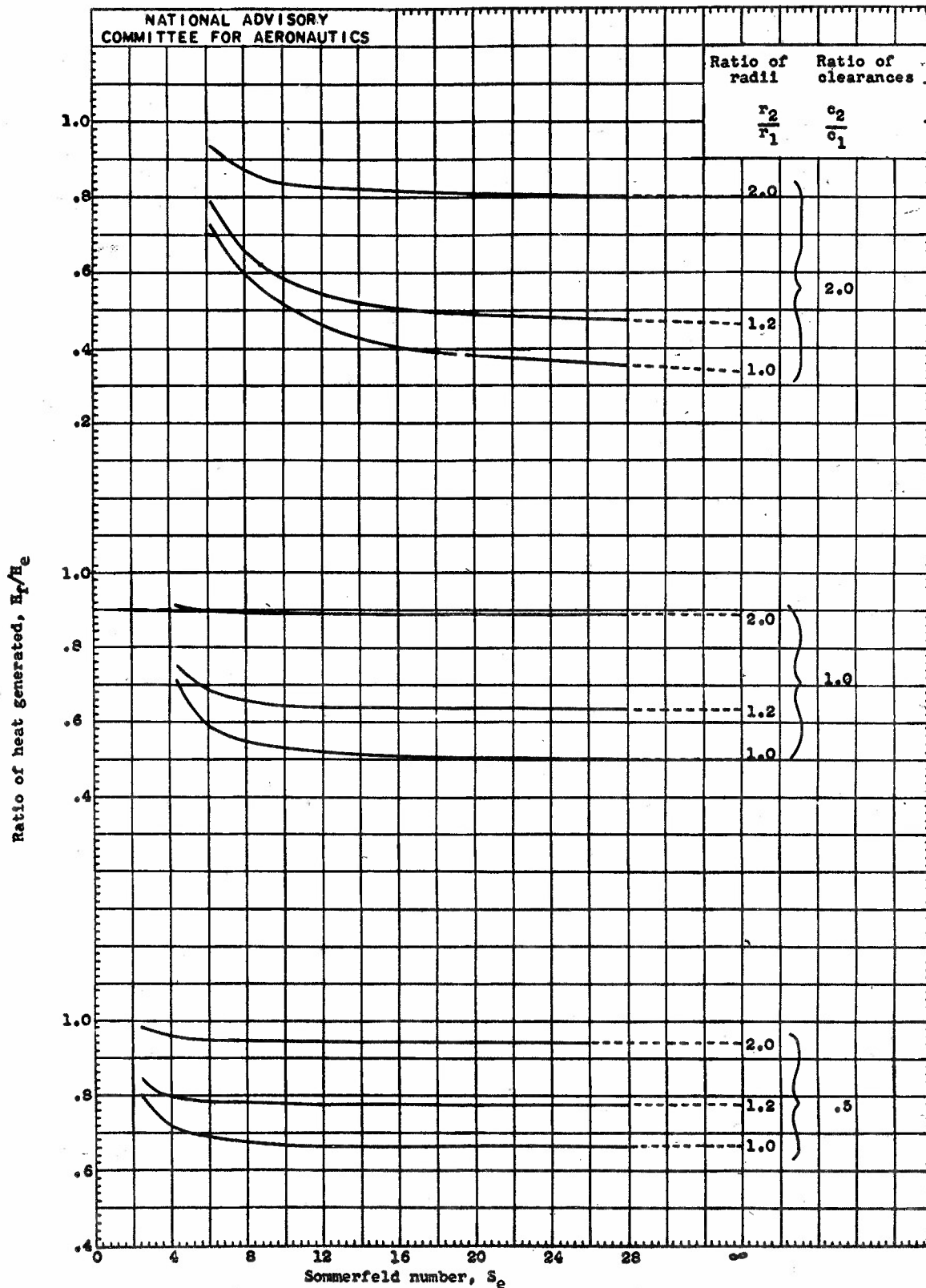

Figure 4. - Variation of ratio of heat generated in full-floating bearing to heat generated in an equivalent journal bearing with Sommerfeld number.

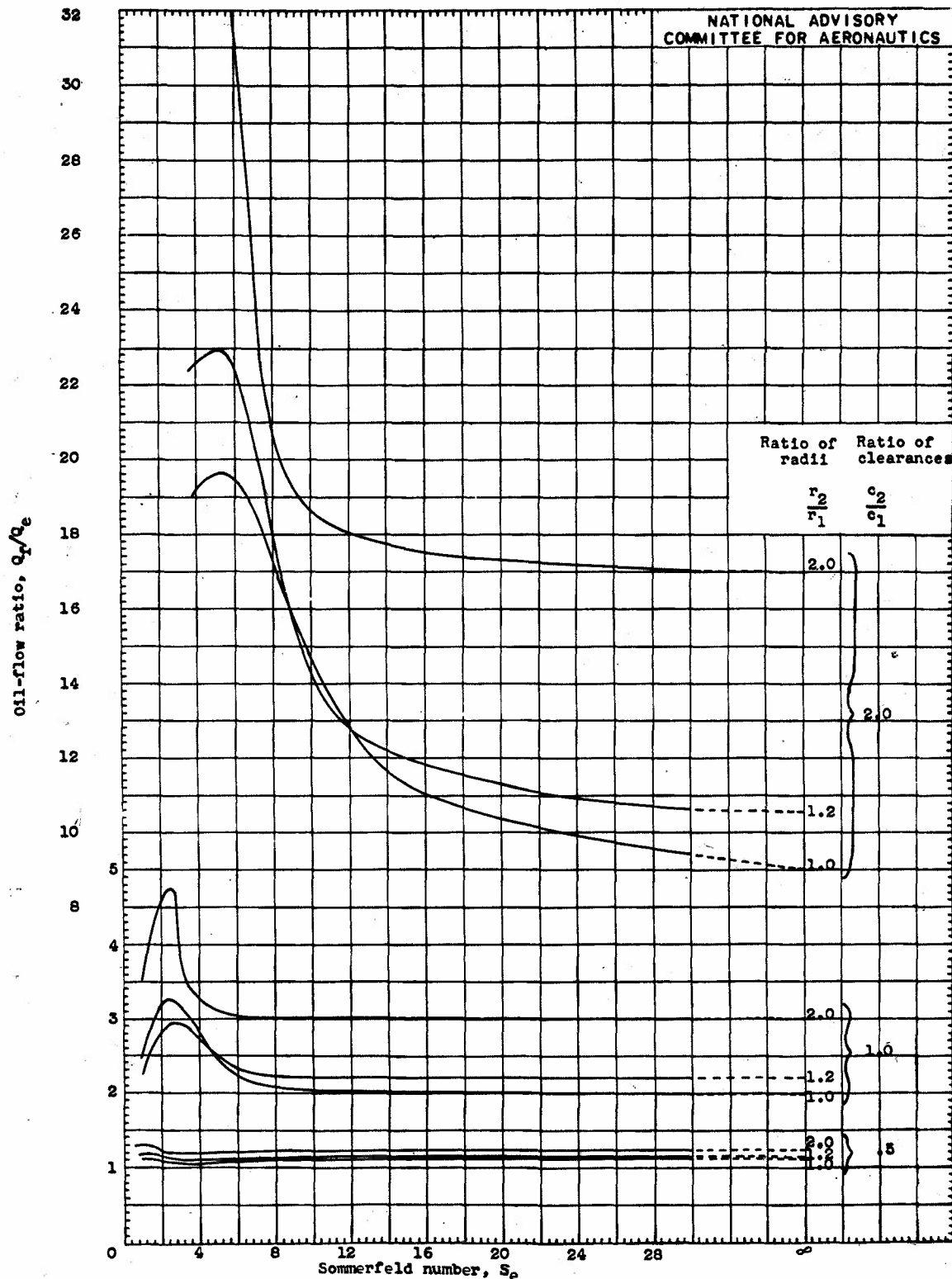

Figure 5. - Variation of oil-flow ratio in full-floating bearing to that in an equivalent journal bearing with Sommerfeld number.

650

Fig. 6

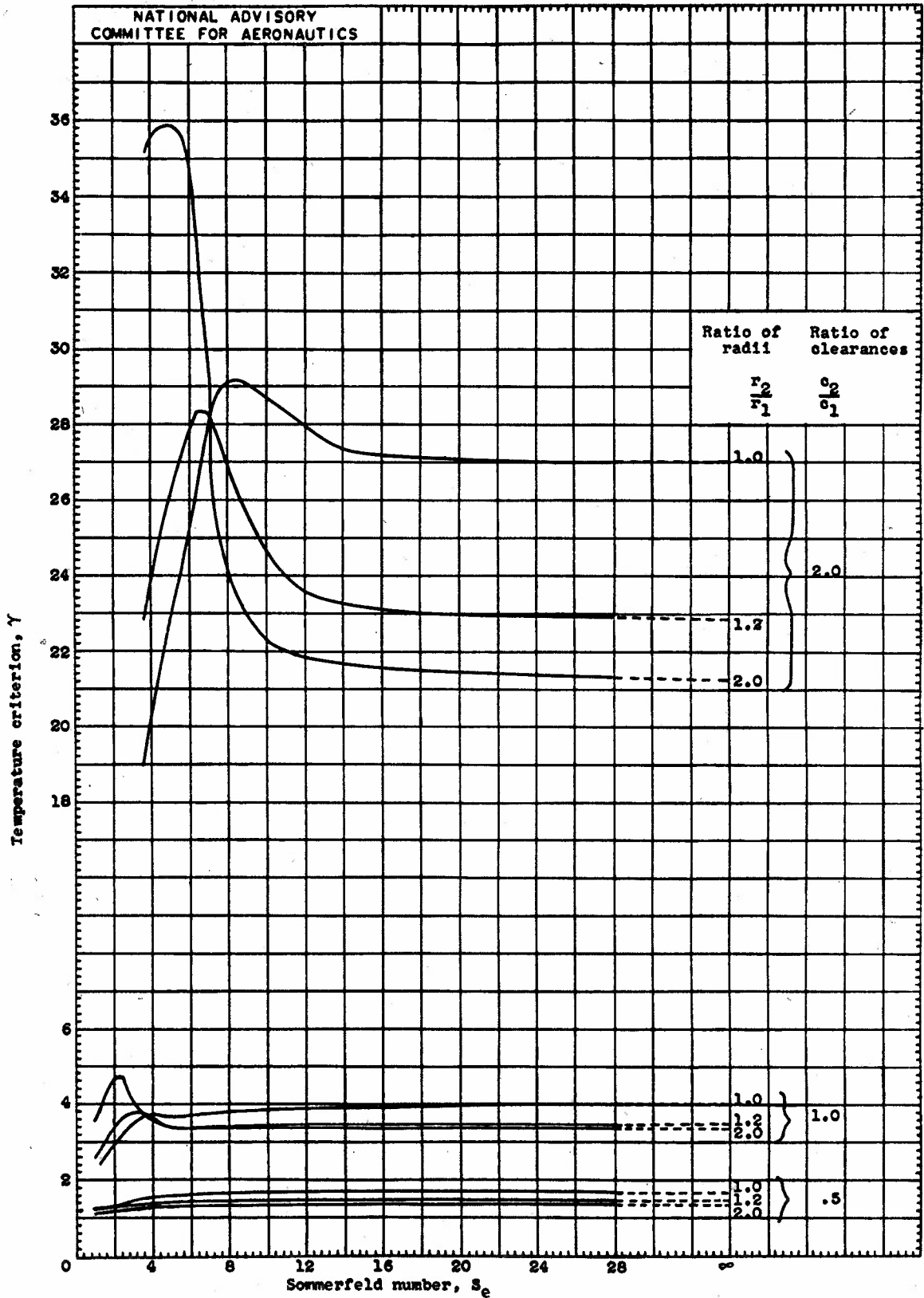

Figure 6. - Variation of temperature criterion with Sommerfeld number.

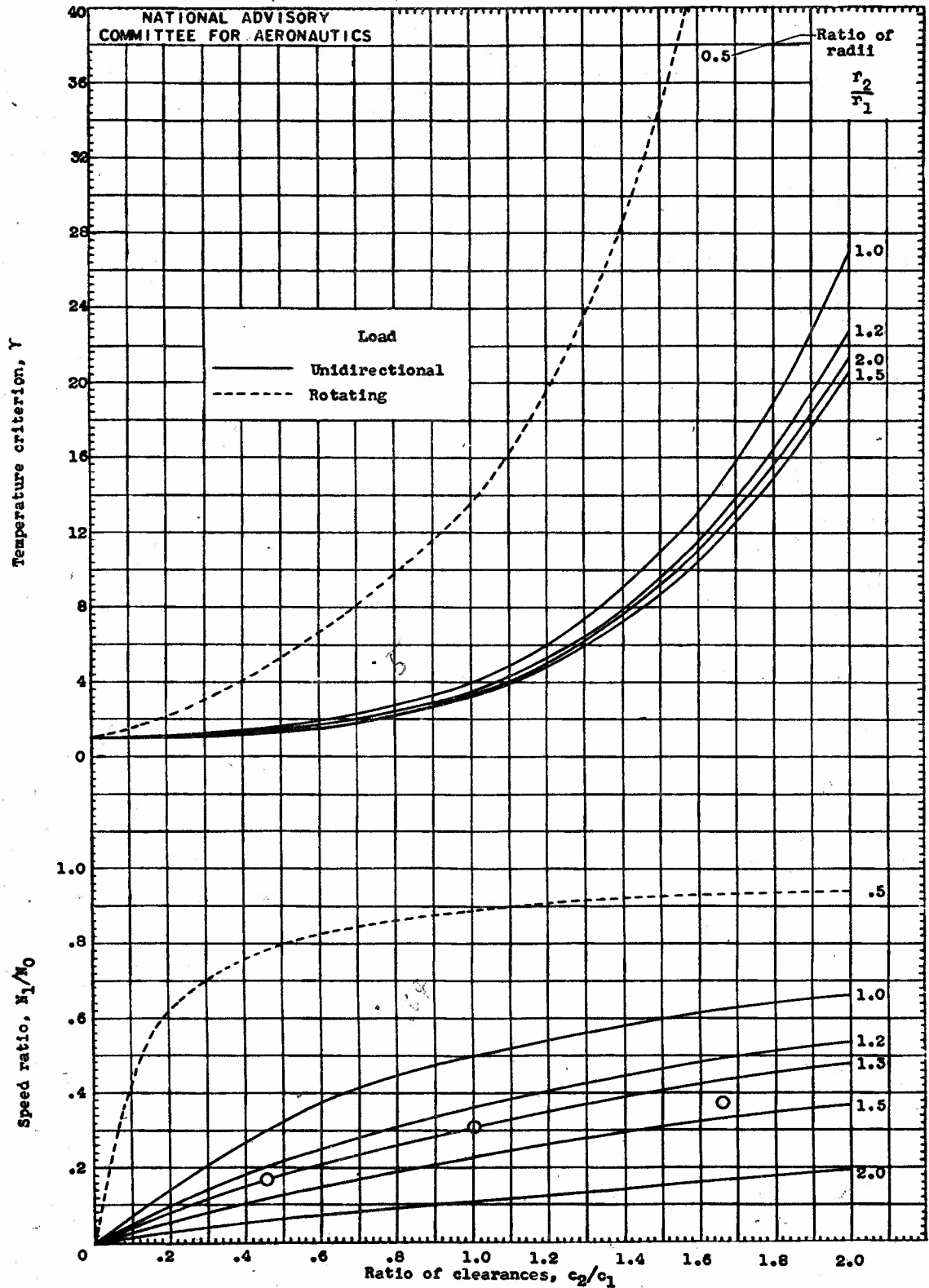

Figure 7. - Effect of ratio of clearances upon temperature criterion and speed ratio of unloaded full-floating bearing. Points are data experimentally determined for value of r_2/r_1 of 1.3.

650

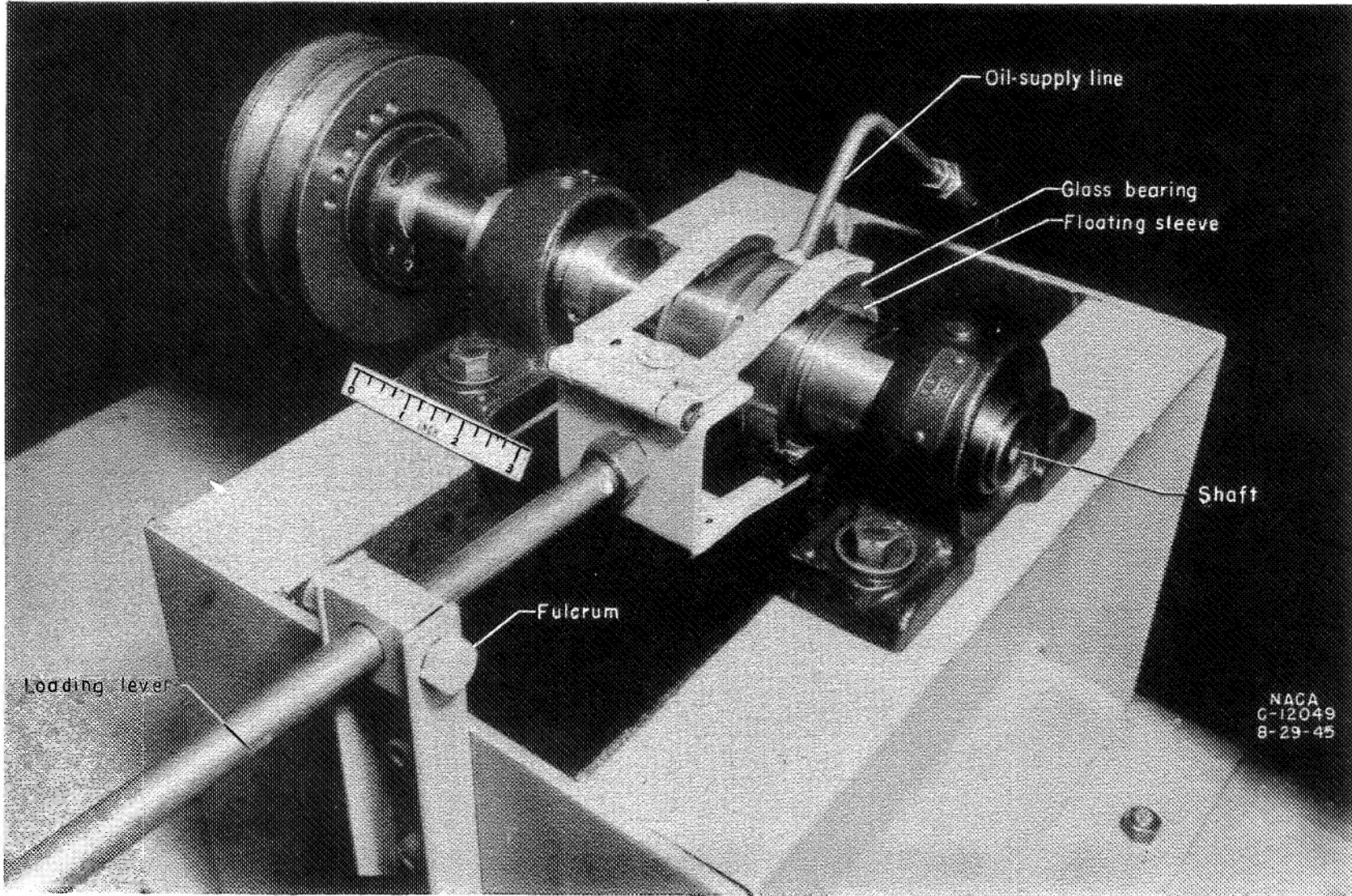

Figure 8.- Apparatus used to study performance of full-floating bearings.

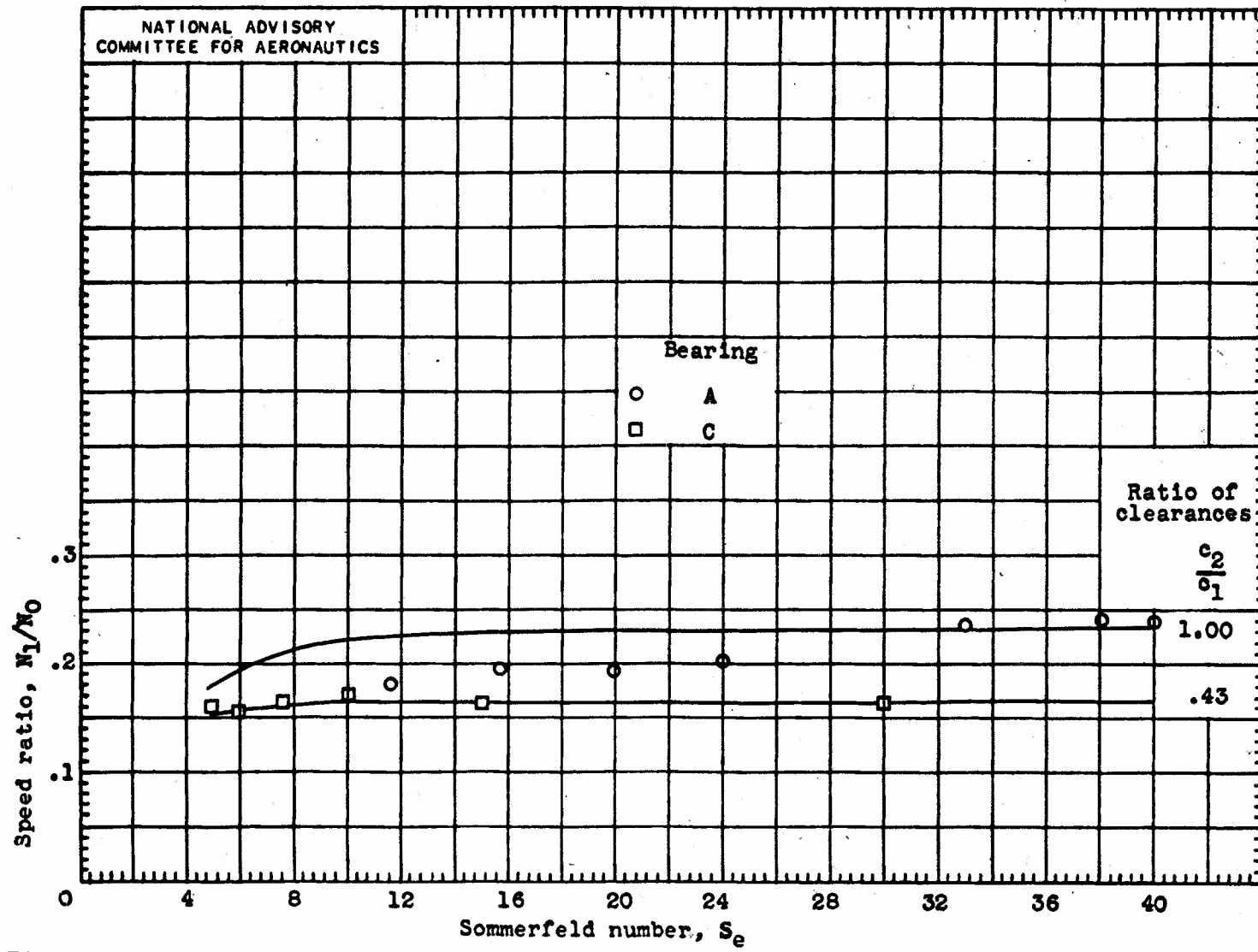
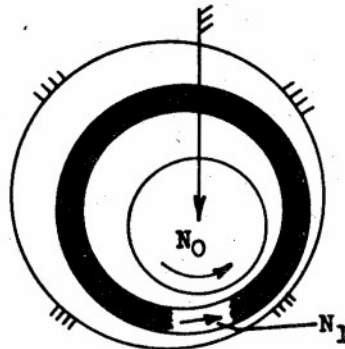
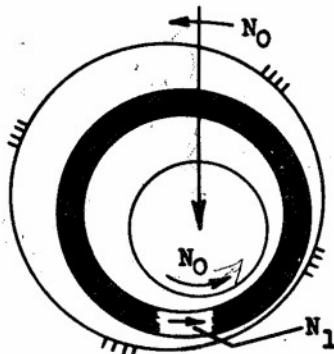

Figure 9. - Comparison of experimental and analytically determined values of speed ratio at different values of Sommerfeld number. Ratio of radii, 1.30.



(a) Rotating sleeve, unidirectional load.



(b) Rotating sleeve, rotating load (relative to ground).

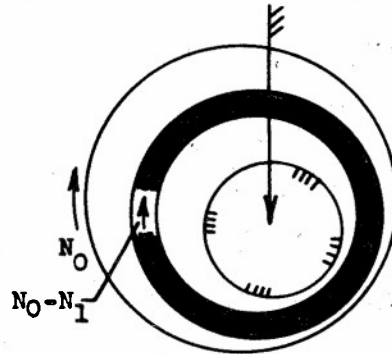

(c) Equivalent to (b), relative to point on load vector

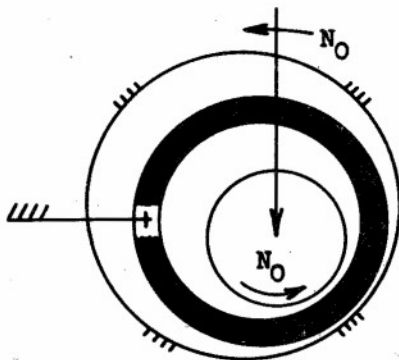

(d) Nonrotating sleeve, rotating load (relative to ground).

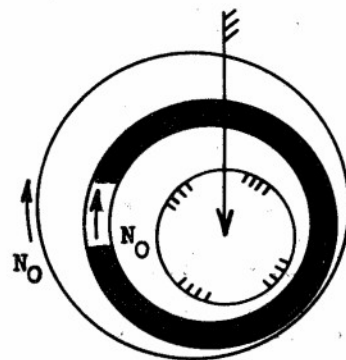

(e) Equivalent to (d), relative to point on load vector.

NATIONAL ADVISORY
COMMITTEE FOR AERONAUTICS

Figure 10. - Diagrammatic representations of floating bearings subjected to unidirectional and to rotating loads.

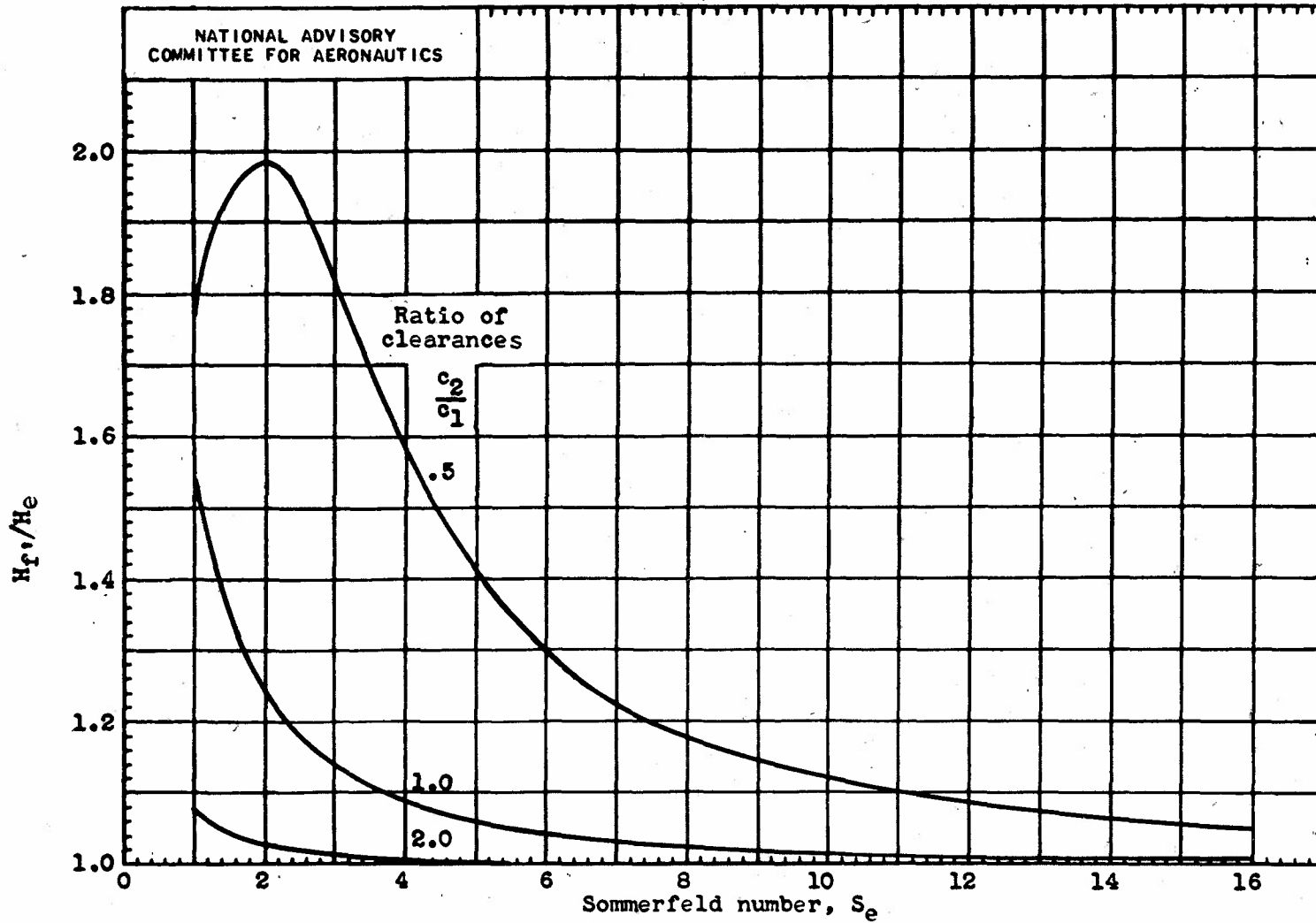
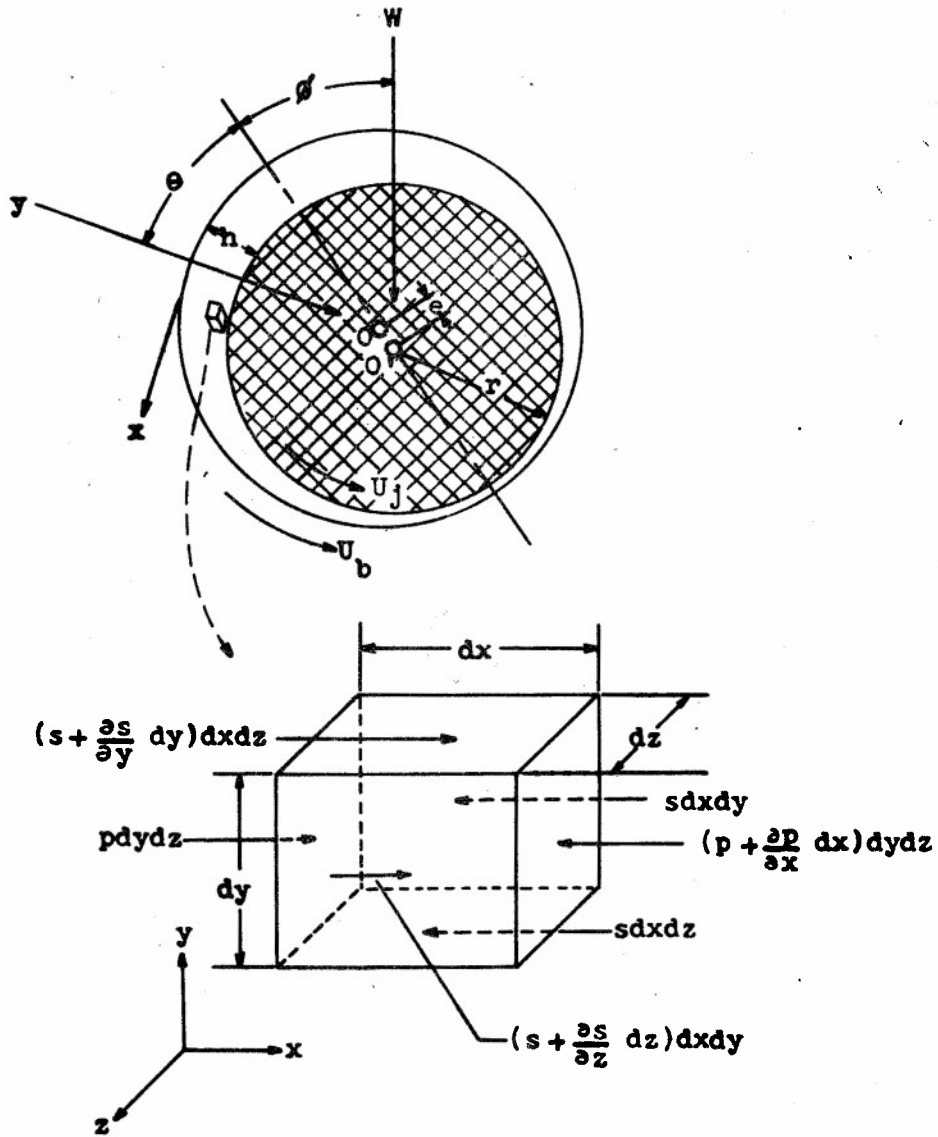

Figure 11. - Ratio of heat generated in bearing of figure 10 (d) to that generated in conventional journal bearing of same shaft diameter plotted against Sommerfeld number. Clearances c_1 and c_2 refer to outer and inner oil films, respectively; ratio of radii, 1.



NATIONAL ADVISORY
COMMITTEE FOR AERONAUTICS

Figure 12. - Diagrammatic representation of forces acting on journal bearing operating under load, showing forces upon elementary particle of lubricant in direction of motion.

650

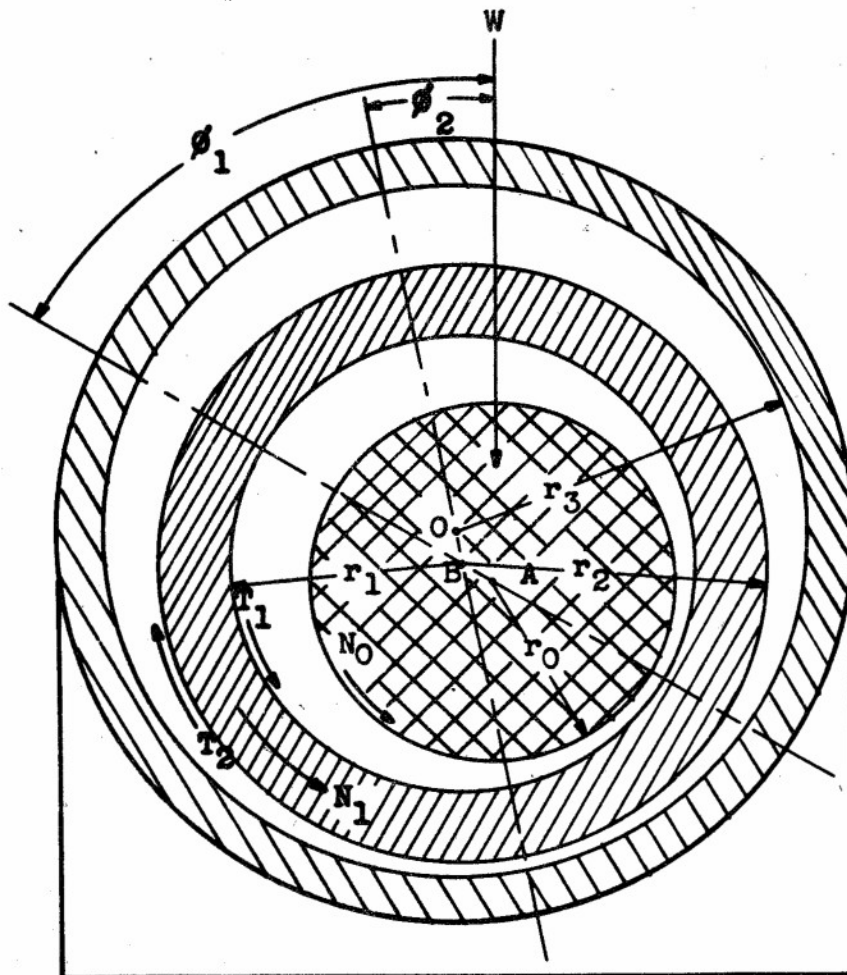

$$AB = e_1$$

$$BO = e_2$$

NATIONAL ADVISORY
COMMITTEE FOR AERONAUTICS

Figure 13. - Diagrammatic representation of forces acting on full-floating journal bearing operating under load.

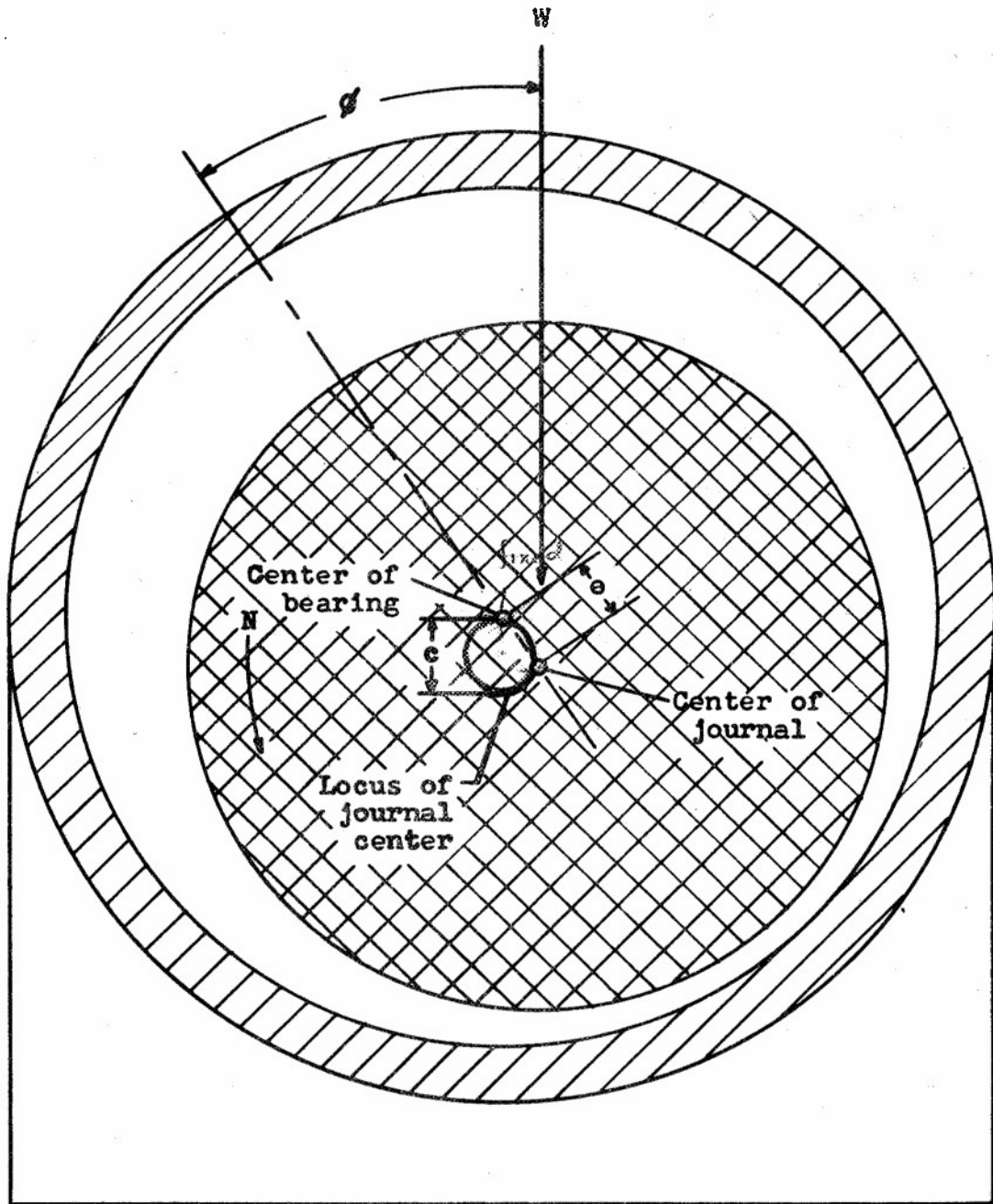

NATIONAL ADVISORY
COMMITTEE FOR AERONAUTICS

Figure 14. - Path taken by center of journal as applied load is increased.

UNCLASSIFIED

UNCLASSIFIED

RESTRICTED

ATI- 12436

Shaw, H. C.
Rusdorfer, TDIVISION: Power Plants, Reciprocating (6)
SECTION: Components (11)
CROSS REFERENCES: Bearings - Testing (16000)

ORIG. AGENCY NUMBER

RM-E7A28a

REVISION

AUTHOR(S)

AMER. TITLE: An analysis of the full-floating journal bearing

FORG'N. TITLE:

ORIGINATING AGENCY: National Advisory Committee for Aeronautics, Washington, D. C.

TRANSLATION:

COUNTRY	LANGUAGE	FORG'N. CLASS.	U. S. CLASS.	DATE	PAGES	ILLUS.	FEATURES
U.S.	Eng.		Restr.	Jan'47	41	15	photos, table, diagrs, graphs

ABSTRACT

Floating sleeve can operate over a wide range of speeds for a given shaft speed; exact value depends principally upon the ratio of clearances and upon ratio of radii of bearing. Lower operating temperatures at high rotative speeds are to be expected by using a full floating bearing. This lower operating temperature could be obtained at expense of load-carrying capacity of bearing, if, for comparison, clearances remain the same for both bearings.

NOTE: Requests for copies of this report must be addressed to: N.A.C.A., Washington, D. C.

T-2, HQ., AIR MATERIEL COMMAND

AIR TECHNICAL INDEX
RESTRICTED

WRIGHT FIELD, OHIO, USAAF

177-0-21 MAR 47 22,000