

~~CONFIDENTIAL~~
~~SECRET~~
NATIONAL ADVISORY COMMITTEE FOR AERONAUTICS

WARTIME REPORT

ORIGINALLY ISSUED
June 1943 as
Advance Restricted Report 3F15

PRELIMINARY TANK TESTS WITH PLANING-TAIL SEAPLANE HULLS

By John R. Dawson and Kenneth L. Wadlin

Langley Memorial Aeronautical Laboratory
Langley Field, Va.

NACA

WASHINGTON

NACA LIBRARY
LANGLEY MEMORIAL AERONAUTICAL
LABORATORY

Langley Field, Va.

NACA WARTIME REPORTS are reprints of papers originally issued to provide rapid distribution of advance research results to an authorized group requiring them for the war effort. They were previously held under a security status but are now unclassified. Some of these reports were not technically edited. All have been reproduced without change in order to expedite general distribution.



NATIONAL ADVISORY COMMITTEE FOR AERONAUTICS

ADVANCE RESTRICTED REPORT

PRELIMINARY TANK TESTS WITH PLANING-TAIL SEAPLANE HULLS

By John R. Dawson and Kenneth L. Wadlin

SUMMARY

Preliminary tests have been made with simplified models of two types of hulls that differ considerably from conventional types. In both of the new types there is a single main planing surface that is combined with after-planing surfaces placed directly below the aerodynamic tail surfaces. One type has twin-tail extensions supporting the planing surfaces and the other has a single-tail extension.

The type of hull that has twin tails can be arranged in such a manner that the air drag probably could be made lower than that of the equivalent conventional hull, although at the expense of increased water resistance. The structural problems inherent in the arrangement may, however, be prohibitive.

The type of hull that has a single tail is found to give lower resistance than conventional hulls and has desirable trim characteristics. Indications are that the stability characteristics would be satisfactory.

Hulls with planing tails, however, have high trims at rest, have less room for useful load aft of the center of gravity than conventional hulls, and introduce restrictions on the types of tail surfaces that may be used.

INTRODUCTION

Existing types of seaplane floats and hulls are probably capable of being developed to a much higher degree of efficiency than has yet been achieved. It is possible, however, that other types can be made to meet some of the current requirements of aircraft more effectively than do the conventional types of floats and hulls. For some time the NACA has been engaged in research on

hydrofoils and their applications to seaplane hulls. Arrangements of planing surfaces other than those usually used may also be found to have merit. Two such systems are considered herein and the results of some preliminary tests that were made at NACA tank no. 2 in March 1943 are given.

ARRANGEMENTS CONSIDERED

A seaplane hull that supported its load primarily by displacement of the water throughout the take-off run would have far too much resistance to be practicable. The weight of the seaplane must then be supported largely by dynamic lift from the water in all but the low-speed part of the take-off run. If this lift is obtained by planing surfaces, a minimum of two surfaces (one running aft of the other) is required in order to get satisfactory trims. Lateral stability can be obtained by making one of the planing surfaces sufficiently wide, or by adding another surface, displaced laterally. Four planing surfaces are usually used.

In a flying-boat hull or a single-float seaplane, the planing surfaces are the forebody, the afterbody, and either side floats or stub-wing stabilizers. Twin-float and twin-hull seaplanes each has four planing surfaces, the forebodies and afterbodies of each of the two hulls. Early float seaplanes had a total of three planing surfaces on stepless floats, two main floats and a tail float that were used in an arrangement similar to the arrangement of the landing gear of a landplane.

Other arrangements of planing surfaces can be made to perform all the functions of the usual float system, but the effectiveness of such alternates will largely depend on how the surfaces are incorporated into the seaplane.

The arrangement shown in figure 1 has a total of three planing surfaces provided on the bottoms of the main hull and the two side fuselages. It is apparent that a large amount of spray thrown by the main planing surface will strike the side fuselages and cause some increase in resistance. The torsional load applied to the wings by the tail planing surfaces is undesirable from a structural standpoint and if these planing surfaces are

spread far enough to provide adequate lateral stability, the structure that will be required by the center section of the wing may be too heavy to be practicable. There still may be some merit in the arrangement even if side floats or stub-wing stabilizers are required to give additional lateral stability, especially because such an arrangement offers some possibility of reducing the air drag of a seaplane.

One limitation in the reduction of the air drag of a seaplane has been the necessity for keeping the propellers clear of spray. This necessity has caused hulls to be built deeper than would be needed for other requirements. The larger the seaplane the less serious this limitation becomes because the diameters of propellers do not increase in direct ratio to the size of the craft and, for equal operating conditions, heights of waves do not increase at all. The arrangement shown in figure 1 includes a rather radical scheme for minimizing this difficulty. The propellers are located forward of the bow where there will be almost no spray from the main hull and, because this configuration can be made so that the trim will be reasonably high throughout take-offs and landings as well as at rest, the propellers will be clear of the water even though the wing is close to the water. This location of the propellers adds more torsional loads to the wing end it would almost certainly be necessary to drive the propellers through long shafts from engines located aft. As a matter of fact, inasmuch as difficulty would undoubtedly be experienced in getting the center of gravity far enough back in the configuration shown, placing the engines as far aft as feasible would be desirable.

A somewhat less radical arrangement is shown in figure 2. In this scheme two planing surfaces are provided on a single hull. This arrangement resembles a conventional hull with the planing part of the afterbody removed. The after planing surface is supplied by properly shaping the bottom of the tail extension. The trailing edge of the forebody is shown pointed in plan form because of aerodynamic considerations, although hydrodynamically this pointed plan form is not necessary. In this case the tail planing surface would have to ride in the wake of the forebody and the effectiveness of the planing surface would depend on its being properly located with respect to the high roach that normally follows a forebody.

It might be possible to eliminate the planing surfaces on the tails in either of the schemes proposed by substituting a hydrofoil somewhat in the manner shown in figure 2. Hydrofoils in general lead to serious stability problems and it is difficult to judge just how practicable they would be if used in this manner. Apparently, it would be feasible to retract these hydrofoils because they would carry a relatively small portion of the total load on the hull and would therefore be reasonably small. Retracting these hydrofoils during take-off would probably be desirable because their lift would not be needed in the high-speed portion of the take-off run and their retraction would increase the range of stable trims that would be available. Tail hydrofoils might conceivably be made controllable, in which case they would act as water elevators to provide trim control.

Floot systems similar to those described may have been actually used in the early days of aviation, but in any case an examination of them in the light of present-day requirements of seaplanes seems desirable.

TESTING PROCEDURE

The experimental work that was done was very preliminary in nature because of the limited time available for testing. The tests were intended primarily to examine the feasibility of the arrangements suggested and to get enough data to permit the laying out of a more comprehensive test program. No tests were made with hydrofoils.

The lines of the models that were tested are shown in figures 3 to 5. These models were assembled from parts of other models that were available and the simple forms used gave rather crude representations of the arrangements of figures 1 and 2.

All the tests were made at constant speeds. The load on the models was applied by dead weights in accordance with the loading curve given in figure 6, except with two of the forebodies for which additional tests were made for other loading conditions in order to evaluate the loads carried by them.

Free-to-trim and fixed-trim tests were made; trim, trimming moment, draft, and resistance were measured in accordance with standard practice at the NACA talks.

Tests were made with one of the models to determine critical trims for longitudinal stability and these tests were made by the method described in reference 1. The tail surface used in the tests of reference 1 was also used for the tests reported herein.

RESULTS AND DISCUSSION

Investigation of Twin Planing Tails

The arrangement shown in figure 3 (designated model 160C-1) was assembled from two models of side floats combined with a model of an existing body. Because the after planing surfaces were supplied by floats that were relatively short compared to the length available from side fuselages, they did not provide a true representation of the tail planing surfaces at low speeds where the bows of the side floats could be struck head-on by heavy water.

This model was tested free to trim but the data obtained were affected so much by the dissimilarity between the model and the scheme of figure 1 that it is believed their presentation here would be more confusing than helpful. The resistance rose to an extremely high peak before the normal hump speed was reached, because of the manner in which the bows of the side floats dug into the water - a peak that would not be expected had the side planing surfaces been a part of a continuous fuselage running very far forward. At the normal hump speed the side floats provided a sufficient area of planing surface to permit their bows to rise clear of the water's surface. Throughout the whole speed range the resistance was higher than would be obtained from a conventional hull and, although this was largely caused by the short length of the side floats, there were indications that in general this type of hull would have higher than normal resistance.

Investigation of Single-Planing Tail

Model 160D-2.- An approximation of the scheme shown in figure 2 was made by assembling with the forebody of model 160C-1 a long V-bottom box to form model 160D-2, as shown in figure 4. Tests were first made with the tail 3 inches lower than shown in the figure, but the trims obtained were too small and the model was altered to the configuration shown. The results from the tests with this model

are shown in figure 7 where the free-to-trim resistance is compared with the minimum resistance of the hull of a conventional flying boat (designated hull A) that is representative of current design. The resistances are compared on a basis of equal beams for both hulls; that is, at the same load coefficients.

The higher resistance obtained from model 160D-2 was believed to be largely due to the fact that it had a less efficient forebody. The forebody was therefore tested without the afterbody at two loading conditions and, by a comparison of the drafts, the load that the forebody was carrying during the tests of the complete model was estimated. That portion of the resistance that was contributed by the forebody was then derived by interpolation of the resistance curves of the forebody. The results are shown in figure 8 where the load-resistance ratios (Δ/R) of the forebody and the complete model are compared. It is evident from these curves that the forebody had considerably lower values of Δ/R than did the complete model. The indications are that the higher resistance of model 160D-2 was largely due to the inefficient forebody.

Model 160E-1 - resistance.- In order to obtain better resistance characteristics than those of model 160D-2, model 160E-1 was assembled. (See fig. 5.) The planing surface provided as a forebody for this model is extremely efficient and it is believed that because of its pointed trailing edge it can be incorporated into a hull that will have a lower air drag than a hull using a planing surface with a square trailing edge. This model was tested free to trim and at sufficient fixed trims to determine approximately the minimum resistance curve. The results are shown in figure 9 where the resistance is compared with that of hull A at the same load coefficients. Only in the highest part of the speed range did the free-to-trim resistance of model 160E-1 depart sufficiently from the minimum resistance to warrant the inclusion of the minimum resistance curve here.

The hump resistance of model 160E-1 when free to trim was considerably less than the minimum hump resistance of the conventional flying-boat hull. At speeds just beyond the hump, hull A had a slightly lower resistance. The minimum resistance of model 160E-1 in this region was not greatly different from that of hull A, but the resistance is not usually critical in this speed range. At high speeds, model 160E-1 had less resistance than hull A.

In figure 10 the load-resistance ratios of the forebody of model 160E-1 and the complete model are compared. The curve for the forebody was obtained in the same manner used to get the Δ/R ratios of the forebody of model 160D-2. At the hump speed the values of Δ/R for both the forebody and the complete model are considerably greater than those that have been obtained in the NACA tanks from any conventional flying-boat hull at the load coefficient tested. The forebody is less efficient than the afterbody except in a narrow range near the hump speed.

The low resistance obtained at the hump is believed to be largely due to the efficiency of the forebody that was used. The forebody of a practical flying boat cannot be made this efficient because the bow must be shaped for seaworthiness and clean running without increasing excessively the length of the forebody; the curved buttocks that result from these requirements produce a surface that is inferior for planing to one with straight buttocks.

At high speeds, however, the reduction in resistance is an inherent characteristic of the hull with a planing tail. The resistance of a conventional flying-boat hull in this region is usually increased by "afterbody interference," a condition in which the afterbody is struck by spray from the forebody in such a manner that resistance is added without a comparable increase in lift. This condition could not be obtained with model 160E-1 and at high speeds when the trim was increased until the tail came into the water (at about 7° trim) the tail acted as a very effective planing surface.

The resistance of the planing surface used as a forebody in these tests is compared in figure 11 with that of a planing surface that has a square trailing edge. In the curve for the surface with a square trailing edge the air drag of the model (obtained from tare measurements) has been added to the values of resistance taken from reference 2 in order to make them comparable to those of the present tests. Although the methods used in correlating the two types of planing surfaces are subject to some inaccuracies, figure 11 indicates that, other things being equal, there should be no appreciable penalty in resistance resulting from the use of a forebody with a pointed stern.

Trim and trimming moment.- The trims obtained in the free-to-trim tests (fig. 9) varied over a small range up to speeds of about 34 feet per second and for most of this

region they were close to the trim for minimum resistance of both the complete model and the forebody. At speeds beyond 34 feet per second the trim decreased rapidly. When the model was at rest the trim was determined by the relation between the center of gravity and the buoyancy of the submerged parts. At the hump speed the tail rode on the high roach that followed the forebody and it was the height of this roach that kept the trim down. As the speed was increased, the roach moved aft until its crest was behind the model and the tail rode on the forward slope of the roach thus causing the trim gradually to increase. The trim continued to increase with speed up to 30 feet per second at which point the tail was riding on the water ahead of the roach. The decrease in trim after this was caused by the planing characteristics of the forebody, the resultant force vector of the forebody moved aft until it passed through the center of gravity, and the tail naturally cleared the water at that speed.

In figure 12 the trimming moments of model 16OE-1 and hull A are compared at equal load coefficients. The curves show that for a given range of available control moments a greater range of trims could be obtained with hull A than with model 16OE-1. It is significant, however, that in the case of model 16OE-1 the trims for minimum resistance lie in the range of trims for which the trimming moments of model 16OE-1 are small. Not only would the pilot be able to hold such a hull at its best attitude but, over a considerable portion of the take-off run, he would be prevented from trimming the craft at trims greatly different from this attitude.

Longitudinal stability.- The results of the attempt to determine the longitudinal stability limits for model 16OE-1 are given in figure 13 where the complete curve for the lower limit of stability is shown together with as much of the upper limit as could be obtained with the facilities that were available. Because low-angle porpoising is a phenomenon peculiar to a single planing surface, this type of instability does not occur until the model reaches a speed at which the tail is clear. With model 16OE-1 the tail did not clear until about 75 percent of get-away speed was reached. The afterbody of a conventional hull with a similar speed coefficient at get-away would normally clear the water at approximately 50 percent of get-away speed. Although the occurrence of low-angle porpoising in model 16OE-1 was thus postponed until a relatively high speed was reached, the lower trim

limit was rather high. The tendency for a planing surface of this type to have a lower trim limit that is higher than usual was also found in reference 3 and this tendency is believed to be characteristic of planing surfaces the trailing edges of which have plan forms similar to that of model 160E-1.

Because of the extremely large trimming moments required to increase trim when the tail of the model was in the water, a determination of the upper limit of stability was not feasible except in the very highest part of the speed range. (See fig. 13.) Although the simplified model (no wing or power, indefinite moment of inertia, etc.) would probably not indicate the motion that would be obtained in an actual flying boat, it is notable that when porpoising did occur at the high trims it was very mild, the model usually oscillating no more than $1/2^\circ$ in trim. Attempts to increase the severity of this motion by artificially disturbing the model were unsuccessful. The upper limit was found to be practically the same when determined by increasing the trim until an unstable region was reached or by decreasing the trim from this region until the model became stable again. Because of the very large trimming moments that would be required to reach the critical trim, it is doubted that high-angle porpoising could be obtained in an actual flying boat with this type of hull except near get-away speed.

Insufficient depth of step has been the cause of a form of longitudinal instability encountered in a number of flying-boat designs. This instability usually occurs at high speeds and is particularly noticeable in landings. The planing-tail hull could, of course, not have this difficulty.

Directional stability.— No tests were made specifically to check the directional stability. Models with the customary pointed afterbodies have, however, usually shown a tendency to be directionally unstable in the low-speed range when tested with the towing gear used in the present tests and this tendency has been found in the full-size aircraft. Although model 160E-1 ran stable in direction throughout the tests, difficulties with directional stability may limit the region in which the chines can be removed from the tail.

Directional instability has also been found at high speeds in conventional flying boats in both take-offs and landings. It occurs when the trim is low and hence when

the wetted length ahead of the center of gravity is long. Low-trim landings are made in order to avoid longitudinal instability (in some cases due to shallow steps). Low-trim take-offs are made for the same reason and also to avoid the high resistance caused by spray striking the afterbody. It is believed that if flying boats are so made that there is no reason to avoid reasonably high trims, landings and take-offs will habitually be made at higher trims and directional instability at high speed will be generally reduced. A hull having the characteristics of model 160E-1 could be taken off or landed stably at approximately 7° trim with minimum resistance. Perhaps with this type of hull landings at even higher trims would be advantageous; the tail would thus be set down first or simultaneously with the forebody. The feasibility of this type of landing would depend on the longitudinal-stability characteristics of the seaplane as well as on the loads imposed on the structure of the tail.

Spray.- The forebody of model 160E-1 carried a smaller proportion of the total load than is carried by the forebody of a conventional hull. Differences in spray thrown by the forebodies of this type of hull and the usual type should then be in favor of the planing tail if there were no differences in trims. The higher trims inherent at low speeds in a hull with a planing tail should reduce the possibilities of spray troubles in this region.

It might be expected that the tail surfaces on planing-tail hulls would be subject to more spray than those on conventional hulls and spray considerations might limit the region in which the chines could be removed from the tail. Twin vertical fins would probably be impracticable on a hull of this type, but it is believed that if a single vertical fin were used, no great difficulty would be experienced in locating the tail surfaces in an effective position at which they would be reasonably clear from the spray. Many conventional flying boats pass through a region in which the roach strikes the tail, and under such conditions it would probably be better for the roach to strike a planing surface as in model 160E-1 than to strike the rounded tail extensions commonly used.

Potentialities Indicated by Tests

Twin planing tails.- The information obtained from the tests of the model simulating the arrangement with twin

planing tails was too meager to be of much assistance in evaluating the possibilities that it may have. The tests indicate that such an arrangement would probably have a higher water resistance than a conventional hull but, if it could be designed to give lower air drag, the increased resistance would be acceptable in a craft designed for high performance where considerable power would be available for take-off. The structural problems involved will probably determine the feasibility of this arrangement.

Single planing tail.- The tests indicate that the hull with a single planing tail may provide some definite improvements over the conventional flying-boat hull.

It is apparently possible to design a flying-boat hull of this type that will have all of the following desirable characteristics:

1. Hump resistance at least as low as that of a conventional hull having a comparable forebody
2. Resistance at high speeds appreciably less than can be obtained from a conventional hull
3. Restricted departures from the trims for minimum resistance throughout the first part of the take-off run
4. Trims for minimum resistance obtainable with reasonable control moments in the last part of the take-off run
5. Speed at which low-angle porpoising begins greater than is found in conventional hulls
6. Elimination of difficulties of the types that require ventilation of the step to remedy them

There are indications that it may also be possible to design such a hull with the following characteristics in addition to those listed above:

1. High-angle-porpoising characteristics improved
2. Bow spray at speeds below the hump improved
3. Directional-stability characteristics improved
4. A simplification in the technique of piloting in take-offs and landings

Proper adjustment of the proportions of a hull of this type should make it possible to effect desired improvements with no more sacrifice in other qualities than is usually made in the compromises that obtain in the design of a hull. For instance, an increase in the upper trim limit for longitudinal stability could be obtained by either moving the tail up or making it shorter. If the tail were moved up the trim would be increased at all speeds at which the tail is in the water (in particular at the hump speed). Whether the hump resistance would thus be increased or decreased would depend on the value of the best trim for the forebody at that speed. Best trim for a forebody changes little with load when the ratio of load coefficient to forebody length is small but increases rapidly with load when this ratio is large. In the case of the models tested the trim at the hump speed was several degrees less than that normally obtained. If the upper limit were moved up by shortening the tail, the trim at the hump speed would not necessarily be appreciably increased, but the speed at which low-angle porpoising could start would be decreased.

Reasonable changes in the tail, however, would not affect the high-speed resistance as do similar changes in the afterbody of a conventional hull.

Some disadvantages in the planing-tail hull are apparent. The following are some of the disadvantages that may be found:

1. High trims at rest (The difficulties that would be encountered because of this feature are no worse than those peculiar to a landplane with a conventional landing gear, but they would perhaps be more of a disadvantage because seaplanes are frequently left moored during high winds. It would, of course, be possible to provide inflatable tail supports to hold the tail up when the seaplane is moored.)

2. Structural difficulties that may be caused by the great distance from the center of gravity at which the water loads would be applied to the tail

3. Difficulty in disposing of weights so that the center of gravity would be sufficiently far aft (This difficulty would be more pronounced in small seaplanes than in large ones, because in large seaplanes the tail would be deep enough to be usable for cargo or personnel.)

4. Restrictions in the design of tail surfaces because of their proximity to the water

5. Variations in water performance with changes in load that might be greater than normal because of variations in the height of the roach on which the tail rides

6. An increase in the trim at which low-angle porpoising can occur (unless the forebody were made without the pointed stern, in which case the air drag would probably be increased)

There is probably no single improvement more desired for seaplanes than a reduction in air drag. The limited tests that were made give insufficient data on which to base a design study. Consequently, an estimation of the air drag of a planing-tail hull as compared with that of a conventional hull is difficult. No doubt the potentialities of this type of hull in this respect will be largely determined by the amount of filleting that can be introduced between the forebody and tail and by the distance aft that the chines can be eliminated.

Further experiments.- Further exploratory tests are provided for in a program that includes the investigation of the arrangement having twin tails and the feasibility of substituting hydrofoils for the tail planing surfaces in both the single- and the twin-tail arrangements.

Systematic experiments to determine the effect of changing the various parameters that are peculiar to the afterbody of the hull with a single tail are also planned. In this program the vertical location, the length, the keel angle, the plan form, and the cross section of the afterbody will be varied. The stability characteristics of the best configurations will then be investigated by testing dynamic models.

CONCLUSIONS

From a consideration of the problems involved and from the data obtained in the tests that were made, the following conclusions are drawn:

1. The arrangement using the twin planing tails can possibly be used to advantage in the design of a high-performance seaplane in which low air drag is the

predominant consideration; the structural problems involved are, however, difficult and may impose serious limitations on the practicability of the arrangement. The water resistance will probably be greater for this arrangement than for a conventional hull.

2. The arrangement having a single planing tail may prove to be useful because there are indications that it can be made to give:

- (a) Less resistance than is obtained from a conventional hull
- (b) Desirable trims throughout take-off
- (c) Satisfactory stability characteristics

3. Hulls with planing tails have the following characteristics that limit their usefulness:

- (a) High trims at rest
- (b) Less room for useful load aft of the center of gravity than is found in conventional hulls
- (c) Restrictions in the types of tail surfaces that may be used

Langley Memorial Aeronautical Laboratory,
National Advisory Committee for Aeronautics,
Langley Field, Va.

REFERENCES

1. Benson, James M.: The Porpoising Characteristics of a Planing Surface Representing the Forebody of a Flying-Boat Hull. NACA A.R.R., May 1942.
2. Shoemaker, James M.: Tank Tests of Flat and V-Bottom Planing Surfaces. T.N. No. 509, NACA, 1934.
3. Truscott, Starr, and Olson, Roland E.: The Longitudinal Stability of Flying Boats as Determined by Tests of Models in the NACA Tank. II - Effect of Variations in Form of Hull on Longitudinal Stability. NACA A.R.R., Nov. 1942.

FIGURE LEGENDS

- Figure 1.- Hypothetical flying boat with twin planing tails.
- Figure 2.- Hypothetical flying boat with single planing tail.
- Figure 3.- Lines of NACA model 160C-1.
- Figure 4.- Lines of NACA model 160D-2.
- Figure 5.- Lines of NACA model 160E-1.
- Figure 6.- Loading used in tests.
- Figure 7.- Comparison of resistance of NACA model 160D-2 with that of a conventional flying-boat hull.
- Figure 8.- Comparison of load-resistance ratios of complete model and forebody. NACA model 160D-2.
- Figure 9.- Comparison of resistance of NACA model 160E-1 with that of a conventional flying-boat hull.
- Figure 10.- Comparison of load-resistance ratios of complete model and forebody. NACA model 160E-1.
- Figure 11.- Comparison of resistance coefficients of planing surfaces with square end and pointed trailing edges. Angle of dead rise, $22\frac{1}{2}^{\circ}$.
- Figure 12.- Comparison of moments required to change trim for model 160E-1 and a conventional flying-boat hull.
- Figure 13.- Longitudinal stability limits of NACA model 160E-1.

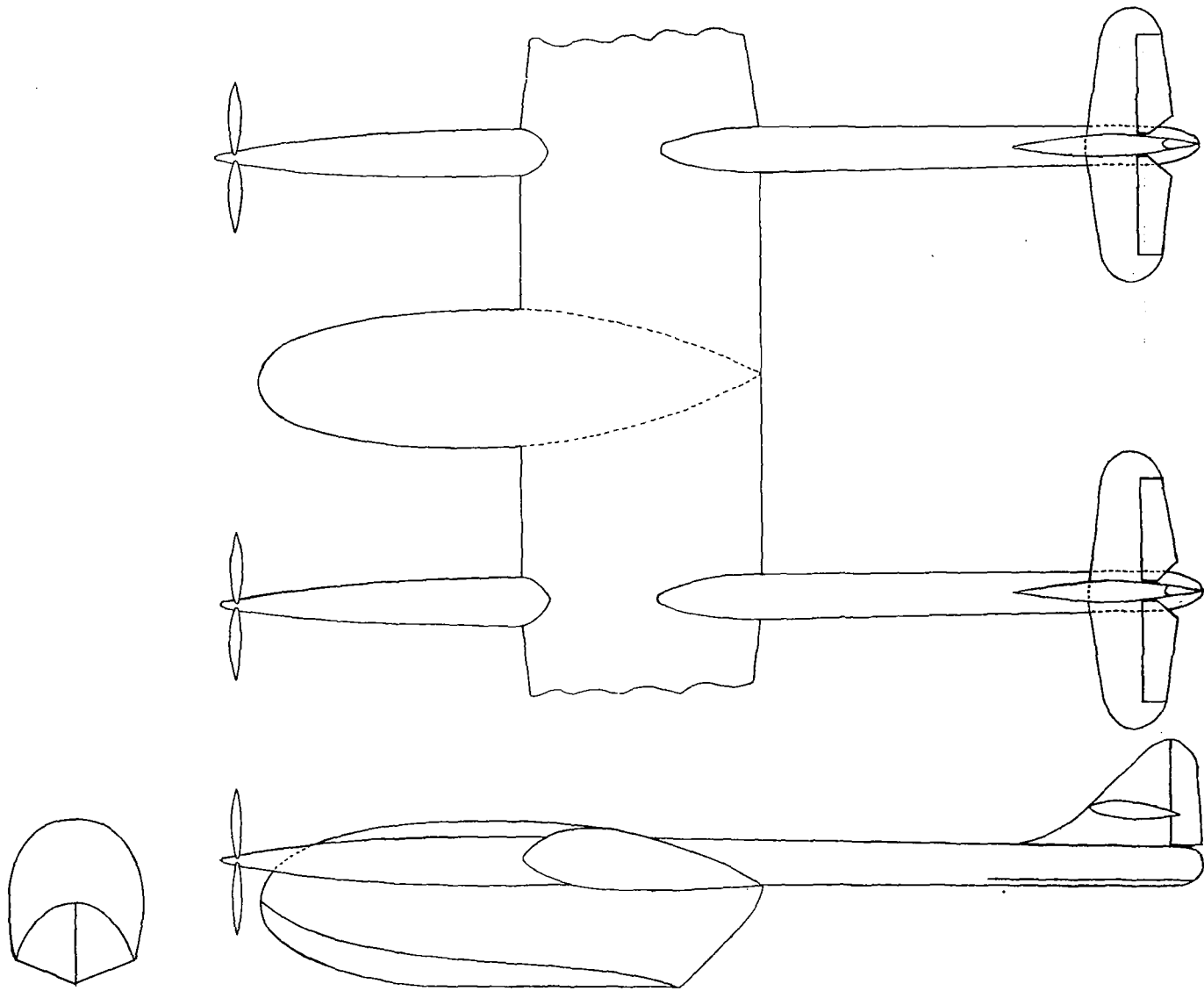

Figure 1.-Hypothetical flying boat with twin planing tails.

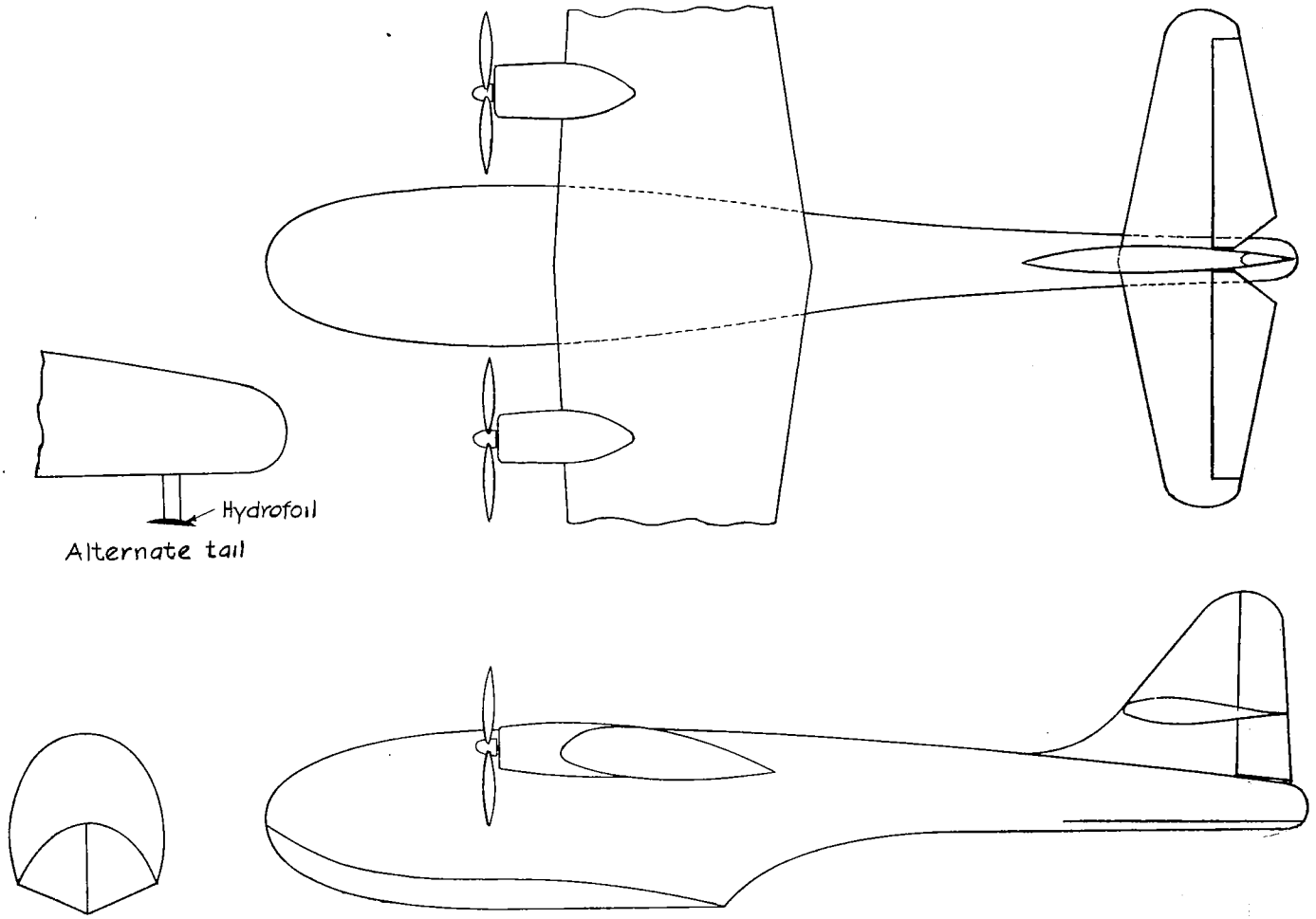

Figure 2—Hypothetical flying boat with single planing tail.

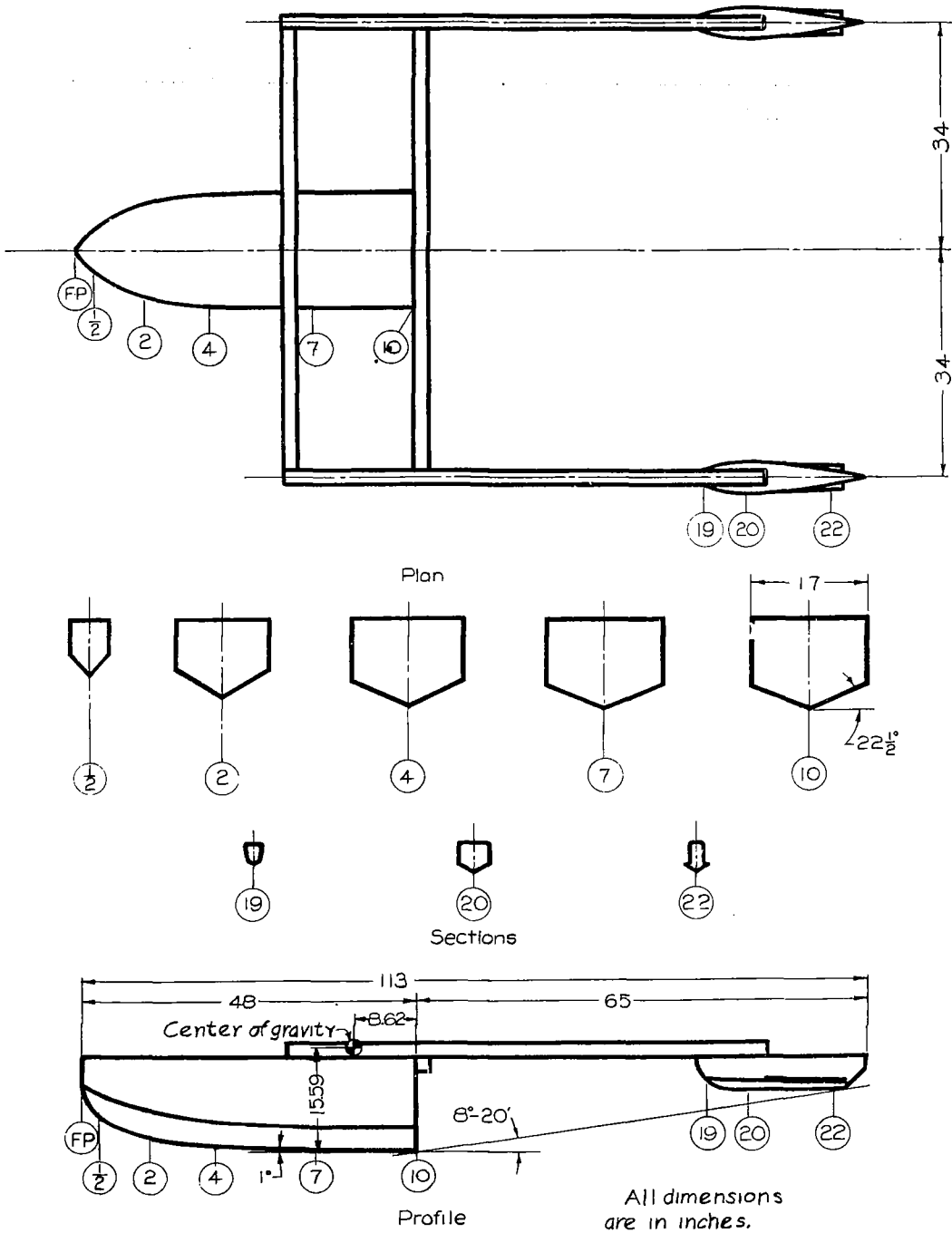

Figure 3-Lines of NACA Model 160C-1.

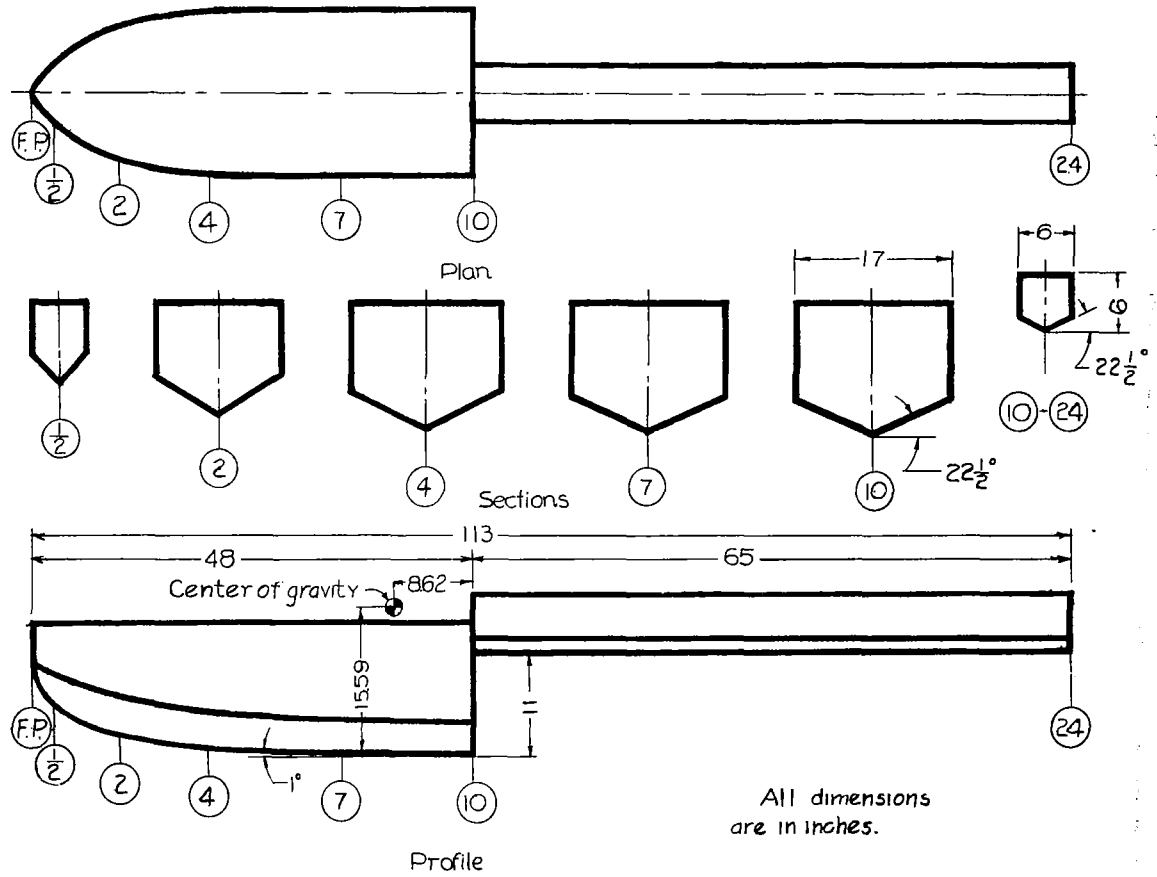
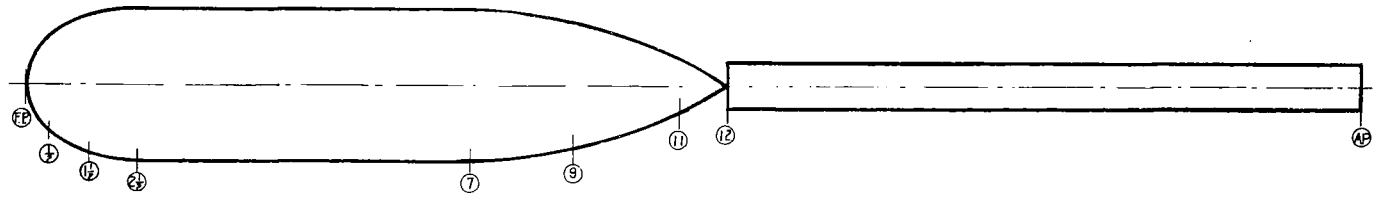
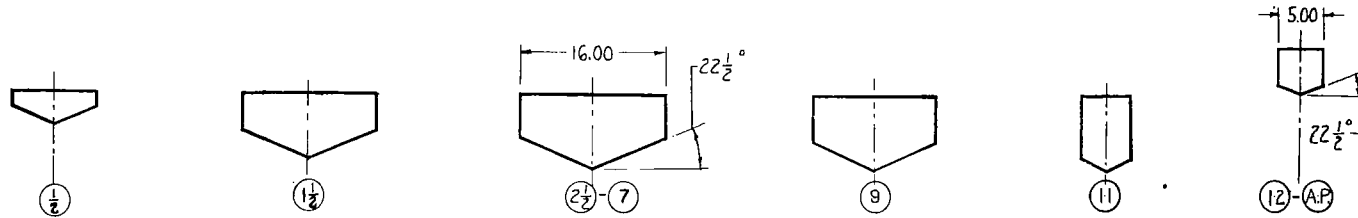

Figure 4.-Lines of NACA Model 160D-2.



Plan



Sections

All dimensions
are in inches.

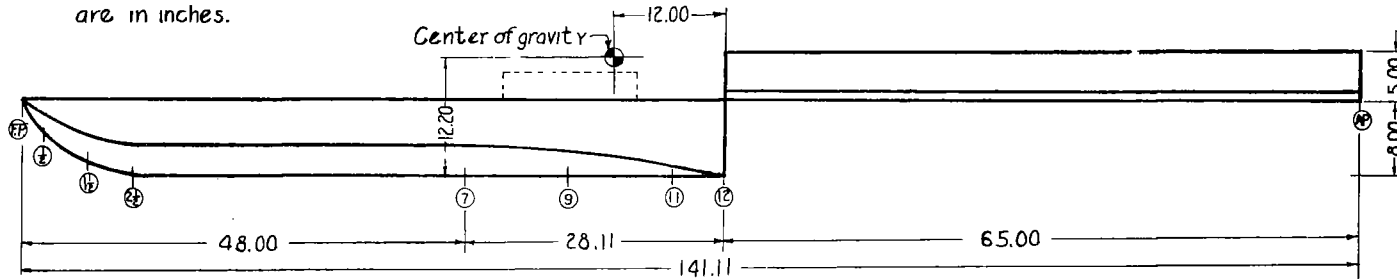

Profile

Figure 5-Lines of NACA Model 160 E-1.

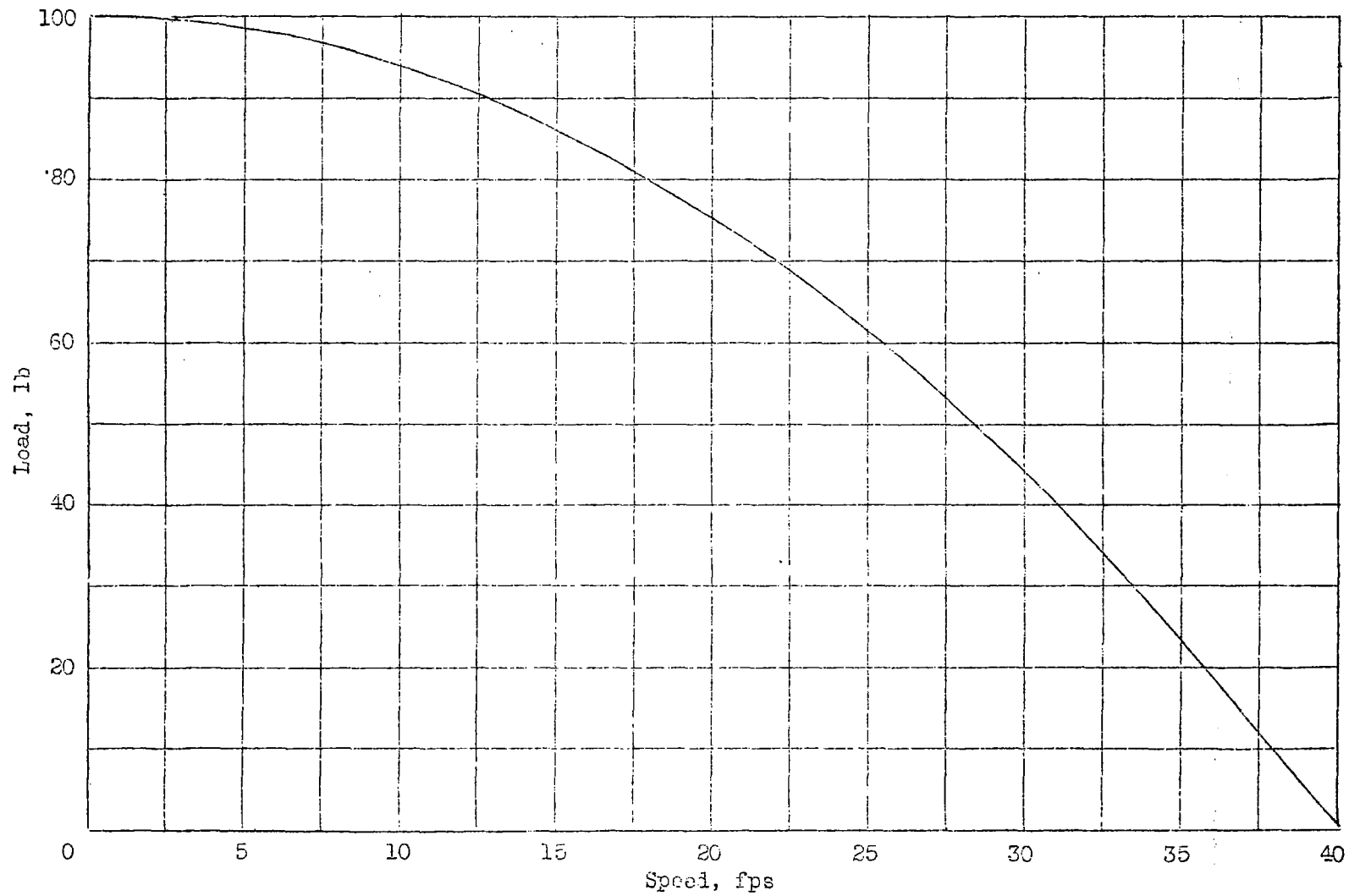

Figure 6.- Loading used in tests.

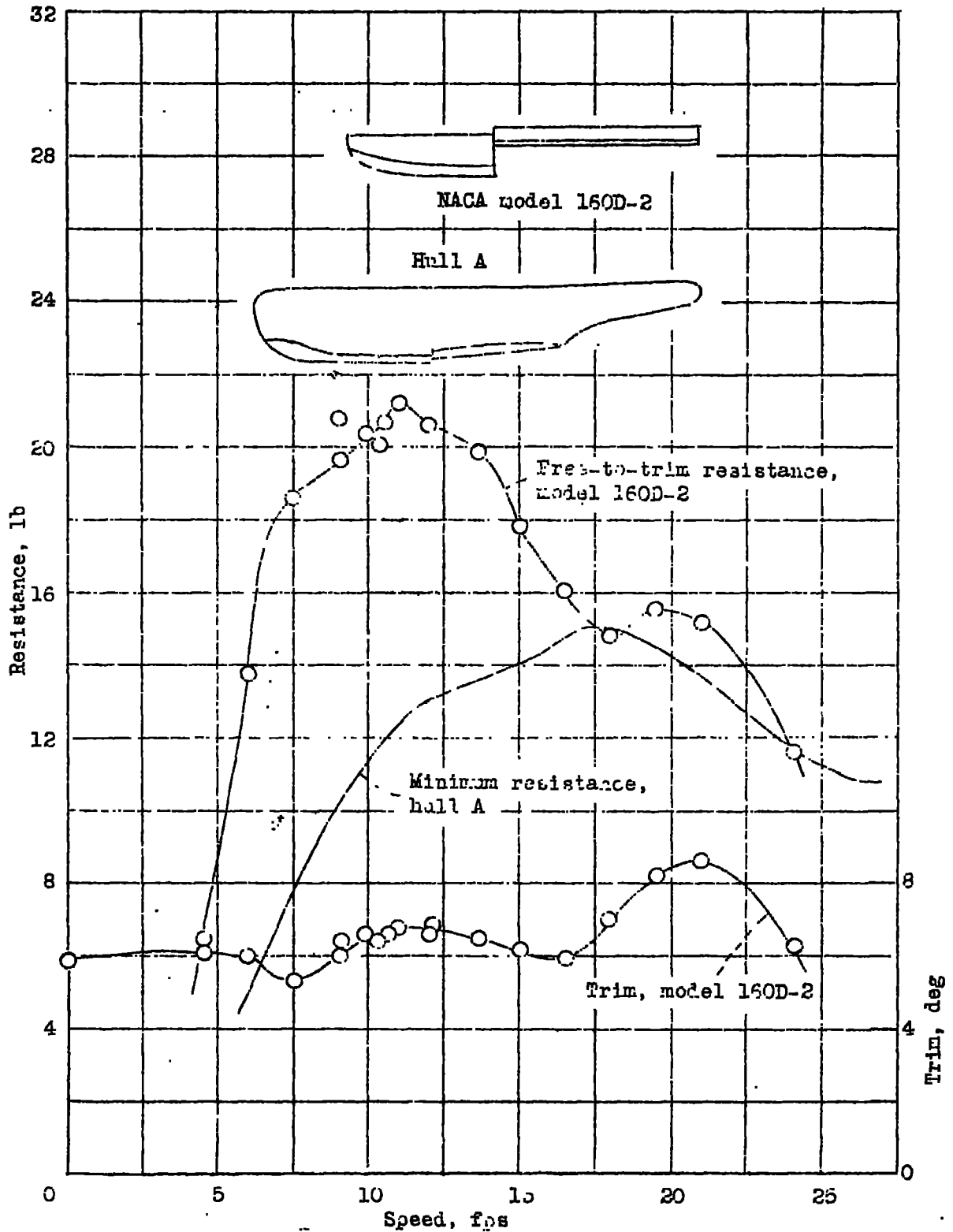

Figure 7.- Comparison of resistance of NACA model 160D-2 with that of a conventional flying-boat hull.

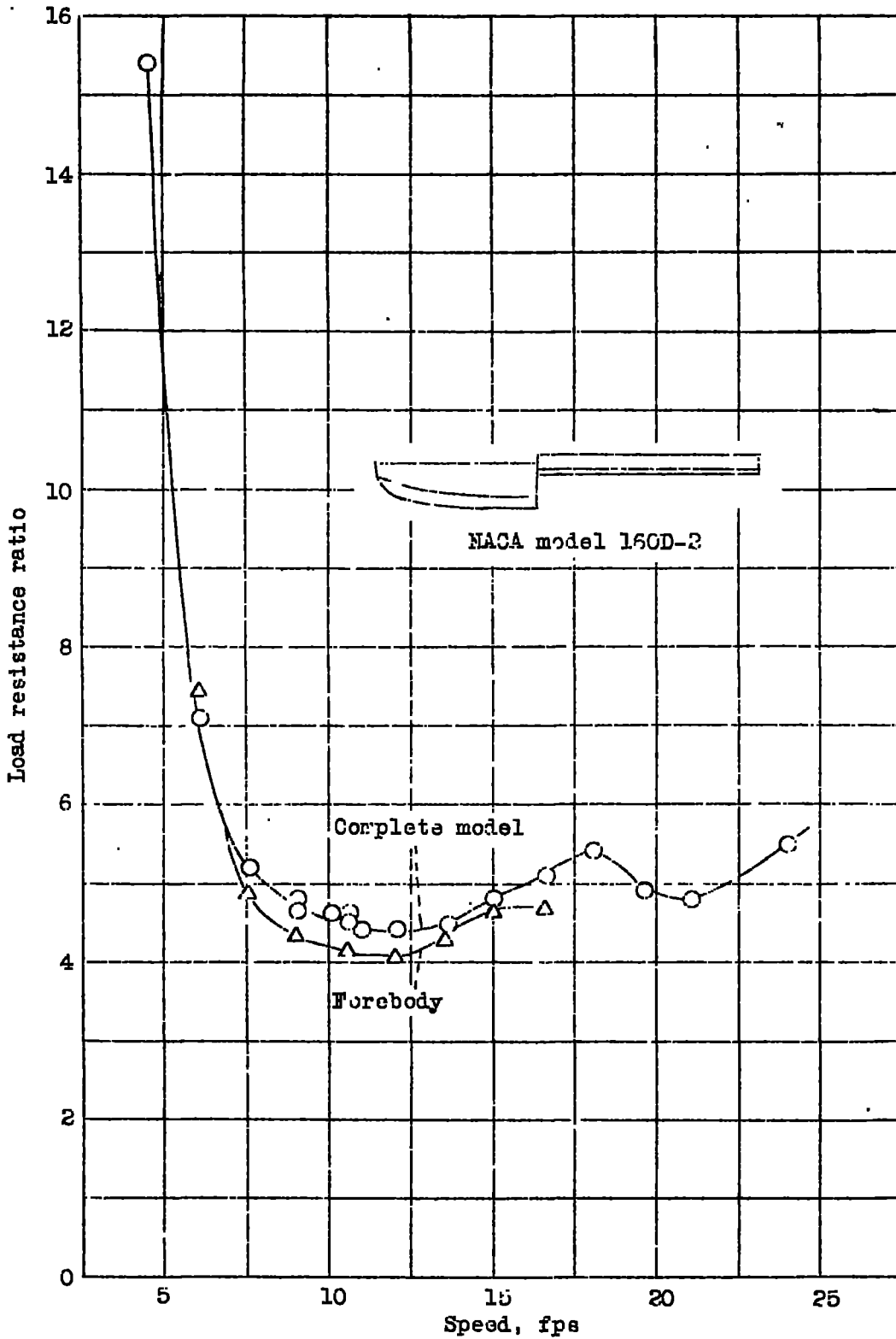

Figure 8.- Comparison of load-resistance ratios of complete model and forebody. NACA model 160D-2.

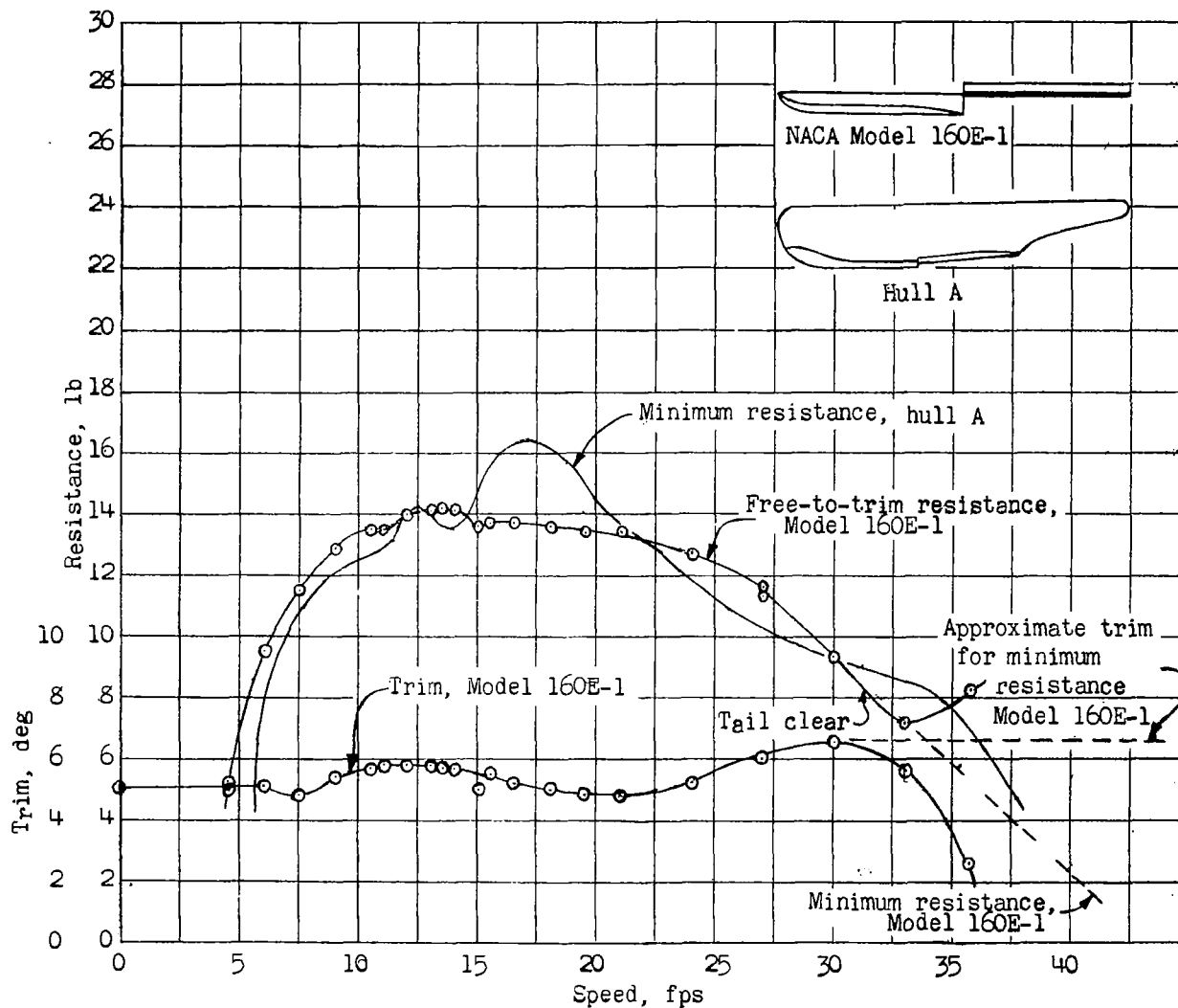

Figure 9.- Comparison of resistance of NACA Model 160E-1 with that of a conventional flying-boat hull.

(1 block = 10/30")

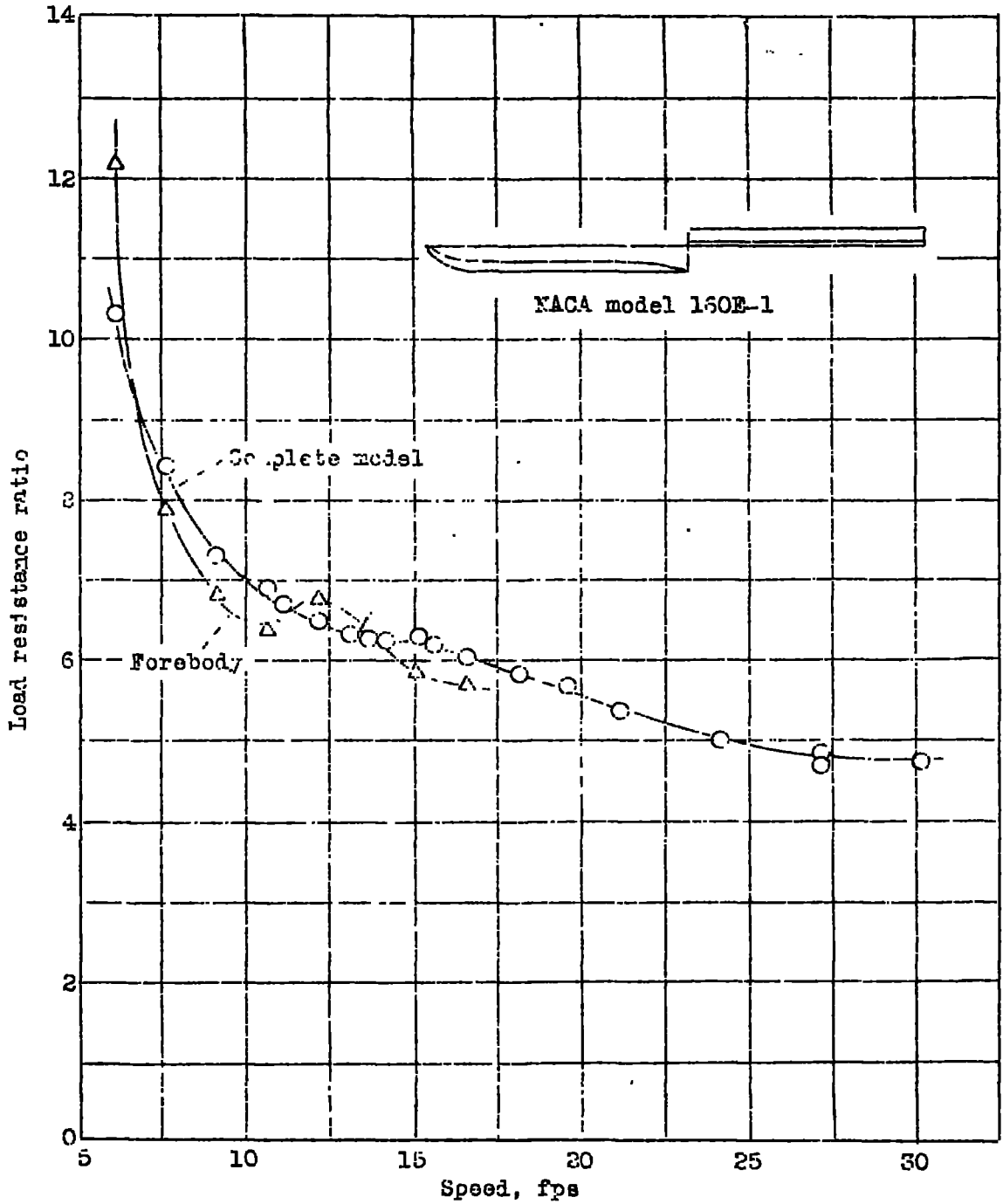

Figure 10.- Comparison of load-resistance ratios of complete model and forebody. NACA model 160E-1.

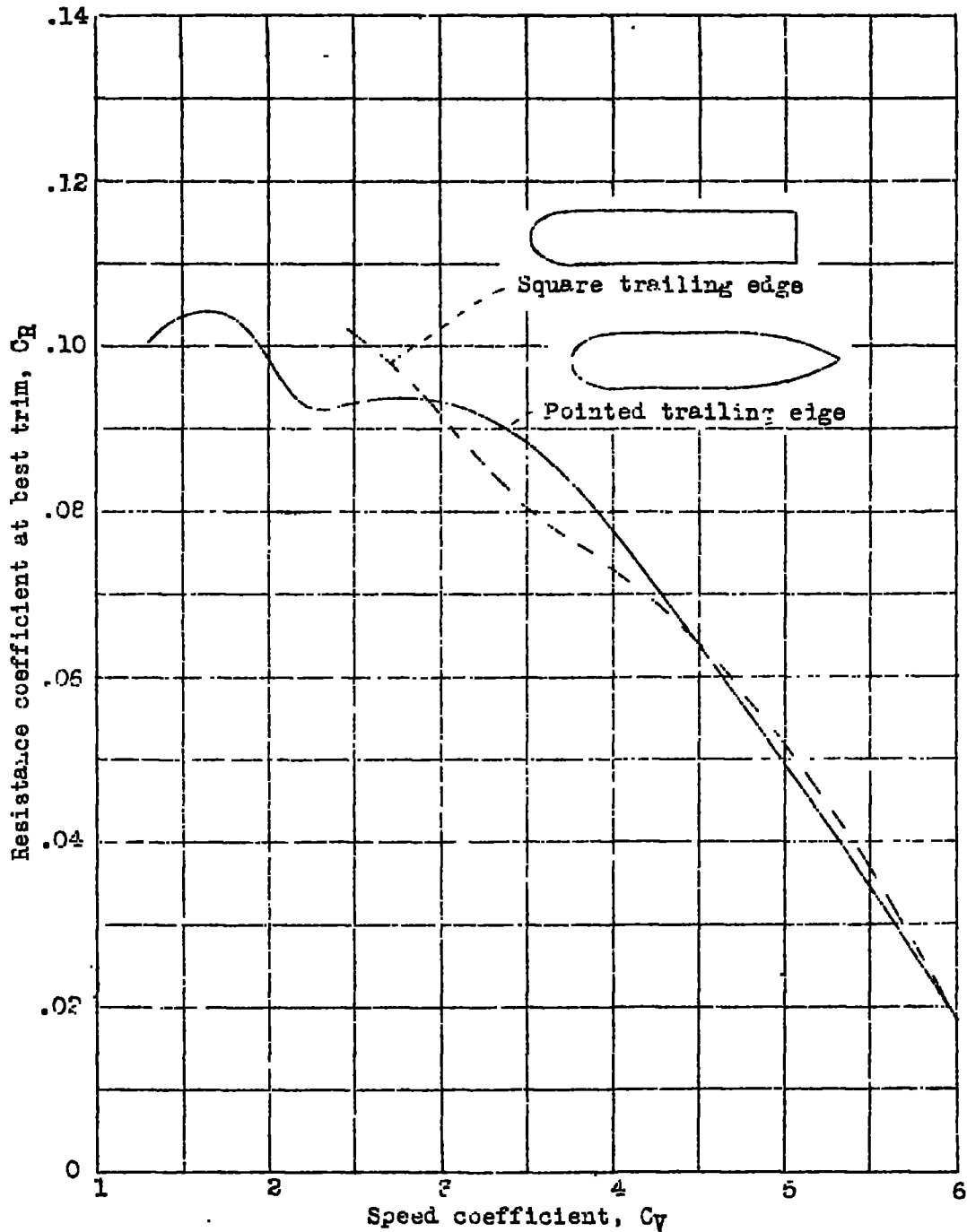
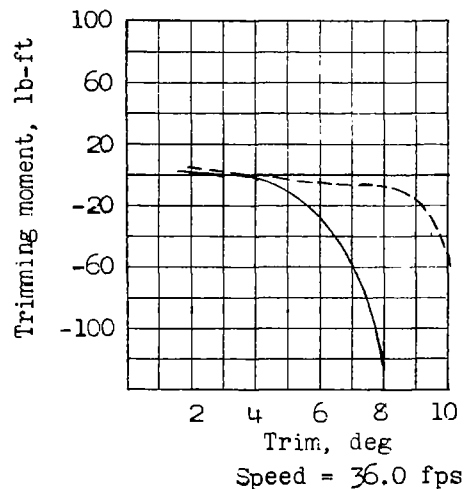
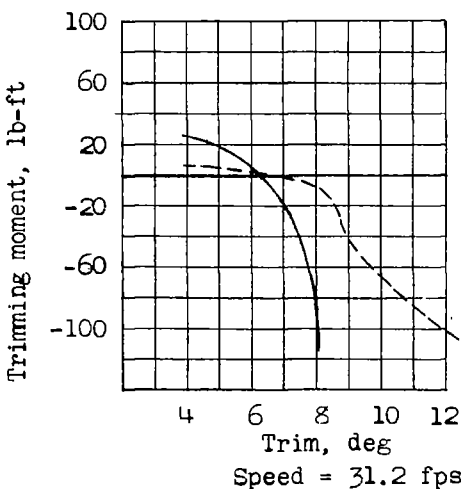
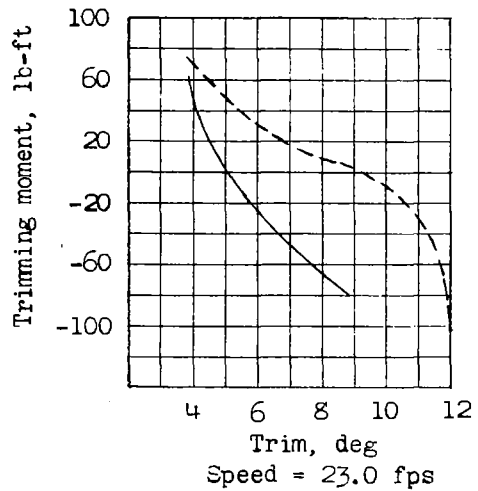
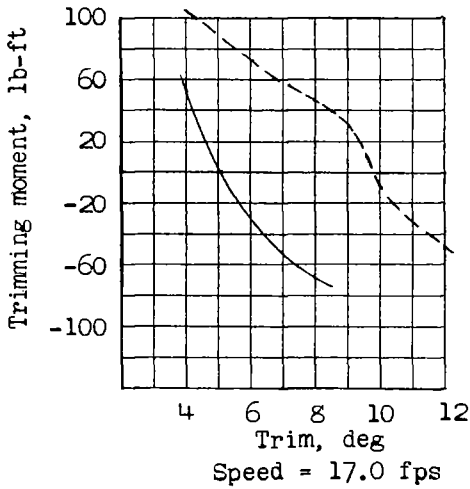
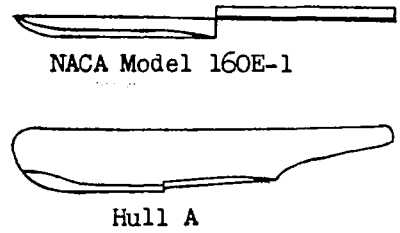
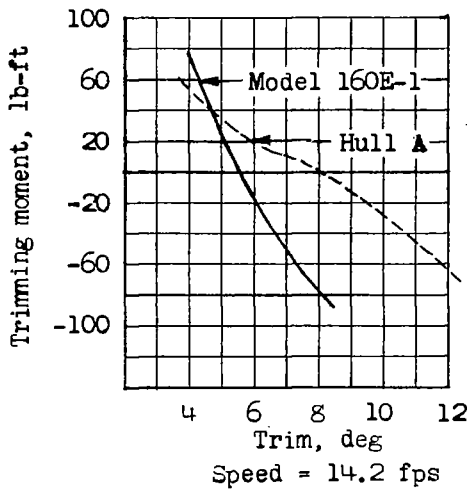

Figure 11.- Comparison of resistance coefficients of planing surfaces with square and pointed trailing edges. Angle of dead rise, $22\text{-}1/2$ degrees.

Fig. 12

NACA



(1 block = 10 divisions on 1/60" Engr. scale)

Figure 12.- Comparison of moments required to change trim for Model 160E-1 and a conventional flying-boat hull.

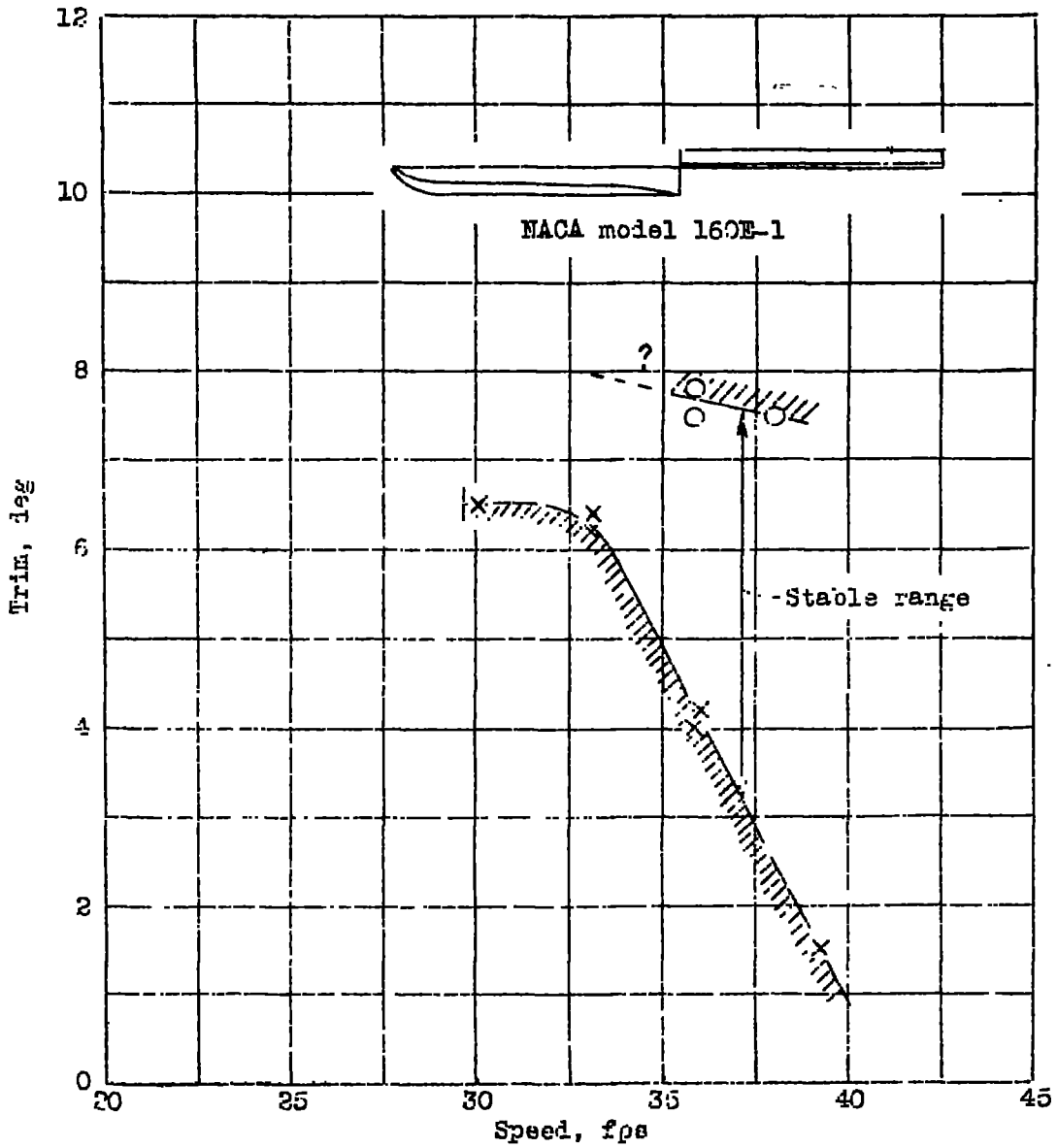

Figure 13.- Longitudinal stability limits of NACA model 16OE-1.

NASA Technical Library



3 1176 01403 3949

TITLE: Preliminary Tank Tests with Planing-Tail Seaplane Hulls

ATI- 7941

REVISION

(None)

AUTHOR(S): Dawson, John R.; Wadlin, Kenneth

ORIGINATING AGENCY: National Advisory Committee for Aeronautics, Washington, D. C.

ORIG. AGENCY NO.

ARR-3F15

PUBLISHED BY: (Same)

PUBLISHING AGENCY NO.

DATE

June '43

DOC. CLASS.

Unclass.

COUNTRY

U.S.

LANGUAGE

Eng.

PAGES

28

ILLUSTRATIONS

graphs, drwgs

ABSTRACT:

Preliminary tests were made with simplified models of two types of hulls that differ considerably from conventional types. In both types, there is a single main planing surface that is combined with after-planing surfaces placed directly below aerodynamic tail surfaces. It was concluded that hulls with planing tails have high trims at rest, have less room for useful load aft of center of gravity than conventional hulls, and introduce restrictions on types of tail surfaces that may be used.

DISTRIBUTION: Request copies of this report only from Originating Agency

DIVISION: Aerodynamics (2)

SECTION: Performance (2)

SUBJECT HEADINGS: Drag, Aerodynamic (31080); Take-off - Hydrodynamics (91635); Flying boats - Hulls - Hydrodynamics (41754); Seaplanes - Performance (84055)

ATI SHEET NO.: R-2-2-8