

DEC 28 1946

RB No. L4I13

NATIONAL ADVISORY COMMITTEE FOR AERONAUTICS

WARTIME REPORT

ORIGINALLY ISSUED
November 1944 as
Restricted Bulletin L4I13

PRELIMINARY INVESTIGATION OF THE RELATION OF THE
COMPRESSIVE STRENGTH OF SHEET-STIFFENER PANELS
TO THE DIAMETER OF RIVET USED FOR
ATTACHING STIFFENERS TO SHEET

By Norris F. Dow and William A. Hickman

Langley Memorial Aeronautical Laboratory
Langley Field, Va.

NACA

WASHINGTON

NACA LIBRARY
LANGLEY MEMORIAL AERONAUTICAL
LABORATORY
Langley Field, Va.

NACA WARTIME REPORTS are reprints of papers originally issued to provide rapid distribution of advance research results to an authorized group requiring them for the war effort. They were previously held under a security status but are now unclassified. Some of these reports were not technically edited. All have been reproduced without change in order to expedite general distribution.

NATIONAL ADVISORY COMMITTEE FOR AERONAUTICS

RESTRICTED BULLETIN

PRELIMINARY INVESTIGATION OF THE RELATION OF THE
COMPRESSIVE STRENGTH OF SHEET-STIFFENER PANELS
TO THE DIAMETER OF RIVET USED FOR
ATTACHING STIFFENERS TO SHEET

By Norris F. Dow and William A. Hickman

SUMMARY

Compressive tests were made of 24S-T aluminum-alloy sheet-stiffener panels, which had five ratios of stiffener thickness to sheet thickness. For each ratio the rivets used to attach the stiffeners to the sheets had five (except in one case, four) different diameters. The tests showed that for the panels of this investigation, which failed by local buckling at average stresses greater than 35,000 psi, the compressive strengths increased with an increase in the diameter of the rivets for the rivet spacings used until the ratio of rivet diameter to over-all thickness (sheet plus stiffener) reached approximately 1.25.

INTRODUCTION

In the design of stressed-skin structures for aircraft, the rivet diameter and spacing used to attach stiffeners to sheet have been determined mainly by rule of thumb. Investigations have been made (references 1 and 2) in order to correlate the strength of a skin-stiffener panel with the spacing of the rivets. There appear to be no quantitative data, however, from which to determine the size of the rivets, especially for panels designed to withstand relatively high compressive stresses.

In order to obtain information on the riveted joint required between the sheet and the stiffener to

develop the potential strength of sheet-stiffener combinations, an investigation has been started to determine experimentally an adequate size and spacing of rivets. The results of the first series of tests for this investigation are reported herein.

TEST SPECIMENS AND METHOD OF TESTING

The specimens consisted of panels having simple triangular stiffeners, as shown in figure 1. The stiffeners on all panels were identical. The sheet thickness was varied to give five selected ratios of stiffener thickness to sheet thickness. The proportions of the 24S-T aluminum-alloy panels (table I) were chosen to give potential strengths of over 40,000 psi, since it was believed that the design of the riveted joints would be most critical on panels having high potential strengths.

The rivets used throughout the investigation were Al7S-T flat-head rivets (AN442AD). Except in one case, five different rivet diameters were used for each ratio of stiffener thickness to sheet thickness. On 24 of the panels, the rivets were driven by the NACA flush-riveting process, in which the rivet is inserted with the head opposite the countersunk end of the hole and the shank of the rivet is driven into the cavity formed by the countersink. A countersink angle of 60° was used throughout. Rivets driven by the NACA flush-riveting process have been shown (reference 3) to give tighter joints than rivets driven by the conventional machine-countersunk flush-riveting process.

Ten additional panels were constructed in which noncountersunk rivets were used. In these panels the flat heads were placed on the sheet side of the panel; and the formed heads, on the stiffener side. Except for the method of riveting, these panels were identical to groups 2 and 4 of table I.

Ultimate compressive loads for the specimens were determined in a hydraulic testing machine having an accuracy of ± 1 percent of the load. The ends of the specimens were ground square and parallel before testing to ensure an even distribution of load over the panel. The lengths of the panels were so chosen that there were no column failures.

RESULTS AND DISCUSSION

For the 24S-T aluminum-alloy panels, which failed by local buckling at average stresses greater than 35,000 psi (fig. 2), the compressive strengths increased with an increase in the diameter of the rivets until the ratio of rivet diameter to the sum of the thicknesses of sheet and stiffener $\frac{d}{t_s + t_w}$ reached approximately 1.25. Figure 2 also shows that, for the rivet spacings used, no appreciable increase in panel strength occurred for values of $\frac{d}{t_s + t_w}$ greater than 1.25. Except for one test specimen, the results for the panels having NACA machine-countersunk flush rivets did not differ appreciably from the results for the panels having non-countersunk rivets.

There are two possible explanations for the fact that the panels reached maximum strengths. Either the potential local buckling strengths were achieved for the rivet spacings used, or the compressive strengths of the panels were limited by rivet strength for

$$\frac{d}{t_s + t_w} > 1.25.$$

In an effort to determine which explanation is the more nearly correct, a series of tests was run, in the manner described in reference 4, to determine the strength of NACA flush rivets in tension. The tensile properties were investigated because the appearance of the panels after failure suggested that, although the loads induced on the rivets were undoubtedly combined shear and tension, the tension probably was the load that more greatly influenced failure. Evidence of the tensile loads on the rivets is given in figure 3, which shows that even for the panel having the largest rivets, the sheet tended to pull away from the stiffeners and thereby induced tension on the rivets.

The tensile strengths of the rivets are plotted in figure 4. For all the ratios of t_w/t_s investigated at a constant value of t_w of 0.064 inch, the strengths of the rivets in tension continued to increase as $\frac{d}{t_s + t_w}$ increased above 1.25. Because the greater rivet strengths did not produce corresponding increments in average stress at maximum load

for the panels, it appears unlikely that the potential local buckling strengths of the panels are substantially above those achieved at $\frac{d}{t_s + t_w} = 1.25$.

Additional testing will be required to establish the effects of rivet spacing, stiffener spacing, and type of failure upon the value of $\frac{d}{t_s + t_w}$ at which the potential strength of a panel is substantially achieved.

CONCLUSION

For the 24S-T aluminum-alloy skin-stiffener panels of the present investigation, which failed by local buckling at average stresses greater than 35,000 psi, the compressive strengths depended upon the diameter of the rivets. For the rivet spacings used, the compressive strengths increased with an increase in the diameter of the rivets until the ratio of rivet diameter to over-all thickness (sheet plus stiffener) $\frac{d}{t_s + t_w}$ reached approximately 1.25.

Langley Memorial Aeronautical Laboratory
National Advisory Committee for Aeronautics
Langley Field, Va.

REFERENCES

1. Howland, W. Lavern: Effect of Rivet Spacing on Stiffened Thin Sheet under Compression. Jour. Aero. Sci., vol. 3, no. 12, Oct. 1936, pp. 434-439.
2. Levy, Samuel, McPherson, Albert E., and Ramberg, Walter: Effect of Rivet and Spot-Weld Spacing on the Strength of Axially Loaded Sheet-Stringer Panels of 24S-T Aluminum Alloy. NACA TN No. 856, 1942.
3. Lundquist, Eugene E., and Gottlieb, Robert: A Study of the Tightness and Flushness of Machine-Countersunk Rivets for Aircraft. NACA RB, June 1942.
4. Schuette, Evan H., Bartone, Leonard M., and Mandel, Mervyn W.: Tensile Tests of Round-Head, Flat-Head, and Brazier-Head Rivets. NACA TN No. 930, 1944.

TABLE I.- NOMINAL DIMENSIONS OF TEST PANELS AND RIVET SPACING.

[All dimensions are in in.]

Group	Sheet thickness, t_s	Width of panel, W	Length of panel, L	Spacing of stiffeners, b_s	Diam. of rivets, d	Spacing of rivets, p	Depth of countersink, c
1	0.051	11.154	6.06	2.858	1/16	5/8	0.035
					3/32	5/8	.040
					1/8	5/8	.050
					5/32	5/8	.060
					3/16	5/8	.050
2	.064	12.129	5.84	3.183	1/16	3/4	.035
					3/32	3/4	.040
					1/8	3/4	.050
					5/32	3/4	.060
					3/16	3/4	.065
3	.081	13.395	5.64	3.605	3/32	7/8	.040
					1/8	7/8	.060
					5/32	7/8	.065
					3/16	7/8	.075
					1/4	7/8	.080
4	.102	15.979	5.20	4.133	3/32	7/8	.050
					1/8	7/8	.060
					5/32	7/8	.070
					3/16	7/8	.080
					1/4	7/8	.090
5	.125	17.004	5.00	4.808	1/8	7/8	.070
					5/32	7/8	.080
					3/16	7/8	.090
					1/4	7/8	.100

NACA RB No. L4T13

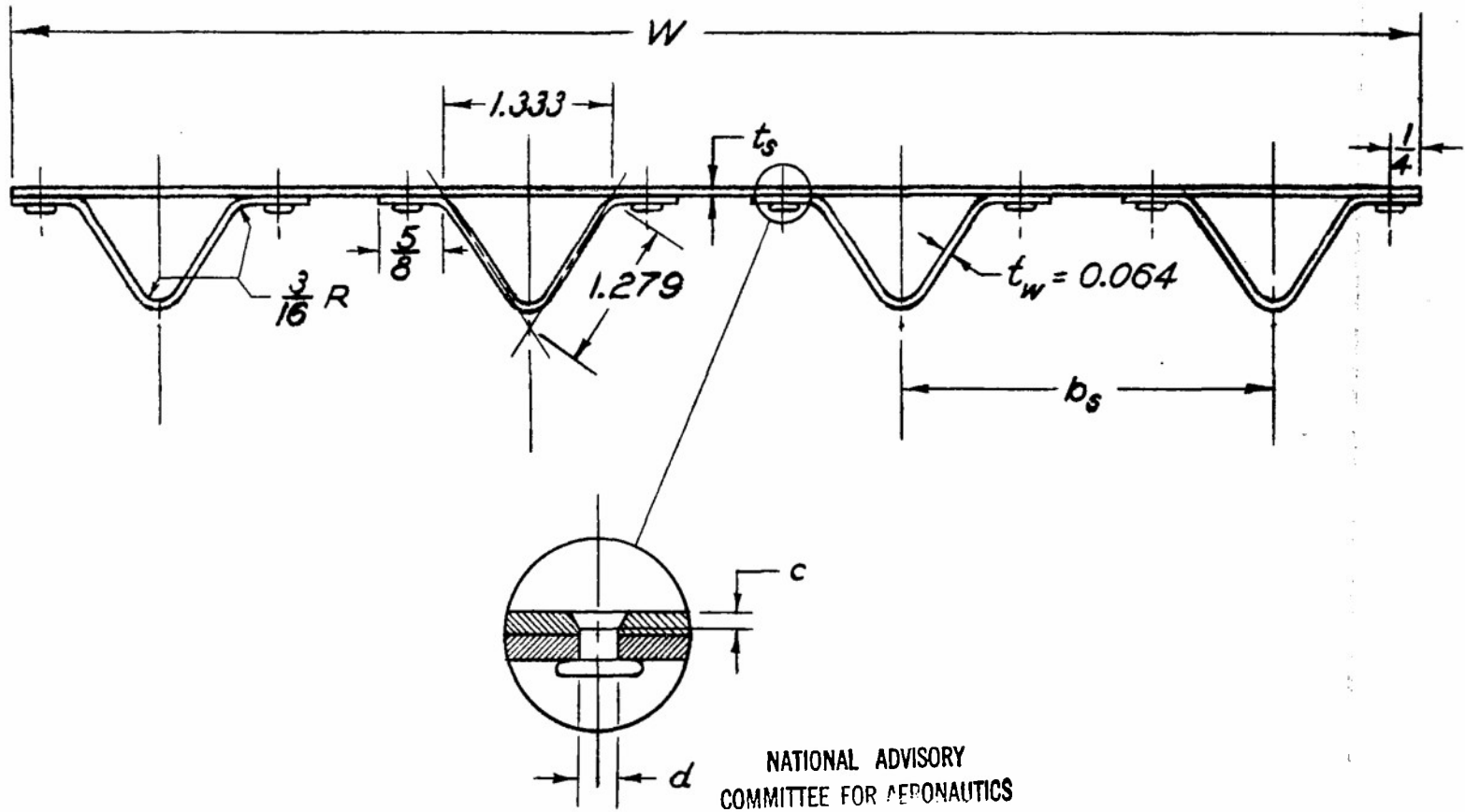

Figure 1. - Test specimens.

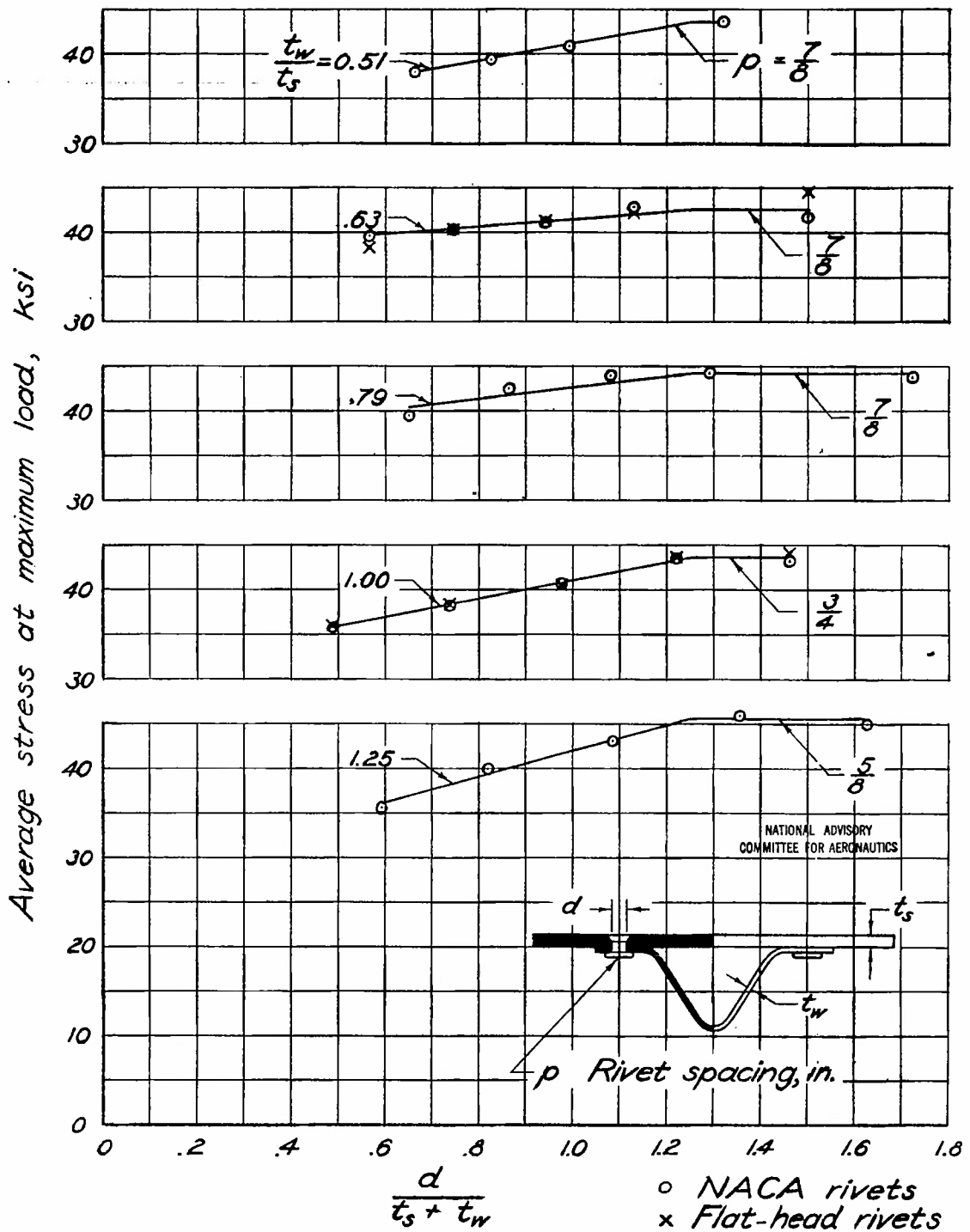

Figure 2. - Variation in local buckling strength of panels with rivet diameter.



Figure 3.- Panels after failure. $t_w/t_s = 1.00$.

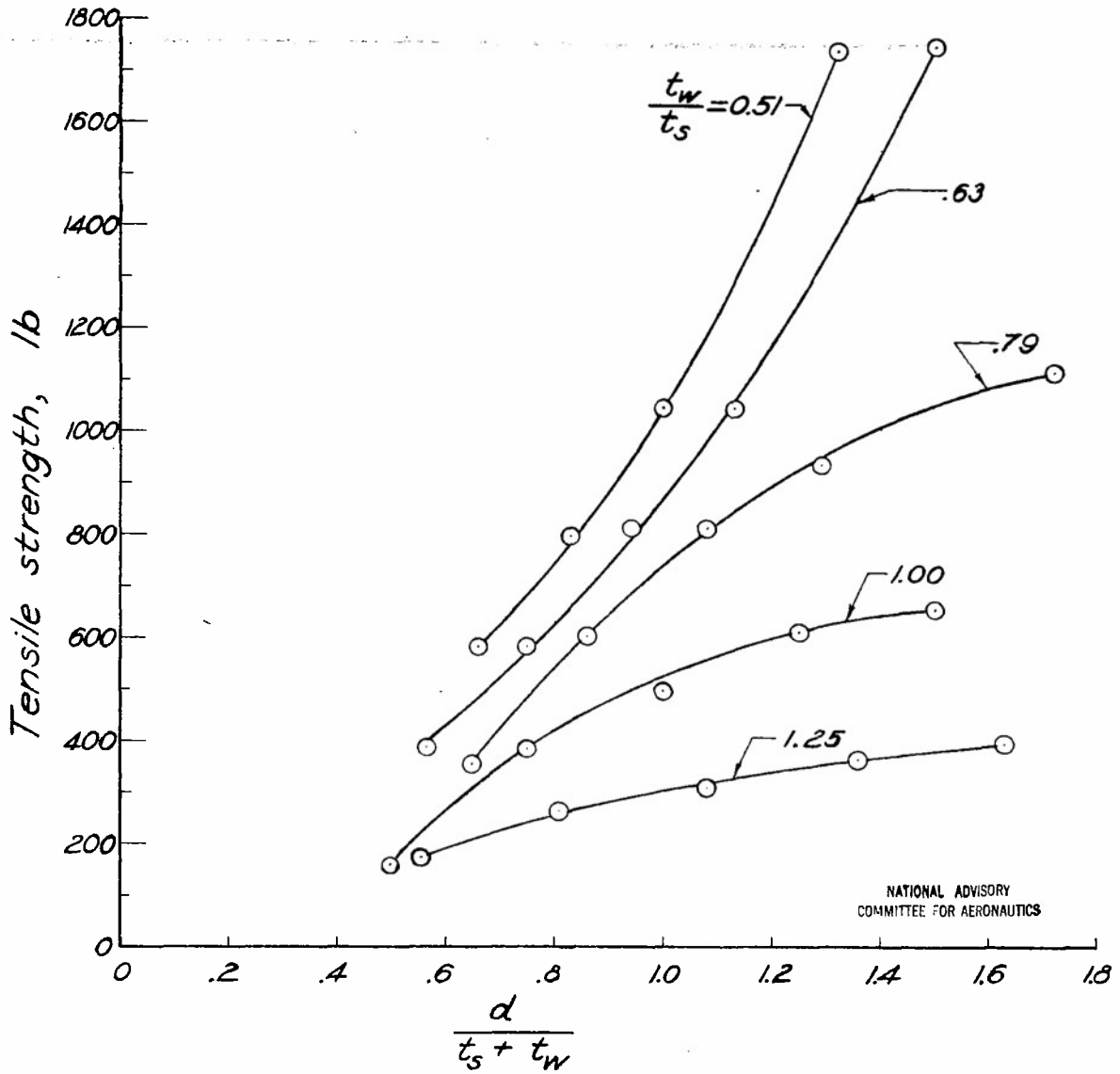

Figure 4.— Increase in tensile strength with diameter for NACA 60° countersunk flush rivets. $t_w = 0.064$.

NSIC FORM 69 (13 NOV 67)

Dow, Norris F.
Hickman, W. A.

R. 7-3-8
DIVISION: Stress Analysis and Structures (7)
SECTION: Structural Design and Details (3)
CROSS REFERENCES: Panels, Stiffened - Strength (68747.7)

ATI-7432

ORIG. AGENCY NUMBER

RB-L4113

REVISION

AUTHOR(S)

AMER. TITLE: Preliminary investigation of the relation of the compressive strength of sheet-stiffener panels to the diameter of rivet used for attaching stiffeners to sheet
FORG'N. TITLE:

ORIGINATING AGENCY: National Advisory Committee for Aeronautics, Washington, D. C.

TRANSLATION:

COUNTRY	LANGUAGE	FORG'N. CLASS.	U. S. CLASS.	DATE	PAGES	ILLUS.	FEATURES
U.S.	Eng.		Unclass.	Nov '44	10	5	photos, tables, graphs

ABSTRACT

Compressive tests were made of 24S-T aluminum alloy sheet stiffener panels which had five ratios of stiffener thickness to sheet thickness. In four of the ratios, five diameters of rivets were used to attach the stiffeners to the sheets while in the fifth ratio only four diameters were utilized. The tests showed that for the panels which failed by buckling at average stresses greater than 35,000 psi, the compressive strengths increased with an increase in the diameter of the rivets for the rivet spacings used until the ratio of rivet diameter to over-all thickness reached approximately 1.25.

NOTE: Requests for copies of this report must be addressed to: N.A.C.A., Washington, D. C.