

NATIONAL ADVISORY COMMITTEE
FOR AERONAUTICS

TECHNICAL NOTE

No. 1182

CASE FILE
COPY

A COLLECTION OF THE COLLAPSED RESULTS
OF GENERAL TANK TESTS OF MISCELLANEOUS
FLYING-BOAT-HULL MODELS

By F. W. S. Locke, Jr.

Bureau of Aeronautics, Navy Department



Washington

March 1947

208

NATIONAL ADVISORY COMMITTEE FOR AERONAUTICS

TECHNICAL NOTE No. 1182

A COLLECTION OF THE COLLAPSED RESULTS OF GENERAL TANK TESTS OF
MISCELLANEOUS FLYING-BOAT-HULL MODELS

By F. W. S. Locke, Jr.

SUMMARY

This report presents summary charts of the collapsed results of general tank tests of about one hundred flying-boat-hull models. These summary charts are intended to be used as an engineering tool to enable a flying boat designer to grasp more quickly the significance of various hull form parameters as they influence his particular airplane. The form in which the charts are prepared is discussed in some detail in order to make them clearer to the designer.

This is a data report, but no attempt has been made to produce conclusions of the usual sort or correlations. However, some generalizations are put forward on the various methods in which the summary charts may be used.

INTRODUCTION

The increasing size of modern flying boats will no longer permit the designer to make a mistake. When flight tests of the first prototype show up some undesirable hydrodynamic characteristic, too much time and money are usually involved in attempting to correct it. The designer must, therefore, be given the tools whereby he may predict the performance of a proposed flying boat with reasonable accuracy.

In order to improve both the air and the water performance of future flying boats, there is imperative need of systematic design studies to determine the influence of the hull. It is hardly fair to expect the designer to wade through great masses of data in order to make these studies. He needs some simple, clear, and relatively accurate means of getting an over-all picture of the effect of various hull variables.

The usual forms of plotting the results of general tank tests are so complex that from 12 to 20 sheets of paper are often required to present the data for one hull model. Under these circumstances a long, laborious study is required to find out which is the better of the two hulls for a given purpose. The problem of finding the best of a group of hulls is practically unmanageable, both because of the work and because the method of presentation gives the designer no mental picture of the behavior of the models.

During the last 15 years or so general tank tests have been run on a very large number of hull models. This report presents the results of all the published NACA general tank tests, and some from the SIT and RAE tanks, in such form that they will be of immediate usefulness for design purposes. All the data for any one model are presented on a single summary chart which may be used to make either specific or general comparisons.

NOTATION

The test results are presented in terms of the standard NACA sea-plane coefficients. Throughout this report the following notation and definitions are used:

Load coefficient	$C_{\Delta} = \Delta/wb^3$
Speed coefficient	$C_V = V/\sqrt{g'b}$
Resistance coefficient	$C_R = R/wb^3$
Trimming-moment coefficient	$C_M = M/wb^4$
Longitudinal-spray coefficient	$C_X = X/b$
Lateral spray coefficient	$C_Y = Y/b$
Vertical-spray coefficient	$C_Z = Z/b$
Forebody length/beam ratio	L_f/b
Afterbody length/beam ratio	L_a/b
Step height/sternpost angle ratio	h/σ
Pitching "gyradius" constant	k/L

Aerodynamic pitch damping constant

$$M_q/V \frac{\rho w}{2} b^4$$

where

- Δ load on water, pounds
- w specific weight of water, pounds per cubic foot (62.3 for RAE and SIT, 63.5 for NACA, and 64.0 for sea water)
- b beam at main step, feet
- V speed, feet per second
- g acceleration of gravity (32.2 ft/sec²)
- R resistance, pounds
- M trimming moment, pounds
- X longitudinal position of main-spray point of tangency, measured fore (positive) or aft (negative) of the step centroid, feet
- Y lateral position of main-spray point of tangency, measured from the hull centerline, feet
- Z vertical position of main-spray point of tangency, measured from the tangent to the forebody keel at the main step, feet
- L_f forebody length, measured from the intersection of chine and keel to the step centroid along a line parallel to the tangent to the forebody keel at the main step, feet
- L_a afterbody length, measured from the step centroid to the second step centroid or sternpost, whichever is shorter, feet
- L forebody plus afterbody lengths, feet
- h step height at the step centroid, percent of beam at step
- σ sternpost angle, the angle between the tangent to the forebody keel at the main step and a line joining the tip of the step and the sternpost or second step, whichever is lower, degree

β_f	forebody dead rise at keel and main step, degree
α	afterbody angle, the angle between the forebody and afterbody keels, degree
β_a	maximum afterbody dead rise regardless of where it occurs, degree
M_q	aerodynamic tail damping derivative (See reference 1 for complete definition.)
k	pitching radius of gyration, feet

Moment data are referred to the center of gravity and water trimming moments which tend to raise the bow are considered positive.

Trim (τ) is the angle between the tangent to the forebody keel at the main step and the free water surface in all cases.

Heel (ϕ) is the angle between the centerline plane of the hull and a plane perpendicular to the still water surface.

The coordinates of the center of gravity are measured above the tangent to the forebody keel at the main step and forward of a plane perpendicular to the keel and passing through the step centroid. The step centroid is the center of gravity of the area on the forebody bounded by the tip of the step and a line joining the intersections of the step faces with the chines.

The following combinations of the coefficients defined above are used:

Planing Range

Lift coefficient	$\sqrt{C_{\Delta}}/C_V$	(reference 1)
Resistance coefficient	$\sqrt{C_R}/C_V$	(reference 2)

Displacement Range

Speed coefficient	$C_V^2/C_{\Delta}^{1/3}$	(reference 2)
Resistance coefficient	$C_R/C_V^2 C_{\Delta}^{2/3}$	(reference 2)
Longitudinal-spray coefficient	$C_X/C_{\Delta}^{1/3}$	(reference 3)

Lateral-spray coefficient	$C_V/C_\Delta^{1/3}$ (reference 3)
Vertical-spray coefficient	C_Z/C_Δ (reference 3)

The courtesy of the National Advisory Committee for Aeronautics in furnishing detailed test data on certain models which had not previously been published is deeply appreciated. It should be noted that the resistance and porpoising data on SIT models 294-79 and 406 were determined under the auspices of the Glenn L. Martin Company. The data on SIT models 618 and 621 were determined for the Grumman Aircraft Engineering Corporation in connection with a flying boat being developed for the U. S. Navy.

DEVELOPMENT OF CHART

Figures 1 to 103, summary charts used to present the data shown in this report, are the result of a coordinated development program. It is of importance to the user of these charts to understand how they are laid out so that he can get the maximum benefit from them.

(a) Title box.-- At the top of the summary chart is information defining certain characteristics of the model and the test, which must be known before intelligent comparisons can be made between charts. With the exception of the designation they are believed to be self-explanatory. Very careful consideration was given to the definition of this designation. By itself, the designation will give a crude measure of what are, perhaps, the most important hydrodynamic characteristics of the hulls of modern flying boats. Thus, if a chart has the designation:

4.00 - 1.00 - 25.0

it would mean

$L_f/b - h/\sigma - \beta_f$

which, in turn, are a measure of

Spray Skipping Impact

A further advantage of this system of designating the hull is that each of the particular hydrodynamic characteristics improves as the number gets larger. Like most things in nature, however, changing the hull shape to improve one hydrodynamic characteristic may harm another. The designation system is therefore not foolproof and should be used with caution.

Background for the assumption that the forebody length/beam ratio controls the main spray of the hull may be found in references 4 and 5.

Both of these references show quite good correlation of the main-spray characteristics of existing flying boats in terms of forebody/length beam ratio. While it is undoubtedly quite true that other hull form variables have a powerful influence on the main spray characteristics, the forebody length/beam ratio appears to be the primary parameter. Reference 6 indicates that one of the most important hull form variables governing the skipping characteristics is the step height/sternpost angle ratio. Recent and as yet unpublished NACA tests indicate that the afterbody length has considerable influence on skipping, but other factors seem to have only secondary effects. It is generally accepted that forebody dead rise is the hull-shape parameter controlling the violence of the landing impact. Hence, it is believed that the parameters chosen are eminently suitable for a crude and quick evaluation of the potentialities of a particular hull.

No matter how clever a designation system is devised, it cannot hope to describe completely a shape as complex as a flying-boat hull. For this reason, to the right and just underneath the title box, is a simple body plan of the hull. This should materially aid the user of the summary chart in getting a quick picture of the shape under consideration.

A few other important dimensions and particulars of the hull models may be found in the tables on pages 12 to 14. These tables may also be used as an index of the summary charts included in this report. If any particular hull should prove to be of direct interest, it is strongly recommended that reference be made to the original reports. The tables also give the source of the data.

(b) Main spray data.-- The form in which the spray data is shown near the top of the chart was developed in reference 3. This method of plotting has the very powerful advantage of allowing direct comparisons between hulls, regardless of the loads at which the tests were made. A rather strong disadvantage is that the curves are not visibly related to the hull itself. One way to overcome this difficulty is to compare the height and lateral positions of the points of tangency of different models at the same longitudinal position. If it is expected to load the different hulls in different manners, care must be exercised. A comparison of this sort is only possible at all because of the fact that there is relatively little difference in the

$C_X/C_{\Delta}^{1/3}$ curves for the various hulls tried so far.

Plots shown in reference 3 may be used to make an estimate of the accuracy of this form of plotting through the scattering of test points.

(c) Displacement range resistance.-- In the middle of the summary chart are shown the free-to-trim resistance and trim as determined in

the displacement range. This form of plotting was developed in reference 2 and was chosen in preference to that shown in figure 23 of reference 3 because it yields definite clues to two other very important hydrodynamic characteristics.

The bow spray in rough water (windshield wetting) is an exceedingly important characteristic of military flying boats and a simple means for evaluating it is very desirable. It appears that a reasonably reliable criterion for evaluating bow spray is the peak of the curve of

$C_R/C_V^2 C_\Delta^{2/3}$. The peak occurs at values of $C_V^2/C_\Delta^{1/3}$ near 1.5, which is in the vicinity of the speed at which bow spray is at its worst. This peak should, under no circumstances, be confused with the true hump which occurs much later. The peak in the $C_R/C_V^2 C_\Delta^{2/3}$ curve is caused primarily by water piling up ahead of the bow. It therefore makes an excellent criterion for measuring the effectiveness with which the bow cuts the water. The lower the peak the greater the ease with which the bow cuts the water. Hence, by inference, it may be used as a measure of the bow spray in rough water, which appears to be directly related to the ease with which the bow cuts through waves. (See reference 7.)

With the lower power loadings coming into general use, it appears that the free-to-trim trim is more important than the resistance. It is hardly worth while doing much work to reduce the take-off time 10 percent if the time is already about 20 seconds; whereas it is important if the time is near 60 seconds. On the other hand, if the trim is too high or too low the spray is likely to be quite bad and, even though its duration is short, it may do structural damage. The scale adopted for trim is twice as large as that used in figure 23 of reference 3. True, the resistance scale is much smaller in the vicinity of the hump ($C_V^2/C_\Delta^{1/3}$ between about 8 and 12), but it is believed to be large enough for most practical purposes.

In references 2 and 8 will be found data, plotted in this manner, which may be used to get an estimate of the accuracy to be expected through the amount of scatter.

(d) Planing range.— In the planing range the results are presented in the same manner as was developed in references 1 and 2. Contours of the planing resistance coefficient $\sqrt{C_R}/C_V$ have been omitted where they would be more than 2° or 3° outside of the limits of longitudinal stability. Since there would not be much hope of being able to operate a flying boat in this region of instability, regardless of how good the resistance might be, omitting the data should avoid some confusion. An exception is the region near get-away in which the hull is riding with the forebody clear. Under this circumstance, the contours were prepared whenever data was available.

In some cases contours of constant C_M are included - at least where it was not too time-consuming to dig them out of the original data. Actually, plotting C_M in this way is completely irrational. Constant C_M was used for two reasons: it works quite well (see data plots in references 1, 8, and 9), and it is simpler than the rational form $\sqrt{C_M/C_V}$.

The manner in which the various contours in the planing range were derived deserves careful attention at the low-speed end. At the higher values of the planing-lift coefficient, $\sqrt{C_\Delta/C_V}$, the collapsing process breaks down. The resistance at constant trim and trim at constant moment for specific values of C_Δ peel off the main curves. Examples of this peeling-off process may be found in references 2 and 8. When the designer is preparing resistance or trim curves from the displacement and planing range, care should be taken to see that the curves from the two regimes overlap. The lower values from either regime should then be used. This matter is discussed in greater detail in reference 8. The peak of the lower limit sometimes, but not always, performs a similar peeling off. The breakdown of the collapsing process at the lower end of the planing range is regarded primarily as an inconvenience. It can be overcome by practice in using the charts and good judgment.

The accuracy of the various contours in the planing range may be judged by plots of data shown in references 1, 2, 8, and 9. The reason that no test points have been shown on any of the charts in this report is merely to avoid the confusion to the eye of a great mass of black spots.

One last point that deserves mention is that speed increases toward the right everywhere on the summary charts.

DISCUSSION

(a) Using the chart.- The crucial job in designing a flying boat is to ensure that the hull and air structure fit together as a single working unit to give both good air and water performance. Just as airplanes designed for different purposes require different wing and power loadings, so do hulls have to be custom-tailored for the particular jobs they are expected to perform.

The designer is badly hampered, when hull data is reported in the conventional manner, by the multiplicity of charts he has to wade through to select a hull suitable for the job he has in mind. The summary charts presented with this report should aid considerably in getting to the

root of the problem of selecting a suitable hull. Basically, there are at least three methods for using these charts. Depending on the time and staff available, best results will often be obtained by using a combination of all three methods.

The first and simplest method of using the summary charts is to select those which contain hull form parameters of interest and spread them out over a large table. By merely standing back and looking at the group of charts the designer can readily pick out, without further ado, those hulls having characteristics completely unsuitable for the job he has in mind. This method is not very effective for finding the best hull for a particular job, but what is very important is that it will quickly get rid of the deadwood. It will be noted that this type of analysis will be greatly facilitated by keeping the summary charts in a loose-leaf binder when they are not in use.

Because of the job that the hull is expected to perform, certain of the hydrodynamic characteristics will have predominating influence. The criteria measuring these characteristics may be plotted against the controlling hull-shape parameters. This process will undoubtedly show the bow of one hull is best, the afterbody of another hull, and so on. This should allow the designer to fit the various parts together to produce a hull having the performance he wants, and at the same time he will have quite a good idea of its characteristics. At this stage the designer should undertake tank tests to get the specific characteristics of his hull, if the importance of the project warrants the time and money.

The third method of using summary charts is actually to fit hulls with satisfactory hydrodynamic characteristics to an airplane and determine the aerodynamic performance. A quick method of determining the hydrodynamic characteristics for specific airplanes from the summary charts will be found in reference 8. If the airplane is being designed for maximum range, for instance, at the expense of other characteristics, range may be plotted against various hull parameters. This type of design study yields its clearest results when confined to a series of hulls having some systematic change. Several such series will be found in this report. Unfortunately, they are small families; however, in the near future several more complete studies should be available.

(b) General.— The designer will undoubtedly be highly irritated when he finds a hull with some one interesting characteristic, but the data on the other hydrodynamic characteristics missing. Unfortunately, this is likely to happen quite frequently since, out of all the charts included, only about half a dozen are complete. This disadvantage should not weigh too heavily, however, because it is a relatively simple matter to get the additional data necessary. Should such a hull or hulls turn up, the designer should make his needs known.

In this connection, it is worth noting that the testing establishments would make a good deal faster progress if they deliberately left gaps in various types of data used in preparing a summary chart. For instance, as far as large military flying boats are concerned, present design trends seem to indicate that stability and spray are the controlling criteria. Work on these two characteristics, at the expense of others, would appear well worth while. When interesting hulls have been found it is very simple to go back and get the missing data.

As pointed out previously, the manner in which the displacement range resistance and trim is plotted was selected because it gave clues to the bow spray and main spray even though they were not actually tested. Similarly, the resistance contours in the planing range may be used as a clue to the upper limit porpoising and skipping characteristics. Ordinarily, the upper limit of porpoising may be expected to be about 1° below the line which shows where the forebody comes clear. Further, it will be reasonably parallel to it. This will locate the primary upper limit, but not the secondary upper limit.

At very low values of the planing lift coefficient and moderately high trims, the resistance contours frequently bend to the right. This bending is associated with afterbody wetting, and hence presumably may be taken as at least an indication of the skipping characteristics. On a few hulls the bending occurs quite suddenly, and it is expected that then skipping will be found only at trims above the lowest sharp bend.

The temptation to select some hull from this or other similar collections of summary charts as the final design should be strenuously resisted. Because a certain hull was satisfactory on some given design does not necessarily mean that it will be equally good for a new and different design. These charts should be regarded as an engineering tool for determining trends to arrive at a better hull. If kept in this light, no matter how closely they are pushed, no insuperable difficulties should arise from the use of the summary charts.

CONCLUDING REMARKS

The group of summary charts presented in this report should be a valuable tool to assist the designer in selecting a hull for a particular purpose. By using the charts and getting familiar with them, the designer will be able more quickly to arrive at the point of most interest to him - a high-performance aircraft.

Aviation Design Research Branch,
Bureau of Aeronautics, Navy Department,
Washington, D. C., January 1946.

REFERENCES

1. Locke, F. W. S., Jr.: General Porpoising Tests of Flying-Boat-Hull Models. NACA ARR No. 3117, 1943.
2. Locke, F. W. S., Jr.: General Resistance Tests on Flying-Boat-Hull Models. NACA ARR No. 4P19, 1944.
3. Locke, F. W. S., Jr.: "General" Main-Spray Tests of Flying-Boat Models in the Displacement Range. NACA ARR No. 5A02, 1945.
4. Locke, F. W. S., Jr.: An Analysis of the Main-Spray Characteristics of Some Full Size Multiengine Flying Boats. NACA TN No. 1091, 1946.
5. Parkinson, John B.: Design Criteria for the Dimensions of the Forebody of a Long-Range Flying Boat. NACA ARR No. 3K08, 1943.
6. Locke, F. W. S., Jr.: An Analysis of the Skipping Characteristics of Some Full-Size Flying Boats. NACA ARR No. 5J24, 1946.
7. Locke, F. W. S., Jr.: Some Systematic Model Experiments of the Bow-Spray Characteristics of Flying-Boat Hulls Operating at Low Speeds in Waves. NACA ARR No. 3L04, 1943.
8. Locke, F. W. S., Jr.: A Graphical Method for the Interpolation of the Hydrodynamic Characteristics of Specific Flying Boats from the Collapsed Results of General Tests of Flying-Boat Hull Models. NACA TN 1259 (to be published).
9. Davidson, Kenneth S. M., and Locke, F. W. S., Jr.: General Tank Tests on the Hydrodynamic Characteristics of Four Flying-Boat Hull Models of Differing Length-Beam Ratio. NACA ARR No. 4F15, 1944.

Model No.	Designation		L/b	L _a /b	L _f /L	h/b	α (deg)	β _a max	Center-of-gravity position		Model beam (in.)	Remarks	Source	Fig.
	L _f /b	h/c							Pr	Fwd/b				
NACA MODELS														
11	2.82	0.43	22.5	1.65	0.630	3.31	6.5	22.5	0.36	1.19	17.00		TN 464	1
11-A	2.82	.43	22.5	1.65	.630	3.31	6.5	22.5	.36	1.19	17.00		TN 470	2
11-B	2.82	.32	22.5	1.65	.630	3.31	9.0	22.5	.47	.91	17.00	Longitudinally concave forebody	TN 545	3
11-C	2.82	.43	22.5	1.65	.630	3.31	6.5	22.5	.47	.91	17.00		TN 535	4
11-C-7	2.82	.76	22.5	1.65	.630	3.31	3.5	22.5	.47	.91	17.00		TN 541	5
11-C-8	2.82	.55	22.5	1.65	.630	3.31	5.0	22.5	.47	.91	17.00		TN 541	6
11-C-9	2.82	.36	22.5	1.65	.630	3.31	8.0	22.5	.47	.91	17.00		TN 541	7
11-C-10	2.82	.30	22.5	1.65	.630	3.31	10.0	22.5	.47	.91	17.00		TN 541	8
11-C-11	2.82	.11	22.5	1.65	.630	.74	6.5	22.5	.47	.91	17.00		TN 535	9
11-C-12	2.82	.26	22.5	1.65	.630	1.84	6.5	22.5	.47	.91	17.00		TN 535	10
11-C-13	2.82	.69	22.5	1.65	.630	5.88	6.5	22.5	.47	.91	17.00		TN 535	11
11-C-30° S	2.87	.61	22.5	1.60	.643	4.31	6.5	22.5	.52	.91	17.00	30° Swallow-tail step	TN 539	12
11-C-45° V	2.74	.27	22.5	1.73	.613	2.41	6.5	22.5	.39	.91	17.00	45° V-step	TN 539	13
11-E	2.82	.75	7.5	1.65	.630	5.76	6.5	22.5	.47	.91	17.00	Two longitudinal steps on forebody	TN 574	14
11-F	2.82	.75	14.8	1.65	.630	5.70	6.5	22.5	.47	.91	17.00	-----do-----	TN 574	15
11-G	2.82	.43	22.5	1.65	.630	3.31	6.5	22.5	.47	.91	17.00	Some chine flare on forebody	TN 531	16
11-M	2.82	.75	18.7	1.65	.630	5.76	6.5	22.5	.47	.91	17.00	One longitudinal step on forebody	TN 574	17
11-N	2.82	.75	7.5	1.65	.630	5.76	6.5	22.5	.47	.91	17.00	-----do-----	TN 574	18
12	3.00	.44	22.5	1.75	.630	3.31	6.5	22.5	.39	1.19	17.00		TN 491	19
13	2.64	.43	22.5	1.54	.630	3.31	6.5	22.5	.34	1.19	17.00		TN 491	20
14	2.52	.39	20.3	1.48	.630	2.95	6.5	20.3	.32	1.07	19.00		TN 491	21
15	3.20	.49	25.1	1.87	.630	3.73	6.5	25.1	.41	1.35	15.00		TN 491	22
16	2.44	.56	23.0	2.56	.488	4.85	8.0	20.0	0	1.03	15.42		TN 471	23
18	2.84	.51	22.5	1.83	.608	3.8	6.25	22.5	.49	.78	16.84	"Hook" on forebody at step	TN 681	24
22	2.12	2.88	10.0	2.36	.475	17.3	0	10.0	-.23	.80	17.00	Pointed step	TN 488	25
22-A	2.28	2.88	10.0	4.64	.492	17.3	0	10.0	0	.80	17.00	-----do-----	TN 504	26
26	2.75	.45	22.0	1.78	.607	3.2	6.55	22.0	.24	.82	17.86		TN 512	27
27	∞	∞	0.0	∞	∞	∞	∞	∞	∞	∞	∞		TN 509	28
28	∞	∞	10.0	∞	∞	∞	∞	∞	∞	∞	∞	Planing surface	TN 509	29
29	∞	∞	20.0	∞	∞	∞	∞	∞	∞	∞	∞	-----do-----	TN 509	30
30	∞	∞	30.0	∞	∞	∞	∞	∞	∞	∞	∞	-----do-----	TN 509	31
35	2.92	3.77	15.0	6.15	.475	22.6	0	15.0	.08	.97	13.00	Pointed step	TN 551	32
35-A	2.92	3.77	20.0	6.15	.475	22.6	0	20.0	.08	.97	13.00	-----do-----	TN 551	33
35-B	2.92	3.77	25.0	6.15	.475	22.6	0	25.0	.08	.97	13.00	-----do-----	TN 551	34
36	3.57	.55	20.0	5.71	.625	4.0	6.25	20.0	.71	1.00	14.00	-----do-----	TN 638	35
40-AC	3.12	.44	20.0	5.57	.560	3.7	7.5	20.0	.30	1.12	13.47		Rep. 543	36
40-AD	3.12	.44	20.0	5.57	.560	3.7	8.5	20.0	.30	1.12	13.47		Rep. 543	37
40-AE	3.12	.41	20.0	7.43	.420	3.7	8.5	20.0	.30	1.12	13.47		Rep. 543	38
40-BC	3.12	.44	20.0	5.57	.560	3.7	7.5	20.0	.30	1.12	13.47		Rep. 543	39
40-BE	3.12	.41	20.0	7.43	.420	3.7	8.5	20.0	.30	1.12	13.47		Rep. 543	40

Model No.	Designation			L _r /b	h/c	c _f	L/p	L _a /b	L _r /L	h/b	α (deg)	σ (deg)	β _{max}	Center-of-gravity position x _{wg} /b	Center-of-gravity position above/b	Model beam (in.)	Remarks	Source	Fig.
	L _r /b	h/c	c _f																
NACA MODELS																			
41-A	3.56	0.86	26.0	5.98	2.42	0.595	7.75	7.5	9.0	26.0	0.44	2.04	2.04	12.00		TN 563	41		
41-D	3.58	.98	26.0	6.00	2.42	.597	7.75	6.0	7.9	26.0	.58	2.04	2.04	12.00		TN 566	42		
44	2.76	.51	22.5	4.48	1.72	.616	3.1	5.0	6.1	22.5	.48	.97	.97	17.00		TN 566	43		
46	2.60	.98	-2.0	5.24	2.64	.497	6.8	4.6	6.92	24.0	0	.80	.80	14.24		TN 590	44		
47	2.38	.38	26.0	4.68	2.30	.509	3.45	8.0	9.0	25.0	.13	1.31	1.31	16.26		TN 590	45		
52	2.76	.47	22.5	3.62	.86	.773	4.0	5.8	8.5	22.5	.44	.88	.88	17.00		TN 576	46		
57-A	3.37	.85	20.0	6.74	3.37	.500	6.8	7.0	8.25	20.0	.36	1.93	1.93	12.45		TN 716	47		
57-B	3.37	.85	25.0	6.74	3.37	.500	6.8	7.0	8.25	20.0	.36	1.93	1.93	12.45		TN 716	48		
57-B-5	4.17	.85	25.0	7.54	3.37	.555	6.8	7.0	8.25	25.0	.36	1.93	1.93	12.45		TN 716	49		
57-C	3.37	.85	30.0	6.74	3.37	.500	6.8	7.0	8.25	30.0	.36	1.93	1.93	12.45		TN 716	50		
61-A	3.73	4.09	26.0	6.70	2.97	.556	24.5	0	6.0	26.0	.45	2.04	2.04	12.00	Pointed step	TN 656	51		
62-AD	2.82	.36	22.5	4.59	1.77	.615	3.3	9.0	9.15	22.5	.37	.91	.91	17.00		TN 725	52		
66	2.34	.47	26.0	4.49	2.15	.522	4.6	7.5	8.8	30.5	.08	.96	.96	21.60	30° V-step	TN 858	53		
73	3.73	4.09	26.0	6.70	2.97	.556	24.5	0	6.0	26.0	.45	2.04	2.04	12.00	Faired pointed step	TN 656	54		
74-A	3.15	.26	R	5.24	2.09	.601	1.95	6.8	7.5	R	.45	.93	.93	15.92	Circular bottom	TN 668	55		
75	2.87	2.44	20.0	5.42	2.55	.530	19.5	1.5	8.0	20.0	.17	.45	.45	15.90	Faired pointed step	TN 668	56		
83	3.09	.63	25.0	4.58	1.49	.675	2.6	2.2	4.15	37.0	.42	.72	.72	17.70		TN 836	57		
84-AP	3.24	.34	20.0	5.38	2.14	.603	2.58	6.8	7.5	20.0	.46	1.16	1.16	15.92		ARR 3115	58		
84-EP-1	3.24	.34	20.0	5.38	2.14	.603	2.58	6.8	7.5	20.0	.46	1.16	1.16	15.92		ARR 3115	59		
84-EP-3	3.24	.57	20.0	5.38	2.14	.603	4.52	6.8	7.9	20.0	.46	1.16	1.16	15.92		ARR 3115	60		
84-EP-4	3.24	.47	20.0	5.38	2.14	.603	4.52	6.8	9.6	20.0	.46	1.16	1.16	15.92		ARR 3115	61		
126A-1	2.82	.88	17.5	5.04	2.22	.560	5.0	5.0	5.7	17.5	.31	1.17	1.17	14.00		ARR 3B23	62		
126A-2	2.82	.58	17.5	5.04	2.22	.560	5.0	7.5	8.7	17.5	.31	1.17	1.17	14.00		ARR 3B23	63		
126A-3	2.82	.47	17.5	5.04	2.22	.560	5.0	9.3	10.6	17.5	.31	1.17	1.17	14.00		ARR 3B23	64		
126B-1	2.82	.88	22.5	5.04	2.22	.560	5.0	5.0	5.7	22.5	.31	1.17	1.17	14.00		ARR 3B23	65		
126B-2	2.82	.58	22.5	5.04	2.22	.560	5.0	7.5	8.7	22.5	.31	1.17	1.17	14.00		ARR 3B23	66		
126B-3	2.82	.47	22.5	5.04	2.22	.560	5.0	9.3	10.6	22.5	.31	1.17	1.17	14.00		ARR 3B23	67		
126C-1	2.82	.88	27.5	5.04	2.22	.560	5.0	5.0	5.7	27.5	.31	1.17	1.17	14.00		ARR 3B23	68		
126C-2	2.82	.58	27.5	5.04	2.22	.560	5.0	7.5	8.7	27.5	.31	1.17	1.17	14.00		ARR 3B23	69		
126C-3	2.82	.47	27.5	5.04	2.22	.560	5.0	9.3	10.6	27.5	.31	1.17	1.17	14.00		ARR 3B23	70		
144	3.14	.74	20.0	5.23	2.09	.601	6.28	6.8	8.45	20.0	.45	1.13	1.13	15.92		ARR 3J23	71		
145	3.94	.85	20.0	6.54	2.60	.601	7.02	6.8	8.27	20.0	.51	1.26	1.26	14.24		ARR 3J23	72		
146	4.71	.95	20.0	7.84	3.13	.601	7.70	6.8	8.14	20.0	.55	1.38	1.38	13.00		ARR 3J23	73		
184	5.80	.66	20.0	10.50	4.70	.553	5.0	7.0	7.60	20.0	.46	1.40	1.40	11.81		ARR L5G19	74		
185	5.80	.66	24.5	10.50	4.70	.553	5.0	7.0	7.60	24.5	.46	1.40	1.40	11.81		ARR L5G19	75		
185-A	5.80	1.22	24.5	10.50	4.70	.553	10.0	7.0	8.20	24.5	.46	1.40	1.40	11.81		ARR L5G19	76		
207	3.78	1.10	25.0	7.00	3.22	.540	9.0	8.3	9.90	35.0	.83	.83	.83	14.74	45° V-step	RMK L5H06a	77		
207A	3.78	1.06	25.0	7.00	3.22	.540	9.0	8.3	9.57	35.0	.83	.83	.83	14.74	With chine flare on afterbody	RMK L5H06a	78		
207C	3.78	1.06	25.0	7.00	3.22	.540	9.0	8.3	9.57	35.0	.83	.83	.83	14.74	Chine lowered near bow	RMK L5H06a	79		

Model No.	Designation			L/b	L _g /b	L _r /L	h/b	α (deg)	σ (deg)	β _a max	Center-of-gravity position fwd/b	Model beam (in.)	Remarks	Source	Fig.
	L _r /b	n/σ	β _r												
	RAE MODELS														
L/b = 5.5	2.31	0.38	20.0	1.47	2.16	0.516	3.07	7.3	8.11	20.0	0.18	10.92		BA 1350	80
L/b = 7.0	2.94	.48	20.0	5.70	2.76	.516	3.91	7.3	8.11	20.0	.23	8.56		BA 1350	81
L/b = 8.5	3.57	.58	20.0	6.91	3.34	.516	4.75	7.3	8.11	20.0	.28	7.06		BA 1350	82
L/b = 10.5	4.20	.69	20.0	8.14	3.94	.516	5.58	7.3	8.11	20.0	.32	6.00		BA 1350	83
Shetland	3.69	1.06	27.0	7.29	3.67	.497	10.0	7.2	9.0	37.0	.24	6.17	Faired 24° V-step	Aero 1745	84
N2/42-A1	2.85	1.30	21.5	6.40	3.55	.445	11.0	6.5	8.5	26.0	.16	6.64	Faired transverse step	Aero 1858	85
N2/42-Q	2.87	1.11	20.0	6.40	3.53	.448	9.5	6.8	8.5	23.5	.16	6.56	-----do-----	Aero 1858	86
OEH	4.02	.98	27.5	8.28	4.26	.485	8.6	7.0	8.8	42.0	.10	6.58	Fully faired step	Aero 2029	87
FEH	4.02	1.09	27.5	8.28	4.26	.485	9.9	7.3	9.1	42.0	.10	6.58	Parabolic step	Aero 2029	88
294-79	3.68	0.31	20.0	6.74	3.06	0.545	2.6	7.5	8.4	30.0	0.44	5.10		Unpublished	89
339-1	3.32	.62	20.0	6.07	2.75	.547	5.0	7.0	8.00	20.0	.35	5.40		ARR AF15	90
339-15	3.32	.64	20.0	6.57	3.25	.505	5.0	7.0	7.75	20.0	.35	5.40		Unpublished	91
339-20	2.72	.62	20.0	5.47	2.75	.497	5.0	7.0	8.00	20.0	.35	5.40		Unpublished	92
339-22	2.72	.61	20.0	4.97	2.25	.547	5.0	7.0	8.25	20.0	.35	5.40		ARR AF15	93
339-23	3.93	.64	20.0	7.18	3.25	.547	5.0	7.0	7.75	20.0	.35	5.40		ARR AF15	94
339-46	4.54	.67	20.0	8.29	3.75	.547	5.0	7.0	7.50	20.0	.35	5.40		ARR AF15	95
339-49	3.93	.67	20.0	7.68	3.75	.547	5.0	7.0	7.50	20.0	.35	5.40		Unpublished	96
439-1	3.32	.62	20.0	6.07	2.75	.547	5.0	7.0	8.00	20.0	.43	5.40		ARR 3K11	97
439-2	3.32	.62	10.0	6.07	2.75	.547	5.0	7.0	8.00	10.0	.43	5.40		ARR 3K11	98
439-3	3.32	.62	30.0	6.07	2.75	.547	5.0	7.0	8.00	30.0	.43	5.40		ARR 3K11	99
406	3.28	.59	20.0	6.02	2.74	.545	5.0	7.5	8.50	30.0	.37	5.45		Unpublished	100
618-1	3.32	.73	20.0	5.76	2.44	.576	6.3	7.5	8.60	20.0	.39	5.40	45° V-step	Unpublished	101
621-2	3.36	.87	20.0	6.12	2.76	.549	8.0	7.5	9.20	20.0	.40	5.40	Straight step	Unpublished	102
621-8	3.36	.87	20.0	6.11	2.75	.550	8.0	7.5	9.20	27.0	.40	5.40	Chine lowered fwd. afterbody vary	Unpublished	103

MODEL No. II
MODEL BEAM: 17.00"

C.G. = 0.36 b FWD. OF CENTROID
1.19 b ABOVE KEEL

$C_{d_0} =$ (NOMINAL)
 $k/L =$

TESTED AT NACA No. 1 TANK
DATE: '32

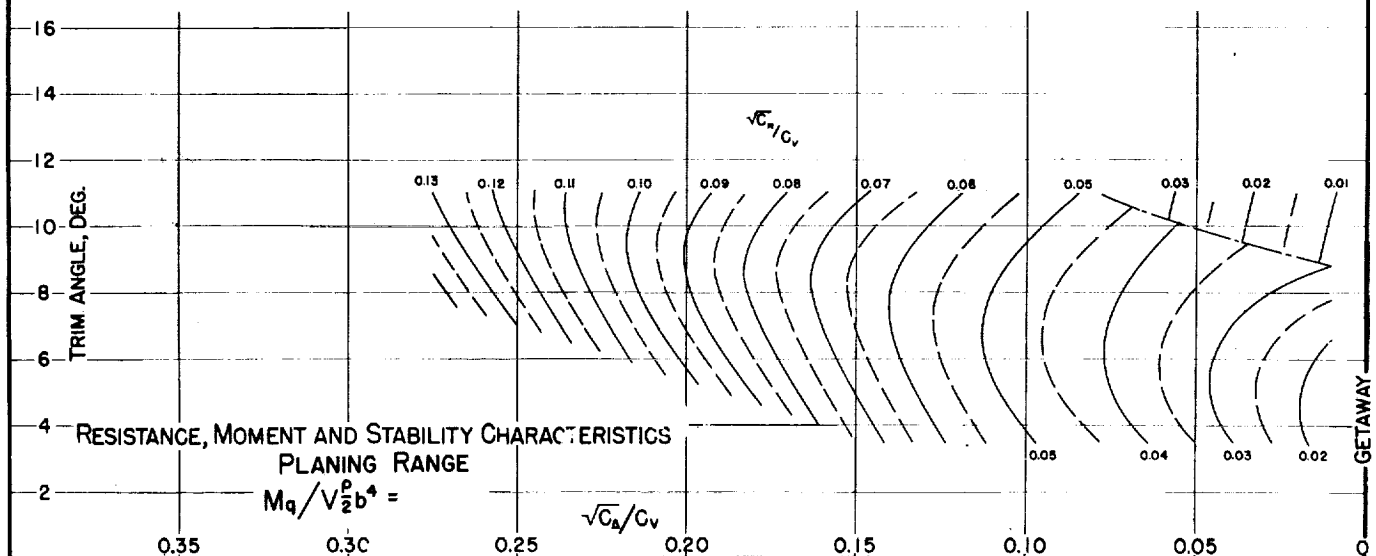
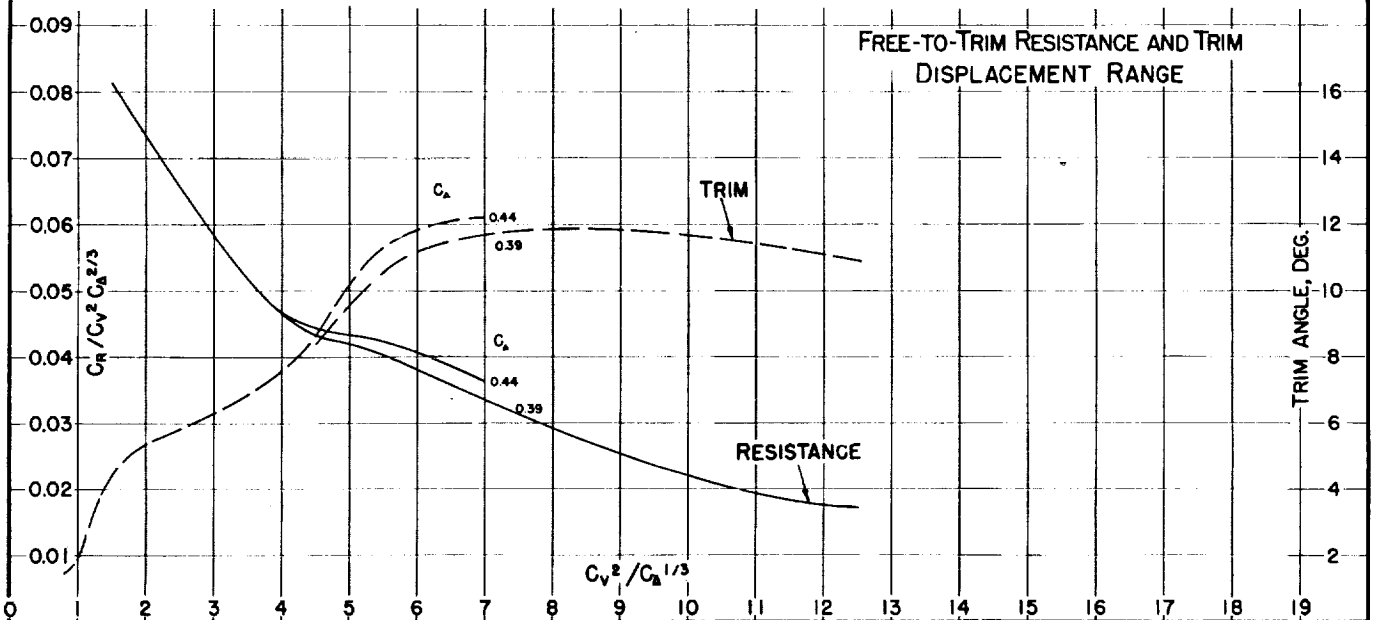
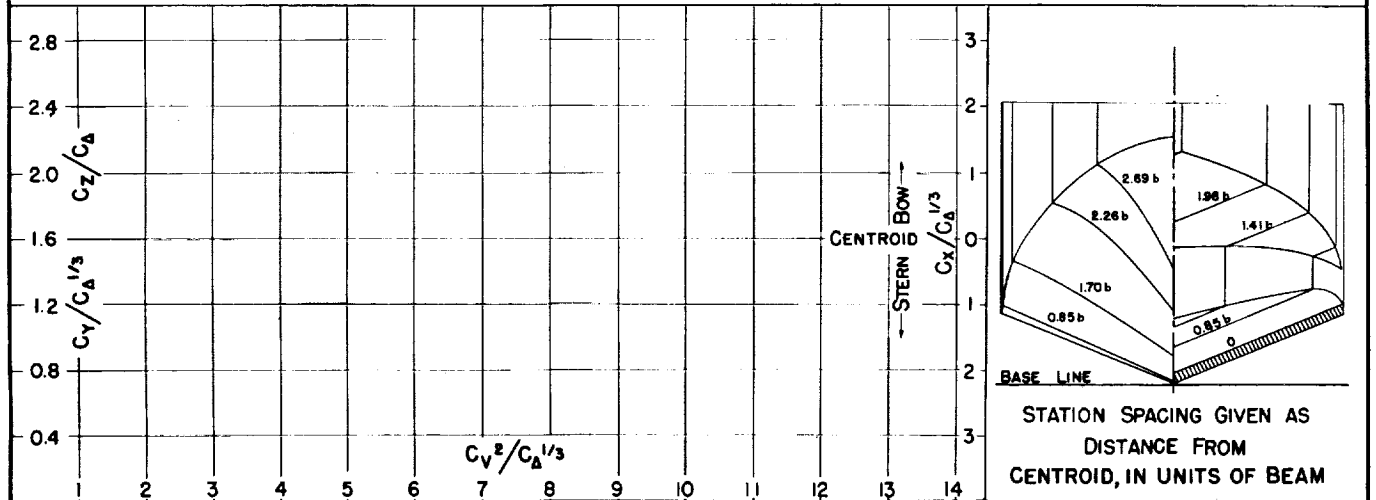

Fig. 2

DESIGNATION: 2.82-0.43-22.5 NACA TN No. 1182

MODEL No. 11-A
MODEL BEAM 17.00"

C.G. = 0.36 b FWD. OF CENTROID $C_{d0} =$
1.19 b ABOVE KEEL $k/L =$

(NOMINAL)

TESTED AT NACA No. 1 TANK
DATE: 4/33

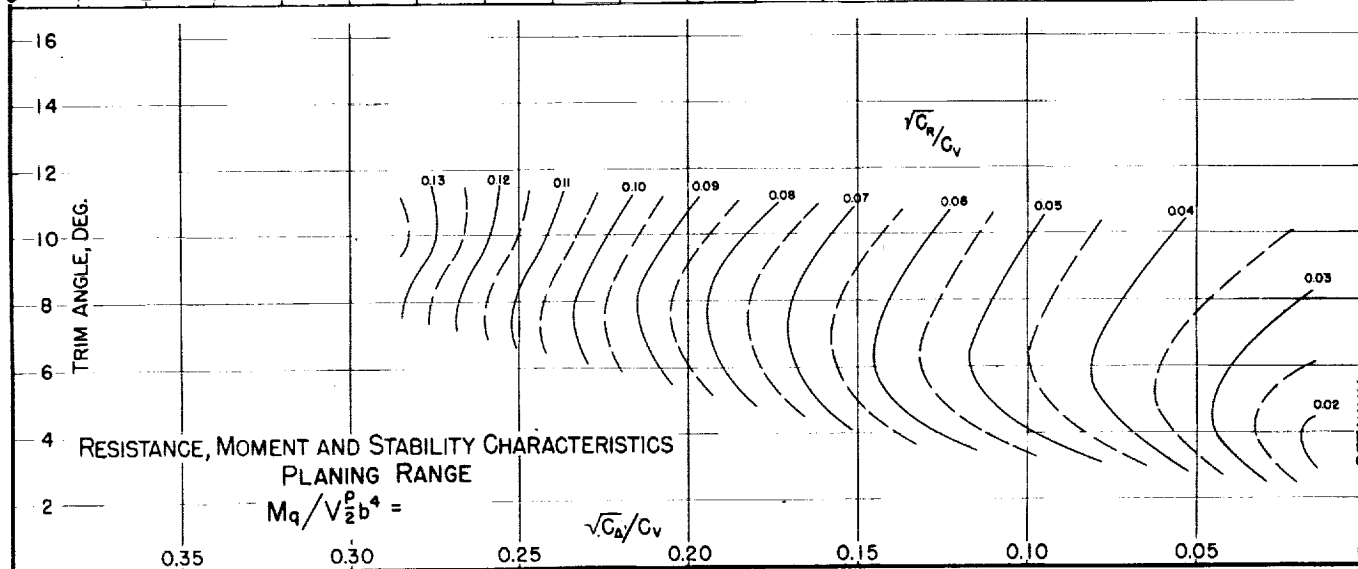
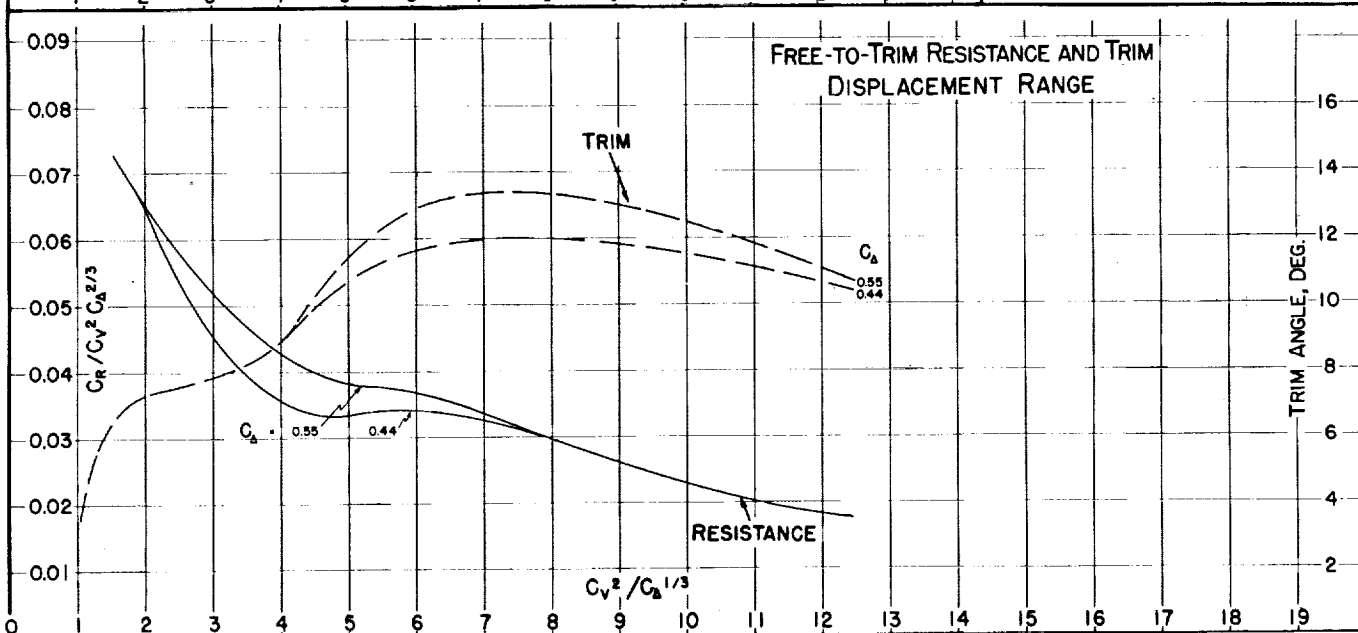
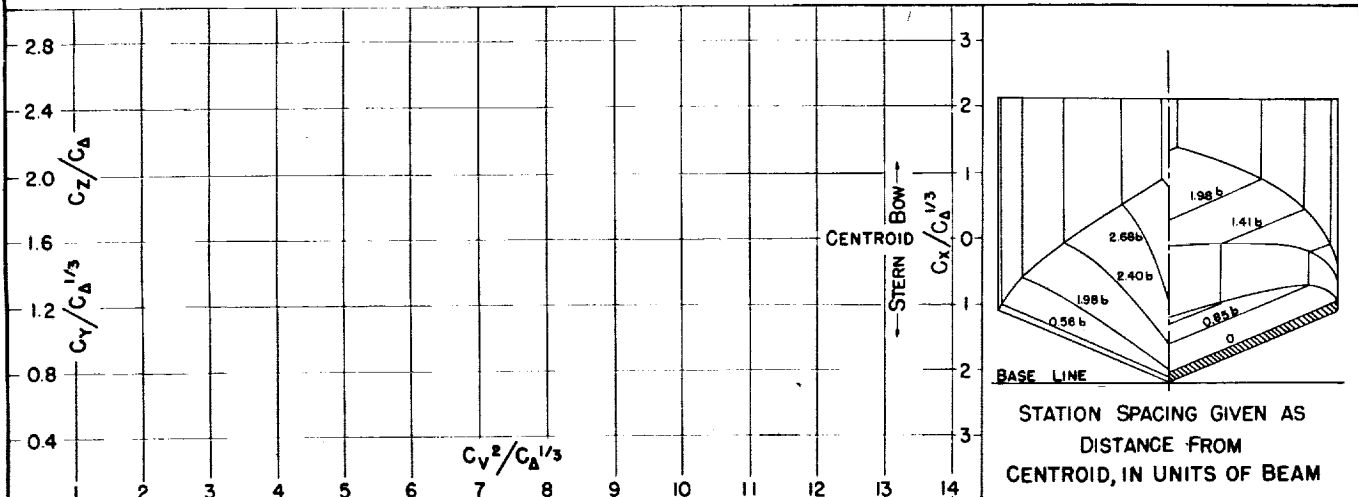

MODEL No. II-B
MODEL BEAM: 1700"

C.G. = 0.47 b FWD. OF CENTROID
0.95 b ABOVE KEEL

$C_{d,0} =$ (NOMINAL)

TESTED AT NACA No. 1 TANK

DATE: 8/34

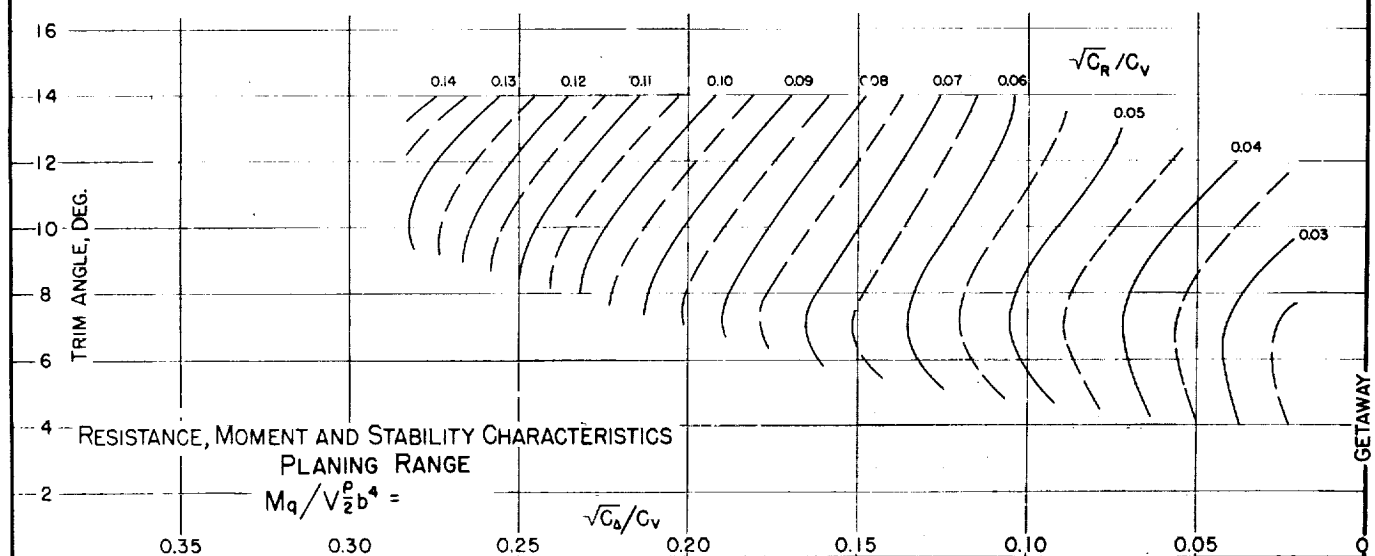
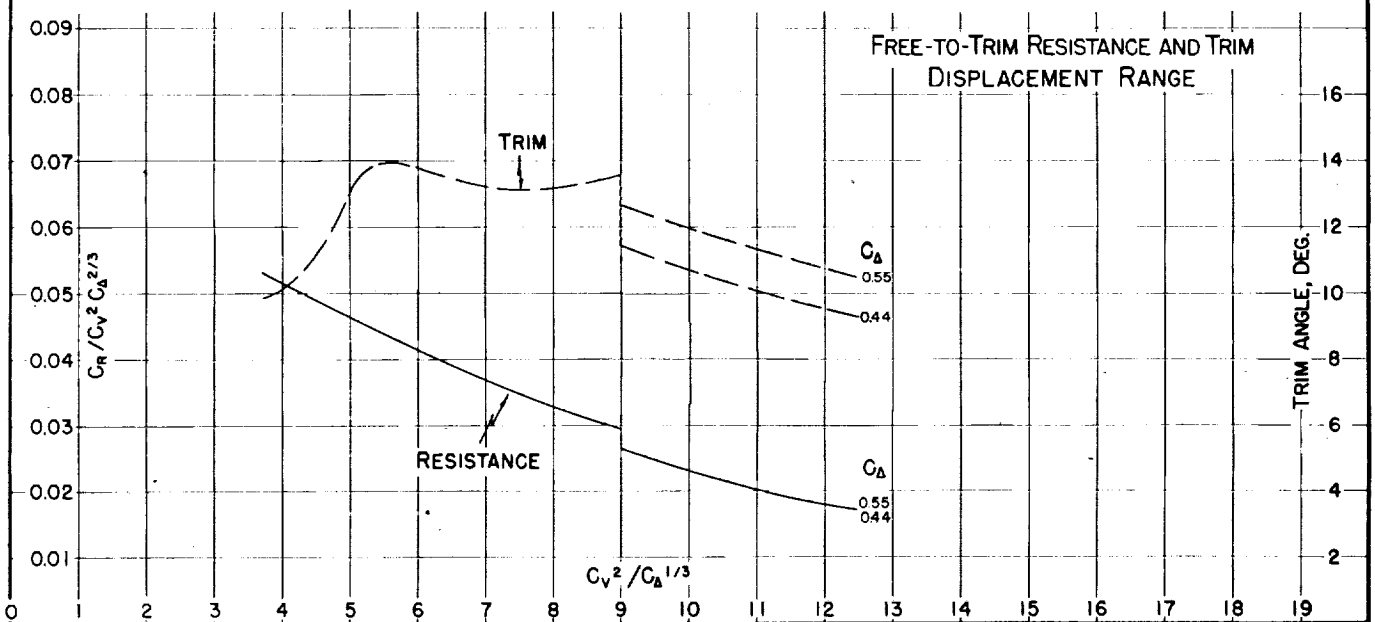
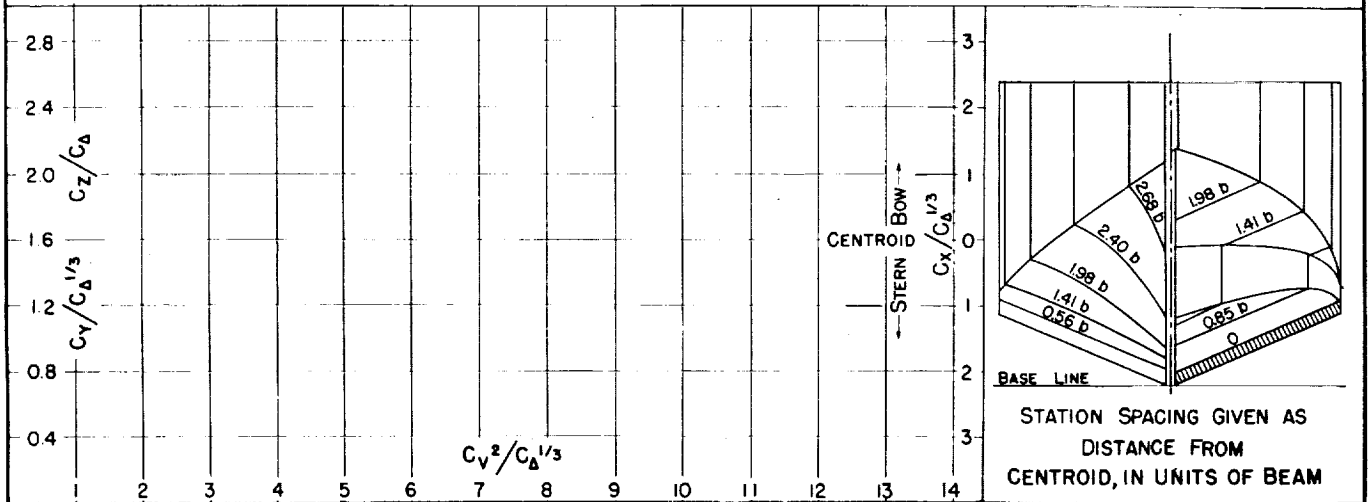

GETAWAY

Fig. 4

DESIGNATION: 2.82-0.43-22.5 NACA TN No. 1182

MODEL No. II-C
MODEL BEAM: 17.00"

C.G. = 0.47 b FWD. OF CENTROID $C_{d0} =$ (NOMINAL)
0.92 b ABOVE KEEL $k/L =$

TESTED AT NACA No. 1 TANK
DATE: 7/34

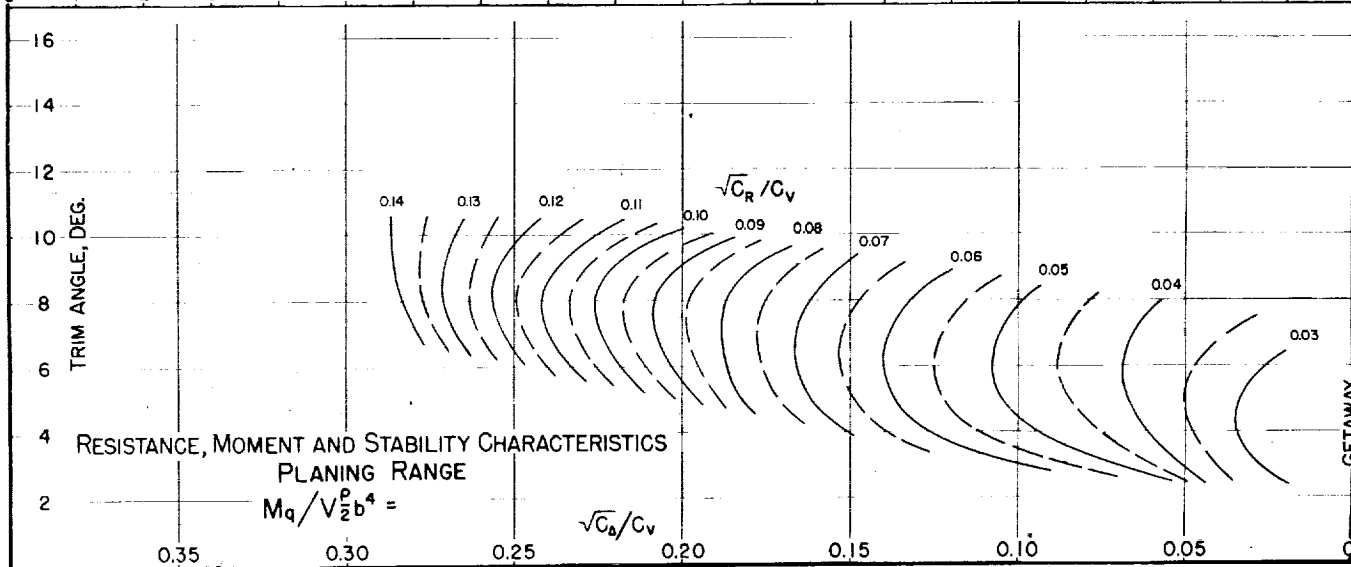
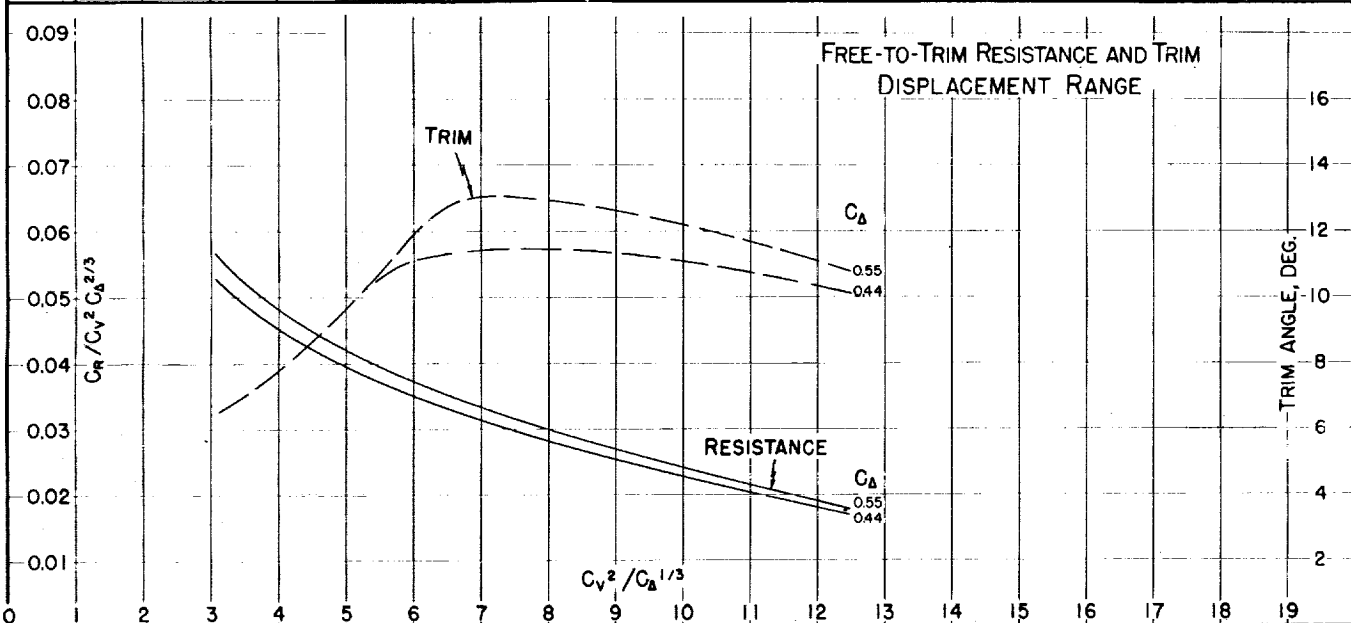
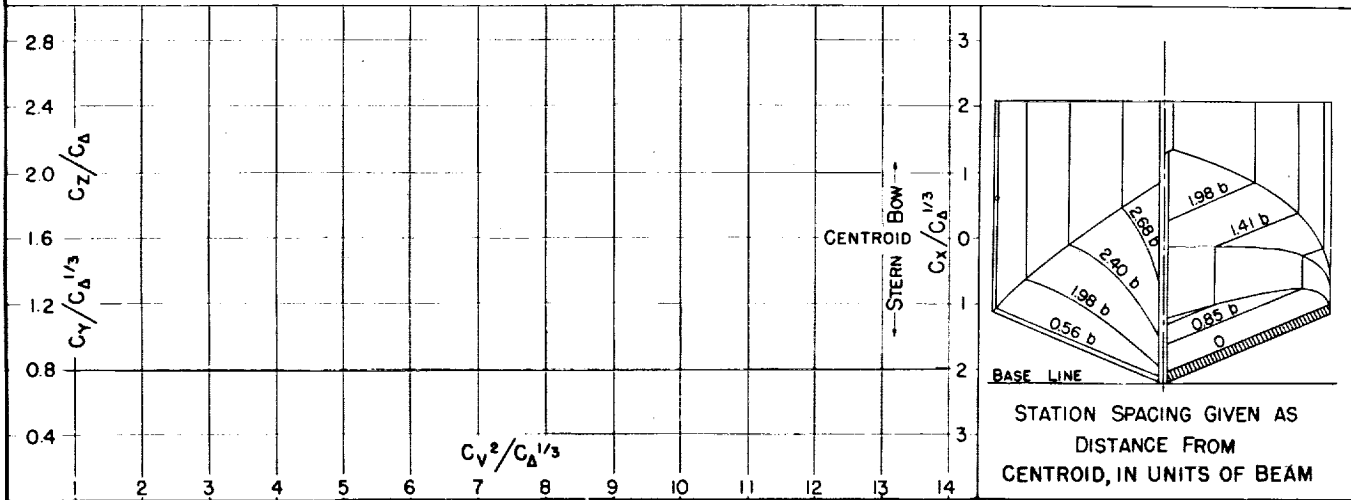

MODEL NO. 11-C-7
MODEL BEAM: 1700"

C.G. = 0.47 b FWD. OF CENTROID $C_{D0} =$
0.91 b ABOVE KEEL $k/L =$

(NOMINAL)

TESTED AT NACA No. 1 TANK
DATE:

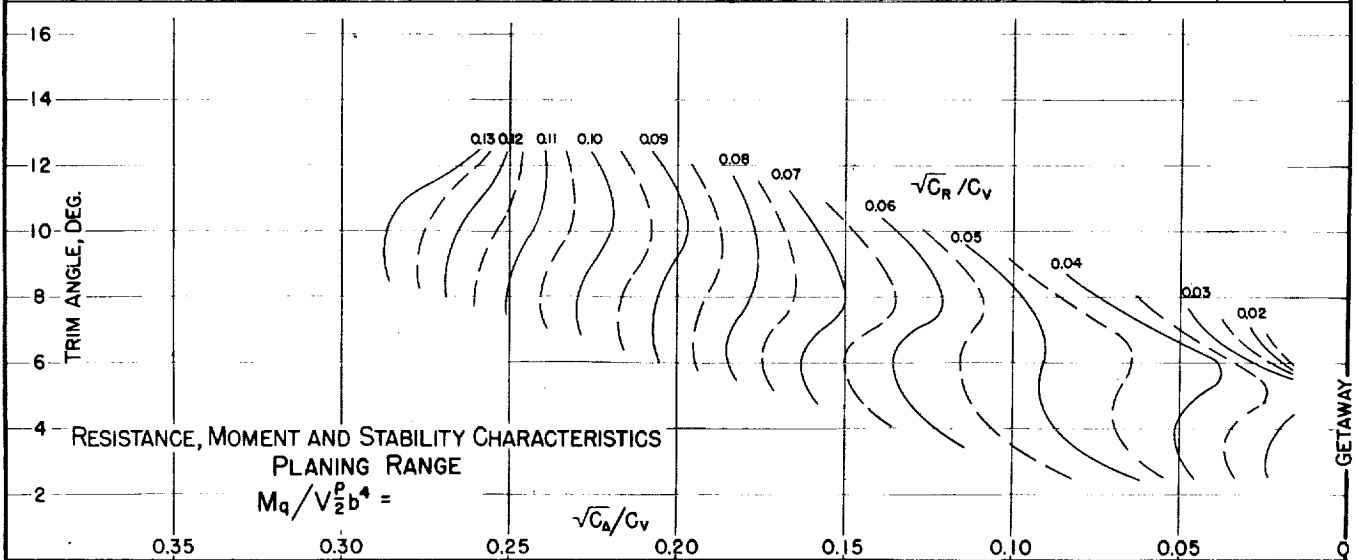
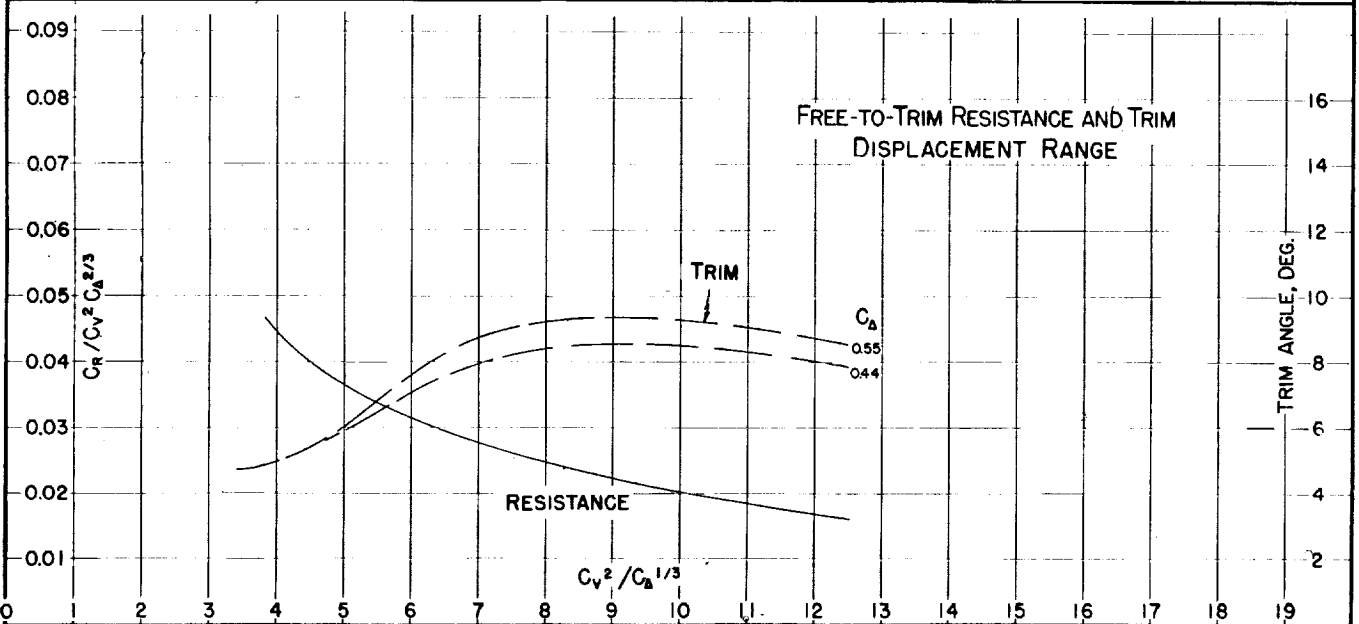
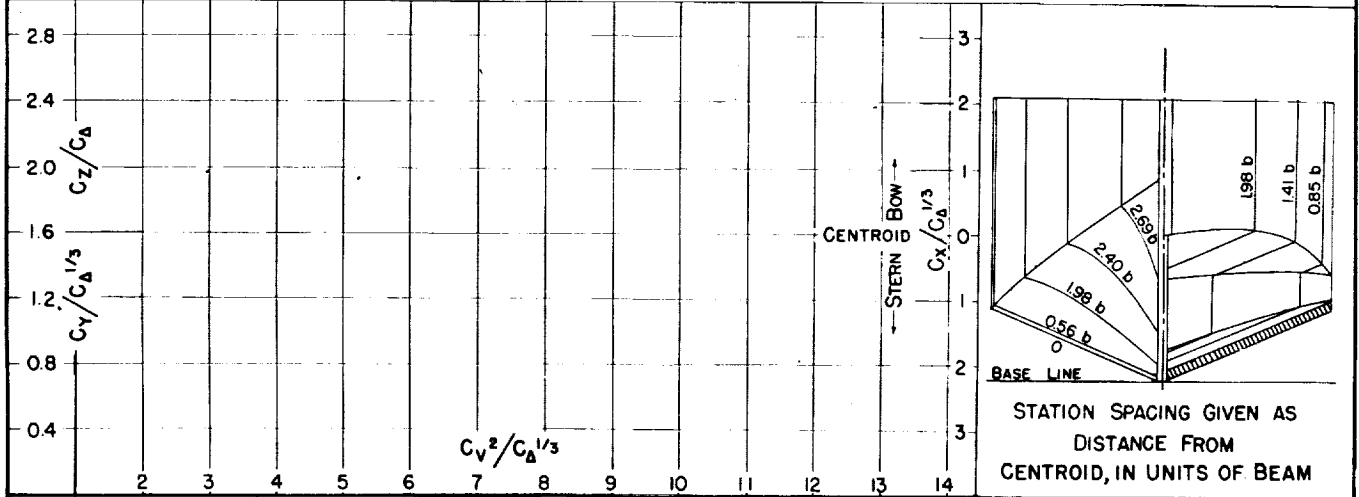

GETAWAY

Fig. 6

DESIGNATION: 2.82-0.55-22.5

NACA TN No. 1182

MODEL No. II-C-8
MODEL BEAM: 17.00"

C.G. = 0.47 b FWD. OF CENTROID $C_{a_0} =$
0.91 b ABOVE KEEL $k/L =$

(NOMINAL)

TESTED AT NACA No. 1 TANK
DATE: '34

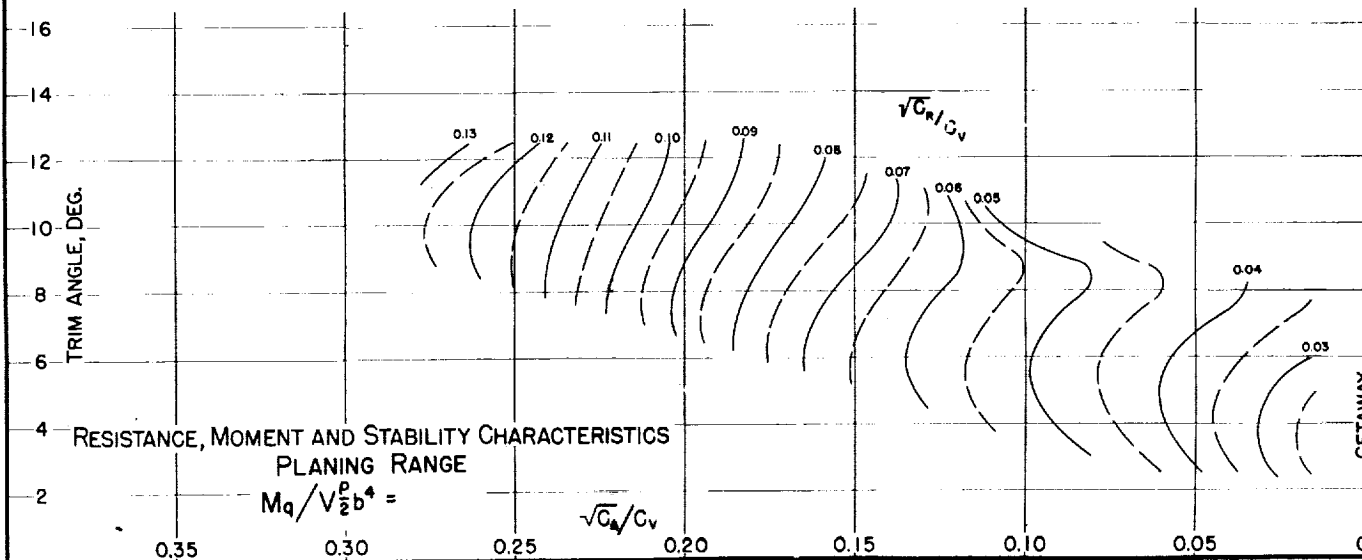
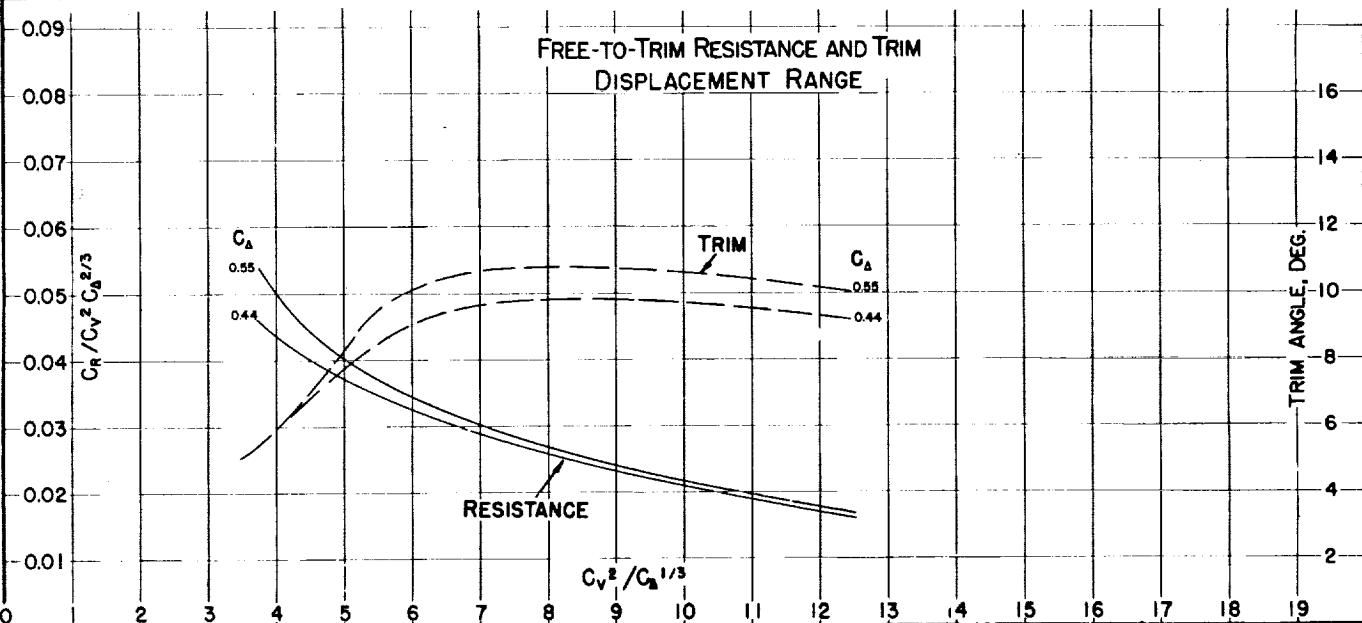
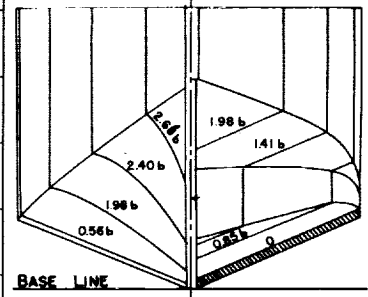
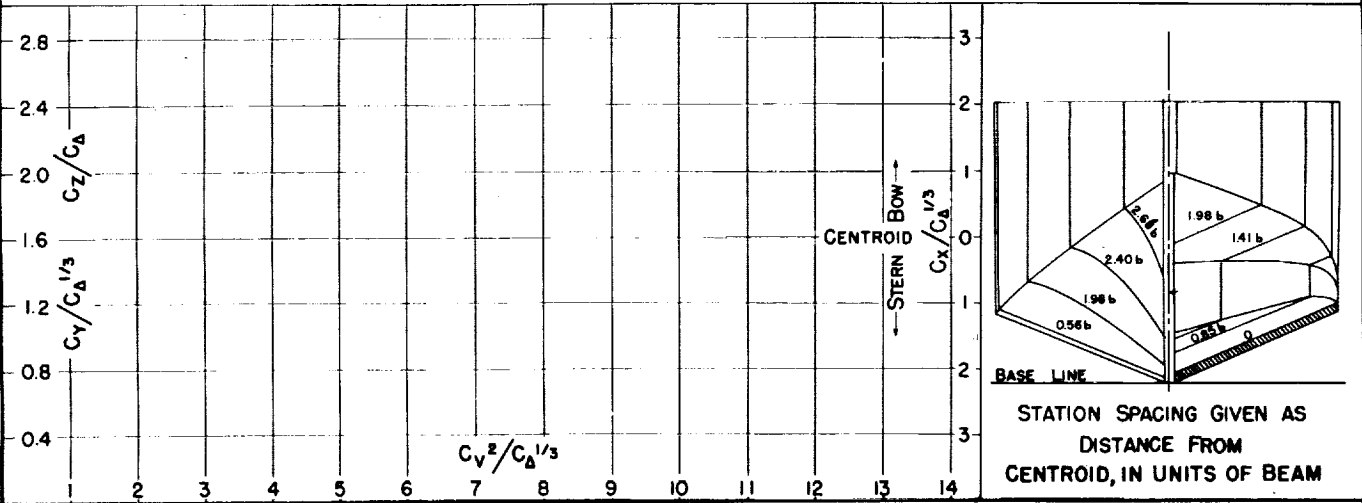

MODEL No. 11-C-9
MODEL BEAM 17.00"

C.G. = 0.47 b FWD. OF CENTROID
0.91 b ABOVE KEEL

$C_{d0} =$ (NOMINAL)
 $k/L =$

TESTED AT NACA No. 1 TANK
DATE: '34

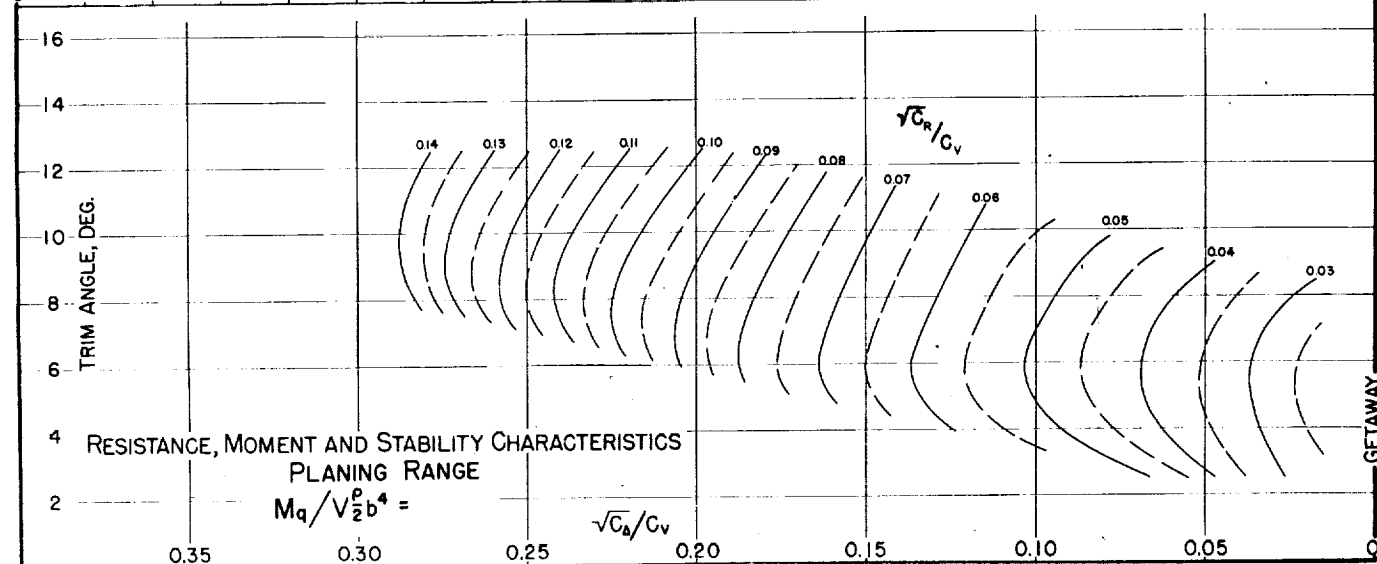
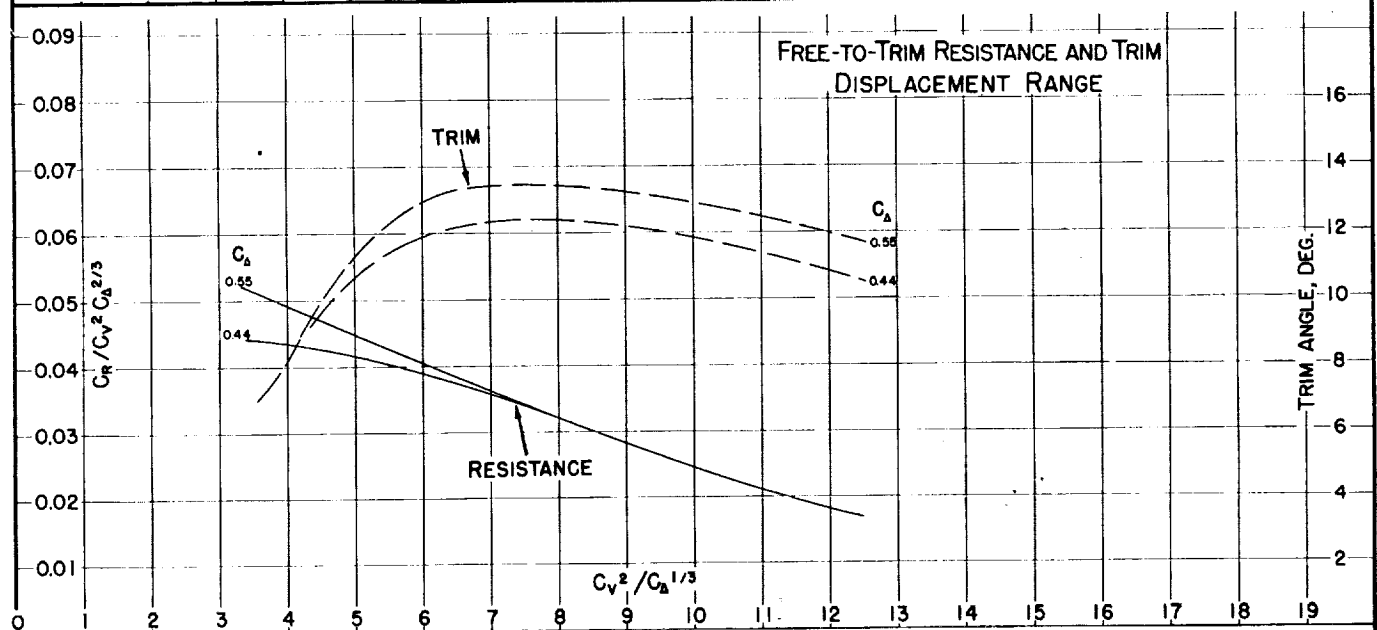
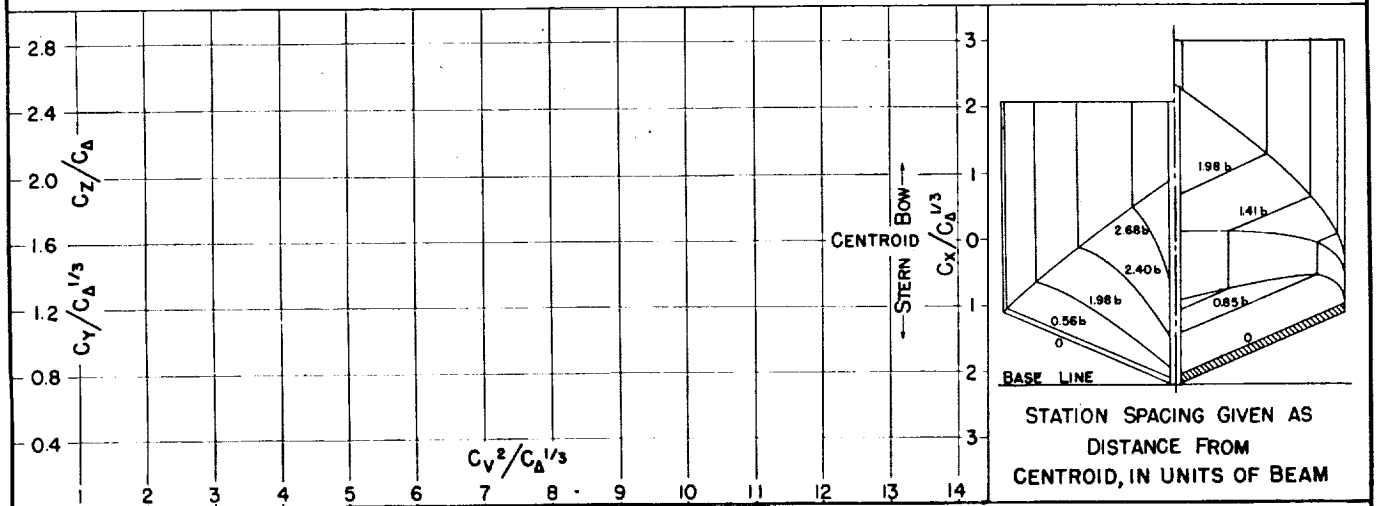

GETAWAY

Fig. 8

DESIGNATION: 2.82-0.30-22.5 NACA TN No. 1182

MODEL No. 11-C-10
MODEL BEAM: 17.00"

C.G. = 0.47 b FWD. OF CENTROID $C_{d0} =$
0.91 b ABOVE KEEL $k/L =$

(NOMINAL)

TESTED AT NACA No. 1 TANK
DATE: '34

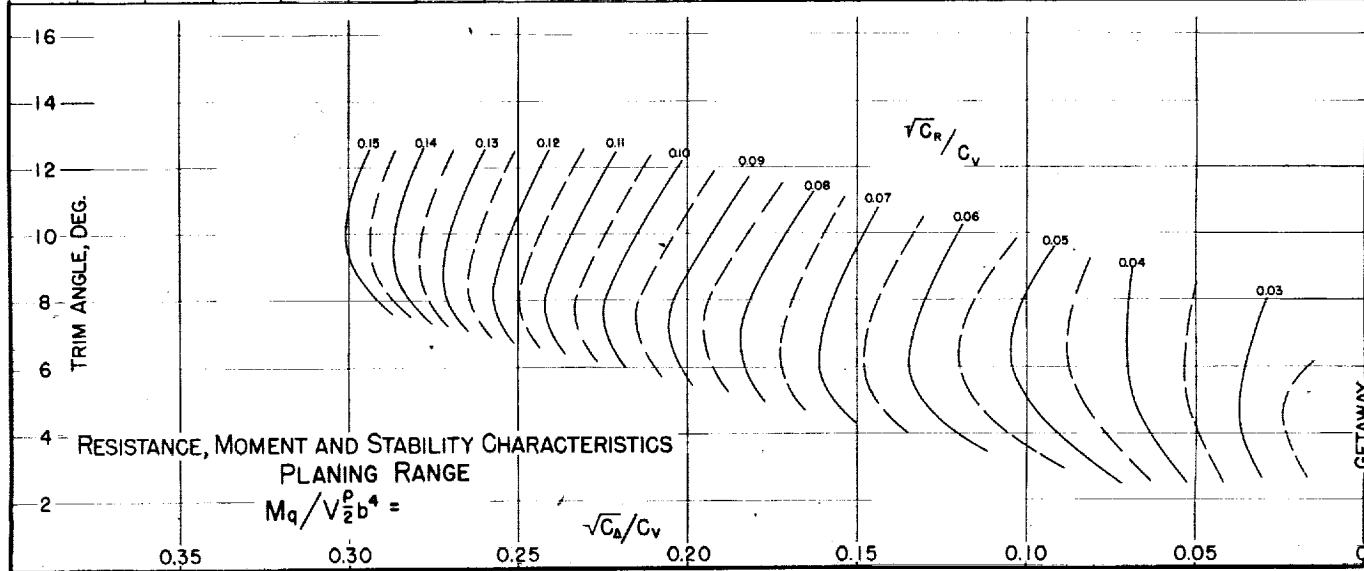
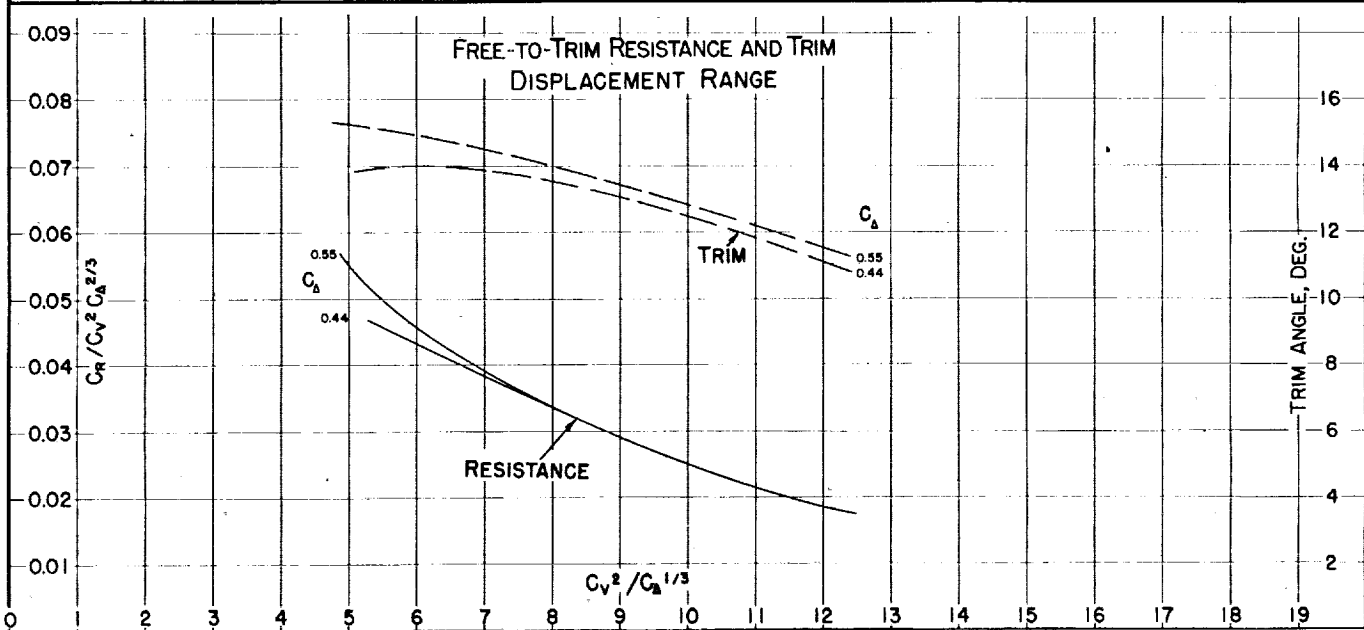
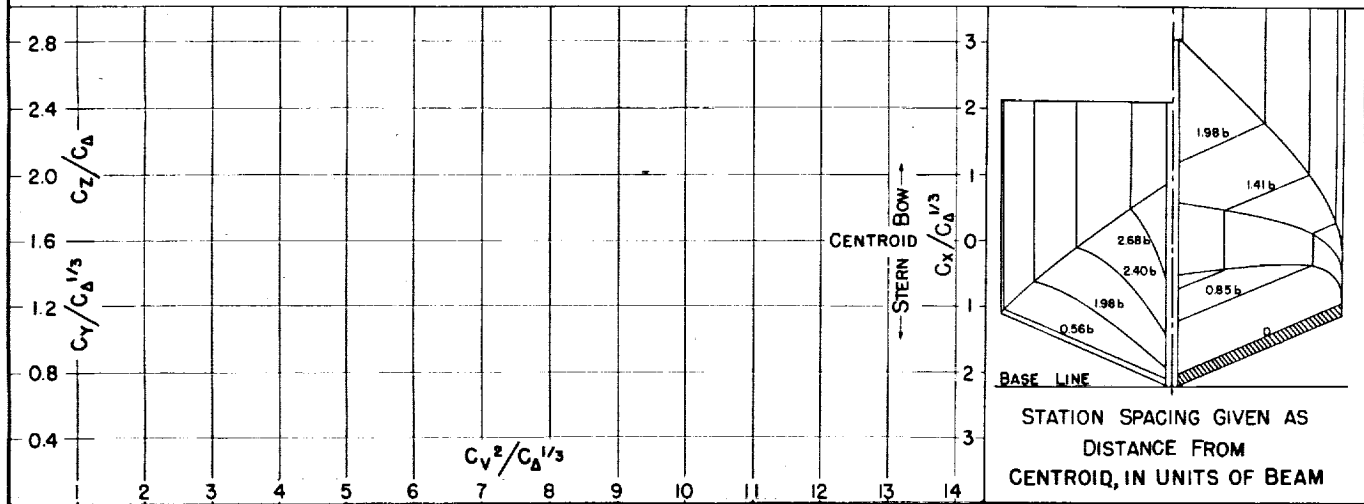

MODEL No. 11-C-II
MODEL BEAM: 17.00"

C.G. = 0.47 b FWD. OF CENTROID
0.91 b ABOVE KEEL

$C_{d0} =$ (NOMINAL)
 $k/L =$

TESTED AT NACA No. 1 TANK
DATE: '34

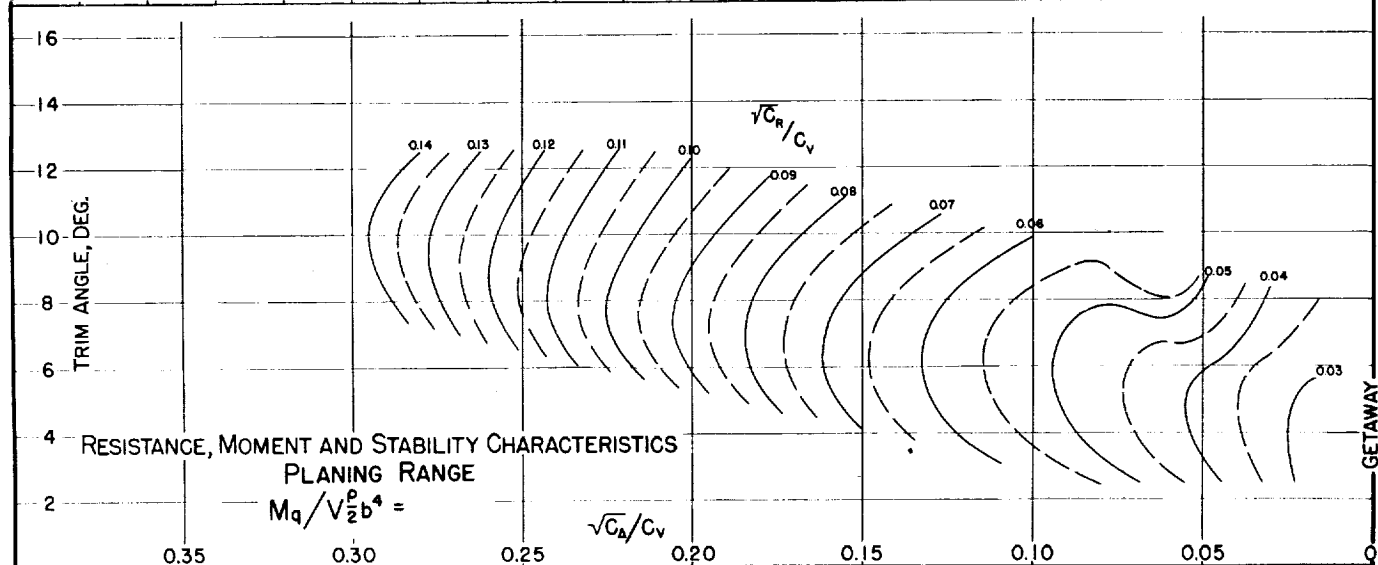
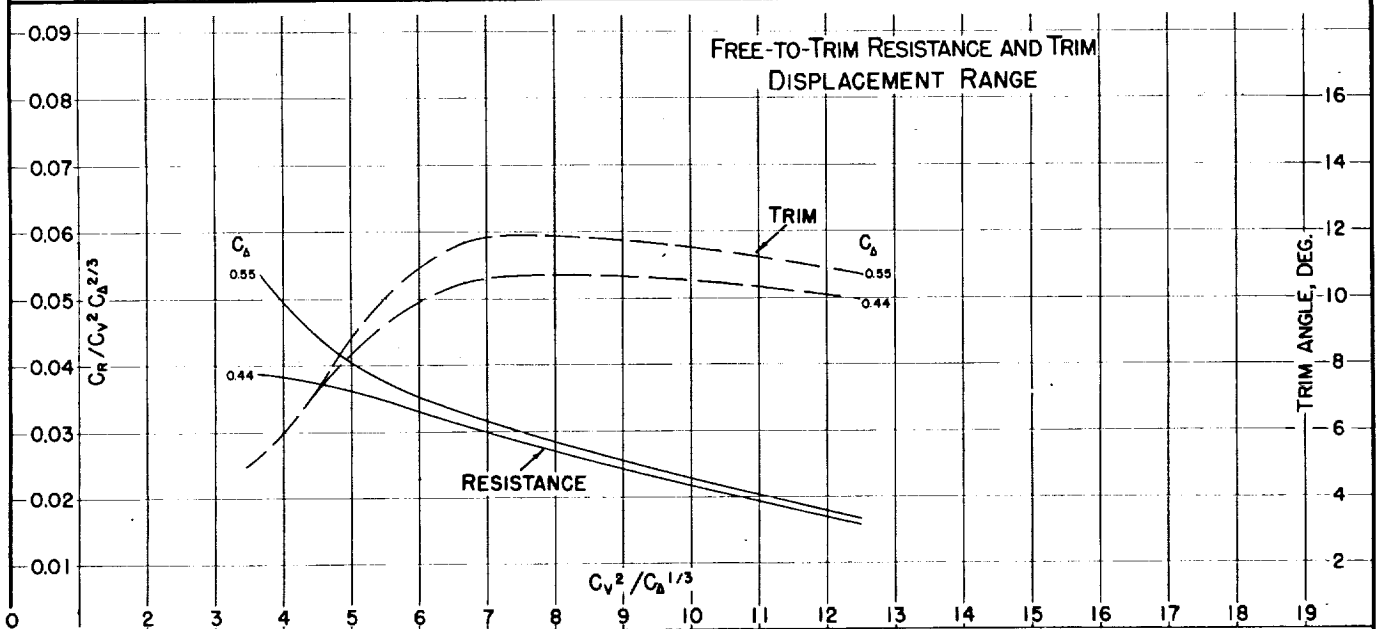
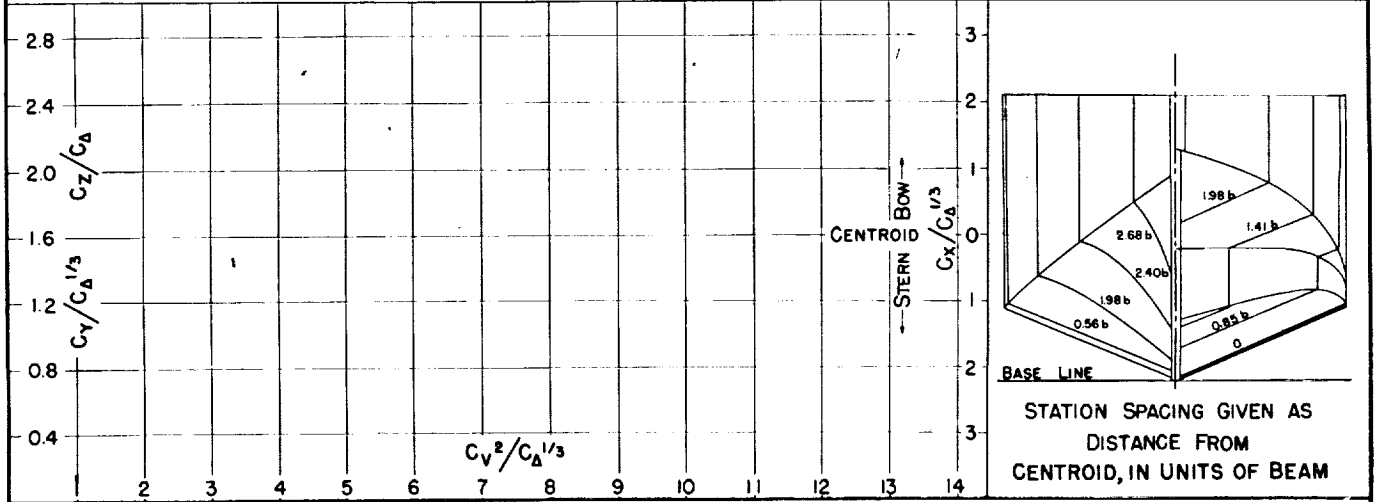

Fig. 10

DESIGNATION: 2.82-0.26-22.5

NACA TN No. 1182

MODEL No. 11-G-12
MODEL BEAM: 17.00"

C.G. = 0.47 b FWD. OF CENTROID
0.91 b ABOVE KEEL

$C_{\Delta_0} =$ (NOMINAL)
 $k/L =$

TESTED AT NACA No. 1 TANK
DATE:

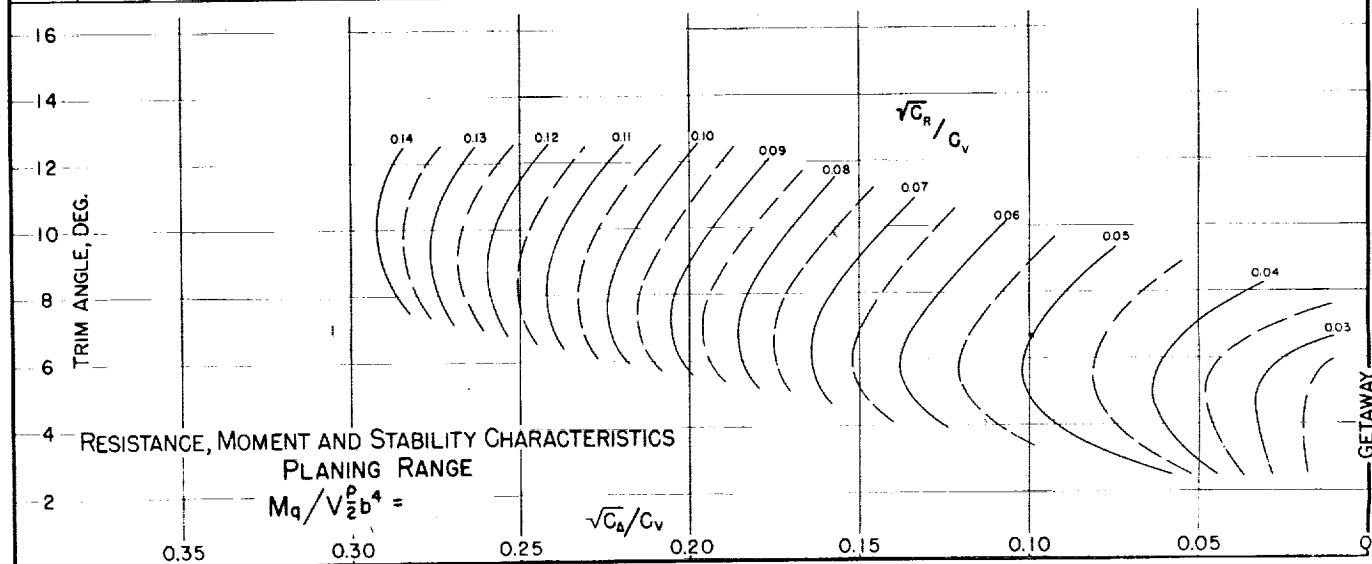
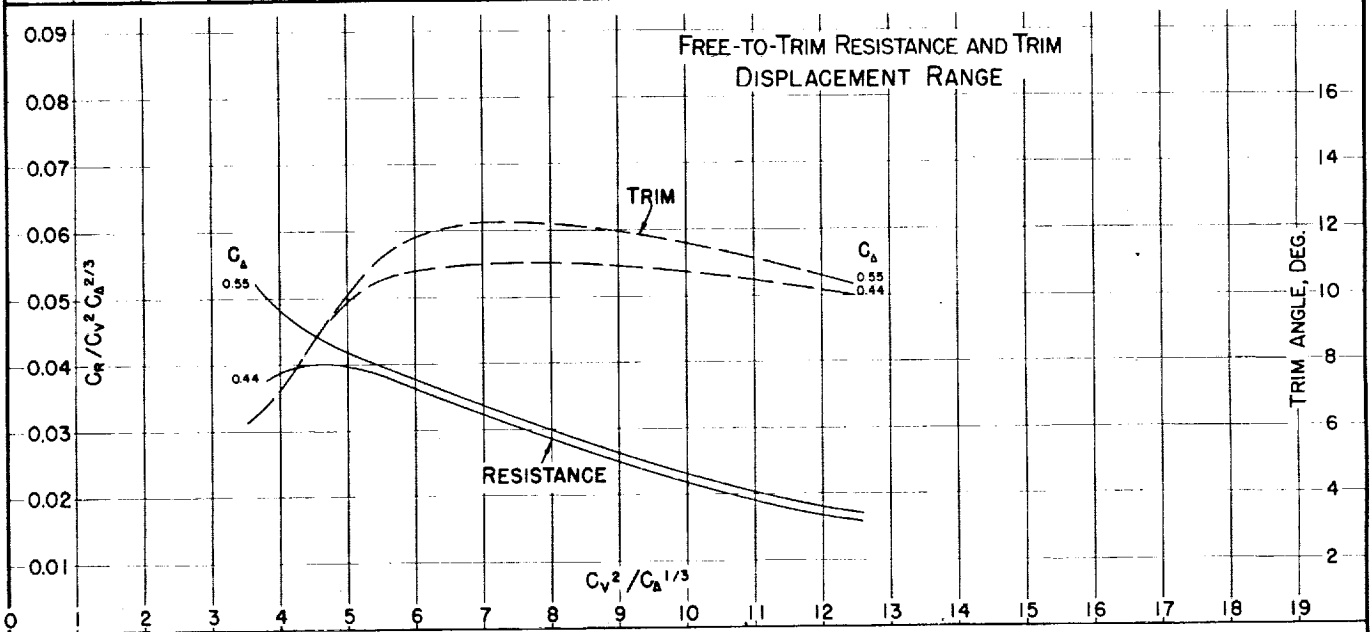
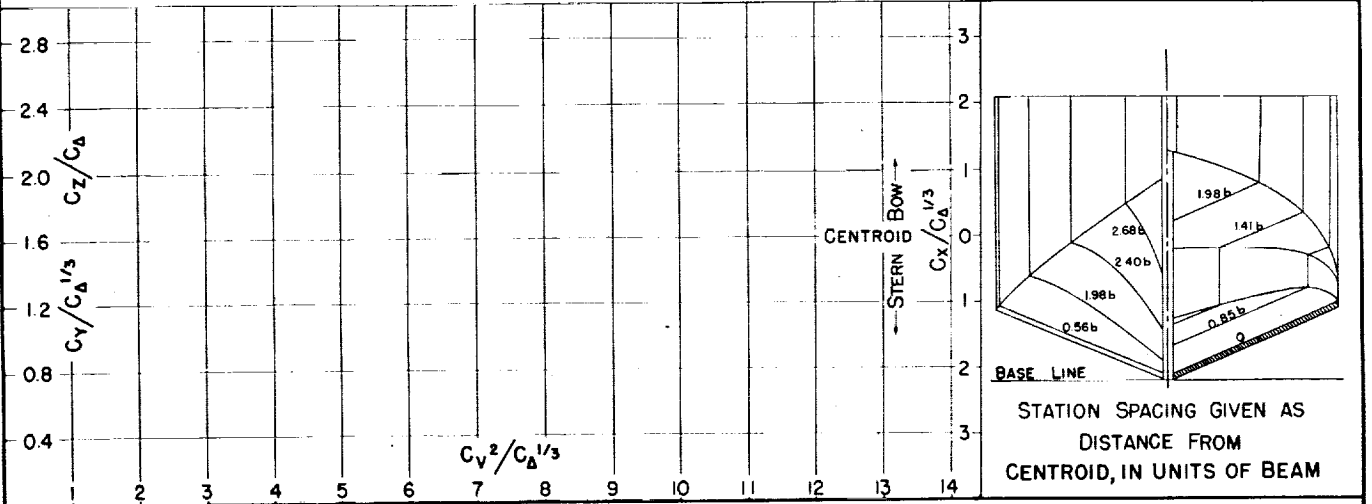

MODEL No. 11-C-13
MODEL BEAM 17.00"

C.G. = 0.47 b FWD. OF CENTROID
0.91 b ABOVE KEEL

$C_{D0} =$ (NOMINAL)
 $k/L =$

TESTED AT NACA No. 1 TANK
DATE: '34

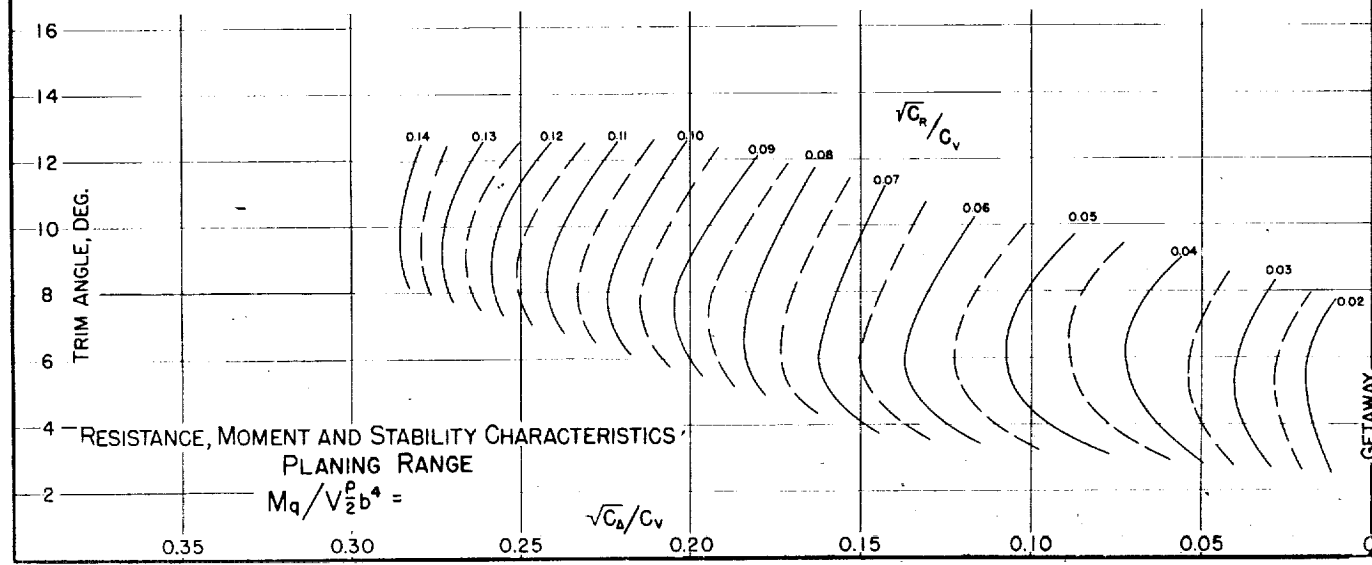
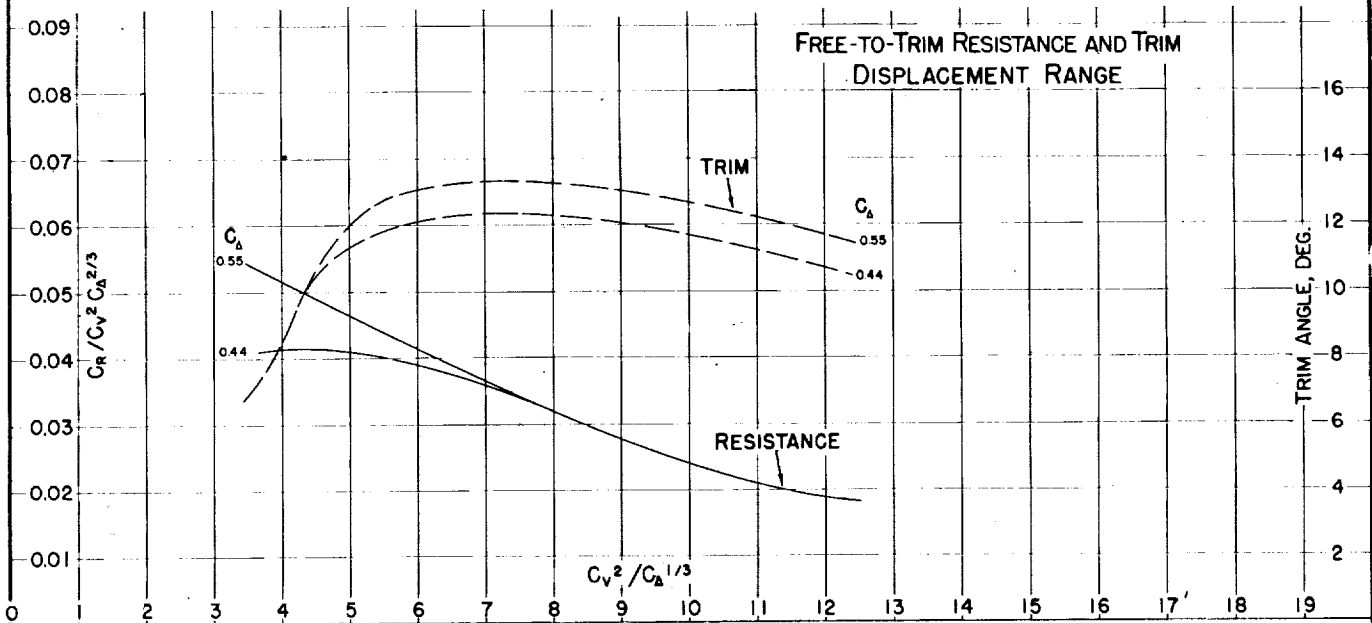
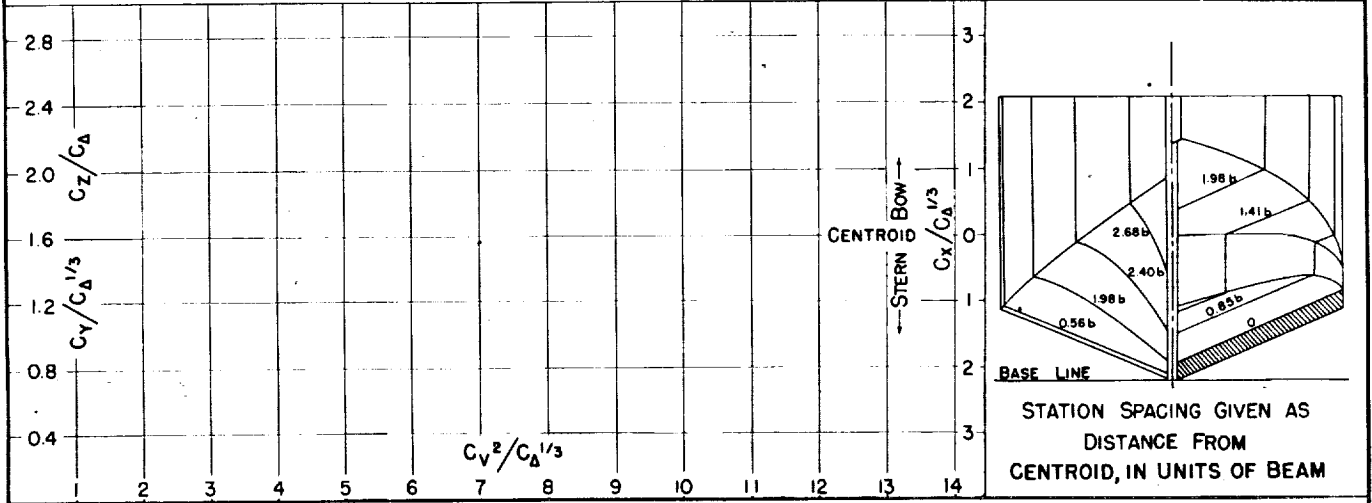

Fig. 12

DESIGNATION: 2.87-0.61-22.5

NACA TN No. 1182

MODEL No. 11-C-30°S
MODEL BEAM: 17.00"

C.G. = 0.52 b FWD. OF CENTROID
0.91 b ABOVE KEEL

$C_{d_0} =$
 $k/L =$

(NOMINAL)

TESTED AT NACA No. 1 TANK

DATE: '35

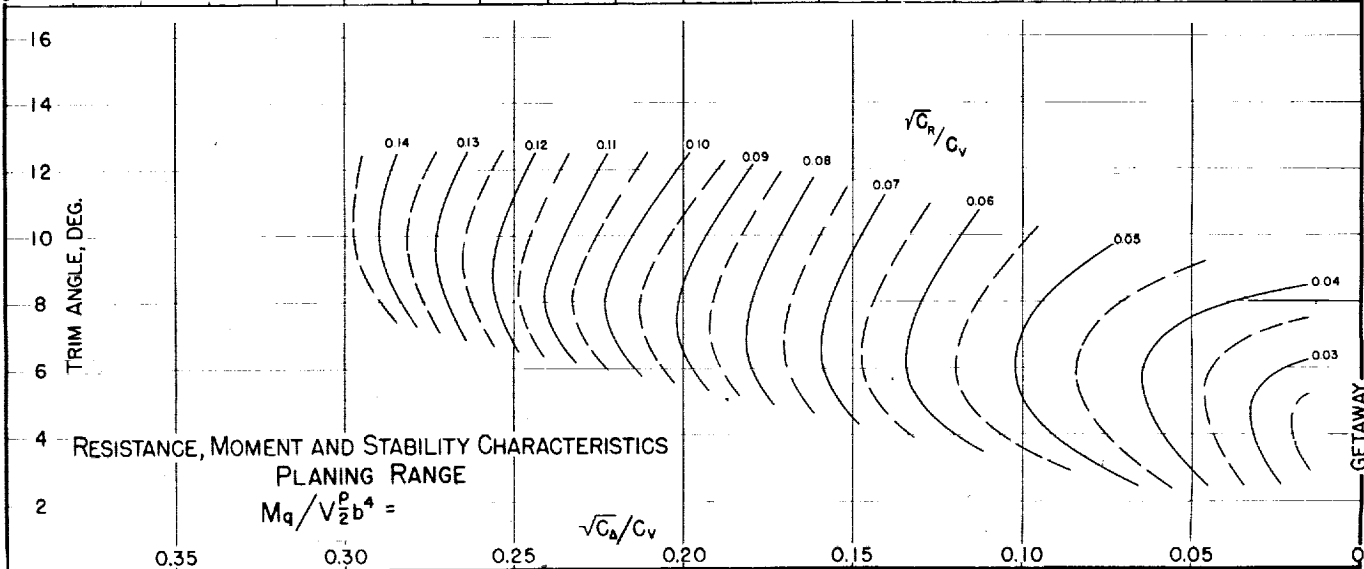
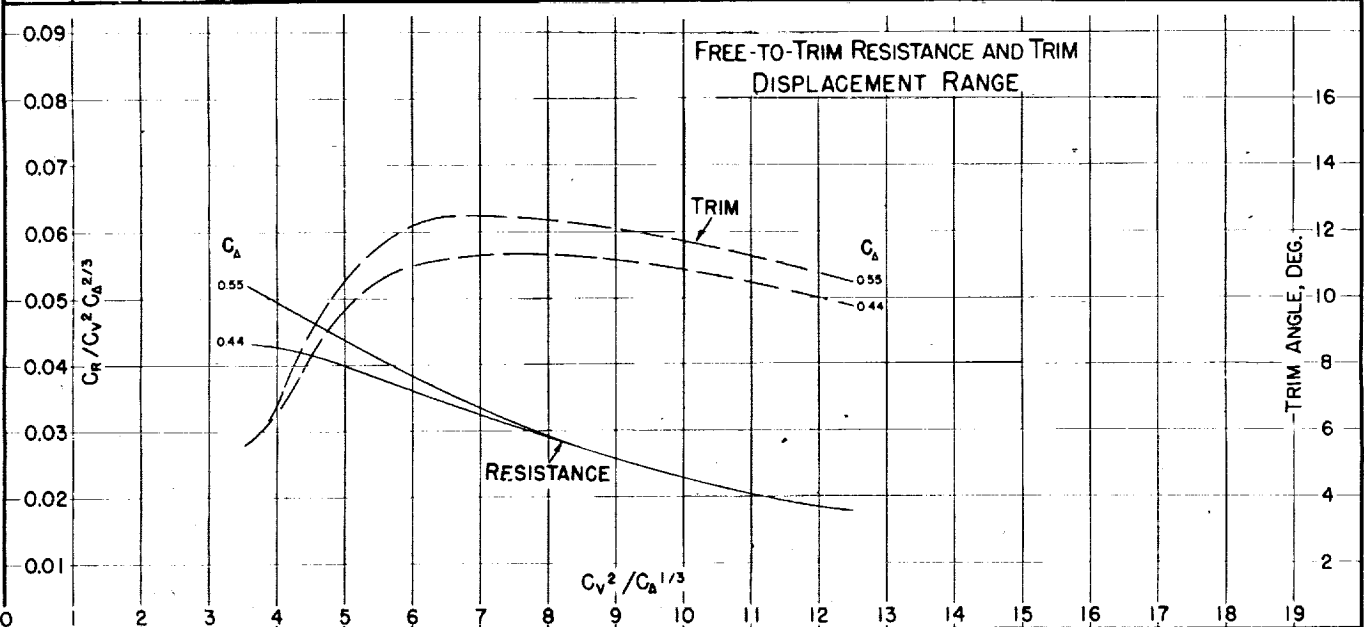
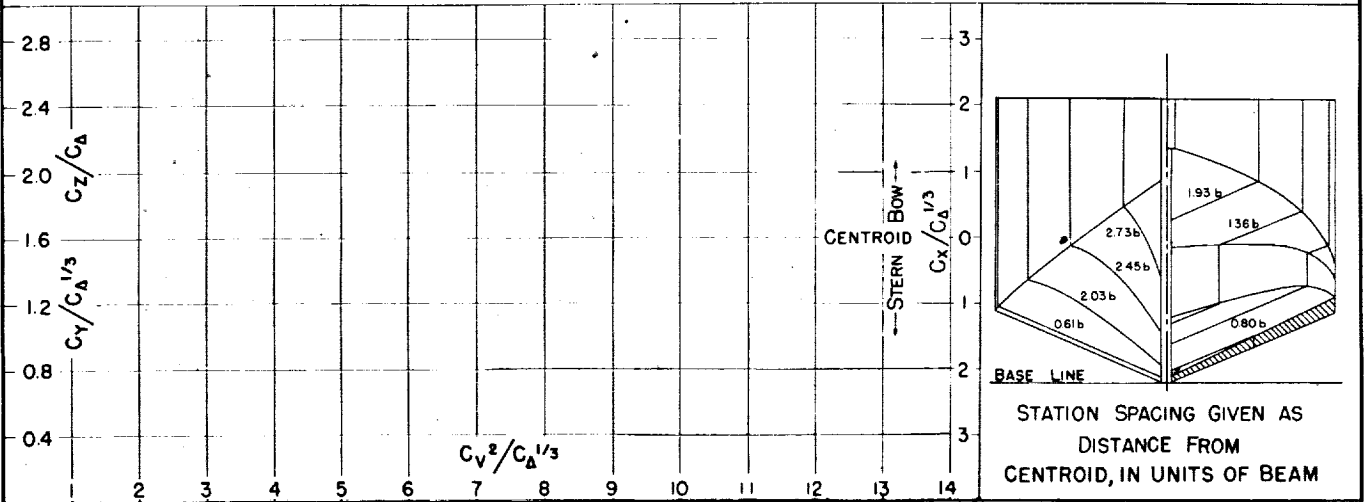

MODEL No. II-G-45°V
MODEL BEAM: 17.00"

C.G. = 0.39 b FWD. OF CENTROID
0.91 b ABOVE KEEL

$C_{d.o.} =$ (NOMINAL)
 $k/L =$

TESTED AT NACA No. 1 TANK
DATE: '35

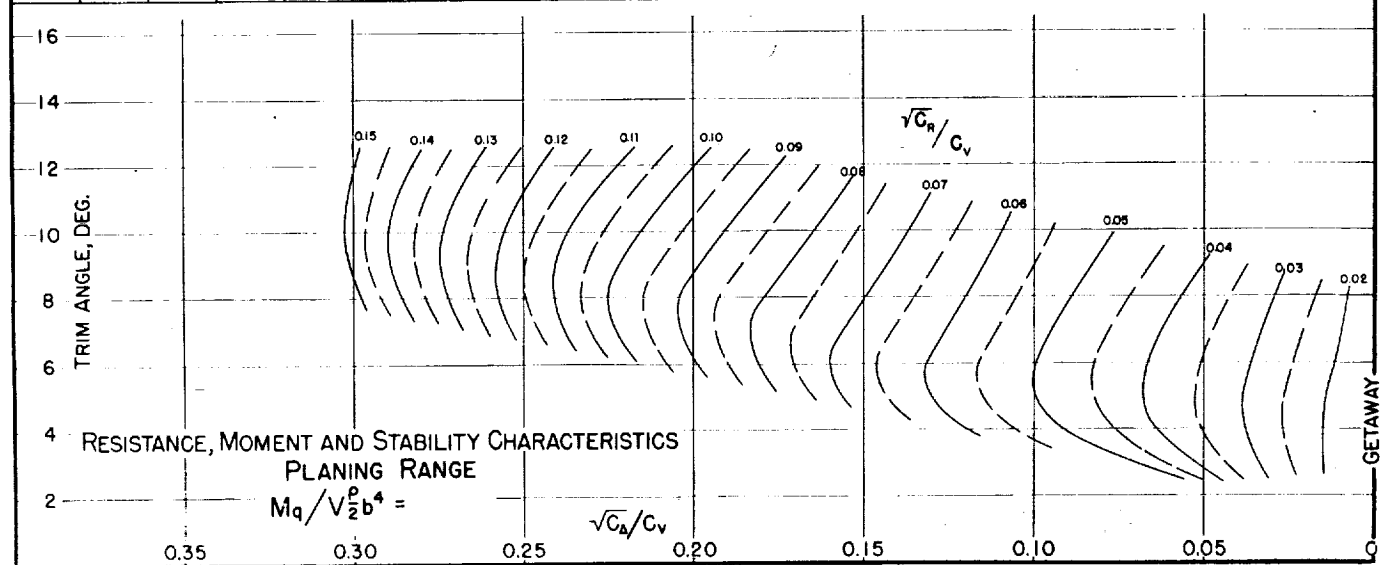
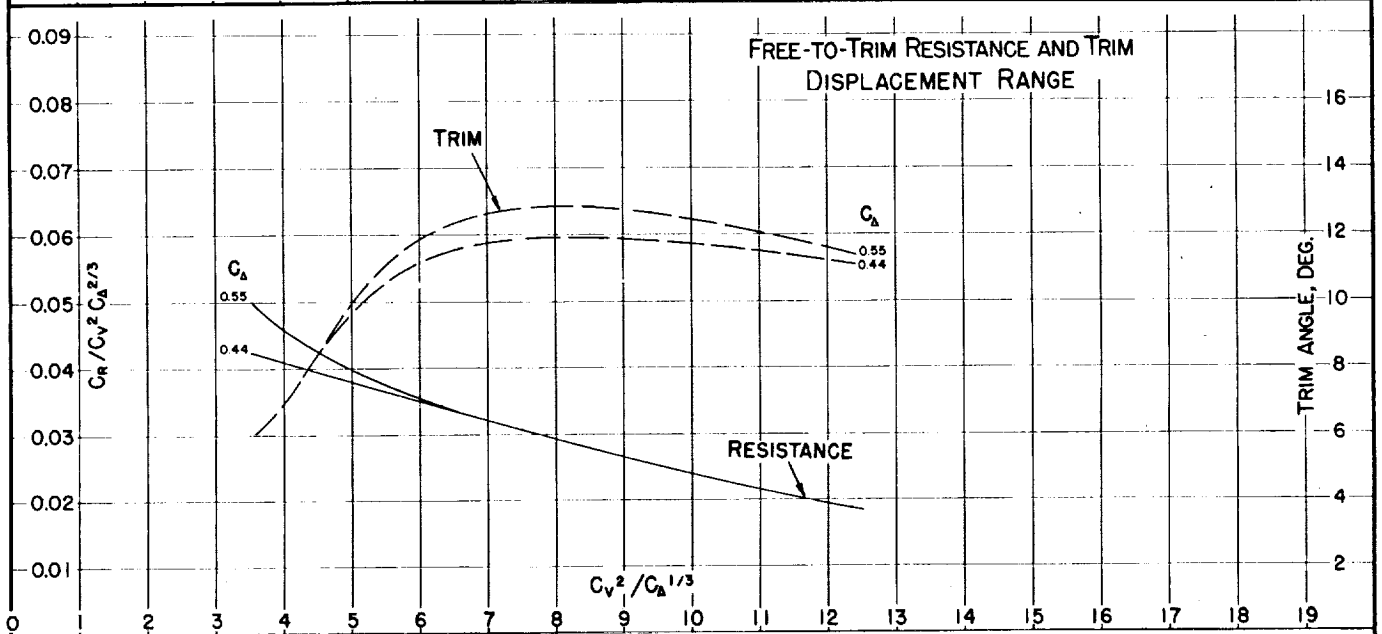
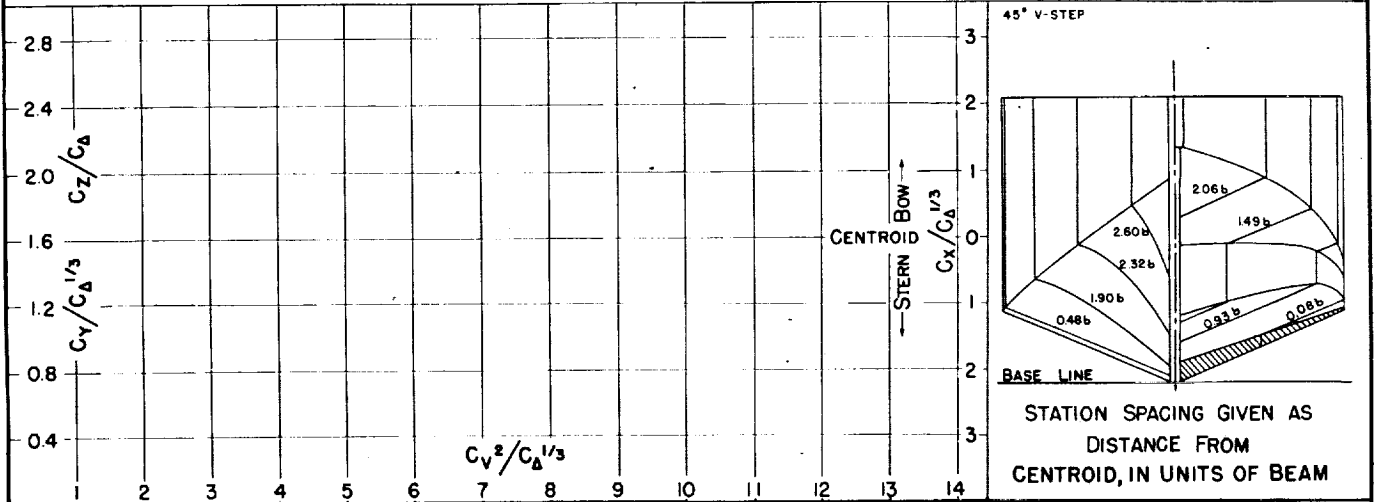

Fig. 14

DESIGNATION: 2.66-0.75-7.5

NACA TN No. 1182

MODEL No. II-E
MODEL BEAM: 1700"

C.G. = 0.47 b FWD. OF STEP
0.92 b ABOVE KEEL

$C_{d0} =$ (NOMINAL)
 $k/L =$

TESTED AT NACA No. 1 TANK
DATE: 3/35

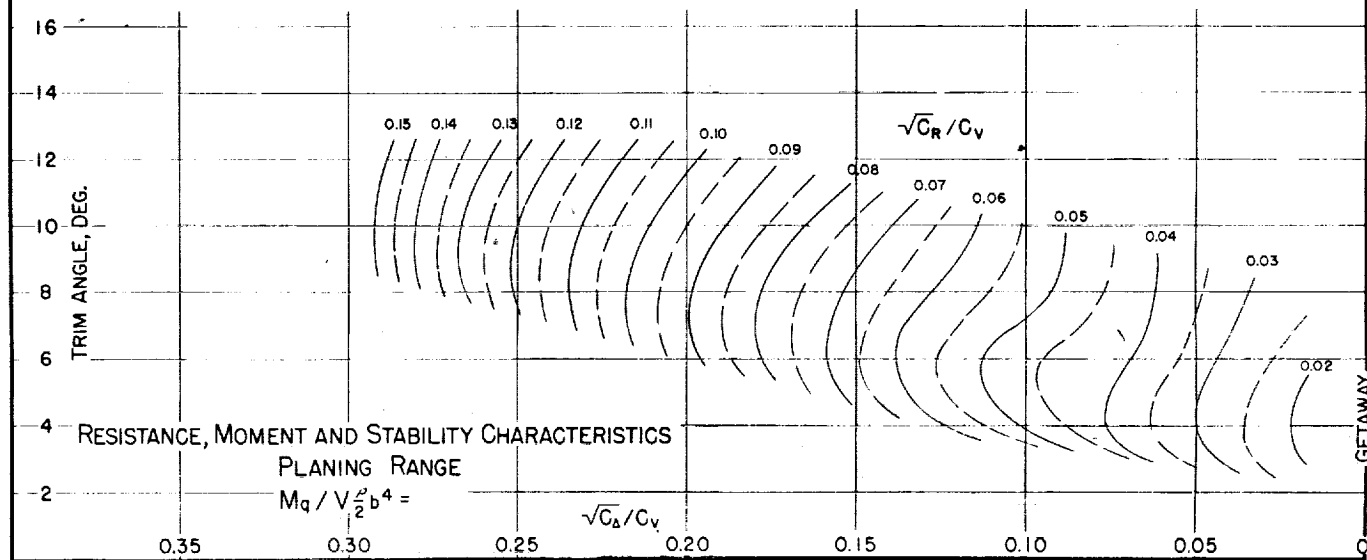
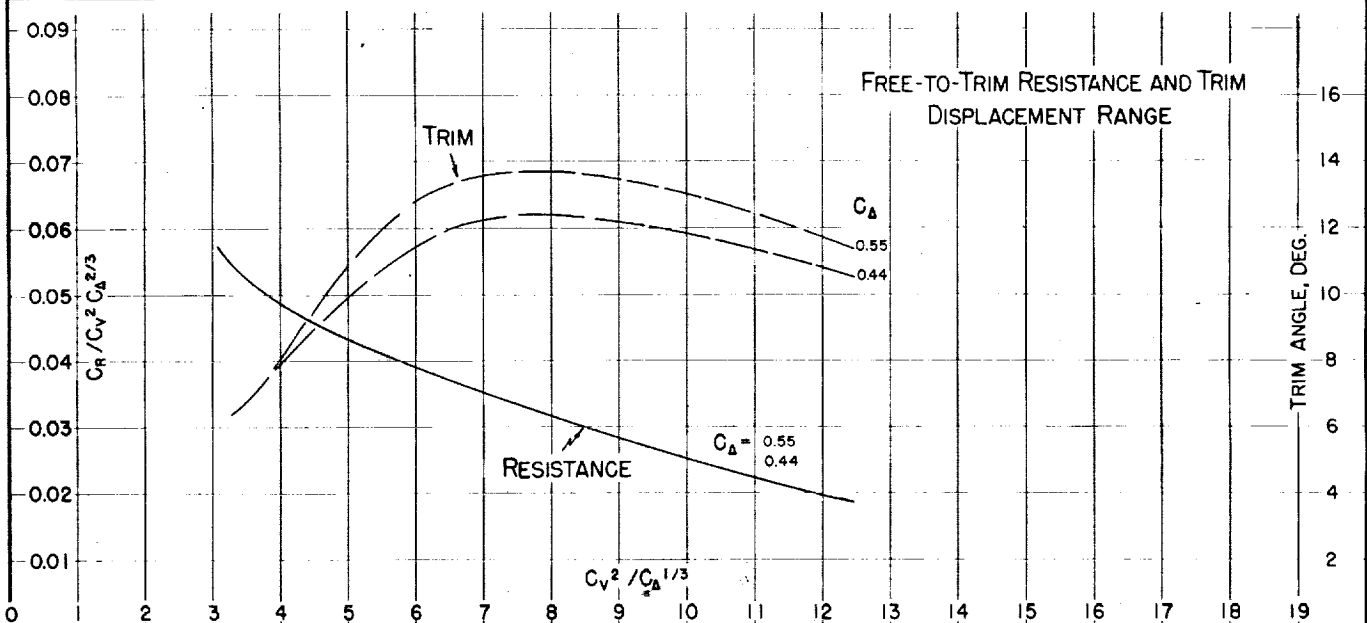
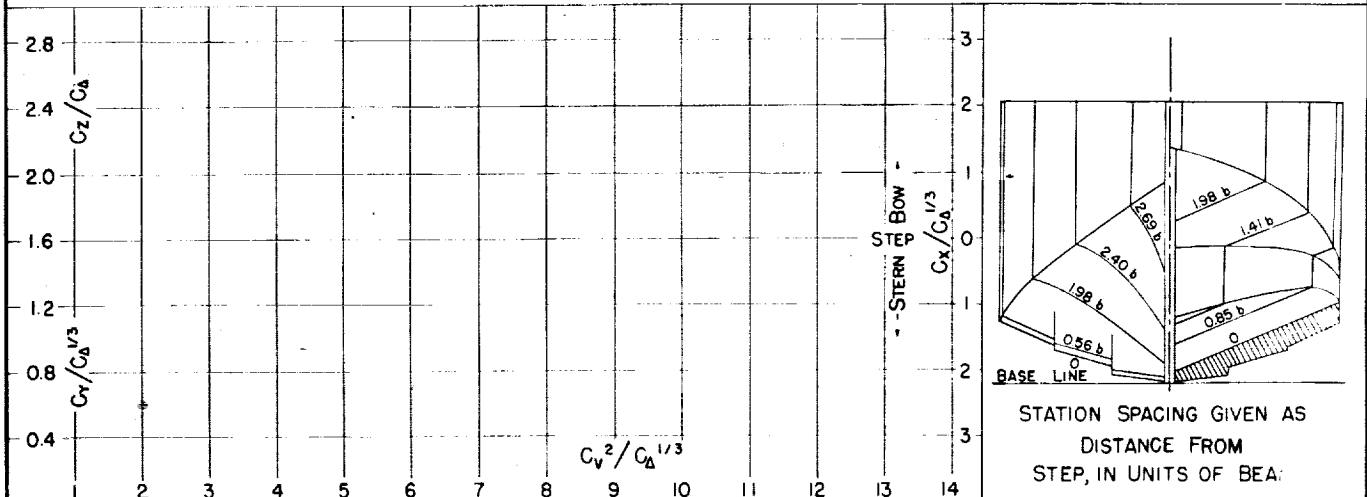

MODEL No. II-F
MODEL BEAM: 17.00"

C.G. = 0.47 b FWD. OF CENTROID
0.92 b ABOVE KEEL

$C_{d_0} =$ (NOMINAL)
 $k/L =$

TESTED AT NACA No. 1 TANK
DATE: 4/35

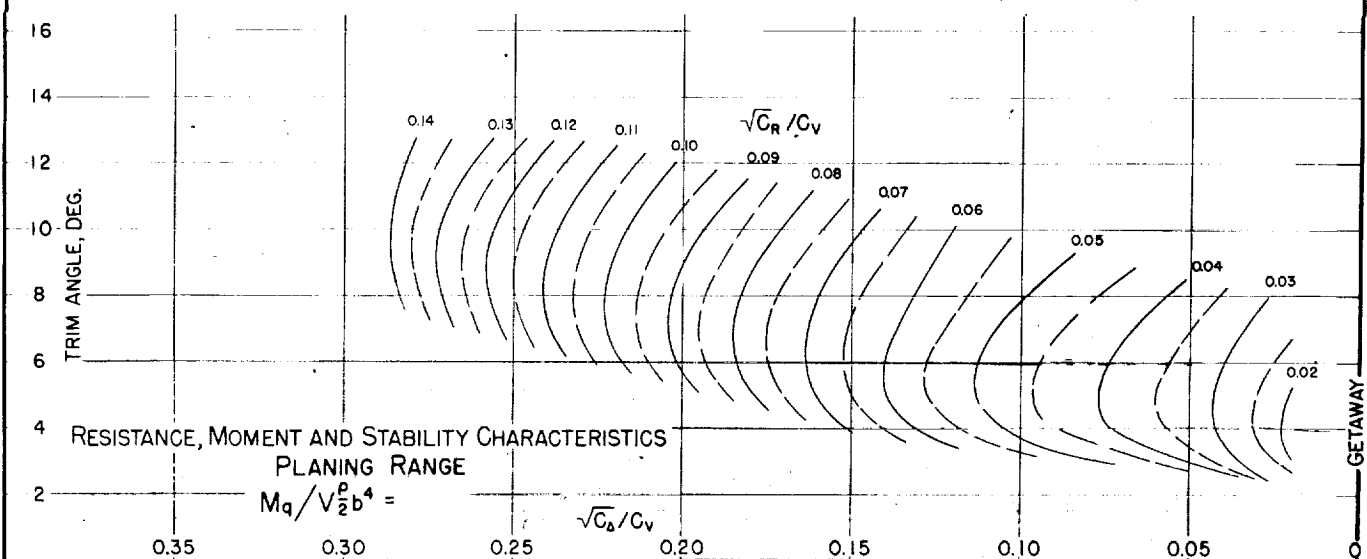
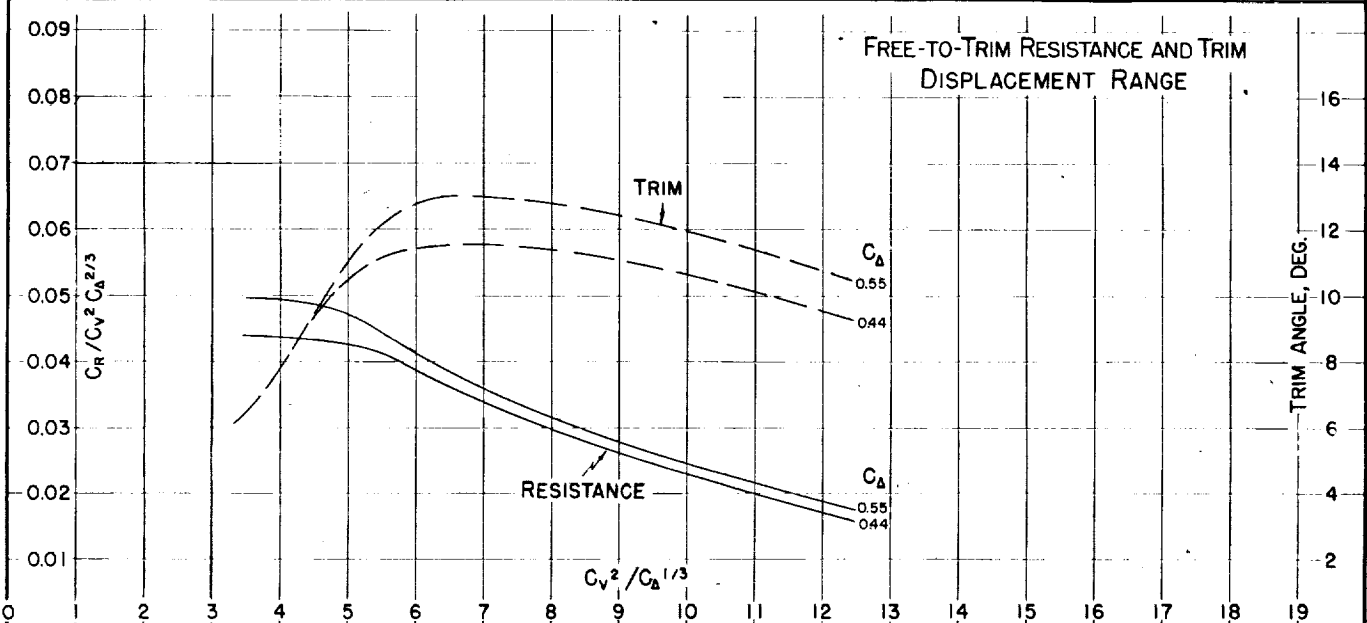
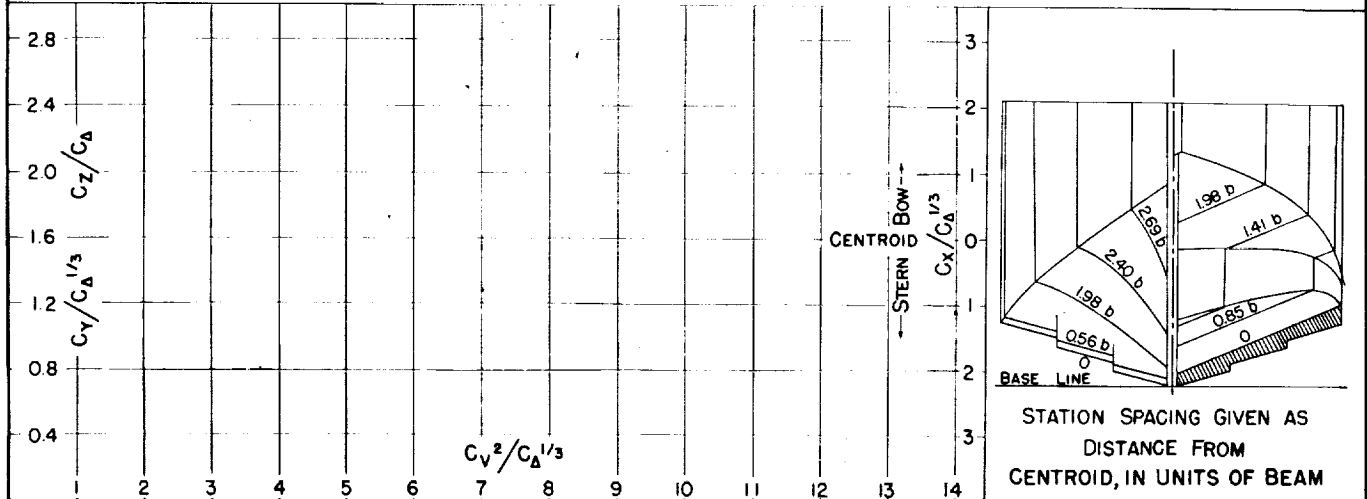

Fig. 16

DESIGNATION: 2.82-0.43-22.5

NACA TN No. 1182

MODEL NO. 11-G
MODEL BEAM 17.00"

C.G. = 0.47 b FWD. OF CENTROID
0.91 b ABOVE KEEL

$C_{d0} =$ (NOMINAL)
 $k/L =$

TESTED AT NACA NO. 1 TANK
DATE: 8/34

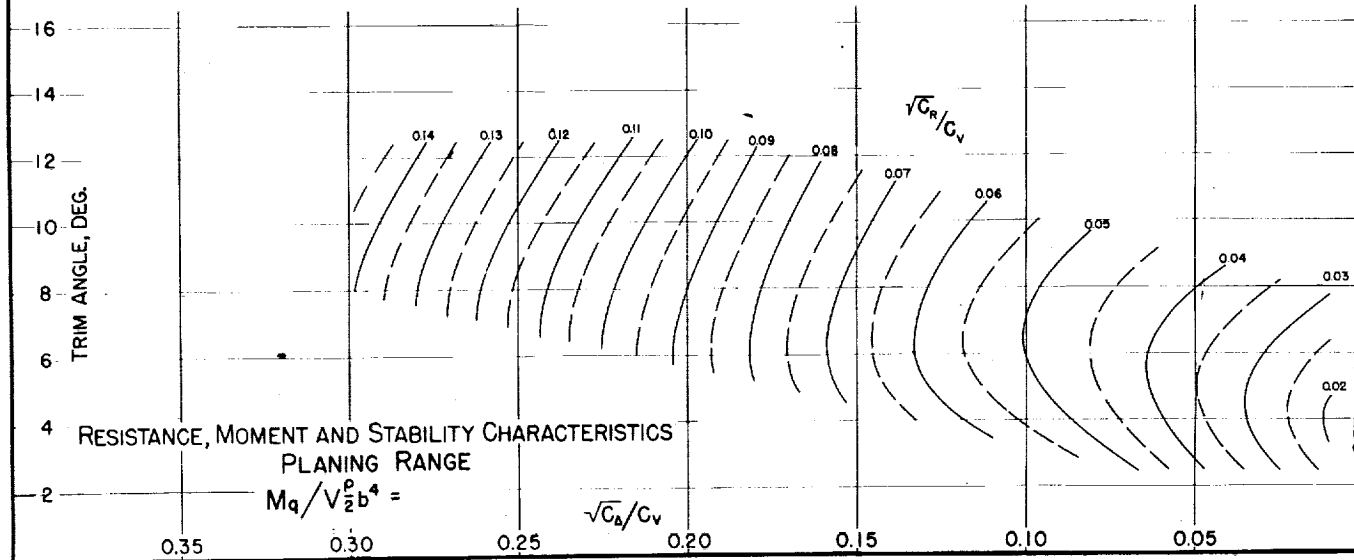
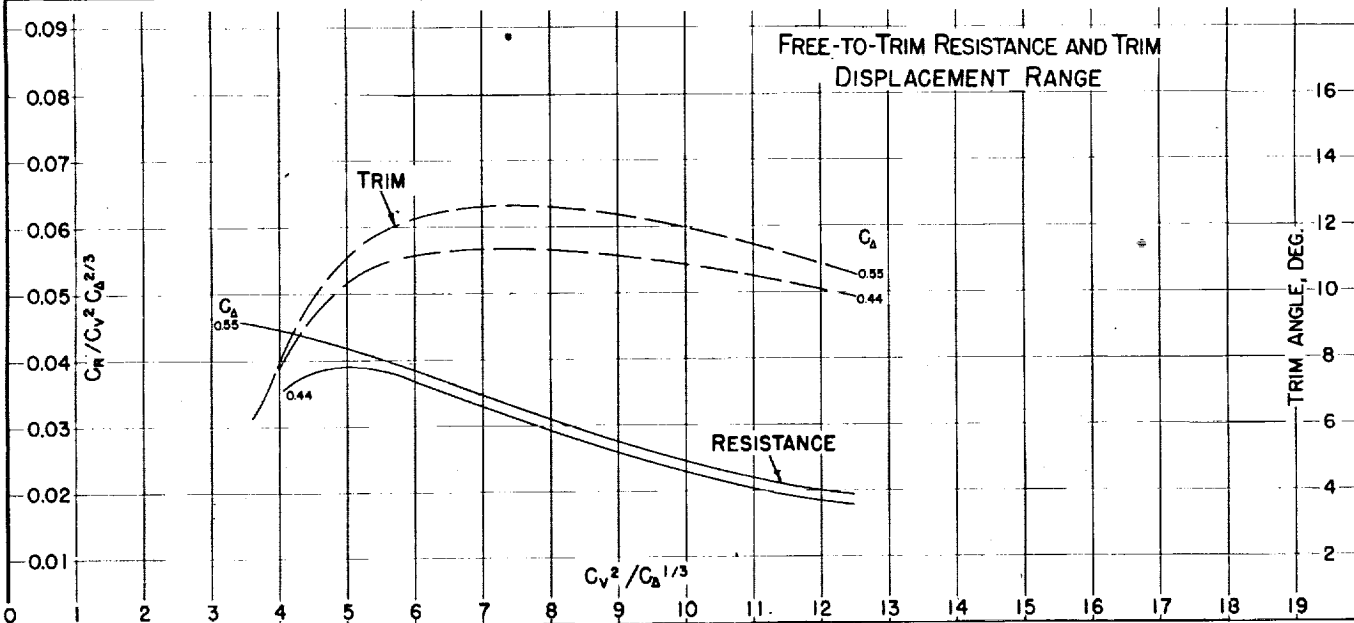
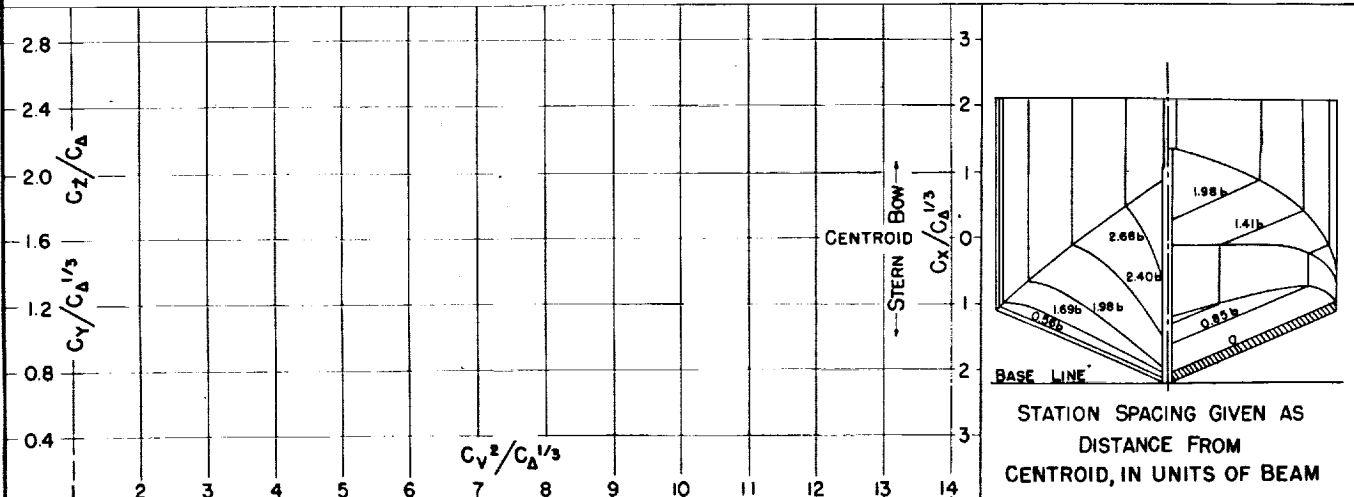

MODEL NO. II-M

C.G. = 0.47 b FWD. OF STEP
0.92 b ABOVE KEEL

$C_{d_0} =$ (NOMINAL)
 $k/L =$

TESTED AT NACA No. 1 TANK
DATE: 10/35

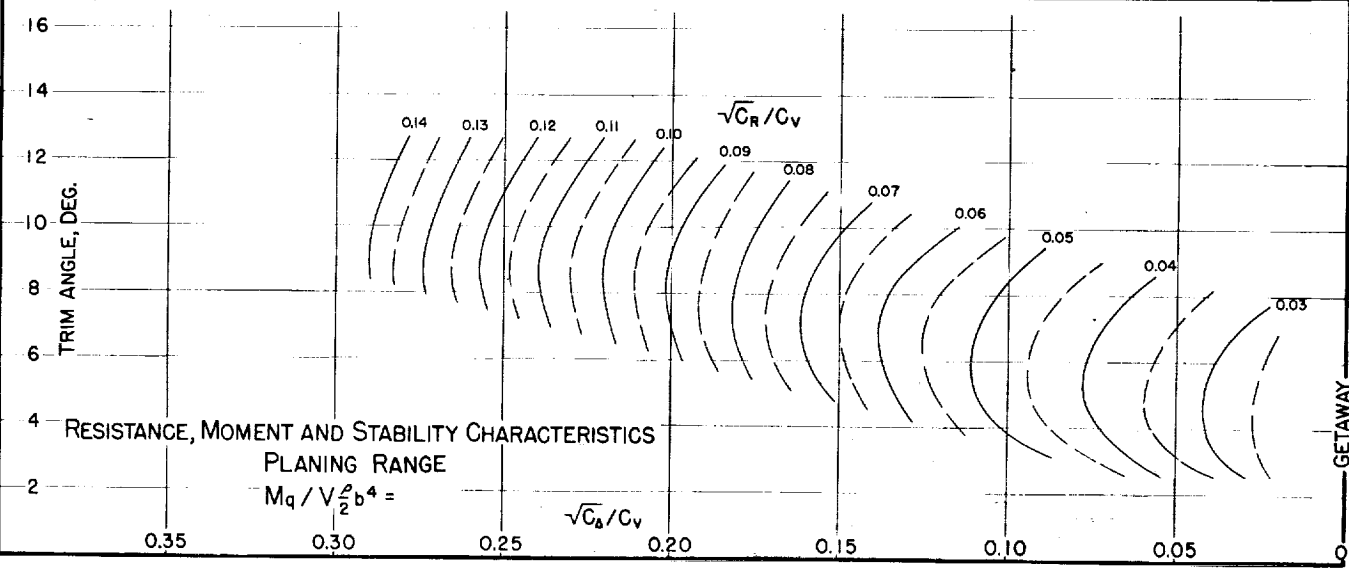
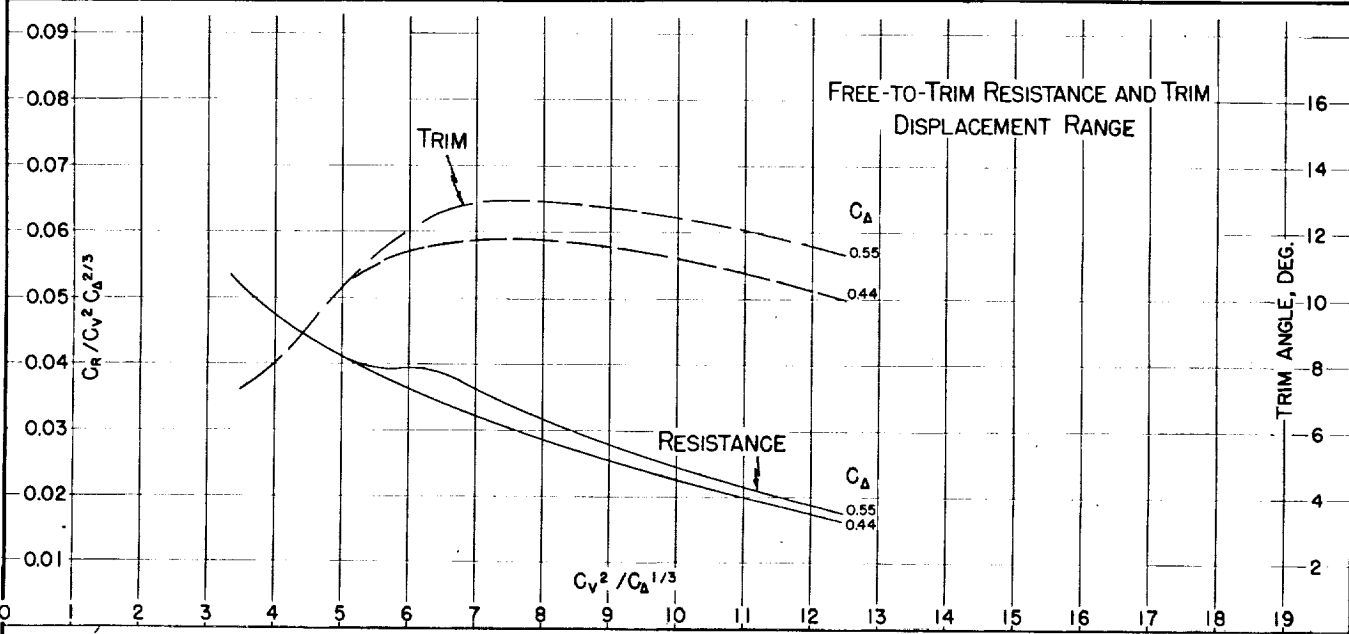
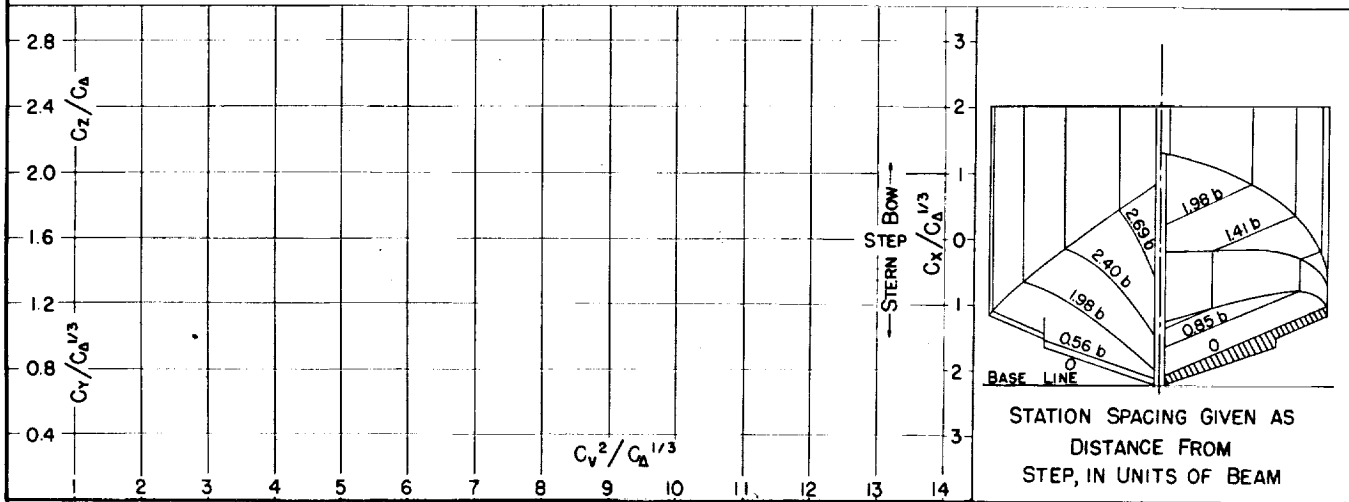

Fig. 18

DESIGNATION: 2.82-0.75-22.5

NACA TN No. 1182

MODEL No. 11-N
MODEL BEAM: 17.00"

C.G. = 0.47 b FWD. OF CENTROID $C_{\Delta 0} =$
0.92 b ABOVE KEEL $k/L =$

(NOMINAL)

TESTED AT NACA No. 1 TANK
DATE: 11/35

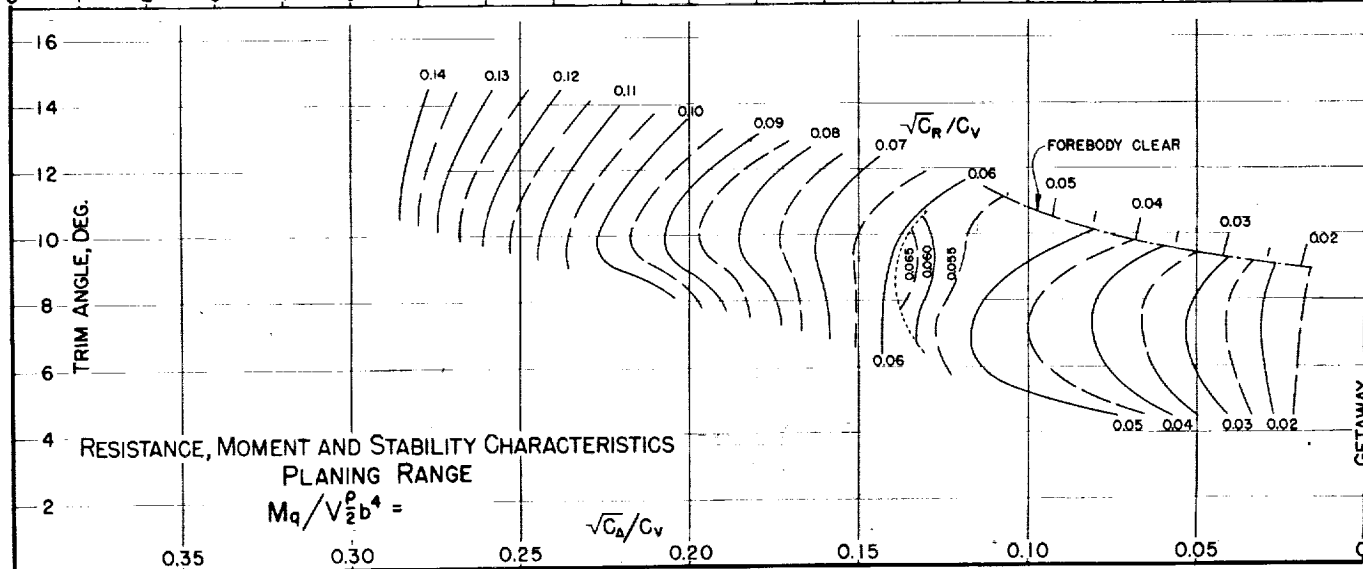
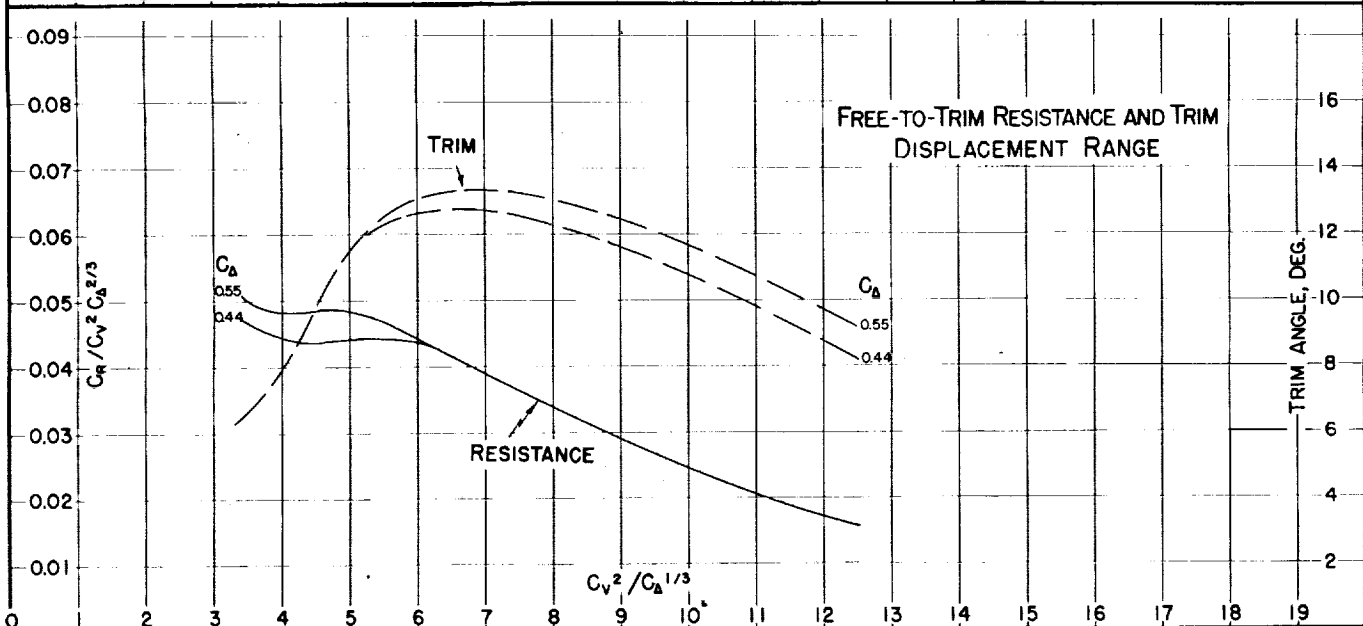
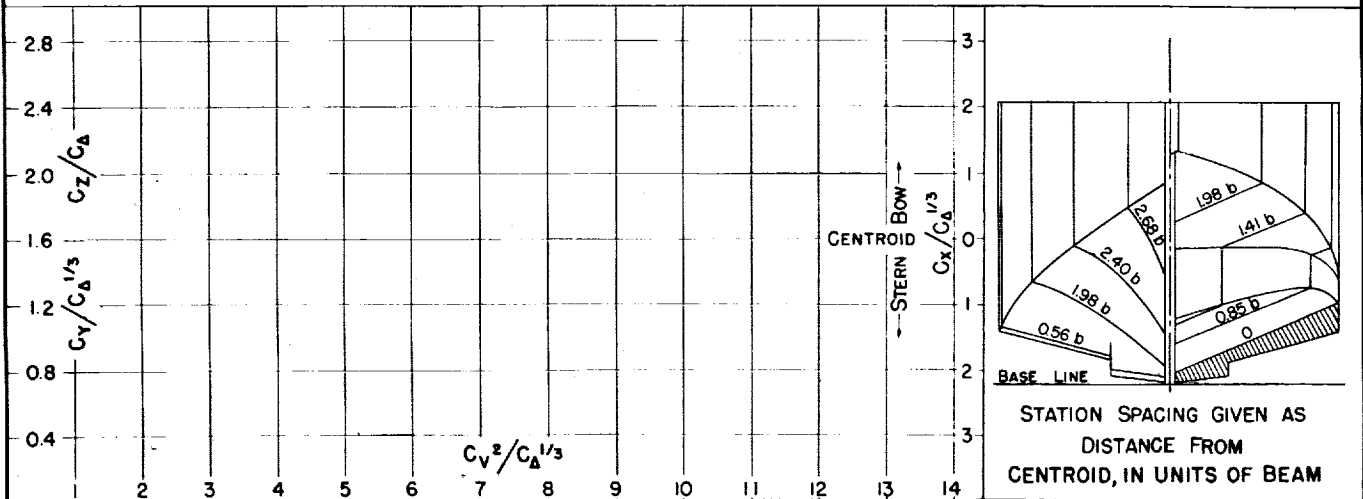

MODEL No. 12
MODEL BEAM: 17.00"

C.G. = 0.39 b FWD. OF CENTROID $C_{d,0} =$ (NOMINAL)
1.19 b ABOVE KEEL $k/L =$

TESTED AT NACA No. 1 TANK
DATE: '33

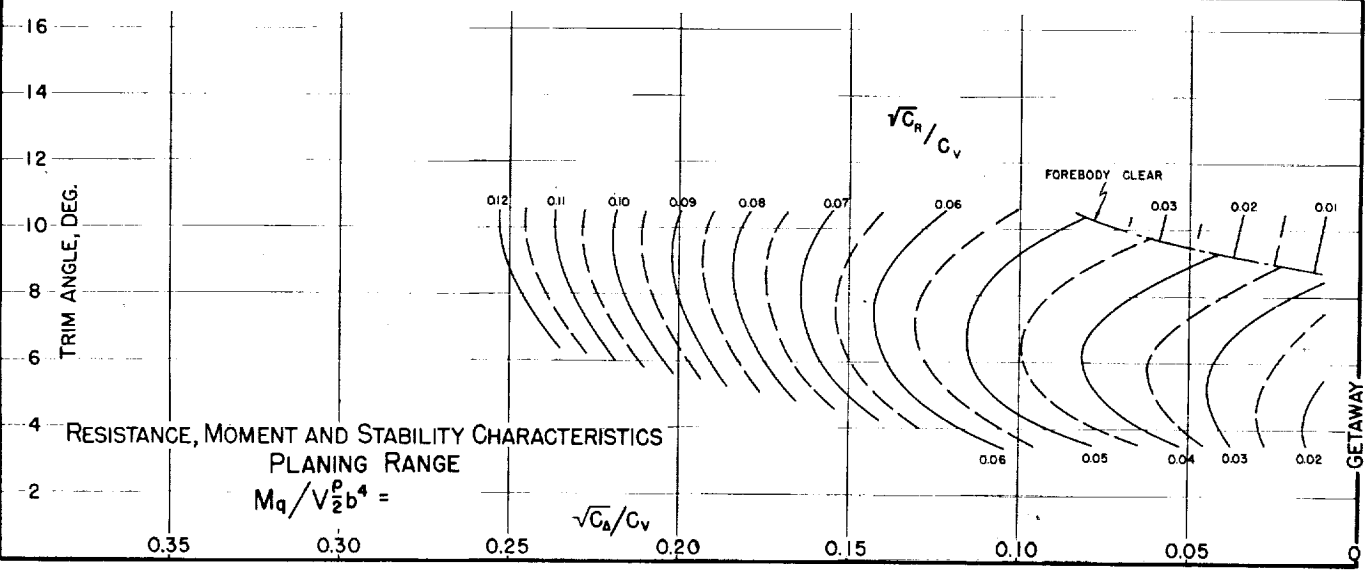
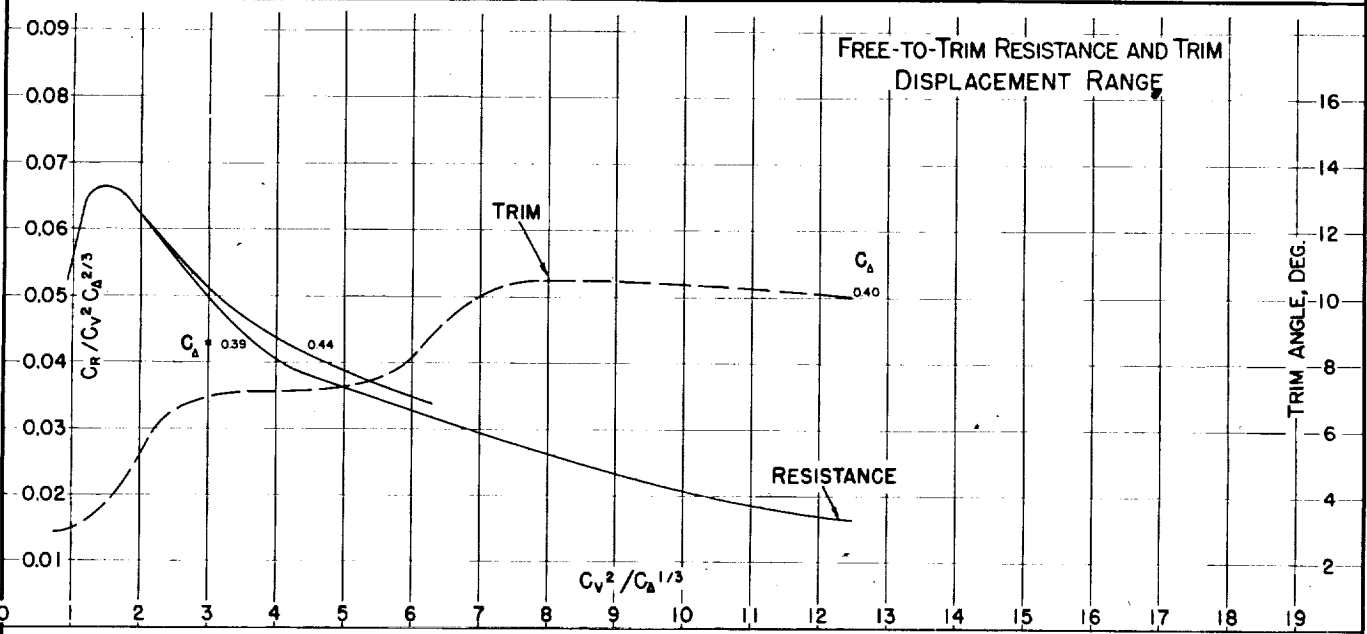
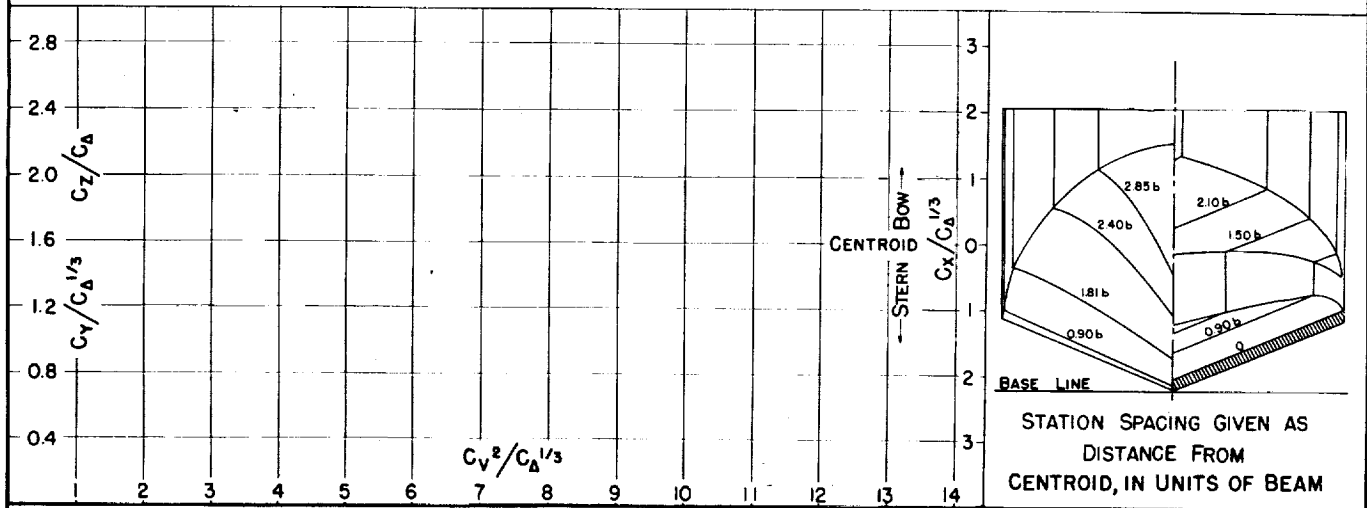

Fig. 20

DESIGNATION: 2.64-0.43-22.5

NACA TN No. 1182

MODEL No. 13

MODEL BEAM 17.00"

C.G. = 0.34 b FWD. OF CENTROID
1.19 b ABOVE KEEL

$C_{d_0} =$
 $k/L =$

(NOMINAL)

TESTED AT NACA No. 1 TANK

DATE: '33

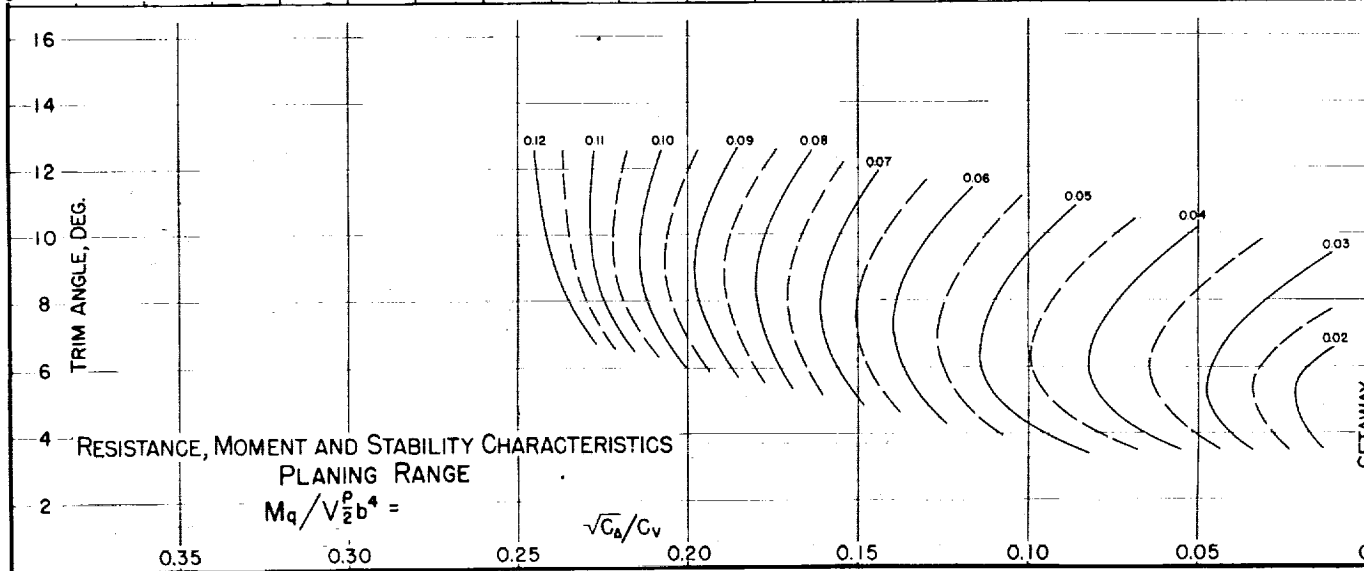
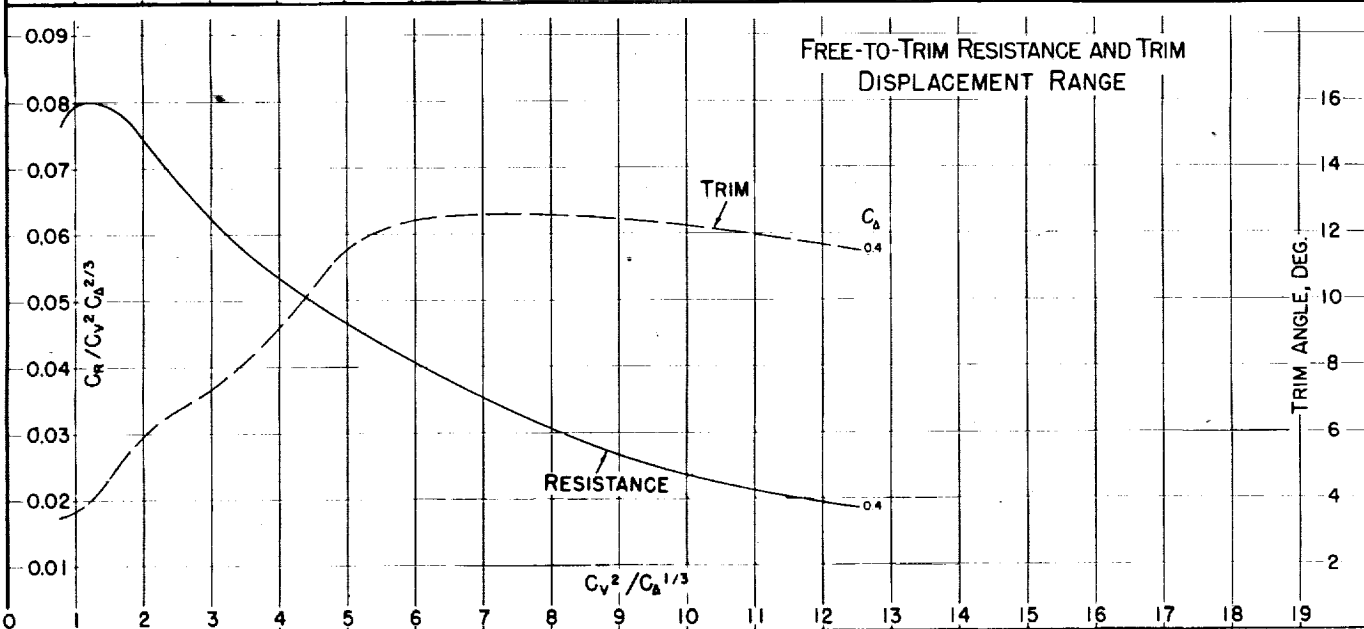
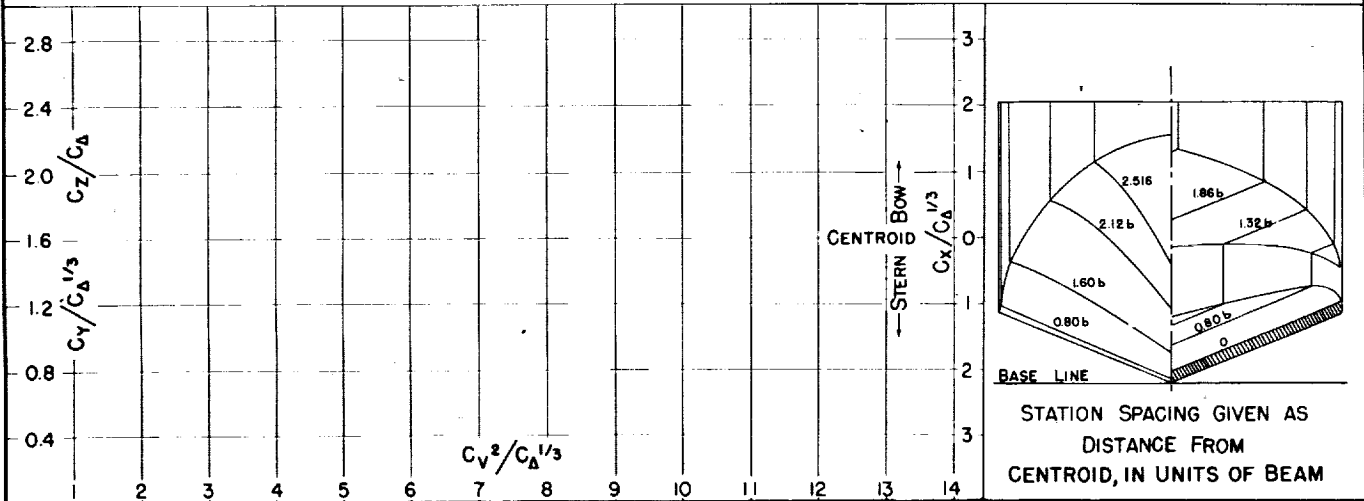

MODEL No. 14
MODEL BEAM: 19.00"

C.G. = 0.32 b FWD. OF CENTROID
1.07 b ABOVE KEEL

$C_{d_0} =$ (NOMINAL)

TESTED AT NACA No. 1 TANK
DATE: '33

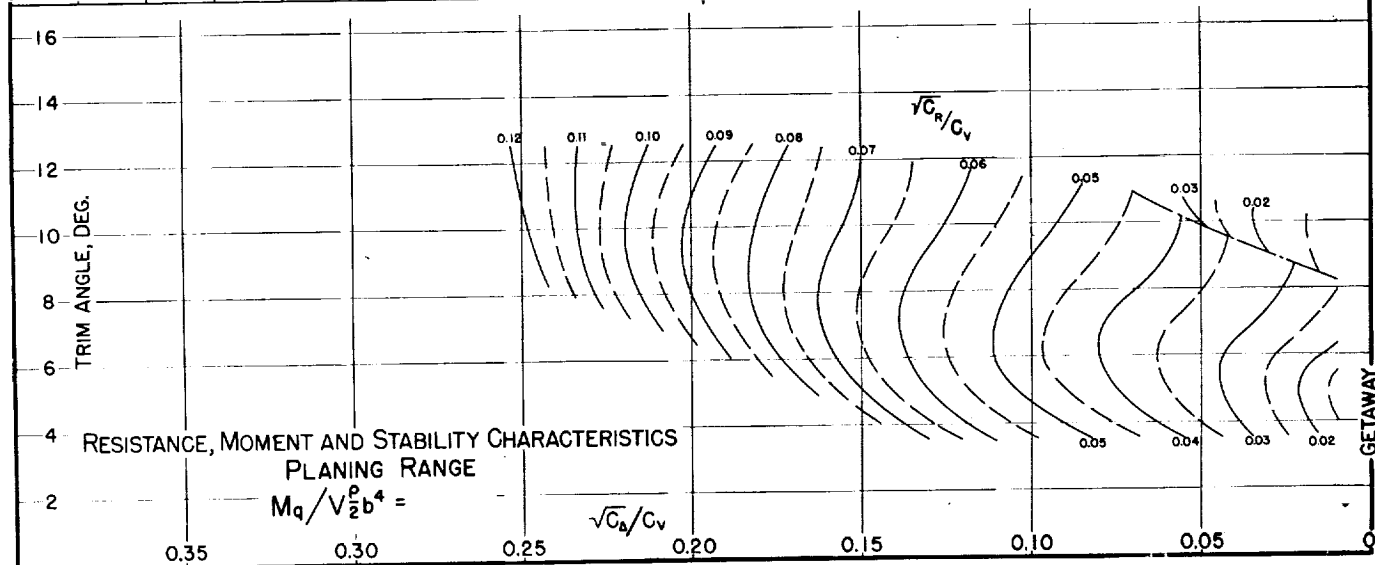
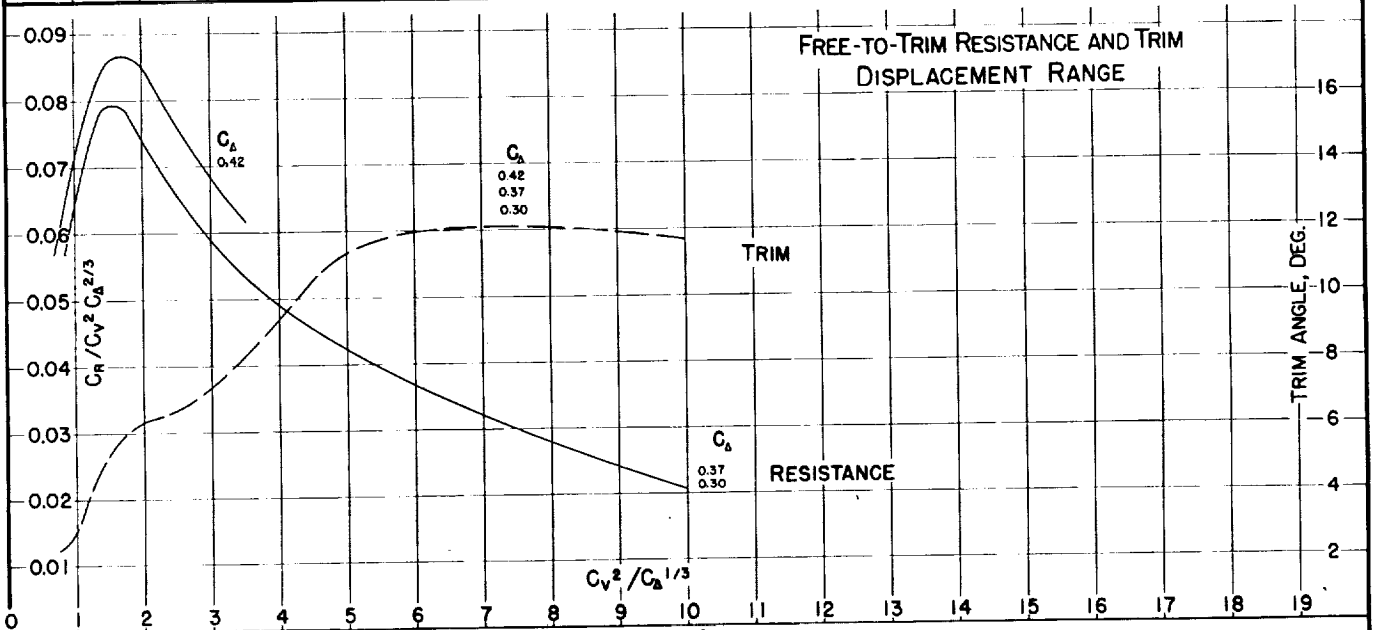
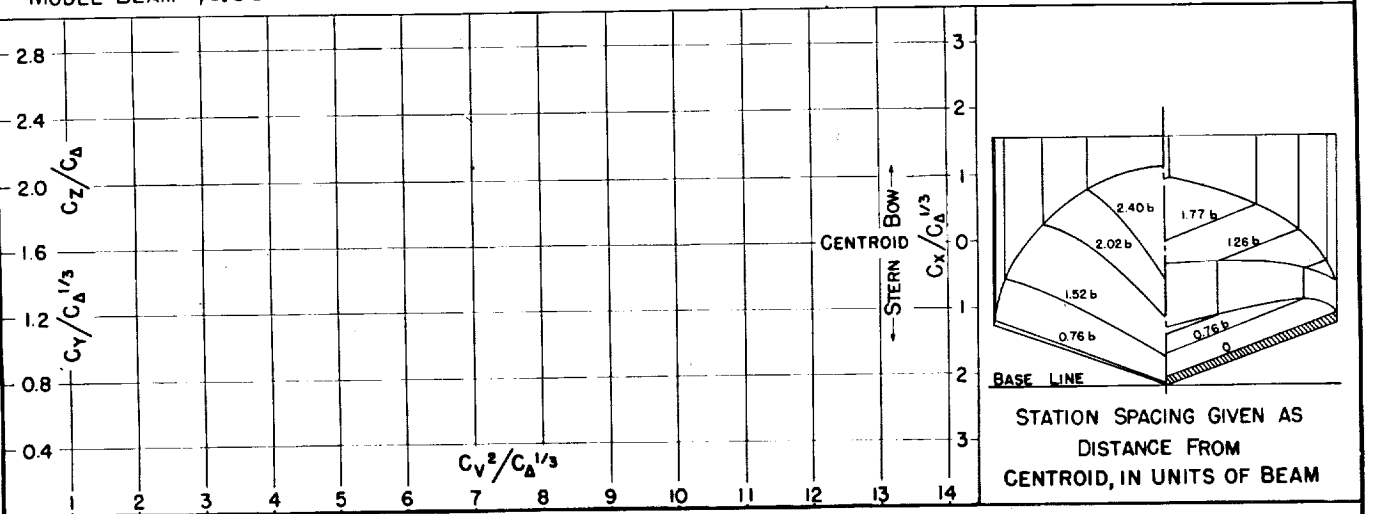

Fig. 22

DESIGNATION: 3.20-0.49-25.1

NACA TN No. 1182

MODEL No. 15
MODEL BEAM: 15.00"

C.G. = 0.41 b FWD. OF CENTROID
1.35 b ABOVE KEEL

$C_{d,0} =$ (NOMINAL)
 $K/L =$

TESTED AT NACA No. 1 TANK
DATE: '33

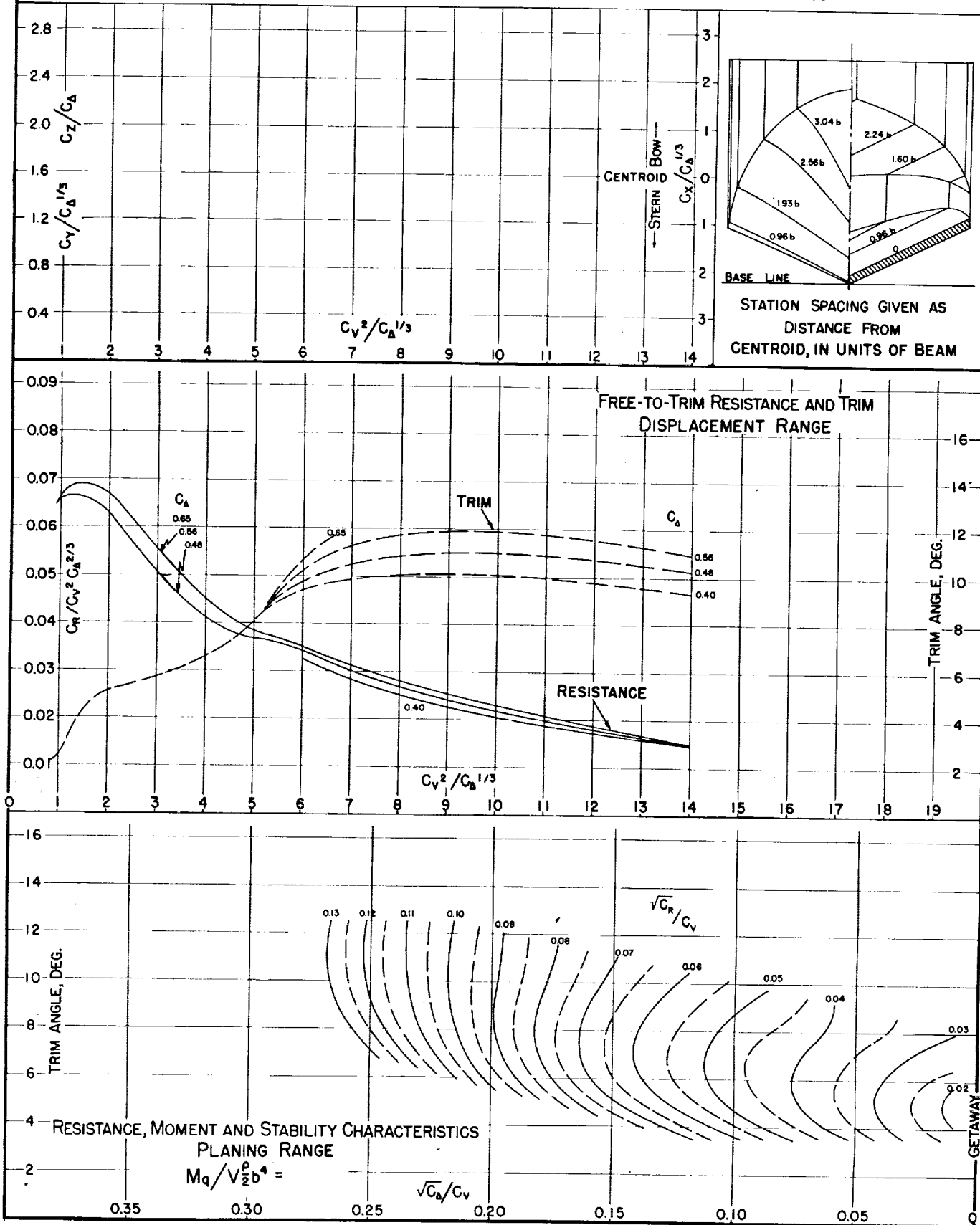

MODEL No. 16
MODEL BEAM: 15.42"

C.G. = 0 b FWD. OF CENTROID $C_{A0} =$
1.03 b ABOVE KEEL $k/L =$

(NOMINAL)

TESTED AT NACA No. 1 TANK
DATE: 12/32

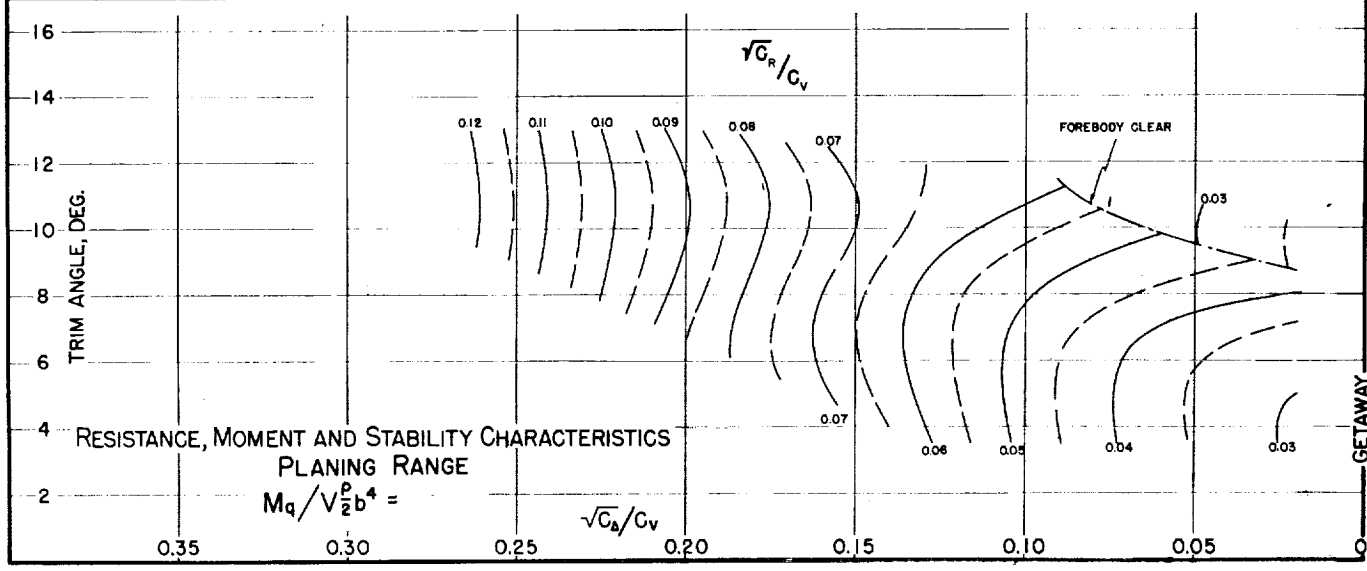
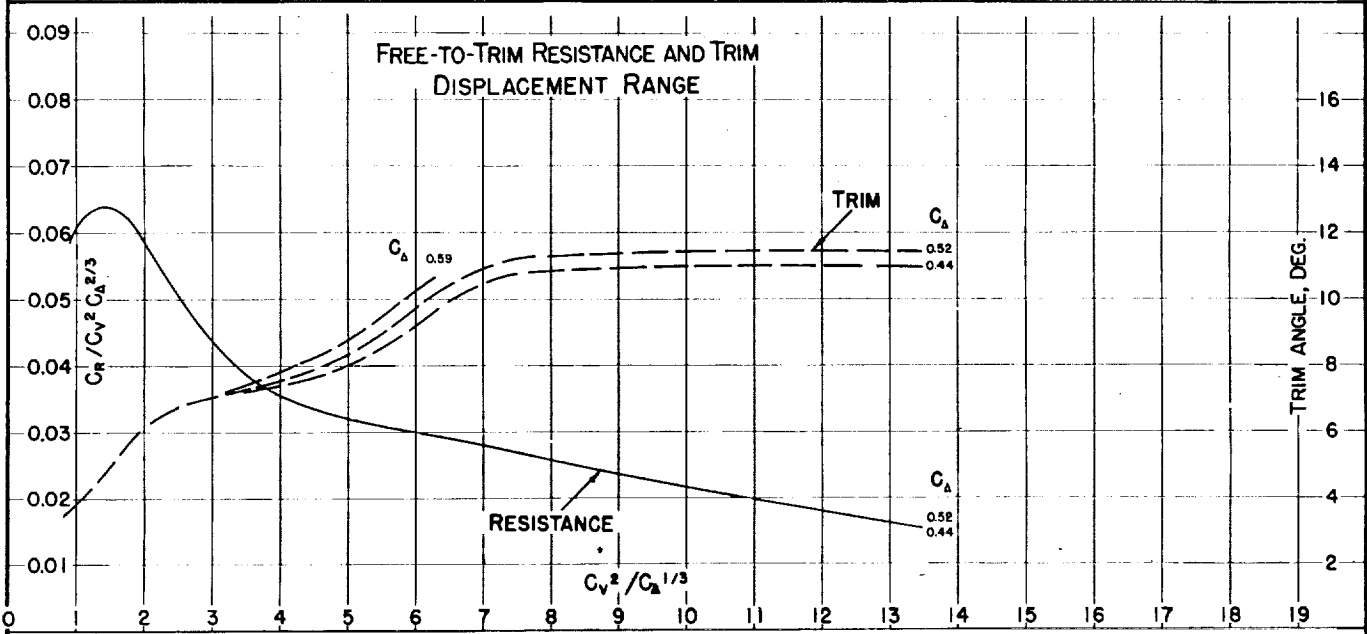
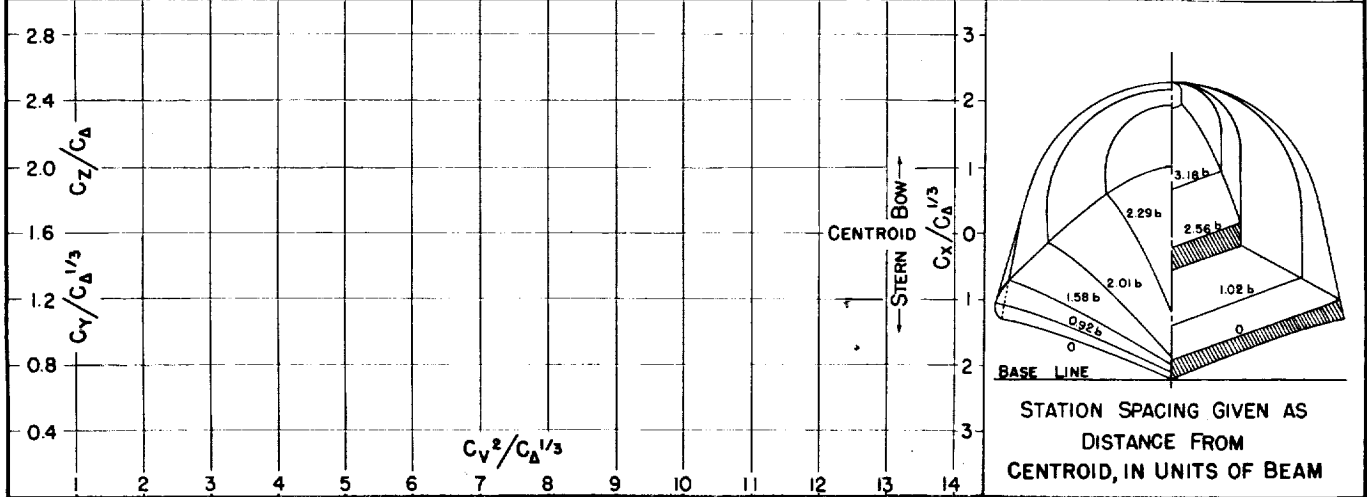

Fig. 24

DESIGNATION: 2.84-0.51-22.5

NACA TN No. 1182

MODEL No. 18
MODEL BEAM: 16.84"

C.G. = 0.49b FWD. OF STEP
0.78b ABOVE KEEL

$C_{d0} = 0.60$ (NOMINAL)
 $k/L =$

TESTED AT NACA No. 1 TANK
DATE: 10/37

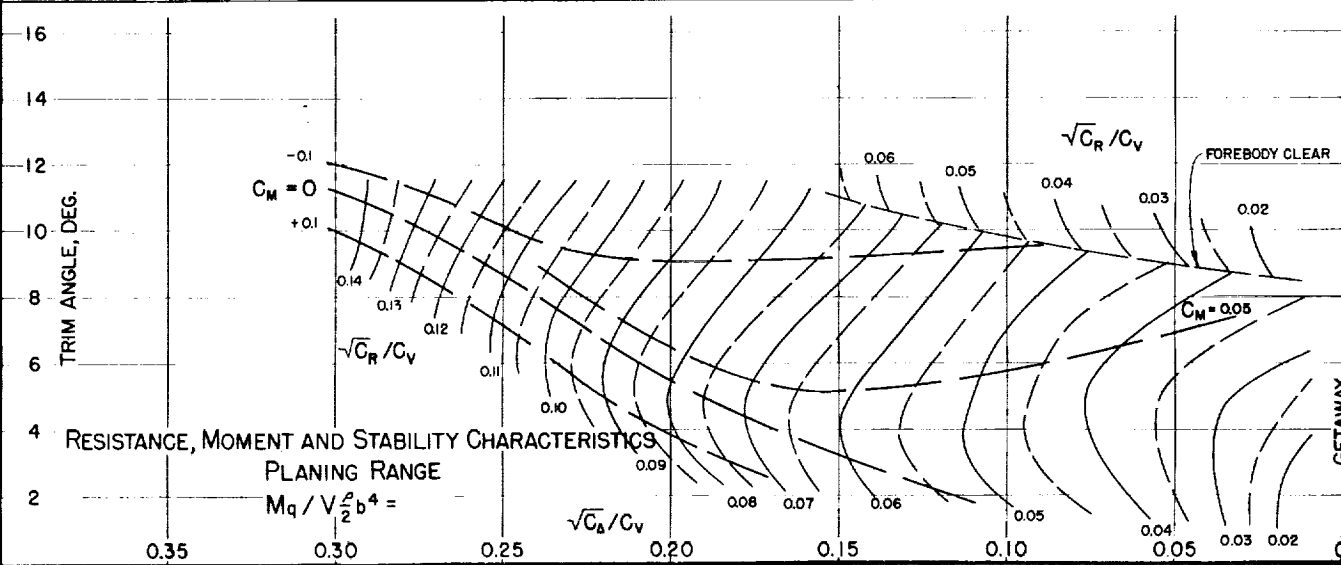
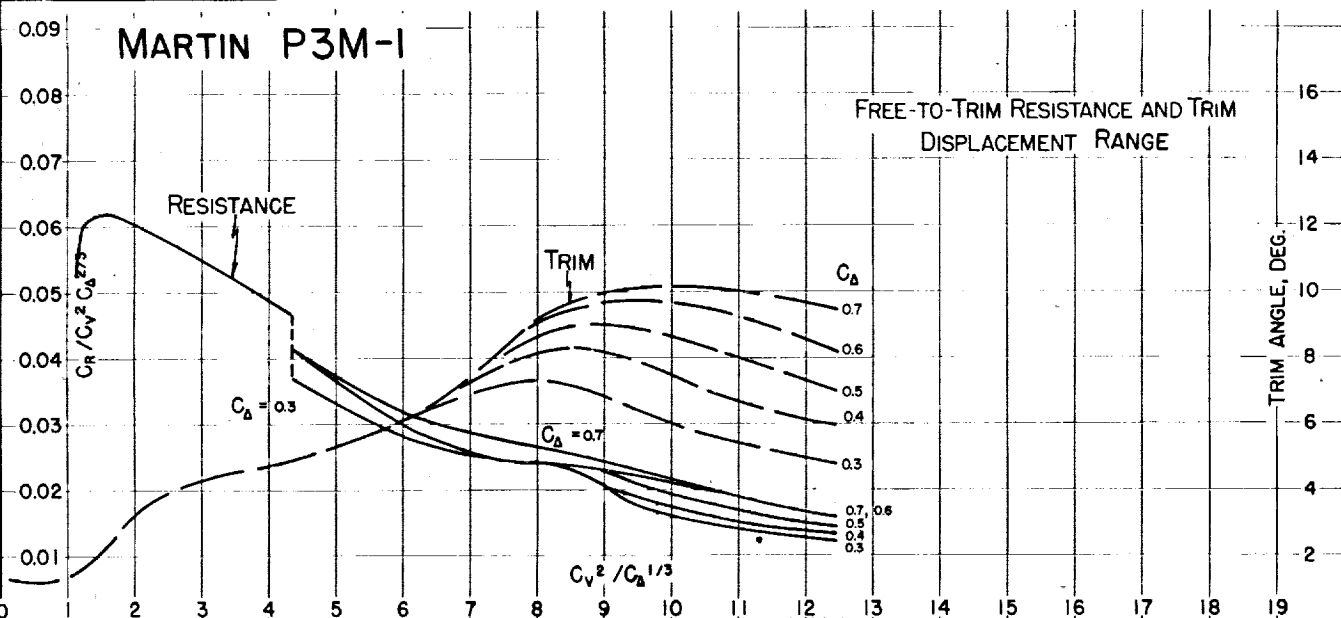
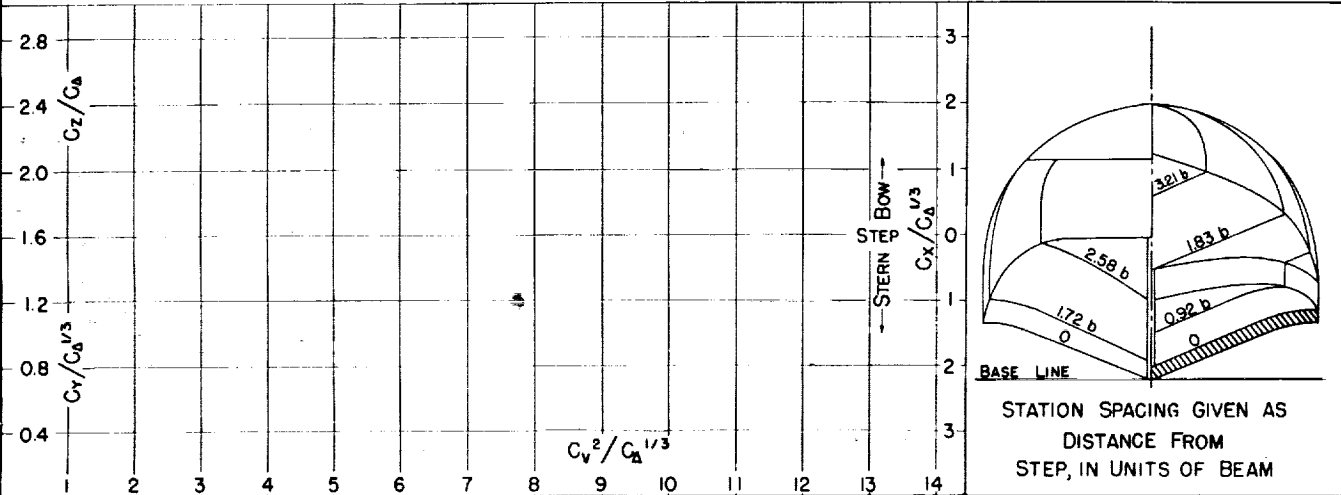

MODEL No. 22
MODEL BEAM 17.00"

C.G. = -0.23b FWD. OF CENTROID
0.80b ABOVE KEEL

$C_{d0} =$ (NOMINAL)
 $k/L =$

TESTED AT NACA No. 1 TANK
DATE: 7/33

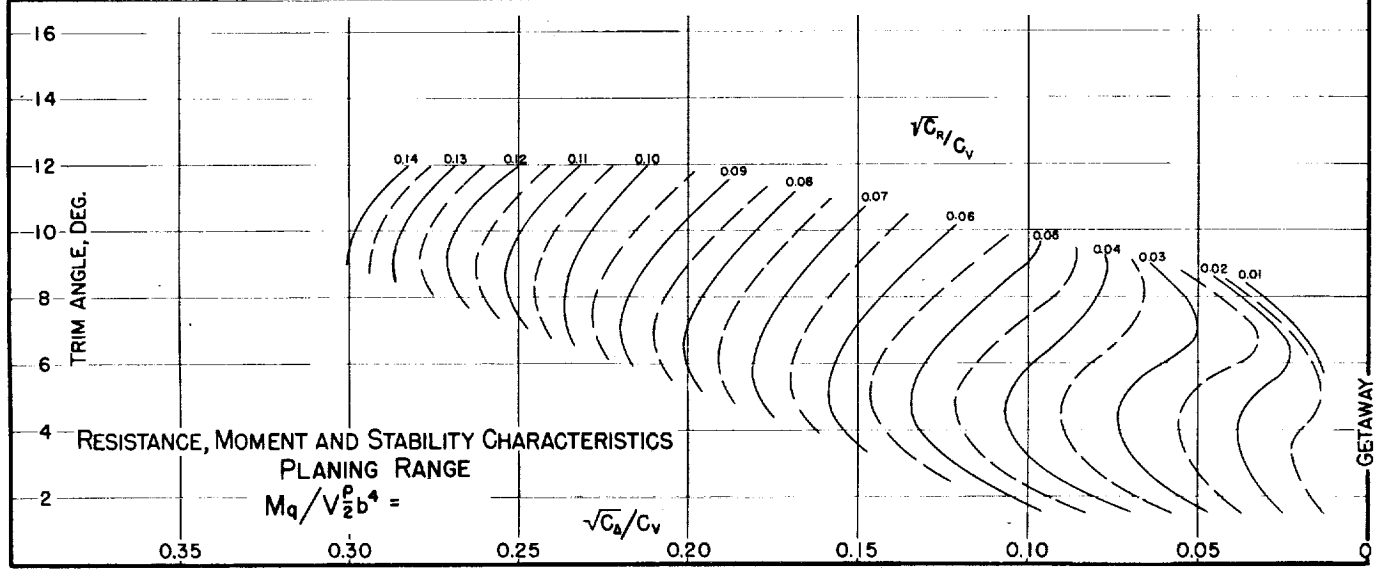
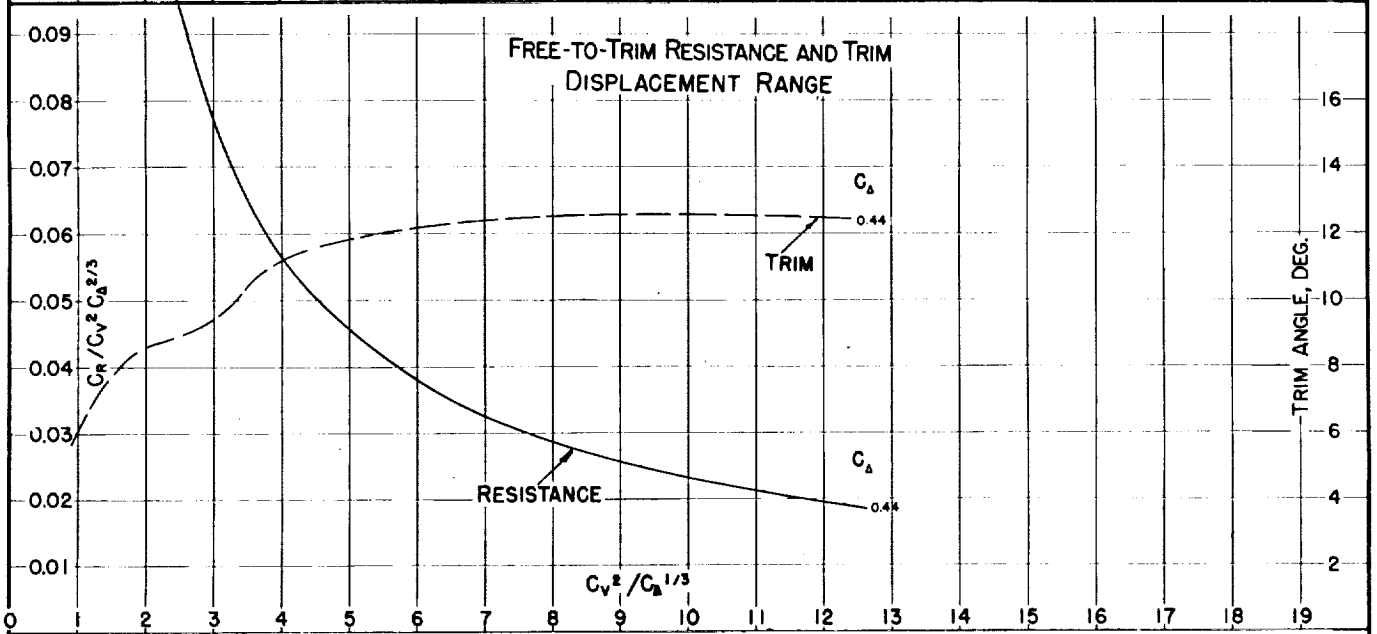
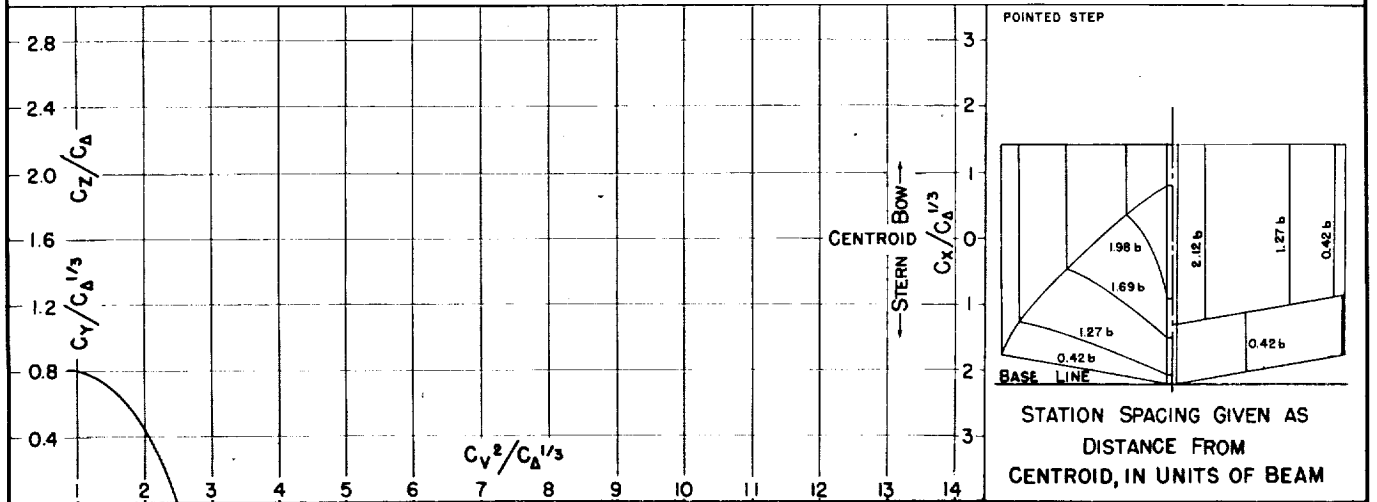

GETAWAY

Fig. 26

DESIGNATION: 2.28 - 2.88 - 10.0 NACA TN No. 1182

MODEL No. 22-A
MODEL BEAM: 17.00"

C.G. = 0 b FWD. OF CENTROID
0.80 b ABOVE KEEL

$C_{d_0} =$
 $k/L =$

(NOMINAL)

TESTED AT NACA No. 1 TANK

DATE: 11/33

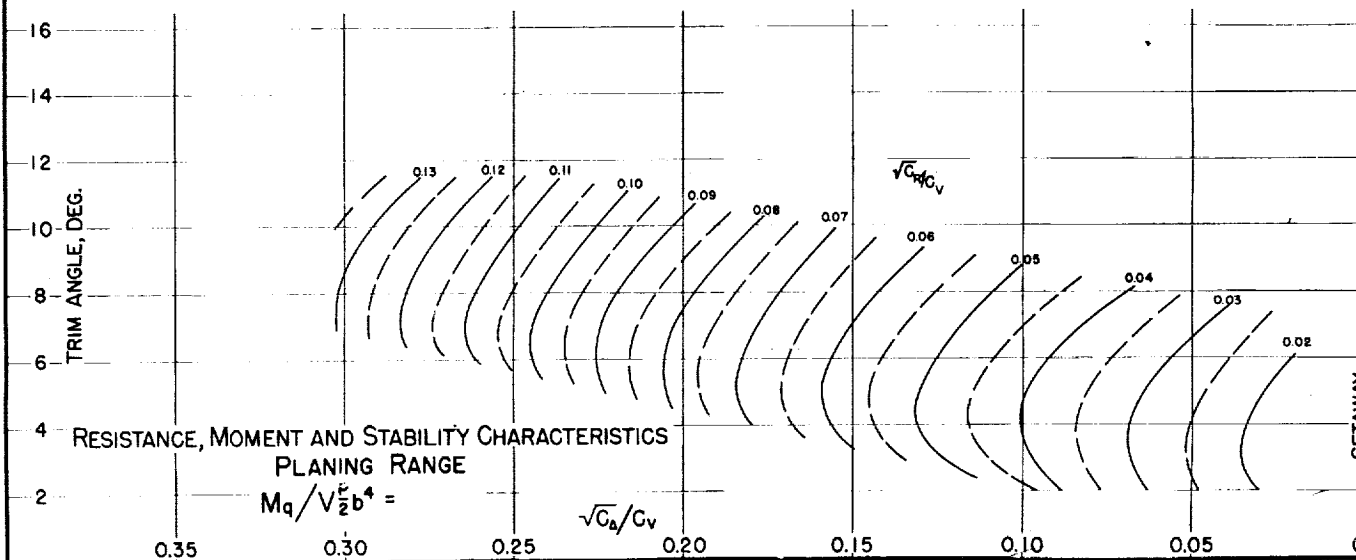
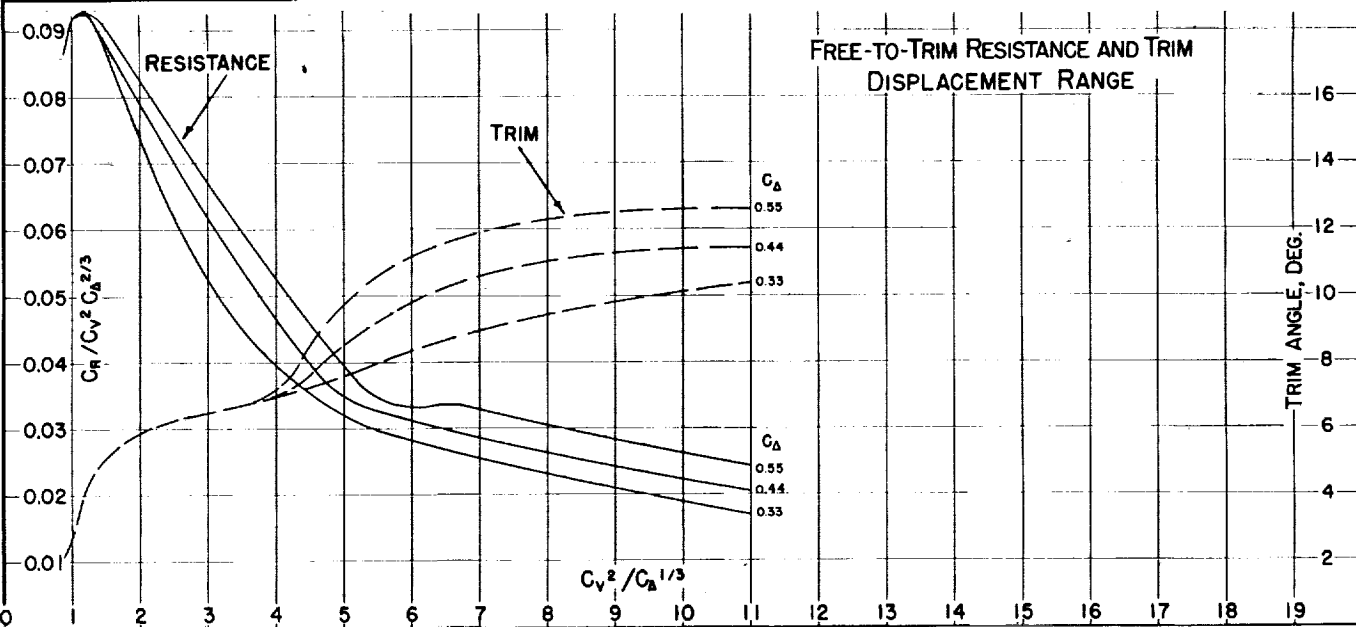
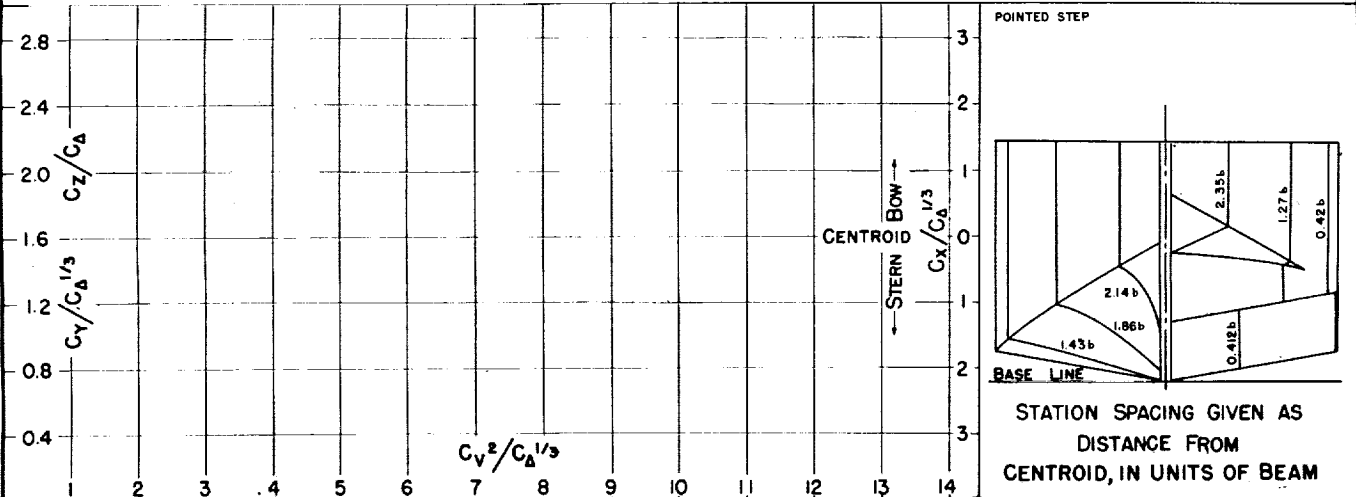

GETAWAY

MODEL No. 26
MODEL BEAM: 1786"

C.G. = 0.24 b FWD. OF CENTROID
0.82 b ABOVE KEEL

$C_{d,0} =$ (NOMINAL)

TESTED AT NACA No. 1 TANK
DATE: 6/34

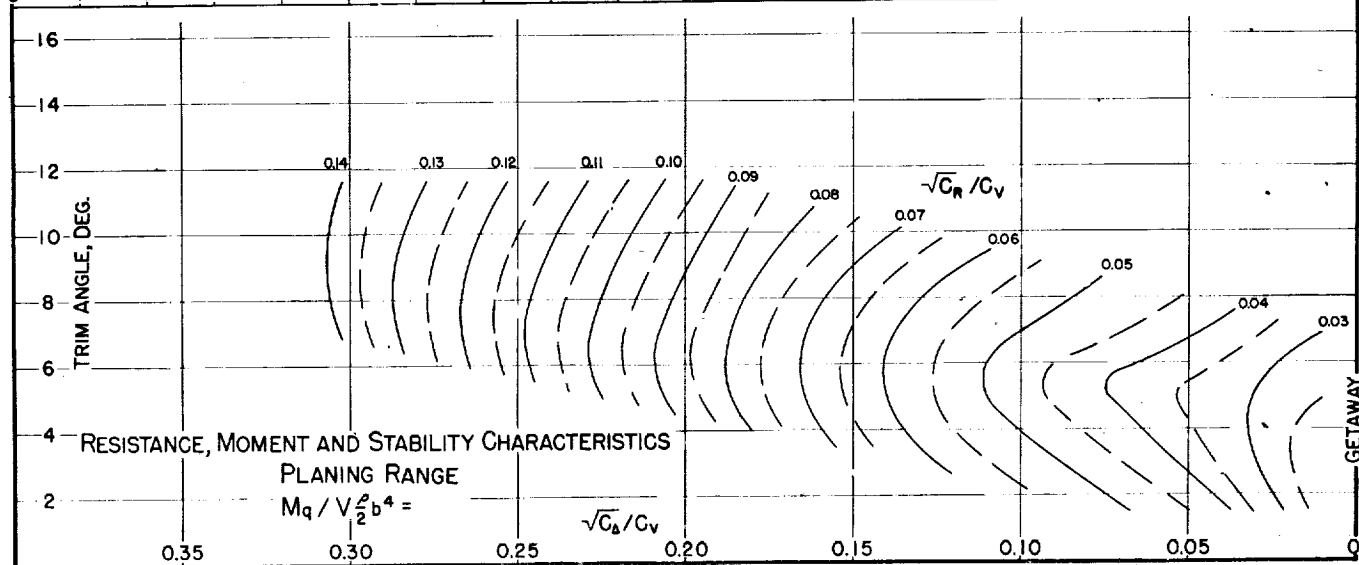
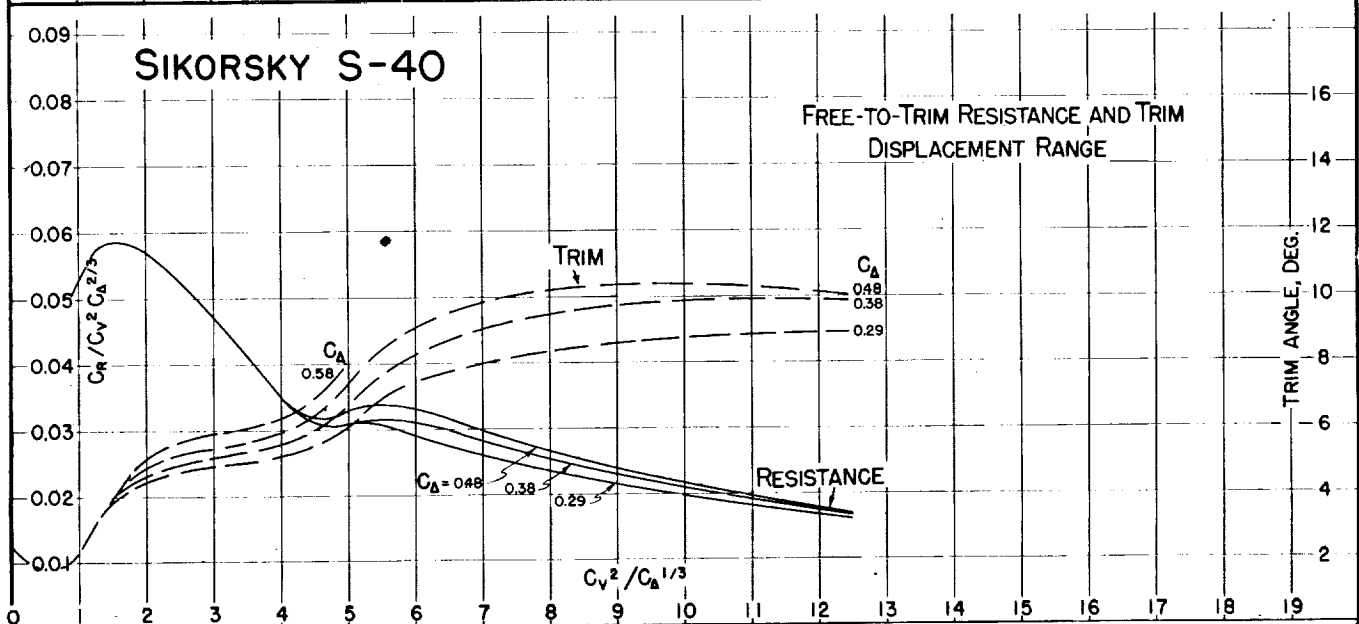
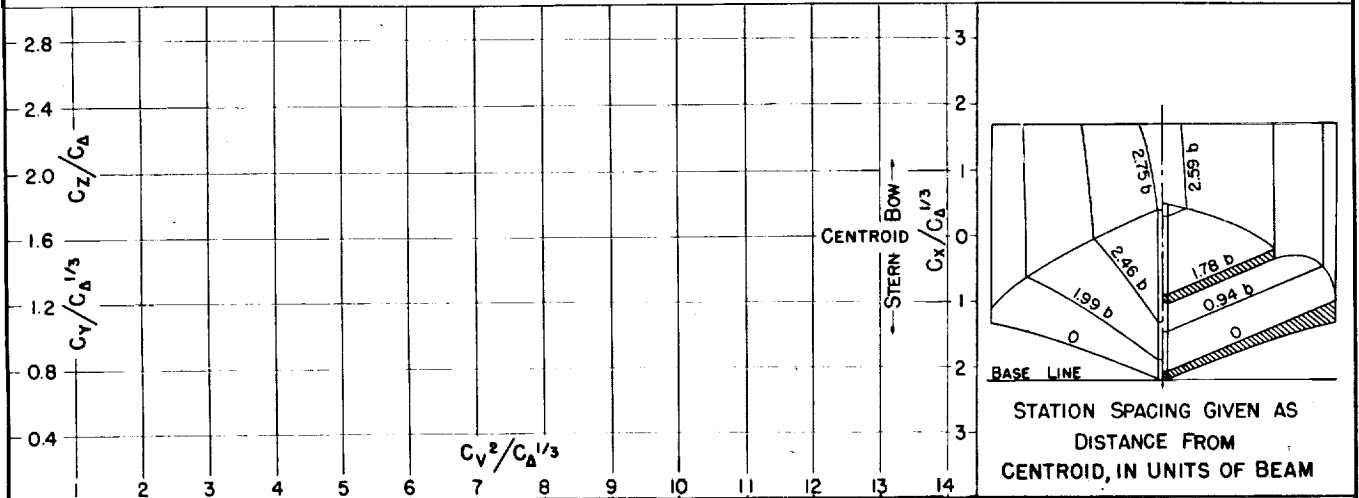

Fig. 28

DESIGNATION: $\infty - \infty - 0.0$

NACA TN No. 1182

MODEL No. 27
MODEL BEAM: 16.00"

C.G. =

b FWD. OF CENTROID $C_{d_0} =$ (NOMINAL)
b ABOVE KEEL $k/L =$

TESTED AT NACA No. 1 TANK
DATE: '34

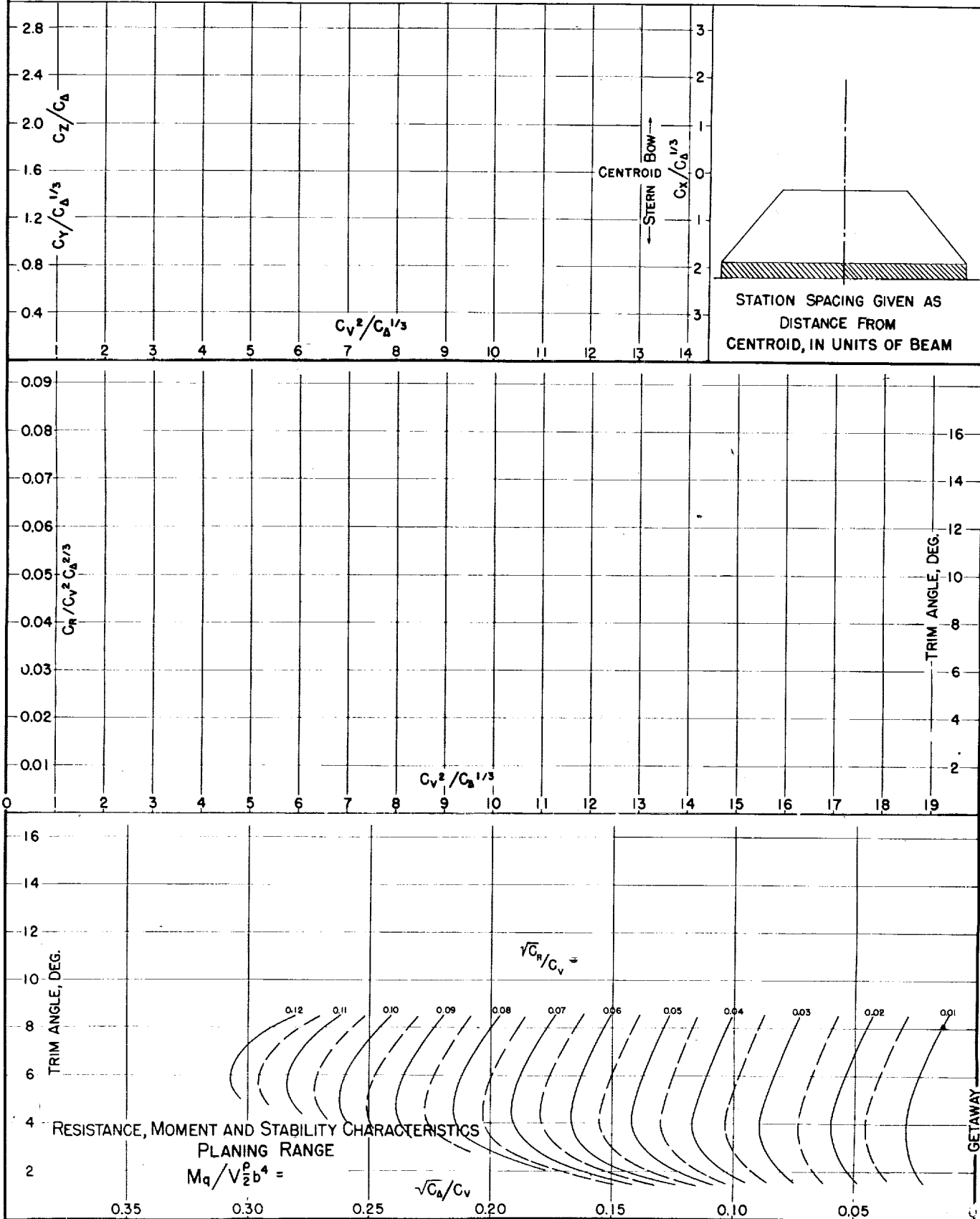

MODEL No. 28
MODEL BEAM: 16.00"

C.G. =

b FWD. OF CENTROID $C_{\Delta 0} =$
b ABOVE KEEL $k/L =$

(NOMINAL)

TESTED AT NACA No. 1 TANK
DATE: '34

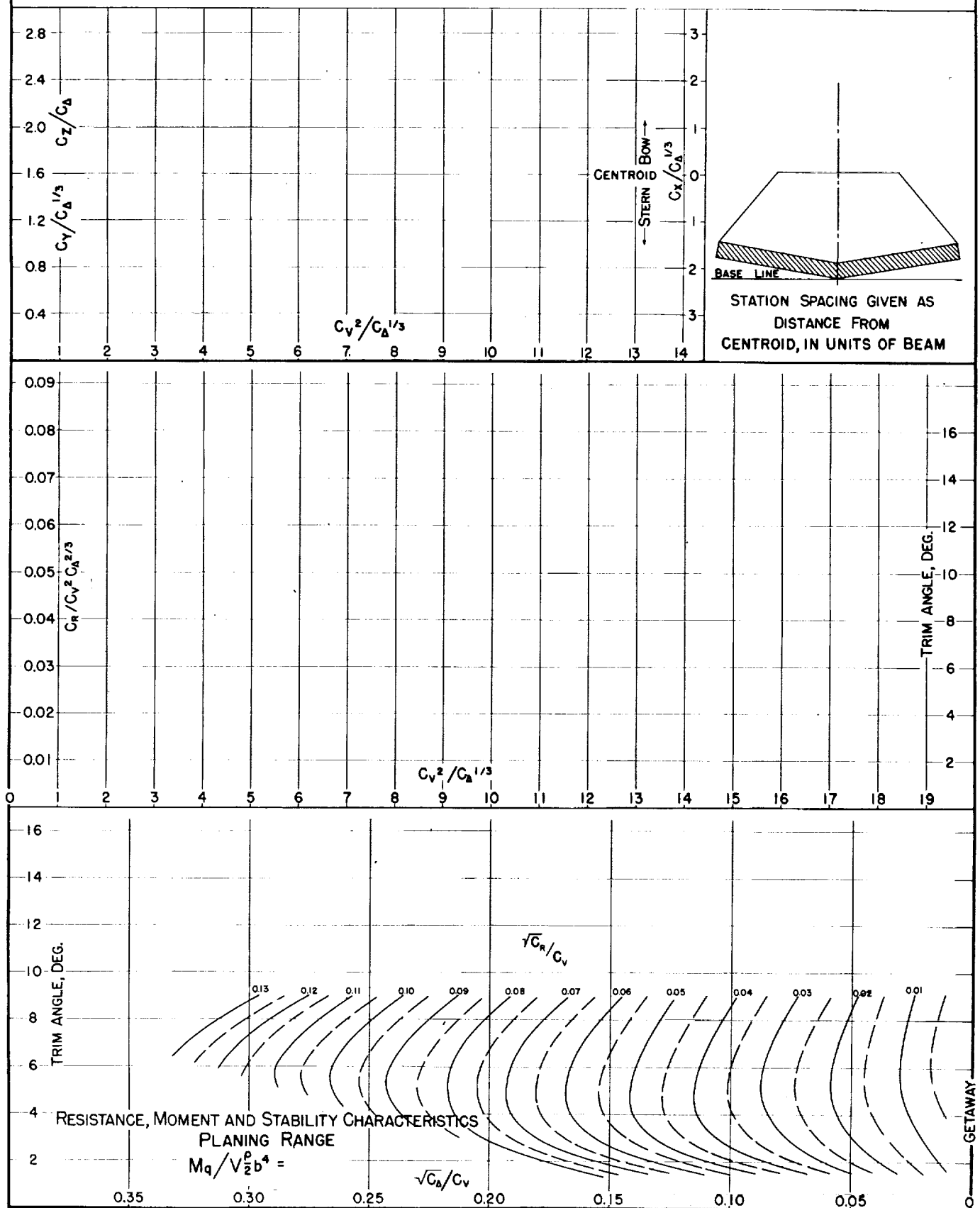

Fig. 30

DESIGNATION: $\infty - \infty - 20.0$

NACA TN No. 1182

MODEL No. 29
MODEL BEAM 16.00"

C.G. =

b FWD. OF CENTROID $C_{d0} =$
b ABOVE KEEL $k/L =$

(NOMINAL)

TESTED AT NACA No. 1 TANK
DATE: '34

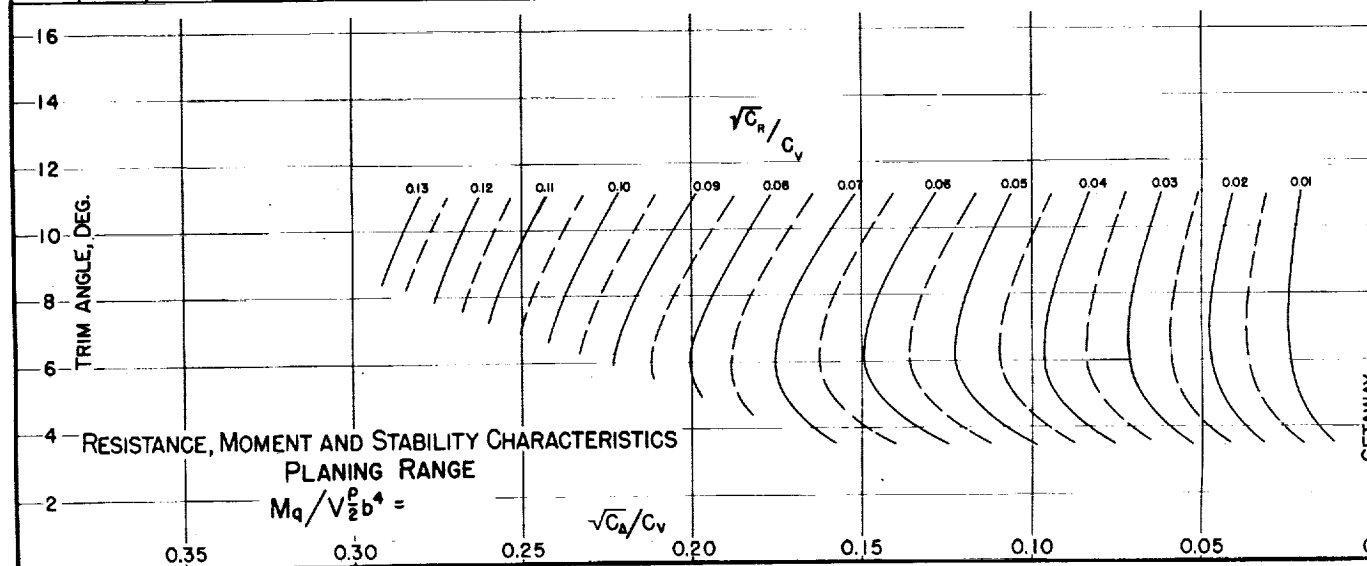
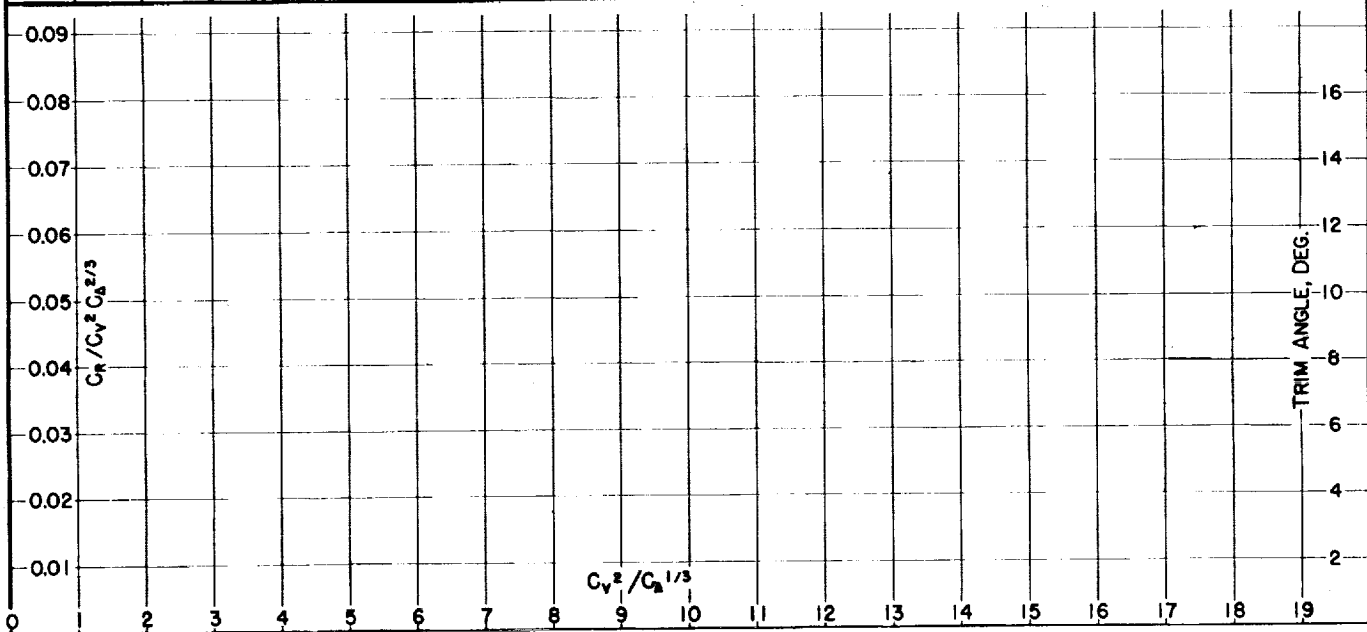
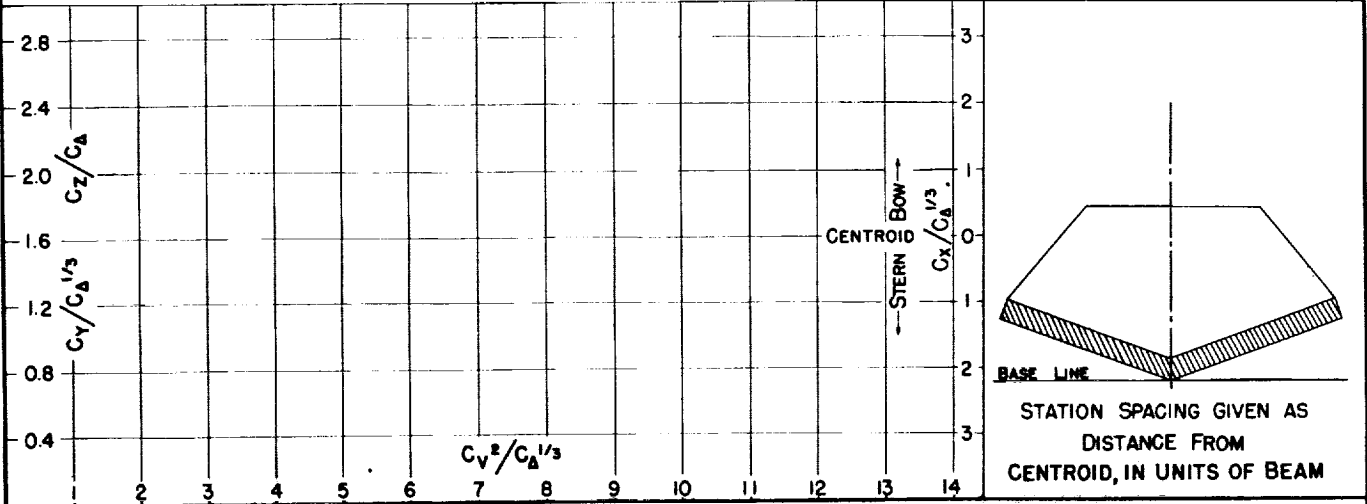

NACA TN No. 1182

DESIGNATION: $\infty - \infty - 30.0$

Fig. 31

MODEL No. 30
MODEL BEAM 16.00"

C.G. =

b FWD. OF CENTROID $C_{a_0} =$
b ABOVE KEEL $k/L =$

(NOMINAL)

TESTED AT NACA No. 1 TANK
DATE: '34

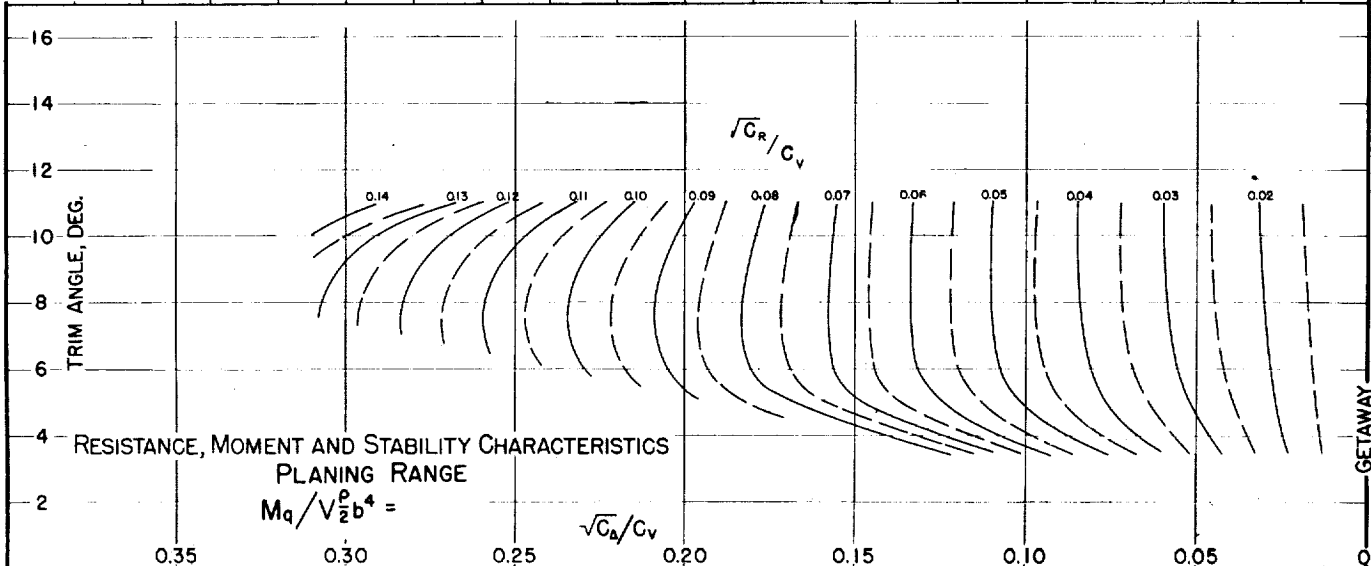
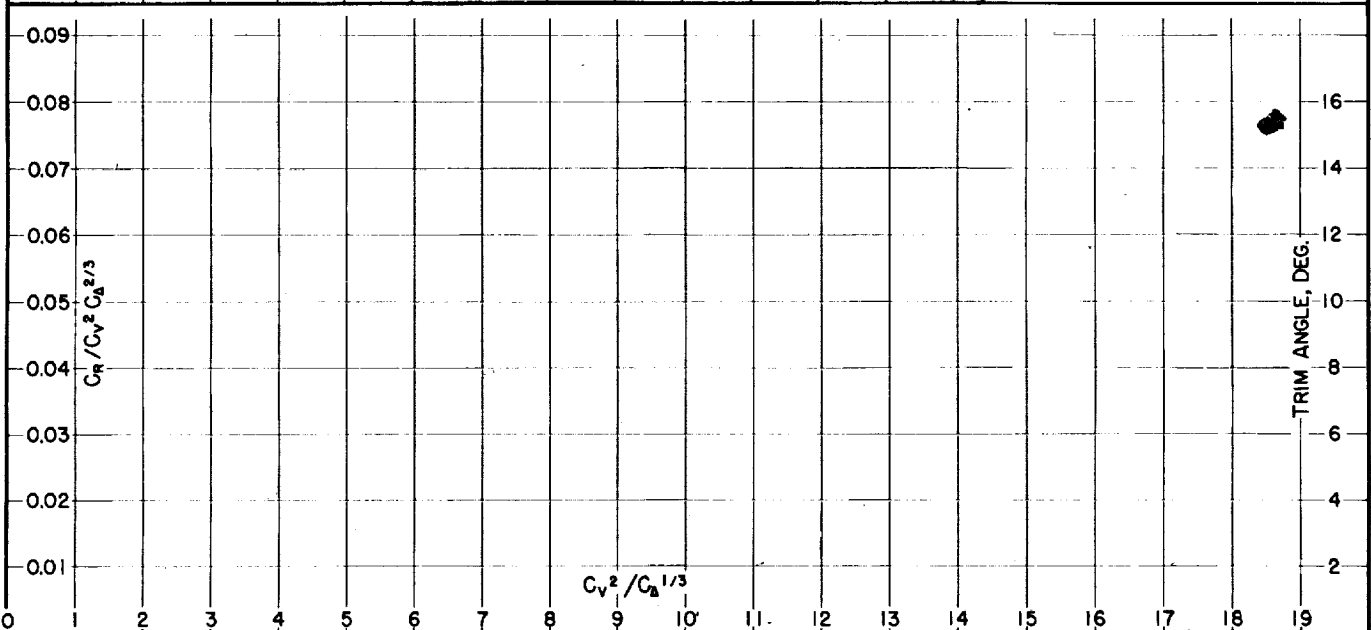
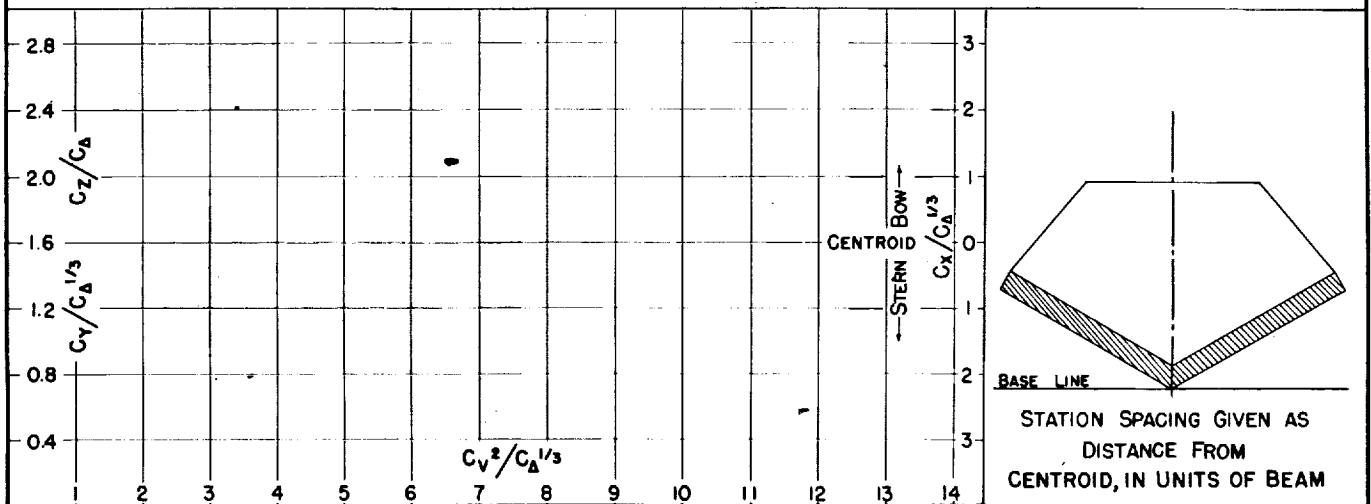

RESISTANCE, MOMENT AND STABILITY CHARACTERISTICS
PLANING RANGE

$$M_q/V_{\infty}^2 b^4 =$$

GETAWAY

Fig. 32

DESIGNATION: 293-377-150

NACA TN No. 1182

MODEL No. 35
MODEL BEAM: 13.00"

C.G. = 0.08 b FWD. OF CENTROID
0.97 b ABOVE KEEL

$C_{d.0} =$ (NOMINAL)
 $k/L =$

TESTED AT NACA No. 1 TANK
DATE: 35

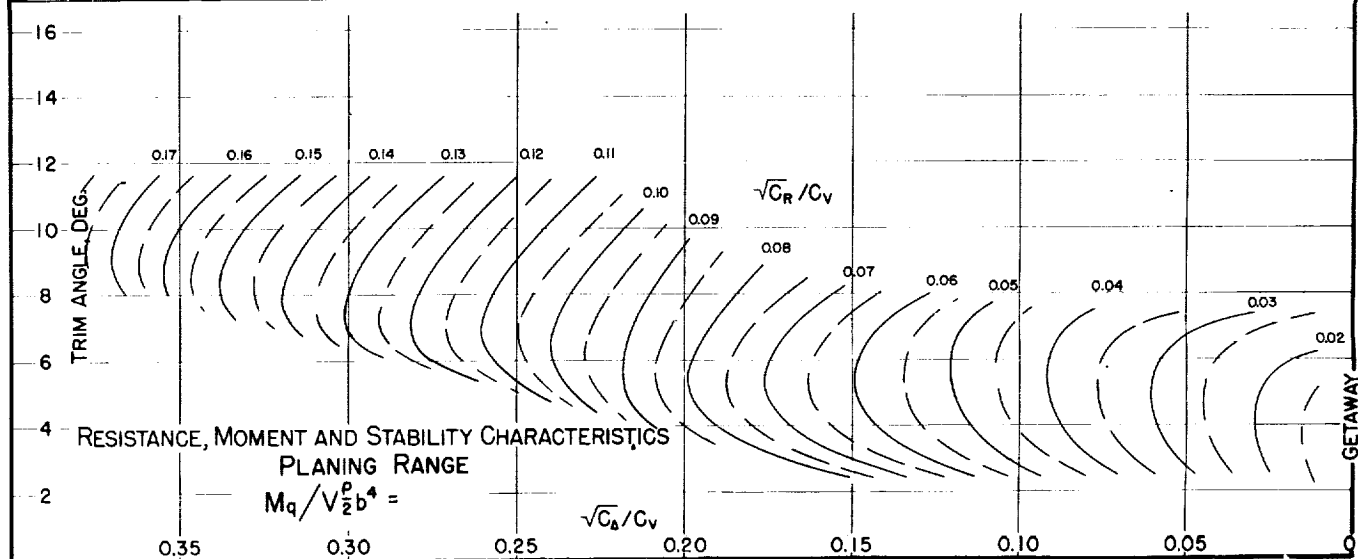
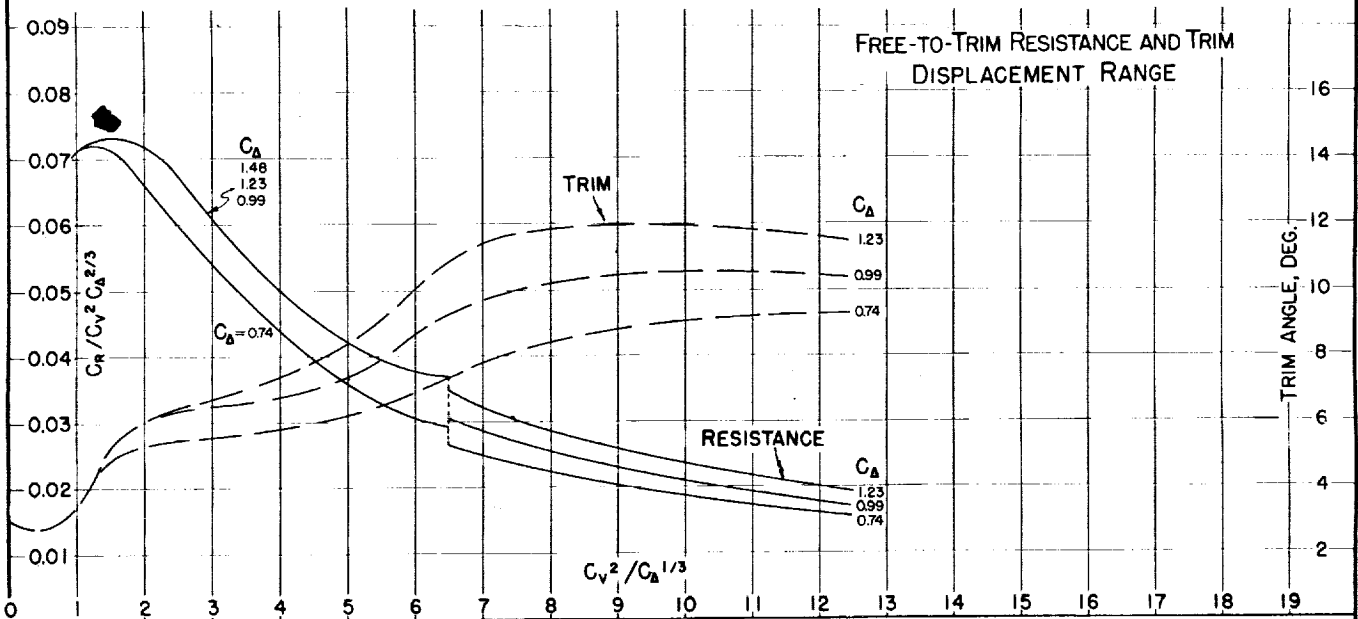
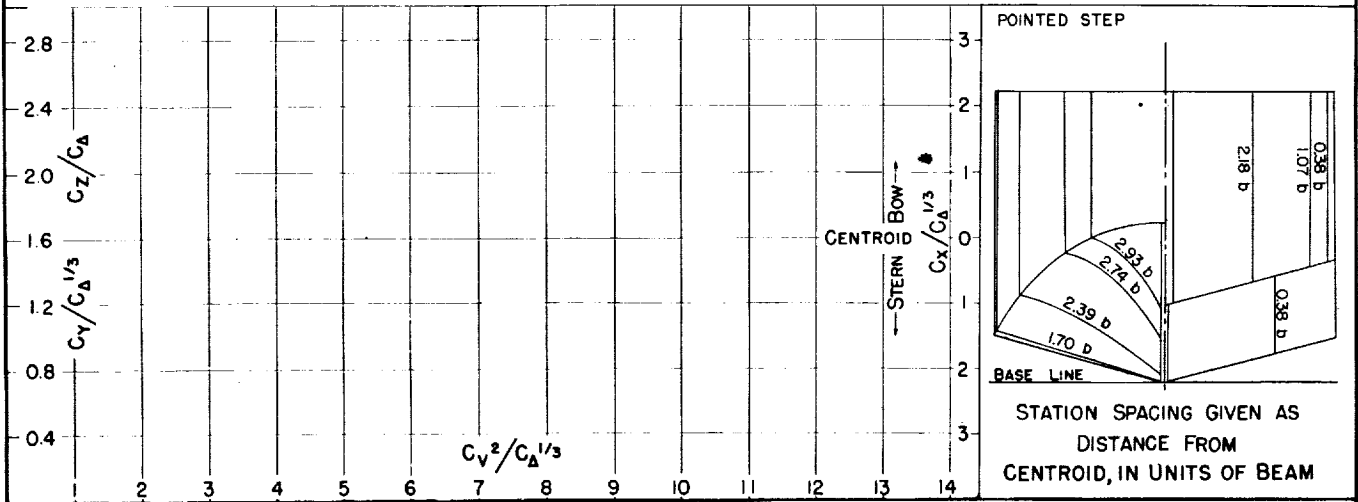

MODEL No. 35-A
MODEL BEAM: 13.00"

C.G. = 0.08 b FWD. OF CENTROID
0.97 b ABOVE KEEL

$C_{d,0} =$ (NOMINAL)
 $k/L =$

TESTED AT NACA No. 1 TANK
DATE: 35

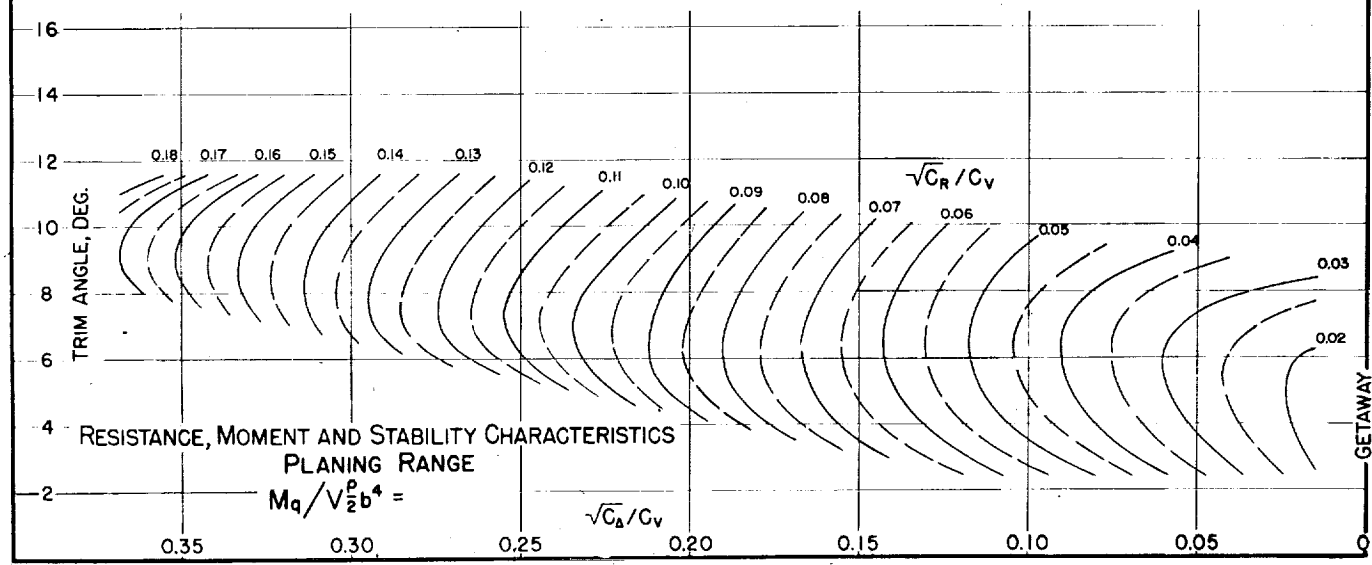
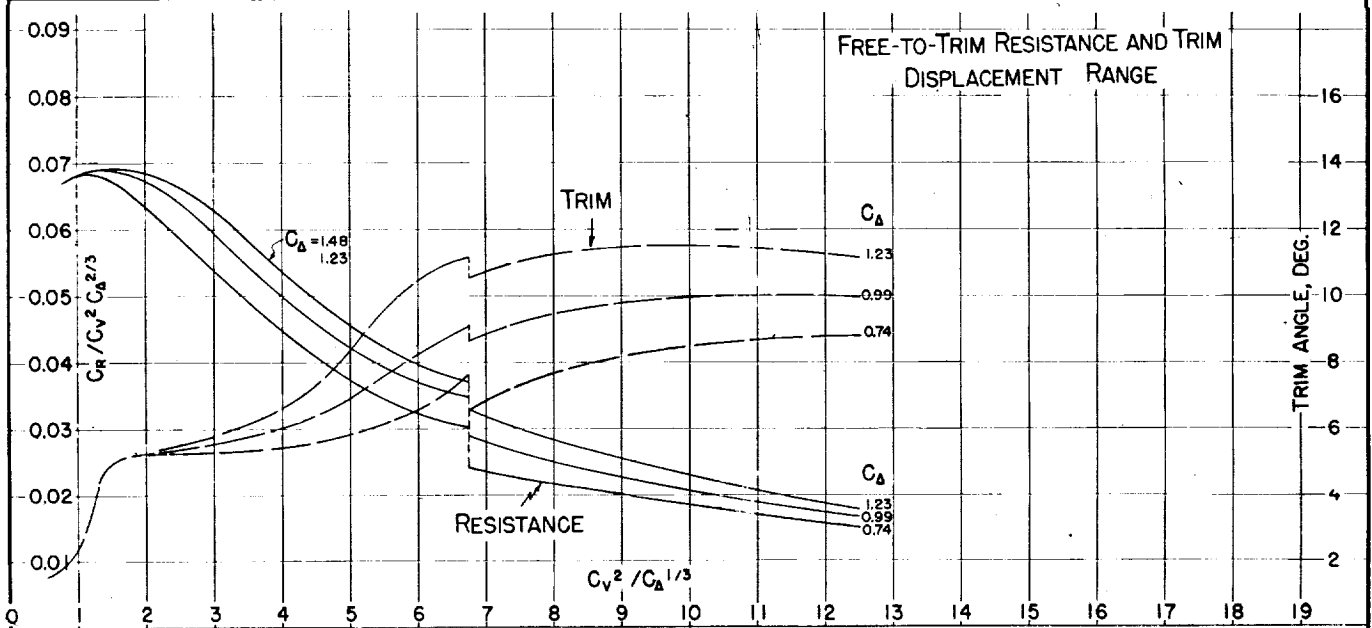
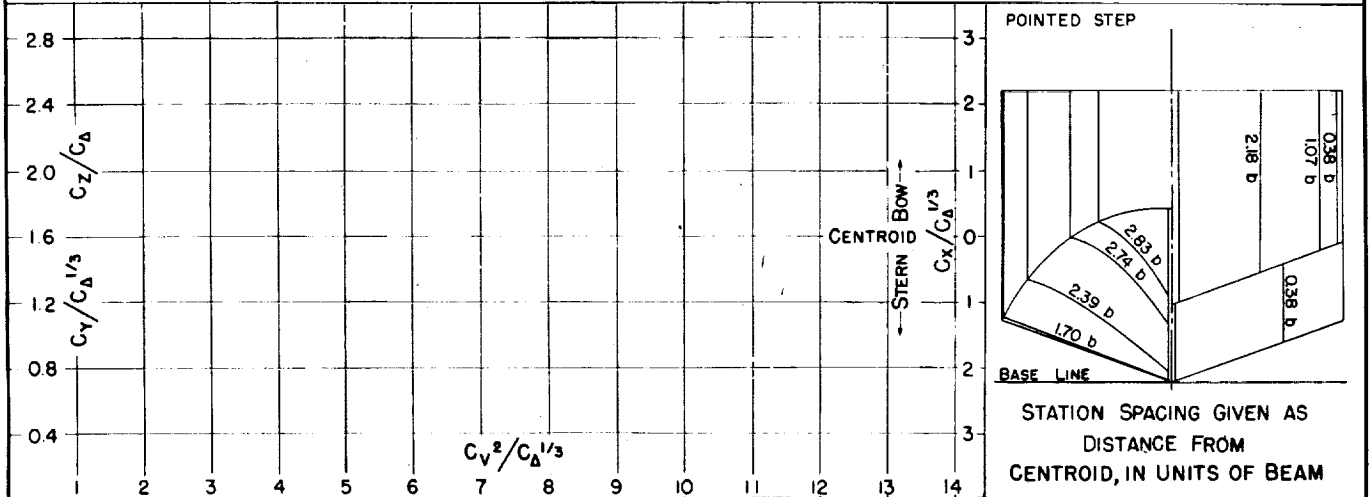

Fig. 34

DESIGNATION: 2.93-3.77-25.0

NACA TN No. 1182

MODEL No. 35-B
MODEL BEAM: 1300"

C.G. = 0.08 b FWD. OF CENTROID
0.97 b ABOVE KEEL

$C_{d0} =$ (NOMINAL)
 $k/L =$

TESTED AT NACA No. 1 TANK
DATE: 35

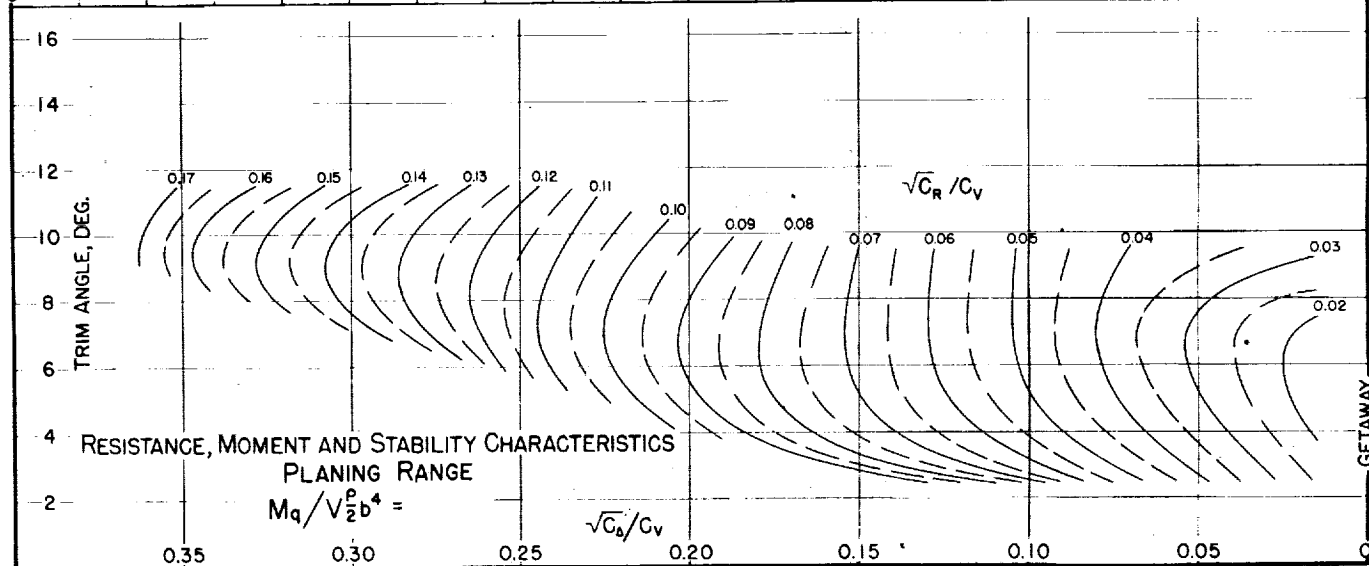
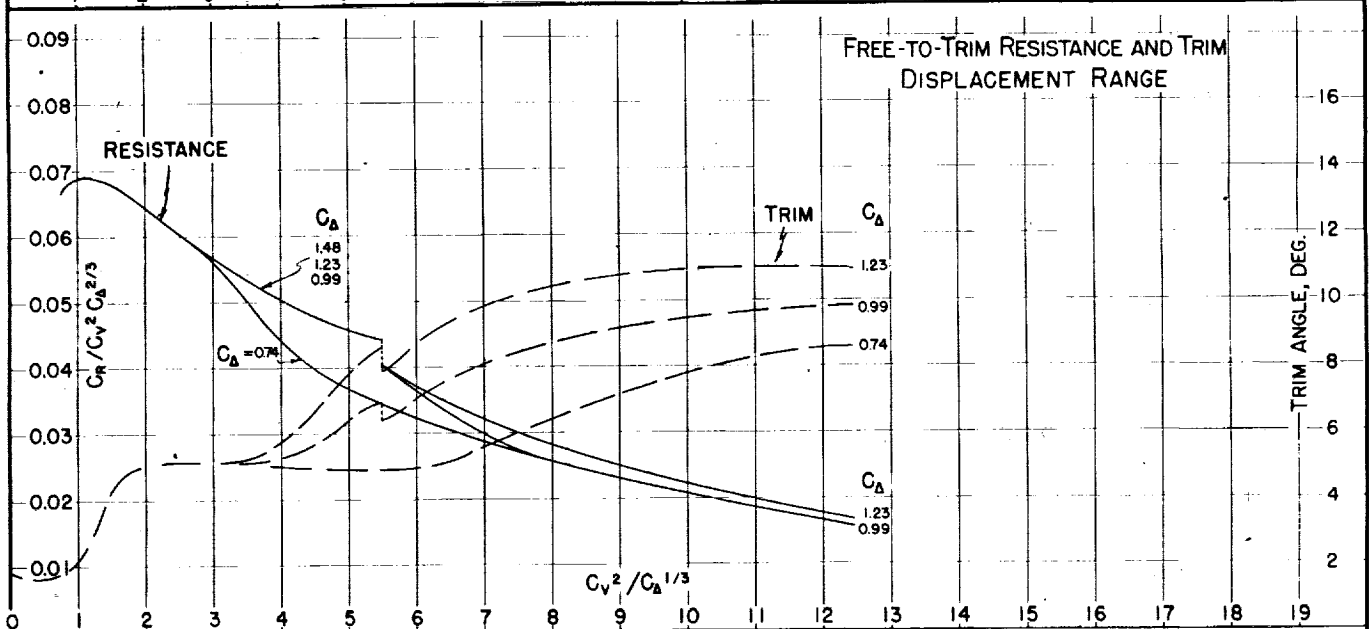
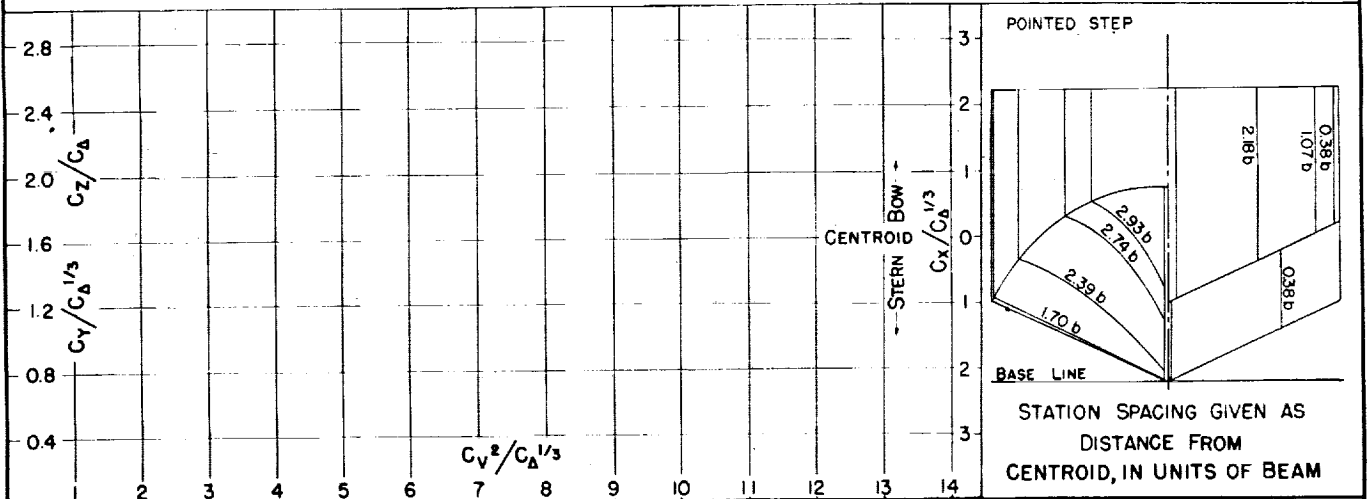

GETAWAY

MODEL No. 36

MODEL BEAM: 14.00"

C.G. = 0.71 b FWD. OF CENTROID
1.00 b ABOVE KEEL

$C_{A0} =$ (NOMINAL)
 $k/L =$

TESTED AT NACA No. 1 TANK
DATE: 3/36

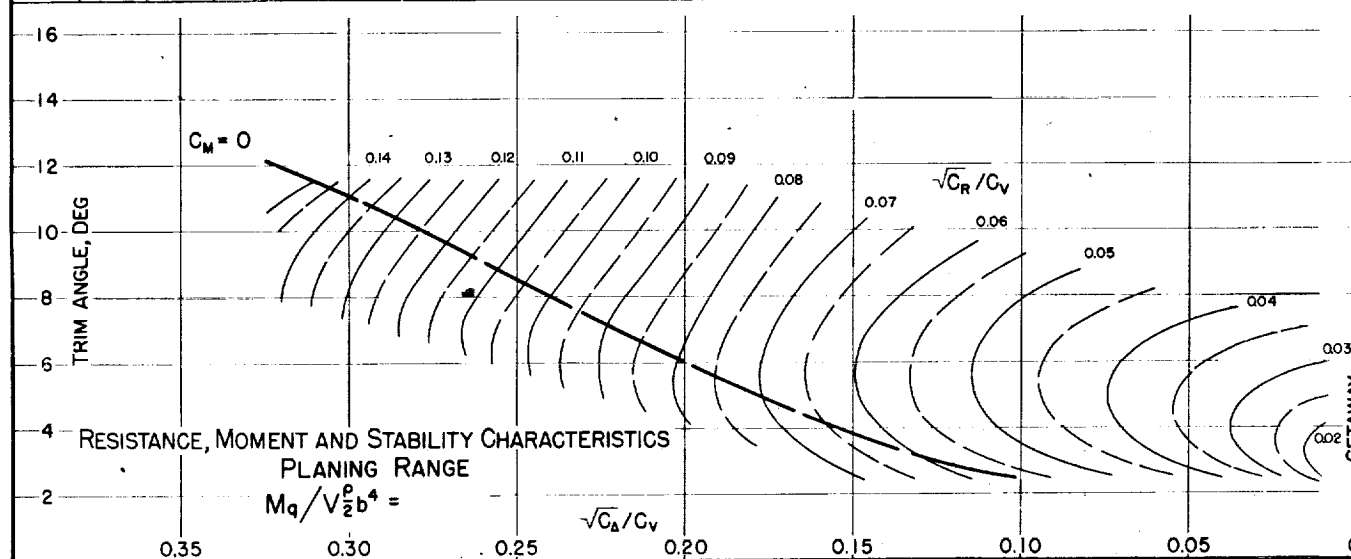
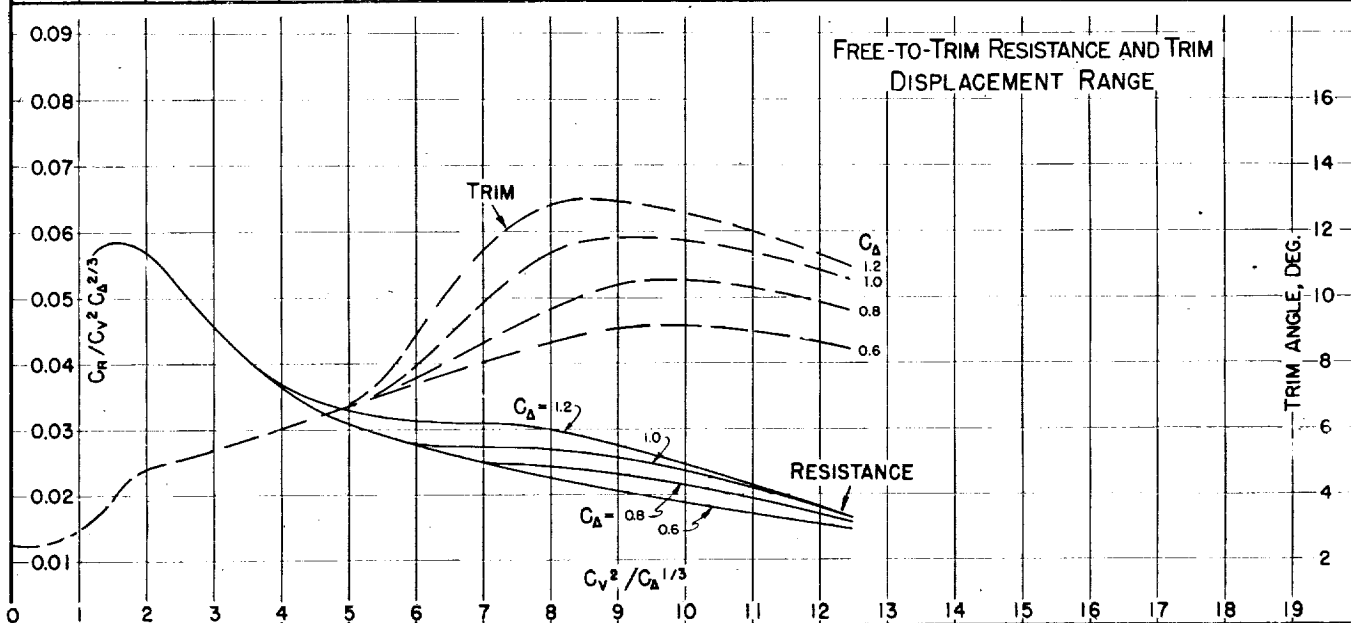
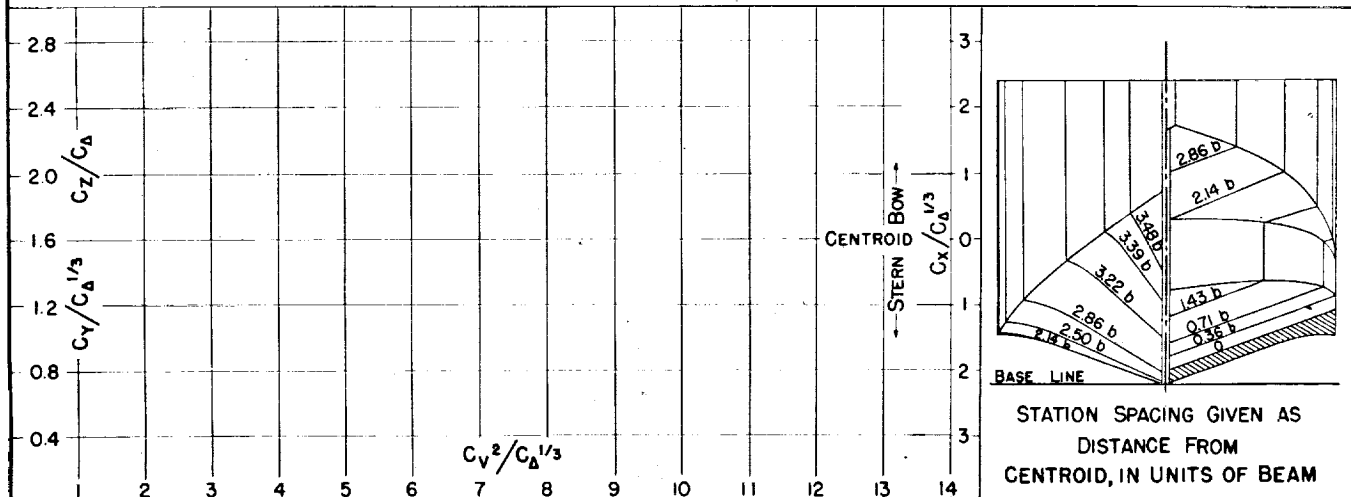

Fig. 36

DESIGNATION: 3.12-0.44-20.0 NACA TN No. 1182

MODEL No. 40AC
MODEL BEAM: 13.47"

C.G. = 0.30b FWD. OF STEP
1.16 b ABOVE KEEL

$C_{a_0} =$ (NOMINAL)
 $k/L =$

TESTED AT NACA No. 1 TANK
DATE: 5-25-34

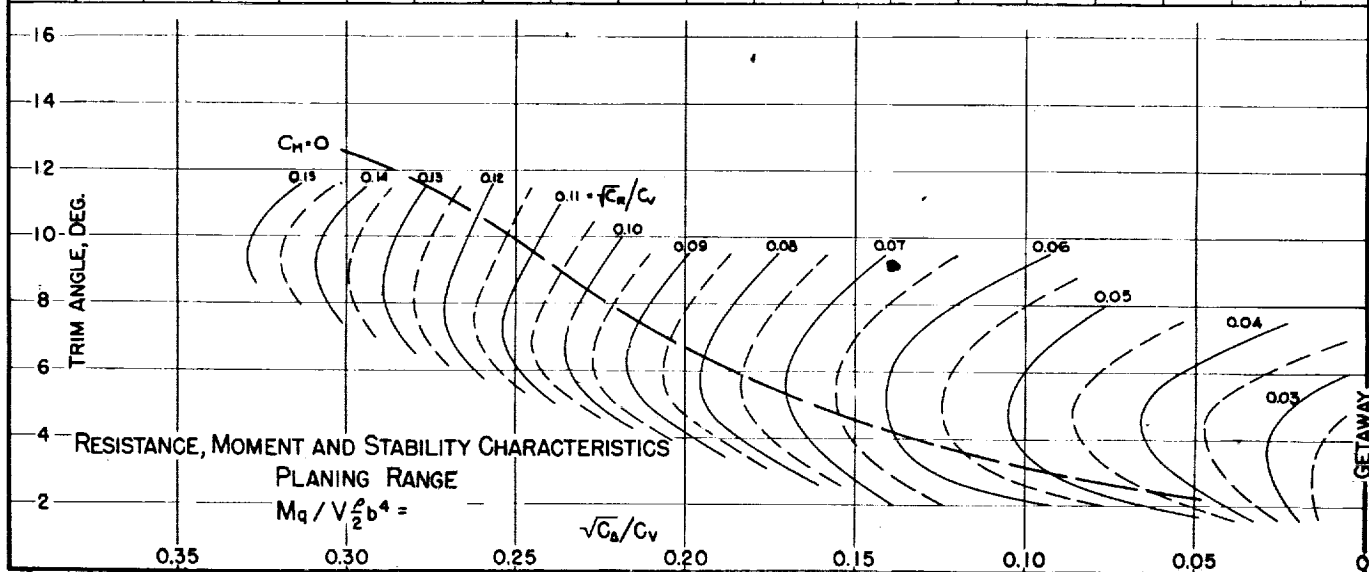
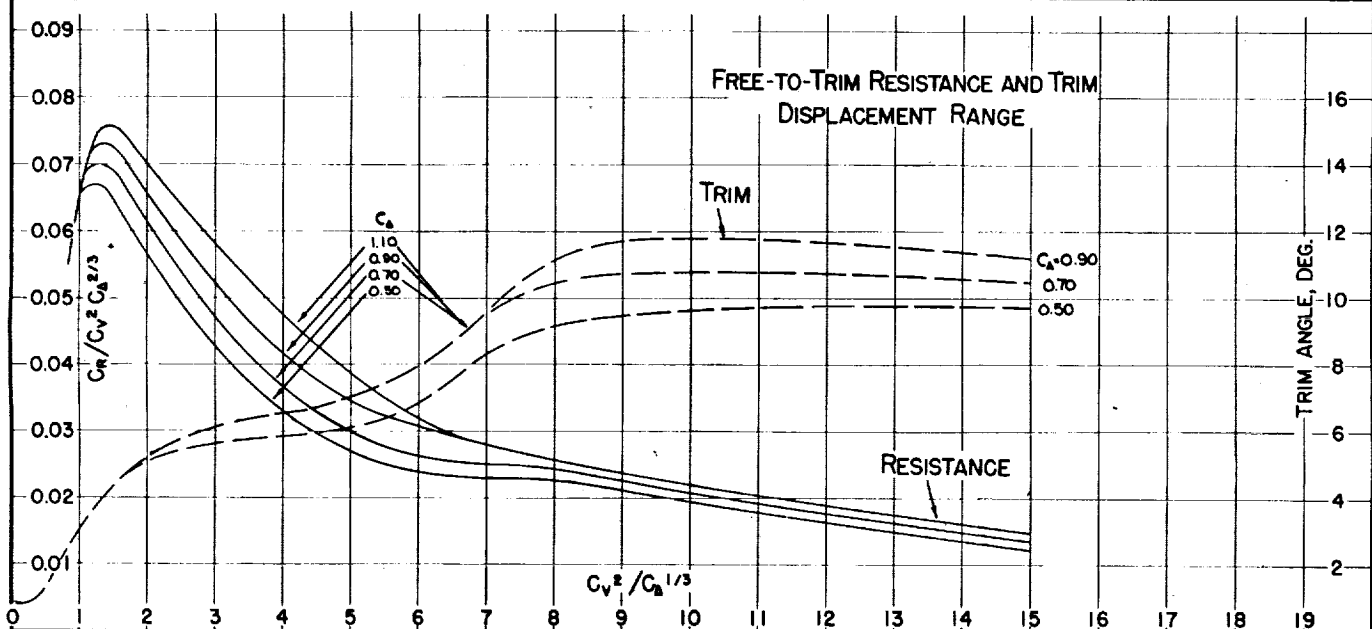
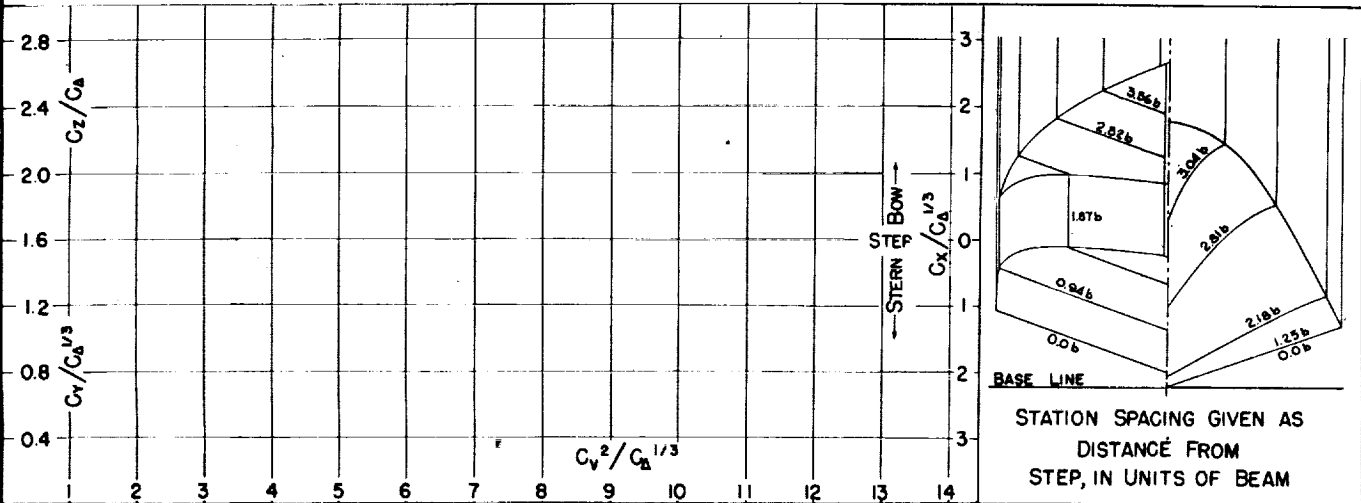

MODEL No. 40-AD
MODEL BEAM: 13.47"

C.G. = 0.30 b FWD. OF STEP
1.15 b ABOVE KEEL

$C_{d0} =$ (NOMINAL)
 $k/L =$

TESTED AT NACA No. 1. TANK
DATE: 6/34

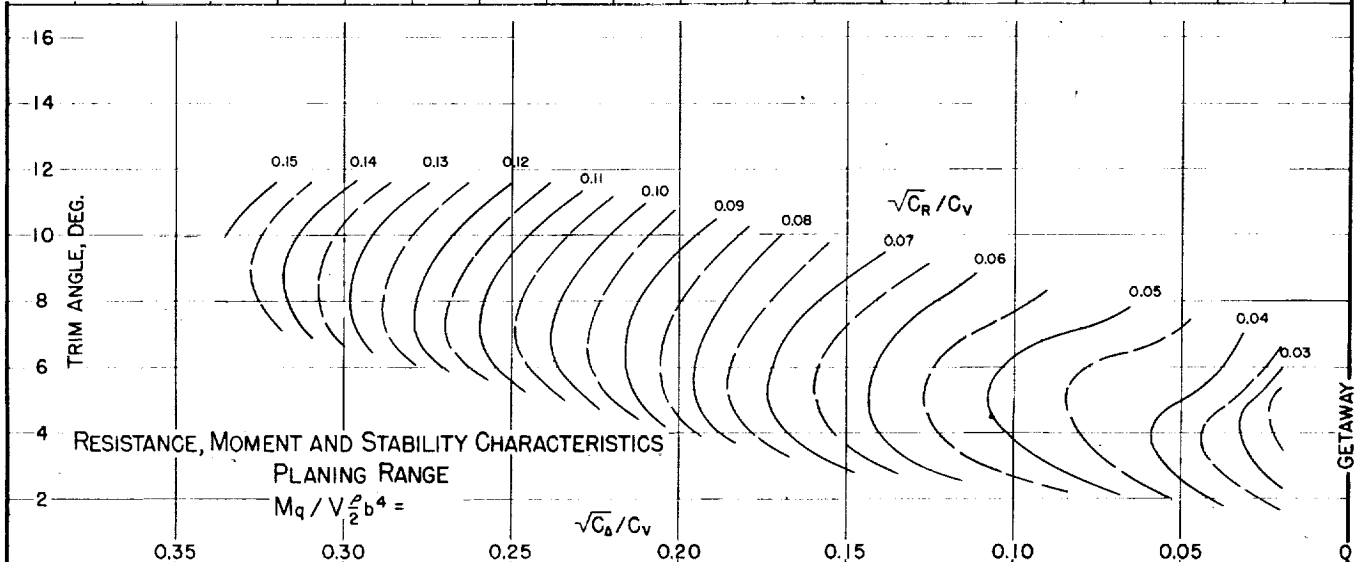
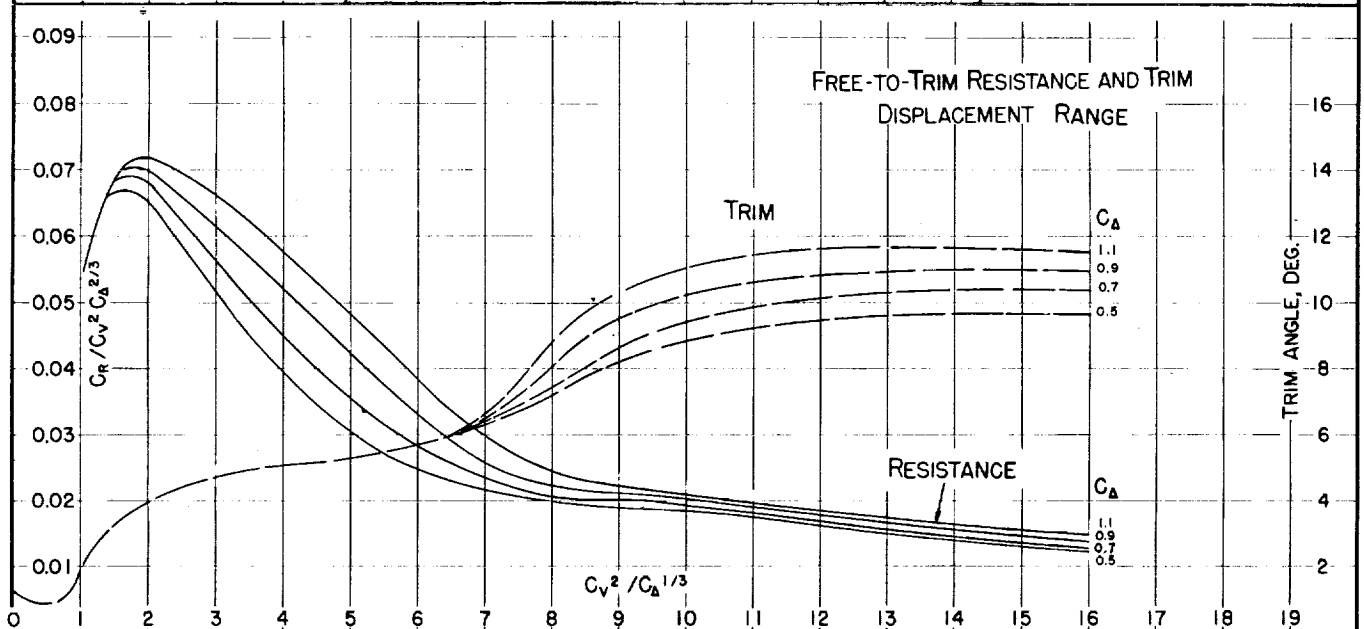
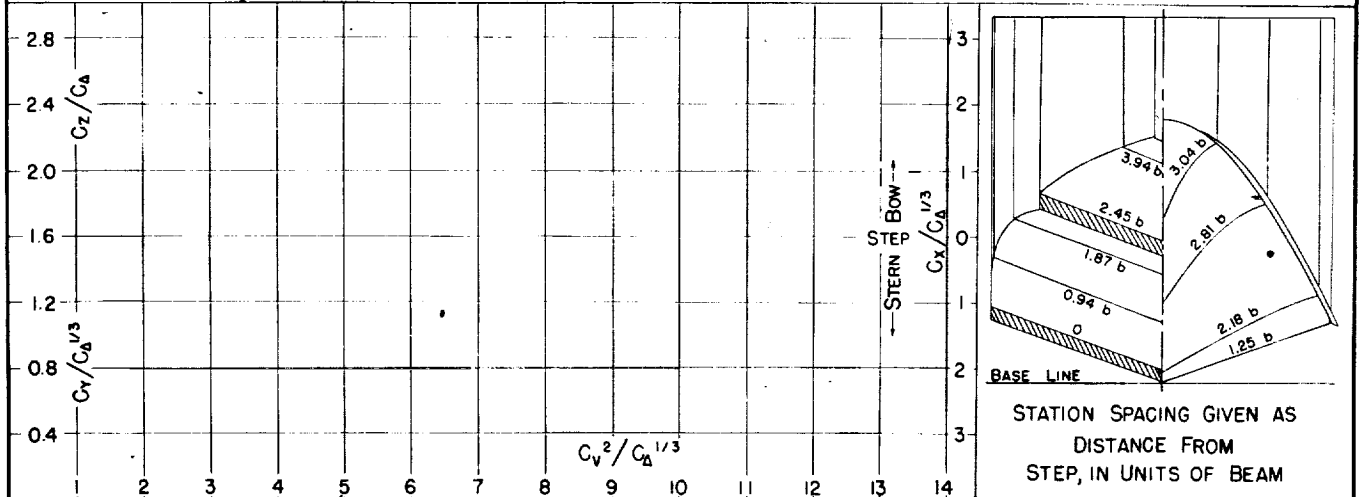

Fig. 38

DESIGNATION: 3.12-0.41-200 NACA TN No. 1182

MODEL No. 40-AE
MODEL BEAM: 13.47"

C.G. = 0.30 b FWD. OF STEP
1.15 b ABOVE KEEL

$C_{d0} =$ (NOMINAL)
 $k/L =$

TESTED AT NACA No. 1 TANK
DATE: 6/34

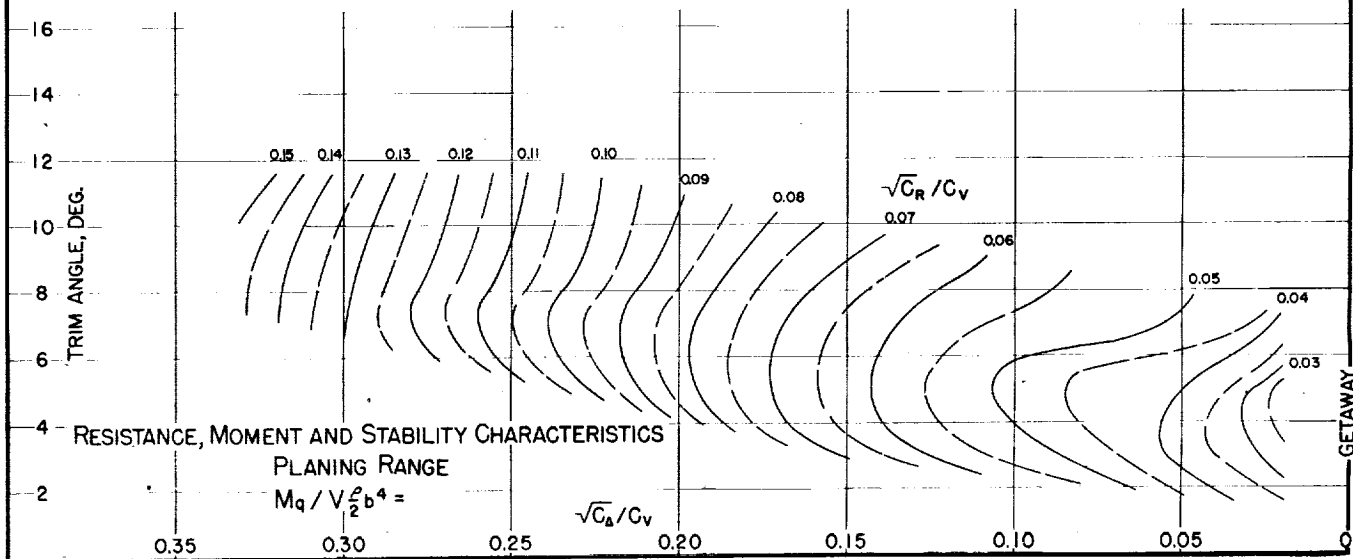
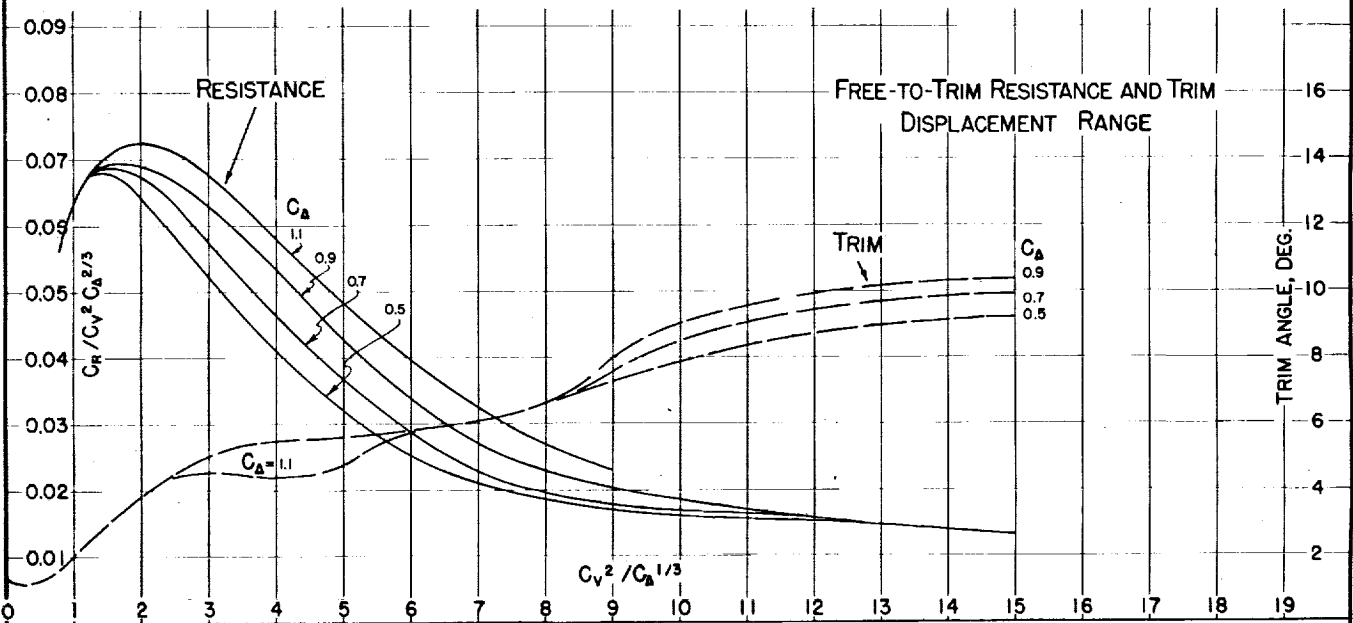
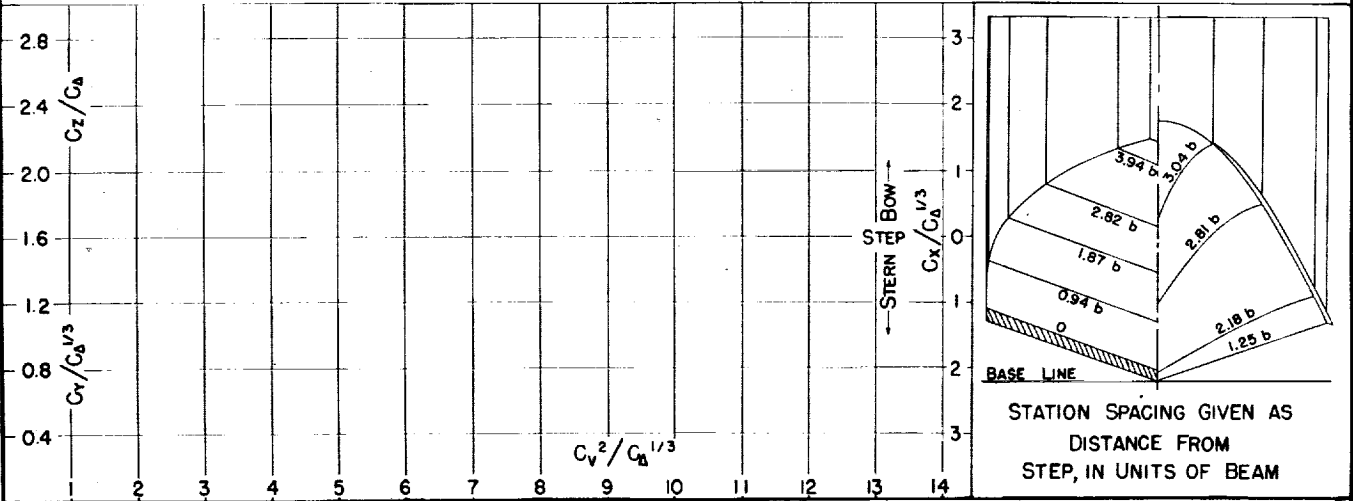

MODEL No. 40-BC
MODEL BEAM: 13.47"

C.G. = 0.30 b FWD. OF STEP
1.15 b ABOVE KEEL

$C_{D0} =$ (NOMINAL)
 $k/L =$

TESTED AT NACA No. 1 TANK
DATE: 5/34

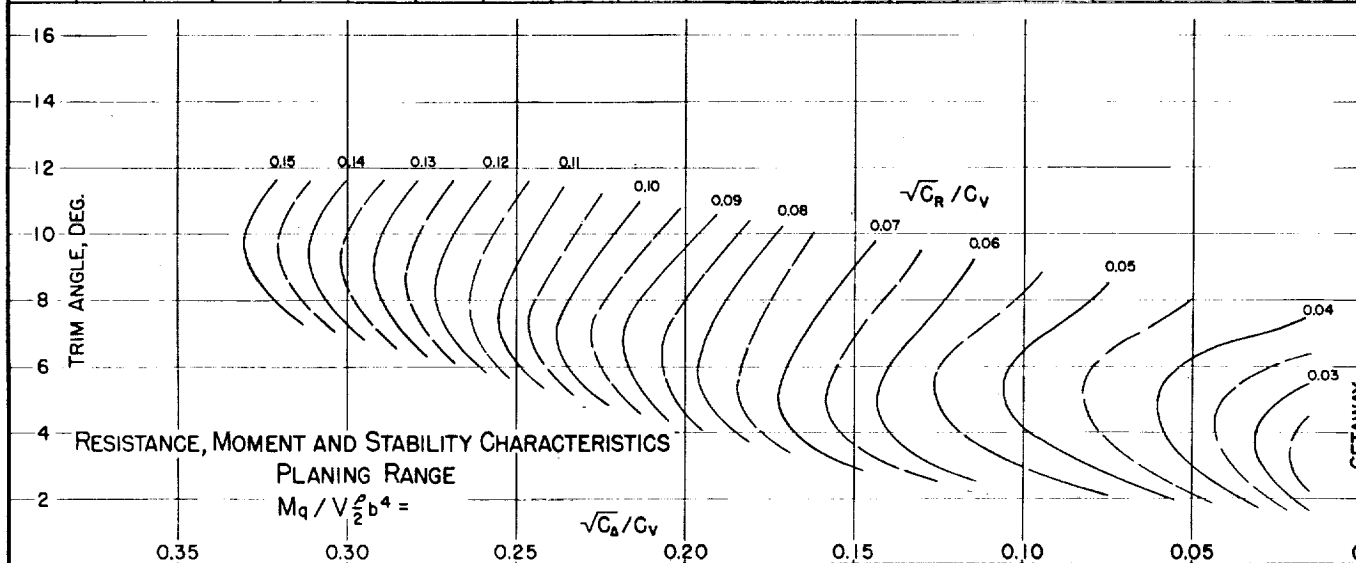
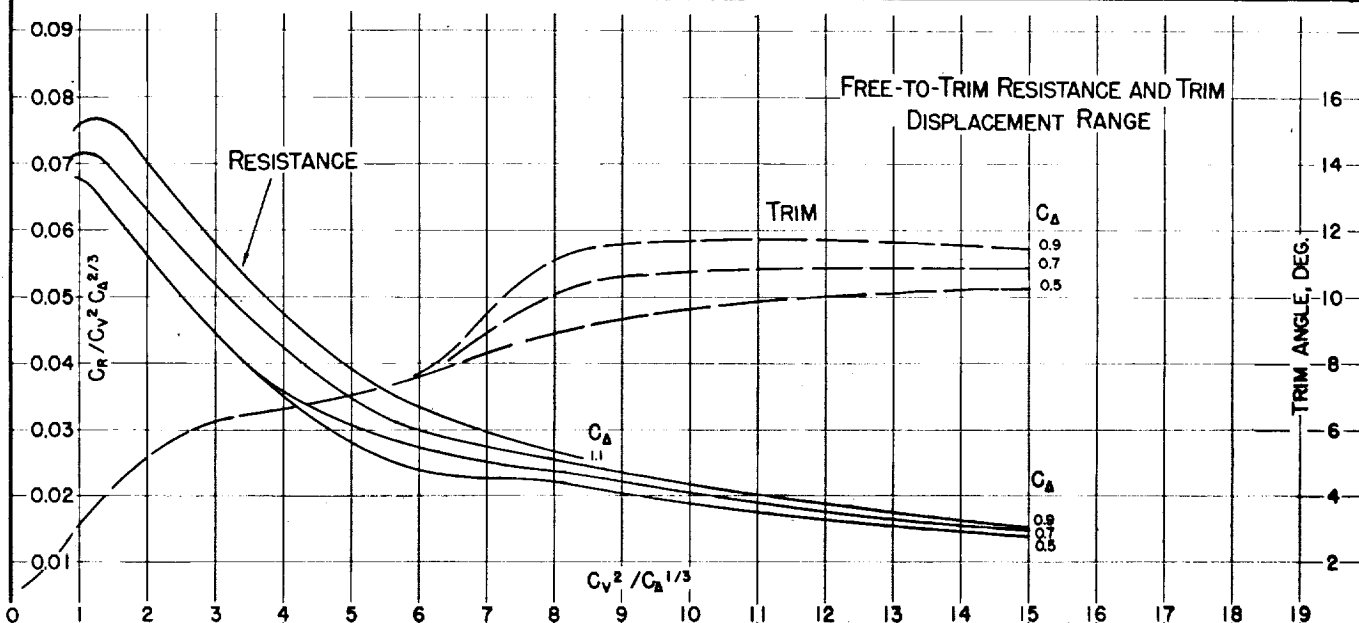
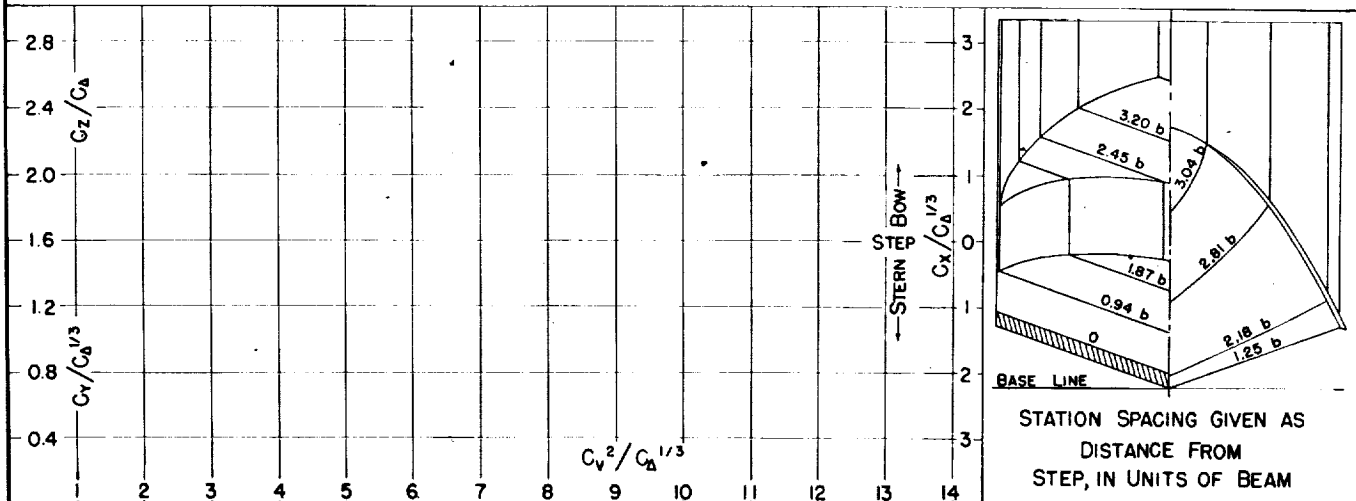

Fig. 40

DESIGNATION: 3.12-0.41-200 NACA TN No. 1182

MODEL No. 40-BE
MODEL BEAM: 13.47"

C.G. = 0.30 b FWD. OF STEP
1.15 b ABOVE KEEL

C_{d0} = (NOMINAL)
 k/L =

TESTED AT NACA No. 1 TANK
DATE: 5/34

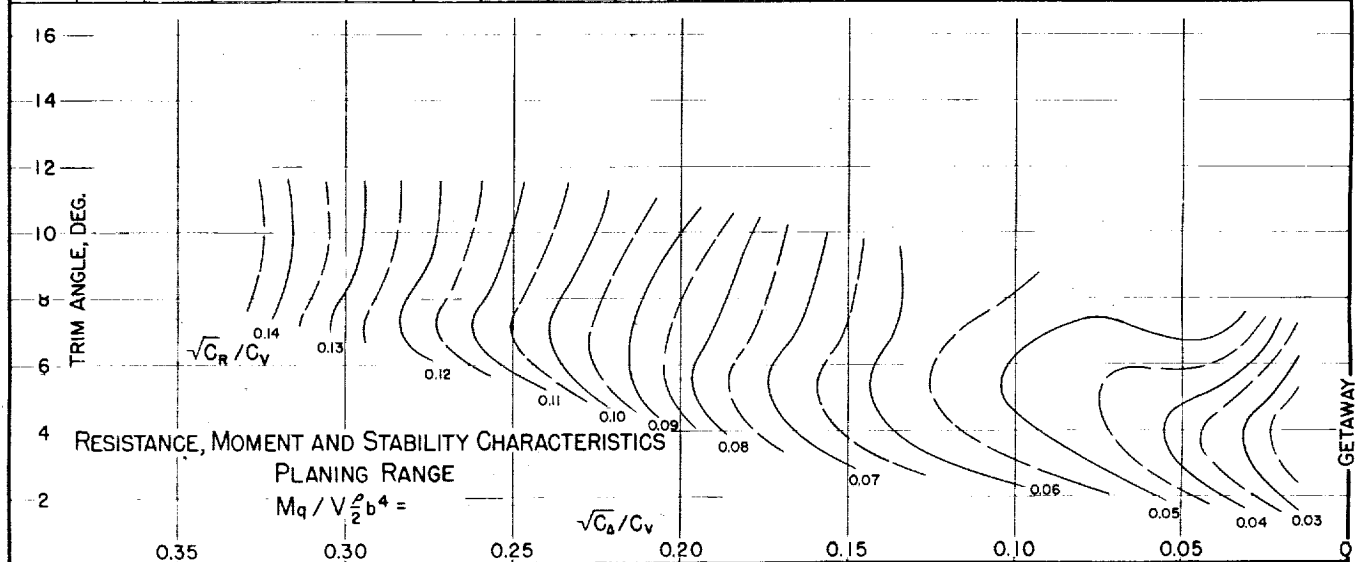
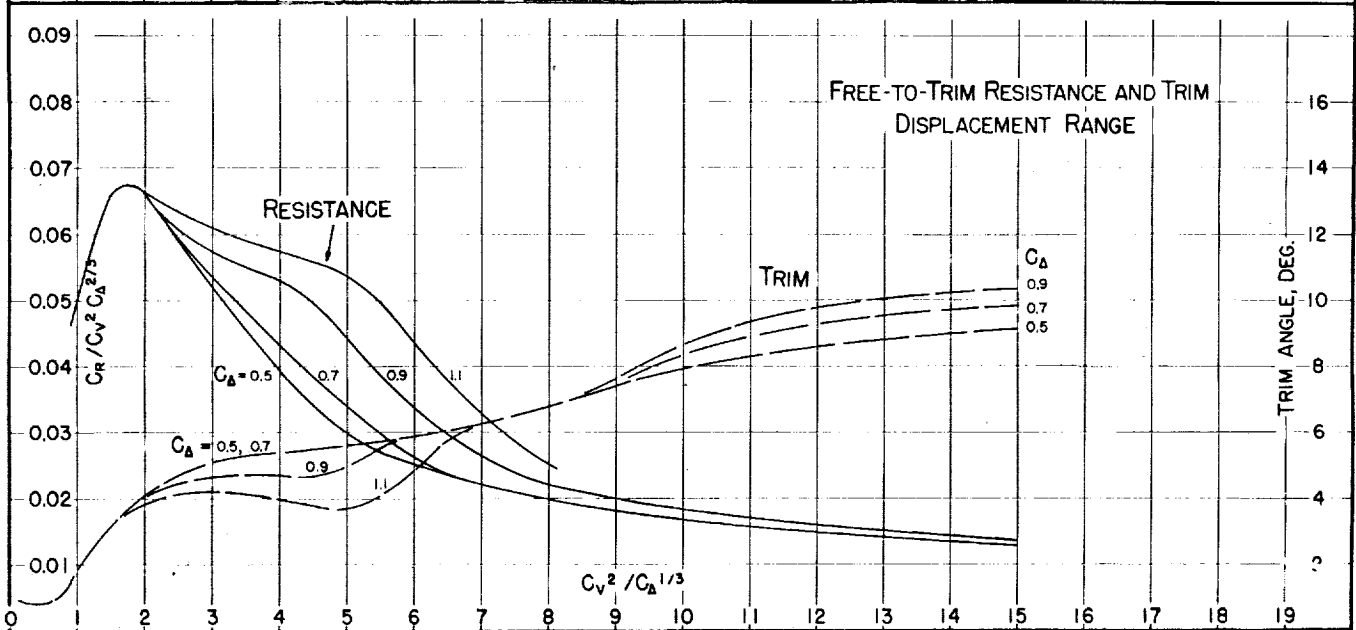
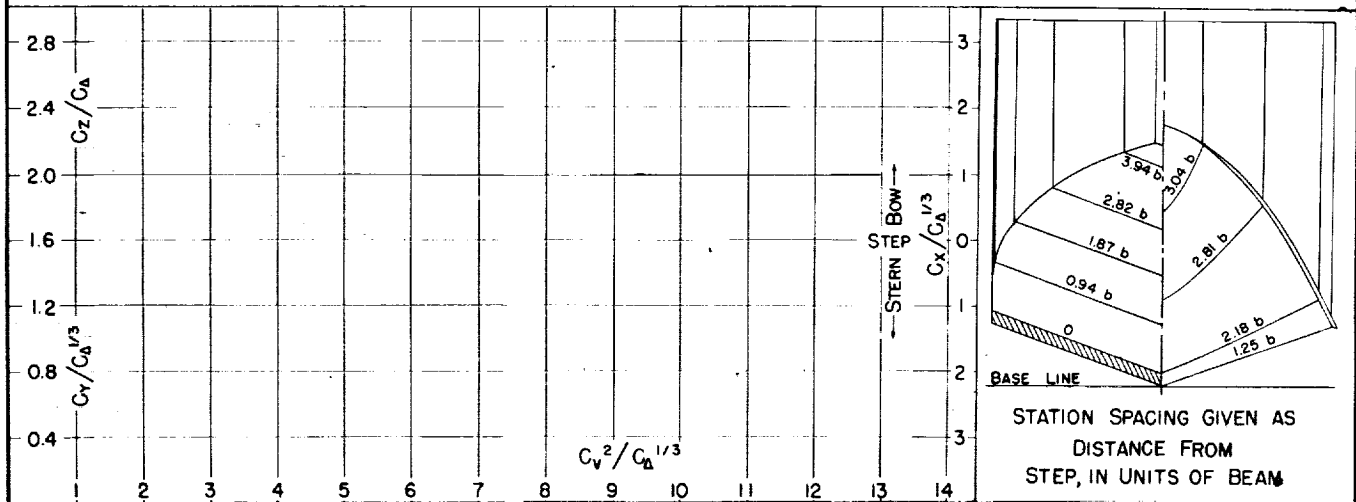

MODEL No. 41-A
MODEL BEAM: 12.00"

C.G. = 0.44 b FWD. OF CENTROID $C_{d0} = 1.40$ (NOMINAL)
2.04 b ABOVE KEEL $k/L =$

TESTED AT NACA No. 1 TANK
DATE: 8/35

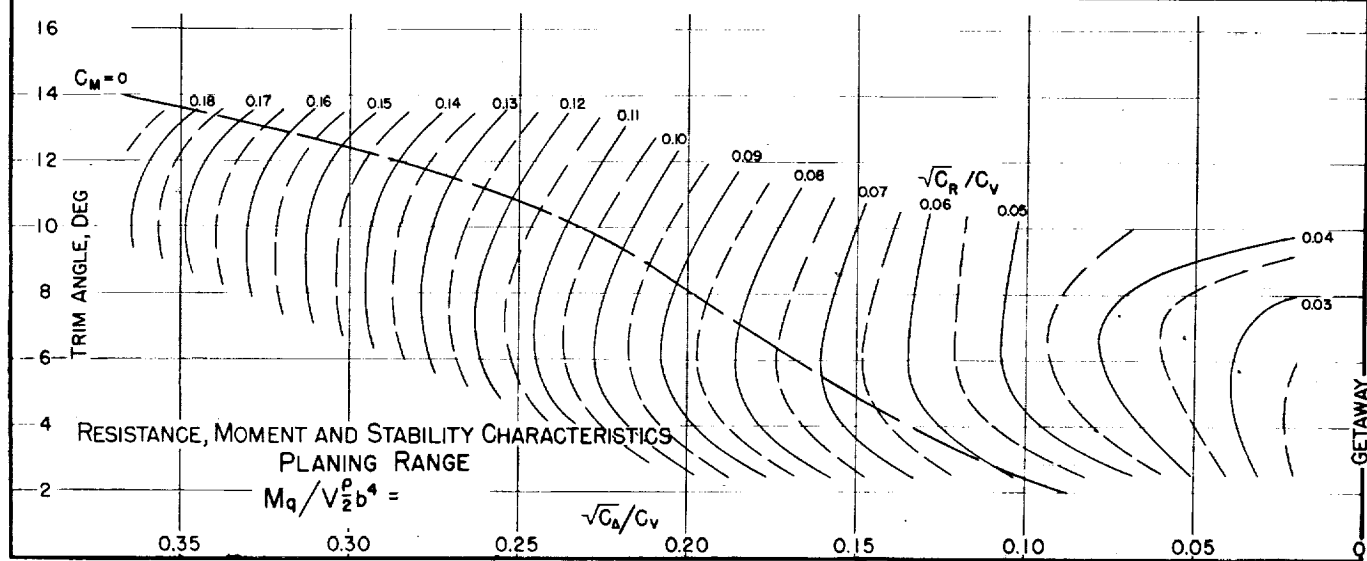
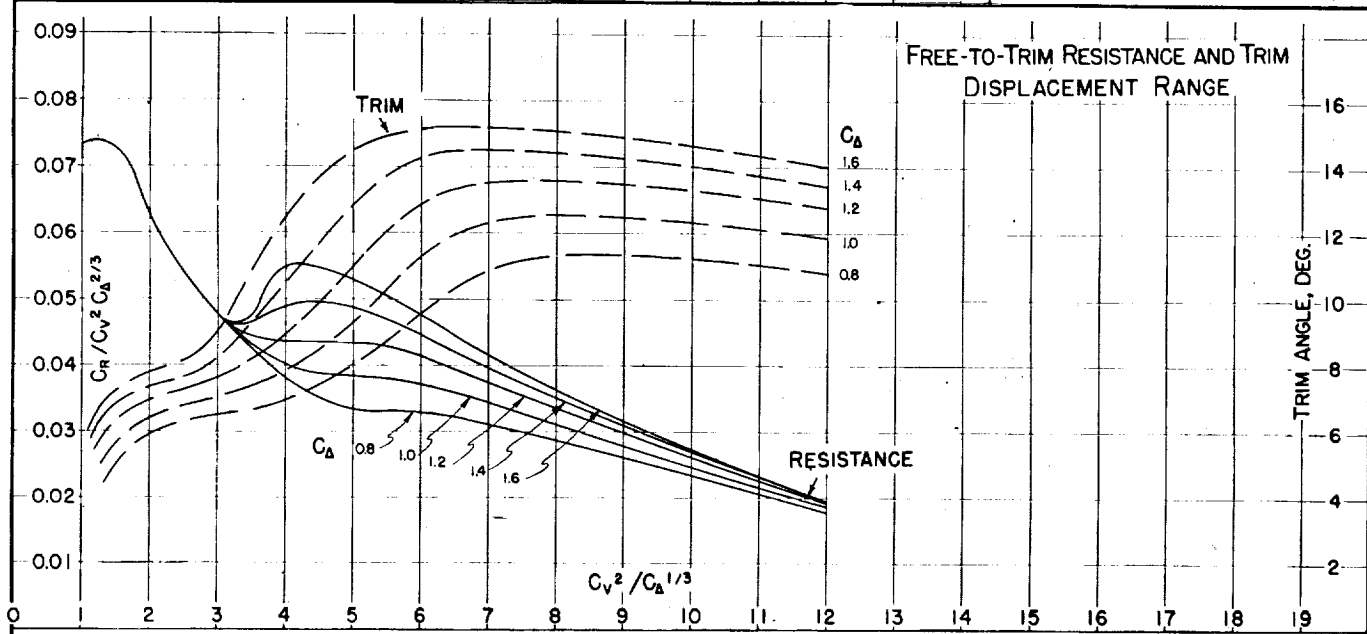
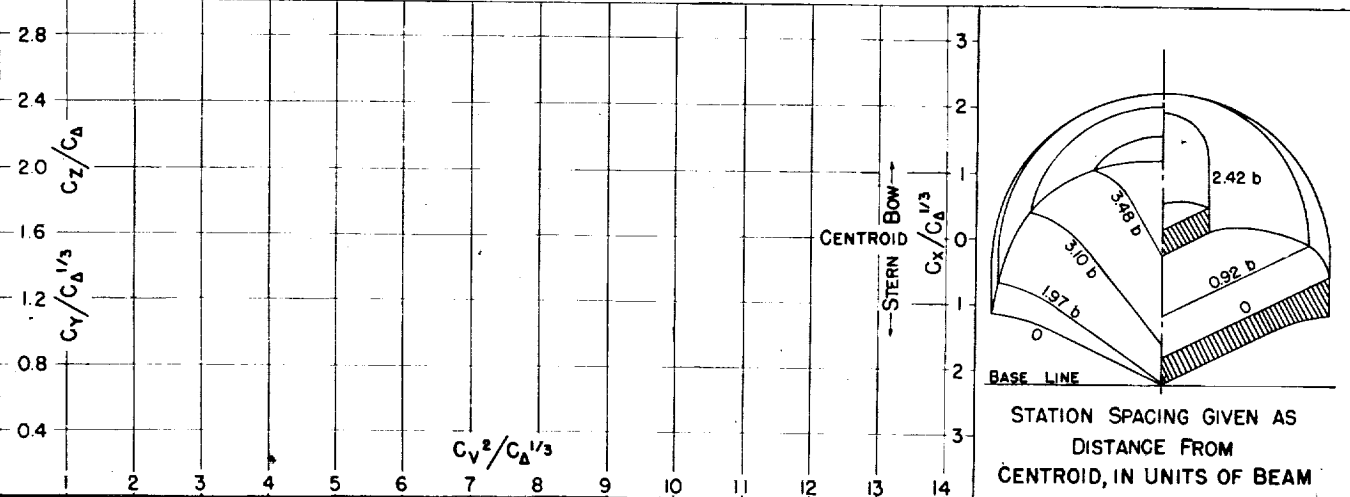

Fig. 42

DESIGNATION: 3.58-0.98-26.0

NACA TN No. 1182

MODEL No. 41-D
MODEL BEAM: 12.00"

C.G. = 0.58b FWD. OF CENTROID $C_{\Delta_0} = 1.40$ (NOMINAL)
2.04b ABOVE KEEL $k/L =$

TESTED AT NACA No. 1 TANK
DATE: 4/36

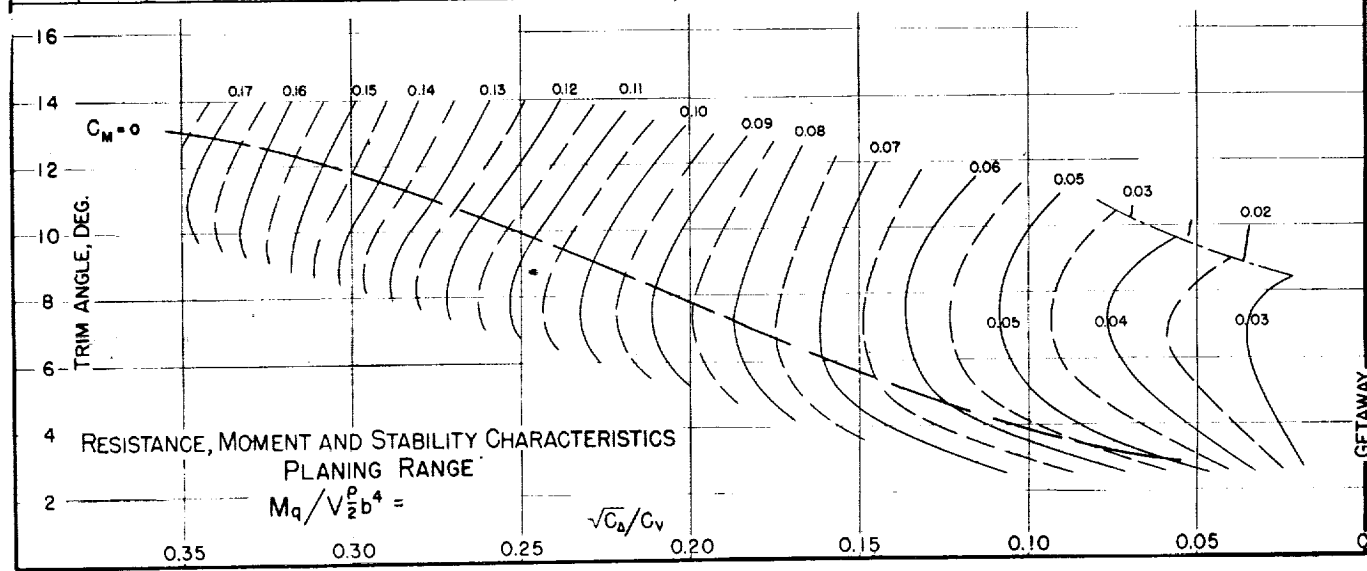
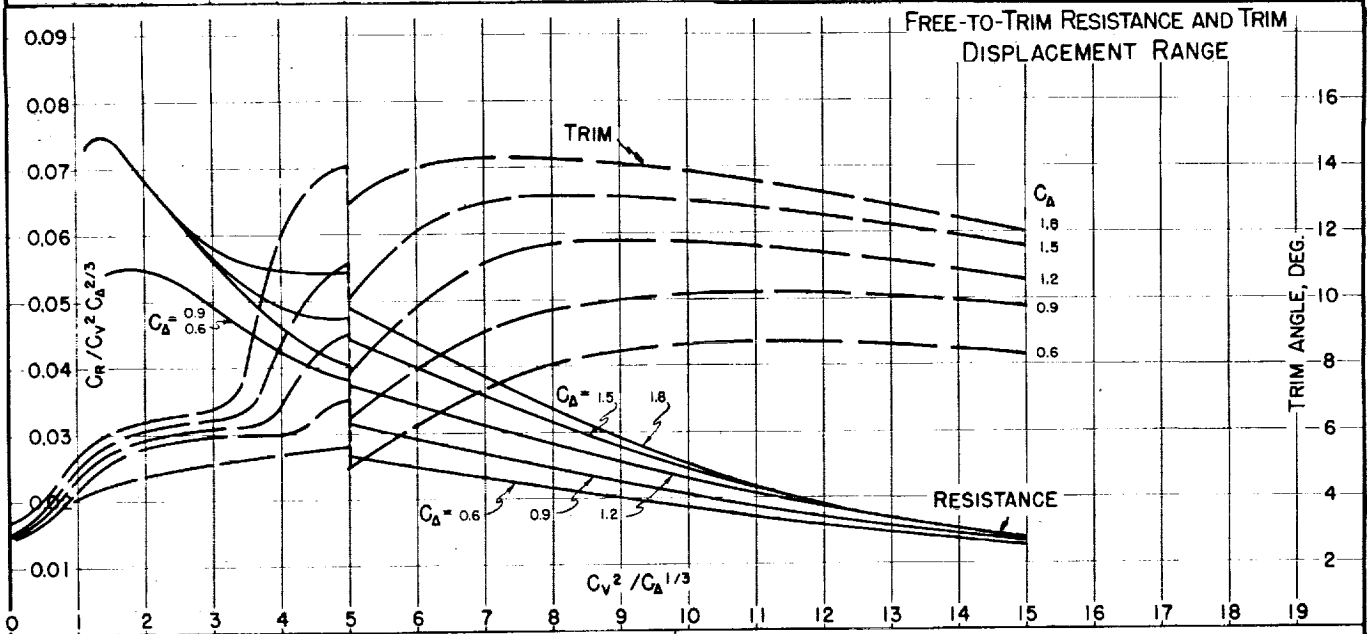
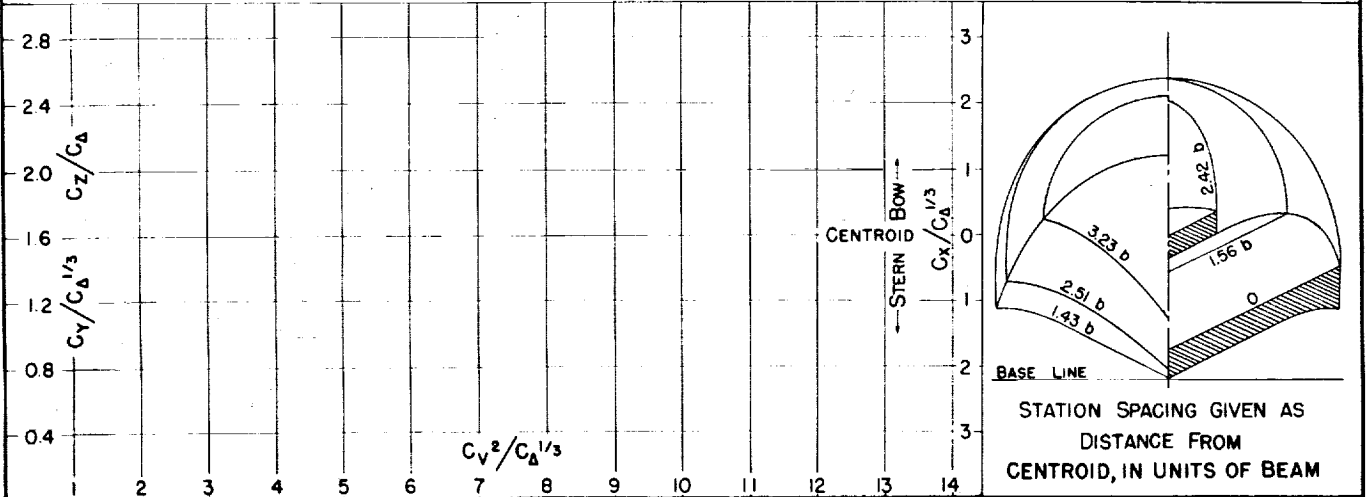

GETAWAY

MODEL No. 44
MODEL BEAM: 1700"

C.G. = 0.48 b FWD. OF STEP
0.97 b ABOVE KEEL

$C_{d_0} = 0.44$ (NOMINAL)
 $k/L =$

TESTED AT NACA No. 1 TANK
DATE: 6/35

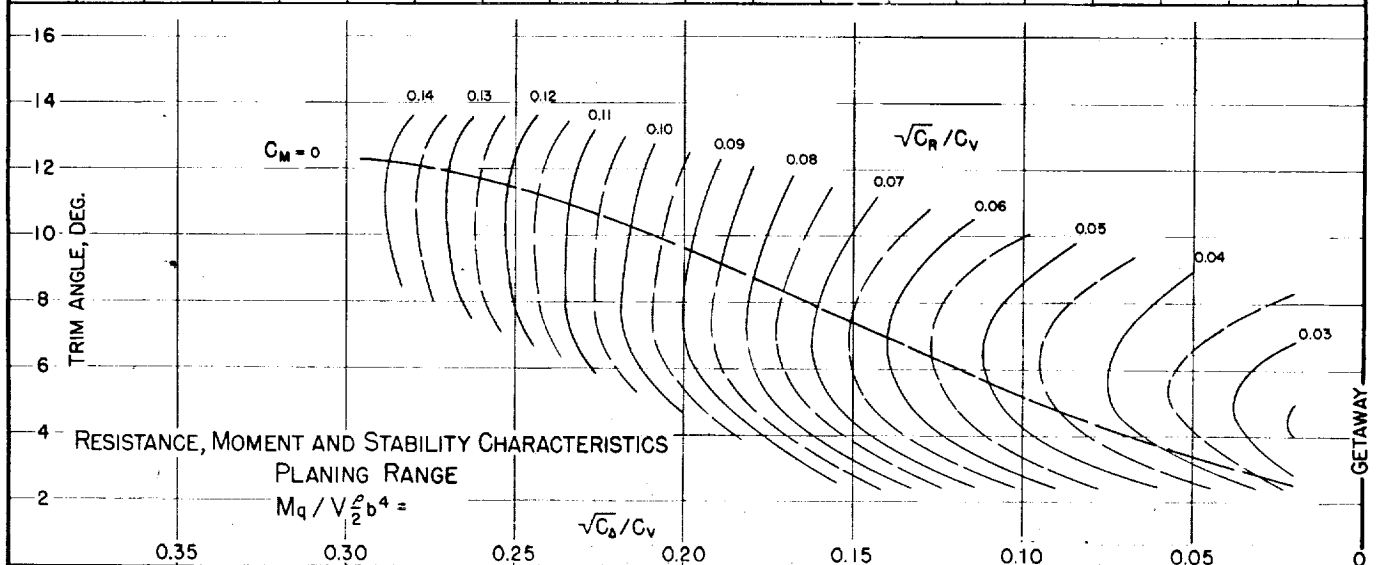
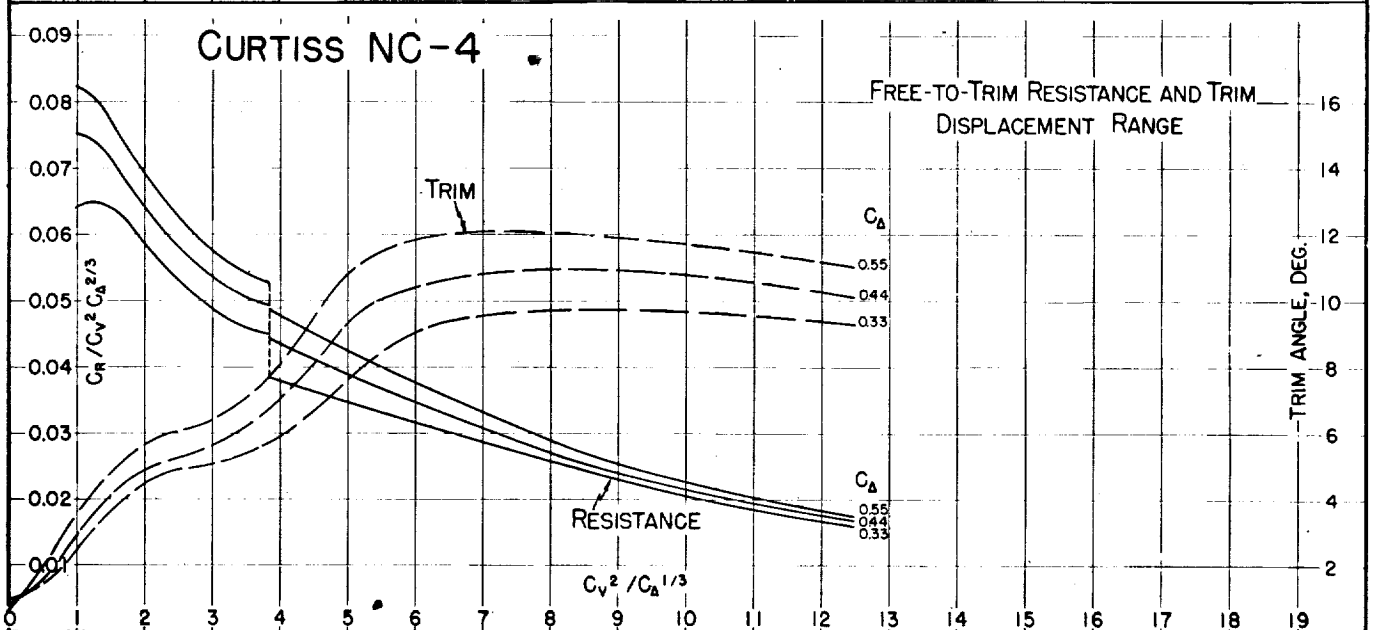
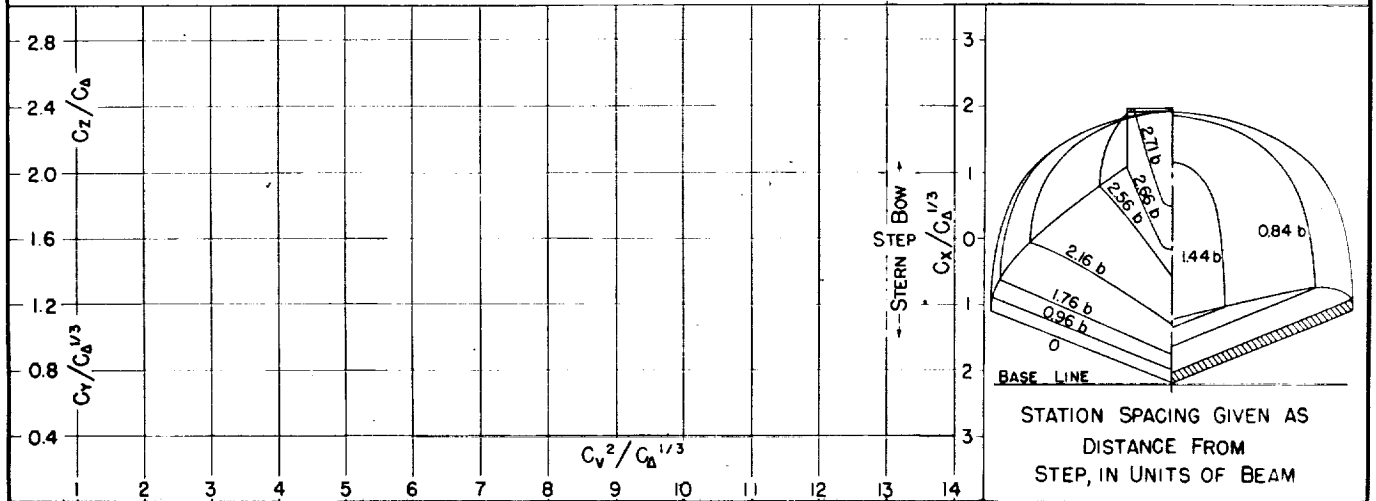

Fig. 44

DESIGNATION: 2.60-098--2.0 NACA TN No. 1182

MODEL No. 46

C.G. = 0 b FWD. OF STEP
0.80 b ABOVE KEEL

$C_{d0} = 0.75$ (NOMINAL)
 $k/L =$

TESTED AT NACA No. 1 TANK
DATE: 2 / 35

MODEL BEAM: 14.24"

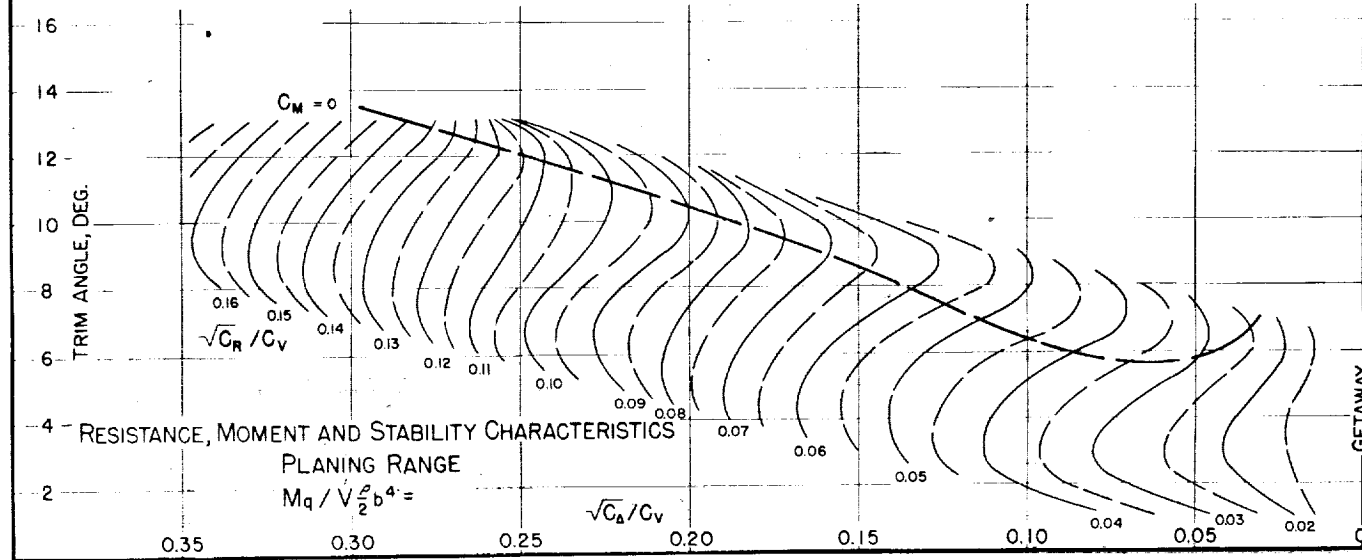
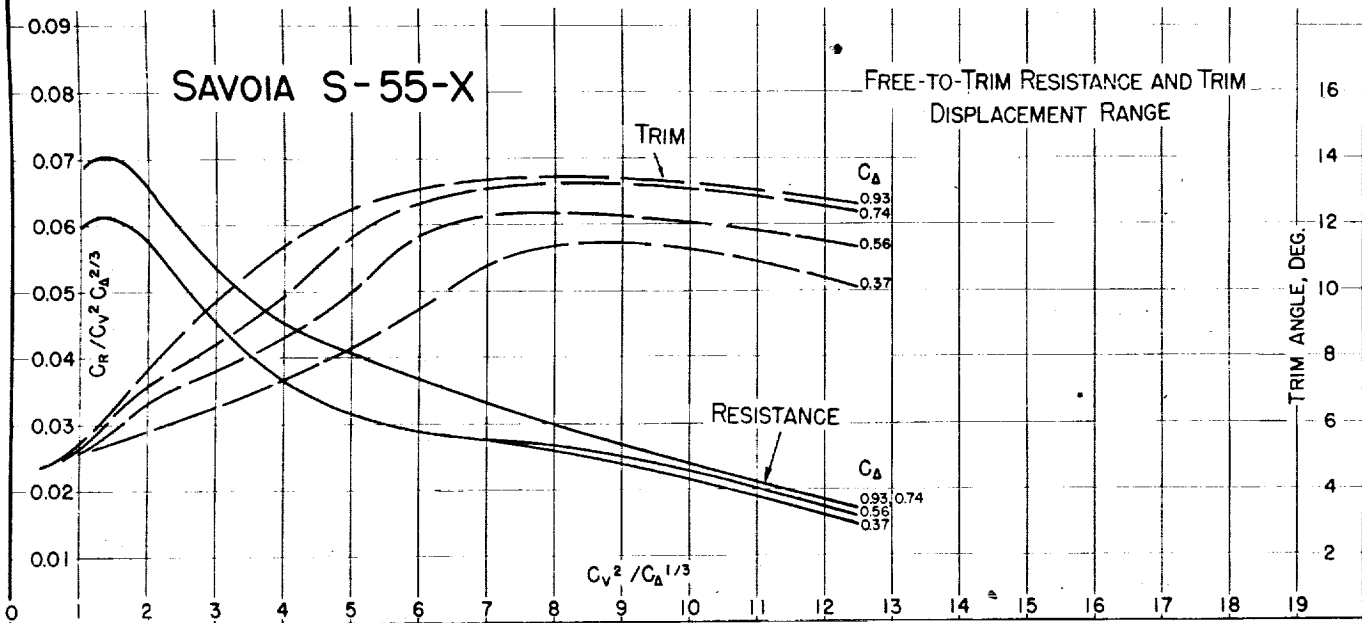
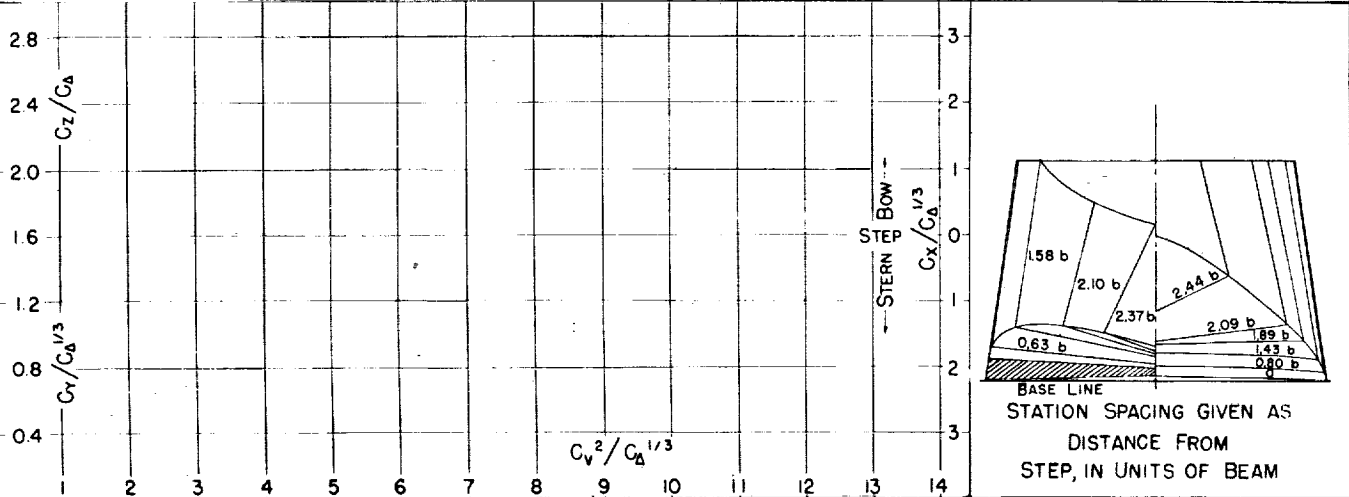

MODEL No. 47
MODEL BEAM: 1626"

C.G. = 0.13 b FWD. OF STEP
1.31 b ABOVE KEEL

$C_{D0} = 0.35$ (NOMINAL)
 $k/L =$

TESTED AT NACA No. 1 TANK
DATE: 10/35

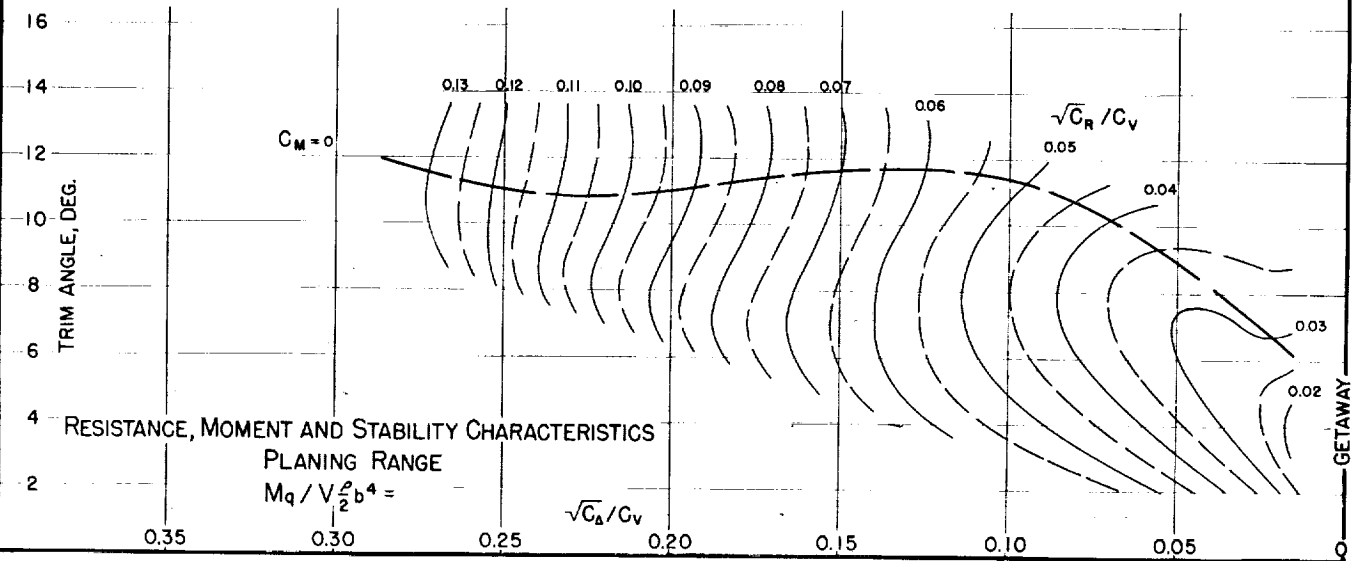
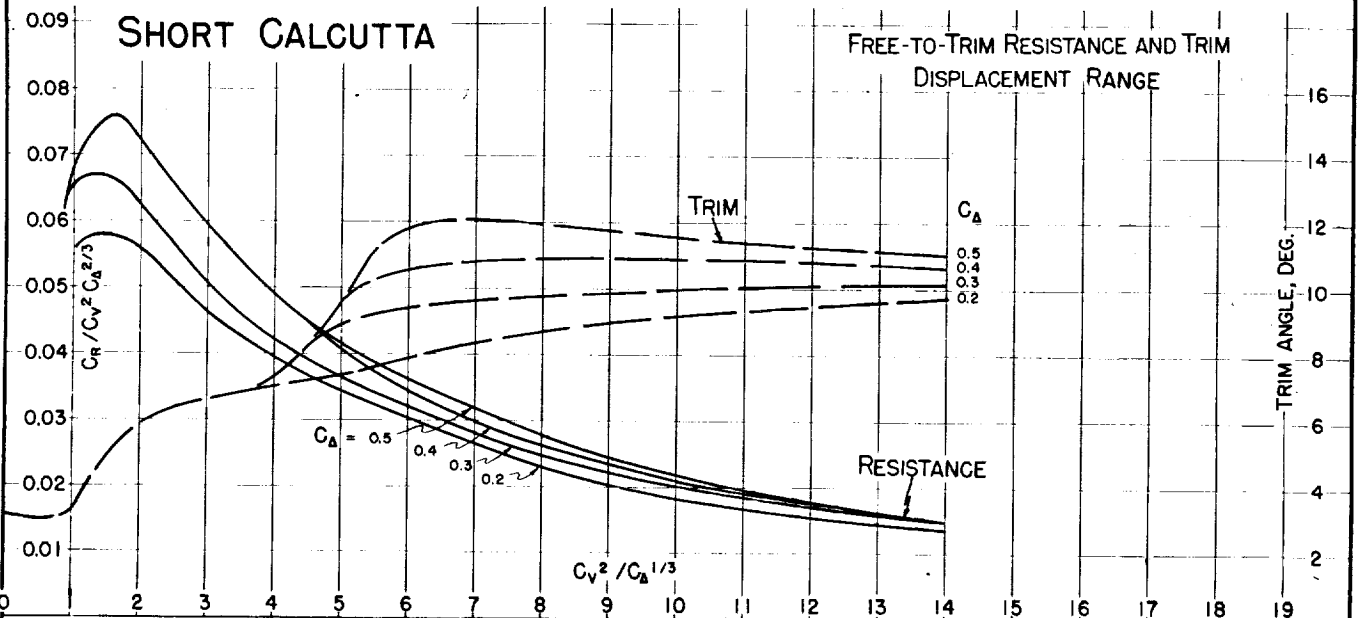
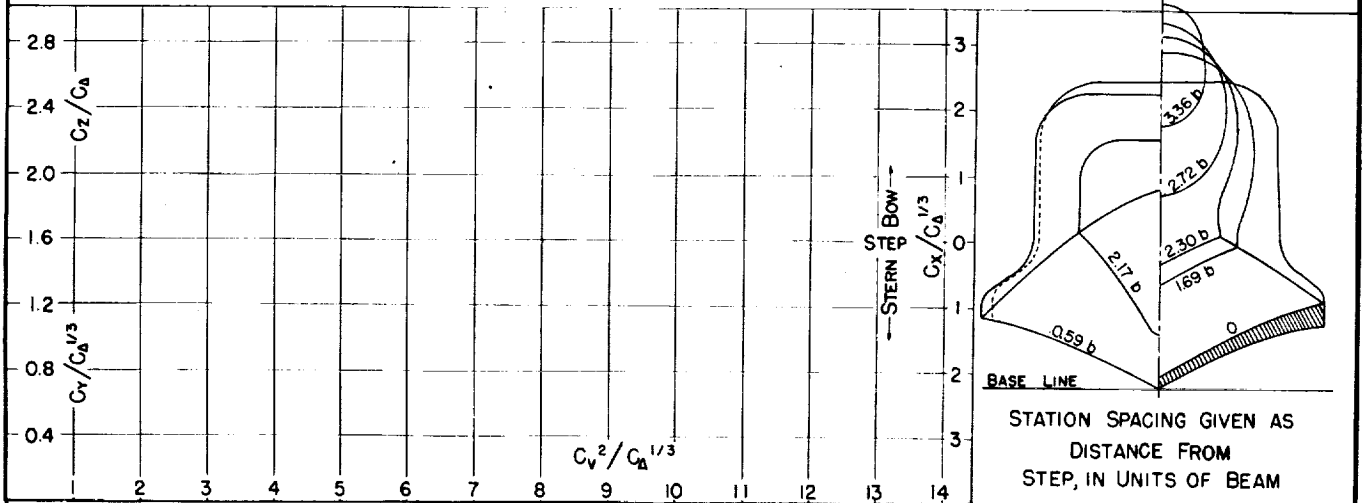

Fig. 46

DESIGNATION: 2.76-047-22.5

NACA TN No. 1182

MODEL No. 52

C.G. = 0.44 b FWD. OF CENTROID $C_{d_0} = 0.46$ (NOMINAL)
 0.91 b ABOVE KEEL $k/L =$

TESTED AT NACA No. 1 TANK

DATE: 6/35

MODEL BEAM: 1700"

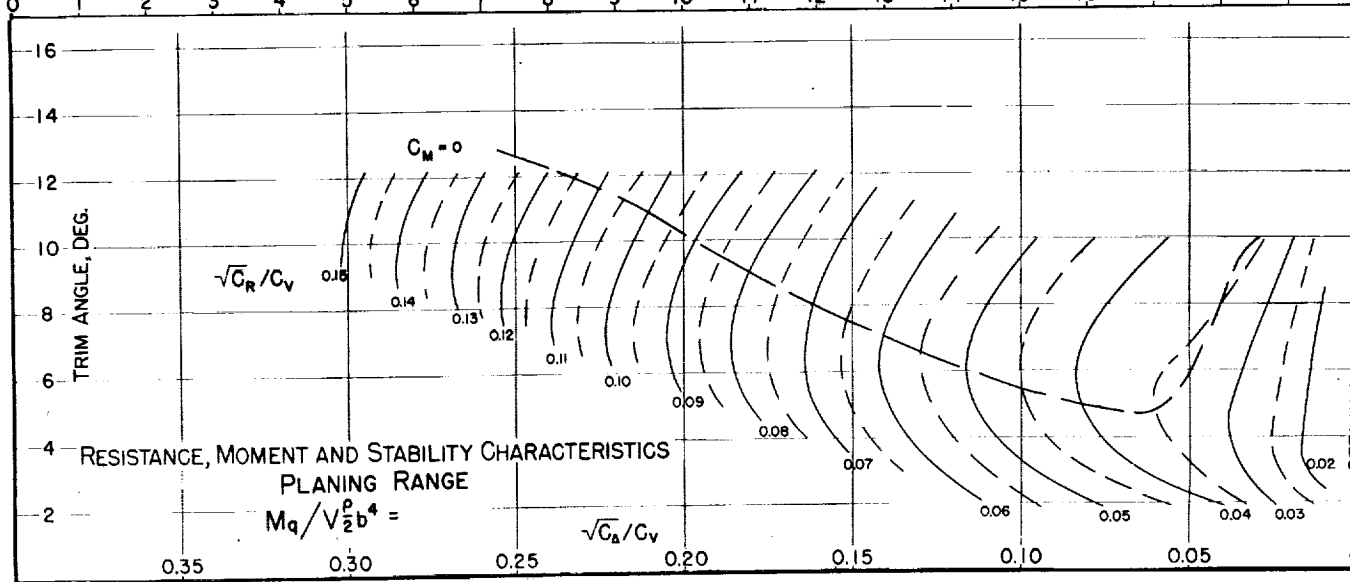
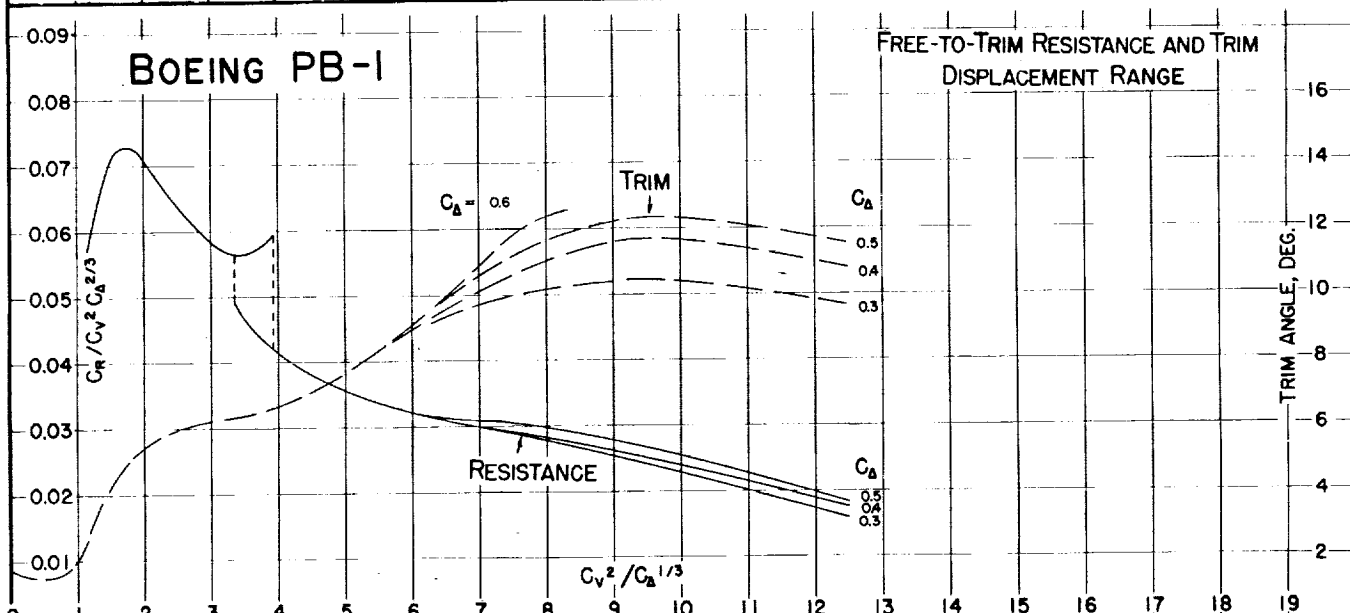
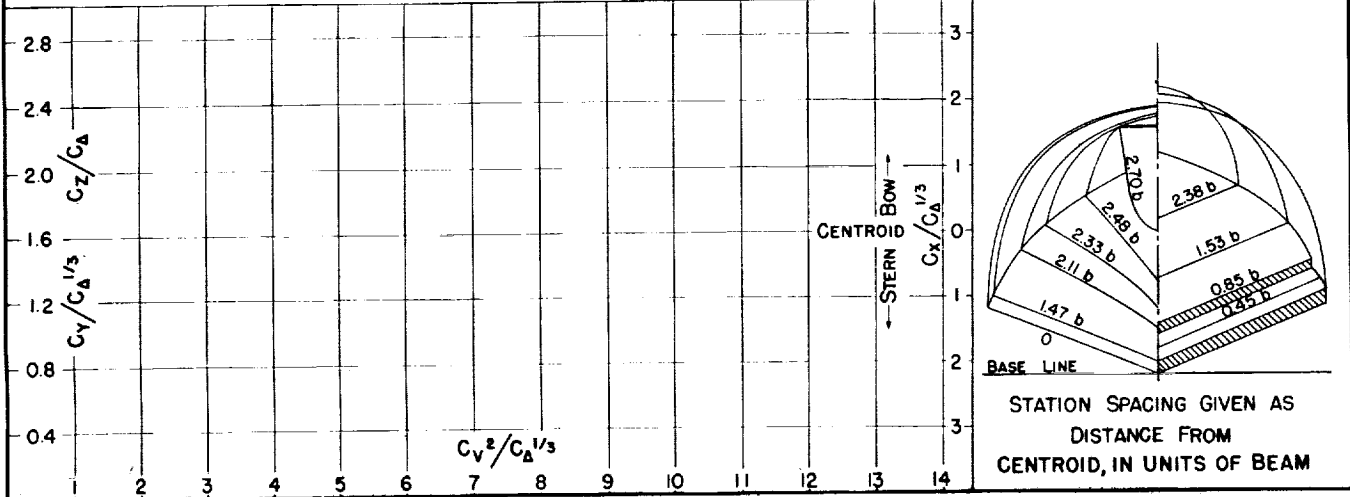

MODEL No. 57-A
MODEL BEAM: 12.45"

C.G. = 0.36 b FWD. OF CENTROID
1.93 b ABOVE KEEL

$C_{d0} =$ (NOMINAL)
 $k/L =$

TESTED AT NACA No 1 TANK
DATE: 6/38

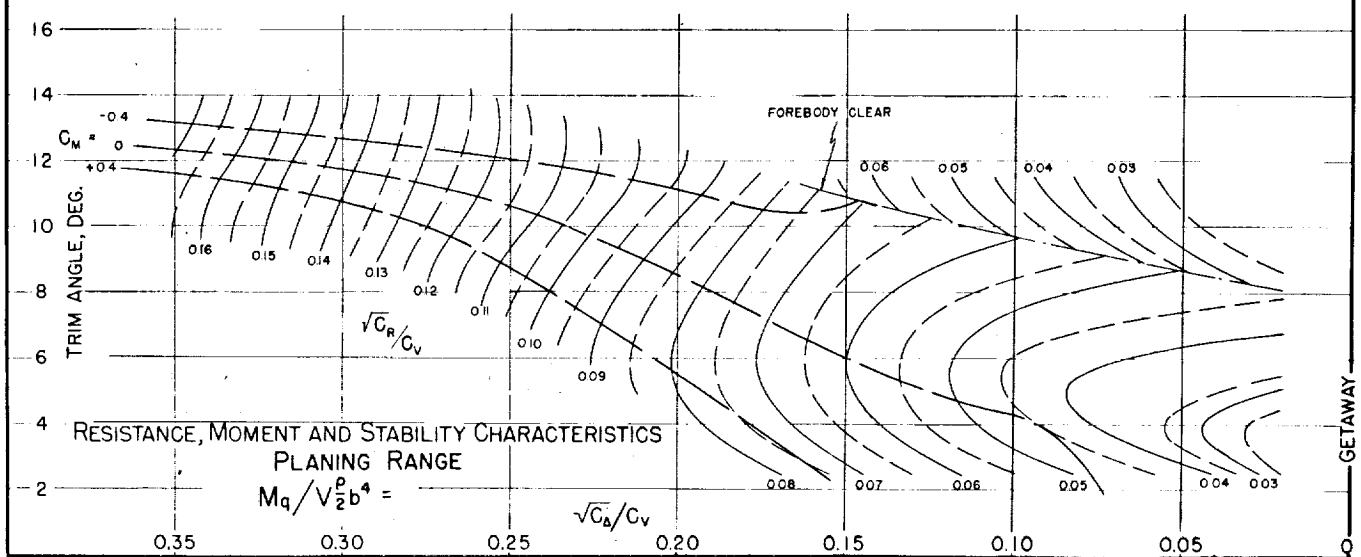
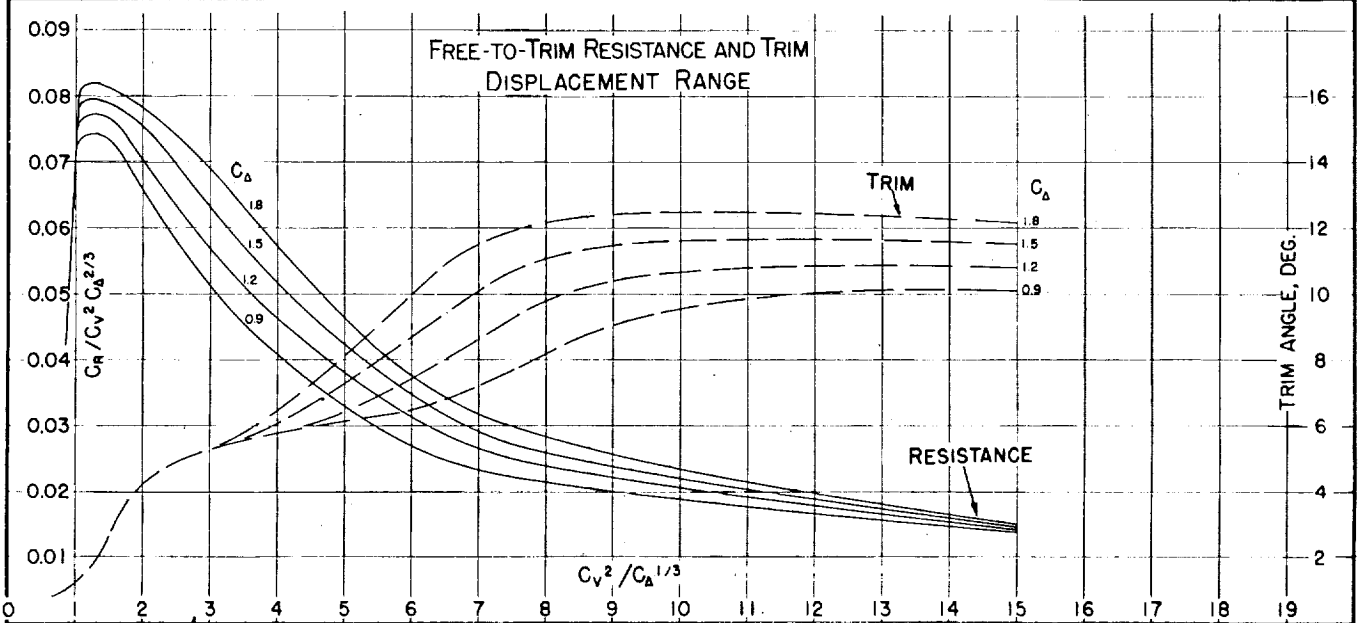
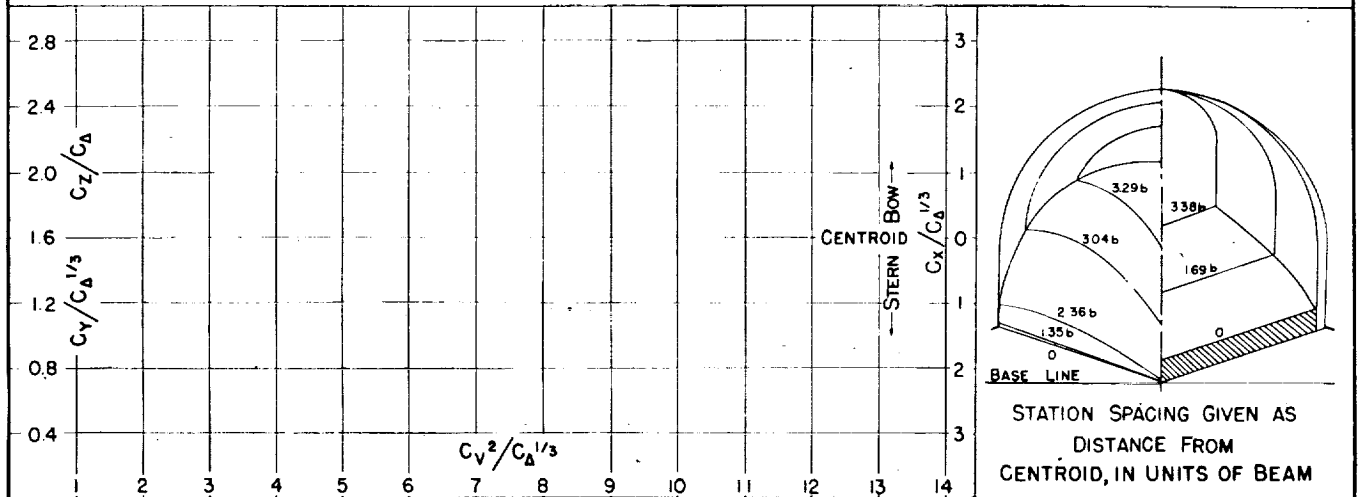

Fig. 48

DESIGNATION: 3.38-0.85-25.0 NACA TN No. 1182

MODEL No. 57-B
MODEL BEAM 12.45"

C.G. = 0.36 b FWD. OF STEP
1.93 b ABOVE KEEL

$C_{d_0} =$ (NOMINAL)
 $k/L =$

TESTED AT NACA No. 1 TANK
DATE: 5/38

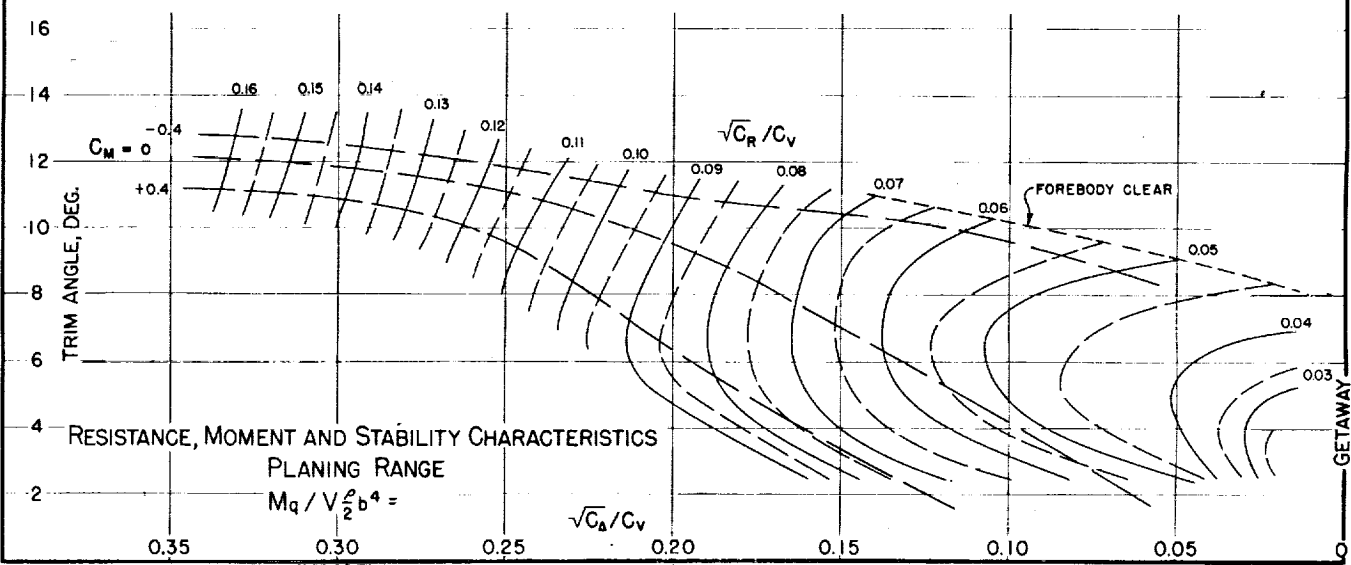
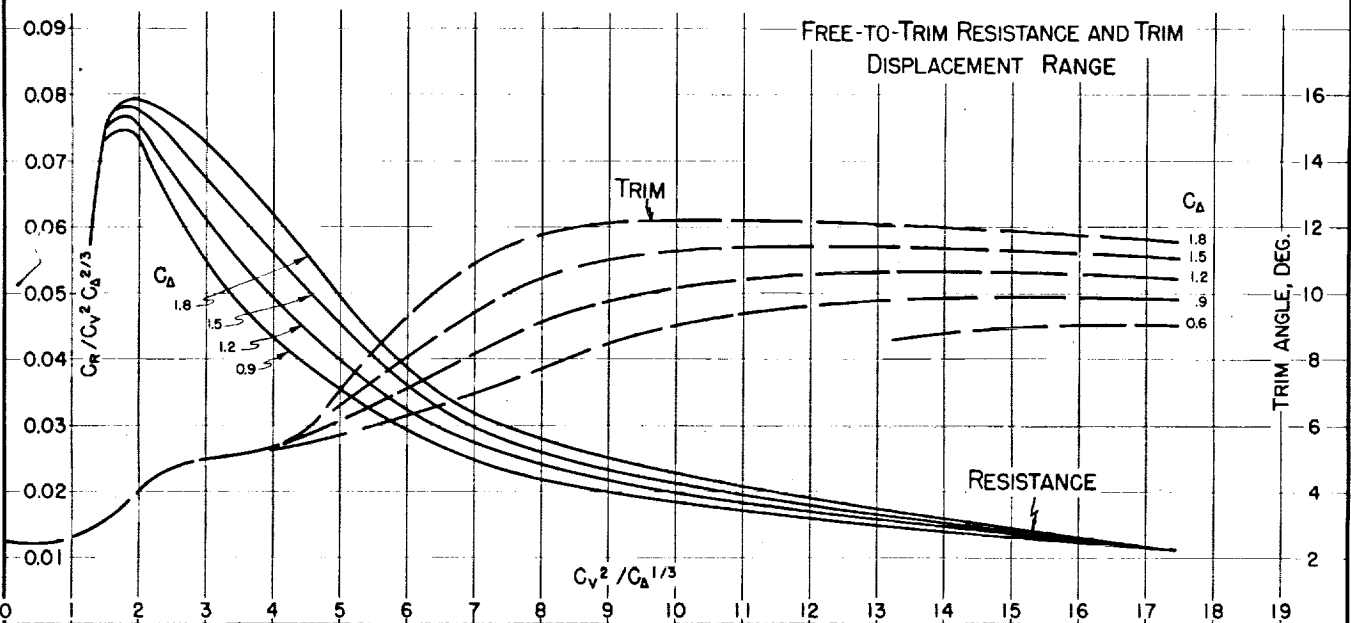
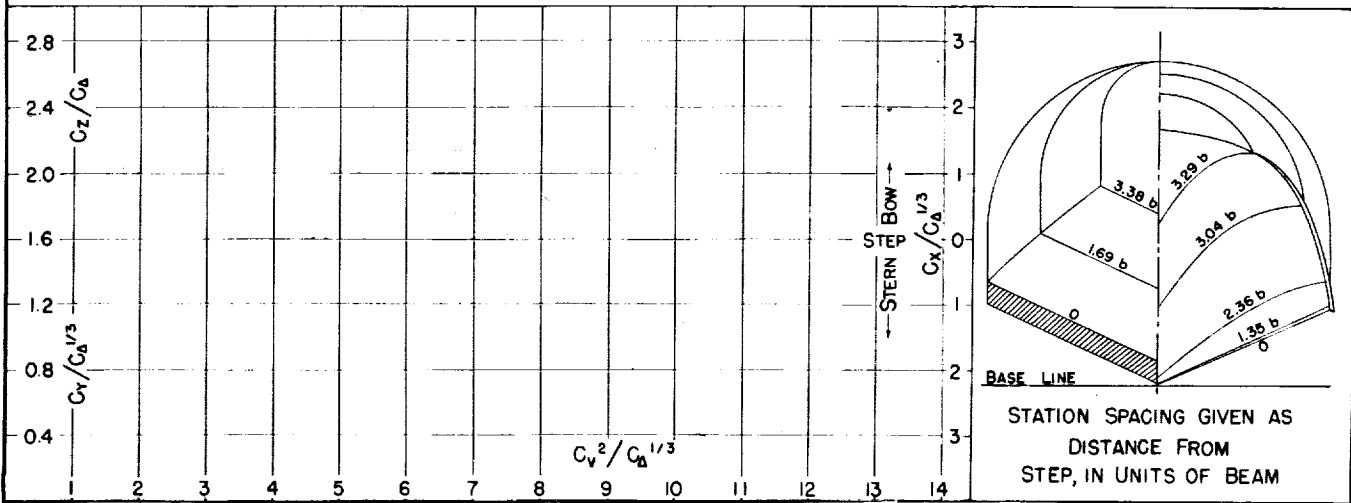

MODEL No. 57-B-5
MODEL BEAM: 12.45"

C.G. = 0.36 b FWD. OF CENTROID
1.93 b ABOVE KEEL

$C_{d.o.} =$ (NOMINAL)
 $k/L =$

TESTED AT NACA No. 1 TANK
DATE: 7/38

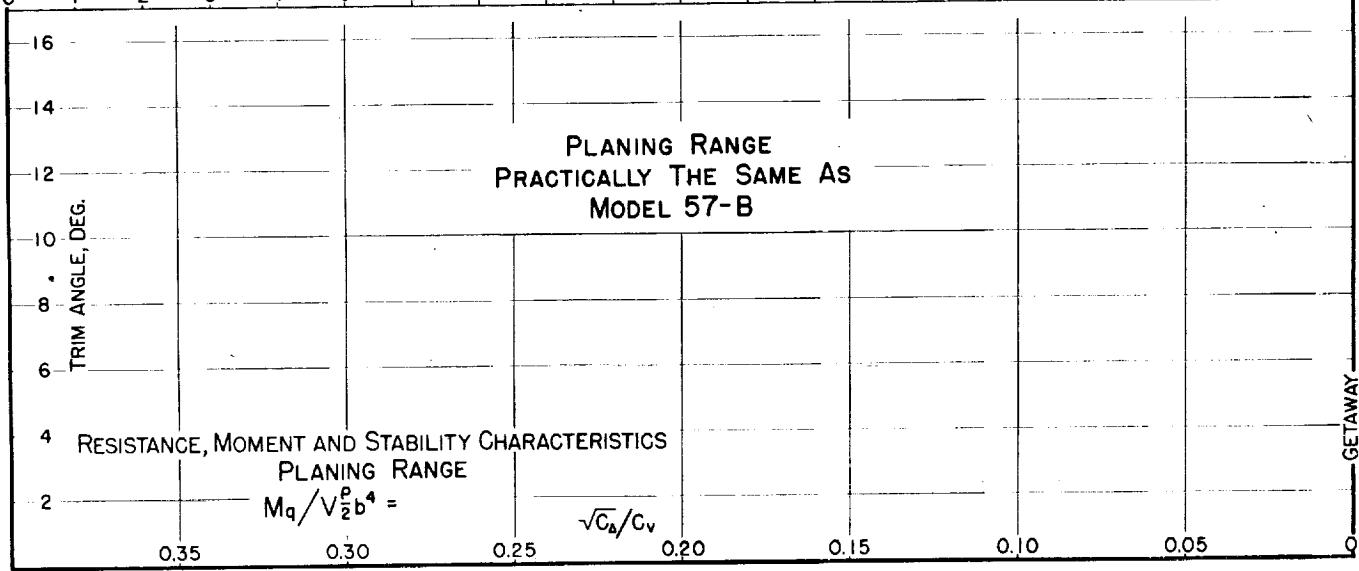
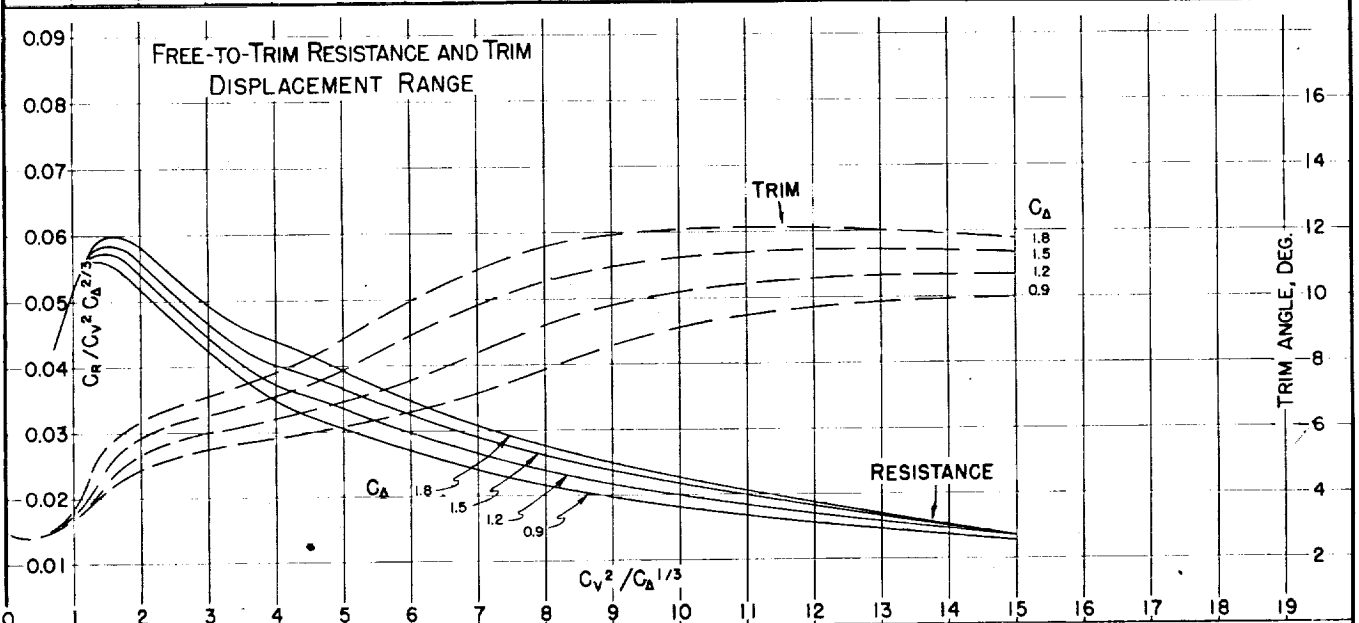
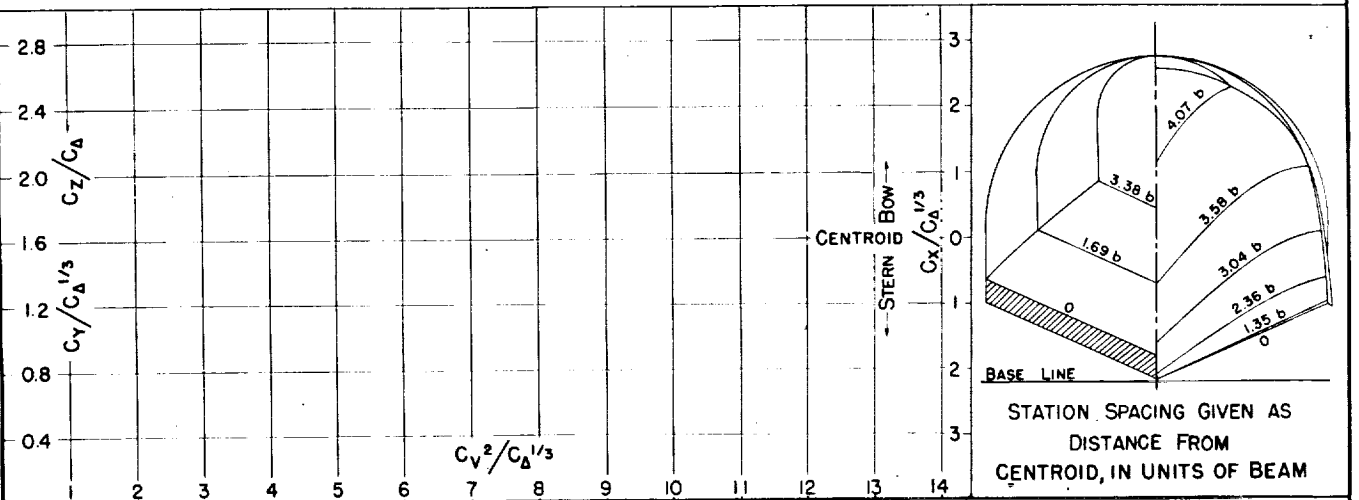

GETAWAY

Fig. 50

DESIGNATION: 3.37 - 0.85 - 30.0 NACA TN No. 1182

MODEL No. 57-C
MODEL BEAM: 12.45"

C.G. = 0.36 b FWD. OF CENTROID
1.93 b ABOVE KEEL

$C_{d_0} =$ (NOMINAL)

TESTED AT NACA No. 1 TANK

DATE: 6/38

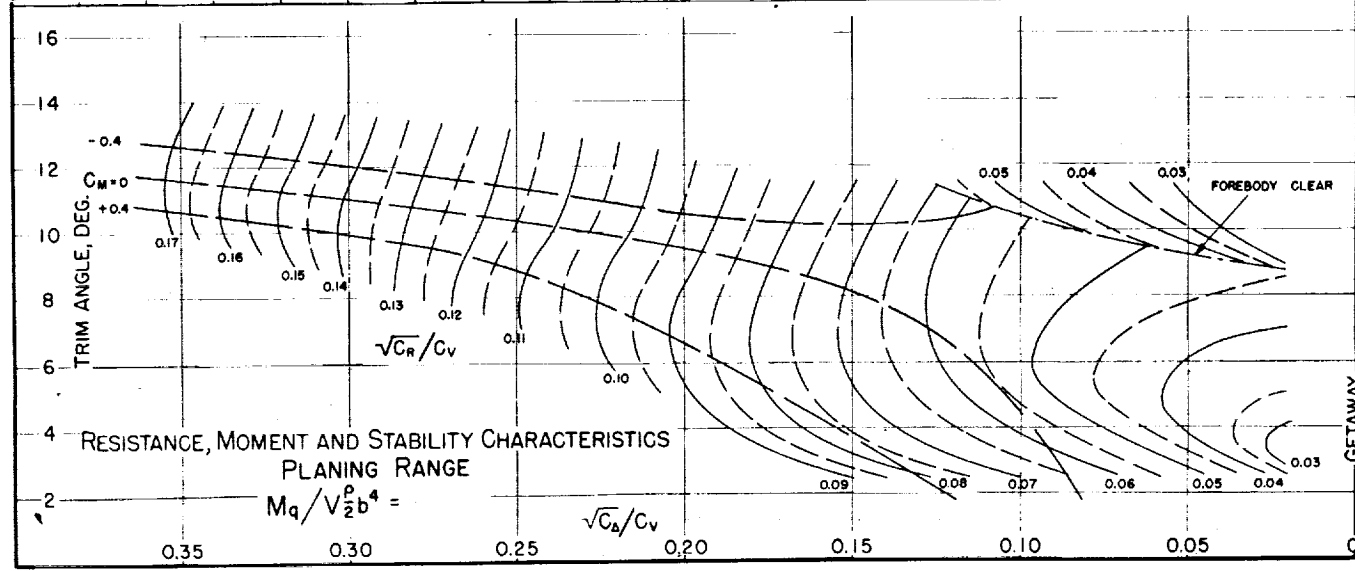
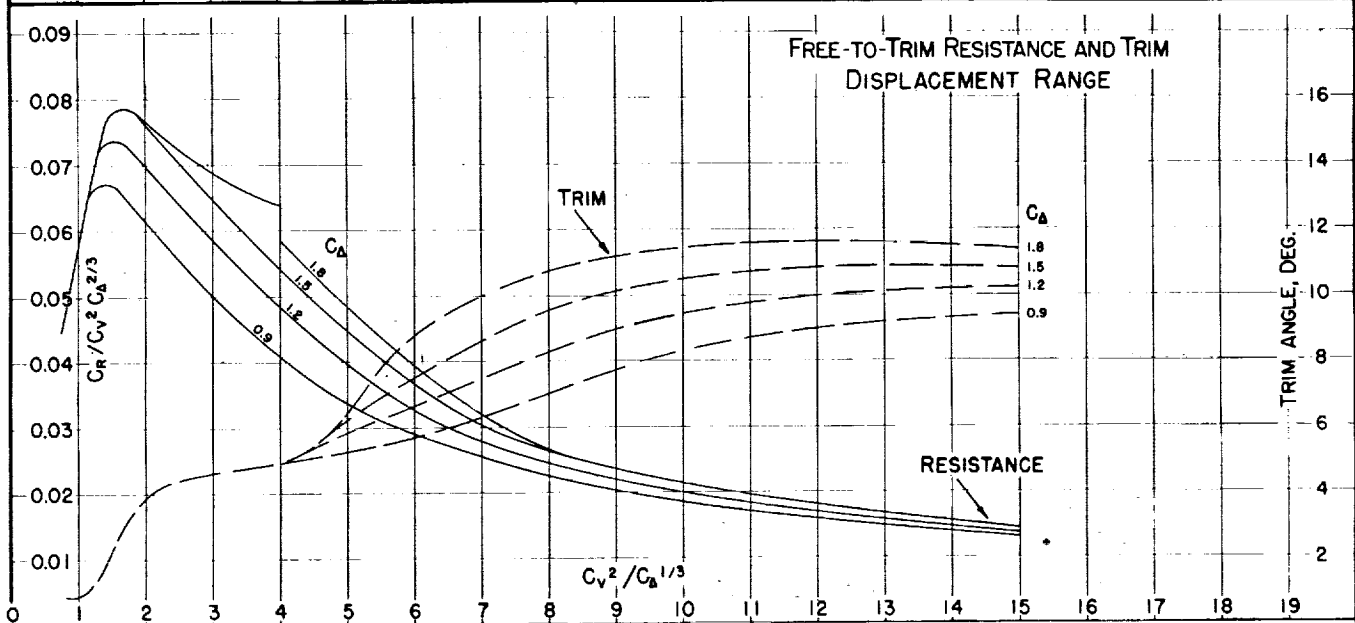
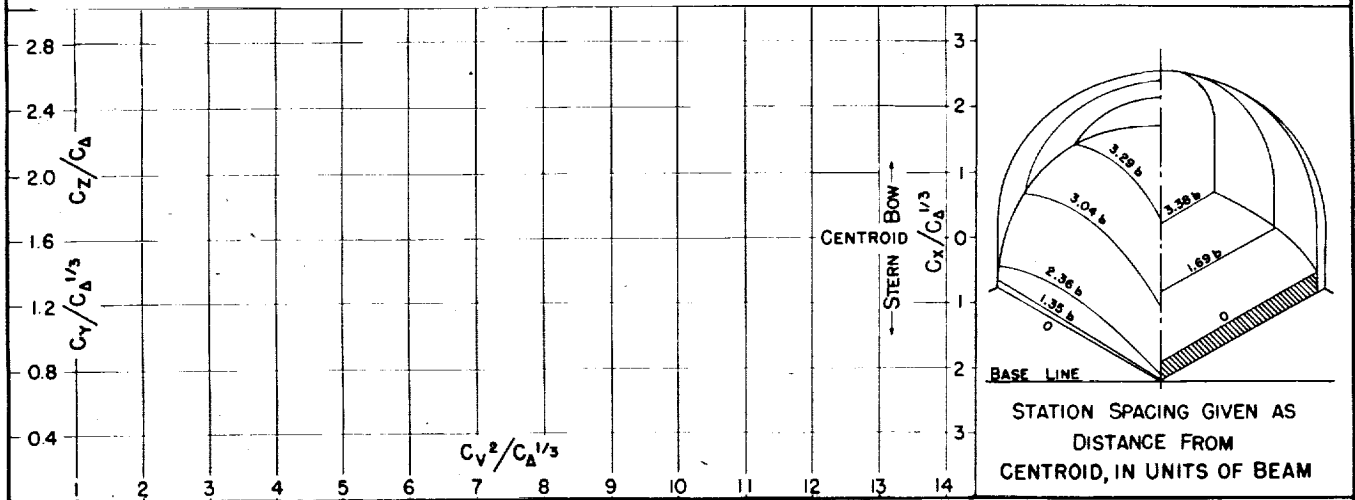

MODEL No. 61-A
MODEL BEAM: 12.00"

C.G. = 0.45 b FWD. OF STEP
2.03 b ABOVE KEEL

$C_{d0} =$ (NOMINAL)
 $k/L =$

TESTED AT NACA No. 1 TANK
DATE: 8/36

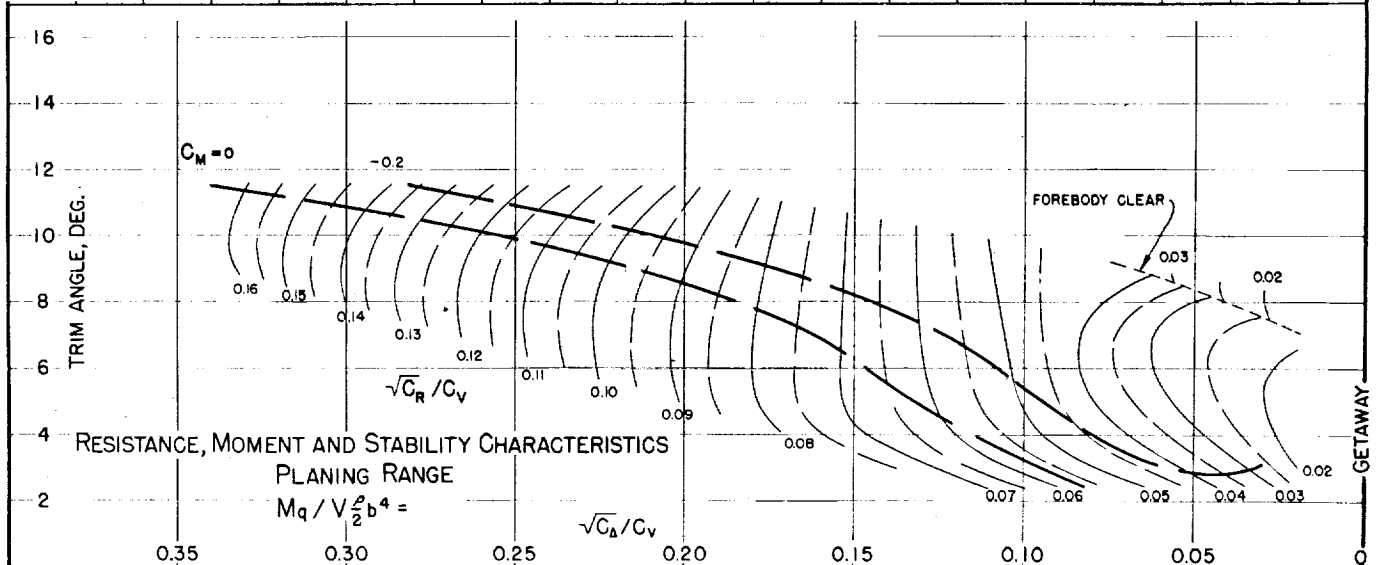
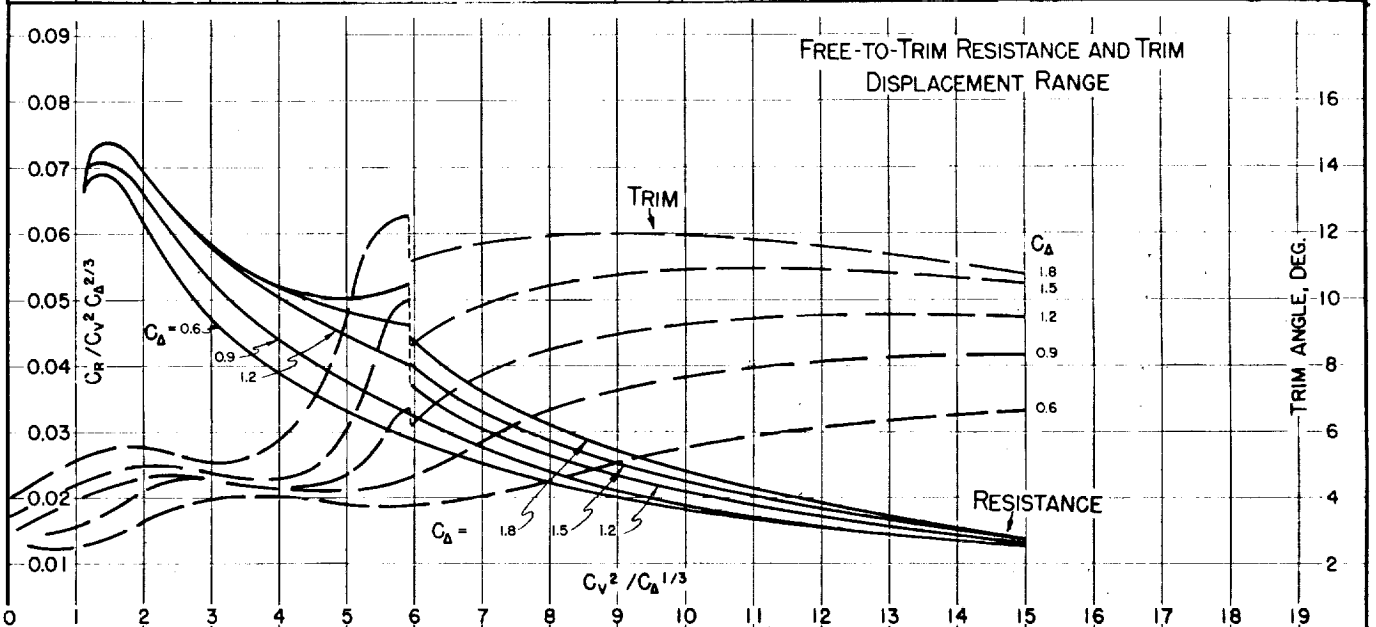
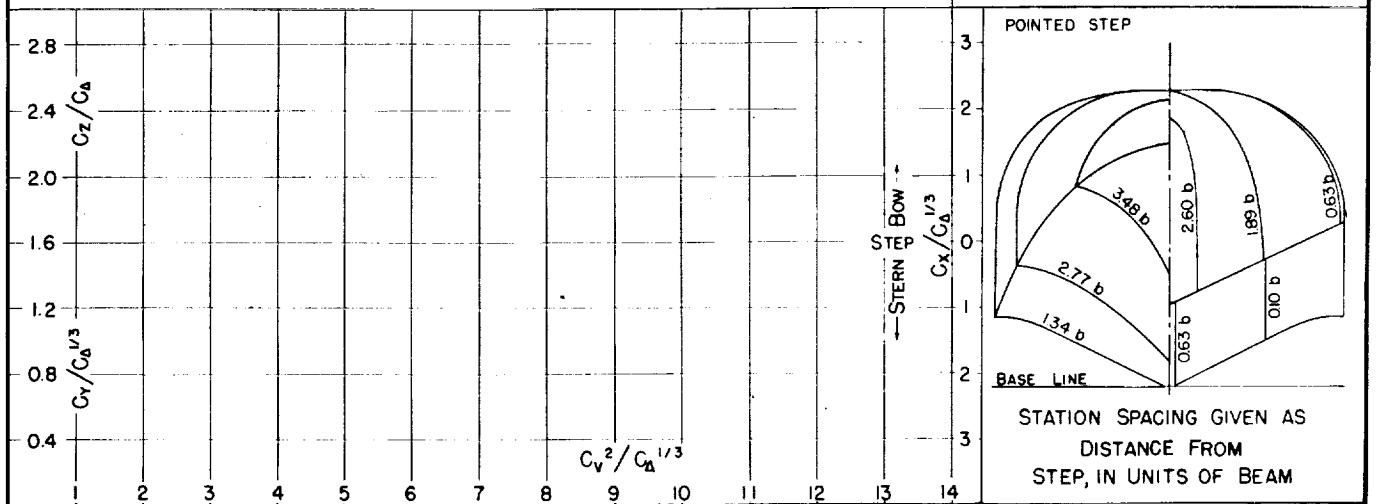

Fig. 52

DESIGNATION: 2.82-0.36-22.5 NACA TN No. 1182

MODEL No. 62-AD
MODEL BEAM: 17.00"

C.G. = 0.37 b FWD. OF STEP
0.91 b ABOVE KEEL

$C_{d0} =$ (NOMINAL)
 $k/L =$

TESTED AT NACA No. 1 TANK
DATE: 10/38

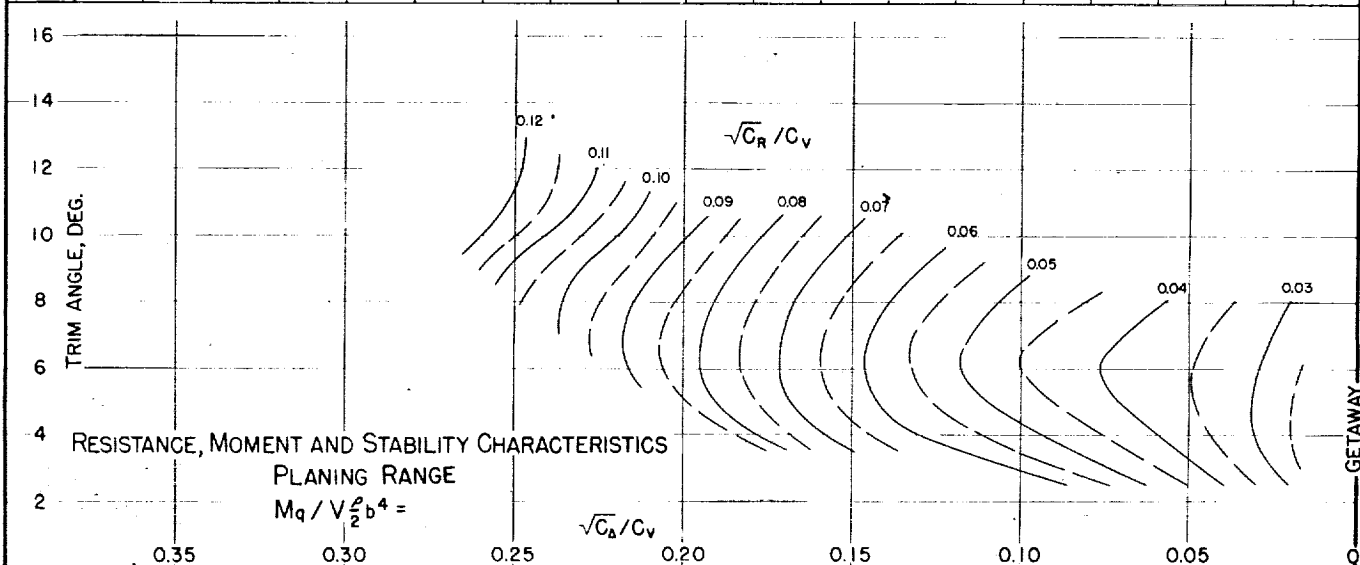
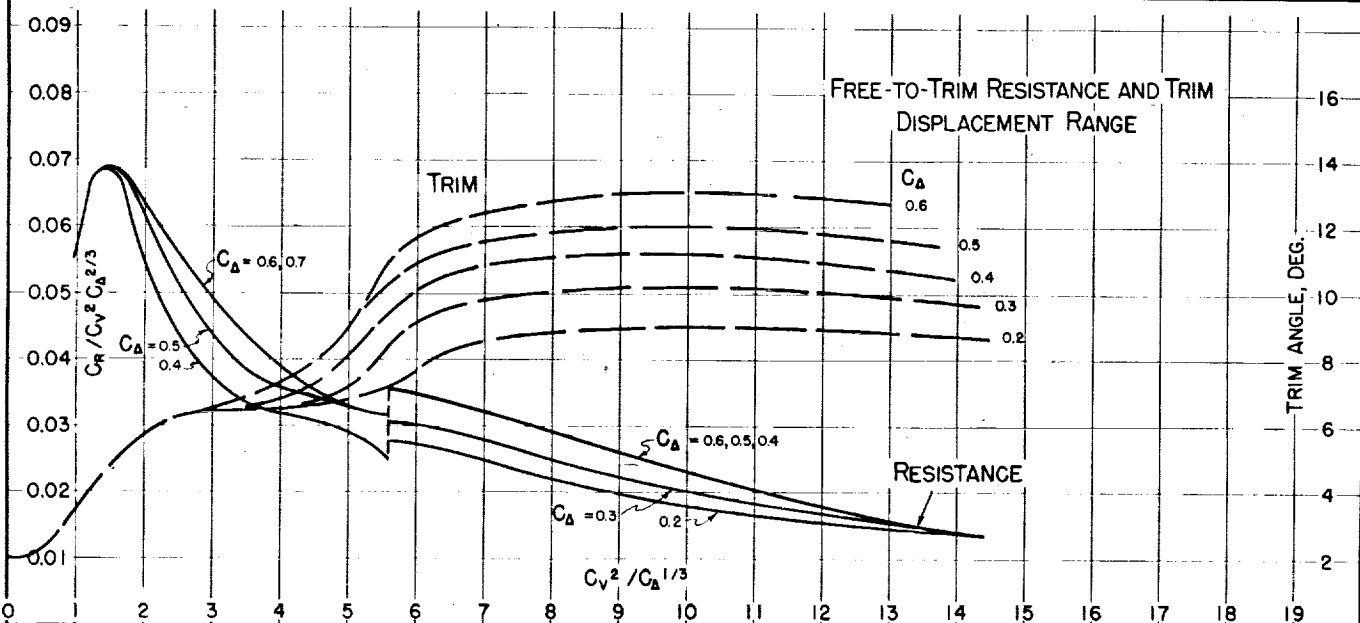
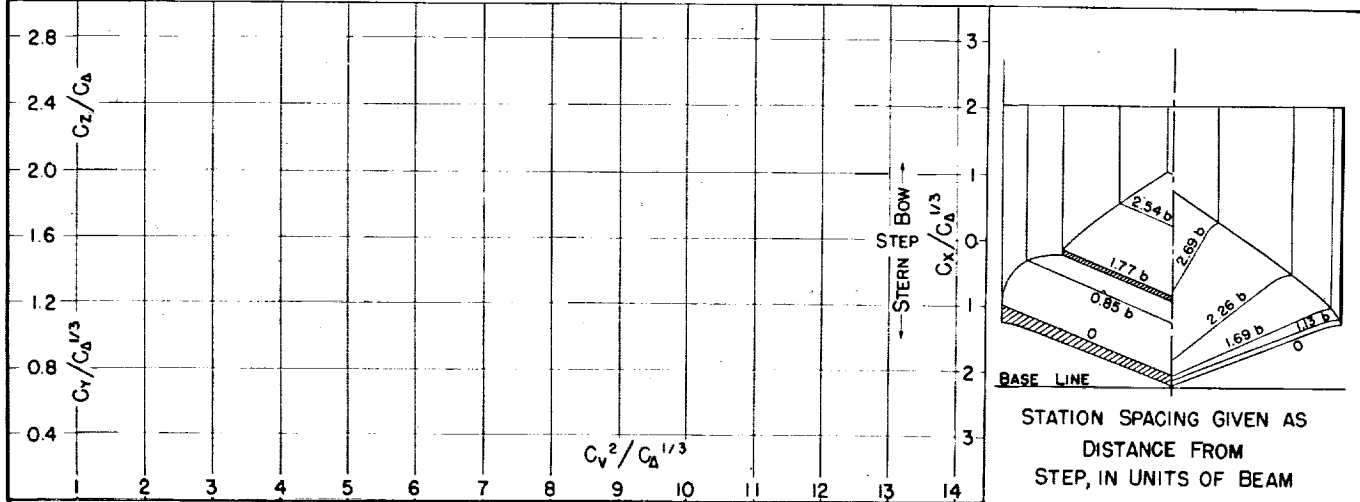

MODEL No. 66
MODEL BEAM: 2160"

C.G. = 0.08 b FWD. OF CENTROID $C_{d_0} = 0.32$ (NOMINAL)
0.96 b ABOVE KEEL $k/L =$

TESTED AT NACA No. 1 TANK
DATE: 36

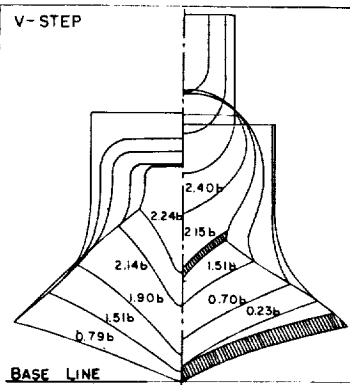
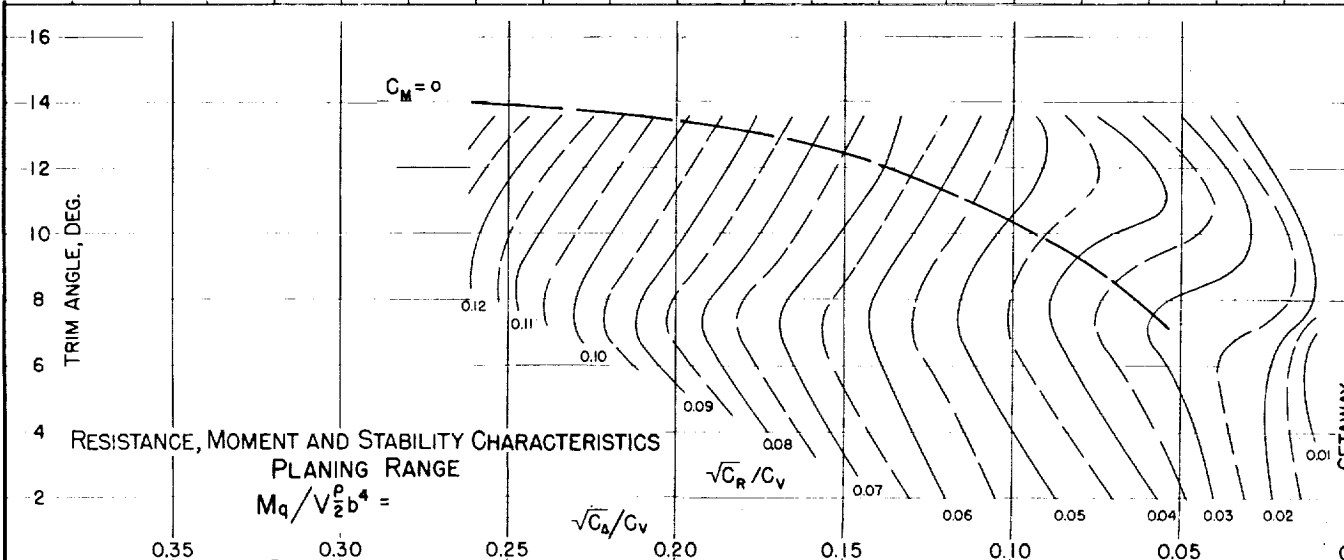
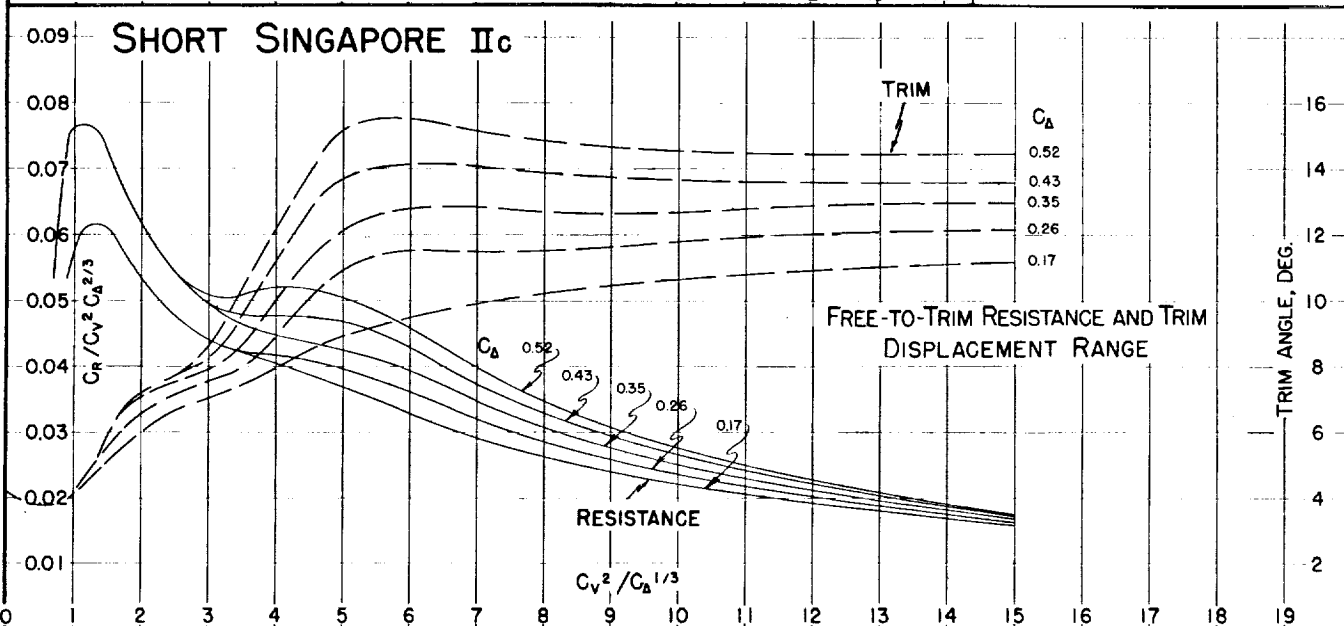
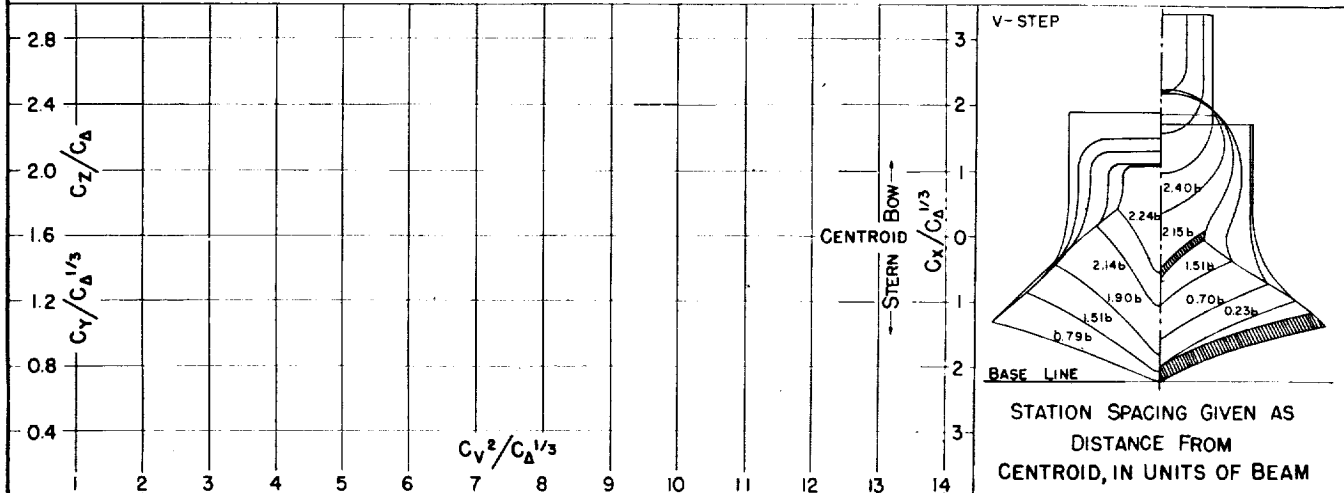

STATION SPACING GIVEN AS DISTANCE FROM CENTROID, IN UNITS OF BEAM

Fig. 54

DESIGNATION: 3.73-4.09-26.0

NACA TN No. 1182

MODEL No. 73

C.G. = 0.45 b FWD. OF STEP
2.03 b ABOVE KEEL

$C_{D0} =$ (NOMINAL)
 $k/L =$

TESTED AT NACA No. 1 TANK
DATE: 10/36

MODEL BEAM: 1200"

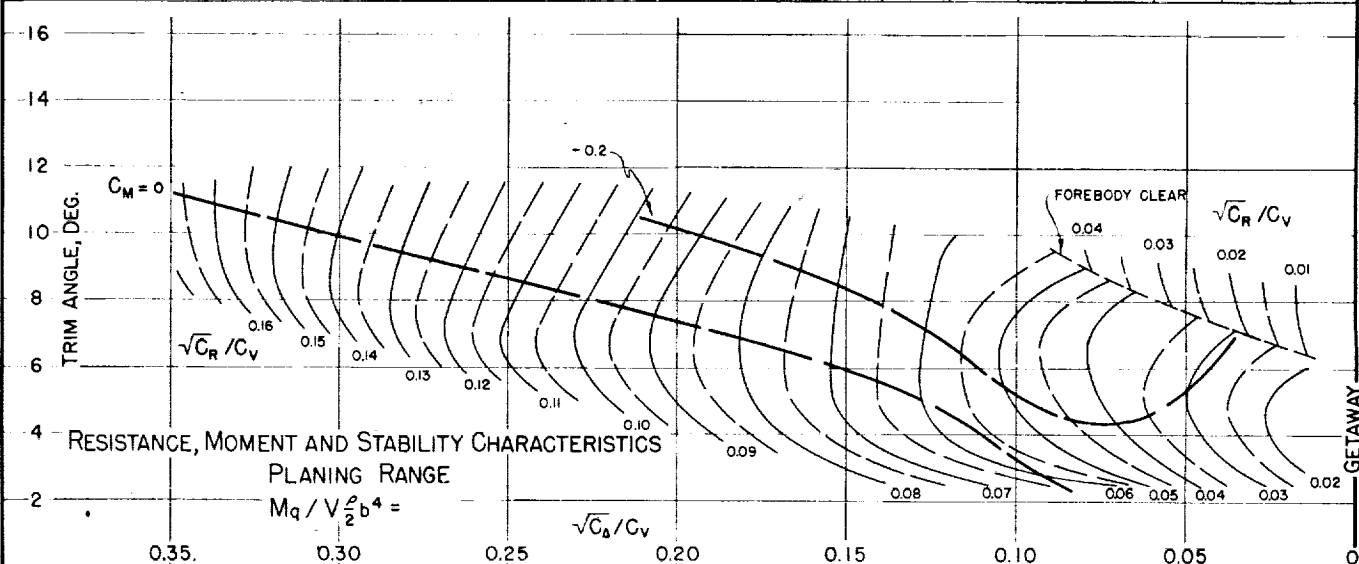
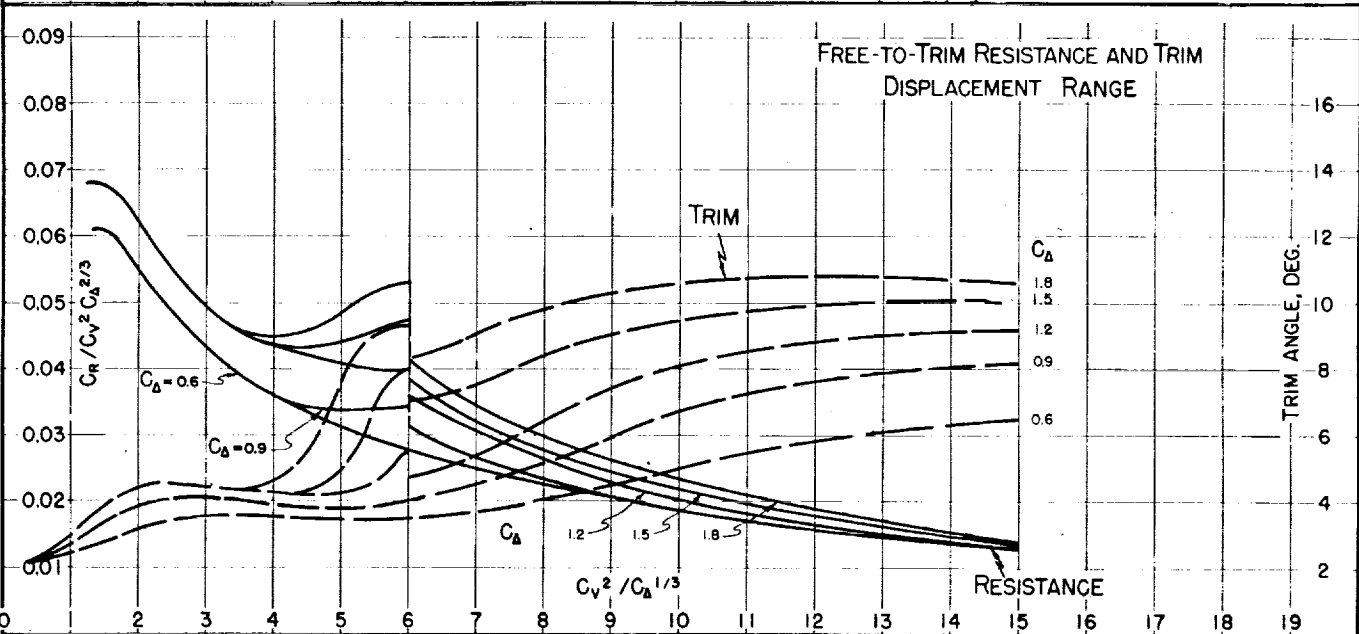
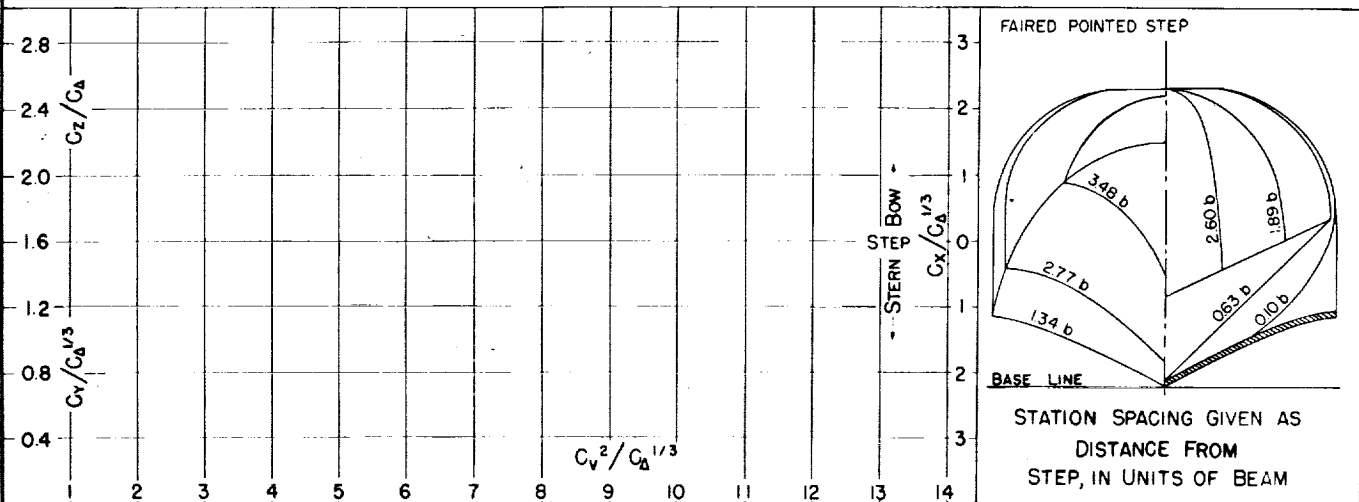

MODEL No. 74-A
MODEL BEAM: 15.92"

C.G. = 0.45 b FWD. OF CENTROID
0.93 b ABOVE KEEL

$C_{d_0} =$ (NOMINAL)
 $k/L =$

TESTED AT NACA No. 1 TANK
DATE: 10/37

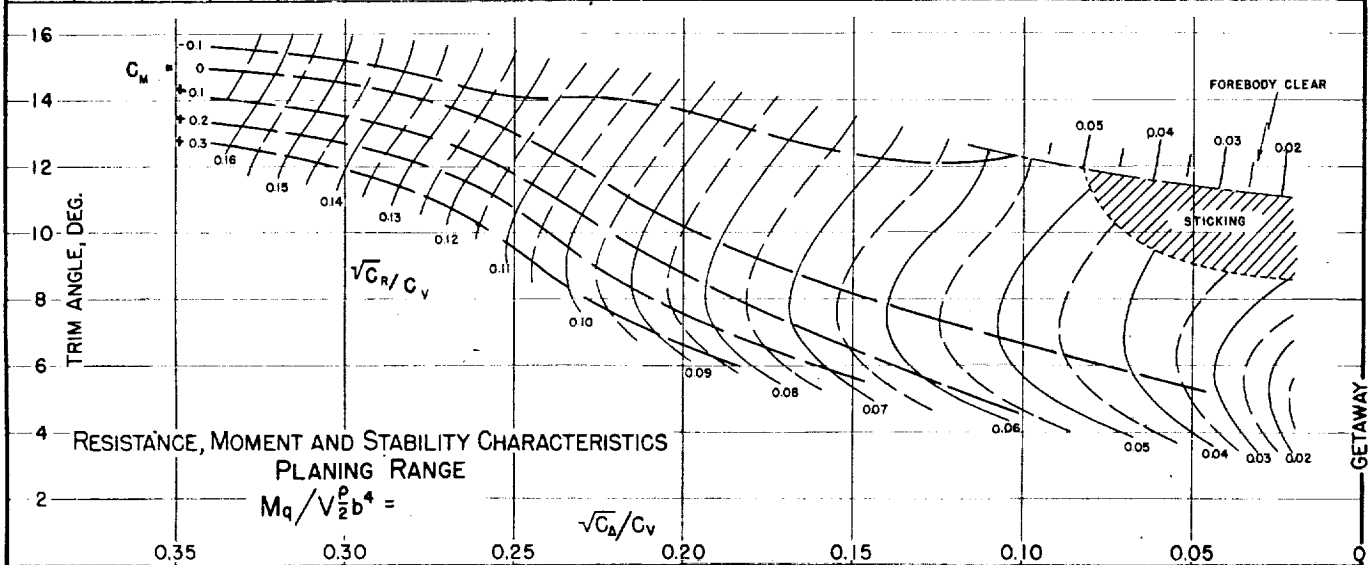
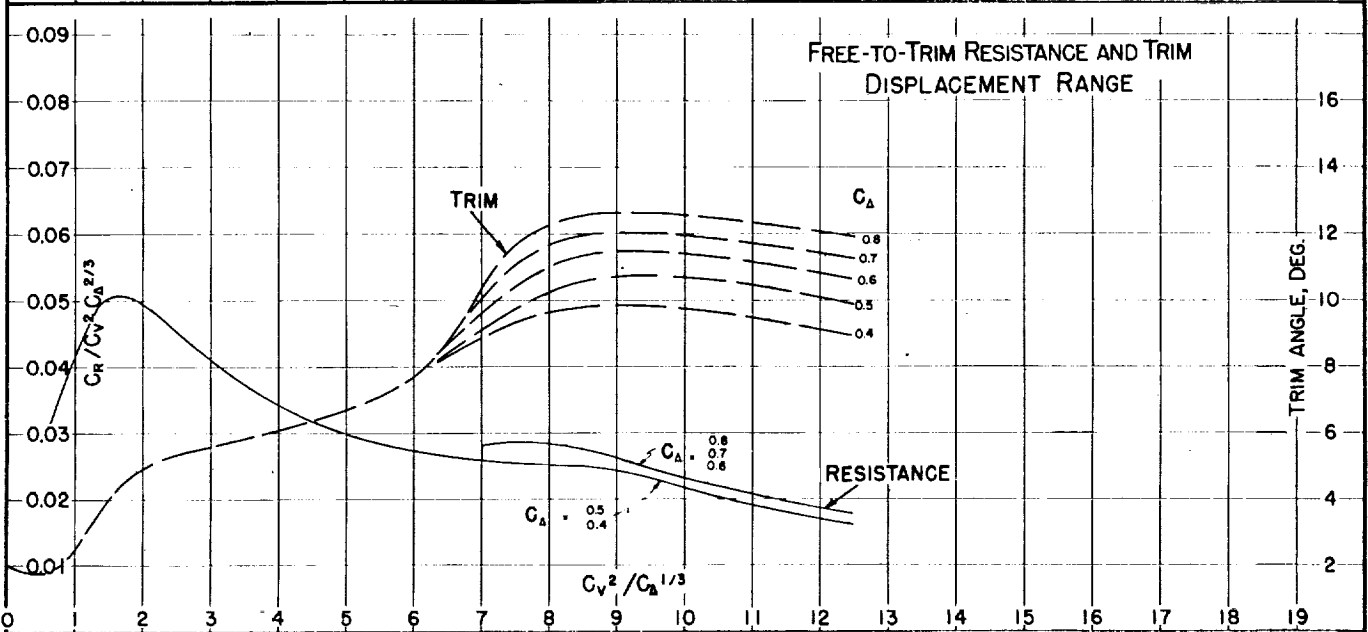
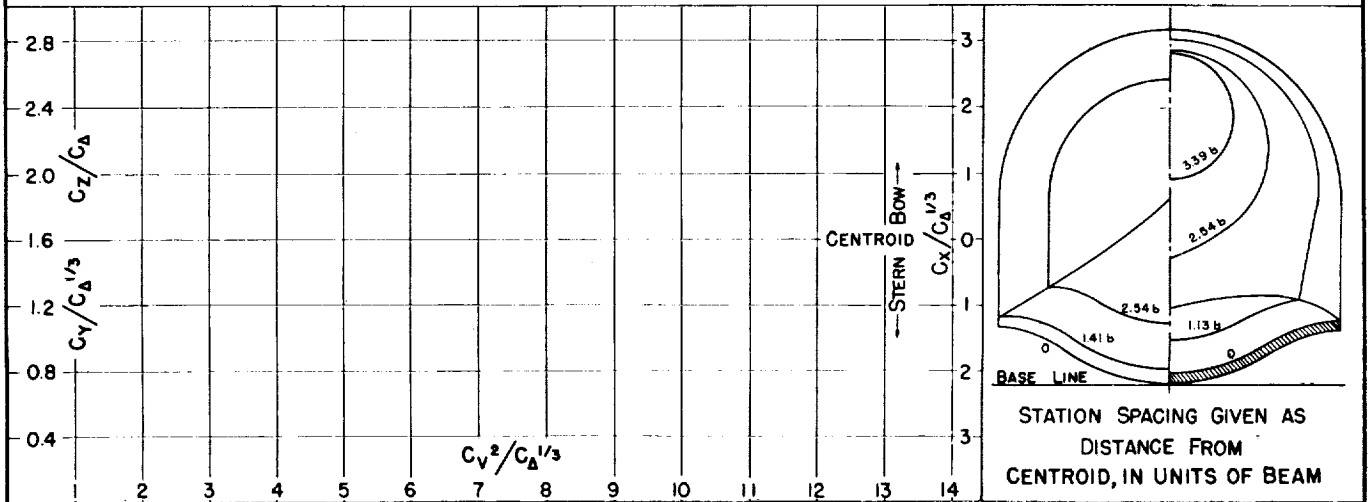

Fig. 56

DESIGNATION: 2.87-2.44-2.00 NACA TN No. 1182

MODEL No. 75
MODEL BEAM: 15.9"

C.G. = 0.17 b FWD. OF CENTROID $C_{d0} =$ (NOMINAL)
0.98 b ABOVE KEEL $k/L =$

TESTED AT NACA No. 1 TANK
DATE: 10/37

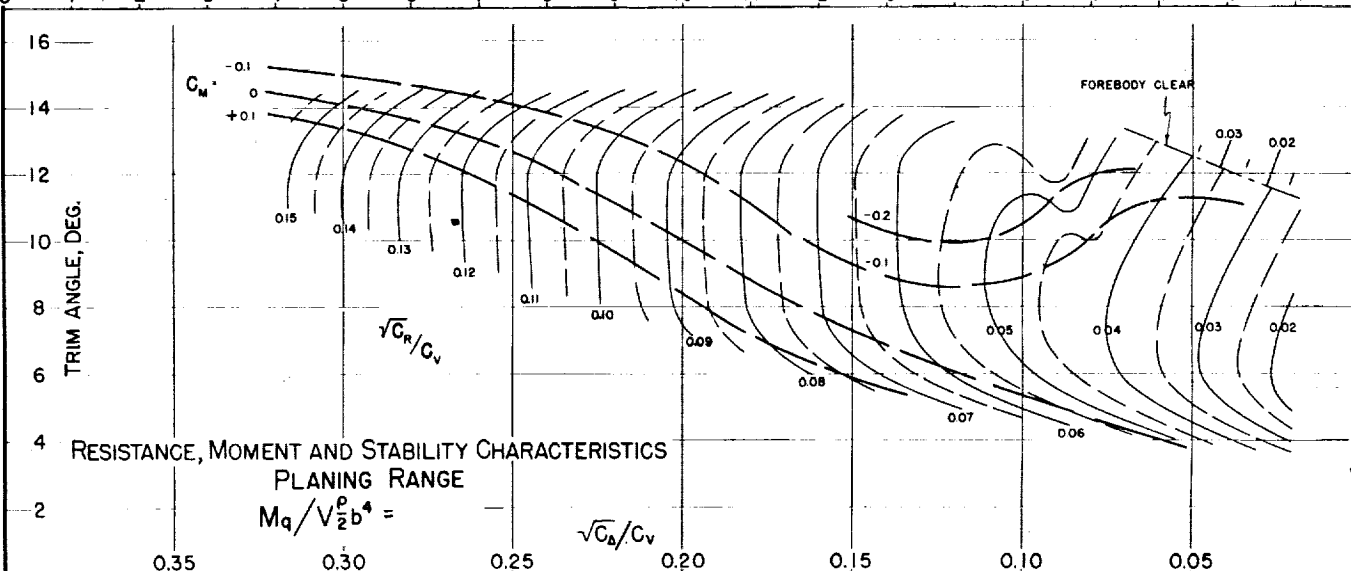
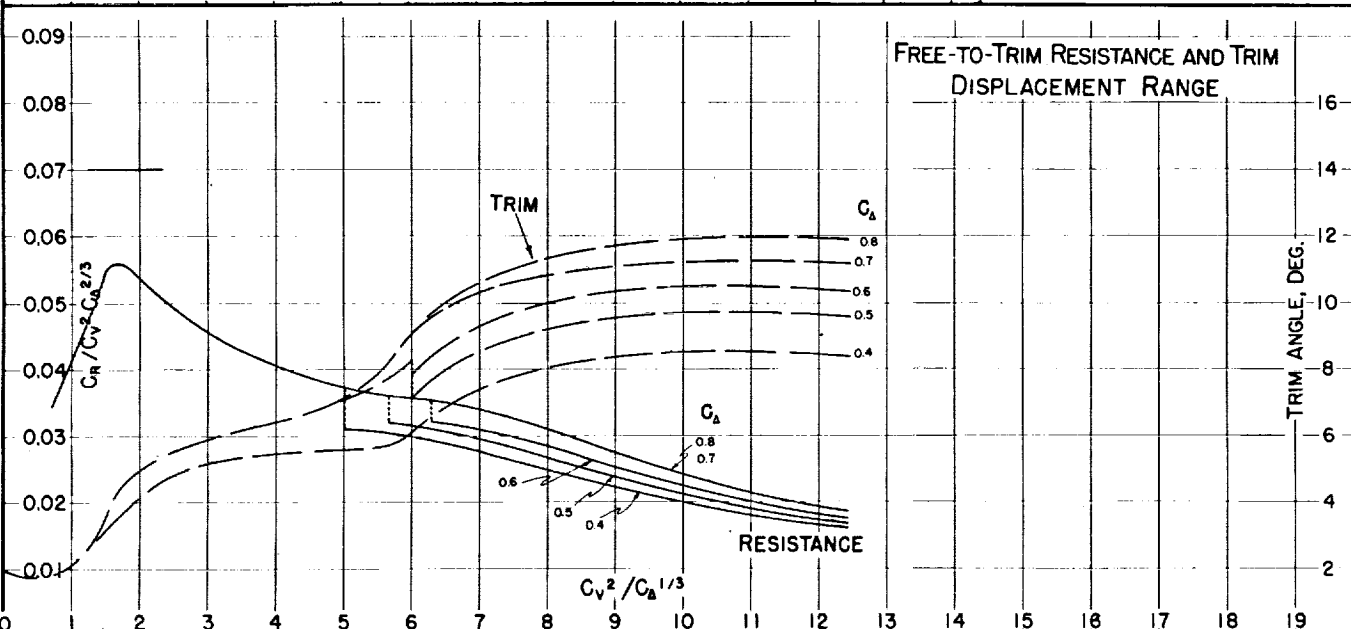
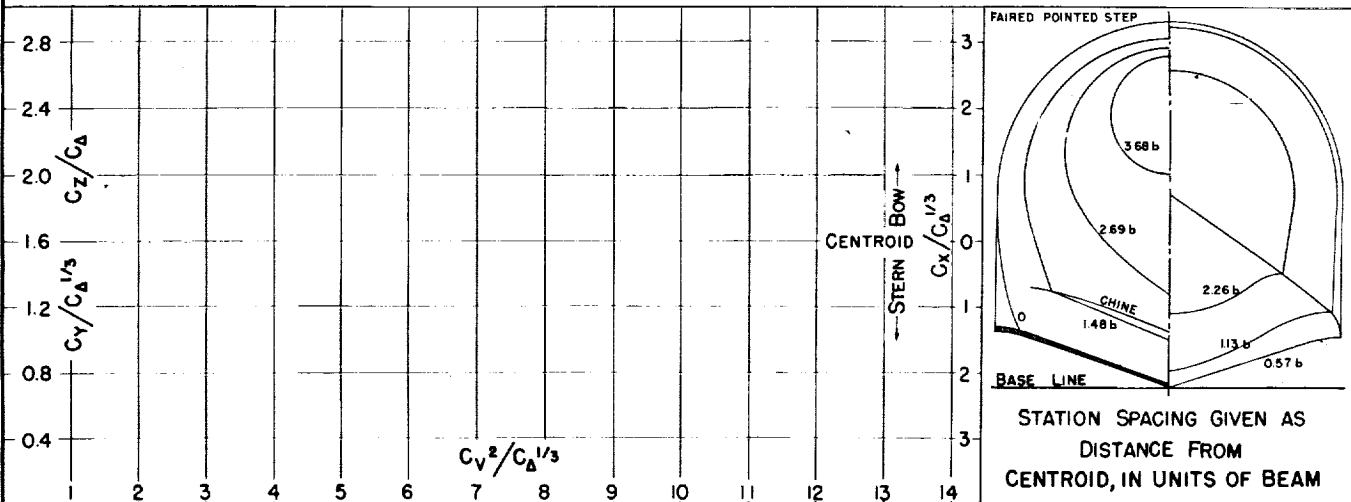

RESISTANCE, MOMENT AND STABILITY CHARACTERISTICS
PLANING RANGE

$$M_q/V^2 b^4 =$$

MODEL No. 83

MODEL BEAM: 17.70"

C.G. = 0.42 b FWD. OF STEP
0.72 b ABOVE KEEL

$C_{d0} =$ (NOMINAL)
 $k/L =$

TESTED AT NACA No. 1 TANK
DATE: 1/40

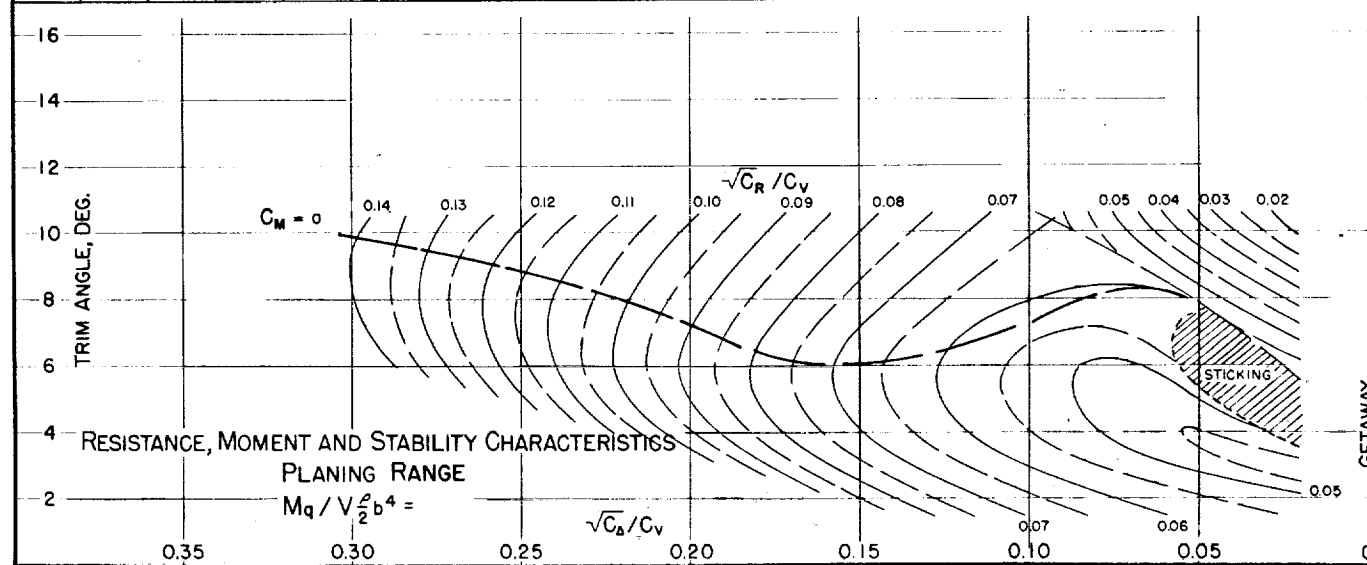
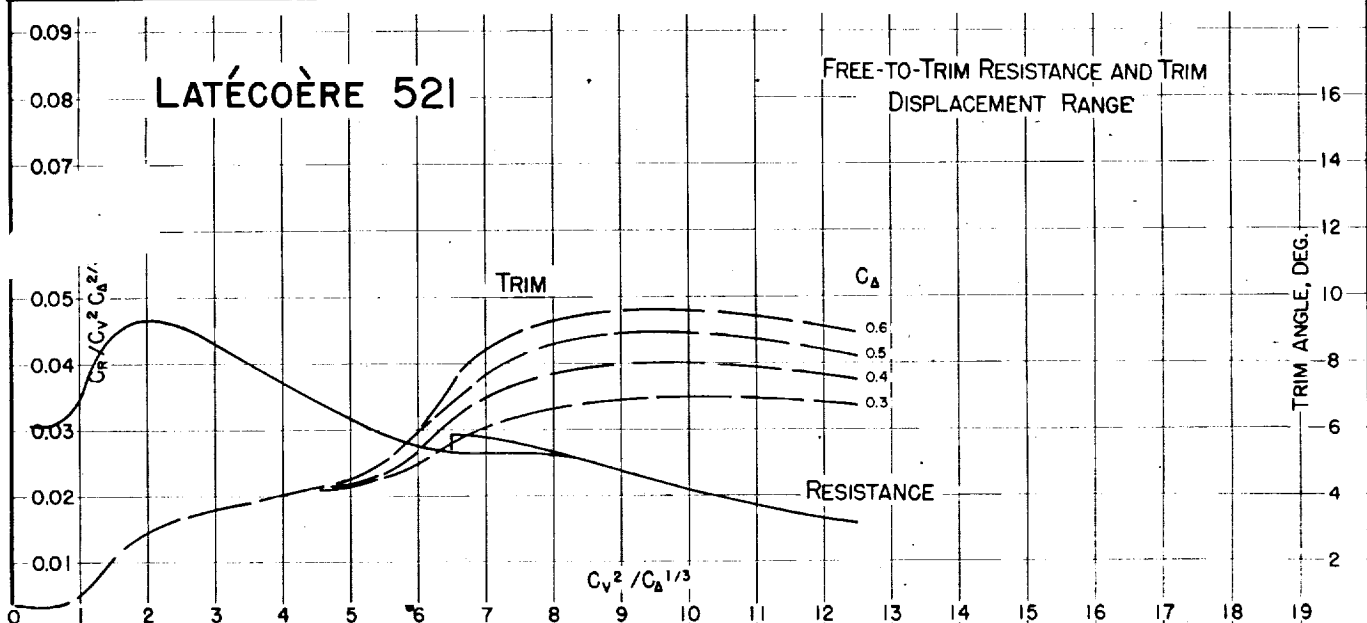
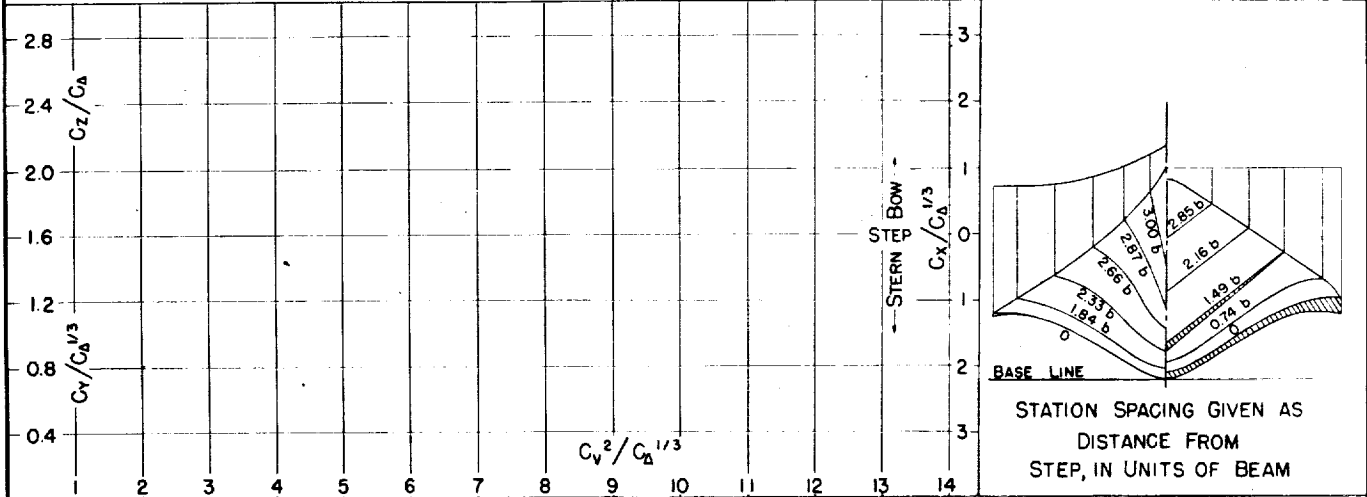

GETAWAY

Fig. 58

DESIGNATION: 3.24-0.34-20.0 NACA TN No. 1182

MODEL No. 84-AF
MODEL BEAM: 15.92"

C.G. = 0.46 b FWD. OF CENTROID
1.16 b ABOVE KEEL

$C_{d,0} =$
 $k/L =$

(NOMINAL)

TESTED AT NACA No. 1 TANK

DATE: 3/39

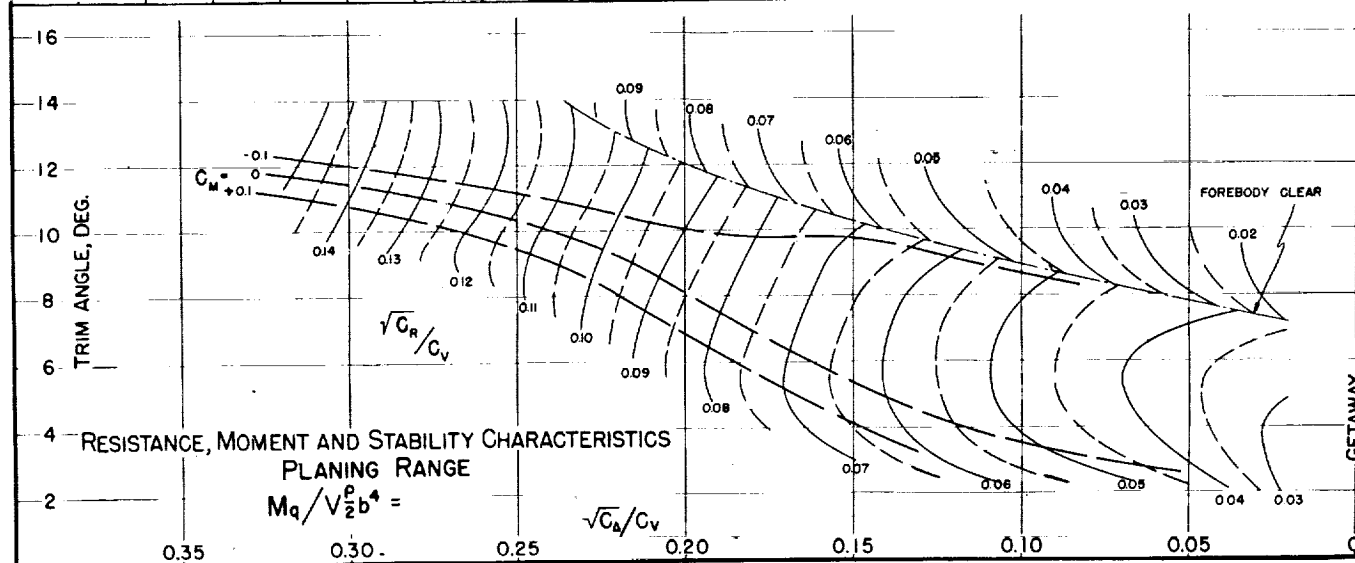
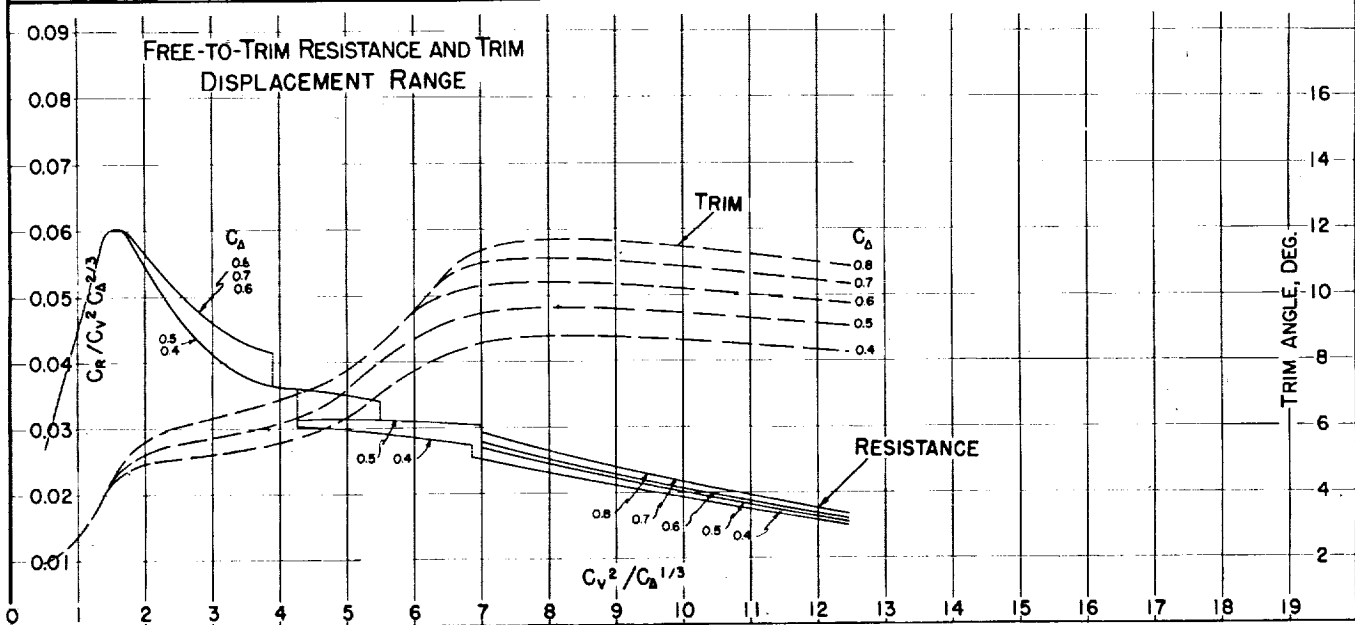
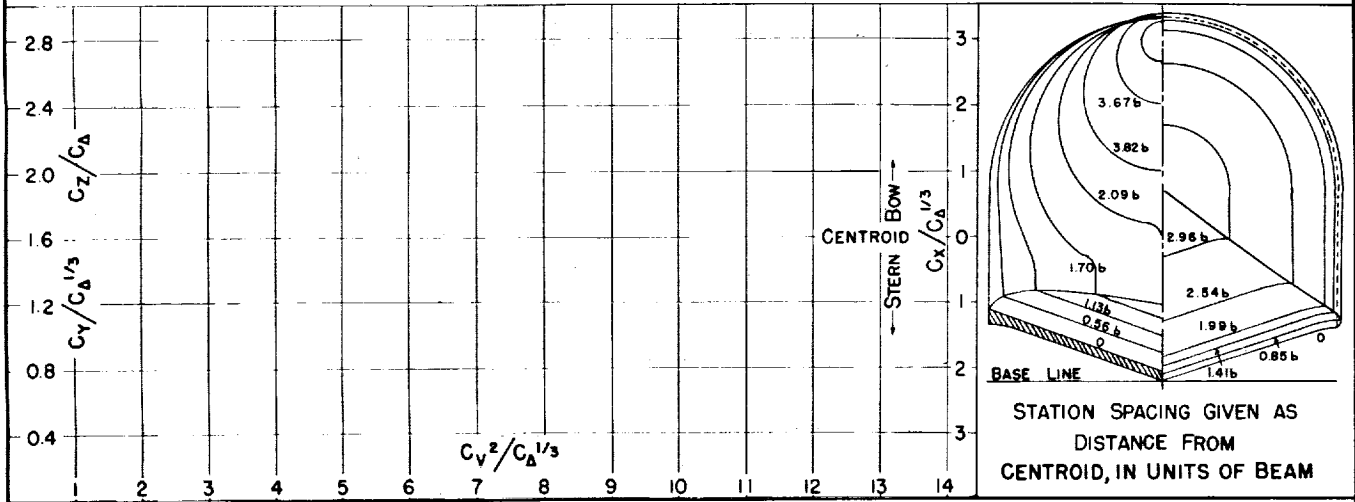

MODEL No. 84-EF-1
MODEL BEAM: 15.92"

C.G. = 0.46 b FWD. OF CENTROID
1.16 b ABOVE KEEL

$C_{D0} =$
 $k/L =$

(NOMINAL)

TESTED AT NACA No. 1 TANK

DATE: 3/39

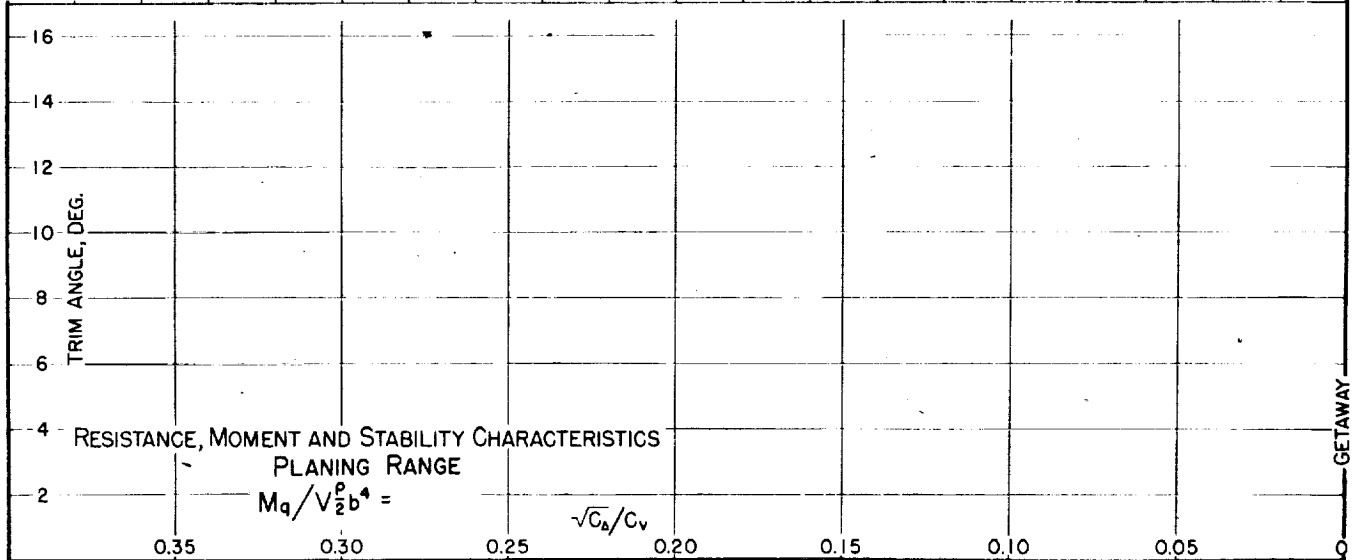
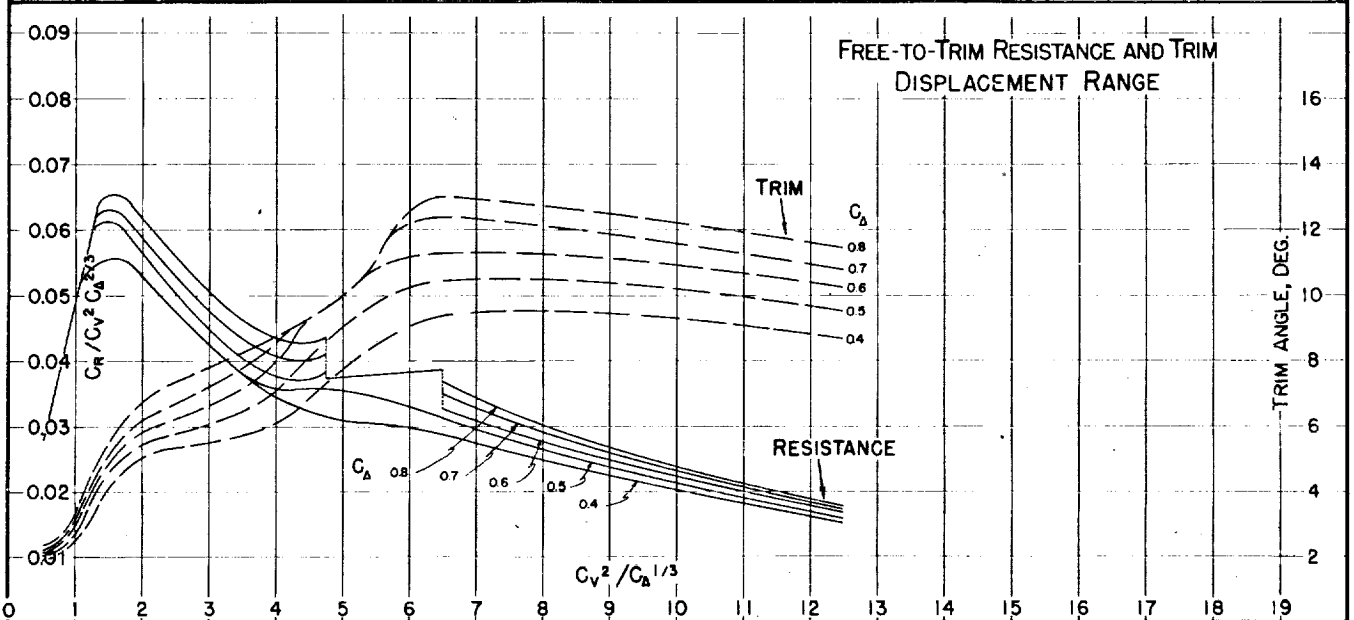
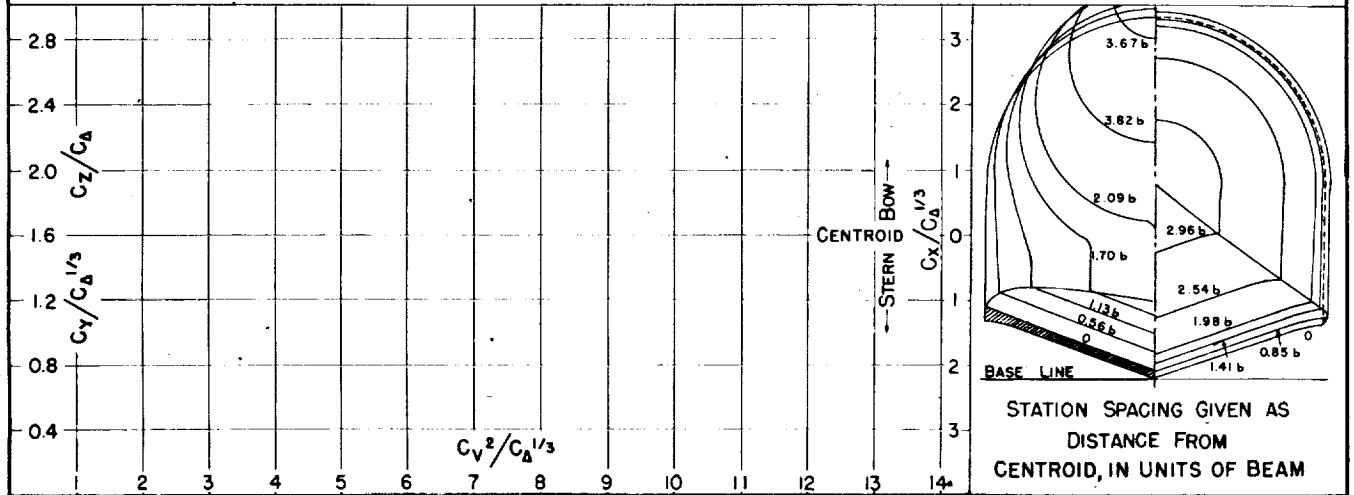

GETAWAY

Fig. 60

DESIGNATION: 3.24-0.57-20.0 NACA TN No. 1182

MODEL No. 84-EF-3
MODEL BEAM: 15.92"

C.G. = 0.46 b FWD. OF CENTROID
1.16 b ABOVE KEEL
 $C_{A0} =$ (NOMINAL)
 $k/L =$

TESTED AT NACA No. 1 TANK
DATE: 3/39

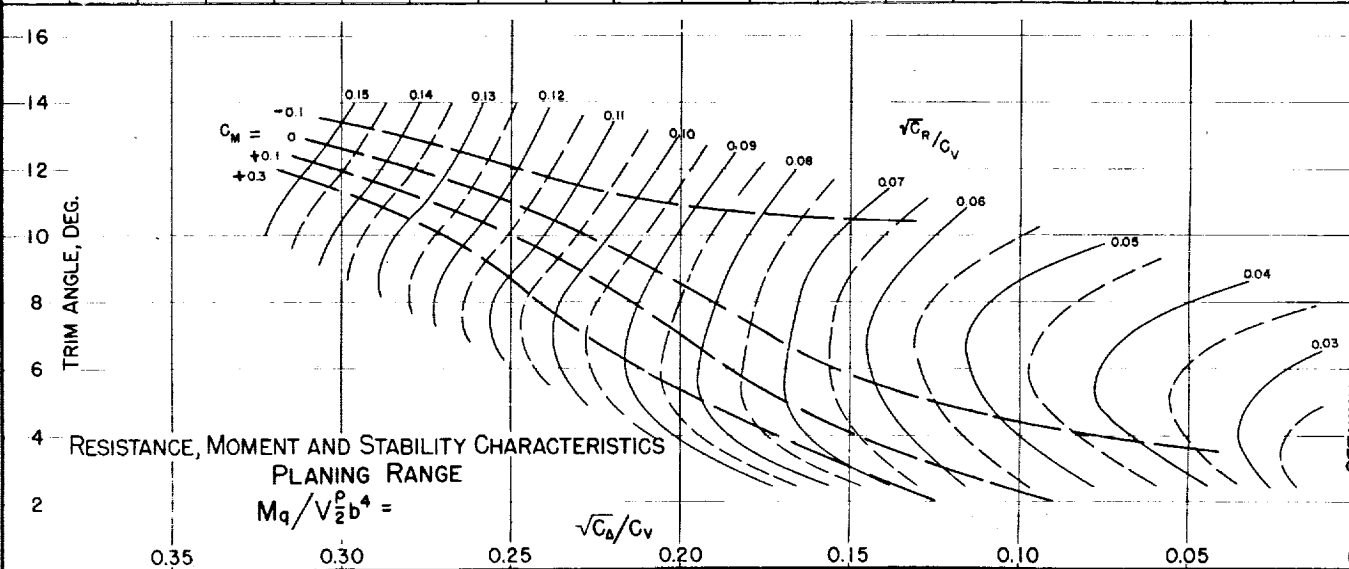
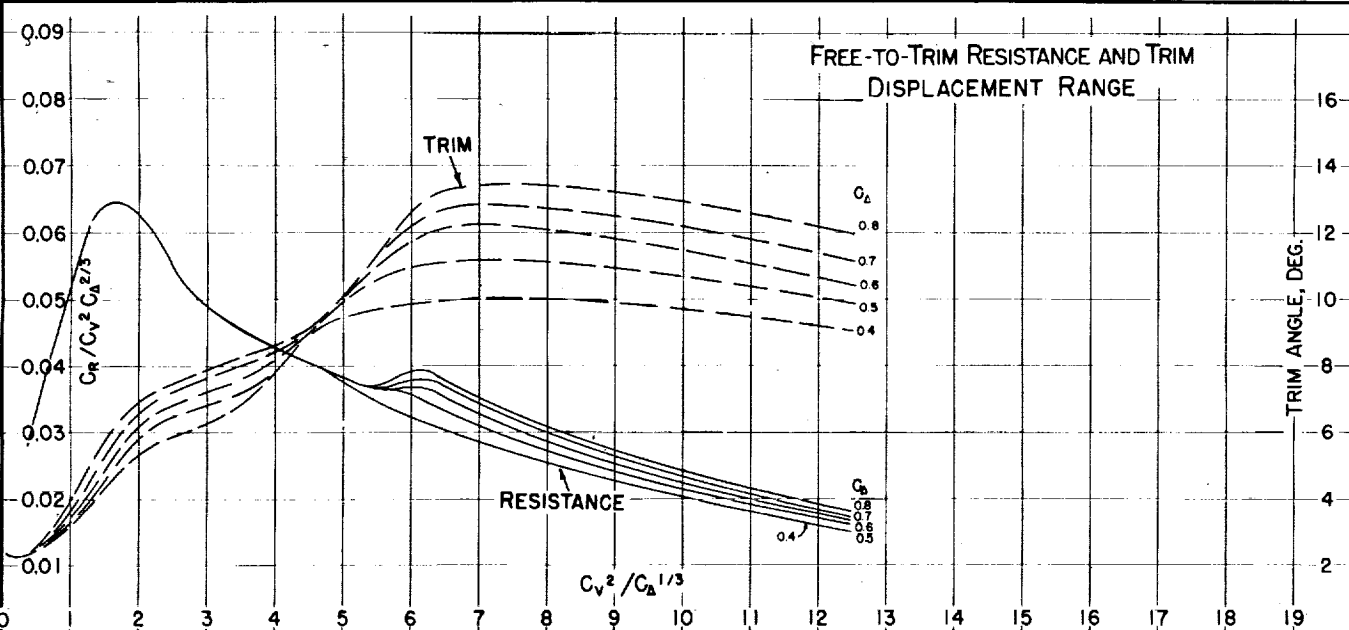
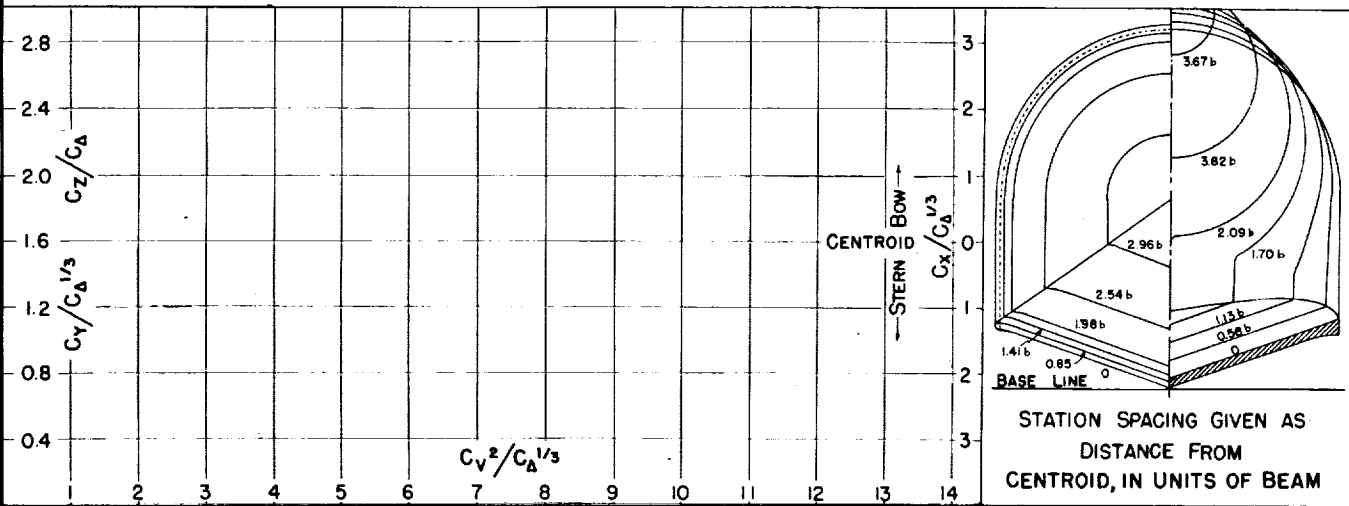

MODEL No. 84-EF-4
MODEL BEAM: 15.92"

C.G. = 0.46 b FWD. OF CENTROID
1.16 b ABOVE KEEL

$C_{d_0} =$ (NOMINAL)
 $k/L =$

TESTED AT NACA No. 1 TANK
DATE: 3/39

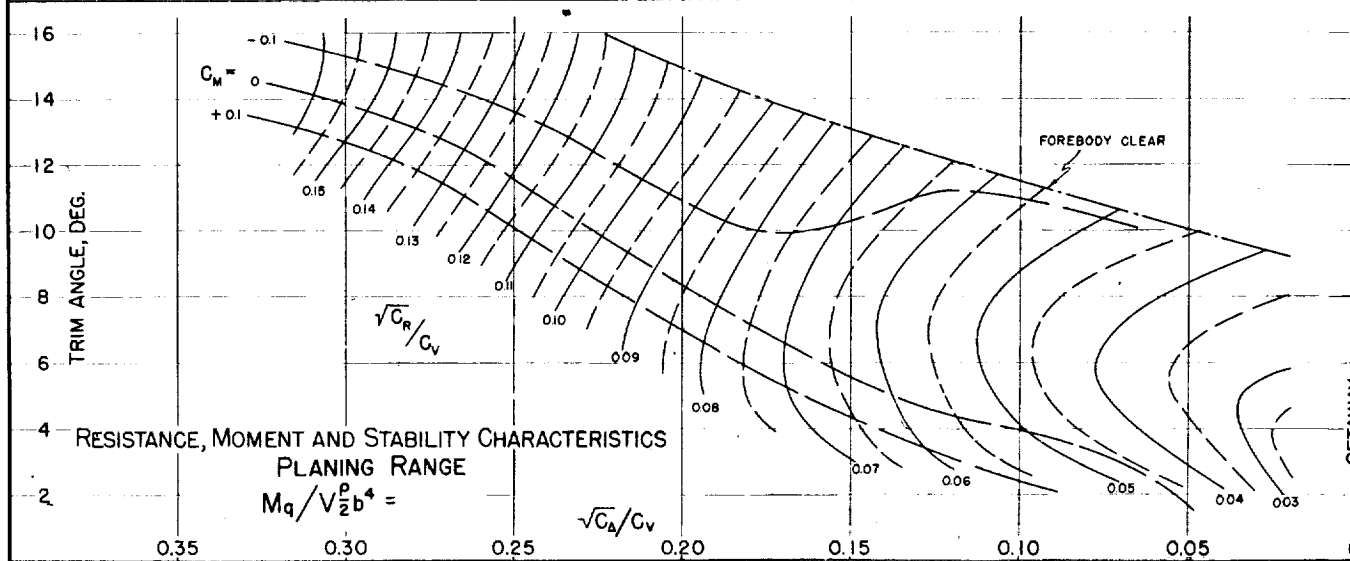
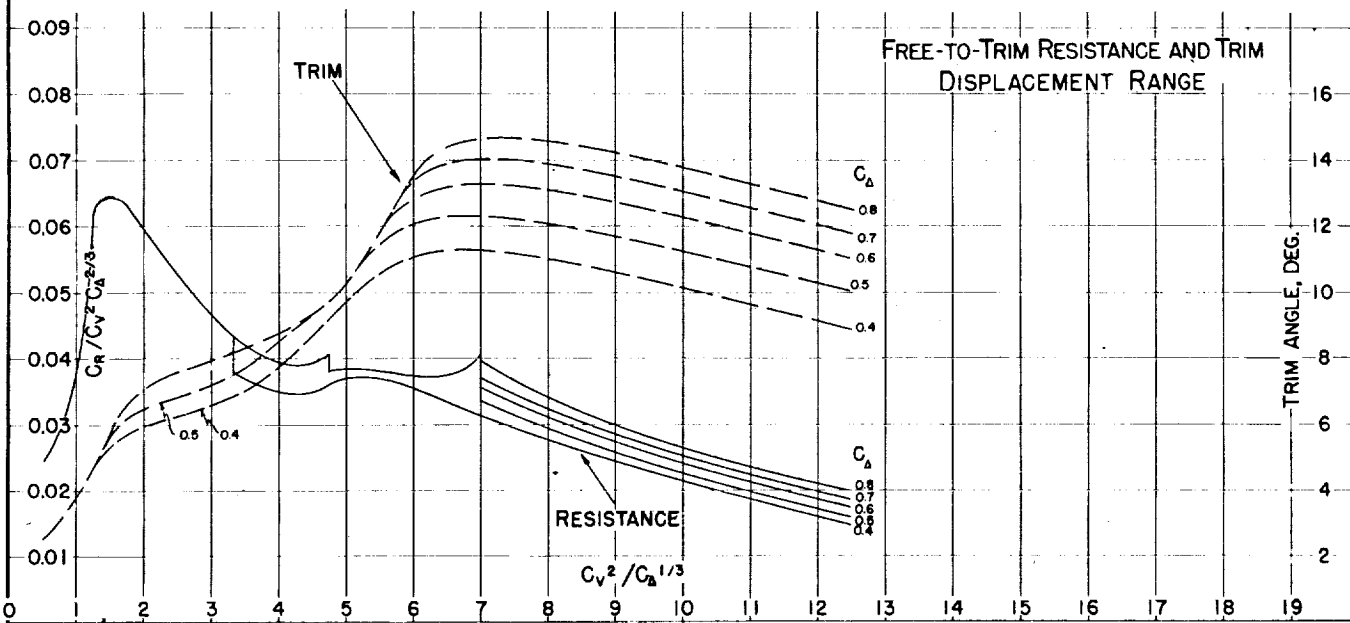
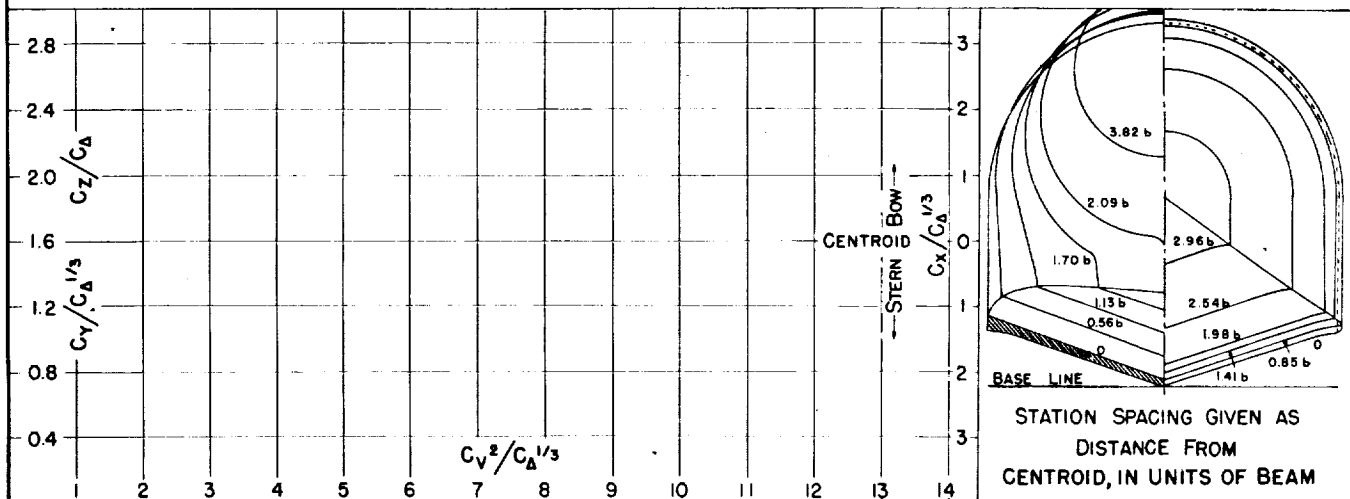

GETAWAY

Fig. 62

DESIGNATION: 2.82 - 0.88 - 17.5 NACA TN No. 1182

MODEL No. 126 A-1
MODEL BEAM 14.00"

C.G. = 0.31 b FWD. OF CENTROID
1.17 b ABOVE KEEL

$C_{d0} =$
 $k/L =$

(NOMINAL)

TESTED AT NACA No. 1 TANK

DATE: 7/42

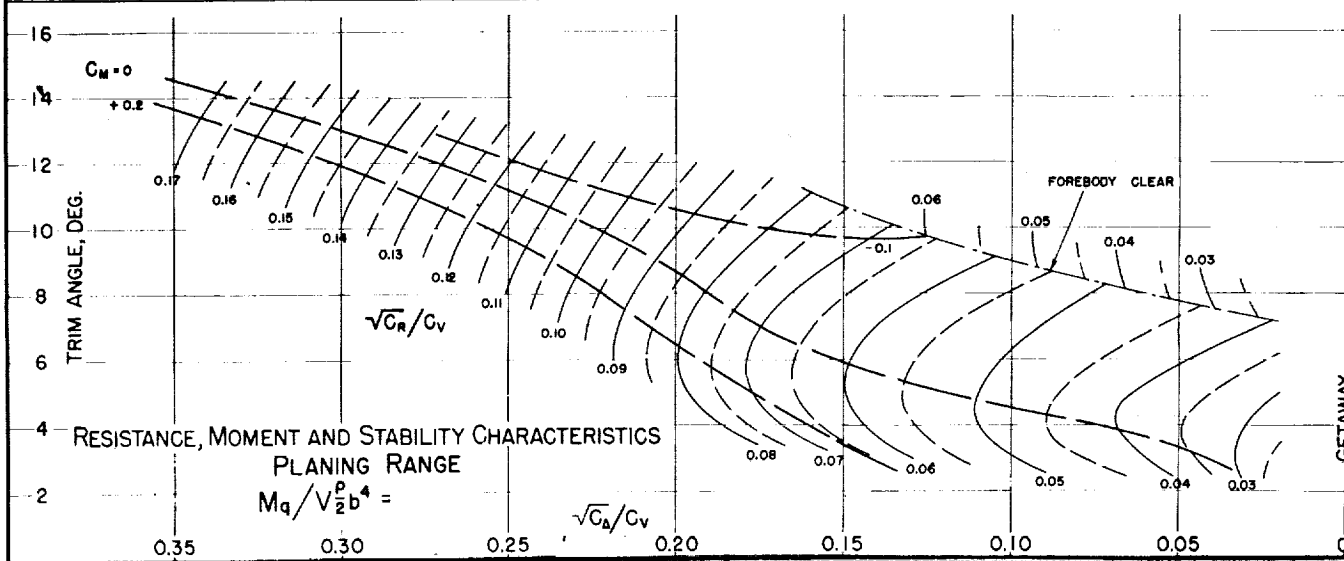
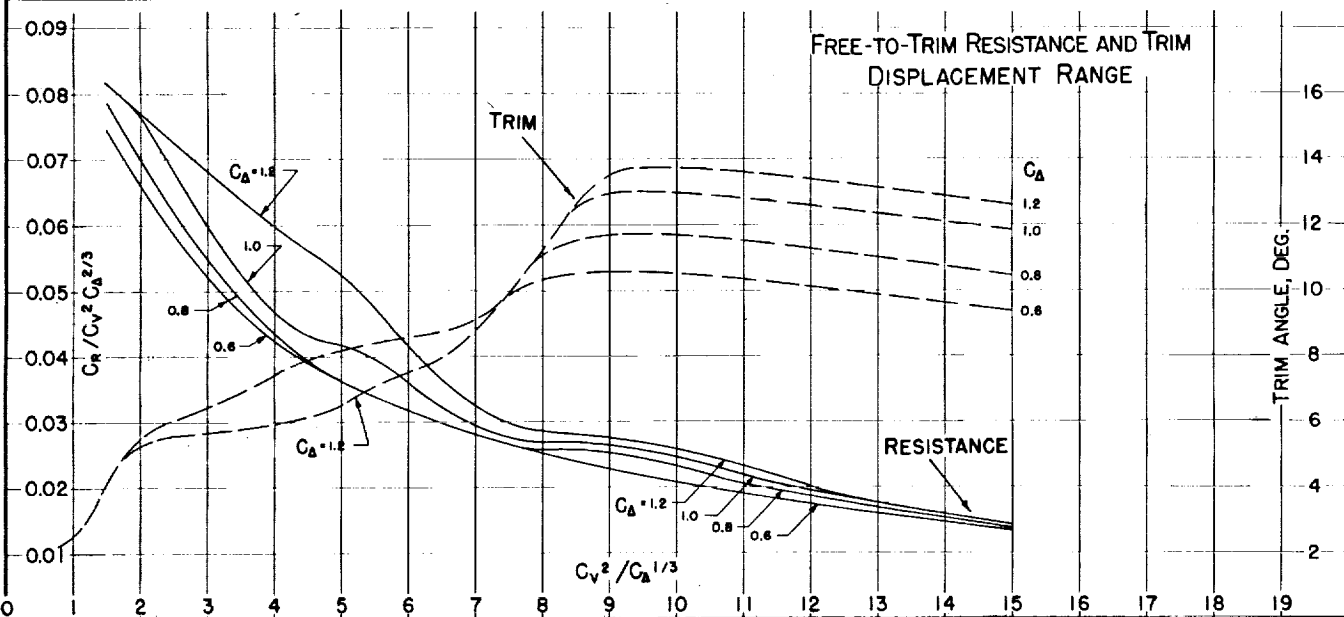
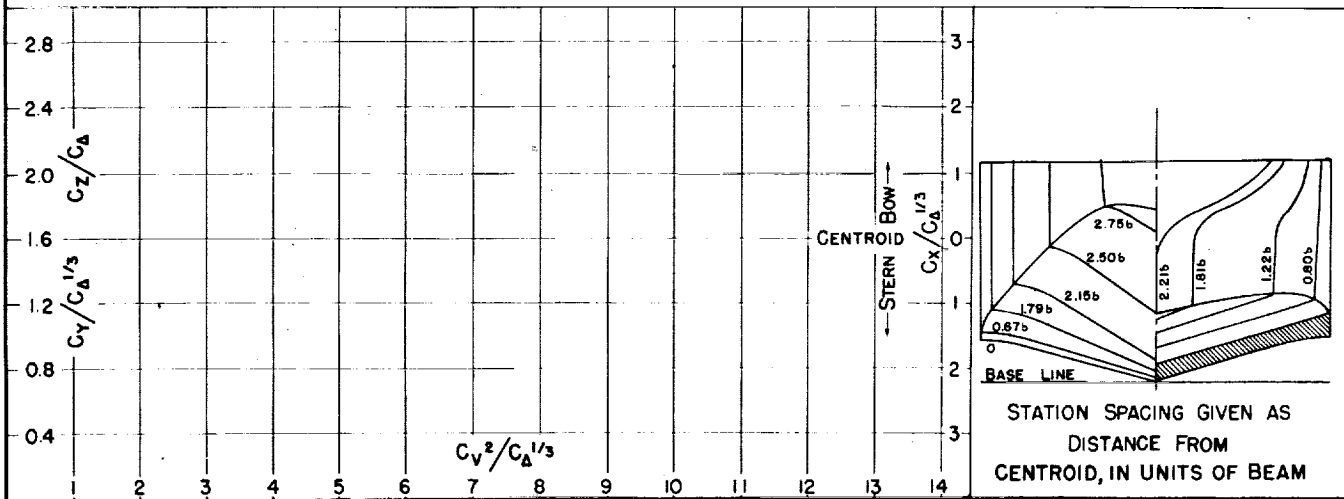

MODEL No. 126 A-2
MODEL BEAM 14.00"

C.G. = 0.31 b FWD. OF CENTROID
1.17 b ABOVE KEEL

$C_{d_0} =$ (NOMINAL)
 $k/L =$

TESTED AT NACA No. 1 TANK
DATE: 7/42

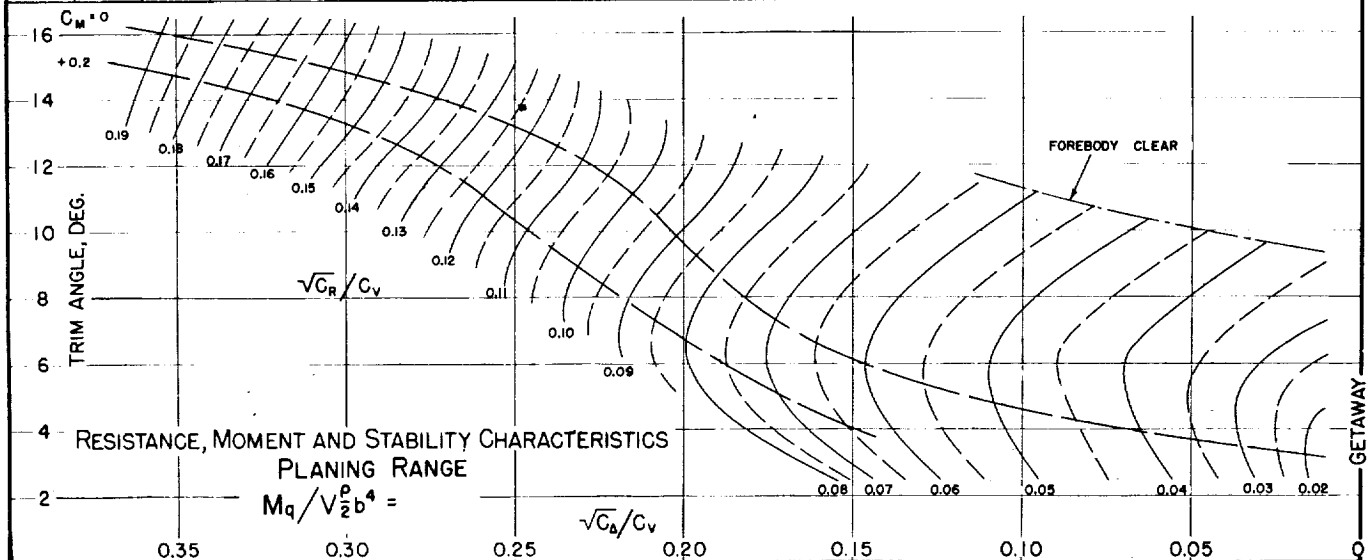
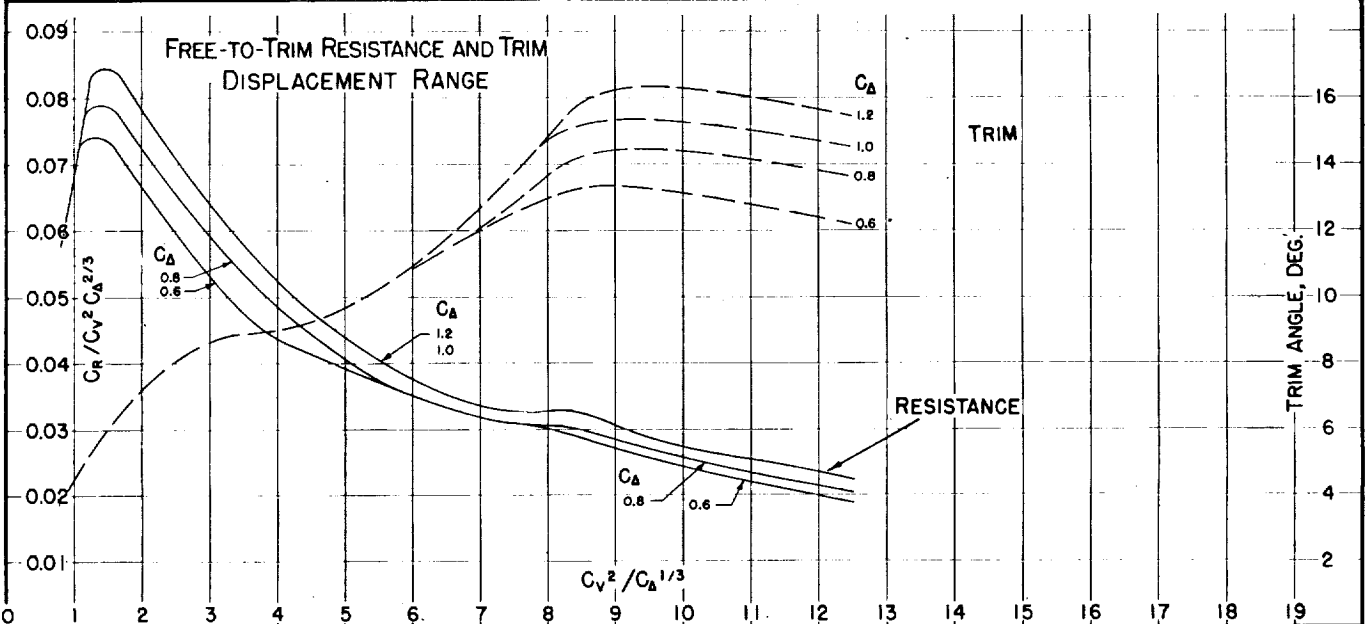
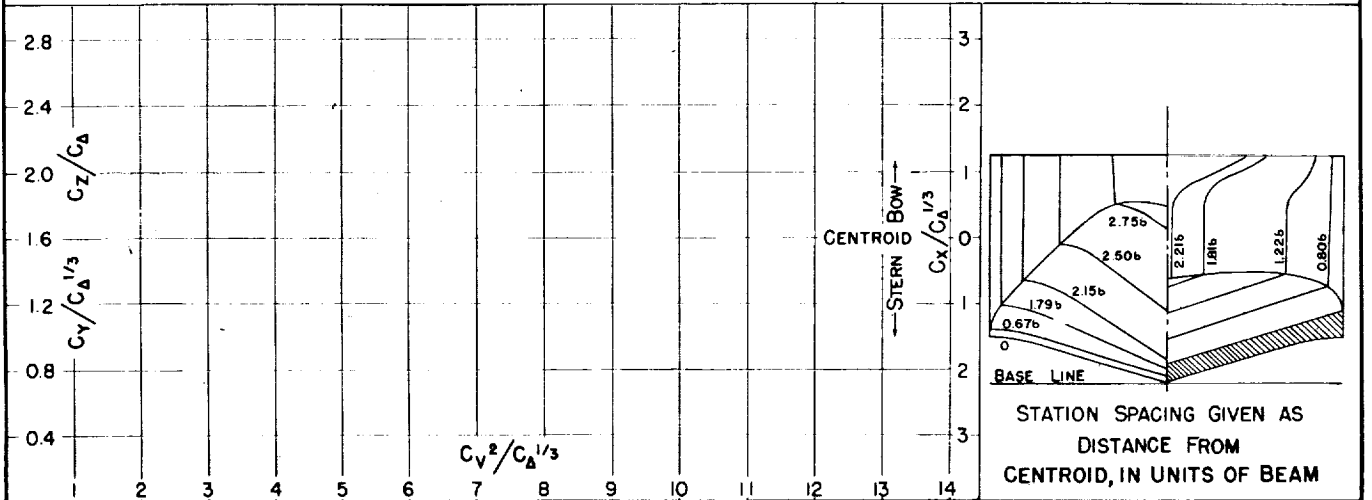

Fig. 64

DESIGNATION: 2.82 - 0.47 - 17.5 NACA TN No. 1182

MODEL No. 126 A-3
MODEL BEAM: 14.00"

C.G. = 0.31 b FWD. OF CENTROID
1.17 b ABOVE KEEL

$C_{a_0} =$
 $k/L =$

(NOMINAL)

TESTED AT NACA No. 1 TANK

DATE: 7/42

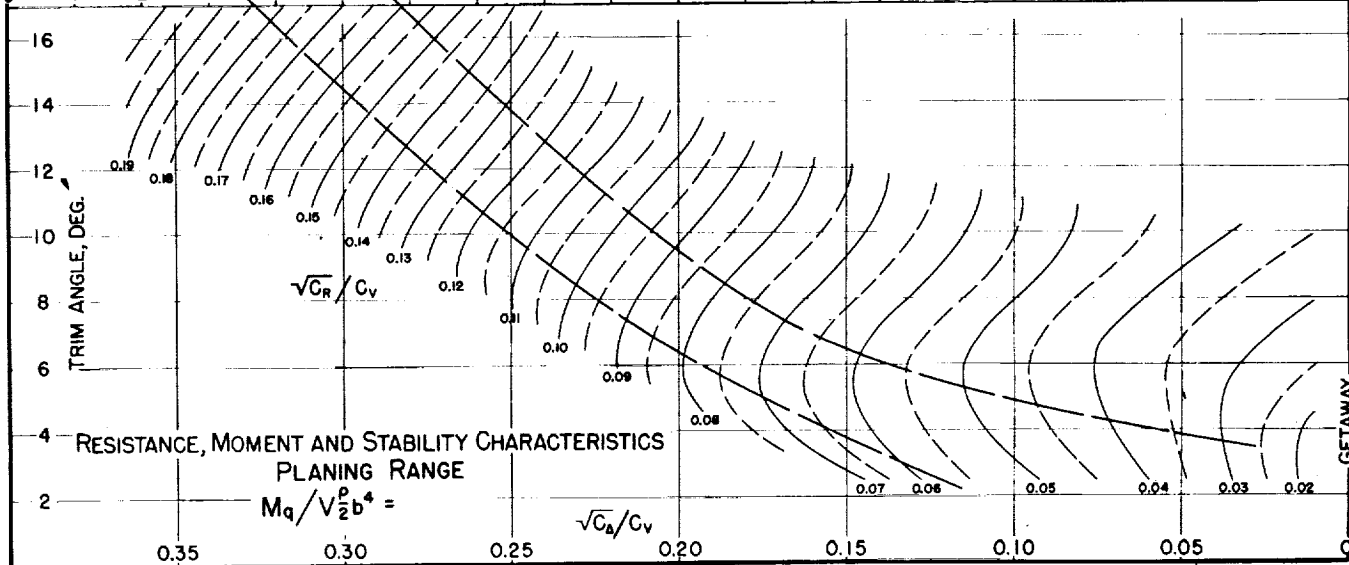
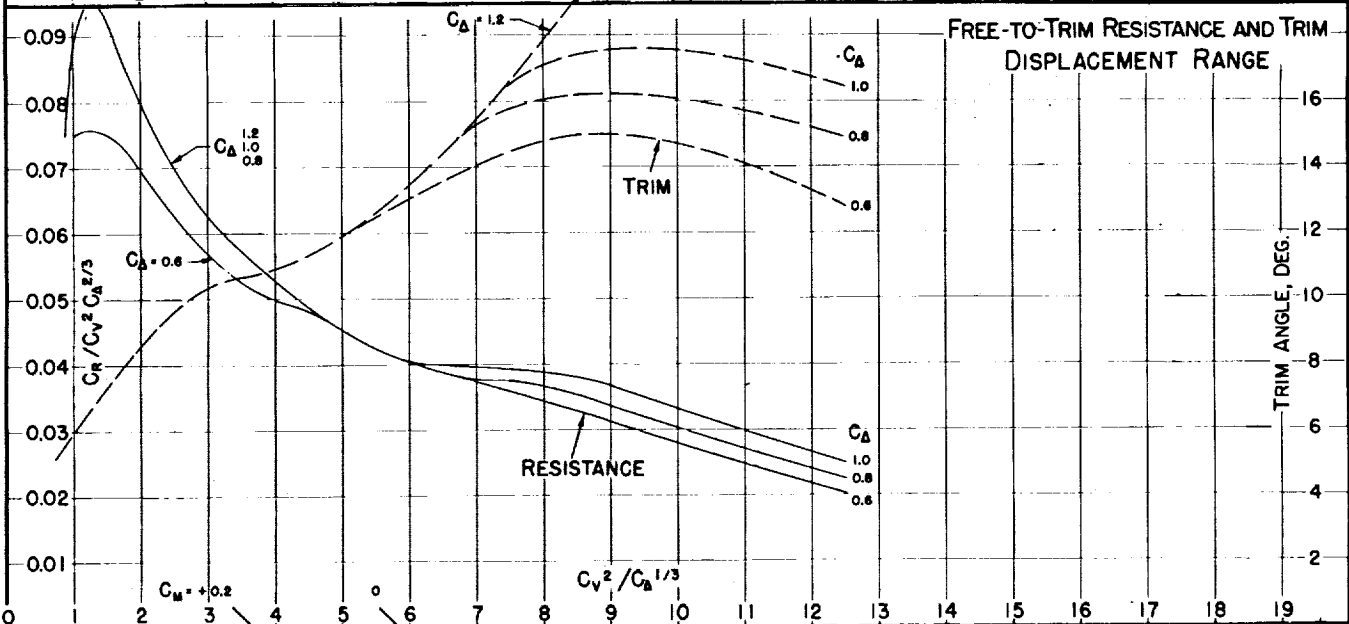
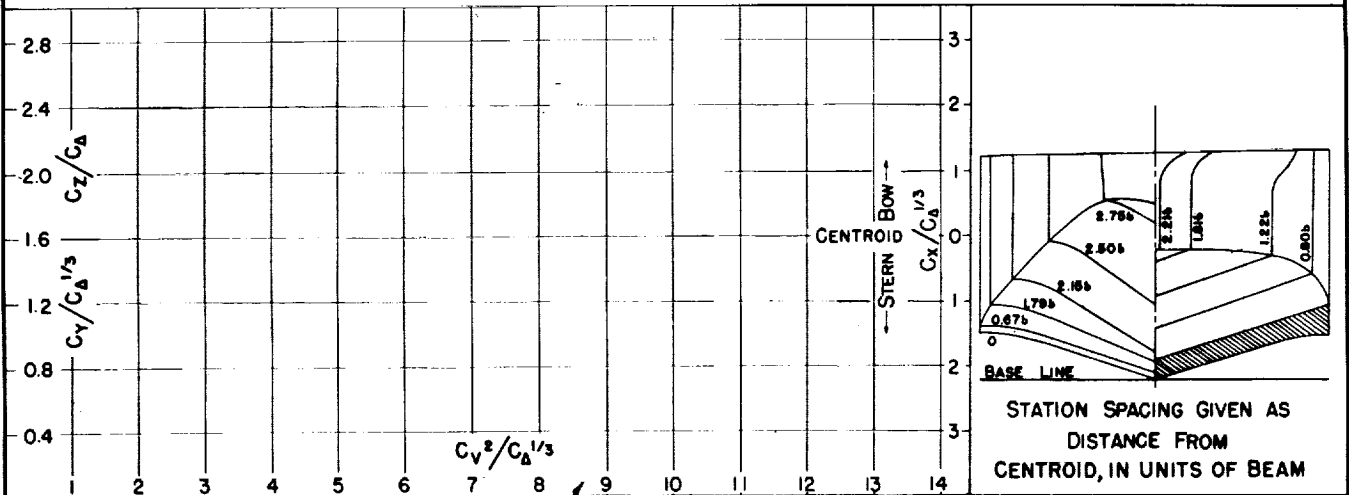

MODEL No. 126 B-1
MODEL BEAM 14.00"

C.G. = 0.31 b FWD. OF CENTROID
1.17 b ABOVE KEEL

$C_{\Delta} =$ (NOMINAL)

TESTED AT NACA No. 1 TANK

DATE: 2/42

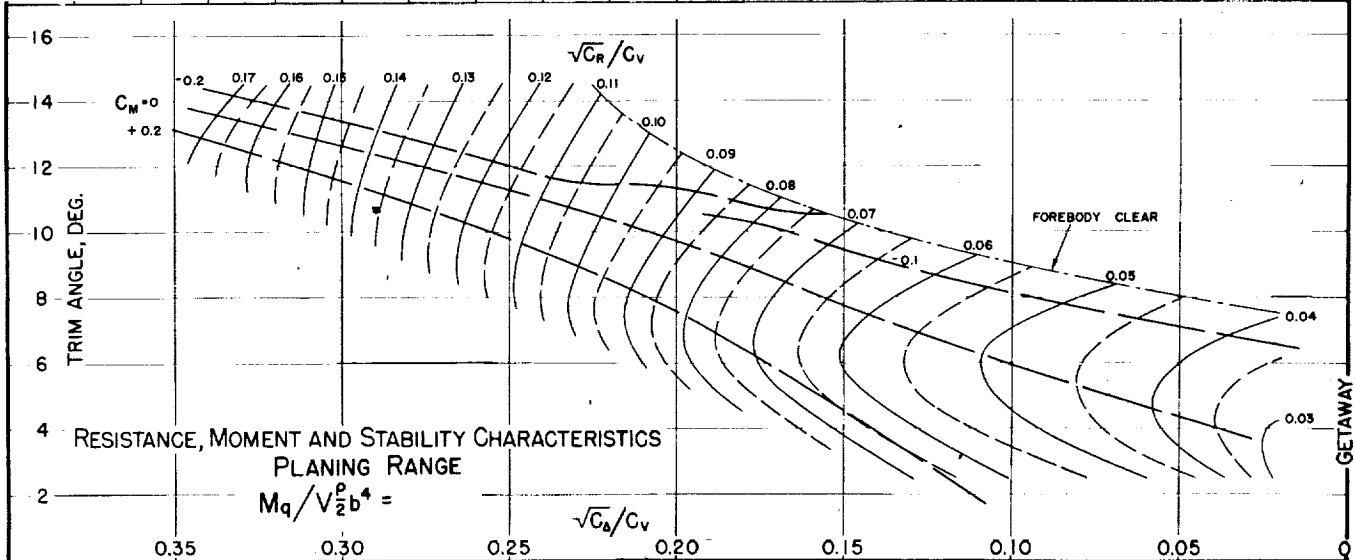
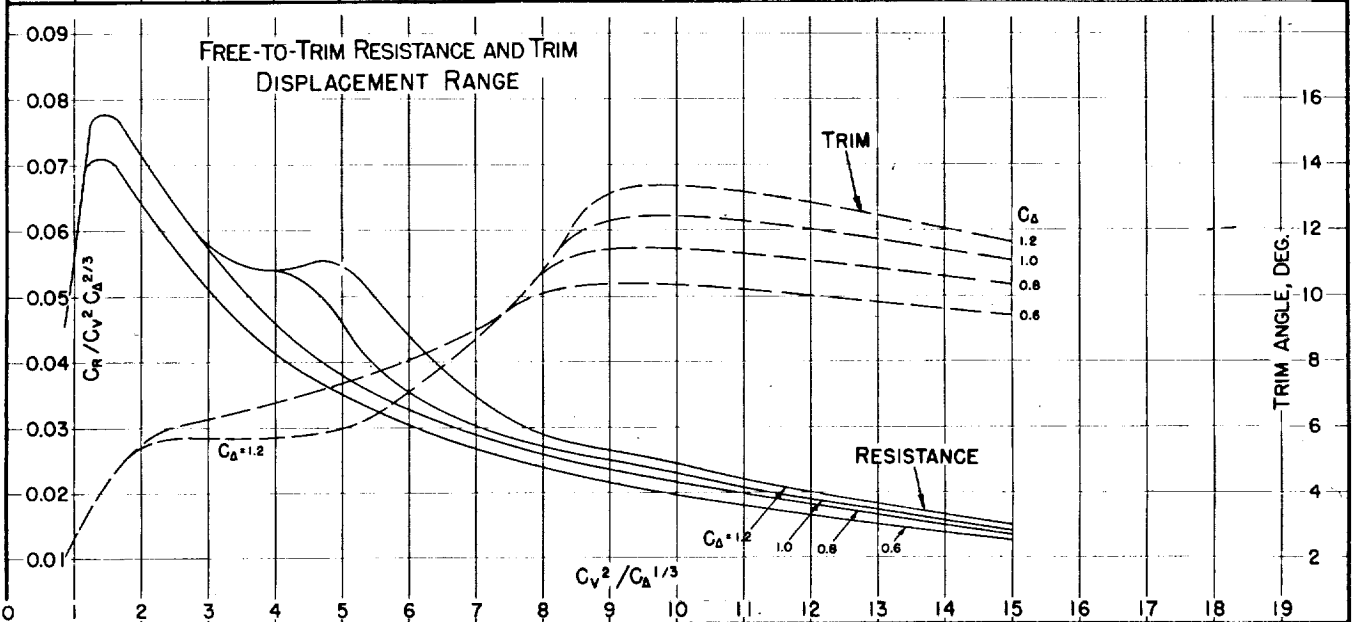
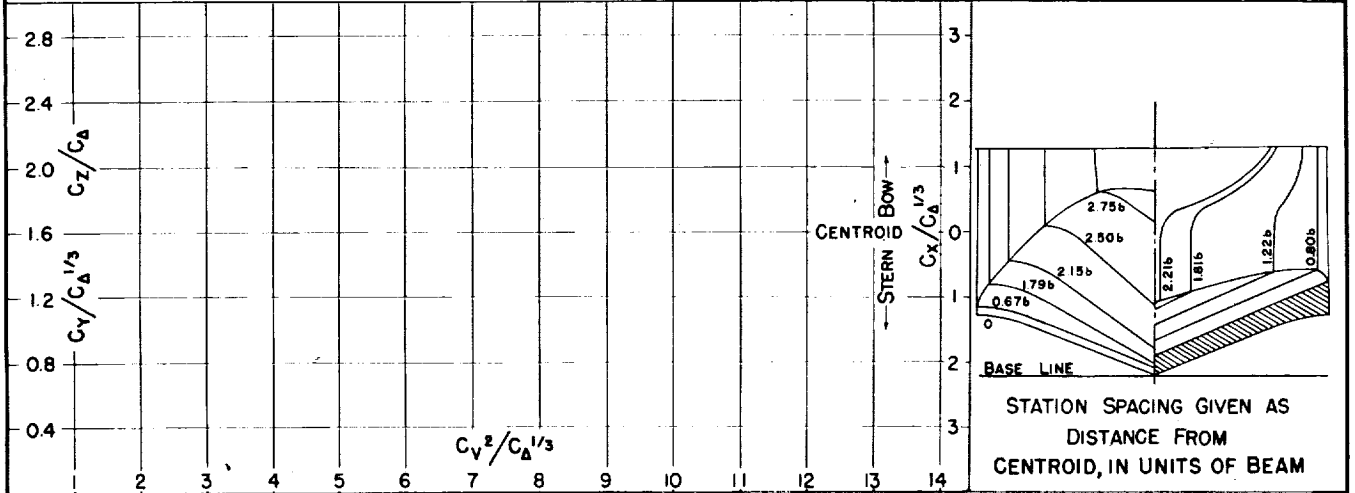

Fig. 66

DESIGNATION: 2.82-0.58-22.5 NACA TN No. 1182

MODEL No. 126B-2
MODEL BEAM: 14.00"

C.G. = 0.31 b FWD. OF CENTROID
1.17 b ABOVE KEEL

$C_{d_0} =$ (NOMINAL)

TESTED AT NACA No. 1 TANK

DATE: 2/42

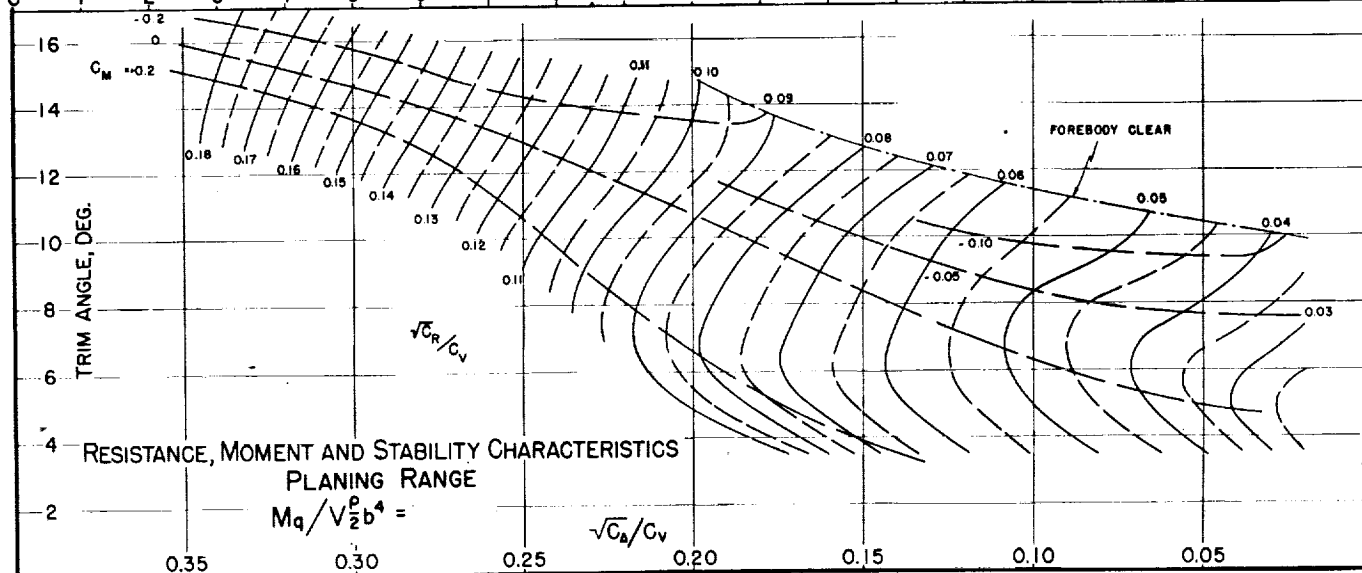
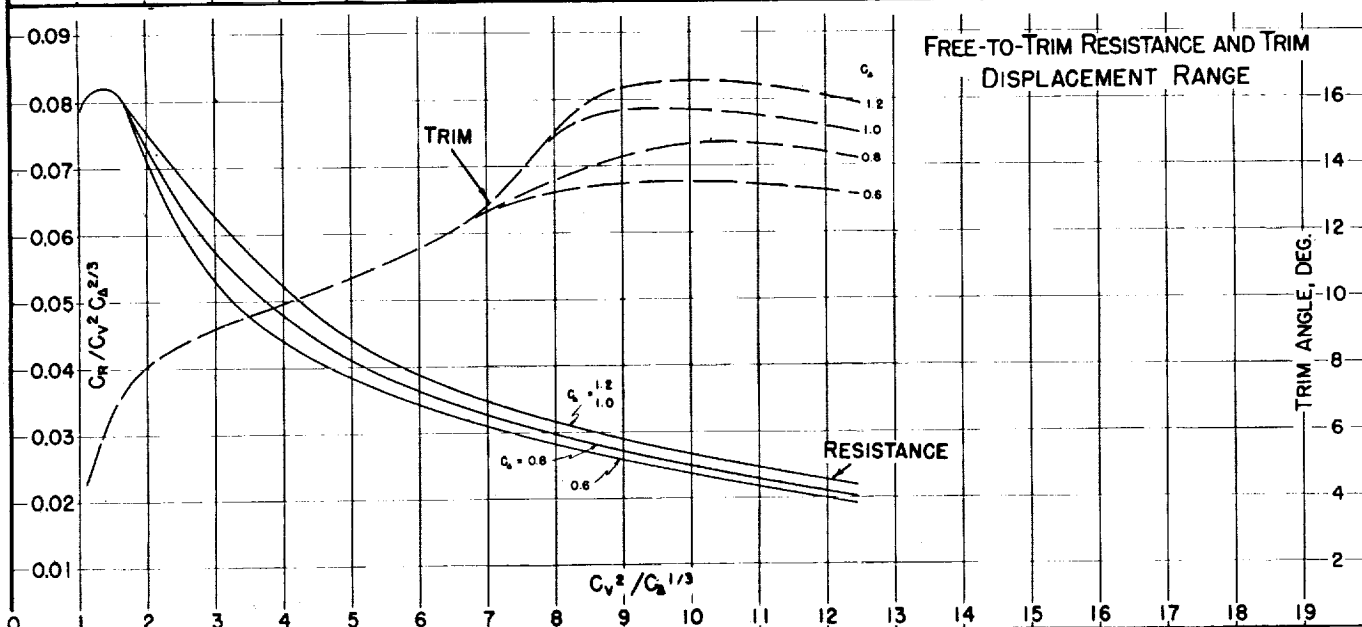
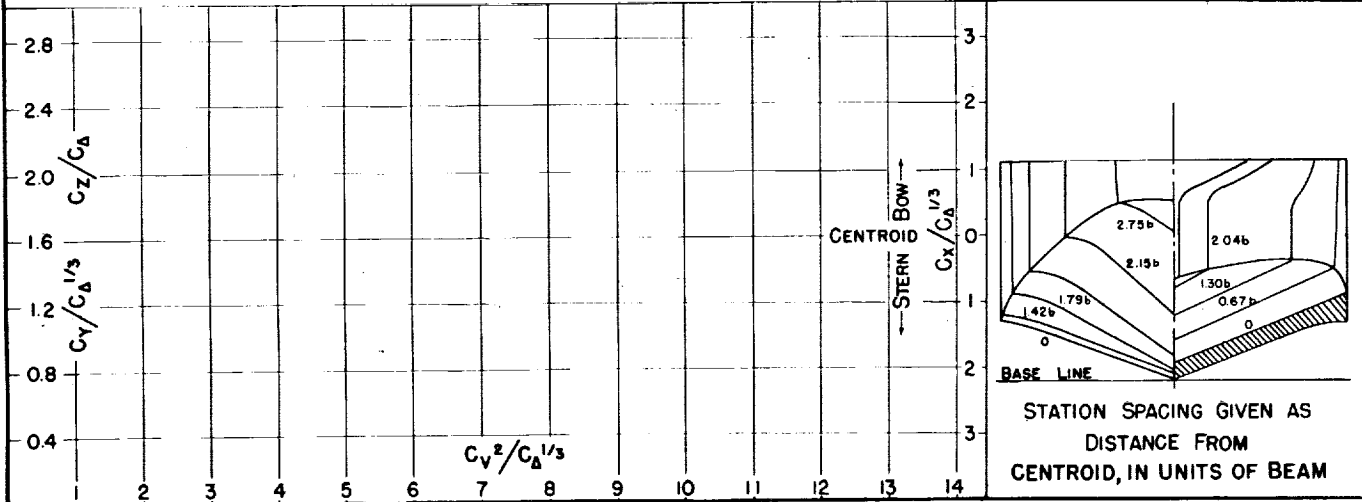

GETAWAY

MODEL No. 126 B-3.
MODEL BEAM: 14.00"

C.G. = 0.31 b FWD. OF CENTROID
1.17 b ABOVE KEEL

$C_{d0} =$ (NOMINAL)
 $k/L =$

TESTED AT NACA No. 1 TANK
DATE: 2/42

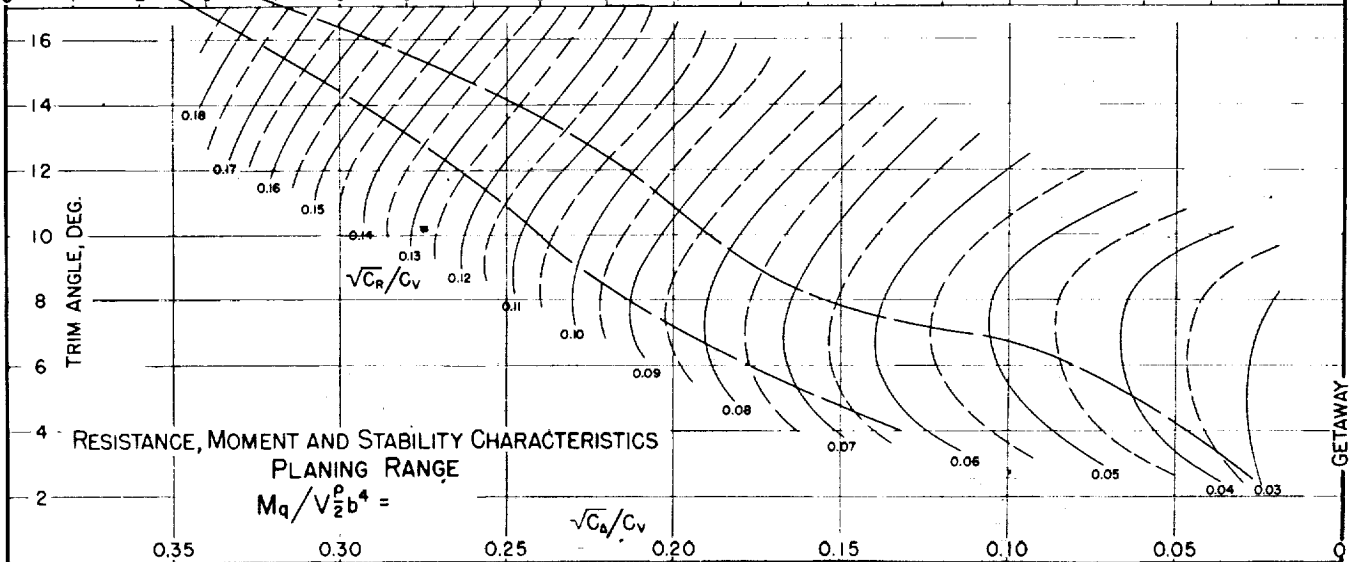
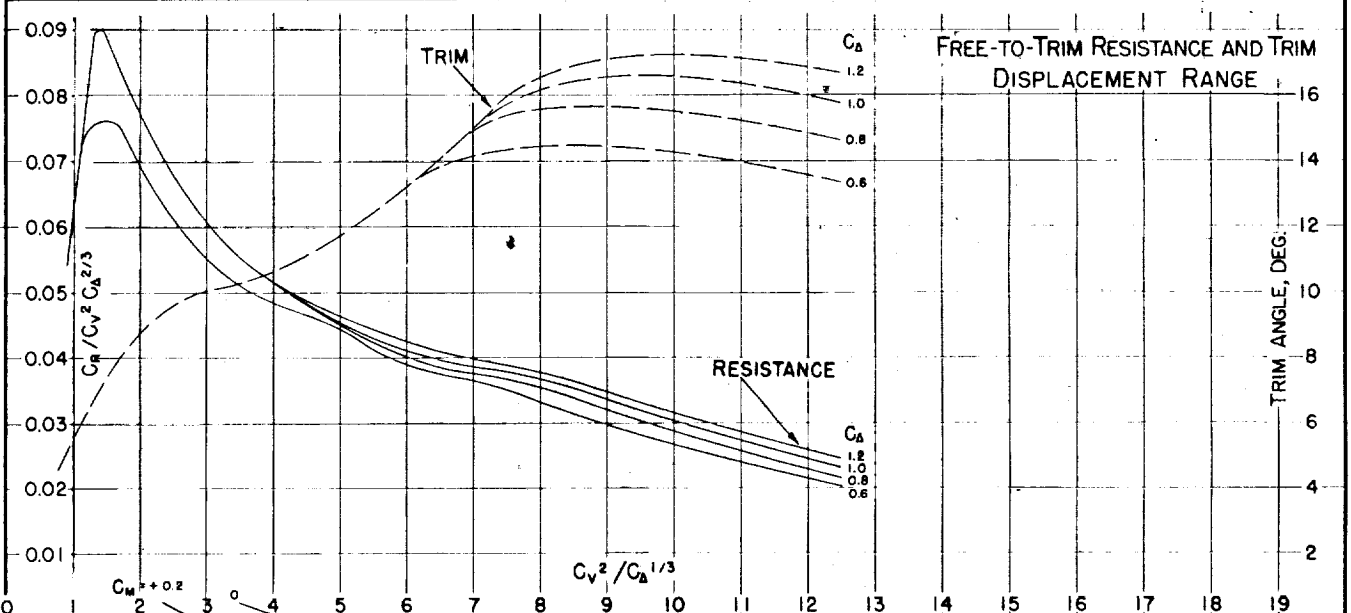
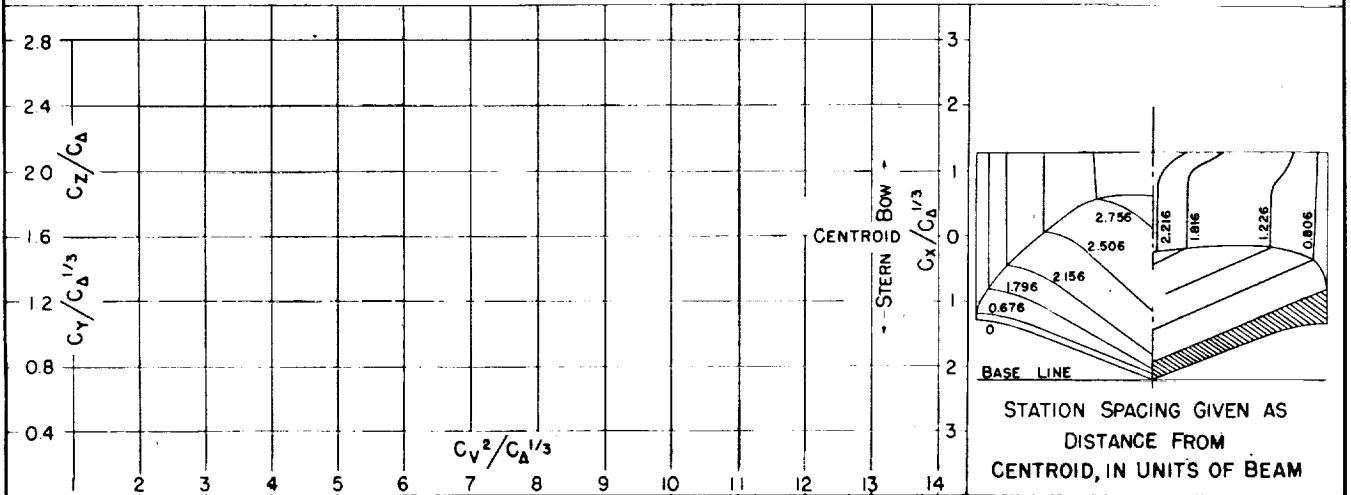

GETAWAY

Fig. 68

DESIGNATION: 2.82 - 0.88 - 27.5 NACA TN No. 1182

MODEL No. 126 C-1
MODEL BEAM 14.00"

C.G. = 0.31 b FWD. OF CENTROID
1.17 b ABOVE KEEL

$C_{d0} =$
 $k/L =$

(NOMINAL)

TESTED AT NACA No. 1 TANK

DATE: 7/42

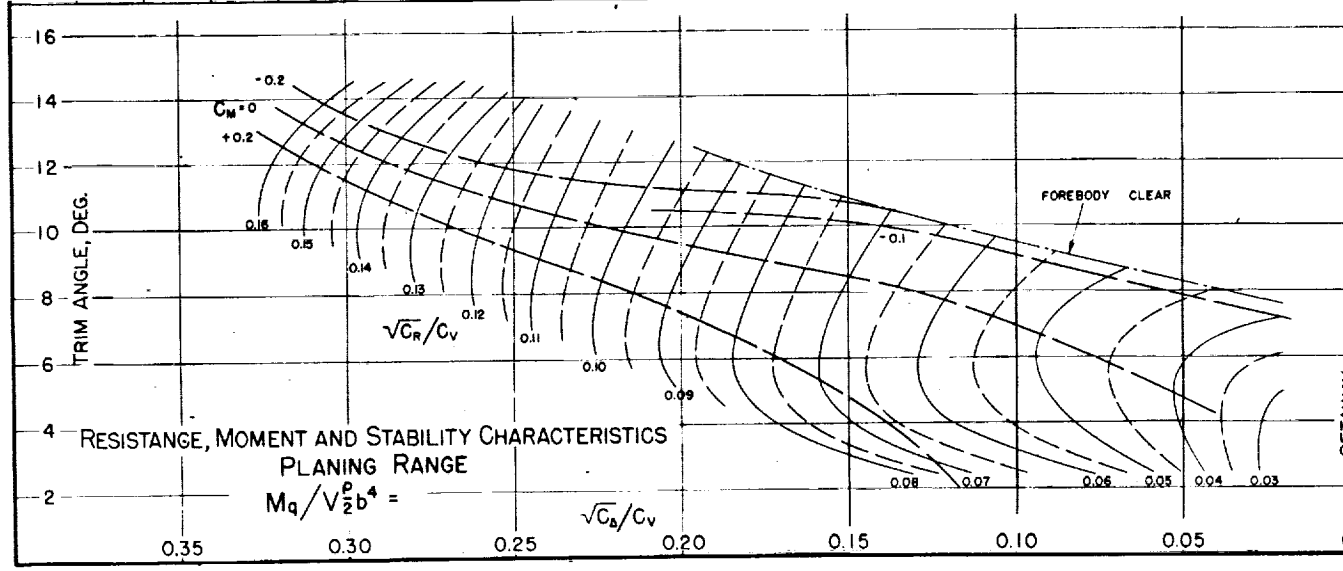
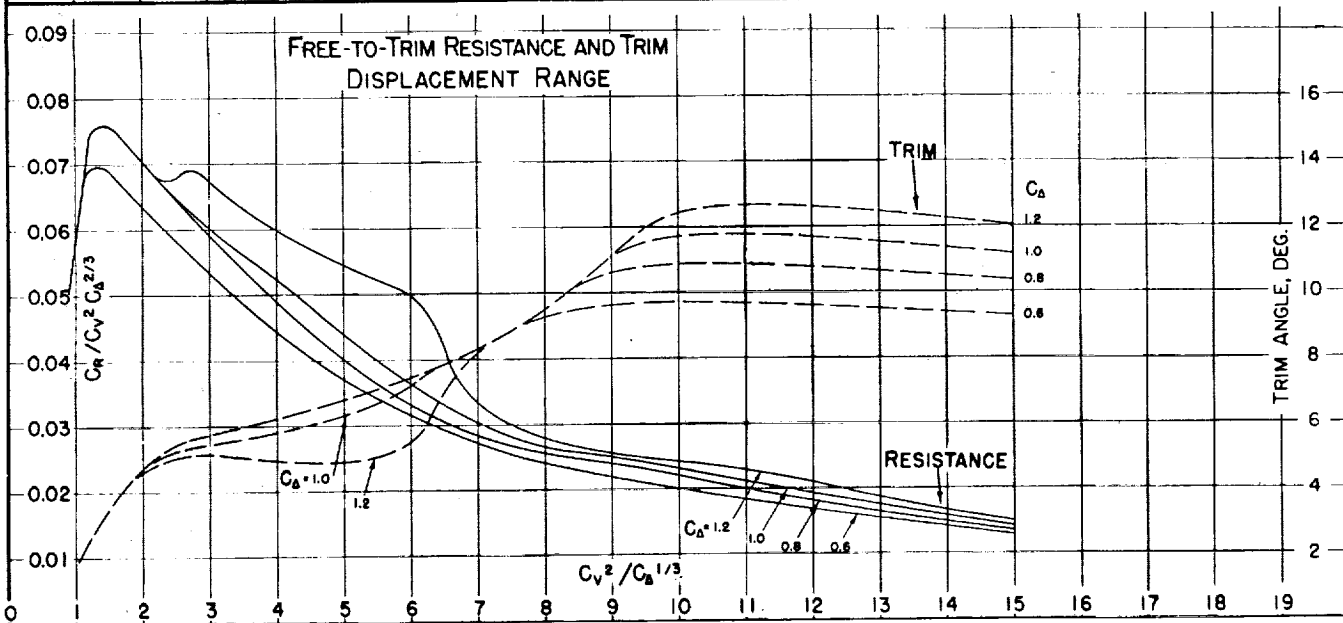
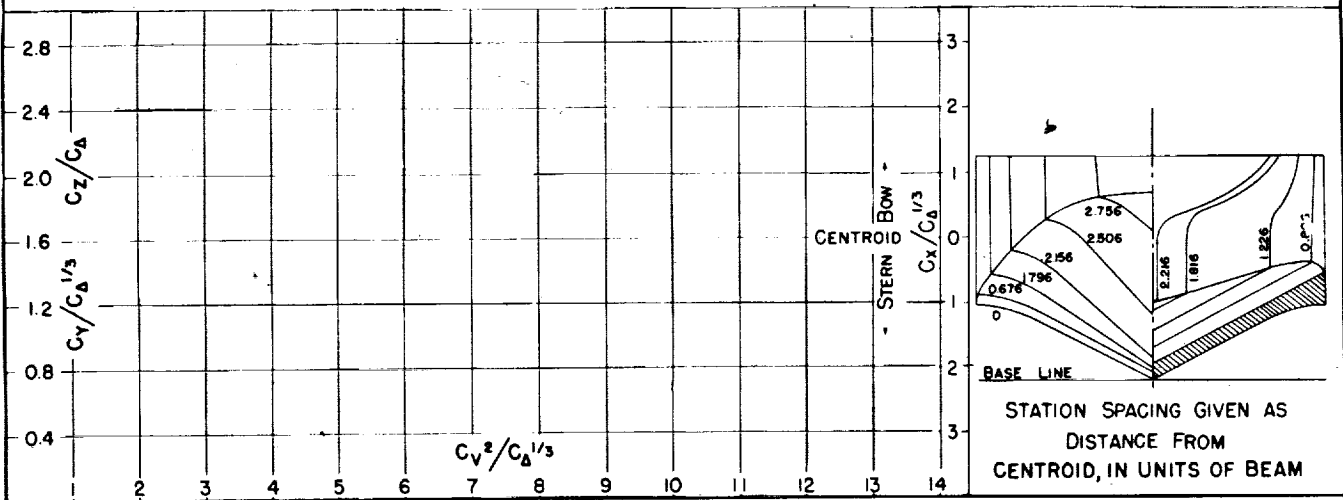

MODEL No. 126 C-2
MODEL BEAM: 14.00"

C.G. = 0.31 b FWD. OF CENTROID
1.17 b ABOVE KEEL

$C_{D0} =$ (NOMINAL)
 $k/L =$

TESTED AT NACA No. 1 TANK
DATE: 7/42

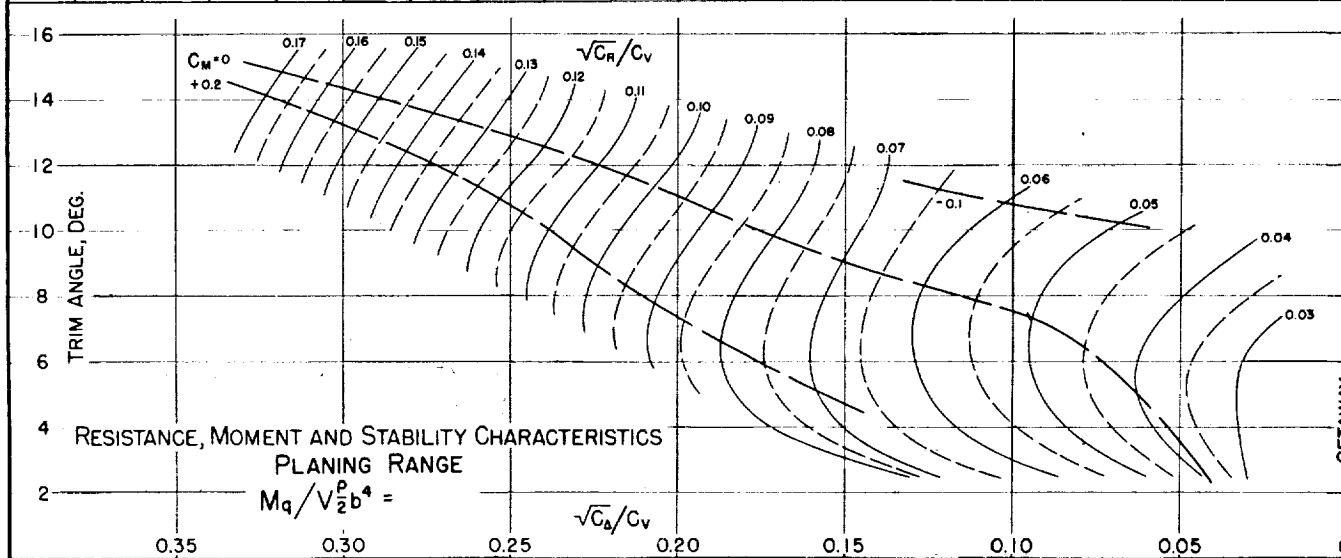
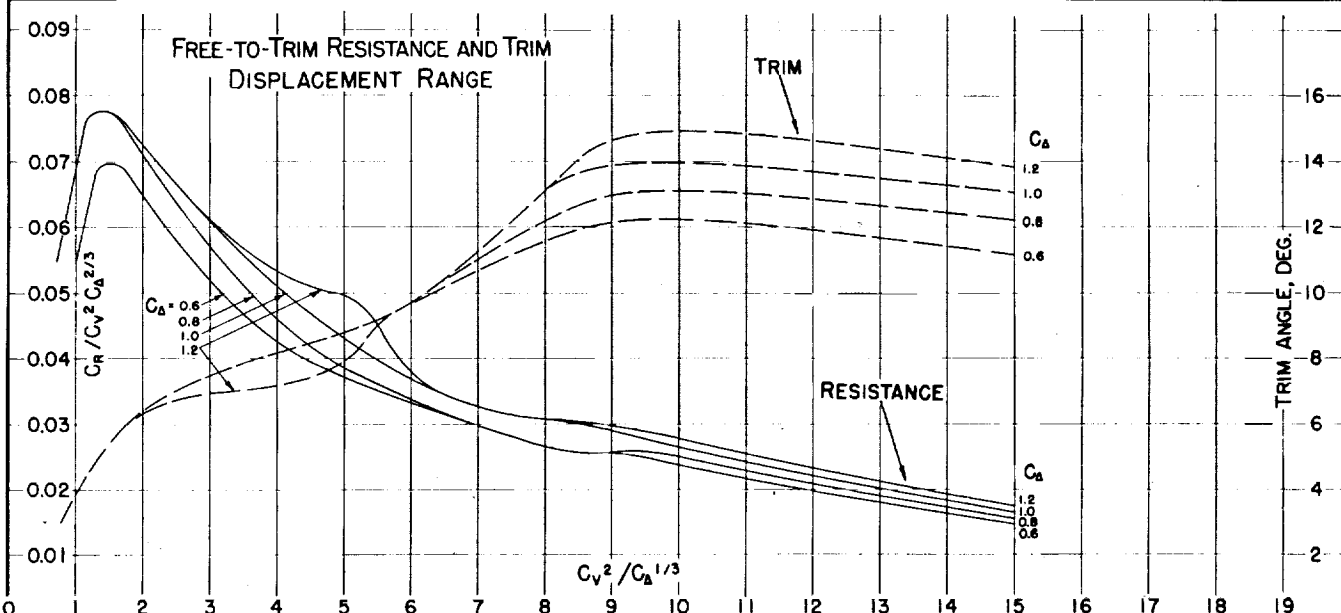
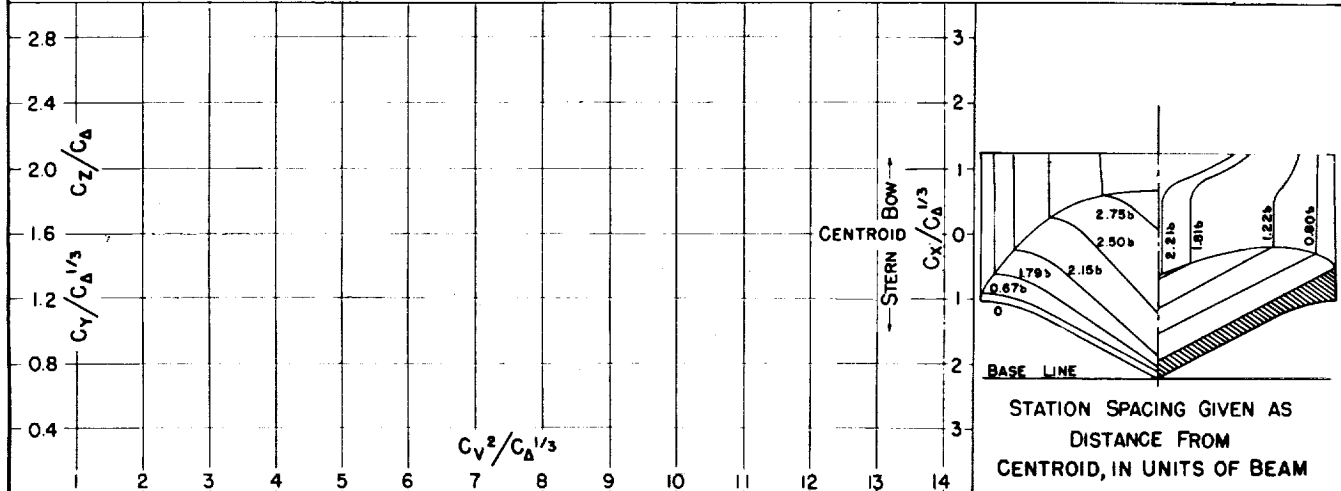

GETAWAY

Fig. 70

DESIGNATION: 2.82 - 0.47 - 27.5 NACA TN No. 1182

MODEL No. 126 C-3
MODEL BEAM: 14.00"

C.G. = 0.31 b FWD. OF CENTROID $C_{d_0} =$
1.17 b ABOVE KEEL $k/L =$

(NOMINAL)

TESTED AT NACA No. 1 TANK
DATE: 7/42

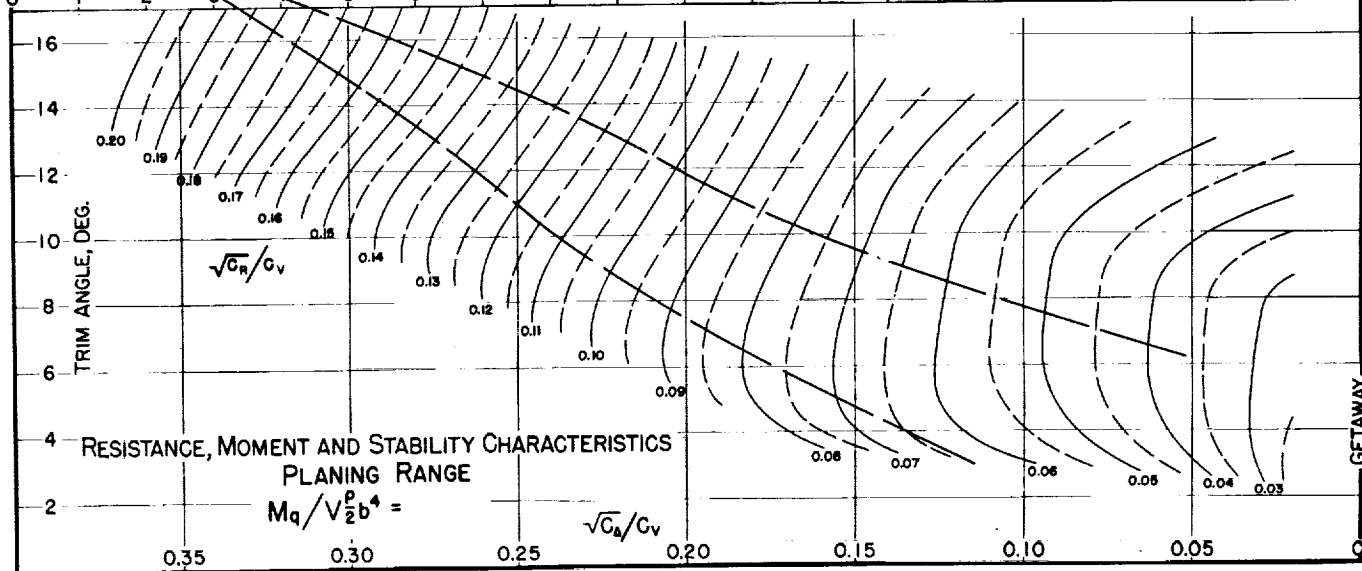
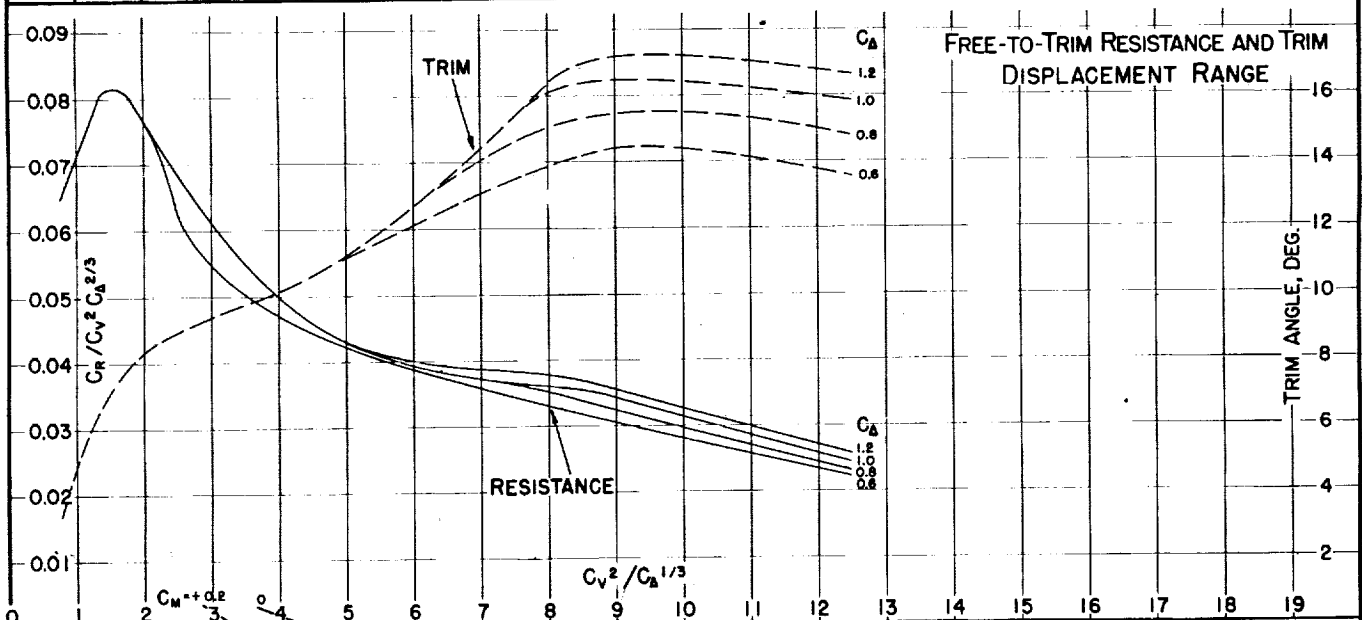
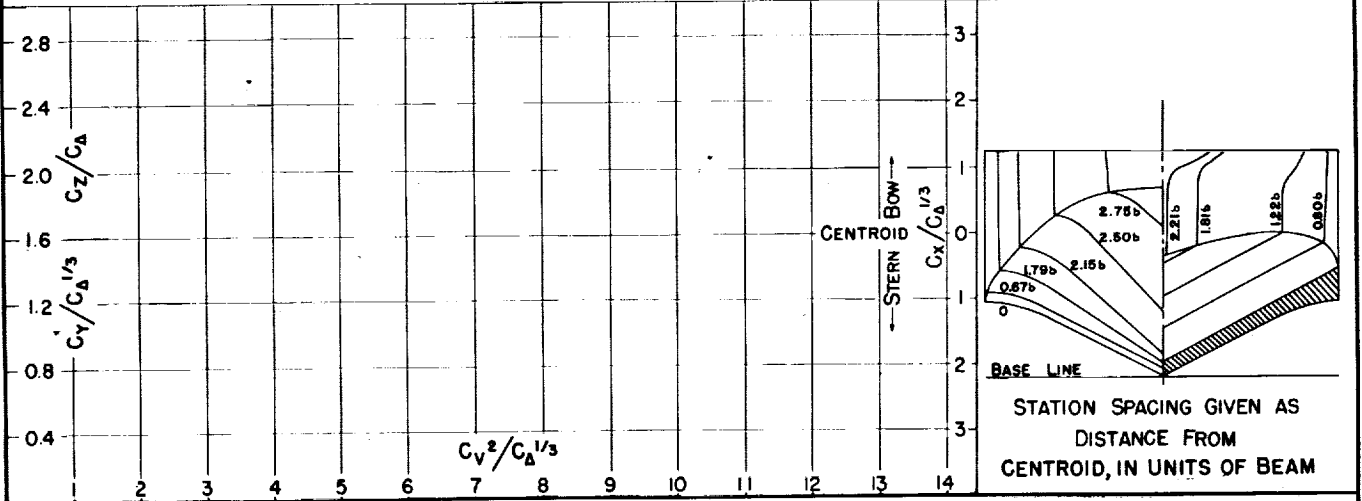

GETAWAY

MODEL No. 144
MODEL BEAM: 15.92

C.G. = 0.45 b FWD. OF STEP
1.13 b ABOVE KEEL

$C_{d0} =$ (NOMINAL)
 $k/L =$

TESTED AT NACA No. 1 TANK
DATE: 7-42

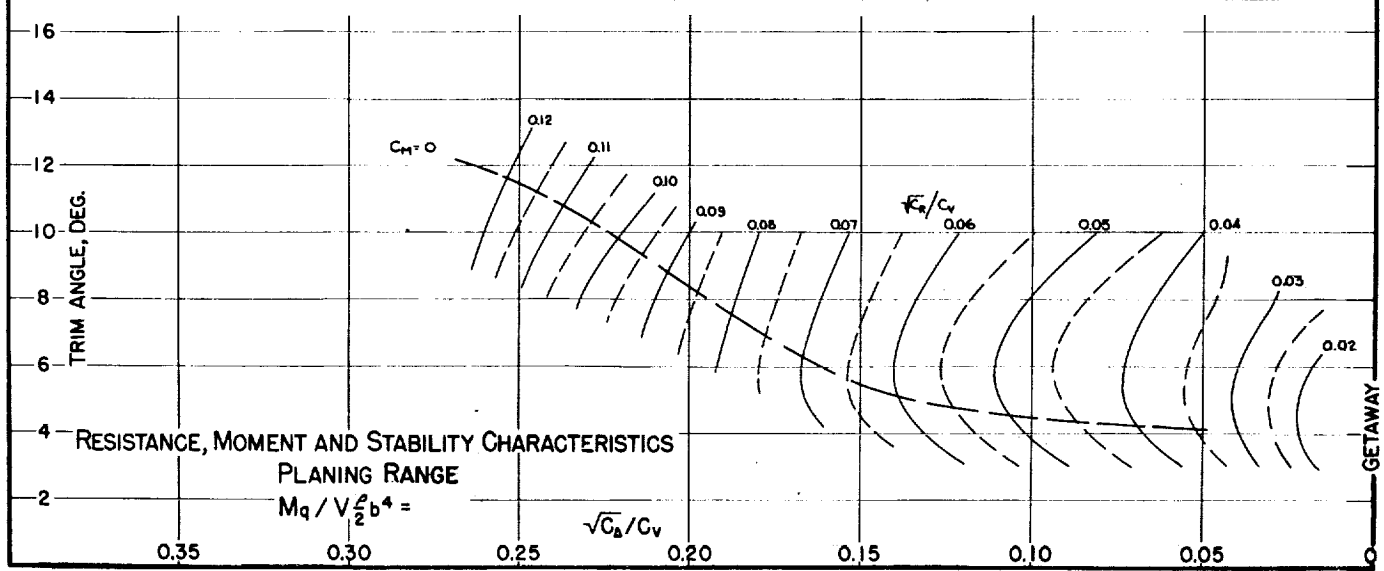
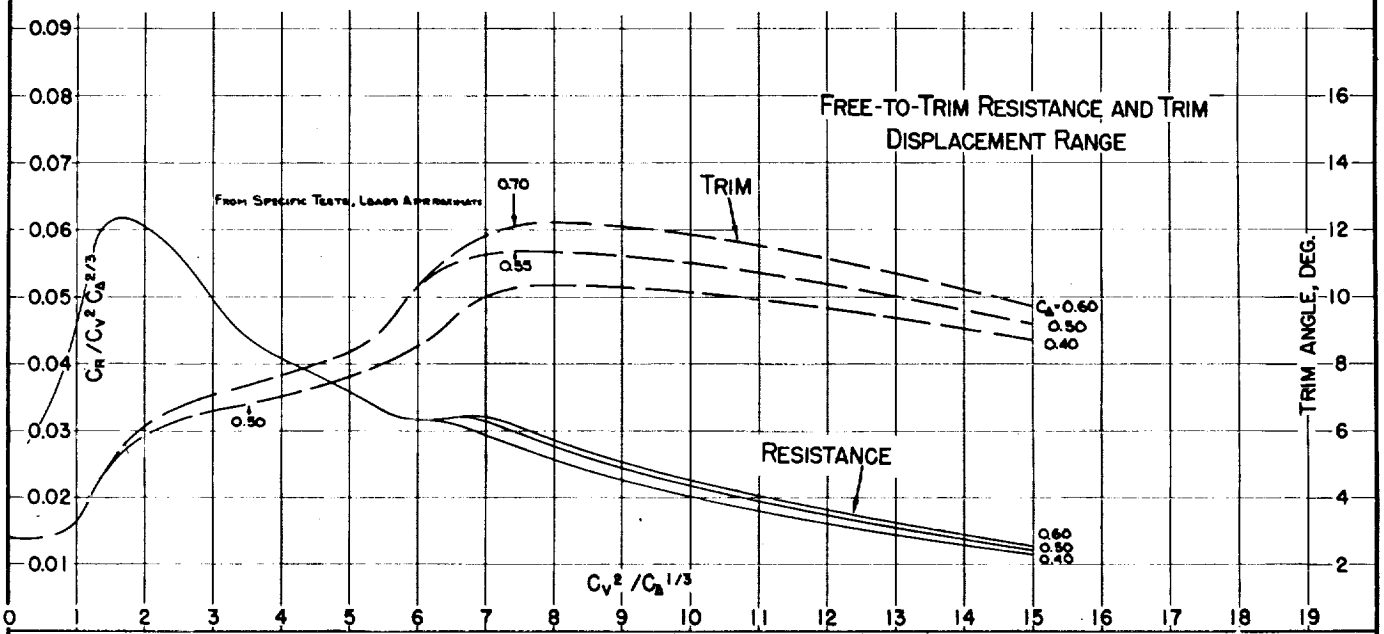
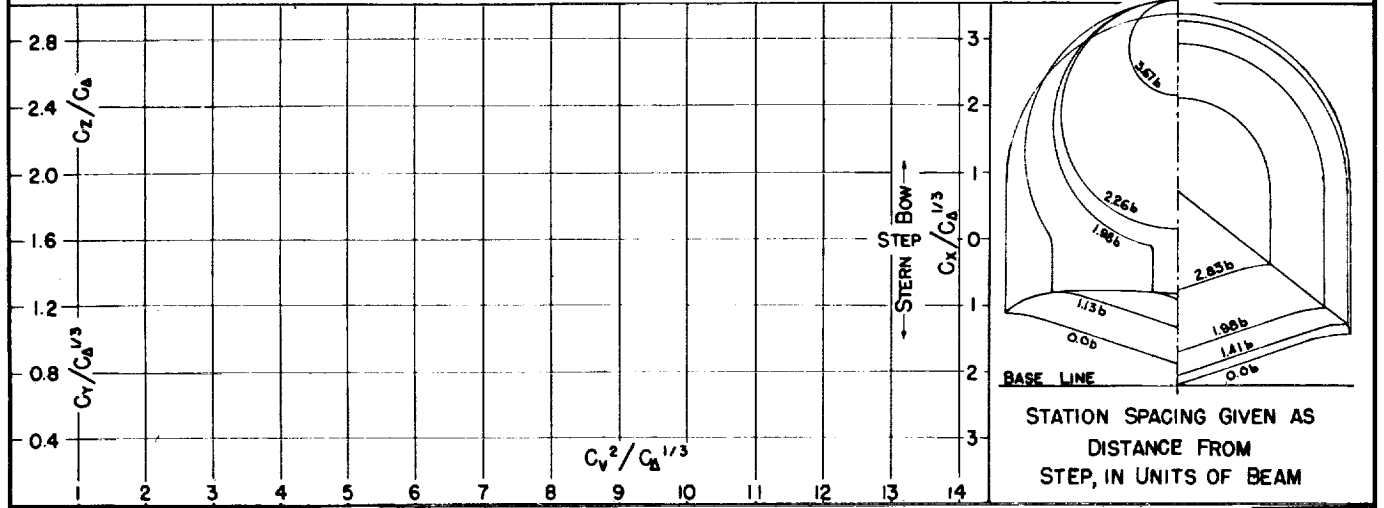

Fig. 72

DESIGNATION: 3.94-0.85-20.0 NACA TN No. 1182

MODEL No. 145
MODEL BEAM 14.24

C.G. = 0.51 b FWD. OF STEP
1.26 b ABOVE KEEL

$C_{d0} =$ (NOMINAL)
 $k/L =$

TESTED AT NACA No. 1 TANK
DATE: 7-42

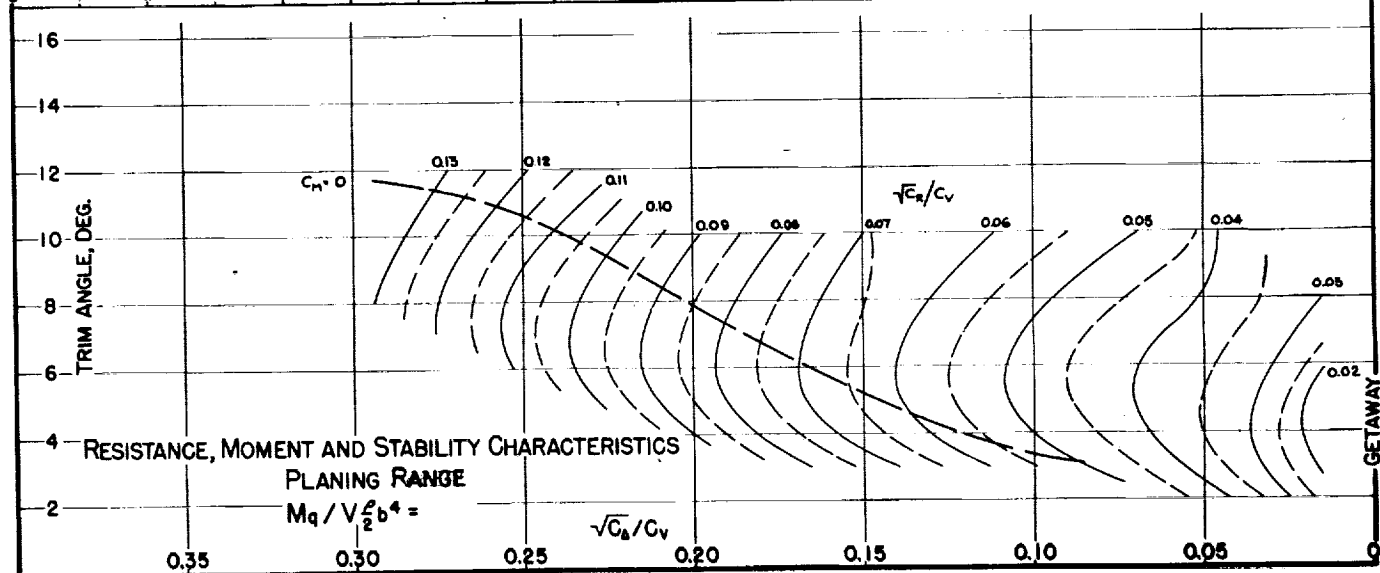
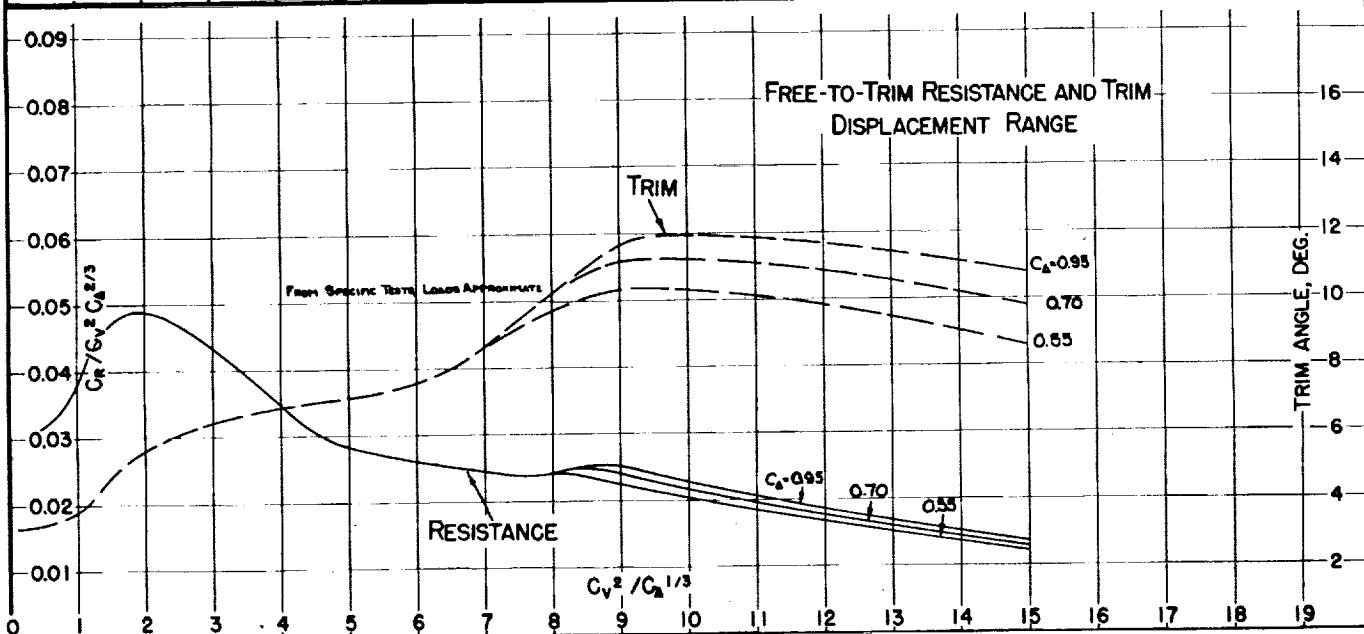
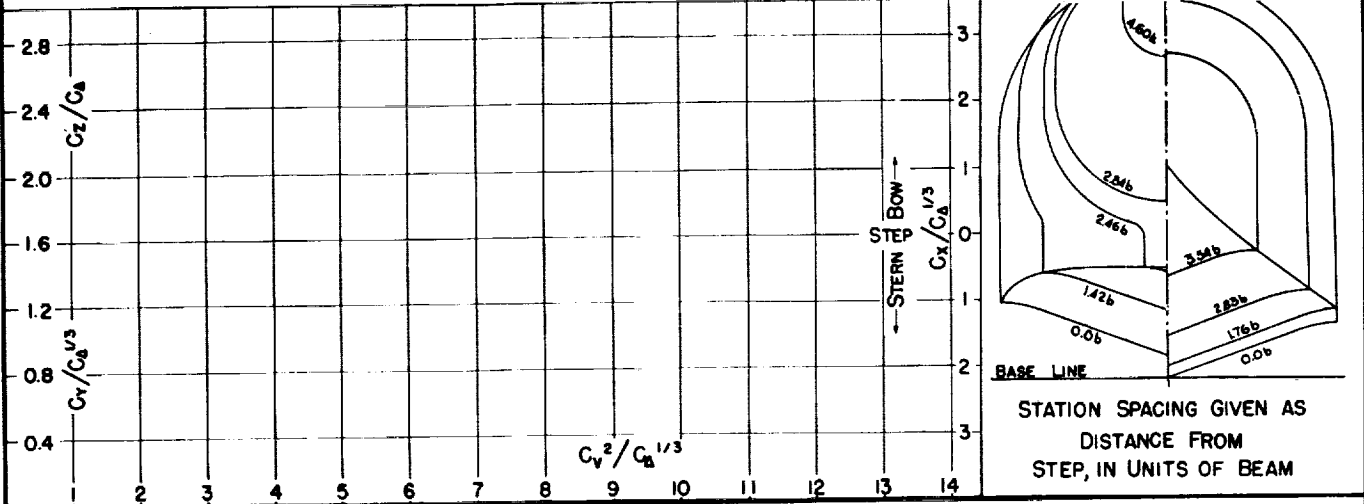

MODEL No. 146
MODEL BEAM: 13.00"

C.G. = 0.55 b FWD. OF STEP
1.38 b ABOVE KEEL

$C_{d0} =$ (NOMINAL)
 $k/L =$

TESTED AT NACA No. 1 TANK
DATE: 7-42

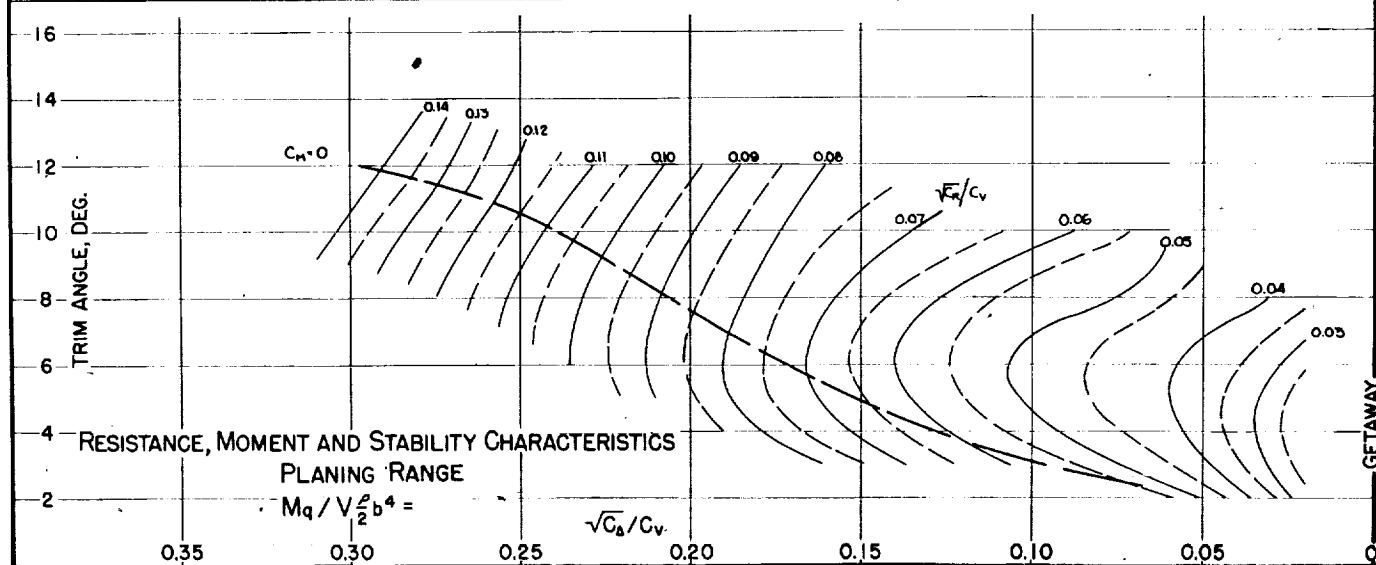
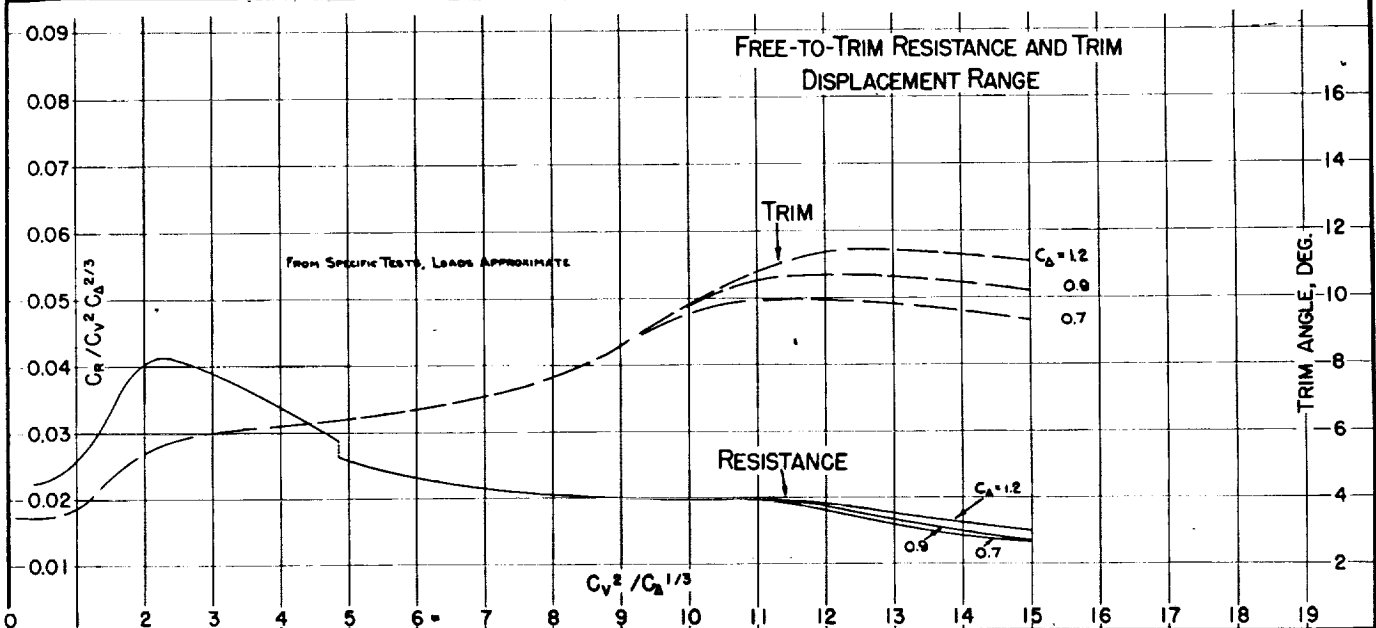
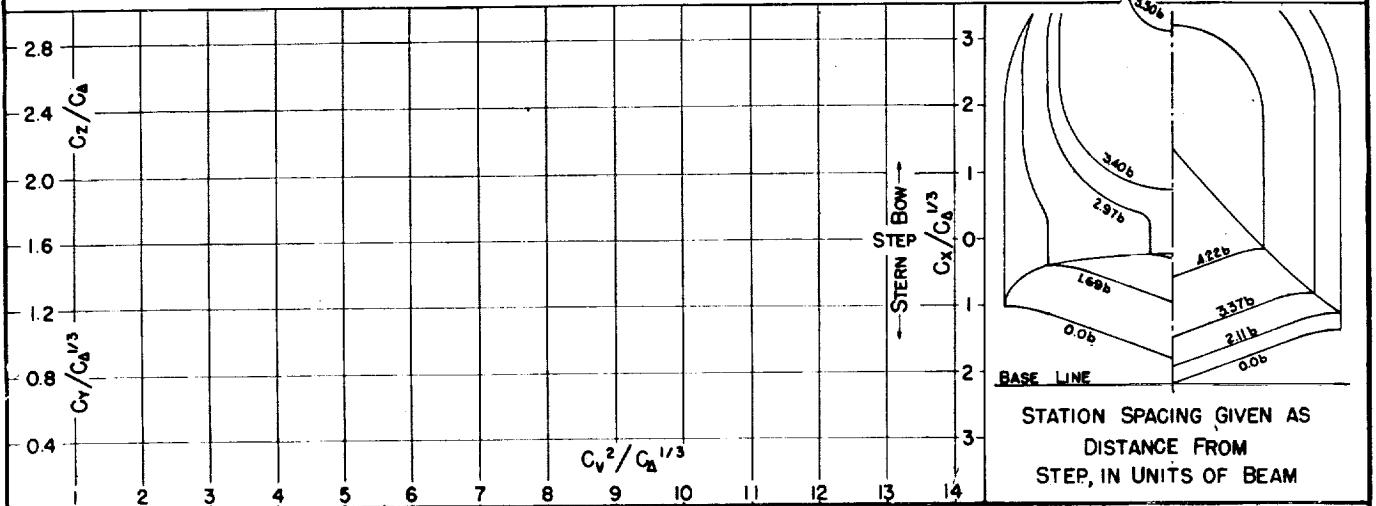

Fig. 74

DESIGNATION: 5.80-0.66-20.0 NACA TN No. 1182

MODEL No. 184

C.G. = 0.46b FWD. OF CENTROID $C_{d0} =$ (NOMINAL)
 1.40b ABOVE KEEL $k/L =$

TESTED AT NACA No. 1 TANK

MODEL BEAM: 11.81"

DATE: '44

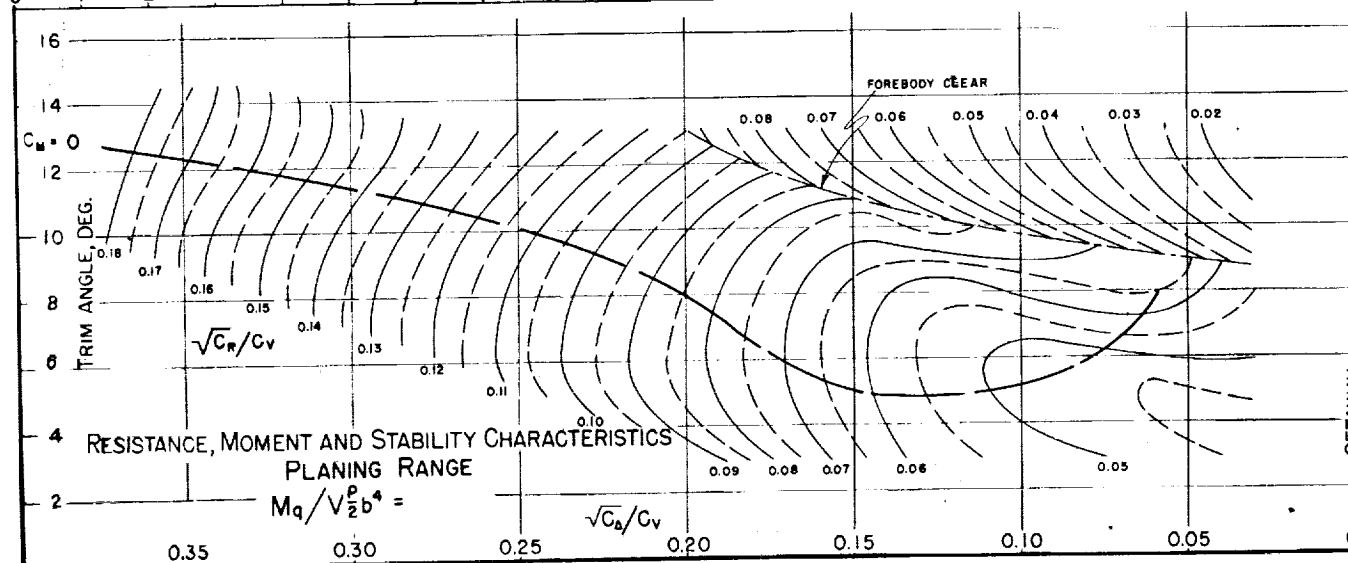
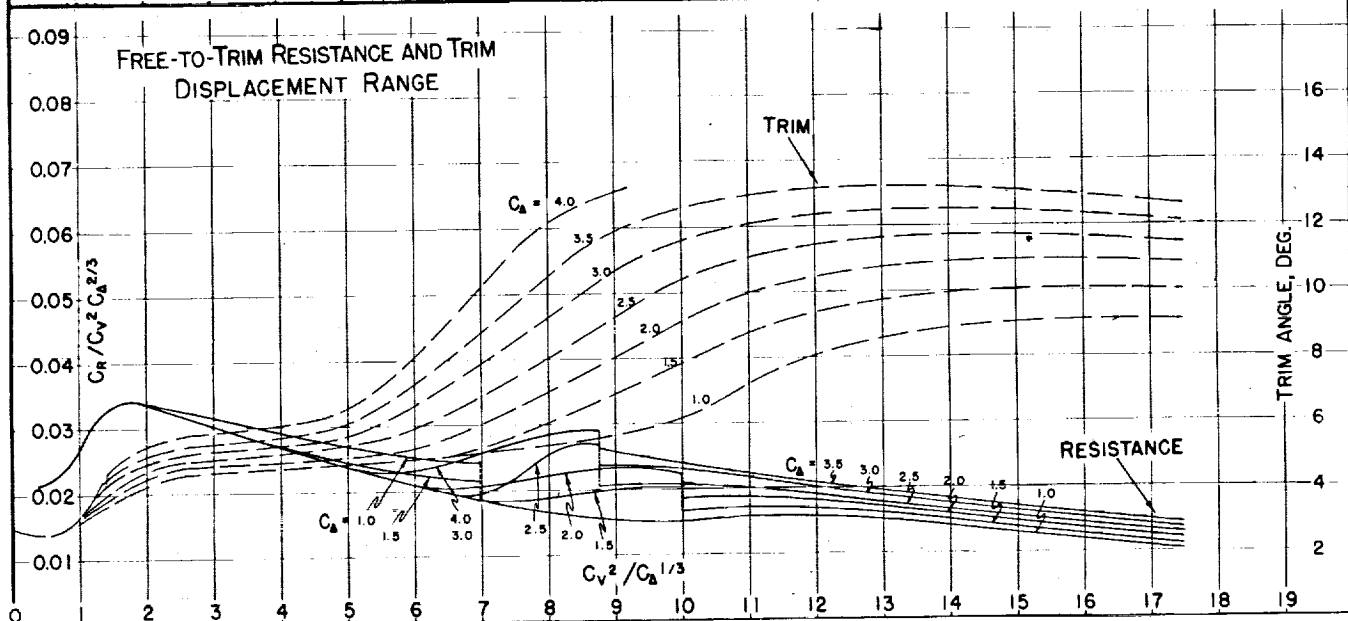
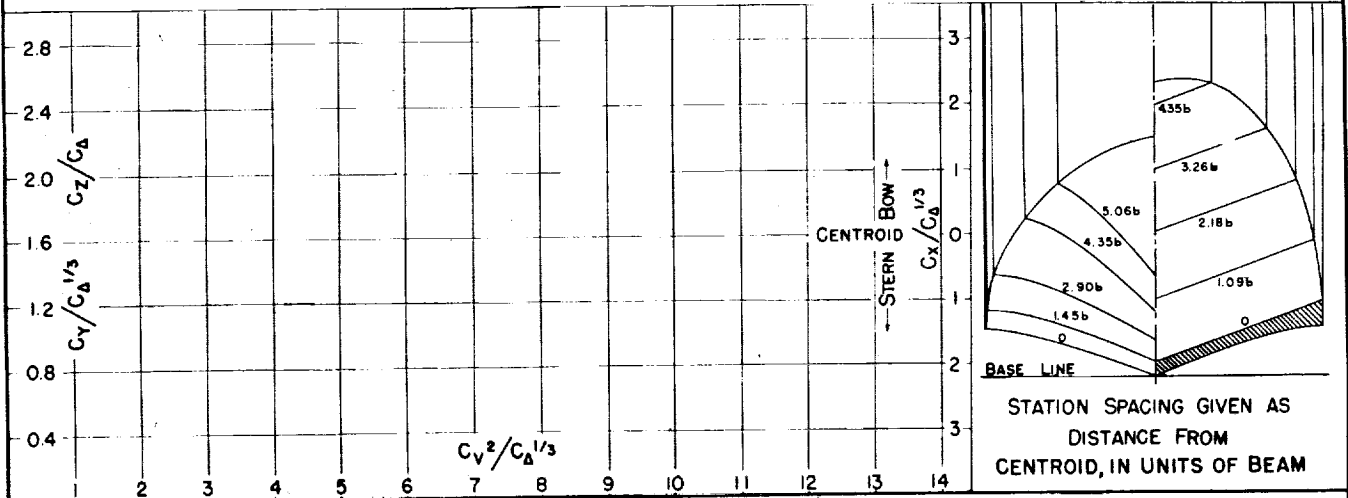

MODEL No. 185

MODEL BEAM: 11.81"

C.G. = 0.46 b FWD. OF CENTROID
1.40 b ABOVE KEEL

$C_{d_0} =$
 $k/L =$

(NOMINAL)

TESTED AT NACA No. 1 TANK

DATE: '44

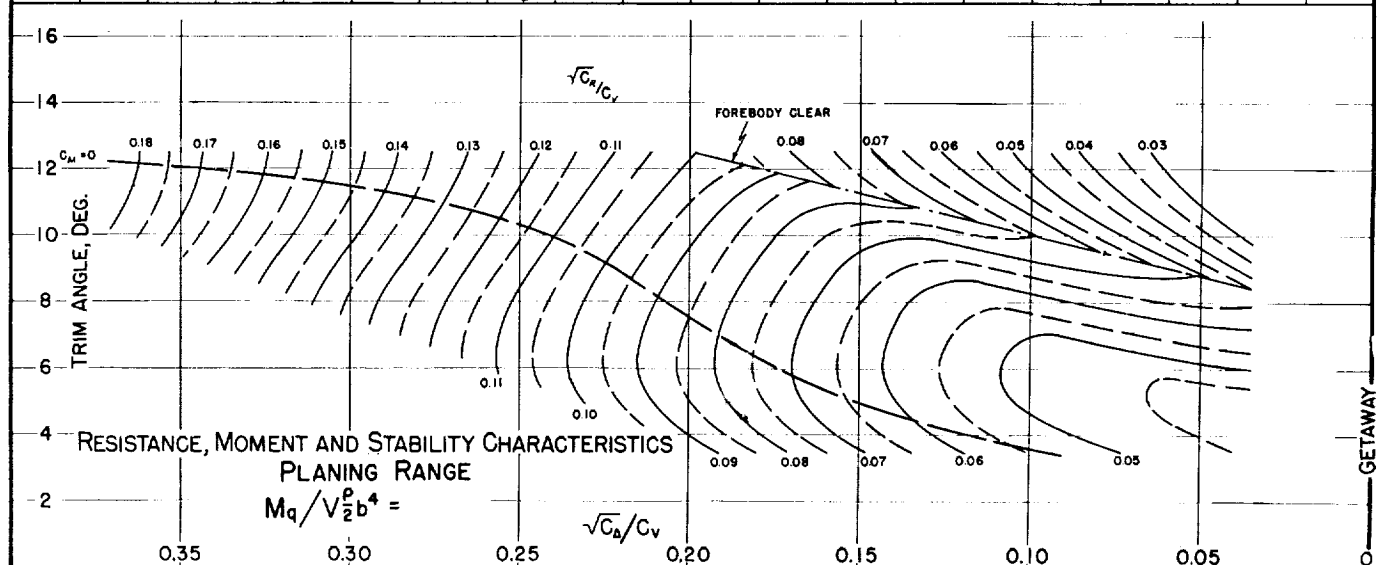
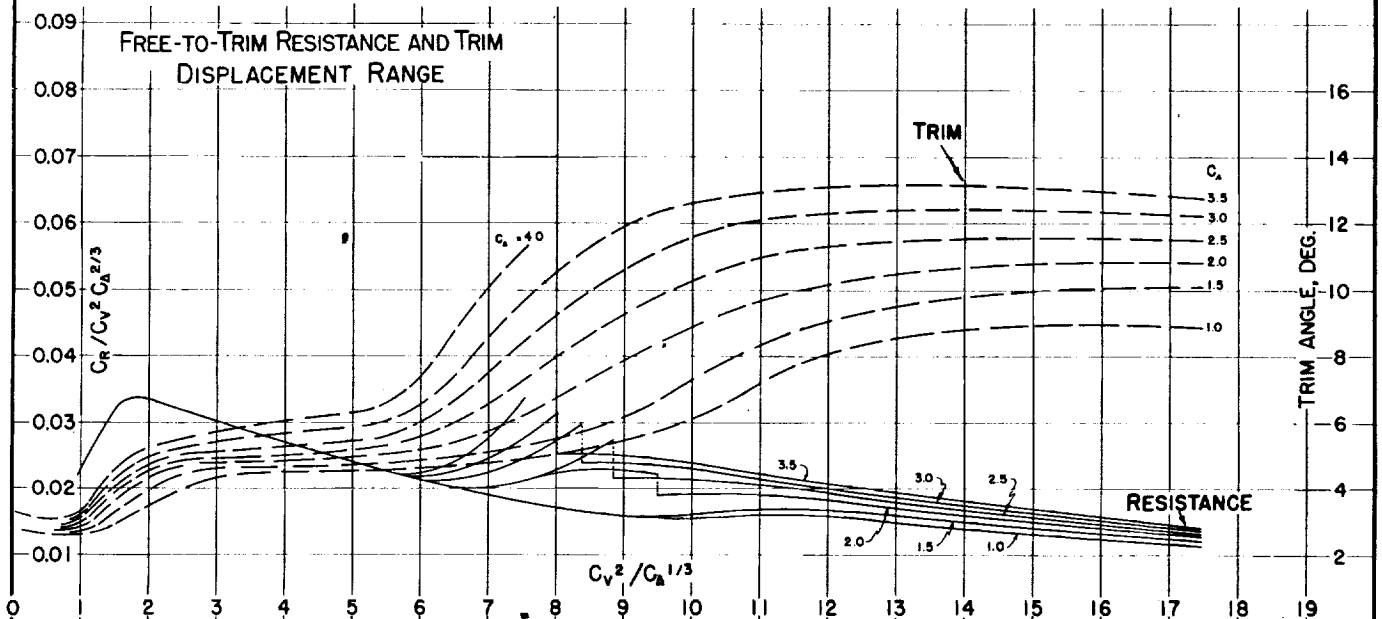
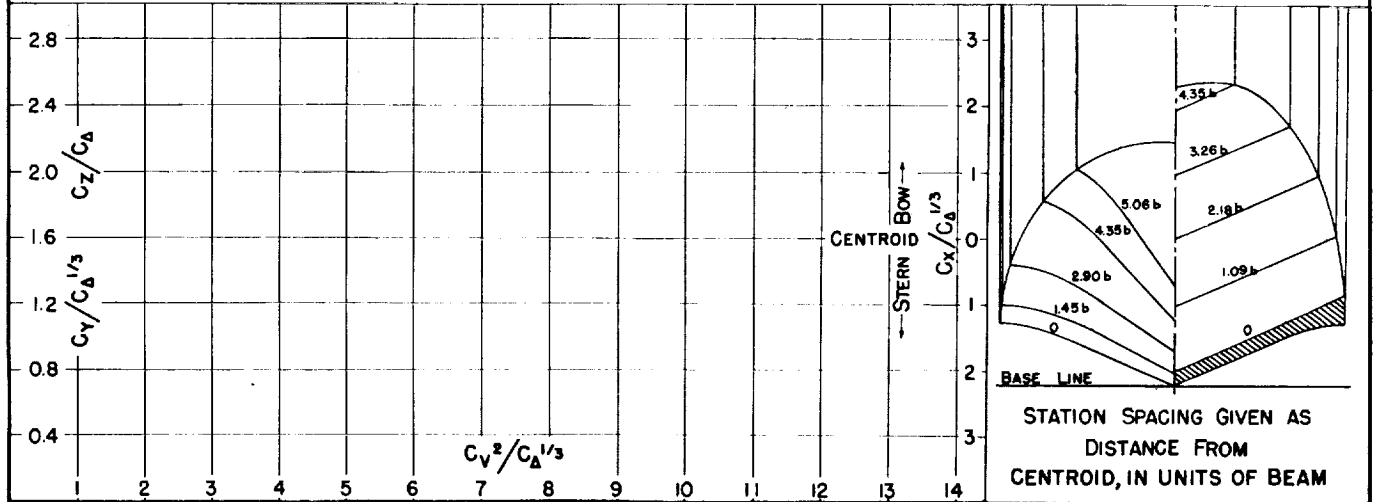

Fig. 76

DESIGNATION: 5.80-1.22-24.5 NACA TN No. 1182

MODEL No. 185-A
MODEL BEAM: 11.81"

C.G. = 0.46 b FWD. OF CENTROID
1.40 b ABOVE KEEL

$C_{A0} =$
 $k/L =$

(NOMINAL)

TESTED AT NACA No. 1 TANK
DATE: 1/44

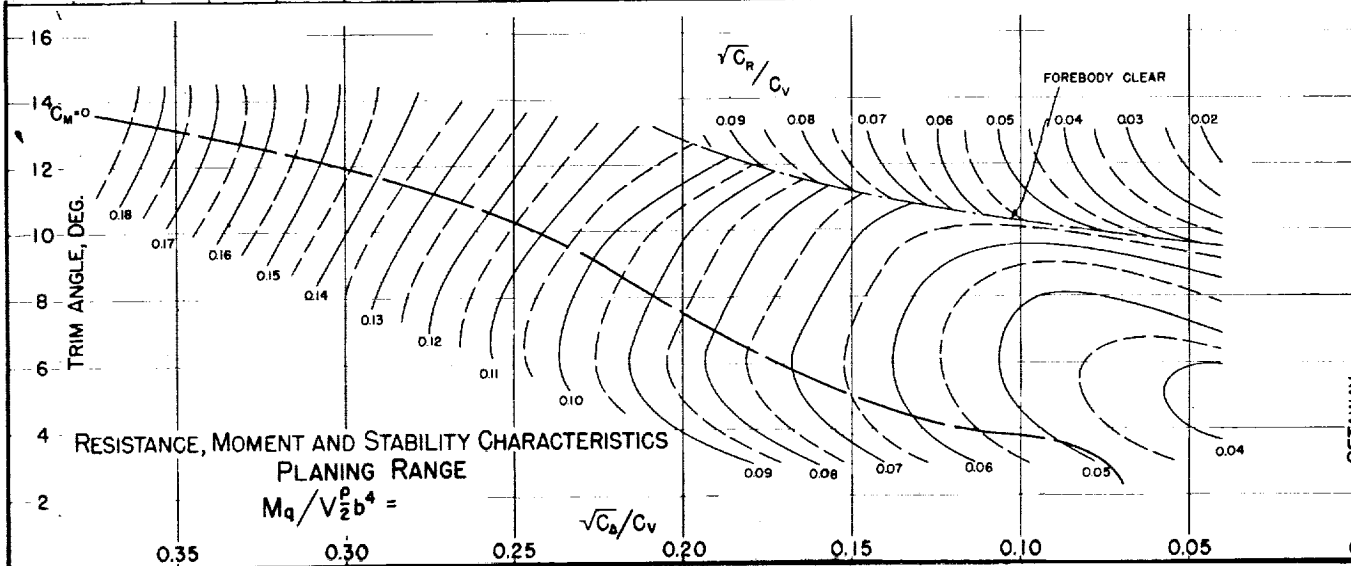
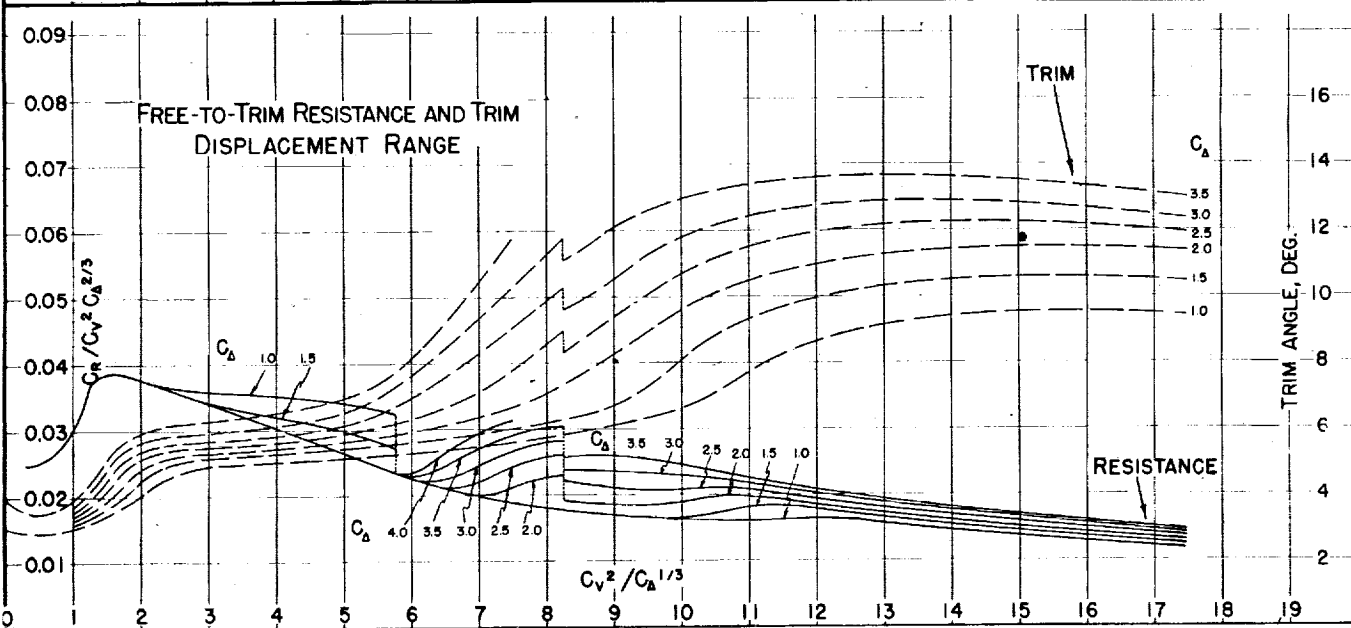
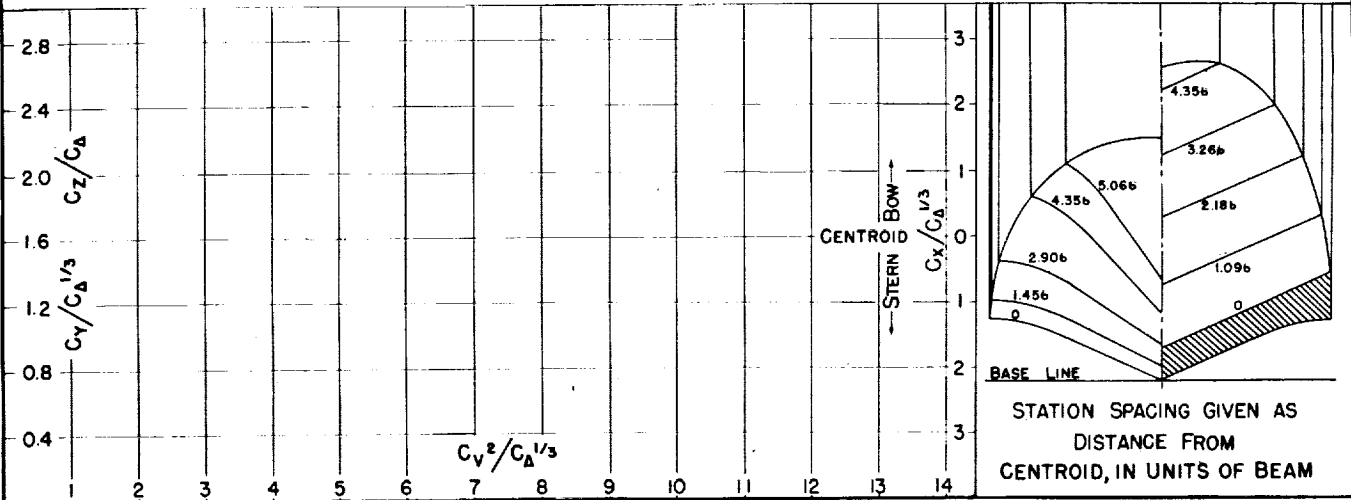

GETAWAY

MODEL No. 207
MODEL BEAM: 14.74"

C.G. = 0.31b FWD. OF CENTROID
0.83b ABOVE KEEL

$C_{D0} = 0.67$ (NOMINAL)
 $k/L =$

TESTED AT N.A.C.A. No. 1 TANK
DATE: 12-44

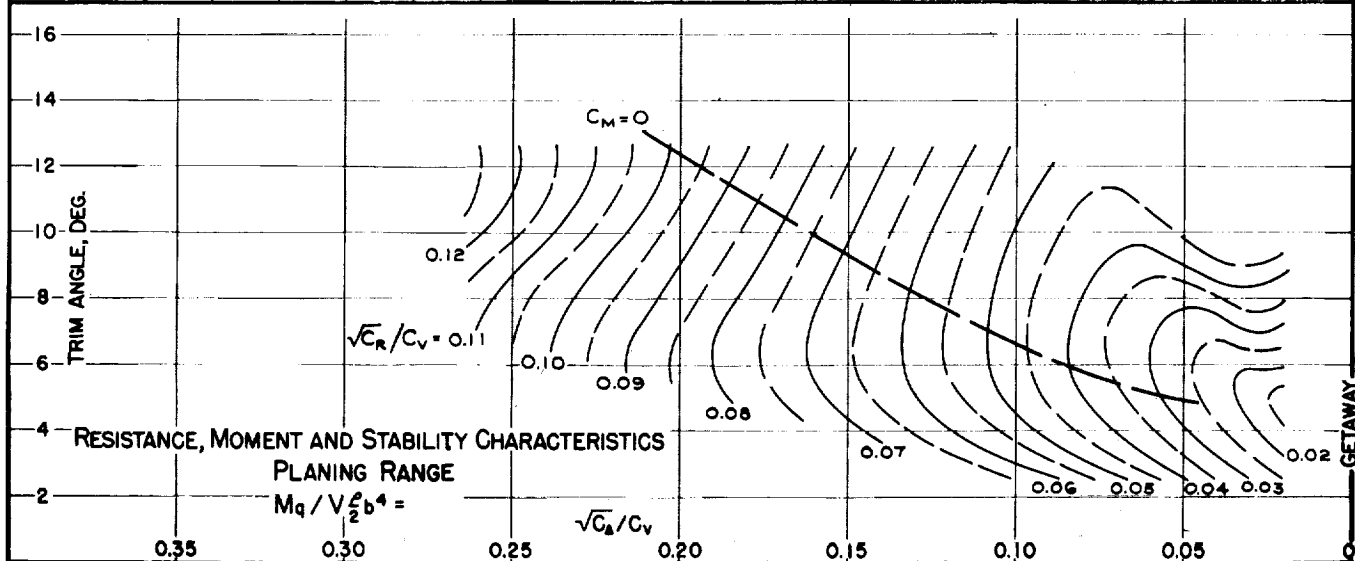
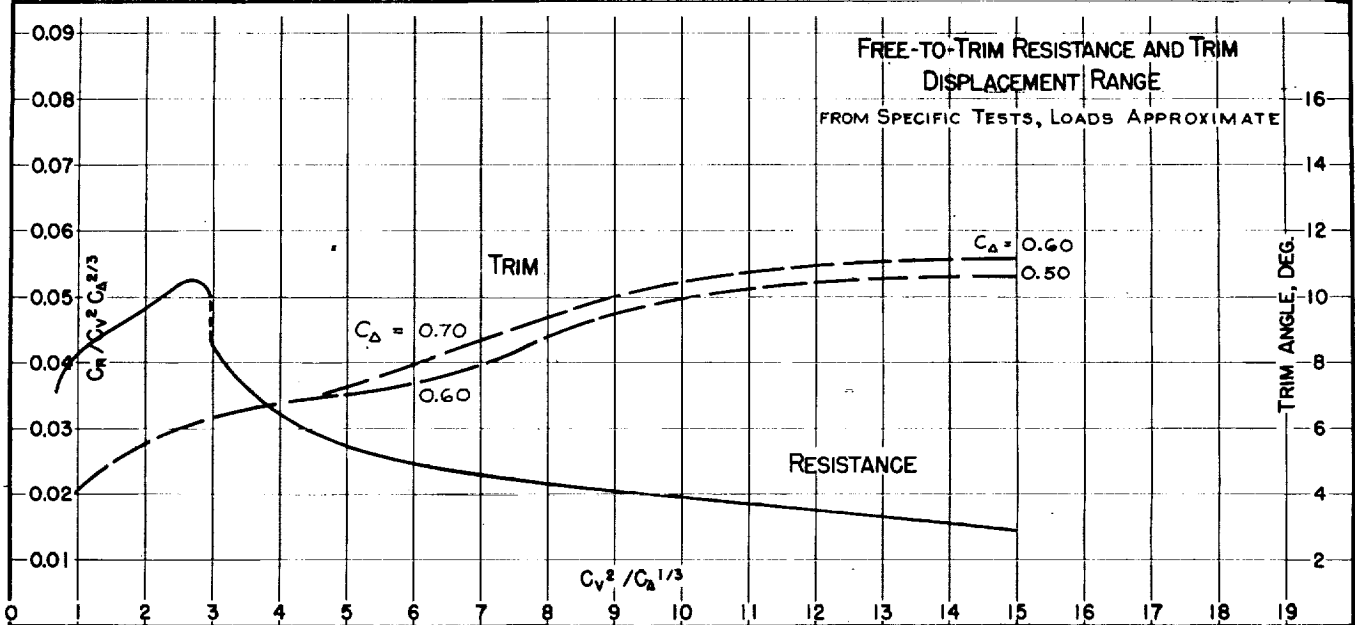
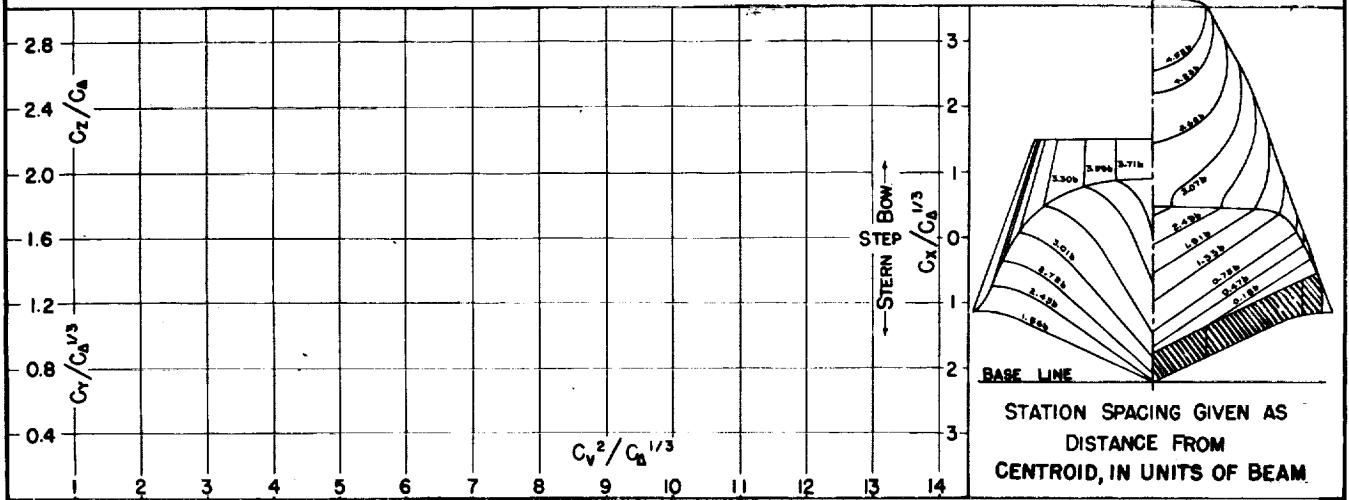

Fig. 78

DESIGNATION: 3.78-1.06-25.0

NACA TN No. 1182

MODEL No. 207A
MODEL BEAM 14.74"

C.G. = 0.31b FWD. OF CENTROID $C_{a_0} = 0.67$ (NOMINAL)
0.83b ABOVE KEEL $k/L =$

TESTED AT N.A.C.A. No. 1 TANK
DATE: 12-44

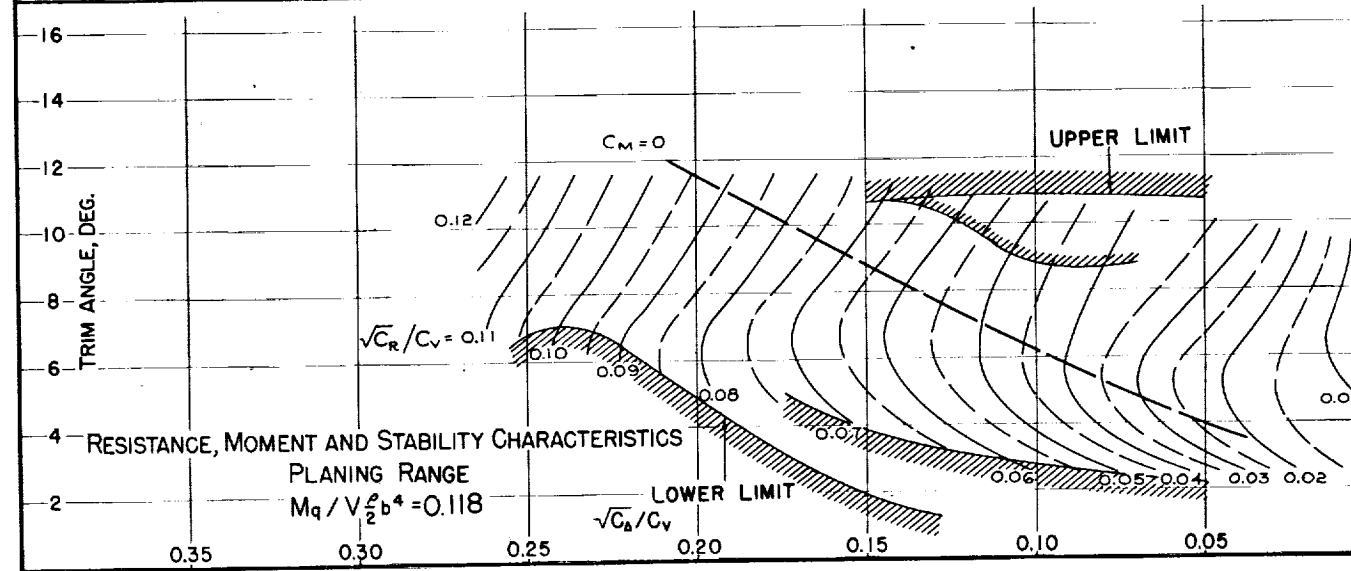
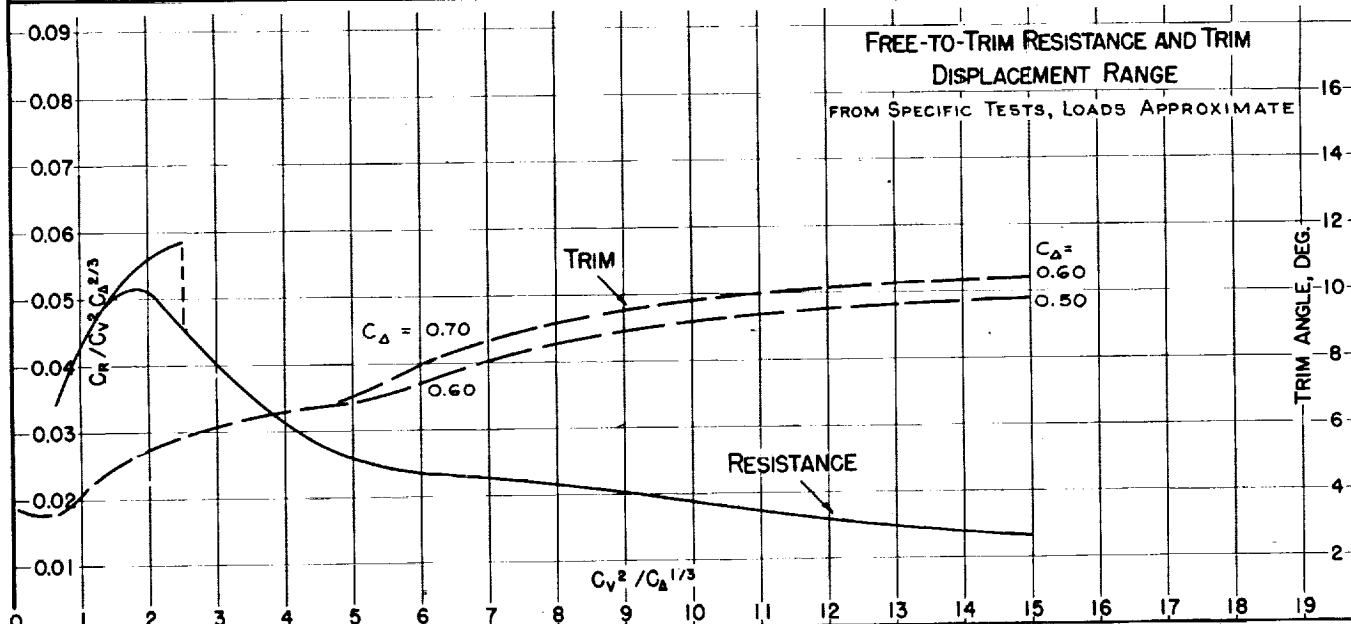
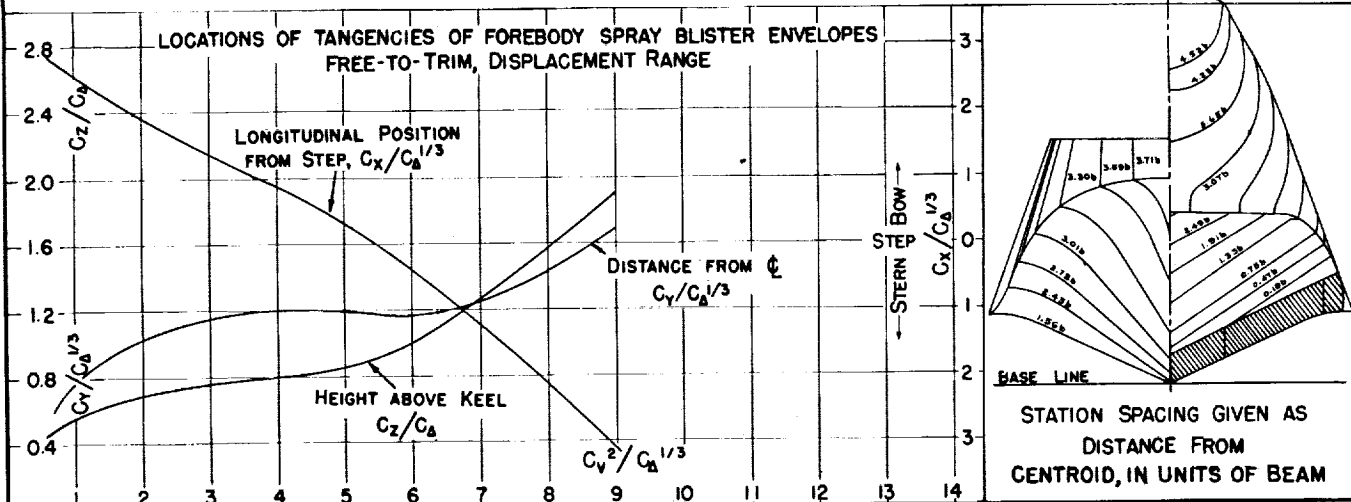

MODEL No. 207 C
MODEL BEAM: 14.74"

C.G. = 0.31 b FWD. OF CENTROID $C_{a_0} =$
0.83 b ABOVE KEEL $k/L =$

(NOMINAL)

TESTED AT NACA No. 1 TANK
DATE: 9/45

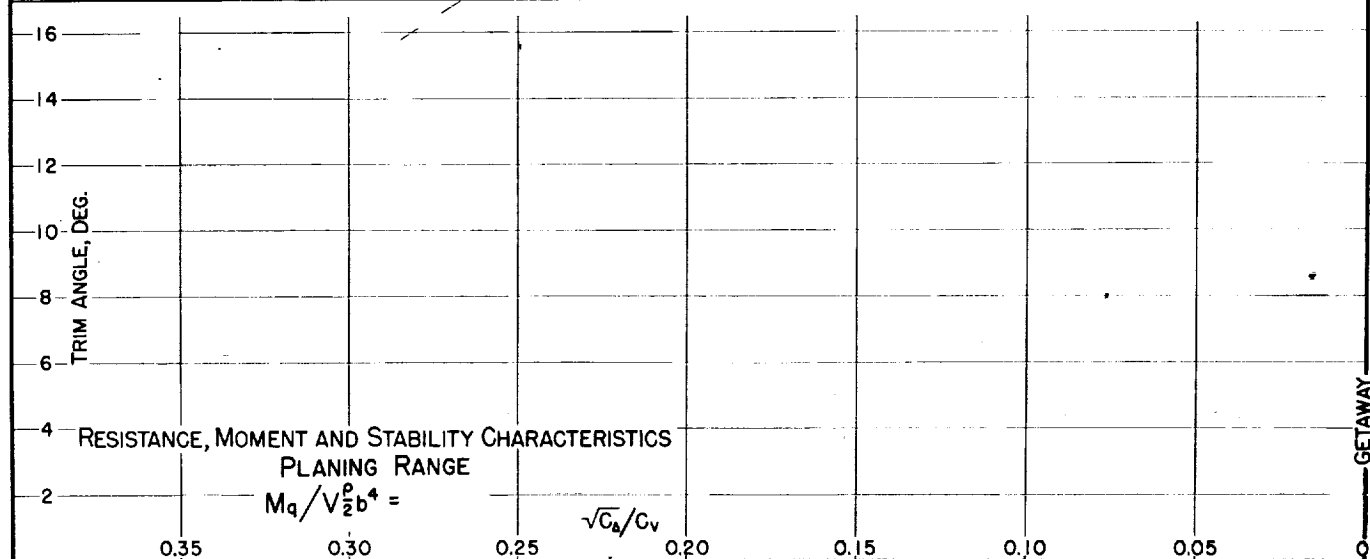
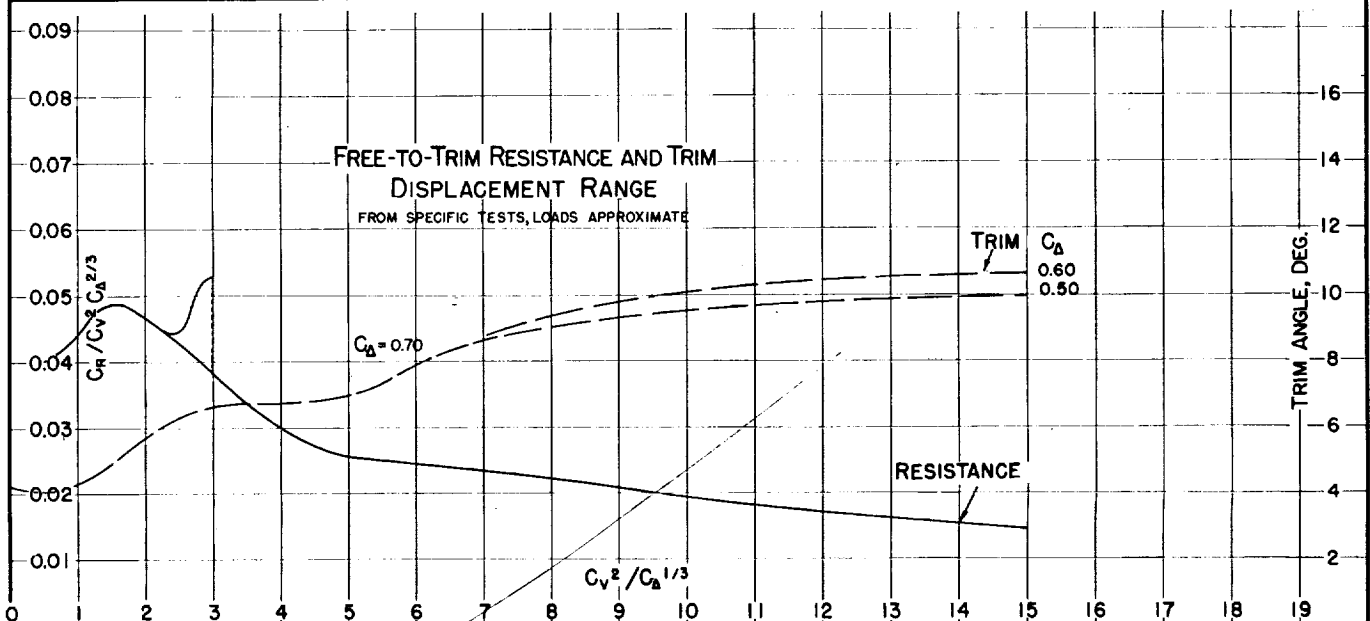
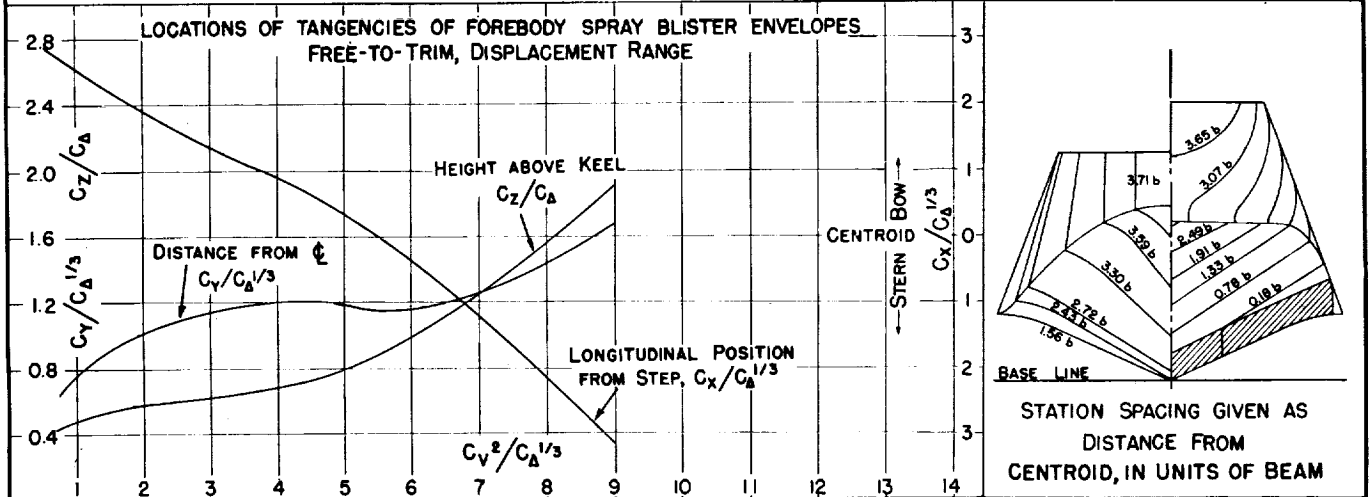

GETAWAY

Fig. 80

DESIGNATION: 2.31-0.38-20.0

NACA TN No. 1182

MODEL NO. L/b-55
MODEL BEAM: 1Q92'

C.G. = 0.18 b FWD. OF STEP
1.11 b ABOVE KEEL

$C_{d,0} =$ (NOMINAL)
 $k/L =$

TESTED AT RAE TANK
DATE: 5-35

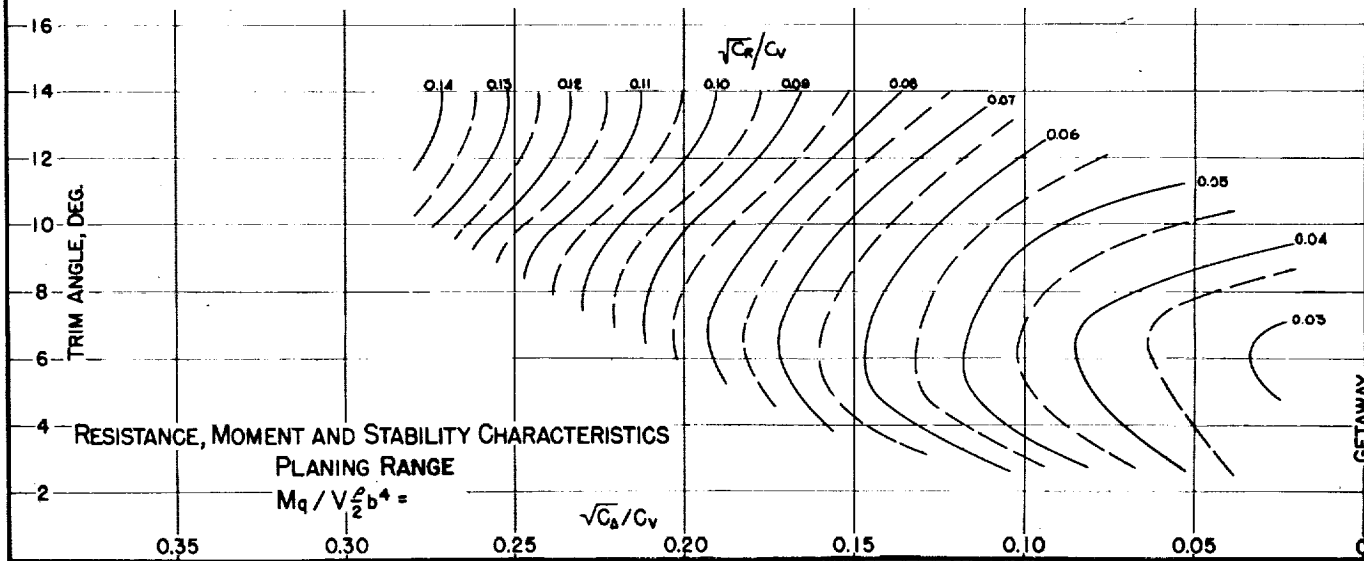
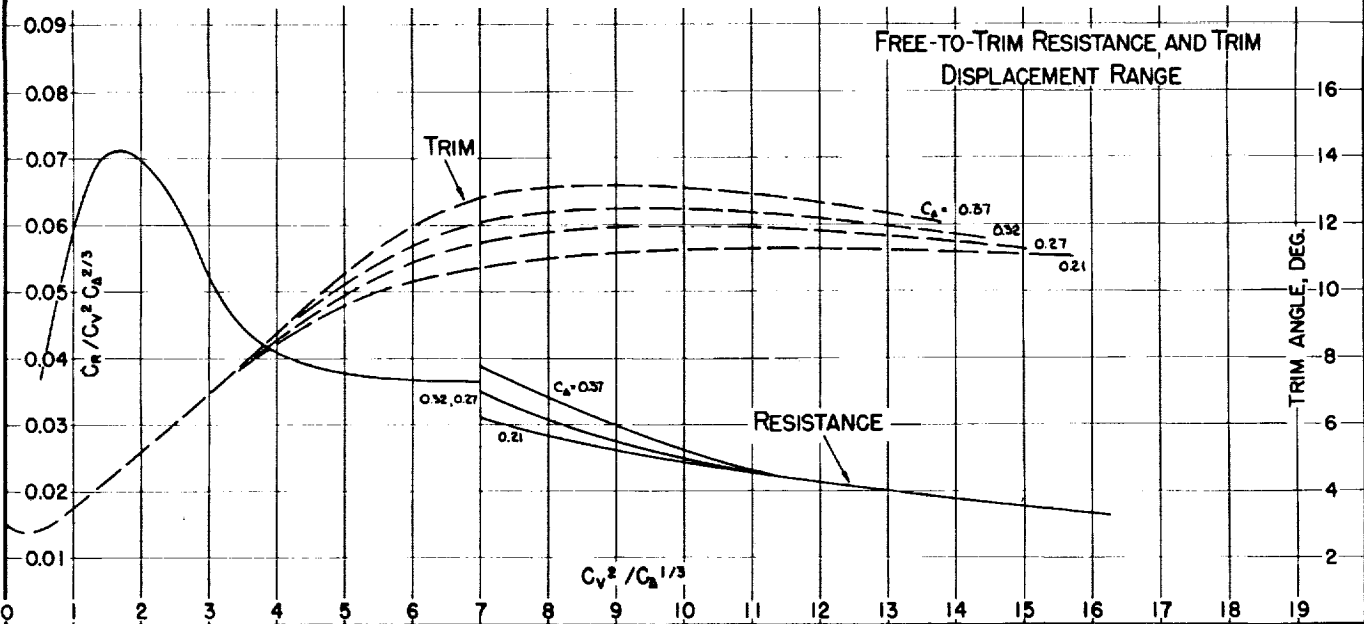
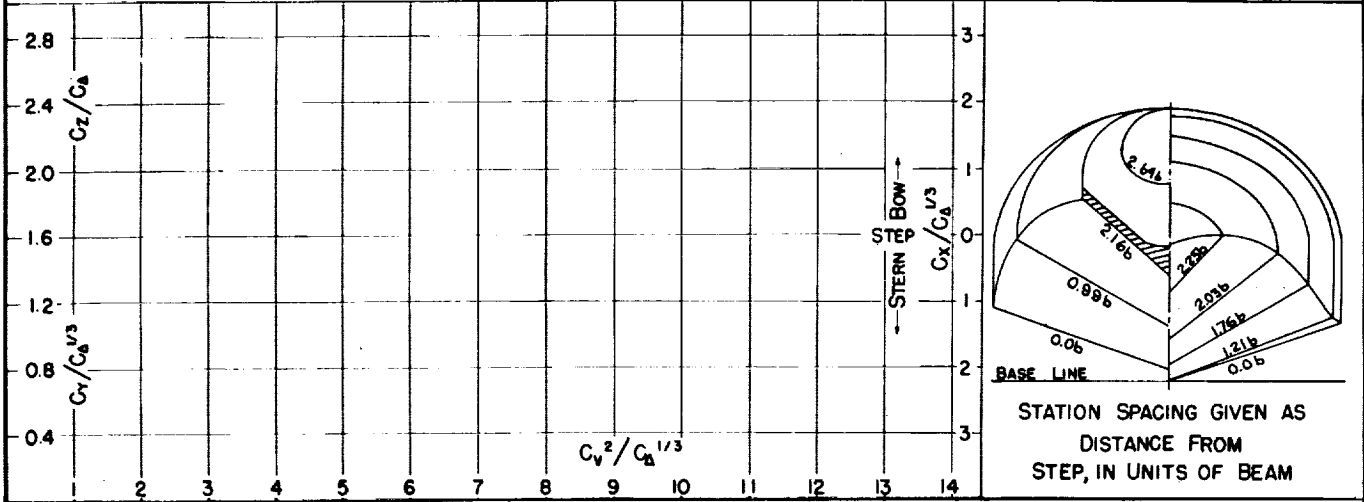

MODEL No. L/b=7.0
MODEL BEAM: 8.56"

C.G. = 0.23 b FWD. OF STEP
1.42 b ABOVE KEEL

C_{d0} = (NOMINAL)
k/L =

TESTED AT RAE TANK
DATE: 9-35

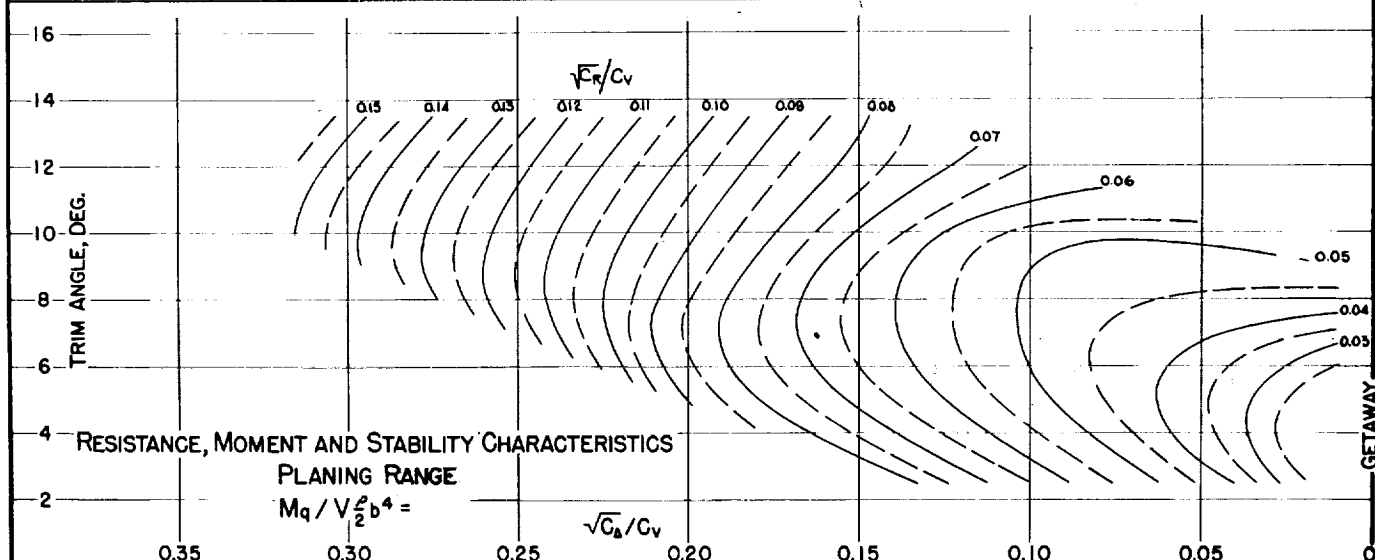
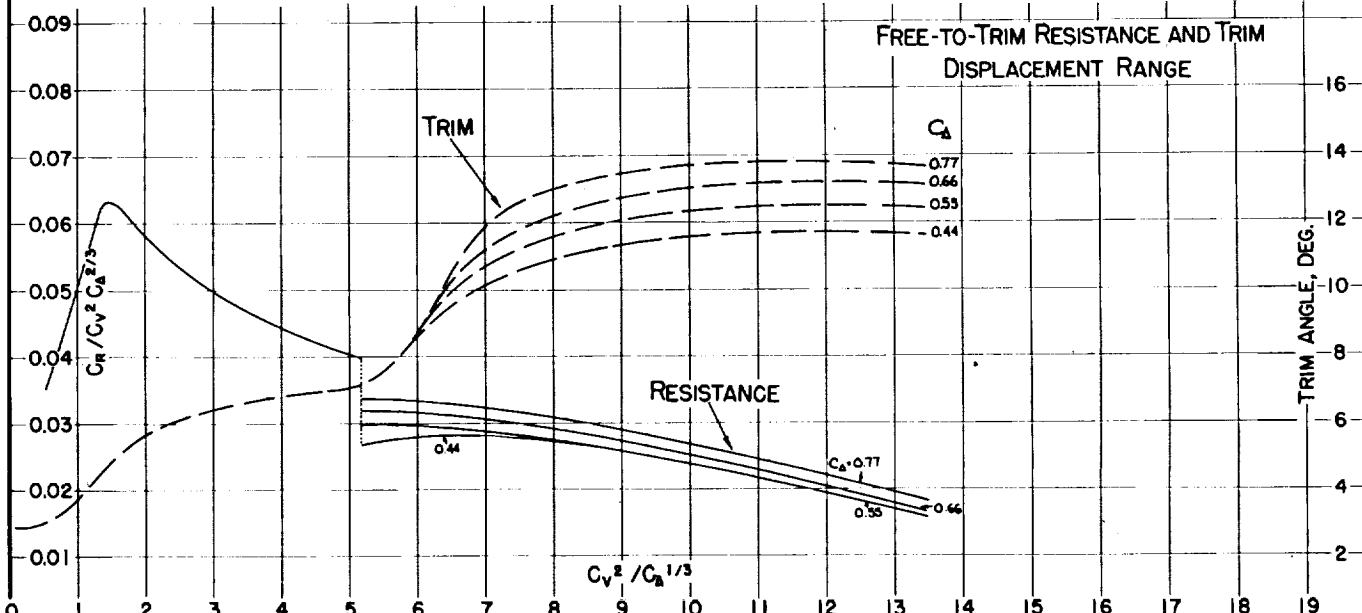
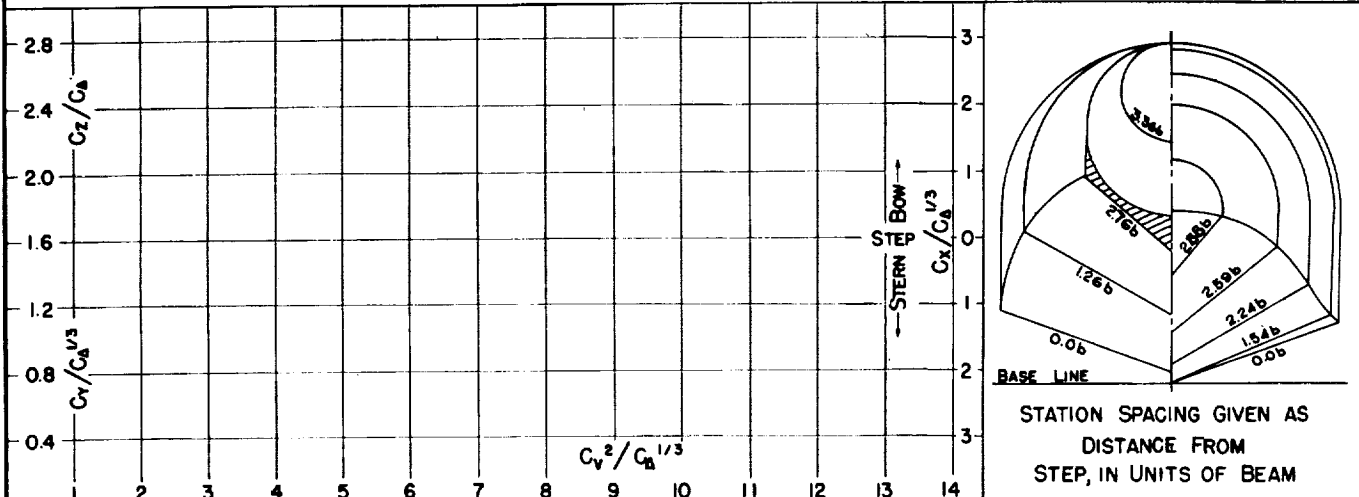

Fig 82

DESIGNATION: 3.57 - 0.58 - 20.0 NACA TN No. 1182

MODEL No. L/b-8.5
MODEL BEAM: 7.06'

C.G. = 0.28 b FWD. OF STEP
1.72 b ABOVE KEEL

$C_{d0} =$ (NOMINAL)
 $k/L =$

TESTED AT RAE TANK
DATE: 1-36

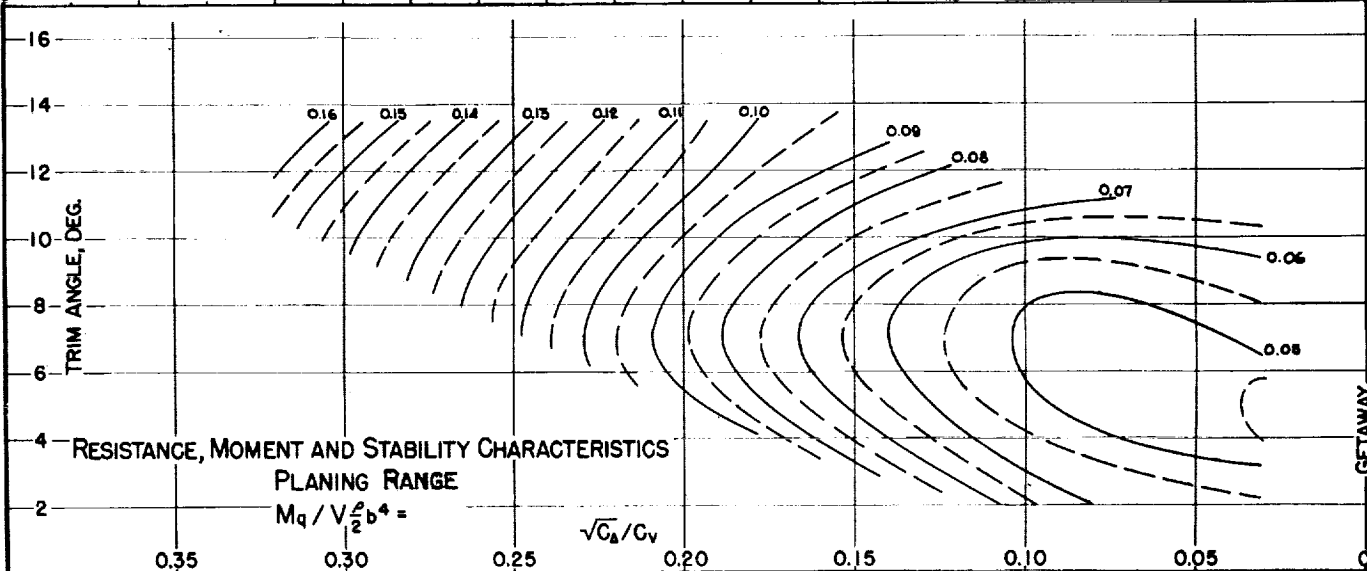
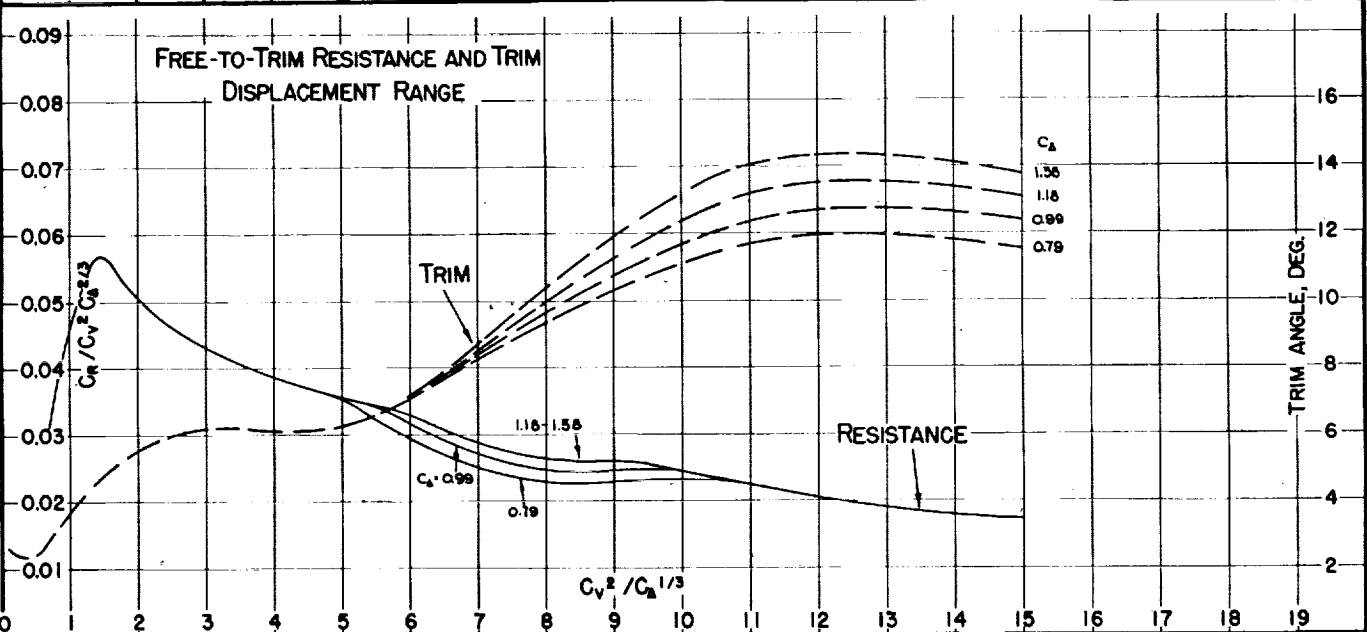
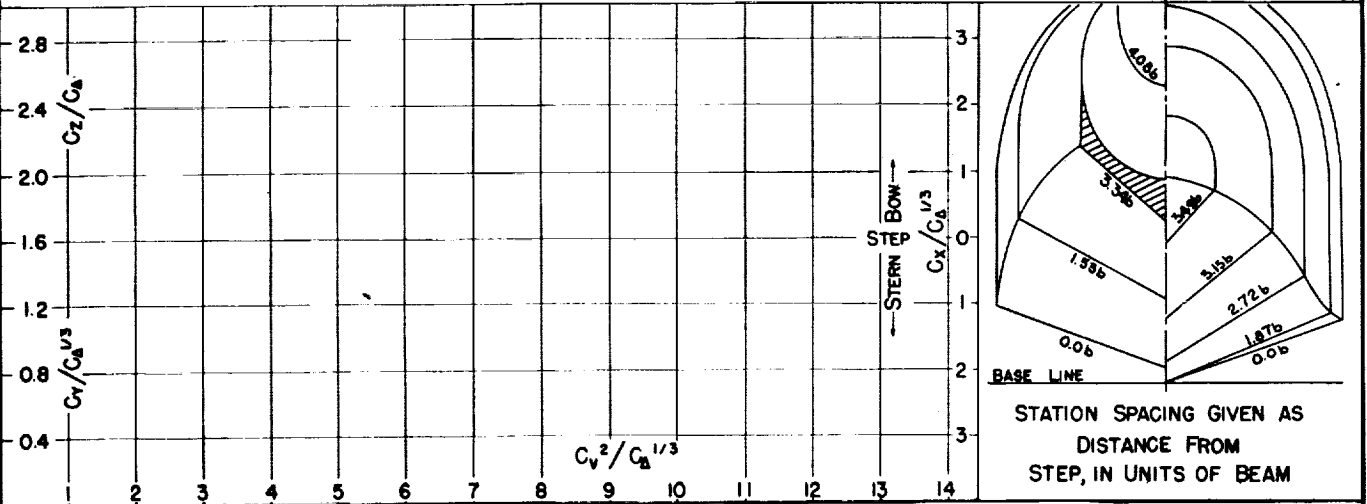

MODEL No. L/b=10.0
MODEL BEAM: 6.00"

C.G. = 0.32 b FWD. OF STEP
2.02 b ABOVE KEEL

$C_{D0} =$ (NOMINAL)
 $k/L =$

TESTED AT RAE TANK
DATE: 5-36

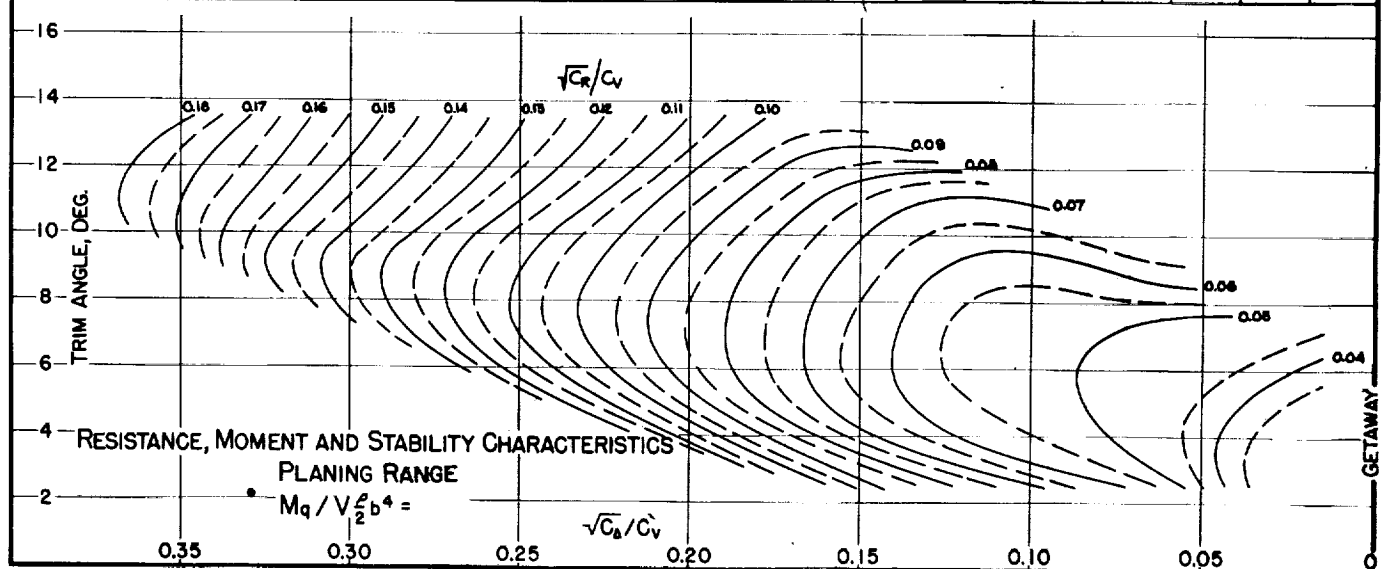
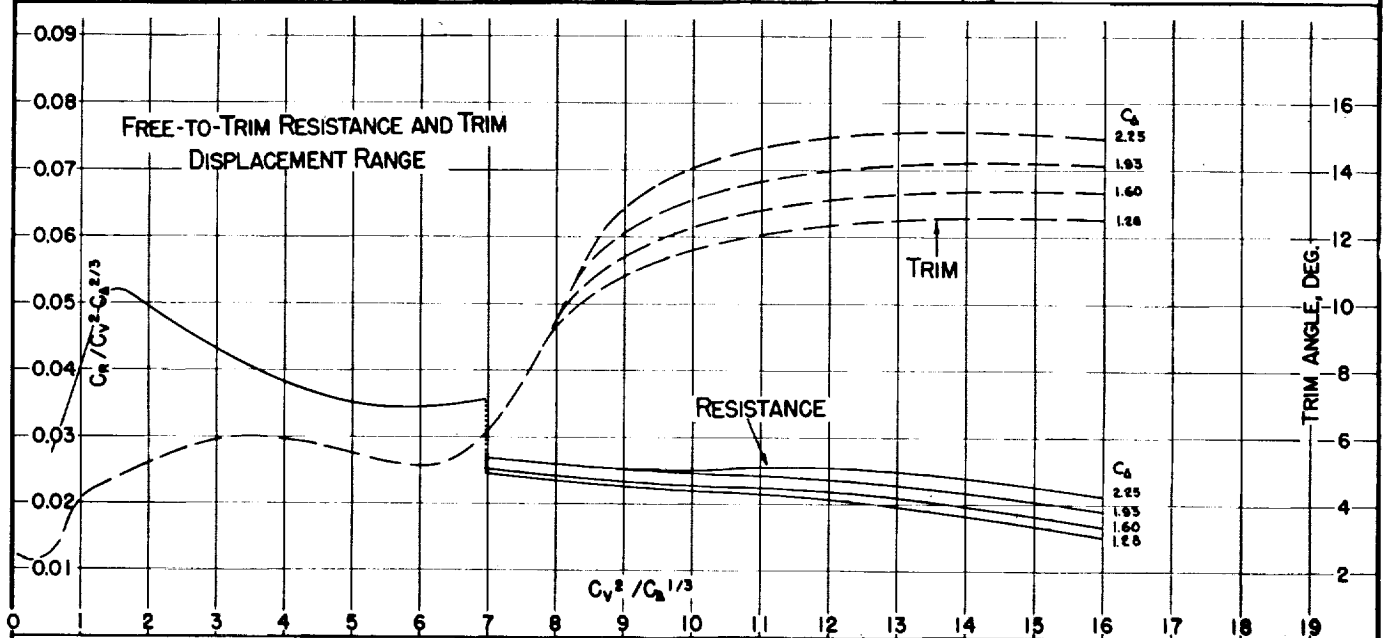
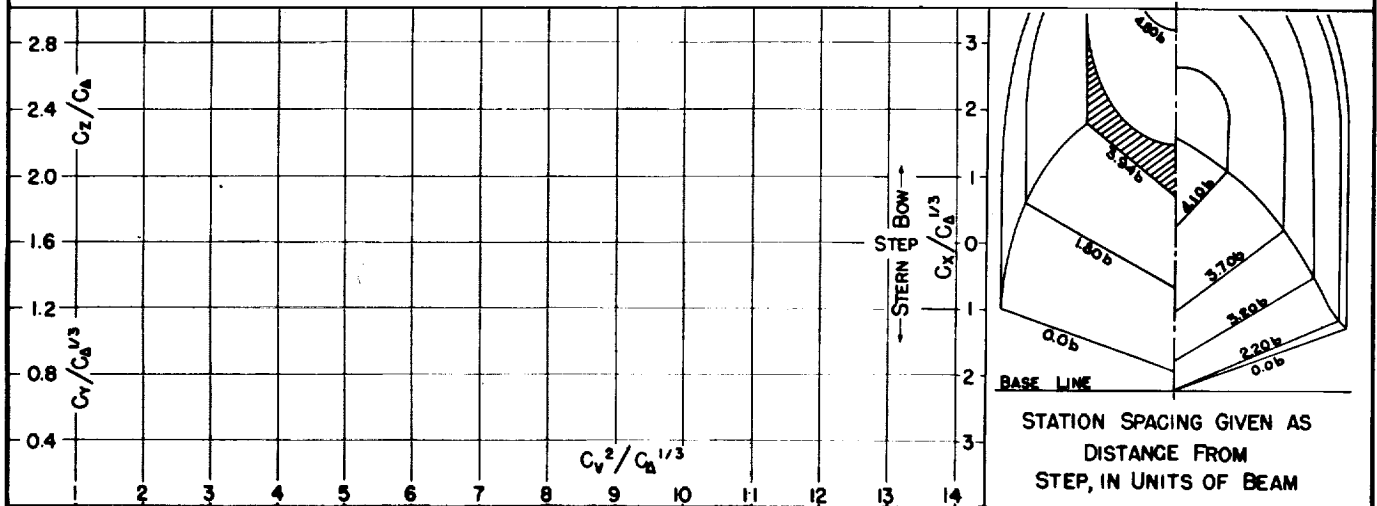

Fig. 84

DESIGNATION: 3.69-1.06-27.0 NACA TN No. 1182

MODEL No.
MODEL BEAM: 717 "

C.G. = 0.24 b FWD. OF STEP
1.32 b ABOVE KEEL

$C_{d0} = 1.28$ (NOMINAL)
 $k/L = 0.228$

TESTED AT R.A.E. TANK
DATE: 2/42

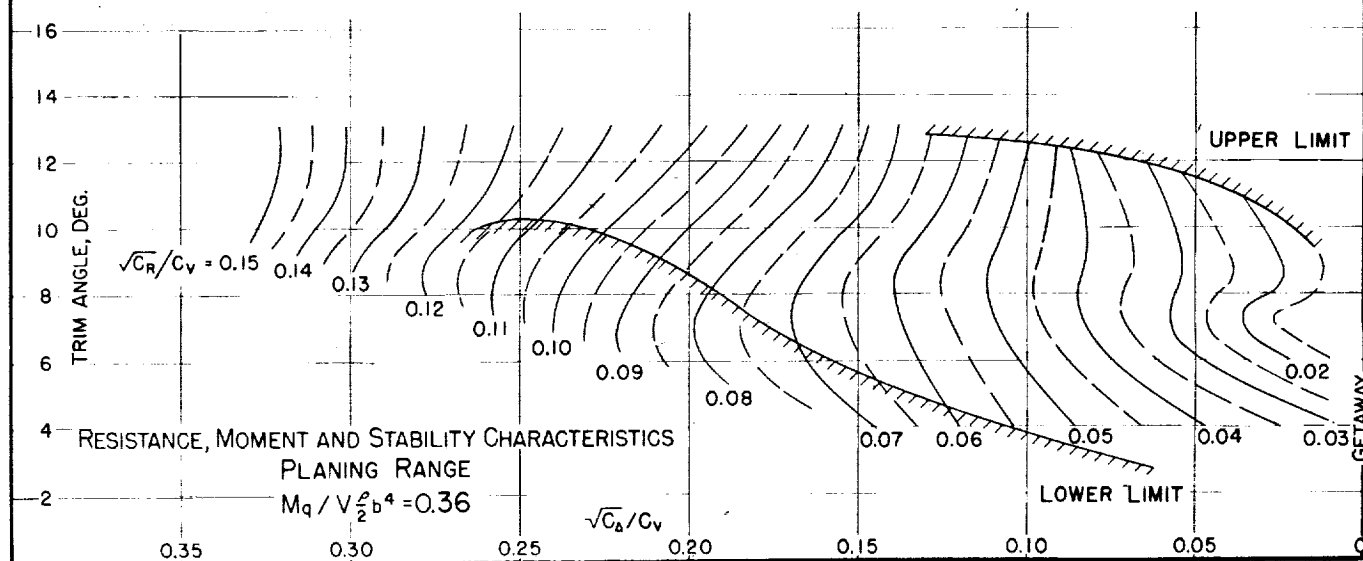
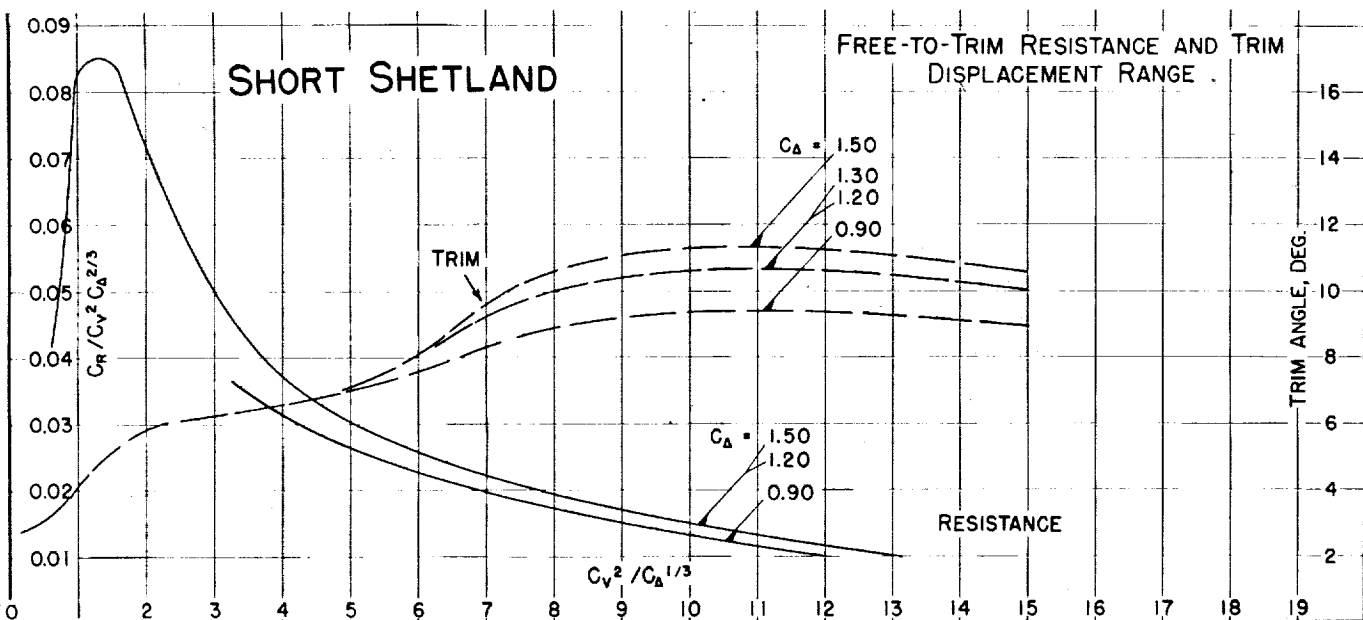
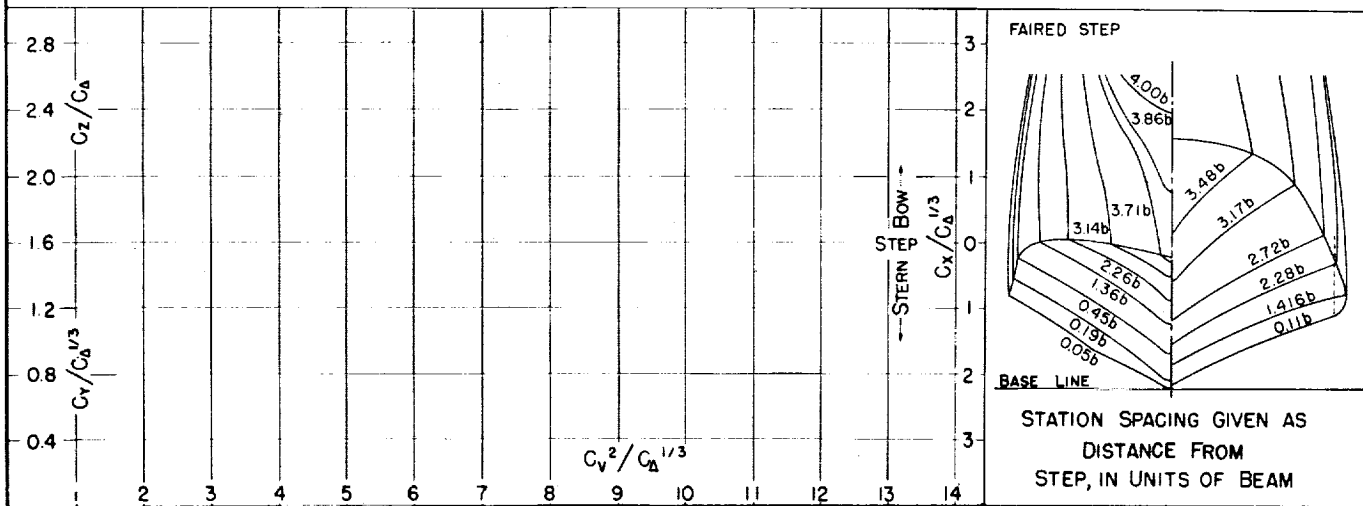

MODEL NO. N2/42-AI
MODEL BEAM: 6.64"

C.G. = 0.16 b FWD. OF CENTROID
1.92 b ABOVE KEEL

$C_{d_0} = 1.35$ (NOMINAL)
 $k/L = 0.218$

TESTED AT RAE TANK
DATE: '43

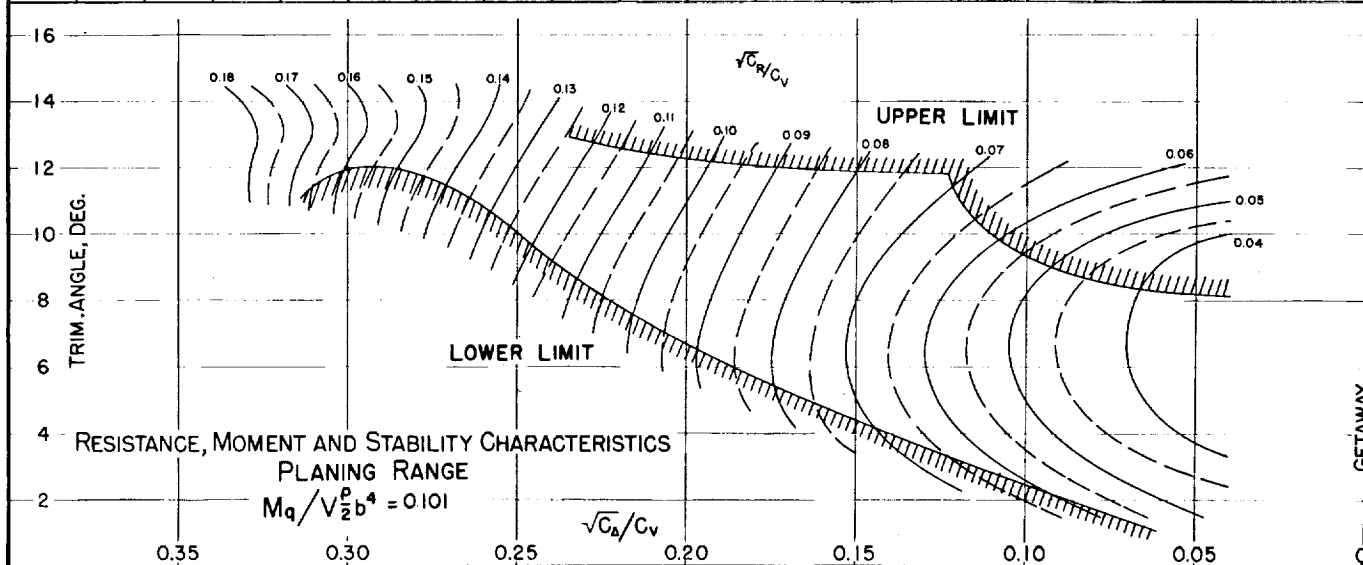
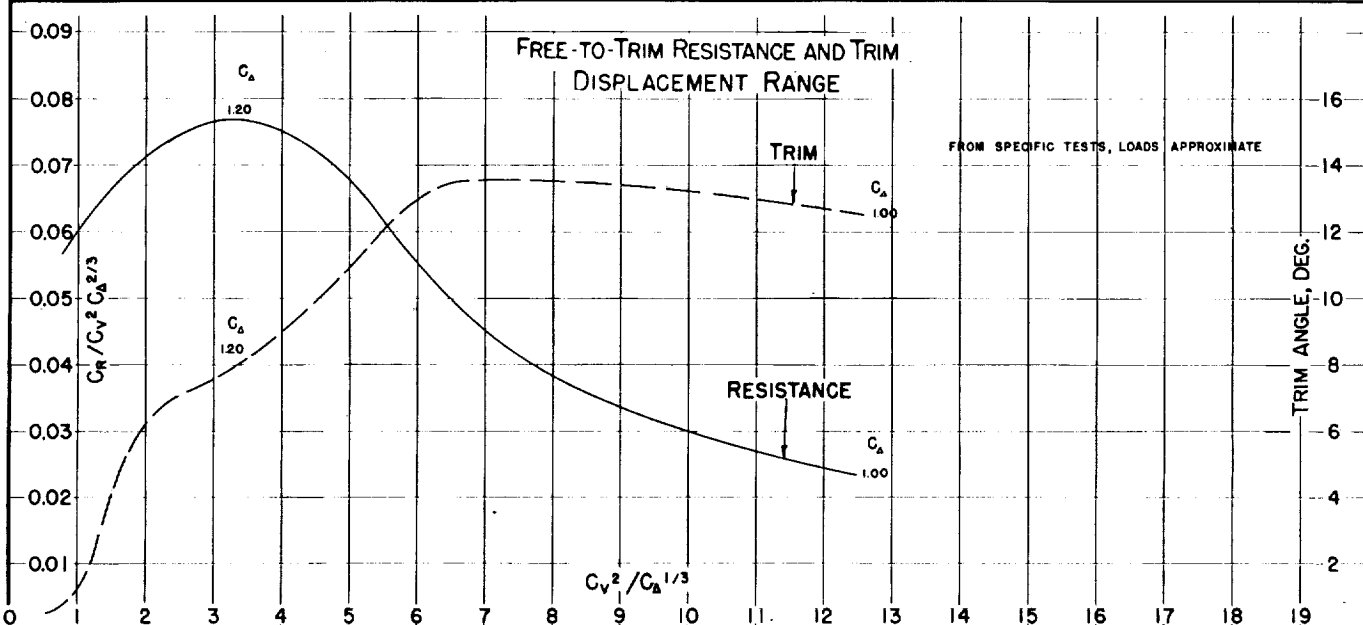
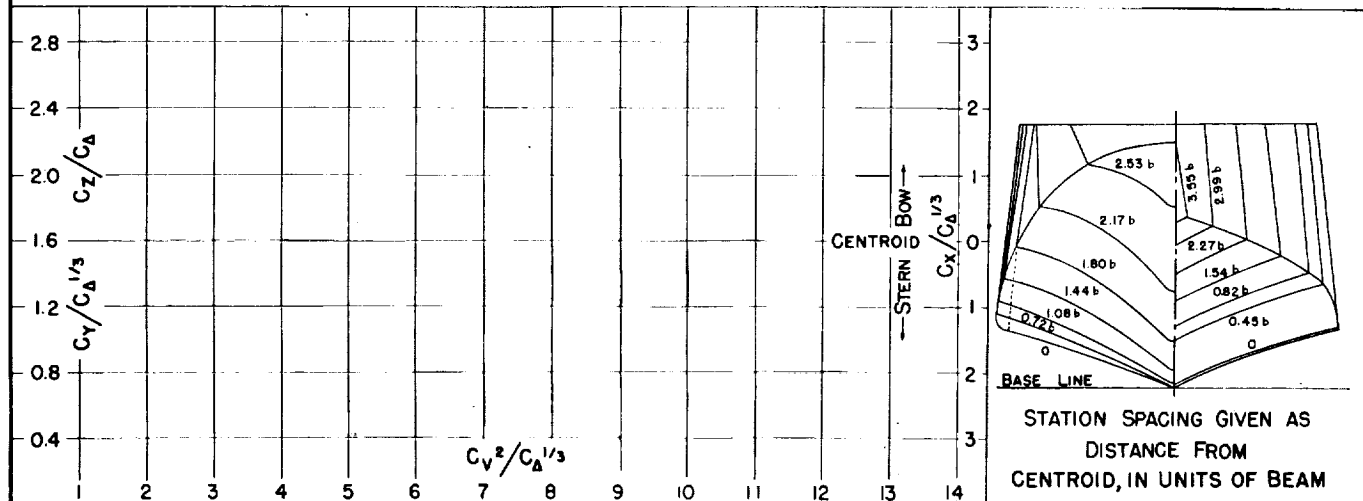

Fig. 86

DESIGNATION: 2.87-1.11-20.0 NACA TN No. 1182

MODEL No. N2/42-Q
MODEL BEAM: 6.56"

C.G. = 0.16 b FWD. OF CENTROID $C_{d_0} = 1.40$ (NOMINAL)
1.95 b ABOVE KEEL $k/L = 0.218$

TESTED AT RAE TANK
DATE: '43

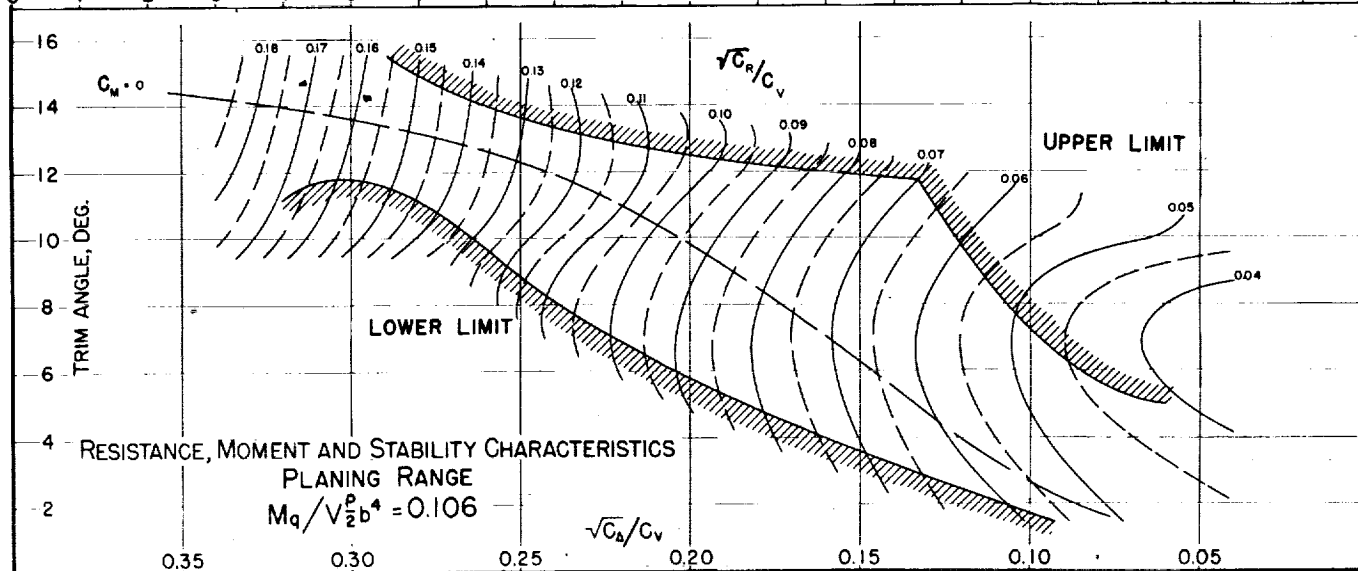
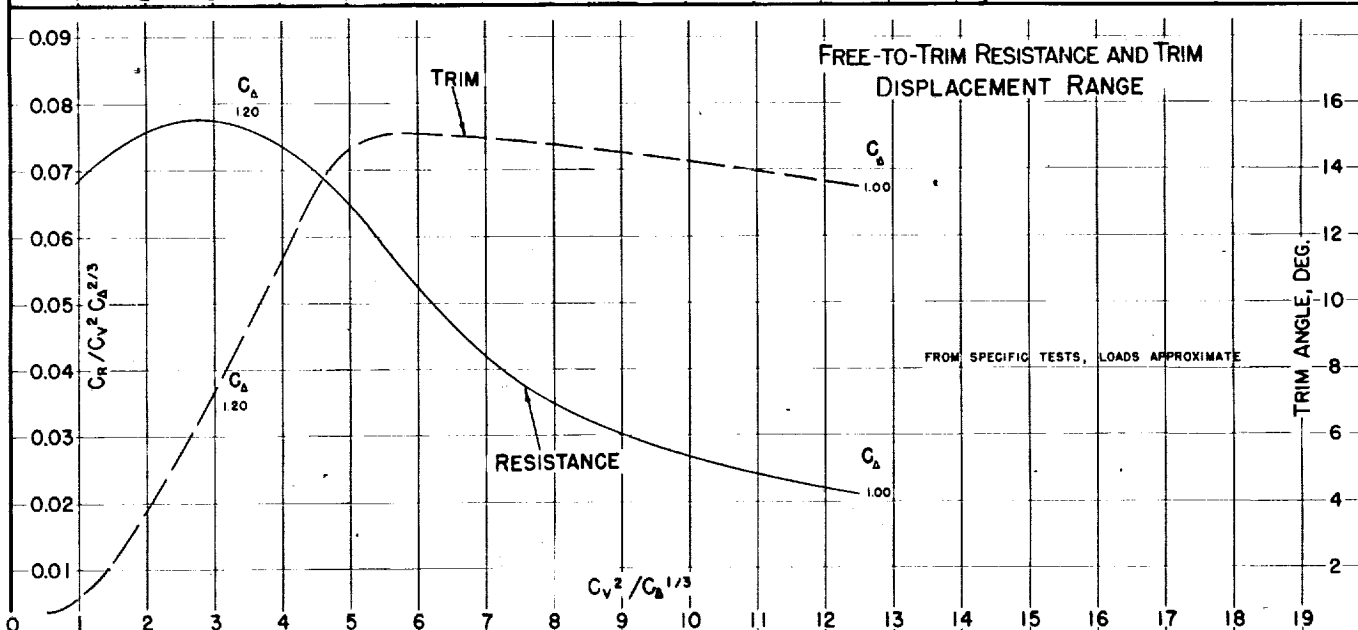
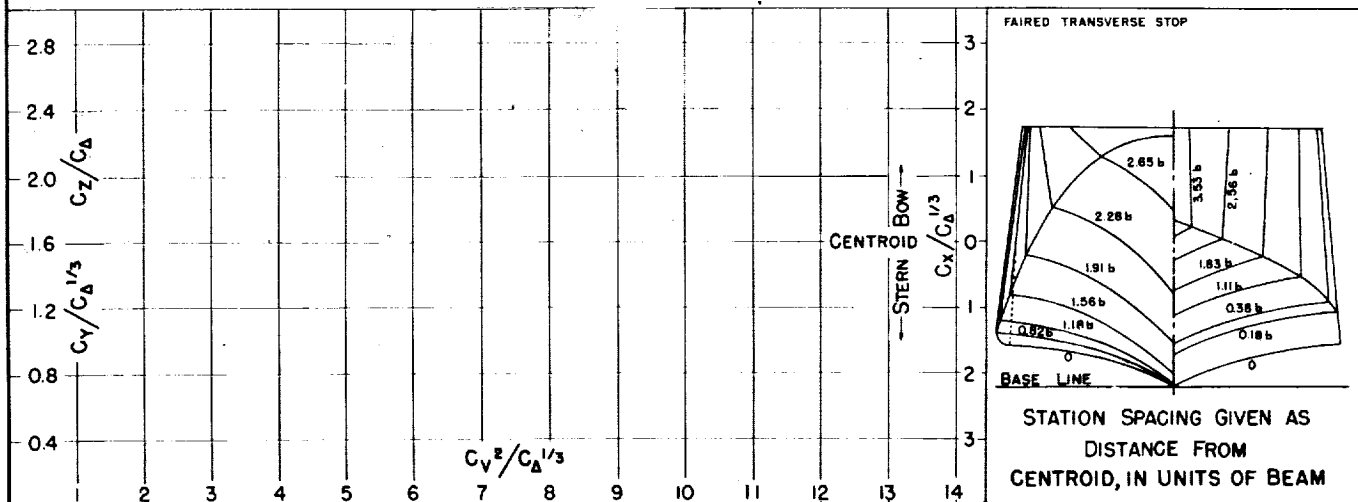

GETAWAY

MODEL NO. OEH
MODEL BEAM: 6.58"

C.G. = 0.10 b FWD. OF CENTROID $C_{d0} = 1.65$ (NOMINAL)
1.29 b ABOVE KEEL $k/L =$

TESTED AT RAE TANK
DATE: 2/45

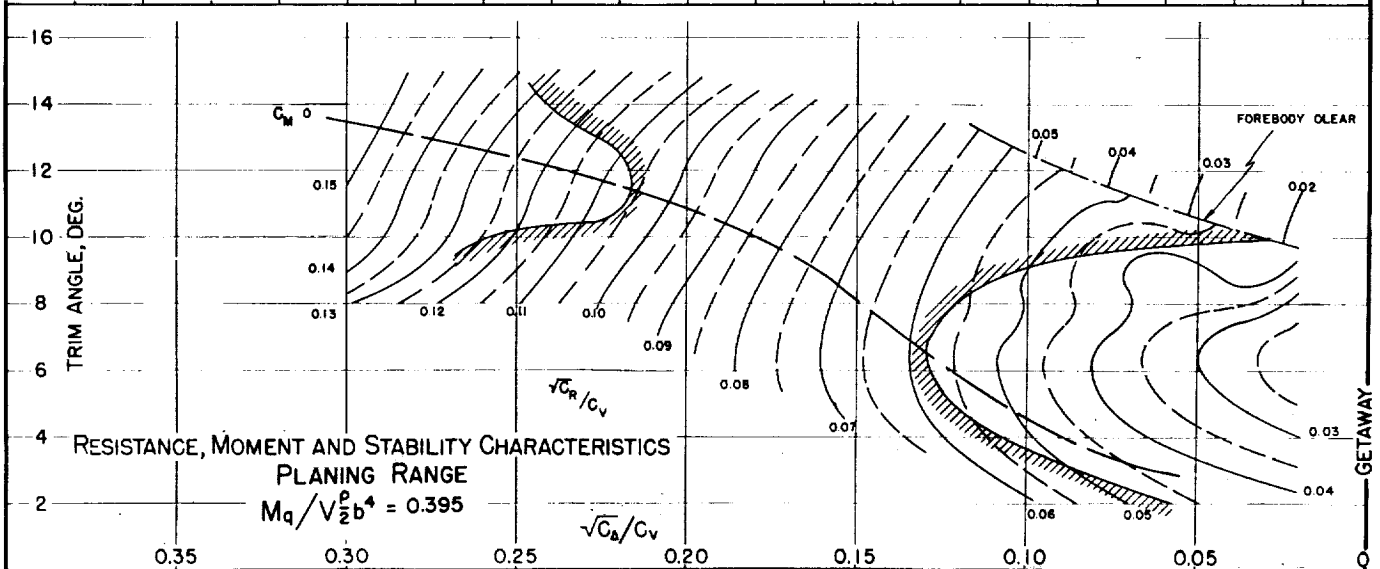
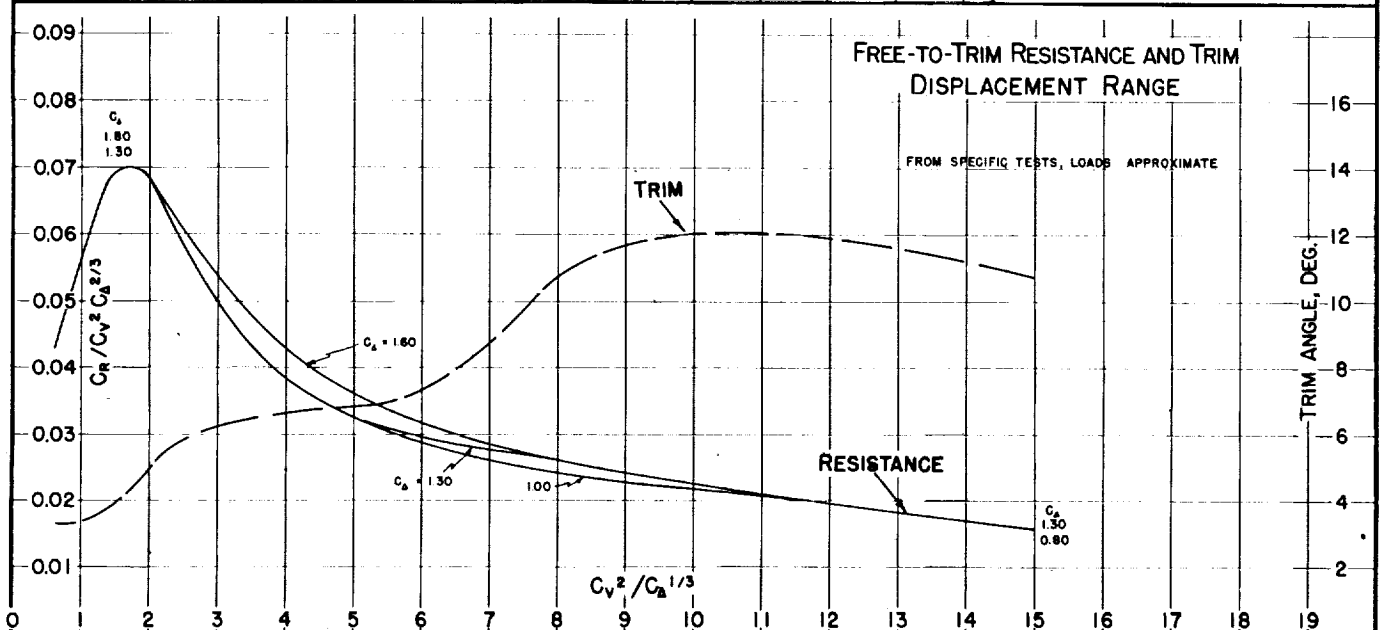
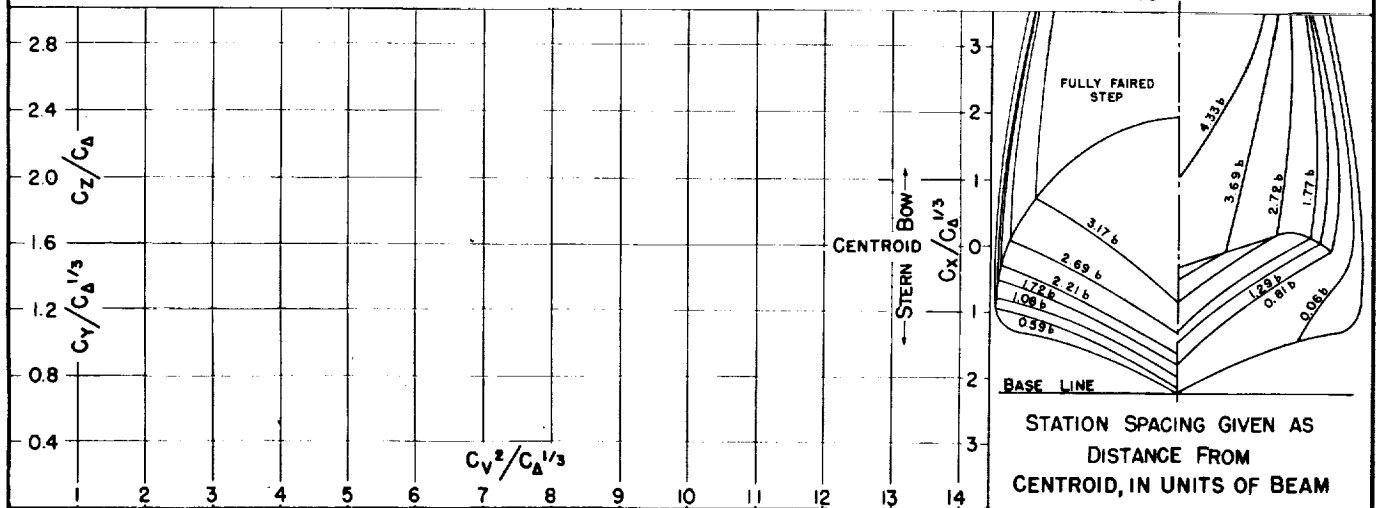

Fig. 88

DESIGNATION: 4.02-109-275 NACA TN No. 1182

MODEL No. FEH
MODEL BEAM: 6.58"

C.G. = 0.10 b FWD. OF CENTROID $C_{A_0} = 1.65$ (NOMINAL)
1.29 b ABOVE KEEL $k/L =$

TESTED AT RAE TANK
DATE: 2/45

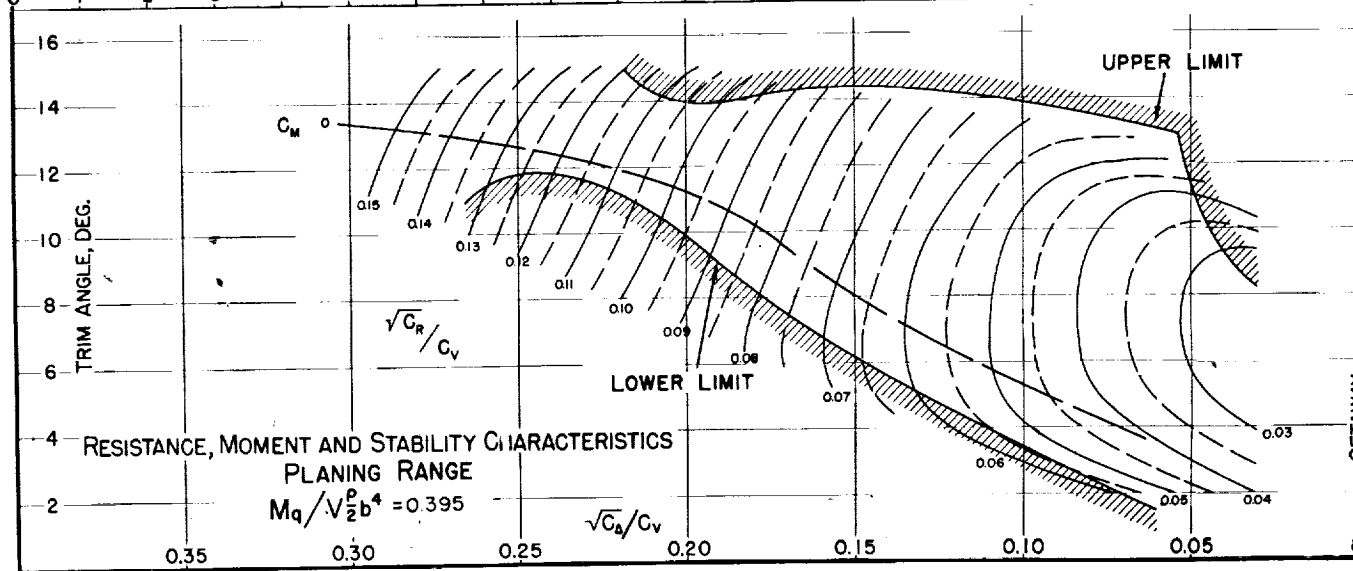
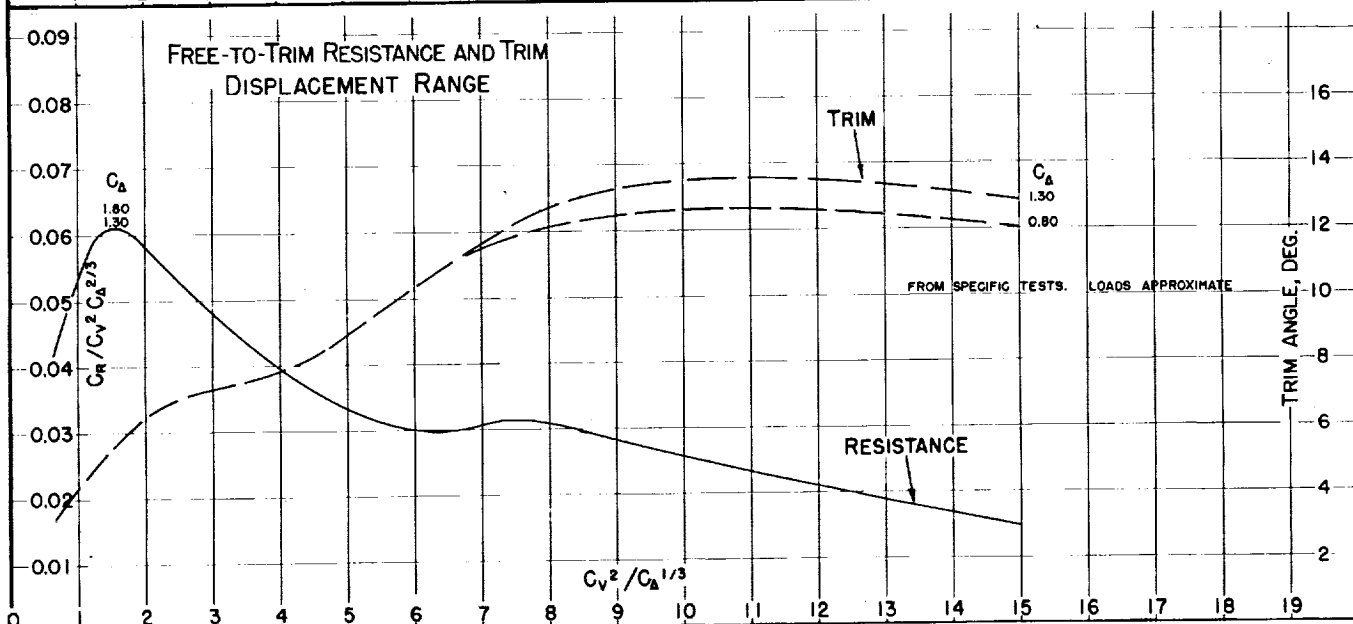
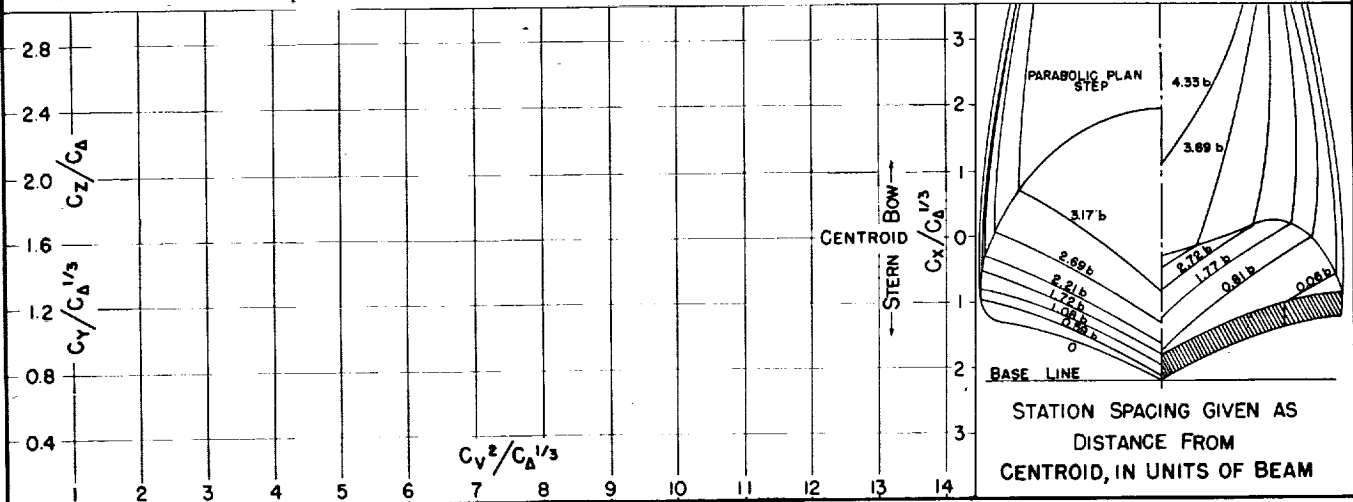

MODEL No. 294-79
MODEL BEAM: 5.10"

$C.G. = 0.44 b$ FWD. OF CENTROID $C_{d0} = 1.02$ (NOMINAL)
 $1.22 b$ ABOVE KEEL $k/L =$

TESTED AT SIT No. 1 TANK
DATE: 5/42

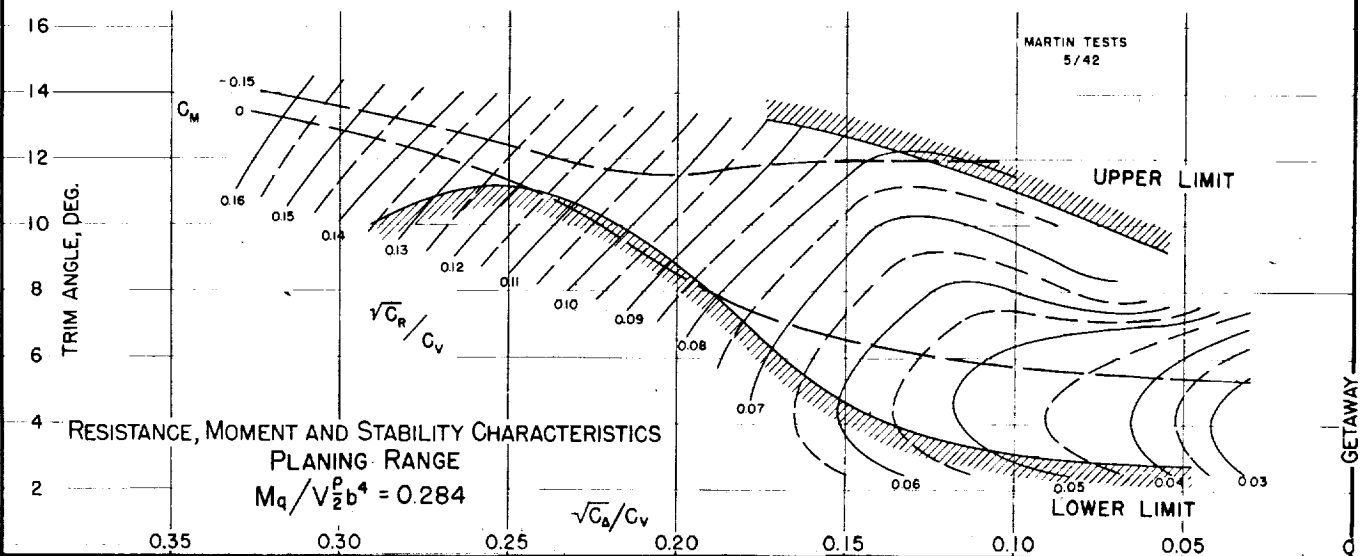
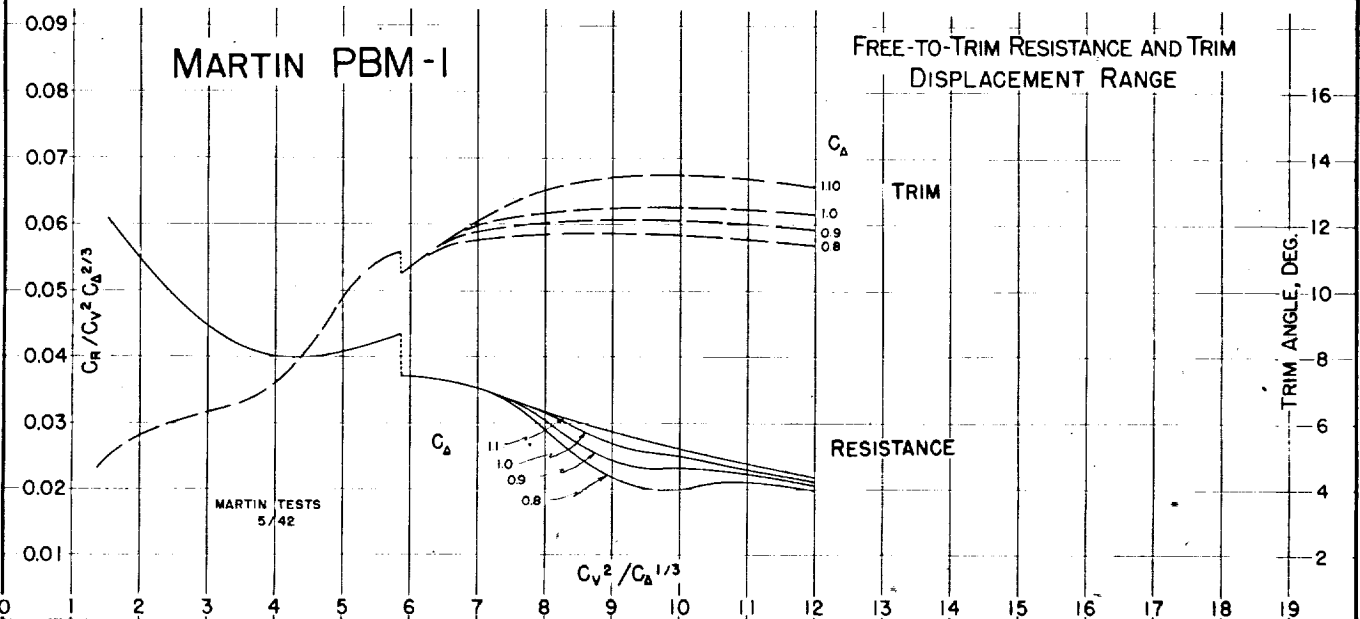
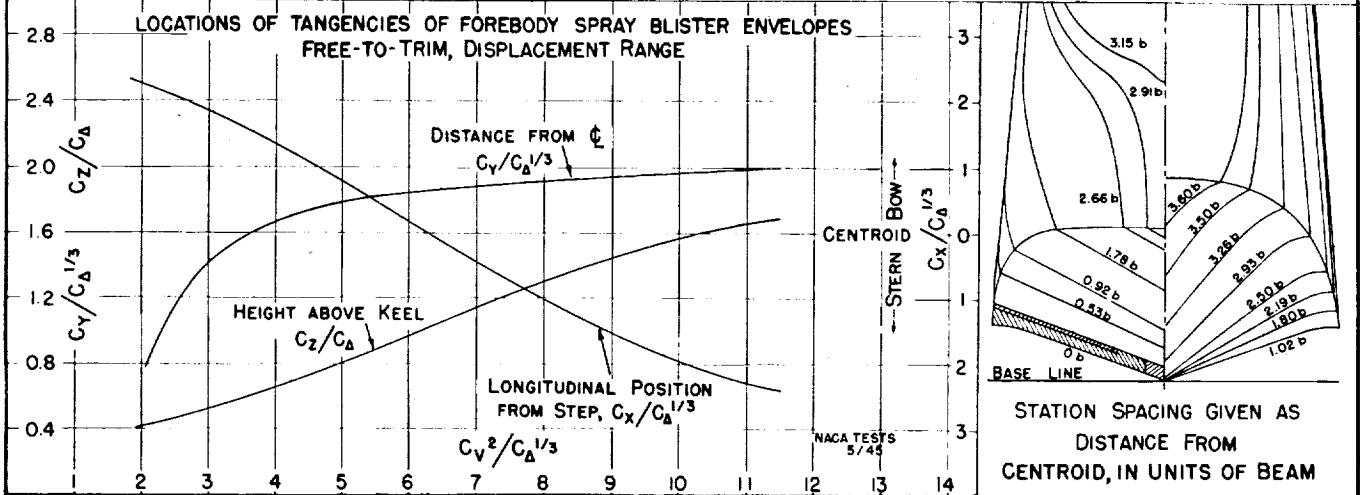

GETAWAY

Fig. 90

DESIGNATION: 3.32-0.62-20.0

NACA TN No. 1182

MODEL NO. 339-1
MODEL BEAM: 5.40"

C.G. = 0.35b FWD. OF STEP
0.90b ABOVE KEEL

$C_{A0} = 1.069$ (NOMINAL)
 $k/L = 0.225$

TESTED AT S.I.T. NO. 1 TANK
DATE: 11-4-43

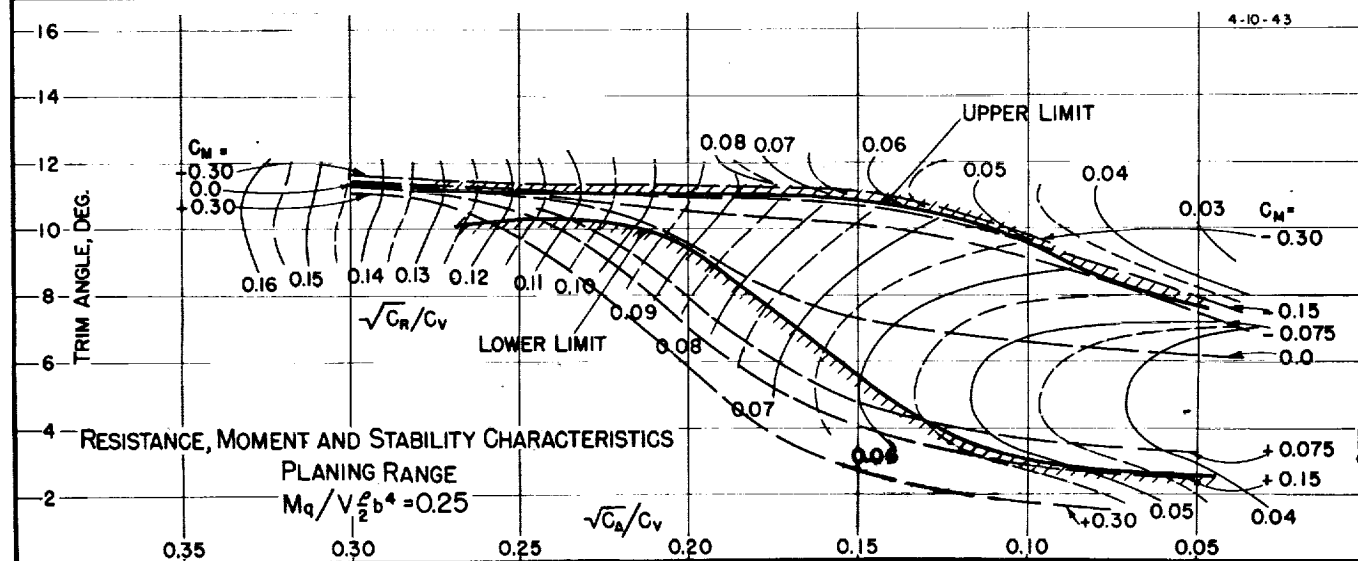
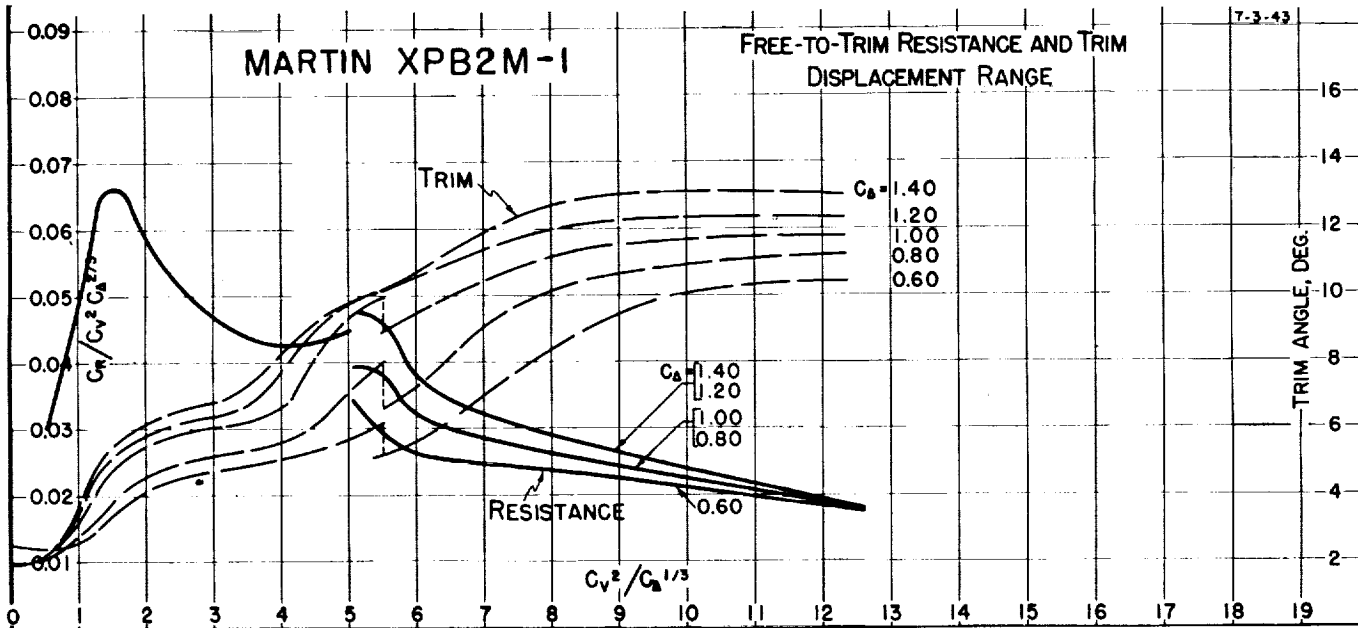
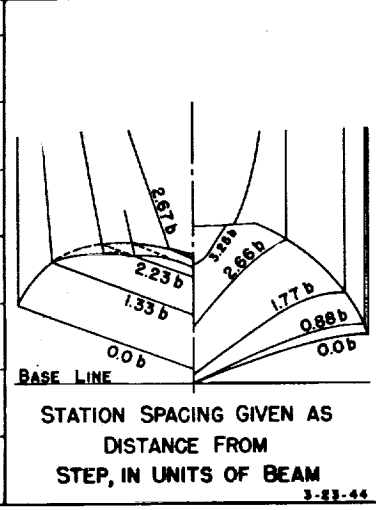
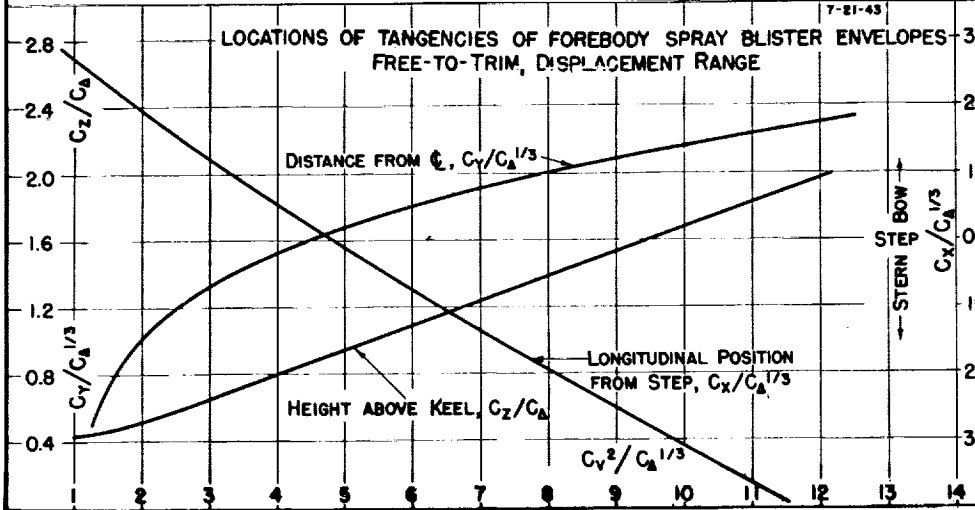

GETAWAY

MODEL No. 339-15
MODEL BEAM 5.40

C.G. = 0.55b FWD. OF STEP
0.90b ABOVE KEEL

$C_{d0} =$ (NOMINAL)
 $k/L =$

TESTED AT SIT No. 1 TANK
DATE: 5-13-44

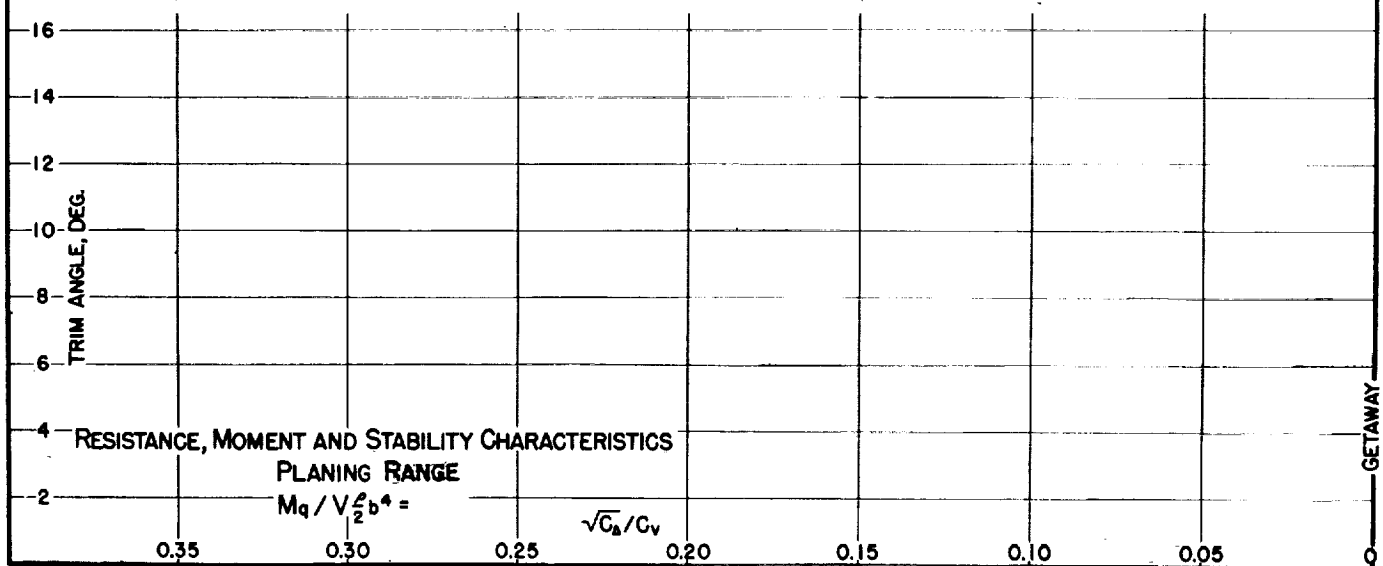
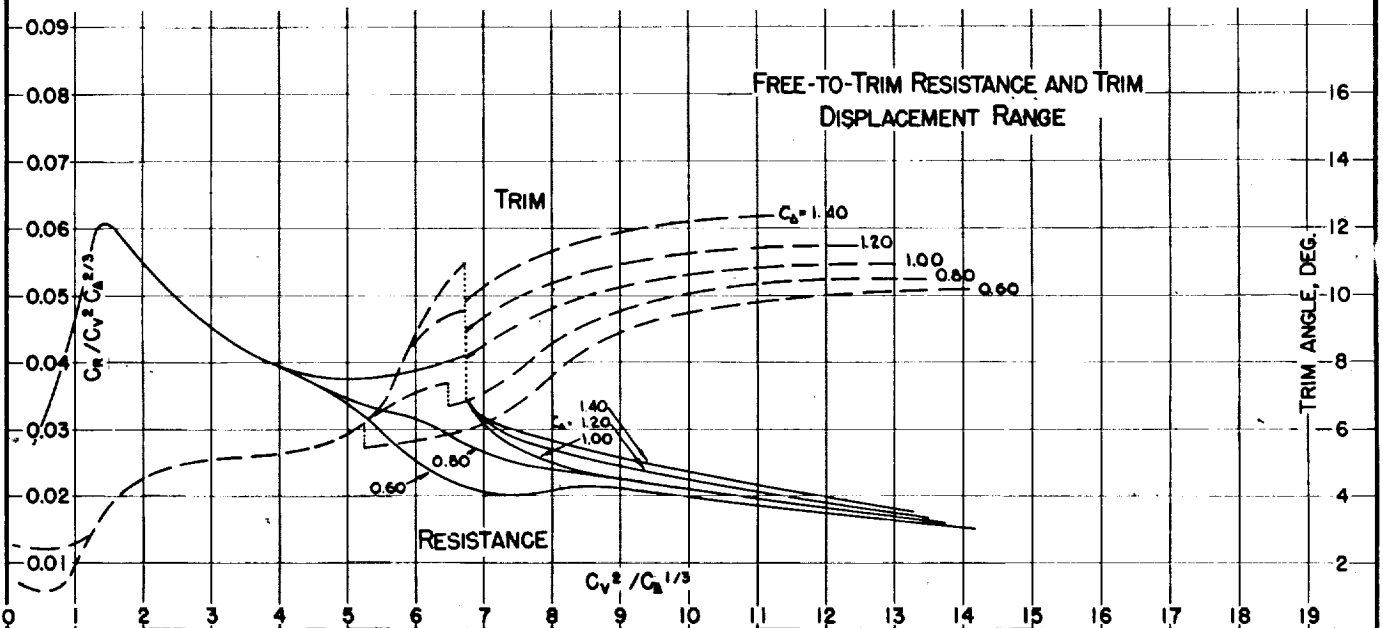
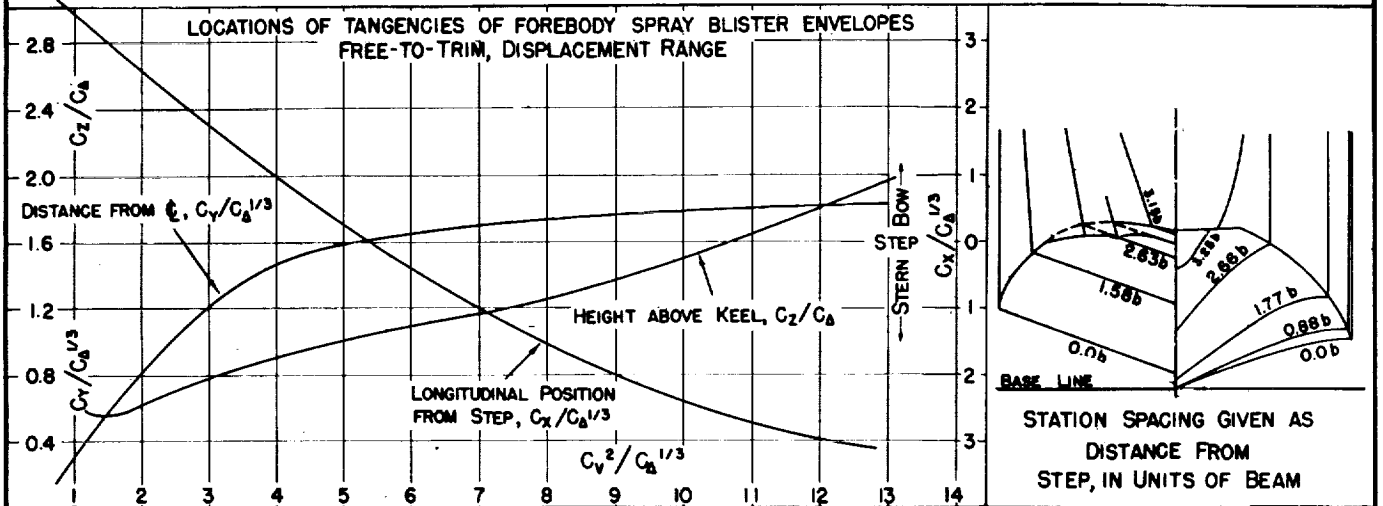

Fig. 92

DESIGNATION: 2.72-0.62-20.0 NACA TN No. 1182

MODEL No. 339-20
MODEL BEAM: 5.40"

C.G. = 0.35 b FWD. OF STEP
0.90 b ABOVE KEEL

$C_{d0} =$ (NOMINAL)
 $k/L =$

TESTED AT SIT No 1 TANK
DATE: 5-13-44

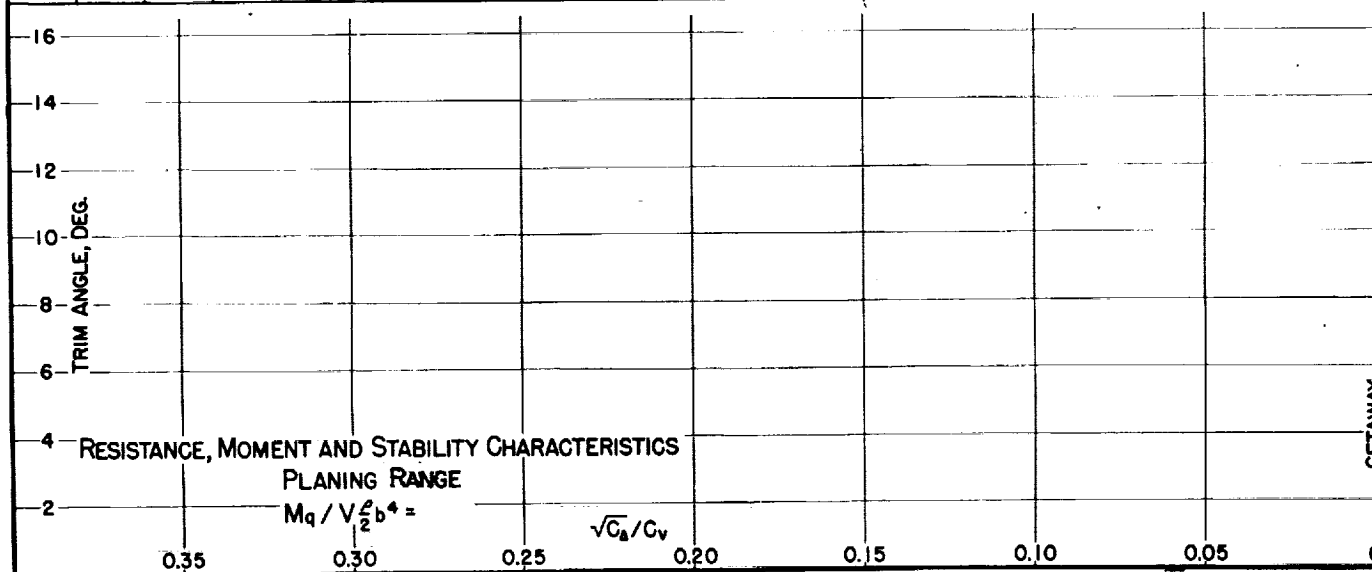
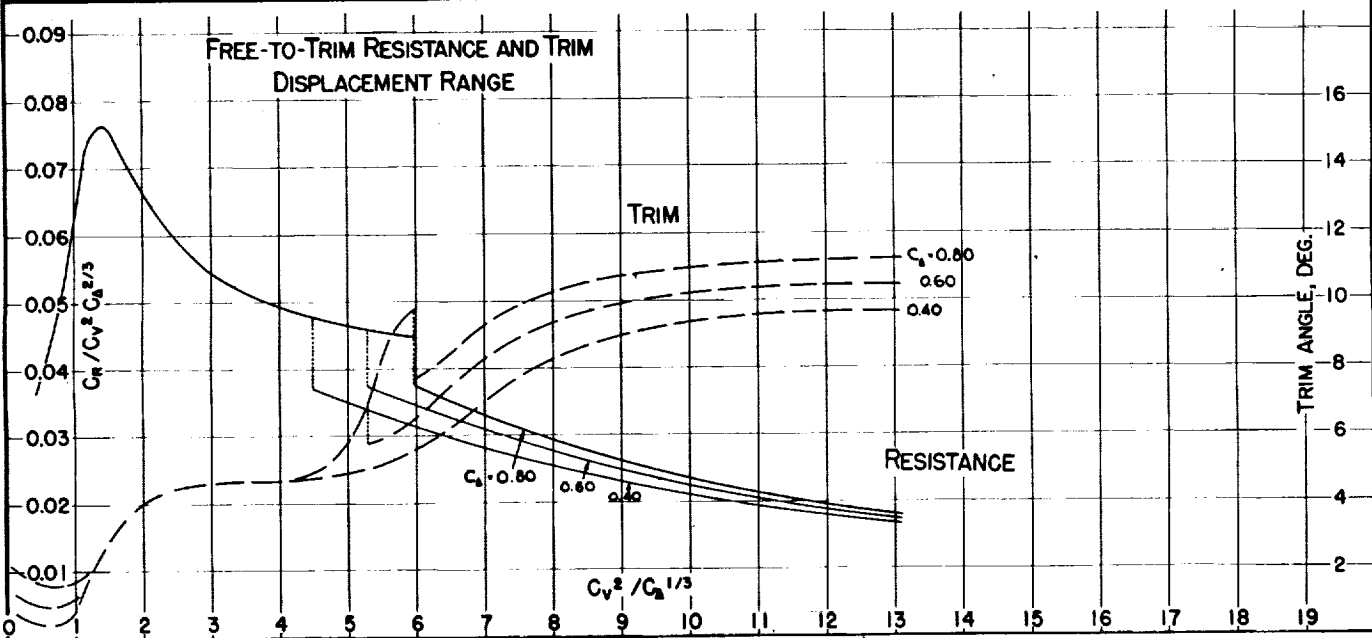
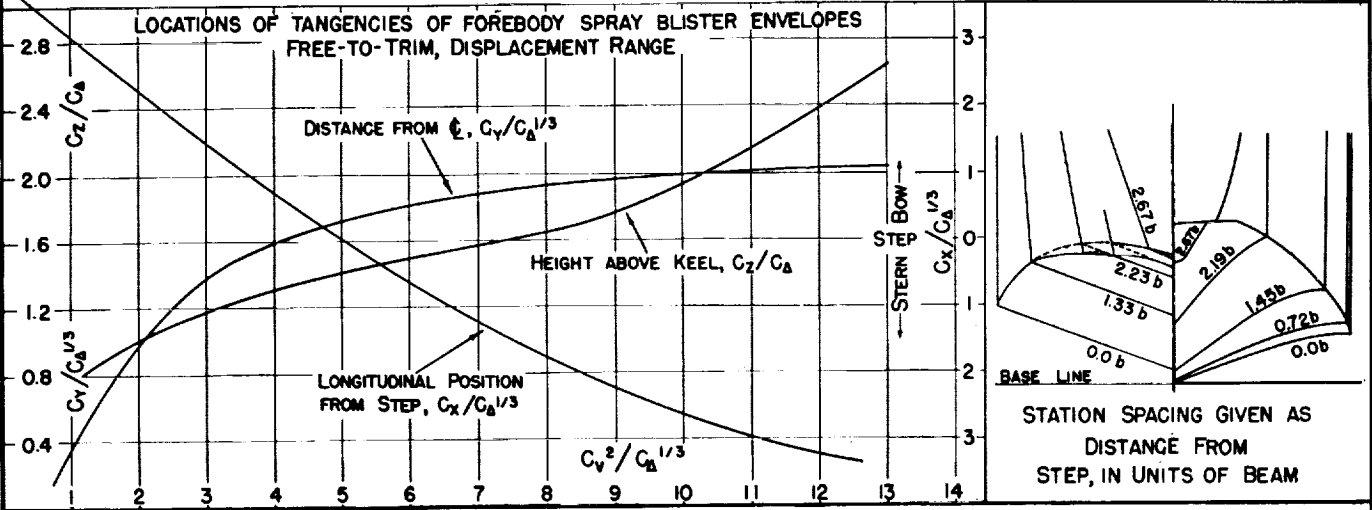

GETAWAY

MODEL NO. 339-22
MODEL BEAM: 5.40"

C.G. = 0.35b FWD. OF STEP
0.90b ABOVE KEEL

$C_{A_0} = 0.588$ (NOMINAL)
 $k/L = 0.225$

TESTED AT S.I.T. NO. 1 TANK
DATE: 11-4-43

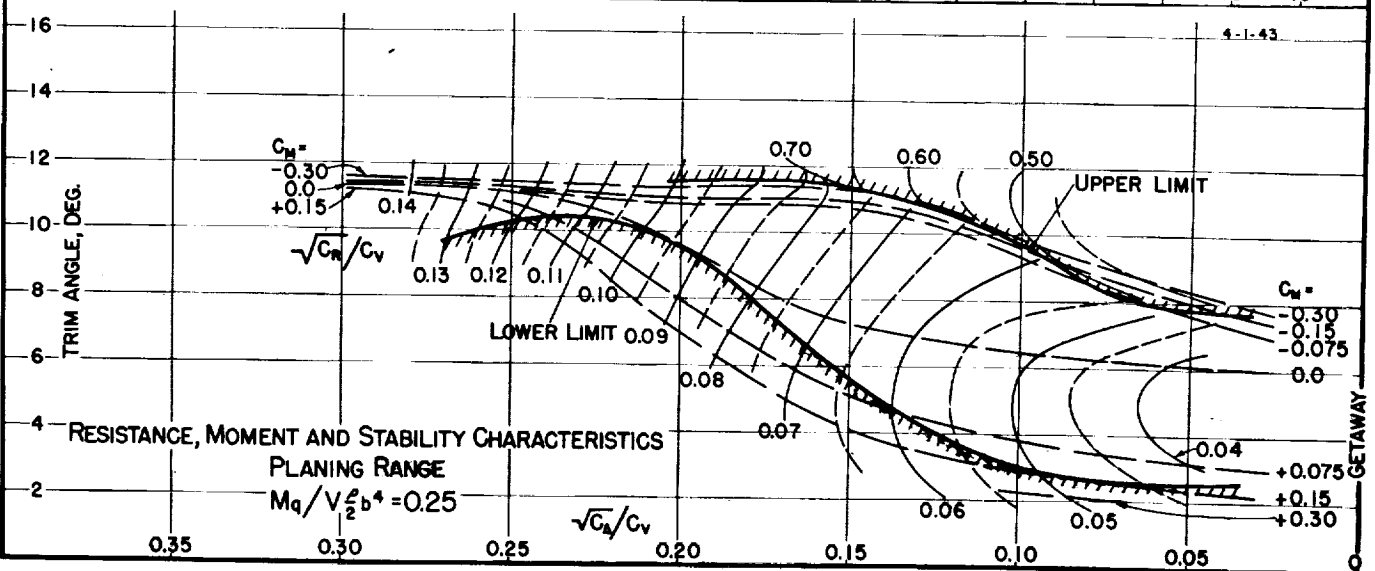
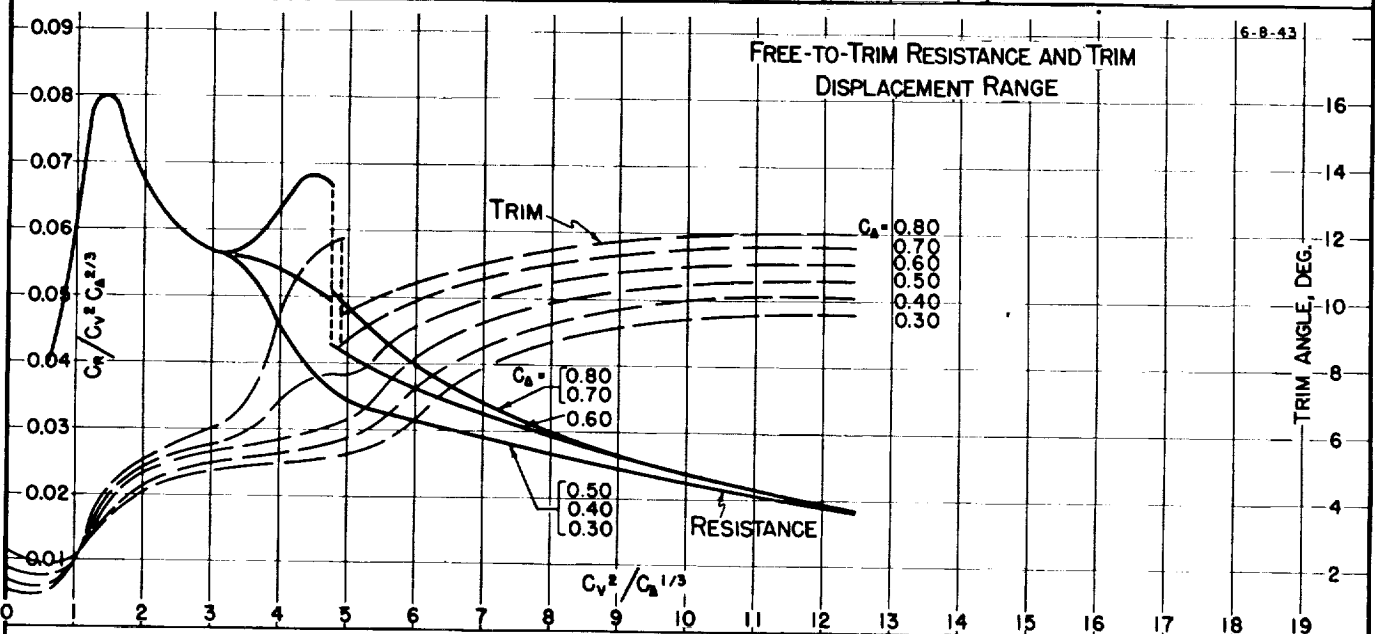
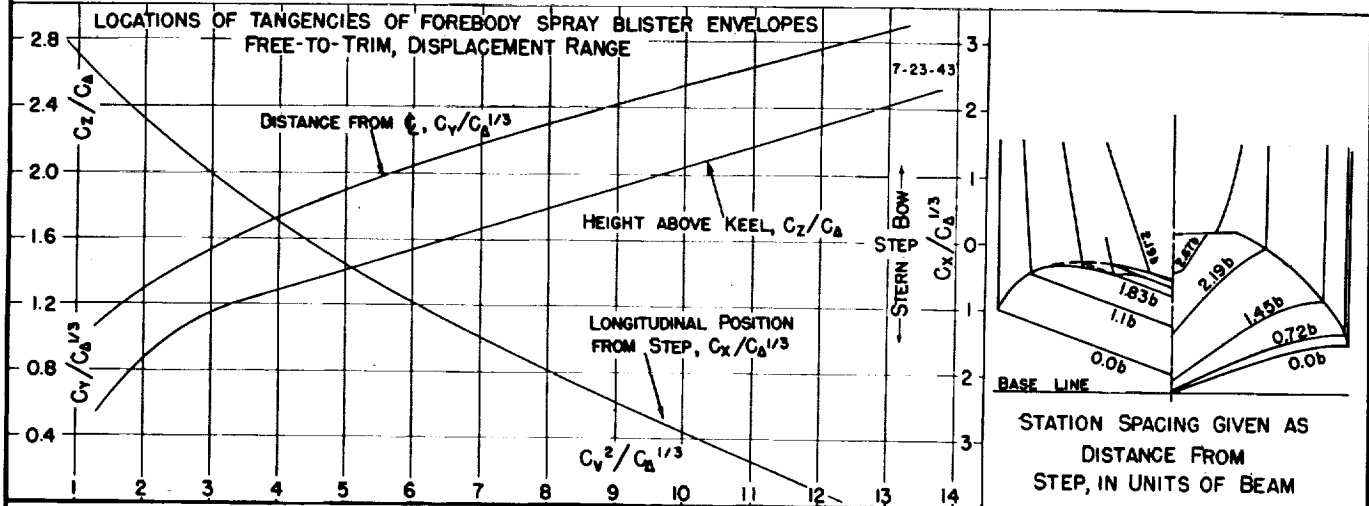

Fig. 94

DESIGNATION: 3.93-0.64-20.0 NACA TN No. 1182

MODEL NO. 339-23
MODEL BEAM: 5.40"

C.G. = 0.35b FWD. OF STEP
0.90b ABOVE KEEL

$C_{A_0} = 1.770$ (NOMINAL)
 $k/L = 0.225$

TESTED AT S.I.T. NO. 1 TANK
DATE: 11-4-43

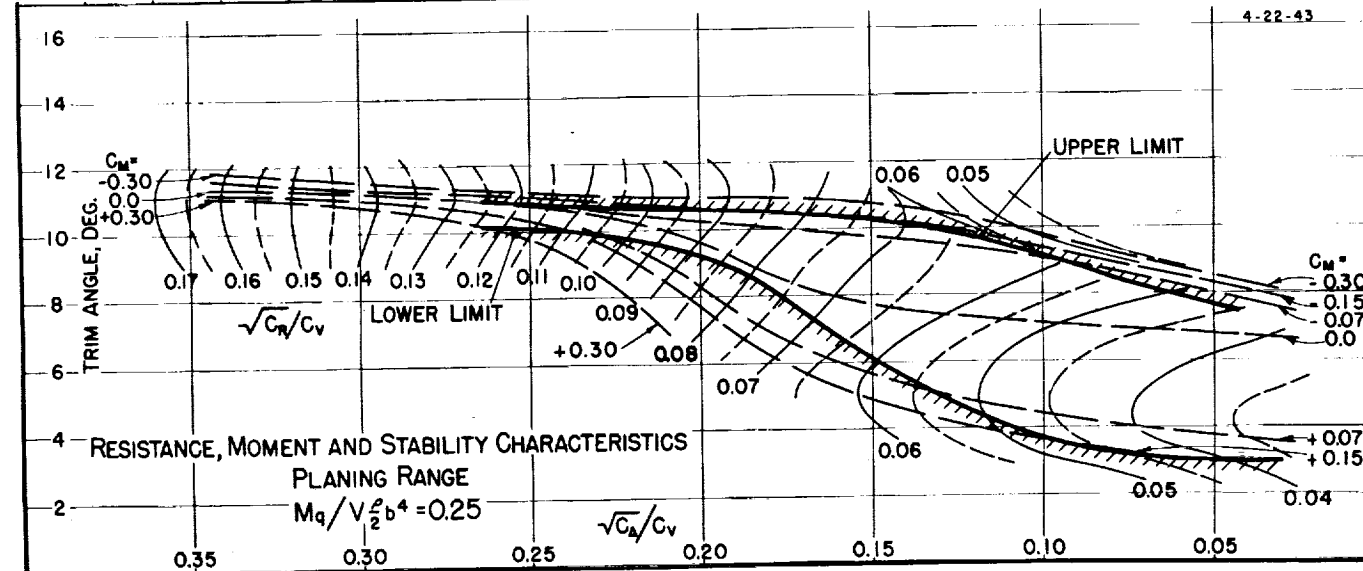
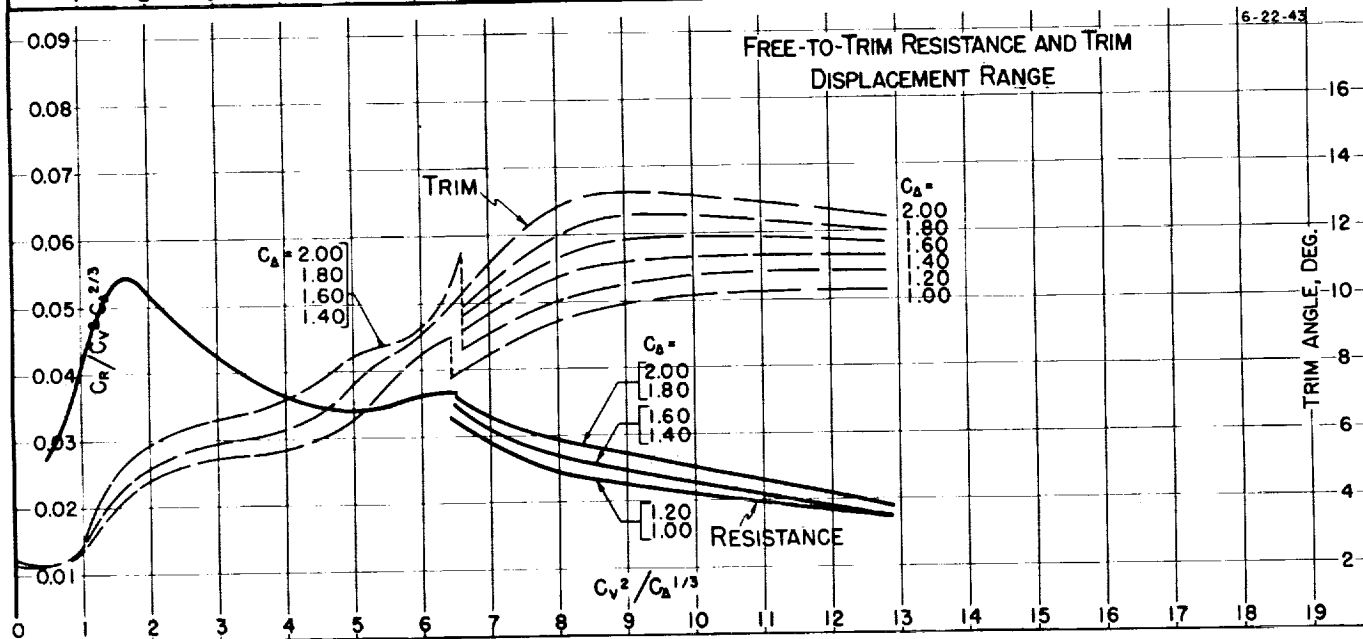
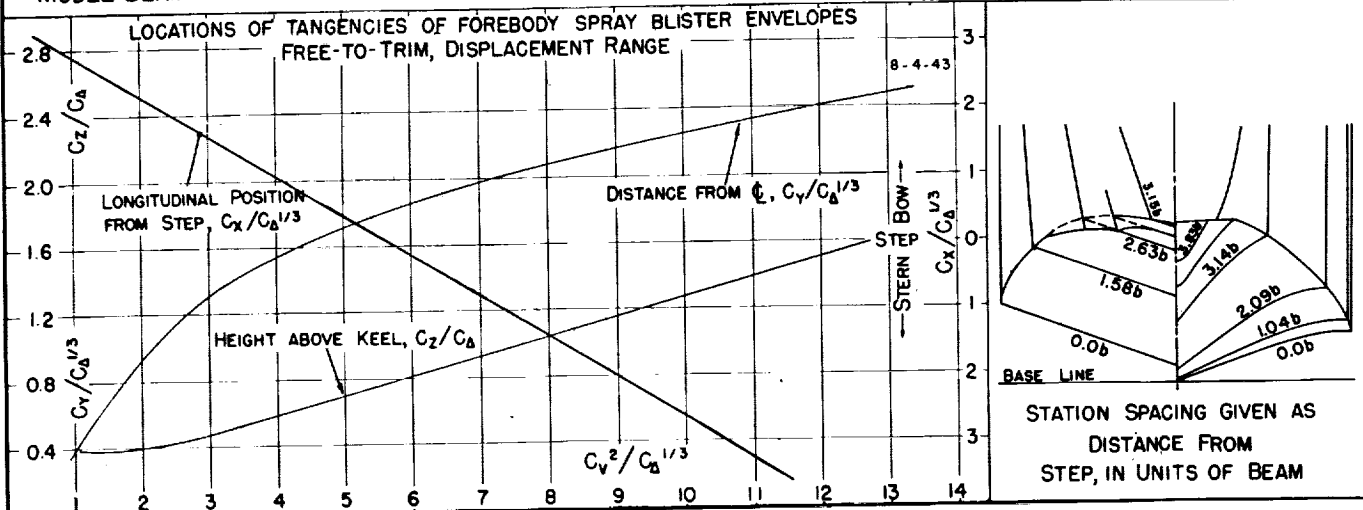

MODEL No. 339-46
MODEL BEAM: 5.40"

C.G. = 0.35b FWD. OF STEP
0.90b ABOVE KEEL

$C_{\Delta_0} = 2.722$ (NOMINAL)
 $k/L = 0.225$

TESTED AT S.I.T. NO. 1 TANK
DATE: 11-4-43

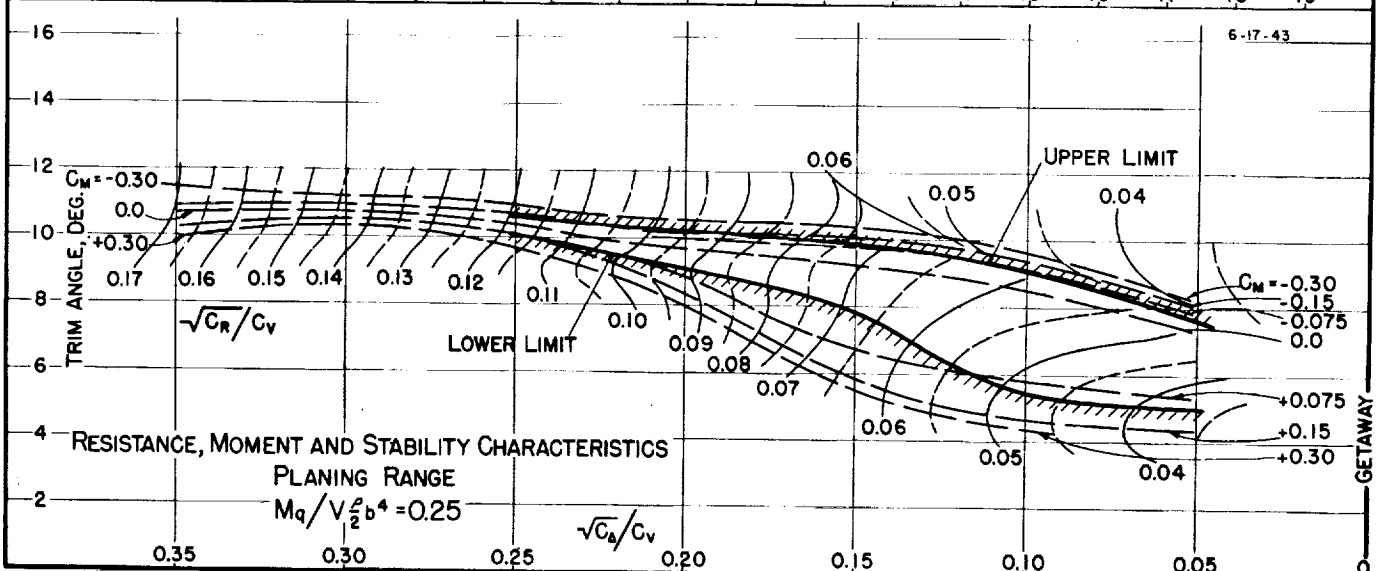
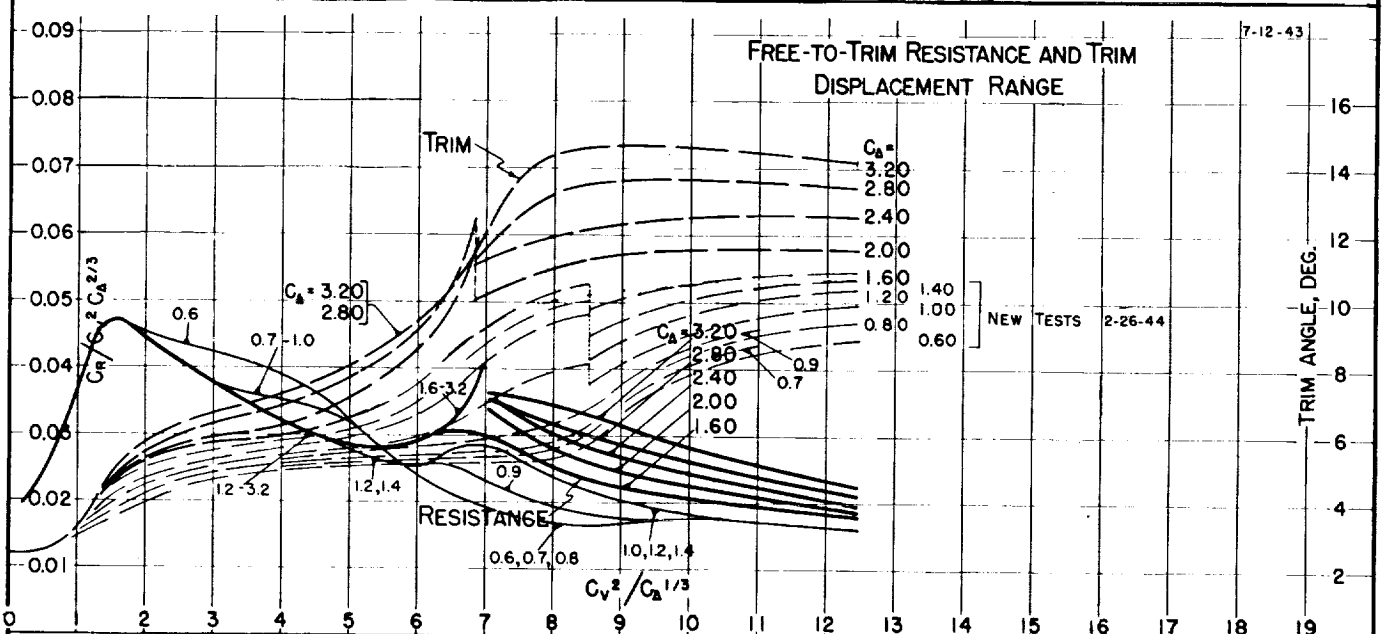
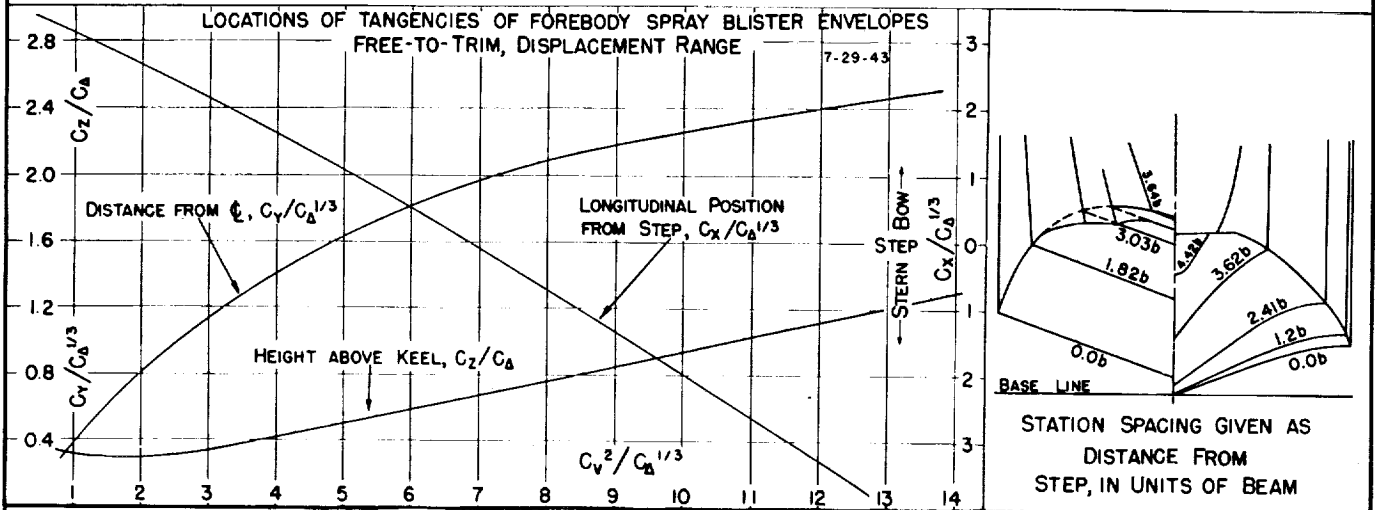

Fig. 96

DESIGNATION: 3.93-0.67-20.0 NACA TN No. 1182

MODEL No. 339-49
MODEL BEAM: 5.40"

C.G. = 0.35 b FWD. OF STEP
0.90b ABOVE KEEL

$C_{d,0} =$ (NOMINAL)
 $k/L =$

TESTED AT SIT No. 1 TANK
DATE: 5-13-44

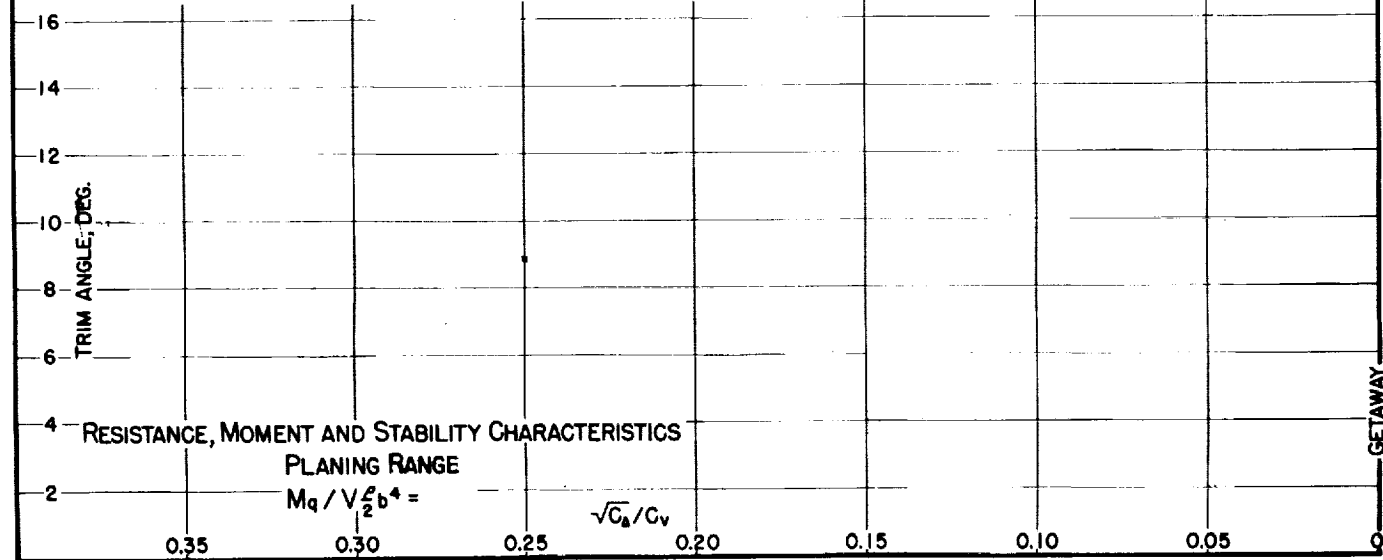
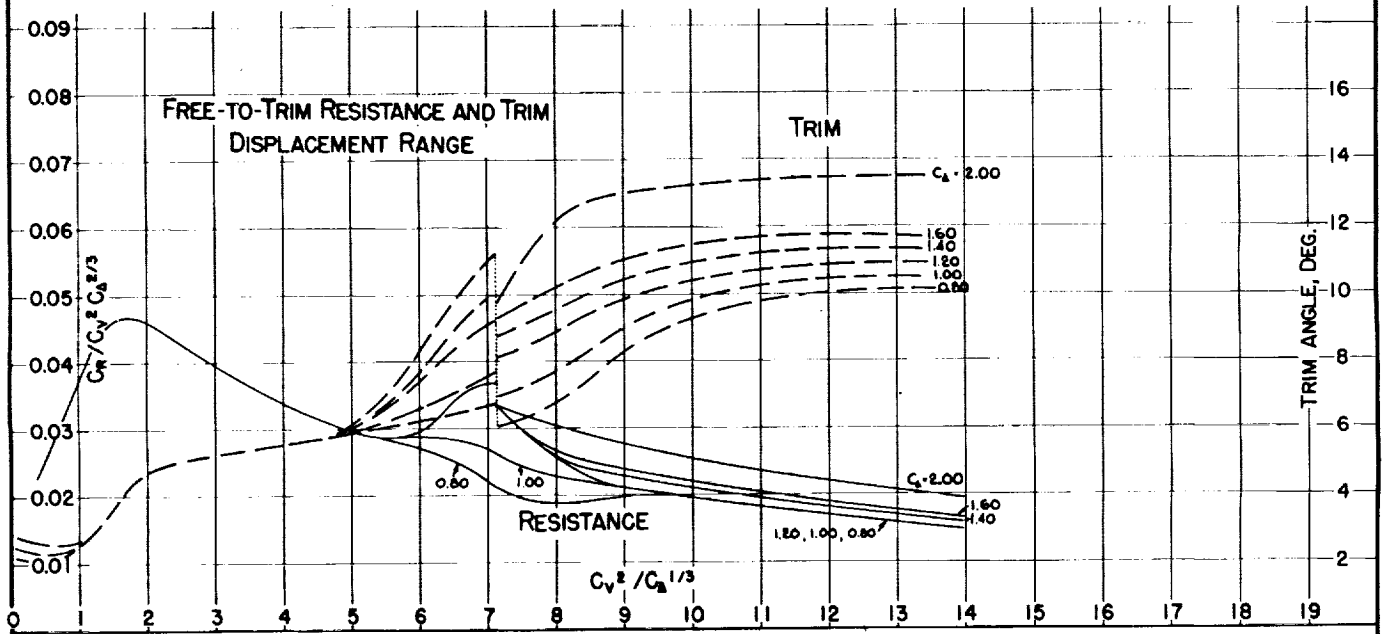
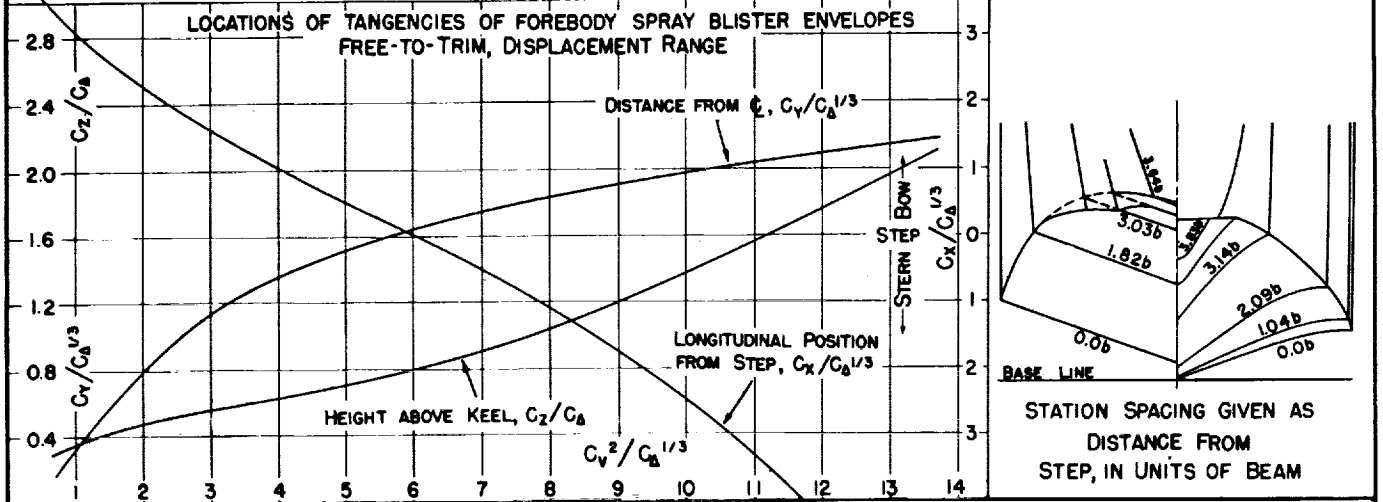

GETAWAY

MODEL No. 439-1
MODEL BEAM: 5.40"

C.G. = 0.43 b FWD. OF CENTROID $C_{d_0} = 0.90$ (NOMINAL)
0.90 b ABOVE KEEL $k/L =$

TESTED AT SIT No. 1 TANK
DATE: 3/43

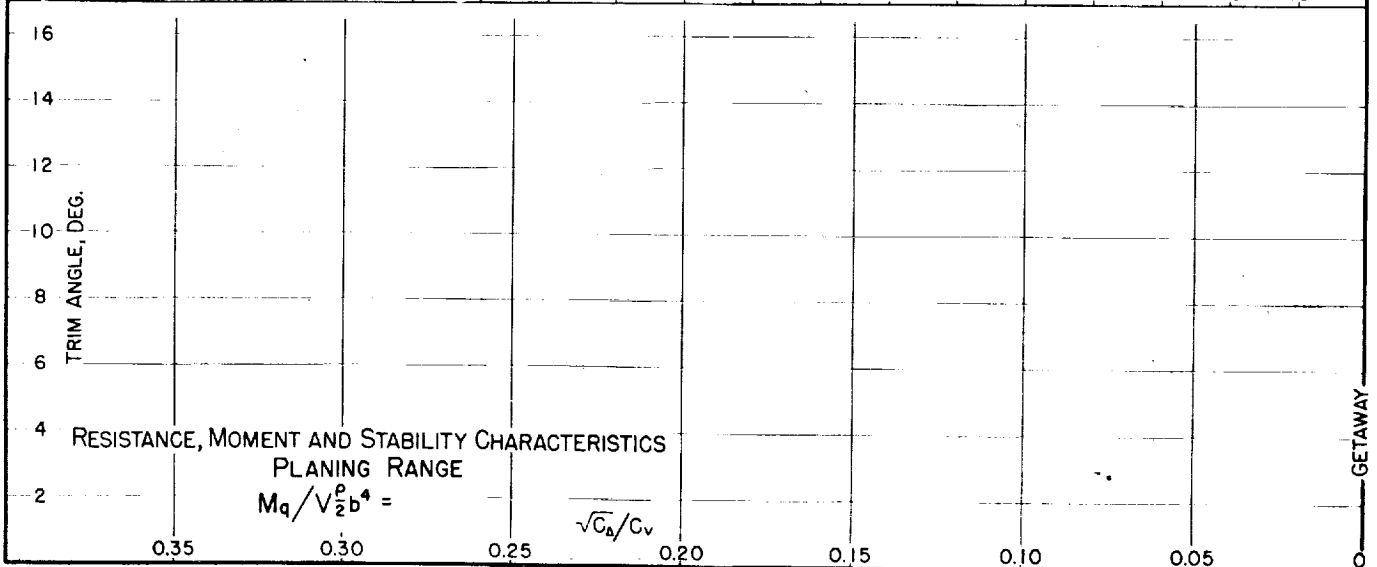
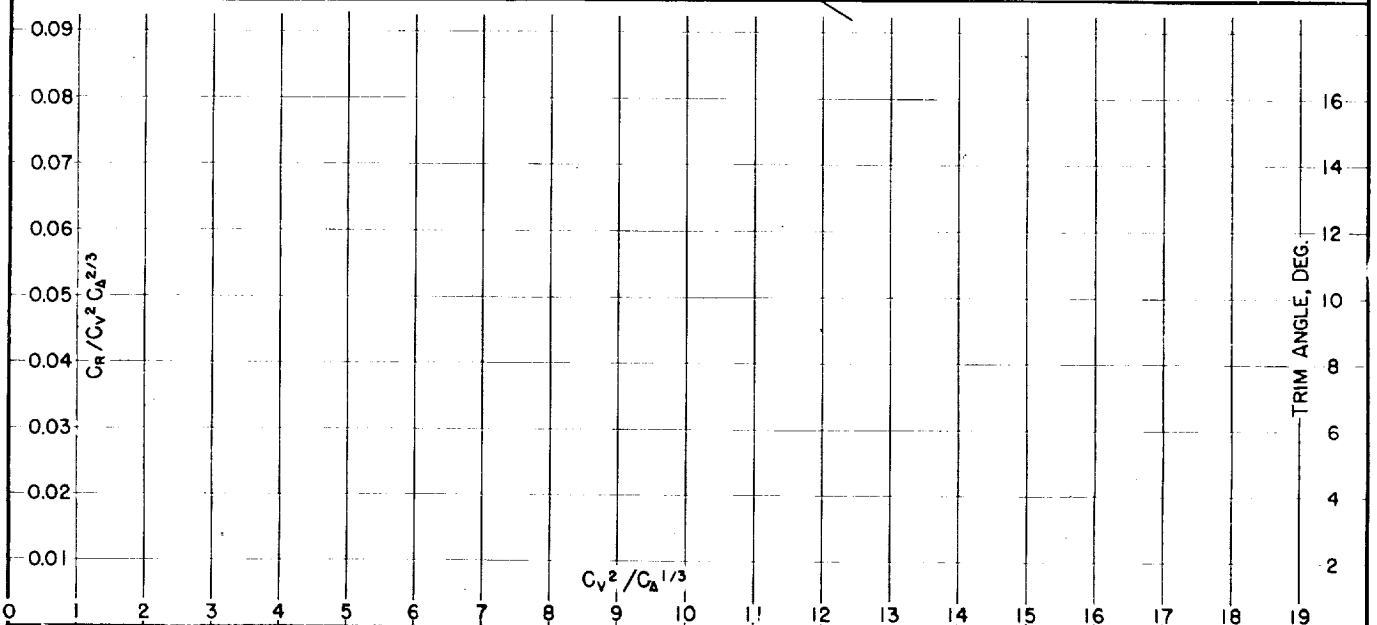
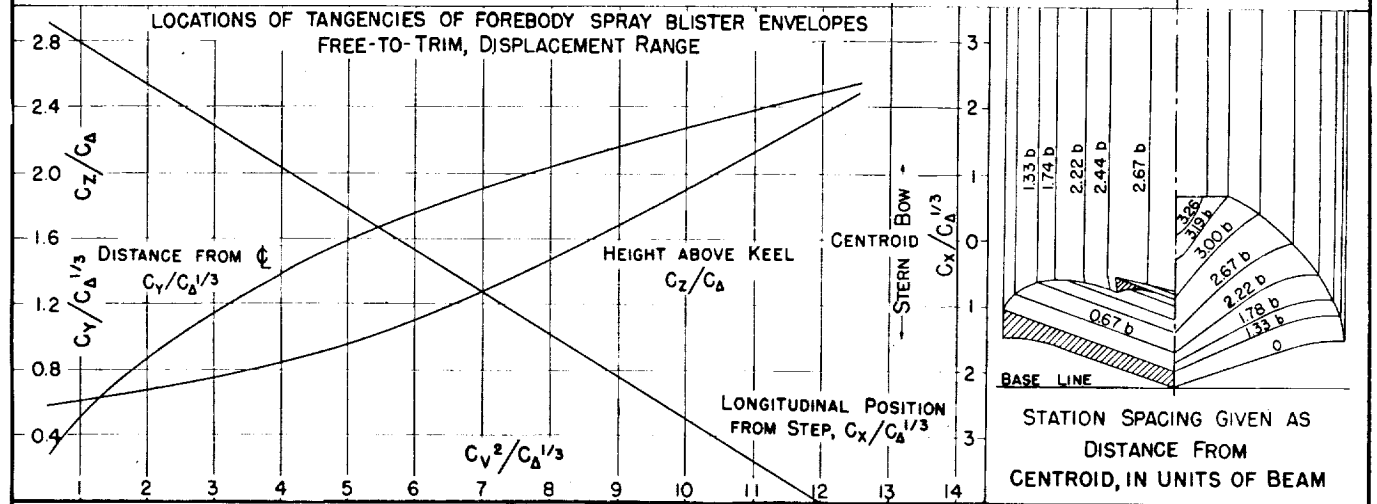

Fig. 98

DESIGNATION: 3.32-0.62-100 NACA TN No. 1182

MODEL No. 439-2
MODEL BEAM: 5.40"

C.G. = 0.43 b FWD. OF CENTROID $C_{d_0} = 0.90$ (NOMINAL)
0.90 b ABOVE KEEL $k/L =$

TESTED AT SIT No. 1 TANK
DATE: 3/43

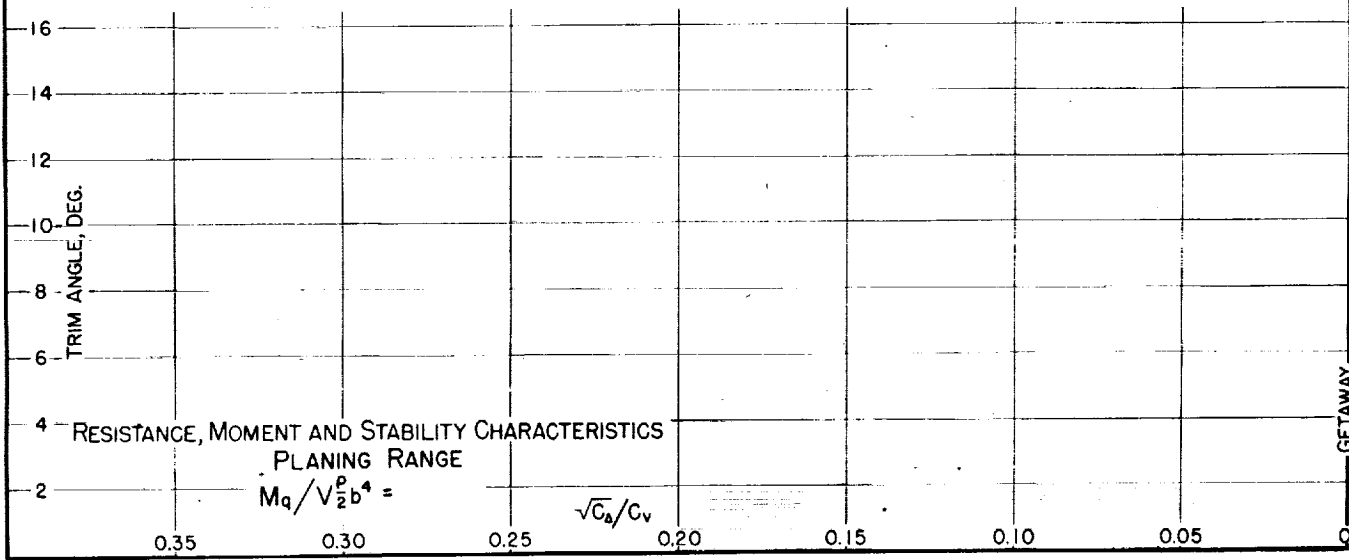
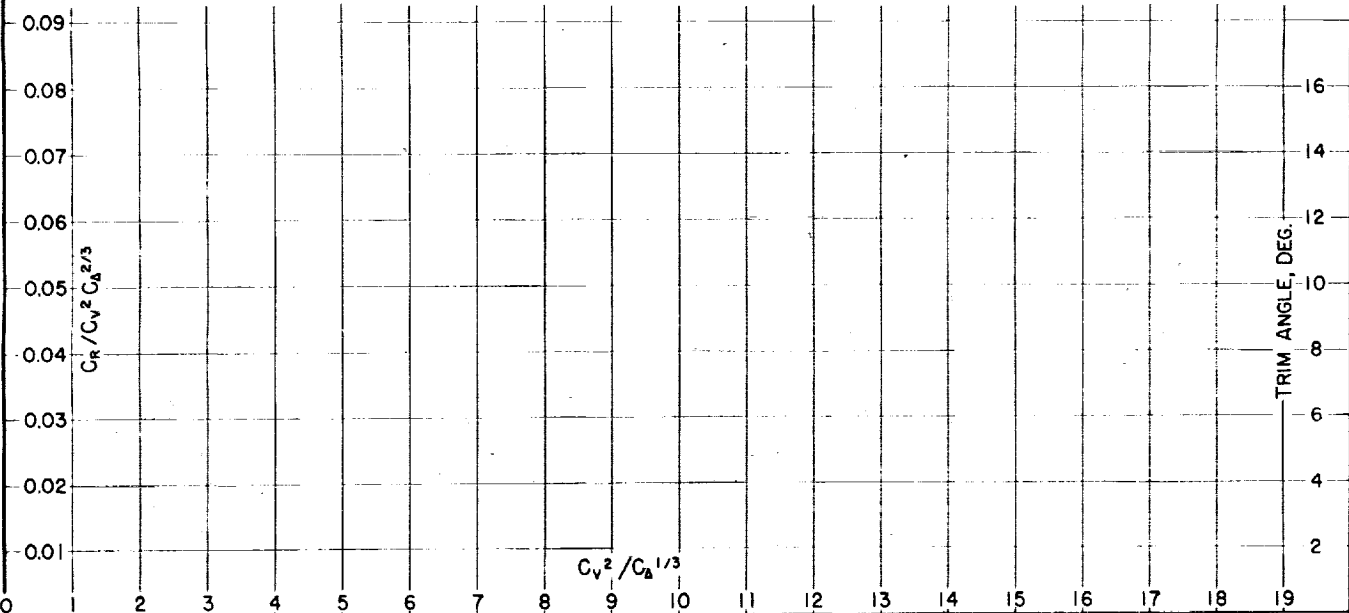
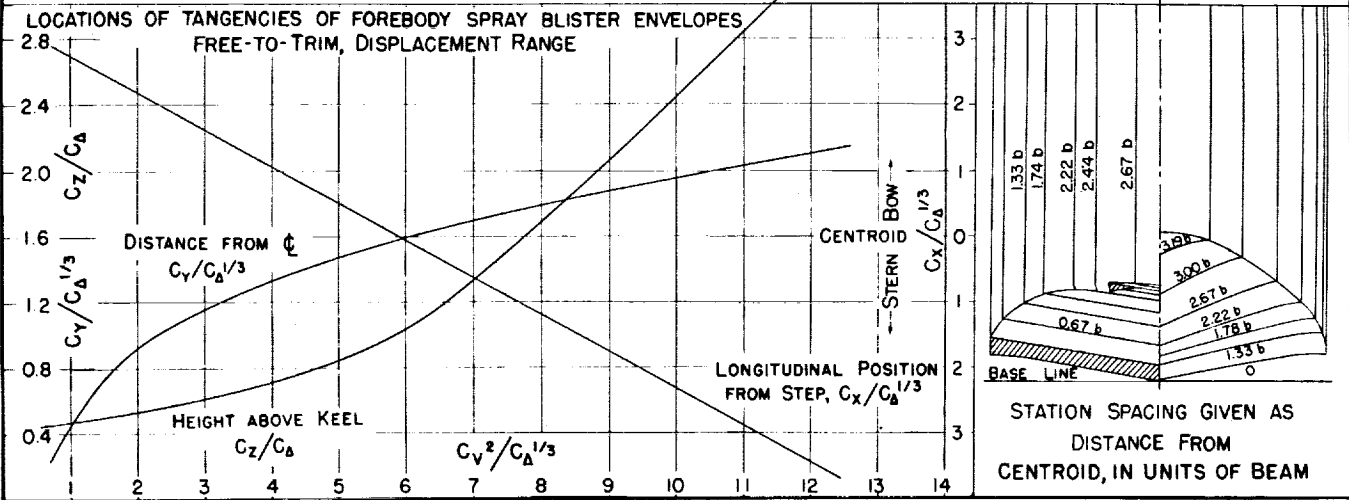

GETAWAY

MODEL No. 439-3
MODEL BEAM: 540"

C.G. = 0.43 b FWD. OF CENTROID $C_{d_0} = 0.90$ (NOMINAL)
0.90 b ABOVE KEEL $k/L =$

TESTED AT SIT No. 1 TANK
DATE: 3/43

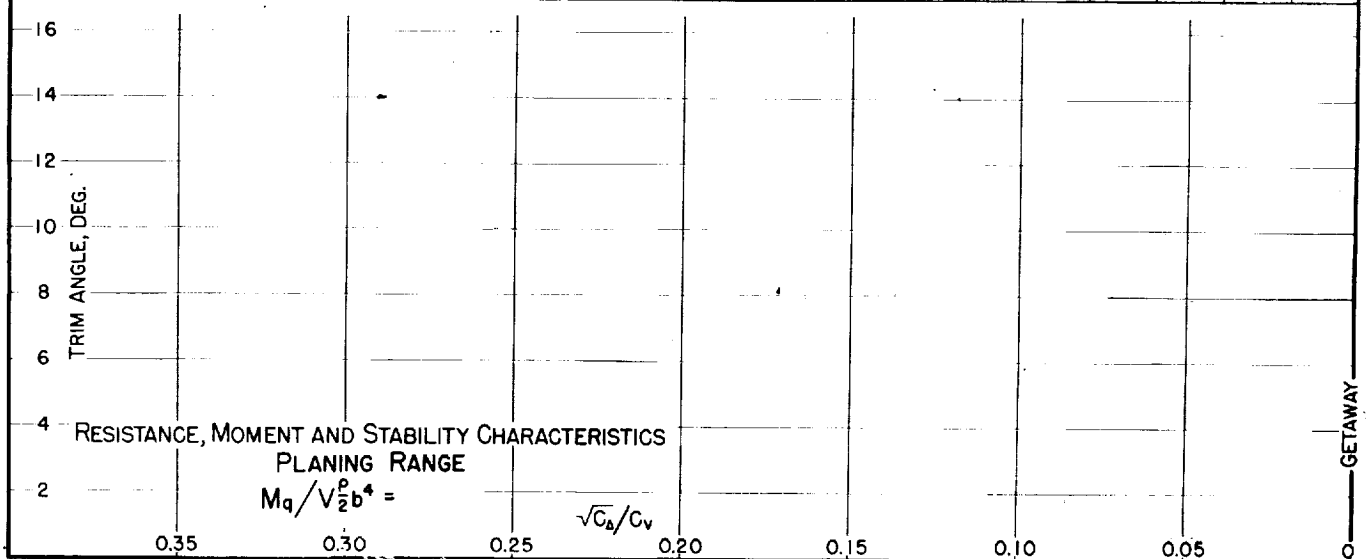
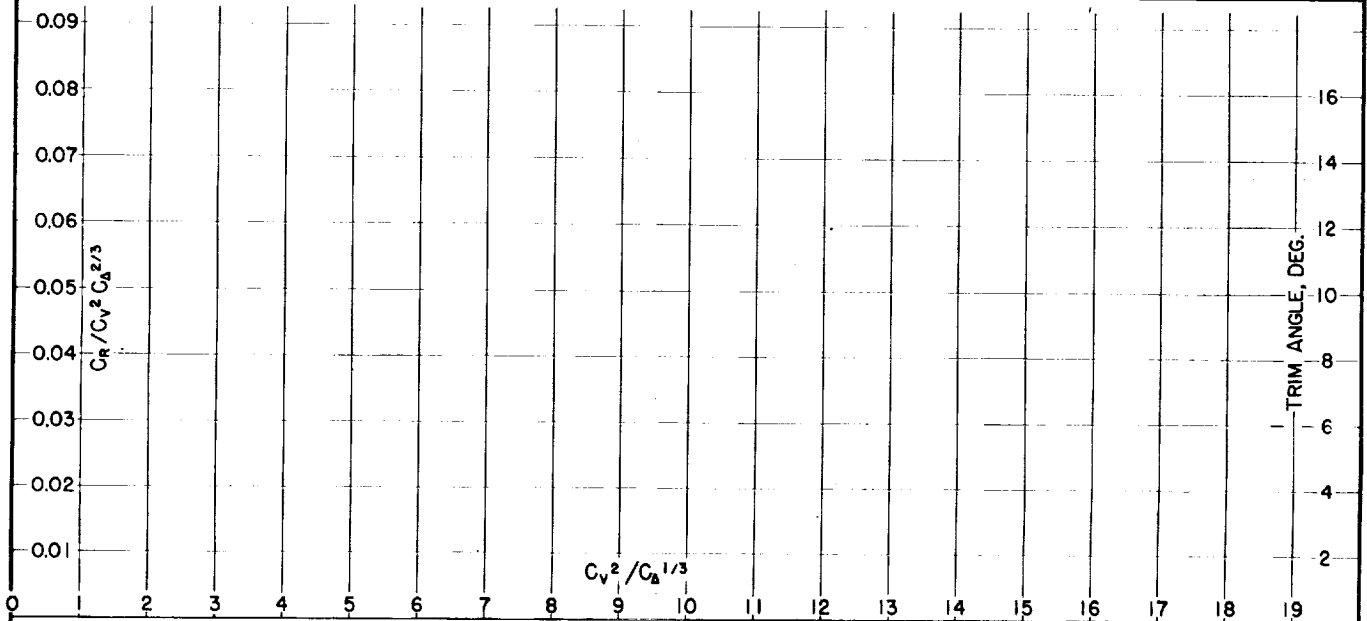
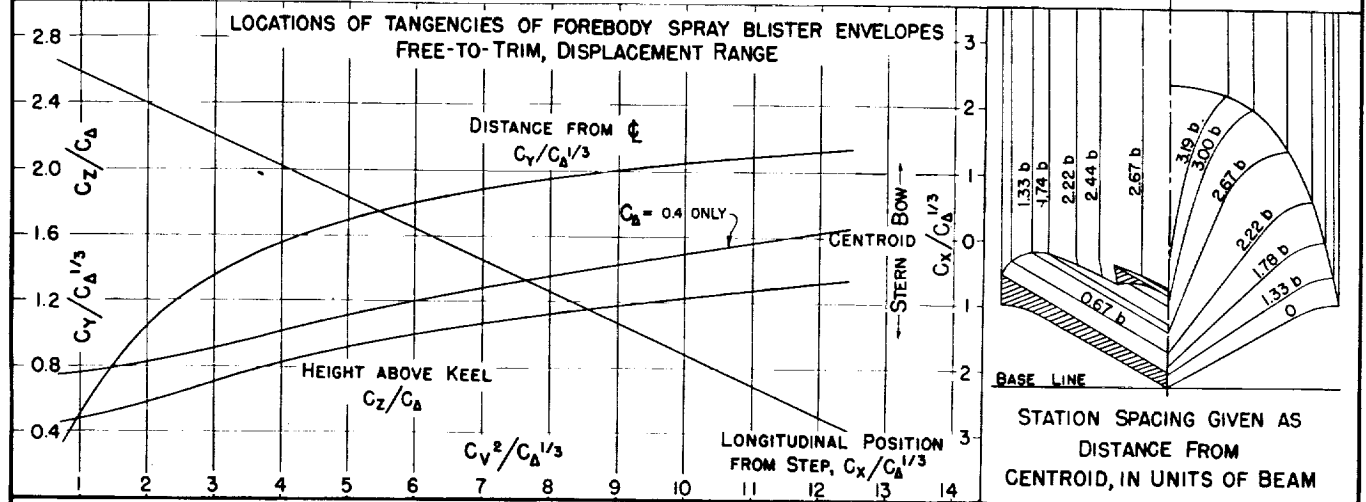

GETAWAY

Fig. 100

DESIGNATION: 3.28-0.59-20.0 NACA TN No. 1182

MODEL No. 406
MODEL BEAM 5.45

C.G. = 0.37 b FWD. OF CENTROID $C_{d_0} = 0.73$ (NOMINAL)
1.10 b ABOVE KEEL $k/L =$

TESTED AT SIT No. 1 TANK
DATE: 3/42

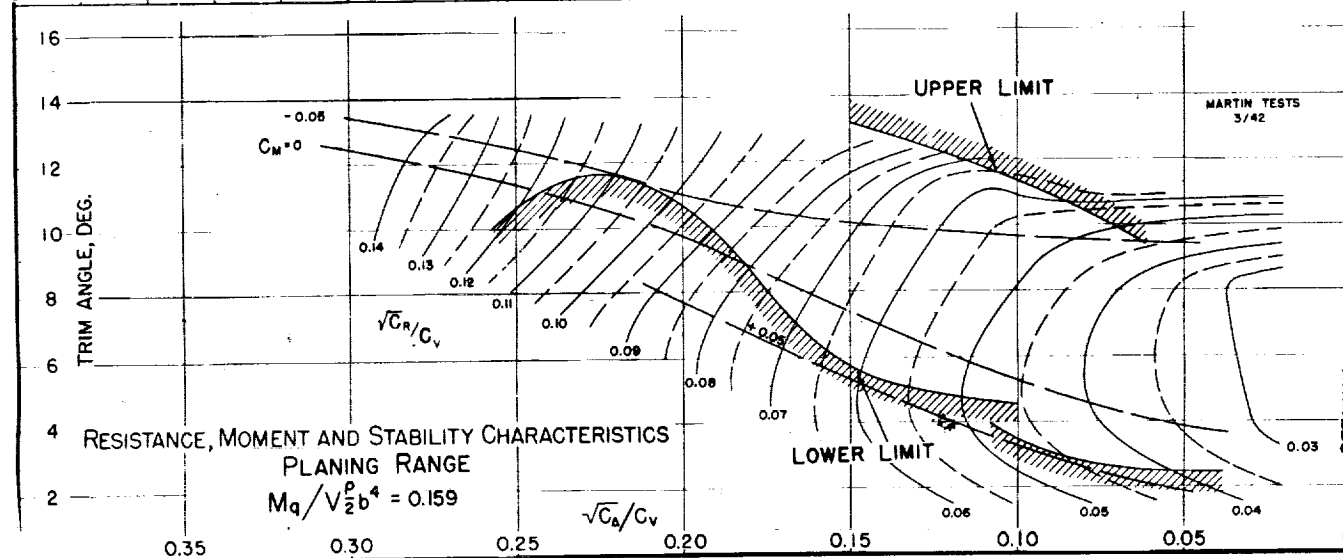
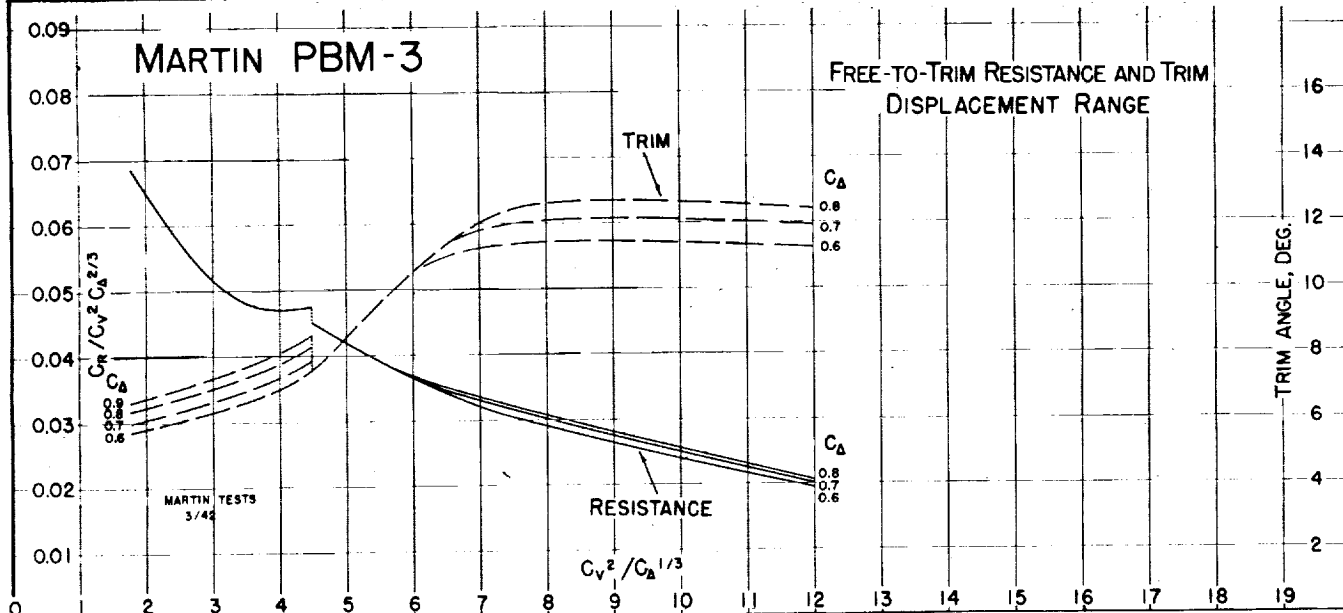
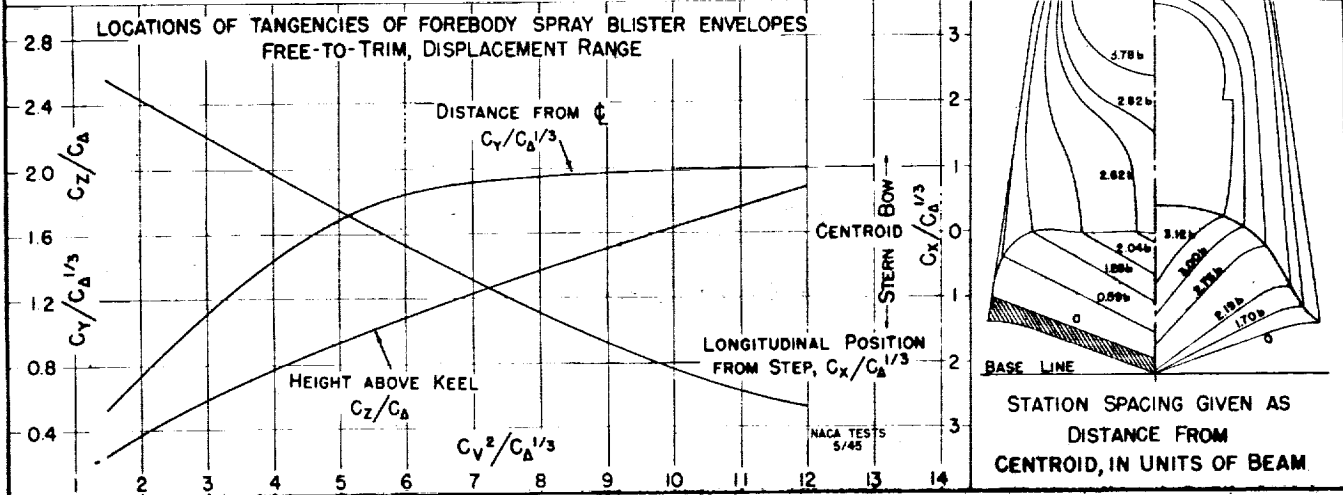

MODEL No. 618-1
MODEL BEAM: 5.40"

C.G. = 0.39 b FWD. OF CENTROID
1.05 b ABOVE KEEL

$C_{d0} =$ (NOMINAL)
 $k/L =$

TESTED AT SIT No. 1 TANK
DATE: 9/44

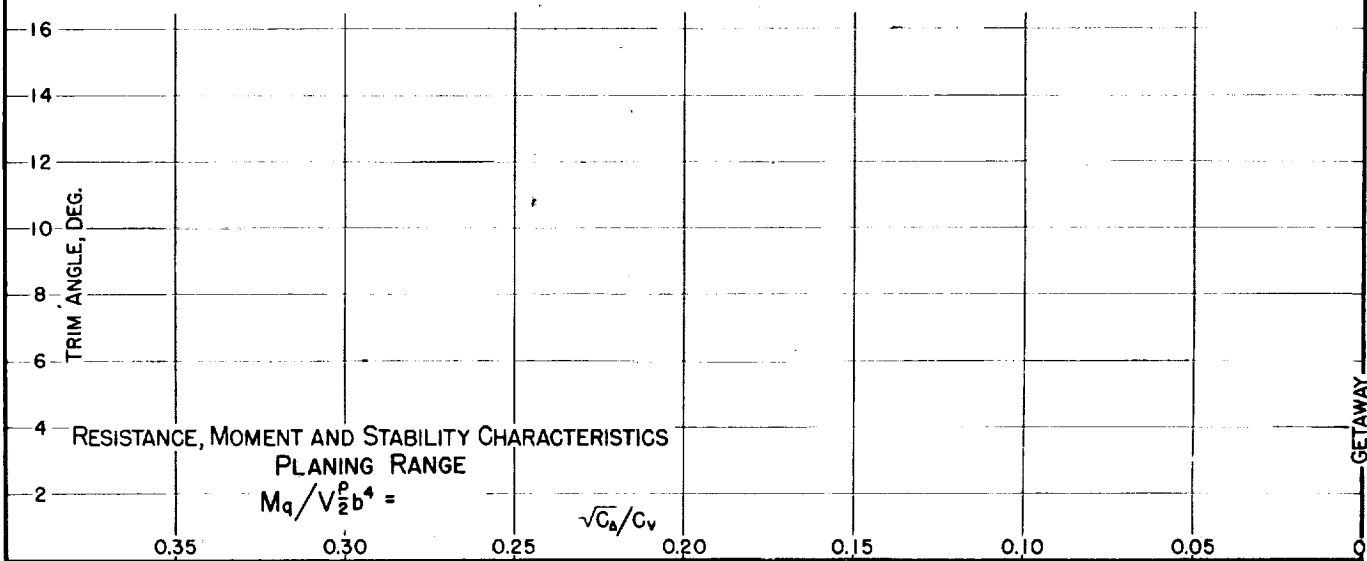
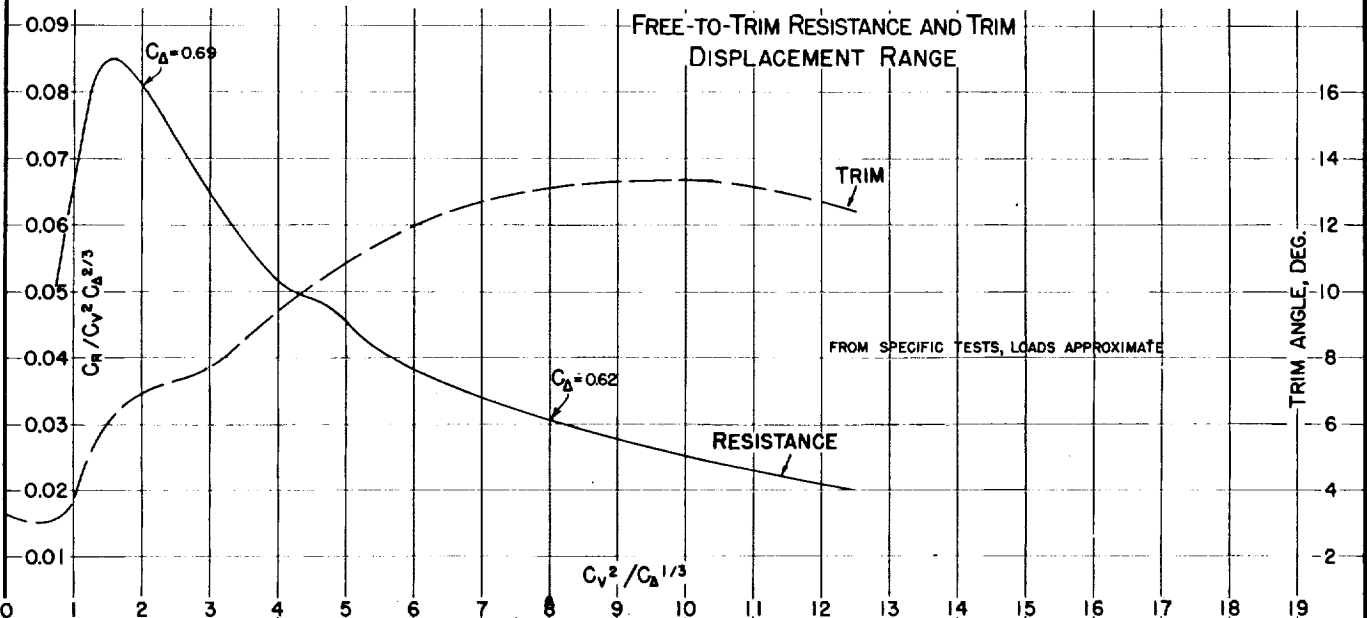
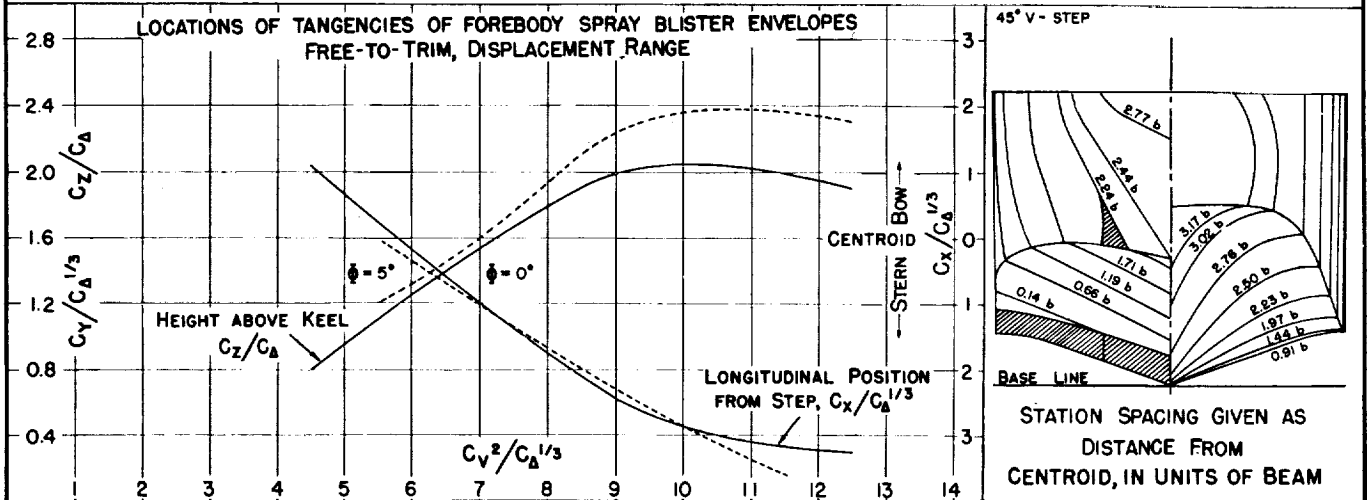

Fig. 102

DESIGNATION: 3.36-0.87-20.0 NACA TN No. 1182

MODEL No. 621-2
MODEL BEAM: 5.40"

C.G. = 0.40 b FWD. OF CENTROID $C_{d,0} =$
1.05 b ABOVE KEEL $k/L =$

(NOMINAL)

TESTED AT SIT No. 1 TANK
DATE: 10/44

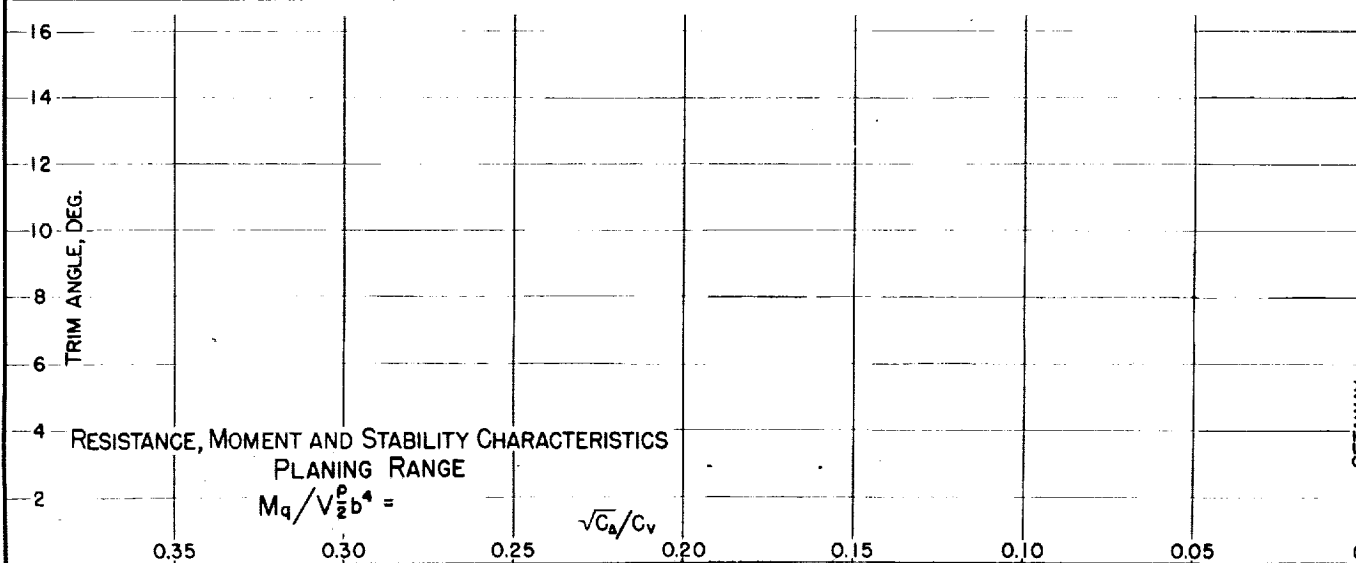
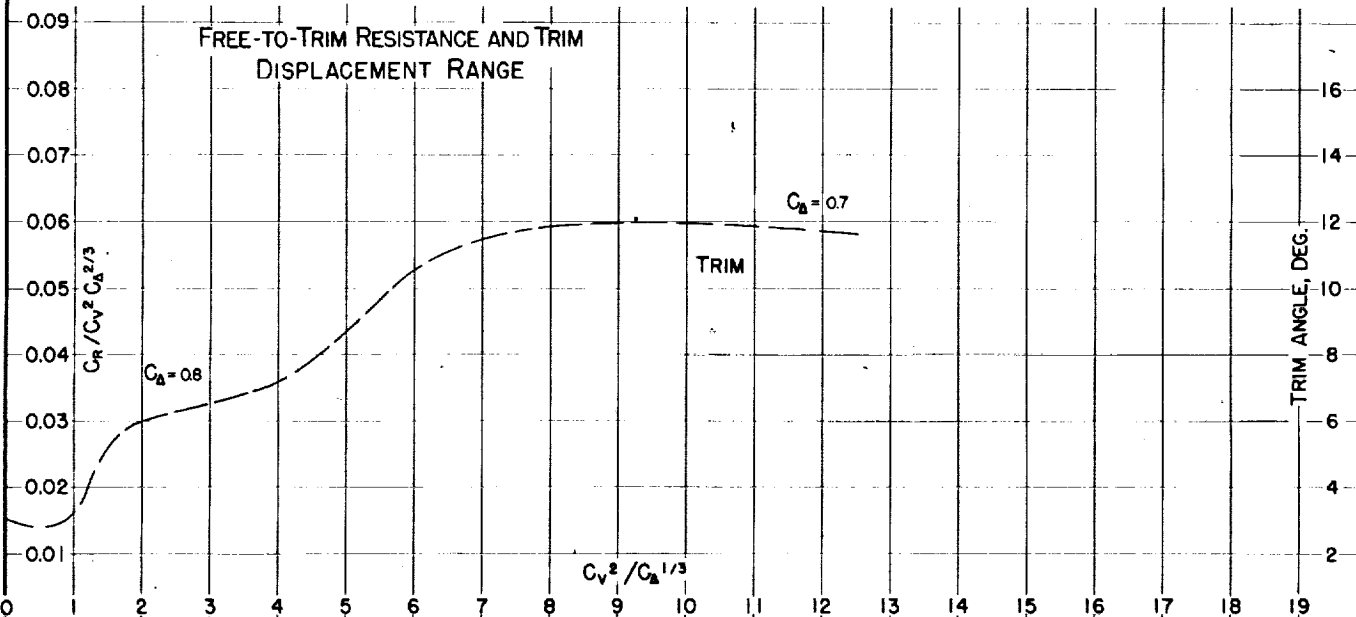
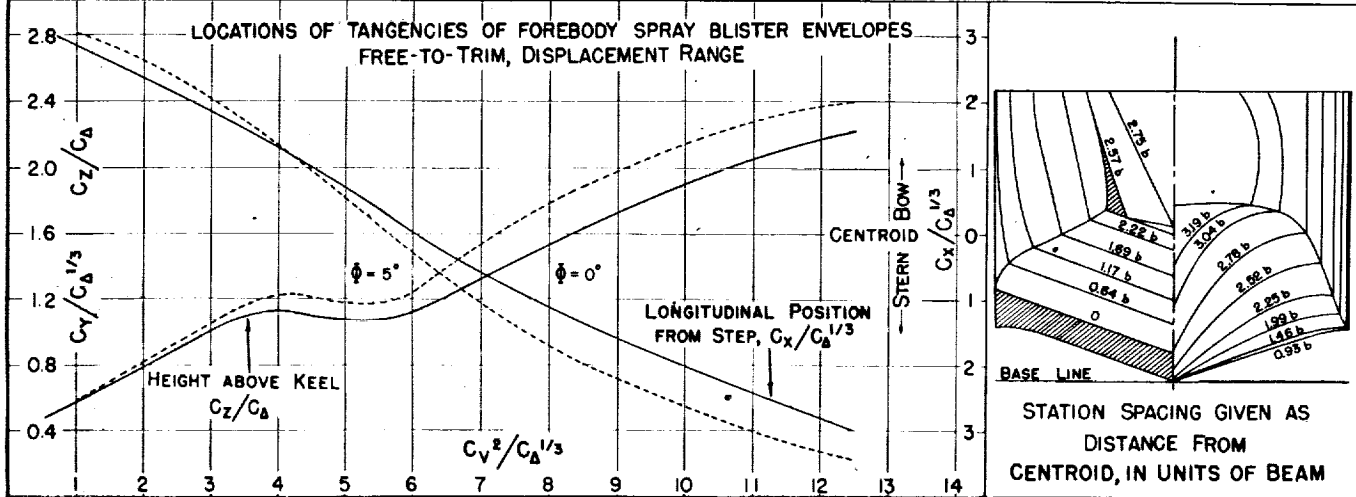

GETAWAY

MODEL No. 621-8
MODEL BEAM: 5.40"

C.G. = 0.40 b FWD. OF CENTROID
1.05 b ABOVE KEEL

$C_{d_{0.0}} =$ (NOMINAL)
 $k/L =$

TESTED AT SIT No. 1 TANK
DATE: 1/45

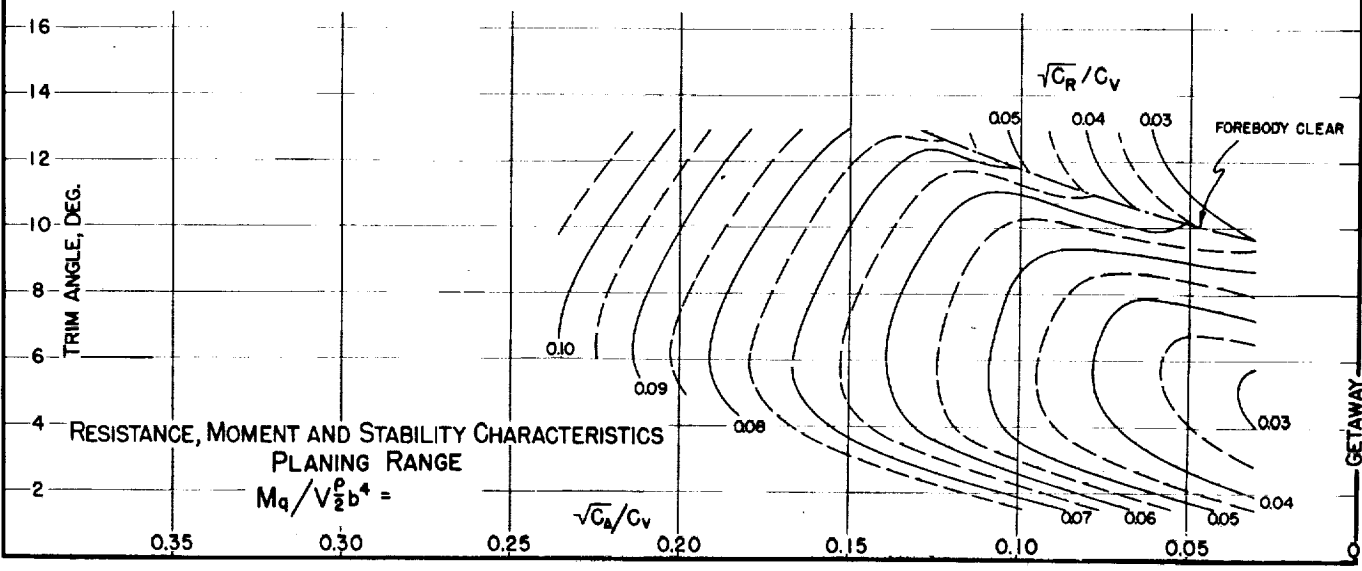
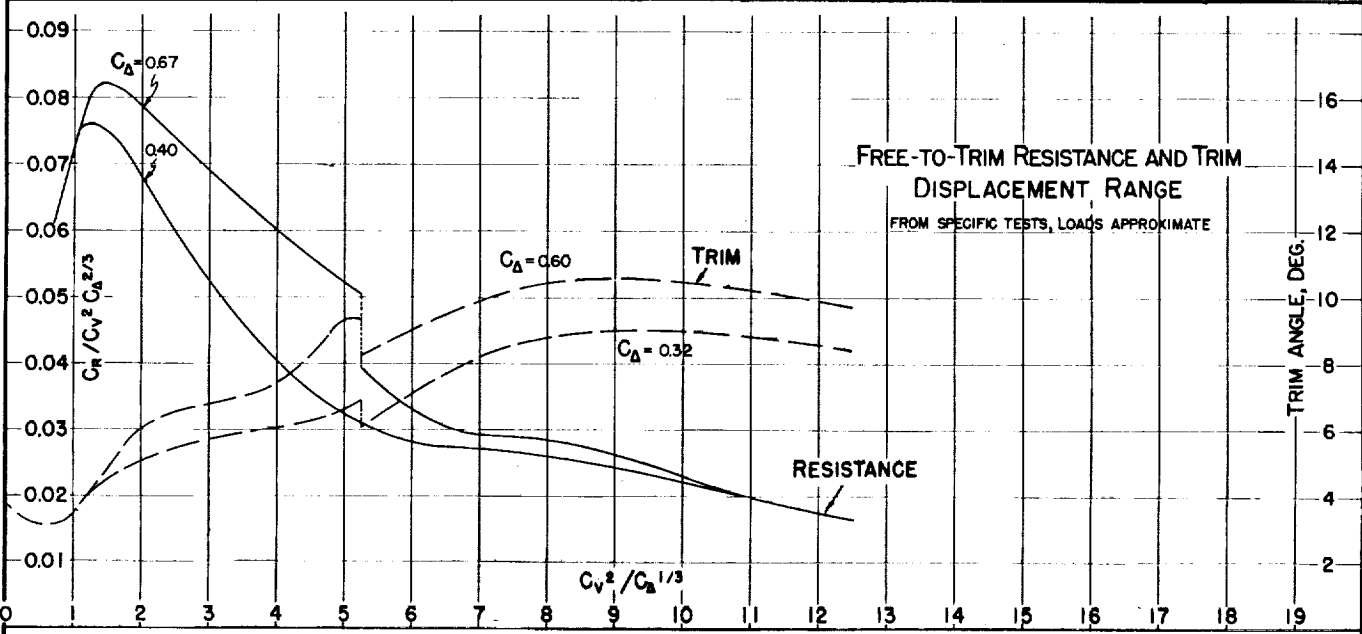
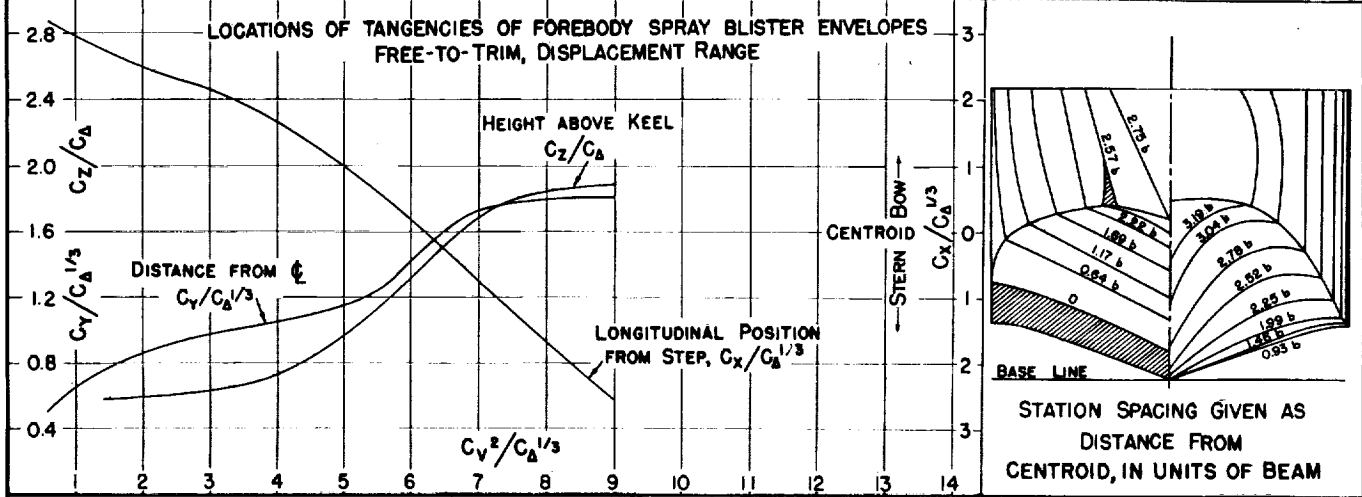

TITLE: A Collection of the Collapsed Results of General Tank Tests of Miscellaneous Flying-Boat-Hull Models

AUTHOR(S) : Locke, F. W. S.

ORIG. AGENCY : National Advisory Committee for Aeronautics, Washington, D. C.

PUBLISHED BY : (Same)

ATI- 7988

EDITIONS

(None)

ORIG. AGENCY NO.

TN-1182

PUBLISHING AGENCY NO.

(Same)

DATE	DOC. CLASS.	COUNTRY	LANGUAGE	PAGES	ILLUSTRATIONS
March '47	Unclass.	U.S.	English	119	tables, graphs

ABSTRACT:

Charts shown are intended to be used as engineering tool to enable flying boat designer to quickly grasp the significance of various hull form parameters as they influence a particular airplane. No attempt is made to produce conclusions of the usual sort or correlations. However, some generalizations are given on the various methods in which the summary charts may be used.

DISTRIBUTION: SPECIAL. All requests for copies must be addressed to: Originating Agency

DIVISION: Water-Borne Aircraft (21)
SECTION: Design and Description (10)

SUBJECT HEADINGS: Hulls - Design (49698.8); Hulls-
Specifications (49705)

ATI SHEET NO.:

Control Air Documents Office
Wright-Patterson Air Force Base, Dayton, Ohio

AIR TECHNICAL INDEX