

AUG 19 1946

# NATIONAL ADVISORY COMMITTEE FOR AERONAUTICS

TECHNICAL NOTE

No. 1116

STRAIN-GAGE STUDY OF INTERNALLY COOLED EXHAUST VALVES  
HAVING VARIOUS THROAT DESIGNS

By Arthur G. Holms and Richard D. Faldetta

Aircraft Engine Research Laboratory  
Cleveland, Ohio



Washington  
August 1946

NACA LIBRARY  
LANGLEY MEMORIAL AERONAUTICAL  
LABORATORY  
Langley Field, Va.



NATIONAL ADVISORY COMMITTEE FOR AERONAUTICS

TECHNICAL NOTE NO. 1116

STRAIN-GAGE STUDY OF INTERNALLY COOLED EXHAUST VALVES  
HAVING VARIOUS THROAT DESIGNS

By Arthur G. Holms and Richard D. Faldetta

SUMMARY

Three internally cooled exhaust valves having the same external dimensions but different throat designs were investigated to determine a method of obtaining increased coolant-flow area without increasing stresses. The valves were statically loaded to simulate stresses in the throat region caused by valve closure. Tests showed that a constriction in the coolant-flow passage can be removed without increasing stresses. Such an increase in the coolant-flow area lowers the crown temperature.

INTRODUCTION

A combination of excessive operating stresses and temperatures causes exhaust valves to fail at the crown. The importance of valve temperature and resulting types of failure are presented in reference 1. Measurements of crown operating temperatures are discussed in reference 2, which shows that the crown temperature can be reduced by increasing the coolant-flow area. An increase of the coolant-flow area in the region of the throat necessitates a reduction in the cross-sectional area of the valve stem at this location; such a reduction would ordinarily be thought to increase the maximum stresses. Valves have been known to fail at the throat and examples of such failures are described in references 3 and 4. It would be desirable to enlarge the coolant-flow area without increasing the stresses in this region.

Strain-gage tests to compare the strain-distribution characteristics of three exhaust valves having the same external contours in the region of the throat were conducted at the NACA Cleveland laboratory. One of the test valves had a relatively small coolant-flow area, whereas the other two had larger coolant-flow areas. The strain distributions for the three valves were compared

for an axial tensile load of 1000 pounds. This comparison is indicative of the relative operating stresses in the throats during closure when the inertia forces of the stems induce tensile stresses in the throat regions.

#### APPARATUS AND TEST PROCEDURE

The apparatus shown in figure 1 was used in conjunction with a tensile testing machine to apply tensile load to the valves. An initial load of 50 pounds was used to seat the parts and the increment of strain resulting from a 1000-pound increment of load was measured. The strains were measured with wire resistance strain gages having a strain sensitive element of one-sixteenth by one-sixteenth inch. Bakelite cement BC-6035 was used as the bonding agent. The gages were located on the valve as illustrated in figure 2, which shows the gages oriented to measure the longitudinal strain, that is, the surface strain in the direction of the longitudinal axis. On the first two valves tested, gages were also oriented to measure the surface strain in a circumferential direction. Gages at points where the strains should be the same (on opposite sides of the valve, for example) showed a maximum deviation from the mean of 8.4 percent. The average of mean deviations for nine such instances was 2.5 percent.

The cross sections of the three valves tested (designated A, B, and C) are shown to scale in figure 3. The internal contours were determined from X-ray photographs of the valves, with the exception of the dotted portions, which were obtained from drawings. The special features of each throat are given in the following table:

Valve	Figure	Description of throat
A	3(a)	Tapered bore in stem with sharply constricted coolant-flow area
B	3(b)	Same as valve A except coolant-flow area in the constricted region is enlarged by drilling
C	3(c)	Same external dimensions and bore as valve B but with heavier section between throat and seating surface

## RESULTS AND DISCUSSION

In the diagrams of figure 3 the strain-gage measurements are plotted in a direction normal to the exterior outline of the valve from points at which the strain gages were located. The exterior outline of the valve is the zero or datum line for the ordinates. Curves of circumferential strain for valves A and B (figs. 3(a) and (b), respectively) show that the variation of the circumferential strain in the critical throat region is insignificant.

Valve A (fig. 3(a)) has a peak of longitudinal strain in the region a-c. Valve B (fig. 3(b)) has no such strain peak. Figure 4 is a rectangular coordinate plot of strain against distance along the valve external contour from point d (fig. 3(a)) of the seating surface and shows that valves B and C have smoother strain curves in the region of the throat than valve A. The tensile load would have a tendency to reduce the curvature of the fillet in the region a-c (fig. 3(a)) with a corresponding tendency for high tensile strain in this region. The constriction in the region b-c of valve A is believed to produce considerable stiffness in this region and thus to confine the deformation to the region a-b. Hence, the constriction at b is considered to be the cause of the longitudinal strain peak between a and b. Valves B and C lack such a sharp peak, which is attributed to the absence of the local stiffness (constriction) that was present in valve A. The coolant-flow area for valves B and C is four times that of valve A. Examination of figure 4 shows that this increase was obtained with lower peak stresses in the throat region.

## CONCLUDING REMARKS

A constriction in the valve throat that reduces the coolant-flow area has been shown to increase valve-crown temperature.

These steady-load tests have shown that such a constriction can be removed without increasing peak stresses. The optimum design of the throat region is considered to be one having no constriction.

Aircraft Engine Research Laboratory,  
National Advisory Committee for Aeronautics,  
Cleveland, Ohio, April 30, 1946.

REFERENCES

1. Sanders, J. C., Mulcahy, B. A., and Peters, M. D.: Some Factors Affecting Failures of Exhaust Valves in an Air-Cooled Cylinder. NACA ARR No. 4A19, 1944.
2. Mulcahy, B. A., and Zipkin, M. A.: Tests of Improvements in Exhaust-Valve Performance Resulting from Changes in Exhaust-Valve and Port Design. NACA ARR No. E5G26, 1945.
3. Young, Vincent C.: Aircraft-Engine Valve Mechanisms. SAE Jour., Vol. 44, No. 3, March 1938, pp. 109-116.
4. Colwell, A. T.: Modern Aircraft Valves, SAE Jour., vol. 46, no. 4, April 1940, pp. 147-165.

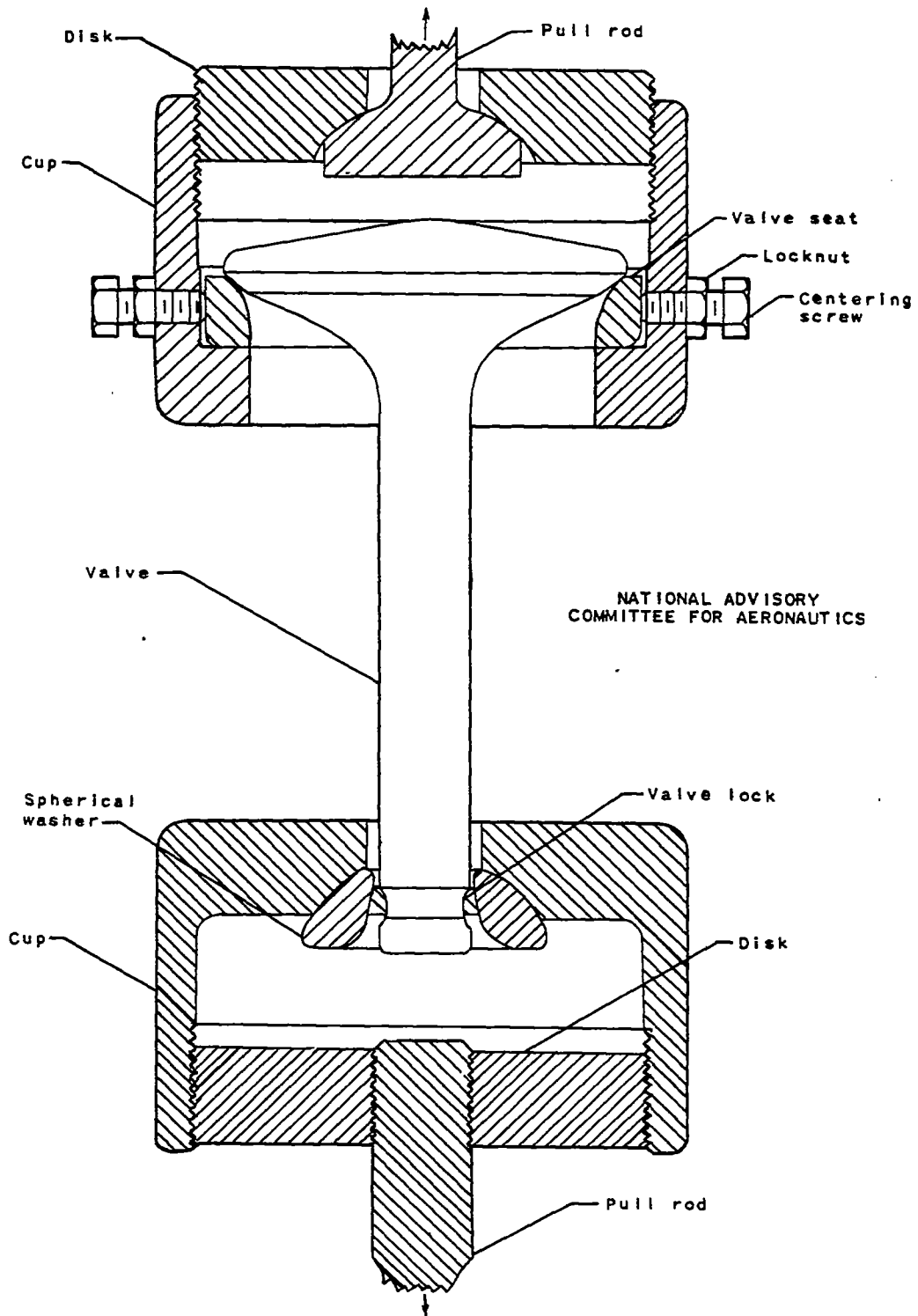

Figure 1. - Apparatus for subjecting valve to tensile load.

283-655

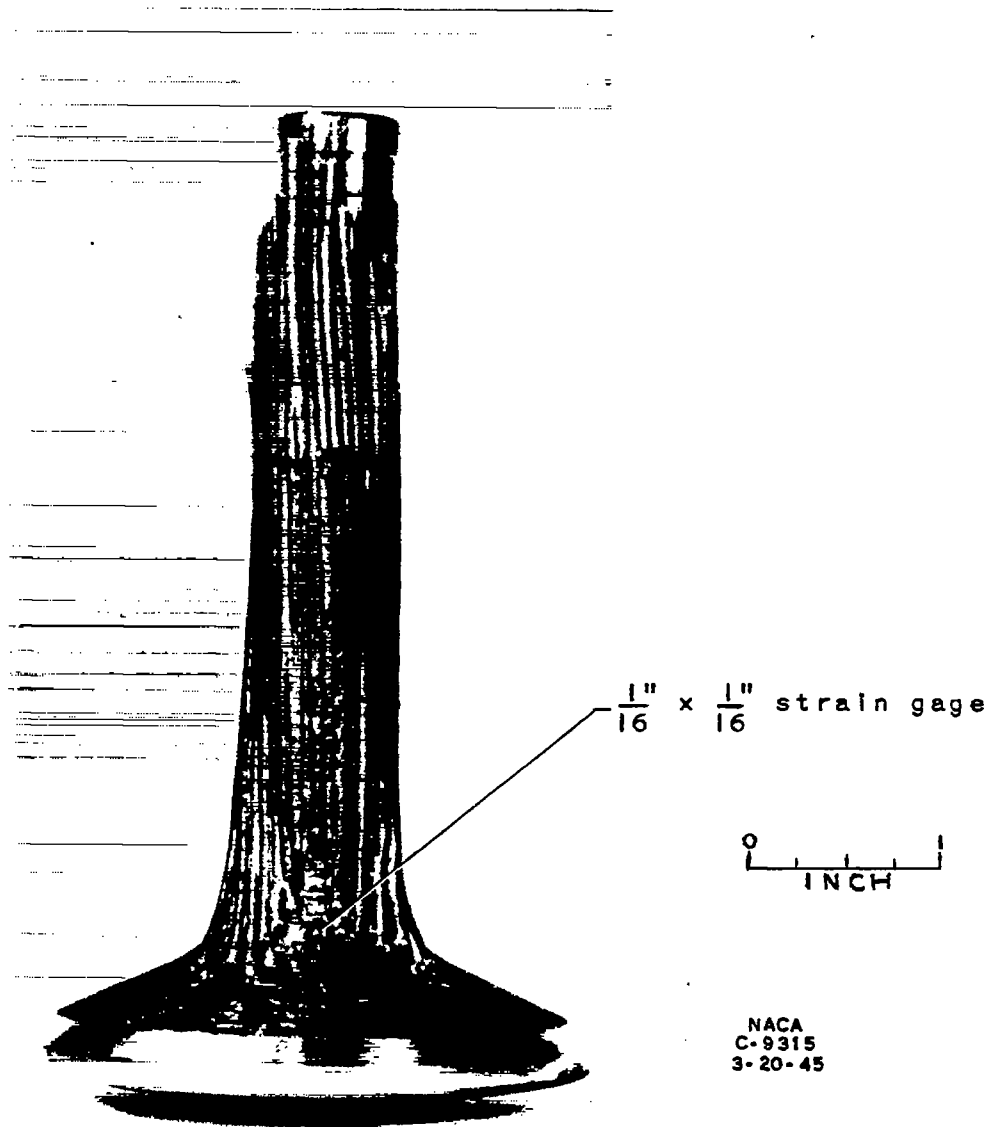
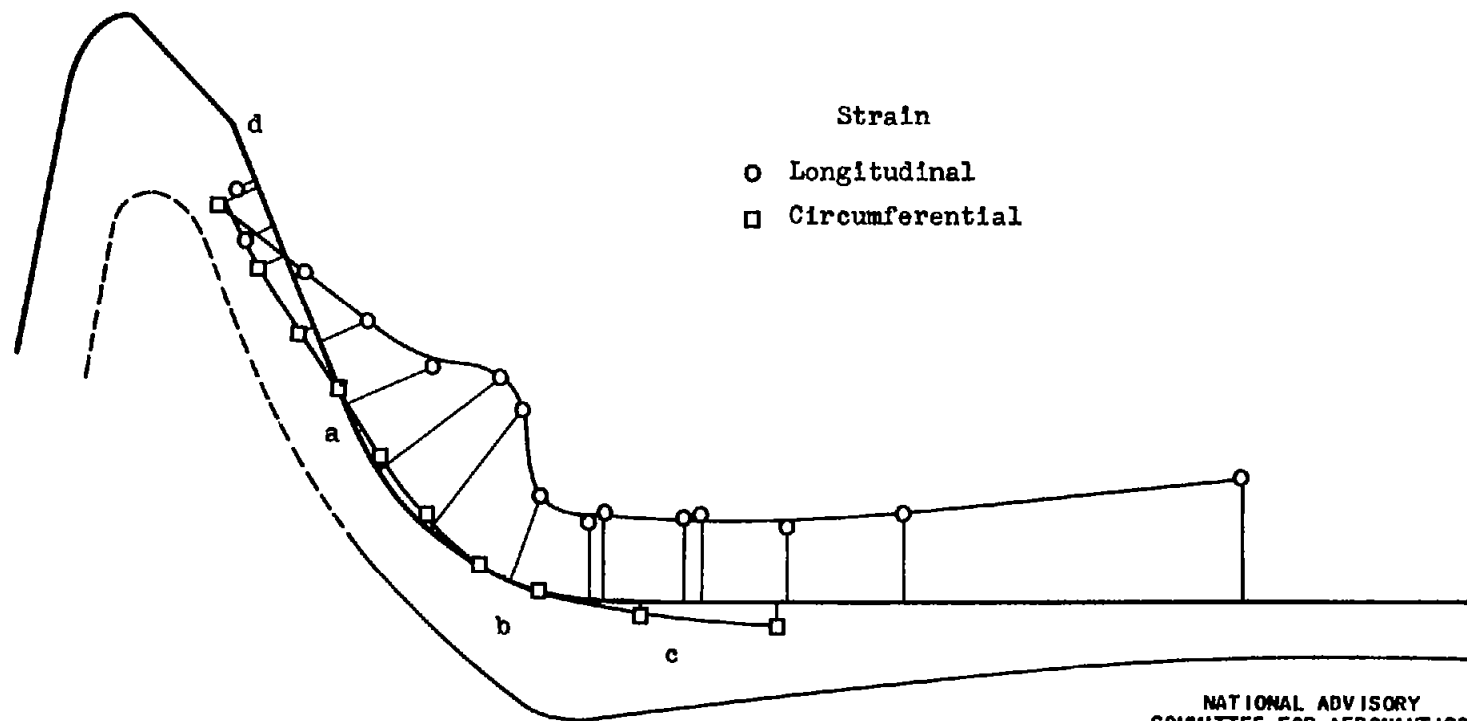

Figure 2. - Arrangement of strain gages on test valve.



(a) Valve A.

Figure 3. - Cross-sectional view of test valves. Space scale, three times full size; strain scale, 1 inch represents 200 microinches per inch for 1000-pound tensile load. Tensile strains are plotted outward from and normal to exterior outline of valve from points where strain gages were located. Contours were taken from X-ray photographs, except dotted portions, which were taken from drawings.



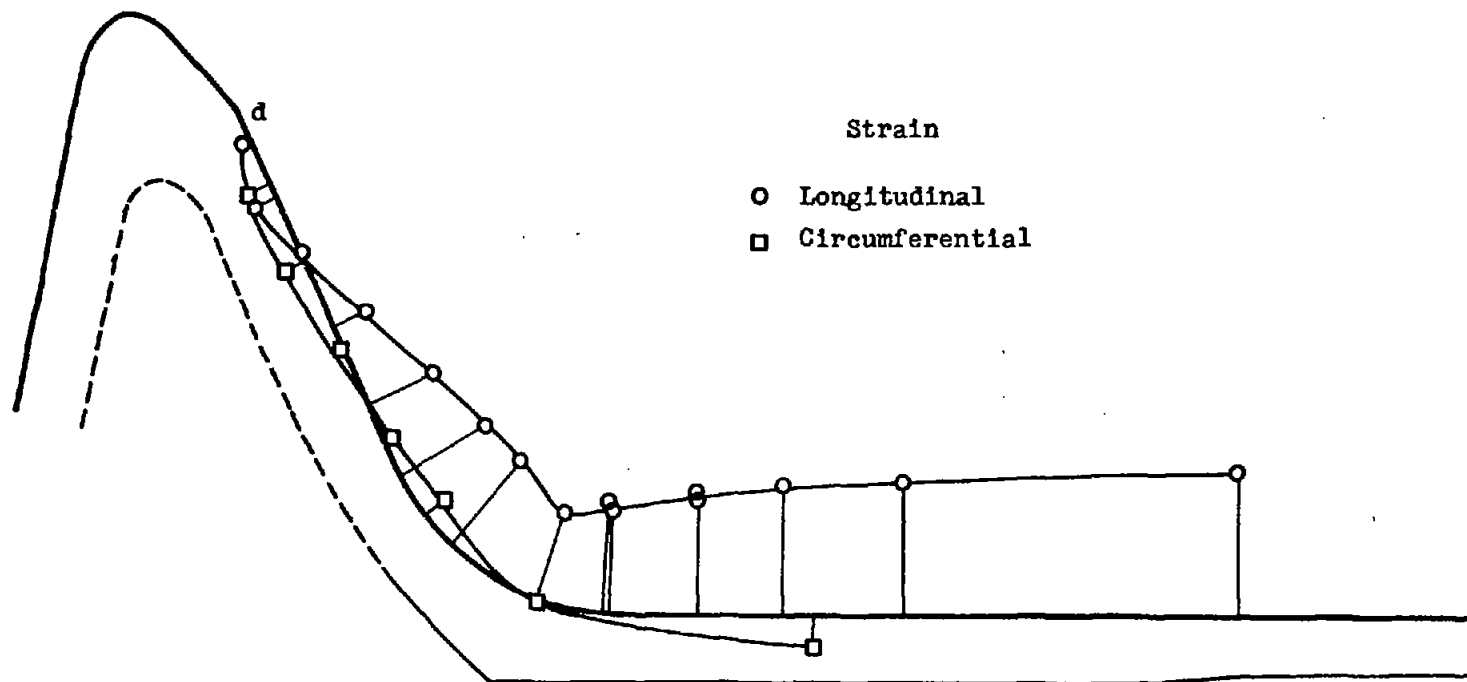

NATIONAL ADVISORY  
COMMITTEE FOR AERONAUTICS

(b) Valve B.

Figure 3. - Continued. Cross-sectional view of test valves. Space scale, three times full size; strain scale, 1 inch represents 200 microinches per inch for 1000-pound tensile load. Tensile strains are plotted outward from and normal to exterior outline of valve from points where strain gages were located. Contours were taken from X-ray photographs, except dotted portions, which were taken from drawings.

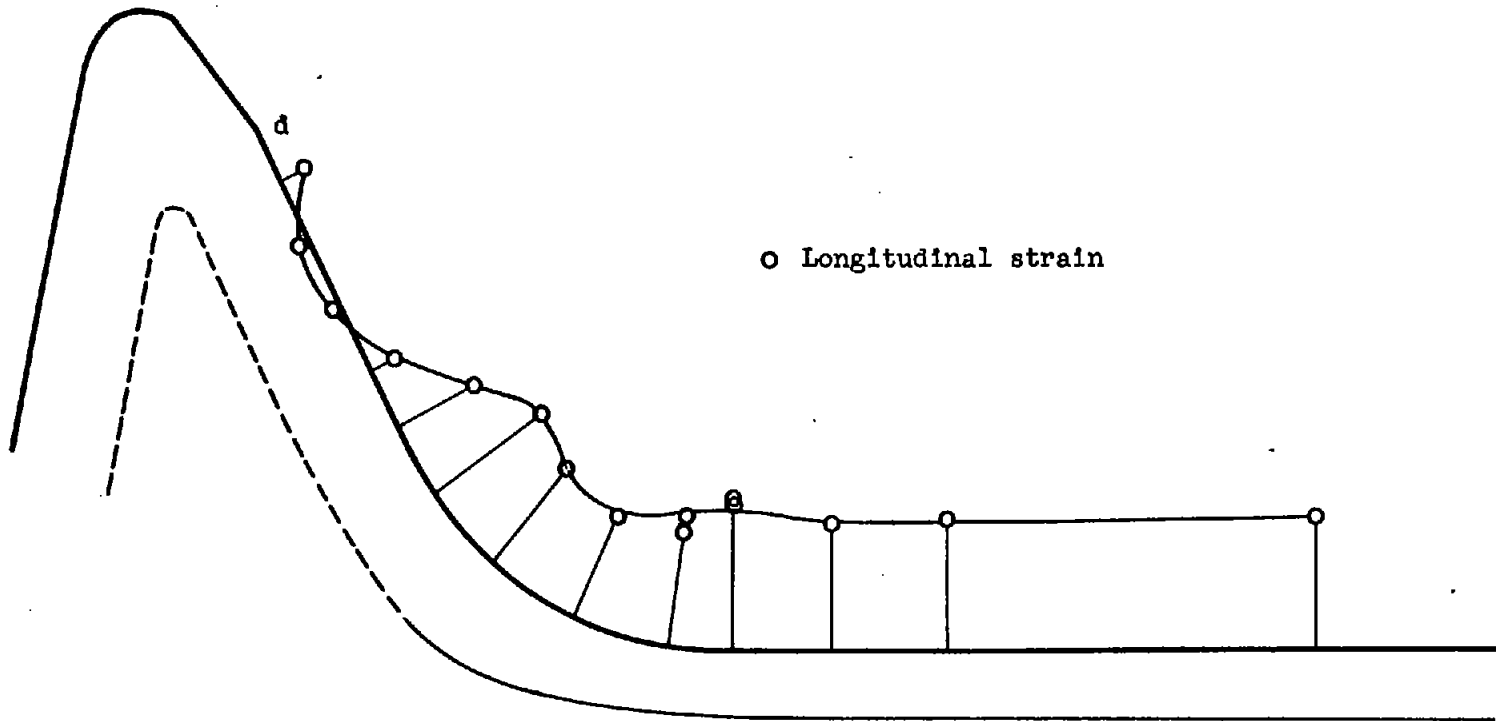

NATIONAL ADVISORY  
COMMITTEE FOR AERONAUTICS

(c) Valve C.

Figure 3. - Concluded. Cross-sectional view of test valves. Space scale, three times full size; strain scale, 1 inch represents 200 microinches per inch for 1000-pound tensile load. Tensile strains are plotted outward from and normal to exterior outline of valve from points where strain gages were located. Contours were taken from X-ray photographs, except dotted portions, which were taken from drawings.

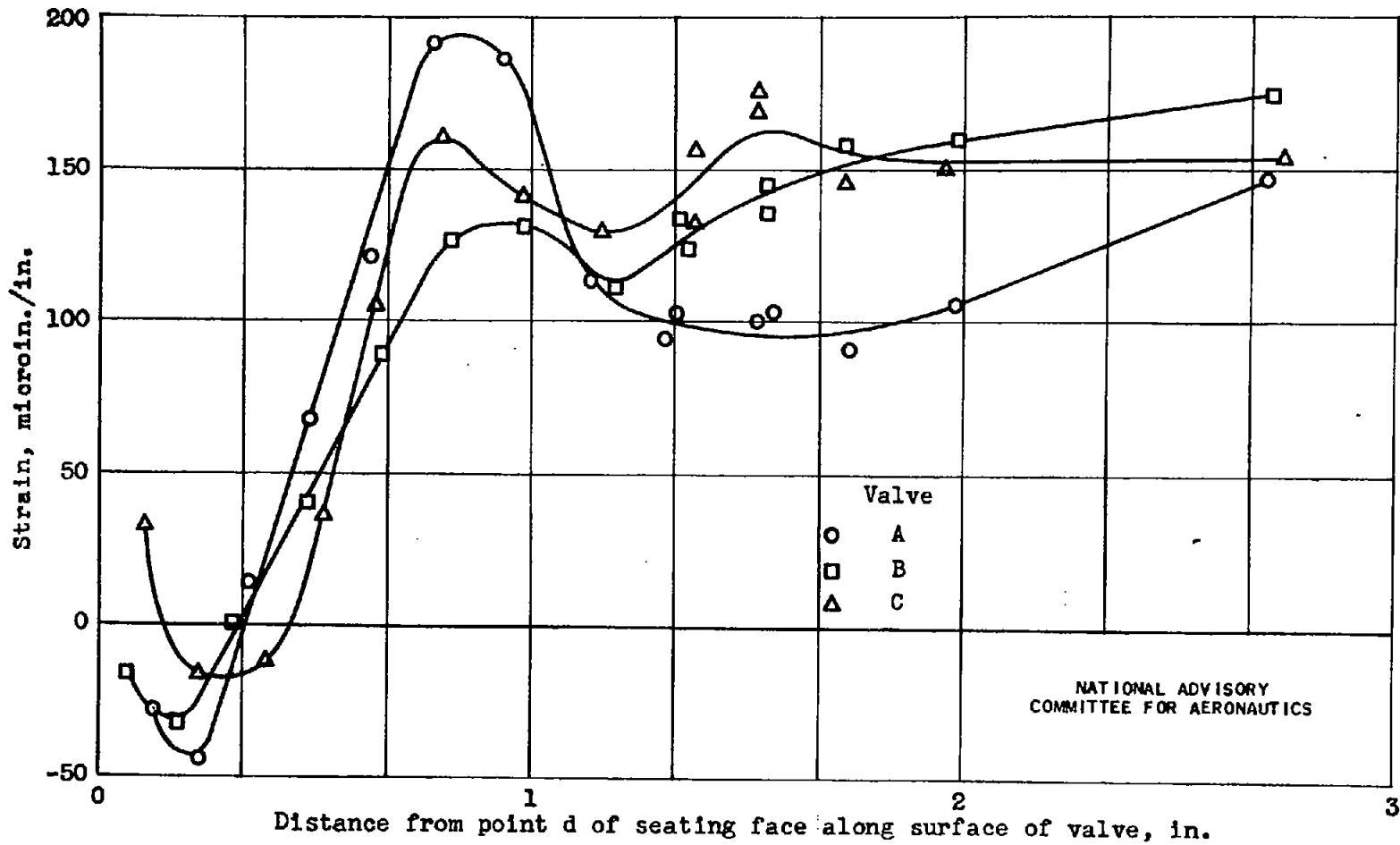

Figure 4. - Comparison of longitudinal strains for valves A, B, and C. Tensile load, 1000 pounds.

FORM 100 (13 MAR 47)

Holms, Arthur G.  
Faldetta, R. D.

DIVISION: Power Plants, Reciprocating (6)  
SECTION: Exhaust System (5)  
CROSS REFERENCES: Valves, Exhaust (96210)

ATI- 7871

ORIG. AGENCY NUMBER

TN-1116

REVISION

AUTHOR(S)

AMER. TITLE: Strain gage study of internally cooled exhaust valves having various throat designs

FORG'N. TITLE:

ORIGINATING AGENCY: National Advisory Committee for Aeronautics, Washington, D. C.

TRANSLATION:

COUNTRY	LANGUAGE	FORG'N. CLASS.	U. S. CLASS.	DATE	PAGES	ILLUS.	FEATURES
U.S.	Eng.		Unclss.	Aug '46	9	6	photo, graphs, drawings

ABSTRACT

Three internally-cooled exhaust valves having the same external dimensions but different throat designs were investigated to determine the method of obtaining increased coolant-flow area without increasing stresses. Valves were statically loaded to simulate stresses in the throat region, caused by valve closure. Constriction in the valve throat that reduces the coolant-flow area has been shown to increase valve-crown temperature, but can be removed without increasing peak stresses.

NOTE: Requests for copies of this report must be addressed to: N.A.C.A., Washington, D. C.