

# Model-Based Fault Diagnosis in Electric Drives Using Machine Learning

Yi L. Murphey, *Senior Member, IEEE*, M. Abul Masrur, *Senior Member, IEEE*,  
ZhiHang Chen, BaiFang Zhang

**Abstract** – Electric motor and power electronics based inverter are the major components in industrial and automotive electric drives. In this paper we present a model based fault diagnostics system developed using machine learning technology for detecting and locating multiple classes of faults in an electric drive. Power electronics inverter can be considered to be the weakest link in such a system from hardware failure point of view, hence this work is focused on detecting faults and finding which switches in the inverter cause the faults. A simulation model has been developed based on the theoretical foundations of electric drives to simulate normal condition, all single-switch and post-short-circuit faults. A machine learning algorithm has been developed to automatically select a set of representative operating points in the (torque, speed) domain, which in turn is sent to the simulated electric drive model to generate signals for the training of a diagnostic neural network, “Fault Diagnostic Neural Network” (FDNN). We validated the capability of FDNN on data generated by an experimental bench setup. Our research demonstrates that with a robust machine learning approach, a diagnostic system can be trained based on a simulated electric drive model which can lead to correct classification of faults over a wide operating domain.

**Index Terms** – Model-based diagnostics, power electronics, field oriented control, inverter, motor, electric drives, neural network, fuzzy techniques, electric vehicle, hybrid vehicle, machine learning.

## I. INTRODUCTION

3-phase induction motors using techniques such as the Field Oriented Control (FOC) [1-7] to provide precise torque are widely used in various industrial applications including the automotive power train for electric and hybrid vehicles. The control in these drives is realized by solid state electronic switches (e.g. IGBT, MOSFET etc.) being turned on or off [8]. In response to a control algorithm, a reference voltage is generated, and the inverter synthesizes this voltage reference command using techniques such as pulse-width modulation (PWM) or space-vector modulation (SVM) [4]. If a switch fails to function in the way it was intended to, the voltage synthesis process will be impaired, leading to failure in getting proper voltage at the motor terminals, and hence, the failure in

obtaining the requisite torque at the motor shaft. Failure of the switches can take place in the form of “open” and “short” circuit, and as well as the failure of reverse diodes in the switches.

Although motor is relatively a more robust device compared to the inverter, motor windings can deteriorate with time, which can result in either open or shorted windings, fully or partially. When this happens, motor will fail to generate proper shaft torque or any torque at all, in spite of the fact that the inverter is applying proper voltage input to the motor. Hence, the electric drive can malfunction due to the fault of either the inverter or the motor. However, inverter is considered to be the weakest link in the system. Our objective is to develop a robust diagnostic system that has the capability of accurately detecting the state of the drive and correctly locating faults as soon as they occur. We present a machine learning approach to train a diagnostic system, FDNN (Fault Diagnostic Neural Network), that detects and locates faulty switch or switches in the inverter. When a fault occurs, the FDNN can point out which switch or switches failed, so the system can be shut down properly or lead to the reconfiguration of the system based on the nature of the fault. In other words the diagnostic results provided by FDNN can be used to make a gracefully degradable [9-10] operation of a faulty drive possible.

Fault diagnostics for internal combustion (IC) engine vehicles has been well investigated [11-15], but not to the same extent for electric or hybrid vehicles. However, there are active researches in electrical system diagnostics [16-25]. Rule-based expert systems and decision trees are two traditional diagnostic techniques, but they have serious limitations. A rule-based system often has difficulties in dealing with novel faults and acquiring complete knowledge to build a reliable rule-base, and is system dependent. A decision tree can be very large for a complex system, and it is also system dependent such that even small engineering changes can mean significant updates [18]. More recently model based approaches, fuzzy logic, artificial neural networks (ANN), and case based reasoning (CBR) are popular techniques used in various fault diagnostics problems in electrical systems. Moseler and Isermann [16] described a black box type of model using a polynomial differential-algebraic equation with application to a brushless dc machine. In their work the estimated system parameters under normal and faulted conditions are compared with the current system parameter values, and if any discrepancy with normal condition is seen, then a faulty condition is declared. However, the parameter-estimated model of this kind can

Manuscript received January 18, 2005; revised August 19, 2005. The research described in this paper was supported in part through a funding from the US Army RDECOM-TARDEC ILIR (In-house Lab. Independent Research) program.

Y. Murphey, Z. Chen, and B. Zhang are with the Univ. of Michigan-Dearborn, Dearborn, Michigan, USA (e-mail: yilu@umich.edu).

M. Abul Masrur is with the US Army Tank-Automotive Rsch. Dev. & Engr. Center, Warren, Michigan, USA (e-mail: masrura@tacom.army.mil).

## Report Documentation Page

*Form Approved  
OMB No. 0704-0188*

Public reporting burden for the collection of information is estimated to average 1 hour per response, including the time for reviewing instructions, searching existing data sources, gathering and maintaining the data needed, and completing and reviewing the collection of information. Send comments regarding this burden estimate or any other aspect of this collection of information, including suggestions for reducing this burden, to Washington Headquarters Services, Directorate for Information Operations and Reports, 1215 Jefferson Davis Highway, Suite 1204, Arlington VA 22202-4302. Respondents should be aware that notwithstanding any other provision of law, no person shall be subject to a penalty for failing to comply with a collection of information if it does not display a currently valid OMB control number.

1. REPORT DATE <b>09 AUG 2005</b>	2. REPORT TYPE <b>Technical Report</b>	3. DATES COVERED <b>09-08-2005 to 09-08-2005</b>	
4. TITLE AND SUBTITLE <b>MODEL-BASED FAULT DIAGNOSTICS IN ELECTRIC DRIVES USING MACHINE LEARNING</b>		5a. CONTRACT NUMBER	
		5b. GRANT NUMBER	
		5c. PROGRAM ELEMENT NUMBER	
6. AUTHOR(S) <b>Yi Lu; Abul Masrur; ZhiHang Chen; Baifang Zhang</b>		5d. PROJECT NUMBER	
		5e. TASK NUMBER	
		5f. WORK UNIT NUMBER	
7. PERFORMING ORGANIZATION NAME(S) AND ADDRESS(ES) <b>University of Michigan-Dearborn, Dearborn, MI, 48128</b>		8. PERFORMING ORGANIZATION REPORT NUMBER <b>; #15101</b>	
9. SPONSORING/MONITORING AGENCY NAME(S) AND ADDRESS(ES) <b>U.S. Army TARDEC, 6501 E.11 Mile Rd, Warren, MI, 48397-5000</b>		10. SPONSOR/MONITOR'S ACRONYM(S)	
		11. SPONSOR/MONITOR'S REPORT NUMBER(S) <b>#15101</b>	
12. DISTRIBUTION/AVAILABILITY STATEMENT <b>Approved for public release; distribution unlimited</b>			
13. SUPPLEMENTARY NOTES			
14. ABSTRACT <b>Electric motor and power electronics based inverter are the major components in industrial and automotive electric drives. In this paper we present a model based fault diagnostics system developed using machine learning technology for detecting and locating multiple classes of faults in an electric drive. Power electronics inverter can be considered to be the weakest link in such a system from hardware failure point of view, hence this work is focused on detecting faults and finding which switches in the inverter cause the faults. A simulation model has been developed based on the theoretical foundations of electric drives to simulate normal condition, all single-switch and post-short-circuit faults. A machine learning algorithm has been developed to automatically select a set of representative operating points in the (torque, speed) domain, which in turn is sent to the simulated electric drive model to generate signals for the training of a diagnostic neural network, ?Fault Diagnostic Neural Network? (FDNN). We validated the capability of FDNN on data generated by an experimental bench setup. Our research demonstrates that with a robust machine learning approach, a diagnostic system can be trained based on a simulated electric drive model which can lead to correct classification of faults over a wide operating domain.</b>			
15. SUBJECT TERMS <b>Model-based diagnostics, power electronics, field oriented control, inverter, motor, electric drives, neural network, fuzzy techniques, electric vehicle, hybrid vehicle, machine learning</b>			
16. SECURITY CLASSIFICATION OF:			17. LIMITATION OF ABSTRACT <b>Same as Report (SAR)</b>
a. REPORT <b>unclassified</b>	b. ABSTRACT <b>unclassified</b>	c. THIS PAGE <b>unclassified</b>	
			18. NUMBER OF PAGES <b>15</b>
			19a. NAME OF RESPONSIBLE PERSON

easily lose the intuitive focus of the system, and in general does not point towards the specific problem and its location. In addition, sometimes the model can encounter a topological change after a fault, and hence the premises based on which the model was originally developed and the parameters estimated, may not hold anymore. Ribeiro, Jacobina and Silva [17] investigated four different techniques for fault detection in voltage-fed asynchronous machine drive systems, all based on direct comparisons of the measured voltages to their reference voltages obtained from the PWM reference signals. Fenton, McGinnity, and Maguire [18] gave an overview on the fault diagnostics of electronic systems and emphasized on the need for automated diagnostic tools such as ANN, fuzzy logic, and etc. In particular they recommended hybrid solutions such as model based approaches combined with CBR, or fuzzy logic or ANN. Kim and Parlos presented a model-based fault detection and diagnosis system for electric motors [19]. Their system used a transient empirical predictor modeled by a dynamic recurrent neural networks and wavelet packet decomposition. Their diagnosis system was tested on a 373-kW and a 597-kW induction motor, and its diagnostics accuracy reached about 93%. Filippetti et. al. investigated the applications of various artificial intelligence (AI) techniques [20] to induction motor drive fault diagnostics. They presented an ANN architecture to quantify a stator short-circuit condition, and a fuzzy logic system for the detection of broken rotor bars fault severity, with an adaptive fuzzy-NN applied to stator short-circuit detection. Zidani et. al. [21] presented a fuzzy logic system for induction motor stator fault diagnosis based on the stator current Concordia patterns. One fuzzy output is used to assess the fault severity in four conditions in fuzzy terms: zero, light, medium and high. A comprehensive list of books, workshops, conferences, and journal papers related to induction motor fault detection and diagnosis can be found in [22] and a good discussion on ANN and fuzzy logic methodologies for studying faults in the motor and mechanical faults can be found in [23].

Two quite different approaches used in fault diagnostics in electric motor and drives have also influenced our research. In [24] Kस्था and Bose systematically described the effect of different types of fault in a voltage-fed PWM inverter induction motor drive that uses the open loop volts/hertz speed control method. The important fault types including single line to ground, rectifier diode short circuit, and earth fault on dc bus, were identified in the beginning and followed by preliminary analysis of the selected fault types. Systematic simulation study was then conducted to substantiate the analytical study. Kस्था and Bose pointed out that the study of fault performance of the drive system is extremely complex. The complexity is further aggravated due to a modeling problem of the machine under saturation and unsymmetrical condition. Smith et. al. presented a time-domain response based method for the on-line detection of the intermittent misfiring of the switching devices in a voltage-fed PWM inverter [25]. They pointed out that frequency domain methodologies are not suitable for the purpose and that time domain techniques are considered more appropriate.

Our research is one step more advanced from those published works. Whereas most of the existing diagnostic systems are built to detect a faulty condition against the normal condition, very few addressed small classes of faulty conditions. We are investigating an advanced machine learning technology combined with model based approach for the development of a robust diagnostic system that has the capability of detecting and locating multiple classes of faults in an electric drive operating at any valid (torque, speed) conditions.

Faults in electric drives can be classified into two basic groups: (a) motor related, and (b) power electronics related. Within the motor related faults there are mechanical and electrical faults. Mechanical faults are related to motor bearings and other mechanical unbalances leading to vibrations. Electrical faults within the motor such as partial/full winding (including inter-turn) short circuit, open circuit etc., and an unbalanced inverter output applied to the motor can all result in unbalanced current and magnetic field in the motor. Power electronics faults are related to inverter failure, e.g. open or short circuited switches, or reverse diodes. Such faults can be of either permanent nature or intermittent type. As mentioned earlier, this research is focused on the problem of power electronics inverter fault diagnostics. Power electronics inverter can have single switch failure (open or short), reverse diode failure (open or short), or multiple of these faults. However, the probability of multiple failures is much lower than single failure event. Other inverter failure can be due to leads breaking down, shorting, or connector problems. In this paper we focus on the classification of inverter open circuit faults in switches using machine learning technology. The techniques presented in the paper are general and can be easily extended to detecting other types of faults, either electrical and/or mechanical. We want to point out that in the cases of simple discrete open faults (or short circuit faults) the signatures can be significantly different from normal conditions and those faults can sometimes be detected by simple methods such as rule based algorithms. But our methodology is general enough to detect different classes of faults occurring at different locations, which can be intermittent, and whose signatures may be subtle involving multiple signal analysis. As we will see in the experiment section, such faults are difficult to detect and locate with 100% accuracy. Furthermore, our approach shows that a fault diagnostic system can be developed using machine learning techniques on simulated data and performs fault diagnostics robustly under any valid operation conditions.

With the above in perspective, the research presented in this paper has the following distinct features compared to the existing techniques:

- It combines a model based diagnostics approach with a machine learning technique to train a robust fault diagnostic system.
- The resulting fault diagnostic system has the capabilities of detecting and locating up to 10 different classes of faults in a six-switch inverter. Signal signatures of a faulty condition against the normal condition are relative easy to identify,

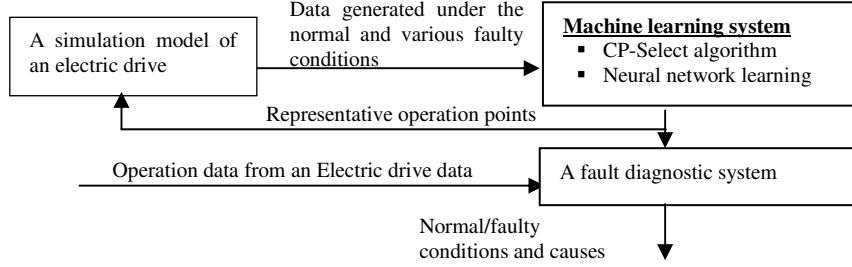

Figure 1. Illustration of a model based fault diagnostic system driven by machine learning.

whereas the signal signatures of one fault against another fault are often subtle, and not easy to detect.

- During the development phase of a fault diagnostic system there is no need to take direct measurements of data from electric drives, which is time consuming and costly.
- The resulting system has been validated using the data generated by an experimental inverter-motor system and proven to be effective.

Figure 1 illustrates our approach to fault diagnostics of electric drive. “SIM\_drive”, a simulation model of a field oriented control (which can be closed or open loop) electric drive with a power electronics based inverter and a 3-phase induction motor is developed and implemented using the Matlab-Simulink software. SIM\_drive has the capability of simulating normal operation condition of an electric drive as well as the faulty conditions of the open and post-short-circuit faults in an inverter switch. A post-short-circuit fault implies that if a particular switch of the inverter is short circuited, very shortly thereafter the other inverter switch located on the same limb will be gated to turn on, leading to a complete short circuit of the limb. Eventually the complete limb where the short circuit occurred will burn out to become permanently open. In our on-going work, we extended the problem scope to include a short circuit fault where it is assumed that the inverter will be shut-down by a proper protective mechanism when the current exceeds a certain threshold. We have found that our methodology works successfully on these faults as well, and we plan to report this in a subsequent paper.

In the SIM\_drive model we assume a minimal amount of current and voltage sensors available in a drive system: sensors in series with any two of the inverter output lines and two voltage sensors across any two of the output terminals of the inverter. The SIM\_drive model operates at any selected (torque, speed) operating point under normal and various faulty conditions. Since in real world an electric drive can operate at different (torque, speed) points, a diagnostic system should be trained to be robust throughout the (torque, speed) domain. A machine learning algorithm is developed to select representative operating points from the (torque, speed) domain for use by the SIM\_drive model to generate training data. The objective of the machine learning approach is to train a diagnostic system on the representative data so that it has the capability of performing accurate fault diagnostics in an electric drive that operates at any valid operating point. The intelligent system used in this research is a multi-class

neural network system. We will describe two possible neural network architectures and discuss their pros and cons. It should be noted that once a model based ANN has been trained, its implementation in a real-time environment is rather simple, since it amounts to having just the weights of the neurons in the ANN burned in an inexpensive microprocessor.

Experiments were conducted both on the simulated data and the data generated by an experimental bench setup. The results show that the proposed diagnostic system is very effective in detecting multiple classes of faulty conditions of an inverter in an electric drive operating at any valid (torque, speed) point.

## II. A 3-PHASE ELECTRIC DRIVE MODEL

In this section, we briefly describe the basics in the development of a simulation model of an electric drive. The structure of the electric drive system using an induction motor with an optional closed loop is shown in Figure 2 (a). The inputs to the system are the dc voltage, reference torque, reference air gap magnetic flux in the induction motor, and the mechanical source/sink input in the form of shaft speed or load torque in the shaft. The controller is a FOC [3-7] that generates a reference 3-phase voltage. This reference voltage is then synthesized through a PWM process. In the open loop configuration, the feedback torque loop shown in Figure 2(a) does not exist, and the controller simply generates a voltage and frequency reference using any scheme which can include, among others, constant volts per hertz (V/Hz). The motor is represented by the following standard set of equations with d-q axis fixed in the stator [3, 5-7].

$$V_{ds} = (R_s + pL_s) I_{ds} + pM I_{dr} \quad (1)$$

$$V_{qs} = (R_s + pL_s) I_{qs} + pM I_{qr} \quad (2)$$

$$0 = pM I_{ds} + \omega_r M I_{qs} + (R_r + pL_r) I_{dr} + \omega_r L_r I_{qr} \quad (3)$$

$$0 = -\omega_r M I_{ds} + pM I_{qs} - \omega_r L_r I_{dr} + (R_r + pL_r) I_{qr} \quad (4)$$

where and  $R_s$ ,  $R_r$  are stator and rotor resistances,  $L_s$ ,  $L_r$ , are stator and rotor self inductance, and  $M$  is the stator/rotor mutual inductance,  $\omega_r$  is the electrical rotor angular velocity,  $V_{ds}$ ,  $V_{qs}$  are d and q axis stator voltage,  $I_{ds}$ ,  $I_{qs}$  are d and q axis stator current,  $I_{dr}$ ,  $I_{qr}$  are d and q axis rotor current, and  $p$  is the differential operator  $d/dt$ . The rotor is assumed to be shorted and hence the voltages are 0 in equations (3) and (4). The electromagnetic torque is defined as  $T_e = (3/2) (P/2) M (I_{qs} I_{dr} - I_{ds} I_{qr})$ , where  $P$  is the number of poles. In a FOC scheme

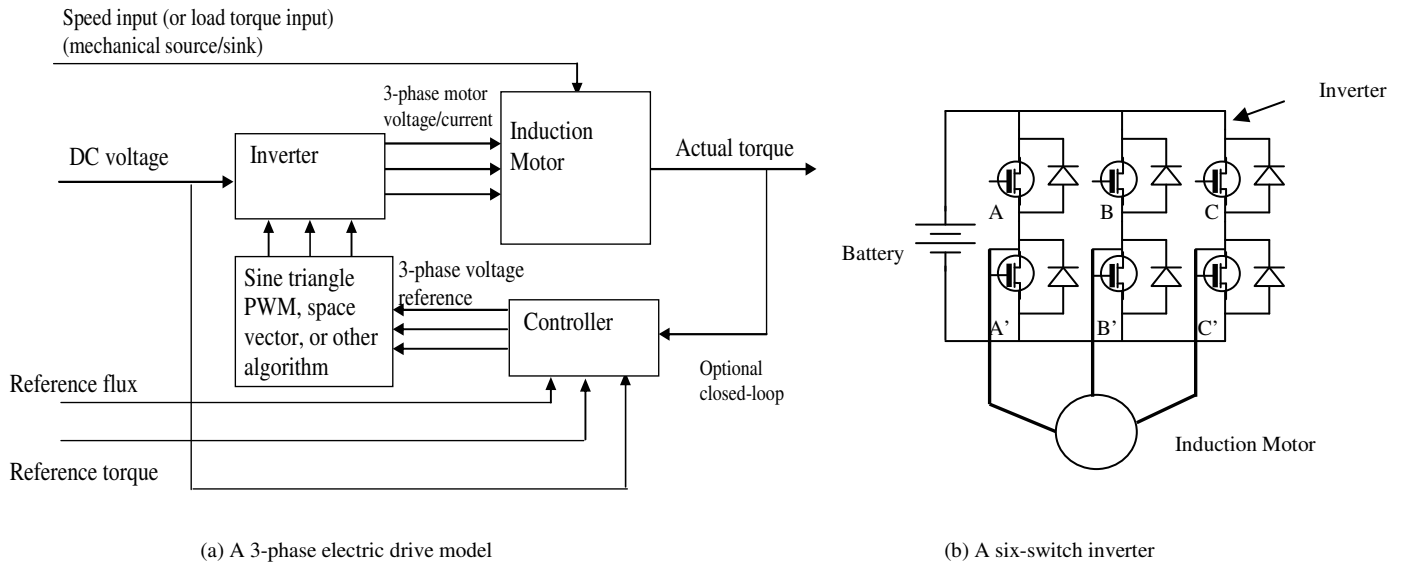

(a) A 3-phase electric drive model (b) A six-switch inverter  
Figure 2. A 3-phase electric drive model and a six-switch inverter in a 3-phase electric drive.

this torque equation can be simplified further by dropping the second term within the parenthesis leading to a simple control [3]. The mechanical equation of motion for the motor shaft is given by  $T_e - T_L = P/2 [J (d\omega_m/dt) + B\omega_m]$ , where  $\omega_m$  is the mechanical shaft speed, and the excitation frequency  $\omega = (P/2)\omega_m$ .  $T_L$  is the load torque,  $J$  is the moment of inertia, and  $B$  is the friction coefficient. These equations are numerically solved for currents during the implementation of a simulation model using Matlab-Simulink. Specifically, we intend to simulate various faults for the six-switch scheme shown in Figure 2(b).

One possible approach for fault diagnosis in an inverter is to have sensors installed at all possible locations to flag any abnormalities, assuming that the sensors do not fail as well. For example, to detect open circuit fault conditions within an inverter, we would need to place current sensors at every single switch and reverse diode to detect whether a particular switch or diode is faulty. This is not cost/weight effective, and real-life inverters do not contain that many sensors. Our approach assumes that only a minimal amount of current and voltage sensors exist in an electric drive system: the current sensors in series with any two of the inverter output lines, and two voltage sensors across any two of the output terminals of the inverter. We also assume a Y-connected 3-phase induction motor stator, without any return connection from the neutral of the Y. The problem statement can thus be summarized as follows: *For a 6-switch inverter driven 3-phase induction motor embedded with two current sensors in the output inverter line and two voltage sensors across the lines, a robust diagnostic system is to be developed to accurately identify any single faulty inverter switch among the six switches, or one failed vertical switch pair.*

The above theoretical model was implemented in a simulation model, SIM\_drive, using the Matlab-Simulink software. SIM\_drive has the capability of simulating the normal and faulty operations within the 3-phase induction motor drive at any given (torque, speed) point. Table 1 shows the normal operation of the scheme shown in Figure 2(b). The

numbers in the voltage columns are to be multiplied with the dc voltage  $V$ , in order to obtain the true voltage applied to the motor phase windings. In the implementation, we assume that a gating signal 1 implies that the switch is turned on, and 0 implies that the switch is turned off. We also assume that if the upper switch A is on, then the lower switch A' will be off, and vice versa, to prevent any possibility of direct short circuit of the dc voltage source. Table 2 shows the states of the six-switch inverter when the switch A is open-faulted. In this case, although switch A (upper limb) is supposedly turned on, in reality it remains off due to an open-circuit fault. In addition to the 6 states shown in the Table 1, we also have two null states corresponding to all switches being on or off simultaneously. These null states amount to short circuiting of the motor terminals. The model is also used to simulate three post-short-circuit cases corresponding to the three vertical switch pairs open, one pair at a time, namely, the pairs A and A', B and B', and C and C' respectively. The operating conditions used in the simulation are specified in Table 3.

Figure 3 shows examples of the simulated signals generated under the normal operation condition by SIM\_drive. In Figure 3(a) the step function is the command torque, and the actual torque is seen to ultimately follow the command with a delay depending on the controller settings. Figure 3(b) shows the current signals  $I_a$ ,  $I_b$ , and  $I_c$ . Figure 4 shows the signal behaviors with switch A open circuited at time 0.1 seconds. Figure 4(a) shows the torque command (step function) and the actual torque signal (oscillatory with changing amplitude). Figure 4(b) shows the currents  $I_a$ ,  $I_b$ , and  $I_c$  (3 currents in different shadings, with 120 degrees phase shift from each other in steady state) acquired after the fault. Note that we used short trigger time for the purpose of clarity in viewing the faulty signal features. It should also be noted that in simulations no restriction was imposed on the current magnitude, whereas in an experimental system there is a limit to the allowable current in order to prevent any damage to the system or the components. Figure 5 shows the signal behaviors of one post-short-circuit case in which the pair A

and A' become open circuited at time 0.25 second. As discussed earlier, short circuiting switch A made A' open eventually, since the latter is gated to be on, shortly after the

short circuit, causing the entire A and A' limb to become open.

Table 1: Switching table for normal operation of the switches

STATE #	SWITCH A	SWITCH B	SWITCH C	V <sub>an</sub> / V	V <sub>bn</sub> / V	V <sub>cn</sub> / V
Null	0	0	0	0	0	0
1	0	1	0	-1/3	2/3	-1/3
2	0	1	1	-2/3	1/3	1/3
3	0	0	1	-1/3	-1/3	2/3
4	1	0	1	1/3	-2/3	1/3
5	1	0	0	2/3	-1/3	-1/3
6	1	1	0	1/3	1/3	-2/3
Null	1	1	1	0	0	0

Table 2: Switching table for the faulted operation in which Switch A is permanently open

STATE #	SWITCH A	SWITCH B	SWITCH C	V <sub>an</sub> / V	V <sub>bn</sub> / V	V <sub>cn</sub> / V
Null	0	0	0	0	0	0
1	0	1	0	-1/3	2/3	-1/3
2	0	1	1	-2/3	1/3	1/3
3	0	0	1	-1/3	-1/3	2/3
4	0	0	1	-1/3	-1/3	2/3
5	0	0	0	0	0	0
6	0	1	0	-1/3	2/3	-1/3
Null	0	1	1	-2/3	1/3	1/3

Table 3: The operating conditions used in the simulated sine-PWM-closed-loop model

Variable name	Description	Value
V <sub>DC</sub>	DC voltage provided by battery	500V
PWM carrier frequency	Frequency of the sine wave	8 kHz
Speed	Fixed running speed of the motor	60, 300, 600, 900, 1800 rpm
Reference torque command	Mechanical torque desired from the motor	10, 50, 100, 200 Nm
Simulation time	Simulation time	6.25s
Trigger time	Time point to trigger the fault condition	0.25s
Sampling rate	Sampling rate to get the output data.	0.001s
Points of data	Points of data	6000

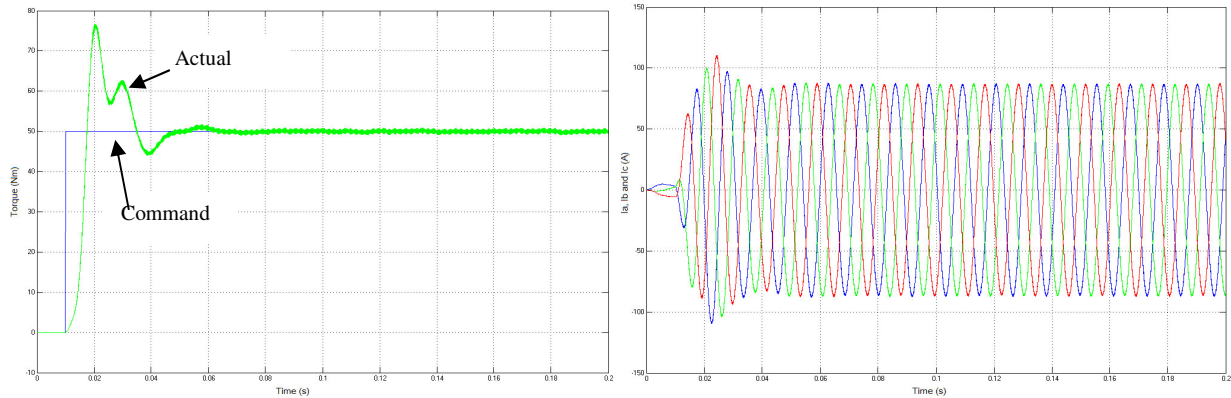

(a) Torque signal. (b) Ia, Ib and Ic signals  
Figure 3. Signal behaviors in the normal condition generated by SIM\_drive.

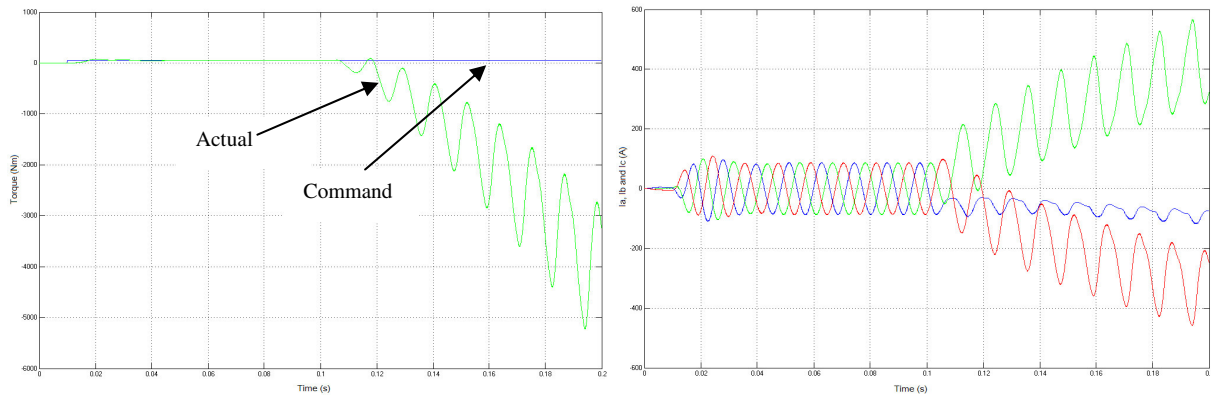

(a) Torque signal. (b) Ia, Ib and Ic signals  
Figure 4. Signal behaviors generated by SIM\_drive in an condition that switch A is open.

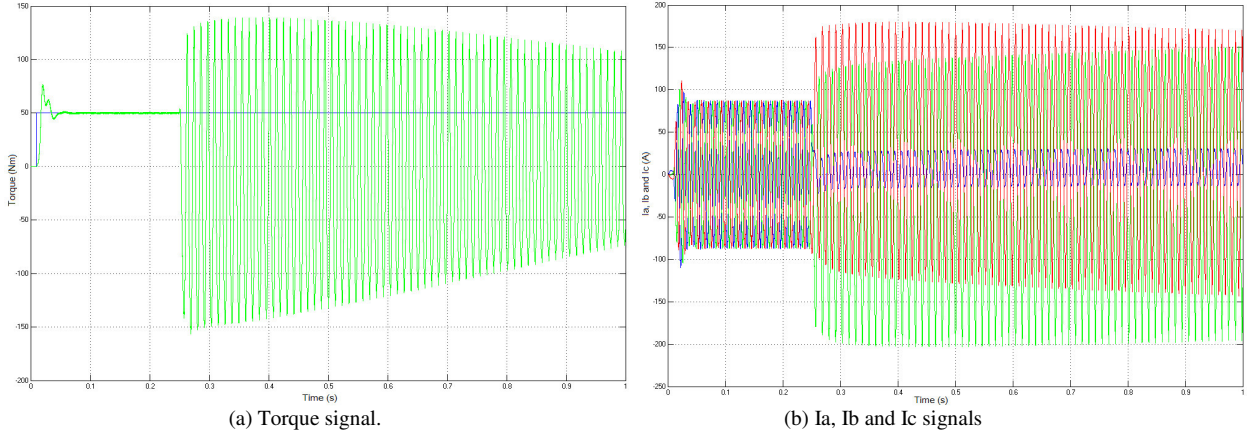

Figure 5. Signal behaviors in an abnormal condition that both switches A and A' are open in a sine-PWM-closed-loop model.

### III. ELECTRIC DRIVE FAULT DETECTION USING SIGNAL ANALYSIS AND MACHINE LEARNING

Fault diagnostics in electric drive can be performed by developing an intelligent system that can learn to detect signal faults under various faulty circuit conditions. The challenges in developing such robust diagnostic systems lie in the fact that it is easier to identify signatures of a faulty condition against the normal condition, whereas signal signatures of one fault against another one are often quite subtle. We model the fault diagnostics in electric drive as a multi-class classification problem. The input space consists of relevant signals (e.g. voltages and currents among others) from the electric drive system, and the output space consists of class labels,  $\{f_0, f_1, \dots, f_k\}$ , where  $f_0$  is considered to be the normal operational condition, and  $f_1$  through  $f_k$  are the  $k$  faulty conditions in the electric drive, which in our case correspond to the 6 switches, one open at a time, and the three cases of post-short-circuits. Figure 6 illustrates the computational steps involved in the signal fault detection system, where the input consists of the voltages  $V_{an}, V_{bn}, V_{cn}$  to the motor, the currents  $I_a, I_b, I_c$ , and the motor electro-magnetic torque  $T_e$ . Note that we use time domain signals instead of frequency domain signals in our diagnostic system for the same reasons as indicated by Smith et. al. in [25]. The first computational step is to segment the signals and extract the signal features from each segment. The signal segments are then analyzed by an artificial neural network, which is trained on the signals generated by SIM\_drive at the parameter points selected by the CP-Select algorithm, a machine learning algorithm. The major research contribution in this section is the machine learning technology used to train a neural network that can robustly detect and locate faults inside an electric drive operated under any given valid condition.

#### A. Signal segmentation and feature extraction

Signal fault detection is performed on a segment-by-segment basis. All input signals are segmented using the same fixed sized segments and the two adjacent segments are overlapped in  $1/3$  of the segment width in order to maintain continuity of information flowing between segments. The

basic frequency of the signals is over 80 Hz, and sampling frequency is chosen to be 1000 Hz, which is sufficient for this purpose. We chose to use 16 samples in each segment with an overlap of 5 samples between two adjacent segments. A signal of 3000 data samples is segmented into 272 segments. Figure 7 illustrates the segmentation scheme. The solid vertical lines indicate the beginning of segments, the dashed vertical lines indicates the ending of segments, the signal between a dashed line and the subsequent solid line is the overlap portion of the two adjacent segments. Each signal segment is represented by the following features:

- Max: maximum magnitude of the signal within the segment
- Min: minimum magnitude of the signal within the segment
- Median: median of the signal within the segment
- Mean: mean of the signal within the segment
- Standard deviation: standard deviation of the signal segment
- Zero-frequency component of the power spectrum

The detection of signal faults within a time period requires one segment from each input signal and each segment is represented by the 6 features listed above. Since we have 7 input signals (3 voltage signals, 3 current signals, and 1 torque signal), the combined feature vector to represent a particular state in the electric drive at a particular time is a vector of 42 dimensions. The feature vector is the input to a neural network classifier that determines whether the 7 signals within this time period manifest any fault.

#### B. Smart selections of operation parameters

In a drive system, the current and voltage signals behave differently under different operation conditions specified by torque and speed. The issue of smart selection of “control parameters” (also referred to as operating point) in the (torque, speed) domain is important for all electric drive diagnostic systems that are trained on simulated data.

A diagnostic system trained on more representative data is more likely to perform better diagnostics in real world system under any operation condition. Figure 8 illustrates the proposed machine learning algorithm, CP-Select (Control



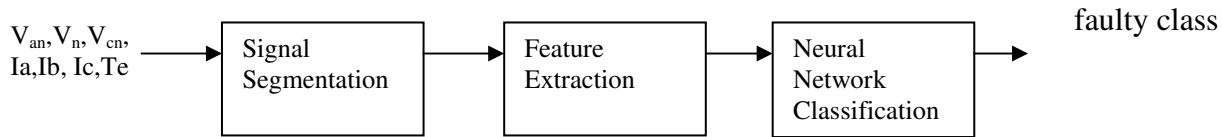

Figure 6. Major computational steps in a signal fault detection system.

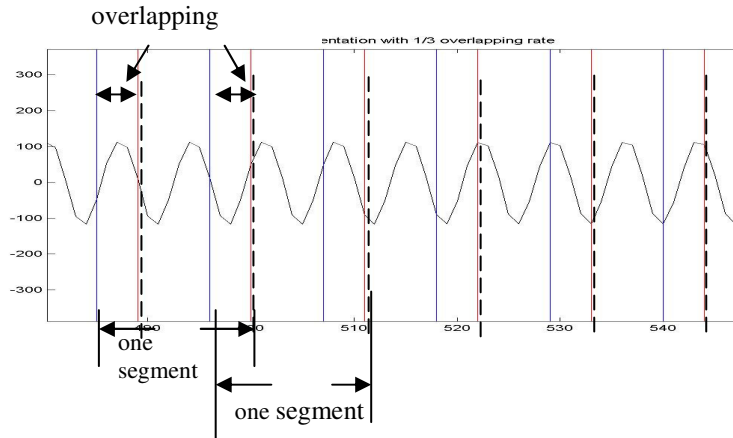

Figure 7. Illustration of signal segmentation

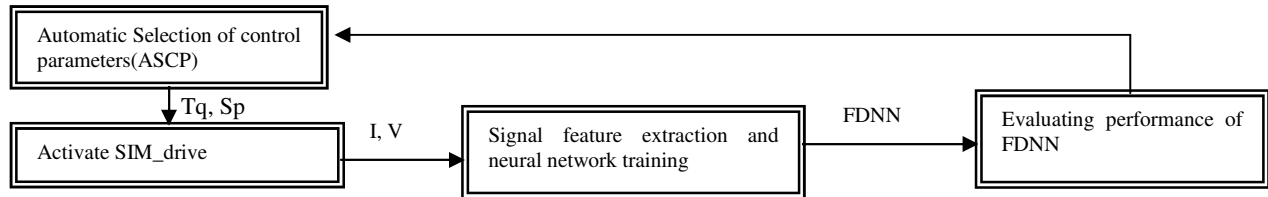

Figure 8. Illustration of CP-Select algorithm for an electric drive diagnostic system.

point-Select), for the generation of a robust electric drive diagnostic system. The CP-Select algorithm, automatically selects representative operating points in a given domain of control parameter (CP) space to generate representative training data for a neural network system for fault diagnostics. The operating space for a drive system has two components, i.e. torque ( $T_q$ ) and speed ( $S_p$ ). The  $T_q$  and  $S_p$  pair selected by CP-Select is sent to SIM\_drive, which in turn, generates current and voltage signals,  $I, V$ , at all three phases at the given speed and torque point under normal and faulty conditions. Collectively, these signals are denoted as  $I, V$ , where  $I = \{I_0, I_1, I_2, \dots, I_c\}$  and  $V = \{V_0, V_1, V_2, \dots, V_k\}$ , where the elements  $I_i$  and  $V_i$  (with  $i = 0$  to  $k$ ) within the  $I$  and  $V$  vectors are current and voltage signals obtained under normal (with index 0) and  $k$  faulty conditions.  $I_i$  and  $V_i$  themselves can be vectors that contain several signals acquired at different locations of the circuit. Diagnostic features are extracted from these signals and feature vectors are used to train an ANN called FDNN, and the performance of the FDNN is evaluated on a validation data set  $T_v$ . If the performance is satisfactory, the algorithm stops, otherwise, more operating points are selected.  $T_v$  is a validation data set containing features extracted from signals generated by SIM\_drive that operates

on a set of randomly selected control parameters (operating points) in the (torque, speed) domain.

The most complicated component in the CP-Select algorithm is ASCP (Automatic Selection of Control parameters). Initially  $\Phi$  contains the rectangular space (refer to Figs. 9 and 10) that includes all valid torque and speed points used by a real world electric drive. As the process goes on,  $\Phi$  contains all subspaces from which potential parameters can be selected. The ASCP algorithm repeatedly removes one parameter space from  $\Phi$  at a time and performs an iterative process until  $\Phi$  is empty or the performance of the trained FDNN is satisfactory. At each iteration ASCP selects three sets of points, and each set goes through a simulation, training and evaluation process as shown in Figure 9. The first set of points contains the four corner points and the center point of the current parameter space  $C_{CP}$  (see  $X_1, X_2, X_3, X_4, X_5$  in Figure 10) and are stored in  $P_0$ . The points in  $P_0$  that have not been selected before are sent to SIM\_drive to generate new training data. The newly generated training data are combined with the existing ones to form the current training data set,  $T_r$ . FDNN is trained on  $T_r$  and evaluated on validation data set  $T_v$ . If the performance of FDNN on  $T_v$  is satisfactory, the process stops. Otherwise it goes on to select the second set of



points, which are the interior points of the current parameter space  $C\_CP$  (see  $X_6, X_7, X_8, X_9$  in Figure 10). The same simulation, training, and evaluation steps are repeated on this set of points. If the performance of FDNN at this stage is satisfactory, the process stops. Otherwise the third set of parameters is selected, which contains the four center points on the four sides of  $C\_CP$  (see  $X_{10}, X_{11}, X_{12}, X_{13}$  in Figure 10). Again, the same simulation, training and evaluation process is applied to this set of parameters as well. If the performance of FDNN at this stage is satisfactory, the ASCP algorithm stops, otherwise, the current parameter space  $C\_CP$  is evenly divided into four subspaces  $CP_1, CP_2, CP_3$  and  $CP_4$ , which are appended to the parameter space set  $\Phi$ . All the parameter spaces in  $\Phi$  are sorted based on the performances of FDNN on the validation points in the space, and then the entire process repeats.

We have conducted an experiment to evaluate the CP-Select algorithm by using the SIM\_drive described in section II. We identified a valid (torque, speed) space as {Torque (Nm): [10, 200], Speed (rpm): [50, 1800]} as an initial parameter space denoted as  $C\_CP$ . For every pair of (torque, speed) points ( $T_q, S_p$ ) selected by the CP-Select algorithm, we ran the simulation model for about 6 seconds to generate seven sets of current and voltage signals in the 3-phases. One set is normal signal series, and each of the other six sets corresponds to one faulty condition. All these signals are segmented and signal features are extracted, and a FDNN is trained to classify the single-switch faults in the inverter in an electric drive. The CP\_Select algorithm selected 8 random points within the  $C\_CP$  space to form the (torque, speed) validation set,  $T_v = \{(25, 236), (75, 360), (36, 1149), (96, 1502), (121, 119), (135, 518), (146, 672), (176, 1401)\}$ , which are shown in cross marks in Figure 11. The points shown in diamonds were selected at the first iteration, the points marked in squares and triangles were generated by the CP-Select algorithm at the second and third iterations respectively. The points marked in asterisks are the randomly selected test data. Figure 12 shows the performance of a 6-class neural network system trained to classify the single switch faults in a 3-phase inverter. The performance was obtained by evaluating the neural network on the validation set  $T_v$  after it is trained on at each iteration. We chose to use performance threshold  $per\_th = 99\%$ . At the first iteration, training data  $Tr_0$  contains signal data generated by SIM\_drive on the control points selected in the first iteration (see Figure 11). A neural network FDNN0 is trained on  $Tr_0$  and the overall performance of FDNN0 evaluated on the validation set is  $94.62\% < Perf\_th = 99\%$ . Its performance on individual classes is shown in the curve connecting the diamond points in Figure 12. At the second iteration, the neural network FDNN is trained on  $Tr_0 \cup Tr_1$ , where  $Tr_1$  is the signal data generated by SIM\_drive on the points selected by the CP\_Select at the second iteration, and its performance on  $T_v$  is shown in the curve connecting the square points in Figure 12. The overall performance is  $96.06\% < Perf\_th = 99\%$ . At the third iteration, the neural network FDNN is trained on  $Tr_0 \cup Tr_1 \cup Tr_2$ , where  $Tr_2$  is the signal data generated by the SIM\_drive on the points selected by the CP\_Select at the third iteration, and its performance on

$T_v$  is shown in the curve connecting the triangular points in Figure 12. The overall performance at the third iteration is  $100\% > Perf\_th = 99\%$ , therefore the algorithm stops.

### C. Multi-class Fault Classification using Artificial Neural Networks (ANN)

Artificial neural networks are capable of capturing underlying numerical or logical relationships among training examples. Neural networks have been successfully applied to a broad range of problems including engineering diagnosis, pattern classification, intelligent manufacturing, control problems and computer vision [25-34]. A neural network architecture using feedforward backpropagation consists of specification of the number of layers, number of units in each layer, type of activation function of each unit, and the connection weights between the units of different layers, which are determined by a machine learning algorithm. According to Huang et al. [30], two-layer or sometimes called one-hidden layer perceptrons, can implement any convex open or closed decision regions. Therefore, we chose to use a one-hidden-layer architecture for signal fault detection. Most of the research in neural networks has been in the development of learning and training algorithms for 2-class classifiers, i.e. classifiers with one output node that represent classes 0 and 1. However, fault diagnostics in electric drive has six classes of single switch faults and three classes of post-short-circuit classes. The most common architectures which have been proposed for multi-class neural networks [35], involve a single neural network with  $K$  output nodes, where  $K$  is the number of faulty classes, and a system of binary neural networks combined with a posterior decision rule to integrate the results of neural networks. A system of binary neural networks requires separate training of each neural network and each trained neural network generates a decision boundary between one class and all others. The most noticeable limitation in this approach is that the decision boundaries generated by the different 2-class neural network classifiers can have overlapped or uncovered regions in the feature space [35]. For the feature vectors that fall on an overlapped region in the feature space, more than one 2-class classifiers can claim the input as their classes, resulting in ambiguity. The feature vectors falling on the regions that are not claimed by any neural networks will be rejected by all neural networks. As a result the resulting system may not generalize well. Another type of multi-class neural network system is to use a single neural network with  $k$  output, where  $k > 1$ . This type of the neural network architecture has the advantage of simple training procedure, and only one neural network is trained for all  $m$  classes, where  $m > 2$ . If trained properly, a neural network system implemented in this architecture should reduce the ambiguity problem [35].

Based on the single neural network architecture, we implemented two different systems of neural networks as illustrated in Figure 13 for the diagnosis of 10 classes of faults in an electric drive: one class represents the normal condition, six classes represent six single switch faults, and the last three classes represent the three post-short-circuit faults.

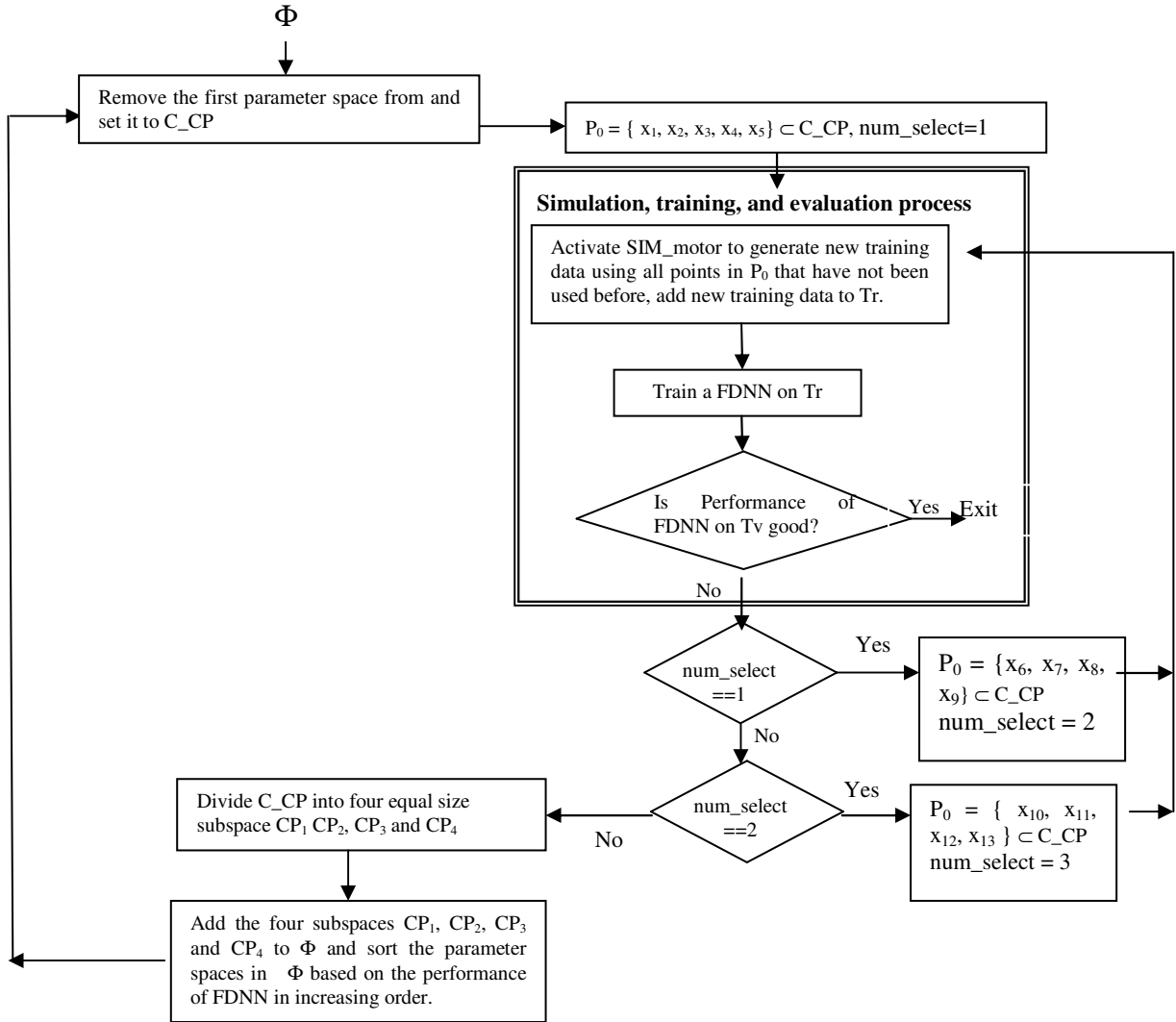

Figure 9. Computational Steps in ASCP component. Please refer the points  $x_i, i = 1, \dots, 13$  to Figure 10.

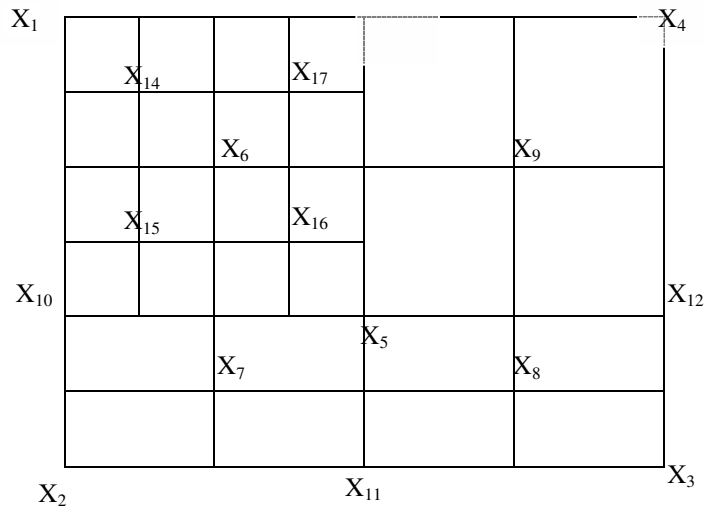

Figure 10. Illustration of operating points in a two-dimensional CP space

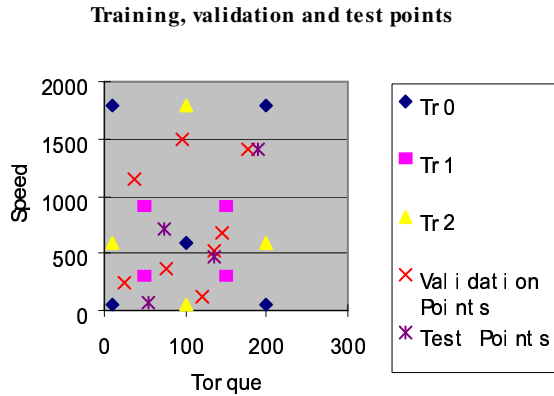

Figure 11. Randomly selected test and validation set, and the train data selected by CP-Select algorithm.

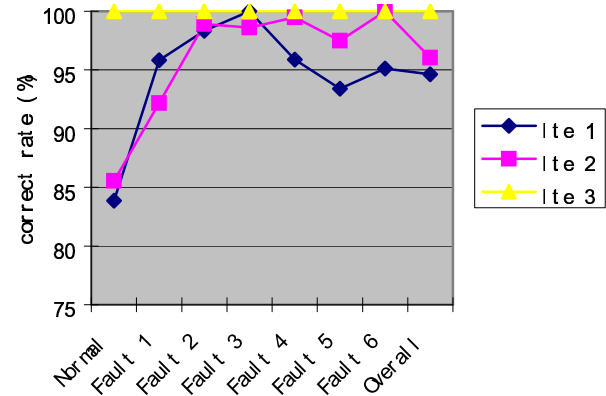

Figure 12: The performance of the FDNN trained on data generated by SIM\_drive using the control points generated by the CP-Select during three iterations.

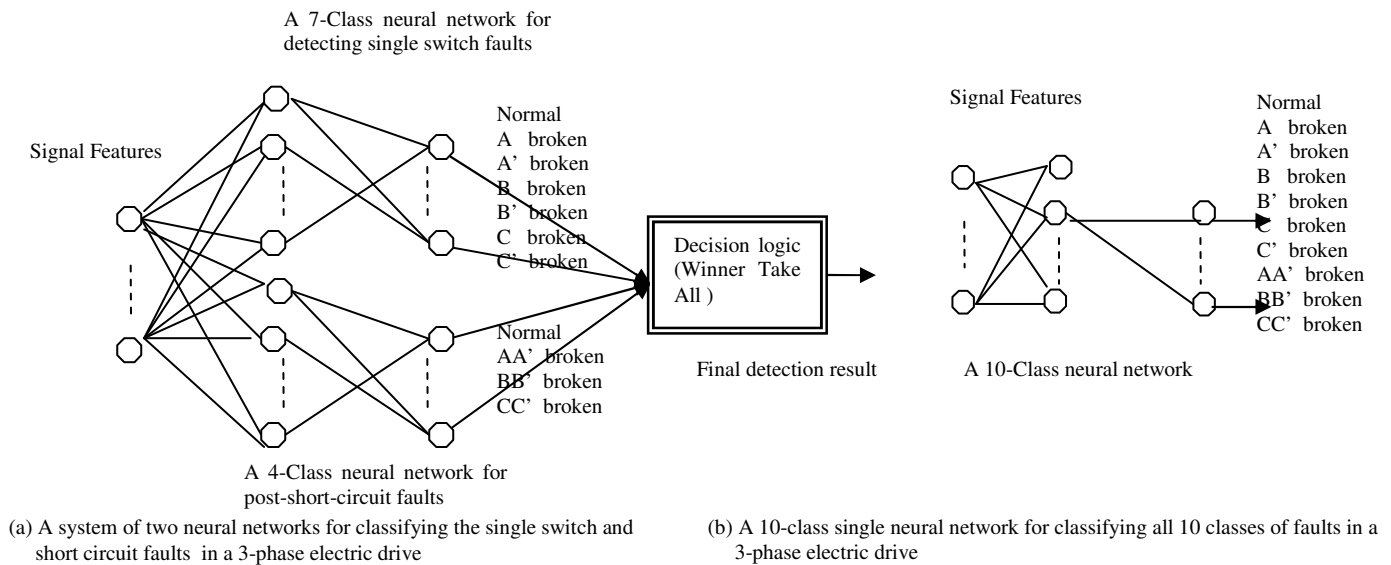

Figure 13. Two neural network architectures developed for the fault classification in a in an electric drive.

Figure 13 (a) shows a structured diagnostic system consisting of two neural networks, one is trained to classify single switch faults, and the other classifies the post-short-circuit faults, and WTA [35] approach is used to integrate the results from the two neural networks. Figure 13(b) shows a single neural network trained to classify all 10 classes: normal, six single switch faults, and 3 post-short-circuit faults. One important issue in a multi-class neural network is how to encode the classes in the output nodes of the neural network. In both neural network architectures, we chose to use a "one-hot spot" method described as follows. For a  $k$ -class classification problem, we need an output layer of  $k$  bits, each class is assigned a unique binary string (codeword) of length  $k$  with only 1 bit set to "1" and all other bits are "0." For example if it is a six-class classification problem, class 0 is assigned a codeword of 000001, class 1 is assigned a codeword of 000010, class 2 is assigned of a codeword 000100, etc. The advantage of this encoding is that it gives

enough tolerance among different classes. We use the back propagation learning algorithm to train all the neural networks.

In order to evaluate these two neural network systems, we conducted the following experiments using simulated data. The structured multi-class neural network system contains two separately trained neural networks, both having 42 input nodes and 1 hidden layer with 20 hidden nodes. The neural network for single switch fault classification has 7 output nodes, which represent the normal class and the 6 faulty classes. The neural network for the post-short-circuit classification has 4 output nodes, which represent the normal class and the 3 post-short-circuit classes.

The randomly selected validation and test parameters, and the training parameters generated by the CP-Select algorithm for the six single switch faults are shown in Figure 11 and the parameters (operating points) for the post-short-circuit are shown in Figure 14.

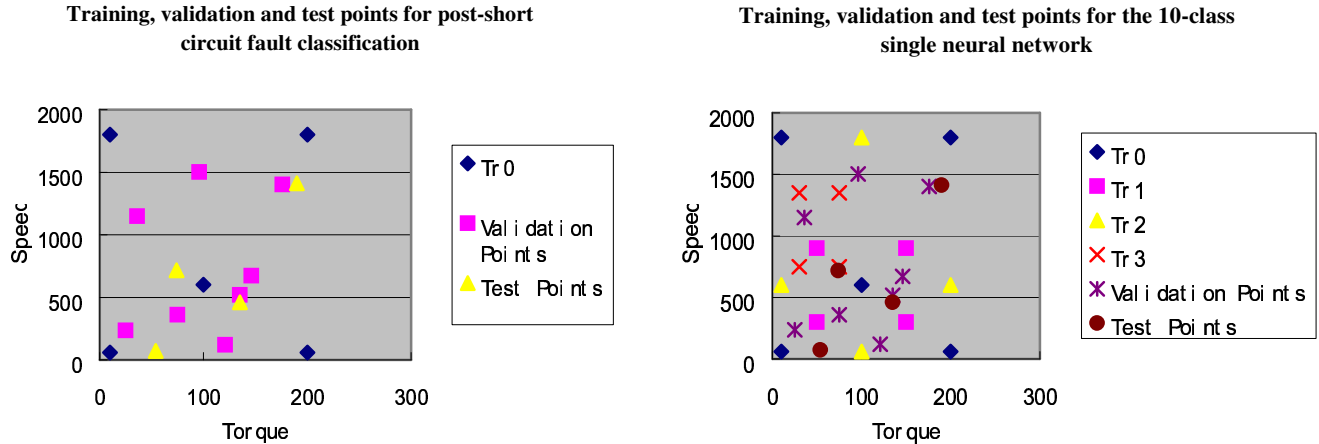

(a) Randomly selected test and validation parameters, and the training parameters selected by the CP-Select for classifying post-short-circuit faults.

(b) Randomly selected test and validation parameters, and the training parameters selected by the CP-Select using a single neural network classification system.

Figure 14. Randomly selected test and validation parameters, and the training parameters selected by the CP-Select for classifying post-short-circuit faults.

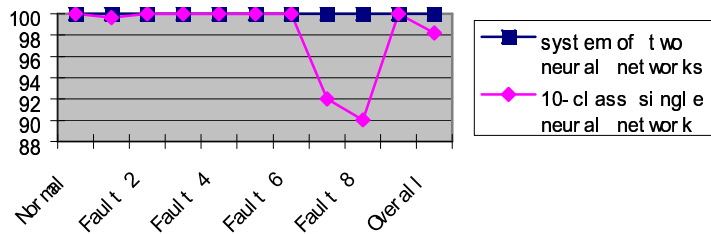

Figure 15: Performances of two different neural network systems

The single-switch fault classification neural network was trained on the control parameters in  $Tr_0$ ,  $Tr_1$  and  $Tr_2$  generated by the CP-Select algorithm using 3 iterations as described in section III. C. The post-short-circuit fault classification neural network was trained on the control parameters (operating points) in  $Tr_0$  shown in Figure 14, which gave 100% correct performance on the validation data shown in the squared points in Figure 14. Therefore the CP-Select algorithm stopped at the end of the first iteration. The four randomly selected test points are shown in triangular in Figure 14. For the 10-class single neural network system, the CP-Select algorithm generated the training points in four iterations resulting in  $Tr_0$ ,  $Tr_1$ ,  $Tr_2$  and  $Tr_3$ , which are shown in Figure 15 along with the validation points and test points. The 10-class neural network has 42 input nodes and 1 hidden layer with 20 hidden nodes, and 10 output nodes, where one node represents the normal class, and 6 represent the single switch fault classes, and 3 represent the three post-short-circuit faulty classes. It is trained on the data generated by the SIM\_drive using the operating points in  $Tr_0 \cup Tr_1 \cup Tr_2 \cup Tr_3$ .

The test data for both diagnostic systems were the signals generated by SIM\_drive from the same four (torque, speed) points as shown in Figure 11 and 14. 11320 feature vectors were extracted from these signals among which 6792 data samples contain the six single switch faults, and 3396 contain the three post-short-circuit faults, and 1132 are normal. The

performances of these two diagnostic systems on the test data set are shown in Figure 15. The structured diagnostic system correctly detected and located all 9 faulty classes and the normal class with 100% correct detection. The single neural network system correctly detected with 100% all the 6 single switch faults, but detected correctly with only 90% and 92% on test data from the post-short-circuit faulty class 1 and class 2. We want to point out that if there were signal data on the data generated from real time operation, FDNN can be trained by combining the simulated and real time signals. The resulting FDNN is then expected to be more robust. Since operation data is difficult to obtain at the design stage, it is also possible to train the FDNN using only the simulation data initially, and then incrementally train the FDNN as the real operation data becomes available, which has been discussed in one of our papers [36].

#### IV. PERFORMANCE OF FDNN ON DATA GENERATED FROM BENCH SETUP

A reasonable question about model based diagnostic approaches based on simulation data is how well the system can operate on real data, which often contain noise and are not as stable in the sense that signals generated under the same faulty condition vary in certain features. In order to evaluate the robustness of the proposed model based diagnostic system

trained through machine learning, we developed an experimental bench setup of an electric drive in the VE (Vehicle Electronics) lab at the University of Michigan-Dearborn in an attempt to generate data as close to real operation as possible. Figure 16 shows the system setup and the 3-phase open-loop inverter circuit that has the capability of generating signals under normal and various faulty conditions.

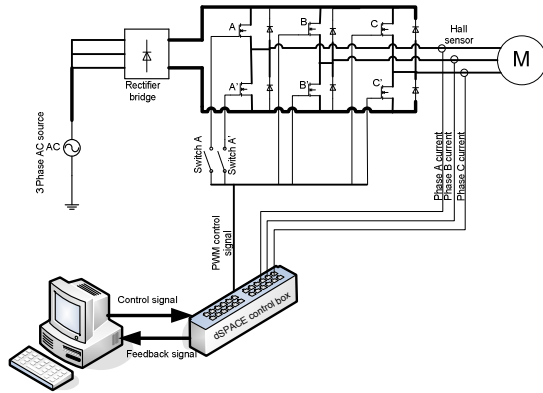

Figure 16: Experimental set up of the electric drive system.

The bench set up has the following components: Matlab Simulink, dSPACE control desk and control box, Hampden

IM-100 induction machine, three phase transformer, three phase rectifier, inverter, interface boards, and Hall sensor. The signals generated by the bench setup are not stable in the sense that signals generated under the same faulty condition but at different run can have different behavior. Figure 17 and 18 show the signals generated in two separate runs by the bench setup system when switch A is broken and both A and A' are broken respectively. It is obvious that the signals generated by the bench setup under the conditions are not identical in the two separate runs. Figure 19 shows the  $I_a$ ,  $I_b$ , and  $I_c$  signals generated by a simulated model in which the switch A was broken in Fig. 19(a) and both switch A and A' were broken in Fig. 19 (b). It is clear that the signals generated by SIM\_drive are smooth and have expected behaviors, and the signals generated by the bench set up and SIM\_drive are similar but have small variations. A neural network system developed using the machine learning approach described in section III has been tested on the data generated by the experimental bench setup system shown in Figure 16 and the results are shown in Figure 20. The three classes of post-short-circuit fault were detected and located with 100% accuracy. The six classes of single switch faults were detected and located correctly within 98% of all the cases. The lowest detection rate is on the normal condition, which is close to 96% over all cases.

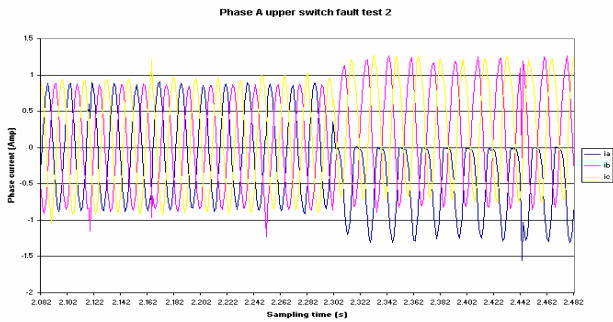
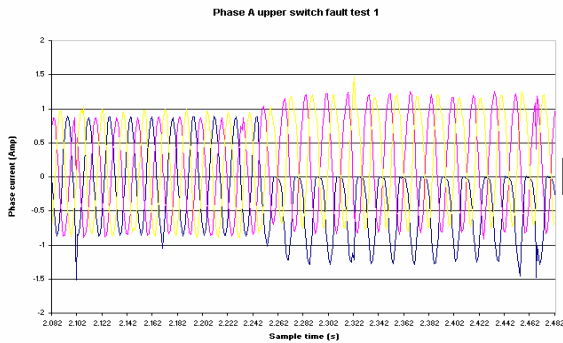

Figure 17:  $I_a$ ,  $I_b$ ,  $I_c$  signals generated at two separate occasions with switch A broken.

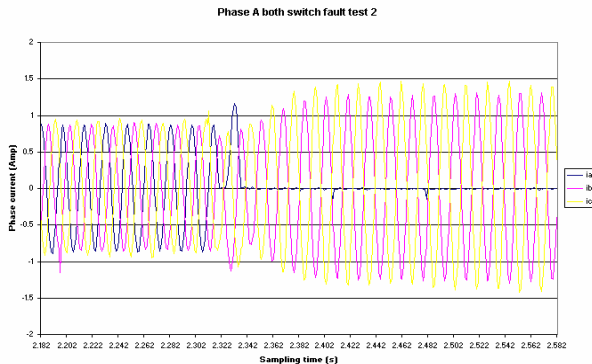
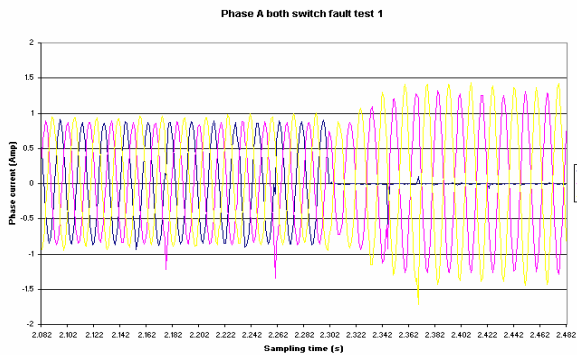

Figure 18.  $I_a$ ,  $I_b$  and  $I_c$  generated by the bench set up circuit system with switches A and A' broken.

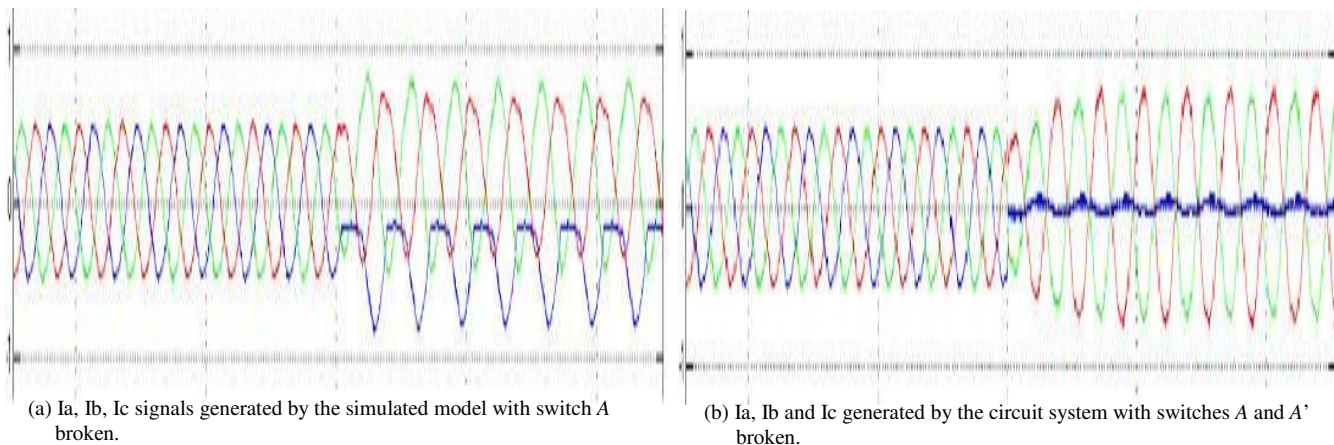

Figure 19. Current signals generated by SIM\_drive with switch A broken and both A and A' broken.

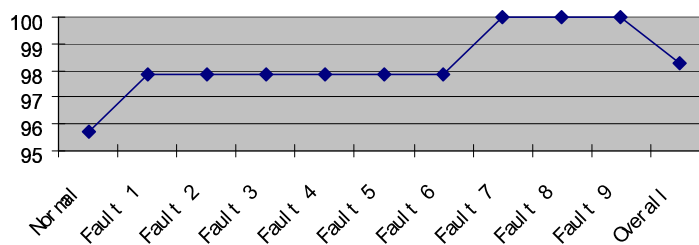

Figure 20. Performance of a model based fault diagnostic system on data generated by experimental bench setup system.

## V. SUMMARY AND CONCLUSIONS

In order to effectively detect and locate multiple classes of faults, it is important to develop a diagnostic system that is robust for an electric drive operating at any valid torque and speed. We have presented a model based diagnostic system framework driven by a machine learning algorithm for multi-class fault detection in an electric drive system with a three phase induction motor. The framework consists of a simulated model of an electric drive and implemented using Matlab-Simulink, a machine learning algorithm for the smart selection of vehicle operating points from the (torque, speed) space for the use by the simulated model, SIM\_drive to generate representative training data, and a neural network classification system developed and trained on the signals generated at the representative operating conditions for the fault diagnostics of electric drive inverters.

The SIM\_drive assumes minimum number of sensors and contains control mechanisms for generating current and voltage signals at all switches under the normal operation condition, all single switch broken and post-short-circuit conditions. The simulated electric drive model uses a closed loop field oriented control, and sine-triangle PWM method for synthesizing reference voltage command generated by the FOC.

A machine learning algorithm, CP-Select, was designed to select the representative operating conditions in terms of torque and speed such that the signals generated by SIM\_drive at these operating points can be used to train a robust

diagnostic system. The CP-Select uses a novel procedure: “select-simulation-evaluation”, that systematically selects the torque-speed operating points for training, generate signals at the selected points, and evaluates the system trained at these points, and CP-Select stops when the system performance is satisfactory. We presented two neural network architectures, a structured multi-neural-network system, and a single-neural-network system. The structured multi-neural-network system showed superior performance, whereas the single-neural-network system is easier to implement and train.

The proposed model based diagnostic system trained with machine learning technology has been evaluated by two sets of experiments. In the first set of experiments, we used the test signals generated by the SIM\_drive that contain normal and 9 faulty classes. In the second set of experiments, we used the data generated by a bench setup in the laboratory to test the model-based fault diagnostic system trained on the signals generated by the simulated electric drive. The model based fault diagnostic system performed very well in both sets of data. We are particularly encouraged by the results obtained on the data generated by the bench setup, where the model based fault diagnostic system prediction accuracies were close to 98% or above in detecting 9 classes of faults: six single switch broken classes and three post-short-circuit fault classes.

In conclusion, the proposed model based fault diagnostics approach is found to be very effective in detecting multiple classes of faults in an electric drive inverter. The authors would like to point out that the training phase in the proposed

approach is elaborate to make the resulting diagnostic system accurate and robust. However, once the training is complete, the implementation in a diagnostic system is quite simple since thereafter the weights of the resulting diagnostic neural network can be stored in and processed by a fast and low cost processor. A significant contribution of this work is the presentation of a generalized methodology for developing fault diagnostics systems: a technically sound simulated system model combined with machine learning techniques to train a robust diagnostic system, which can be applied to a broad range of applications including real-time systems.

#### ACKNOWLEDGMENT

The authors would like to thank Professor Chris Mi and graduate student Henry Wu at the ECE department, University of Michigan-Dearborn for building the 3-phase induction motor setup in the lab and performing many experiments to generate the data needed for validating the work presented in this paper.

#### REFERENCES

1. C. C. Chan and K.T. Chau, "Modern electric vehicle technology" (book), Oxford University Press, c2001.
2. R. Hodkinson and J. Fenton, "Lightweight electric/hybrid vehicle design" (book), SAE International, 2001. Warrendale, PA, USA.
3. D. W. Novotny and T. A. Lipo, "Vector control and dynamics of AC drives" (book), Oxford Sc. Pub., 1996
4. A. Bakhshai, G. Joos, J. Espinoza, H. Jin, "Fast Space Vector Modulation based on a Neurocomputing Digital Signal Processor", Applied Power Electronics Conference and Exposition, 1997, Vol. 12, pp 872-878.
5. N. Mohan, T. Undeland, and W. Robbins, "Power Electronics" (book), John Wiley, 1995
6. Y. Kao and C. Liu, "Analysis and design of microprocessor-based vector-controlled induction motor drives", IEEE Trans. on Ind. Electronics, Vol 39., No. 1, Feb. 1992, pp. 46-54.
7. C. Liaw, K. Chao, and F. Lin, "A discrete adaptive field-oriented induction motor drive", IEEE Trans. on Power Electronics, Vol. 7, No. 2, Apr. 1992, pp. 411-419.
8. J. Holtz, "Pulse width modulation – a survey", IEEE Transactions on Industrial Electronics, Vol. 39, No. 5, Dec. 1992, pp. 411-420.
9. M.A. Masrur, X. Xu, and F. Liang, "Fault Isolation in an Induction Motor Control System", U.S. Patent 5469351, Nov 1995.
10. J. Klima, "Analytical investigation of an induction motor drive under inverter fault mode operations", IEE Proc.- Electr. Power Appl., Vol 150, No. 3, May 2003, pp. 255-262.
11. J. Gertler, M. Costin, X. Fang, Z. Kowalczyk, M. Kunwer, R. Monajemy, "Model Based Diagnosis for Automotive Engines-Algorithm Development and Testing on a production Vehicle", IEEE Trans on Control Systems Technology, Vol. 3, No. 1, 1995
12. M. Nyberg, "Model-based Diagnosis of an Automotive Engine Using Several Types of Fault Models", IEEE Transaction on Control Systems Technology, Vol. 10, No. 5, pp 679–689, 2002.
13. Yi Lu Murphey, Hong Guo, Jacob A. Crossman, and Mark Coleman, "Automotive Signal Diagnostics Using Wavelets and Machine Learning," IEEE Transaction on Vehicular, November, 2000.
14. Jacob A. Crossman, Hong Guo, Yi Lu Murphey, and John Cardillo, "Automotive Signal Fault Diagnostics: Part I: signal fault analysis, feature extraction, and quasi optimal signal selection," IEEE Transaction on Vehicular, July 2003
15. Yi Lu Murphey, Jacob A. Crossman, ZhiHang Chen, and John Cardillo, "Automotive Fault Diagnosis Part II A Distributed Agent Diagnostic System," IEEE Transaction on Vehicular, July 2003.
16. O. Mosler, R. Isermann, "Application of Model-Based Fault Detection to a Brushless DC Motor", IEEE Trans on Industrial Electronics, Vol. 47, No. 5, pp 1015-1020, 2000.
17. R. Ribeiro, C. B. Jacobina, E. Silva, "Fault Detection of Open-Switch Damage in Voltage-Fed PWM Motor Drive System", IEEE Trans on Power Electronics, Vol. 18, No. 2, March 2003, pp 587-593.
18. W. Fenton, T. McGinnity, and L. Maguire, "Fault diagnosis of electronic systems using intelligent techniques: a review", IEEE Trans. on Systems, Man, and Cybernetics – Pt. C, Vol. 31, No. 3, Aug 2000, pp. 269-281.
19. K. Kim and A. G. Parlos, "Induction motor fault diagnosis Based on neuropredictors and wavelet signal processing," IEEE/ASME Transactions on Mechatronics, Vol. 7, No. 2, June 2002.
20. F. Filippetti, G. Franceschini, C. Tassoni, and P. Vas, "Recent Developments of Induction Motor Drives Fault Diagnosis Using AI Techniques", IEEE Trans. on Ind. Electronics, Vol. 47, No. 5, Oct. 2000, pp. 994-1004.
21. F. Zidani., M. Benbouzid, D. Diallo, and M. Said, "Induction Motor Stator Faults Diagnosis by a Current Concordia Pattern-Based Fuzzy Decision System", IEEE Trans. on Energy Conversion, Vol. 18, No. 4, Dec 2000, pp. 469-475.
22. M. Benbouzid, "Bibliography on Induction Motor Faults Detection and Diagnosis", IEEE Trans. on Energy Conversion, Vol. 14, No. 4, Dec 1999, pp. 1065-1074.
23. M. Chow, "Methodologies of Using Neural Network and Fuzzy Logic Technologies for Motor Incipient Fault Detection" (book), World Scientific, 1997.
24. D. Kastha and B. Bose, "Investigation of Fault Modes of Voltage-Fed Inverter System for Induction Motor Drive", IEEE Trans. on Industry Appl., July/Aug, 1994, pp. 1028-1038.
25. K. Smith, L.Ran, and J. Penman, "Real-Time Detection of Intermittent Misfiring in a Voltage-Fed PWM Inverter Induction-Motor Drive", IEEE Trans. on Ind. Electronics, Vol. 44, No. 4, Aug 1997, pp. 468-476.
26. Y. LeCun, L. Bottou, and Y. Bengio and P. Haffner, "Gradient-Based Learning Applied to Document Recognition," Proceedings of the IEEE, (86) 11, pp. 2278-2324, 1998
27. L. A. Feldkamp and G. V. Puskorius, "A Signal Processing Framework Based on Dynamic Neural Networks with Application to Problems in Adaptation, Filtering, and Classification," Proceedings of The IEEE, Vol. 86, No. 11, November, 1998
28. K. Fukushima, "A Neural Network for Visual pattern Recognition", IEEE Computers, March 1998
29. Zhao, L.; Thorpe, E., "Stereo- and neural network-based pedestrian detection," IEEE Transactions on Intelligent Transportation Systems, Volume: 1, Issue: 3 , Sept. 2000, Page(s): 148 -154
30. W. Y. Huang, and R.P. Lippmann, "Neural net and traditional classifiers" in D. Z. Anderson (Ed.), Neural Information Processing Systems, pp. 387-396. New York: American Institute of Physics.
31. E.L. Allwein, R.E. Schapire, "Reducing Multiclass to Binary: A Unifying Approach for Margin Classifiers," Journal of Machine Learning Research 1, pp. 113-141, 2000
32. D. Price, S. Knerr, "Pairwise Neural Network Classifiers with Probabilistic Outputs," Neural Information Processing Systems, vol. 7, 1994
33. S. Har-Peled, Roth, and D. Zimak. Constraint classification: A new approach to multiclass classification. In *Proc. 13th International Conf. of Algorithmic Learning Theory*, pages 365–397, 2002
34. Tie Qi Chen, Yi L. Murphey, Robert Karlsen, and Grant Gerhart, "Classification of Objects in Outdoor Scenes," submitted to the Journal of Pattern Recognition, Oct. 2003.
35. Guobing Ou, Yi L. Murphey, Lee Feldkamp, "Multiclass Pattern Classification Using Neural Networks," International Conference on Pattern Recognition, Cambridge, UK, 2004.
36. Yi Lu Murphey, ZhiHang Chen and Lee Feldkamp, "Incremental Neural Learning and Its Application in Vehicle Diagnostics," to appear in the Journal of Neural Networks, 2005.



**Yi Lu Murphey** (S'85, M'88, SM'97) received a M.S. degree in computer science from Wayne State University, Detroit, Michigan, in 1983, and a Ph. D degree in Computer, Information and Control Engineering from the University of Michigan, Ann Arbor, Michigan, in 1989. Currently she is a Professor of Electrical and Computer Engineering at the University of



Michigan- Dearborn. Prior to joining the Univ Michigan in 1992, she was a research scientist at the Environmental Research Institute of Michigan, Ann Arbor, Michigan. Her research interests lie in the areas of machine learning, computer vision and intelligent systems. Her recent research projects include fault diagnostics, distributed agent systems, computer vision systems for robotic vehicles, incremental learning in neural networks, Support Vector Machine Learning from large data sets, hybrid learning system with neural networks and Genetic Algorithms, data mining from text documents, data mining from time series data.



**M. Abul Masrur** (M'84, SM'93) received the Ph.D. in Electrical Engineering from the Texas A & M University, College Station, Texas, USA in 1984. He was with the Scientific Research Labs. of the Ford Motor Co. from 1984 to 2001 and was involved in research and development related to simulation and control for electric drives for electric and hybrid electric vehicles

(EV & HEV) and power electronics, advanced automotive electric energy management and vehicular power system architecture, automotive multiplexing systems, and related works. Dr. Masrur joined the US Army RDECOM-TARDEC in its Vetronics Technology Department in 2001, and is involved in various vehicular electric power system architecture concept design and development for military applications. He has over 40 publications, and 6 US patents. He received the Best Automotive Electronics Paper Award from the IEEE Vehicular Technology Society, USA, in 1998. Dr. Masrur is a Senior Member of the IEEE and since 1999 he has been serving as an Associate Editor of the IEEE Transactions on Vehicular Technology.

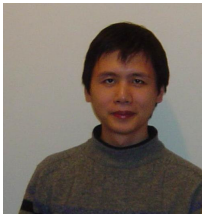

**ZhiHang Chen** received the Ph. D degree in applied mathematics from Peking University, Beijing, P. R. China, in 2000. Currently, he is a Research Associate at the University of Michigan-Dearborn. His research interests include machine learning, intelligence system, neural networks, genetic algorithms and fuzzy logic.



**Baifang Zhang** received the B.S. degree in computer science from East Normal University, Shanghai, China in 1998. He had been working for Panaelectronics Inc. for 4 years till 2002. Currently he is a student on a Master of Engineering program of computer engineering at the University of Michigan-Dearborn. His research areas include signal/time series analysis using artificial intelligent methods, vehicle fault diagnosis and vehicle control systems.