

REPORT DOCUMENTATION PAGE			Form Approved OMB NO. 0704-0188	
<p>The public reporting burden for this collection of information is estimated to average 1 hour per response, including the time for reviewing instructions, searching existing data sources, gathering and maintaining the data needed, and completing and reviewing the collection of information. Send comments regarding this burden estimate or any other aspect of this collection of information, including suggestions for reducing this burden, to Washington Headquarters Services, Directorate for Information Operations and Reports, 1215 Jefferson Davis Highway, Suite 1204, Arlington VA, 22202-4302. Respondents should be aware that notwithstanding any other provision of law, no person shall be subject to any penalty for failing to comply with a collection of information if it does not display a currently valid OMB control number. PLEASE DO NOT RETURN YOUR FORM TO THE ABOVE ADDRESS.</p>				
1. REPORT DATE (DD-MM-YYYY)		2. REPORT TYPE New Reprint		3. DATES COVERED (From - To) -
4. TITLE AND SUBTITLE Electrostatic discharge sensitivity and electrical conductivity of composite energetic materials			5a. CONTRACT NUMBER W911NF-11-1-0439	
			5b. GRANT NUMBER	
			5c. PROGRAM ELEMENT NUMBER 611102	
6. AUTHORS Chelsea Weir, Michelle L. Pantoya, Gautham Ramachandran, Tim Dallas, Daniel Prentice, Michael Daniels			5d. PROJECT NUMBER	
			5e. TASK NUMBER	
			5f. WORK UNIT NUMBER	
7. PERFORMING ORGANIZATION NAMES AND ADDRESSES Texas Technical University Box 41035 349 Admin Bldg Lubbock, TX 79409 -1035			8. PERFORMING ORGANIZATION REPORT NUMBER	
9. SPONSORING/MONITORING AGENCY NAME(S) AND ADDRESS(ES) U.S. Army Research Office P.O. Box 12211 Research Triangle Park, NC 27709-2211			10. SPONSOR/MONITOR'S ACRONYM(S) ARO	
			11. SPONSOR/MONITOR'S REPORT NUMBER(S) 58857-EG.22	
12. DISTRIBUTION AVAILABILITY STATEMENT Approved for public release; distribution is unlimited.				
13. SUPPLEMENTARY NOTES The views, opinions and/or findings contained in this report are those of the author(s) and should not be construed as an official Department of the Army position, policy or decision, unless so designated by other documentation.				
14. ABSTRACT Composite energetic material response to electrical stimuli was investigated and a correlation between electrical conductivity and ignition sensitivity was examined. The composites consisted of micrometer particle aluminum combined with another metal, metal oxide, or fluoropolymer. Of the nine tested mixtures, aluminum (Al) with copper oxide (CuO) was the only mixture to ignite by electrostatic discharge. Under the loose powder conditions of these experiments, the AlCuO minimum ignition				
15. SUBJECT TERMS Spark, Ignition, Sensitivity, Energetic Materials, Electrical Conductivity, Electrostatic Discharge				
16. SECURITY CLASSIFICATION OF:		17. LIMITATION OF ABSTRACT	15. NUMBER OF PAGES	19a. NAME OF RESPONSIBLE PERSON
a. REPORT UU	b. ABSTRACT UU	c. THIS PAGE UU		Michelle Pantoya
				19b. TELEPHONE NUMBER 806-742-3563

## **Report Title**

Electrostatic discharge sensitivity and electrical conductivity of composite energetic materials

### **ABSTRACT**

Composite energetic material response to electrical stimuli was investigated and a correlation between electrical conductivity and ignition sensitivity was examined. The composites consisted of micrometer particle aluminum combined with another metal, metal oxide, or fluoropolymer. Of the nine tested mixtures, aluminum (Al) with copper oxide (CuO) was the only mixture to ignite by electrostatic discharge. Under the loose powder conditions of these experiments, the AlCuO minimum ignition energy (MIE) is 25 mJ and exhibited an electrical conductivity two orders of magnitude higher than the next composite. This study showed a similar trend in MIE for ignition triggered by a discharged spark compared with a thermal hot wire source.

---

**REPORT DOCUMENTATION PAGE (SF298)**  
**(Continuation Sheet)**

---

Continuation for Block 13

ARO Report Number 58857.22-EG  
Electrostatic discharge sensitivity and electrical ...

Block 13: Supplementary Note

© 2013 . Published in Journal of Electrostatics, Vol. 71 (1) (2013), (1 (1)). DoD Components reserve a royalty-free, nonexclusive and irrevocable right to reproduce, publish, or otherwise use the work for Federal purposes, and to authorize others to do so (DODGARS §32.36). The views, opinions and/or findings contained in this report are those of the author(s) and should not be construed as an official Department of the Army position, policy or decision, unless so designated by other documentation.

Approved for public release; distribution is unlimited.

Contents lists available at [SciVerse ScienceDirect](http://www.sciencedirect.com)

## Journal of Electrostatics

journal homepage: [www.elsevier.com/locate/elstat](http://www.elsevier.com/locate/elstat)

## Electrostatic discharge sensitivity and electrical conductivity of composite energetic materials

Chelsea Weir<sup>a</sup>, Michelle L. Pantoya<sup>a,\*</sup>, Gautham Ramachandran<sup>b</sup>, Tim Dallas<sup>b</sup>, Daniel Prentice<sup>c</sup>, Michael Daniels<sup>c</sup>

<sup>a</sup> Department of Mechanical Engineering, Texas Tech University, Corner of 7th and Boston Avenue, Lubbock, TX 79409, USA

<sup>b</sup> Department of Electrical Engineering, Texas Tech University, Lubbock, TX 79409, USA

<sup>c</sup> Idaho National Laboratory, PO Box 1625, Idaho Falls, ID 83415, USA

### ARTICLE INFO

#### Article history:

Received 9 April 2012

Received in revised form

13 July 2012

Accepted 1 October 2012

Available online 18 October 2012

#### Keywords:

Electrostatic discharge

Electrical conductivity

Energetic materials

Spark

Ignition

Sensitivity

### ABSTRACT

Composite energetic material response to electrical stimuli was investigated and a correlation between electrical conductivity and ignition sensitivity was examined. The composites consisted of micrometer particle aluminum combined with another metal, metal oxide, or fluoropolymer. Of the nine tested mixtures, aluminum (Al) with copper oxide (CuO) was the only mixture to ignite by electrostatic discharge. Under the loose powder conditions of these experiments, the Al–CuO minimum ignition energy (MIE) is 25 mJ and exhibited an electrical conductivity two orders of magnitude higher than the next composite. This study showed a similar trend in MIE for ignition triggered by a discharged spark compared with a thermal hot wire source.

© 2012 Elsevier B.V. All rights reserved.

### 1. Introduction

It is becoming increasingly important to understand the electrostatic discharge (ESD) sensitivity of energetic materials. Probably the most common form of ESD is the spark, which occurs when the static electric field strength exceeds approximately 4–30 kV/cm (i.e., the dielectric field strength of air [1]). Invisible forms of ESD can also deliver sufficient energy to ignite an energetic material; some electronic devices can be damaged by invisible ESD threshold energies as small as 0.082 nJ [2]. In fact, ESD is a large cause of ignition in powders such as dust [3], food [4], and textiles [5], as well as explosives [6–9].

In the above example, the particulate mixture accumulates a charge that could induce a spark when in contact with another object. However, this scenario is different from the literature reporting electrostatic discharge sensitivity of energetic materials by inducing a charge that is discharged as a spark onto an energetic material [6–9]. Both approaches to examining electrostatic discharge ignition should be explored for the safe handling of energetic materials.

A material's electrical resistivity shares an inverse relation with conductivity; these properties define how well a given material will dissipate charge. The electrical conductivity of mixtures may be altered by introducing additives or impurities. For example, aluminum (Al) is added as a metallic filler to increase electrical conductivity in epoxy coatings [10]; whereas, silica fume (fine grain SiO<sub>2</sub> particles) is added to cement paste to decrease its electrical conductivity resulting in more corrosion resistance [11].

Many researchers have studied ESD sensitivities of high explosives using an apparatus that discharges a spark into a sample. Larson et al. [9] specifically looked at explosive grain sizes and their effect on ignition sensitivity. They concluded that as the particle size decreases, the ESD sensitivity increases; particles with greater surface area tend to be less sensitive but as the surface area to volume ratio increases, ESD sensitivity correspondingly increases. They explain that the spark is forced to take a longer more circular path through large grain size media, resulting in a lower energy density in the spark. Studies simulated the static electric energy output of the human body that can dissipate up to 8.33 mJ of energy [12]. Simpson and Foltz [8] tested high explosive powder samples ranging from 3 to 5 mg, and concluded that the samples' minimum ignition energy exceeded 1 J, above the human body threshold and classified as spark insensitive. Another study [6] revealed that RDX

\* Corresponding author. Tel.: +1 806 742 3563; fax: +1 806 742 3540.  
E-mail address: [michelle.pantoya@ttu.edu](mailto:michelle.pantoya@ttu.edu) (M.L. Pantoya).

is the most ESD sensitive powder, igniting at 0.15 J and TATB is the least sensitive of the tested materials with ignition energy of 2.56 J. They link this behavior to the thermal properties of the material such as critical temperature for thermal runaway and temperature for thermal decomposition, but did not examine electrical properties [6].

Explosives are monomolecular energetic materials and ignition is controlled by breaking a molecular bond. In contrast, composite energetic materials (CEM) can be described as a mixture of fuel and oxidizer particles combined together to create an energetic powder. A common fuel used in CEM is Al while the oxide may consist of solid particles of another metal (intermetallic) [13,14], a metal oxide (thermite) [13–15], or a fluoropolymer [16,17]. They can be used as additives in explosives to decrease activation energy, increase combustion rate, and tailor blasting properties for specific applications [18].

There has been some research on the ESD ignition of CEM, also using an apparatus that discharges a spark into a sample. Foley et al. [19] used Al and copper oxide (CuO) nano-particle composites and added Viton A in varying concentrations. They showed threshold ESD ignition energy is increased when Viton A is added to Al–CuO. This study did not measure electrical conductivity or resistivity of the mixtures but predicted that Viton A may effectively increase the mixture's electrical resistivity. They then reasoned that a higher mixture electrical resistivity would lead to an increased minimum ignition energy threshold [19]. Their goal was tailoring the formulation so that ESD sensitivity would be decreased while maintaining reactive performance of the CEM. It is noted that the exact opposite was shown in a study by Glor [3] when examining dust particles dispersed in air that naturally accumulated a charge through inter-particle interaction. Glor [3] showed that a material that has a larger electrical resistivity poses a greater ESD ignition threat because the charge accumulates on the particles thereby increasing its electric field strength. The paradox between these two studies may be explained by the way in which the electrostatic discharge is created: in Foley et al. [19], ESD was delivered to the sample, whereas in Glor [3], ESD was generated within the sample. This paradox should be explored further because the reported results in one case argue that mixture electrical resistivity should be tailored to increase [19] while in the other case should be tailored to decrease [3] in order to decrease ESD sensitivity to ignition. Future research will explore this paradox further.

Beloni et al. studied ESD ignition delay of micron aluminum (Al) [20], magnesium (Mg) [21], and titanium (Ti) [22] to characterize the sensitivity of these metal fuel powders to a spark discharged from an apparatus. Results showed that as the spark discharge energy increased, the delay time for ignition decreased [21]. Two different sizes of Al were tested and a linear correlation was found between burn time and joule energy for the coarser powder [20]. The ignition delay for Mg was 0.5–3.5 ms and the authors observed that of the 11 mJ of spark energy delivered, 5 mJ was available through joule heating. Unlike the studies on Al and Mg, Ti particles fused together when the spark was discharged, reducing joule heating of the powder [22]. These studies concluded that individual particles are heated by the spark and then begin heating and oxidizing the rest of the powder through joule heating [20–22].

While there is a significant literature base for the ESD ignition sensitivity of high explosives [6,8,9], there is significantly less research on ESD ignition sensitivity of thermites and intermetallics. Because thermites are composed of particulate media and widely used, they pose a significant danger if their ESD ignition sensitivity is not well understood. There are key relationships between particle properties and ESD ignition sensitivity that need to be more clearly understood. For example, a correlation between ESD ignition sensitivity and electrical conductivity in CEM has not been

studied and other important parameters such as particle size, morphology, and packing density may also be critical in understanding how electrical energy accumulates and ignites a mixture. In fact, reported baseline measurements for the electrical conductivity of CEM are extremely limited in the literature. Understanding the influence of electrical conductivity on ESD ignition sensitivity is a first step toward developing formulations that are safe to handle and use, yet offer ideal performance tailored to an application. The objectives of this work are to explore the relation between electrical conductivity and ESD sensitivity in terms of a discharged spark into a CEM and also to understand how this form of ESD stimuli relates to thermal ignition. The secondary objective was motivated through the literature [20–22] that explored the multi-modal mechanisms (i.e., spark and joule heating) responsible for ESD ignition in particulate media. These objectives were accomplished through developing an apparatus that measures the electrical conductivity of a CEM by sending a current through the powder and measuring its voltage consumption. These measurements are coupled with ESD ignition sensitivity using a diagnostic that discharges a spark at a specific voltage into a powder and monitors ignition by measuring an optical response produced by the reaction's luminosity.

## 2. Materials and methods

### 2.1. Materials

Powders with particle sizes that are on the micron scale were used in this study. In all mixtures, the Al powder was maintained constant such that fuel particle size and morphology is a controlled variable. It is noted that the reactants' particle size may influence electrical properties and this correlation will be explored in future work. Powder descriptions are presented in Table 1 including supplier and average particle size.

The Al fuel was combined with each entry in Table 1 as per the reactions shown in Table 2. The mixtures were prepared using measurements for a stoichiometric equivalence ratio ( $\phi$ ) calculated from Eq. (1).

$$\phi = \frac{(F/O)_{\text{act}}}{(F/O)_{\text{sto}}} \quad (1)$$

The equivalence ratio is a mass based calculation. The numerator is the actual (act) fuel (F) to oxidizer (O) mass ratio, and the denominator is the stoichiometric (sto) fuel to oxidizer ratio. The stoichiometric ratio  $(F/O)_{\text{sto}}$  is calculated using Eq. (2) where  $M_{\text{fuel}}$  and  $M_{\text{ox}}$  are the masses of the fuel and oxidizer, respectively.

$$(F/O)_{\text{sto}} = \frac{MW_{\text{fuel}}}{MW_{\text{ox}}} \quad (2)$$

Stoichiometric reactions and calculated stoichiometric fuel to oxidizer ratios for the mixtures examined are presented in Table 2.

**Table 1**  
Powder description.

Powder	Supplier	Particle size ( $\mu\text{m}$ )
Aluminum (Al)	Alfa Aesar	4
Bismuth trioxide ( $\text{Bi}_2\text{O}_3$ )	Sigma Aldrich	0.210
Copper oxide (CuO)	Alfa Aesar	44
Iodine pentoxide ( $\text{I}_2\text{O}_5$ )	Sigma Aldrich	335
Iron oxide ( $\text{Fe}_2\text{O}_3$ )	Alfa Aesar	44
Molybdenum trioxide ( $\text{MoO}_3$ )	Nanotech	0.044
Nickel (Ni)	Sigma Aldrich	1
Silicon (Si)	Alfa Aesar	0.1
Polytetrafluoroethylene ( $\text{C}_2\text{F}_4$ ) <sub>n</sub>	Sigma Aldrich	35
Titanium (Ti)	Sigma Aldrich	149

**Table 2**  
Formulations and stoichiometric fuel to oxidizer ratios.

Stoichiometric reaction	(F/O) <sub>sto</sub>	Volumetric fuel %	Heat of reaction (kJ/g)	Adiabatic flame temperature (K)
2Al + Bi <sub>2</sub> O <sub>3</sub> → Al <sub>2</sub> O <sub>3</sub> + 2Bi	0.116	27.63	2.959	4176
2Al + 3CuO → Al <sub>2</sub> O <sub>3</sub> + 3Cu	0.226	34.58	4.076	5718
2Al + Fe <sub>2</sub> O <sub>3</sub> → Al <sub>2</sub> O <sub>3</sub> + 2Fe	0.338	39.61	3.956	4382
10Al + 3I <sub>2</sub> O <sub>5</sub> → 5Al <sub>2</sub> O <sub>3</sub> + 3I <sub>2</sub>	0.269	33.20	36.317	1486
2Al + MoO <sub>3</sub> → Al <sub>2</sub> O <sub>3</sub> + Mo	0.375	39.44	23.322	1124
Al + Ni → NiAl	0.459	60.27	1.381	2362
Al + Si → SiAl	0.960	45.33	0.00012	No Rxn
4Al + 3 (C <sub>2</sub> F <sub>4</sub> ) <sub>n</sub> → 4AlF <sub>3</sub> + 6C	0.359	22.67	8.809	4539
Al + Ti → TiAl	0.563	48.44	1.004	1597

The calculations for heat of reaction and adiabatic flame temperature were made using a thermal equilibrium software program (REAL) assuming thermal equilibrium conditions exist.

A dry powder mixture with a mass of 300 mg was prepared for each formulation. The reactants were combined with approximately 50 mL of hexanes and mixed using a sonication process with a Misonix Sonicator 3000. Solutions were transferred to a Pyrex pan and placed on a hot plate held at low temperature inside of a fume hood. The hexanes were allowed to evaporate for 15 min or until the mixture was dry. Once dry, the powder mixture was removed from the pan using a grounded metal brush to prevent static electricity and potential ignition. The reclaimed powder mixture was then used for further experimentation.

The theoretical maximum density (TMD) describes the bulk density of the mixture and was calculated using Eq. (3).

$$TMD = \frac{1}{\frac{\%M_f}{\rho_f} + \frac{\%M_{ox}}{\rho_{ox}} + \frac{\%M_{Al_2O_3}}{\rho_{Al_2O_3}}} \quad (3)$$

In Eq. (3), %M is the percent of the total mass, ρ is the density and the subscripts f, ox, and Al<sub>2</sub>O<sub>3</sub> represent fuel, oxidizer, and aluminum oxide passivation shell surrounding the Al particles. The percent of TMD for this study was kept constant at roughly 15% for each powder corresponding to loose powder. This is a low packing density with 15% solid particles and 85% void space. The void spacing and packing density may influence ESD sensitivity and electrical properties and were maintained constant. Also, atmospheric conditions were maintained in a controlled environment with a relative humidity of 10%, temperature of 26 °C and standard atmospheric pressure. These conditions were held constant such that the focus of this study was on examining ESD sensitivity and electrical properties as a function of composition.

The Al + CuO mixture was studied further by varying the stoichiometry as a function of volumetric fuel/oxidizer ratios. The effect of the volume fraction of fuel on ignition was examined using Eq. (4) in terms of the fuel volume percentage (V<sub>f</sub>) in the mixture. Note that in Eq. (4) M<sub>f</sub> includes Al and also the alumina passivation shell surrounding Al particles.

$$V_f = \frac{M_f/\rho_f}{M_f/\rho_f + M_{ox}/\rho_{ox}} * 100 \quad (4)$$

### 2.2. Electrostatic discharge apparatus

The approach used for energetic material ESD ignition testing is based on a human body model (HBM) [6,8,9,23–25]. The HBM uses a capacitor that is charged to a certain voltage, and discharges stored electrical energy through a resistive network into the material being tested [23–26]. It is used to simulate the transfer of electrostatic charge from a human body to an energetic material sample [6,8,9]. The HBM ESD apparatus was manufactured by Franklin Applied Physics and a diagram is provided in Fig. 1 [27].

Energy is delivered and discharged into the sample through a capacitor setup. A variable amount of energy delivered to the sample is dependent on the capacitor size as well as the capacitors charge voltage. The ESD apparatus charged a 0.002 μF capacitor to a known voltage ranging from 1 to 10 kV. A nylon washer was attached to a smooth faced steel disk using double sided tape. The nylon washer was filled with energetic material (~8 to 30 mg depending on the formulation) and covered with transparent tape. The sample was then placed directly under the capacitor so that the pin electrode would penetrate the sample when the capacitor was lowered as seen in Fig. 1. The energy stored in the capacitor was then discharged into the sample. This resulted in either a go or no-go ignition of the powders. Each powder was tested at 10,000 V. If ignition occurred, the powder was tested at a lower voltage until threshold ignition energy was observed. All powders were tested 5–10 times for repeatability at each ignition voltage as described in the Bruceton method [28]. To calibrate this system, the ESD sensitivity of nano Al + CuO were measured and compared to the reported value of ESD sensitivity for nano Al + CuO. The measurement is within 12% of the reported value and the deviation may be due to a difference in particle size and packing density of the materials.

### 2.3. Electrical conductivity measurements

A two point probing method, seen in Fig. 2, was used to measure the electrical conductivity of the compositions shown in Table 2. A powder sample was coupled with a high resistance/low

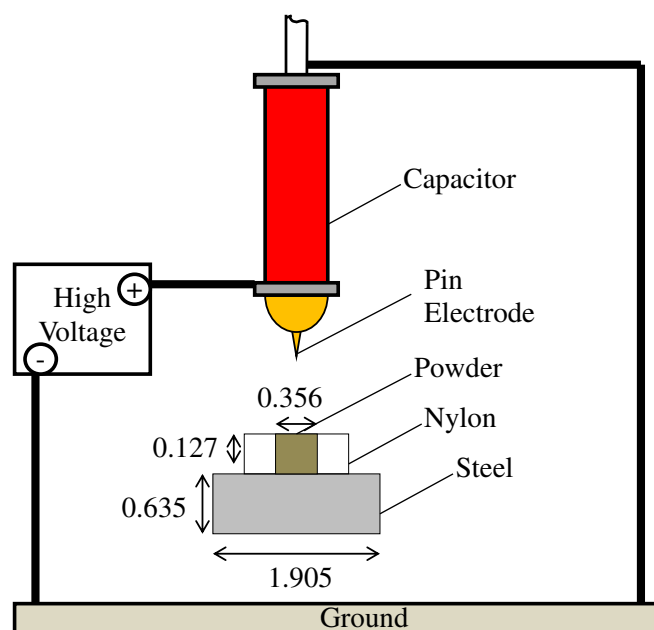

Fig. 1. Schematic of ESD apparatus and high voltage circuit. All units are in cm.

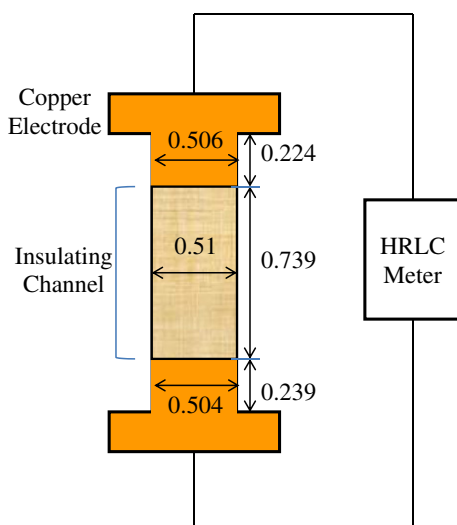

Fig. 2. Electrical conductance measurement apparatus. All units are in cm.

conductance (HRLC) meter using two copper electrodes, alligator clips, and cables. The HRLC was a HR2 model by AlphaLab, Inc. and used to measure electrical conductance of the powders with an accuracy of  $\pm 2\%$ .

The meter and cables were calibrated using the current offset. With the cables disconnected from the setup seen in Fig. 2, the current offset was adjusted until the average conductance reading was zero. A channel was created in an electrically insulating material (acrylic). Loosely packed (15% TMD) powder samples were placed in the channel. Two copper electrodes connected to the HRLC meter were placed in either end of the channel to create a conductive medium as seen in Fig. 2. The channel and electrodes were placed inside a rigid acrylic container covered in aluminum foil to create a noise shield for testing. The container was connected to a high impedance amplifier on the HRLC meter which used the feedback to control distortion from outside disturbances. This meter applied a constant 1 V across the conductive sample. Conductance measurements were recorded. Similar setups were used by Montes et al. [29], Benci et al. [30], and are also described in ASTM d 257 [31]. To further calibrate this system, the electrical resistivity of loosely packed aluminum oxide ( $\text{Al}_2\text{O}_3$ ) particles were measured and compared to the reported value of electrical resistivity for  $\text{Al}_2\text{O}_3$  (this data was obtained from the supplier). The measurement is within 3% of the reported value. Repeatability of these measurements is within 3% for this constant voltage setting.

#### 2.4. Thermal ignition measurements

Thermal ignition using a “hot wire” is a very common method for igniting a CEM [32–34]. Samples were ignited thermally using a nichrome wire setup as seen in Fig. 3. A Variac voltage transformer was used to supply an AC current through a 7.62 cm nichrome wire with a resistance of 5.2854  $\Omega/\text{m}$ . The nichrome was bent to produce a localized hot spot; this allows for the location of the ignition to be controlled. Samples ranging from (8–30 mg depending on the formulation) were placed on a steel sample disk. The sharp bend of the Nichrome wire was then placed in contact with the powder. The nichrome filament was heated after the Variac voltage source was triggered resulting in either a go or no-go ignition. Each formulation was tested 3 times at 5 VAC and 10 VAC. This setup was used to determine the thermal ignition of the powders due to joule heating and provides a comparison of the ignition sensitivity of a mixture from thermal versus electrostatic stimuli.

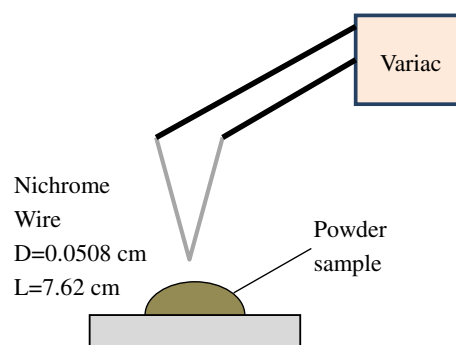

Fig. 3. Thermal ignition schematic using a hot wire.

### 3. Results

The minimum ignition energy (MIE) is defined here as the smallest amount of energy that is needed to initiate a reaction. The total energy available during electrostatic discharge can be calculated from Eq. (5) where  $C$  is capacitance and  $V$  is the voltage that is discharged through the capacitor.

$$(MIE)_{\text{ESD}} = \frac{1}{2}CV^2 \quad (5)$$

As the voltage is decreased the energy dissipated into the sample also decreases. The total thermal energy discharged during “hot wire” testing is calculated using Eq. (6) and  $I$  is current through the Variac voltage transformer,  $V$  is applied voltage, and  $t$  is time to sample ignition.

$$(MIE)_{\text{HW}} = I*V*t \quad (6)$$

In both ESD and thermal ignition testing, a smaller MIE corresponds to a more ignition sensitive material.

Electrical conductivity ( $\sigma$ ) can be calculated using Eq. (7) and  $G$  is the measured conductance of the material,  $A$  is the cross-sectional area of the channel in which the material is being tested and  $L$  is the length of the channel.

$$\sigma = \frac{G*L}{A} \quad (7)$$

Electrical conductivity and ESD ignition results for all formulations tested are shown in Fig. 4.

Values for the electrical conductivity for all formulations tested are presented in Table 3. From repeatability we have estimated the uncertainty on these measurements to be 3%.

The electrical conductivity for the formulations presented in Fig. 4 and Table 3 range from 0.25 to 1246.25 nS/m; note the two order of magnitude difference in electrical conductivity between Al–CuO and all others tested. The ESD ignition behavior shown in Fig. 4 was selected for the maximum voltage setting on the equipment (10 kV). The only formulation that resulted in ESD ignition was Al + CuO, as indicated on the figure.

The power ( $P_e$ ) that is consumed by the sample during ESD at a constant 10 kV was calculated using Eq. (8) where  $V$  is the constant applied voltage and  $R_e$  is the calculated electrical resistance of the powder. Electrical conductance and electrical resistance have an inverse relation as does electrical conductivity and electrical resistivity. The electrical resistances ( $R_e$ ) of the powders were calculated using  $R_e = 1/G$ .

$$P_e = \frac{V^2}{R_e} \quad (8)$$

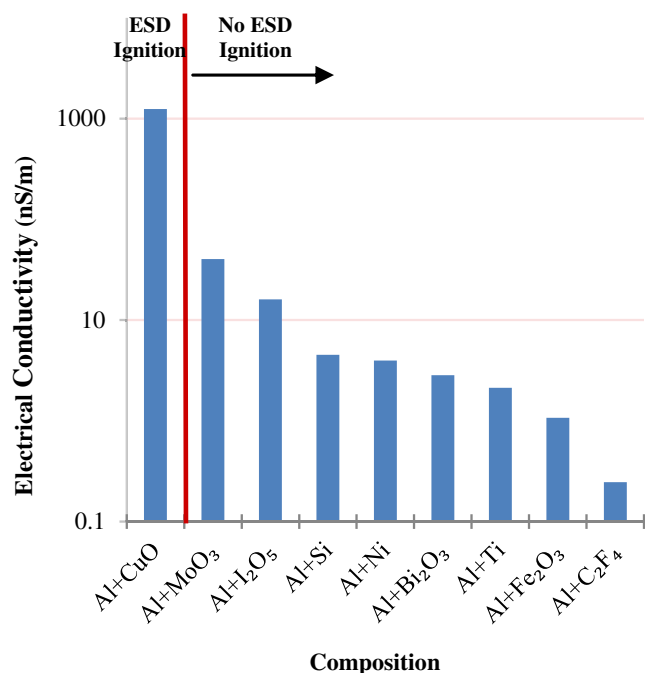

Fig. 4. Electrical conductivity of multiple compositions and ESD ignition for 10 kV setting.

Fig. 5 shows the power consumed by each mixture. Again, the only mixture that ignited using ESD is Al + CuO. Fig. 5 implies that there may exist a power and resistance threshold above or below which triggers ESD ignition. Further investigation is needed to understand these relationships more completely but Fig. 5 is a first step toward identifying critical conditions for ESD ignition.

The thermal energy stored ( $E_{st}$ ) in each oxidizer tested was calculated using Eq. (9) with  $\rho$  representing the density of the oxidizer,  $V$  the sample volume (a constant for every mixture tested),  $C_p$  the specific heat of each oxidizer, and  $\Delta T$  the difference between micron Al particle ignition temperature and ambient, using 1600 °C as the ignition temperature of Al [35,36].

$$E_{st} = \rho V C_p \Delta T \quad (9)$$

The thermal energy stored in each oxidizer is shown in Fig. 6.

To better understand ESD sensitivity, Al–CuO was studied further by varying the stoichiometry as a function of volumetric fuel percentage. Results are shown in Figs. 7 and 8 and Table 4.

Values for the electrical conductivity of Al + CuO with varying volumetric ratios are presented in Table 4. From repeatability we have estimated the uncertainty on these measurements to be 3%.

There exists a range of electrical conductivities in which ESD ignition is achieved: 0.45 nS/m to 162.80  $\mu$ S/m (Table 4). The 50%

Table 3  
Electrical conductivity of multiple compositions.

Composition	Electrical conductivity (nS/m)
Al + CuO	1246.25
Al + MoO <sub>3</sub>	40.30
Al + I <sub>2</sub> O <sub>5</sub>	16.05
Al + Si	4.50
Al + Ni	3.95
Al + Bi <sub>2</sub> O <sub>3</sub>	2.85
Al + Ti	2.10
Al + Fe <sub>2</sub> O <sub>3</sub>	1.10
Al + C <sub>2</sub> F <sub>4</sub>	0.25

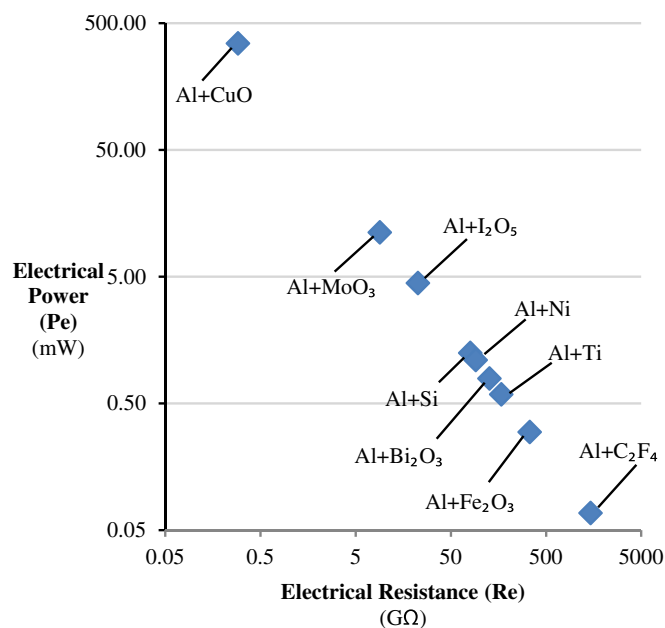

Fig. 5. Variation of electrical power with electrical resistance.

fuel mixture is the most ESD sensitive with a MIE of 4 mJ and an electrical conductivity of 533.60 nS/m; this stoichiometry corresponds to a slightly fuel rich composition. This result is consistent with Granier et al. [16] that showed in laser ignition studies of various stoichiometries of Al + MoO<sub>3</sub> a slightly fuel rich mixture ignites with the lowest ignition energy [16]. Fig. 7 also shows that there is no direct correlation between electrical conductivity and MIE. Instead, MIE may be more closely related to diffusion controlled kinetics dictated by stoichiometry as long as the mixture electrical conductivity falls within a range as shown in Fig. 7.

Fig. 8 shows that the same electrical conductivity range also correlates with thermal “hot wire” ignition sensitivity. As with ESD ignition, the smallest thermal MIE corresponds with a 50% volumetric fuel mixture, also consistent with [16]. No direct correlation exists between electrical conductivity and MIE.

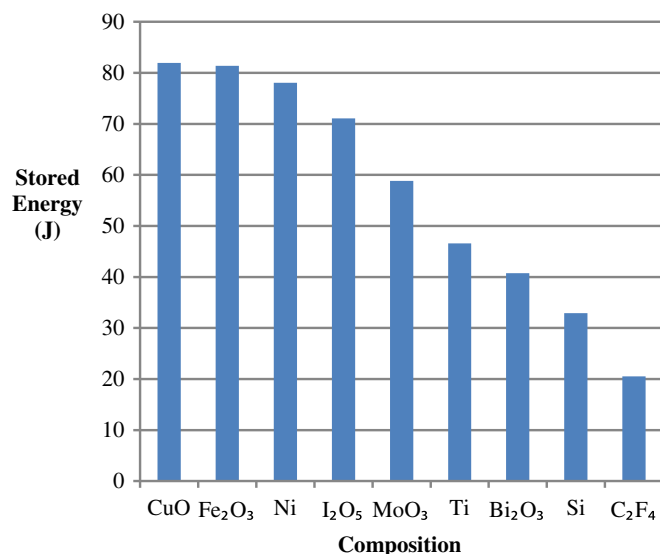

Fig. 6. Thermal energy stored for each oxide.



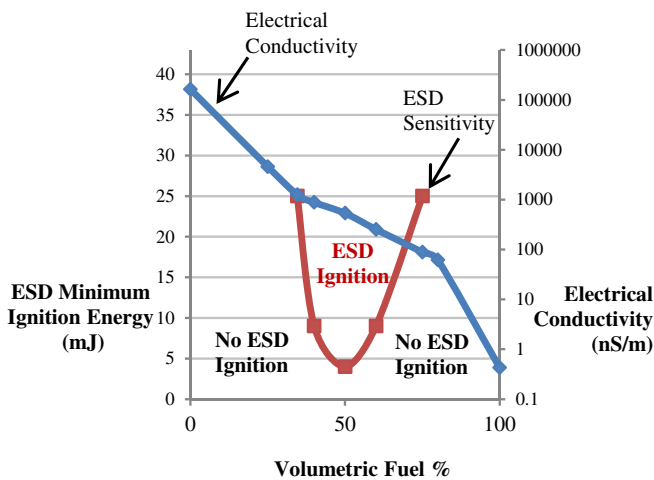

Fig. 7. Electrostatic discharge ignition and electrical conductivity of Al + CuO with varying volumetric fuel ratios.

It is interesting to note that three orders of magnitude greater energy level is required to produce the MIE using a hot wire (i.e., Fig. 8) than ESD (i.e., Fig. 7). This may be because the ESD stimulus is more locally concentrated.

4. Discussion

With the electrostatic discharge stimuli, energy is delivered by a spark and also through joule heating of the powders [20–22]. The powders ignite when the discharge energy exceeds the minimum ignition energy of the material. The mixtures with lower conductance (as in Fig. 4) and higher resistance (as in Fig. 5) did not ignite; a result that is consistent with observations in [19]. The non-ignitable formulations may not have received sufficient joule heating. The Al particles are passivated with an alumina shell and these fuel particles are constant for all mixtures such that ESD ignition is a strong function of the oxide. Because the aluminum oxide shell is highly resistive, the spark energy may accumulate on the Al particles in all mixtures but be more readily dissipated into the highly electrically conductive CuO (Fig. 4). In fact, Fig. 6 shows Al–CuO is able to store thermal energy as well as or better than the other oxides examined. This property, coupled with Al–CuO high

Table 4

Electrical conductivity of Al + CuO with varying volumetric fuel ratios.

Volumetric fuel %	Electrical conductivity (nS/m)
0	162789.80
25	4576.20
35	1246.25
40	879.05
50	533.60
60	253.25
75	88.65
80	61.50
100	0.45

electrical conductivity, may explain the result that only the Al–CuO mixture is ESD ignition sensitive at the maximum ESD energy discharge setting of our system. A mixture with combined properties of electrical conductivity greater than 0.45 nS/m and high capacity for thermal energy storage (Fig. 6) will conduct electrical energy and accumulate joule heating to trigger ESD ignition.

It is interesting to note that three orders of magnitude greater energy level is required to produce the MIE using a hot wire (i.e., Fig. 8) than ESD (i.e., Fig. 7). This may be because the ESD stimulus is more locally concentrated. The difference in magnitudes is further examined by evaluating the power, rather than energy required by the stimuli to achieve ignition. The minimum power required for ignition is calculated using Eqs. (10) and (11). Eq. (10) corresponds with ESD power ( $P_{ESD}$ ) and  $t$  is the ignition delay of the mixture and measured as an average of 100  $\mu$ s for each stoichiometry analyzed.

$$P_{ESD} = \frac{MIE_{ESD}}{t} \tag{10}$$

Eq. (11) corresponds with hot wire power ( $P_{HW}$ ) and  $I$  is the current and  $V$  is the voltage applied to the Nichrome wire.

$$P_{HW} = I \times V \tag{11}$$

Noted in [20–22], electrostatic discharge stimuli include both energy from joule heating and energy from the discharged spark. An estimate of the percent of thermal power that may be available from an ESD ignition and attributed to joule heating is calculated using Eq. (12).

$$P\% = \frac{P_{HW}}{P_{ESD}} \times 100 \tag{12}$$

Overall, ESD ignition requires significantly less energy than thermal ignition (i.e., mJ compared with J from Figs. 5 and 6); but, ESD creates more power than the hot wire, such that only 27% of the power generated from the electrostatic stimuli may produce joule heating and ignite the mixture, as calculated in Eq. (12). Beloni et al. [21] found that approximately 20% of the minimum ignition energy in an ESD event is provided through joule heating. Power is a function of energy and time so a relatively small fraction of ESD energy that may be attributed to joule heating in this study (i.e., 27%) correlates well with the result of Beloni et al. [21] of 20%.

5. Conclusion

Fundamental measurements of electrical conductivity were made for many Al based energetic material composites. These measurements were correlated to electrostatic discharge ignition sensitivity for each composite. Only micron scale particles were examined. Our results show only the Al–CuO mixture resulted in ESD ignition and this mixture also exhibited the highest electrical conductivity of 1246.25 nS/m, two orders of magnitude higher than the next highest composite of Al + MoO<sub>3</sub> (40.30 nS/m), which did

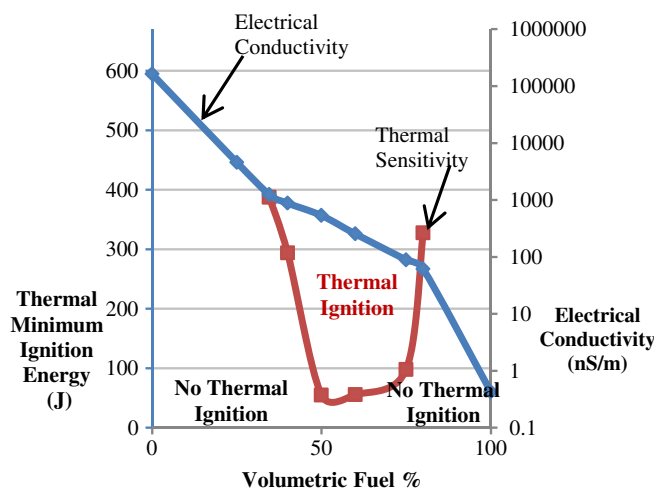

Fig. 8. Thermal ignition and electrical conductivity of Al + CuO with varying volumetric fuel ratios.

not ignite from ESD stimulus. The Al particles are passivated with an alumina shell and these fuel particles are constant for all mixtures such that ESD ignition is a strong function of the oxide. Because the aluminum oxide shell is highly resistive, the spark energy that accumulates on Al particles is more readily dissipated into the highly electrically conductive CuO. In fact, the heightened electrical conductivity of the Al–CuO composite may explain the result that only the Al–CuO mixture ignited at the maximum ESD setting. A mixture with high electrical conductivity will conduct electrical energy and accumulate joule heating to trigger ESD ignition.

The Al–CuO mixture was further examined for minimum ignition energy for ESD and thermal, hot wire ignition as a function of conductivity and stoichiometry. The interesting observation is that the flammability limits for both ESD and thermal hot wire ignition correspond. The ESD provides spark and joule heating and it was estimated that roughly 27% of the ESD energy may be delivered as joule heating. The results presented here link electrical conductivity to ESD ignition sensitivity and expound on the notion of multi-modal energy transfer in the form of electrical and joule heating toward energetic material ignition. These results are a first step toward developing formulations that are safe to handle and use, yet offer ideal performance tailored to an application.

### Acknowledgments

The authors M. Pantoya and C. Weir are grateful for support from the Army Research Office contract number W911NF-11-1-0439 and encouragement from our program manager, Dr. Ralph Anthenien. Idaho National Laboratory is also gratefully acknowledged for supporting this collaborative work with internal funds via the LDRD program. G. Ramachandran thanks Texas Tech University's Graduate School for support.

### References

- [1] M. Glor, Ignition hazard due to static electricity in particulate processes, *Powder Technology* 135–136 (2003) 223–233.
- [2] R. Tao, F.G. Zhao, Threshold of ESD damage to GMR sensor, in: *Electrical Overstress/ESD Symposium Proceedings, 2000*, pp. 327–329.
- [3] M. Glor, Hazards due to electrostatic charging of powders, *Journal of Electrostatics* 16 (1985) 175–191.
- [4] D.G.L. Thorpe, S. Singh, P. Cartwright, A.G. Bailey, Electrostatic hazards in sugar dust in storage silos, *Journal of Electrostatics* 16 (1985) 193–207.
- [5] Z. Wu, Y. Chen, X. Hu, S. Liu, Research on ESD ignition hazards of textiles, *Journal of Electrostatics* 57 (2003) 203–207.
- [6] D. Skinner, D. Olson, A. Block-Bolten, Electrostatic discharge ignition of energetic materials, *Propellants, Explosives, Pyrotechnics* 23 (1998) 34–42.
- [7] M.B. Talawar, A.P. Agrawal, M. Anniyappan, D.S. Wani, M.K. Bansode, G.M. Gore, Primary explosives: Electrostatic discharge initiation, additive effect and its relation to thermal and explosive characteristics, *Journal of Hazardous Materials* 137 (2006) 1074–1078.
- [8] L.R. Simpson, M.F. Foltz, LLNL small-scale static spark machine: static spark sensitivity test, *Energy* (1999) 1–15.
- [9] T. Larson, P. Dimas, C.E. Hannaford, Electrostatic sensitivity testing of explosives at Los Alamos, in: *Ninth Symposium (International) on Detonation, Naval Surface Warfare Center, 1976*, p. 6.
- [10] K. Strzelec, P. Pospiech, Progress in Organic Coatings Improvement of mechanical properties and electrical conductivity of polythiourethane-modified epoxy coatings filled with aluminium powder, *Progress in Organic Coatings* 63 (2008) 133–138.
- [11] İ.B. Topçu, T. Uygunoğlu, İ. Hocoğlu, Electrical conductivity of setting cement paste with different mineral admixtures, *Construction and Building Materials* 28 (2012) 414–420.
- [12] W.D. Greason, Electrostatic discharge characteristics for the human body and circuit packs, *Journal of Electrostatics* 59 (2003) 285–300.
- [13] Z.A. Munir, U. Anselmi-Tamburini, Self-propagating exothermic reactions: the synthesis of high temperature materials by combustion, *Materials Science Reports* (1989) 277.
- [14] S.H. Fischer, M.C. Grubelich, A survey of combustible metals, thermites and intermetallics for pyrotechnic applications, in: *32nd AIAA/ASME/SAE/ASEE Joint Propulsion Conference, 1996*.
- [15] K.W. Watson, M.L. Pantoya, V.I. Levitas, Fast reactions with nano- and micrometer aluminum: a study on oxidation versus fluorination, *Combustion and Flame* 155 (2008) 619–634.
- [16] J.J. Granier, M.L. Pantoya, Laser ignition of nanocomposite thermites, *Combustion and Flame* 138 (2004) 373–383.
- [17] Q.S.M. Kwok, R.C. Fouchard, A.-M. Turcotte, P.D. Lightfoot, R. Bowes, D.E.G. Jones, Characterization of aluminum nanopowder compositions, *Propellants, Explosives, Pyrotechnics* 27 (2002) 229–240.
- [18] D. Spitzer, M. Comet, C. Baras, V. Pichot, N. Piazzon, Energetic nano-materials: opportunities for enhanced performances, *Journal of Physical and Chemistry of Solids* 71 (2010) 100–108.
- [19] T. Foley, A. Pacheco, J. Malchi, R. Yetter, K. Higa, Development of nanothermite composites with variable electrostatic discharge ignition thresholds, *Propellants, Explosives, Pyrotechnics* (6) (2007).
- [20] E. Beloni, E.L. Dreizin, Ignition of aluminum powders by electro-static discharge, *Combustion and Flame* 157 (2010) 1346–1355.
- [21] E. Beloni, E.L. Dreizin, Experimental study of ignition of magnesium powder by electrostatic discharge, *Combustion and Flame* 156 (2009) 1386–1395.
- [22] E. Beloni, E.L. Dreizin, Ignition of titanium powder layers by electrostatic discharge, *Combustion Science and Technology* 183 (2011) 823–845.
- [23] The ESD Association, White Paper ESD Phenomena and the Reliability for Microelectronics (2002).
- [24] M.P. Mergens, W. Wilkening, G. Kiesewetter, S. Mettler, H. Wolf, J. Hieber, et al., ESD-level circuit simulation impact of interconnect RC-delay on HBM and CDM behavior, *Journal of Electrostatics* 54 (2002) 105–125.
- [25] EOS/ESD DS 5.3-1993 ESD Association Standard for Electrostatic Discharge (ESD) Sensitivity Testing – Charged Device Model (CDM) – Component Level, (1993).
- [26] ESD STM 5.1-1998 ESD Association Standard test Method for Electrostatic Discharge (ESD) Sensitivity Testing – Human Body Model (HBM) – Component Level, (1998).
- [27] A.L., M.H.J., Performance tests for energetic materials, in: *US Army Research and Development, Proceedings of the Conference on the Standardization of Safety and Performance Tests for Energetic Materials, 1977*.
- [28] C.D. Fuh, J.S. Lee, C.M. Liaw, Design aspect of the bruceton test for pyrotechnics sensitivity analysis, *Journal of Data Science* 1 (2003) 83–101.
- [29] J. Cintas, J.M. Montes, F.G. Cuevas, Electrical resistivity of a titanium powder mass, *Granular Matter* (2011) 439–446.
- [30] S. Benci, M. Manfredi, G.C. Salviati, Electrical properties of WO<sub>3</sub> powders, *Solid State Communications* 33 (1980) 679–682.
- [31] ASTM International, ASTM d 257-07, Standard Test Methods for DC Resistance or Conductance of Insulating Materials, ASTM International, 2007.
- [32] S.K. Chan, R. Turcotte, Onset temperatures in hot wire ignition of AN-based emulsions, *Propellants, Explosives, Pyrotechnics* 34 (2009) 41–49.
- [33] C.A. Crane, E.S. Collins, M.L. Pantoya, B.L. Weeks, Nanoscale investigation of surfaces exposed to a thermite spray, *Applied Thermal Engineering* 31 (2011) 1286–1292.
- [34] T.S. Ward, M.A. Trunov, M. Schoenitz, E.L. Dreizin, Experimental methodology and heat transfer model for identification of ignition kinetics of powdered fuels, *International Journal of Heat and Mass Transfer* 49 (2006) 4943–4954.
- [35] A.G. Merzhanov, Y.M. Grigorjev, Y.A. Gal'chenko, Aluminum ignition, *Combustion and Flame* 29 (1977) 1–14.
- [36] S. Yuasa, Y. Zhu, S. Sogo, Ignition and combustion of aluminum in oxygen-nitrogen mixture streams, *Combustion and Flame* 108 (1997) 387–390.