

THE LATVIAN LEGION (1943–1945) AND  
ITS ROLE IN LATVIA'S HISTORY

A thesis presented to the Faculty of the U.S. Army  
Command and General Staff College in partial  
fulfillment of the requirements for the  
degree

MASTER OF MILITARY ART AND SCIENCE  
Military History

by

EDMUNDS SVENCIS, MAJOR, LATVIAN ARMED FORCES  
B.A., Latvian National Defense Academy, Riga, 2000  
M.A., Riga Teacher Training and Educational Management Academy, 2002

Fort Leavenworth, Kansas  
2013-01

Approved for public release; distribution is unlimited.

| <b>REPORT DOCUMENTATION PAGE</b>                                                                                                                                                                                                                                                                                                                                                                                                                                                                                                                                                                                                                                                                                                                                                                                                                                                                                                                                                                                                                                                                                                                                                                                                                                                          |                    |                                          | <i>Form Approved</i><br><i>OMB No. 0704-0188</i> |                                                          |                                              |
|-------------------------------------------------------------------------------------------------------------------------------------------------------------------------------------------------------------------------------------------------------------------------------------------------------------------------------------------------------------------------------------------------------------------------------------------------------------------------------------------------------------------------------------------------------------------------------------------------------------------------------------------------------------------------------------------------------------------------------------------------------------------------------------------------------------------------------------------------------------------------------------------------------------------------------------------------------------------------------------------------------------------------------------------------------------------------------------------------------------------------------------------------------------------------------------------------------------------------------------------------------------------------------------------|--------------------|------------------------------------------|--------------------------------------------------|----------------------------------------------------------|----------------------------------------------|
| Public reporting burden for this collection of information is estimated to average 1 hour per response, including the time for reviewing instructions, searching existing data sources, gathering and maintaining the data needed, and completing and reviewing this collection of information. Send comments regarding this burden estimate or any other aspect of this collection of information, including suggestions for reducing this burden to Department of Defense, Washington Headquarters Services, Directorate for Information Operations and Reports (0704-0188), 1215 Jefferson Davis Highway, Suite 1204, Arlington, VA 22202-4302. Respondents should be aware that notwithstanding any other provision of law, no person shall be subject to any penalty for failing to comply with a collection of information if it does not display a currently valid OMB control number. <b>PLEASE DO NOT RETURN YOUR FORM TO THE ABOVE ADDRESS.</b>                                                                                                                                                                                                                                                                                                                                 |                    |                                          |                                                  |                                                          |                                              |
| <b>1. REPORT DATE (DD-MM-YYYY)</b><br>14-06-2012                                                                                                                                                                                                                                                                                                                                                                                                                                                                                                                                                                                                                                                                                                                                                                                                                                                                                                                                                                                                                                                                                                                                                                                                                                          |                    | <b>2. REPORT TYPE</b><br>Master's Thesis |                                                  | <b>3. DATES COVERED (From - To)</b><br>AUG 2012-JUN 2013 |                                              |
| <b>4. TITLE AND SUBTITLE</b><br><br>The Latvian Legion (1943-1945) and Its Role in Latvia's History                                                                                                                                                                                                                                                                                                                                                                                                                                                                                                                                                                                                                                                                                                                                                                                                                                                                                                                                                                                                                                                                                                                                                                                       |                    |                                          | <b>5a. CONTRACT NUMBER</b>                       |                                                          |                                              |
|                                                                                                                                                                                                                                                                                                                                                                                                                                                                                                                                                                                                                                                                                                                                                                                                                                                                                                                                                                                                                                                                                                                                                                                                                                                                                           |                    |                                          | <b>5b. GRANT NUMBER</b>                          |                                                          |                                              |
|                                                                                                                                                                                                                                                                                                                                                                                                                                                                                                                                                                                                                                                                                                                                                                                                                                                                                                                                                                                                                                                                                                                                                                                                                                                                                           |                    |                                          | <b>5c. PROGRAM ELEMENT NUMBER</b>                |                                                          |                                              |
| <b>6. AUTHOR(S)</b><br><br>Svencs, Edmunds, Major                                                                                                                                                                                                                                                                                                                                                                                                                                                                                                                                                                                                                                                                                                                                                                                                                                                                                                                                                                                                                                                                                                                                                                                                                                         |                    |                                          | <b>5d. PROJECT NUMBER</b>                        |                                                          |                                              |
|                                                                                                                                                                                                                                                                                                                                                                                                                                                                                                                                                                                                                                                                                                                                                                                                                                                                                                                                                                                                                                                                                                                                                                                                                                                                                           |                    |                                          | <b>5e. TASK NUMBER</b>                           |                                                          |                                              |
|                                                                                                                                                                                                                                                                                                                                                                                                                                                                                                                                                                                                                                                                                                                                                                                                                                                                                                                                                                                                                                                                                                                                                                                                                                                                                           |                    |                                          | <b>5f. WORK UNIT NUMBER</b>                      |                                                          |                                              |
| <b>7. PERFORMING ORGANIZATION NAME(S) AND ADDRESS(ES)</b><br>U.S. Army Command and General Staff College<br>ATTN: ATZL-SWD-GD<br>Fort Leavenworth, KS 66027-2301                                                                                                                                                                                                                                                                                                                                                                                                                                                                                                                                                                                                                                                                                                                                                                                                                                                                                                                                                                                                                                                                                                                          |                    |                                          | <b>8. PERFORMING ORG REPORT NUMBER</b>           |                                                          |                                              |
| <b>9. SPONSORING / MONITORING AGENCY NAME(S) AND ADDRESS(ES)</b>                                                                                                                                                                                                                                                                                                                                                                                                                                                                                                                                                                                                                                                                                                                                                                                                                                                                                                                                                                                                                                                                                                                                                                                                                          |                    |                                          | <b>10. SPONSOR/MONITOR'S ACRONYM(S)</b>          |                                                          |                                              |
|                                                                                                                                                                                                                                                                                                                                                                                                                                                                                                                                                                                                                                                                                                                                                                                                                                                                                                                                                                                                                                                                                                                                                                                                                                                                                           |                    |                                          | <b>11. SPONSOR/MONITOR'S REPORT NUMBER(S)</b>    |                                                          |                                              |
| <b>12. DISTRIBUTION / AVAILABILITY STATEMENT</b><br>Approved for Public Release; Distribution is Unlimited                                                                                                                                                                                                                                                                                                                                                                                                                                                                                                                                                                                                                                                                                                                                                                                                                                                                                                                                                                                                                                                                                                                                                                                |                    |                                          |                                                  |                                                          |                                              |
| <b>13. SUPPLEMENTARY NOTES</b>                                                                                                                                                                                                                                                                                                                                                                                                                                                                                                                                                                                                                                                                                                                                                                                                                                                                                                                                                                                                                                                                                                                                                                                                                                                            |                    |                                          |                                                  |                                                          |                                              |
| <b>14. ABSTRACT</b><br><br>This thesis provides research on the largest Latvian military formation that served Nazi Germany from 1943 until the end of World War II. As the most decorated non-German Waffen-SS formation, it fought from the outskirts of Leningrad until the defensive lines of Berlin. However, it also has become a focal point of heated contemporary discussions between historians of Western Europe and the Russian Federation. Accusations that the Latvian Legion engaged in war crimes and supported the Nazi ideology are just part of this discussion. The thesis first looks at the historical background of the development of the Latvian nation, and analyses what influence both of its neighbors (Russia and Germany) have had on it. Historically, the Latvian people have always been under the geopolitical influence of one of these states, at times facing the worst of their foreign policies—forced occupation and genocide. It then looks into the written works of the Legion's survivors, the research of domestic historians, the reports of the foreign ambassadors and the historical opinions of Russia's experts. Finally, the thesis seeks answers to the two primary questions on how Latvian Legion is perceived in today's Latvia. |                    |                                          |                                                  |                                                          |                                              |
| <b>15. SUBJECT TERMS</b><br>Latvian Legion, Soviet Occupation of Latvia, German occupation of Latvia, Eastern front, Waffen-SS                                                                                                                                                                                                                                                                                                                                                                                                                                                                                                                                                                                                                                                                                                                                                                                                                                                                                                                                                                                                                                                                                                                                                            |                    |                                          |                                                  |                                                          |                                              |
| <b>16. SECURITY CLASSIFICATION OF:</b>                                                                                                                                                                                                                                                                                                                                                                                                                                                                                                                                                                                                                                                                                                                                                                                                                                                                                                                                                                                                                                                                                                                                                                                                                                                    |                    |                                          | <b>17. LIMITATION OF ABSTRACT</b>                | <b>18. NUMBER OF PAGES</b>                               | <b>19a. NAME OF RESPONSIBLE PERSON</b>       |
| <b>a. REPORT</b>                                                                                                                                                                                                                                                                                                                                                                                                                                                                                                                                                                                                                                                                                                                                                                                                                                                                                                                                                                                                                                                                                                                                                                                                                                                                          | <b>b. ABSTRACT</b> | <b>c. THIS PAGE</b>                      |                                                  |                                                          | <b>19b. PHONE NUMBER (include area code)</b> |
| (U)                                                                                                                                                                                                                                                                                                                                                                                                                                                                                                                                                                                                                                                                                                                                                                                                                                                                                                                                                                                                                                                                                                                                                                                                                                                                                       | (U)                | (U)                                      | (U)                                              | 137                                                      |                                              |

Standard Form 298 (Rev. 8-98)  
Prescribed by ANSI Std. Z39.18

MASTER OF MILITARY ART AND SCIENCE

THESIS APPROVAL PAGE

Name of Candidate: Major Edmunds Svencs

Thesis Title: The Latvian Legion (1943–1945) and Its Role in Latvia’s History

Approved by:

\_\_\_\_\_, Thesis Committee Chair  
Jonathan M. House, Ph.D.

\_\_\_\_\_, Member  
John A. Suprin, M.A.

\_\_\_\_\_, Member  
LTC Mark D. Mumm, M.S.

Accepted this 14th day of June 2013 by:

\_\_\_\_\_, Director, Graduate Degree Programs  
Robert F. Baumann, Ph.D.

The opinions and conclusions expressed herein are those of the student author and do not necessarily represent the views of the U.S. Army Command and General Staff College or any other governmental agency. (References to this study should include the foregoing statement.)

## ABSTRACT

THE LATVIAN LEGION (1943–1945) AND ITS ROLE IN LATVIA’S HISTORY, by Major Edmunds Svencs, 137 pages.

This thesis provides research on the largest Latvian military formation that served Nazi Germany from 1943 until the end of World War II. As the most decorated non-German Waffen-SS formation, it fought from the outskirts of Leningrad until the defensive lines of Berlin. However, it also has become a focal point of heated contemporary discussions between historians of Western Europe and the Russian Federation. Accusations that the Latvian Legion engaged in war crimes and supported the Nazi ideology are just part of this discussion.

The thesis first looks at the historical background of the development of the Latvian nation, and analyses what influence both of its neighbors (Russia and Germany) have had on it. Historically, the Latvian people have always been under the geopolitical influence of one of these states, at times facing the worst of their foreign policies—forced occupation and genocide.

It then looks into the written works of the Legion’s survivors, the research of domestic historians, the reports of the foreign ambassadors and the historical opinions of Russia’s experts.

Finally, the thesis seeks answers to the two primary questions on how Latvian Legion is perceived in today’s Latvia.

## ACKNOWLEDGMENTS

A sincere gratitude first goes to my thesis committee whose tolerance and patience along with the absolute trust in my performance kept me going when my motivation waned.

I am also grateful to two ladies that trusted my ability to finish this journey—Maxine Hunter and Michelle Crook.

Unmatched support with extensive and rare informational material from the Brig. Gen. (Ret.) Vilmars Kukainis and Lt.Col. (Ret.) Visvaldis Ķīmenis provided, for what I am very thankful.

I dedicate this work to my children, Līva and Matīss—may you never forget that your roots lay in the proud nation.

## TABLE OF CONTENTS

|                                                                              | Page |
|------------------------------------------------------------------------------|------|
| MASTER OF MILITARY ART AND SCIENCE THESIS APPROVAL PAGE .....                | iii  |
| ABSTRACT.....                                                                | iv   |
| ACKNOWLEDGMENTS .....                                                        | v    |
| TABLE OF CONTENTS.....                                                       | vi   |
| ACRONYMS.....                                                                | viii |
| ILLUSTRATIONS .....                                                          | ix   |
| CHAPTER 1 BACKGROUND .....                                                   | 1    |
| Introduction/Overview .....                                                  | 1    |
| Overview of Geography and History of Latvian territory .....                 | 3    |
| 700 years of German rule–Latvian tribes failed to accept globalization ..... | 5    |
| Swedish times–power of enlightenment (1629–1721) .....                       | 6    |
| Russian Empire–emergence of Latvian nobility (1721–1918).....                | 9    |
| CHAPTER 2 ROAD TO INDEPENDENCE AND FIRST REPUBLIC (1918–1940).....           | 14   |
| Rise of socialism in Latvia.....                                             | 14   |
| War on two fronts–Baltic States unity .....                                  | 18   |
| Politics and diplomatic relations with the world .....                       | 22   |
| Economic and social structure in the Interwar Latvia .....                   | 26   |
| National Defense Forces .....                                                | 30   |
| CHAPTER 3 A DREADFUL YEAR (1940–1941).....                                   | 38   |
| Molotov–Ribbentrop Pact.....                                                 | 38   |
| Invasion.....                                                                | 42   |
| “Sovietization” and the new government .....                                 | 46   |
| Litene camp and draft into the Red Army .....                                | 50   |
| CHAPTER 4 NAZI GERMANY’S OCCUPATION AND ORIGINS OF LATVIAN<br>LEGION.....    | 58   |
| New liberators, new order and another ideology.....                          | 59   |
| Wehrmacht in trouble. Order for creation of Latvian Legion.....              | 63   |

|                                                                     |     |
|---------------------------------------------------------------------|-----|
| CHAPTER 5 LATVIAN LEGION.....                                       | 70  |
| Political aspects and military circumstances of LL's creation ..... | 73  |
| Build-up and integration of the Legion. Battle path .....           | 78  |
| CHAPTER 6 THE LATVIAN LEGION AFTER WORLD WAR II.....                | 91  |
| Accusations and Nuremberg Trial .....                               | 92  |
| Latvian Legion today. President's initiative .....                  | 99  |
| CHAPTER 7 CONCLUSIONS .....                                         | 110 |
| BIBLIOGRAPHY .....                                                  | 121 |

## ACRONYMS

|      |                                                                                   |
|------|-----------------------------------------------------------------------------------|
| LL   | Latvian Legion, soldiers of both the 15th and 19th Waffen SS Grenadier Divisions. |
| SS   | The executive force of the German police power or the Schutzstaffel.              |
| USSR | Union of Soviet Socialist Republics                                               |



## ILLUSTRATIONS

|                                                                            | Page |
|----------------------------------------------------------------------------|------|
| Figure 1. Baltic tribes .....                                              | 4    |
| Figure 2. King Gustav II Adolf .....                                       | 8    |
| Figure 3. New Latvians [ <i>Jaunlatvieši</i> ] .....                       | 11   |
| Figure 4. Janis Plieksans [ <i>Jānis Pliekšāns</i> ] .....                 | 16   |
| Figure 5. Proclamation of Republic of Latvia.....                          | 20   |
| Figure 6. Fifth National Armed Forces Mobilization plan.....               | 31   |
| Figure 7. Peacetime Task organization of Latvian Armed Forces (1938) ..... | 33   |
| Figure 8. Partition of Europe according the Molotov–Ribbentrop pact.....   | 39   |
| Figure 9. Soviet invasion made the headlines in New York Times. ....       | 44   |
| Figure 10. Deportations of June 1941. ....                                 | 50   |
| Figure 11. Anti–Semitic propaganda.....                                    | 64   |
| Figure 12. LL Waffen–SS Division’s Task Organization.....                  | 80   |
| Figure 13. March 16, 2013 by the Monument of Freedom, Riga, Latvia. ....   | 105  |

## CHAPTER 1

### BACKGROUND

[H]istory reveals freedom dies when people take it for granted, yet everywhere in the world there are many who take for granted the right to speak, the right to worship and the right to go about their daily occupations without fear of arbitrary arrest. Indeed there are many who take for granted all the priceless privileges of freedom and are careless about preserving them.

— John G. Diefenbaker, *House of Commons*

#### Introduction/Overview

Globalization processes “shrink” the world, but they also narrow one’s ability to dedicate enough time for thorough and independent studies of specific topics. In an era of rapidly spreading globalization, information flow is to a major extent uncontrolled, as are speculations without facts. The speed at which a spoken word or a picture snapshot travels today is close to the light speed. With the same lack of hesitation people nowadays, tend to subdue and follow their immediate emotional drive, not always analyzing the truth beyond the reason itself. Can we blame them for that? Especially when knowing that the reasoning for many historical events is a subject for contemporary interpretations, most of the time being a privilege of the dominant governmental (political) groups or movements. Facts, however, remain unbiased.

This is the reason why the general perception of the Latvian Legion (LL) in former Soviet countries and in Russia particularly is somehow related to Nazi crimes. We can observe such a trend every year on March 16 when Latvians commemorate those who gave their lives within the ranks of the Legion. Ever since March 16 has been established as an unofficial Legion Remembrance Day, a cordon of police around the

monument of freedom is present, attracting the attention of international media, radicals and foreign tourists. Some of the spectators who stand outside the perimeter listen to protesters and make their own conclusions that usually tend to be compliant with saying, “go with the flow.” This is where we who live now make mistakes without knowing or willing to know the history of “then and there.”

The author of this thesis was born and half of his life lived in Soviet Latvia. Firsthand he witnessed the regime, a “cold war” ideology and a troublesome time during the collapse of the union. He was astonished at the extent of information that this research provided. Moreover, he was also surprised at how little about the LL his contemporary generation abroad knows or is being purposely misled. This situation encouraged the author to settle his own debt with his nation’s history and provide his foreign colleagues with a wide range of facts regarding the LL and key events of the Latvian history.

This research will provide English-speaking readers with information regarding the creation and functions of the Latvian Legion, and how those circumstances still influence perception today. However, before proceeding to the discussions regarding the LL, the reader must be familiar with the general Latvian history. The first two chapters of this study cover the historical background of the main geopolitical, social and economic aspects that shaped the contemporary Latvian history. These chapters will show how important role Russia and Germany played in the evolution of Latvian nation. A historical “breaking point” in Latvia’s relationships with latter countries occurred in the dawn of the World War II, and the events leading to them are covered in the chapter 3. The LL’s genesis and history is captured in chapters 4 and 5. Chapter 6 analyzes those aspects of the LL’s history that shape today’s perception of the unit.

## Overview of Geography and History of Latvian territory

The present territory of the Republic of Latvia lies on the southeastern coastline of the Baltic Sea. With the ratification of the treaty regarding the international border between Latvia and Russia on September 5, 2007, Latvia's border stretches now over 1840 kilometers (1143 miles).<sup>1</sup> The Latvian coastline is 490 km (304 mi) long. Latvia borders with Estonia, Russia, Belorussia and Lithuania and is commonly known as one of three Baltic States. The territory of Latvia covers 64,000 square kilometers (24,710 sq. mi).

Like the other Baltic States Latvia was always an attractive area for many larger powers. Its geographical location and previously undiscovered travelling routes made Latvia's territory excellent for sea or land trading. Evidence of human activities in the present Latvian territory can be dated as far back as 9000 years BC; however, only around 2000 years BC did Baltic tribes settle on the southeastern coast of the Baltic Sea. Finally, around the 2nd century BC four distinct tribes on the Latvian territory were identified: Couronians [*kurši*], Selonians [*sēļi*], Zemgalian [*zemgaļi*] and Letgalian [*latgaļi*]. With minor differences in the dialects all tribes spoke fairly similar languages (see figure 1).<sup>2</sup>



Figure 1. Baltic tribes

*Source:* Virtual school of Latvian history, “Uzdevumi.lv,” <http://www.uzdevumi.lv> (accessed November 24, 2012).

Although similar in traditions and language, later tribes lacked political unity. Every separate tribe was more concerned with its own domestic issues rather than taking care of the whole region. At most, short term (7–10 years) treaties of collective protection were formed (i.e. between Couronians and Zemgalians) but most of the time these tribes were engaged in harassing raids and short wars with every neighboring tribe around them (i.e. Couronians versus Livonians and Zemgalians versus Zhemaitians).<sup>3</sup> Ego-centrism and mutual distrust of the Latvian ethnic tribes in turn became very helpful to the Germanic traders and priests of the Roman Catholic Church as well as the Teutonic knights who followed them.

700 years of German rule–Latvian tribes failed  
to accept globalization

The development of agriculture and raising livestock in the pre–historic Latvian territory established closer merchant ties with neighboring states such as Russia in the east and Scandinavian countries to the north. Successful trade of the rare Baltic Sea amber and rapid development of households resulted in the overall growth of people’s wealth. That, in turn, regionally expanded Latvia’s role as the locale for successful trade. Unfortunately, arriving merchants of those days could be viewed as both purely interested in trade or conducting the reconnaissance prior to a raiding force. As the word spread, more and more merchants from across the seas and lands were attracted to the wealthy lands of Baltics. The Curonians who occupied Latvia’s western coast felt growing pressure from Scandinavian Vikings and in turn conducted regular raids into Denmark and Sweden. Letgaliens in the east were under constant threat from the Russian tribes. Unfortunately, even in the face of obvious common benefit what unity might offer individual ambitions prevented the four major Latvian tribes to establish a common state. Such an opportunity was well exploited by German merchants.<sup>4</sup>

Historians emphasize two main reasons for the conquest of the Baltic States, particularly today’s Latvian and Estonian territory. The first was the German merchants’ will to control the trading routes with Russian lands. The second was Rome’s effort to expand Christianity further to the north.<sup>5</sup> Following the Christian Church’s official guidelines, waves of crusaders were blessed and sent to subdue the mutinous Baltic people. Systematically supporting and bribing one tribe in its fight with another and thereafter conquering the weaker and depleted winner, German crusaders compelled Selonians and Letgaliens first, then Curonians and Zemgaliens. Although Latvians fought

as independent tribal states, it took almost 100 years before the German Catholic church ruled all Latvian and Estonian territories. Inferior armament, absence of strong fortifications (fortresses) and limited human resources in Latvia were of no match to the German's sheer numbers and power. The lack of unity and persistent internal cross-tribal conflicts prevented Latvians from achieving peace and retaining independence.

In the following centuries, the German nobility controlled Latvia. Even during the ensuing Polish, Swedish and Russian rule, German noblemen owned the manors and people. With the conquest of Latvian lands, tribes lost their independence and basic rights to govern everyday life.<sup>6</sup> However, at the same time, this conquest eliminated long lasting tribal conflict and formed a basis for the growth of nationalism and formation of one common nation in the future. A lasting isolation of Latvian tribes, incorrect perception of the global trends in the rest of the European territory, and inability to unite against one common adversary were the dominant factors that led to the conquest of the Latvian territory at the end of the 13th century.

#### Swedish times—power of enlightenment (1629–1721)

In this thesis, the Swedish times refer to the period from the conquest of Estonian territory and Vidzeme (northeastern Latvia) in 1629 by King Gustav II Adolf until the end of the Great Northern War in 1721 when Sweden lost all of its European claims. Long time history lecturer at the Theology Faculty of the Latvian University, Professor Robert Feldman concluded that the King Gustav II Adolf's rule enhanced the prosperity and sparked the "enlightenment" times of Latvia's northeastern territory.<sup>7</sup> Partially motivated by the ongoing protestant reformation processes in Europe, but mainly because of the similar social policy in Sweden, King Gustav initiated a thorough socio-political

reformation that specifically addressed the Latvian population. This reform advocated two changes that were revolutionary at the time: education and individual rights.<sup>8</sup>

Sweden did not accept the German nobility's use of serfdom. Serfdom meant that a peasant family who lived on a noble's land was the noble's property. They could not inherit the land they maintained nor could they leave it. Serfdom was a form of slavery in all parts of Latvia. Because the Swedes did not practice serfdom in mainland Sweden, Swedish King Charles XI (ruled from 1660 until 1697) attempted to abolish it entirely all across the Swedish empire. His attempts were met with resistance from German proprietors who wanted to expand their rights to enslave locals. Local ruling authorities called "landtags" refused every attempt of serfdom abolishment. Eventually, serfdom remained; yet, peasants had more rights to claim their legislative protection from the King's courts in Tartu and Stockholm.

Among the most notable implications of the Swedish period listed by Professor Raimonds Ceruzis (Latvian University) was an emergence of the written Latvian language and the creation of schools for children of Latvian peasants. Professor Ceruzis concluded that "the Lutheran Reformation and Catholic Counter-Reformation in Livonia stimulated the consolidation of the Latvian nation and emergence of the written Latvian language."<sup>9</sup> The first books in the Latvian language were published. The two churches had competed for membership by publishing texts in Latvian even prior to the Swedish times. Following the Catholics' printing of the *Catechismus Catholicorum* in 1585, the Lutheran church printed its own catechism, the *Enchiridion*, in 1586. The Lutheran faith itself was accepted in Courland, Zemgalia and Livland, but the Roman Catholic faith



maintained its dominance in the eastern territory of Latvia–Latgale (Inflanty or Polish Latgale, Latgallia). It remains so to this day.

Finally, the establishment of the University of Tartu must be mentioned, as it played a very important role just 200 years later. King Gustav II Adolf founded the University of Tartu in 1632. It was initially called the *Academia Dorpatensis*, and it was modeled after the University of Uppsala in Sweden. The first Latvian nationalists met there as students, marking the period of national rebirth.



Figure 2. King Gustav II Adolf

*Source:* Nekropole, Electronic online encyclopedia, <http://nekropole.info/lv/Gustavs-II-Adolfs> (accessed December 18, 2012).

Although Swedish domination lasted only for roughly a century, an awareness of the Latvian identity began during that time. The Couronians, Latgalian, Selonians, Zemgalians and part of the Livs (around Riga bay) began to identify themselves as a culturally unified nation—the Latvians [*latvieši*].<sup>10</sup> For the first time the long oppressed Latvian peasantry had a chance to prove their rights in the land courts, send their children

to schools and, most importantly, express the national traditions in writing and transfer them to the next generations.

### Russian Empire—emergence of Latvian nobility (1721–1918)

At the end of the 17th century, tension around the Baltic region grew as a coalition of Russia, Denmark and Saxony opposed Sweden. In the initial stage of the Northern War (1700–1721) Denmark and Poland withdrew as the luck of war was on the side of the Swedish King Charles XII. The Russian Emperor Peter I, however, persisted in his effort to “open the window to the Europe” by getting the access to the Baltic Sea. In a relatively short time, he managed to modernize the Russia’s army and in 1709 defeated King Charles’s army at the battle of Poltava. By the end of 1709, the emperor’s army was at the gates of Riga and a new era for Latvians dawned.<sup>11</sup>

In his historical analysis of the “Russian times” in Latvia, Professor Janis Stradins emphasized that during this period Latvian nationalism expanded to the higher levels of society. Those Latvians who initially tried to associate themselves with the German population (or Germanized) and hid their actual roots started to realize the importance of being a part of one nation. Latvians managed to send their children to schools, seminaries and even to universities. Lawyers, accountants, doctors, engineers and teachers, submits Professor Stradins, eventually formed the initial Latvian intelligentsia.<sup>12</sup> Before 1817, Latvians were mainly living the peasant life on the countryside, working for their nobleman—usually a Baltic German. After the abolishment of serfdom, for the first time, Latvians were given equal opportunities to participate and to shape the existing society, influencing the processes around them. Although the German nobility continued to dominate every aspect of Latvian social life, more and more Latvians managed to earn

the positions that allowed them to shape political decisions in the Baltic region. As a lynchpin to the national rebirth, Professor Stradins mentions the Latvian intelligentsia, which formed during the 1850s, and was called New Latvians [*Jaunlatvieši*].<sup>13</sup> This movement deserves more in–depth description as it represents a major shift in building the Latvian nation.

Members of New Latvian movement (see figure 3) came together at Tartu University. The core of the movement was a group of three Latvian students Krisjanis Valdemars [*Krišjānis Valdemārs*], Krisjanis Barons [*Krišjānis Barons*] and Juris Alunans [*Juris Alunāns*].<sup>14</sup> The most progressive thinker was Krisjanis Valdemars who expressed his thoughts in powerful narrative writings, inspiring the hearts of many other Latvians. Witnessing the rise of other small nations (in Finland, Ireland and Estonia) he appealed to the national feelings of the Latvian nation encouraging to think in a modern way, to educate and to take control of the nation into their own hands. His words reflected that motivation, “Compatriots, think of how much has changed in these last 30–40 years! Centuries before were not even close to the speed of today’s pace. Do not let anyone say that Latvians do not know what to do with all that freedom they suddenly got. Be smart, study hard and love your fatherland. Don’t let us be ashamed.”<sup>15</sup>

As more Latvians became educated and occupied important governmental positions, others were encouraged to follow. Through education, Latvians gained knowledge and skills that led them to wealth. By 1914, Latvians owned around 330 merchant ships; however, most of the economic elite still consisted of the landowners. Some of the big real estate owners (at the time called Latvian “grey barons”) were even outsourcing the German nobility, called “black barons.”<sup>16</sup>



Figure 3. New Latvians [*Jaunlatvieši*]

*Source:* Letonika.LV, Electronic online encyclopedia, <http://www.letonika.lv> (accessed December 19, 2012). Note: From left to right: K.Valdemārs, J.Alunāns, and Kr.Barons.

New Latvians were principally in conflict with the existing German nobility, and because the German rule in Latvia did not give equal space for Latvians, the Latvian elite was forming in exile—Estonia and Russia. German oppression was taking its toll; therefore, most of the new Latvian elite intentionally focused on Russian culture and supported the Russia's policies. Appealing to the Russian political leaders, they managed to initiate significant national projects, the most important of which was the National Song Festival in 1873. Wealthier Latvians created foundations that supported their national brothers financially in the drive for better education and lifestyle. Foundations paid stipends for most promising Latvian students, enabling a higher quality of the selection process. At the same time, resources were found to support activities related to identifying, collecting and preserving national Latvian folklore—poems, songs, fairytales, and beliefs.<sup>17</sup>

The next chapter includes a more in–depth analysis on the development of the first independent Latvian State. The importance of the period from roughly 1835 to 1914 is critical to understanding Latvian history. During this period, two nationalistic generations were raised, and a strong believes in their capabilities as Latvians served as a unifying bond. Ironically, Latvians would again support German forces in 1941, seeing them as liberators from the Soviet dominion. Until then, the Russian Empire allowed nationalism to develop and flourish. In connection with this growth, German nobility refused to accept the global trend of emerging nationalism. This was similar to the mistake Latvian tribes made some 600 years ago. These German noblemen paid for their obstinacy when they were exiled to Germany at the end of the World War I.

---

<sup>1</sup>Ministry of Foreign Affairs of the Republic of Latvia, *The Republic of Latvia and the Russian Federation On the State border of Latvia and Russia*, <http://www.am.gov.lv/en/policy/bilateral-relations/4542/Russia/Treaty/> (accessed November 24, 2012).

<sup>2</sup>Endre Bojtár, *Foreword to the Past. A cultural history of the Baltic people* (New York: Central European University Press, 1999), 6–22.

<sup>3</sup>Ābrams Feldhūns, *Indriķa hronika* (Rīga: Zinātne, 1993).

<sup>4</sup>*Latvijas valsts, tās vesture, tautas kultūra, tradīcijas un valsts tiesiskie pamati* (Rīga: Latvijas Tautas skola, 2004), 18.

<sup>5</sup>Ibid.

<sup>6</sup>Ibid., 19.

<sup>7</sup>Roberts Feldmanis, *Zviedru laiki Vidzemē* (series of lectures read at the Latvian University, Riga, November 9, 1992), <http://www.robertsfeldmanis.lv/lv/?ct=bvesture&fu=read&id=1219785146> (accessed December 16, 2012).

<sup>8</sup>Ibid.

<sup>9</sup>The Latvian Institute, *History of Latvia. A Brief Survey* (Riga: The Latvian Institute, 2007), 12.

<sup>10</sup>Ibid., 14.

<sup>11</sup>Leonid Arbuzov, *Essay on the History of Livonia, Estonia and Kurland* (Moscow: Troitsa, 2009), 115.

<sup>12</sup>Jānis Stradiņš, "Personības un strāvojumi Latvijas un 'Austruma' vēsturē," *Akadēmiskā Dzīve*, no. 46 (2009): 60–70.

<sup>13</sup>Ibid.

<sup>14</sup>Jānis Stradiņš, *Latvijas intelektuālās un politiskās elites izveidošanās: problēmas un pretrunas*, Latvian Academy of Science Webpage, [http://www.lza.lv/LZA\\_VestisA/III%20kongres-Stradins.pdf](http://www.lza.lv/LZA_VestisA/III%20kongres-Stradins.pdf) (accessed December 18, 2012).

<sup>15</sup>Stradiņš, *Personības un strāvojumi*, 60–70.

<sup>16</sup>Indulis Ronis, *Latviešu buržuāzijas politika 1907–1914.gadā* (Rīga: Zinātne, 1978), 239.

<sup>17</sup>Jānis Stradiņš and Dzintra Cēbere, "Pirmās latviešu iedibinātās prēmijas zinātnes veicināšanai un Eduarda Veidenbauma godināšana. Nova Miscellanea Historiae Scientiarum Baltica" (23rd International Baltic Conference on the History of Science, Riga, October 9–10, 2008), 97–99.

## CHAPTER 2

### ROAD TO INDEPENDENCE AND FIRST REPUBLIC (1918–1940)

[A] revolution is impossible without a revolutionary situation; furthermore, it is not every revolutionary situation that leads to revolution. What generally are the symptoms of a revolutionary situation? We shall certainly not be mistaken if we indicate the following three major symptoms: (1) when it is impossible for the ruling classes to maintain their rule without any change; when there is a crisis, in one form or another, among the “upper classes,” a crisis in the policy of the ruling class, leading to a fissure through which the discontent and indignation of the oppressed classes burst forth.

— Vladimir I. Lenin, *The collapse of The Second International*

#### Rise of socialism in Latvia

Echoing this citation of V. I. Lenin, which mostly represents those ideas of Karl Marx, the second half of the 19th century Europe was filled with national unrest. Many of the little nations sought to gain independence; countries occupied by other powers (i.e. Greeks, Irish, Bulgarians, Serbs, Hungarians, Czechs, Belgians etc.) demanded wider range of freedom and choice. The old order cracked.<sup>1</sup> As pointed out by Professor Williamson A. Murray, the “dark side” of the industrial progress during the late 19th century and the policies pursued by the political leaders inevitably drove Europe to the brink of war that seemed an increasingly acceptable alternative. Overall growth of wealth created the illusion that a nation can sustain a protracted war effort, and the increasing complexity of societies enabled its outbreak.<sup>2</sup>

At the end of the 19th/ beginning of the 20th century a sense of uncertainty and urgency arose among Baltic Germans as well. Although they still ruled over the land orders, growing tension from the czar’s Russia along with the mutinous Latvian intelligentsia showed the fragility of German positions in Latvia. For centuries ruling in

their own way, the barons never bothered to gain the lasting support of their serfs. University of Stockholm Professor Uldis Germanis [*Uldis Ģermanis*] submits that this was the most appropriate time when barons could have established some positive contact and understanding with Latvians—a nation serving them for a long time. This step, however, would only diminish the hatred against barons without eliminating it. A popular saying of those times regarding the baron was that barons have not forgotten anything and have not learned anything, either. Some of the progressively thinking barons understood the necessity to unite (at least temporarily) their efforts with the Latvians against the political pressure of the Russian Empire; however older ones rejected any of such attempts. The chance was lost; the nation's striving for freedom was unstoppable. So were the czarist's sanctions and "russification."<sup>3</sup>

Before proceeding it is necessary to provide an overview of the situation around 1902–1904 in Latvian territory. As described above, neither Latvians nor German barons expressed the decisive will to cooperate, initially at the national level, perhaps, later at the political. Persistent domestic resistance forced Latvian intelligentsia into exile in Russia, Germany, Switzerland and the Scandinavian countries. A majority of progressively thinking Latvians moved to live in Russia where they actively attempted to manipulate Russian politicians and pushed them to initiate aggressive reforms against Baltic barons. This, however, provided more losses than gains for Latvians. Russian political officials angered by the German dominance and astonished by the slim presence of Russian speaking citizens in occupied countries, ordered harsh reforms. German barons were widely pushed aside from the ruling positions, the Russian language was declared mandatory in schools and official institutions, and hordes of Russian administrators



[*chinovnyiki*] were assigned to every county. Disobedience led to exile to Siberia.

However, it should not be assumed that the influence of the Latvian exile intelligentsia was the dominant factor for such a drastic shift in Russia's attitude. A new threat to the czar's dominance emerged outside the Empire's borders—socialism.

Originating in Switzerland and Germany, ideas of socialism were very attractive to the “worker's class.” Oppressed nations also recognized that this model of society would fit their demands for independence. Latvian poet, writer and later politician Janis Plieksans [*Jānis Pliekšāns*] was the social democrat whose efforts led to the establishment of the Party of Latvian Social Democrats in 1904 (see figure 5). Later he was sent to exile in Russia but his ideas kept the underground movement alive.<sup>4</sup> In general, the theory submits that “socialism” advocates the collective or governmental ownership and administration of the means of production and the distribution of goods. Subsequently, it promotes the type of society where no private ownership exists.<sup>5</sup> Everyone would be paid equally to the work done or benefit to the society provided.

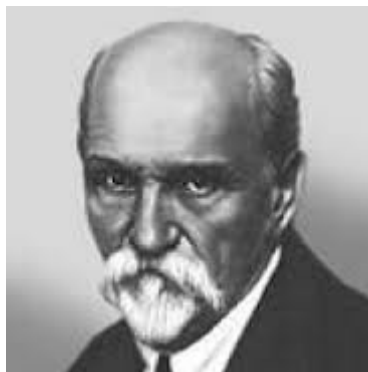

Figure 4. Janis Plieksans [*Jānis Pliekšāns*]

*Source:* Daily news magazine about Latvia, <http://www.latviannews.lv/famous-latvians/> (accessed December 19, 2012).

The ideas of socialism became extremely popular in Latvia at this particular time for three main reasons. First, by its national composition Latvia was an occupied state where the majority of the population was Latvian. This fact promoted nationalism. Second, influential administrative and political positions were filled by other nations (primarily, Russians and Germans) thus precluding Latvians of altering the course of events in Latvia. Many Latvians were successful merchants at the time; however, they had to play by someone else's rules. Finally, freedom of press and speech were banned. Additionally, an industrial revolution in Europe widened the gap between the "working" and "ruling" classes. In the name of higher profits, industry owners were only concerned with the increase of production rate, not about the safety or well-being of workers. The wealthy were getting richer and the poor were getting poorer.

At the same time, the ruling czar's family in Russia was losing its grip and support of population. The Latvian emigrant, publicist and historian Agnis Ilmars Balodis [*Agnis Ilmārs Balodis*] provides a detailed analysis of how numerous factors and events in czarist Russia led to the collapse of an Empire. Following events of the revolution in 1905, defeat in Russian-Japanese war (1904-1905) and unforgivable operational mistakes in the World War I showed how ineffective was the leadership, army, and how corrupt was the administrative leadership. Although, from the outside the Empire seemed united and solid, unsolved internal problems and sluggishness of bureaucratic apparatus precluded rapid and effective reforms. Reforms that were so much needed to match the contemporary social and political environment. Socialists and particularly communists saw it as another opportunity to prove that only a "total reset" advocated by them would

strengthen Russia and form better life for its citizens.<sup>6</sup> A stage was set for the major shift in Russian Empire and Baltic states in particular.

#### War on two fronts–Baltic States unity

For the duration of World War I, Latvia once again became a scorched battlefield. Representatives of political rule in Latvia (Russians) wanted to reestablish the former czarist regime; however, the real rulers (Baltic Germans) hoped to capitalize on the success of Kaiser Wilhelm's troops. In the midst of them Bolsheviks wanted to build a new world–socialism. Each side pursued its own goals, and Latvians had to take sides one more time. After the destruction of the First Russian Army near the Masurian Lakes, the road to the Baltics was open for German forces, and by October of 1915, they closed on Riga. German forces occupied two Latvian provinces (Courland and Zemgale). The retreating Russian army forced most of the citizens into refuge and drafted more Latvians into the ranks of the czar's units.

With historical hatred against barons in their hearts, Latvian riflemen fought fiercely within the ranks of the czar's Army against the Kaiser's troops, and set an example to the Siberian divisions of which they were part of. On August 1, 1915 (July 19 according the old style) the commander of the Northwestern Front, General Mikhail V. Alekseyev [*Михаил Васильевич Алексеев* (1857–1918)], signed the order that allowed a formation of Latvian battalions.<sup>7</sup> A new milestone was achieved–for the first time Latvians formed their own, national military formations. Russian commanders hoped that knowledge of local terrain and language along with the anger against the Baltic German rule would sustain motivation and boost the morale amongst Latvians. Gaining more confidence in their own forces and witnessing the continuous defeat of Russian forces,

the nation sought a historical opportunity to free itself from both powers. More and more of them asked themselves “why blood was shed for others not for their own land.”

Professor Balodis further submits that the year 1918 bore another significant meaning for the Latvian nation. First, self-proclamation of independence by Estonia (February 24) and Lithuania (February 16) set the stage for a new united political drive in the Baltic States and urged the three countries to free themselves from occupation. Second, the Latvians learned of the unfair terms of the Brest-Litovsk agreement (peace agreement between Lenin’s Russia and Germany, signed on March 3, 1918). According to this agreement, Latvia would be divided into two parts under the rule of Russia and Germany. Understanding the tragedy if this agreement became effective, different political parties in Riga united and on November 18, 1918, proclaimed the independent Republic of Latvia (see figure 6).<sup>8</sup> Trusting its Army, putting everything at stake, a new, and yet internationally unrecognized Latvian government decided to free the nation from both occupants: German army in the southwest and “Bolshevik” forces in the east. Together, these armies occupied almost 50 percent of Latvian territory.

Up to this point, both powers (Russia and Germany) were struggling with their internal national unrest and subsequent revolutions that led to the change in the major rule of the nations. Protracted world war drained the political, economic and physical power from their people to carry on with the bloodshed. The Baltic States were given a unique chance to clear the remnants of the occupying armies from their territory. They were also given the opportunity to do it together.



Figure 5. Proclamation of Republic of Latvia.

*Source:* Blog at Wordpress.com, “Latvian History,” <http://latvianhistory.wordpress.com/2010/11/17/18-november-the-latvian-independence-day/> (accessed February 16, 2013).

A veteran of the Latvian Liberation War, General Peteris Radzins [*Pēteris Radziņš*] in his memoirs describes some of the aspects of unity and dissonance among Baltic States as they fought against the occupying forces of Germany and Russia. From July until December of 1919, all three Baltic countries united their efforts to expel the German forces led by Count Rudiger von der Goltz.<sup>9</sup> Although the Treaty of Versailles marked the end of World War I remnants of the German Eighth Army still occupied parts of Baltic territory supposedly providing a “speed bump” in the path of the Bolsheviks and awaiting their evacuation back to homeland.<sup>10</sup> However, as the members of Entente were more concerned with the emerging bolshevism in the east, von der Goltz was not pressed decisively to withdraw. He was still seen as the resort to counter the communist forces should they decide to move westwards. Only after the defeat by Latvian–Estonian combined forces in July 1919 did German army remnants begin their withdrawal westwards. Estonian and Latvian forces drove von der Goltz’s Army out into the

Lithuania where the newly formed Lithuanian Armed forces joined and spearheaded the effort until this army was completely expelled to the territory of Germany.<sup>11</sup> The liberation of Riga was largely possible thanks to the British Royal Navy that provided much-needed gun fire support during the fighting in the capital and the defeat of von der Goltz's forces on the west bank of the river Daugava, thus reaching the break-point in the offensive.<sup>12</sup>

In the meantime, Bolshevik troops in the eastern Latvian region only maintained their presence as decisive Red Army battles were fought against Kolchak's White army in the heart of Russia. General Radzins submits, "it was Latvia's luck that Soviet Russia was engaged in the battles with Whites. Should Kolchak's Army have been defeated a couple of months earlier, the Bolsheviks would have pressed unstopably towards Riga as the Latvians pursued von der Goltz southwest of it."<sup>13</sup> Nevertheless, the rapid defeat of the Whites freed more of the Red Army's troops, which joined the occupation force in Eastern Latvia. Although the communists shielded their propaganda with words like "freedom" and "brotherhood," loss of the Baltic coast was not on the Red Russia's agenda. Subsequently, the growing threat on the Baltic's eastern border forced the Estonian ally to withdraw its troops from Latvia in order to stage effective resistance against the advancing Red Army in Estonian territory. Eventually, on January 3, 1919, Estonia was forced to negotiate a truce with the Soviets. Lithuania in the south was just as busy holding back the Red Army from its territory and still pursuing the retreat of von der Goltz's forces. Additionally, to make matters more complicated, Lithuania claimed rights over Latvia's southeastern town Daugavpils. With Estonia's absence and uncertainty of Lithuania's eventual political intentions, the Latvian temporary

government accepted Poland's military help, and on January 3, 1919, began the offensive against Bolshevik forces in east Latvia. The Latvian liberation officially ended on August 20, 1920, with the peace treaty between Latvia and Soviet Russia.<sup>14</sup>

For the first time Latvia emerged on the world's map as an independent state with internationally recognized borders, its own language, government and armed forces. The persistence of nationalism, self-sacrifice of soldiers and regional military cooperation were the enabling factors in the background of major events in Europe that led to a collapse of two Empires, Russia and Germany. Although the loss of the Baltic territory was bitter to both of the latter States, other European countries were equally skeptical about Latvia's ability to survive as an independent entity. Throughout the next 20 years Latvia managed to reform its economy, gain international recognition, stabilize its monetary system and grow a professional army. This thesis will not provide deeper analysis of the independent Latvian Republic from 1920 until 1940 because of the magnitude of the informational material; rather it would be a good topic for another independent study. However, the purpose of next paragraphs is to introduce the readers to the overall situation and major aspects that shaped the Latvian geopolitical situation in the interwar period.

#### Politics and diplomatic relations with the world

Most of the European countries looked upon Latvia's emergence with skepticism, doubting its ability to withstand a post-war period. Formally, after the peace treaty between Latvia and Russia was signed in 1920, Russia was the first to recognize Latvia's independence status as *de jure*. Next, recognition was expressed by the Italian parliament; France followed suit in 1921. It was not until July 28, 1922, that the United States under

the presidency of Warren G. Harding officially recognized the Republic of Latvia.

Finally, on September 22, 1922, Latvia joined the League of Nations.<sup>15</sup>

If we are better to understand Latvia's role in the Interwar Europe, it is necessary first describe the contemporary feelings of the rest of the world regarding the new Baltic States. Professor Daniel Moran submits that "shared ambivalence and uncertainty [of the Great Powers] allowed the initiative to pass, for a time, to smaller states in which the determination to act, given the opportunity, had been building for years, if not for generations."<sup>16</sup> Widely cited British diplomat and later historian Edward Hallett Carr was an official British representative in Riga during 1920s.<sup>17</sup> He recalled that Riga "was then to Soviet Russia what Hong Kong is to China."<sup>18</sup> Most of the European countries wanted to see a stable and reliable Russia without much of the decisive preference of its internal structure—Bolsheviks or Whites. It was important that whatever government was established in Russia, it should be a reliable partner in the possible future conflicts with Germany. The majority of Europe was cautiously looking upon new Latvia and more concerned of the course of events in Russia and Germany. Edward Carr later recalls, "National governments of Baltic States are more viable than it had seemed initially."<sup>19</sup>

Much of these attitudes originated from the internal politics of Great Britain, France, Soviet Union and Germany. Professors Williamson Murray and Allen R. Millett provide a compiled and generally descriptive overview of the Western Europe's attitudes and individual policies during the Interwar period. The British strategic goal, as they describe, was to maintain dominance at sea and to have a small expeditionary army for "attacks on the periphery (as well as on colonies)." Therefore, it was in Britain's best interests to establish and maintain good relations with coastal countries. France, on the



other side, realized that as a continental European state it would have no other choice then to be engaged in every major future conflict in mainland Europe. Subsequently, its logical move was to seek an Ally, preferably a strong one. In 1921, France concluded an alliance with Poland, and on May 2, 1935, after Germany clearly showed its Nazi intentions, France signed a mutual assistance pact with Soviet Russia. Ironically, just four years later, the Soviets and Germans signed the Molotov–Ribbentrop pact that was to decide Europe’s fate.<sup>20</sup> Germany’s politics, undergoing the crash of the economy and suffering under the strict imposing sanctions by the Treaty of Versailles inevitably fell into the favor of charismatic and nation–uniting nationalist ideas. Not fully comprehending the results of the World War I, the political developments in Germany soon took ownership over the Army’s development and with Hitler’s defined end state–“subjugation of the continent”–the nation steadily progressed towards a new conflict or total bankruptcy.<sup>21</sup>

A hero of the Crimean battles and the leader of the Revolutionary Military Council, in 1925 Mikhail Frunze defined Soviet Russia’s position. He wrote that:

Between our proletarian state and the rest of the bourgeois world there can only be one condition–that of a long, persistent, desperate war to the death: a war which demands colossal tenacity, steadfastness, inflexibility, and a unity of will. . . . The common, parallel existence of our proletarian Soviet state with the states of the bourgeois world for a protracted period is impossible.<sup>22</sup>

Enormous civilian losses in World War I, the November Revolution and the ensuing Civil War defined Soviet Russia’s strategic ideology of “total war” that would be backed by mobilization of the national economy and military doctrine that preached the “relentless pursuit” of the ideological enemy. Comparing the contemporary ideologies, it

seems logical that Soviet Russia and Nazi Germany felt sympathies to each other. However, neither of them was foreseeing peaceful and lasting co-existence in the future.

From the historical evidence submitted, a reader can now see the general European geopolitical picture in the post-World War I era. It was clearly a “times of Alliances.” The governments of France and Britain were mainly betting on the efficiency of the Treaty of Versailles, for the guarantees of their national security and dominance. Poland, historical and long-term ally of Lithuania in earlier times, forcefully occupied Vilnius (Lithuania’s capital) on October 8, 1920, and maintained a “non-declared” state of war with Lithuania until World War II.<sup>23</sup> Besides, Poland was also relying heavily on the treaty with France. As a sign of protest, Lithuania concluded a non-aggression pact with Soviet Russia and evolved into the autocratic regime of President Smetona.<sup>24</sup> Latvia’s newly emerged regional neighbor in the north, Finland, avoided the Baltic States Alliance and joined the “Scandinavian” alliance instead. Taking into an account that Latvia and Lithuania still had unsolved issues regarding the city of Daugavpils, the only Latvian option for an alliance remained Estonia. On November 1, 1923, the two countries signed the bilateral defensive agreement. It was not until September 12, 1934, that Lithuania joined the alliance by signing the Baltic Entente agreement.<sup>25</sup>

In summary, the World War I and the following revolutions led to the emergence of new countries (including Latvia) and collapse of the old ruling systems. Previous great powers Russia and Germany were shaken by the internal unrests but their centers of gravity—their people, never gave up the idea of dominance. In fact, they both were on the path to a new revolution, this time driven by much powerful force—ideology and nationalism. World War II was a logical outcome executed by the new generation, which

had been raised and groomed by the old and restless one. Besides Germany and Soviet Russia, other European powers rushed to establish alliances or to conclude seemingly adequate non-aggression pacts. One would question whether the European States were fully aware of the fragility of these pacts, which proved to be worthless during the Sudeten Crisis in 1938.<sup>26</sup> Amidst these events, Latvia as a novice political actor, was trying to define its own course while recovering from the devastations of the previous conflicts. It is obvious that Latvia sought the alliance with Estonia as another way to increase the security locally. Latvia's biggest hope, submits Dr. Germanis, was on the integrity of Western Europe's support.<sup>27</sup>

#### Economic and social structure in the Interwar Latvia

From 1915 until 1920, Latvia was in the zone of active warfare, which devastated its people and resources. Additionally, Baltic Germans who historically owned estates took every advantage to influence the government in order to retain their properties. In the countryside 10 percent of all buildings were destroyed (78,278), and an additional 14 percent (104,576) were damaged. The agricultural sphere, which was the lynchpin of the economy, was also significantly disrupted—about 25 percent of all arable land was spoiled. Many workers lived in the improvised shelters or cellars.<sup>28</sup>

Therefore, as a high priority the new government initiated agrarian reforms that became effective in a multi-phased process over the course of four years (1920–1924). Agrarian reform should be viewed as another historic turning point in Latvia's history, as for the first time Latvians were officially given what belonged to them—the land. Professor Balodis describes how that agrarian reform requisitioned the land belonging to German manors, other domain properties, church and private estates as well as the

properties of corporations owned by the noble Baltic Germans. As the result of appropriations, 3,396,000 hectares were requisitioned. The government retained ownership over 52 percent of land, the rest was divided into 144,681 farms and allocated to families who were willing to work and develop their individual businesses.<sup>29</sup> Lawmakers viewed small farms (15–40 hectares) as the basic agrarian building element that can sustain the family of the farmer and maintain productivity. Initially, some experts foresaw the economic crash down.<sup>30</sup>

The agrarian reform in fact was a social revolution that restructured Latvian economy and society, and the effectiveness of this reform fully became obvious around 1937. During the course of reform the quantity of arable land expanded, productivity increased and by the 1930s, country was able to sustain itself completely by agricultural production. At a time when Danish agronomy was set as Europe's example, productivity from one hectare of land in Latvia was close to the level of Danish farming. By 1938, submits Balodis, Latvia was the fourth largest exporter of dairy and meat products in Europe.<sup>31</sup>

As Latvia's only natural resources were land and forests, it should be emphasized that the main cause of agrarian reform was political, not economic. By the success of this reform, two main goals were achieved. First, the nation's elected government seized ownership over the crucial economic domain—resources. Before reform, all control of this economic cornerstone was in the hands of the minority—Baltic Germans. Second, central ownership of all resources by the government excluded any friction between different classes of society in Latvia. Subsequent controlled allocation of property to the citizens established equal opportunities for everyone to own the land and expand its production.

More importantly, governmental structures were imposing strict qualitative control over the use of individual properties, to battle the complacency and misuse of the valuable national resources. National policies encouraged people to own the land but it also demanded responsible use of it. In such an environment, any communist propaganda especially that of the underground movement was not supported by the population.

Interesting factual material for analysis reveals the development of the social structure amongst Latvia's population during the 1920–1940. According to data provided by the Central Statistics bureau within this timeframe, the amount of people living in Latvia increased from 1.6 to 1.95 million. Around 1935, Latvia's largest minorities were Russians (206,500), Jews (93,500), Germans (62,000), Poles (49,000), Byelorussians (26,900) and Lithuanians (22,900).<sup>32</sup> However, the size of a minority did not correlate to its political or economic activity. Intellectually and politically, Germans were the most active group who almost completely participated in every state election. They were competing with Jewish communities, which successfully participated in economic sphere. Ironically, this historical caprice put Germans in the same role that Latvians were playing a century ago, uniting them. However, it should be noted that unity of the German minority and persistence in achievement of their goals resulted in almost 5 percent of national votes, which was sufficient to be represented in parliament (minimum vote—2.5 percent). The least active minority were Russians. Although they numbered 10.6 percent of population, only 6.8 percent votes were counted.<sup>33</sup> Mainly, submits Germanis, this can be explained by the fact that there was the lowest literacy rate amongst Russian minorities, especially those living on Latvia's eastern border, in Letgalia province. Russian interests were largely represented through the religious organizations.<sup>34</sup>

Fulfilling its promise to the League of Nations, the Latvian government practiced freedom of religion, human and cultural rights. Decisive measures were imposed against radical political groups: *Pērkonkrusts* (Thunder cross) on the radical rights and communists on the radical lefts. The Communist Party was declared illegal in 1920 and despite significant financial support from Soviet Russia never gained decisive support from the citizens. *Pērkonkrusts* also was declared illegal in 1934 and around 800 of its members were imprisoned due to its radical ideas of nationalism. Latter organization has been subject to a much resonate discussions then and now due to its activity. The general opinion of historians is that members of this organization were opposed in particular to president Karlis Ulmanis [*Kārlis Ulmanis*]. Because of their anti-Semitic policy and demand of a “Latvian only” nation, these ideas seemed too extreme to the democratic policy of the government. With the emergence of Nazism in Germany, members of *Pērkonkrusts* echoed the conspiracy theory of “Jewish world dominance” in Latvia. Although they showed sympathy to the Nazi ideology during the German occupation in 1941, the German military and political leadership was far too concerned with its own goals and closed the *Pērkonkrusts* organization in August of 1941. Its leader Gustavs Celmins was imprisoned in one of the concentration camps in Germany.<sup>35</sup>

As the collapse of German and Russian empires created the ideological vacuum, radical ideas were filling the nations’ ranks. After the national revolutions and Civil War (in Russia’s case), Nazism and Communism were steadily advancing to their ideological dominance and subsequently put it to work before World War II. Being entrenched between a growing and power flexing Nazi Germany and Soviet Russia, the Latvian

government had to keep focused on the values that made this country possible to exist. One of such values was Latvia's armed forces.

#### National Defense Forces

As described previously, the Baltic States like the rest of the Europe relied heavily on the alliances and the possible help from the Western powers like France, Poland, Great Britain and United States. Estonia and Latvia developed their armed forces pending the possible threat and based on the adversary's most likely course of actions. Initially, only Soviet Union appeared to be an adversary, however, by the mid-1930s possible conflict in the Baltic Sea was believed to happen with Nazi Germany. Historical evidence shows that during the period of 1920-1939 the Latvian General Staff developed four mobilization plans with subsequent disposition of troops to defeat the most probable enemy advance.<sup>36</sup> Military planners assumed that due to the unfavorable terrain for armored warfare in Latvia's eastern regions, the aggressor would use only the road and railroad network for movement and limited maneuvers (see figure 6).

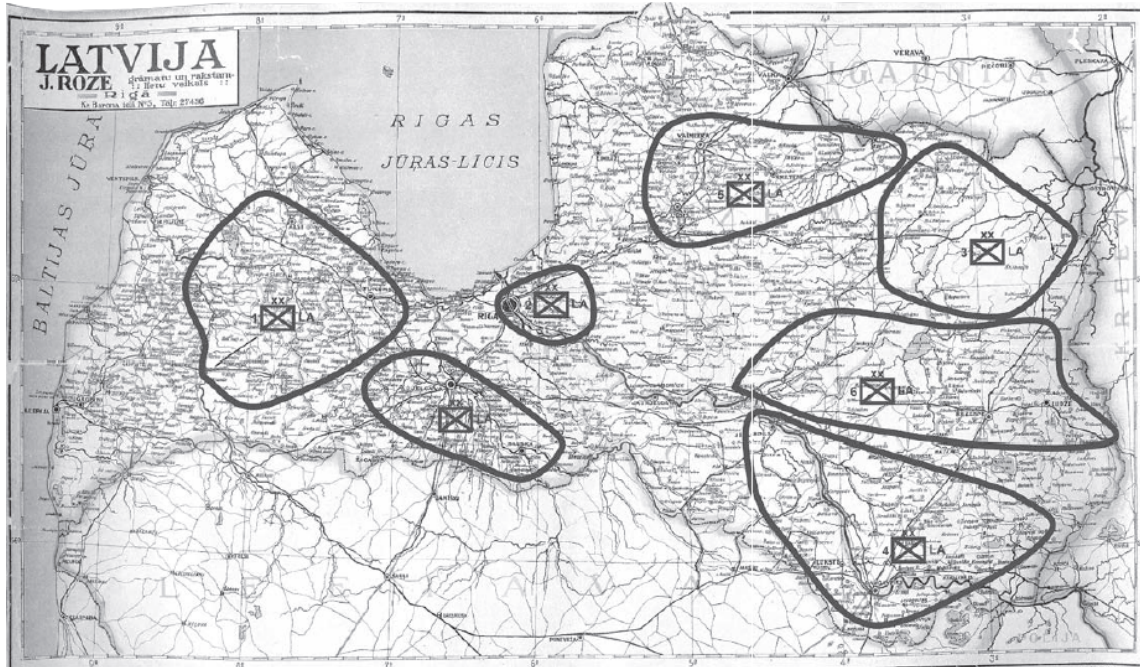

Figure 6. Fifth National Armed Forces Mobilization plan.

*Source:* Valdis Kuzmins, “Latvijas bruņoto spēku mobilizācijas un aizsardzības plāni 1939.gada beigās–1940. gada sākumā,” *Militārais Apskats*, no. 3/4 (2009): 56, 57.

As seen in figure 6, in a very short period (fall 1939–spring 1940) officers of the Latvian General Staff had to redraw plan “No. 4” with priority of defensive actions against an aggressor from the east–Soviet Russia. Four infantry divisions would hold off the initial approach of the enemy along the avenues of approach while the remaining three divisions in the rear completed mobilization and reinforce the frontline units as deemed necessary. The primary form of maneuver was retrograde into the depths of Latvia until mobilization in the rear was completed. In March 1940, the results of a map exercise conducted in the General Staff showed that enemy armor formations would be blocked around 50 km away from the border.<sup>37</sup> This assumption was never tested in reality.



On the other side, analysis of Soviet Russia's and Germany's military plans reveals that both of these states were assessing and later planning to seize the Baltic countries in order to block the advancing enemy and protect their own flanks. Additionally, straits and islands in the Baltic Sea had to be controlled in order to disrupt enemy's sea lines of supply and communications.<sup>38</sup> Specifically, according to the Soviet Union's military plans of the 1930s, both Latvia and Estonia were to be eliminated by a single strike of mechanized troops, but the Finnish Gulf would be mined in order to block the German naval advance.<sup>39</sup> The Baltic States were of significant strategic importance for Russia and Germany but only in terms of territory.

Following the global trend in Europe, after World War I the Latvian government downsized its National Army to roughly 20,000 personnel. Every male reaching the age of 20 was drafted and had to serve 18 months (later reduced to 12 months). Following the demobilization, men were enlisted in the ranks of reservists where they remained until the age of 50. Considering the high numbers of non-ethnic Latvians, military service was also a successful domain for integration of other nationalities. Besides, the core of the instructors and officers were participants in the Liberation war and kept the standards of morale and patriotism very high.<sup>40</sup>

Archival evidences of the Latvian General Staff states that Latvia maintained four infantry divisions and one technical division in the Land Forces. Each infantry division consisted of three infantry regiments and one artillery regiment. The Technical Division was comprised of combat support units such as the electronic warfare regiment, aviation regiment, engineer regiment and armored regiment. As separate units were heavy artillery, coastal artillery, air defense, cavalry and armored train regiments. The Latvian

Navy performed mainly Coast Guard functions with one cruiser, two submarines and two minesweepers. Protection of the borders fell under the responsibility of the Ministry of Interior, tasking one border guard brigade (see figure 7).<sup>41</sup>

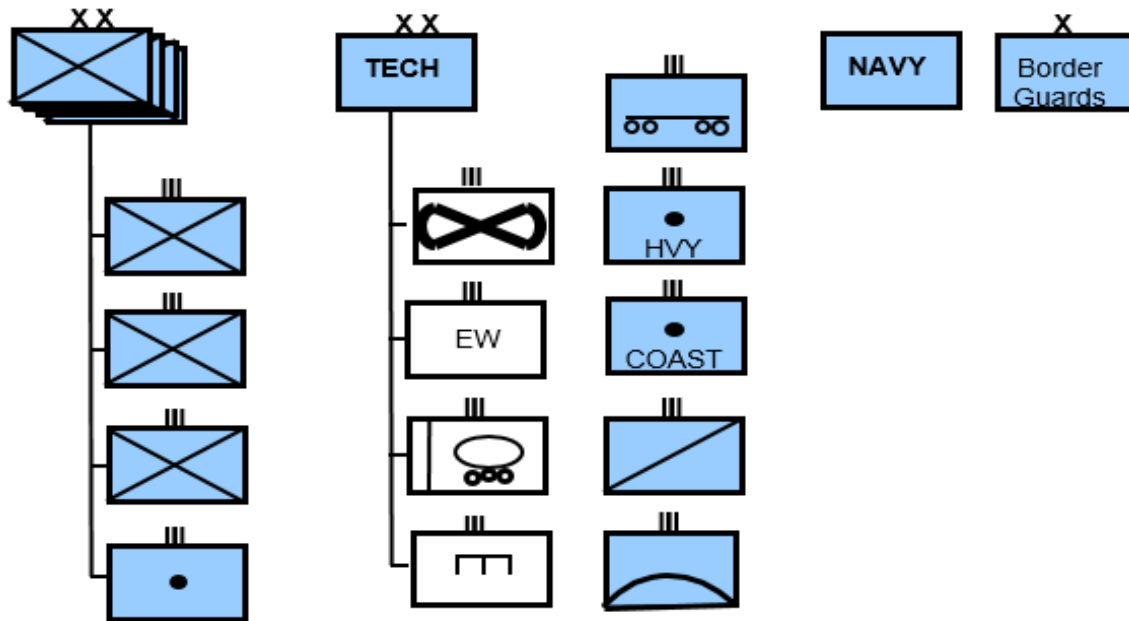

Figure 7. Peacetime Task organization of Latvian Armed Forces (1938)

Source: Drawn by the author.

Altogether, it was estimated that roughly 180,000 men were fit for combat duty by 1940. However, submits Professor Balodis, modernization of armed forces started too late—in 1938 when the threat from Germany was obvious. Germany’s aggressive actions in Czechoslovakia “woke up” President Ulmanis and he ordered the development of the armed forces ready to meet the existent threat. Without hesitation, the Latvian General Staff and Ministry of Defense initiated a large modernization campaign that mainly tied to purchase of new equipment, weapon systems and specialized training. The major

impediment to this process was that Europe was preparing for war and everyone needed weapons, munitions, ships, airplanes and submarines. Latvian soil was once again on the path of Europe's superpowers.

In conclusion, the history of interwar Latvia must be viewed through the contextual prism of events in Europe and could be characterized by three overarching and sometimes overlapping paradigms. First, devastations and horrific casualties during the last war as well as the terror of military destructions dominated the people's minds. People strove for peace and prosperity. The nation's manpower and economies were pushed to the limit. Second, former colonial superpowers such as France and Great Britain realized the emergence of another force: Germany, Russia and Japan were able to compete and claim their share of land and water. Finally, the collapse of political and ideological regimes in Russia, Germany, Austro-Hungary and Turkey in 1918 created favorable conditions of radical ideas. Revolutions in Russia and Germany marked the emergence of Communism and Nazism.<sup>42</sup>

Entrenched between these Great Powers Latvia was heavily relying on Western support in case of major war breakout in Europe. Close economic ties with Denmark, the Netherlands, France and Poland gave a sense of stability that no aggressor would dare to challenge the existing rule and order. Besides, the small but active German minority, sensing the growth of ethnic power in the west, more decisively involved itself in the political realm and was very eager to confront the existent order.

Focusing much of the attention on the expansion of Nazi Germany, the Latvian government underestimated the threat indicators from the East. It was not until mid-1938 when Soviet Russia showed its true intentions openly. The Winter War with Finland and

Soviet Russia's ultimatum to Estonia (demanding the deployment of Soviet troops in Baltic space) certified the decisiveness of the communist leaders. They never abandoned the idea of reunification for the once Great Russian Empire. As Mikhail Frunze stated earlier, the time had come to "free the oppressed."

---

<sup>1</sup>Uldis Ģērmanis, *Latviešu tautas piedzīvojumi I-IV* (Stockholma: Memento, 1998), 141.

<sup>2</sup>Geoffrey Parker, *The Cambridge Illustrated History of Warfare* (New York: Cambridge University Press, 2009), 242–243.

<sup>3</sup>Ģērmanis, 153–159.

<sup>4</sup>Ibid., 162.

<sup>5</sup>Merriam Webster Dictionary, <http://www.merriam-webster.com/dictionary/socialism> (accessed January 21, 2013).

<sup>6</sup>Agnis Ilmārs Balodis, *Latvijas un latviešu tautas vēsture* (Rīga: Kabata, 1991), 147–159.

<sup>7</sup>Ibid., 161–162.

<sup>8</sup>Ibid., 177.

<sup>9</sup>Spencer C. Tucker, *World War I. A Student Encyclopedia* (Santa Barbara: ABC–CLIO Inc., 2008), 790–792.

<sup>10</sup>Hans Stöber, *Die Lettischen Divisionen im VI. SS–Armeekorps* (Osnabrück: Munin Verlag, 1981), 14–28.

<sup>11</sup>Pēteris Radziņš, *Latvijas atbrīvošanas karš* (Rīga: Avots, 1990), 117.

<sup>12</sup>Daniel Moran, "The Baltic Patrol: From counter–Revolution to National Liberation," *Baltic Security and Defense Review* 11, no. 2 (2009): 81.

<sup>13</sup>Radziņš, 118.

<sup>14</sup>Ibid., 123, 244.

<sup>15</sup>Ģērmanis, 244–247.

<sup>16</sup>Moran, 82.

<sup>17</sup>Alex Holachek, *Ethical Historiography: The Berlin–Carr debate and the revolutionary Realism of Alexander Herzen* (Middletown: Wesleyan University, 2010), 26–27.

<sup>18</sup>Jonathan Haslan, “E. H. Carr and the History of the Soviet Russia,” *The Historical Journal* 26 (1983): 1022.

<sup>19</sup>Gērmanis, 245.

<sup>20</sup>Molotov–Ribbentrop non–aggression pact–pact between Germany and the Soviet Union that was concluded only a few days before the beginning of World War II and which divided eastern Europe into German and Soviet spheres of influence, signed on August 23, 1939. Definition provided in *Encyclopedia Britannica*.

<sup>21</sup>Williamson Murray and Allen R. Millett, eds., *Military Innovation in the Interwar Period* (New York: Cambridge University Press, 1998), 8–18.

<sup>22</sup>Михаил Фрунзе, “Единая Военная доктрина Красном Армии,” *Военная наука и Революция*, no. 2 (1921), 39.

<sup>23</sup>Ever since emerging as the new states in 1920 Lithuania and Poland did not regain diplomatic relationships until shortly before the World War II with each other due to Poland’s claim over the historical capital city of Lithuania–Vilnius. Latvia maintained neutrality in this question and occasionally tried to negotiate the resolution of the conflict albeit unsuccessfully.

<sup>24</sup>Timothy Snyder, *The reconstruction of Nations: Poland, Ukraine, Lithuania, Belarus, 1569–1999* (New Haven: Yale University Press, 2003), 77–78.

<sup>25</sup>Gērmanis, 247.

<sup>26</sup>On October 1, 1938, German troops occupied the Sudetenland. Shortly afterwards, Polish and Hungarian troops took areas of Czechoslovakia which contained a majority of Poles and Magyars. These actions took place according the Munich Agreement, concluded on September 30, 1938, which was signed by Germany, Great Britain, France, and Italy and permitted German annexation of the Sudetenland in western Czechoslovakia, later of which was not taking part during the discussions.

<sup>27</sup>Gērmanis, 300.

<sup>28</sup>Balodis, 200.

<sup>29</sup>*Ibid.*, 210.

<sup>30</sup>Many foreign experts doubted the effectiveness of this reform as such a system required significant government financial involvement (around 700 million lats, which were equivalent to 129.63 million USD).

- <sup>31</sup>Balodis, 211.
- <sup>32</sup>Central Statistical Bureau of Latvia, *Statistics of 1920–30s*, <http://www.csb.gov.lv/en/statistikas-temas/statistics-1920s-1930s-33017.html> (accessed December 21, 2013).
- <sup>33</sup>Balodis, 212.
- <sup>34</sup>Gērmānis, 254.
- <sup>35</sup>Mārtiņš Kaprāns and Vita Zelče, eds., *Pēdējais karš: Atmiņa un traumas komunikācija* (Riga: University of Latvia, 2010), 82.
- <sup>36</sup>Valdis Kuzmins, “Latvijas bruņoto spēku mobilizācijas un aizsardzības plāni 1939.gada beigās–1940. gada sākumā,” *Militārais Apskats*, no. 3/4 (2009), 49–59.
- <sup>37</sup>*Ibid.*, 58.
- <sup>38</sup>John Hiden and Thomas Lane, eds., *The Baltic and the Outbreak of the Second World War* (New York: Cambridge University Press, 1992), 52–66.
- <sup>39</sup>Олег Николаевич Кен, *Мобилизационное планирование и политические решения: конец 1920–х–середина 1930–х гг* (Санкт–Петербург: Издательство Европейского университета, 2002), 266, 338, 339.
- <sup>40</sup>Balodis, 239.
- <sup>41</sup>Kuzmins, 57.
- <sup>42</sup>Geoffrey Parker, ed., *The Cambridge Illustrated History of Warfare: The Triumph of the West*, rev. and ed. (Cambridge: Cambridge University Press, 2008), 294–298.

## CHAPTER 3

### A DREADFUL YEAR (1940–1941)

[I] find the Molotov-Ribbentrop pact to be one of the most important issues for testing the condition of our society. First, one must study and assess the historical event truthfully, because this would be a step towards the improvement of social awareness, for the morale of the Soviet society and for morality. It is clear that without solving this problem we cannot expect to have normal relations with Estonia, Latvia, Lithuania and Moldova. Normal relations must not be based on lies and falsifications.

— Professor Yuri Afanasyev,  
Rector of the Moscow Institute of Historical Archives

#### Molotov–Ribbentrop Pact

Indecisiveness and sluggishness of the western world in response to Hitler’s activities in the Rhineland (1936) and later in Austria and Czechoslovakia (1938) completely persuaded the Soviet Union of the ineffectiveness of the League of Nations. The head of the Communist Party’s Central committee, Josef Stalin, saw Hitler’s methods as the embodiment of his own desires. After several opening moves (diplomatic meetings and official correspondence) on August 23, 1939, Ministers of Foreign Affairs representing both governments signed the bilateral non–aggression agreement between Germany and Soviet Union. The terms of this pact guaranteed that signatories would not intervene in each other’s actions aimed at the third country. Decades later, this agreement acquired a more symbolic name as Molotov Ribbentrop pact. As signatories, the Foreign Minister of Soviet Russia Vyacheslav Molotov and Germany’s Joachim von Ribbentrop united their nations as “partners in crime.”<sup>1</sup>

The terms of an additional (secret) protocol to this agreement decided the fate of all Eastern Europe. Both Soviet Russia and Germany were to expand their areas of

influence, establish the contiguous border between each other, and occupy neighboring countries in direct vicinity. Therefore, in the agreement, Latvia, Estonia and Finland fell under the annexation of the Soviet Union, while western Poland and Lithuania were doomed to the German occupation. Shortly before signing the agreement most of the Lithuania's territory was also added to the future Soviet territory (see figure 8).<sup>2</sup> According to Ribbentrop's remarks in the Nuremberg trial, Hitler was forced to accept the terms dictated by Stalin, who specifically requested the Baltic States and half of Poland under Soviet rule.<sup>3</sup>

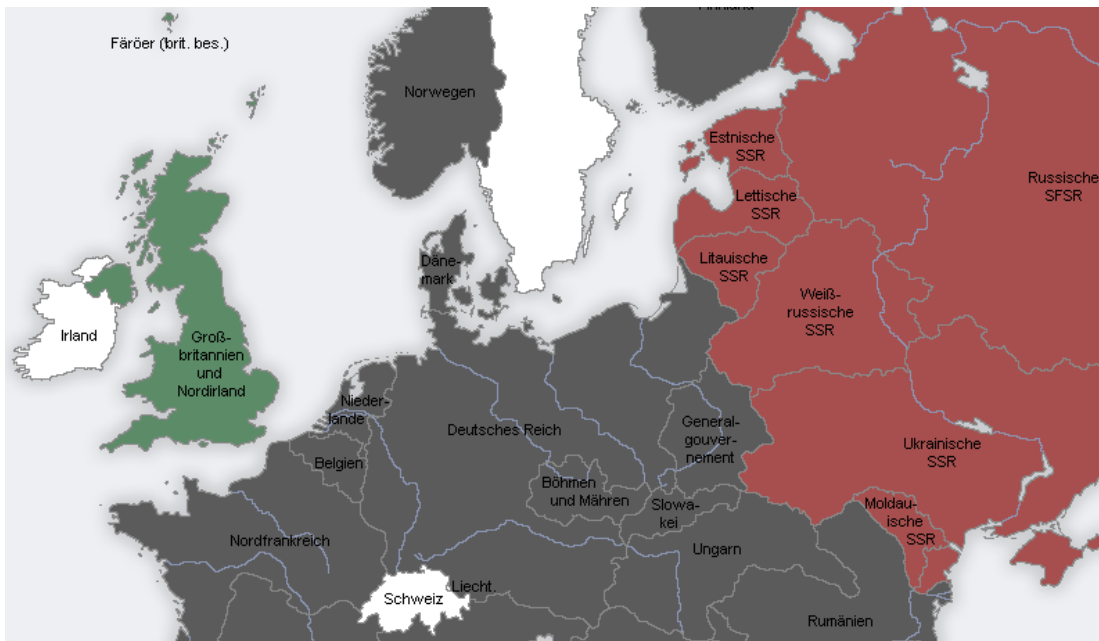

Figure 8. Partition of Europe according the Molotov–Ribbentrop pact.

Source: Wikipedia, Electronic online Encyclopedia, [http://en.wikipedia.org/wiki/Molotov-ribentrop\\_pact](http://en.wikipedia.org/wiki/Molotov-ribentrop_pact) (accessed February 23, 2013).



Neither the Soviets nor the Nazis hesitated to exploit the situation. Germany, feeling safe from the Soviet threat, invaded Poland on September 1, 1939. The Soviet Union followed suit roughly two weeks later (September 17). Stalin then proceeded with safeguarding Soviet Union's northern flank (Baltic coastline) against possible attack from his "temporary colleague, Hitler." Following the momentum, the Soviet Union imposed "mutual assistance" agreements with Estonia (September 28), Lithuania (October 10), and Latvia (October 5). Under the auspices of the agreement, the governments of Baltic States would allow disposition of Red Army forces in their territories. The Soviet Union based its demands on the assessment regarding the Germany's future aggressive.<sup>4</sup> A stage was set for the invasion forces to occupy their designated assembly areas in all three Baltic countries. Before describing the invasion of the Red Army into Latvian territory, a broader picture of current thought regarding the Molotov–Ribbentrop pact should be provided.

Generally, experts in the history of International Affairs define the Molotov–Ribbentrop pact as a solemn non–aggression treaty. Additionally, the secret protocol depicting the new Europe's borders did nothing more than "demarcated their (Soviet Union and Nazi Germany) spheres of interest . . . in order to avoid any controversial issues."<sup>5</sup> Colonial history is filled with similar examples, they say. However, controversy occurs when different perspectives provided the analysis of methods how this pact was executed. While former British ambassador in Latvia Henry Carr submits that the secret protocol was only the Soviet Union's efforts to ensure peace,<sup>6</sup> the other side considers this treaty to be a war crime.<sup>7</sup> Extended atrocities and genocide conducted in occupied

countries under the dictatorship of Bolshevik and Nazi regimes lend more truth to the latter side of historians.

Sharing their assessment, Baltic historians also agree that both Stalin and Hitler were to a significant extent under the pressure of “contemporary momentum” to sign the treaty to at least guarantee their own temporary safety. However, Latvian and Estonian experts argue, no justification other than the cruelty of totalitarianism defines the forcible annexation of occupied territories and the swift cleansing of certain ethnicities, military and national leadership and intelligentsia in the occupied territories.<sup>8</sup>

On December 24, 1989, Russian historians and officials formally denounced this pact as an “act of personal power and to be illegal since the moment of signing.”<sup>9</sup> However, the latest trends in Russia’s historical articles demonstrate avoiding and even justifying tactics when it comes to the direct reasoning of the morality of this pact. At times they are counter aggressive and claiming that Soviet Union’s intentions were purely peaceful. Member of Russian Parliament (Duma) historical committee Alexander Dyukov [*Александр Дюков*] concludes that signing the pact was an “unfortunate but pressing necessity under the circumstances” and that the Baltic countries are the first ones to blame for that. Historian Dyukov points out that the Molotov–Ribbentrop pact is just as “immoral” as the Munich Agreement that divided Czechoslovakia in 1938.<sup>10</sup> In this case, the author leaves the judgment to the reader.

Finally, historical evidence suggests that both Soviet Russia and Nazi Germany were well aware of the fact that at some point in time they would have to settle the dominance in Europe between them by war.<sup>11</sup> If one could call the terms of the Brest–Litovsk agreement<sup>12</sup> as the ending point of one conflict between Russia and Germany,

then the Molotov–Ribbentrop pact was definitely the beginning of another. Both sides needed to strengthen their starting positions (the purpose of Molotov-Ribbentrop pact) before charging at each other. The world was astonished at the impudence of the two but was too slow to react.<sup>13</sup>

### Invasion

Europe was preparing for the war and independent states including Latvia sought alliances with each other. As the Baltic States found themselves politically isolated from Central Europe, they felt forced to accept the terms of Soviet Union that demanded the disposition of its forces on the territory of Latvia, Lithuania and Estonia. Although Latvia and Estonia had an existing mutual assistance agreement, both governments decided not to put up any military resistance. Military assessment showed that a war against the hordes of the Red Army would result in rapid and enormous human losses that would be unacceptable for the small nations. Besides, following the common trend in Europe, Latvia was more concerned with promoting prosperity and peace rather than modernization of military equipment.<sup>14</sup>

The events that followed an acceptance of Soviet demands formed decisive and lasting implications on the Latvian nation's attitude towards Soviet Union and, probably, towards Russian speaking society in general. Most definitely, it was one of the decisive enabling factors for the rapid creation of the Latvian Legion. Shortly after the Latvian government signed the treaty of "mutual assistance" with the Soviet Union, the Red Army deployed into Latvia's western region and capital. 25,000 military personnel stationed near the Baltic Sea and in Riga exceeded the size of the Latvian Armed forces just by numbers alone. The presence of military force, submit historians, offered three

strategic advantages to the Soviet Union. First, a close monitoring of Latvia's external activities was established. In fact, it enforced control over cross border activities, especially with the western powers. This control made it easier to isolate Latvia from the rest of Europe. Second, the immediate Soviet presence in Latvia allowed constant observation and assessment of every movement of the Latvian Armed forces. Tensions arose as both sides tried to avoid any provocations. Third, every existing Latvian mobilization plan became ineffective. With the deployment of Red Army troops in its rear, the Latvian Army would face a war on two fronts, being isolated in the center of the country.<sup>15</sup>

Professor Germanis from Sweden submits that only the Soviet–Finnish conflict delayed Soviet Union's next decisive action—the complete occupation and subsequent annexation of the Latvian territory. As the rest of the world held its breath, Latvians too watched the heroic Finnish nation fighting back in the Winter War. Carl Gustaf Mannerheim recalled after the end of war “by saving Western civilization, Finland has paid its debt till the last penny.”<sup>16</sup>

Nevertheless, after seizing strategic terrain on the former territory of Finland, the Red Army directed its attention back to Baltic States. On June 16, 1940, Moscow accused the Latvian government of attacking the Red Army near the international border. In retaliation for this alleged aggression, the Red Army destroyed one Latvian border post along with numerous civilians and issued an ultimatum that required immediate deployment of an “additional Red Army contingent.”<sup>17</sup> The government of President Ulmanis accepted these terms and later in the day, Soviet tanks entered the capital (see figure 9).<sup>18</sup> Swift and decisive actions caught the rest of the world by surprise. It took

almost a month for the United States to define an official position, declared by Undersecretary of the State Sumner Welles on July 23, 1940. The US condemned such action and refused to admit the annexation of Latvia, however, later in the Tehran conference President Roosevelt admitted that in the name of saving the Europe from Nazism, this sacrifice had to be made.<sup>19</sup>



Figure 9. Soviet invasion made the headlines in New York Times.

Source: Virtual museum, *Occupation of Latvia*, www.occupation.lv (accessed February 26, 2013).

Concerned with the rapid spread of aggressive Nazism in Europe, Allied leaders underestimated Stalin's thrust for power and the spread of global communism. Part of the invasion plan of the Baltic States was also the complete incorporation of those territories

into Russia's pre-World War I borders. To attain this goal, occupying military force was reinforced with the Communist Party's political personnel, instructed to "revolutionize" the governmental system in Latvia.

Here, the author would like to provide additional insights that may answer some of the research questions, and particularly-why Latvia did not stand up during the Soviet invasion. Since its declaration of independence from the Soviet Union on May 4, 1990, two dominant opinions have prevailed. The first advocated that President Ulmanis had made the correct decision and did so in an attempt to preserve the population of Latvians from extinction. The second insisted that the Latvian Army had to fight and trade every bit of land for a high price. The author will provide some of the details on both opinions.

Supporters of the logic of Ulmanis's decision not to oppose the Soviet aggression submit that such a step was not his individual choice but rather the whole of government's conclusion (a vote). As historical evidence indicates, in his report to the President, Latvia's Defense Minister and Commander of the Armed forces Krisjanis Berkis [*Krišjānis Berķis*] stated that the Latvian army, youth-guard and territorial guard units would stand and fight, but this would lead to the "suicide" of the Latvian nation.<sup>20</sup> In case of ethnic cleansings, it would be very likely that there would have been insufficient surviving Latvians to regain their independence in 1990. In 1989, 52 percent of the population on Latvia's territory were ethnically Latvian.<sup>21</sup> Additionally, advocates of non-resistance to the Soviet invasion submit that after the Winter War the Red Army possessed a better-trained equipped and operationally prepared force that would easily overcome any resistance, especially, given the option to fight in summer. After the enormous losses in fighting the Finns, Stalin would not have hesitated to "burn every

house and destroy every Latvian.”<sup>22</sup> Mass murders were already a reality for Stalin after the invasion of Poland. Lastly, supporters of the latter opinion argue that unlike Finland Latvia did not have strong guarantees from the Western Europe, and its only formal ally, Estonia, similarly had Red Army bases on its territory.

One of the popular opponents to the previously described arguments is Latvia’s current Defense Minister, Professor Artis Pabriks. During an interview with the media, Professor Pabriks expressed the opinion that “the decision not to oppose the Red Army in 1939/1940 was the ultimate mistake.” The minister contended that the national motivation to fight was at the highest level during that time. In general, Doctor Pabriks represented the opinion of those who argue that military resistance would not have caused more casualties than the mass deportations to Siberia, NKVD extinctions and World War II taken together inflicted on the Latvian nation. Considering the national morale and a circumstance that the Latvian Armed Forces possessed a high readiness and performance capacity, Latvians would have staged a fierce and bloody resistance that ultimately would draw world’s attention and support. At least, says the minister, “Today we would not have had to explain our history to the rest of the world.”<sup>23</sup>

There are additional facts and arguments supporting both opinions in the following chapters. All we can do today is imagine the full context of circumstances Latvian national leadership had to deal with.

#### “Sovietization” and the new government

In July 1940, during a conversation with the Lithuanian Deputy Prime Minister, Soviet Commissar for Foreign Affairs Molotov explained that Russia had aspired to have the Baltic countries since the time of its former ruler Ivan the Terrible and added, “in the

modern world small states have no future.”<sup>24</sup> Stalin’s plan was to stage national elections, form a loyal government and subsequently annex Latvia as another republic of the Soviet Union. With Hitler’s guarantees presented, the German armed forces focusing on France, the Finns recovering from the Winter War and Great Britain fighting the German air attacks off the mainland, the Soviet machinery initiated a well–orchestrated process–“sovietization.” One of the easiest ways was to dress it like a national revolution.<sup>25</sup>

Although some of the Soviet newspapers in 1940 described this process as democratic and mainly driven by the Latvian nation itself, Baltic history experts and witnesses alike strongly deny the fact of unbiased elections.<sup>26</sup> For example, a first Secretary of the French Embassy in Riga Zhack de Boss [*Jacques de Beausset*], in his diary wrote “tomorrow with the irony we all will see how the country consisting of 90 percent anti–communists will elect [a] 95 percent communist government. Finally, on August 5 this comedy ended.”<sup>27</sup> After President Ulmanis refused to accept the Soviet–proposed cabinet list, the futility of this refusal soon became obvious. An organized mass of demonstrators was delivered to Riga and poured on the streets. Witnesses recall the involvement of around 25,000 demonstrators in the capital, which led to bloody confrontations with police. Just two days later, an official governmental newspaper had published the new members of cabinet albeit without the signature of President Ulmanis. Ulmanis himself was deported to the Soviet Union and until this day, his grave has not been found.<sup>28</sup> Microbiologist Professor August Kirhenstein [*Augusts Kirhenšteins*] became the new head of government, much to his own cost.<sup>29</sup> The first step of “sovietization” was achieved–Soviet newspapers applauded the will of the “oppressed.”



To complete the “sovietization” under the watchful eye of the Soviet Union, the new Kirhenstein government staged national elections where the only party registered was the “People’s worker block.” At the same time, Soviet rule aided the emergence of the Latvian communists, who for years have been driven underground, pursued and arrested. Masses of criminals and political prisoners released from the Riga Central Prison were replaced by “mutinous” anti–communistic elements. Crime on the streets increased. Former inmates were given the chance to arrest their prosecutors, and even more—to interrogate them. Many popular politicians, artists, doctors and social activists were either executed within months or sent to exile.<sup>30</sup> To make this “sovietization” appear more legal, under the umbrella of an official request by the new puppet government, Latvia was annexed and became the Soviet Republic of Latvia on August 5, 1940. One should acknowledge the effectiveness of such a system—within five weeks Latvia, along with the rest of the Baltic States, ceased to exist on the world map. The longest part of the plan was the cleansing of anti–loyal elements. Who were they?

In order to execute the cleansing operations effectively within the Baltic territories clear guidance of the timeline, amount and the target people’s group had to be defined. Some researchers refer to the published instruction given by the USSR’s Deputy People’s Commissar of Public Security, Ivan Serov or the “Serov directive.”<sup>31</sup> According to this directive, which none of the historians have been able to locate as evidence to this day, farmers, officers, large land owners, academic personnel of universities and many others were to be detained and either executed or deported to the labor camps in Soviet Union. Other lower level executive orders have been found after the rapid retreat of Soviet leadership in summer of 1941, however, the original of this overarching “Serov’s

directive” is claimed to be still under the seal of the secrecy.<sup>32</sup> Remarkably, Russian historians also do not deny the existence of such a directive and still admit the fact of mass deportations of the Baltic States in the 1940.<sup>33</sup>

Following the orders of this directive in the spring of 1941, all prisons in Latvia were filled to four times their capacity, therefore initial groups of exiles departed to the GULAG camps.<sup>34</sup> Thousands were packed into cattle wagons and sent to Siberia or even more remote areas of Soviet Union. Reaching its peak on June 13 and 14, 1941, different sources confirm that almost 35,000 men, women and children departed different train stations across Latvia. Sixty two percent of those sent into exile were farmers. People began to avoid going home and some families hid in the forest, exercising the same tactics their ancestors used while earlier wars swept through the territory of Latvia.<sup>35</sup>

In Latvian history, the year from 1940 until 1941 has received its name as the “Dreadful year.” Witnesses and children of those sent in exile still bear the tragic memories of this despair. Intellectuals were especially targeted, because during the Latvian Independence War almost the entire student and academic personnel body of University of Latvia volunteered to fight against the Red Army. Then, in 1941, they already were lecturers, professors, artists, politicians—those who bore and reminded the enormous cost this nation has paid. They were of special value to the troops of the NKVD.<sup>36</sup>

Professor Balodis submits that during the “dreadful year” the Latvian nation “encoded” into its genes a hatred for communism. During the years of independence a whole new generation was raised,<sup>37</sup> a generation that witnessed the atrocities first hand. Just one month later, in July 1941, the same generation was ready to join the ranks of

German forces—some in retaliation, and some for the higher cause, not to allow a repetition of the “dreadful year” (see figure 10).



Figure 10. Deportations of June 1941.

*Source:* Virtual museum, *Occupation of Latvia*, [www.occupation.lv](http://www.occupation.lv) (accessed March 10, 2013).

#### Litene camp and draft into the Red Army

In addition to effectively seizing the physical terrain, dominating the political ground, and formally announcing the international legitimacy of its actions in annexing the Baltic States, the Soviet Union also made a parallel effort to destroy the Latvian Army. Because of its popularity and significance in the Independence War, soldiers of the National Armed Forces were a well-respected social group. The nation never forgot who bore the burden of liberation. The NKVD initially targeted the higher Latvian military leadership, but later mass apprehensions swept through all military units and

ranks.<sup>38</sup> At the end of August 1940, the newly established Baltic Military District headquarters received Order no. 0191 to reform the Latvian Army into the 24th Territorial Corps with two rifle divisions.<sup>39</sup> Special emphasis was put on the extinction of previous traditions and introduction of a new rank and positional system. The highest priority, though, was the integration of ideological work and the so called “politruks” (political officer) cadre whose primary role was to spread the communist propaganda. Every unit from battalion and above was assigned one “politruk” with the authority to overrule the unit commander’s decision.

All personnel were initially encouraged to show up for ideology classes but as the attendance was beyond poor, personnel attendance at these classes became mandatory.

An enlisted soldier of an infantry unit in his memoirs recalls:

The daily schedule of personnel was arranged in the way so as not to give us any free time. Although military regulations required us to sing the national anthem, this along with many other Latvian unit songs was further forbidden, and rule-breakers were punished. One day our commander was sentenced to 7 years imprisonment for saluting the Monument of Freedom as regulations required it.<sup>40</sup>

This, however, was only the warm up before actions more decisive.

During the period of August 1940 until June 1941, Soviet “politruks” conducted a synchronized effort of identifying the potentially dangerous elements within the ranks of the Latvian military, and consequentially either arresting or relieving them from the military service. Those who managed to stay in their positions did so mainly because of their knowledge of the Latvian language, and were under very close observation. The Latvian Army was transformed into the 24th Territorial Corps with two rifle divisions (181st and 183rd) and one cavalry regiment (20th). By June 16, 1941, significant numbers of the commanders were of Russian nationality, while the remaining Latvians

were either completely obedient or ideologically loyal.<sup>41</sup> Most senior officers had to report for “special courses” in Moscow where they were either shot or sent to the GULAG.<sup>42</sup>

In the spring of 1941, a rumor spread that all units of the 24th Territorial Corps would be ordered to conduct an annual military maneuver training in summer camp near Litene. To the surprise of the Latvian officers, all soldiers that had served two years were demobilized, leaving the units at only 50% strength. It was obvious that any tactical training under such conditions would lose its meaning and training value. To appease the growing sense of dissatisfaction among the Latvian military leadership and provocations within the enlisted ranks, a fresh draft was sent to the corps from Moscow, Leningrad and Kaliningrad. With that, almost half of the troops were of Russian speaking nationality. Demobilization of Latvian soldiers continued until the last day before departure to the summer camp—June 1.<sup>43</sup> Lieutenant Colonel Karlis Aperats [*Kārlis Aperāts*] in his memoirs recalls that most of the draftees were members of the communist youth group “komsomol” which meant an absolute trust by the communist party. Also, writes Aperats:

Politruks were worrying more with every day about the possible war with Germany. We officers were dragged into discussion so to certify whether Latvian commanders could be trusted in case of German attack. Soon, commanding positions were filled with Russian officers, Latvians were to play role as the mentors. It was soon obvious that new lieutenants’ understanding of tactics did not reach further then identifying the west direction—direction of enemy.<sup>44</sup>

Constant arrests and disappearance of officers continued. Only the guard detail had access to the weapons; however, ammunition was under the control of the “politruks.”

The Litene tragedy culminated in the same time when tens of thousands of other Latvian citizens were deported to Siberia, on the night of June 13. On the previous day, all Latvian officers were ordered to gather in one place where they were picked up the

next morning and loaded on the trucks. Under the guise of relocation, 120 Latvian officers were driven into the woods, disarmed and apprehended. As one of them tried to resist, killing one of the politruks, everyone was tied up and murdered. Throughout the day, transports with remaining officers and soldiers made their way to the closest train station at Gulbene where they were locked in cattle wagons and sent to the camps in Norilsk (central Russia). A research of Professor Valdis Lumans (University of South Carolina) identified at least 500 Latvian officers as deported or executed. Altogether, 4665 soldiers, non-commissioned officers and officers were arrested, deported or murdered. Only 70 soldiers made it back to Latvia from those sent into exile.<sup>45</sup>

Chapter 3 of this thesis is the closing part that describes the historical background of the evolution of Latvian nation before World War II. In the broad description above, three distinctive periods were identified. First, from the 16th until the 18th centuries, national identity and written language emerged. Second, in the 19th century the Latvian Nation formed among the citizens of Russian Empire. Lastly came the 20th century when Latvia emerged as a separate country with its borders on the world map. We can observe that major trends in the politics, culture and social structure were impacted by Russia and Germany. Likewise, it should be noted that very little effort was observed in creating the lasting cooperation with neighboring countries—Lithuania and Estonia. Apparently, all three nations were too immature to face the brutality of the ideological affairs that dominated Europe in the 20th century.

Today's issues between Latvia and Russia are no longer about the borders. Question of borders has been settled for some years already. It is still the dispute about the past, and Russia's demand, that the Baltic countries acknowledge that they willingly

and by a large vote joined the Soviet Union and accepted communism as their ideology. Also, a majority of Russians still think of Latvia and the other Baltics as being a part of Russia.<sup>46</sup>

---

<sup>1</sup>Geoffrey Parker, ed., *The Cambridge Illustrated History of Warfare: the Triumph of the West*, rev. and ed. (Cambridge: Cambridge University Press, 2008), 304.

<sup>2</sup>Inesis Feldmanis, *Molotova–Ribentropa pakts un Latvija: problēmas nostādne* (Materials of an International Conference, June 14–15, Riga, 2000), 5.

<sup>3</sup>Зоря Ю.Н., Лебедева Н.С. “1939 год в нюрнбергских досье,” *Международная жизнь*, vol. 9 (1989), 137.

<sup>4</sup>Uldis Ģērmanis, *Latviešu tautas piedzīvojumi I–IV* (Stokholma Memento, 1998), 277, 278.

<sup>5</sup>Zoltan Maruzsa, ed., *Unknown Clauses: The Background Deals of Totalitarian Systems in the Face of World War II. The Molotov–Ribbentrop pact* (Budapest: Lorand University, 2010), 13.

<sup>6</sup>Edward Hallett Carr, *German–Soviet Relations between the two world wars 1919–1939* (New York: Ayer Co, 1979), 136.

<sup>7</sup>Jean–Louis Panné, Andrzej Paczkowski, Karel Bartosek, Jean–Louis Margolin, Nicolas Werth, and Stéphane Courtois, *The Black Book of Communism: Crimes, Terror, Repression* (London: Harvard University Press, 1999), 5.

<sup>8</sup>Heiki Lindpere, *Molotov–Ribbentrop pact: Challenging Soviet History* (Tallinn: Foreign Policy Institute, 2009), 7–12; Andris Caune, Inesis Feldmanis, Heinrihs Strods, and Irēne Šneidere, eds., *Totalitarian occupation regimes in Latvia in 1940–1964* 13 (2004), 13, 14.

<sup>9</sup>Борис Хавкин, *К истории публикации советских текстов советско–германских секретных документов 1939–1941 гг.*, <http://www1.ku-eichstaett.de/ZIMOS/forum/docs/7Chavkin7.pdf> (accessed February 24, 2013).

<sup>10</sup>Александр Дюков, *Пакт Молотова–Риббентропа в вопросах и ответах* (Москва: Историческая память, 2009), 11, 12, 27, 28–33, 52.

<sup>11</sup>David James Smith, Artis Pabriks, Aldis Purs, and Thomas Lane, *The Baltic States: Estonia, Latvia and Lithuania* (London: Routledge, 2002), 25, 26.

<sup>12</sup>Peace Agreement concluded between German Empire and Russian Provisional Government on March 3, 1918. Agreement ended Russia's participation in the World War I and allowed Germany to close the Eastern Front.

<sup>13</sup>Sir Basil Henry Liddell Hart, *History of the Second World War* (New York: Da Capo Press, 1999), 27, 43–44.

<sup>14</sup>Maruzsa, 68.

<sup>15</sup>Valters Nollendorfs, Ojārs Celle, Gundega Michelle, Uldis Neiburgs, and Dagnija Staško, eds., *The Three Occupations of Latvia 1940–1991* (Riga: Occupation Museum Foundation, 2005), 11.

<sup>16</sup>Gērmanis, 278, 279.

<sup>17</sup>Ibid., 281.

<sup>18</sup>Agnis Ilmārs Balodis, *Latvijas un latviešu tautas vēsture* (Riga: Kabata, 1991), 281.

<sup>19</sup>John Hiden, Vahur Made, and David James Smith, eds., *The Baltic Question during the Cold War* (New York: Routledge, 2008), 42.

<sup>20</sup>Juka Rislaki, *Kur beidzas varavīksne. Krišjānis Berķis un Hilme Lehtonena* (Rīga: Jumava, 2004), 227.

<sup>21</sup>Data provided by Central Statistics Bureau, [http://www.popin.lanet.lv/en/index\\_eng.html](http://www.popin.lanet.lv/en/index_eng.html) (accessed March 22, 2013).

<sup>22</sup>Viljams Trotters, *Krievu–somu 1939.–1940. gada Ziemas karš* (Rīga: Atēna, 2005).

<sup>23</sup>Full text of the interview available in Latvian language on the website, [http://la.lv/index.php?option=com\\_content&view=article&id=376128:aizsardzibas-ministrs-nepretoans-padomju-armijai-bija-kda&catid=95:intervijas&Itemid=439%20class=](http://la.lv/index.php?option=com_content&view=article&id=376128:aizsardzibas-ministrs-nepretoans-padomju-armijai-bija-kda&catid=95:intervijas&Itemid=439%20class=) (accessed March 22, 2013).

<sup>24</sup>V. Stanley Vardis and Judith B. Sedaitis, *Lithuania. The rebel Nation* (Boulder: Westview Press, 1997), 51–52.

<sup>25</sup>Smith et al., 28.

<sup>26</sup>“Избирательная кампания в Советской Латвии,” *Московский большевик*, no. 270 (1940).

<sup>27</sup>Žans de Boss, *Franču diplomāta piezīmes Latvijā 1939–1940* (Rīga: Liesma, 1997), 160.



<sup>28</sup>Romuald J. Misiunas and Rein Taagepera, *The Baltic States: Years of Dependence, 1940–1980* (Berkeley: University of California Press, 1983), 21.

<sup>29</sup>Alfred Bilmanis, *A History of Latvia* (Westport: Greenwood Press reprint, 1970), 394.

<sup>30</sup>Alexander V. Berkis, “Soviet Russia’s Persecution of Latvia, 1918 to the Present,” *The Journal of Historical Review* 8, no.1, (1988): 29.

<sup>31</sup>Aleksandras Shtromas, *Totalitarianism and the prospects for the world order: Closing the door on the Twentieth Century* (Lanham: Lexington Books, 2003), 291.

<sup>32</sup>Berkis, 30; Balodis, 329; Ģērmanis, 287.

<sup>33</sup>Никита Васильевич Петров, “Первый председатель КГБ генерал Иван Серов,” *Отечественная история*, no. 5 (1997), 23–43.

<sup>34</sup>GULAG camps—labor camps where prisoners were used as a labor force for works in mainly harshest regions of Soviet Union. Initially these camps consisted of criminals. Later, however, a steady stream of political prisoners filled the camps. Brutal inner wars between these groups along the scarce sanitation and food made it almost impossible to survive more than two years in these camps. Those who survived were degraded morally and physically, and had to live with the mark of the “enemy of the state.”

<sup>35</sup>Berkis, 31.

<sup>36</sup>NKVD or People’s Commissariat for Internal Affairs later became KGB and is commonly referred to as the Secret Police. Today’s successor of KGB is the FSB (*Federal'naya sluzhba bezopasnosti Rossiyskoy Federatsii*).

<sup>37</sup>Balodis, 300.

<sup>38</sup>Arvids Memenis, *Karavīri bēdājās* (Rīga: Poligrāfists, 1992), 14.

<sup>39</sup>*1941 год: в 2-х книгах* (Москва: Международный фонд “Демократия,” 1998), 37.

<sup>40</sup>Memenis, 15.

<sup>41</sup>Alberts Liepiņš, *I.Jātnieku Pulks: Dievs, Tēvija, Pulks* (Lansing: A.Liepiņa un Gauja apgāds, 1980), 244.

<sup>42</sup>Valters Nollendorfs et al., 15.

<sup>43</sup>*Latviešu karavīrs II Pasaules kara laikā* (Stokholma: Daugavas Vanagu izdevniecība, 1970), 205–207.

<sup>44</sup>Ibid., 209.

<sup>45</sup>Valdis O. Lumans, *Latvia in World War II* (New York: Fordham Univ. Press, 2006), 133.

<sup>46</sup>Jukka Rislakki, *The Case for Latvia. Disinformation campaigns against a small nation* (Amsterdam–New York: Rodopi, 2008), 203.

## CHAPTER 4

### NAZI GERMANY'S OCCUPATION AND ORIGINS OF LATVIAN LEGION

[A]nd then one of commissars stood up, approached our table and asked, “What would be better, the fact that we came first or the Germans?” I thought for a split second and answered, “If Germans would have come first they would get our hearts.”

— Captain K.Kārklīš, *Via Dolorosa of our Cavalry*

At the outset of the occupation, Nazi leadership presented Eastern Europeans especially those under Soviet occupation with a political question: the meaning of “liberation.” Although Nazi Germany’s rule was not more liberal than the Soviet one and deserves to be condemned because of its genocidal actions in particular, for the Latvian nation the Germans were seen as the liberators. There were objective reasons for Latvians to believe that the Nazis had liberated them from the bloody Soviet yoke. However, soon it was not easy for them to understand what the Nazis understood by the term “liberation.” By their actions, it turned out as a complete control of the occupied territory and almost total denial to the people of the territories of the fruits of their lands. Some understood the Nazi deception in a matter of weeks, others took months, but some never did.

This chapter will closely discuss the circumstances that led to the creation of the LL and describe the contemporary development of national thought that prevailed during the Nazi occupation. It will also seek answers to some of the primary and secondary research questions. In particular, we will try to describe the level of support Latvians offered the German occupation force, as well as determine whether the creation of the LL was based solely on a voluntary basis. Finally, we will consider the internal ideological

atmosphere that dominated the ranks of the LL, and the kind of relationships that the Latvian military leadership had with the German one.

#### New liberators, new order and another ideology

On June 22, 1941, Nazi Germany's troops crossed the border and entered the Baltic region. Inflicting chaos on the Red Army, the Third Reich's tanks advanced rapidly towards Riga. On July 1, Riga was captured, and a week later (July 8) all Latvian territory was under the new occupying force.<sup>1</sup> The Red Army retreated without significant resistance, gaining its supplies from plundering the area. Sights of the weakness and turpitude of Soviet soldiers, in turn, initiated a widespread resistance movement amongst the Latvian populace. Retreating Red Army units were constantly attacked and harassed by partisan groups led by former Latvian officers or even full size units that deserted from the 24th Territorial Corps.

In the afternoon of July 1, the commander of the German battle group in his radio speech greeted the people of Latvia with the liberation from Soviet rule.<sup>2</sup> It is significant that, however different the banner of the Third Reich was from the Soviet one, neither of the occupants allowed themselves to be branded as an occupier. Both attempted to prove to the whole world, and particularly to the over-run people themselves, that they entered these areas only as "protectors," "saviors" and "liberators" of the peoples inhabiting them.

Former Latvian legionnaire Arvids Memenis observed that the war between the Soviet Union and Nazi Germany reminded him of a tragicomedy. Just as honest were the service members of the German Armed Forces [*Wehrmacht*], as brutal and ideologically overwhelmed was the political leadership of the Third Reich. "Any gain that *Wehrmacht*

achieved, the Security Service leveled to nothing,” wrote Memenis. An initially friendly attitude towards German troops was replaced by deep disappointment. With its actions, the German Schutzstaffel (SS) sealed the fate of any success in the East, any sympathetic feelings were erased by the ambitions of the Nazi party. A partisan movement once again erupted and the German Wehrmacht was forced to withdraw some divisions from the front line in order to secure the lines of supply.<sup>3</sup> How short can one’s memory be?

With the 27th Red Army units retreating and the German 291st Infantry Division closing on Riga, political activities once again reconvened in the capital. On the eve of June 28th members of the largest partisan groups met to discuss the possible governmental structure of liberated Latvia. All agreed that Latvia’s independence and national administrative board were the first priorities. Professor Balodis submits that the highest German military command in the Baltic space was only concerned at that time with maintaining order in his rear. Therefore, the military leadership of the German *Wehrmacht* did not object to any political movement in Latvia as far as it enabled unrestricted maneuvers and movement of troops.<sup>4</sup> Speed for Plan “*Barbarossa*” was of paramount priority. The tide changed when Nazi Germany’s political leadership arrived after the fighting force and learned of the rapidly established Latvian self-governance. A contemporary witness of the Nazi occupation, Captain Adolf Blakis [*Adolfs Blāķis*] in his memoirs writes, “A new policy demanded that Riga becomes “Germanized.” Streets and cities were assigned new names—now they proudly bore portraits of Hitler, Manteuffel, and Goering.”<sup>5</sup> Earlier Nazi plans regarding the Baltic States demanded that Latvia had to be incorporated into Greater Germany’s territory: an independent administration consisting of the local national element was not in neither Hitler’s nor Reich Minister

Alfred Rosenberg's plans.<sup>6</sup> It soon became clear that a Nazi occupation had replaced the Soviet one. Handling of weapons and wearing of Latvian uniforms were forbidden, any armed elements were disarmed, and retired General Oskars Dankers was appointed to head a government loyal to Nazi Germany.<sup>7</sup>

Refining its plans regarding the newly occupied eastern states, Nazi Germany further subdivided its administrative and security control. As of July 31, 1941, the General District Latvia<sup>8</sup> was established under the overarching Reich Commissariat Ostland headed by Reich Commissar for Ostland Heinrich Lohse. As his direct subordinate, Commissar General Dr. Otto Drechsler headed the General District Latvia. His organization implemented Nazi policy in the occupied territory.<sup>9</sup> Parallel to this, in order to maintain security in the occupied territory the SS controlled and directed the executive policing functions. The SS completely rejected and prohibited all attempts at forming the renewed Latvian Armed forces. However, in order to provide at least some economy of Nazi Germany's resources, a small unit of not more than 3000 men was allowed to be formed. It performed the role of assisting a police force under the command of higher SS leadership. As directed by SS Reichsfuhrer Heinrich Himmler, local police units formed in the "Ostland" were to be called "Order Police" [*Schutzmannschaft*]. At first, national armed force responsibility for Latvian self-determination was given only at the local recruitment centers. The head of the Riga Order Police was Lieutenant Colonel Voldemar Veiss [*Voldemārs Veiss*].<sup>10</sup>

Colonel Veiss was also responsible for leading the recruitment process for the Order Police. Initially, volunteers poured into the recruitment centers. They primarily were the ones whose relatives had been killed or sent to Siberia under the Soviet rule.

The first tasks of such recruits were aimed at identifying and exterminating of Latvian Jews.<sup>11</sup> Five Order Police battalions formed up in Riga by the end of 1941 (174 officers and 2799 NCOs and enlisted). Starting in September of 1941 and ending in July of 1944, a total of 48 Latvian Police battalions were formed. In 1942, they were comprised of 10,535 men, in 1943–9710 men, in 1944–14,884 men.<sup>12</sup> In the summer of 1942, the flow of volunteers dried out. As members of police battalions additionally were sent to the frontlines and usually put at the most dangerous fighting sectors, Latvian youth was much less eager to sacrifice itself for unknown reasons and idols.<sup>13</sup> It became obvious that Plan *Barbarossa* has failed and quick victory was not achievable.

Historical evidence, interviews of contemporary witnesses and independent research by Latvian and foreign historians help us to find answers to some of the research questions in this thesis. It should be recognized that during the first months a majority of the Latvian population provided significant support for Nazi efforts after the Wehrmacht entered the occupied Baltic territories. First, many felt an oppressive sense of guilt for allowing the Soviet Union to occupy Latvia without a single shot. Back in the summer of 1940, the Latvian population was ambiguously aware of the ultimate goals of the Soviet Union; however, they still naively believed that promises given by the “mutual assistance” treaty would be fulfilled peacefully. Therefore, the ferocity of NKVD men and the ensuing extermination of Latvian intelligentsia left an indelible psychological imprint on the contemporary generation. Additionally, a well-conceived and cleverly executed Nazi ideological campaign<sup>14</sup> kept fanning the anti-communist feelings of the Latvian people, making them a perfect tool that fought fiercely until the end. Second, non-negotiable SS directives and direct subordination to the SS Police court (equivalent

to Field Court Martial) forced some of the Latvian Police battalions to take direct part in the repressive actions in Poland, Belorussia, Ukraine and Latvia. These actions included supporting the extermination of the targeted groups of people: Jews, Gypsies, and communists.<sup>15</sup>

Finally, in the midst of these horrific times the Jewish population was the one most exploited and targeted: they were the best-manipulated tool of propaganda. In 1940, the communists accused the Latvian government of supporting Nazi Germany: Moscow had deliberately put mostly Jews in charge of the NKVD punishment force: prisons, police, secret police etc. Therefore, in 1941, when the Nazis occupied Latvia, they were successfully and without difficulties “putting the Jewish face” on almost every horrific crime that the communists had performed in the “dreadful year” (see figure 11). One would name it an excellent example when theory (ideology) and reality aligned. The exhausted Latvian nation was easy to manipulate, especially when the Nazi German leadership gave vague promises of self-determination.

#### Wehrmacht in trouble. Order for creation of Latvian Legion

After the exhausting attempts to seize Moscow on the Eastern Front, the German offensive stalled in the winter of 1941. A former spokesperson for Joachim von Ribbentrop and author of historic research on the Wehrmacht’s march against Russia, Paul Carell argues that such circumstances were mainly possible due to Stalin’s decision to introduce fresh Siberian divisions detached from the Soviet Union’s 9,000 km long eastern border. Aware of Japanese plans to attack Pearl Harbor and accepting the risk in the east, writes Carell, Stalin reinforced Moscow’s defense with units best suited for winter warfare.<sup>16</sup> The Red Army's experience and lessons learned in the war against



Finland, along with the misery suffered by Wehrmacht troops in the cold weather, paid off. The German momentum was lost, and indications of protracted warfare emerged. The Soviet Union had evacuated much of its essential war industry behind the Ural Mountains whereas the Wehrmacht's lines of supply continued to stretch in every direction. Although the Wehrmacht regained some operational advantage during the summer offensive in 1942, its fate was sealed; an advance of every kilometer to the east doubled the stretch of the frontlines to the north and south. The complete failure of Plan "Barbarossa" was obvious after the Wehrmacht's defeat at Stalingrad. Tying up for months at least seven Red Armies, states Carell, Field Marshal Paulus's Sixth Army finally had to capitulate.<sup>17</sup> Nazi Germany desperately needed new units.



Figure 11. Anti-Semitic propaganda

Source: Virtual museum, *Occupation of Latvia*, [www.occupation.lv](http://www.occupation.lv) (accessed March 15, 2013).

As mentioned in the previous subchapter, parallel to the extensive political work, the Reich Commissariat “Ostland” conducted active recruitment of the Latvian population and formation of Latvian Order Police battalions. As long as the voluntary drive of Latvians sustained the Commissariat’s desires, there was little evidence of forced draft into the ranks of the occupation force. Clear resistance to forced conscription and cases with open desertion escalated only in the end of 1944, when Commissar General Otto Drexler [*Otto Drechsler*] reported that “out of 101,918 registered draftees only 85,869 showed up upon the request.”<sup>18</sup> However, this fact should be tied to the larger global perspective of difficulties Nazi Germany was facing across all of its occupied lands.<sup>19</sup> In any event, on February 10, 1943, Adolf Hitler issued an order authorizing the formation of a “Latvian voluntary SS Legion.” Coordinating instructions included that “Strength and size of the units depend upon the availability of Latvian manpower.”<sup>20</sup> Therefore, it is suitable at this point to answer one of the secondary research questions on whether the Latvian Legion was formed solely by the nation’s voluntary will.

To start with, let us understand the judiciary framework of the contemporary environment in Latvia as it formed the basis for subsequent orders and instructions, and is still an urgent topic of discussions amongst radical groups in today’s Latvia.

After the complete expulsion of the Red Army forces, Nazi Germany declared that Latvia was not a sovereign and freed country, but just another territory of Soviet Union, which the Wehrmacht had fought for, and would be treated accordingly.<sup>21</sup> According to this underlying philosophy the formation (and size) of any paramilitary civil protection and order units were only authorized under executive order No. 1 (July 20, 1941) issued by Major General Walter Shtaleker.<sup>22</sup> On November 6, 1941, Nazi

Germany's Reich Fuhrer SS, Heinrich Himmler, ordered the reorganization and expansion of the existent Latvian paramilitary formations and authorized the formation of the Latvian Order Police battalions.<sup>23</sup> As described previously, this order remained effective until re-occupation by Soviet Union and led to the creation of 42 Latvian Order Police battalions (an additional seven battalions were created from ethnic Russians living in Latvia during the same period).

Additionally, in order to sustain an effective administration over the Baltic territory, on December 19, 1941, Reich Minister for Ostland Alfred Rosenberg published the decree "Introduction and Organization of German Judiciary in the Occupied Eastern Areas."<sup>24</sup> Under the auspices of this decree, voluntary labor service<sup>25</sup> was offered to Latvian youth, especially men of a younger age and graduates of high schools or universities. Under the "umbrella" of this service, Rosenberg "offered" young boys to join the labor camps across all Reich and support the construction of an "equal and happy future." One can observe the similarity to the Soviet ideology. Latvian National governance was only allowed in the local affairs (farming, justice etc.), consisted of several directors and was named the General Directorate Latvia. Professor Ezergailis's historical analysis suggests that these labor camps were only another way to recruit young men into the "brown shirt" organization.<sup>26</sup> To complete the full legislative control, and later reinforce conscription into the Latvian Legion, Nazi Germany was still appealing to the previously existing Latvian Law of Mandatory Service.<sup>27</sup> The Germans made a public appeal and even the enforcement of the latter legislative document was exercised from March of 1943 until September of 1944. Ultimately, a declaration of total mobilization on July 20, 1944, revealed the true extent of Nazi Germany's intentions. Not

only was the Wehrmacht suffering a general defeat, but also the will to “squeeze every juice” from occupied territories became apparent. Latvians born between 1906 and 1928 were the target group, and avoidance of the draft was declared as crime.<sup>28</sup>

To summarize, young Latvian men who by the end of 1942 had not yet joined any of the Reich’s organizations voluntarily eventually did not have the luxury of staying home. A popular saying of those days was “shovel or rifle” meaning that youth could either perform labor duties somewhere in the Third Reich or enlist in the ranks and become “cannon fodder.” The Nazi Germany system aimed at total exploitation of all manpower existing in the occupied territories. Therefore, it would be fair to recognize that the word “voluntary” with respect to joining the LL only extends to the individual’s choice between two evils: joining the partisans in the forest or enlisting in the ranks of the Legion. In the first case, young men would endanger their whole families whereas joining the LL they would only risk their own lives. Different historical sources submit that as many as 150,000 Latvians have fought within the different Nazi formations (not just the LL) throughout World War II.<sup>29</sup> In turn, as a side note it is also worth mentioning that an equal situation existed during the brief first Soviet Occupation, where almost 65,000 Latvians served within the ranks of the Red Army.<sup>30</sup>

---

<sup>1</sup>Arvids Memenis, *Karavīri bēdājās* (Rīga: Poligrāfists, 1992), 34.

<sup>2</sup>Ibid., 35.

<sup>3</sup>Ibid.

<sup>4</sup>Agnis Ilmārs Balodis, *Latvijas un latviešu tautas vēsture* (Rīga: Kabata, 1991), 301.

<sup>5</sup>Adolfs Blāķis, *Medaļas otrā puse: okupācijas varu pavadā un jūgā, 1940–1945* (Buenoaires: La Voz, 1956), 10.

<sup>6</sup>Ibid., 302, 303.

<sup>7</sup>Karlis Kangeris, “Kollaboration vor der Kollaboration? Die baltischen Emigranten und ihre ‘Befreiungskomitees’ in Deutschland 1940/41,” in *Okkupation und Kollaboration (1938–1945)*, ed. Werner Röhr (Berlin and Heidelberg, 1994), 181.

<sup>8</sup>In total, there were four General Districts in the Reich Commissariat Ostland: Latvia, Estonia, Lithuania and White Ruthenia (territory of Belorussia).

<sup>9</sup>Andrew Ezergailis, Ed., “Voldemārs Salnais’s Reports: 1941–1944,” *Stockholm Documents. The German Occupation of Latvia 1941–1945. What did America know?* (Riga: Historical Institute of Latvia, 2002), 16.

<sup>10</sup>Kārlis Kangeris, “Policijas struktūras Latvijā vācu okupācijas laikā 1941–1945,” in *Latvijas Vēsturnieku komisijas raksti, 16.sēj.: Okupētā Latvija 20.gadsimta 40.gados. Latvijas Vēsturnieku komisijas 2004.gada pētījumi*, ed. Dzintars Ērglis (Rīga: Latvijas vēstures institūta apgāds, 2005), 287.

<sup>11</sup>Uldis Neiburgs and Vita Zelča, eds., *Divas puses. Latviešu kara stāsti. Otrais pasaules karš karavīru dienasgrāmatās* (Rīga: Mansards, 2012), 62, 63.

<sup>12</sup>Kangeris, *Policijas struktūras Latvijā*, 295.

<sup>13</sup>Kārlis Kangeris, “Latviešu Policijas bataljonu izveidošanas otrā fāze– ‘lielervēšanas’ akcija. 1942. gada februāris–septembris,” in *Latvijas Vēsturnieku komisijas raksti, 10.sēj.: Okupācijas režīmi Latvijā 1940.–1959. gadā. Latvijas Vēsturnieku komisijas 2002.gada pētījumi*, ed. Dzintars Ērglis (Rīga: Latvijas vēstures institūta apgāds, 2003), 318.

<sup>14</sup>Pauls Kovalavskis, Oskars Noritis, and Mikelis Goppers, eds., *Latvia: Year of Horror* (Riga: Zelta Abele, 1942).

<sup>15</sup>Алексей Михайлович Литвин, *Латвийские коллаборационистские формирования на территории Белоруссии, 1942–1944 гг.* (Москва: Фонд “Историческая память,” 2009), 27–53.

<sup>16</sup>Pauls Karells, *Barbarossa. Karagājiens pret Krieviju* (Brooklin: Grāmatu draugs, 1964), 177–202.

<sup>17</sup>Ibid., 625–638.

<sup>18</sup>Haralds Biezais, “Latviešu Leģions un dezertieri,” *Kara Invalīds* 31 (1986): 14–26.

<sup>19</sup>On November 24, 1943, a special War Trial was established to execute the deserters. In the summer of 1944, Berlin published a memo that allowed executing any person within 48 hours if he avoided the draft.

<sup>20</sup>Kārlis Kangeris, “Latviešu leģions–vācu okupācijas varas politikas diktāts vai latviešu ‘cerību’ piepildījums,” in *Latvijas Vēsturnieku komisijas raksti, 24.sēj.: Baltijas reģiona vēsture 20.gadsimta 40.–80.gados*, ed. Dzintars Ērglis (Rīga: Latvijas vēstures institūta apgāds, 2009), 62.

<sup>21</sup>Ezergailis, 16.

<sup>22</sup>Walter Shtaleker [*Walter Stahlecker*]–SS Major General of Nazi Germany’s Security Police, commander of operational group “A” in Ostland. With his order No 1, on July 20, 1941, he authorize only limited size of Latvian Order Police battalions.

<sup>23</sup>*Latviešu karavīrs 2.Pasaules kara laikā 2* (Stockholm: Daugavas Vanagu apgāds, 1972), 29.

<sup>24</sup>Antonijs Zunda, “Vācijas okupācijas varas politika Latvijā (1941–1945): vērtējums historiogrāfijā,” in *Latvijas Vēsturnieku komisijas raksti, 11.sēj.: Latvija Nacistiskās Vācijas okupācijas varā, 1941–1945*, ed. Dzintars Ērglis (Rīga: Latvijas vēstures institūta apgāds, 2004), 19.

<sup>25</sup>Ezergailis, 36.

<sup>26</sup>*Ibid.*, 37.

<sup>27</sup>Inesis Feldmanis, “Latviešu un citu nevācu tautību ieroču SS vienības Otrajā pasaules karā: formēšana, ideoloģija un cīņas mērķi,” in *Latvijas Vēsturnieku komisijas raksti, 10.sēj.: Okupācijas režīmi Latvijā 1940.–1959. gadā. Latvijas Vēsturnieku komisijas 2002.gada pētījumi*, ed. Dzintars Ērglis (Rīga: Latvijas vēstures institūta apgāds, 2003), 339.

<sup>28</sup>Neiburgs et al., 66–68.

<sup>29</sup>Zunda, 18.

<sup>30</sup>Modris Eksteins, *Walking since Daybreak. A story of Eastern Europe, World War II, and The Heart of Our Century* (Boston: Mariner Books, 2000), 114.

## CHAPTER 5

### LATVIAN LEGION

“[I]t is hard to understand or describe what both Latvian Divisions achieved in the face of overwhelming Russian odds. Words cannot express what I want to say, but before both these courageous divisions, I bow my head.”

—Lt Col F.E. Whitton, US Army Command and General Staff College

This chapter introduces the reader to specifics of the LL’s structure, details of its creation as well as describes its internal social diversities within the LL. Creation of the LL for the most part was a direct result of General Mobilization in 1943 and 1944, and restructuring the existing Latvian frontline units. Although Nazi Germany was using the term “voluntary” this was only done to meet the Hague Convention of 1907, which stated that occupying powers are forbidden to mobilize the citizens of occupied lands into their own ranks. Additionally, this led to a decision that any non-German unit could not be drafted into the ranks of the Armed Forces or Wehrmacht.<sup>1</sup> However, under the existing conditions a large portion of Latvians saw their mission as a fight for Latvian freedom—at least a freedom from Soviet yoke, even within the ranks of Nazi Germany’s Waffen-SS. A general difference between Latvia and the rest of Western Europe lies in the fact that countries in Central and Western Europe had seen only one, Nazi German, occupation whereas the Baltic States experienced firsthand the destruction of their independence in 1940 by the Soviet Union.<sup>2</sup> In 1943, it was obvious that this same power had become a realistic threat and re-occupation was likely to occur once again.

By 1942, German manpower resources were stretched to a breaking point. Nazi Germany’s troops were on the frontlines from North Africa to Norway and from the Bay of Biscay to the Caucasus. The “legion program” was the SS attempt to increase numbers

by calling for non-German volunteers to fight the communists. Initially, Waffen-SS legions were formed of the volunteers from Germanic countries (Danes, Norwegians, Flams, Swedes and Belgians), later legionnaires from France, Latvia, Russia, Croatia and other ethnicities filled the ranks. It is estimated that in October of 1944, when around 910,000 men served within the ranks of Waffen-SS, 57 percent of them were other than German ethnicity.<sup>3</sup> Nazi Germany needed volunteers. The volunteers came from all over Europe, but the largest legion by far was the Latvian Legion. With a peak strength of 87,000 men the LL was more than ten times as large as any of the other volunteer legions.<sup>4</sup>

Before proceeding, a reader should be clear about the term “Latvian Legion.” In the much broader sense this term emerged already in 1941, however, throughout World War II this label was used in numerous ways and according the different needs. Researching the historical evidence of the occupation of Latvia by Nazi Germany, Latvian University professor Haralds Biezais submits that in reality such a unit never existed. However, the term itself was widely used by the German and Latvian senior military and administrative leadership, when informally describing all armed formations consisting of mainly Latvian ethnicity.<sup>5</sup> For the first time, the official term “Latvian voluntary Waffen-SS Legion” emerged in Hitler’s instructions to SS Reich Fuhrer Heinrich Himmler on January 9, 1943. Following these instructions, Himmler initiated the creation of the first Latvian frontline units under this new term.<sup>6</sup> Professor Biezais concludes that although Himmler himself initially was against the creation of a real Latvian Legion in 1941, Hitler’s directive appealed to his ultimate goal to command his “own” army.<sup>7</sup> This fact also reveals internal disputes between Himmler and Hitler.



Himmler supposedly wanted to create a reliable force strengthening his political position with respect to the Nazi Germany's Armed Forces—the Wehrmacht. As the war progressed, Hitler's dissatisfaction with his generals, whom he had praised in the beginning of the war, grew into arrogance and therefore Himmler steadily strengthened his own position.

Looking from the previously described perspective, the Latvian nation once again had become a pawn not only in the hands of a bigger occupational force but also as a tool of one's selfish desire for glory and satisfaction. Consequent analysis of the LL's evolution will show that as Nazi Germany faced more losses in the Eastern front, its methods of LL creation became more drastic just as promises to the Latvian nation were more surrealistic. In order to avoid any further misinterpretation, and as per Hitler's order, in this thesis the term "Latvian Legion" will be applied only to two Latvian divisions (*Waffen Grenadier Division der SS 15 und 19*), created after the official publication of the order of February 10, 1943. Motivation to do so is based on two aspects. First, the author desires to exclude misapplication of this term to numerous other Latvian paramilitary formations. As described before, Latvians were drafted into the ranks of Order Police, Penitentiary Security Police, Highway Security Police, Harbor Police, Railway Police etc.<sup>8</sup> Second, national and international unrest in today's Latvia is linked to the unofficial remembrance day of Latvian Legion—March 16. On this day in 1944, both divisions temporarily fought side by side on the Eastern front and executed operations under unified Latvian command. Amongst the survivors of both divisions this day was chosen for its symbolic meaning not so much for its strategic impact on the course of war. Lastly, the author does not intend to belittle the sacrifice of Latvians in

other units; rather, he is attempting to keep a clear focus on the issue. The limits of this thesis do not allow the author to objectively portray the history of all Latvian military formations in World War II.

#### Political aspects and military circumstances of LL's creation

As mentioned previously, Nazi Germany's force and area administration disbanded the paramilitary formations that were rapidly stood up by the Latvian resistance during the Red Army's retreat. Further creation of any armed services had to be under the close control and command of entrusted Nazi leadership. Therefore, renewed discussions over the creation of more formalized uniformed Latvian combat units restarted in the mid-1942, when streams of "voluntary" Latvian youth halted and the Red Army's threat grew rapidly.<sup>9</sup> The reason for the sudden decrease of voluntary interest was the overall dissatisfaction with the dissonance of the Nazis' initially stated intent for these units and the reality of their employment. Order Police battalions were largely sent to the front lines and thrown into the most dangerous sectors, becoming involved in the partisan battles with often-insufficient sustainment and equipment. Some of them were also involved in the executions of civilian population or "enemies of the Reich." For most of these Latvians, it was hard to accept this mistreatment since their voluntarism was driven by the will to defend their own country and defeat communism. Once, during his visit to one of the Latvian Order Police battalions, Col. Veiss concluded, "it was a ragamuffin army."<sup>10</sup> Besides, the main promise to remain and defend their fatherland turned out to be fake. Dissatisfaction grew and some open confrontations with German leadership were registered. What could Nazi Germany's administration offer in order to change the tide?

One of the answers is provided in German Foreign Office expert Peter Kleist's memoirs where he recalls, "in February 1943 an autonomy statute for three Baltic States was drawn up by one of Rosenberg's officials."<sup>11</sup> Doctor Kleist also submits that such a plan had Himmler's approval since he hoped that this would secure much better recruitment for his SS army.<sup>12</sup> Himmler also was optimistic because of the people who, even if they did not speak an Aryan language, were mainly blond and blue-eyed with strong admixtures of Scandinavian and German blood.<sup>13</sup> Therefore, we can conclude that Himmler's proposition was the promise of self-governance for Latvian people within a larger Reich constellation. In return, the General Commissariat for Ostland requested active support and enlistment of the Latvian population. How active was the Latvian side in answering this call?

At this point, it would be beneficial to provide the insight of two dominant and fairly opposite thoughts in Latvian history that describe the level of national (Latvian) support to the creation of the LL. First one supported the creation of the LL and emphasized it as the necessary act, an argument supported by the Latvian military leadership who later commanded the LL's units in the Eastern Front. The other opinion was and still is largely a critique of this act. This insight will help us to answer one of the research questions regarding the loyalty or collaboration of Latvian-run General Directorate with the Nazi Germany's appointed leadership. It will also depict the internal diversity that occasionally poisoned the relationships amongst Latvians.

As mentioned, military personnel that survived the Soviet occupation supported the idea of establishing the LL. In particular, we can mention General Rudolf Bangerskis and Colonel Arturs Silgailis, both serving in the General Directorate. Once the forced

draft of Latvian youth became inevitable, officers of the once independent Latvian armed forces (including the mentioned ones) realized that passiveness would be of more harm to these young men instead of an attempt to shape the LL's creation process. In his memoirs, Colonel Silgailis expressed a concern that, "Latvian boys called up through the labor boards would be sent in every direction within the Third Reich and lost for Latvia forever."<sup>14</sup> These officers could not stand aside and decided to engage themselves in an attempt to keep Latvian manpower in one place (unit) under the unified Latvian command. Colonel Janums, in turn, in his memoirs, writes, "in order to preserve Latvian youth and prevent its dissemination, a Board of General Directorate ordered the Inspector General<sup>15</sup> to call up former commissioned and non-commissioned officers of the Latvian Army."<sup>16</sup> The senior Latvian military leadership consciously was cradling the dream of a strong Latvian military unit that ultimately might help regain the national independence that developed after the World War I. Additionally, as stated earlier and as it happened before, Latvians still hoped for the support of the Western European countries (Allies). Colonel Silgailis writes, "the possibility that [the] Allies would allow the Red Army to march until the Elbe was not even considered by any politically rationally thinking person."<sup>17</sup> Another former legionnaire, Mintauts Blossfelds, also confirms this thought. In his memoirs, he writes, "even here, in prisoners' camp there were rumors circulating concerning the coming war between the Western Powers and the Russians. To us such an outcome seemed inevitable. We could not imagine the Western Powers allowing the Communists to continue occupying our own and other Eastern European countries."<sup>18</sup> Therefore, officers of the Latvian Army saw their mission not only as the commanders of their youth, but also as the protectors of the dream for independence. At least, they hoped

to hold the Red Army until the Allies could settle with the Nazi Germany. So far Latvian officers were in consonance with Hitler's idea and, probably, with the goals of Allies.

On the opposite side, the critique of the previous group mainly consists of "too extensive" collaboration with the Nazi leadership. Former legionnaire Arvids Memenis argues that the best thing the Latvian nation could do was to avoid any draft and ignore every enlistment order. In his memoirs, he writes, "1943 was the year of Germany's general retreat. In order to 'plug the holes' in the front lines the Nazis ordered creation of the LL. 'Servants' from the General Directorate enthusiastically followed the orders. Why? For drafting our boys and to hand them over to the Germans—that's why."<sup>19</sup> Memenis even goes as far as accusing senior military leaders of being selfish and only willing to earn more "iron crosses," therefore sending the soldiers to the "craziest" tasks.<sup>20</sup> The author of this thesis was able to find a statistical supportive data of Memenis's latter argument—around 3,000 Latvian soldiers were decorated with Iron Crosses. Additionally, sixteen Latvian soldiers received a German Cross in Gold and twelve received the highest award, Knight's Order of the Iron Cross, which makes both divisions the most decorated non-German Waffen-SS units in the World War II.<sup>21</sup> As Memenis himself witnessed the battles firsthand, he argues that only those officers and civilian leaders who tried to save the nation from worthless fighting or the draft are worthy of praise.<sup>22</sup> Like Memenis, Professor Biezais has expressed a similar critique. Biezais addresses his accusations mainly at the civilian leadership of the General Directorate: Oskar Danker and Martins Primanis. He argues that any effort to stand on the demands of national self-determination was simply overridden by both Dankers and Primanis, mainly because they were repatriates and of Baltic German origins.<sup>23</sup>

In fairness to both sides, however, it must be mentioned that initially (on January 27, 1943) members of the General Directorate refused the Nazi proposal to form the LL. They were ready to discuss this issue only after the guarantees of broader national self-determination would be granted.<sup>24</sup> Nazi Germany's representative, General *Schröder*, in turn answered that such discussions were outside his competency; however, he promised to voice these concerns up the chain of command. An absence of one common vision and internal disputes within the General Directorate split Latvians into two camps—those who supported the demands and those who supported the immediate fulfillment of the orders. One should not forget that Nazi Germany never gave a direct answer to the earlier demands. One can recall the first chapter of this thesis and see the situational coincidence with the deliberate diplomacy that German knights used once arriving at the Latvia's shores to degrade the unity of Latvian tribes. Eventually, the Nazi side ran out of patience and under the umbrella of total mobilization in the first part of February decided to draft Latvians through the labor administration boards. Once the young men reported for labor, they were redirected to the military training camps.<sup>25</sup>

From the historical evidence provided above as well as through the analysis of different opinions and memoirs, we can conclude that the General Directorate supported the creation of the LL. However, once again this was primarily through coercion rather than commitment, at least on the part of most Directorate personnel. Diversity of ambitions and absolute trust in one's own truth did not spare a place for compromise that would later be positively characterized by the historians. In any case, the Latvian nation faced another burden in front of it—in the ranks of Waffen-SS.

### Build-up and integration of the Legion. Battle path

In this subchapter the author intends to highlight only the major events and facts that are connected with the formation process of both divisions. Detailed information on numbers, persons and equipment of the LL nowadays can be found in Latvian, German, Russian and English languages and, probably would be suited for wider but separate research. Here, the author wants to discuss less the technicalities of the LL's build-up, instead seeking the answer to the research questions that may provide an insight on how ideologically and politically united were members of LL within the Nazi ranks.

On January 24, 1943, after the receipt of Hitler's guidelines and during a visit to the Eastern front Himmler ordered the creation of the first predominantly Latvian unit to be above the size of a battalion. After pulling together six Order Police Battalions<sup>26</sup> that were serving in the frontlines near Leningrad (currently-Saint Petersburg) he established a 2nd Motorized Waffen-SS (Latvian) Voluntary Brigade headed by a German commander. Later, in 1944, this brigade became the core of the 19th Waffen-SS Grenadier Division (Latvian No 2).<sup>27</sup> However, the first LL Division (the 15th Waffen-SS) started its recruitment and training in mid-March 1943. A recruitment center was established in Riga, with training camps in western Latvia (Paplaka, Vaiņode).

Despite the initial promise that the LL's leadership would be formed of Latvians, none of them could be identified as having served as a LL division commander or at the head of any staff position.<sup>28</sup> It is quite surprising that Latvian leadership was even considered and indicates the urgency and desperation of the SS leadership in general. By its philosophy, the Waffen-SS was ultimately (after the war) designated to be the police of the New Reich Order,<sup>29</sup> therefore according to the "German Law" the position of SS

Division commander could be occupied only by the owner of the German citizenship and a graduate of an SS Officer's school. As a side note, in Mark Yarger's research we can see that as Nazi desperation grew, they relaxed their standards during the course of war resulting in appointing of some non-German commanders for the SS divisions. This was true initially for officers from the Axis nations (Hungary, Italy), and then later from the occupied territories (Russia, Ukraine).<sup>30</sup> In order to appease the initial Latvian discontent, SS leaders created a position of the Chief of the Division's Infantry at the headquarters. Latvians filled and commanded organizations below the divisional headquarters.<sup>31</sup>

In any case, the structures of both LL divisions were similar; they were composed of five components: infantry units, artillery units, special troops units, service and support units, and reserve. Further breakdown consisted of three infantry regiments (two battalions and one anti-tank company in each), one scout battalion, one artillery regiment, and separate battalions of signal, sapper, air defense and anti-tank troops. Service and support consisted of one veterinarian company, two medical companies, quartermasters' trains, companies of bakers, maintenance, butchers, and motorized transportation, plus two squadrons of horse-drawn transportation. Four infantry companies constituted the reserve (see figure 12). Colonel Silgailis also notes that from the beginning of the LL's build-up, the table of organization of the division changed often, however, the authorized strength hovered around 14,800 men. Additionally, he submits that neither of the divisions ever reached their full authorized strength and due to the constantly collapsing German northern front, units fought half-manned, half-trained, and underequipped.<sup>32</sup>



Although a build-up of both divisions was organized in two different locations it was executed at the same time. As mentioned earlier, the 2nd Motorized (Latvian) Brigade was located in the vicinity of the eastern frontlines, near Leningrad. Temporarily (from February until May 1943) this brigade was withdrawn to the rear for train-up, reorganized and sent back to the front. From May 1943 until May 1944, the brigade was in constant retrograde; numerous times it was attached to different higher *Wehrmacht* units but in general remained as a separate entity. Any recruits for these units had to be Latvians of Aryan ethnicity, without criminal charges and possessing a height of not less than 1.68 meters.<sup>33</sup>

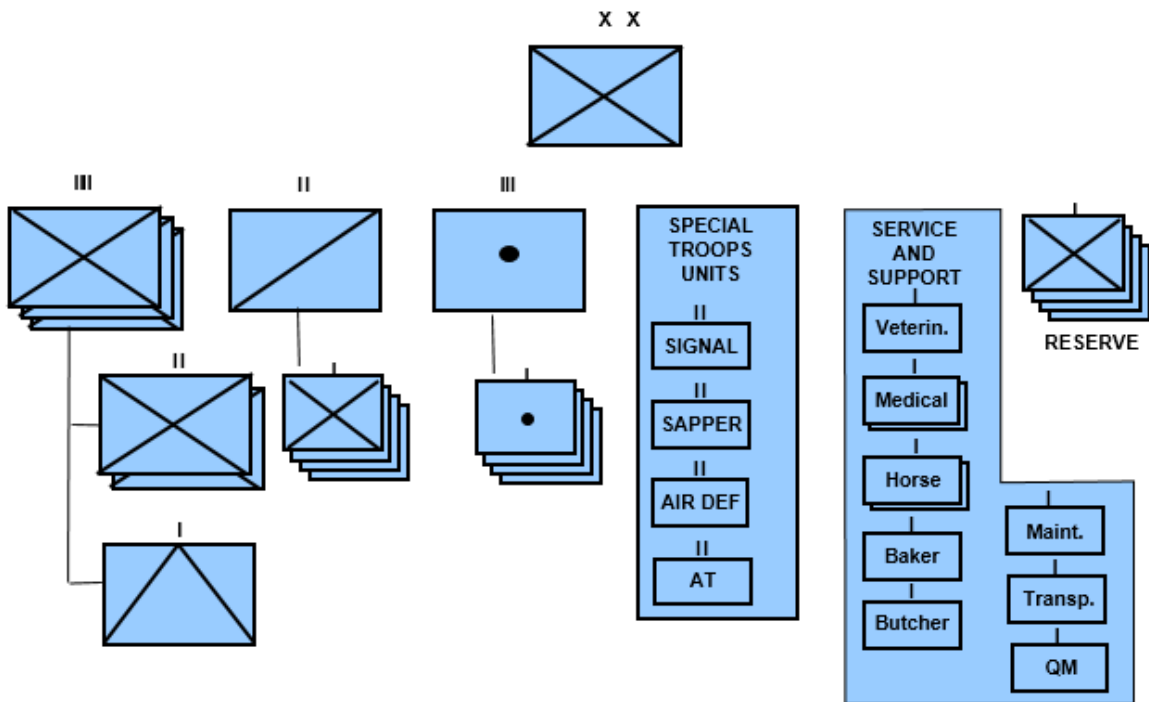

Figure 12. LL Waffen-SS Division's Task Organization

Source: Author's drawing based on the description provided by Colonel Arturs Silgailis.

Despite the fact that the LL was the most decorated non-German formation of the Waffen-SS, and although German written evidence certifies a high respect for the combat skills and bravery of the LL, cooperation and relationships between the two nations were far from friendly. At best, they could be described as “unstable with the tendency of confrontation.” Attitudes in the LL towards Nazi Germany reflected the overall feelings of the Latvian nation.

It all started with the attitude of the population. Latvians soon realized that Nazi Germany’s occupation was following the same pattern as the Soviet one, albeit with less brutality. In October 1943, sentiment amongst the Latvian population grew almost hostile and filled with hatred. A young Latvian sailor remembers, “at that time most of us believed that the Germans really wanted to help us get rid of the Russian barbarians... Today the life of every Latvian is an incessant simulation.”<sup>34</sup> Additionally, a conversation between Alfred Rosenberg and General Bangerskis on February 15, 1944, says it best:

Latvia cannot be granted any extended rights since all other small nations under German rule would then claim the same rights and Berlin would become crowded with all kinds of delegations. In the course of events, the Latvian “völkische Substanz” will be preserved, to be sure, and the Latvians will be given the opportunity of developing their culture . . . in Latvia either the Germans or the Russians could rule and there is no third possibility.<sup>35</sup>

A reader can easily recall that in chapter 3 of this thesis the Soviet Union’s Foreign Minister Molotov expressed a similar statement to his Lithuanian colleague.

Since the 2nd Motorized (Latvian) SS Brigade was made up of previously serving members, tactically it integrated into the frontlines with less difficulty. The only discontent occurred when on March 29, 1943, 1,000 Latvian draftees and their commanders were sent to the Eastern Front without prior training as reinforcement for

this brigade. Indignation was expressed not only from the Latvian side but also from the German commanding officer who received these men.<sup>36</sup>

In the next paragraphs, the author provides a general overview of the LL's battle path and focuses only on the key dates and events as the limits of this thesis does not allow the complete description of all Legion's campaigns and battles.

As mentioned, the 2nd Motorized (Latvian) Brigade was formed directly on the front lines. Comprised of two Latvian infantry regiments and one artillery battalion, the German leadership headed it. As Colonel Silgailis recalls, this brigade along with the other German units was constantly involved in frontline battles, some recruits had to learn their skills for the first time by firing heavy weapons at the enemy armor. Only in November 1943 did the recruits receive an uninterrupted training period (three weeks) when they finally collectively performed their training near the front lines. During most of January 1944, under the command of SS Brigadefuehrer Shuldt<sup>37</sup> the brigade was desperately holding back the Soviet offensive. In order to keep the frontline somehow intact and to withstand the Red Army's pressure, until the beginning of February the 2nd Brigade was used as a "firefighting" unit to counter the threats in the most critical sectors. Covering almost 200 km of the front, the brigade's normal combat pattern was fighting during the day and retreating during the night.<sup>38</sup> From February 28, the brigade occupied Velikaiya River positions just northwest of the 15th Division (Latvian No 1) where it remained until April. In late March and early April, though, the brigade had to fall back another 50 km. During the March–July period, the brigade received reinforcement of a third infantry regiment and became the Waffen–SS 19th Grenadier Division (Latvian No 2). Both divisions were integrated into the VI Waffen–SS Corps of the 18th Army.<sup>39</sup>

The LL had to face dramatic battles on June 22–28 when the Red Army concentrated the 3rd and 10th Shock Armies in front of both divisions. Under such pressure, the LL retreated west and by July reached the borders of Latvia. A tragic day for 15th Division was July 16 when its 32nd Regiment lost 328 soldiers within five hours of fighting while covering the retreat of the rest of the corps. The regimental commander (LtCol Kārlis Aperāts) stayed behind and committed suicide after watching how Soviet tanks crashed through a field hospital with 300 wounded Legionnaires. After such losses, the German higher command decided to withdraw remnants of this division and send it to Eastern Prussia for reorganization.<sup>40</sup> The 19th Division, however, remained in the ranks and after continuous fighting and retreating to the west, on October 13 ended up in the “Courland pocket.” This was Nazi Germany’s last fortress, located in Latvia’s northwestern area and remained undefeated until the end of war. Different sources indicate that the Red Army’s 1st and 2nd Belarusian Fronts committed around 450,000 soldiers and up to 100 divisions.<sup>41</sup> From October of 1944 until May 1945, the Red Army sacrificed the lives of 90,000 soldiers conducting six major offensives against the Courland pocket.<sup>42</sup>

Meanwhile, the 15th Division (Latvian No 1) started its formation in Latvia in March 1943. This division was formed from the fresh recruits of the homeland, and as the reader will see, its personnel attitude concerning the Nazi regime (and German units as well) was very negative. Because the origins of the 19th Division lay in the 2nd Motorized (of international mix) brigade,<sup>43</sup> it had less friction with its German counterparts than the 15th Division. It was intended that recruits of the 15th Division would spend at least six months in training, assuming they would have necessary

equipment, before deploying to the front lines. This was a naïve expectation, recalls Colonel Janums, one of the Division's regimental commanders, because the first recruits for the division's combat units arrived only on June 26; recruits for the reconnaissance battalion arrived only on November 14. Initial weapon distribution started in July, however by November 27, the division lacked a significant amount of its authorized heavy weapons, horses and basic winter equipment.<sup>44</sup> The constantly collapsing Eastern Front and chronic lack of combat units forced the German military command to deploy the division before its scheduled time and not as one organic unit. This division was "just out of luck," and when it deployed to the frontlines around 25 percent of its personnel had roughly two weeks of initial training. The introduction into the combat sectors was very fitful; some units were attached to different German units immediately. For example, the division's 33rd Infantry Regiment regained its organizational integrity only on March 5, 1944, when its 1st Battalion returned after fighting within the ranks of the German 205th Infantry Division for three months.<sup>45</sup> As described previously, between March and July the 15th Division fought alongside the 2nd Motorized (Latvian) Brigade. After being mauled by the Red Army offensives, it finally withdrew to Riga. Some of the unit's combat effective formations were detached to the 19th Division. Later, on August 22, 1944, remnants of the division were transferred to western Prussia where its general location was nine km from Bitov or roughly 77 km west from Danzig (today Poland's Gdansk).

Within the first days in Prussia, the division's Latvian leadership was detached and sent to various courses in Germany and Czechoslovakia. Meanwhile, young German SS officers assumed the training and command of recruits. It was not until mid-

December that Latvians took ownership of their units. Starting from January 22, 1945, the 15th Division began its battling journey westwards towards Berlin. Under Red Army pressure the division bled itself white during a desperate retreat of 446 km, was split and regrouped into smaller battle groups, and finally surrendered to the American and British forces northwest and southwest of Berlin.<sup>46</sup> The division's reconnaissance battalion under the command of Lieutenant Neilands was completely destroyed while defending Berlin. Ironically, the last defenders of Berlin were foreign legionnaires, including Danes, Norwegians, Latvians and Frenchmen.<sup>47</sup>

Research by Latvian (Silgailis, Memenis, Janums, Ezergailis) and some foreign historians (Stöber, Bishop) characterizes the route of distrust between the Latvian and German soldiers. Incidents on the frontlines mainly stemmed from the fact that the German Wehrmacht was in ideological opposition to the Waffen SS. Ironically, once it arrived on the Eastern Front, the Waffen-SS was dependent on the overall Wehrmacht's logistical system that sometimes put not only Legionnaires but also German SS troops in the role of "scavengers and beggars." For example, in his memoirs the commander of one of the infantry regiments in the 15th Waffen-SS Division, Colonel Janums, lists numerous examples of poor performance of the German command; at times these commanders openly exhibited cowardice.<sup>48</sup> He also recalls in his memoirs that most of the disciplinary problems occurred when young and energetic but tactically incompetent SS division staff officers tried to exercise their "inherited rights" to direct and command. Sometimes this led to open confrontations with some of the senior-ranked Latvian officers.<sup>49</sup> Janums submits that such dissonance between Latvians and Germans was also a reflection of the general war context: the senior division leadership was getting tired of

constant retreat and fear of encirclement whereas new generations of junior officers felt more ideologically motivated to fight until the end. “The closer to Berlin we got,” wrote Janums, “the less certainty we gained.” In February 1945, Janums witnessed a near collapse of the German fighting morale when the division commander appealed to the “fellowship” of all soldiers and unity against communism to overcome the differences between each other.<sup>50</sup>

In conclusion, we can answer the primary research question on how well received the Nazi ideas were in the LL. The author would like to cite Colonel Janums who, after another confrontation with the division’s commander (General Ax), declared, “. . . we are not Germans and we are not men of the SS. For years and with pride we had worn the Latvian uniform. As soon as this war is over we will take off our current uniforms.”<sup>51</sup> Although we cannot completely exclude the possibility that some of the Latvians shared the Nazi ideas, they mainly were either part of the Nazi socialistic parties (as in the rest of the Europe) or were “brainwashed.” Similar trends were observed during the Soviet Occupation in 1940. After fighting through the numerous encirclements, witnessing overall disorder in the retreating German Army and losing the idea of protecting their homeland, soldiers of the LL were only left with protecting themselves. After the retreat from the Pomeranian fields in Eastern Germany, Janums was constantly preoccupied with only one idea—to surrender to the Allies, which was in total opposition to the Nazi ideology of fighting “till the last breath.”

Additionally, we can answer some of the secondary research questions. First, historical evidence provided by the actual members of the LL as well as independent and later researchers determines that none of the Latvians was allowed to command the

Waffen-SS division or its headquarters. Furthermore, looking at the geopolitical and military trends in the Germany's Eastern Front, the Latvian Legion by its functions was dedicated to increasing the strength of the Eastern Front and primarily became a frontline fighting unit, not an instrument of repression or genocide. Battling the partisans and security of the lines of supply eventually were turned to the less combat capable units, for example, the French Voluntary Legion.<sup>52</sup>

---

<sup>1</sup>Mirdza Kate Baltais, *The Latvian Legion: Selected Documents* (Toronto: Amber Printers and Publishers, 1999), 3–22.

<sup>2</sup>Uldis Neiburgs, “Latviešu leģions–pagātne un mūsdienas,” *Latvijas Vēsture* 3 (2000): 103–109.

<sup>3</sup>Bruce Quarrie, *Waffen-SS Soldier: 1940–1945(warrior, No.2)* (Oxford: Osprey Publishing, 1993), 4.

<sup>4</sup>Chris Bishop, *SS Hitler's Foreign Divisions: Foreign volunteers in the Waffen SS 1940-1945* (London: Amber Books, 2005), 88, 89.

<sup>5</sup>Haralds Biezais, *Latvija kāškrusta varā: sveši kungi, pašu ļaudis* (Lansing, MI: Gauja, 1992), 185–230.

<sup>6</sup>Kārlis Kangeris, “Latviešu leģions–vācu okupācijas varas politikas diktāts vai latviešu ‘cerību’ piepildījums,” in *Latvijas Vēsturnieku komisijas raksti, 24.sēj.: Baltijas reģiona vēsture 20.gadsimta 40.–80.gados*, ed., Dzintars Ērglis (Rīga: Latvijas vēstures institūta apgāds, 2009), 62.

<sup>7</sup>Biezais, 232.

<sup>8</sup>Arturs Silgailis, *Latviešu Leģions* (Kopenhāgena: Imanta, 1964), 11.

<sup>9</sup>Silgailis, 18.

<sup>10</sup>Biezais, 236-238.

<sup>11</sup>Peter Kleist, *Zwischen Hitler und Stalin* (Bonn: Athenäum-Verlag, 1950), 167.

<sup>12</sup>Ibid.

<sup>13</sup>Gerald Reitlinger, *The SS alibi of a nation 1922–1945* (New York: Da Capo Press, 1989), 205.



- <sup>14</sup>Silgailis, 24.
- <sup>15</sup>On March 29, 1943, General Rudolf Bangerskis was appointed as the Inspector General for the Latvian Legion.
- <sup>16</sup>Vilis Janums, *Mana pulka kauju gaitas* (Eufīne: A.Ozoliņa iespiestuve, 1953), 7.
- <sup>17</sup>Silgailis, 20.
- <sup>18</sup>Mintauts Blossfelds, *Stormtrooper On the Eastern Front: Fighting with Hitler's Latvian SS*, ed. Lisa Blossfelds (Barnsley: Pen and Sword, 2008), 204.
- <sup>19</sup>Arvids Memenis, *Karavīri bēdājās* (Rīga: Poligrāfists, 1992), 73.
- <sup>20</sup>Memenis, 196.
- <sup>21</sup>Patrick Agte, *Europas Freiwillige der Waffen-SS. Biographien Aller Inhaber Des Ritterkreuzes, Des Deutschen Kreuzes in Gold, der Ehrenblattspange Und der Nahkampfspange in Gold, Die Keine Deutschen Waren* (Pluwig: Munin Verlag, 2000), 202–300.
- <sup>22</sup>Memenis, 197.
- <sup>23</sup>Biezais, 257.
- <sup>24</sup>Silgailis, 22.
- <sup>25</sup>Ibid.
- <sup>26</sup>The first six Latvian Order Police battalions who formed the 2nd Motorized (Latvian) Waffen SS voluntary Brigade were the 16th, 19th, 21st (1st Regiment) and 18th, 24th, 26th (2nd Regiment).
- <sup>27</sup>David Littlejohn, *Foreign Legions of the Third Reich: Poland, the Ukraine, Bulgaria, Rumania, Free India, Estonia, Latvia, Lithuania, Finland and Russia* (San Jose: R James Bender Pub, 1987), 182.
- <sup>28</sup>Silgailis, 55, 56.
- <sup>29</sup>Bishop, 9.
- <sup>30</sup>Mark C. Yerger, *Waffen-SS Commanders: the Army, Corps, and Divisional Leaders of a Legend* (Atglen, PA: Schiffer Publishing, 1997).
- <sup>31</sup>Silgailis, 29.
- <sup>32</sup>Ibid., 347–365.

- <sup>33</sup>Ibid., 26.
- <sup>34</sup>Andrew Ezergailis, Ed., “Voldemārs Salnais’s reports: 1941–1944,” *Stockholm Documents. The German Occupation of Latvia 1941–1945. What did America know?* (Riga: Historical Institute of Latvia, 2002), 175.
- <sup>35</sup>Ibid., 180.
- <sup>36</sup>Silgailis, 28.
- <sup>37</sup>David Almon Miller, *Die Schwerterträger der Wehrmacht. The Recipients of the Knight’s Cross with Oakleaves and Swords* (Bennington: Merriam Press, 1988), 55.
- <sup>38</sup>Osvalds Freivalds, ed., *Latviešu karavīrs otrā pasaules kara laikā. Dokumentu un atmiņu krājums. 3.sēj.: Latviešu Leģions* (Västerås: Daugavas Vanagu Centrālā valde, 1974), 143–249.
- <sup>39</sup>Christopher Ailsby, *SS: Hell on the Eastern Front. The Waffen-SS War in Russia 1941–1945* (Osceola: Zenith Press, 1998), 186.
- <sup>40</sup>Hans Stöber, *Die Lettischen Divisionen im VI. SS-Armeeekorps* (Osnabrück: Munin Verlag, 1981), 90–97.
- <sup>41</sup>Steven H. Newton, *Retreat from Leningrad, Army Group North, 1944/1945* (Atglen: Schiffer Publishing, 1995), 272–287; Howard D. Grier, *Hitler, Dönitz, and the Baltic Sea: the Third Reich’s Last Hope, 1944–1945* (Annapolis: Naval Institute Press, 2007), 81–106.
- <sup>42</sup>Werner Haupt, *Das War Kurland: Die Sechs Kurland-Schlachten Aus der Sicht der Divisionen* (Friedberg: Podzun-Pallas, 1987), 87–131; Franz Kurowski, *Bridgehead Kurland: the Six Epic Battles of Heeresgruppe Kurland* (Winnipeg: J. J. Fedorowicz Publishing, Inc., 2002), 147–173.
- <sup>43</sup>Silgailis, 31.
- <sup>44</sup>Janums, 9-21; Silgailis, 58, 59.
- <sup>45</sup>Janums, 94; Werner Haupt, *Leningrad, Wolchow, Kurland: Bildbericht der Heeresgruppe Nord 1941–1945* (Friedberg (Dorheim): Podzun-Pallas-Verlag, 1976), 54.
- <sup>46</sup>Janums, 287.
- <sup>47</sup>George H. Stein, *The Waffen SS: Hitler’s Elite Guard at War, 1939–45* (Ithaca: Cornell University Press, 1984), 164.
- <sup>48</sup>Janums, 201, 213, 216, 244, 252, 257, 268

<sup>49</sup>Ibid., 144, 145.

<sup>50</sup>Ibid., 215.

<sup>51</sup>Ibid., 145.

<sup>52</sup>Bishop, 40.

## CHAPTER 6

### THE LATVIAN LEGION AFTER WORLD WAR II

“[T]he psyche of Germany and the Soviet Union was also different from that of the Western nations. Both countries had been under totalitarian rule for many years, and an entire generation of Germans, and two generations of Soviets...were encouraged to believe that their own system was inherently superior to any other. It was inevitable that when these two cultures clashed, the result could only be the complete destruction of one or the other.”<sup>1</sup>

— Prit Buttar, *Battleground Prussia*

Along with the capitulation of National Socialist Germany on May 8, 1945, the LL ceased to exist. Some legionnaires faced the capitulation already in captivity (i.e. Janums’s regiment), while others were still in the fighting formations (i.e. 19th Division in the Courland pocket). The latest research estimates that roughly 110,000–115,000 Latvian soldiers (52,000 of them in the ranks of Waffen-SS) served on Nazi Germany’s side. At the end of the war, around 25,000 were captured by the Western Allies, but almost 50,000 ended up in Soviet captivity serving various terms of imprisonment in filtration and labor camps of the GULAG. Similar estimates also suggest that between 30,000 and 50,000 Latvians gave up their lives on the battlefield.<sup>2</sup>

After being on the crossroads of the political, ideological and military clashes between Soviets and Nazis, Latvian soldiers were never given a chance to serve their country, their people and their independence. Partially voluntarily but mostly by force they had to wear the uniforms of either Nazi Germany and Soviet Union. Be it as “voluntary” Latvian legionnaires or Red Army riflemen, they both fought for the right cause. Their enemy was “right,” however “wrong” their ally was. Neither Hitler nor Stalin had plans for Latvian independence. Within the presence of two occupational

powers, freedom of action and possibility to choose for Latvian soldiers can at best be characterized as severely restricted.

This final chapter describes the period immediately after the war and analyses the discussions that were associated with the LL in the first post-war decade. It also will look into the contemporary situation of legionnaires living within and outside the Latvia. Eventually, it is the author's intent to seek answers to the remaining research questions on how justified are criminal accusations against the LL and what is the society's perception of the LL in today's Latvia.

### Accusations and Nuremberg Trial

The author is by no means a qualified historian, rather he represents a generation born and mainly raised in Soviet Latvia that has been purposely denied objective information and been subjected to ideologically-directed historical thought. This generation's "collective memory" was stolen by the autocratic Soviet government.

An expert on U.S. -Russia relationships and anthropology, Professor at Washington University James Wertsch submits that the totalitarian Soviet regime held complete control over the narratives of its history. Moreover, it directed its writing and influenced its understanding.<sup>3</sup> Therefore for most of Russia's citizens who feel associated with the heritage of the Soviet Union a sense of guilt and a wounded pride do not allow an unbiased examination of the facts. The same can be said about some Latvians.

When the Latvian government issued its declaration of independence on May 4, 1990, it was a sobering experience for many of Latvia's citizens—many of whom did not even know that Latvia had previously been independent. Topics such as the LL were a taboo. Independence reopened the "flood gates" and gave plenty of materials for heated

discussions on numerous facts and events of World War II. Therefore, the author's intent is to provide only the key points of this discussion. He encourages the reader to think critically and always seek the opportunity to double check the facts as well as to confirm the realism of different opinions in multiple sources. Besides, it is the author's opinion that knowing the history of one's own nation helps one to understand the existing environment, but in no way should it be taken solely as the only "prescription" for shaping its future policy as geo-cultural and political context keeps changing constantly. The current generations will appropriate the discontent of the previous ones, once accepting this fallacy.

Today, those who accuse the LL are basing their arguments on the commonly known principle of "guilt by association" and justify it by one historical fact that none of the subject related historians deny—Himmler's Decree of May 26, 1943<sup>4</sup> that defines the term Latvian Legion as a formation incorporating all Latvian uniformed SS formations, including police battalions.<sup>5</sup> An attentive reader also remembers that ever since Latvia's occupation by Nazi Germany, the Baltic region was subordinated under the overall SS leadership. The SS intended that this area would be first cleared of those elements hostile to the Third Reich and then re-occupied by a population friendly to Nazi ideology. The Soviets had pursued a similar policy. The author has seen little or no disagreement amongst the historians of Baltic history—both Soviets and Nazis planned to use the Baltic lands as their colony.

Under this factual "umbrella," the Ministry of Foreign Affairs of the Russian Federation (MFA) published an official decree in 2004, accusing the LL as a criminal organization, and condemning the activities conducted by its members. Moreover, an

appeal towards Nuremberg trial decisions was staged. Most of the sources cited in this decree are in either the Russian Federation State archives or FSB (Security police) archives and are therefore unavailable for verification.<sup>6</sup> Let us take a closer look at the narrative of this decree.

A central role in these accusations is dedicated to the Latvian Police battalions and the crimes they committed.<sup>7</sup> The Baltic historians have recognized the fact that some Latvian Police battalions were supporting the SS operations in occupied territories.<sup>8</sup> The author also would like to note that Latvian Order Police soldiers in this case were subject directly to the SS Field Courts, so that refusal to execute an order would place the rejecting one on the target line himself.<sup>9</sup> Individual police officers allegedly were conducting these tasks with enthusiasm, especially in the “Arajs commando” case.<sup>10</sup> However, the essence of the analysis in this thesis is related to the functions of the Waffen-SS divisions of the LL. Using the fallacy of the previous argument (Himmler’s decree) the LL is accused of crimes done by members of almost every Latvian uniformed formation. The decree of the MFA lists numerous criminal acts, everyday events and even units for which the author could not find any of the supporting arguments, including when a rare non-Russian source was used to justify the accusations. The author would like to submit that these mishaps, while rarely substantiated, falsely depict the overall situation, thus shaping the perception of any reader. This is not intended to drag the reader into unending discussions of who is wrong or right. Rather, the author would like to describe the methodology how allegations against the LL had been staged and point out the most obvious fallacies.

First, the authors of the MFA decree contend that the 2nd Motorized Infantry SS Brigade was established in February of 1942 comprising four Latvian Police battalions and that in autumn it was sent to the Eastern Front. Within the same timeframe, Latvian soldiers of this unit allegedly committed war crimes in the villages Lubnici, Osec and Krechno (60 km northwest of Novgorod). Additionally, later in the decree, the Russians assert that the 2nd Latvian voluntary SS brigade was established in November of 1943. Both the titles of the unit and the dates of its evolution are conflicting.

Unfortunately, the source cited (R. J. Bender and H. P. Taylor, *Uniforms, organizations and history of the Waffen SS*, Vol.4) by the authors of the decree does not support their statement. It does state, though, that 2nd Latvian SS Brigade began to form on January 24, 1943, after Himmler ordered the creation of first Latvian Waffen-SS unit (the brigade).<sup>11</sup> Additionally, the disconnect within the factual data in the decree appears in the different source by the same authors (Bender, Taylor, Vol. 5) where they explicitly explain that the 2nd SS (Latvian) Brigade as a Latvian unit was not completely formed until January 1944.<sup>12</sup> Finally, it is somewhat misleading to state that the 2nd SS Motorized Brigade was formed solely out of the four Latvian battalions. The history of this brigade starts in the summer of 1941 when, along with the 1st SS Motorized Brigade, it was made up of units from the 14th, 5th and 14th *Totenkopf Standarten* regiments. The brigade was international and included Dutch, Flemish and Norwegian voluntary legions.<sup>13</sup> With that, the author of this thesis questions the credibility of the decree's accusation alleging that only Latvians were members of the 2nd SS Motorized (Latvian) Brigade.



Second, members of the LL's 19th Division reportedly had committed atrocities on January 21, 1944, in the village of Gluchovo (west of Krechno, Novgorod district). Moreover, the same forces allegedly conducted another mass shooting in the concentration camp located in city of Porohovo (Belorussia). In total, the decree states that members of 19th Latvian Division executed close to 1,300 people and destroyed 23 villages between December 18, 1943, and April 2, 1944. Again, the cited sources of this are in the Russian archives, without reference to their stock numbers and therefore unavailable for verification.

An expanded research does not support this accusation as well and other "less restricted" available sources depict a different picture. First of all, it again should be restated that 19th Waffen-SS (Latvian) Division formed up no earlier than March of 1944, when the 2nd SS (Latvian) Brigade was co-located with the 15th Waffen-SS (Latvian) Division in the river Velikayia positions.<sup>14</sup> Next, let us ignore the confusion with unit numbers and refer to the diary of the 2nd SS Motorized (Latvian) Brigade, which was located in that vicinity. On January 21, Col Veiss's (Latvian) battle group was fighting off the Red Army's assault some 20 km south of Glukhaya (Tatino railway station); whereas the forces of the 49th *Jäger* Regiment (German) occupied the combat sector near Glukhaya.<sup>15</sup> Once again, it should be remembered that this brigade remained multinational with a Latvian majority. In no way does the author of this thesis suggest that accusations should be pointed at the German unit, but clearly the Latvian involvement in this alleged event is uncertain. Finally, some confusion exists concerning the alleged shootings in the concentration camp in Porohovo. Besides the difficulty of finding such an urban area (even a city) in Belorussia, the list of Nazi concentration

camps in Belorussia does not show any of the camps with names even close to the spelling above.<sup>16</sup> Even if one accepts the misspelling of the camp, two of the Nazi camps in Belorussia that are mentioned (Maly Trostinets and Koldichevo) geographically were 733 km and more south of the combat sector of 2nd SS (Motorized) Brigade. With all due respect to the authors of the MFA decree, the author of this thesis encourages them to be more precise and questions the credibility of this accusation in its current guise.

Besides the accusations from the Russian Federation, for 60 years soldiers of the LL were held responsible for killings of Polish prisoners of war (POW). On January 31, 1945, as the 15th Waffen-SS Division was trying to escape encirclement by the Red Army forces, 32 Polish POWs were murdered in the aftermath of a battle near Podgaye (Flederborn) village. The latest (2011) results of independent investigations follow the battle order in the vicinity of this village as well as describe in details all the events of that specific campaign. Legionnaires of the 15th Waffen-SS (Latvian) Division were not found guilty of any involvement related to the execution of these POWs.<sup>17</sup>

As much as the author would like to continue with the detailed analysis of each allegation mentioned in MFA decree, the limits of this thesis force us to proceed with other insights. Nonetheless, it should be apparent that the accusations that the LL committed atrocities remain, at best, inconclusive.

After the war, ex-Legionnaires were held in different POW camps mainly on the European continent. The majority of them reportedly ended up in the British POW camps.<sup>18</sup> The Soviet Union performed a major agitation campaign urging Latvians to return “home,” and some of the LL’s soldiers actually believed the communists. Tired of fighting and willing to reunite with the families, they silenced their doubts. The Soviets

knew far too well that the truth about the horror they drew upon the Baltics will soon to be revealed to the world.

The Nuremberg trials found none of the soldiers of Latvian Waffen-SS divisions guilty in any of the war crimes.<sup>19</sup> Many Latvian legionnaires served as the guard details under US command—they were entrusted to secure the accused SS personnel awaiting trial. Moreover, already on September 2, 1946, US 3rd Army HQ in Heidelberg, Germany in its decree No. 29 to all US units in area publicized a statement recognizing the Latvian and Estonian Waffen-SS units that fought against the Red Army as separate from both Waffen-SS and *Wehrmacht* entities.<sup>20</sup> Additionally, in his reply to the Latvian representative in Washington, on September 12, 1950, United States' Displaced People Commissioner Harry J. Rosenfield repeated with the commission's official statement:

The Baltic Waffen-SS Units (Baltic Legions) are to be considered as separate and distinct in terms of purpose, ideology, activities, and qualifications for membership from the German SS, and therefore the Commission holds them not to be a movement hostile to the Government of the United States under Section 13 of the Displaced Persons Act, as amended.<sup>21</sup>

To conclude this subchapter, the author would like to submit that the MFA decree published on 2004 seems questionable because it rejects the official statement of Nuremberg Trial regarding the LL. To add to the controversy even more, well-known Russian historian and law expert Alexander Zvyagintsev in his historical research concluded that, “[the] Nuremberg Tribunal found guilty all members of SS organization; except persons, which were called-in by officials represented governmental structures in the way that they did not have the right to choose, and did not commit any crime against humanity.”<sup>22</sup>

It seems that historians of Russian Federation are still struggling with defining one common vision and putting it in precise terms. Without denying the possibility that individuals may have committed war crimes, the author contends that the Latvian Legion as a whole has been tarred with a broad brush that overlooks both the method of its involuntary recruitment and the manner in which it fought. Moreover, one should possess a lot of patience and courage in order to research and critically analyze the events that happened in the course of war. There is little humanity to be found in the long and bloody “business” called war. One thing, though, is certain—if someone is to be accused of crimes against humanity, those accusations must be clear, precise and based on well-supported arguments.

#### Latvian Legion today. President’s initiative

Thanks to the historians like Timothy Snyder, today the Western world has access to a variety of information on the actual events happening during the World War II east of Berlin. Though Western Allies liberated concentration camps, they never reached the death factories, killing fields, and starvation sites where Hitler and Stalin murdered civilians on a massive scale. Snyder wrote:

[T]he very worst killing began when Hitler betrayed Stalin and German forces crossed into the recently enlarged Soviet Union in June 1941. Although the Second World War began in September 1939 with the joint German-Soviet invasion of Poland, the tremendous majority of its killing followed that second eastern invasion.<sup>23</sup>

Therefore, only those legionnaires who were captured by the Americans and British forces and released after the imprisonment were able to deliver the truth to the rest of the western society. Already on December 28, 1945, in the Zedelghem’s POW camp (in Belgium) former soldiers of the LL formed the association “Daugava’s Hawks”

[*Daugavas Vanagi*] with the purpose of helping former Latvian soldiers and their families. With the majority in the British area of responsibility (northern Germany), roughly 25,000 Latvian POWs were locked in the various camps. Members of latter organization were allowed to communicate amongst all camps where Latvians were held. Some of the released legionnaires purposely moved to live in the refugee settlements so to continue assist Latvian families. In the beginning of the 1950s, Latvians left refugee settlements and dispersed across the world to Australia, Western Europe, Canada, Sweden, Britain, and American continents. Today, as the ranks of surviving legionnaires grow thinner, their children pick up the mission and try to promote Latvian nationalism within their families and maintain contacts with their relatives in Latvia. Today, they bear the recollections of memories and carry on the ideological struggle against crime accusations. As good as these intensions might be, they still possess a rather mediated influence on the events happening on the Latvian soil. An important part of settling the disputes between Russia and Latvia should first take place in both of those countries. So, what is happening in today's Latvia?

Finnish journalist Jukka Rislakki in his book of 2008 *The Case for Latvia. Disinformation campaigns against a small nation* provides a well-organized systematic analysis of Latvia's latest relations with its eastern neighbor. As the main reason for bilateral discontent Rislakki mentions Russia's inability to accept that Baltic States (and Latvia in particular) will hardly ever admit the volunteerism in joining the Soviet Union, and accepting communism as their system. "As to the majority of Russians it means," writes Rislakki, "without saying so overtly, that the Baltic countries are still the part of Russia."<sup>24</sup> Indeed, the author concludes, "For decades Latvian historians were not able to

research their own countries' history and write about it; it was not only forbidden but also dangerous. But is it not so that if we forget our past or allow someone else to steal it, we will be condemned to repeat it."<sup>25</sup> Emphasizing the significance of the fact of the lengthiness of the Soviet Occupation, historians Valters Nollendorfs and Ervin Oberländer submit, "The occupier's version of history, of the 'truth' about the Baltic countries, was effectively spread to the world and even into the minds of the Latvians themselves."<sup>26</sup>

Here, let us pause and reflect on some obvious details that historically have been misinterpreted or even largely overlooked. Describing things metaphorically, the author of this thesis concludes that today the LL is another "principal" question for the Russian Federation to be answered as it embodies the peoples' strive for freedom and independence of Latvian nation and was largely the counter-reaction against the Soviet occupation. In turn, until a commonly acceptable definition of Soviet Occupation will not be defined, there will be very little change in feelings against the LL. On another hand, a settlement over the LL's role in the World War II would serve as a stepping-stone towards an agreement regarding the occupation in 1940 between Russia and Latvia. Rislakki also highlights the diversity in Russia's attitudes towards Finland and Latvia. Once, during a visit in Finland (also a former territory of Russian Empire), writes Rislakki, president Putin laid flowers on the tomb of Russia's archenemy, Marshal Carl Gustav Mannerheim. "At the same time, Russia finds it impossible to approve the choices the Latvians were forced to make during the war."<sup>27</sup>

Same results should be pursued regarding the historical perception of the West. The author of this thesis believes that he has provided substantial historical evidence that

the Western World has already recognized the LL as a non-criminal organization, starting with the Nuremberg Tribunal. Yet, still, either pursuing popularity ratings, or being purposely misled by influential groups (political parties, radical ethnic organizations), the “western” media tends to accuse dozen of old veterans in promoting Nazism—the ideology for which the Latvians themselves paid an unbearable price. Previously cited Finnish journalist Jukka Rislakki, describing the meetings on March 16 with sarcasm writes, “There are already more journalists, camera crews and demonstrators of different sorts on the spot for the observance than there are veterans, whose ranks are constantly growing thinner.”<sup>28</sup> Ironically, following the fallacy of “association by guilt” on this day Latvian people are portrayed as somehow sympathizing with the Nazi ideology. This accusation is made against the people of a country that has never declared a war on any other country in the history of its existence.

Therefore, the role of this thesis is to provide the English-speaking audience with a variety of facts and interpretations about the LL, especially within the scope of a larger historical picture. The author once again urges the reader to be always critical in weighing the fairness of different opinions and not to fall into the fallacies of dominant dogmatic ideologies. Although the data in this thesis about Latvia’s geopolitical history may seem excessive, it shows how deeply connected Latvia has been with Russia and Germany for centuries. Despite this, Latvia managed to develop its own national sense and remained distinct from both.

In the next paragraphs, the author would like to provide the insight of current initiatives and historico-political activities in Latvia. Like many other smaller and recently emerged European nations, the present Latvian nation with as little as 23 years

of independence is on the evolutionary path. For Latvia, there are new allies to be found, new economic strategies to be defined, and above all—a settlement with the past to be arranged. Although this thesis is focused only on the LL, the author submits that the Latvian government owes a “homework assignment” to promote equal treatment of Latvians who served on both fronts and armies. Like legionnaires, Latvians were mobilized in the Red Army as well, and in similar way, there were those who believed the ideology of a better future, including a future for their nation, for which it was worth fighting and dying. For the frontline trench soldier there is little time to reflect upon the full extent of the complexities of the ideology.

In the spring of 2012, the president of Latvia, Andris Berzins [*Andris Bērziņš*], appealed to the Latvian veterans of both armies and urged them to find a mutual settlement. “If soldiers [of both sides] would settle amongst themselves and express publicly their good will, it would disarm those groups who purposely use history to raise animosity in the Latvia’s society.”<sup>29</sup> It is clear that each side had suffered from the opposite regime, however, argues the President, foremost every Latvian soldier was a victim of a power he served, since none of both opponents was fighting for the Latvian independence. Proposing May 8 as the remembrance day of the victory over the Nazism, the President intends to use this day as a uniting date and not the one that confronts.<sup>30</sup>

Finally, let us summarize the key points in this chapter. First, analysis of various non-Latvian sources from Western Europe indicates two dominant paradigms. One of them is encompassed in wide range of documents that certifies on how aware were Western Allies on the innocence of the LL. This was expressed not only in different reports from the Nuremberg trial (and various embassies) but also in trust shown towards



the Latvian soldiers in the immediate post-war period. Another paradigm reveals a quite worrying disconnect in today's generation's historical understanding of the events in the eastern front in both Western and eastern societies. The "West" suffered from the absence of objective information mainly because of a lack of trustworthy bilateral relations with the USSR. An "iron curtain" made sure nothing stems out of and even less gets in the Soviet Union. For Latvian emigrants, almost the only way to communicate with their relatives was through the International Committee of Red Cross. Besides, an extensive in-depth propaganda campaign conducted in the Soviet Republics shaped historical understanding of two generations. The author of this thesis was surprised himself when he found out that Latvia actually was a sovereign republic for two decades. At last, bearing in mind that Latvia and other Baltic countries are still in Russia's area of political influence, the international media tend to portray the LL-related events in Latvia as pro-Nazism. A careful researcher will notice that on the pictures from the memorial services of March 16, ex-legionnaires are carrying the flowers and national flags, not the symbols of Nazi ideology (see figure 13).



Figure 13. March 16, 2013 by the Monument of Freedom, Riga, Latvia.

*Source:* Online news server, <http://www.reitingi.lv/lv/news/politika/76917-latvijas-iedzivotaju-domas-dalas-par-legionaru-atceres-pasakumu-rikosanu-16-marta.html> (accessed April 9, 2013).

Second, for Russia’s government it is obviously difficult to accept the collapse of a once mighty empire. Moreover, as more archives get declassified and emigrants return home, accusations of Soviet terror from the Baltics, Ukraine, Belorussia, and the Caucasus region pile up. Naturally, this causes a Russian counter–reaction in various forms: counter–accusations, economic sanctions, cyber–attacks, diplomatic protests on the international stage etc. In this regard, the author concludes that Russia largely became a victim of Soviet forced settlement politics when millions of exiles from the occupied nations were sent to GULAG camps and a Russian population was put in their place.<sup>31</sup> One of my grandmothers was among the many Soviet young people who were offered “better” life in Latvia, and left starving Russia in the aftermath of war. Shortly after Latvia regained its independence, these people found themselves suddenly surrounded by

an unfriendly society that accused them of being “occupiers.” Ironically, now Russia cannot offer them the same “good” life back home. On one hand, this paradox united them even more as a minority; on the other hand, it delays the integration process. Amidst all of these events, Russia tries to demonstrate a strong human rights policy towards these people, but in fact does very little in its own country.

Third, the Baltic countries, having recently regained their independence, are still on the “path of discoveries.” Each of these countries has barely ten years behind their backs as the members of European Union and North Atlantic Treaty Organization, and they still are defining their ultimate course in geopolitics. The author argues that the Latvian people are still pursuing their national identity and more importantly their national maturity. Within this evolution, Latvians first will have to settle their debt with the past, and only then, they can be sure that no other power will deflect them from their correct aim—ethnic unity. Therefore, today the LL serves as an artifact, a guiding example for many Latvians and signifies a non—stoppable struggle for independence. The LL by its actions is a cornerstone of Latvian bravery, ferocity, and love for their fatherland. However bitter the truth is—it was formed under the occupational power. This fact raises the question of national guilt by some of the contemporaries in Latvia today. Chapter 3 of this thesis describes the two dominant thoughts of the first Soviet occupation—was it better to resist or to accept the occupation? Moreover, why were Latvians so eager and brave fighting within other formations whereas they did not take the opportunity to stand for themselves? These are open questions, which the author does not intend to answer here but rather offers as an emerged component of this thesis and the result of self—reflection.

Lastly, the author believes that the research of the history of various Latvian units that served within the ranks of the Red Army would be very beneficial for creating the shared historical understanding and depicting the both sides of the events that took place in Latvia during the World War II. Most importantly, pursuing the policy of cross-accusations between ex-legionnaires and former Red Army riflemen is metaphorically seeking to repeat the “bad” history when the Latvian nation was divided and subsequently conquered. Does that mean that Latvians can be united only in the presence of an actual “materialized” enemy? This research merely provides an insight of how historic mistakes from the 13th century were repeated again and again and how the Latvian nation counter-aligned, defeated, and reemerged. History had shown the Latvians as a nation formed in captivity, but will they have enough wisdom to mature in independence?

---

<sup>1</sup>Prit Buttar, *Battleground Prussia: the Assault On Germany’s Eastern Front 1944-45* (Oxford: Osprey Publishing, 2010), viii.

<sup>2</sup>Tāļivaldis Vilciņš, “Latviešu leģionārs 50 gadu pēc kara: Socioloģisks aspekts,” *Latvijas Arhīvi* 2 (1994).

<sup>3</sup>James V. Wertsch, *Voices of Collective Remembering* (New York: Cambridge University Press, 2002), page, 67–94.

<sup>4</sup>Haralds Biezais, *Latvija kāškrusta varā: sveši kungi, pašu ļaudis* (Lansing, MI: Gauja, 1992), 185, 186.

<sup>5</sup>Martin Windrow, *The Waffen-SS*, Revised Ed. (London: Osprey Publishing, 1989), 64.

<sup>6</sup>Official Website of Ministry of Foreign Affairs of Russian Federation, *Об участии латышского легиона СС в военных преступлениях в 1941–1945 гг. и попытках пересмотра в Латвии приговора Нюрнбергского трибунала (справочная информация)*, <http://www.in.mid.ru/ns-dgpch.nsf/0/431e781edaef5c79c3256e3f002bcdb0?OpenDocument> (accessed March 30, 2013).

<sup>7</sup>Алексей Михайлович Литвин, “Латышские полицейские ‘шудцманшафт’ батальоны в Белоруссии (1941–1944 гг),” in *Уничтожить как можно больше...: Латвийские коллаборационистские формирования на территории Белоруссии, 1942–1944 гг. Сборник документов*, eds., Дюков Александр, Владимир Симиндей, et al. (Москва: Фонд “Историческая память,” 2009), 27–53.

<sup>8</sup>Kārlis Kangeris, “Latviešu policijas bataljoni lielajās ‘partizānu apkarošanas’ akcijās,” in *Latvijas Vēsturnieku komisijas raksti, 13.sēj.: Totalitārie okupācijas režīmi Latvijā 1940.–1964. gadā. Latvijas Vēsturnieku komisijas 2003.gada pētījumi*, ed., Dzintars Ērglis (Rīga: Latvijas vēstures institūta apgāds, 2004), 332–357.

<sup>9</sup>Uldis Neiburgs and Vita Zelča, eds., *Divas puses. Latviešu kara stāsti. Otrais pasaules karš karavīru dienasgrāmatās* (Rīga: Mansards, 2012), 65.

<sup>10</sup>Andrej Angrick and Peter Klein, *The “Final Solution” in Riga: exploitation and annihilation, 1941-1944*, English–language ed. (New York: Berghahn Books, 2009), 65–72.

<sup>11</sup>Roger James Bender and Hugh Page Taylor, *Uniforms, Organization and History of the Waffen–SS Vol. 4* (New York: R James Bender Pub, 1986), 68, 69.

<sup>12</sup>Roger James Bender and Hugh Page Taylor, *Uniforms, Organization and History of the Waffen–SS Vol. 5* (New York: R James Bender Pub, 1986), 57–66.

<sup>13</sup>Chris Bishop, *SS Hitler’s Foreign Divisions: Foreign volunteers in the Waffen SS 1940–1945* (London: Amber Books, 2005), 166, 167.

<sup>14</sup>Arturs Silgailis, *Latviešu Lēģions* (Kopenhāgena: Imanta, 1964), 88; David Littlejohn, *Foreign Legions of the Third Reich: Poland, the Ukraine, Bulgaria, Rumania, Free India, Estonia, Latvia, Lithuania, Finland and Russia* (San Jose: R James Bender Pub, 1987), 183.

<sup>15</sup>Silgailis, 39–43.

<sup>16</sup>Germany’s State Ministry of Justice [*Bundesministerium der Justiz*], [http://www.gesetze-im-internet.de/begdv\\_6/anlage\\_6.html](http://www.gesetze-im-internet.de/begdv_6/anlage_6.html) (accessed April 1, 2013).

<sup>17</sup>Juergen Fritz and Edward Anders, “Murder of Polish POWs at Podgaje (Flederborn), February 1945,” in *The Second World War and Latvia: events and consequences 1940s–1960s. Research of the Commission of the Historians of Latvia, 2011, and Reports of a Scientific Conference “Extermination of the Latvian Army, 1940–1941,” 14 June 2011, Litene*, ed. Daina Bleiere (Rīga: Zinātne, 2011), 127–146.

<sup>18</sup>Arvids Memenis, *Karavīri bēdājās* (Rīga: Poligrāfists, 1992), 170–179.

<sup>19</sup>Mirdza Kate Baltais, *The Latvian Legion: Selected Documents* (Toronto: Amber Printers and Publishers, 1999), 160.

<sup>20</sup>Ibid., 94, 95.

<sup>21</sup>Andrejs Plakans, *Experiencing Totalitarianism: the Invasion and Occupation of Latvia by the USSR and Nazi Germany, 1939–1991: a Documentary History* (Bloomington, IN: AuthorHouse, 2007), 138, 139.

<sup>22</sup>Александр Звягинцев, *Нюрнбергский Набат: Репортаж из прошлого, обращение к будущему* (Москва: ОЛМА Медиа Групп, 2007), 1009.

<sup>23</sup>Timothy Snyder, *Bloodlands: Europe between Hitler and Stalin* (New York: Basic Books, 2010), xi.

<sup>24</sup>Jukka Rislakki, *The Case for Latvia. Disinformation campaigns against a small nation* (Amsterdam–New York: Rodopi, 2008), 203.

<sup>25</sup>Ibid., 215.

<sup>26</sup>Valters Nollendorfs and Erwin Oberländer, *The Hidden and Forbidden History of Latvia Under Soviet and Nazi Occupations: 1940–1991: Selected Research of the Commission of the Historians of Latvia* (Riga: Institute of the History of Latvia, 2005), Introduction.

<sup>27</sup>Rislakki, 133.

<sup>28</sup>Ibid., 137.

<sup>29</sup>Radio news of July 30, 2012, <http://banga.latvijasradio.lv/zinas/anketa2.sqt?aID=54245&aGR=218> (accessed April 9, 2012).

<sup>30</sup>Every year those who remember their fallen LL comrades and relatives are gathering and laying flowers on March 16, whereas the Latvian veterans of the Red Army meet every May 9–Russia’s official day of victory.

<sup>31</sup>Lynne Viola, *The Unknown Gulag: the Lost World of Stalin’s Special Settlements* (New York: Oxford University Press, 2007), 183.

## CHAPTER 7

### CONCLUSIONS

To start with, let us restate the problem that motivated the author to conduct this research.

Every year on March 16, veterans of the LL gather to lay flowers in memory of their fallen comrades. This gathering draws the unusually negative attitude worldwide not only from the Russian side but also by the Western media agencies. By contrast, the festivities of alcohol-intoxicated mainly Russian youth on May 9, Russia's official Victory day, draws at best the headlines of local boulevard press. Why such a disparity in press coverage? Is it a sign of Latvian over-tolerance or lack of understanding?

After conducting random individual research and discussing this issue with foreign colleagues, the author concluded that western society is largely unaware of events behind the "iron curtain" during the Cold War. In part, this is because of the high-tempo lifestyle that prevails in a contemporary environment driven by the globalization processes. In part, though, these misperceptions are the product of well-orchestrated and consistent ideological propaganda, indoctrinated through speeches and history classes for two generations of Soviet rule. The products of this indoctrination spread across the globe after the collapse of the Soviet Union. Finally, most western countries have settled their historical debts with the past. By contrast, new countries like the Baltic States are still on the path of discoveries, reopening the archives and reinitiating the discussions on the sensitive to all people's world topics of the biggest human tragedy—World War II.

Few in the Western world are aware of the historical and emotional depth that lies beneath the newspaper headlines of March 16. This was a major motivator to conduct the

research on the LL since it serves as an artifact for the Latvian nation and is the epic center for heated discussions between Latvia and Russia. The author hopes that this research not only provided wide factual evidence but also broadened a reader's horizons, and, more importantly, encouraged him to be a critical researcher himself.

For almost 50 years, Soviet rule forbade open discussions on the realities that involved the LL. Unfortunately, in today's Russia we can see a return of these Soviet traditions, especially when discussing the last century's history. The decree of February 23, 2004 published by Russia's Foreign Ministry is another indicator of such policy that tends to illustrate Latvian history and history of the LL in particular as the "national chauvinism" and "collaborationism." At the same time, Latvia's eastern neighbor is reluctant to discuss openly the crimes against humanity performed by the Soviet NKVD soldiers in Ukraine, Caucasus, Baltics and eastern Germany before, during and after World War II. The Russians blame even the Finns for provoking the Soviet Union into the Winter War, because they refused to cooperate by giving up their strategic land.<sup>1</sup>

The author suggests that for a better understanding the history of LL should be viewed in a much broader context. A context that contains at least three elements: an historical geopolitical perspective including the years of first independence, three occupations of Latvia that happened within just a five years period, and a post-Soviet society that forms Latvia today. Given this framework, in the subsequent subchapters the author provides a summary of this thesis and offers his answers to the research questions.

First, let us reflect on some of the key historical aspects that dictated the national narratives in Baltic territory. Most national historians agree that the evolution of Latvians can be divided into three slightly overlapping periods. The initial one started after the



occupation of Baltic tribes by the German Teutonic Order (13th century) and lasted until the end of the “Swedish times” (18th century). During this time, the Baltic peoples realized that their inability to unite the effort against a common enemy (mainly because of the reluctance to abandon individualistic ambitions) led to defeat and conquest. This situation served as a catalyst for the emergence of a united cultural group with shared beliefs and artifacts (religion, rituals, and lifestyle) and united the occupied tribes as a minority. It also created a deep and burning hatred against the Baltic barons.

The second period covers mainly the “Swedish times” and Russian Empire’s rule (17–19th century). In the pursuit of the numbers, Lutheran and Catholic Church appealed with the religious ceremonies to the barbaric by their standards Latvian tribes in the language close to their understanding. Although the symbols initially were Germanic (Latin based), and later Cyrillic, they all replicated the sound of the Latvian tribal language. A common written language emerged along with the name “Latvians.” Now Latvians could not only speak, but also express themselves in writing. Following the Oxford definition, Latvians finally could identify themselves as a “nation.”<sup>2</sup>

A third period was the collapse of the Russian Empire and a first emergence of the Latvian State at the beginning of the 20th century. A reader remembers that mainly because of the tsars’ generous initial policy regarding the Baltic people, in the beginning of the 19th century the Latvian intelligentsia formed a strong national nucleus outside its historical borders. Doctors, lawyers, students and merchants of Latvian ethnicity were able to wage a strong intellectual and political opposition against Baltic barons, thus announcing the new “nation” that demanded equality and fairness in treating its people.

United at last (after almost 700 years), Latvians drove out both occupiers—the remnants of the Russian and German armies.

Although this first Latvian independence lasted roughly two decades, Latvia managed to develop its state to high European standards. During this period one generation of free Latvians was raised, a generation that was born in a free country and saw the free people. This generation understood the price paid for its liberty.

It must be admitted that although Russian and German occupiers sought strictly individual and selfish goals in Baltic territory, they played a crucial role in the evolution of Latvian nation before its first independence. Unfortunately, the National Socialism and communism that was born in the interwar period later brought tragedy and despair to the Baltic nations, and “uncovered” some of the historical wounds, thus renewing the hatred among the nations and ethnicities. Echoes of this hatred can be heard today, and it is hard to predict how many generations more it will take to forgive or forget.

Next, although Russia tries to portray the LL as exceptional and or even equal by its functions and tasks to the ethnically German SS units, as an entity itself the LL was not an unusual phenomenon in wartime Europe. The LL was rather a formation created as many others just a bit too late. Had it been created in the beginning of the Nazi occupation, when the outcry against communist atrocities was at its peak, the outcome of many battles might have been very different. In any case, since the beginning of World War II, there were many “Germanic” volunteers (Netherlands, Denmark, Belgium, Sweden, and Norway) already in place, serving as members of the Waffen-SS. Closer to the end of war, the SS troopers lost their “elite” characteristics and from the “führer guards” turned into a multinational anti-bolshevik army. The military difficulties of Nazi

Germany, the high casualty rate and the crisis in the sign-up of the Germanic volunteers forced the SS leadership to abandon the “elite’s commandments” and to lower the standards, subsequently allowing the non-Germanic ethnicities to join the fight. The SS started to form units of soldiers coming out of the France, Ukraine, Belarus, Russia, Italy, Croatia, Hungary and other countries just to maintain an operational capacity to continue the fight against the overwhelming Allies’ pressure. As a special occasion, the Muslim units should be mentioned: troopers from eastern Turkey, the Tatarian mountain brigade and regiments of the Balkan Muslims. At the end of the war, none of the 38 Waffen-SS divisions was formed solely of the German soldiers, and 19 divisions consisted of foreigners predominantly.<sup>3</sup> Therefore, it is misleading to call the LL a volunteer unit, as the historical evidence clearly shows that it was created as the result of forced mobilization starting in the March of 1943. This fact also explains the historical function of the LL.

As far as the accusations of collaborationism and sharing the Nazi ideology, the author would like to note that the LL was created in the timeframe when the general Latvian attitude against Nazi Germany was very negative.<sup>4</sup> As naïve as Latvians might have been right after the Nazi occupation in 1941, they soon realized that the new power was not much better than the previous one. The general feeling of the Latvian people can be described as desperate. They clearly understood that Nazi Germany did not intend to grant them independence, yet the return of the Soviets seemed even worse. Reports of open anti-German attitude were part of the German division commander’s reports throughout the wartime. On January 27, 1945, the 15th Waffen-SS Division’s commanding officer, General Ax, wrote:

[T]hey are first and foremost Latvians. They want a sustainable Latvian nation state. Forced to choose between Germany and Russia, they have chosen Germany, because they seek co-operation with western civilization. The rule of the Germans seems to them to be the lesser of the two evils. Latvia's occupation deepened hatred of Russia. They consider the fight against Russia to be their national duty.<sup>5</sup>

Besides, a total mobilization under the threat of the “death penalty” would force every rationally thinking person in Europe to obey in those times. The bottom line is that Latvia like many other European countries was not in the position of choosing an ally during the World War II—it could either comply or commit suicide. Even the most developed European countries were not taking sides based on their moral or ideological beliefs; decisions were made based upon the immediate situation in the specific time. Soldiers of the LL did not share the Nazi values, yet Germany was their only ally in the “crusade” against the bolshevism. This, in part answers the question of why today’s Russia pays so much attention to condemn the Baltic Waffen-SS formations.

Finally, we can discuss the findings of the research questions regarding the contemporary society in Latvia and its attitudes toward the LL. Let us first briefly look at the ethnic dynamics and a composition of Latvian population during the decades before the Latvia’s last independence.

The number of ethnic Russians living in Latvia in 1940 (present-day borders) was approximately 170,000 while the corresponding figures for Estonia and Lithuania were around 50,000 and an estimated 95,000 ethnic Russians respectively.<sup>6</sup> In total, there were some 315,000 ethnic Russians in the current borders of the Baltic States. Almost 50 years later (by 1989), those numbers have increased enormously. In Latvia alone the increase was 735,000 Russian immigrants, bringing the total ethnic Russian numbers to almost a million (906,000).<sup>7</sup> The majority of these post-war newcomers were in essence economic

refugees from poor rural areas in the western Russia. Additionally, almost 100,000 Russian military families were brought to Latvia, as it became the Soviet Union's frontier military district (Baltic Military District).

After the war, Soviet terror and deportations continued. A guerrilla war against the Soviet occupation continued into the 1950s, but thousands of the country's indigenous inhabitants were deported to the East. In 1950, according to one estimate, approximately 10 percent of the pre-war Latvian population ended up living in the West as political refugees, while a slightly higher percentage, perhaps 12 percent, were deported to Soviet prisons and labor camps. According to this estimate, about 22 percent of ethnic Latvians were thus forced to live outside their homeland.<sup>8</sup> Most researchers agree that in the immediate aftermath of World War II, the number of permanent inhabitants in Latvia had dropped by approximately 30 percent of its pre-war population, compared to approximately 25 percent in Estonia and 15 percent in Lithuania. Emigration and wartime displacements led to between 115,000 and 129,000 inhabitants of Latvia leaving, never to return. Another estimate has put the number at 130,000.<sup>9</sup>

Summarizing the information above, we can conclude that a major share of today's Russians or other Russian-speaking population living in Latvia are descendants of either the economic refugees or military members who arrived to Latvia in the aftermath of World War II. Logically, the dominant party constantly assured them that Latvian people are very friendly and that the nation as a whole voluntarily joined the USSR. Since the atrocities and exile were usual occurrences in the Soviet Union itself during the mid-1930s-1940s, no one questioned the reasons why thousands of Latvians

were deported. None also asked who lived in a house or an apartment before they were settled in. Does it not remind the reader of similar Nazi actions in displacing the Jews?

Although the bitter and sobering collapse of the Soviet Union forced many ethnic Russians to resettle back to Russia, a large minority remains in the Latvian territory (26 percent). They have to find a way to cope with the past and to establish a respectable lifestyle in the country where they spent most of their life yet now find themselves as foreigners. More progressively thinking ones are learning the Latvian language, actively engaging in the political life and enabling the integration of their families. However, a significant part of the Russian-speaking minority<sup>10</sup> remains unintegrated. Some of them are showing their disrespect more openly, some protesting covertly. It is not an unusual thing to see an old woman ask questions in Russian on the streets of Latvia and young Latvians refuse to answer in the same language.

Therefore, the author would like to state that attitudes towards the LL in contemporary Latvia are just as diverse as is the ethnic composition and historical background of its population. In general, we can distinguish three major attitudes. For older Russian citizens it is still the unshakeable belief in the glorious victory of the Red Army. Subsequently, former Soviet soldiers (even Latvians) still view the LL as the regular unit of their opponent—Nazi Germany. On the other side, there is an older generation of the Latvian emigrants that were forced to leave the motherland during World War II. For them, many of whom are former legionnaires, the LL remains the symbol of national hope and independence, which they believed in and cherished. Some of them or their children have returned to Latvia discovering that both the country and the

people have been subdued in to a more pessimistic condition, thus adding to the frustration even more.

Then finally, there is the younger generation, some of whom were born in an independent Latvia. This, in fact is a target audience for radical movements. These are the holders of anti-Nazi or anti-Soviet placards and simply are pawns in the hands of the “puppet masters.” At times, the congressional representatives of one or another wing party join them, as long as the cameras are rolling.

As far as the official government position stands, the President of Latvia has encouraged the veterans of both fronts to find a peace of mind between them, thus starting a larger moral reconciliation movement. On March 14, 2013, the Latvian parliament rejected the proposal to recognize the March 16 as an official remembrance day, thus once again restating that although for veterans individually the LL was a matter of a fight for national independence, objectively the LL represented the interests of Nazi Germany. Prime Minister Valdis Dombrovskis concluded that this date is dividing the Latvian population rather than uniting it.<sup>11</sup>

The author leaves the decision to the reader as to which of the attitudes is correct, however he insists that a fair treatment to soldiers of both sides should be pursued. They all were mobilized in ranks, trained to fight in units and sent to die in battlefields. Subsequently, the ability to pay respect to a fallen comrade should be each one’s rightful choice. There are very few alive of those who 70 years ago marched the fields of death, and it is shameful to see that they are used for political games.

Finally, the author thinks that it will take at least another generation before Russia will admit Soviet crimes fully and open the secret archives. A long stagnating

relationship between the former Soviet people and the Communist Party during the existence of the USSR created a deep mistrust between the both. Although the previous regime has taught well the loyalty to the Party, the existing Russian government cannot afford more failures and lies to its citizens. This partially explains the anxiety and desperation that Russian officials display at times in defending Soviet achievements and condemning the others outside Russia. The mere fact though remains valid—the present Russian minority in Latvia is reluctant to leave and return to its motherland.

---

<sup>1</sup>РИА Новости, *Путин: СССР в войне с Финляндией хотел исправить ошибку 1917 года*, <http://ria.ru/society/20130314/927341148.html> (accessed April 23, 2013).

<sup>2</sup>According the online Oxford dictionary, nation is “a large aggregate of people united by common descent, history, culture, or language, inhabiting a particular country or territory,” [http://oxforddictionaries.com/us/definition/american\\_english/nation](http://oxforddictionaries.com/us/definition/american_english/nation) (accessed April 23, 2013).

<sup>3</sup>Inesis Feldmanis and Kārlis Kangeris, “Par latviešu SS brīvprātīgo leģionu,” in *Latvijas Vēsturnieku komisijas raksti, 15.sēj.: Totalitārie režīmi Baltijā: izpētes rezultāti un problēmas*, ed., Dzintars Ērglis (Rīga: Latvijas vēstures institūta apgāds, 2005), 238.

<sup>4</sup>Ibid., 244.

<sup>5</sup>Hans Werner Neulen, *An deutscher Seite: Internationale Freiwillige von Wehrmacht und Waffen-SS* (Munich: Universitas, 1985), 294.

<sup>6</sup>Bruno Mežgailis, “Latvija un tās iedzīvotāju dabiskā kustība,” *Latvijas Vēstnesis*, no. 139/140 (854/855) (10 June 1997): 1, 2.

<sup>7</sup>Ibid.

<sup>8</sup>Andrejs Plakans, *The Latvians. A short history* (Stanford: Hoover Institution Press, 1995), 155.

<sup>9</sup>Pēteris Zvidriņš and Inta Vanovska, *Latvieši. Statistiski demogrāfisks portretējums* (Rīga: Zinātne, 1992), 48.

<sup>10</sup>According the latest data from the Latvian Office of Citizenship and Migration Affairs, on January 1, 2013 there were 195,734 Russians non-citizens in Latvia, <http://www.pmlp.gov.lv/lv/statistika/iedzivotaju.html> (accessed April 23, 2013).



<sup>11</sup>Online news portal Delfi.lv, <http://www.delfi.lv/news/national/politics/saeima-noraida-na-ieceri-16martu-noteikt-par-atceres-dienu.d?id=43143306> (accessed April 23, 2013).

## BIBLIOGRAPHY

- 1941 год: в 2-х книгах. Москва: Международный фонд “Демократия,” 1998.
- Agte, Patrick. *Europas Freiwillige der Waffen-SS. Biographien Aller Inhaber Des Ritterkreuzes, Des Deutschen Kreuzes in Gold, der Ehrenblattspange Und der Nahkampfspange in Gold, Die Keine Deutschen Waren*. Pluwig: Munin Verlag, 2000.
- Ailsby, Christopher. *SS: Hell on the Eastern Front. The Waffen-SS War in Russia 1941-1945*. Osceola: Zenith Press, 1998.
- Arbuzov, Leonid. *Essay on the History of Livonia, Estonia and Kurland*. Moscow: Troitsa, 2009.
- Balodis, Agnis Ilmārs. *Latvijas un latviešu tautas vēsture*. Rīga: Kabata, 1991.
- Baltais, Mirdza Kate. *The Latvian Legion: Selected Documents*. Toronto: Amber Printers and Publishers, 1999.
- Bender, Roger James, and Hugh Page Taylor. *Uniforms, Organization and History of the Waffen-SS Vol. 5*. New York: R James Bender Pub, 1982.
- . *Uniforms, Organization and History of the Waffen-SS Vol. 4*. New York: R James Bender Pub, 1986.
- Berkis, Alexander. “Soviet Russia’s Persecution of Latvia, 1918 to the Present.” *The Journal of Historical Review* 8 (1988): 29.
- Biezais, Haralds. “Latviešu Leģions un dezertieri.” *Kara Invalīds* 31 (1986): 14-26.
- . *Latvija kāškrusta varā: sveši kungi, pašu ļaudis*. Lansing, MI: Gauja, 1992.
- Bilmanis, Alfred. *A History of Latvia*. Westport: Greenwood Press, 1970.
- Bishop, Chris. *SS Hitler’s Foreign Divisions: Foreign volunteers in the Waffen SS 1940-1945*. London: Amber Books, 2005.
- Blāķis, Adolfs. *Medaļas otrā puse: okupācijas varu pavadā un jūgā, 1940-1945*. Buenosaires: La Voz, 1956.
- Blofelds, Mintauts. *Stormtrooper On the Eastern Front: Fighting with Hitler's Latvian SS*. Edited by Lisa Blofelds. Barnsley: Pen and Sword, 2008.
- Bojtar, Endre. *Foreword to the Past. A cultural history of the Baltic people*. New York: Central European University Press, 1999.

- Buttar, Prit. *Battleground Prussia: the Assault On Germany's Eastern Front 1944–45*. Oxford: Osprey Publishing, 2010.
- Carr, Edward Hallett. *German–Soviet Relations between the two world wars 1919–1939*. New York: Ayer Co, 1979.
- Caune, Andris, Inesis Feldmanis, Heinrihs Strods, and Irēne Šneidere, eds. *Totalitarian occupation regimes in Latvia in 1940–1964*. 13 (2004): 13, 14.
- Central Statistical Bureau of Latvia. *Statistics of 1920–30s*. <http://www.csb.gov.lv/en/statistikas-temas/statistics-1920s-1930s-33017.html> (accessed December 21, 2013).
- Eksteins, Modris. *Walking since Daybreak. A story of Eastern Europe, World War II, and The Heart of Our Century*. Boston: Mariner Books, 2000.
- Ezergailis, Andrew, ed. “Voldemārs Salnais’s reports: 1941–1944.” *Stockholm Documents. The German Occupation of Latvia 1941–1945. What did America know?* Riga: Historical Institute of Latvia, 2002.
- Feldhūns, Ābrams. *Indriķa hronika*. Rīga: Zinātne, 1993.
- Feldmanis, Inesis. “Latviešu un citu nevācu tautību ieroču SS vienības Otrajā pasaules karā: formēšana, ideoloģija un cīņas mērķi.” In *Latvijas Vēsturnieku komisijas raksti, 10.sēj.: Okupācijas režīmi Latvijā 1940.–1959. gadā. Latvijas Vēsturnieku komisijas 2002.gada pētījumi*, edited by Dzintars Ērglis, 339. Rīga: Latvijas vēstures institūta apgāds, 2003.
- . *Molotova–Ribentropa pakts un Latvija: problēmas nostādne*. International Conference, June 14–15, 2000, Riga.
- Feldmanis, Inesis, and Kārlis Kangeris. “Par latviešu SS brīvprātīgo leģionu.” In *Latvijas Vēsturnieku komisijas raksti, 15.sēj.: Totalitārie režīmi Baltijā: izpētes rezultāti un problēmas*, edited by Dzintars Ērglis, 238. Rīga: Latvijas vēstures institūta apgāds, 2005.
- Feldmanis, Roberts. *Zviedru laiki Vidzemē*. Lectures, Latvian University, Riga, November 9, 1992. <http://www.robertsfeldmanis.lv/lv/?ct=bvesture&fu=read&id=1219785146> (accessed December 16, 2012).
- Freivalds, Osvalds, Ed. *Latviešu karavīrs otrā pasaules kara laikā. Dokumentu un atmiņu krājums. 3.sēj.: Latviešu Leģions*. Västerås: Daugavas Vanagu Centrālā valde, 1974.
- Fritz, Juergen, and Edward Anders. “Murder of Polish POWs at Podgaje (Flederborn), February 1945.” In *The Second World War and Latvia: events and consequences 1940s–1960s. Research of the Commission of the Historians of Latvia, 2011, and*

- Reports of a Scientific Conference “Extermination of the Latvian Army, 1940–1941,” 14 June 2011, Litene*, edited by Daina Bleiere, 127-146. Rīga: Zinātne, 2011.
- Ģermanis, Uldis. *Latviešu tautas piedzīvojumi I–IV*. Stokholma: Memento, 1998.
- Grier, Howard. *Hitler, Dönitz, and the Baltic Sea: the Third Reich's Last Hope, 1944–1945*. Annapolis: Naval Inst. Press, 2007.
- Haslan, Jonathan. “E. H. Carr and the History of the Soviet Russia.” *The Historical Journal* 26 (1983): 1022.
- Haupt, Werner. *Das War Kurland: Die Sechs Kurland–Schlachten Aus der Sicht der Divisionen*. Friedberg: Podzun-Pallas, 1987.
- Haupt, Werner. *Leningrad, Wolchow, Kurland: Bildbericht der Heeresgruppe Nord 1941-1945*. Friedberg (Dorheim): Podzun–Pallas–Verlag, 1976.
- Hiden, John, and Thomas Lane, eds. *The Baltic and the Outbreak of the Second World War*. New York: Cambridge University Press, 1992.
- Hiden, John, Vahur Made, and David James Smith, eds. *The Baltic Question during the Cold War*. New York: Routledge, 2008.
- Holachek, Alex. *Ethical Historiography: The Berlin–Carr debate and the revolutionary Realism of Alexander Herzen*. Middletown: Wesleyan University, 2010.
- Janums, Vilis. *Mana pulka kauju gaitas*. Eufīne: A.Ozoliņa iespiestuve, 1953.
- Kangeris, Karlis. “Kollaboration vor der Kollaboration? Die baltischen Emigranten und ihre ‘Befreiungskomitees‘ in Deutschland 1940/41.” In *Okkupation und Kollaboration (1938–1945)*, edited by Werner Röhr, 181. Berlin and Heidelberg, 1994.
- . “Latviešu leģions–vācu okupācijas varas politikas diktāts vai latviešu ‘cerību’ piepildījums.” In *Latvijas Vēsturnieku komisijas raksti, 24.sēj.: Baltijas reģiona vēsture 20.gadsimta 40.–80.gados*, edited by Dzintars Ērglis, 62. Rīga: Latvijas vēstures institūta apgāds, 2009.
- . “Latviešu policijas bataljoni lielajās ‘partizānu apkarošanas’ akcijās.” In *Latvijas Vēsturnieku komisijas raksti, 13.sēj.: Totalitārie okupācijas režīmi Latvijā 1940.–1964. gadā. Latvijas Vēsturnieku komisijas 2003.gada pētījumi*, edited by Dzintars Ērglis, 332–357. Rīga: Latvijas vēstures institūta apgāds, 2004.
- . “Latviešu Policijas bataljonu izveidošanas otrā fāze–‘lielervēšanas’ akcija. 1942. gada februāris–septembris.” In *Latvijas Vēsturnieku komisijas raksti, 10.sēj.: Okupācijas režīmi Latvijā 1940.–1959. gadā. Latvijas Vēsturnieku*

- komisijas 2002.gada pētījumi*, edited by Dzintars Ērglis, 318. Rīga: Latvijas vēstures institūta apgāds, 2003.
- . “Policijas struktūras Latvijā vācu okupācijas laikā 1941–1945,” In *Latvijas Vēsturnieku komisijas raksti, 16.sēj.: Okupētā Latvija 20.gadsimta 40.gados. Latvijas Vēsturnieku komisijas 2004.gada pētījumi*, edited by Dzintars Ērglis, 287. Rīga: Latvijas vēstures institūta apgāds, 2005.
- Kaprāns, Mārtiņš, and Vita Zelče, eds. *Pēdējais karš: Atmiņa un traumas komunikācija*. Riga: University of Latvia, 2010.
- Karells, Pauls. *Barbarossa. Karaģājiens pret Krieviju*. Brooklin: Grāmatu draugs, 1964.
- Kleist, Peter. *Zwischen Hitler und Stalin*. Bonn: Athenäum-Verlag, 1950.
- Kovalavskis, Pauls, Oskars Noritis, and Mikelis Goppers, eds. *Latvia: Year of Horror*. Riga: Zelta Abele, 1942.
- Kurowski, Franz. *Bridgehead Kurland: the Six Epic Battles of Heeresgruppe Kurland*. Winnipeg: J. J. Fedorowicz Publishing, Inc., 2002.
- Kuzmins, Valdis. “Latvijas bruņoto spēku mobilizācijas un aizsardzības plāni 1939.gada beigās–1940. gada sākumā.” *Militārais Apskats* 3/4 (2009): 49–59.
- Latviešu karavīrs 2.Pasaules kara laikā, vol. 2*. Stockholm: Daugavas Vanagu apgāds, 1972.
- Latvijas valsts, tās vesture, tautas kultūra, tradīcijas un valsts tiesiskie pamati*. Rīga: Latvijas Tautas skola, 2004.
- Liddell Hart, Basil H. *History of the Second World War*. New York: Da Capo Press, 1999.
- Liepiņš, Alberts. *1.Jātnieku Pulks: Dievs, Tēvija, Pulks*. Lansing: A.Liepiņa un Gauja apgāds, 1980.
- Lindpere, Heiki. *Molotov–Ribbentrop pact: Challenging Soviet History*. Tallinn: Foreign Policy Institute, 2009.
- Littlejohn, David. *Foreign Legions of the Third Reich: Poland, the Ukraine, Bulgaria, Rumania, Free India, Estonia, Latvia, Lithuania, Finland and Russia*. San Jose: R James Bender Pub, 1987.
- Lumans, Valdis. *Latvia in World War II*. New York: Fordham Univ. Press, 2006.

- Maruzsa, Zoltan, ed. *Unknown Clauses: The Background Deals of Totalitarian Systems in the Face of World War II. The Molotov–Ribbentrop pact*. Budapest: Lorand University, 2010.
- Memenis, Arvids. *Karavīri bēdājās*. Rīga: Poligrāfists, 1992.
- Merriam Webster Dictionary. <http://www.merriam-webster.com/dictionary/socialism> (accessed January 21, 2013).
- Mežgailis, Bruno. “Latvija un tās iedzīvotāju dabiskā kustība.” *Latvijas Vēstnesis*, no. 139/140 (854/855) (1997).
- Miller, David Almon. *Die Schwertträger der Wehrmacht. The Recipients of the Knight’s Cross with Oakleaves and Swords*. Bennington: Merriam Press, 1988.
- Ministry of Foreign Affairs of the Republic of Latvia. *The Republic of Latvia and the Russian Federation On the State border of Latvia and Russia*. <http://www.am.gov.lv/en/policy/bilateral-relations/4542/Russia/Treaty/> (accessed November 24, 2012).
- Misiunas, Romuald and Rein Taagepera. *The Baltic States: Years of Dependence, 1940–1980*. Berkeley and Los Angeles: University of California Press, 1983.
- Moran, Daniel. “The Baltic Patrol: From counter–Revolution to National Liberation.” *Baltic Security and Defense Review* 11, no. 2 (2009): 41.
- Murray, Williamson, and Allen R. Millett, eds. *Military Innovation in the Interwar Period*. New York: Cambridge University Press, 1998.
- Neiburgs, Uldis. “Latviešu leģions–pagātne un mūsdienas.” *Latvijas Vēsture* 3 (2000): 103–109.
- Neiburgs, Uldis, and Vita Zelča, eds. *Divas puses. Latviešu kara stāsti. Otrais pasaules karš karavīru dienasgrāmatās*. Rīga: Mansards, 2012.
- Neulen, Hans Werner. *An deutscher Seite: Internationale Freiwillige von Wehrmacht und Waffen–SS*. Munich: Universitas, 1985.
- Newton, Steven. *Retreat from Leningrad, Army Group North, 1944/1945*. Atglen: Schiffer Publishing, 1995.
- Nollendorfs, Valters, and Erwin Oberländer. *The Hidden and Forbidden History of Latvia Under Soviet and Nazi Occupations: 1940–1991: Selected Research of the Commission of the Historians of Latvia*. Riga: Institute of the History of Latvia, 2005.

- Nollendorfs, Valters, Ojārs Celle, Gundega Michelle, Uldis Neiburgs, and Dagnija Staško, eds. *The Three occupations of Latvia 1940–1991*. Riga: Occupation Museum Foundation, 2005.
- Panné, Jean–Louis, Andrzej Paczkowski, Karel Bartosek, Jean–Louis Margolin, Nicolas Werth, and Stéphane Courtois. *The Black Book of Communism: Crimes, Terror, Repression*. London: Harvard University Press, 1999.
- Parker, Geoffrey, ed. *The Cambridge Illustrated History of Warfare: the Triumph of the West*, rev. and ed. Cambridge: Cambridge University Press, 2008.
- Plakans, Andrejs. *Experiencing Totalitarianism: the Invasion and Occupation of Latvia by the USSR and Nazi Germany, 1939–1991: a Documentary History*. Bloomington, IN: AuthorHouse, 2007.
- Plakans, Andrejs. *The Latvians. A short history*. Stanford: Hoover Institution Press, 1995.
- Quarrie, Bruce. *Waffen–SS Soldier: 1940–1945 (warrior, No.2)*. Oxford: Osprey Publishing, 1993.
- Radziņš, Pēteris. *Latvijas atbrīvošanas karš*. Rīga: Avots, 1990.
- Reitlinger, Gerald. *The SS: alibi of a nation 1922–1945*. New York: Da Capo Press, 1989.
- Rislakki, Jukka. *The Case for Latvia. Disinformation campaigns against a small nation*. Amsterdam–New York: Rodopi, 2008.
- Ronis, Indulis. *Latviešu buržuāzijas politika 1907–1914.gadā*. Rīga: Zinātne, 1978.
- Shtromas, Aleksandras. *Totalitarianism and the prospects for the world order: Closing the door on the Twentieth Century*. Lanham: Lexington Books, 2003.
- Silgailis, Arturs. *Latviešu Leģions*. Kopenhāgena: Imanta, 1964.
- Smith, David James, Artis Pabriks, Aldis Purs, and Thomas Lane. *The Baltic States: Estonia, Latvia and Lithuania*. London: Routledge, 2002.
- Snyder, Timothy. *Bloodlands: Europe between Hitler and Stalin*. New York: Basic Books, 2010.
- . *The reconstruction of Nations: Poland, Ukraine, Lithuania, Belarus, 1569–1999*. New Haven: Yale University Press, 2003.
- Stein, George. *The Waffen SS: Hitler's Elite Guard at War, 1939–45*. Ithaca: Cornell University Press, 1984.

- Stöber, Hans. *Die Lettischen Divisionen im VI. SS-Armee Korps*. Osnabrück: Munin Verlag, 1981.
- Stradiņš, Jānis. *Latvijas intelektuālās un politiskās elites izveidošanās: problēmas un pretrunas*. Latvian Academy of Science Webpage, [http://www.lza.lv/LZA\\_VestisA/III%20kongres-Stradins.pdf](http://www.lza.lv/LZA_VestisA/III%20kongres-Stradins.pdf) (accessed December 18, 2012).
- . “Personības un strāvojumi Latvijas un ‘Austruma’ vēsturē.” *Akadēmiskā Dzīve* 46 (2009): 60–70.
- Stradiņš, Jānis, and Dzintra Cēbere. “Pirmās latviešu iedibinātās prēmijas zinātnes veicināšanai un Eduarda Veidenbauma godināšana. Nova Miscellanea Historiae Scientiarum Baltica.” 23rd International Baltic Conference on the History of Science, Riga, October 9–10, 2008.
- The Latvian Institute. *History of Latvia. A Brief Survey*. Riga: The Latvian Institute, 2007.
- Tucker, Spencer. *World War I. A Student Encyclopedia*. Santa Barbara: ABC-CLIO Inc., 2008.
- Vardis, V. Stanley, and Judith B. Sedaitis. *Lithuania. The rebel Nation*. Boulder: Westview Press, 1997.
- Vilciņš, Tāļivaldis. “Latviešu leģionārs 50 gadu pēc kara: Socioloģisks aspekts.” *Latvijas Arhīvi* 2 (1994): 23.
- Viola, Lynne. *The Unknown Gulag: the Lost World of Stalin's Special Settlements*. New York: Oxford University Press, 2007.
- Wertsch, James. *Voices of Collective Remembering*. New York: Cambridge University Press, 2002.
- Yerger, Mark. *Waffen-SS Commanders: the Army, Corps, and Divisional Leaders of a Legend*. Atglen, PA: Schiffer Publishing, 1997.
- Zunda, Antonijs. “Vācijas okupācijas varas politika Latvijā (1941–1945): vērtējums historiogrāfijā.” In *Latvijas Vēsturnieku komisijas raksti, 11.sēj.: Latvija Nacistiskās Vācijas okupācijas varā, 1941–1945*, edited by Dzintars Ērglis, 19. Rīga: Latvijas vēstures institūta apgāds, 2004.
- Zvidriņš, Pēteris, and Inta Vanovska. *Latvieši. Statistiski demogrāfisks portretējums*. Rīga: Zinātne, 1992.
- Žans de Boss. *Franču diplomāta piezīmes Latvijā 1939–1940*. Rīga: Liesma, 1997.



- Дюков, Александр. *«Пакт Молотова–Риббентропа» в вопросах и ответах*. Москва: Историческая память, 2009.
- Звягинцев, Александр. *Нюрнбергский Набат: Репортаж из прошлого, обращение к будущему*. Москва: ОЛМА Медиа Групп, 2007.
- Зоря, Юрий Николаевич and Наталья Сергеевна Лебедева. “1939 год в нюрнбергских досье.” *Международная жизнь* 9 (1989): 137.
- Избирательная кампания в Советской Латвии, *Московский большевик*, no. 270 (1940).
- Кен, Олег Николаевич. *Мобилизационное планирование и политические решения: конец 1920–х–середина 1930–х гг.* Санкт–Петербург: Издательство Европейского университета, 2002.
- Литвин, Алексей Михайлович. “Латышские полицейские ‘шудцманшафт’ батальоны в Белоруссии (1941–1944 гг).” In *“Уничтожить как можно больше...”: Латвийские коллаборационистские формирования на территории Белоруссии, 1942–1944 гг. Сборник документов*, edited by Александр Дюков, Владимир Симиндей, Д.С. Валиева, Д.А. Василевский, О.В. Драницина, and Юрий Зверев, 27–53. Москва: Фонд “Историческая память,” 2009.
- Литвин, Алексей Михайлович. *Латвийские коллаборационистские формирования на территории Белоруссии, 1942–1944 гг.* Москва: Фонд “Историческая память,” 2009.
- Петров, Никита Васильевич. “Первый председатель КГБ генерал Иван Серов.” *Отечественная история* 5 (1997): 23–43.
- РИА Новости, *Путин: СССР в войне с Финляндией хотел исправить ошибки 1917 года*. <http://ria.ru/society/20130314/927341148.html> (accessed April 23, 2013).
- Фрунзе, Михаил. “Единая Военная доктрина Красной Армии.” *Военная наука и Революция* 2 (1921): 39.
- Хавкин, Борис. *К истории публикации советских текстов советско–германских секретных документов 1939–1941 гг.* <http://www1.ku-eichstaett.de/ZIMOS/forum/docs/7Chavkin7.pdf> (accessed February 24, 2013).