

REPORT DOCUMENTATION PAGE			<i>Form Approved</i> <i>OMB No. 0704-0188</i>	
Public reporting burden for this collection of information is estimated to average 1 hour per response, including the time for reviewing instructions, searching existing data sources, gathering and maintaining the data needed, and completing and reviewing this collection of information. Send comments regarding this burden estimate or any other aspect of this collection of information, including suggestions for reducing this burden to Department of Defense, Washington Headquarters Services, Directorate for Information Operations and Reports (0704-0188), 1215 Jefferson Davis Highway, Suite 1204, Arlington, VA 22202-4302. Respondents should be aware that notwithstanding any other provision of law, no person shall be subject to any penalty for failing to comply with a collection of information if it does not display a currently valid OMB control number. PLEASE DO NOT RETURN YOUR FORM TO THE ABOVE ADDRESS.				
1. REPORT DATE (DD-MM-YYYY) 14-06-2013		2. REPORT TYPE Master's Thesis		3. DATES COVERED (From - To) 23-07-2012 to 14-06-2013
4. TITLE AND SUBTITLE The Relevance and Future of Joint Logistics Over The Shore (JLOTS) Operations			5a. CONTRACT NUMBER	
			5b. GRANT NUMBER	
			5c. PROGRAM ELEMENT NUMBER	
			5d. PROJECT NUMBER	
			5e. TASK NUMBER	
6. AUTHOR(S) LTC Rhonda L. Fisher, USA			5f. WORK UNIT NUMBER	
7. PERFORMING ORGANIZATION NAME(S) AND ADDRESS(ES) Joint Forces Staff College Joint Advanced Warfighting School 7800 Hampton Blvd Norfolk, VA 23511-1702			8. PERFORMING ORGANIZATION REPORT	
9. SPONSORING / MONITORING AGENCY NAME(S) AND ADDRESS(ES)			10. SPONSOR/MONITOR'S ACRONYM(S)	
			11. SPONSOR/MONITOR'S REPORT NUMBER(S)	
12. DISTRIBUTION / AVAILABILITY STATEMENT Approved for public release, distribution is unlimited				
13. SUPPLEMENTARY NOTES				
14. ABSTRACT While the United States military is unmatched in its ability to project forces anywhere in the world, this advantage is only enjoyed because of reliance on strategic airlift and sealift combined with world-class port and airfield infrastructure. As an option, Joint Logistics over the Shore (JLOTS) operations enable strategic ship offload through inadequate or damaged ports, or over a bare beach. To ensure this option, the Department of Defense (DoD) must invest in a common, integrated approach to ensure a capability that is sufficient and integrated across the Joint Force. History has shown the advantage of projecting forces onto the shores of the enemy. However, periods between conflicts have often resulted in decreased budgets and less emphasis on capabilities such as amphibious operations and JLOTS. To continue to provide this flexible logistics option, both the Services and the joint community must emphasize its importance through continued investment and increased joint collaboration. A comprehensive study to determine concepts, capabilities, and requirements for JLOTS to support future Joint force structures will ensure an accurate starting point for assessing JLOTS. Doctrine must reflect the importance of JLOTS to emerging concepts such as seabasing to ensure seamless transition from one method of logistics delivery to another. Continued and expanded training opportunities will increase the breadth of JLOTS experience across all the Services. The platforms and capabilities existing today for JLOTS must continue to receive required funding to ensure availability when needed for the next contingency. Finally, the joint community must explore all opportunities to enhance JLOTS capability, whether commercial or emerging technology, to ensure viable capability as older platforms and capability reach their economical useful life.				
15. SUBJECT TERMS				
16. SECURITY CLASSIFICATION OF:			17. LIMITATION OF ABSTRACT Unclassified Unlimited	18. NUMBER OF PAGES
a. REPORT Unclassified	b. ABSTRACT Unclassified	c. THIS PAGE Unclassified		
			19b. TELEPHONE NUMBER (include area code) 757-443-6301	

NATIONAL DEFENSE UNIVERSITY

JOINT FORCES STAFF COLLEGE

JOINT ADVANCED WARFIGHTING SCHOOL



**THE RELEVANCE AND FUTURE OF JOINT LOGISTICS OVER THE SHORE
(JLOTS) OPERATIONS**

by

Rhonda Lee Fisher

Lieutenant Colonel, United States Army

**THE RELEVANCE AND FUTURE OF JOINT LOGISTICS OVER THE SHORE
(JLOTS) OPERATIONS**

by

Rhonda Lee Fisher

Lieutenant Colonel, United States Army

A paper submitted to the Faculty of the Joint Advanced Warfighting School in partial satisfaction of the requirements of a Master of Science Degree in Joint Campaign Planning and Strategy. The contents of this paper reflect my own personal views and are not necessarily endorsed by the Joint Forces Staff College or the Department of Defense.

This paper is entirely my own work except as documented in footnotes.

Signature: 

9 April 2013

**Thesis Adviser:
Name**

Signature: 

Richard Wiersema, Colonel, Thesis Advisor

Approved by:

Signature: 

Robert M. Antis, PhD, Committee Member

Signature: 

Steven Guiliani, Captain, Committee Member

Signature: 

**James B. Miller, Colonel, USMC
Director, Joint Advanced Warfighting School**

ABSTRACT

While the United States military is unmatched in its ability to project forces anywhere in the world, this advantage is only enjoyed because of reliance on strategic airlift and sealift combined with world-class port and airfield infrastructure. As an option, Joint Logistics over the Shore (JLOTS) operations enable strategic ship offload through inadequate or damaged ports, or over a bare beach. To ensure this option, the Department of Defense (DoD) must invest in a common, integrated approach to ensure a capability that is sufficient and integrated across the Joint Force.

History has shown the advantage of projecting forces onto the shores of the enemy. However, periods between conflicts have often resulted in decreased budgets and less emphasis on capabilities such as amphibious operations and JLOTS. To continue to provide this flexible logistics option, both the Services and the joint community must emphasize its importance through continued investment and increased joint collaboration.

A comprehensive study to determine concepts, capabilities, and requirements for JLOTS to support future Joint force structures will ensure an accurate starting point for assessing JLOTS. Doctrine must reflect the importance of JLOTS to emerging concepts such as seabasing to ensure seamless transition from one method of logistics delivery to another. Continued and expanded training opportunities will increase the breadth of JLOTS experience across all the Services. The platforms and capabilities existing today for JLOTS must continue to receive required funding to ensure availability when needed for the next contingency. Finally, the joint community must explore all opportunities to enhance JLOTS capability, whether commercial or emerging technology, to ensure viable capability as older platforms and capability reach their economical useful life.

TABLE OF CONTENTS

CHAPTER 1: INTRODUCTION	1
CHAPTER 2: BACKGROUND	5
Strategic Environment.....	5
Types of Missions as Outlined in National and Defense Strategic Documents.....	6
Joint Logistics Doctrine	8
Air Mobility Capability.....	10
Sealift Capability.....	12
Surface Capability.....	15
JLOTS Operations.....	19
Seabasing	23
CHAPTER 3: HISTORICAL EXAMPLES	26
Operation OVERLORD – Normandy Invasion – World War II, 1944	26
Operation CHROMITE – Inchon Landing – Korea, 1950.....	29
Operation CORPORATE – British Invasion of the Falkland Islands, 1982.....	33
Operation UNIFIED RESPONSE – Port Au Prince, Haiti, 2010.....	36
Summary	40
CHAPTER 4: JOINT LOGISTICS OVER THE SHORE (JLOTS) ANALYSIS.....	42
JLOTS Advantages and Disadvantages	42
Current JLOTS Capabilities.....	47
JLOTS Requirements.....	54
Commercial and Multi-National JLOTS.....	57
Summary	59
CHAPTER 5: RECOMMENDATIONS.....	61
CHAPTER 6: CONCLUSION	67
BIBLIOGRAPHY.....	70

CHAPTER 1: INTRODUCTION

President Barack Obama's words within the recently issued Defense Strategic Guidance provide a glimpse into the expected future requirements for the United States military.

“Going forward, we will also remember the lessons of history and avoid repeating the mistakes of the past when the military was left ill-prepared for the future. As we end today's wars and re-shape our Armed Forces, we will ensure our military is agile, flexible, and ready for the full range of contingencies.”¹

Secretary of Defense (SECDEF) Leon Panetta's Defense Budget Priorities and Choices states that (after budget reductions) “...the resulting joint force, while smaller and leaner, will remain agile, flexible, ready, innovative, and technologically advanced...It will be a force that is...ready, rapidly deployable, and expeditionary such that it can project power on arrival.”² Both leaders' remarks illustrate the necessity of the nation's military to project its power anywhere in the world. Additionally, the SECDEF's vision indicates awareness that the past luxury of long-lead-time deployments and lengthy Joint Reception, Staging, Onward movement and Integration (JRSOI) processes is unlikely in future applications of the military instrument of power.

While defense budget cuts and force reductions are inevitable, national and military strategic documents indicate the U.S. armed forces will continue to operate around the world and require expeditionary capability. There are also indicators that important lessons learned regarding sustainment of expeditionary operations are at risk of being ignored or forgotten. The Joint Operational Access Concept (JOAC) states: “For

¹U.S. Department of Defense, *Defense Strategic Guidance: Sustaining U.S. Global Leadership: Priorities for 21st Century Defense* (Washington, DC: Department of Defense, January 2012), i.

² U.S. Department of Defense, *Defense Budget Priorities and Choices* (Washington, DC: Department of Defense, January 2012), 1.

decades, the American ability to project military force from the United States to an operational area has gone essentially unopposed. During the Gulf War of 1990-1991, for example, Coalition forces flowed into the operational area unhindered for six months in the build-up to Operation Desert Storm. Coalition forces similarly deployed uncontested into Afghanistan in 2001 for Operation Enduring Freedom (OEF) and into Kuwait in 2003 for Operation Iraqi Freedom (OIF).”³ While both OEF and OIF were conducted as forcible entry operations into Iraq and Afghanistan, the strategic deep-water ports in Pakistan and Kuwait allowed for an unhindered build-up of equipment for each operation. Additionally, such modern and large capacity airports such as Kuwait City and Kabul, Afghanistan ensured access for large aircraft and the continuous flow of personnel quickly into the theater. Unfortunately, as the U.S. reduces its forward-based presence and relies more heavily on a CONUS-based military, deployments will continue to rely on strategic airlift and sealift, require world-class port and airfield infrastructure, and entail a significant JRSOI process for building combat power in theater.

However, what happens when those seaports and airfields are not available, or are denied to the U.S.? The JOAC recognizes the importance of having options beyond traditional access via deep-water ports or capable airfields:

In some situations, it may be preferable for joint forces to sustain themselves via seabases, which increases employment options by decreasing reliance on airfields and other ashore sustainment infrastructure. Large-scale distribution from a seabase will require new capabilities and capacities. Ship-to-ship and ship-to-shore connectors will be required for the configuration and distribution of a broad variety of sustainment packages, under challenging seastates and in support of continuous sustainment demands.⁴

³ U.S. Department of Defense, *Joint Operational Access Concept (JOAC)* (Washington, DC: U.S. Department of Defense, January 17, 2012), 2.

⁴ *Ibid.*, 32-33.

This concept envisions a future that could entail forces flowing into an area without the benefit of deep-draft ports or adequate airfields. While the JOAC specifies a future requirement with possible new platforms and capacity, the joint force already has a capability that can enhance and enable these types of operations. Joint logistics-over-the-shore (JLOTS) operations enable strategic ship offload through inadequate or damaged ports, or over a bare beach and is officially defined as:

A logistics-over-the-shore (LOTS) operation is the process of loading and off-loading ships in austere areas where ports are damaged, unavailable, or without the benefit of adequate fixed port facilities. LOTS also provide a means of intratheater sealift to move forces, equipment, and sustainment cargo closer to tactical assembly areas. Joint logistics-over-the-shore operations (JLOTS) occur when Service LOTS forces conduct LOTS operations together under a joint task force.⁵

Over the past twenty years of operations, JLOTS served as a logistical option in few operational contingencies, with the use of the elevated causeway in Kuwait for Operation Iraqi Freedom and the earthquake relief effort in Haiti as just two examples. While training exercises regularly occurred, this limited use of JLOTS in operations is largely due to the availability of improved ports and infrastructure as well as sufficient time to build up quantities of supplies and equipment. However, this does not mean JLOTS should not remain an option, especially based on the guidance found in the JOAC and other national strategic documents.

Having the greatest military in the world is meaningless if its forces and subsequent sustainment cannot reach the required point and place in time. The deployments of the past twenty years have illustrated this nation's unparalleled ability to project power when world-class seaports and airfields are available. However, this power

⁵ U.S. Joint Chiefs of Staff, *Joint Logistics Over-The-Shore*, Joint Publication 4-01.6 (Washington, DC: U.S. Joint Chiefs of Staff, November 27, 2012), ix.

projection capability is severely reduced when those ports are unavailable, denied, or degraded. This thesis proposes that the Department of Defense must invest in a common, integrated approach to JLOTS operations in order to continue to provide the Joint Force Commander with logistical options for sufficient and timely cargo throughput at locations where fixed port facilities are either denied or unavailable.

Combatant Commanders must know and understand the capabilities of the mobility forces available to them, especially in the event of potential conflict in areas that do not have the required infrastructure to project military personnel, equipment, and supplies. In addition to these capabilities, they must also know the shortfalls in order to develop a viable plan in the event of conflict. This thesis will define doctrinal terms and identify the types of operations in which JLOTS could be a viable logistics solution to enable effective support. Historical examples from World War II through the recent disaster relief support to Haiti will illustrate the importance of JLOTS and the potential for future use. A discussion on current JLOTS capability to include future investment plans will also contribute to understanding the overall situation within Department of Defense with regard to JLOTS. Alternatives and complementing strategies will offer recommended changes to how Department of Defense approaches JLOTS for future operations.

CHAPTER 2: BACKGROUND

In order to understand the importance of Joint Logistics Over The Shore (JLOTS) as a capability, one must first understand the strategic environment faced both today and in the future along with the types of missions the joint force is, and will be, expected to perform. Additionally, certain doctrinal terms require discussion to ensure an understanding of the ways in which the nation's military moves its forces and equipment, to include the logistical support methods that are available to the Joint Force Commander. A JLOTS description follows for comprehension of the basics of a typical JLOTS operation. Finally, a discussion of seabasing illustrates its important relationship with JLOTS.

Strategic Environment

Today's strategic environment consists of state and non-state actors, criminal organizations, traffickers, and terrorist groups who all challenge the United States' assured access to and freedom of maneuver within the global commons – shared areas of sea, air, space and cyberspace. The rise of new powers, the growing influence of non-state actors, the spread of weapons of mass destruction, and other destructive enabling technologies, and a series of enduring and emerging trends pose profound challenges to international order.¹ By developing anti-access/area-denial (A2/AD) capabilities and acquiring technologies such as missiles and autonomous and remotely-piloted platforms, these actors challenge U.S. ability to project power from the global commons and increase our operational risk. Thus, the future joint force cannot assume availability or

¹ Robert M. Gates, *Quadrennial Defense Review Report* (Washington DC: U.S. Department of Defense, February 2010), 5.

access to sea and aerial ports anywhere in the world, and must plan accordingly for other methods to project power and provide sustainment to forces operating in areas where those facilities are nonexistent or denied.

Types of Missions as Outlined in National and Defense Strategic Documents

Given the strategic environment, the Secretary of Defense laid out the following ten missions for the military as of January 2012:

1. Counter Terrorism and Irregular Warfare
2. Deter and Defeat Aggression
3. Project Power Despite Anti Access/Area Denial (A2/AD) Challenges
4. Counter Weapons of Mass Destruction (WMD)
5. Operate Effectively in Cyberspace and Space
6. Maintain an Effective Nuclear Deterrent
7. Defend the Homeland and Provide Support to Civil Authorities
8. Provide a Stabilizing Presence
9. Conduct Stability and Counterinsurgency Operations
10. Conduct Humanitarian, Disaster Relief, and Other Operations²

Deter and Defeat Aggression, Project Power Despite A2/AD Challenges, and Conduct Humanitarian or Disaster Relief Operations all could easily entail the destruction, nonexistence, or unimproved existence of port facilities and infrastructure.

In fact, according to the Defense Strategic Guidance (DSG), the Joint Force is expected to assess its capabilities in several areas and make additional investments to ensure ability to accomplish several stated missions, including Defeat and Deter Aggression, where ground forces must remain responsive and rely on balanced lift, presence, and prepositioning to maintain agility. Additionally, under Project Power Despite Anti-Access/Area Denial Challenges, "...the United States must maintain its ability to project power in areas in which our access and freedom to operate are

² U.S. Department of Defense, *Defense Strategic Guidance: Sustaining U.S. Global Leadership: Priorities for 21st Century Defense* (Washington, DC: Department of Defense, January 2012), 5-6.

challenged.”³ Finally, for Humanitarian, Disaster Relief, and Other Operations, the rapidly deployable capabilities of U.S. military forces are important, to include both airlift and sealift. Thus, for many of the missions outlined in the Defense Strategic Guidance, JLOTS could become a critical capability.

Additional documents emphasize the same requirements. The Joint Operational Access Concept (JOAC) states, “As a global power with global interests, the United States must maintain the credible capability to project military force into any region of the world in support of those interests. This includes the ability to project force both into the global commons to ensure their use and into foreign territory as required.”⁴ The document goes on to specify the implications for the performance of the Joint Functions. Under sustainment, the obvious implication is the likelihood of sustainment becoming even more of an enemy target in the opposed access types of operations described in the JOAC. As a result, joint forces will require new sustainment concepts that account for adversary capabilities along with innovations that may require new platform designs, more robust information networks, and the ability to more rapidly reach distributed combat forces operating in contested areas. This is especially important when considering the way the joint force currently deploys and how they might deploy in the future. The past twenty years have shown how the strategic seaports and airfields used for deployment of personnel and equipment have largely been uncontested and have not experienced enemy interdiction or attrition. The future will require not only new capabilities, but also the possible use of options such as JLOTS.

The National Military Strategy also confirms that development of anti-access and

³ Ibid., 4.

⁴ Ibid., i.

area-denial capabilities will interfere with freedom of action as these other actors obtain technologies as missiles and even unmanned aerial platforms to challenge power projection capability. Finally, the recently released Capstone Concept for Joint Operations lists implications on the joint functions for the future. Under movement and maneuver, the Joint Force must improve strategic and operational mobility. “Growing lift capability, decreasing lift and sustainment requirements, and the intelligent use of prepositioned equipment could each improve strategic and operational mobility. Determining the most cost-effective mix of these various approaches will require careful analysis considering technology advancements and expected fiscal constraints between now and 2020.”⁵ Thus, the realization among senior leaders exists. The traditional use of improved nodes for deployment and sustainment cannot be the automatic assumption in the future. All these documents call on the Services to re-look that ability and apply fiscally sound solutions to enable mission success.

Joint Logistics Doctrine

In order to understand where JLOTS fits in the logistics realm, a general understanding of joint logistics is necessary. Joint Publication (JP) 4-0, Joint Logistics, recognizes that effective joint logistics is essential to the Nation’s ability to project and sustain combat power. Joint Logistics is “the coordinated use, synchronization, and sharing of two or more Military Departments’ logistic resources to support the joint force.”⁶

Within joint logistics exists the core logistics capabilities, which include supply,

⁵ U.S. Department of Defense, *Capstone Concept for Joint Operations: Joint Force 2020* (Washington DC: Department of Defense, September 10, 2012), 11.

⁶ U.S. Joint Chiefs of Staff, *Joint Logistics*, Joint Publication 4-0 (Washington DC: Joint Chiefs of Staff, July 18, 2008), GL-7.

maintenance, health service support, engineering, logistic services, operational contract support, and the one that brings us to JLOTS: deployment and distribution. This cornerstone capability for joint logistics supports the movement of forces and unit equipment during deployment and redeployment, and supports materiel movement during the logistical sustainment of operations, which is the distribution portion of this capability. United States Transportation Command (USTRANSCOM) is an important element because it supports the joint force providers during the planning and execution of the deployment and redeployment process. As the Distribution Process Owner (DPO), USTRANSCOM is responsible for coordinating and overseeing the DoD distribution system to provide interoperability, synchronization, and alignment of DoD wide, end-to-end distribution.⁷ Collaboration with other logistics agencies and commands is essential to ensure efficient movement of materiel through the distribution pipeline.

During the planning phase for joint logistics, JLOTS is a consideration for deploying and/or sustaining the joint force. Planners must consider the sequence of personnel and logistics to ensure provision of all the core capabilities mentioned earlier. For the purposes of this paper, emphasis is on planning for the deployment and distribution core capability. USTRANSCOM and other transportation providers must identify air, land, and sea transportation resources to support the approved Concept of Operations (CONOPS), which could include apportioned inter-theater transportation, GCC-controlled theater transportation, and transportation organic to the subordinate commands. Two key elements in development of the support plan are transportation feasibility and logistics supportability analysis (LSA). Transportation feasibility determines whether available strategic and theater lift assets, transportation infrastructure,

⁷ Ibid., II-7.

and competing demands and restrictions, can support the CONOPs.

The LSA attempts to define the total unconstrained logistical requirement for execution of a CONOPS and highlights deficiencies and their associated risk to supporting theater operations. Logistic planners must also identify limitations en route to or within the theater to avoid overloading lines of communication (LOCs). Limited unloading capacities at ports and airfields, lack of asset visibility, and limited inland transportation can constrain the operational reach of combat forces. Planners must assess the impact on US force deployments when multinational land, naval, and air forces compete for real estate, ship berthing and unloading facilities, transportation, labor, and construction materials. Finally, “planners must evaluate the impact of using seaports of debarkation (SPODs), aerial ports of debarkation (APODs), and/or joint logistics over the shore when preparing for operations.”⁸ Thus, as joint planners develop the concept of support for an operation, they must identify the options available to both deploy and sustain the force. If improved ports or airfields are not available, the planners will seek other ways, such as JLOTS, to flow the force, including sustainment, into the theater. In the next few paragraphs, air mobility, sealift, surface, and port capabilities are presented to illustrate many of the options available to the Joint Force Commander when considering logistics support to operations.

Air Mobility Capability

Air mobility is a network of systems that combines airlift, airdrop, aeromedical evacuation, air refueling, and air mobility support assets, processes, and procedures into

⁸ Ibid., III-9.

an integrated whole to support the transport of personnel and materiel.⁹ When considering a concept of support, the ability to use airlift and/or airdrop is a key factor because all modes of transportation offer advantages and disadvantages. Obviously, airlift and airdrop operations allow speed, flexibility, and range for commanders; thus, enabling rapid response that other modes cannot offer in a wide variety of circumstances.

Air Mobility Command (AMC), as the Air Force's Service Component Command of USTRANSCOM, is responsible for all CONUS-based common-user air mobility assets and conducts both intertheater and intratheater common-user operations.

Intertheater airlift operations (also known as strategic airlift) links airlift between theaters or between the continental United States and theaters. Intratheater airlift operations occur within a particular theater and provide air movement and delivery of personnel and equipment directly into objective areas through air landing, airdrop, extraction, or other delivery techniques as well as the air logistic support of all theater forces, including those engaged in combat operations, to meet specific theater objectives and requirements.

While airlift operations provide significant capabilities, there are numerous considerations required. Air mobility's flexibility and vulnerability make it a responsive, but potentially costly alternative. Logistics support requirements for air mobility operations is extensive as is its dependence on ground equipment for some operations. Air mobility assets are vulnerable to air and surface threats, requiring air superiority, threat avoidance, or low-threat environments as a condition for success. Additionally, air mobility assets are a limited asset, both in terms of quantity available and the limitations placed on cargo dimensions and weight. The Civil Reserve Air Fleet (CRAF) program

⁹ U.S. Joint Chiefs of Staff, *Air Mobility Operations*, Joint Publication 4-17 (Washington, DC: Joint Chiefs of Staff, October 2, 2009), ix.

provides airlift through the commercial sector when the need exceeds the availability of military aircraft, usually only during emergencies. Careful prioritization of these scarce assets is paramount, especially when distances are long or in the absence of a well-developed surface infrastructure. Because of these considerations, joint doctrine states as a general guideline that consideration is first given to sealift and surface assets over airlift as long as shipment timeline requirements are met. Thus, when deep draft ports are not available, denied, or degraded, the automatic solution is not just airlift. Other options, such as JLOTS, require consideration.

Sealift Capability

Military Sealift Command (MSC), the Navy Service Component Command of USTRANSCOM, provides worldwide ocean transportation of cargo during peacetime and war. In fact, as the fastest and most cost-effective way to transport large amounts of materiel, over 90% of joint force materiel is transported by sealift.¹⁰ Several programs support sealift capability. MSC has a fleet of dry cargo ships to satisfy the roll-on/roll-off (RO/RO) ship requirement in the event that US-flagged commercial industry cannot. Surface Deployment and Distribution Command (SDDC), the Army Service Component Command of USTRANSCOM, can also establish universal service contracts with commercial shipping industry for movement of cargo at a reduced rate. When commercial service is not adequate to meet OPLAN requirements for joint operations, the Voluntary Intermodal Sealift Agreement (VISA) can provide contractually committed, time-phased, sealift capability.¹¹ VISA is a capacity-oriented program instead of a ship-

¹⁰ U.S. Joint Chiefs of Staff, *Distribution Operations*, Joint Publication 4-09 (Washington, DC: Joint Chiefs of Staff, February 5, 2010), II-8.

¹¹ *Ibid.*, II-9.

by-ship program.¹² Participating commercial industries guarantee space on board ships in terms of square feet or short tons, not actual numbers of vessels. The majority of the dry cargo fleet is enrolled in VISA, with other types of ships including container, RO/RO, heavy lift, breakbulk, tugs, and barges.¹³ This agreement provides the process for DOD and industry to develop flexible concepts of operations for contingency sealift in support of CCDR OPLANs.

An important program within the sealift capability is the Contingency Support Fleet, which consists of three categories of vessels: Large Medium Speed Roll-on/Roll-off (LMSR) vessels, the Afloat Prepositioning Force (APF), and the Ready Reserve Force (RRF).¹⁴ These are all strategic assets that can provide rapid response and pre-positioning worldwide. Not intended for routine movement of peacetime cargo, these assets can satisfy exercise, surge, and contingency requirements. LMSRs are slower than their predecessors, the Fast Sealift Ships (FSS), but can carry approximately twice the amount of cargo.¹⁵ They are civilian contracted and are berthed on the East, West, and Gulf coasts of the US, able to reach ports of debarkation within a few days, or they may be prepositioned around the world.

APF ships include all the service pre-positioning ships: the Marine Corps' maritime pre-positioning force (MPF); the Army's prepositioned stocks (APS); and Navy, DLA, and Air Force pre-positioning ships.¹⁶ These ships provide mobile materiel storage and delivery capabilities that can defer the need for strategic air and sealift. They provide critical supply capability for early phases of a particular OPLAN or contingency.

¹² Ibid.

¹³ Ibid.

¹⁴ Ibid.

¹⁵ Ibid.

¹⁶ Ibid., II-10.

The RRF, the last category of vessels within the contingency support fleet, is a fleet of ships in reduced operating status that DOD can use when required.¹⁷ Like the LMSRs, these ships are strategically located at various places to ensure just a few days voyage to a port of debarkation. However, these ships all require activation time, anywhere from 5 to 17 days, depending on the type of vessel and location.¹⁸ FSSs are located in the RRF, which can travel at speeds up to 27 knots (compared to the LMSR's 24 knots).¹⁹ Some of these higher use, higher demand vessels are located at commercial or government berths near their activation yards and loading ports to ensure proper response time.

Of importance with the description of the above sealift assets is the fact that all of the assets described require deep-water ports for their use. The majority of sealift assets found within the RRF are essentially useless if ports are damaged, inadequate, or unavailable. However, within the category of sealift capability is one that is a critical enabler of JLOTS and can help to mitigate the enemy's ability to implement anti-access/area denial strategies. Army watercraft platforms do the heavy lifting associated with waterborne operational maneuver and the intratheater sealift of units, equipment, and supplies.²⁰ Army watercraft organizations include heavy and medium boat units, logistic support vessel detachments, floating craft companies, modular causeway companies, and harbormaster detachments.²¹ All of these units are an integral part of JLOTS operations.

¹⁷ Ibid.

¹⁸ Ibid.

¹⁹ Ibid.

²⁰ Ibid., II-11.

²¹ Ibid.

Surface Capability

Military Surface Deployment and Distribution Command (SDDC), as the Army Service Component Command of USTRANSCOM, provides surface transportation and is DOD's single port manager (SPM) for all common-user seaports of embarkation (SPOE) and debarkation (SPOD).²² Acting as the SPM, SDDC works closely with MSC and commercial shipping industry to coordinate and manage the arrival, discharge, loading and unloading of vessels as required by GCC priorities. In addition to coordinating and managing nearly all land transportation necessary, SDDC also monitors the status of worldwide infrastructure, including ports, inland waterways, and pipelines, all to support the strategic flow of the deploying forces' equipment and supplies to and from the theater.²³ USTRANSCOM contributes immensely during the planning phase as they have information and oversight over all major ports around the world and can identify potential seaports and airports for use during military operations. When selecting ports, the capability can be either fixed or expeditionary.

Fixed ports include both seaports and airports used for debarkation operations into a theater. Aerial or Seaport Ports of Debarkation (APOD/SPODs) are the points from which materiel flows from the intertheater to the intratheater leg of joint distribution.²⁴ These PODs can be the most constraining aspect of global distribution; selection and successful operation is critical to distribution support of joint forces. Port capabilities, facilities, physical security, throughput capability, and proximity to adequate roads, rail lines, inland waterways, and pipelines are important factors in port selection.²⁵

²² Ibid.

²³ Ibid.

²⁴ Ibid., II-16.

²⁵ Ibid.

USTRANSCOM, through its subordinate commands (AMC, MSC, and SDDC), is the primary DOD agency to determine and assess port throughput capabilities.

Aerial port operations are dependent on several factors that affect throughput. Runway length, taxiways, ramp space, Materiel Handling Equipment (MHE), and the ability of the runway to support the weight of large aircraft all affect the ability of a particular airfield to provide effective support.²⁶ Additionally, the maximum (aircraft) on the ground (MOG) factor along with the impact of commercial traffic or other activities in the port area could also affect the ability of the APOD to support global distribution operations.²⁷ Improvements to the airfield (runway lengthening, additional ramp construction, provision of more MHE) can mitigate some APOD shortfalls.

Personnel, equipment, and supplies arriving via sealift flows from the SPOD via theater distribution capabilities such as intratheater air, highway, rail, barge, and pipeline. SPOD physical considerations such as navigability, channel depths, numbers and sizes of ship berths, cargo handling equipment, and explosive handling limitations all contribute to the ability to maximize throughput and are not easily changed in the short term, requiring long lead time and significant resources to improve.²⁸ An alternative is to augment inadequate SPODs through JLOTS capabilities until other infrastructure enhancements are complete.

Where fixed ports are not available or sufficient, forces must contend with the expeditionary environment. Although every Service has capability to conduct theater opening operations in an expeditionary environment, these capabilities may or may not sufficiently address issues during rapid response operations or in a joint operation. Thus,

²⁶ Ibid.

²⁷ Ibid.

²⁸ Ibid.

in the last ten years, USTRANSCOM created Joint Task Force – Port Opening (JTF-PO), which gives the supported GCC rapid port opening capability to facilitate crisis response in austere environments.²⁹ A joint expeditionary capability, JTF-PO can rapidly establish and initially operate an APOD and/or SPOD and a distribution node, thus facilitating throughput for contingency response. JTF-PO quickly establishes C2 and visibility of cargo moving from the PODs and through the theater of operations. In addition to operating a fixed port, JTF-PO can serve as the initial C2 for a JLOTS operation. However, JTF-PO is designed to operate in a permissive environment and is only capable of operating for 45-60 days, thus requiring relief from follow-on forces.³⁰

Within the Army's force structure exist units capable of providing assets that can function in expeditionary ports around the world. Transportation battalions plan and execute common-user water terminal and surface distribution operations within a geographic area. Terminal battalions are usually attached to the sustainment brigade assigned the port opening mission and provide effective and efficient flow of materiel and personnel into and out of theater. Seaport operating companies perform terminal service operations to discharge and load containerized cargo and wheeled/tracked vehicles in fixed seaports or in logistics over-the-shore (LOTS) sites. Lastly, heavy and medium boat companies perform waterborne transportation of personnel, cargo, and equipment during water terminal or JLOTS operations.

The Navy's expeditionary port capabilities are the Naval Beach Group (NBG) and the Navy Expeditionary Logistics Support Group (NAVELSG). Following an amphibious assault or offload of Maritime Prepositioning Ship, the NBG puts equipment

²⁹ Ibid.

³⁰ Ibid.

and supplies on the shore. The NBG provides beach traffic control, pontoon lighterage, causeways, ship-to-shore bulk fuel systems, limited construction capabilities, landing craft, beach salvage capability, and communications to properly facilitate the flow of troops, equipment, and supplies ashore.³¹ NAVELSG is a Navy Reserve command organized, trained, and equipped to load/off-load Navy and Marine Corps cargo aboard ships and/or military-controlled aircraft, and operate temporary ocean and air cargo terminals.³²

Air Force capability for expeditionary port operations includes the Expeditionary Mobility Task Force (EMTF), with one each on the East and West Coast of the United States and establishes expeditionary air mobility presence and infrastructure or expands existing fixed facilities.³³ Air Mobility Command has two Contingency Response Wings (CRWs) which open forward airbases and/or extend infrastructure in an expeditionary environment. For long term operations, the Contingency Response Groups (CRG) and the Contingency Response Elements (CRE) provide for deployment expeditionary C2, airlift and air refueling operations, aerial port, aircraft maintenance personnel, and air mobility operations management.³⁴

Thus, when planning for logistics support, the air, sealift, and surface capabilities must all receive consideration. Some equipment and personnel will move by air while sealift will move the majority of the assets required for the operation. Surface considerations will determine what types of ports to use, whether fixed or expeditionary. If planning considerations point to expeditionary seaports, then JLOTS becomes a critical

³¹ Ibid., II-19.

³² Ibid.

³³ Ibid.

³⁴ Ibid., II-20.

capability needed for mission success.

JLOTS Operations

As described in the previous chapter, JLOTS delivers forces, equipment, and sustainment cargo in areas where ports are damaged, unavailable, or inadequate. The Army and Navy have the majority of the forces and equipment required for JLOTS operations, with the Marine Corps maintaining limited capability primarily aimed toward its MPF. Navy units usually provide JLOTS capability for discharge of MPF assets, with limited augmentation capability from the Marine Corps.

The scope of JLOTS operations depends on geographic, tactical, and time considerations and extends from initial operation planning, through deployment/set up of JLOTS forces and equipment/enablers, to arrival of ships for cargo off-load and delivery to inland staging and marshaling areas.³⁵ JLOTS operations are scalable and can occur over a bare beach, an austere port, a damaged fixed port to mitigate limited port access, or to augment existing fixed port facilities to counter throughput shortfalls.

Bare beach operations are typically used when fixed ports are not available, destroyed, or denied. Various smaller vessels such as landing craft (referred to as lighterage) are used to off-load ships, at anchor, away from the shore (in-stream discharge), and then cargo is moved over a beach via the ramps of the lighterage. Bare beach operations are not ideal for prolonged use as they have inherent challenges such as effective operation in wind, sea state, and tidal cycle.

An austere or unimproved port may have shortfalls in berthing space, required MHE, or required draft depth for larger ships. A damaged port might have all the

³⁵ U.S. Joint Chiefs of Staff, *Joint Logistics Over-The-Shore*, Joint Publication 4-01.6 (Washington, DC: U.S. Joint Chiefs of Staff, November 27, 2012), I-2.

requirements for offload, but damage from earthquakes, hurricanes, tsunamis, or even enemy activity has hindered use of the facility. These types of JLOTS operations are typically less vulnerable to weather and tidal conditions, require less engineer support, and generally offer increased throughput when compared with bare beach operations.³⁶ Operation UNIFIED RESPONSE in Port-au-Prince, Haiti, discussed in more detail in Chapter 3, is a recent example of JLOTS operations at a heavily damaged fixed seaport.

An undamaged port facility with modern MHE and good supporting infrastructure will generally offer significantly greater throughput at lower cost in material and manpower compared to a JLOTS operation.³⁷ However, JLOTS may prove useful to augment throughput when joint operations throughput requirements exceed the capacity of a fixed port. During Operation IRAQI FREEDOM, the port of Al Shuaiba, a modern port with adequate depth and infrastructure, lacked the space to handle both the commercial sealift and the vessels carrying deploying forces equipment. To increase the ability of the port to offload vessels, the Navy employed its elevated causeway system (ELCAS) at Kuwait Naval Base near the commercial port.

Ship discharge operations consist of RO/RO, container, and breakbulk discharge. RO/RO discharge uses either the ramps contained within the RO/RO ships, or auxiliary crane ships such as the T-ACS. During favorable weather conditions, personnel drive vehicles off the RO/RO ships onto roll-on/roll-off discharge facilities (RRDFs) that are moored alongside the ships. An RRDF is causeway sections assembled into a platform that operates as a floating pier. Once the vehicles are discharged onto the RRDF, they are then driven onto lighters for transit ashore. The T-ACS is used primarily to offload

³⁶ Ibid., I-3.

³⁷ Ibid., I-4.

containers, but can also lift vehicles if weather precludes the use of the RRDF. Of all the types of cargo to offload, breakbulk discharge is by far the most challenging. Non-homogenous cargo such as pallets, bags, bales, carton, crates, cases, barrels, or drums are all considered breakbulk cargo. In most cases, breakbulk cargo is discharged directly over the side of the ship using the ship's organic equipment. Figure 2-1 depicts a typical JLOTS operation.

Once discharge operations are complete, lighters move the cargo ashore. Various lighters are associated with JLOTS and listed in Figure 2-1. Additionally, operations that result in discharge directly on a beach will require the use of either the causeway pier (CWP) or an elevated causeway system (ELCAS). Typically, RO/RO cargo is discharged directly onto the beach; however, if circumstances prevent this, a floating CWP or ELCAS can be erected and cargo will discharge onto this pier and then drive onto the beach. Cranes offload containers and breakbulk cargo from lighters directly onto trucks waiting on the CWP or ELCAS and then driven ashore.

Beach Clearance Units (BCUs) organize the beach area for throughput. An Army cargo transfer company from a terminal service battalion, a Navy beachmaster unit, or a Marine Corps landing support company can all serve as BCUs, with primary responsibility consisting of unloading lighters and transferring cargo to the marshaling area. Once cargo arrives in the marshaling area, the Service components prepare it for onward movement in accordance with their established Service procedures.³⁸

Finally, the Offshore Bulk Fuel System (OBFS) has the capability to transfer fuel from offshore to the beach. The Marine Corps' amphibious bulk liquid transfer system (ABLTS) and the Army's Offshore Petroleum Discharge System (OPDS) both can

³⁸ Ibid., IV-27.

provide this capability, with the ABLTS arriving with MPF equipment.

Typical Joint Logistics Over-the-Shore Operation

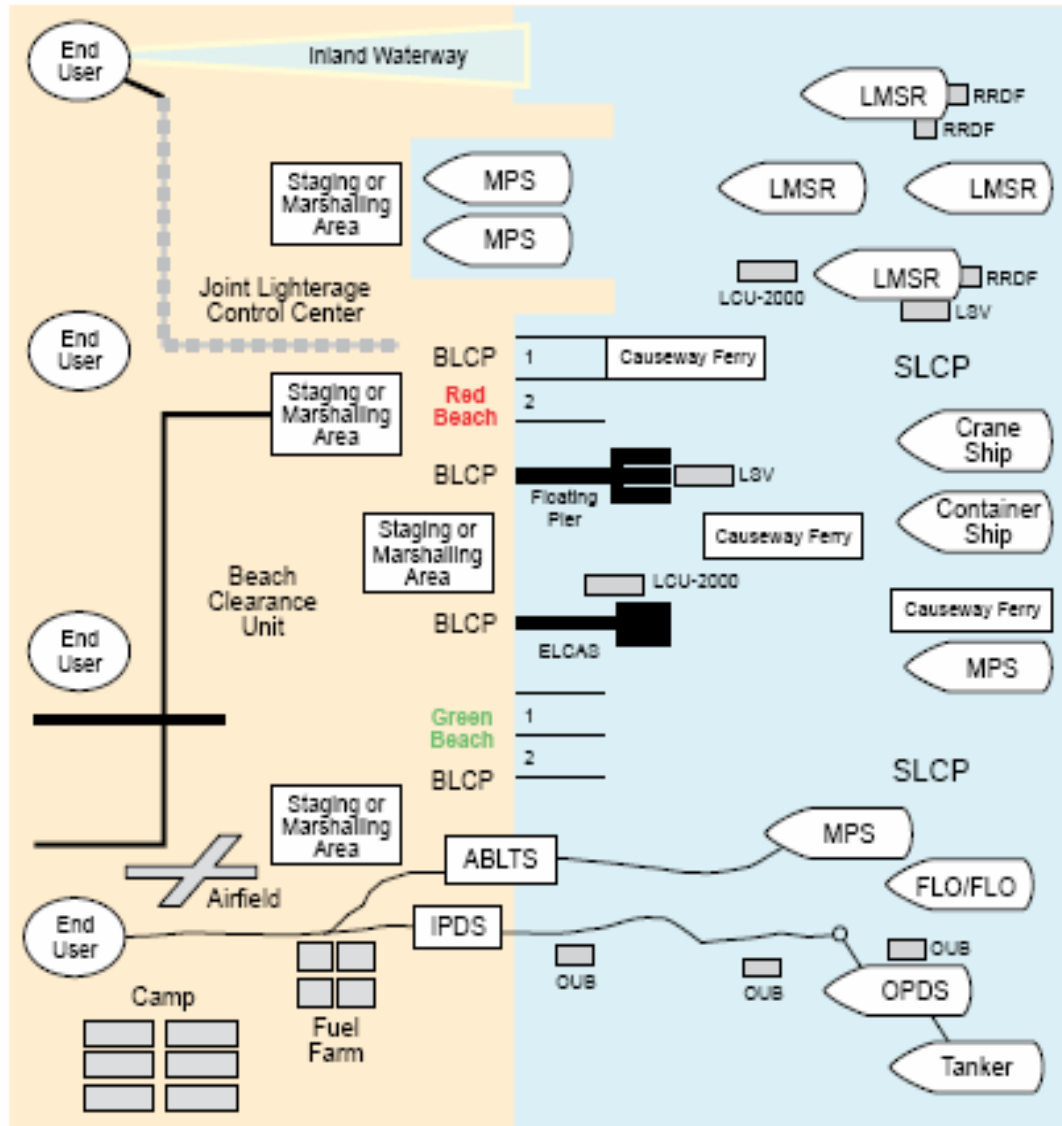

Legend

ABLTS	amphibious bulk liquid transfer system	LMSR	large medium speed roll-on/roll-off
BLCP	beach lighterage control point	LSV	logistics support vessel
ELCAS	elevated causeway system	MPS	maritime pre-positioning ships
FLO/FLO	float-on/float-off	OPDS	offshore petroleum discharge system
IPDS	inland petroleum distribution system	OUB	offshore petroleum discharge system utility boat
LCU-2000	landing craft, utility - 2000 class	RRDF	roll-on/roll-off discharge facility
		SLCP	ship lighterage control point

Figure 2-1³⁹

³⁹ Ibid., IV-24.

Seabasing

The relationship between JLOTS operations and seabasing is important since JLOTS, and the capability it provides, is an integral part of the concept. Joint seabasing provides a solution to the challenge of conducting joint missions across a range of operations from the sea, across the littorals, and ashore.⁴⁰ While it provides for the application of specific naval capabilities through the leveraging of joint, interagency, and multi-national efforts, U.S. Fleet Forces Command, the Marine Corps Combat Development Command, and the Army Capabilities Information Center all jointly endorse the concept, signing a Memorandum of Agreement in June 2010. Factors such as diplomatic, military, infrastructure, geographic, environmental, and force protection limitations will all increasingly restrict access to overseas basing in the future. To overcome these access challenges, the Navy, Marine Corps, and Army have espoused joint seabasing as a method to provide strategic and operational options in support of diplomatic, military, or humanitarian efforts.⁴¹

Seabasing supports a broad range of military missions such as forcible and non-forcible entry operations, amphibious operations, power projection, theater security cooperation, and humanitarian assistance. It can significantly reduce the ashore footprint and the joint force's reliance on port infrastructure, thus providing both operational maneuver and assured access. By synchronizing with other means of force projection, joint seabasing enables the scalable employment of larger ground forces and capabilities that deploy not *from* but *through* the sea base, thus increasing strategic responsiveness

⁴⁰ U.S. Fleet Forces Command, *Concept for Employment of Current Seabasing Capabilities: Integrating Seabasing Capabilities Into Exercises and Experiments* (Norfolk, VA: U.S. Fleet Forces Command, June 29, 2010), 1.

⁴¹ *Ibid.*, 2.

and providing additional force projection and sustainment options to the joint force commander.⁴²

The seabasing concept envisions a variety of individual platforms such as Carrier Strike Groups (CSGs), Amphibious Readiness Groups/Marine Expeditionary Units (ARG/MEUs), Expeditionary Strike Groups (ESGs), Amphibious Forces (AF), Maritime Prepositioning Ships Squadrons (MPSRON) with embarked Naval Forces, Army Afloat Prepositioned Stocks, and legacy strategic sealift.⁴³ Seabasing offers a variety of capabilities. Platforms and systems are brought together in various combinations to enable several capabilities, including at-sea transfer; selective offload; austere access; sustainment; command and control; force projection ashore and maritime strike; seabase defense; intelligence, surveillance and reconnaissance (ISR); and medical support.⁴⁴ Of these capabilities, at-sea transfer, selective offload, austere access, and sustainment directly relate to JLOTS.

At-sea transfer moves people and equipment between ships and is a key enabler for deploying, employing, and sustaining joint forces from the sea. It combines platforms for surface or air movement and involves surface connectors such as landing craft with air connectors such as MV-22 Ospreys or helicopter assets. The transfer systems used include the RRDF, the INLS, and causeway ferries. All of these assets comprise a JLOTS operation. Similarly, the concepts for selective offload, austere access, and sustainment all involve the use of both sea and air assets. The sea capabilities are the same platforms described for at-sea transfer. Air assets, such as the MV-22, are crucial to the concept; however, they are only viable when moving a brigade formation or smaller

⁴² Ibid., 4-5.

⁴³ Ibid., 5.

⁴⁴ Ibid.

without accompanying heavy equipment. Thus, the capabilities for seabasing rely heavily on JLOTS assets, especially when deploying units with heavy equipment.

Thus, seabasing, while a viable concept for countering anti-access/area-denial operations, still requires the ability to move equipment and personnel to an austere, underdeveloped, or nonexistent port or shore. Rather than thinking of JLOTS as in competition with seabasing, a more useful approach is to think of JLOTS as an important element, or part, of seabasing. Unfortunately, current joint doctrine does not address seabasing and JLOTS together, instead just highlighting JLOTS as an operation that can occur in conjunction with seabasing, but offering no details on the conduct of the two operations together.

This chapter has illustrated the importance of the current and future strategic environment, described doctrinal terms to ensure baseline understanding of how the joint force provides logistical support, illustrated how a JLOTS operation occurs, and highlighted a similar concept known as seabasing. The next chapter will examine relevant historical examples to understand what type of operations may require JLOTS capability, and how these capabilities have been employed in the past.

CHAPTER 3: HISTORICAL EXAMPLES

Military history affirms the requirement to land forces on unprepared beaches and to sustain those forces during combat operations. As illustrated by a previous Commandant of the Marine Corps, General Robert H. Barrow, “Ever since the days of the Phoenicians, the ability to land on defended shores has been a source of strength for those who possess it and a source of concern for those must oppose it.”¹ In order to support those amphibious landings, some sort of logistics support is required. While the term JLOTS did not yet exist for some of the following examples, it is nonetheless a significant part of the operations. This chapter will explore key historical operations and illustrate the importance of Joint Logistics Over The Shore (JLOTS) to those operations. Operation OVERLORD during World War II and Operation CHROMITE in the Korean War both illustrate large-scale amphibious operations and the need for sustainment capabilities to successfully support them. More recently, Britain’s Operation CORPORATE in the Falkland Islands shows the similar issues an ally nation had when providing an over-the-shore capability for a significant operation. Finally, Operation UNIFIED RESPONSE in Haiti shows the utility of JLOTS to support a humanitarian operation.

Operation OVERLORD – Normandy Invasion – World War II, 1944

One of the most famous examples of JLOTS operations is the Normandy Invasion during World War II. Operation OVERLORD was the code name given to the Allied invasion of France scheduled for June 1944 which involved millions of tons of supplies,

¹Merrill L. Bartlett, *Assault from the Sea: Essays on the History of Amphibious Warfare* (Annapolis, MD: Naval Institute Press, 1983), xi.

thousands of ships, and hundreds of thousands of personnel. This operation involved the type of logistical issues that no army had ever had to cope with before and the plan was for the Allies to have landed a vast amount of both men and equipment by the end of D-Day itself.

Because of the sheer scale of the Normandy operation, planning and preparation began two years prior to execution and took several months to plan. Artificial harbors known as Mulberries were built to substitute for major ports to unload landing ships early in the invasion. These were extremely complicated engineering projects with floating steel units serving as breakwaters. As the commander of the assault force and responsible for the planning and execution of the landing of half the American ground troops at Normandy, Admiral John Leslie Hall, Jr., United States Navy, was not convinced of the utility of these Mulberries. He argued that “landing between one hundred fifty and three hundred LSTs on one tide would be far more efficient than unloading only two ships at a time on a Mulberry.”² He firmly believed his task force would succeed, “in spite of bothering with a useless, fancy dock that would be unable to weather the first severe storm.”³ Despite Hall’s misgivings, many other American and British naval officers supported the use of Mulberries and the ultimate decision was to construct two, one each for the American and British forces. These Mulberries were actually the precursor to today’s Modular Causeway Systems in the Army and Navy.

Additionally, large landing craft called tank landing ships (LSTs) were also designed during this preparatory time. Their ability to drive right onto the beach to discharge tanks, troops, and all types of cargo and supplies was paramount for success of

² Ibid., 314.

³ Ibid.

the operation. Also, barges ferried equipment from British ports directly to Normandy. During this two year planning and preparation period, more than 17 million tons of cargo was shipped from the United States to the United Kingdom for pre-staging, including not just the Mulberries, LSTs and barges, but other crucial items such as blood plasma, maps, a replacement rail network, general supplies, toothbrushes, and even cigarettes.⁴

The invasion fleet was drawn from eight different navies, comprising 6,939 vessels: 1,213 warships, 4,126 transport vessels (landing ships and landing craft), and 736 ancillary craft and 864 merchant vessels.⁵ The warships provided cover for the transports against the enemy—whether in the form of surface warships, submarines, or as an aerial attack—and gave support to the landings through shore bombardment. The plan required movement of more than 100,000 men and nearly 13,000 vehicles in the first three days, with a total of 3 million men in 47 divisions over the course of the invasion.⁶

Resupply of the five beaches (Omaha, Utah, Gold, Juno, Sword) selected for the landing would prove to be difficult. As an example, the beaches with American responsibility, Omaha and Utah, experienced issues with resupply, with only approximately 25% of the planned cargo discharging in the first 3 days of the operation.⁷ Quartermaster units arrived with the assault forces to provide such sustainment functions as resupply, transportation and mortuary affairs.

While the Mulberries facilitated receipt of supplies and equipment from cargo ships, sometimes the quantity of incoming supplies exceeded the capability, thus requiring the use of bare beach LOTS operations. Use of resupply right onto the beach

⁴ Ibid., 314.

⁵ John Keegan, “Encyclopedia Britannica’s Guide to Normandy 1944”, <http://www.britannica.com/dday/browse?browseId=237147> (accessed November 17, 2012).

⁶ Ibid.

⁷ Ibid.

kept the invasion force moving forward, resulting in daily discharge of 56,200 tons of supplies, 20,000 vehicles, and 180,000 troops at Omaha and Utah beaches.⁸

The Normandy invasion was one of the biggest logistics operation ever attempted, with the D-Day landing and force buildup alone involving millions of tons of supplies, thousands of ships, and hundreds of thousands of personnel. This operation clearly illustrates the viability of having a capability to assault a beach and subsequently supply a force via unimproved means. While the Mulberries may not have convinced all leaders of their utility, having them as an option enabled the commander to attain depth in sustainment support. The resupply operation in Normandy using JLOTS operations not only enabled the success of Operation OVERLORD, but also the Allied advance through Western Europe.⁹ The use of bare beach operations to complement the discharge of cargo using the Mulberries is the hallmark of JLOTS operations and illustrates vividly what flexibility the capability can provide for the Joint Force Commander. While our armed forces have not seen the likes of a Normandy operation in recent years, the environment we operate in today and in the future do not preclude these large-scale amphibious operations requiring significant sustainment support

Operation CHROMITE – Inchon Landing – Korea, 1950

The landings at Inchon, just six years after Normandy, exemplified again how successful amphibious operations can occur through the exploitation of a beachhead. Operation CHROMITE was very similar to OVERLORD, involving successful risk taking, decisive maneuver from the beachhead, and sustainment until forces could secure

⁸ Frederick V. Godfrey, "The Logistics of Invasion," *Army Logistician* (November 2003), http://www.thefreelibrary.com/The_logistics_of_invasions.-a0110459247 (accessed November 17, 2012).

⁹ Keegan, 1.

air and seaports. However, the significance is not found in the conduct of the operation itself, but in the years leading up to the Korean War when amphibious operations, and the required logistics to support them, were regarded as irrelevant or antiquated.

Nearly one year prior to the landing, the chairman of the Joint Chiefs of Staff (JCS), General of the Army Omar Bradley, spoke to the House Armed Services Committee, saying “I predict that large-scale amphibious operations will never occur again.”¹⁰ Even the Secretary of Defense in 1949, Louis Johnson, remarked,

...the Navy is on its way out...There’s no reason for having a Navy and Marine Corps. General Bradley tells me that amphibious operations are a thing of the past. We’ll never have any more amphibious operations. That does away with the Marine Corps. And the Air Force can do anything the Navy can do nowadays, so that does away with the Navy.”¹¹

The defense posture of the United States at the close of 1949 was precarious to say the least. Inter-service rivalry prevailed with the notion that air power would decide future war. Therefore, new development and funding focused on airpower at the expense of new munitions or vehicles, to include landing craft that are so critical to logistical support of amphibious operations.

The army’s focus was on converting stocks of supplies from World War II to civilian use. Divestiture or long-term storage became the fate for landing craft and significant reductions in force structure were the norm. While the senior leadership in the NCO and Officer ranks still had significant experience from World War II, this experience was quickly becoming dated. Additionally, the Navy’s lack of focus on amphibious operations also resulted in a detriment to equipment on hand: “Although the Navy had 610 amphibious ships in commission in 1945, only 91 were left four years

¹⁰ Bartlett, 337.

¹¹ Ibid.

later. In 1948, the navy scrapped 510 landing craft and built one.”¹²

So, when the North Korean People’s Army (NKPA) crossed the 38th parallel into South Korea with its armored columns in June 1950, the United States found itself in an unanticipated war, with some experience in the senior ranks, but with definite equipment shortages. Within days, the South Korean capital of Seoul was lost and the Republic of Korea Army (ROKA) fled south. By mid-August, forces were at a stalemate in a small perimeter around Pusan. General Douglas MacArthur, commander of all United Nations forces in Korea, then called for a conference in Tokyo to consider a seaborne attack against the North Koreans, a decisive troop movement behind enemy lines. His plan was to land at Inchon, seize Seoul, cut the enemy lines of communications, and destroy the North Koreans.

Inchon was not the ideal location for a landing, but the advantages of location outweighed the many disadvantages. For example, the tidal range is 32 feet with currents remaining steady at 3 knots, with areas as high as 7 or 8 knots.¹³ Even with these high currents, the waters around Inchon are minable with many heights and islands surrounding, allowing for enemy fire on any minesweepers. The Salee River, which approaches Inchon, is very narrow with insufficient room for maneuver. There are no beaches on Inchon, just breakwaters and seawalls. The tidal heights needed for successful maneuver of the landing craft only occurred once a month at Inchon, and only for 3 to 4 days. One general commented that Inchon was “the worst possible place where we could bring in an amphibious assault.”¹⁴

Despite the apparent disadvantages of the chosen landing site, OPERATION

¹² Ibid., 338.

¹³ Ibid., 340.

¹⁴ Ibid.

CHROMITE, commenced on 5 September and was made up more than 250 ships sailing from Yokohama, Japan.¹⁵ Assembling this fleet of ships was no small feat. Mothballed naval and merchant ships were called back into service along with the reservists to crew them. Landing craft that were in heavy preservation on both coasts of the U.S. were also used, after much maintenance work to bring them to operational status.

Despite the scrambling that occurred to assemble the required capability for the landing, Operation CHROMITE was a success. “D-day operations were completed on schedule with all objectives taken, at a cost of but 21 killed and 175 wounded. Twelve days later, after heavy fighting in and around Seoul, the Korean capital was re-conquered, and – as MacArthur had predicted from beginning to end – the North Korean People’s Army was destroyed.”¹⁶ The success of the landing changed the course of the entire Korean War, causing the disintegration of the NKPA perimeter around Pusan, liberating Seoul, and returning the United Nations to the 38th parallel, thus preserving the Republic of Korea.

The landings at Inchon emphasized what America had nearly forgotten in the five years since World War II: that amphibious operations were still needed along with the ability to logistically support them through JLOTS operations. Operation CHROMITE showed that the U.S. military cannot ignore or dismiss certain types of operations as antiquated or unnecessary. While the operation was successful without maintaining a large fleet of landing craft and other ships, the landings identified the need to maintain the capability at a level that can easily expand as necessary.

¹⁵Ibid., 351.

¹⁶Ibid., 352.

Operation CORPORATE – British Invasion of the Falkland Islands, 1982

To understand the significance of the Falklands War as an amphibious operation and the logistical implications prevalent, it is important to understand the strategic mindset of the British political and military leadership leading up to this conflict. Similar to the U.S. thoughts on amphibious operations following WWII, the British continued this outlook on future war twenty years later. “Back in 1966, the British defense minister declared that British armed forces would never again have to face another opposed land, and never have to operate on their own.”¹⁷ Throughout the years following WWII and the beginnings of the Cold War, Britain experienced the same fiscal issues as the U.S. and believed the threat posed by the Soviet Union was the one that really mattered. The United Kingdom moved toward more participation in the European Union and maintaining a strong deterrent in West Germany. As a result, budget cuts on the Royal Navy fell more heavily than on the other services. “It was all too easy for skeptics to write-off the Royal Navy as having no role in ‘the next’ NATO conflict, which, they argued, would be over in a matter of days and certainly before we had ships and submarines in the operating area.”¹⁸ While the Royal Navy ultimately maintained an abbreviated ability to land part of an Amphibious Task Group during planned operations, considerable merchant shipping was required if a full force was to be deployed from sea.

Thus, the strategic mindset was not favorable for amphibious operations. In fact, the environment expected depended on unrealistic assumptions difficult to ensure:

To assume, as was the case at that time, that future NATO operations would have a ‘host nation’ supplying welcoming facilities such as prepared beaches, jetties, docks and transport at the start of an amphibious

¹⁷ Ibid., 429.

¹⁸ Michael Clapp and Ewen Southby-Tailyour, *Amphibious Assault Falklands: The Battle of San Carlos Water* (Annapolis, MD: Naval Institute Press, 1996), 2.

operation was naivety on a large scale: the one ‘war’ that Britain had not yet fought since 1945 was a ‘NATO’ one, with or without a host nation. Given the likely location and time-scale of British unilateral operations the chances of achieving a landing without some degree of opposition despite the host nation offering ‘welcoming’ facilities were minimal and in the Falklands, of course, out of the question.¹⁹

Therefore, when the military junta of Argentina invaded the Falklands on 2 April 1982, Great Britain was faced with a reduced military capability, especially in the realm of logistical support ships. When diplomatic solutions did not prevail, the British landed on 21 May, after short but intense naval and air battles. While Port Stanley offered more favorable conditions for a landing (improved airfield and adequate port), Argentine forces were already located there and expected an amphibious assault on their shores. By choosing a landing site on the opposite coast from Stanley, the British enjoyed several advantages, including difficulty of enemy attack by submarine and air, sheltered anchorage, good beaches, minimal enemy defense, and, the most important advantage, surprise.

The landings were successful, with very few casualties, and subsequent land battles resulted in the British taking the high ground by early June, resulting in Argentina’s surrender by 14 June. “British casualties were 256 killed and 673 wounded with Argentine having 1,798 dead and wounded, with another 3,300 men unaccounted for, with no mention of those taken prisoner.”²⁰ Despite Britain’s ability to accomplish objectives with such speed and relatively minimal casualties, they still faced similar logistical obstacles as the U.S. had at Inchon more than thirty years earlier.

Despite the nearly 8,000-mile logistic line across the ocean, “the British moved

¹⁹ Ibid., 8.

²⁰ Bartlett, 436.

over 100,000 tons of supplies and equipment as well as 9,000 troops to the islands.”²¹

About halfway to the Falklands, Ascension Island was a forward staging area throughout the conflict, where troops were married up with ships to allow for redistribution and reloading of cargo. Because the merchant ships were hastily acquired and haphazardly loaded at home station, redistribution to other ships once at Ascension was essential for reconfiguration of combat loads for the amphibious assault. Formally called the Royal Fleet Auxiliary, these ships were more commonly called STUFT – Ships Taken Up From Trade and “the British requisitioned or chartered over 50 ships from 33 separate companies to support sealift need.”²² Most STUFT ships served as logistics support ships to include cargo carriers, hospital ships, and tankers for refueling operations.

In order to use STUFT ships for military operations, all had to undergo significant modifications to meet deployment requirements such as military communications and installation of replenishment-at-sea gear. “Sixteen ships received helicopter flight decks and this proved to be a critical modification as the British unloaded most ships over-the-shore at San Carlos.”²³ These ships hauled supplies, ferried Harriers and helicopters, and even served as an offshore maintenance facility for helicopters.

During the amphibious landing, the British did not have air superiority and the Argentine forces flew interdiction sorties against ships in the harbor. This resulted in the sinking of one vessel that had 3 of the 4 heavy-lift helicopters on board.²⁴ Thus, losing 75% of the British heavy lift resources seriously impacted their amphibious over-the-

²¹ W.J. Tustin, Major, “The Logistics of the Falklands War, Part I,” *Army Quarterly and Defence Journal* (July 1984): 296, quoted in Paul Valovcin, *Logistics Lessons for the Operational Commander, The Falklands War* (Newport, R.I.: Naval War College, 1992), 1.

²² *Ibid.*, 5.

²³ Trotter, Neville, “The Falklands Campaign Command and Logistics.” *Armed Forces Journal International* (June 1983), 32, quoted in Paul Valovcin, *Logistics Lessons for the Operational Commander, The Falklands War* (Newport, R.I.: Naval War College, 1992), 5.

²⁴ *Ibid.*

shore capability. Because of the lack of air superiority and minimum heavy lift helicopter assets, British forces had to leave cargo and amphibious ships at sea and then bring them in under cover of night, and for only six hours at a time. Sea-states posed problems as well, with 12-foot seas hampering the landing craft from making safe landfall.²⁵ Additionally, STUFT ships could only process an average of 25% of the cargo that the specialized naval amphibious ships could process in an hour, making an already slow operation even slower.²⁶ Thus, reliance on helicopter lift to move supplies beyond the beachhead, the shortage of medium lift helicopter assets, the lack of roads, the loading problems, and the issues surrounding the use of commercial assets (STUFT ships) all combined to make sustainment a slow and laborious process.

The significance of Operation CORPORATE is two-fold. First, the operation shows how the U.S. was not the only nation discounting future conflicts involving amphibious operations and the extensive logistical support required. Such fiscal versus strategic thinking was not just an American fault. Second, Operation CORPORATE illustrates the operational advantage gained from an approach over an unprotected beachhead and the ability to sustain the subsequent advance to the objective without reliance on developed infrastructure. This is an important lesson learned as today's joint force, despite being charged with becoming more expeditionary, continues to rely on developed logistical infrastructure around the world.

Operation UNIFIED RESPONSE – Port Au Prince, Haiti, 2010

When a 7.0 magnitude earthquake struck Haiti in January 2010, the combination of poor infrastructure and the extreme devastation precluded the country's ability to

²⁵ Ibid.

²⁶ Ibid.

recover rapidly. Based on the magnitude of this disaster, there was little doubt among political and military leaders that the U.S. would offer assistance. The United States decision was to deploy the 22nd and 24th Marine Expeditionary Units, the 2nd Brigade Combat Team of the 82nd Airborne Division, the 3rd Expeditionary Sustainment Command, the 7th Sustainment Brigade, a brigade sized medical task force, three amphibious vessels that included 2,000 Marines, and one hospital ship, the USNS Comfort.²⁷

The first issue associated with projecting the initial forces into Haiti was the lack of deep-water ports, exacerbated by the fact that the earthquake hit within ten miles of Port-au-Prince, the best marine terminal on the entire island.²⁸ The port infrastructure (cranes and associated equipment) had essentially crumbled and fallen into the harbor, thus making relief efforts difficult.

To establish a command and control capability off the coast and provide support to the ground forces, several ships were deployed to Haiti, including the USS Carl Vinson, the Bataan, the Nassau, and the Carter Hall.²⁹ The Carl Vinson, an aircraft carrier, provided a robust airlift capability, medical relief, and was critical to providing water to Haiti's population. Two amphibious assault ships, the Nassau and the Bataan, ensured security on the beach to enable relief supplies distribution. The Carter Hall, a Landing Ship Dock, transported personnel, landing craft, vehicles, and cargo from the

²⁷ Richard E. Killblane, "Operation Unified Response, Haiti Trip Report", (Fort Eustis: Office of the Chief of Transportation, 2010), 2, <https://www.us.army.mil/suite/doc/12720672&inline=true> (accessed December 19, 2012) . Richard Killblane serves as the Command Historian for the United States Army Transportation Center, Fort Eustis. He deployed to Haiti to collect historical information on sustainment operations during Operation Unified Response in Haiti in 2010. Richard Killblane's reports, interviews, and other pertinent documents are stored online in an Army Knowledge Online (AKO) Sustainment Knowledge Network (SKN) Virtual Network Library Suite titled "Haiti Relief Operations."

²⁸ Ibid.

²⁹ Ibid.

ship to the beach. In addition, engineer teams were sent to assess the airport and seaport. While the airport was opened and operational within 30 minutes of arrival³⁰, the seaport would take much more time, based on the devastation encountered.

Port-au-Prince and Cape Haitien are Haiti's main ocean terminals and initial analysis indicated both were capable of berthing vessels in the twenty-five to twenty-nine foot draft range.³¹ Unfortunately, of the twenty-seven medium-sized roll-on roll-off vessels within the Maritime Administration's (MARAD) inventory, only six had drafts in this range.³² More importantly, the LMSR, the vessel used primarily for OIF and OEF, had draft depths of 34 feet and higher, far out of the range of the available ports in Haiti. Even if the drafts were acceptable, most of the existing facilities and equipment had crumbled into the harbor. Cape Haitien provided better reach into Haiti's hinterland, but the infrastructure was much worse and the depths even more shallow than Port-au-Prince.

Thus, in order to use the DoD's large vessel fleet, in-the-stream discharges at depths of 35 feet or greater was required. This necessitated the joint deployment of Army watercraft and stevedores working with the Navy in order to conduct JLOTS. Fortunately for the Army and the Navy, the units slated for support to Haiti had just participated in annual JLOTS training the previous year; thus, highlighting the importance of such exercises.

Operation UNIFIED RESPONSE also saw the use of USTRANSCOM's newest units to assist in opening the ports in Haiti, the Rapid Port Opening Elements (RPOE). Three RPOEs entered active army service between 2008 and 2009, each consisting of

³⁰ Ibid.

³¹ Ibid.

³² Ibid.

small transportation-expert teams.³³ USTRANSCOM deployed the RPOEs as part of the JTF-PO SPOD operations and as the Army element to the Joint Assessment Team (JAT). RPOEs were used previously in Kuwait, but Haiti represented the first use of them during a contingency operation. Opening both the seaport and airport, the RPOE and JAT deployments were unique in that the advanced party along with its equipment sailed to Haiti via the MV Huakai, a Hawaiian superferry that was on contract with MARAD.³⁴

Initial reports from the Joint Assessment Team's indicated a clear need for JLOTS assets and inland lighterage systems. The Army sent both watercraft and a floating causeway system while the Navy sent its Improved Navy Lighterage System (INLS), a newer capability with improved performance during higher sea states.³⁵ DoD also contracted two barges from Crowley Maritime Corporation that were used to create a pier. This commercial company creatively constructed an 800-foot pier from the two 400-foot long barges, which became critical to increasing throughput. Crowley also provided additional large and medium sized landing crafts to augment the operation.

The Army's Logistics Support Vessel (LSV) was crucial to the operation until the pier was constructed. This vessel was able to approach the shallow port area and offload critical supplies using its ramp. The Army's five LSVs are ported at Fort Eustis and Hawaii. Since it can only travel at less than twelve knots per hour, the only LSVs that were available were those at Fort Eustis, which home ports three of the five, with the other two home ported on Ford's Island on Oahu, Hawaii.³⁶

³³ Ibid.

³⁴ Ibid.

³⁵ Defense Industry Daily, "Whatever Floats Your Tank: The USN's Improved Navy Lighterage System," *Defense Industry Daily* (May 12, 2009), <http://www.defenseindustrydaily.com/whatever-floats-your-tank-the-usns-improved-navy-lighterage-system-02251> (accessed December 3, 2012).

³⁶ Killblane, "Operation Unified Response, Haiti Trip Report."

The capability provided by the commercially procured ferry, the Huakai, was invaluable to success. This high-speed, shallow-draft vessel made several shuttles of crucial equipment from Jacksonville to Haiti, a distance of more than 1,000 miles. While the Huakai clearly provided an advantage for the operation, the distance for this scenario was relatively small as the ferry was located out of Jacksonville, Florida. Should future missions occur further away, such as in Africa or Asia, consideration for time and distance factors is needed, which could determine where these types of vessels should be located, or made available. Additionally, while using commercial assets such as the Huakai or hiring Crowley to build a pier and provide additional lighterage does not alleviate the need for JLOTS, it does enhance the ability to rapidly project power and support the commander's needs.

Operation Unified Response is an important example of the real-world use of JLOTS and the problems encountered when faced with a significantly damaged port. Occurring just two years ago, this humanitarian crisis showed the U.S. military the numerous challenges still faced when projecting resources into a foreign nation. The relief effort in Haiti also illustrated the benefits of using commercial industry to fill in capability gaps such as with the pier constructed from barges, as well as the shortfall in certain assets, such as lighterage. These lessons learned could offer potential insight into possible ways to face the projection and sustainment challenges in the future.

Summary

The four examples highlight important aspects of JLOTS and its significance to military operations. Both OVERLORD and CHROMITE emphasize the importance of recognizing the potential to conduct certain operations in the future even though newer

technology, such as airpower, might indicate an advantage that would preclude those types of operations from occurring again. Operation CORPORATE highlights how other nations also wrestle with the same issue of maintaining a capability that the future may or may not require. While both CHROMITE and CORPORATE succeeded by employing both retired and commercial assets, had strategic leadership anticipated the need for the capability, a different, more organized approach may have produced even more favorable results. Finally, Operation UNIFIED RESPONSE illustrated the full utility of JLOTS, showing how such capability can assist to reduce suffering and provide needed relief. Additionally, both UNIFIED RESPONSE and CORPORATE showed the utility of partnering with the commercial industry to provide needed capabilities, especially when the strategic environment precludes maintaining large inventories of assets or the mission is so catastrophic that any and every asset proves useful. The next chapter will build upon the lessons learned in these operations and analyze the current JLOTS capability.

CHAPTER 4: JOINT LOGISTICS OVER THE SHORE (JLOTS) ANALYSIS

JLOTS, as previously discussed, is one of several viable methods for delivery of logistics, particularly in situations when a port is either unavailable or damaged. Historical examples illustrated how JLOTS is appropriate for combat and humanitarian assistance operations. Several of those examples highlighted how leadership did not always anticipate or expect the requirement for those capabilities, which resulted in a reduction in force structure, causing difficulty in executing the JLOTS operations, but not mission failure. In order to continue providing JLOTS as a viable option, an analysis of the current capability is required. This chapter will describe the advantages and disadvantages associated with JLOTS, outline current capabilities and requirements, and present commercial and multinational aspects in order to provide recommendations as to the future viability of JLOTS as an option for the Joint Force Commander (JFC).

JLOTS Advantages and Disadvantages

As a method to provide logistics support to an operation, JLOTS offers a significant advantage to the JFC, especially in light of recent strategic guidance requiring armed forces' ability to deploy anywhere in the world on short notice. In 2003, an Army port study of Central Command (CENTCOM) and Pacific Command (PACOM) Areas of Responsibility (AORs) evaluated accessibility of 282 ports in 26 countries. The study found that Large Medium Speed Roll-on/Roll-off (LMSR) ships can only access 27 percent of these ports due to its draft of 9.1 to 10.5 meters.¹ Thus, JLOTS could become important to successful logistical support of operations in areas where large vessels such

¹ U.S. Department of the Army, *Quick Reaction Requirements Analysis For The Theater Support Vessel (TSV)* (Washington DC: U.S. Department of the Army, April 4, 2003), 1.

as the LMSR are unable to access the ports due to draft constraints or even port damage, as illustrated in Operation UNIFIED RESPONSE in Haiti.

However, providing such flexibility does not come without disadvantages. A significant limitation to JLOTS is the physical condition of the operational area. Soil type, beach gradient, water depth, tides and tidal range, currents, weather, and sea state are all factors that are largely outside of the control of the JFC. Beach soil type can affect the ability of units to move cargo across the beach. If the soil is too soft, heavy cargo and the equipment used to haul it may bog down, resulting in throughput bottlenecks and potentially increased damage to equipment. Special matting equipment can help to mitigate these shortfalls, but can add more time to preparation. Mild or flat beach gradients result in shallow conditions, causing lighters to run aground prior to reaching the beach. If beach gradient is too steep, currents can affect the ability of lighters to handle effectively, thus increasing the safety risk. In these types of conditions, the discharge operation must move into the sea, creating safety hazards to equipment and personnel as well as increasing discharge time. Additionally, tides and tidal ranges can often dictate when JLOTS operations can and cannot occur. Positioning causeways is also important since cargo transfer from lighters to causeways is accomplished more safely beyond the surf zone.

Taking all of the limitations above into account, the most critical physical condition for JLOTS is weather, to include sea state. Unfortunately, JLOTS operations, in order to consider both safety and throughput, must often wait for favorable weather and sea state conditions. Lighterage operations alongside a vessel are particularly

hazardous if more than a moderate sea (e.g., sea state 2) is running.² While JLOTS is still possible at higher sea state levels, the inherent risks to personnel and equipment, together with the limited productivity possible, make JLOTS operations in sea state 3 or greater inadvisable.³

The requirement for force protection is another potential limiting factor. Because JLOTS operations are critical for logistic support to the joint force, attacks are not only possible, but also expected. Both offshore and beach reception area security is the responsibility of the JFC. Primary threats are air and rocket attacks, ground attack by adversary forces, guerrillas or insurgents, sabotage, pilferage by locals or organized theft by criminal groups, and CBRN (chemical, biological, radiological, and nuclear) attack.⁴ Additionally, reduced throughput could result from personnel and asset diversion to force protection or from limitations imposed by wearing protective gear.

Another disadvantage with JLOTS is the time required to offload equipment. Of course, a port with excellent infrastructure and ability to receive deep-draft vessels will always have greater throughput than a JLOTS operation. When factoring in the time required for preparation of a JLOTS area of operation, it becomes evident that efficiency is not an advantage of this type of operation. However, as stated earlier in this thesis, improved ports with required infrastructure cannot be the expectation in the future.

A final challenge facing JLOTS is the lack of importance based on its limited use, which has resulted in reduced training. As previously discussed, the past 10 years of rotational deployment have involved world-class, modern ports like Kuwait and Karachi,

² U.S. Joint Chiefs of Staff, *Joint Logistics Over-The-Shore*, Joint Publication 4-01.6 (Washington DC: U.S. Joint Chiefs of Staff, November 27, 2012), III-6.

³Ibid., IV-13.

⁴Ibid., III-15.

Pakistan. Haiti's disastrous earthquake in 2010 is the last time an austere location required JLOTS assets, but this was for a humanitarian and not a combat mission. Operations in Iraq and Afghanistan have dominated the training landscape and units no longer train on large amphibious landings requiring JLOTS support. Annual JLOTS exercises still occur, but on a much smaller scale due primarily to decreased availability. Additionally, JLOTS exercises suffer from the same training environment as most others – the tendency to wait for the optimum conditions. Many times, cancellations occur due to weather or undesirable sea state. As stated earlier, JLOTS is only a viable option in environments up to sea state two; however, many exercises will only take place in sea state one. The training environment must replicate at least what could happen in real world conditions. Additionally, limiting enemy contact is also the norm, with exercise conditions not involving such variables as disabling equipment or personnel. Unfortunately, limiting the training to only those favorable situations promotes an unrealistic sense of optimism about JLOTS and its ability.

United States Transportation Command (USTRANSCOM), responsible for all JLOTS related programs and plans, coordinates, and executes the annual JLOTS training schedule. While the scenarios attempt to mirror potential real world JLOTS situations, the high dollar cost and detailed planning required have limited the JLOTS exercises to one per year. The latest JLOTS exercise occurred in July-August 2012 at Fort Story, Virginia. 10th and 11th Transportation Battalions, the two remaining active-duty transportation terminal battalions, teamed with Navy vessels and the Beach Master Unit 2 from Little Creek Amphibious Base in Norfolk, Virginia to conduct the joint training exercise. "The main goal of this exercise is to test the operational capabilities of both the

Army and Navy working together," said Lt. Col. Karl Linderman. "Both Soldiers and Sailors, on the ships and on the beaches, are working together to provide command and control of these vessels as we take vehicles and equipment from the ships to the beach."⁵

USTRANSCOM conducted the largest JLOTS exercise in peacetime in 2008. The "Pacific Strike 2008" JLOTS exercise's mission was to move the 3d Brigade, 25th Infantry Division, from ship to shore and onward to the National Training Center at Fort Irwin, California, for predeployment training before it headed to Iraq. Deemed a huge success, the 3d Brigade's equipment was delivered to Fort Irwin ahead of schedule, the operation was completed safely, and all forces were retrograded home. Pacific Strike validated to the U.S. Pacific Command, USTRANSCOM, and U.S. Army Pacific that the Army-Navy team of JLOTS professionals can move a heavy force from ship to shore anywhere in the world to support both combat and humanitarian missions.⁶

While the training program administered by USTRANSCOM seems like a resounding success, there are potential areas for improvement. For example, conducting just one exercise per year will not promulgate JLOTS experience throughout the entire Army, Navy, and Marine Corps. Additionally, these exercises are conducted in favorable sea states and without any simulation of enemy activity. Of course, there is agreement that every training event is needed and beneficial. However, more realism and a comprehensive program that ensures depth across the joint force are still required.

⁵ Alexander Burnett, SSG, "'Resolute' Warriors Take Over the Seas During JLOTS," The Official Website of Joint Base Langley Eustis, entry posted August 27, 2012, <http://www.jble.af.mil/news/story.asp?id=123315673> (accessed December 17, 2012).

⁶ Richard A. Paquette, "Expeditionary Logistics in its Truest Form," *Army Logistician* 41, no. 2 (March/April 2009), <http://search.proquest.com/docview/197293524?accountid=12686> (accessed December 19, 2012), 23.

Current JLOTS Capabilities

Doctrine is a good starting point to analyze current JLOTS capabilities. Despite having a current publication (November 2012), there are still shortfalls. For example, JP 4-01.6 does reference the different Roll-on/Roll-off Discharge Facilities (RRDF) and causeway piers operated by each service and describes the differences between them.⁷ While both Services assemble, operate, and maintain this piece of critical equipment, the Army's RRDF is more stable and practical for vehicles. Additionally, its design makes it easier for Logistic Support Vessels (LSV) to approach the pier and is safer for mooring; thus making it the preferred RRDF for LSV operations. Unfortunately, the current version of JP 4-01.6 does not describe the advantages and disadvantages associated with each platform nor does it describe the safety aspects of each one. The joint publication also does not capture recent exercise lessons learned and contains no vignettes relative to JLOTS exercises, which could be a viable way to highlight lessons learned. Finally, a short section on the JLOTS training program would help to emphasize the importance of joint training.

As described earlier in Chapter 2, both the Army and the Navy possess JLOTS capabilities and share many of the same competencies associated with this type of operation. During joint operations the Army typically focuses on operations ashore, to include transportation to inland staging areas; preparation of unimproved beach surfaces; preparation of marshaling areas for the storage of containers, breakbulk cargo, and rolling stock; and installation and operation of Inland Petroleum Distribution Systems (IPDS) (from the high water mark).⁸ Navy responsibilities typically focus on operations at sea,

⁷ Ibid., IV-3.

⁸ Ibid., II-4.

which include tactical control over the disposition and operation of participating ships as necessary to provide force protection; installation and operation of Overland Petroleum Discharge System (OPDS) (to the high water mark); installation of cargo discharge facilities such as elevated causeway systems or floating causeways; lighterage operations; and production of hydrographic surveys and engineering reconnaissance for logistics-over-the-shore operations area (LOA) selection.⁹ Additionally, force protection is a critical concern during JLOTS. The Combatant Commander (CCDR) may designate the Marine Corps as responsible for force protection of the LOA. The Coast Guard can also handle force protection responsibilities using their Port Security Units; also providing cargo-handling specialists for munitions and explosives.¹⁰

Recent changes within the Army affect organization for JLOTS. Prior to 2011, the Army's command and control mechanism for JLOTS resided in the 7th Transportation Group at Fort Eustis, Virginia. However, when the unit converted to a sustainment brigade and rotated regularly to Iraq and Afghanistan, the Army no longer had a brigade-sized unit organized for theater port-opening capability or JLOTS. Additionally, the recent Total Army Analysis (TAA) review revealed the inactivation of all table of organization and equipment (TOE) transportation battalions with the exception of two terminal battalion headquarters. This leaves just two active duty units that can perform the JLOTS mission for the Army, with six additional headquarters in the reserves.¹¹

As described in earlier chapters, JLOTS equipment is vast and varied across both the Army and Navy. JLOTS requires low-density equipment specifically built for use in

⁹ Ibid., II-5.

¹⁰ Ibid., II-3.

¹¹ Jennifer Trossbach, CW5, interview by author, Washington D.C., 31 January 2012. CW5 Trossbach is a marine engineering officer assigned to the Strategic Mobility Division, Department of the Army G-4, and is regarded by the Joint Staff as a subject matter expert on JLOTS.

areas of insufficient infrastructure. JLOTS is dependent on the Army's watercraft fleet as described in Chapter 1 of this paper. The current Army watercraft fleet consists of 115 platforms, with 86 lighters and 29 floating craft (tugboats, causeways, and cranes).¹² The composition of the Army's current watercraft fleet is found at Table 4-1.

Key platforms within the Army watercraft fleet are the Logistics Support Vessel (LSV), Landing Craft Utility 2000 (LCU-2000), and the Landing Craft Mechanized-8 (LCM-8). The LSV provides worldwide transportation support of vehicles and sustainment cargo and is used mainly for intra-theater line-haul for tactical resupply missions to remote underdeveloped coastlines and inland waterways. Additionally, the LSV is used to discharge strategic sealift vessels such as the LMSR, often done "in-the-stream" when drafts within a port are not deep enough to receive the larger vessels. LSVs are able to transport all tracked and wheeled vehicles, to include the M1 tank. The LCU-2000 has similar capabilities as the LSV; however, it is limited as a worldwide deployable vessel by distance, weather, and sea conditions.

Smaller than the LCU-2000, the Landing Craft Mechanized-8 (LCM-8) can transport one M1 tank and is limited to littoral operations, requiring support from other larger vessels. The oldest of the lighters are the LCM-8s with the Mod 1's built in 1972. The LCM-8 Mod 2's are the newest, built in 2005. With the Economic Useful Life (EUL) of the vessel hulls at 30-40 years, the LCM-8 Mod 1's will be the first to reach EUL in the 2022 timeframe. The implementation of the Service Life Extension Program (SLEP) has helped to increase the useful life of the LSVs, built in 1988. The LSV SLEP program is nearly complete with the LCU-2000 SLEP beginning in 2013. The Army watercraft fleet was reduced by nearly two-thirds in the 2001 timeframe, which required

¹² Ibid.

logisticians to extract as much as possible from the existing fleet of JLOTS enablers.¹³

Army watercraft are stationed around the world to support the combatant commanders. The majority of all AC watercraft are located at Joint Base Langley Eustis on the east coast, with two of the LSVs located in Hawaii. One of the AC LSVs is also stationed on a rotational basis in Kuwait. The RC watercraft are located on both the east and west coast, primarily in Baltimore, Tampa, Morehead City, Tacoma, and Mare Island. One of the RC LSVs is also rotated to Kuwait. The prepositioned watercraft is located at both the APS 4 storage site in Japan and the APS 5 storage site in Kuwait.¹⁴ These strategic locations enable worldwide operations; however, sail times are slow (less than 10 knots) and must receive consideration in the planning process.

Watercraft	Active Component (AC)	Reserve Component (RC)	Army Prepositioned Stocks (APS)	Total
Logistics Support Vessel (LSV)	5	3	0	8
Landing Craft Utility 2000 (LCU-2000)	7	7	20	34
Landing Craft Mechanized 8 (LCM-8 Mod 1)	8	8	14	30
Landing Craft Mechanized 8 (LCM-8 Mod 2)	1	1	4	6
Large Tugboat	1	2	4	7
Small Tugboat	2	6	8	16
Modular Causeway Systems (MCS)	1	0	2	3
Barge Derrick	0	2	2	4
Harbormaster C3	3	4	0	7
Total	28	33	54	115

Table 4-1¹⁵

Navy capabilities include many of the same lighterage as the Army, but other systems such as the Rapidly Installed Breakwater System (RIBS), the Improved Navy

¹³ Ibid.

¹⁴ Ibid.

¹⁵ Ibid.

Lighterage System (INLS), and the auto-compensating crane. RIBS is designed to augment existing port facilities, enabling greater throughput in a safer environment, by reducing sea state 3 conditions to sea state 2 or less upon installation.¹⁶ INLS, as described in the Haiti example in Chapter 2, acts as a floating pier, or causeway system, comprised of powered and non-powered floating platforms. INLS is more operable in higher sea states, has a longer service life, and reduces maintenance costs. The auto-compensating crane facilitates ship and beach cargo transfer operations by mitigating movement between platforms.

There are a variety of future solutions for seabasing and JLOTS within the Joint Capabilities Integrated Developed System (JCIDS) process. Unfortunately, many of them have not moved beyond the conceptual phase. The four ‘big ideas’ include the Joint High Speed Vessel (JHSV), the Joint High Speed Sealift/Austere Access (JHSS/AA), the Afloat Forward Staging Base (AFSB), and the Joint Future Theater Lift (JFTL). While the JHSS/AA is projected to improve access by approximately 32% and the JFTL by 50%, they, along with the AFSB, are still only in the concept phase, with artist rendition only available.¹⁷ These new capabilities will improve access for the operating environment expected in the future and bridge the sea state gap described earlier. The constraint of only operating in sea state 2 or lower has been an enduring problem with JLOTS and future concepts and acquisition attempt to overcome this limitation. Unfortunately, the JHSV is the only one that actually exists and is the only system described and discussed for this paper. While all four systems are designed to contribute and enhance both JLOTS and seabasing capabilities, the current status of the JHSV, as

¹⁶ Ibid.

¹⁷ Ibid.

depicted in the following paragraphs, should caution against expectations of a system from conception to actual delivery.

The United States Naval Ship (USNS) *Spearhead*, the first of 10 Joint High Speed Vessels (JHSV), was delivered to Military Sealift Command on 5 December 2012. Designed for rapid intra-theater transport of troops and associated equipment, the JHSV is a 338-foot long aluminum catamaran, capable of transporting approximately 600 tons of military troops, vehicles, supplies and equipment 1,200 nautical miles at an average speed of 35 knots. It can operate in shallow-draft, austere ports and waterways.¹⁸ The JHSVs' aviation flight deck supports a wide variety of aircraft, including CH-53 Super Stallions. Each JHSV has sleeping accommodations for up to 42 crew members and 104 mission personnel; and airline-style seating for 312 people.¹⁹ All of the JHSVs will be civilian-crewed, with the first four crewed by civil service mariners and the last six by civilian mariners working for a private company under contract to MSC.

“Flexibility may be the best attribute of this ship,” said civilian Capt. Douglas D. Casavant, Jr., *Spearhead*'s civil service master who has been sailing for MSC for 23 years. “Our 20,000-square-foot mission bay area can be reconfigured to quickly adapt to whatever mission we are tasked with, for instance, carrying containerized portable hospitals to support disaster relief or transporting tanks and troops.”²⁰ Originally slated for procurement by both the Army and the Navy, all current and future JHSVs were transferred to the Navy in 2011 after discussions between Army and Navy related to

¹⁸ Meghan Patrick Henderson, “Military Sealift Command Accepts Delivery of First JHSV,” Sealift: Official Blog of the U.S. Navy’s Military Sealift Command, entry posted December 10, 2012, <http://mscsealift.dodlive.mil/2012/12/10/military-sealift-command-accepts-delivery-of-first-jhsv/> (accessed December 19, 2012).

¹⁹ Ibid.

²⁰ Ibid.

Army watercraft.²¹ For the Army, JHSV was envisioned as an enabler in support of operational maneuver from the sea and Army was funded to receive 5 JHSV's by FY15.²² Unfortunately, as the first vessel was in production and various changes to the configuration were required, it became apparent that it could not support a combat configured BCT and could only load and offload in Sea State 1. Additionally, the present JHSV configuration can only transport ammunition as secondary loads. Finally, the fact that contract mariners operate the vessel restricts its operation to benign environments, such as humanitarian assistance or disaster relief. Thus, while the JHSV offers an enhanced capability to both seabasing and JLOTS, it is restricted permissive environments, translating to the continued existence of a capability gap for the Army.

Fortunately, funding for the JHSV program is proceeding on track, despite the fiscal realities both now and in the future. As already stated, the first of 10 JHSVs were delivered. The second JHSV is scheduled for delivery in May 2013 with the third in August 2013. Both of these are more than 50% complete. The fourth is only about 5% complete, with delivery projected for February 2014.²³ JHSV-5 through JHSV-10 have not yet begun construction; therefore, these could experience delays based on impending defense cuts and the results of sequestration.

The Navy has several systems in development. As discussed earlier, JHSV, as a concept, is a key enabler for both seabasing and JLOTS operations. Also in development is the Ship-to-Shore Connector (SSC) which the Navy recently awarded the contract for design and construction of the test and training craft. There is the advanced Interface Ramp Technologies (IRT) that envisions an improved at-sea interface transfer.

²¹ Trossbach, interview.

²² Ibid.

²³ Ibid.

Originally intended for the JHSV, the technology made the vessel too heavy. Currently, funding exists for installation on a high-speed ferry for test and evaluation. The Mobile Landing Platform (MLP) and the Advanced Mooring System should improve the ability to perform at-sea transfers for seabasing operations, thus enabling follow-on JLOTS operations, if necessary. There are four MLPs projected with scheduled deliveries beginning mid-2013 and funding secured through FY15.²⁴ The Advanced Mooring System is still in the Science and Technology (S&T) phase, with funding in place for further research.²⁵

JLOTS Requirements

With all these platforms, systems, and capabilities in both existence and in the acquisition pipeline, just what is the requirement for Department of Defense (DoD) to maintain with regard to JLOTS capabilities? No requirements documents exist to specify what, at a minimum, should be in the Services' inventories. There have been many studies over the years focused on mobility. DoD conducted several studies to help identify the capabilities needed for force projection in support of the National Security Strategy and subsequent departmental strategies. The most recently published study, the Mobility Capabilities and Requirements Study 2016 (MCRS-16), completed in early 2010, did not study the entire JLOTS capability, picking out only particular platforms such as the JHSV or the OPDS.²⁶

As of this writing, the latest Mobility study (Mobility Capability Assessment 2018, or MCA 18), directed from the latest Defense Planning Guidance, is underway and

²⁴ Ibid.

²⁵ Ibid.

²⁶ Ibid.

is expected to be complete in mid-2013. Unfortunately, there exist shortfalls with MCA 18 and previous studies in that they do not cover the entire spectrum of operations from the strategic to the tactical. For example, despite the need for a holistic approach to the entire transportation system, DoD has chosen not to study Army Watercraft or JLOTS in its latest mobility study. In fact, DoD was not even going to study intratheater lift until Department of the Army (DA) staffers insisted on it based on the dissolution of the C27J program.²⁷ The C27J was to become the fixed wing, intratheater aircraft to assist with low altitude requirements. Army was to receive the aircraft until the decision was to transfer the program to the Air Force. Once transferred, the Air Force promptly cancelled the program. Thus, it was imperative that the latest study take into consideration intratheater lift since the ability for the Army to accomplish that mission may be severely limited without the C27J, or other similar platform. Despite the similar need for a holistic approach to JLOTS, DA staffers could not convince DoD to apply the same logic to JLOTS.²⁸ The same argument as the C27J applied. When the JHSV was transferred to the Navy as a result of its modifications affecting its ability to fulfill the needs of the Army, a capability gap existed once again for the Army. This is the same capability gap that existed prior to the inception of the JHSV concept. DoD's refusal to include JLOTS, or at the very least JHSV, means that the final study will not provide a holistic assessment of mobility, which is what the entire study is supposed to address.

Without specified requirements for JLOTS, the next question becomes one of oversight and responsibility. USTRANSCOM is the organization tasked with overseeing JLOTS, even though the Services (specifically the Army and Navy) develop their own

²⁷ Ibid.

²⁸ Ibid.

portfolios to fulfill their responsibilities in a JLOTS operation. This fragmented approach can have negative effects. For example, in the development of causeway requirements, both Services developed their solutions in a vacuum. As a result, both Services have causeways, but they are not interoperable and this consideration during planning, if not acknowledged, could result in mission failure. Another example is with the development of seabasing. As discussed in Chapter 2, this is a new concept and although Army, Navy, and Marine Corps have agreed in concept to develop the capability together, evidence suggests otherwise. JLOTS is not considered an integral part of seabasing despite the need to get equipment and supplies ashore, even if a successful seabase could be created. As pointed out earlier, airlift cannot be the only solution, especially if the assaulting force requires heavy equipment such as tanks or personnel carriers.

There exists no joint capability or program manager for JLOTS. The Joint Staff has just one officer assigned to JLOTS, in the J4. Actually, this officer, among other duties, serves as the Sealift Officer, which includes JLOTS within the officer's responsibilities.²⁹ Additionally, USTRANSCOM has created a JLOTS Working Group, which has a charter that charges it with the mission "to facilitate and streamline the coordination between Services and within the JLOTS community of interest; initiatives, doctrine, training and procedures in support of the Combatant Commanders' JLOTS requirements, and to advocate enhancements and sustainability of JLOTS capabilities."³⁰ The JLOTS Working Group meets at the action officer level quarterly and any issues that cannot reach resolution at this level are elevated to the Distribution Steering Group level at USTRANSCOM. All Services are represented on the Working Group with the senior

²⁹ Ibid.

³⁰ United States Transportation Command (USTRANSCOM), *Charter for the Joint Logistics Over the Shore Working Group*, (Scott Air Force Base, IL: July 31, 2012).

member a COL/0-6 from the respective senior Service logisticians.

Commercial and Multi-National JLOTS

Logistics can often drive the cost of any operation to exorbitant levels; thus, when budget cuts are required, logistics capabilities are often chosen over combat capability. Senior military officials, when faced with a blanket cut and given the choice between the operational parts of their force and the support elements, do not normally favor the latter.³¹ With declining budgets and limited assets, continued procurement of any new systems for JLOTS is questionable, if not impossible. Commercially procured assets or even capabilities deserve consideration. In addition, multi-national or host nation support (HNS) capability evaluation is necessary. Both commercial and multi-national considerations are required because many of the areas of the world where JLOTS could occur may not have the infrastructure needed. Even retired Brigadier General Frank Steer (United Kingdom) believes that “no Army in the world, not even the U.S. Army, can go to war without HNS.”³² However, later operations such as Rwanda and Afghanistan illustrated the need for logistical support other than HNS since neither country could offer much of it to the joint force. Thus, both commercial and multi-national capability is necessary for consideration.

Within the Marine Corps, exercises such as BOLD ALLIGATOR and EXPEDITIONARY WARRIOR are reemphasizing large-scale amphibious operations. However, in order for the Marines to accomplish such exercises on a larger scale, they will require logistical support from not only the Navy, but also the Army. Since the

³¹ Frank R. Steer, "The Impact of Commercial Involvement on Military Operational Logistics," *Logistics Spectrum* 36, no. 3 (Jul-Sep 2002), <http://search.proquest.com/docview/195310850?accountid=12686> (accessed December 19, 2012).

³² Ibid.

Army is also facing aging equipment and dwindling budgets, all the Services will have to rely increasingly on friendly nations and the commercial sector for this capability.

"As time goes on, we're going to get driven to more commercial solutions," Marine Lt. Col. Dutch Bertholf, a Joint Staff planner, told participants at the Marine Corps' annual "[Expeditionary Warrior](#)" wargame, as he displayed a slide showing the projected decline in the Navy's logistics fleet after 2020. Already, he noted, "we got to see this a bit in Haiti," where the U.S. hired contractors to bridge the gap in earthquake response until its over-committed military assets could arrive. "Part of the future will be looking at commercial industry to help us out...especially as we become more fiscally challenged," he said: Commercial shippers use tugs, barges, and other equipment to move goods all the time, including through the kind of austere or non-existent port facilities that the Marines expect to encounter in Third World countries, and the government can hire them as needed without having to pay the ownership cost.³³

Even though Expeditionary Warrior 2012 was predominately designed for the Marine Corps, there was significant Army participation. The scenario also emphasized international participation with participants coming from the United Kingdom, Canada, Japan, Singapore, Brazil, and Finland.

The commercial market may have considerable LOTS-like capabilities to bear in certain scenarios such as Humanitarian Assistance. Many shipping companies, marine husbanding services, and offshore mineral exploration/development companies have lighterage, causeways, and MHE available for hire.³⁴ Similar to Operation CORPORATE, DoD or interagency organizations could contract these resources to supplement or reinforce JLOTS forces. Operation UNIFIED RESPONSE also illustrated how a commercially contracted superferry brought Soldiers and equipment to Haiti from

³³ Sydney J. Freedberg, Jr., "Marines Will Depend On Army, Allies, Private Sector to Get Ashore," AOL Defense Website, entry posted March 8, 2012, <http://defense.aol.com/2012/03/08/marines-will-depend-on-army-allies-private-sector-to-get-ashor/> (accessed December 17, 2012).

³⁴ U.S. Joint Chiefs of Staff, *Joint Logistics Over-The-Shore*, Joint Publication 4-01.6 (Washington DC: U.S. Joint Chiefs of Staff, November 27, 2012), I-11.

Florida. Superferries are located around the world and present an opportunity to assist in conducting JLOTS operations. However, all of these types of opportunities need study and exercising to ensure interoperability before the actual conflict or event.

In today's operating environment, nations seldom perform military operations unilaterally. This future aspect of the environment reveals an opportunity in the way JLOTS is conducted not only in the U.S. but in other countries. Many partner nations maintain watercraft fleets to support amphibious forces. In addition, many nations, particularly in the Baltic, Mediterranean, and Southeast Asia, have extensive commercial ferry fleets (many approximating logistics support vessel [LSV] size and configuration), which can function as naval auxiliaries.³⁵ Additionally, much like the U.S., many nations have large merchant fleets to transport military cargo during a contingency. Considering all these aspects is essential when developing a U.S. strategy for JLOTS capability.

Summary

The analysis of JLOTS reveals there are many disadvantages associated with JLOTS operations: environmental limitations such as weather or beach gradient/soil composition, sea-state limitations, slower throughput, force protection requirements, and a lack of emphasis on robust training. However, despite these limitations, JLOTS is a viable option when ports are denied, degraded, or nonexistent. Granted, airlift is an option; however, due to cost and limited airframes, it cannot be the only option.

JLOTS current capability shows that while doctrine is current, there are some areas in need of improvement. Additionally, the Army's recent decision to move all but two of its JLOTS units to the reserves could have repercussions if multiple worldwide events occurred. While expected in a time of fiscal austerity, the risk is the potential inability to react to these

³⁵ Ibid, I-12.

events quickly. There exists a vast quantity of equipment to support JLOTS, some of it legacy and reaching the end of its Economical Useful Life. There are also concepts in development along with newer fielded equipment, such as the JHSV, in existence. However, caution is required with these new systems since the acquisition process is long and the final product sometimes does not meet the capability as required on the outset. Finally, without a specified requirement for JLOTS capability, it becomes difficult for the Services to anticipate just what is required for development or retention. The creation of a JLOTS Working Group assists the process of de-confliction of priorities and helps to retain visibility over JLOTS, but is it enough to ensure JLOTS, which the research has revealed is not a program of record like other capabilities, remains viable?

Lastly, looking at both commercial and multi-national aspects of JLOTS helps to formulate options to consider when possible further fiscal constraints could entail reduced JLOTS capabilities in the future. Based on current operations and those of the last decade, the commercial industry and multi-national partnerships have both proved invaluable to the success of military operations and this aspect must remain a consideration for the future.

CHAPTER 5: RECOMMENDATIONS

This thesis has illustrated the need for Joint Logistics Over The Shore (JLOTS) by analyzing the National Strategic documents and dialogue. Historical examples highlighted the utility of this operation and the issues associated. After analyzing current JLOTS capability and doctrine, the research indicates a future for JLOTS that is somewhat uncertain given the fiscal environment and the lack of cohesive, comprehensive planning and oversight of the capability. JLOTS operations are complicated and highly technical, requiring specialized platforms, trained personnel, and extensive planning in order to ensure adequate capability exists to meet established requirements. Several recommendations are presented to ensure logistical options such as JLOTS continue to exist for the Joint Force Commander when operating in locations where fixed port facilities are either denied or unavailable. In order to obtain a common, integrated approach to JLOTS, particular improvements are essential to success. Changes must occur if the United States (US) military expects to successfully execute JLOTS operations in an environment other than training.

The first recommendation will help to identify just what the desired requirement should be for JLOTS. As discussed previously, Department of Defense (DoD) mobility studies over the past ten years have narrowly focused on strategic lift assets and not on the intra-theater modes of transportation such as JLOTS. In order to identify whether the capability today is sufficient, a comprehensive study, similar to Mobility Capability Requirements Study 16 (MCRS 16) or the ongoing Mobility Capability Assessment 18(MCA 18), is required. United States Transportation Command (USTRANSCOM), as the functional combatant command directed as having oversight over JLOTS, could

direct a study specifically targeted on JLOTS to accurately determine concepts, capabilities, and requirements to support future Joint force structures and operational environments. The JLOTS Working Group, discussed previously, could oversee the study since Service participation is already part of that venue.

The second recommendation involves the JLOTS Working Group and the lack of a program manager for JLOTS. As discussed in the previous chapter, the JLOTS Working Group is the primary venue for JLOTS issues. This organization provides oversight of requirements, capabilities, and training to ensure shortfalls and duplications are identified for joint resolution under the Joint Capabilities Integration and Development System (JCIDS) process.¹ While this is a step in the right direction to ensure JLOTS remains a viable capability, a more robust management or oversight mechanism is needed. Joint Staff, in conjunction with USTRANSCOM, should explore options such as creating a Program Manager for JLOTS to ensure the entire capability is considered in the proper venue.

A third recommendation targets the relationship between JLOTS and seabasing, with the results from the previously recommended proposed study providing context. While seabasing is mentioned in the latest version of JP 4-01.6, the publication does not even provide an overview of the concept as it does with other operations: "...this publication does not discuss seabasing operations, which may include Navy logistics over-the-shore (LOTS) as well as JLOTS capabilities as a complement to its operations."² Interestingly, the publication does choose to include procedures when JLOTS is conducted in conjunction with amphibious operations or Maritime

¹ Trossbach, interview.

² U.S. Joint Chiefs of Staff, *Joint Logistics Over-The-Shore*, Joint Publication 4-01.6 (Washington, DC: U.S. Joint Chiefs of Staff, November 27, 2012), I-2.

Prepositioned Force (MPF) operations. The same should apply to seabasing.

The connection between JLOTS and seabasing is critical and without its support, the seabasing concept would not be complete. Seabasing is a viable attempt to address the anti-access/area denial environment; however, it is not a concept that can overcome the challenges associated with putting personnel and equipment ashore when ports or airfields are denied or destroyed. The concept of using aircraft is touted as the solution, but this will only work for small formations, a Brigade Combat Team (BCT) or smaller, and light equipment. Should the force required be larger than a BCT or require heavier equipment, other means to project that force ashore is needed. Regardless of the disadvantages JLOTS has, the potential use of this operation is evident and doctrine must address its use. Of course, seabasing is a fairly new concept in relation to published doctrine (seabasing was not mentioned once in the 2005 edition of Joint Publication 4-01.6). At the very least, JLOTS in conjunction with seabasing should be addressed in the same way that it is for amphibious or MPF operations.

A fourth recommendation is to increase training opportunities for JLOTS. As discussed, training for JLOTS does occur on an annual basis. This training must continue, even in a constrained fiscal environment, to maintain the skills of both those that must conduct JLOTS operations and those that might actually participate in a JLOTS operation, particularly the unit or units owning the equipment. Of course, increasing the interval of exercises to two per year would be ideal, but with declining budgets, USTRANSCOM should concentrate on keeping the annual exercise robust and relevant. Training should also replicate real world conditions as much as possible, which could involve JLOTS operations in adverse weather conditions or in a threat environment.

Operation Enduring Freedom is scheduled to end in December 2014, resulting in many more units remaining in the Continental United States (CONUS) and able to train on full spectrum operations. The JLOTS exercises that focus on units rotating through the National Training Center attempt to replicate real world situations by moving equipment by sea to the port, offloading using JLOTS, and then moving the equipment to Fort Irwin. While this type of exercise is beneficial, it assumes a permissive environment. USTRANSCOM must seek opportunities to train on JLOTS in areas where anti-access/area denial training operations are possible. As illustrated earlier, possibilities exist at Fort Story, Virginia or even in other countries. By implementing this next level of training, JLOTS may identify other lessons learned that could inform other aspects, such as doctrine, capabilities, or acquisition.

The fifth recommendation addresses the current and future JLOTS capabilities and the need to ensure that the present fiscal situation does not degrade the capability. As highlighted in the historical examples, the military has a long legacy of expeditionary operations, many of which require austere access in the form of an over-the-shore capability. Continued success in an ever-increasing complex environment depends upon using existing JLOTS capabilities in more scenarios that replicate the future environment, as described above with training recommendations. In addition, making selected joint investments in JLOTS capabilities, whether in the military or commercial realm, can more fully enable the military's ability to respond to expeditionary operations both today and in the future.

Continued investment and procurement of the planned number of Joint High Speed Vessels (JHSV) is critical. Regardless of the configuration changes that have

affected the ability of the JHSV to fulfill the Army requirements initially proposed, the vessel will still provide added capability to both JLOTS and the seabasing concept. While an entire BCT cannot move with all organic equipment, smaller forces can; therefore, this method of employment must continue testing and refinement to enhance capability.

The Navy must also ensure its newest systems, such as the Mobile Landing Platform, Advanced Mooring System, Ship to Shore Connector, and the Advanced Interface Ramp Technologies, all continue to receive adequate funding. As discussed in the previous chapter, many of these systems are in the first stages of development and pending budget cuts could adversely affect continuation of these programs. Because these systems complement both JLOTS and seabasing, identifying just which systems are more critical to one or the other is critical. Because of the lack of integration between seabasing and JLOTS, a comprehensive study, as offered in the first recommendation, is critical to identify and prioritize key capabilities required for both seabasing and JLOTS.

The Army must prioritize and fund its own programs that support JLOTS, specifically the Army Watercraft System (AWS). The Transportation Capability Portfolio Review (CPR) for the Army consists of more than just Army Watercraft. Also within this portfolio exists the Tactical Wheeled Vehicle (TWV) program, the Joint Light Tactical Vehicle (JLTV), Medium and Heavy Tactical Vehicles (MTV and HTV), and the High Mobility Multi-Purpose Wheeled Vehicle (HMMWV) programs. On 26 November 2012, the Vice Chief of Staff for the Army (VCSA) approved the CPR for Transportation with five priorities: TWV, Network Interoperability and Mission Command, Reduction of Fleet Age and Operational Costs, Additional Protection

Procurement, and Maintaining A2/AD Capability.³ AWS programs and initiatives are prevalent in four of the five priorities, requiring the Army to ensure proper funding remains for this important capability, despite pending budget and force reductions.

The Services must also consider commercial strategies in their approaches to fulfilling the JLOTS capabilities requirements, especially during times of fiscal constraint. Precedent has already been made in the commercial industry with the Voluntary Intermodal Service Agreement (VISA) program, which allows for commercial sealift capability during times when increased capacity is required. Similarly, the Civil Reserve Air Fleet (CRAF) program provides increased commercial airlift capability when required. Exploring a similar program to assist with JLOTS execution and not require a large lighterage inventory could prove beneficial. The use of a civilian high-speed ferry during earthquake relief in Haiti is an excellent example of using commercial assets that do not yet exist within the military's inventory, or do exist, but not in enough quantities.

The five recommendations discussed above – a comprehensive study to determine current JLOTS capability and requirements, creation of a program manager for JLOTS, doctrinal connections between seabasing and JLOTS, improved training opportunities, and priority emphasis on both military and potential commercial JLOTS capabilities – are all critical to the future of JLOTS as a logistics capability. Implementing all will ensure this important option for the Joint Force Commander remains viable and will continue to receive the focus necessary for successful future operations. At the very least, the comprehensive study must become a priority for both USTRANSCOM and Joint Staff to ensure a basic starting point to chart the way forward for this important logistical capability.

³ Trossbach, interview.

CHAPTER 6: CONCLUSION

While the United States military is unmatched in its ability to project forces anywhere in the world, this advantage is only enjoyed because of a profound reliance on strategic airlift and sealift combined with world-class port and airfield infrastructure. Also enabling success is the luxury of long lead times for deployments and an ability to build up supplies and equipment in areas safe from enemy fire and through allies and partners who allow our presence. This environment is not guaranteed in future conflicts. As an option for the Joint Force Commander, Joint Logistics Over The Shore (JLOTS) operations enable strategic ship offload through inadequate or damaged ports, or over a bare beach. However, in order to continue to provide JLOTS as an option, the Department of Defense (DoD) must invest in a common, integrated approach to ensure a capability that is sufficient and integrated across the Services and within the Joint Force.

History has shown the advantage of projecting forces onto the shores of the enemy and sustaining them through over-the-shore options. However, periods between conflicts often result in decreased budgets and less emphasis on capabilities such as JLOTS. After Operation OVERLORD in World War II, many strategic thinkers believed amphibious operations would never occur again. Just a short six years later, Operation CHROMITE occurred in Inchon, Korea. The U.S. was not immune to the refusal to recognize the potential for these types of operations. The British scrambled to put together an amphibious force for Operation CORPORATE in the Falklands. While both of these historical examples managed to attain success by scrambling for both retired and commercial assets, had strategic leadership anticipated the need for the capability, a different, more organized approach may have resulted in even more favorable results.

Operation UNIFIED RESPONSE illustrated how JLOTS can enhance and enable relief operations. Additionally, both UNIFIED RESPONSE and CORPORATE showed how partnership with commercial industry can also provide needed capabilities. Thus, the historical examples have shown both the successes and challenges associated with JLOTS operations, yet also illustrate the importance of having this logistical option for the warfighter.

JLOTS is among the tools in the combatant commander's kit bag to support the fight or to execute disaster relief.¹ To continue to provide this flexible logistics option, the joint community must emphasize its importance through continued investment and increased joint collaboration. Because DoD mobility studies have narrowly focused on strategic lift assets and not on the intra-theater modes of transportation such as JLOTS, a seemingly positive picture is presented of the mobility capability to support current operations. These studies of the past do nothing to illustrate needed future capability in environments vastly different from those faced in today's conflicts. A comprehensive study to determine concepts, capabilities, and requirements for JLOTS to support future Joint force structures and operational environments will ensure an accurate starting point for assessing JLOTS. This study could also analyze the current management of the JLOTS program, possibly recognizing the need for a program manager to allow for empowerment and more involvement across the joint community.

Additionally, doctrine must reflect the importance of JLOTS to emerging concepts such as seabasing to ensure seamless transition from one method of logistics

¹ Mark MacCarley, Brigadier General, and Brian F. Coleman, Lieutenant Colonel, "8th Theater Sustainment Command Leads the Way During Operation Pacific Strike 2008," *Army Logistician* (March/April 2009), 24.

delivery to another. Continued and expanded training opportunities during the annual USTRANSCOM-sponsored JLOTS exercise will increase the breadth of JLOTS experience across all the Services. The platforms and capabilities existing today for JLOTS must continue to receive required funding to ensure availability when needed for the next contingency. Finally, the joint community must explore all opportunities to enhance JLOTS capability, whether commercial or emerging technology, to ensure viable capability as older platforms and capability reach their economical useful life.

The deployments of the past 20 years have illustrated this nation's unparalleled ability to project power when world-class seaports and airfields are available. However, when power projection capability is limited by unavailable, denied, or degraded ports, JLOTS provides an essential capability. To continue to provide that option, the recommendations in this paper will ensure JLOTS remains at a level of proficiency that ensures our national defense in accordance with the strategic guidance.

BIBLIOGRAPHY

- Bartlett, Merrill L. *Assault from the Sea: Essays on the History of Amphibious Warfare*. Annapolis, MD: Naval Institute Press, 1983.
- Burnett, Alexander SSG. "Resolute' Warriors Take Over the Seas During JLOTS." The Official Website of Joint Base Langley Eustis. <http://www.jble.af.mil/news/story.asp?id=123315673> (accessed December 17, 2012).
- Clapp, Michael and Ewen Southby-Tailyour. *Amphibious Assault Falklands: The Battle of San Carlos Water*. Annapolis, MD: Naval Institute Press, 1996.
- Defense Industry Daily. "Whatever Floats Your Tank: The USN's Improved Navy Lighterage System." *Defense Industry Daily* (May 2009). <http://www.defenseindustrydaily.com/whatever-floats-your-tank-the-usns-improved-navy-lighterage-system-02251> (accessed December 3, 2012).
- Freedberg, Sydney J. Jr. "Marines Will Depend On Army, Allies, Private Sector to Get Ashore." AOL Defense Website. <http://defense.aol.com/2012/03/08/marines-will-depend-on-army-allies-private-sector-to-get-ashor/> (accessed December 17, 2012).
- Gates, Robert M. *Quadrennial Defense Review Report*. Washington, DC: U.S. Department of Defense, February 2010.
- Godfrey, Frederick V. "The Logistics of Invasion." *Army Logistician* (November 2003). [http://www.thefreelibrary.com/The logistics of invasions.-a0110459247](http://www.thefreelibrary.com/The+logistics+of+invasions.-a0110459247) (accessed November 17, 2012).
- Henderson, Meghan Patrick. "Military Sealift Command Accepts Delivery of First JHSV." *Sealift: Official Blog of the U.S. Navy's Military Sealift Command*. <http://mscsealift.dodlive.mil/2012/12/10/military-sealift-command-accepts-delivery-of-first-jhsv/> (accessed December 11, 2012).
- Jackson, Lee. "Public - Private Partnerships." *Defense Transportation Journal* 66, no. 2 (April 2010). <http://search.proquest.com/docview/346121205?accountid=12686> (accessed December 19, 2012).
- Keegan, John. "Encyclopedia Britannica's Guide to Normandy 1944." <http://www.britannica.com/dday/browse?browseId=237147> (accessed November 17, 2012).
- Killblane, Richard E. "Operation Unified Response, Haiti Trip Report." Fort Eustis: Office of the Chief of Transportation, 2010. <https://www.us.army.mil/suite/doc/12720672&inline=true> (accessed December 19, 2012).

- Kratz, Louis A. "Logistics Transformation: DoD's Opportunity to Partner with the Private Sector - A Time for Action." *Logistics Spectrum* 42, no. 2 (April-June 2008): 22-5. <http://search.proquest.com/docview/195310520?accountid=12686> (accessed December 19, 2012).
- MacCarley, Mark Brigadier General, and Lieutenant Colonel Brian F. Coleman. "8th Theater Sustainment Command Leads the Way During Operation Pacific Strike 2008." *Army Logistician* (March/April 2009): 24-28.
- McNabb, Duncan J. "We Measure Success through the Eyes of the War Fighter." *Air & Space Power Journal* 25, no. 4 (Winter 2011): 8-18. <http://search.proquest.com/docview/918713415?accountid=12686> (accessed December 19, 2012).
- Mullen, Michael G., ADM. *The National Military Strategy of the United States of America*. Washington, D.C.: U.S. Department of Defense, 8 February 2011.
- Paquette, Richard A. "Expeditionary Logistics in its Truest Form." *Army Logistician* 41, no. 2 (March/April 2009): 20-23. <http://search.proquest.com/docview/197293524?accountid=12686> (accessed December 19, 2012).
- Rutner, Stephen M., Maria Aviles, and Scott Cox. "Logistics Evolution: A Comparison of Military and Commercial Logistics Thought." *International Journal of Logistics Management* 23, no. 1 (2012): 96-118. <http://search.proquest.com/docview/1019932937?accountid=12686> (accessed December 19, 2012).
- Steer, Frank R. "The Impact of Commercial Involvement on Military Operational Logistics." *Logistics Spectrum* 36, no. 3 (July-September 2002): 31-4. <http://search.proquest.com/docview/195310850?accountid=12686> (accessed December 19, 2012).
- Trossbach, Jennifer, CW5. Interview by the author. The Pentagon, 31 January 2012. CW5 Trossbach is a marine engineering officer assigned to the Strategic Mobility Division, Department of the Army G-4, and is regarded by the Joint Staff as a subject matter expert on JLOTS. On active duty since 1985, she has vast experience in the JLOTS arena, having served in several key positions such as the transportation capability manager at Army Training and Doctrine Command and as a key instructor at the Maritime Training Center, an academic department of the Army Transportation Center and School.
- Trotter, Neville. "The Falklands Campaign Command and Logistics." *Armed Forces Journal International* (June 1983): 32-41. Quoted in Paul Valovcin, *Logistics Lessons for the Operational Commander, The Falklands War*. Newport, R.I.: Naval War College, 1992.
- Tustin, W. J. Major. "The Logistics of the Falklands War, Part I." *Army Quarterly and Defence Journal* (July 1984): 295-301. Quoted in Paul Valovcin, *Logistics Lessons*

- for the Operational Commander, The Falklands War.* Newport, R.I.: Naval War College, 1992.
- U.S. Department of the Army. *Quick Reaction Requirements Analysis For The Theater Support Vessel (TSV).* Washington, DC: U.S. Department of the Army, April 4, 2003.
- U.S. Department of Defense. *Capstone Concept for Joint Operations: Joint Force 2020.* Washington, DC: Department of Defense, September 10, 2012.
- *Defense Budget Priorities and Choices.* Washington, DC: Department of Defense, January 2012.
- *Defense Science Board Task Force on Mobility.* Washington, DC: Department of Defense, September 2005.
- *Defense Strategic Guidance: Sustaining U.S. Global Leadership: Priorities for 21st Century Defense.* Washington, DC: Department of Defense, January 2012.
- *Joint Operational Access Concept (JOAC).* Washington, DC: U.S. Department of Defense, January 17, 2012.
- U.S. Fleet Forces Command. *Concept for Employment of Current Seabasing Capabilities: Integrating Seabasing Capabilities Into Exercises and Experiments.* Norfolk, VA: U.S. Fleet Forces Command, 2010.
- U.S. Joint Chiefs of Staff. *Joint Logistics.* Joint Publication 4-0. Washington, DC: Joint Chiefs of Staff, July 18, 2008.
- *Joint Logistics Over the Shore.* Joint Publication 4-01.6. Washington, DC: Joint Chiefs of Staff, November 27, 2012.
- *Distribution Operations.* Joint Publication 4-09. Washington, DC: Joint Chiefs of Staff, February 5, 2010.
- *Air Mobility Operations.* Joint Publication 4-17. Washington, DC: Joint Chiefs of Staff, October 2, 2009.
- U.S. President. *National Security Strategy.* Washington, DC: May 2010.
- U.S. Transportation Command (USTRANSCOM). *Charter for the Joint Logistics-Over-the-Shore Working Group.* Scott Air Force Base, IL: July 31, 2012.

VITA

Lieutenant Colonel Rhonda L. Fisher is a native of Hampton Roads, Virginia and graduated from Christopher Newport College, Newport News, Virginia, in 1991 with a Bachelor of Science degree in business administration. Commissioned in the Transportation Corps through ROTC, Lieutenant Colonel Fisher also holds a master's degree in administration from Central Michigan University. Her military education includes the Transportation Officer Basic Course, the Combined Logistics Officer Advanced Course, and Command and General Staff College. She is currently attending Senior Service College at the Joint Advanced Warfighting School in Norfolk, Virginia.

Lieutenant Colonel Fisher has served in a variety of staff and command positions including Platoon Leader, 503rd Transportation Company, Heidelberg, Germany; Assistant Professor of Military Science, Santa Clara University, Santa Clara, California; and Company Commander, 1098th Transportation Company (Medium Boat), Fort Eustis, Virginia. She has also served as the Support Operations Officer, Executive Officer, and Battalion Commander (Rear), 28th Transportation Battalion, Mannheim, Germany; International Logistics Staff Officer and Executive Assistant to the Director, Logistics, Engineering, and Security Assistance, United States Pacific Command, Camp H.M. Smith, Hawaii; and Battalion Commander, 831st Deployment and Distribution Support Battalion, Manama, Bahrain. Most recently, she served as Team Chief, Strategic Mobility Division, Army G4 at the Pentagon. Her next assignment is with United States Africa Command in Stuttgart, Germany. Lieutenant Colonel Fisher is married to Colonel William (Bill) Fisher. They have two children, Nicole, 21, and Melissa, 18, who both live in Baltimore, Maryland.