

Analyzing the United States Air Force Organizational Structure – A Case for Reorganization

**A Monograph
by
Lt Col Jeffrey P. Sundberg
United States Air Force**



**School of Advanced Military Studies
United States Army Command and General Staff College
Fort Leavenworth, Kansas**

AY 2010-2011

REPORT DOCUMENTATION PAGE

Form Approved
OMB No. 0704-0188

Public reporting burden for this collection of information is estimated to average 1 hour per response, including the time for reviewing instructions, searching existing data sources, gathering and maintaining the data needed, and completing and reviewing this collection of information. Send comments regarding this burden estimate or any other aspect of this collection of information, including suggestions for reducing this burden to Department of Defense, Washington Headquarters Services, Directorate for Information Operations and Reports (0704-0188), 1215 Jefferson Davis Highway, Suite 1204, Arlington, VA 22202-4302. Respondents should be aware that notwithstanding any other provision of law, no person shall be subject to any penalty for failing to comply with a collection of information if it does not display a currently valid OMB control number. **PLEASE DO NOT RETURN YOUR FORM TO THE ABOVE ADDRESS.**

1. REPORT DATE (DD-MM-YYYY)

16-05-2011

2. REPORT TYPE

SAMS Monograph

3. DATES COVERED (From - To)

June 2010 - May 2011

4. TITLE AND SUBTITLE

Analyzing the United States Air Force Organizational Structure - A Case for Reorganization

5a. CONTRACT NUMBER**5b. GRANT NUMBER****5c. PROGRAM ELEMENT NUMBER****6. AUTHOR(S)**

Lt Col Jeffrey P. Sundberg, United States Air Force

5d. PROJECT NUMBER**5e. TASK NUMBER****5f. WORK UNIT NUMBER****7. PERFORMING ORGANIZATION NAME(S) AND ADDRESS(ES)**School of Advanced Military Studies (SAMS)
250 Gibbon Avenue
Fort Leavenworth, KS 66027-2134**8. PERFORMING ORGANIZATION REPORT NUMBER****9. SPONSORING / MONITORING AGENCY NAME(S) AND ADDRESS(ES)**Command and General Staff College
731 McClellan Avenue
Fort Leavenworth, KS 66027-1350**10. SPONSOR/MONITOR'S ACRONYM(S)**
CGSC**11. SPONSOR/MONITOR'S REPORT NUMBER(S)****12. DISTRIBUTION / AVAILABILITY STATEMENT**

Approved for Public Release; Distribution Unlimited

13. SUPPLEMENTARY NOTES**14. ABSTRACT**

The United States Air Force (USAF) faces a fiscally constrained environment today and will likely become even more constrained in the near future. With a reduced budget and important programs and critical functions that require funding, the USAF must find opportunities to save and reallocate these limited resources. This monograph will analyze the top-level USAF organization to address specifically whether organization and personnel changes can provide needed savings, while at the same time improving the USAF organization to support the combatant commanders and become more geographically focused to handle the complex global environment and nature of conflict.

While the size of force and force structure have shrunk to the lowest points in USAF history, organizational analysis finds the USAF structure overmanned with staff officers and civilians. Further examination finds an organization with significant depth and primarily organized in a functional manner. Given these issues, this monograph proposes eliminating a layer of the USAF organization by removing major commands and promoting numbered air forces subordinate to the Headquarters USAF. This type of organization can better support combatant commands, advance USAF regional expertise and focus through the numbered air forces, adapt quicker to global situations, and also ensure important USAF history and traditions endure.

15. SUBJECT TERMS

United States Air Force, Organization, Major Commands, Numbered Air Forces, Reorganization, Air Force History, Headquarters Air Force, Air Force Staff, Staff Officers,

16. SECURITY CLASSIFICATION OF:

Unclassified

17. LIMITATION OF ABSTRACT**18. NUMBER OF PAGES****19a. NAME OF RESPONSIBLE PERSON**
Wayne W. Grigsby Jr.
COL, U.S. Army**19b. TELEPHONE NUMBER (include area code)**
913-758-3302**a. REPORT****b. ABSTRACT****c. THIS PAGE**

77

SCHOOL OF ADVANCED MILITARY STUDIES

MONOGRAPH APPROVAL

Lt Col Jeffrey P. Sundberg

Title of Monograph: Analyzing the United States Air Force Organizational Structure – A Case for Reorganization

Approved by:

Dan C. Fullerton, Ph.D.

Monograph Director

Wayne W. Grigsby, Jr., COL, IN

Director,
School of Advanced
Military Studies

Robert F. Baumann, Ph.D.

Director,
Graduate Degree
Programs

Disclaimer: Opinions, conclusions, and recommendations expressed or implied within are solely those of the author, and do not represent the views of the US Army School of Advanced Military Studies, the US Army Command and General Staff College, the United States Army, the Department of Defense, or any other US government agency. Cleared for public release: distribution unlimited.

Abstract

Analyzing the United States Air Force Organizational Structure – A Case for Reorganization by Lt Col Jeffrey P. Sundberg, USAF, 77 pages.

The United States Air Force (USAF) faces a fiscally constrained environment today and will likely become even more constrained in the near future. With a reduced budget and important programs and critical functions that require funding, the USAF must find opportunities to save and reallocate these limited resources. This monograph will analyze the top-level USAF organization to address specifically whether organization and personnel changes can provide needed savings, while at the same time improving the USAF organization to support the combatant commanders and become more geographically focused to handle the complex global environment and nature of conflict.

While the size of force and force structure have shrunk to the lowest points in USAF history, organizational analysis finds the USAF structure overmanned with staff officers and civilians. Further examination finds an organization with significant depth and primarily organized in a functional manner. Given these issues, this monograph proposes eliminating a layer of the USAF organization by removing major commands and promoting numbered air forces subordinate to the Headquarters USAF. This type of organization can better support combatant commands, advance USAF regional expertise and focus through the numbered air forces, adapt quicker to global situations, and also ensure important USAF history and traditions endure.

Table of Contents

Introduction	1
Air Force Organizational History	2
Army Aviation Organizational History: 1907-1947	3
Air Force Organizational History: 1947-2010.....	15
Air Force Organization Today: 2011.....	24
Air Force Organization Structure Analysis	26
Organizational Size	27
Organizational Width and Depth.....	35
A Functional Organization	41
Potential Air Force Organizational Changes	44
Recent Reorganization Efforts, Legal Constraints, and Official Guidance.....	45
Organizational Tenets: Maintaining Air Force Traditions	49
General Organizational Concepts.....	52
Reorganization Proposal.....	58
A Case for a Robust General Staff	64
Difficulty with Reorganization.....	65
Conclusions	67
BIBLIOGRAPHY	69

Introduction

With the United States (US) Air Force's largest baseline budget decrease since 1994 and the largest Department of Defense (DoD) budget decline since 1991, and more cuts likely, financial pressures have forced the Air Force (AF) to identify areas to reduce costs and improve efficiencies.¹ With the US Secretary of Defense (SecDef) attempting to improve efficiencies in the Department, the AF must consider several options to save money in this constrained fiscal environment. When looking across the spectrum of options, the doctrine, organization, training, material, leadership and education, personnel and facilities (DOTMLPF) solution space provides a framework to help identify areas to save money, also commonly termed as 'accept risk'. A foundation for the Joint Capabilities Integration Development System (JCIDS), DOTMLPF provides this analytical framework for military services in annual budgetary work.² While not often addressed in Air Staff money drills and capabilities assessments, this paper will look specifically at the AF top-level organizational structure targeting primarily the organization and personnel categories of DOTMLPF. Given the environment of budget pressures, a significantly reduced force, and to seek financial savings in these two areas, should the AF consider major

¹ "The Air Force in Facts and Figure, 2010 USAF Almanac," *Air Force Magazine*, May 2010, 56. "USAF Almanac, The Air Force in Facts and Figures," *Air Force Magazine*, May 2000, 58. Measured in constant dollars, the AF baseline budget declined in 2010 by 5.22% from previous year. The baseline budget declined 7.52% in 1994. The DoD's projected budget, also measured in constant dollars, for 2011 will decrease 8.85%. The last DoD budget decrease greater than this happened in 1991 with a 12.8% decrease, Office of Management and Budget, *Historical Tables, Budget of the U.S. Government, Fiscal Year 2010*, 2009, 123-126.

² JCIDS plays a key role in identifying the capabilities required by the warfighters to support the National Defense Strategy, the National Military Strategy, and the National Strategy for Homeland Defense. Successful delivery of those capabilities relies on the JCIDS process working in concert with other joint and DOD decision processes. The primary objective of the JCIDS process is to ensure the capabilities required by the joint warfighter are identified with their associated operational performance criteria in order to successfully execute the missions assigned, Chairman of the Joint Chiefs of Staff, *Joint Capabilities Integration and Development System*, CJCS Instruction 3710.01G, March 1, 2009, A-1.

reorganization to gain efficiencies, save money, and reallocate those scarce resources to other programs and parts of the DOTMLPF spectrum?

In analyzing the AF organizational structure, several areas will be explored to provide common understanding of how the organization developed and the history behind the changes. This effort will trace the AF organizational structure from inception through current day. Then, an in-depth look at force structure will compare the size of the structure to manning and mission systems levels over time and build a sense of the overall width and depth of the organization. This study will focus primarily above the wing level, starting at the numbered air forces through the Air Staff. Throughout the organizational examination, the pitfalls and inefficiencies of the large AF bureaucracy will be exposed, specifically looking at theoretical challenges, an inability to adapt given today's technology and nature of warfare, and redundancies across the staffs.

Given the need to improve efficiency within the DoD and should the AF consider a major reorganization, there are several options to consider which could achieve organizational and personnel savings. The primary suggestion presented here would remove a layer of the organization to flatten the organizational structure, specifically eliminating the major commands and increasing responsibilities of the Air Staff, numbered air forces, and wings. The Air Staff would absorb a large number of administrative functions currently held by the major commands. The numbered air forces would regionally align with combatant commands providing the crucial links to warfighting commanders and dedicate air staffs to handle regional conflicts and requirements. If these suggested recommendations can address organizational inefficiencies, reduce financial costs, and maintain traditions, the AF can improve operational effectiveness and save finite resources for other critical programs.

Air Force Organizational History

The 1947 National Security Act created a separate Air Force and established a new service with an initial organizational structure built from its Army roots. Over the next 63 years,

the organization morphed and expanded to its current structure, seen in figure 1. The following detailed look will focus on the history of the AF organization above wing level and how the organizational structure developed over time. With a lot of the history and initial structure in place prior to 1947, the discussion will begin just after first flight in 1903. Throughout, several themes have resonated at every step of organizational development. Any future organizational changes must consider these principles to capture important historical lessons and cultural traditions.

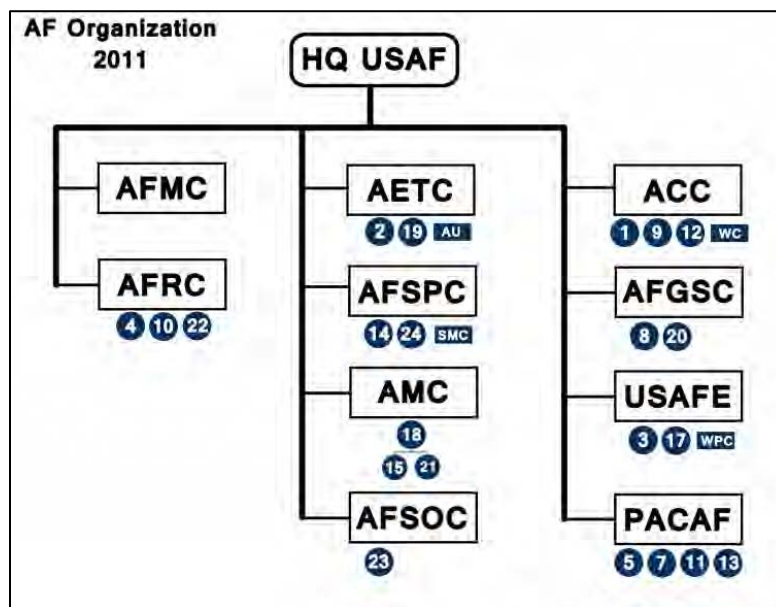

Figure 1. Air Force Organization Structure, 2011.³

Army Aviation Organizational History: 1907-1947

The Army first created an Aeronautical Division in the US Army Signal Corps on August 1, 1907.⁴ Shortly thereafter, the Signal Corps purchased and accepted the first Wright Flyer

³ “The Air Force in Facts and Figure, 2010 USAF Almanac,” *Air Force Magazine*, May 2010, 36-102. In these organization graphics, the blue circles represent numbered air forces subordinate to major commands and blue rectangles depict major centers, except for all of AFMC’s centers.

aircraft on August 2, 1909.⁵ In March 1911, the US Congress penned the first legislation for aviation authorizing \$125,000 in funds for military aeronautics.⁶ Three years later on July 18, 1914, the US Congress passed a law creating an Aviation Section in the Signal Corps.⁷ The next important piece of legislation, the National Defense Act of 1916, further authorized and increased the new Aviation Section to eight aero squadrons, over 1,100 personnel, and 55 airplanes.⁸ In the first organizational transformation shortly after World War I hostilities commenced, a Presidential executive order transferred responsibility from the Signal Corps to the Secretary of War who then created the Air Service.

In early 1917, after observing World War I front-line operations in Europe and in preparation for US aviation support, Major William “Billy” Mitchell envisioned and recommended an Air Service with two components. One force would include tactical aviation forces directly supporting ground forces, while the other would consist of strategic groups to target enemy forces deep inside their own territory.⁹ General John J. Pershing, the Commander of the American Expeditionary Force, rejected this split and opted for the direct support option only. Nevertheless, Major Mitchell’s proposal would set the stage and foreshadowed future organization divisions.

⁴ Warren A. Trest, *Air Force Roles and Missions: A History*, (Air Force History and Museums Program, 1998), 2. After the Wright brothers first flight in 1903, the Army began negotiations to investigate the use of the airplane for military operations. Brigadier General James Allen, Chief Signal Officer of the Army, created the Aeronautical Division in anticipation of the investigation outcome, as well as use of military balloons and other possible air machines.

⁵ *Ibid.*, 2.

⁶ Air Force Association (AFA), *History of the United States Air Force, 1907-1957*, (AFA, 1957), 6.

⁷ Trest, *Air Force Roles and Missions: A History*, 9.

⁸ *Ibid.*, 10.

⁹ AFA, *History of the United States Air Force, 1907-1957*, 21.

In May 1918, as a result of Executive Order 2862, the new Air Service reorganized as two groups consisting of the Bureau of Aircraft Production and Division of Military Aeronautics.¹⁰ In World War I, the Air Service peaked at 190,000 personnel with a nearly \$100 million annual budget in 1919 before post-war demobilization reduced the service to 27,000 personnel with an average \$33 million annual budget.¹¹ With some limited success in World War I, early airpower advocates pushed for two basic principles following the war: concentration of forces under a centralized air commander and operational priority against enemy air forces.¹² Even with increasing airpower stature and aviation proponents making these arguments, few changes, however, happened for the Air Service in the twilight of World War I.

The next evolution came in the Army Reorganization Act of 1920 which gave the Air Service statutory recognition as a combatant arm, on par with other combatant arms including infantry and armor.¹³ Further changes, however, came slowly for the Air Service during the interwar years. A lack of funding for aviation, which stayed steady around \$33 million annually, effectively slowed innovation, advancements and weapons improvements necessary for post-war airpower development. Nevertheless, doctrine changes and employment discussions continued. Effective in January 26, 1926, the War Department Training Regulation 440-15, *Fundamental Principles for the Employment of the Air Service*, authored by the Air Service, discussed primary

¹⁰ Charles A. Ravenstein, *The Organization and Lineage of the United States Air Force*, (United States Air Force Historical Research Center, Office of Air Force History, 1986), 3.

¹¹ Trest, *Air Force Roles and Missions: A History*, 30.

¹² AFA, *History of the United States Air Force, 1907-1957*, 18-30. In the first major test of aviation, the Air Service learned first how to establish an aircraft production base in which to build a force. In order to become combat capable, the Air Service faced significant challenges and lessons in training and with supporting logistics. In all, once deployed in Europe and organized into the allied structure, the Air Service achieved some success bombing enemy targets and claiming over 780 aircraft kills.

¹³ Edwin L. Williams, Jr., "Legislative History of the Air Arm", *Military Affairs* 20, no. 2 (Summer 1956): 84.

assignment of all air units to supported ground forces. However, it left open the possibility that control of air units could vary according to the situation.¹⁴ Later that year, the Air Corps Act of July 2, 1926, changed the Air Service to the Air Corps while also adding aviation representation to the Army General Staff.¹⁵ Also during the middle 1920s, Army staff language first adopted and referenced the term 'air force.'¹⁶

In March 1928, Army Regulation 95-10 split the aviation forces into two groups, the forces attached directly to ground units and all other combat aviation forces.¹⁷ These other combat aviation forces, also known as the air reserve, comprised General Headquarters (GHQ) aviation which fell directly under the General Staff. The Air Corps squadrons, dedicated to ground forces, stayed under the control of the nine corps area commanders.¹⁸ Although the Chief of the Air Corps position existed, he had no authority over these corps aviation forces to provide overall unity of command. With the ensuing Army reorganization from nine corps to four field armies, several groups studied how to better incorporate the air forces.¹⁹ Of the different organizational designs considered and debated, the fledgling GHQ Air Force structure gained momentum. The GHQ Air Force concept, originally a wartime-only construct born of the strategic reserve air forces in World War I, began provisional testing during the peacetime years

¹⁴ Thomas H. Greer, *The Development of Air Doctrine in the Army Air Arm, 1917-1941*, (Office of Air Force History, 1955), 40.

¹⁵ Trest, *Air Force Roles and Missions: A History*, 47.

¹⁶ *Ibid.*, 49.

¹⁷ John F. Shiner, "Birth of the GHQ Air Force", *Military Affairs* 42, no. 3 (1978): 114.

¹⁸ *Ibid.* Detail on the Army organization at this time can be found in *Military Organization of the United States*, (General Service Schools Press, 1928).

¹⁹ Greer, *The Development of Air Doctrine in the Army Air Arm, 1917-1941*, 71-74. In 1914, the Secretary of War appointed the Baker Board to study the air arm as part of national defense. The Baker Board's findings, building on the 1919 Dickman Board and 1933 Drum Board studies, informed the Department on suggested roles and missions for the Air Corps.

of 1933 and 1934, setting the stage for a new chapter prescribing the independent air mission and centrally controlled air forces.²⁰

Effective March 1, 1935, the new revision of War Department Training Regulation 440-15 officially established the GHQ Air Force, bringing reserve combat aviation forces under the command of a single airman for the first time, reporting directly to the General Staff.²¹ Three wings formed under the new GHQ Air Force, as seen in figure 2, including the 1st Wing at March Field, the 2nd Wing at Langley Field, and the 3rd Wing at Barksdale.²² During wartime,

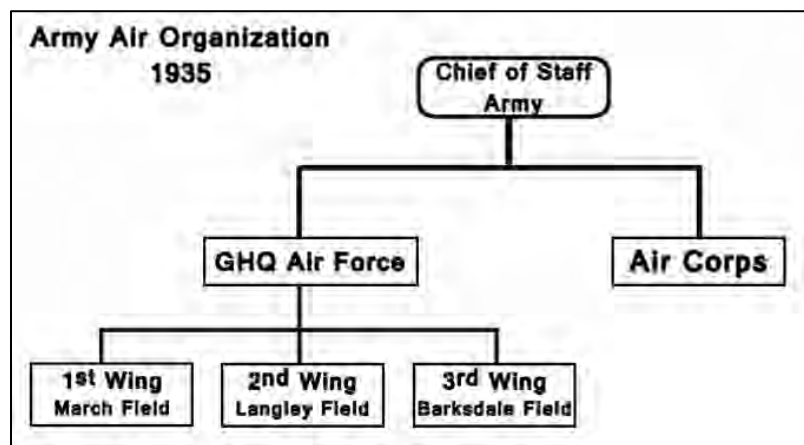

Figure 2. Army Air Organization Structure, 1935.²³

GHQ Air Force would report directly to the operational theater commander. The Chief of Air Corps remained at the same echelon with GHQ Air Force Commander, and kept responsibility for training and supply of the Army air forces. While some critiques contested this further divide of air forces and restricted force employment, the majority saw this arrangement as a step in the

²⁰ Trest, *Air Force Roles and Missions: A History*, 59-60.

²¹ Richard G. Davis, *The 31 Initiatives: A Study in Air Force - Army Cooperation*, (Office of Air Force History, 1987), 7.

²² Herman S. Wolk, *The Struggle for Air Force Independence, 1943-1947*, (Air Force History and Museums Program, 1997), 15.

²³ Ibid.

right direction with aviation representation at higher levels and somewhat improved unity of command.²⁴ Nevertheless, aviation remained fragmented between two commands, no separate air budget existed, and corps still controlled personnel administration for aviators.

To alleviate the fragmentation of air assets, Major General Frank M. Andrews, the first Commander of GHQ Air Force, championed that effective airpower required centralized control of air combat units, including attack, bombardment, pursuit, and reconnaissance units.²⁵ He also believed fragmentation of forces created “insufficient coordination and direction,” while at the same time emphasized that the “proper amount of decentralization” should remain at the appropriate command levels.²⁶ As believed by Major General Andrews and others, aviation forces required these key principles to operate and maximize mission effectiveness. Celebrating a small victory, by gaining administrative control over air stations, and demonstrating the new organizational growth, Major General Andrews and the GHQ Air Force began to compete with and create tensions with the existing Air Corps. As highlighted earlier, both GHQ Air Force and the Air Corps advised the War Department as coequals, but both did not always agree on aviation issues. This tension persisted until March 1939 when the War Department placed the GHQ Air Force directly under the new Chief of the Air Corps. Major General Henry “Hap” Arnold, the new Chief of the Air Corps, would assume centralized command over the entire air arm. The new Field Manual (FM) 1-5, *Employment of Aviation of the Army*, replacing 440-15, introduced a new functional approach to the GHQ Air Force by dividing air forces into strategic strike forces,

²⁴ Trest, *Air Force Roles and Mission: A History*, 60-61. Specifically, the Joint Board’s guidance enforced strict boundaries on the employment of GHQ Air Force units.

²⁵ Ibid., 68.

²⁶ Ibid.

defensive forces, direct ground support forces, and special forces for other missions.²⁷ One of the primary reasons the Army chose to functionalize missions was to ensure ground commanders would receive their allocation of ground support forces during any future conflict. This functional division would set an early precedent for future air force organizational structures, a structure that expanded and persists even today.

With the outbreak of World War II and a reaction to growing air forces worldwide, the US Congress promptly authorized a significant increase in aircraft production and personnel. With increased funds approved in 1939, the Air Corps planned for a force of 5,500 planes with 48,000 personnel.²⁸ With the pressure of impending war and the need for greater aviation autonomy and consolidation of authorities, Secretary of War Henry L. Stimson directed a major organizational change to Army aviation.²⁹ As a response, Army Chief of Staff General George C. Marshall reorganized and established the Army Air Forces (AAF) as its own air arm within the Army.³⁰ Major General Arnold subsumed the AAF chief position and remained a deputy working directly for General Marshall, yet responsible for all aviation matters and with an increased level of authority in the War Department. This new regulation also officially ended the GHQ Air Force and created the Air Force Combat Command.³¹ While these efforts moved another step towards air independence, several command divisions and coordination challenges persisted as the country went to war.

²⁷ Greer, *The Development of Air Doctrine in the Army Air Arm, 1917-1941*, 113-114.

²⁸ AFA, *History of the United States Air Force, 1907-1957*, 44.

²⁹ Greer, *The Development of Air Doctrine in the Army Air Arm, 1917-1941*, 127.

³⁰ Edwin L. Williams, Jr., 91. The new Army Regulation 95-5, dated June 20, 1941, directed the AAF creation.

³¹ Trest, *Air Force Roles and Missions: A History*, 73.

After the start of World War II, and to further jump-start aircraft production, the War Department approved the Second Aviation Objective which provided for 85 combat air groups, 7,800 combat aircraft, and 400,000 personnel by mid-1942.³² This AAF expansion and geographical dispersion of air forces would require significant organizational growth and development. Effective April 9, 1942, the War Department FM 31-35, *The Employment of Air Power*, subordinated air forces to the theater commander allowing him to attach air units directly to ground units thereby decentralizing execution.³³ The War Department also issued FM 100-20, *Command and Employment of Air Power*, which contained a prominent feature giving an air force commander centralized control over air forces while the theater commander oversaw combined operations.³⁴ Both of these directives demonstrated a need for air forces to work in support of theater commanders. Yet in these arrangements, air forces were still unlikely to work as a concentrated effort and achieve synergistic effects.

The AAF recognized these airpower challenges through the early World War II years. The AAF opposed permanent attachment of aviation units to ground forces and insisted these units always remain under an air commander.³⁵ In the European theater specifically, the message of centralized control of air forces persisted from General Arnold to the Supreme Commander Allied Expeditionary Force, General Dwight D. Eisenhower. In an effort to have the Eighth Air Force Commander, Major General Andrew “Tooe” Spaatz, direct air forces under General Eisenhower throughout both Europe and North Africa, General Arnold wrote: “unless we are

³² AFA, *History of the United States Air Force, 1907-1957*, 48.

³³ Davis, *The 31 Initiatives: A Study in Air Force - Army Cooperation*, 7.

³⁴ War Department, *Command and Employment of Air Power, Field Manual 100-20*, (United States Government, 1944), 4.

³⁵ Greer, *The Development of Air Doctrine in the Army Air Arm, 1917-1941*, 129.

careful, we will find our air effort in Europe dispersed the same way we are now dispersed all around the world. We will find as many different bases of operations operating under as many different directives and commanders as there are land commanders. This must be prevented.”³⁶ In March 1942, addressing these concerns from the aviation leaders, the Army promoted the AAF and the new Army structure consisted of three major forces: the AAF, Army Ground Forces, and Army Service Forces. By 1943, the continued pressure from AAF components and leaders, now established at the highest levels of the War Department, solidified the integration, use, and validity of airpower throughout the ground campaigns.

With the massive expansion of army aviation forces, numerous organizational expansions and changes occurred. The genesis of numbered air forces began and they stood up in the US and all over the world supporting theater operations. Four Air Districts formed under Continental Air Forces in late 1940 to control US-based air forces, which would become the First, Second, Third, and Fourth Air Forces.³⁷ The Far East, Seventh, Sixth, and Eleventh Air Forces likewise stood up in the Philippines, Hawaii, Panama, and Alaska respectively. As wartime need dictated AAF expansion, several other numbered air forces were established and moved into various theaters including: Ninth Air Force to North Africa and later Europe, Twelfth Air Force in Europe, Eighth and Fifteenth Air Forces to Europe under US Strategic Air Forces in Europe, Tenth Air Force in the China-Burma-India theater, and Fourteenth Air Force in China.

As the advance continued towards Japan, the Twentieth Air Force directed strategic bombing operations by B-29s against the mainland. General Arnold, however, insisted upon

³⁶ Trest, *Air Force Roles and Missions: A History*, 88.

³⁷ Ravenstein, *The Organization and Lineage of the United States Air Force*, 7.

maintaining direct control over Twentieth Air Force from AAF headquarters.³⁸ Violating the unity of command principle for the Pacific air forces and Army direction allocating these forces to the theater commander, this exception set the precedent for Strategic Air Command (SAC) after the war with air forces reporting directly to the Joint Chiefs of Staff.³⁹ Along with the numbered air forces, several support or functional major commands came and went with various name changes, ultimately resulting in the supporting Air Service Command, AAF Training Command, and Air Transport Command.⁴⁰ Figure 3 depicts a snapshot of the AAF during the war.

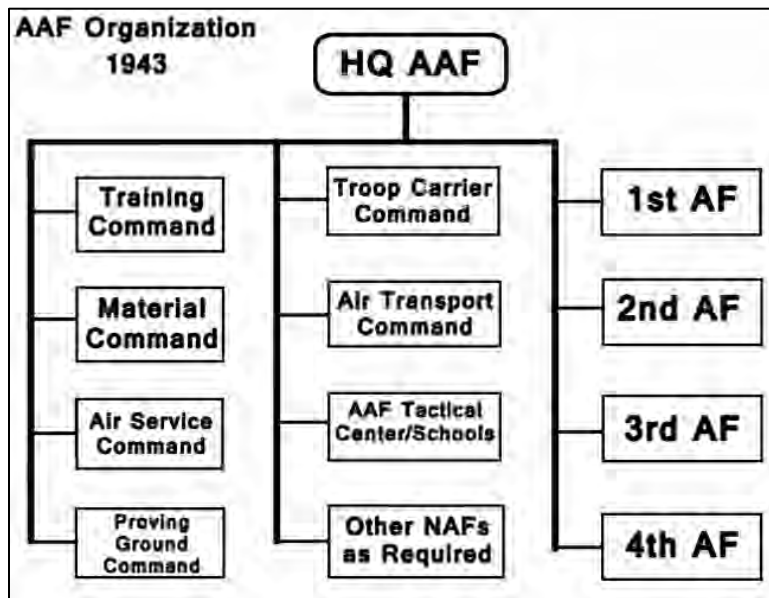

Figure 3. Army Air Force Organization Structure, 1943.⁴¹

³⁸ Ibid., 8-9. The Twentieth Air Force contained all the B-29s and acted as the ‘global air force’ (AFA, *History of the United States Air Force, 1907-1957*, 85).

³⁹ Trest, *Air Force Roles and Missions: A History*, 106.

⁴⁰ Ravenstein, *The Organization and Lineage of the United States Air Force*, 7-9.

⁴¹ Wolk, *The Struggle for Air Force Independence, 1943-1947*, 36.

A function of rapid growth and limited doctrine, organization and command problems developed in the European theater, specifically under General Eisenhower in the Supreme Headquarters, Allied Expeditionary Force (SHAEF). In early preparation for Operation Overlord, the US Strategic Air Forces (USSTAF) in Europe stood up to command the Eighth Air Force in England and the Fifteenth Air Force in Italy. The strategic air forces stood separate from the tactical forces, which consisted of the Ninth Air Force and the Royal Air Force (RAF) 2nd Tactical Air Force. General Eisenhower fought to have all air forces under one commander, the Deputy Supreme Commander, Air Chief Marshal Arthur Tedder. USSTAF, RAF Bomber Command, and even the British Prime Minister protested this move, claiming strategic bomber forces should not fall under SHAEF control. General Eisenhower requested relief of command over this issue and eventually gained 'direction' of the strategic bomber forces, but not under the command of Air Chief Marshal Tedder.⁴² This arrangement created numerous coordination challenges and tensions, especially in allocation of airpower, within the European theater. Although airpower would prove decisive in Europe and during World War II as a whole, organization and command problems persisted.

At its World War II peak, the AAF had 2,400,000 personnel, 243 combat groups, and almost 80,000 aircraft.⁴³ Prior to the end of World War II, the AAF began planning for the permanent, post-war air forces. After much discussion and debate, the War Department approved a plan for 400,000 airmen and 70 groups comprising over 17,000 aircraft in all components.⁴⁴ Following the end of World War II and a rapid demobilization beyond planned levels, the AAF

⁴² Forrest C. Pogue, *The European Theater of Operations, The Supreme Command*, (Center of Military History: 1996), 123-125.

⁴³ AFA, *History of the United States Air Force, 1907-1957*, 49.

⁴⁴ Wolk, *The Struggle for Air Force Independence, 1943-1947*, 78-81.

saw personnel shrink from its peak to less than 350,000 men by 1947, while the civilian force dropped from over 300,000 down to 110,000.⁴⁵ With a drastically reduced AAF and the end of the war, several major organizational structure changes occurred within the AAF and the War Department.

In March 1946, the post-war Continental Air Forces divided into three major functional entities, Tactical Air Command (TAC), Strategic Air Command (SAC), and Air Defense Command (ADC).⁴⁶ General Arnold assigned ADC the mission to plan for and execute the air defense of the continental US. TAC, as promised by General Spaatz to then Army Chief of Staff General Eisenhower, was dedicated to supplying the Army's airpower needs.⁴⁷ Strategic aviation forces fell under the new SAC which soon after became a specified command.⁴⁸ SAC, TAC, ADC, and Air Transport Command would become the four core operational major commands for the post-war AAF.

Further War Department directions and changes had even more impact to the AAF organization. Following the success of unified commands in World War II, the Joint Chiefs of Staff (JCS) made these organizations permanent in the 1946 Outline Command Plan (OCP). Unified commands would oversee operations under direct control of the JCS, leaving service chiefs the primary role of organizing, training and equipping their respective forces.⁴⁹ The OCP created seven geographic unified commands: Far East Command, Pacific Command, Alaskan

⁴⁵ AFA, *History of the United States Air Force, 1907-1957*, 161.

⁴⁶ Trest, *Air Force Roles and Missions: A History*, 114.

⁴⁷ Davis, *The 31 Initiatives: A Study in Air Force - Army Cooperation*, 9.

⁴⁸ Functional commands, also referred to as specified commands, organize by specific capabilities by function, e.g. air transportation in Air Transport Command. Geographic commands, defined by a geographic region, represent the other type of Joint Chief of Staff command.

⁴⁹ Wolk, *The Struggle for Air Force Independence, 1943-1947*, 245.

Command, Northeast Command, The Atlantic Fleet, Caribbean Command, and European Command.⁵⁰ Although not identified as a specified command at the time, the JCS acknowledged the AAF's new SAC and made it directly responsible to the JCS. Lastly, the 1946 War Department Circular Number 138 identified and established key principles the services should follow in post-war reorganization, to include simplicity, flexibility, decentralization, and a single continuous chain of command from top to bottom.⁵¹ These principles, discussed in detail later, would help the AAF rebuild the post-war organization and define the structure in the upcoming organizational transformations during the Cold War and beyond.

Air Force Organizational History: 1947-2010

On July 26, 1947, President Truman signed the National Security Act defining three coequal services thereby creating the new Department of the Air Force for official establishment on September 18. Executive Order 9877 further outlined the responsibilities of the new AF, stating the AF will begin

preparing to carry out prompt and sustained wartime offensive and defensive air operations . . . organizing, training, and equipping air forces for operations unilaterally or jointly with other services . . . gaining and maintaining general air supremacy . . . strategic strike and reconnaissance; airlift and support for airborne operations; air support to land and naval forces; air transport for armed forces, . . . and coordination of air defense among all services.⁵²

Clearly defined here in 1947, these roles and functions did not change significantly over time and remain nearly identical today.

⁵⁰ Joint Chiefs of Staff, *Outline Command Plan*, December 12, 1946, 2-5.

⁵¹ War Department, *War Department Reorganization, Circular No. 138*, May 14, 1946, 3.

⁵² President Harry S. Truman, *Executive Order 9877, Functions of the Armed Forces*, July 26, 1947, 4. Title 10, and with more detail, Department of Defense Directive 5100.01 dated December 21, 2010, identify these functions and missions for the AF today.

Given the newly defined AF mission and existing AAF legacy, the early AF leaders struggled with how to organize the service. Several studies identified three main principles, which included simplicity, unity of command, and that the structure must be compatible with the mission.⁵³ AF leadership considered three different organizational structures that would sharply reduce the time required to make decisions: the “one-man show,” a general staff system, or a deputy system.⁵⁴ The leaders rejected the “one-man show” because of the sheer size and responsibility of the organization. They also eliminated the general staff option because it was thought to limit authority and fail to take responsibility. Consequently, the new organization adopted the deputy system delegating authorities into three deputy positions: Deputy for Personnel and Administration, Deputy for Material and Logistics, and Deputy for Plans and Operations.⁵⁵ The Chief of Staff saw the deputies as commanders, vice an advisory only function, with decentralized authority to make decisions on behalf of him. Subordinate to the deputies and the newly constructed Air Staff, major commands were built to manage different parts of the mission.

In the beginning, the AF established fourteen major commands, which included: Air Defense Command (ADC), Air Material Command, Air Proving Ground Command, Air Training Command, Air Transport Command, Air University, Alaskan Air Command, Bolling Field Command, Caribbean Air Command, Far East Air Forces, Seventh Air Force, Strategic Air

⁵³ Wolk, *The Struggle for Air Force Independence, 1943-1947*, 207.

⁵⁴ *Ibid.*, 206. As detailed by Wolk, the ‘one-man show’ concept gave complete control to one person. Additionally, the deputy system would delegate authority to multiple deputy positions and better be more adept at filling a policy vacuum because a deputy holding responsibility and authority would, according to General Spaatz, “not remain in jeopardy through lack of a policy to cover his actions. A general staff, on the other hand, having no command responsibility, is too often content to let the matter slide.”

⁵⁵ *Ibid.*, 207.

Command, Tactical Air Command, and US Air Forces in Europe (USAFE).⁵⁶ Figure 4 illustrates the initial organization structure for the fledgling AF. Changes came quickly. In June 1948, the AF Air

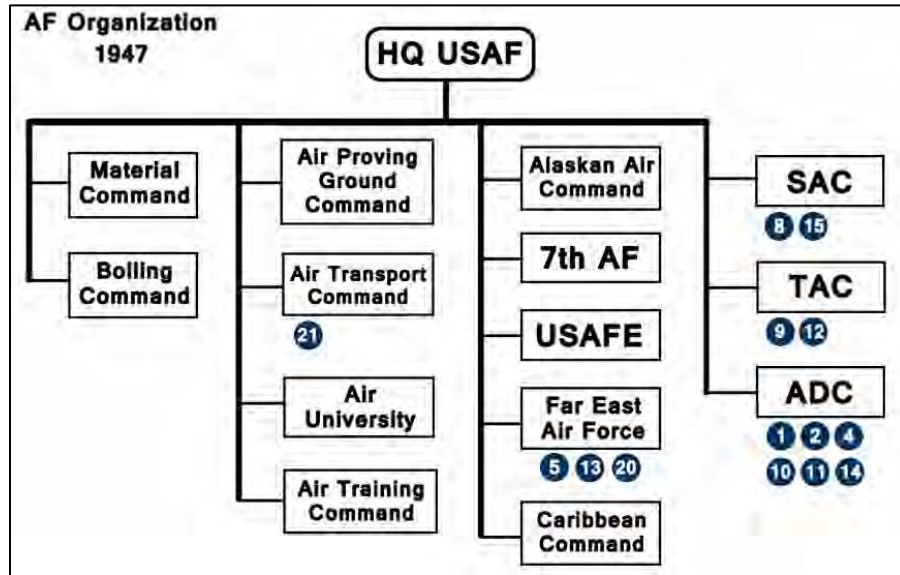

Figure 4. Air Force Organization Structure, 1947.⁵⁷

Transport Command and Naval Air Transport Service merged forming the Military Air Transport Service (MATS) under AF leadership.⁵⁸ Other changes resulted from funding limits and challenges with army support aviation forces. These issues prompted the AF to deemphasize TAC in late 1948, considered a broken promise to General Eisenhower and contested by the Army, and moved it along with ADC under Continental Air Command.⁵⁹ The Army's protest stemmed from the anticipated loss of TAC's integration with and support to ground forces. This situation would receive renewed attention in the next two years.

⁵⁶ Ravenstein, *The Organization and Lineage of the United States Air Force*, 11.

⁵⁷ Wolk, *The Struggle for Air Force Independence, 1943-1947*, 214.

⁵⁸ Trest, *Air Force Roles and Missions: A History*, 122.

⁵⁹ Davis, *The 31 Initiatives: A Study in Air Force - Army Cooperation*, 9.

By 1950, the Army and Air Force Authorization Act established personnel and equipment ceilings of 70 groups, 502,000 active duty personnel, and 24,000 aircraft.⁶⁰ Shortly into the Korean War and rectifying earlier Army Ground Forces concerns with air support to tactical forces, Continental Air Command dissolved after two years with TAC and ADC reestablished as major commands.⁶¹ Further Congressional law reaffirmed the three major air commands of TAC, SAC, and ADC, in the Air Force Organization Act of 1951.⁶² However, that same public law also gave the Secretary of the Air Force liberty to establish other commands and organizations “in the interest of efficiency and economy of operation.”⁶³ This freedom of organization remains for the AF today with current Title 10 statutes repeating the same message.

In the Korean War, the air component commander created a functional FEAF Combat Command to execute air operations. Within FEAF Combat Command, the Fifth Air Force provided the tactical air arm, FEAF Bomber Command executed strategic bombing, and FEAF Combat Cargo Command carried out airlift.⁶⁴ While Lieutenant General George Stratemeyer, Commander of FEAF Combat Command, wanted total control of all air forces, to include the Navy fleet aircraft, a nebulous compromise of “coordination control” left little authority for integrated joint campaign planning and integration.⁶⁵ Interservice and joint operational problems

⁶⁰ US Congress, *Army and Air Force Authorization Act of 1949*, Public Law 604, Chapter 454, July 10, 1950, 2-3.

⁶¹ Trest, *Air Force Roles and Missions: A History*, 136.

⁶² US Congress, *Air Force Organization Act of 1951*, Public Law 150, Chapter 407, September 19, 1951, 9.

⁶³ *Ibid.*

⁶⁴ Trest, *Air Force Roles and Missions: A History*, 139-140. After the Korean War began, Commander-in-Chief of the United Nations Command General Douglas MacArthur maintained control as the land commander, but established separate naval and air components within his Far East Command.

⁶⁵ *Ibid.*, 141.

continued when Marine air forces arrived under separate command, directly supporting landings at Inchon, but not as part of the FEAF Combat Command. Airpower deficiencies during the early Korean War stemmed from this challenge of centralized control, which would eventually improve later in the conflict.⁶⁶ Another result of Korean War growth, the AF organizational structure expanded, depicted in figure 5.

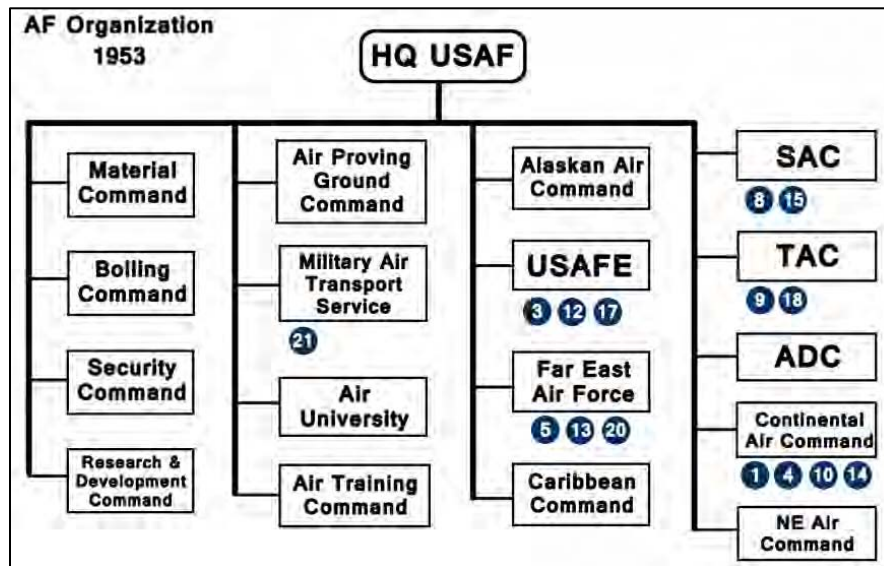

Figure 5. Air Force Organization Structure, 1953.⁶⁷

Following the Korean War and with Cold War tensions heightened, several organizational changes ensued over the next four years. In 1954, the joint Continental Air Defense Command (CONAD) established directly under the JCS absorbed ADC, Army

⁶⁶ Ibid., 145. For a detailed account of airpower deficiencies during the Korean War, see the Spring 1990, Major Roger F. Kropf, *Airpower Journal* article "The US Air Force in Korea, Problems that Hindered the Effectiveness of Airpower." The article can also be found at: <http://www.airpower.au.af.mil/airchronicles/apj/apj90/spr90/3spr90.htm>. Improvements in joint airpower usage came with the eventual reorganization and unification of the United Nations Command.

⁶⁷ Ravenstein, *The Organization and Lineage of the United States Air Force*, 10-38.

Antiaircraft Command, and certain Navy radar systems.⁶⁸ More prominent during this period, the growth and domination of SAC resulted as that command took primary stage in defending the nation through deterrence. At the time, SAC consisted primarily of bomber aircraft, but also included several fighter units for dedicated escort. Additionally, in July 1955, the AF created the Nineteenth Air Force to coordinate field training with the Army and serve as global task force command performing tactical contingency tasks.⁶⁹ By 1957, SAC divested itself of all fighter wings leaving TAC responsible for fighter and fighter-bomber aircraft.⁷⁰ In 1957, with the deactivation of Far East Air Forces, the new major command Pacific Air Forces (PACAF) became the single organization for all air forces in the Pacific area.⁷¹

The revolutionary Department of Defense Reorganization Act of 1958 both grew and centralized the SecDef powers by providing geographic and specified commands control over combatant forces while further removing the service chiefs from the operational chain of command.⁷² The SecDef refocused the individual military services primarily to organize, train, and equip their respective forces. A few more major organizational changes transpired in the years leading up to the Vietnam War. Figure 6 shows the pre-Vietnam War AF organization

⁶⁸ Joint Chiefs of Staff, *Continental Air Defense Command, JCS Memorandum*, August 2, 1954, 2. CONAD eventually became North American Air Defense Command (NORAD) in 1958.

⁶⁹ Trest, *Air Force Roles and Missions: A History*, 166.

⁷⁰ AFA, *History of the United States Air Force, 1907-1957*, 125. It became apparent to the AF that fighter aircraft did not belong in SAC, therefore the move to TAC would help consolidate all fighter forces within one command.

⁷¹ Ravenstein, *The Organization and Lineage of the United States Air Force*, 19. Additionally, the geographic Pacific Command replaced Far East Command in a 1958.

⁷² US Congress, *Department of Defense Reorganization Act of 1958*, Public Law 85-899, August, 6, 1958, 1.

structure. One of those changes worth noting happened in 1965 as MATS officially redesignated to Military Airlift Command (MAC). MAC eventually became a specified command in 1977.⁷³

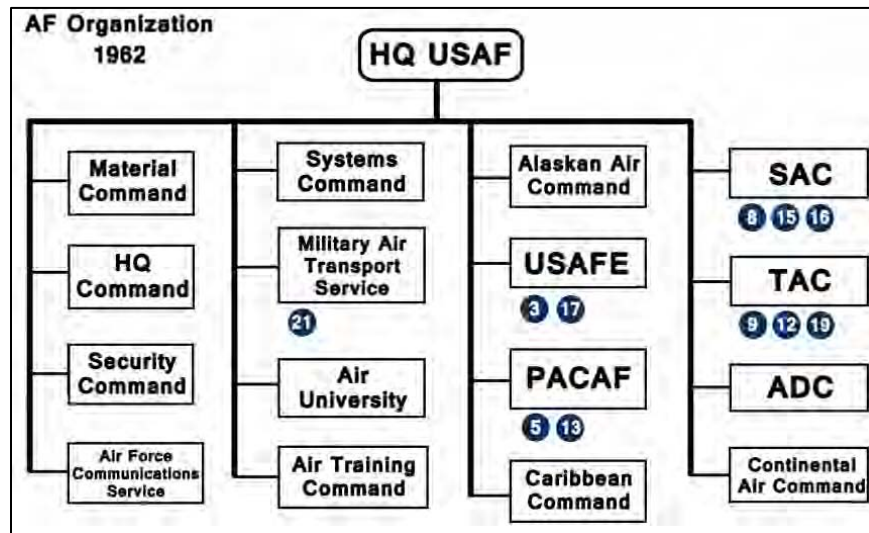

Figure 6. Air Force Organization Structure, 1962.⁷⁴

In the Vietnam War, Seventh Air Force commanded air forces throughout Vietnam, but was not given responsibility for all US aviation forces. B-52 heavy bombers remained under the control of SAC. The Marine and Army air forces also remained under control of their respective organizations, even though all service aircraft operated in the same airspaces. This fragmented command and control structure created several redundancies, including multiple air control systems operating in theater, and did not achieve the integration and synergy possible with the vast airpower resources. The Seventh Air Force Commander, General William W. Momyer, believed the greatest mistake of the war to be the failure to establish a unified theater command,

⁷³ Department of the Air Force, *Redesignation of the Headquarters, Military Air Transport Service*, October 11, 1965, 1.

⁷⁴ Ravenstein, *The Organization and Lineage of the United States Air Force*, 10-38.

even stating it was worse than during the Korean War.⁷⁵ This would be the last major test of airpower command and control until Operation Desert Storm.

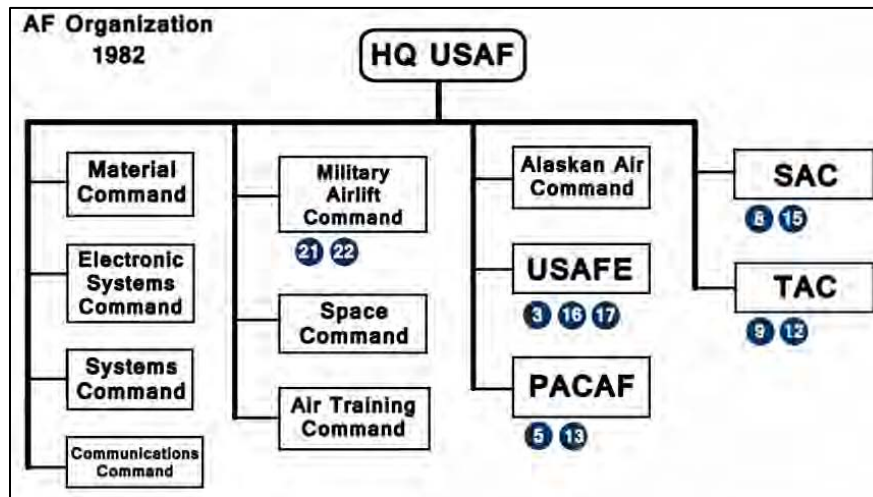

Figure 7. Air Force Organization Structure, 1982.⁷⁶

The AF activated its Space Command in September 1982, three years prior to the establishment of the specified US Space Command.⁷⁷ Figure 7 illustrates the 1982 AF organization. The Goldwater-Nichols Reorganization Act of 1986 brought further, fundamental changes to the Department of Defense giving more power to the Chairman of the Joint Chiefs of Staff and increased authorities for combatant commanders. Operational command of warfighting forces clearly fell under control of the new combatant commands. Many proponents argued that victory in Operation Desert Storm validated the new model, with successful US Central Command leading the effort and US Transportation Command supporting. Attributed to the

⁷⁵ Trest, *Air Force Roles and Missions: A History*, 199-200. As noted earlier, Korean War deficiencies are discussed in Major Kropf's *Airpower Journal* article.

⁷⁶ Ravenstein, *The Organization and Lineage of the United States Air Force*, 10-38.

⁷⁷ Trest, *Air Force Roles and Missions: A History*, 235.

success in the Gulf War, Goldwater-Nichols had forced increased service cohesion and unity of effort, especially in the use of airpower.⁷⁸

Although several changes occurred as highlighted since 1947, the overall organizational stayed surprisingly stable with a constant structure until the early 1990s.⁷⁹ Dramatic changes began in 1990, as the AF Special Operations Command (AFSOC) stood up as a major command. Then in 1992, under downsizing pressures subsequent the end of the Cold War and following success in the Gulf War, the AF dismantled SAC and TAC, merging them into the new Air Combat Command (ACC). With SAC's conclusion, US Strategic Command (STRATCOM) assumed the strategic mission set. Air Force Systems Command and Air Force Logistics Command also merged to form the new Air Force Material Command (AFMC), albeit with the same name of the 1946 major command. To complete the sweeping reorganization, Military Airlift Command became Air Mobility Command (AMC) and Air Training Command converted to Air Education and Training Command (AETC). Additional AF actions taken during this period eliminated the Air Division from the organization hierarchy.⁸⁰ As a result, at the end of 1992, the AF had shrunk to eight major commands, 465,749 active duty personnel, 207,633 civilians, and over 9,500 systems.⁸¹

⁷⁸ Ibid., 248.

⁷⁹ Prior to the major organizational changes in the 1990s, eight major commands remain principally intact since the original 1947 organization. As of 1990, the eight standing commands would include Air Force Systems Command, Military Airlift Command, Air Training Command, Alaskan Air Command, USAFE, PACAF, SAC, and TAC.

⁸⁰ The Air Division, a command level originally taken from the Army Air Force, was subordinate to a numbered air force and normally controlled more than one wing and sometimes smaller units.

⁸¹ Air Force Personnel Center, "Air Force Strength from 1948 thru 2010," <http://w11.afpc.randolph.af.mil/demographics/ReportSearch.asp> (accessed January 10, 2011). James C. Ruehrmund, Jr., and Christopher J. Bowie, *Arsenal of Airpower: USAF Aircraft Inventory, 1950-2009* (Mitchell Institute Press, 2010), 23-24. AF systems totaled 8,500 aircraft plus nearly 1,000 intercontinental ballistic missiles and operational satellites.

Since 1992, only a few more major changes occurred in the upper levels of the AF organization. In 1997, the Air Force Reserve Command (AFRC) elevated from a field operating agency to the ninth major command as part of Title 12 public law.⁸² AFRC would eventually include the Fourth, Tenth, and Twenty-Second Air Forces. At the combatant command level and critical to key AF missions, STRATCOM absorbed US Space Command and also assumed the cyberspace mission in 2002. The last significant change at the major command level occurred in 2009 as AF Global Strike Command (AFGSC) activated, responsible for combat-ready nuclear forces and global strike operations.⁸³ Shortly after, AFGSC added the Twentieth Air Force and the Eighth Air Force from AF Space Command (AFSPC) and ACC, respectively. Given the vast changes since 1947, the AF has maintained an overall top-level functional organizational structure throughout and that continues to be seen in the current AF.

Air Force Organization Today: 2011

With the start of 2011, the mission of the AF and the responsibilities of the organization have changed little since 1947. As noted earlier, Title 10 currently states the following general duties:

the Air Staff shall . . . prepare for such employment of the Air Force, and for such recruiting, organizing, supplying, equipping (including those aspects of research and development assigned by the Secretary of the Air Force), training, servicing, mobilizing, demobilizing, administering, and maintaining of the Air Force.⁸⁴

⁸² Air Force Reserve Command Fact Sheet, http://www.af.mil/information/factsheets/factsheet_print.asp?fsID=151& (accessed January 31, 2011).

⁸³ Air Force Global Strike Command Web site, <http://www.afgsc.af.mil/main/welcome.asp> (accessed April 20, 2011).

⁸⁴ US Congress, *Title 10*, Section 8032.

Ultimately, the Air Staff prepares the air forces to fight the nation's wars, at such a time those forces are assigned to the appropriate combatant command to execute the mission.

In achieving this mission today, the AF organization consists of ten major commands, organized both geographically and functionally, to execute this Title 10 mission. In general, the eight US-based major commands align functionally while the two overseas major commands, USAFE and PACAF, organize by geographic areas. Except for AFMC, every major command contains at least one numbered air force.

A total of twenty numbered air forces currently fall subordinate to nine major commands. Primarily found in AFMC, sixteen centers also manage crucial AF functions. For example the Aeronautical Systems Center at Wright-Patterson Air Force Base "designs, develops and delivers dominant aerospace weapon systems and capabilities" for the AF, an important research and development function.⁸⁵ Subordinate to the numbered air forces and centers, 131 active duty and 34 reserve wings generate the basic combat units for employment. To review, figure 8 represents the current AF organization structure.

The AF, as of 2010, consists of 330,000 active duty personnel with over 170,000 supporting civilians. As a whole, the air force flies approximately 4,600 active duty systems to train, test and fight.⁸⁶ The force structure continues to shrink based on recent budget actions, recapitalization programs, and planned fighter restructuring all in effect to reprioritize AF funds.

⁸⁵ Aeronautical Systems Command Fact Sheet, <http://www.wpafb.af.mil/library/factsheets/factsheet.asp?id=6162> (accessed July 1, 2010). Other functions managed by centers include logistics, flight test, systems, weapons, and research.

⁸⁶ "The Air Force in Facts and Figure, 2010 USAF Almanac", *Air Force Magazine*, May 2010, 60-62. In 2010, the air force maintained just over 4,000 aircraft in the active duty inventory and another 1,500 aircraft with the Air National Guard and AF Reserve units. Intercontinental ballistic missiles stand at 450 systems while 52 satellites fly under AF control.

Given this current state and the history of the air force organization, the next section will examine the organization structure from several different perspectives.

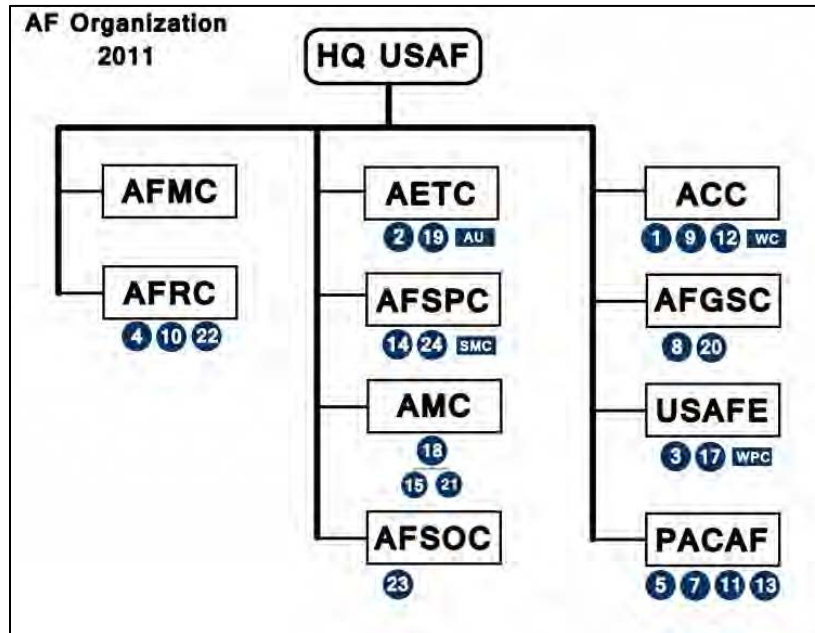

Figure 8. Air Force Organization Structure, 2011.⁸⁷

Air Force Organization Structure Analysis

As just discussed, the AF organizational structure finds its roots in the Army, and, since becoming a separate service in 1947, has made several changes. Given the sheer size and structure of the AF organization, there are bound to be problems that have developed from change and the bureaucracy itself. While these fractures can be found in almost all organizations, there may be opportunities to gain efficiencies as well as mitigate or eliminate problems completely. SecDef Robert Gates stated this requires attention now in a 2010 DoD Efficiency Initiative: “I am directing a series of initiatives designed to reduce duplication, overhead, and excess, and instill a

⁸⁷ “The Air Force in Facts and Figure, 2010 USAF Almanac,” *Air Force Magazine*, May 2010, 36-102.

culture of savings and restraint across the DoD.”⁸⁸ Undoubtedly, the unintended inefficiencies of 63 years of patchwork AF organizational growth can no longer be tolerated.

Dramatic changes have occurred in the size of the force and the force structure over time. These two aspects indicate an overgrowth of staff officers and civilian personnel disproportionate to the decreasing size of force and force structure. These two factors will be analyzed first. These lead to a look at the overall depth and width of the organization, addressing operational efficiency and redundancies across the structure. Lastly, the functional nature of the organization will be examined. Throughout, bureaucratic and organizational theories will highlight potential flaws and areas to improve with the AF structure as it exists at the start of 2011.

Organizational Size

Several factors have affected the AF organizational size over the course of history. Technology and the acquisition of new weapons systems have been the primary organizational drivers since AF inception and continue in that role today. The nature of the threat, budgetary limitations, and wars have also had impact on the growth or reduction of the AF.⁸⁹ In all categories, the AF of 2011 is much smaller than those of the past. In analyzing the overall organization over time, this effort will look into two key statistics: size of force and force structure. **Size of force** will refer to the number of active duty airmen or civilians in the service. The significant, and difficult to measure, contracting force was not considered, although the Defense Business Board identified “there has also been an explosive growth in the number of

⁸⁸ Secretary of Defense, *Department of Defense (DoD) Efficiency Initiatives*, August 16, 2010.

⁸⁹ For example, the two World Wars sparked massive production of aircraft and resulting increases in the organizations. Additionally, the Soviet development of nuclear weapons and the ensuing Cold War created new organizations in order to manage new capabilities. Lastly, as seen most recently, budget priorities and pressures forced the reduction in F-22 aircraft acquisitions.

DoD contractors.”⁹⁰ Meanwhile, force structure will specifically speak to the machines that make up the AF warfighting capabilities, as well as training and testing systems. **Force structure**, other than where noted, will include all aircraft, nuclear missiles, and spacecraft operated by the active duty.

From 1947 to today, the size of the force increased dramatically during the Korean War and then steadily declined with spikes during Vietnam and prior to Desert Storm, see figure 9.

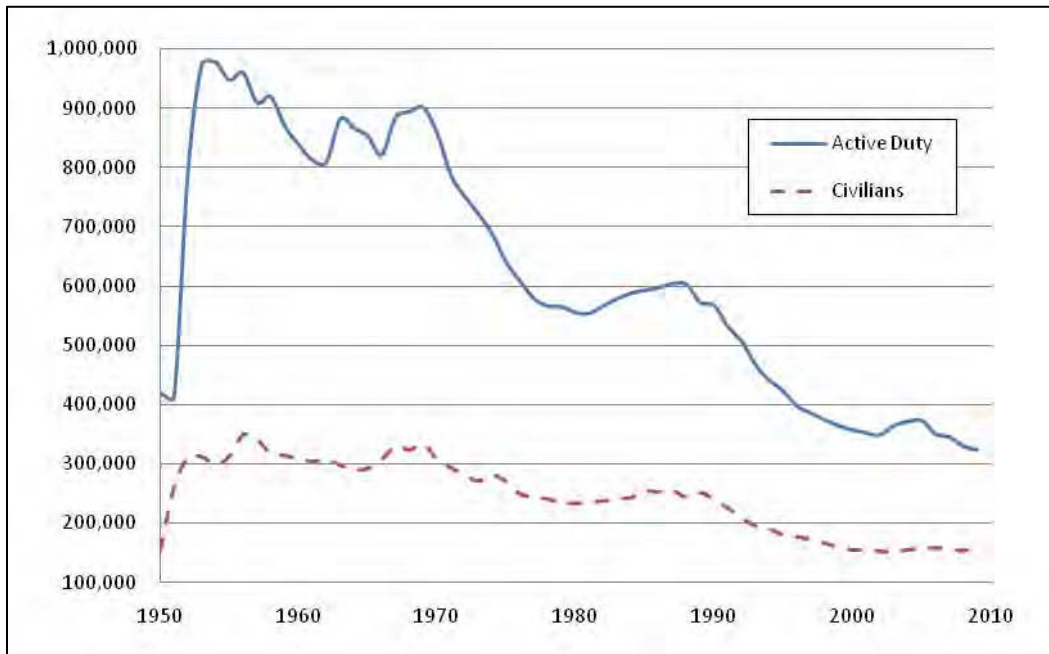

Figure 9. AF Active Duty / Civilian Personnel totals by year.⁹¹

⁹⁰ Arnold Punaro, Defense Business Board (DBB), *Public Session Defense Business Board Quarterly Meeting Notes*, July 22, 2010, 9. A difficult problem to measure, Mr. Punaro goes on to state the following in regard to the DoD’s contractor force: “it is impossible for any leadership to control costs and manage personnel if they don’t know how many people work for them . . . The Department is as frustrated as we are since there seems to be no precise answers. Under Secretary Carter just signed-out a document that pegs the number of contractors at approximately 766,000 at a cost of about \$155 billion. This exceeds the 745,000 civil service workforce. This does not include the intelligence organizations.”

⁹¹ Air Force Personnel Center, “Air Force Strength from 1948 thru 2010,” <http://w11.afpc.randolph.af.mil/demographics/ReportSearch.asp> (accessed January 10, 2011). DoD Civilian

When the AF began as a separate service, it contained less than 350,000 airmen in nearly 70 groups, considered wing equivalents. Near its Korean War peak in 1955, the AF employed nearly 960,000 airmen and 312,000 civilians.⁹² Today, the active duty component employs only 330,000 airmen and 170,000 civilian personnel within 131 wings and other organizations.⁹³ With the significant manpower changes over the past 60 years, the staff organizations have adjusted as well. The first question to consider is if these staffs have grown proportionately and appropriately to support the overall size of force.

The numbers of field grade officers and civilian personnel can offer an indication and insight to the staff size in comparison to overall personnel strength. Staff organizations above the wing level contain the majority of field grade officers, to include colonels, lieutenant colonels, and majors. The same holds true for civilian personnel. For the purpose of further analysis, the ‘field grade’ category will include only lieutenant colonels and majors. Colonels will represent a separate category.⁹⁴ With the size of force statistics from the 1950 to present day, a simple ratio will compare the number of each category with the total size of force. The three categories examined include colonels, field grade officers, and civilians. The ratios will represent the

Personnel Statistics Database, <http://siadapp.dmdc.osd.mil/personnel/CIVILIAN/CIVTOP.HTM> (accessed January 31, 2011).

⁹² Ibid.

⁹³ Although with a large number of contractor to civilian personnel conversions, the 2011 projected total is over 190,000 civilians. Therefore, all the following calculations could show even greater impact to the organization (Department of the Air Force, “FY11 Force Structure Announcement” Briefing, <http://www.af.mil/shared/media/document/AFD-100511-082.pdf> (accessed February 4, 2011), 17).

⁹⁴ These two categories were utilized to provide more fidelity on specific rank structures in the AF and how they relate to the size of force and force structure. Although not addressed due to limited data, general officer trends appear to follow these same trend lines over the same period. Since 1975, the number of AF general officers has declined 17 percent, while both the size of force and force structure have declined more rapidly at 47 percent. AFA, “USAF Almanac, 1980”, May 1980. AFA, “USAF Almanac, 2010”, May 2010. Air Force Personnel Center, “Air Force Strength from 1948 thru 2010,” <http://w11.afpc.randolph.af.mil/demographics/ReportSearch.asp> (accessed January 10, 2011).

number of each category per 1,000 active duty personnel. The graphic results, depicted in figures 10, 11, and 12, show clear trends indicating all three categories unequivocally increase over time.

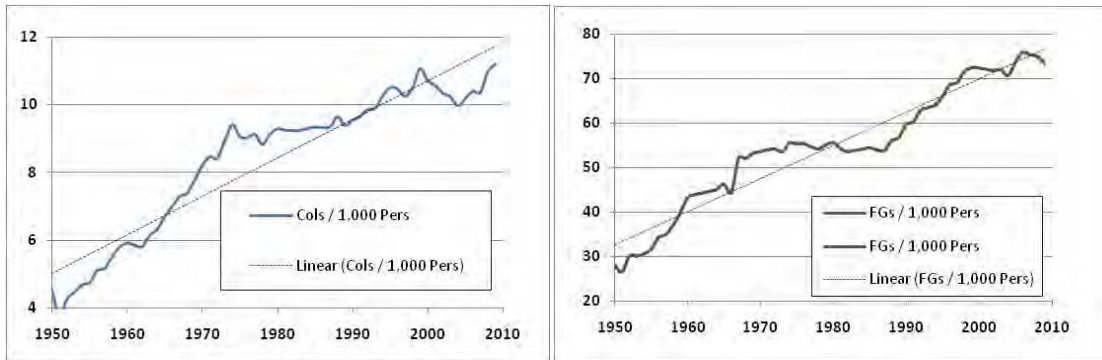

Figure 10. Colonels per 1,000 AF personnel.⁹⁵ Figure 11. Field Grades per 1,000 AF personnel.⁹⁶

In other words, for every 1,000 personnel in 1950, the AF employed 4.5 colonels, 28 field grades, and 376 civilians. By 1980, the officer numbers essentially doubled to 9.3 colonels and 56 field grades, while the civilian number increased to 421. By 2009, the numbers had increased further still with 11 colonels, 74 field grades, and 488 civilians per every 1,000 airmen. These ratios

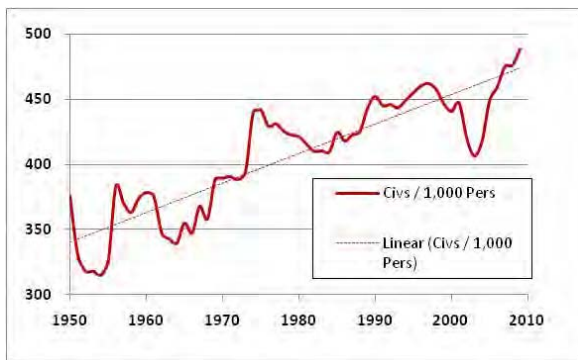

Figure 12. AF Civilians per 1,000 personnel.⁹⁷

⁹⁵ Air Force Personnel Center, “Air Force Strength from 1948 thru 2010,” <http://w11.afpc.randolph.af.mil/demographics/ReportSearch.asp> (accessed January 10, 2011).

⁹⁶ Ibid.

⁹⁷ Ibid. DoD Civilian Personnel Statistics Database, <http://siadapp.dmdc.osd.mil/personnel/CIVILIAN/CIVTOP.HTM> (accessed January 31, 2011).

indicate the organization growing significantly more top heavy over time. These statistics suggest the organization's requirement for staff positions has increased steadily. If that is not the case, then the AF staff has grown disproportionately and needs adjustment. Several theories provide ideas on why and how this potential staffing overgrowth can happen.

Max Weber, a famous German sociologist, discusses several reasons for overgrowth of staff positions and the challenge with organizational changes over time. In his writings, he states "once established and having fulfilled its task, an office tends to continue in existence and be held by another incumbent."⁹⁸ Due to this, organizational offices will perpetuate, often well past usefulness, until forcibly changed or eliminated. As a result, an over-staffed bureaucracy can generate unintended consequences for a military organization. Professor of Political Science Lloyd Matthews and retired Army Colonel Don Snider, in writing *The Future of the Army Profession*, discuss this problem for an over-bureaucratic organization which can dangerously erode military professionalism. Specifically, should the professional basis decline due to stagnation, they suggest the tensions between the military professionals and dominating bureaucrats can lead to an ineffective bureaucracy.⁹⁹ With increased civilian ratios, and without even considering the significant amount of contracted support, the AF bureaucracy could someday overshadow its strong professional base creating an organization with weakened discipline and no ability to adapt to future requirements.¹⁰⁰

⁹⁸ Max Weber, *On Charisma and Institution Building*, (Chicago: University of Chicago Press, 1968), 67.

⁹⁹ Lloyd J. Matthews and Don M. Snider, *The Future of the Army Profession*, (McGraw-Hill Custom Publishing, 2005), 15.

¹⁰⁰ *Ibid.*, 15.

Looking at force structure levels provides another insight to consider. Again, force structure will include all the systems in the active duty AF inventory. This will primarily analyze how the staff presence, indicated by levels of higher ranking officers and civilians, varies over time as a function of force structure. As utilized earlier, colonel, field grade, and civilian categories will encompass the analyzed measures. First, however, looking at the total number of personnel per system will give some measure to assess. Except for significant fluctuations during and after the Korean War, the total personnel to system ratio stabilizes in the region of 65 airmen, (see figure 13 below). Therefore, the AF has maintained a directly proportional relationship between the number of systems and total active duty personnel strength. The minor increase over time, which seems reasonable, may be explained by increasingly technological systems requiring more personnel for operations, information processing, and maintenance.

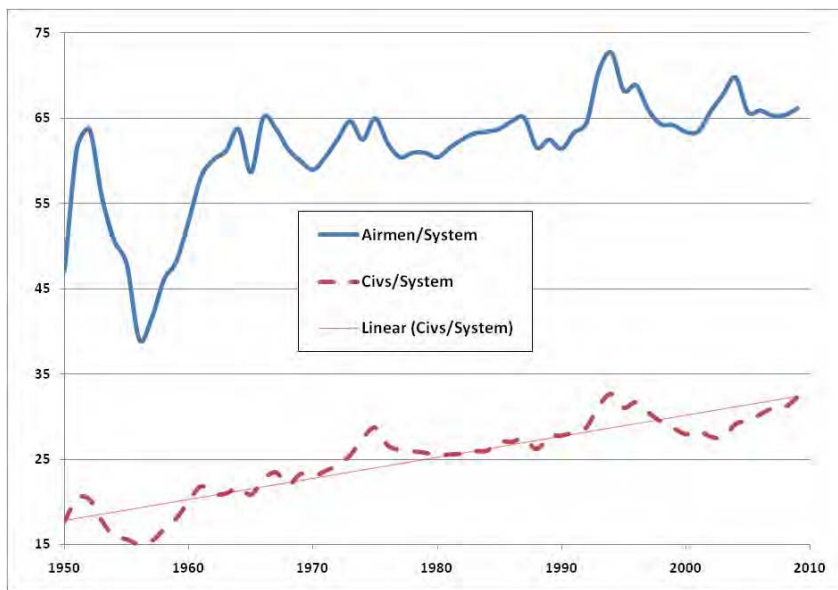

Figure 13. Total Active Duty Airmen and Civilians per AF system.¹⁰¹

¹⁰¹ Air Force Personnel Center, “Air Force Strength from 1948 thru 2010,” <http://w11.afpc.randolph.af.mil/demographics/ReportSearch.asp> (accessed January 10, 2011). DoD Civilian

All other categories show a different, increasing trend over time. In the 1960s, the civilian force stayed steady around 18 civilians per AF system. After peaking temporarily at 24 civilians per system in the mid-1990s, the ratio dropped but eventually returns to this level in 2009. With the expected 2011 AF civilian total to pass 190,000, from just over 160,000 in 2009, the civilian ratios will increase substantially.¹⁰² For the rank of colonel, the measure increases steadily since a low of 0.2 colonels per system in 1957, see figure 14. By 1980, the colonel ratio was above 0.5 per system. Although the numbers trended downward prior to 2005, this ratio reached the highest level in 2009 at 0.7 colonels for every AF system. A nearly identical path follows for the field grades, as illustrated in figure 15. In 1957, the ratio reached a low of 1.4 field grades per system. Although still climbing, a plateau developed from 1967 to 1991 when the ratio leveled off at 3.4 field grades for each system. After this, the ratio continued to climb constantly until reaching the current level of 5.0 field grades per AF system. There are no clear reasons for the increasing ratios. While high technology systems can substantiate slight increases for civilians and possibly require more staff management, these cannot alone justify these significant trends. Other possibilities, including the diversity of systems, different types of systems, and operating requirements, do not give good reason for these increases as well. The trends seem to indicate over-bureaucratic tendencies, as predicted by Max Weber and others.

Personnel Statistics Database, <http://siadapp.dmdc.osd.mil/personnel/CIVILIAN/CIVTOP.HTM> (accessed January 31, 2011). James C. Ruehrmund, Jr., and Christopher J. Bowie, *Arsenal of Airpower: USAF Aircraft Inventory, 1950-2009* (Mitchell Institute Press, 2010), 15-26.

¹⁰² “FY11 Force Structure Announcement” Briefing, 17. The main drivers for civilian end-strength increases are contractor to civilian conversions, joint basing, acquisition excellence, intelligence, surveillance, and reconnaissance (ISR), fitness assessment cells, and warfighter and family services.

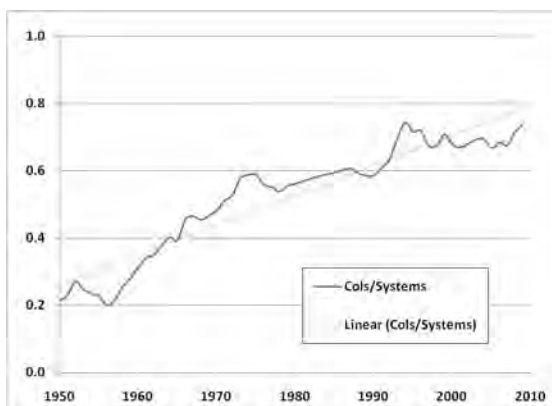

Figure 14. Colonels per AF System.¹⁰³

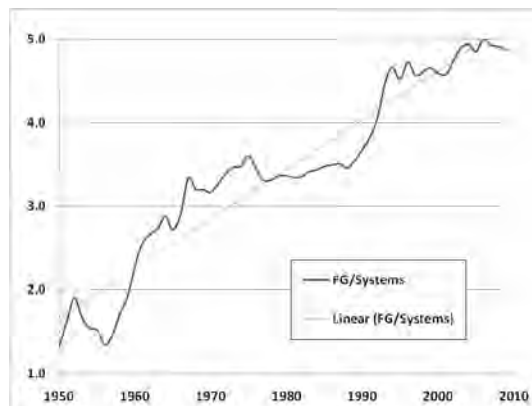

Figure 15. Field Grades per AF System.¹⁰⁴

The numbers speak quite clearly, the significant increases in field grade officers and civilians, compared to both size of force and force structure, imply an organization overflowing with staff personnel. While most staff organizations would suggest they have inadequate manpower, such as numbered air force and major command staffs, the problem evidently arises from too many staff organizations spreading the available manpower too thinly.¹⁰⁵ To reverse these climbing trends, a closer look at the AF organizational hierarchy may provide areas to reduce staffing.

¹⁰³ Air Force Personnel Center, “Air Force Strength from 1948 thru 2010,” <http://w11.afpc.randolph.af.mil/demographics/ReportSearch.asp> (accessed January 10, 2011). James C. Ruehrmund, Jr., and Christopher J. Bowie, *Arsenal of Airpower: USAF Aircraft Inventory, 1950-2009* (Mitchell Institute Press, 2010), 15-26.

¹⁰⁴ Ibid.

¹⁰⁵ A documented RAND briefing suggests numbered air forces do not have adequate manpower to manage future conflicts, Lawrence M. Hanser, Maren Leed, and C. Robert Roll, *The Warfighting Capacity of Air Combat Command's Numbered Air Forces*, (Documented Briefing, RAND - Project AIR FORCE, 1998), viii. A vivid sign of manning disparity in the Spring of 2009, only 75 of 1450 rated, active duty officer staff positions would be filled by the Air Force Personnel Center, AFPC “Road Show” PowerPoint Briefing Presented at Nellis Air Force Base, November 2008, 12.

Organizational Width and Depth

The second effort to examine the AF organization will explore the width, depth, and functionality of the structure. Specifically, width will refer to the numbers of subordinate units per unit of command, or how flat the structure appears. A flat organization would have several sub-units one level below. Depth refers to the distance from the top of the hierarchy to the bottom. This discussion will examine the depth down to wing level. However, an important point to remember regarding the full organizational depth, the typical airmen in a flight works at least four levels below the wing.¹⁰⁶ Hence, multiple command and staff levels still remain at and below the wing. Lastly, the issue of functional commands will build upon these width and depth issues and evaluate the current functional nature of major commands.

The width of an organization, also commonly referred to as span of control, describes the number of major subordinates under a single command. For the Headquarters AF, ten major commands represent the width. Each major command has a different width, varying from AFMC with eleven centers to AFGSC with two numbered air forces. Excluding AFMC, the major commands average three subordinate numbered air forces and centers. The number of wings subordinate to numbered air forces varies even more. While Thirteenth Air Force and Nineteenth Air Force have fourteen and twelve wings respectively, the majority of numbered air forces have either two or three subordinate wings. Averaging all wings in the numbered air forces results in an average of 4.7 wings per numbered air force.¹⁰⁷ While the average is merely trivial, the vast

¹⁰⁶ Below wing, the hierarchy continues down to group, then squadron, and lastly flight.

¹⁰⁷ Although, First Air Force and Seventeenth Air Force contain zero wings. Not including these two in the average results in 5.3 wings per numbered air force.

difference in the numbered air force wing allotment may suggest a poor distribution and widely varied spans of control for each numbered air force commander.

Early span of control theory, as developed by business management experts Lyndall Urwick and V.A. Graicunas, suggests a limit of five or six subordinates per leader.¹⁰⁸ Johns Hopkins University academicians Doris Entwisle and John Walton reiterate this notion, posing three factors that limit the control: the leader's span of attention, multiplication of intergroup combinations, and management of clique formation.¹⁰⁹ All of these three factors increase complexity and tend to negatively impact larger spans of control.

To counter these challenges, which military organizations have seemingly overcome for years, the key concepts of decentralization and a general staff have developed to tackle a large group of subordinates. Decentralization, with adequate trust, autonomy, and execution, reduces the attention span required by the leader to allow a larger number of subordinates. The AF continues to promote decentralization as a tenet to the organization and enables structures to expand control.

However, as noted earlier, Headquarters AF initially chose the 'deputy system' type organization, instead of a general staff system, which still prevails today. A general staff concept, as seen in other militaries such as the German Bundeswehr and originally developed by the Prussians in the early 1800s, may realize superior management with a flatter organization. A

¹⁰⁸ Lyndall F. Urwick, "The Manager's Span of Control," *Harvard Business Review*, (May-June 1956): 39-41. Fred Nickols further explains Graicunas' theory which states the number of interactions, given n subordinates, equals the sum of $n + n(n-1) + n(2^n / 2 + n-1)$. The first n represents the number of single, direct relationships with subordinates. The second product represents the interactions between subgroups, or cross relationships. Lastly, the third product equals the total combinations of direct group relationships created. The number of relationships for a commander will rise exponentially after four subordinates (Fred Nickols, "The Span of Control and the Formulas of V.A. Graicunas," 2003).

¹⁰⁹ Doris R. Entwisle and John Walton, "Observations on the Span of Control," *Administrative Science Quarterly*, (1961): 533.

general staff focuses on training staff officers to institutionalize the collective knowledge of the organization, thereby becoming the true brains of the system, focusing and improving bureaucratic function.¹¹⁰ Hence, the general staff system helps mitigate those problems created by intergroup combinations and clique formation by consolidating the administrative work. The general staff frees up the leader to focus on key decisions and allows adequate time to visit with a larger group of subordinates. This concept will prove useful in subsequent discussions regarding organizational change.

With the varying distribution of subordinate units for the top three layers, Headquarters AF, major commands, and numbered air forces, it appears that some have an overextended span of control, while others appear underutilized.¹¹¹ On the surface, it seems opportunities exist to adjust organizational width. However, as Lyndall Urwick goes on to emphasize, the only goal in flattening an organization should not be solely to create efficiencies by stretching leaders to the extreme, but should promote in concert “democratic participation, greater efficiency, and substantially improved organizational morale.”¹¹² All these warnings deserve ample consideration in any reorganization to alter width. While this flattening may eliminate depth, reduce staff personnel, shorten the chain of command, and increase the speed of communications, Urwick continues to warn that a “careful balancing act” must happen to achieve efficiencies without

¹¹⁰ For a detailed history of the general staff concept, see German Lt Col Michael Schoy’s monograph, titled “The Bundeswehr in the 21st Century – between Prussia’s Glory and Design,” School of Advanced Military Studies, US Army Command and General Staff College, 2010-2011.

¹¹¹ Major command examples include AFMC with eleven centers vice AFGSC with two numbered air forces. For the numbered air forces, 13th Air Force and 19th Air Force have fourteen and twelve wings respectively, while First Air Force and Seventeenth Air Force have no wings.

¹¹² Urwick, “The Manager's Span of Control,” 47.

violating span of control principles.¹¹³ Overall, the width issue highlights an area that may prove fruitful in future reorganization discussions.

Inextricably connected to the issue of organizational width, the depth of a hierarchical structure generates additional issues. AF organizational depth was originally created to manage span of control, align functions, and overcome issues of distance generated by the global positioning of air forces. The depth of the AF organization from the top to the wing level consists of the four levels discussed here. To review from top to wing level, first is Headquarters AF, then major commands, then numbered air forces or centers, and finally the wings. Therefore, the full organizational depth, down to the airman in a flight discussed earlier, will include eight levels from top to bottom. The eight levels of depth, while typical and prevalent, do not cover every situation within the structure. More importantly, this depth has remained steady for nearly twenty years, although the size of force, nature of warfare, and technology has changed considerably.

During the early 1990s effort to reorganize, which impacted both width and depth, the air force completely eliminated the air division level between numbered air forces and wings. This elimination represents the only reduction of depth in AF history and happened at a time when the size of force had reduced by half from twenty-four years earlier.¹¹⁴ Although, this returns the air force to the same organizational depth prescribed for the 1943 AAF, at its peak with 2,400,000 airmen and nearly 80,000 aircraft. Army FM 100-20, *Command and Employment of Air Power*, stated “tactical air units of the Army Air Forces from the smallest to the largest are designated to

¹¹³ Urwick, “The Manager's Span of Control,” 41.

¹¹⁴ AF active duty personnel numbered just over 900,000 in 1968 and reached 465,000 in 1992, 24 years later, Air Force Personnel Center, “Air Force Strength from 1948 thru 2010,” <http://w11.afpc.randolph.af.mil/demographics/ReportSearch.asp> (accessed January 10, 2011).

flight, squadron, group, wing, division, command, and air force.”¹¹⁵ The division is now replaced with numbered air force. As of 2010, just eighteen years after the removal of the air division, the size of force has shrunk another thirty percent, yet this same organizational depth persists.

Just as with width, excessive depth can create challenges for any organizational structure. For the AF, communications and redundancies provide two excellent examples. Prior to the age of computers, information flowed slowly and certain coordination and communication was impossible over the great distances involved. Today, no such limitations exist for information flowing throughout an organization. David Mitchell, an international business manager and author, in his book *Control Without Bureaucracy*, talks about the problems with information flowing up and down an organization. Trying to manage the volume of information of today with the speed of communication only becomes more difficult with excessive organizational depth. In fact, Mitchell says depth of the hierarchy ‘acts as a powerful amplifier,’ essentially creating an overload of information to manage.¹¹⁶ Practically, this is prominent today with every level’s need to stay informed and the overwhelming flow of reporting, correspondence, and email uphill into the upper echelons. Even more concerning, the excessive attention required can manifest in a leader that micromanages, creating inefficiencies and likely ineffective results.

With an overflow of information and a deep hierarchy, Mitchell also highlights the fact that good ideas tend to get lost in the noise or get filtered.¹¹⁷ Therefore, the depth of the AF hierarchical organization may not allow those great ideas to flow easily from the field to the Air Staff. Mitchell also argues the filtering effect makes it difficult for leaders to control operations

¹¹⁵ War Department, *Command and Employment of Air Power*, FM 100-20, July 21, 1943, 6.

¹¹⁶ David Mitchell, *Control without Bureaucracy*, (McGraw-Hill Book Company (UK) Limited, 1979), 54.

¹¹⁷ *Ibid.*, 65.

strategically as condensed information does not build adequate situational awareness for educated decision making.¹¹⁸ Major William Thomas adds further concern, writing for *Air and Space Power Journal*, stating that excessive organizational layers, which hamper the flow of information up and down the chain of command, also jeopardizes AF responsiveness.¹¹⁹ The more layers, the more time information takes to flow and the slower the corresponding response times.

Excessive redundancies may also develop based on the organizational depth. Each level will require a certain level of administration and redundant functions. For each branch of the hierarchy, every leaf connected to that branch can develop a function that may mirror the same function as a separate leaf on the same branch. A certain amount of these redundancies are necessary, but others are wasteful and could be eliminated. For example, every major command has a command supplement instruction to the 105 page AF Instruction 10-207, *Command Posts*. ACC's supplement adds another 153 pages of instructions, AFSPC adds 136 pages, and so on. With the AF having only 73 major installations worldwide, this represents a function that could be standardized at a higher level to avoid the extra effort in creating and administering these major command level instructions. This illustrative example is one of many, since each major command produces hundreds of supplements and command instructions. In the end, while every organization requires hierarchical depth and some level of duplication, this discussion serves to highlight pitfalls to avoid and potential efficiencies to gain.

¹¹⁸ Ibid., 72.

¹¹⁹ William C. Thomas, "The Cultural Identity of the United States Air Force", *Air & Space Power Journal* (January 30, 2004): 7. Thomas states "responsiveness is essential if air forces are to maintain escalation dominance and effectively threaten an adversary."

A Functional Organization

While depth creates redundancies in different command chains, the functional nature of major commands can further exacerbate this problem. As highlighted earlier, seven US-based major commands organize functionally.¹²⁰ For example, AMC provides global mobility forces, AFSPC controls space capabilities, and AFSOC manages air force special operations. Several organizational theories discuss this type of functional structure, and these theories identify numerous problems found in the AF organization. Specifically, the challenges of functional ‘rice bowls’ and ‘tribes’ will highlight these deficiencies.

While seemingly logical and possibly easier to manage, delegating missions and responsibilities in a functional organization can present several difficulties. First, the development of functional ‘rice bowls’ becomes one of the most apparent issues.¹²¹ Given a problem and need to develop a capability, AFSPC will most certainly answer with a space solution while ACC will develop an aircraft-based option. Samuel Huntington, a famous American political scientist, identifies this issue clearly, stating this in reference to the military soldier: “he tends to stress those military needs and forces with which he is particularly familiar. To the extent that he acts in the manner he becomes a spokesman for a particular service or branch interest rather than for the military viewpoint as a whole.”¹²² With functional commands manned with expert operators grown from within the command, an unhealthy competition develops between functional

¹²⁰ Air Force Reserve Command, which functionally manages AF Reserve forces, will not be considered.

¹²¹ Generically, ‘rice bowls’ refers to coveted or internally protected departments, projects, etc.

¹²² Samuel P. Huntington, *The Soldier and the State*, (Massachusetts: Belknap Press, 1957), 67.

commands to secure the limited resources available, much like the competition between the different US military services.

Max Weber also predicts this problem with functional organizations stating “the tendency of officials to treat their official function from what is substantively a utilitarian point of view in the interest of the welfare of those under their authority.”¹²³ Further, Weber’s concern with this patrimonial-like organization, which develops excessively loyal authorities and recruits primarily from within, conflicts with and inhibits the bureaucracy from achieving its ultimate potential.¹²⁴

David Mitchell captures all of these points thoroughly and summarizes:

Complex functional organizations are particularly liable to this fault (they shift emphasis to the immediate, rather than the common goal - or even personal status and advancement). They may break down under the load of their own complexity, as more people are added to handle sub-function, side function, coordinating functions, and specialist functions. Finally, this makes it almost impossible to operate a complex hierarchical organization which lacks a great common goal to suppress all the little ones. Nobody can coordinate so many hidden functions effectively and the little goals break out everywhere.¹²⁵

Clearly highlighted by these scholars, several challenges exist for any functional organization.

In the AF, the functional major commands tend to breed and perpetuate elite corps of individuals. For example, the bomber pilots of SAC dominated the service for years, later displaced by the fighter pilots of TAC and ACC.¹²⁶ Major Thomas, in his AF cultural discussions, echoes this exact issue and warns about the creation of ‘subcultures’ or ‘tribes’ and repeats the

¹²³ Max Weber, *The Theory of Social and Economic Organization*, (New York: Free Press, 1947), 340.

¹²⁴ *Ibid.*, 342-3. Weber defines ‘patrimonial bureaucracy’ as a hierarchical organization with impersonal spheres of competence, but occupied by unfree officials (who function in a formal manner).

¹²⁵ David Mitchell, *Control without Bureaucracy*, 46.

¹²⁶ Colonel Mike Worden’s book, *Rise of the Fighter Generals, The Problem of Air Force Leadership, 1945-1982*, provides an excellent account of this phenomenon as the bomber pilot generals ran the early AF and eventually give way to a generation of fighter pilot generals.

warning of Huntington by stating “the AF may experience difficulties in achieving goals because members of subcultures do not remain focused on the overall goals of the organization, emphasizing instead the advancement of their specialty or of themselves.”¹²⁷

The effort to develop a long range strike (LRS) capability provides a good example for what can happen with a functional structure.¹²⁸ To make things clear as mud, similar capability efforts considered part of this effort include: prompt global strike, next-generation bomber, hypersonic cruise vehicle, and long range strike system. Each of these efforts, often driven by different major commands, not just the Air Staff, consume extraordinary effort and tremendous amounts of funding. As the requirements process begins for the major commands, resident tribal experts in each command would certainly provide a solution they were familiar with. ACC will develop and submit aircraft-based solutions to the Air Staff, while AFSPC presents conventional missile system capabilities.¹²⁹ A major command would not only present, but champion, the concept for selection and funding, even though the solution may not be in the interest of the AF organization to pursue. One could argue these functional approaches have kept the AF working on LRS capability development for the past ten years and nowhere near a production solution.

With these ‘rice bowls’ and ‘tribes’ throughout the organization, one must question whether the functional division can ensure the AF, as a service, can achieve the overarching

¹²⁷ William C. Thomas, “The Cultural Identity of the United States Air Force,” *Air & Space Power Journal* (January 30, 2004): 3-4.

¹²⁸ AF Chief of Staff General Schwartz defined the LRS capability in a 2010 speech at an Air Force Association Conference: “an Air Force core contribution that combines multiple systems to provide the Nation with the capability to overcome area-denial measures, penetrate contested airspace and networks, and assure freedom of action to deliver air, space, and cyber power effects.”

¹²⁹ The October 2005 *Aviation Week* article, “USAF Eyes Study on Long-Range Strike,” provides an excellent summary of ACC’s efforts to pursue a bomber study while AFSPC conducts a similar analysis on its conventional intercontinental missile system, known as Prompt Global Strike (Marc Selinger, “USAF Eyes Study on Long-Range Strike,” *Aviation Week* (October 3, 2005)).

organizational goals in the most effective manner. To steal an insightful quote and concept from General Charles C. Campbell, the previous Commanding General of Army Forces Command, the AF must “transform the functional silos to optimize the organization.”¹³⁰ With this general environmental analysis of the AF organizational structure and exploration of concepts and theories, several courses of action and solutions can follow in the pursuit of efficient change.

Potential Air Force Organizational Changes

After understanding the historical and current environment of the AF organization, along with the development of problems addressed previously, then next section will explore potential solutions and concepts for changing the current structure. First, recent and existing organizational and personnel changes will be addressed for consideration as part of ongoing reorganizational efforts. To ensure organizational legalities and that historic lessons and tenets continue, the key concepts that have underpinned the AF organizational design will also be discussed. Then, specific organizational design improvements and theory will provide considerations for AF reorganization options. Lastly, fundamental changes will be proposed that would eliminate organizational depth and address functional challenges, while attempting to better achieve the AF mission and support global combatant commands.

Before attempting to discuss change, what would the overarching strategy be for reorganizing the AF structure? With any large organization, a large command structure and administrative function develops to achieve the goals, manage the resources, and execute operations required. Clearly the AF structure has grown over time, perhaps well beyond the desired goal. The generic goal of an administration function is to achieve a bureaucracy, in the

¹³⁰ General Charles C. Campbell, quote from US Army Forces Command Briefing, Advanced Operational Art Studies Fellowship Fieldwork, December 2, 2010.

ideal sense of the definition. Eluded to earlier, Max Weber states this objective: “the purely bureaucratic type of administrative organization, from a purely technical point of view, capable of attaining the highest degree of efficiency and is in this sense formally the most rational known means of carrying out imperative control over human beings.”¹³¹ Therefore, not only are efficiencies the objective of change, but effectiveness of the administration must improve the ability of the AF to execute the stated mission with the available resources and people.

In detail, three objectives need thorough consideration. First, as just mentioned, the effectiveness of the organization must improve. To do this, given the technical expertise inherent in the AF whole, a better structure must exploit these technical capabilities and professional skills. Secondly, achieving the ideal bureaucracy will require leveraging the vast pool of functional knowledge present through the existing structure. In other words, knowledge wielded properly equals power in a bureaucracy and is critical for creative, complex, and rapid problem solving needed.¹³² Lastly, to reiterate the primary motivation, any reorganization must create the fiscal efficiencies necessary to reallocate money to critical, high-priority AF programs.

Recent Reorganization Efforts, Legal Constraints, and Official Guidance

The 2004 USAF Transformation Flight Plan spoke of transforming the AF organization, specifically proposing the use of “transformational organizational arrangements” to better execute the mission.¹³³ One construct instituted from this wave of transformation included the warfighting headquarters concept to support combatant commanders. These warfighting headquarters would

¹³¹ Weber, *The Theory of Social and Economic Organization*, 337.

¹³² J. T. Hage, “Organizational Innovation and Organizational Change,” *Annual Review of Sociology* 25 (1999): 605.

¹³³ Department of the Air Force, *The U.S. Air Force Transformation Flight Plan 2004*, 37-40.

represent the AF's single voice to the combatant commander and unify air forces to accomplish the mission. As a result, each new warfighting headquarters staff included a small core of personnel to support the specific combatant commander.

In 2006, after reexamining command and control structures, the AF promptly ended the warfighting headquarters initiative as the numbered air forces subsumed the function. These retooled numbered air forces became more “operationally-oriented,” with an assigned Air and Space Operations Center (AOC) and staff to support the respective combatant command.¹³⁴ The current version of AFI 38-101, *Air Force Organization*, written in 2006 to address these changes, identifies a few important points regarding numbered air forces (NAFs), stating:

NAFs are tactical echelons that provide operational leadership and supervision. They are not management headquarters and do not have complete functional staffs. Many NAFs are responsible for major command operations in a specific geographic region or theater of operations. The number of persons assigned to a NAF headquarters varies from case to case, but should not exceed 99 manpower authorizations without an approved waiver.¹³⁵

These numbered air force staff and manpower limitations may require adjustment with future changes. Although the 2004 flight plan proposed major organizational renovation, the small changes and redirections that occurred do not achieve the desired transformation goals.

The 2008 AF Strategic Plan continues with these themes, identifying one of five priorities to “Modernize Our Air and Space . . . Organizations,” and setting a specific goal to “Align Organization and Processes with AF Core Functions and DoD Core Competencies.”¹³⁶ No concrete evidence suggests changes occurred as a result of this strategic plan. While not directly linked to these strategic goals, another effort to manage the organization came in 2009 as the Air

¹³⁴ Department of the Air Force, *Air Force Doctrine Document 2, Operations and Organization*, April 3, 2007, 45.

¹³⁵ Secretary of the Air Force, *Air Force Organization*, AFI 38-101, April 4, 2006, 11.

¹³⁶ Department of the Air Force, *2008 Air Force Strategic Plan*, October 2008, 8-9.

Force Chief of Staff directed unit manning minimums in the Organizational Threshold Review (OTR). The OTR effort, focused at and below the wing level, forced smaller units to merge and reorganize to meet these requirements.¹³⁷ While a concerted effort to reorganize and simply consolidate units, the review did not address bigger AF structure problems in order to become a more effective organization as identified in the 2008 AF Strategic Plan. More recently, Major General Al Flowers, AF Budget Director, recently announced a new reorganization proposal to consolidate four AOCs and more importantly, three numbered air forces.¹³⁸ All these documents and efforts show concern to revamp the AF organization, but they fail to address the core challenges highlighted earlier.

Looking at legal limitations, the US Congress has placed few restrictions on the overall AF structure. Although historically, the trinity of SAC, TAC, and ADC were originally mandated by Congress in the Air Force Organization Act of 1951, no other command structure has been so directed.¹³⁹ In fact, Title 10 unequivocally states “except as otherwise prescribed by law or by the Secretary of Defense, the Air Force shall be divided into such organizations as the Secretary of the Air Force may prescribe.”¹⁴⁰ The Congress did, however, place limits on the size of the Air

¹³⁷ Department of the Air Force, *Organizational Threshold Review Memorandum*, August 17, 2009. The memorandum stated guidelines for wings, groups, and squadrons, requiring a minimum threshold of 1,000 airmen, 400 airmen, and 35 airmen respectively, for each unit. Units not meeting these minimums were required to dissolve, often transitioning to a lower echelon or merge with other units to meet the threshold.

¹³⁸ AF News Service, “Efficiencies, balance main focuses of FY12 budget,” <http://www.af.mil/news/story.asp?id=123242539> (accessed April 7, 2011). Since further details were not yet available for consideration, they will not factor into the reorganization proposal.

¹³⁹ US Congress, *Air Force Organization Act of 1951*, Public Law 150, Chapter 407, September 19, 1951.

¹⁴⁰ US Congress, *Title 10*, Section 8074.

Staff, not to exceed 2,639 total military and civilian personnel of which no more than 1,585 officers and 60 general officers.¹⁴¹

Several key AF documents address the organization, including Air Force Doctrine Document (AFDD) 2-2, AF Pamphlet (AFPAM) 38-102, AF Instruction (AFI) 38-101, and AF Policy Directive (AFPD) 38-1. AFDD 2-2 mostly builds on basic AF doctrine by expanding on the commanding and organizing of air and space forces, to include key roles and responsibilities. AFPAM 38-102, although dated 2004, provides detail on the basic Air Staff organization and functions. Both of these, as well as AFI 38-101, provide thorough background and specific requirements detailing the current AF organizational structure.

Further adding to these requirements, AFI 38-101 provides some guidance in how the organization should structure. Specifically, the instruction lays out four organizational principles to follow: emphasis on wartime tasks, functional grouping, lean organizational structures, and a skip-echelon structure. Emphasis on wartime tasks will always remain at the forefront of all organizational designs. The functional grouping and skip-echelon structure principles will be challenged later in suggested changes. Lastly, the lean organizational structure discussion highlights the need for a flatter structure with minimal layers, stating:

Organizations must encourage rapid decision making, so they should be flat structures without intermediate levels, unless mission requirements cannot otherwise be met . . . Organizational levels that exist only to review and transmit information or tasking should be eliminated. Both the number of supervisors and the number of internal subdivisions within organizations should be designed to minimize layers and maximize worker-to-supervisor ratios.

Further, AFPD 38-1 outlines more organizational principles that build upon AFI 38-101. These principles will be detailed in the next section. Overall, while some guidance exists for the

¹⁴¹ Ibid., Section 8014.

organizational structure, the AF maintains the freedom to design and develop an organization to meet the mission. Before discussing any specific concepts for change, and as explored in the historical review, AF culture and traditions must be understood and preserved when possible.

Organizational Tenets: Maintaining Air Force Traditions

Over the history of aviation forces in the US military, different principles for the new and evolved organizations rang true for leaders. Several of these AF organizational themes resonant from the historical analysis captured earlier and were also directed by the War Department in the early years. When applicable and appropriate, these historical principles capture important AF traditions that must be incorporated into any current reorganization scenarios. These historical tenets will be highlighted first, then contrasted and compared with the existing AF published organizational principles to ensure these important lessons learned endure.

The first principle that developed in the early airpower years focused on the concentration of air forces. In the early 1920s, leaders such as Air Service Chief Brigadier General Mason Patrick began the campaign to concentrate air forces to maximize combat effect. Having independent air units working separately did not achieve expected synergies anticipated by early airpower advocates. World War II forced increased integration and concentration of different aviation forces. Documented airpower successes demonstrated this principle, as found with the composite grouping of bomber and pursuit forces of Eighth Air Force during European operations, such as the “Big Week” and Operation Overlord.¹⁴²

¹⁴² AFA, *History of the United States Air Force, 1907-1957*, 66-68. With the addition of long-range fighters to protect the bombers, Eighth Air Force dealt a massive blow to German industries in February 1944, known as “Big Week.” Further attacks deeper into Germany took its toll as the US fighters heavily damaged the German fighter inventory and this success established the air superiority foundation in western Europe needed for Operation Overlord.

Another historic tenet that developed early and was pushed hard throughout the early years was for all air forces to be controlled under one commander, or simply unity of command. In the early Army years, aviation forces were initially under ground force commanders. Airpower leaders, including aviation pioneer Italian General Giulio Douhet and Major “Billy” Mitchell, made the early case to construct aviation units under the command of a single airman. These arguments persisted for the first 40 years as the push for a separate air commander, co-equal with the ground and naval commanders. Eventually, the GHQ Air Force would begin the evolution to an airman in control and ultimately resulted in the separation of aviation forces into a new service. Even with the achievement of a separate AF and unity of service, a considerable tension persists within joint combat operations as all US military services maintain separate ‘air forces.’

Another historic theme championed the need for proper coordination between the three types of forces: air, ground, and naval. A seemingly obvious statement and a directed function in Title 10, the AF must support and cooperate with both the Army and Navy forces appropriately.¹⁴³ In the early days of the airplane, as separate commands developed aviation forces, the need became apparent for increased coordination between combat units of all services. To illustrate the early importance placed on jointness, TAC moved its headquarters from MacDill Army Air Field to Langley Army Air Field in order to foster better coordination with the Atlantic Fleet headquarters at Norfolk and Army Ground Forces headquarters at Fort Monroe.¹⁴⁴

¹⁴³ US Congress, *Title 10*, Section 8013. Title 10 states the responsibility for “effective cooperation and coordination between the Department of the Air Force and the other military departments and agencies of the Department of Defense to provide for more effective, efficient, and economical administration and to eliminate duplication.”

¹⁴⁴ AFA, *History of the United States Air Force, 1907-1957*, 139. TAC would execute the move to Langley Army Air Field in 1946.

In addition to these historic themes visible in the course of US airpower development, the War Department Reorganization of 1946 also laid out several guiding principles for the AAF to follow. The War Department expected a simple and flexible organization to satisfy requirements while maximizing efficiency.¹⁴⁵ Additionally, the principle of decentralization was emphasized, along with the need for a single, continuous chain of command. Lastly, the AAF should provide for intelligence activities and a first-rate research and development program. Reiterating this last fact, General “Hap” Arnold stated his most important lesson from World War II for the AAF: “the first essential of the airpower necessary for our national security is preeminence in research.”¹⁴⁶ This cemented the need for both intelligence along with a corresponding research and development function.

These War Department principles and historic tenets have shaped the AF organization of today. In accordance with AFPD 38-1, written in 1996 and certified current in 2010, the AF continues to restate several of these principles. Specifically, the directive contains characteristics desired for all AF organizations: mission orientation, unambiguous command, decentralization, agility, flexibility, simplicity, and standardization.¹⁴⁷ Most of these parallel the historic themes. Building on these, mission orientation speaks to the warfighting requirements inherent from the beginning. The directive also introduces the concepts of agility and standardization. Agility highlights the ability of organizations to fix problems quickly, while standardization attempts to promote similar structures among all organizations. Figure 16 captures all these principles from the past and present.

¹⁴⁵ War Department, *War Department Reorganization, Circular No. 138*, May 14, 1946, 3.

¹⁴⁶ AFA, *History of the United States Air Force, 1907-1957*, 97.

¹⁴⁷ Secretary of the Air Force, *Air Force Policy Directive 38-1, Organization*, June 1, 1996, 1.

<i>Historic AF Organizational Themes</i>	<i>AF Organization Principles Today</i>
Concentration of Airpower	Mission Orientation
Unity of Command	Unambiguous Command
Decentralization	Decentralization
Simple	Simplicity
Flexible	Flexibility
Research & Development / Intelligence	Agility
Joint Coordination	Standardization

Figure 16. AF Historical and Modern Organizational Principles.¹⁴⁸

These historic tenets and themes, along with the characteristics identified today in AF directive, provide a solid foundation to base future organizational changes.

General Organizational Concepts

With a solid foundation and basic understanding of the current organizational environment, several concepts need to be considered to find structural solutions. The SecDef Robert Gates makes it clear that the time is now for change, stating in a 2011 DoD Press Release:

this Department simply cannot risk continuing down the same path – where our investment priorities, bureaucratic habits, and lax attitudes towards costs are increasingly divorced from the real threats of today, the growing perils of tomorrow, and the nation’s grim financial outlook.¹⁴⁹

¹⁴⁸ Ibid. War Department, *War Department Reorganization, Circular No. 138*, May 14, 1946, 3.

¹⁴⁹ Department of Defense, “DOD Announces \$150 Billion Reinvestment from Efficiencies Savings,” DoD Press Release, <http://www.defense.gov/releases/release.aspx?releaseid=14178> (accessed January 6, 2011).

The SecDef's direction, and several other edicts for transformation over the past ten years, clearly suggests change is necessary now.¹⁵⁰ Before tackling reorganization proposals, several concepts and solutions need to be explored first. To start, a 2009 Institute for Defense Analyses (IDA) study provides useful lessons learned categorizing several common failures for organizations developing capabilities, a key AF function. Next, the cross-functional structure, another concept gaining momentum in military organizations, may provide another building block for redesign. Then the problem of staff rotation and continuity will consider another challenge to address that directly impacts all levels of the organization. Finally, the technology of today revolutionizes the ability of organizations to communicate, with increase speed, agility, and throughput. Exploiting these new capabilities, in concert with the following concepts will provide a backbone to address reorganization.

In its historical assessment of military roles and missions, as directed by the Legislative and Executive Branches, IDA identified these five service failures attributed to the functions in developing capabilities: orphaned missions, capability gaps, complete omissions, confused chain of command, and a slowness to adapt.¹⁵¹ These past lessons provide further points to address in developing the future of the AF organization. First, orphan missions, such as the new cyberspace arena, must find adequate advocacy and representation to develop fully. Secondly, capability gaps continue to persist with "high demand/low density" assets, especially with reduced aircraft force structure creating lower densities across almost all mission sets. Third, omission of priority

¹⁵⁰ As discussed earlier, the 2004 AF Transformation Flight Plan, 2008 AF Strategic Plan, and early 2011 public statement from the AF Office of Business Transformation all advocate organizational change.

¹⁵¹ James H. Kurtz and John H. Crerar, *Military Roles and Missions, Past Revisions and Future Prospects*, (Institute for Defense Analyses, 2010), 49-50. An orphan mission, such as the new cyber mission, normally cross-cuts all military services, yet not one can or will take sole responsibility.

missions has culminated in the recent failures of AF nuclear forces.¹⁵² Fourth, a confusing chain of command, or excessive depth, will not achieve the necessary efficiencies required. Lastly, as highlighted earlier, the organization must adapt to address the current world environment and changing military roles. As a recent example, military roles have required an increased emphasis on counter-insurgency operations. As highlighted, each of these five failures created a major dilemma easily identified within the AF today. Undoubtedly, any organizational changes need to address these five key lessons and consider other modern concepts.

The positive lessons developing from the utilization of cross-functional teams (CFTs), as found in the International Security Assistance Force (ISAF) Joint Command in Operation Enduring Freedom, suggest another concept to consider.¹⁵³ A cross-functional team would be defined as group of personnel from various functional areas of the organization who focus on specific objectives and synthesize their expertise to create a holistic situational understanding and solve problems. A prominent management systems expert, Jamshid Gharajedaghi reiterates the concept of holistic thinking and how these types of design cells and circular organizations can vastly improve operations by maximizing the system's ability to solve complex problems.¹⁵⁴ Lyndall Urwick also endorses this concept in dealing with organizational divisions, stating "one good way of reducing the difficulties connected with structural divisions is to encourage lower-

¹⁵² Michael Hoffman, "Nuclear safety slipped years before Minot," *Air Force Times*, http://www.airforcetimes.com/news/2008/02/airforce_250208_nukesafety/, February 25, 2008. On August 30, 2007, Air Force officials discovered a B-52 Stratofortress bomber had mistakenly flown six nuclear warheads from Minot Air Force Base, North Dakota, to Barksdale Air Force Base, Louisiana.

¹⁵³ To see how a small cross-functional team in Operation Enduring Freedom worked, read the July 2, 2010 article "Shaping the Information Environment in Afghanistan" from *Small Wars Journal*. Find the article on the Web at: <http://smallwarsjournal.com/blog/journal/docs-temp/466-rader.pdf>.

¹⁵⁴ Jamshid Gharajedaghi, *Systems Thinking, Managing Chaos and Complexity*, (Elsevier, 2006), 107-151. Gharajedaghi's book discusses valuable techniques in solving complex problems, including discussions of how to 'formulate the mess' in a three-phase iterative process of searching, mapping, and telling the story. His bubble models also provide excellent examples of how to map complex structures.

level personnel in developing cross relationships and communication to the maximum.”¹⁵⁵ CFTs within the Air Staff may help improve complex problem solving and administration required in all military operations and planning today.

Implementing the CFT concept full-scale within the headquarters may require a restructuring of the existing traditional joint staff model.¹⁵⁶ Instead of the functional nature of most staff divisions, e.g. the intelligence-dominated A2 division, teams would bring expertise from all facets of the AF community. For example, an AF CFT might contain officers from the fighter, bomber, and transport communities, as well as space professionals, maintenance officers, and logistics specialists. Normally these officers would remain in their traditional air staff directorates, such as A3, operations, or A4, logistics. In the case of ISAF, their four CFTs were built from the traditional joint staff headquarters structure and included: Current Operations, Future Operations, Future Plans, and the Information Dominance Center.¹⁵⁷ This ISAF construct suggests a good model to consider and assess for utilization within the headquarters organizations.

While ISAF’s CFT structure continues to work successfully, a similar effort at US Southern Command (SOUTHCOM) combatant command did not. In 2008, SOUTHCOM

¹⁵⁵ Urwick, “The Manager's Span of Control,” 45.

¹⁵⁶ The traditional joint staff headquarters structure generally includes directorates for manpower and personnel (J1), intelligence (J2), operations (J3), logistics (J4), plans (J5), communications (J6), as well as others deemed necessary. The Air Staff uses the same divisions, however named with ‘A’ prefixes, e.g. operations (A3).

¹⁵⁷ CDR Ingrid Rader, “Shaping the Information Environment in Afghanistan”, *Small Wars Journal*, <http://www.smallwarsjournal.com>, July 2, 2010, 15. Rader contends “Cross Functional Teams were foreign to the area of responsibility, and so ISAF Joint Command was by definition a prototype organization. We recognize now that the Cross Functional Team concept has achieved a degree of partnered synchronized communications capability not previously possible. The ISAF Joint Command Future Operations CFT synchronized communications team approached Information Operations, Psychology Operations, and Public Affairs differently than they had done in previous assignments – we had to if we were to be successful.”

restructured away from the traditional joint staff model into a CFT-type model. Following its inability to function adequately responding to the 2010 Haitian earthquake, SOUTHCOM subsequently abandoned the structure. Based on the Government Accounting Office (GAO) 2011 report assessing this organization failure, SOUTHCOM's structure could not handle a major crisis response. Although SOUTHCOM had problems with this type of organization, the GAO found that inadequate manpower, augmenting military personnel, and mission alignment contributed more to the problem than the actual design of the cross-functional organization.¹⁵⁸ The SOUTHCOM example represents a much different set of operational circumstances that would not exist for the static Air Staff. Therefore, SOUTHCOM's combatant command organizational failures do not predict similar problems for a service headquarters organization that has a predictable organize, train, and equip mission. Nevertheless, both the ISAF and SOUTHCOM reorganizations provide good examples in understanding CFTs and their implementation.

As SOUTHCOM's problems highlighted, a lack of personnel contributed to the organizational problems. Not only can a manpower shortage inhibit staff potential, but a lack of cohesion and continuity also challenge the overall effectiveness. With a seemingly constant rotation of military staff officers, some with a year or less per tour, a staff will not achieve the levels of cohesion necessary for peak performance. David Segal and Mady Segal, sociologists from the University of Maryland, echo this problem by identifying "the cause of the decline in the

¹⁵⁸ US Government Accountability Office, *U.S. Southern Command Demonstrates Interagency Collaboration, but Its Haiti Disaster Response Revealed Challenges Conducting a Large Military Operation*, (July 2010), 2.

cohesion of the fighting unit is attributed to the military rotation system.”¹⁵⁹ Morris Janowitz, a renowned sociologist, also trumpets this, in his classic *The Professional Soldier*, stating leaders “fail to see that control of rank and file leadership, based on positive group cohesion, is essential to maintain both decentralized initiative and operational control over widely dispersed militarily formations.”¹⁶⁰ While staff cohesion builds on several other factors, the constant rotation impacts significantly in cohesion of personnel and also directly impacts organizational continuity.

Continuity, especially in today’s complex world, matters immensely. The majority of AF staff continuity resides with the civilian work force. With the low levels of military staffing, increased military billet conversions to government civilians, and out-sourced contracts, the AF risks losing the crucial military professional continuity needed in key staff organizations. To improve continuity, the AF should consider a concerted effort to lengthen staff tours and enforce minimum tour lengths. Segal and Segal highlight how the Army implemented home-basing programs which helped to improve unit cohesion.¹⁶¹ A 1998 RAND study addressing numbered air force warfighting capabilities specifically identifies adequate tour length to build the experience and continuity necessary to operate the staff effectively.¹⁶² Clearly, adequate time and military tour lengths will help develop the critical staff cohesion and continuity needed. Any reorganization strategy developed must address continuity of military staff personnel and perhaps a new approach in military professional staff manning.

¹⁵⁹ David R. Segal and Mady Wechsler Segal, “Change in Military Organization”, *Annual Review of Sociology*, no. 9 (1983): 156.

¹⁶⁰ Morris Janowitz, *The Professional Soldier*, (United States of America: Free Press, 1960), 48.

¹⁶¹ Segal and Segal, *Change in Military Organization*, 157. They specifically relate the theory of Janowitz to Army unit cohesion.

¹⁶² Lawrence M. Hanser, Maren Leed, and C. Robert Roll, *The Warfighting Capacity of Air Combat Command's Numbered Air Forces*, (Documented Briefing, RAND - Project AIR FORCE, 1998), 9.

Lastly, the AF must consider and understand how current technology, primarily the speed of communication, has changed the ability of organizations to function. Distance no longer inhibits the exchange of information, with real-time communications available to every AF location. Given this fact, as discussed earlier by David Mitchell and William Thomas, improved communications should enable a flattened and shallower hierarchy to operate more efficiently than the existing AF organization.

Reorganization Proposal

If a radical reorganization should be considered, based on the challenges and principles highlighted earlier, a few approaches stand out. The first approach would decrease organizational depth. Assuming the Air Staff and wings would remain, eliminating a layer would require the removal of either major commands or numbered air forces. The second method to consider would reduce organizational width by combining units. As seen in the Organizational Threshold Review effort of 2009 and recent efficiency measures taken by the AF, this option represents the ‘main effort’ to date in reorganization. Lastly, a combination of width and depth consolidation and elimination, while a more aggressive approach, can attempt to achieve more synergistic organizational effects while achieving greater efficiency.

While all approaches were considered, the suggestion discussed hereafter would remove the major command level while also consolidating certain functions and units. Figure 17 provides a conceptual model of this reorganization. As depicted, a much flatter organization results with thirteen numbered air forces, AFMC, and AFRC reporting directly to HQ USAF. To clarify a few points of liberal consolidation, Second Air Force subsumes Nineteenth Air Force and replaces AETC. In Europe, Eighth Air Force would replace USAFE and absorb Third Air Force. Thirteenth Air Force replaces PACAF and gains Fifth and Eleventh Air Forces. With an active Korean theater, maintaining Seventh Air Force seems a logical choice and an example of creating additional numbered air forces to support specific missions and command structures. As

highlighted, the organization still contains functional commands, however these directly support specified combatant commands. Nevertheless, the organization primarily takes on a regional focus based along combatant command lines.

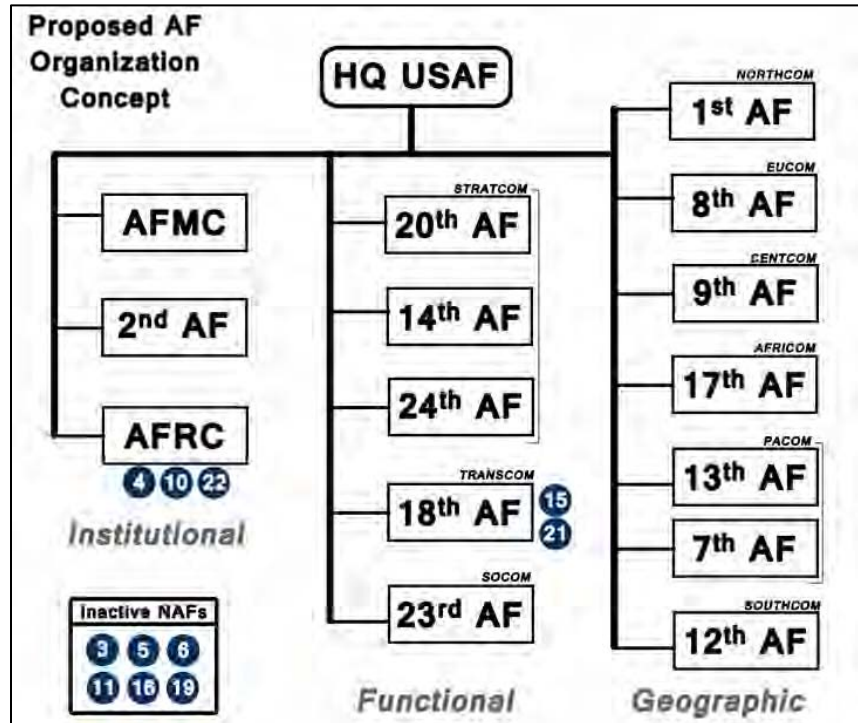

Figure 17. Proposed Air Force Reorganization.

The motivation to keep numbered air forces vice major commands came down to four factors, based primarily on the need to geographically focus the organization. First, since numbered air forces currently organize geographically, and the following proposal focuses the air force organization along combatant commands, keeping numbered air forces fits more logically than the predominately functional major commands. Second, geographically-focused staffs, with dedicated regional expertise, should generate more flexible and adaptive organizations needed in the complex and conflicting environments throughout the world. Third, the focus from national levels to improve theater security cooperation and build partners demands organizations that focus regionally as well. Last, the rich history of numbered air forces throughout the development of aviation and wartime should be preserved and their traditions carried forward.

Examining the first factor, with the elimination of one layer, the primary strategy to focus reorganization should revolve around the primary customer – combatant commands. To focus the organization globally and improve the capability to support combatant commands, a geographical organization split makes logical sense. Several sources point to the benefits of this type of arrangement. Starting with Title 10, which implies the importance and requires the AF to “investigate and report upon the efficiency of the Air Force and its preparation to support military operations by combatant commands.” Social scientist and public administration expert Luther Gulick clearly identifies the advantages of this type of arrangement:

first of the greater ease of coordination of services rendered and controls exercised within a given area; second, of the greater tendency to adapt the total program to the needs of the areas served, not alone because of the discretion resting within the divisions, but also because the needs and difference of the areas will be more vigorously represented at headquarters in the general consideration of broad policy; and third, of the greater ease with which cooperative relations may be established with subordinate governmental units, which are of necessity first of all geographically defined units. Decentralization of geographical division strengthens these tendencies, and serves, moreover, to . . . cut red tape, and speed up all joint activities and administrative decisions.¹⁶³

The 2010 DoD Directive 5100.01 also makes a strong case for aligning the AF to maximize support to the combatant commands, stating that the individual Military Departments must:

Perform Military Department functions necessary to fulfill the current and future operational requirements of the Combatant Commands, including the recruitment, organization, training, and equipping of interoperable forces; Provide forces to enhance military engagement, conduct security cooperation, build the security capacity of partner states, and deter adversaries to prevent conflict. These actions shall be coordinated with the other Military Departments, Combatant Commands, US Government departments and agencies, and international partners, as required; Provide, as directed, administrative and logistical support to the headquarters of the Combatant Commands, to include direct

¹⁶³ Luther Gulick and Lyndall F. Urwick, *Papers on the Science of Administration, Volume IV*, (Institute of Public Administration, 1937), 31.

support of the development and acquisition of the command and control systems of such headquarters.¹⁶⁴

The draft 2010 UCP language further emphasizes this command and control relationship with forces assigned geographically: “except as otherwise directed . . . all forces operating within the geographic AOR assigned to a combatant command . . . will be assigned or attached to and under the command of that commander.”¹⁶⁵ Carl Builder, a former RAND military expert, also identified this strategy in his 1995 article highlighting the need to shift the AF organization regionally toward the combatant commands, to better prepare the AF for future crises and conflicts.¹⁶⁶

Adding more justification for this type of structure, dedicating numbered air forces assigned to combatant commands automatically creates a Commander, Air Force Forces (COMAFFOR) and Joint Force Air Component Commander (JFACC) standing in place with committed AOCs to execute operations per AF doctrine.¹⁶⁷ While this situation essentially exists today, this arrangement would solidify the command and control function. Given a more robust staff, each numbered air force should also have adequate manpower to manage the full spectrum of doctrinal duties without augmentation, as is often required today and negatively impacts cohesion and continuity discussed earlier.

¹⁶⁴ Department of Defense, *Functions of the Department of Defense and Its Major Components*, DoD Directive Number 5100.01, December 21, 2010, 25-27. DoD Directive 5100.01 dictates the functions of the DoD and its major components. The directive lists a total of sixteen general responsibilities for the respective military departments, of which five directly highlight the need of services to support combatant commands, numbers 3, 8, 9, 13, and 15.

¹⁶⁵ Secretary of Defense, *Unified Command Plan 2010 – Draft*, March 11, 2011, 2.

¹⁶⁶ Carl H. Builder and Theodore W. Karasik, *Organizing, Training, and Equipping the Air Force for Crises and Lesser Conflicts* (Santa Monica, California: 1995), 29.

¹⁶⁷ Department of the Air Force, *Air Force Doctrine Document 2, Operations and Organization*, April 3, 2007, ix.

Another challenge and second factor of this reorganization proposal should ensure the AF structure can rapidly adapt and flex to meet the changing, complex global environment. One of two 2010 Quadrennial Defense Review (QDR) conclusions identifies this requirement: “the second theme to emerge from QDR analyses is the importance of ensuring that US forces are flexible and adaptable so that they can confront the full range of challenges that could emerge from a complex and dynamic security environment.”¹⁶⁸ A seemingly obvious statement for operational forces, this should also apply to the staff functions and organizations. With a more streamlined organization and number air forces reporting directly to the HQ USAF, the Air Staff should be able to better coordinate and deconflict these challenges quicker and address requirements across the entire globe.

Also emphasized in the 2010 National Security Strategy (NSS), National Military Strategy, and QDR, one of the key military missions focuses on theater security cooperation, the third factor. These three strategic guiding documents all stress the need to strengthen international security, build partner state capacities, and promote peace through international order.¹⁶⁹ More specifically, the CJCS directs responsibilities for all forces and combatant commands: “the Joint Force, Combatant Commanders, and Service Chiefs shall actively partner with other US Government agencies to pursue theater security cooperation to increase collective security skills

¹⁶⁸ Department of Defense, *Quadrennial Defense Review Report*, February 2010, 18.

¹⁶⁹ “Strengthening international and regional security requires that our forces be globally-available, yet regionally-focused,” (CJCS, *The National Military Strategy of the United States of America*, 2011, 10). “Build the security capacity of partner states,” (Department of Defense, *Quadrennial Defense Review Report*, February 2010, 2). Also in the QDR Report, the CJCS’ response also states: “building the capacity of our partners to deter and prevent conflict makes them more capable of providing assistance as we address common threats together.” The NSS identifies one of the key strategic approaches: “an international order advanced by US leadership that promotes peace, security, and opportunity through stronger cooperation to meet global challenges,” (President of the United States, *National Security Strategy*, May 2010, 7).

with a wider range of partners.”¹⁷⁰ Without doubt, a regionally-focused organization must develop to meet these key strategic needs and can better develop a staff to have the required cultural and area expertise.

The fourth factor needs little explanation as maintaining tradition and culture should pervade any reorganization effort. As highlighted earlier, the cultural principles and history should remain prevalent and carry on AF traditions. As a good example, the tremendous accomplishments and rich history of Eighth Air Force, exemplified in the European theater during World War II, can carry on as a dedicated numbered air force to US European Command. Further problems worth reemphasizing, as opportunities in an organization with reduced depth, include the presence of technological advancements and inefficient redundancies. With the technology of today, a flatter hierarchy allows the best ideas and critical information to flow quicker up the chain and also reduces the amplifying effects of information overload. Redundant functions found at lower levels should be eliminated by consolidating at higher levels, most effectively at the Air Staff.

Should the AF eliminate a layer in the organization, several subsequent benefits should be gained. Where possible and avoiding duplication, devolving functions from major commands to numbered air forces will permit decentralized execution for direct support of the key customers, combatant commands. Additionally, elimination of an entire level will free those staff positions to both bolster HQ USAF, numbered air force staffs, and wing staffs, and allow for the elimination of staff manpower with ensuing savings. To achieve measureable savings, a significant overall staff manpower reduction should be seen, vice a shell game that simply moves manpower around to new locations. By increasing staffing at the remaining top three levels, a

¹⁷⁰ CJCS, *The National Military Strategy of the United States of America*, 2011, 15.

necessity with increased organizational responsibilities, the robust general staff model may represent a better approach in which to rebuild the Air Staff.

A Case for a Robust General Staff

The current Air Staff contains 3,021 active duty, reserve, and civilian personnel.¹⁷¹ While a fairly robust staff exists today, the headquarters should take on a greater role with increased responsibilities in a reorganization. With the removal of one layer in the organization, restructuring would require moving a portion of those personnel up into the headquarters. The increase in personnel would provide the necessary manpower to manage the increased responsibilities encompassing AF-wide issues. This personnel increase could permit the development of a full general staff, as highlighted earlier, to better support the AF Chief of Staff. As noted earlier, the newly created AF adopted the deputy chief system, which largely remains today. Once considered at the start, it may be time to reconsider a general staff option.

The general staff concept strives to develop the brains of the organization, or the “commanding machine” as coined by Lyndall Urwick. Both Urwick and Max Weber reaffirm the requirement for expert military staff officers, as found in the German General Staff, specifically highlighting the need for professional continuity.¹⁷² Prior concerns about the general staff taking responsibility and challenges with cross-coordination could be overcome with today’s improved communications and more staff professionals. The AF Chief of Staff needs this large staff, especially with a larger span of control and flatter organizational hierarchy, to work the vast issues not requiring intimate commander involvement and to control cross-coordination efforts.

¹⁷¹ Department of the Air Force, *Airman, The Book 2010*, (Defense Media Activity: 2010), 3.

¹⁷² Urwick, “The Manager's Span of Control,” 46-57. Weber, *On Charisma and Institution Building*, 68.

Therefore, should a reorganization eliminate one level of the hierarchy, the AF must increase HQ USAF personnel and develop the appropriate staff structure with professionals, both military and civilians, to do the work necessary in supporting the entire AF organization.

In growing and rebuilding a staff, this would be the time to address and consider the cross-functional team concept and whether that would better leverage the expertise intrinsic with a larger pool of diverse staff officers and civilians. Also, the five lessons identified by IDA must be incorporated as well as the key principles and tents from AF doctrine and history. As stated earlier, the AF has complete freedom to build an organization that can execute the mission. The only legal constraint would be the Title 10 officer limits on the Air Staff. If a new staff, designed properly, would require a greater number, then the AF would need to engage the US Congress to adjust these limits. In this reorganization effort, if the AF can show improved stewardship or savings with taxpayer dollars, it will certainly get the necessary attention and consideration of the US Congress for any legislation changes.

Difficulty with Reorganization

While it may be worth the effort to pursue this type of reorganization in order to create a more efficient and effective AF organization, several experts warn about the difficulties of any reorganization. First, the powers in place are very difficult to move and change, creating significant resistance to reorganization. Additionally, any change will likely take several years to achieve any noticeable effect. This extended period can often be equated to failure. Lastly, as mentioned earlier by Matthews and Snider, any reorganization must focus on effectiveness first while still achieving the motivating efficiencies. Therefore, the AF must address these road blocks to overcome the existing bureaucratic inertia.

As seen through history and evident in the short existence of the AF, once the bureaucracy matures and becomes entrenched, any major change becomes extremely difficult. Max Weber states this well-known truth about the bureaucracy: “once it is fully established, it is

among the social structures which are the hardest to destroy.”¹⁷³ The towers of power developed in each sub-organization grow roots and rarely do leaders volunteer their organization for closing or reduction. Often these leaders are commanders who have earned their position and they do not want to be the one known for closing the command. Certainly that might not take on a positive theme in their annual report and may keep the leader from completing a necessary command tour.

New commanders often take over an organization and recognize over-bureaucratic processes. Several courses of action will arise, some will generate short-term results and others will take longer. David Mitchell discusses the time factor and highlights the fact that fundamental changes will take 1-2 years before effects can be realized.¹⁷⁴ But will these commanders make an effort to change knowing they will not likely get credit for the results due to length of time changes may take. In order to make organizational changes for the good of the AF, commanders will have to envision a future organization and make decisions that might take a long time to reach fruition, may disband current units, and jeopardize command positions. Hopefully, the upper echelons of leadership will recognize the selfless efforts that can make the AF a better organization.

Lastly, as a cautionary reminder, a better organization means an effective professional organization. Just ‘doing more with less’ may save resources, but what does an organizational change do to overall effectiveness? As Mathews and Snider highlighted, the Army, in an effort to become more efficient during the 1990s fiscal reductions, overemphasized efficiency instead of effectiveness and thus the Army bureaucracy grew at the expense of professionalism and

¹⁷³ Weber, *On Charisma and Institution Building*, 75.

¹⁷⁴ David Mitchell, *Control without Bureaucracy*, 76.

effectiveness.¹⁷⁵ Again, this highlights an important lesson for the AF to heed in future reorganization efforts.

Conclusions

The AF of today finds its force structure and manning at all time lows, yet the staffing positions have increased steadily and disproportionately over the past sixty years. In order to reverse this trend, reduce organization depth, move away from functional commands, and create the necessary efficiencies, the AF should consider removing the major commands and promoting the numbered air forces subordinate to HQ USAF.

A primarily geographic restructuring will permit the AF to best support the most important customers, the combatant commanders. Additionally, regionally-focused numbered air forces will improve theater security challenges and adapt quicker to complex global conflicts and conditions. A good example to highlight a current organizational incongruity arose with Operation Odyssey Dawn, where the US struck Libya to prevent civilian deaths.¹⁷⁶ The numbered air force supporting US Africa Command, Seventeenth Air Force, stood up to lead the air effort. However, Seventeenth Air Force is subordinate to the major command USAFE, an illogical and confusing organizational arrangement which highlights an inflexible patchwork structure.

More importantly, the tradition and culture of numbered air forces, as developed earlier, should be maintained in any future AF organization. A reorganization and improved AF bureaucracy may generate additional benefits, including improvement of the QDR-identified AF acquisition problems and even improve retention of the best personnel. Tim Kane, in his article

¹⁷⁵ Matthews and Snider, *The Future of the Army Profession*, 22.

¹⁷⁶ Operation Odyssey Dawn, which began in March 2011, is the US part of the international military operation in Libya to enforce United Nations Security Council Resolution 1973.

on why the best officers are leaving the military, discovered after interviewing veterans, that the top reason for departing military service was “frustration with military bureaucracy,” cited by eighty-two percent of respondents.¹⁷⁷ Therefore, improved retention of top personnel may provide another positive side effect for an improved AF organization.

The AF faces budgetary pressures from many different threats, starting at the US President, down through the SecDef, and even internally in order to fund critical capabilities and programs. Finding effective strategies to create the necessary efficiencies will be difficult and require genuine institutional introspection. Given the current composition of the AF today, the AF must consider a reorganization strategy for the top level structure to cut the bureaucracy and become a more efficient and effective organization. The AF should wholeheartedly consider reorganization by eliminating the major commands, thereby elevating the numbered air forces, to become more geographically focused and better suited to support the US combatant commands. Ultimately, reorganization should create significant financial savings needed in today’s constrained environment and maintain the critical airpower principles and traditions for a more effective warfighting United States Air Force.

¹⁷⁷ Tim Kane, “Why Our Best Officers Are Leaving,” *The Atlantic*, <http://www.theatlantic.com/magazine/archive/2011/01/why-our-best-officers-are-leaving/8346/>, January/February 2011, 2.

BIBLIOGRAPHY

- Aeronautical Systems Command Fact Sheet,
<http://www.wpafb.af.mil/library/factsheets/factsheet.asp?id=6162> (accessed July 1, 2010).
- Air Force Association (AFA). *History of the United States Air Force, 1907-1957*, (AFA, 1957).
- Air Force Association. "USAF Almanac, 1951," *Air Force Magazine*, September 1951.
- Air Force Association. "USAF Almanac, 1980," *Air Force Magazine*, May 1980.
- Air Force Association. "USAF Almanac, 2005," *Air Force Magazine*, May 2005.
- Air Force Association. "USAF Almanac, 2000," *Air Force Magazine*, May 2000.
- Air Force Association. "USAF Almanac, 2010," *Air Force Magazine*, May 2010.
- Air Force Global Strike Command Web site, <http://www.afgsc.af.mil/main/welcome.asp> (accessed April 20, 2011).
- Air Force News Service. "Efficiencies, balance main focuses of FY12 budget,"
<http://www.af.mil/news/story.asp?id=123242539> (accessed April 7, 2011).
- Air Force Personnel Center. AFPC "Road Show" PowerPoint Briefing Presented at Nellis Air Force Base, November 2008.
- Air Force Personnel Center. "Air Force Strength from 1948 thru 2010,"
<http://w11.afpc.randolph.af.mil/demographics/ReportSearch.asp> (accessed January 10, 2011). DoD Civilian Personnel Statistics Database,
<http://siadapp.dmdc.osd.mil/personnel/CIVILIAN/CIVTOP.HTM> (accessed January 31, 2011).
- Air Force Reserve Command Fact Sheet,
http://www.af.mil/information/factsheets/factsheet_print.asp?fsID=151& (accessed January 31, 2011).
- Bartol, Thomas J. *Organization Structure and Technological Innovation in the Air Force*. Air University, Air Command and Staff College Student Report 85-0165, April 1985.
- Biddle, Stephen, and Long, Stephen. *Democracy and Military Effectiveness: A Deeper Look*. The Journal of Conflict Resolution, Vol. 48, No. 4 (August 2004), pp. 525-546.
- Builder, Carl H. *The Masks of War: American Military Styles in Strategy and Analysis*. The Johns Hopkins University Press, February 1, 1989.
- Builder, Carl H., and Karasik, Theodore W. *Organizing, Training, and Equipping the Air Force for Crises and Lesser Conflicts* (Santa Monica, California: 1995).
- Carey, Timothy N. *Reorganizing American Defenses, The United States Air Force in the Post-Cold War World*. Air University, Air War College, April 16, 1992.
- CJCS. Chief Joint Chiefs of Staff Instruction 3170.01G. *Joint Capabilities Integration and Development System (JCIDS)*. Joint Chiefs of Staff, March 1, 2009.
- CJCS. *The National Military Strategy of the United States of America*, 2011.
- Condit, Kenneth W., Johnstone, John H., and Nargele, Ella W. *A Brief History of Headquarters Marine Corps Staff Organization*. Historical Division, Headquarters, U.S. Marine Corps, 1970.

- Controvich, James T. *United States Air Force and its Antecedents Published and Printed Unit Histories*. Jan 2001.
- Correll, John T. *The First 60 Years, The Air Force, 1947 to 2007*. Air Force Association, 2006.
- Davis, Richard G. *The 31 Initiatives: A Study in Air Force – Army Cooperation*. (Office of Air Force History, 1987).
- Department of Defense. *Functions of the Department of Defense and Its Major Components*, DoD Directive Number 5100.01, December 21, 2010.
- Department of Defense. “DOD Announces \$150 Billion Reinvestment from Efficiencies Savings” DoD Press Release, <http://www.defense.gov/releases/release.aspx?releaseid=14178> (accessed January 6, 2011).
- Department of Defense. *Quadrennial Defense Review Report*, February 2010.
- Department of the Air Force. *2008 Air Force Strategic Plan*, October 2008.
- Department of the Air Force. *2010 USAF Posture Statement*, February 9, 2010.
- Department of the Air Force. *Air Force Doctrine Document 2, Operations and Organization*, April 3, 2007.
- Department of the Air Force. *Airman, The Book 2010*, (Defense Media Activity: 2010).
- Department of the Air Force. “FY11 Force Structure Announcement” Briefing, <http://www.af.mil/shared/media/document/AFD-100511-082.pdf> (accessed February 4, 2011).
- Department of the Air Force. *Organizational Threshold Review Memorandum*, August 17, 2009.
- Department of the Air Force. *Redesignation of the Headquarters, Military Air Transport Service*, October 11, 1965.
- Department of the Air Force. *The U.S. Air Force Transformation Flight Plan 2004*.
- Draper, Hal. *Karl Marx's Theory of Revolution, Volume 1: State and Bureaucracy*. New York: Monthly Review Press, 1979.
- Entwisle, Doris R., and Walton, John. “Observations on the Span of Control,” *Administrative Science Quarterly*, (1961).
- Gates, Robert M. *Department of Defense (DoD) Efficiency Initiatives*, Secretary of Defense Memorandum, August 16, 2010.
- Gharajedaghi, Jamshid. *Systems Thinking, Managing Chaos and Complexity*, (Elsevier, 2006).
- Greer, Thomas H. *The Development of Air Doctrine in the Army Air Arm, 1917-1941*, (Office of Air Force History, 1955).
- Gropman, Alan L. *The Air Force Integrates, 1945-1964*. Office of Air Force History, 1985.
- Gulick, Luther, and Urwick, Lyndall F. *Papers on the Science of Administration, Volume IV*, (Institute of Public Administration, 1937).
- Hage, J.T. *Organizational Innovation and Organizational Change*. *Annual Review of Sociology*, Vol. 25 (1999), pp. 597-622.

- Hanser, Lawrence M., Leed, Maren, and Roll, C. Robert. *The Warfighting Capacity of Air Combat Command's Numbered Air Forces*, (Documented Briefing, RAND - Project AIR FORCE, 1998).
- Hoffman, Michael. "Nuclear safety slipped years before Minot," *Air Force Times*, http://www.airforcetimes.com/news/2008/02/airforce_250208_nukesafety/, February 25, 2008.
- Hoffman, R. B., and Archibald, R. W. *Introducing technological change in a bureaucratic structure*. The Rand Corp, New York, 1968.
- Huntington, Samuel. *The Soldier and the State*, Cambridge, MA: Harvard University Press, 1959.
- Huzar, Elias. *Reorganization for National Security*. The Journal of Politics, Vol 12, No. 1 (February 1950), pp. 128-152.
- Janowitz, Morris. *The Professional Soldier*, (United States of America: Free Press, 1960)
- Johnson, David E. *Learning Large Lessons: The Evolving Roles of Ground Power and Air Power in the Post-Cold War Era*. Rand Corporation, July 25, 2006.
- Joint Chiefs of Staff. *Continental Air Defense Command, JCS Memorandum*, August 2, 1954.
- Joint Chiefs of Staff. *Outline Command Plan*, December 12, 1946.
- Kane, Tim. "Why Our Best Officers Are Leaving," *The Atlantic*, <http://www.theatlantic.com/magazine/archive/2011/01/why-our-best-officers-are-leaving/8346/>, January/February 2011.
- Kropf, Roger F. "The US Air Force in Korea, Problems that Hindered the Effectiveness of Airpower," *Airpower Journal* (Spring 1990).
- Kurtz, James H., and Crerar, John H. *Military Roles and Missions, Past Revisions and Future Prospects*, (Institute for Defense Analyses, 2010).
- Matthews, Lloyd J., and Snider, Don M. *The Future of the Army Profession*, (McGraw-Hill Custom Publishing, 2005).
- Meloy, Vincent J. *Class I, II, III, and IV Supplies for an Air Force in the Theater of Operations*, March 26, 1936.
- Millsap, Ralph, and Posey, D.B. *Organizational Options for the Future Aerospace Force*. Aerospace Power Journal, Summer 2000, pp. 48-52.
- Mitchell, David. *Control without Bureaucracy*, (McGraw-Hill Book Company (UK) Limited, 1979)
- Nickols, Fred. "The Span of Control and the Formulas of V.A. Graicunas," 2003.
- Office of Management and Budget. *Historical Tables, Budget of the U.S. Government, Fiscal Year 2010*, 2009.
- Pogue, Forrest C. *The European Theater of Operations, The Supreme Command*, (Center of Military History: 1996).
- President Harry S. Truman. *Executive Order 9877, Functions of the Armed Forces*, July 26, 1947.
- President of the United States. *National Security Strategy*, May 2010.
- Punaro, Arnold. Defense Business Board (DBB), *Public Session Defense Business Board Quarterly Meeting Notes*, July 22, 2010.

- Rader, CDR Ingrid. "Shaping the Information Environment in Afghanistan", *Small Wars Journal*, <http://www.smallwarsjournal.com>, July 2, 2010.
- Ravenstein, Charles A. *The Organization and Lineage of the United States Air Force*. Office of Air Force History, 1986.
- Ruehrmund, James C., Jr., and Bowie, Christopher J. *Arsenal of Airpower: USAF Aircraft Inventory, 1950-2009* (Mitchell Institute Press, 2010).
- Secretary of Defense. *Department of Defense (DoD) Efficiency Initiatives*, August 16, 2010.
- Secretary of Defense. *Unified Command Plan 2010 – Draft*, March 11, 2011.
- Secretary of the Air Force. *Air Force Instruction 38-101, Air Force Organization*, April 4, 2006.
- Secretary of the Air Force. *Air Force Pamphlet 38-102, Headquarters United States Air Force Organization and Functions (Chartbook)*, January 1, 2004.
- Secretary of the Air Force. *Air Force Policy Directive 38-1, Organization*, June 1, 1996.
- Secretary of the Air Force. *FY 2010 Budget Overview*, <http://www.saffm.hq.af.mil/budget> (accessed February 7, 2011).
- Segal, David R., and Segal, Mady Wechsler. *Change in Military Organization*. Annual Review of Sociology, Vol. 9 (1983), pp. 151-170.
- Selinger, Marc. "USAF Eyes Study on Long-Range Strike," *Aviation Week* (October 3, 2005).
- Shaw, Frederick J., Jr., and Warnock, Timothy. *The Cold War and Beyond, Chronology of the United States Air Force, 1947-1997* (Air University Press, 1997).
- Shiner, John F. *Birth of the GHQ Air Force*, Military Affairs, Vol. 42, No. 3 (October 1978), pp. 113-120.
- Spatz, Carl. *Evolution of Air Power: Our Urgent Need for an Air Force Second to None*. Military Affairs, Vol. 11, No. 1 (Spring 1947), pp. 2-16.
- Thomas, William C. *The Cultural Identity of the United States Air Force*. Air & Space Power Journal, January 30, 2004.
- Trest, Warren A. *Air Force Roles and Missions: A History*. Air Force History and Museums Program, 1998.
- US Army Military History Institute. *Military Organization of the United States*, (General Service Schools Press, 1928).
- US Congress. *Air Force Organization Act of 1951*, Public Law 150, Chapter 407, September 19, 1951.
- US Congress. *Army and Air Force Authorization Act of 1949*, Public Law 604, Chapter 454, July 10, 1950.
- US Congress. *Department of Defense Reorganization Act of 1958*, Public Law 85-899, August, 6, 1958.
- US Congress. Title 10.
- US Government Accountability Office. *U.S. Southern Command Demonstrates Interagency Collaboration, but Its Haiti Disaster Response Revealed Challenges Conducting a Large Military Operation*, (July 2010).

- Urwick, Lyndall F. "The Manager's Span of Control," *Harvard Business Review*, (May-June 1956).
- War Department. *Command and Employment of Air Power*, FM 100-20 (United States Government, 1944).
- War Department. *War Department Reorganization*, Circular No. 138, May 14, 1946.
- Warren, Jonathan. *Air Force Organizational Transformation: Merging the Active and Reserve Components*. U.S. Army War College, February 16, 2005.
- Weber, Max. *On Charisma and Institution Building*, (Chicago: University of Chicago Press, 1968).
- Weber, Max. *The Theory of Social and Economic Organization*. Translated by A.M. Henderson and Talcott Parsons. London: Collier Macmillan Publishers, 1947.
- Wikipedia. *Bureaucracy*. <http://en.wikipedia.org/wiki/Bureaucracy>.
- Williams, Jr., Edwin L. *Legislative History of the Air Arm*. *Military Affairs*, Vol. 20, No. 2 (Summer 1956), pp. 81-93.
- Wilson, Woodrow. *The Study of Administration*. *Political Science Quarterly*, Vol. 2, No. 2 (June 1887), pp. 197-222.
- Wolf, Richard I. *The United States Air Force: Basic Documents on Roles and Missions*. Office of Air Force History, 1987.
- Wolk, Herman S. *The Struggle for Air Force Independence 1943-1947*. (Air Force History and Museums Program, 1997).