

A 240 GHZ POLARIMETRIC COMPACT RANGE FOR SCALE MODEL RCS MEASUREMENTS

Guy B. DeMartinis, Michael J. Coulombe, Thomas M. Horgan, Robert H. Giles
University of Massachusetts Lowell, Submillimeter Wave Technology Laboratory
175 Cabot Street, Suite 130
Lowell, MA 01854

William E. Nixon
U.S. Army National Ground Intelligence Center
2055 Boulders Road
Charlottesville, VA 22911-8318

ABSTRACT

A fully-polarimetric compact radar range operating at 240 GHz has been developed for obtaining Ku-band RCS measurements on 1:16th scale model targets. The transceiver consists of dual fast-switching, stepped, CW, X-band synthesizers driving dual X24 transmit multiplier chains and dual X24 local oscillator multiplier chains. The system alternately transmits horizontal (H) and vertical (V) radiation while simultaneously receiving H and V. Software range-gating is used to reject unwanted spurious responses in the compact range. A flat disk and rotating circular dihedral are used for polarimetric as well as RCS calibration. Cross-pol rejection ratios of better than 45 dB are routinely achieved. The compact range reflector consists of a 60" diameter, CNC machined aluminum mirror fed from the side to produce a clean 27" FWHM quiet zone. In this paper a description of this 240 GHz compact range is provided along with an ISAR measurement example.

Keywords: Compact Range, Instrumentation, Millimeter-Wave, RCS Measurements, Scale Modeling, Terahertz.

1. Introduction

In order to effectively implement target recognition or RCS reduction a detailed knowledge of how targets, and target features, scatter radiation must be determined. Due to the complexity of acquiring radar signatures for many targets of interest (e.g. sea vessels, airplanes, tanks) it is frequently costly or impractical to directly obtain the necessary signature information for a given radar wavelength regime. Thus the use of target models scaled down in physical size and illuminated with identically wavelength-scaled electromagnetic radiation, has become a proven and practical method of obtaining the radar signatures of full-size targets [1].

The use of submillimeter-wave radiation for scale model RCS measurements was first reported in the late 1970s [2] but the concept dates back to the work of Sinclair in the

1940s [3]. The early systems were based upon the use of optically pumped narrow-band submillimeter-wave lasers and are still typically used for generating frequencies above 700 GHz [2]. For frequencies below 700 GHz the use of solid-state multiplier chains (cascades of multipliers and amplifiers) is typically employed [4].

The University of Massachusetts Lowell's Submillimeter-Wave Technology Laboratory has devised a number of terahertz compact radar ranges for imaging applications, including RCS measurements, over the past 25 years [5]. Laser-based ranges have been developed to operate at frequencies as high as 1.56 THz [6] and solid-state ranges presently exist at 160 GHz [7] and 520 GHz [8].

The new 240 GHz compact range is based upon a fully polarimetric transceiver consisting of dual fast-switching, stepped, CW, X-band synthesizers driving dual X24 linearly-polarized transmit multiplier chains, and dual X24 local oscillator (receiver) multiplier chains. The low-noise 2-stage IF down-converter provides final 50-kHz signals input to DSP lockin amplifiers. The system provides high-resolution imaging typically measuring 3800 frequency points over 32 GHz of system bandwidth. This allows range resolution of the entire measurement chamber and, following identification of the appropriate target range bins, software range gating may be applied.

The following sections of this paper detail the 240 GHz transceiver including an overview of the compact range and transceiver layouts, software range gating including sample range profiles, and an overview of the calibration approach used. An ISAR image of a complex target is presented as sample data acquired with this system.

2. Compact Range

The 240 GHz compact radar range, shown in Figure 1, consists of four functional components; the transceiver, the collimating reflector, the target and calibration positioning system, and the data acquisition system.

Report Documentation Page

Form Approved
OMB No. 0704-0188

Public reporting burden for the collection of information is estimated to average 1 hour per response, including the time for reviewing instructions, searching existing data sources, gathering and maintaining the data needed, and completing and reviewing the collection of information. Send comments regarding this burden estimate or any other aspect of this collection of information, including suggestions for reducing this burden, to Washington Headquarters Services, Directorate for Information Operations and Reports, 1215 Jefferson Davis Highway, Suite 1204, Arlington VA 22202-4302. Respondents should be aware that notwithstanding any other provision of law, no person shall be subject to a penalty for failing to comply with a collection of information if it does not display a currently valid OMB control number.

1. REPORT DATE OCT 2010		2. REPORT TYPE		3. DATES COVERED 00-00-2010 to 00-00-2010	
4. TITLE AND SUBTITLE A 240 GHZ Polarimetric Compact Range for Scale Model RCS Measurements				5a. CONTRACT NUMBER	
				5b. GRANT NUMBER	
				5c. PROGRAM ELEMENT NUMBER	
6. AUTHOR(S)				5d. PROJECT NUMBER	
				5e. TASK NUMBER	
				5f. WORK UNIT NUMBER	
7. PERFORMING ORGANIZATION NAME(S) AND ADDRESS(ES) U.S. Army National Ground Intelligence Center, 2055 Boulders Road, Charlottesville, VA, 22911-8318				8. PERFORMING ORGANIZATION REPORT NUMBER	
9. SPONSORING/MONITORING AGENCY NAME(S) AND ADDRESS(ES)				10. SPONSOR/MONITOR'S ACRONYM(S)	
				11. SPONSOR/MONITOR'S REPORT NUMBER(S)	
12. DISTRIBUTION/AVAILABILITY STATEMENT Approved for public release; distribution unlimited					
13. SUPPLEMENTARY NOTES Antenna Measurements Techniques Association (AMTA), Atlanta, GA, October 2010, pp. 3-8. U.S. Government or Federal Rights License					
14. ABSTRACT A fully-polarimetric compact radar range operating at 240 GHz has been developed for obtaining Ku-band RCS measurements on 1:16th scale model targets. The transceiver consists of dual fast-switching, stepped, CW X-band synthesizers driving dual X24 transmit multiplier chains and dual X24 local oscillator multiplier chains. The system alternately transmits horizontal (H) and vertical (V) radiation while simultaneously receiving H and V. Software range-gating is used to reject unwanted spurious responses in the compact range. A flat disk and rotating circular dihedral are used for polarimetric as well as RCS calibration. Cross-pol rejection ratios of better than 45 dB are routinely achieved. The compact range reflector consists of a 60" diameter, CNC machined aluminum mirror fed from the side to produce a clean 27" FWHM quiet zone. In this paper a description of this 240 GHz compact range is provided along with an ISAR measurement example.					
15. SUBJECT TERMS					
16. SECURITY CLASSIFICATION OF:			17. LIMITATION OF ABSTRACT	18. NUMBER OF PAGES	19a. NAME OF RESPONSIBLE PERSON
a. REPORT	b. ABSTRACT	c. THIS PAGE			
unclassified	unclassified	unclassified	Same as Report (SAR)	6	

The transmit chains in the transceiver each produce approximately 1 mW average transmit power over 32 GHz of bandwidth centered at 240 GHz. This radiation is coupled to the transmit horn as an 8.5 degree FWHM beam via an orthomode transducer. The beam propagates 6.3 meters to the primary (antenna) mirror which collimates the beam and allows it to propagate downrange to the target location 10 m from the antenna mirror. Backscattered radiation from the target retraces the transmit path to the receive horn which has an identical pattern as the transmit horn. The backscattered signal is down-converted through several stages to the final IF of 50 kHz where a DSP lockin amplifier measures the signal amplitude and phase. The combined transmit and receive patterns result in a 27 inch, 3 dB diameter quiet zone at the target. The receive aperture is located adjacent to the transmit aperture resulting in a 0.3 degree bi-static system configuration.

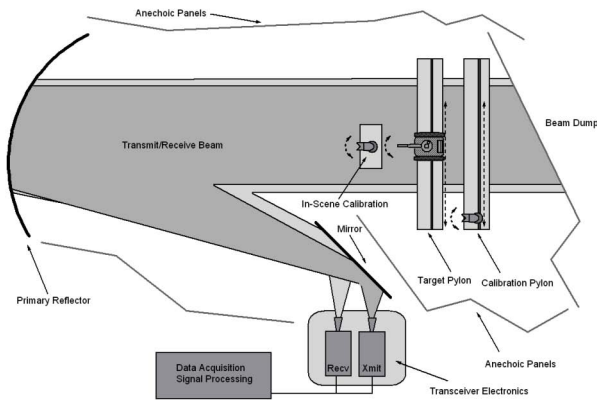

Figure 1 – Top View of Compact Range

The compact radar range primary reflector (antenna mirror) is a 1.5 meter diameter, 6.3 meter focal length, CNC machined, hand polished, aluminum mirror (See Figure 2). The mirror has an optical finish which greatly aids in the alignment of the system as well as testing of the antenna using optical techniques. The mirror is supported on an adjustable mount allowing fine changes in orientation for alignment purposes. The outer edge of the mirror is treated with custom designed anechoic [9] in order to reduce scattering of the beam.



Figure 2 – Primary (Antenna) Mirror in Compact Range with Surrounding Anechoic (Complex Target Simulator (CTS) and In-Scene Dihedral Visible in Reflection)

The target positioning system automates the measurement and calibration operations (see Figure 3). The positioner allows for the translation of the calibration, target and in-scene calibration object pylons into and out of the beam. The target pylon positions the target in azimuth and elevation. The calibration pylon is used to mount the ogive-terminated flat plate and dihedral calibration objects. The calibration dihedral can be rotated to any seam orientation via a high-resolution stepping motor equipped with an optical encoder. The in-scene calibration pylon is used to mount an ogive-terminated dihedral with the dihedral seam oriented to provide strong return signals in all four system channels. A detailed description of the calibration algorithm that is applied to the acquired polarimetric data during post-processing is given in reference [10].

The entire compact radar range chamber is covered with a custom fabricated, wedge-style material [9] designed at UMass STL. The anechoic is mounted onto large, movable panels which allows the angle of the anechoic to be optimized to reduce backscatter, minimize target-chamber interactions, and deflect unwanted radiation to appropriate areas of the chamber (e.g. beam dumps).

All target positioning and transceiver operations are controlled via a PC-based data acquisition system. All data acquisition and processing software are written in National Instrument's LabVIEW® graphical programming software. Data processing allows acquired data to be presented as TRCS plots, HRR profiles, and ISAR images.



Figure 3 – Front Angled View of Target Positioning System with Calibration Pylon at the Rear (Right), Target Pylon with Adjustable Elevation (Middle), In-Scene Calibration Pylon with Dihedral (Front-Left)

3. Transceiver

The transceiver consists of six modules: the two frequency synthesizers, the transmit multiplier chains module, the receive multiplier chains module, the IF and reference frequency converter, the I/Q demodulators (via lockin amplifiers), and data acquisition. A simplified diagram of these modules is presented in Figure 4.

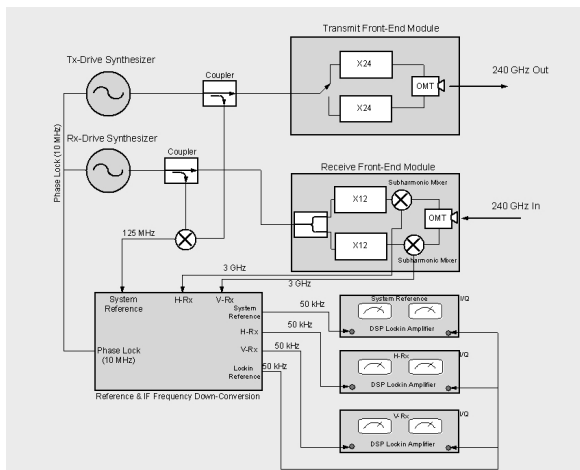

Figure 4 – Block Diagram of the 240 GHz Transceiver

The Rx-drive synthesizer provides X-band RF power (9.2083 GHz to 10.5417 GHz) for the receive front-end module, with one x12 frequency multiplier chain and subharmonic mixer for H-polarization receive and the other for V-polarization receive. The Tx-drive synthesizer provides X-band RF power (9.3333 GHz to 10.6667 GHz) for the transmit front-end module, with one x24 frequency multiplier chain providing H-polarization transmit and the other providing V-

polarization transmit. The frequency difference between the transmit and receive millimeter-wave signals results in a 3 GHz intermediate frequency (IF) which is down-converted to 50 kHz for lockin-amplifier detection and data acquisition.

The transmit and receive frequency synthesizers are phase-locked (10 MHz) with a 3 GHz oscillator, the output of which is down-converted to a 50 kHz signal and provided to each lockin amplifier reference input port. A portion of the power from the transmit and receive synthesizers are combined in a mixer to provide a 125 MHz difference frequency ($3 \text{ GHz} \div 24$) which is multiplied in frequency (x24) and subjected to two stages of frequency down conversion creating a complex system reference signal (termed “System Reference” in Figure 4), tracking phase variations of the synthesizers, that is phase-subtracted in software from the down-converted V-pol and H-pol lockin amplifier detected signals. The outputs of two additional system oscillators act as the LO input sources to each of the four separate 2-stage frequency down-converters in the system (e.g. V-Rx, H-Rx, Lockin Reference, System Reference).

(See Figure 5) The millimeter-wave multiplier chains are configured as separate V-pol and H-pol transmit and receive sub-modules joined at a common orthomode transducer (OMT), with one OMT for the transmit module (joining the V-pol and H-pol Tx chains) and one OMT for the receive module (joining the V-pol and H-pol Rx chains). The output (input) port of the transmit (receive) module includes a horn with an 8.5° FWHM pattern. The OMTs and horns were designed and fabricated by Custom Microwave Inc. (CMI). The millimeter-wave multiplier chains were designed and built by Virginia Diodes Inc. (VDI) with some minor component additions performed by UML-STL as part of system design and integration efforts.

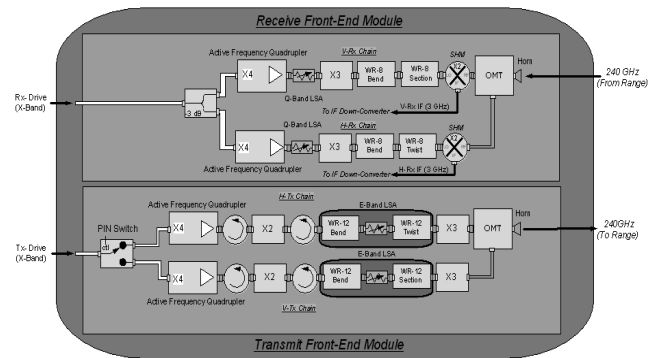

Figure 5 – Diagram of 240 GHz Transmit and Receive Multiplier Chains

Each transmit chain consists of an active frequency quadrupler followed by a varactor frequency doubler with a Q-band isolator on the varactor doubler input and an E-band isolator on the varactor doubler output port (See Figure 5).

The E-band isolator is followed by an E-band level set attenuator (LSA) custom built by Millitech Corporation, to specifications provided by UML-STL, to incorporate desired waveguide bends and twists into a single component. This was desired in order to reduce the overall electrical lengths of the transmit chains, with shorter chain lengths having been found to reach thermal equilibrium more quickly and remain stable for longer periods of time relative to electrically longer chain lengths (as noticed in systems built previously [4,7,8]). A varistor frequency tripler follows the output of each E-band LSA with the LSA adjusted to provide optimal drive power to the tripler over the system bandwidth. The output of each of the 240 GHz varistor frequency triplers is input to the appropriate port of the transmit module OMT. The system transmits a single linear polarization state at a time by employing a PIN switch at the input to the transmit module. The polarization purity (cross-polarization reduction) provided by the combination of the CMI orthomode transducer and horn is typically 25 dB.

Each receiver chain consists of an active frequency quadrupler followed by a Q-band LSA (attenuation set during design and characterization by VDI). A varistor frequency tripler is attached to the output of the Q-band LSA adjusted to provide the optimal LO power level to the desired WR3.4 subharmonic mixer (SHM). The RF signal to each SHM is provided by the output from the CMI OMT. The IF output from each SHM is a 3 GHz signal that is amplified and down-converted to a 50 kHz signal as discussed earlier in this paper. The 50 kHz down-converted V-pol and H-pol IF signals are detected by separate lockin-amplifiers with the I&Q voltages digitized with 16 bit A-D converters and stored for subsequent data processing.

4. Software Range Gating

In order to achieve accurate RCS measurements of targets any undesired spurious responses within the system must be isolated and removed. The 240 GHz system is a stepped-frequency CW system which allows the possibility of software range gating of data after the application of the Fast Fourier Transform (FFT) to the complex data set. The FFT transforms the acquired complex frequency domain data to range domain data at which point the desired target range bins may be windowed, essentially rejecting any system spurious responses falling outside of the target zone.

Examples of range plots generated with the 240 GHz system are provided in Figure 6 (Note that HV represents H-pol transmit with V-pol receive). The lower range plot of Figure 6 reveals the range response of the system from the zero reference plane to the end of the compact range (beam dump) with no target in the range. The upper plot in Figure 6 is of the chamber with a calibration flat plate (disk) present in the range. The various primary sources of scattering in the chamber are identified in each of the figures.

It is of interest to note the sources of the dominant range returns within the compact range chamber. Scattering from the treated edges of the antenna mirror as well as return from the beam dump at the rear of the range (just beyond the target zone) are clearly the primary contributors. However, range spurs are also produced by transceiver leakage and reflections near and upon the millimeter-wave module. Some additional range spurs are noticeable in the vicinity of the antenna (collimating) mirror, these are related to the fact that the mirror is slightly over-filled since the system horns were originally designed for a larger collimating mirror. The return arising from the suspended ceiling panel is due to scattering from the upper portion of the antenna mirror treated edge interacting with the edge of the suspended panel. Similarly the return from the anechoic panel apparent near 225 inches is also related to the over-fill of the antenna mirror and was found to actually be significantly improved by the presence of this panel at that location in the chamber.

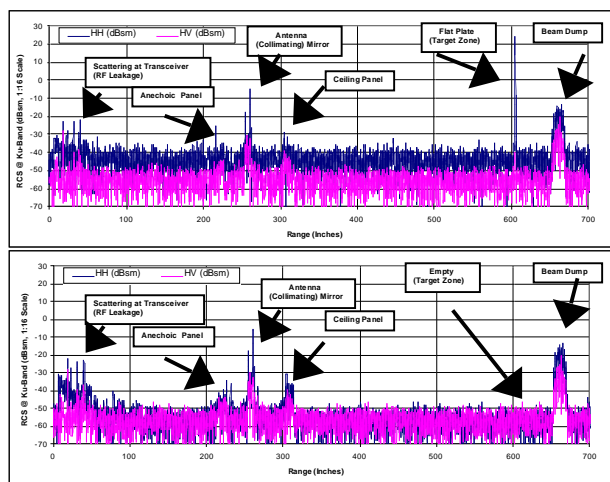

Figure 6 – Range Plots of 240 GHz Compact Range Measurement Chamber (HH & HV); Upper Figure with Calibration Plate in Chamber and Lower Figure without Plate in Chamber

The results of implementing the software calibration described in the next section of this report are confirmed by the better than 60 dB of cross-polarization rejection apparent at the range location of the calibration disk. (The RCS values presented in the plots of Figure 6 are scaled by 1:16 scale factor to represent full-scale data acquired at Ku-band).

5. Calibration

Fully polarimetric calibration is accomplished via implementation of the algorithm described by Chen et al. [10]. Two calibration objects with 1:16 scaled RCS values greater than approximately 20 dBsm are used in the calibration procedure. The calibration approach consists of the measurement of the flat plate in the range followed by a background measurement (empty chamber) and then two

measurements of a dihedral, one with seam at 90° (seam horizontal) and then with seam at 22.5° (providing significant simultaneous co and cross-pol responses). Each measurement consists of a set of averaged frequency sweeps with amplitude and phase measured at each frequency for the 4 possible system channels (linear polarization states) of HH, HV, VH and VV followed by complex subtraction of the acquired background data.

The system cross-polarization rejection ratio is improved from approximately 25 dB prior to calibration to better than 45 dB after software calibration (See Figure 7).

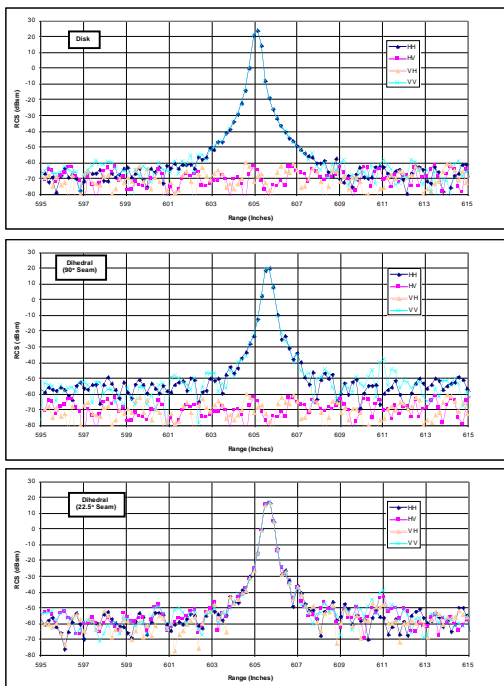

Figure 7 – Range Profiles of Calibration Object Measurements: Disk (Uppermost), Horizontal Seam Dihedral (Center), and 22.5° Seam Dihedral (Lower)

6. Measurements

The Complex Target Simulator (CTS), visible in Figure 8, is a complex model developed by STL in conjunction with the National Ground Intelligence Center (NGIC) and is used as a reference target during the development of various compact ranges. The CTS is a solid metal target which consists of several simple scattering centers positioned at strategic locations upon a tank-like silhouette. The scattering centers include dihedrals, trihedrals, frustra and a cone-sphere which each have well known scattering characteristics.

For this paper the CTS was mounted in a free-space configuration (on a pylon without a ground plane) and measured in the far-field. The system configuration was 32 GHz of bandwidth at a center frequency of 237 GHz and an angular increment of 0.0283° . This configuration corresponds

to modeling of a (1:16 scale) Ku-band system employing a center frequency of 14.8125 GHz with 2 GHz of bandwidth and a resolution of approximately 7.5 cm.



Figure 8 – Complex Target Simulator (CTS)

An RCS ISAR image of the CTS for HH (Co-Pol) with the target oriented at 247° Azimuth and 15° Elevation is included in Figure 9 (where the system transmit radiation is incident from the bottom of the figure). In the figure the RCS ISAR image is overlaid with a transparent CAD wire-frame model of the CTS. The RCS values (in dBsm) are scaled to Ku-band (taking into account the 1:16 scale factor) whereas the x and y axes dimensions are maintained at the actual model scale (in Inches) in order for the reader to better visualize the actual system resolution.

The return from the five corner reflectors along the lower edge of the CTS are easily visible demonstrating the excellent spatial resolution of the system (notice the scale in Inches). The RCS values presented by the scattering centers on the CTS vary from approximately +6 dBsm for the cone-sphere to as low as -40 dBsm for the small corner reflectors, while still being well above the noise floor of the system. This variation demonstrates the excellent dynamic range of the transceiver. The white trapezoidal region noticeable on the left side of Figure 9 is a structure which is part of the CAD model and should not be confused with the ISAR RCS portion of the figure.

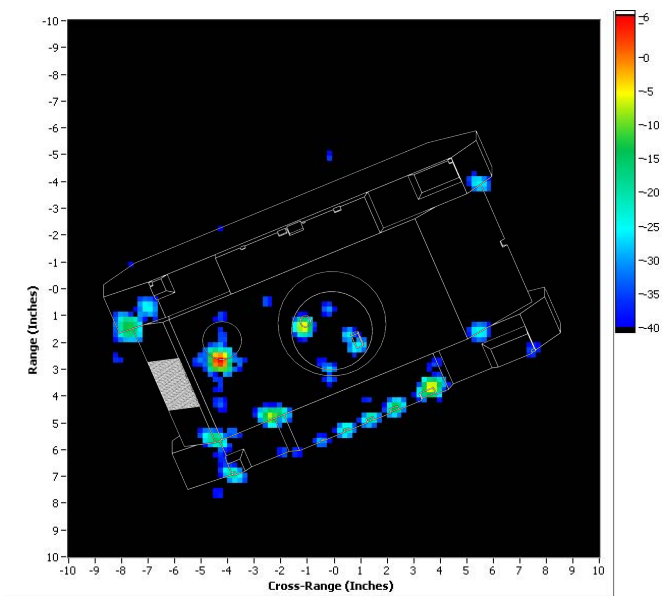

Figure 9 – An Example of Ku-Band (1:16 Scale) RCS (dBsm) ISAR Image of the CTS (247° AZ, 15° EL, HH Polarization) Overlaid with Transparent Wire-Frame CAD Drawing of CTS

7. Summary

A fully polarimetric compact radar range based on two X-band sources (synthesizers) driving x24 multiplier transmit and receive chains to produce (and receive) radiation at 240 GHz has been described. The system uses software range gating and calibration techniques to achieve a clean target profile with cross-pol rejection ratios greater than 45 dB. Because high fidelity scaled targets are relatively inexpensive to fabricate and the space requirements for this form of range are modest, submillimeter compact ranges have proven to be a cost effective viable complement to full-scale compact ranges and computer RCS prediction codes.

An ISAR image of a complex object (Complex Target Simulator) was presented to demonstrate the excellent performance of the system in terms of dynamic range and spatial resolution.

8. REFERENCES

- [1] Currie, Nicholas C. (Editor) August 1994, "Radar Reflectivity Measurement: Techniques and Applications", Norwood, MA, Artech House, Inc., 1989
- [2] Waldman, J., et al., "Submillimeter Model Measurements and their Application to Millimeter Radar Systems", Fourth Int. Conf. on Infrared and Millimeter Waves and Their Applications, Miami Beach, FL. December 10-15, 1979, pp.49-50

- [3] Sinclair, G., "Theory of Models of Electromagnetic Systems", Proc. IRE, Vol. 36, No. 11, Nov. 1948, pp.1364-1370

- [4] Coulombe, M.J., et al., "A 585 GHz Compact Range for Scale Model RCS Measurements", Proceedings of the Antenna Measurements and Techniques Association, Dallas, TX, 1996, pp.239-244

- [5] Coulombe, M.J., et al., "Submillimeter-Wave Polarimetric Compact Ranges for Scale Model Radar Measurements", Microwave Symposium Digest, 2002 IEEE MTT-S International Volume: 3 2002, pp.1583-1586

- [6] Dickinson, J.C., et al., "High Resolution Imaging using 325 GHz and 1.5THz Transceivers", Fifteenth International Symposium on Space Terahertz Technology (STT2004), April 27-29, 2004 Northampton, MA

- [7] Coulombe, M.J., et al., "A 160 GHz Polarimetric Compact Range for Scale Model RCS Measurements", Proceedings of the Antenna Measurements and Techniques Association, Seattle, WA, Oct. 1996

- [8] Coulombe, M.J., et al., "A 520 GHz Polarimetric Compact Range for Scale Model RCS Measurements", Proceedings of the Antenna Measurements and Techniques Association, Monterey, CA, Oct. 1999

- [9] Giles, R.H., et al., "Tailoring Artificial Dielectric Materials at Terahertz Frequencies", Proc. of Fourth Int. Symp. Of Space THz Technology, Los Angeles, CA, 1993

- [10] Chen, T.J., et al., "A New Calibration Algorithm of Wide-Band Polarimetric Measurement System", IEE Trans. Of Antennas and Propagation, Vol. 39, No. 8, August 1991

9. ACKNOWLEDGMENTS

The authors wish to thank David Jillson (UML STL – Electrical Engineer) for efforts involved in RF and DC wiring of the system; Lucille DeRoeck (UML STL – Range Engineer) for acquiring the sample ISAR data presented in this paper and taking the photos of the antenna mirror (Figure 2) and Complex Target Simulator (Figure 8) used in this paper; as well as Brett Goldberg (UML STL – IT Systems Administrator) for assistance with the CAD/ISAR image overlay.

This work has been supported by the U.S. Department of the Army National Ground Intelligence Center (NGIC).