

Anti-aircraft **JOURNAL**

MARCH-APRIL, 1949

A COMBINED EFFORT

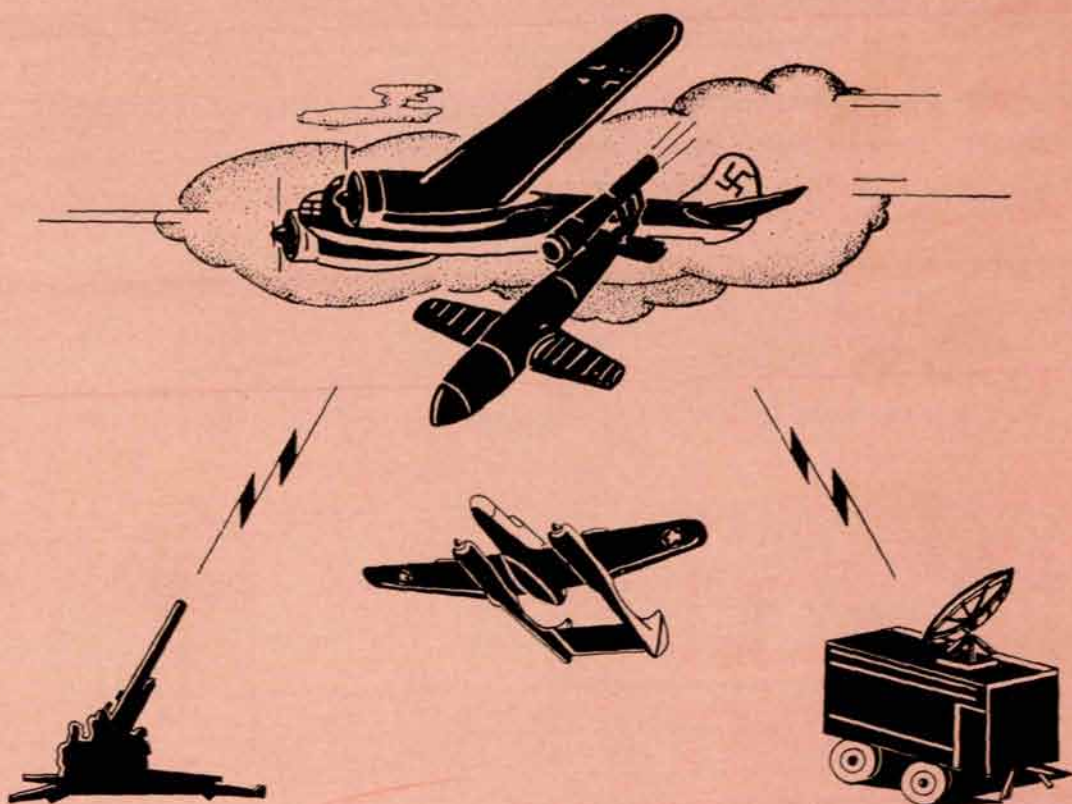

AAA

FIGHTERS

EARLY WARNING

Featuring IX Air Defense Command

Report Documentation Page

*Form Approved
OMB No. 0704-0188*

Public reporting burden for the collection of information is estimated to average 1 hour per response, including the time for reviewing instructions, searching existing data sources, gathering and maintaining the data needed, and completing and reviewing the collection of information. Send comments regarding this burden estimate or any other aspect of this collection of information, including suggestions for reducing this burden, to Washington Headquarters Services, Directorate for Information Operations and Reports, 1215 Jefferson Davis Highway, Suite 1204, Arlington VA 22202-4302. Respondents should be aware that notwithstanding any other provision of law, no person shall be subject to a penalty for failing to comply with a collection of information if it does not display a currently valid OMB control number.

1. REPORT DATE APR 1949	2. REPORT TYPE	3. DATES COVERED 00-03-1949 to 00-04-1949			
4. TITLE AND SUBTITLE The Coast Artillery Journal. Volume 92, Number 2, March-April 1949		5a. CONTRACT NUMBER			
		5b. GRANT NUMBER			
		5c. PROGRAM ELEMENT NUMBER			
6. AUTHOR(S)		5d. PROJECT NUMBER			
		5e. TASK NUMBER			
		5f. WORK UNIT NUMBER			
7. PERFORMING ORGANIZATION NAME(S) AND ADDRESS(ES) Coast Artillery Training Center, Coast Artillery Journal, Fort Monroe, VA, 23651		8. PERFORMING ORGANIZATION REPORT NUMBER			
9. SPONSORING/MONITORING AGENCY NAME(S) AND ADDRESS(ES)		10. SPONSOR/MONITOR'S ACRONYM(S)			
		11. SPONSOR/MONITOR'S REPORT NUMBER(S)			
12. DISTRIBUTION/AVAILABILITY STATEMENT Approved for public release; distribution unlimited					
13. SUPPLEMENTARY NOTES					
14. ABSTRACT					
15. SUBJECT TERMS					
16. SECURITY CLASSIFICATION OF:			17. LIMITATION OF ABSTRACT	18. NUMBER OF PAGES	19a. NAME OF RESPONSIBLE PERSON
a. REPORT unclassified	b. ABSTRACT unclassified	c. THIS PAGE unclassified	Same as Report (SAR)	68	

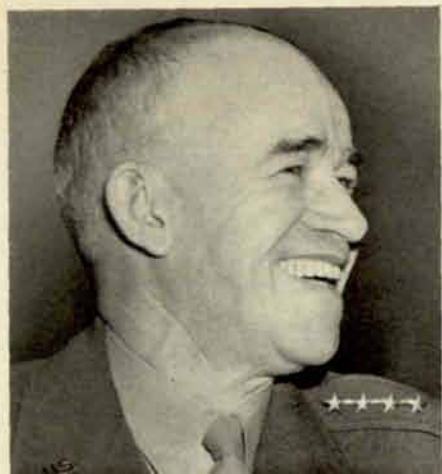

Statement by
GEN. OMAR N. BRADLEY
Chief of Staff
United States Army
ARMY DAY, 1949

The Army job in 1949 is no small task. As part of the defense team, we must give the citizens of the United States a full dollar's worth of security for a dollar spent. At the same time, we are trying to make the Army an interesting, appealing career, open to all. Men and women in the Army are making many personal sacrifices in the work of guarding the frontiers, and deserve the full support of the Nation in this great task.

We have pledged ourselves to a speedy, effective unity among the Armed Forces. Within our service, we are striving to build a team of mobile divisions trained and ready for instant use in case of emergency. And in our plans, we are relying on the rising strength of the National Guard and Reserve Corps for the broad base of any future mobilization.

In all these plans, we are pledged to a constant observance, in the true democratic tradition, of the right and dignity of the individual.

On Army Day, 1949, we of the Army restate these pledges, and invite your interest in the progress we are making in the accomplishment of the missions the people have assigned to us.

THE UNITED STATES
COAST ARTILLERY
ASSOCIATION

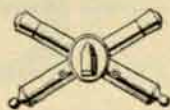

OFFICERS

LT. GEN. LEROY LUTES
PRESIDENT

MAJ. GEN. LYMAN L. LEMNITZER
VICE-PRESIDENT

COL. W. I. BRADY
SECRETARY-TREASURER

ADDITIONAL MEMBERS OF THE
EXECUTIVE COUNCIL

BRIGADIER GENERAL JOHN C. HENAGAN
COLONEL CHARLES M. BOYER
COLONEL PAUL H. FRENCH
COLONEL LEONARD L. DAVIS
COLONEL JOHN H. MADISON
LIEUTENANT COLONEL SAM C. RUSSELL
MAJOR BERGEN B. HOVELL

The purpose of the Association shall be to promote the efficiency of the Coast Artillery Corps by maintaining its standards and traditions, by disseminating professional knowledge, by inspiring greater effort toward the improvement of matériel and methods of training and by fostering mutual understanding, respect and cooperation among all arms, branches and components of the Regular Army, National Guard, Organized Reserves, and Reserve Officers' Training Corps.

The JOURNAL prints articles on subjects of professional and general interest to personnel of all the components of the Coast Artillery Corps in order to stimulate thought and provoke discussion. However, opinions expressed and conclusions drawn in articles are in no sense official. They do not reflect the opinions or conclusions of any official or branch of the Department of the Army.

The JOURNAL does not carry paid advertising. The JOURNAL pays for original articles upon publication. Manuscript should be addressed to the Editor. The JOURNAL is not responsible for manuscripts unaccompanied by return postage.

PUBLICATION DATE: April 1, 1949

Antiaircraft JOURNAL

Founded in 1892

Published from 1892 until 1922 as
THE JOURNAL OF THE UNITED STATES ARTILLERY

Published from 1922 until 1948 as the
COAST ARTILLERY JOURNAL

VOL. LXXXII

MARCH-APRIL, 1949

NO. 2

CONTENTS

Cover—A Graphic Illustration of the Combined Air Defense Team Activities of the IX Air Defense Command. <i>By Lt. Col. William L. Thorkelson, CAC</i>	2
Fort Bliss Low Cost Housing Plan. <i>By Brig. Gen. R. W. Berry</i>	9
About Our Authors	12
Self-Propelled AAA In Ground Support Of Infantry In Combat. <i>By Major Bergen B. Hovell, GSC (CAC)</i>	13
Missiles vs. Missiles	23
The Interception of Long-Range Rockets. <i>By Willy Ley</i>	24
1st Guided Missile Regiment	27
Byrnes Committee Submits Report On Future Of Guard and Reserve ...	29
Operational Aspects of Guided Missiles. <i>By Lt. Col. Howard B. Hudiburg, GSC and Lt. Col. Richard G. Thomas, CAC</i>	31
Preference Cards and Assignments. <i>By Col. Joe D. Moss, CAC</i>	34
The First Successful Firing Of A Two-Stage Liquid-Fuel Rocket. <i>By Lt. Col. James G. Bain, OD</i>	35
Report of Industry-Army Day Conference. <i>By Col. Harold R. Jackson, CAC, PMS&T, MIT</i>	36
AAA Should Be More Flexible. <i>By Captain Keith W. Bose, CAC</i>	37
Some Electronic Aids To Meteorology. <i>By Norman Abbott</i>	38
The Soviet Air Force	42
Fighter-Bomber Tactics	44
A German Antiaircraft General Speaks	46
Expendable Rockets. <i>By Kenneth W. Gatland</i>	47
News and Comment	48
Seacoast Service Test Section	53
Coast Artillery Orders	54
Coast Artillery Newsletter	55
Book Reviews	57

COLONEL W. I. BRADY, Editor
LIEUTENANT COLONEL RICHARD W. OWEN, Associate Editor
DR. ANCEL ST. JOHN, Technical Adviser
M Sgt Fred P. Presnell, Business Manager
Sgt Ralph N. Charleston, Cir. Mgr.
Sgt Fred A. Baker, Bookkeeper
Sgt Leo A. Donelon, Order Dept. Clerk



A

CTIVITIES OF

AIR DEF



THE IX DEFENSE COMMAND

By Lieutenant Colonel William L. Thorkelson, Coast Artillery Corps

Air defense as a coordinated operation of all means used to destroy, damage, or deter enemy aircraft in the air was a relatively new concept at the beginning of World War II. In 1943 the War Department charged the Army Air Forces with the responsibility of air defense. The IX Air Defense Command was organized in the European Theater of Operations by the Air Forces to execute this responsibility. The IX Air Defense Command combined fighter aircraft, anti-aircraft artillery, signal air warning units, and the necessary services under one commander. It was itself an integrated headquarters capable of handling all of these type units in varying numbers as the tactical situation dictated.

This article tells the story of the organization and functioning of the IX Air Defense Command in the European Campaign. The narrative is divided into three parts. First, the story of how the IX Air Defense Command was organized; second, a brief description of the various type units which were part of the Command and their functioning; and third, the narrative of the Command, its missions, how these were accomplished, and what changes were made in the Command at various times during the war.

Late in 1943 when the Ninth Air Force drew up the plans for an Air Defense Command, two ideas were foremost in the minds of the planning staff. First, to keep the fighters of their Tactical Air Commands concentrated on offensive missions; and second, to implement War Department Doctrine by organizing an Air Defense Command to execute the Air Forces responsibility of air defense. The mission of this Command was the protection of bases, lines of communications, and airfields of the Air, Ground, and Service Forces participating in operation "Overlord," the invasion of Europe.

In December 1943, a skeleton Air Defense Command headquarters was set up with personnel borrowed from the 51st and 52d AAA Brigades, and from the 118th AAA Group. On 30 March 1944, the organization of the IX Air

Defense Command was announced in War Department activation orders, and took its place as one of the major commands of the Ninth Air Force.

Brig. Gen. William L. Richardson arrived from the United States to assume command in December 1943. He was especially qualified to fill the position initially occupied by Brig. Gen. Dale D. Hinman, who was relieved because of illness shortly after his arrival in the United Kingdom. General Richardson's qualifications for this position included experience as director of combined training of the antiaircraft and air force units of the Fourth Air Force, and an earlier assignment as defense officer of the Eighth Air Force.

The IX Air Defense Command was composed of the three essential elements for air defense, namely, fighter aircraft, anti-aircraft artillery, and signal air warning units. During the period of its active operations in the European Campaign the number and type of these units varied. This will be covered more in detail later in the narrative.

Fighter aircraft assigned were of the night fighter type. In June 1944, two squadrons, each equipped with twelve P-61 Black Widow night fighters, joined the Command. At the same time Mosquito night fighters of 85th Group (RAF) were placed under the Headquarters to bolster the fighter aircraft strength. These fighters were used on night interception missions. Also, although not assigned, a number of day fighter squadrons were earmarked by the Commanding General, Ninth Air Force, for the augmentation of this Command.

Control of the fighter aircraft was exercised from provisional air defense wings, through the fighter control centers. Likewise, operational control of anti-aircraft units was exercised from the wings through the control centers. This is shown diagrammatically in Figure 1. The provisional air defense wings were formed to simplify the control problem of air defense, each wing being responsible

for a portion of the total area defended by the Command.

Fighter Control Squadrons operated the Wing fighter control centers and manned the Direction Finding and Ground Control Intercept Stations so essential to the actual positioning of the fighter aircraft on intercept missions.

Antiaircraft units in the IX Air Defense Command were the normal ones with which the reader is familiar, but the number of AAA units assigned is a rather startling figure. For instance, on 4 February 1945, there were 8 brigades, 8 operations detachments, 14 groups, 7 mobile gun battalions, 14 semimobile gun battalions, 6 mobile AW battalions, 20 semimobile AW battalions, and 4 searchlight battalions. In addition to these major antiaircraft units there were a number of supporting units, such as Ordnance Battalions, Ordnance Maintenance Companies (AA), Signal Radar Maintenance Units, Engineer Searchlight Maintenance Units, and a Radio Controlled Target Detachment.

The principal signal units were the Signal Air Warning Battalions. These battalions, with a flexible organization changed to fit a particular type mission, were the chief source of long-range early warning information essential for an air defense system. Similar units assigned to the Tactical Air Commands of the Ninth Air Force provided additional long-range warning information. In practice, the signal battalions with the Tactical Air Commands were employed well forward, while this Command's signal battalions were deployed to fill in the gaps not covered by the others. By a

mutual exchange of information the most complete long-range warning coverage possible was obtained.

In January of 1944, after completing its initial organization, the Air Defense Command planned for the coordinated air defense of Ninth Air Force and Communications Zone installations during operation "Overlord." This, together with preparation for the combined training of air, AAA, and signal troops in the performance of their air defense mission, was the first task of the Command.

During February and March, antiaircraft units in increasing numbers began to arrive in the United Kingdom and a number of them were attached to the Command, being utilized to defend Ninth Air Force operational airfields while others were given additional combined training with air force units.

To implement the mission of training and airfield defense, an AAA brigade with its attached AAA units was made available to each of the tactical air commands of Ninth Air Force. The first brigade to be used in this manner was the 51st AAA Brigade, commanded by Brig. Gen. Charles C. Curtis, which worked with the XIX Tactical Air Command, then located at Middle Wallop, England. AAA units of this Brigade engaged in both the defense of XIX Tactical Air Command airfields and in combined air defense training with XIX Tactical Air Command flying units. The teamwork and efficiency demonstrated by this Brigade-Tactical Air Command arrangement established

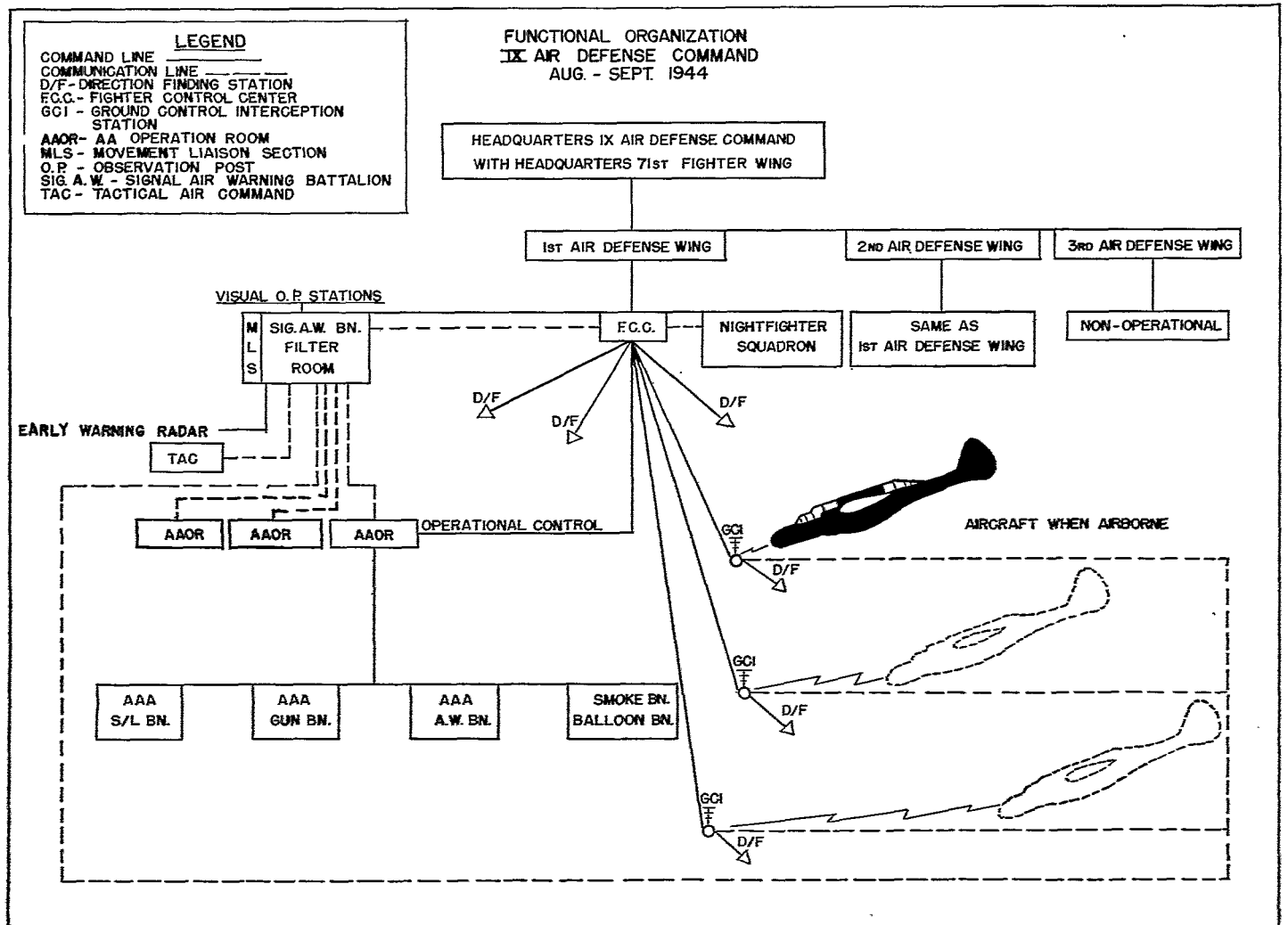

AAA UNITS WHICH SERVED WITH IX ADC, ETC.

BRIGADES

31st (Chapin)
47th (Finley)
50th (Armstrong)
51st (Curtis)

52d (Burnell)
54th (Hickey)
56th (Badger)
74th (Meyers)

GROUPS

17th (Adams)
21st (Betha)
22d (Mabbot)
29th (Putnam)
30th (Russell & Stark)
31st (Scott & Heilfron)
45th (Forman)
71st (Lewis)

80th (Cole)
92d (McCaulstland)
105th (Turnbull)
108th (Mitchell)
114th (Dunn)
118th (Campbell)
213th (Bowers)

AAA SEARCHLIGHT BATTALIONS

225th (Terrill)
226th (Gearhiser)

231st (Root)
357th (Adams)

AAA GUN BATTALIONS (MOBILE)

118th (Guiney)
125th (Land)
126th (Robbins)
133d (Mayer)

136th (Langston)
143d (Fleming)
184th (Albergotti)

AAA GUN BATTALIONS (SEMIMOBILE)

112th (Eubank)
113th (Heilfron)
114th (Sommers)
167th (Murrin)
405th (Johnson)
407th (Coles)
414th (Toenes)

494th (Armstrong)
495th (Brandon)
519th (Key)
601st (Shafer)
602d (Forbes)
605th (Echtermach)
940th (Boynes)

AAA AW BATTALIONS (MOBILE)

439th (Durgin)
451st (Snyder)
558th (Frank)
564th (Nash)

566th (Sandifer)
568th (Fuller & Nestor)
893d (Utke)
894th (Chandler)

AAA AW BATTALIONS (SEMIMOBILE)

204th (Watson)
385th (Hayman)
386th (Gibbs)
391st (Stahl & Owen)
397th (Straub)
400th (Hempstead)
480th (Martin)
481st (McCall)
491st (Roemer)
776th (Johnson)

784th (Haynes)
787th (Stark & Parsell)
788th (Sack)
789th (Lowry)
791st (Catlett)
792d (Budd)
794th (Morgan)
795th (Borum & Walker)
863d (Warrick)
896th (Anderson)

a policy that was followed by this Command throughout operations in the European Campaign. This teamwork on the Brigade-Tactical Air Command level was carried down to the lower echelons wherein one or two batteries of an automatic weapons battalion were teamed with a fighter group whose airfield they were defending. As far as was possible the team of AAA and fighter units was kept together. The effectiveness of this combination was later demonstrated during the German Air Force raids of 1 January 1945.

Another early mission of the IX Air Defense Command in the spring of 1944 was training Ninth Air Force ground crews to use antiaircraft machine guns. To supplement the AAA defense of airfields, salvaged aircraft machine guns were placed on improvised AAA mounts and manned by airfield ground crews. By D-Day over 800 officers and enlisted men of the various Ninth Air Force units had received this training.

Meanwhile, combined training of the newly arrived night fighter squadrons, AAA units and the signal air warning battalions was initiated. A training area of about 20,000 square miles was selected on the east coast of England between the Tyne and Humber Rivers, and the signal air warning battalions were ordered there under simulated tactical conditions to deploy and to provide early warning for vital installations within the area. Control was exercised through a combined operations center established near Newcastle-on-Tyne. Here, P-61 aircraft flew intercept missions using ground controlled interception techniques. As training and teamwork progressed on the part of all concerned, 20 or more interceptions a night were not unusual.

Use of searchlights for night homing of lost aircraft proved so successful in this training period that it was continued throughout the war. However, although in subsequent operations on the Continent, searchlights were used a majority of the time for night homings, their primary

mission of illuminating hostile aircraft for automatic weapons was never changed.

As D-Day approached, the staff of the IX Air Defense Command Headquarters had been built up to the point where it was fully integrated. Officers representing all of the arms used for air defense: air force, antiaircraft artillery, signal, and the services, were now assigned to appropriate staff sections in the Headquarters. It was capable and trained to handle any number and type of combined arms used in air defense.

The 71st Fighter Wing joined the Command early in June and supervised the night fighter squadrons. Meanwhile, some antiaircraft units of the Command were positioned to defend marshalling areas and troop carrier fields as these were the most vulnerable targets in the preinvasion days. Attacks on them by the German Air Force were anticipated. Other battalions reverted to Army control for movement to the Continent. Armies were to assume responsibility for their own rear area defense until such time as the initial beachhead was large enough to permit establishment of a IX Air Defense Command defense of the Communications Zone.

When the first V-1 flying bomb attacks against England came on the night of 12 June 1944, units of the IX Air Defense Command were in position to take effective action against them. The 21st AAA Group's battalions, firing from positions in Kent, destroyed ten flying bombs during the first 11 hours of the initial attack. The night fighter squadrons were also used against them with some success.

On D-Day, 6 June 1944, an advance element of the IX Defense Command Headquarters landed immediately following the assault waves to maintain liaison with the Armies and Ninth Air Force. However, the complete functioning of the Command as an Air Defense Headquarters did not start until 26 July 1944, at which time the mission of night fighter defense of the Cherbourg peninsula was assigned.



The P-61 Black Widow night fighter with which the 442d and 425th Night Fighter Squadrons were equipped.

This was accomplished with the 422d Night Fighter Squadron and the Mosquito night fighter aircraft of the 85th Group (RAF). The following day, 27 July 1944, a SHAEF decision attached all AAA units in or scheduled for use in the Communications Zone to IX Air Defense Command. These attachments became effective 7 August 1944 and from that date to the end of the European Campaign, air defense was provided in rear of the Army Rear Boundary and later in rear of the Army Group Rear Air Boundary by this Command. Operations were executed in conformity with SHAEF Operational Directives.

In Figure 1 is a chart showing the functional organization of the IX Air Defense Command from early August 1944 to the end of September 1944. Brig. Gen. Ned Schram was in command during this period.

The means available to the Command had to be apportioned to give an effective defense of the most vital installations. Obviously, all installations could not be given a theoretically perfect defense. The night fighters provided defense against individual enemy aircraft at night, while AAA provided both day and night defense for objectives that warranted it. Selection of installations to be given anti-aircraft defense was made on a priority basis, ordinarily by the brigade commanders, who were in the best position to make final decisions. Each brigade was sent a letter of instructions which included a statement of communications zone installations, and Ninth Air Force Airfields and installations to defend. The relative importance of the Air Force sites was obtained by the brigade commander directly from the Commanding General of the Tactical Air Command with which his unit was teamed. Communications Zone installations were listed in the instructions in the order of their relative importance as determined by the Commanding General, Communications Zone. Constant changes were made in the letters of instructions in keeping with the tactical situation.

From the time of the Invasion through the summer months of 1944 it became increasingly apparent that our tactical air forces had very effectively reduced the German Air Force to a point where it could operate but sparingly. Therefore, the threat was less than anticipated in earlier planning. At the same time our tactical air forces needed all available planes to spearhead the rapid advance of the

Armies. Accordingly, in October 1944, the Commanding General, Ninth Air Force, decided that more efficient use would be made of the night fighter squadrons by releasing them from assignment to the IX Air Defense Command and placing them with the Tactical Air Commands for offensive missions. As a result of this decision, the night fighter squadrons were assigned to IX and XIX Tactical Air Commands in early October and the Fighter Control Squadrons to XIX Tactical Air Command on 5 November, while the provisional air defense wings were disbanded. Concurrently, the 71st Fighter Wing was relieved from the Command that it might be used as the nucleus for the First Tactical Air Force, Provisional.

The loss of the night fighter aircraft and their auxiliary units did not change the mission of the IX Air Defense Command but merely the manner in which the mission was performed. It was agreed by the Commanding General, Ninth Air Force, that should the German Air Force threat to vital installations increase to the point where AAA could not by itself accomplish the mission, fighter aircraft would be placed at the disposal of the IX Air Defense Command. In the meantime, air defense would be provided by AAA and Signal Air Warning units.

On 23 November the air defense mission of the IX Air Defense Command was extended to cover all the territory in Southern France behind the rear boundary of the Seventh Army. At the same time more AAA units were attached to the Command. This expansion included the important ports of Marseilles, Toulon, and Port de Buc, and also a large number of bridges and marshalling yards. With this expansion, units of the Command were located throughout France and a large portion of Belgium, from the channel port of Cherbourg to Metz, and from the South Coast ports of Marseilles to the inland port of Antwerp.

The story of "Antwerp X" and the IX Air Defense Command troops which defended the important supply port of Antwerp against the German V-1 attacks from October 1944 through March 1945, has been told in detail in the September-October 1945 issue of the *COAST ARTILLERY JOURNAL*. Antwerp was defended largely by anti-aircraft artillery units of the IX Air Defense Command, which were requested by the British for these defenses because of the demonstrated superiority of American AAA guns and fire control equipment. Although operational control was exercised by the British 21st Army Group, the training, supply, and administration of these units remained a responsibility of this Command.

A-2 estimates made early in December indicated that there had been a substantial build-up in enemy fighter and fighter-bomber forces in Western Germany. Further, it was predicted that a penetration in force to a distance of 60 miles behind the front lines was possible, and that such effort was likely to occur between the First and Ninth Armies within two weeks. AAA commanders were advised accordingly. Emphasis was placed on the dispersal of equipment and supplies on airfields and other vital installations. Every effort was made by this Command to have a minimum AAA defense of two automatic weapons batteries for all forward airfields.

This A-2 estimate proved extremely accurate, for in the middle of December the Ardennes Offensive of the German Army was launched. A number of AAA units of the IX Air Defense Command were in the path of the German thrust. These, and other units hurriedly rushed from the Antwerp X defenses, were placed under the First Army to meet the emergency. In all a total of 1 brigade, 4 groups, and 21 battalions were attached for operations to the First Army during this critical period. These units were principally assigned antitank roles, although some were used to provide AAA defenses of vital supply establishments.

The morning of 1 January 1945 brought the long expected German Air Force attack on Allied Tactical airfields. Methodically and thoroughly planned, the German effort was not as brilliantly executed. Furthermore, the attackers were met by a well trained, efficient air defense team. Here the value of the signal air warning—fighter aircraft—AAA combination proved its merit. This was clearly demonstrated at Y-29, Asch, one of the many airfields attacked. Five minutes of warning was provided by the long-range signal air warning units. Fighter aircraft returning to this field from a raid were directed to intercept the attacking planes. In the ensuing action, friendly aircraft had to rearm and refuel. As the fighters came in to land, German aircraft followed them, but the AAA on the field engaged and drove off or shot down the attackers. Out of a probable 50 enemy aircraft the fighter destroyed 35 and the AAA 9. When the action was over, the Airfield Commander was asked if he thought a "hold fire" order for the AAA would have given greater freedom to his planes. He replied that a "hold fire" was not necessary, for he had complete faith in the AAA defending the field. This is a result of the fact that this AAA-fighter team had been together for a long period of time.

Shortly after the January First raids, the enemy's jet-propelled aircraft became increasingly more important, and steps were taken to combat the type attack anticipated from these planes. All of the IX Air Defense Command units were alerted to the new threat, and the same information was passed to the Army AAA sections. Specific action taken included turning in the M5 directors in all but six of the automatic weapons battalions and utilization of this personnel for additional AAAS OP's, issuing additional SCR 543 radio sets to be used in the warning nets of battalions located within ME 262 range, placing one AN/TPS2 early warning radar on all forward airdromes, and installing high-speed traversing gears on all 40mm guns. Although units of this Command were thus prepared for jet attacks, and several abortive attacks were made, the threat did not materialize to the extent anticipated. This can be attributed to the fact that on the attacks made which were judged to be reconnaissance flights, the German found no weakness in the defenses. He did not choose to attack in force vital installations well protected by AAA.

The air defense responsibility of this Command up to 19 January 1945 had included all of the Communications Zone. When Ninth Air Force airfields were in Army area, and the Army did not have sufficient AAA to defend these fields, units of this Command were attached to the Army for this task, which necessitated constant changes of command. The Supreme Commander, after a review of the air

defense problem in the theater, directed the establishment of a clear-cut division of air defense responsibilities between the Armies and Air Defense Command.

This division was a line known as the Army Group Rear Air Boundary, or more commonly referred to as the AGRAB line. It was first promulgated on 19 January 1945. The air defense responsibility of everything in rear of the AGRAB line was then vested in the Air Defense Command, and that forward of the line with the Armies. Since the line was established normally well forward of the Army Rear Boundary, the Army Commanders were then free to conduct ground operations without constant distractions arising from the problem of air defense. No longer, except when forward of the AGRAB line, which was exceptional, was it necessary to attach AAA units of this Command to the Armies for protection of airfields or vital Communications Zone installations within the Army area.

With the advance of the Armies in the early spring offensive, the German Air Force, already reduced to a state of impotence by the Allied Air Forces, was further hampered in its operations by the loss of many airfields. In the last stages of the war, the German Air Force was very ineffective. Isolated attacks were made on rear area installations, but its strength was used on targets of more immediate tactical importance, such as the Remagen bridgehead and some of the Third Army Rhine River crossings. As the Armies continued to advance farther into Germany, the air defense and ground security of the Rhine River crossings became the responsibility of the IX Air Defense Command and here were concentrated most of the units of the Command at the end of hostilities.

Also, as the war drew to a conclusion 13 battalions were turned over to Communications Zone for prisoner of war guard units. With the unconditional surrender of the German Armed Forces, most of the remaining battalions of this Command were placed on Ninth Air Force airfields for an interim mission of airfield security pending redeployment. Two groups and six battalions were utilized under the Ninth Air Force Service Command Disarmament Division for the disarmament of German flak installations.

This narrative has touched the highlights in the many activities of the IX Air Defense Command. In the opera-



An automatic weapons fire unit prepares for engaging group targets—Europe 1944.

tion of this Command, two major difficulties were encountered. First, air defense in practice was new in our armed services and not everyone understood its functioning. Second, being an Air Force headquarters with a large proportion of Ground Force troops, a division of administration and supply responsibilities resulted. These administrative and supply difficulties were aggravated by the fact that the AAA units were attached to the Command, not assigned. In the spring of 1945, this policy was changed

and units were placed on an assigned basis.

The IX Air Defense Command demonstrated that an integrated air defense headquarters possessed the necessary flexibility so that the number and type of air defense troops could be varied as the situation dictated. The teamwork of air, antiaircraft, and signal air warning units under one commander was so successful that not one important vital area defended by this Command received more than slight damage from what was the greatest air force in the world.



THE AFFAIR AT SCAURI*

By Colonel William T. Fitts, Jr., Infantry**

The souvenir-hunting antiaircraft gunner wouldn't even tell the General how he had walked unmolested into a German-held town and out again with three prisoners.

In April, 1944, the 85th Division was occupying a position on the western side of the Italian boot south of Rome. Its left flank rested on the shore of the Mediterranean just south of the little resort town of Scauri. The Germans had incorporated Scauri into the organized position that ran through Cassino clear across the peninsula. Scauri's stone and brick buildings were nearly all demolished, but its basements had been made into pillboxes and it bristled with automatic weapons. Mine fields were everywhere, and a huge antitank trench ran across in front of it. Just back of the town was a hill called Mount Scauri from which the Germans had excellent observation over that part of our line. Any daylight movement on our part in front of Scauri was the signal for the Germans to open fire. In consequence, our outposts stayed in their holes during the day and were relieved at night. We were anxious to obtain prisoners, but were seldom able to do so, as the Germans were aggressive and just as anxious to get prisoners from us. Our patrols went out at night and had plenty of fights, but got few prisoners.

One day our luck changed, and in a way that was the talk of the division for a long time. On this particular day a man on outpost duty saw an American soldier moving toward Scauri near our front lines. He halted the soldier and found that he was a member of one of the AA gun teams

located near by. When told how dangerous it was to move in that area, he seemed unimpressed; and when asked what he was doing, he said he was hunting souvenirs. He was sent back to company CP by a covered route, where he was again warned of the danger of being in the open in that area. He declared, however, that he had been up there before and that if given permission to pass our lines he would bring back a prisoner. He talked so convincingly that finally he was told to go ahead. He disappeared in the direction of Scauri. Some time passed without any sign of him, but finally the outpost saw a procession heading out of Scauri—three krauts and the antiaircraft soldier. Not a shot was fired at them as they came through our outpost line and went on back to the company CP.

There was much elation over our prisoners, but more amazement at the whole affair. How had this AA man gone into Scauri without being shot by the Germans, who always before had been only too anxious to shoot anything that moved? How had he found the Germans before they saw him? How had he induced them to surrender within their own stronghold and how had he been able to bring them back through their lines and ours without the whole place opening up on him? These and similar questions were immediately asked and partially answered. The AA gunner said he had simply walked in and wandered around town until he saw three Germans sawing timber to improve an emplacement, whereupon he covered them with his pistol and marched them home. As he was pressed for details he became more and more reticent and finally wouldn't say any more. The division commander even went up to see him, but the best he could get out of him was, "I have ways of my own, General."

There was lots of speculation as to how this man did it, but to this day, so far as I know, no one except the gunner himself knows how he went into Scauri, took three prisoners and came out alive. And he won't tell, or wouldn't.

*Reprinted with permission from the December 1948 issue of *Infantry Journal*.

**Colonel Fitts was Chief of Staff, 85th Division.

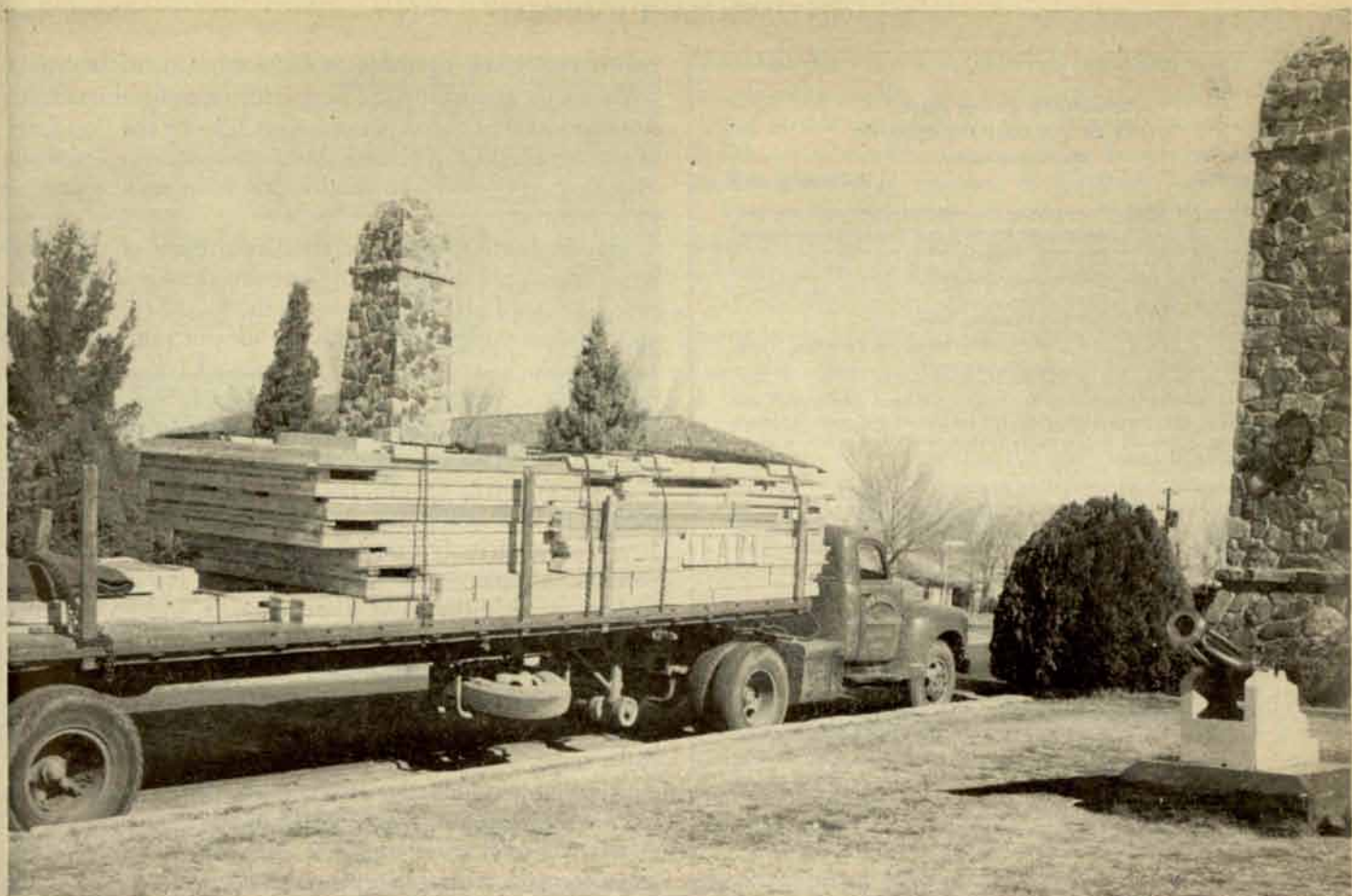

AAA and Guided Missile Center, Fort Bliss, Texas. Arrival of First House 0930 hours, Friday, 26 November 1948.

FORT BLISS LOW COST HOUSING PLAN

By Brigadier General R. W. Berry
President, Fort Bliss Housing Board

When the Fort Bliss Housing Board met for the first time in mid-September 1948 it was evident that the housing situation in El Paso was desperately acute and would deteriorate rapidly with the scheduled arrival of more officers and men to participate in the anti-aircraft expansion program. It also was evident that morale and efficiency were being affected adversely by local living conditions and that our sorely needed and highly trained enlisted specialists would not reenlist for Fort Bliss unless something were done. There was no possibility of obtaining housing in time to meet our most critical need by conventional appropriation and budgetary methods. There was considerable material available in the way of speeches, articles, letters and directives all emphasizing the critical nature of the problem but no solution. It looked as though Mark Twain's comment

on the weather was applicable to Army housing. A lot of people were talking about it but we still didn't have quarters for our married personnel.

Having decided that an unconventional approach was the only possibility, the Fort Bliss Housing Board developed the plan which is the subject of this article. It is not a cure-all, for the housing problem doesn't lend itself to solution by a single method. It is only one phase of the extensive program we are carrying out at Fort Bliss. Its great value lies in the speed with which it can produce houses; the fact that it is complete, practical and approved in all its details; and finally that it is applicable to any post in the United States which will be occupied on a permanent basis.

The Fort Bliss plan was initiated by the formation of an Association of 200 first three grade noncommissioned officers

DEPARTMENT OF THE ARMY
OFFICE OF THE ASSISTANT SECRETARY
Washington, D. C.

CSGLD/C2

28 December 1948

MEMORANDUM FOR: Commanding General,
Antiaircraft Artillery and Guided Missile Center,
Fort Bliss, Texas

THRU: Commanding General,
Fourth Army,
Fort Sam Houston, Texas

SUBJECT: Low Cost Housing Project at Fort Bliss, Texas

1. It is my understanding that you have formed a Housing Association of enlisted men at Fort Bliss, Texas, and that local civic leaders and bankers of El Paso have given their full support to this most important undertaking by loaning the necessary funds to erect houses for the members of the Association.

2. This project is of outstanding importance, not only to the Post of Fort Bliss, but to the Army as a whole, in that it aids in solving the critical housing situation at your station, and thereby contributes to improving the morale and efficiency of the Army. It also indicates what can be accomplished when military personnel cooperate with the local civilian communities adjacent to military installations.

3. The Fort Bliss Housing Association has my wholehearted support and approval and I desire that it be given your personal and continuing support, with particular attention to insuring proper management, adequate maintenance and full occupancy. Every possible legal effort must be made to insure that those who have supported us during the critical housing shortage do not suffer a financial loss thereby.

4. This letter will be placed on file in your headquarters, and in event of any future change in your assignment as Commanding General at Fort Bliss, you will personally deliver it to your successor in command with my express wish that he continue to render full support to the project.

/s/ Gordon Gray
The Assistant Secretary of the Army

who were at the top of the list awaiting assignment to the few existing Government quarters. Each of these noncommissioned officers bought membership in the Association with a \$300.00 down payment. They were assisted in this by the Army Emergency Relief which loaned up to \$250.00 to any individual who could not otherwise have raised the necessary amount.

The Association then went to the Department of the Army and procured a lease for fifteen years on a part of the Fort Bliss Military Reservation large enough to permit building 200 sets of quarters on 50' x 75' lots. The annual rental was based on 4% of the appraised value of the land. The lease is extremely favorable from the standpoint of the Association, particularly with respect to the termination clauses. These provide that the lease may be terminated by the Government only if rental is not paid or if there is a declaration of a national emergency by the President or the Congress of the United States. If the lease is terminated under the emergency provision, the Government will acquire title to any improvements made on the leased area by compensating the Association in an amount not greater than the appraised fair market value of such improvements. To determine this value appraisers will be selected, one by the Association, one by the Government, and a third, if necessary, by the first two.

The Department of the Army also made money available for the laying of sewer, water, gas and electric lines and for the construction of necessary roads in the leased area. The funds needed for this purpose were modest because the area selected was adjacent to existing utility lines, and is almost as flat as a billiard table. Also the subsurface was of such a

nature that black-top roads could be constructed with relatively simple foundations. The specifications for these utility lines and roads were prepared at Fort Bliss by the Post Engineer, checked in the Fourth Army and rechecked again in Washington to assure their adequacy from an Engineering standpoint.

Having been assured that the Department of the Army would do its share in carrying out the various steps of the plan, the Association next went to the local Sears, Roebuck and Company distributor with the idea of purchasing 200 packages each containing a prefabricated house and all of the required fixtures. The personnel of Sears, Roebuck picked up the idea with great enthusiasm, and to be sure of its feasibility and to accumulate exact data and specifications, delivered a sample house to Fort Bliss. This was erected on the leased area by members of the Association. It was an immensely valuable contribution to the plan as it permitted developing the most economical layout of utilities and an exact estimate of the materials and tools which would be needed.

The Sears, Roebuck package includes the house itself, a seven-cubic-foot electric refrigerator, a four-burner gas stove, a kitchen sink with drainboard and cabinet, shower bath, toilet, wash basin, medicine cabinet, space heater, electric light fixtures, hardware, nails, paint, electric wire, interior plumbing and gas pipes. In short, when put together it provides a complete house with necessary appliances to make it livable and usable. The total cost of the package delivered at Fort Bliss is approximately \$1500.00.

After the arrangements with Sears, Roebuck had been completed, the Association was in a position where it could build 200 sets of quarters if it could raise \$300,000. Of this, \$60,000.00 could be made available by the down payments of members of the Association. A loan of \$240,000.00 was necessary. On January 15th, Mr. John W. Cordts, President of the Southwest National Bank of El Paso, decided that the plan was so sound and the need so great that he loaned the Association \$55,000.00. This is permitting construction of the first group of houses, while the Association is seeking the additional backing necessary to complete the 200-unit project. This, as well as any other loan obtained is secured by a chattel mortgage on the houses, and backed by all other assets of the Association.

After negotiating the loan with the Southwest National



Erecting Gable of Prefabricated House. Two days—2½ Hours later.



Completed Prefabricated House. Four days—3½ Hours after arrival of materials.

Bank the Association ordered fifty Sears, Roebuck housing packages. The first carload of six arrived 22 February and thirty were on hand by March first. Construction is proceeding rapidly as the pictures testify. Men of every necessary skill are members of the Association. There are carpenters, painters, plumbers, electricians, pipe fitters, roofers, concrete experts, men who can construct the necessary concrete forms, artists, bookkeepers, surveyors and tinsmiths. These men have been organized into construction crews and are erecting the houses on their spare or leave time. So soon as a house is ready for occupancy a member and his family will move in. Houses will be allocated to members in order of their standing on the list of the Association.

Beautification of the area also has been considered. At present it is a bare, sandy plain, with a caliche base, much like the surrounding desert-type landscape. The plan is to plant grass, trees and shrubs in the areas around the quarters. This will prevent erosion and reduce the annoyance of dust storms. Two different colored roofs are being used and the color of the trim of each house matches the color of its roof. Rules and regulations governing the police of the area will serve to keep it attractive and make it a pleasant place in which to live.

The Constitution and By-Laws of the Association establish the structure under which the project will be operated. Rent will be \$40.00 per month. The first month's rent, payable in advance, will go into the working capital of the Association. Thereafter rent will be utilized to pay the following obligations: \$30.00 to the bank to amortize the loan; \$4.00 for gas, water and electricity charges based on the amount used; Insurance \$1.00; and rent of land 50¢. The remainder of the rent will go into the working capital of the Association.

If a member is ordered away from Fort Bliss the Association will return to him his down payment of \$300.00. This payment may be made entirely to the individual who paid the full amount himself; or part to the individual and that part to Army Emergency Relief which represents the unpaid balance of the original Army Emergency Relief loan to the individual. The Association thus will assure repayment of any loan made to the individual as part of his original down payment. Any new members taken into the Association will be required to make a down payment of \$300.00 so that the working capital of the Association will not be

reduced. After the bank loan has been completely paid off, which will be in less than four years, members will continue to pay rent at the same rate of \$40.00 per month. This will build up the working capital of the Association and permit each member to be returned his \$300.00 down payment.

Routine maintenance of the houses will be a responsibility of the occupant. Major repairs not caused by neglect will be financed by the Association. Under the Constitution and By-Laws, the Association reserves the right to inspect the houses and, if maintenance is not being performed satisfactorily, to cause necessary repairs to be made and charged to the occupant. This will be accomplished by the Association paying for the repairs and reducing by a corresponding amount the \$300.00 which the individual otherwise would receive.

The Association is administered by a Board of Governors consisting of five members elected for a period of one year and a manager appointed by the Post Commander, Fort Bliss, Texas. The manager is bonded and keeps all accounts, receives and disburses all monies, maintains correspondence files and records minutes of meetings. He acts as Secretary-Treasurer of the Association and as agent thereof in carrying out the directives of the Board of Governors which have been approved by the Post Commander. These directives will include all matters pertaining to administration and operation of the housing project, such as contracts for the purchase, erection or maintenance of housing units or appurtenances thereto, or mortgages on any property owned by the Association or sale of such property.

When the lease expires after fifteen years, the Association may remove its property and restore the area to its original condition, or with approval of the Department of the Army, leave the houses in place in lieu of restoration. These provisions of the lease will permit an equitable solution upon the termination of the fifteen-year lease period.

The foregoing plan harks back to the old American custom of accomplishing, by husking bees and barn raisings, tasks which were impossible of execution by a single individual or family. Notice that there have been utilized the combined efforts of the noncommissioned officers themselves, the Army Emergency Relief, the Department of the Army, the local bank, and the facilities of Sears, Roebuck and Company. The erection of the houses is being done as a community project with all members of the Association



Status of Construction on 2 March 1949. Volunteer Troop Labor Rush Building in Record Time.

contributing their skills to the accomplishment of the task. By having the individual members of the Association, supported by AER, contribute a down payment, and by having the Department of the Army defray the cost of extending utility lines and build roads, we have reduced the proportion of the funds which must be obtained from civilian lending agencies to only 60% of the total amount required. As a consequence, the Association will own houses which, according to a disinterested contractor, could not be duplicated in El Paso for less than \$4200.

One of the great advantages of the plan is the speed with which houses can be made ready for occupancy once the

groundwork has been laid. The Kelleher Manufacturing Company which produces the houses for Sears, Roebuck and Company delivered them to Fort Bliss starting two weeks after the order was placed at the rate of thirty per week. The houses are being erected as rapidly as Mr. Kelleher delivers them.

It is quite definite that all fifty will be occupied by the fifteenth of April and that the money for the remaining 150 houses will be made available in the near future. By late spring, 200 of our noncommissioned officers should be comfortably settled on the post in quarters belonging to the Fort Bliss Housing Association.

ABOUT OUR AUTHORS

Brig. Gen. Robert Ward Berry was graduated from the United States Military Academy June 1924, and was commissioned a second lieutenant, Coast Artillery Corps.

In August 1940 he was assigned to the Personnel Division, War Department, General Staff in Washington, D. C. He served with the General Staff throughout the war and was awarded the Legion of Merit, Distinguished Service Medal, and Order of the British Empire.

He recently returned from the Caribbean Defense Command, Canal Zone where he commanded successively the 76th AAA brigade, AA Defense Pacific Side and the Atlantic Sector. At present he is in command of the 35th AAA Brigade, Fort Bliss, Texas.

Col. Joe D. Moss is Chief of the Coast Artillery Branch, Career Management Group, Personnel and Administration, General Staff, United States Army. He commanded the 112th AAA Group in the European Theater.

Lt. Col. James G. Bain, Ord. Dept., is Chief of the Guided Missiles Section, Rocket Branch, Research and Development Division, Office Chief of Ordnance. He graduated from the United States Military Academy, West Point, in 1928 and was commissioned in the Coast Artillery Corps. During World War II, he commanded an AAA Battalion in Panama and was a member of the Developments Section, Headquarters, Army Ground Forces. He was detailed to the Ordnance Department in 1945 and transferred to that branch in 1947.

Lt. Col. William L. Thorkelson was commissioned a 2d Lt. CAC on 1 September 1939 by an honor graduate appointment. He served in Iceland as a battery commander and Executive Officer of the 26th CA Battalion. He joined the IX Air Defense Command in Jan. 1945 and assigned to the A-3 Section. From Feb. 1946 to Dec. 1946 was a member of General Clay's secretariat in Berlin, and on return to the US was assigned to the Plans Section of Army Field Forces. At the present time he is doing graduate work at Syracuse University in Public Administration.

Capt. Keith W. Bose enlisted in the 168th FA Regt. Colorado National Guard in 1936. He entered active Fed-

eral Service in Feb. 1941, attended AAAOCS, graduated and was commissioned in Nov. 1942. Subsequently assigned to the 413th AAA Gun Bn, he served overseas with this organization as S-2 and battery officer until March, 1945. Upon relief from active service he accepted a commission in the ORC until reentering the National Guard in 1947. Presently assigned as commanding officer, Battery A, 720th AAA Gun Bn. California National Guard.

Lt. Col. Richard G. Thomas, CAC, was commissioned in the Infantry in 1936 and was transferred to the CAC in 1940. During the war he was detailed in GSC. Since August 1947 he has been Assistant Director of the Guided Missile Department, AA & GM Branch, TAS, Fort Bliss, Texas.

Maj. Bergen B. Hovell, GSC (CAC), entered the Regular Army under Thomason Act in July 1940. As commanding officer of the 209th AAA AW SP Battalion in the Pacific Theater, he served at Luzon and in the occupation of Japan. He is now assigned to the Plans and Control Office Research and Development Group, Logistical Division of the General Staff.

Lt. Col. Howard B. Hudiburg, GSC, is assigned to the Air Requirements Section, Research and Development Group, Logistics Division, General Staff, United States Army. During World War II, he was Executive of the 31st AAA Group with the First Army and the IX Air Defense Command in Europe.

Norman Abbott has been associated with the research and development of Army radar equipment since 1940 as Chief Engineer on ground radar in the Engineering and Technical Division, Office of the Chief Signal Officer.

Mr. Willy Ley—one of the outstanding authorities on rockets. He came to this country from Germany in 1935 where he had been vice-president of the German Rocket Society before it was dissolved in 1933 as a result of Hitler's rise to power. For several years he was science editor of the New York daily, *PM*, but is now a research engineer with the Washington Institute of Technology.



Self-Propelled AAA In Ground Support Of Infantry In Combat

By Major Bergen B. Hovell, GSC (CAC)

This article is being published as an excellent example of a thought-provoking contribution on the dual role of AAA. It is understood that a number of the changes recommended by the author have been under study by Army Field Forces for some time, and the bulk of them have been incorporated in FM 44-1 now under revision.

Since the termination of hostilities, several important developments have focused attention upon the concepts of employment of self-propelled automatic weapons in the ground support role. The first, and most important, change was the designation of the self-propelled automatic weapons battalion as an organic element of the standard Infantry and Armored Divisions. Of almost equal importance was the development of new self-propelled weapons with improved characteristics that were designed to meet the exacting requirements established by the increased capabilities of modern aircraft and ground weapons.

At first glance, the assignment of the self-propelled automatic weapons battalion to the Infantry Division may appear to be merely an administrative change, but a careful examination of the new status reveals that the significance is more real than apparent since by this assignment the battalion becomes a member of the team of combined arms whose primary mission is the destruction of enemy *ground* forces.

When present concepts of employment of self-propelled automatic weapons are considered in the light of this new

status, it appears that they must be revised in order that SP's may be employed to the full limit of their capabilities. Basic AAA doctrine relegates the employment of self-propelled automatic weapons in the ground support role to the category of "secondary" mission based upon the premise that responsible commanders should not normally employ such units in that role as long as the threat of air attack is present. It is the purpose of this paper to recommend that this doctrine be modified to state that self-propelled automatic weapons units be assigned either of two *alternate* missions, namely, the antiaircraft mission or the ground support mission. It should further state that missions be assigned based upon the relative capabilities of enemy air and ground forces and upon the means available to meet them. It is believed that these changes would accord emphasis to the ground support mission commensurate with its relative importance and would encourage the development of the aggressive spirit that is essential to the conduct of successful ground support operations.

Since operations are undertaken when the results to be

gained justify the risks involved, it is obvious that a commander may decide to employ all or part of the self-propelled automatic weapons units in the ground support role while the threat of air attack is present if he feels that enemy ground forces offer the *greater threat to the successful accomplishment of his mission*. Based upon experiences of the last war, it is reasonable to assume that ground operations will continue long after the enemy air force has been neutralized and that in such operations self-propelled automatic weapons will be employed exclusively in the ground support role.

The proposed revision of basic concepts is based upon an analysis of ground combat operations of the 209th AAA AW Bn (SP) in the Luzon campaign. The designation of the unit and campaign are of interest only for historical purposes; the important considerations are the types of missions assigned and the effects of tactics, organization, state of training, and performance of equipment upon the degree of success attained.

The Battalion was never properly assigned the ground support mission—rather, it assumed it by increments. It had been organized as a mobile automatic weapons battalion and one battery had been awarded the Presidential Unit Citation for outstanding performance in the ground support role at Roosevelt Ridge in New Guinea in August, 1943. The Battalion later was reorganized as a self-propelled unit and the new equipment arrived just in time to be waterproofed for the landing at Lingayen. Several of the batteries fired courses at towed targets while they were en route to the landing beaches but the first effective practice was conducted against hostile air and ground targets during the capture and defense of Manila. Elements of the Battalion successively were assigned ground support missions with the 1st Cavalry Division in Manila; the 32d Infantry Division on the Villa Verde Trail; the 37th Infantry Division at Baguio; the 38th Infantry Division at Ipo Dam, Mount Purro, and Woodpecker Ridge; the 43d Infantry Division at San Jose; and the 6th and 37th Infantry Divisions in the Cagayan Valley. Elements of the Battalion spearheaded the final drive of the 37th Infantry Division in the race for Appari when the division drove 200 miles in 31 days to end organized enemy resistance.

Weapons consisted of 56 M-16's and 8 M-15 Specials (M-15's with the 37mm gun and two caliber .50 machine guns replaced by a 40mm Bofors) custom built by base ordnance units assisted by personnel from the Battalion. Extra radios were issued to provide radio communication in each half track. With these exceptions, the Battalion was organized and equipped as a standard self-propelled unit.

During active combat periods the Battalion simultaneously supported as many as three infantry divisions conducting independent operations along a front of over 300 miles. Normally one battery, or a battery reinforced with one platoon, was attached to a division. Occasionally one platoon was attached to a division for special operations. The decision to commit the Battalion piecemeal was dictated by the law of supply and demand and by the fact that mountainous terrain and enemy tactics had restricted our operations to isolated engagements of relatively small forces in narrow corridors. Batteries were assigned specific missions by the units to which they were attached. The tre-

mendous fire power and flexibility of the weapons enabled units to render effective support over a wide range of operations that may be grouped into the following general types.

CLOSE SUPPORT OF INFANTRY

Infantry units accomplish their missions by the use of fire, movement, and shock action. Local fire superiority is essential to reduce the effectiveness of hostile fire, to inflict casualties, and to deny enemy observation so that our forces may move to positions from which more effective fire may be delivered and final assaults may be launched to destroy the enemy and seize the objective.

The half tracks were employed to reinforce the fires of infantry weapons, and in the attack were placed well forward where they could render close and continuous support. Concentrations were fired into areas suspected of harboring enemy troop concentrations as our infantry units prepared to attack. When these units encountered determined resistance, they marked the targets with smoke grenades and withdrew while the half tracks moved into favorable positions from which they could destroy these strong points by direct fire. The high rate of fire and flat trajectory of the SP's made them ideally suited for these operations. The following extract from a commendation by an infantry regimental commander to the leader of a supporting SP platoon contains his evaluation of the effectiveness of the support rendered by these weapons:

"1. The officers and men of this regiment are most appreciative of the close fire support given us by the 2d Platoon of Battery B. Without their support, rendered under hazardous and difficult conditions, our task would have been far more difficult and, without question, much costlier.

"2. Materially aided by your platoon, our regiment killed 1,027 Japs, took 26 PW's and gained over 9,000 yards of ground under heavy machine-gun and rifle fire. Your mounts moved simultaneously with our leading elements and their fire combed the hillsides and bamboo thickets, effectively pinning down and neutralizing enemy positions, enabling our troops to seize their objective with a minimum of casualties."

In several operations, M-16's and towed 40mm guns were employed in teams in an effort to utilize all available weapons in the ground support of infantry units. Half tracks were used to tow the guns to the positions where they were to be emplaced and both weapons were employed against suitable targets. When the fire mission was completed or the positions became untenable, half tracks towed the guns to new positions. Although this procedure did provide the additional fire power desired, it is not recommended for normal operations for the following reasons:

(a) The combination of the M-16 and 40mm gun provided no adequate transportation for 40mm ammunition, and the presence of 40mm crewmen in the half track during movement prevented effective operation of the turret in the event of attack.

(b) The mobility of the half track was reduced to that of the 40mm gun, and since the towed and carried load far exceeded that for which the vehicle had been designed.

clutches burned out and rear ends failed, leaving half tracks disabled in exposed positions. One platoon leader describes a typical experience in these words: "The infantry unit was deployed in an area composed almost entirely of rice paddies where roads were nonexistent. In order to reach the selected positions it was necessary to move through this boggy terrain. An M-16 towing a 40mm gun would go as far as possible, then when it bogged down the M-16 would be uncoupled and would proceed to the nearest hard ground. Then it would turn around and winch the 40mm gun through the mud. Nine separate winching operations were required to move the half tracks and guns into position. A total of 3 miles was traveled in 8 hours. Needless to say, much damage was incurred by the half tracks. In fact, one half track did not reach its position because its differential was damaged."

(c) Because guns were required to move forward with the infantry in order to provide continuous support, time did not permit crews to prepare emplacements, so casualties were heavy. Lack of mobility in poor terrain made crews reluctant to change positions as often as was necessary in order to avoid being subjected to enemy artillery concentrations. One extract from an action report of a platoon illustrates the results of failure to shift positions and failure to dig in:

"The next day, 40mm units were employed against caves located in a small knoll some 2,500 yards distant. At 1400 hours enemy artillery began to shell the positions. Four men were wounded and all half tracks were damaged. After the shelling it was decided to change positions because it was evident that present positions were known."

EMPLOYMENT AS ASSAULT GUNS

In situations where conformation of the terrain prevented or severely restricted the effective employment of towed field artillery weapons in support of infantry operations, M-15 Specials and M-16's were successfully used as assault guns. Because heavy enemy mortar and artillery fire made it undesirable to maintain weapons in firing positions along the forward slopes of the hills, half tracks were held in readiness in defiladed positions five or six hundred yards to the rear. Continuous contact was maintained with the infantry by means of SCR-300 radios provided by the supported unit. When a fire mission was assigned, half tracks moved quickly to firing positions and opened fire. Upon completion of each mission, half tracks returned to defiladed positions to await the next call.

Targets were pointed out by observers in the vicinity of the firing positions or marked with smoke grenades by patrols operating in the area. M-16's equipped with Mark IX sights were effective against personnel and machine-gun positions at ranges up to 1,700 yards. M-15 Specials were effective against light fortifications (principally OP's, caves, and pillboxes) and against light artillery (75mm field pieces and light AA guns) at ranges up to 2,800 yards. During two months of combat, one platoon definitely destroyed 26 caves and pillbox positions, 8 machine guns, one 75mm gun and 3 enemy artillery OP's. On one occasion an enemy 77mm AA gun was holding up the advance of the infantry with effective time fire. When the gun position was finally located, an M-16 opened up at 1,800 yards and the gun was



M-15 Specials were effective against light fortifications and artillery at ranges up to 2,800 yards.

silenced with 800 rounds of caliber .50 ammunition. It was later found that the gun had been riddled by caliber .50 slugs and the recoil mechanism destroyed.

The adjustment of our mortar fire on targets of opportunity was usually too slow to be effective. Good results were obtained against similar targets by both M-15 Specials and M-16's. M-15 Specials used automatic fire only for fire for effect against enemy troop concentrations because smoke usually obscured the vision of gun pointers when automatic fire was employed. 40mm HE ammunition was especially effective against caves since direct hits were required and the high muzzle velocity and flat trajectory provided the high degree of accuracy required for destroying such targets.

EMPLOYMENT AS ARTILLERY

Long-range fire was observed and adjusted by means of an artillery B.C. scope located near the firing positions and by the use of forward observers. On one occasion, fire was successfully adjusted by an aerial observer who later reported that he was amazed at the speed with which he could "pin point" 40mm concentrations on objectives and by the fact that he could make adjustments of less than five yards at ranges up to 2,500 yards. Since guns were laid "by guess and by golly" because suitable sights and range or elevation scales were not available, ammunition expenditure was excessive.

RECONNAISSANCE AND ESCORT MISSIONS

During rapid advances, difficult terrain and extremely limited road nets caused the divisions to become overextended in depth. The threat of encirclement of advanced elements became apparent as strong enemy forces were by-passed and pressure against supply lines increased. Con-

voys were ambushed when they encountered road blocks established by the enemy at critical points along mountain trails deep in our territory.

This situation was improved when self-propelled automatic weapons units were attached to a division for the purpose of conducting reconnaissance and escort operations. M-16's attached to a division reconnaissance troop were employed on motorized patrols in the areas adjacent to the flanks and rear of front-line units to provide early warning of enemy attempts to isolate these units. The additional fire power afforded by these weapons enabled the troop to assume a more aggressive role and extended the effective radius of reconnaissance.

Other self-propelled automatic weapons units patrolled the supply lines and provided escorts for the movement of supply and ration trains, tanks, and personnel. This practice eliminated attacks on our convoys and permitted supplies to move forward without interruption.

When reconnaissance in force was required, half tracks habitually were assigned to the armored spearhead and generally were placed behind the tanks and self-propelled tank destroyers since the lack of heavy armor made the half tracks extremely vulnerable in assault operations. A typical armored column was composed of weapons formed in the following order:

- 2 M-4 Tanks
- 2 Tank Destroyers
- 1 M-20
- 2 M-16's
- 1 M2A1
- 2 M-4 Tanks
- 2 Tank Destroyers
- 4 M-7's
- 4 M-16's

Armored vehicles were employed in the point of infantry march columns to insure the uninterrupted advance of the main body. Usually the order of march was 2 M-4 tanks, 2 tank destroyers, 2 M-16's followed by the infantry. The half tracks generally were employed as antipersonnel weapons. When resistance was encountered, tanks and tank destroyers concentrated on enemy armor while the half tracks moved to positions from which they could strafe areas offering resistance, and from where they could support infantry elements advancing to press the attack.

On several occasions columns were ambushed by enemy light tanks. In one instance the M-16's were called upon to assist some Sherman tanks that had been ambushed by 8 enemy light tanks. Two M-16's moved into the fight and knocked out one light tank by setting it afire with API ammunition. The remaining enemy tanks were destroyed or forced to withdraw. No half tracks were damaged or destroyed.

GROUND DEFENSE OF IMPORTANT OBJECTIVES

Elements of the Battalion were assigned missions of defending important objectives such as bridges, dams, and water filtration plants against enemy ground action. These units generally were attached to infantry units and the weapons were employed in the infantry perimeters although

on occasions self-propelled units were assigned sectors of responsibility within the division zone in the defense of large installations. Batteries were subjected to heavy enemy artillery and small-arms fire and constantly were threatened by the attempts of enemy groups to infiltrate the positions. These attempts were repulsed with heavy enemy losses. During the hours of darkness the enemy became especially active. One night a battery defending a ponton bridge detected an enemy demolition team in a canoe silently approaching the bridge with the intent of destroying it. When the M-16's opened fire, the demolitions exploded and the target disintegrated.

Half tracks available at division C.P.'s were employed in the perimeter defenses to provide security against the constant threat of infiltration. They also provided a mobile striking force capable of quickly reinforcing any threatened position. During the confusion incident to the hasty evacuation of a division C.P. that had been brought under fire by light artillery, half tracks covered the withdrawal and protected elements of the headquarters during movement to a more favorable position.

COMMENTS AND RECOMMENDATIONS

In the operations of the 209th AAA AW Bn (SP) in this campaign, field expedients had to compensate for inherent weaknesses in the organization and equipment of self-propelled automatic weapons units for ground support operations. These expedients have been proven in combat by the men who devised them—the officers and men of the firing batteries.

Sound weapons and skilled men

The important factors in the conduct of successful ground support operations are weapons that are basically sound and men who are skilled in the art of employing them to the full limit of their capabilities. Officers and men must know the weapons so thoroughly that they are capable of making all tests and adjustments during hours of darkness with no illumination, for in ground operations one malfunction may be disastrous. They must know the capabilities and limitations of their equipment and have complete confidence in their weapons and in their ability to employ them. The actions taken by a young lieutenant when an M-16 was badly damaged by artillery fire illustrates the effect of confidence upon the conduct of personnel under hazardous conditions. The half track had halted and the crew was on the ground behind the half track reloading ammunition chests when an enemy artillery piece opened fire at close range and scored a direct hit on the vehicle. The officer quickly surveyed the damage and found that although the half track was badly damaged, the guns and turret still worked and there were no casualties. He ordered the crew to take cover and, assisted by one volunteer, he engaged and silenced the artillery piece; then he kept it under continuous fire until infantry patrols could reach it. The infantry encountered no resistance, for the enemy gun crew was dead and the gun was useless. The odds were high but the officer succeeded because his determined attitude was based upon knowledge of the capabilities of his weapons and complete confidence in his ability to use them. A typical infantry regimental commander emphasized the close relationship



M-16 and Tank near Kiangan, Northern Luzon, P. I.

that exists between determination and success in combat in the following remarks from the commendation he sent to the Commanding Officer of a supporting automatic weapons platoon:

"The outstanding performance of your 2d Platoon during the period 8 May 1945 to 26 May 1945 was very instrumental in the destruction of the enemy. In spite of enemy small-arms fire, they continued to attack in close support of the infantry. The determination and will-to-win displayed by your officers and men was in keeping with the highest traditions of the United States Army."

Intensive tactical training

While technical proficiency is a prerequisite to the successful employment of highly specialized equipment, this training must not be unduly emphasized at the expense of tactical training. Units should be assigned or attached to divisions for intensive training with combined arms before they are committed in ground support operations. Personnel must know and understand the organization, mission, and methods of employment of each element of the division. Emphasis should be placed upon tactics and technique of employment of infantry units and upon methods and techniques that may be employed by self-propelled automatic weapons units in order that they may render maximum support to Infantry units in the accomplishment of their assigned missions.

Dependable supply of replacements

It is of the utmost importance that AAA replacements, like other supplies, be obtained through normal Division channels rather than from some remote AAA Command or Headquarters. The Division G-1 can requisition AAA replacements by "spec number" just as he requests cannoneers for field artillery battalions and riflemen for rifle companies. The doctrine that maintains that AAA is highly specialized and that extensive technical training is required for all personnel is unquestionably sound but it must be tempered with reason when such well trained replacements are urgently needed but aren't available. In the event that serious losses are incurred and AAA replacements are not readily available, infantry or field artillery replacements (if available) make fine basics and can learn to be apprentice AAA cannoneers overnight if need be. From

the standpoint of immediate effectiveness, they would be as desirable as replacements from, for example, an AAA gun battalion. Here is a typical situation that arose during these operations. The firing batteries were committed in support of various divisions but were required to obtain their replacements through AAA channels rather than through Division channels. The Battalion strength dropped to such a point that two firing batteries were reduced to platoon strength and headquarters personnel had to be transferred to the platoons to keep them operational. When replacements finally arrived at Battalion Headquarters late one afternoon, it was found that they had been extensively trained with every known type of AAA equipment—except self-propelled automatic weapons. They learned the rudiments of self-propelled matériel that first night and by the next afternoon they had reached the firing batteries where they immediately began getting practical experience with the weapons on platoon combat missions. That is the way angels are made! Certainly under such conditions it would be preferable to take any readily available replacements as losses are incurred and to give them proper training before they are assigned to units in contact.

Assignment of suitable missions

Unit commanders must maintain effective command liaison with the units they support. Infantry commanders must be advised of the capabilities and limitations of the weapons so that missions may be assigned that will permit the units to render maximum support without incurring excessive losses. Liaison should be maintained by an experienced officer—one who will constantly seek improved methods for rendering better support with fewer casualties.

Good fire discipline

Good fire discipline is essential to successful operations. The continuous type fire required against aircraft is not suitable for ground operations because it is wasteful of ammunition under conditions where resupply is difficult, causes barrels to become overheated when there may be no opportunity to change them, and draws fire by revealing the location of the guns to the enemy. In order to avoid these difficulties, it is recommended that the guns be fired intermittently. Although existing doctrine recommends firing only two machine guns simultaneously in order to save ammunition, it is recommended that all four machine guns of the M-16 be fired simultaneously in order that the maximum volume of fire may quickly be placed on any targets (especially tanks) that suddenly threaten the position.

Care of equipment

Maintenance of equipment is a critical problem in ground operations. Rain, dust, and powder fouling raise havoc with weapons—they can be depended upon to function properly only when they have been cleaned, oiled and adjusted at every available opportunity. A stoppage or malfunction is serious when an airplane is within hitting range, but it's even worse when a 105 has just zeroed in on your position. Although it is not feasible to maintain time schedules for maintenance while the squads are actively engaged, it is essential that guns be rotated out of action when lulls

occur so crews can make essential tests and adjustments and insure that the moving parts are clean and lubricated. Unit commanders must establish the *habit* of good maintenance *before* their units are committed, for when men are dirty and exhausted after prolonged operations they perform tasks best when they have learned to do them by repetition. The unjustified belief that a unit that is sloppy in training will suddenly become a snappy one in combat invariably leads to disaster.

Perimeter defense training

At night or when visibility is restricted, crews of halted vehicles must quickly establish a perimeter defense around the vehicle. Although a skeleton crew must be readily available at the position to man the weapon, the perimeter should be extended far enough from the position to insure the detection of infiltrating enemy personnel before they approach near enough to damage or destroy the half track by hurling grenades or similar devices. In selecting positions, advantage should be taken of the protection afforded by perimeters established by adjacent infantry units. Rules prescribed for firing or withholding fire must be rigidly enforced. One experience will illustrate what may happen if these precautions are not observed. A half track along the Villa Verde Trail was in position at night and the squad had established a close-in perimeter defense. The half track was located inside the infantry lines and received incidental protection from guerrilla forces. The men kept to their fox-holes; the rule was to shoot anything that moved at night. They were especially alert because enemy patrols had proved to be skilled in the practice of infiltrating our lines. Only a few nights before, an M-4 tank had mysteriously exploded and burned. Unfortunately, members of the friendly guerrilla forces had been allowed to make a practice of coming to the position to learn the time. This night a guard saw three figures approaching the position and, thinking they were guerrillas, he challenged them. One figure threw a grenade which exploded and wounded the guard. The others were carrying demolition charges which they hurled at the half track. Luckily they did not explode and the wounded gunner, assisted by another soldier, drove the enemy off with small-arms fire. Next morning, the crew found thirty sticks of TNT about six feet from the half track—the fuze had not been activated. The failure to extend the perimeter defense and to observe the rule for firing at anything that moved at night cost one casualty, and only a stroke of good fortune saved the half track and other members of the crew.

Reorganized AAAIS Section

While self-propelled automatic weapons units have demonstrated that they are capable of conducting successful ground support type operations, the design of the equipment and the organization of the units primarily for antiaircraft operations has placed severe limitations upon the effectiveness of such units when they are employed in the ground support role.

For ground support operations, a well balanced organization must contain four basic elements, namely, a reconnaissance element, a fixing force, a maneuvering force, and a base of fire. The self-propelled automatic weapons battalion contains three of these basic elements, but the absence of a

reconnaissance element in the Table of Organization is a serious weakness in ground support operations. Although some degree of protection may be afforded by adjacent units, the battalion must provide for its own security and early warning information, and must actively exploit all possible sources of intelligence. Minimum requirements for intelligence in such operations include, but are not restricted to, the following:

CRITICAL TERRAIN INFORMATION—such as ground conformation, road nets, principal and alternate routes of advance and withdrawal, location and capacities of bridges (with estimates of materials required for shoring to permit safe passage of battalion loads), depths of rivers and locations of fords, location and extent of mine fields and obstacles, location and disposition of adjacent units, and suitable positions for ground and air defense.

INFORMATION OF THE ENEMY—such as indications of initial or renewed enemy air or ground activity, especially evidence of intended use of armor; presence or absence of enemy patrols; and details regarding any enemy resistance encountered.

To provide the battalion with an effective organic reconnaissance element, the AAAIS Section should be reorganized, trained, and equipped as an Intelligence and Reconnaissance (I. & R.) Platoon operating under the direct supervision of the battalion S-2. The enlisted complement of the platoon should be provided by increasing the present strength of the AAAIS Section. An additional lieutenant should be authorized in the Table of Organization for the purpose of providing an Assistant S-2 to supervise operation of the AAOR and AAAIS net for air defense operations and to command the I. & R. Platoon during ground support operations. For air defense operations, the I. & R. Platoon would establish and operate the AAOR and AAAIS net.

The transportation now available in the AAAIS Section is inadequate for ground reconnaissance purposes, for, although the I. & R. Platoon ordinarily would not seek engagements with the enemy, it must be prepared to brush aside light opposition in order to secure desired information. The jeeps have no armament, afford insufficient protection against small-arms fire and fragments, and have only limited cross-country mobility. Although the M-3 half track does offer the relative advantages of some fire power and light protective armor, other characteristics render it unsuitable for this purpose. Cross-country mobility of the M-3 is limited by low flotation and preponderance of weight resting on the front wheels. Also the long turning radius (38 feet) and restricted speed of this vehicle make it unsuitable for situations where "peek and run" tactics must be employed. It is not capable of providing adequate security for battalion march columns since by design it is restricted to the speed of the combat vehicles in the main body. Vehicles of the M-8 armored car type offer marked advantages in speed, maneuverability, fire power, quietness of operation, and protective armor and also have sufficient cross-country mobility to meet the requirements of the reconnaissance troop of the infantry division. Eight of these vehicles should be provided in the Table of Equipment to replace the eight jeeps authorized for the AAAIS Section, since the M-8's could also operate effectively as the Battalion OP's for air defense operations. An additional vehicle of this type should be

authorized for the Assistant S-2 in his capacity as commanding officer of the I. and R. Platoon for ground support operations.

Reorganized firing batteries

The present organization of the firing battery is outmoded and should be revised in order that the battalion may support the division more effectively. As it is now organized, the battery is the square peg in the triangular hole for although the battery features a rectangular organization, the division organization is triangular. The battery organization was evolved by considering only the requirements for AAA defense of point and area objectives and is a carry-over from the period when infantry brigades and square divisions were in favor.

For ground operations it is generally desirable to attach a battery to each infantry regiment. The battalion can meet this requirement and still hold one firing battery in reserve for reinforcing the batteries that have been committed. It may also be used to defend important division installations or those of the division artillery. However, platoons generally are further attached to the infantry battalions and it is at that point that the present organization fails to meet the requirements. There are nine infantry battalions, and if all eight of the AAA Platoons are committed, one infantry battalion still will not be supported. Even if that limitation could be accepted, the arrangement would be unsatisfactory for ground operations because there would be no reserve available to reinforce the units committed.

It is recommended that the firing battery be reorganized to provide 3 Platoons of 3 Sections each and that each section consist of 1 M-19 (or M-15) Squad and 1 M-16 Squad. It is further recommended that the commissioned complement consist of 5 officers: 1 Captain (Battery Commander), 1 First Lieutenant (Executive), and 3 First or Second Lieutenants (Platoon Commanders). Platoon Sergeants should act as Platoon Executives and be prepared to assume command in the event the Platoon Commanders become casualties. Four M-8 Armored Cars should be provided in each battery to replace the 3 M-3 half tracks for command and reconnaissance purposes because the additional protective armor, fire power, and mobility are required by platoon and battery commanders for operations in forward areas. For similar reasons, 5 M-8 Armored Cars should be provided to replace the M-3 half tracks assigned to the Battalion commander, S-2, S-3, S-4 and MTO.

Figure 1 is a schematic diagram of the present and proposed organizations of the firing battery. Figure 2 is a schematic diagram of the principal fighting elements of the division showing the attachments of batteries and platoons to infantry regiments and battalions that would be possible if the firing batteries were reorganized. Each infantry battalion would be supported by one AAA AW Platoon (SP) and an adequate reserve would be provided by the remaining battery.

Any proposed organization of the firing batteries and platoons must meet the requirements of the AAA defense of point and area objectives. Since more guns are provided in the proposed organization, it is obvious that it would meet the requirements of area AAA defense. For the defense of point objectives, AAA doctrine states that a minimum de-



Enemy attempt to infiltrate position was repulsed with heavy losses.

fense of four guns is essential. That does not necessarily mean that all four guns must be of the same caliber. It is believed that the proposed organization is capable of providing the desired degree of AAA protection for a point objective.

Expanded and reorganized maintenance elements

The battalion is organized, trained, and equipped to perform its mission effectively as a unit. When the fighting elements of the battalion are widely dispersed, administrative and logistic requirements may exceed the capabilities of the unit unless certain adjustments are made in the organization and method of operation of the service elements of the battalion. It was found advisable to reinforce the batteries with mechanics from the Battalion Motor Maintenance Section to assist in the performance of essential second echelon maintenance in battery shops in order that deadlined vehicles might promptly be repaired and returned to service. Like a circuit rider, the Battalion Motor Officer made his rounds of the batteries where he supervised maintenance and dispensed advice, replacements, and spare parts. A minimum of two spare half tracks complete with turrets was maintained in the Battalion Maintenance Section to replace equipment damaged or destroyed by hostile action. When batteries reported that equipment had been damaged or destroyed, battalion maintenance personnel (consisting of the fire control electrician, artillery mechanic, and an automotive mechanic) were dispatched with a spare half track and wrecker to the battery shops where they replaced the turret and/or half track with a new unit and brought the inoperative equipment to the battalion shop for repair or salvage. These spares are considered to be essential for ground support operations, and may in addition be employed in the perimeter defense of the battalion C.P. and for training maintenance personnel and replacements. During one week of operations, a spare half track was rushed to one platoon where the turret was used to replace one that had been badly damaged in combat. Just after the maintenance personnel returned to the battalion shop with the stripped half track, it was dispatched to another platoon

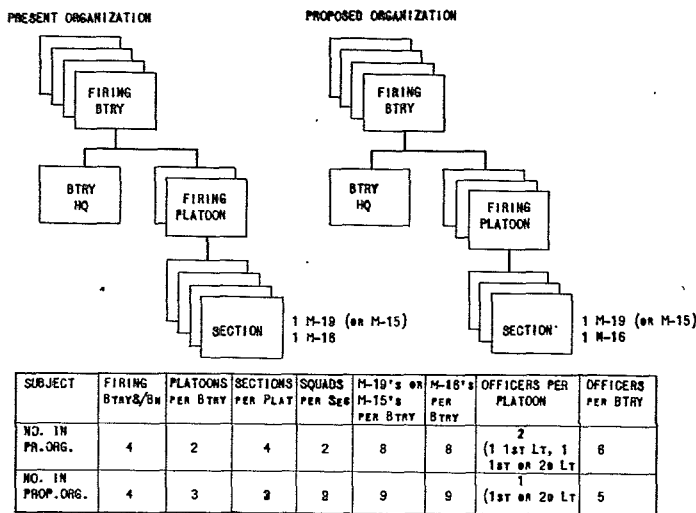

Figure 1—Comparison of present and proposed organization of firing batteries.

where maintenance personnel lifted a serviceable turret from a half track destroyed by artillery fire and mounted it on the stripped half track. In this way two badly needed half tracks were quickly repaired by the use of one spare M-16.

Division ordnance units rendered all possible support to the batteries but were ineffective since they lacked critically needed spare parts and had no ordnance AA light maintenance technicians for the repair of fire control equipment. Solenoids and turret drive switches required frequent replacement and, although a limited number of spares was maintained in each battery, lack of adequate ordnance support in the divisions made it necessary for the battalion to take these items over 100 miles to an ordnance AA light maintenance detachment for repair and to return serviceable replacements to the batteries. This detachment sent ordnance teams to each battery as frequently as possible but it was not feasible to render adequate support over such extended distances. Since the self-propelled automatic weapons battalion is now organic to the infantry and armored divisions, it is essential that division ordnance units contain AA light maintenance detachments.

Redesigned communications system

The communications system must be redesigned to meet the requirements imposed by operations with other arms. FM radios in the half tracks were generally satisfactory for communications within the unit but they could not operate in the net with the supported units. SCR-300 radios borrowed from infantry units were satisfactory for situations where movement was restricted but this makeshift solution was not satisfactory for prolonged operations. To permit effective operation when the battalion is extended, long-range radio equipment should be provided in the vehicles assigned to the Battalion Commander, Executive, S-2, S-3, AAIS Section (for employment in the proposed I. & R. Platoon as well as for AA operations), and to the four firing battery commanders. Radio communications must be available in every half track.

More and heavier armor

More and heavier armor should be provided and all guns

should depress to a minimum of minus 10 degrees. This is especially important if the weapons are to be employed in assault operations. Casualties among cannoneers were heavy since they were completely exposed while serving the guns. Inability to depress the guns sufficiently created a large "dead space" around each half track and the long turning radius of the vehicle required a large area for turn around when it became necessary to make a hasty withdrawal. On one occasion, an M-16 advanced along a trail in support of an infantry unit after the infantry reported that the enemy had been cleared from the high ground on each side that dominated the trail. The enemy reoccupied both ridges and the half track was trapped in an area where it was impossible to turn the vehicle around. The crew was subjected to heavy small-arms fire from the ridges and both cannoneers were casualties. Finally the driver managed to back the track down the trail to a protected position.

Several expedients were employed to prevent or reduce losses in later operations. Infantry patrols accompanied the half tracks to cover the "dead space" around each vehicle. Half tracks generally were employed in pairs so that each could cover the movement of the other. When more than two were used, the additional tracks were of little advantage and only cluttered up the narrow trails. On narrow roads or trails and where the distance to be traversed was not too great, cannoneers on the M-16's loaded the machine guns and took cover by kneeling on the floor of the half track with small arms ready, and then the half track was backed toward the objective. Thus gunners had a better field of fire since the cab no longer was an obstruction, casualties among crewmen were reduced, and the cannoneers employed their small arms to cover the "dead space" around the half track. If the enemy closed in, the half track withdrew by the same route it had used in the assault.

Mine detection

The battalion must have adequate equipment for the detection of enemy mines. While no vehicles were destroyed by mines in these operations, the need for such equipment is indicated by the narrow escape of one squad during an operation. The squad was attempting to reach a new firing position when the route was blocked by a light bridge of questionable capacity that spanned a deep ravine. Since it was almost dark, the squad leader decided to select an alternate position and to find an alternate route forward the next day. The following morning engineer troops found that the

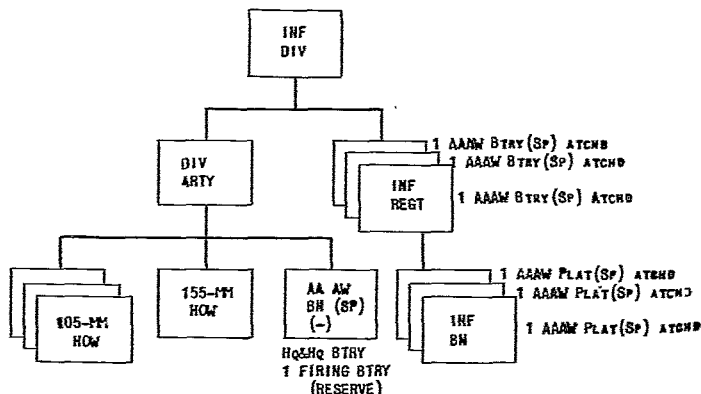

Figure 2—Attachments to elements of an infantry division (Proposed AAA organization).

opposite approach to the bridge had been heavily mined. If the squad had crossed the bridge the night before it unquestionably would have been destroyed, because mine detectors were neither available nor had the men been trained to use them.

Fire control equipment

Suitable sights, deflection and elevation scales, leveling devices, and range finding equipment must be provided as existing weapons cannot safely or effectively deliver close overhead fire or attack masked targets. Equipment should be designed to permit firing night concentrations based upon predetermined firing data. With present equipment, fire support generally is restricted to concentrations fired during daylight by the use of direct fire methods.

Special emphasis should be placed upon the development of improved means for effectively engaging mechanized targets. Although self-propelled automatic weapons are not designed for employment as tank destroyers and normally do not seek engagements with armored vehicles, they must be capable of defending their own positions and those of the supported unit. Since such targets usually have the advantages of heavier armor protection and larger caliber guns capable of inflicting greater damage at longer ranges, the necessity for self-propelled automatic weapons to be capable of firing the first round effectively cannot be overemphasized. For this reason, weapons must be equipped with suitable range finders and lead computing sights that are accurate and simple to operate.

Ammunition

The employment of self-propelled automatic weapons in the ground support role established requirements for types of ammunition other than those now available. The standard 40mm HE and armor-piercing ammunition generally performed satisfactorily in the ground support role but did not meet all of the requirements peculiar to such operations.

The need for smokeless and flashless propellants is well known since present propellants obscure the vision of gun pointers and will reveal the position of the weapon to the enemy before the target can be destroyed. In order to obtain

better penetration of armor, increased muzzle velocity should be provided even if this must be obtained at the expense of shortening tube life since more weapons are destroyed by failure to defeat enemy armor than would be rendered inoperative by excessive erosion of gun tubes.

Two types of fuzes should be available for HE ammunition. An instantaneous or "super quick" fuze is required to secure "tree bursts" that have proved to be effective against personnel occupying wooded areas. They are also required when impact areas are soft or muddy as delay fuzes permit the round to penetrate deeply before detonation and observers are unable to obtain sensings. "Delay" fuzes permit the use of ricochet fire to obtain air bursts over enemy positions and such fire is a satisfactory means of obtaining the desired results without having to resort to the use of "time fire." The most suitable delay fuze should be determined by analysis of average terminal velocity, fragmentation characteristics of the projectile, and the desired height of air burst.

The standard HE projectile is satisfactory where an instantaneous fuze is required but no projectile with a delay fuze is available for use against ground targets. There is a definite need for a projectile provided with a selective setting device (similar to that used by the Field Artillery) that offers a choice between super quick and delay fuzes. It may be technically feasible to modify the standard HE projectile by the addition of a delay fuze and a selective setting device that would permit the employment of the projectile in the antiaircraft role as well as in the ground support role. The number of types of ammunition must be kept to a minimum, because the stowage space available in any combat vehicle is limited, and during engagements cannoners would be unable to locate or identify the particular type of ammunition desired if many types were available.

Caliber .50 ammunition was very effective, and no ammunition failures were noted. In a surprise engagement, a command half track knocked out a light tank at point-blank range with one caliber .50 machine gun. The armor-piercing incendiary ammunition penetrated the light armor and nearly severed the turret from the body of the tank. The half track suffered no damage in this attack. Incendiary



An M-16, an M-4 Tank, and a Tank Destroyer employed in the armored point of an infantry march column encounter heavy fire in the Cordon Section, Luzon, P. I. (37th Division infantrymen have taken cover in the ditch at side of road.)

ammunition is required but it should have delayed igniters because tracers blind gun pointers during night firing and reveal to the enemy the number and locations of half tracks. Since adjustment of fire is based upon observed deviations, a few rounds of explosive projectiles similar to the 20mm projectile should be contained in each belt of caliber .50 ammunition to facilitate spotting.

General

Although the deficiencies noted herein placed limitations upon the methods of employment of these weapons in ground support operations, the over-all performance was excellent. This estimate is confirmed by the following message received from a Division G-3: "Request immediate attachment of two more platoons of half tracks. They are the best support weapons the infantry has." The results obtained with the M-15 Specials are particularly significant in that these weapons serve to bridge the gap between standard weapons employed in combat operations by other units and their modern counterparts listed in current Tables of Equipment. By careful extrapolation of the results obtained with the M-15 Specials, we may accurately estimate the combat effectiveness that reasonably may be expected of modern equipment that may be employed in future opera-

tions. Of even greater significance is the fact that in the event of war in the immediate future, the initial phases necessarily would be fought with similar weapons of World War II vintage now in the hands of troops in training.

The particular combat missions outlined here are intended to illustrate the need for revising present doctrine, organization, and tactics, and are not necessarily recommended as normal assignments for self-propelled automatic weapons units employed in ground support operations. For example, it is obviously uneconomical to employ SP's in the ground defense of installations if sufficient infantry and field artillery units are available for that purpose.

The dominant characteristics of the self-propelled automatic weapons battalion are great mobility, flexibility, and fire power. The battalion is most effective when it is employed in support of infantry and armored units for it is not designed to conduct independent ground operations. Missions should be selected so as to exploit these important characteristics fully within the capabilities and limitations of the weapons. Given a balanced organization, equipped with improved weapons and skilled personnel imbued with an aggressive spirit, the SP's will continue to be what an infantry division G-3 termed "the best support weapon the infantry has."



Army Lengthens Basic Training Period To Fourteen Weeks

A revised fourteen-week program of basic military training for enlisted men has been put into effect by the Army, replacing the present eight-week course, the Department of the Army announced recently.

The new program will be adopted in the following training divisions:

- Third Armored Division, Fort Knox, Kentucky.
- Fourth Infantry Division, Fort Ord, California.
- Fifth Armored Division, Camp Chaffee, Arkansas.
- Fifth Infantry Division, Fort Jackson, South Carolina.
- Ninth Infantry Division, Fort Dix, New Jersey.
- Tenth Infantry Division, Fort Riley, Kansas.

The Army explained that the eight-week basic course was being increased, as previously planned, to fourteen weeks now that the Army has reached its authorized strength.

The present eight-week course was inaugurated in the spring of 1948 in order to train as rapidly as practicable volunteers and men selected for service by the Selective Service Act of 1948, who were urgently required for the expansion program of the Army.

The mission of the basic program is to effect a smooth transition from civilian to Army life and produce trained soldiers through the study of fundamental military subjects essential to all branches of the Army. It emphasizes physical conditioning and discipline; develops soldierly qualities, pride in self and pride in the Army, and promotes high standards of responsibility, conduct, manner and morale; and gives weapons training in small arms. It does not provide branch training.

In the new program there are courses which are intended to "imbue the soldier with the traditions of military service." One of these courses, entitled "Achievements and Traditions of the Army," provides material of an inspirational value that will foster *esprit de corps*.

Other courses are those concerned with "Military Justice" and "National Defense Establishment." In the latter the Army seeks to provide a general knowledge of the "establishment" and its major components as well as to create a realization of the necessity for cooperation among the U. S. Army, Navy and Air Force.

After completion of basic training, the majority of the men will join units in the United States or overseas. In the various units, the new soldiers will receive advanced individual and branch training. Still others will be selected to attend technical schools for advanced training in military specialties.

General Jacob L. Devers, Chief of the Army Field Forces, who is responsible for training of Army personnel, has continuously emphasized the importance of the proper training of recruits, men new to Army life. It is through this training that the new men receive their first and lasting impressions of the Army, he has said.

In accordance with current training policies, in the new basic program instructors will continue to insure that, while the recruit learns to conform with the Army pattern, observes its customs and traditions, and fits into its discipline, he will remain an individual. As an individual, he will be trained to think, act and respond on his own initiative.

MISSILES VS. MISSILES*

Rounding up prize exhibits for a showing to Congress, the Air Force called its new bomber specimens from West Coast bases to Andrews Field, Md. And they really whizzed. The Northrop "flying wing" B-49, pushed by eight jets, came in from California nonstop in four and a half hours—average speed, 511 miles per hour. The six-jet Boeing B-47 made it from Moses Lake, Wash., in three and three-quarter hours, for a sensational average of 607 miles per hour.

Could such bombers be shot down? Not by ordinary anti-aircraft guns. The problem of defense against the new high-speed monsters was stated clearly last week by Dr. Ralph E. Gibson, director of the applied-physics laboratory of Johns Hopkins University, which developed the proximity fuse for anti-aircraft guns during the last war and is now the Navy's agent for the "Bumblebee" guided-missile program. He discussed the program with members of the Institute of Aeronautical Sciences and the American Rocket Society.

"Consider," he said, "a bomber flying at 600 miles per hour or 880 feet per second being attacked by gunfire in which the average time of flight of the shell is 15 seconds . . . Between the time the shell leaves the gun and arrives at the predicted point of aim the bomber travels 2½ miles. In order to reach the point of aim the bomber must fly with an accuracy of one part in 10,000, or, in other words, if he is careless and his course deviates by as little as half a degree, he will miss the shell by 106 feet."

In other words, the pilot of the B-47 could hardly be hit by an anti-aircraft shell even if he tried.

Chasers: So what is the defensive answer? In a mouth-filling phrase, it is the "supersonic guided missile"—a rocket and/or jet-propelled weapon that will fly faster than any bomber and change its course in flight to pursue the plane.

With permission from the Navy, Gibson outlined the methods by which such missiles can be propelled and controlled. Simultaneously the Navy announced an important advance: A "booster rocket," with a ground-level thrust "considerably in excess of that developed by the German V-2 rocket," had been flown successfully at Inyokern, Calif. Its purpose is to lift a missile quickly to supersonic speed, then drop off and let the missile hunt its target under its own power.

The "booster rocket" (it has as yet no other or fancier name) is a souped-up development of the Fourth of July fireworks rocket in that it uses the flash of a solid fuel for quickest pickup. It will be especially useful as a starter for the ram-jet missiles of the Bumblebee project, which perform at their best only after they have passed beyond the speed of sound. The booster rocket, the Navy said, "was

particularly designed for use in the Bumblebee guided-missile program."

Given a rocket and ram-jet combination that will quickly get up to speeds perhaps two or three times as fast as those of the newest jet bombers, how will it sense the split-second changes of direction needed to hit the target?

Even with remote control, no ground controller can think fast enough to push the right buttons. "In order to eliminate delays due to human reaction times," said Gibson, "the whole process of supply and use of intelligence must be made automatic and as rapid as modern electronic servo-mechanisms and aerodynamic control permit."

Controls: Without giving away secret details, Gibson described three methods of automatic control:

1—*Command guidance.* A ground radio-radar station tracks both the missile and target "and then computes what adjustments should be made to the missile's course to bring the two into collision . . . In this system the missile only needs to carry enough mechanism to receive and obey commands from the ground. Its order of intellect is, therefore, quite low. However, the ground installation must have considerable rapid-computation ability."

2—*Beam-rider guidance.* An artificial path from launcher to target is marked out by a radar beam, and the missile is provided with a mechanism for knowing when it deviates and correcting its course. Such a "beam rider" missile "is much more complicated, it has a higher order of intellect than a command-guided missile. On the other hand, many missiles may ride the same beam and the ground installations are comparatively simple."

3—*Homing guidance.* The missile obtains a directional signal directly from the target. It "recognizes its quarry and goes after it," a characteristic that requires "a still higher order of intelligence in the missile . . . Such systems offer the possibility of great accuracy in the terminal phases of the missile's course but . . . suffer from range restrictions and are usually used in conjunction with other systems for initial and mid-course guidance."

How successful these systems have been in actual practice was not disclosed. But it is clear that the armed services now have a variety of missiles to send aloft and to guide one way or another.

With such weapons under development, a new note of optimism about the capabilities of defense was evident at the meeting. An outstanding expert in the new art of ram-jet missiles, Wilbur H. Goss, associate supervisor of the Bumblebee laboratory, remarked that when the last war ended he wouldn't have wanted to bet on the defense. But now, he said, while the intercontinental guided missile is still a blueprint, interceptor missiles are being perfected to a point that has tilted the balance well toward the defense.

*Reprinted with permission from 21 February 1949 issue of *Newsweek*.



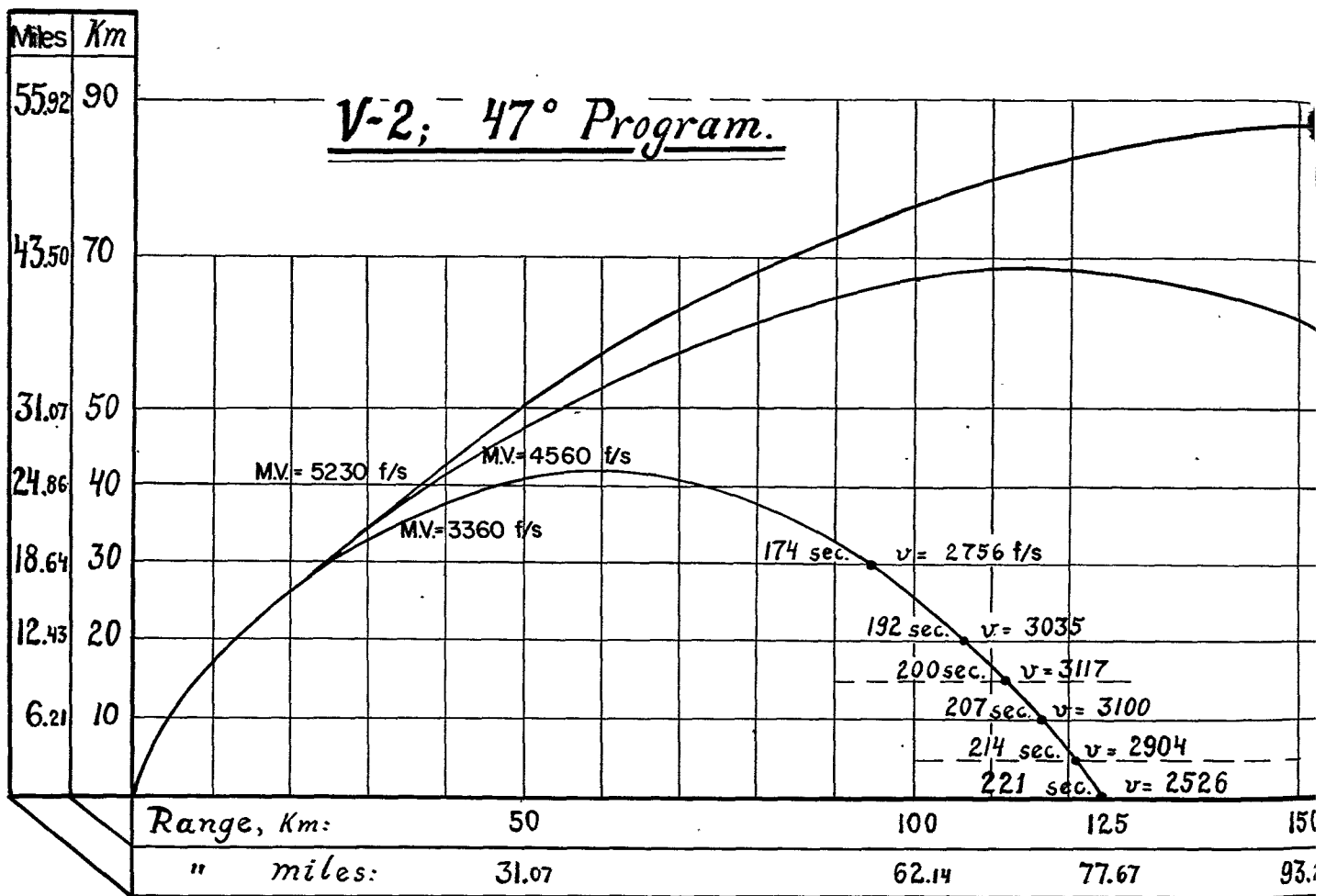

The so-called 47° Program of V-2 trajectories, according to German sources. [Courtesy of Research and Development Service Sub-office (Rocket), Fort Bliss, Texas.] The figure of 47° refers to the amount of tilt of the rocket at the end of its burning period and is measured from the *vertical*. (47° Program indicates 43° elevation.)

The Interception of Long-Range Rockets

By Willy Ley

As has been pointed out repeatedly in recent issues of the *ANTI-AIRCRAFT JOURNAL* there are essentially two types of long-range missiles, the aerodynamically supported (or "cruising") missile and the aerodynamically unsupported missile which has to be a true rocket. The interception of both are A.A. jobs, but in the case of the "cruising" missile the problem is still that of interception of a flight path. New aspects arise from the high speed of such missiles, their relatively small size and the probably high altitude of flight.

But the interception of a long-range rocket is a completely novel problem. For the first time in military history it becomes necessary to intercept a trajectory. The trajectory of a long-range rocket (see Fig. 1) can be compared directly with that of an artillery projectile if the instant of fuel cut-off in the rocket is compared to the gun muzzle. The ballistic performance of the rocket from that moment on is the same as that of a projectile fired from a gun with its muzzle at an altitude of some 20 miles. The range of the missile is

determined by the cutoff velocity and may be varied by means of an integrating device in the missile which is preset for the desired range. As the range decreases, the angle of fall increases.

Until recently it has been customary to regard trajectories as parabolas because this simplified mathematical treatment. But the underlying assumption was that the line from battery to target is a straight line. Actually, it is not, since that line is part of a circle, the earth's surface. For ranges up to, say, twenty miles this factor is small as compared to other factors causing dispersion. But it grows in importance with increasing range.

In reality the trajectory is not a parabola but part of an ellipse. One of the two focal points of that ellipse coincides with the center of the earth. It follows that the plane of the ellipse must be such that it will bisect the earth into two halves. It also follows that the projectile or rocket will move slowest when at maximum height above the ground.

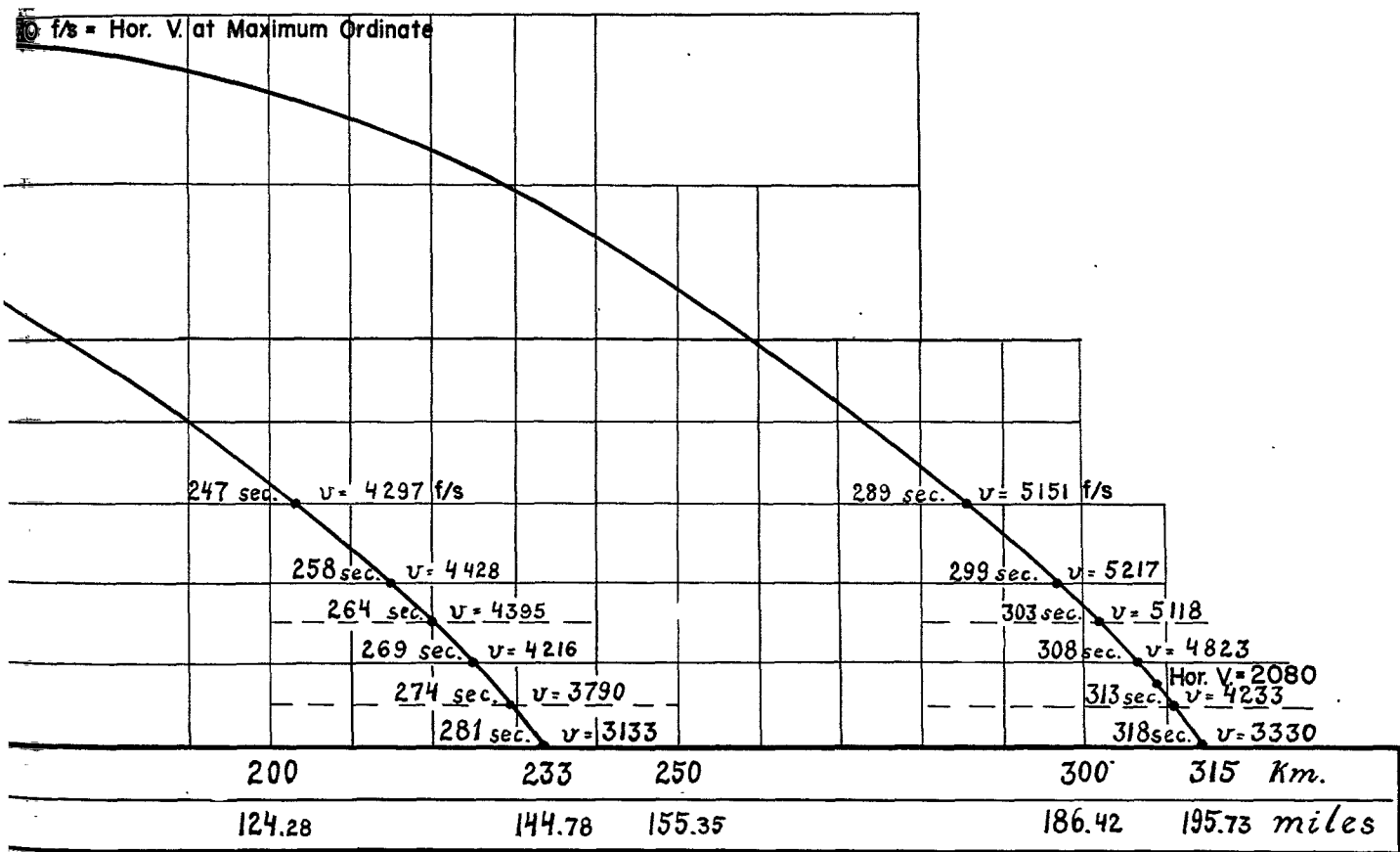

On the descending branch of the trajectory the velocity increases steadily due to gravity and if air resistance did not interfere the impact velocity would be equal to the muzzle velocity.

Since every falling body has its so-called terminal velocity, at which the acceleration due to gravity and the drag produced by air resistance balance each other, the impact velocity is always less than the muzzle velocity. High density projectiles have a rather high terminal velocity but this fact rarely became noticeable in the past. The projectile of the Paris Gun, which shelled Paris from a distance of about 80 miles in spring, 1918, lost only a few hundred feet per second to air resistance. Its maximum velocity on the descending branch was about 3100 feet per second, its impact velocity about 2800 feet per second.

But as can be seen from the diagram the maximum velocity of a V-2, when fired at maximum range, is more than 5200 feet per second on the descending path, while the impact velocity is 3330 feet per second. The main reason for this high loss is because the cross-sectional density of an empty rocket is very low.

This phenomenon is bound to increase with increasing range. A rocket which is to be fired over a longer range requires a high mass-ratio which means that its cross-sectional density, when empty, will be lowered accordingly. Its terminal velocity will be lower. But having been fired over a longer range it will enter the denser layers of the atmosphere at a higher velocity. Therefore the decrease in velocity will begin at an earlier stage of the descending path which is just another way of saying that it will reach its maximum velocity at a higher altitude.

It may be mentioned in passing that the attitude of a

long-range rocket after the fuel cutoff point cannot be predicted. Theoretically the attitude of the rocket will be the attitude which it had at the fuel cutoff point until air resistance begins to influence it. But it has been observed that rockets tumbled end over end, presumably because a small amount of leftover fuel in the pipes still caught fire after the motor had been shut off and produced a sidewise component. Since this takes place in very highly rarefied layers of the atmosphere the tumbling does not influence the ballistic performance.

It follows from the characteristics of the rocket's trajectory that the chances of interception are highest if the intercepting weapon travels along a trajectory the plane of which coincides with that of the trajectory of the attacking missile. This does not mean that the intercepting weapon necessarily has to travel along the same trajectory in the opposite direction. That, of course, would be the ideal case, but it would be very hard to realize.

Naturally such intercepting weapons would have to be missiles themselves, especially since the point or points of interception should be as high above and as far away from the target as possible. It can be taken for granted that no enemy would expend very long-range missiles unless he is able to equip them with atomic warheads. In a transatlantic missile, for example, the warhead would weigh somewhat less than one per cent of the take-off weight of the missile, which would have to be a two-step rocket. Obviously the warhead has to be very potent, else the take-off weight would assume impossible proportions.

But if the incoming missile carries an atomic warhead the interception would have to be such that this warhead is set off at a considerable height and horizontal distance from the

target. The height at which the atomic bombs were exploded over Hiroshima and Nagasaki has not been revealed, but it is generally assumed to have been on the order of half a mile. The intensity of the atomic blast of an equivalent warhead set off at an altitude of twenty miles would therefore be weakened by the square of the additional distance. Since this is forty times as far away (under these assumptions) the effect should be 40 times 40 = 1600 times weaker, and presumably would do little harm.

The fact that attacking long-range missiles will carry atomic warheads has a bearing on the interception problem in addition to the fact that interception should take place at long distances and high altitudes from the target. It may, strangely enough, make interception somewhat easier.

The most probable fuze for a long-range missile with atomic warhead is a VT fuze of considerable range. Presumably an atomic bomb must be exploded at some height over the target for maximum effect and while a time fuze is a possibility it seems more logical to equip such a missile with a VT fuze which activates the bomb mechanism in response to the nearness of the ground. If this is the case, the VT fuze would probably also function if an intercepting missile approached to within its sensitive range. A direct hit of the intercepting missile is therefore not necessary.

If the enemy should avoid using a VT fuze in his missiles for just this reason the same effect can still be produced by equipping the intercepting missile with a VT fuze, provided the interceptor can be guided to within the effective range of the VT fuze.

The intercepting missile, SAM, would have to be a rocket of considerable size, probably of about the dimensions of a V-2. It would have to be characterized by a rather high acceleration at take-off which would best be accomplished by providing a large solid-fuel booster unit. The SAM would have to be capable of correcting its own trajectory upon receipt of commands from the ground in order to insure that the plane of its trajectory coincides with the plane of the trajectory of the attacking missile as closely as the latter can be determined. The purpose of the SAM is, naturally, to frustrate the attacking missile. This is accomplished most definitely by exploding the attacker, but if that should fail the intercepting missile will still have served its

purpose if it, by its own explosion, throws the attacker so far off that it will miss the target area. Therefore the intercepting missile should carry a high-explosive charge of large size and great power.

As regards guidance of the intercepting missile, three possible methods exist. One is the command system which consists of tracking the target with one radar beam and the missile with another and of transmitting the necessary corrections to the missile as calculated by a computer on the ground.

The second method, the beam rider, has, in certain respects, several advantages over the command system. In this system, the missile has a built-in guidance system which is designed in such a way that the missile will stay within the radar beam which is tracking the target. Besides the advantage of requiring a minimum of ground control equipment, it is theoretically possible with this system to launch several antimissiles into the same beam in succession.

The third method is the homing method, a method to cause the weapon to home on the target, but it is unlikely that any homing mechanism could function from take-off to the point of interception because of the long distance involved. If a homing mechanism is used at all it will be reserved for final corrections after the missile has been put into the proper trajectory by one of the methods described above.

In conclusion it must be mentioned that a third type of very long-range missile is possible, a kind of combination of "cruising" missile and long-range rocket. The so-called A-9 plus A-10 project of the Germans visualized a modified stub-winged V-2 (redesignated as A-9) as the upper step of a rocket designated as A-10. The whole was to function as a transatlantic rocket, but the upper step, after reentering the atmosphere, was to become partly airborne.

The winged missile, although it would follow an arched elliptical trajectory most of the way, was supposed to extend the range by another hundred miles or so by performing as a high-speed glider. Such a missile would have to approach the target area in a long slanting glide at a fairly constant rate of speed. Its interception, therefore, would again be flight path interception and would be left to smaller antiaircraft missiles and to conventional antiaircraft artillery.



Some men are natural leaders; most men are not. All men can develop their leadership by diligent application and proper understanding. Leadership is not the winning of popularity, but the earning of respect. It is firmness, not harshness; understanding, not weakness; justice, not license; humaneness, not intolerance; generosity, not selfishness; pride, not egotism.—GENERAL OMAR N. BRADLEY.

1st Guided Missile Regiment*

The 1st Guided Missile Regiment was activated on 31 May 1948 at Fort Bliss, Texas. By the same order the 1st Guided Missile Battalion, which had been in existence since 11 October 1945, became the 1st Battalion of the 1st Guided Missile Regiment and from its ranks, the first commander and staff officers were selected for the Regiment. Lt. Col. George F. Pindar, CAC, became the regimental commander, with Maj. Cecil M. Sanders, Inf, Executive Officer. Maj. Ralph N. Ross, CAC, commanded the 1st Battalion, and Maj. James A. Lotozo, CAC, became the 1st Battalion Executive Officer.

On 10 June 1948, Col. Guy H. Stubbs, CAC, assumed command of the regiment upon his graduation from the Guided Missiles Course, AAA & GM Branch, TAS. He was succeeded by Col. A. H. Bender on 1 October 1948, who presently commands the regiment.

The regiment is authorized a bulk allotment of 85 officers, 19 Warrant Officers, and 899 enlisted men. The Table of Distribution provides for a Regimental Headquarters and Headquarters Battery, two Battalion Headquarters and Headquarters Batteries, an Instrumentation Battery, and six lettered batteries.

At present, Regimental Headquarters and Headquarters Battery are at Fort Bliss. The 1st Battalion, a surface-to-air unit, consists of Headquarters Batteries and Batteries A and D with the Instrumentation Battery attached, and is located at the White Sands Proving Ground.

The 2d Battalion, a surface-to-surface unit, consists of Headquarters Battery and Batteries B, C and F, and is located at the Ordnance Research and Development, Sub-office (Rocket), Fort Bliss, Texas. However, Battery F at the present time is reduced to a paper status.

The reason for the non-alphabetical assignment of the batteries to the battalions is because of the geographical location of the batteries.

Battery E is with the Navy Department, one platoon and battery headquarters at the Naval Air Missile Testing Station, Point Mugu, California, and the other platoon at the Naval Ordnance Testing Station, China Lake, California. Work at both of these stations is on missile projects of interest to Army Field Forces.

The bulk allotment of grades and ratings for the Regiment is as follows:

Commissioned Officers:

Colonel	Lt. Colonel	Major	Captain	Lieutenant	Total
1	4	21	34	25	85

Warrant Officers:

19

Enlisted Men:

I	II	III	IV	V	VI & VII	TOTAL
83	86	128	175	195	222	889

It was necessary in the original request for enlisted grades to ask for a higher number of the first three grades than is

normal in the usual organization, in an attempt to hold enlisted specialists in the unit. In the 1st Guided Missile Battalion, enlisted personnel were doing about the same work as civilian technicians drawing larger salaries, which caused dissatisfaction, and in some cases, loss of the enlisted personnel, who upon termination of their enlistments, took positions with civilian contracting agencies.

As the missile program continues, service schools will teach enlisted courses in guided missiles, and initially the Regiment undoubtedly will furnish the majority of enlisted instructors.

MISSION

One of the missions of the Regiment is to be prepared to furnish cadres for new guided missile units after the missiles have been service tested and accepted by the Army.

Additional missions of the regiment include the following:

1. To assist the Ordnance Department in the work being conducted on guided missile projects of interest to the Army at White Sands Proving Ground, New Mexico, and elsewhere.
2. To assist the Navy Department in conduct of test firings of guided missiles of interest to the Army.
3. To assist the Air Force in conduct of test firings of guided missiles of interest to the Army.
4. To develop doctrine for tactical and technical employment of ground-launched guided missiles.

Missile projects are assigned to batteries to accomplish these missions. A distinction is made between surface-to-surface and surface-to-air type missiles, and only one general type is assigned to a battery as a project.

In the shops, soldier machinists and sheet-metal workers make minor repairs and fabricate small parts; a soldier ground crew handles transportation, erection, fueling, orientation, and test equipment; soldiers are utilized in various instrument sections concerned with radar, plotting boards, and various optical instruments and precision cameras. The skills required in this type of unit are of the highest order. However, the usual administrative and housekeeping duties require a certain number of clerks, cooks, drivers, mechanics, and duty soldiers.

The Regiment has assumed the responsibility of furnishing officers as Project Officers. These officers are the over-all specialists on the missiles, and cooperate with the civilian contractors and technical agencies so as to become familiar with every detail of the missile or missiles with which they are primarily concerned. Their duties consist of the following:

1. Assist in the scheduling of firing dates for incoming projects.
2. Establish local liaison between the 1st Guided Missile Regiment, missile contractors, and the various agencies of White Sands Proving Ground.
3. Receive and store, in a suitable place, property necessary for projects.

*Prepared by personnel of the 1st Guided Missile Regiment.

4. Supervise missile assembly procedure.
5. Coordinate technical facilities, including necessary ground equipment, communications, and ballistic instrumentation.
6. Designate Safety Officers for projects, who are responsible for working procedures to eliminate the possibility of accidents.
7. Conduct firings, which include supervising missile erection and servicing, checking completion of prefiring checks and tests determining whether or not a missile is safe to fire, announcement of actual firing time, causing necessary signal flares and smoke signals to be fired at proper times, and operating the command net to the ballistic instrumentation.

The Regiment's mission of studying tactics and technique and evolving tables of organization and equipment is of necessity a long-range project because missiles must be much further along in their development before any firm conclusions may be reached. Furthermore, field service tests must be conducted to determine the missile's suitability for use as a tactical weapon. The responsibility for these service tests will be with Army Field Forces Board No. 4, assisted by personnel of the Regiment. For these reasons, the operations section of the regiment is increased in size over a normal regimental operations section to permit concurrent studies on both surface-to-surface and surface-to-air type missiles.

Officers and enlisted personnel of the Regiment come from many different arms and services. Where no suitable MOS numbers exist, personnel are requisitioned on the basis of civilian training, educational background, or avocational interests. A desirable qualification is training in the field of mechanical arts, electronics, chemistry and general sciences. Enlisted personnel are supposed to have two years to serve on current enlistment upon joining the organization and also to have a minimum AGCT score of 80, but neither of these requirements has been met in actual practice. Intensive schooling has been resorted to in an attempt to provide qualified men.

The organization of the Regiment has permitted a higher degree of specialization in studies of development trends, tables of organization and equipment, and evolution of tactics and techniques of handling guided missiles. Had it been activated later in the program, it would have caused delays in development of guided missile tactical employment studies.

The Regimental Commander is the Guided Missile Special Staff Officer to the Commanding General, AAA & GM Center, which makes it possible to coordinate all guided missile activities within the command, maintain liaison with all guided missile activities in the Fort Bliss area not within the command, and conduct studies on organization, tactics, and long-range planning.

Having at least two battalions (one surface-to-surface and one surface-to-air) completely organized and unit-trained by the time guided missile service-test activities are scheduled seems desirable. These units will provide cadres for other units subsequently activated. Experience of the 1st Guided Missile Battalion indicated that many personnel problems are to be expected in guided missile units; therefore, technically

trained personnel must be obtained and held in the unit.

REGIMENT IDEALLY LOCATED

With the Antiaircraft Artillery and Guided Missile Center and Ordnance Research and Development Division Sub-office (Rocket), at Fort Bliss; the Air Forces Guided Missile Projects at Alamogordo, New Mexico; and White Sands Proving Grounds; all located in the immediate vicinity, Fort Bliss is the ideal location for the 1st Guided Missile Regiment.

White Sands Proving Ground is an Army Ordnance installation used as a proving ground for the test firing of certain types of missiles during their development. Located 40 miles north of Fort Bliss and 35 miles southwest of the White Sands National Monument, the camp area is isolated, and the rather limited facilities for recreation make living conditions somewhat less than ideal. However, an extensive construction program is now under way and the important and interesting nature of the work being done tends to offset these conditions. Possessing the longest instrumented overland range in the United States, this proving ground has gained a position of national importance. Here is the site of the first V-2 flight test conducted in this country, and it remains the site of the continuing program of upper air research conducted under the direction of the V-2 Upper Atmosphere Research Panel. Several missiles developed under the Ordnance Department, including those developed by the California Institute of Technology, have been fired here, and the Navy is now in the midst of a test firing program at White Sands.

THE FUTURE OF THE REGIMENT

The activation of any Guided Missile unit at the present time presents the problem of a unit without a primary arm. This problem, of course, is not new. For example, we know that many Table of Distribution units were organized during the past war prior to availability of primary weapons.

Too early activation would obviously present personnel and training problems. There are no FM's and TM's for guided missiles. This means that technical reports prepared by development agencies have to be digested, and put into suitable form for troops.

Although there are still many difficulties to be overcome, there are also many reasons why the Regiment is needed at this time.

The first group of especially selected officers has just completed graduate work closely allied to guided missile development at civilian universities, and officers have been graduating from the Guided Missile Course at Fort Bliss. Assignments must be provided that will keep them in touch with guided missiles or they will drift to other assignments and valuable training will be lost.

Present trends indicate that guided missiles will affect artillery in certain significant ways: (1) Surface-to-surface type guided missiles will be a new tactical weapon to supplement field artillery; (2) Surface-to-air type guided missiles will be a new weapon to supplement antiaircraft artillery.

That guided missiles in the near future will replace present-day armament is an idea highly to be discounted. Guided missiles will be used to supplement our present armament for some time to come and cannot replace it.

Byrnes Committee Submits Report On Future Of Guard and Reserve

The Secretary of the Army's Committee on Civilian Components, headed by former Secretary of State James F. Byrnes, has submitted to Secretary Kenneth C. Royall a report containing its recommendations for the future National Guard and Organized Reserve.

With approval of the Chairman, the report, which follows, has been edited to some small degree for reasons of national security only.

As a prerequisite to any solution to the maximum utilization of our present reserve force structure, it is essential that our National Guard and Organized Reserves be built up. The integrity of each of them must be maintained. Each of them must receive the complete and enthusiastic support not only of the Regular Army itself but of the people as a whole.

In the case of the National Guard we must secure the continued active cooperation of the States, who have contributed and are contributing to it so heavily. Without their support the Guard, of course, could not exist. They have made possible the heroic record which the National Guard has written into our country's history.

We must give complete support to the thousands of patriotic and loyal citizens who compose the organized Reserve. We must recognize the tremendous contribution they have made to our Nation. Without this trained body of loyal citizens we could never fill our wartime needs.

It should be pointed out that in approaching this problem your Committee has been limited by the requirements presented by the Department of the Army which necessarily is restricted by the funds made available to date by the Congress, and by the shortage of personnel to implement a larger program. It has also been restricted by the lack of armories and other training facilities as well as by the lack of essential equipment to provide for a larger M-Day force than present plans call for.

Until adequate appropriations are available to remove these restrictions a realistic utilization of the vast potential of trained manpower available from the last war will necessarily be restricted.

With these basic considerations and limitations in mind, we recommend that:

1. *The troop basis of the National Guard* be adjusted to provide:

- | | |
|--|---------|
| a. 13 Divisions at 75% Strength (13,500) | 175,500 |
| b. 14 Divisions at 40% Strength (7,350) | 102,900 |
| Total in Divisions | 278,400 |

NOTE: Officer strength to be at full T/O&E strength as presently authorized.

The percentage strength of these divisions should not be less than that indicated. However, if Congress fails to appropriate funds necessary to maintain these units at this

strength it must be understood that they may be maintained at a lesser strength.

c. Separate RCT's to be maintained at such strength as will be acceptable to the respective governors concerned.

d. Nondivisional combat support type units, including Regimental Combat Teams, for the purpose of supporting units needed during the early phase of mobilization.

Combat Strength	192,600
-----------------	---------

e. Bulk requirements for state headquarters, etc.	4,000
---	-------

Grand Total National Guard	475,000
----------------------------	---------

2. *The troop basis of the Organized Reserve Corps* be adjusted to provide:

a. 25 Class "B" Officers	200% (1876)	46,900
Divisions EM	10% (2000)	50,000

Total	96,900
-------	--------

b. Combat support units for purpose of supporting Regular Army and other units needed during early phases of mobilization:

*Officers 200%	24,000
EM	125,400
	149,400

c. Service support units for purpose of supporting Regular Army and other units needed during early phases of mobilization:

*Officers	72,000
EM	170,000
	242,000

d. Bulk for T/D units required during early phases of mobilization:

Officers	51,000
EM	40,000
	91,000

*See Paragraph 3d.

Grand Total Organized Reserve Corps	579,300
-------------------------------------	---------

Total program National Guard and Organized Reserve Corps	1,054,300
--	-----------

3. The foregoing recommendations contemplate that:

a. Without in any way violating existing statutes, laws, or policies it will be entirely feasible, with the cooperation of the several states, to adjust the current National Guard Program.

b. Under the basic plan and in case of mobilization, all units of the National Guard and Organized Reserve Corps should be considered available for mobilization in accordance with actual strategic requirements.

c. The bulk of these reserve divisions will probably not be mobilized early, and that many of the officers and enlisted men assigned will be required for earlier assignment or will desire to be called to active duty with other organizations or staffs ahead of the time their division may be needed for activation. Insofar as practicable, and as called for by actual mobilization requirements, Organized Reserve Corps Divisions be called as organized with officers and enlisted personnel intact. This will be facilitated by the assignment of officer overstrength as discussed in paragraph 3d.

d. Because of current manpower limitations, first priority and effort should be directed toward the building up to a usable strength of those units required for early deployment; *i.e.*, divisions and supporting units of both the National Guard and Organized Reserve Corps. Officers who are not assignable to these units should be attached for training purposes to Organized Reserve Corps units. It would be advisable to permit 100 per cent overstrength attachment of officers to units for this purpose and to accord to them the same opportunities for promotion, pay and retirement credits as provided for officers assigned to these units.

e. Field type corps headquarters be established as training units to assist in providing definite unit assignments to unassigned Organized Reserve Corps and National Guard officers.

f. The possibility for expansion of units to a higher status be enhanced by the provision of additional training equipment and facilities.

g. The qualifications for inactive duty training pay of Organized Reserve Corps officers, other than those assigned to Class "A" units, be independent of the numbers of enlisted men attending training with the unit.

h. The proposed 13 National Guard Divisions at 75% strength be allocated to ZI Armies to meet the requirements of the Department of the Army, but that at least one of these Divisions be allocated to each ZI Army.

i. In order to assist the National Guard and Organized Reserve Corps units in reaching the authorized strength indicated above the provisions of the Selective Service Law be made applicable to the reserve components; and that the presently organized Army Recruiting Service assist recruiting for the reserve components.

4. Recommendations relative to the determination of the most satisfactory method of maintaining the interest of and improving the military skills presently possessed or acquired by civilian component personnel.

a. Locate all units of a reserve division preferably in a single state and in not more than two states and in fairly concentrated areas near centers of reserve population. It is of particular importance that these locations be near fed-

erally owned property, which can be developed as training centers similar to the one now being operated in the Sixth Army Area, for approximately 16 thousand Reserve Officers in the Los Angeles area.

b. For Reserve Officers not in units, or in isolated training units, take maximum advantage of near-by National Guard and Regular Army units for training and insure that inactive duty training credit is given therefor.

c. Set up District or Area Headquarters for the purpose of conducting training of all reserve components. Whereas these Headquarters must be kept small with only training functions, they should be earmarked for expansion as needed in an emergency as a Corps Headquarters.

d. Utilize Army Headquarters and the potential Corps Headquarters, to provide mobilization assignments and training for Reserve Corps officers.

e. Encourage the use of regular Army units and service schools to develop traveling instructional groups and demonstration teams along the lines of those presently organized within the Sixth Army for the purpose of augmenting the training program of Reserve units. It is believed that in many cases National Guard units may also find that they can advantageously use such teams.

f. Develop at each Army Headquarters an adequate staff for the purpose of handling civilian component affairs. This should be an operating staff, not administrative, headed by a general officer, assisted by a senior National Guard and senior Reserve officer called to active duty for a year's period.

g. Pool Organized Reserve and National Guard Regular Army instructors wherever possible, improve the caliber of this instructor personnel, streamline their functions, reduce their paper work.

h. Provide pay for administrative assistants to assist Reserve organizations in administrative work. All instructor personnel of the civilian components when ordered to such duty to report to Army Headquarters for a short period of special instruction.

i. During field training periods, Regular Army and National Guard units to act as sponsoring or training organizations for appropriate Reserve units.

It is submitted that if the above program is wholeheartedly implemented, it will eliminate much of the dissatisfaction, uncertainty and confusion incident to the current Reserve program.

Our recommendations are based upon present strategic requirements and the limitations heretofore referred to. We recommend that there be a continuing study of the problems of the Reserve components, looking to the greater utilization of both commissioned and enlisted Reserves.



Operational Aspects Of Guided Missiles

By Lieutenant Colonel Howard B. Hudiburg, GSC and
Lieutenant Colonel Richard G. Thomas, CAC

PART II—TACTICAL EMPLOYMENT

In the January-February issue of the JOURNAL, the authors presented a general background of the guided missile art, including the types of missiles, and emphasized that the use of these new weapons would introduce many new tactical and logistical problems. They assumed for planning purposes that our first weapons of primary interest to ground forces would encompass:

SAM (AA): Antiaircraft
SSM : 0-150 mile range, surface-to-surface
SSM : 150-500 mile range, surface-to-surface
SAM (AM): Anti-missile

The first weapon which we will consider is a surface-to-air antiaircraft missile (SAM-AA). It is a liquid-fuel, rocket-propelled, supersonic vehicle, approximately 20 feet in length, 18 inches in body diameter, 3 feet in control surface span, weighing 1,000 pounds, assembled and fueled, employing a preset initial guidance system, command mid-course guidance and homing terminal guidance, the over-all *terminal-guidance-fuze-warhead* combination such that the single shot kill probability for a single aircraft flying 500 miles per hour at 45,000 feet altitude is 0.25. The missile employs a two-propellant propulsion system and, in addition, requires a 1,000-pound solid-fuel booster for launching.

Now, let us examine the situation which makes it desirable to develop and employ such a heavy, expensive, and highly complex weapon. The target plane with the capabilities listed above is in actual existence *today*, and is being produced in ever-increasing numbers by most of the major powers of the world. Just as offensive action makes such a plane desirable, defensive planning requires that adequate protection against it be developed.

If this target plane were to fly at 35,000 feet altitude instead of 45,000 feet, then we *might* be able to devise a partial defense against it with conventional antiaircraft guns. However, a few calculations will show that at this altitude it would require approximately three battalions of the heaviest antiaircraft guns available to provide a minimum gun density of from 8 to 12 over the inner half of the critical zone which would be involved in the defense of a *point* target. The defense of an area target would require much more. If the enemy plane came in 5,000 feet higher, or at 40,000 feet, four battalions would be required instead of three to provide the same defense. In either case the guns would be spread over an area approximately 25,000 yards in diameter. At its best, a defense of this type could not expect to destroy or seriously damage more than one plane out of every ten it engages. When you consider the vast amount of personnel and armament involved, together with

the results obtained, this, then, is an expensive defense. But what about the same planes at 45,000 feet! This same defense would be ineffective against the attacking aircraft and some designers of AA guns state that it is impractical to develop mobile guns with a range much greater than those now available. Obviously, some new type of defensive weapon is necessary, and we believe our hypothetical missile described above will meet our needs.

Let us see what the organization might be for a unit employing our SAM-AA in defense against 500 mph aircraft flying at altitudes above 45,000 feet. First, consider the firing battery. Experience dictates that a mobile unit, using one mess, should not exceed approximately 200 men; otherwise, it becomes administratively top-heavy and loses considerable mobility. Allowing approximately 10% for overhead, this leaves a maximum of 180 men per battery to do *all* the normal combat jobs in a unit such as handling the matériel, driving trucks, manning the launchers, plus the many new types of jobs in a guided missile unit, such as toxic fuel handling, surveying, and operation of many new fire control devices.

Although it is impossible to predict how many men it will take to service a missile launcher until the final-type launcher and missile are actually built, a logical organization appears to be 10 men per launcher. If there are five launchers per platoon, this would then form a platoon of 50 men. It is estimated that in addition to firing 5 launchers, this platoon could also move, emplace in alternate positions, and fire, as required, 5 additional launchers. Three platoons of this type would then make up the firing units of one firing battery. In a battery of 200 men this would leave 30 men for the battery commander's fire direction section, including survey men, radio and radar operators, and other allied specialists. If it is assumed that each launching crew is capable of reloading its launcher, including all pre-firing tests, once every 15 minutes, then each platoon would be capable of firing 20 missiles per hour. Therefore, a battery of 3 firing platoons would be able to maintain a rate of fire of 60 missiles per hour, or one per minute.

From the above figures it is readily seen that one battery could fire only 3 missiles at any one instant followed by others, up to a total of 15 as rapidly as the control equipment could handle the acquisition problem. Then they would have to reload the launchers. Remember that the missile and booster together weigh more than a ton, and that this assembly is made up of relatively sensitive equipment. Even with the best in mechanical handling equipment, reloading in a field position promises to be a relatively slow process.

In World War II it was generally accepted that an attacking air force could not, on an average, withstand a loss of more than 10% of the planes in any one raid and most

AA defenses considered their job well done if they destroyed an average of 5% of the planes taken under fire. With the advent of the atomic bomb it not only became desirable, but a necessity, that the air defense approach 100% effectiveness, if at all possible.

Based on a single shot kill probability for a single aircraft of 0.25, it would require approximately one missile per attacking plane to insure that 25% of the attackers were knocked down in a sustained engagement of such scope as to give us a true statistical evaluation. However, to be 70% sure that any one plane would be destroyed would require 4 missiles, to be 95% sure would require 10 missiles, and to be 100% sure that any one plane would be destroyed would of course, require an infinite number of missiles, if each missile had a single shot probability of a kill of 0.25. You can be certain of destroying any one plane *only* when a missile is developed which has a single shot probability of a kill of 1.0.

Thus, the problem, at this point, requires information from Intelligence, for Intelligence must ascertain the type of bomb the enemy is using, estimate the number of planes which may be expected in each raid, and, if possible, determine the most likely avenue of approach. The priority of the defended area must be determined. Once these data are supplied, it is possible to determine how many batteries of our hypothetical missiles will be needed and how they should be placed on the ground, to accomplish our mission. War-gaming assists in evaluating the effectiveness of our defense.

In the organization of surface to surface missile (SSM) unit the same principles as to the size of the firing battery are applicable. Because of the difference in missile size and type of fire control equipment used, the internal organization of the battery may be expected to be much different. Larger crews will probably be necessary at each launcher and highly specialized equipment will be necessary for "observation" of fire. It is likely that fire observation will be effected by some unit other than the firing battery which would make the conventional forward observer unnecessary in surface to surface missile units.

Based on the assumption that our SSM unit is equipped with a 15,000-pound missile, carrying a 1,000-pound conventional warhead, having a range of 150 miles and a circular probable error of one-half mile, it is logical to expect that this unit will be employed at some level higher than division, possibly at Army level. Since a missile of this type would be very expensive and, at the same time, would not possess pin-point accuracy, the most likely targets would be critical cities, railroad yards, supply areas, and similar area targets. This type of employment would be expected to provide neutralization and not destruction, and would be of paramount value under conditions denying tactical air support.

The warning nets required in the employment of SAM, and the defense against SSM, will of necessity possess greater capabilities in range and speed than previously considered possible.

The ground components of the National Military Establishment are interested in all types of guided missiles, with perhaps the possible exception of AAM: in the defensive role, we must protect ourselves from attack by ASM and

SSM; in an offensive role, we shall employ SAM and SSM to supplement our conventional artillery weapons and our tactical air support requirements.

Antiaircraft guided missiles, SAM(AA), are needed to supplement conventional antiaircraft artillery. The ground force commander must be capable of providing defense against attack by conventional aircraft and guided missiles at such vital points as supply depots, points of debarkation, communications centers, command centers, troop reserves, march columns and defiles, and front-line troops. The overall defense commander will be vitally concerned with a similar problem at industrial centers, points of embarkation, cities, road nets and other points presenting suitable targets to the conventional or atomic weapons of the enemy.

The entire antiaircraft problem of the future is vastly more complex than any previous similar problem because enemy employment of ASM will make it impractical to provide a defense such as was formerly employed against aircraft carrying free-fall bombs. Further, the future antiaircraft defense must approach 100% effectiveness since one atomic bomb, properly placed, may accomplish the enemy mission. No longer will attrition rates of 10 to 20%, or even higher, allow an antiaircraft "pay-off"!

Regardless of air superiority, an enemy, even though his air arm may be totally destroyed, can effectively strike vital targets with V-2 type weapons. Even today, we know that the V-2 is only a crude predecessor of more accurate and longer range weapons. It is, therefore, mandatory that the ground commander have at his disposal a guided missile capable of defending vital elements of his command against attack by such weapons.

The short-range SSM (0-150 miles) that we have assumed will be needed to cover targets beyond field artillery range with specific missions of harassing reserves, interdicting the movement of troops and supplies, interruption of communications, destruction of command posts, and counterbattery or countermissile fire. In the past, the tactical air command has been called upon to accomplish these missions. In the zone of contact, air missions against the enemy are most difficult to control, are most expensive and are, in general, least effective, when compared to other missions of the tactical air force. Here, targets are usually well dispersed, small and difficult to locate from the air and present severe identification problems to the airman in distinguishing friendly ground troops. These reasons, in addition to frequent hampering of aircraft operations by weather, darkness, smoke, interception by fighters, and flak make such targets especially favorable for engagement by our short-range SSM, thus freeing the tactical air force to accomplish higher priority missions. The overlapping of artillery and SSM facilitates an integration of these weapons and will make possible an extension of present artillery techniques.

The longer range SSM (150-500 miles), which we have assumed available to the ground commander, is needed to supplement air force operations in isolating the battlefield, the specific mission being to prevent the enemy from moving troops into, out of, or within the battle zone, and to destroy supply dumps, signal communications and enemy troops in reserve or in retrograde movement. By employment of SSM, the ground commander can contribute materially to isolation of the battlefield, leaving air forces free

to accomplish the primary mission—the gaining and maintaining of air superiority. Thus, isolation of the battlefield will not have to wait until air superiority is attained. The employment of the V-2 against Antwerp as an artillery weapon by the Germans is an outstanding example of employment of such weapons to isolate the battlefield by denying troop and supply movement through that port, satisfactory employment being possible even though the enemy did not have air superiority. Few will deny that, had the Germans had atomic warheads available for these missiles, that portion of the battlefield would have been isolated.

There are many examples in World War II where SSM would have been a decisive factor in obtaining an earlier decision.

In coastal defense systems, SSM, with suitable modifications, may be employed to supplement conventional seacoast defense weapons. Such application of SSM will greatly increase the possibility of providing adequate defense for such vital targets as harbors, ports of embarkation, supply depots, coastal industrial centers, and invasion beaches. Further, possessing tactical mobility, SSM launching sites could be moved inland and continue the attack in the event of a successful hostile landing, a capability not possessed by fixed seacoast artillery.

It is obvious that the degree of the impact of guided missiles upon present tactics and techniques is dependent upon the time element. In other words, as the period of peace is extended, we may expect an ever-increasing growth of guided missile capabilities. This growth now requires, and will continually require in the future, close observation. Should an early conflict throw early developments “into the line,” we may expect such weapons to have the capabilities of supplementing present, conventional weapons. However, should the guided missile art progress to a high state of perfection before being called into action, existing tactics and techniques might possibly be revolutionized, radical changes in the art of winning a war would result—“push-button” warfare as envisioned by the most revolutionary thinking might be an actuality. It therefore is self-evident that, to a greater extent than ever before, the concepts of warfare will change rapidly, the rate of change being pro-

portional to the rate of development in the guided missile art. Hence, this problem must be thoroughly evaluated at all times and military planners must be ever-cognizant of the status of these new weapons. Operational analysis to determine the value of, and the proper employment of, such new weapons is truly a “must.”

In summarizing our tactical and strategic considerations, let us set forth the following thoughts:

1. Guided missiles will affect our tactics and techniques and, perhaps, our over-all strategy. The impact of guided missiles is proportional to the time elapsed prior to their employment and will vary from supplementing existing weapons to true “push-button” warfare. We must be ever-cognizant of their existing status at all times.

2. Tactics and techniques will change as guided missile capabilities are increased in military value. Operational control must be flexible and such weapons must be employed in a manner as to increase our over-all, military capabilities to the maximum extent possible.

3. The economics involved in the employment of high unit cost weapons dictates the need for constant operational analysis to determine the true, over-all values and proper employment techniques of these weapons. From this standpoint, such weapons will, of necessity, be multiple-purpose, interservice weapons to the extent possible.

4. Guided missiles are vital to all services and will be employed in all phases of military operations.

5. These new weapons will increase our over-all capabilities, performing new tasks, as well as accomplishing old tasks better. Tactically, our all-weather capabilities will be notably increased. The capability of the ground forces to furnish their own support fires will be greatly increased and, thus, air and naval forces may to some extent be relieved of such missions to concentrate their efforts on higher priority missions.

6. The communications zone will be highly vulnerable at all times. Hence, dispersal must be the keynote. Highly remunerative targets must be avoided to the maximum extent possible. Conversely, we can afford to employ these weapons only on the most important targets presented to us by the enemy.

(To be concluded)



The Doctrine of the Informed Soldier*

The American citizen soldier can be led but not driven, does not follow blindly, nor accept without question, nor go forward without purpose, nor place his faith or confidence without reason. But properly informed he will understand the necessity for unity of purpose and action, for discipline, for the authority and responsibility of command. With such understanding comes willing subordination of the individual and a spirit of spontaneous cooperation toward the accomplishment of mission.

*From the Basic Doctrines of Troop Information and Education.

Preference Cards and Assignments

By Colonel Joe D. Moss, CAC

The Coast Artillery Branch of the Career Management Group has recently been screening a large number of preference cards which were submitted in accordance with regulations. Perhaps a brief description of how these cards are used and a few "do's" and "don't's" may assist you and also help us to help you.

Upon receipt of the preference cards by this office, they are reviewed so that anything of immediate interest or value may be taken care of. The cards are then filed for future reference. Ordinarily there is no further need for these cards until your time for reassignment arrives. At that time the preference card is withdrawn from file and considered together with your records before an assignment is made. If any of your desires fit in with existing vacancies, if you meet the necessary qualifications, if the position fits in with your career pattern as set up by the career management program, and if the various other needs of the service are covered, you will get the assignment. As you can see, there are a large number of "if's" between your desires and your actual assignment. The needs of the service must take first priority. Far more people ask for certain assignments or areas than there are vacancies existent, and certain assignments which must be filled are never requested by any officer. In fairness to all, an attempt is made to give each individual his proportionate share of the desirable and undesirable areas and duties. You can improve your chances of getting a desirable assignment, if you take the above factors into account before you fill out your preference card. For example, do not ask for an ROTC assignment at a university where no Coast Artillery unit exists. Do not expect continued assignments in staff duty if you are seriously lacking in troop duty. It is useless to request the Armed Forces Staff College if you do not have credit for the Command and General Staff College. Remember that the career management program does not anticipate keeping you in a limited field for your entire career. Although you may be a specialist in one particular line, this must be rounded out with other training and experience in order that you may be fully qualified for higher command.

If you have legitimate compassionate reasons for desiring a certain area of assignment, do not depend upon the preference card to get you that assignment. Don't forget, your preference card is used normally only at the time of expiration of your present tour. Submit a letter, through channels, giving your reasons and inclose the necessary affidavits or certificates to substantiate your request. If your reasons are medical, a doctor's certificate is required. The statement, "for personal reasons," is not sufficient. If your reasons are considered to be adequate, every effort will be made to comply as nearly as possible with your request.

If you desire to take advantage of the Army's civil school-

ing program, you must submit a written request, through channels, and include the required data showing your qualifications. Similarly, requests for detail or transfer to another branch of the service or for assignment to Military Attaché or Military Mission duty must be submitted by letter through channels. A statement on your preference card is not sufficient.

On the other hand, student assignments to Service Schools, such as the Branch schools, the Command and General Staff College, the Armed Forces Staff College, and the National War College, do not require letters. As a matter of fact, such letters are not even considered. Eligibility lists for these schools are maintained. Impartial selections for attendance at the various schools are made from these lists. All Regular Army officers who have not already received constructive credit for the basic and advanced courses of the branch schools are required to be sent to these courses. It is anticipated that about 50 per cent of the officers will be sent to the Command and General Staff College, about 12½ per cent to the Armed Forces Staff College, and about 3 per cent to the National War College. In all cases, consideration is given to efficiency reports, duties performed, age, availability, and other pertinent factors prior to selection. The Coast Artillery Branch selects the branch officers who are to attend the Basic and Advanced Courses at The Artillery School. However, we merely nominate officers for attendance at the higher schools. Final selections are made by higher levels. The more advanced the school, the higher the level that makes the final selections.

While on the subject of schools, it is a good idea to indicate on your preference card any special courses you desire to attend such as associate courses, Guided Missiles Course, Naval or Air War College, or foreign military schools. Occasionally there are openings for some of these schools and our only way of knowing your desires is through your preference card.

The last comment pertains to volunteering for overseas duty. Once again, a statement on the preference card is not sufficient. You must submit a letter through channels. However, there is one important thing to remember. Once you volunteer, although you may specify the theaters you prefer, you become eligible for assignment to any theater.

In summarizing, prepare your preference card with care. It may be the deciding factor in determining your assignment. However, submit letters, through channels, when you desire civil schooling, Military Attaché or Military Mission duty, when you have compassionate reasons for requesting certain assignments, or when you desire to volunteer for overseas duty. Although the fulfillment of your desires cannot be guaranteed, every possible consideration will be given to them.

The First Successful Firing Of A Two-Stage Liquid-Fuel Rocket

By Lieutenant Colonel James G. Bain, OD

On 24 February 1949 a two-stage liquid-fuel rocket, launched by the Ordnance Department at White Sands Proving Ground attained an altitude of more than 250 miles. At the peak of its flight it was higher above the earth than any man-made object had ever gone before and was, for all practical purposes, outside the earth's atmosphere.

The record-breaking missile was made up of a captured German A-4 rocket with the warhead modified to accommodate the second stage, an American designed WAC Corporal. This combination was chosen because both missiles were fully developed and available and their use would be much less expensive, in terms of manpower as well as funds, than an entirely new design.

The mere setting of an altitude record, though, is no justification for even the relatively modest cost of the project. It has long been recognized that the multistage principle offers the most efficient means of obtaining long range or great altitudes with rockets. Dr. Goddard did some preliminary design work on such a missile as did the Germans at Peenemunde. No one, however, had actually built and launched a multiple-stage liquid-fuel rocket.

Strictly speaking, many two-stage rockets have been built and fired, both in this country and abroad. But the first stages of these have been what are generally known as jatos or booster rockets whose job is to get the primary missile up to an optimum operating velocity or altitude in the shortest possible time. To date, jatos have been mostly short duration, solid propellant units which separate from the second stage at relatively low altitudes and speeds.

The generally accepted conception of a two-stage rocket consists of a combination of long burning liquid fuel units. This type of missile presents some unique problems, perhaps the most important of which is the matter of ignition of the second stage. Obviously this should take place at or just prior to separation of the two rockets. With a long-duration first stage this will occur at altitudes where the air is extremely thin. The effect of the very low ambient pressure on the mixing and ignition of liquid propellants was largely unknown and considerable time and effort was spent in developing devices that would insure that the WAC "fired up" at the proper moment.

A second serious problem was the maintenance of stability of the second stage during its burning period. Any lack of stability would have sent the WAC into wild gyrations. Again, the almost total lack of atmosphere at and above the separation point made the use of aerodynamic surfaces of very little value, so another solution had to be found.

Many other problems arose, such as the heating effect of

the anticipated high velocities on the skin of the WAC Corporal. The solutions to these as well as to the major problems stated above, are classified and cannot be revealed, but great credit should go to the scientists and engineers of the General Electric Company, Douglas Aircraft Company and the Jet Propulsion Laboratory, California Institute of Technology who collaborated on the project. These three Ordnance Department contractors acted as a team in successfully coping with all of the many difficulties encountered.

The radio doppler tracking system developed by the Ballistic Research Laboratories, Aberdeen Proving Ground, provided data on the entire flight of the missile. Four channels of telemetering, incorporated in the missile-borne doppler unit furnished valuable information on performance of the second stage rocket and aerodynamic conditions during flight. At the peak of the trajectory, atmospheric pressure was many times less than the best vacuum ever produced in a laboratory. The satisfactory operation of this equipment under these conditions is a major achievement in electronic engineering.

A very serious problem, peculiar to this particular project, was presented by the geographical limitations of White Sands Proving Ground. Even though the probability of hitting any person with the descending WAC Corporal second-stage was extremely small (less than one chance in two million), the missile had to be kept within the range boundaries. Major modifications were made in the safety system and several rockets with reduced fuel in the second stage were fired experimentally in order to insure that an erratic missile could be brought down before it could leave the proving ground.

The first full-powered flight was entirely successful. Separation occurred at approximately 20 miles altitude and the WAC Corporal reached a velocity of more than 7400 feet per second on its way to the 250-mile peak of the trajectory. Time of flight to the summit was six and one-half minutes and to impact approximately twelve minutes. The V-2 first stage landed 20 miles north of the launching site. Tracking instruments indicated that the WAC Corporal came down about 85 miles north of the launcher although the exact impact point has not been found. A correction of 9.5 degrees in azimuth was required to take care of the expected deviation due to rotation of the earth during the time of flight.

The success of this flight marks an important forward step in the history of rocket development. In addition to opening up entirely new and unexplored regions of the upper atmosphere for scientific research, the results obtained from this and similar flights will prove to be of significant value to the designers of long-range missiles of the future.

Report Of Industry-Army Day Conference

By Colonel Harold R. Jackson, CAC, PMS&T, Massachusetts

Institute of Technology

In accordance with a letter dated 29 November 1948 I attended the annual meeting of the Industry-Army Day conference of leaders of industry and of the Army, as a representative of the Coast Artillery Association.

I attended the Ordnance luncheon which was held at the University Club in Boston. I estimated that there were about 300 people present. The principal speaker was Maj. Gen. Everett S. Hughes, Chief of Ordnance, who stated that in his opinion there are too many gadgets provided in the Tables of Organization for Army units, many of which are not absolutely necessary. In the interest of economy, many of them could well be eliminated.

After the luncheon, most of the guests present went to the First Corps of Cadets Armory on Arlington Street, where we listened to the addresses by Assistant Secretary of the Army Gordon Gray, Gen. J. Lawton Collins, and Maj. Gen. Anthony C. McAuliffe. Mr. Gray discussed the importance and ultimate saving in money and time of preparedness contracts for industry. He also explained that Army stock piles were seriously depleted at the close of World War II because too fast demobilization prevented the proper maintenance of stocks on hand. He explained that planning studies would in the long run save time and money. For example, planning studies costing \$70,000 would reduce from 12 months to 9 months the time to get incendiary bombs into mass production, and would save millions of dollars in time of emergency.

General McAuliffe discussed our neglect of research and development before World War II. Before the war we expended \$20,000 annually in research and development, whereas during the war we expended \$20,000,000 a year. He mentioned radar, the proximity fuze, and the atomic bomb as products of research and development that may be considered as having had a decisive bearing on the outcome of the war. General McAuliffe stressed the importance not only of developing new weapons and new types of equipment, but also of operations research. He stated also that measures are under way to achieve the greatest possible standardization of equipment among the free nations.

General Collins spoke on the world military situation. He quoted Clemenceau as saying that "war is too important to be left to the military." General Collins agreed that military men alone cannot fight wars. He stated that before World War II there were five areas outside the United States that could generate enough power to wage modern war: Great Britain, Western Europe, Germany, Russia, and Japan. He added that Germany and Japan are no longer important. He stated that Russia had recently developed a long-range strategic air force, separate from their normal air force, and had copied B-29's that had been forced down in Russian-controlled territory. General Collins stated that although

air power is of decisive importance, ground troops will still be essential in modern warfare. He stated that industry can further preparedness in many ways. It can grant leaves to employees to enable them to participate in training, and can aid in the establishment of affiliated units of the reserves. In discussing the importance of affiliated units, General Collins stated that before World War II there was only one signal battalion in the Army. Because signal battalions are essential parts of armies and corps, and because other signal units are needed in divisions, General Collins stated, he didn't know what we could have done without signal units established by civilian industrial organizations.

He stated that the services have observed economy in making up their estimates for defense projects. All services were asked to limit their estimates to what they would absolutely have to have in the event of an emergency.

During the question-and-answer period, General Collins stated that the National Guard is very important. For example, National Guard units are ready to move quickly to protect vital areas in an emergency.

The banquet in the evening was held at the Statler Hotel, and I estimated that about 500 people were present. After the banquet, the assemblage was addressed by Mr. Benjamin F. Fairless, President of U. S. Steel, and by Gen. Omar N. Bradley. The speakers were introduced by Mr. Joseph P. Spang, Jr., Chairman of the Industry-Army Day Executive Committee, and President, Associated Industries of Massachusetts. Mr. Fairless predicted an all-time record steel production of 98 million tons by the end of 1950. He also stated "Our system of responsible private initiative, or American way of life, has built a nation of the highest rank in world affairs. That exalted position has not been achieved and held by the arbitrary operations of a despot or bureaucracy. Neither is it the material result of collectivism. The ambitions and efforts of free citizens and free institutions have built the complicated structure which has served us so well."

In his talk General Bradley emphasized two points. One was that we must not wreck our national safety on the false assumption that we can depend entirely upon air power. The combined efforts of all the services are essential to insure security, and it is dangerous for us to count on a decisive knockout in the first round, i.e., victory through air power alone. An air war of attrition would be dangerous. We must commit ourselves to reserving a springboard for ultimate attack by ground arms. General Bradley also stated that, "in subscribing to the need for prudence in military spending, I say to you that I would much prefer to take some military risk rather than have to weather the dangers of an economic bust."

AAA Should Be More Flexible

By Captain Keith W. Bose, CAC

Fire power and mobility will always remain the predominant characteristics of the artillery weapon, regardless of its assigned primary mission. Artillery has, in the past, become more and more specialized toward some definite primary mission. Heavy AAA in World War II was organized into highly specialized battalions with one definite primary mission—the destruction of high-flying aircraft. In the organization and training of these units, little provision was made for employment in any other role. When combat circumstances made this necessary, and the units were assigned ground missions, results were as could be expected in the light of hasty action necessary.

Many advantages would accrue from making our AAA more versatile by reorganization into compact, highly mobile organizations capable of rendering maximum support to the front-line infantryman or tank *including* the engagement and destruction of high-flying aircraft with all the effectiveness of units specialized for this purpose.

In field artillery, maximum efficiency came from the control and direction of fire from the bulk of available guns by a single individual, whether he was a senior artillery commander, or a solitary forward observer.

If it were possible, by some means, to mass and direct AAA fire, a target would be engaged suddenly and overwhelmingly before it was capable of evasive action. Let us assume that some means had been developed for the continuous transmission of target present position data by radio or wire. Such means could easily be provided in the light of present knowledge. The batteries are now relieved of all AAA tracking apparatus and radar, which is grouped in specialized units, and properly disposed. The computer itself, with a means of data reception, is located at the battery, and the location of each remote radar is handled as is our present parallax correction. If one individual of a higher echelon could be provided with oscilloscopes, presenting targets received from the remote radars, a technique might be developed for closely controlled mass fire, and the AAA battery then becomes once more an instrument for the delivery of fire, just as was the battery of Civil War days. Furthermore, relieved of the responsibility of fire control, the battery might absorb more guns, something which has already been found desirable. From the radar standpoint, certain radars may be specialized for search, others for fire control.

The idea goes further than control of AAA fire, however, since field artillery observers and fire direction centers may also be tied into the scheme. The battery commander now receives all data and commands necessary for the delivery of fire and target selection from one source. He may fire on an aerial target, transfer fire to a ground target, or scheduled ground missions, all on command of his fire direction center. His responsibility lies in the delivery of accurate fire from present-position data received.

To begin with, AAA weapons must be capable of 360 degrees traverse and high elevation and must possess an automatic means of setting data, that is, azimuth and elevation clocks and selsyns.

The weapon must be equipped with some sort of accurate sight for terrestrial fire, such as the panoramic sight.

A serious limitation of AAA guns used in support fire is the flat trajectory. This must be remedied by the use of semi-fixed ammunition of the proper charge zones. Since the gun must be capable of high elevations anyway, it may then render plunging, howitzer-type fire.

It may also be possible to do away with the bulky platforms used with present AAA guns.

Needless to say, the weapon must have a low silhouette and be capable of giving direct fire without emplacement. Finally, it may be possible to develop an efficient self-propelled mount to give greater mobility.

No unit should be considered trained until it could operate with combined branches in every conceivable tactical situation, and all officers, particularly the commanders, thoroughly grounded in the tactics of ground combat.

The organization and grouping of the fire control apparatus is a matter for experiment, but, in any case, should be kept separate from the fire units, allowing both to be grouped as the situation warrants. Possibly, a fire control unit sufficient to control the fire of a corps would be sufficient, with sections which might be detached for isolated operations. Guns might be grouped in battery fire units, and batteries into battalions, with the battalion commanders primarily concerned with survey, communication, and movement, rather than fire control.

Although the senior AAA commander, or artillery commander, as the case may be, is responsible for fire control and target selection, the actual job of selection, control, and the assignment of fire missions to the batteries must be performed by highly skilled officers from positions at the target-presentation oscilloscopes.

Furthermore, they should be aided as much as possible by automatic means. One form of this could be an automatic time-on-target computer, with a signaling arrangement to the batteries to fire. Thus, the bulk of fire would arrive simultaneously at the target, notwithstanding variations in times of flight due to the relative positions of the various batteries.

There is a particular advantage in the central command of all radar apparatus, since it makes for ease in maintenance, places the responsibility for maintenance on one commander.

In conclusion, it is hoped that the foregoing discussion may prove of interest to members of all branches of artillery. The conclusions made here are the result of the writer's experience as an AAA officer in the ETO from June 6, 1944, to the cessation of hostilities.

Some Electronic Aids To Meteorology

By Norman Abbott

Accurate weather prediction is vital in military planning and operations, in aircraft scheduling and operation, and in many other fields of endeavor. With the application of new methods of instrumentation in probing the upper air, it is expected that there may be a possibility of obtaining answers to some of the design and operational problems in connection with the propagation of sound, light, heat, and electromagnetic radiation. Electronic equipments are among the most widely used by the modern meteorologist in his attempts to outguess nature.

THE RADIOSONDE SYSTEM

Probably the earliest application of electronics to the field of meteorology was the radiosonde system, for obtaining data on pressure, temperature, humidity and wind conditions in the upper atmosphere. This system is composed of three major elements; one which is sent aloft into the atmosphere, a second which is used on the ground to receive information from the airborne unit, and a third which is used to make a permanent record of the received information for study and action. The data obtained are used for forecasting, ballistics correction, flying altitude selection, etc.

The device sent aloft to make soundings of the atmosphere and to automatically transmit these soundings to the ground stations is termed a radiosonde. It is fastened to a gas-filled balloon which is carried by the wind in free flight. Generally the balloon used is such as to give a rate of rise of approxi-

mately 1,000 feet per minute. At its maximum altitude the balloon bursts and the equipment is lowered to the ground by parachute. During flight radio signals are transmitted which are a function of the atmospheric pressure, temperature and humidity at the radiosonde; and the drift of the balloon provides an indication of wind direction and speed.

The radiosonde includes a meteorological "modulator" unit which contains the elements affected by the surrounding pressure, temperature and humidity, and a radio transmitter. Meteorological conditions in the atmosphere through which the radiosonde is carried, cause changes in the transmitted radio signal by means of a variation in the resistance contained in the grid circuit of a modulating oscillator tube in the transmitter.

The pressure element in the modulator unit is a bimetallic temperature-compensated aneroid barometer type element which, through a crank and lever system moves a contact point across a commutator assembly of metallic and insulating segments. As the pressure changes, the contact point moving across the commutator connects various resistance elements into the transmitter circuits. These resistance elements include one affected by temperature, one affected primarily by humidity, and two reference standards.

The temperature measuring element used in most present-day radiosondes is a ceramic resistor which has a high speed of response and is quite rugged. The resistance of this element varies considerably with changes in temperature, and each one is calibrated for operation between temperature limits of $+60^{\circ}\text{C}$. to -90°C . The humidity element is composed of a polystyrene strip with a hygroscopic lithium chloride coating and two metallic electrodes along the edges. The resistance between these two electrodes is a function of the absorbed moisture and the temperature. The humidity elements are calibrated to measure relative humidity between 15 and 100%. Pressure is determined by knowledge of the position of the contact point on the commutator.

The older radiosonde transmitters used in this country operated at a carrier frequency of 72 megacycles per second. An equipment now in use by the U. S. armed services and Weather Bureau operates at a carrier frequency of 403 megacycles per second, and a more recent development by the Signal Corps utilizes a frequency of approximately 1700 megacycles per second. The higher frequency of operation is important in the ground direction finder unit, to be discussed later, to enable tracking the radiosonde to lower angles of elevation than presently possible and for more accurate angular determination of the position of the radiosonde in space.

The signals transmitted by the radiosonde are received at the ground stations by one of two general methods and then indicated and recorded for analysis and use.

Where interest lies only in the pressure, temperature, and humidity at the airborne instrument a simple receiving-recording system is used. Two antennas are located at physically separated positions and are so used that as the balloon-

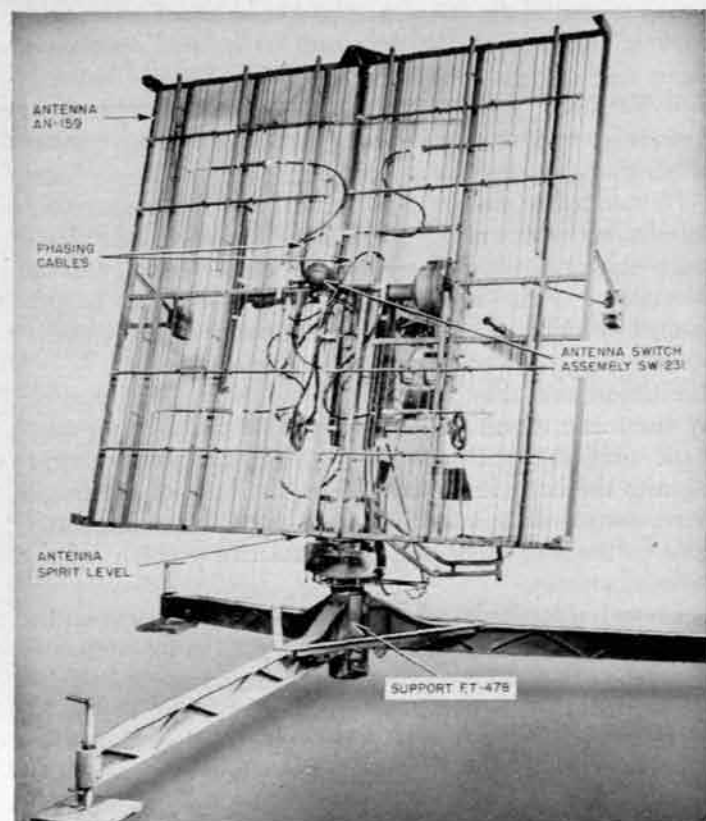

Figure 1—General view of meteorological direction finder.

borne radiosonde is carried by the wind the most efficient of the two antenna locations is utilized. The radio receiver has three output channels. One of these feeds a loud-speaker for aural monitoring purposes, a second channel feeds a signal intensity meter for indicating the strength of the signal being received, and the third channel is used to provide a signal of appropriate wave form for operation of a frequency meter and recorder.

In the more usual case, however, where in addition to pressure, temperature, and humidity, information is also desired on wind direction and speed as the radiosonde is carried aloft (or if information on wind velocity only is required), a direction finder is used to track the transmitter. A pair of optical theodolites served this purpose until the advent of modern electronics. Optical means fail under conditions of darkness or fog, or when the balloon passes through a cloud, but these conditions are overcome by means of the radio direction finder.

Figure 1 shows a general view of the meteorological direction finder SCR-658. Unlike the more common direction finder which provides azimuth data only, this unit utilizes more recent techniques and provides both azimuth and elevation data. In addition, the receiver has a channel through which the frequency modulated radiosonde signals are passed and converted into the amplitude and wave shape required by the recorder unit. The set is transportable, weighing about 2,000 pounds fully packed for domestic shipment. It operates on a frequency of approximately 400 mc, and uses a mattress type antenna with vertically polarized radiating elements. It is so arranged that it can be operated by one man or two. The operator, or operators, turn handwheels which rotate the antenna in azimuth and elevation so that it tracks the balloon-borne transmitter. The operators are guided by the indication on a cathode ray tube using a radar type A presentation.

The antenna array contains elements arranged into 4 bays which are so connected by means of a rotary switch as to provide 4 different combinations in rapid succession. As the motor driven switch rotates, the antenna receiving pattern takes positions of "up elevation," "left azimuth," "down elevation," and "right azimuth" in succession. This provides what is termed split pattern tracking, and will be familiar to those who have had previous experience with the early radar set SCR-268. By comparing the signal strength obtained from one lobe with that from its companion lobe, the direction from which the wave is arriving can be determined and the antenna may be set directly "on target." The four signals received from the lobe positions are presented on the face of a cathode ray tube in a dual type "A" presentation, and by comparing the amplitudes of the two sets of traces the operator can keep the antenna pointed directly at the radiosondes. By recording the azimuth and elevation angles of the antenna and combining this with knowledge of the altitude of the radiosonde as obtained from the pressure unit, the position of the balloon and the wind velocity are readily determined.

For use with the 1700 megacycle radiosonde equipment a replacement for the SCR-658 has been developed which even more closely represents radar equipment. This device bears the Army nomenclature AN/CRD-1. Instead of the multiple-dipole antenna with rotating switch as previously

used, it now becomes feasible to use a rotating, slightly offset reflector, in front of a single dipole antenna to obtain a rotating antenna pattern in space. Again by a suitable switching means the amplitude of the received signal in azimuth and elevation is compared to put the antenna squarely "on target." However, there is a major difference in the method of tracking. Whereas in the older method the operators turn their handwheels to track the balloon, in this version the set tracks the target automatically and at the same time produces a printed record of azimuth, elevation, pressure, temperature, and humidity.

As has been indicated the modulated r.f. signals emanating from the balloon-borne equipment are received on the ground either by use of a receiver or a direction finder type equipment. In both methods the signals are converted into an audio frequency which varies at a rate depending upon the meteorological conditions at the airborne sonde. The radiosonde recorder makes a printed record of the frequencies measured by a frequency meter fed by the receiver.

The recorder is an electro-mechanical device, the principal components of which are the recorder meter, a photoelectric scanning assembly, and the printing mechanism which produces a continuous record of the position of the pointer of the recorder meter with respect to time, thereby recording the measured frequencies which, in turn, represent the intelligence transmitted by the radiosonde.

In terms of electronics, the most interesting part of the recorder is the printing control mechanism. A light beam in the photoelectric scanner sweeps across the pointer of the meter once during each cycle of operation and produces a pulse whose time phase is dependent upon the position of



Figure 2—Radio set SCR-658 and Radiosonde, AN/AMT-2, right, rear $\frac{3}{4}$ view, showing set tracking radiosonde prior to launching.

the meter pointer. This pulse is used to energize the taper bar magnets to cause the printing mechanism to tap a dot on the recorder paper, the horizontal position of which is proportional to the audio frequency measured by the frequency meter.

Before leaving radiosondes it might be of interest to inspect one of a slightly different type. Here, rather than being sent aloft by balloon as in the preceding case, the equipment is dropped from an airplane in flight over some remote or otherwise inaccessible region. During the course of its fall with parachute, the radiosonde transmits meteorological data along the path of fall. This data is received and recorded either by the launching plane, or by weather reconnaissance equipment located at other points. The use of this equipment enables obtaining data on meteorological conditions which might not otherwise be available.

The over-all dimensions of this "Parachute Radiosonde" including parachutes and batteries are about 10" x 6" x 19" and it weighs about 9 pounds. The meteorological elements are an aneroid cell, and, unlike the previously described units, a bimetallic thermometer, and a hair hygrometer. The modulator is a mechanical device comprising a 3-volt permanent magnet d.c. motor driving what may be described as a sort of phonograph record, and three pickup arms which are positioned on a coded record disc by the pressure, temperature and humidity elements respectively. Each modulator is individually calibrated. The record is a 6-inch plastic disc with a couple of hundred grooves. One 90° sector is offset from the normal plane of the disc by 1/16 inch. All the codes are impressed in this portion. There are, roughly, 200 two-letter Morse code groups, one for each of the grooves.

As the record rotates, each of the pickups contacts only the raised sector. As the stylus is vibrated by the impressed code groups they cause a make and break in a relay which keys the transmitter. The transmitter is a simple 1-tube cw oscillator, crystal controlled for frequency. The pickups are spaced to provide a definite cycle of pressure, temperature, and humidity measurements during each revolution of the record. The operator at each signal pickup point receives the transmitted signals and translates the codes into meteorological conditions at the sonde.

SFERICS

Another device, referred to as "sferics" equipment, is utilized to locate and track atmospheric static discharges. The information obtained by this equipment is useful in plotting the course of lightning storms and is of assistance in forecasting.

Disturbances set up by static discharges in the atmosphere at distances as great as 2,000 miles are intercepted and their direction from each station indicated on a cathode ray tube. To determine the location of the source of the disturbance, two or more simultaneous observations on the same static discharge are made by stations separated by several hundred miles. The usual triangulation method for centering the storm location is used.

Coordination to assure that each of the sferics stations is taking a bearing on the same static discharge is accomplished by means of two-way communication equipment between all stations in the network. Plotting and recording are

performed in the usual manner.

CEILOMETER

In connection with airport traffic control and flying safety it is desirable to know the height of the cloud ceiling and its rate of rise or fall. By means of an optical device the location of the intersection of a vertical light beam with the cloud base may be determined, and then the height of the cloud may be solved from simple trigonometric computations. The automatic ceilometer is a system for measuring and recording the height of a cloud ceiling above ground level continuously, both day and night. Measurement is made by triangulation of a modulated light beam projected vertically to the cloud, with the reflection from the cloud base picked up at a photoelectric detector located at a known distance from the projector. Signals of pickup and angle of elevation at pickup are recorded on a chart. Modulation of the light beam gives it an identifying characteristic which enables it to be distinguished from the high intensity level of daylight.

The projector uses an air-cooled high intensity 25 million candlepower mercury vapor lamp in a parabolic mirror. The major part of the visible light can be filtered out so that the beam is not seen at night. The projector includes a device containing 3 spare lamps in addition to the one in operation. Should the operating lamp fail, a relay is caused to operate due to the loss of current in a series transformer in the lamp circuit. This automatically causes the next spare lamp to enter the proper operating position. If, after a 20-second delay, this lamp is not operating, the next lamp is automatically fed into the operating position. When the fourth lamp fails a limit switch prevents further operation of the changer until manually reset.

The major problem encountered in this equipment is to differentiate between the small signal returned from the cloud and the high noise level created by daylight acting on the phototube. Simply modulating the light source and then trying to amplify the 120-cycle signal is not sufficient in itself to separate the modulated signal from the noise, as the noise amplitude may be many times that of the desired signal voltage.

AUTOMATIC WEATHER STATION

Another important application of electronics to the art of meteorology is in connection with the automatic weather station. Basically, the automatic weather station is a collection of more or less standard meteorological elements which is placed in an isolated location such as a mountain peak, a small island or an arctic region and left unattended. Periodic observations of the instrument readings are transmitted by radio to a receiving and recording station which is located in a more habitable region. Among the meteorological elements measured are surface-wind direction and speed, pressure, temperature, and humidity, amount of rainfall and amount of sunshine.

The variations in meteorological elements, as in the case of the radiosonde, may be converted into a change in electrical resistance which in turn produces a change in the rate of keying a radio carrier wave. Low keying frequencies may be used to enable direct keying of the transmitter and the use of simple frequency measuring equipment at the receiver.

The power supply is turned on by clock control at preset periods of time shortly before the station is to go on the air, to permit a warm-up period. Then after transmitting identifying and reference frequency signals the various element-modulated frequencies are transmitted in a predetermined sequence actuated by means of a rotary switch. After a couple of cycles of such operation, the power is turned off until the next period.

Among the major problems which must be solved for any particular installation are type and size of power plant to use—that is whether wind or engine driven generator or batteries, frequency and power of radio transmitter in view of location, and fading and interference phenomena. Since the equipment is to be located in an isolated location, maintenance and adjustment problems become of primary magnitude.

RADAR

It was known for a long time that cloud and precipitation areas returned radar echoes. At first these effects were considered to have nuisance value only, but more complete study has led to practical applications. The reflection of radar pulses from the raindrops or precipitation in the atmosphere provides the meteorological echo on the radar screen. At a given distance the more moisture in the air, the stronger is the received echo—hence we have a qualitative factor for determining presence and severity of clouds and storms. The radar frequency enters into the problem, as does the transmitter power available at the different wave lengths and atmospheric absorption of the radiated energy. At the shorter wave lengths water vapor and atmospheric gases cause attenuation. We find that available radar sets at, say, 10 cm wave length provide long-range detection of storms but that higher frequency equipments provide greater detail on size and separation and detect weaker storms. Radar sets can detect showers, storms, warm and cold fronts, hurricanes and tornadoes. Fog or light clouds are generally not detectable. Ranges for storm detection will vary with the storm content but they have been recorded at well over 150 miles.

Echoes obtained from meteorological phenomena are distinguished from those from solid objects by the manner in which they constantly change in size, shape, and intensity. Cloud echoes have a motion distinguishing them from large fixed echoes, are irregular in shape with changing edges and have a vertical extension unlike ground targets. Different types of phenomena may be recognized on the radar screen from their different characteristics. For example, cold front precipitation is usually in the form of a line squall and is very bright, whereas a warm front generally produces indistinct echoes covering a wide, irregular arc on the screen and changes continuously in shape. Thunderstorms have a bright central area with an irregular margin. Hurricanes and typhoons give an interesting and readily identifiable signal with whorls and circular shape to the cloud pattern.

Among other things, the information obtained from these data may be used to provide flying instructions to pilots to enable flying around bad spots, to find the best route through a front or large area of bad weather, and to get advance warning on storm conditions which may close (or open) airports. Flight tests indicate that severe turbulence is fre-

quently encountered within areas of radar echo. Aerologists can use this data to predict quite accurately the time of approach of a storm.

The wind structure of the atmosphere can be obtained by using practically any radar set which can provide range, azimuth, and altitude data. The method used is to send up a balloon with a radar reflector on it. The 200 mc target reflector comprises 3 dipoles made from aluminum foil-wrapped balsa wood. To eliminate polarization effects due to swinging of the balloon we used the crossed dipoles rather than a single radiator. At 3000 mc a corner reflector assembly is used. The corner reflector possesses the property of returning a signal in the same direction from which it was received. A multiplicity of corners is used to maintain directivity as the target swings and turns. The shape of the top corner is designed to prevent undue drag from slowing the rate of ascent of the balloon. The ranges obtained depend upon the capabilities of the particular radar set but ranges greater than 100,000 yards are not uncommon. This type of data is particularly valuable to artillery units to enable making ballistics corrections. The fire control radars of the organization can be utilized directly for such reflector target tracking without necessity for adding any additional auxiliary equipment.

By data transmitting and radar relay means, a radar set utilized for met purposes may be located at a favorable site and the data sent to a more conveniently located meteorological center, where it may be utilized and further distributed either by additional radar relay or by facsimile. Weather maps are now being transmitted daily out of the Washington area by facsimile over some 15,000 miles of circuits in 4 networks. Both domestic and international weather maps are transmitted every half hour by this facility.

ROCKETS

In pursuit of knowledge of the atmosphere to altitudes of about 100,000 feet the meteorological balloon is quite satisfactory and relatively economical. But for altitudes beyond this range the balloon has proved unsatisfactory to date. As a result the meteorologist is turning to rockets to carry his instruments to the higher altitudes. This creates a problem in obtaining instruments which are accurate at both high and very low pressures, temperatures and humidities, and which must have a speed of response to conditions commensurate with the speed of travel of the vehicle in which they are contained.

Here again the electronic art is playing a considerable part. Radar equipment on the ground is used to track and plot the position of the missile. Measured parameters are telemetered from the missile to ground stations. Beacons in the missile assist in tracking. Fuel cutoff is controlled from the ground through a special receiver and control valves. Electronic timers are used to operate sample bottle valves to obtain specimens of the atmosphere at the upper altitudes, to cause the emission of devices to enable determining wind velocity and atmospheric temperature, and finally to cause actions such as nose blowoff or parachute ejection to enable return of the instruments to ground for study of film records obtained during flight.

THE SOVIET AIR FORCE*

The Soviet conception of air power is diametrically opposed to the British concept, in that there is no Soviet Air Force as such; almost all air units are directly under the army or navy. The majority of the air units comes under direct army control. Furthermore, the air armies were used almost solely as instruments for the direct and immediate support of the land forces.

Whatever lessons have been taught by the last war they have made no difference to the broad policy of the Soviets to air power. As the Red Army grew in power and efficiency in the years between the two World Wars, so did the air squadrons, but always tied closely to the army. The progress of World War II did nothing to alter the original policy but, if anything, strengthened it. The successes of Anglo-American strategic bombing again had no effect on the Kremlin's policy. The end of World War II found Russia with a vastly more powerful air force than she had in 1929, but still her policy and aim remained unchanged. All air forces are divided between the army and the navy, the army having by far the greater proportion.

ARMY AND NAVAL AIR

The naval air forces were divided between the fleets of the Northern Seas, the Baltic Sea, the Black Sea, and the Pacific. The equipment of the naval forces was similar to the Army Air Forces, thus helping standardization and production, but at a sacrifice of operational efficiency. The military air forces were divided into Air Armies, the Long-Range Force, and the Fighter Arm of the Air Defense Force. Of these the Air Armies were by far the most important, absorbing some 75 per cent of the total air strength of Russia. They acted under the control of the Army Group Commanders and their sole purpose was to assist the operations of their groups.

The air armies were divided into fighter forces, ground-attack forces, and bomber forces, the fighters being the most numerous. The Long-Range Force, although independent in status, was in no way comparable with the Strategic Air Forces of England and America. Its equipment was the same as that of the Air Armies, and its function was more to assist specific offensives than to accomplish true strategic bombing. In spite of its name and independent status it should be regarded in the main organization as a reinforcement force for army groups.

Although the Russians were the first to experiment on a large scale with parachute troops, airborne forces did not figure largely in their organization. The broad picture, therefore, is one of a force designed and built up to work in close support of the land forces. Aircraft production was standardized for this main purpose and the airplanes designed for army work had to serve the needs of the navy as well.

OPERATIONAL EFFICIENCY AND TACTICS

The main aims of their air armies in attack were to destroy the German forward defense screen and smash his

strong points. Their attention was then directed to armor or infantry disposed for support. These tasks came before attack on airfields or even the countering of enemy air activity, and took precedence over attacks on artillery, transport and main reserves. In defense, the air armies concentrated mainly on armor, infantry, field artillery and immediate reserve formations.

The normal policy was to reduce front-line strength before a big offensive and to build up a reserve; the first phase started some three months in advance, involving continual air reconnaissance. Then came increased activity by the air forces against the enemy back areas, up to 120 miles behind the line. The third phase concentrated on transport and communication, and, in the last phase, the ground attack aircraft and the bombers slacked off their operations in favor of intensified fighter activity. Finally came the offensive, with all aircraft helping tanks and infantry.

The fighter forces in particular were adept at improvisation and the correct exploitation of war experience. Their operations showed not only tactical flexibility but also ruthless and unorthodox employment of aircraft in abnormal roles. Their main tasks during an offensive consisted of patrolling the battle area and airfields, cooperation with infantry and tanks, and a certain amount of reconnaissance work, both visual and photographic. Patrol heights varied from 2,000 to 20,000 feet unless enemy bombers were expected, or there was bad weather. For escort work, fighters were split into two groups—one, the assault group, flying some three-quarters of a mile ahead of the bombers and about 200 feet above. The other group acted as close escort just behind and above the bombers.

Night-fighter tactics were crude and mainly depended on searchlights guiding the fighters into the defended area. After that they had to look after themselves, for there was little effective control from the ground. The artistic and complicated system of controlled interception used in Great Britain was being developed in the SAF, but had little use during the war.

Ground-attack aircraft usually operated in formations of four in a blunt arrowhead. Early tactics were to approach at very low level, but later on the efficient German light flak forced up approach heights to between 2,500 and 8,000 feet. Bombs were dropped in a shallow dive at below 500 feet, and aircraft broke away from the target individually.

Medium bombers usually worked in flights of three, with three flights making up a V formation at staggered altitude, and flying loosely before and after attacks, but in close formation over the target. Bombs were dropped from a shallow glide on the signal of the flight leader. Operations were frequently carried out at division strength with four, five, or even more groups taking part.

The Long-Range Force (LRF) was in no way a strategical force like our own. Admittedly it carried out some minor and ineffective attacks against German towns in 1941 and 1942, and, in 1944, a series of raids were made on Finland with the idea of accelerating peace terms. All such raids were most unimpressive, both in plan and execution.

For most of the time, the LRF operated within 120 miles

*Extracted from the March 1949 issue of the *Military Review*. From an original article in *The Aeroplane* (British) August 1948.

of the front and its function was largely tactical. In spite of superior training the navigation of the LRF was weak and its instruments inefficient. However, at the end of the war improvements were being made and experimental work was being done with radar navigation. Tactics by day were similar to those of the bomber forces; by night the "stream" of bombers was mainly determined by the take-off times. Heights for night attack generally ranged from 10,000 to 16,000 feet and target marking was seldom used. Inefficient though it was, the operations of the LRF gave the Russians very valuable experience which will stand them in good stead should they decide to develop a strategic force.

Airborne operations were very limited in scope during the war, despite the fact that the SAF started taking interest in this during 1930. However, the airborne forces were an independent part of the Russian armies, being responsible directly to the Supreme Headquarters; their strength at the end of the war was about 21,000. Paratroops were used on a small scale in 1941 during defensive operations at

Smolensk and in the Crimea, but these were a failure. In 1943 a large-scale operation was carried out on the Dnieper, but the airborne forces were not accurately dropped and were too lightly armed. The operation was a complete failure, and the forces were not used again until 1945 in Manchuria and Korea, where there was no opposition.

Tactics for airborne home forces were to assemble the aircraft about 100 miles behind the line and send on one aircraft to reconnoiter the landing grounds. Aircraft were then directed by radio and light signals and went forward in two groups, the first carrying the parachute men equipped with rifles and light machine guns, and the second group bringing the mortars and light guns in glider or transport aircraft. However, despite many years of pioneer work in the tactics and training of airborne forces, their operations were a sad disappointment, although they were used considerably for helping guerrilla warfare. But valuable experience has been gained and no doubt this arm could be expanded rapidly in time of necessity.



88th AA Abn Stages First Bliss Jump

The 88th Airborne Antiaircraft Battalion, first paratroop outfit to be stationed at Fort Bliss, was activated here on December 16, 1948. Major Elmer W. Fox is commanding officer.

Fort Bliss is a "hard" post for the jumping troops, the men say. In this high altitude, they fall from three to four feet faster per second (18 to 20 feet instead of the average 15 to 16 feet) and strike the ground harder than in lower country.

In full equipment the paratrooper jumps with a burden of about 125 pounds but jumps here will probably be made with about 60 pounds of equipment.

Men of the 88th carry the usual big parachute, 28 feet in diameter, and a smaller emergency parachute.

A trained paratrooper can jump from 1200 feet, strike the ground, release his 'chute and have his rifle ready in slightly more than a minute's time.

Paratroopers get the normal soldier's training at Bliss and in addition a special five-week course at Fort Benning, Ga.

Excellent physical condition is demanded for carrying out the paratrooper's duties. The routine schedule calls for two hours of physical training a day.



U.S. Army Photograph

Members of the 88th Airborne Antiaircraft Battalion recently activated at Fort Bliss, Texas, land on desert terrain in one of the first mass jumps made by personnel of the new unit.

FIGHTER-BOMBER TACTICS*

(Best Air Force opinion reflects a change in thinking on fighter tactics with the advent of jet propulsion. However, this article vividly illustrates the constant battle of wits between attacking fighter pilots and AAA ground defense units. Methods may vary with changing equipment but the tactical problem remains virtually intact.—Ed.)

In our fighter bomber tactics, normally a well defended field would not be attacked by fighters. Attention was given to less well defended fields and installations.

When a field was attacked, however, tactics similar to the following (474th Group) were typical:

Flights would approach the objective at altitudes from 8,000 to 12,000 feet. Two planes would come down to about 5,000 feet for a dry run. They would fire a few bursts and feel out the AAA defenses. They would make another dry run pass at about 2,000 feet. (One pilot recommends that AAA withhold fire during the first of these passes, and use tracer and smokeless ammunition during the second pass.) If heavy flak were encountered, they would pass on; if only light flak were encountered, they would normally press the attack home.

When pressing home the attack, one flight would spread out and attack the planes on the field, another flight would act as an antifiak flight, and a third flight would afford top cover. It was found in most instances that antiaircraft sections stopped firing when fired upon.

German flak personnel were funny—we never knew when we were going to be fired upon. Five groups have been known to pass over a target without being engaged, and then with the sixth group, all hell would break loose. Ordinarily they would not fire unless they felt their positions were known by the pilots.

TACTICS FOR DIVE BOMBING

The planes would come over flight-at-a-time at an altitude of approximately 10,000 feet, roll over into a 50° or 60° dive, build to a speed of 290 to 400 mph, and release their bombs at 4,000 to 5,000 feet if the field was well defended. If defenses were not too strong, release would be later, but the pilot had to pull out above an 800-foot minimum to avoid the blast, unless a time delay mechanism were used. If it were possible to hit the deck from 10,000 feet, the speed approximated 500. The pilot had, of course, to maintain a straight course on the bomb run. After the plane came out of the dive, the maneuver was normally regular with a skid to the right or left. After the first plane came out of the dive, the odds were that the following three of the flight would come out in the same manner. In some cases the machine guns on the plane were used to deliver harassing fire while diving.

*An extract from an interview of officers from the Operations and Flak Analysis Sections of the IX Air Force.

METHODS RECOMMENDED AGAINST DIVE BOMBING

When the planes are circling the field at approximately 10,000 feet prior to diving, fire may cause them to give up the mission.

Since the planes come over in echelon and peel off in roughly the same place, it is possible to anticipate the maneuver of those following.

Effective fire can be delivered while the plane is on the bomb run. Even if fire does no physical damage, it will appreciably decrease the accuracy of the bombing. Also, the pilot's attention may be diverted to such an extent that he will run into the bomb blast.

After pull-out, maneuver of lead plane may indicate maneuver of following planes.

ROCKET FIRING TACTICS

For effective launching of rockets, straight flight and a speed of from 250 to 270 mph must be maintained, and they must be launched from 1,400 to 1,800 feet. At present, planes can carry rocket bombs and ammunition, but cannot rocket and strafe at the same time since the trajectories differ.

OBSERVATIONS ON ANTI-AIRCRAFT TACTICS

The following are observations made by one officer based on his experience as a pilot:

Camouflage of positions should be emphasized because:

(1) Counterflak flight has found it difficult to kill a well concealed gun.

(2) Visits to German fields which were captured indicated the existence of positions which had not been previously located, either before, during, or after the fields were attacked.

(3) If a planned attack is made based on reconnaissance, the effectiveness of the attack is appreciably reduced if only a percentage of the gun sections is located.

Dummy positions should be used, because they complicate the job of the counterflak flight. In some instances fire is expended on dummy positions before they are recognized as such.

Bait, such as dummy convoys and planes, should be used, because planes have been shot down while attacking what looked like enemy targets but which in reality were anti-aircraft positions.

Most any type of harassing fire pays in the long run, since:

(1) If the fire is not very accurate, it still acts as a disturbing influence on the pilot and affects the accuracy of his bombing or strafing.

(2) In the presence of heavy flak, a pilot may decide to try a new pass or to give up the mission.

(3) To act as a deterrent, the firing must of course be seen by the pilot, so tracers or bursts must be ahead of him.

(4) In one instance when flights were at 10,000 feet, a red burst (signal for enemy fighters) was noted at 20,000

feet. While accomplishing nothing in itself, it at least for a time diverted the attention of the fighters.

(5) A single heavy gun delivering ineffective fire may still be sufficient to prevent an attack being pressed home.

REPORT OF FLAK ANALYSIS OFFICER

From intelligence information on flak positions, it has been possible to route flights to and from objectives with a minimum of hazard.

When a field or installation is well defended, a planned attack is made based on information as to location of gun positions. It is normally a surprise attack, well coordinated, in order to reduce losses to a minimum. Fighter bombers approach on deck from different predesignated directions, bounce up 50 or more feet (depending on terrain features)

when they near the objective, find the target, fire, and then hit deck to get away. Attacks are coordinated to saturate defenses. Sun, clouds, hills, and other terrain features are used to maximum advantage. Only one pass is made, since surprise is important. Attrition would be too great on subsequent attacks.

Long narrow objectives are approached from a slight angle off center. If the objective is a train, the flak wagons are hit first before disposing of the train itself.

For reconnaissance work 5,000 feet is considered a suitable altitude since it is between effective ranges for heavy and light guns.

For dive bombing, the use of a high dive angle, and twisting and turning in the early part of the dive, is recommended. After the dive, the pilot should stay low to prevent exposing under surfaces.



SUPPORTING RAIDS*

I think a good example of improvisation and initiative was provided by the action of a Detachment of No. 3 Commando, on the Dieppe raid. This also serves as an example of a raid which is mounted in support of a larger operation, either indirectly, at some distance from the main objective, and possibly well before it is time, for deception purposes, or directly in support in the form of diversions or attacks on isolated targets with which the main body does not wish to become involved.

In the case of the Dieppe Operation, it was the last of these roles in which the Commandos were employed. The Canadian Division attacked in the area of Dieppe itself, but there were two coast defense batteries on the flanks, one to the northeast and the other to the southwest, and it was essential that they should be silenced, since they might otherwise have played havoc with our shipping off the main beaches. No. 3 Commando was allotted the northeast battery at Berneval.

Almost from the start everything went wrong with No. 3 Commando. The first thing that happened was that by ill luck the landing craft flotilla ran afoul of a heavily escorted German convoy which happened to be sailing south that night. The escorts shot up our landing craft and the flotilla got hopelessly adrift in the dark. Some landing craft were sunk, other were disabled, and there were many casualties among the soldiers, some of whom were swimming about helplessly in the dark. Five of the R boats beached about two miles from the correct beach and never re-embarked.

One landing craft, however, beached nearly in the right place, and it contained a strange party, including the Second-in-Command and some of the Headquarters staff. The whole detachment totalled three officers and seventeen other ranks. They had one Garand rifle, nine service rifles, one Bren gun and six Tommy guns among them. Two of the men were runners, two were signalmen with no one to signal to, and four were spare men from a mortar detachment. But, this is the point: Those three officers and seventeen men managed to do the job. Their task was to stop the coastal defense guns firing at our shipping, and none ever fired anywhere near our ships until the main operation was over and our ships were at extreme range or out of range.

A party of three officers and seventeen other ranks isn't very large for an attack on a battery manned by 200 men, but they managed to scale the cliff and to get well inland in the rear of the battery without being seen. Then, by dashing about and shouting bogus orders, and showing themselves in different places, they succeeded in completely shaking the confidence of the battery commander, who obviously thought he was being attacked by at least a Commando 350 strong. He lost his head sufficiently to traverse his guns round and shoot at the soldiers on the shore instead of at the ships at sea.

Only one of our party was killed, and he was blown up on a mine on the way back to the cliff at the bottom of which the remainder successfully re-embarked. This they did when the main operation was over, and they had done the job which 350 men had set out to do.

*Extracted from the March 1949 *Military Review*.

A German Antiaircraft General Speaks

Interrogation of prisoners of war showed that German AAA problems were similar to our own.

General der Flakartillerie Walther von Axthelm and Major Friedrich Wilhelm Schober of the German General Staff were interrogated on June 9, 1945 at Headquarters Ninth Air Force.

General von Axthelm answered all questions at some length. He gave the impression of being an enthusiastic antiaircraft artilleryman and a highly competent professional officer. He talked as though the problems he had encountered were similar to our own, and as if his experience added to ours might assist in the solution of them. His enthusiasm led him to occasional exaggeration, which Major Schober corrected with deferential politeness. The conversation with the two PW's lasted about three hours.

PERSONNEL AND TRAINING

Originally, the General said, German antiaircraft personnel were specially selected men, who were superior in morale, discipline, and smartness. Careful mental, physical, and "moral" investigations were made of them before they were accepted for the service. Thereafter, they were given a year's training before they were considered ready for combat. Six months of this was comparable to our basic training, and culminated in a target practice. Men were then assigned to units, and underwent unit training for the remaining six months of the period. Even more rigid selection was made of officers, with comparably stricter training standards. The General stated with pride that every officer had to be proficient in any duty which he could order a man to perform.

As the war progressed, the initial six months of basic training was cut to three, and the unit training was conducted on operational sites. Both the General and the Major agreed that this reduction in basic training time was a mistake.

Eventually, the selectness of the organization was ruined by having about 75% of the men pulled out for duty in other arms, and replaced by volunteer Russian PW's, members of the Hitler Jugend, and women and girls. The General spoke of this in bitter terms.

Heavy guns were always manned by AAA units; light guns at specific industries were manned by Heimat Flak units composed of factory workers.

Firing ranges were difficult to find because of the density of the population. There were four in the vicinity of Rostock with fields of fire over the Baltic, one near Fecamp on the Channel, and one near Antwerp. Inasmuch as there were over 2,000 batteries to be fired, transportation difficulties made these ranges available only to a limited number of units, and finally it became customary to fire target practices from the gun positions, with warnings to the population to clear out.

Towing planes were invariably too slow. The Luftwaffe provided no modern airplanes to tow targets, and the General's efforts to get better ones were not very successful; they were too badly needed elsewhere. Finally, they secured the services of a few captured airplanes.

FIRE DIRECTION OF HEAVY GUNS

Every heavy gun battery had a primary firing sector. If enemy planes appeared in that sector, the battery had to fire at them. As to which of several formations entering the sector would be engaged, the decision rested with the battery commander. Thus, fire direction rested with the fire unit. The battery could fire outside its sector in the absence of a target in the sector, but first it had to inform the operations room, which permitted the operations officer to exercise negative fire direction by revoking the decision of the battery commander.

Tactical:

Never defend a metropolitan area as such; defend only the important industrial or transportation objectives in the area as established by a war-planning board. Indiscriminate bombing of cities has no military value.

Although radar-jamming is very often effective, it can be overcome by training and special equipment. In addition, there are always some radars in every firing sector which are unaffected, and if an accurate system of satellite plotting is in use, effective fire can be delivered by all fire units on this data.

Radio is sufficiently secure from jamming to be considered a primary means of communication.

Most batteries did not perform trial fire, depending instead upon the accuracy of the met message (every 3 hours), the formula for M-V decrease with rounds fired, and the record of powder temperatures, etc., taken at the battery itself.

EARLY WARNING

Early warning in general was excellent. Normally, AAA units received about two hours' warning of bomber attacks. (The General remarked that the Luftwaffe should have attacked take-offs. He tried, he said, to convince both Hitler and Goering that this would have been effective, but with scant success.) After the invasion of France, warning was given while planes were still 200 kilometers distant from their targets. German listening services picked up warning as soon as American planes began to warm up at English bases. The General stated that American pilot radio discipline was very poor.

RULES FOR ENGAGEMENT

Batteries were permitted to fire on unidentified planes. There was "much confusion" because German pilots did not observe the rules for restrictions to flying.

German friendly flights in the zone of communications were reported to a central point prior to take-off, but when there was an allied raid in progress, the system did not function properly and gun positions were not informed in advance when a friendly flight would pass over their area.

The General stated that allied pilots were often taken in by German dummy positions.

EXPENDABLE ROCKETS*

By Kenneth W. Gatland

Step Rocket: A rocket comprised of independent sections, each having separate engine and propellant, which fire successively and jettison when expended.

The above is the normal definition, but it is intended later to introduce a conception of step design in which there is one engine deriving its power from propellant in expendable tanks.

The three principal advantages of step construction are: (a) that "dead-weight" is reduced by the jettisoning of the spent sections; (b) that each section starts with the velocity attained by the impulse of the preceding sections; and (c) that each new section to fire does so at an improved altitude, gaining progressively better operating efficiency in air of decreasing density.

HISTORICAL

It is surprising to learn that the "step" idea was abroad long before Oberth and Goddard featured it in their early theoretical studies. There is, in fact, evidence of a kind of step-rocket firework as far back as 1700, though the sectional arrangement then was used not to improve range but to evoke a better display from small rockets which fired from the sides of the parent.

Serious applications, however, may be said to have begun with the development by Colonel Boxer at the Royal Laboratory, Woolwich, in 1855, of the two-step life-line rocket.

THE "RHEINBOTE"

Apart from one or two war missiles using rocket boosters (such as the "Rheintochter"), there appears to have been only one true step-design. This was the "Rheinbote," a long-range rocket using solid propellant produced by Rheinmetall-Borsig, of which about 20 were fired from Zwolle (Holland) against Antwerp (Belgium) in November, 1944.

Such particulars as are available give the total weight of the three actual steps and booster as 1,715 kg., including a 40 kg. warhead, with the final weight on impact at target, 135 kg. The range of the early models was between 145 and 160 kms., whilst later improved models were striking around 220 kms. from the launching point, and a new launching technique under development at the time of the surrender was understood to increase this figure still further.

VELOCITIES

Booster	260 m/s
First Step	510 m/s
Second Step	990 m/s
Maximum (final step)	1,640 m/s

SEQUENCE IGNITION

The method originally adopted for launching (as seen in the last reel of the film, "Development of Rocket Flight"), was for the weapon to be fired from rails. A powder booster cleared the rocket from the launcher, propulsion being taken over by the first step as it jettisoned.

The ignition sequence was obtained as follows: In the case of take-off booster, the charge was fired electrically by means of a threaded primer, whilst firing of the three main steps was performed by a clockwork fuze sensitive to acceleration. A composition of flashlight powder and nitroglycerine as a combustion initiate, together with burning charge of black-powder with aluminum, ensured same ignition at any temperature, velocity, and altitude.

Detonation of the warhead was achieved by a percussion fuze likewise specially developed which rendered premature detonation impossible.

The method of joining the steps was both simple and effective. The head of each step was an open cylinder which telescoped between the nozzle and outer shell of the next so that at the time of separation, there was a definite explosive action as the jet pressure built up between and blew them violently apart.

FIRST STEPS INTO SPACE

Who will be the first to reach space with guided missile seems a matter for the U.S. Army and Navy to decide. The Navy's "Neptune" rocket is expected to take instruments more than 350 kms. into the upper atmosphere, and plans are afoot to launch small secondary rockets to heights of from 300 to 1,000 kms., using rockets now available as the primary carriers. News of trials of such rocket combinations, we gather, may be expected from the Army Department at any time.

Competition between the U.S. Service Departments has always been keen, and it will be interesting to watch developments in the respective programmes, if that is possible in these guarded times.

In view of the extreme secrecy which exists in all branches of military research the progress that has been made in the U.S. since the war is difficult to assess.

Certainly vast sums have been poured into the development of guided missiles, rivalled only by the expenditure on the atomic bomb, and if Glenn L. Martin's recent statement that the U.S. now plans rockets capable of travelling several thousand miles can be relied upon, then it seems likely that something very similar to the A-9/A-10 project is envisaged. Von Braun's original calculations, it will be recalled, gave the point-to-point range of the boosted A-9 as 5,000 kms.

*Reprinted from the July 1948 issue of the *Journal of the British Interplanetary Society*.

News and Comment

New Associate Editor Assigned

Lieutenant Colonel Richard W. Owen arrived in Washington on August 14 to take over the duties of Major H. G. Wood who has been reassigned to duty with the Secretary of the Office of the Chief of Staff.

Col. Owen joins the JOURNAL from Fort Bliss, Texas where he had recently participated in the AAA Expansion program. He had previously been assigned as assistant senior state ORC Instructor for Connecticut.

Having had wide experience in newspaper, magazine and public relations work in civil life, he is no stranger to the requirements of editing a service publication.

As an officer in the Connecticut National Guard prior to World War II, he entered active service in January 1941. He served in England, France, Belgium and Germany as an antiaircraft artillery group executive and as a battalion commander.

During his three years in the European Theater, he served in Luxemburg and Nurnburg deputy in charge the major war criminals, was president of a War Crimes Intermediate Courts-Martial at Dachau, Germany, and just prior to his return to the United States, he was engaged in the preparation of the German operational history in enemy actions against American and Allied Forces.

/ / /

To Our Readers

The following is the proposed outline of a plan to establish an Honor Roll system whereby antiaircraft artillery and guided missile units will receive credit to the extent to which their officers support the JOURNAL by subscribing.

The plan has received much favorable comment from individual queries and our readers are urged to let the JOURNAL know their views.

School, detachments and similar units will be considered later.

We solicit your opinion as to the feasibility of this idea with suggested changes in the plan.

Antiaircraft Journal Honor Roll Criteria

1. To qualify for a listing on the JOURNAL Honor Roll, units must submit the names of subscribers and total number of officers assigned to the unit on date of application.
2. Battalions with 80% or more subscribers among the officers assigned to the unit are eligible for listing, provided that the unit consists of not less than 20 officers.
3. Brigades and groups with 90% or more subscribers among the officers assigned to the unit are eligible for listing, provided that the unit consists of not less than seven officers.
4. Units will remain on the Honor Roll for one year even though they fall below the 80% requirement during the year.

5. Lists of subscribers and statement of number of assigned officers must be submitted annually by units in order to remain on the Honor Roll.
6. Battalions with 90% of officers subscribing will qualify for one star placed after the unit's designation on the Honor Roll. Battalions with 100% subscribers will qualify for two stars.
7. Groups and brigades cannot qualify for one star but may qualify for two stars by having 100% subscribers.
(Units of all components will be listed together in the order of their percentages, beginning with the unit with the highest percentage.)

(Each unit listed on the Honor Roll will be given a one-year complimentary subscription to the JOURNAL.)

(Name of unit commander and date unit initially qualified for the Honor Roll will be listed with the designation of the unit.)

/ / /

Wanted—Authors and Ideas

It has been suggested that we devote more space in the JOURNAL to the day-to-day problems of the battery commander. We have also been requested to use more material designed to hold the interest of junior officers and enlisted men.

We are always anxious to publish articles with the broadest possible range of interest. We welcome material dealing with basic military subjects and we are constantly on the alert to locate individuals capable of producing such manuscripts.

The JOURNAL is the publication of antiaircraft artillerymen. Their knowledge and experience, reduced to writing reaches those who are vitally interested, and in need of information.

Our readers are urged to submit articles of common interest or at least to submit ideas and suggestions on subject matter that they would specifically like to have published.—EDITOR.

/ / /

Very Active "INACTIVE" Officers

The Editor:

I am sorry that I will be unable to attend the (Executive Council, Coast Artillery Association) meeting as I am going to be at Fort Bragg, N. C. for the 2-3 April for a demonstration of Aggressor Force. We are carrying 61 officers from our division (51st Inf. Div. South Carolina National Guard) up for this demonstration and I am sure it will be very worth while. I am taking part in an Army Day Program in Marion, S. C. on 5 April. I am speaking before a Rotary Club on April 4 in connection with Army Day and on the 7th I leave for Fort Leavenworth, Kans. for a week's refresher course.

JOHN C. HENNAGAN,
Brig. Gen., SCNG.

/ / /

Letter to the Editor

We have a very active reserve organization here—the 656th Composite Group, which is shortly going to be designated as a Logistical Division. I find myself very busy as G-3. In fact, I have accumulated 12 points since January (6 weeks) which means an average of two nights a week devoted to this work. Under our wing we have an engineer

construction battalion, a regimental combat team, a CAC guided missile battalion, a signal depot, an evacuation hospital, an ordnance depot, a port battalion, a railway operations battalion, 2 MP companies, an armored cavalry regiment, and a QM depot battalion. Believe me, it keeps me hopping, what with working at my civilian job, running the training of all these units, studying on the C&GS School Course, being on the program committee of the Sacramento Section of the American Society of Civil Engineers and on the Board of Governors of the Sacramento Reserve Club.

Cordially,

Lt. Col., CA Reserve.

(The foregoing clearly indicates the sacrifice in time and effort expended by officers of the Organized Reserve and National Guard, who, in addition to conducting their civilian affairs, devote many valuable hours to playing their part in the National Defense program. It would prove interesting to note the number of active military personnel, not with troops, devoting several evenings each week to their profession.—Ed.)

✓ ✓ ✓

To the Editor

This is in reply to your note enclosing the letter from a PMS&T in the Sixth Army Area.

We all recognize the desirability of conducting ROTC camps at the school station of the branch concerned. However, travel funds available simply will not permit such procedure. We are presently conducting camps for some of the technical and administrative services at their school stations because of conditions peculiar to certain of those branches. The continuance of this practice after this year is in doubt.

We hope that the separation of artillery instruction will result in good AAA ROTC camps. The choice of sites for AAA camps is extremely limited, and as you know, supporting troops are not available. AAA camps will be at Edwards, McCoy, Bliss and Lewis. The students at McCoy will fire in Sheboygan area on Lake Michigan and those at Lewis at Yakima.

Sincerely,

G. P. PRIVETT

Colonel, GSC

Chief, ROTC Branch

Office, Chief, Army Field Forces.

✓ ✓ ✓

Letter to the Editor

Your letter of 11 February brings unwelcome and puzzling news. I have read the COAST ARTILLERY JOURNAL since 1919 and have subscribed to it for a dozen or more years.

It is my considered opinion that your ANTI-AIRCRAFT JOURNAL has set a higher standard than ever before, and it has never been other than excellent in all the years I have read it.

The articles on Radar and guided missiles alone have been worth many times the entire subscription price. The value of Colonel Parker's "atomic capsule text" to anyone is difficult to assess. I am interested in "Nuclear Physics," have attended several condensed lectures by Dr. Millikan

and others of his staff, and have his text on "Electrons." For all that I find Colonel Parker's offering opens up undiscovered relationships.

I write you this, because I am no longer, except at heart, a professional artilleryman of any kind. Father Time caught up with me and my present assignment is pure "Branch Immaterial." However, I still value my ANTI-AIRCRAFT JOURNAL and cannot see why any Coast Artilleryman of any vintage would not enjoy it and profit by it.

The list I enclose is one of California Officers, which may be puzzling coming from a Florida resident. I have met very few Florida Antiaircraftmen because of my assignment and even in California I was given—and gratefully accepted—a TC assignment.

Perhaps the officers I name may be subscribers. If not, they should be.

I will be glad to give your message to the meeting of the AAA units here in Miami. I am sure that the COs will cooperate and hope that it may prove of some slight help.

Should you find an increase in the subscription price essential, I will be glad to continue.

With best wishes.

Sincerely,

RUSSEL K. HAVIGHORST,
Colonel, CAC.

✓ ✓ ✓

National Guard Organizes 62 AAA Battalions

The National Guard has completed organization of sixty-two antiaircraft artillery battalions, it was announced recently by Major General Kenneth F. Cramer, Chief of the National Guard Bureau.

Now organized within the guard are 4,425 Army units representing eighty per cent of the 5,486-unit troop basis authorized.

The following National Guard CAC units have been Federally recognized since the last issue of the JOURNAL:

Arkansas.

Medical Detachment (less 5 Battalion Detachments)
39th Division Artillery, Little Rock.

California.

Battery D, 149th Antiaircraft Artillery Automatic
Weapons Battalion (Self-Propelled), Menlo Park.

Battery A, 636th Field Artillery Battalion, Sacramento.
Medical Detachment, 719th AAA Gun Battalion, Alameda.

Battery "D," 730th AAA Gun Battalion, El Cajon.
Headquarters & Headquarters Battery, 718th AAA
Gun Battalion, San Francisco.

Battery A, 718th AAA Gun Battalion, San Francisco.

Connecticut.

Medical Detachment, 745th AAA Gun Battalion, Norwich.

Georgia.

Heavy Mortar Company, 121st Infantry, Perry.

Illinois.

Battery D, 144th AAA AW Battalion (SP), Gibson
City.

Battery D, 698th AAA Gun Battalion, Chicago.
 Tank Company, 123d Infantry, Springfield.
 Company F, 228th Infantry, Cicero.
 Medical Detachment, 223d Field Artillery Battalion,
 Rock Island.
 Medical Company (less 3 Battalion Platoons), 228th
 Inf, Villa Park.
 Battery D, 133d Antiaircraft Artillery Automatic
 Weapon Battalion (Self-Propelled), Chicago.
 Company I, 228th Infantry, Des Plaines.
 Battery A, 233d Field Artillery Battalion, Carthage.

Michigan.

Headquarters & Headquarters Battery 146th AAA AW
 Battalion (SP), Detroit.
 Battery A, 593d AAA AW Battalion, Ironwood.

Mississippi.

Medical Detachment, 631st Field Artillery Battalion,
 Pascagoula.

Missouri.

Company B, 135th Heavy Tank Battalion, Webb City.

New Mexico.

Medical Detachment, 716th AAA Gun Battalion, Sil-
 ver City.
 Medical Detachment, 717th AAA Gun Battalion, Al-
 buquerque.
 Medical Detachment, 697th AAA AW Battalion, Ros-
 well.
 Medical Detachment, 726th Antiaircraft Artillery Gun,
 Santa Fe.

Ohio.

Battery D, 137th Antiaircraft Artillery Automatic
 Weapon Battalion, Cleveland.

Tennessee.

Medical Detachment, 765th Tank Battalion, Cooke-
 ville.
 Headquarters and Headquarters Detachment, 215th
 Medical Battalion, Memphis.

Texas.

Company A, 176th Engineer Combat Battalion, Vic-
 toria.

EM Leaders Train at Bliss

First of a series of Leadership Courses for enlisted men at Fort Bliss closed on January 22 with 33 graduates. All graduates, members of the 35th AAA Brigade and the 267th AAA Group, were promoted from recruit to private.

Speakers at the graduation ceremonies included Maj. Gen. J. L. Homer, Commanding General of Fort Bliss, Brig. Gen. Robert W. Berry, and Chaplain Clifton Bell.

The six-week Leadership Courses are run on an overlapping schedule. Three classes in all have been graduated and two more are under way.

The Leadership Course is taught in two phases. The first is four weeks of classroom work in which students learn methods of instruction, interior guard duty, combat tactics, military courtesy and other basic subjects.

In the second phase of two weeks, the men serve in different units as acting noncommissioned officers (first sergeant, platoon sergeant and squad leader) to gain practical experience in the subjects they have studied in the classroom.

New Reserve Group

Sixth Army announces the recent activation of the 320th AAA Group (ORC) with headquarters at Stilwell Hall, Presidio of San Francisco, California. Assuming command of the group was Colonel C. Harris Potts. A full complement of fourteen officers are assigned and participating actively in the bimonthly training program.

Presentation of the National Colors by Brigadier General Frederic B. Butler, Central Military District Commander, to Colonel Potts was made at a ceremony held at Stilwell Hall, March 21st. This ceremony marked the importance of the new reserve impetus given by President Truman in his Executive Order of October 15, 1948.

Two attached units were in attendance at the ceremony which also marked official recognition of their activation. These were the 844th AAA AW Battalion, commanded by Lt. Col. Harrison S. Payne and the 356th AAA Operations Detachment, commanded by Major James K. McManigal.

F-86 Jet Fighter Named "Sabre"

The U. S. Air Force's fastest jet fighter, the North American F-86, has been named "Sabre."

The single-place, low-wing fighter established the world's speed record of 670.981 miles an hour at Muroc, California, Air Force Base, last September, carrying its normal operational armament and ammunition.

The "Sabre" has a sweep-back of 35 degrees for both wing and tail assembly, which reduces drag and increases maximum speed.

Powered by a General Electric J-47 turbo-jet engine rated at approximately 5,000 pounds' thrust at take-off, the F-86 employs a single straight ram duct which has its opening in the nose.

The "Sabre" has a service ceiling of over 40,000 feet and a combat radius of more than 500 miles.

Its wing span is 37 feet, length 37 feet, and height 14 feet. It is equipped with a pressurized cabin and a pilot ejection seat. The landing gear is the conventional tricycle type with a steerable nose wheel.

Hq AFF Comment on "Airborne Thoughts for Future . . ."

The following comment from Headquarters, Army Field Forces, was inadvertently omitted from "Airborne Thoughts for Future Airborne AAA Development," by Lt. Col. James H. Farren, which appeared in the January-February issue of the JOURNAL:

The Office of the Chief, Army Field Forces, is presently reviewing Load Tests conducted by the 82d Airborne Division, and it is expected that certain recommended changes in proposed T/O and E's will be made prior to submission to the Department of the Army for approval and publication.

Nation-wide Screen of Radar Stations

Establishment of a radar network to provide immediate warning of any approach of hostile planes to sensitive points in the nation has been asked by Secretary of Defense James V. Forrestal.

A bill to purchase the necessary land and equipment has been introduced in Congress and hearing on the measure begun.

Present plans call for the expenditure of \$112 million more to establish a two-stage radar net which would provide ample warning of approaching fast bombers. Money already appropriated for this purpose would bring the total to \$161 million.

The system would be linked with Canadian radar developments to provide the best possible cover against surprise attacks over the polar regions. Air Force spokesmen said that the U.S. and Canada have coordinated their respective deployment in detail.

The proposals have been studied and approved by the Joint Chiefs of Staff, and by Dr. Karl T. Compton, chairman of the Research and Development board of the National Defense Establishment, the Air Force said.

The two-stage system would cover from 200 to 300 miles, except in the coastal areas. There the system would be supplemented by radar picket vessels operated by the Navy. Four such vessels for experimental link-ups with the land system have been requested.

/ / /

U. S. Air Force B-47 Jet Bomber Flies Across Country In 3 Hours, 46 Minutes

On February 8, the U. S. Air Force's Boeing B-47 Stratojet bomber flew from Moses Lake Air Force Base, Moses Lake, Washington, to Andrews Air Force Base, Camp Springs, Maryland, in three hours and 46 minutes at an average ground speed of 607 miles an hour.

The Stratojet made its first flight December 17, 1947, and was accepted by the Air Force in December, 1948, after completing numerous flight tests at Moses Lake AFB. A second B-47 is undergoing flight tests at Muroc Air Force Base, Muroc, California. Ten more are on order, and will be manufactured at Boeing's Wichita, Kansas, plant.

The B-47 is in the 600-mile-an-hour class, has a combat radius of more than 800 miles, and can carry a bomb load in excess of 10 tons. It has swept-back wings and tail surfaces and is powered by six General Electric J-35 jet engines producing a total of 24,000 pounds' thrust. Four of the engines are mounted in pairs, slung under the wings, and an additional engine is mounted near each wing tip. Eighteen JATO (jet-assisted take-off) units provide 18,000 pounds of auxiliary power during take-off.

The Stratojet has a design gross weight of 125,000 pounds and a service ceiling of more than 35,000 feet. Its wing span is 116 feet, it is 108 feet long, and is 28 feet in height.

The B-47's landing gear is of the tandem type, with two double-wheel units folding forward and aft into the fuselage. Small outrigger wheels, which retract into the in-board power plant nacelles, provide stability during ground operation.

Army Adds Unit Administrators to Warrant Officer Specialties

Full details for the selection and appointment of warrant officers to serve as unit administrators to commanding officers of combat companies, otherwise known as the "Unit Administrator Career Warrant," the latest addition to a program already embracing 50 specialty career fields, have been announced in Department of the Army Circular 25.

Except for one modification, criteria for selection follow generally those already established for the 50 specialties in which integrations recently have been made. Because the unit administrator career warrant is designed for combat-type soldiers, eligibility for the new career field is restricted to combat-type personnel. Men presently holding warrants are ineligible to apply for appointment on the premise that they are eligible for career fields other than unit administrator due to present assignment.

In keeping with this criterion, officers competing for appointment must have at least two years' service at regimental or lower level with combat units.

Application for appointment in this field will be submitted to the immediate commanding officer on DA AGO Form 61. Final type physical examination is required, although no physicals will be given before April 1, 1949.

To be eligible for consideration an applicant must have passed his 21st birthday on date of application but not have passed his 45th birthday prior to July 1, 1949, except for service personnel of World War II who may be accepted if they passed their 45th birthday subsequent to December 7, 1941.

/ / /

Army Halts Recall of Officers For Extended Duty

The Department of the Army announced that civilian component officers, other than those for whom orders have already been issued, will no longer be called to duty under Section 7 of the Selective Service Act. This section of the Selective Service Act provides that civilian component officers with less than 90 days' active service may be called to active duty for 21 months.

It was stated that, in view of the reduction in the planned strength of the Army, it is no longer necessary to implement Section 7 of the Selective Service Act as a means of procuring officers for extended active duty.

/ / /

Army Citation Certificates Available

Major General Edward F. Witsell, The Adjutant General, Department of the Army, has advised all holders of World War II military decorations that they may obtain certificates attesting to the awards by writing directly to him.

Medal winners will receive certificates of the diploma type, each bearing a replica of the decoration for which it is granted.

Winners of decorations should address their requests for certificates to The Adjutant General, Department of the Army, Washington 25, D. C., indicating the number, date, and headquarters of the general orders which awarded the decoration originally, and enclosing copies of the general orders and of the complete citations, if available. In the case of decorations awarded posthumously, the next of kin may obtain the certificate.

National Guard Offers Opportunities for Commissions

A broad variety of opportunities to obtain commissions in the National Guard now are available to civilians.

Commissions in Army units of the National Guard may be given civilians in the following categories:

(1) Former officers who served at least six months in World War II.

(2) Any man up to 32 years of age who has an aggregate of at least one year of service on active Federal duty or in the National Guard, or both, and completes the 10-series Army correspondence courses. Age limit drops to 28 years after July 15, 1949.

(3) Any man up to 32 years of age who served in the first three enlisted grades or as a warrant officer for at least six months in World War II.

(4) Any man who after at least six months' service in World War II who was graduated from an accredited college not offering a ROTC course or with insufficient academic time to permit graduation from the advanced ROTC course.

(5) Graduates of a recent advanced ROTC course.

(6) Any man who was recommended for or offered appointment to commissioned grade while serving in the Army during the war but was taken prisoner of war before final action on the commission could be taken can be appointed a first lieutenant if he has not reached his 35th birthday on date of appointment.

(7) Civilian specialists such as doctors, dentists and ministers may be commissioned without previous military training.

✓ ✓ ✓

Extra National Guard Training to Raise Combat Efficiency

Extra week-end training has been authorized for National Guard Army units during 1949. Week-end drills will be in addition to the 48 weekly armory training periods now taken by the National Guard. They will permit units to complete individual training in the handling and firing of small arms at their home stations or in the vicinity, leaving more time for tactical training during summer field encampments.

During calendar year 1949, Army units are authorized to take the equivalent of one week-end training period of two days in addition to their regular armory training. In most units this will be spread over four week ends with part of the unit personnel participating each period to an aggregate total of 90 per cent. Personnel of the unit acting as instructors—about 10 per cent of the total strength—will participate in all four extra training periods.

Guardsmen will receive two full days' additional pay, and instructors eight days' pay for the extra training. This will be in addition to the full day's pay received by National Guardsmen for each of 48 annual two-hour armory training periods, and the full two weeks' pay for field training.

Because of the lack of funds in the past such training was carried on by the several States on a very reduced scale through local unit schools.

It is expected that the extra training program will be expanded in scope as its value is demonstrated through the first months of 1949.

Pentagon Assignments Open to Guard Officers

Selected National Guard officers, majors or higher, will be assigned for 90-day tours of active duty in the Personnel & Administration, Intelligence, Logistics, Organization & Training, and Plans and Operations Divisions. They must not be more than 50 years old. They must also have had either staff experience at brigade or higher level, or been graduated from or have constructive credit for General Staff College, or have had outstanding performance in command assignments. Nominations are to be made by the Adjutants General, to the National Guard Bureau.

✓ ✓ ✓

Comptroller General Reverses Eligibility Ruling for Reservists' Retirement Benefits

The Office of the Comptroller General, in a letter received by Secretary of Defense James Forrestal, agreed that any member of a Reserve Component of the Armed Forces with 20 years of satisfactory service is entitled to retirement benefits under Public Law 810 when he becomes 60 years old regardless of his status then.

Previously the Comptroller General's Office had ruled that if such a member was separated from his component before he was 60 he was not entitled to these benefits.

✓ ✓ ✓

Retirement Forms Beings Prepared

Reservists who have applied for retirement without the aid of proper instructions and required forms are advised by the Department of the Army that such instructions and forms are being prepared. Under Public Law 810, 80th Congress, reservists are entitled to nondisability retirement pay privileges when they have completed 20 years of satisfactory Federal Service and have reached the age of 60. Those not yet eligible must earn 50 qualifying points per year through attendance at training assemblies, active duty or correspondence courses.

✓ ✓ ✓

National Guard Withholding Tax

Henceforth, National Guard pay will be subject to collection of taxes—at the source. Army Department Circular 347 and Air Force Letter 173-18 contain full details and have been distributed to all units. Briefly, the system works in two parts: deductions from field training pay and from armory drill pay. Taxes will be withheld from all Guardsmen's field training pay, but virtually no one will be taxed for armory drill pay, because of the small amount of income involved. Records required will be kept by each unit's Personnel Officer. Forms are being distributed to State AG's.

✓ ✓ ✓

Navy Hospitals To Care For Army Dependents

Naval activities having facilities for medical care of dependents have been authorized to provide such care for dependents of active duty personnel of the Army and Air Force in like manner as now provided for dependents of Navy and Marine Corps personnel. This new policy is in line with a recent policy announcement by Defense Secretary James Forrestal. The per diem charge for inpatient hospitalization of Army and Air Force dependents at naval activities within and outside the United States will be \$1.75. There will be no charge for outpatient treatment.

SEACOAST SERVICE



TEST SECTION

Any individual, whether or not he is a member of the service, is invited to submit constructive suggestions relating to problems under study by the Seacoast Service Test Section, Army Field Forces Board No. 1, or to present any new problem that may properly be considered by the Section. Communications should be addressed to the President, Seacoast Service Test Section, Army Field Forces Board No. 1, Fort Baker, California.

Items pertaining to Antiaircraft Artillery should be sent to the Antiaircraft Test Section, Army Field Forces Board No. 4, Fort Bliss, Texas.

Any recommendations made or views expressed herein are those of Army Field Forces Board No. 1 and are not to be construed as representing the opinion of all Department of the Army or Army Field Forces Agencies.

COLONEL R. E. DINGEMAN, Coast Artillery Corps, Director

LT. COL. WILLIAM B. HAWTHORNE, Coast Artillery Corps

LT. COL. JAMES T. BARBER, Coast Artillery Corps

LT. COL. RICHARD R. MOORMAN, Coast Artillery Corps

LT. COL. FREDERICK N. WALKER, JR., Coast Artillery Corps

LT. COL. WILLIAM L. SCHREIBER, Coast Artillery Corps

MAJOR FRANCIS J. PALLISTER, Field Artillery

CAPTAIN WILLIAM G. MATHEWS, Coast Artillery Corps

CAPTAIN HAROLD R. BRANTNER, Coast Artillery Corps

CWO JOHN E. HUNTOON, JR., United States Army

WOJG JOSEPH A. PROTENIC, United States Army

Mine Flotilla: A gradual modernization of vessels of the mine flotilla is beginning to take shape. This modernization is under the cognizance of the Transportation Corps and is being accomplished by development of new vessels and modification of existing vessels. Units of the flotilla affected are:

Mine Planter—Of major importance to the modernized flotilla is the new 127-foot mine planter now under construction at New York, later to be launched and completed at Todd's Shipyard, Charleston, S. C. After some delays this prototype planter, which has been designated USAMP Sgt. Truman O. Olson, is being rushed to completion. Incorporating all possible features which will make for efficient operation in the mine field, and eliminating those features which caused the old planters to become general purpose ships, the 127-foot planter will be the first such ship designed for submarine mine work exclusively. One innovation which has great promise is the use of cycloidal propellers. This type of propulsion should make the new planter highly maneuverable.

Distribution Box Boat—Test of the modified DB Boat L-73, reported in last issue, is continuing. New improvements are being sought with a view to producing a prototype vessel that may be used as a model for future production.

Mine Yawl—An investigation is being conducted into the feasibility of replacing Radio Sets SCR-536 on mine yawls with a voice radio for communicating with mine planter. The SCR-536 has proved to be inadequate. The system of communicating by voice or signals frequently is difficult, if not impossible, during periods of unfavorable weather. This necessitates the yawl's return to the planter for instructions. A Navy type MQ-1 Radio has been tested and found satisfactory; however, other types will be investigated.

Synthetic Insulated Loading Wire—Tests are now in

progress to determine the suitability of synthetic insulated loading wire for submarine mine work. Loading wire is the term used to designate short lengths of insulated copper wire conductors primarily used to connect mine cables to devices used in mines and distribution boxes. The shortage of natural rubber in the United States during World War II has established an essential requirement for a suitable synthetic rubber substitute for submarine mine work. Experience with synthetic insulated submarine mine cables, has demonstrated that such materials are equal, and in some respects, superior to natural rubber in the characteristics and performance required for submarine mine work. For example, it is known that certain compounds such as Neoprene are exceptionally resistant to light, heat, and oil. The use of such heat and light resistant compounds for loading wire insulation would be an added advantage since natural rubber is subject to rapid deterioration when exposed to light and heat over 80 degrees F.

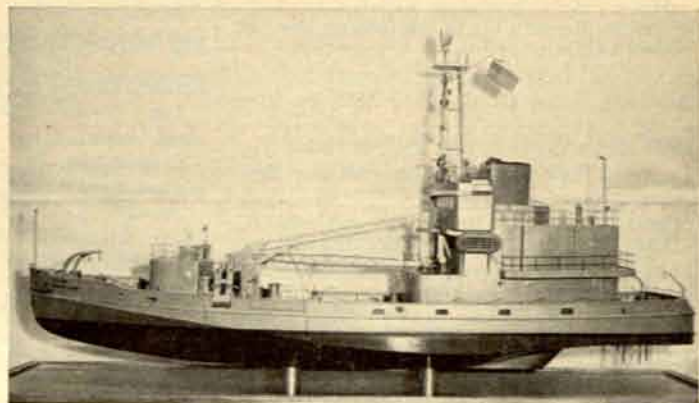

Latest type of 127-foot mine planter soon to join the Seacoast Service modernized flotilla.

COAST ARTILLERY ORDERS

DA and AFF Special Orders covering the period 13 December 1948 through 28 February 1949. Promotions and Demotions not included.

COLONELS

Adams, Nyal L., Retired from active service.
Burgess, George R., to Hq., Sixth Army, Presidio of San Francisco, California.
Dutton, Donald L., to 2517th ASU, Delaware NG Instructor Group, Wilmington, Delaware.
England, John M., to GSC.
Englehart, Carl E., to Hq., Sixth Army, Presidio of San Francisco, California.
Gettys, Charles W., to GSC, Hq., MDW, Washington 25, D. C.
Hendrix, Raleigh R., to GSC.
Kreuter, Robert H., to GSC.
McCarthy, Edward B., to First Army, 1108th ASU, Fort Adams, R. I.
Melberg, Reinold, to Hq., Sixth Army, Presidio of San Francisco, California.
Miller, Robert L., to GSC.
Potts, Adams E., Retired.
Putman, Webster F., Retired.
Van Volkenburgh, Robert H., to ORC Instructor Group, Fort MacArthur, Calif.

LIEUTENANT COLONELS

Burt, William T., to ORC Instructor Group, Nashville, Tenn.
Coleman, Clarence N., to European Command, Frankfurt, Germany.
Ebel, Henry W., to 4052d ASU, Fort Bliss, Tex.
Foster, Kenneth W., to Infantry.
Grimes, George R., to Far East Command, Yokohama, Japan.
Layton, Myron M., to Far East Comd., Yokohama, Japan.
Mackenzie, Alan F., to GSC.
Owen, Richard W., to Antiaircraft Journal, 631 Pennsylvania Ave., N.W., Washington 4, D. C.
Pohl, Marion G., to Office, Joint Chiefs of Staff, Washington, D. C.
Rakes, Adams E., Retired.
Ratcliffe, Lamar C., to Stu. Det., Armed Forces Staff College, Norfolk, Va.
Sandford, Arthur L., to 4052d ASU, Ft. Bliss, Tex.
Santos, Melecio M., to Ft. Winfield Scott, Calif.
Steele, John C., to US Army Pacific, Ft. Shafter, TH.
Stevens, John D., to 4052d ASU, Ft. Bliss, Tex.
Van Ormer, Henry P., to OC of S, Washington, D. C.
Wickham, Kenneth G., to 4th Infantry Div., Ft. Ord, Calif.

MAJORS

Anastasas, Henry D., to 4052d ASU, Ft. Bliss, Tex.
Cox, Joseph C., to 4052d ASU, Ft. Bliss, Tex.
Daugherty, Lyle S., to Fifth Army Missouri Rctg. Dist., Kansas City, Mo.
Higgins, Harold D., to 6815th ASU, ROTC, Utah State Agricultural College, Logan, Utah.
Huston, Robert M., to 4052d ASU, Ft. Bliss, Tex.
Jennings, Cleveland H., USAF to CAC.
Masterson, William E., to US Army Forces, Antilles, San Juan, P. R.
Marnfeld, Robert, to Ryukyus Comd., Okinawa.
Morse, Henry Pernelee, to 4052d ASU, Ft. Bliss, Tex.
Nichols, James R., to Far East Comd., Yokohama, Japan.

Ringgold, Charles L., to 34th AAA Brig., Ft. Bliss, Tex.
Ruddell, Noel C., to Cp. Stoneman, Calif.
Walker, Berrisford H., to The Arty. Sch., Ft. Sill, Okla.
Wood, Harland G., to Office, Chief of Staff, DA, Washington, D. C.

CAPTAINS

Anske, Leander H., to Ft. Winfield Scott, Calif.
Armstrong, George J., to Second Army, Virginia Rctg. Dist., Richmond, Va.
Baines, Thomas R., to Fourth Army, 4052d ASU, Ft. Bliss, Tex.
Barker, George E., to 4052d ASU, Ft. Bliss, Tex.
Barlett, Henry H., to 3344th ASU, Georgia NG, Instrs., Atlanta, Ga.
Brown, Walter J., to Hq., Army Security Agency, Washington, D. C.
Caffall, Joseph M., USAF to CAC.
Calvert, Lawrence R., to Far East Comd., Yokohama, Japan.
Campbell, Merle E., to 4052d ASU, Ft. Bliss, Tex.
Chrest, John F., to Far East Comd., Yokohama, Japan.
Clifton, Joseph M., to Pers. Cen., Cp. Kilmer, N. J.
Cruickshank, William G., to Second Army Rctg. Dist., Indianapolis, Ind.
Dickinson, David L., to ORC Instr. Gp., Ft. MacArthur, Calif.
Dosssett, Robert C., to Far East Comd., Yokohama, Japan.
Foote, William C., to Office, Sec. of the Army, Washington, D. C.
Ghent, Daniel T., to JAGD.
Green, Julius S., to Ryukyus Comd., Okinawa.
Hay, Robert B., to 4052d ASU, Ft. Bliss, Tex.
Helmick, Glenn B., to 6th Fa. Bn., Ft. Sill, Okla.
Hiles, John C., to 4052d ASU, Ft. Bliss, Tex.
Holsinger, Samuel J., to European Comd., Bremerhaven, Germany.
Hoseman, Joseph F., to Ryukyus Comd., Okinawa.
Jesurun, Gladstone M., to ROTC Unit, Univ. of P. R., Rio Piedras, P. R.
Johnson, Ralph L., to Far East Comd., Yokohama, Japan.
Jones, Ellie C., to Far East Comd., Yokohama, Japan.
Kalbfleish, Edwin, to Hq., Fifth Army, Chicago, Ill.
Kellum, George A., to 4052d ASU, Ft. Bliss, Tex.
Klein, Patrick L., to Armed Forces Info. Sch., Carlisle Bks., Pa.
LeClerc, Leon A., to Far East Comd., Yokohama, Japan.
Levine, Alexander, to Lang. Sch., Presidio of San Francisco, Calif.
Lingner, Frederick A., to Arty. Sch., Ft. Sill, Okla.
McCallum, Herman D., to 4052d ASU, Ft. Bliss, Tex.
MacNeil, Mark K., to US Army Rctg. Sta., Providence, R. I.
Maker, Charles M., to Armed Forces Sp. Wpns. Project, Sandia Base, Albuquerque, N. Mex.
Nielsen, Tage Kaj G., to Ft. Winfield Scott, Calif.

Norling, Malcolm R., to 34th AAA Brig., Ft. Bliss, Tex.
O'Connor, Robert G., to Far East Comd., Yokohama, Japan.
Olsen, Bob Gillham, to 4052d ASU, Ft. Bliss, Tex.
Parham, Douglas F., to CE.
Peterson, Leonard O., to 4052d ASU, Ft. Bliss, Tex.
Pierce, David F., to CIC Cen., Cp. Holabird, Md.
Recsieck, Daniel M., to Inf.
Rolston, Brown, to Far East Comd., Yokohama, Japan.
Sarles, Theodore, to AGO.
Schmader, Wilbur P., to Far East Comd., Yokohama, Japan.
Skipper, John D., to 34th AAA Brig., Ft. Bliss, Tex.
Sobke, Llewellyn, to 4052d ASU, Ft. Bliss, Tex.
Turkovich, Joseph P., to 4052d ASU, Ft. Bliss, Tex.
Vandervolt, Charles E., to 4052d ASU, Ft. Bliss, Tex.
Wallace, James J., Jr., to Far East Comd., Yokohama, Japan.
Wertz, Clyde E., to 4052d ASU, Ft. Bliss, Tex.
White, Paul R., to Ryukyus Comd., Okinawa.
Whitten, Richard C. B., to 4052d ASU, Ft. Bliss, Tex.

FIRST LIEUTENANTS

Barrett, Joseph W., to ROTC, Univ. of Del., Newark, Del.
Brickner, Fred W., to Far East Comd., Yokohama, Japan.
Bryant, William A., to US Army, Alaska.
Cohen, Reuben, to Pers. Cen., Ft. Lawton, Washington.
Coon, John E., to Ryukyus Comd., Okinawa.
Daniels, George B., to Ryukyus Comd., Okinawa.
Daniel, Preston N., to Far East Comd., Yokohama, Japan.
Doll, Clarence E., to 4052d ASU, Ft. Bliss, Tex.
Errigo, Joseph A., to 34th AAA Brig., Ft. Bliss, Tex.
Esco, Oliver N., to 4052d ASU, Ft. Bliss, Tex.
Faber, Charles F., to Ryukyus Comd., Okinawa.
Guston, Gusta B., to European Comd., Frankfurt, Germany.
Hagney, Frank J., Reld. from Inf.
Hannon, Laurence K., to 4052d ASU, Ft. Bliss, Tex.
Helinski, Joseph P., to 4052d ASU, Ft. Bliss, Tex.
Hibbard, Preston H., to 9th Inf. Div., Ft. Dix, N. J.
Hughes, David W., to Far East Comd., Yokohama, Japan.
Jones, Bertand H., to US Army, Alaska.
Kemper, George E., to 4052d ASU, Ft. Bliss, Tex.
Leaken, Richard M., to Ryukyus Comd., Okinawa.
Leal, George P., to 34th AAA Brig., Ft. Bliss, Tex.
Levalley, Miller W., to CIC Cen., Cp. Holabird, Md.
Marberger, John to 9th Inf. Div., Ft. Dix, N. J.
Marconi, Sabatine R., to 4052d ASU, Ft. Bliss, Tex.
Moloney, Thomas F., to Second Army, 2304th ASU, Virginia Mil. Dist., Richmond, Va.

(Continued on page 56)

Coast Artillery Newsletters

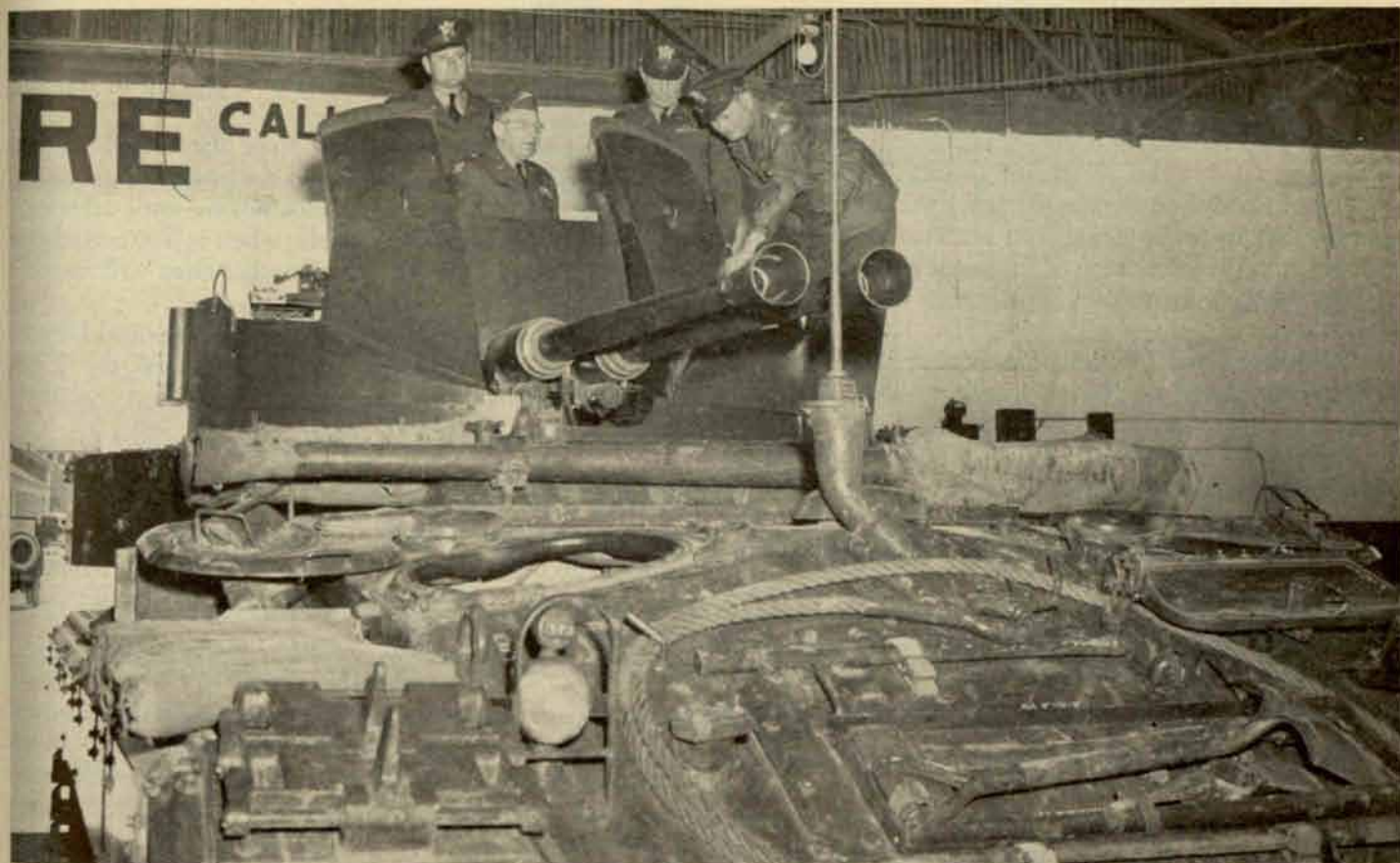

Brig. Gen. Julius Klein of Chicago, first senior National Guard officer to attend the senior officers' indoctrination course at Fort Bliss, Texas, receives instruction on the M-19 Self-Propelled "twin-forty." With General Klein are: Maj. Ray Isensen, Illinois National Guard Instructor and Colonel John H. Madison, Director of Training at the AAA & GM School.

109th AAA BRIGADE

NATIONAL GUARD OF ILLINOIS

BRIG. GEN. JULIUS KLEIN, *Commanding*

My stay at the Antiaircraft and Guided Missiles School at Fort Bliss taught me Antiaircraft Artillery is the first line of defense for our own home shores, our cities, villages and our very lives. This school is the nerve center for those men who develop, test and ultimately defend us with their guns and guided missiles.

Major General John L. Homer, one of the most brilliant officers of our Army, and one who many years ago recognized the importance of an AA defense, commands this progressive businesslike Army Post. Colonel Bryan L. Milburn, considered a top expert in AAA, is the Chief of Staff of this command and right-hand man of General Homer.

In my capacity as Commanding General of the 109th Antiaircraft Brigade, Illinois National Guard, it was my privilege to attend a 15-day senior officers indoctrination course at the Antiaircraft and Guided Missiles Branch of The Artillery School at Fort Bliss. Brigadier General Charles E. Hart, with a team of brilliant young officers, conducted

the course in a manner that could well be the envy of our finest universities.

♦ ♦ ♦

309th AAA GROUP (ORC)

SEATTLE, WASHINGTON

COLONEL DANIEL C. NUTTING, *Commanding*

The 309th AAA Group and the attached 327th Operations Detachment have maintained an almost perfect 100% attendance during the first quarter of 1949 and interest is ever mounting.

The first draft of detailed mobilization plan has been completed by the Group staff. This plan, together with a plan for the AAA defense of Puget Sound Area, was completed by the various staff sections on their own time and was assembled at a CPX last December.

Regular drills for the Group have been conducted in accordance with DA TM No. 1. The Group S-3 prepared two examinations for records of proficiency in basic subjects and AAA tactics. These examinations are given to each new officer and enlisted man as he is assigned to the Group.

Ninety per cent of the Group Officers and 75% of the enlisted men have indicated their desire for 15 days' summer training. The exact time, place and scope of the training is the main topic of Group interest at the present time.

/ / /

197th AAA GROUP (ORC)

NATIONAL GUARD OF NEW HAMPSHIRE

COL. ALBERT S. BAKER, CAC, *Commanding*

The big news in the 197th Antiaircraft Artillery Group since the first of the year was the feat of the Group Headquarters Battery in reaching 100 per cent of its enlisted strength, and the celebration of the event by presentation to it of the colors of its wartime predecessor by the Governor of the state.

Headquarters and Headquarters Battery shares the field in Concord, capital of New Hampshire, with Battery A, 744th Gun Battalion, the 3643d Ordnance Company, MM, the State Staff Detachment, and the 358th Signal Maintenance unit.

By reaching its full enlisted strength, Headquarters Battery of the 197th AAA Group became the first unit in the New Hampshire National Guard to accomplish this objective. Major credit for achieving the goal belongs to First Lieutenant Frederick H. Welcome, battery commander, and First Sergeant Nelson Maltais, both of whom served in the Headquarters Battery of the prewar 197th Coast Artillery Regiment (AA).

The regiment served throughout World War II in the Southwest Pacific area under the command of General Douglas MacArthur and participated in most of the major actions up to and including the liberation of the Philippines.

The regiment's colors had been in the custody of Brigadier General Charles F. Bowen, the Adjutant General of New Hampshire. On the night of 31 January 1949, the General brought the colors to the state armory in Concord under armed escort and in the impressive ceremony that followed, handed them to Governor Sherman Adams who,

in turn, presented them to Colonel Albert S. Baker, group commander. The colors were then accepted by color bearers and the entire Headquarters and Headquarters Battery passed in review before the Governor as commander in chief.

After the presentation, Governor Adams made a brief address in which he reviewed the wartime record of the predecessor regiment and congratulated the unit on reaching its full strength and the part it is playing in the new national security force.

Organization and recognition, since the first of the year of two authorized units, completes the present organization of the Group and its attached battalions until additional armory facilities become available, when it is expected that two additional automatic weapons batteries will be activated.

New units federally recognized are the Medical Detachment of the 744th AAA Gun Battalion and the 358th Radar Maintenance Unit.

/ / /

About \$2,000,000,000 in checks to 14,000,000 veterans, involving refunds on premiums for wartime insurance, are likely to be held up until 1950. Some officials feel that the economic, and maybe political, effect of these checks would be bigger next year than this.

* * *

U. S. military planners are not convinced that American arms in Europe will insure effective resistance if Russian armies should march westward. There is fear that the arms might end up in Russian hands in somewhat the same manner that arms were lost in parts of China.

* * *

Guided missiles are being developed by the Armed Forces faster than space can be found to test them. Missiles already manufactured will travel over 500 miles, and present testing areas are only about 150 miles long. Proposed 3,000-mile proving ground won't be ready for months.

Coast Artillery Orders

(Continued from page 54)

Nichoff, John J., to Pers. Cen., New Orleans, La.
Otterbourg, Charles R., to 34th AAA Brig., Ft. Bliss, Tex.

Powers, George H., to Ryukyus Comd, Okinawa.
Randazzo, Joseph S., to Hq., Army Security Agency, Washington, D. C.

Rembijas, Michael F., to Hq., First Army, Governors Island, N. Y.

Riha, John D., to 4052d ASU, Ft. Bliss, Tex.

Ruppel, Raymond P., to 4052d ASU, Ft. Bliss, Tex.

Russell, Robert C., to Inf.

Samuels, Julius A., to 4052d ASU, Ft. Bliss, Tex.

Schreiner, Carl E., to 4052d ASU, Ft. Bliss, Tex.

Smith, Howard C., to European Comd., Bremerhaven, Germany.

Solari, Joseph M., to 5th Armd. Div., Cp. Chaffee, Ark.

Sprague, Ernest L., to Pers. Cen., Cp. Stoneman, Calif.

Stack, Richard J., to Ryukyus Comd., Okinawa.

Summers, William R., to 4052d ASU, Ft. Bliss, Tex.

Tufte, Chester O., 34th AAA Brig., Ft. Bliss, Tex.

Walker, Harold R., to Ryukyus Comd., Okinawa.

Waltz, Charles C., to Arty. Sch., Ft. Sill, Okla.

Weiner, John A., to 7025th ASU, Ft. Myer, Va.

Yevich, Andrew M., to Far East Comd., Yokohama, Japan.

SECOND LIEUTENANTS

Currier, Russell E., to Ryukyus Comd., Okinawa.
Davis, Robert T., to 4052d ASU, Ft. Bliss, Tex.
Djal, Moses D., to 4052d ASU, Ft. Bliss, Tex.
Gordon, Bernard I., to 4052d ASU, Ft. Bliss, Tex.
Hare, Jean M., to 4052d ASU, Ft. Bliss, Tex.
Sachs, Phillip B., to 34th AAA Brig., Ft. Bliss, Tex.

Sands, Phillip E., to 4052d ASU, Ft. Bliss, Tex.
Shaw, Frank W., to 4052d ASU, Ft. Bliss, Tex.
Slater, Paul W., to 503d Abn. AA Bn., Ft. Bragg, N. C.

Thompson, Wayne W., to 4052d ASU, Ft. Bliss, Tex.

Vaseliades, Achilles W., to 4052d ASU, Ft. Bliss, Tex.

Wood, Don P., to 4052d ASU, Ft. Bliss, Tex.

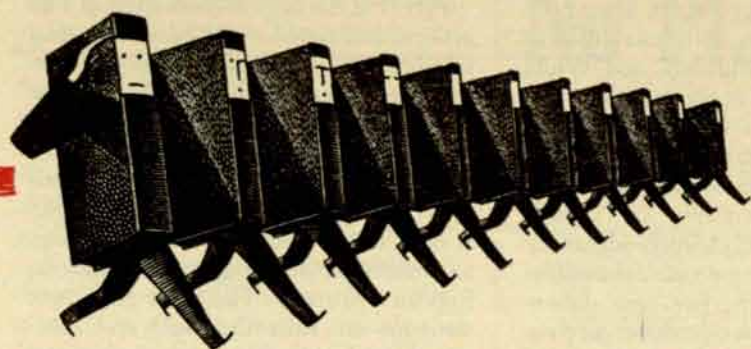

BOOK REVIEWS

Two Great Outfits

FOLLOW ME! THE STORY OF THE SECOND MARINE DIVISION IN WORLD WAR II. By Richard W. Johnston. Random House, 1949. 305 Pages; Illustrated; \$6.00.

EIGHT STARS TO VICTORY: A HISTORY OF THE VETERAN 9TH U.S. INFANTRY DIVISION. By Captain Joseph B. Mittelman. The 9th Infantry Division Association, 1948. 406 Pages; Illustrated; \$5.00.

These are the histories of two of the great divisions of World War II, divisions as competent and tough and professional as any that ever went into battle for the United States. It may be that two or three other divisions were better known, but these two were workhorses of combat—on opposite sides of the world.

The 9th Infantry Division had only a brief period of activation during World War I, but the regiments which would comprise the 9th for World War II—the 39th, 47th, and 60th—saw bitter service in three different offensives: Aisne-Marne, St. Mihiel, and Meuse-Argonne. The Second Marine Division had no World War I incarnation, but its World War II keystone, the Sixth Marines, achieved immortality at Chateau-Thierry and Belleau Wood.

The 9th Division of World War II fought in North Africa, fought again in Sicily, slugged its way brilliantly through Normandy and across France, fought in the gloom of the Hürtgen Forest, stood fast through the Ardennes counteroffensive and then stormed back into the bat-

tle for the Roer River dams, and with the 9th Armored Division, held and expanded the Remagen bridgehead across the Rhine until enough force could be built up for a breakthrough.

In the Pacific, the Second Marine Division had been committed early to the battle against the Japanese. Elements of the Division landed on Tulagi and Gavutu under General Vandegrift when the First Marine Division assaulted Guadalcanal. Later, the other elements fought side by side with the Army's 25th and Americal Divisions under General Patch in the drive out of the Marine beachhead which resulted in the taking of the other seven-eighths of the island. From Guadalcanal, after a period of reorganization in New Zealand, the Second Division went ashore into one of the shortest but bloodiest battles of the war—Tarawa. In seventy-six hours of violent action, just under a thousand Second Division Marines were killed and more than two thousand wounded in the speedy capture of the island. From Tarawa the Second went back to Hawaii, then on to Saipan and Tinian, and, finally, the 8th Marines, first Second Division unit committed to battle, became the last to fight when it was briefly committed on Okinawa.

Both of these histories are fitting tributes to their first-rate fighting units. Captain Mittelman and Mr. Johnston have written fairly and objectively, both of their own units and of the outfits that fought beside them. When other units fought not so ably as these two, the authors of these two books have very rightly

concluded that there is little reason to make an issue of it at this late date.

Maps and illustrations are uniformly excellent. Only in occasional oddities of design and style and several unfortunate typographical errors does *Eight Stars to Victory* betray the fact that Captain Mittelman is not a professional writer and the 9th Infantry Division Association not a professional publisher. Mr. Johnston and Random House are.—O. C. S.

Cartridges Cleared Up

CENTERFIRE METRIC PISTOL AND REVOLVER CARTRIDGES. VOLUME I OF CARTRIDGE IDENTIFICATION. By H. P. White and B. D. Munhall. A Sportsman's Press Book. The Infantry Journal Press, 1948. 100 Pages; Illustrations; \$7.50.

CARTRIDGES: A PICTORIAL DIGEST OF SMALL ARMS AMMUNITION. By Herschel C. Logan. Standard Publications, Inc., 1948. 200 Pages; Illustrations; \$5.00.

It is remarkable how two books dealing with the same subject can approach it from such divergent views that there is absolutely no duplication between them.

Munhall and White take the purely professional approach and their book is loaded with thousands of facts that shooters, collectors, ballisticians, identification experts and dealers have long prayed for. The authors bring order out of the chaos of nomenclature, dimensions and ballistics which has long plagued the cartridge field. Few authorities have ever realized for example, that the 9mm Browning

(the familiar .38 Colt) masquerades under fifteen other names—or that the 9mm Parabellum has sixteen other standard names, that it is fired from some seventy weapons, and that it comes in fifteen different cartridge types with four different kinds of primers. Munhall and White have nailed down every provable fact they could about cartridges by examining, weighing, measuring, firing and photographing them. Their silhouette photographs, incidentally, are superb, and make for precise and easy identification. The data they give are exhaustive: two-bullet diameters, five case dimensions, cartridge types, case material, powder types, primer types, instrumental velocity, history and what weapons use it. The book is a foolproof and invaluable reference. Lest the title worry you, remember that many cartridges which we consider American (the .25 ACP, the .32 ACP and .38 for example) are really European, and are covered in this book.

Logan's book is a pictorial digest of small-arms ammunition, done in a style similar to his *Hand Cannon to Automatic*. He keeps technical data to the minimum, and in a pleasantly discursive style he discusses the different types of cartridges, gives interesting historical facts and little known sidelights. His illustrations are pleasing. This is a book to thumb through and mull over rather than to use for identification, and a very pleasant time you'll have with it, too.—R. G. McC.

Rifle Classic

RIFLES. Volume II of the NRA BOOK OF SMALL ARMS. By W. H. B. Smith. The National Rifle Association-Military Service Publishing Company, 1949. 546 Pages; Illustrations; Appendices; Index; \$12.50.

This second volume of the series of books on weapons sponsored by the National Rifle Association well maintains the high standards set by the first volume on handguns.

The historical introduction is a masterful roundup of all that is provable about the origin of weapons and cartridges. The first documented formula for gunpowder dates from the middle of the thirteenth century, which effectively squelches German claims that Berthold Schwartz invented it in 1313. The first picture of a cannon, reproduced in the frontispiece, is dated 1326, and the first handgun found can be definitely attributed to 1399. The modern rifle had been theoretically possible many years before the development of the metallic cartridge in the 1840s made it a practical weapon, and for almost a hundred years there has

been relatively little improvement in the weapons themselves. Cartridges are being improved daily, but the rifle as we know it seems to have reached its peak.

Part II of the book is an analysis of rifle actions, and covers every basic operating principle from the single-shots to the semiautos. Part III, the main body of the book, contains detailed descriptions of the standard military and sporting rifles. These weapons are considered alphabetically under the country where the rifle is most used. Adequate cross references and excellent indexing make it easy to find any weapon. The most important weapons are fully discussed and illustrated with identification photos and with fine sectional drawings. There are many scale cartridge illustrations, and the ballistic data are good, too. The glossary establishes definite nomenclature for the rifle fraternity.

Anyone with a serious interest in rifles must consider this a standard reference book. It stands unique in the field for its approach and scope.—R. G. McC.

A Boy Meets Life

THE WILD COUNTRY. By Louis Bromfield. Harper and Brothers. 274 Pages; \$2.75.

From a reviewer's standpoint, the recent pictorial review of the life of Louis Bromfield, which appeared in a weekly picture magazine, was most fortuitous. Perhaps Mr. Bromfield concurs in this since the article appeared almost simultaneously with the release of his latest novel, under discussion here. However, our evaluations of the article differ sharply. To Mr. Bromfield, it provides a stimulus to the sale of his works. To this reviewer, it helps to provide some explanation of his decline as an author.

The magazine article tells us of Mr. Bromfield's overwhelming enthusiasm for his model "Malabar Farm." On this farm, he has incorporated all that is modern in agricultural science. Curious sightseers, as well as interested agriculturists, flock to "Malabar Farm" to partake in the guided tours conducted by the author himself. In the interests of agriculture this may be a fine thing but it certainly hasn't helped his writing any. As a matter of fact, *The Wild Country* is written as though he were late for one of his guided tours.

The Wild Country starts out to be a portrait of a sensitive young boy growing into maturity. His youth is spent in a quiet, rural valley where he learns as a boy the beauty of Nature firsthand. He acquires a working knowledge of birds and fish in their native habitat. He

knows the quiet peace of country life. Ronnie, the boy, is being raised by his grandfather and maiden aunt, who are both gentle and kind. From such an environment, growing into maturity is a far more unnerving process than for a youngster reared under other conditions. In more patient hands, Ronnie's development into manhood could have been a powerfully gripping drama, but the author has not taken the trouble. What started out to be a portrait, rapidly deteriorates into a sketch.

In an effort to point up the boy's impact with the facts of life, the author dwells at length on the amoral activities of several friends and relatives. To be sure, a certain amount of this sort of thing would be necessary to the telling of the tale, but it is overdone. The boy's sense of shock on discovering the moral degeneration of a close family friend, whom he had always admired, is well done. Likewise, his discovery of infidelity in the wife of another close friend serves admirably to portray the crushing mental adjustment of approaching maturity. However, the story gains nothing from the other sexual adventures it relates except, of course, they will probably help boost sales under existing literary evaluations.

Mr. Bromfield still has a knack with the written word. His last few offerings indicate, however, that he may be sacrificing quality for quantity. This is not the Bromfield that we knew in *The Rains Came*, *Night In Bombay*, and *Mrs. Parkington*. That author Bromfield has other interests is quite evident, for he no longer takes the time to give his reading public his best efforts. On second thought, though, in these days we couldn't buy many of his farm products for \$2.75 either.—ROBERT F. COCKLIN.

Foreign Service Snafu

AN AFFAIR OF STATE. By Pat Frank. J. B. Lippincott Company. 256 Pages; \$2.75.

Readers who buy this book on the strength of the author's *Mr. Adam* are due for a disappointment. Where *Mr. Adam* was good clean fun interlarded with some food for thought, *An Affair of State* is all meant to be food for thought and less palatable food.

The year is 1949. Jeff Baker, an All-American Boy type, aged 30, combat veteran of the war in Italy, joins the Foreign Service of the State Department because he has been groomed for it all his life and now has a burning and sincere desire for peace. His first assignment is in Budapest, organizing resistance groups against the "inevitable" day

we fight Russia. A rare assortment of cartoon types of Embassy and State Department personnel, with a beautiful Hungarian dancer, a brave and disillusioned Red major and other odd characters thrown in for good measure, throw the expected snafus and body blocks, and Baker is sent home in disgrace because he dared to do what was right. A loyal girl friend and a loyal friend of Baker's dead father prove to the understanding, overworked, but extremely capable Secretary of State that Jeff is innocent and right, and save his good name.

Mr. Frank undoubtedly has a point to make, and he has made it. Whether he has made it the right way is a question. The point would have been more effectively made without the burlesque. Peace and our Department of State seem to this reviewer, at least, two subjects that should neither be kidded nor kitized. Every American should give both of these subjects mature thought, but not in the fashion it is presented here.—A. S.

Statement of Intent

THE TRUMAN PROGRAM: ADDRESSES AND MESSAGES BY PRESIDENT HARRY S. TRUMAN. Edited by M. B. Schnapper. Public Affairs Press. 261 Pages; \$2.95.

There has been considerable conjecture surrounding President Truman's recent victory at the polls. His election has been attributed to a number of things including the failure of a Republican Congress to deal with serious domestic issues, Mr. Dewey's overconfidence, the American love for a courageous fighter and an apathy on the part of a large segment of the Republican voters. Perhaps the real truth partakes of all of these, although the consensus is that the over-all Truman program was a secondary factor. To be sure, labor remembered his veto of the Taft-Hartley Bill; the farmers voted for continuing price supports; and the aged and infirm supported his program of broadened social security. But how many took the trouble to investigate this program beyond their selfish ken?

The President takes office in an enviable position. He is beholden to no man and he has a friendly and largely grateful Democratic majority in Congress. All of which probably means that much of his legislative program will be favorably received and much of it enacted into legislation affecting each of us as individuals. In spite of this, it is unlikely that one in a hundred Americans will be sufficiently concerned as to read this book or the material which it contains as it appears in the press, on the radio and in magazines.

The Truman Program is not entertaining reading. It is verbose, dull and full of campaign oratory. Nonetheless, it outlines in some detail much of the major legislation that will be presented in the 81st Congress. The material has been arranged by subject matter so that the administration's view on a given subject may be readily ascertained. One notable omission from the soldier's point of view is the absence of any comment on the President's National Defense proposals—one of the current "hot potatoes."

A wag has suggested that although this volume may not become a best seller, it stands a good chance of making the "required reading" list in Republican headquarters. It tells how to "give 'em hell" by the numbers.—ROBERT F. COCKLIN.

Roosevelt Letters

F.D.R.: HIS PERSONAL LETTERS. Volume II—1905-1929. Edited by Elliott Roosevelt. Foreword by Eleanor Roosevelt. Duell, Sloan & Pearce. 674 Pages; Illustrated; Index; \$5.00.

There were no indifferent feelings about Franklin D. Roosevelt. People either loved him or detested the mention of his name. But even his detractors were forced to admit his greatness. A toast by William Allen White, a staunch Republican, succinctly summed up the opposition point of view when he said, "We, who hate your gaudy guts, salute you." The fullness of F.D.R.'s stature remains for history to record, but we are fortunate indeed to have a wealth of material from which to make our own estimates.

Much of the filmy grandeur surrounding Washington and Lincoln has been stripped away by the patient work of historians. We have come to realize that these sainted figures are not without human failings and that they have been credited with much more than was their just due. But all of this has taken decades of diligent digging on the part of historical scholars and still their portraits are not complete. Franklin Delano Roosevelt was of our generation, and it is gratifying to see so much detailed information being made available about him before it has had time to become lost or buried.

The Roosevelt family has made a remarkable contribution to history by releasing the personal correspondence of F.D.R. These letters were not written for public consumption, and consequently present an historical figure stripped of any pomp or reticence. Volume II is much more interesting reading than Volume I was. We see the development and formative years of Roosevelt, the man

No Place To Hide

By DAVID BRADLEY

NO PLACE TO HIDE is the story of what an atomic bomb can do to ships, or water, or land, and to human beings. It was written by a man who acted as radiological monitor at the Bikini tests—a man whose business it was to measure the radioactivity which was left after the bomb had exploded.

Some people are wondering why the Navy is towing battleships out to sea and sinking them by gunfire. David Bradley tells why—quietly and effectively.

After the underwater explosion at Bikini, every tarred seam, every painted deck, every hull was broadcasting a warning of ugly death. The water of the lagoon, the floating oil slick, the sand of the bottom, the coral and rocks radiated destruction. And even after shorter-lived radiation faded the menace of free plutonium remained—the most insidious poison known, the most difficult to detect.

The persistent power of the bomb after it has exploded is its greatest menace. One bomb could spread contamination over the mightiest seaport—and render it uninhabitable for years, perhaps forever. "The problem of decontaminating the total surface of a battleship or the brick and cement of a future Hiroshima remains practically insoluble."

\$2.00

ANTI-AIRCRAFT JOURNAL

631 Pennsylvania Avenue, N.W.
Washington 4, D. C.

**NOW you can get—
in ONE package—
BOTH sides of the fight—**

CORAL AND BRASS



By GENERAL HOLLAND M. SMITH, USMC

The vitriolic memoirs of "Howlin' Mad" Smith, including his own story of the 27th Division on Saipan.

\$3.00

and

The History Of The 27th INFANTRY DIVISION

By EDMUND G. LOVE

Official historian with the 27th Division, author of "Smith vs. Smith" in the November *Infantry Journal*, author of the story of Saipan which appeared in the *Saturday Evening Post*.

\$10.00

Order from

ANTIAIRCRAFT JOURNAL

631 Pennsylvania Avenue, N.W.
Washington 4, D. C.

and master politician. His experiences during these years carry the emotional impact of a lifetime, and yet this volume concludes with his election as Governor of New York in 1928.

The year 1910 marked the entry of F.D.R. into politics, in a victorious contest for State Senator in New York. He gained early prominence by his successful opposition to a Tammany-chosen candidate for national Senator. Heading a group of young Liberals, he successfully eliminated the original Tammany man and forced a compromise candidate.

By far the greater part of the book is devoted to the years as Assistant Secretary of Navy under Josephus Daniels, which embraced the era of World War I, a period which gave Roosevelt his education in national politics and markedly advanced his own political prominence. The book also covers the unsuccessful candidacy for Vice President with James M. Cox as his running mate, the tragic struggle with infantile paralysis, and his refusal to run for office until he was finally prevailed upon by Al Smith to enter the New York gubernatorial contest of 1928, and his success in this election which started his political star on its ascendancy.

These letters make an absorbing volume aside from their historical importance.—ROBERT F. COCKLIN.

JANE'S FIGHTING SHIPS, 1947-48.

Edited by Francis E. McMurtrie. The Macmillan Company, 1948. 498 Pages; Illustrations; \$20.

This fiftieth anniversary issue of *Jane's Fighting Ships* is one of the best. Much special matter has been added which will make it of particular interest to the naval student. A short history traces the development of the book from the first issue in 1897, and gives a summary of the career of Fred T. Jane, that remarkable man who founded the book. All the facts known about the monstrous Japanese warships of the *Yamato* class—the biggest ever built—are set forth with very interesting action photos. Some notes on the changes in general appearance of warships, illustrated by silhouette sketches, trace the development of ironclads from 1860 to 1945. A special index lists the more important ships that have been recorded in the fifty editions. The main body of the book contains intimations that the Japanese fleet is about to rise like a phoenix, and a sharp parallel is drawn between it and the German fleet after World War I. Much fresh information, and over fifty new photographs, have been included on the Soviet Navy. Many new technical advances are listed, and

in general the material has been brought up to date in the thoroughly dependable manner so characteristic of *Jane's*. All in all, this anniversary issue is an outstanding volume—R. G. McC.

U. S. CAMERA, 1949. Edited by T. J. Maloney. U. S. Camera Publishing Corporation, 1948. 392 Pages; Illustrated; \$6.50.

Editor Maloney has selected an impressive collection of photographs for this year's *U. S. Camera* annual. The book is divided into two sections, one for the year's best salon photographs and a second for the year's best news photographs. Many of the editor's choices for his salon section are open to question, although the best of them are magnificent, but the news pictures he has selected show clearly that in this field the camera reigns supreme. I think that the photographer who deliberately sets out to achieve a work of art has less chance of succeeding than the artist in any other media, but the photographer who catches on his plate a piece of the drama of the world we live in has achieved artistic expression beyond the wildest dreams. *U. S. Camera, 1949* shows this with striking clarity.—O. C. S.

THE PORTABLE SHERWOOD ANDERSON, THE PORTABLE VOLTAIRE, THE PORTABLE THORSTEIN VEBLÉN, THE PORTABLE DANTE, THE PORTABLE SWIFT, THE PORTABLE HAWTHORNE, THE PORTABLE CHARLES LAMB. The Viking Press, Inc. \$2.00 each.

This series of anthologies, now numbering some fifty volumes, has sometime since become a valuable addition to great writings for American readers. Each volume contains an introduction by a critic or other authority of standing and 500 to 600 pages of the writer's works. There is usually one major full-length book of the writer, selections from other books, from shorter works, and from his more notable letters. I assume that the series will be continued indefinitely and that it will eventually include practically all major writers of the world, past and present. But as it stands today the Portable Library already gives a wide choice from works, some of which are no longer in print.

The first of this series was *As You Were*, a wartime reader for men in war and the people working behind them. It was edited by Alexander Woollcott and it was one of the last literary chores carried out by that notable commentator, ham actor, and tear-jerking writer of

moving scenes from the lives of the famous. And he did a swell job of selection. *As You Were* is still a first-rate buy for the military reader.—G. V.

THE WAR WE LOST: YUGOSLAVIA'S TRAGEDY AND THE FAILURE OF THE WEST. By Constantin Fotitch. New York; The Viking Press. 1948. 344 Pages; \$3.50.

A whole shelf full of books about Yugoslavia has appeared since World War II—most of them by American and British authors who were on the outside looking in, or trying to look in. Now there is an authoritative report on current Yugoslav history by the Yugoslav ambassador to the United States from 1935 to 1946. Mr. Fotitch views with skepticism the break between Tito and the Cominform. He says that there is nothing new in rifts among Communist leaders. Tito may, if he can stay out of Moscow, escape the fate of Bukharin, Zinoviev, Trotsky and other heretics to the dominant Communist dogma. But the United States must not again be misled into throwing their strength back of Tito. The United States must hold "its position as a defender of moral principles and of democracy." American prestige, so upheld, may eventually help in the overthrow, not only in Yugoslavia but also in other oppressed nations, of ruthless, dictatorial regimes.—P. W. M.

THE HOLLOW OF THE WAVE. By Edward Newhouse. William Sloane Associates, Inc., 1949. 318 Pages; \$3.50.

This story of a liberal millionaire publisher who believed so firmly in freedom of opinion that he lost his own business to Communist sympathizers—this isn't an exaggeration of life—has a smooth style and a special interest for the military reader in that the last third or more of the story lies in the postwar Army. Mr. Newhouse's army is no distortion whatever of the Army as it is, and his publishing backgrounds are equally accurate.—G. V.

FOOTLOOSE IN FRANCE. By Horace Sutton. Rinehart & Company. 382 Pages; Illustrated; Index; \$4.00.

Whether you want this book or don't, depends on what you want to know about France. If it is the hot spots, the gambling casinos, the popular bathing beaches, the best hotels and the high price restaurants for gourmets you are interested in, then here is your guidebook. It will tell you how to get there, what you will find, how much it will

cost, and all about international big shots you will see on the promenade. It even mentions the points of historic interest that a tourist might want to visit on a conducted tour. If you are interested in the way of life of the French suburbanites or the French farm families; if it is the charm of wayside taverns on back roads you remember best from invasion times; if you have a nostalgic yearning to visit again with the friendly folk you met during the war all the way from Valognes to Metz—then you may be disappointed because you won't find them in this book.—P. W. M.

Histories With Current Impact

THE UNITED STATES ARMY IN WORLD WAR II. THE ARMY GROUND FORCES: THE PROCUREMENT AND TRAINING OF GROUND COMBAT TROOPS. By Robert R. Palmer, Ben J. Wiley and William R. Keast, of the Historical Section, Army Ground Forces. Historical Division, Department of the Army, Washington, D. C., 1948. 663 Pages; Index. Government Printing Office, \$4.50.

By Colonel W. S. Nye, Field Artillery

This second published volume of the official history of the late war has extreme timeliness and value because of the current Army expansion program. It is to be hoped that it has been brought to the attention of all officials charged with making high-level decisions. It should be studied also by individuals and agencies engaged in the procurement, classification, distribution and training of personnel in the Army.

It would be impossible to review the entire book in a few words by doing other than listing the topic headings. It seems preferable, therefore, to discuss in detail only the subject matter of the first section; namely, the procurement of enlisted personnel. The reader is urged to give equally close study to the remainder of the work.

In 1942 the Army received personnel generally of poorer quality than the other armed forces. And in the Army itself, the combat arms in turn received the bulk of the substandard inductees. For this there were various reasons, at least one of which has not been widely understood. After World War I, possibly as a result of imperfect classification and assignment procedures used therein, there was a general urge to adopt more scientific methods should a new emergency arise. One of the keenest criticisms of the Army has been that it did not make proper use of occupational skills held by prospective citizen soldiers. Consequently, in 1940 and 1941, even be-

The Civil War ORDEAL BY FIRE

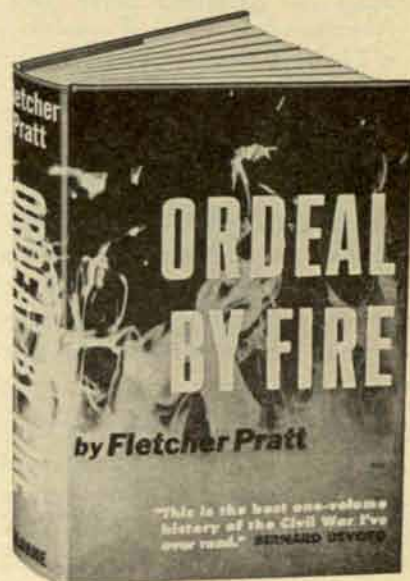

By Fletcher Pratt

Here, in countless details, flashes of insight, and penetrations of character, the whole flaming story of the Civil War comes to life and into focus. *ORDEAL BY FIRE* gives the reader a complete understanding of the logic of those years of fighting by studying the characters of men such as Hooker, Thomas, Sherman, Grant and Lee.

"The best one-volume history of the American Civil War."

Bernard DeVoto

\$5.00

CRUSADE IN EUROPE

A Personal Account of World War II

By GENERAL OF THE ARMY
DWIGHT D. EISENHOWER

Dwight Eisenhower held the reins over one of the most unruly teams in history. He forged a half-dozen nations and peoples into a powerful and effective army. He directed the greatest campaign of all history. *CRUSADE IN EUROPE*, his own personal story of the war in Europe, is available for immediate shipment.

\$5.00

Order from

ANTI-AIRCRAFT JOURNAL

631 Pennsylvania Avenue, N.W.
Washington 4, D. C.

The Medal of Honor of the United States Army

Here is the complete history of the Medal of Honor in the United States.

Here is the story of 172 years of combat—a story told the hard way in terms of the men whose gallantry beyond the demands of duty won the highest recognition which the United States could give them.

These are brief, pointed stories of sheer courage ranging from the first award made in the Civil War to Private Francis Donald, Company A, 11th New York Infantry, to Gus Kefurt, Staff Sergeant, Company K, 15th Infantry, in World War II for two days of brilliant, savage fighting which culminated when "he refused to be evacuated, but, during several more counterattacks moved painfully about under intense small-arms and mortar fire stiffening the resistance of his platoon by encouraging individual men and by his own fire until he was killed."

Beautifully bound, beautifully printed, THE MEDAL OF HONOR is an official publication of the Department of the Army, includes photos of Medal of Honor winners of World War II, lists of persons who have won the Medal of Honor, broken down by wars and campaigns, by last names, states from which they entered service, and an appendix listing the decorations and service medals of the Army, and the number of Medals of Honor won in each campaign fought by the Army.

\$4.50

Order from

ANTIAIRCRAFT JOURNAL

631 Pennsylvania Avenue, N.W.
Washington 4, D. C.

fore the United States was actually in the war, a new system was developed whereby men were to be classified by physical and mental capability and also according to occupational skills. This was undoubtedly a great step forward. Some inequities occurred during the implementation, however, which possibly could not have been foreseen. The net result was serious—almost calamitous—to the actual fighting units of the Army.

"Classification and Assignment by Physical Capacity," according to Dr. Palmer's opening chapter, "was very broad. For induction, detailed and fairly high physical standards, including psychiatric standards, were prescribed. Once in the Army, men were classified on simple lines. Whereas the British and German armies recognized several grades of physical capacity, according to muscular strength, endurance, agility, coordination, and other criteria, and assigned men to positions making corresponding demands on physique; the United States Army recognized only one category of general service and one category of limited service. In 1943, limited service was abolished as a category in classification."

Dr. Palmer's study points out that this system worked out less than perfectly in practice. Even today assignment agencies are handicapped by the exclusive use of "general service" as a means of physical classification. In effect the Surgeon General has placed the burden on assignment agencies of deciding where and how certain physically substandard personnel (particularly officers) may be utilized. This sometimes poses fine questions as to the American principle of preserving human rights.

"Classification by Mental Capacity," Palmer continues, "was more precise. For this purpose inductees were given an Army General Classification Test (AGCT) designed to measure the ability to learn. Numerical scores were grouped into five classes of which Class I represented men of the highest intelligence and Class V the lowest. To qualify as an officer candidate a man had to fall into Class I or II. Other things being equal (which they were not), all arms and services were to receive the same proportionate distribution of men in the five AGCT classes."

The third method of classification, namely by occupational skills, had been widely publicized prior to 1942 in an effort to make compulsory service more palatable. So much emphasis had been placed on this method that the satisfaction of the hopes of the prospective inductee that his civilian skills would be properly utilized was deemed an impor-

tant morale factor. Hence, occupational classification, though not adapted primarily to the needs of the combat arms, was, nevertheless, the main basis of assignment. The War Department was aware that civilian vocation was not, in itself, an adequate basis for military assignment. The trouble was that no definite means had been developed to determine a man's potentialities as a fighter or as a combat leader. The net result was that men being established in trades or skills in civilian life tended to be assigned to the noncombat elements of the Army. The loss of civilian skills to the ground arms was of slight importance since most military skills had to be learned after induction; but the loss of the type of men who had acquired skills in civilian life left the ground arms with a subaverage portion of the available manpower.

In addition, the Army Air Forces, the Army Specialist Training Program, and many of the Army Service Forces were given heavy preference in the assignment of men according to intellectual capacity. For the six months preceding 1 March 1942, the Army average of men assigned by AGCT scores was below the general average for the armed forces, and that of the combat arms was below the average for the Army. One might expect that the two artilleries, on account of their need for technicians to operate survey, meteorological, fire-control, and communication equipment, in addition to numerous types of motor vehicles and complicated weapons, might expect to receive at least the average accorded the combat arms. Such was not the case. The Field Artillery received the poorest men (i.e., the fewest Class I, II and III, and the most Class IV and V), and the Coast Artillery (AAA) was next to the bottom.

	Class I	II	III	IV & V
Ground Force				
Average	6.9%	26.8%	31.1%	35.2%
Field Artillery	6.3%	25.9%	31.2%	36.6%

During the next six months the relative position of the combat arms deteriorated still further. It remained unfavorable until late in 1944 when many thousands of air cadets and ASTP men were transferred to the ground arms in a belated effort to remedy a desperate situation. This occurred too late to raise the standard of the fighting units, for the new men didn't get much farther than the "repple depples" before the war was over.

"Another remedy tried was the Infantry Program, which gave Infantry in combat somewhat better pay and a badge which became a coveted honor. Another was the Physical Profile system. Although it was adopted too late and ad-

ministered too loosely to produce decisive results, it pointed out a direction in which a solution for the problem of pre-selecting men suitable to the needs of the ground forces might be found. A solution for the problem of assigning to the ground forces men with adequate combat qualifications will continue to be a matter for national concern until ground combat can safely be eliminated from calculations in regard to war."

These and other important matters are set forth in the first 86 pages of the book. The remainder is devoted to equally vital topics: Procurement of officers, the provision of enlisted replacements, the operation of the service schools, the training of officer candidates and enlisted replacements, the building and training of infantry divisions and nondivisional units, the preparation of units for overseas movement, and redeployment training.

As the titles indicate, these topics are of keen interest, particularly at the present time. The portions dealing with training do not appear to be exhaustive, some important phases such as the maneuvers

being treated rather skimpily. I did not altogether like the arrangement of material in this part of the volume; but perhaps that stemmed from the impossibility of treating, either purely topically or chronologically, subjects which are interrelated and occur simultaneously. The book as a whole, like the first published volume, is of great value as a reference and a text, but is not to be regarded as light reading.

Reprinted *Field Artillery Journal*.

↑ ↑ ↑

New Books

FOR DOCTORS ONLY. By Dr. Francis Leo Golden. Frederick Fell, Inc. 273 Pages; Illustrated; \$2.95. A collection of humorous stories with a medical twist.

THE EMBERS STILL BURN. By Ira A. Hirschmann. Simon & Schuster. 272 Pages; \$3.00. A report critical of our easy policy in Germany.

TRIAL AND ERROR. By Chaim Weizmann. Harper & Brothers. 498 Pages; Index; \$5.00. The Autobiography of Chaim Weizmann, First President of Israel.

THE GERMANS ON TRIAL. By Heinz Lunau. Storm Publishers. 180 Pages; \$2.50. A frankly pro-German plea by a German who arrived in the United States in 1940 and was naturalized in 1947.

THE WAR OF 1812. By Francis F. Beirne. E. P. Dutton & Company. 410 Pages; Maps; Index; \$5.00. The "inside" story of what the British call "that unfortunate little war." The author is Associate Editor of the Baltimore *Evening Sun*, widely known under the name of Christopher Billopp.

THE LAW OF THE SOVIET STATE. By Andrei Y. Vishinsky. The Macmillan Company. 749 Pages; Index; \$15.00. The university and law school textbook of Soviet administration and constitutional law.

THE TAX DODGERS. By Elmer L. Irey as told to William J. Slocum. Greenberg, Publisher. 288 Pages; \$3.00. How the T-men caught up with the evaders.

ENEMIES OF PROMISE. By Cyril Connolly. The Macmillan Company. 265 Pages; Index; \$4.00. A reissue of a 1938 book by the editor and founder of *Horizon*, the English literary monthly.

THREE NEW WORLD WAR II OFFICIAL HISTORIES

Compiled and published by the Historical Division Department of the Army, these three long awaited volumes form an integral part of any military library.

The War in the Pacific

OKINAWA: THE LAST BATTLE

By

Roy E. Appleton, James M. Burns, Russell A. Gugeler and John Stevens with Complete Photos and Maps. Price \$6.00.

The Army Ground Forces

THE PROCUREMENT AND TRAINING OF GROUND COMBAT TROOPS

By

Robert R. Palmer, Bell I. Wiley and William R. Keast of the Historical Section Army Ground Forces. Price \$4.50.

The Army Ground Forces

THE ORGANIZATION OF THE GROUND COMBAT TROOPS

By

Kent Roberts Greenfield, Robert B. Palmer and Bell I. Wiley of the Historical Section Army Ground Forces. Price \$3.25.

Order from

Antiaircraft
JOURNAL

631 Pennsylvania Avenue, N.W.

Washington 4, D. C.

BOOKS — MANUALS

The books listed here are available for prompt shipment. Titles preceded by a star (*) can be purchased only by members of the armed forces.

BEST SELLERS

Fiction

Command Decision (Haines)	2.50
Heart of the Matter	3.00
Lord Hornblower (Forester)	2.50
Raintree County	3.95
Rhubarb (Smith)	2.00
Tales of The South Pacific (Michener)	3.00
Woman With a Sword	3.00

Non-Fiction

Art of Plain Talk	2.50
Age of Jackson (Schlesinger)	5.00
Civilization on Trial (Toynbee)	3.50

Company Commander (MacDonald)	3.00
The Egg and I (MacDonald)	2.75
Goebbels' Diaries	4.00
I Chose Freedom (Krivchenko)	1.49
Iron Curtain (Gouzenko)	3.00
Lo, the Former Egyptian (H. Allen Smith)	2.00
Marshall—Citizen Soldier (Frye)	3.75
Men Against Fire (Marshall)	2.75
On Active Service (Stimson, Bundy)	5.00
The Plotters (Carlson)	3.50
The Price of Power (Baldwin)	3.75
Soldier's Album	5.00
Struggle for the World (Burnham)	3.00
Together (Marshall)	3.50
Tour of Duty (Das Passos)	3.00
World Communism Today (Ebon)	5.00

WORLD WAR II

The Big Picture

Dark December (Battle of the Bulge) (Merriam)	3.00
Fighting Divisions (Kahn & McLemore)	2.50
Industry—Ordnance Team (Campbell)	5.00
I Saw Poland Betrayed	3.50
Iron Out of Calvary (Hall)	4.00
The Lost War (Kato)	2.75
Operation Victory (de Guingand)	3.75
Paper Bullets (Margolin)	2.50
1939 to 1943—Report on the Army (Gen. Marshall)	
Cloth edition 1.50. Fighting Forces edition25
1943 to 1945—General Marshall's Report	
Fighting Forces edition25
Map supplement	1.25
Secret Missions (Zacharias)	3.75
Secret Session Speeches of Winston Churchill	2.00
Selected Speeches and Statements of General	
of the Army George C. Marshall	
Cloth edition 2.75. Fighting Forces edition25
Sub Rosa (Alsop and Broden)	2.50
12 Months That Changed the World (Lesueur) ..	3.00
The War As I Knew It (Patton)	3.75
The War Reports (Marshall, King, Arnold)	7.50
World War II (Shugg and DeWeerd)	3.75

Air Forces in Action

Air Forces Reader (Carlisle)	3.75
Our Fighting Planes (Kinert)	3.75
Target Germany (VIII Bomber Command)	1.00
Thirty Seconds Over Tokyo (Lawson)25
War in the Air, 1939-41 (Barnett)	3.50

CBI Theater

Burma Surgeon (Seagrave)	
Cloth edition 3.00. *Fighting Forces edition25
Merrill's Marauders (Official)40
Thunder Out of China (White & Jacoby)	3.50

European Theater

Armies on Wheels (Marshall)	2.50
Bastogne: The First Eight Days (Marshall)	3.00
Battle of The Atlantic (Morrison)	6.00
Blitzkrieg: Armies on Wheels (Marshall)25
Brave Men (Pyle)	1.49
Defeat in The West (Shulman)	4.50
Eisenhower's Report (6 June 44-8 May 45)	1.00
48 Million Tons to Eisenhower (Leigh)	2.00
From the Volturno to the Winter Line (Official)35
Modern Battle (Thompson)25
My Three Years With Eisenhower (Butcher) ..	5.00
New York to Oberplan (101st Inf.) (Hardin) ..	2.50
Normandy to the Baltic	5.00
Omaha Beachhead (WD Historical)	1.75
Purple Heart Valley (Bourke-White)	3.00
Saint Lo (Official)	1.25
Solerno (Official)60
The Stilwell Papers	4.00
The Last Phase (Millis)	2.50
The Six Weeks War (Draper)	3.00
Tank Fighter Team (Gerard)	1.25
Top Secret (Ingersoll)	3.00
Up Front (Mauldin)	1.00
Volturno35

North African Theater

Artist at War (Biddle)	3.50
The Battle is the Pay-Off (Ingersoll)	
Cloth edition 2.00. Fighting Forces edition25
One Continent Redeemed (Ramsey)	2.50
Operation in North African Waters	6.00
Pipeline to Battle (Rainier)	
Cloth edition 2.50. Fighting Forces edition25

Pacific Theater

Admiralties40
The Assault (Marines on Iwo Jima)	2.50
Bridge to Victory (Handleman)	2.00

To ORDER ANY BOOK

listed in this book list

HANDY ORDER FORM

CUT OUT AND MAIL

ANTI-AIRCRAFT JOURNAL
631 Pennsylvania Avenue, N.W.
WASHINGTON 4, D. C.

Please send the following books:

.....

.....

.....

.....

.....

.....

I enclose \$.....

Send bill to Company Fund,

Name (Please print)

Please charge to my account.

Name (Please print)

(Address or box number)

(Town or APO)

(Postal zone)

(State)

LET US DO YOUR ENGRAVING

The Journal is equipped to handle all your engraving requirements.

All orders receive our immediate attention and will be mailed out about three weeks after receipt of your order.

Please make your selection from styles shown.

Lieutenant and Mrs. Luke Allen Murdock

HAND SHADED ANTIQUE

Mrs. Laurence Bennett Garland

SHADED MODIFIED ROMAN

Mrs. John Clinton Reese

LINED MODIFIED

Mr. and Mrs. Michael Peter Davis

ARTISAN

Mr. and Mrs. Robert Lewis Carroll

BLACK ANTIQUE ROMAN

MR. CHARLES MATTHEW HOWARD

MEDIUM GOTHIC

MR. MICHAEL RICHARD ENDICOTT

LIGHT ROMAN

Mary Ruth Murdock

ELONG ROMAN

Mr. and Mrs. John Howard Trumbull

ITALIC SCRIPT

Mr. and Mrs. Carl Gordon Sills

COLONIAL SCRIPT

Mr. and Mrs. Richard George Harding

CAROL TEXT

Mrs. Carlton John Farrell

BELVEDERE

Mrs. James Nelson Carroll

ST. JAMES SCRIPT

Mr. and Mrs. Harold Russell

ENGLISH SCRIPT

Mrs. Helen Smith Kimball

ST. MORITZ

Mrs. Eric Gunnar Oldfield

SPENCERIAN SCRIPT

Military Cards (3 lines)

100 cards with new plate	\$6.75
100 cards with your plate	2.70
100 additional cards (either plate)	1.80

Visiting Cards (1 line)

100 cards with new plate	\$4.05
100 cards with your plate	2.70
100 additional cards (either plate)	1.80

Informals (1 line)

100 cards with new plate	\$5.35
100 cards with your plate	4.45
100 additional cards (either plate)	3.15

Birth Announcements

(1 card type)

50 cards with new plate	\$7.65
100 cards with new plate	9.00
50 additional sets	3.15

(2 card type—ribbon tied)

50 cards with new plate	\$10.80
100 cards with new plate	13.50
50 additional sets	4.50

Wedding Announcements or Invitations

50 sets (7 lines only)	\$18.00	100 sets (7 lines only)	\$19.80
50 sets (9 lines only)	19.80	100 sets (9 lines only)	21.60
additional sets of 50	\$3.60		

Reception or At Home Cards

50 sets (4 lines only)	\$8.10	100 sets (4 lines only)	\$9.00
additional sets of 50	\$1.80		

All prices include envelopes when appropriate.

Quotations will be forwarded on request for any social engraving not listed here.

ORDER FROM

Antiaircraft Journal

631 Pennsylvania Avenue, N.W.

WASHINGTON 4, D. C.

Now Available in Book Form

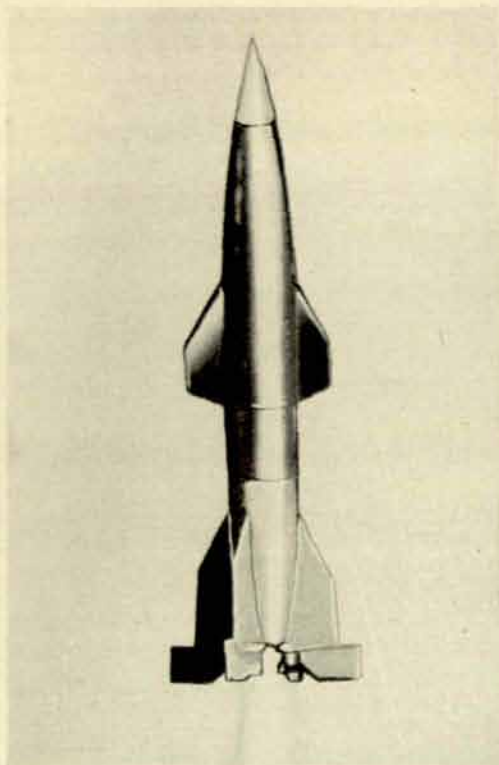

Dictionary of Guided Missile Terms

No one who has any interest in the latest military developments can afford to be without this invaluable Dictionary. It's a must book for every military man who wants to keep abreast of the terminology in this increasingly important field.

The definitions in this Dictionary have been carefully selected to provide an easily accessible reference for the meanings of technical and specialized terms which are in current usage.

Included in the Dictionary are definitions of terms in the following categories:

1. New words coined for the guided missile art.
2. Words in general usage but with different meanings when applied to guided missiles.
3. General technical terms related to the guided missile field.

The "Dictionary of Guided Missile Terms" is available to the readers of the Journal at \$1 a copy for the cardboard edition and at \$2 for the clothbound edition.

Order today from

Antiaircraft
JOURNAL

631 Pennsylvania Avenue, N.W.

WASHINGTON 4, D. C.