

# COAST ARTILLERY JOURNAL



*Photo by U. S. Army Signal Corps.*

ARTILLERY OBSERVATION POST, FRANCE.

JULY-AUGUST, 1934

# Report Documentation Page

Form Approved  
OMB No. 0704-0188

Public reporting burden for the collection of information is estimated to average 1 hour per response, including the time for reviewing instructions, searching existing data sources, gathering and maintaining the data needed, and completing and reviewing the collection of information. Send comments regarding this burden estimate or any other aspect of this collection of information, including suggestions for reducing this burden, to Washington Headquarters Services, Directorate for Information Operations and Reports, 1215 Jefferson Davis Highway, Suite 1204, Arlington VA 22202-4302. Respondents should be aware that notwithstanding any other provision of law, no person shall be subject to a penalty for failing to comply with a collection of information if it does not display a currently valid OMB control number.

1. REPORT DATE <b>AUG 1934</b>		2. REPORT TYPE		3. DATES COVERED <b>00-07-1934 to 00-08-1934</b>	
4. TITLE AND SUBTITLE <b>The Coast Artillery Journal. Volume 77, Number 4, July-August 1934</b>				5a. CONTRACT NUMBER	
				5b. GRANT NUMBER	
				5c. PROGRAM ELEMENT NUMBER	
6. AUTHOR(S)				5d. PROJECT NUMBER	
				5e. TASK NUMBER	
				5f. WORK UNIT NUMBER	
7. PERFORMING ORGANIZATION NAME(S) AND ADDRESS(ES) <b>Coast Artillery Training Center, Coast Artillery Journal, Fort Monroe, VA, 23651</b>				8. PERFORMING ORGANIZATION REPORT NUMBER	
9. SPONSORING/MONITORING AGENCY NAME(S) AND ADDRESS(ES)				10. SPONSOR/MONITOR'S ACRONYM(S)	
				11. SPONSOR/MONITOR'S REPORT NUMBER(S)	
12. DISTRIBUTION/AVAILABILITY STATEMENT <b>Approved for public release; distribution unlimited</b>					
13. SUPPLEMENTARY NOTES					
14. ABSTRACT					
15. SUBJECT TERMS					
16. SECURITY CLASSIFICATION OF:			17. LIMITATION OF ABSTRACT	18. NUMBER OF PAGES	19a. NAME OF RESPONSIBLE PERSON
a. REPORT <b>unclassified</b>	b. ABSTRACT <b>unclassified</b>	c. THIS PAGE <b>unclassified</b>			

# Gunners' Instruction



THE COAST ARTILLERY JOURNAL announces that it has issued a complete series of new and thoroughly up-to-date GUNNERS' INSTRUCTION PAMPHLETS for all branches of the Coast Artillery, covering the requirements for qualification as set forth in Training Regulations 435-310 (Examination for Gunners).

---

NUMBER	GUNNERS' INSTRUCTION PAMPHLETS	PRICE
I.	2nd Class Gunner, Antiaircraft Artillery (Except Searchlight Btry.) . . .	\$0.75
II.	2nd Class Gunner, Antiaircraft Artillery (Searchlight Btry.) . . . . .	0.50
III.	1st Class Gunner, Antiaircraft Artillery (Except Searchlight Btry.) . . . .	0.65
IV.	1st Class Gunner, Antiaircraft Artillery (Searchlight Btry.) . . . . .	0.40
V.	2nd Class Gunner, Fixed Seacoast Artillery (All Units) . . . . .	0.55
VI.	1st Class Gunner, Fixed Seacoast Artillery (All Units) . . . . .	0.50
VII.	2nd Class Gunner, Mobile Seacoast Artillery (All Tractor-Drawn and Railway Units) . .	0.75
VIII.	1st Class Gunner, Mobile Seacoast Artillery (All Tractor-Drawn and Railway Units) . .	0.75
IX.	Expert Gunner, Antiaircraft Artillery . . . . .	1.25
X.	Expert Gunner, Fixed Artillery . . . . .	1.00
XI.	Expert Gunner, Mobile Seacoast Artillery . . . . .	1.25
XII.	Submarine Mining . . . . .	1.50

---

All Pamphlets are now available. They cover the instruction of all 2nd Class, 1st Class, and Expert Gunners of Antiaircraft, Fixed and Mobile Artillery.

These pamphlets are invaluable for the training and instruction of Coast Artillery personnel. Each enlisted man of a submarine mine detachment should have a copy of "Submarine Mining"

The above prices are retail (postpaid) for single copies. On orders for 10 or more copies we allow a discount of 10% (postpaid).

*To ORGANIZATIONS of the military establishment a discount of 20% will be allowed on any order regardless of number. F.O.B. Washington, D. C.*

## The Coast Artillery Journal

1115 17th St., N. W.

Washington, D. C.

# THE COAST ARTILLERY JOURNAL

Member Affiliated Military Magazines

Published as the Journal of the U. S. Artillery from 1892 to 1922

LIEUT. COL. E. E. BENNETT, C.A.C., Editor

VOLUME LXXVII

JULY-AUGUST, 1934

NUMBER IV

Publication Date: August 1, 1934

## Contents

Notes of the Coast Artillery Association .....	242	Mechanical AA Target .....	286
Frontispiece .....	246	By Lieutenant Courtland H. Smith.	
The Japanese Campaign in Jehol—1933 .....	247	A Safety Board .....	287
By John G. Stipler.		By Captain Edmund H. Stillman.	
Extracts from Address of Major General Hase.....	255	Expedients vs. Expense .....	289
Low Thoughts About High Fliers.....	257	By Lieutenant Louis J. Storck.	
By Lieutenant Colonel Robert P. Glassburn.		Coast Artillery Board Notes .....	291
Jungle Warfare (Part II) .....	259	Coast Artillery Activities .....	294
By Ingram Cary.		Hawaiian Separate C.A. Brigade News Letter—	
A Broadcast Hook-Up for AA Intelligence Net.....	268	Activities at Fort Mills—Calumpan Barrio—Battery	
By Lieutenant G. H. Stubbs.		Team Wins Philippine Championship—Fort Mac-	
Antiaircraft Defenses: Their Development During the War	269	Arthur Notes—Panama Canal Department News	
Machine-Gun Towers .....	275	Letter—Fort Monroe News Letter.	
By Lieutenant G. F. Heaney, Jr.		Coast Artillery Orders .....	305
More Cries from the Wilderness .....	277	The Foreign Military Press .....	307
High-Speed Target .....	281	Reviewed by Major A. L. P. Johnson.	
By Captain Riley E. McGarraugh.		National Guard Notes .....	312
Training AA Machine Gunners in Tracer Control .....	283	National Guard Publicity.	
By Major J. L. Daneker.		Reserve Notes .....	314
News and Comment .....	284	Military Training—Reserve Officers' Contact Camp—	
What the Coast Artillery Needs—Changes in Chief's		Cadet Training in Gloucester High School ROTC	
Office—More About the Coast Artillery Song—		Unit—Activities 621st C. A. (HD) Res.	
Trophy Presented to 249th C.A.		Book Reviews .....	318

THE COAST ARTILLERY JOURNAL IS NOT RESPONSIBLE FOR OPINIONS EXPRESSED IN PUBLISHED CONTRIBUTIONS

THE COAST ARTILLERY JOURNAL pays for original articles upon publication.

Published bi-monthly under the supervision of the United States Coast Artillery Association for the information of the Coast Artillery personnel of the Regular Army, National Guard and Organized Reserve.

Publication Offices, 1406 East Franklin Street, Richmond, Virginia; Editorial Offices, 1115 17th Street, N.W., Washington, D. C.

Terms: \$4.00 per year. (Coast Artillery Association members, \$3.00 per year.) Single copies, 75 cents.

Entered as second class matter at Richmond, Virginia, under the Act of March 3, 1879, for mailing at special rate of postage provided for in Section 412, Act of October 3, 1917.

Copyright, 1934 by the United States Coast Artillery Association.

# Notes of the Coast Artillery Association

## Report of Meeting of Coast Artillery Association and Extracts from Addresses of Major General Hase

THE fourth annual meeting of the United States Coast Artillery Association was held in the metropolitan area of New York City on June 8th, 9th and 10th last. New York City was selected as the place of meeting at the invitation of Brigadier General J. J. Byrne, N.Y.N.G., President of the Metropolitan Chapter. This proved to be a very happy choice for the reason that it gave visiting members an opportunity to inspect the latest anti-aircraft matériel at Ft. Totten; also, an opportunity to visit elements of the Atlantic Fleet. In addition there were the usual attractions always to be found in the metropolis. Immediately after the invitation was accepted by the Executive Council of the Association, General Byrne appointed a committee in charge of arrangements. The program worked out was unusually interesting and instructive.

The first day was devoted to an inspection of the equipment and matériel of the 62d C.A. (AA) at Ft. Totten. Guns were placed in position and all elements of the regiment were prepared for action including the communication hookup. The matériel was then inspected by Major Gen. William F. Hase, Chief of Coast Artillery; Brig. Gen. Wm. E. Cole, Commanding the 2nd Coast Artillery District; Brig. Gen. John W. Gulick, Brig. Gen. J. J. Byrne and the visiting members of the Association. Many favorable comments were heard concerning the condition and appearance of the matériel and the thoroughly businesslike and soldierly way in which the personnel functioned. As the inspection progressed brief explanatory remarks were made by officers of the 62d C.A. (AA). Following the inspection there was a

review of the troops at Ft. Totten terminating with retreat parade. Major General Hase received the review. This fully occupied the time until supper which was served to approximately 300 members and guests, the battery mess halls being utilized for this purpose. A most excellent menu was provided for the very nominal sum of 75c per person. After supper the business meeting of the Association was held. Address of welcome was made by the president and the secretary-treasurer submitted a report. Following this there was some general discussion on topics of interest to all Coast Artillerymen. Many constructive ideas were advanced; it is hoped that later they will bear fruit. After the business meeting the visitors had an opportunity to witness a searchlight demonstration while the Air Corps staged a simulated attack directed at Ft. Totten. As usual in such cases, it was difficult to obtain planes for the flying mission, the number finally dwindling to one. The day's activities were concluded with a reception in honor of General and Mrs. Hase, held in the historic Ft. Totten Club. This was followed by a dance which was thoroughly enjoyed by all. Great credit is due the commanding officer and all the personnel at Ft. Totten for the instructive demonstrations and excellent arrangements for the comfort, entertainment and convenience of members and their guests.

The forenoon of Saturday, June 9, was given over to a visit to the elements of the Atlantic Fleet then in New York harbor. This consisted of visits to battleships *New Mexico*, *West Virginia*, *Colorado* and *Wyoming* and the aircraft carriers *Lexington* and *Saratoga*. The members

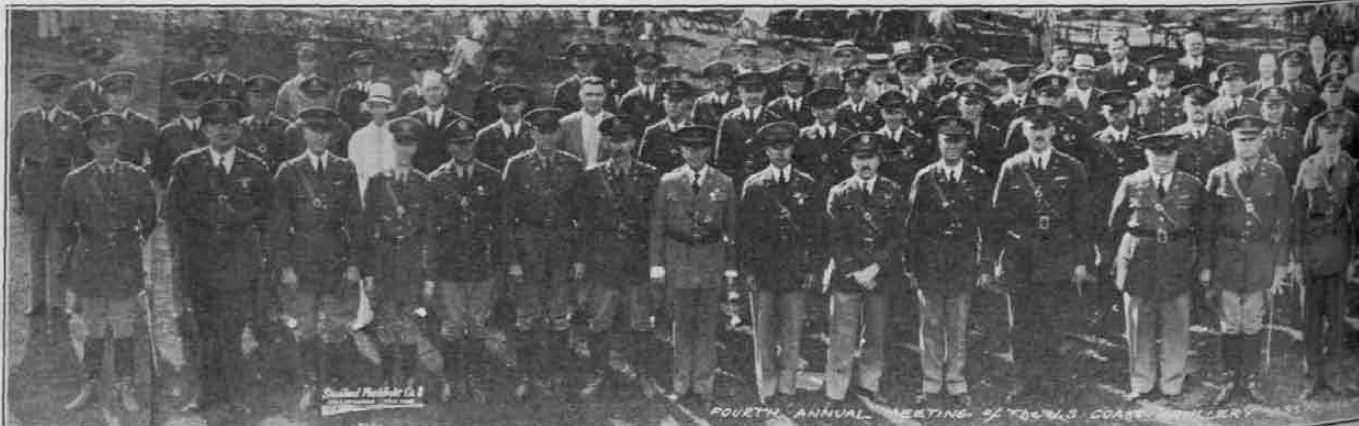

Fourth Annual Meeting of the U. S. Coast Artillery Association

were divided into small groups and conducted over the various ships by naval officers. This part of the program was most instructive and gave members an opportunity to inspect the latest in naval anti-aircraft artillery.

Saturday afternoon was the occasion of a review followed by a retreat parade participated in by the entire Coast Artillery Brigade, New York National Guard, consisting of the 211th C.A. (AA), the 244th C.A. (TD) and the 245th C.A. (HD). Major General Hase received the parade. This was an impressive sight with approximately 3,000 Coast Artillerymen participating in the formation; probably the largest number of Coast Artillery troops that can be conveniently assembled in one place within the continental limits of the United States. The troops presented a fine appearance and much credit is due Brig. Gen. J. J. Byrne and the officers of the Brigade.

On Saturday evening a banquet was held in the Builders and Employers Club, 2 Park Avenue, New York City, the guests of honor being Major General William F. Hase, Brig. Gen. William E. Cole, Brig. Gen. John W. Gulick and other distinguished guests. The meeting was presided over by Brig. Gen. J. J. Byrne who acted as toastmaster. Following the banquet, dancing was enjoyed until a late hour.

No organized activities were held on Sunday, June 10, it being considered advisable to permit members to visit the near-by points of interest, depending upon individual desires. Many availed themselves of the opportunity to visit the United States Military Academy at West Point; others enjoyed a trip to Coney Island.

Approximately 250 members of the Association assembled at Ft. Totten on the 8th and about 230 members and guests were present for the banquet. The attendance, while not as large as had been hoped for, was considered to be quite satisfactory and indicated the interest in the Association and its activities. Many expressions of approval were heard and it is anticipated that these meetings will become annual affairs.

### General Hase Speaks

MAJOR GENERAL HASE presided at the business meeting and delivered the address of welcome and greetings from the Association. Extracts from this address are as follows:

"The Coast Artillery Corps is in the midst of many important developments. It is a period when common understanding, mutual support and coöperation are essential to our well-being. The Association and its official organ, the COAST ARTILLERY JOURNAL, provide a means for keeping the membership fully informed on all important questions, thus insuring coöordinated action whenever this is necessary. While membership in the Association carries no obligation for subscribing to the JOURNAL, it should be kept in mind that the income of the Association can be increased only from the surplus revenue of the JOURNAL; also, a subscription is the best and most tangible support which you can give.

"I am fully appreciative of the loyal support given by members to the JOURNAL yet I am mindful that there is much to be desired in this respect. At the present time the membership in the Association amounts to more than 4,500. Of this number nearly 3,000, or 66%, are non-subscribers.

\* \* \*

"With the approaching end of the depression and the restoration of the pay cuts I sincerely hope that a larger number of members will become subscribers and thereby give a tangible manifestation of their support of the Association.

"It may be well to point out that the only revenue which the Association receives is the comparatively small amount of interest accruing from funds received from the JOURNAL. If and when the JOURNAL can be established on a paying basis it should show a modest profit on its business activities. Revenue accruing from this source will be converted to the Association. By this means we hope to build up a larger trust fund which will enable the Association to expand its activities and increase its usefulness.

"So far the revenues of the Association have been ex-



Totten and New York City, June 8, 9, and 10, 1934.

pended largely for the purchase of trophies awarded to the several components of the Army. It is felt that these serve a very useful purpose in stimulating interest, developing *esprit de corps*, pride in the organization, and fostering a spirit of friendly competition which is always beneficial. To date the Association has awarded six trophies, one each to the Regular Army, National Guard and Organized Reserves for the fiscal years of 1932 and 1933.

\* \* \*

"It is hoped that these meetings will become annual events and that they will be anticipated with pleasure by all members of the Association. These meetings afford an excellent opportunity to renew acquaintances, make new contracts, cement a spirit of good will and good fellowship among all components of the Army. In these respects alone they serve a most useful purpose; in addition there is the dissemination of professional information and an opportunity to witness the latest developments in matériel and technique in the Coast Artillery.

"I want to take this opportunity to assure you that it is the desire of the Executive Council to serve the members of the Association to the fullest possible extent. The Association and the COAST ARTILLERY JOURNAL are maintained and operated for your benefit and advantage. There should be no hesitancy on the part of any member in calling upon the Executive Council or the Secretary of the Association for advice or information pertaining to any of the activities of the Coast Artillery Corps. It is your organization and as such I suggest that you take the fullest advantage of its facilities; at the same time I urge you to lend your support to the Association and to take an active interest in the affairs of the local chapters. It is my earnest desire that new chapters be organized wherever a sufficient number of Coast Artillery officers are located to warrant their organization, and that those already organized be developed to the fullest extent. These chapters will provide a means of making the influence of the Association felt if and when such action becomes desirable. Civic organizations can exert a very considerable influence in either local or national affairs. This influence, because of the backing and prestige which the organization carries, is far in excess of the influence exerted by a great number of individual actions. No one can foresee when such concerted action will be needed, therefore, it is all the more important that we maintain and develop our organization in order that we can present a united front when demanded by the situation."

\* \* \*

General Hase also delivered the principal address at the banquet on Saturday evening in which he dwelt upon the mission of the Coast Artillery Corps, its past attainments, present activities and larger objectives. Extracts from this address are as follows:

"Owing to the fact that we must keep 57% of our total strength outside of the continental limits of the

United States there is left available within these limits in the harbor defense regiments of the regular Army 2,417 enlisted men. The National Guard of the Coast Artillery has an approximate strength of 4,569, or a total of 6,986. The total corresponding officer strength is 562. The requirements for the harbor defense armament and accessories now installed within the continental limits of the United States are 1,170 officers and 30,558 enlisted men, therefore there is a shortage of 608 officers and 23,572 enlisted men.

"These figures indicate that personnel requirements for our part in National Defense are great, and in a major war where our borders would be threatened, the need for the Coast Artilleryman, either seacoast or antiaircraft, would be immediate. Let us then see that every officer and soldier is a key man, trained and fitted to carry out his part in expansion, capable of imparting to others military and technical knowledge, and more important still, capable of leadership in the advanced position to which he would undoubtedly be assigned. Although our opportunities and facilities for peace-time training may at times appear meager, we must get the maximum out of these opportunities in order that we may efficiently play our part.

"Reëxamine the mission! What does it direct? That we keep the invader away from our shores and out of our territory! That we attack by fire our assailants whether approaching by air or by sea! To preserve the integrity of one's home-land is a high mission, the contemplation of which should kindle the fires of patriotism in every American!

"In order that we may obtain maximum use of our training facilities, and to avoid dispersing our small strength in the many existing harbor defenses, we have adopted the system of concentrating the bulk of our harbor defense troops in five important harbor defenses: Long Island Sound, Chesapeake Bay, Pensacola, San Francisco, and Puget Sound, and in placing in the other harbor defenses, maintenance detachments of a strength only sufficient to keep the armament and accessories in good condition. This system has been most satisfactory, and appears to be the only one practicable with our personnel.

"In order to make the best use of existing harbor defense armament to get rid of existing elements of doubtful value, thereby reducing the expense of upkeep, and to strengthen weak spots in our harbor defenses, we have frequently made detailed surveys of the condition and needs of our harbor defenses. The results of these surveys and studies are set forth in Harbor Defense Projects, which provide a systematic scheme of meeting the requirements of the defense with a proper assignment of priorities for work to be done. The final details of a recent revision of the projects are now being carried out, in so far as the planning features are concerned, and it is hoped that funds will be forthcoming to the end that we may have thoroughly modernized defenses. In determining the harbor defenses required and in working out their

needs, we have acknowledged the undesirability—in fact the impossibility—of a cordon defense, and are retaining fixed defenses only for the harbors where we visualize enemy attacks might be made under probable war conditions. Furthermore the fixed armament in the harbor defenses is being kept at a minimum, rather than in quantity sufficient to combat all possible attacks of whatever magnitude. This course can be adopted because we have at hand the means of reinforcing our defenses by mobile seacoast artillery.

“The principal elements of our mobile seacoast artillery are the 8” railway guns and the 12” railway mortars, neither of these need a prepared emplacement, as they can deliver all-round fire from the track; and the 155-mm. guns, tractor drawn, which can be traversed on the wheeled mount through 60 degrees, but which require a prepared concrete platform for a wider arc of fire, since shifting of the trail would be impracticable for uninterrupted fire on a fast moving naval target. These platforms for 155-mm. guns are simple and inexpensive, and can be put in with little delay using modern fast drying concrete. There are also a few 12” Batignolles railway guns and mounts on hand. This gun is a powerful long-range weapon which however requires an emplacement, i.e. a concrete platform, for firing in the wide arcs necessary against naval targets.

“Our more recent 3” antiaircraft guns are accurate long-range weapons capable of high rates of fire. In these respects they have been most satisfactory. Certain features affecting mobility and upkeep have not been so satisfactory. To overcome these deficiencies, the Ordnance Department has developed for us a lighter and simpler gun, on a single axle mount, which retains the desirable features of accuracy and rapidity of fire of the present standard gun.

“In our fire-control equipment, much progress has been made and we hope to have before long a simpler, less expensive director for antiaircraft guns and a suitable computer for seacoast artillery. Another recent important improvement in matériel was the development of the metal-mirror searchlight. In all our matériel development work, we are keeping particularly in mind the desirability of having matériel and equipment which can be produced rapidly and economically in case of an emergency. Our expansion will be great and our store of matériel on hand, particularly antiaircraft guns and accessories, is small.

“The world is now in such a disturbed condition, and international relations are generally so fraught with danger, that even the most pacifically inclined should feel (unless he is wholly unconcerned over the future of our country) that we should look well to our means of national defense. His concern should be with our truly defensive installations, as he visualizes expeditionary forces and military action outside our confines, as steps of aggression. Whatever the merits of the pacifists thoughts

and conclusions, it is certain that we should have at hand ample means of keeping the enemy outside our gates. Our fleet, in carrying out its mission against hostile naval forces or through being committed to action in one ocean, might leave at least part of our shores open to access by the enemy. Furthermore, necessary bases and shore installations for the Navy should be safeguarded. A repetition of the situation of the World War, when there was no possible real threat against our coast, is most unlikely.

“Our air forces, as well as our fleet, must be free to act. They can not be immobilized or dispersed for defense. They will not always be able to intercept an attacker. A believer in any form of safeguarding and insurance must recognize the necessity for antiaircraft defense and seacoast defense. As long as individuals remain what they are, we require police and fire departments. With nations what they are and as long as their vital needs are conflicting, we need national defense and armies and navies to insure it. And what can be more essential to national defense—not national aggression—than seacoast and antiaircraft defense!

“Let every agency of the Coast Artillery keep in mind our mission, know our means for carrying it out, and dispense that knowledge so that our ends may be accomplished intelligently and expeditiously. May all who are eligible endeavor to attend our schools, which best give the opportunity to increase one’s professional knowledge and keep abreast of development. Let all keep informed in a professional way through that excellent medium, the COAST ARTILLERY JOURNAL, which I consider indispensable to the interested Coast Artilleryman. And last, but not least, let us make our Association a vehicle of enthusiasm, a developer of *esprit*, which will not only incite Coast Artillerymen to greater endeavor but will also set forth and make apparent to all the need for, and the economies in, our existing system for seacoast and antiaircraft defense. Our plans are modest, our armament minimum, and so, when we read of European neighbors constructing continuous defenses on their borders, let us resolve at least to make our few vital fixed defenses effective, our mobile artillery, seacoast and antiaircraft—efficient.”

### Coast Artillery Cadet Honored

WORD has been received from the University of Illinois that the highest honors in the military department have been awarded to a member of the Coast Artillery contingent of the cadet corps, in that Cadet Colonel A. E. Lawson had been presented with a jeweled saber. It will be recalled that the University of Illinois maintains one of the largest R.O.T.C. units in the United States, therefore it is a signal honor that was bestowed upon a member of the Coast Artillery contingent.





*Battalion of 155-mm. GPF's in Firing Position, Hawaii.*

*Photo by Signal Corps, U. S. Army.*

# The Japanese Campaign in Jehol—1933

BY JOHN G. STIPLER, Massachusetts Institute of Technology

THIS account of the Japanese campaign of 1933 in Jehol covers the period between February 20th and April 22d. No attempt has been made to describe the events subsequent to the latter date and culminating in the Armistice of Tangku, May 31, 1933. We feel that though the advance on Peiping and Tienstin was the natural outgrowth of the earlier operations, it had no significance in relation to the actual conquest and defense of Jehol.

Although every effort has been made to attain accuracy in this account, no statements can be guaranteed, and confirmation of many assumptions will have to await the publication of the war diaries and records of the units engaged.

An attempt has been made to render as completely unbiased an account as possible, offering praise where praise is due without regard to personal likes or dislikes. We, of course, realize the practical impossibility of such an effort.

## THE THEATRE AND THE ACTORS

Down the western or Mongolian frontier of Jehol stretches a long mountain chain, forming a continuation of the Khingan range to the north. From these mountains a number of spurs are thrown off to the east, shelving off toward the coastal plain, while all the principal rivers of the province find their way from the network of hills and valleys thus formed into the Gulf of Chihli or some river system in Manchuria. A subsidiary range running down from the main line of mountains to Pingchuan and thence to the sea at Shanhaikwan forms a watershed between the Luan River system, which flows into the Gulf of Chihli through northern China, and the Taling Ho, which enters the Gulf of Chihli through Manchuria. Further north we have the Liao Ho, one of the great rivers of northern China, which rises in Northern Jehol to find its way to the sea by way of the central valley of Manchuria. The valleys of the last two rivers offer the principal routes of advance from the plains of Manchuria to the interior of Jehol.

There are no improved highways in Jehol, all roads being old provincial caravan or cart routes. Of these, some 205 miles have been repaired to a certain extent during the past thirty or forty years, though of course no such thing as pavement exists. The principal roads from a military point of view are shown on the map. There are no railways in Jehol, but a railhead at Paiyintala, sixty miles from Kailu in the Liao Ho valley, and another at the Peiping coal mines about thirty miles from Chaoyang in the Taling valley are of particular importance for

operations against the province. The routes leading inland from the coast are abominable and easily defended because of the numerous passes they go through in the vicinity of the watershed between the Luan and Taling Rivers.

Jehol is cut off from China proper on the south by the great wall through which are various gates or passes. Of military importance are (1) those in the Shanhaikwan-Chumenkow area; (2) those in the Chiehlingkow-Taolenkow-Lengkow area; (3) the Hsifengkow or Luan River valley area; (4) the Lowenyu and adjacent passes; and (5) the Kupeikow area.

In this vast theatre of about the size of the state of Colorado the armies of the Emperor of Japan and the feudal war lords of China were facing each other toward the middle of February, 1933. In order to consolidate her position and prepare for the invasion of Jehol, Japan in January, after a sharp action near the seaward end of the great wall, had occupied Shanhaikwan in spite of a fairly creditable but unsupported defense by Major General Ho Chu-kuo.

Preparatory to the opening of the Jehol Campaign the Nipponese distributed their forces along the border of the province from Kailu in the north to Shanhaikwan in the south, concentrating for the projected operations the following forces: Lieutenant General Nishi's 8th Division with the 4th Brigade (Suzuki) and 16th Brigade (Kawahara), about 12,000 men; Lieutenant General Sakamoto's 6th Division with the 11th Brigade (Matsuda) and the 4th Cavalry Brigade (Mogi), about 9,000 men; the 14th Infantry Brigade under Major General Hattori, about 4,000 men, or a grand total of 25,000 men. In addition the 33rd Brigade under Major General Nakamura was detached from the 10th Division at Harbin and entrusted with the defense of Shanhaikwan. Later in the campaign one additional brigade appeared on the scene under Major General Hiroga; this appears to have been the 28th Brigade of the 14th Division under Lieutenant General Gama-boku, which was not available till toward the end of March. All these forces give a total of between 35,000 and 40,000 Japanese in immediate contact with the Chinese in the Jehol area. To this should be added approximately 25,000 Manchukuo troops under General Chang Hai-ping, Chief of Staff of Henry Pu-yi the chief executive of Manchukuo.

On the Chinese side we find between 110,000 and 150,000 troops of various descriptions scattered throughout Jehol, of whom the majority are under the directions of the Chairman of the Provincial Government, General Tang Yu-lin. This general, born in Chaoyang, Jehol,

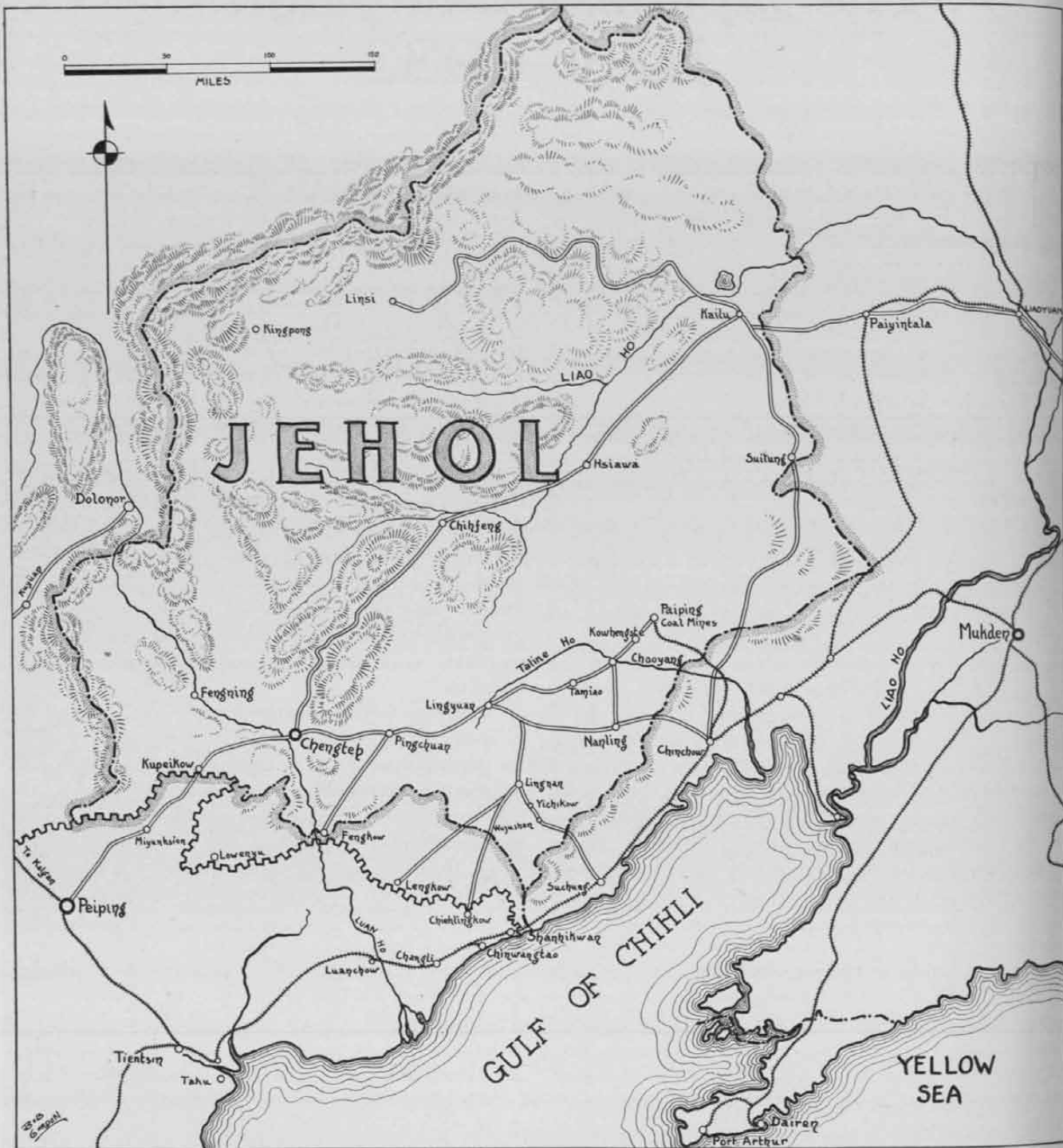

General Map of Jehol.

1871, served in various capacities under Chang Hsueh-liang and his father, Chang Tso-lin, until in 1929 he gained the office he held at the opening of the Jehol campaign. Between 1924 and 1929 he alternated between the post of military governor of Jehol and commander of a force under the Changs in the civil wars of China. During this period the worthy Tang built up a thriving opium trade and a large private fortune, the desire to preserve which led him to sign the Manchukuo Declaration of Independence, February 16, 1932. Pressure from Chang Hsueh-liang, however, brought him back to his allegiance to the Nationalist Government in time to oppose the

Japanese advance into Jehol. It was on this none too trusty instrument and his poorly trained and equipped troops that the inexperienced but sanguine "Young Marshal" depended for the defense of the province.

In addition to the forces in Jehol, Chang Hsueh-liang, who held the office of Chairman of the Peiping Branch of the National Military Council, had about 170,000 troops in Chihli Province just south of the Great Wall, while in Charhar Province and northern Chihli were some 50,000 men of the former "Kuominchun" or "People's Army" of General Feng Yu-hsiang. These troops were incomparably the best in China and were to prove

their worth again and again during the ensuing months. Unfortunately the "Young Marshal" lacked the ability of his father, and as a result the opening of the Japanese drive on February 23d found none of the forces available in a position to dispute the Japanese advance.

As a final reserve General Chiang Kai-shek, Chairman of the National Military Council and most powerful man in China, had, theoretically at least, almost a million men on which to call for service against the Japanese. Actually, however, a large number of these were absorbed in operations against the so-called communists in Kiangsi and Hupeh, while others had to watch the Cantonese Army, which, in spite of vociferous anti-Japanese proclamations from the safe distance of over a thousand miles, was only waiting the chance to drive a knife into the back of Nanking Government. As President of the Legislative Yuan at Nanking, Sun Fo failed to show any of the ability of his father, Sun Yat-sen, therefore, until the return of Wang Ching-wei from his sojourn abroad the Presidency of the Executive Yuan was poorly filled.

In short, we might compare the armies of China to the assembly of feudal French nobles called together by the unfortunate Philip VI to do battle with the highly organized and well trained forces of Edward III at Crecy. Only such princes as felt inclined led out their private contingents, and then only after driving a bargain with their King as to their share of the spoils, while still others openly joined the enemy. In this case, however, the confusion is made worse by Chiang Kai-shek's fear of Chang Hsueh-liang's resentment if he attempted in person to handle affairs in the latter's sphere of influence.

Moreover even if China succeeded in checking the Japanese advance they would have to count on the latter bringing in considerable reinforcements in the form of a brigade of the 10th Division from Harbin, the 14th Division from Tsitsihar, the 1st Cavalry Brigade from somewhere between the Chinese Eastern Railway and Mukden, and the 19th and 20th Divisions from Korea—a total of about 45,000 men which added to the 25,000 originally, concentrated on the Jehol frontier gives a grand total of approximately 70,000 Japanese. Part of these troops, however, would be required to counter the Russian menace, while still others were needed to keep order in unruly Heilunkiang and Kirin Provinces. Indeed it is significant that even before the final Japanese drive south of the Great Wall reached its climax (April 30th), a brigade was detached to Harbin.

That, then is the scene, and these the actors who are about to enter on to the wintery stage of Jehol, February, 1933.

#### THE CONQUEST OF JEHOL

On February 23d a twenty-four hour ultimatum was delivered by the Manchukuo Government to Marshal Chang Hsueh-liang at Peiping and to the Nationalist Government at Nanking demanding the withdrawal of all Chinese troops from Jehol. This appears to have been accompanied by a Japanese "aide memoire," setting forth

the Japanese position. Upon the expiration of the ultimatum on February 24th, and after the receipt of a Chinese reply expressing their refusal to comply with the Japanese demands, the Imperial forces launched their campaign.

In the meanwhile, however, the Japanese had been consolidating their position and pushing their forces forward in an effort to gain a favorable position for the rapid assumption of the offensive. Thus we find Major General Tsui Hsin-wu, garrison commander of Kailu, in Northern Jehol, and commander of the 9th (Jehol) Independent Cavalry Brigade, reporting Japanese reinforcements arriving on the Liao River, while all along the front clashes occurred on the 21st and 22d between the advancing Japanese and the would-be defenders of Jehol. But before taking up the details of the campaign let us glance briefly at the plans of the opposing commanders.

Field Marshal Nubuyoshi Muto, commander-in-chief of the Kwantung Army and in his capacity of Ambassador to Manchukuo, virtual viceroy of Manchuria, commanded in person the operations of the Japanese forces attacking Jehol. His general plan involved (1) holding the Chinese immobile on the Shanhaikwan front, while (2) a brigade pushed up the Suichung-Lingnan-Lingyuan Road, (3) another force attacked Nanling and pushed on toward Lingyuan, (4) the main force captured Chaoyang, finally to push on to Chengteh, the provincial capital, and (5) a force, after turning the enemy line stretching north from the Great Wall to beyond Chaoyang, advanced through Kailu on Chihfeng. The general intention appears to have been to exploit any weak spots developing on the easily defended "Great Wall-Chaoyang" line while depending for the thrust through Kailu to deal the final blow, forcing the Chinese to retreat for purely strategical reasons. Incidentally, it was felt that the route through Chaoyang was probably too well fortified to warrant expectation of an early success in this direction, while a thrust via one of the two lower routes through Nanling or Lingnan would be more or less unexpected. For the purpose of carrying this plan into execution Field Marshal Muto divided his forces into the following general "task groups" with the indicated "task assignments":

Major General Kaoru Nakamura (GOC, 33rd Brig.)  
 33rd Brigade (10th Division) ..... 4,000  
 Auxiliary Forces ..... 1,000  
 Mission: To contain the Chinese forces under General Ho Chu-kuo along the line Chinwangtao-Chumenkow.

NOTE: The 33rd Brigade was later reinforced by Lieutenant General Gamabaku's 16th Division.

Major General Haijiro Hattori (GOC, 14th Brig.)  
 14th Brigade (7th Division) ..... 4,000  
 Armored Car and Tank Units ..... 500  
 Regiment of Cavalry ..... 1,000  
 Field Artillery ..... 500  
 Mission: To advance along the Suichung-Lingnan-Lingyuan road with Lingyuan as first objective.

Lieutenant General Yoshikazu Nishi (GOC, 8th Div.)  
 8th Division ..... 12,000  
 4th Brigade (Suzuki).  
 16th Brigade (Kawahara).  
 Auxiliary troops including Artillery, Tanks, and Cavalry.

Mission: To advance along the Nanling-Lingyuan and Chaoyang-Lingyuan roads, with Lingyuan as immediate objective and Chengteh as the eventual objective.  
 Lieutenant General Masayemon Sakamoto (GOC, 6th Div.)  
 6th Division ..... 10,000  
 11th Brigade (Matsuda).  
 36th Brigade (Takato).  
 4th Cavalry Brigade (Mogi).  
 Auxiliary troops including light artillery.  
 Manchukuo Cavalry (Chang Hai-ping) ..... 4,000  
 Mission: Advance on Chengteh via Kailum, Chihfeng, etc.

Manchukuo Forces: These were under the nominal orders of Chang Hai-ping, who actually appears to have been directly in command of only the 4,000 cavalry attached to Lieutenant General Sakamoto's column. The remainder of his forces—about 25,000 men—were attached to the other three "task groups" for mopping-up purposes.

Turning to General Tang Yu-lin we find no attempt at developing a planned defense. His troops were scattered haphazardly along the frontier of the province, each commander apparently defending the sector which appealed to him, or, if none met his approval, remaining inactive. In Peiping, Chang Hsueh-liang appears to have entertained a vague idea that Tang Yu-lin would be able to hold out long enough for him to bring some of the troops at his disposal south of the Great Wall into Jehol in time to check the Japanese before they reached Chengteh. Indeed a few thousand troops succeeded in crossing into the doomed province between February 24th, the date of the opening of the campaign, and March 4th, the date of the fall of Chengteh.

Chiang Kai-shek and numerous other Chinese war lords, however, appear to have had few illusions as to the probability of holding Jehol under the existing conditions. They probably felt, moreover, that the situation offered an excellent opportunity to eliminate the once all-powerful Changs through the "loss of face" which would result from the fall of Jehol. Once the "Forbidden Province" had fallen and Chang Hsueh-liang had fled in disgrace, Chiang Kai-shek could step in and check the Japanese south of the Great Wall, while even if Peiping fell, he would lose nothing, as under the existing conditions Chihli was outside his sphere of influence. The fall of Peiping, moreover, might very possibly result in Japanese complications with foreign powers—the very end toward which all Chinese policies tended.

On February 20, 1933, while Mr. Matsuoka was announcing before the assembled dignitaries of Europe the intention of the Japanese Empire to withdraw from the League of Nations, Marshal Chang Hsueh-liang was making a speech in Chenteh reiterating his determination to resist the Japanese to the bitter end, and a Japanese air squadron bombed Chaoyang in preparation for the advance of the 4th Brigade (Suzuki) of the 8th Division (Nishi).

On the morning of the following day (February 21st), General Nishi ordered the 16th Brigade (Kawahara) to begin its attack on Nanling supported by four tanks, ten armored cars and several planes. Part of General Tung

Tu-tung's reinforced 38th (Jehol) Brigade put up a stiff resistance, so that as a result of the day's fighting and by grace of the easily defended terrain the Japanese advanced by the Chinchow-Lingyuan Road was completely checked.

An attack of the 4th Brigade (Suzuki) assisted by two armored cars and five or six planes on the Chinese positions at Kowpangtse (also held by part of General Tung Tu-tung's forces) met with greater success. As a result the Chinese fell back on Chaoyang, which they were in turn forced to evacuate on the 25th before General Suzuki's advance. General Tung then proceeded to take up a strong position at Tamiao, ten miles west of Chaoyang, while his outposts stretched away to the south in an effort to keep in contact with those of General Liu Hsiang-chin. In the meanwhile General Nishi appears to have brought the 16th Brigade up to the main highway after its unsuccessful attack at Nanling.

The 26th was given over to the consolidation of the Chaoyang position preparatory to a general attack on the Chinese defenses at Tamiao on the 27th. The battle of Tamiao began early on the 27th and ranged throughout the day without much impression on the defenders. Attacks were made under the cover of heavy artillery bombardment, which appears to have been maintained pretty steadily for 48 hours. On the 28th the attack was renewed in conjunction with a turning movement to the north, with the result that the evening found General Tung's troops in full flight towards Lingyuan—not to be rallied again this side of the Great Wall. The road to Chengteh was now open to General Nishi's 8th Division. Now let us see how the other columns had fared in the accomplishment of their missions.

To the south of the 8th Division February 21st found a thousand cavalry belonging to Major General Hattori's column pushing along the Suichung-Lingyuan Road, feeling out the positions occupied by the volunteer generals Peng Chen-kuo and Cheng Kwei-lin. A sharp skirmish seems to have occurred at Lishwokowmen, slightly north of the main road. On February 26th the 14th Brigade supported by some Manchukuo detachments attacked the entrenchments of Major General Liu Hsiang-chin's reinforced 51st (Jehol) Brigade at Wutzushan and Laoyehmiao, but were beaten back. On the 27th, however, the Chinese were forced to evacuate their positions—probably as a result of a turning movement. General Hattori then proceeded to occupy Yehchikou after an aerial bombardment. General Liu Hsiang-chin's forces retreated in the direction of Lingyuan, while during the succeeding days the Japanese column fought its way to Lingnan where it found itself on March 1st at the time of the collapse of the Chinese defence.

Turning to the north we find Major General Mogi's 4th Cavalry Brigade and General Chang Hai-ping's Manchukuo Cavalry driving General Tsui Hsin-wu's 9th (Jehol) Cavalry Brigade out of Kailu on the 24th of February. On the 25th and 26th General Mogi's Brigade moved to Hsiawa about eighty miles to the southwards.

while apparently the 11th Infantry Brigade (Matsuda) began to move south from Kailu accompanied by the Manchukuo forces. On the 27th the 4th Cavalry Brigade began a long march through sand and snowstorms on Chihfeng which was finally occupied with little or no opposition on March 2nd. From here the northern column pushed down to Chenteh by easy stages, the mere effect of their presence at Chihfeng being largely responsible for the final collapse of the Chinese resistance.

Meanwhile the 8th Division led by the 4th Brigade pushed forward through Lingyuan to Pingchuan, encountering little or no opposition. On March 3rd the incompetent Tang Yu-lin requisitioned 160 trucks intended for the transportation of ammunition and, after loading them with the fruit of years of illicit opium traffic, fled south to safety behind the Great Wall. During the campaign he had at no time attempted to direct or coordinate the operations of his forces, his only function having been the issuing of optimistic statements to the press. As evidence of the utter aimlessness of the Chinese defence we need only mention the statement of the American reporter who encountered troops of General Sun Tien-ying still plodding northwards to the defence of Chihfeng long after that city had fallen. It appears, moreover, that the various Chinese bands which had infested Jehol for several years took advantage of the unsettled conditions to increase their depredations on the unfortunate inhabitants. To this pastime a large number of the so-called volunteer defense corps likewise subscribed. "Thus it was little wonder that when the Japanese troops came in, the people put on their best clothes and went out into the streets to welcome them, not only unafraid and relieved but plainly happy at the prospect of a much more even-handed rule."

On the morning of March 4th, after defeating 3,000 Chinese troops at Tienchaoshan on the outskirts of the city, Major General Suzuki's 4th Brigade entered Chengteh and the conquest of Jehol was complete. In the course of ten days 100,000 square miles had been added to the Empire of the Rising Sun.

#### THE GREAT WALL

For thousands of years the Great Wall of China has withstood the pressure of countless invader races. Often as not, as in the case of the Mongol Armies of Ghenghiz Khan or the hosts of the Boy King of the Manchus, it has failed in its purpose and the invaders have swept victoriously into the fertile plains of Chihli and Shansi. But always the Great Wall has formed a rallying point and a potential line of defence which has been of tremendous importance to the Chinese. Today the names of Hsifengkow, Kupeikow, Lengkow, Chiumenkow, and Lowenyu all attest to the fierceness and gallantry with which they contested the line of the Great Wall. The battles which took place at these passes are by far the deadliest which have occurred to date in the Sino-Japanese dispute.

On March 6th General Chiang Kai-shek left Kiangsi by plane and flew north to Peiping to take the situation

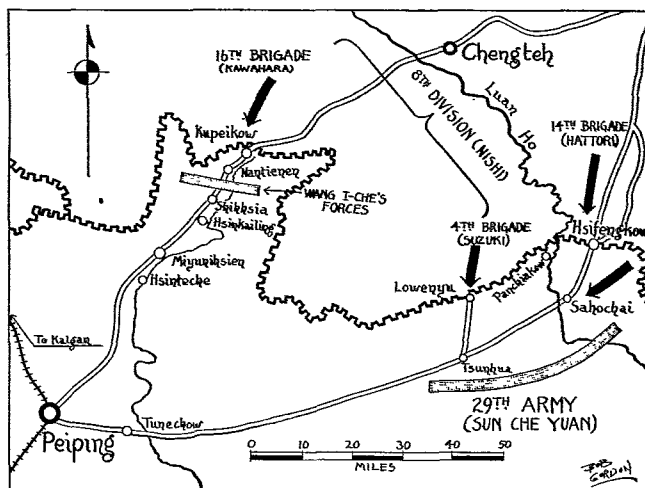

*The Kupeikow and Hsifengkow Sectors.*

in hand and attempt to retrieve the disasters brought on by Chang Hsueh-liang and his Lieutenant, Tang Yu-lin. The "Young Marshal" admitted his shortcomings, resigned his offices and went abroad to complete his education. Tang Yu-lin fled to Shanghai and later turned up in Charhar under the tutelage of the redoubtable Feng Yu-hsiang. Meanwhile Chiang Kai-shek beat China's northern armies into some sort of organization and got them to the Great Wall in time to meet the Japanese troops and dispute the control of the principal passes. Indeed the Chinese contemplated a counter-attack to regain Jehol, but this was beyond their power—it would have required too much coordination.

Between March 4th and 10th the Japanese forces in Jehol were put in motion for the Great Wall in order to secure the passes into Chihli and gain time for the consolidation of their conquests. General Nishi established the headquarters of the 8th Infantry Division at Chengteh and dispatched the 16th Brigade (Kawahara) to Kupeikow on the main road to Peiping. It arrived on the 7th, and on the 8th a sharp engagement occurred in which General Kawahara dislodged some of General Wang I-che's troops from outlying sections of the town. During the ensuing week the Japanese appeared to have undertaken siege operations interspersed with sharp fighting, while on the 14th they blew up the North Gate and in a stiff engagement forced the Chinese to evacuate the city. General Wang, however, took up a strong position further down the pass, which he continued to hold till April 11th or 12th. During this time the Chinese launched several counter attacks, while both they and the Japanese were reinforced, the Chinese by an additional division and the Japanese apparently by part of General Suzuki's 4th Brigade from Lowenyu.

On April 10th the Japanese began an offensive all along the Great Wall in a determined effort to shake off the Chinese. At Kupeikow General Kawahara, after a concentrated artillery bombardment, began a vigorous attack on General Wang's positions. The attack, which in some places at least developed as far as a bayonet charge and

hand-to-hand fighting, was continued on the 11th and 12th with the result that Wang I-che was dislodged and thrown back toward Shih-hsia. Between April 12th and 20th the Japanese consolidated their advanced position in the Kupeikow area, and, upon rumors of a Chinese counter attack, carried out an aerial bombardment of Shih-hsia on the 17th and 18th; the Chinese report that 60 bombs were dropped resulting in several deaths and 10 other casualties. It was probably the same squadron which on April 18th dropped three bombs on Tungchow, twelve miles east of Peiping, and at the same time dropped pamphlets in the vicinity of Miyunhsien calling upon the Chinese to unite with their protectors, the Japanese, in order to throw off the yoke of their oppressors.

On or about April 20th Field Marshal Muto, considering that the purposes of the April 10th offensive had been accomplished, ordered his forces in Northern Chihli to fall back from their advanced positions and occupy the strategic passes in the Great Wall. In accordance with these orders, General Kawahara withdrew the 16th Brigade to Kupeikow between April 20th and 22nd. On April 22nd, however, General Wang I-che resumed the offensive and attacked the Japanese, who appear to have taken up their old position at Nantienmen at the southern extremity of the Kupeikow pass. The Chinese attacked with five divisions, one of which under General Hsu Ting-yao attempted a turning movement east of Nantienmen. As a result of the day's fighting Nantienmen fell to the Chinese, although the Japanese, supported by a heavy artillery preparation, counterattacked again and again. "The Chinese, it is claimed, resisted strongly and repulsed the Japanese after a severe engagement in which the heights changes hands several times."—(*China Weekly Review*.)

After a severe artillery and aerial bombardment, General Kawahara on April 25th made another attempt to retake Nantienmen, but with no better result than had attended his preceding effort. On the same day forty bombs were dropped on Shih-hsia in the Chinese rear. Between April 25th and 29th the Nantienmen position was subjected to a continuous bombardment, with the result that when the 16th Brigade attacked again on the 29th, Wang I-che was forced to evacuate his positions and fall back on Hsinkailing which he appears to have previously fortified. On the 29th, then, the 16th Brigade finally completed its occupation of Kupeikow pass and took up the positions which it was to hold till the middle of May.

Meanwhile, sometime between March 8th and 18th—probably about the 12th—General Nishi sent the 4th Brigade of his division to Lowenyu to occupy that pass and hold it against General Liu Ju-min. On the 19th the Chinese general attacked but was repulsed while on the 20th General Suzuki attacked in an effort to clear the area in front of him, but with little better success than his opponent. After this the situation in this sector appears to have stabilized till well along in May. Part, at least, of the 4th Brigade was sent to reinforce the 16th

Brigade, which was meeting difficulties in the Kupeikow sector.

After taking Lingnan on or about March 1st, the 14th Brigade turned south and occupied the pass of Lengkow with part of its strength, while the rest marched against Hsifengkow. Here General Hattori encountered General Sung Che-yuan with his 29th Army (an old Kuominchun unit) firmly ensconced in the pass, while additional Chinese units were continually arriving. On March 9th the 14th Brigade (Japanese) attacked but was badly repulsed, while on the 10th, 11th and 12th fierce skirmishing developed between the two forces. General Hattori took advantage of this opportunity to bring up the forces he had left at Lengkow, and on the 13th launched a determined attack which the Chinese repulsed and followed up with a counter-attack. At about this time 1,300 men of the Chinese "Dare-to-die" Corps equipped with big swords and stripped bare to the waist closed with the Japanese. Only thirty came back alive. On March 15th General Hattori renewed his attack supported by thirty planes but again met only failure. On March 17th the Chinese turn came with the result the Japanese suffered a partial defeat, their right being enveloped and badly cut up. The high land in front of Hsifengkow was captured by General Sung Che-yuan.

Finally, on March 18th, a Japanese detachment from the 14th Brigade crossed the Great Wall southeast of Hsifengkow and occupied Sahochiao, thus threatening the Chinese flank and forcing them to evacuate the town. After General Hattori had occupied the pass, the Japanese proceeded to withdraw from Sahochiao, which in turn was taken over by Sung Che-yuan.

Between the 18th of March and the 10th of April the Hsifengkow sector remained comparatively quiet, but on April 10th General Hattori undertook an offensive in conjunction with similar efforts made at Lengkow, Chiehlingkow, and other points along the Great Wall. The 14th Brigade's objectives were Sohaicho and Panchiakow. A fierce struggle ensued in which Sohaicho changed hands twice before it finally fell to the Japanese. The 14th Brigade was supported in these operations by various air corps units, but part of the brigade appears to have been detached to support Takata's Brigade and the 33rd Brigade at Lengkow. On April 22nd, in accordance with orders from GHQ, the 14th Brigade took up a defensive position along the Great Wall, which it maintained until the middle of May.

When in about the middle of March the two Brigades of the 16th Division began to arrive in Shanhaikwan, the 33rd Brigade under Major General Nakamura was transferred to the Chiehlingkow and Lengkow passes. On the 21st of March it executed an attack on General Shan Shen's 32nd Army, which was holding the Chiehlingkow pass, but was thoroughly repulsed. Toward the beginning of April, the 11th Brigade (Matsuoda) of the 6th Division was moved down to Shanhaikwan from the interior of Jehol, thus permitting the Takata (27th or 28th) Brigade

to shift to the support of the 33rd. Thus reinforced the 33rd Brigade, after a stiff engagement, succeeded in dislodging General Shan from Chihlingkow on April 4th. On the 10th the Takata and part of the 14th Brigades attacked Lengchow which fell at 7:00 a.m. the following morning. Later, on the 11th, Kienchening was occupied, while on the same day the 33rd Brigade at Chihlingkow started a drive southward toward Taitouying, which it captured after a rather heavy action on the following day. The entire series of operations was supported by 7,000 Manchukuo troops and copious numbers of planes, tanks and artillery, while it was opposed by General Shan Shen's 32nd Army assisted by General Sung Chey-yuan's 29th Army. After April 12th a large part of the forces utilized in the Lengchow-Chihlingkow area were transferred to the Shanhaikwan sector.

Between the 1st and 24th of March the Chinese troops in the Shanhaikwan sector, under General Ho Chu-kuo, were steadily being augmented and consolidated in their positions immediately south of Shanhaikwan along the Shih Ho and Tashih Ho as far north as Shihmenchai. On March 24th a Manchukuo force succeeded in occupying Shihmenchai, a strategic point west of Chumenkow, but evacuated it thereafter. On March 31st, however, a combined Japanese and Manchukuo force advancing from Chumenkow attacked the Chinese at Shahochai and along the line of the upper Tashih Ho. The following day—April 1st—eighteen planes assisted by artillery carried out a severe bombardment of the Shihmenchai position, with the result that a determined Japanese attack in the afternoon forced a Chinese withdrawal in the direction of Hsiaopulao, thus giving the Nipponese access to the comparatively broad Tang Ho valley.

On the afternoon of April 1st a Japanese aircraft carrier arrived off Chinwangtao, and her planes, combined with army planes already available, systematically bombed the Haiyang and Hsiaopulao districts in the Tang Ho valley. At 2:00 a.m. on April 2nd the Japanese resumed the offensive down the Tang Ho valley assisted by a squadron of armored cars, operating between the Tang Ho and the upper reaches of the Shih Ho. As a result the Chinese were driven back on Haiyang, while the forces along the Shih Ho were forced to evacuate their positions and withdraw from the Chinwangtao area. At this point the Japanese, considering that they had accomplished their mission of driving the Chinese back from the vicinity of Shanhaikwan, ceased their attacks and withdrew at least part of their forces.

In Chinwangtao a somewhat anomalous situation seems to have existed after the Chinese withdrawal, as the Japanese, afraid of international complications, refrained from occupying the town. Finally on April 7th an unauthorized Manchukuo column under a General Li occupied the city, which in the interim appears to have been policed chiefly by the 15th U. S. Infantry and British Marines. On April 9th, however, the Chinese counter-attacked all along the Shanhaikwan front, with the result

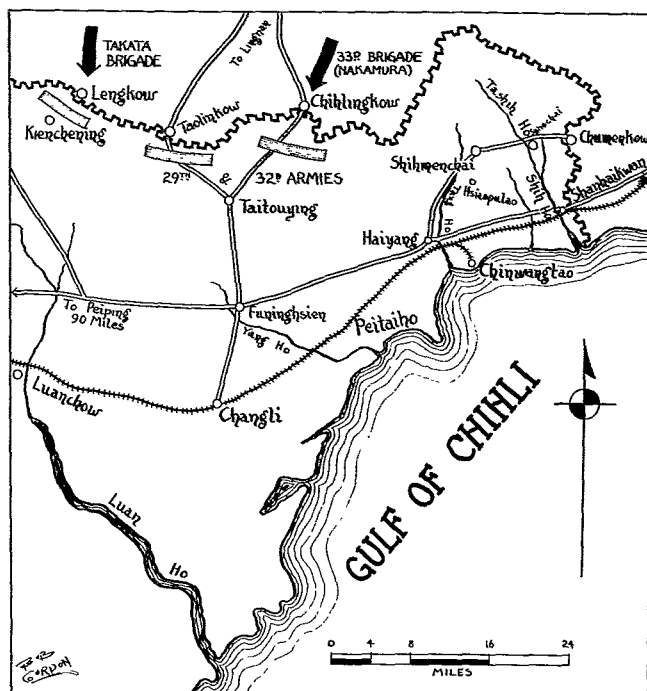

*Eastern End of the Great Wall.*

that Shihmenchai was retaken, and General Ho Chu-kuo was enabled to reoccupy his position along the Shih Ho, driving the Manchukouans out of Chinwangtao.

On April 13th the tide of war swung once again to the side of the Japanese when General Gamaboku attacked with some of the forces released from the Lengchow-Chihlingkow area. Shihmenchai was retaken followed by Haiyang and Peitaho. Early on the morning of the 15th, Manchukuo forces attacked along the Shih Ho, supported by masses of Japanese planes and artillery, and by afternoon Chinwangtao was occupied. Another Manchukuo force appears to have advanced southwards from Taitouying, threatening the Chinese rear and finally occupying Changli on the 17th. Meanwhile the Japanese drive southwards from Haiyang had forced General Ho Chu-kuo to retire to the right bank of the Luan, where April 19th found him disconsolately rallying his beaten forces.

Meanwhile perhaps the most portentous of all the events which followed the fall of Chengteh was the advance of Major General Mogi's 4th Cavalry Brigade and 10,000 Manchukuo troops to Dolonor in April, where they threatened the great caravan route across Mongolia to Urga and Russia. If Kalgan, strategic city of the frontier, falls, China's claim on her far-flung Mongolian and Sinkiang Dominions will approach the vanishing point.

Administratively there are several points to be noted. At Peiping, Chiang Kai-shek had turned over the command of the Chihli front to General Ho Ying-chin, whose principal functions appear to have been the maintenance of order behind the front. About the end of March Chiang Kai-shek, himself, returned to Kiangsi to continue his "anti-communist" activities. Meanwhile Field Marshal



Muto had set up General Chang Hai-ping as Governor of Jehol.

Thus with the occupation of the passes to the plains of Chihli and of Dolonor the conquest of Jehol is secured, and the long trail which began at Kailu and Chaoyang finds a resting place in the shadow of the Great Wall.

COMMENTS

The strategical problem with which Field Marshal Muto was confronted on February 21st was briefly the conquest and occupation of Jehol in the face of resistance offered by a disorganized but numerically superior foe. The cardinal principle of making the destruction of the enemy's forces in the field the primary objective could not apply, chiefly because it would be impossible to force the irregular hordes in Jehol into a general engagement. Any operations tending toward that end would only result in an everlasting bandit chase through the innumerable mountain valleys of the province. It is for this reason that the Japanese did not push along the Great Wall from Shanhaikwan, thus cutting the Chinese line of retreat into Chihli, maneuver, which against organized forces would have brought on a general engagement under conditions unfavorable to the enemy. In the case of Jehol, moreover, the Chinese were already disorganized, so that one aim of military operations—the disrupting of the enemy's organization—had already been accomplished. It is because of these facts, and only because of them, that Field Marshal Muto was justified in adopting his general plan of invading Jehol; under any other conditions it would have failed miserably.

In the matter of detail, the advance of the 14th, 16th and 4th Brigades along such widely separated lines appears to have been a mistake. All that was needed was a determined effort on the Chaoyang front, calculated to contain the Chinese along the eastern frontier of the province while General Sakamoto's Northern Column penetrated from Kailun.

Any attempt at comment on the Chinese operations is necessarily rendered hopeless by their total lack of organization or plans. With the forces available in Chihli and Jehol, even a very average commander should have been able to concentrate a large force in the Lingyuan area from whence he could crush in turn the heads of the

isolated Japanese columns as they struggled up from the coastal plain. Any success which might be gained by these means could be exploited by a thrust at Chinchow, thus cutting off Shanhaikwan from the rest of Manchuria.

It is interesting to note the similarity between the Japanese campaign of 1933 in Jehol and the opening phase of Napoleon's campaign of 1796 in Italy. In both cases the attackers found themselves extended over a narrow coastal strip, and in both cases they drove into the mountains, separating their poorly handled enemy and crushing each portion in turn, finally to emerge victoriously into the fertile plains of Chihli and Lombardy. But here the comparison ends, for the disparity between the opposing forces in the campaign of 1933 indicate military conditions which are more nearly comparable to the campaigns of Cæsar against the Gauls than to those of Napoleon in one of the greatest of his campaigns.

The disparity in casualties is even greater than one would expect. According to an announcement of the Tokyo War Office in the *Osaka Mainichi*, the Japanese casualties during the entire series of operations in Jehol and along the Great Wall from February 23 to June 1, 1933, were:

Killed .....	467
Wounded .....	2,005
	2,472
Total .....	2,472

During the same period, according to the official bulletin issued by the Japanese Military Headquarters at Tientsin in June, 1933, the Chinese killed and wounded totalled 120,000. We feel that both these figures must be taken with a grain of salt.

From the military point of view there are two important lessons to be derived from the Nipponese incursion into the "Forbidden Province." First, that in a war military organization with its system of responsible command is all important, and secondly, that in war no single principle remains constant but changes in accordance with the innumerable conditions under which it is applied. Perhaps if some day the Sleeping Dragon awakes, or if some other power arises to challenge the plucky islanders for the hegemony of Asia, military principles will be applied more along lines bequeathed us by centuries of European warfare.



THE APPLICATION OF THE GOLDEN RULE to international affairs is a worthy goal, but unfortunately nations are just as self-centered and just as sensitive to opposition as are individuals that compose them.—CAPTAIN A. T. BEURGARD, U. S. NAVY.

# Extracts from the Address of Major General William F. Hase at Graduation Exercises of the Coast Artillery School

IT gives me great pleasure to be here today to participate in the graduation exercises of the Class of 1934. This school means much to me. I came here in 1901 after I had been in the service for three short years. During that time I had served at a small isolated post where the Captain was the commanding officer and I was "the staff departments." I learned the administrative features of the small post but had very little artillery training. True, I had participated in a target practice at a stationary target up at Sheridan Point, Virginia (now the site of abandoned Fort Hunt). In order to conduct this target practice we had to improvise all fire control material, did most of the calculating on a pad, and used wig-wag signals to get the base-end angles from the other side of the river. I learned much during that first year's course at the School and my enthusiasm was difficult to repress. Later, in 1908, I returned to be a member of the first Advanced Course. The Submarine Mine School at Fort Totten having been abandoned, the two courses were amalgamated and were instituted in this building which had just been completed.

I look upon the Coast Artillery School with more regard and thankfulness than I do upon my own alma mater. Throughout my service I have felt the great influence which this school has had upon my career. The motivating spirit, from its inception in 1824, has been the fulfillment of Colonel Abraham Eustis' idea expressed in the order opening the school, namely, "To devote our undivided energies to our professional improvement and the perfection of the Artillery." That spirit has become a tradition here and I hope that in the years to come it will constantly hew to that line.

In the office of the Chief of Coast Artillery, when a particularly knotty problem is presented, we usually say, "Why not send it to the Coast Artillery School for remark?" The War Department recognizes that this is the proper procedure, for it sanctions direct correspondence between the Chief of Coast Artillery and the Commandant of the Coast Artillery School.

In September, 1921, when President Harding addressed the War College Class he mentioned the fact that many times he felt distressed and perturbed because he could not see the solution of the perplexing questions confronting him, but he soon learned that there was someone somewhere in one of the departments who had the right answer. And so it is with us—when we do not know the answer we turn to the Coast Artillery School and we usually get erudite solutions. I am deeply grateful to the Commandant and the faculty for their assistance and I feel that I can lean on them heavily.

You graduates in this year's class have written another chapter in your book which you might designate "My Personal Military History." You have added much to your professional knowledge and you will be called upon

to demonstrate your capabilities. You must not forget the lessons learned here and must not cease your studies. By continued study and reading of professional papers and by seizing the opportunities for practical demonstration, you will progress and reach the goal of the efficient officer, and you will be recognized as such.

There is great opportunity for the efficient officer, because in these days, rapid improvement and constant development are being made of mechanical appliances applicable to military use. In the past three years, the mechanization and motorization of the Army have made rapid strides, and for this work, alert and zealous officers are needed. *Duty with troops should be your slogan, for it is there that the ambitious officer can demonstrate the attributes of real leadership.*

Especially do I invite attention to our foreign garrisons. Now that Congress has repealed the law requiring the three-year tour, a detail of two years in Panama, Hawaii and the Philippine Islands should particularly appeal to the young, ambitious officer. As you know, all our foreign garrisons are kept at full strength and excellent opportunities exist for comprehensive training. Not only do you have the chance to participate in this active training while on foreign service, but you also have the pleasure and advantage of travel in foreign countries.

I realize full well that there are not enough command jobs in the Army to take care of all of our commissioned personnel. In our Corps we have 1,021 officers, of whom 665 are on duty in the Corps, while the remainder are on detached jobs. This latter work must be carried on; otherwise the interest of the civilian components would lapse, and other important activities would cease. It will be my policy to relieve from detached assignment an officer who has been away from troop duty for four years. If an officer remains away for a longer period, he loses touch with his own arm, especially at this time when many changes and rapid progress are being made. I believe it is a wise policy to have every officer serve a tour with one of the civilian components. It gives him a broader viewpoint and makes it easier for him to comprehend the many problems confronting us. Living in a civilian community will enable him to understand better the civilian attitude.

Lack of thorough understanding is what causes certain propagandists to write the critical articles which have recently appeared with reference to our ROTC training. The advocates of abolishing military training, charge "militarism"; their opponents cry "pacifism." Militarism in a derogatory sense connotes force, the destruction of civil authority by military authority—"Prussianism." On the other hand, "pacifism" suggests spineless inactivity in international affairs. Fortunately there is a middle road, well defined by the National Defense Act, namely, a sufficiently large Regular Army, a National Guard and

a complement of well trained officers for use with the units of the civilian components if the emergency comes. The ROTC units will produce leaders of ability. They are democratic, efficient, and economical cogs in our national defense system. I believe reasonable preparedness is a doctrine which we, in the military service, should preach. I have firm faith in the judgment of the American people if the arguments pro and con are elucidated clearly.

I believe that you graduates, assisted by your wives, should chart your courses. Look ahead. Do not try to keep your ship constantly in smooth water. There are duties to perform, which may not be to your entire pleasure or liking, but which must be carried on.

Now a word about the detail of officers at Leavenworth and the Army War College. Last October, the Chief of Coast Artillery was directed to nominate eleven officers to pursue the 1934-1936 courses at the Command and General Staff School. Of these one-half were to be less than forty years of age. All were to be less than forty-eight. The nominees were to be evenly distributed among the eligible grades (above second lieutenant), and were to be officers of the "highest general efficiency rating." For the Army War College the allotment was seven, all above the grade of first lieutenant. No officer over fifty-two was to be nominated, and one-half were to be less than forty-four. The officers nominated for the course were to have a general efficiency rating of "Excellent" or above and were required to be on the General Staff Corps Eligible List. Thirty per cent were to be available, after graduation, for at least a three-year detail on the War Department General Staff. With these limitations definitely stated, my predecessor was confronted with the difficult task of selecting the officers to be nominated. The records of all officers were examined, and work sheets were made up, covering all efficiency reports since 1920. I believe that the nominees forwarded by my predecessor were selected without favor or affection, and that they were based wholly on merit. I shall continue that policy. Numerous letters are received from Senators, Representatives, members of the Cabinet, and from other sources on behalf of certain officers. These are all treated in a "pro-formo" manner and are answered, saying that the record of the officer will be given full consideration when selections for a future class are to be made. You officers have a right to examine your efficiency reports when you are in Washington, and by letter AG 201.61, dated September 6, 1933, you are privileged to write direct to your Chief of Arm asking what your efficiency rating is at the present time.

Now let me discuss for a brief moment the question of the elimination of officers. The appropriation bill provides that no funds will be used for the pay of officers commissioned prior to June 1, 1934, if the number of such officers is in excess of 11,750 after September 30 next. It was estimated that there would be about 12,050 officers on the rolls on September 30th. It is necessary,

therefore, that approximately 300 must be eliminated before that date. You have no doubt noted that a great number of officers have been ordered to appear before retiring boards. The Surgeon General's Office has examined the records of all officers who heretofore have had long hospital records, or who have been found to have physical ailments which were believed to unfit these officers for full field duty. A total of almost 300 have been ordered to appear before retiring boards.

In addition to the determination of physically unfit officers, a classification board was appointed to meet on May 7th to examine the records of all officers who were classed as mediocre. The selections have been made, and these officers have been notified that they are placed provisionally in Class B.

The selections are in grades from colonel down to and including second lieutenant. These officers have certain rights which are covered in AR 605-200 dated May 1, 1934, just published and distributed in mimeograph form.

The present Congress has passed a bill which requires that promotion by selection in the Navy be made applicable to the grade of lieutenant. Heretofore this selective system has applied only down to include the grade of commander. In the discussion of this bill on the floor of the House, it was clearly indicated that a similar bill, applicable to the Army, would probably be passed at some future time.

The thorough, courageous, and resourceful officer need have no fear of the future. The one, however, who has been drifting with the tide, ebbing and flooding, will have to seek a keedge anchor on the flood, for unless he does, he will surely find himself sinking in deep water.

I believe it would be wise for each officer to procure a copy of the blank Form No. 67, Efficiency Report, proceed to his study and introspect himself for an hour, and as he reads each lettered and numbered paragraph on the blank form, ask himself a few questions, such as:

How can I improve myself?

Am I keeping myself physically fit?

What can I do to show that I have tact, force, and leadership?

What is my attitude towards my command?

Do I control my temper at all times?

Am I just in dealing with my men?

You may find that this close introspection will be most helpful and beneficial. And here is where the wives can help a lot. Don't let your husband go forth with a grouch; see that his leather equipment is well polished, that his clothes are spotless and that he sallies forth with his head up, determined to do better work today than he did yesterday. You wives can do much to make a happy and contented garrison.

I want to mention at this time the pride and admiration I have for our noncommissioned staff officers. Without them we would have a difficult task. In the continental United States there are 305; on foreign service there are

154 of our noncommissioned staff. These trained specialists are constantly at work maintaining searchlights, power plants, radio, fire control lines and other technical accessories. All of them have been educated here, are graduates of this school, and have done much to make the Coast Artillery efficient and ready to accomplish its mission. The Department of Enlisted Specialists can, and no doubt does, feel proud of its offspring.

To you Enlisted Specialist graduates, let me point out that your predecessors have set a high standard of accomplishment, and when you receive your appointments, you will have to work hard to keep up the pace. The high grade of service rendered by them has fully repaid the government for the time and expense in educating them here.

I am also pleased that there are four Marine officers in the graduating class. The Coast Artillery and the Navy

have many common tasks and it is proper that we should have a common understanding.

In closing I wish to express my keen appreciation and thanks to the Commandant, the Assistant Commandant, and the Faculty for the progressive and efficient manner in which they have conducted this school during the past year.

I congratulate the members of the graduating classes on their performance. The Research Studies, in which a variety of subjects were under investigation, were of especial interest to me. I am sure that as a result of them, your international horizon has widened.

I trust you will continue to be interested in study and deep thinking and that you will resolve to continue in the path so well pointed out in 1824 by Colonel Eustis in his words of advice: "To devote our individual energies to our professional improvement and the perfection of the artillery."

## Low Thoughts About High Fliers

BY LIEUT. COL. ROBERT P. GLASSBURN, C.A.C.

79-b. "Unless the army antiaircraft artillery can take over the protection of some of the corps rear establishments, it will be found necessary in most cases to attach one additional antiaircraft artillery regiment to each corps. When an army antiaircraft artillery regiment is attached to a corps it should be given missions in the rearward portions of the combat area and the organic regiment given missions in the forward portion of this area. This saves much readjustment in case the army regiment is withdrawn unexpectedly from attachment."—*Coast Artillery Field Manual*, Vol. II, Antiaircraft Artillery, Part One, Tactics.

THE quoted paragraph is to be found in the instructions for the use of antiaircraft artillery in support of the offensive. It occurs to this scribe that the "tail wagged the dog" when it was written. An offensive is planned. The purpose of an offensive is to push forward. It is planned in the belief that it will be successful. That belief, of itself, is an essential element of success.

The offensive is going to push forward, then. That means an eventual forward displacement of the antiaircraft artillery is to be contemplated. It means, in the normal case, that the enemy's waning power of resistance will be increasingly focused against the main forward elements of the attacking force when the time for forward displacement has come; and that the aerial menace to the rearward installations of divisions and of the corps will be diminished. If, then, the army attached regiment has been placed, for the early phases of the attack, in the forward areas, it will be in position to carry the burden of antiaircraft protection, and take over the protection of advancing installations, while the organic regiment makes its forward displacement—having been emplaced originally in rear of the reinforcing regiment—to accompany the attack.

It seems to me that the writer of this paragraph had his mind more concentrated on the abnormal possibility of

an unexpected withdrawal of an attached regiment, than upon the normal desiderata of the offensive. He fears too much that the army giver of reinforcements is an Indian giver.

Why did the Army give the reinforcing regiment in the first place? Because the corps needed it. In reaching that decision, the army evaluated the need of the corps. If the corps is the one entrusted with the main blow, it is unlikely that the army would suddenly, and with little warning, withdraw a reinforcing element associated with the execution of the task, the success or failure of which is inseparable from the success or failure of the army. If the corps is charged with a contributory mission the army should know, from the general situation, whether or not the likelihood of a sudden withdrawal of the reinforcements should be envisaged. In that case the army would unquestionably call that likelihood to the attention of the corps so that the antiaircraft artillery plan of the corps would take it into consideration; or even stipulate that the reinforcing regiment should be employed in a prescribed manner, favorable to quick withdrawal without too much violence to the general antiaircraft articulation.

Figure 17, page 67 of the *Manual* is a "Diagram showing two antiaircraft machine gun battalions covering a corps in defense." The main hostile blow is shown directed at the sector of the corps on the left of the one defended, and at an angle of about 30° to the axis of both corps. The diagram shows approximately one-half the machine-gun units in the area of the supply establishments and the airdrome of the defended corps while the remainder are emplaced in the sector of the corps on the left—that is, the corps which will receive the shock of the hostile main effort—and grouped in depth along the expected axis of

the attack. The sector of the corps defended is as innocent of antiaircraft machine guns as a frog is of hair.

It seems to the jaundiced eyes of this scribe that the composer of the diagram was under the impression that the aerial forces accompanying the attack would have to travel the same groove as the attacking ground troops. Apparently the not inconsiderable freedom of action of the airplane was left entirely out of consideration. The antiaircraft machine gun is for the close protection of troops, or installations, on the ground against low flying planes. The diagram supposes that the defended corps needed more than normal protection against such planes for it reinforces the corps by one antiaircraft machine gun battalion. It then emplaces the machine gun units where they cannot possibly give any protection to the corps which they should protect, and leaves the entire forward areas of that corps denuded of machine guns save those carried in the normal equipment of the Infantry and Terrestrial Field Artillery. Briefly, an antiaircraft machine gun battalion given the mission of reinforcing the Umpty-Umpth Corps is actually used to reinforce the Umpty-Steenth Corps on its left.

"98. General.—a. If a division is operating alone, it will generally have attached to it not less than the following antiaircraft artillery: A machine-gun battalion less two batteries; one battery of 3-inch guns; a platoon of searchlights; and a section of the combat train of the first battalion. This organization may be taken from the corps antiaircraft artillery regiment of which the division is a part or may come from the army antiaircraft artillery brigade.

"b. The gun battery is for the purpose of denying observation by relatively high-flying enemy airplanes, although bombers and flights of attack airplanes will be fired upon if the opportunity presents itself."—*C. A. Field Manual*, Vol. II, Part One.

The Staff Officer's Field Manual, part three, gives as the total length of the Infantry Division, including field trains, as 45,335 yards. There is great probability that its road length would be increased by reinforcing terrestrial artillery. It is improbable that it would march on a single road. It is equally improbable that it would march on

more than four roads and very rarely could it find four roads utilizable within the limitations of its independent mission. But even with four roads and an even distribution, it would still be over 11,000 yards in depth, with no allowances made for distances imposed by requirements of reconnaissance and security.

Now the horizontal radius of the antiaircraft gun is 6,000 yards. Two 6,000's is 12,000. Furthermore, the battery must function as a unit. It cannot be split into platoons to increase its area of action and to permit leap-frogging to give continuous protection to large columns. I do not see how one antiaircraft gun battery can "deny observation by relatively high flying enemy airplanes" in such a situation. It seems to me that the only assistance a single battery can render an independent regiment is at such critical moments as the passage of defiles, or the beginning, or the ending of the day's march. It seems to me necessary, in the interest of reality, and because the *Manual* is presented to the non-professional officers as authoritative, that the *Manual* state frankly that the minimum antiaircraft artillery reinforcement for an independent division, in order to give constant and adequate protection, is one antiaircraft regiment, less two machine gun batteries. If less is available, the maximum protection which may be required of it should be stated.

Further arguments to support the above derive from the need for protection of the division in bivouac, and the inescapable dimensions of bivouac which will surely be beyond the possibility of one battery to protect. Of course, this whole problem will be influenced by the capacity for antiaircraft fire developed by the all-purpose gun with which the Field Artillery is now working.

Inevitably, unless and until that gun demonstrates ability to furnish march protection for the Infantry Division, and at the same time be prepared to take up its terrestrial missions on behalf of the Division, it would seem advisable to amend the *Manual* as indicated.



THE LIMITATION OF ARMAMENT CONFERENCES *have dealt in national prestige far more than they have in either economy or national defense. In theory, all nations have equal sovereign rights and are entitled to adequate national defense. To impose inferiority in either, by agreement or otherwise, is subversive of the doctrine of complete sovereignty, which subversion cannot be explained away by a laudable though specious alibi of economy. There are enough reasons for nations to quarrel among themselves without quarreling unnecessarily about armament ratios.*—COMMANDER E. S. R. BRANDT, U. S. NAVY.



# Jungle Warfare

by  
Ingram Cary

## Part II

WHAT HAS GONE BEFORE: *With ten days' rations, Captain Cochrane, Lieutenant Hazzard, and a company of 146 Macabebe Constabulary were put ashore at San Ramon, Samar, to hold that town against the Pulajantes, and if possible locate and capture their stronghold.*

*Cochrane found that San Ramon had been burned and was deserted, but that the site was surrounded by hostile natives. Building a fort, he waited the arrival of supplies, before penetrating the interior, meanwhile eking out an existence for his troops with bats, snakes, apes, and whatever else was edible, if not tasty, in the surrounding jungle. After two months with no contact with civilization, Captain Cochrane decided to attack.*

ON the day preceding the departure a reconnaissance was made of the trail leading to the interior for about two miles to the west. The usual braying of *boujons* occurred and the trail was found to be covered by the Pulajan's posts on Forrest Hill and Lookout Mountain, the approaches to which were carefully reconnoitered by members of the patrols detailed for their capture.

At two o'clock on the morning of the departure, the two patrols led respectively by First Sergeant Bustos and Sergeant Alalay, set out on their dangerous missions. At a designated place a short distance from the Fort they were to rejoin the Company, which leaving at half-past four was to clear the Peninsula of San Ramon and reach the forest-covered mountain side before daybreak. This preliminary operation was accomplished without mishap, but neither patrol brought in a prisoner, each leader claiming that the man he had spared for use as a guide had refused to be captured and it had been necessary to kill him. They had crept up on the Pulajans, all of whom were asleep, and had used the long daggers carried by each soldier inside his legging with such silent efficiency that only one of the enemy had escaped.

The failure to obtain a guide had no influence upon the Captain's determination to continue with the expedition. After sending two squads ahead as an advance guard he

pushed on, following the almost obliterated trail which led directly into the unknown wilderness to the west. The going became increasingly steep and difficult the farther the coast was left in rear. A halt was made at noon in a deep valley down which a mountain stream brawled its way through jagged masses of volcanic rock. The men sought resting places on the rocks and even in the water, to avoid the leeches that infested the forest seemingly in millions. After a short rest the advance was resumed up the bed of the stream over giant boulders and around waterfalls almost hidden by curtains of interlaced vines. The crest of a high watershed was passed over in the midst of a downpour of icy rain which obscured the view and made the trail almost impassable.

Gathering darkness found the column of bedraggled and weary men trailing laboriously across a valley where underfoot there was black mud, waist deep in places, and overhead the matted foliage of a forest so dense that the gloom in it was that of night. The rain continued to fall in torrents, but Cochrane pushed on, as a halt for the night in that morass was out of the question. In the middle of the valley a sluggish stream with steep and miry banks presented a formidable obstacle. The men floundered through it in mud and water reaching to their shoulders, one helping another across the stream and up the bank on the other side. Fortunately rising ground was soon encountered, and the Company went into camp after a march of fourteen hours from San Ramon.

A body of white troops in a similar situation no doubt would have spent a miserable night lying shelterless in drenched clothing on the soaked ground. It was not so with Cochrane's seasoned campaigners. Within half an hour a circle of rain-proof leaf huts floored with boughs had sprung up, the undergrowth had been cleared away

---

**Abandoned in an isolated outpost, Captain Cochrane takes the offensive.**

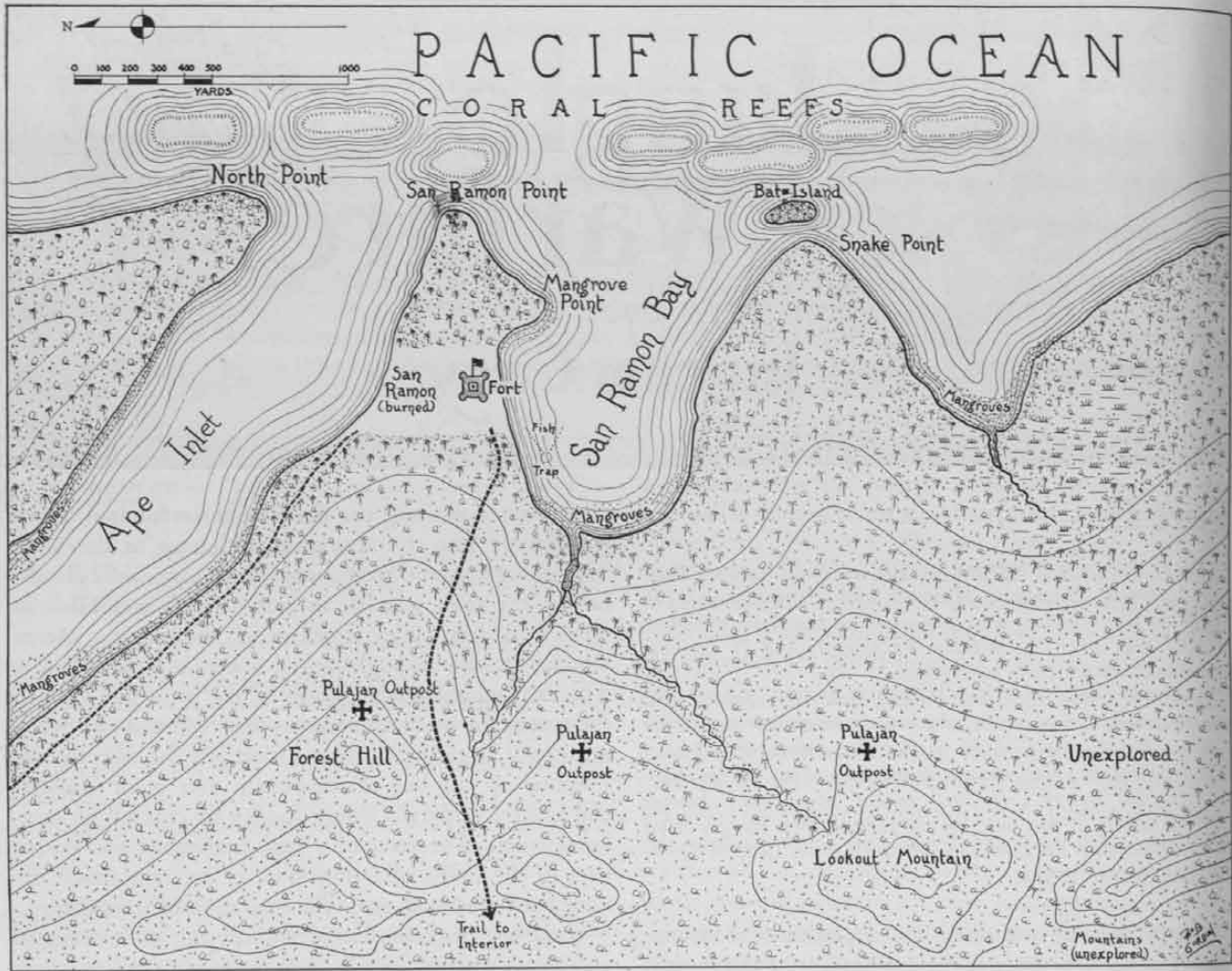

Sketch of San Ramon and Vicinity (from memory)

for a field both of view and of fire, and the men were wringing out their blankets and outer garments before huge fires built against the open sides of the huts. The only things needed to make them perfectly comfortable were a bowl of smoking-hot rice and a few cigarettes apiece, but as these luxuries were not forthcoming, they philosophically made the best of it and chattered away happily over the scanty meal prepared by the cooks. Meanwhile the covering groups had been relieved and a "running guard" detailed, four double sentry posts being established near the edge of the clearing.

When supper was over the men finished drying their clothing and dressed, scraped the mud from their shoes, wiped off their arms and equipment, and packing themselves together by squads with loaded rifles at hand, proceeded to take a well-earned rest. Cochrane had a separate hut, built in the center of the circle, and the men vied with each other in making him as comfortable as possible under the circumstances. He noticed a peculiar phenomenon on this night, which was that all the objects in the vicinity of the camp were phosphorescent, the strange brilliancy extending half-way up the tree trunks and giving the forest a weird and unearthly aspect.

The march to the westward was resumed early the next morning. The trail led over another mountain range and then down into a maze of ridges. It was impossible to determine the general slope of the land as the streams seemed to flow in every direction. Heretofore the trail had shown no indication of recent use, but numerous freshly made footprints were now observed. It was evident that the Pulajans on the San Ramon coast did not use the old trail the column had followed, but had another and more direct route leading straight through the jungle.

Cochrane joined the advance guard on this morning and the march was continued with redoubled caution. Several *camote* patches were passed during the morning and before noon the column arrived at a burned hut where the trail forked, one leading to the southwest and the other towards the north. Cochrane took the latter because it showed more use, and halted at noon only long enough for the men to roast some *camotes*. During the afternoon several other cultivated fields and burned houses were passed. Towards evening the column descended into a wide valley, covered with *cogan* grass over ten feet in height, and the trail, after branching several

times, finally terminated in a series of runways tunneled under the long grass in half a dozen directions.

Cochrane halted the column and taking a squad from the advance guard went forward to reconnoiter. He followed a well used runway leading in the original direction and it was often necessary to crawl on hands and knees through the mud to avoid the saw-edge growth overhead. As it was quite dark under the closely matted grass he had to call his keenest faculties of observation into play to avoid getting bewildered in the network of runways, each of which seemed exactly like the other.

Advancing with extreme caution he had progressed but a short distance when he emerged into a trail—almost a road—hard packed by the pressure of hundreds of bare feet. It was not an ordinary trail, worn smooth by traffic; it was more like a track left by a regiment of foot troops, only there were no shoe prints. There were many signs to indicate that the body of men by whom it had been made had passed within a few hours, travelling in an easterly direction.

The track came from the northwest. Cochrane moved along it in that direction to the first bend and as he turned this, came face to face with three Pulajans. They had baskets strapped on their backs, but each was in full uniform and armed with two *bolos* and a dagger. Cochrane spoke to them quietly, telling them to drop the weapons they had drawn and promising to spare their lives if they would surrender. The man in front, a big muscular native, edged forward, making a motion at first as though he intended to hand over his arms. When he got within reach, however, instead of surrendering he made a terrific cut at Cochrane's neck while at the same time one of his companions tried to stab the officer in the side

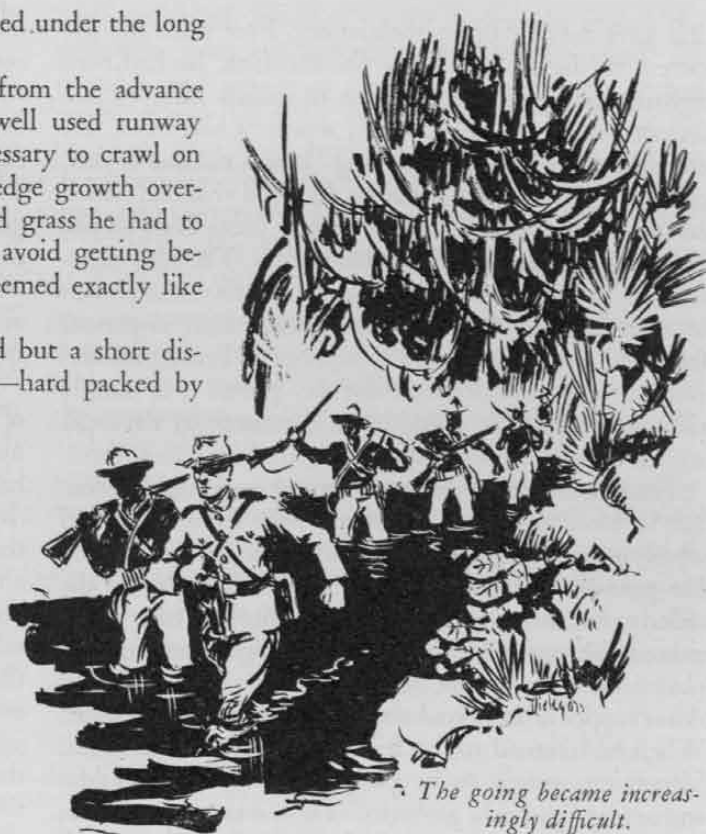

The going became increasingly difficult.

and the third man rushed in with an uplifted *bolo* in each hand. Cochrane saved himself by a quick leap to one side and Sergeant Alalay, who appeared on the scene just at the opportune moment, let drive with his pump-gun, first at the leader and then at the second man, the heavy charges of buckshot killing them both instantly. Cochrane then dropped the remaining Pulajan with his revolver, and the incident was closed.

The First Sergeant brought the Company up at the double time when he heard the firing. The Macabebes manifested great joy when it was found that the baskets taken from the dead men contained rice and *carabao* meat in sufficient quantity to provide a full meal for all. A package of cigarettes found on the big native was handed to Cochrane, who presented it to Sergeant Alalay with expressions of thanks for his timely action. When the arms and papers had been removed, the corpses were thrown into the long grass and the column was reformed. It was now nearly dark and the usual rain was falling, so the selection of a camp site was of paramount importance.

Sergeants Bustos and Alalay estimated the strength of the force from which the three Pulajans evidently had straggled, at between five hundred and eight hundred men. Cochrane was resolved to pursue the Pulajans regardless of their strength. Realizing, however, that his men were tired and hungry, he followed the trail to the eastward only to the first stream; up the bed of which he led the Company until a place was found, isolated from the beaten paths, where wood for fuel and leaves for shelter could be obtained. The Company then went into camp, the usual arrangements for comfort and security being made under the direction of the First Sergeant, with whose measures the Captain did not often find it necessary to interfere.

As soon as Cochrane's hut was finished, he entered it

Cochrane saved himself by a quick leap to one side.





and gave himself up to meditation. Ever since the discovery of the trail made by the Pulajans, he had been fighting off a peculiar impulse to march back to San Ramon at once by the route over which he had come. He could not understand this feeling. It was not one of fear, of this he was sure, for although the band that had passed outnumbered his own company many times over, he had often accepted similar risks voluntarily. The idea of returning empty-handed when the opportunity was present to engage under favorable circumstances an important force and also to capture food supplies and take prisoners from whom information could be gained was simply ridiculous! No. He would be on the march by daybreak and he would continue the pursuit until he struck them.

Thus he estimated the situation and made his decision, but for some reason he did not enjoy the serenity of mind which usually came after the completion of such an act. He paid little attention to the supper brought by the orderly, but when he saw Alalay's grinning face poked around the corner he did not fail to light the cigarette placed carefully on the leaf which served as a platter. After supper he inspected the arrangements for the night. When he returned to the hut the obsession came again. Something seemed to be pulling him by the shoulder and saying "go back, go back." He was not superstitious in the least and he had no faith in omens and presentiments, yet the absurd impulse persisted in returning again and again.

He was aroused from the deep reverie into which he had fallen by the sergeant of the guard who reported that one of the sentinels had seen something white moving about near the edge of the clearing and wished to know if he should fire should it appear again. Going with the sergeant to the post, he found the corporal and several other members of the guard standing beside the sentinel. The object had reappeared and could be seen indistinctly, standing motionless a few yards beyond the circle of light cast by the fires. Cochrane directed two men to follow him and walked out to it. It was a little white dog. When he called to it in English, it flew at him and leaped into his arms, barking, whimpering, licking at his hands and face and showing unbounded delight in every way that a dog can. He carried it to the fire to examine it and was greatly astonished to find that it was a white man's dog—a fox terrier.

The mystery of its appearance was not explained when one of the Macabebes, who while recovering from wounds, had spent several weeks at a station on the South Coast, declared that this dog belonged to a lieutenant of Scouts named Harris, on duty then at the same station, and further that the dog's name was "Espote." Cochrane called to him, "Here Spot," and the little fellow responded by barking joyfully.

"He is Harris' dog, all right. The question is, how did he get out here in this wilderness? It is too mysterious and I give it up." So saying to himself, Cochrane took the dog in his arms and lay down, Spot pressing against

him as though he could not get close enough. But he could not sleep; again and again came the impulse to return to San Ramon. He fought it off and at last dozed a little, only to awaken with the feeling that someone was tugging at his shoulder and saying "go back, go back." This broke down his opposition. Arousing the First Sergeant he gave the curt order to prepare the Company to march within ten minutes. The noncommissioned officer looked at him in amazement but a sharp repetition of the order brought him to his senses and within less than the specified time the column was in readiness to move out.

It would have been difficult to find a more severe test of the discipline in the organization than the order to march, coming as it did on such a night when the men had just settled down to sleep in comfort after a hard day's journey. The Macabebes knew, however, that while the Captain never spared them when effort was necessary, on the other hand he sedulously protected them from all unnecessary hardship and exertion. They resigned themselves, therefore, to a night of discomfort and fatigue and thought no more of it. Probably no other body of troops on the Island could have been induced to make such a journey under similar circumstances, and as Cochrane thought bitterly, no sane commander would ever have tried to make men do such a thing. He stopped on the trail only long enough for the men to eat what food was left and to take a few hours of rest when they became too exhausted to proceed. Late on the following night, the third after the departure from San Ramon, they staggered

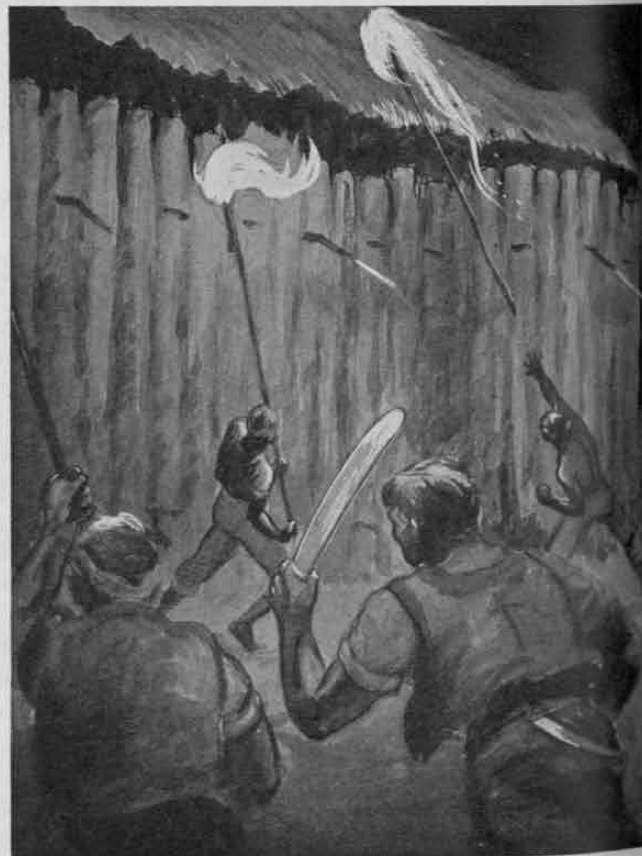

*A multitude of flaming meteors*

into the fort and threw themselves down, too utterly worn out to care for food, drink, or anything but rest.

Hazzard had no news to impart as everything had been absolutely tranquil at the fort and in the vicinity. He expressed astonishment at the quick return, but as the Captain vouchsafed no explanation, refrained from further comment upon the subject. Cochrane lay down, feeling, as he told himself, like "fifty-seven varieties of a damn fool" and this time he had no trouble in falling asleep. He was awakened by the crash of a heavy volley of musketry, followed by the ringing notes of "call to arms," and tumbled off his bunk to see what looked like a multitude of flaming meteors cleaving the air towards the fort. At the same time bullets were zipping through the *nipa* roof and the Pulajan war cry of *tad-tad, tad-tad*, (chop, chop to pieces) was going up on all sides. The fort had been assaulted in force by the Pulajans.

Knowing that the weak point of the fort lay in the inflammable *nipa* thatch, the Pulajan Chief had provided the first line of attackers, consisting of some fifty or sixty men, with torches fastened to long poles, his plan evidently being to set the roof on fire and thus force the defenders to evacuate the work in disorder, in which case they would become easy victims to his hordes of *bolo* men. The plan was well conceived and it would have succeeded, had not the white man who planned the fort taken cognizance of such a contingency and provided a counter-measure. The leading wave dashed in immediately after the opening volley and leaning the torches

against the roof, swarmed up the stockade to engage the defenders with the weapons which they carried unsheathed and swung to their wrist by thongs. It had rained during the night and the roof was damp but the thatching underneath being dry as tinder it soon took fire in a dozen places and flared up, illuminating the surroundings until the scene was as clear as under the light of day.

Thinking that the defenders were doomed, the hordes of Pulajans in waiting on the edge of the jungle as though by a prearranged signal, now charged across the open, their hideous ape-like faces, red uniforms, and the long white capes flapping from their shoulders, giving them the appearances of devils. Bare armed and bare legged, each man grasping two heavy *bolos* and whirling first one weapon and then the other in a double moulinet so rapidly executed that he seemed to be carrying two revolving disks of scintillating steel, the mass of fanatics struck the stockade and surged around it as breakers dash against a lighthouse built on a rock in the sea.

Meanwhile their riflemen kept up a heavy fire at the Fort regardless of whether they struck friend or foe. There were some who in an excess of frenzy threw down their rifles and, drawing their *bolos*, charged blindly at the Fort, cutting to the right and left and in sheer madness, hewing down their own people who got in the way. The defenders, however, were in good courage. Within a few seconds after the alarm was given each soldier was at his post, and although the first wave of the fanatics succeeded in firing the roof, not one of them reached the inside of the stockade alive. Cochrane heard one Macabebe say to another as they watched a fanatic scale the fifteen foot stockade as easily as a monkey runs up a coconut tree; "You hold him, when he gets up, and I'll stab him," and watched them do this, both laughing heartily when the corpse flopped to the ground.

The Captain made a hasty tour of the Fort, finding every man at his post and the pump-guns doing excellent work with their flanking fire. Then he and the orderly on duty placed some open ammunition cases within easy reach of the men, after which he sent the orderly to hoist the flag and himself sprang into the bastion nearest the jungle in order to size up the situation. The volume of fire from the jungle rather astonished him as he had not thought the Pulajans were so well provided with rifles and ammunition. From where he stood he could look along two faces of the Fort, and to his eyes the sheets of flames spurting from the double tier of loopholes formed a beautiful sight. The Macabebes were yelling, cursing, singing and daring the Pulajans to come on as they fired.

All this time he had an idea in the back of his head that something needed his attention and when the roof flared up and the Pulajan main body charged the Fort, he realized what it was. To seize a *bolo* and cut the *bejucos* holding the thatching in place required but a few seconds. He did this just as the heaviest rush of fanatics struck the stockade on three sides, and the flaming roof, bursting into greater blaze as it fell, dropped squarely



cleaving the air towards the fort.



*Within a few seconds each soldier was at his post.*

into the thick of them, deluging them with fire. The Pulajans were prepared to meet bullets, bayonets or *bolos*; but the charms they wore sewed in their uniforms or bound upon their foreheads had no provision against being roasted alive, so those who were able to move fell back, screaming with pain and rage.

The soldiers were using ammunition loaded with black powder and a dense pall of smoke settled over the Fort as soon as the flames died down in front of the stockade. There was a lull in the fighting then and Cochrane thought the Pulajans had fled, but he was mistaken for they charged again, this time against the face of the stockade to seaward. Then they charged on all sides and repeated this again and again, the soldiers peering through the smoke to hack at them or to shoot them down as they continued to come on as though bent upon their own destruction. At last the dawn came, suddenly, as it does in the tropics, and there in the open a few yards from the stockade stood a mere handful of Pulajans chanting their prayers in preparation for a last charge. As Hazzard expressed it, killing them had ceased to become a pleasure, but a final volley brought an end to the desperate attempt and then "cease firing" was sounded. The fight was over.

Presently the dancing notes of reveille rang out and the sun popped up over the rim of the Pacific, its golden rays bestowing new beauty upon the flag floating above, before descending to dissipate the mists of night from a scene too ghastly to seem real. Of the six or seven hun-

dred fanatics who had attacked the Fort, nearly a hundred lay dead or mortally wounded on the field, while bloody paths leading from the clearing showed where many others had dragged themselves off to die like wild beasts—which indeed they were—in the recesses of the forest. The remainder of the band, including the less seriously wounded, were dispersed in every direction.

The casualties of the defenders were: one soldier killed, one mortally wounded and eight others with wounds more or less slight, none of which appeared to be dangerous. One man had two fingers shot away and seemed to look upon the matter as a joke, judging by the grin on his face when he displayed the bloody stumps to the officers.

After the wounded Macabebes had been attended to, the gate was thrown open and a party went out under Hazzard to search for any remnant of the band that might have reassembled. Another party under the First Sergeant combed the jungle near by for survivors in hiding. Meanwhile Cochrane supervised the work of collecting the dead. The bodies were aligned in a row near the stockade, with the arms and papers taken from each placed opposite the head.

One body, that of a little boy not over nine years old, attracted his attention. As he leaned over to examine it, the child opened his eyes and, with the rapidity of a vicious snake, thrust at the Captain's side with a long dagger. The blow very nearly found its mark. Rendered peevish, by the close shave, Cochrane knocked the child senseless with the butt of a gun and directed the corporal of the guard to carry him inside the Fort. After this incident the Macabebes took no chances in handling the bodies. Without instructions they slipped their long needle-like poniards into the breast of each Pulajan before they started to move the body.

Never in the history of the Island had a greater killing of Pulajans been made. The dead in the immediate vicinity of the Fort numbered eighty-one, eleven other bodies were dragged in from the jungle and various bodies found subsequently at a distance from the fort were left where they lay.

After breakfast a long trench was dug in the soft sand of the plaza opposite the pyramid of skulls and in this the bodies of the dead were placed, two deep, and buried. The officers agreed that some sort of marker should be placed over the grave to commemorate the hecatomb which had taken place.

The mortally injured Macabebe died before evening. He had been wounded in the stomach by some curious projectile that made three perforations. Cochrane sat by his side and held his hand as he passed out. Just before he died he indicated that he had something to say. The Captain bent over to listen and was barely able to catch the faint whisper, "I don't mind dying, my Captain, but I do hate to think of that six months' pay due me that I'll never be able to spend."

These were the poor fellow's last words. He and his

comrade—were buried at sunset. The Company was paraded for the funeral and presented arms as the bodies, sewn in blankets, were borne past and placed on the edge of the double grave. The flag was then draped over the bodies and Cochrane made a short address, saying that these men had met their death while fighting for a flag that meant justice and right and liberty for the people of the Philippine Islands; that they had died as he or any other soldier would wish to meet his end, while fighting in a good cause; and he would see to it personally that the story of their brave death be published at Macabebe. The First Sergeant then spoke for a few minutes in a similar vein, and when the company had again presented arms the bodies were lowered into the grave. A firing squad then fired three volleys, and “taps,” beautifully played by the musician of the guard, concluded the ceremony. Two substantial wooden crosses were placed at the head of the grave and it was carefully enclosed with blocks of red and white coral.

After the men had been dismissed, Hazzard called Cochrane aside and with some pride displayed a piece of board on which were inscribed the following words:

“Feb. 28, 1904”

“Here lie the bones of 100 Pulajan murderers, who on this day were punished for their crimes and buried by Company A, 1st Battalion, P.C.”

“The wages of sin *is* death.”

Cochrane was pleased with the epitaph and thought the scriptural admonition at the end of it especially impressive but he took exception to the statement relative to the number of dead, because there were only ninety-two bodies in the trench. Hazzard mumbled something about poetic license but the Captain was inexorable, declaring that he did not wish the Company to take credit for anything that it had not accomplished and that the number would have to be changed. The matter was settled only by Hazzard’s agreeing to drag in eight more bodies from the jungle and inter them with the others.

The day had been such a busy one that Cochrane had not thought about the prisoner, the little boy who had tried to stab him. After supper the child was brought to the officer’s quarters for examination. The men had fed him and dressed his wounds. He had one buckshot in his shoulder and another in his arm. Evidently he was not accustomed to kind treatment, for it had transformed him. When he entered the bastion where the officers were seated, he knelt and bowed until his forehead touched the floor at Cochrane’s feet. He was an intelligent looking little chap, unusually light in color for a native and with something about his expression that was both roguish and winning.

“What’s your name, little Pulajan?” Cochrane asked, his features relaxing into a smile. The child smiled back, rather faintly at first, and replied that his name was “Feliciano.”

“That’s a pretty nice name for a little boy who goes around trying to stab people,” was the Captain’s half bantering remark.

Feliciano’s smile changed to a look of deepest shame. A white child would have cried probably, but he did not although tears came to his eyes. Dropping on his knees he placed his forehead on the floor and remained in that position, his little naked figure pitifully expressive of abjection and penitence. Cochrane reassured him with kindly words and won his complete confidence by giving him a brightly coloured silk handkerchief for use as a breech clout. The present delighted him so he could hardly take his eyes from it, while he conversed with Cochrane and the First Sergeant. They extracted his story gradually by letting him do most of the talking, prompting him when necessary with questions to which he replied freely and artlessly. Some of his statements were startling. At the end of half an hour he was permitted to rest and squatted down on his haunches, never ceasing to finger the silk handkerchief.

Cochrane sent for some of the ammunition picked up near the fort. When the orderly returned with a handful of cartridges, he looked them over, selected one and hammered at it with the back of a *bolo*. The bullet came loose and dropped into his hand together with two others which rolled out of the same cartridge. “Hum,” he said, showing the bullets to Hazzard, “Multiball ammunition, and that’s where they got it. I thought something was wrong when I saw they had so many guns. That, the three bullet holes in poor Marcelino’s stomach, Spot’s coming to us, and our not getting any rations, are all explained now. The kid is a regular mine of information and he has told the truth.” Hazzard stared at him blankly, “I’ll explain,” continued Cochrane, realizing that Hazzard had not understood the conversation, which has been in Visayan.

“When the Pulajans captured Catubig, a town in the northern part of the Island, several months ago, they killed this boy’s father, mother and baby sister, and carried away his older sister, whom he has not seen since. After they burned Catubig they burned some villages on the coast north of here and then the main body, led by Antonio Anugar, moved south and attacked Oras, a town on the east coast which I have been told has, or had, over ten thousand inhabitants. There was a detachment of Scouts there and the people helped them put up a fight, with the result that several hundred of the town’s people and every one of the Scouts, including an American hospital corpsman, were killed. They burnt Oras, and after sending some of the loot to Maslog, went on to the south to a town where there was an American officer who must have been Harris, in command of a Scout detachment of about fifty men. Anugar’s band struck them just before daylight. Harris was camped in the plaza and there was nothing to stop their rush. He put up a good fight, but they killed him and all his men. Then they marched to

Maslog, left their loot there, came on down here to take us in and got what was coming to them."

There was a long pause while each officer tried to appreciate the situation as it had just been revealed. Finally Hazzard spoke. "Probably we are the only troops left on the whole Island between Tubig and Lauang."

"No doubt we are" Cochrane answered. "After all their victories the Pulajans must have believed, before they struck us, that their medicine was good. Feliciano says that Anugar, who by the way appears to have escaped alive, would not let his men stop to cook breakfast before they attacked us. He had the gall to tell them they could eat our breakfast and that they would have coffee to drink."

"Precious little good our breakfast would have done them," Hazzard growled, "what in the hell is the Government doing letting us starve like this? I could eat any army mule right now."

"That I think I can explain also" Cochrane responded after a moment's reflection. "I had thought of keeping it from you because I didn't wish to lower your morale by giving you more bad news, but I guess you can stand it. Feliciano tells me there is a ship wrecked on the reefs off the northeast corner of the Island. It is probably the Coast Guard cutter which had our supplies on board."

Hazzard rose and resting his elbows on the bamboo parapet, gazed out on the waters of the bay. Cochrane spoke a few words to the boy and dismissed him. Then he rejoined Hazzard and the two officers stood there in silence, their eyes fixed upon the flashes of white out to seaward where the long combers of the ocean were dashing themselves into clouds of phosphorescent spray in the never ending conflict with the coral reefs. Within the bay the water had the sheen of molten silver. Under the moon's transforming light the long familiar scene was endowed with a beauty unearthly and exquisitely sad. Cochrane gave an involuntary shiver and roused himself.

"A drink of whiskey wouldn't go at all bad now, would it, old Sour Face?" he exclaimed, slapping Hazzard on the shoulder.

"No," replied the Lieutenant, "and how about the grill room of the La Salle with a planked steak two inches thick just coming on the table—and a fluffy girl with silk stockings on to dance with and make love to afterwards."

The Captain did not share his enthusiasm about the latter feature because an intense shyness gave him such an absurd fear of girls that their mere presence sufficed to make him utterly miserable. His answer was to close the shutter and to call loudly to the orderly for lights.

"I don't miss the food very much," he said, when the soldier had brought in the coconut shell *quinques* filled with oil from the same nuts, which were used as lamps. "I got used to going hungry when I was a kid and I've had to do it off and on ever since, but I am sorry for you and the men."

Hazzard made a deprecatory gesture. "Oh don't worry about me," he said hastily, "you've enough to bother you without that; I'll manage to get along. Still I don't see what's the matter at headquarters. We've been holding this damned place down over two months, living on fish and bats, both of which are getting scarce and I don't know what's to become of us."

"It is about our situation that I wish to speak now," answered Cochrane, weighing each word carefully. "I am responsible that the orders given me are complied with exactly. On the other hand I am also responsible for the lives of the men of this company. No doubt I would be justified in abandoning the station and marching either to the north or south to find some place where there are troops and supplies. However, I have never yet deserted a post which has been confided to me and I do not propose to do so in this case. There are, therefore, three courses open to me. The first is to stay here and do nothing until help comes; that, of course, you know I shall not do. The second is to march to Maslog and attack it. We should have no trouble in finding the way, with the trail made by the Pulajans to follow and Feliciano also to guide us. That course is impracticable because we have no extra food except two sacks of rice and a few pounds of dried fish found among the articles captured this morning.

"The third course, the one I have decided to follow, is for me to take sixty of the men in best condition and make a forced march to the south to get supplies at one of the towns on the coast. I intend to return by sail-boat with the supplies. If possible I shall get a boat large enough to transport about eighty men from here to a village to the north that Feliciano says is only a short distance from Maslog, as by going that way we can save three days of hard marching."

Cochrane's speech had a tone of finality that showed his decision could not be changed. Hazzard had a request to make, however, and did so hesitatingly as though he feared it would be refused. It was that he be permitted to accompany the expedition.

Rather to his surprise the Captain assented, saying that the First Sergeant was competent to command the Fort until their return and that he had not invited Hazzard to go with him because he feared the Lieutenant, not being inured to marching in Samar, would be unable to withstand the hardships sure to be encountered. Hazzard asserted stoutly that so long as he was heading in the direction of something to eat besides bats and fish he could keep going as long as anyone in the Company.

It was decided then that the start would be made as soon as the men who had gone on the previous expedition were sufficiently rested. These men were yet fatigued from the forced march made in response to the strange summons received by the Captain. He did not mention that occurrence and dismissed it from his mind as one of those inexplicable happenings that few believe to be true and no one can make clear.

The departure was signalized only by Spot's lamentations at being left behind, and the first day's journey to the camp in the phosphorescent forest was made without incident other than the usual deluge of rain. No *boudjons* were heard, from which it was assumed that the Pulajan outpost in the vicinity of San Ramon had been abandoned. On the second day the trail leading southward was taken at the road fork by the burned hut. This trail was badly overgrown and after leading the column for hours in the direction of every point in the compass, it finally became obliterated in an evil-smelling morass from which the fagged out men were barely extricated before it became dark.

The men required considerable urging that night to get them started on the leaf shelters, but they could hardly be blamed for this in view of the darkness and rain. Never before had Cochrane witnessed such a rainfall. The air was so saturated with moisture that breathing was difficult and it was impossible to get a fire started. Exposure and hardships had brought on several cases of fever, which in the weakened condition of the men was a serious matter. Hazzard was one of the first to succumb, but with blue lips and chattering teeth he had staggered on until the halt was made. Then he dropped to the ground and lay there unable to move. The night was spent without food or sleep, the men lying in their sodden rags on the wet leaves, their teeth chattering an accompaniment to the rain beating upon them.

The next morning Cochrane made shift to get a fire started and cooked the last of the rice except a small hidden store which he carried himself as a reserve for the sick men. The hot food, scanty as the ration was, revived the spirits of the Macabebes, but their pinched features and gaunt, even skeleton-like, bodies made Cochrane's heart ache. He could see they had almost reached the limit of their endurance and he knew that it would be his cruel task to drive them to this limit—and beyond it.

His plan was to travel by the compass to the southward in the hope of finding a stream leading to the coast. He had no map, but according to his recollection of the vague and inaccurately drawn Spanish charts he had seen, there was a large navigable river heading well up towards the northeastern corner of the Island, which flowed towards the south or southeast, and at the mouth of which was the town of Oras. It was this stream, or one flowing parallel to it, that he hoped to find.

That day's journey was one of indescribable torment. Towards noon Hazzard became delirious and had to be carried. The other sick men were forced along by cor-

porals, one being assigned to each man. Cochrane moved from one end of the column to the other as by sheer force of will power he drove the men forward through a wilderness hitherto untrodden of jungle, mountain and morass. It wrenched his heart to see men who had risked their lives again and again to save him from danger, goaded like beasts by his own orders, but there was nothing else to do.

Towards the middle of the afternoon the column, bearing its burden of helpless ones, was struggling through an entanglement of plants covered with tough spines which stung when they touched like the bite of a venomous reptile. The Captain was at the head of the column seeking a camping place, for some of the men could be driven no farther, when he emerged suddenly on the bank of a broad and deep stream. A glance at his compass told him that the direction of its flow at that place was southeast. There was no trail along the bank—the jungle being unbroken and more dense than usual and at a bend down stream could be seen the face of a high precipice crowned with the usual matted growth of vegetation. Here was a new problem for solution. He was turning it over in his mind when he heard a sound coming from up stream which made him tingle with joy. It was the noise of an approaching steamer. The men heard it too, and lined the bank eagerly, their unshorn hair and mud-covered rags of uniforms giving them the appearance of a band of castaways.

When around the bend came a large launch with a brass gatling gun mounted at the bow and the blue shirts of a group of soldiers showing under the awning stretched over the deck, the Macabebes went wild, dancing, screaming and throwing their arms about in paroxysms of happiness.

Through his glasses Cochrane saw one of the lounging soldiers on board spring to life and point out his men to an officer. He expected then that the launch would move towards him. Instead it sheered away towards the opposite bank and increased its speed. Cochrane yelled to the Macabebes to lie down and himself stood there alone waving his hat. His command was given just in time, for the gatling gun came into action and raked the shore where they had stood, Cochrane barely escaping the rain of bullets by throwing himself backward into the mud. The firing continued until the launch rounded the bend down stream and passed out of sight, the noise of its propeller soon dying out in the distance. They had been mistaken for Pulajans.

(To be concluded.)



# A Broadcast Hook-Up for AA Intelligence Net

BY LIEUTENANT G. H. STUBBS, C.A.C.

THE early part of 1933 brought the usual quota of sorrow to the Communications Officer and the Intelligence Officer in battling with time while aircraft swooped down on Corregidor.

Our system of intelligence was a more or less standard set-up which had just grown and grown. It called for the following procedure: An observer, seeing a plane, would ring the switchboard operator and ask for a clerk, the clerk recorded the message and handed it to the Intelligence Officer, the Intelligence Officer decided on disposition of the message and ordered another clerk to transmit it to interested units.

The chief trouble with this system was lack of speed. It was not at all unusual for a plane to be overhead, the roar of its motor interfering with conversation, while we were trying to transmit news of its approach. Then, too, all observers and a few battery positions would often see a plane at the same time and all try to report it at once, which was very bad indeed on the nerves of the switchboard operators, clerks, and in fact everyone. The whole net had grown tremendously in size and complication under constant efforts to speed things up—the original lonely switchboard had grown into four switchboards and a sketch of our telephone lines looked like an intricate geometric problem.

If the Commanding Officer's expression when he entered the private madhouse which we hopefully called our Intelligence Room was any criterion, something must be done and done promptly.

The Problem—to devise a system that would be accurate, dependable, quick as lightning, and simple. The material available: field wire and underground cables from all O.P.'s and battery switchboards, each terminating in one of four switchboards at the C. P., plenty of excellent telephone and switchboard operators and the old reliable EE5 telephone. To those unfamiliar with the EE5, let me explain this excellent piece of equipment, whose designer knew one primary God—simplicity. It consists of a hand magneto for ringing, a coil, a condenser, a flashlight battery and a handset holding the transmitter and receiver. The handset has a push button which has to be pressed when transmitting but the receiver is connected across the line at all times so that the operator may "listen in" on his line at any time without pressing the transmitting button. This is of great value on a "party line" where the operator may repeat a message for recording or immediate action without interrupting the person transmitting.

The decision: I invented the two commands "Broadcast Hookup" and "Normal Hookup." At the command "Broadcast Hookup" each telephone operator was ordered to hold his receiver to his ear and listen in on the

line continually until relieved by the command "Normal Hookup." For "Broadcast Hookup" we plugged in all lines at the C.P. and Battery Switchboards so that we now had a gigantic "party" line with thirty-five telephones connected at once. The first person to see an approaching plane pressed his transmitting button and reported the plane (note that competition will keep you observers on the job) and each battery, platoon and intelligence position in the regiment got the news instantly. No delay, no ringing, no repetition, no confusion no relaying and no Intelligence Officer. The little flashlight battery used in the EE5 was found to be capable of transmitting satisfactorily to all thirty-five phones at once over our short lines without materially reducing its life, but just to be sure we use four dry cells at the observation posts and C.P. where 95 per cent of the transmitting is done. Reception, on actual test, was found to be better than before.

The application of the broadcast hookup by means of simply plugging in all lines at the switchboards has three distinct advantages: (1) no change in our communications net was involved, (2) we can revert to the old system in whole or in part for rest periods or on special occasions, and (3) a short-circuited line (which could ruin the whole system) can be located by test and disconnected on a moment's notice.

Discipline on such a hookup is a feature that can make or break the entire system. Telephone operators *must* not press their buttons unless they have a pertinent message. Everyone of the thirty-five operators on our net is assured of a large audience at any time with little chance of detection so I generally listen in at the C.P. and give a growl at the slightest inappropriate sound, but even so an occasional "when do we eat" or "soupy" will come over the line. The slightest indication of a formal message always gets silence and undivided attention, however.

The intelligence room is now a veritable morgue for silence and the switchboard operators are learning to sleep sitting up. Actual experience soon showed that the broadcast was dead for so much of the time even during the height of an "attack" that routine commands, intelligence, ammunition expenditure reports, etc., could be sent. Also, anyone having a message for an officer, communication sergeant, etc., absent from his normal position can grab any phone and call for his party with assurance that if his party is within sight of any phone in our net he will get him on the line promptly. Of course intelligence has priority and any operator having real news to send interrupts by giving the old call "Flash, Flash."

# Antiaircraft Defenses: Their Development During the World War

BY MAJOR A. F. ENGLEHART, C.A.C.

## PART II

### THE UNITED STATES

AT the time of our entry into the World War, there was no American antiaircraft matériel. Antiaircraft matériel to equip our Expeditionary Forces consisted of the French 75-mm. cannon on auto trailer and semi-fixed mounts, some of which were obtained from the United States. The French Hotchkiss machine guns were used throughout the machine-gun battalions, while the searchlight companies were equipped with lights varying from 36" to 60" in diameter, some of which were obtained in the United States.

Starting with nothing, the antiaircraft service grew, by the end of the war, to include seven gun battalions of five batteries each and twenty separate batteries (5,000 artillery); six antiaircraft machine-gun battalions (4,500 infantry), and ten antiaircraft searchlight companies (2,500 engineers). Of this number, only one battery (B, 1st Antiaircraft Battalion) saw service at the front with its own guns. Twelve batteries, having no guns of their own, served, as additional personnel, with French units at the front, while the other batteries were in various stages of training or manning guns in the rear areas. Two antiaircraft machine-gun battalions and five searchlight companies saw active service.

The Chief of the Antiaircraft Service was in direct command of fixed antiaircraft defenses, with antiaircraft service in each army subject to his inspection and recommendations. The Chief of the Antiaircraft Service in each army was in direct command, under the supervision of the Chief of Artillery of the army, of all the antiaircraft service assigned to the army. This included guns, machine guns and searchlights.

The subordinate gun, machine-gun and searchlight companies were independent of each other. Each pair of guns was supposed to be in direct telephonic communication with each adjacent pair, with each balloon in range, with the sector commander and with army headquarters.

The system of watching and listening posts, whereby alerts were signalled to places in the rear of the army areas, was entirely in the hands of the French.

In the Service of Supply, the tactical control was different. All units of antiaircraft were under one officer. This officer was in telephonic communication with each unit under his control, and in addition was in constant touch with the French alert system.

In the First American Army for the St. Mihiel offensive, there were thirty-four 75-mm. cannon, consisting of trailers, auto-cannon, and semi-fixed mounts. The semi-

fixed guns were placed about four kilometers in rear of the front and from three to five kilometers apart. The mobile guns were deployed in suitable positions along the corps fronts in groups of three batteries of two guns each, and the trailers were in the Moselle Valley in one group.

For the Meuse-Argonne operation, the guns were of the semi-fixed, auto-cannon, and trailer variety, fifty-four for the protection of the front lines, and twenty-eight for protection of the rear of the army.

Upon the organization of the Second American Army, thirty-one guns, of the semi-fixed and trailer mounts, were assigned to the army, with two additional guns assigned later.

From about 17 July to November, 1918, the antiaircraft guns were credited with bringing down seventeen hostile planes, with an expenditure of 10,273 shots, or an average of 605 shots per plane.

Gun batteries were able to keep up with the advancing infantry when they were furnished transportation with which to move. They limited the activities of the hostile planes and made bombing costly.

Contrary to the practice in other armies, the American Expeditionary Force supplied antiaircraft machine guns to the armies at the front for the specific purpose of combating low-flying planes. These guns were installed in groups not to exceed four guns at intervals of not less than one thousand yards and within range of the front line troops. They were to keep up with the infantry advance.

During the St. Mihiel operation, the First American Army received five American companies and one French section. In the five days of the St. Mihiel attack, they kept up with the infantry support lines, advancing by leap-frogging sections. They fired at seventeen targets, totaling eighteen planes, with the following results:

"One plane shot down; one plane attempting to bomb a bridge at Atton driven off; and the remaining sixteen planes, engaged in observation, driven off."

During the period between the St. Mihiel and Meuse-Argonne attacks, antiaircraft machine guns fired at thirty-four targets, totaling sixty-eight planes, with results:

"Four planes brought down; sixty planes forced to go out of range or turn back; three planes fired at in the dark with no noticeable results; and one plane continued on and accomplished its mission of destroying an observation balloon."

During the period 26 September-18 October, 1918, three companies of machine guns fired on 128 planes,



brought down eleven and forced the other 117 to keep out of range.

East of the Meuse, in the period 26 September-11 November, 1918, three companies fired on 113, totaling 395 planes, brought down twelve, allowed four to accomplish their mission of destroying balloons and strafing infantry, and six, disabled, to limp off. These three companies were under almost continuous artillery fire and frequently were fired on by machine guns from the target planes.

For the St. Mihiel operations, two searchlight companies, manning American matériel, were sent to the First American Army. Each company consisted of five platoons, operating two or three lights each. These lights were placed near the probable line of hostile approach, and with reference to the positions of the antiaircraft gun batteries. They were grouped in approximately two lines, covering an area of about 350 square kilometers. From 14-20 September, 1918, they illuminated fifty-four planes for an average of two and a half minutes each.

As a result of these operations, the officer in charge of these searchlights recommended that:

"a. Searchlights be arranged in four staggered lines.

"b. A band of light should be located close to the front.

"c. The bands of light must be continuous so as to be impossible to skirt the flanks.

"d. Both airplanes and antiaircraft batteries should defend the lighted areas.

"e. That the tactical work of the searchlights, antiaircraft guns, and airplanes be coordinated under one head."

During the period of the Meuse-Argonne operations, German aviation bombed fifty-six localities at night. One of these raids was made by crossing the lighted area, eight were on the flanks of the lighted areas, ten were on the edge of the lighted areas, and the remaining raids were in front of the bank of lights. On 1 November, 1918, another company of ten lights was added, making it possible to light up the entire front of the two American Armies.

In the Service of Supply, the antiaircraft defense was divided into nine sectors. Only three of these sectors were completed prior to the armistice. At Is-sur-tille, four American batteries, of two 75-mm. guns, each, mounted on American improved carriages, and nine searchlights were installed. No German bombing planes reached this important base after this installation was completed.

The defenses of Colombey-les-Belles (1st Air Depot) were started in September, 1918. Eight guns and six 60" searchlights were installed. Three raids were made by the Germans; the first, on 2 September, before the installation was completed; the second on 28 October, when bombs damaged fifty planes; and the third, on 30 October, when twenty bombs were dropped in the woods near the airdrome. Only during the last raid is there any record of firing the guns, when it is stated that "they

put up a very fine barrage which doubtless afforded efficient protection."

#### DEVELOPMENTS SINCE THE WORLD WAR ENGLAND

In the two years following the World War, the whole of the air defense of England disappeared. The following table shows the decline of the Air Defense of London:

	Guns	Searchlights
Existing at the Armistice .....	286	387
Establishments proposed in December, 1918....	164	256
Establishments proposed in June, 1919.....	42	60
Establishments proposed in September, 1919..	32	34
Establishments proposed in December, 1919..	8	8
Remaining in 1920 .....	0	0

The eleven R. A. F. squadrons also melted away until nothing remained. Efforts were made to retain the system of communication and control rooms at the Horse Guards, and at the various squadrons, but without avail.

In 1924, an inter-departmental committee was formed to prepare a plan for the London Air Defense. The scheme adopted was based on the London Air Defense as developed just prior to the armistice. Two air defense brigades, each composed of two brigades of artillery, a battalion of searchlights, and a signal company, were authorized for the home defense.

It was recognized that "all troops for air defense require special treatment in the matter of establishments, and that these, if ever wanted, will be wanted at full strength and full training at a few hours' notice. In principle, the peace and war establishments of the air defense troops should be the same, as in no other way can the defenses hope to be ready when wanted."

The first object was to organize an efficient observers' corps for the observation and intelligence system. County constables were appointed as special observers, and connected by telephone with a sub-control post, which, in turn, was connected with the central office.

It is intended to use the antiaircraft guns and searchlights and the fighter airplanes as a unit, under one command. Exercises are conducted each year during the Air Maneuvers, to test out the system and train the personnel.

Considerable work has been done in the training of antiaircraft gun and searchlight units. Target practices were at first conducted against slow-moving smoke bursts, then at actual airplanes, using reduced charges. Of late, practices have been held against sleeve targets towed by airplanes. Improved fire control instruments, such as the Vickers computer, have been manufactured.

The training has been conducted on the principle that antiaircraft guns are fired at the target to destroy, or at least, to break up the formations, to make an easy prey for the friendly pursuit airplanes. It is not believed that any system of defense can be so strong as to prevent a large hostile force from having part of their planes reach their objective. However, in such an attempt, the attacking force will suffer such great losses as to discourage aerial bombing.

Searchlights are to be used to illuminate the target, and

not to establish a lighted belt. Once a target is in the beam, it will be held there during attacks of antiaircraft guns and fighter airplanes.

In the protection of vulnerable areas, represented by a circle of five miles radius, guns, searchlights and pursuit airplanes will be used. Immediately outside of the vulnerable area will be a belt for gun fire from three to four miles in depth; next, a belt of ten miles in depth for friendly pursuit airplanes; then, one belt of six miles for the outer gun fire; and a final belt, from forty-five to seventy-five miles wide, covered with a network of observation posts, each of which can be from ten to fifteen miles of the other. By night, searchlights will be used in the gun and airplane belts for the illumination of targets.

#### FRANCE

The "Instructions for the tactical employment of large units" for the French Army prescribe that the antiaircraft service is a subdivision of the air service. All means for the attack and defense against aircraft is to be under one head.

In time of war, the antiaircraft defense includes the following two distinct organs:

"The antiaircraft defense of the armies under the commander-in-chief, and the antiaircraft defense of the interior under the orders of the Ministry of War."

In each army, the antiaircraft service includes an antiaircraft defense command, an integral part of the air service command, and some defense units, variable in number, placed at the disposal of the Army. In addition, a general antiaircraft reserve is formed, and placed at the disposal of the commander-in-chief.

The rôle of the antiaircraft artillery engaged in the front line, is to attack all hostile airplanes which attempt to fly over friendly territory. The group, which is the tactical unit, is not broken up in principle. It generally engages in the form of a triangle, with each side about five kilometers long, with two batteries in front and one battery in rear, the great base turned toward the enemy. In the second line, in rear of the front, antiaircraft artillery is employed for the defense of sensitive points (headquarters, cities, ammunition dumps, etc.). In this case, economy may necessitate the breaking up of the group, but the battery, the unit of fire, is never broken up. Fire should be concentrated at critical points, not distributed over a wide area. The batteries to be employed for the defense of sensitive points should be placed in proximity, (one to three kilometers distant) to those points, and as far as possible on the side of the probable arrival of hostile aircraft.

Searchlights are to be used only in rear of the front, and will generally be placed at the disposal of the army commander. They should be used to create a zone for the pursuit airplanes. Zones of night pursuit are organized with reference to the routes of approach of hostile airplanes, without, however, necessitating proximity to sensitive points. In no case will they be placed over sensitive areas.

Antiaircraft machine guns will not form a part of the air defense. All arms will protect themselves against low-flying aircraft.

The antiaircraft defense will consist of: (a) a limited number of mixed regiments, composed of two antiaircraft artillery batteries and one group of two searchlight companies, and (b) a certain number of antiaircraft defense batteries, attached to the artillery regiments and charged with furnishing and instructing the complementary personnel necessary for the territorial defense not mobilized by the antiaircraft defense regiments.

Information is gathered by "Lookout Posts" (lookout by day and listening by night) which are distributed along, and in rear of, the front, including the seacoast, so that not a single airplane can penetrate without being seen or heard, and being recorded. This information is centralized by grouping lookout posts in information centers, which exploit this information and transmit it to those concerned (command, air service command, pursuit aviation, antiaircraft artillery command, etc.). Within armies and in the interior of the territory around sensitive points, every antiaircraft defense post is a lookout post. Special lookout posts are not organized, except in cases where the lines of the antiaircraft defense are not continuous.

On the march, the first line antiaircraft defense moves forward by bounds and successive echelons, in such a manner as to assure the continuity of the frontal barrage, and to cover the troops passing through defiles.

#### GERMANY

Each unit of the German Army, the size of a division or larger, in time of war, will be provided with antiaircraft defense, this defense to consist of guns, machine guns and searchlights.

In the division, the antiaircraft artillery will be employed as a unit under the direction of the division commander. The antiaircraft artillery commander is to be subordinated to the artillery commander, who keeps him informed of the intentions of the command and the area to be especially protected against attacks from the air. On the march, the antiaircraft artillery is to be placed in position where protection against attack from the air is of special importance, e.g., in defiles, when crossing open terrain, etc. In such situations, the antiaircraft artillery is pushed forward by bounds, and, when the main body has crossed the defile, they are to follow on parallel roads. The tactical situation will dictate what areas are to be given priority in protection, that is, main artillery positions, assembly areas for the infantry, routes of approach for enveloping columns or reserves, railroad centers, de-training stations, ammunition dumps, etc.

For use in the combat area of each division zone of action, in meeting engagements and the attacks in mobile situations, more than an antiaircraft artillery unit will be employed. One unit will be designated to accompany the advance of the troops after successful attack. Frequently, a part of the small caliber antiaircraft guns and

machine guns will be attached to the leading troops for protection against hostile attack airplanes.

In large units, corps and army, several antiaircraft defenses, under a central command, will be organized laterally and longitudinally. For the defense in stabilized situations, antiaircraft defense units will be placed in conjunction with the adjacent units, so as to create two successive zones in form of checkerboard squares. For important establishments, such as ammunition dumps, railroad stations, and the heaviest guns, special protection is to be provided, generally by combining small caliber antiaircraft guns, machine guns and searchlights. At night, routes of approach for reserves, supply columns, etc., will be given special protection by use of small caliber antiaircraft guns and machine guns, with searchlights.

The first duty of the antiaircraft service will be to organize the air-lookout system. This antiaircraft lookout system will watch the probable routes of aerial approach, allowing no enemy airplanes to penetrate the front line without being reported promptly. This intelligence system is to be centralized under the army.

Searchlights are to be employed at night to locate hostile airplanes and to direct aimed fire against them.

Under the terms of the Peace Treaty, Germany is allowed to have antiaircraft guns in the Fortress of Königsberg only. In October, 1930, tests were made of the alert system, antiaircraft defenses and warnings to the civil population. Here, observation stations, some six to seven miles apart, were established to give information of the approach of hostile airplanes. These observation posts were connected with a central station which disseminated the information, giving it to the defending airplanes, antiaircraft artillery and to particular cities when it was known the raid would include them. The results of the exercises, conducted both day and night, showed the efficiency of the air lookout service in picking up the targets, and of the antiaircraft artillery in bringing the targets under effective fire.

#### UNITED STATES

The duties and basic organization of antiaircraft artillery are prescribed in Field Service Regulations as follows:

"The organization of corps and higher commands includes antiaircraft artillery units, equipped with antiaircraft guns, machine guns, searchlights, and the matériel required for observation, listening, . . . , and signal communications.

"In principle, other combatant arms and other artillery units take the necessary measures for their own immediate protection against low-flying hostile aircraft.

"Antiaircraft artillery reinforces the antiaircraft measures of other arms and units and operates especially against hostile aircraft flying beyond the range of their matériel. By driving hostile aircraft to higher altitudes, it decreases the effectiveness of enemy observation, fire control and bombardment. Its searchlights and listening service enable it to operate at night.

"Antiaircraft artillery is also employed in the immediate

protection of sensitive points in the areas in rear of the leading troops.

"Antiaircraft artillery coöperates with the air service. In night defense, its searchlights create illuminated zones within which the night pursuit of the air service is enabled to attack hostile aircraft coming under observation.

"Antiaircraft artillery informs the command and the air service relative to hostile aerial activity. It establishes an observation and communication system which enables it to give prompt warning to the air service and threatened elements of impending attack.

"The various means of antiaircraft artillery are combined in the regiment which includes gun battalions and machine-gun battalions. Gun battalions include gun and searchlight batteries."

In an advance, "when danger of aerial attack exists, units designated for antiaircraft defense march in a state of readiness for action. Elements of antiaircraft artillery advancing by bounds follow the advance guard and the tail of the combatant elements of the main body or move on parallel roads when the latter are not occupied by adjacent columns."

In attack or defense, "units are especially designated for defense against low-flying hostile aircraft, in order that other units may not be forced to divert their attention from their assigned objectives."

In shelter areas, "antiaircraft artillery is assigned in groups in accordance with the relations of their areas to the general plan of antiaircraft defense as regulated by higher commanders."

In a stabilized situation, "antiaircraft batteries are distributed in checkerboard formation in such manner as to create as far as practicable two continuous zones of antiaircraft fire. In addition units of antiaircraft artillery are assigned to the local defense of important roads and installations (railroad stations, ammunition parks, airdromes, etc.). The antiaircraft intelligence service, employing the special communication net at its disposal, gives prompt warning to antiaircraft units, the air service and the troops concerned."

The primary objective of antiaircraft guns is bombardment aviation. Secondly, they are to attack observation airplanes as soon as within range (to drive them off, to force them to fly at high altitudes, or to force them to maneuver to avoid being hit), thus preventing the accomplishment of their mission. In addition, they are to furnish protection, within range of the guns, to friendly balloons and observation airplanes, engaged in registering artillery fire or in other missions.

Antiaircraft searchlights are employed to discover and to illuminate or outline enemy aircraft, so that it may be fired upon by antiaircraft guns and machine guns, and to indicate to the pilots of friendly pursuit airplanes the position of the enemy aircraft.

The firing unit of antiaircraft machine guns is the platoon of four guns. They are disposed so as to protect the

greatest possible number of important undefended elements against attacks by low-flying aircraft. Troops, command posts, distributing points, railheads, and airdromes comprise the elements thus protected. The entire area of a division and a corps is covered with machine guns, with an interval of about 2,000 yards between platoons. Each gun battery is equipped with a platoon of four guns for its immediate protection. In advance, anti-aircraft machine gun platoons are distributed in the columns, particularly during the passage of defiles or the crossing of any open terrain, with special attention being given to the head of the column and the trains. Reserves in shelter areas and during their approach to combat are given special anti-aircraft machine-gun support.

A brigade, of anti-aircraft artillery, consisting of three regiments, is assigned to each army. This brigade is to protect the rear installations in the army service area, the reserves, and any vulnerable defiles. It may be used in the defense to assist the corps, when occupying a wide front, or, in an advance, to take over from the corps, protection of the rear of the corps area. Each corps has assigned an anti-aircraft regiment. This is used to protect the front line elements, division and corps reserves, and important establishments in the corps area.

In a detached division, some anti-aircraft guns, searchlights, and machine guns are assigned for the immediate protection of the ground troops and trains.

It is contemplated that the gun batteries of the corps anti-aircraft regiment will be disposed in a triangle, each side about 5,000 yards long, and that longitudinal and lateral coordination will be accomplished between corps, so as to form at least two lines of defense. Gun batteries of the army anti-aircraft brigade are located with reference to the disposition of the corps batteries, and the protection of certain vital points in the army rear area.

In the communication zone, the localities requiring anti-aircraft protection include supply depots and establishments of all kinds, ports of debarkation, critical points on the lines of communications, manufacturing and industrial establishments and cities. All of these require special treatment, and not all can be covered, due to the amount of anti-aircraft artillery necessary to perform that function. Certain vital areas are protected by anti-aircraft defense furnished from the General Headquarters reserve.

An anti-aircraft intelligence service is vital to the proper defense against hostile aircraft. The coordination of this service in the army area is a function of the army commander. In rear of this area and within the theater of operations, appropriate commanders organize the necessary anti-aircraft intelligence service and maintain communications with the services of the armies in their front, under the general direction of General Headquarters. When the zone of the interior adjoins the theater of operations and is within the radius of action of enemy aerial operations, similar action is taken by the territorial commanders responsible. In this manner, a continuous chain of communication is maintained from the line of contact

with the enemy to the rearmost element exposed to enemy attack or observation.

#### ANALYSIS AND CRITICISM

Sufficient thought and preparation had not been given to the subject of defense of ground troops and installations prior to the World War. Once the countries were in war, they were too busy equipping the troops at the front with the necessary supplies and matériel to devote sufficient time and thought to the subject of anti-aircraft defense.

For the first two years of the war, measures taken were, for the most part, temporary expedients, lagging far behind the developments of aircraft. As a result of the damage to cities and ground troops by aerial bombing and low-flying aircraft, means were developed to combat these planes.

The defensive means were, for the most part, identical in all countries. For the protection of her cities, England depended far more upon the pursuit airplane, than did France or Germany. All countries realized that the proper defense against aircraft included anti-aircraft artillery and pursuit aviation. All countries, except the United States, relied upon the machine guns of combatant units to furnish protection for ground troops against low-flying planes, in addition to firing on ground targets. The United States provided special anti-aircraft machine-gun units for the protection of ground troops.

In the final stages of the war, searchlights were used to illuminate targets for anti-aircraft artillery and friendly pursuit aviation. The need for searchlights at the front was established. In some cases, lighted belts were developed in rear of the front to limit hostile aircraft. In all cases, searchlights were used to assist the defense of cities and important rear establishments.

All countries realized the importance of prompt and accurate reports of the approach of hostile aircraft. The intelligence system developed in the different countries was similar in extent. This intelligence system, operating over separate telephone wires, was established from the front to include important establishments and cities in the rear.

It was found that no defense was strong enough to prevent some hostile airplanes from carrying out their missions. However, a defense, that made aerial bombing, ground strafing and observation work very costly to the enemy, was developed.

All countries, in a general way, are working toward the same objective since the World War. It is realized by all that a proper defense against aircraft cannot be developed at the outbreak of war. Peace establishments must be strong enough to provide a strong defense at the outbreak of war and form a nucleus for rapid expansion. Countries with contiguous borders, or in close proximity, are providing stronger peace establishments.

Improvements in proper organizations and matériel are proceeding rapidly in all major countries. Frequent Air Corps-Anti-aircraft Artillery maneuvers are being held

to increase knowledge of antiaircraft defense tactics and technique. Yearly target practices are being held to increase the effectiveness of antiaircraft artillery fire.

#### CONCLUSIONS

Proper defense against enemy aircraft is dependent upon an efficient observation and intelligence system. The antiaircraft service of the army must be so organized as to furnish quick and accurate information of any enemy airplanes crossing the front to all elements of the army. This system must be extended to the lines of communication and far enough into the zone of the interior to cover the radius of action of enemy bombers. A specially constructed communication net must be established in order to expedite the transmission of this information to all vitally interested. All antiaircraft artillery stations, friendly airdromes and higher headquarters must be connected in this net.

Within the army, an intelligence battery should be organized to form a part of the antiaircraft artillery brigade to establish and perform antiaircraft intelligence for the army. In the communication zone and the zone of the interior, special batteries should be organized to perform like functions for that area.

It is impossible to prevent some enemy airplanes from crossing the front and executing missions to the rear, but it is believed possible to limit these flights and the extent of damage by proper antiaircraft and aircraft defense.

The present system of assignment and distribution of antiaircraft artillery units to the army and lower com-

mands as adopted by the United States, is sound. It is believed proper that an antiaircraft regiment should consist of antiaircraft guns, machine guns, and searchlights. The composition of the batteries within the regiment is beyond the scope of this paper.

Within the army, the antiaircraft artillery and the aviation should be coördinated and mutually supporting—this does not necessarily mean unified command. In the protection of the lines of communication and zone of the interior, the antiaircraft artillery and aviation should be unified under one commander.

It is impossible to protect all vulnerable points in rear of the army; decision by higher commanders must be made as to the most important points and ample protection afforded them. Antiaircraft defense should not be dissipated over a wide area, but rather concentrated at the vital points. Extensive use should be made of antiaircraft artillery for the protection of vital points, in order to free friendly aviation for offensive action.

For the protection of certain vital areas, aviation should be assigned to assist the antiaircraft artillery. In this case, the antiaircraft artillery should be employed to destroy the enemy, or at least break up the formations to make them vulnerable target for friendly aviation.

Fortifications, vital to the defense, should receive first consideration. Guns, machine guns, and searchlights should be used in the defense. Guns should be located with respect to the object defended and to each other, so as to bring enemy airplanes under fire prior to reaching their objective and to have the fire of two batteries concentrated on any point.

## Thanks

WE ARE indebted to that interesting news sheet *The Track-tor* published by the 628th C.A. (TD) (formerly the 608th C.A.) with headquarters in Los Angeles, Calif. The commanding officers of this regiment deserve great credit for the energy, initiative and resourcefulness in publishing a regimental news sheet. The item which attracted our attention is as follows:

"At various times in the past, the attention of officers has been called to the COAST ARTILLERY JOURNAL and the United States Coast Artillery Association. The JOURNAL is the official instrument by which the members of the Corps are kept in contact with the progress made in the development of the Coast Artillery, and with various items which emanate from the other services and from the office of the Chief of Coast Artillery. The latest issue of the JOURNAL is just here, and on glancing through it, several fine articles are to be seen, especially one on Mobilization, and the one on antiaircraft defense around Paris. The news from the foreign posts and that pertaining to the Reserves is always interesting. Every officer of the Coast Artillery Corps should consider it an obligation on his part to join the Coast Artillery Association (which has no dues or other fees) and to subscribe to the JOURNAL, the official magazine of our arm. DO IT NOW."

# Machine Gun Towers

By LIEUTENANT G. F. HEANEY, JR., 60TH C.A. (AA)

FOR use in a fixed defense, where the terrain does not permit clearing the trees to provide a sufficient field of fire, the high-pedestal mount for anti-aircraft machine guns, as built by Battery F, 60th C. A. (AA), at Fort Mills, P. I., has been found satisfactory.

The original plan contemplated construction of a frame tower for each gun. In 1932 we built two experimental towers, each twenty feet high. One was of four 6" x 6" wooden columns with suitable braces. The other was of rope-lashed bamboo. These towers were considered to be reasonably satisfactory for their height, but did not give promise of sufficient steadiness at heights of thirty feet or more. The single-pole towers were designed in the expectation that they would be both steadier and cheaper

than the frame towers. In tests so far they have proved to be very satisfactory.

The support consists of a single pole, with concrete footing and wire-rope guys. In its top is a cast-iron socket to receive the shank of the yoke of the anti-aircraft machine gun tripod mount, M1. A platform is built on outriggers to accommodate the gun crew. The pole is of the proper height to bring the gun to the level of the tree-tops.

The poles used were purchased by the Engineer Department from the Quartermaster. They were of heavy tropical wood; the length was from 35 to 42 feet, and diameter at the smaller end was from eighteen to twenty inches. (The trees at the position were from thirty to thirty-eight feet high.) No tests were made with poles smaller than eighteen inches, so the minimum size is a matter of conjecture; it is believed that a fourteen-inch tree would be satisfactory for a thirty-foot pole if strongly guyed. The poles were not creosoted except at the bases, partly for economy and partly because of the injurious effect of creosote on the clothing of men climbing the poles.

The poles were set six feet in the ground. One foot of concrete was placed under the butt, and about eighteen inches around the sides. In the top surface of the concrete a trench was provided to hold crude oil, to keep out white ants.

Three guys were used on the first pole; from experience with that pole we decided to use four guys on the others. The guys are made of  $\frac{5}{8}$ " steel rope. The upper ends were wound twice around the pole, just below the platform, and fastened with cable clamps. The lower ends were made fast to deadmen consisting of six-foot pieces of steel rail buried in concrete. On the first pole standard anchor rods were used between the turnbuckles and the deadmen. The eye of one of the rods yielded under the strain, so we substituted pieces of the wire rope for the anchor rods. To retard rusting of the rope we surrounded the buried part with four-inch fiber conduit filled with cement.

The platforms are supported on four 4" x 6" timbers, ten feet long, set in the form of a double cross. The timbers are set in galls on the pole, and each is fastened by two eight-inch lag screws. Each beam is braced by two  $\frac{1}{4}$ " x 2" x 48" iron crossarm braces. For greater strength, the timbers are not mortised into each other at the crossing points; we therefore used blocking on the lower pair of timbers to make the deck planking level. The planking is made of 2" x 6" boards, fastened down by four-inch lag screws. A trapdoor is left over the climbing spikes. All around the deck is a railing supported by 2" x 4"



Poles, guys and platform are clearly shown here.

posts at the corners. A guard rail six inches high is fastened around the edge of the deck.

The socket to receive the shank of the yoke is made of cast iron. These were cast at the post foundry and machined by the Ordnance Department. Had the facilities for their manufacture not existed the sockets from the issue tripods could have been used satisfactorily. A wide flange was cast on the top of the socket so that it could be fastened by lag screws to the top of the support. A drain hole was bored laterally through the pole to the bottom of the socket.

An iron band constructed similar to a hose clamp was placed around the top of the support to prevent splitting. This clamp served a double purpose by extending the ends to accommodate a hoisting pulley to raise the gun and other material to the platform.

Climbing spikes were constructed by the blacksmith from pieces of  $\frac{3}{4}$ " concrete reinforcing bars. These were set in opposite sides of the support with a thirty-inch vertical spacing. Many different spacings were tried out but experience proved this to be the most satisfactory.

The length and weight of the supports rendered it impracticable to use a garrison gin or pike poles, but a shear constructed from two steel trolley poles borrowed from the Quartermaster was found to be satisfactory. Wooden telephone poles would have served the purpose equally as well. The top of the shear was guyed by three tackles,



Socket and shank of machine-gun yoke.

one in the direction of the weight to be raised and the others equally spaced at  $120^\circ$ . Five-eighths-inch new manila rope was used for tackles with double and treble blocks increasing the power five times. The base of the shear was set on a line about ten feet in rear of the point where the center of the support would rest. The bottom of the hole had been cemented far enough in advance to permit the cement to harden. Climbing spikes were inserted and gains for the platform beams prepared while the support was on the ground. Poles were raised to a vertical position by taking up or slacking off the shear guys. To test for verticality two plumb bobs were hung from tree branches on lines of right angles to each other from the pole. Shear guys were not disturbed until the cement footing of the support had time to harden.

The four supports for the platoon were set on the sides of a square about 30 yards apart. This siting agrees with the "approved solution" as shown on page 117 of the C. A. E. M., Volume II. For camouflage, reliance will be placed principally upon the surrounding trees. The guns are approximately in the same horizontal plane as the tree tops, therefore they are scarcely noticeable. The presence of the personnel will present a different problem.

Firing tests were held with both caliber .30 and caliber .50 guns. The mounts were found to be surprisingly steady, perhaps more so than the regular tripod mount held down by sand bags. No side sway of the platform or support has been detected. The only apparent motion is a torsional twist of the platform around the pole. This is set up by the men moving on the platform and not by the firing of the gun.

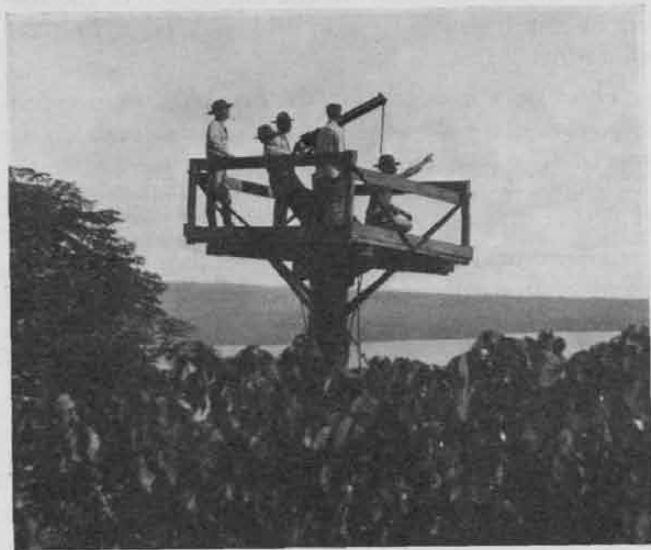

The manned machine-gun tower. For camouflage, reliance will be placed on surrounding foliage.



THE UNITED STATES ARMY in size ranks seventeenth among the armies of the world. While there is no thought of enlarging this small force, which is only the framework of an army to be created in case of emergency, I am in favor of making it the most modern and effective military organization possible in the interest of national defense.—THE HON. G. H. DERN.

# More Cries from the Wilderness

LET THE AXE FALL WHERE IT MAY

Attention of:  
Major Ima Jinx, S.O.L.

Dear Editor of the Journal:

Major Ima Jinx, S.O.L., in the May-June 1934 number of the JOURNAL, under the heading "Elimination, Promotion, or What Have You," made several quite pungent remarks anent the woeful lack of promotion in our army. He advances a most admirable suggestion that the senior colonel be promoted to fill a vacancy in the grade of brigadier-general of the line, or else that the said senior colonel be retired, and so on down the list of colonels until the new brigadier is selected.

The foregoing plan is suggested as a means of relieving the stagnation in promotion. It would accomplish the desired result if only there were as many generals in our army as in some foreign establishments. Major Ima Jinx, S.O.L., therefore, to quote his own words, is guilty of a "timorous attempt at applying a palliative." Any plan, for that matter, which aims at correcting our famous marking-time-in-place system of promotion and which starts in by considering the *top* of the promotion list is rather apt to result in another such "timorous attempt at applying a palliative."

All of the preceding remarks, as the reader may suspect, are merely to prepare the unwary for a ruthless and let-the-axe-fall-where-it-may plan for energizing our promotion list. The writer's plan is based on just one hypothesis: *A good system of promotion must provide a guarantee that junior officers will advance in rank at the desired rate of promotion.*

To devise a promotion scheme which will fulfill the condition just stated, it is necessary to assume what is believed to be the "desired rate of promotion." In recent years, time and time again, the best of authorities have repeatedly stated that the *ideal* rate of promotion for our army would make an officer a captain in about nine to ten years of service, a major after fifteen to seventeen, a lieutenant colonel in twenty-two to twenty-three years, and a colonel after twenty-six to twenty-eight years of service.

Our promotion list includes all officers below the grade of colonel, 10,400 officers, approximately, lieutenant colonels to second lieutenants, both grades inclusive. Dividing 10,400 by 26 shows that the *ideal* number of casualties which must occur in the promotion list (by either promotion out of the list, or by deaths, retirements, or eliminations) is in the neighborhood of 400 a year. In other words, the lowest ranking second lieutenant in the army each year should gain 400 files in his first year of service.

A brief inspection of the promotion list as it now stands immediately shows that a great many of our officers are now two grades below the rank they should be holding

## Here are the pros. Have we any cons?

according to the ideal requirements. This means that a higher rate of promotion list attrition than 400 files a year should be set up during at least the first few years of the operation of a new promotion plan, so that these officers may eventually attain the rank of colonel after a reasonable period of service.

There are now about 578 lieutenant colonels on the promotion list. The senior *major* at this writing, Emmons, Delos C., Air Corps (No. 649, A. L. & D., July 20, 1933), has constructive service due to his place on the promotion list of about 25 years. He ought to become a *colonel* in 26 to 28 years. Obviously, all of the lieutenant colonels in the army cannot be promoted or otherwise taken off the promotion list in just one year, but it is necessary to accede to the years-of-service pressure being exerted by the middle and lower portion of the promotion list, so we will make the requirement that all of the officers on the promotion list senior to Emmons, Delos C., A.C. (No. 649), be promoted or retired in the next three years. This definitely commits us to the period of three years for the first application of our plan, and although it may seem drastic, yet it merely means that sufficient colonels of the army must be retired to provide vacancies for the lieutenant colonels it is desired to promote. This is an assurance that the very high percentage of our lieutenant colonels who are surperior will be promoted much sooner than they can now anticipate.

There are about 1,725 majors on the promotion list. The now senior *captain*, Luke, Ittai A., O.D. (No. 2406, A. L. & D., July 20, 1933), has now about 17 years of service; he should become a *lieutenant colonel* after 22 to 23 years of service. For him to gain this number of files in due time, vacancies must be created among the officers between Emmons, Delos C., A.C., and Fuller, Horace H., F.A. (Nos. 649-2405 incl.), at the rate of 345 a year. The number of vacancies to be filled in the grade of lieutenant colonel is definitely limited to 578 in three years; therefore, 457 officers in the group, Nos. 649-2405 incl., must be removed from the promotion list in the same three years.

There are about 3,434 captains on the promotion list. The present senior *first lieutenant*, Hill, Ployer P., A.C., (No. 5919, A. L. & D., July 20, 1933), has now about 15 years of service; he should become a major after 15 to 17 years, but it is obvious that all of the present captains cannot be promoted or eliminated in just two years, for there lies the hump. Anyway, it would not be economical, if I may coin an understatement.

The senior first lieutenant cannot immediately gain his proper rank, but he can be gotten there eventually. There are about 5,737 officers ahead of him on the pro-



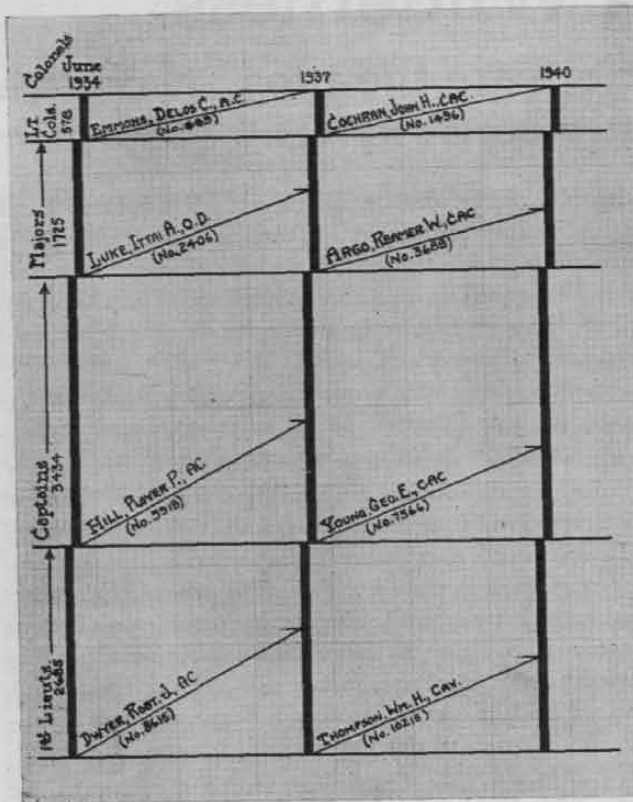

motion list, and for him to become a colonel in due time, he should gain about 522 files a year for the next eleven years. We are now concerned with the next three years, and since we have shown how the now senior captain, Luke, Ittai A., O.D., No. 2406, can begin to move up at the rate of 345 files a year, the difference between 345 and 522 indicates that 177 officers of the group, Nos. 2406-5918 incl., must be removed from the promotion list each year during the next three years.

Naturally, since the senior first lieutenant is to gain files at the rate of 522 a year, the second lieutenants are assured of advancing faster than 400 a year, initially, and none of the present first lieutenants need be forcibly removed from the promotion list. These particular officers, however, will be exposed to the risks of such removal as they get older and higher ranking.

To summarize, the initial Three-Year-Plan calls for the following:

Group	Casualties to be Created			How Created
	1934-35	'35-'36	'36-'37	
Above No. 649	192	193	193	Promotions, retirements, or eliminations.
Nos. 649-2405	153	152	152	Retirements or eliminations.
Nos. 2406-5918	177	177	177	Retirements or eliminations.

At the end of the first three years, stock is to be taken again of the promotion situation, the lengths of service of the junior officers considered, and new rates determined which will advance them in rank properly.

We may now enter the delightful field of conjecture, and get an estimate of what would happen.

A brief session with a slide rule indicates that Cochran, John H., C.A.C. (No. 1496, A. L. & D., July 20, 1933), would then be the senior major in the army in 1937 with

about 22 years of service at that time, approximately his correct place on the promotion list according to the ideals set down. The senior captain would probably be Argo, Reamer W., C.A.C. (No. 3689, A. L. & D., July 20, 1933), with about 20 years service, really not very far below his proper place on the list. The senior first lieutenant would perhaps be Young, Geo. E., C.A.C. (No. 7566, A. L. & D., July 20, 1933), with about 13 years of service as compared with the fact that our senior first lieutenants today have been lieutenants some sixteen years. The senior second lieutenant would probably be someone in the vicinity of Thompson, Wm. H., Cav. (No. 10215, A. L. & D., July 20, 1933), with four years of service at that time.

To set up rates for a new period of three years, we first consider Thompson, Wm. H., Cav., No. 10215, the senior second lieutenant. He must advance not more than 383 files a year, or else he will become a "boy major." The normal casualties to be expected between Thompson and the senior first lieutenant, Young, Geo. E., C.A.C., No. 7566, may not exceed one a month since the glamorous prospect of promotion is now dazzling the lieutenants, and so we have 383 minus as the prescribed rate of advancement for Young, 371 files a year, or 1,113 files in three years.

Since we must give every officer in the hump, remaining in the service, a reasonable chance to become a colonel, a brief inspection shows that all of the lieutenant colonels again must be either promoted or retired in three years. (Three years as a lieutenant colonel, it will be noted, agrees with the ideals set forth.) This means then that 578 of the 1,113 files Young, Geo. E., C.A.C., must gain will be accounted for by the lieutenant colonels, leaving a total of 535 officers who must be removed from the promotion list in three years between Cochran, John H., C.A.C., No. 1496, and Young, Geo. E., C.A.C., No. 7566. Dividing this number proportionately between the two groups involved, we find that 65 of the officers per year between Cochran, John H., C.A.C., No. 1496, and Argo, Reamer W., C.A.C., No. 3689, must be removed from the promotion list; also, that 120 of the officers per year between Argo, Reamer W., No. 3689, and Young, Geo. E., C.A.C., No. 7566, must be removed from the list.

To summarize again, the second Three-Year-Plan calls for the following:

Group	Casualties to be Created			How Created
	1937-'38	'38-'39	'39-'40	
Above No. 1496	192	193	193	Promotions, retirements, or eliminations.
Nos. 1496-3688	65	65	65	Retirements or eliminations.
Nos. 3689-7565	120	120	120	Retirements or eliminations.

It is too difficult to attempt to prophesy just who would be the senior officers in each grade in 1940, but at that time consideration should be again given to the length of service of the respective junior officers and the attrition requirements again established. Inspection of the chart should be sufficient to indicate just how the interested reader would benefit under the scheme outlined.

The following are advantages of the Three-Year-Plan for regulated promotion:

1. No definite number of lieutenant colonels must be eliminated. This permits considerable latitude in handling the situation among the senior officers of our army, it being necessary to retire only enough colonels to provide vacancies for our sterling and physically-fit lieutenant colonels.

2. The number of majors and captains to be removed from the list is not excessive, about 6.4% per year for the first three years and about 3.6% per year during the next three years.

3. It is possible that no legislation may be needed to remove the required number of officers from the promotion list, unless it is definitely proved that hewing to the line in physical examinations will not cause enough retirements for disability.

4. The additional cost to the government in dollars and cents will be more than discounted by the resultant improvement in morale, physical fitness, and efficiency of our officers.

In submitting this lovely plan to you, Dear Editor, I cannot help but mention a needed bit of legislation which would affect both morale and the promotion situation. Today, there is no method whereby an officer who has served honestly and faithfully can voluntarily depart from our ranks *with his earned equity in retired pay*. He has earned an equity in retired pay, and this equity has been recognized and evaluated by Congress in the laws concerning Class B. To be exact, an officer who has served honestly and faithfully for ten years or more has earned an equity in retired pay of 2½% of his pay per year of service. Why not permit an officer to signify his desire to retire, and then let him retire with his 2½% per year of service?

Many of us have heard dissatisfied officers complain, "I sure would like to quit the army, but I can't afford to throw away my years of service for nothing in return!"

Then, too, think what a boon it would be! Captain Alwaze Crabbing crabs too loudly once too often, and five majors back him into a corner, "Put in your request for retirement at 2½%, or keep quiet from now on, forevermore!"

Think of the saving in Class B boards and the accompanying distasteful work. The choice could be offered, "Will you voluntarily retire on your 2½% or do you prefer a Class B Board?" There would be less dirty linen waved in the breeze.

Hopefully yours,

SUNKIN A. DITCH,  
Lieut. D.O.M.L.  
(Down on my luck.)

The Editor,  
Dear sir:

During the last ten years, service publications have been filled with discussions of the stagnation of army pro-

motion. Very properly, most of the comment relates to the gloomy prospects for those now captains or lieutenants. Only too frequently it is suggested, either specifically or by inference, that in the field grades all is rosy.

The writer now has about 24 years of commissioned service. When the smoked cleared away after the 1920 reorganization, he found himself about 33% of the way up the majors' block on the promotion list. He is now 89% of the way up. Thus in 14 years, he has advanced 56% of the way through that grade, or an average gain of 4% per year. At this rate (and so long as present methods are employed, little reason exists to expect improvement), an officer gaining the major's grade today must expect to remain there 25 years without hope of any further promotion. A steady deterioration of leadership among those in command is the inevitable consequence.

Conditions can be rectified only by a greatly expedited attrition from the top. The plan suggested by "Ima Jinx" is the most conservative one which holds out any prospect of genuine relief for 95% of our officers.

Very respectfully,

"STASIS."

Dear Major Jinx:

Now that both the Navy and the Marine Corps have workable promotion systems, the army is our only branch which suffers from paralysis. "During the past week, no promotions were made to the grades of colonel, lieutenant colonel, and major." This sentence greets our eyes in almost every issue of the *Army and Navy Register*. "Few die and none resign," and it might be added that practically none retire until forced to do so.

It is probably true that retirement would not be fought so vigorously if it did not entail a loss of 35% to 45% of an officers' income, instead of 25% as it was before the 1922 pay act. Correction of this very real injustice might relieve the situation to some degree.

But knowing the morose persistence and the dismal fortitude of the type we are both thinking of, I feel sure that some measure more positive than mere persuasion will be necessary. Your remedy strikes at the zone where senile decay is most advanced and the resultant damage to the service is the greatest. I'm all for you—more power to you!

"STAG" NATION,

S.O.L.—2.

The Editor of the JOURNAL:

Like Major Jinx, I feel sure that my plan of promotion will receive no serious consideration. It is a voice crying in the wilderness, but *I think its a darn good idea*.

I wonder if in any other organization there are as many malcontents as there are among the colonels of the army? I am not criticizing them, merely stating what seems to me to be a fact. There is no need to go into the lack of logic displayed: the fact that only one of many may be

chosen seems not to dim their aspirations nor to diminish their disappointment when they are passed over.

Many who are so skipped have given honorable, faithful and efficient service. I cannot believe that the difference between the average General Officer and the best of the Colonels is wide enough to justify the present policy—it puts a certain power and prestige for life into the hands of one and dooms the other to frustration.

My remedy is this: in peace times do away entirely with the grade of Brigadier General. Make all promotions from the grade of Colonel to that of Major General *in order of rank and for four years only*. Should the Colonel at the top of the list be unfit for higher command he would automatically retire.

The lowest ranking Major General would naturally take the jobs now filled by Brigadiers.

By file promotion only, morale would be improved, bitterness would be a thing of the past and the system would be purely military.

Making the appointments for four years would simply be carrying the present policy of the branch-chiefs to its logical conclusion. In time of emergency there would be many more men who had had actual experience with higher commands so efficiency would be strengthened. At the end of four years give the option of retirement as Major General or demotion to the rank of Colonel *with no exceptions*. In this way men who desire to remain in until sixty-four could do so without delaying the promotion of others.

A real stumbling-block is the difficulty of deciding who may be unfit for higher command. Let the man so skipped have a hearing before the most unprejudiced board possible to assemble. Allow no strings to be pulled, no politics used, but give him an honest hearing and leave the decision to the board.

In times of peace, have the man's character, his culture and refinement, his entire personal life count as much for promotion as his military prowess. It is humiliating to give deference to a man for whom one has no personal respect. Often a serious weakness does not appear on efficiency reports but the army has never been reticent of personalities, and there are ways of discovering facts other than official.

This plan seems simple, American, and fair. Something is wrong with morale and that something has to do largely with promotion.

Yours to cut out cut-throat politics,  
VOICE IN THE WILDERNESS.

✓ ✓ ✓

#### ON SELECTION OUT

Dear Editor:

Ima Jinx and the JOURNAL of May-June invite discussion of an ever-burning subject—so here goes.

Two of the four requisites for a satisfactory promotion

system enumerated in The Chief of Staff's very sound report for 1933, are as follows:

1. The solution must call for no great increase of cost to the Government.
2. The solution must be accepted, as fair to all, by a large majority of our officers.

Jinx's proposal to select out, as they reach the top, those senior colonels not chosen for brigadiers appears to fall down on both requisites. Nevertheless it seems worthy of further thought.

*Increased Cost to the Government:* We may as well assume that Congress will not stand for any increase in cost of the retired list. The remedy therefore lies in finding a means of employing "selected outs" in a way that will appeal to Congress—a way of paying them active duty pay and giving them suitable federal assignments that will cut down the number of federal employees, as well as the ever-growing federal pay rolls. To such a proposition, Congress might listen. Possibly suitable federal assignments, particularly of an executive or administrative nature, exist at the present time. Bear in mind the selected-out colonels would be efficient men—not Class B material, nor yet presumably of the highest type of brigadier material. The field would constitute the bulk of our colonels, for very few of us, as we reach that grade, can expect further promotion in peace time.

Many senior officers doubtless feel they must remain on active duty for financial reasons. Although enjoying little or no hope of further promotion, they nevertheless must keep up insurance, educate children, help support relatives, and meet other exacting responsibilities that continue or increase in later life. Their financial plans have been based on active duty pay until sixty-four. If offered federal positions on active duty status, as already outlined, it is quite possible many would apply voluntarily for retirement. Thus would they avoid the stigma of any forced retirement; and the army would benefit by an increased flow of promotion.

A HOPEFUL SENIOR.

✓ ✓ ✓

EDITOR'S NOTE: The last issue of the JOURNAL carried an inspired article under the caption "Elimination, Promotion or What Have You?" The editor expressed the hope that the publication of the article would start an argument. This hope has been partly realized in that we have received many communications favoring the plan proposed by Major Jinx but no one has raised his voice in direct opposition thereto. It is not possible to reproduce all of the communications received, however, the foregoing are indicative of the general trend. As was to be expected there is a diversity of ideas especially in minor details as to the carrying out of the general plan. This indicates that those who have given serious thought to the matter are agreed that something should be done to accelerate promotion and improve morale. Out of the welter of ideas presented it is hoped that those responsible for forming legislative policies will be able to evolve something constructive to submit to the Military Affairs Committee at the next session of Congress.

# High Speed Target

By CAPTAIN RILEY E. MCGARRAUGH, C.A.C.

WITH apologies to Ripley I make the statement that I traveled more than a thousand miles on a U. S. N. destroyer but did not get out of sight of Corregidor.

The reason for such unusual sea-going is explained by the fact that it fell my lot to be liaison officer for the Coast Artillery with the Navy during tests of the new high speed target and later tug officer during the target practices.

Acting under authority from the Chief of Coast Artillery, the Harbor Defense Ordnance Officer had a special target constructed upon specifications furnished from that office and officially known as "Target, Seacoast, Fast Towing M2."

The target used in the tests and practices was made at Fort Mills using soldier and prison labor. It was the outgrowth of several experiments which have been conducted by the Navy, the object being to perfect a target of sled design that would be satisfactory for high speed towing.

An extract from the reports of the first tests of the high speed target may be of interest. "Tests were made in the U. S. Experimental Model Basin, Navy Yard, Washington, D. C., and as a result of these tests the present target was constructed. The new target is 25 feet long and 12 feet wide. The target successfully passed the tests in November and December, 1931, at varying speeds from 6 to 27½ knots. At 27½ knots the towline parted with about 1,000 feet of the 6-inch towline out." (This parting of the towline seems to be the chief trouble with the high speed target, as we later found out.)

The first towing of the Fort Mills target was done by the mine planter *Harrison*, using a 6-inch manila hemp towline. This test demonstrated that the target is unsuited to the low speed of a mine planter. With about 1,800 feet of towline out the target twice emulated a submarine, the second time going completely out of sight and sweeping off the mast. In this case the water was a little rough and the speed was insufficient to give the target the sea-sled action necessary to keep the bow up and out of the water.

Arrangements were then made by the Commanding General of Fort Mills with the Commandant of the 16th Naval District for the destroyer *Bulmer* (222) in command of Lieutenant Commander Partello for a speed test with the target.

On October 31, 1932, the *Bulmer* picked up the target and the 2,000 feet of 6-inch manila towline which previously had been used by the Mine Planter. The towline was made in two pieces and joined by a long splice.

On the first course about 1,000 feet of towline was let out thus putting the splice immediately in rear of the towing vessel. Speed was built up gradually to 20 knots.

The bow of the target came out of the water at about 15 knots and it rode nicely with the sea-sled action at this speed and above.

The destroyer was slowed down so more towline could be let out. Then the speed was stepped up to 22 knots. After about an hour of towing at this speed the line parted at the long splice. It was with considerable difficulty that we were able to pick up the line attached to the target.

The break occurred about ten miles out at sea and in water from about 50 to 100 fathoms deep. The line seemed to hang vertically under the target since the bridle was fastened well back on the side frames. No safety line had been provided from the target to the bridle. (Later this was added but usually it was worn in two by the force of the water against the edge of the target.)

The line on the target was finally picked up by under-running the target with a bight of rope which was weighted down with a heavy clevis. This done, towing was continued at 22 knots with about 700 feet of line out. As a final spurt the last 20 minutes were run at 25 knots. (This plotted out to be 28 land miles per hour.)

There seemed to be no real difficulty with the target. It admirably withstood the severe pounding which it received from the choppy sea. There were times when it

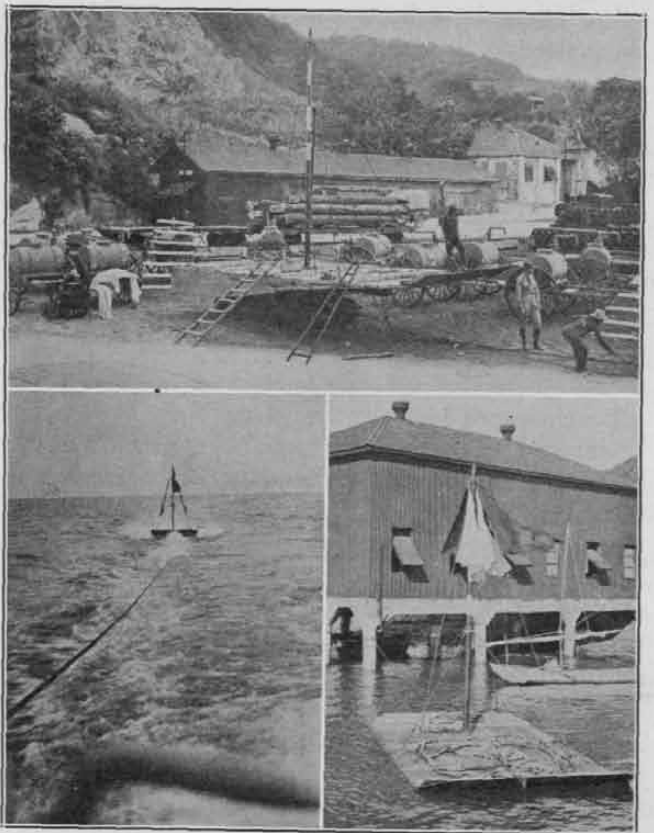

The High Speed Target

seemed as if the target were about to "take off," at least it had the appearance of leaving the water.

The next test for high speed towing was on December 19th. The Asiatic Fleet Commander assigned the destroyer *John D. Ford* (228), commanded by Lieutenant Commander Lewis, for this test.

On this occasion we had a new 6-inch manila towline, 2,400 feet long all in one piece, this had been especially manufactured for the high speed towing. It was supposed to be a stronger line than the one used previously. Our experience seemed to indicate otherwise.

The first break occurred after 25 minutes of towing at 20 knots and at about the middle of the rope. Our previous experience with the long splice now prompted us to join the two pieces of rope by "bending" the ends together.

Later when this line broke, we found that the knot had not pulled out but rather the sharp turn of the rope at the bend had caused it to break. To eliminate this weakness two heavy thimbles were put in the ends of the rope and these joined by a heavy clevis.

Towing was resumed and after about an hour at 22 knots this rope parted for the third time. On this occasion the break was just astern of the destroyer where the rope entered the water. It seemed to be subjected to a great stress in cutting the surface of the water which had an abrasive action on the rope.

After this unsatisfactory experience with the 6-inch manila rope, a trial with a steel cable was seriously considered; but the difficulty in securing a suitable cable, the problem of handling it, and the possibility of it sinking the target caused us to make one more attempt with the hemp rope.

Commander Lewis offered to secure three Navy 8-inch hemp hawsers, each 100 fathoms long, and join them together with thimbles and clevises for a trial. One of these hawsers is carried aboard each destroyer to be used in an emergency.

The test with the new hawsers was made on January 5th. Speed was kept down to 20 knots and for 7 hours we ran without a break.

Being cheered by the success of the Navy hawsers, the Ordnance Department had a special 8-inch manila hawser 2,200 feet long made to order. It was manufactured in two pieces and spliced in the factory. The order was placed January 6th and the rope was delivered to the destroyer in Manila on January 9th. Quite a record for rope manufacture, especially in this *manana* land. This rush was necessary in order that the first service practice slated for January 10th could be run off on schedule.

The new towline handled well and we ran for 5 hours at about 20 knots. Four batteries fired during this run; one a 3-inch, one a 6-inch, and two batteries of 155 G.P.F's.

The next high speed practice was one week later when one 3 inch battery and two batteries of 155 G.P.F's, fired.

On this day we towed for about three hours at 20 knots. The only difficulty experienced was the fouling of the rope on the destroyer's rudder as we passed the towline from the harbor boat to the destroyer.

The final day of the high speed towing was January 19th. At this time we ran for two major caliber gun practices—one at 20 knots and the other at 22. Just after the trial shots had been fired on the course for the 14-inch guns at 22 knots the bridle cable broke loose from the target. As soon as the destroyer had cleared the field of fire the mine planter, standing by with a standard target, finished the course for this practice.

I will not attempt to go into the details of these practices, but a few observations from my work with the Navy on this problem might be of interest.

One of my first difficulties was the translation of radio messages from Coast Artillery terms into Naval phraseology. The necessity for some one to do this was quite evident on many occasions. For example: when I wanted them to run up the "red flag" on the destroyer I found that I should request that they "two block the Baker." Also with the Navy a red streamer had an entirely different meaning than it does with the Coast Artillery.

It is apparent that the destroyers were never intended to be used for towing purposes; no provision having been made for a towing bit. On one destroyer the line was run around the base of the rear gun mount and made fast to a cleat about midships. On the other craft the line was fastened well forward.

There were no power winches suitable for handling the towline; in all cases it has to be "man handled." The pulling in by hand of 2,000 feet or more of water-soaked 8-inch hawser attached to a target weighing about five tons, always against the current in order that there would be no danger of fouling the propellers, is a real job. It took more than an hour to haul the towline aboard the destroyer.

It is believed that this difficulty could be overcome by passing the end of the towline, while still out, to a mine planter or harbor boat and then haul in the rope on a winch or capstan. Also the destroyer when taking over the target could pick up the end of the towline after the mine planter had let it out. For ten days during December and January we had the destroyer run over approximate course, at about 20 knots, without a target. This gave an opportunity for all batteries to train in high speed tracking and plotting. The destroyer without a target could change direction 180 degrees in less than a minute. This presented a real problem to the range sections. On several days more than 100 miles were covered for one tracking mission.

These tests demonstrated that a high speed target fills a long-felt want and make target practice more nearly approach service conditions. They should be used whenever possible.

# Training Antiaircraft Machine Gunners in the Use of Tracer Control

By MAJOR J. L. DANEKER, C.A. NG.

THE problem of an antiaircraft machine gun organization, as I see it, is the training of individual gunners to be alert and capable of accurately directing their fire on the target at any particular instant. Normal targets, the hedge-hopping attack planes, will remain in the field of fire for only a few seconds; and my experience in command of the Antiaircraft Battalion of the 243rd Coast Artillery (HD), Rhode Island National Guard, leads me to believe that tracer control is the most practical method of finding and staying on the target.

Three years ago, by means of auxiliary cross wires on the forward area sight, an elaborate set of calculated sight settings with leads set off as windage and range corrections, and the target flown as accurately as possible on definitely prescribed courses at constant speed and altitude, a score of 123.7 was obtained by the machine gun battery of my battalion at slant ranges of 800 to 850 yards. However, I feel that such planning defeats the purpose of target practice, for it in no way approaches service conditions.

With this thought in mind at the 1931 camp, sights were used to track the target until just previous to opening fire. The gunners then jumped the guns forward the required lead (estimated by individual gunners), forgot the sight, determined the accuracy of their fire, and made adjustments by watching the tracers.

Unfortunately, this plan was not very successful. Hits were obtained on all courses but not in any volume, although all gunners were men who had been to previous camps and had spent considerable time on balloon firing with tracers, obtaining excellent results.

The 1932 camp brought up the same problem. Studying the firing of individual gunners, I decided that they were not observing the tracers properly. While they apparently ceased using the sight after opening fire they unconsciously followed the line of metal. All mounts were equipped with back rests instead of the issue arm brace and we endeavored to make the men place the crosspiece at the small of the back, keeping the body erect, thus forcing the head away from the gun. However, they seemed to hunch themselves up and get the eyes in prolongation of the line of metal anyway.

Finally metal shields about eighteen inches in diameter were taped to the water jacket just forward of the rear sight, and the sights were discarded entirely. The gunner simply watched the target as it came into the field of fire and endeavored to follow it with the gun by means of coordination between the eye and body. By observing the tracers, he could tell if the cone of fire was directed properly.

The shields were of such height that they prevented the gunners from even using the front sight to help in



alignment. Proof that the gunners had been unconsciously following the line of metal was given when they complained that the shields made it hard to align the guns on the target.

That the plan was helpful is borne out by the results obtained. Previous to using the shields, from ten to twenty holes were secured in a preliminary practice with sleeves at 1,800 feet altitude. On the first use of the shield, forty-nine holes were secured, while ninety-one were obtained on the second practice. The altitude was increased to 2,000 feet and seventy-one holes were secured. On all practices the plane flew one ninety, one forty-five degree, and three zero degree courses. When the record target was dropped it showed 107 holes.

Based on this improvement, which for lack of any other reason I attribute to the shields, they were used from the start at the 1933 camp. The results were even more gratifying than the previous year, the number of holes per sleeve varying from 125 to 200 per practice in preliminary firing. Two record practices were fired, with altitudes of 1,500 and 1,800 feet, the slant ranges varying from 700 to 1,000 yards. On the first record practice 226 holes were secured and on the second, at a higher altitude, the count was 204, giving scores of 137.22 and 118.44.

This plan unquestionably wastes a few rounds until the gunner secures his coordination, but the increase in hits more than offsets this loss.

# NEWS AND COMMENT

## What the Coast Artillery Needs

IT is fully realized that it is hopeless to attempt to expound the above title without writing a lengthy treatise, nor is it possible to define exactly what the author has in mind without a complicated and involved definition. If I were compelled to translate this thought into a single word the answer would be *vision*. The great majority of inventions and developments have been brought about by men of vision; men who were looking into the future; men who could see things not as they are but as they should be; men who were not content to accept the conditions of the moment as being the final and ultimate answer to the problem; men who were continuously searching for a better way to accomplish the desired result. We wonder what would be the status of Coast Artillery matériel and technique, had it not been for such men as Ruckman, Whistler, Hearne, Lewis, Cloke, and a long list of others who had vision, imagination, initiative and the other related qualities which enabled them to work for a better way to solve the problems vitally affecting the efficiency of the Coast Artillery Corps.

To say nothing further can be done is to admit defeat. Nothing is static in the material world, there must be progress or stagnation, and stagnation is equivalent to going backward. The strides made in the improvement of artillery matériel during the past decade have been great but this does not mean that we have reached the ultimate. There is an equal, or perhaps greater need for further development in the improvement of fire control and fire efficiency. Some of the problems crying for solution may be enumerated as follows:

- a. The development of a substitute for searchlights to locate high-flying airplanes accurately.
- b. The development of a method of detecting and tracking non-visible airplanes with a sufficient degree of accuracy to permit the delivery of artillery fire.
- c. An improvement in accuracy in the use of the present sound locators or of a substitute for these.
- d. A method of effective fire control for .30 and .50 caliber machine guns. It is realized that tracer fire is necessary, possibly it is the only practical method to be employed against a hedge-hopping airplane suddenly appearing close to the machine guns and remaining in the field of fire for a very short time, but at altitudes between 2,000 and 4,000 feet tracer control is inefficient and wasteful of ammunition. There should be some way of bringing under effective machine gun fire targets within this altitude band. If a better method is found it undoubtedly could be applied to the 37-mm. gun.
- e. The development of a simplified director that will handle targets travelling over 200 miles per hour.

f. The necessity for simplification of matériel combined with a reduction in weight and increased mobility.

g. What is the best solution of the problem concerning the proper organization and proper distribution of antiaircraft matériel when charged with the mission of furnishing protection against aircraft for troops on the march?

b. Improvement in the methods of fire control when firing at non-visible targets on the water.

Considering the question of the tactical employment of artillery we are constrained to ask several questions:

a. Are two directors necessary for each antiaircraft battery to provide against breakdowns and to permit a battery to change targets without loss of time?

b. What is the proper amount and proper organization of mobile antiaircraft artillery when operating with the field armies?

c. What is the proper tactical doctrine for the employment of gun batteries?

d. How can we increase the usefulness of mobile artillery in supplementing seacoast artillery?

The foregoing are some of the problems confronting the Coast Artillery. All of them have been given consideration. A certain degree of progress has been made but the ultimate has not been reached. Twenty years from now the present methods will be looked upon as archaic or entirely relegated to the discard. We hope that there are enough officers with vision and a clear understanding of the problems who can gaze into the crystal and see what the future holds. The first step is to visualize the ideal, the next step is to work for the consummation of the vision. This item is published with the hope that we can "start something" by inducing officers to put their thoughts and ideas on paper; undoubtedly there will be others to pick them to pieces. By this means we hope to foster an argument. Perhaps from this there will result a crystallization of thought which most certainly will react to the benefit of the Corps. The JOURNAL invites contributions on the subjects listed above or any relevant subjects. We are especially anxious that authors project their ideas into the future rather than adhering to a discussion of matériel already developed or tactics now considered orthodox.

✓ ✓ ✓

## Changes in the Chief's Office

BY the time this issue of the JOURNAL comes from the press several changes in the official family will have become an accomplished fact. For the benefit of those who have not kept up with official War Department orders we will say that Major G. Ralph Meyer, who, for the past three years has been busily engaged in bringing the projects for the various harbor defenses up to date and

harmonizing them with the problems of sea frontier defense, will be on his way to that high seat of learning, the Army War College. Major Meyer, ably assisted by Major R. V. Cramer, has done a fine piece of work. Both of these officers deserve unstinted commendation for the thorough and painstaking way in which an arduous task has been performed. While the work is not finished it is well on the way to completion. There yet remains many details to be worked out, but those who next take up the tools will appreciate the vision and thorough understanding of the problem which these two officers have incorporated into the work already done, this they will leave as their heritage.

Major Cramer goes to the shrine of the Coast Artillery Corps, the School at Fort Monroe, as a director in one of the departments. This is not a new assignment to him as he filled a similar position about ten years ago.

The new faces to appear at the family council table belong to Major Charles W. Bundy, and Major C. M. S. Skene. The former was a member of the latest graduating class of the Army War College, while the latter has just completed a tour of duty as Instructor at the Coast Artillery School. They bring with them a superior equipment for the many problems they will be called upon to solve.

The third officer to join the family will be Lieutenant Colonel H. T. Burgin. While no definite pronouncement has been made it is understood that Colonel Burgin will be the Executive. It will be recalled that he served a tour in the Chief's office from 1926 to '30 when he occupied the personnel desk; while on this duty he did much to remove the feeling which prevailed a number of years ago when many officers felt that the chief function of the personnel section was to find out where they wanted to go for station and then have orders issued sending them in the opposite direction. We feel sure that Colonel Burgin will carry the same sympathetic attitude and understanding to his new assignment.

### More About the Coast Artillery Song

IN March, 1933, the JOURNAL announced that it would foster a contest to select a song for the Coast Artillery Corps. It even went so far as to offer a cash prize of \$50.00 for the lyrics and an equal amount for the music. Some months later we announced that the contest had closed and a very creditable number of entries had been received. Since that time the subject completely disappeared from the picture. Like a deciduous plant it had to remain dormant for a long time. Some of our readers entertained the idea that it had passed into the great unknown and had been completely forgotten. Several of the contributors have, figuratively speaking, held their breath waiting for each mail to bring them the long hoped for announcement of the award and the cash prize. Much to our regret and chagrin we had to counsel patience and return soft answers to a few of the irate contributors. The reasons for the delay need not be men-

tioned here. Our only explanation is that the committee on award hibernated for the winter; being a long, cold, hard winter we were afraid that it had given up the struggle and decided that existence was not worth while.

We are happy to announce that the subject now shows signs of rejuvenation. It has put forth a tiny shoot indicative of life. We hope that with patience, nourishment and tender care it will blossom forth and become a full grown plant to shed its luster upon the Coast Artillery Corps for years to come. We had hoped to be able to make some definite pronouncements in this issue of the JOURNAL, but careful consideration leads to the conclusion that an announcement at this time may be a little premature. Notwithstanding all the delay it appears certain that something worthwhile will result, and in the next issue of the JOURNAL we have every expectation of publishing the full details including the name of the winner, the lyrics and the score.

### Trophy Presented to the 249th C.A. (HD)

THE March-April issue of the JOURNAL announced that the trophy awarded annually to a National Guard regiment by the U. S. Coast Artillery Association for general excellence had been won by the 249th C.A. (HD) Ore. N.G. The actual presentation of the trophy was deferred until the regiment was assembled at Fort Stevens, Oregon, for the annual encampment. This made it possible for the entire personnel to be present at the presentation ceremonies, a condition which could not be brought about at any other time. The regiment was assembled on the parade ground of Fort Stevens, Oregon, on June 21. Colonel John T. Geary, C.A.C., in charge of National Guard affairs for the Ninth Corps Area arrived by airplane from Fort Lewis, Washington, and made the presentation on behalf of the Coast Artillery Association. In presenting the trophy Colonel Geary talked intimately to the men, accentuating their record of accomplishment and pointing out the necessity for sustained effort in order that the regiment could maintain the degree of excellence it has reached as attested by the fact that the 249th won the trophy in competition with all of the National Guard regiments in the United States. Lieutenant Colonel Clifton M. Irwin, received the trophy on behalf of the regiment and made a few appropriate remarks in which he expressed his pleasure at the signal honor bestowed upon the regiment and his determination to continue to maintain the high standard.

As an aftermath and in recognition of the distinction won by the regiment, Major General George A. White, Adjutant General of the State of Oregon, showed his appreciation by designating the 249th as the one regiment in the State of Oregon to be issued the new uniform consisting of serge coat and elastique breeches, made to special measurements. This award was a most welcome surprise to the personnel and will go far toward increasing morale and soldierly appearance.



# Mechanical AA Target

BY LIEUTENANT COURTLAND H. SMITH, C.A. (NG)

OFFICERS assigned to AA units are frequently handicapped in the instruction of range and gun sections by lack of a target that will closely resemble actual field conditions. It was this condition in our battery that led me to construct the mechanical target now in use in our armory.

The outfit consists of a target moving at controlled speed, supported by a thin line traveling over pulleys

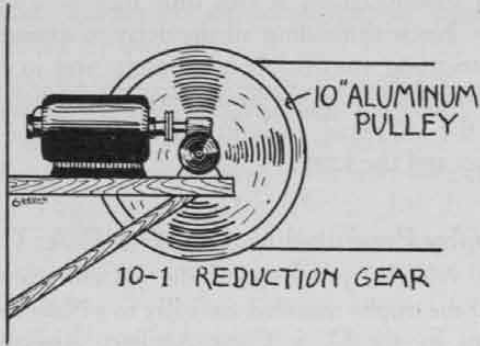

Figure I.

located at opposite sides of the armory drill shed, and driven by a small electric motor connected to the lighting circuit. The details of the driving assembly are shown in Fig. I. The essential elements are a small motor of about 1/16 H.P., driving a 10-inch V-belt pulley through a 10-1 reduction gearing.

The motor and gearing are assembled on a wooden base as shown, and mounted on a bracket attached to the wall at one side of the armory drill shed about fifteen feet from the floor. In our installation the motor speed, and consequently that of the target, is controlled by a fiber brake acting on the motor shaft as illustrated in Fig. II. A rheostat could be used with the added advantage of remote control.

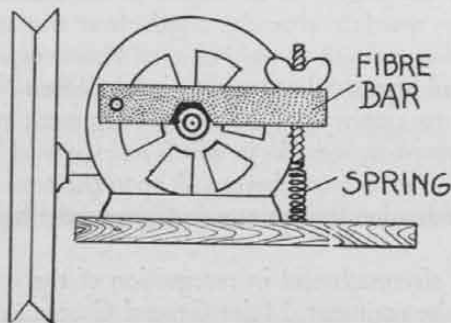

Figure II.

The target, cut from thin sheet tin in the shape of an airplane silhouette, is about six inches in length, and are drilled as shown in Fig. III, for the supporting wires. painted to resemble an observation plane. Two 1/8" holes

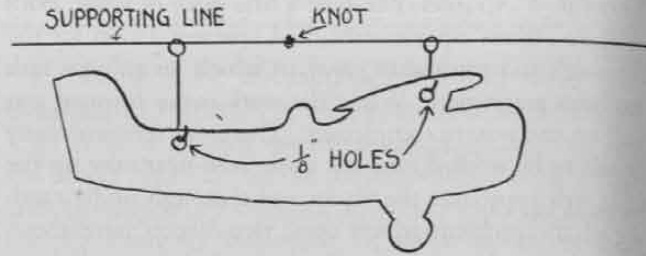

Figure III.

These are bent from No. 18 iron wire and are of sufficient length to allow the target to hang about an inch below the supporting cord. This cord is of light, gray fish line which is practically invisible in the instruments. A knot tied in the line between supporting wires will prevent the target sliding along the cord, which would result in jerky action of the target.

At the opposite side of the drill shed is mounted the idler pulley. Fig. IV shows a side and top view of this unit. It is a 10" aluminum pulley similar to the driven pulley, mounted on an iron bracket as shown. To this bracket is fastened a guard or deflector, of 1/32" sheet iron. This deflector is 3" wide and bent to the shape

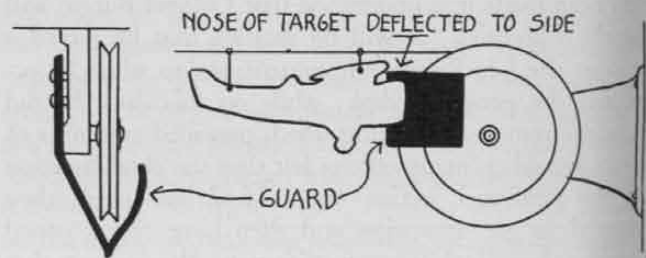

Figure IV.

shown in the drawing. Fastened to the bracket as shown it serves to deflect the target approaching on the upper line from running into the pulley. The target is simply thrust to one side and rides over and down around the pulley, its own weight swinging it into position as it reaches the bottom. The driving pulley needs no shield, as the target approaches from the bottom, rides up and over, and swings into position again.

The action of the target is continuous, requiring no attention other than a change of speed if desired. By setting up the instruments at different locations on the floor, different angles of approach and angular heights may be obtained. With this target it is possible for us at each drill to set up the instruments, connect telephone lines, and obtain and transmit real data, besides giving the gun pointers and observers practice in tracking a moving target. This training has proved of great value and benefit in the annual target practice.

# A Safety Board

By CAPTAIN EDMUND H. STILLMAN, C.A.C.

**T**RAINING regulations 435-55 require that measures be adopted to check the safety pointing of guns and mortars. Usually this is accomplished by line of metal observers but it is a well known fact that this method is at best a guess; also, it frequently happens that in mortar and long range gun fire the gun is actually pointed ahead of the towing tug at the instant of firing. Line of metal observers cannot sight along the longitudinal axis of the gun in the case of large caliber mobile weapons and in cases where the view from the gun is obstructed. For fixed guns and mortars in Case III firing safety measures are accomplished by checking the azimuth setting, however, all types of artillery are not adapted to this. Most heavy guns have a fixed azimuth circle in the lower carriage, but it is not adjustable, and in many cases is graduated in mils and difficult to read.

It was to remedy these conditions that a safety board was developed. It requires some additional personnel to operate but the security and protection it provides, combined with a check on the accuracy of the azimuth setting, more than justifies its use. As battery commander I felt for the first time in all my service that the towing vessel was absolutely safe during both the subcaliber and record practice.

In all Case III firing when the piece is announced "ready" and the safety board is in operation it shows instantly:

1. Azimuth of target when piece is fired.
2. Azimuth of tug when piece is fired.
3. Azimuth of longitudinal axis of bore when piece is fired.
4. The azimuth of the expected point of splash.

The operators use the data as it appears on the display board. An error in the data will show up immediately. The board also gives a close check on the final orientation of the piece during trial fire at a hypothetical target.

Briefly the following data are necessary to operate the board:

- a. Angular displacement of azimuth circles which are not oriented (railway mortars, for example).
- b. Azimuths at which the guns are set to fire.
- c. An estimation of the azimuth of target at the instant of firing.
- d. Angle subtended by the tow line, in degrees and hundredths. This is a continuously varying quantity. (See chart herewith).
- e. Algebraic sum of the travel of target during time of flight and the drift.
- f. Elevation at which guns will fire.

The board is operated on the following hypotheses:

- a. That the target adheres closely to a predetermined course for which data has been computed. The factors which enter into this computation are the angles subtended by the tow line, the angular travel of target and drift of the projectile.
- b. That the towing tug continues on its course.
- c. That no considerable amount of parallax exists between the BC observer and the gun.
- d. That the angular deviation of the projectile is not materially affected by wind.

It is realized that none of these hypotheses are strictly true, however, the data furnished by the safety board is a close approximation and it furnishes one method of obtaining data by which the safety pointing observer may determine whether or not it is safe for the gun to fire.

The safety board practically eliminates all chance of a hit on a towing tug. It furnishes, at all times, a picture of the approximate position of the splash and the exact position of the target and tug at the instant of splash. If the tug turns or slows down it is immediately detected. On several occasions in subcaliber firing the board brought to attention dangerous errors in direction with the result that the piece was not fired on the data. Analysis of drill proved that it should not have been fired on these occasions.

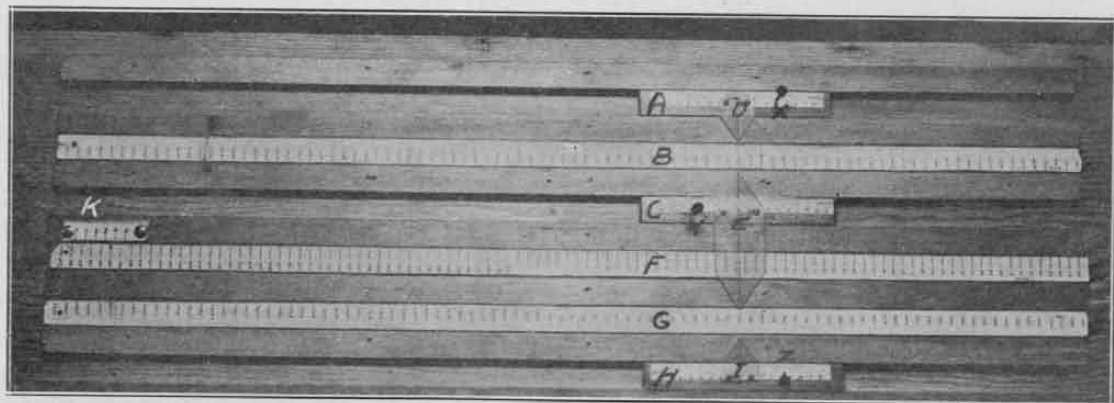

The Safety Board.

## DESCRIPTION OF BOARD

Scale 10"=36°=640 mils. Board covers about 100°.

"A" slides in groove. Has pointer "D" fixed at the center. Graduations are in degrees and hundredths, right and left of center line on "D." Zero is at "D" and this scale is fixed. "D" represents the azimuth of the axis of the bore of Gun No. 1.

"B" slides in groove, graduated in mils. (Do not number graduations until gun is oriented).

"C" is a slide similar to "A", but with a larger pointer "E". It has a scale exactly like the one on "A". The center line of "E" set on "F", represents the position of the target at any time.

"F" is a rule similar to "B", but graduated in degrees and hundredths, and numbered for the known azimuth of the field of fire.

"G" is exactly like "B". (Graduations should not be numbered until guns are oriented.)

"H" is exactly like "A" and represents Gun No. 2.

"K" is a fixed, graduated scale (degrees and hundredths) exactly like arbitrary correction scale on the mortar deflection board. It is for the applying of the same arbitrary corrections as those applied to the mortar deflection board.

"X"- "Z" are pins for No. 1 and No. 2 guns respectively, set out from "D" and "I" the amount called for in the table. They show, in degrees, the amount the axis of the bore must lead the splash. The valuations are obtained by a combination of drift and angular travel during the average time of flight of the projectile.

"Y" is a pin, set as called for in the table and repre-

## CHART

SPEED	ZONES VI AND VII		TARGET PRACTICE
150 yards in 30"	Length of towline in degrees (approximate)		Towline 540 yards
	AZIMUTH	LENGTH OF TOWLINE (degrees)	
	330°	2.50	
	340°	3.50	
	350°	4.30	
	etc.	etc.	

## ZONE VI

TARGET TRAVELING TO THE LEFT			TARGET TRAVELING TO THE RIGHT		
ELEVATION	Drift + Ave. Ang. Travel during time of flight.		ELEVATION	Drift - Ave. Ang. Travel during time of flight.	
45°	3.90°		45"	.50°	
50°	4.20°		50°	.80°	
55°	4.70°		55°	1.30°	
57°-30'	5.10°		57°-30'	1.70°	
etc.	etc.		etc.	etc.	

## ZONE VII

(To be calculated in a similar manner as the Zone VI chart.)

The easiest way to make this chart is to get the towing vessel to run the approximate course. Plot this on the board and draw in the zone arcs. Obtain the length of towline. Take the firing tables and prepare a chart similar to the one above for each zone in which firing will be conducted. Mount it on cardboard and give it to the operators of the Safety Board.

## SUB-CALIBER — ZONES II AND III

Speed—175 yards per minute. Length of Towline—300 yards.  
Length of Towline in Degrees and Hundredths (Approximate).

TARGET TRAVELING TO THE LEFT			TARGET TRAVELING TO THE RIGHT		
ELEVATION	Drift + Ave. Ang. Travel during time of flight.		ELEVATION	Drift - Ave. Ang. Travel during time of flight.	
45°	2.8°		45°	-.40°	
50°	3.1°		50°	-.30°	
55°	3.4°		55°	0.00°	
57°-30'	3.6°		57°-30'	+.20°	
60°	3.8°		60°	.40°	
62°-30'	4.1°		62°-30'	.70°	
65°	4.4°		65°	1.00°	

EDITOR'S NOTE: The Commanding General, Hawaiian Separate Coast Artillery Brigade, in a letter to the Adjutant General, subject "Annual Report of Target Practices, Fiscal Year 1933," dated August 10, 1933, stated as follows:

"5. c. Attention is invited to the 'Safety Board' designed by Captain E. H. Stillman, 41st Coast Artillery, which is fully described in the Target Practice Report of Battery A, 41st C.A.

This board indicates at all times the relative position of the target and the splash. It was used with very satisfactory results during both the sub-caliber and service practices of the two mortar batteries of the 41st Coast Artillery, and is of particular interest in view of the provisions, relative to safety precautions, of Par. 3 d. Sec. I 'Instructions for Coast Artillery Target Practices, Fiscal Year 1934.'"

sents the towing vessel and its angular length ahead of the target.

Wind is ignored in these tables as it is variable and of small value. not important in connection with the safety of the towing vessel.

#### ORIENTATION

When the guns are in the firing position and oriented, lay the No. 1 gun to a known azimuth in the field of fire by means of the panoramic sight if no datum points are available. Do not then disturb the gun. At some convenient point directly above the fixed azimuth circle on No. 1 gun, make an arrow (with chalk or paint) pointing to an even mil graduation which can be readily seen through the whole field of fire—the lateral limits of this must be known. For example, if the gun is pointing at an azimuth of  $50^\circ$  and the index arrow is drawn above 2,300 mils on the fixed azimuth circle on the gun, slide rule "F" to the center of the board. Next, slide rule "B" so that an even mil graduation is directly above the  $50^\circ$  on "F". Now number all of rule "B" graduations with 2,300 mils opposite  $50^\circ$ . Similarly repeat the operation for gun No. 2 and number the graduations on rule "G".

Make a small index arrow at some convenient place well to the left, on "F" as at "K" and thumbtack the arbitrary correction scale down opposite this arrow with 3 (normal) opposite it. The photograph shows the board, in operation, correctly set, with an arbitrary correction of 3.60.

#### OPERATION

The board is set on a table midway between and in rear of the guns. Four men operate it as follows, each operation is very simple:

A noncommissioned officer sets pins "X", "Y" and "Z", and observes the setting of the two gun pointers, "D" and "I" and notes the position of the splash or

splashes. The two pins, "X" and "Y", should be within a half a degree of being directly over or under the center line of "E". "E" moves in small jumps every ten or fifteen seconds, or it could be made to "creep". "D" and "I" move when the gun pointers signal "Ready". Arbitrary corrections are kept at the same setting as the mortar deflection board in the plotting room. They are telephoned out when changes occur.

No. 1 operator, of this board, sets "D" to the azimuth at which the gun is actually laid. An accuracy of 5 mils is considered sufficient. An assistant is stationed where he can observe the azimuth setting and remains there, calling out the azimuth recorded under his index each time he hears the command, "No. 1 Ready".

No. 2 sets "I" for No. 2 gun in exactly the same manner by hearing his assistant at No. 2 gun call out the reading to be set.

No. 3 wears a telephone headset and hears the azimuth of the target called to him over the telephone every ten or fifteen seconds. This information comes from a man in the B. C. station or some other station in the vicinity of the guns, from which the target can be seen. This man has an oriented azimuth instrument. No 3 sets "E" to this value on "F" and "creeps".

As the pins set on "A" and "H" at "X" and "Z" represent the position of the splash of the projectile, it is seen that the Safety Board operators can instantly see if the splash is going to be at the target, the tug, between the two or in rear of the target. They can just as readily avoid a gun firing a considerable distance in rear of the target as ahead of it; but the safety of the tug is their real mission and they "defended" it well, in our firings. The data on the board show that the shots will fall about 4 degrees to the right of the target. The towing vessel is about  $4\frac{1}{2}$  degrees ahead of the target. Target being towed from right to left.

## Expedients vs. Expense

BY LIEUTENANT LOUIS J. STORCK,  
*66th Infantry (Light Tanks)*

**I**N these days of curtailment and economy, no small amount of ingenuity has been necessary to keep up the high standard of efficiency, equipment and appearance of the Army in general and the kitchens in particular. At Fort Devens, Massachusetts, an experiment in economy has just been completed in the 66th Infantry. The kitchen of Company "H" is an outstanding example of the exercise of much ingenuity in assembling equipment that would be modern in appearance and practical in use, and above all, inexpensive in cash outlay.

In the accompanying picture, showing equipment that met all these requirements, it will be seen what a great improvement these "homemade" fixtures are over various

old-style equipment and methods still in use in some kitchens.

The table, the can rack near the window, the rolling stands for the large electrical units and for the mixing bowls and trays, the frame for the drawer—also the drawer itself—were all constructed by company labor from salvaged material. The only expense involved was for aluminum paint and the ball-bearing casters, and both these items can be purchased at low cost from the 5-and-10-cent stores.

The kitchen table has a zinc cover closely fitted over a wooden top. This top is a salvaged mess table. The table top is not attached to the supporting frame, made of old pipe and pipe fittings. The uprights supporting the top rail, on which hang large dippers, spoons, whips, cleaver, scales and other utensils too large for the drawer, are integral with the table top. This overhead rack was made



*The Kitchen of Company H, 66th Infantry.*

high enough to prevent the hanging utensils from interfering with the cooks while at work. The S hooks for utensils are moveable along the pipe.

The table drawer rests on a rolling frame of pipe and, when in place, fits directly under the table. For convenience in working, the drawer can be moved entirely clear of the table or to any desired position under the table. The drawer box is wooden with a sheet of tin on the under side to prevent excessive wear due to a wood-metal contact. It was constructed of salvaged lumber and stained to correspond to the other woodwork in the mess.

The rack for large cans—in which are kept coffee, beans, sugar, flour, cereal and other dry stores—was constructed from salvaged pipe. The frame supporting the electric meat chopper and the frame for the electric ice cream freezer were both made of salvaged pipe, and all metal frames were painted with aluminum paint. Aluminum paint was chosen because it is more durable than enamel, is easier to keep clean, does not chip off, and its silvery sheen brightens the kitchen considerably. In case a part of any frame is scratched or marred and inspection is imminent, the spot is hastily touched up with more paint which also dries more quickly than enamel paints.

The stand for the mixing bowls was made from two salvaged tire irons and strips of scrap sheet iron. This stand has ball-bearing casters to permit easy rolling, but can be held stationary when in use by releasing the L-shaped clamp which is hinged to the frame and placing

it in contact with the floor.

The double tray-cart frame was made of salvaged bed irons from discarded wartime cots, mounted on salvaged rubber-tired wheels from baggage trucks. The two trays were made from sheet zinc and finished with aluminum paint.

The excellent appearance of this equipment made from the salvage heap is obvious from the accompanying photograph, but also note the added convenience of this type of kitchen fixtures. Everything, except the stoves, is a foot or more above the floor; and everything, except the stoves and the washing sink, is either on rollers or easily movable because of its light framework. With the floor so accessible to soap and water, there is no excuse, indeed scarcely any inclination even, on the part of the K. P. to skip the daily scrubbing. The fact that the table top is removable and can thus be more easily scoured on its underside makes it highly improbable that any little bit of grease or dirt can accumulate in that locality.

The draining boards in conjunction with the sinks, while not of salvaged material, are worthy of mention in view of their contribution to the convenience and cleanliness of this kitchen. These drain-boards are wooden with monel metal tops, and are so attached and hinged to the pipe frames supporting them that they may be raised to an upright position to facilitate drying, consequently no little cockroaches, ancient enemy of army kitchens, are tempted to move in and settle down in choice locations around damp drainboards.

# COAST ARTILLERY BOARD NOTES

*Any individual, whether or not he is a member of the service, is invited to submit constructive suggestions relating to problems under study by the Coast Artillery Board, or to present any new problems that properly may be considered by the Board. Communications should be addressed to the President, Coast Artillery Board, Fort Monroe, Virginia.*

## THE COAST ARTILLERY BOARD

COLONEL A. H. SUNDERLAND, C.A.C., *President*  
MAJOR IRA A. CRUMP, O.D.  
MAJOR A. F. ENGLEHART, C.A.C.  
MAJOR C. E. COTTER, C.A.C.

CAPTAIN S. L. MCCROSKEY, C.A.C.  
CAPTAIN C. S. HARRIS, C.A.C.  
CAPTAIN E. T. CONWAY, C.A.C.  
1st LIEUT. WALTER J. WOLFE, C.A.C.

### SECTION I

#### Projects Completed Since the Last Issue of the Journal

No projects, as such, have been completed since the publication of the May-June issue of the COAST ARTILLERY JOURNAL. This situation does not indicate a period of inactivity on the part of the Board. Much work has been done on many of the projects now before the Board, but the laws of probability just did not operate to bring about the conclusion of any of these since the last issue. A contributing factor to this condition is the fact that just now the projects are, in several cases, of wide scope, requiring much research and study, and others involve long-continued tests before any definite conclusions can be reached.

### SECTION II

#### Projects Under Consideration

From the discussion offered in the previous section, it is obvious that this section should include just those projects that were shown as unfinished in the last issue of the JOURNAL, plus the new ones ordered by the Chief of Coast Artillery.

##### OLD PROJECTS

PROJECT No. 929—EXPERIMENTAL FIELD CHRONOGRAPH (JACKSON).—Several references to this instrument have appeared in previous issues of the JOURNAL. Nothing new has transpired. The Chief of Ordnance has not yet reported that he has completed his test on this instrument.

PROJECT No. 953—RADIO-CONTROLLED HIGH-SPEED TARGET.—The Coast Artillery Board has received a 28-foot motor boat with a 200-horsepower engine. The boat is also equipped with gyroscopic steering control. Preliminary tests indicate that it can attain quite a high speed, and that the gyroscope will hold the boat on a fixed, straight course. The Chief Signal Officer has cooperated and is supplying a radio sending and receiving set, and the Board is busy with the making and installing on the boat of the necessary additional controlling mechanism. It is not known when the final tests can be made,

and it is a matter of considerable discussion and thought as to whether or not one would dare fire directly at this expensive boat. On the one hand, it would appear fairly safe to proceed with preliminary fire adjustment at long range, using the boat itself as a target. On the other hand, in the final analysis, unless the Coast Artillery does hit targets, there is no reason for having guns. However, no uneasiness for the present, is caused the Coast Artillery Board in finding the answers to such questions as: will a survey officer hold a battery commander responsible for a lucky shot destroying valuable government property, or will it be necessary to fire at an offset point? The Board's problem is to make the target ready.

PROJECT No. 973—TEST OF LACQUERS AND VARNISHES FOR USE AS RUST PREVENTIVES.—This test of transparent covering for the bright parts of guns is still progressing. Some of the materials tested show great promise, while others that, at first, seemed well adapted to this use, are turning brown. These materials can be applied easily, and if it is found that they can be removed easily it would appear that, even if they do discolor and present a rusty appearance after a period of a few months, such materials still present some advantages over slushing oil.

PROJECT No. 975—TEXT ON TRACER CONTROL.—This is a text which the Chief of Coast Artillery directed the Coast Artillery Board to prepare with a view to instructing personnel in the firing of antiaircraft machine guns. Authorities on the subject are few, and their views are so divergent that a decision on the methods of procedure is most difficult. As stated before, this paucity of views and divergence of opinions indicate the necessity for some such text. Work has progressed so far that it is safe to state that the paper will be submitted for the action of the Chief of Coast Artillery early in July.

PROJECT No. 987—LUMINOUS PAINTS FOR GUNS.—This paint has been applied at various places around the breech of a 155-mm. gun with a view to making it possible to load and fire the gun without the use of any lights that might disclose at night the location of the gun to a hostile airplane. No proper test has yet been made of this

luminous paint, largely due to the fact that the troops of the Harbor Defense of Chesapeake Bay have been so engaged in other duties that it has been impossible to assemble on nights that are sufficiently dark, enough trained men for a gun detachment to make conclusive test. Such paint has been on one gun for nearly two months and frequent examinations indicate that it is still retaining its luminous properties.

PROJECT NO. 989—AZIMUTH AND ELEVATION CHECKING DEVICES FOR 155-MM. GUNS.—This checking device was used by the Coast Artillery School personnel in firing 155-mm. guns at Fort Story during the month of June. While the formal report has not been made up due to the absence of the testing officers on other duties the informal reports indicate that the device is not entirely satisfactory in its present form.

PROJECT NO. 990—TEST OF DULUX, NON-OXITE AND OTHER PAINTS.—These paints have been applied to the guns and carriages of four antiaircraft fixed mounts at Fort Monroe and, unless some one paint performs much more poorly than is expected, it will be many months before any conclusive report can be made.

PROJECT NO. 998—RANGE DISPERSION, SEACOAST GUNS.—As stated in the previous issue of the JOURNAL, this is a project undertaken by the Coast Artillery Board and, naturally, cannot take precedence over the work which is assigned by the Chief of Coast Artillery. To date, little has been done on the project. However, the Board would welcome any information that any reader of the JOURNAL can supply on the subject.

#### NEW PROJECTS

PROJECT NO. 999—TIME INTERVAL APPARATUS FOR MOBILE ARTILLERY.—Even in the good old days when everything the Coast Artillery used had been standardized for a number of years, there was more or less trouble with the time interval devices, particularly when attempts were made to vary the interval between bells. The apparatus developed at that time was not adaptable to field service, and considerable difficulty has been experienced in securing and standardizing time interval apparatus for tractor-drawn and railway artillery. It now appears that the problem, through the agency of the Signal Corps, nears a satisfactory solution. The latest developments were tried out at Fort Story during battle practice by the personnel of the Coast Artillery School in June. Features of the new installation include an improved time interval device operated by an electric clock, motor-driven tone source, and improved "howlers" for the guns. The tone source was designed to take the place of unsatisfactory buzzer-operated devices which had been improvised previously. The new tone source provided abundant power for four gun howlers, and in addition, provides suitable signals for four observers' or readers' line. The tone source is satisfactory in all respects, except that the current consumption is excessive. It is hoped that this objection may be overcome either by the use of a small motor-generator or by the development of an improved vibrator.

PROJECT NO. 1,000—INSTRUCTIONS FOR MARKING ANTI-AIRCRAFT MACHINE GUN BULLETS.—There has just been concluded a very interesting test on the mixing of ink and the coloring of bullets for antiaircraft machine guns. This procedure permits the identification of hits on a sleeve target. It was found that the grade of ink commercially known as lithograph ink gives the best results. It was also found that turpentine is, if not the best, at least a very good solvent for such ink; that is, it is better than linseed oil. Colored .30 caliber bullets mark the target more distinctly than do the .50 caliber bullets. Certain colors applied to .30 caliber bullets permit the use of the bullets up to a time six days after the coloring thereof. The Coast Artillery Board prepared, for the action of the Chief of Coast Artillery, instructions for the operation of coloring such ammunition. Assuming favorable action on these instructions, they should be published at an early date.

PROJECT NO. 1,001—SEARCHING AND ILLUMINATING SEARCHLIGHTS FOR ANTI-AIRCRAFT ARTILLERY DEFENSE. A question has arisen concerning the number and kinds of searchlights to be supplied mobile antiaircraft regiments. The cost and difficulty of procurement of the lights themselves and the accessories thereto has caused the Chief of Coast Artillery to direct that a study be made to determine, among other things, whether or not it is necessary that each antiaircraft searchlight of a platoon be accompanied by a sound locator with distant electrical control. A questionnaire on this subject has been sent out to several officers in the service asking their assistance in preparing this study.

PROJECT NO. 1,002—REVISION OF TABLES OF ORGANIZATION—MINIMUM SPECIFICATIONS AND INDEX FOR OCCUPATIONAL SPECIALISTS.—Preliminary work on this project leaves the Coast Artillery Board somewhat in doubt as to just what is required, but the problem, in general, is that of "hooking up," so to speak, tables of organization with publications already in existence that cover the specifications for occupational specialists, as well as the modification of such publications.

PROJECT NO. 1,003—DRILL CARTRIDGES FOR 3-INCH ANTI-AIRCRAFT GUNS.—The Ordnance Department has made certain modifications of the drill cartridge for the 3-inch antiaircraft guns, M1917, M2 and M4; 1918, M1 and M3. The cartridges have been received at Fort Monroe and will be given a service test at the first opportunity. It appears that the crux of the test is to determine the serviceability of the sliding type base involving the use of a spring.

PROJECT NO. 1,004—SERVICE TEST OF SWITCHBOARDS, TYPES BD-71, BD-72, BD-76, AND BD-82.—These are understood to be field type telephone switchboards which are modifications of older models. It is understood that these are to be given a service test by other branches of the service. The material has not been received at Fort Monroe.

PROJECT NO. 1,005—IMPROVED HOWLERS FOR TIME INTERVAL APPARATUS.—These two devices have just been

received by the Coast Artillery Board, but too late to be tried out in the firings by Coast Artillery School personnel at Fort Story during May and June. These are merely modifications of howlers already tested, and are designed with a view to making the devices more rugged. They will be tested at the earliest opportunity.

PROJECT NO. 1,006—RAILWAY MOUNT FOR 8-INCH NAVY GUN, M1925E.—Recently the Coast Artillery Board was called upon to make the service tests to determine the advisability of standardization of this mount, which is an adaptation of the M1918 railway mount for the 20-caliber, 12-inch howitzer. This mount gives all-round fire by traverse of the top carriage and is emplaced by anchoring the truck platform in the same manner as the present 8-inch railway and 12-inch railway mortar mounts. The 1925E differs from the 8-inch M1918M1 railway mounts in that the former has a stiffer truck frame and uses hydro-pneumatic counter recoil instead of springs. Ordnance Department personnel conducted exhaustive tests to determine stability of the mount and suitability of the recoil system. It was found that the stability was far superior to the present 8-inch railway mount and that the recoil and counter-recoil systems functioned perfectly with the 45-caliber Navy gun. The Board has completed its service tests during which it was found that, in general, the mount was superior to the present 8-inch mount as a shooting weapon but that the convenience for loading, pointing and firing was somewhat less than the present 8-inch railway mount. In other words, the M1925E, though usable, is not the fulfillment of all the desires of the railroad artilleryman.

### SECTION III

#### Miscellaneous

The following subjects, not taken up as projects, but upon which the Coast Artillery Board has acted more or less completely since the last publication of the JOURNAL, may be of interest.

ANTIAIRCRAFT MACHINE GUNS.—The Board is making every effort to solve the antiaircraft machine-gun fire control problem. A collection is being made of the descriptions of all directors and sights that have ever been tried, and in cases in which the actual device can be found, examinations are being made with a view of selecting the good features thereof and incorporating them in a simplified mechanism that will put someone in charge of machine-gun fire rather than the individual gunner who, in present practice, goes on his unsupported way, and, failing to hit, brings forth the verdict that it is "just too bad." There are many intangible features of the

problem. The general line of procedure includes:

a. The supplying of a sight so that the gunner aims directly at the target, not at a hypothetically rapidly shifting point in the sky, and

b. Someone other than the gunner is responsible for the setting of this sight.

Recent developments in flexible shafts have assisted greatly in the operation of setting sights from some point well removed from the gun.

This problem, of course, is closely allied with Project No. 975, Text on Tracer Control.

SIGNAL CORPS EQUIPMENT.—Captain F. T. Gillespie, Signal Corps, brought to Fort Monroe during June several field telephone switchboards, reel units, and a sample of a light telephone field wire. No tests were made but the equipment was carefully examined. The Board recommended that three Reel Units, Type RL-31-T2, be made up for service test. The unit consists of a simple frame carrying an axle on which may be mounted either a one-mile or a half-mile reel. The unit may be mounted in a truck and the wire paid out in the usual manner, or the legs may be folded together and the unit pulled along the ground with the rims of the wire drum acting as wheels. An additional feature is that the legs may be opened outward until they are in prolongation of each other with the axle at the center, thus permitting the unit, including a reel of wire, to be carried as a litter. The Board further recommended service test of some of the switchboards and the new wire.

SIGNAL LAMPS.—Correspondence is still being carried on with a view to the development by the Signal Corps of a suitable signal lamp. This matter was discussed at some length in the last issue of the JOURNAL.

VISITS OF INSTRUCTION AND INSPECTION.—During the month of June it was necessary for certain members of the Board to be present at Aberdeen Proving Ground to witness the test of the 8-inch railway carriage (Project No. 1,006 mentioned above). Majors Cotter and Englehart and Captain Harris were detailed to this duty. Captain Harris stayed over to witness some firing tests of an antiaircraft gun. He also proceeded to Frankford Arsenal to select equipment for machine-gun fire control. Majors Cotter and Englehart included in their itinerary Frankford Arsenal, the Signal Corps Laboratories at Fort Monmouth, New Jersey, Watertown Arsenal, and the Sperry Plant at Brooklyn, New York. These two officers also inspected a partially completed antiaircraft machine-gun computing sight at Fort Totten, New York, which device was designed and constructed by Lieutenant John J. Meadows, CA-Reserve.



FORTRESSES ARE EQUALLY USEFUL *in offensive and defensive warfare* It is true they will not in themselves arrest an army, but they are an excellent means of retarding, embarrassing, weakening, and annoying a victorious enemy.—NAPOLEON.



# Hawaiian Separate Coast Artillery Brigade

## News Letter

BRIGADIER GENERAL R. S. ABERNETHY, *Commanding*  
 CHIEF OF STAFF, LIEUT. COL. F. Q. C. GARDNER, C.A.C.

S-1, LIEUT. COL. W. V. CARTER, A.G.D.  
 S-2, CAPTAIN WILLIAM F. LA FRENZ, C.A.C.

S-3, LIEUT. COL. A. G. CAMPBELL, C.A.C.  
 S-4, MAJOR FREDERICK A. MOUNTFORD, C.A.C.

By *Lieutenant John R. Lovell and Captain William F. LaFrenz, CAC*

### THE PRESIDENT'S REVIEW

THE proposed visit of the President of the United States to the Territory of Hawaii is being anticipated with much pleasure by the Army. It is expected that the Commander in Chief will be here for three or four days, and during that time the Army will conduct a Department Review in his honor. It is expected that the entire Hawaiian Division, the 18th Composite Wing, and the Hawaiian Separate Coast Artillery Brigade with all its Artillery and equipment will pass before the Reviewing Stand.

Instead of marching as Infantry as in past years, it is expected that all Coast Artillery troops will man either primary or secondary Coast Artillery armament for this occasion. In general, the Coast Artillery troops will be organized as follows:

1. First and Second Battalion, 55th Coast Artillery, as one Regiment of 155 GPF's.
2. Batteries A and B, 41st Coast Artillery, and Battery C, 16th Coast Artillery, organized as an Antiaircraft Searchlight Battalion.
3. Batteries A and D, 16th Coast Artillery, and Batteries A, B and C, 15th Coast Artillery, as an Antiaircraft Gun Regiment.
4. The 64th Coast Artillery as a regular Antiaircraft Regiment.

The Coast Artillery will conduct a real show with three Regiments and one Battalion of personnel and matériel in the formation.

### BRIGADE ATHLETICS

*Baseball.* The Honolulu Sector-Navy Baseball League opened about the middle of May, and after the dust settled on all of the local diamonds upon completion of the first round of play, we find two splendid soldier teams from Fort Shafter and Luke Field tied for the leadership of one of the best baseball leagues in our service. All the teams in the circuit are very evenly matched, with one possible exception. Following is the standing of the League after the first round of play:

Team	Played	Won	Lost	Officer in Charge
Shafter .....	7	6	1	Capt. W. E. Timberlake, CAC.
Luke Field .....	7	6	1	Capt. Frank Cook, AC.
Submarine Base..	7	5	2	Lt. Cmdr. C. D. Leffler, USN.
Fleet Air Base....	7	4	3	Lt. F. Leslie, USN.
Harbor Defenses	7	3	4	Lt. Wayne L. Barker, CAC.
Fort Kame-				
hameha .....	7	2	5	Lt. Lewis Kirkpatrick, CAC.
Staff .....	7	2	5	Capt. Norris W. Osborne, OD.
Marines .....	7	0	7	Lt. Wallace A. Thompson, USMC.

*Golf.* Lieutenant Bob Stunkard, of Luke Field, won the Officers' Golf Championship of the Hawaiian Depart-

ment after a grueling 72-hole match. This competition drew a large number of entries from the Hawaiian Division and the office personnel of the Honolulu Sector. The tourney was for medal play, no handicaps being permitted. Contestants were divided into three flights as follows: Flight A, handicaps 0-10, Flight B, handicaps 11-15, and Flight C, handicaps all over 15.

Major Carl S. Doney, Commanding Officer of Fort DeRussy, won the Flight B Championship with a score of 376, and Captain K. P. Flagg, of Fort DeRussy, won the Flight C Championship with a card of 383. Following is a partial list of the results:

Name	1st Rd.	2nd Rd.	3rd Rd.	4th Rd.	Total
Lieut. R. A. Stunkhard, A.C. ....	81	74	82	77	314
Capt. H. J. Liston, Inf. ....	81	79	76	82	318
Capt. Don Riley, Inf. ....	83	76	77	84	320
Capt. J. F. Bohlender, M.D. ....	85	77	83	81	326
Major Carl S. Doney, C.A. ....	98	94	93	91	376
Capt. E. W. Duncan, A.C. ....	97	89	93	98	377
Col. G. L. Hicks, A.G.D. ....	97	94	94	95	380
Capt. K. P. Flagg, C.A. ....	97	97	88	101	383

*Athletic Officer.* It is with regret that we announce at this time that Lieutenant Joe Dillon has been relieved as the Honolulu Sector Athletic Officer. In addition to his duties in connection with athletics, Dillon has been the Brigade Judge Advocate and apparently has been so successful in his efforts that he was ordered to the Hawaiian Department Headquarters as the Department Trial Judge Advocate.

Lieutenant Dillon has unquestionably developed athletics in the Honolulu Sector to a very high degree. The performances of competitors have been greatly improved in all branches of sports, and the contests have been attended by tremendous crowds. Athletics in the Brigade have been a great morale factor during the past two years, and the recreational value of them has been inestimable. Lieutenant C. W. Gettys has been detailed to replace Lieutenant Dillon as the boss of Brigade Athletics.

### BRIGADE GUNNERY

As this is being written, the last shot of the 1934 sea-coast target practices has been fired, and everyone is busy with pencil, slide-rule, and Coast Artilleryman's bible, TR 435-55. This year, our old friend "Alibi" is, to a large extent, absent, as the practices have demonstrated that the organizations over here are "shooting" batteries.

Friday, April 13th, was a lucky day for the 41st Coast Artillery, as was predicted by your scribe in the last issue of the JOURNAL. For many a target practice season these 12-inch railway mortars have been haunted by that infamous "score devourer," the sliding center of impact.

This year, Major Ira B. Hill, ably assisted by Captains Frederick H. Koerbel, Battery "A," 41st Coast Artillery, and Edmund Stillman, Battery "B," 41st Coast Artillery, fought the "slide" with the assistance of "empirical curves" based on previous firings, and utterly routed the enemy. As a result, they continuously rocked the target with 12 and 7 hits out of 14 rounds, respectively, to the dismay of all concerned, as there was only one high-speed target available and a wrecked target would have meant delay for the organizations still to shoot.

Not to be outdone by the railway mortars, Battery "C," 16th Coast Artillery, Lieutenant H. E. C. Breitung commanding, demonstrated that the 12-inch seacoast mortars could gather 12 hits (5 BS, 7 BO) out of 14 rounds, with the assistance of the "sliding center of impact" curves.

Battery "C," 15th Coast Artillery, led by Lieutenant L. S. Kirkpatrick, showed what could be done with a 6-inch D.C. battery, using the bracketing method of adjustment. Twelve hits (3 BS, 9 BO) out of 14 rounds were gathered in by this organization to uphold its former records.

Battery Williston, manned by Battery "A," 15th Coast Artillery, under command of Captain Supple, fired a 155-mm. ex-caliber practice on May 9, 1934, using the major caliber fire control equipment to fire the battery at

ranges approaching 15,000 yards.

Captain Rodney Jones and Battery "A," 16th Coast Artillery, at Fort DeRussy, decided to give the tourists at Waikiki a thrill and cause the Artillery Engineer much "pilikia"—trouble to you—in knocking the target out of the water at 11,000 yards with 6" D.C. sand-loaded shells, and to show Battery "C," 15th Coast Artillery, of Fort Kamehameha, their old rivals, how to shoot a 6" battery. Much to our surprise (I say "our" advisedly, as they knew it all the time), and their elation, they did just that little thing, and ruined one rather expensive high-speed target with two salvos, registering direct hits. But having seen the shooting this year, this possibility was foreseen and a new high-speed target was brought out to complete the practice. More to the point, however, was the fact that they beat their Fort Kamehameha rivals by 0.9 on the score.

Now that all the guns have been swabbed out and put away until next year, everyone is starting on their anti-aircraft assignment work.

The 64th Coast Artillery, anti-aircraft regiment supreme, whose motto is "We Aim High," have, from all appearances, started out with a full belief in their motto. The two searchlight batteries held their annual exercises at Pearl City during the last two weeks in May. While the target practice reports have not come in, rumor

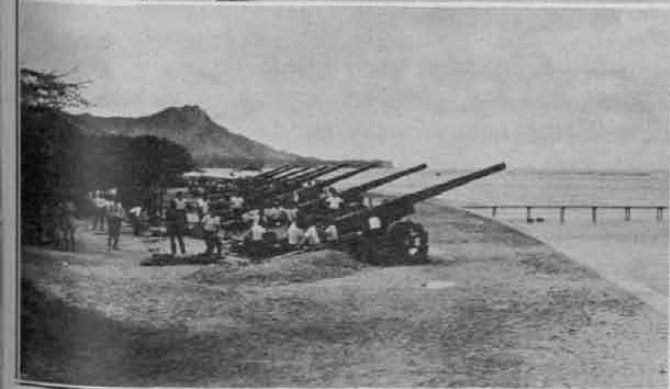

Above, left—64th Coast Artillery Section in Memorial Day parade. Right—Hawaiian Department enlisted men's dance in honor of Lieutenant Colonel and Mrs. H. W. T. Eglin. Below, left—Battalion of 155's at Hawaii. Right—Aloaha parade at Fort Shafter; left to right—Major and Mrs. M. F. Du Frenne, MC; Captain and Mrs. Arthur Winton, CAC; Lieutenant and Mrs. L. R. Bullard, CAC; Major L. R. Mitchell, Adjutant; Colonel W. G. Peace, Commanding Officer; Lieutenant Colonel W. W. Hicks, Executive; Captain M. C. Handwerk, P&T Officer; Chaplain P. J. Ryan.

has it that they have nearly reached the maximum score of 128.0 in their exercises. At any rate, observing the action of the lights, each of the six platoons showed what the modern lights and sound locator systems could do. From appearances, it looks as if a night air raid on Oahu will be of dubious value with the "eyes" of the 64th Coast Artillery on the job.

These practices were followed by some very interesting combined A.A.-Air Corps exercises, which were of much benefit to both services.

A feature of this year's practices worthy of note was the fine work and cooperation extended us by the 18th Composite Wing. The Air Corps spotting for the sea-coast practices was especially fine, the average air spotting error being less than 25 yards. As for the cooperation between the A.A. and the Air Corps, that was of the highest, and a large part of our success was due to their excellent and unflinching support.

Note: Since the above was written, the scores of all sea-coast practices have been computed and the results are indicated in the following table:

Organization	Armament	Score	Battery Commander	Rounds Fired
B, 15th	12" B.C.	237.0	Capt. Foster	13
A, 41st	12" Ry.	92.2	Capt. Koerbel	18
B, 41st	12" Ry.	83.6	Capt. Stillman	18
C, 16th	12" S.C.	89.0	Lieut. Breitung	18
C, 15th	6" D.C.	97.2	Lieut. Kirkpatrick	18
A, 15th	155 m/m	73.0	Capt. Supple	16
A, 16th	6" D.C.	98.1	Capt. Jones	18
A, 55th	155 m/m	79.1	Capt. Read	23
B, 55th	155 m/m	103.7	Capt. Higgins	23
C, 55th	155 m/m	46.7	Lieut. Gettys	23
D, 55th	155 m/m	120.3	Capt. Hardie	23
E, 55th	155 m/m	68.2	Capt. Ryan	23
F, 55th	155 m/m	72.7	Capt. Fiskin	23
D, 16th	155 m/m	83.9	Capt. Flagg	23
A, 64th	{1st Pl. AA.SL.	119.8	Capt. Wilson	
	{2nd Pl. AA.SL.	123.5		
	{3rd Pl. AA.SL.	116.3		
E, 64th	{1st Pl. AA.SL.	121.6	Capt. Bonney	
	{2nd Pl. AA.SL.	126.1		
	{3rd Pl. AA.SL.	126.8		

### 155 GPF GUN DRILL

The Executive Officer of one of the 155-mm. GPF Batteries in the Brigade, during the last target practice season, revised the drill for members of the gun crews. This drill complies with all safety precautions and works very smoothly in practice. In fact, the drill worked so smoothly that the guns were loaded and ready for firing in ten seconds during practice. As this may be of interest to other members of the Corps, we are publishing herewith the duties of the members of the gun crews in brief:

#### DUTIES OF GUN CREW

##### 155-mm. Gun Battery

###### Gun Commander

1. Supervises drill of the gun section.
2. Inspects powder chamber after sponging.
3. Checks elevation with gunner's quadrant.
4. Calls "ready," with upraised left arm, when the gun is properly laid and loaded.
5. Releases percussion hammer safety lock with right hand, at executive command "ready."

6. Is responsible for enforcement of all safety regulations.

###### Gun Pointer

1. Checks cross level bubble as soon as gun is fired.
2. Sets new azimuth.
3. Traverses, and then after breech is closed, taps gun to left until vertical hair is on aiming point.
4. Calls "set" in loud tone of voice as soon as gun is properly pointed.

###### Elevation Setter

1. Sets correct elevation on elevation scale.
2. Sets gun in elevation (Bubble must come from rear after breech is closed).
3. Calls "Bubble" in loud tone of voice when gun is properly laid.

###### Number One

1. Releases firing mechanism and opens breech as soon as gun is fired.
2. Dips left hand in bucket of water and washes off mushroom head.
3. Closes block as soon as powder is inserted.
4. Fires gun at executive command.

NOTE: (Number One to wear canvas glove on left hand.)

###### Number Two

1. When breech is open, moves percussion hammer safety lock to "close" position.
2. Releases firing mechanism from housing.
3. Changes primer, throwing old one over the trail.
4. Reams out firing vent.
5. When block is closed, inserts firing mechanism and stands clear.

NOTE: Number two to be equipped with pliers and screwdriver.

###### Number Three

1. At command "Load," grasps rammer in left hand about the center of gravity—the right hand just back of the rammer head so rammer may be properly guided.
2. Places head of rammer against base of projectile and gives the command "Home," pushing projectile off shot tray.
3. Assists number four in ramming at the command "Ram."
4. Carries rammer back from the breech.

###### Number Four

1. Follows rammer shaft to breech and after number three gives the command "Home," number four gives the command "Ram," at the same time smashing projectile up into forcing cone as hard as possible. "Feet should be firmly emplaced on ground during ramming operation so that entire weight of body may be put behind the rammer."
2. Pulls rammer out of powder chamber.

###### Number Five

1. Lifts sponge out of the water bucket.
2. Sponges powder chamber completely up to forcing

cone *in one continuous motion* as soon as number one opens breech.

3. Returns sponge to bucket of water outside left trail provided for this purpose.

#### *Number Six*

1. Lifts shot tray with left hand, right hand being under rear end of tray to balance it.

2. Steps forward with inside foot, and then with outside foot, placing the shot tray into the breech ring. (Two-step football shift.)

3. As soon as rammer has pushed projectile off tray, the tray is dropped by number seven and taken back to stand by number six.

4. Number six must be careful not to interfere with number eight coming forward with new powder charge.

#### *Number Seven*

1. Grasps handle of shot tray in right hand, left hand under the rear of tray to balance it.

2. Steps forward with inside foot and then with outside foot, placing shot tray into the breech ring. As soon as projectile has been pushed off tray, drops his end of shot tray, runs to rear, grasps new projectile, and puts it in shot tray, when number six has replaced it on the stand.

#### *Number Eight*

1. Takes powder charge from number nine, so that black powder end is in right hand.

2. Races to breech as soon as preceding shot is fired.

3. Inserts powder charge in powder chamber as soon as rammer clears breech ring.

4. Black powder end of charge must be inserted in the powder chamber so that it touches mushroom head when the breech block is closed.

5. Races back to powder pit for next charge.

#### *Number Nine*

1. Takes powder charge out of container so that black powder end of charge is in left hand. Hands powder charge to number eight.

#### OVERS AND SHORTS

Major General Halstead Dorey arrived in the Hawaiian Department on June 2, 1934, and assumed command of the Hawaiian Division, the largest single command in the United States Army, relieving Major General Albert J. Bowley, who departed recently for his new station as Commanding General of the Fifth Corps Area.

General Dorey returned General Abernethy's call at Fort DeRussy, on June 7th. The new General met the members of the staff of the Brigade, and then complimented Major Carl S. Doney on the splendid appearance of the Guard of Honor.

Two weddings of interest to Coast Artillery personnel took place recently in Honolulu. Miss Janet Grant, the only daughter of Colonel and Mrs. Homer S. Grant, became the bride of Lieutenant Albert F. Cassevant at the Central Union Church on the afternoon of June 5, 1934. Miss Ruth Steele, the only daughter of Colonel and Mrs.

Harry L. Steele, became the bride of Lieutenant J. W. Davis, U. S. Navy, at the St. Andrew's Cathedral, on the afternoon of May 29. Both weddings were attended by large groups of friends.

The U.S.S. *Ontario* is a large Naval tug stationed in the American Samoan Islands. This vessel recently came to Pearl Harbor for its bi-yearly overhaul. By a special act of Congress, a portion of the crew are full-blooded Samoans, who are able to interpret the songs and dances of their native land. The Battery Commander of Battery D, 16th Coast Artillery, Captain K. P. Flagg, was able to secure the services of this group at a Battery celebration, at Fort DeRussy, recently; and the entertainment was so successful that it was scheduled later at the Royal Hawaiian Hotel. The Samoan dances are quite different from those of Hawaii. The soldiers greatly enjoyed the program. Mr. Rocky Brooks, one of the professional wrestlers at Honolulu, conducted a strong-man act which was enjoyed greatly. Mr. Brooks inflated an inner tube by blowing in it until the tube burst. Before bursting, the tube expanded to a diameter of approximately two feet. Mr. Brooks then tied a two-inch rope around his neck and permitted six strong men to conduct a tug-of-war with his neck in the rope. He was lifted completely off the floor before No. 1 Gun Section succeeded in winning. These battery rallies or smokers are quite popular in Hawaii.

Recent departures from the Coast Artillery in Hawaii include Lieutenant Colonel H. W. T. Eglin, Major LeRoy Lutes, Major Austin G. Frick, Captain James R. Townsend, Captain V. P. Foster, Captain Wm. R. Carlson, Lieutenant O. A. Nelson, Lieutenant John Dwyer, Lieutenant C. W. Wolff, Lieutenant L. R. Bullene, Lieutenant L. O. Shutt, and Lieutenant Wm. I. Brady.

Recent arrivals include Major Edward P. Noyes, Major Gerald B. Robinson, Major Benjamin H. L. Williams, Major Bird S. Dubois, Captains Geo. W. Ricker, Arthur K. Chambers, Frank J. McSherry, LeRoy A. Whittaker, Lieutenants V. C. Stevens, J. A. Sawyer, and Louis T. Vickers.

1 1 1

#### Activities at Fort Mills

By Lieutenant W. I. Allen, C.A.C.

#### CORREGIDOR'S NEW OFFICERS' SWIMMING BEACH

IN an attempt to provide better swimming facilities at Corregidor a new project has been initiated and nearly completed. This project is the construction of a shark net and bath house and the improvement of a natural swimming beach. The Corregidor Club swimming pool, completed under the direction of General C. E. Kilbourne has afforded endless enjoyment to the garrison; but for the satisfaction of those who find a natural swimming beach more to their liking, the suggestion was made that the beach at Kindley Field, located near the garage of the 92nd C.A. (PS), be improved, or that a reconnaissance be made to determine if a better location existed.

A survey was made and it was determined to construct

the shark net and bath house at a beach on the north side of Corregidor Island, in the cove west of and near Kindley Field. This site was selected because it was believed that for all the year-round swimming a better beach for a longer season could be had.

The plans included the building of a bath house, 50 by 40 feet, the construction of a shark net and the improvement of the road leading to the beach. Battery A, 91st C.A. (PS) (the mine battery), being well equipped to perform such a task, was given the job of making the shark net. The erection of the bath house was assigned in rotation to the available batteries of the regiment. The improvement of the road leading to the club was made by a detail of Bilibid prisoners under the direction of Lieutenant G. E. Hill. A condemned garage, furnished a large part of the material for the building.

A line of steel rails was driven to support the shark net. Marlin-covered steel cable was then clamped to poles and anchored at the shore ends to form a horizontal support from which to swing the wire. Rolls of heavy, galvanized iron wire were purchased and fastened together to form the net. This made a very effective barrier. It was later discovered that sea weed fastened itself in the wire and caused such a strain that the wire was gradually broken up. It was then decided to reconstruct the fence using vertical drops made of salvaged mine cable. This was done, more than six miles of cable being used.

The primary consideration in the erection of the bath house was the building of a durable, simple structure, using such materials as could be obtained at little or no cost. Bamboo was chosen for this purpose while cogon grass was used for the roof. The walls of the building are of linked bamboo construction, made by taking a piece of bamboo, splitting it lengthwise into two sections, knocking out the fiber at the joints and fitting one section over the other then securing the pieces to the framework. In making the roof a bamboo grill was put together to form the base and on top of this was laid overlapping bundles of cogon grass. The showers and storeroom have concrete floors. The floor of the large front porch is made of split bamboo. A small wharf extends into deep water. The approach to the club is over a foot bridge, spanning the small stream adjacent to the club. The completed building is very attractive. The installation includes dressing rooms for ladies and gentlemen, each equipped with ample plumbing facilities, a storage and supply room between the two dressing rooms, and storage space beneath the building proper.

### Calumpan Barrio

**C**ALUMPAN BARRIO is one of the most interesting activities of the 91st C.A. (PS). This barrio is still

in the primary stage of its development but it has been, and will continue to be, a project of the 91st C.A. (PS).

It is located on the Calumpan Military reservation east of Fort Frank. In November, 1929, a report was received in Harbor Defense Headquarters that civilian natives had been trespassing on the Calumpan reservation. The Commanding General recommended that a resident civilian guard be established on the reservation to prevent trespassing and to protect government property. This recommendation never was approved and finally after considerable discussion and further difficulties, including a destructive fire on the Calumpan reservation, the Commanding General sent in another request asking permission to build a house for the use of guards, and stating that the house was also expected to form the nucleus of a barrio to be constructed for the use of Filipino soldiers stationed at Fort Frank. Approval of this project was received in June, 1931. Shortly after this the Commanding General designated the limits of the "Calumpan Barrio" and vested the administration and control of same in the Commanding Officer, 91st C.A. (PS). Residence was restricted to enlisted personnel of Fort Frank and civilian government employees.

Since that time the Regiment has cleared, graded and drained the land for the barrio, constructed the Sinalam River Dam, built nine double houses and a combined school-house and residence for the school-teacher.

### Battery Team Wins Philippine Championship

**B**BATTERY "A," 60th C.A. (AA), Fort Mills, P. I., won the Philippine Amateur Athletic Federation Basketball Championship. This is not only the first military basketball team to win a Philippine championship, but also the first American team to win the Filipino trophy.

Entered as a dark horse, Battery "A," appeared on the floor of the Santo Tomas gymnasium of January 27, 1934, for the first game of the championship series. Many exclamations of surprise and mirth came from the rooters. The so-called "giants" of the American Team, apparently were given little chance against the fast and shifty smaller members of the best Filipino teams. Much to everyone's surprise, Battery "A" won its first game against the Santo Tomas "B" Team by the overwhelming score of 72 to 26. The fine sportsmanship and clean playing displayed by all teams is deserving of special comment.

Battery "A" has had the championship basketball teams of the 60th C.A. (AA), for the past five years. In addition for the four years that the Sixtieth was entered in the Philippine Department Basketball League, Battery "A" furnished the majority of the players.

# Fort MacArthur Notes

BY LIEUTENANT H. S. ALDRICH, C.A.C.

## THE 63RD FIGHTS A WAR IN SOUTHERN CALIFORNIA

ORIGINALLY, the annual two-weeks' march of the 63rd Coast Artillery, to include the Corps Area Commander's tactical inspection somewhere en route was planned for the period June 4-18.

Check lists were getting well be-penciled, bedding rolls strapped, garrison uniforms hung away with a nicely estimated two-weeks' supply of moth balls in the pockets, trucks loaded and everything looking slightly hectic and thoroughly well disarranged when General Craig hurled a bolt from Mount Olympus (Presidio to you). The annual tactical inspection, directed by the General, would be held during the period June 6-8 and would be preceded by a garrison inspection and review. Needless to say, Ft. MacArthur lost its intriguing disarrangement by 11 a.m., June 6th, when the Commanding General arrived, although a noticeable aroma of naphthalene still clung to uniforms. At 2 p.m. sealed orders were opened and it was learned that the regiment was to clear the Post by 4 p.m., and be in position before dark the following day to protect roads and an ammunition dump located at the Marine Corps Rifle Range near La Jolla, about 15 miles north of San Diego and some 105 miles from San Pedro.

The regiment had been the proud recipient of six new Harley-Davidson motorcycles the previous week, and for the first time in many years battery commanders were

enabled to precede their battery columns and make a reconnaissance well before the arrival of the troops and armament, which occurred in this case at 3 a.m., the next day, after a forced night march from San Pedro. This march was made without mishap or breakdown—an indication of the care the personnel has given its old class "B" transportation.

By dark that day, antiaircraft defense of the area and an intelligence net covering the sector *La Jolla-Oceanside-Escondido-Ramona-Poway-Miramar-La Jolla* were established. Especial attention was given to camouflage. It is interesting to note that, while the camouflaging of the first machine-gun platoon (as seen on the ground) was so successful that the inspecting staff was unable to locate it without a guide (although the guns were but a few yards from the main highway in an open field); from the air its position was easily located, while that of the second platoon was not. After dark, planes maneuvering above a ceiling of low-hanging clouds which the search-light beams could not pierce, dropped bombs (flares); a large number of these fell some distance to the west of the defense area.

After a critique during which General Craig (who is by no means given to voicing undeserved praise), expressed himself as being impressed and highly satisfied by the quietness, ease and efficiency with which Lieuten-

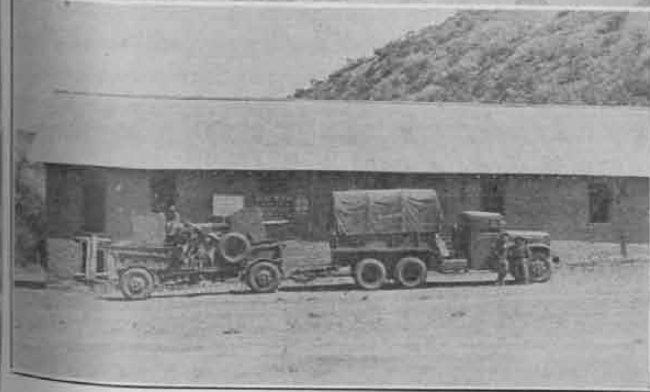

*The Camp, Delano High School Grounds. Going Down from San Marcos Pass. Fort Lyon. Lieutenant Turner, Mr. Resta and Ranger at Grant Forest.*

ant Colonel Oldfield and his staff and the officers and men of the regiment had conducted the problem. The regiment then crawled gratefully into its pup tents for a well-earned night's sleep.

The following morning the return march to Ft. MacArthur was begun by the slow column, the wire being taken up by elements of the fast column which overtook the main column at Long Beach.

The next day preparations were re-commenced for the annual march which was then set for the period June 12-26. The march took the regiment north, and with the tactical inspection out of the way, this original itinerary was adhered to and was as follows:

Fort MacArthur-San Fernando.....	48	miles
San Fernando-Ft. Tejon .....	53	"
Ft. Tejon-Visalia .....	106	"
Visalia-Sequoia National Park.....	43	"
Sequoia-Delano .....	74	"
Delano-Atascadero .....	114	"
Atascadero-Santa Maria .....	50	"
Santa Maria-Santa Barbara.....	73	"
Santa Barbara-Malibu Beach.....	68	"
Malibu Beach-Ft. MacArthur.....	41	"

The general situation which was followed throughout the march for the numerous tactical exercises carried out was: "Red has invaded the United States (Blue), landing on a wide front in Southern California, in the face of a strong Blue aerial and weak Blue ground resistance. Red forces have occupied Southern California and are advancing north with their right resting on the Sierra Nevada Mountains."

The 63rd Coast Artillery was "Red" and attached to the III Red Army Corps. The latter was generally successful and on the offensive until the northernmost point of the march was reached when suddenly and most conveniently, at least for the 63rd, it seemed to lose its initial vim and vigor. With forces decimated, its morale seemingly "shot," it began to fall back south, not too grimly accompanied by the valiant 63rd which meanwhile had swelled to a full-grown war-strength regiment only to shrink again to its former mere shadow of a peace-time battalion.

The tactical exercises had a wide range and included antiaircraft defense of railway tunnels, landing fields, bivouacs, defiles, bridges, mountain passes, as well as forced night marches over routes crowded with troops and with closely timed priorities. In some of these problems armament was actually emplaced and camouflaged and attacked or flown over by planes from March Field. In others the problems consisted of terrain exercises conducted by the officers alone. Particular attention was given the interesting problem of smoke defense, inasmuch as smoke screens are becoming a major part of Air Corps offensive operations.

A particularly valuable feature of these exercises was the rotating of battery commanders as acting regimental

commanders; they were assisted by the lieutenants as acting plans and training officers. These acting staffs were handed sealed orders in each case and prepared all orders and took full charge of indicated movements. Each problem was followed by a critique, during this each officer was given an opportunity to express his opinions regarding the solutions.

Needless to say this schedule gave the greatest possible training to all concerned; both regular and reserve officers were unanimous in evaluating the march, from a professional standpoint, as one of, if not, *the* best they had experienced.

From a recreational standpoint also, the march was a success. The high point was the visit to Sequoia National Park where Colonel White, the Superintendent, and his Park Service personnel, did everything possible to make the regiment's visit enjoyable. No one making the trip can forget the awe inspired by the Grant Forest, a truly Brobdingnagian Forest which includes the General Sherman Tree, oldest and largest living thing, 37 feet base diameter and 272 feet high; nor can one forget the magnificence of the view atop Morro Rock of the High Sierras and their wonder at the hardy Americans who first traversed them.

A tactical problem conducted at Santa Barbara, involving the defense of San Marcos Pass, 2,224 feet above the sea, caused much interest. In the first place, it was the general opinion that the prime movers and guns could not negotiate the hairpin switchbacks of the road up to the pass. Captain Greenwood and Captain Bartlett verified their own opinions that the road could be traversed successfully by measurements on the ground. With "B" Battery's expert drivers at the wheel, no trouble was experienced although in some places it was a matter of a few inches clearance. Secondly, this was the first time any military forces had traversed the Pass since 1846, when Fremont marched over it, outwitting the Californians who were waiting for him with huge boulders in ambush on the cliffs above Gaviota Pass to the northwest, and captured Santa Barbara with barely a shot fired.

An account of the annual march would not be complete without mention of another historic point visited, namely, old Fort Tejon, just south of the "Grapevine" on the Ridge Route. This old Fort, which still stands, was established in 1854 to guard the pass there and control the Indians. On the old walls is a tablet in memory of First Lieutenant Thomas Castor and 13 soldiers of Co. "A," 1st Regiment, U. S. Dragoons.

The last camp site at Malibu Beach was too near home for even the treat (not accorded the general public) of swimming on a beach worth nearly the weight of its sand in gold or the presence of favorite movie actresses in bathing costume, to keep the regiment from rising betimes and taking off in a cloud of dust, mostly raised by the impressive police motorcycle escort provided by Santa Monica.

# Panama Canal Department News Letter

*Department Artillery Officer*  
COLONEL PERCY M. KESSLER, C.A.C.

*Fort Amador*  
COLONEL RUSSELL P. REEDER,  
4th C.A. (AA)

*Fort Sherman*  
COLONEL CLARENCE G. BUNKER,  
1st C.A.

*Fort Randolph*  
COLONEL RICHARD I. MCKENNEY,  
1st C.A.

TURN about is fair play. In the last issue we told about our trip to the Atlantic Side for the Joint Maneuvers. To square things up, we were honored by the presence of the Atlantic Side troops on the Pacific Side for the Navy Maneuvers.

We were in position awaiting the arrival of the enemy (?) for several days prior to the big attack, aided and abetted by our friends, the Infantry, the Field Artillery, the Engineers, the Air Corps and the local naval defense forces. We of the heavy artillery (leaning towards dear old Auntie Aircraft) had hopes that this maneuver would give our esteemed Auntie something to think about. We were not disappointed. Can you imagine the difficulty, not to say the almost impossibility, of identifying targets, at bombing altitudes, with about four hundred planes in the air! Well let's begin at the beginning.

The Engineers armed with rifle and bayonet, took up positions with the Infantry; these were supported by the Field Artillery. These troops were scattered along the Pacific coast in readiness to repel landing parties. Our trusty 155's were located at strategic points. The Atlantic Siders augmented the manning of all armaments of the Harbor Defenses. Portable radio sets and field telephone sets manned by the antiaircraft Intelligence Service were located at isolated points in the interior and in proximity to lonely beaches. Information was promptly transmitted to the AA nerve centers.

We did not know how the attack or attacks were coming, but were prepared for the three possibilities—the air raid or bombardment, the landing attack and the naval bombardment. For several days prior to the arrival of the United States Fleet, the Air Corps and the submarines from Coco Solo had plenty to keep them occupied. First they had to locate the enemy and then determine their probable course of action. Needless to say there was a lot of "watchful waiting."

Information was received that the fleet would not be in striking distance until about 5:00 a.m. At 4:00 a.m. all stations and batteries were manned. Just before the first streaks of dawn came an aerial attack, and let me say right here that this hour favors the attacker. It is too light for the searchlights to have much penetrating power, but still not light enough to pick up easily the planes with the eye or with glasses. Just about the time that this fight was getting exciting our observers began reporting ships on the sky-line and from then on until the end of the attack I did not see anything, and will have to report from hearsay.

We all realize that the conditions and some of the problems which we had to solve in the presence of 113 ships and about 400 airplanes will probably never confront any Coast Artillery command in actual warfare; but it did point out to us in a very forceful manner some weaknesses which we will have to correct. The old problem of the AA's, that is, getting two base end stations on the same target in the presence of many targets, was emphasized. The same problem confronted our sea-coast batteries. Personally, I was glad that I had plenty of vertical-base stations. With six, eight or ten battle divisions as possible targets, all running at high speed on varying courses, it was exceedingly difficult for a battery commander to get two observers at opposite ends of a long base line on the same target at the same time.

The enemy placed several heavy smoke screens around some of our observation stations, and while interruptions were caused for a few second, targets were so numerous that fire was scarcely interrupted.

The defending naval forces claimed to have placed some well-aimed torpedoes at one of the airplane carriers, also the air force claims to have made hash of the Navy planes while on the decks of two of the carriers. On the other hand the Navy claims to have caught elements of our air force on the ground on several occasions. After the smoke of battle cleared one could hear the question on all sides, "Who won the war?" Up to the time of ticking this out the question remains unanswered.

The big part of the maneuver, as far as the Navy was concerned, was expressed by the Commander in Chief, Admiral Sellers, who stated "The presence of the entire Fleet at the Canal in a movement from one ocean to the other presents this excellent opportunity to execute a movement involving the rapid transit as might have to be done in case of an emergency." All civilian shipping was suspended during the transit of the Fleet. Before we realized that the Fleet was with us it had passed to the Atlantic Side and into the Caribbean. The total transit was completed in forty-eight hours.

I would like to quote from an editorial in the *Star-Herald*, which expresses in more fluent language than I have at my command the feeling that we have down here towards the operations just past:

"The airplanes, sweeping and diving by the dozens, almost by the hundreds, have given a thrill to the holders of that phase of the mimic attack on the Canal and the gallant defense waged by the home boys. This is quite regardless of the fact that to the limited obser-



vation of most of us laymen, it is impossible to tell who is winning, if anyone. The high menacing hum of the motors, the swift passage of plane on plane, the sudden dives from the clouds—into loud zooming descent, they make a gallant show which needs no further explanation. The arrival of the great Fleet itself was more on the majestic side. One hour the empty bay, placid in its immemorial shelter, quiet and thoughtless; the next, enlivened by the slow onward sweep of lines of great ships; and in the next the resting place of fortresses afloat. It is a grand sight.

"Pity it is that in these days of so-called civilization, we must spend so much human energy and wealth on the business of aggression and defense. But since it is a job that must be done to keep that civilization from being completely overwhelmed by aggressive elements bent on conquest, the manner of the performance of that job remains for our admiration. The orderly control of this great mass of ships and men is a fine demonstration of organization. If that great fleet is as efficient in material, management and men as it looks to be, we may well feel that the Navy is on to its job.

"The successful transit of the United States Fleet through the Panama Canal in two days may demonstrate something very important in naval strategy. To us, as interested and admiring observers of the Canal organization, it was a demonstration, more than anything else, of the ability of the pilots, the lock operators, the signalmen and dispatchers to keep hitting the ball steadily through a long and exacting grind. Secondarily, there would appear to have been excellent coöperation and timing on the part of the Navy people.

"One of the great reasons for the existence of the Canal is its service to the Navy. The importance of keeping the waterway in the best of shape, and manned with the best of personnel, is emphasized by such demonstrations as this one just completed.

"Appreciation of that importance has made the Panama Canal something in the nature of a fair-haired child in the eyes of the people and the Government of the United States. Their expenditures and their faith have received another vindication."

The two-year foreign service bill is going to make a lot of unanticipated changes but many of us will get in our last "rits" at a target practice before we leave. Phil Taliaferro is planning some new stunt with airplane tracking and spotting. According to his plan, the plane will fly directly from the battery towards the target and will be plotted every thirty seconds, this will establish a number of rays from the battery to the target. At a pre-arranged signal the plane will turn off its course, thus signifying the range and from then on will perform spotting duties. The details will be described in the next issue. Parry Lewis had hoped to use his long-range railway

guns against one of the new high speed targets, but from the present outlook, no Navy ship will be on hand capable of towing at the necessary high speed.

Colonel Russell P. Reeder, Captain Phil Taliaferro and Lieutenant Jack Madison, accompanied the Fleet into the Caribbean to witness the manuevers. Upon his return Colonel Reeder gave a very interesting talk covering the general situation and the mechanics of the solutions. Among the things that impressed him was the utmost respect with which the Navy regarded antiaircraft emplacements (theoretical) during a period of their landing operations. Plenty of ammunition was expended in order to reduce these batteries before landing was attempted.

We all hate to see the old-timers come to that period in their career when the final curtain must be rung down on active service. First Sergeant Neil Mason of Battery "T" 4th C.A. (AA) recently reached that goal. In honor of Sergeant Mason, the entire regiment tendered him a review commemorating the retirement of one who has given long and faithful service. The best wishes of the members of the regiment go to Sergeant Mason at this time.

A great deal of interest was shown this year in the annual Department Horse Show, the finals of which were held at Fort Clayton. The outstanding representative from Fort Amador was Miss Narcissa Reeder, daughter of Colonel and Mrs. Reeder. Narcissa started off the day by taking first place in the Ladies' Jumping Class "with an exhibition," to quote the local sports writer, "that would have done credit to the best of the male riders entered in the show." This gives her first place for the second successive year in this event, against the hardest kind of competition. Congratulations to our home equestrienne!

Considerable interest in antiaircraft artillery is being shown by local reserve officers of other branches. There is no doubt that antiaircraft is one of the most, if not the most, important defense weapon of the Canal. First Lieutenant Herbert Conklin, C.A. Res. (Staff Sergeant and our prize Master Gunner) is primarily responsible for this increased enthusiasm. He has organized classes, selected instructors and arranged a complete course of instruction for their benefit. This course consists of Basic Gunnery for AA Artillery, C.A. Ammunition, Organization of the Coast Artillery, AA Weapons and Matériel and Identification of Aircraft. After passing successfully the subjects of this course these officers may obtain the certificates of capacity with a view to transferring to the Coast Artillery reserves. The classes meet on Wednesday evening and Sunday mornings and will continue for a period of several months. We are exceedingly fortunate in having a man stationed here of Sergeant Conklin's mental capacity and constructive enthusiasm.

# Fort Monroe News Letter

BRIGADIER GENERAL JOS. P. TRACY, U. S. ARMY  
Commanding

COLONEL H. E. CLOKE, 2d C.A.,  
Commanding Harbor Defenses of the Chesapeake Bay.

MAJOR J. D. BROWN, 2d C.A.,  
Commanding 3d Bn., 52d C.A.

COLONEL GEO. L. WERTENBAKER, 52d C.A.,  
Commanding 3d Bn., 52d C.A.

MAJOR NELSON DINGLEY III, 52d C.A.,  
Commanding Prov. Bn., 2d C.A.

*By Major Joshua D. Powers, 51st C.A.*

THE Coast Artillery School year came to an end on June 15th, with the graduation of all of the classes. We hope that this breaks last year's jinx, when the school was closed a month ahead of time so that the staff, faculty, and students could go out into the field with the CCC. Fort Monroe was fortunate this year in having Major General W. F. Hase, the Chief of Coast Artillery, to make the graduating address and to present the diplomas. General Hase made a most interesting and inspiring address, which appears elsewhere in this issue of the JOURNAL.

An escort of honor consisting of the 51st C.A. and the band of the 2d C.A. under the command of Colonel Wertenbaker received General Hase in front of the Commanding Officer's quarters and escorted him to the Coast Artillery School. After the graduation exercises a review for General Hase was held by the Harbor Defense troops. There was a 100 per cent turnout, even the service battalion being present, with the Quartermaster, Ordnance and Medical Detachments.

General and Mrs. Hase remained at Fort Monroe until the following Monday, renewing old acquaintances and enjoying the coolness of Old Point after sultry Washington. The general was introduced to the bass fishing at the Big Bethel Reservoir, where he caught the legal limit for one day's fishing.

The annual trip of the Coast Artillery School to Fort Story took place the last part of May. A CCC Company was persuaded to move out of its buildings, so the school had serviceable screened barracks, instead of the dilapidated war-time barracks formerly used.

The time at Story is divided between the departments of tactics, engineering, and gunnery. Since there is a general impression (right or wrong) that the grades are made up before the Story trip, the chief interest of the class is in the firing, which they feel is the real objective of every artilleryman. Ammunition supply was low this year—75's were used for adjustment problems, and 155's substituted for 16 inch in the simulated long-range shoot with aircraft position finding. The battle practice was quite successful—two guns 8" Ry. Batteries and two gun GPF. Batteries—230 rounds altogether. A freighter came along about the middle of the battle practice, and there was a delay; the tugs were sent back to the starting point, and a second phase completed the practice. Unfortunately, these battle practices are rehearsed and drilled in advance on a time schedule just like a theatrical performance, and there can be no deviation from the pre-

scribed order of firing. In this case, when fire was no longer safe at the leading targets, all batteries could have been concentrated on the rear two targets, and then when the freighter came too close to them, shifted back to the leading targets, but that would have involved changing the prescribed schedule. We would like to see a battle practice approximating service conditions—targets well out toward the limit of range of the guns—targets behind smoke screens at the beginning of the problem and coming into view during the problem—no particular idea of firing as many shots as fast as possible—but groupment and group commanders to make their decisions, and then order batteries to fire on certain designated targets. A problem like this would start before dawn, and might last quite some time. The chances are that all batteries would not be firing at the same time. After the problem all commanders would have the satisfaction of knowing that they had actually commanded artillery organizations under conditions such as they might face in actual war.

Captain Mabbott has brought back from Detroit a speed boat for the Coast Artillery Board. This is to be the radio-controlled high speed target that all of us have been waiting for. It seems that the boat is second-hand and formerly belonged to Mrs. Wood. It has a 200 horsepower engine, is 28 feet long, and makes 30 to 35 miles per hour. On account of being second-hand, Gar Wood let the Board have it for \$2,600, though he says the gyroscope in it alone cost him \$3,000, and the boat new, without gyroscope, lists at \$5,000. All the battery commanders want a chance to fire a practice at this boat, but if the Board wants to keep the boat above the water, they had better use it for tracking only.

The new addition to Randolph Hall will not be finished until fall, but there are nearly always rooms for visiting officers and families in the main section. It is advisable to make reservations. Rates are: One person in room (with bath), meals included: \$2.90 per day; \$16.50 per week; \$61.00 per month. Two persons in one room (with bath), meals included: \$5.30 per day; \$28.00 per week; \$100.00 per month.

We are having a breathing spell from construction on the post, waiting for the appropriations which we are to receive July 1st. Work on the sea wall, Randolph Hall addition, and new NCO quarters is continuing, as all of these are being built by contract. The architects have made the preliminary plans for the new Post Administration building, Mill Creek bridge, children's school,

and theatre, and work on actual construction of these can be started very shortly after the money is allotted.

We are in the midst of the Summer Training Camps. The first to arrive were the ROTC, 268 strong, with Lieutenant Colonel E. J. Cullen as Camp Commander. As Colonel Cullen and Lieutenant Tredennick, his adjutant, have been here each summer for the past five years, we knew what they wanted. Some barracks were washed away last August, and some were needed for the CCC, so the ROTC is more crowded than usual, but they are snapping into the work in their energetic way. The families inside the old post know that summer is here, when they are awakened each morning by calisthenics, and mass commands of the ROTC.

An innovation this year was to order 50 reserve second lieutenants to Fort Monroe for training coincident with the first two weeks of the ROTC. These lieutenants are men who graduated from college this June, and who were at Fort Monroe in the ROTC last summer. It shows the present ROTC what they are working toward to see these officers all spick and span in white uniforms. They are being given an intensive course in Antiaircraft Artillery, by the officers of the 2d C.A.

The CMTC this year is to consist of 100 men only, organized into one battery, which will fire the GPF's. We wonder what the future of the CMTC will be—our normal strength is 420, and surely for the small expenditure involved, it is a shame not to give more civilians the basic military training they receive in the CMTC.

The officers of five Reserve Regiments come to Fort Monroe for training this summer, so there is very little leisure time for the regular garrison.

This year the West Point Cadets are to go to Fort Benning for their Infantry, Field Artillery, and Air Corps training. For the past several years the first class has come to Old Point by transport, and then has been divided into three sections, one going to Fort Bragg, one to Langley Field, and one to Fort Monroe. After a week, the sections moved on to the next post. In three weeks each man had received practical training in Coast Artillery, Field Artillery, and Air Corps, and had been able to form a good idea of life on Army posts. No wonder so many graduates choose the Coast Artillery. The Infantry began to feel that it was not getting a fair break, so this year the entire first class goes to Savannah by transport, and thence to Benning by truck. Anyone who has been in Benning in July can imagine how glad the cadets will be to reach Fort Monroe after two weeks of practical field exercises over the Georgia hills. The cool breezes at Fort Monroe, the Beach Club swimming pool, and the well known attractions of Phoebus and Hampton should make the coast more popular than ever before. The present plan calls for the cadets to be at Fort Monroe from August 9th to August 14th, with 8" Ry, 155 MM, 12" D.C., and 3" AA firing (\$10,000 worth of ammunition, even in these hard times). This looks like lots of work for "Dave" Latimer, formerly our Personnel Adjutant,

and now the senior Coast Artillery Tac at West Point.

This summer the 260th C.A. (District of Columbia National Guard Antiaircraft) will not come to Fort Monroe, but will make a march down the Shenandoah Valley, working out tactical problems during the march. The 2d C.A. is sending searchlights to accompany the 260th, in charge of Lieutenant E. N. Chace, and our detachment is to furnish searchlight demonstrations for the people in each town where the 260th camps.

The 246th C.A. Va. NG (HD) comes to Fort Monroe again this summer, in spite of their experience last summer, when the tornado flooded their barracks, washed away much of their property and personal equipment, and stopped all but two of their target practices. Instead of firing, they spent their last week in helping clean up the debris of the storm. They are returning this year with enthusiasm, and we hope the new sea wall will protect them from floods.

With so many different organizations in the same camp area, many problems of administration and coordination have come up. Colonel Cloke has solved them very successfully by establishing an advanced Harbor Defense Headquarters in the summer camp area (like an advanced C.P. in the field). The Harbor Defense Commander has a desk there, and in the same room there are desks for Colonel Wertenbaker, second in command, and the Harbor Defense Commander's representative for summer camps, the Camp Adjutant, the Executive for CCC, the CMTC Officer, the ROTC representative, the Recreation Officer, and telephones directly connected to the Supply Officer and Mess Officer. In this way conflicts are avoided, questions which come up are settled on the spot, command is exercised with a minimum of mimeographed orders, and coordination and cooperation are assured.

Major Gen. Paul B. Malone, Commanding the Third Corps Area, made his administrative inspection of Fort Monroe on May 23 and his tactical inspection of the Harbor Defense troops at Fort Story on May 24th. General Malone was enthusiastic about the post, and sent many letters of commendation. He was particularly pleased with the construction and repair work which has been done since the storms last autumn.

For the past two summers, General Malone has occupied quarters at Fort Monroe, and this summer he has one of the brick sets on Ingalls Road across from the hospital. The morning of his arrival at Fort Monroe, he was received in front of his quarters by an escort of honor, commanded by Major Dingley, consisting of the 2d C.A. (the band wearing its dazzling nickle-plated helmets). Mrs. Malone watched the ceremony from the porch. The General's comments were "superior" "excellent; approaching superior." Mrs. Malone turned to the writer, and asked "What is this? I have never before heard the General say anything but excellent when inspecting." The writer, who used to serve in the Infantry with General Malone, replied, "Superior means the Coast Artillery."

# COAST ARTILLERY ORDERS

Colonel L. R. Burgess, report to president Army retiring board, Hq. 9th Corps Area.

Colonel W. A. Covington, report to president Army retiring board, Hq. 9th Corps Area.

Colonel M. S. Crissy, report to president Army retiring board, Hq. 9th Corps Area.

Colonel F. K. Fergusson, from 2d C.A. Dist., New York, to 62d, Ft. Totten, September 1.

Colonel Frank Geere, report to president Army retiring board, Ft. Hayes.

Colonel C. H. Hilton, report to president Army retiring board, Presidio of San Francisco.

Colonel P. M. Kessler, from Panama, to 7th, Ft. Hancock.

Colonel H. L. Steel, from Hawaii, to assistant commandant, C. A. School, Ft. Monroe.

Colonel F. W. Stopford, proceed to home and await retirement.

Colonel G. L. Wertenbaker, from 52d, Ft. Monroe, to Hawaii, sailing New York, September 28.

Lieutenant Colonel D. M. Ashbridge, report to president Army retiring board, Walter Reed General Hospital.

Lieutenant Colonel H. T. Burgin, from 9th C. A. Dist., Presidio of San Francisco, to Office, Chief of Coast Artillery, September 1.

Lieutenant Colonel J. S. Dusenbury, from instructor, Maine Natl. Guard, Portland, to Panama, sailing New York, August 21.

Lieutenant Colonel R. H. Fenner, upon his own application retired September 30.

Lieutenant Colonel W. S. Fulton, report to president Army retiring board, Ft. Sam Houston.

Lieutenant Colonel R. P. Glassburn, from 51st, Ft. Monroe, to Org. Res. 7th Corps Area, St. Louis.

Lieutenant Colonel P. J. Horton, upon his own application retired September 30.

Lieutenant Colonel W. C. Knight, retired, Ft. Hancock.

Lieutenant Colonel K. B. Lemmon, from Panama, to recruiting duty, Omaha.

Lieutenant Colonel W. R. McCleary, report to president Army retiring board, Hq. 9th Corps Area.

Lieutenant Colonel C. T. Marsh, from 62d, Ft. Totten, to Michigan State College of Agriculture and Applied Science, East Lansing.

Lieutenant Colonel F. A. Mountford, from Hawaii, to 2d C. A. District, New York, N. Y.

Lieutenant Colonel E. W. Putney, report to president Army retiring board, Boston.

Lieutenant Colonel R. H. Smith, to instructor at army center of Coast Artillery instruction, Rio de Janeiro, Brazil.

Lieutenant Colonel H. F. Spurgin, report to president Army retiring board, Omaha.

Lieutenant Colonel C. W. Waller, proceed to home and await retirement.

Lieutenant Colonel B. H. L. Williams, from San Francisco general depot to Hawaii, sailing San Francisco August 9.

Major G. P. Anderson, report to president Army retiring board, Hq. 2d Corps Area.

Major H. R. Behrens, from the Philippines to Org. Res., Ninth Corps Area, Portland.

Major W. M. Chapin, from student, C. & G. S. School, Ft. Leavenworth, to instructor, Maine Natl. Guard, Portland, June 25.

Major A. D. Chipman, report to president Army retiring board, Omaha.

Major J. F. Cottrell, from student, Army Industrial College, Washington, D. C., to 2d, Ft. Monroe.

Major B. S. DuBois, from 6th, Ft. Winfield Scott, to Hawaii, sailing San Francisco, August 9th.

Major F. A. Hause, from Org. Res., Third Corps Area, Philadelphia, to Hawaii, sailing New York, September 28.

Major J. L. Hayden, from 51st, Ft. Monroe, to West Point, August 25.

Major I. B. Hill, from Hawaii, to Org. Res., Seventh Corps Area, Duluth.

Major D. D. Hinman, from student, Army War College, to General Staff Corps, Ft. Sam Houston, July 1.

Major J. C. Hutson, from student, C. A. School, Ft. Monroe, to 61st, Ft. Sheridan. Previous orders amended.

Major H. F. Loomis, from student, Ecole de Guerre, Paris, to 62d, Ft. Totten.

Major J. P. McCaskey, Jr., report to president Army retiring board, Boston.

Major C. F. Maguire, from student, C. A. School, Ft. Monroe, to 51st, Ft. Monroe.

Major Reinold Melberg, from 3d, Ft. Stevens, to the Philippines, sailing San Francisco, September 12.

Major E. P. Noyes, from Org. Res., 9th C. A. District, Los Angeles, to Hawaii, sailing San Francisco, August 9.

Major C. D. Y. Ostrom, from student, C. & G. S. School, Ft. Leavenworth, to 6th, Ft. Winfield Scott.

Major A. E. Potts, from student, C. & G. S. School, Ft. Leavenworth, to University of Minnesota, June 30.

Major W. K. Richards, report to president Army retiring board, Ft. Lewis.

Major G. B. Robison, from student, C. & G. S. School, Ft. Leavenworth, to Hawaii, sailing New York, July 17.

Major E. C. Seeds, report to president Army retiring board, Ft. McPherson.

Major Willis Shippam, from University of Minnesota to Org. Res., 9th Corps Area.

Major E. B. Spiller, report to president Army retiring board, Omaha.

Major W. R. Stewart, from U. S. Disciplinary Barracks, Alcatraz, to 3d, Ft. Stevens, June 19.

Captain C. R. Adams, from 11th, Ft. H. G. Wright, to 10th, Ft. Adams.

Captain Percy Adams, upon his own application retired, September 30.

Captain T. R. Bartlett, from 63rd, Ft. MacArthur, to Panama, sailing San Francisco, September 1.

Captain C. O. Bell, from instructor, Illinois National Guard, Chicago, to the Philippines, sailing New York, August 21.

Captain C. L. Berry, from student, C. A. School, Ft. Monroe to Panama, sailing New York, July 17.

Captain Napoleon Boudreau, from the Philippines, to 63d, Ft. MacArthur.

Captain W. C. Braly, from student, C. & G. S. School, Ft. Leavenworth, to instructor, University of California, Berkeley.

Captain H. F. E. Bultman, from student, C. & G. S. School, Ft. Leavenworth, to the Philippines, sailing New York, August 21.

Captain W. J. Burke, from University of Kansas, Lawrence, to the Philippines, sailing New York, August 21.

Captain W. R. Carlson, from Hawaii, to 11th, Ft. H. G. Wright.

Captain A. K. Chambers, from Georgia School of Technology, Atlanta, to Hawaii, sailing New York, July 17.

Captain H. P. Detwiler, from submarine mine depot, Ft. Monroe, to 2d, Ft. Monroe, August 21.

Captain D. L. Dutton, promoted Major, June 1.

Captain V. P. Foster, from Hawaii, to 52d, Ft. Hancock.

Captain J. K. Freeman to proceed to home and await retirement.

Captain R. T. George, from 11th, Ft. H. G. Wright, to Panama, sailing New York, October 4.

Captain W. J. Gilbert, report to president Army retiring board, Governors Island.

Captain D. M. Griggs, from Panama, to 63d, Ft. MacArthur.

Captain H. F. Grimm, Jr., promoted Major, May 1.

Captain L. Y. Hartman, from instructor, Arkansas National Guard, Fayetteville, to Panama, sailing New York, October 4.

Captain N. E. Hartman, from Panama, to 6th, Ft. Winfield Scott.

Captain Milton Heilfron, from 62d, Ft. Totten, to Hawaii, sailing New York, July 17.

Captain J. L. Hogan, from Panama, to 8th, Ft. Preble, revoked.

Captain W. D. Hohenthal, to instructor at army center of Coast Artillery instruction, Rio de Janeiro, Brazil.

Captain J. P. Jacobs, from 52d, Ft. Monroe, to Hawaii, sailing New York, September 28.

Captain P. W. Lewis, from Panama, to 52d, Ft. Monroe.

Captain H. C. Mabbott, from Ft. Monroe, to Hawaii, sailing New York, July 17, revoked.

Captain J. J. Maher, report to president Army retiring board, Ft. McPherson.

Captain H. A. McMorrow, from student, C. A. School, Ft. Monroe, to instructor, Arkansas National Guard, Fayetteville, June 25.

Captain E. W. Miller, report to president Army retiring board, Hq. 9th Corps Area.

Captain Maurice Morgan, to San Francisco, sailing New York, August 21.

Captain H. E. Pendleton, from Panama to 62d, Ft. Totten.

Captain G. W. Ricker, from student, C. & G. S. School, Ft. Leavenworth, to Hawaii, sailing New York, July 17.

Captain A. B. Smith, report to Army retiring board, Ft. Lewis.

Captain J. H. Smith, from U. S. Disciplinary Barracks, Alcatraz, to C. & G. S. School, Ft. Leavenworth, June 19.

Captain E. H. Stillman, from Hawaii, to 14th, Ft. Worden.

Captain W. H. Sweet, from duty Org. Res., to Hawaii, sailing New York, September 28.

Captain J. E. Troupe, to Panama, sailing New York, August 9.

Captain H. W. Ulmo, report to president Army retiring board, Ft. McPherson.

Captain L. A. Whittaker, from student, C. A. School, Ft. Monroe, to Hawaii, sailing New York, August 21.

Captain A. V. Winton, from Hawaii, to 11th, Ft. H. G. Wright.

First Lieutenant W. I. Allen, from Philippines to U. S. Military Academy, West Point, September 10.

First Lieutenant D. J. Bailey, from U. S. Military Academy, West Point, to student, C. A. School, Ft. Monroe, August 31.

First Lieutenant Edward Barber, from 52d, Ft. Monroe, to student, Mass. Inst. of Technology, Cambridge, June 1.

First Lieutenant C. N. Branham, from 6th, Ft. Winfield Scott, to Hawaii, sailing San Francisco, October 20.

First Lieutenant L. R. Bullene, from Hawaii, to 52d, Ft. Hancock.

First Lieutenant J. R. Burnett, placed on detached officers' list, April 10.

First Lieutenant W. H. Burns, report to president Army retiring board, Boston.

First Lieutenant, W. V. Davis, from student, C. A. School, Ft. Monroe, to Panama, sailing New York, July 17.

First Lieutenant J. C. Delaney, from Panama, to 13th, Ft. Barrancas.

First Lieutenant J. J. Earle, Jr., report to president Army retiring board, Ft. McPherson.

First Lieutenant E. C. Englehart, from 2d, Ft. Monroe, to submarine mine depot, Fort Monroe, May 15.

First Lieutenant J. F. Gamber, from 69th, Ft. McClellan, to Panama, sailing New York, October 4.

First Lieutenant H. P. Gard, from 10th, Ft. Adams, to Ft. Monroe, revoked.

First Lieutenant L. E. Gray, report to president Army retiring board, Hq. 9th Corps Area.

First Lieutenant C. W. Holcomb, from U. S. Military Academy, West Point, to student, C. A. School, Ft. Monroe, August 31.

First Lieutenant David Hottenstein, from 52d, Ft. Hancock, to instructor, Georgia School of Technology, Atlanta.

First Lieutenant J. F. Howell, from 3d, Ft. Stevens, to the Philippines, sailing San Francisco, September 12.

First Lieutenant J. W. Huyssoon, from 11th, Ft. H. G. Wright, to West Point, August 25.

First Lieutenant J. S. Keller, CA-Res., promoted Captain, June 25.

First Lieutenant L. L. Lemnitzer, from the Philippines to U. S. Military Academy, West Point, September 10.

First Lieutenant W. J. McCarthy, from 63d, Ft. MacArthur, to Panama, sailing San Francisco, September 1.

First Lieutenant F. A. Mitchell, from 11th, Ft. H. G. Wright, to West Point, July 1.

First Lieutenant L. M. Morton, Ft. Monroe, report to president Army retiring board, Baltimore.

First Lieutenant W. F. Niethamer, from student, C. A. School, Ft. Monroe, to 51st, Ft. Monroe.

First Lieutenant H. C. Reuter, from the Philippines to 3d, Ft. Stevens.

First Lieutenant I. H. Ritchie, from Ordnance Department, Ordnance School, Aberdeen Proving Ground, to West Point, August 25.

First Lieutenant Arthur Roth, from 62d,

Ft. Totten, to the Philippines, sailing New York, August 21.

First Lieutenant Samuel Rubin, from 7th, Ft. Hancock, to the Philippines, sailing New York, August 21.

First Lieutenant W. C. Rutter, from 69th, Ft. McClellan, to student, C. A. School, Ft. Monroe, August 31.

First Lieutenant J. A. Sawyer, from student, C. A. School, Ft. Monroe, to Hawaii, sailing New York, July 17.

First Lieutenant C. V. R. Schuyler, from Panama, to 52d, Ft. Monroe.

First Lieutenant J. P. Shumate, from U. S. Military Academy, West Point, to student, C. A. School, Ft. Monroe, August 31.

First Lieutenant P. W. Shunk, from U. S. Military Academy, West Point, to student, C. A. School, Ft. Monroe, August 31.

First Lieutenant L. O. Shutt, from Hawaii, to 62d, Ft. Totten.

First Lieutenant V. C. Stevens, from student, Quartermaster Corps Motor Transport School, Holabird Depot, Baltimore, to Hawaii, sailing New York, July 17.

First Lieutenant Raymond Stone, Jr., from U. S. Military Academy, West Point, to the Philippines, sailing New York, August 21.

First Lieutenant G. E. Thrans, from 2d, Ft. Monroe, to 13th, Ft. Barrancas, revoked.

First Lieutenant M. W. Tracy, from U. S. Military Academy, West Point, to student, C. A. School, Ft. Monroe, August 31.

First Lieutenant Vern Walbridge, from 2nd, Ft. Monroe, to Panama, sailing New York, September 6.

First Lieutenant W. H. Webb, from Hawaii, to 9th, Ft. Banks, revoked.

First Lieutenant C. W. West, from student, George Washington Law School, Washington, D. C., to West Point, August 25.

First Lieutenant A. E. Wilson, from instructor, University of Pittsburgh, Pittsburgh, to Panama, sailing New York, September 6.

First Lieutenant C. C. Witman, report to president Army retiring board, Army & Navy General Hospital, Hot Springs, Ark.

Second Lieutenant N. K. Adkinson, CA-Res., promoted first lieutenant, June 5.

Second Lieutenant D. S. Alexander, from Panama, to 63d, Ft. MacArthur.

Second Lieutenant L. H. Brownlee, from Panama, to 6th, Ft. Winfield Scott.

Second Lieutenant W. H. Brucker, from 52d, Ft. Monroe, to Hawaii, sailing New York, September 28.

Second Lieutenant R. G. Butler, Jr., promoted first lieutenant, June 1.

Second Lieutenant C. E. Calverley, CA-Res., promoted first lieutenant, June 15.

Second Lieutenant G. R. Carey, from 2d, Ft. Monroe, to Hawaii, sailing New York, September 28.

Second Lieutenant E. F. Cook, from Panama, to 52d, Ft. Hancock.

Second Lieutenant G. E. Decker, CA-Res., promoted first lieutenant, June 14.

Second Lieutenant A. J. Demars, Jr., CA-Res., promoted first lieutenant, June 27.

Second Lieutenant J. L. Dodson, CA-Res., promoted first lieutenant, June 19.

Second Lieutenant H. C. Donnelly, from 52d, Ft. Monroe, to Panama, sailing New York, September 6.

Second Lieutenant W. G. Fritz, from 2d, Ft. Monroe, to Panama, sailing New York, September 6.

Second Lieutenant A. L. Fuller, Jr., from 2d, Ft. Monroe, and from Army mine planter *Schofield*.

Second Lieutenant Waldon Gunnell, CA-Res., promoted first lieutenant, June 9.

Second Lieutenant R. W. Hain, from 52d, Ft. Monroe, to Panama, sailing New York, September 6.

Second Lieutenant A. R. Hartman, from 63d, Ft. MacArthur, to student, C. A. School, Ft. Monroe, August 27.

Second Lieutenant Martin Harwitz, CA-Res., promoted first lieutenant, June 26.

Second Lieutenant E. B. Hempstead, to San Francisco, sailing New York, August 21.

Second Lieutenant E. W. Hiddleston, from Panama, to 61st, Ft. Sheridan.

Second Lieutenant L. J. Hillberg, from 51st, Ft. Monroe, to Panama, sailing New York, September 6.

Second Lieutenant F. M. Humphries, from 2d, Ft. Monroe, to Panama, sailing New York, September 6, revoked.

Second Lieutenant E. H. Kibler, Jr., from 52d, Ft. Monroe, to Panama, sailing New York, September 6.

Second Lieutenant L. B. Knutsen, CA-Res., promoted first lieutenant, June 15.

Second Lieutenant R. J. Lawlor, from 61st, Ft. Sheridan, to Panama, sailing New York, October 4.

Second Lieutenant C. R. Longanecker, from 63d, Ft. MacArthur, to Panama, sailing San Francisco, September 1.

Second Lieutenant M. M. Mason, CA-Res., promoted first lieutenant, May 5.

Second Lieutenant J. E. Metzler, from 2d, Ft. Monroe, to Panama, sailing New York, October 4.

Second Lieutenant M. G. Pohl, promoted first lieutenant, May 16.

Second Lieutenant M. B. Raymond, from student, C. A. School, Ft. Monroe, to Panama, sailing New York, August 21.

Second Lieutenant J. F. Rodenhauser, from Panama, to 61st, Ft. Sheridan.

Second Lieutenant C. E. Routh, CA-Res., promoted first lieutenant, June 6.

Second Lieutenant F. G. Sciuillo, CA-Res., promoted first lieutenant, June 11.

Second Lieutenant A. R. Thomas, from 52d, Ft. Hancock, to student, C. A. School, Ft. Monroe.

Second Lieutenant L. T. Vickers, from student, C. A. School, Ft. Monroe, to Hawaii, sailing New York, July 17.

Second Lieutenant C. E. Wheatley, Jr., transferred to Cavalry, June 10, to 11th Cav., Presidio of Monterey.

Second Lieutenant N. B. Wilson, from Panama, to 11th Ft. H. G. Wright.

Warrant Officer Theodore Bingert, from 69th, Ft. McClellan to Panama, sailing New York, October 4.

Master Sergeant J. J. Flanagan, 64th, Ft. Shafter, retired, May 31.

Master Sergeant Erwin Smith, 4th, Ft. Amador, retired, June 30.

Master Sergeant J. L. Tilley, 13th, Ft. Moultrie, retired, June 30.

First Sergeant Elmer Briggs, 6th, Ft. Winfield Scott, retired, June 30.

First Sergeant A. C. Curtis, 2d, Ft. Monroe, retired, June 30.

Sergeant Onofre DeJesus, 59th, Ft. Mills, retired, June 30.

# THE FOREIGN MILITARY PRESS

Reviewed by Major Alexander L. P. Johnson, Infantry

ARGENTINA—*Revista Militar*—January, 1934.

## ANTI-AIRCRAFT DEFENCE AND SIGNAL COMMUNICATIONS. By Lieutenant Colonel Justo P. Gonzales.

Aircraft in war will seek to reduce the striking power of hostile armies. Its primary objectives will be the vital parts of a country: its manufacturing centers, stores of supplies, railways, important bridges and the like. Defence against hostile aircraft constitutes, therefore, a problem of paramount importance. Successful anti-aircraft defence, the author writes, depends upon effective observation and efficient service of signal communications.

The author describes the AA defence system developed in Germany. There, he writes, the AA guard is the basic link in the chain of AA defence. It receives information of approaching planes from its observation posts and transmits it either directly to the AA battery or to so-called "centers of prevention." The AA guard consists of an officer and eight men. Since airplanes are as a rule located by sound before visual observation, it is important to locate the guards in positions protected against wind, yet at the same time providing them with a maximum range of observation. The guard or observation post is the basic element in the anti-aircraft defence. It must be capable of locating and identifying aircraft, its speed and direction of flight, under all kinds of weather and visibility conditions. The efficacy of observation depends, however, upon an efficient and effective net of signal communications for the rapid transmission of vital information to the AA batteries.

The author discusses the various means of signal communications available to AA defence with particular reference to the systems adopted by France and Germany. Two schematic diagrams showing the AA telephone and telegraph nets respectively illustrate this interesting discussion.

CANADA—*Canadian Defence Quarterly*—April, 1934.

## THE TSITSIHAR OPERATION. By A. M. Nikolaieff.

The campaign for the conquest of Manchuria, initiated by the Japanese after the capture of Mukden and the South Manchuria railway zone in September, 1931, the author writes, required sixteen months notwithstanding the fact that Chinese resistance was not very serious. Incidentally, he notes, the conclusion of the Manchurian campaign coincided with the beginning of the Jehol campaign which opened with the attack on and the capture of Shanhaikwan, on January 2, 1933.

The city of Tsitsihar was for strategic and political reasons the first objective of the Japanese campaign in Manchuria. Politically its importance was due to the circumstance that it was the capital of the Province of

Heilungkiang, largest of the three provinces of Manchuria. Its geographical position near the Great Khingan ridge, an impassable barrier between Manchuria and its western-most part, the region of Bara which borders on the Russian Province of Trans-Baikalia, confers upon the city of Tsitsihar strategic importance. Moreover, the city was headquarters of the Chinese General Mah Chan Shan, governor of the province, who had under his command some 20,000 troops comprising infantry, cavalry and artillery. Poorly trained and equipped, these troops were no match for the Japanese army, but the possibility existed that they might receive Russian support in the event the latter decided to stop the Japanese advance. The author believes that this possibility was the basic reason for the Japanese decision to undertake the operation against Tsitsihar without delay. The Japanese were so anxious to get hold of the approaches to the Great Khingan Pass that they were willing to postpone action against Marshal Chang Hsiao-ling's army of 35,000 men concentrating at Chinchow, notwithstanding the fact that these troops seriously menaced the rear of the Japanese army operating in Northern Manchuria.

On October 8, 1931, the Japanese sent a squadron of six scouting planes and five bombers to attack Chinchow with the expectation that it would prevent the Chinese command from completing the organization of their troops. They also reckoned with the probable moral effect of the bombing upon the Chinese. The author notes

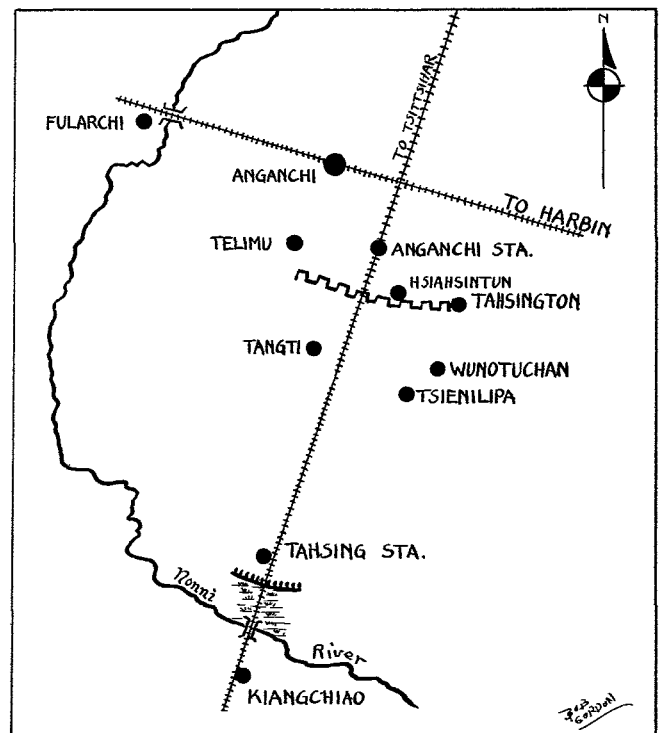

Map of the Tsitsihar operation.

that the barracks and government buildings, although the principal targets of that attack, escaped without any damage whatever.

The destruction of bridges over the Nonni River by troops under General Mah supplied the immediate cause for Japanese action against Tsitsihar. Two battles were fought in this campaign, the battle of the Nonni, which began on November 4, and the battle of Angangchi ten days later. Of the first, a Japanese semi-official description states that it "was occasioned by an act of treachery on the part of a detachment of the Heilungkiang army" under General Mah Chan Shan. The Lytton Commission report makes no such accusation against the Chinese.

The battle lasted three days. It began with a Japanese company being fired upon south of Tahsing. Suffering fifteen casualties, the company fell back to the bridgehead where it was joined by the main body of the detachment. Owing to the swamps in front of the Chinese position, the detachment commander, Captain Hamamoto, decided to envelop the Chinese left flank, and to capture the hill on which that flank rested. Japanese airplanes assisted by bombing the Chinese position on the hill, about 3 kilometers northeast of Tahsing. The Japanese took the hill at 8:30 p.m., November 4. On the following day, reinforced by a battalion, the Japanese continued the attack but were unable to obtain decisive results. The Lytton report, the author observes, states that "the Japanese troops were forced to retire and for the second time they could do nothing but hold their position until nightfall."

On November 6 the Japanese were further reinforced by two additional battalions of infantry and three batteries of artillery. Major General Hasebe assumed command. A renewed attack rolled up the Chinese front and by noon Tahsing station fell into Japanese hands. The Japanese estimated the strength of the opposing Chinese forces at "no less than 2,000 infantry with a large body of cavalry." Assuming the peace strength of the Japanese battalions at 600, the author estimates that the opposing forces were about equal in infantry. The Japanese had superiority of artillery and aircraft. Japanese casualties were: 36 killed, including one officer; 138 wounded, including seven officers; 3 airplanes damaged. The Chinese left 200 dead on the battlefield including two "Russians."

Immediately after the battle of the Nonni, the Chinese withdrew toward Angangchi. Although this victory placed the Japanese in a position to repair the bridges whose destruction caused the trouble, they presented new demands to the Chinese, notably the evacuation of Tsitsihar, and still later, that Japanese troops be permitted to occupy Angangchi and Tsitsihar stations. General Mah declined to accede to these demands, and by his refusal furnished cause for the next attack.

The Japanese 2d division, under General Tamon, had practically completed its concentration at Tahsing and in the vicinity of Kiang-Chiao. The aggregate strength of this force amounted to about 3,000 infantry and cavalry,

and more than 20 pieces of artillery. A contingent of the 8th Division (General Suzuki) was dispatched to reinforce Tamon's command, and a "relief party" of this division was ordered to Tahsing. On November 17, as an emergency measure, the air units of the 3d, 12th and 20th divisions were likewise summoned to participate in the Tsitsihar operation. In the meantime, two battalions of infantry and two troops of cavalry of the Nonni detachment concentrated near Tahsing were dispatched to Tsienilipa to watch developments on the Japanese right flank. Another part of the detachment occupied Wunotuchan, ten kilometers northeast of Tahsing, and the high ground 1,500 meters south of Taguti.

The total strength of the Japanese troops assembled before the attack on Angangchi the author estimates on the basis of Japanese data in excess of eight battalions of infantry, probably twelve, a unit of cavalry, probably a regiment, a total of about 6,000 men with probably 24 field and 12 mountain guns, and a considerable air force. According to Japanese estimates, the Chinese forces under General Mah in the vicinity of Tsitsihar amounted to between 20,000 and 30,000 infantry and cavalry, 30 pieces of artillery, more than 10 trench mortars, and two AA guns. Of this force about 10,000 infantry and cavalry with 20 pieces of artillery stood near Angangchi.

On November 17 General Tamon decided to attack the Chinese line, making his main effort in the direction of Sanchienfang, on the Chinese right, and after penetrating the hostile position, to push forward to the east and northeast. The Japanese deployed four battalions east of the railway with the mission to attack the enemy in the neighborhood of Hsiaoshintun. Four battalions deployed west of the railway to attack in the direction of Sanchienfang. The bulk of the artillery occupied positions north of Tangti, the remainder in rear of the right and left wings. The reserve, in readiness, south of Tangti. The Japanese began their advance to the jump-off position, about 700-800 meters in front of the Chinese line, thirty minutes after midnight, November 17, and they were ready to launch the attack at 3:00 a.m. It was a pitch dark night, intensely cold, with the thermometer registering 20 degrees below zero, the wind blowing from the northwest. The Chinese apparently discovered the Japanese movement and opened fire about 3:00 a.m., increasing its intensity at daybreak. The Japanese artillery opened at 6:30 a.m. At the same time Japanese aviation bombed the Chinese position. The infantry jumped off at nine o'clock. Hand-to-hand fighting occurred at several points, and by 10:30 a.m. the Chinese were in full retreat along the entire front, falling back along the Taonan-Angangchi railroad. The Japanese 2d division promptly took up the pursuit in the direction of Tsitsihar and prevented the Chinese from making another stand in their second position. After midnight, November 18, the Japanese had reached a point four kilometers south of Tsitsihar. The main body of the Japanese 2d division then concentrated along the line Tamintun-Shiwulitun,

south of Tsitsihar, whence it marched, on November 19, in two columns on Tsitsihar, entering that town at 3:00 p.m. the same day. The main body of General Mah's army withdrew in the direction of Hailun, 120 kilometers north of Harbin. The Japanese lost in this action 31 killed, 104 wounded, 13 missing and 200 cases of frost-bite. No reliable data are available relative the Chinese losses.

The Chinese made a poor show of resistance at Angungchi. They seem to have derived no advantage from their numerical superiority. In the author's opinion, the combined effect of Japanese artillery and aircraft was in the main responsible for the failure of the Chinese. On the other hand, the inability of the Japanese to score a decision at the Nonni, he attributes in part to the omission of the Japanese to bring up adequate artillery support, and in part to the swampy ground in front of the Chinese position which prevented the Japanese artillery from getting within effective range.

The occupation of Tsitsihar, the author concludes, enabled the Japanese to protect their operations in Central Manchuria from the west, and supplied them with an advanced base for future operations for the conquest of Northwestern Manchuria and Barga.

COLOMBIA—*Revista Militar del Ejercito*—January, 1934.

HORSE-BREEDING IN HUNGARY. By Lieutenant Kálmán de Móritz.

Although motorization is making rapid strides in all armies, the horse has not yet lost his military usefulness. As a matter of fact, considerable attention is being given to the cavalry everywhere these days as an important component of the mechanized-motorized "rapid" forces. The author points out that Hungary still is one of the most important horse-breeding centers of the world, and that she regularly supplies the military establishments of several countries with a considerable portion of their remount requirements. In 1930 Hungary exported close to 28,000 horses.

Horse-breeding in Hungary is under strict govern-

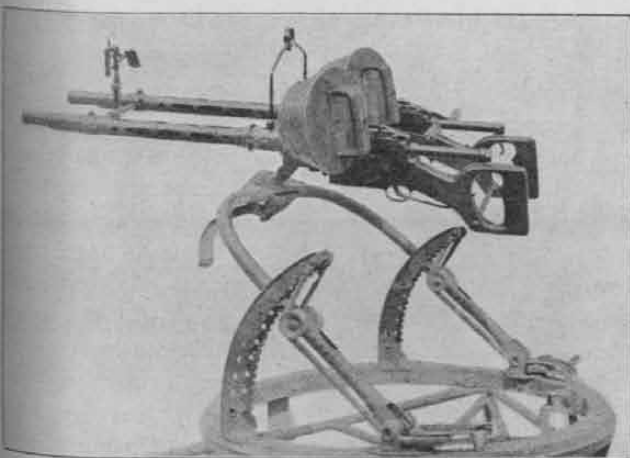

The "Madsen" Light Machine Gun Airplane Twin Mount.



The "Madsen" Light AA Machine Gun.

mental supervision, and great care is being exercised to maintain the purity of strain. The country is divided into breeding districts, and only a specific type is permitted to be bred in each. The principal types are: the Arab, the pure-blooded English race horse, and the Anglo-Arab. The available stock is so large that prices are considerably lower than anywhere else. Thus, the author states, while the French government pays an average price of 4,000 francs for a remount, the average price for a good horse in Hungary is only 2,300 to 2,600 francs, approximately one hundred dollars.

FRANCE—*Revue de l'Armée de l'Air*—January, 1934.

#### GENERAL INFORMATION.

*Chinese Aviation:* "A secret treaty has been concluded between China and the United States whereby the latter undertakes to reorganize Chinese aviation and to provide, in 1936, a total of 3,000 airplanes."

*Some Notes on Soviet Aviation:* The Air Force of Soviet Russia, though consisting of separate military and naval aviation, is under the control and supervision of the People's Commissar for Military and Naval Affairs. On January 1, 1931, Soviet authorities stated that their Air Force consisted of 750 planes in commission and 28,000 men. The five-year plan provided for 5,000 airplanes by 1935. In spite of the industrial development of Soviet Russia, and notwithstanding the aid supplied by foreign industry, it is believed, that it will take several years before the Soviet Union can actually put in commission and maintain in time of war an Air Force of that size.



*The Madsen A.A. Guns:* There are two types of Madsen anti-aircraft guns, the cal. 20 mm. A.A. cannon, and the cal. 11.35 mm. light machine gun. The cannon has a rate of fire of 300 to 350 rounds p.m. with an effective rate of 125 rounds. The projectile has an initial velocity of 730 m.p.s. and will pierce chrome-nickel armor plate 40 mm. thick at 200 meters, and a 20 mm. plate at 1000 meters. For aerial combat an explosive projectile is provided which has an initial velocity of 890 meters and its armor-piercing power but slightly reduced. The 20 mm. explosive bullet has a super-sensitive fuse which will act on piercing the silk of the fuselage. The gun weighs 55 kg.

The light machine gun has a rate of fire of 900 to 1000 rounds p.m. and weighs 10.5 kg.

*Japanese Air Maneuvers.*—February, 1934.

Elaborate air maneuvers were held in Japan, August 9-11, 1933, in which military and naval forces as well as the civilian population participated. The Tokio garrison had charges of the ground exercises which involved a territory having a population of 15 million. The situation assumed an attack on Tokio and the naval base at Yokosuka by a hostile fleet with aircraft carriers. The defending force included the A.A. units of ten divisions, aggregating 5,000 men and considerable matériel. The first line of defence was organized at a distance of 150 kilometers around Tokio. Police, firemen, students and patriotic organizations cooperated with the military au-

thorities in the maintenance of communications. The population was at all times fully informed of developments by means of the radio. During night attacks all lights were extinguished although automobiles were permitted to run with headlights covered with black and violet material which produced a very dim and diffused light. Policemen controlled traffic at street crossings by means of small green and red traffic lights.

*Revue Militaire Francaise*—May, 1934.

PROMOTION OF OFFICERS IN THE ITALIAN ARMY.

The Minister of War (Mussolini) submitted to the chamber for approval a new system of promotion for officers in the Italian army. According to this plan eligibility for promotion will be contingent upon completing successfully a tour of duty in actual command of troops for a stated length of time. Thus, promotion to the grade of captain would require three years' effective command of a platoon either as a lieutenant or first lieutenant. Three years of successful command of a company will qualify for promotion to the grade of major. Four years' command duty as a major or lieutenant colonel will qualify for promotion to the grade of colonel with the proviso that at least half of this time be served in actual command of a battalion, and at least one year on duty with another arm. Colonels will become eligible for promotion under the proposed plan after having had command of a regiment for two years (18 months for engineers) comprising two series of maneuvers (one for engineers). Brigadier Generals may be promoted after one year in command of a brigade including one period of maneuvers in major units. Division generals will require one year actual command of a division including two series of maneuvers which will enable superior authorities to judge their qualification for higher command.

The project includes certain provisions for eligibility for general staff duty in the various grades.

ITALY—*Rivista di Artiglieria E Genio*—August-September, 1933.

THE TRANSMISSION OF PHOTOGRAPHS BY WIRELESS AND ITS MILITARY UTILITY. By Lieutenant Colonel Umberto Ravazzioni, Engineers.

After describing in detail the functioning of a modern wireless apparatus for the transmission of photographs, the author discusses some of its possible military uses. Thus, he points out, the equipment can be advantageously employed for the transmission of secret messages without the danger of interception by the enemy. Such transmission of coded messages would greatly relieve the congestion of other communication nets. Again, several messages could be transmitted simultaneously at a considerable saving of time. The greatest utility of this method of transmission of military information would, in the author's opinion, accrue to the higher commanders, who could be supplied within short space of time photo-

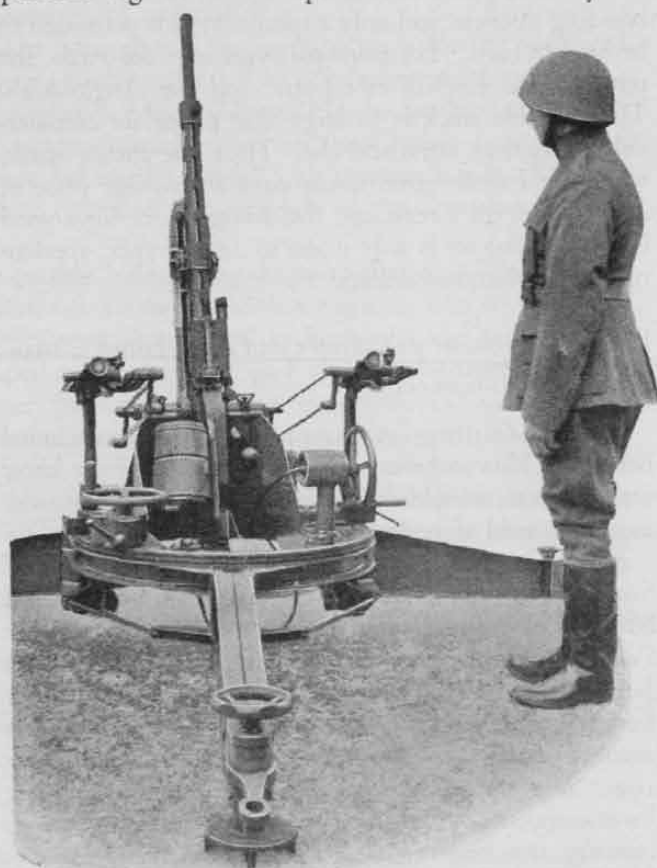

The "Madsen" 20-mm. A.A. Cannon.

graphic views of terrain features, field fortifications, etc., obviating to a considerable extent the necessity of detailed personal reconnaissance. Much further experimentation, however, is necessary, the author writes, to develop a satisfactory type of apparatus for field service, and which, in his opinion, should then become standard equipment of the communications net.

#### GERMANY—*Deutsche Luftwacht*.

A most ambitious enterprise serving the interests of aviation, both military and civil, made its bow with the beginning of the current year under the general heading and title "Deutsche Luftwacht" (German Air Watch). In reality it is a triple periodical, being published in three different and distinct editions, each with a distinctive sub-title, a specific field and mission. The first of the triplets, and seemingly the sturdiest, bears the sub-title "Luftwehr" (Air Defense), and is published monthly. As the title indicates, it is devoted to military aviation. It is an up-to-date compendium of information regarding the latest developments in the field of military aviation in all countries other than Germany which, under the terms of the treaty of Versailles is not supposed to have and maintain an air force.

The "Luftwelt" (The Air World), published twice monthly, is devoted to matters of general interest to aviation and aviators, especially in the civil and commercial field, at home and abroad. It includes air sport news of the German Aeronautical League.

"Luftwissen" (Air Science), published monthly, is devoted exclusively to scientific and technical questions in the field of aviation.

Each of these periodicals is splendidly edited, richly illustrated, resembling in size, quality of paper and print our own service journals. E. G. Mittler & Sohn, Berlin, are the publishers.

#### *Militär Wochenblatt*—25 December, 1933.

"Kransnaya Swyezda" (Red Star), official Soviet military periodical, publishes interesting information relative an amphibian wheel tank "recently adopted by the United States Army." The new war monster, as the illustrations shows, resembles somewhat the antedeluvian type large-wheel bike, and is said to be capable of a speed of 160 kilometers an hour. It is supposed to travel 112 kilometers on one litre of benzol. The motor is mounted below the driver's seat within the big wheel. The armament consists of one machine gun. Now it would be interesting to know whether it is Welsh-rabbit or vodka that makes people see or invent these things.

#### SPAIN—*Memorial de Infanteria*—March, 1934.

##### THE MILITARY ESTABLISHMENT OF SOVIET RUSSIA.

According to an article by Lieutenant Colonel Reboul published in "La Science et la Vie," the Soviet Army consists of 21 army corps comprising 29 regular divisions, 41 divisions of territorials, 10 cavalry divisions and 10 independent cavalry brigades. The infantry division consists of three infantry regiments, one regiment of field artillery, one squadron of cavalry, one signal company and one company of engineers.

The infantry regiment consists of headquarters, one chemical warfare platoon, one camouflage platoon and one pioneer platoon; headquarters company with a platoon of mounted scouts, a communications platoon, band and clerical force; three battalions, each consisting of a communications platoon, howitzer platoon (58 mm. trench mortar and 37 mm. gun), three rifle companies and one machine gun company; an artillery battalion of two batteries armed with three 76 mm. guns; supply, sanitary and veterinary services and a well-organized regimental school.

The armament of the rifle companies includes 12 light and 4 heavy machine guns. The machine gun companies have 12 heavy machine guns.

Military service is universal and obligatory. Systematic pre-military training begins at nine years of age. Russian industry is still far from being able to supply all needs of the army. This applies particularly to artillery matériel. Much of the artillery equipment is old. An automatic rifle, the "Federoff," Cal. 6.5 mm. is in an experimental stage. Soviet Russia has made considerable progress in the field of industrial mobilization. War industries constitute Group A of the five-year plan, and maximum effort is being made to develop them. The capacity of the airplane industry is already adequate to supply all demands. Airways, which in 1930 covered but 26,000 kilometers, exceeded a total of 70,000 in 1932. They are serviced exclusively by planes of Russian make. Chemical warfare receives particular attention and, according to German sources of information, the author states, experiments on a huge scale have been conducted recently in the valley of the Volga.

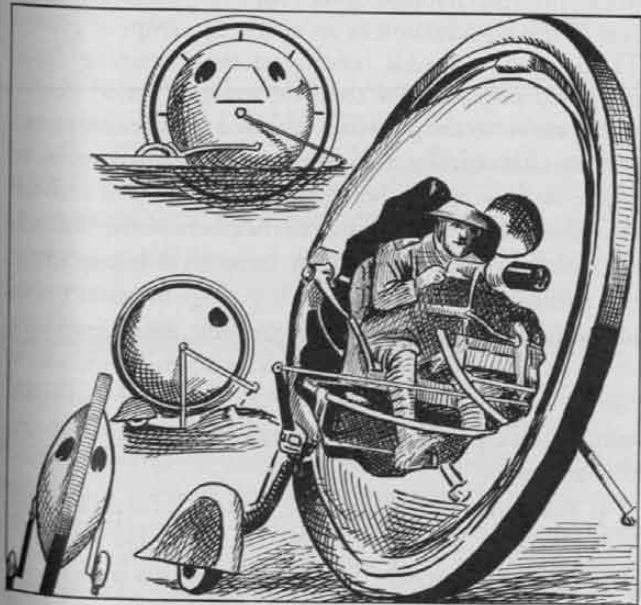

*Vodka or Welsh-Rabbit?*

# NATIONAL GUARD NOTES

## National Guard Publicity

By LIEUTENANT WILBUR H. ROSE

SINCE the World War the National Guard forces of the United States have received far more favorable mention in the newspapers than during any like period before the war. This is due in part to a greater nationwide interest in the citizen soldier, caused by many public services rendered the nation and the states by the National Guard since 1920.

The Guard has made and is making a wonderful record in public service. Floods, fires, and other misfortunes and disasters, taking their toll of property and human life, have been occasions for the highest type of service on the part of the guardsman.

Work of that type by the citizen-soldier needs no publicity expert to keep it in the newspapers; but to keep the Guard's activities at the home station week in and week out before the public requires constant attention and intelligent planning by the company commander, for upon his shoulders this work will fall.

National Guard news in the local papers helps recruitings, builds up morale, and molds favorable public opinion. It gives to the officer personnel a certain prestige in the community—a prestige tainted with so-called militarism; yet the National Guard officers of this country are representatives of the type of men who left their work to fight and die at Lexington and Concord.

Regarding the practical side of National Guard publicity, there are many methods of handling it, and to make this easier the following plan is suggested, which has been used, and was found to be very successful. This plan may be considered twofold: first, through the newspapers of general circulation in the community where the organization is stationed; second, the public may be invited to the armory to stated drills, and the guardsmen may attract attention and win favor by taking part in parades and by appearing in public on occasions when by so doing some community or patriotic interest is furthered.

The ideal plan is a combination of the two methods: that is, tying up newspaper stories (articles in newspapers are always called stories by members of the newspaper profession) with these public appearances.

Before the editor of a paper can prepare Army news intelligently he must be informed concerning the National Guard. It is an important duty of the company commander to see that the newspapers, through their editors, are kept informed of the various Guard activities. Only a few Guard officers have had the necessary training to write news acceptable to the average newspaper; so the best plan is full and explicit notes and let the editor or reporter write his own copy.

If the paper is a morning daily, get the notes to the editor as soon after drill or the event described as possible. If it is an afternoon sheet, hand the notes in early the following morning. If the publication is a weekly, have the editor make plain the time most suitable to him for handing in news, and have the notes handed in on time.

The following is a list of events that may be turned into newspaper copy and so used as to take advantage of every opportunity to give the editor live news concerning the organization:

1. Annually Army Inspection. Fourth week in advance of the date of inspection, announce the date and the purpose. Third week in advance, give the name of the inspecting officer, and if possible secure his picture (a metal cut will be still better) for the paper. Second week in advance, sketch the preparations going on at the armory for the inspection. Final week, inspection story. Give to the society editor an account of the dinner tendered the inspection officer. Immediately after the inspection hand in a detailed report, including any showing made by the Guard or by individual members in which the community may take pride. Here is a total of five weeks publicity featuring one event.

2. Summer Camp. Ten weeks of mention may be secured in this manner. Seven weeks in advance give the editor the date of the camp and its location. Sixth week give him a list of the vacancies in the organization, such as cooks, buglers, automatic riflemen and other specialists; for the machine-gun company, mule drivers. Fifth week, an article on the issuing of camp equipment. Fourth week, any special interest notes featuring individual members of the organization or an article on camps in general. Third week, a special training story concerning organizing and preparing for the field training period. Second week, notes on the activities planned for the camp, such as entertainment for the enlisted men. Final week, an article on leaving the home station and date of probable arrival at camp, with a roster of members of the unit who are making the trip. While at camp have letters sent to the paper by the company clerk giving interesting items of camp life. On the return of the unit from camp hand in an article on trophies, medals and other awards won at camp, making sure to include the names of individual winners. Ten weeks publicity may be secured featuring this one event.

3. Participation in Holiday Exercises. Usually the unit will parade at least once yearly on a holiday for which pay drill is authorized. This is good for two weeks newspaper mention: the week before the parade, announcing the Guard's part in it, and the week after.

4. Payrolls. Payrolls are sent to the finance office four times each year. Utilizing the week they are sent to the finance office and the week payment is made to the troops eight weeks publicity may be secured.

5. Community Value of the Guard. One of the best articles that can be prepared is one concerning the economic value of the Guard to a community. This story should show the amount of money spent by the State and Federal Governments in the maintenance of the unit. Payrolls, armory rental, freight, express, postage, visits of Guard officers and instructors, repairs to armory, range rental, transportation to and from camp, and any other expense incident to taking care of a Guard unit should be itemized. For a one-company station in a small town the total will average something like \$1,000.00 a month, which represents quite a factor in the economic life of a small community.

6. Visits of Regular Army Instructors and higher National Guard Officers. In addition to inspection such visits occur at least twice each year and each may be featured.

7. Quarterly Examinations. These examinations for the selecting of men for promotion to higher rating are held as a rule about four times each year.

8. Social Affairs. A birthday party, Christmas banquet or other social event may be utilized twice, the week before to announce it, the week following to describe it.

9. Promotions. The promotion of individuals to non-commissioned grade is always a good story, and there are usually a few of these each quarter.

10. Comparative Statistics. When no other news is available an article may be prepared comparing the present strength of the unit with its strength the same month the preceding year, naming vacancies. This can be done at least twice a year.

11. Small Arms Repairman. Before the visit of the ordnance repairman his coming may be announced, and afterward a story may be run featuring the condition of small arms and other ordnance.

12. Federal Property Invoice. Announce the coming of the invoicing officer. After his visit feature the property, its value and approximate condition. If possible secure a picture of the invoicing officer.

13. Honor Lists. After the last drill in December the local paper will be glad to have and print a list of the men who have made 100% drill attendance records during the calendar year, or other lists of honor men.

14. Miscellaneous. New equipment, officers' meetings, chemical warfare, drill and range firing at the home station. This is usually good for at least three weeks.

By following the above schedule it is possible to secure newspaper mention practically every week in the year. The schedule may be varied, and almost any organization, even the smallest, may find enough to fill out the other four weeks. Of course events will overlap once in a while and accounts of them must be combined into one story. But other items of interest, even of a general na-

ture, may be substituted and still a weekly story appear in the paper. The above plan provides for at least 48 weeks, as is shown by the following:

#### SUMMARY

Annual Armory Inspection .....	5 weeks
Summer Camp .....	10 weeks
Holidays .....	2 weeks
Pay Rolls .....	8 weeks
Economic Value Story .....	1 week
Visits .....	2 weeks
Examinations .....	4 weeks
Social Affairs .....	2 weeks
New NCO's .....	4 weeks
Strength Comparison .....	2 weeks
Small Arms Inspection and Repairs....	2 weeks
Property Check .....	2 weeks
Honor Lists .....	1 week
Miscellaneous .....	3 weeks
Total .....	<u>48 weeks</u>

Get as many names of individuals into the various stories as possible. Newspaper men like to print names of individuals, for years of experience has taught them that articles featuring names of individuals in their territory help to build and hold circulation. Give the junior and noncommissioned officers as much publicity as possible. The company commander's publicity will come naturally, as he is the head of the organization.

Be patient with the editor if a name happens to get misspelled. It might have been the fault of the individual who gave the paper the information, or the newspaper personnel might have been to blame.

Make it a rule to give the editor, along with other information, notes concerning the individual soldier. There are many opportunities for this: Enlistment or reenlistment, taking examinations, promotion, going to camp, winning medals or trophies at any time, occasions when the enlisted man is given charge of any phase of drill, and on his discharge.

Editors of small town or small city newspapers are not supported by endowment, and advertising is the lifeblood of their business. A page advertisement bringing fifty or sixty dollars is good business and not hard to secure. The company commander may show the editor how a page bringing that much or more can be sold to the local merchants through the cooperation of the Guard.

Lay out a page advertisement with the advertising manager of the paper, calling for new recruits, or pointing out one or more of the desirable features of the National Guard. Have a representative of the paper and a member of the Guard sell space on the page to the local merchants at the rate of two or three dollars for each business. Twenty or thirty merchants can be sold on this proposition in a short time, bringing the paper fifty or sixty dollars. The paper will pay the guardsman a good commission for helping to sell the page of advertising.

# RESERVE NOTES

## Military Training . . .

BY LIEUTENANT COLONEL CONVERSE R. LEWIS  
*Infantry*

**M**ILITARY training — an asset to a business career." How many times have we read and heard this statement. We read many articles and speak to many people who are sincere in their belief that military training is an asset to a business career. At the same time we come in contact with many individuals who are Doubting Thomases and believe the opposite—that military training is not an asset, but a liability. They believe that it is only a training to cause war and arouse violence. They fail to see that military training is not only an asset in time of trouble, when it helps protect the American citizen and his country, but that it is also an asset in time of peace when it teaches the men who are fortunate enough to receive this training to be able to manage men and carry out orders. The man who cannot see the advantage of military training to a business career does not realize that this training gives executive ability and all those fine qualities of character which are necessary, no matter what profession or vocation may be followed, and which every employer is seeking for in his employees.

Usually the believers are those who have actually experienced efficient and progressive military training. Such training includes not only physical military drill, which is only a disciplinary agency, but also mental military training, which strengthens the character, quickens the perception, and helps one to arrive quickly at a definite, clear-cut decision. It also teaches one how to issue instructions in a logical sequence to subordinates so that they can intelligently cooperate in carrying out the decision and plan. It teaches subordination of one's self to the team for the benefit of all. It trains one to give instantaneous, willing, loyal obedience and cooperation to a superior, not only to an order or wish expressed or implied, but in the absence of these in case of emergency to take action such as the subordinate believes the superior would take if present. In fact, military training has for its objective the development of all those characteristics in the individual which goes to make him efficient.

The persons who have come in contact with this type of training will invariably tell you that it has been a distinct asset to them in their business life. They will tell you that the nine immutable tactical principles which enter into the solution of any military combat problem can be adjusted so as to assist in solving the problems arising in business life.

On the other hand, the Doubting Thomases are usually

## An asset to a business career

those who have not been fortunate enough to have experienced a well-balanced course of progressive military training—their training having begun and ended with what is popularly known as military drill.

Military training, as well as scholastic education, has its progressive steps from the elementary to the higher branches of training. In education, we progress from the elementary schools, to the high schools, and then to the colleges. Our progress in both military training and education depends upon our own personal and individual powers and limitations. Some students are capable of receiving only the elementary education. Likewise, some military students are capable of receiving only the elementary military training. Such students usually have not the scholastic education necessary, or they are lacking in those characteristics which go to make an executive; namely, loyalty, honor, courage, decision, self-discipline, willingness to work and to accept responsibility, and vision.

Let us investigate, very generally, the system of military education or training. Our kindergarten scholar is called the recruit. He starts in from the very beginning. He must know all those things which we include in what we call the school of the soldier. There, emphasis is placed upon discipline, both mental and physical. He must know his drill precisely and accurately because precise drill is an agency by which the by-product discipline is practically gained—meaning discipline of body, perception coordination of mind and muscle, alertness, and poise. Here, also, he is taught how properly to subordinate himself as a member of a team, taught to react cheerfully, willingly, and instantaneously to a duty or to the will of a superior, expressed or implied. Later he is taught leadership, the handling and management of men, and that in such the "morale factor is to the physical as three is to one."

During this period he absorbs or learns those things which make for system, neatness, and orderliness of arrangement, both physical and mental, a constructive outlook on life—one of optimism, courage, and respect for constituted authority. If his age, moral, mental and educational qualities are such, and he has the qualifications necessary for executive timber, his education progresses to a training for higher leadership in the command, management, and training of men. This proceeds to a training which develops his own mental powers to solve and

handle military tactical situations; and then to the higher study of tactics and technique of the profession of arms. This includes the preparation and solving of minor tactical problems using the prescribed scientific methods. It also includes the proper giving of orders, arriving at precise, definite decisions without straddling, thus developing him into an individual who reacts promptly and decisively, taking action quickly after systematic and logical estimate of any situation, using only the time necessary in arriving at the decision which the situation permits.

During all this time the individual is an integral part of an organization, in a sub-executive capacity. In this position he has an opportunity to exercise his own initiative within the regulations and policies laid down for him by higher authority. He learns quickly to determine the sphere in which he is allowed full initiative, bounded only by the policies and regulations fixed by higher authority; and with his assigned mission within this sphere of responsibility, he determines the objectives that he wants to accomplish and uses his initiative and resourcefulness to develop all things for the purpose. He is also trained to understand that he and his particular activity are but a part of the whole and that there is a superior watching over him who coördinates a group of activities of which his is but an integral part and must be subservient to the good of the group. He also realizes the necessity of each integral part of that group working as a team and the necessity for coöperation and loyalty to the group and its leader.

I believe enough has been said in a general way to indicate that the properly trained military man is taught to function in an organization. As a matter of fact, there is no profession or business more highly organized than is the military service. Coördination and control begin at the War Department at Washington and extend down through the several corps areas within the United States through each division, brigade, regiment, battalion, company, and platoon until they reach the smallest organization—the squad, which is composed of seven privates and one corporal who is their executive. The channel of command, control, and dissemination of orders is precise, exact, and highly systematized. It requires a high sense of the fitness of things for a proper performance of duty and a high morale and understanding is necessary for the proper management and administration of the personnel. To bring about all this is the aim of military training and education.

If one has had the opportunity to function as a noncommissioned or commissioned officer in any of the three components which go to make up the Army of the United States—the Regular Army, the National Guard and the Organized Reserve—he cannot help but be impressed with the necessity for organization. He cannot help but understand and appreciate the necessity for discipline, loyalty, coöperation, and a proper helpful subordination to a superior who carries the big load and responsibility.

Primarily, the military service is organized for combat and for the purpose of quickly and efficiently restoring to a peaceful status any act of violence requiring the intervention of arms, domestic or foreign. In the daily routine of the maintenance, administration, supply and training, all professions and vocational trades that are found in civil life enter into its make-up. In the military organization, these professions and vocations function under very precise disciplinary supervision.

Today big business operates on a scale comparable to the army organization. Thousands of men must be properly controlled to function for the particular purposes for which the business is primarily organized. No one individual is capable of personally directing such a business in detail. Dependence and responsibility must be placed in the hands of subordinate executives in the chain of organization. These subordinates are guided by general policies and directives.

This coördination of authority which takes place in a business organization follows very closely the military organization. Aside from his professional knowledge, it is essential that both the military and business executive possess the same characteristics which go to make the successful leader. Both must have an intimate general knowledge of the business for which the organization has been created. Both must be loyal, honorable, self-disciplined, responsible, industrious, courageous, and able. Both must react quickly to any situation, make clear-cut decisions, and give intelligent instructions. They must have poise, self-confidence and respect, and they must be able to manage men.

Men at the helm of large business organizations of this generation are diligently searching for men who not only know how to perform some specific job which they are paid to do, but who can also fit into the organization and perhaps some day become an executive. This requires a man, among other things, to have an appreciation of the fact that organization and teamwork are absolutely necessary for success. This principle is recognized by the Army and by business executives everywhere.

There are many instances, too numerous to mention, of men trained in the Army who have, and are, holding high positions as executives in large business firms. At the end of the World War I was told that one of the largest corporations in the United States was offering every man in the commissioned grades, with a certain length of service, an opportunity to be tried out for an executive position within its organization. Major General James G. Harbord, an officer of long service and the head of the Service of Supply for the A.E.F., left the Army to head the Radio Corporation of America, which was just being organized at that time. The President of Sears, Roebuck and Company received his early training in the Army. Major General George S. Gibbs, former Chief of the Signal Corps, recently left the service to become President of the Postal Telegraph Company.

In the files of the university military department are

many letters from young men who have completed the Advanced Course in one of the several units, and who have since that time entered business. They have voluntarily stated that the training they received in their four-year course in the military department has been one of their greatest assets in assisting them to adjust themselves in different business situations.

So, when we speak of military training, let us visualize beyond the picture of men in uniform drilling with rifles and going through many evolutions, realizing this physical drill furnishes and assists in getting but one by-product—discipline—and that military drill forms only a small part of military training.

Let us visualize and evaluate the training from the standpoint of national security, and the maintenance of domestic tranquility, so far as the nation is concerned. For the individual, let us evaluate the training from the basis of assisting in preparing him to become an efficient, loyal citizen—properly prepared for his position in a business career.

/ / /

### Reserve Officers' Contact Camp

BY MAJOR FRANK A. KEATING  
*Infantry (DOL)*

THE Cincinnati Military District, one of the very active units of the Organized Reserves, staged a unique Contact Camp on May 26-27, at Fort Thomas, Kentucky. The use of the adjective "unique" is not designed to place the district in a super class, nor may it be the first time such an experiment has been worked with Reserve personnel; nevertheless, when a group of reserve officers who have many other things to do beside devoting long hours to learning the art of war get together and stage a CPX involving a reënforced division in defense, with all command posts manned and functioning like a well-oiled machine, and stick to their jobs throughout the night, and run the "war" without using "canned messages," it's unique in any language. And that is what they did and did superbly.

On March 12th, in preparation for the Contact Camp, a troop school for the regularly organized staff of the Cincinnati Military District was inaugurated. The problem of organization of the ground and the preparation of a field order and subsequent administrative order for a position defense of an infantry division, reënforced by a detachment of Coast Artillery troops (AA), consisting of one gun battery, one machine-gun battery and three machine-gun platoons, an Observation Squadron, a Balloon Squadron and a squadron of Cavalry, formed the basis for the training schedule.

After an assurance that the appointed Commanding General, the Chief of Staff, the four G's, the four assistant G's and a few of the special staff, would attend school and be present at the Contact Camp, the mission of selecting the defensive position, the proper organization thereof, the preparation of the division field order and

administrative order, and following up all subsequent field orders of subordinate units, was assigned and schooling began. The division of time for each school night was on the basis of one hour for the instructor during which time tactical principles or logistics were discussed, and one hour for the students to work on the problem.

No better compliment can be paid than to say they fulfilled every task imposed on them to a most satisfactory degree. They also had that deep feeling of satisfaction in seeing the fruits of their effort materialize in a very successful camp. It was a problem for and by reserve officers.

Working on a time schedule the field orders of all subordinate units were prepared, all situation maps were posted, all assignments to staff positions in every unit to and including battalions were made, a complete divisional communications net (wire) was established in the Drill Hall, and all instructions with reference to the conduct of the problem were completed, published and circulated days before the zero hour of the problem. The only remaining work to do at camp was a very simple card system of registration and the duties involved by the problem proper.

Canned messages were dispensed with. In lieu thereof, a group of umpires (Reserve officers), carefully coached and schooled, acted as the "Red" force and also performed the usual duties of an umpire in picking up information for constructive criticism. These umpires substituted for canned messages by using a system of "overlay graphs" which showed the location of red forces as of every thirty minutes of the problem, and coordinated their efforts by predetermined and mimeographed tables of red artillery fires and aerial bombardments and flights. This system, tried for the first time with Reserve personnel, worked very satisfactorily. It prevented that artificiality of telling the command where and when Red would strike (as is the case with prepared messages in envelopes with the time marked thereon), and provided flexibility of red movements. No effort was made to conform to a hard and fast system of attack as is common with canned messages, but red was maneuvered by the director in accordance with the reaction of blue.

Although officers were encouraged to split the time during the night with their assistants, many stayed right through and when, hours later, the "close station" call was sent out, they showed signs of fatigue but were still full of pep and ready to carry on.

The final phase, the critique, was held immediately after the close of the problem and was a precise and brief affair. Each speaker (five), except the director, was limited to five minutes during which time he was to discuss only those points that were marked violations of the tactics of his branch or which were outstanding administrative errors. Trivial matters were omitted. This move resulted in a short, snappy critique (much to the appreciation of the group) covering the cream of the errors and with the presumption that simple mistakes were corrected by umpires as the problem progressed.

Fifty minutes after "close station" was flashed, the group assembled, heard the critique, and were dismissed.

The assistance rendered by the 147th Infantry, Ohio National Guard, in lending their field telephones, switchboards and communications personnel, and the hard work on the part of the 10th Infantry at Fort Thomas in erecting 39 pyramidal tents and setting up the bunks, etc., and the installation of the wire net, all materially helped toward the comfort of the 206 reserve officers and 53 enlisted men that participated and to the success of the camp.

/ / /

### Cadet Training in the Gloucester High School R.O.T.C. Unit

BY LIEUTENANT COLONEL P. H. OTTOSEN  
C.A.C.

THE following notes are prompted by some comments which appeared in a pamphlet recently issued by the Civilian Military Education Fund of Washington, D. C., under the title "Orientation of R.O.T.C. Duty." Many officers are prone to wonder what the P.M.S. & T. of a high school Reserve Officers' Training Corps had to do. Also officers newly appointed to this duty have considerable difficulty in visualizing the nature of their duties, what they can do in the way of stimulating interest, building *esprit*, increasing the prestige of the unit and many other questions of a similar nature. The following comments are submitted in the belief that they will answer some of these questions:

The battalion at this school consists of 346 cadets. Drill is held twice each week during the last school period of the day. The Corps is organized into three rifle companies, each of 100 cadets and a band of 46 pieces. When climatic conditions are favorable drill is held out of doors. During the winter months we have authority to use the National Guard armory for drill and target practice. Rifles are not issued to the cadets at the beginning of the school term. During the fall months close order drill without arms is emphasized. At the beginning of the winter term arms are issued and the manual taught in the school basement.

In addition to the drill period each cadet attends one class a week. These classes are held during each day on exactly the same basis as classes in any other subject of the curriculum. This means that I have seven sophomore, seven junior and four senior classes per week in addition to a class exclusively for cadet officers. Only the seniors use a text book (*Basic Military Training*). This text is furnished gratis by the school board.

In this unit the traditional school of pedagogy has been supplanted by the progressive school. Students no longer sit at desks, they move about as their work requires. Formerly the boy learned by memorizing lessons; now he is taught to think his own thoughts and to evaluate his

lessons. Formerly the aim was mental discipline; the aim now is to produce a tolerant understanding and to encourage coöperation, good sportsmanship as well as scholarship. In line with the present progressive ideas long lectures are avoided and the practical part of the work is emphasized. Marksmanship and musketry find each cadet with a rifle in his hands, learning by doing. Scouting and combat principles require informal work between the instructor and the cadets with the use of a terrain board and a map. This means much advanced preparation on the part of the instructor because there are no text books or manuals exactly suited for this purpose. The instructor needs at least two hours' preparation for each lesson.

Military instruction has been an essential feature of this high school for 48 years. Almost every successful man in the city was at some time a cadet officer in the high school unit. Other communities may have theories about the value of military training in the schools but Gloucester is fully satisfied with what has been accomplished. Stores close for the annual military field day. The high school military parties are the most important social events of the community. The cadet officers are the recognized leaders in all student activities. They are selected from seniors of high class standing who are on the athletic eligible list and have demonstrated outstanding qualities of leadership.

/ / /

### Activities 621st C.A. (Hd) Res.

THE regimental troop school closed on May 23rd when all sub-courses scheduled for this inactive season were completed. During the month of May, 37 sub-courses have been completed by members of this regiment for 543 credit hours. This gives the regiment a total of 131 sub-courses for a total of 1,797 credit hours for this training season.

On May 24th, Colonel A. E. Tanner, Commanding Officer 621st C.A.; Major W. M. Cravens, Unit Instructor, and a number of Reserve officers of this regiment attended the exercises of the R.O.T.C. graduating class at the University of Delaware, Newark, Del. Colonel Tanner, on behalf of the 621st Coast Artillery, presented sabres to the Cadet Major and the Cadet Adjutant. This regiment held its annual encampment at Fort Delaware the week-end of May 26-27th. Over 30 officers attended this outing and a very pleasant time was enjoyed by all.

Major W. M. Cravens, CAC Unit Instructor of this regiment has been ordered to Fort Totten, N. Y., for the period June 17-30. Major Cravens will supervise the instruction. Eighteen Reserve officers members of the 621st C.A., mostly graduates of the University of Delaware R.O.T.C. class of 1934 have been ordered to active duty at Fort Totten, N. Y.



## BOOK REVIEWS

CAN WE LIMIT WAR? By Hoffman Nickerson.  
Frederick A. Stokes Co., New York, 1934. 317 pages.  
Price, \$2.75.

*By Major General H. D. Todd, Jr., Ret.*

In a masterly written preface we learn the mission of the book and the thesis upon which it was constructed. The book is a development of the idea of estimating "the future of war in terms of the social forces recently active together with military methods recent and proposed" and is based upon the belief that "war, the use of organized force between human groups, inevitable because men are imperfect, because any social order demands armed police power, finally because an individual or group determined to attack another can be restrained only by superior force."

The chapter on the Inevitability of War is most logical and should be read by those who honestly believe that all wars can be abolished by simply abolishing all weapons. This chapter is followed by an historical narrative of the wars of the world beginning with those of Greco-Roman world and showing very clearly the difference between "limited" and "unlimited" war.

For instance, in wars fought for limited objectives, it is brought out that governments made war not to conquer their enemies altogether but merely to exercise pressure for the sake of colonial advantages or of conquests along frontiers; consequently as the author shows, defeated states seldom had to fear disaster; at most they might expect a supportable diminution of wealth and power. In these limited wars comparatively small forces were used. They were generally composed of professional soldiers, and society in general was not seriously involved. This was particularly true of the era of Louis XIV and the eighteenth century. However, whenever democracies were in control the author shows by historical examples that the limits of war were extended until the war objectives approached the complete subjugation or destruction of the enemy nation.

Finally to the question "Can We Limit War?" the author's answer is: "We do not know. It depends on how the world uses whatever time may remain before the next war." Then with the statement "we do not know that every country and especially every province in Christendom can help towards a general and strict limitation of war only insofar as its own circumstances permit," the author turns to the military conditions and the military policy of the United States, which he considers under "National Strategy of the United States" and the closely related subjects: "Economy and the Army," "Regular Offices," and "U. S. Policies and World Peace." Starting with a saying quoted by Foch from Von der Goltz as

follows: "Whoever writes on strategy or tactics should limit himself to teaching national tactics, for no other method can be profitable to the nation he is addressing," the author states his views on our National Defense Act.

He gives three reasons for maintaining armed forces in the United States, viz:

- a. Emergency police work
- b. Security against invasion
- c. Contingencies of natural policy.

He then discusses the question "How well does our present establishment under the National Defense Act of 1921 answer our national requirements?" The studies of the author have led him to the conclusion that the act of 1921 should be greatly modified and that the national requirements are not met by the large force now being planned.

He is firm in the belief "that security and economy could be combined, first of all by organizing the Regular Army (as a covering force) of four full divisions ready for immediate service; allowing for surplus enlisted men and for a generous number of surplus officers, say a hundred thousand enlisted and six thousand officers."

Then, as the author is almost a fanatic on the subject of tanks, he would not build this indispensable covering force around its infantry but around a powerful tank corps. A whole chapter contains a discussion of "Regular Officers." The author's keen power of observation and his confidence in the correctness of his own opinions make it very interesting.

While many highly educated officers of long experience will not agree with some of his statements his treatment of this subject is very fair and to a certain degree very logical. The civilian who reads this chapter will learn a great deal of the officer corps of the American Army—a subject of which the average American is densely ignorant; while the professional soldier will be both interested and amused to see himself as an amateur sees him.

Then there is the usual civilian idea in regard to the West Point education being "a little too exclusively technical, a little lacking in breadth." However, all West Pointers will be greatly relieved when they read his statement: "That after all the West Point product has been by no means unsatisfactory." While the author undoubtedly tries to be just in all his arguments he omits the fact that shortly after the World War the War Department, with the approval of the Administration, made a strong effort to produce a highly efficient striking or covering force of five divisions and had gone far in the organization of such a force when stopped by insufficient appropriations.

Also it is not believed that with more knowledge of the subject, the author would contend that housing, feeding, clothing, equipping, training and in general maintaining such a force would be more economical than the present set up, particularly in view of the fact that under existing world conditions self-preservation would also require the maintenance of a framework upon which to build a great army in case a hostile coalition should force us to wage an unlimited war. He also does not make clear that the present state of the mechanical equipment of the Army is due entirely to lack of money instead of being due as he infers to extremely conservative, if not antique, views on the part of the commissioned personnel.

In conclusion it can be said that the book is the result of an enormous amount of reading by a man who is well educated, who saw some service in the World War and who has the courage of his convictions.

**INFANTRY IN BATTLE.** Prepared by members of the Historical Section, The Infantry School. Published by The Infantry Journal, Inc., Washington, D. C., 1934. 380 pages, indices, 98 maps. \$3.00, postpaid.

This volume treats of the tactics of small units as illustrated by examples drawn from the World War. It checks the ideas acquired from peace-time instruction against the actual experience of war. It is to emphasize the practical as distinguished from the theoretical that this book has been prepared. In our peace-time instruction we generally assume trained organizations at normal strength, subordinates are competent, supply arrangements function, communications work and orders are carried out. In war any or all of these conditions may be absent, and the veteran knows that this confusion is normal and his mental processes are not paralyzed when he finds himself in a situation where nothing is as he was taught to expect. He knows that he must carry on in spite of seemingly insurmountable difficulties and regardless of the fact that the tools with which he has to work are worn or broken. Moreover, he knows how to go about it. This volume is designed to give the peace-time officer something of this viewpoint of the veteran.

The book contains 28 chapters; each chapter consists of a series of tactical discussions based on the operation of small infantry units. Many of the examples are taken from the personal experience monographs prepared at The Infantry School during the years since the war. By the use of numerous historical examples which tell of the successful as well as describe the unsuccessful conduct of troops in the absence of information, the lack of time, and the confusion of battle, the reader becomes acquainted with the realities of war and the nature of the problems to be solved and the conditions under which they must be solved when in the face of an enemy. In so far as through the past twelve years material has become available, these examples are taken from the verified battle experiences of definite American troop units, but the combat experience of German, British and French units

## ENGRAVING

THE COAST ARTILLERY JOURNAL is prepared to render prompt and efficient service in filling orders for all classes of engraving, to include visiting cards, wedding invitations, announcements, Christmas cards, and stationery.

## MAGAZINES

We specialize in subscriptions for magazines and periodicals. Give us a chance to quote club rates. We will meet the price of any reputable magazine agency or broker.

## BOOKS

We will obtain for you any book in print, foreign or domestic. Military books are our specialty. Substantial discounts given on all books ordered through us. Our service is convenient and economical.

The following **NEW** books are especially recommended:

- WITH MY OWN EYES  
By Frederick Palmer . . . . . Price \$3.50
- CAN WE LIMIT WAR?  
By Hoffman Nickerson . . . . . Price \$2.75
- SOLDIERS WHAT NEXT?  
By Katherine Mayo . . . . . Price \$3.50
- THE FAR EASTERN FRONT  
By Edgar Snow . . . . . Price \$3.75
- WHAT WOULD BE THE CHARACTER  
OF THE NEXT WAR?  
By Eighteen Experts . . . . . Price \$2.50

A substantial discount from list will be given.

**The Coast Artillery Journal**

1115 17th Street, N. W. Washington, D. C.



If you cannot keep  
your magazines in  
place use the  
**UNIVERSAL  
PERFECTION  
MAGAZINE  
BINDERS**

with the permanent  
lock feature.



The Universal Perfection Magazine lock binders are made in two popular colors (brown and black) of fabrikoid, with permanent lock feature. The crossbar of substantial metal will not bend. Made to fit any size magazine. Magazines cannot be removed from binders without key.

Three lines of lettering in gilt allowed without charge, i.e., name of magazine, organization and location. Instead of location you may substitute "Do Not Remove From Day Room."

#### PRICES

- No. A.66 Brown or Black Fabrikoid:  
1 to 11 Binders inclusive \$2.15 each, any size  
12 to 22 Binders inclusive 1.90 each, any size  
23 to 30 Binders inclusive 1.80 each, any size  
31 Binders and up \$1.75 each, any size

F.O.B. Factory

Quotations for full leather will be given upon request  
Order from

THE COAST ARTILLERY JOURNAL

## Coast Artillery Field Manuals

The following Coast Artillery, Staff Officers' and Basic Field Manuals are now available:

1. C.A.F.M. Vol. I, Seacoast Arty. Part 1—  
Tactics ..... \$ .15
2. C.A.F.M. Vol. I, Seacoast Arty. Parts 2 and 3  
—Technique and Reference Data ..... .25
3. C.A.F.M. Vol. II, Antiaircraft Arty. Part 1—  
Tactics ..... .20
4. C.A.F.M. Vol. II, Antiaircraft Arty. Part II  
—Technique and Reference Data ..... .50
5. Staff Officers F.M. Part 1. Staff Data ..... .20
6. Staff Officers F.M. Part 3. Organization, Road  
Spaces and Camping ..... .10
7. Basic F.M. Volume III. Basic Weapons,  
Part I, Chapter I. Rifle Marksmanship... .10
8. Basic F.M. Volume IX. (Signal Communica-  
tions) ..... .30
9. Basic F.M. Volume V (Transport) ..... .60

The above prices are F.O.B. Washington.

The JOURNAL is prepared to supply your needs on these or any other official Government publications.

**The Coast Artillery Journal**

1115 17th Street, N. W.

Washington, D. C.

also have been utilized to supplement that of our own, especially when examples were needed to illustrate problems characteristic of warfare of maneuver.

It is noted that each situation is stated realistically, in few words, and completely illustrated by maps. The discussion of each incident drives the simple lessons home and the conclusion is a practical and succinct summary of important lessons.

**TOO MANY BOATS.** By Charles L. Clifford. Little, Brown & Co., Boston, 1934. 314 pp. \$2.00.

Reviewed by Lieutenant Colonel Paul D. Bunker

An abridged version of this tale was first published in *The Red Book* under the title of "Parade Ground."

I too was going to write a book on Army life, and it was going to be a humdinger. It was to have all the vilifying characteristics required of a best seller and the muck-raking technique which is now the mainstay of persons writing about hitherto respected officials.

The scene of my book was, of course, some Army post in the tropics because there, according to our embryo Boccaccios, degeneration reaches its full perfection. The colonel in command, a lecherous old goat, has (ex-officio) the *droite du seigneur* with all lieutenants' wives. His own wife, honor graduate of a bawdy house, occupies her leisure in selling cocaine to the enlisted men.

The major on the post is a martinet who shoots at least one soldier a day for failure to salute him with sufficient *éclat*. His wife, formerly a matron of a girl's reformatory (to which position she rose from the ranks) has formed an attachment with the daughter of a colored sergeant and consequently cannot devote as much time as she would wish to the still she operates in the troop latrine.

My hero demands careful delineation, because he must not be entirely praiseworthy; no character in such a book ever is. I had thought of making him a cross between Clark Gable and Wallace Beery, a hot louie who, being an ex-gigolo, naturally falls in the rôle of assistant to his colonel in assuaging the cosmic urge which inevitably and perpetually possesses all the ladies of the garrison.

The hero falls into a trap laid by the Major—the badger game, let's say. The major is sore at the hero because the said hero is not a West Pointer. Neither is the major, for that matter, but we've got to bring in this mythical West Point jealousy complex somehow. Well, anyway, the major can not wait on the law's delay, so, all on his own, he sentences the hero to a million years at hard labor and throws him into the hoosegow to keep company with two recruits whom the colonel has already condemned to death for not buying his wife's cocaine.

The colonel now shoots the major, the provost sergeant hangs the hero out of sheer jealousy, the women drink the colonel into delirium tremens and the commissary sergeant (a German spy in disguise) blows up the post.

I said I was going to write this book, and name it, "Flag Pole, or Too Many Prunes." Judging by precedent, its profits should offset my pay-cut and, incidentally, bring me a certain fame. But I doubt that I shall ever write it. Even a skunk will not foul its own nest.