

# NANOSTRUCTURED ENERGETIC MATERIALS

R.V. Shende, S. Subramanian, S. Hasan, S. Apperson, K. Gangopadhyay, and S. Gangopadhyay\*

Department of Electrical and Computer Engineering

University of Missouri-Columbia,

Columbia, MO 65211

P. Redner, D. Kapoor, and S. Nicolich

US Army ARDEC

Picatinny, NJ 07806

## ABSTRACT

This paper reports synthesis of metastable intermolecular composite (MIC) containing CuO nanorods, nanowires combined with aluminum nanoparticles. These composites were prepared using ultrasonic mixing and self-assembly approach. The combustion wave speed as high as  $2300 \pm 100$  m/s was achieved for the MIC composites. We also report that the combustion wave speed can be easily tuned from 1 m/s to 2300 m/s for the nanoenergetic composites prepared using mesoporous  $\text{Fe}_2\text{O}_3$  gel, nanoparticles of  $\text{WO}_3$ ,  $\text{MoO}_3$ ,  $\text{Bi}_2\text{O}_3$ , and CuO mixed with Al-nanoparticles and addition of other chemicals in nanoscale. Tunable combustion speed is found to depend not only on the type of oxidizer but also on the nanostructural arrangement present in the energetic composites.

## 1. INTRODUCTION

Nanotechnology plays a significant role in the development of novel energetic materials. The goal of reducing the size of an energetic system while maintaining performance has become a reality with the introduction of nanosized fuels and oxidizers. Merely mixing these components will create random hot spot density distribution and thus, limit the energy transfer rates. Homogenous mixing or organization of fuel and oxidizer nanoparticles, however, should enhance the interfacial contact area and accelerate the combustion wave front. Organization of nanoparticles is achieved using self-assembly approaches (Subramanian et al., 2005; Kim et al., 2004). When spherical nanoparticle morphology is selected, self-organization may restrict few smaller nanoparticles on larger ones against cylindrical (rod like) morphology, where relatively larger number of nanoparticles can be assembled. Due to the organization of nanoparticles, higher contact area is established between fuel and oxidizer components, which effectively improve the combustion wave characteristics. These tunable nanoenergetic materials will be useful for various applications such as high-temperature non-detonable gas

generators, adaptable flares, green primers for propellants and explosives, high power/energy explosives. Overall, the nanoenergetic materials together with MEMS (Microelectromechanical Systems) technology should provide improved level of performance with the reduction in the size of current warheads and weapon systems.

The synthesis of oxidizer rod-like geometry (nanorod) has been reported using solid templates like mesoporous silica (Martin, 1994), polymeric systems (Bhattacharya et al., 2000), arc discharge methods (Zhou et al., 1999), and laser ablation (Morales and Lieber, 1998). They were also synthesized by inorganic condensation method following a sequential route of ololation and oxolation reactions in an aqueous solution (Jean-Pierre, 2000). Among these methods, the wet chemical approach of inorganic condensation is attractive for the nanorods synthesis because this method has better control over the size and aspect ratio of the nanorods (Wang et al., 2003).

Low aspect ratio nanorods can be made into high aspect ratio nanowires using various processes. Surfactant templating (Wang et al., 2002, 2000), hydrothermal (Yang et al., 2006), membrane templating (Martin, 1994) etc. are available for the synthesis of nanowires and nanorods. When higher surface area oxidizer nanowires are used, higher interfacial contact area between fuel and oxidizer should enhance the rate and extent of energy release.

Nanostructured energetics can also be prepared by combining mesoporous oxidizer with fuel nanoparticles. Mesoporous materials have pores in the range of 20-500 Å in diameter provide larger surface area. This can be easily prepared using the sol-gel approach. To achieve ordered arrangement of pores and uniform pore size distribution, surfactant templating method is very effective (Mehendale et al., 2006). By ordering of mesopores in an energetic composite, hot spot density of

# Report Documentation Page

*Form Approved  
OMB No. 0704-0188*

Public reporting burden for the collection of information is estimated to average 1 hour per response, including the time for reviewing instructions, searching existing data sources, gathering and maintaining the data needed, and completing and reviewing the collection of information. Send comments regarding this burden estimate or any other aspect of this collection of information, including suggestions for reducing this burden, to Washington Headquarters Services, Directorate for Information Operations and Reports, 1215 Jefferson Davis Highway, Suite 1204, Arlington VA 22202-4302. Respondents should be aware that notwithstanding any other provision of law, no person shall be subject to a penalty for failing to comply with a collection of information if it does not display a currently valid OMB control number.

1. REPORT DATE <b>01 NOV 2006</b>	2. REPORT TYPE <b>N/A</b>	3. DATES COVERED -			
4. TITLE AND SUBTITLE <b>Nanostructured Energetic Materials</b>		5a. CONTRACT NUMBER			
		5b. GRANT NUMBER			
		5c. PROGRAM ELEMENT NUMBER			
6. AUTHOR(S)		5d. PROJECT NUMBER			
		5e. TASK NUMBER			
		5f. WORK UNIT NUMBER			
7. PERFORMING ORGANIZATION NAME(S) AND ADDRESS(ES) <b>Department of Electrical and Computer Engineering University of Missouri-Columbia, Columbia, MO 65211</b>		8. PERFORMING ORGANIZATION REPORT NUMBER			
9. SPONSORING/MONITORING AGENCY NAME(S) AND ADDRESS(ES)		10. SPONSOR/MONITOR'S ACRONYM(S)			
		11. SPONSOR/MONITOR'S REPORT NUMBER(S)			
12. DISTRIBUTION/AVAILABILITY STATEMENT <b>Approved for public release, distribution unlimited</b>					
13. SUPPLEMENTARY NOTES <b>See also ADM002075., The original document contains color images.</b>					
14. ABSTRACT					
15. SUBJECT TERMS					
16. SECURITY CLASSIFICATION OF:			17. LIMITATION OF ABSTRACT <b>UU</b>	18. NUMBER OF PAGES <b>38</b>	19a. NAME OF RESPONSIBLE PERSON
a. REPORT <b>unclassified</b>	b. ABSTRACT <b>unclassified</b>	c. THIS PAGE <b>unclassified</b>			

self-propagating combustion wave front can be controlled, which will improve the performance of nanoenergetic composite.

The extent of energy release also depends on the oxidizer material used in the energetic composite. For example, in the energetic reactions of the composites containing  $\text{Fe}_2\text{O}_3$ ,  $\text{WO}_3$ ,  $\text{MoO}_3$ ,  $\text{Bi}_2\text{O}_3$ , and  $\text{CuO}$ , combined with Al, the theoretical energy release greatly varies (Fisher and Grubelich, 1998). Ideally, when these oxidizers react with fuel, energy release should correspond to the theoretical energy. However, in reality, the size of oxidizer and fuel components and their structural arrangement provide resistance to mass and heat transfer processes, which primarily govern the combustion characteristics of the MIC materials.

Superior combustion wave speeds can be achieved if fuel and oxidizers are placed in the closest possible proximity. Nanostructural arrangement is possible using self-assembly approach where fuel and oxidizer can be placed next to each other using a molecular linker. Self assembly is achieved via electrostatic interaction mechanism (Kim and Zachariah, 2004), charge transfer processes (Shimazaki et al., 1997), and polymers binding methods (Malynych et al., 2002). If polymer monolayer is used to bind fuel and oxidizer nanoparticles, the combustion characteristics should improve the performance of the energetic composite. At higher concentration range similar to that of typical binders, however, polymers will act as heat sink and reduce the hot-spot density of a self-propagating combustion wave front. Therefore, self-assembled arrangement of fuel and oxidizer will play significant role in achieving the desired combustion characteristics of MIC materials.

In this paper, oxidizer nanorods and nanowires were prepared using surfactant templating approach and later, they were combined with Al-nanoparticles using ultrasonic mixing and self-assembly process to prepare MIC materials. Mesoporous ordered  $\text{Fe}_2\text{O}_3$  gel was synthesized and combined with Al-nanoparticles. In addition, the composites of several oxidizers mixed with Al-nanoparticles were also prepared and evaluated. We show that tunable combustion wave speed and pressure wave velocity can be achieved by varying the nanostructural arrangements and addition of chemicals in nanoscale.

## 2. EXPERIMENTAL

### 2.1 Materials

Nanoparticles of  $\text{CuO}$  (8-10 nm) (Alfa Aesar, MA),  $\text{WO}_3$  (Aldrich, WI),  $\text{MoO}_3$  and  $\text{Bi}_2\text{O}_3$  (Accumet Materials, NY) and nanoparticles of Al (avg. size 80 nm with 2 nm passivation layer from Nanotechnologies, Inc. TX) were

obtained and used to prepare energetic composites. The precursor,  $\text{CuCl}_2$  for nanorod and nanowire synthesis was obtained from Fisher Scientific and used without purification. Poly(4-vinyl pyridine) (P4VP) for self-assembly, polyethylene glycol octadecyl ether (Brij76), and propylene oxide were obtained from Sigma Aldrich, WI.

### 2.2 Composite of oxidizer and fuel nanoparticles using ultrasonic mixing

Accurately weighed 0.2 g of  $\text{CuO}/\text{WO}_3/\text{MoO}_3/\text{Bi}_2\text{O}_3$  and Al-particles were mixed together at an equivalence ratio of 1.6 and placed in 2-propanol in a sealed bottle. The mixture was sonicated in an ultrasonic bath (Fisher 8835) for 6-8 hrs. The slurry was dried at  $95^\circ\text{C}$  for 15 min to obtain powder.

### 2.3 Synthesis of $\text{CuO}$ nanorods/nanowires

In the method,  $\text{CuCl}_2 \cdot 2\text{H}_2\text{O}$ , NaOH and PEG-400 were mixed in a weight ratio of 1:0.6:1.2 and ground together with a pestle and mortar. Mixing and grinding were continued for 30 min, which resulted in black colored slurry. This was sonicated in 500 ml of de-ionized water for 3 hrs and then centrifuged at 4000 rpm for 10 min to obtain a precipitate of  $\text{CuO}$  (Wang et al., 2003). The precipitate was dried at  $100^\circ\text{C}$ , pulverized and calcined at  $450^\circ\text{C}$  for 4 hrs.

To synthesize  $\text{CuO}$  nanowires, about 1 g of  $\text{CuCl}_2 \cdot 2\text{H}_2\text{O}$  was dissolved into 8 ml of PEG-400 (polyethylene glycol) in deionized water. Solution of 0.6 g of NaOH in 8 ml of PEG-400 was prepared and mixed with  $\text{CuCl}_2$  solution. The growth of nanowire started with the addition of excess amount of ethanol into the final solution. The precipitate was then washed thoroughly with ethanol and calcined at  $400^\circ\text{C}$  for 6 hrs.

### 2.4 Synthesis of mesoporous $\text{Fe}_2\text{O}_3$ gel

Solution of 17% Brij 76 was prepared in ethanol and it was heated to  $60^\circ\text{C}$  and maintained for 15 min under constant stirring. One gram of  $\text{Fe}(\text{NO}_3)_3 \cdot 9\text{H}_2\text{O}$  was dissolved in 5.5 ml of ethanol, which was slowly added to solution of Brij 76 under gentle stirring. The resultant solution mixture was then placed in sonication bath for another 10 minutes. After sonication, 5.2 ml of the propylene oxide was added to this solution under gentle stirring. The gel time was around 1-2 minutes (Mehendale et al., 2006).

### 2.5 Self-assembled composite

In the first step, 0.5 g of  $\text{CuO}$  nanorods were sonicated for 4 hrs in 500 ml of 2-propanol containing 0.1% (w/v) P4VP polymer. After sonication, the solution

was centrifuged at 4000 rpm for 10 min to separate nanorods from the solution. These P4VP coated nanorods were washed with 2-propanol to remove excess polymer and the solution was centrifuged to recover the nanorods. Finally, the polymer coated CuO nanorods were dried at 120°C for 1.5 hrs to remove the solvent and to establish a bonding with the oxidizer surface. In the second step, 0.4 g of P4VP coated nanorods were mixed with 0.17 g of Al-nanoparticles in 1.5 ml of 2-propanol and the mixture was dispersed for several hrs in a sonic bath. Finally, the particles were separated by repetitive centrifugation, washing and dried at 95°C for 10 min.

## 2.6 Combustion wave velocity measurement

The combustion wave speed of the composites were measured using on-chip diagnostic technique (Bhattacharya et. al., 2006; Apperson et al., 2006) and by the optical method (Plantier et al., 2005). The on-chip method is based on time-varying resistance (TVR) of sputter-coated thin platinum film, in which the resistance of the film changes as energetic reaction propagates over it. By knowing the voltage differential over a time period and the length of a TVR film, the combustion speed was determined. For the optical method, a Lexane tube of 0.8 cm<sup>3</sup> volume was filled up with the 200 mg of nanoenergetics powder and inserted into an aluminum block. This block was mounted with the holders for the optical fibers. Tektronix TDS460A 4-channel digital oscilloscope was fitted to a set of spatially spaced ThorLabs photodiodes and optical fibers. The energetic reaction was triggered with a spark igniter at one end of the tube and the oscilloscope recorded an output voltage signal in time for the sequentially placed photo detectors. The combustion wave speed of energetic material was then calculated on the basis of the differential between signal rise times of the individual photo detector.

## 3. RESULTS AND DISCUSSION

Nanorods of CuO were synthesized by reacting CuCl<sub>2</sub> with NaOH in the presence of PEG micelles. This reaction is moderately exothermic, produces Cu(OH)<sub>2</sub>, which on heating dehydrates into CuO. Adsorption of PEG on the surface of colloids in a solution reduces the rate of growth of the colloid limited by the adsorbed surfaces. When the entire surface adsorbs the surfactant, the growth of colloid into macrostructure is restricted and more controlled and directed growth in a specific crystallographic orientation occurs. TEM image of calcined CuO is shown in Fig. 1, which shows rodlike geometry.

The combustion wave speed as a function of equivalence ratio ( $\Phi = (F/O)_{\text{actual}} / (F/O)_{\text{stoichiometry}}$ , where F is fuel and O is oxidizer) is shown in Fig.2. The optimum

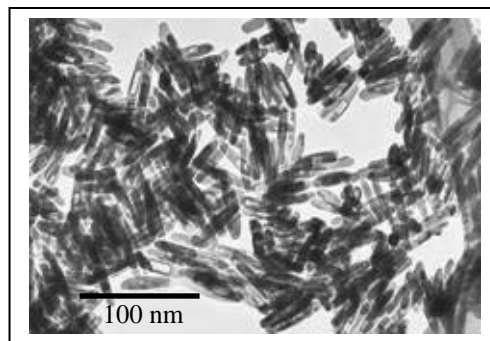

Fig.1 CuO nanorods prepared using PEG- micelles.

speed corresponds to a slightly fuel-rich composite with  $\Phi$  ranging from 1.2 to 1.8. At  $\Phi=1.4$ , the combustion wave speed is 1300 m/s, which increases to about 1650 m/s at  $\Phi=1.6$  and decreases to 900 m/s at  $\Phi=1.8$ . Thus, equivalence ratio of 1.6 is considered optimum for a composite of CuO nanorods and Al-nanoparticles. Overall, the combustion flame velocity is found to be a strong function of the equivalence ratio.

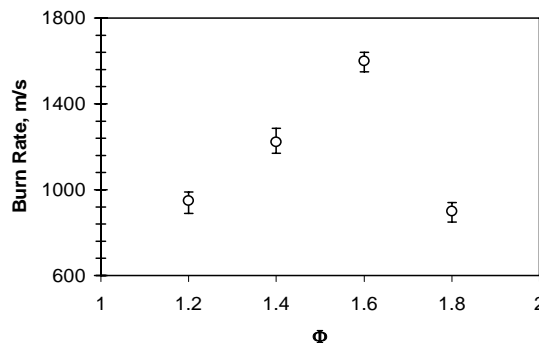

Fig.2 Combustion wave velocity as a function of equivalence ratio for CuO nanorods mixed with Al (80 nm) particles.

Lower molecular weight non-ionized PEG surfactant was chosen to prepare copper oxide nanowires as it forms chain like structure when self-assembled in water due to its flexible structure. Copper oxide nanowires with average length of 100~1000 nm (Fig. 3) were synthesized using wet chemistry approach, elaborated earlier in the experimental section. These nanowires were mixed with Al-nanoparticles at the equivalence ratio of 1.6, which produced combustion wave speed of 1900 m/s, about 20% higher than the speed of the MIC composite containing CuO nanorods and Al-nanoparticles. Enhancement in the combustion wave front speed is due to the increase in the surface area in the case of nanowire morphology as compared with the nanorod.

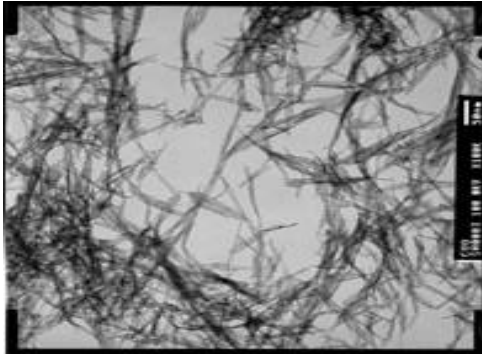

Fig. 3 TEM image of CuO nanowires prepared using PEG surfactant.

The combustion wave speeds of various nanoenergetic composites are shown in Figure 4. We observed a burn rate of 550-780 m/s for a conventional mixture of CuO (Alfa Aeser) and Al nanoparticles (Composite 6) which increased to an average value of 1650 m/s for a mixture of CuO nanorods/Al-nanoparticles (Composite 7). The combustion wave speed can be further increased if fuel and oxidizer are placed in the closest possible proximity. The self-assembly process was employed where Al-nanoparticles were assembled on CuO nanorods using poly(4-vinyl pyridine) (P4VP) polymer (Gangopadhyay et al., 2005). The mechanism of self assembly is attributed to the nitrogen of pyridyl group in the polymer, which has a lone pair of electrons available for donation to form a covalent bond with metals and interact also with metal oxides. The combustion wave speed recorded of the self-assembled composite showed the best value of about  $2300 \pm 100$  m/s, which is significantly higher than the physical mixtures. Such supersonic self-propagating combustion waves generate shock waves with Mach Number higher than 2. Thus, by creating nanostructured organization of fuel and oxidizer, combustion characteristics can be easily improved.

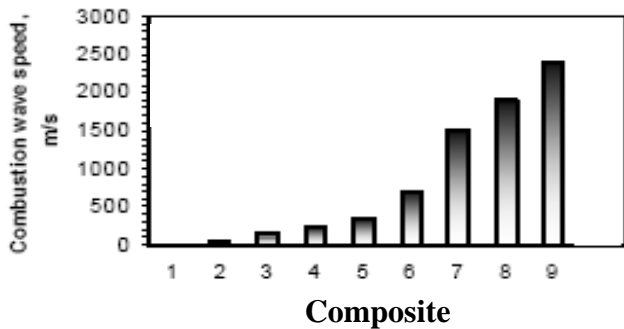

Fig. 4 Tunable combustion wave speeds of nanoenergetic materials (1) porous  $\text{Fe}_2\text{O}_3$ , (2)  $\text{WO}_3$ , (3)  $\text{MoO}_3$ , (4)  $\text{Bi}_2\text{O}_3$ , (5) ordered mesoporous  $\text{Fe}_2\text{O}_3$ , (6) CuO nanoparticles, (7)

CuO nanorod, (8) CuO nanowires, and (9) self-assembled; all mixed with Al-nanoparticles (80 nm)

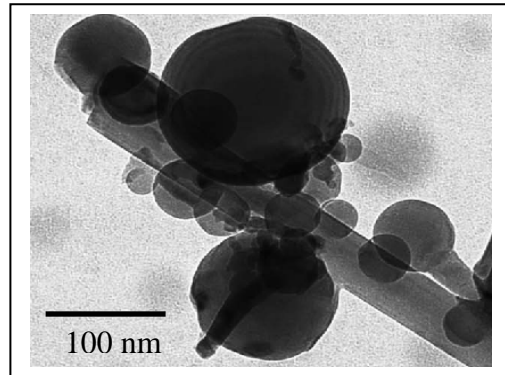

Fig. 5 TEM image of self-assembled Al-nanoparticles around CuO nanorods.

Other than CuO, we also synthesized mesoporous  $\text{Fe}_2\text{O}_3$  following sol-gel route where iron nitrate was hydrolyzed and the sol was polymerized in presence of Brij-76 surfactant (Mehendale, 2006). The mesoporous  $\text{Fe}_2\text{O}_3$  prepared with the use of surfactant templating produced ordered porous structure, which is shown in Fig. 6. In the absence of surfactant templating no ordering of the pores was observed. These mesoporous oxidizers were combined with Al-nanoparticles to prepare energetic composites. The combustion velocities are shown earlier in Fig. 4, which indicate that the combustion speed is higher for the composite prepared with ordering of mesopores (Composite 5), believed to happen due to uniform hot spot density distribution in the self-propagating combustion wavefront.

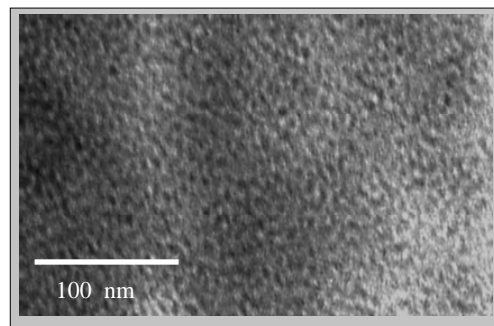

Fig.6 Mesoporous  $\text{Fe}_2\text{O}_3$  gel was prepared using Brij-76 surfactant templating.

If polymers are combined with nanostructured oxidizers, MIC materials can be further modified to tune their pressure characteristics as well. Additionally, polymers also reduce the electrostatic discharge ignition sensitivity of MIC materials.

## CONCLUSION

Higher combustion wave velocity of CuO nanowire based MIC composite can be attributed to higher surface area creating higher hot spot density as compared with the nanorods. Further improvement in the performance is achieved by linking fuel and oxidizer components via self-assembly approach. Tunable combustion wave speeds are obtained by selecting various oxidizer materials mixed (or, self-assembled) with different sizes of nanoaluminum and by changing the equivalence ratio. Among the oxidizers, the composite of Fe<sub>2</sub>O<sub>3</sub> yields lowest combustion wave speed whereas, CuO shows highest speeds. In general, the composites of CuO are found to be superior to the composites of WO<sub>3</sub>, MoO<sub>3</sub> and Bi<sub>2</sub>O<sub>3</sub> nanoparticles. Overall, composites prepared by combining nanostructured oxidizers with Al-nanoparticles are shown to have improved combustion characteristics as compared to random mixing of oxidizers and fuel nanoparticles.

## ACKNOWLEDGEMENTS

Authors gratefully acknowledge the financial support by the US Army, ARDEC, Picatinny, NJ and the National Science Foundation.

## REFERENCES

- Apperson, S., Bhattacharya, S., Gao, Y., Subramanian, S., Hasan, S., Hossain, M., Shende, R.V., Redner, P., Kapoor, Niccolich, S., Gangopadhyay, K., Gangopadhyay, S., 2006: On-Chip Initiation and Burn Rate Measurement of Thermite Energetic Reactions, *Proc. Mater. Res. Soc. Symp.* 0896-H03-02.
- Bhattacharya, S., Saha, S. K., Chakravorty, D. 2000: Nanowire Formation in a Polymer Film, *Appl. Phys. Lett.* **76**, 3896-3898.
- Bhattacharya, S., Gao, Y., Apperson, S., Subramanian, S., Talantsev, E., Shende, R.V., and Gangopadhyay, S., 2006: A Novel On-Chip Diagnostic Method to Measure Burn Rates of Energetic Materials, *J. Ener. Mater.* **24**, 1-15.
- Fisher, S.H. and Grubelich, M.C., 1998: Theoretical Energy Release of Thermites, Intermetallics, and Combustible Metals, *Proc. 24<sup>th</sup> International Seminar*, Monterey, CA.
- Gangopadhyay, S.; Shende, R., Subramanian, S.; Hasan, S.; Gangopadhyay, K. Synthesis of Nanoenergetic Materials, US Patent, Oct. 2005 (applied).
- Jean-Pierre, Metal Oxide Chemistry Synthesis, From Solution to Solid State, Wiley, 2000.
- Kim, S.H. and Zachariah, M.R., 2004: Enhancing the Rate of Energy Release from NanoEnergetic Materials by Electrostatically Enhanced Assembly, *Adv. Mater.*, **16**, 1821-1825.
- Malynych, S.; Luzinov, I.; Chumanov, G. 2002: Poly(Vinyl Pyridine) as a Universal Surface Modifier for Immobilization of Nanoparticles, *J. Phys. Chem. B* **106**, 1280-1285.
- Martin, C. R., 1994: Nanomaterials: A Membrane-Based Synthetic Approach, *Science* **266**, 1961-1966.
- Mehendale, B., Shende, R.V., Subramanian, S., Gangopadhyay, S. 2006: Nanoenergetic Composite of Mesoporous Iron Oxide and Al-nanoparticles, *J. Ener. Mater.* (in press).
- Morales, A.M., Lieber, C.M., 1998: A Laser Ablation Method for the Synthesis of Crystalline Semiconductor Nanowires, *Science*, **279**, 208-211.
- Prakash, A.; McCormick, A.V.; Zachariah, M.R. 2004: Aero-Sol-Gel Synthesis of Nanoporous Iron-Oxide Particles: A Potential Oxidizer for Nanoenergetic Materials, *Chem. Mater.* **16**, 1466-1471.
- Plantier, K.B.; Pantoya, M.L.; Gash A.E. 2005: Combustion Wave Speeds of Nanocomposite Al/Fe<sub>2</sub>O<sub>3</sub>: The Effects of Fe<sub>2</sub>O<sub>3</sub> Particle Synthesis Technique, *Combust. Flame*, **140**, 299-309.
- Shimazaki Y., Mitsuishi M., Ito S.; Yamamoto M. **1997**: Preparation of the Layer-by-Layer Deposited Ultrathin Film Based on the Charge-Transfer Interaction, *Langmuir* **13**, 1385-1387.
- Subramanian, S., Hasan, S., Bhattacharya, S., Gao, Y., Apperson, S., Hossain, M., Shende, R.V., Gangopadhyay, S., Redner, P., Kapoor, D., and Niccolich, S., 2005: Self-Assembled Nanoenergetic Composite, *Proc. Mater. Res. Soc. Symp.* 0896-H01-05.1.
- Wang, W.; Liu, Z; Liu, Y.; Xu. C.; Zheng, C.; Wang, G. 2003: A simple wet-chemical synthesis and characterization of CuO nanorods, *Appl. Phys. A-Mater. Sci. Proc.* **76**, 417-420.
- Wang, W.Z., Wang, G.H., Wang, Y.J., Zhan, Y.J., Liu, Y.K., Zheng, C.L., 2002: Synthesis and Characterization of Cu<sub>2</sub>O Nanowires by a Novel Reduction Route, *Adv. Mater.* **14**, 67-69.
- Wang L.; Cui S.; Wang Z.; Zhang X. 2000: Multilayer Assemblies of Copolymer PSOH and PVP on the Basis of Hydrogen Bonding, *Langmuir* **16**, 10490-10494.
- Yang, L., Ying, C., Meiye, L., Lili, L., Lihong, D., 2006: *In situ* synthesis and assembly of copper oxide nanocrystals on copper foil via a mild hydrothermal process, *J. Mater. Chem.* **16**, 192-198.
- Zhou Zhou, Y.; Yu, S.H.; Cui, X.P.; Wang, C.Y.; Chen, Z.Y. 1999: Formation of Silver Nanowires by a Novel Solid-Liquid Phase Arc Discharge Method *Chem. Mater.*, **11**, 545-546.



# NANOSTRUCTURED ENERGETIC MATERIALS

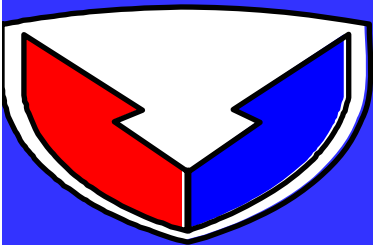

AMC

**Shubhra Gangopadhyay**

LaPierre Chair Professor

Department of Electrical and Computer Engineering  
University of Missouri – Columbia  
Columbia, Missouri 65211-2300 USA

**Tel.** – (573) 882-4070, **Fax** – (573) 882-0397

**Electronic Mail** – gangopadhyays@missouri.edu



**Research Team:** Keshab Gangopadhyay, Rajesh Shende,  
S. Subramanian, S. Hasan, S. Apperson University of Missouri – Columbia

**Collaborators:** P. Redner, D. Kapoor, and S. Nicolich,  
US Army ARDEC Picatinny, NJ 07806

**Supported by Picatinny, ONR and NSF**





# OUTLINE



❖ MOTIVATION

❖ SYNTHESIS OF OXIDIZER NANOSTRUCTURES  
MATERIAL SYSTEMS – CuO, Fe<sub>2</sub>O<sub>3</sub>, MoO<sub>3</sub>

❖ STRUCTURAL CHARACTERIZATION

❖ SELF ASSEMBLY OF OXIDIZER NANORODS AND FUEL NANOPARTICLES  
CONCEPT  
EXPERIMENTAL

❖ PERFORMANCE OF NANOENERGETIC MATERIALS

❖ CONCLUSION

❖ SCOPE FOR FUTURE WORK





# MOTIVATION



## Micron sized Energetic Particles

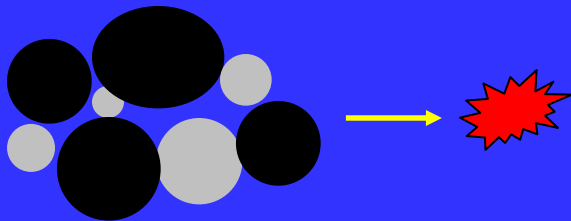

## Nano Energetic Particles

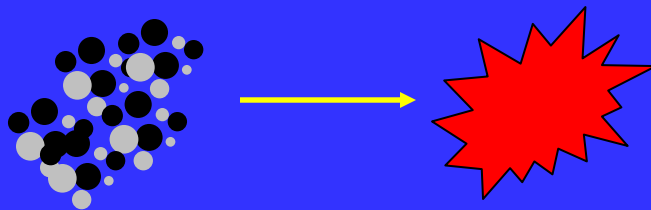

## Ordered Nanoenergetic composite

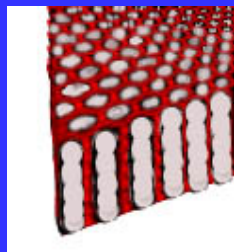

Modified  
sol-gel

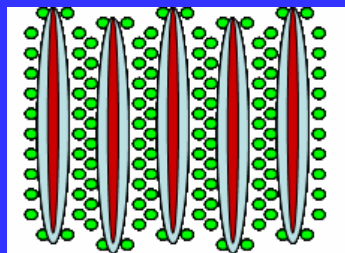

Nanorods self  
assembled with  
fuel

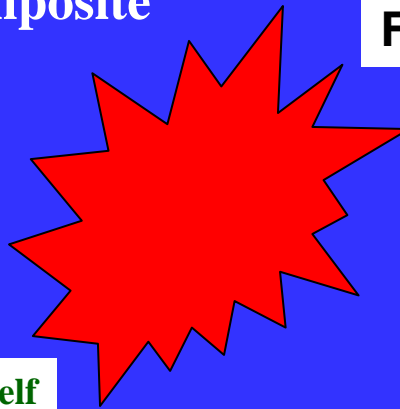

Random &  
inhomogeneous

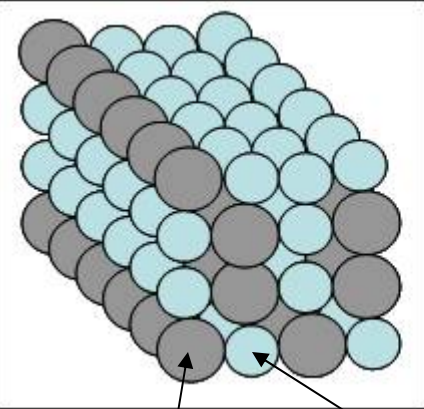

Fuel

Ordered &  
homogeneous

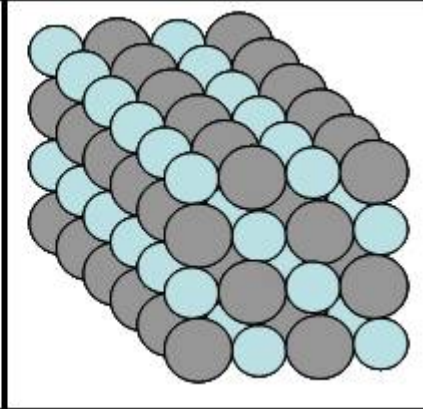

Oxidizer

- \* Reduced mass transport
- \* Higher Energy Release

# Existing technologies

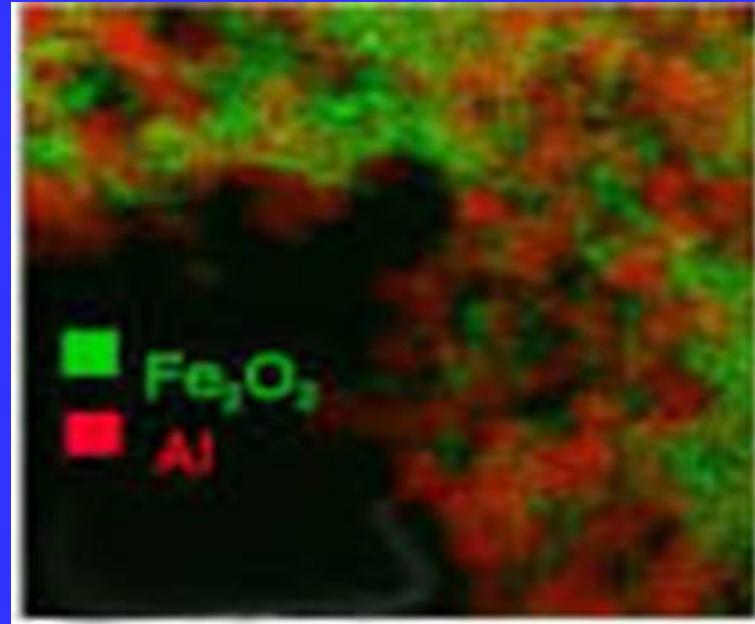
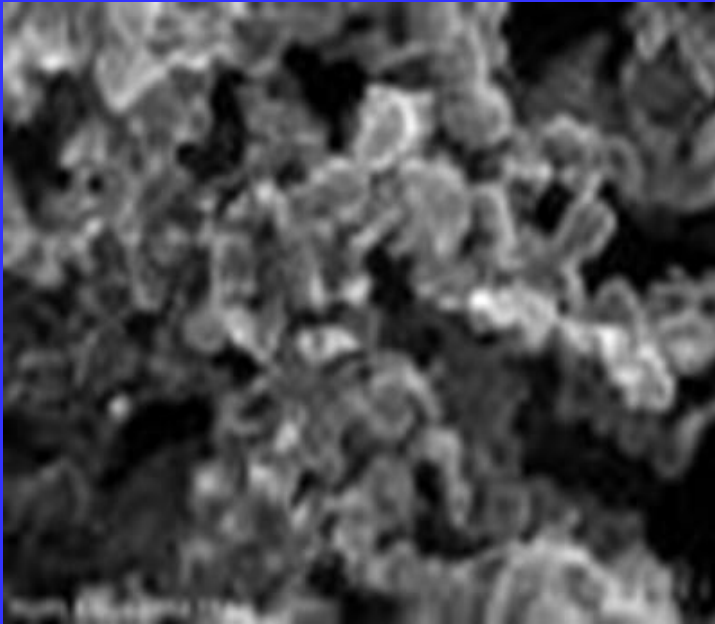

Particles mixing (Image at 60 eV)

Sol-gel with Al nanoparticles  
(AMPTIAC, 6 (1), 43 (2002))



**Problems:** Particles coagulation, non-homogenous distribution  
Therefore, lower interfacial area for the reaction and lower energy release

# Self-assembly of micelles

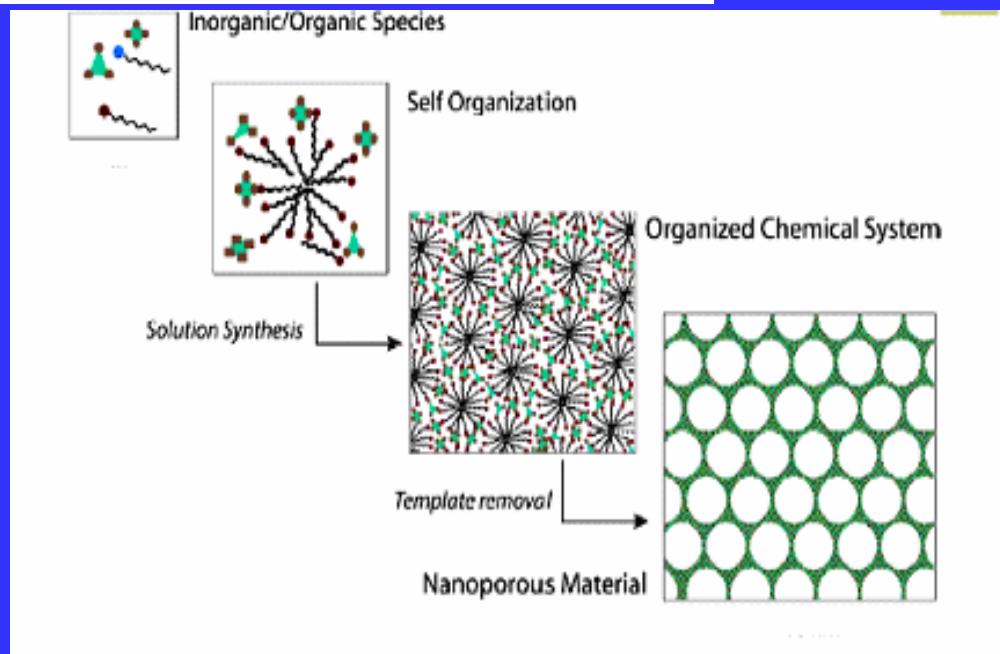
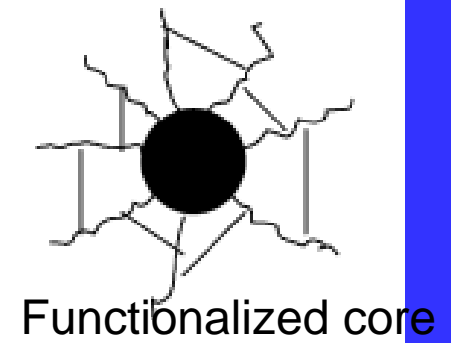
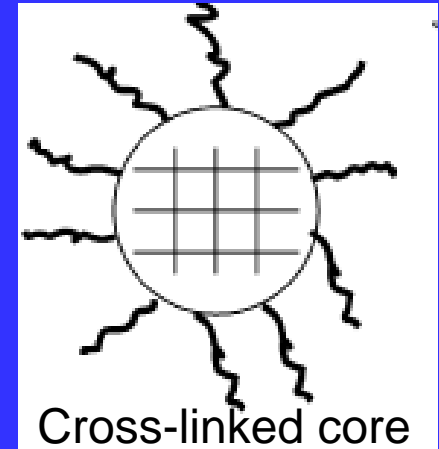
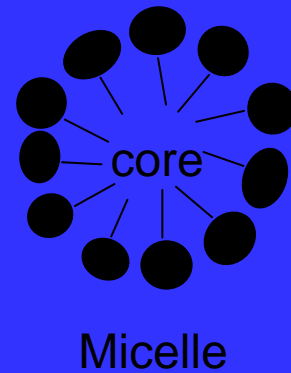
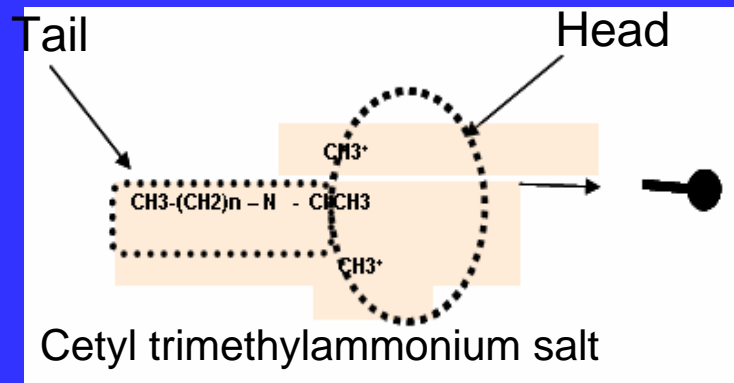



# SYNTHESIS OF CuO NANOSTRUCTURES

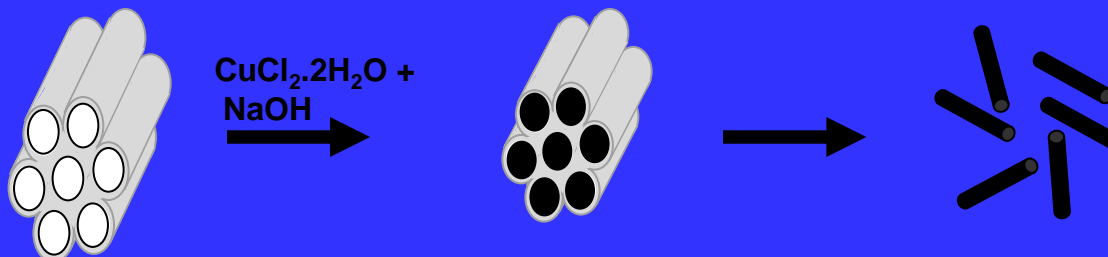

Cylindrical Micelle formation of surfactant in aqueous solution.

Reaction in the presence of PEG

Removal of surfactant by repeated washing in water and ethanol yields free standing nanorods.

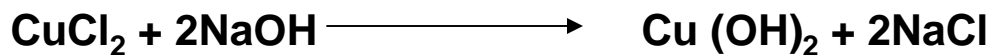
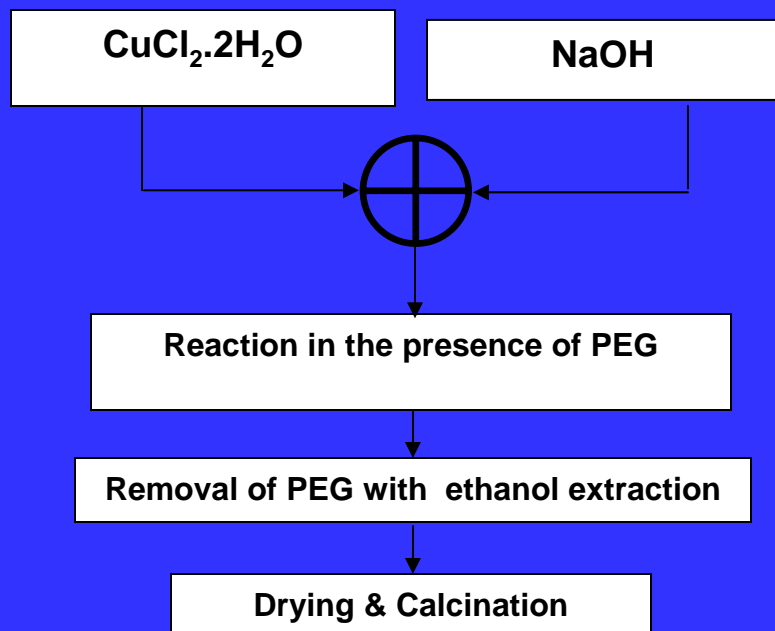

Schematic of the experimental steps

Depending on the molecular weight of PEG used, the aspect ratio of the nanostructures can be tuned and thus leading to formation of nanorods or nanowires. One can also obtain nanowires by slightly changing the mixing procedure.



# TEM IMAGES OF CuO NANOSTRUCTURES

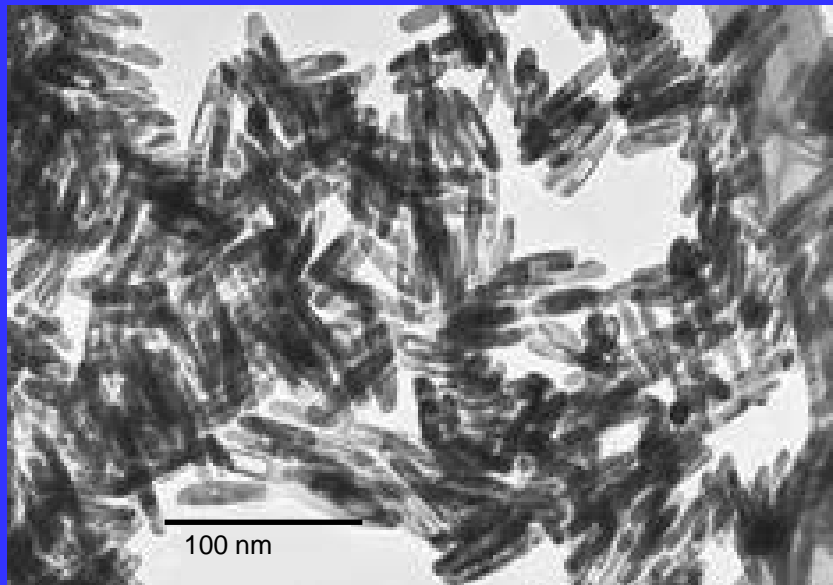

**NANORODS**

Aspect Ratio of Nanorods is about 4.

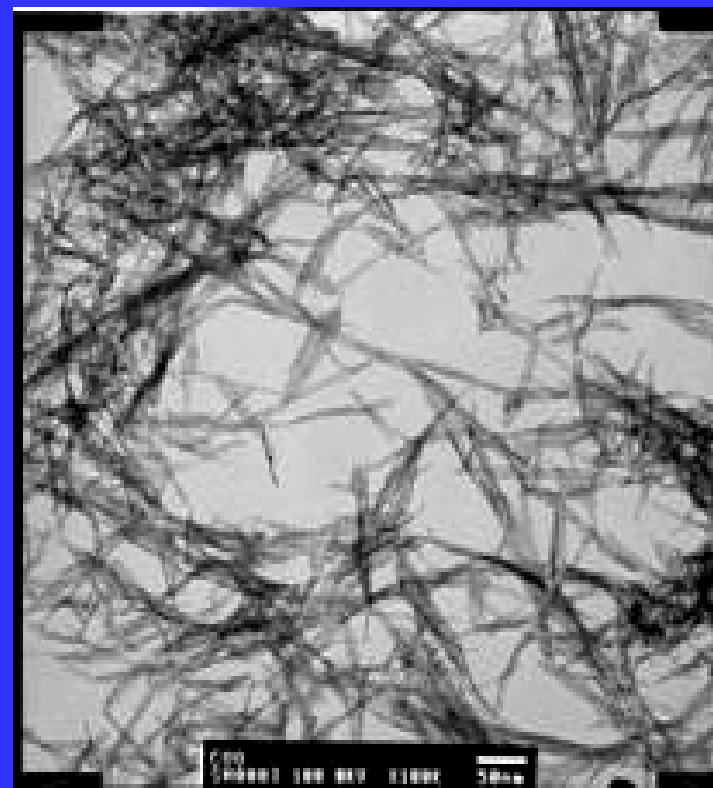

**NANOWIRES**

Mean Aspect Ratio of nanowires is about 50.



# TEM IMAGES OF $\text{Fe}_2\text{O}_3$ and $\text{MoO}_3$ NANORODS

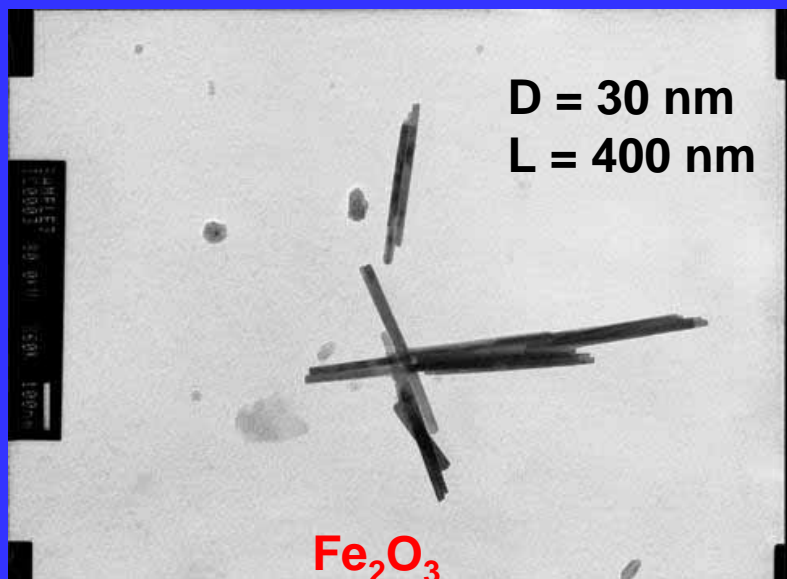

$\text{Fe}_2\text{O}_3$  was prepared by the reaction of ferrous chloride with sodium nitrate, adjusting the pH with HCl and controlling the temperature.

$\text{MoO}_3$  nanorods were prepared using the inorganic condensation method using PEG surfactant

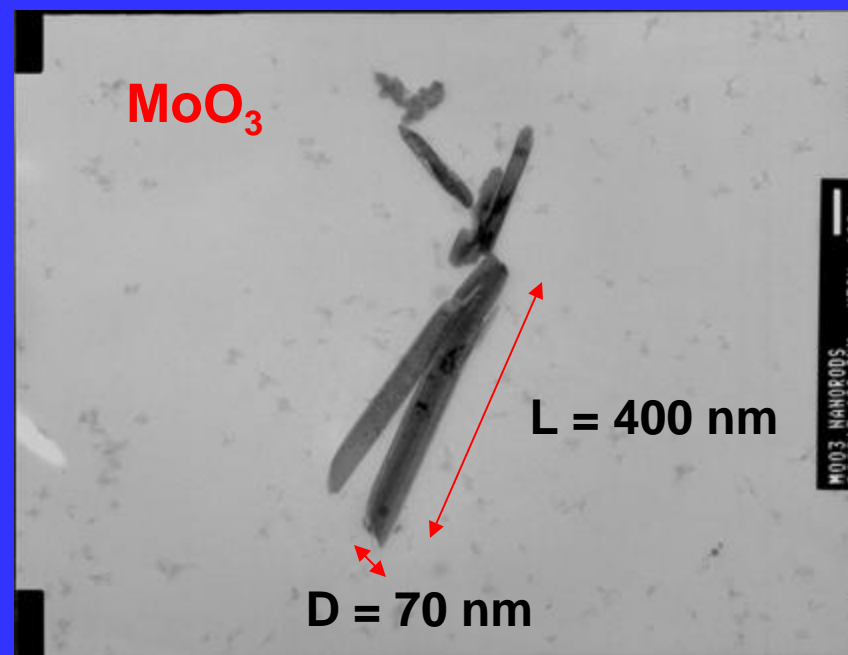



# X-RAY DIFFRACTION

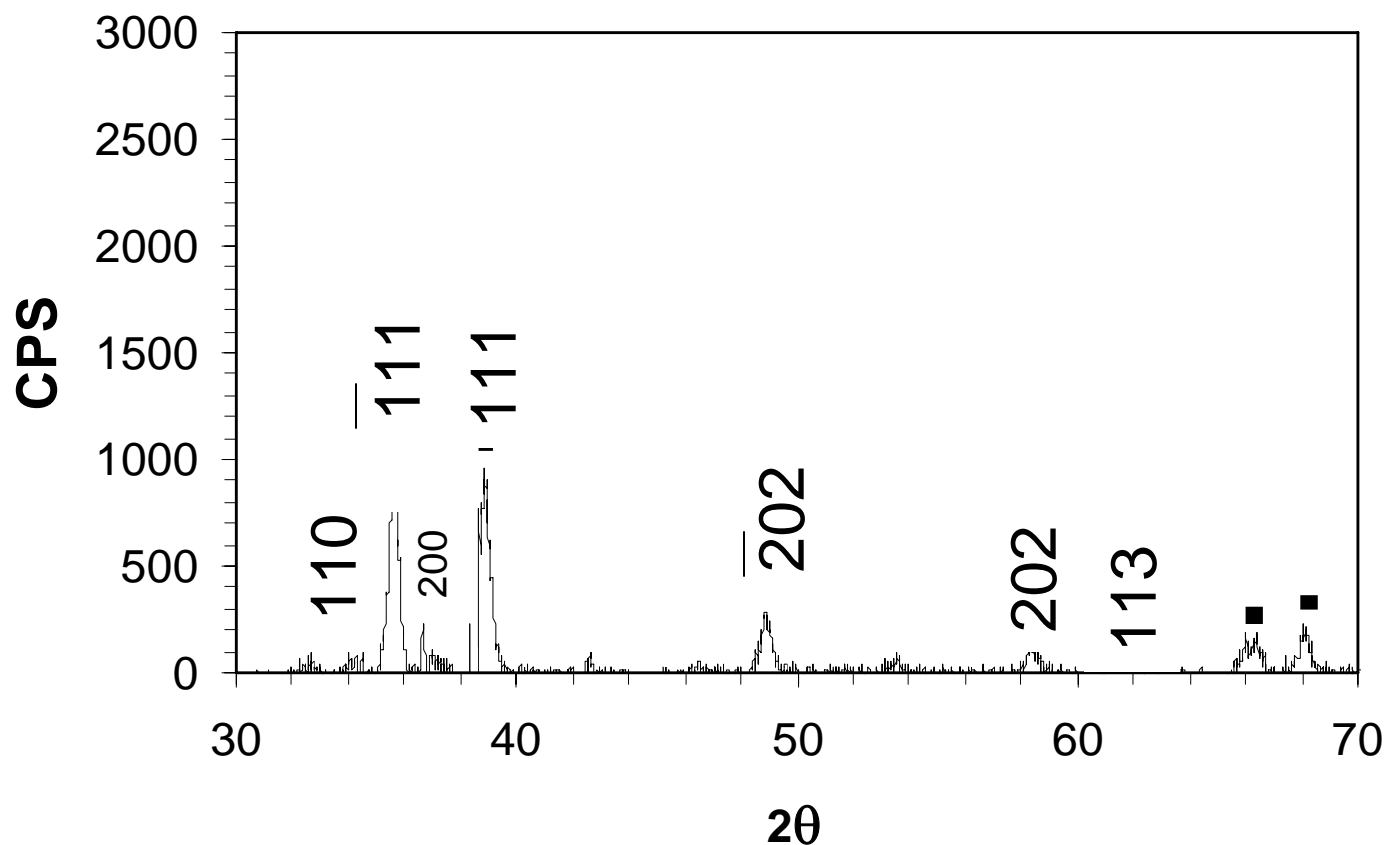

**Comparison of the X-ray diffraction data with that of ICDD confirm the formation of monoclinic phase of CuO. The crystal structure is monoclinic phase with lattice constant of**



# FTIR SPECTRA OF CuO NANOSTRUCTURES

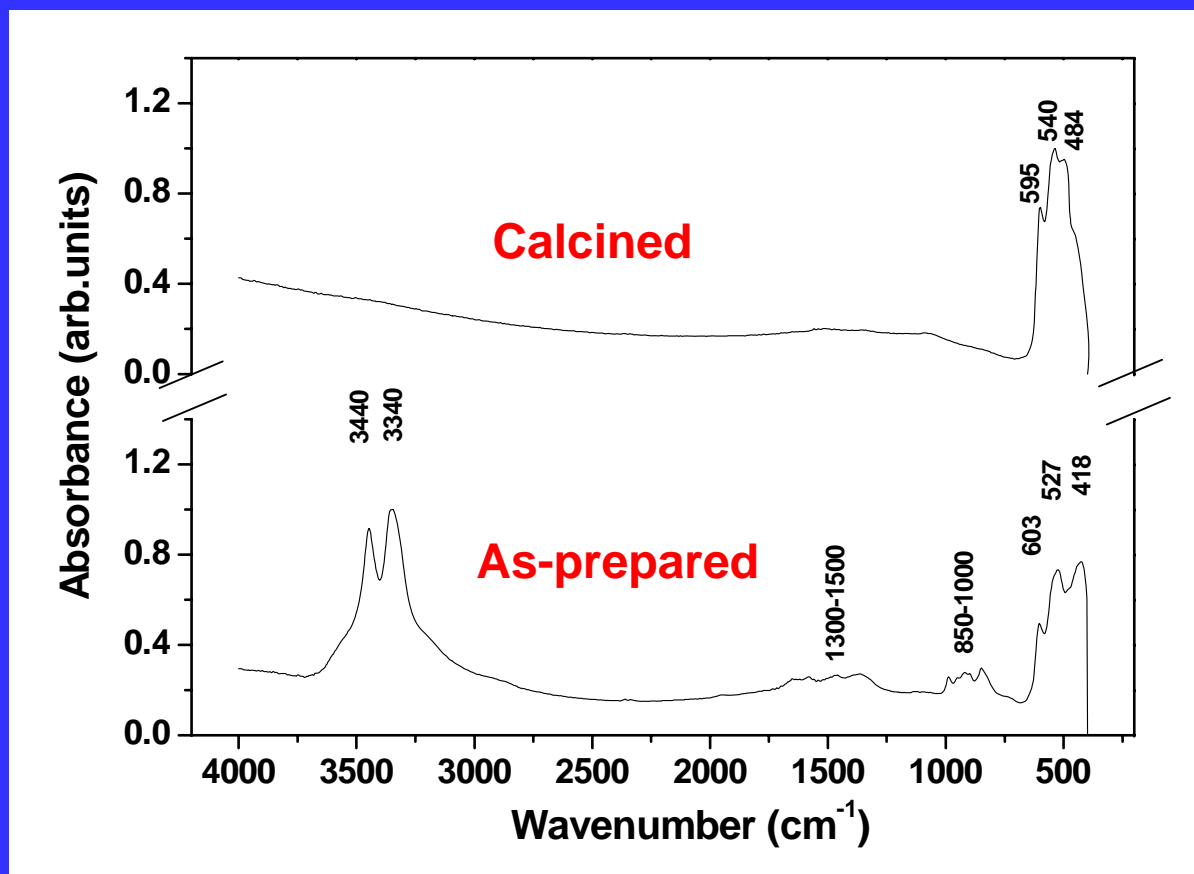

The absorption peaks observed in our samples match closely with the reported one for CuO by G. Kliche and Z.V. Popovic, *Phys. Rev. B* 42 (1990), p. 10060.





# TEM IMAGES OF POROUS OXIDIZERS



Porous iron oxide  
without surfactant

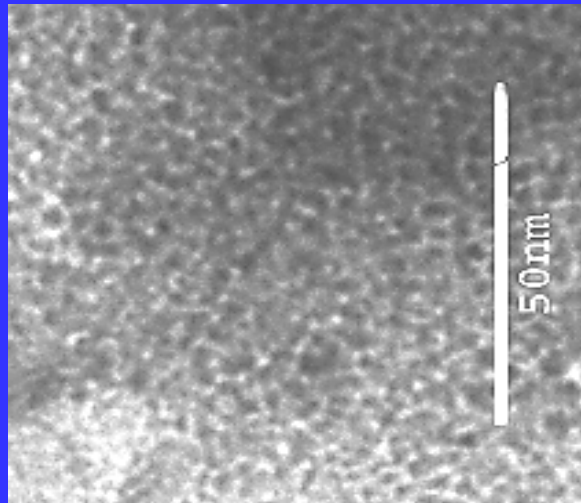

ORDERED MESOPOROUS  
iron oxide with Brij 76  
templating

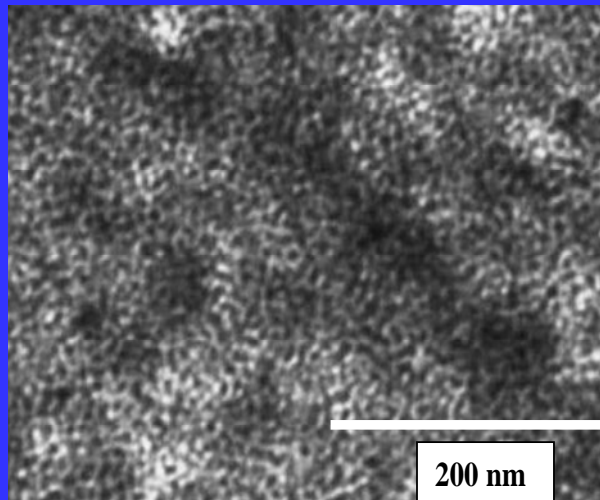

Porous copper oxide  
nanoparticles

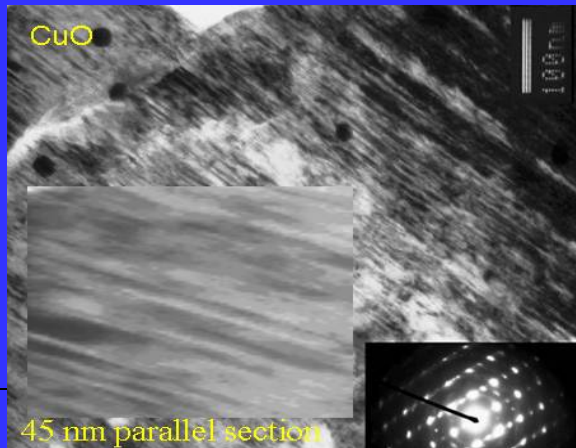
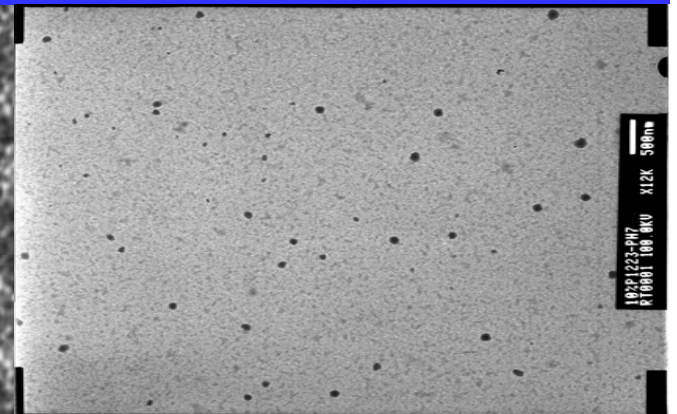

CuO Nanowells  
with P123

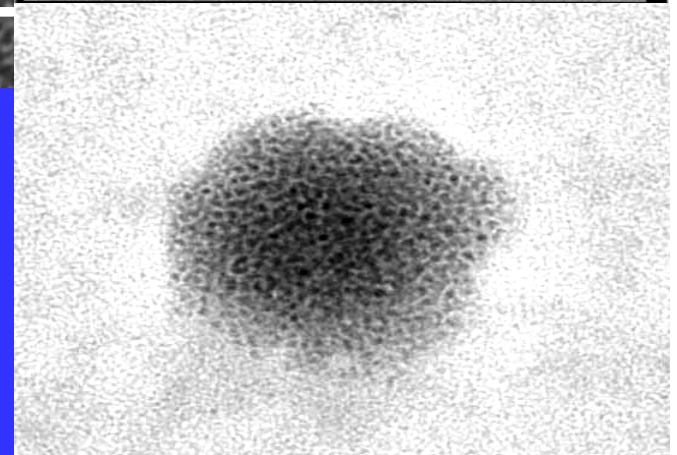

US 45 nm parallel section



# CONCEPT OF SELF ASSEMBLY



The nitrogen group present in PVP has a lone pair of electrons, readily available for forming covalent bonds with oxygen in CuO or with oxygen present in Al<sub>2</sub>O<sub>3</sub> (2 nm passivating layer on Al nanoparticles). Using optimized concentration of PVP leads to monolayer coating either on nanorods or Al nanoparticles. Subsequent mixing of the oxidizer nanorods and fuel nanoparticles facilitate self assembled energetic composite, where the fuel nanoparticles are in close proximity to the oxidizer nanostructures.

PVP

“py” group bonded to CuO and Al

schematic of the self-assembled structure showing “py” groups bonded to Cu and Al through oxygen,

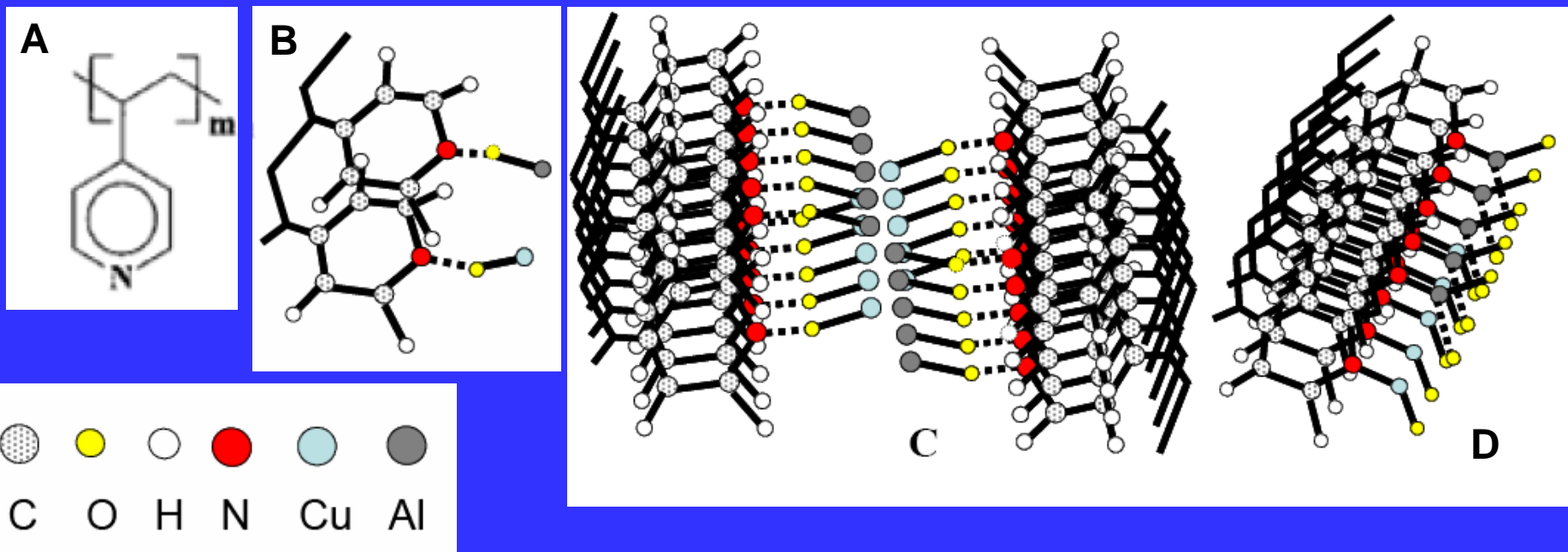



# EXPERIMENTAL APPROACH



## Scheme1

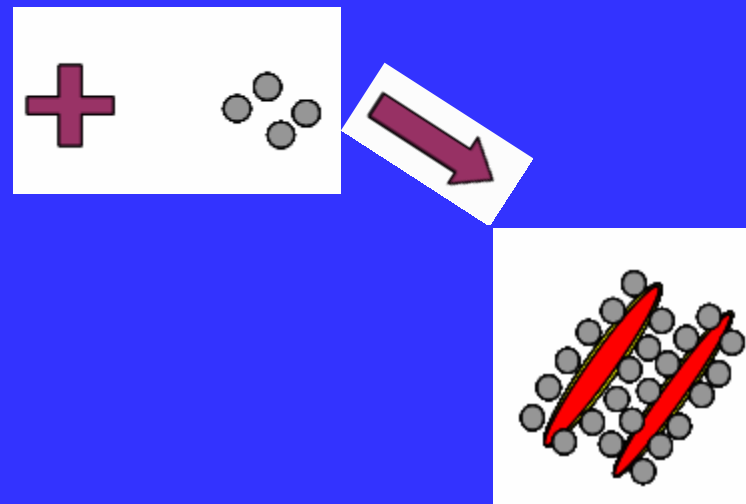
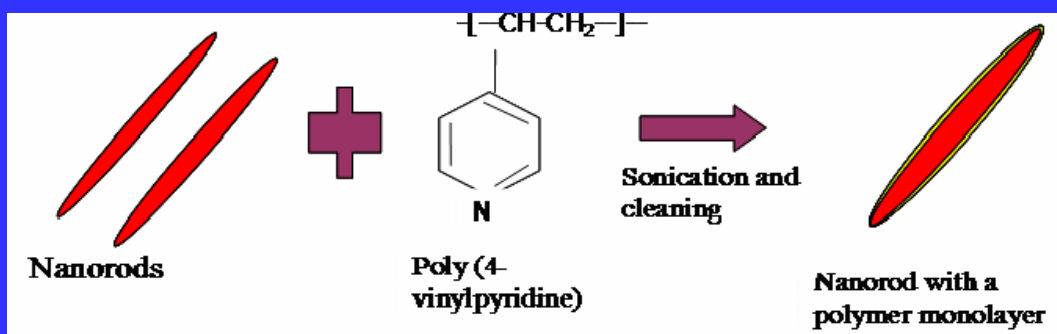

## Scheme2

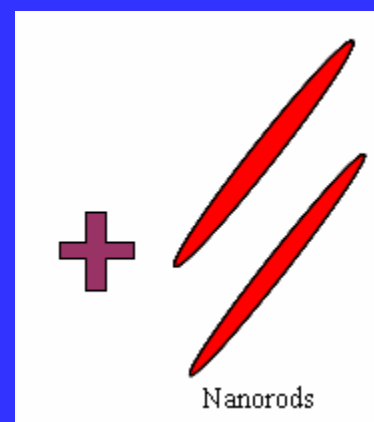
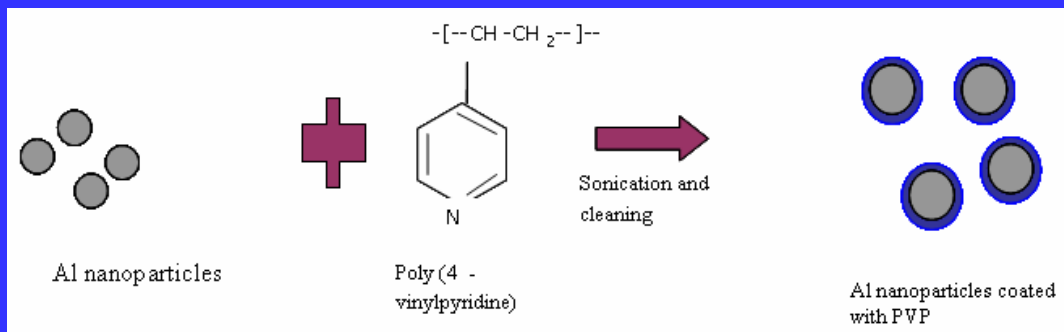



# TEM IMAGES OF SELF ASSEMBLED ENERGETIC COMPOSITE

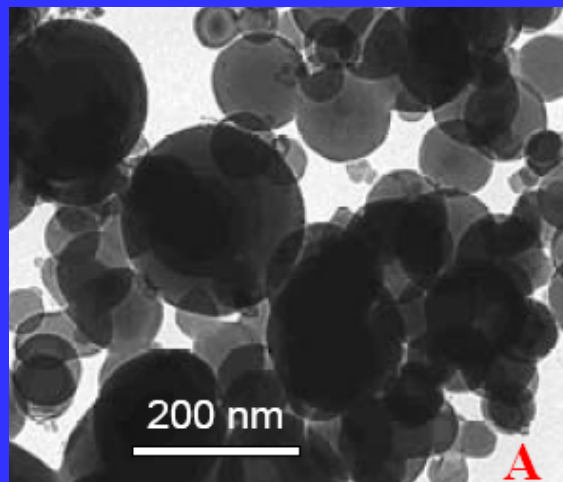

**(A) Al nanoparticles**

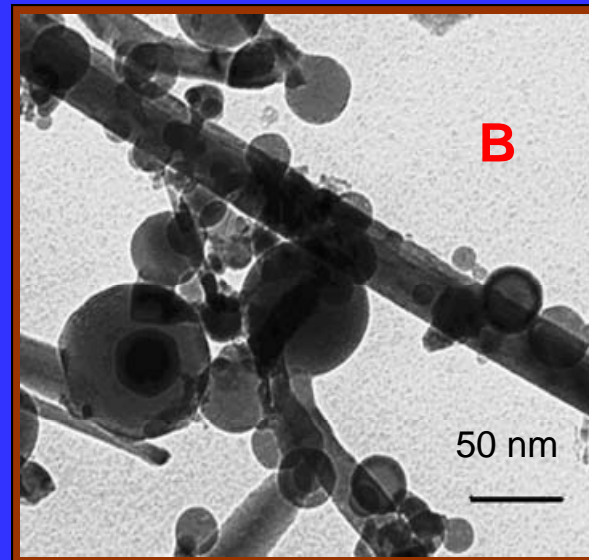

**(B) Al nanoparticles self-assembled with CuO nanorods**

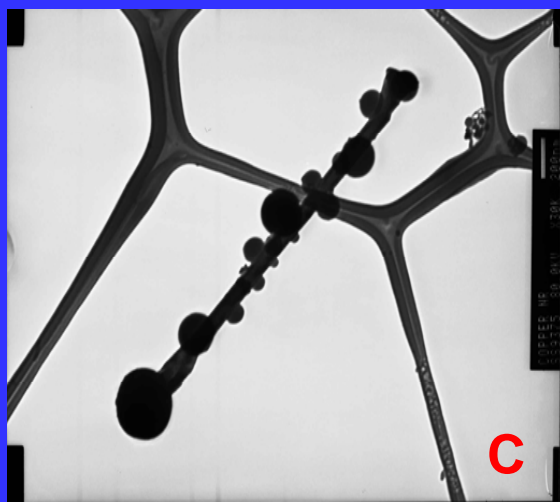

**(C) Al nanoparticles self-assembled with Fe<sub>2</sub>O<sub>3</sub> nanorods**





# EXPERIMENTAL SET-UP FOR BURN RATE AND PRESSURE MEASUREMENTS

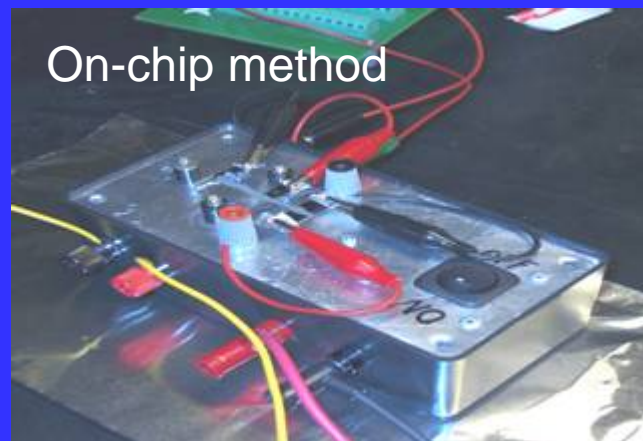
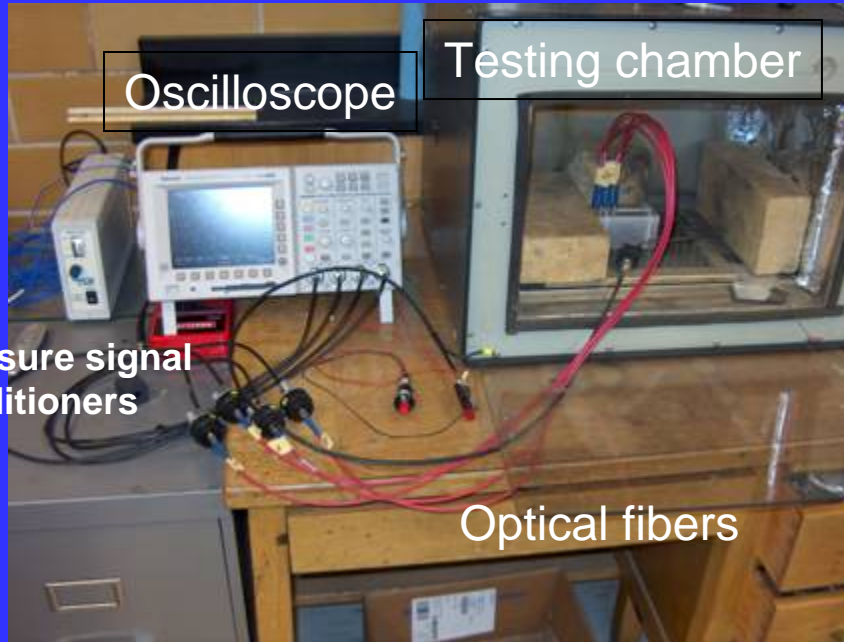



# BURN RATE AS A FUNCTION OF EQUIVALENCE RATIO

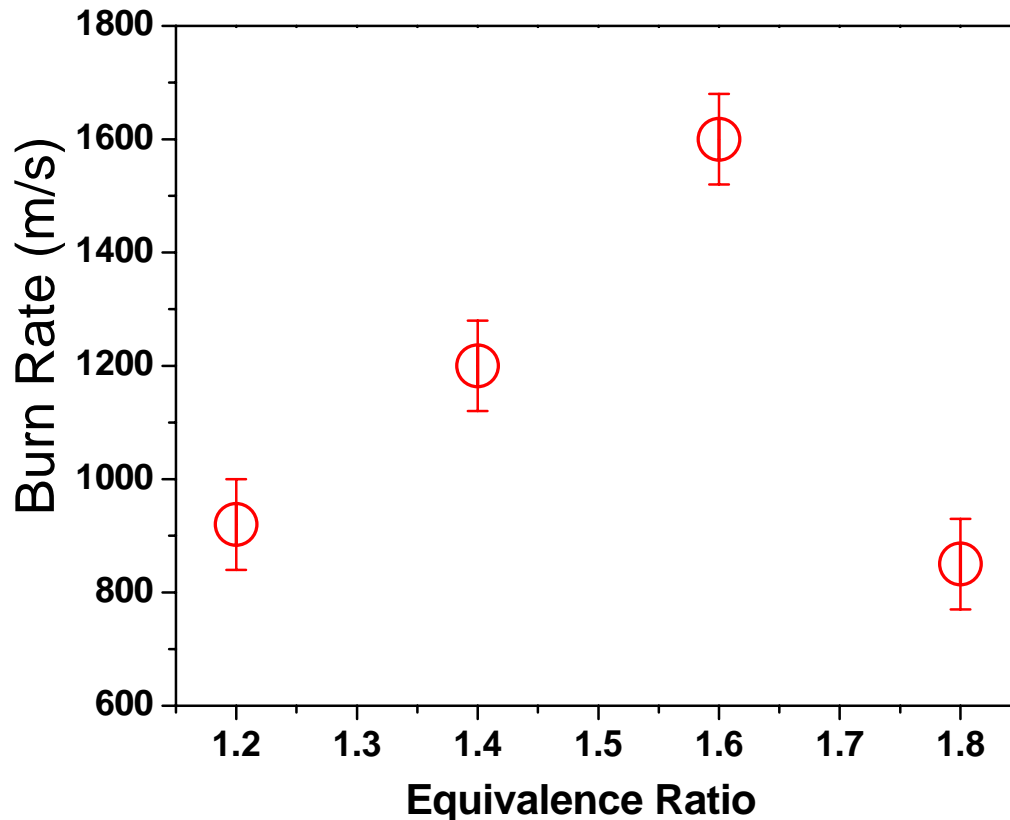

$$\Phi = \frac{(F/O)_{\text{actual}}}{(F/O)_{\text{stoichiometric}}}$$

Our results indicate that burn rate is strongly dependent on equivalence ratio and it is optimum at a ratio of 1.6 for CuO-Al system.



# TUNABLE BURN RATES

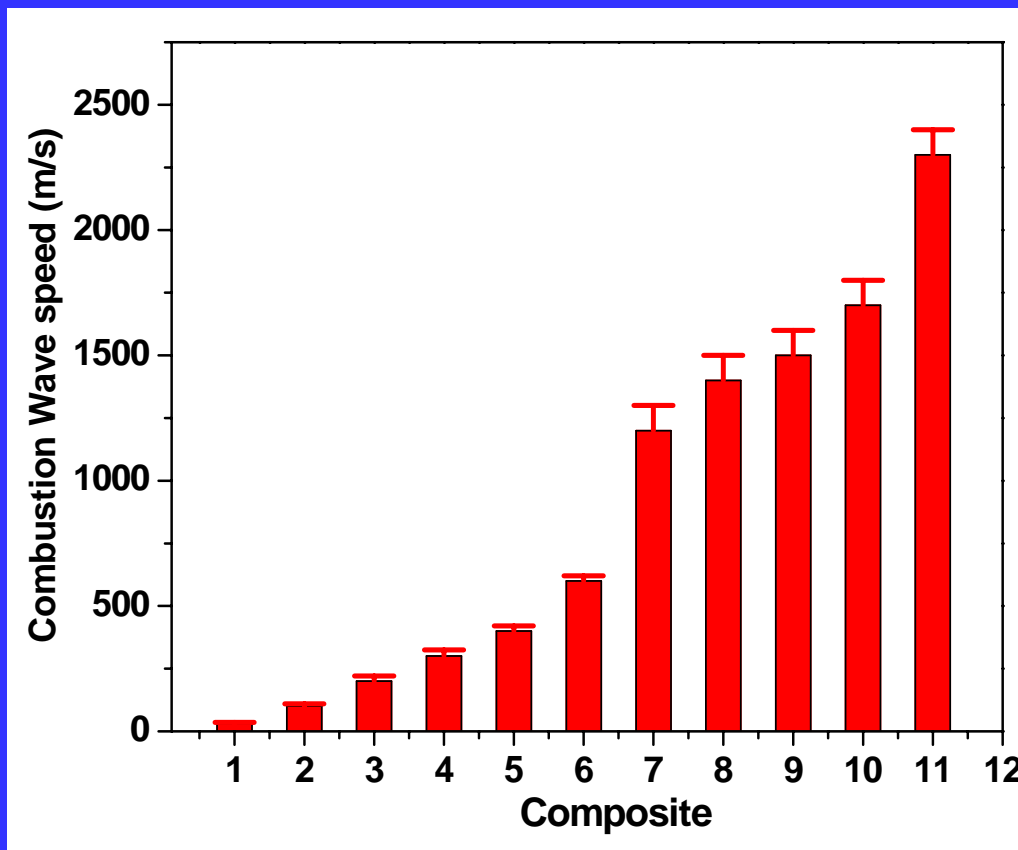

1) Porous  $\text{Fe}_2\text{O}_3$ , (2)  $\text{WO}_3$ , (3)  $\text{MoO}_3$ , (4)  $\text{Bi}_2\text{O}_3$ , (5) ordered mesoporous  $\text{Fe}_2\text{O}_3$ , (6) CuO nanoparticles, (7)  $\text{MoO}_3$  nanorods (8) Mesoporous CuO nanoparticles (9) CuO nanorods, (10) CuO nanowires, and (11) self-assembled CuO system; all mixed with Al-nanoparticles (80 nm)

# Shock Wave Generation in a Polycarbonate Tube and in a Microchip

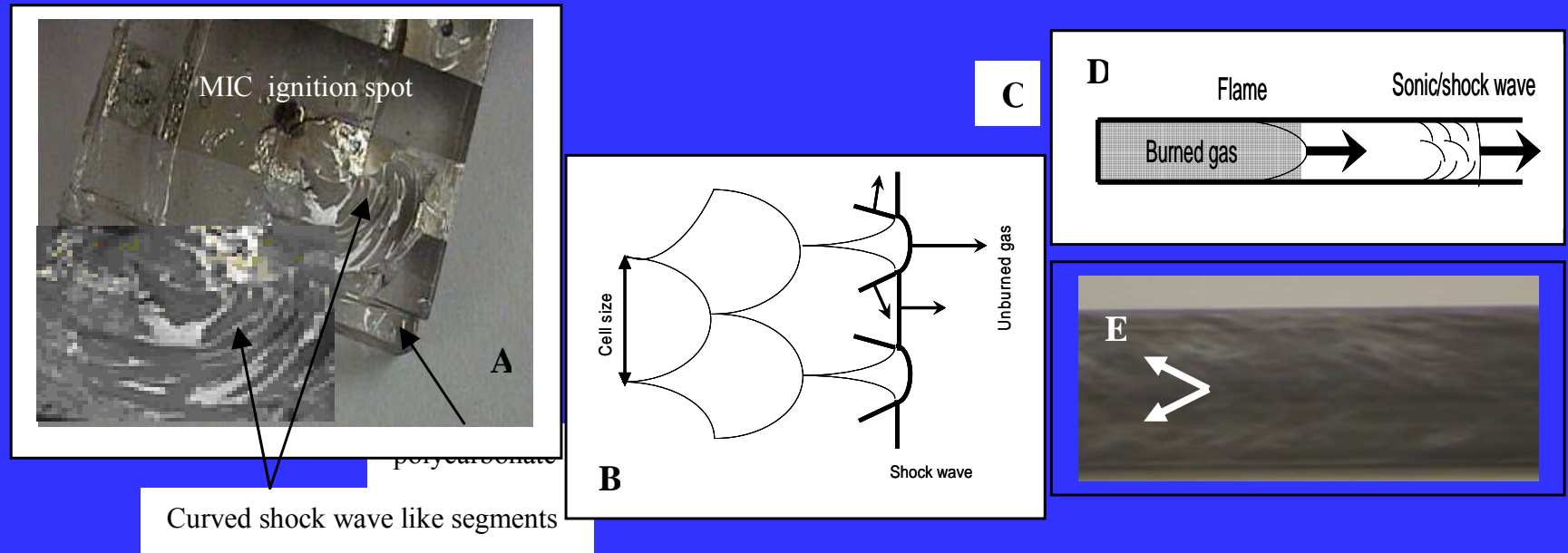

**Fig. 3** **A)** Photograph showing shell like pattern on a chip produced after ignition of MIC 3 in a polycarbonate well and it is similar to curved shock wave segments, **B)** 2-D pattern of shell like curved segments of shock wave with Mach stem, **C)** shock wave and reaction zone generated during propagation of a supersonic combustion wave into unburned gas, **D)** supersonic combustion flame front creating a shock wave inside a tube, and **E)** a pattern created after a well-dispersed slurry of MIC 3 was coated inside a tube, dried, and ignited using a spark igniter.



# Shock Tube Experiments using pressure sensors and optical sensors

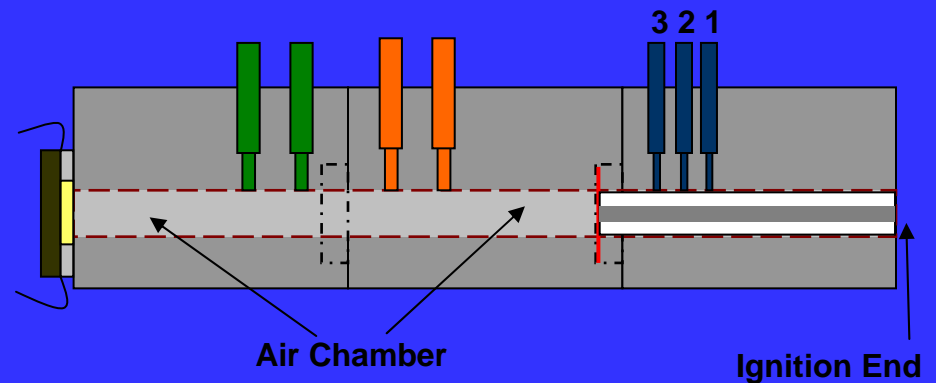
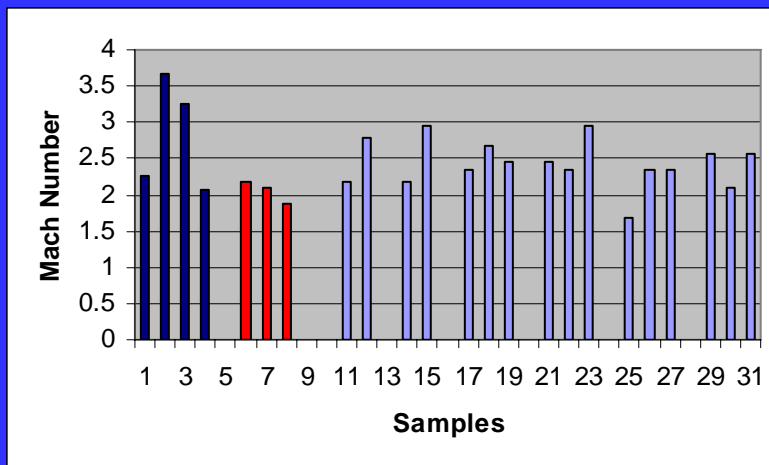
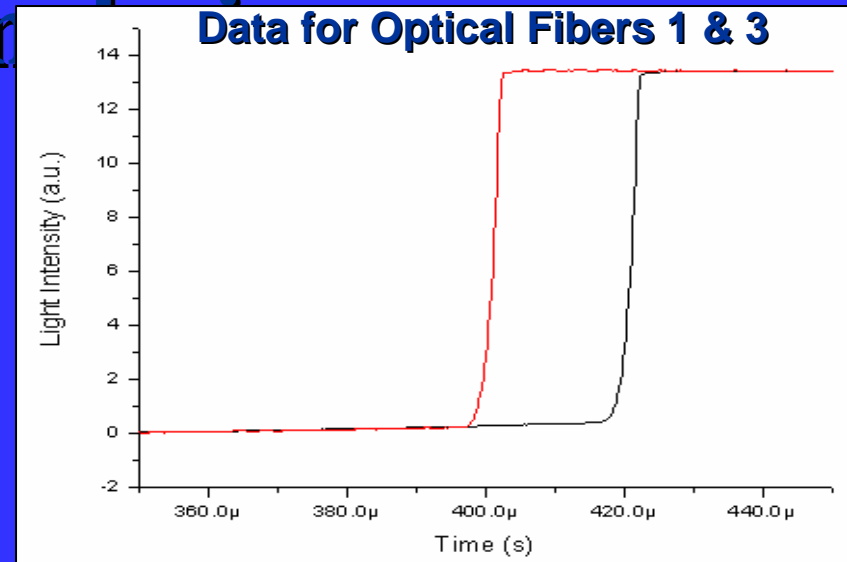
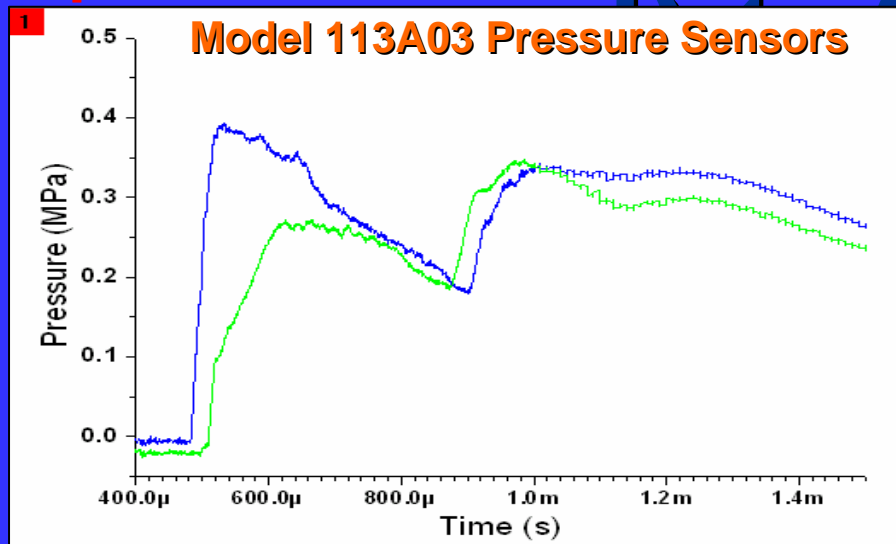

**Top Left:** Pressure sensors shown in orange.

**Top Right:** Light sensor data for the first and third sensors shown in blue

**Bottom Right:** Schematic for reference

**Bottom Left** Mach number for various nanoenergetics



# TEM images of Teflon coated Al Nanoparticles

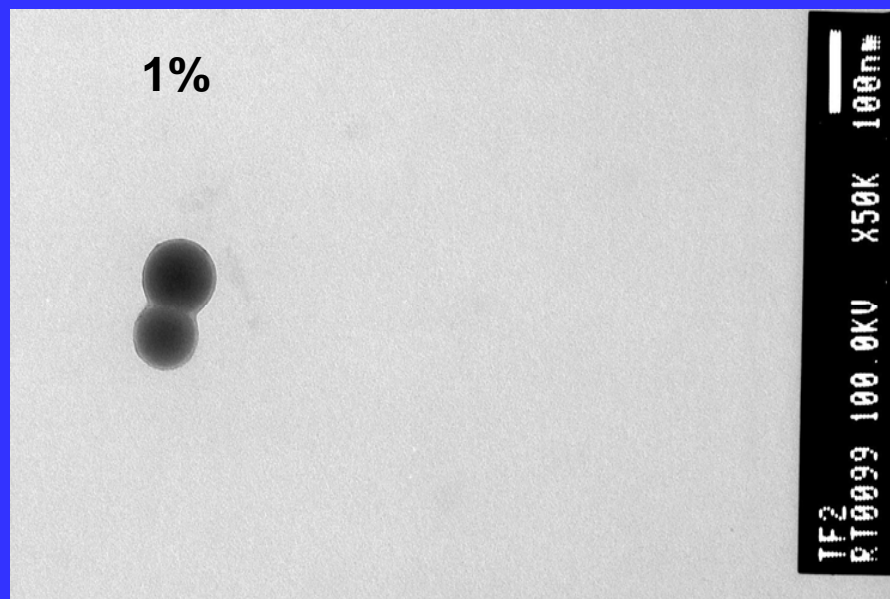
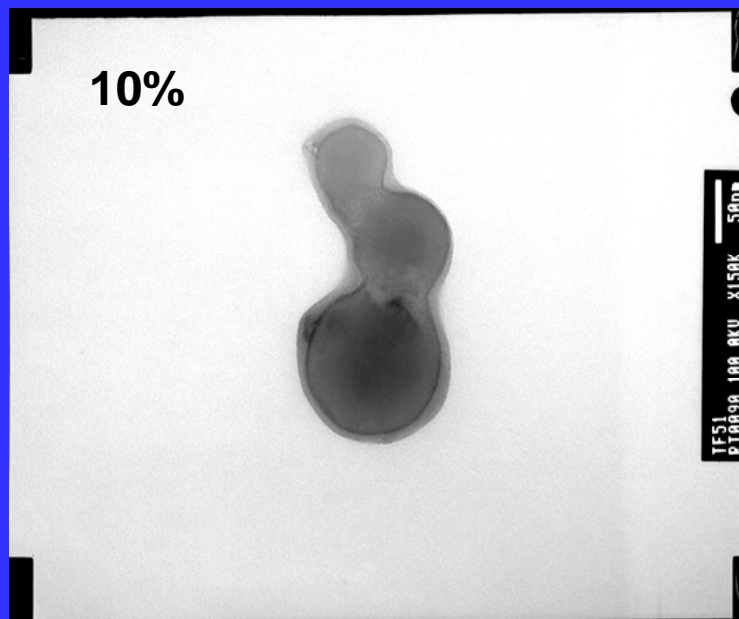
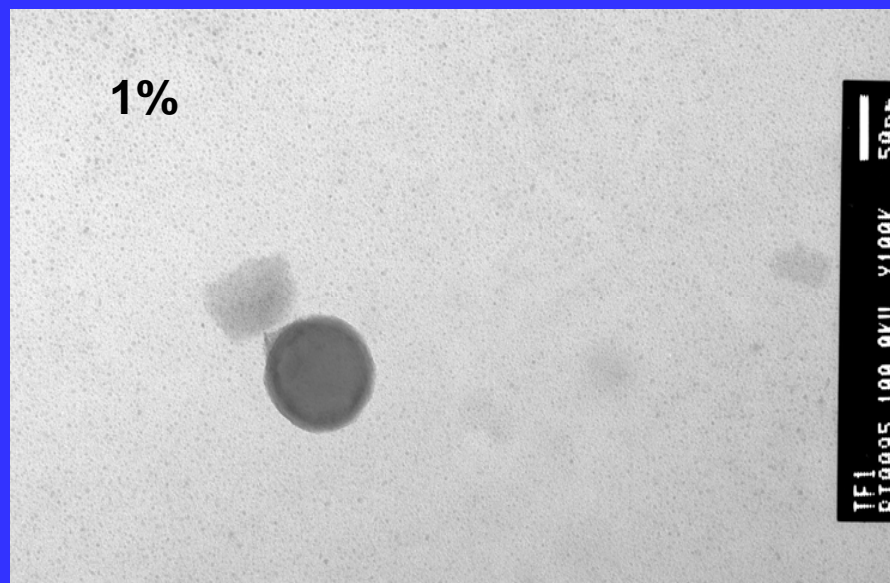
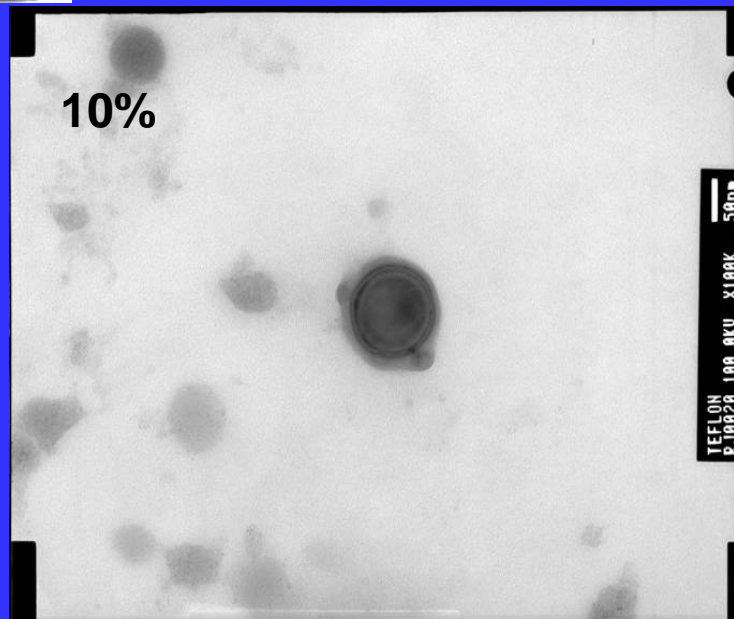



## ESD Energy of teflon coated Al nanoparticles

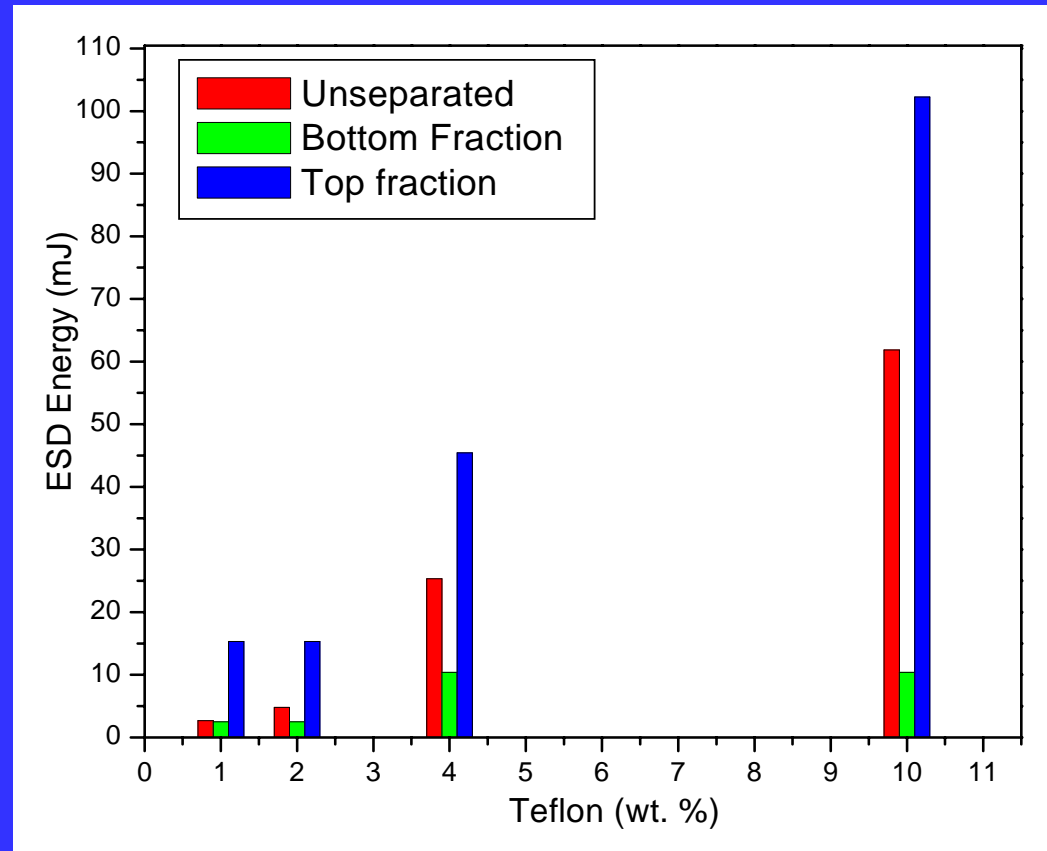

- Uncoated Al nanoparticles (APS: 80 nm) have ESD energy of 0.98 mJ.
- Burn rate and Pressure of CuO – uncoated Al nanoparticles MIC materials are 1500 m/s and 2.2 MPa respectively.
- Burn rate and Pressure of CuO – 1% Teflon coated Al nanoparticles MIC materials are 1200 m/s and 7.2 MPa respectively. Further work is in progress.

# Microencapsulation of energetic nanoparticles

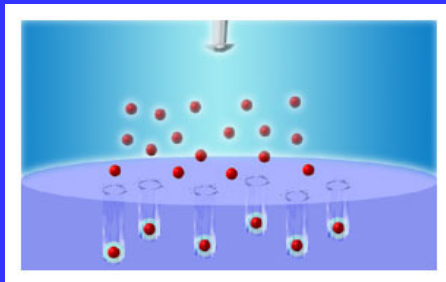
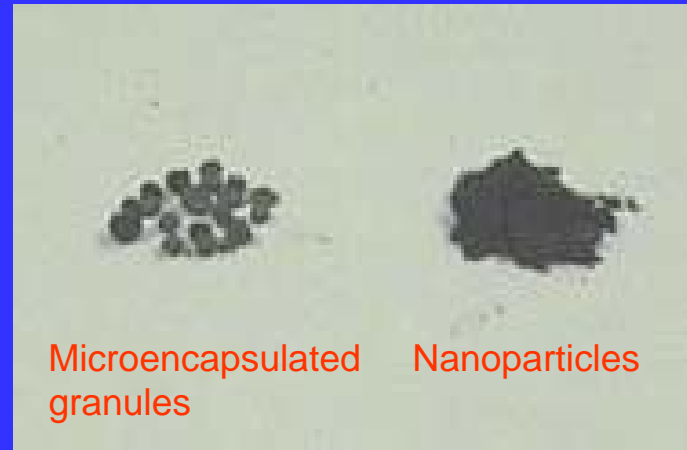
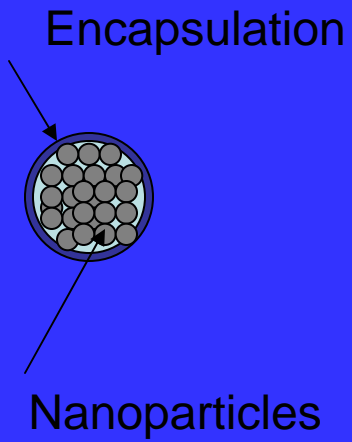



**MIC MATERIAL PRESSURE  
MEASUREMENTS IN MILLIMETER SCALE CELL**



# Experimental Setup

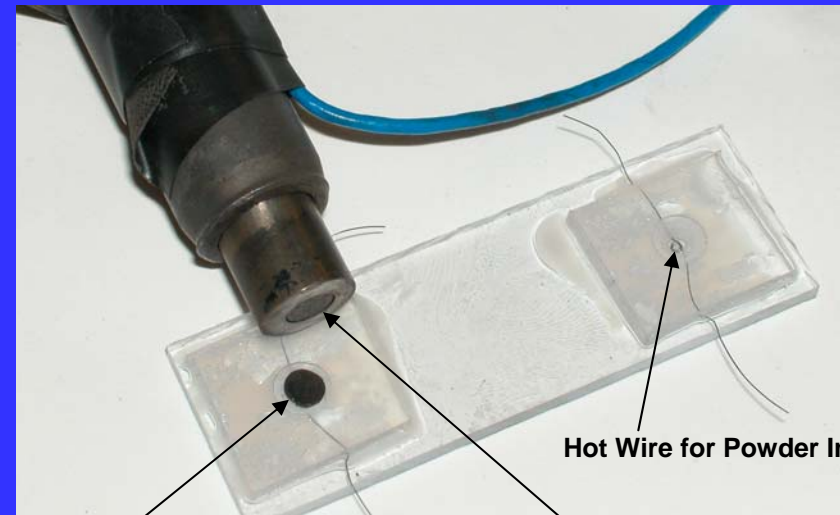

Hot Wire for Powder Initiation

MIC Powder Loaded into MilliCell    Pressure Sensor

MIC Material Powder Loaded into MilliCell

**Pressure measurements on lexane millicell 20mg of each material.**

**Volume of the cell 30 cubic mm.**

**HMT - Hexamethylenetetraamine**

# Pressure Records for Regular CuO(nanorods)+Al(80)

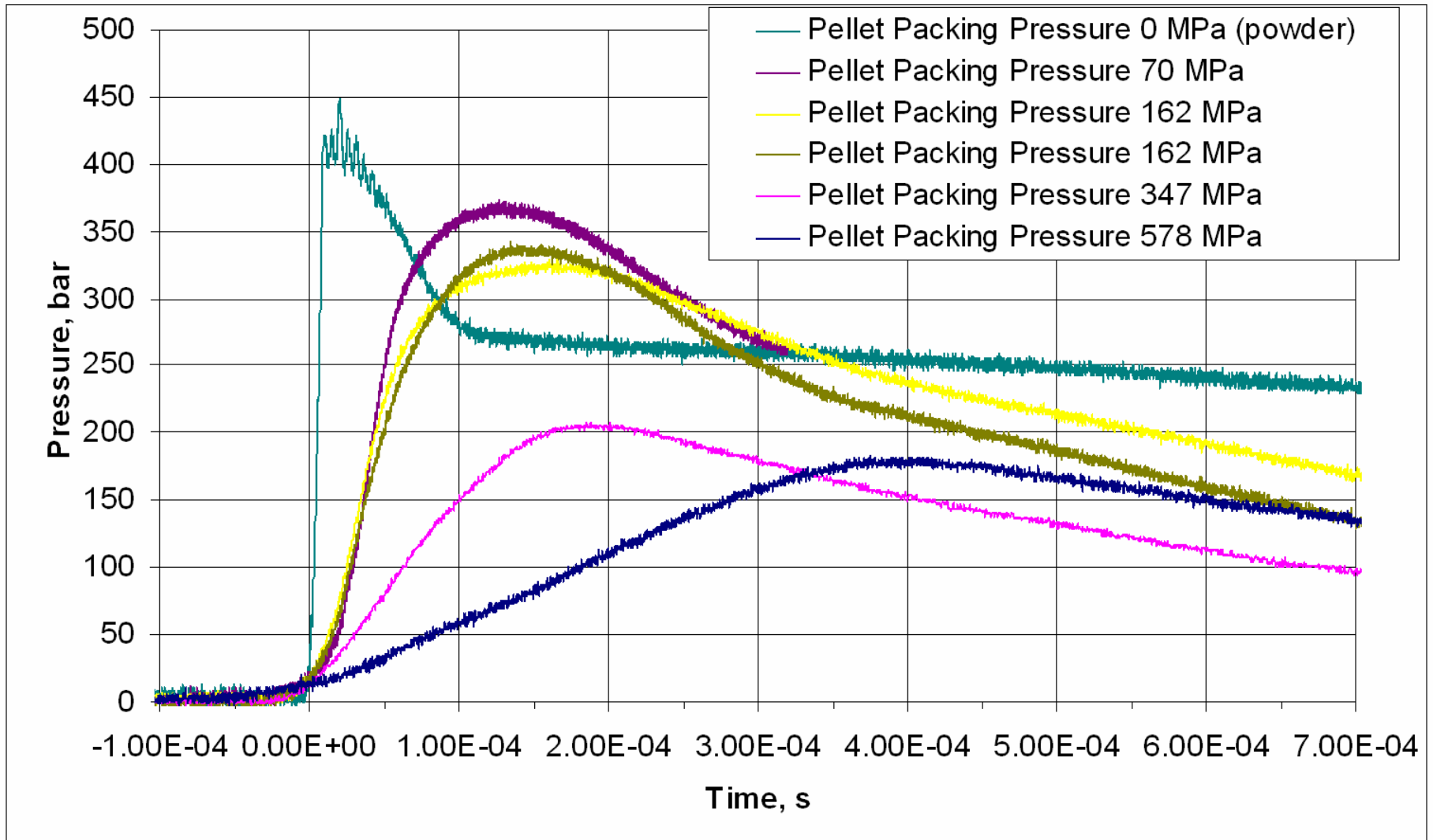



# Pressure Records for Self Assembled CuO(nanorods)+Al(80), Fe<sub>2</sub>O<sub>3</sub>(porous)+Al(80), CuO(nanorods)+2%HMT+Al(80), MoO<sub>3</sub>+Al(80)

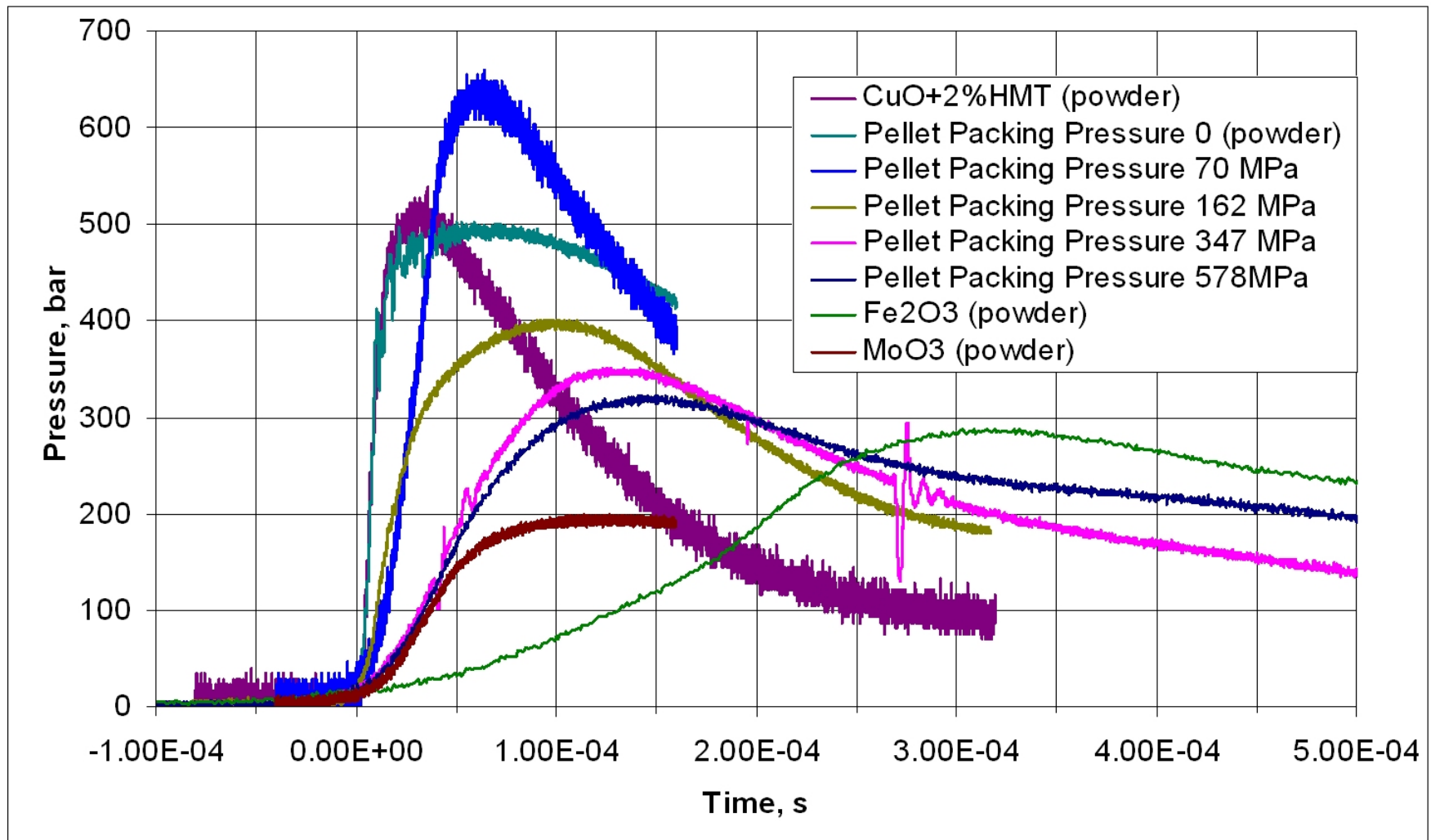



# Pressurization Rate vs. Packing Pressure

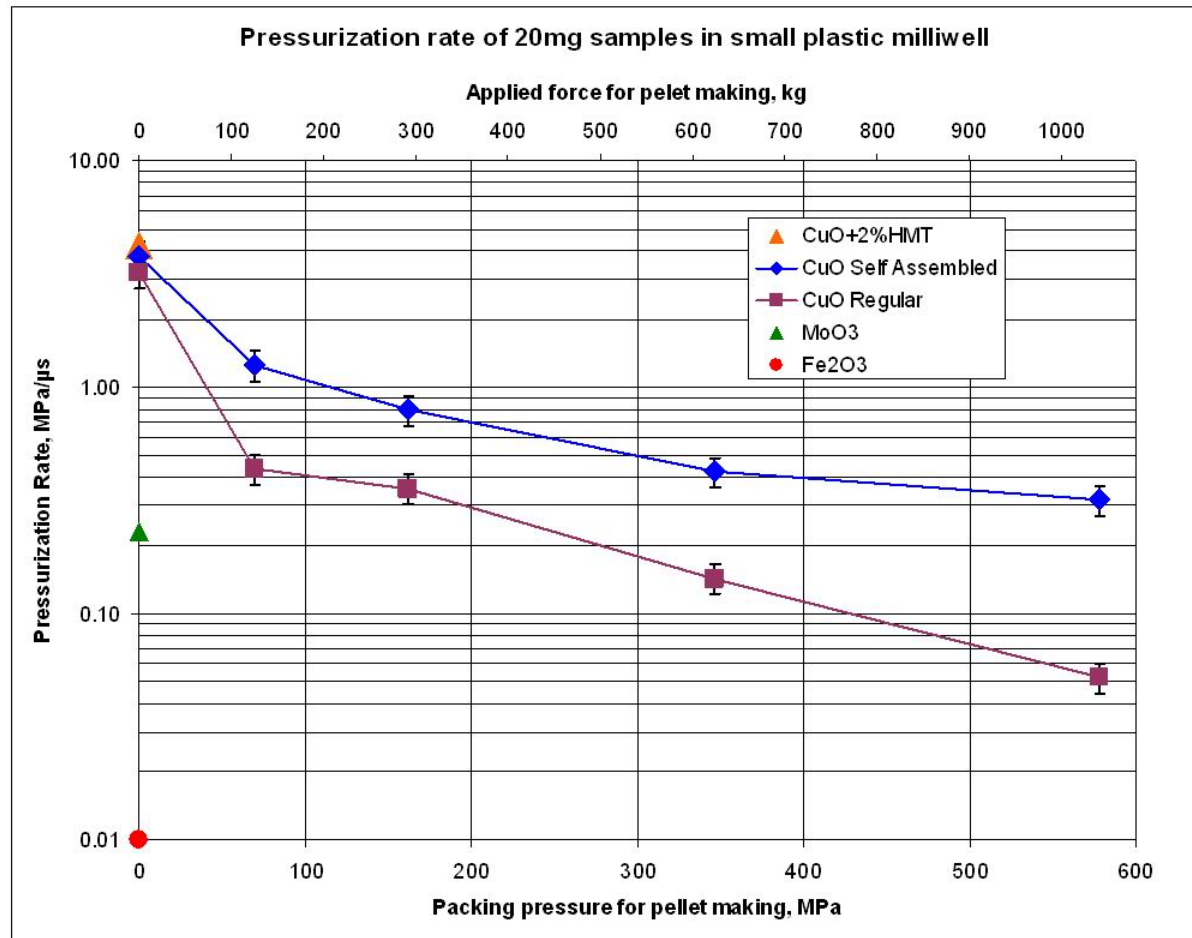

# Peak Pressure vs. Packing Pressure

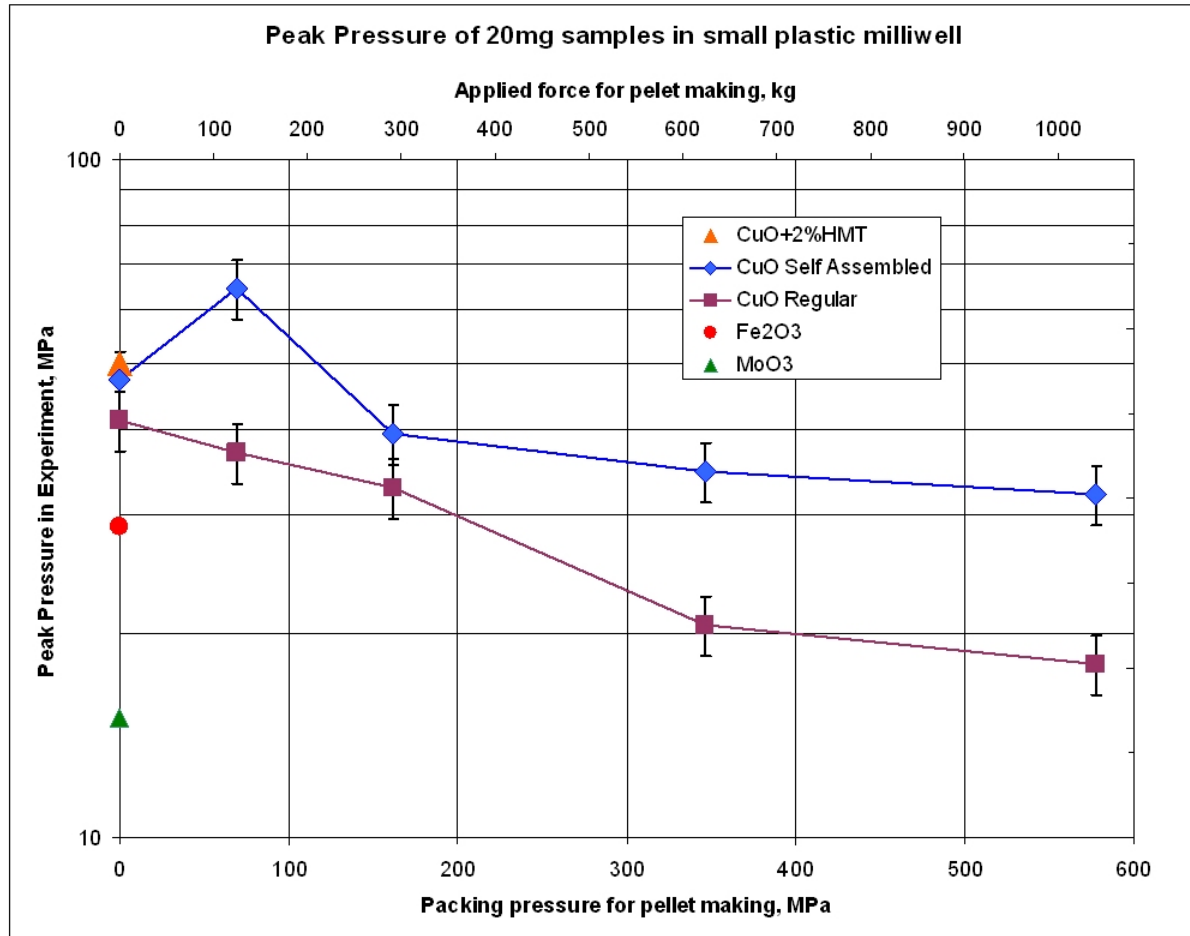

**TEM micrographs  
of ammonium nitrate,  
ammonium perchlorate and  
nitrocellulose nanoparticles**

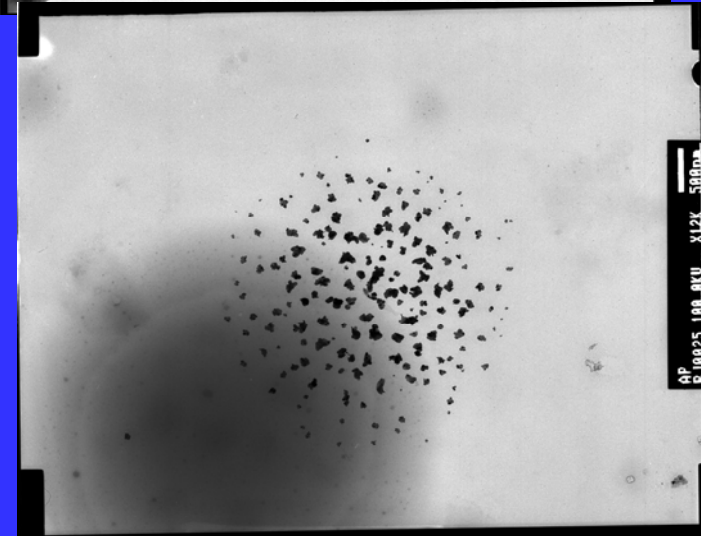
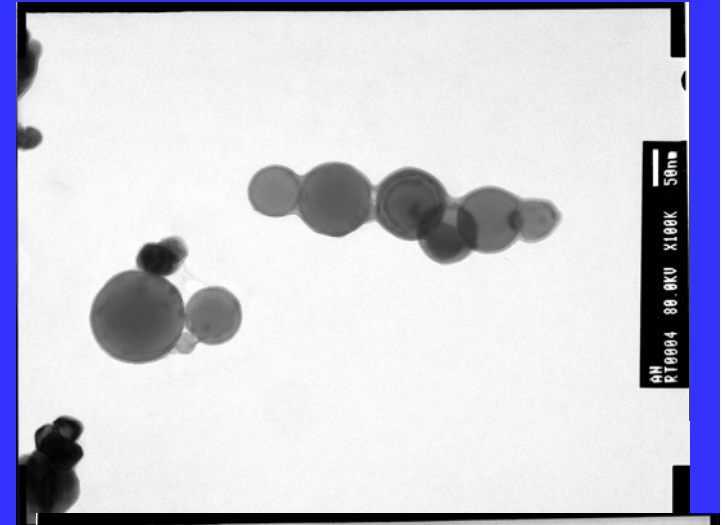
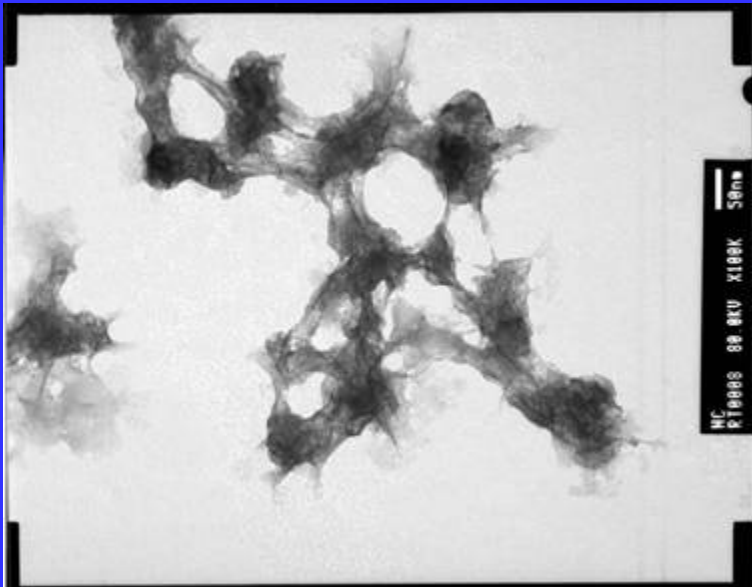

# CuO and iron oxide based composite for propellant application

Ammonium nitrate nanoparticles

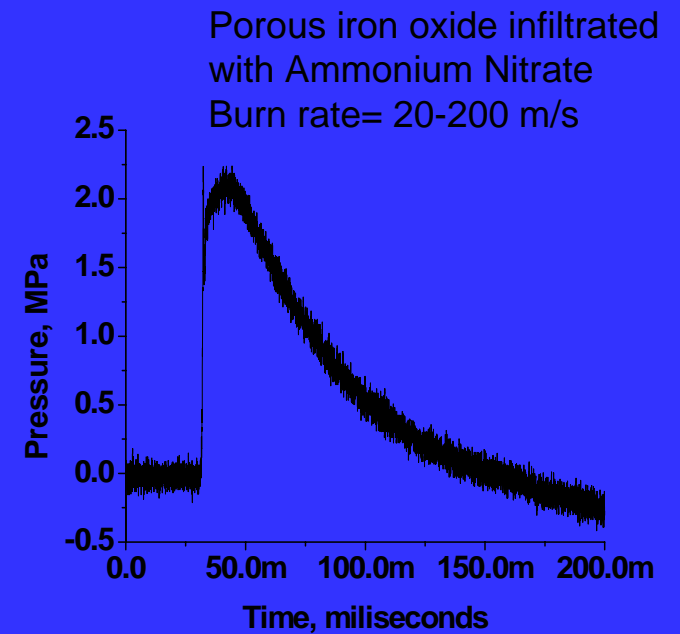
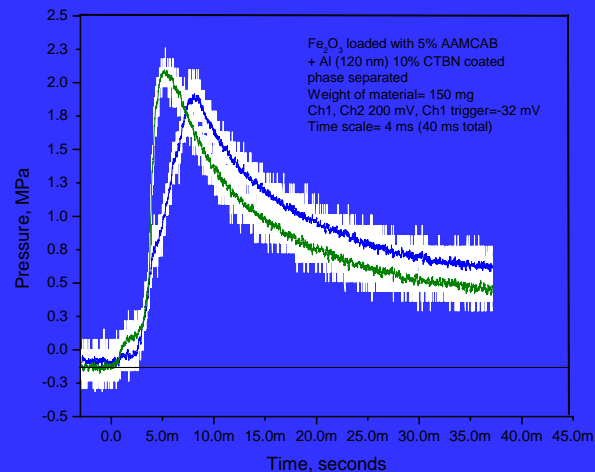
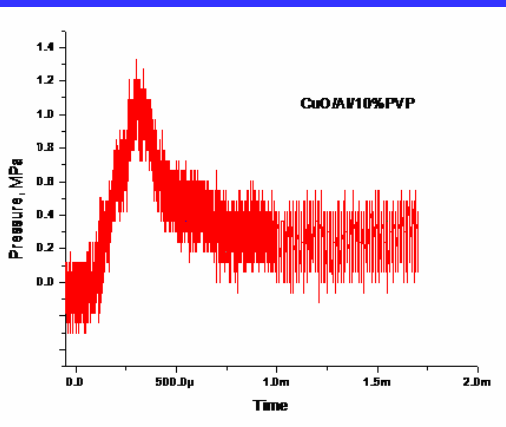
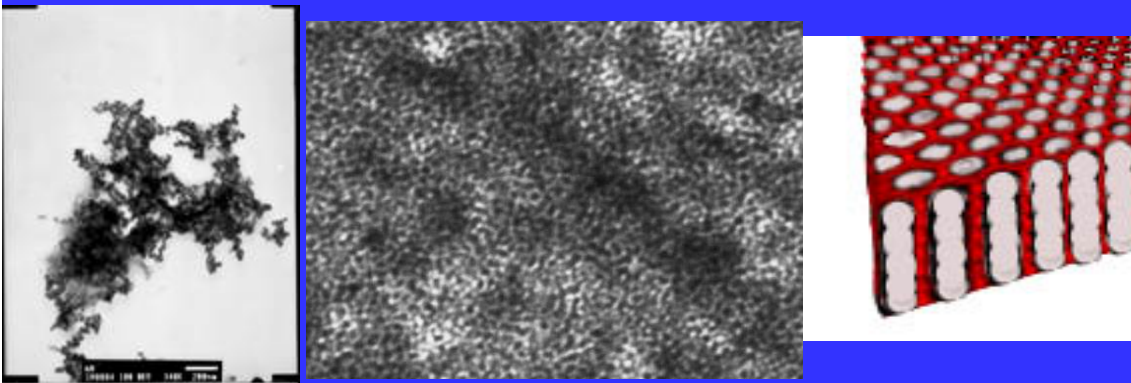

# Patterned energetics on a micro chip

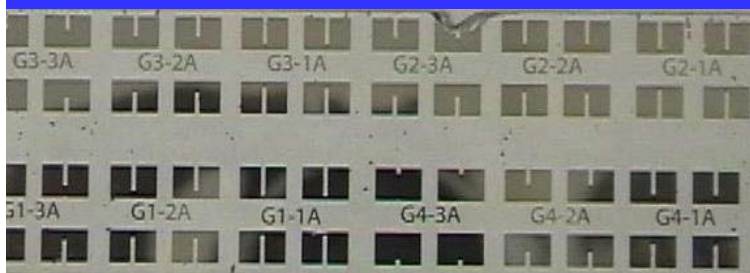
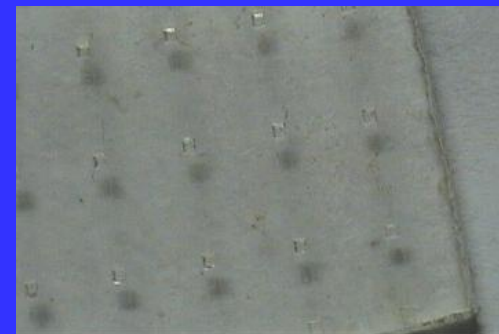
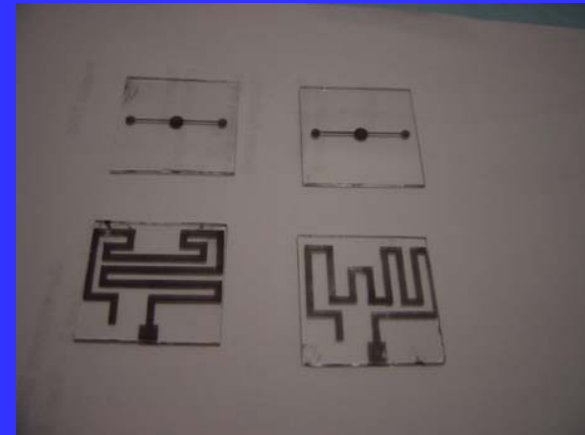
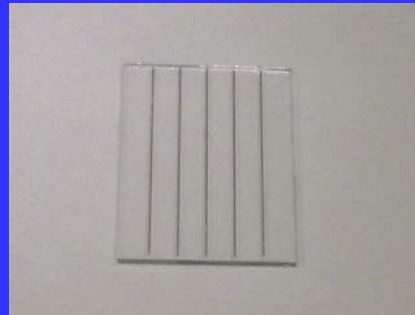
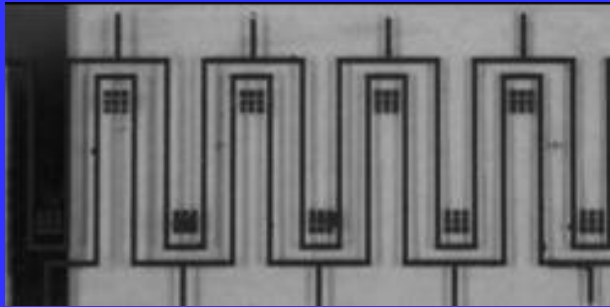

**Circuit for Point-Selectable Initiation**

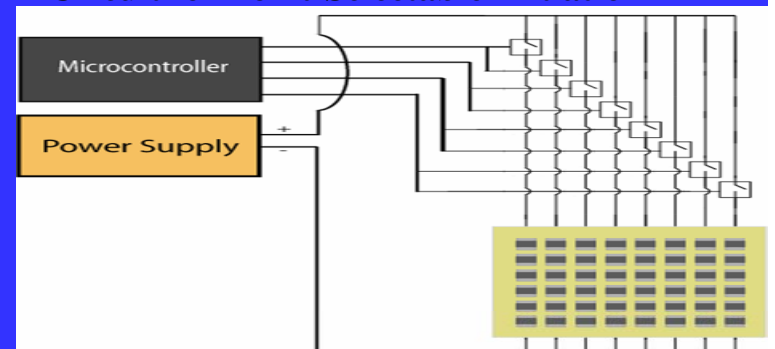







## CONCLUSION



- ❖ Higher combustion wave velocity of CuO nanorods and nanowires based MIC composite can be attributed to higher surface area creating higher hot spot density as compared with bulk.
- ❖ Our results demonstrate tunable combustion wave speeds can be obtained by selecting various oxidizer materials mixed (or, self-assembled) with different sizes of nanoaluminum and by changing the equivalence ratio.
- ❖ Among the oxidizers, the composite of  $\text{Fe}_2\text{O}_3$  yields lowest combustion wave speed whereas, CuO shows highest speeds.
- ❖ Within the CuO-Al MIC system, self assembled composite wherein fuel Al nanoparticles lie in close proximity to oxidizer nanostructures exhibit the highest speed of  $2300 \pm 100$  m/s.
- ❖ CuO based MIC materials are found to produce shockwaves with a Mach number of
- ❖ These materials can be very effective in a number of applications as Green Primers, Propellants, Reactive Blast Materials.