

Report No.  
23/46

~~SECRET~~  
~~SECRET~~

Report No.  
23/46

UNCLASSIFIED

Copy No. 69

CLASSIFIED BY *Source Document*

Exempt from General Declassification  
Schedule of Executive Order 11652

653694

Exemption Category 1

INV 88

ARMAMENTS DESIGN ESTABLISHMENT  
MINISTRY OF SUPPLY

Reviewed 19 47 PICATINNY ARSENAL

Retain Present Classification  
 Downgrade to \_\_\_\_\_  
 Destroy

DISTRIBUTION STATEMENT A  
Approved for Public Release  
Distribution Unlimited

MONOGRAPH No. 3,404, TYPE B

THE DEVELOPMENT OF BRITISH INCENDIARY BOMBS  
DURING THE PERIOD OF THE 1939-45 WORLD WAR

F/Lt. G.T. BOLAN, R.A.F.V.R.

~~EXCLUDED FROM AUTOMATIC REGRADING  
DOD DIR 5200.10 DOES NOT APPLY~~

INV 90

NOTICE

OFFICIAL SECRETS ACTS  
Any unauthorised person finding this document  
should read the instructions on the back cover.

(69)  
526760

20071109056

17401-57-001

Best Available Copy

December, 1946

UNCLASSIFIED

~~664200373~~

The initial distribution of numbered copies was as follows:-

1	C.S.A.R.
2	A.R.E. Library
3	Sec. O.B.
4	D.R.A.E.
5	D.Arm.R.D.
6	A. and A.E.E.
7	E.A.A.S. Manby
8-10	T.P.A.3/T.I.B. (Records and loan)
11-160	T.P.A.3(c) (For distribution)

## A.D.E.

161	C.E.A.D.
162	D.C.E.A.D.(C)
163	S.A.F.R.
164	Library
165	Central File
166-200	T.1 Registry

REPORT NO. E-1072-50 WDCS - INTELLIGENCE REPORT I.D. NO. 653694  
 SUBJECT: The Development of British Incendiary Bombs during 1939-45 World War  
 FROM: ARMYAT-London REFERENCES:  
 EVALUATION: DATE OF INFORMATION: DATE OF REPORT: 28 March 1950  
 INCL. 1 PREPARED BY: F. R. GERHARD, Colonel, GSC SOURCE: Ministry of Supply

SUMMARY OR SID REPORT: 1. The Naval and Air attaches have each received copies of the report.  
 2. Inclosed herewith are 40 copies (Nos. 23-52 and 63-72), Report No. 23/46, Armaments Design Establishment, Ministry of Supply, Monograph No. 3,404, Type F, subject "The Development of British Incendiary Bombs during the Period of the 1939-45 World War", dated December, 1946, by F/Lt. G. T. Folan, R.A.F.V. R.  
 3. This monograph traces the development of the various types of incendiary bombs. No attempt is made to cover the various fillings in detail, although, for convenience, the bombs are classified according to their type of filling. A brief outline of the operational use of incendiary bombs and the choice of incendiary bombs for a particular target is included. A statement of the general principles of design of incendiary bombs to meet operational requirements is then given and the application of these principles is pointed out in the detailed examination of the individual bombs developed to date which follows. The detailed survey of the work carried out on the individual bombs includes investigations which were fruitless as well as those which gave successful results.

COMMENT: It is suggested that the inclosures be distributed by G-2, Reading Panel per agreement with the Research and Development Board.  
 APPROVED, FOR THE ARMY ATTACHE:

P. H. DRAPER, Jr.  
 Lt. Colonel, GSC  
 Executive Officer

40 Incls - As above

NOTE: This document contains information affecting the national defense of the United States within the meaning of the Espionage Act, 50 U.S.C. 31 and 32, as amended. Its transmission or the revelation of its contents in any manner to an unauthorized person is prohibited by law.	<b>SECRET</b>	contents in any manner to an unauthorized person is prohibited by law.
---	---------------	--

MANUFACTURED BY OLD FOLEY PAPER & CARBON COMPANY, BROOKLYN, N.Y. JANUARY 14, 1949

*Pic-K*

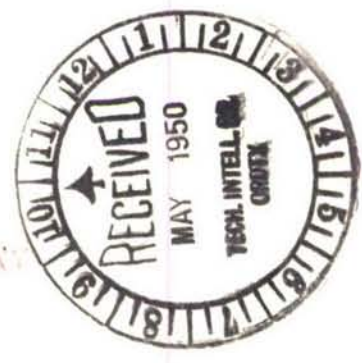

**SECRET**

UNCLASSIFIED

UNCLASSIFIED

~~DISCREET~~

~~SECRET~~

ARMAMENTS DESIGN ESTABLISHMENT

TECHNICAL REPORT

No. 23/46

Monograph No. 3,404, Type B

THE DEVELOPMENT OF BRITISH INCENDIARY BOMBS  
DURING THE PERIOD OF THE 1939-45 WORLD WAR

F/Lt. G. T. Bolan, R.A.F. V.R.

Abstract

This monograph traces the development of the various types of Incendiary Bombs. No attempt is made to cover the various fillings in detail, although, for convenience, the bombs are classified according to their type of filling. A brief outline of the operational use of incendiary bombs and the choice of incendiary bombs for a particular target is included. A statement of the general principles of design of incendiary bombs to meet operational requirements is then given and the application of these principles is pointed out in the detailed examination of the individual bombs developed to date which follows. The detailed survey of the work carried out on the individual bombs includes investigations which were fruitless as well as those which gave successful results.

Armaments Design Establishment,  
Ministry of Supply,  
Fort Halstead, Kent.  
Phone, Sevenoaks 2301.

December, 1946.

**DISTRIBUTION STATEMENT A**  
Approved for Public Release  
Distribution Unlimited

**Best Available Copy**

UNCLASSIFIED

	<u>Contents</u>	<u>Page</u>
List of Illustrations.		
Section	1 - General	1
"	2 - The Magnesium - Thermite Type of Bomb	7
"	3 - The Non-Magnesium Incendiary Bombs	30
"	4 - The Jet Type Incendiary Bomb	51
"	5 - The Dust Type Incendiary Bombs	57
"	6 - Appendices and Bibliography	58

List of Illustrations

Fig.1	Diagrammatic assembly of C.S.A.R's Rocket Unit in AN-M52, 2 lb. Incendiary Bomb.
Fig.2	Messrs. Worssam's design of Rocket Unit for 3 lb. I.B.
Fig.3	C.S.A.R's Separating Anti-personnel Head for 2 lb. and 4 lb. Incendiary Bombs.
Fig.4	Messrs. Worssam's design of Separating Anti-personnel Unit for 2 lb. Incendiary Bomb.
Fig.5	C.E.A.D. design of Separating Anti-personnel Unit for 3 lb. Incendiary Bomb.
Fig.6	C.E.A.D. design of Separating Anti-personnel Head for 3 lb. Incendiary Bomb.
Fig.7	Messrs. Worssam's design of Anti-personnel Head for 3 lb. Incendiary Bomb.
Fig.8	I.C.I. design using same components as Worssam's design.
Fig.9	C.E.A.D. design of Air-armed and Shuttered Anti-personnel head.
Fig.10	Bomb, Incendiary, Small Size.
Fig.11	Bomb, Incendiary, Small Size, fitted with delay explosive charge.
Fig.12	Bomb, Incendiary, a/c, 4 lb. Mk.1.
Fig.13	Proposed Skeleton Tail Plug No.1.
Fig.14	" " " " No.2.
Fig.15	Proposed Modified Cast-iron Nose.
Fig.16	Bomb, Incendiary, a/c, 4 lb. Mk.3.
Fig.17	Midgley-Harmer Pistol, First design.
Fig.18	" " " Final "
Fig.19	Bomb, Incendiary, a/c, 4 lb. Mk.5.
Fig.20	" " " 4 lb. Mk.1E.

UNCLASSIFIED

Fig.21 Bomb, Incendiary, a/c 4 lb. Mk.1E.  
 Fig.22 " " " " 4 lb. Mk.4E.  
 Fig.23 Bomb Incendiary, a/c, 4 lb. X Type.  
 Fig.24 " " " " "  
 Fig.25 " " " " "  
 Fig.26 " " " " "  
 Fig.27 " " " " " Mk.1.  
 Fig.28 " " " " " "  
 Fig.29 Alternatives Noses for Bomb, Incendiary a/c, X, 4 lb.  
 Fig.30 Bomb, Incendiary, a/c, X, 4 lb. Mk.2.  
 Fig.31 " " " X, 4 lb. Mk.3.  
 Fig.32 " " " 4 lb. celluloid body filled  
 thermite.  
 Fig.33 " " " , 25 lb.  
 Fig.34 " " " " Mk.1.  
 Fig.35 " " " " " Suspension Band.  
 Fig.36 " " " " " Modified Tail Cone  
 Fixing.  
 Fig.37 " " " " Mk.2.  
 Fig.38 " " " " Parachute and Striker Release.  
 Fig.39 " " " 30 lb.  
 Fig.40 " " " " Simultaneous ejection.  
 Fig.41 " " " " Non-ejection Type, Nose  
 Ignition.  
 Fig.42 " " " " Non-ejection, Tail Ignition.  
 Fig.43 " " " " Non-ejection, Tail Ignition.  
 Fig.44 " " " 30 lb. Single ejection.  
 Fig.45 " " " 40 lb. Mk.1.  
 Fig.46 Alternative Suspension Arrangements for 40 lb. Incendiary  
 Bomb.  
 Fig.47 Bomb, Incendiary, a/c, 40 lb. Mk.2.  
 Fig.48 " " " 32 lb.

UNCLASSIFIED



- Fig.78 45 lb. I/O Bomb.
- Fig.79 Modified Flame Float for Oil Ignition.
- Fig.80 Oil Ignition Float.
- Fig.81 30 lb. Type J Bomb.
- Fig.82 3-ways fuze for use in 30 lb. 'J' Type Bomb.
- Fig.83 Pistol Body No.1.
- Fig.84 " " No.2.
- Fig.85 Pistol No.3.
- Fig.86 Suggested Arming Device.
- Fig.87 30 lb. Incendiary Bomb, Type 'J' Mk.I.
- Fig.88 30 lb. Incendiary Bomb, Type 'J', Mk.I Tail End.
- Fig.89 22 lb. 'J' Incendiary Bomb, Original Type with Fabric Tail.
- Fig.90 " " " " Type 'A' with drum and rod tail.
- Fig.91 " " " " " 'B' with cylindrical tail.
- Fig.92 20 lb. 'J' " " Mk.II, with parachute tail.
- Fig.93 18 lb. Incendiary Bomb.



SECTION I

GENERAL

Contents

	Introduction	...	...	...	Page 1.
Chapter 1:	The Operational Use of Incendiary Bombs	...	...	...	Page 2.
Chapter 2:	General Principles of the Design of Incendiary Bombs	...	...	...	Page 4.

## Introduction

This monograph traces the development of British Incendiary Bombs during the period of the 1939-45 World War. In cases, where necessary for the sake of clearness, the story of the development has been started rather earlier but in such cases a brief outline of the development prior to 1939 is all that is attempted.

It is written throughout from the point of view of the design of the bombs, and modifications to fillings or change of fillings are noted only briefly unless such changes caused changes in the design of the bomb case or other components.

### Layout of the Monograph

The Monograph is divided into six Sections viz:

- Section 1    General.
- Section 2    The Magnesium - Thermite Type of Bombs.
- Section 3    The Non-Magnesium Type Bombs.
- Section 4    The Jet Type Bombs.
- Section 5    The Dust Type Bombs.
- Section 6    Appendices and Bibliography.

Each of these sections is divided into chapters, a separate chapter being used for each bomb. The numbering of chapters is continuous throughout the monograph and, for convenience, a contents table is provided for each section in addition to the table of contents of the complete monograph.

In Section 6 is provided, for reference, a complete list of Ordnance Board Proceedings on the subject of Incendiary Bombs and a bibliography of the sources of information used in the compilation of the monograph together with other relevant reports, etc.

## Chapter 1. The Operational Use of Incendiary Bombs.

1.1 Incendiary bombs may be used either alone or in combination with other types of bombs, e.g., High Explosive, according to the type of target to be attacked. As a general rule, where the target is very inflammable, e.g., Japanese cities or dumps of inflammable stores in the open, incendiary bombs may be used alone. If the target is "hard", e.g. inflammable stores in a reinforced concrete structure such as a warehouse, H.E. bombs may be used to shatter the building before incendiary bombs are dropped to ignite the contents. In some cases, e.g., tank forms and oil targets generally, H.E. bombs alone may suffice to cause sufficiently large fires to destroy the target in view of the very inflammable nature of the contents of the tanks. Generally speaking, targets in which there are normally high fire risks and are, therefore, well equipped with firebreaks such as concrete walls, need H.E. bombs as well as incendiary bombs in order to destroy these fire breaks and disrupt the fire-fighting services. Fragmentation bombs with either instantaneous or delay and anti-disturbance fuzes may also be used in order to discourage fire-fighters.

1.2 The type of incendiary bomb to be used for the attack of a target is decided by the nature of the target, viz., whether it is hard or soft, whether it is compact or well dispersed, the type and location of firebreaks, the efficiency of the fire-fighting services and the material of which the target is constructed. The incendiary bomb used must be capable of burning for a sufficiently long time to raise the target to its ignition temperature. This interval of time obviously varies with the target and is affected by the inflammability of the target and whether the fires in neighbouring targets mutually support each other. It is also affected by the position in the target in which the bomb comes to rest. The object of all incendiary bomb design is to produce a bomb such that the interval between the bomb striking and the fire in the target becoming self-supporting is as short as possible.

1.3 Hard targets, e.g., warehouses of heavy construction, multi-storied buildings etc., may be first shattered by H.E. and the resulting rubble, with the inflammable contents of the building, ignited by incendiary bombs, in which case almost any type of bomb may be used. Alternatively, a penetrating type of incendiary bomb may be used to penetrate the structure and cause fires among the contents. The size of the incendiary bomb used in this latter case depends very largely upon the inflammability of the contents and the size of the fire areas inside the target. Where the fire areas are small, a large number of small bombs would be used to increase the probability of getting bombs into each fire area. If the fire-breaks are formed by clear lanes between stacks of material, small bombs may be used to increase the probability of getting bombs into the dispersed stacks or a large bomb which bursts and spreads burning filling over a large area may be used for the same purpose.

1.4 Soft targets, e.g., inflammable stores in open dumps, parked aircraft etc., may be attacked with bombs which have a high capacity and relatively weak body construction. Penetration

is not of very great importance in this case and may even be a disadvantage as the bomb may completely penetrate the target and burn harmlessly in the ground underneath. If the targets are well-dispersed or relatively non-inflammable, a large concentration of bombs may be used to increase the chances of starting a fire. If they are readily inflammable or fairly closely-spaced, the concentration may be reduced. In the special case of the attack of small craft and floating oil on water, the falling of the bomb must be such that it will produce an intense fire whilst floating on water and the method of ignition must be such that it will function on water impact. In some British bombs, petrol and fuel oil ignited by some chemical such as KOFQR, which ignites on contact with water, have been used for this purpose.

1.5 In all cases, where the targets are small, aimability of the store used is important. In the larger bombs, a stream-line shape may be adopted while, for smaller bombs, an aimable cluster to contain the bombs may be used. The height of opening of such a cluster would be decided by the concentration of bombs required on the target and the striking velocity required with the individual bombs.

## Chapter 2. General Principles of the Design of Incendiary Bombs.

2.1 The points which have to be decided in the design of a new incendiary bomb are basically:

- (a) Size of Bomb.
- (b) Type of bomb.
- (c) Strength of body etc.
- (d) Shape of bomb.
- (e) Type of stabiliser to be used.

All these are decided by consultation between the various interested Departments viz. Operations, Research, Design and Development. In all cases the operational use of the bomb must be constantly borne in mind.

2.2 The condition of the target, e.g., hard or soft, easily inflammable or relatively non-inflammable, and the types of aircraft on which the bomb is to be carried will usually fix the size and filling of the bomb. The ease of inflammability will generally decide the type of bomb. The shape of the bomb body and the materials to be used will be decided mainly by the strength necessary for penetration and ability to withstand impact, but the shape will also be influenced by ballistic considerations, e.g., aimability and stability. In the case of small bombs, the need for using a shape which can be clustered economically will also affect this aspect of the problem. The need for stability and aimability coupled with stowage limitations will decide the type of stabiliser to be used, e.g., fins, parachute, streamers etc. In most cases it will be found that these various requirements conflict, e.g., good penetration demands a strong case while maximum charge/weight ratio demands a light case. The best compromise can only be arrived at by the closest co-operation between the user and designer in order to decide the order of priority of the various requirements. This liaison is of the greatest importance as only in very rare cases can an original user requirement be fully met by the designer.

2.3 An operational requirement should, ideally, specify the type of target to be attacked, the stowage or stowages on which the bomb is to be carried, the proposed operational heights and the special safety and handling characteristics required. More usually, the weight and size of the bomb are also specified, which may considerably hamper the development in some cases.

2.4 With the requirement stated as above, the filling, type of bomb and weight of filling required are decided by the Research Department as a result of trials. The shape of the body is then decided by the need for penetration and considerations

of ballistics. The Road Research Laboratory carried out, during the war, trials to decide how to meet the penetration requirement and the ballistic requirement was advised upon by R.A.E. Considerations of maximum capacity and stowage limitations generally lead to a cylindrical design of body in the case of large bombs or a hexagonal shape in the case of small clustered bombs. Ballistics normally require that the bomb shall have a streamlined shape but providing the radius of the edge of the nose exceeds  $0.07d$  ( $d =$  diameter of bomb body) the bomb should have a reasonable Terminal Velocity (1)\*. The stability of the bomb can be assessed by comparing it with other bombs of similar shape and C.G/L ratio, for which data are available (2).

2.5 The shape, weight and type of filling and type of bomb having been decided upon the design of the bomb properly commences. The striking velocity necessary to penetrate a given target with a known weight of bomb can be found by R.R.L. by means of their mortar trials against a representative target. From this data the set-up forces acting on the bomb at impact can be calculated and a suitable wall-thickness and method of construction devised to withstand these stresses without impairing the efficiency of the bomb as a fire-raiser after penetration. In this connection, it must be borne in mind that if the bomb wall is not consumable, i.e., not of magnesium or other inflammable substance, it must be burst open to allow the contents to function. If the method of construction is strong, a heavy burster will have to be used and this may excessively shatter the filling so that the pieces of filling are so small as to be of comparatively little use as fire-raisers. A large proportion of the filling may also be consumed in the initial flash, contributing very little to the incendiary effect of the weapon. This consideration does not apply to the specialised case of the Jet Type Bombs.

2.6 The material of the body is decided by the strength required and the type of filling and the production capacity available. The materials used obviously decide the method of construction of the body and other components.

2.7 As a result of the penetration trials, the striking velocity required for the necessary penetration has been decided. From this information, together with the design of bomb body produced as outlined above and a consideration of the stowage available, R.A.E. are enabled to design the best type of stabiliser. Generally speaking, a fin type of stabiliser is used where a high striking velocity is required and a parachute or streamers where a lower striking velocity is required.

2.8 It will be obvious that the steps outlined above are not as clear-cut as has been indicated, e.g. R.R.L. have to fire a bomb of certain weight to enable an estimate of the striking velocity required for penetration to be made. However, the weight of the bomb is not known until this information has been used to calculate the set-up stresses thus enabling the wall thickness to be decided. In this a certain amount of intelligent anticipation must be used to reduce the amount of trial and error necessary to produce the final result. Generally speaking,

\* () See Appendix I

the bomb will first be designed as a fire-raiser, and the penetration which is obtained with this bomb with a striking velocity which can be obtained by any reasonable type of stabiliser will be accepted, providing it is not so small that it will not penetrate into a building of normal construction.

2.9 Throughout the course of design, the closest contact must be maintained with the firms who are to be responsible for production of the finished bomb. A knowledge of the production capacity available at the beginning of design work will enable a design which gives a satisfactory performance and is easy to produce to be evolved. If the design is prepared without taking account of the production capacity available, it is very likely that compromises will have to be made during experimental production and that the efficiency of the store will be reduced.

SECTION 2.

THE MAGNESIUM - THERMITE

TYPE OF BOMB

<u>Contents:</u>		Page
Chapter 3.	The 3 lb. Incendiary Bomb	7
"	4. The Shortened 4 lb. Incendiary Bomb	10
"	5. The 4 lb. Incendiary Bomb	12
"	6. The 4 lb. Type 'E' Bomb.	15
"	7. The 4 lb. Type 'X' Bomb	16
"	8. The 4 lb. Celluloid Bomb	21
"	9. The 25 lb. Incendiary Bomb	24
"	10. The 40 lb. Incendiary Bomb	26
"	11. The 50 lb. Parachute Incendiary Bomb.	29



## General

This section is taken to include all the bombs in which the incendiary portion is of the same type as on the 4 lb. incendiary bomb, viz., the case is consumable, and is filled with a composition which initiates the case, the main incendiary effect coming from the burning of the case.

### Chapter 3. The 3 lb. Incendiary Bomb.

3.1 This bomb was developed to meet a requirement for a bomb to attack Japanese structures such as light one and two storey buildings constructed of wood, paper, etc. It was found that the normal Japanese type of dwelling house was not very susceptible to damage by fire if the bomb landed in the middle of a floor owing to the lack of furnishings in this type of dwelling. If, however, the bomb came to rest against a vertical surface, the building could be fairly readily destroyed (3). The standard 4 lb. incendiary bomb and the AN-M52 American 2 lb. incendiary bomb were found to have too great a penetration for this type of target at their normal striking velocities. The AN-M52 was chosen as a starting point as it was found that this bomb contained the smallest quantity of magnesium which was capable of starting a continuing fire in the structure.

3.2 The problem of causing the bomb to come to rest against a vertical surface was first tackled by C.S.A.R. This Department produced a small cordite rocket unit which propelled the bomb tail first after impact until it came to rest against a vertical surface. The unit weighed 3 oz. complete and fitted into the tail end of the bomb, being capable of propelling the bomb for a distance of 20-25 ft. Fig.1 shows the unit which consisted of a steel cylinder drilled with vents inclined towards the nose of the bomb. Vents were drilled in the bomb body but it was found that the magnesium was easily burned through by the hot gases of the rocket without interfering with the functioning of the unit. This cylinder contained a tubular cordite charge, castellated at the ends and centred by three 1/10 in. wide strips of cellulose acetate, and was closed at each end by a plug carrying a sleeve with a thermal diaphragm. Upon impact, the flash from the detonator ignited the delay in the first sleeve. This, in turn ignited the priming composition via the thermal diaphragm. This priming ignited the cordite and the bomb was then propelled tail first along a horizontal surface. The incendiary portion of the bomb was ignited by the priming in the second sleeve, this priming being ignited by the delay via the thermal diaphragm. The delay was ignited from the flash of the cordite when it ignited. The device proved unsatisfactory in that the rocket was not sufficiently powerful to overcome quite small inequalities in the surface over which the bomb was propelled, and a broken or splintered piece of board would bring the bomb to rest. On trials the unit proved capable of moving the bomb over matting and cinders except when the bomb was resting against an obstruction when the rocket ignited.

A further objection was that the incendiary part of the bomb was not ignited directly from the cap. Two further links in

the ignition chain were introduced by the thermal diaphragms and delays and failure of any one caused complete failure of the bomb. The thermal diaphragms were also found to be difficult to produce on a large scale.

A design on the same basis was produced by Messrs. Worssams as shown in Fig.2 (5). The idea of sealing the propellant chamber by means of a copper washer on the top of the striker is interesting but the design had many drawbacks. The rocket unit used a separate fuze which made the incendiary portion independent of the rocket in functioning, but increased the number of components to be manufactured. This was an important consideration in a bomb of this type where production was to be in millions. The rocket tended to push the bomb into the ground instead of pushing it out if it buried itself. It also suffered from the drawback of C.S.A.R.'s design in that it was not capable of surmounting even small obstacles in its path despite the radius on the edge of the nose.

3.3 It was agreed, at this stage, that there was a greater chance of achieving the desired result by separating the magnesium incendiary part of the bomb from the nose and propelling it some distance, to come to rest against a vertical surface, by means of a gunpowder charge. This also enabled an anti-personnel head to be incorporated. The development, accordingly, proceeded on these lines, the requirement being modified to call for complete air-arming and shuttering of the anti-personnel head.

3.4 C.S.A.R. put forward the design shown in Fig.3, as a method of filling of a nose proposed for the 4 lb. 'X' bomb by D.Arm D. This was objected to on the grounds that it occupied too much space due to the use of a pressed delay and it also necessitated the use of two fuzes.

3.5 A design put forward by Messrs. Worssam's is shown in Fig.4. This uses only one fuze but used a delay composition which was not approved. The fuze could not be shuttered but had the advantage of working if the bomb struck on either end, which increased the chance of functioning. It also had the advantage that the insertion of the C.E. pellet was the last operation in filling, which made the bomb safer for handling in the filling factory.

3.6 C.E.A.D. produced the two designs shown in Figs. 5 and 6 which used standard Bickford Fuze delays and had only one fuze. The fuze was air-armed by means of a small metal drogue which pulled out an arming wire, thus releasing the spring-out safety plunger. It was decided, however, to proceed with Messrs. Worssam's design, shown in Fig.7, for immediate production. This was similar in principle to the design shown in Fig.4 but used plastic-cored fuze for the delay to the anti-personnel charge. The method of air arming used on C.E.A.D.'s design was adopted. The thermal delay and plastic box of gunpowder did not prove very satisfactory on production and Messrs. I.C.I. simplified the design, as shown in Fig.8, by pressing the separating charge in the magnesium body. Arrangements had been

made for the production of these types on a development contract, for comparative purposes, at the cessation of hostilities.

3.7 C.E.A.D., meanwhile, proceeded with the longer term project of producing a fully air-armed and shuttered unit. The design shown in Fig.9, was eventually produced and to date has shown great promise. Its action is fully described in reference (6). Various materials for the body have been tried and it is interesting to note that an aluminium alloy body has proved superior to steel from the fragmentation point of view (7). Steel and R.R.77 bodies showed no appreciable deformation on impact at 180 ft./sec., R.R.5 bodies compressed slightly and brass bodies compressed about .3 in.

3.8 Stabilisers which were tried included the standard type of cone and drum tail of the AN-M52, but it was found that with this the striking velocity was too high. Streamers were also tried and three streamers 20 in. by 2 in. were found to be sufficient to give stability and the required striking velocity. It was found, however, that a parasheet gave more consistent results and this was adopted. The striking velocity aimed at was 160-170 ft./sec. which was shown by trials to be suitable (4).

The chief difficulty with the design was the requirement for delays of up to 6 mins. in an efficient anti-personnel device fully air-armed and shuttered, the whole to be incorporated within the existing length and weight limits of the bomb without reducing the efficiency of the bomb as a fire-raiser. The weight was eventually raised from 2 to 3 lb. and the use of a parasheet in a small box, which was considerably shorter than the ordinary cone and drum tail, made more space available for the head. Another point which had to be constantly borne in mind was that the production of the bomb was to be in very large quantities. Accordingly, machining had to be kept down to a minimum and the materials chosen for easy machining so as to facilitate production. It was these considerations which led to the trials of noses in free-cutting steel, commercial brass and aluminium alloys.

3.10 The final size of the bomb was approximately 14½ in. long with a hexagonal cross-section 1.7 in. across the flats and 1 15/16 in. across the corners. It weighed just under 3 lb.

## Chapter 4. The Shortened 4 lb. Incendiary Bomb

4.1 Early in the war, the shortage of magnesium made it necessary to reconsider the design of incendiary bombs in an attempt to economise as much as possible in the use of this metal. The Ordnance Board arranged trials of various incendiary bombs in the standard frame devised by the A.R.D. at the Forest Products Research Laboratory at Princes Risborough and these trials were carried out in January 1942 (8). From the results, the A.R.D. drew the conclusion that no great loss of efficiency resulted from reducing the length of the standard 4 lb. incendiary bomb by 2 inches, particularly if larger numbers of these shortened bombs could be carried on aircraft (9).

4.2 As a result of this, a requirement was placed on comparatively low priority for the development of a bomb containing  $\frac{3}{4}$  lb. of magnesium instead of the 1 lb. 1 oz. used in the standard 4 lb. Mk. IV. The bomb was to be capable of being carried in small bomb containers and expendable clusters, the same weight of magnesium being carried in each case as was carried when these containers were filled with the standard 4 lb. Mk. IV bombs.

4.3 Two designs, shown at Figs. 10 and 11, were produced by C.E.A.D. in the middle of 1942. These met the requirement regarding the quantity of magnesium to be used by keeping to the cross-sectional area of the 4 lb. Mk. IV, and having the maximum number of components interchangeable with that bomb, being only half the overall length of the 4 lb. Mk. IV. These designs were objected to on the following grounds:-

- (a) A full container load would be too heavy for carriage in existing containers.
- (b) The C.G/L ratio was too great for stability.
- (c) The bomb had a low charge/weight ratio.

4.4 D.Arm D. also proposed a design having a 7 in. magnesium body and utilising a springout tail which compressed over the body when in transit. The bomb had an overall length of 8 in. with the tail compressed and, although it had no steel nose-plug, had a C.G/L ratio of 0.25-0.30 with the tail extended, which was adequate for stability. The design was objected to on the grounds that the spring-out tail would probably cause the bombs to jam in an S.B.C. This objection would be overcome in clusters which were being considered at this time.

4.5 A comparison of the bombs on the basis of container loads gave the following results: C.E.A.D.'s design would weigh 500 lb. per container load, containing 135 lb. of magnesium and 180 points of fire. D.Arm.D.'s alternative would give a load of 300 lb. containing 180 lb. of magnesium and 240 points of fire.

Table 1

Type	Total Weight lb.	C,G.from Nose in.	Saving in Magnesium	
			per bomb	per million bombs
Service	3.97	6.37	-	-
Modifications to tail				
Fig.13 (a) Magnesium	3.80	6.02	.166 lb.	74 tons
" " (b) Aluminium	3.91	6.22	.366 lb.	150 tons
" 14 (c) Magnesium	3.79	5.99	.176 lb.	78½ "
" " (d) Aluminium	3.89	6.19	.336 lb.	150 "
Using modified C.I. Nose Fig.15 (C of G can be adjusted by lightening nose)			.09 lb.	40 tons

4.6 The development was eventually stopped when the Ordnance Board, in the middle of 1943, endorsed the Incendiary Bomb Test Panel view that a reduction in weight of the 4 lb. incendiary bomb would adversely affect its performance (10). This conclusion was arrived at when firing trials had shown that the decreased penetration of such a bomb would more than offset the advantage of the greater numbers carried. The Panel pointed out that all the conclusions regarding increased efficiency of the smaller bomb had been based upon adequate penetration being secured and this had not been realised in practice.

## Chapter 5. The 4 lb. Incendiary Bomb.

5.1 This bomb was in production when the war commenced and was in continuous production all through the war without a great deal of modification. Modifications to design have been made, generally, with a view to economising on materials which were in short supply at various times during the war. The other major alterations to the design were the incorporation of a deterrent gunpowder charge, the type 'E' (Chapter 6) or a lethal anti-personnel charge, the type 'X' bombs (Chapter 7).

5.2 The original Mk.1 bomb is shown in Fig.12. This consisted of a hexagonal magnesium body with a steel nose and a tin plate tail. The safety devices of the striker were a safety plunger, brass ferrule and creep spring. It had a 1.62 grain detonator and a solid magnesium tail plug.

5.3 The Mk.II bomb was essentially the same as the Mk.I except that the safety plunger was chamfered to prevent the striker catching up, which had been found to be a cause of failure in the Mk.I bomb. It also used a 1.7 grain detonator, which was a more satisfactory detonator than the 1.62 grain and the length of the tail was shortened by 1/10 inch. to enable the bomb to be carried in the S.B.C. with strengthened division plates. This bomb was completed early in 1940.

5.4 Trials (11) and (12) were now commenced to find a substitute for the steel nose which was turned from hexagon bar and took a comparatively large number of man-hours to produce. Cast iron and "Mechanite" noses were tried and it was found that, while these sometimes broke off, the bomb functioned correctly. The spigots of the noses in this case were recessed in the same way as the steel spigots and the magnesium swaged on by drawing through a die. In order to prevent damage to the die, the cast-iron heads were made slightly smaller across the flats than the bomb. A method of casting the magnesium body on to the cast-iron nose with a plain spigot was tried and found satisfactory.

5.5 It was also found on trials that the magnesium detonator plate sheared on impact and set forward into the body of the bomb causing either 'blinds' or explosion of the filling. A brass detonator plate was found to cure this trouble. Trials also showed that four vent holes in the rear end of the bomb for venting the priming were not necessary. One hole was sufficient but, in order to ensure that at least one hole should be free from earth when the bomb came to rest, two holes diametrically opposite were used.

5.6 About this time, August 1940, the shortage of magnesium became acute and a means had to be found of saving magnesium in the manufacture of incendiary bombs. Owing to the enormous production of these bombs, even a very small saving on each bomb amounted in the aggregate to a great weight of magnesium saved monthly. By using a skeleton tail plug, as detailed below, and increasing the bore of the bomb by 1/8 inch over 150 tons of magnesium per month was saved.

5.7 The method of operation of the bomb was critically

examined to see if there was any part of the bomb which was made of magnesium and did not contribute to the incendiary effect of the bomb. The magnesium tail plug was one part which did not contribute 100% since it was shrouded by the tail and very often fell away when the bomb had been burning for a short time. The skeleton tail plugs shown in Figs. 13 and 14 were proposed. Such a skeleton casting was found to be suitable on trials. A table showing the estimated saving of magnesium by using these castings in magnesium and aluminium is given as Table 1.

5.8 Another part of the bomb which was found to contribute very little to the incendiary effect was the magnesium surrounding the nose spigot which, owing to the chilling effect of the heavy nose, was often left unburnt. It was suggested that the length of magnesium might be reduced by reducing the length of the nose spigot, the same overall length being maintained by lengthening the nose. This would result in an increase in the all-up weight of the bomb unless the nose casting was wasted. The nose proposed is shown in Fig. 15 but the decrease in length of the spigot was not accepted as it was felt that any weakening of the joint between the body and the nose would be detrimental from the penetration point of view.

5.9 Increase of the bore of the bomb was also suggested and trials (13) showed that a bomb with a 1 inch bore was sufficiently strong for penetration. Burning trials showed that this increase of the bore was an advantage in that the magnesium melted more quickly, the delay from impact to a fire starting being reduced. Alloys of magnesium and aluminium, and magnesium, zinc and aluminium for the main body casting were also investigated in collaboration with Messrs. High Duty Alloys, but, in view of the savings effected by the above modifications, this line of investigation was not proceeded with.

5.10 A Mk. III design of bomb (Fig. 16) was prepared to cover these amendments to design. The Mk. III bomb, therefore, differed from the Mk. I and II bombs in the following particulars:-

- (a) Cap holder in brass instead of magnesium.
- (b) Cast-iron nose instead of steel.
- (c) Skeleton magnesium tail plug instead of solid magnesium plug.
- (d) Increased bore.
- (e) Two vent holes instead of four.

In all other respects, the bombs were identical with the Mk. II bombs.

5.11 A further modification proposed when the Mk. III design had been cleared was a simplified steel tail pistol to replace the tail plug and striker mechanism of the Mk. III bombs. This was developed by D. Arm D. and Messrs. Midgley-Harmer and the first design was as shown in Fig. 17. The design was considerably simpler than the old mechanism and was secured by drive screws

instead of being screwed into the body. The outside pressing, however, gave some difficulty in assembly. The safety device was a shear wire in place of the creep spring and brass ferrule, as previously, and the standard spring-out plunger was also used.

5.12 As a result of experience gained on trials with this mechanism, the design was modified to that shown in Fig.18. The body was made in steel or brass and the outer pressing omitted. A new safety device in the form of a brass cruciform striker support replaced the shear wire of the earlier design and this was secured to the striker by a drive-screw. This type of striker mechanism was incorporated in the design and the mark of the bomb advanced to Mk.IV. The Mk.IV bomb was otherwise identical with the Mk.III bombs. Exhaustive trials of this bomb and mechanisms were carried out and are described in references (14) to (21).

5.13 During 1941, the 4 lb. Mk.IV bombs were put into production in the U.S.A. for supply to both the R.A.F. and the U.S.A.A.F. American suggestions to facilitate production in the U.S.A. were -

- (a) Nose and body to be fixed by a pin or crimped.
- (b) Floating anvil detonator and blunt striker point to be used.
- (c) Primed cambric to be omitted.
- (d) Vent holes to be closed by copper cups cemented in.
- (e) Alternative igniting composition to be used.

With the exception of (a) and (c), these were agreed. The standard method in use in this country, viz. casting the magnesium body on to the spigot of the nose was adopted in U.S.A. C.S.A.R. found that the omission of the primed cambric made the functioning of the bomb more uncertain. The priming composition was pressed with a stepped drift in accordance with standard American practice and the bomb was as shown in Fig.19. These bombs were manufactured to American drawings under the nomenclature of AN-M50-AI and were introduced into the British service as the 4 lb. Mk.V.

5.14 The Air Staff safety requirement for these bombs was originally that they should not function when dropped 6 ft. nose first on to concrete. In view of the difficulty in meeting this requirement while still retaining sensitivity of the fuze so that the bomb would function on soft targets, this was relaxed in Dec. 1941 to not functioning when dropped from 5 ft. under the same conditions, an occasional one functioning from 6 ft. being accepted. Some of the American bombs had a safe height of drop of only 2 ft. 6 in. and great difficulty was experienced in reaching the standard required by the Air Staff for bombs for R.A.F. use. In August 1944, the U.S. authorities asked if the safety requirement could be relaxed since the bombs were supplied in M17 clusters. The matter was referred to the Ordnance Board who recommended that the safety heights be retained at 5 ft. even when the bombs were supplied in clusters (22).



## Chapter 6. The 4 lb. Type 'E' Bombs.

6.1 These bombs were designed to meet a requirement for a bomb containing an explosive charge to deter fire-fighters. Trials were carried out by R.R.L. to decide the quantity of charge required and its optimum position. As a result of these trials it was concluded that 6 gms of gunpowder in the nose of the bomb were more effective than 10 gms of gunpowder in the body, but, even with the gunpowder in the nose, the fragments would not penetrate a 1/32 in. steel plate or a 1/4 in. plyboard (23). Despite this, it was decided to put the charge in the body in order to utilise the same bodies as the standard 4 lb. incendiary bomb.

6.2 The development was started in 1938 and the original design is shown in Fig.20. The filling was done by Messrs. I.C.I. and they asked, at an early stage in the development, that the asbestos wrapping and tight-fitting millboard discs of the original design should be replaced by a cylinder made of paper, grey, hard, so that the complete gunpowder unit could be made up at another factory and assembled in the bomb before pressing. A Design was prepared to incorporate these modifications and is shown in Fig.21. The cylinders contained 10-11 grms of loose gunpowder and could be produced at the production rate envisaged for the bombs, i.e. 10,000 per day.

6.3 Trials carried out against concrete and shingle showed that the functioning of the bomb was satisfactory against concrete the delays to explosion varying from 1 min. 56 sec. to 4 min. 9 sec. Against shingle, however, it was found that the bombs penetrated for a short distance and the cooling effect of the damp shingle extinguished the bomb before it had burned down sufficiently to cause explosion (24). This result was considered satisfactory and, with minor alterations, the design was accepted, formal approval being given by D. Arm D. on 6th April 1939.

6.4 The advancement of Marks and differences between the Marks were the same as the standard 4 lb. incendiary bomb (Chap.5). In the Mk.III.E and IV.E bombs, the gunpowder container was made of tinned plate with a dished lid, in place of the paper container of the Mk.I bombs. Trials of these bombs showed that a small proportion, 3 out of 120 in a preliminary trial, exploded on impact. This was traced to pinching of the gunpowder between the lid and container and was overcome by forcing in an oversize millboard disc on top of the gunpowder, before fitting the lid, and shell-acking it in position. The final Mk.IV bomb is shown in Fig.22. The Mk.IV.E produced in the U.S.A. had the American nomenclature of AN-M50X - A1.

## Chapter 7. The 4 lb. 'X' Type Bombs.

7.1 In December 1940 the Air Staff requested that the 4 lb. incendiary bomb should be redesigned to incorporate a more lethal explosive charge than that of the existing Mk.III.E. It was considered by D. Arm D. that the replacement of the gunpowder charge of the Mk.III.E. by H.E. or a steel container of H.E. would not be satisfactory since the amount of explosive and steel would be small and its effect would be reduced by the magnesium body. Factory regulations would also make production of such a bomb difficult. It was suggested that a steel container screwed on to the tail end of the bomb with a nose fuze similar to the German design might be suitable. Containers of a C.W. agent could then be easily substituted for the H.E. container if the Air Staff withdrew its objection to this method of discouraging fire-fighters (35).

7.2 The priority allotted to this work was low and for the first six months of 1941 discussions on methods of construction took place and experiments on the H.E. charge were carried out by C.S.A.R. By the middle of July, a design based upon Allied Iron-founders Sketch No.482 was prepared and circulated. The design was as shown in Fig.23 and was criticised by the Ordnance Board on the following grounds:-

- (a) The free plunger in the nose was not liked as it might be lost if the bombs were unpacked from the liner.
- (b) Since the bombs burned from the nose and the standard bomb from the tail, it was quite unnecessary to include a dummy plunger in the tail. They recommended that the dummy plunger be deleted and a standard safety plunger be incorporated in the nose.

A meeting of the interested Departments agreed that bombs as modified, in accordance with the Ordnance Board's recommendations (Fig.24) should be made up for dropping trials. The Research Department, meanwhile, continued its experiments to increase the lethal effect of the explosive charge. The shortage of C.E. made it desirable that some other explosive should be used and various designs of containers and different explosives were tried (26).

7.3 The Design Department stated at this time that there was considerable difficulty in designing an efficient safety device for the nose pistol and that a design on entirely different lines might be necessary. Difficulties in production were also anticipated due to the radical departures from the standard 4 lb. incendiary bomb design. It was considered that a special factory would be needed and that the amount of machining necessary at the nose was also an undesirable feature.

In view of these criticisms the suggestion was made that it might be possible to meet the requirement by increasing the powder charge of the Mk.II.E. bombs. D.Arm.D. stated that this would not increase the lethal effect of the bomb to any appreciable extent so the proposal was not considered further. The suggestion of replacing the gunpowder charge by C.E. in a metal container was revived but this was objected to on two grounds.

- (a) C.E. was in short supply.
- (b) Inserting a C.E. unit, complete with detonator, into the bomb would cause difficulties at incendiary bomb filling factories because of safety regulations.

7.4 In order to obtain first-hand information of the effect upon fire-fighters of this type of bomb, a visit was paid by representatives of the interested Departments to the London Fire Force headquarters where the consensus of opinion appeared to be that bombs of this type did not materially hinder fire-fighting. The (unofficial) views expressed were that, during a heavy night raid on towns, the fire brigades were so busy fighting fires, clearing debris, performing rescue work etc., the presence of incendiary bombs with small lethal charges, or small H.E. bombs, would not be a deterrent to fire-fighting.

7.5 As far as disrupting the fire fighting by breaking hoses was concerned, after a heavy raid such a large proportion were damaged through general wear and tear in fire-fighting that the odd additional one broken by a small H.E. charge was not a serious consideration. Another point was that small H.E. bombs would not be seen in the black-out and, therefore, would not be picked up by anybody. Should a few casualties result when this type of bomb was first dropped, instructions would be given that any bomb which looked like a 4 lb. bomb but had not functioned must be treated with suspicion and left alone until later, when it would be dealt with by Bomb Disposal squads. The incendiary Bomb Committee failed to reach a conclusion when the matter was discussed from the householder's point of view (27).

7.6 A Ministry of Home Security Report (28) stated that "An analysis of the 103 records which comprise this report shows that most casualties occur during the course of fire fighting and there is a preponderance of splinter wounds from E.I.B's. As a rule, there is not more than one casualty per bomb and many people in the neighbourhood of an exploding I.B. escape unhurt. It must be assumed, too, that many E.I.B's cause no injuries at all. The danger of fatal casualties is very slight and, in general, injuries are of a minor character. In view of the responsible nature of the task of fighting I.B's it may be concluded, in general, that the risk attaching to E.I.B's is not excessive".

7.7 The Ordnance Board recommended that the requirement should be reviewed in the light of these opinions and that the London Fire Force and Home Office should be consulted before any serious development work was put in hand (29). D.Arm.D., accordingly brought this information to the notice of the Air Staff who confirmed that this did not alter their requirement for an incendiary bomb containing a lethal explosive charge and "the more irregular the explosive - cum - incendiary effect, the better". D.Arm.D. agreed that a redesign on completely different lines from Fig.23 might be desirable (30).

7.8 C.E.A.D. in accordance with this decision, prepared a design utilising, as far as possible, the components of the 4 lb. Mk.IV Incendiary bomb. This bomb was preferred to that shown in Fig.23 because:

- (a) Many of the components were used in the 4 lb. incendiary, which would facilitate production.
- (b) It would be more difficult to distinguish the bomb from the non-explosive type.

The Research Department had carried out experiments with capsules similar to, but larger than, that of the German 'X' incendiary bomb and had obtained delays of up to 4 mins., but fragmentation would not be relied upon. If the heat ignited the C.E. before it was initiated by the detonator, the capsule exploded but did not detonate. In the design shown in Fig.25, the detonator should ignite from the filling about 90 sec. after impact and various ways of increasing this delay were considered, viz:-

- (i) Pellets of slow burning composition or a coil of safety fuze to replace part of the filling.
- (ii) A delay fitment in the nose spigot.
- (iii) Utilizing the comparatively slow burning of the magnesium around the spigot to control the delay. The nose filling could be ignited from powder pellets or detonators inserted in small holes drilled through the side of the bomb into the spigot.

Suggestion (i) was eventually adopted, using a delay element of pressed pellets to replace part of the filling. The Research Department continued its experiments with T.N.T., P.E.T.N. and C.E., in an attempt to find a design of nose which would detonate with lethal effect.

7.9 At this time, January, 1942, D.Arm.D. had suggested to Air Staff that the use of 'X' bombs in incendiary loads should be different from the use of 'E' bombs. Instead of carrying a small percentage of 'X' bombs in each load, it was suggested that extensive use should be made of them at first, up to 50% of the load being 'X' bombs. This should be continued for a time until instructions had been issued to German fireguards to leave incendiary bombs alone for four to five minutes. The load could then be switched back to 100% incendiary in the hope that these standard incendiaries would remain undisturbed for a sufficient length of time to enable them to start a continuing fire. The Ordnance Board concurred in this initial extensive use but considered that a small percentage should be carried in all loads in order to maintain the harassing effect (31).

7.10 In February 1942, the requirement suddenly became urgent with an Air Staff demand for 2000 bombs for operations by March 1st. A meeting held at the Ordnance Board discussed the design and agreed to manufacture bombs to Fig.26, the Research Department agreeing that the design of head was good from the lethality aspect. The maximum delay obtainable with existing moulds was  $4\frac{1}{2}$  minutes although shorter delays could be obtained. It was agreed to make the bombs required urgently with this delay. The charge was C.E. but, since the quantity required was less than 1 oz. per bomb, this could be met despite the shortage (32).

The design was slightly modified during this production, at the request of the manufacturers, by reducing the number of pellets from five to four and amending the length, diameter and density.

7.11 During dropping trials of these bombs, the explosive charges failed to detonate in some cases. A representative of the Research Department, who was present, attributed the failures to the following causes:-

- (a) Displacement of the detonator and/or explosive pellets on release of the pressure generated by the gunpowder pellet situated between the delay column and the explosive charge.
- (b) Melting of the bitumen of the safety fuze which, owing to supply difficulties, the firm was permitted to use instead of the instantaneous fuze originally specified, so that the gunpowder train was prevented from igniting.
- (c) Ignition of the C.E. charge by heat conducted to it through the steel nose before the delay burns through.

These faults were rectified (a) by omitting the gunpowder pellet and replacing it by a primed cambric disc, (b) the instantaneous fuze was replaced by a non bituminous fuze No.3. 2 $\frac{1}{2}$  Lea; (c) this fault was not rectified until the Mk.III version. The production of the bomb was continued despite these faults as the incendiary effect was obtained even if the bomb did not detonate.

7.12 Static fragmentation trials were done (33) which showed that the fragmentation of this bomb was markedly inferior to that of the German bomb with explosive nose. Research Department trials showed that an improved performance could be obtained by omitting the gunpowder pellet, particularly in the bombs with two minute delays. The functioning was also more reliable if the H.E. charge was thermally insulated. It was concluded that the lethal effect could not be improved within the limits of weight and size of the bomb as designed and that no alternative to C.E. could be recommended (34).

7.13 The Method of Filling of the bomb was several times modified at the request of I.C.I., particularly with regard to the method of take-over from the pyrotechnic delay system to the explosive system. The two methods of filling which were finally sealed as alternatives are shown in Figs. 27 and 28, Fig.28 being the I.C.I. method.

7.14 An alternative nose was proposed by Messrs. Stone and Co.Ltd., Deptford, and this was incorporated on the sealed designs. The two alternative noses are shown in Fig.29, 'B' being Messrs. Stone's design. In both designs of nose the cannellures had been modified by making them radiused instead of square-edged, as in the original design, as it had been found in production that the square-edged cannellures caused cracks in the magnesium bodies after casting.

7.15 The characteristics of the Mk.I Bombs (Figs. 27 and 28) and Mk.II bombs (Fig.30) were, therefore:

The Mk.I bomb has the Mk.III 4 lb. Incendiary bomb ignition device and may have either safety fuze or quickmatch take-over from the delay column to the detonator. The nose may be to one of two alternative designs.

The Mk.II bomb has the 4 lb. Mk.IV Incendiary bomb ignition device and used only Messrs. Stone's design of nose. The take-over from delay column to detonator is always quick-match.

7.16 In March 1943, while the drawings of the Mk.I and II bombs were being prepared for sealing, the question was raised of providing a bomb with a delay to explosion of up to 10 minutes. In order to do this it had been found necessary to insulate the H.E. charge in the head, and a nose with a wider bore to permit the pellets to be insulated by a paper tube had been designed.

7.17 Fragmentation and impact trials were done (35) and it was found that the fragmentation of this bomb was similar to that of the Mk.I bomb except that fragment velocities were slightly higher. When the radius at the base of the spigot of the nose was 1/4 in. the bombs were damaged on striking a concrete slab at normal incidence at 420 ft./sec. but reduction of this radius to 1/8 in. cured this trouble. No damage was caused to bombs with either radius on ricochet impact between two blocks of concrete at an angle. Dropping trials (36) of 90 bombs from 70-80 ft. and 150 bombs from 4000 ft. gave only one failure attributable to the modified nose. The modified nose was, accordingly, regarded as satisfactory and a requirement was stated for the design of a bomb incorporating this nose.

7.18 Bombs with this modified nose were designated Mk.III bombs and the design was cleared on highest priority. Various amendments to the method of filling this type of bomb were incorporated in the design to bring it into line with current I.C.I. filling practice. The final design (Fig.31), therefore, differed from the Mk. I and II bombs in the following respects:-

- (a) The bore of the nose was 3/4 in. instead of 0.6 in. as in the Mk.I and II bombs,
- (b) The detonator is reversed so that the lugs are towards the striker,
- (c) The star washer filled with priming composition, used on the Mk.I and II bombs, is replaced by a millboard washer covered with a muslin disc secured by shellac.
- (d) A paper collar is inserted in the bomb after consolidation of the pellets.

7.19 In September 1943 the Mks.I and II bombs were declared obsolescent and in October, the Mk.III design was finally sealed. The Mk.III bomb was manufactured in the U.S.A. under the nomenclature of AN-50X-A2.

## Chapter 8. The 4 lb. Celluloid Bomb

8.1 In the middle of 1940, the shortage of magnesium rendered urgent the provision of a bomb which did not contain this metal. It was suggested that a bomb on the lines of the 4 lb. incendiary bomb might be developed using some material other than magnesium for the body and celluloid was suggested as a suitable alternative, the bomb being to the same outside dimensions as the 4 lb. incendiary bomb.

8.2 From the production point of view a cylindrical body produced by boring out an extruded bar, made by Messrs. B.X. Plastics, was the most satisfactory. This bar was easily produced but production of a similar bar in hexagonal section presented considerable manufacturing difficulties. The bar required an appreciable time for drying out of the solvent used in its manufacture, a tube with  $3/8$  in. walls requiring 45 days, and a tube with  $1/4$  in. walls 28 days, to cure. This was improved when the tubes were made by rolling up celluloid sheet. The tubes had a tensile strength of 3000 to 8000 lb./sq.in. depending upon the rate of application of the load.

8.3 Two sketch designs of bombs were produced for discussion, one containing celluloid capsules of fuel oil and the other being filled with thermite pellets in the same way as the standard 4 lb. magnesium incendiary bomb. Since the standard safety plunger could not be used with a cylindrical bomb, it was suggested that the bomb might be nose fuzeed.

8.4 The development of a bomb on these lines was requested on high priority in August, 1940, when the supply of magnesium became so short that the cessation of production of the 4 lb. incendiary bomb and all other bombs containing magnesium was ordered. The Research Department trials on the celluloid tubes produced by Messrs. B.X. Plastics showed that the burning rate was about 1 in. per 10 sec. but that the flame was in the nature of a torch which might be a drawback if the tubes were used in an incendiary bomb.

8.5 In view of the breaking off of the cast iron noses of the standard 4 lb. incendiary bomb, it was felt that a nose fuze would not be sufficiently reliable and that the bomb should be tail fuzeed. Ballistically, the cylindrical shape was slightly less stable than the hexagonal shape but its stability was considered adequate. Further consideration by the Design Department resulted in the conclusion that a tail pistol was not a feasible proposition and, a design with a nose pistol was proceeded with, thus giving useful weight at the nose end where it was required for stability. The design produced embodied a nose pistol with a spring-out safety plunger held in place, until the bomb was released from the container, by a bakelite safety cap. It was designed to fit into the same containers as the 4 lb. incendiary bomb and is shown in Fig.32.

8.6 This design was suitable for stowage in the 4 lb. incendiary containers providing the strength of the body was sufficient not to distort under drop-bar reaction but the functioning of the arming cap was thought by R.A.E. to be doubtful. A similar cap on the No. 29 pistol had been failing to come off at airspeeds above 150 m.p.h. and the design of spring intended

to remove the cap in this bomb was criticised. Since the coils had a constant pitch, the rate of the spring varied during compression the maximum load being required only in the last stages of compression. It was pointed out that the air pressures on this cap at release speeds of the order of 250 m.p.h. would be 4 lb. even with the bomb pointing along its trajectory. The spring had, therefore, to be able to exert this force, at least, when extended  $3/4$  in. so that the cap just cleared but, on the other hand, the spring had not to be so strong as to cause the bomb to stick in the container.

8.7 The Research Department specified that holes should be drilled in the mild steel adapter and a chamber formed, for venting the gaseous products of the priming, by inserting a perforated disc under the pellet of priming composition. D.Arm.D. criticised the design particularly from the point of view of fuzeing. The nose fuze was objected to for the following reasons:-

- (a) In the event of the nose either breaking away or leaving the body, the bomb would be a blind.
- (b) The bomb would not function from low altitudes with the same consistency as the 4 lb. bomb, which would function from 50 ft.
- (c) An oblique strike would cause the nose to break off and thus render the bomb blind. It was pointed out by Design Department in reply to this that the spigot was  $2.1/2$  times as strong in bending as a solid spigot of the same material.
- (d) It was doubtful if the arming cap would come off even if holes were drilled in it.

8.8. D.Arm.D. proposed two alternative designs which were worked out in collaboration with Messrs. B.X. Plastics.

(i) A cylindrical steel or cast-iron nose with a spigot fastened to a cylindrical celluloid body. At the tail end was fixed a bakelite tail plug similar to the tail plug of the 4 lb. incendiary bomb, but cylindrical instead of hexagonal. The ignition system was as for the 4 lb. bomb and the safety device was a spring-off cap on the tail.

(ii) The nose was hexagonal, of steel or cast iron, the the body cylindrical and the tail plug to the same design as that of the 4 lb. bomb, but in bakelite. The safety and ignition devices were as for the 4 lb. bomb.

A comparison of these bombs is given below:-

Type	Weight	Weight of Celluloid	Weight of Thermit	Charge/Weight ratio	Distance of C.G. from nose
1	3.91 lb.	1.464 lb.	0.500 lb.	51%	7.4 in.
2	3.9 "	1.132 "	0.372 "	38%	6.4 in.
Fig.32	4.05 "	1.030 "	0.523 "	38%	6.3 in.



Further work on the design was held up pending a decision on the ballistic of these bombs.

8.9 In December 1940 supplies of Magnesium for incendiary bombs could be once again guaranteed so the development was held up and with the further easing of the supply position in 1941, the requirement was finally cancelled in March 1941.

8.10 During the progress of the development, a suggestion was made that waste cinema film, which was available at the rate of 700 tons per annum, might be used. The fire risk involved in stripping this film and remaking it as sheet is very high and the suggestion to pack rolls of film in a metal case was not regarded as feasible so no development along these lines was carried out.

## Chapter 9. The 25 lb. Incendiary Bomb

9.1 The original design of 25 lb. "Firepot" type of bomb was produced some years before the outbreak of war and had the tail adapter secured by 12 shear screws. This bomb is shown in Fig.33. Trials indicated that instantaneous release of the tail on impact was critical to ensure functioning so that in the Service Mk.I version of the bomb, Fig.34, the tail plate was secured by only six shear screws. It also differed from Fig.33 in having no grub screw to secure the nose, this being replaced by larger notches into which more metal was punched than was the case in the original design. Cement R.D.No.1 was used to coat the threads of the nose in lieu of the luting used on the original design. The Ordnance Board recommended (34) that trials be done with a tail adapter held by eight screws. Rough usage trials were carried out and it was found that the six-screws were sufficient to prevent any loosening of the tail plate.

9.2 A suggestion was made by the contractor manufacturing the bomb that the tail plate be held in by cannelluring. Trials were carried out on bombs with the tail fixed in this manner as the method simplified construction and was cheaper than the standard method. The modified construction presented no difficulty in filling and was satisfactory on rough usage but gave very variable results in a trial to find the force required to remove the tail plate. 0.8 to 4.07 tons were necessary to remove a tail plate cannellured in as compared with 0.72 tons for removal of a tail plate held in by the normal brass shearing screws. It was stated by the manufacturer that the strength of the cannellure could be guaranteed within narrow limits on production but, since the production of 25 lb. bombs was being stopped at this time (August 1940) the investigation was dropped.

9.3 The striker spring was modified as a result of an accident which occurred in the assembly of bombs in 1938 by Messrs. I.C.I. An operator, in screwing home the striker housing, forced the end of the spring into the cap of the detonator. The direction of winding of the spring was altered to anti-clockwise and the end was turned in at right angle to the axis for a distance of 1/8 in. This was effective in overcoming the fault and was incorporated in the design.

9.4 Early in 1939, it was proposed that a lug, originally developed by Messrs. Bulpitt, for the Smoke Float, a/c, navigation, should be used on the 25 lb. bomb. This lug was a welded type of lug and was intended to replace the forged lug shown in Fig.35. At first, trouble was experienced with this lug owing to the ends of the loop not projecting sufficiently far through the band to ensure fusion on welding. Sufficient protrusion to ensure fusion of the metal was guaranteed by introducing a gauging operation consisting of measuring the height of the loop as it came from the machine and after welding to the band. This gave satisfactory results and the lug was adopted.

9.5 The 25 lb. bomb was very unsatisfactory in it's performance against targets on dropping trials, particularly against the power station at Gretna, the body in almost every case buckling and preventing ejection of the firepots. A stronger design of bomb was requested and the first line of approach was to modify existing bombs as shown in Fig.36. Later, Messrs. Trojans

suggested a strengthened design in which one firepot was removed and a threeways pistol inserted inside the tail end of the body, being located by a steel plate. Between this steel plate and the actual tail plate was a steel ring. A mild steel cylinder was placed around the existing body to give additional strength, the nose of the cylinder being welded to the nose adapter. The nose joint was also strengthened by the addition of a screwed collar at the nose and welded to the body. A cone of 3/16 in. mild steel plate, shaped to fit over the nose for about 1 in. downwards from the body, was screwed onto this. The bombs gave good results on trials and were stable in flight with a T.V. of 1075 ft./sec. (38). It met the requirement of penetrating 4 in. of concrete (39)

9.6 The next modification to this bomb was in the method of attaching the tail. Three schemes were suggested:

- (i) Tail held on by 4 spring clips.
- (ii) D.Arm.D's scheme of holding the tail by three equally spaced screws. This was objected to on grounds that there was not much metal in the adapter for the screw threads.
- (iii) Tail held on by 3 steel clips which were held in position by adhesive tape or wire.

The last suggestion was preferred and rough usage trials were done to decide if the attachment was sufficiently firm. When the rivets holding the clips were altered from 3/32 in. aluminium to 3/16 in. mild steel and the material of the clips altered from mild steel to spring steel, the method was satisfactory. With this method of attachment a stool was necessary in the box to ensure that the tail was supported in transit.

9.7 A Mk.II design of bomb, shown in Fig.37, was prepared to cover these modifications to the Mk.I bomb. The Mk.II bomb, therefore, had the tail attached by strips of spring steel, a strengthened body, and a squat three-ways pistol. The strengthening piece was increased from 1.3/4 in. to 2 in. internal diameter to accommodate the squat fuze and a steel tail with a new method of locating the arming rod was used. These Mk.II bombs were all conversions of Mk.I bombs and for this reason the design was not sealed.

9.8 It was proposed that this bomb might be suitable for the attack of pine-woods if the striking velocity was reduced. R.A.E. attacked this problem along two lines. Retarder rings were fitted to the bomb to cause it to strike at an angle to its trajectory but this was not considered satisfactory chiefly owing to doubt about the functioning of the pistol which required 4.1/2 times the height of drop for functioning at normal impact when dropped at 45°. The other line of attack was to develop a parachute attachment to fit into the tail of the bomb. Such an attachment was successfully designed and is shown in Fig.38.

9.9 The requirement for this type of bomb was eventually cancelled in 1941 as none of the designs produced had been capable of meeting it.

## Chapter 10. The 40 lb. Incendiary Bomb

10.1 In July 1939, concurrently with the attempts to strengthen the existing 25 lb. incendiary bomb, [9.5]<sup>#</sup> five designs of heavier bombs were produced to meet the requirement for a bomb which would penetrate a heavy building and be capable of functioning inside. These designs are shown in Figs. 39 - 45 and had the following characteristics:-

- Fig.39 A strengthened body with the complete firepot unit of the existing 25 lb. bomb. The bomb was fitted with an "allways" mechanism.
- Fig.40 A strengthened body with six firepots, instead of seven, arranged for simultaneous ejection. An igniter based on the 4 lb. incendiary bomb igniter was used and recessed into the bomb for protection. A safety bolt was provided for transit but safety in the aircraft was dependent upon the ferrule.
- Fig.41 A design of a non-ejection type of bomb with a simple magnesium body. It contained six sets of pellets arranged as in the 4 lb. incendiary bomb. Ignition was from the nose end and safety was dependent upon a shear wire.
- Fig.42 This was similar to Fig.40 but had seven sets of pellets initiated by three 4 lb. bomb igniters. Safety was dependent upon the ferrules with no external safety device. If one central igniter were used, a safety rod could be incorporated.
- Fig.43 Similar to Figs. 41 and 42 but in the 30 lb. L.C. shape to improve ballistics.

The weights of all these bombs were in the region of 30 lb.

10.2 A meeting was held to consider these designs and Air Staff stated a requirement for a design of bomb, similar to Fig.40, on high priority, and for a design of allways fuze on lower priority. The requirement specified that the maximum weight should be 31 lb. and the stowage dimensions should be as for the 30 lb. L.C. bombs. As many as possible of the components of the 25 lb. bomb were to be used.

10.3 The design shown in Fig.44 was produced to meet this requirement. The bomb had an all-up weight of 30 lb. and included seven firepots to the existing design. The nose was filled with gunpowder instead of thermite, in order to ensure that all the incendiary composition was ejected, and a small initiating charge was substituted for the "tail blowing" charge of the standard 25 lb. bomb, the tail then being blown off with the ejection of the first firepot instead of on impact. A longer thread was used for the attachment of the nose to the body, the outline of the body being altered thereby to cylindrical with a straight cone tail. R.A.E. considered that this design would be more stable than the existing design because of the more forward position of the c.g. A further design fitted with a "three-ways" mechanism was later produced.

# [ ] Chapter and paragraph.

10.4 As a result of trials, bombs to this latter design were modified as follows -

- (i) A brass strip 0.014 in. thick was soldered across the mouth of the body tube to prevent premature ejection of the firepots on impact. This strip (which was melted away by the first firepot) was found satisfactory.
- (ii) Steel bands were fitted around the centre and ends of the body to prevent splitting of the welds which caused the firepots to be ejected en bloc.
- (iii) An external band of hard steel was fitted at the mouth of the tube to prevent distortion of the mouth causing the firepots to fail to be ejected.
- (iv) Tails were fastened directly to the body and the stiffening rings secured by six No.6 B.A. shearing screws. The experience gained in these trials enabled the design of the bomb shown in Fig.45 to be produced. This gave considerably improved results in trials and was approved as the 40 lb. Mk.I in December 1939.

10.5 The bombs were accepted for Fleet Air Arm use and a design for carriage on the light series carrier was requested. The design shown in Fig.46a was produced, utilising a lug spot welded to the body as in the 40 lb. G.P. Mk. I and III. It was not considered satisfactory and the design of suspension band shown in Fig.46b was put forward and accepted after slight modifications to make it suitable for use on catapulted aircraft. The knuckle bar on this design was placed at 45° to the lug in order to make it suitable for use on the "Battle" Aircraft.

10.6 Messrs. Trojans suggested that the drawings of the bomb should be modified and the threaded portion of the nose adapter made in zinc alloy and fastened to a steel plate by counter-sunk screws. This was to prevent distortion of the steel adapter during welding and was agreed to. In the middle of 1940, the shortage of steel led to trials of noses cast in malleable cast iron, "Mechanite" metal and nitro alloy. None of these gave satisfactory results and the nose continued to be manufactured in steel.

10.7 By the middle of 1941, the No.43 "allways" fuze had been developed, and the design of 40 lb. bomb was modified to take this. The design is shown in Fig.47 and was known as the Mk.II. Actually it replaced Fig.45 as the Mk.I bomb since bombs to Fig.45 were never put into service. The differences from Fig.45 were

- (i) Threaded hole amended to take the 43 fuze.
- (ii) No.43 fuze fitted on filling.
- (iii) Air arming device as for the 25 lb. bomb but the tail is fastened by screws instead of spring clips and the length of arming rod is different.

10.8 At the same time as the requirement for the "firepot" type of bomb was stated a further requirement was stated for a

bomb of magnesium with a thermite filling. The requirement was:-

- (i) Weight of bomb not to exceed 40 lb.
- (ii) Dimensions so that three or four bombs will fit the S.B.C.
- (iii) Bomb to penetrate 4 in. of concrete plus a glass, slate or corrugated iron roof from 5,000 ft.
- (iv) T.V. to be not less than 850 ft./sec.
- (v) To be filled plain thermite and magnesium as the 4 lb. incendiary bomb and to have a final bursting charge as for the 4 lb. 'E' type bombs.

10.9 A design on this basis was produced and contained thermite pressed in a separate container to facilitate production. On trials, failures occurred due to blow-back of the detonator and by breaking off of the nose. The blow-back faults were overcome by using a 1.7 grain detonator in place of the 1.62 grain detonator of the original design. Increase in the size of the nose spigot from 2 in. with a 8 T.P.I. thread to 4.3/4 in. with a 14 T.P.I. thread prevented the break-off of the nose. This modified design is shown in Fig.48, and was satisfactory on dropping trials (40).

10.10 The shortage of magnesium and the fact that the bomb was uneconomical on an aircraft load basis led to the cessation of this development and, in the middle of 1941, The Air Staff cancelled the requirement for 40 lb. bombs.

## Chapter 11. The 50 lb. Parachute Incendiary Bomb

11.1 This project was commenced in June 1940 to meet the same requirement as the 25 lb. Incendiary Bomb with parachute (9.8) viz. the attack of pinewoods. The suggestion was made that the 4.5 in. or 5.5 in. Reconnaissance Flares should be fitted with a candle having a magnesium case so that, on ignition, the case would melt and give "drips" of burning magnesium to fire the woods. The parachute would cause it to be caught in the treetops and remain suspended so enabling the candle to function in this manner.

11.2 The Research Department developed a candle on these lines consisting of a tube of magnesium 4.3/4 in. outside diameter, 2.7 in. inside diameter and 16 in. long. It was filled with S.R.306 and primed in the same way as the standard 5.5 in. flare candle. It was interchangeable with the standard 5.5 in. candle when fitted in a sheet iron container and was attached directly to the 5.5 in. flare parachute. Trials showed that it functioned correctly when ejected from the 5.5 in. flare body.

11.3 A burning trial showed that for the first 40 secs. a shower of sparks issued from the 1 in. hole in the base of the iron container and these were succeeded by a rapid stream of large drops of burning magnesium which continued until 2 mins. 20 sec. after ignition. The stream then moderated and finally ceased 2 mins. 50 sec. after ignition.

11.4 This candle, complete in iron case, weighed 27 lb. and contained 12 lb. of magnesium of which 9.3/4 lb. dripped to the ground. Slight modifications brought the weight down to less than 2 lb. heavier than the standard 5.5 in. flare candle. In this form, the candles were made up for dropping trials.

11.5 Dropping trials against woods gave good results with the candles dripping for from 3 to 3.1/2 mins. It was found, however, that some flares came to rest in a horizontal position due to partial failure of the parachutes. This reduced their incendiary effect as much of the magnesium remained in the iron container. D.Arm.D. suggested that the container should be perforated with 1/4 in. holes so that the flare would drip independent of the position in which it came to rest. It was felt that 1/4 in. holes would slag up on burning so 1 in. holes were drilled in either end of the container so catering also for the condition where the candle came to rest with the nose elevated.

11.6 This design was approved in January 1940 and the Ordnance Board suggested that it should be used in conjunction with the 25 lb. bomb with parachute as it had the advantage of feeding the fires if the undergrowth was damp or difficult to ignite. The final design, designated "Bomb, parachute, incendiary, aircraft, 50 lb. Mk.I is shown in Fig.49.

SECTION 3.

NON MAGNESIUM INCENDIARY BOMBS

<u>Contents</u>	<u>Page</u>
Chapter 12 - The Penetrating Thermite-Fuel oil Bomb	30
" 13 - The 30 lb. Incendiary Bomb	34
" 14 - The 2700 lb. Incendiary Bomb	38
" 15 - The 400 lb. Oil Incendiary Bomb	40
" 16 - The 250 lb. Incendiary Bomb	41
" 17 - The 5.5 in. Incendiary Bomb	42
" 18 - Aircraft overload tanks as Incendiary Bombs	47
" 19 - The 500 lb. Incendiary Bomb	48
" 20 - The 45 lb. Oil Igniting Bomb	49



## Chapter 12. The Thermite-Fuel Oil Bomb

12.1 In November 1939 D.Arm.D. requested the Ordnance Board to consider the problem of producing a bomb which did not contain magnesium, since the supplies of this metal were likely to be insufficient for all purposes. They requested that the problem should be studied from the following points of view.

- (a) Availability, including weight of effective unit, cost of materials and the plant required for preparation and filling, and the type of bomb construction necessary.
- (b) The type of incendiary effect produced including the time interval before an "appliance" fire developed.
- (c) Degree of difficulty of extinguishing the fire in its early stages on account of smoke or explosive effects.
- (d) Any special effects of particular media.

It was suggested that fuel oil or petrol with a charge of thermite to eject and ignite it would probably be most generally effective and readily available. A design of such a bomb capable of penetrating 4 in. of concrete was requested on high priority and a design of bomb capable of penetrating an ordinary roof and functioning on the floor below on lower priority.

12.2 The Research Department gave consideration to this problem of alternative fillings and produced on the table shown in Table 2 to afford an easy comparison of the various types of fillings available (41). From this table they concluded that the most suitable substitutes for magnesium were phosphorus, inflammable liquids and sodium. They suggested the following four fillings for trials, utilising the ability of thermite to bring other incendiary agents into action.

- (i) Phosphorus and thermite
- (ii) Sodium and thermite
- (iii) Volatile liquids such as petrol
- (iv) Heavy oils and thermite

A bomb on the lines suggested by D.Arm.D. and containing equal quantities of heavy oil and thermite would have the wood penetrating properties of thermite combined with the flames of an oil fire.

12.3 Alternatives (i) and (ii) of the Research Department's suggestions were not considered practicable propositions as the expansion of the phosphorus industry was not easy and sodium was produced by only one plant in the country and that was unfavourably placed strategically. Accordingly the design of a thermite fuel oil bomb was concentrated upon, in accordance with D.Arm.D.'s request. This bomb was to contain 1/2 - 3/4 gallon of hydrocarbon oil with the appropriate amount of thermite and was to be limited to 32.8 in. long and 5.015 in. diameter in order to fit the S.B.C.

12.4 The designs shown in Figs. 50 and 51 were produced to meet this requirement using fillings of thermitite/fuel oil and thermitite/pitch. Owing to the low T.V. of both bombs, (approx. 500 ft./sec) and the blunt nose, the penetration was low. Fig. 51 was also bad ballistically owing to its high c.g./L coefficient of .328. On burning trials, bombs to Fig. 50 functioned and gave oil fires lasting for 15 mins. but only about 1/4 of the thermitite was burned owing to quenching by the oil. Bombs to Fig. 51 gave very small fires although all the thermitite burned. All development on the thermitite-pitch type was, therefore, abandoned and efforts were directed towards increasing the incendiary efficiency and penetration of the thermitite/fuel oil type.

12.5 In view of the large numbers of 25 lb. incendiary bomb bodies available, D.Arm.D. requested that a design should be produced of these bodies filled plain thermitite and also filled thermitite-fuel oil. It was recognised that the quantities of thermitite and fuel oil would not be in accordance with C.S.A.R.'s table. The design of 21 lb. Thermitite-fuel oil bomb produced to meet this request is shown in Fig. 52. These bombs were not efficient from the incendiary aspect and their penetration was poor. Trials at Boscombe Down showed that the bomb would not stand up to hard impact and would not function on downland from 1000 ft. to 3000 ft. (42). This line of development was, therefore, discontinued.

12.6 The development of a bomb on the lines of Fig. 50 with increased penetration continued and two designs shown in Figs. 53 and 54 were produced. These were on similar lines, the main differences being the all-up weights 33.1/2 lbs., giving 8 or 6 bombs per S.B.C. Nose pistol No. 34 and detonator systems similar to those of the 35 lb. and 40 lb. incendiaries were used. The forward part of the body contained a pellet of thermitite and behind this was a container of fuel oil made of tin plate or rolled paper with tinplate ends. Cellulose acetate was also tried for the container but proved unsuitable.

12.7 These bombs had T.V s of 480 and 540 ft./sec. respectively and were excellent bombs ballistically but in July 1940 the requirement for these bombs was cancelled and no further development was done.

TABLE 2

Material	Estimated equivalent weight of incendiary material	Approximate weight of bomb	Type of incendiary effect	Probable time to produce a fire requiring a trained squad	Degree of difficulty in extinguishing the incendiary material	Special Characteristics
Magnesium	lb. 1½	lb. 4	Local intense heat persisting for 10-15 minutes. Chars through and inflames wood easily. Scattered particles ignite textiles. Does not melt through steel.	On wood, 10-15 minutes	Formidable fire which can be extinguished by a water jet directed from 10 feet or over.	The most effective incendiary material against wood. Does not require a container. The incendiary weight is required for ballistic purposes only.
Thermite	6 - 10	20 - 30	Fierce combustion of short duration. Some flame and sparks. Hot molten slag which can char and inflame wood and can melt through steel.	Will produce an effective fire only under favourable conditions.	The hot residue can easily be extinguished.	Can melt through steel. Requires a container.
Thermalloy	6 - 10	20 - 30	As for thermite but more flame emitted. Does not melt through steel as readily as thermite	Somewhat more likely than thermite to produce an effective fire.	As for thermite	As for thermite
Phosphorus	2 - 3	8 - 15	When ignited by thermite it produces large flames and a considerable volume of smoke. The flame ignites wood. It melts easily and the flaming molten mass penetrates cracks.	On wood, 10-15 minutes.	Easily extinguished by water but liable to reignite if any phosphorus remains.	The fire is easily discovered owing to the dense white smoke produced and will instantly attract fire-fighters. After the fire is extinguished the presence of unburnt phosphorus will make the room uninhabitable until the phosphorus has been removed.

TABLE 2 (cont'd.)

Material	Estimated equivalent weight of incendiary material	Approximate weight of bomb	Type of incendiary effect	Probable time to produce a fire requiring a trained squad	Degree of difficulty in extinguishing the incendiary material	Special Characteristics
Sodium	lb. 4	16 - 25	When ignited by thermit, chars through and ignites wood easily, producing considerable flame and smoke.	On wood, 10-15 minutes	Dangerous to attack with water but easily extinguished by sand.	The fire is immediately revealed owing to the dense white smoke produced.
Pyrotechnic composition containing aluminum or magnesium	10	20 - 30	Fierce combustion with large flame persisting for about 2-4 minutes.	Will produce a fire under favorable conditions.	Not easily extinguished by small supplies of water.	
Pyrotechnic composition not containing aluminum or magnesium e.g. pitch compositions	10	20 - 30	Burns with fairly large flame persisting for 5-6 minutes.	"	Easily extinguished by small supply of water.	
Petrol and other inflammable liquids.	$\frac{1}{2}$ - $\frac{3}{4}$ gal.	15 - 25	Large flames	5 minutes	Approach difficult on account of large amount of flame	To obtain the best results the inflammable liquid should be made to flow over the target.

## Chapter 13. The 30 lb. Incendiary Bomb

13.1 Because of the magnesium shortage in the middle of 1940, consideration was given to the design of a bomb not containing this metal. For preliminary investigations, four types were considered, viz:-

- (i) Thermite/liquid Incendiary Bomb (Chapter 12)
- (ii) Liquid incendiary bomb employing the tail ejection principle of the 30 lb. L.C. bomb Mk.1.
- (iii) Liquid incendiary bomb of the disruptive type on the lines of the German 110 Kilo bomb.
- (iv) A bomb which broke up on impact and scattered its charging, which would be subsequently ignited, on the lines of the 30 lb. L.C. bomb Mk.II. This bomb would not have the same degree of penetration as the above three types but would penetrate light roofs satisfactorily.

13.2 A consideration of the results of the Gretna trials and of the area of contamination produced by the 30 lb. L.C. bomb indicated that an intense fire might be expected from a bomb functioning on these lines. Since smaller numbers of this type of bomb than of the 4 lb. bomb could be carried on an aircraft, it was considered that a certain amount of scatter of the filling would be an advantage. This scatter could be controlled by the size of bursting charge employed and would obviously be restricted by walls, etc., when bursting in a building. Under these conditions the scatter of filling would not be as great as that of a bomb bursting in the open.

13.3 From experience gained on bombs with vesicant charging, it was known that a bomb functioning by disruption by H.E. gave a smaller drop size than a bomb functioning by tail ejection. With an incendiary filling, this smaller drop size would give a greater tendency to explosion and less incendiary effect. Since there were large stocks of 30 lb. L.C. bombs available, which were not required for other purposes, it was decided to concentrate on the development of this bomb as an incendiary.

13.4 Trials by the Research Department established that, with a gel of 5% rubber in benzole as the main filling, very little ignition of the filling occurred with the Service burster of 35 gms. of gun powder, as used in the 30 lb. L.C. bomb. Four alternative methods of increasing the ignition were proposed, three using phosphorus and one using Grade 3 magnesium in the burster before filling with gunpowder. Of the three varieties of phosphorus proposed, viz.,  $1\frac{1}{2}$  lb. "liquid" phosphorus,  $1\frac{1}{2}$  lb. White phosphorus, or 1 lb. amorphous phosphorus, the white phosphorus was eventually chosen as the standard filling.

13.5 Dropping trials of the 30 lb. L.C. bomb Mk.1 with incendiary filling (43) were satisfactory and this bomb was accepted for service use as the 30 lb. Incendiary Bomb Mk.1. The original bombs were identical in design with the 30 lb. L.C. Bomb Mk.1 and used the No.38 fuze. This design is shown in Fig.55. Shortage of machining capacity, however, led to the adoption of a pressed steel nose in lieu of the machined nose of the 30 lb.L.C. bomb and the 38 fuze was replaced by the No.846 which was completely recessed

into the burster so obviating the necessity of the aluminium nose fairing. Further modifications to the empty to aid production were the omission of shot blasting and varnishing of the internal surface of the bomb and replacement of the burster container threaded into the nose-plug by one welded into the plug. The nose-plug and burster ring were also made in one piece and the burster cup welded to this component.

13.6 In order to utilise existing plant, the filling of the Mk. I bombs was 7% rubber in special petrol and the white phosphorus was replaced by "liquid" phosphorus. After climatic trials had been done, the air space above the filling was increased from 1" to 1½" minimum as it was found that, due to the very high coefficient of expansion of benzole, distortion of the tail plate and leakage occurred with the smaller airspace.

13.7 The design of empty bomb was considerably modified during production, and eventually, a completely new design was produced by Messrs. Luxfers. Trials of this bomb, the Mk. II, were satisfactory. It had the following advantage over the Mk. I bomb:-

- (i) It was easier and cheaper to manufacture.
- (ii) It had a higher c/w ratio.
- (iii) No space was wasted at the nose end.
- (iv) It was fitted with the 846 fuze which was easier and cheaper to manufacture than the 38.
- (v) Fuzing in service was easier since no spanners were required.

13.8 These designs were submitted to other manufacturers and various amendments were proposed, mainly to suit the individual manufacturers and the most important of which were as follows:-

- (a) Manufacture of the body and nose in one piece by spinning over the end of the solid drawn tubing. This method did not permit the manufacture of a returned piece in the nose as in the standard design and the nose was thereby weakened. It was not brought into general use but was permitted as an alternative method of construction.
- (b) It was agreed that the length of parallel portion of the nose should be adjusted to suit the length of tube available and that the ruling dimension should be the overall length of the bomb.
- (c) The manufacture of the burster by flash welding was permitted but a suggestion that the burster be formed by spinning over the end of steam tubing and closing the central hole by welding was not proceeded with.
- (d) A malleable cast iron taper plug in lieu of the steel one was permitted and, later, replaced the steel plug completely.
- (e) A tail without an adjusting bolt was adopted. This tail had a slightly longer drum and a slightly greater overall length than the tail of the 30 lb. L.C. bomb Mk. I. Various other modifications were

made to save machining and, before the design finally went into production, the use of sheet steel in lieu of tin plate and of a spot-welded construction for the tail were permitted. These were permitted to meet the shortage of tinplate and also to suit manufacturing capacity available. The Mk. II design is shown in Fig. 56.

13.9 Messrs. Luxfers proposed an alternative burster with a shoulder resting on the nose of the bomb which would give additional resistance to impact. This burster was better from the welding point of view, but increased the machining necessary, and was eventually incorporated in the design. The filling of the bomb was as for the Mk. I, viz.  $1\frac{1}{2}$  lbs. of White Phosphorus and 6 lbs of gel of 5% rubber in benzole. The airspace was  $\frac{3}{4}$ " to  $1\frac{1}{2}$ " with the bomb standing on its nose in a vertical position. This airspace was increased to  $2" + \frac{1}{2}"$  as a result of climatic trials.

13.10 Owing to the shortage of solid drawn tubing in 1941, consideration was given to the fabrication of the body tube of the bomb by rolling steel plate and welding longitudinally. This method proved satisfactory and bombs with bodies manufactured in this way went into service as the Mk. III. The bomb functioned by disruption instead of tail ejection as in the Mk. II bomb and, as a result of this, it was found possible to reduce the quantity of white phosphorus in the nose of the bomb from  $1\frac{1}{2}$  lbs to 1 lb. The bomb was otherwise identical with the Mk. II.

13.11 The Mk. IV bomb differed from the Mk. III mainly in the thickness of plate used for the body tube. In the Mk. III bomb, the body tube was made from 10 gauge steel while, in the Mk. IV bomb, it was made of 12 gauge steel plate. Since the internal diameters of the bomb bodies were the same, the Mk. IV bomb had a slightly smaller outside diameter than the Mk. III bomb. This permitted greater eccentricity tolerances on the Mk. IV bombs and also permitted manufacture of the body in a truly circular section without the flat at the weld as in the Mk. III. (Fig. 57).

13.12 All the above Marks of bombs were fitted with locating pieces and suspension bands when required for carriage on carriers, bombs so fitted being distinguished by an M after the Mark number, e.g. Mk. II M. The provision of the bombs was mainly for Naval Service as the R.A.F. normally carried the bombs in Small Bomb Containers.

13.13 With the invasion of Malaya, rubber for use in these bombs was not available. Gels containing scrap perspex were first substituted for the rubber/benzole gel of the original bombs and, later, a preparation of cellulose acetate was used.

13.14 Trials of the Mk. II L.C. bomb were also carried out in the early stages of this development (44 & 45) and the spread of the filling on break-up was found to be satisfactory although the penetration from low altitude was not good. The use of self-igniting fillings was agreed to be undesirable in a bomb of such a fragile construction, so the design of an igniter was put in hand. The first design was for an air armed igniter and trials by C.S.A.R. at Boscombe Down showed this to be satisfactory when the weight of gunpowder was increased from 25 gms to 35 gms. Since the Navy had no requirement for the L.C. Mk. II as an incendiary bomb, the design of an igniter without air-arming was requested.

13.15 While preparing the design of an igniter without air-arming, the Design Department pointed out that:-

- (a) Air Arming had been found necessary for the 25 lb Incendiary Bomb after the shear wire and safety rod arrangement had been found unsatisfactory.
- (b) The light case of the bomb would start to break up before the shear wire was severed. Position of the contents of the bomb relative to the fuze when it operated would be problematical.
- (c) It was presumed that the fuze would have to be safe for an 8-10 ft. drop, and this would render functioning on soft targets uncertain. While the bomb might be primarily for hard targets, it was a very useful weapon for attack of grounded aircraft already damaged by bomb splinters or machine gun fire. The air armed igniter proposed would provide a fuze suitable for all conditions.
- (d) The troubles caused by modified fuzing arrangements were exemplified by the 25 lb bomb.
- (e) In containers, after the safety pin was removed, the only safety device would be the shear wire. If the bomb were dropped on to concrete, the destruction of the aircraft would result.
- (f) A similar arming device on the A.D.D. bomb had proved effective and safe.

It was suggested that wind tunnel trials of the air arming device might be carried out.

13.16 These trials were eventually done and showed the design to be satisfactory from the functioning aspect of the air arming device. The design, after minor amendments to meet criticisms of some of its functioning aspects, is shown in Fig. 58.

13.17 Fig. 59 shows a design of bomb prepared by C.E.A.D. at the end of 1941, as a possible replacement for the 30 lb Mk. II. Points claimed in its favour were:-

- (i) The design was suitable for mass production in this country. Suitable equipment and steel were available and production could be started at an early date.
- (ii) What little welding was necessary would be done in several ways to build up production while projection welders were being obtained.
- (iii) Output would be considerably greater than that of the Mk. II bomb.

It was decided to continue with the Mk. II bomb and the above design was not proceeded with.

13.18 The 30 lb and 4 lb bombs together represented the greater part of the incendiary bombs dropped on German targets by the R.A.F.



## Chapter 14. The 2700-lb. Incendiary Bomb.

14.1 This design originated in a requirement by the Pathfinder Force, in July, 1942, for a ground marker bomb to give a distinctive mark on the ground for thirty minutes. The use of the 4,000 lb. H.C. Bomb case filled with incendiary gel was proposed and two methods of functioning were considered, viz:-

- (a) The use of a burster to disrupt the bomb on impact and ignite the filling.
- (b) The use of a viscous charging together with liquid phosphorus on the assumption that the bomb would break up on impact.

Scheme (a) was preferred since it was almost certain that both the standard 4,000 lb. H.C. bomb and the special bomb, designed for "Dithekite" liquid H.E. filling, would not break up on soft targets. It also avoided the carriage of liquid phosphorus in aircraft as this was regarded as undesirable.

14.2 The burster first suggested was T.N.T./AI, 80/20, which it was thought would give sufficient flash to ignite the filling. Trials of this burster in cooled 30 lb. Incendiary Bombs showed that ignition could not be guaranteed so the use of phosphorus in the bomb had to be accepted. This was cast into a steel tube which contained about 100 lb. of white phosphorus and was concentric with the burster tube, which it surrounded. An exploder container at the rear end of the bomb, to make a modified No. 27 pistol, was also provided.

14.3 This bomb is shown in Fig. 60 and contained approximately 1,500 lbs. of 7% perspex benzole gel with a 7% airspace and had an all-up weight of approximately 2500 lbs. The T.V. of the bomb was low, about 650 ft./sec., so that the S.A.B.S. Mk. II could not be used for dropping it. The principle of "aiming off" with the Mk. XIV bombsight was accepted by Pathfinder Force for this bomb. Trials of the filled bombs showed that most of the filling was consumed in the initial flash and a sustained fire was not produced. The burning time of the statically fired bombs was not up to that required. Some bombs to this design were, however, dropped on operation against Germany and the aircrews reported favourably on them as an initial marker. Information on the burning time of these bombs was not obtained by the crews in view of the short time each aircraft spent over the target. Confirmation of the aircrews' reports could not be obtained from the trials carried out in this country but about 100 bombs were made and used operationally.

14.4 The design of a bomb to eject a container of incendiary material in the air was commenced in view of the disappointing trial results of the impact fused bombs. This container could be weak and so would break up, or would need only a very small disrupting charge to scatter the filling, on impact. The design shown in fig. 61 was produced, the container being made of "Pytram". Consideration was given to the use of either barometric or radio-proximity fuzeing, barometric fuzeing being chosen since the proximity fuze would need further development while the No. 860 nose barometric fuze was immediately available. The C.E.A.D. design of electric barometric fuze was not accepted on the grounds that the airflow over the nose of the bomb would not guarantee functioning of the generator unit.

14.5 It was found in wind-tunnel trials (46 & 47) that the pressure on the nose of the bomb was such that the height of functioning of the fuze would increase by 300 ft. for every 1000 ft. increase in dropping height if the bomb had a T.V. of 1000 ft./sec. There were, however, points on the bomb and tail which had a very low dynamic pressure and these points could be joined to the fuze by a pipe. Dropping trials of half-scale models showed that the bombs would have good stability with the shapes proposed.

14.6 The amount of gunpowder used in the burster was reduced from 4 lbs to 1 lb as a result of static trials of inert filled bombs (49 & 50). The larger charge caused break-up of the container, particularly in the U-groove which was provided to clear the internal beam of the bomb case. This break-up was much reduced when the smaller bursting charge was used. Static trials of gel-filled bombs (51 & 52) showed that the igniters originally called for in the container design were unnecessary and were even a disadvantage in that they caused excessive scattering of the filling. The final bomb with a 1-lb. burster and no igniters for the container gave a burning time of 30 - 35 minutes.

14.7 In December 1942, the requirement for the bomb as a marker was cancelled in view of the more economical aircraft loading obtainable with 250 lbs. T.I. bombs. The impact-fuzed bomb was revived early in 1944 as a possible weapon for the low altitude attack of fortified objectives in Europe and Asia. The bomb was fuzed with the air-armed No. 55 pistol in the nose and air-armed No. 54 pistol in the tail and a special cone and drum tail was developed.

This tail necessitated the use of an adjustable arming rod as shown in fig. 62. The use of this type of arming rod was undesirable and an attempt was made to devise a method of tolerancing the tail and end of the bomb body in such a way that a standard type of arming rod system could be used. It was not found possible to do this without altering the method of securing the tail to the same type of fastening as used in the 4000 lb M.C. bomb. The scheme shown in fig. 63 was prepared but was not proceeded with as the bomb did not go into production.

14.8 Trials of the bomb showed that a furious fire was caused on impact if the filling was confined by the bomb case or a concrete structure but a large area of scattered small fires resulted if the bomb burst in the open. The development ceased when the Japanese War came to an end.

## Chapter 15. The 400 lb. Oil Bomb.

15.1 This bomb was designed in 1944 to meet an Air Staff requirement for a bomb to fit into a 1000 lb. stowage and function effectively against land or water. The primary object was the attack of sampans and other small craft in the East when in harbour. The first design was scaled down from an American mock-up bomb consisting of a 55 gallon oil drum, filled crude oil, to the rear end of which was welded a 4 gallon petrol tin filled with gel. The drum broke up on hitting land or water giving a patch of crude oil which was ignited by lumps of burning gel from the rear container which was burst by a burster and fuze. The scaled down version had a gel container bolted to the tail plate and was fuzed with a No. 30 tail pistol and a No. 52 detonator with a gunpowder burster as shown in fig. 64.

15.2 The bomb was proposed for the attack of fortified objectives in Europe since it was so far advanced in its development when the requirement for such a weapon became urgent. Trials (53) showed that the bomb would penetrate a 9" concrete wall when released from "Thunderbolt" aircraft from low altitude but the rear containers generally broke off and remained in front of the wall. An intense petrol fire was caused for about 1 minute but rapidly died out. It was concluded that the bomb was not as suitable for this purpose as other stores under development, e.g., the 500 lbs L.C. bomb charged incendiary. (Chapter 20).

15.3 The stores used in these trials were similar to fig. 64 being 60½" long x 17" diameter having a 16 gauge cylindrical body with a cast iron nose weight for ballistic purposes. The main filling was petrol with a 10% air space and the rear container was filled with a gel of 6% cellulose acetate and 14% cresylic acid in benzole. The burster consisted of C.E. and magnesium in cardboard containers.

15.4 As a result of experience the bomb was modified for a gel filling with a standard rear exploder container in place of the rear gel container. Trials (54) showed that this bomb functioned on downland and calm water giving an area of burning gel of approximately 100 ft. diameter on water and approximately 70 yds. x 19 yds. on downland. These bombs were filled with approximately 28 gallons of a gel consisting of 6% aluminium laurate and 2% ortho cresol in pool petrol with the addition of 7 quarts of K.O.F.Q.R. to improve functioning on water. The rear exploder container was the standard 500 lbs. exploder container and contained a special burster of 100 gms. of magnesium and gunpowder in the form of pellets. These pellets were perforated to take a No. 52 detonator and the bomb was fuzed with a No. 60 pistol which is a modified multiways pistol No. 54.

15.5 Ballistic trials (55) showed that the bomb was on the limit of satisfactory ballistic consistency from 15,000 ft. but was stable for release from that height. The final design of this bomb was as shown in fig. 65 and a few hundred were made for use in the Far East. None of these bombs was ever used on operations, however, and the bomb was not considered to be suitable for general introduction into the Service. The T.V. was about 800 ft./sec. in the final version.

## Chapter 16. The 250 lb. Incendiary Bomb.

16.1 This bomb began in 1940 as an emergency conversion of the 250 lbs. L.C. bomb for incendiary filling. The Mk. I version shown in fig. 66 was identical with the 250 lbs. L.C. bomb except that the nature of the charging rendered varnishing of the internal surfaces unnecessary. The charging consisted of "sausages" of rag about 1" diameter and 12" - 18" long tied by means of string and inserted into the bomb before screwing home the nose container. 8 gallons of paraffin were then poured into the bomb through the charging hole in the tail plate and the bomb exploded with a standard gunpowder burster. The all-up weight of the bomb was 200 lbs. and a few hundred were made and used on operations.

16.2 Trials of bombs with gel filling were next carried out. 3% and 5 $\frac{1}{2}$ % solutions of rubber/benzole gel, with 18 $\frac{1}{2}$  lbs. of stick phosphorus in the nose of each bomb, were tried and both were found to function although the 5 $\frac{1}{2}$ % gel was considered most satisfactory. The fuze used was the No. 36 fuze, as used in the 250 lb. L.C. bomb, modified by removal of the delay so as to give instantaneous functioning. Bombs fuzed thus, functioned satisfactorily on hard targets but were not so satisfactory on soft targets due to burying on impact. Even if the fuze failed, the bomb would break up and function satisfactorily on a hard target.

16.3 This bomb, filled 5% rubber/benzole gel was submitted to the Air Staff for acceptance in August 1941 and accepted as the Mk. II bomb. Further trials (57) showed that bombs filled with 5% rubber/benzole gel and fuzed with the No. 36 fuze, modified by removing the delay, functioned satisfactorily without phosphorus and equally satisfactorily with 6 lb. of phosphorus cast into the nose. The only real advantage of the phosphorus was that it ensured ignition in the event of a fuze failure and bomb break-up. The Air Staff decided that the bombs should be filled with the gel only, without phosphorus. The filling consisted, therefore, of 87 lb. of 5% rubber/benzole gel with 0.1% anhydrous trisodium phosphate and had a burster of 11 ozs. of gunpowder. This bomb is shown in fig. 67.

16.4 Climatic trials showed that bulging of the tail plate and leakage of bombs occurred due to the very high coefficient of expansion of benzole. In order to overcome this, the air space was increased to 2 $\frac{1}{2}$ " +  $\frac{1}{2}$ " with the bomb in a vertical position standing on its nose. With these amendments the Mk. II design went into production and was used on operations.

16.5 During the early part of 1942, this bomb, filled with petrol and K.O.F.Q.R. was tried as a possible weapon for the ignition of fuel oil on water. The trials (58) showed that the bomb would not ignite the fuel oil even if it functioned in a comparatively thick layer of oil. This application was not, therefore, proceeded with.

## Chapter 17. The 5.5 Incendiary Bomb.

17.1 In the middle of 1942, consideration was given to the design of an incendiary bomb as a replacement for the 30 lb Incendiary bomb to permit the carriage of larger numbers on aircraft. Preliminary discussions indicated that the minimum quantity of filling required was 6 lbs of gel, requiring a capacity of 228 cu. ins. The bomb was to function by scatter or bursting and was to be capable of penetrating a roof and an attic floor from a height of 5000 ft. at an airspeed of 250 m.p.h., the strength being such that the bomb would be capable of functioning after such penetration. It was to be suitable for carriage in S.B.C's or clusters and to give a distribution of one bomb per 400 sq. yds. when dropped from a height of 15,000 ft. at an airspeed of 250 m.p.h.

17.2 The bomb first proposed is shown in fig. 68. This was a hexagonal bomb of approximately 25 lbs. all-up weight containing 6 lbs of gel. Calculations showed that the bomb should have the required ballistics. The hexagonal shape was chosen as the best shape for clustering but it was found that the increase of capacity was only 10% over that of a bomb having a cross-section of the inscribed circle of the hexagon. In production this would be further reduced to 5% owing to the radius which would have to be allowed on the corners of the hexagon. It was decided that this increased capacity did not justify the added difficulties of production of the hexagonal bomb.

17.3 Various diameters of bombs were considered in an attempt to find the optimum size of bomb for all conditions of stowage and the table shown in Table 3 was produced. Figs. 69 - 73 show some of the schemes considered. Consideration of Table 3 led to the conclusion that a 5.5" bomb (Scheme H) would be most efficient for the following reasons:-

- (a) For the required 6 lbs. of charging it had the highest charge/weight ratio.
- (b) For Wellington and Stirling aircraft, which were the most important cases, it had the highest total weight of incendiary filling per aircraft load.
- (c) The number of points of fire per aircraft load was the second highest in the case of the Stirling and the highest in the case of the Wellington.
- (d) The maximum loads per aircraft were not reached in the cases of the Lancaster and Halifax aircraft but in each case an efficient incendiary load was obtained.
- (e) The minimum charge of 6 lbs of gel was easily reached and there was a margin for increasing the charge per unit if this was found necessary.
- (f) Clustering of the bomb was easy since the packing takes the form of a circle and there was no sharp radii to be followed by the cluster gonds.
- (g) The packing dimensions of the 3 bombs of 7 bombs were 63" x 16.5" which allowed ample space for the cluster components.

17.4 The design of bomb shown in fig. 74 was, accordingly, produced for trials to determine scatter of filling and ballistics. The bomb did not proceed beyond this stage as, in March 1943, the 30 lbs J Type bomb was being developed and effort was concentrated on producing this type of bomb. The 5.5" bomb was not regarded as being any improvement on the 30 lbs bomb since a special cluster projectile, containing no more bombs than the simple cluster of standard 30 lbs. I.B., would be needed.

Table 3 (a)

Scheme	Bomb	Carriage in a/c	Wt. of Bomb lb	Wt. of Filling lb.	c/w ratio %	Weight of cluster lbs.
A	30 lbs. I.B.	S.B.C.	25	7.5	30	200
B	"	2 x 7 clusters	25	7.5	30	350
C	4.4" diam.	3 x 10 clusters	25.4	5.3	20.6	762
D	4.5" diam. max. c/v ratio	3 x 10 clusters	32	6.35	19.5	960
E	4.6" diam. max. charge	3 x 9 clusters	27.6	5.9	21.3	745
F	4.6" diam. opt. c/w ratio	3 x 9 clusters	18.8	5.1	27.2	507
G	4.6" diam. opt. wt. per cluster	3 x 9 clusters	24.6	5.7	25.2	664
H	5.5" diam. opt. c/w ratio	3 x 7 clusters	25.3	7.0	27.6	531
I	5.5" diam. opt. wt. per hook	3 x 7	31.3	7.7	24.6	637

Table 3 (b) Stirling Stowage

Scheme	No. of Stowages	Load lbs.	Wt. of Charge lbs.	No. of points of fire.
A	24	4,800	1,344	192
B	24	8,400	2,352	336
C	13	9,945	2,067	390
D	10	9,600	1,875	300
E	15	10,690	2,430	405
F	20	10,120	2,754	540
G	15	9,945	2,065	405
H	20	10,500	2,940	421
I	15	10,000	2,422	315

Table 3 (c) Halifax Stowage

Scheme	No. of Stowages	Load lbs.	Wt. of Charge lbs.	No. of points of fire.
A	15	3,000	840	120
B	15	5,250	1,470	210
C	12	9,180	1,908	360
D	9	8,640	1,687	270
E	13	9,008	2,106	351
F	15	7,590	2,070	405
G	14	9,282	1,928	372
H	15	7,375	2,205	315
I	14	9,334	2,263	294



Table 3 (d) Lancaster Stowage

Scheme	No. of Stowages	Load lbs.	Wt. of Charge lbs.	No. of points of fire.
A	15	3,000	840	120
B	15	5,250	1,470	210
C	13	9,945	2,067	390
D	10	9,600	1,875	300
E	15	10,690	2,430	405
F	15	7,590	2,070	405
G	15	9,945	2,065	405
H	15	7,375	2,205	315
I	15	10,000	2,422	315

Table 3 (e) Wellington Stowage

Scheme	No. of Stowages	Load lbs.	Wt. of Charge lbs.	No. of points of fire.
A	9	1,800	504	72
B	9	2,700	756	108
C	5	3,835	795	150
D	4	3,840	750	120
E	5	3,730	795	105
F	-	-	-	-
G	-	-	-	-
H	6	3,150	882	126
I	5	3,330	808	105

Chapter 18. Aircraft Overload Petrol Tanks  
as Incendiary Bombs.

18.1 During 1944, the use of aircraft overload petrol tanks as incendiary bombs for the attack of various targets in the open was proposed. The tanks were filled with gel and ignited by means of phosphorus grenades fitted with all-ways fuzes. In the case of the American drop-tanks, a special igniter was developed in the U.S. consisting of a M.3 allways fuze and M.15 phosphorus grenade made as an assembly to screw into the filler cap hole. The British igniter system consisted of two No. 80 phosphorus grenades fitted with No. 854 all-ways fuzes, held on the suspension band on the outside of the tank.

18.2 Two drop-tanks were given nomenclature as bombs, viz., the 108 gallon standard American metal drop tank, which was given the nomenclature of 750 lb. Incendiary Bomb. Mk. I. The 750 lb Mk. II bomb was identical with the Mk. I. except that it had a single lug adapter to enable it to be carried on British aircraft. Trials of these bombs are described in refs. 59 - 61.

18.3 The other tank was specially designed and given the nomenclature of 1000 lb. Incendiary Bomb Mk. I. This tanks is shown in fig. 75 and consisted of a simple streamlined form of tank without a tail unit. It was constructed of steel plate and had a capacity of 100 gallons. British and American lugs were provided and the tank had baffles fitted internally to prevent surge of the filling. The igniter was as described in 18.1, sets being fixed to the circumference of a band clamped around the bomb. Trials (62) showed that when the body was made of 20 gauge steel, break-up was certain, whereas with 16 gauge steel the functioning was more unreliable. Trials of this bomb are described in reference 63 and 64.

18.4 Various types of drop tanks were tried and the results of the trials are reported in references 65 and 66. With the exception of the 1000 lb Incendiary Bomb described above, however, these were all standard drop-tanks and, accordingly, are of no interest from the bomb design point of view. They are noted here purely for the sake of completeness of the incendiary warfare picture.

## Chapter 19. The 500 lb. Incendiary Bomb

19.1 In order to meet a requirement for an incendiary bomb for the attack of fortified objectives, the 500 lb. L.C. bomb, charged with incendiary fillings, was tried. The intention was that the bombs, which were filled with free-flowing incendiary liquids, should break up on the target and the filling should seep or flow through holes or cracks in the concrete. In order to initiate bombs which missed the main objective, a burster charge was incorporated and an 11 seconds delay was included to safeguard the aircraft.

19.2 Trials (67) were carried out with bombs filled with four different types of filling, viz:-

- |         |   |             |
|---------|---|-------------|
| Type 1. | Filled 100% liquid phosphorus.<br>All-up weight about 400 lb. |             |
| Type 2. | Filled 50% liquid phosphorus.<br>All-up weight about 325 lb.  | 50% petrol. |
| Type 3. | Filled 25% liquid phosphorus.<br>All-up weight about 270 lb.  | 75% petrol. |
| Type 4. | Filled 25% liquid phosphorus.<br>All-up weight about 290 lb.  | 75% fuel.   |

All the bombs had a burster and were fuzed with pistol No. 30 with an 11 seconds delay detonator.

19.3 It was found that bombs which struck a concrete target and penetrated it gave fires, but those which did not penetrate did not ignite until the burster functioned. This was considered to be partly due to the "wick" action of dust and debris from the penetration of the wall. The liquid phosphorus seeped through cracks in the concrete and gave fumes which were completely unbearable in a confined space. The petrol, on the other hand, was almost completely consumed in the initial flash. It was considered, therefore, that a filling intermediate between types 1 and 2 above would be the optimum for this type of target.

19.4 The 500 lb. L.C. bomb is shown in Fig. 76. The development of this bomb as an incendiary was purely experimental and the series of trials to find the best bomb for the attack of fortified objectives had not been completed when the requirement was cancelled.

## Chapter 20. The 45 lb. Oil Igniting Bomb.

- 20.1 The requirement for this bomb was stated in August 1941. The bomb was required for setting fire to fuel oil on water in enemy harbours and was to be capable of carriage on Light Series carriers or in a small Bomb container on T.S.R. aircraft. The weight was to be preferably below 40 lb and the bomb was to be capable of functioning when released at operational heights by Naval aircraft at release speeds between 90 and 150 knots.
- 20.2 Experiments by P(W)D showed that oil on water could not be ignited by sparks from a gunpowder/electron mixture but could be ignited by petrol under suitable conditions. K.O.F.Q.R. would also ignite oil on water. Preliminary trials were therefore carried out with 30 lb. L.C. bombs filled with petrol/K.O.F.Q.R. mixture and five gallon tins filled with the same mixture (68). The 5 gallon tins functioned and gave a time of burning of approximately 1-1/4 minutes. Since these tins had been filled with the K.O.F.Q.R. and petrol ready mixed and had proved safe even in bombs containing a small quantity of water, the original requirement for the K.O.F.Q.R. to be housed in a separate container to break up on impact was cancelled. The 30 lb. L.C. bombs gave unsatisfactory results.
- 20.3 Further trials were carried out using 65 lb. L.C. bombs (fig. 77) in place of the five gallon cans and once again functioning was satisfactory even with a smaller quantity of K.O.F.Q.R. per bomb than had been used previously. The bombs functioned with K.O.F.Q.R. contents of 2 pints, 1 pint and 1/2 pint per bomb, although the flame appeared less intense with the reduced quantities (69). The 30 lb. L.C. bomb Mk. II once again failed to function.
- 20.4 As a result of the promising results obtained with the 65 lb. L.C. bomb dropped on water, trials (70) were done against an oil patch. The patches were successfully ignited by the 65 lb. bombs. The 65 lb. L.C. bomb Mk. I was accordingly recommended for approval for immediate introduction into the Service as the 45 lb. O.I. bomb Mk. I. Design action was taken, meanwhile, to produce a bomb with better aiming characteristics than the 65 lb. L.C. bomb.
- 20.5 The design shown in fig. 78 was produced for trials as a replacement of the Mk. I bomb. It had an all-up weight of 42-1/2 lb. and a C.G/L ratio of 0.385. Various other schemes were considered. A modification of the flame float as shown in fig. 79 was one scheme.
- 20.6 Another proposed store was the modified 200 lb. smoke float shown in fig. 80. This had a scaled container of K.O.F.Q.R. with the petrol on the float chamber. An inertia-operated water entry valve in the nose allowed the water to enter the float chamber and force the K.O.F.Q.R./petrol mixture up the central tube of the buoyancy chamber. The petrol flowed over the top of the float on to the floating oil and was ignited by the K.O.F.Q.R.
- 20.7 A further proposal was a 4.5" flare body containing four incendiary units. These units were ignited and ejected by a burster charge just above the surface of the water. Each unit consisted of six large gelatine ampoules, containing petrol, surrounding a large central initiator. Two lengths of delay fuze, one at either side, had the bottom ends embedded in the composition of the initiator and the upper ends in large grain gunpowder priming on the upper surface of the top wooden end piece. The bottom of

the unit was closed by a similar wooden end piece and the whole unit was surrounded by a doped fabric covering. The flare was fuzeed with a No. 35 fuze and the delay fuze to the units was ignited by the ejection charge. This fuze after a delay of 15 seconds, ignited the heating composition which boiled and ignited the petrol causing it to be ejected.

20.8 Trials (58) of these stores showed that the 45 lb. O.I. bomb was the only bomb which would ignite the oil patches. The 200 lb. floats failed to work because of faulty valves and the incendiary flares functioned but failed to ignite the oil. The 45 lb. O.I. bomb was, accordingly, passed into Service.

SECTION 4.

THE JET-TYPE INCENDIARY BOMBS

<u>Contents</u>	<u>Page</u>
Chapter 21: The 30 lb. 'J' Bomb:	51
Chapter 22: The 20 lb. 'J' Bomb:	54
Chapter 23: The Cordite-operated 'J' Bomb:	56

## Chapter 21. The 30 lb. 'J' Bomb.

21.1 This bomb was developed by Messrs. Worssam in collaboration with D.Arm.D. The bomb was an attempt to produce a "blaze" type of bomb and gave a jet of flame approximately 15 ft. long by 2 ft. wide on functioning. The filling was a solution of methane in petrol giving an internal pressure of 90 - 110 lbs/sq.in. in the bomb. The complete bomb was 21" long by 5.5" diam. and weighed 32 lbs. It contained 1 lb. of the thermite and 1.3 gallons of methanised petrol and had a T.V. of 160 - 180 ft./sec. when falling suspended from its parasheet.

21.2 In the early stages of the design it was intended that the jet should be at the end of a flexible tube so that on functioning it would oscillate and sweep a large area with the flame. This proposal was found impracticable and the design proceeded with a fixed jet. The bomb was originally designed to have a body of 12g thick solid drawn tubing. Owing to the difficulty of producing a solid-drawn tube 5.5" diameter in this thickness, the body tube thickness was increased to 10g steel. It became evident early in the development that the supply of solid-drawn tube could not be guaranteed and the use of a welded tube for the body was investigated.

21.3 Early bombs to this design were tried by single release against a concrete target (71). The design at this stage is shown in Fig. 81. It was found that the wooden block at the nose end was effective in cushioning the shock of impact if the bomb struck normally, but that the tack-welds were often ripped and the wood block removed if the bomb struck at an angle. Bombs which struck under these conditions split at the longitudinal weld of the body. Bombs which struck normally were swollen at the nose end but functioned correctly. Circumferential welding of the ring retaining the hardwood block was first tried and, finally, the block was completely covered by a metal cap. This latter modification prevented the removal of the hardwood block although it would break up on oblique impact. A suggestion to use a strawboard nose was not proceeded with because of supply difficulties.

21.4 The bombs still split at the nose weld and longitudinal welds on hard impact and I.C.I. carried out an investigation into the materials and method of construction. They recommended that the bodies and noses of the bombs should be fully annealed after manufacture. Owing to the shortage of capacity for annealing body tubes, mortar trials of bombs with annealed noses and unannealed body tubes were done. These showed very little improvement over the completely unannealed bombs. The body and nose of each bomb were, accordingly, fully annealed before fabrication. Results of hard impact trials of the bomb were then regarded as satisfactory.

21.5 Mortar firing trials of bombs against concrete at 40°C showed that the nose welds split under these conditions. Annealing of bodies and noses before fabrication made no difference. The bombs would satisfactorily penetrate a German attic structure at this temperature, and would also penetrate 3" of concrete. A trial against a target consisting of a 1" thick wooden board in front of solid concrete, representing a single-storied industrial structure, were satisfactory and the bomb also withstood impact on solid concrete at - 20°C. It was not found possible to modify the body construction so as to enable it to withstand impact at 40°C on solid concrete.

21.6 Since the bomb contained liquid filling under pressure it was felt that it might be very vulnerable to attack by enemy ammunition. Trials were done against the single bombs (72) and clusters (73). These showed that the single bomb was more dangerous for carriage in an aircraft than the 30 lb. Incendiary Bomb but was not as dangerous as the 4.5" Reconnaissance Flare. The cluster would probably ignite if one of the bombs was ignited, the fire being propagated by the parasheets and wooden noses. This risk was minimised in the modified bomb which had the nose enclosed in a metal cap. Even when the cluster did ignite, the danger to the aircraft was small.

21.7 Early burning trials showed that a bomb with three jets caused a fire beyond stirrup pump control in less than a minute and gutted the room in six minutes. A bomb with a single jet started a self-maintaining fire of reasonable magnitude but this could be controlled by a stirrup pump in its early stages. It was evident from this trial that a blaze bomb would have to incorporate some device for blowing out the windows of the room in which it came to rest, to provide ventilation. Attempts were made to incorporate an explosive charge in the nose spigot of the bomb, but, in view of the complication of production, since explosive could not be filled in the factories filling the bombs, and since the charge could not be detonated till the bomb had finished burning so that ventilation was not available at the time the bomb was burning, the scheme was not incorporated in production.

21.8 Trials at Dugway Proving Ground, U.S.A., gave disappointing results in that no continuing fire was caused. This was considered to be due to the different test conditions in the U.S., particularly the type of furniture used. Three bombs were fired in the Dugway building, the one in the attic caused no continuing fire and one fired in a room gave a fire which went out in 2.1/2 mins. The other bomb fired in a room gave a small continuing fire. Two bombs with different size jets were fired at Watford to investigate the effect of jet size on fire-raising. The bomb with an 0.062" jet gave no continuing fire while the bomb with an 0.042" jet gave a rapid continuing fire. The jet size on production bombs was, therefore, altered to the latter figure.

21.9 Dropping trials (74 - 79) showed that the cluster broke up satisfactorily and the parachutes functioned. Bombs with four-armed striker supports did not function on impact on downland or on striking a roof. The striker support was reduced to two arms giving a safe height of drop of only 9" on to concrete. This weak striker support was satisfactory for initiation but relied upon the cluster for safety in handling and transport. Dropping trials against the Braid Fell target showed that the bomb would penetrate the heavy roof in the absence of major obstructions. Some bombs struck flat and, accordingly, a design of 3 - ways fuze was requested. The design shown in Fig.82 was produced but was not proceeded with as it was considered too large and too sensitive. The development of a 3 - ways fuze was then taken over by Messrs. Worssams who produced several designs but no fuzes were manufactured.

21.10 During the progress of the design, various failures of priming components occurred. These were overcome by modifying the pyrotechnic components and pressing the priming increments in a paper tube. A filling of 10% alcohol and 90% shale oil was also developed and was approved as an alternative filling. This filling had the advantage that the bomb was not under pressure after filling and filling was considerably easier, the counter-pressure valve components were not necessary, and the jet could be considerably simplified.



21.11 The arming of the pistol and initiation arrangements for the bomb were not completely satisfactory and attempts were made to provide air-arming of the pistol. Three alternative forms of pistol bodies are shown in figs. 83, 84 and 85. None of these were proceeded with as a modified form of 4 lb. incendiary bomb pistol in magnesium was used. This was burned away by the thermite in the central tube on functioning. A suggested arming device is shown in fig. 86. Owing to the probability of the threads getting tangled with the parachute cords it was not proceeded with.

21.12 The final form of bomb is shown in fig. 87 and consisted of a cylindrical steel body to one end of which was welded a dished steel nose plate having a central spigot welded to its inside. A steel ring was welded to the nose plate, and a wooden nose protected by a thin metal cap secured by screws to the ring. Near the other end a tail plate was welded to the bomb body, and a steel central tube which projected through the tail plate was welded to the tail plate and to the spigot of the nose plate. The striker housing screwed on to this tube and held the detonator plate in position, the central tube being sealed by a cellophane disc. The tail plate also carried the jet and counter-pressure valve attachments. The parachute was housed in a container which was held in the tail end of the bomb by six retaining screws. The container had a hole located above the jet and the cover was secured to two opposite rigging lines of the parachute by weak cords. The cover carried a safety pin retaining sleeve and a spring container housing a compressed spring. The tail end of the bomb is shown in detail in fig. 88.

21.13 In view of the delay in getting the 20 lb. 'J' Mk. II into Service it was decided to attempt to "tropicalise" the 30 lb. 'J' bomb. Satisfactory rustproofing and rotproofing of components were found possible and a further scheme was to fit the No. 888 "Allways" fuze of the 20 lb. 'J' bomb into the bomb by means of a magnesium adapter ring. Firing trials (80 and 81) showed that the bomb would penetrate into a Japanese structure and produce a "blaze" fire but would not pass through the structure unless it struck on a piece of floor not covered by Tatami matting. It was not practicable to reduce the striking velocity sufficiently to prevent the bomb penetrating the floor in this latter case.

21.14 With the ending of the Japanese war all development ceased on this store. The bomb was used against Germany with indifferent results and was not used against Japan.

## Chapter 22. The 20 lb. 'J' Bomb.

22.1 This bomb started its development during 1943 as a scheme put forward by D.M.D.1. for a 12 lb. bomb which was intended to be an addition to the range of incendiary bombs intermediate in size between the 4 lb. and 30 lb. bombs. The bomb consisted of a steel pressing 8-1/2" long x 5-1/2" diameter with walls about .1 thick, closed at the tail end by a plate carrying a central priming holder on which was mounted a striker mechanism similar in principle to that of the 4 lb. Incendiary Bomb Mk. IV. The tail plate was pierced by 3 equispaced holes about 1/2" diameter. The bomb was filled with naphthalene cast around and between the turns of a roll of material loaded with pyrotechnic composition. A spring-out fabric tail was incorporated and the bomb was intended to pack in the same cluster as the 30 lb. 'J' bomb and to have the same striking energy and penetration as that bomb.

22.2 The bomb functioned by vaporisation of the solid filling by means of the heater composition, the vapour issuing as a high-velocity gas jet from large orifices. The aeration of such a high velocity jet was sufficiently good to ensure complete combustion of the vapour giving a flame which was fierce and intense, although shorter than that of the 30 lb. 'J' bomb, being 7 to 8 ft. long. The main advantage of the bomb over the 30 lb. 'J' Type was the simplicity compared to the 30 lb. bomb since the complication of sealing the bomb to maintain the pressure, which was necessary with the liquid filled bomb, was avoided. The burning time of the bomb was 40 - 50 secs., but this could be varied within wide limits. The length of the flame was, however, not so easily increased. The weight of 11-1/2 lbs. was made up as follows:-

Solid fuel (naphthalene)	...	4-1/2	lb.
Heater	...	2-1/2	"
Body and fuze	...	4-1/2	"
		<hr/>	
Total	...	11-1/2	lb.

22.3 Upon trials at Rackham Street, the 12 lb. bomb was found to be inadequate as a fire-raiser and, accordingly, the development of a 22 lb. version of this type of bomb was undertaken by D.M.D.1. This bomb was shown on trials to be about as efficient as the 30 lb. 'J' bomb as a fire-raiser and could be carried 21 per 500 lb. cluster compared to the 14 per 500 lb. cluster for the 30 lb. 'J' Bomb. A window-breaking charge was incorporated in order to increase ventilation in the room in which the bomb came to rest. The bomb still used the spring-out fabric tail as on the 12 lb. bomb. This design is shown in fig. 89. The one-way fuze was armed by a fly-off plate which withdrew a safety-pin when the cluster opened and the tail extended.

22.4 Body strength trials (82) showed that the bombs would withstand impact on concrete at their T.V. of 300 ft./sec. and would penetrate a roof and attic floor. At 400 ft./sec. they would penetrate for this distance, breaking a joist and a beam in its passage, but would not meet the Air Staff requirement for penetration of a roof, attic floor and one other floor even at a striking velocity of 600 ft./sec.

22.5 Some difficulty was experienced in getting the bomb ballistically stable with the fabric tail. This tail was eventually replaced by the drum and rod type of spring-out tail. This type of bomb was known as the Type 'A' Bomb and is shown in fig. 90. A design of tail which made filling easier and was simple on production was also tried. This consisted of a simple cylinder, with slots cut in it, which collapsed over the outside of the bomb body when clustered and sprang out on cluster break-up. The bomb with this type of tail was known as the Type 'B' bomb and is shown in fig. 91. A 3-ways fuze was also incorporated in place of the one-way fuze and the type 'B' bombs were sealed as the "Bomb, Incendiary, Aircraft, 20 lb. 'J', Mk. I", the fuze being given the nomenclature of "Fuze, Always, Aircraft Bomb, No. 888, Mk. I."

22.6 Very extensive rough usage trials were carried out to test the safety of the unshuttered detonator of the fuze and the unshuttered azide sleeve of the windowbreaker. These are fully reported in O.B. 'Q' Proceedings. Dropping trials of the Bomb against the Braid Fell target showed that the main causes of failure of the bomb upon impact with a resistant target were -

- (a) Set down of the window breaker on impact causing it to be retained in bomb and disrupting the case on ignition.
- (b) Removal of the tail plate.

(a) was overcome by strengthening the window-breaker container and (b) was lessened by increasing the turnover of the end of the case on the tail plate.

22.7 Since production of these bombs was held up because of the high priority on cordite manufacture in 1945, which resulted in no plant being available for extruding the heater mixture, the bomb was tried against a Japanese target. Trials (83) showed that the bomb would penetrate into a Japanese single-storey house at 135 ft./sec. and come to rest on the Tatami matting on the floor. If no matting was present it would penetrate the floor. The design of a parachute attachment was, therefore, started to reduce the striking velocity to 135 ft./sec. It was recommended by the Incendiary Bomb Test Panel that the window-breaking charge should be deleted from this version of the bomb on the grounds that in Japanese native structure its effect would be negligible and that efficient ventilation of targets was obtained by H.E. bombs dropped with the incendiary bombs on Operations. The advantage of such deletion on production would be that there would be less empty components, the storage and transport of the bomb as a straightforward incendiary bomb would be much simpler, and the necessity to design a shuttered azide sleeve to render the bomb completely safe for handling would be avoided. The Air Staff, however, considered that the window-breaker had a certain anti-personnel value and it was retained. The parachute version was known as the Mk. 2 and is shown in fig. 92.

22.8 Trials (84) showed that the bombs were relatively invulnerable to enemy fire in the bomb-bay of an aircraft and even when one was ignited, a series of ignitions and explosions resulted and not a bulk explosion. The bomb was not available in quantity before the end of hostilities both in Europe and the Far East and was not used operationally.

## Chapter 23. The Cordite - Operated 'J' Bomb.

23.1 This development originated in 1943, in a request to C.S.A.R. by R. & E. Department of the Ministry of Home Security for a scheme for expelling petrol from a bomb by means of a cordite charge. The original size of bomb envisaged was one of approximately 10 lb. all-up weight. After trials, C.S.A.R. issued a report (85) which showed that a bomb with a capacity of 1300 c.c. had been made and the petrol ejected by a slow-burning cordite charge in 45 secs. at a mean pressure of 270 lb./sq.in. Heating of the petrol before expulsion did not seem to make any difference to the flame. The drop size was about five times the optimum size found on test at Leeds University.

23.2 It was pointed out that a bomb of 10 lb. wt. had been shown in trials, particularly with the 20 lb. 'J' bombs, to be too small for a "blaze" type of bomb and work was put in hand on a larger model of about 30 lb. A report (86) was issued on this work which listed the following advantages of cordite operation -

- (i) It was not necessary to pressurise the fuel.
- (ii) Very reproducible results could be obtained since the burning of cordite could be closely controlled.
- (iii) The pressure throughout the ejection period could be maintained at a fairly steady figure.
- (iv) The construction of the bomb could be made simple.
- (v) There need be no delay between igniting the charge and the start of the ejection.

The principle disadvantage was that a pilot flame was necessary to ignite the jet.

23.3 Shale oil was ejected from the bomb in 60 seconds, 90 seconds or 3 minutes by controlling the orifice and charge, the mean pressure being 220 to 250 lb./sq.in. The cordite charge was small size P.V.C. - coated cordite. In view of the fact that the 30 lb. 'J' bomb was considered obsolescent and would become obsolete on the introduction of the 20 lb. 'J' bomb, all work on this project was stopped by Air Staff in January 1945.

SECTION 5.

THE DUST TYPE INCENDIARY BOMBS

Contents:

Page

Chapter 24: The 16 lb. Magnesium Dust Bomb. 57

## Chapter 24. The 18 lb. Magnesium Dust Bomb.

24.1 In December, 1944, demonstrations were given in the U.S.A. of the use of magnesium dust dispersed in a room as an incendiary agent. The technique was intended for use for sabotage purposes, the magnesium dust being contained in a paper bag and dispersed and ignited by a small gunpowder charge. It was considered that the principle might be of use in an aircraft bomb and preliminary work was commenced in this country to determine the weight of magnesium necessary to ignite a Japanese house. As a result of these trials, the weight of magnesium per unit was reduced from 15 lb. to 6-7 lb., which would ignite a Japanese building in 10 - 20 seconds.

24.2 This principle was applied to an aircraft bomb by developing a bomb which would eject its contents after penetrating the roof and while passing through a building. Mortar firing trials by C.S.A.R. at their test room at Tondu showed that the bomb functioned more efficiently under these conditions than it did statically. In order to develop the bomb quickly, the case of the 20 lb. 'J' bomb was modified to take a gunpowder burster and an angle ring to locate the tail plate. The No. 873 fuze was modified by fitting a gunpowder magazine, replacing the 5 grain AZ detonator by a 5 grain S9/Z type to increase the storage life of the fuze in the tropics, and by enlarging the vanes to 5" overall diameter in order to render arming more certain. The tail was also increased in length to increase the stability and the spring was modified to a conical shape so that it would compress flat on the tail plate of the bomb.

24.3 The final bomb is shown in fig. 93 and ballistic trials established that the bomb was a practicable proposition. Static trials at B.R.S., Watford, showed that the bomb gave excellent results against Japanese type buildings, in that a fire which could not be controlled by an amateur fire party with stirrup pumps developed very quickly. Against the German type of building the bomb was not effective. Trials at Leeds University established that this type of bomb was suitable only for small rooms and that an increase in the magnesium content gave nothing approaching a proportionate increase in the size of the room which could be ignited by the bomb.

24.4 The bomb was intended for use in nose-ejection clusters and sealed as the "Bomb, Incendiary, a/c 18 lb. Mk. 1". With the cessation of hostilities, however, the provision of the bomb to Service was not proceeded with and the bomb was never used operationally.

SECTION 6.

APPENDICES AND BIBLIOGRAPHY

	<u>Page</u>
Appendix 1. References.	58
" 2. Abbreviations.	63
" 3. List of O.B. Proceedings.	65
" 4. List of O.B. 'Q' Proceedings.	89
" 5. List of C.S.A.R. Reports.	95
" 6. List of R.R.L. Reports.	96
" 7. List of O.R.S. Reports.	101
" 8. List of A. & A.E.E. and M.A.E.E. Reports.	102
" 9. List of Incendiary Bomb Test Panel Reports and Papers.	106
" 10. List of R.A.E. Reports.	117

Appendix 1.

- | <u>No.</u> | <u>References</u>  |
|------------|--|
| 1.         | R.A.E. Technical Note: No. Aero. 1304 (Wind Tunnels), dated October 1943, "Wind Tunnel Tests on Bombs: a collection of data on drag" by M.A. Morrison, M.A., and R. Hills, B.A.              |
| 2.         | R.A.E. Armament Department Note No. Arm.199, dated 7th July, 1943, "Note on Assessing the Stability of Bombs".   |
| 3.         | U.S. Report No. TDMR No. 713, dated 30th July, 1943, "Test of Incendiary Bombs AN-M50A1, AN-M52 AN-M54 and M 69 at Dugway Proving Ground, Simpson Springs, Utah, 17th May - 16th July, 1943" |
| 4.         | R.R.L. Report: No. MAP/126/KLCF, dated September 1944, "Penetration Tests on Japanese domestic structures with the 3 lbs British Incendiary Bomb".   |
| 5.         | Report, dated 28.6.44, by Messrs. Worssam on Development Contract No. SB/27436/C.11 (b) (D. Arm. D. reference S.B.5677; C.E.A.D. ref. P/13/11).  |
| 6.         | O.B. Proc. Q. 3,011.   |
| 7.         | R.R.L. Report: Note No. MAP/149/GBT, dated July 1945, "The Fragmentation of the explosive noses of 3 lbs Incendiary Bombs designed by C.E.A.D."  |
| 8.         | Forest Products Research Laboratory, Progress Report Part iv, dated 20.1.42.   |
| 9.         | O.B. Proc. 16833.  |
| 10.        | O.B. Proc. 23252.  |
| 11.        | A. & A.E.E. report: S 503/Arm, dated 17th August, 1940, "4 lbs Incendiary Bombs".  |
| 12.        | A. & A.E.E. report: AAEE/S505/Arm., dated 3rd February, 1941, "Replacement of steel in the nose of 4 lbs. I.B. Trials of modified Bombs".  |
| 13.        | A. & A.E.E. report: AAEE/S503/Arm, dated 12.4.41.  |
| 14.        | R.R.L. report: Note No. MAP/48/KLCF, dated January 1943, "Penetration of German Roofing Rafters by the 4 lbs British Incendiary Bomb".   |
| 15.        | A. & A.E.E. Report: AAEE/ATO/G5, Report No. 12 dated 2nd November, 1941, "Trials of Mk. III bombs with loose fillings".  |
| 16.        | A. & A.E.E. Report: AAEE/ATO/G5 Report No. 15, dated 4th April, 1942, "Trials of modified Mk. III bombs with loose fillings".  |
| 17.        | A. & A.E.E. Report: AAEE/ATO/G5 Report No. 21, dated 29th March, 1943, "Loose Fillings - functioning Trials".  |



- | <u>No.</u> | <u>References</u>   |
|------------|---|
| 18.        | A. & A.E.E. Report: A.AEE/ATO/G5 Report No. 22, dated 6th May, 1943, "Bombs with modified method of filling - functioning trials".  |
| 19.        | A. & A.E.E. Report: A.AEE/ATO/G5 Report No. 23, dated 17th May, 1943, "Bombs with modified method of filling - High level functioning trials".  |
| 20.        | A. & A.E.E. Report: A.AEE/ATO/G5 Report No. 24, dated 24th May, 1943, "Bombs with modified striker housings - functioning trials".  |
| 21.        | R.R.L. Report; Note No. MAP/60/ACW.KLCF, dated May 1943, "Further impact tests on various forms of 4 lbs 'X' Type British Incendiary Bombs having four different types of keying between the spigot and body".    |
| 22.        | O.B. Proc. 30135.   |
| 23.        | O.B. Proc. 5518.  |
| 24.        | A & A.E.E. Report: M/Arm/567/1, dated 5.12.38, "4 lbs Incendiary Bomb with Explosive Pellets".  |
| 25.        | O.B. Proc. 10551.   |
| 26.        | O.B. Proc. 13166.   |
| 27.        | O.B. Proc. 13743.   |
| 28.        | Ministry of Home Security Report 1493, dated 1st August, 1941, "Wounds due to Exploding Incendiary Bombs".  |
| 29.        | O.B. Proc. 14575.   |
| 30.        | O.B. Proc. 15670.   |
| 31.        | O.B. Proc. 16048.   |
| 32.        | O.B. Proc. 16320.   |
| 33.        | R.R.L. Report ARP/367 ACW.GBT, dated September 1942, "Comparison of the fragmentation of the 4 lbs. British Explosive Incendiary Bomb with the 1 Kg German Incendiary Bomb with explosive nose (Type B2.2-E1-Z)". |
| 34.        | A.R.D. Explosives Report 327/42.  |
| 35.        | R.R.L. Note No. M.A.P./52/A.C.W., dated February 1943, "Fragmentation and impact tests on the 4 lbs. British Incendiary Bomb with a hexagonal steel nose containing a 3/4" cavity".                               |
| 36.        | Braid Fell Report: Ref. WF/BTU/8(a), dated 8th March, 1943, "Dropping Trials of Modified 4 lbs Incendiary Bombs 'X' Type".  |
| 37.        | O.C. Memo. 727.   |
| 38.        | A.AEE/S 502/Arm. dated 3.4.40.  |
| 39.        | A. & A.E.E. Report: A.AEE/S 503/Arm., dated 21.9.40, "25 lbs Incendiary Bombs".   |

<u>No.</u>	<u>References</u>
40.	A. & A.E.E. Report: AAEE /S501/Arm., dated 3.4.40, "40 lbs Incendiary Bomb Mk. 1".
41.	O.B. Proc. 4627.
42.	A. & A.E.E. Report: AAEE /S503/Arm., dated 3.7.40, "Bomb, Incendiary, 21 lbs (Thermite - fuel oil)".
43.	A. & A.E.E. Report: AAEE/S503/Arm., dated 25.12.40, "30 lbs L.C. bomb, Mk. I, as Incendiary Bomb".
44.	A. & A.E.E./S503/Arm., dated 20.10.40.
45.	A. & A.E.E./S503/Arm., dated 8.1.41, "Use of the 30 lbs L.C. bomb Mk. II as an Incendiary Bomb".
46.	R.A.E. Armament Department Note: No. Arm. 145, dated 17.12.42, "Note on Distribution of Pressure around 4000 lbs Marker Bomb Body".
47.	R.A.E. Armament Department Note: No. Arm. 160, dated January 1943, "Further note on distribution of pressure around the 4000 lbs. Marker Bomb Body".
48.	R.A.E. Armament Department G.I. Section Test Record No. B.2., dated 4th November, 1942, "4000 lbs Incendiary Bomb".
49.	S. of E., Shoeburyness, Report: BB No. Q5, dated 5.11.42, (C.S.A.R. ref XP No. 9.1.184) "Static Trials of 4000lbs Incendiary Bomb".
50.	S. of E. Shoeburyness, Report, BB No. Q5, dated 11.11.42 (C.S.A.R. ref. XP No. 9/1/184) "Static Trials of 4000 lbs Incendiary Bomb".
51.	S. of E. Shoeburyness, Report: BB No. Q5, dated 28.11.42, (C.S.A.R. ref. XP No. 9/1/184) "Static Trials of 4000 lbs Incendiary Bomb".
52.	S. of E. Shoeburyness, Report: BB No. Q5, dated 8.12.42, (C.S.A.R. ref XP No. 9/1/184) "Static Trials of 4000 lbs Incendiary Bomb".
53.	A. & A.E.E. Report: AAEE/ATO/G89, dated 30th April, 1944, "400 lbs Oil Incendiary Bomb. Report No. 1. Trials against the concrete wall target at Porton".
54.	A. & A.E.E. Report: AAEE/ATO/G89, dated 22nd October, 1944, "400 lbs Incendiary Bomb. Report No. 2. Functioning Trials on Water and Downland".
55.	O.R.S. Report: No. BT 103; dated 10.3.45 "400 lbs Incendiary Bomb Mk. I".
56.	A. & A.E.E. Report: AAEE/ATO/G89, dated 20th February, 1945, "400 lbs Incendiary Bomb. Report No. 3. Arming of No. 60 (Multiways) Pistol".
57.	A. & A.E.E. Report: AAEE/ATO/G6(a), dated 10.9.41, "250 lbs Incendiary Bomb".

- | <u>No.</u> | <u>References</u>   |
|------------|---|
| 58.        | M.A.E.E. Report: No. H/Arm/80, dated 16.3.42, "Methods of setting fire to fuel oil on water. Trials in Loch Striven, February 1942".  |
| 59.        | A. & A.E.E. Report: AAEE/ATO/G96, dated 16.12.44, "750 lbs Incendiary Bomb Mk. I. Trials to determine safe height of release from Thunderbolt aircraft".  |
| 60.        | A. & A.E.E. Report: AAEE/ATO/G96, dated 20.1.45, "Trials of 750 lbs. Incendiary Bomb Mk. II from Typhoon aircraft".   |
| 61.        | A. & A.E.E. Report: AAEE/Arm/30, dated 31st May, 1945, "Trials of 750 lbs Incendiary Bomb Mk. I from Mustang aircraft fitted with American carriers".   |
| 62.        | A. & A.E.E. Report: AAEE/ATO/G96, dated 23rd January, 1945, "Trials of 100 lbs Incendiary Bomb Mk. I from Typhoon aircraft".  |
| 63.        | A. & A.E.E. Report: AAEE/Arm/27, dated 27th May, 1945, "1000 lbs Incendiary Bomb Mk. I. Functioning Trials from Tempest V aircraft".  |
| 64.        | A. & A.E.E. Report: AAEE/Arm/24, dated 29th April, 1945, "1000 lbs Incendiary Bomb Mk. I. Medium Level Release".  |
| 65.        | A. & A.E.E. Report: AAEE/ATO/G96, dated 14th November, 1944, "Overload petrol tanks as Incendiary Bombs. Report No. 1. Preliminary trials of 100 gallon petrol tanks released from wing stowages on Mosquito aircraft". |
| 66.        | A. & A.E.E. Report: AAEE/Arm/41, dated 14th August, 1945, "Overload Tank Incendiary Bombs. Functioning trials of 125 gallon tank from Hellcat aircraft".  |
| 67.        | A. & A.E.E. Report: AAEE/ATO/G6(a), dated 29th April, 1944, "500 lbs. L.C. Bomb. Trials with special fillings for use against fortified objectives".  |
| 68.        | A. & A.E.E. Report: AAEE/ATO/G43, dated 20.10.41, "Trials of 5 gallon tins and 30 lbs L.C. Mk. II bombs, filled petrol and "Cough Mixture".   |
| 69.        | A. & A.E.E. Report: AAEE/ATO/G43, dated 2.11.41. "Trials with 65 lbs L.C. bombs and 30 lbs L.C. bombs Mk. II".  |
| 70.        | A. & A.E.E. Report: AAEE/ATO/G43, dated 9.11.41. "Ignition of Oil on Water. Report No. 4".  |
| 71.        | A. & A.E.E. Report No. AAEE/ATO/G6a dated 29th April, 1943. "Bomb, incendiary, 30 lb, 'J' Type Mk. I. Report No. 1. Functioning Trials".  |
| 72.        | Orfordness Report No. ORS/FT 291 dated February 1943.   |
| 73.        | Orfordness Report No. ORS/FT 299 dated July 1943.   |
| 74.        | A. & A.E.E. Report No. AAEE/ATO/G6a dated 6th September, 1943 "Trials of cluster projectile 'J' Type 1.B".  |

<u>No.</u>	<u>References</u>
75.	A. & A.E.E. Report No. AAEE/ATO/G6a, dated 6th September, 1943 "Acceptance Trials 'J' Type 1.B".
76.	A. & A.E.E. Report No. AAEE/ATO/G6a, dated 18th October, 1943 "Functioning of Production Bombs, Type 'J'".
77.	A. & A.E.E. Report No. AAEE/ATO/G6a dated 15th November, 1943 "Demonstration at Leysdown 7.10.43".
78.	A. & A.E.E. Report No. AAEE/ATO/G6a dated 16th November, 1943 "Functioning and Scatters of clusters released from High Altitude".
79.	A. & A.E.E. Report No. AAEE/ATO/G6a dated 19th November, 1943 "Further Penetration and Functioning Trials at Leysdown".
80.	R.R.L. Report. Note No. MAP/125/KLCF. HE. dated September, "Penetration and burning Tests on Japanese Domestic Structure with 30 lb British Incendiary Bombs, Type 'J' Mk. I."
81.	R.R.L. Report. Note No. MAP/142/KLCF dated February, 1945, "Penetration tests on Targets representing Single-storey Japanese Domestic Structures with 30 lb. British Incendiary Bomb, Type 'J'".
82.	R.R.L. Report. Note No. MAP/114/KLCF. DSW. dated March 1944, "Penetration of German structures by 22-lb. 'J' type Incendiary Bombs".
83.	R.R.L. Report. Note No. MAP/136/ACW.KLCF. dated January 1945 "Penetration Tests on Japanese Single-storey Domestic Structures with British Incendiary Bombs, Type 'J' 20, at various striking velocities".
84.	Orfordness Report No. O.R.S./FT351 dated July 1945, "Vulnerability of 500 lb. bundle type clusters of 20 lb. incendiary bombs, 'J' type, Mk. I, to enemy fire".
85.	C.S.A.R. Report: ARD/Ball/Report 78/43.
86.	C.S.A.R. Report: Ballistics (LPB) Note No. 107 dated October, 1944. "The development of a cordite-operated 'J' Bomb of one gallon capacity".

Appendix 2. Abbreviations.

(a) Establishments.

D. Arm. D.	Director of Armament Development, Ministry of Aircraft Production (now Director of Armament Research and Development, (D.Arm.R.D.) Ministry of Supply).
M.A.P.	Ministry of Aircraft Production.
D. Arm. P.	Director of Armament Production, Ministry of Aircraft Production.
R.A.E.	Royal Aircraft Establishment, South Farnborough, Hants.
A. & A.E.E.	Aeroplane and Armament Experimental Establishment, Boscombe Down.
M.A.E.E.	Marine Aircraft Experimental Establishment, Helensburgh (Now at Felixstowe).
R.R.L.	Road Research Laboratory, Department of Scientific and Industrial Research (D.S.I.R.).
C.E.A.D.	Chief Engineer & Superintendent of Armament Design, Ministry of Supply.
A.D.D.	Armament Design Department, Ministry of Supply.
C.S.A.R.	Chief Superintendent of Armament Research, Ministry of Supply.
A.R.D.	Armament Research Department, Ministry of Supply.
O.R.S.	Orfordness Research Station, Ministry of Supply.
C.I.A.	Chief Inspector of Armaments, Ministry of Supply.
A.I.D.	Aeronautical Inspection Department.
A.I.D./E.A.U.	A.I.D./Explosives and Ammunition Unit (now C.I.A. (Air)).
D.M.D.I.	Directorate, M.D.I., Whitchurch.
O.B.	Ordnance Board.
O.C.	Ordnance Committee (altered to O.B. 1st January, 1939).
P.(W) D.	Petroleum (Warfare) Department.
M of H.S.	Ministry of Home Security.
R & E Dept.	Research and Experiments Department of the M. of H.S.

I.B.T.P. Incendiary Bomb Test Panel, M.A.P.  
M. of S. Ministry of Supply.  
B.T.U. Bombing Trials Unit, R.A.F., West Freugh.

(b) Terms.

T.V. Terminal Velocity.  
S.V. Striking Velocity.  
C.G./L ratio. Ratio of distance of centre of gravity from nose of bomb to overall length of bomb.  
C/W ratio. Ratio of weight of charge to all-up weight of bomb.  
C/V ratio. Ratio of weight of charge to volume of space in the bomb-bay occupied by the bomb.  
I.B. Incendiary Bomb.  
E.I.B. Used by M. of H.S. for "Explosive Incendiary Bomb".  
H.E. High Explosive.  
G.12,G,20, etc. Grades of gunpowder.  
g.p. gunpowder.  
S.R. (followed by number) )  
R.D. (followed by number) ) Identification symbols for Research Department compositions.  
S.B.C. Small bomb container.  
C.I. Cast Iron.  
C.W. Chemical Warfare.  
L.C. Light case (applied to aircraft bombs).  
H.C. High Capacity (applied to aircraft bombs).  
M.C. Medium Capacity (applied to aircraft bombs).  
M.S. Mild Steel.

Appendix 3.

List of Proceedings of the Ordnance Board on the  
subject of Incendiary Bombs and Related Subjects

(Prior to 1st January, 1939, the Ordnance Board was called the Ordnance Committee and issued O.C. Memos. O.C. Memos. from September 1938 are included under this heading as they deal with the development of some of the stores mentioned in the text of the monograph).

<u>Number</u>	<u>Date</u>	<u>Title</u>
O.C. Memo.1173	9. 9.38	Bombs Aircraft. Incendiary. Method for extinguishing burning phosphorus bombs.
" " 1183	9. 9.38	Bombs Aircraft. Incendiary. Method of filling 4 lb. Mk. I bombs. Inclusion of explosive pellets.
" " 1288	20. 9.38	Bombs Aircraft. Incendiary. 25 lb. Mk. I. Proposed modification to design DD/L/7694.
" " 1362	27. 9.38	Bombs Aircraft. Incendiary. Penetration trial to obtain the remaining velocity of the 1 Kilo. bomb after passing through normal tiled and slated roofs.
" " 1405	30. 9.38	Bombs Aircraft. Incendiary. Method of filling 4 lb. Mk. I. Bomb. Trials with fluted bombs.
" " 1673	25.10.38	Bombs Aircraft. Incendiary. Splitting of firepots in 25 lb. Mk. I bombs. Proposed amendment to specification.
" " 1701	28.10.38	Bombs Aircraft. Incendiary. Invention by Messrs. Edgar Brandt - Supply of bombs for trial.
" " 1747	1.11.38	Bombs Aircraft. Incendiary. Method of filling 4 lb. Mk. I. bombs. Designs DD/L/9215 and DD/L/9275/1 showing modifications to introduce powder charge in nose of bomb.
" " 1800	8.11.38	Bombs Aircraft. Incendiary. Ignition of Oil. Trials to test various fillings (Attack on Oil Storage installations).
" " 1913	18.11.38	Boxes Bomb. Bomb demonstration, incendiary, 2-1/4 lb. Mk. I. Design DD/L/9152 - Approval.
" " 1923	18.11.38	Bombs Aircraft. Proposed trials with various types. To be carried out at Gretna Green (Longtown).
" " 2053	2.12.38	Bombs Aircraft. Incendiary. Method of filling of 4 lb. Mk. I bomb. Design DD/L/8932A of modified filling with burster.

<u>Number</u>	<u>Date</u>	<u>Title</u>
O.C. Memo. 2065	2.12.38	Bombs Aircraft. Incendiary. Parachute flares 4 lb. and 25 lb. Starting of forest fires - Investigation.
" " 2109	9.12.38	Bombs Aircraft. Incendiary. 4 lb. Mk. I bombs. Report of dropping trials after rough usage.
" " 2147	13.12.38	Bombs Aircraft. Incendiary. Method of filling 4 lb. Mk. I bombs. Trials with fluted bombs. No further action - Approval.
O.B. Proc. No.		
14	2. 1.39	Bombs Aircraft. Incendiary. Parachute flares - 4 lb. and 25 lb. Starting of forest fires - Investigation.
23	2. 1.39	Bombs Aircraft. Incendiary. Method of filling 4 lb. bomb. Messrs. I.C.I. proposal to lengthen the plain portion of the ferrule.
55	3. 1.39	Bombs Aircraft. 25 lb. Incendiary. Report of bombs released in salvos at modern operational speeds.
100	6. 1.39	Bombs Aircraft. Incendiary. Splitting of firepots in 25 lb. Mk. I bombs. Proposed amendment to specification.
191	13. 1.39	Bombs Aircraft. Incendiary. Method of filling 4 lb. and 25 lb. bombs. Suitability of composition S.R. 306.
193	17. 1.39	Bombs Aircraft. Incendiary. Trial to obtain the remaining velocity of the 1 Kilo. bomb after passing through normal tiled and slated roofs.
245	20. 1.39	Bombs Aircraft. Incendiary. Process for the manufacture of magnesium. Invention by Professor D. Gardner.
247	20. 1.39	Bombs Aircraft. Incendiary 25 lb. Mk. I Reinstatement of grub screw. Proposed amendment of designs and specification.
248	20. 1.39	Bombs Aircraft. Trials with various types. To be carried out at Gretna Green (Longtown).
370	31. 1.39	Bombs Aircraft. Incendiary. 4 lb. Mk. I.E. filled with explosive pellets. Markings - nomenclature.
371	31. 1.39	Bombs Aircraft. Incendiary. 4 lb. Mks. I and I.E. Storage life of filled bombs.
372	31. 1.39	Bombs Aircraft. Incendiary. 4 lb. Mk. I.E. - Method of Filling, inclusion of explosive pellets.



<u>O.B. Proc. No.</u>	<u>Date</u>	<u>Title</u>
373	31. 1.39	Bombs Aircraft. Incendiary. 4 lb. Mk. I Stowage in H.M. Ships.
374	31. 1.39	Bombs Aircraft. Incendiary. 4 lb. Mk. I.E. filled with explosive pellets. Stowage in H.M. Ships.
388	3. 2.39	Bombs Aircraft. Incendiary. Insertion of metal container partly filled with water in thermite bomb. Proposal by Messrs. W.C. Crocker.
396	3. 2.39	Bombs Aircraft. Incendiary. 25 lb. Mk. I. Results of rough usage trials. Proposed further trial.
434	7. 2.39	Bombs Aircraft. Attack of dispersed aircraft on the ground and of aerodrome surface. Trials at Netheravon.
584	21. 2.39	Bombs Aircraft. 25 lb. Incendiary. Report of dropping trials against hard target at Porton.
595	21. 2.39	Bombs Aircraft. Incendiary. 4 lb. Mk. I. Report of dropping trials against hard target at Porton.
747	7. 3.39	Bombs Aircraft. Incendiary. Method of filling of 4 lb. Mk. I bomb. Amended design DD/L/8932.A. of modified filling with burster.
820	14. 3.39	Bombs Aircraft. Incendiary. 4 lb. Mk. I.E. filled with explosive pellets (i) Markings - nomenclature, (ii) Preparation of packing design and specification.
1148	21. 4.39	Bombs Aircraft. Incendiary. 25 lb. Mk. I Rough usage - further trials.
1182	25. 4.39	Bombs Aircraft. Incendiary. Mourlaque type - Investigation.
1479	19. 5.39	Bombs Aircraft. Incendiary. 4 lb. Mk. I and Mk. I.E. Markings - nomenclature.
1498	19. 5.39	Bombs Aircraft. Incendiary. 4 lb. Mk. I Stowage in H.M. Ships - Classification Group - Approval.
1671	9. 6.39	Bombs Aircraft. Incendiary. Method of filling 4 lb. Mk. I bomb. Alteration in the design of the ferrule.
1762	16. 6.39	Bombs Aircraft. Incendiary. Parachute flares - 4 lb. and 25 lb. Forest Trials - Report of trials.
1783	20. 6.39	Bombs Aircraft. Incendiary. 4 lb. Carriage in aircraft. Method of constructing timed plate cases.

<u>O.B. Proc. No.</u>	<u>Date</u>	<u>Title</u>
1815	23. 6.39	Bombs Aircraft. Incendiary. Method of filling - Inclusion of sodium peroxide and calcium carbide - Proposal by Mr. W.M.C. Nicolson.
1920	30. 6.39	Bombs Aircraft. Incendiary. 4 lb. Mk. I.E. Secrecy of design DD/L/8932A and Specification AIR.292.
1959	30. 6.39	Bombs Aircraft. Trials at Gretna Green.
2056	11. 7.39	Bombs Aircraft. Incendiary. 3, 5, 10 & 25 Kg. bombs by the Societe France-Bugrais, Paris.
2099	14. 7.39	Bombs Aircraft. Practice incendiary electron bomb. Supply of bombs for filling.
2162	21. 7.39	Bombs Aircraft. Incendiary. Ignition of heavy oil and petrol. Trials to test various types of bombs.
2203	25. 7.39	Bombs Aircraft. Practice incendiary electron bomb. Supply of bombs for filling - Approval.
2376	15. 8.39	Bombs Aircraft. Incendiary. 25 lb. Mk. I. Supply of bombs for Trial.
2447	22. 8.39	Bombs Aircraft. Incendiary. Composition of incendiary material - Information required.
2649	2. 9.39	Bombs Aircraft. Incendiary. New designs (i) Ejection type - Design DD/L/9982 (37 lbs). (ii) Design DD/L/9981 (thermite 37 lb.)
2690	9. 9.39	Bombs Aircraft. Incendiary. 25 lb. Mk. I tail plates - Retaining by cannelluring.
2770	18. 9.39	Bombs Aircraft. Incendiary. Parachute flares 5.5" - Incendiary candles (i) Design DD/L/10034 (ii) Trial of dripping containers.
2938	4.10.39	Bombs Aircraft. Incendiary. Ignition of heavy oil. Trials.
3053	11.10.39	Bombs Aircraft. Incendiary. 4 lb. and 25 lb. bombs. Extinguishing trials - Report.
3070	11.10.39	Bombs Aircraft. Incendiary and H.E. Ignition of heavy oil. - Trials.
3120	13.10.39	Bombs Aircraft. Incendiary and H.E. Ignition of heavy oil. - Trials.
3217	20.10.39	Bombs Aircraft. Method of starting forest fires. 25 lb. incendiary bombs fitted with parachutes to design Arm.2761. Approval for production.

<u>O.B. Proc. No.</u>	<u>Date</u>	<u>Title</u>
3277	27.10.39	Bombs Aircraft. Incendiary. Delay action, self-igniting bomb. Invention by Mr. P.H. Richmond.
3444	8.11.39	Bombs Aircraft. Incendiary. Ignition of heavy oil - Trials.
3473	10.11.39	Bombs Aircraft. Incendiary. Parachute flares 5.5" - Incendiary candles to design DD/L/10034. Trial - Report.
3485	13.11.39	Bombs Aircraft. Incendiary. Invention by Messrs. Edgar Brandt. Trials.
3557	17.11.39	Bombs Aircraft. Incendiary and H.E. Ignition of heavy oil - Trials.
3565	17.11.39	Bombs Aircraft. 25 lb. Incendiary bomb fitted with parachute. Designs.
3628	22.11.39	Bombs Aircraft. Incendiary. Protection against thermite and electron-thermite incendiary bombs.
3637	22.11.39	Bombs Aircraft. Incendiary. Invention by Messrs. Edgar Brandt. Trials.
3690	29.11.39	Bombs Aircraft. Incendiary. Parachute flares, 5.5" - Incendiary candles fitted with dripping magnesium container. Firing trial with 0.303 inch bullets against complete flare - Report.
3864	15.12.39	Bombs Aircraft. Incendiary. Invention by Messrs. Edgar Brandt. Further trials - not required.
3873	18.12.39	Bombs Aircraft. Incendiary. Design DD/L/9981A (non-ejection type) and design DD/L/9982 (firepot type). Trials - Production.
3957	22.12.39	Incendiary bomb, 1 Kilo. German bomb captured from Heinkel lll shot down in Scotland.
4049	1. 1.40	Bombs Aircraft. Incendiary and H.E. Ignition of heavy oils - Trials.
4375	19. 1.40	Bombs Aircraft. Protection against thermite and electron-thermite incendiary bombs. Fire-resisting plaster. Trials.
4557	31. 1.40	Bombs Aircraft. H.E. and Incendiary. Ignition of fuel oil - Trials. Report of a meeting of the Oil Depot Committee.
4594	5. 2.40	Bombs Aircraft. Incendiary. Thermite mixture and water. Proposal by High Speed Steel Alloys, Ltd.

<u>O.B. Proc. No.</u>	<u>Date</u>	<u>Title</u>
4627	7. 2.40	Bombs Aircraft. Incendiary. Substitute for magnesium in bombs - Investigation.
4687	12. 2.40	Bombs Aircraft. Incendiary. 4 lb. bomb. Dropping trials.
4797	19. 2.40	Bombs Aircraft. H.E. and Incendiary. Ignition of fuel oil. Trials with modified flame float to design DD/L/7642E.
4834	21. 2.40	Bombs Aircraft. Incendiary. Substitute material for magnesium in bombs - Investigation.
4841	21. 2.40	Bombs Aircraft. Incendiary. Design DD/L/SK3092 of modification to safety plunger.
4936	28. 2.40	Bombs Aircraft. H.E. and Incendiary. Ignition of fuel oil - Trials.
4993	1. 3.40	Bombs Aircraft. Incendiary. 4 lb. bomb - Dropping trials.
5004	4. 3.40	Bombs Aircraft. Bomb, Parachute, incendiary A/C, 50 lb. Mk. I Specification and designs.
5054	6. 3.40	Bombs Aircraft. Petrol bomb. Design DD/L/10615 of cylindrical type of bomb - Trial.
5083	6. 3.40	Bombs Aircraft. Methods of dealing with unignited incendiary bombs.
5093	8. 3.40	Bombs Aircraft. Incendiary (French). Dropping trials of 10 Kg. bombs.
5122	11. 3.40	Bombs Aircraft. 4 lb. Incendiary. Design DD/L/SK3092 of modification to safety plunger.
5170	13. 3.40	Bombs Aircraft. Incendiary 35 lb. and 40 lb. Design DD/L/9981A (non-ejection type) (M. of F). design DD/L/10267 and design DD/L/9982 (fire pot type (M. of F)) design DD/L/10392.
5185	13. 3.40	Bombs Aircraft. Incendiary and H.E. Ignition of fuel oil - Trials.
5240	15. 3.40	Boxes Bomb. 35 lb. Incendiary Bomb. Amendment to design DD/L/10267 to obviate airtight liner.
5368	27. 3.40	Bombs Aircraft. 4 lb. Incendiary. Tinplate liners - Modification.
5396	29. 3.40	Boxes Bomb. 40 lb. Incendiary Bombs. Rough usage trials of modified 25 lb. Incendiary bomb boxes.

<u>O.B. Proc. No.</u>	<u>Date</u>	<u>Title</u>
5418	1. 4.40	Fuzes, Bomb, Aircraft. Bombs Incendiary 35 lbs. long delay pistol to DD/L/9260 - Trials.
5500	3. 4.40	Bombs Aircraft. 4 lb. Incendiary.. Design DD/L/10571, DD/L/10572 and DD/L/10573 with 1.7 grain detonator.
5518	5. 4.40	Bombs Aircraft. Incendiary. 4 lb. Types A and B. Defence against incendiary bomb containing explosive charge. - Result of trial.
5539	5. 4.40	Bombs Aircraft. Petrol bomb. Design DD/L/10615 of cylindrical type of bomb.
5553	8. 4.40	Bombs Aircraft. Incendiary. Use of Nickel Sesquioxide in thermite
5624	10. 4.40	Bombs Aircraft. Incendiary. Replacement of Magnesium in bombs - Trials.
5630	10. 4.40	Bombs Aircraft. 40 lb. Incendiary. Design of proposed suspension band and lug.
5721	15. 4.40	Bombs Aircraft. Foreign. Russian multiple incendiary bomb used in Finland.
5724	15. 4.40	Boxes Bomb. 40 lb. Incendiary bomb.
5734	17. 4.40	Boxes Bomb. 40 lb. Incendiary. Design of proposed suspension band and lug.
5788	19. 4.40	Bombs Aircraft. Incendiary. Magnesium spherical bombs - Trials.
5793	19. 4.40	Bombs Aircraft. Incendiary. Experiments in Germany and Belgium with bomb containing Arsenious Oxide.
5861	24. 4.40	Bombs Aircraft. Incendiary. Use of bodies of bomb, 25 lb. Mk. I for thermite bomb - trials.
5874	24. 4.40	Bombs Aircraft. Development trials - Proposed construction of composite building as target.
5936	29. 4.40	Bombs Aircraft. Foreign, Russian. Multiple incendiary bomb used in Finland.
5980	1. 5.40	Bombs Aircraft. 4 lb. Incendiary. Storage at Chilmark - Climatic trials.
6002	3. 5.40	Boxes Bomb. 40 lb. Incendiary. Rough usage trials of modified 25 lb. Incendiary bomb box.
6104	10. 5.40	Enemy munitions, German. 1 Kg. incendiary bomb.

<u>O.B.Proc.No.</u>	<u>Date</u>	<u>Title</u>
6111	10.5.40	Bombs Aircraft. Incendiary. Mourlaque type - Investigation.
6196	15.5.40	Bombs Aircraft. Incendiary. Use of composition S.R. 359 in place of thermitite and alternative to S.R.306 containing manganese dioxide.
6251	17.5.40	Bombs Aircraft. Petrol bomb. Design DD/L/10615 of cylindrical type of bomb.
6267	17.5.40	Bombs Aircraft. 35 lb. Incendiary bomb. Modification to design of box. Rough usage trials.
6323	22.5.40	Bombs Aircraft. Incendiary. Replacement of magnesium in bombs - Trials.
6338	22.5.40	Bombs Aircraft. Foreign. Japanese 70 Kilo. incendiary bomb.
6367	24.5.40	Bombs Aircraft. 30 lb. L.C. bomb. Use as incendiary bomb.
6409	27.5.40	Bombs Aircraft. H.E. and Incendiary. Ignition of fuel oil - Trials.
6425	27.5.40	Bombs Aircraft. Incendiary. Designs DD/L/10951 and DD/L/10052 of thermitite-fuel oil filling of penetrative type of bomb.
6440	29.5.40	Bombs Aircraft. Incendiary 21 lb. Design DD/L/10406A of thermitite-fuel oil type.
6534	3.6.40	Fuzes, Bomb, Aircraft. Incendiary 35 lb. Long delay pistol to design DD/L/9260.
6537	3.6.40	Bombs Aircraft. 35 lb. Incendiary bomb. Modification to design of box - rough usage trials.
6651	5.6.40	Bombs Aircraft. Incendiary. Magnesium spherical bomb.
6676	7.6.40	Bombs Aircraft. 250 lb. L.C. bomb. Use as an incendiary bomb.
6716	10.6.40	Bombs Aircraft. Incendiary. Mourlaque type - Investigation.
6736	10.6.40	Bombs Aircraft. 4 lb. incendiary. Designs DD/L/10571, DD/L/10572 and DD/L/10573 with 1.7 grain detonator - nomenclature.

<u>O.B. Proc.No.</u>	<u>Date</u>	<u>Title</u>
6768	12.6.40	Fuzes, bomb, aircraft. 3 ways pistol for 35 lb. and 40 lb. Incendiary bombs. Alternative to stainless steel - Investigation.
6805	12.6.40	Enemy Munitions. German Aircraft Bombs.
6828	14.6.40	Bombs Aircraft. 30 lb. L.C. bomb. Use as Incendiary bomb.
6831	14.5.40	Bombs Aircraft. 4 lb. incendiary bomb. Design DD/L/10571.
6832	14.6.40	Bombs Aircraft. Incendiary 25 lb. bomb with parachute attachment - trials.
6908	19.6.40	Bombs Aircraft. Incendiary 4 lb. - Design DD/L/10573 of tinsplate liner - No longer required.
6942	24.6.40	Miscellaneous. Incendiary liquids. Demonstration at Porton by Dr. Schulman.
7101	28.6.40	Boxes and Containers. 40 lb. Incendiary Bomb. Designs DD/L/10058 (2 sheets) of boxes.
7110	28.6.40	Bombs Aircraft. Incendiary. Use of butane for incendiary purposes.
7118	28.6.40	Bombs Aircraft. Incendiary. Suitability of composition S.R.380 for the 35 lb. bomb - Investigation.
7128	28.6.40	Bombs Aircraft. Parachute incendiary, 50 lb. Mk.I. Modification - No further action required.
7139	1.7.40	Bombs Aircraft. Incendiary 25 lb. Mk.I Design of box for parachute attachments for bomb, parachute.
7229	5.7.40	Enemy Munitions. German incendiary bomb. Examination of bombs recovered from aircraft forced to land in Scotland.
7223	5.7.40	Bombs Aircraft 4 lb. Incendiary bomb. Design DD/L/10571.
7234	5.7.40	Boxes 40 lb. Incendiary Bomb. Design DD/L/10552 of box to hold two bombs. Rough usage trials.
7352	10.7.40	Enemy munitions. German aircraft bombs.

<u>O.B.Proc.No.</u>	<u>Date</u>	<u>Title</u>
7368	10.7.40	Bombs aircraft. Incendiary. Invention of incendiary liquid by Messrs. Allbright and Wilson Ltd. Trial in 30 lb. L.C. bomb.
7385	12.7.40	Bombs aircraft. Incendiary 25 lb. bomb with parachute attachment. Trials - Report.
7422	15.7.40	Bombs aircraft. Incendiary and L.C. bombs. Provision of lugs and bands.
7505	19.7.40	Bombs Aircraft. Incendiary. 21 lb. (Thermite and fuel oil). Trials. 21 lb. and 4 lb. - consideration of alternative fillings. 30 lb. L.C. bomb - Incendiary filling for - Conference.
7527	19.7.40	Bombs Aircraft. Incendiary, 25 lb. Mk.I Design DD/L/10984 of box for parachute attachments for bomb, parachute - Approval.
7651	26.7.40	Bombs aircraft. 40 lb. Incendiary. Use of cast iron for nose weight. 25 lb. Incendiary - modification suggested by Messrs. Trojans.
7725	29.7.40	Enemy Munitions. German. Reported glass and thermite bombs.
7752	31.7.40	Fuzes, bomb, aircraft, 3 way pistol for 35 lb. and 40 lb. incendiary bombs. Alternative to stainless steel.
7839	5.8.40	Miscellaneous. Incendiary darts for use from aircraft. Trials.
7889	7.8.40	Enemy Munitions. German bombs. 110 Kg. incendiary.
7958	12.8.40	Boxes. 40 lb. incendiary bomb. Design DD/L/10552 of box to hold two bombs - Approval.
8156	21.8.40	Bombs aircraft. Incendiary 21 lb. (Thermite and fuel oil) Trials. 21 lb. and 4 lb. - Consideration of alternative filling. 30 lb. L.C. bomb - Incendiary filling for - Conference.
8157	21.8.40	Projectiles and Bombs. Incendiary. Invention by Thermoloy's Ltd., and P. Adeline.
8196	23.8.40	Bombs, aircraft H.E. and Incendiary. Petrol fires in storage tanks - further trials.



<u>O.B. Proc. No.</u>	<u>Date</u>	<u>Title</u>
8197	23.8.40	Enemy Munitions. German 1 Kg. incendiary bomb.
8315	30.8.40	Miscellaneous. Incendiary darts for use from aircraft. Trials.
8317	30.8.40	Bombs aircraft. Incendiary. Substitute for magnesium in bombs.
8318	30.8.40	Bombs aircraft. 4 lb. incendiary bomb. Substitute for magnesium. Cylindrical bomb with cast iron nose and celluloid body - Trials.
8319	30.8.40	Bombs aircraft. 25 lb. incendiary filled thermite. Preparation of M of F design.
8320	30.8.40	Bombs aircraft. 30 lb L.C. bomb Mk.1 Modified for use as incendiary - comparative trials.
8337	30.8.40	Bombs aircraft. 25 lb Incendiary. Use of cast iron for the nose weight. Modification suggested by Messrs. Trojans.
8421	4.9.40	Miscellaneous. Method of igniting fuel oil on water-Trials.
8514	13.9.40	Bombs aircraft. Incendiary. Invention of incendiary liquid by Messrs. Allbright and Wilson.
8590	18.9.40	Bombs aircraft. H.E. and Incendiary. Ignition of fuel oil - Trials with 40 lb. G.P. bombs.
8598	18.9.40	Bombs and containers. 25 lb. incendiary bomb. Box for parachute attachment Mk.I - Design.
8719	25.9.40	Bombs aircraft. French - Incendiary, 10 Kg. bombs - Trials.
8797	2.10.40	Bombs aircraft. 35 lb and 40 lb. incendiary bombs. Always pistols with improved safety arrangements - Design DD/L/10,030.
8834	4.10.40	Miscellaneous. Incendiary darts for use from aircraft - Trials.
8894	7.10.40	Enemy Munitions. Italian aircraft bombs. Particulars of recovered bombs and fuzes.
8908	9.10.40	Bombs aircraft. Incendiary 40 lb. and L.C. 30 lb. Mk.II. Provision of suspension bonds and lugs - Designs DD/L/10644A and DD/L/10605A.

<u>O.B.Proc.No.</u>	<u>Date</u>	<u>Title</u>
8940	11.10.40	Bombs aircraft. Development trials - Proposed construction of composite building as target.
9877	14.10.40	Miscellaneous. Method of igniting fuel oil on water - trials.
8981	14.10.40	Enemy munitions. Incendiary. Enemy air raid on Marchwood magazine on 20.6.40 Trials to test method of protection.
9176	23.10.40	Bombs aircraft. Incendiary. Use of butane for incendiary purposes.
9184	25.10.40	Bombs aircraft. Development trials. Proposed construction of composite building as target.
9238	28.10.40	Enemy munitions. German. Collapsible bomb container - Examination.
9242	28.10.40	Bombs aircraft. 4 lb. Incendiary substitute for magnesium (i) Cylindrical bomb with cast iron nose and celluloid body DD/L/11486 - Trials (ii) Utilisation of waste cinema film.
9293	1.11.40	Bombs aircraft. 25 lb. Incendiary - Modification suggested by Messrs. Trojans - Trials.
9321	4.11.40	Enemy munitions. Incendiary bombs and signal cartridges recovered from German Heinkel aircraft near Arbroath and Creetown - Examination.
9324	4.11.40	Bombs aircraft. 35 lb. and 40 lb. incendiary bombs. Always pistol with improved safety arrangements. Design DD/L/10,030.
9473	15.11.40	Bombs aircraft. Incendiary. Arming device for 3 ways pistol for use with incendiary bombs.
9548	20.11.40	Enemy munitions. Italian incendiary and H.E. bombs. Delay fuze attachment for the 1 Kg. incendiary and 2 Kg. incendiary and Spenzoni H.E. bombs.
9567	22.11.40	Bombs aircraft. 30 lb. L.C. Mk.II bomb. Use of, as an incendiary bomb.
9574	22.11.40	Enemy munitions. German Aircraft bombs. Delayed action incendiary bomb containing calcium carbide as a secondary charge - Investigation.

<u>O.B.Proc.No.</u>	<u>Date</u>	<u>Title</u>
9612	25.11.40	Enemy munitions. 1 Kg. German incendiary bomb.
9705	2.12.40	Bombs aircraft. Incendiary - Thermit <sup>e</sup> Invention by the late A.S. Baxendale, Esq.
9764	6.12.40	Enemy munitions. German explosive - incendiary bomb. Examination.
9782	9.12.40	Bombs aircraft. Incendiary. Proposals by J.L. Lebreton of the Ministere de L' Nationale, France.
9836	11.12.40	Pyrotechnics (i) Pyrophoric powder containing 60-70% metallic magnesium - Use in incendiary bombs (ii) Mixture of magnesium and charcoal used in German incendiary bombs (iii) Aluminium powder used in sea markers - Risk of spontaneous inflammation if not matured.
9890	16.12.40	Bombs aircraft. Incendiary. Limit of calcium content in magnesium. Specification.
9913	18.12.40	Bombs aircraft. 25 lb. Incendiary filled thermit <sup>e</sup> (M of F) Design DD/L/11653.
9929	18.12.40	Bombs aircraft. Incendiary-thermit <sup>e</sup> Invention by the late A.S. Baxendale, Esq.
9935	20.12.40	Bombs aircraft. Incendiary 30 lb. L.C. Mk.I - Incendiary filling for - Report on experiments.
10023	27.12.40	Bombs aircraft. French - Incendiary. Trials of 10 Kg. bombs comments by C.S.R.D. on fuze.
10122	3.1.41	Bombs aircraft. 25 lb. Mk.II and 40 lb. Mk.I incendiary bombs. Carriage in Fleet Air Arm, aircraft, Design DD/L/10030.
10156	3.1.41	Bombs aircraft. Incendiary and L.C. bombs. Tests of lugs and bands.
10267	10.1.41	Bombs aircraft. Incendiary. Limit of calcium content in magnesium. Specification.
10280	13.1.41	Bombs aircraft. H.E. and incendiary. Trials of 40 lb. G.P. bombs (i) Ignition of fuel oil. (ii) Penetration of 1/2" plate by fragments. Trial 'D' for Air Raid Precautions Department.

<u>O.B.Proc.No.</u>	<u>Date</u>	<u>Title</u>
10294	13.1.41	Bombs aircraft 30 lb. L.C. Mk.I and 250 lb. incendiary bombs. Filling for - Trials.
10392	22.1.41	Fuzes, bomb, aircraft, No.43 for 25 lb. Mk.II and 40 lb. incendiary bombs. Modifications to air arming device.
10433	22.1.41	Miscellaneous. Trial for the protection of roofs against the 1 kilo. German aircraft bomb.
10519	31.1.41	Bombs aircraft. L.C. 30 lb. Mk.I and 250 lb. incendiary bombs. filling for Trials.
10534	3.2.41	Fuzes, bomb, aircraft. Long delay for 4 lb. incendiary bomb. Design DD/L/11965 - Proposed Trials.
10551	5.2.41	Bombs aircraft. 4 lb. incendiary bomb with explosive charge. Re-design - Trials.
10611	7.2.41	Bombs aircraft. Incendiary 25 lb. Mk.II designs DD/L/11951 (2 sheets) DD/L/11952 (2 sheets), DD/L/11953 and DD/L/11961.
10623	10.2.41	Miscellaneous. Method of igniting fuel oil on water. Trials of floats, flame, navigation, Mk.II modified.
10645	10.2.41	Fuzes, bomb, aircraft. No.43 for 25 lb. Mk.II and 40 lb. incendiary bombs. Modification to air arming device.
10695	14.2.41	Bombs aircraft. Incendiary 25 lb. Mk.II (M of F) design DD/L/11954.
10736	17.2.41	Miscellaneous. Protection of magazine roofs and ships hatches against incendiary bombs. Tests with "Decorstone" no longer required.
10737	17.2.41	Bombs aircraft. 25 lb. incendiary Mk.II (i) Rough usage trials in box - Report. (ii) Method of attachment of tail unit.
10738	17.2.41	Miscellaneous. Magazine roofs. Trials of 1 Kg. incendiary bombs against.
10747	17.2.41	Fuzes, bomb, aircraft. No.43 (squat 3-ways tail fuze for 25 lb. Mk.II and 40 lb. incendiary bombs) made of Mazak No.3. Effect of low temperature on functioning - Proposed test.

<u>O.B.Proc.No.</u>	<u>Date</u>	<u>Title</u>
10814	24.2.41	Bombs, aircraft. 4 lb. incendiary bomb. Incorporation of a long delay fuze to design DD/L/11965 - Trials.
10889	28.2.41	Bombs aircraft. 4 lb. incendiary bomb. Comparative trials with celluloid and magnesium.
10891	28.2.41	Bombs aircraft. Foreign. Russian incendiary bombs-Examination.
10925	3.3.41	Bombs aircraft. Incendiary. Limit of calcium content in magnesium. Spectrographical method of determination.
10988	7.3.41	Miscellaneous. Magazine roofs - Trials of 1 Kg. incendiary bombs against.
11029	10.3.41	Bombs aircraft. 4 lb. incendiary. Trials of modified celluloid.
11188	14.3.41	Bombs aircraft. 40 lb. incendiary. Use of cast iron for the nose Trials.
11170	17.3.41	Enemy Munitions. German aircraft bomb. 110 Kg. incendiary (D.250 (Flam.)) Static Trial.
11171	17.3.41	Miscellaneous. Flame throwers and incendiary. Proposed use of solidified fuels.
11207	19.3.41	Bombs aircraft. 4 lb. incendiary bomb. Use of celluloid. Selection from programme.
11255	21.3.41	Bombs aircraft. Incendiary. Limit of calcium content in magnesium. Spectrographical method of determination.
11257	21.3.41	Bombs aircraft (i) 4 lb. incendiary - Modification of filling (ii) 40 lb. incendiary with explosive charge. Re-design - Trials.
11297	24.3.41	Bombs aircraft. Incendiary, 25 lb. Mk.II Designs DD/L/11951 (2 sheets) DD/L/11952 (2 sheets) DD/L/11953 and DD/L/11961 - Approval.
11316	26.3.41	Bombs aircraft. Foreign. Japanese 70 kilo. incendiary bomb. Examination of fire-pot.
11360	28.3.41	Bombs aircraft. 30 lb. L.C. Mk.II. Use as an incendiary bomb (i) Result of trials. (ii) Future development.

<u>O.B.Proc.No.</u>	<u>Date</u>	<u>Title</u>
11445	2.4.41	Bombs aircraft. 250 lb. L.C. Use as an incendiary bomb. Design DD/L/11942.
11599	11.4.41	Fuzes, bomb, aircraft. Replacement of No.38 fuze in 30 lb. incendiary bomb.
11618	16.4.41	Bombs Aircraft. 250 lb. L.C. with incendiary filling. Static trial for comparison with German 110 Kg. incendiary bomb.
11652	18.4.41	Bombs aircraft. 250 lb. L.C. with incendiary filling (i) Remarks by D.Arm.D. on filling and burster (2) Nomenclature of phosphorus (3) Cooling trial - information required.
11688	21.4.41	Miscellaneous Methods of igniting fuel oil on water. Proposal by Prof. A.M. Low - Trials.
11711	21.4.41	Packages and Containers. 4 lb. incendiary bomb (i) Increase in loads for small bomb containers from 60 to 90 bombs (ii) Designs of case and box (iii) Rough usage trials.
11763	25.4.41	Bombs aircraft 250 lb. L.C. bomb. Use as an incendiary bomb - Design DD/L/11942.
11850	30.4.41	Bombs aircraft 250 lb. L.C. bomb with incendiary filling. (i) Trials (ii) Adoption of 5.1/2% rubber mixture (iii) Standardisation of fuzes for liquid and incendiary fillings.
11882	2.5.41	Bombs aircraft 4 lb. incendiary Mk.II and IIE. Amendments to design DD/L/10571. (i) Alteration of bore (ii) Alteration to flange of cap holder.
11889	2.5.41	Bombs aircraft 4 lb. incendiary bomb with nose fuze and H.E. charge in tail (i) Trials to determine strength of bomb with bore increased to 15/16" and 1" (iii) Re-design of bomb.
11890	2.5.41	Bombs aircraft and Pyrotechnics. Pyrophonic powder containing 60-70% metallic magnesium. Possible use in incendiary bombs - Investigation.

<u>O.B.Proc.No.</u>	<u>Date</u>	<u>Title</u>
11911	5.5.41	Enemy munitions. German aircraft bombs. 1 Kg. incendiary bomb with explosive charge - Trials.
11960	7.5.41	Enemy munitions German aircraft including bombs. Flam C.500. Exploder tube - Examination.
12152	19.5.41	Enemy munitions German aircraft bombs. Fillings and markings of the 1 Kg. incendiary bombs.
12529	13.6.41	Bombs aircraft. 30 lb. incendiary Mk.I (i) Trials with bombs fitted with No.846 fuze (ii) Conversion of Messrs. Luxfer's design to DD/L/series.
12708	27.6.41	Bombs aircraft 4 lb. incendiary (i) Trials with increased bore (ii) Trials with German 1 Kg. bomb to confirm functioning in a vertical position (iii) Explosive charge.
12940	11.7.41	Enemy munitions. Italian aircraft bombs. Particulars.
12972	14.7.41	Bombs aircraft. 30 lb. Mk.I incendiary (i) Report of dropping trials of cooled bombs (ii) Recommended filling.
13025	18.7.41	Bombs aircraft. 4 lb. incendiary with nose fuze and H.E. charge in tail Design DD/L/12707.
13166	23.7.41	Bombs aircraft 4 lb. incendiary Minutes of meeting held on 17.7.41 to consider present position of different types under development.
13286	1.8.41	Bombs aircraft. Attack on forests with incendiary bombs - Trials (i) Report on trials (ii) Report on meeting on future development of incendiary bombs for attack on forests and crops.
13630	25.8.41	Bombs aircraft. Testing of incendiary bombs. Report by the Chief Adviser, Research and Experiments, Ministry of Home Security.
13688	29.8.41	Fuzes, bomb, aircraft. Trials of squat design (M 237) in 4 lb. incendiary bombs.
13817	5.9.41	Packages and Containers. 4 lb. incendiary bomb (container loads of 90) Rough usage trials of (i) Box, bomb, incendiary, aircraft 4 lb. B.268 Mk.II (ii) case, bomb, incendiary, aircraft 4 lb. Mk.III Report.

<u>O.B.Proc.No.</u>	<u>Date</u>	<u>Title</u>
14158	24.9.41	Bombs aircraft. 30 lb. incendiary Mk.II (i) Conversion of Messrs. Luxfer's design Exp.1 to design DD/L/12887 (Sheets 1-2-3-4) Recommendation for approval (ii) Nomenclature.
14261	29.9.41	Bombs aircraft. Attack on forests and crops with incendiary bombs. No development work required on existing incendiary weapons.
14469	13.10.41	Bombs aircraft 30 lb. incendiary Mk.II (i) Nomenclature (ii) Amendments to design DD/L/12887 to assist manufacture (iii) Approval of amended design.
14486	15.10.41	Bombs aircraft (i) arrangements for firing trials of 4 lb. incendiary bombs (inert filled) against typical German buildings. (ii) Notes on a meeting held on 9.10.41.
14575	20.10.41	Bomb aircraft H.E. 4 lb. 'X' - Policy - Mk.I.
14576	20.10.41	Bomb aircraft 250 lb. L.C. with rubber benzole - phosphorus filling. Results of static trial in comparison with German 110 Kg. (Flamm) Bomb.
14828	7.11.41	Packages and containers. Case, bomb, incendiary, aircraft 4 lb. Mk.III (Design DD/L/12384). Approval.
15124	26.11.41	Miscellaneous. Methods of igniting fuel oil on water. Trial at Lyme Bay on 29.10.41 - Results.
15199	1.12.41	Miscellaneous. Methods of igniting fuel oil floating on water (i) Trials in Studland Bay on 8.11.41 (ii) Advance information of result of further trial in Studland Bay on 25.11.41. Recommendation of 5 gallon "tin can" as Mk.I weapon (iii) Requirements for full scale oil trial - Request to Admiralty to allot tanker and site.
15387	15.12.41	Bombs Aircraft. 250 lb. incendiary Mk.II Air Staff decision re filling.
15395	15.12.41	Bombs Aircraft. Incendiary 4 lb. (Type M 54) made in U.S.A. (i) Arrangements for tests (ii) Changes in filling of British 4 lb. bomb to give "sparking" effect.



<u>O.B.Proc.No.</u>	<u>Date</u>	<u>Title</u>
15402	17.12.41	Bombs Aircraft. Incendiary 4 lb. Mk.IV. General information as a result of trials.
15406	17.12.41	Bombs Aircraft. Incendiary 4 lb. Mk.III. Report of trial of bombs with loose filling.
15424	17.12.41	Bombs Aircraft. 4 lb. incendiary Mk.IV and Mk.IVE. Preparation of M of F designs. Design DD/L/13504. M. of F. Mk.IV bomb - Recommendation for approval.
15478	19.12.41	Miscellaneous. Ignition of fuel oil on water. Trials of 250 lb. L.C. bombs (filled petrol and petrol - K of QR) in Lyme Bay - Results.
15510	22.12.41	Miscellaneous. Methods of igniting fuel oil floating on water. Trials of 5 gallon tins in Studland Bay on 25.11.41 - Results.
15522	24.12.41	Miscellaneous Ignition of fuel oil on water. Trials of floats, fuel oil, ignition (Design DD/L/13232) in Luce Bay on 5.12.41 - Results.
15547	24.12.41	Bombs Aircraft. Firing trials of 4 lb. incendiary and German 1 Kilo bombs against typical German buildings. Results.
15563	29.12.41	Enemy Munitions. Italian aircraft bombs (including gas bombs) and fuzes. Information from G.H.Q. Middle East Force.
15633	21.1.42	Miscellaneous. Methods of igniting fuel oil on water. M.T. petrol to be used in Petrol - K.O.F.Q.R. mixture.
15670	5.1.42	Bombs Aircraft. 4 lb. incendiary with lethal explosive charge (X.I.B.). Development work.
15728	7.1.42	Bombs Aircraft. 250 lb. incendiary Mk.II M of F design DD/L/12994. Recommendation for approval.
15899	21.1.42	Bombs Aircraft. 250 lb. incendiary Mk.II M of F design DD/L/12994. Approval, marking of filled bombs.

<u>O.B.Proc.No.</u>	<u>Date</u>	<u>Title</u>
15901	21.1.42	Bombs Aircraft. 4 lb. incendiary (i) Simplified method of marking - concurrence by the Board. (ii) Design DD/L/13504 (M of F) Mk.IV bomb - Approval. (iii) Design DD/L/13706 (M of F) Mk.IVE bomb - Recommendation for approval. (iv) Air Staff decision on safety heights of drops for Mk. IV and IVE bombs.
15940	23.1.42	Miscellaneous. Methods of igniting fuel oil floating on water. Arrangements for trials at Loch Striven.
15956	26.1.42	Bombs Aircraft. 30 lb. incendiary bomb Mk.II, with one-piece burster container - Trial - adoption.
16048	2.2.42	Bombs Aircraft. 4 lb. incendiary bomb with lethal explosive charge (X.I.B.) (i) Use of bomb in operations. (ii) T.N.T. and Pentolite to be used in preliminary trial.
16207	11.2.42	Miscellaneous. Methods of igniting fuel oil floating on water. Trials at Loch Striven. Inclusion of stores filled aviation petrol.
16260	16.2.42	Bombs Aircraft. 4 lb. incendiary Mk.IVE. Design DD/L/13706. Approval.
16320	20.2.42	Bombs Aircraft. 4 lb. incendiary with lethal explosive charge (X.I.B.) Minutes of meeting held on 12.2.42.
16418	27.2.42	Miscellaneous. Methods of igniting fuel oil floating on water. Arrangements for trials at Loch Striven. Minutes of meeting held on 20.2.42.
16534	4.3.42	Bombs Aircraft, and Fuzes, Bomb, Aircraft. 30 lb. incendiary bomb Mi.II and fuze No.846. Designs DD/L/12887A and M of F DD/L/13066 of bomb, and DD/L/11000 and DD/L/11000/1 of fuze, approved for Naval Service.
16833	17.3.42	Bombs Aircraft. Incendiary (i) Report of comparative trials of 4 lb. and M.50 and M.54 bombs (ii) mechanics of fire-raising by incendiary bombs - Analysis.
16961	3.4.42	Bombs Aircraft. 250 lb. incendiary Mk.II M of F design DD/L/12994. Marking of filled bombs.

<u>O.B.Proc.No.</u>	<u>Date</u>	<u>Title</u>
17218	24.4.42	Miscellaneous. Methods of igniting fuel oil floating on water. Trials at Loch Striven. M.A.E.E. Report No. H/Arm/80.
17614	20.5.42	Miscellaneous. Methods of igniting fuel oil floating on water. Minutes of meeting held on 6.5.42.
17877	8.6.42	Fuzes, bomb, aircraft. Long delay for 4 lb. incendiary bomb. Results of further trials of fuze to design M.239 (Midgley - Harmer).
17963	10.6.42	Enemy Munitions. Bombs, including 1 kg., believed to be of French origin, used by the enemy.
18117	22.6.42	Bombs Aircraft. 250 lb. incendiary Mk.II. Report of trials April and May 1942.
18491	15.7.42	Fuzes aircraft bomb. Long delay for 4 lb. incendiary bomb. No further action required.
18510	15.7.42	Bombs aircraft. 4 lb. incendiary bomb with lethal explosive charge. Failures to detonate - Investigation.
18786	31.7.42	Bombs aircraft. Re-design of non-magnesium incendiary bomb. 1. Statement of requirements. 2. Arrangement for design of stores for trials.
19604	21.9.42	Bombs aircraft. 30 lb. incendiary Mk.I. Attack of merchant shipping. Proposal for trials.
19776	2.10.42	Bombs aircraft. Incendiary. Magnesium incendiary smaller than 4 lb. Investigation of qualities.
20113	23.10.42	Bombs aircraft. Incendiary. Magnesium incendiary bombs smaller than 4 lb. Spring-out tails.
20285	4.11.42	Bombs aircraft. Incendiary. Magnesium incendiary smaller than 4 lb. Spring-out tails. Fagotting scheme.
20288	4.11.42	Bombs Aircraft. Incendiary, 30 lb. Mk.II Approval.
21147	6.1.43	Enemy munitions. Japanese aircraft bombs. A.M. Instruction 190 Schedule of Japanese aircraft bombs.

<u>O.B.Proc.No.</u>	<u>Date</u>	<u>Title</u>
21283	15.1.43	Detonators aircraft bomb. 1.7 grain detonators for aircraft bomb detonators and 4 lb. incendiary bombs (i) Concessions for 1.7 grain detonators in 4 lb. incendiary bombs (ii) Duplication of specifications for aircraft bomb detonators.
21349	20.1.43	Enemy munitions. German aircraft bombs. Incendiary. Use of containers.
22102	12.3.43	Fuzes, aircraft bomb. No.846 Mk.I. Proposed plastic bodies for use with incendiary bombs smaller than 30 lb. A & A.E.E. Report ATO/J10.
22293	22.3.43	Bombs aircraft. Incendiary. Replacement of 30 lb. incendiary bomb - cancellation of requirements for a 5.5" diameter "Gel" filled bomb.
22434	29.3.43	Bombs aircraft. Incendiary 4 lb. - 1.7 grain detonators. (i) Amendment to C.S.A.R's statement recorded in Proc.No.21283. (ii) C.S.A.R's concurrence in concessions.
23103	14.5.43	Miscellaneous. Methods of igniting fuel oil floating on water. Special 4.5" flare developed by D.B.D. (S.H.F.B., Type "A"). Work stopped.
23252	26.5.43	Bombs aircraft. Incendiary. Magnesium incendiary bomb smaller than 4 lb. Investigations.
23355	2.6.43	Bombs aircraft. Incendiary. Mk.IV. Scatter - Orfordness Report O.R.S. B.T.27.
23356	2.6.43	Bombs aircraft. 4 lb. incendiary Mk.IV. Modified method of filling. Report A.A.E.E./A.T.O./G.5 No.22.
23431	7.6.43	Bombs Aircraft. Incendiary 30 lb. A.R.D. Explosives Report No.143/43 on "Some Experiments on rate of loss of solvent vapour from gels".
23442	10.6.43	Enemy Munitions. German "Brand C.250A" Phosphorus incendiary bomb. Report of examination by C.S.A.R.
23801	7.7.43	Bombs Aircraft H.E., incendiary and smoke, clustering of small stores.
24154	24.11.43	Bombs Aircraft. L.C. 30 lb. Mk.II. Use as an incendiary bomb. Cessation of development.

<u>O.B.Proc.No.</u>	<u>Date</u>	<u>Title</u>
25752	8.12.43	Bombs aircraft, 500 lb. cluster No.14 Mk.I (106 x 4 lb. incendiary bombs) O.R.S. report B.T.43 on ballistic trials.
26011	3.1.44	Bombs aircraft, 750 lb. cluster No.15 Mk.I (158 x 4 lb. incendiary bombs) O.R.S. report B.T.46.
26107	10.1.44	Bombs aircraft, 500 lb. cluster No.14 Mk.I (106 x 4 lb. incendiary bombs)(i) C.R.S. Report B.T.63 on ballistic trials Corrigendum (ii) Effect of high velocity of opening of cluster on ballistics of individual bombs.
27052	22.3.44	Bombs aircraft, incendiary and detonators, aircraft bomb. (i) Detonator for use in 4 lb. incendiary bomb to withstand storage at 130°F for 2 years - A.R.D. Explosives Report No. 13/44 on 2.5 gr QF/P detonator in A/B detonators.
27460	26.4.44	Bombs, aircraft, incendiary and fuzes, aircraft bomb (i) Accidental ignitions of 4 lb. incendiary bombs (ii) Assembly of 1.7 gr. detonators in 4 lb. incendiary bomb and No.846 fuze.
27489	1.5.44	Bombs aircraft, 500 lb. cluster No.4 Mk.I. 500 lb. cluster No.6 Mk.I. 500 lb. cluster No.17 Mk.II. O.R.S.reports BT 56, BT 57 and BT 55 of ballistic trials.
27543	5.5.44	Bombs and flares, aircraft, cluster - projectiles and their containers. Standard rough-usage and stacking trials.
27654	15.5.44	Bombs, aircraft. Incendiary. Gello-cotton-petrol fillings for incendiary bombs. A.R.D. Explosives Report 549/44.
27657	15.5.44	Bombs, aircraft, incendiary and fuzes, aircraft bomb. (i) Accidental ignitions of 4 lb. incendiary bombs (ii) Assembly of 1.7 gr. detonators in 4 lb.incendiary bomb and No.846 fuze (iii) Detonator with lead-tin foil disc to be used in No.846 fuze.
27757	24.5.44	Bombs, aircraft, L.C 500 lb. incendiary Trials with special fillings.
28117	26.6.44	Bombs, aircraft, 500 lb. clusters Nos. 4 and 6 and 17. Ballistic trials.

<u>O.B.Proc.No.</u>	<u>Date</u>	<u>Title</u>
28355	19.7.44	Bombs, aircraft. cluster projectiles and their containers. Standard stacking trials - Height of stacks.
28608	16.8.44	Bombs, aircraft. Clusters (i) O.R.S. reports Nos. BT 71 and 72 of ballistic trials of American 500 lb. Clusters M17 and 1000 lb., cluster No.16 Mk.I (ii) List of clusters.
29027	25.9.44	Bombs, aircraft. American 500 lb. M76 incendiary bomb. Ballistic trials.
29243	18.10.44	Bombs, aircraft. Clusters (i) No.4 Mk.I, 500 lb. (14 x 30 lb. bombs, incendiary type J) (ii) No.14 Mk.I 500 lb. (106 x 4 lb. bombs incendiary). Ballistic trials.
30223	5.2.45	Bombs aircraft. Clusters No.20 (62 AN-M69 bombs) Recommendation for trials.
30791	9.4.45	Bombs aircraft. American 500 lb. AN-M76 incendiary. Functioning trials when fuzes with pistol No.52.
31232	28.5.45	Bombs aircraft. Clusters. Nomenclature.
31617	11.7.45	Bombs aircraft. Cluster N.E., 4 lb. I.B.800 lb. Mk.I/Air. Ballistic trials O.R.S. Report BT110.
31772	30.7.45	Bombs aircraft. American M.69 6 lb. oil bomb (i) Results of trials (ii) Proposed introduction.
31803	3.8.45	Fuzes, aircraft bomb. For incendiary bombs. Use of 2.5 grs. detonation filled S9/G20 (i) Design (ii) Arrangements for dropping trials.
31909	20.8.45	Bombs aircraft. Clusters. Cluster E46 containing 38 M-69, 6 lb. oil bombs. Ballistic trials.

Appendix 4

List of O.B. 'Q' Proceedings on the Subject of Incendiary Bombs and Related Subjects

<u>Number</u>	<u>Date</u>	<u>Subject</u>
Q.32	31.5.40	Bombs, aircraft. Incendiary. Incendiary Pellets - Invention by Mr. N. Dobbs and Mr. A. Haven, U.S.A.
Q.97	20.9.40	Miscellaneous. Messrs. Allbright and Wilson incendiary composition "Razzle" - Trial against standing crops.
Q.177	24.2.41	Bombs, aircraft 4 lb. H.E. representing 4 lb. incendiary and fitted with anti-disturbance device - Designs DD/L/12019 and DD/L/12037. Arrangements for trials.
Q.194	14.3.41	Bombs, aircraft 4 lb. H.E. representing 4 lb. incendiary and fitted with anti-disturbance device - Designs DD/L/12019 and DD/L/12037. Arrangements for trials.
Q.255	20.6.41	Bombs, aircraft. 4 lb. H.E. representing 4 lb. incendiary and fitted with anti-disturbance device. Marking.
Q.269	25.7.41	Bombs, aircraft. 4 lb. H.E. representing 4 lb. incendiary and fitted with anti-disturbance device. Nomenclature.
Q.305	17.9.41	Bombs, aircraft 4 lb. Mk.II (H.E.D.) Alteration of nomenclature.
Q.509	27.4.42	Bombs, aircraft. H.E.X. 6 lb. (Replacement of H.E.X. 4 lb.) Designs DD/L/13261 and DD/L/14189. Arrangements for static detonation trial of bomb filled 50/50 Amatol.
Q.566	8.6.42	Bombs, aircraft, incendiary. With characteristic spectrum. Statement of requirements.
Q.633	29.7.42	Bombs, aircraft. 4000 lb. incendiary for use as a marker. Provision of stores for trials. Statement of requirements.
Q.636	31.7.42	Bombs, aircraft. 2000 lb. H.C. incendiary. To be used as a marker - Investigation.
Q.668	24.8.42	Bombs, aircraft. 4000 lb. incendiary for use as a marker. Unfavourable report of trials. Redesign of bomb. The tail ejection principle.
Q.702	11.9.42	Bombs, aircraft. 4000 lb. incendiary for use as a marker. Unfavourable report of trials. Redesign of bomb. The tail ejection principle. General consideration.

<u>Number</u>	<u>Date</u>	<u>Subject</u>
Q.719	21.9.42	Bombs, aircraft. 4000 lb. incendiary for use as a marker. Incorporation of delay fuzing.
Q.744	2.10.42	Bombs, aircraft. 4000 lb. incendiary for use as a marker. Static trials.
Q.766	12.10.42	Bombs, aircraft. 30 lb. incendiary Mk.I and III. Arrangements for trials against 3/8 " m.s. plate. Employment of "cable rig".
Q.866	14.12.42	Bombs, aircraft. Incendiary. Relationship between penetration and fire-raising efficiency.
Q.904	6.1.43	Bombs, aircraft. H.E. 6 lb. Re-statement of requirements.
Q.934	22.1.43	Fuzes, aircraft bomb. Barometric fuzes. Note on the distribution of pressure around the 4000 lb. marker bomb body.
Q.935	22.1.43	Bombs, aircraft. 4000 lb. incendiary for use as a marker. Static trials and wind-tunnel tests.
Q.952	1.2.43	Bombs, aircraft. 30 lb. incendiary Mk. I and III. Trials against 3/8" m.s. plate. Employment of "cable rig". Result of preliminary trials.
Q.977	8.2.43	Bombs, aircraft. Incendiary - Jet flame. Designs submitted by Messrs. Worssam's.
Q.1007	22.2.43	Bombs, aircraft. 4000 lb. incendiary as a marker. Suspension of work on DD/L/15228.
Q.1025	3.3.43	Bombs, aircraft. 4000 lb. incendiary for use as a marker. No further work required.
Q.1093	26.3.43	Bombs, aircraft. Incendiary, 'J' Mk.I. Report of trials to assess (i) Vulnerability to S.A.A. fire (ii) Incendiary effect.
Q.1101	29.3.43	Bombs, aircraft. Incendiary, 'J' 30 lb. Mk.I Flexible tubing - supply difficulties. Suggestion for re-design.
Q.1293	7.6.43	Bombs, aircraft. Mortar firing of 30 lb. incendiary. A.R.D. explosives report 122/43.
Q.1340	30.6.43	Bombs, aircraft. 30 lb. incendiary Mk.I and Mk.III. Trials against ship targets.
Q.1414	21.7.43	Bombs, aircraft. 30 lb. incendiary Mk.I and III Trials against ship targets - No further action required by Air Staff.



<u>Number</u>	<u>Date</u>	<u>Subject</u>
Q.1480	25.8.43	Bombs, aircraft. 30 lb. incendiary Mk.I and Mk.III. Trials against ship targets. No further action required by the Naval Staff.
Q.1484	27.8.43	Bombs, aircraft. Incendiary 30 lb. 'J' Type. Vulnerability of cluster to enemy ammunition.
Q.1485	27.8.43	Bombs, aircraft. 40 lb. incendiary 'X' type, Mks. I and II. Approval of designs.
Q.1535	20.9.43	Bombs, aircraft. 30 lb. incendiary type 'J' Development position.
Q.1542	22.9.43	Miscellaneous. Fire-raising. General Principles of.
Q.1561	1.10.43	Bombs, aircraft. 30 lb. 'J' Type incendiary. Development position.
Q.1567	4.10.43	Bombs, aircraft 4 lb. incendiary 'X' Type Mk.III. Designs DD/L/16984 (Empty Bomb) and DD/L/16985 (M. of F.) recommended for approval.
Q.1589	18.10.43	Bombs, aircraft. 4 lb. incendiary 'X' Type Mk.III. Approval of designs DD/L/16984 and DD/L/16985.
Q.1611	27.10.43	Bombs, aircraft. Incendiary 12 lb. (Small 'J' Type) developed by DMDI - Details and report of demonstration.
Q.1686	24.11.43	Bombs, aircraft. Incendiary 30 lb. 'J' Type. Development position.
Q.1710	6.12.43	Bombs, aircraft. Incendiary 30 lb. 'J' Type. Development position on 20th Nov. 1943.
Q.1761	22.12.43	Bombs, aircraft. 30 lb. incendiary type 'J'. Development position.
Q.1824	14.1.44	Bombs, aircraft. 30 lb. incendiary type 'J'. Reports of functioning trials of bombs and cluster projectile No.4.
Q.1832	17.1.44	Bombs, aircraft. Incendiary 22 lb. 'J' Type. Proposed by DMDI. Development.
Q.1885	31.1.44	Bombs, aircraft. Incendiary 22 lb. (Small 'J' type) developed by DMDI to replace bomb 12 lb. in weight.
Q.1922	14.2.44	Liquid ejection. Cordite operated 'J' 10 bomb. A.R.D./Ball/Report 78/43.
Q.1976	1.3.44	Liquid ejection. Cordite operated 'J' 10 bomb. A.R.D./Ball/Report 78/43.
Q.2024	15.3.44	Bombs, aircraft. 30 lb. incendiary, type 'J' Progress Report.

<u>Number</u>	<u>Date</u>	<u>Subject</u>
Q.2047	22.3.44	Bombs aircraft. Incendiary. Large oil bomb which will function on land or water. Development.
Q.2092	21.3.44	Bombs, aircraft. 30 lb. incendiary type 'J'. Alternative material for liquid charging. Report by Mr. Fox.
Q.2123	14.4.44	Bombs, aircraft. 30 lb. incendiary bomb 'J' Type. Mk.II. Modification and re-design.
Q.2146	24.4.44	Bombs, aircraft. Incendiary. 22 lb.. J. Penetration trial.
Q.2152	28.4.44	Bombs, aircraft, and fuzes, aircraft bomb. Incendiary 22 lb. 'J'. Mk.I. (i) Consideration of designs of bomb and fuze. (ii) Shuttering of fuzes for incendiary bombs.
Q.2223	19.5.44	Bombs, aircraft. Incendiary. 400 lb. Oil bomb. Trials against concrete wall target.
Q.2229	22.5.44	Bombs, aircraft. H.C. 4000 lb. charged incendiary. A.and A.E.E. Report A.T.O/G.88
Q.2344	28.6.44	Bombs, aircraft. Incendiary. Cordite - operated - Development.
Q.2360	5.7.44	Bombs, aircraft. Incendiary. 2 lb. magnesium bomb for use in Far East. Requirements and development.
Q.2679	11.10.44	Bombs, aircraft. Incendiary. 3 lb. magnesium, for use in Far East. Penetration trials.
Q.2680	11.10.44	Bombs, aircraft, and fuzes, aircraft bomb. Incendiary 22 lb. 'J' Mk.I. Development.
Q.2681	11.10.44	Bombs, aircraft. 30 lb. Incendiary type 'J'. Penetration and burning tests against Japanese structures.
Q.2719	23.10.44	Bombs, aircraft. 30 lb. incendiary bomb, 'J' type, Mk.II. No further requirement.
Q.2810	27.11.44	Bombs, aircraft, and fuzes, aircraft bomb (i) Always fuze for 22 lb. 'J' bomb. Development (ii) Consideration of shuttering requirements for fuze and H.E. charge in bomb.
Q.2862	11.12.44	Bombs, aircraft, and fuzes, aircraft bomb 20 lb. (late 22 lb.) 'J' incendiary bomb with Always fuze. Arrangements for rough usage trials of bombs with unshuttered fuzes and unshuttered azide sleeves.
Q.2882	15.12.44	Bombs, aircraft. Incendiary 400 lb. oil bomb. Functioning trials on water and downland.

<u>Number</u>	<u>Date</u>	<u>Subject</u>
Q.2887	15.12.44	Bombs, aircraft. Incendiary, 3 lb. Proposed re-design.
Q.2907	28.12.44	Bombs, aircraft, and fuzes, aircraft bomb 20 lb. 'J' bomb and Allways fuze No.888. (i) Present types of bomb and fuze acceptable for handling and clustering in filling factories (ii) Nomenclature.
Q.2991	24.1.45	Bombs, aircraft, and fuzes, aircraft bomb. Incendiary 20 lb. 'J' Mk.I and fuze "Allways" No.888 Mk.I (i) Nomenclature (ii) Consideration of safety aspect of fuze and window-breaker.
Q.3011	31.1.45	Bombs, aircraft and fuzes, aircraft bomb. Incendiary, 3 lb., with re-designed fuzing system - Development.
Q.3070	16.2.45	Bombs, aircraft and fuzes, aircraft bomb, 30 lb. incendiary type 'J'. (i) Modifications for use in the tropics (ii) Proposed use of fuze No.888.
Q.3129	2.3.45	Bombs aircraft 30 lb. incendiary, type 'J'. Penetration trials.
Q.3130	2.3.45	Bombs aircraft, and fuzes, aircraft bomb 30 lb. incendiary type 'J'. (i) Climatic trials (ii) Use of fuze No.888.
Q.3137	5.3.45	Bombs, aircraft and fuzes, aircraft bomb. Incendiary 20 lb. 'J' Mk.I and fuze "Allways" No.888 Mk.I (i) Acceptance for transport and storage (ii) New designs of modified bomb and shuttered fuze and sleeve.
Q.3138	5.3.45	Bombs, aircraft. Incendiary. 400 lb. oil bomb. Fuze arming trials.
Q.3177	19.3.45	Fuzes, aircraft bomb. For incendiary bombs (i) Use of 2.5 gr. detonators filled S9/G.20 (ii) Use of brass striker in fuze 888.
Q.3198	23.3.45	Bombs, aircraft and fuzes, aircraft bomb. 20 lb. 'J' bomb and fuze, "Allways" No.888 Mk.I. Rough usage and vibration trials.
Q.3243	9.4.45	Bombs, aircraft. 400 lb. incendiary, Mk.I Ballistic trials.
Q.3244	9.4.45	Bombs, aircraft. Incendiary 20 lb. 'J' Type. Window-breaking charge to be retained.
Q.3252	11.4.45	Fuzes, aircraft bomb. Shuttered fuze for 20 lb. incendiary type 'J'. Arrangements for shutter sealing trials.
Q.3280	18.4.45	Bombs aircraft. 20 lb. 'J' Mk.I. Change in design of lead-azide sleeve in window-breaker.

<u>Number</u>	<u>Date</u>	<u>Subject</u>
Q.3586	18.7.45	Bombs, aircraft and fuzes, aircraft bomb. 30 lb. incendiary type 'J' Mk.II. Cancellation of requirements.
Q.3620	30.7.45	Bombs, aircraft and fuzes, aircraft bomb. 18 lb. incendiary bomb and fuze No.891 - Development.
Q.3624	30.7.45	Bombs, aircraft. Incendiary 20 lb. 'J' Mk.I Vulnerability to attack by enemy ammunition.
Q.3738	17.9.45	Bombs, aircraft. Incendiary 20 lb. 'J' Mk.I. Vulnerability to attack by enemy ammunition.

Appendix 5. C.S.A.R. Reports.

In addition to the reports listed below, there are many C.S.A.R. papers containing records of research on particular projects. These were not normally distributed to outside Departments, but are available in the A.R.D. Information Bureau filed under the heading of the store concerned. The following list must not, therefore, be regarded as a complete list of work done by C.S.A.R. on this subject. Most of the work done on specific projects by C.S.A.R. appears in Ordnance Board Proceedings (see Appendices 3 and 4).

<u>Ref.</u>	<u>Date</u>	<u>Title</u>
115/42	-.4.42	4 lb. Incendiary bomb with lethal explosive charge.
327/42	22.10.42	4 lb. Incendiary bomb with lethal explosive charge (3pp).
122/43	11.5.43	Mortar firing of bombs, aircraft, incendiary 30 lb. By R.F. Phillips and C.D. Thomas (12 pp and 38 photos).
290/43	13.9.43	Star washer failures in the 4 lb. incendiary bomb. By S.H. Harvey (5 pp and 6 tabs).
309/43	21.10.43	20 mm Hispano SAP/Incendiary - Report on further trials with P.I.G. enclosed in metal and plastic containers (4 pp).
405/43	4.12.43	The scattering of incendiary materials from aircraft bombs for anti-personnel effect. By R.F. Phillips. (6 pp and 6 tabs).
415/43	13.12.43	Incendiary gel filling for the 4.2" mortar bomb. By R.F. Phillips. (3 pp and tabs)
13/44	4.3.44	Detonator for the 4 lb. incendiary bomb to withstand climatic storage for 2 years. (2 pp and appendix)
549/44	25.4.44	Cellocotton petrol fillings for incendiary bombs. By I.M. Barclay (7 pp, 6 tabs. 1 fig.)
570/44	25.7.44	Mortar firing of bombs, aircraft, incendiary 30 lb. By C.D. Thomas and R.F. Phillips (8 pp, 11 tabs and 10 figs.).
644/44	6.10.44	Mortar firing of bombs, aircraft, incendiary 30 lb. Pt. II. Assessment of incendiary effect. By C.D. Thomas and R.F. Phillips (12 pp).

Appendix 6. List of R.R.L. Reports

In addition to the following reports, R.R.L. carried out trials on foreign incendiary bombs for the M of H.S. and also trials for M.A.P. to try out a specific design point. In such cases reports were sometimes not issued but the results of the work are available in the files of the Departments for which the work was carried out.

MAP/24/KLCF	Dec. 1941	Penetration tests on German designs of buildings with British 4 lb. and German 1 Kg. incendiary bombs.
MAP/41/ACW	Sept. 1942	Fragmentation tests on an improved 4 lb. British explosive I.B.
MAP/44/ACW/KLCF	Nov. 1942	Impact tests on 6 lb. IB's (US Type N 56).
MAP/45/ACW	Dec. 1942	The fragmentation of US-M56 explosive IB.
MAP/48/KLCF	Jan. 1943	Penetration of German roofing rafters by 4 lb. British incendiary bombs.
MAP/49/ACW	Jan. 1943	Fragmentation tests on a 4 lb. British explosive I.B. having a cylindrical steel nose.
MAP/52/ACW	Feb. 1943	Fragmentation and impact tests on 4 lb. British explosive IB with hexagonal steel nose containing a $\frac{3}{4}$ in. diameter cavity.
MAP/53/KLCF	Mar. 1943	Penetration tests on German roofing with small incendiary bombs of various weights.
MAP/54/KLCF	Mar. 1943	Penetration of German roofing rafters by U.S. Type M69 IB's.
MAP/56/ACW.KLCF	Apr. 1943	Trials to investigate the operation of live 4 lb. incendiary bombs fired from a mortar.
MAP/58/KLCF	Apr. 1943	Impact tests on 4 lb. "X" type British incendiary bombs with a single wide cannellure on the steel nose spigot.
MAP/59/ACW	Apr. 1943	Static tests on American M50 (4 lb. incendiary Mk.V) bombs.
MAP/60/ACW.KLCF	May 1943	Further impact tests on various forms of 4 lb. "X" type British incendiary bombs having four different types of keying between the spigot and the body.
MAP/63/KLCF	June 1943	Penetration tests with 30 lb. incendiary bombs. "J" type Mk.IA.

MAP/66/ACW.KLCF	June 1943	Impact tests on "J" bombs fitted with slotted steel detonator plates and magnesium alloy fuze housings.
MAP/67/KLCF	June 1943	Impact tests on "X" type 4 lb. British incendiary bombs with noses made from low-grade steel.
MAP/69/ACW.KLCF	July 1943	Impact tests on 30 lb. British incendiary bombs "Type J" with a thin steel protection cover over the wooden nose block.
MAP/70/KLCF	July 1943	Impact tests on 30 lb. incendiary bomb cases made of cast iron.
MAP/71/KLCF	July 1943	Test on 4 lb. British incendiary bombs to investigate the setting forward of the filling due to impact on concrete.
MAP/72/GBT	July 1943	The detonation of 4 lb. "X" Type Mk.II incendiary bombs.
MAP/73/ACW	July 1943	Trials to determine the cause of "Impact Consolidation" of 4 lb. incendiary bombs.
MAP/74/ACW	July 1943	Impact and Penetration tests on "F" bombs (anti-personnel bombs for inclusion in clusters of "J" bombs).
MAP/76/KLCF	July 1943	Impact tests on the thermite filling in 30 lb. incendiary bombs type "J".
MAP/77/KLCF	Aug. 1943	Further trials to determine the cause of "impact consolidation" of 4 lb. incendiary bombs.
MAP/79/KLCF	Sept. 1943	Tests on the penetration of German roofing and flooring targets by 30 lb. British incendiary bombs fitted with fuze No. 846 Mark IA.
MAP/80/TH.KLCF	Aug. 1943	The effect of the distance between the roof and the attic floor on the penetration of German buildings by 4-lb. British incendiary bombs.
MAP/81/KLCF/ENT	Aug. 1943	The stability of 4-lb. British incendiary bomb fired from a 2-in. mortar.
MAP/84/KLCF	Sept. 1943	Impact trials on 4-lb British incendiary bombs constructed of a special alloy.
MAP/85/ACW/KLCF	Sept. 1943	Impact tests on production model "F" bombs (Type 7).
* MAP/86/KLCF MAP/91/GBT	Sept. 1943	The fragmentation of M50X incendiary bombs with different delays.

MAP/93/KLCF	Oct. 1945	Impact tests on 2-lb. British incendiary bombs.
MAP/94/GBT	Oct. 1943	The fragmentation of 4-lb. "X" type British incendiary bombs.
MAP/96/KLCF	Oct. 1943	Low temperature impact tests on 4-lb. British incendiary bombs fitted with Mazak diecast striker housings.
MAP/98/KLCF	Nov. 1943	Impact tests on proposed welded construction for M.69 incendiary bombs.
MAP/99/KLCF/ECWD	Dec. 1943	Motion of a British 30-lb. incendiary bomb type "J" through a German tiled roof.
# MAP/86/KLCF	Sept. 1943	The Penetration of Italian buildings by 4-lb. British incendiary bombs.
MAP/100/KLCF	Dec. 1943	Penetration tests on an improved form of M.69 American incendiary bomb.
MAP/101/TH.DSW	Dec. 1943	Penetration of German structures by 4-lb. British incendiary bombs. Effect of the tail.
MAP/103/ACW	Dec. 1943	Impact tests on concrete with modified 18-lb. "F" bombs.
MAP/105/KLCF	Feb. 1944	Effect of striking velocity and yaw on the penetration into German structures of 4-lb. British incendiary bombs.
MAP/106/DSW	Feb. 1944	Impact and detonation tests on 4-lb. British incendiary bombs Mark IV "X" (Marked BE/21).
MAP/109/TH.DSW	Feb. 1944	Impact tests on 2-lb. British incendiary bombs fitted with cast-iron nose pieces.
MAP/110/TH.	Mar. 1944	Impact tests on live 2-lb. British incendiary bombs.
MAP/112/TH DSW	Mar. 1944	Impact tests on 2-lb. British incendiary bombs fitted with modified cast-iron nose pieces.
MAP/113/TH	Mar. 1944	Impact and fragmentation tests on the 4-lb. "X" type U.S. incendiary bomb AN.M.50 X, A.2.
MAP/114/KLCF/DSW	Mar. 1944	Penetration of German structures by 22-lb. "J" type incendiary bombs.
MAP/115/KLCF	Mar. 1944	Further impact tests on a proposed form of British incendiary bombs of the U.S. AN.M.69 type.
MAP/116/KLCF/DSW	Apr. 1944	Further low temperature impact tests on 4-lb. British incendiary bombs fitted with Mazak die-cast housings.



MAP/117/KLCF	Apr. 1944	Penetration of imitation Burmese structures by U.S. type AN.M69 incendiary bombs.
MAP/118/TH/DSW	May 1944	Impact tests on "J" bombs taken from current production.
MAP/125/KLCF/HE	Aug. 1944	Penetration and burning tests on Japanese domestic structures with 30-lb. British incendiary bombs type "J" Mk.I.
MAP/126/KLCF	Sept. 1944	Penetration tests on Japanese domestic structures with 3-lb. British incendiary bombs.
MAP/127/DSW/ACW	Sept. 1944	Impact test on 3-lb. "J" bombs fitted with fusible plug jets.
MAP/128/TH.KLCF	Oct. 1944	Penetration tests on reinforced concrete with 22-lb. and 30-lb. British type incendiary bombs.
MAP/129/TH MAP/129/GBT	Oct. 1944	Impact tests on 22-lb. "J" bombs fitted with dummy window breakers in a modified housing.
MAP/130/KLCF/TH	Nov. 1944	Penetration and burning tests on Japanese domestic structures with 22-lb. British incendiary bombs type "J" (striking velocity = 380 ft./sec.).
MAP/131/DSW.TH	Nov. 1944	Impact tests on 4-lb. Mark IV incendiary bombs fitted with a new type of detonator plate.
MAP/134/GBT	Dec. 1944	Impact tests on 30-lb. "J" bombs taken from current production.
MAP/135/GBT/TH	Dec. 1944	Impact tests on 3-lb. "J" bombs fitted with machined light alloy striker housings.
MAP/136/ACW/KLCF	Jan. 1945	Penetration tests on Japanese single storey domestic structures with British incendiary bombs type 320 at various striking velocities.
MAP/137/DSW # MAP/138/DSW	Jan. 1945	Impact tests on tail assemblies for 20-lb. "J" bombs.
MAP/140/KLCF	Jan. 1946	Penetration of German structures by 4-lb. British incendiary bombs released from small bomb containers.
MAP/141/GBT	Jan. 1945	Impact and fragmentation tests on M50XA3 incendiary bombs.
MAP/142/KLCF	Feb. 1945	Penetration tests on targets representing single storey Japanese domestic structures with 30-lb. British incendiary bombs type "J".

MAP/146/ACW	Mar. 1945	The operation of the fuze system of a 30-lb. "J" bomb during impact of concrete at 45°.
MAP/148/GBT.GW	May 1945	Fragmentation tests on explosive noses of 3-lb. incendiary bombs provided by Messrs. Imperial Chemical Industries Ltd.
MAP/149/GBT	July 1945	The fragmentation of the explosive noses of 3-lb. incendiary bombs designed by C.E.A.D.
MAP/152/KLGF/TL	Aug. 1945	Functioning trials of fuze No.873 (modified) fitted to 18-lb. magnesium incendiary bombs.
# MAP/138/DSW	Jan.1945	Impact tests on 3-lb. explosive incendiary bombs fitted with three different types of initiating systems.

Appendix 7. List of O.R.S. Reports

<u>Ref.</u>	<u>Date</u>	<u>Title</u>
O.R.S. B.T.21	Oct. 1942	30 lb. incendiary bomb with two-fin tail.
"	" 27	Mar. 1943 Scatter of 4 lb. incendiary bombs.
"	" 34	May 1943 30-lb. incendiary bomb type "J".
"	" 39	July 1943 30-lb. incendiary bomb, type "J" Mk.I. Second Report.
"	" 40	Aug. 1943 30-lb. incendiary bomb type "J" Mk.I. Third Report.
"	" 43	Nov. 1943 500 lb. Cluster No. 14 Mk.I. (106 x 4 lb Incendiary bombs).
"	" 44	Nov. 1943 30-lb. incendiary bomb, type "J" with Sensitive Striker Support.
"	" 46	Nov. 1943 750 lb. Cluster No. 15 Mk.I. (158 x 4 lb Incendiary Bombs).
"	" 47	Nov. 1943 500-lb. Cluster No. 4 Mk.I (14 x 30 lb. I.B. Type "J", Mk.I).
"	" 50	Dec. 1943 500 lb. Cluster No. 4 Mk.I (14 x 30 lb. I.B's. Type "J").
"	" 51	Jan. 1944 500 lb. Cluster No.14 Mk.I (106 x 4 lb. Incendiary Bombs).
"	" 56	Mar. 1944 500 lb. Cluster No.4 Mk.I with Tail Unit No.44 Mk.II.
"	" 72	July 1944 1000 lb. Cluster No. 16 Mk.I (236 x 4 lb. Incendiary Bombs).
"	" 80	Sept. 1944 500 lb. M.76 Incendiary Bomb.
"	"103	Mar. 1945 500 lb. Incendiary Bomb, Mk.I.
"	" 110	June 1945 Cluster N.E. 4 lb. I.B. 800 lb. Mk.I/Air.

Appendix 8. List of A and A.E.E. and M.A.E.E. Reports

<u>Ref.</u> <u>AAEE/</u>	<u>Date</u>	<u>Title</u>
S503/Arm.	27.4.40	Bomb, Parachute, Incendiary, a/c., 25 lb. Mk.I.
"	2.5.40	Ballistic and Functioning Trials of 35 lb. Incendiary Bomb.
"	13.5.40	Bomb, Parachute, Incendiary, Aircraft, 25 lb. Mk.I.
"	18.5.40	Bomb, Parachute, Incendiary, a/c., 25 lb. Mk.I.
"	25.5.40	" " " " " "
"	1.6.40	" " " " " "
"	6.6.40	Bomb, a/c, Incendiary 25 lb. Mk.I Parachute attachment.
"	17.6.40	Bomb, a/c, Incendiary, 25 lb. Mk.I with Parachute attachment.
"	19.6.40	Bomb, Incendiary 25 lb. Mk. I, Parachute attachment.
"	3.7.40	Bomb, Incendiary, 21 lb. (Thermite-Fuel Oil).
"	30.7.40	Bomb, Incendiary, 25 lb. Mk.I with Parachute attachment.
"	17.8.40	4 lb. Incendiary Bomb.
"	4.10.40	Trials of Modified 25 lb. Incendiary Bomb.
"	20.10.40	Use of 40 lb. L.C. Bombs, Mk.I as an Incendiary Bomb.
"	27.11.40	Bomb, Incendiary, 25 lb. Case, filled Thermite.
"	19.12.40	Air Arming Device for 25 lb. Incendiary Bomb.
"	30.12.40	4 lb. Incendiary Bomb.
"	8.1.41	Use of 30 lb. L.C. Bomb Mk.II as an Incendiary Bomb.
"	3.2.41	Replacement of Steel in nose of 4 lb. Incendiary Bomb. Trials of modified Bombs.
"	7.2.41	No.45 fuze for Incendiary Bombs, Die cast in Mazak.
"	10.2.41	Faggotting of 4 lb. Incendiary Bombs.
"	25.1.41	25 lb. Incendiary Bombs Mk.I with wooden attachment. Functioning and Ballistic Trials.

<u>Ref.</u> NAEE/	<u>Date</u>	<u>Title</u>
S503/Arm.	1.4.41	4 lb. Incendiary Bomb packed 30 per tin.
"	7.4.41	Trials of 250 lb. l.C. bombs with Incendiary fillings.
"	12.4.41	Trials of Modified 4 lb. Incendiary Bombs.
"	12.4.41	Trials of Modified 4 lb. Incendiary Bombs, Type B.
"	16.4.41	Trials of Modified 4 lb. Incendiary Bombs.
"	26.4.41	Modified 4 lb. Incendiary Bomb Report No.3. Trials of Types D1 - D2.
ATO/G5	11.5.41	Modified 4 lb. Incendiary Bomb. Trials of Types D3 - D4.
ATO/G41	22.5.41	25 lb. Incendiary Bomb Mk.II Functioning trials from Albacore a/c.
ATO/G4	22.5.41	25 lb. Incendiary Bomb Mk.II. Functioning trials from Blenheim a/c.
ATO/G6a	24.5.41	Re-designed 30 lb. Incendiary Bomb, Functioning Trials.
ATO/G4	29.5.41	25 lb. Incendiary Bomb Mk.II. Report No.8. Dropping trials from Wellington aircraft.
ATO/G6a	17.6.41	30 lb. Incendiary Bomb Mk.I. Functioning trials of Bombs.
ATO/G4	23.6.41	25 lb. Incendiary Bomb Mk.II. Scatter Trials from S.B.C's.
ATO/G4	28.6.41	25 lb. Incendiary Bomb Mk.II. Functioning trials with modified bombs.
ATO/G3	3.7.41	Modified 4 lb. Incendiary Bomb Trials. Types D5 and D6.
ATO/G5	13.7.41	Modified 4 lb. Incendiary Bomb. Trials of Type C5.
ATO/G6a	22.7.41	50 lb. Incendiary Bomb. Functioning Trials against light structures.
ATO/G5	22.7.41	Modified 4 lb. Incendiary Bomb. Trials of bombs fitted with squat ignition device.
ATO/G5	1.8.41	Modified 4 lb. Incendiary Bombs. Bombs having a 1" Bore with Squat Pistol.
ATO/G5	2.8.41	Modified 4 lb. Incendiary Bomb. Bombs having a 1" Bore and the squat pistol.
ATO/G5	19.8.41	Modified 4 lb. Incendiary Bomb. Trials of squat pistol with safety devices.

<u>Ref.</u>	<u>Date</u>	<u>Title</u>
ATO/G6a	10.9.41	250 lb. Incendiary Bomb.
ATO/G5	17.9.41	Modified 4 lb. Incendiary Bomb.
ATO/G6a	27.10.41	30 lb. Incendiary Bomb Mk.I Ballistic trials of bombs with modified tails.
ATO/G5	2.11.41	Modified 4 lb. Incendiary Bomb. Trials of Mk.III bombs with loose fillings.
ATO/G6	5.11.41	30 lb. Incendiary Bomb Mk.I. Scatter trials from S.B.C.
ATO/G6a	2.12.41	30 lb. Incendiary Bomb.
ATO/G5	5.1.42	4 lb. H.E. Bomb, Incendiary Type.
ATO/G6	8.1.42	30 lb. Incendiary Bomb.
ATO/G6a	25.5.42	30 lb. Incendiary Bomb.
ATO/G5	18.6.42	Modified 4 lb. Incendiary Bomb.
ATO/G5	29.6.42	4 lb. Incendiary Bomb Mk.V.
ATO/G6	28.8.42	30 lb. Incendiary Bomb.
ATO/G5	28.9.42	Modified 4 lb. Incendiary Bomb.
ATO/G5	24.10.42	4 lb. Incendiary Bomb Mk.IV. Use of modified alloys.
ATO/N21	27.12.42	250 lb. Incendiary Bomb Cluster Adaptor.
ATO/G6a	10.3.43	30 lb. Incendiary Bomb for attack on Merchant Ships.
ATO/G5	28.3.43	4 lb. Incendiary Bomb (Mk.V) U.S.A. Version of Mk.IV.
ATO/G5	29.3.43	4 lb. Incendiary Bomb, Mk.IV. Loose Filling.
ATO/G5	29.4.43	4 lb. Incendiary Bomb, Mk.V, American M50.
ATO/G5	6.5.43	4 lb. Incendiary Bomb Mk.IV.
ATO/G5	17.5.43	" " " "
ATO/G5	24.5.43	" " " "
ATO/G5	7.6.43	" " " "
ATO/G5	22.7.43	" " " "
ATO/G5	20.8.43	M50, 4 lb. Incendiary Bomb Mk.V.
ATO/G5	25.8.43	4 lb. Incendiary Bomb Mk.IV.
ATO/G5	29.9.43	4 lb. Incendiary Bomb.

<u>Ref.</u>	<u>Date</u>	<u>Title</u>
ATO/G5	9.10.43	4 lb. Incendiary bomb Mk.IV.
ATO/G5	10.10.43	" " " "
ATO/G6a	18.10.43	30 lb. Incendiary Bomb, J Type Mk.I.
ATO/G5	13.10.43	4 lb. Incendiary Bomb Mk.IV.
ATO/G5	15.11.43	4 lb. Incendiary Bomb AN-M50
ATO/G6a	15.11.43	Incendiary Bomb 30 lb. Type 'J'.
ATO/G6a	16.11.43	30 lb. J. Incendiary Cluster.
ATO/G6a	19.11.43	30 lb. Incendiary Bomb Type 'J'.
ATO/G6a	29.4.44	500 lb. L.C. Incendiary Bomb.
ATO/G89	30.4.44	400 lb. Oil Incendiary Bomb.
ATO/G5	5.6.44	4 lb. Incendiary Bomb Mk.IV.
ATO/G89	22.10.44	400 lb. Oil Incendiary Bomb.
ATO/G96	16.12.44	750 lb. Incendiary Bomb Mk.I.
AAEE/ 5909/5	20.2.45	400 lb. Incendiary Bombs. Arming of No.60 (Multiways) Pistol.
" /7	11.3.45	500 lb. Incendiary Bomb AN-M76. Functioning trials when fuzed with Pistol No.52.
" /6	29.4.45	1000 lb. Incendiary Bomb Mk.I. Medium level release.
" /6	27.5.45	1000 lb. Incendiary Bomb Mk.I. Functioning Trials from Tempest V Aircraft.
MAEE Ref. HB/TE/4400 /25/s	16.3.42	Report No. H/Arm/80. Methods of Setting fire to fuel oil on water. Trials in Lock Striven, Feb. '42.
"	29.4.42	Report No. H/Arm/80A. Ignition of Fuel Oil on Water. Further trials with 250 lb. L.C. bomb and 200 lb. D.l. Floats.

Appendix 9. List of Incendiary Bomb Tests, Panel Reports  
and Papers.

<u>No.</u>	<u>Date</u>	<u>Origin</u>	<u>Contents</u>
1	1942 Feb.	BC.45	Extract giving types of bombs and fuzing for the incendiary attack of various targets.
2	April	LU	Report on the measurement of radiation and convention isotherms from burning liquid magnesium.
3	"	FPRL	Note on methods of testing the fire raising capacity of I.Bs.
4	"	"	Progress Report No.1. on testing of incendiary materials - development of test methods.
5	June	MHS(F Div.)	An enquiry into the action and use of I/Bs.
6	July	LU	Report on the factors involved in the self-propagation of the flame through wood, and the assessment of merit of small I.Bs.
7	"	MAP	Minutes of Meeting to discuss the use of S.B.X. in aircraft bombs.
8	Sept.	MHS(F Div.)	Report on the incendiary properties of experimental S.B.X. bombs at Monument Mine, 28th August, 1942.
9	Oct.	MAP	Report on tests of I.Bs at Leeds, 1st October, 1942.
10	"	ARD	Drawings of standard furniture for incendiary trials.
11	Nov.	LU	Report on the performance of magnesium I.Bs of different weights.
12a	Dec.	IBTP	Report to the I.B. Committee on the probable operational effect of reducing the magnesium content of the British 4 lb. I.B.
<u>1943</u>			
13	Jan.	OSRD	Note on the construction of German cities.
14	"	MHS(F Div.)	Note on the probable effect of a parting charge on the performance of the 4 lb. I.B.
<u>1942</u>			
15	July	"	Report on the scatter of I.B's.
<u>1943</u>			
16	Jan.	LU	Report on "panel" tests carried out with a number of small I.B's.



<u>No.</u>	<u>Date</u>	<u>Origin</u>	<u>Contents</u>
17	March	MHS(F.Div.)	Report on incendiary trials at Bridge Avenue, Hammersmith, 8th March, 1943.
17a	"	"	Report on incendiary trials at Bridge Avenue, Hammersmith, 23rd March, 1943.
18	"	MAP(ADSR)	Note on mortar firing trials with the 30 lb. gel bomb at Tondu.
19	"	MHS(RE8)	Drawings of three typical German dwellings.
20	"	RRL	Report on penetration tests on German roofing with small I.Bs. of various weights.
21	"	MHS(F.Div.)	Report on the optimum density of I.Bs.
22	April	BRS	Report on Test No.3 at I.B. Cottage, 5th March, 1943, using a 30 lb. gel bomb.
23	"	"	Report on Test No.4 at I.B. Cottage, 25th March, 1943, using a British 4 lb. Mark IV magnesium bomb.
24	"	"	Report on Test No.1 at I.B. Cottage, 19th January, 1943, and description of building.
25	"	"	Report on Test No.2 at I.B. Cottage, 4th February, 1943, using a 30 lb. "J" bomb.
26a	May	MHS(F.Div.) and LU	Report on the practical performance testing of small I.Bs. Part 1 - The probability of starting a fire in a typical German domestic target. (See report No.66).
27	June	MHS(RE8)	Note on the construction of Burmese buildings and the combustibility of Burmese timbers.
28	"	LU	Note on the effect of edge screening in the "panel" test.
29	"	MHS(F.Div.)	Report on the graphical and numerical specification of small bomb scatter patterns.
30	July	BRS	Report on tests at I.B. Cottage No.5, 20th April 1943 using a British 4 lb. Mark IV I.B. No.6, 11th May 1943 using a 2.8 lb. A.B.C. gel. No.7A, 4th June, 1943 using a 1.0 lb. A.B.C. gel. No.7B, 4th June, 1943, using a 2.0 lb. A.B.C. gel.

<u>No.</u>	<u>Date</u>	<u>Origin</u>	<u>Contents</u>
31	Aug.	LU	Report on miscellaneous tests with burning gels.
32	"	BRS	Report on Test No.8 at I.B. Cottage, 29th July, 1943, using 2.8 lb. A.B. xylenol gel.
33	"	"	Supplement to Panel Report No.23.
34	"	MHS(F.Div.)	An analysis of fire growth.
35	Sept.	BRS	Report on Test No.9 at I.B. Cottage, 12th August, 1943, using a M.69 I.B.
36	"	ARD	Report on the minimum concentration of oxygen required for the combustion of wood.
37	"	MHS(RE8)	Notes on German industrial buildings.
38	Oct.	BRS	Report on tests at I.B. Cottage, 3rd September, 1943 - No.10A using a 30 lb. "J" bomb. No.10B using a 2.8 lb. of a pyrotechnic gel. No.10C using a M.69 bomb.
39	"	BRS	Report on Tests Nos. 11A and 11B at I.B. Cottage, 10th September, 1943, using a 30 lb. "J" bomb.
40	"	OSRD	Abstract of Report on gasoline-cello-cotton I.B. fillings, and a letter on the optimum combustion rate of small I.Bs.
41	"	BRS	Report on Test No.12 at I.B. Cottage, 6th October, 1943, using a 30 lb. "J" bomb.
42	Nov.	LU	Report on "panel" tests with the M50-4 lb. magnesium bomb.
43	Sept.	MHS(RE8)	Report on the relation between the density of incendiary attack and the extent of visible damage to buildings in the central zones of German cities.
44	Oct.	US B of S.	Data on combustible contents of different rooms.
45	Nov.	BRS	Report on incendiary trials at Rackham St., North Kensington, 12th and 20th October, 1943.
46	Nov.	O.B.	Appendix II to OB Proc. Q1,611 on I.Bs.

<u>No.</u>	<u>Date</u>	<u>Origin</u>	<u>Contents</u>
47	Dec.	BRS	Report on tests at I.B. Cottage. No.14A and 14B 9th November, 1943, using the ARD 30 lb. pyrotechnic gel bomb. Nos. 15A and 15B 18th November, 1943, using a 30 lb. "J" bomb.
48	"	"	Report on tests at I.B. Cottage. No.13A, 28th October, 1943, using a 12 lb. naphthalene bomb. No.16, 26th November, 1943, using a 22 lb. naphthalene bomb. No.13B, 28th October, 1943, using a 2.8 lb. A.B.C. gel.
49	"	LU	Report on "panel" tests with the M50-4 lb. magnesium bomb and a comparison with the British Mark III and Mark IV bombs.
50	"	"	Report on "panel" tests with six hydrocarbon gels.
<u>1944</u>			
51	Jan.	MHS (RE8)	Report on probable extent of window breakage from blast bombs in Germany.
52	"	FPRL	Report on the effect of moisture content on the burning of wood.
53	"	BRS	Note on the moisture content of structural timber in Germany.
54	"	"	Report on incendiary trials at Rackham St. North Kensington, 30th November, 1943.
55	"	"	Report on Test No.17 at I.B. Cottage, 7th December, 1943, using a German 1 kg. magnesium bomb.
56	"	LU	Report on the burning of panels of vary- ing moisture content.
57	"	BRS	Report on Test No.18 at I.B. Cottage, 15th December, 1943, and window breakage test, 6th January, 1944, using a 22 lb. naphthalene bomb.
58	Feb.	LU	Proposed programme for testing incendiary gel efficiency.
59	"	MHS (F Div.)	Meteorological table for Tokyo, 1886-1935
59a	March	"	Meteorological table for Tokyo, 1897-1926 and data for Salt Lake City, Utah for May, June and July, 1943.
60	"	"	A determination of the static intrinsic efficiency of the 30 lb. "J" bomb.

<u>No.</u>	<u>Date</u>	<u>Origin</u>	<u>Contents</u>
61	1944 March	BRS	First Report on I.B. tests in German-type attics (See Report No.78).
62	"	FPRL	Report on moisture content observations in English attics.
63	"	LU	Report on the effect of linoleum on the radius of action of 4 lb. magnesium bombs.
64	"	"	Report on "panel" tests with hydrocarbon gels.
65	April	OSRD	Note on I.B. fillings for use against industrial targets, and air temperature obtained from burning gasoline at various rates in a test building.
66	"	BRS	Report on the practical performance testing of small I.B.s Part 2. - Comparative tests on various bombs and incendiary agents in furnished rooms. (See Report No.26a).
67	"	LU	Report on the minimum thickness of a small area of gel necessary to ignite a panel at zero range.
68	"	MHS (F Div)	Report on the overall efficiency of the 30 lb. gel bomb.
69	"	ARD	Report on mortar firing tests at Tondu with the 30 lb. gel bomb; investigation of the mode of functioning. (See Report No.91).
70	"	MHF (F.Div.)	Note on the optimum I.B. size for precision bombing.
71	May	MAP	Note on the behaviour of the 30 lb. gel bomb based on Intelligence sources.
72	"	MHS (F Div.)	Summary of performance tests to date with the 30 lb. gel bomb.
73	"	BRS	Report on tests at I.B. Cottage, No.19, 11th January, 1944, using an M50 - Mark V magnesium bomb. No.20, 17th February, 1944, using an experimental 10 lb. "J" bomb.
74	"	MHS (RE3)	An estimate of the effectiveness of the 30 lb. gel bomb.
75	"	LU	Report on "panel" tests with Napalim gasoline, P.T. and pyrotechnic gels.
76	"	MHS (F.Div.)	List of Incendiary Bomb Test Panel Reports and Papers to date.

<u>No.</u>	<u>Date</u>	<u>Origin</u>	<u>Contents</u>
77	May	BRS	Report on Test No.22 at I.B Cottage, 25th April, 1944, using three German 1 Kg magnesium bombs.
78	June	"	Second Report on I.B. tests in German type attics (See Report No.61).
79	"	LU	Report on "panel" tests with production models of the 30 lb. "J" bomb Mark I, filled with methanised shale spirit.
80	July	OSRD	Note summarising American developments with the M69 bomb.
81	"	BRS	Report on Tests Nos. 23A and 23B at I.B. Cottage, 19th May, 1944, using a German 1 Kg. magnesium bomb on linoleum floor covering.
82	March	ARD	Report on cello-cotton petrol fillings for I.Bs.
83	July	BRS	Report on incendiary tests at Rackham St. North Kensington, 3rd and 11th May, 1944.
84	"	LU	Report on "panel" tests with production models of the 30 lb. "J" bomb filled with shale spirit and alcohol.
85	May	ARD	Extract from Report on the burning and extinction of P.T. gel.
86	Aug.	MHS (F Div.)	Report of sub-panel appointed to consider the factors, to be studied in forthcoming full-scale incendiary trials.
87	July	BRS	Report on Fire test at No.48, Rackham St. North Kensington, 11th May, 1944.
88	Sept.	"	Report on Test No.24 at I.B. Cottage, 9th June, 1944 using a 22 lb.naphthalene bomb.
89	"	"	Report on incendiary trials at Rackham St. North, Kensington on 20th.June, 1944.
90	Oct.	FPRL	Note on the possibility of conditioning the Japanese houses at BRS to be more representative of Japanese conditions.
91	Aug.	ARD	Report on mortar firing tests at Tundu with the 30 lb. gel bomb, assessment of incendiary effects. (See Report No.69).
92	Oct.	BRS	Interim Note on the progress of incendiary trials in the Japanese houses at BRS.
93	Nov.	MAP	Report on suggestions and comments made by Mrs. Bell after her visit to the Japanese houses at BRS.

<u>No.</u>	<u>Date</u>	<u>Origin</u>	<u>Contents</u>
94	1944 Nov.	BRS	Report on Tests Nos. 25A, 25B and 25C at I.B. Cottage, 29th June, 1944, using three British 4 lb. Mark IV. magnesium bombs.
95	"	"	Report on Test No.26 at I.B. Cottage, 8th September, 1944, using an M69 bomb.
96	"	"	Report on incendiary trials at Rackham St. North Kensington, 18th October, 1944.
97	"	RRL	Report on penetration and burning tests on Japanese domestic structures with the 22 lb. naphthalene bomb.
98	Dec.	BAC	Preliminary note on climatic conditions at Key West, Florida.
99	"	BRS	Report on principles of fire-spread in built up areas.
100	"	LU	Note on the effect of moisture upon the ignitability of wood.
101	"	BRS	Replaced later by Panel Report No.144.
102	Feb.	RRL	Report on effect of striking velocity and yaw on the penetration into German structures of 4 lb. British I.Bs.
	<u>1945</u>		
103	Jan.	RRL	Report on penetration of German structures by 4 lb. British I.Bs. released from small bomb containers.
104	"	BAC	Interim Note on wood moisture content of samples in occupied houses in Key West, Florida.
105	"	"	Further Interim Note on wood moisture content of samples in occupied houses in Key West, Florida.
106	"	BRS	Report on a comparative burning trial of Douglas fir and Western red cedar.
107	"	"	Interim Note on Test No.30 in a Japanese house at BRS, 5th January, 1945, using a 20 lb. naphthalene bomb.
108	"	RRL	Report on penetration tests on Japanese single storey domestic structures with 20 lb. naphthalene bomb.
109	Feb.	OSRD	Note on the penetration of M69 bombs into Japanese domestic structures when released from aimable clusters.

<u>No.</u>	<u>Date</u>	<u>Origin</u>	<u>Contents</u>
110	Feb.	RRL	Report on penetration tests on Japanese single storey domestic structures with the 30 lb. "J" bomb.
111	"	BRS	First Report on I.B. tests in Japanese houses at BRS. (See Report No.140).
112	March	FPRL	Note on the effect of atmospheric humidity on the burning of wood.
113	Feb.	IEP	Report of US/UK Sub-committee on the details of construction and furnishing of the proposed Japanese test room at Edgewood Arsenal.
113a	March	BRS	Interim Note on Test at I.B. Cottage, 8th February, 1945, using an American M.74 bomb.
113b	"	"	Interim Note on Tests Nos. 31-36 in Japanese houses at BRS.
114	"	FPRL	Note on moisture content of wood in Japan.
115	"	BRS	Interim Note on Tests Nos. 37-41 in Japanese houses at BRS.
116	"	IEP	Memorandum (No.6) on further tests to compare the burning characteristics of different species of timber.
117	"	"	Letters (No.12) giving details of some tests in the Japanese room and burning tests against industrial targets with the 20 lb. "J" bomb.
118	April	BRS	Interim Note on Tests made with a magnesium powder bomb at BRS.
119	"	"	Interim Note on Tests Nos. 42 and 43 in Japanese houses at BRS.
120	"	CWS	Report of incendiary mission by the XX Bomber Command against Hankow, 18th December, 1944.
121	"	MAP	Extract from Note on the interrogation of Major General Lindner, head of the Technical Division of the Civil Defence Department of the German Air Ministry.
122	Feb.	MHS (F.Div.)	An analysis of an RAF incendiary attack on Gross Gerau, 25/26th August, 1944.
123	"	"	Note on the incendiary attack on Japanese industrial areas.
124	May	BRS	Interim Note on Tests Nos.50-55 in Japanese houses at BRS, 7th May, 1945, using various I.Bs.

<u>No.</u>	<u>Date</u>	<u>Origin</u>	<u>Contents</u>
125	May	IEP	Letter (No.14) giving details of current burning tests on industrial targets, and extinction tests on P.T. gel.
126	"	BRS	Interim Note on Test No.31 at I.B.Cottage 26th April, 1945, using magnesium powder.
127	"	ISRB	Report on tests with magnesium powder bombs.
128	"	BRS	Comparison of Japanese targets and test results at BRS Edgewood Arsenal and Dugway Proving Ground.
129	June	MHS(RE8)	Comments on the sub-Committee's Interim Note on the static intrinsic efficiency of the British Mark IV 4 lb. magnesium bomb (See Report No.133).
130	April	MAP	Note on the interrogation of Major General Lindner (See Report No.121).
131	May	NFS	Report on visit of NFS officers to Krefeld and Cologne.
132	July	BRS	Interim Note on Tests Nos. 56-58 in Japanese house at BRS, 5th July, 1945, using various I.Bs.
133	June	IBTP	Interim Note on the static intrinsic efficiency of the British 4 lb. Mark IV magnesium bomb.
134	Sept.	FPRL	Note on incendiary test with the Edgewood storage bin target, 23rd August, 1945, using M69, 20 lb. "J" and 30 lb. "J" bombs.
135	"	BRS	Report of tests Nos. 59 - 61 in the Japanese houses at BRS, 6th September, 1945.
136	October	MAP	Report of an interrogation of Dr. Schurfeld, who was concerned with the development and testing of I.Bs.
137	"	"	Memorandum concerning effects of British I.Bs. in Germany.
138	"	"	Report on the static intrinsic efficiencies of the M69 20 lb. "J" and 30 lb. "J" bombs in the Japanese houses at BRS/
139	"	BRS	Report on Tests Nos. 62-64 in the Japanese houses at BRS, 4th October, 1945.
140	Nov.	"	Review of I.B. tests in Japanese houses at BRS (See Report No.111).
141	"	"	Report on heat radiation measurements in Test No.30 in a Japanese house at BRS.



<u>No.</u>	<u>Date</u>	<u>Origin</u>	<u>Contents</u>
142	Aug.	BBRM	Report on fire damage from bombing attacks on German targets, with information on fire defence measures, and an estimate of their efficiency in reducing fire damage.
			<u>1946</u>
143	Jan.	MAP	Note on the variation in incendiary efficiency of magnesium bombs with weight of magnesium - a re-examination of Report No. 12A.
144	"	BRS	Theoretical considerations of the development and spread of fire.
			<u>1945</u>
145	July	LU	Report on the effective range of the British 4 lb. magnesium I.B. against furniture legs.
146	Nov.	"	Report on the comparison of various plywoods as targets for use in the "panel" tests.
147	Aug.	"	Report on "panel" tests with various adaptations of the 22 lb. naphthalene bomb.
148	Sept.	"	Report on "panel" tests with the 30 lb. "J" bomb using beech plywood (see Report Nos. 79 and 84).
			<u>1946</u>
149	Jan.	LU	Magnesium powder as an incendiary agent.
			<u>1945</u>
150	Aug.	LU	Report on "panel" tests with a 24 lb. cordite-operated, liquid-filled jet bomb.
			<u>1946</u>
151	March	MAP	Incendiary bomb evaluation. A study of testing methods used between 1935 and 1945.
		MAP	Abbreviations:- Ministry of Aircraft Production
		MHS	Ministry of Home Security.
		" (F Div.)	Research and Experiments Department F. Division.
		" (RE8)	Research and Experiments Department RE8 Division.
		BRS	Building Research Station.
		RRL	Road Research Laboratory.
		FPRL	Forest Products Research Laboratory.
		ARD	Armaments Research Department.
		OB	Ordnance Board.

Abbreviations continued

BC	Bomber Command
LU	Leeds University, Fuel Department.
IBTP	Incendiary Bomb Tests Panel.
ISRB	Inter Services Research Bureau
NFS	National Fire Service
BBRM	British Bombing Research Mission
BAC	British Air Commission, Washington.
CWS	Chemical Warfare Service, United States Army.
OSRD	Office of Scientific Research and Development, United States.
USB of S	United States, National Bureau of Standards.
IEP	Incendiary Evaluation Project, Edgewood Arsenal.

Appendix 10. List of R.A.E. Reports

<u>New</u>	<u>Ref.</u>	<u>Old</u>	<u>Date</u>	<u>Title</u>
S.1759	Arm	S.111	20.1.38	4 lb. Incendiary Bomb.
"	"	"	14.3.38	Effect of Incendiary Bomb on Asphalt.
"	"	"	27.10.38	Trials to ascertain the effect of functioning of incendiary bombs on mastic asphalt as used roofing purposes performed at R.A.E.
"	"	"	27.3.39	Dropping tests of Models of the 4 lb. hexagonal incendiary bomb.
"	"	"	28.4.39	Dropping tests of Models of the 4 lb. Streamline incendiary bombs.
"	"	"	13.10.39	Record of Progress in Faggoting Schemes for 4 lb. incendiary bombs.
"	"	"	8.5.40	Bomb Incendiary Aircraft 4 lb.
"	"	"	5.8.40	4 lb. Mk.I Incendiary bomb (TV) Reports M/Res 88 a.b.c.d.
"	Arm	S.194	13.4.40	Container (250 lb.) for Small Bomb Mk.I and Mk.II Drop Bar.
"	"	"	18.5.40	Bomb Incendiary Thermite Fuel Oil Penetrative Type.
"	Arm	S.663	8.7.40	Appreciation of Experiment carried out on 2 gallon can filled with petrol.
"	"	"	15.7.40	Ignition of a layer of Fuel oil on water.
"	"	"	25.8.40	Petrol Tin Incendiary Method of Carriage on Aircraft and T.V. of Petrol Tin.
S.1759/F	Arm	S.194	10.10.40	Test of Suspension lug for 25 lb. Incendiary Bomb.
"	"	"	28.11.40	Dropping test of Models of the 25 lb. Incendiary Bomb (Redesign).
S.1759/C	Arm	S.720	23.12.40	4 lb. Incendiary Bomb (Re-design).
S.1759/F	Arm	S.660	5.10.40	Test of Suspension band lug for 40 lb. Inc.bomb.
S.1759	Arm	S.111	19.1.41	Faggoting of 4 lb. Incendiary Bomb for Chute Launching.
"	"	"	17.4.41	4 lb. Incendiary Bomb - Spread of.
"	"	"	11.5.42	4 lb. Incendiary Bomb.
"	"	"	20.4.42	Magnesium Incendiary Bomb (Re-design).

<u>Ref</u>				
<u>New</u>	<u>Old</u>	<u>Date</u>	<u>Title</u>	
S.1759	Arm S.111	29.5.42	4 lb. Incendiary Bomb Carriage in S.B.C. and Expendable Container.	
S.1759/A	Arm S.793	June 42	Trials with two types of Incendiary Bomb used to set fire to petrol tanks as means of destroying Aircraft.	
S.1759/O	Arm S.1067	19.10.42	4000 lb. Incendiary Bomb.	
"	"	4.11.42	"	"
S.1759	Arm S.111	19.3.43	Mortar Trials of 4 lb. Incendiary Bomb at varying T.V.'s.	
"	"	23.9.43	Scatter of 4 lb. Incendiary Bomb.	
"	"	8.7.43	4 lb. Incendiary Bomb.	
"	"	28.9.43	Test with 4 lb. British Incendiary Bombs striking Typical German Structure.	
"	"	3.10.43	Mortar Trials of 4 lb. Incendiary Bomb.	
"	"	Jan.43	The stability in Flight of 4 lb. British Incendiary bombs dropped at Yarm/Yorks on 6th December 1942.	
S.1759	Arm S.1231	29.10.43	Stability of M.52 Incendiary Bomb.	
S.1759/B	"	3.2.44	Ballistic Trials of M.52 Incendiary bombs.	
S.1759	Arm S.111	15.1.44	Stability of 4 lb. I.B.	
S.1759/O	Arm S.1067	1.5.44	Arming Vane Torque, Special Tail for 4000 lb. I.B.	
S.1759/L	Arm S.1321	23.10.44	Test of 1000 lb. Oil Bombs for carriage on Typhoon Aircraft.	
"	"	6.5.44	Tests of 500 lb. Oil Bombs.	
"	"	May 44	3 lb. Incendiary Bombs, Tests on Stability and Terminal Velocity with Parasheet (1)	
"	"	8.9.44	Test of Tail Attachment for the 400 lb. Oil Bomb Mk.I/Air.	
S.1759/N	Arm S.1125	4.1.44	Report on firing trials with coded "T" Bombs.	
S.1759/E	Arm S.1288	8.1.44	Stability and Terminal Velocity of 22 lb. Inc.Bomb.	
"	"	21.3.44	T.V. and Stability of 22 lb. Incendiary Bomb.	

Ref.

<u>New</u>	<u>Old</u>	<u>Date</u>	<u>Title</u>
S.1759/E Arm	S.1288	8.5.44	22 lb. Incendiary Bomb Type T Stability and T.V. Trials.
S.1759/B Arm	S.1231	25.5.44	AN/M.52 2 lb. Incendiary Bombs Tests for stability and Terminal Velocity.
"	"	7.6.44	The determination of low terminal velocities by measurement of striking velocity.
"	"	22.6.44	AN/M.52, 2 lb. Incendiary bomb. Tests on stability and Terminal Velocity.
"	"	28.6.44	AN/M.52, 2 lb. Incendiary Bomb Test stability and Terminal velocity.
"	"	3.7.44	" " " " " "
S.1759/B	"	6.7.44	AN/M.52, 2 lb. Incendiary Bomb Blower Tunnel tests on Streamer Drag.
"	"	27.7.44	3 lb. Magnesium Incendiary Bomb.
"	"	16.8.44	AN/M.52, 3 lb. Incendiary Bomb Stability and Terminal Velocity.
"	"	20.8.44	2 lb. Incendiary Bomb with cone and drum tail Trials at Braid Fell.
"	"	2.9.44	3 lb. Incendiary Bomb Cluster Trials at Cannon Heath.
"	"	5.9.44	3 lb. Incendiary Bomb Drag Measurements on Streamers.
"	"	16.9.44	3 lb. Incendiary Bomb with Streamers Terminal Velocity Trials.
"	"	21.9.44	3 lb. Incendiary Bomb with Streamers - Cluster Trials II.
"	"	26.9.44	Trials of 3 lb. Incendiary with Parasheet.
"	"	20.10.44	3 lb. Incendiary Bomb with Parasheet Terminal Velocity Trials.
"	"	27.10.44	3 lb. Incendiary Bomb with Streamers - Terminal Velocity trials.
"	"	14.11.44	2 lb. Incendiary Bomb Blower Tunnel Tests in Air Arming Scheme.
"	"	13.12.44	Trials of 3 lb. Incendiary Bomb with Parasheet.
"	"	15.12.44	3 lb. Incendiary Bomb.

<u>Ref</u>				
<u>New</u>	<u>Old</u>	<u>Date</u>	<u>Title</u>	
S.1759/L	Arm.S.1321	12.1.45	Test of modified 1000 lb. Incendiary Bomb Mk.I. for carriage on Typhoon Aircraft.	
"	"	11.5.45	Test of 1000 lb. Incendiary Bomb Mk.I.	
Arm.S.1759B	S.1521	12.6.45	The 18 lb. Incendiary Bomb Stability Trials.	
S.1759/L	Arm.S.1321	5.6.45	1000 lb. Incendiary Bomb Mk.I. Strengthened centre Section.	
"	"	18.6.45	Test of Modified 1000 lb. Incendiary Bomb Mk.I.	
"	"	8.12.45	Test of 1000 lb. Incendiary Bomb Mk.I Corsair Bomb Carrier.	
S.1759/B	Arm.S.1231	9.1.45	3 lb. Incendiary Bomb Blower Tunnel Tests on Air Arming Scheme.	
"	"	July 45	The determination of low terminal velocities by measurement of striking velocity Correction for wind.	

## Acknowledgements

The author desires to express his thanks to the following Departments, Panels, etc., for their assistance in supplying material and reports, and for assistance in other ways in the production of the monograph. Where reports issued by these bodies have been used, acknowledgement is made in Appendix 1.

C.S.A.R., Fort Halstead

C.S.A.R., Tondu.

D.Arm.R.D., Ministry of Supply, Millbank.

D.R.R.L. Hammondsworth

D.R.A.E., South Farnborough.

A and A.E.E. Boscombe Down.

M.A.E.E., Felixstowe.

Orfordness Research Station, Ministry of Supply.

Incendiary Bomb Test Panel, M.A.P.

Ordnance Board.

B.T.U., R.A.F., West Freugh.

Extensive use has been made of the published work of the above bodies on the subject of incendiary bombs. In many cases, the task of the author has been merely collection and correlation of these reports, in order to cover as far as possible the complete development of the store concerned.

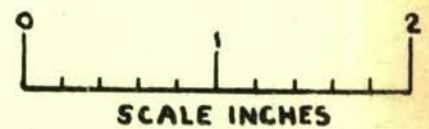
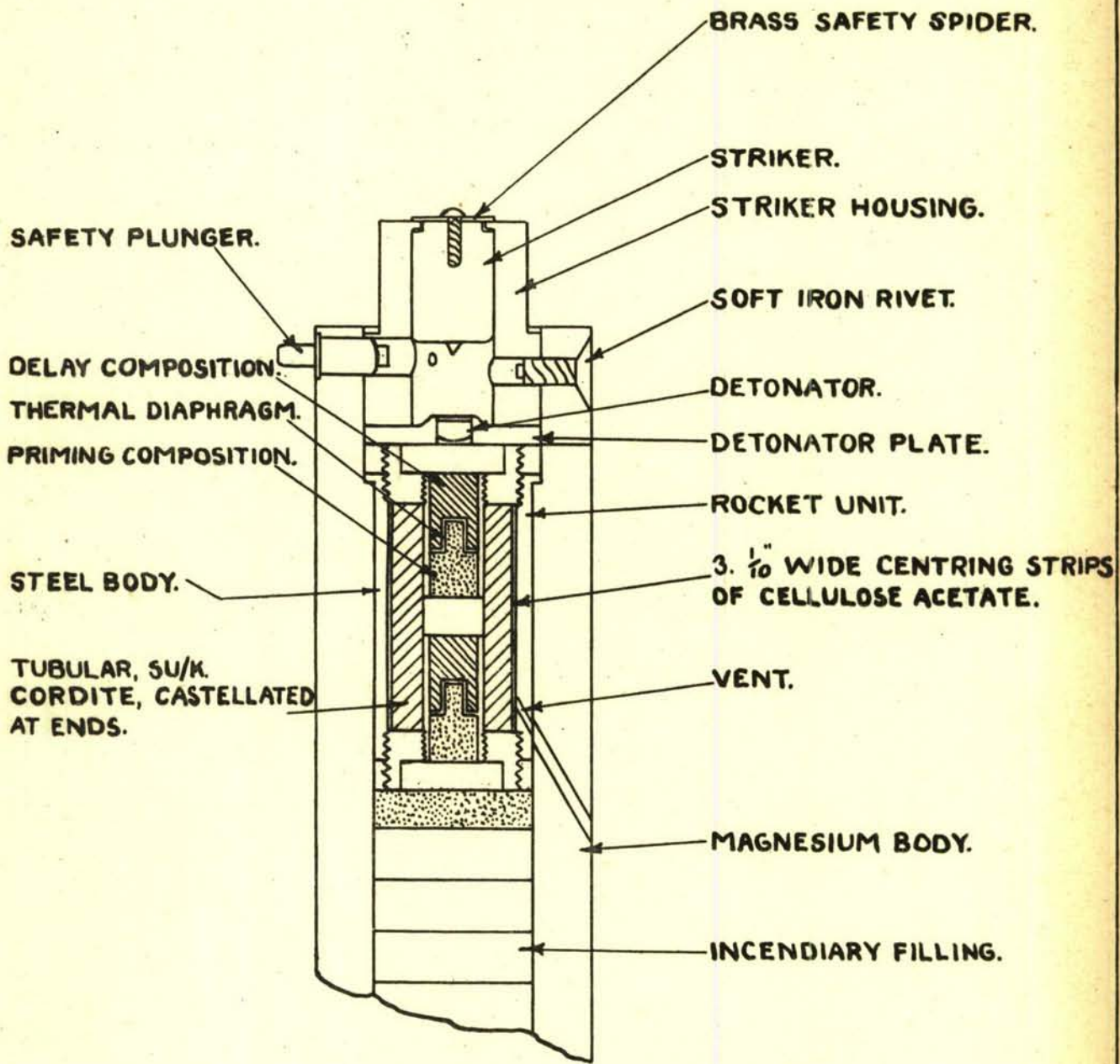

DIAGRAMMATIC ASSEMBLY OF  
C.S.A.R.'s ROCKET UNIT IN  
AN-M52 2LB. INCENDIARY BOMB.



FIG.2

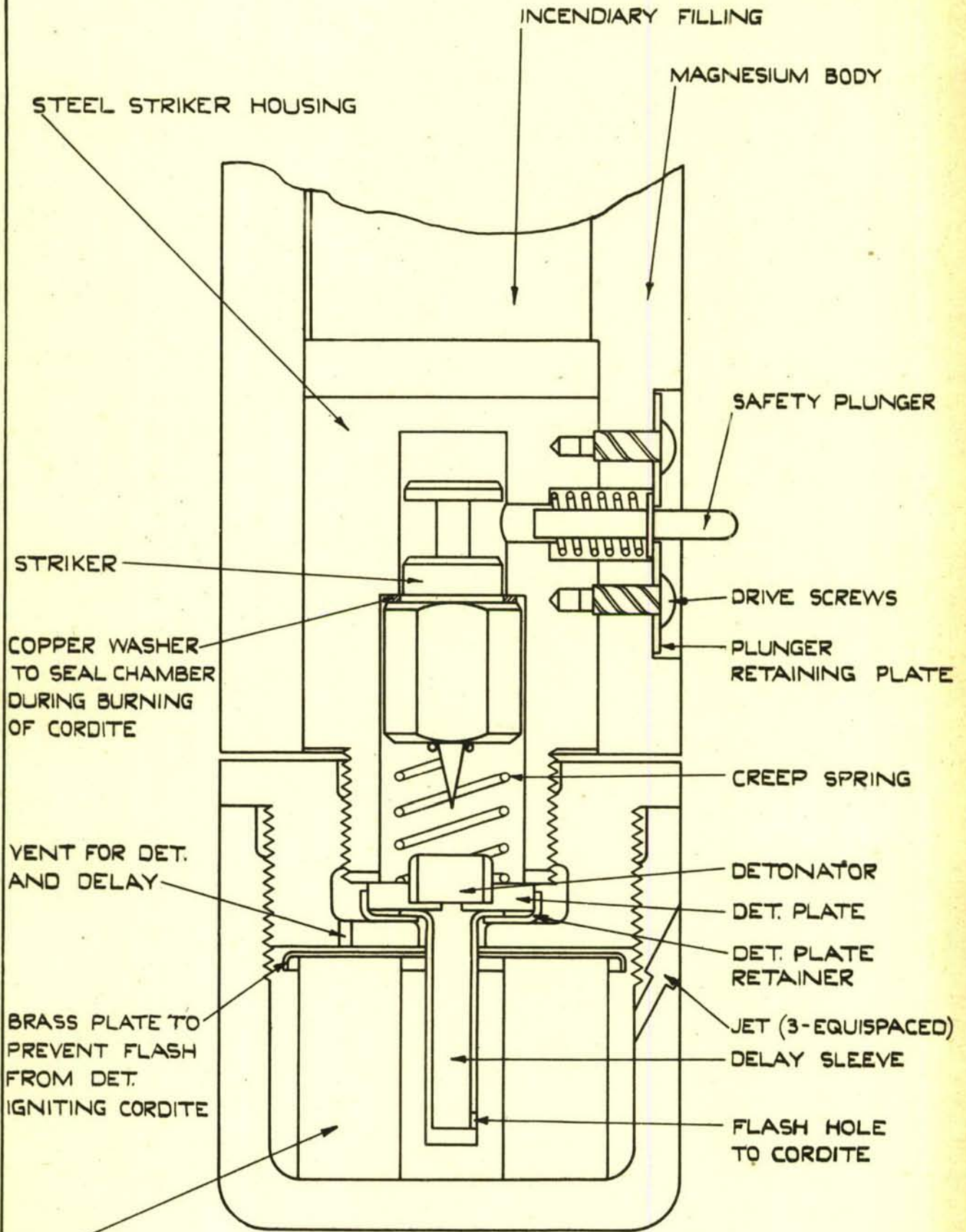

CORDITE 15 GM S.U.K. GIVING  
 PEAK PRESSURE OF 2350 LB  
 / 1" AND THRUST OF 35 LB

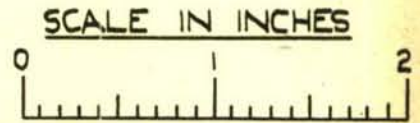

**MESSRS. WORSSAM'S DESIGN  
 OF ROCKET UNIT FOR 3LB IB  
 (BASED ON FIRMS DRAWING N° 8/175/7)**

ADD 23/46

FIG. 3

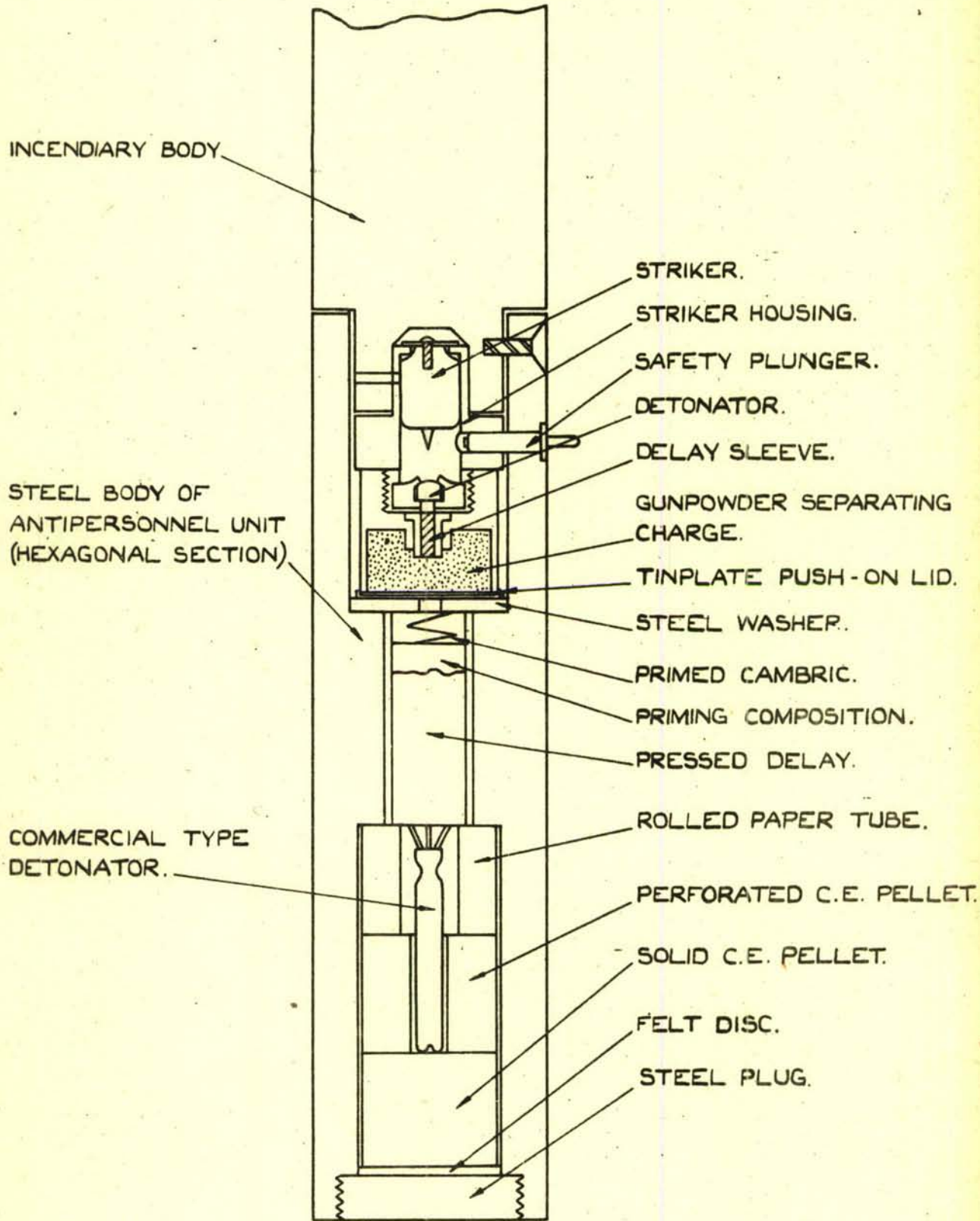

SCALE IN INCHES.

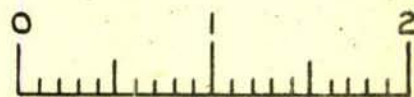

**C.S.A.R.'S SEPARATING ANTI-PERSONNEL HEAD FOR 2 LB. & 4 LB. INCENDIARY BOMBS.**  
**(BASED ON A.R.D. SKETCH REF X C(4) 4016/1/2)**

FIG. 4.

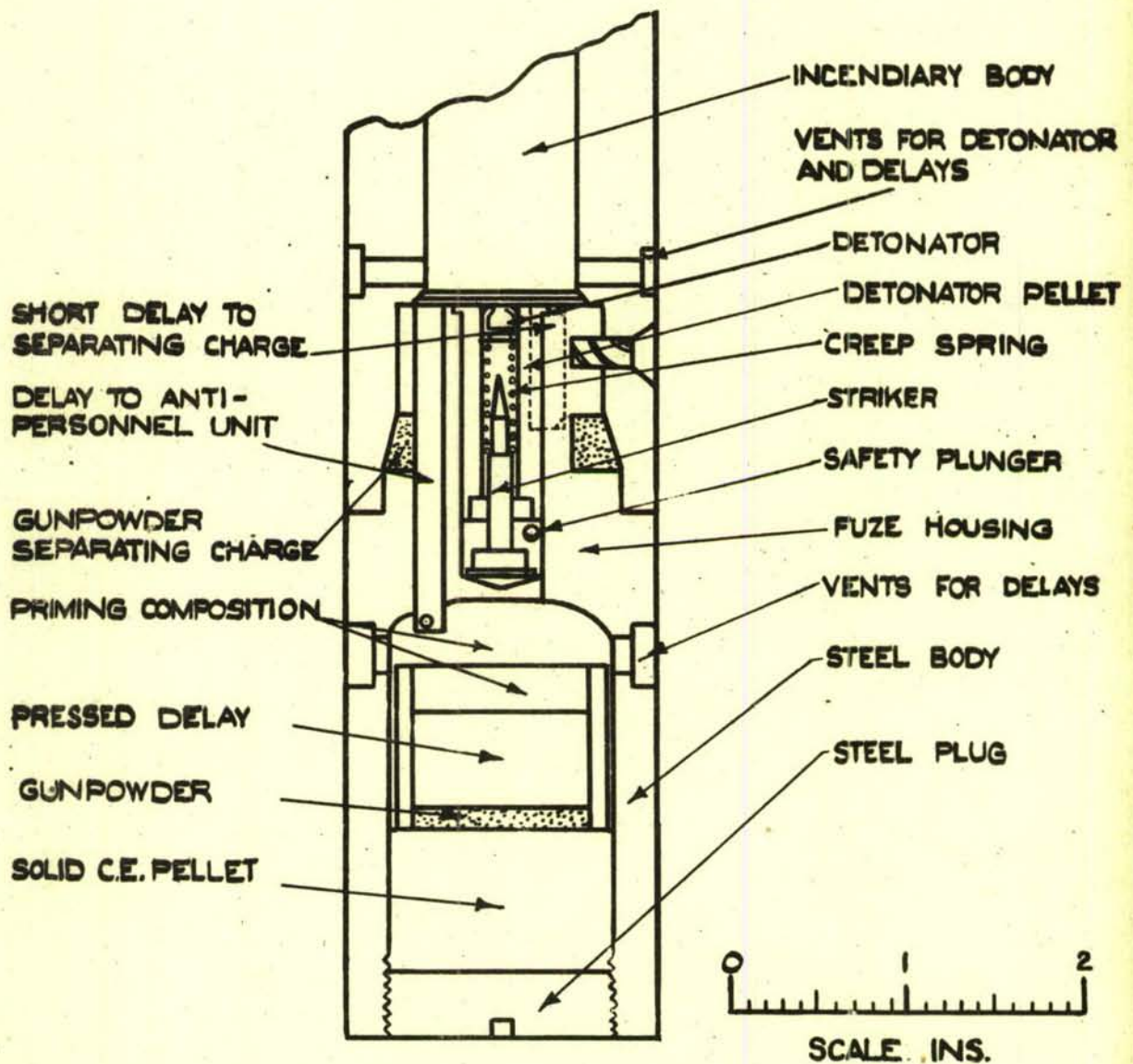

MESSRS. WORSSAM'S DESIGN OF  
SEPARATING ANTI-PERSONNEL UNIT  
FOR 2 LB. INCENDIARY BOMB.  
(BASED ON FIRM'S SKETCH N° 9/175/7.)

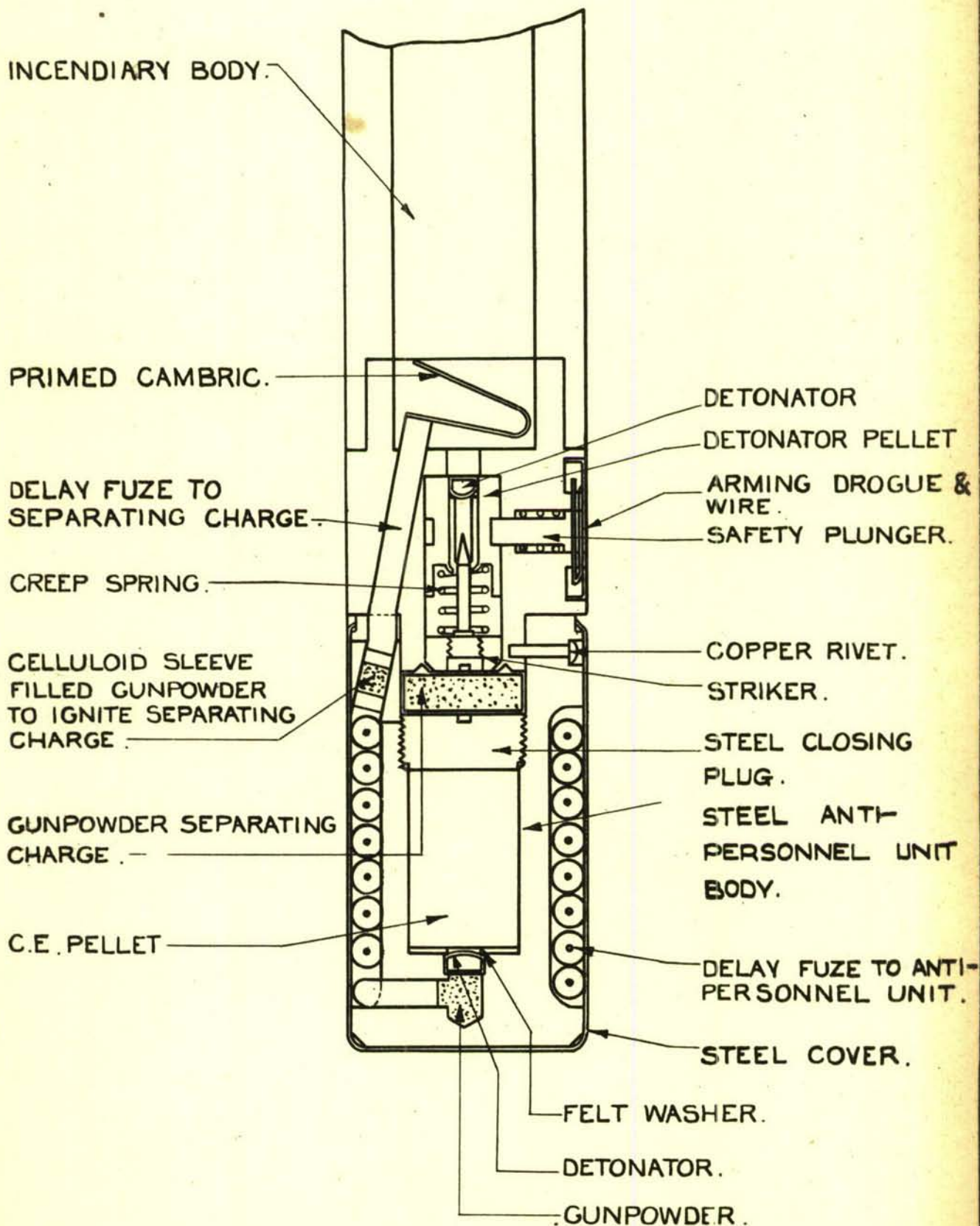

**C.E.A.D. DESIGN OF SEPARATING ANTI-PERSONNEL UNIT FOR 3 LB. INCENDIARY BOMB.**

BASED ON DD(L)17260.

FIG.6.

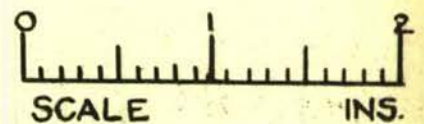
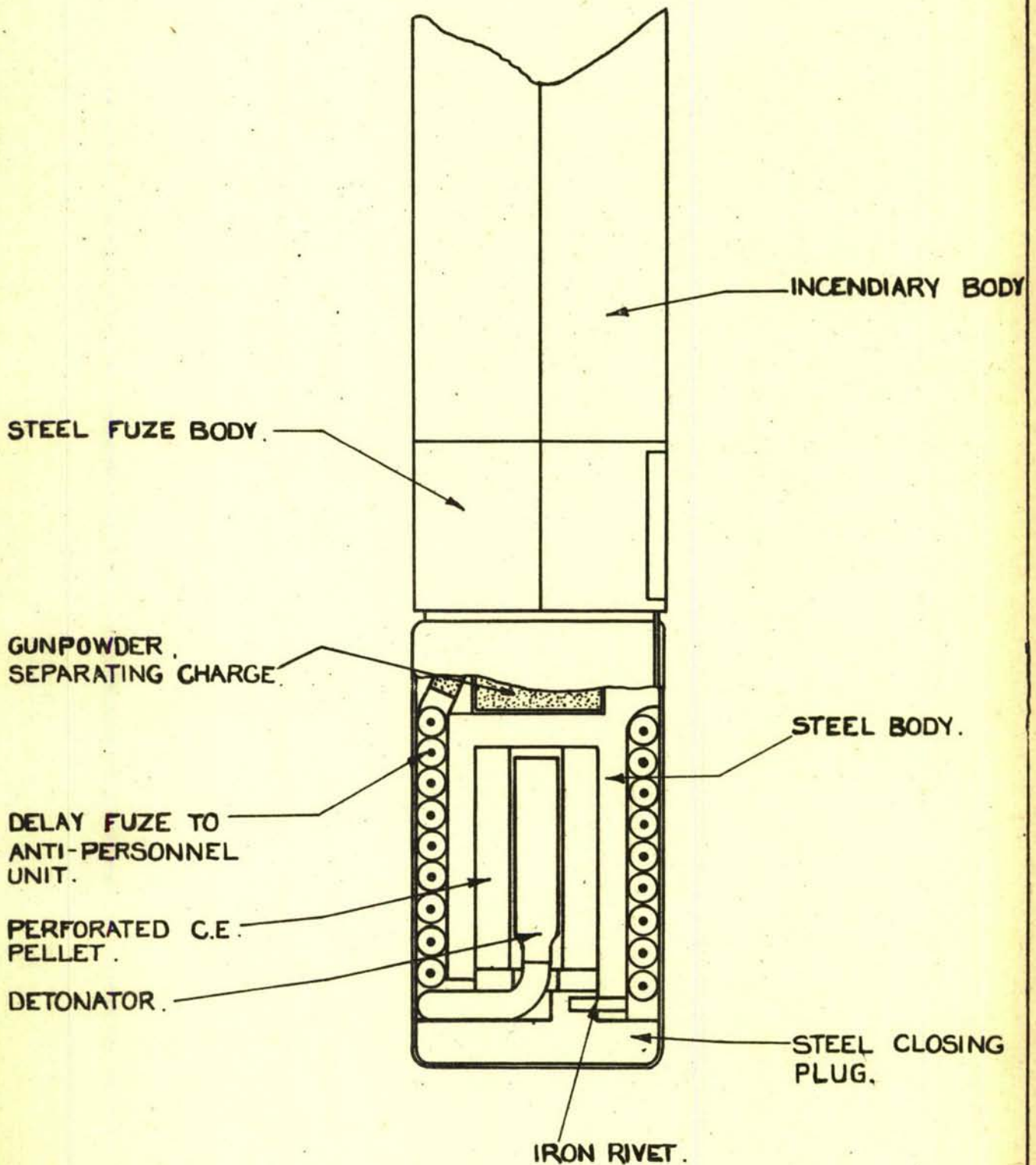

**C.E.A.D. DESIGN OF SEPARATING  
ANTI-PERSONNEL HEAD FOR 3LB.  
INCENDIARY BOMB.**

BASED ON D.D(L)17270

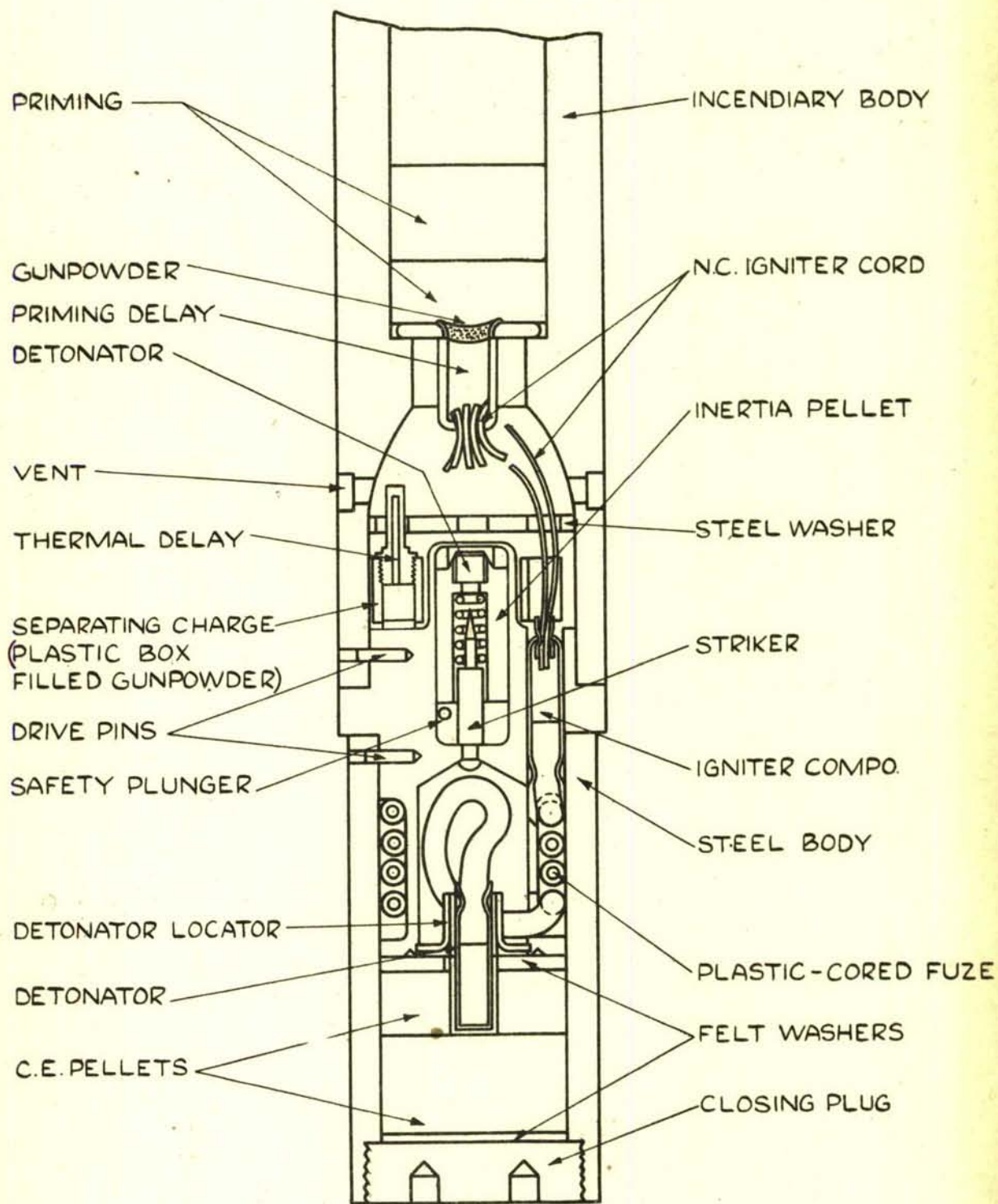

**MESSRS. WORSSAM'S DESIGN OF  
ANTI-PERSONNEL HEAD FOR  
3 LB. INCENDIARY BOMB.  
(BASED ON FIRMS DRAWING N<sup>o</sup> 53/175/6)**

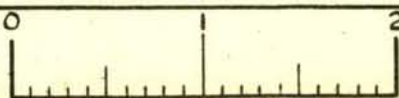

SCALE: IN.

FIG. 8

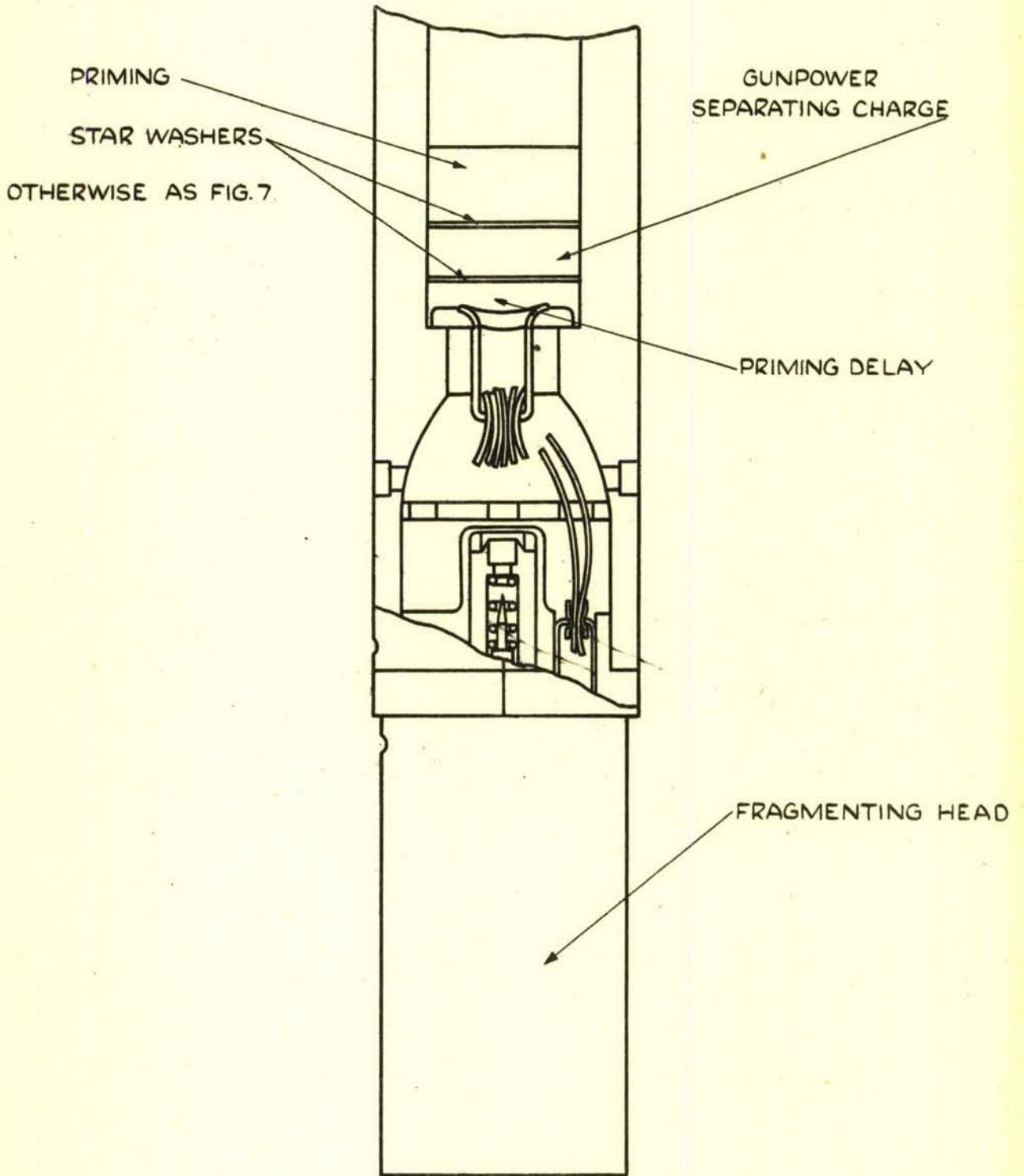

I.C.I. DESIGN USING SAME COMPONENTS AS WORSSAM'S DESIGN.

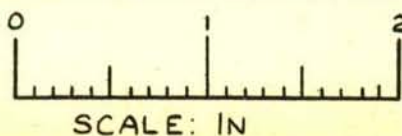

SCALE: IN

ADD 23/48

FIG. 9

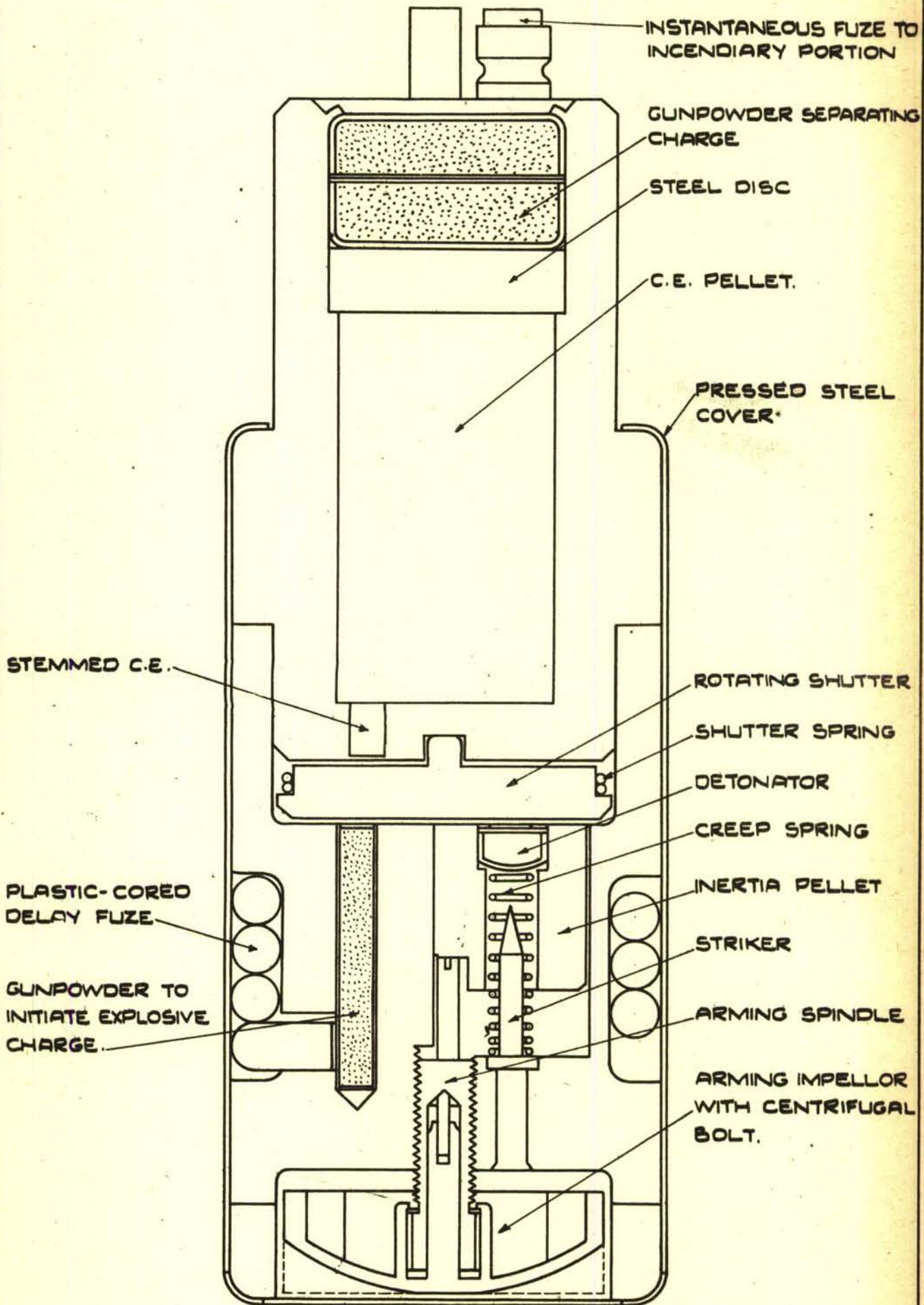

C.E.A.D. DESIGN OF AIR-ARMED AND SHUTTERED ANTI-PERSONNEL HEAD.

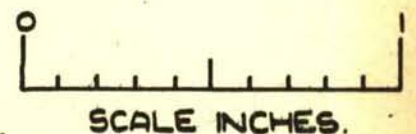

BASED ON D3(L) 684/X/90

A 00 23/46



FIG. 10.

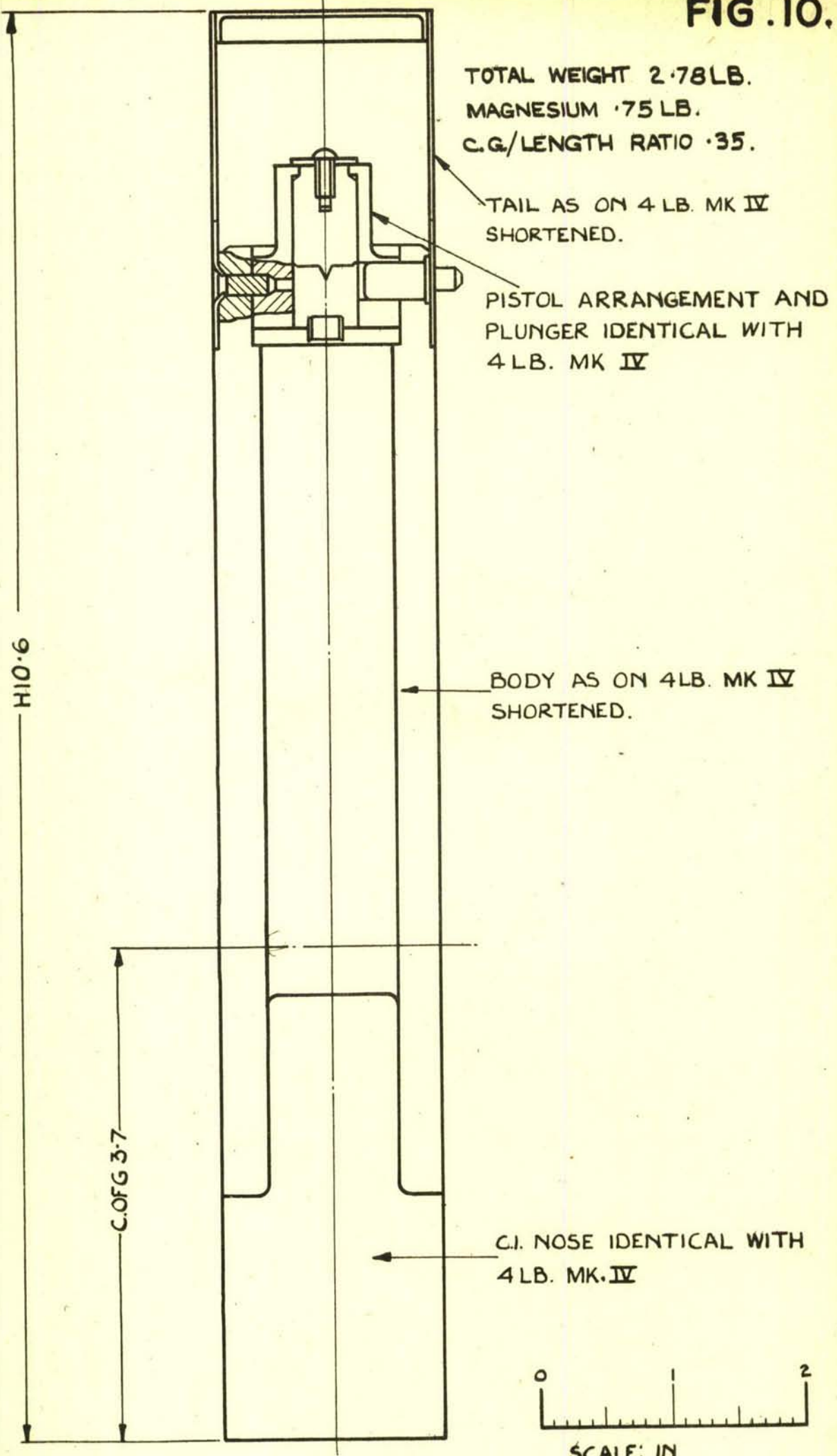

TOTAL WEIGHT 2.78 LB.  
MAGNESIUM .75 LB.  
C.G./LENGTH RATIO .35.

TAIL AS ON 4 LB. MK IV  
SHORTENED.

PISTOL ARRANGEMENT AND  
PLUNGER IDENTICAL WITH  
4 LB. MK IV

BODY AS ON 4 LB. MK IV  
SHORTENED.

C.I. NOSE IDENTICAL WITH  
4 LB. MK. IV

110.6

C.O.F.G 3.7

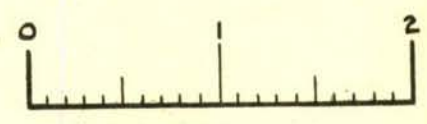

SCALE: IN

BOMB INCENDIARY SMALL SIZE.

BASED ON D.D.(L)14459.

ADD 23/46

FIG. 11.

TOTAL WEIGHT - 2.85 LB.  
MAGNESIUM - .75 LB.  
C.G./LENGTH RATIO .345

SECTION X

X

H 10.6

1 DELAY PELLET AS  
ON 4 LB. MK. IV X.

C.G. 3.66

NOSE AS ON 4 LB. MK. IV X  
SHORTENED.  
FILLED AS ON 4 LB. MK. IV X  
WITH 1 LESS SOLID C.E.  
PELLET.

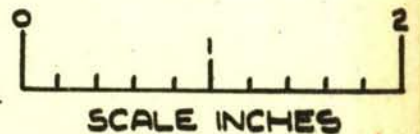

SCALE INCHES

**BOMB OTHERWISE AS FIG. 10 BOMB  
INCENDIARY, SMALL SIZE FITTED WITH  
DELAY EXPLOSIVE CHARGE.**

BASED ON D.D L 14476

ADD 23/46

FIG.12.

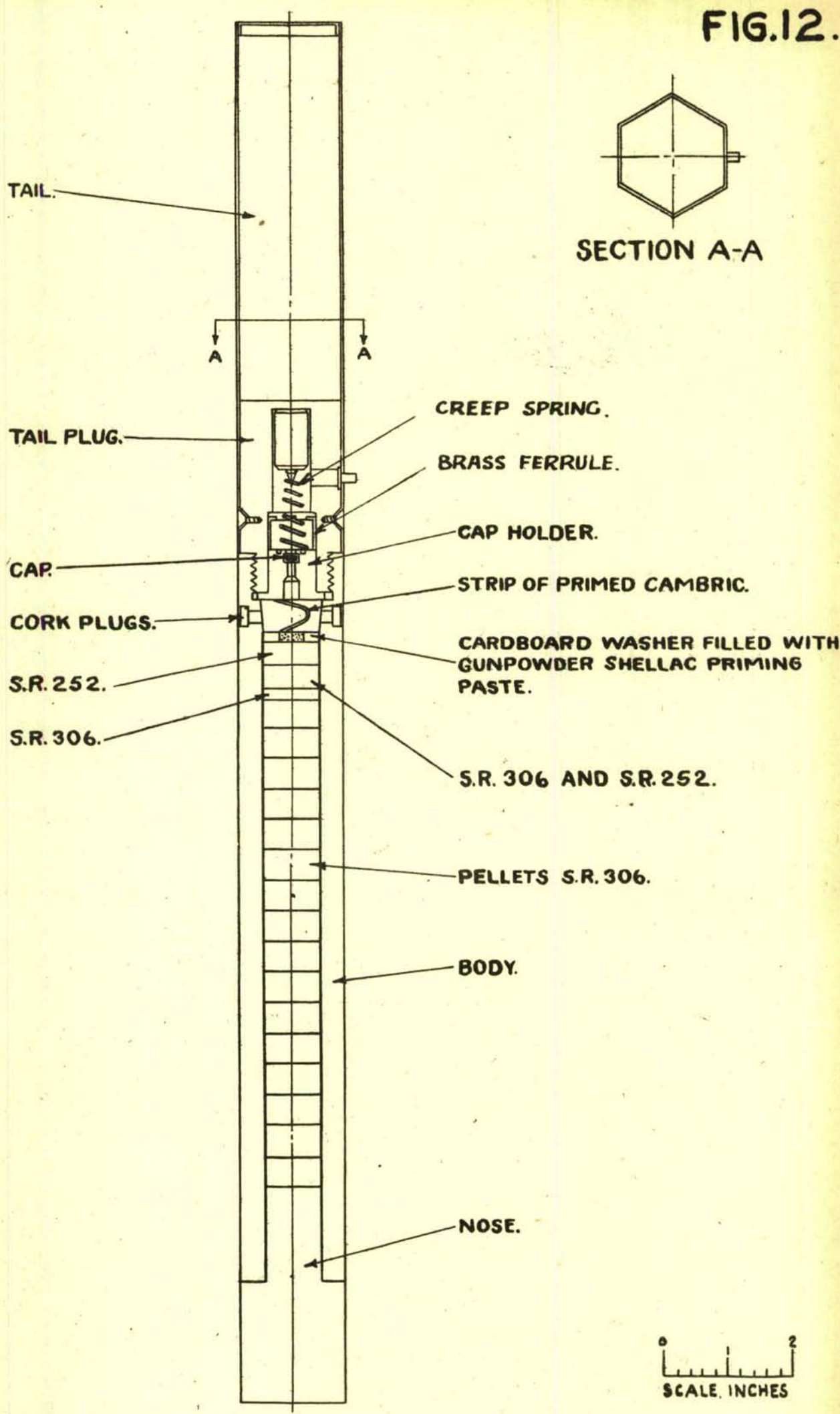

**BOMB, INCENDIARY, A/C, 4LB. MK.I.**

(BASED ON D.O.(L)7728C)

ADD 23/46

FIG.13.

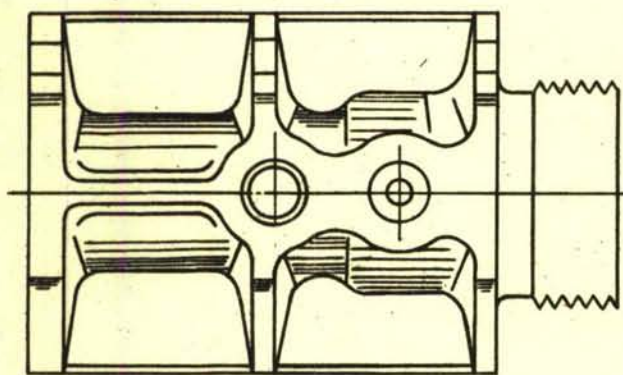
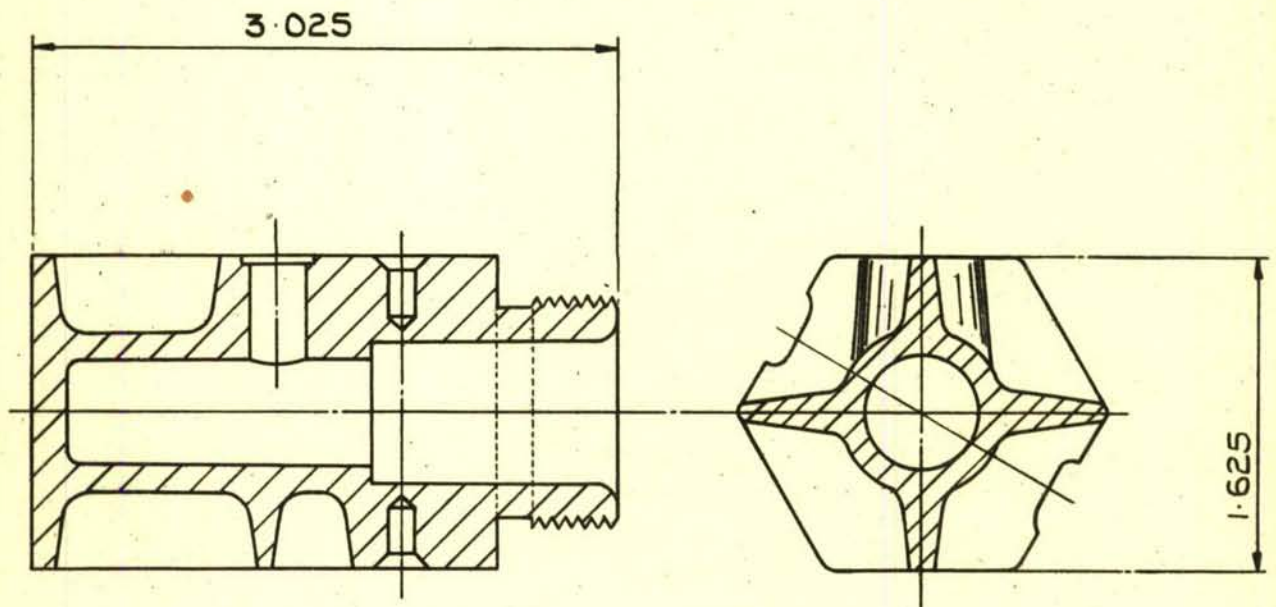

	MG.	ALUM.
MACHINED WT. =	.17 LB.	.27 LB.
UNMACHINED WT. =	201 LB.	.32 LB.

SCALE IN INCHES.



PPOPOSED SKELETON TAIL PLUG N°1.

BASED ON EXP. 37/1

FIG. 14.

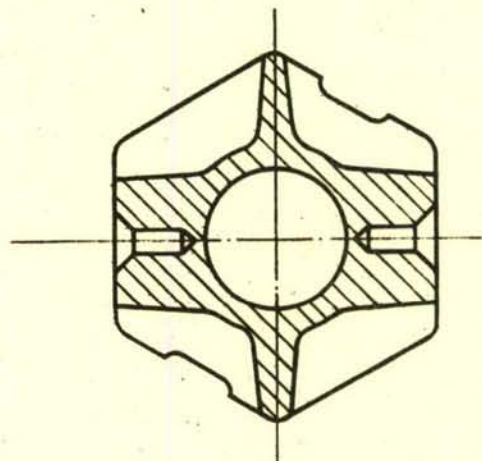
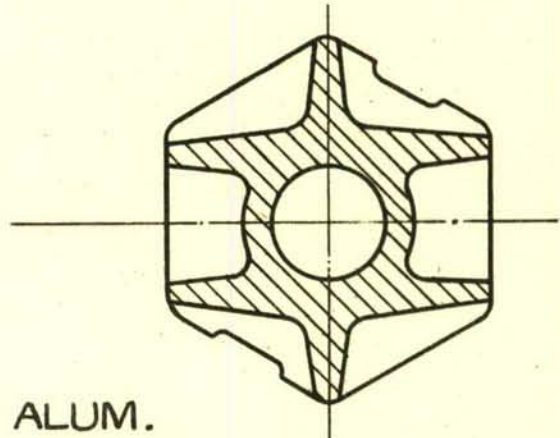
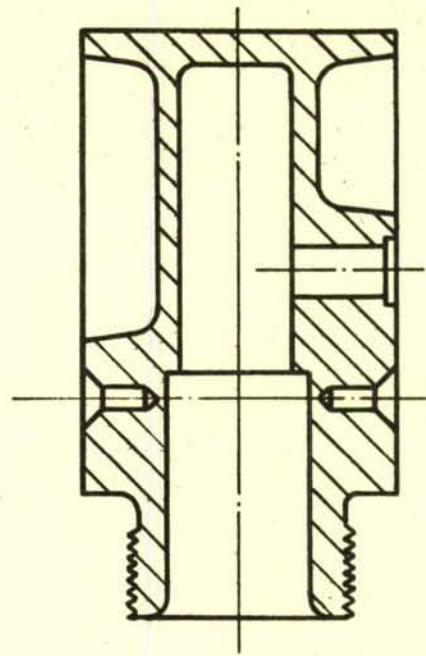
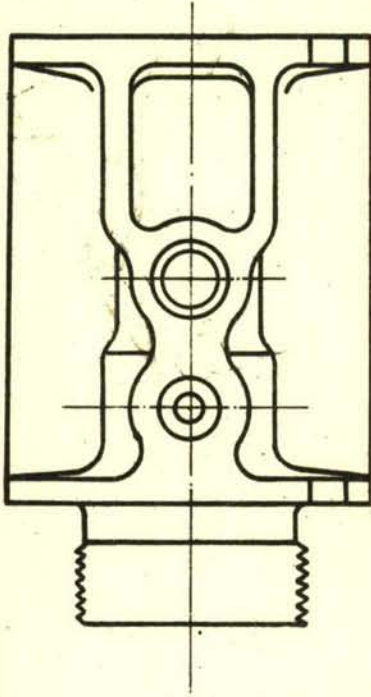

	MG.	ALUM.
MACHINED WT: =	·16 LB.	·256 LB.
UNMACHINED WT: =	·19 LB.	·304 LB.

0 1 2  
SCALE. IN.

PROPOSED SKELETON TAIL  
PLUG No 2.

(BASED ON  
EXP. 37/2)

FIG. 15.

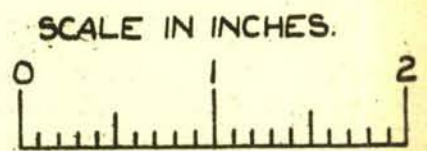
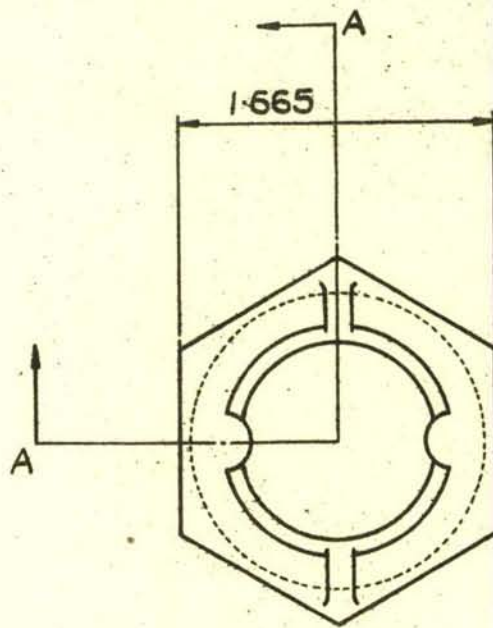
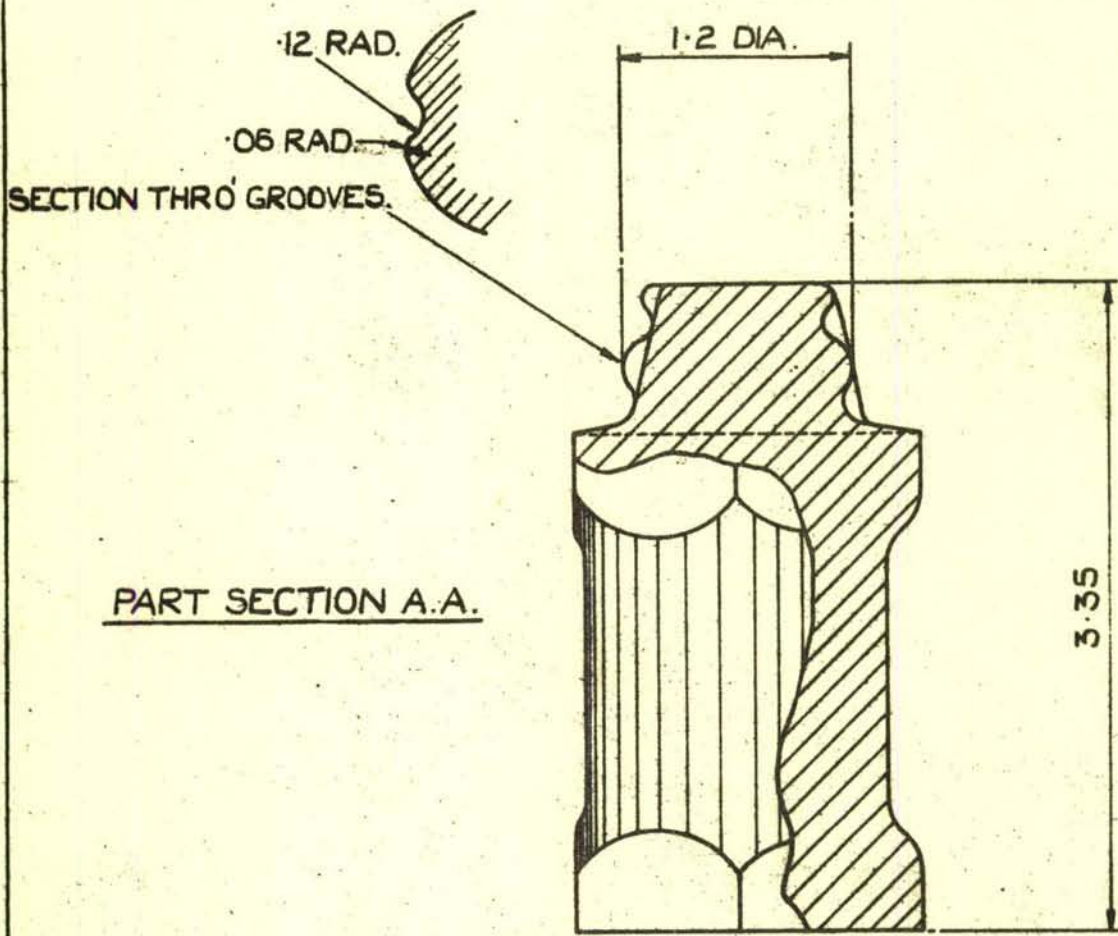

**PROPOSED MODIFIED CAST IRON-NOSE.**

BASED ON EXP. 37

FIG. 16.

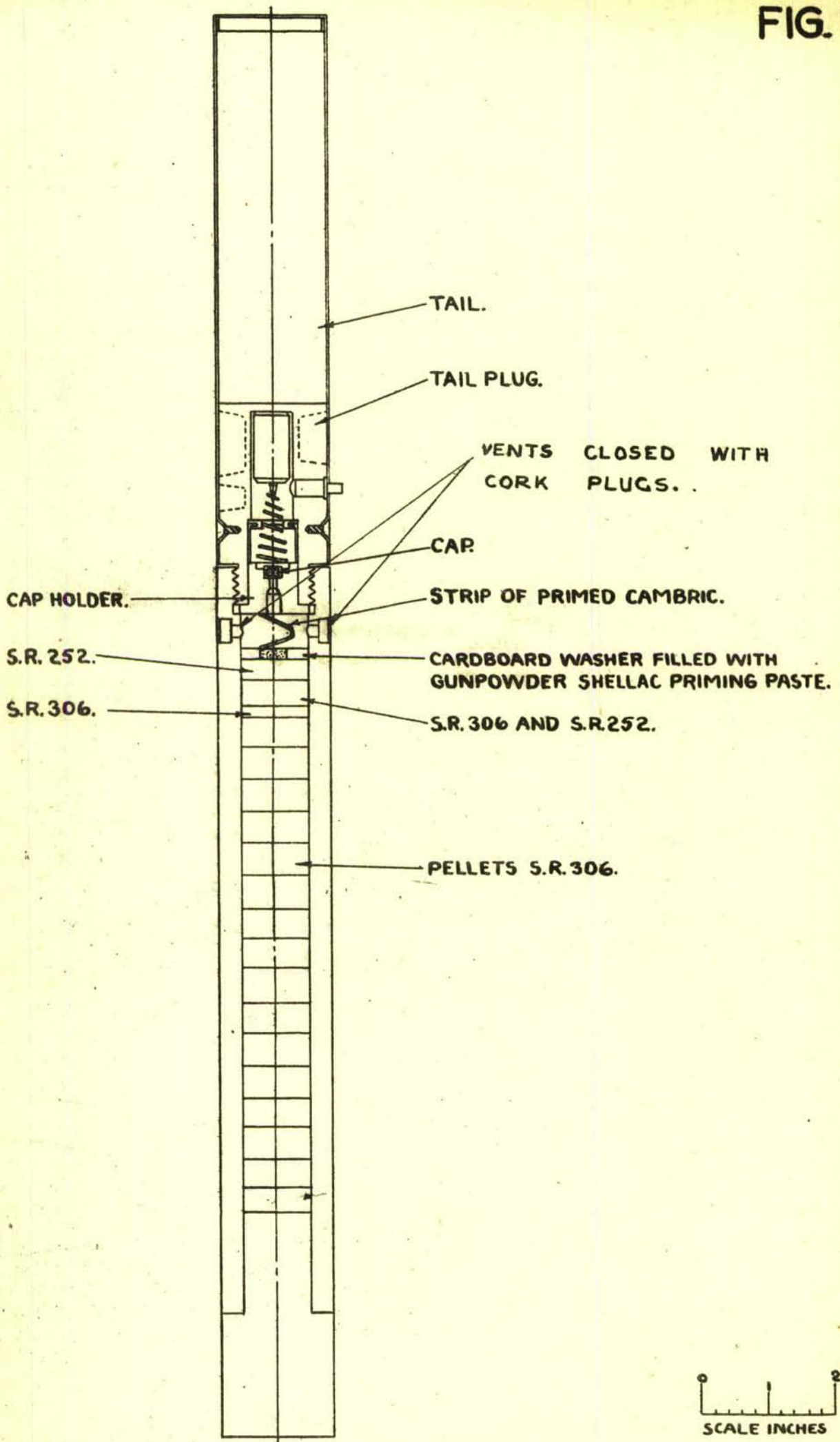

**BOMB, INCENDIARY, A/C, 4 LB.  
MK. 3.**

(BASED ON D.D.(L)13448)

ADD 23/46

FIG. 17

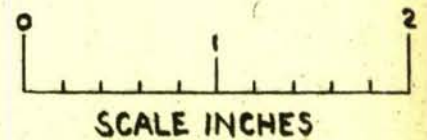
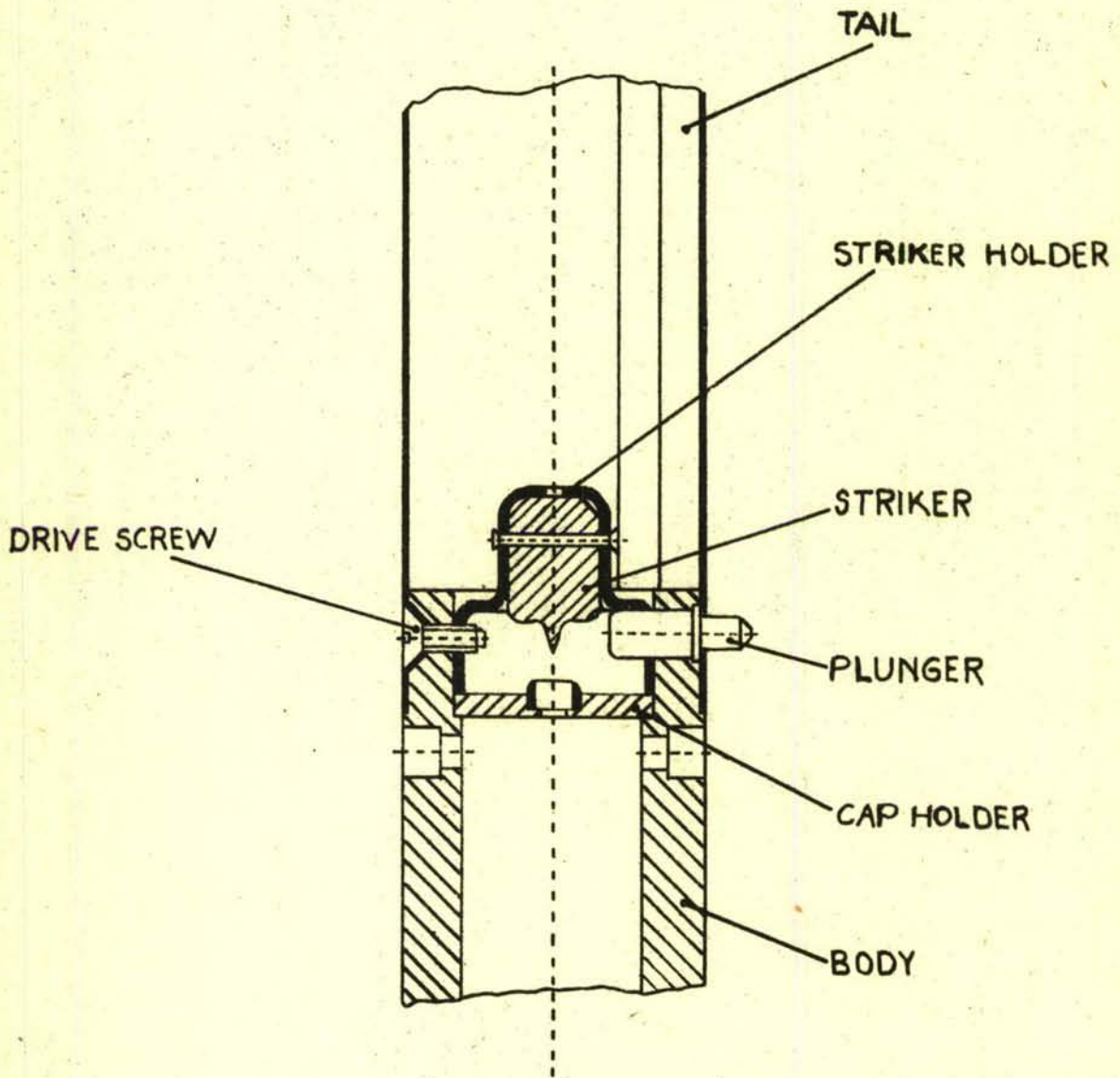

MIDGLEY-HARMER PISTOL  
FIRST DESIGN

(BASED ON M.230)



FIG. 18

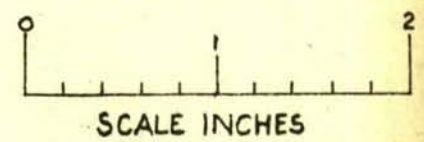
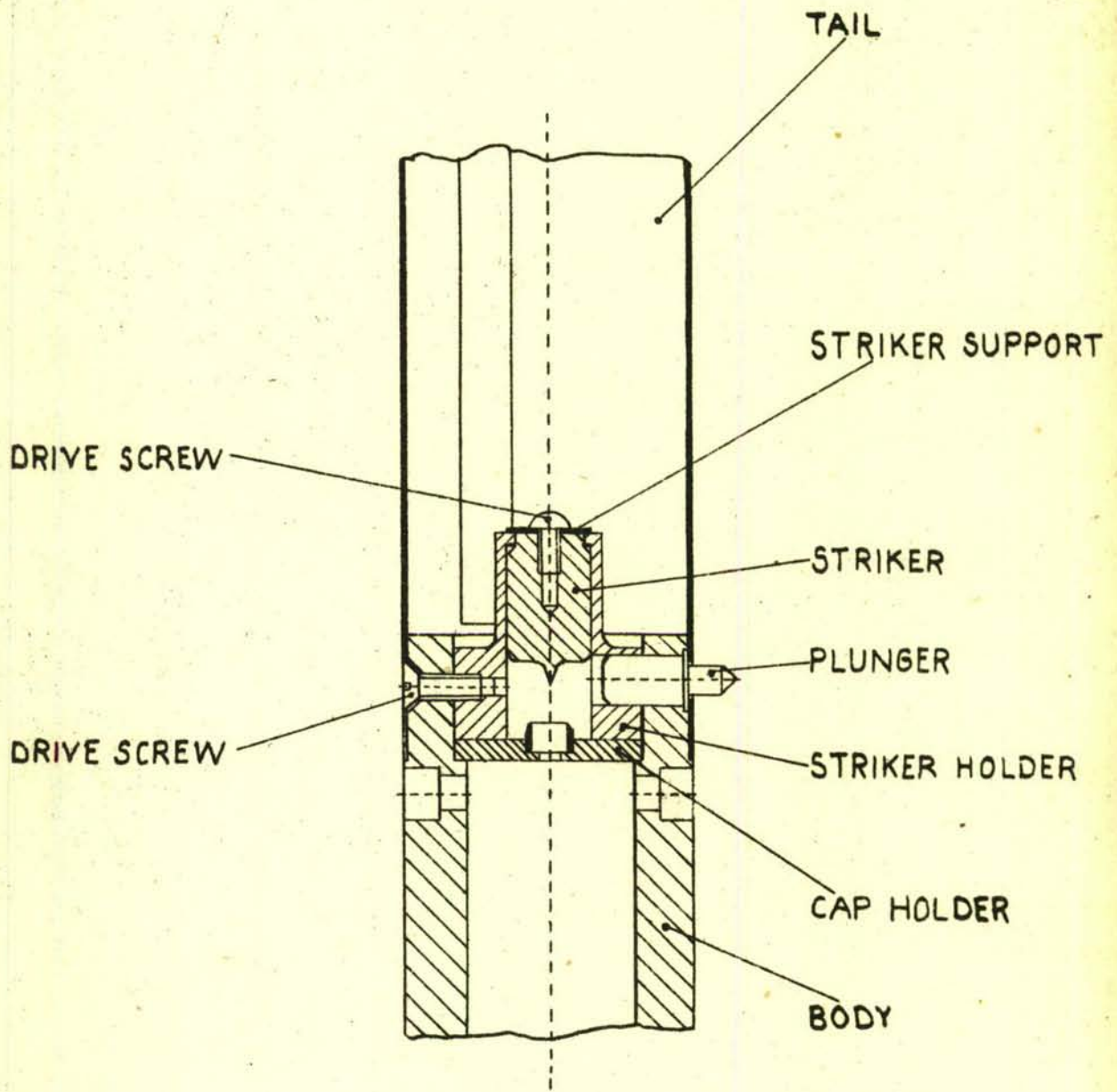

MIDGLEY-HARMER PISTOL  
FINAL DESIGN

(BASED ON M.237)

ADD 23/46

FIG. 19

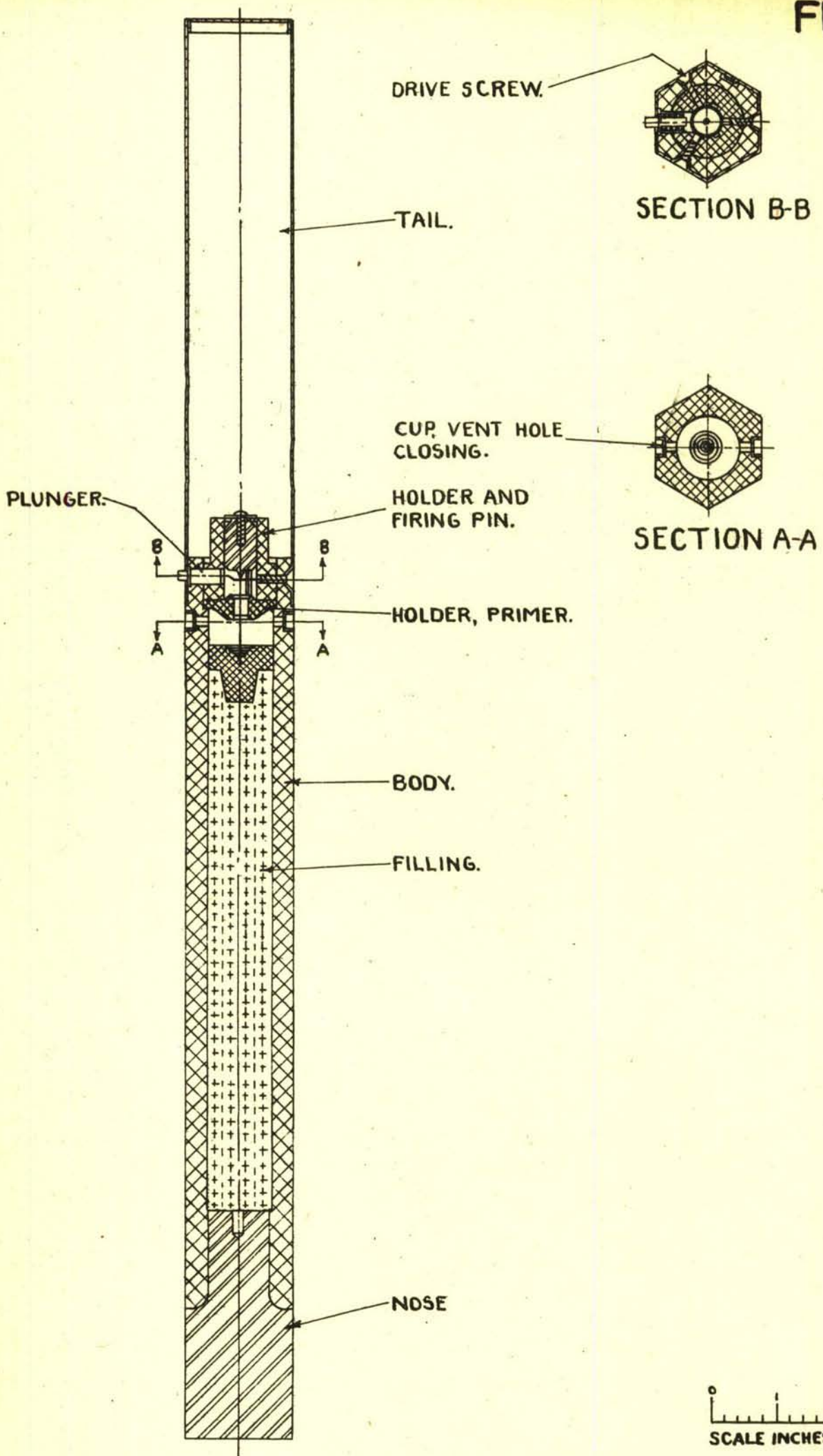

**BOMB, INCENDIARY, A/C, 4 LB.  
MK. 5. (AMERICAN AN-M50-A1) (BASED ON C14-5-110)**

ADD 23/46

FIG. 20

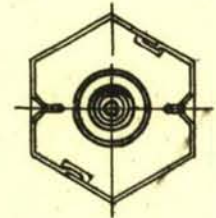

SECTION A-A

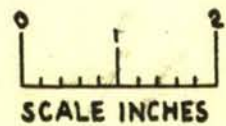
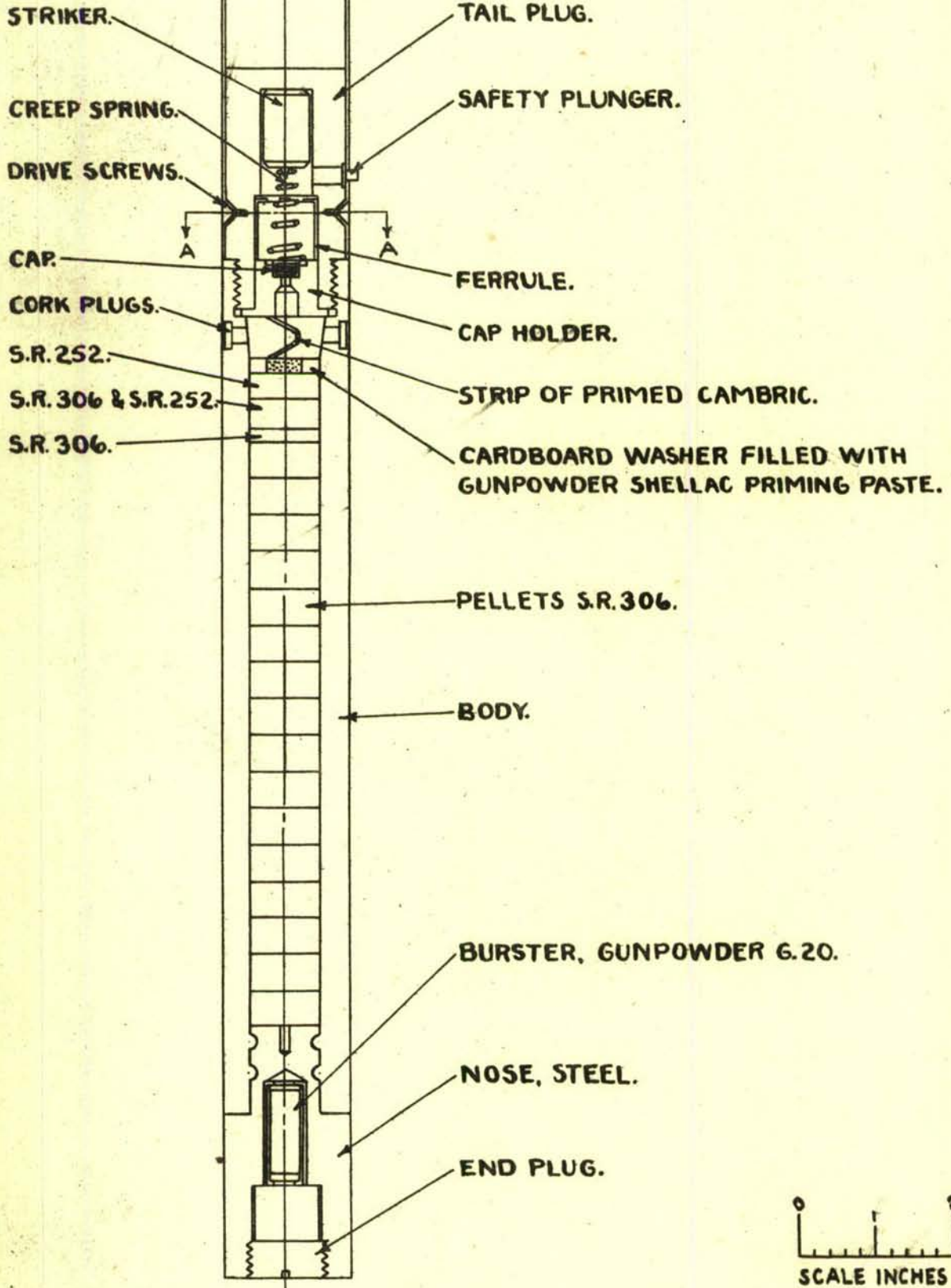

SCALE INCHES

**BOMB, INCENDIARY, A/C, 4LB.**

**MK. I E.**

(BASED ON  
D.D.(L)9275 & D.D.(L)9275)

ADD 23/46

FIG. 21

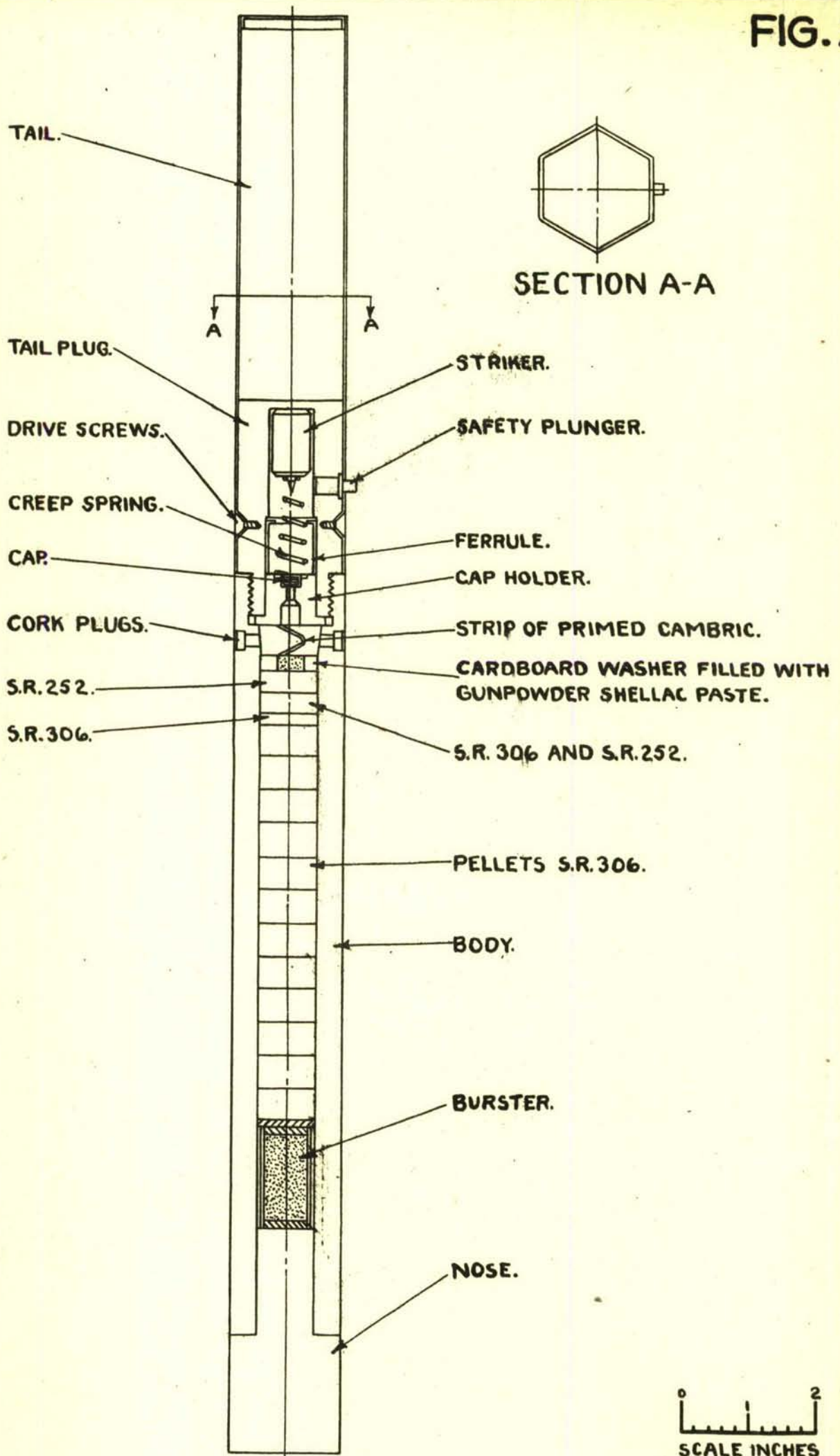

BOMB, INCENDIARY, A/C, 4LB.

MK. I.E.

(BASED ON D.D.(L)8932A)

ADD 23/46

FIG.22

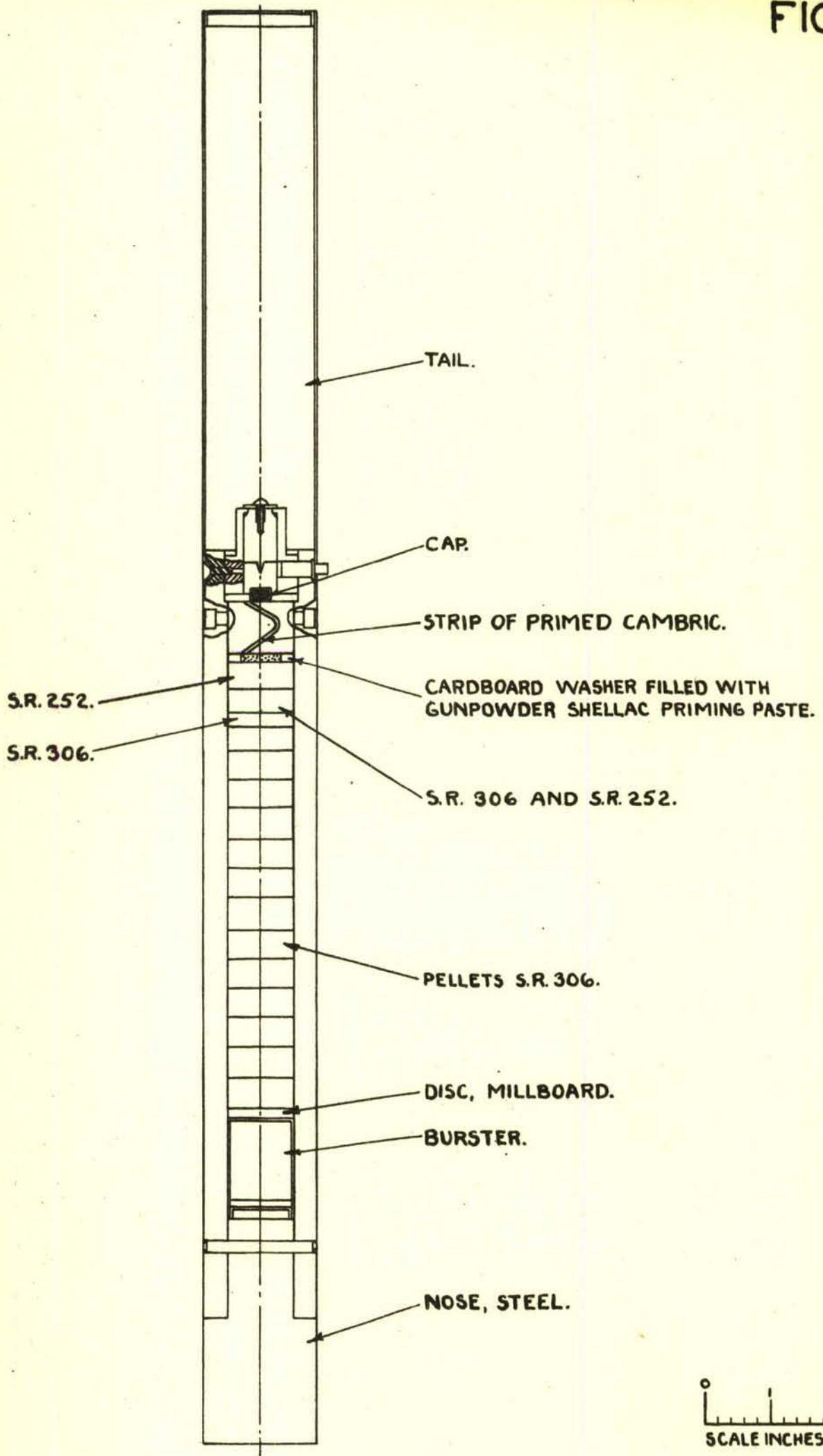

BOMB, INCENDIARY, A/C, 4LB.  
MK. 4E.

(BASED ON D.D.(L)13706)

ADD 23/46

**FIG. 23**

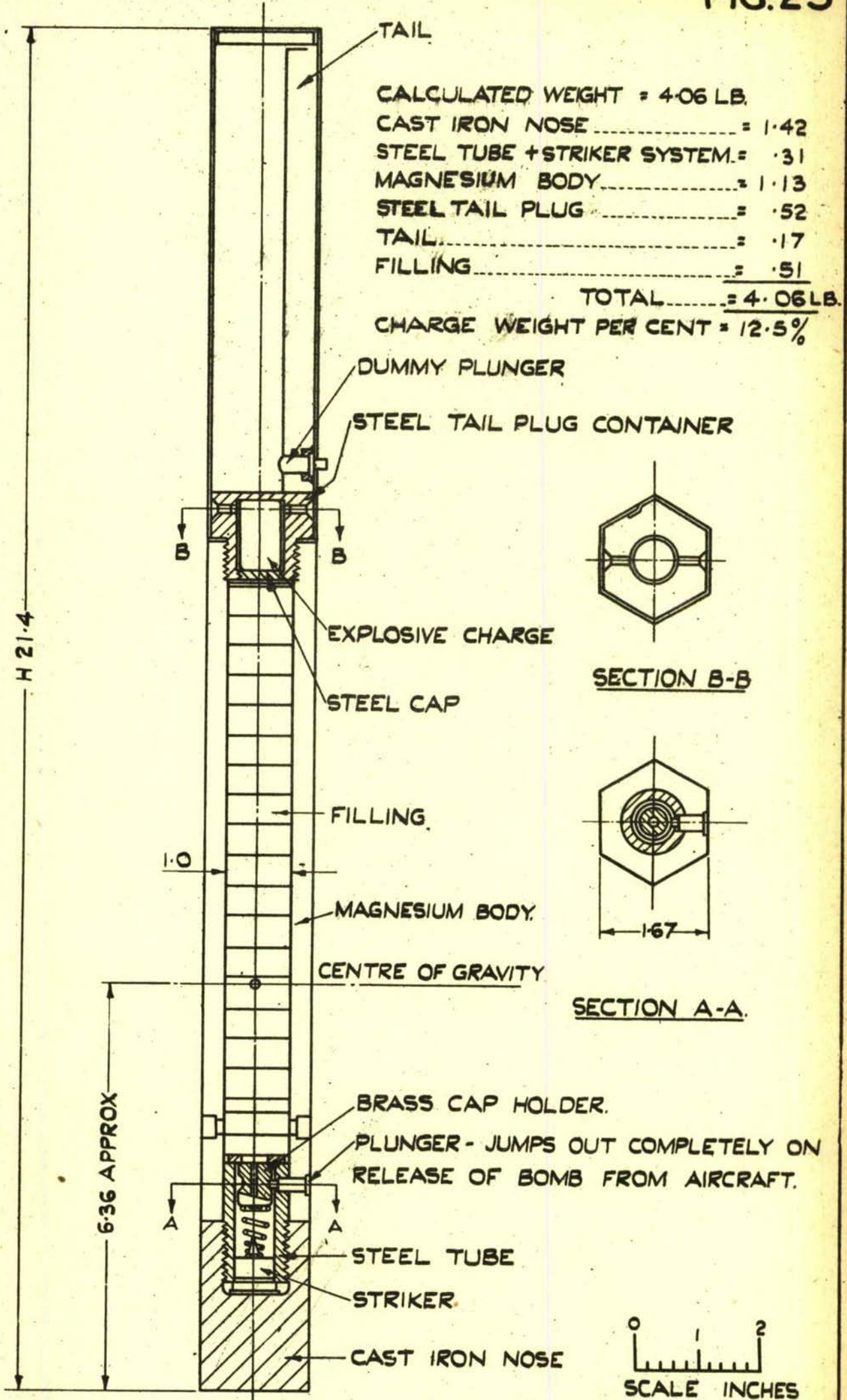

**BOMB, INCENDIARY, A/C. 4 LB.  
X TYPE.**

BASED ON D.D.(L)12707

ADD 23/46

FIG.25.

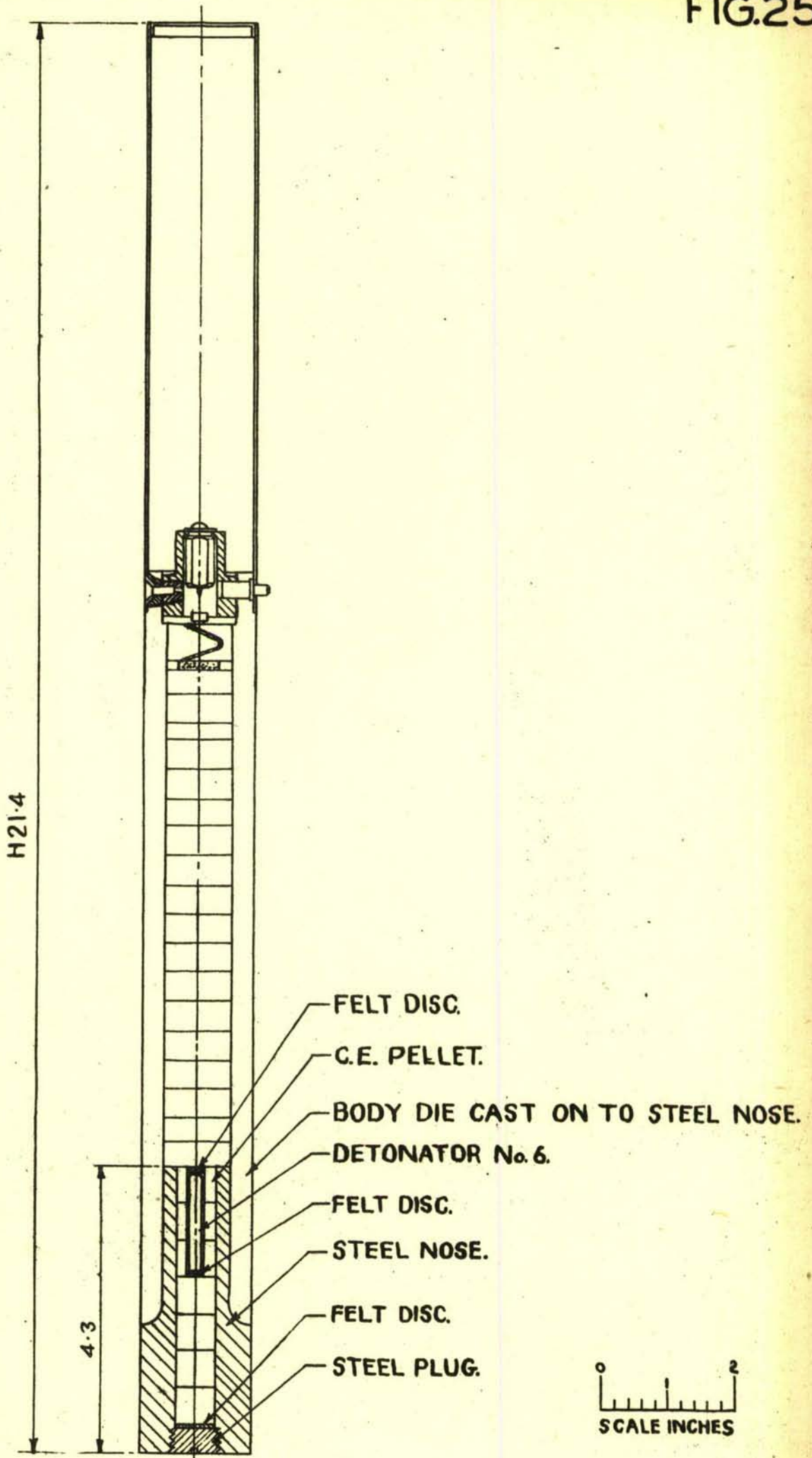

**BOMB, INCENDIARY, A/C, 4LB.  
X TYPE.**

(BASED ON D.D.(L)13609)

ADD 23/46

FIG.26

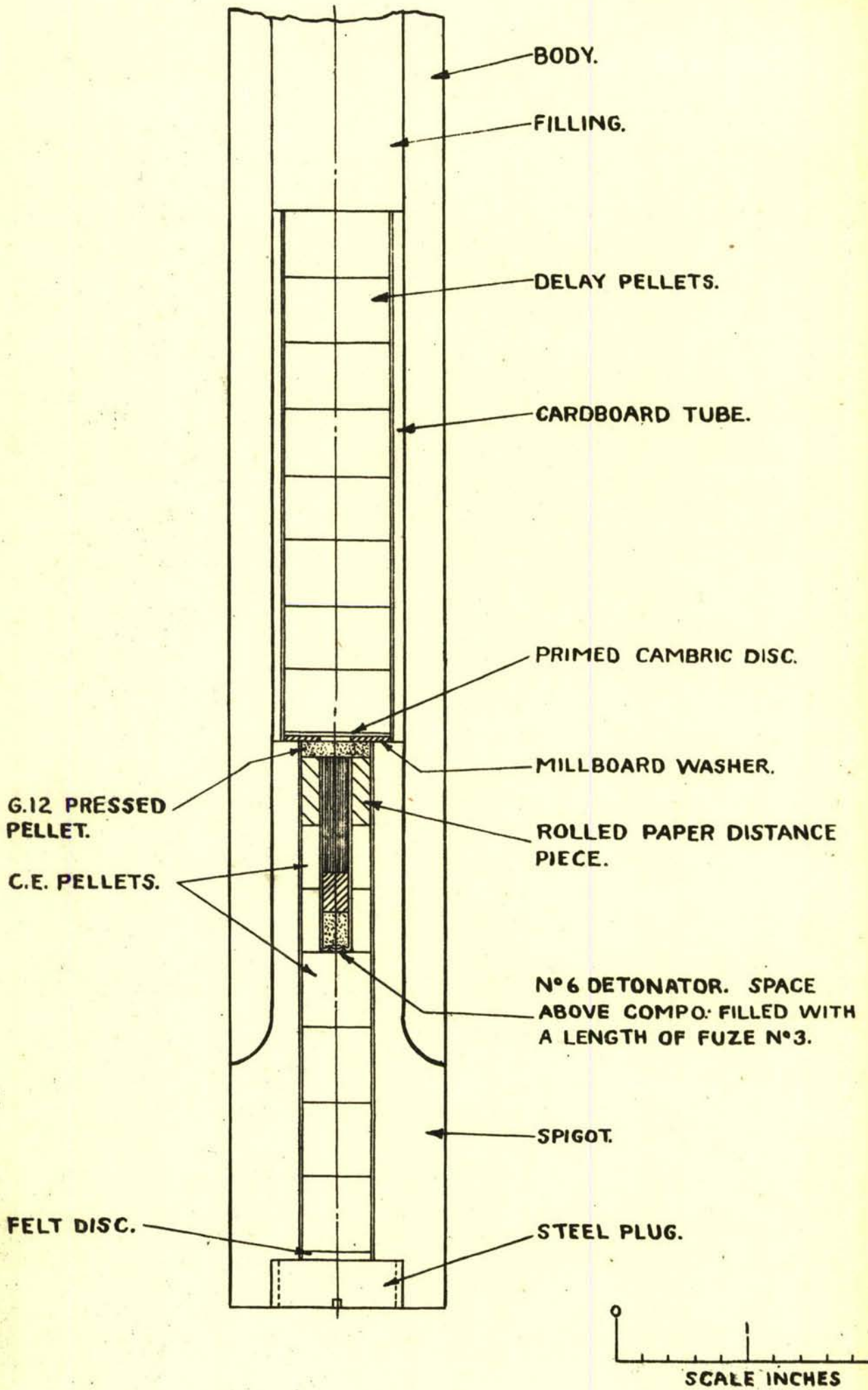

**BOMB, INCENDIARY, A/C, 4LB.  
X TYPE.**

(BASED ON D.D.(L)13609A)

ADD 25/46



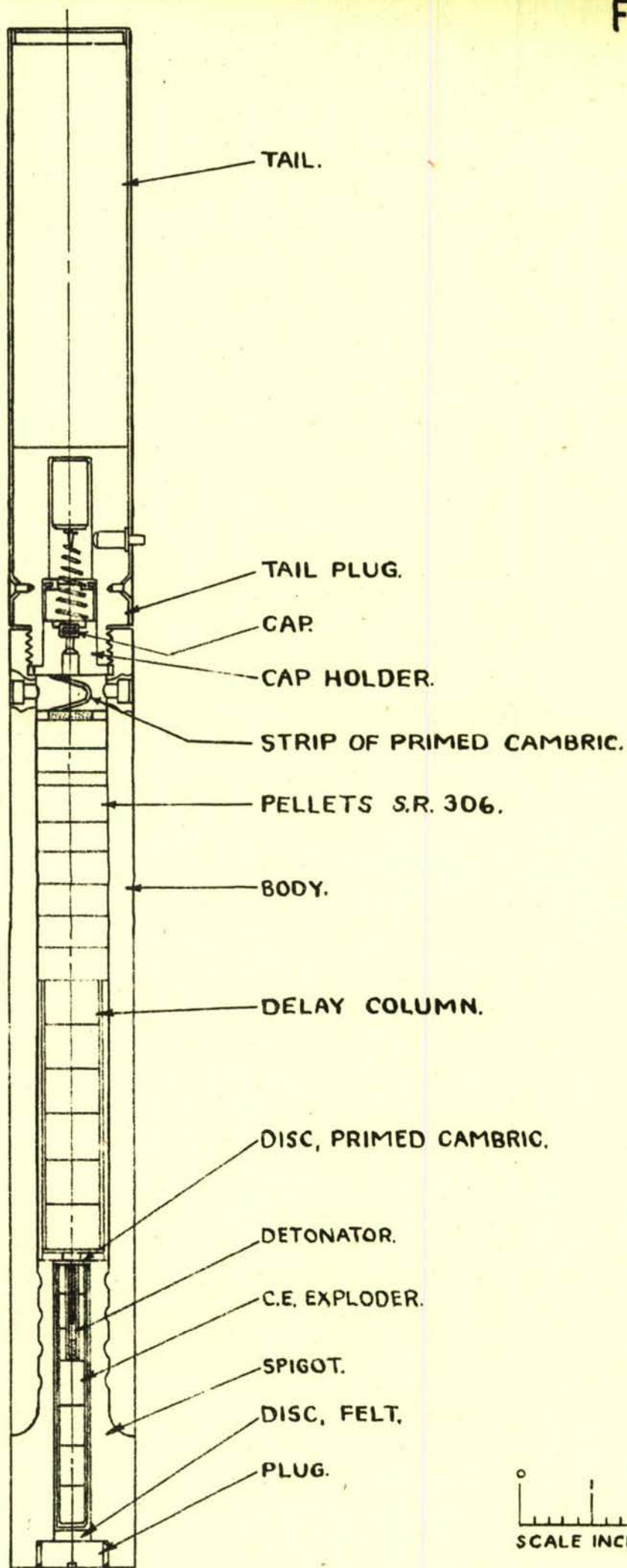

**BOMB, INCENDIARY, A/C, X, 4LB.**  
**MK. I.**

(BASED ON D.D.(L)16454SHT.)

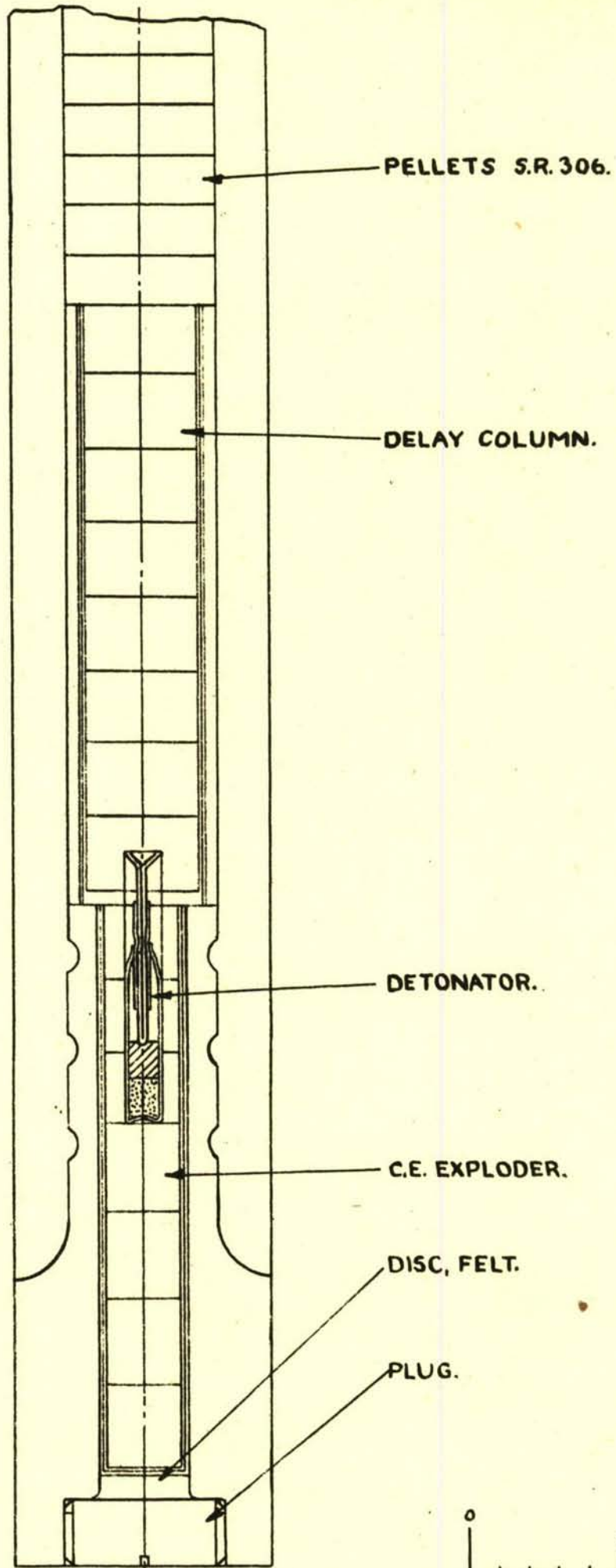

BOMB, INCENDIARY, A/C. X, 4LB.  
MK.I.

(BASED ON D.D.(L)16454 SHT.2)

ADD 23/46

FIG. 29

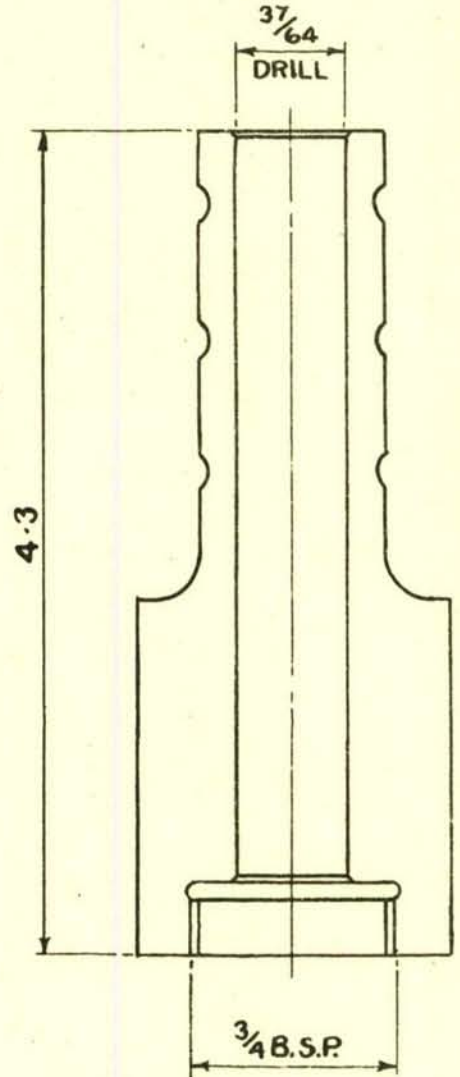
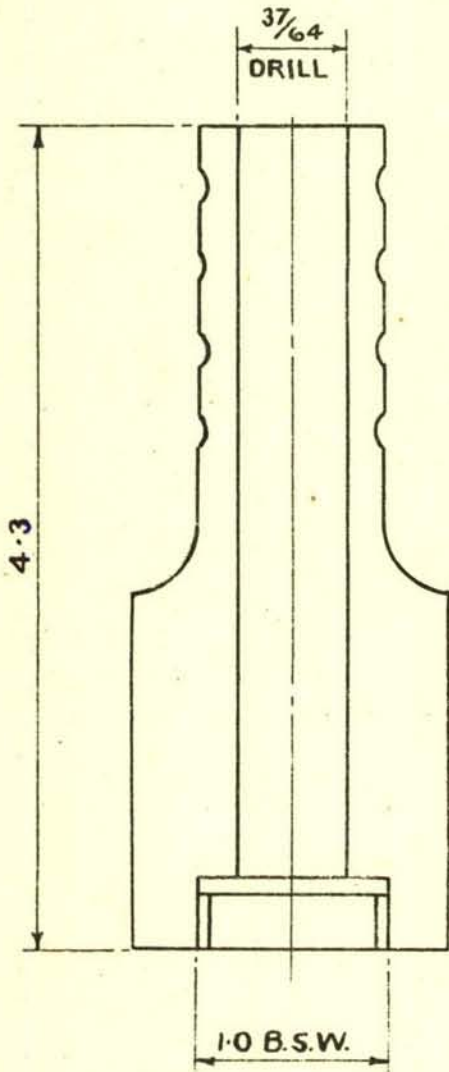
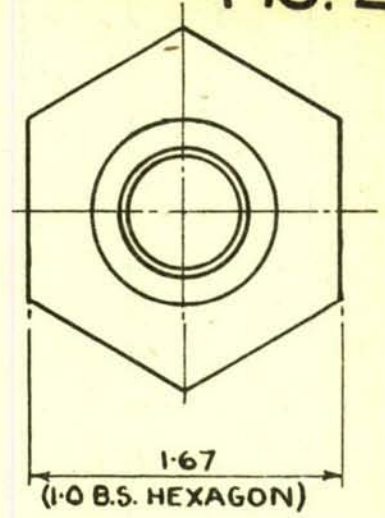
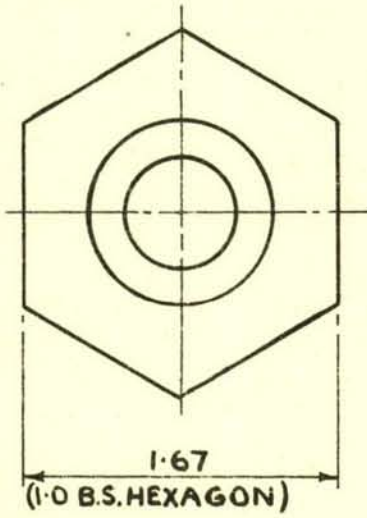

NOSE-STEEL  
"A"

ALTERNATIVE NOSE-STEEL  
"B"

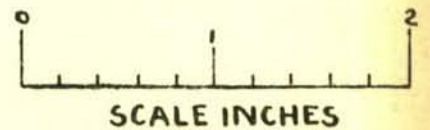

ALTERNATIVE NOSES FOR BOMB,  
INCENDIARY, A/C, X, 4LB.

(BASED ON D.D.(L)16453)  
ITEMS I & IA

ADD 23/46

FIG. 30

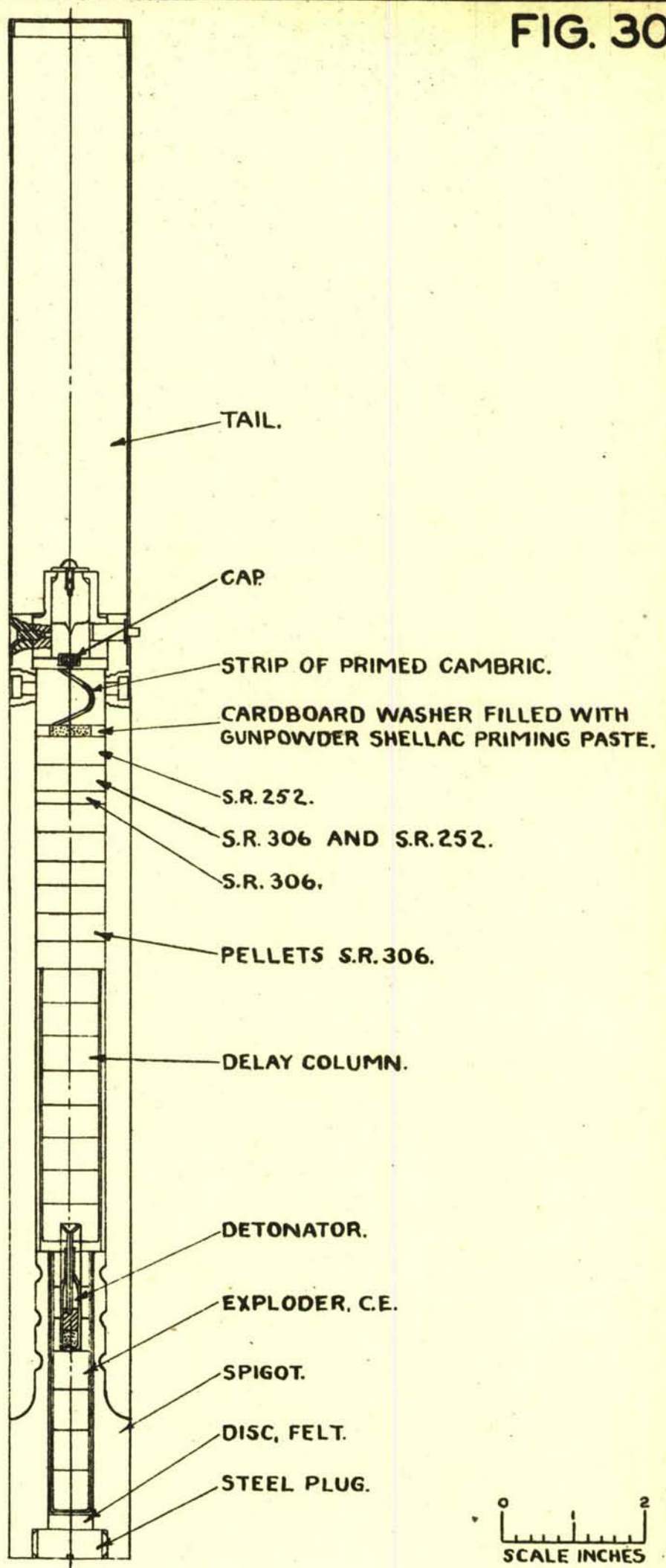

0 1 2  
SCALE INCHES

BOMB, INCENDIARY, A/C, X, 4LB.  
MK. 2.

(BASED ON D.D.(L)16456)

A DD 23/46

FIG. 31

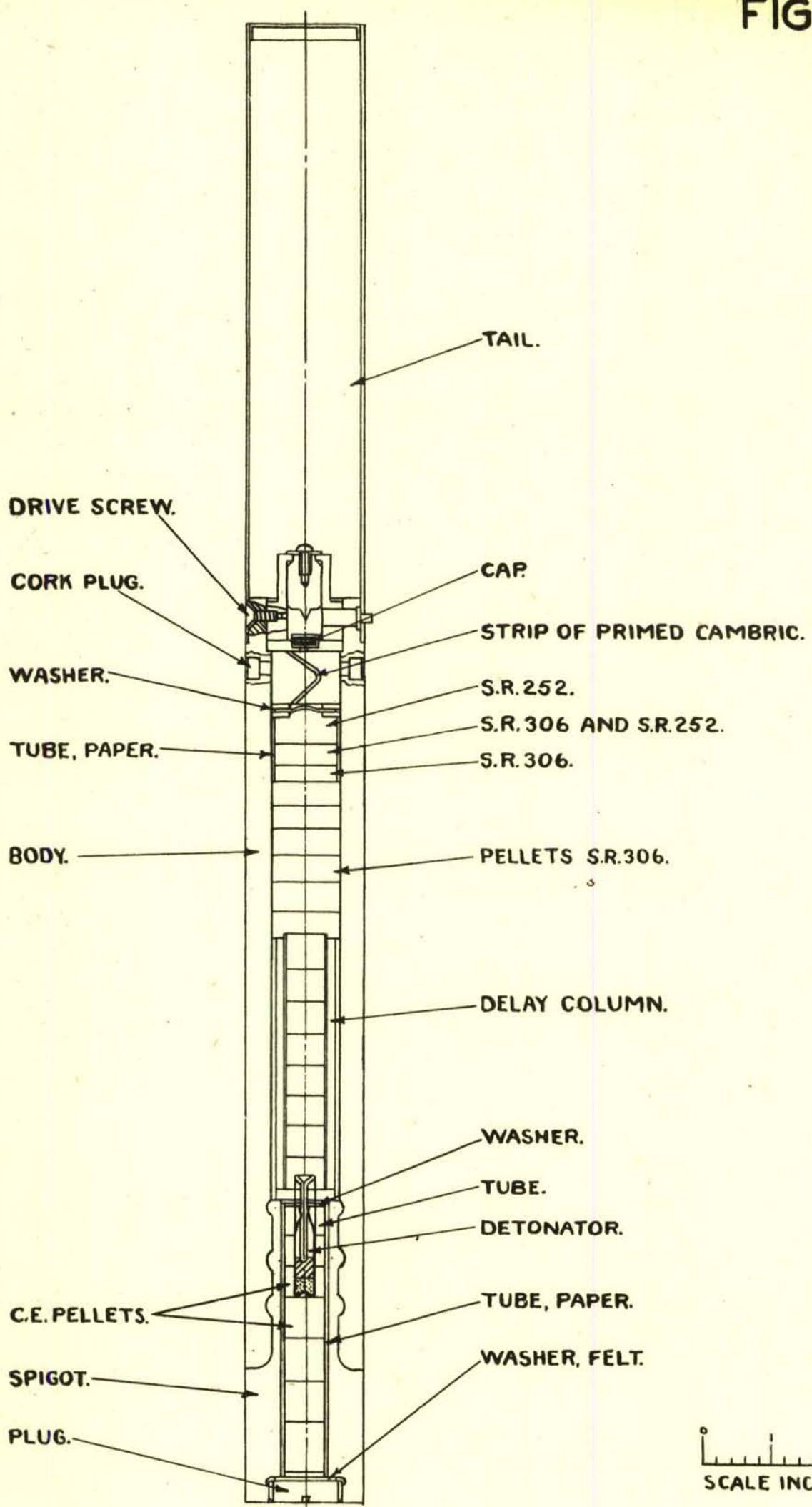

0 1 2  
SCALE INCHES

**BOMB, INCENDIARY, A/C. X. 4LB.  
MK. 3.**

(BASED ON D.D.(L)16985)

ADD 23/46

**FIG. 32**

SAFETY WIRE COPPER  
20 S.W.G. (.036 DIA.)

SAFETY CLIP, MILD STEEL,  
No. 16 S.W.G. (0.064 DIA.)

TAIL, TINNED PLATE I.C. (0.012  
THICK) SECURED TO BODY  
WITH 3- $\frac{1}{8}$  DIA. DRIVE SCREWS

SECTION A-B.

1.67

CLOSING DISC, SEALED TO  
END OF BODY TO PRODUCE  
AIRTIGHT JOINT.

BODY, ROLLED CELLULOID  
SHEET 1.67 EXT. DIA.  
0.75 INT. DIA.

FILLED THERMITE

C.G.

END OF CELLULOID BODY  
SECURED BY PRESSING OVER  
SCREWED END OF ADAPTER.  
JOINT TO BE AIRTIGHT.

DETONATOR HOLDER  
MILD STEEL

21.4

ADAPTER MILD STEEL

DETONATOR AS  
D.D.(L)7728C ABOUT  
 $\frac{1}{2}$  GRAINS.

LENGTH WITHOUT  
SAFETY CAP. 21.2.  
SHEAR WIRE, COPPER,  
SECURED BY TURNING ENDS  
OF WIRE INTO ANNULAR  
GROOVE IN NOSE

6.3

NOSE CAST-IRON

SAFETY CAP, BAKELITE

STRIKER MILD STEEL

SPRING, STEEL

SCALE IN INCHES



**BOMB, INCENDIARY, A/C 4 LB.  
CELLULOID BODY FILLED THERMITE.**

BASED ON D.D.(L)11486.

ADD 23/46

FIG. 33

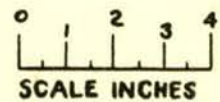
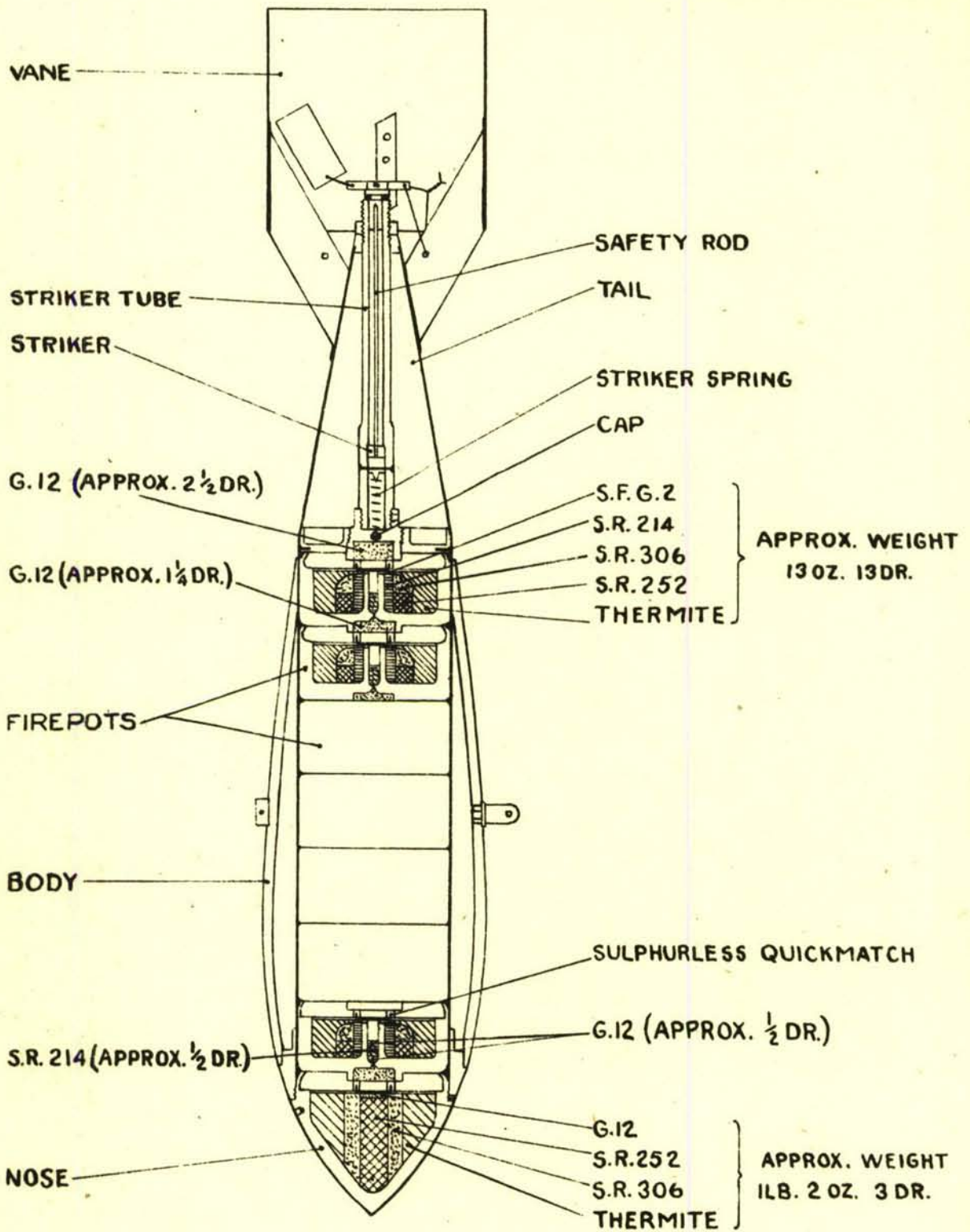

BOMB, INCENDIARY, A/C, 25 LB.

(BASED ON D.D.(L)6091B(1))

ADD 23/46

FIG. 34

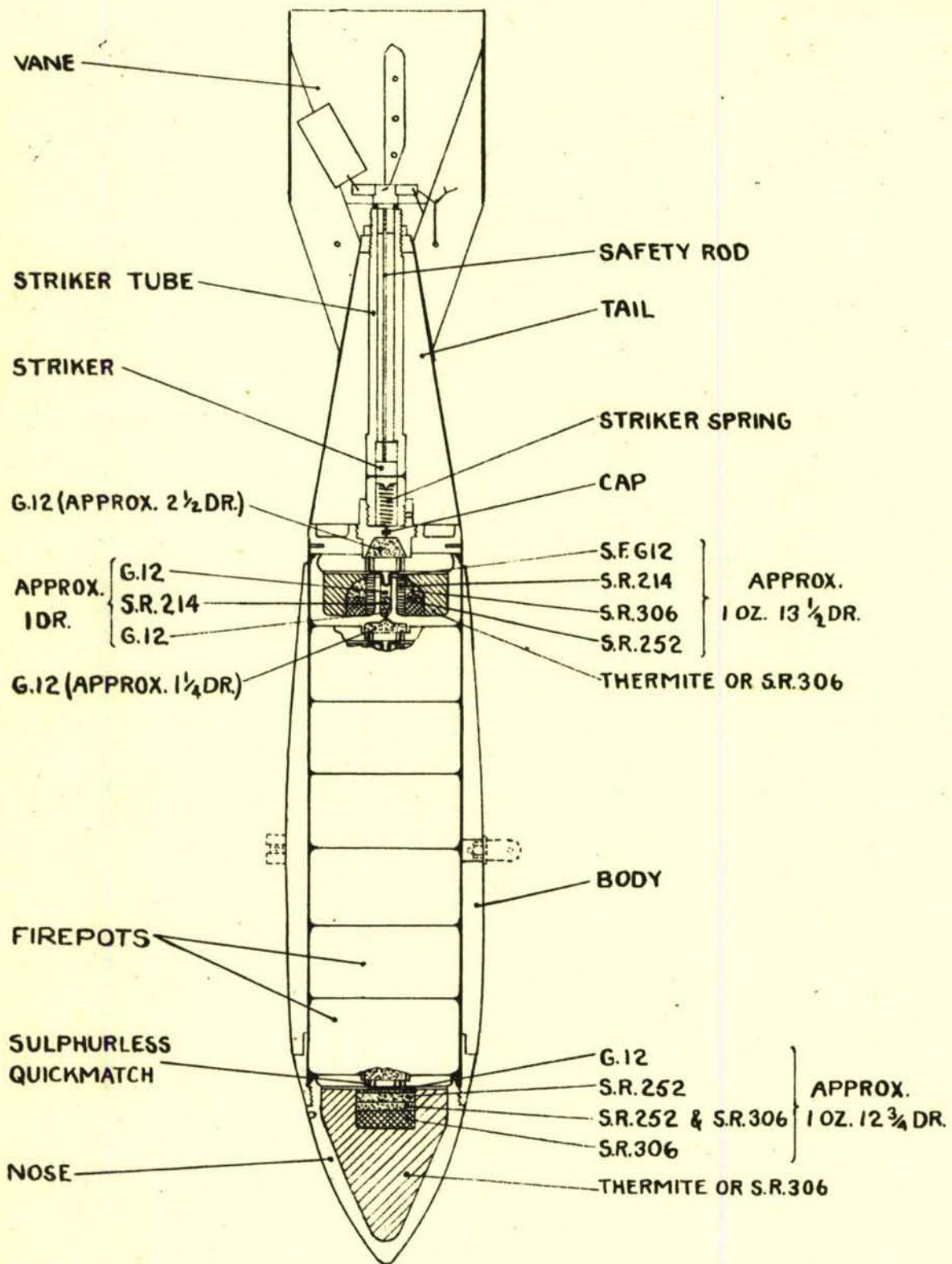

0 1 2 3 4  
SCALE INCHES

BOMB, INCENDIARY, A/C, 25LB.  
MK. I.

(BASED ON D.D.(L)7694)



FIG. 35

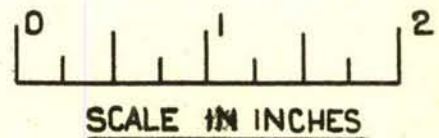
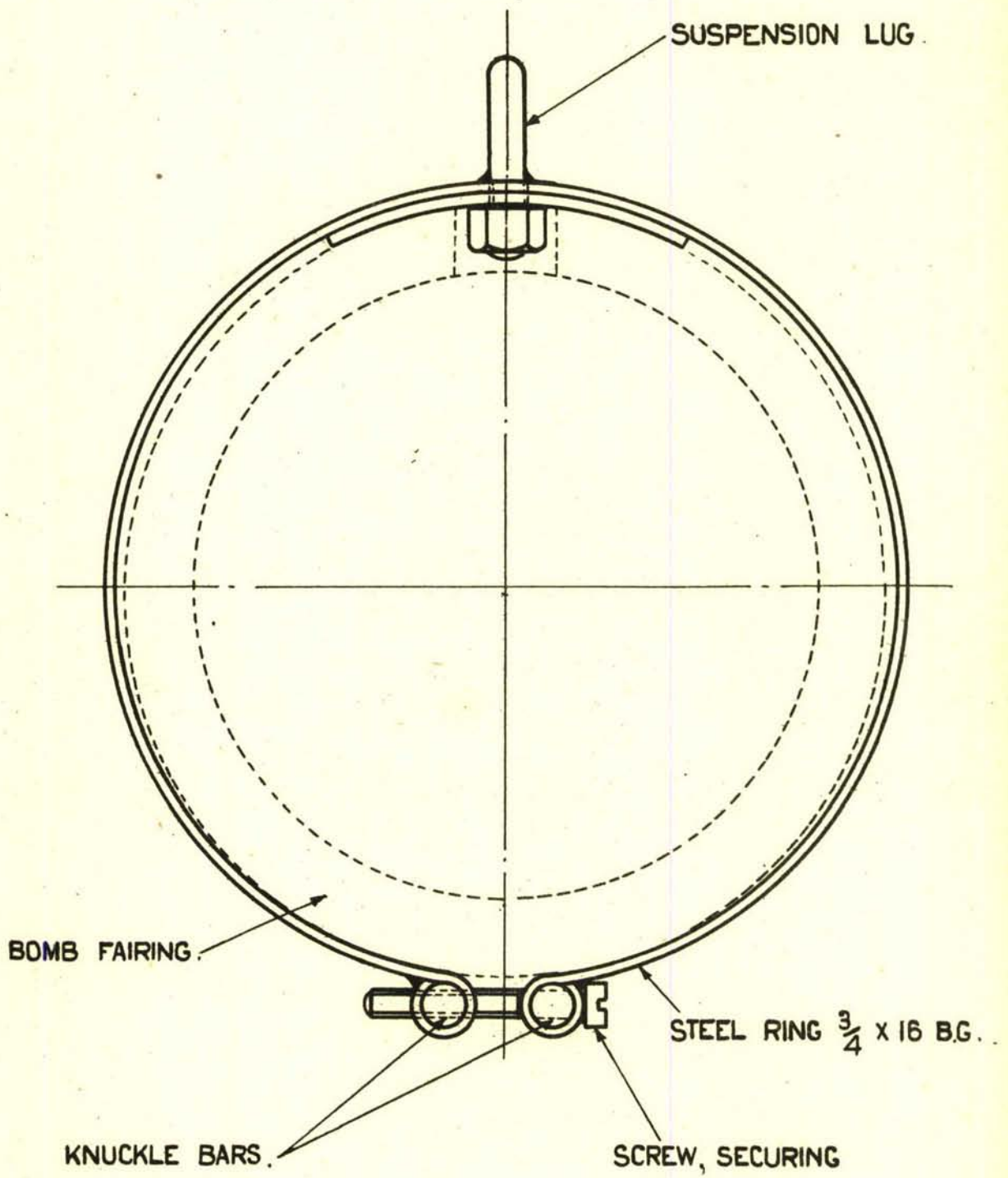

BOMB, INCENDIARY, A/C. 25 LB.  
MARK I. SUSPENSION BAND.

BASED ON :-  
D.D.(L) 7694  
5

ADD 23/46

FIG. 36

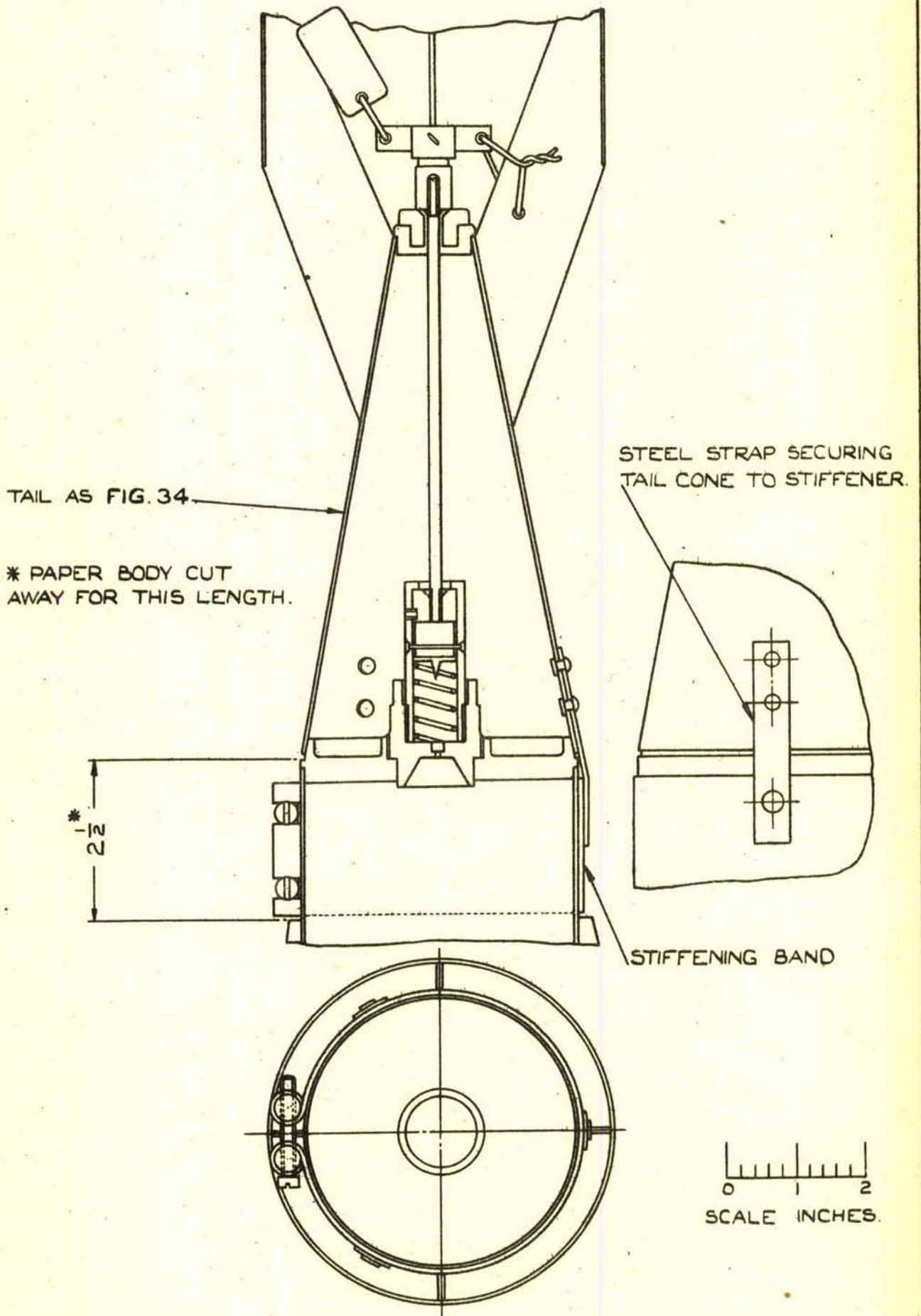

BOMB INCENDIARY A/C 25 LB. MK. I.  
MODIFIED TAIL CONE FIXING.

BASED ON:-  
D.D.(L) 9851

ADD 23/46.

FIG. 37

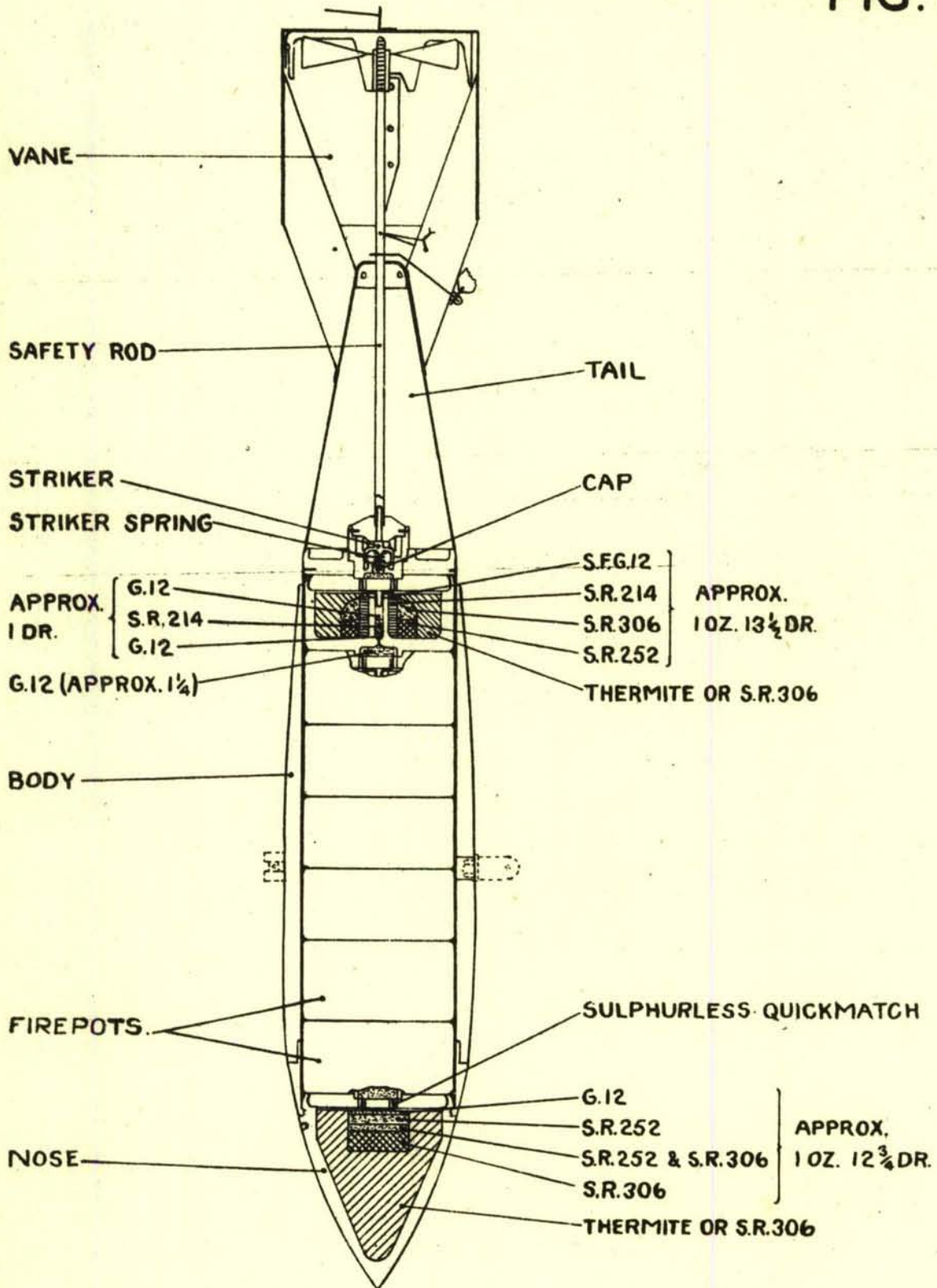

BOMB, INCENDIARY, A/C, 25LB.

MK. 2.

(BASED ON D.D.(L)11954)

FIG. 38

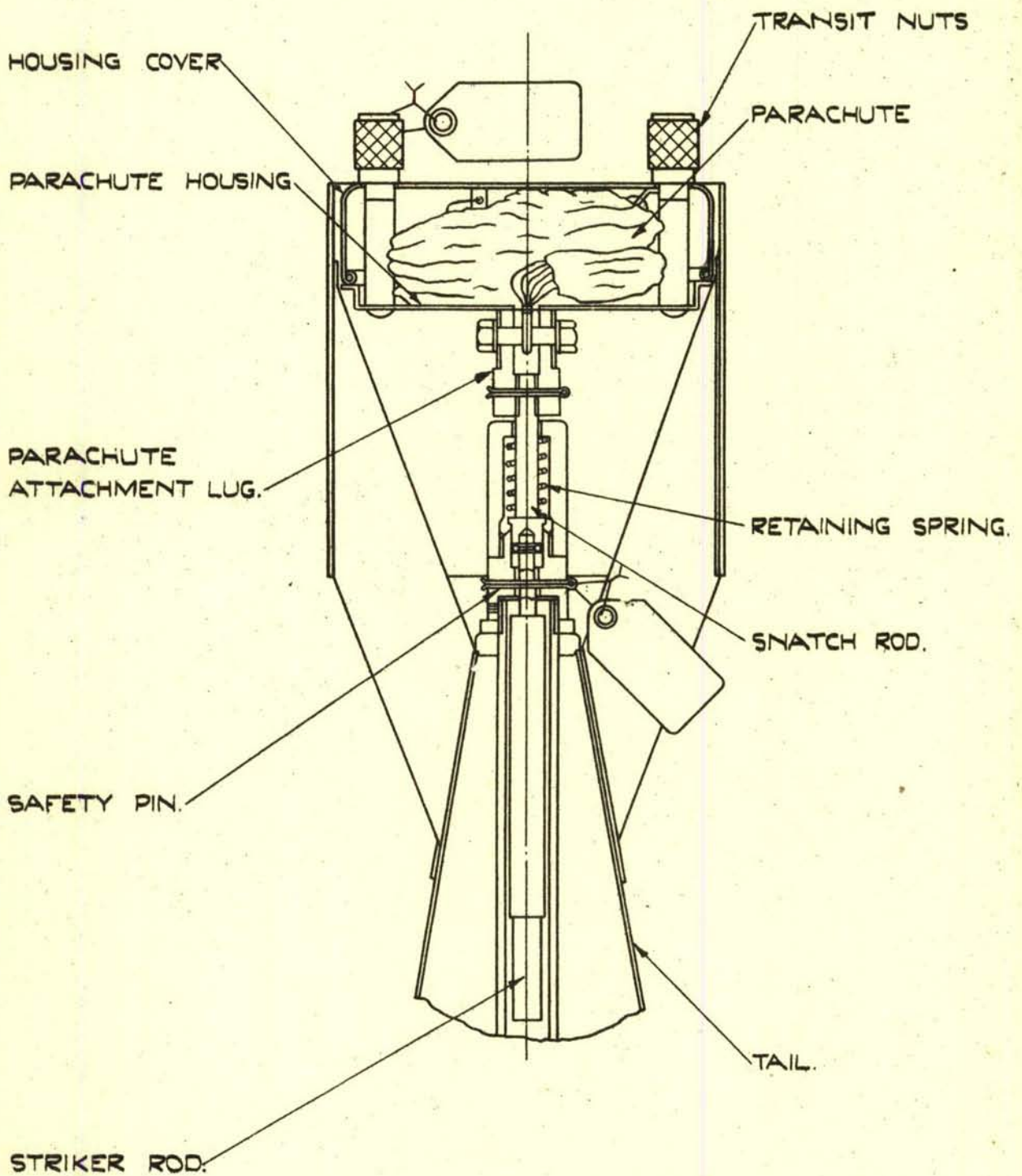

0 1 2  
SCALE :- INCHES

BOMB, INCENDIARY A/C 25 LB.  
PARACHUTE & STRIKER RELEASE.

BASED ON:  
ARM 2761

ADD 23/46

FIG. 39

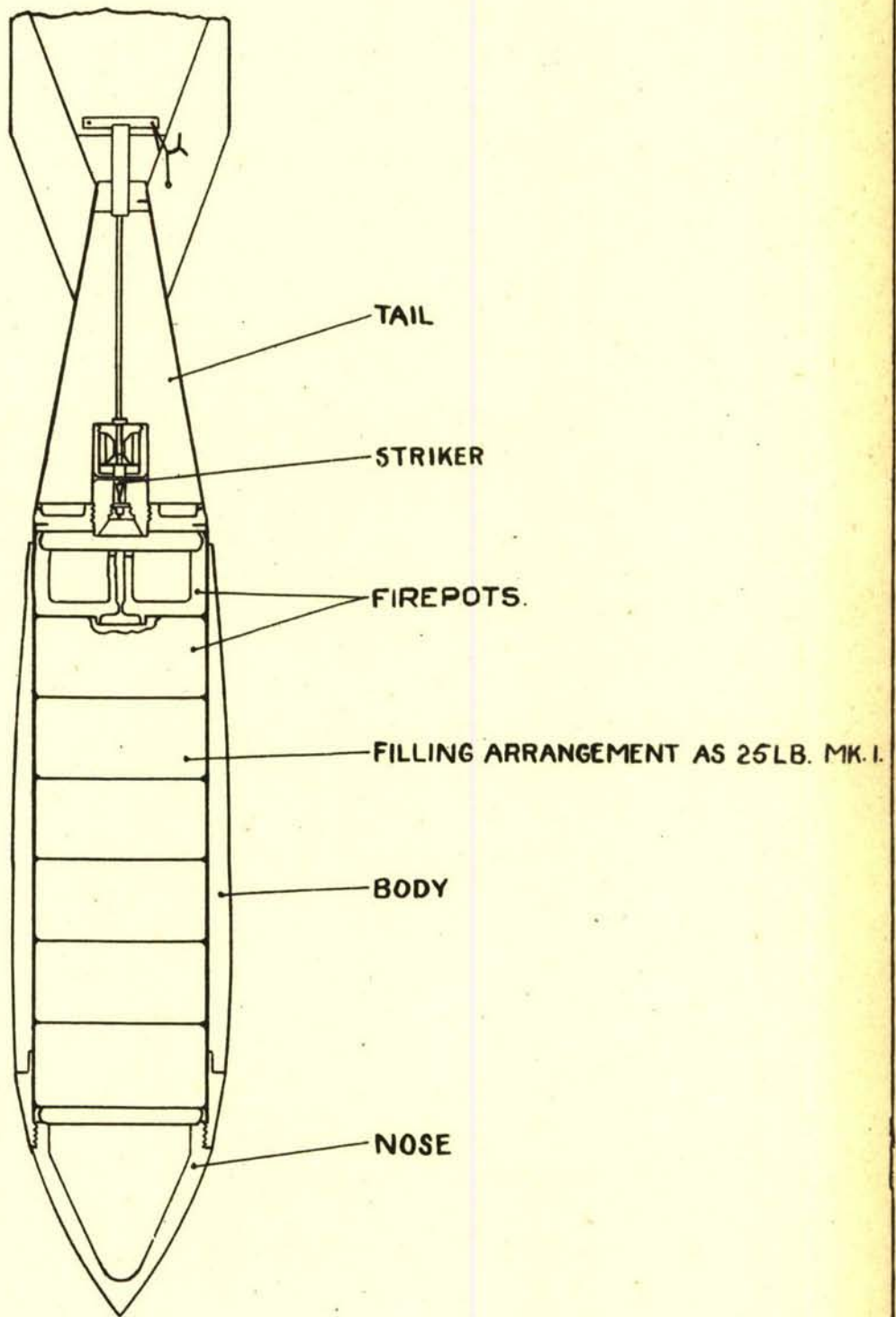

BOMB, INCENDIARY, A/C, 30LB.

(BASED ON D.D.(L)9894)

ADD 23/46

FIG. 40

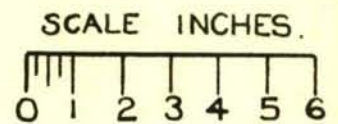
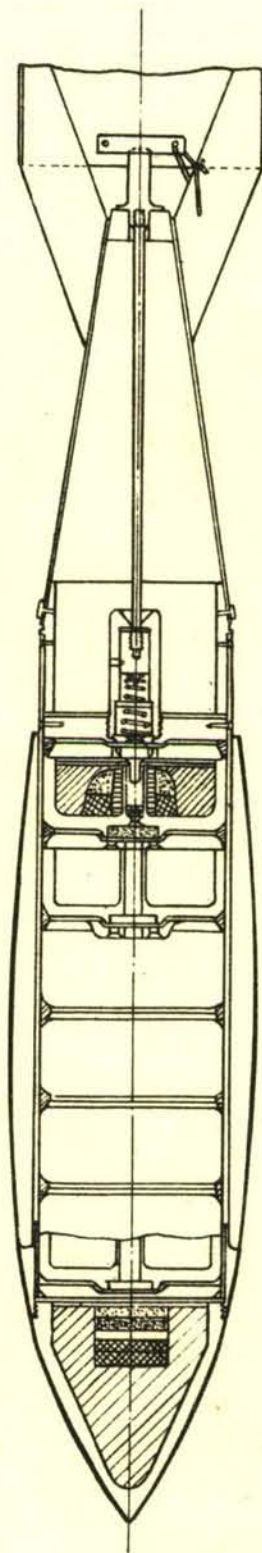

BOMB, INCENDIARY, A/C 30 LB.  
SIMULTANEOUS EJECTION.

(BASED ON DD(L) 9895)

**FIG. 41**

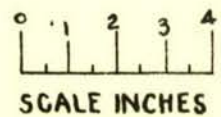
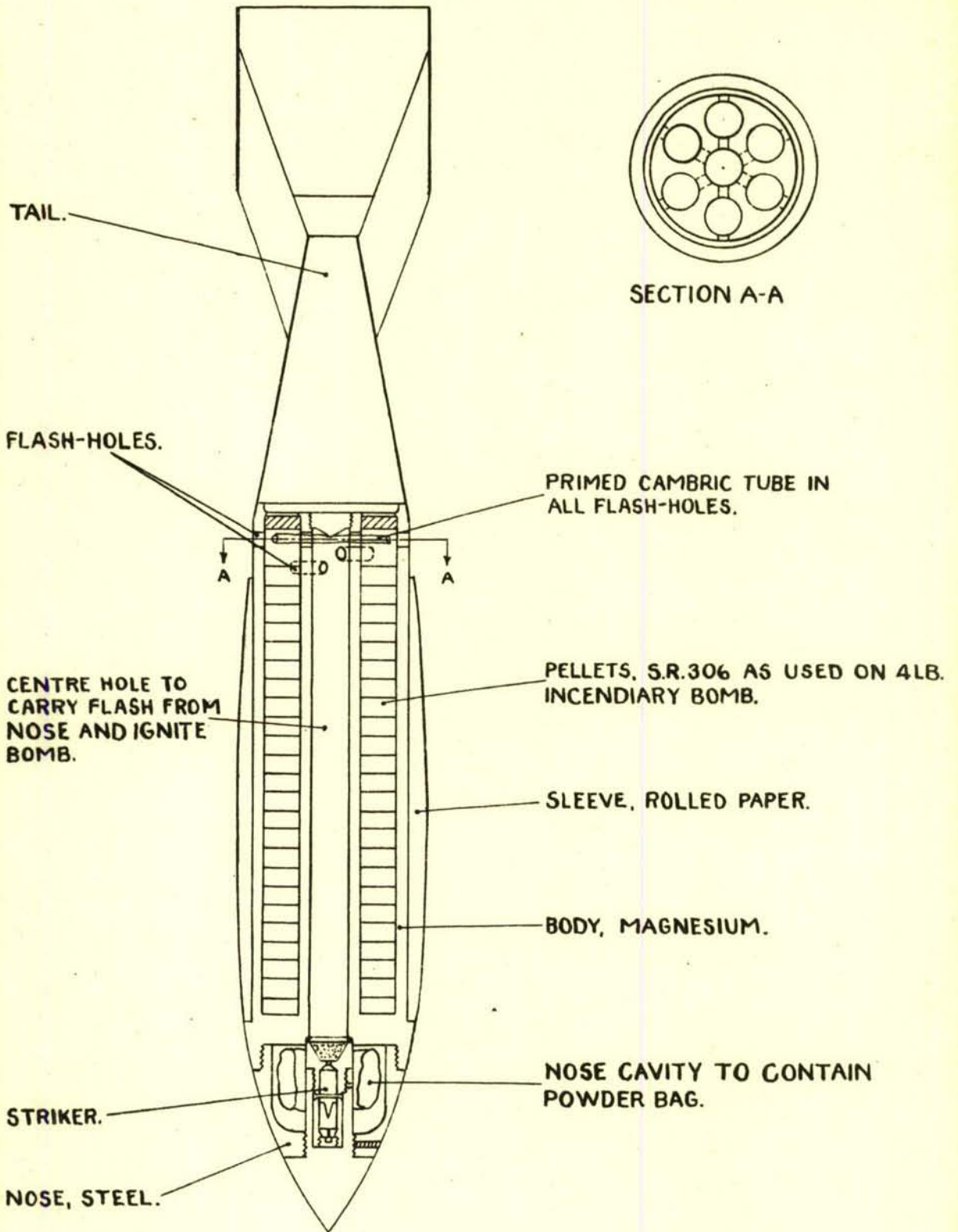

**BOMB, INCENDIARY, A/C, 30LB.**

**NON-EJECTION TYPE, NOSE IGNITION**

(BASED ON D.D.(L) 9896)

ADD 23/46

FIG. 42.

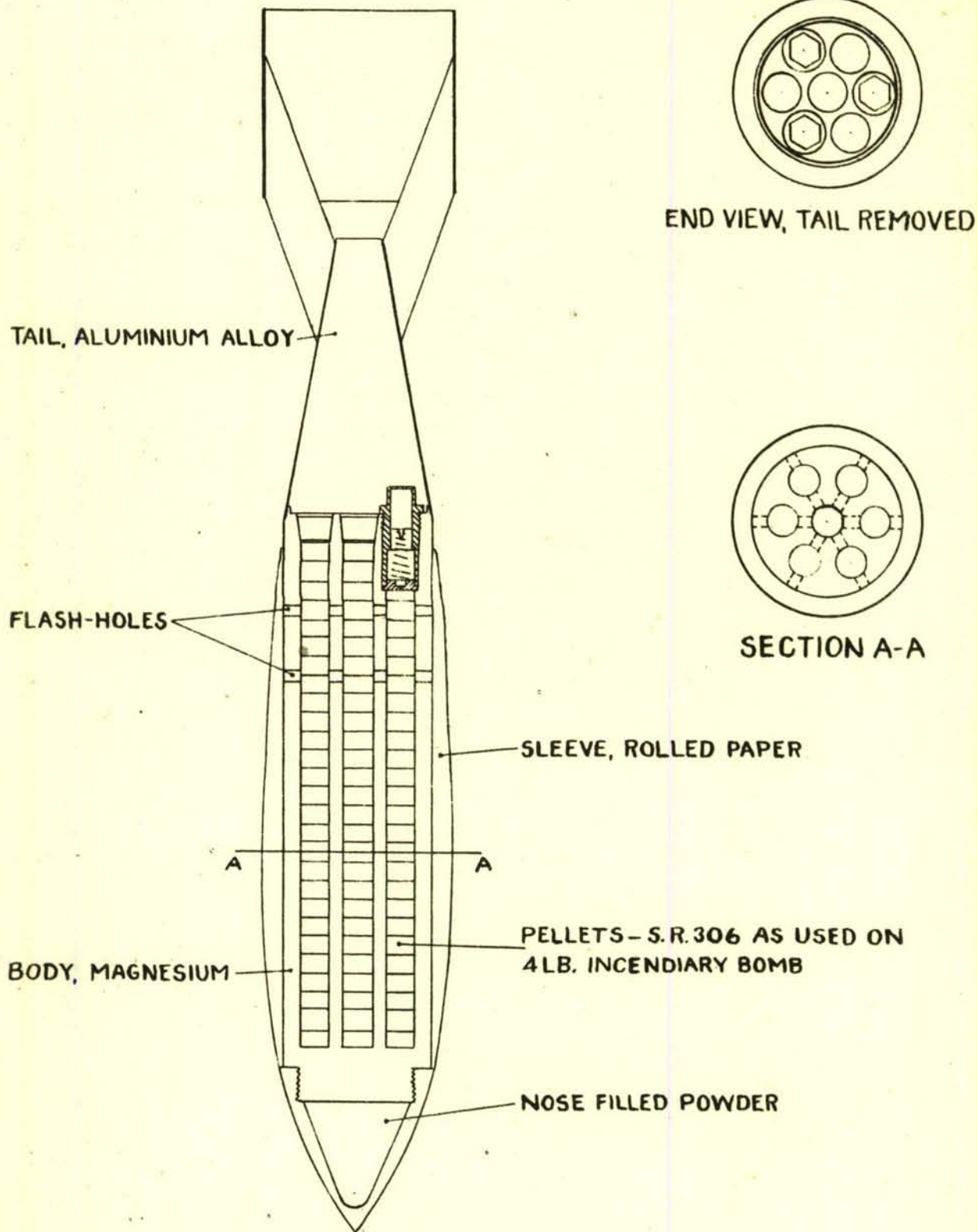

0 1 2 3 4  
SCALE INCHES

BOMB, INCENDIARY, A/C, 30LB.

NON-EJECTION, TAIL IGNITION

(BASED ON D.D.(L)9897)

ADD 23/46



FIG. 43.

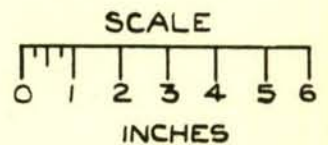
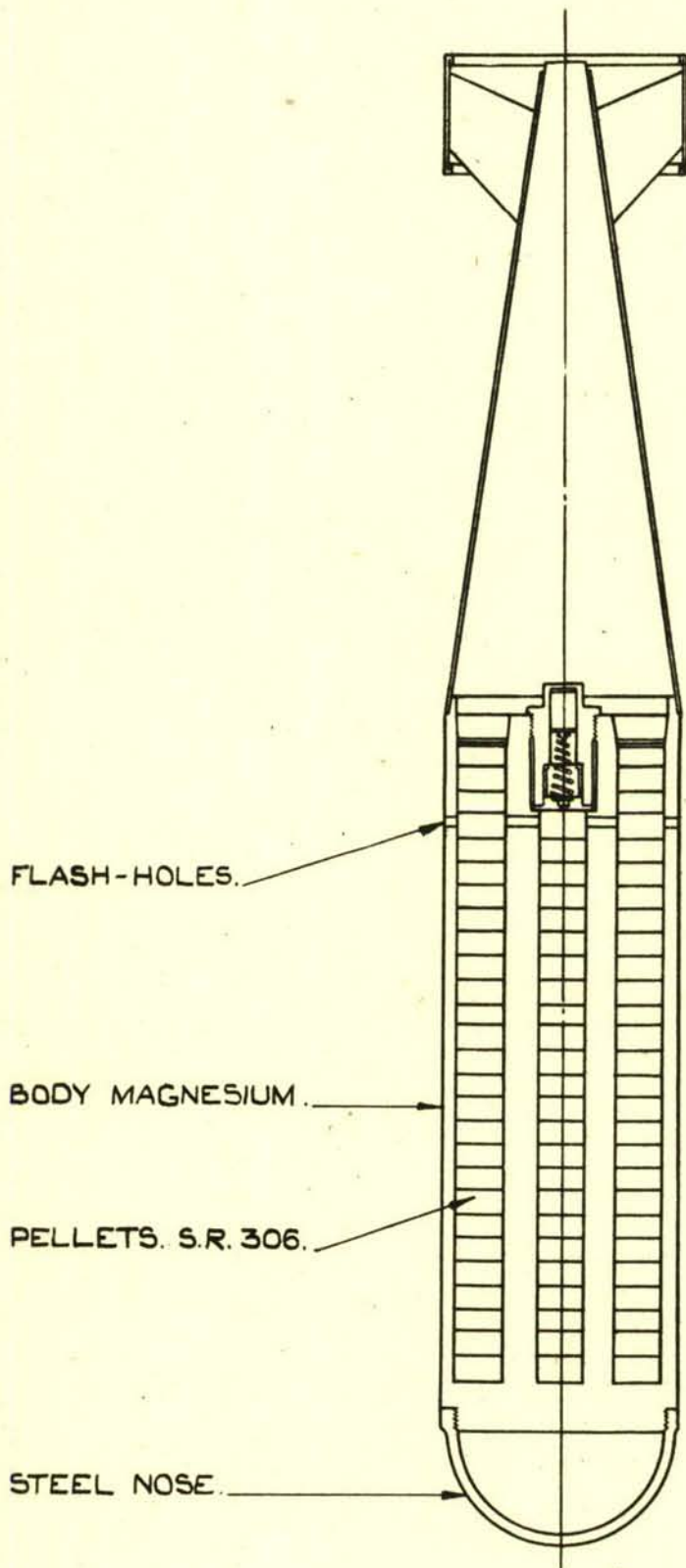

BOMB, INCENDIARY, A/C 30 LB.  
NON-EJECTION TAIL IGNITION.

BASED ON :-  
D.D(L)9898

**FIG.44.**

ESTIMATED WEIGHTS	
BOMB (EMPTY).....	17.29
FILLING.....	11.22
TOTAL.....	<u>28.51</u>
6%.....	1.03
1%.....	.30
PAINT.....	.16
MAX. TOTAL	<u>30.00</u>

RATIO  $C^6/L = .29$

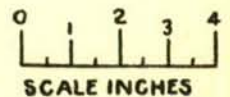
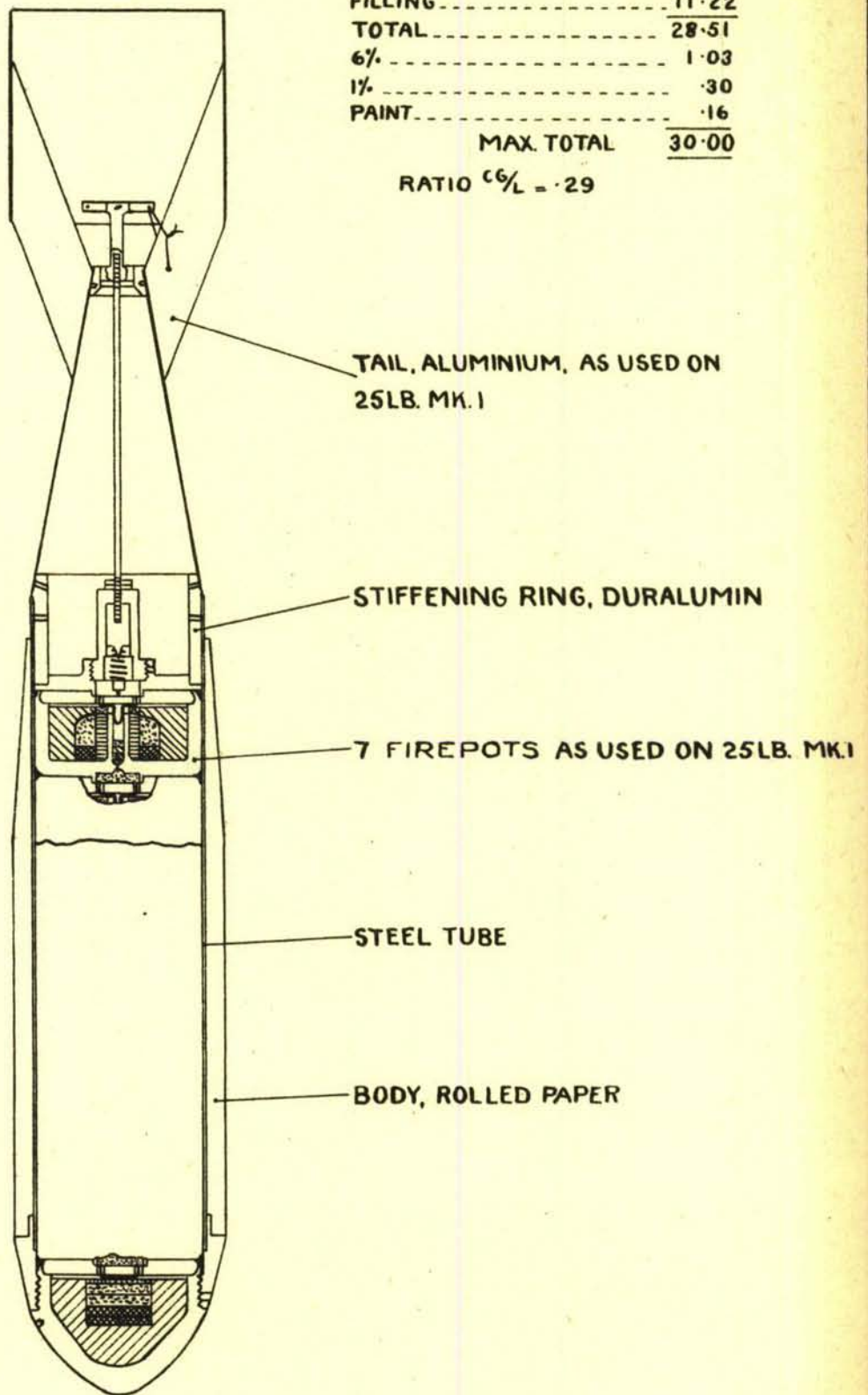

**BOMB, INCENDIARY, A/C, 30LB. SINGLE  
EJECTION.**

(BASED ON D.D.(L)9895A)

ADD 23/46

FIG. 45.

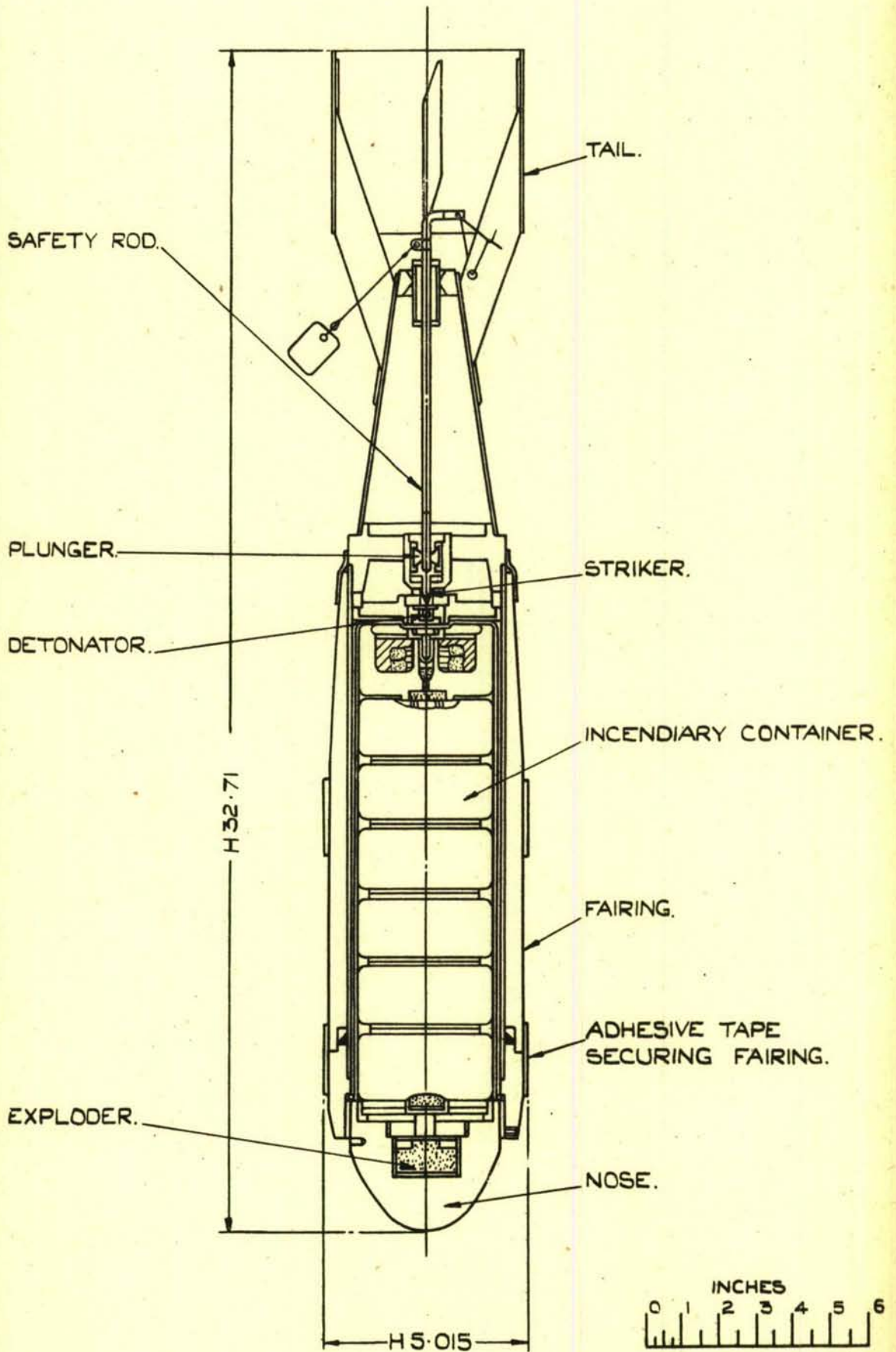

**BOMB, INCENDIARY, A/C 40 LB. MK. I.**

BASED ON:-  
D.D. (L) 10392

ADD 23/46

FIG. 46.

2" SQ. HOLE CUT IN  
PAPER FAIRING

SUSPENSION LUG  
SIMILAR TO 40LB.  
G.P. BOMB, SECURED  
BY 4 SPOT WELDS  
.25 DIA.

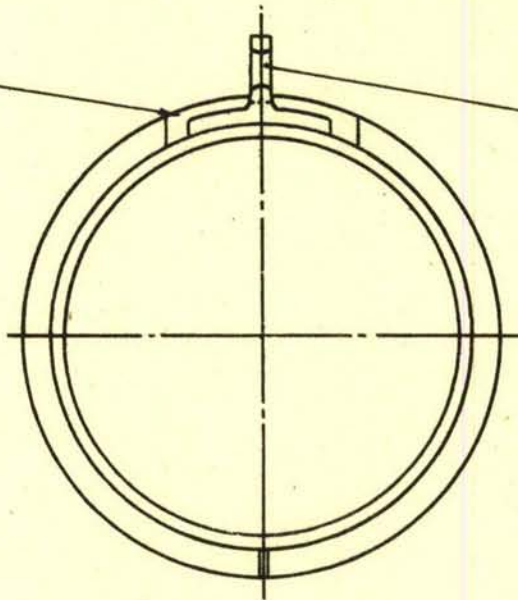

A

EYE BOLT

KNUCKLE BARS

SECURING SCREW

$\frac{3}{4}$ " x 18 B.G. STEEL BAND

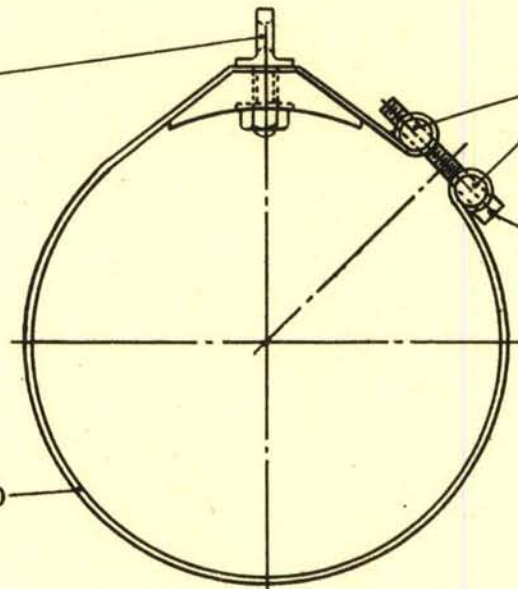

B

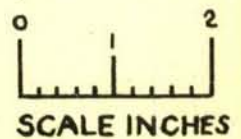

SCALE INCHES

ALTERNATIVE SUSPENSION  
ARRANGEMENTS FOR 40LB.  
INCENDIARY BOMB.

(BASED ON D.D.(L)10584  
& D.D.(L)10664A)

ADD 23/46

FIG. 47.

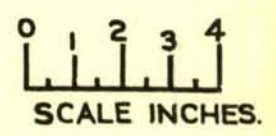
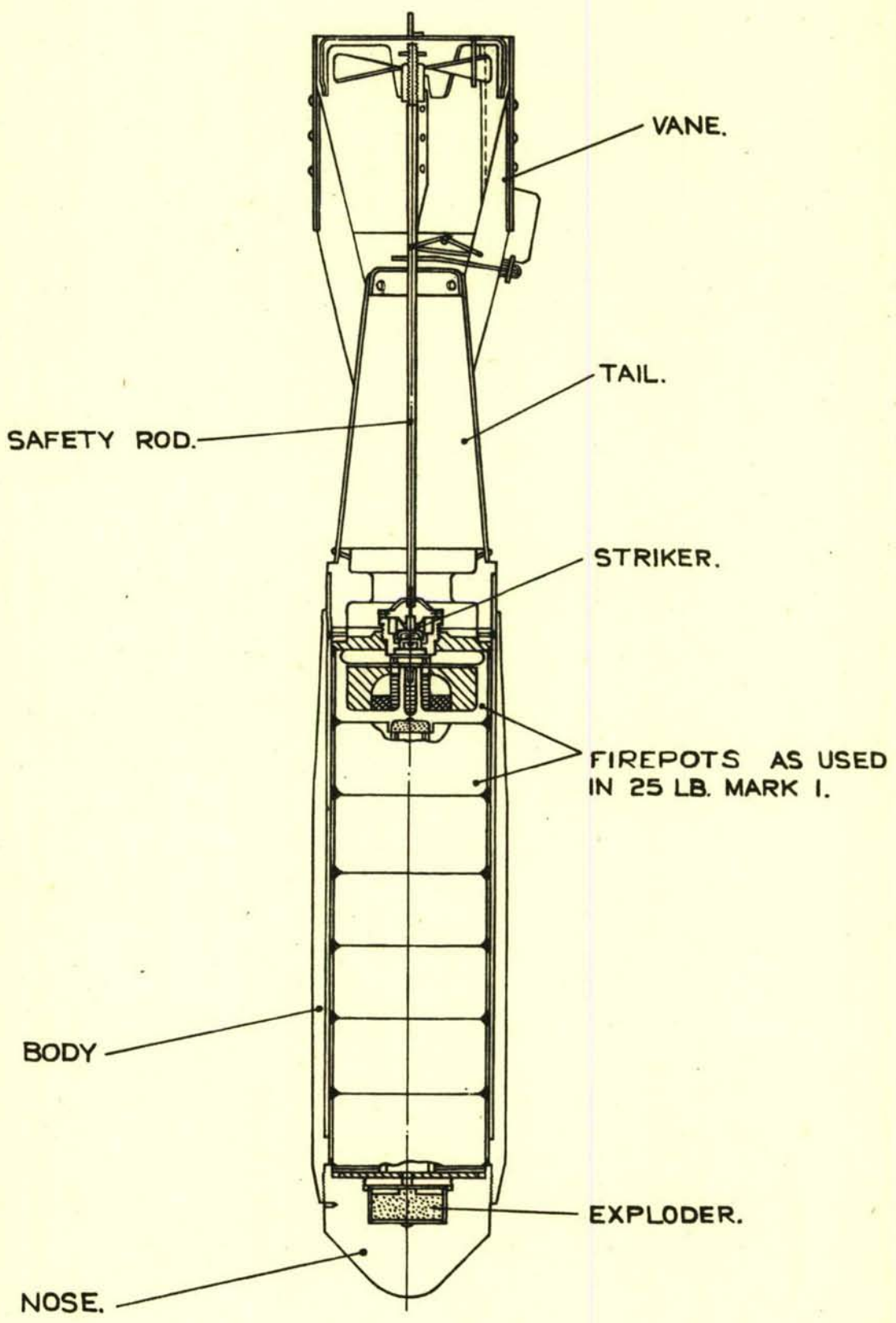

BOMB, INCENDIARY, A/C, 40 LB. MK2

(BASED ON  
D.D.(L)13011.)

FIG. 48.

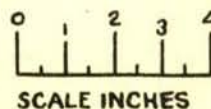
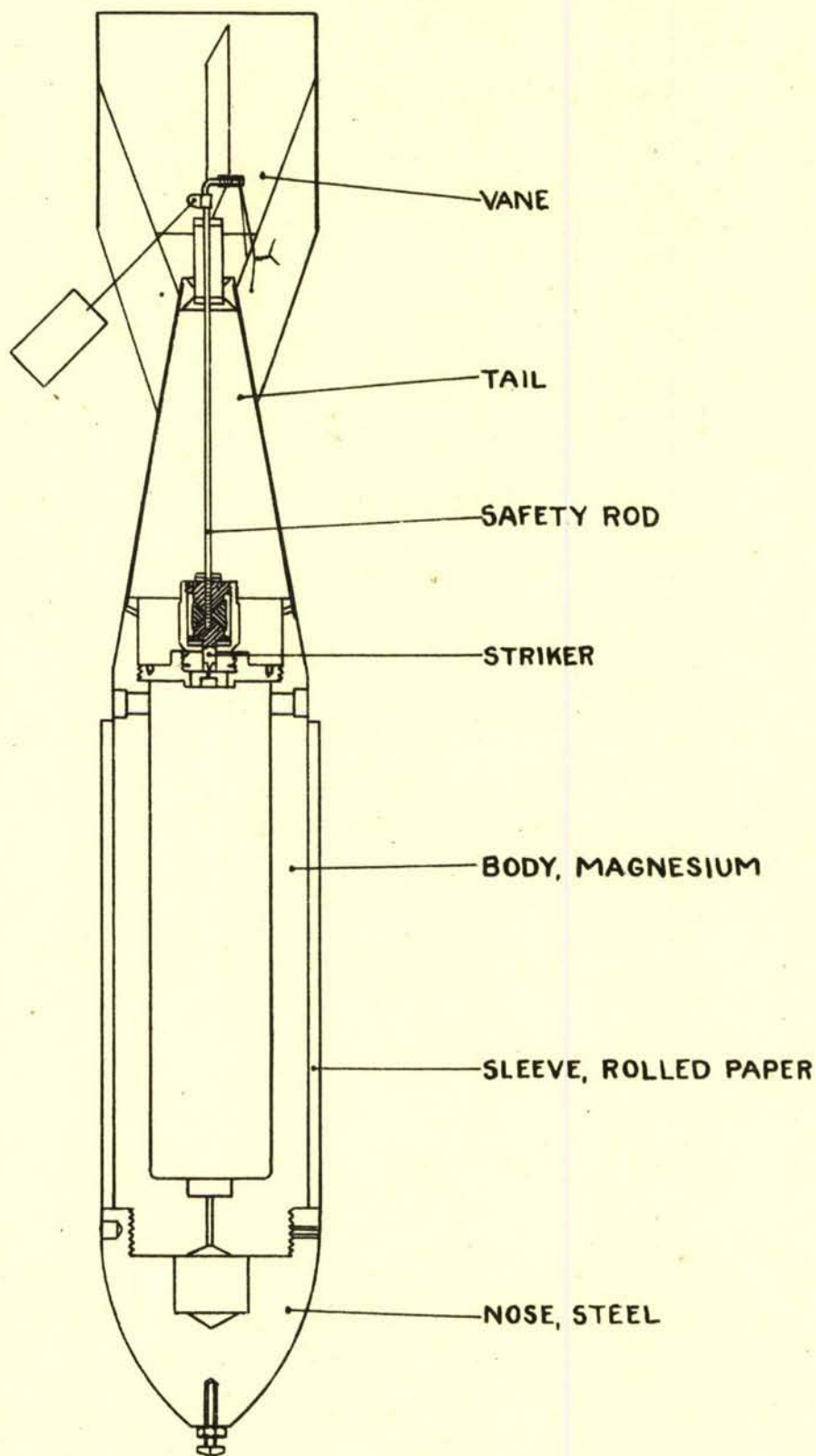

SCALE INCHES

BOMB, INCENDIARY, A/C, 32LB.

(BASED ON DD(L)9981A)

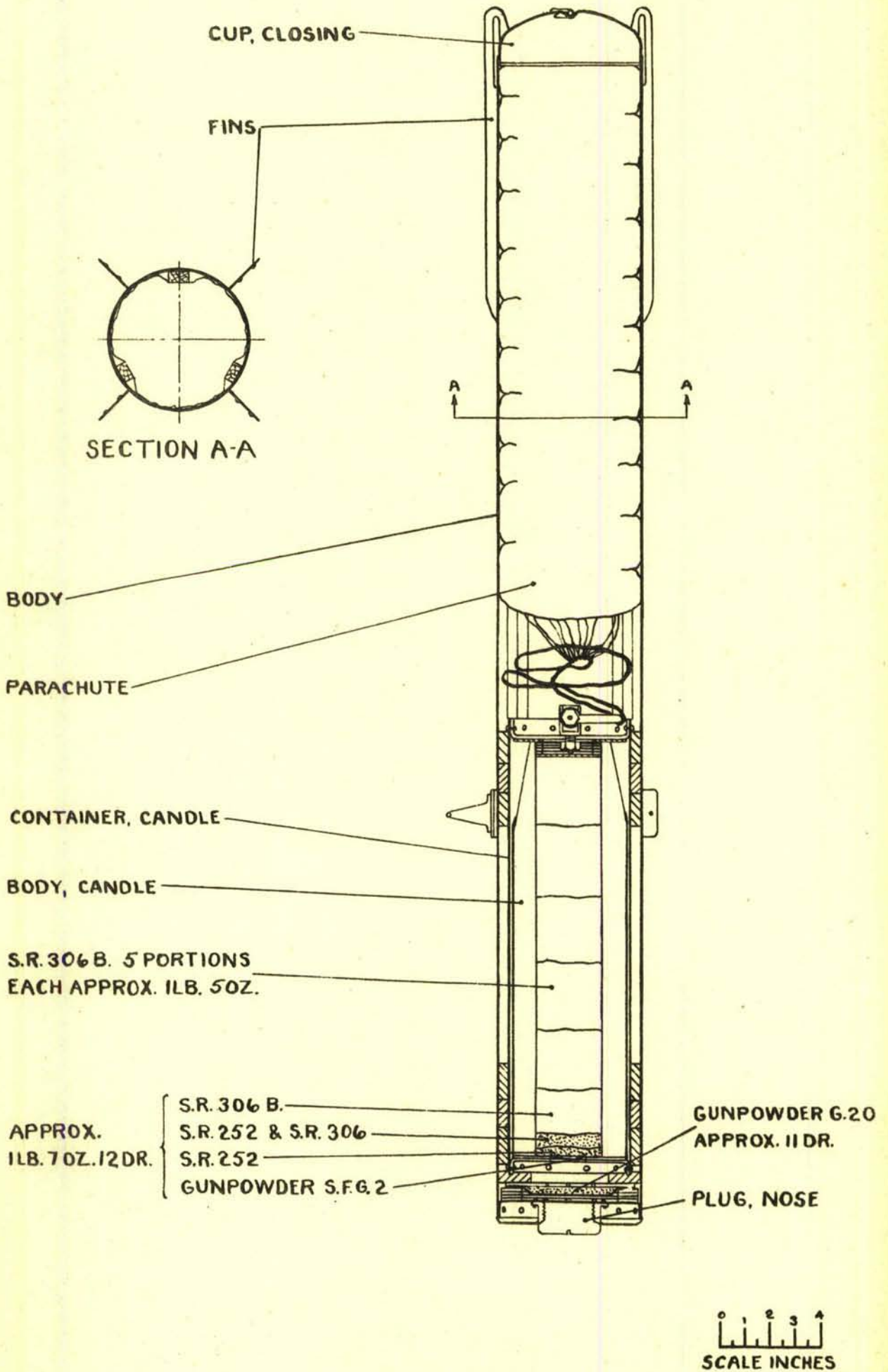

**BOMB, PARACHUTE, INCENDIARY,  
A/C, 50LB. MK I.**

(BASED ON D.D.(L)10034)

ADD 23/46

FIG. 50

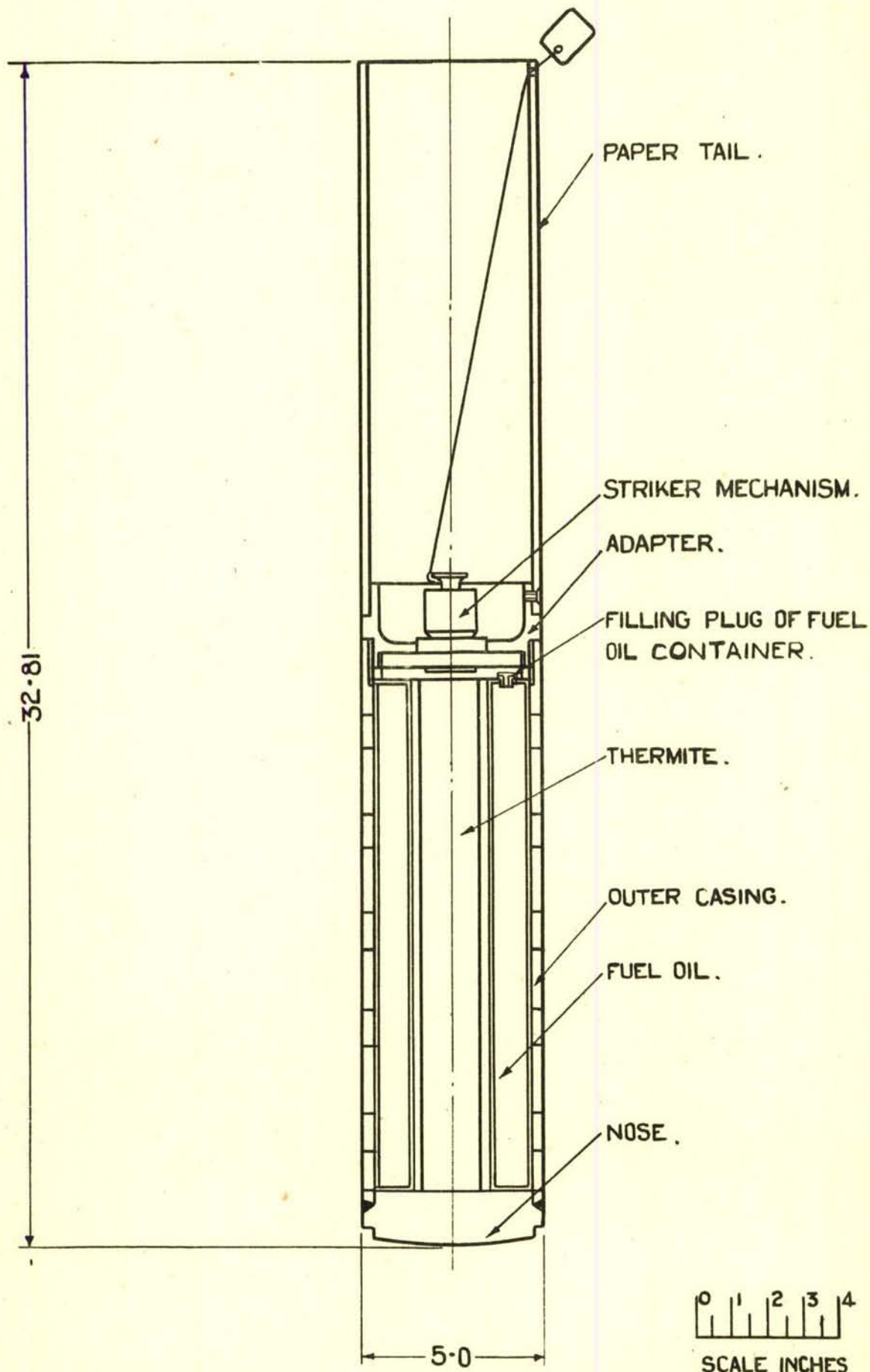

BOMB, INCENDIARY, A/C. 40 LB.  
FILLED FUEL OIL & THERMITE.

BASED ON :-  
D. D. (L) 10772

ADD 23/46



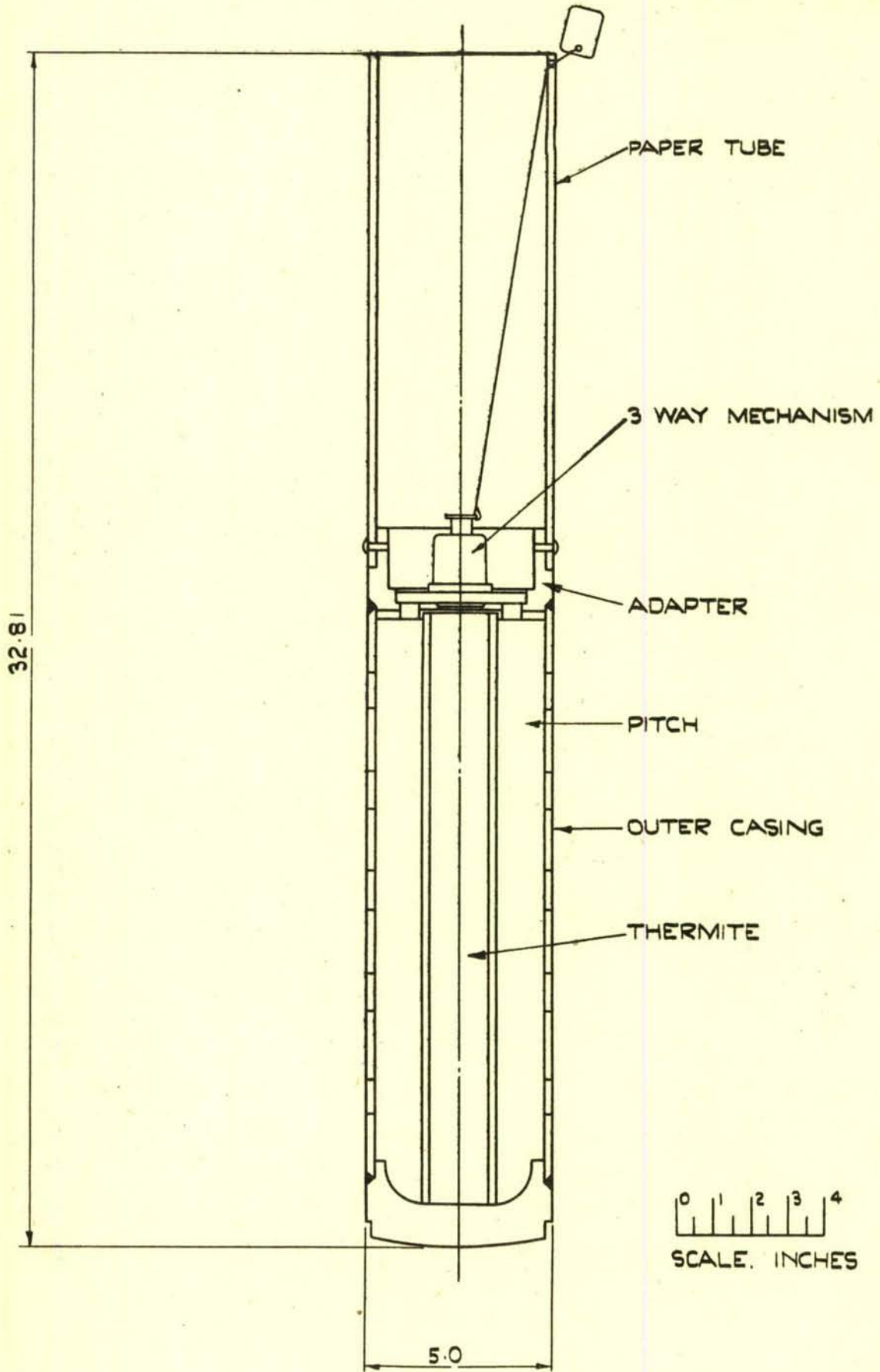

**BOMB. INCENDIARY. A/C 37 LB.**  
**FILLED THERMITE & PITCH.**

BASED ON:-  
D.D.(L) 10775.

ADD. 23/46.

FIG. 52

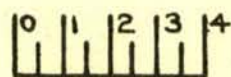
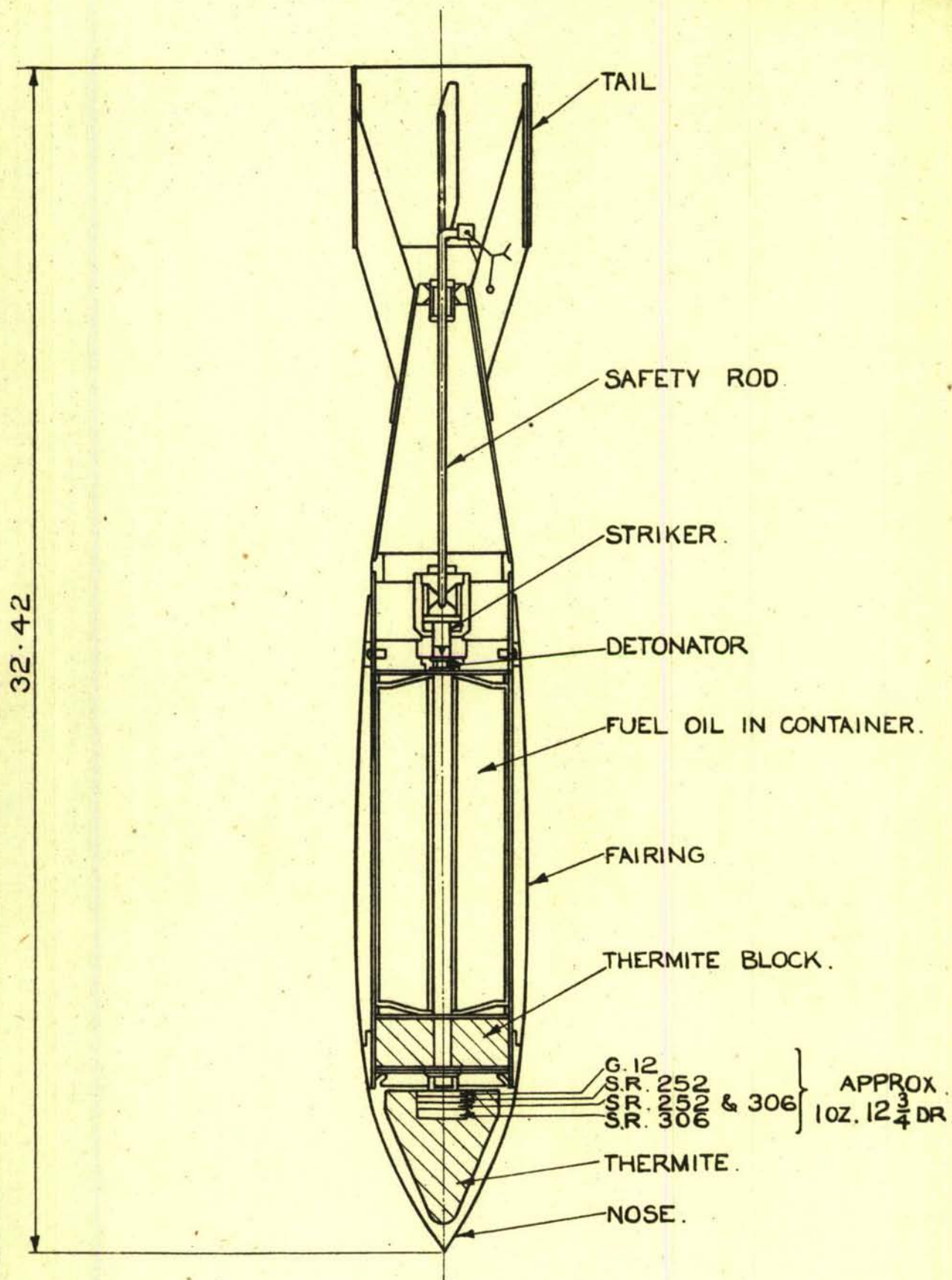

SCALE. INCHES.

**BOMB, INCENDIARY, A/C. 21 LB.**

**FILLED, THERMITE & FUEL OIL.**

BASED ON :-

D.D.(L)10406 A.

ADD 23/46

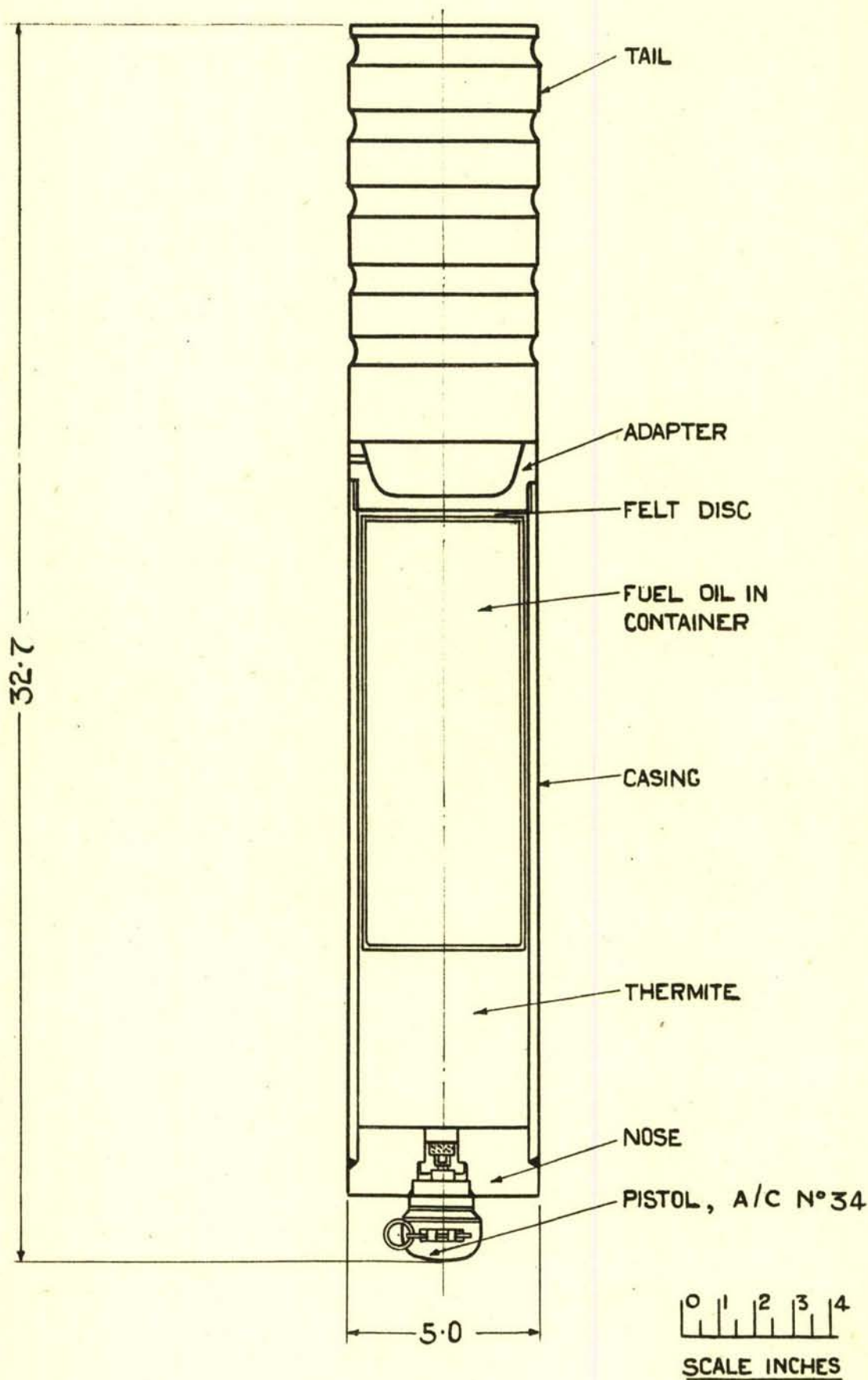

BOMB, INCENDIARY, A/C. 43 LB.  
FILLED FUEL OIL & THERMITE.

BASED ON :-  
D.D.(L) 10952

ADD 23/46

FIG. 54

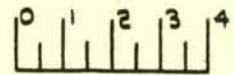
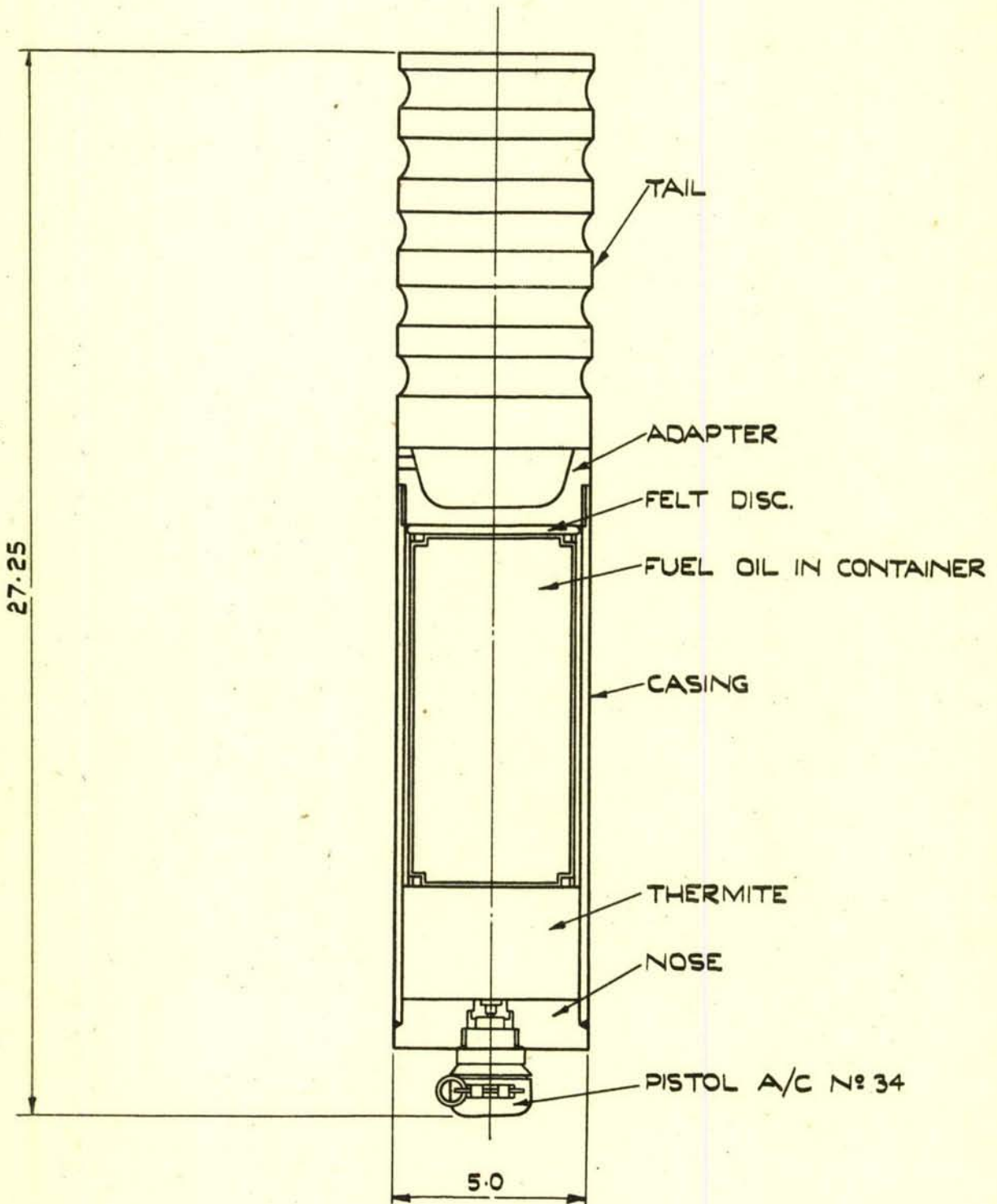

SCALE - INCHES

**BOMB. INCENDIARY A/C 33 1/2 LB.**  
**FILLED THERMITE & FUEL OIL.**

BASED ON:-  
D.D.(L) 10951

FIG. 55

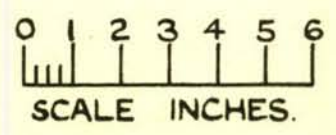
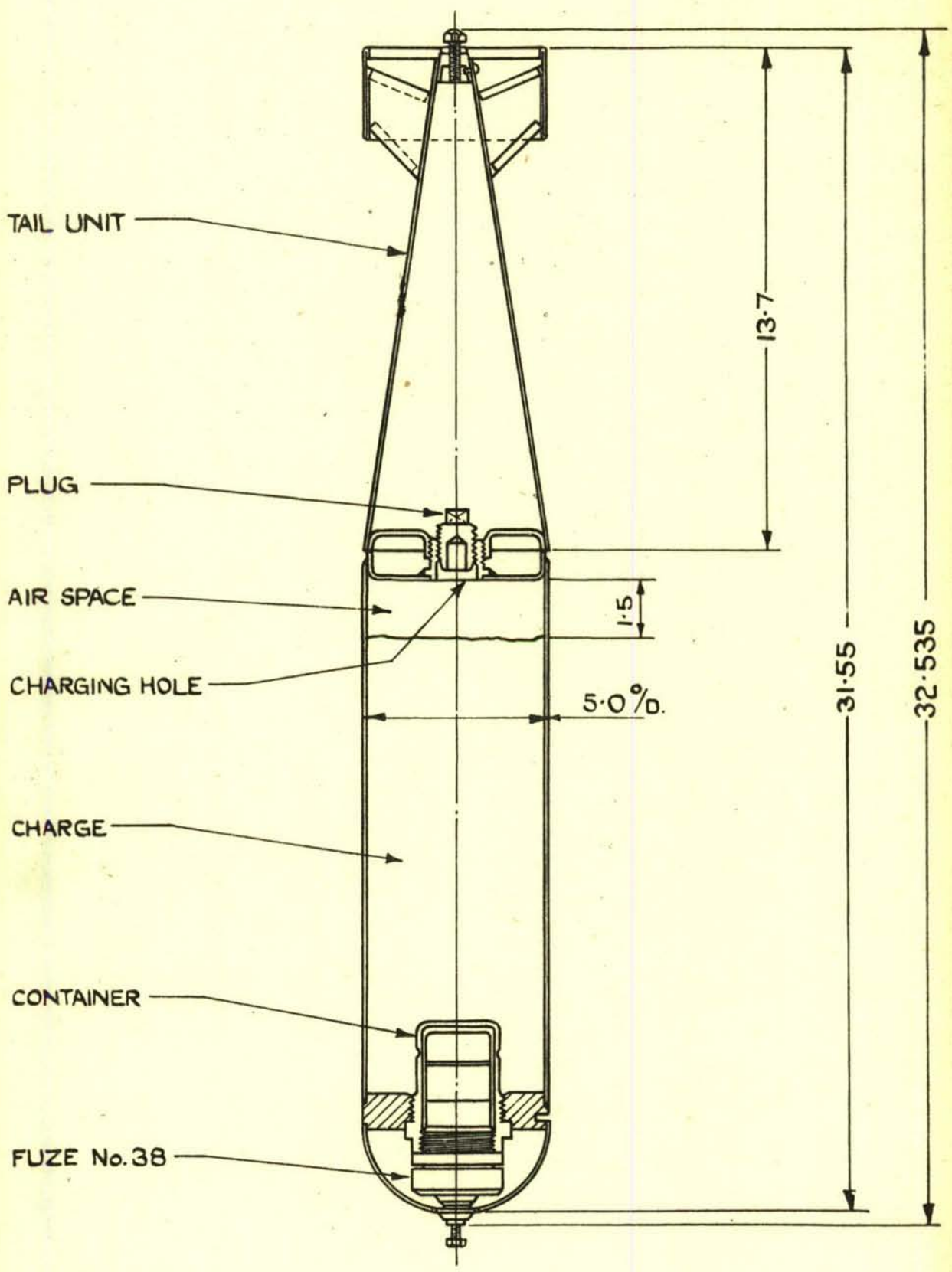

BOMB, AIRCRAFT L.C. 30 LB. MK. I.

BASED ON D.D.(L) 8839

FIG. 56

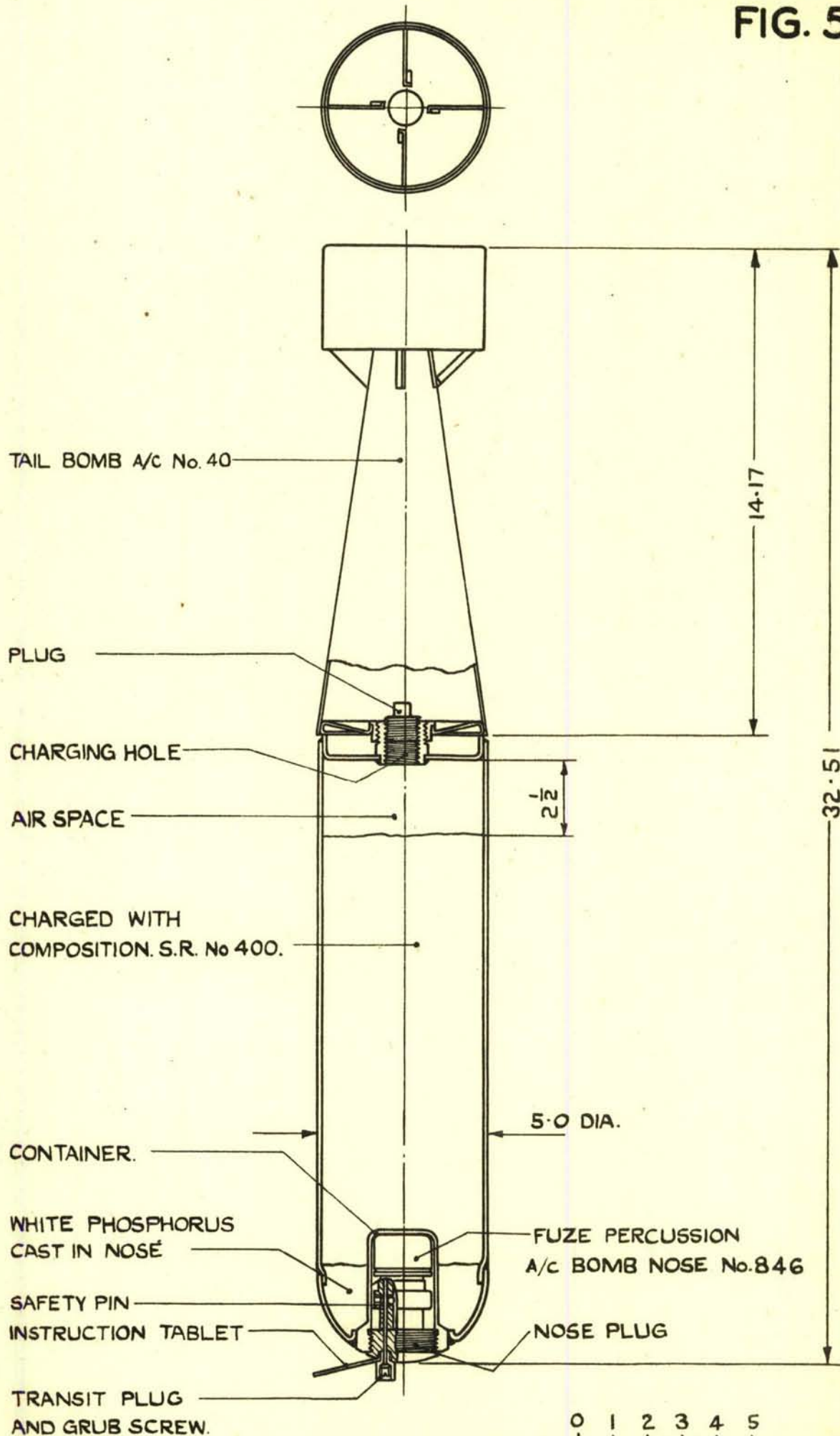

**BOMB INCENDIARY A/C 30 LB. MK II.**

(BASED ON DD.(L)13066)

ADD 23/46

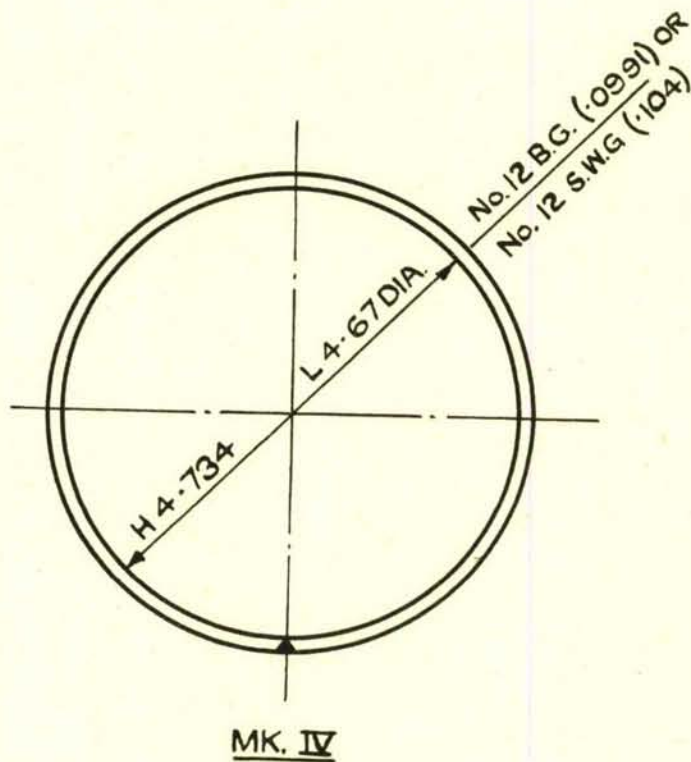
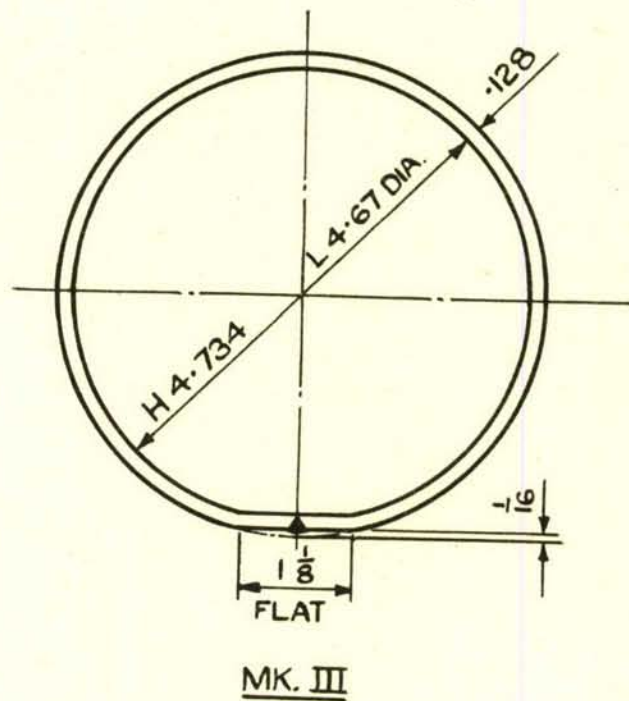

BOMB, INCENDIARY A/C 30 LB. MK III & IV  
CROSS SECTION OF BODIES.

FIG. 58

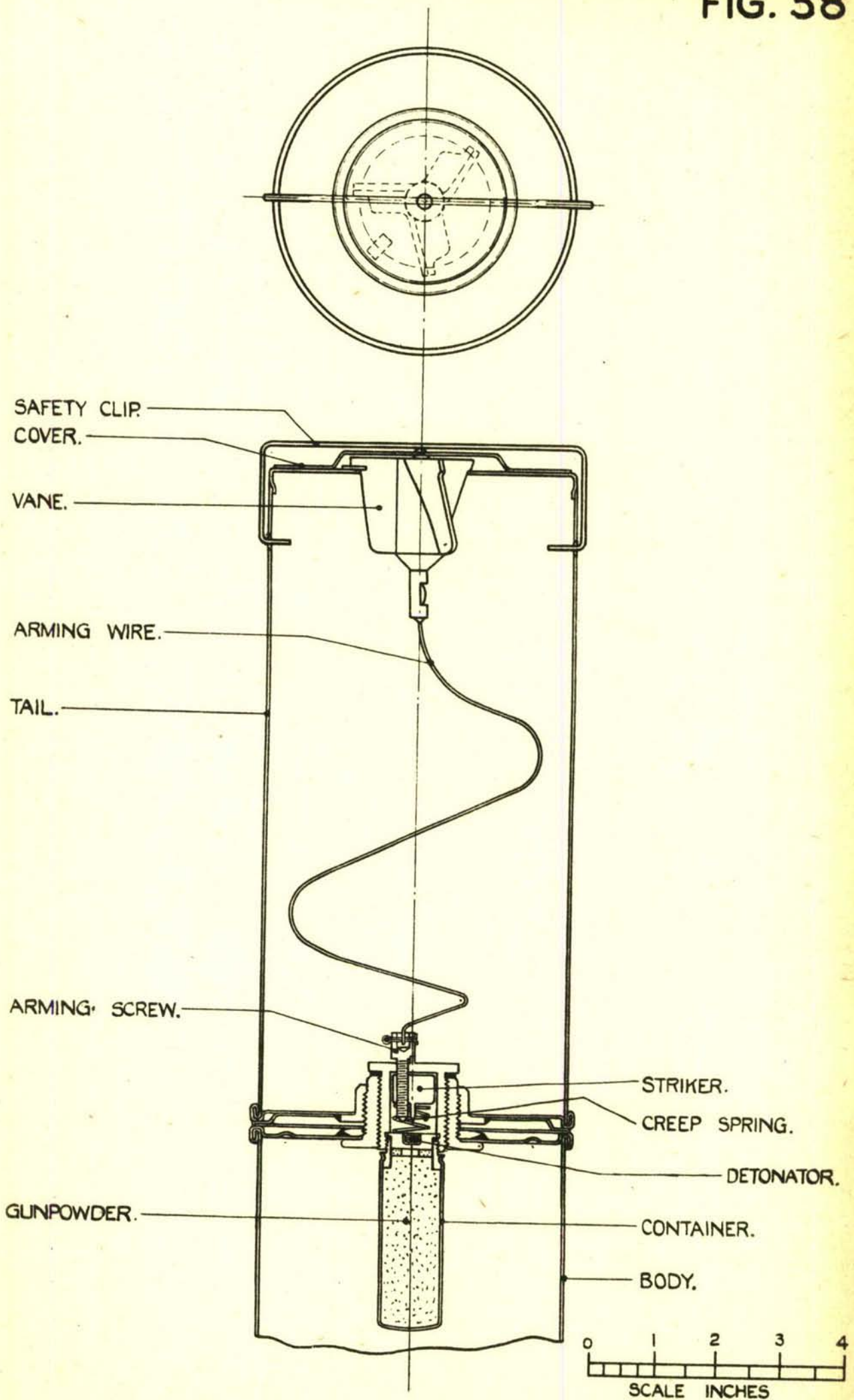

IGNITER FOR BOMB A/C L.C. 30LB. MKII

BASED ON  
D.D.(L)10490 & 13646



FIG. 59

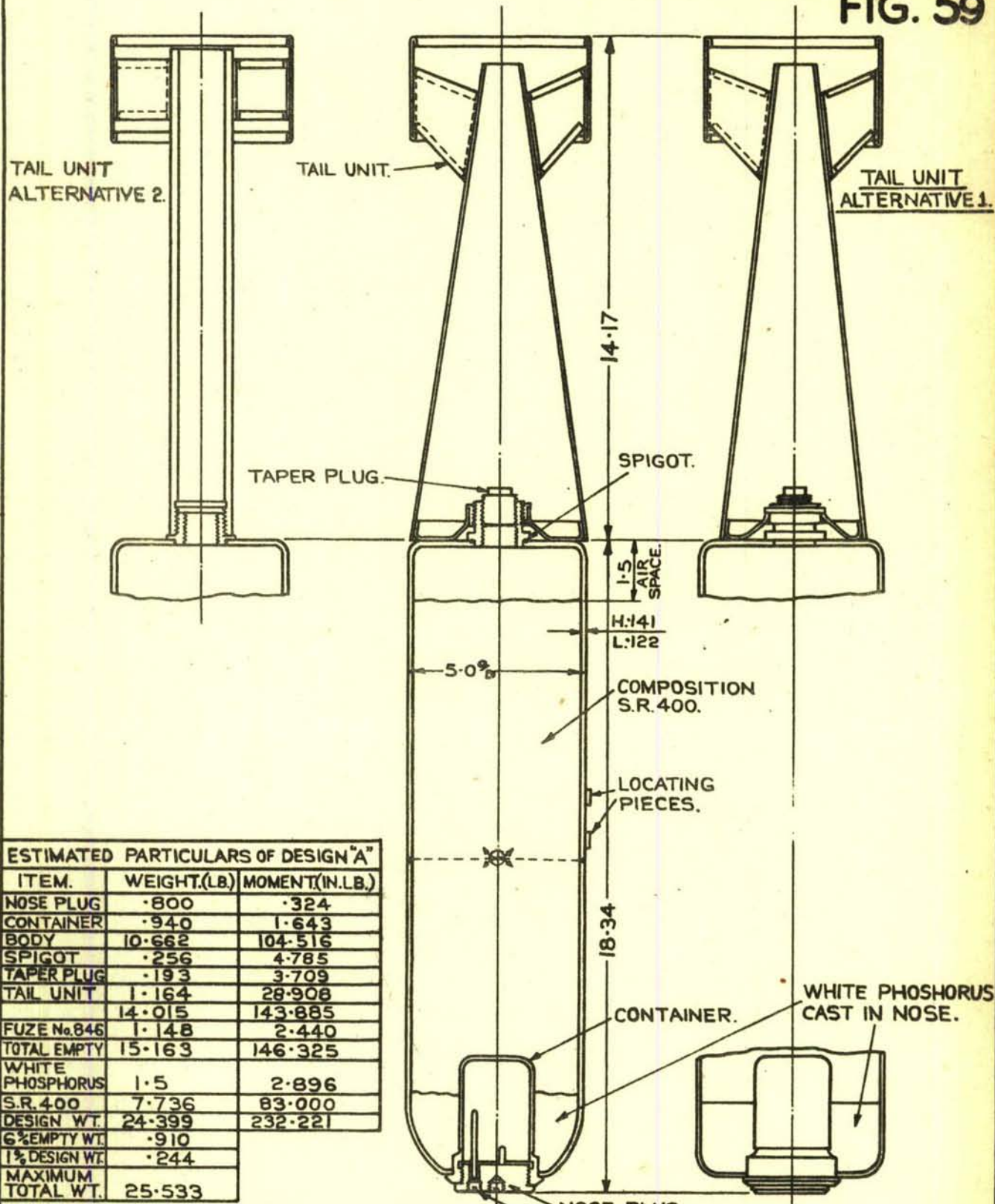

ESTIMATED PARTICULARS OF DESIGN "A"

ITEM.	WEIGHT.(LB.)	MOMENT(IN.LB.)
NOSE PLUG	.800	.324
CONTAINER	.940	1.643
BODY	10.662	104.516
SPIGOT	.256	4.785
TAPER PLUG	.193	3.709
TAIL UNIT	1.164	29.908
	14.015	143.885
FUZE No.846	1.148	2.440
TOTAL EMPTY	15.163	146.325
WHITE PHOSPHORUS	1.5	2.896
S.R. 400	7.736	83.000
DESIGN WT.	24.399	232.221
6% EMPTY WT.	.910	
1% DESIGN WT.	.244	
MAXIMUM TOTAL WT.	25.533	

C.G. FROM NOSE PLUG	$\frac{233.22}{24.4} = 9.52$
C.G. FROM NOSE PLUG WITH FILLING FORWARD	$\frac{227.35}{24.4} = 9.32$
C.G. FROM NOSE PLUG WITH FILLING BACKWARD	$\frac{236.023}{24.4} = 9.67$

DESIGN A.

ALTERNATIVE CONSTRUCTION OF BODY.

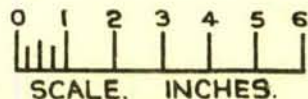

PROPOSED 30 LB. INCENDIARY BOMB.

(BASED ON D.D.(L)13279)

ADD 23/46

FIG. 60

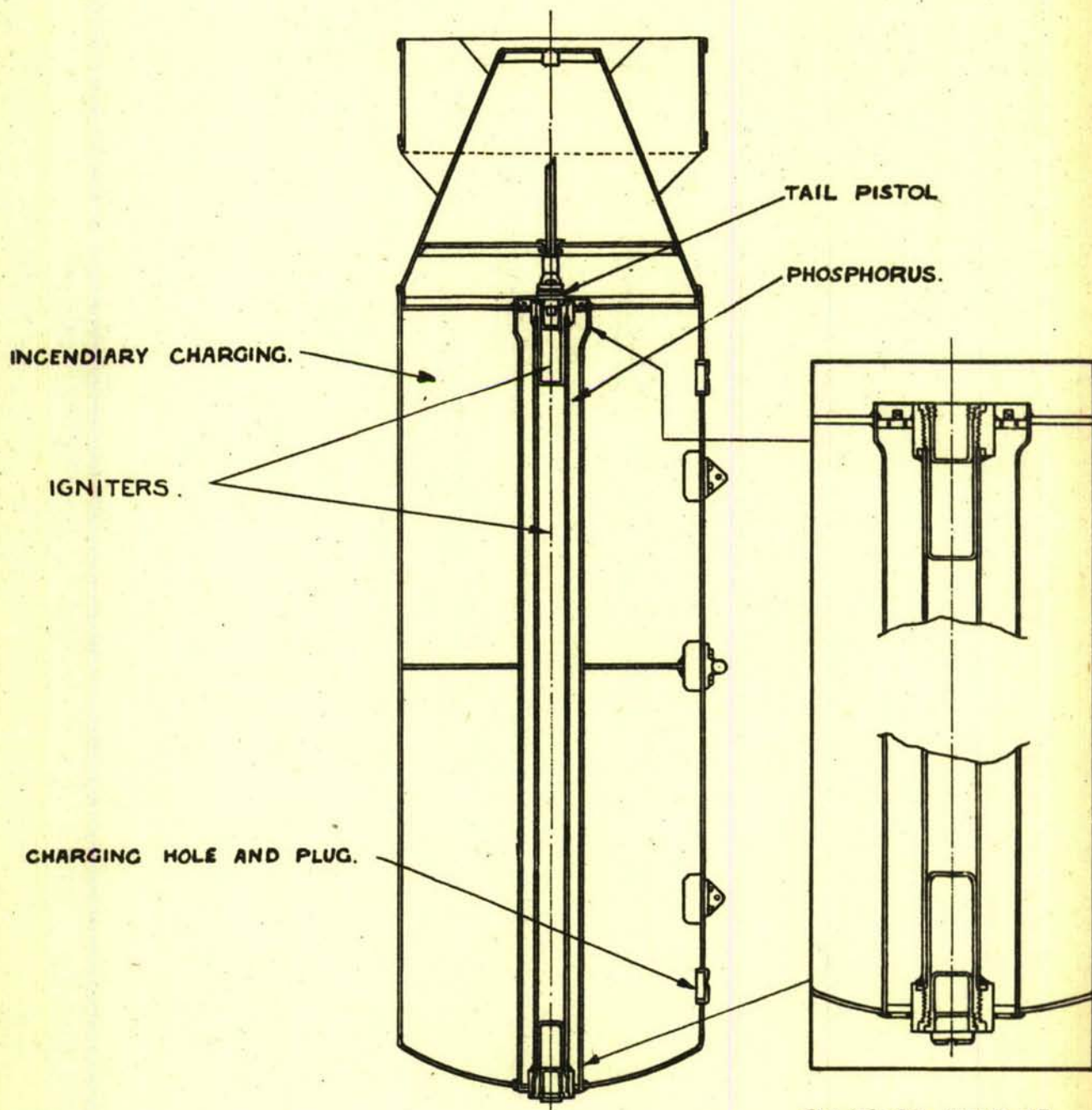

ENLARGED VIEW OF  
ENDS OF CENTRAL  
TUBE.

0 4 8 12  
SCALE. INCHES.

**2700 LB. INCENDIARY BOMB.**

BASED ON L.W. 169  
SOUTH DURHAM STEEL &  
IRON AND D.D.(L) 12436A.

ADD 23/46

FIG. 61

☉ OF SHEAR PINS

IGNITER TUBES

SECTION "A.A."

CONTAINER OF "PYTRAM"

FILLED "GEL"  
WITH 10% AIR SPACE

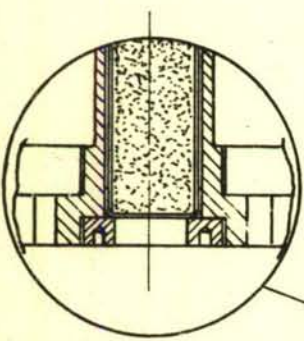

ENLARGED VIEW OF  
IGNITER TUBES

SHEAR PIN

MAGAZINE

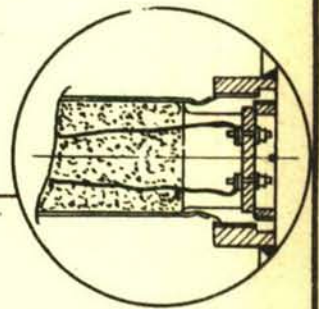

ENLARGED VIEW OF  
EXPLODER & CONNECTIONS  
FOR STATIC TRIALS

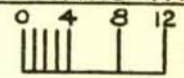

SCALE INCHES

**4000 LB. TAIL EJECTION BOMB**

BASED ON DD.(L)15228

ADD 23/46

FIG. 62

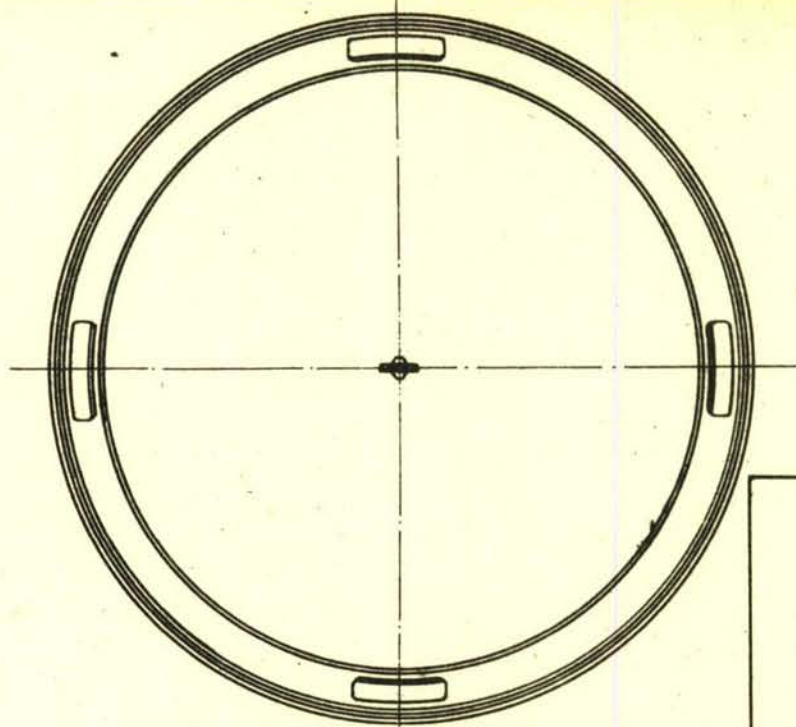

HEXAGONAL  
2 LOCKWASHERS  
LOCKNUT

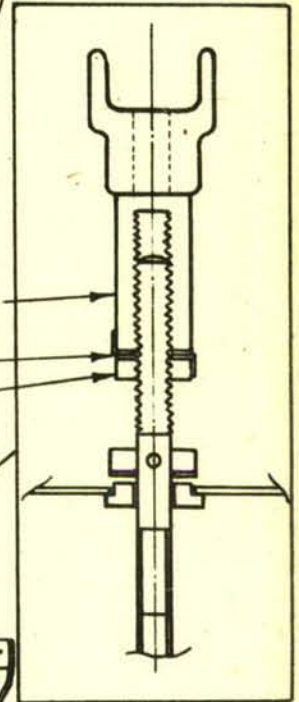

ENLARGED VIEW  
ADJUSTABLE  
ARMING FORK

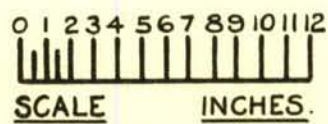
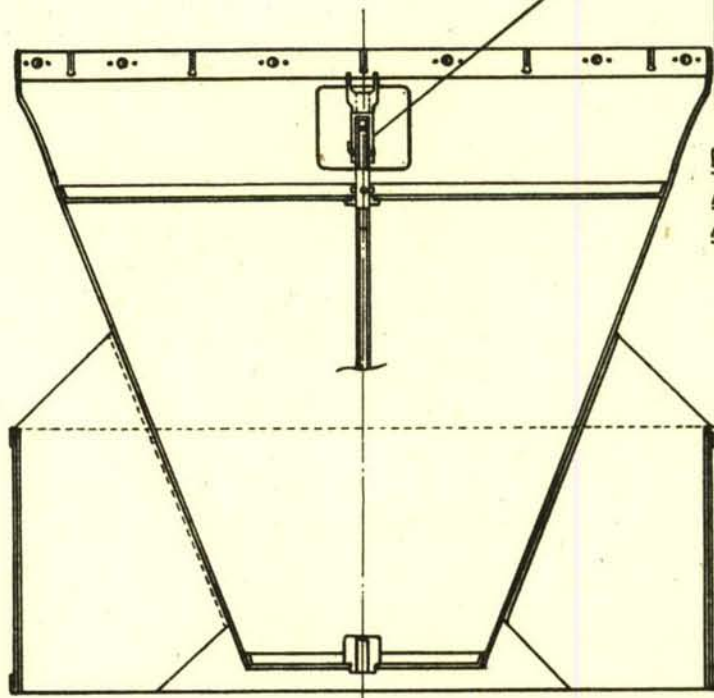

**CONE AND DRUM TAIL WITH  
ADJUSTABLE ARMING FORK.**  
FOR 2700 LB. INCENDIARY BOMB.

BASED ON  
SMITH METERS  
DRG. B.S. 25005

ADD 23/46

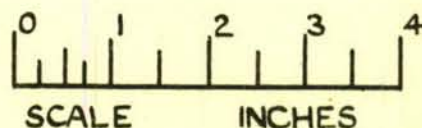
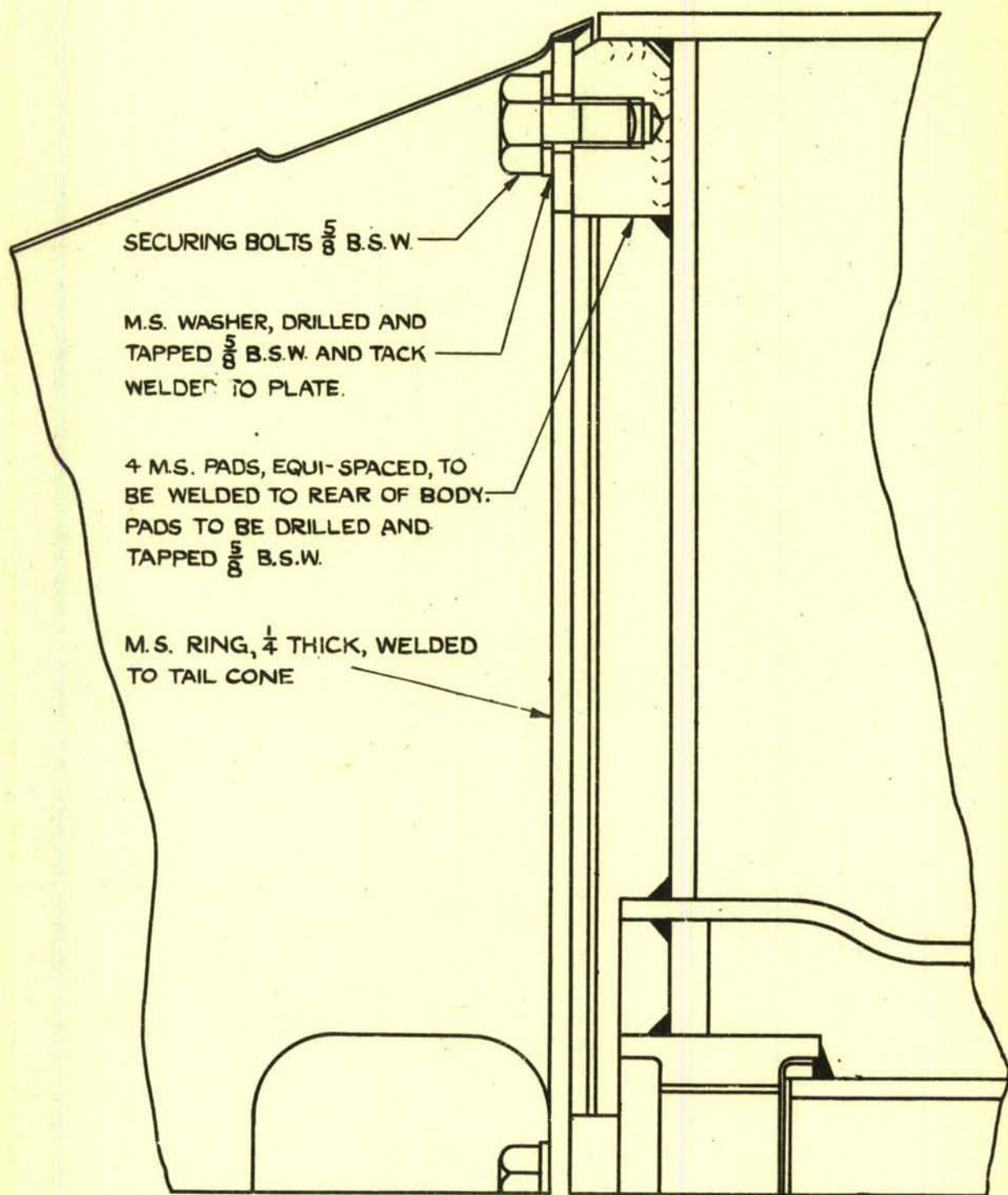

C.E.A.D. SUGGESTED TAIL DESIGN  
FOR 2700LB. INCENDIARY BOMB.

(BASED ON D.D.(L) 19547)

FIG. 64

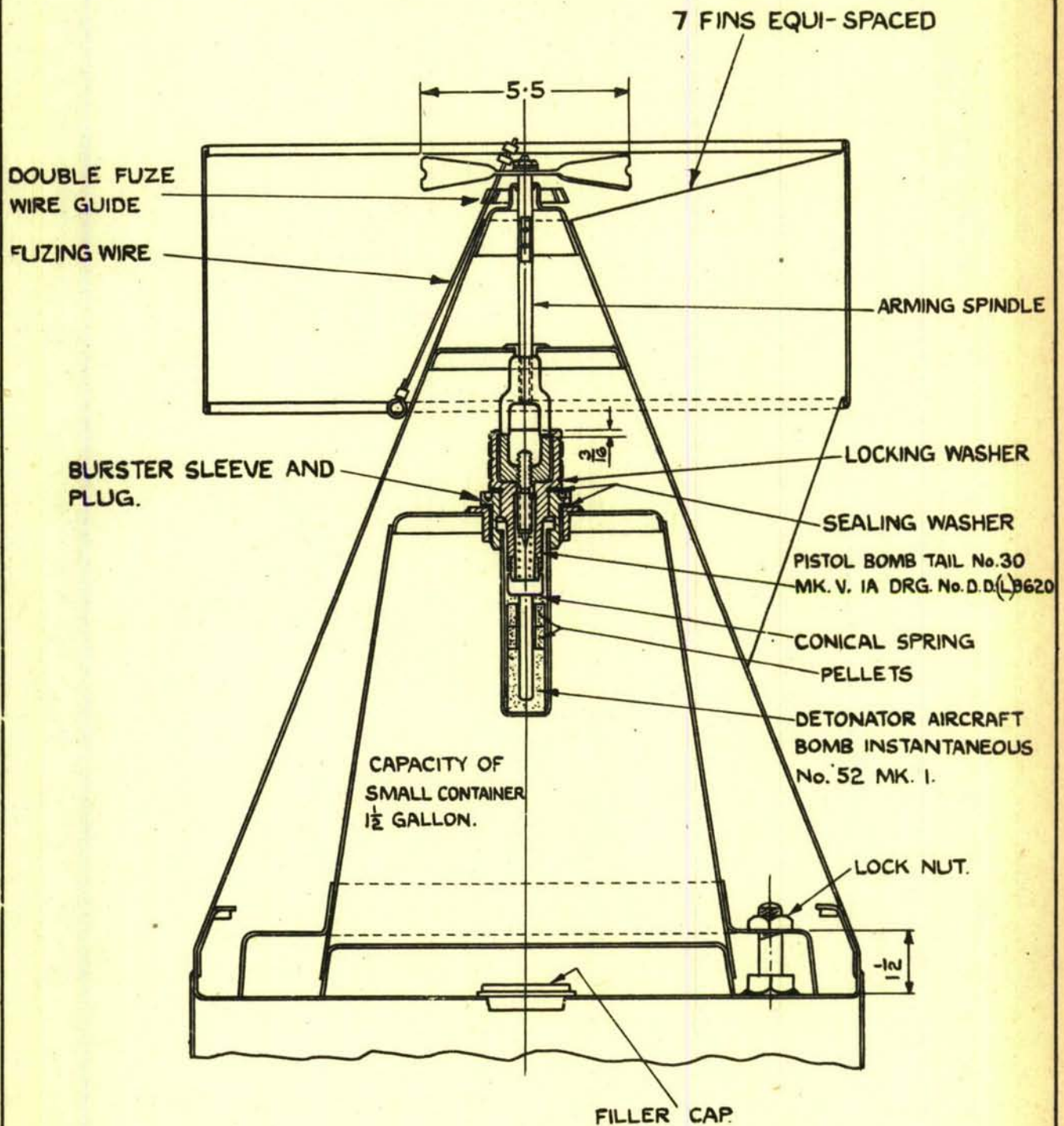

SCALE 0 5 10 INCH

400 LB. OIL BOMB.  
ORIGINAL DESIGN.

BASED ON DRG. R.D. ARM. 8(A)  
SKETCH No. D.D.B. 20

ADD 23/46

FIG. 65

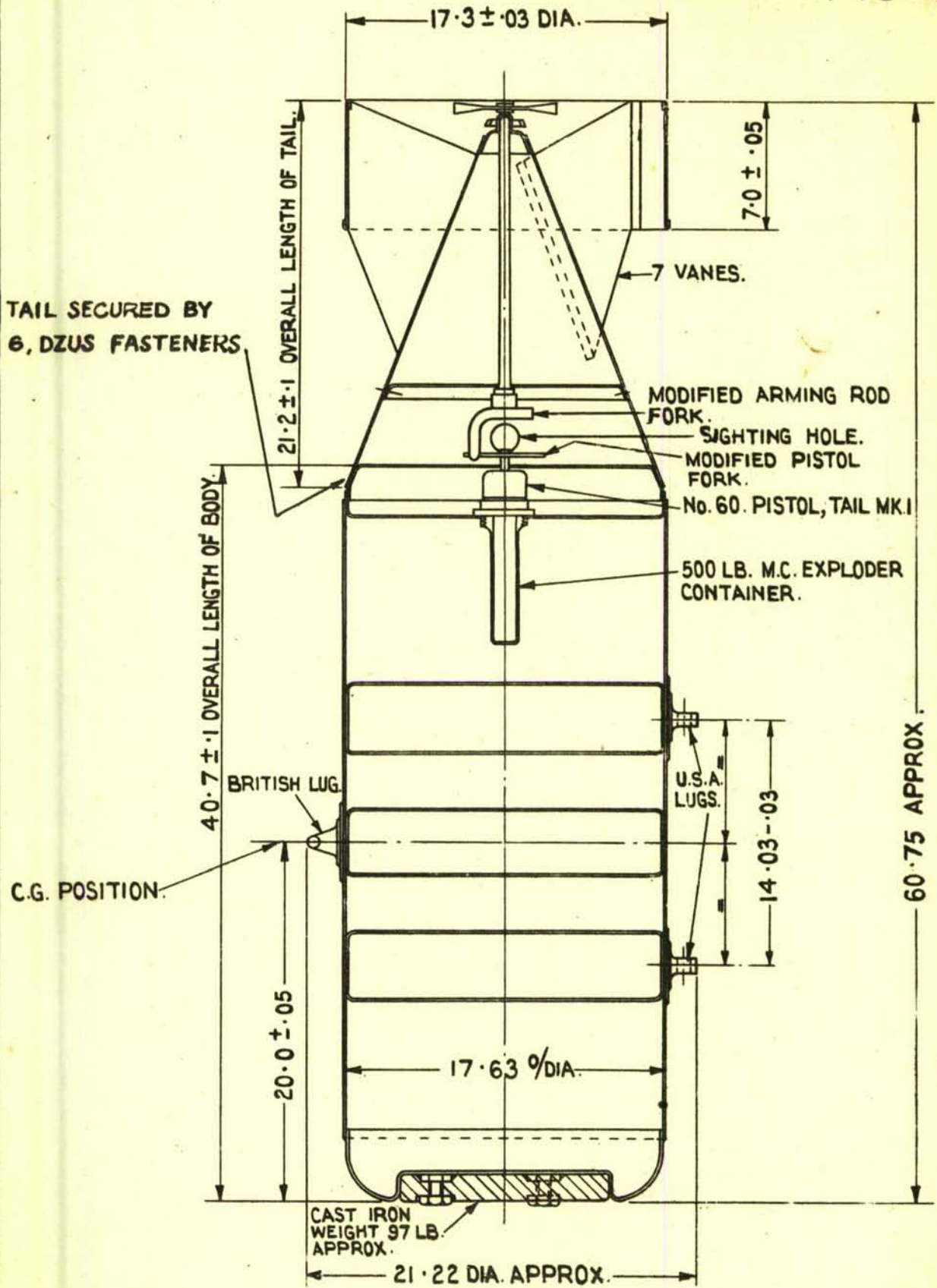

WEIGHT OF BOMB FILLED  
420 LB. APPROX.

SCALE 0 5 10 INCHES.

**BOMB, INCENDIARY, AIRCRAFT.**  
**400 LB. MK. I / AIR.**

BASED ON DRG:-  
R.E. ARM. 8(A) SK. No. D.O.B/30

ADD 23/46

FIG. 66

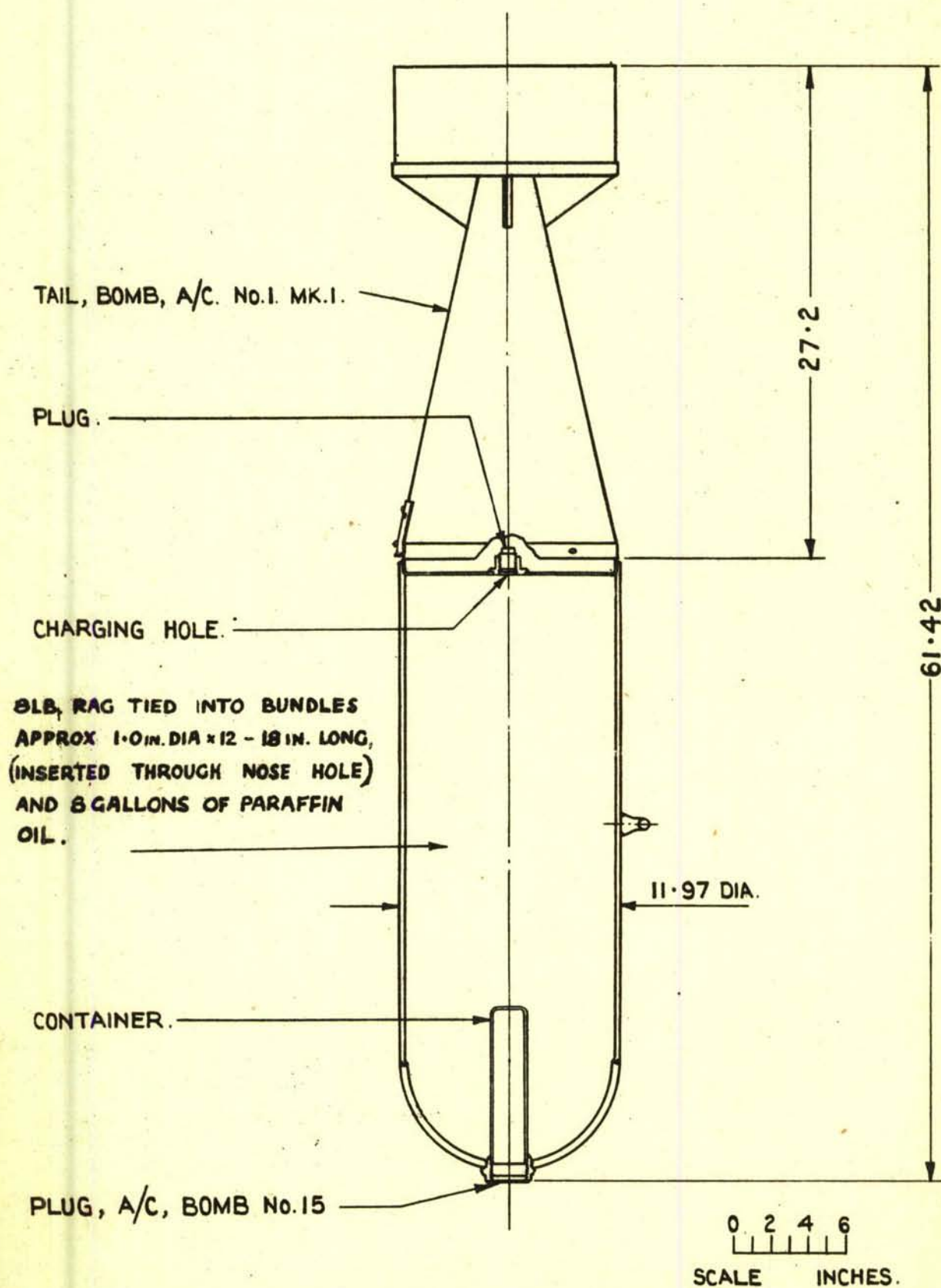

**250 LB. INCENDIARY BOMB MK. I**

(BASED ON D.D.(L)11942).

ADD 23/46



FIG. 67

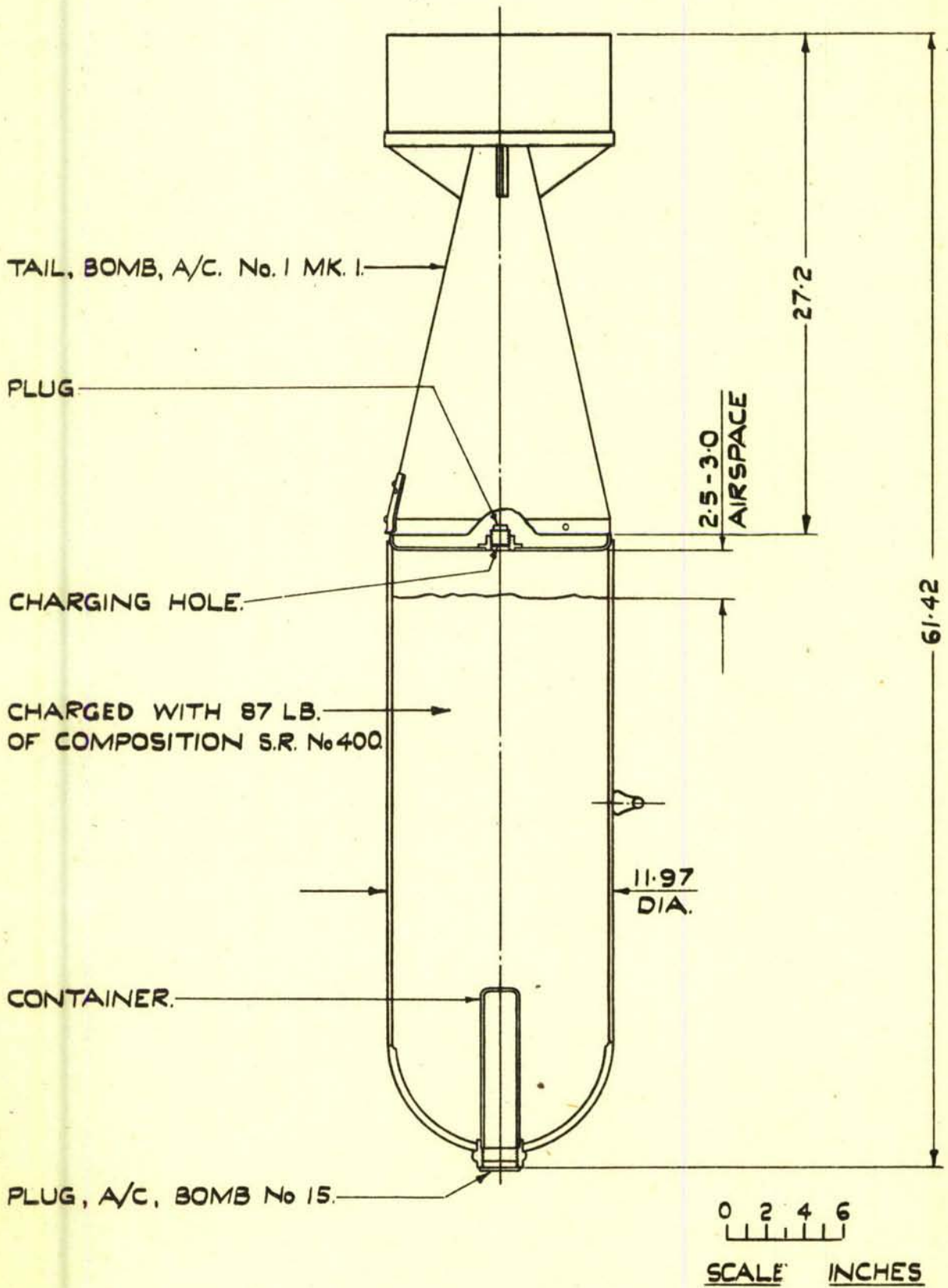

**250 LB. INCENDIARY BOMB MK. 2.**

(BASED ON D.D.(L)12994)

FIG.68

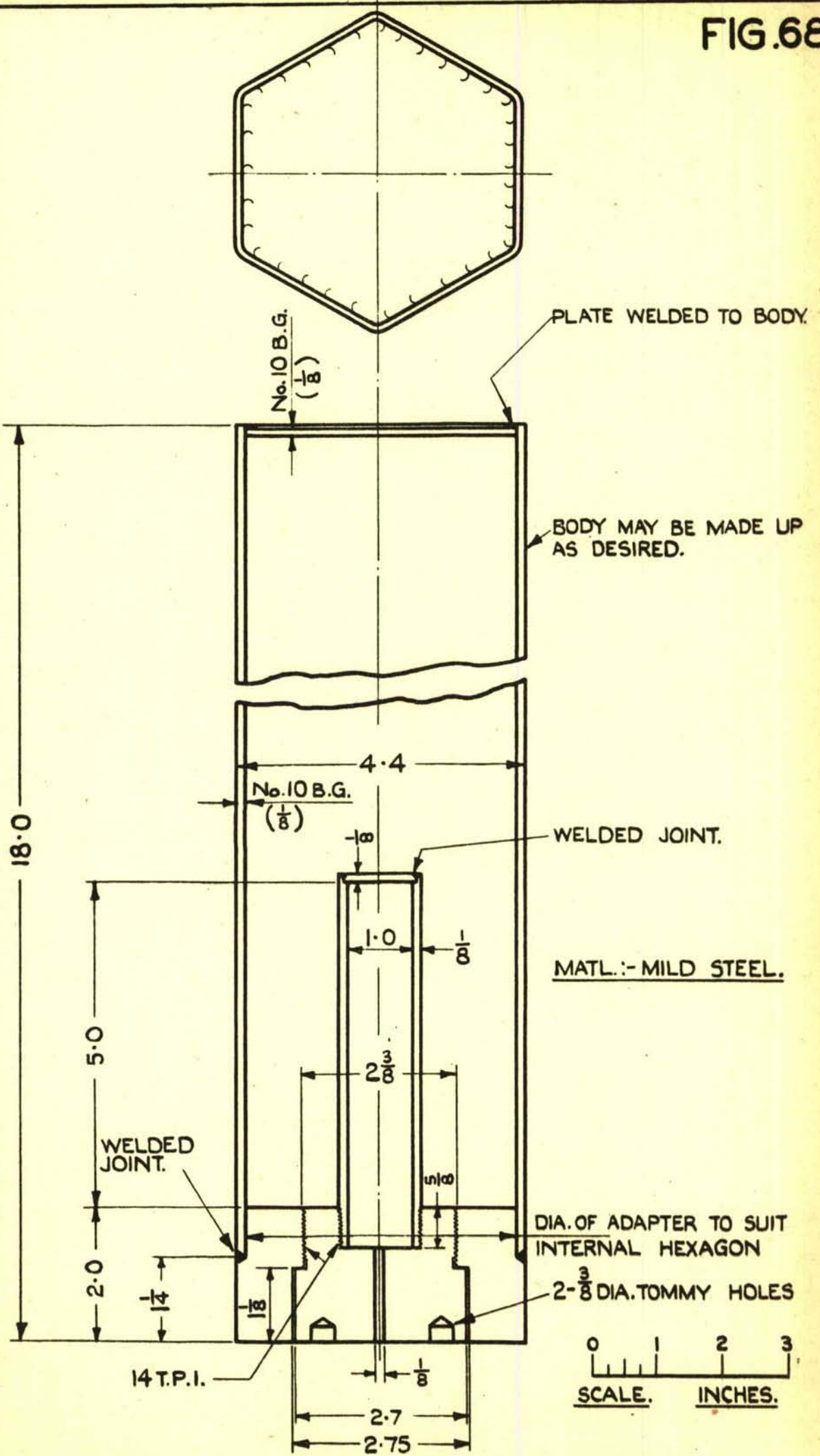

**25 LB. HEXAGONAL  
INCENDIARY BOMB.**

(BASED ON D.D.(L) 14926)

ADD 23/46

FIG. 69

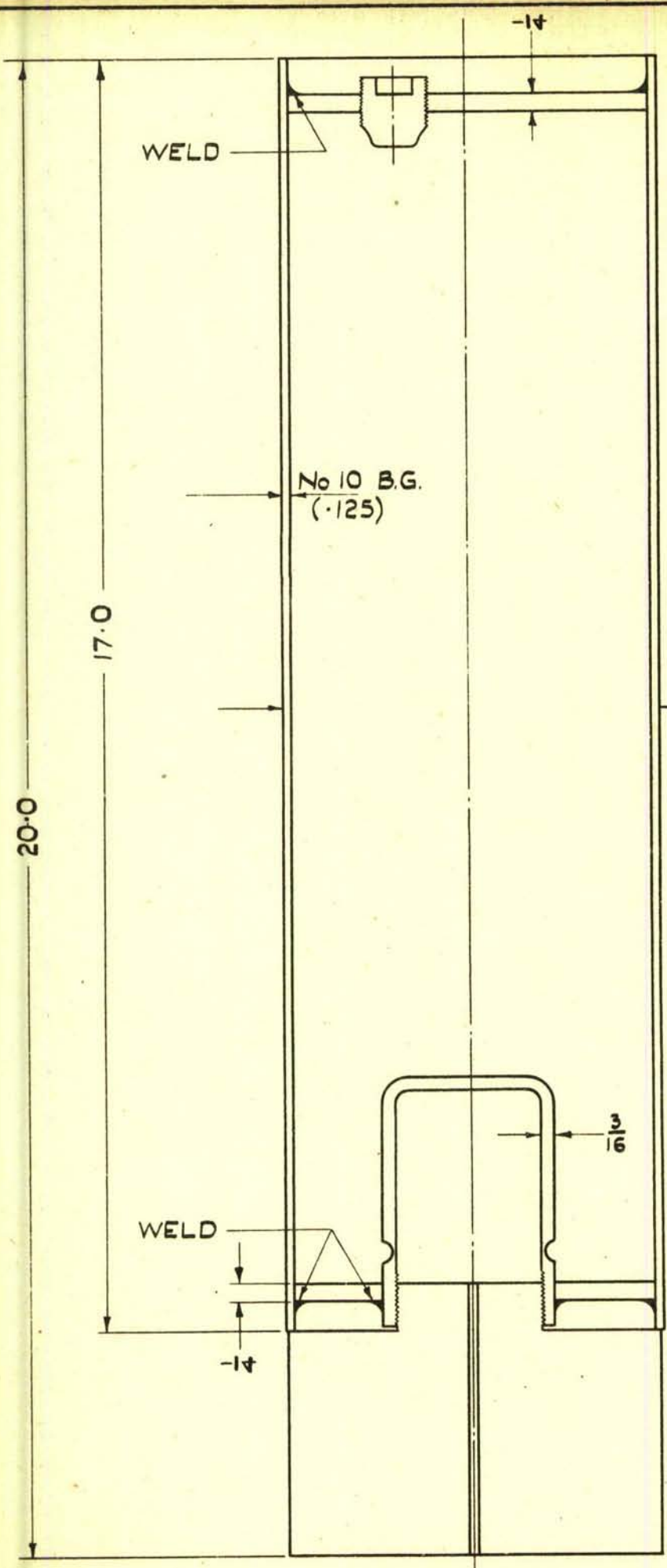

TOTAL FILLED WEIGHT = 38 LB.  
WEIGHT OF FILLING = 8 LB.  
WEIGHT OF NOSE = 16 LB.

5.0 DIA.

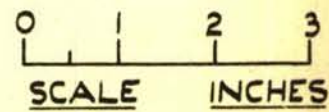

**PROPOSED 38 LB.**  
**INCENDIARY BOMB.**  
LUXFERS A. 5 INCH.

(BASED ON LUXFER  
DRG. E 100/2)

A.D.D. 25/46

FIG.70

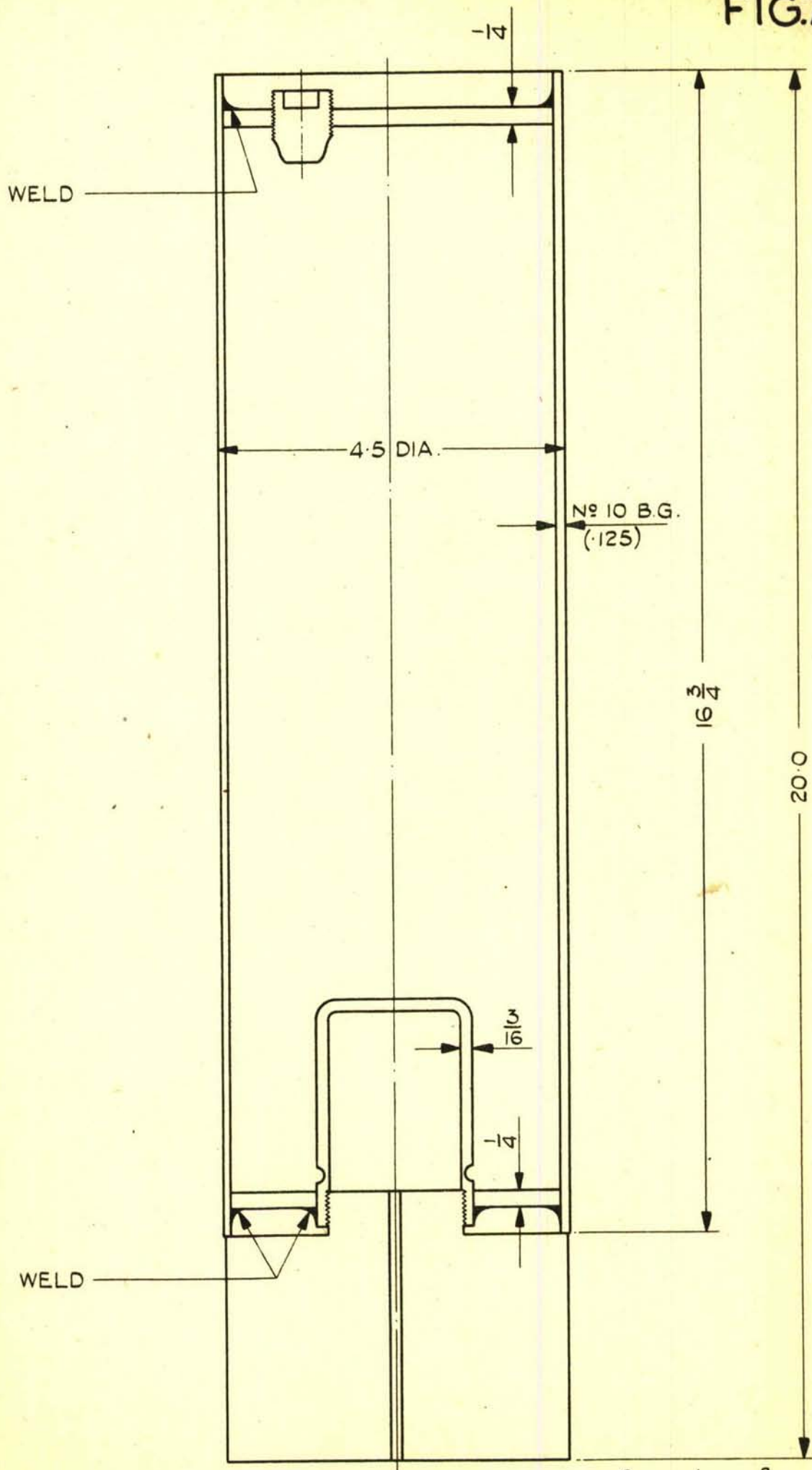

**PROPOSED 32 LB. INCENDIARY BOMB.**  
**LUXFER A 4.5 INCH.**

(BASED ON LUXFER  
DRG. No. E./100/1.)

ADD 23/46.

FIG. 71.

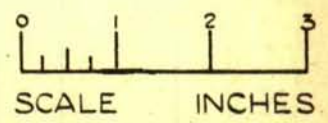
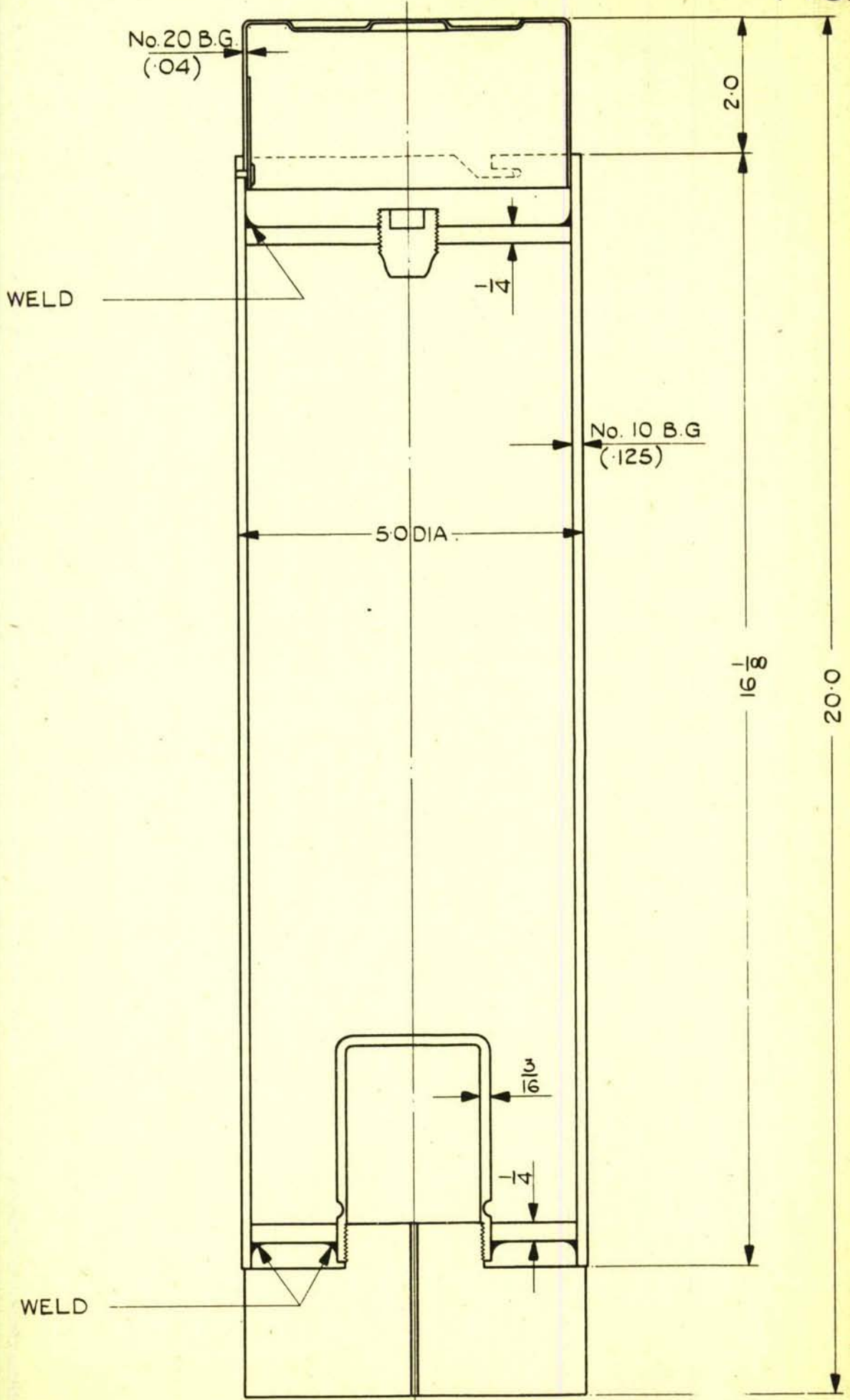

**PROPOSED 30 LB. INCENDIARY BOMB.**

**LUXFER B.5 INCH.**

(BASED ON LUXFER DRG. No. E.100/4.)

ADD 23/46

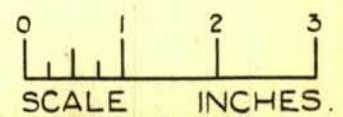
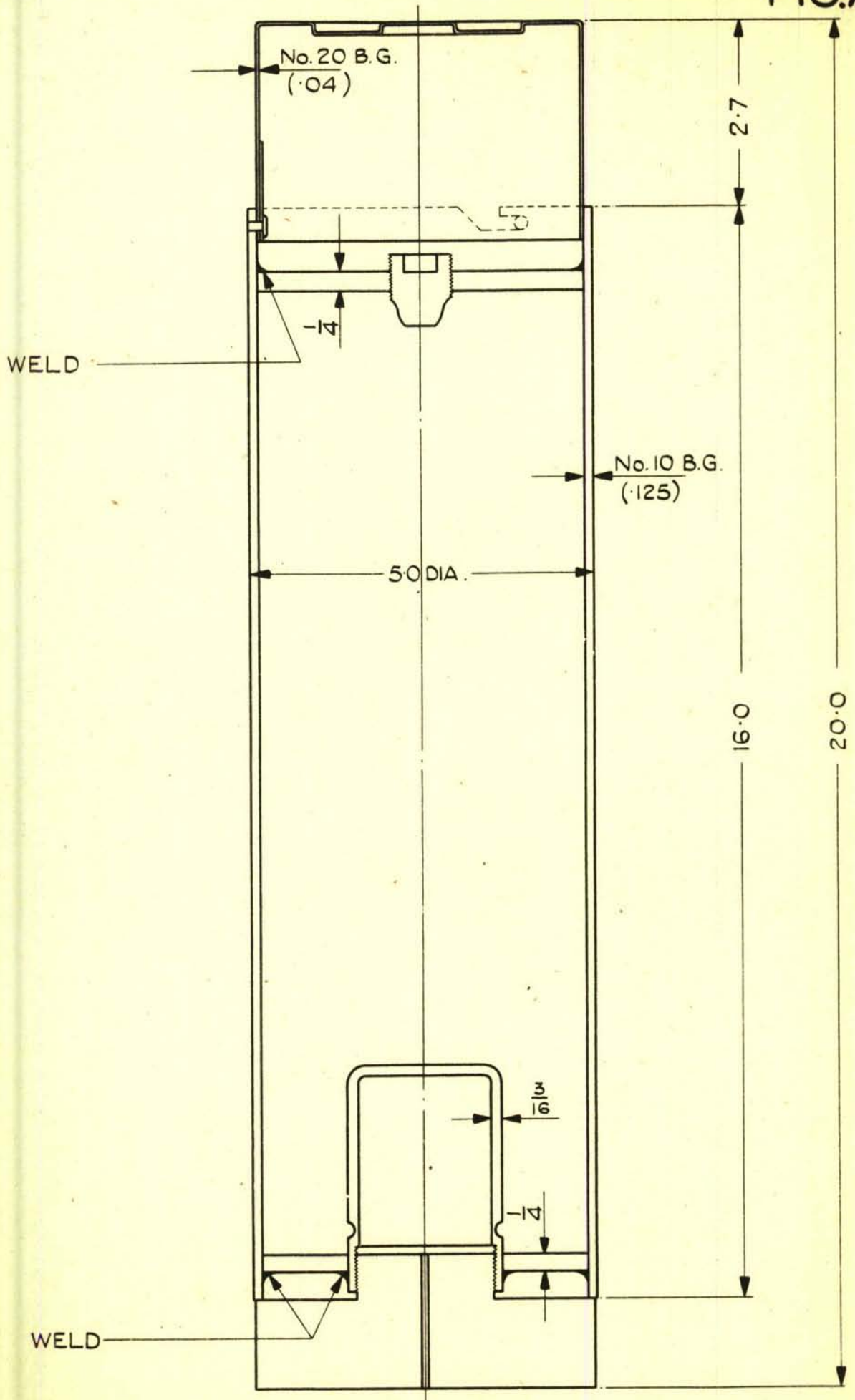

**PROPOSED 27 LB. INCENDIARY BOMB.**  
**LUXFER C.5 INCH.**

(BASED ON LUXFER  
DRG. No. E.100/6).

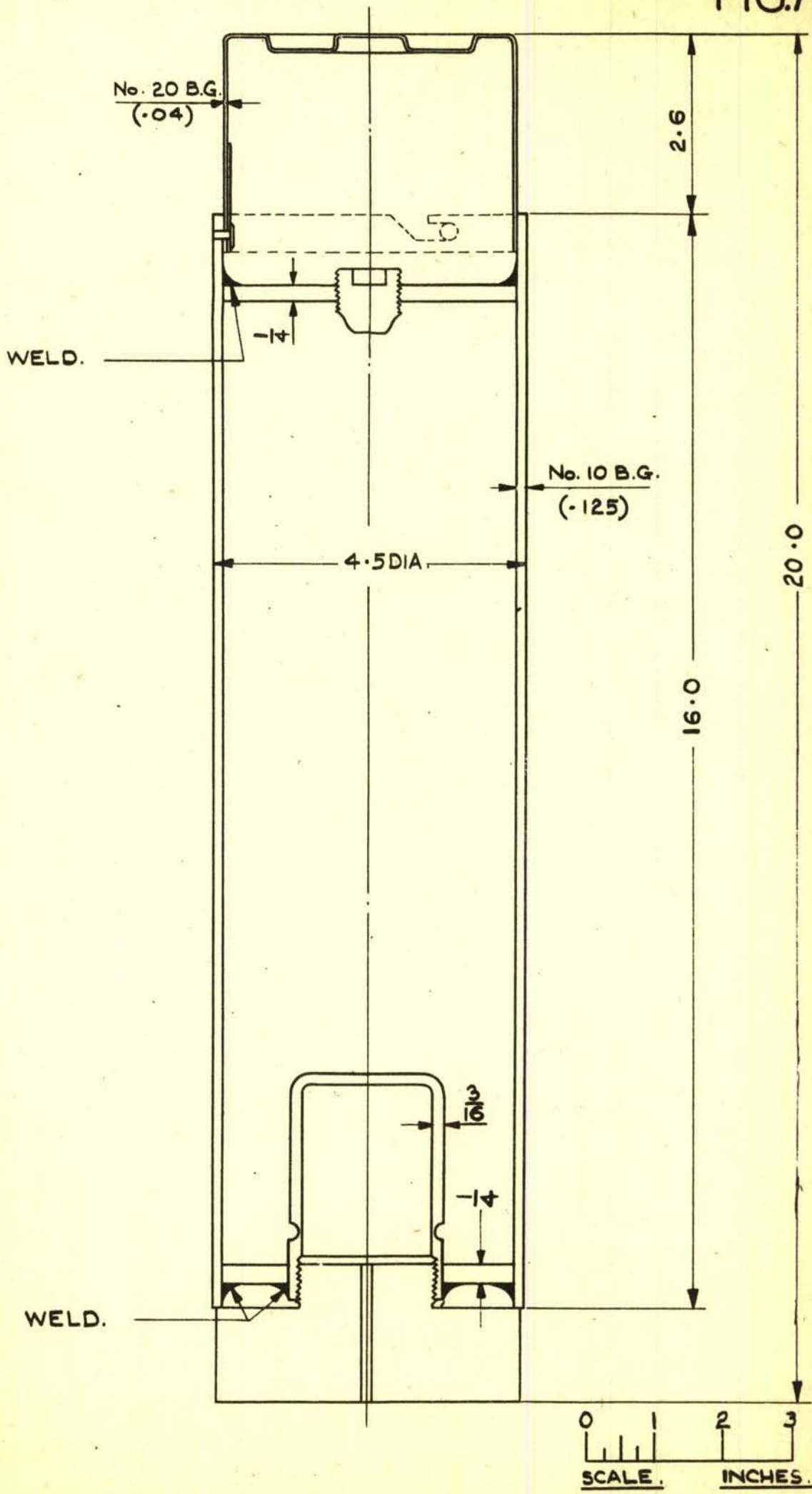

**PROPOSED 24LB. INCENDIARY BOMB.**

(BASED ON LUXFER DRG., No. E.100/5.)

LUXFER C 4.5 INCH.

FIG. 74

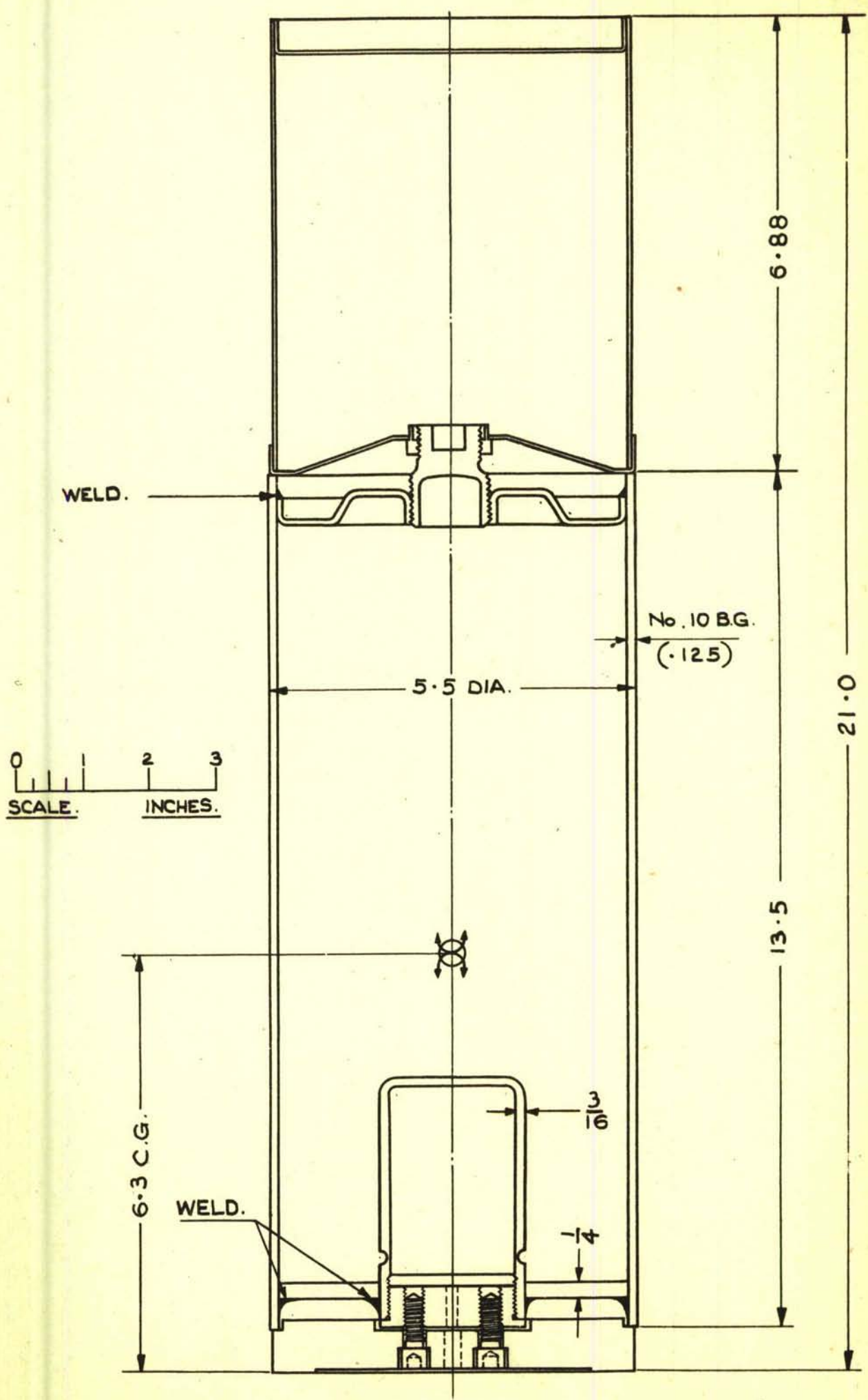

INCENDIARY BOMB 5.5 INCH

(BASED ON LUXFER  
DRG., No. E.100/7.)

ADD 23/46

R.S.M.







FIG.77

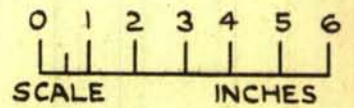
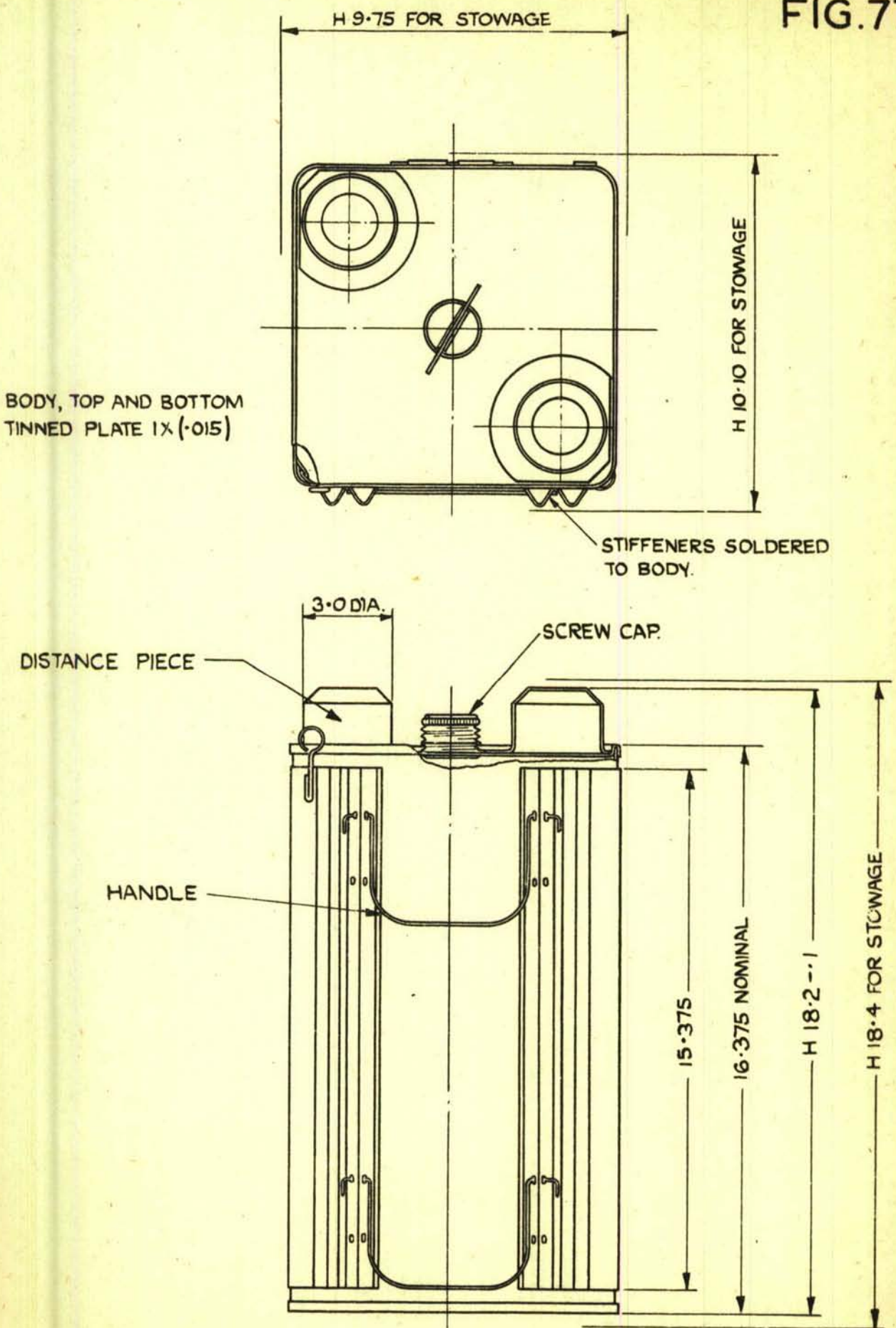

45 LB. I/O. BOMB.

(BASED ON A.I.D.(ARM.) 137)

FIG. 78

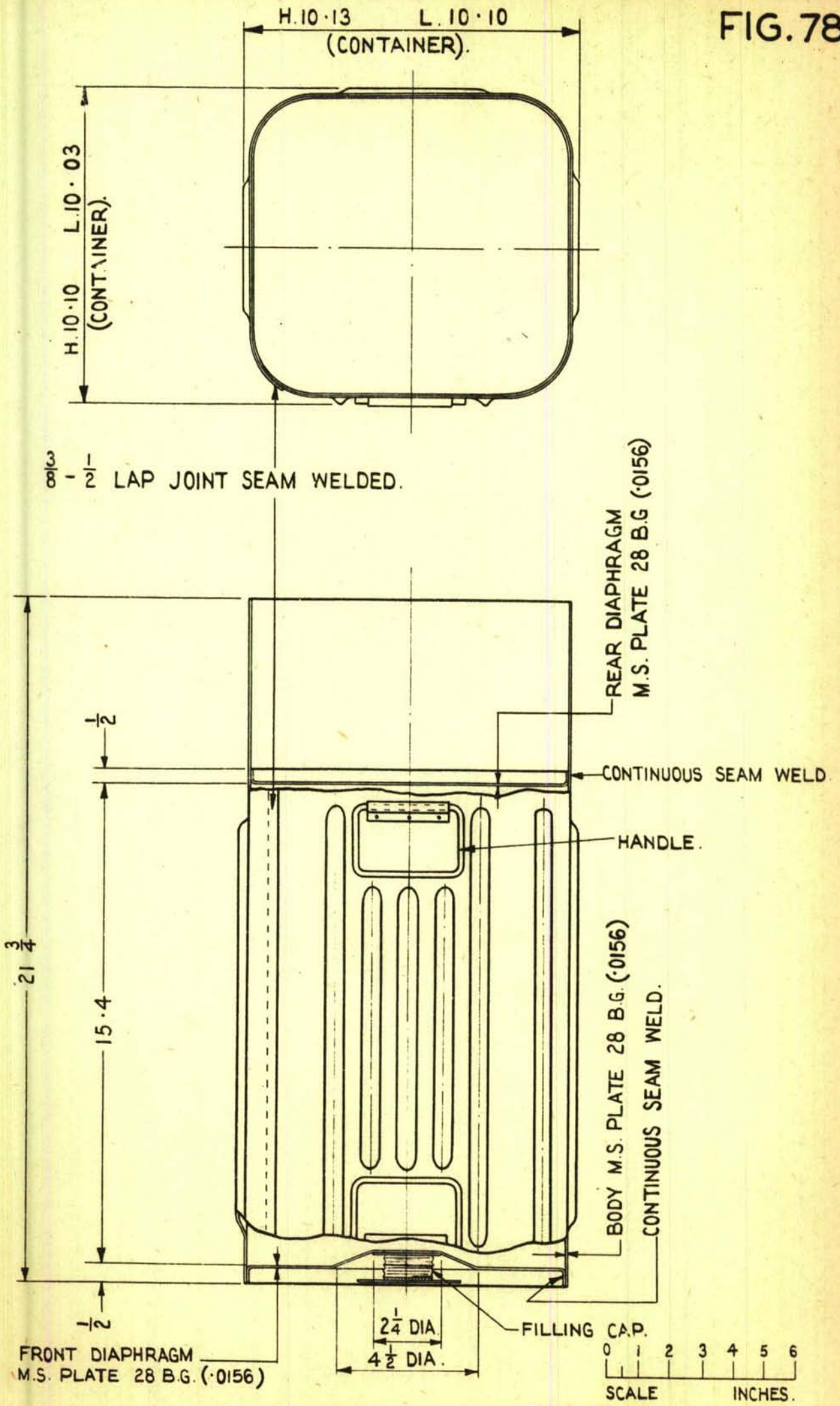

00103 - 1/2 LAP JOINT SEAM WELDED.

**45 LB. I/O. BOMB.**

(BASED ON D.D.(L)14167)

SEAL, .001 THICK  
BRASS LIGHTLY  
SWEATED TO TUBE

SEAL STRIPPING  
WIRE  $\frac{1}{16}$  DIA.  
FLEXIBLE STEEL  
CABLE.

BRACKET.

PETROL CHAMBER  
FILLING PLUG

LEATHER WASHER.

SEAL, PHOSPHIDE  
CHAMBER.

COLLAR RETAINING  
CUTTER.

PETROL EXIT TUBE.

PETROL -  $\frac{1}{2}$  PINT.

TUBE LOCATING  
BRACKET

CALCIUM PHOSPHIDE,  
RAPID VARIETY -  
1 LB. - 6 OZ.

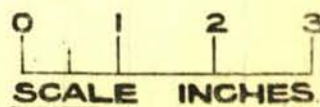
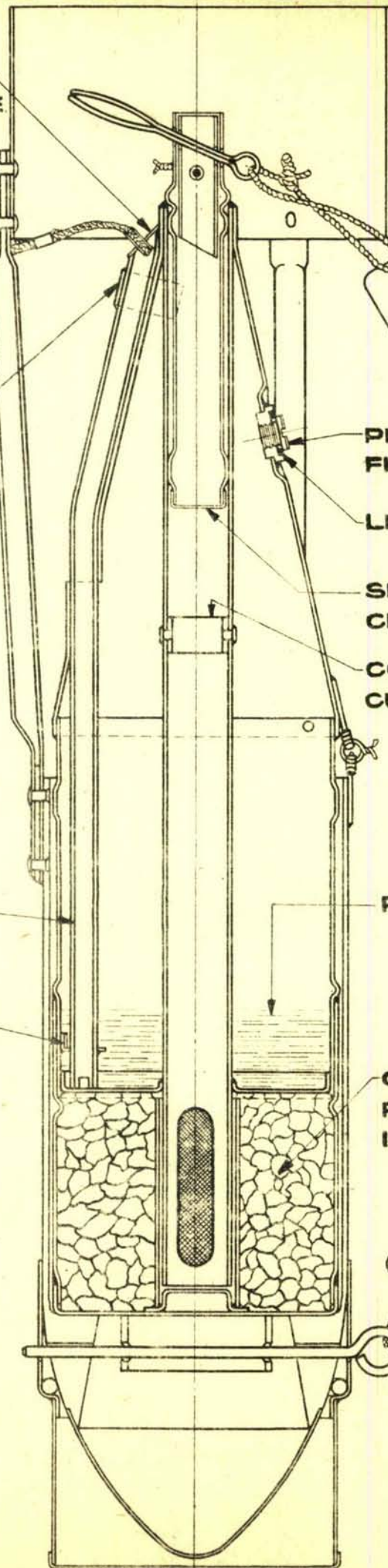

**MODIFIED FLAME FLOAT FOR  
OIL IGNITION.**

(BASED ON  
D.D.(L) 11373.)

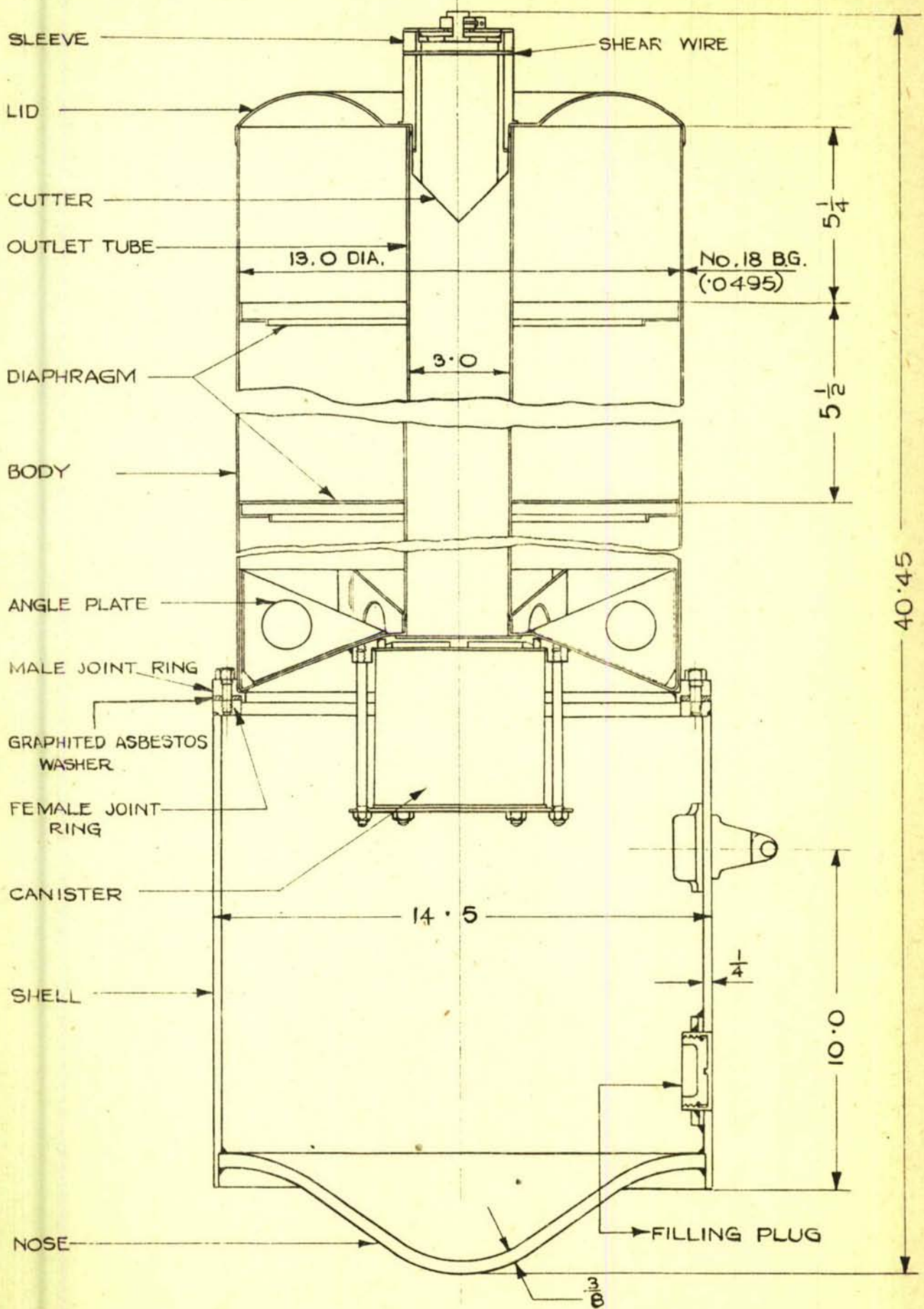

**OIL IGNITION FLOAT**

(BASED ON D.D.(L). 13232)

ADD 23/46

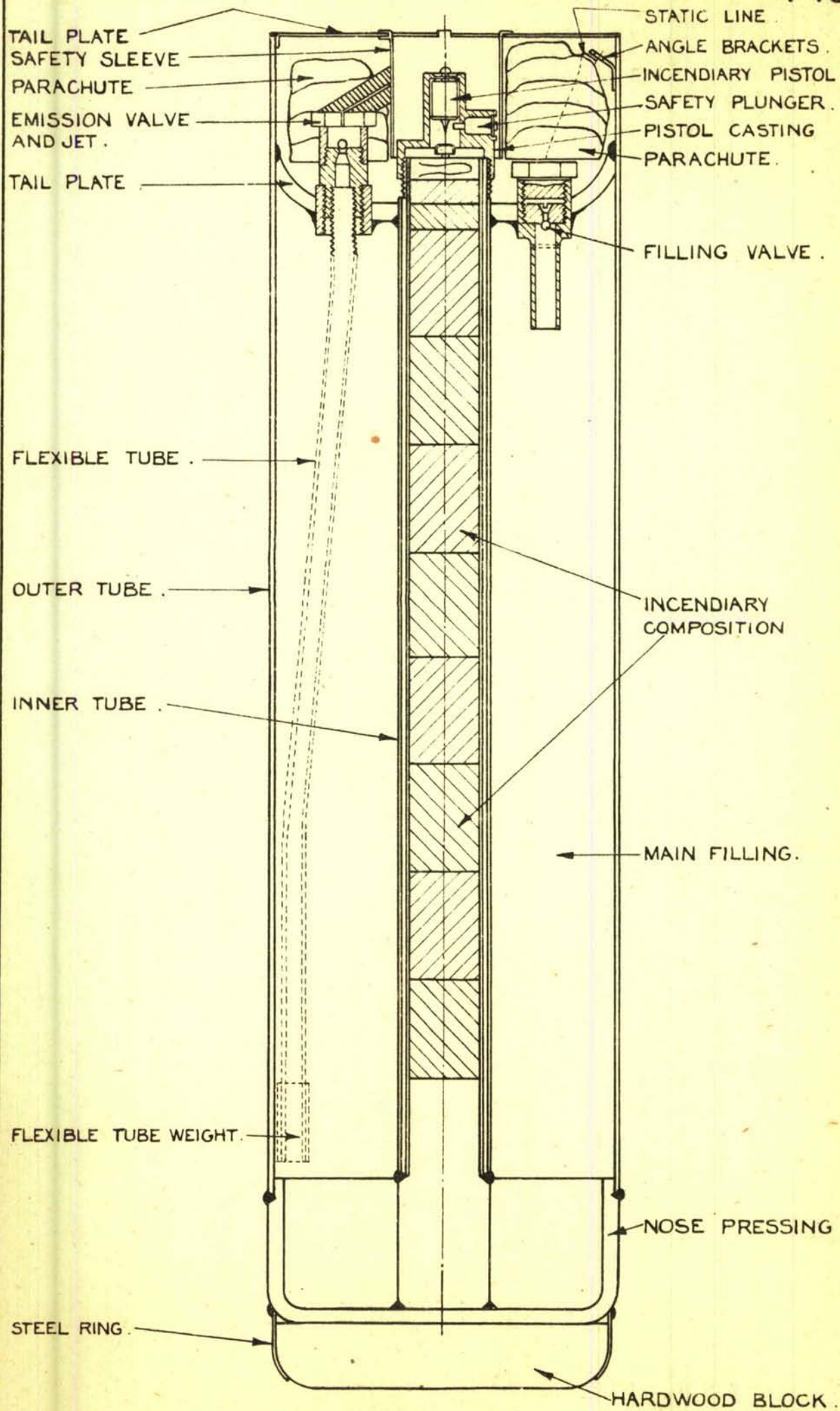

**30 Lb TYPE J. BOMB.**

EARLY DESIGN (A.&AEE /A.T.O./G.6(a). DATE 29.4.43.) (BASED ON DRG.No.)  
 (SK.No.EA.1640)

FIG. 82.

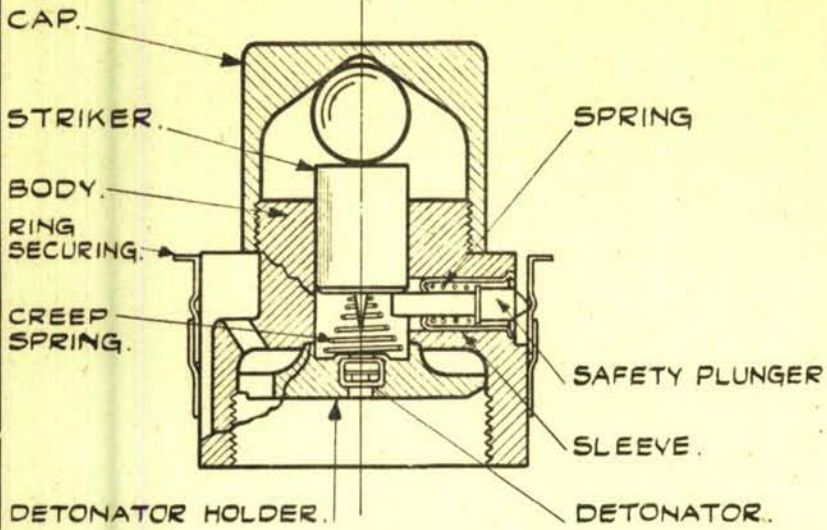

SECTION THRO' C

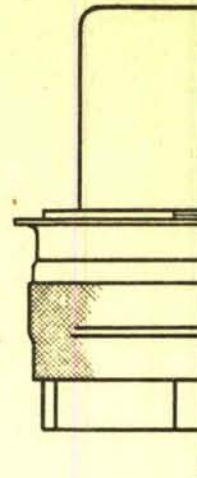

HALF ELEVATION.

FUZE BASED ON DRG. No. D.D.(L)14870.

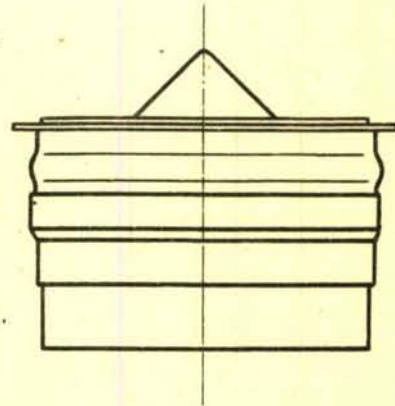
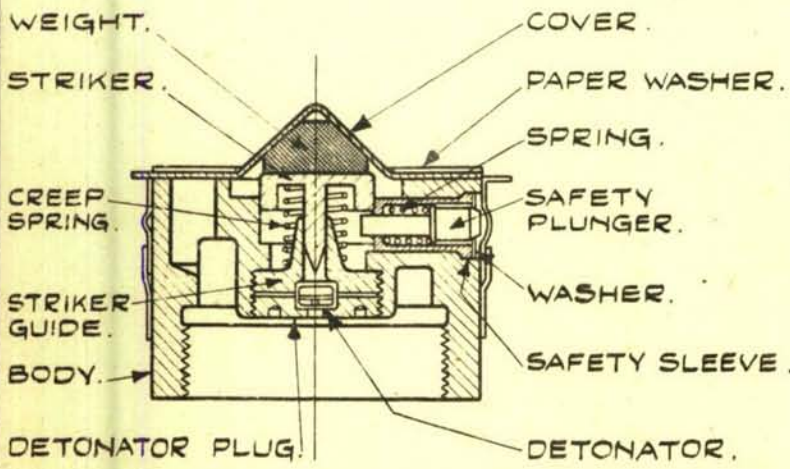

FUZE BASED ON DRG. No. D.D.(L)14870, A.

SCALE. FULL SIZE.

3 WAYS FUZE.

FOR USE IN 30 LB. "J" TYPE BOMB.

BASED ON DRG Nos. D.D.(L)14870 & A.



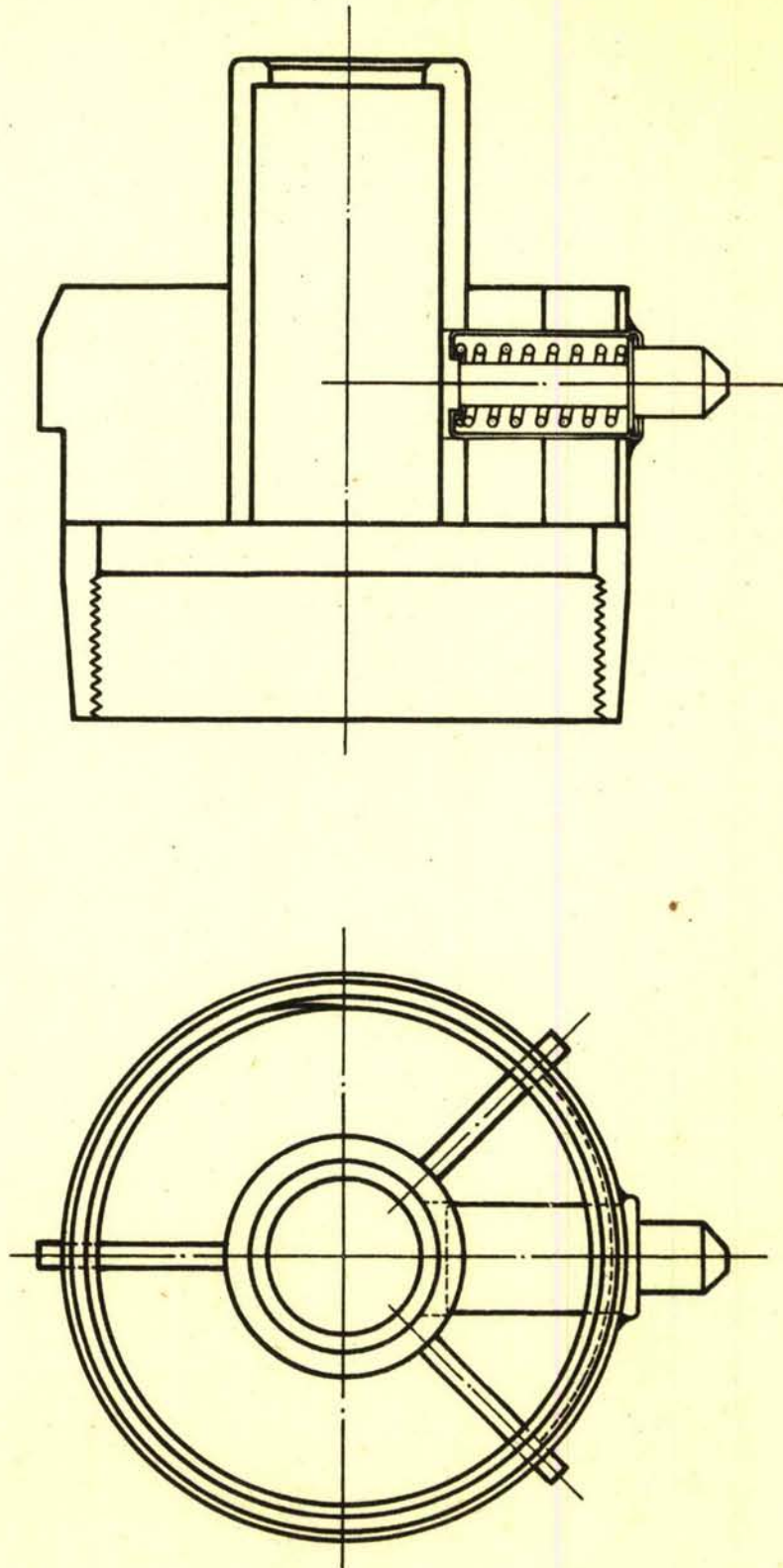

0  
SCALE. INCHES.

PISTOL BODY No. 1.

(BASED ON D.D.(L)SK4820)

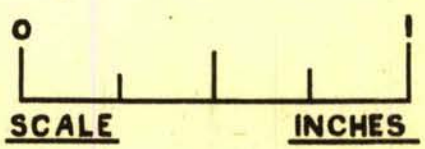
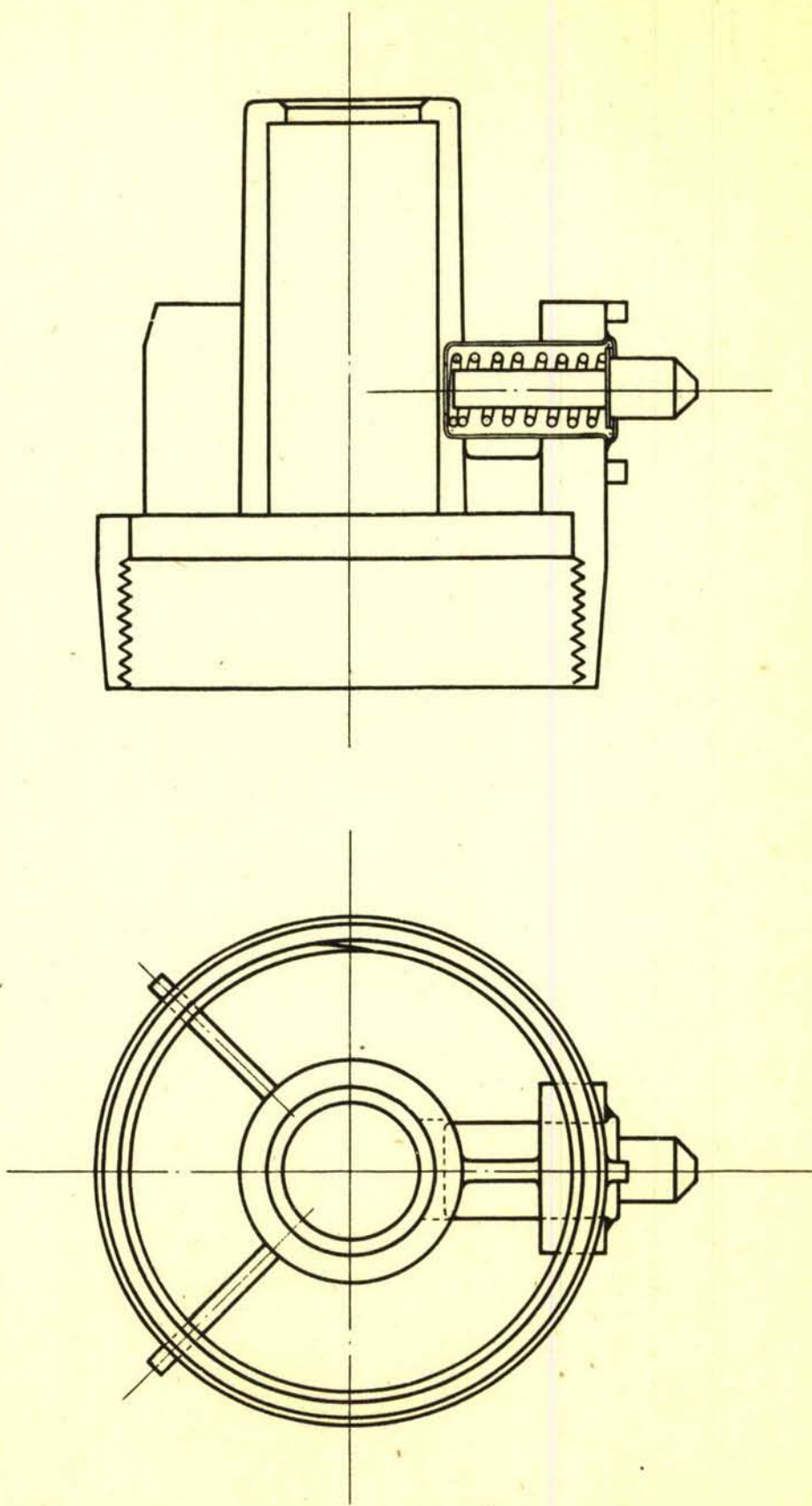

PISTOL BODY No2

(BASED ON D.D.(L)S K.4820)

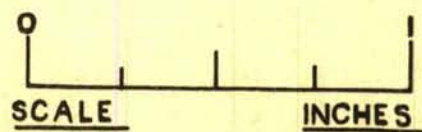
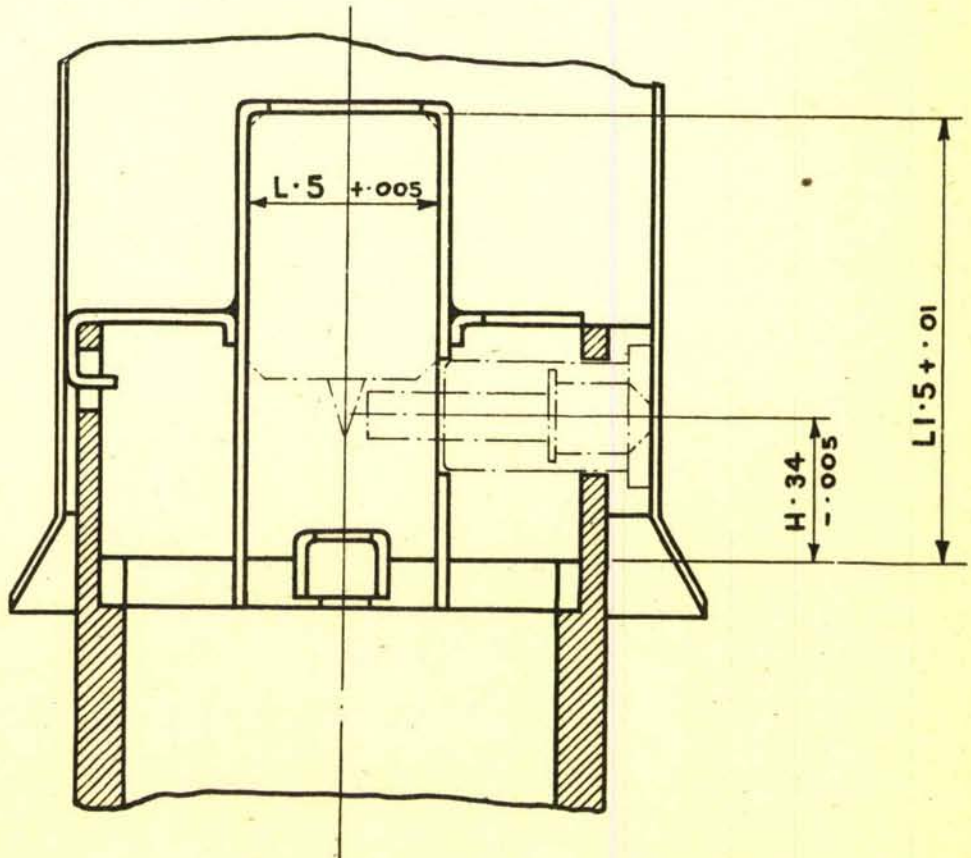
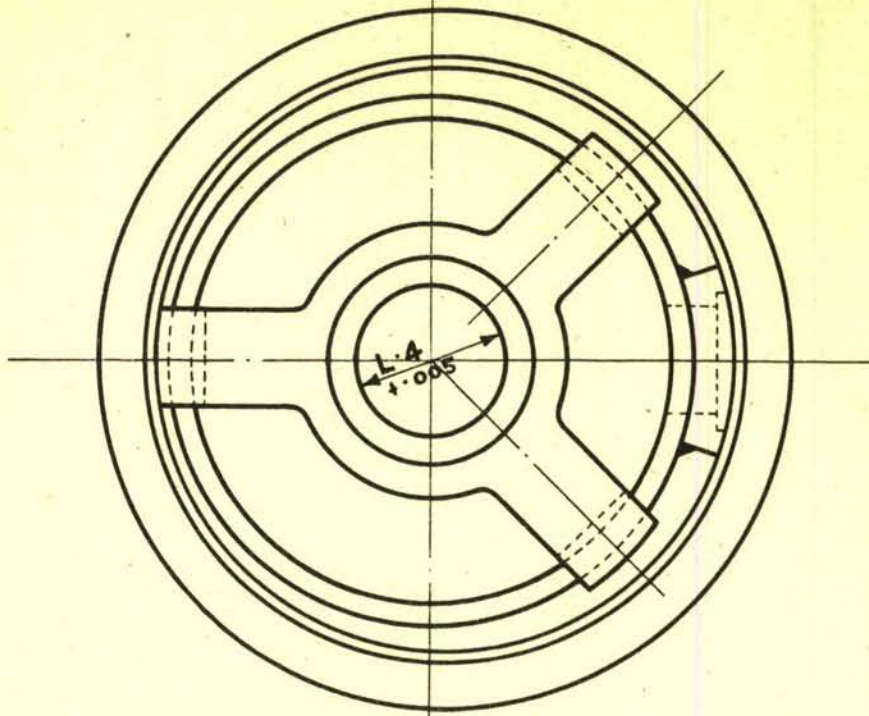

PISTOL No.3

(BASED ON D.D(L)S K.4820)

FIG. 86.

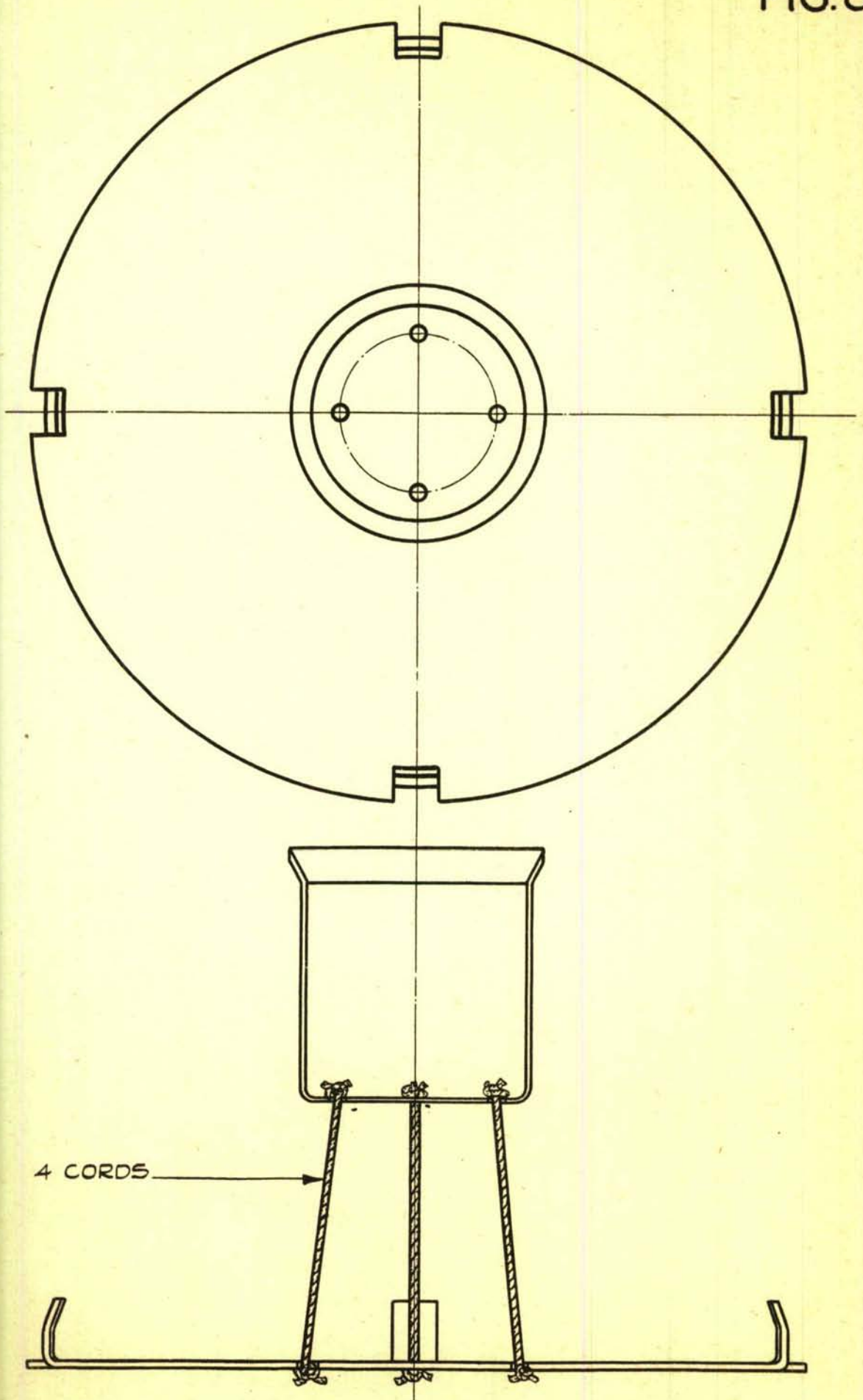

0 1 2  
SCALE INCHES

**SUGGESTED ARMING DEVICE.**

(BASED ON D.D.(L)5K4820).

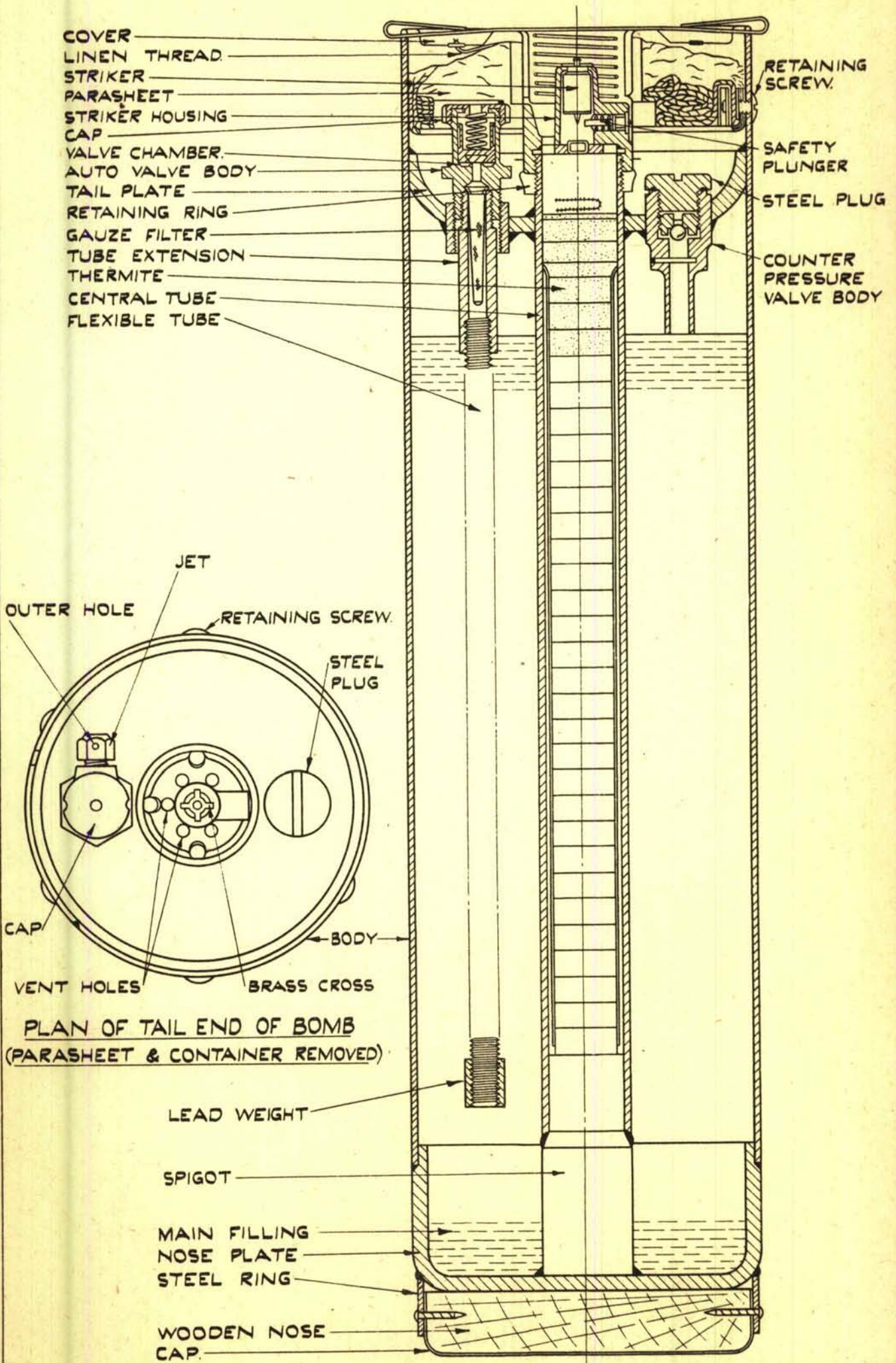

**30 LB. INCENDIARY BOMB**  
**TYPE "J" MK. I.**

BASED ON DRG No  
 S.D. 129/B 40. FIG. 1 & 2

ADD 23/46

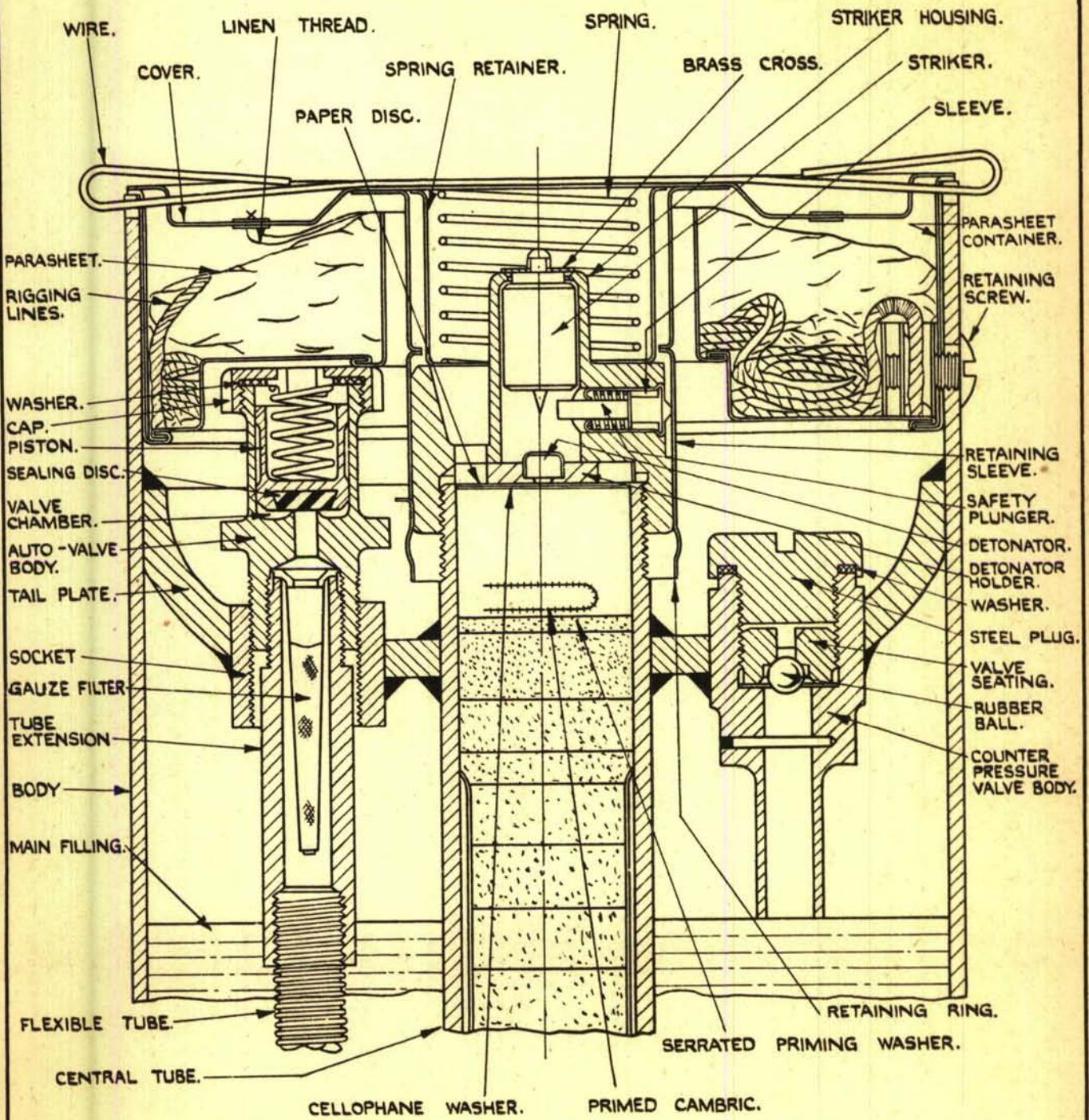

30 LB. INCENDIARY BOMB.

TYPE "J" MK.I. TAIL END.

BASED ON DRG. No.  
S.D.129/B.40 (FIG.No.3)

FIG. 89

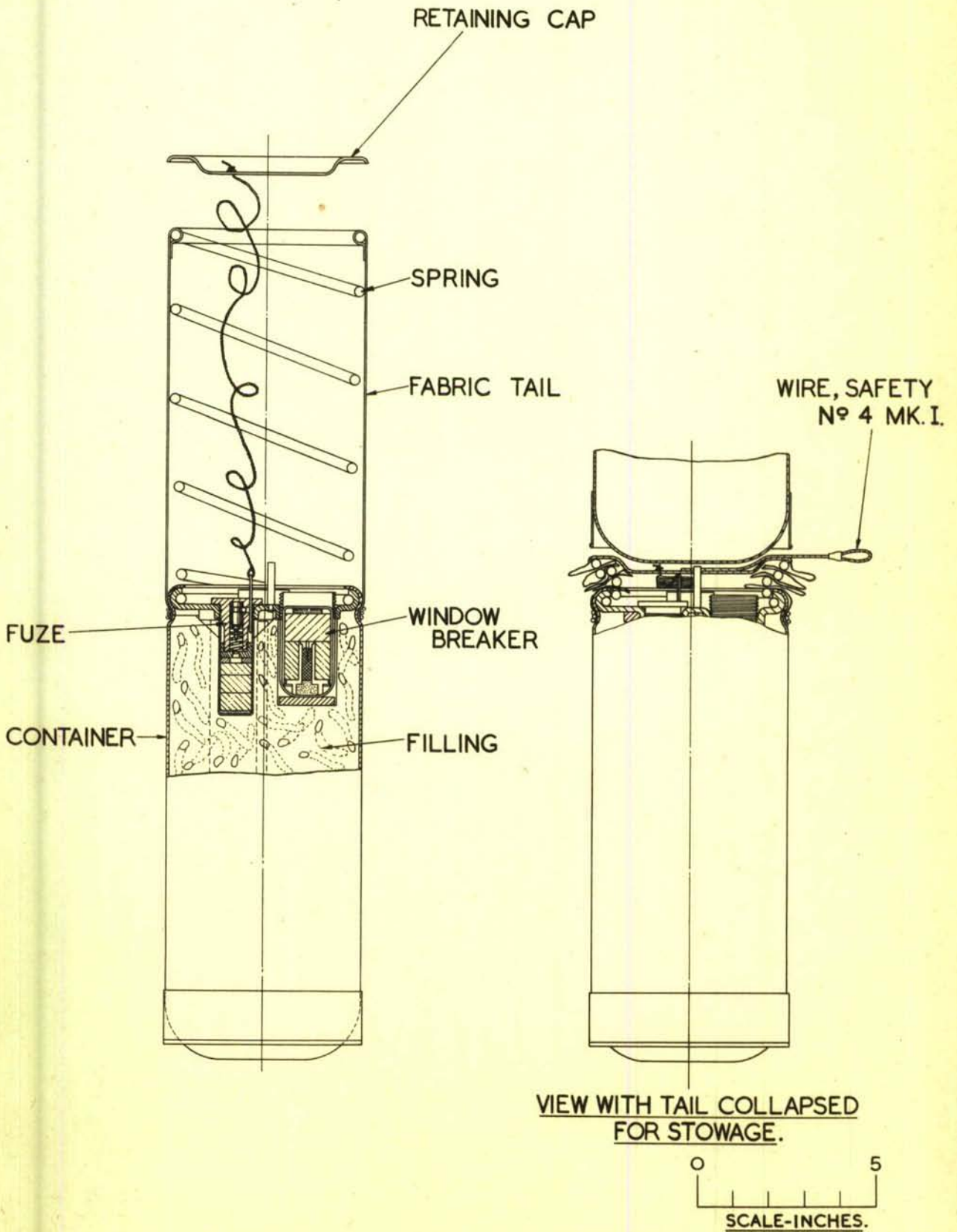

**22 L.B. "J" INCENDIARY BOMB.**  
**ORIGINAL TYPE WITH FABRIC TAIL.**

BASED ON DRG. Nº  
SK. 13500.

FIG. 90

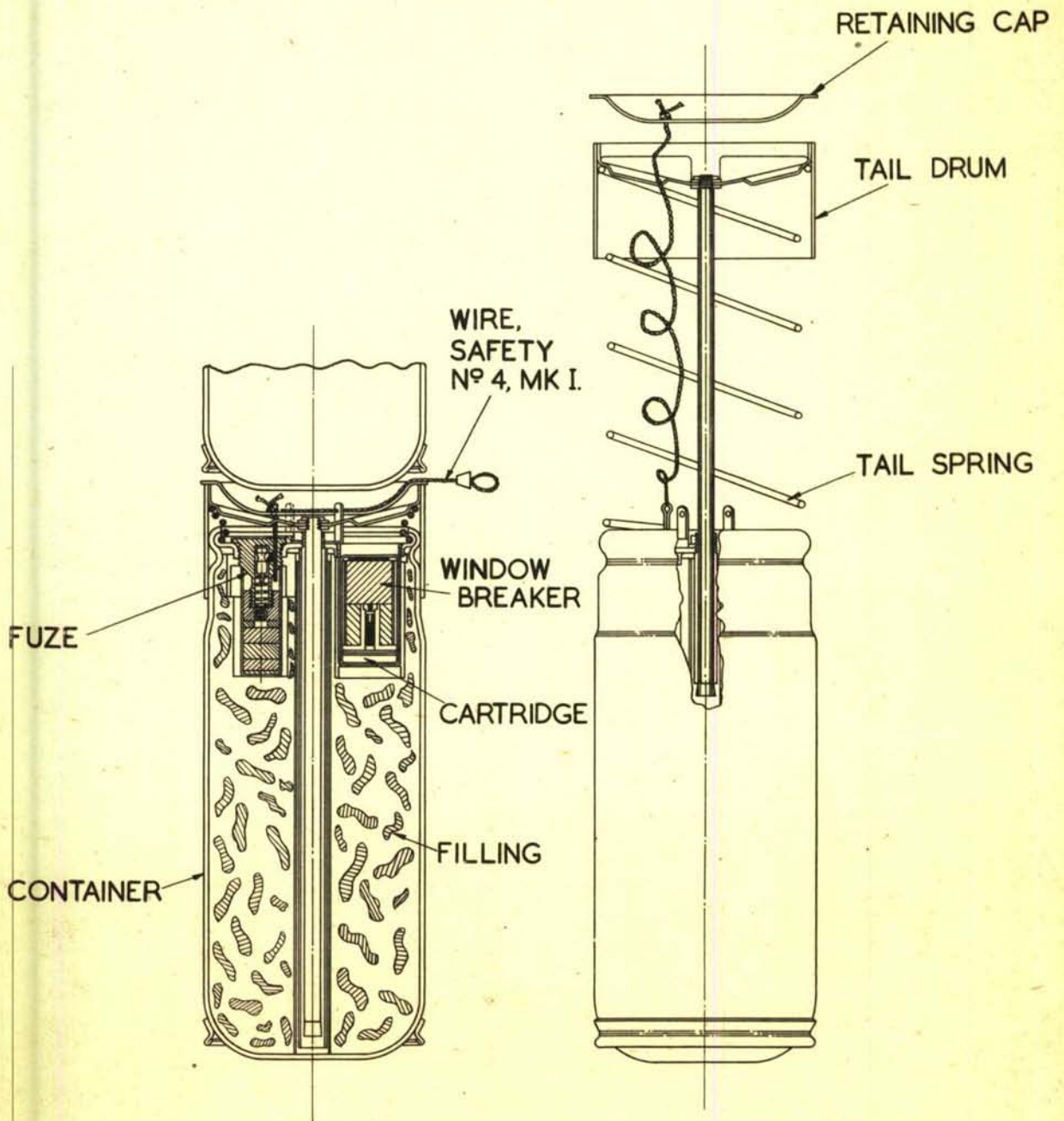

0 5  
SCALE - INCHES

**22 LB. "J" INCENDIARY BOMB.**  
**TYPE "A" WITH DRUM & ROD TAIL.**

BASED ON DRG. No  
D.M.D.I. SK. 13500

A.D.D. 23/46.



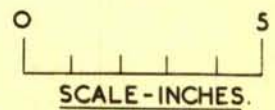
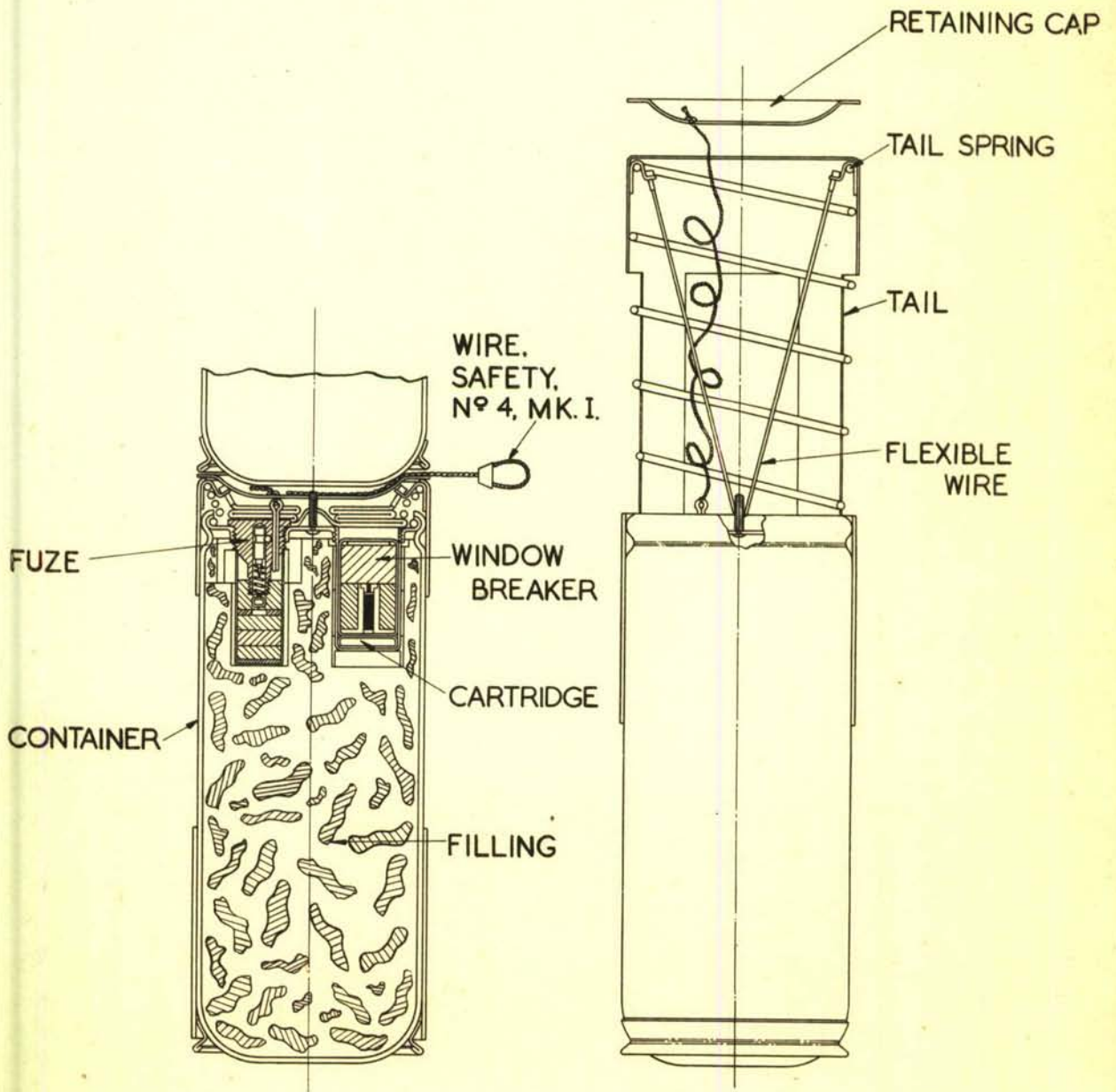

**22 LB "J" INCENDIARY BOMB.**  
**TYPE "B". CYLINDRICAL TAIL**

BASED ON DRG. N°  
D.M.D.I. SK. 13951.

A. D. P. 23/46.

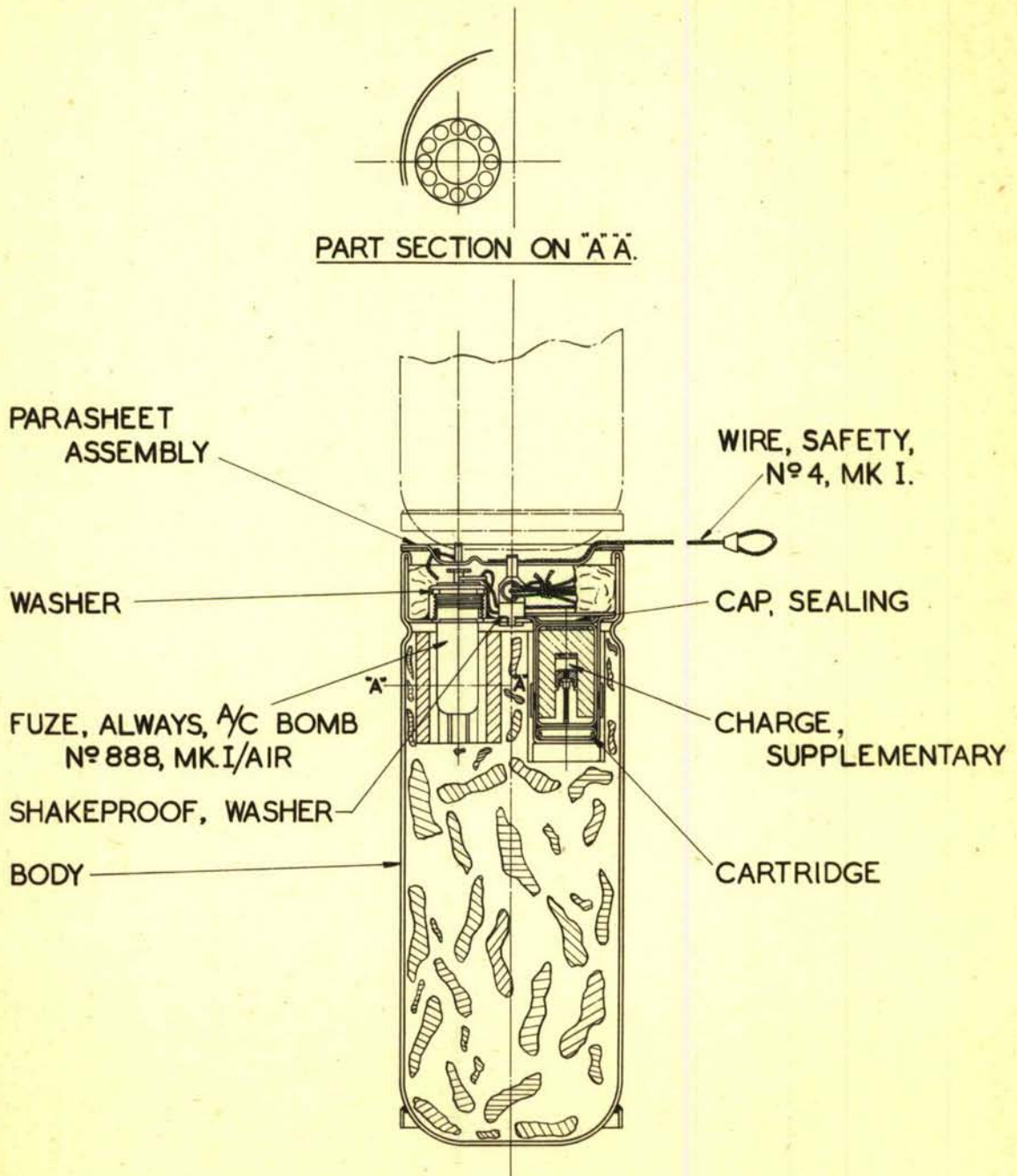

**20LB. J INCENDIARY BOMB, MK 2.**  
**WITH PARACHUTE TAIL.**

A.O.D. 23/46.

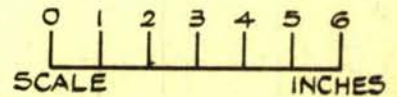
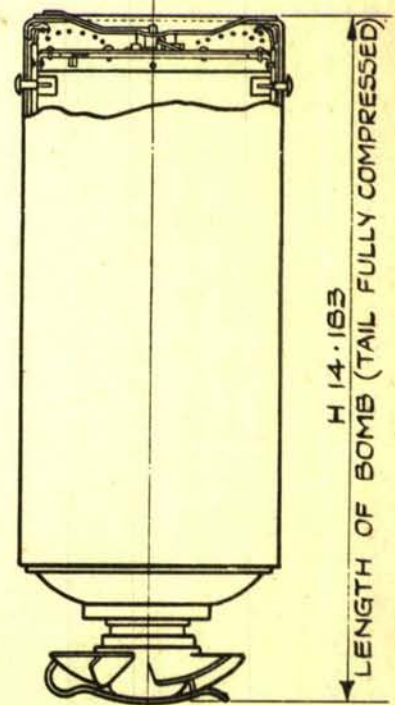
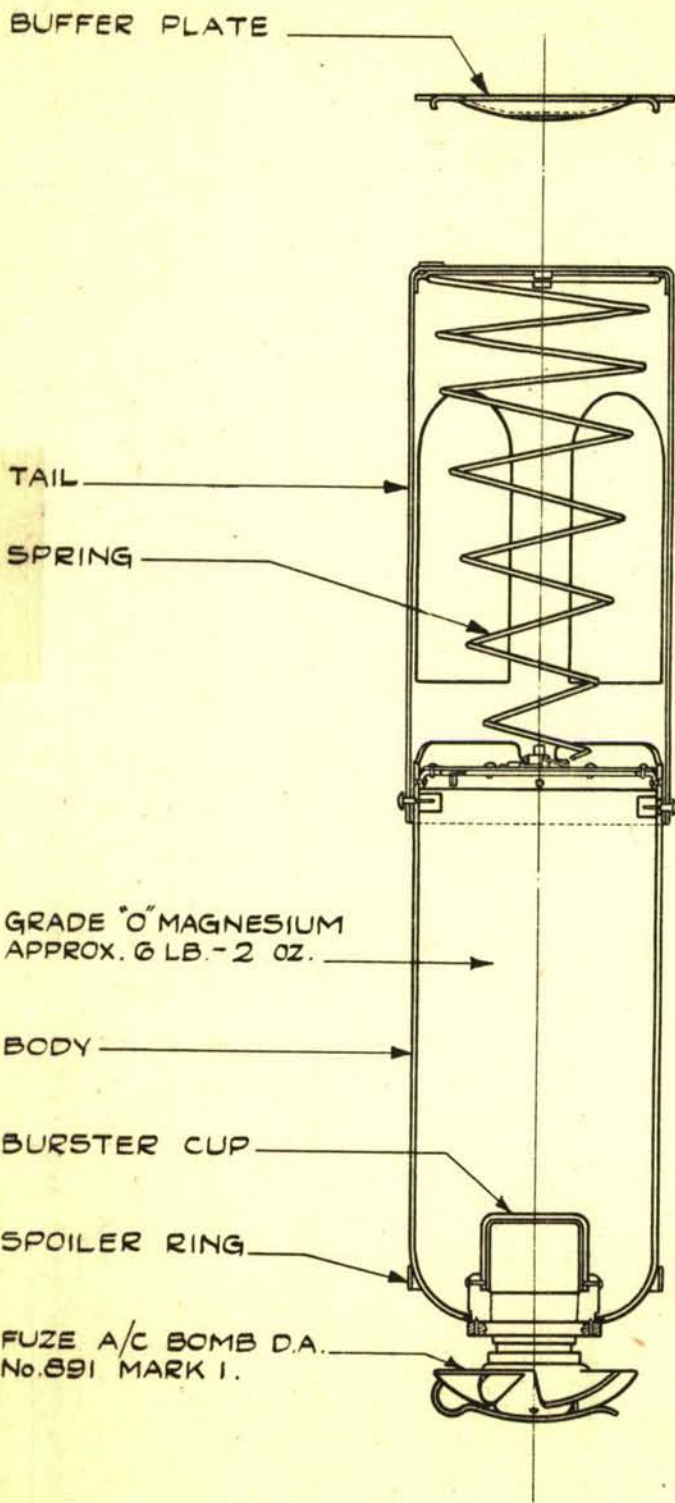

**18 LB. INCENDIARY BOMB.**

ADD 23/46