

Simulation and Experimental Elaboration of Acoustic Sensors for Mobile Robots

Professor V.E. Pavlovsky
Keldysh Institute of Applied
Mathematics of RAS (KIAM)
125047, Miusskaya square, 4, KIAM
Moscow
RUSSIA

T.S. Khashan
Institute for Problems of
Artificial Intelligence (IAI)
prospekt Bogdana Hmelnickogo, 84, IAI
Donetsk
UKRAINE

E-mail: vpavl@keldysh.ru / tsk@iai.donetsk.ua

ABSTRACT

The paper presents the concept and deals with the elaboration of intelligent technical audition sensors for mobile robots. General description of a robot, its control system, and description of an audition system are given in the paper. Simulation and experimental results are presented as well. Experiments were performed with using wheeled robot as a carrier, but audition system may be installed on board of other robots like tracked or helicopter robots.

Key words and phrases: *Technical audition system, mobile robot, sensor, robot, acoustic processes.*

1.0 INTRODUCTION

The paper presents the concept and deals with the elaboration of intelligent technical audition sensors for mobile robots. The using of the robot equipped with such sensors may be, for instance, realizing telepresence functions in a complicated environment. Such complicated environment may occur due to some natural or man-caused collisions, or may arise during collection of research data in those zones where the human presence causes troubles or, more, is strongly impossible. Therefore, the robot is intended for executing exploration of such zones. On elaborating the robot concept it was initially assumed that robot has to move under automatic or remote control mode to the zone of interest and then transmits telemetric data to the remote console from that zone. It is assumed that among the main components of telemetric data there are the sound “pictures” of the surroundings. Accordingly, robot has to be equipped with the system of technical audition. Transmission of such data to the remote console (computer) is executed, for instance, via radio line. Some other missions may be searching sound objects or tracking them.

2.0 GENERAL DESCRIPTION OF A ROBOT

Wheeled mobile robot “Argonaut-2” equipped with acoustic audition systems is shown on Fig. 1. The left picture shows the 1st release of a system, and the right one presents the 2nd release. The 1st and 2nd releases of ‘robot-acoustic-audition system’ differ one from another by the forms and sizes of acoustic antennas as it is shown. The robot was elaborated in the frame of research program on investigating intelligent mobile robots at KIAM.

Report Documentation Page

Form Approved
OMB No. 0704-0188

Public reporting burden for the collection of information is estimated to average 1 hour per response, including the time for reviewing instructions, searching existing data sources, gathering and maintaining the data needed, and completing and reviewing the collection of information. Send comments regarding this burden estimate or any other aspect of this collection of information, including suggestions for reducing this burden, to Washington Headquarters Services, Directorate for Information Operations and Reports, 1215 Jefferson Davis Highway, Suite 1204, Arlington VA 22202-4302. Respondents should be aware that notwithstanding any other provision of law, no person shall be subject to a penalty for failing to comply with a collection of information if it does not display a currently valid OMB control number.

1. REPORT DATE 01 MAY 2005		2. REPORT TYPE N/A		3. DATES COVERED -	
4. TITLE AND SUBTITLE Simulation and Experimental Elaboration of Acoustic Sensors for Mobile Robots				5a. CONTRACT NUMBER	
				5b. GRANT NUMBER	
				5c. PROGRAM ELEMENT NUMBER	
6. AUTHOR(S)				5d. PROJECT NUMBER	
				5e. TASK NUMBER	
				5f. WORK UNIT NUMBER	
7. PERFORMING ORGANIZATION NAME(S) AND ADDRESS(ES) Keldysh Institute of Applied Mathematics of RAS (KIAM) 125047, Miusskaya square, 4, KIAM Moscow RUSSIA				8. PERFORMING ORGANIZATION REPORT NUMBER	
9. SPONSORING/MONITORING AGENCY NAME(S) AND ADDRESS(ES)				10. SPONSOR/MONITOR'S ACRONYM(S)	
				11. SPONSOR/MONITOR'S REPORT NUMBER(S)	
12. DISTRIBUTION/AVAILABILITY STATEMENT Approved for public release, distribution unlimited					
13. SUPPLEMENTARY NOTES See also ADM202032., The original document contains color images.					
14. ABSTRACT					
15. SUBJECT TERMS					
16. SECURITY CLASSIFICATION OF:			17. LIMITATION OF ABSTRACT	18. NUMBER OF PAGES	19a. NAME OF RESPONSIBLE PERSON
a. REPORT unclassified	b. ABSTRACT unclassified	c. THIS PAGE unclassified			

Simulation and Experimental Elaboration of Acoustic Sensors for Mobile Robots

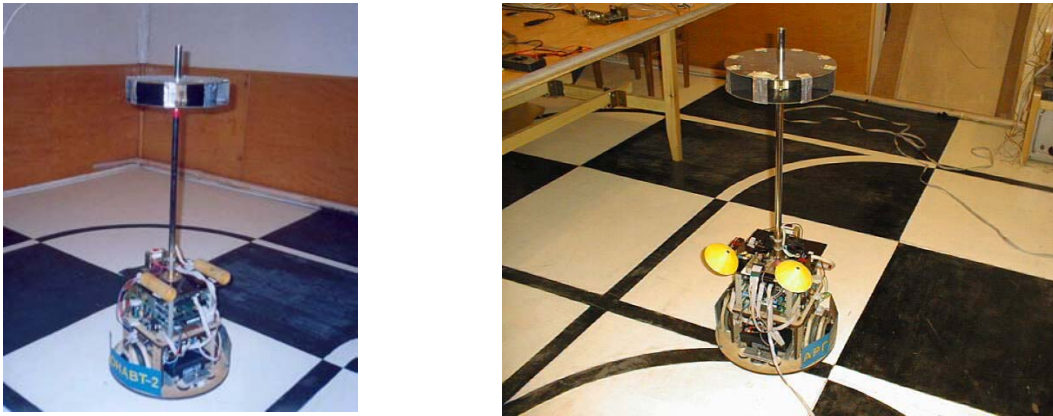

Figure 1: The “Argonaut-2” Mobile Robot Equipped with Audition Sensors.

2.1 Control System of a Robot

As a whole, the control system of the robot is elaborated in according to the client-server technology that is developed at KIAM for controlling mobile robots. The control system is implemented as two main modules – an on-board system (the control server) and a console application (client application), the last one is executed on the same on-board computer, or on a remote computer. The control server and client application are connected via a wire or a wireless (radio) line, the system supports a number of different network protocols. As a main variant, the TCP/IP is used. For example, the connection of a server and control client application may be realized via Internet with the radio-Ethernet segment. The console application displays telemetric data of a remote robot and transmits commands to the robot, those commands may be of low-level type, or may be of high-level type. Last version of a system supports not only data transmitting but loading control program on board as well.

Solution for designing the control system hardware is as following. The system typically includes two computers and those computers are combined into onboard control computer network. The host computer of a network is PC-compatible high-reliable machine. This computer is intended for searching objects and for route planning and is equipped with 8/16-channel ADC card for controlling the sensors. On a low level of control network modular control computer built on a 16-bit INTEL-80196 processor is used. System for wheels control is digital one and implements optical encoders to obtain data of wheels position and speed. The control system includes also PWM modules (cards) equipped with MOSFET H-bridge units to control wheels rotations. The scheme of an onboard part of control system is given on Fig. 2.

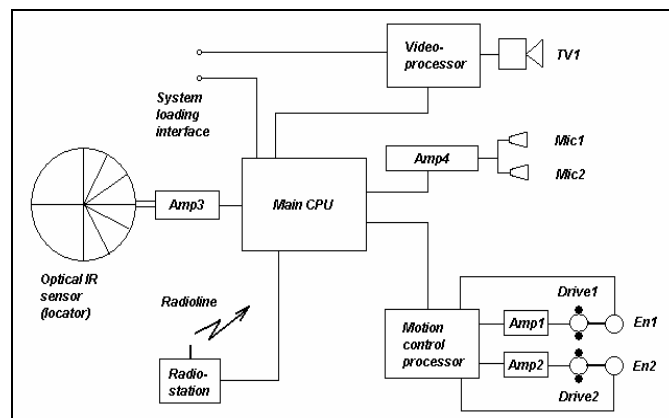

Figure 2: Control System of a Robot “Argonaut-2”.

2.2 Technical Audition System

The technical audition system (TAS) is realized by the set of microphones additionally equipped with special acoustic antennas (a special horn devices) and a software-hardware unit for audition data processing. The system is intended for transmitting the sound data to the remote console, also for direction-finding to the typical sound objects, and for finding location of those objects in a zone being investigated. Those tasks are solved by special audition software module, which is an element of intelligent audition sensor. TAS is shown on Fig.2 as system of *Mic1*, *Mic2* (microphones), *Amp4* (acoustic amplifier) and it is supposed that corresponding part of control programs are running in *CPU*. As advanced release of TAS the system equipped with matrix of microphones (not only with two of them) was investigated as well.

3.0 SIMULATION OF ACOUSTIC PROCESSES IN AUDITION SYSTEM

3.1 Mathematical Models and Simulation System

First, the system of audition sensors was simulated with using special mathematical simulation package WHISPAR [1]. The simulation was based on using the linearized Euler equations (PDE) for describing the motion of an ideal gas. On the base of the simulation the ‘amplitude’ and ‘phase’ algorithms for localizing sound objects were elaborated and their features were tested in details. The appropriate accuracies were obtains for simulated sensor. The so-called phase ‘algorithm’ was chosen. Second, the simulation results allow to use elaborated algorithms for controlling real mobile robot on the next stage.

More exactly, the system of equations (1) was used for simulating. Those equations are continuity equation and Euler equations, they describe the general gas motions and, in particular, they describe acoustic waves propagation.

$$\begin{aligned}
 \frac{\partial \rho}{\partial t} + \frac{\partial(\rho u)}{\partial x} - \frac{\partial(\rho v)}{\partial y} + \frac{\partial(\rho w)}{\partial z} &= 0 \\
 \frac{\partial u}{\partial t} + u \frac{\partial u}{\partial x} + v \frac{\partial u}{\partial y} + w \frac{\partial u}{\partial z} &= X - \frac{1}{\rho} \frac{\partial p}{\partial x} \\
 \frac{\partial v}{\partial t} + u \frac{\partial v}{\partial x} + v \frac{\partial v}{\partial y} + w \frac{\partial v}{\partial z} &= Y - \frac{1}{\rho} \frac{\partial p}{\partial y}
 \end{aligned}
 \tag{1}$$

Here x,y,z are Cartesian coordinates, u,v,w are the gas velocity components, ρ is density, and p is pressure in the gas. X,Y are components of external force. The system of linearized version of (1) for 2D-space and energy equation were used for describing the acoustic waves propagation around acoustic sensors. On the Fig.3 some simulation frames are shown.

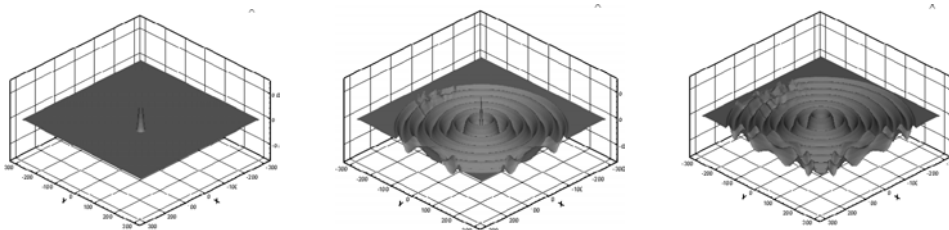

Figure 3: Acoustic Waves around the Audition Sensors, 3D View of 2D-Waves.

**Simulation and Experimental
Elaboration of Acoustic Sensors for Mobile Robots**

The simulation was used for preliminary elaborating the algorithms for sound objects localizing. The so called ‘phase’ algorithm was elaborated and verified on the basis of the numerical model. Next two figures (Fig. 4, left and right) show the geometrical schemes of a ‘phase algorithm’. On Fig. 4-left the full geometrical scheme is shown, and on Fig. 4-right the linear approximation of that scheme is given. As it is shown, the location curve (where the sound source may be located) is a hyperbolic line, under the approximation the asymptote of that hyperbola may be used for fast calculation of the sound source direction. And it is possible to show, that linear approximation is the limit of accurate solution when the sound source ‘goes’ to infinity. Experiments show that the accuracy of such approximation is quite sufficient.

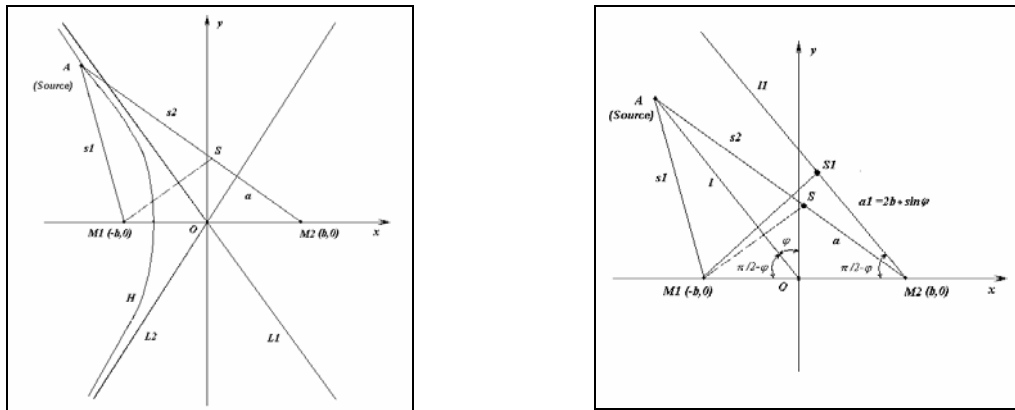

Figure 4: ‘Phase Method’ for Sound Source Direction Finding.

The corresponding scheme of process of calculating the direction to the sound source (the polar angle calculation) is shown on Fig. 5.

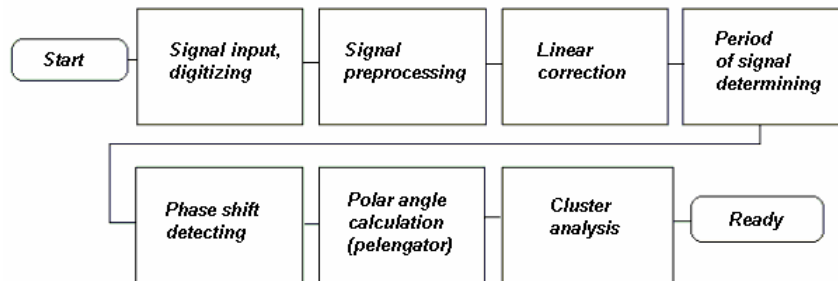

Figure 5: Scheme of Calculation Process.

Main elements of the direction finding process are steps for calculating the time difference in between the moments of detecting the same phases of sound waves by the sensor microphones. To find this it is necessary to determine so called ‘time shift’ between waves on left and right microphones, then geometrical difference between ways of waves propagation may be simply calculated, and on basis of such difference the sound source polar angle may be calculated.

To find ‘time shift’ between sound waves the calculation of the correlation function or calculation of the difference function are used. Note, that such calculation schemes are practically the same ones. Correlation function is

$$R_{xy}(\tau) = \sum_{\tau=0}^{N-\Delta-1} \sum_{n=i}^{i+\Delta} S_1(n)S_2(n + \tau - i) \tag{2}$$

Correspondingly, the ‘time shift’ τ when correlation function $R_{xy}(\tau)$ takes its maximal value is value in interest. If τ is known, it is possible to find direction to the sound source as it is shown on Fig. 5. It is also reasonable to note that function (2) may be calculated with using only integer arithmetic, i.e. with high efficiency.

3.2 Simulation Results

On the next figure (Fig. 6) the scheme of detailed numerical experiment on direction to sound source finding is shown. As Fig. 6 shows, special software utility was developed to process data of simulated acoustic field obtained from simulating system (1).

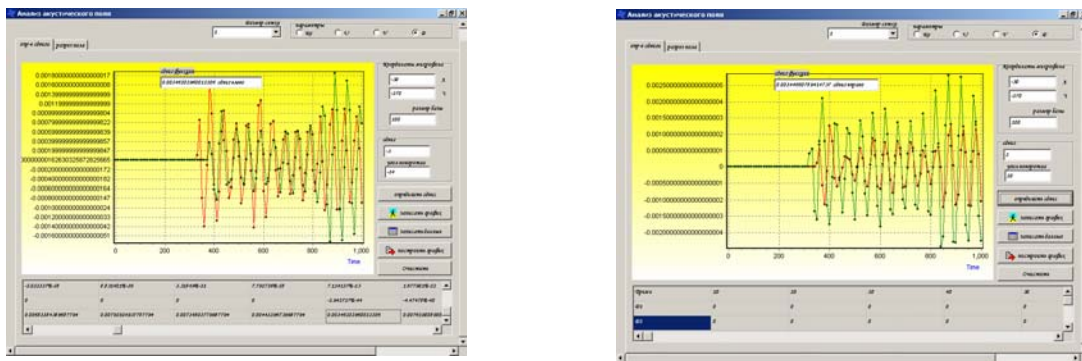

Figure 6: Simulation – Probing the Acoustic Field.

Left: SRC (-150;50), $N_r = 5$, $\tau = -50$, left shift, $a = -50$, $\sin\alpha = -0.5$, $\alpha = -30^\circ$.
Right: SRC (100;50), $N_r = 3$, $\tau = 30$, right shift, $a = 30$, $\sin\alpha = 0.3$, $\alpha = 17.46^\circ$.

The next tables show typical results of verifying the ‘phase algorithm’ with using simulation approach. First table shows the real location of sound source, and the second one shows the corresponding data obtained by the ‘phase algorithm’.

Table 1: Simulated Geometrical Data of Acoustic Scene

Mic	yMic	x1 (SRC)	y1 (SRC)	dist ²	dist	diff	sin(a)	a (grad)
-50	-270	-150	50	112400	335.2611			
50	-270	-150	50	142400	377.3592	-42.0982	-0.42098	-24.8966
-50	-270	50	50	112400	335.2611			
50	-270	50	50	102400	320	15.26109	0.152611	8.778266
-50	-270	100	50	124900	353.4119			
50	-270	100	50	104900	323.8827	29.52925	0.295292	17.17508

Table 2: Geometrical Data Obtained by 'Phase Algorithm'

x_{Mic}	y_{Mic}	$x1 (SRC)$	$y1 (SRC)$			$time\ shift$	$\sin(a)$	$a\ (grad)$	$Accuracy$
-50	-270	-150	50						
50	-270	-150	50			-50	-0.5	-30	5.10343
-50	-270	50	50						
50	-270	50	50			20	0.2	11.53696	2.758696
-50	-270	100	50						
50	-270	100	50			30	0.3	17.45761	0.282528

Comparison of the data given in the tables show sufficiently high accuracy of 'phase algorithm'. As it is shown, the accuracy of direction finding in given numerical examples are from 5.103° to 0.282° . So, the accuracy in all cases is quite sufficient, and, it is necessary to note, in the last example accuracy is better, than 0.3° .

4.0 EXPERIMENTAL ELABORATING

Sensor measurement channel is shown on the Fig. 7. It is necessary to mention that the special amplifier is needed to be installed in this measurement channel, but in the first experiments the linear amplifier was used. As it was mentioned above, the hearing system may include two such channels (microphones and amplifier), or a matrix of such sensors.

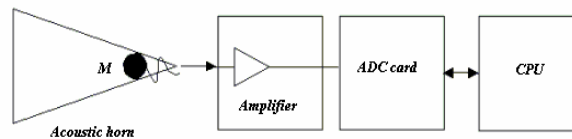
Figure 7: Principal Scheme of a Measurement Channel of Audition Sensors.

The second release of technical audition system is shown on Fig. 8 (the upper view is shown). In the set of experiments the form and sizes of horn antennas were chosen and optimized.

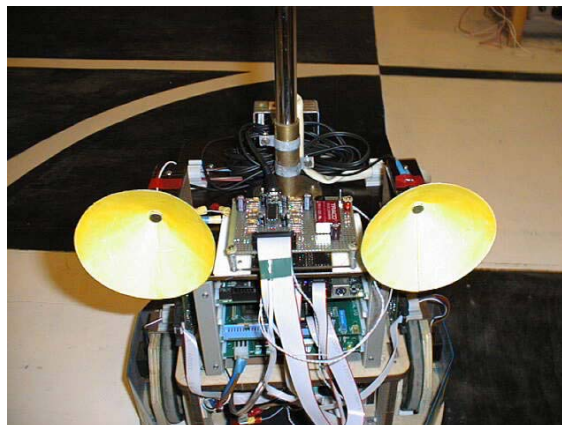
Figure 8: Acoustic (Hearing) System. Detailed View.

Finally, the audition task is solved by special audition digital module, which is an element of intelligent audition sensor. In the frame of developing of this system main efforts were devoted to elaboration of the audition sensor itself and its digital module.

For experiments the phase algorithm was chosen, as phase data are more reliable for measuring on board of robot. Experiments show, however, that it is necessary to build some additional logic levels for that algorithm in comparison with the simulated version. The aim of that logic extension is controlling the measurements and taking only reliable data. Such extension known as cluster analysis was included in the audition system software. The total architecture of software system corresponds to that shown on Fig. 5. With the mentioned logic system the acoustic sensors show sufficient accuracies in the real time mode of operation in the real environment.

The scheme of experiments was the following. The typical computer speaker system (not stereo, but mono-channel one) was used as sound source, it emanates sound as pure harmonic signal with frequency in between 600 - 800 Hz. The robot solves the task of finding direction to sound source, after this it has to move to sound object and has to touch it. To avoid the problem of finding the sound source under the noise of robot drives, the robot runs in the so called 'start-stop' mode. First, the robot is hearing the sound and finding the direction, then moves some way on that direction, and so on. It moves the total way as long as 4-5 meters to sound source with 2-3 intermediate 'stations'. Practically in all experiments the accuracy of touching the sound object was in between 0-3 cm. One set of such experiment scenes is shown on Fig. 9.

Nevertheless, spectral analysis shows that drive noise could be simply separated from the work frequencies of 600-800 Hz. On future experiments such extension based on Fast Fourier Transform will be included in the software system of TAS.

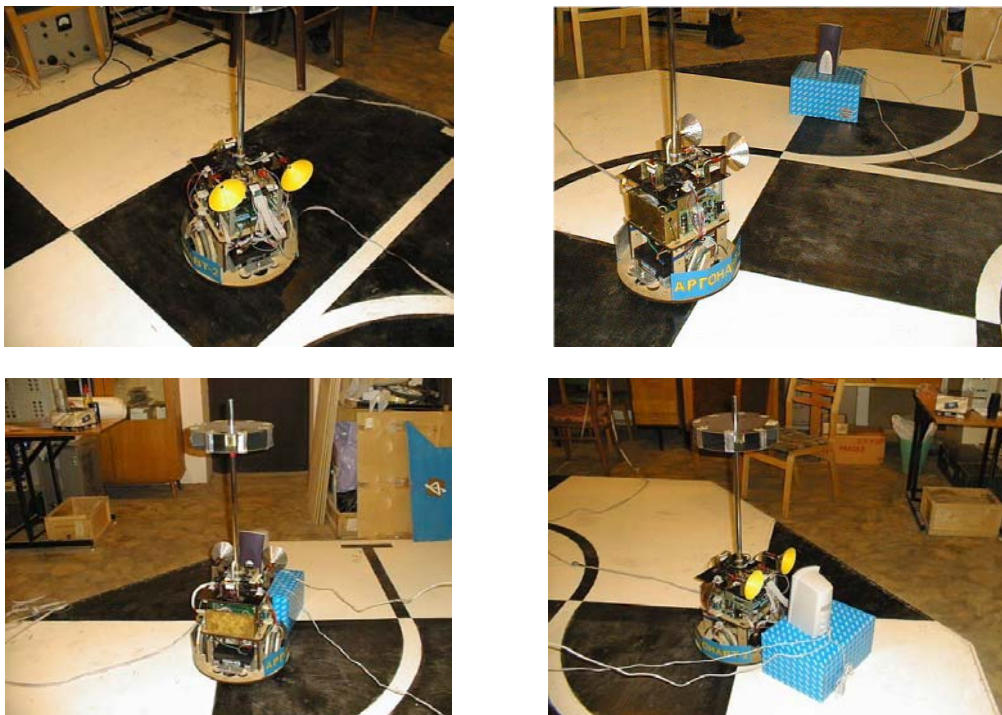

Figure 9: Scenes of Sound Source Searching by "Argonaut-2" Robot.

5.0 CONCLUSION

As a whole, the mobile robot equipped with described intelligent sensors is built on a scheme which follows the biological prototypes, and one of the aims of robot development is investigation of main characteristics of a machine with biologically inspired sensor subsystem. Experiments show that 'phase discriminator' system may be treated as sufficiently good model of audition system for mobile robots.

The described sensor systems may be used to equip different mobile robots (that are intended for telepresence or searching sound objects) with audition systems. As examples the KIAM robots may be mentioned, namely the wheeled-legged robot [2] or tracked robot, or helicopter robot. All mentioned machines could be used as rescue robots, informative robots, research robots, etc., or for other similar applications. Such experiments will be performed on next stages of investigation.

6.0 REFERENCES

- [1] I.A. Abalakin, A.V. Alexandrov, V.G. Bobkov, T.K. Kozubskaya. High Accuracy Methods and Software Development in Computational Aeroacoustics. Journal of Computational Methods in Sciences and Engineering, 2003, Vol. 2, No. 3, pp. 1-3.
- [2] V.E. Pavlovsky, D.V. Shishkanov, A.D. Alexeev, S.V. Amelin, Yu.N. Podoykin. Concept and Modeling of Legged-Wheeled Modular Chassis for High-Adaptive Rover. Proc. of 5th Int. Conf. on Climbing and Walking Robots CLAWAR'2002. Paris, France, 25-27 September 2002, pp. 307-314.