

**10th International Command and Control Research and Technology  
Symposium**

**The Future of C2**

**Future Integrated Fire Control**

**Bonnie W. Young**

Northrop Grumman

2611 Jefferson-Davis Highway Suite 8000

Arlington, VA 22202

(703) 407-4531ph

[bonnieworthyoung@hotmail.com](mailto:bonnieworthyoung@hotmail.com)

# Report Documentation Page

*Form Approved*  
*OMB No. 0704-0188*

Public reporting burden for the collection of information is estimated to average 1 hour per response, including the time for reviewing instructions, searching existing data sources, gathering and maintaining the data needed, and completing and reviewing the collection of information. Send comments regarding this burden estimate or any other aspect of this collection of information, including suggestions for reducing this burden, to Washington Headquarters Services, Directorate for Information Operations and Reports, 1215 Jefferson Davis Highway, Suite 1204, Arlington VA 22202-4302. Respondents should be aware that notwithstanding any other provision of law, no person shall be subject to a penalty for failing to comply with a collection of information if it does not display a currently valid OMB control number.

1. REPORT DATE <b>JUN 2005</b>	2. REPORT TYPE	3. DATES COVERED <b>00-00-2005 to 00-00-2005</b>			
4. TITLE AND SUBTITLE <b>Future Integrated Fire Control</b>		5a. CONTRACT NUMBER			
		5b. GRANT NUMBER			
		5c. PROGRAM ELEMENT NUMBER			
6. AUTHOR(S)		5d. PROJECT NUMBER			
		5e. TASK NUMBER			
		5f. WORK UNIT NUMBER			
7. PERFORMING ORGANIZATION NAME(S) AND ADDRESS(ES) <b>Northrop Grumman, 2611 Jefferson-Davis highway Suite 8000, Arlington, VA, 22202</b>		8. PERFORMING ORGANIZATION REPORT NUMBER			
9. SPONSORING/MONITORING AGENCY NAME(S) AND ADDRESS(ES)		10. SPONSOR/MONITOR'S ACRONYM(S)			
		11. SPONSOR/MONITOR'S REPORT NUMBER(S)			
12. DISTRIBUTION/AVAILABILITY STATEMENT <b>Approved for public release; distribution unlimited</b>					
13. SUPPLEMENTARY NOTES <b>The original document contains color images.</b>					
14. ABSTRACT					
15. SUBJECT TERMS					
16. SECURITY CLASSIFICATION OF:			17. LIMITATION OF ABSTRACT	18. NUMBER OF PAGES <b>65</b>	19a. NAME OF RESPONSIBLE PERSON
a. REPORT <b>unclassified</b>	b. ABSTRACT <b>unclassified</b>	c. THIS PAGE <b>unclassified</b>			

## Future Integrated Fire Control

**Bonnie W. Young**

Northrop Grumman

2611 Jefferson-Davis Highway Suite 8000

Arlington, VA 22202

(703) 407-4531ph

[bonnieworthyyoung@hotmail.com](mailto:bonnieworthyyoung@hotmail.com)

### **Abstract**

Future advances in fire control for air and missile defense depend largely on a network-enabled foundation that enables the collaborative use of distributed warfare assets for time-critical operations. These advances enable major enhancements for tactical fire control. Selecting the best shooter from a set of geographically distributed firing units can improve the chances of intercepting targets and improve the economy of weapon resources. Earlier launch decisions are possible when sensors are intelligently tasked based on shared knowledge of the battlespace. No longer must collocated sensors and weapons be paired for engagements. Lifting such pairing constraints expands the effective kinematic range of weapons and enables additional operational capabilities such as forward pass and off-board engagement support for guidance relay and target illumination. For complex threat environments in which sophisticated or significant numbers of aerospace targets exist, automated collaborative fire control (or Integrated Fire Control (IFC)) may be a necessity for victory. This paper presents research in advanced data fusion and decision aid capabilities as a means of enabling and enhancing IFC. It addresses the importance of achieving distributed information superiority—shared, accurate, and timely situational awareness as the foundation of IFC capabilities. It discusses required IFC design and architecture guidelines. Finally, the paper proposes an IFC concept to meet the complex needs of future warfare.

### **1.0 Integrated Fire Control**

IFC refers to the participation and coordination of multiple non-collocated

warfare assets<sup>1</sup> in tactical engagements of enemy targets. In other words, IFC is the ability of a weapon system to develop fire control solutions from information provided by one or more non-organic sensor sources; conduct engagements based on these fire control solutions; and either provide mid-course guidance (in-flight target updates) to the interceptors based on this externally provided information or in certain cases, have them provided by a warfare unit other than the launching unit. IFC enables expansion of a weapon's battlespace to the effective kinematic range of the missiles and can remove dependency on range limits of the organic/dedicated sensor.

IFC relies on the ability of participating sensors, weapons, and C2 nodes to share target information in real-time and eliminate correlation errors so the engaging weapon system can utilize the information as if it was produced by its organic sensor(s). An architectural solution that enables IFC is based on combining sensor and data networks to overcome individual system limitations and enable collaborative engagements; and providing automated engagement decision aids that use "common" algorithms and the shared data set to simultaneously produce identical engagement recommendations at each participating node, in accordance with established rules of engagement (ROE). The ability to direct distributed warfare resources in a collaborative manner enables major

---

<sup>1</sup> Warfare assets (or warfare resources) are sensors, weapons, command and control (C2) systems, and warfare units (mobile platforms such as ships, aircraft, satellites, land-based units, etc.) Additional assets that support IFC are communication resources and computer/processing systems.

enhancements for tactical fire control as shown in Figure 1.

**Why Integrated Fire Control?**

- Selection of the best shooter from a set of geographically distributed weapons
- Improved chance of interception (by selecting the optimal engagement geometry)
- Improved economy of weapon resources (by reducing redundant shots)
- Earlier launch decisions are possible (remote detection/precision tracking)
- Decoupling of local sensor/weapon pairing constraint
- Sharing engagement control – forward pass
- Off-board engagement support for guidance relay and target illumination
- Enhanced defense against complex threat environments (sophisticated or significant numbers of aerospace targets) – IFC may be a necessity for victory

**Figure 1 – IFC Payoffs**

**1.1 Operational IFC Variants**

Collaboration among distributed warfare resources to perform integrated engagements takes many forms. Distributed collaboration can consist of simply receiving a threat cue from a remote source to the sophisticated integration required to pass engagement control to a remote unit. This section introduces the major types of IFC capabilities from an operational perspective.

**(1) Precision Cue**

The Precision Cue is an IFC capability in which a cue (representing a possible threat) is received from a remote source (i.e., sensor, Intel source, tactical data link, remote operator). The cue is used to direct a local sensor (or sensors) to detect a specific target. The cue is comprised of target information such as a state (location) estimate, target track data, and/or an assessment of the target’s identification (Combat ID).

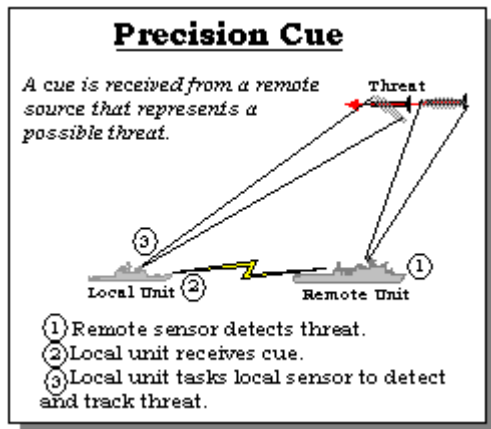
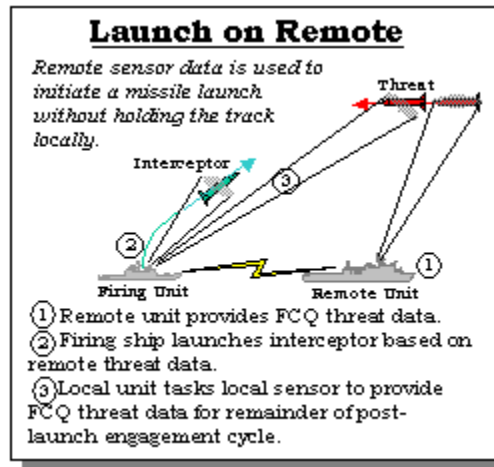

**Figure 2 – Precision Cue**

Figure 2 illustrates the Precision Cue variant, showing how a remote unit detects a threat and transmits the target information to the “local” unit. The local unit then tasks a local sensor to detect and track the threat.

**(2) Launch on Remote**

Launch on Remote (LoR) is an IFC capability in which remote sensor data is used to initiate a missile launch without holding the track locally.



**Figure 3 – Launch on Remote**

Operationally, LoR relies on the ability of a local sensor to track (and provide fire control quality data for) the threat target after missile launch to acquire the data needed to support the in-flight guidance of the interceptor. A related variant of the LoR is “Launch on Composite” in which composite data (comprised of data from multiple sensors—remote and/or local) is used to initiate the missile launch.

Figure 3 illustrates an example of the LoR variant. In this illustration, the remote sensor detects and tracks the threat and provides the data to the firing unit. The firing unit uses this threat data to make a launch decision. The firing unit requires its local sensor to track the threat after launch to support in-flight guidance.

**(3) Engage on Remote**

Engage on Remote (EoR) is an IFC capability in which one or more remote sensors provide data upon which all (or portions) of an engagement is conducted. Variants of EoR include: using remote data to initiate launch as well as support in-flight guidance

computations; using a remote sensor to relay in-flight guidance to the interceptor; and using a remote sensor to illuminate the threat during interceptor endgame. A related variant of EoR is “Engage on Composite” in which composite data is used to provide fire control quality data throughout the engagement to support guidance computations and engagement control.

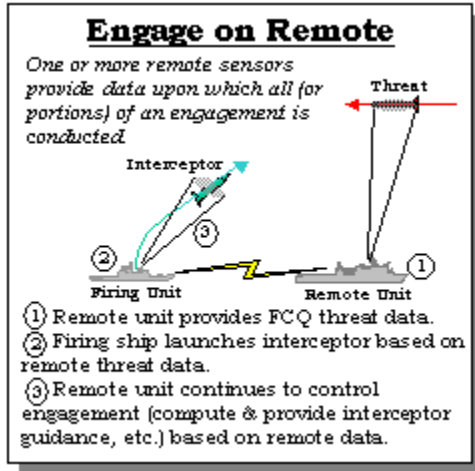

Figure 4 – Engage on Remote

Figure 4 illustrates an example of the EoR variant. In this illustration, the remote unit provides fire control quality (FCQ) data of the threat to the firing unit throughout the engagement. The firing unit uses the remote data to make the launch decision as well as support the entire engagement.

**(4) Forward Pass**

Forward Pass is an IFC capability in which control of the in-flight missile can be handed off (or forward passed) to another unit to complete the intercept. Forward Pass may be used to complete an engagement that otherwise may have been impossible due to constraints on the system that initiated the engagement. A remote system may be strategically located to better provide endgame control. Or perhaps multiple threats require a weapon system to rapidly launch multiple interceptors while handing off engagement control to remote systems.

Figure 5 illustrates an example of the FP variant. This example shows the remote unit taking control of the engagement after launch by tracking the threat and providing guidance directly to the interceptor.

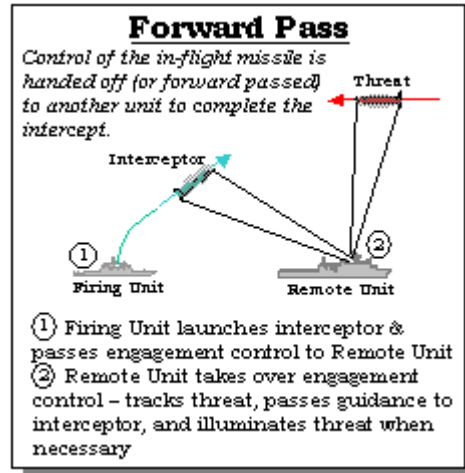

Figure 5 – Forward Pass

**(5) Remote Fire**

Remote fire is an IFC capability in which the launch decision is made by a remote unit (one that is not collocated with the weapon system). For “remote fire”, engagement control can be performed by the remote unit or can be passed to the firing unit.

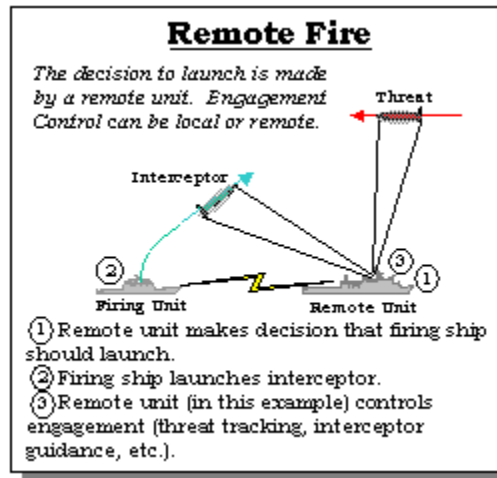

Figure 6 – Remote Fire

Figure 6 illustrates and example of the RF variant. In this example, the remote unit makes the decision that the firing unit should launch its interceptor. After launch, the remote unit takes control of the engagement; however engagement control could reside with the firing unit for the RF variant.

**(6) Preferred Shooter Determination**

Preferred Shooter Determination is an IFC capability in which the optimum weapon (or weapons) from a group of warfare units

(operating collaboratively) is (are) selected to intercept a threat target. The best shooter(s) is (are) selected based on optimum engagement geometry and engageability determination. This capability can be performed in conjunction with any of the other IFC variants. This capability is, in effect, Force-centric weapon-target pairing.

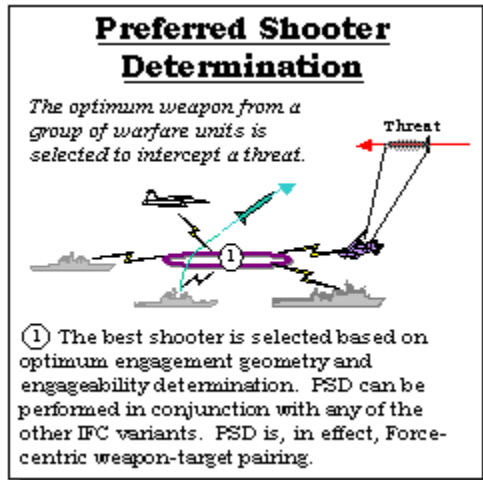

**Figure 7 – Preferred Shooter Determination**

Figure 7 illustrates the PSD variant. This illustration depicts five distributed warfare units sharing data over a network to determine the best engagement strategy (or weapon-target pairing) for the threat. In this example, one of the Destroyers is selected as having the best shot opportunity.

### **1.2 Fire Control Functions**

In order to intercept an aerospace threat, some basic functions must be performed. These fire control functions are “common” in the sense that they are necessary to support the various Joint weapon systems that comprise the aerospace warfare arsenal. The functions listed below are defined broadly enough to encompass basic functions that support fire and forget weapon systems to more complex functionality that supports more sophisticated weapon systems that require in-flight engagement support after launch. This section defines a generic set of fire control functions with the intent of easily aligning with the terminology used for the various Service’s weapon systems.

**(1) Object Observation** – sensor(s) observes aerospace object and produces object measurements.

**(2) Object Tracking and Identification** – sensor measurements (from one or more sensors) are used to estimate an object’s location & kinematics (track); and an assessment of its identity & intent (i.e., friendly, hostile, neutral, etc.).

**(3) Fire Control Quality Data Attainment** – For air targets of interest, data is obtained with enough accuracy and update rate to support engagement (launch decision, guidance calculations, and engagement control). Obtaining data may require tasking sensor resources as well as communication resources (to dedicate a data path, allocate more bandwidth or increase the rate of throughput).

**(4) Engagement Initiation or Launch Decision** – decision to initiate defensive measures against an air target of interest (includes: threat evaluation, engageability determination, shooter selection or weapon-target pairing, and sensor support selection)

**(5) Guidance Calculation** – calculation is made of the interceptor guidance required to intercept target. (Note: this may require target discrimination as well)

**(6) Engagement Control** – engagement is controlled by managing warfare resources that are participating in the engagement (firing interceptor; tasking sensors & communication resources; ensuring resources are committed; monitoring resource performance; ensuring FCQ data is available and validating quality of data; monitoring engagement support & ensuring it is provided (guidance relay, target illumination, etc.); and negating (terminating) engagement if necessary.

**(7) Guidance Relay** – sensor or communication data path provides guidance (in-flight target updates (IFTUs) or target object maps (TOMs)) to interceptor<sup>2</sup> while in flight.

**(8) Target Illumination** – sensor illuminates target to support interceptor<sup>3</sup> homing to target.

### **2.0 IFC Design Considerations**

Just as there are a variety of Operational IFC variants; there are a variety of system

<sup>2</sup> For weapon systems that require in-flight guidance or a “map” of the target.

<sup>3</sup> For weapon systems that require end game illumination of targets.

solutions or mechanisms that can be employed to enable these capabilities. IFC is based on the collaboration of distributed warfare resources. Such collaboration can be enabled manually or in an automated fashion; from a centralized decision-making C2 node or in a de-centralized fashion; using requests and handshakes, bidding processes, or common decision-aids for simultaneously generating identical task sets. To further complicate matters, the most suitable solution depends on the operational situation; and thus various solution configurations must be available to the Joint warfighter. Therefore, the solution must be designed to handle a variety of IFC processes from supporting the manual selection and control of warfare assets during an engagement to providing sophisticated automation to make optimum resource selection decisions in near-real-time to select the best shooter; predict which sensor or combination of sensors can best guarantee fire control quality data throughout an engagement; and/or determine which units are capable of accepting control of an engagement after launch to enable a forward pass.

The manner in which these fire control functions are performed determines the degree of integration achievable and the ability to perform fire control from a Force-centric perspective. The key to achieving *integrated* fire control is the realization that these common fire control functions can be performed in a variety of manners:

- [1] **Locally or remotely**
- [2] **From a Unit-centric or Force-centric perspective**
- [3] **By the weapon system or by common processing**
- [4] **Centralized or De-centralized control**
- [5] **Manually or in an Automated-fashion**

**2.1 Local vs. Remote**

An examination of the various forms of IFC capabilities possible based on performing the basic fire control functions on one or more warfighting units is summarized in Table 1. The columns represent the different IFC variants. The rows list the fire control functions. “L” is used to describe a function performed by a warfare asset that is local (or

collocated with the system that fires the weapon). “R” describes a function performed remotely or on a unit that is non-collocated with the launching unit.

**Table 1 – IFC Options**

	FC	LoR	EoR	FP	RF	PSD
<b>Object Observ.</b>	R	R	R	L or R	R	L or R
<b>Object Trking/ID</b>	L & R	R	R	L or R	R	L or R
<b>FCQ Data Attain.</b>	L	R&L	R	L or R	R	L or R
<b>Eng Initiation</b>	L	L	L	L	R	Force Centric
<b>Guidance Calc</b>	L	L	L	L or R	L or R	L or R
<b>Eng Control</b>	L	L	L	L & R	L or R	L or R
<b>Guidance Relay</b>	L	L	L or R	L or R	L or R	L or R
<b>Target Illumin.</b>	L	L	L or R	L or R	L or R	L or R

A box in each mapping is shaded to indicate that the performance of this particular fire control function determines which IFC variant is taking place. For example, in the case of PC (Precision Cue), the aerospace object is observed by a remote unit. In the case of LoR, FCQ data is provided by a remote unit for making the launch decision; however, after launch the local sensor provides FCQ data.

**2.2 Force-centric IFC**

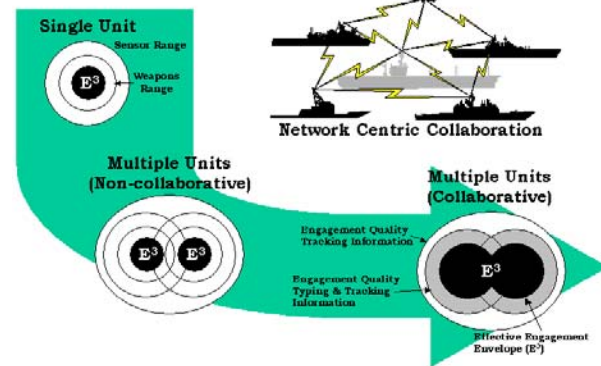

**Figure 8 – Shifting to Force-centric Thinking**

Figure 8 illustrates the expansion of the “effective engagement envelope” from a single unit using only local resources to multiple fully collaborative or integrated units using resources for the benefit of the group rather than the individual unit’s needs. Such collaboration requires system designs that are developed with a “big picture” or force-

centric perspective in which distributed warfare resources are all considered part of a system of systems. Shifting to a Force-centric perspective is key to enabling all IFC capabilities, since IFC involves the collaboration of distributed assets. For example, Force-centric thinking is necessary for selecting the preferred shooter from a group of distributed firing units.

**2.3 Common Processing**

Another IFC challenge lies in the necessary paradigm shift of engagement functionality moving out of weapon systems and instead being performed by common processors across warfare units. This difficult, yet necessary, shift is key to enabling more advanced forms of IFC. When engagement functions (such as: pairing a shooter with a target; determining engageability; determining if sensor support is adequate; and making launch decisions) are performed by weapon systems, the focus is unit-centric. Each weapon system is focused on it’s own engageability—whether it will intercept the target. The weapon system does not have a broader, force-centric, perspective. It cannot determine if it’s the best shooter in the Force; and it will only consider local sensor support.

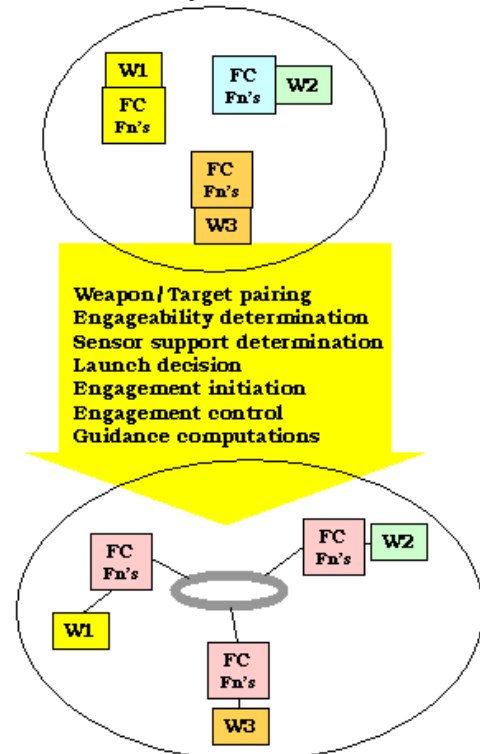

**Figure 9 – Weapon System vs. Common Processing**

In order to shift to a force-centric warfare paradigm, engagement functionality must be performed from a Force-level perspective. This requires access to information concerning all the relevant warfare resources (weapons and sensors, namely) within the Force. In order to perform IFC in a decentralized manner, the engagement functions need to be performed using common (identical) algorithms on each participating unit and be fed by a SIAP and common resource information. Figure 9 shows fire control functions historically performed by weapon systems (as illustrated in the upper circle) shifting out of the weapon system and into separate, but common, processing domains (in the lower circle).

In addition to making the decision to engage, additional fire control functions such as guidance computation and engagement control are best performed by common processes to support forward pass. Performing such functions in an identical manner on each unit will enable control of engagement to be passed between units.

Shifting fire control functions into common processors is also key to managing the various types of resources in a coordinated manner. Having separate resource managers for each resource type—such as a weapon manager, sensor manager, and link manager—focuses the use of these resources too narrowly. Each resource managed separately without considering the others only optimizes for that resource. The resources need to be managed by common processes that consider their interdependence and optimized with a “big picture” perspective.

**2.4 Architecture Considerations**

IFC can be performed using a centralized decision node approach; however there are major advantages to adopting a decentralized approach. The biggest factor is the latency involved in centralized IFC. Aerospace warfare places high demands on rapid decision-making and responses, especially for intercepting hostile aircraft and missiles. Waiting for a launch decision to be made at a remote central decision node may not be an option. In addition, distributing command authority for interceptor launch decisions to



the unit level is a long-standing tradition and has its obvious merits. The future vision for decentralized and distributed IFC upholds unit-level command authority. Equipping units with common algorithms to produce identical engagement recommendations at each participating distributed node enables a decentralized, yet Force-centric, approach to IFC.

Figure 10 illustrates a centralized architecture in the upper portion and a decentralized architecture in the lower half. In the upper half, a centralized BMC2 node receives all data, creates a master tactical picture, determines optimum resource tasking, and issues commands out to the distributed units. Thus, the distributed nodes are “dumb” nodes that simply pass data along and receive commands for managing their local resources.

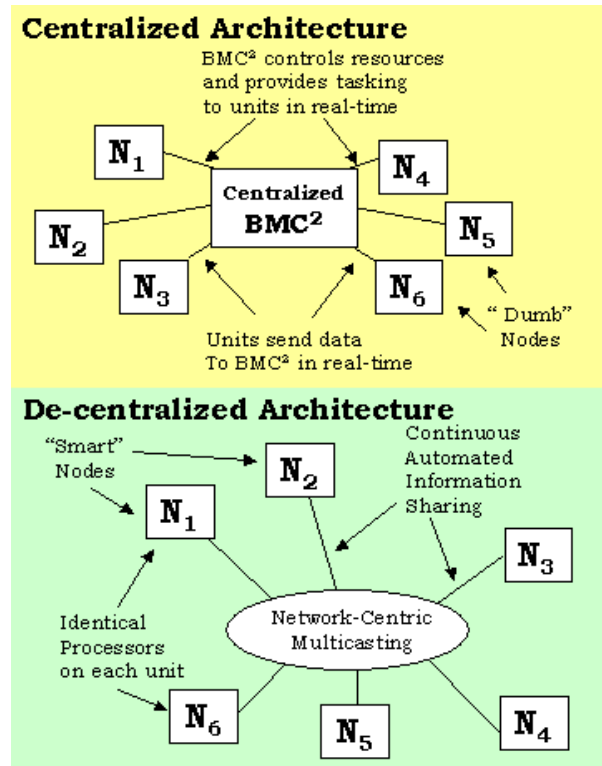

Figure 10 – Architecture Comparison

In the lower half of Figure 10, a decentralized architecture is depicted. In this scene, “smart” nodes communicate and collaborate over a network. In this option, information is shared among the distributed units; each of which develop a shared picture of the

battlespace. From the shared picture, each unit then determines the best use of the Force’s resources and tasks their local resources accordingly.

**2.5 Level of Automation**

Another IFC challenge lies in assimilating a great quantity of information with sufficient rapidity and accuracy to effect decisions that are well informed and that mitigate risk. This process of assimilation may be fully manual, fully automated, or rely on a hybrid of human-machine decision-making interactions. The IFC design will need to accommodate situations in which a human operator makes the shooter selection decisions and sensor taskings. The design must also contain sophisticated automated decision aids that will process information to determine and recommend optimized uses of warfare resources. Fully automated modes will be capable of directly tasking warfare resources; yet will allow operators to “command by negation” (or override automated resource taskings) when the pace of the battle rhythm demands such capability.

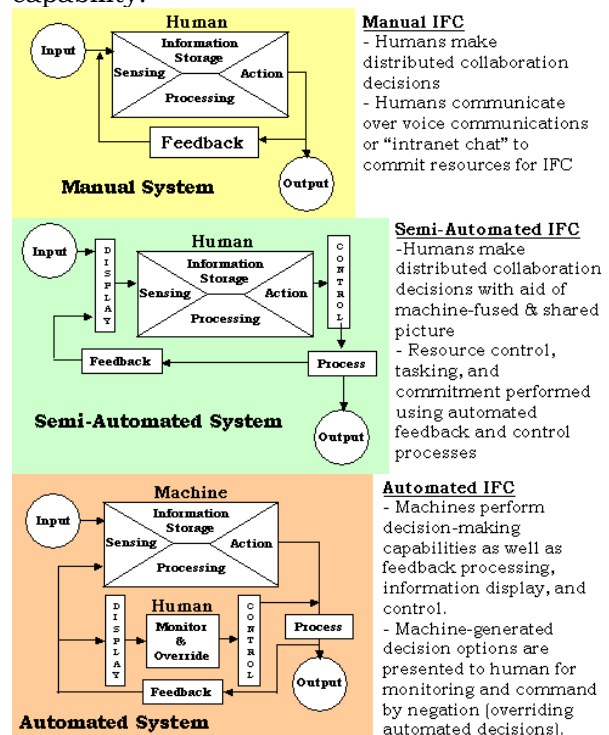

Figure 11 – Levels of Automation

Figure 11 shows the human-machine interactions for the three major levels of

automation for IFC: manual, semi-automated, and fully automated.

**2.6 Control Authority of Warfare Assets**

An important issue related to IFC is the control authority of warfare assets. Historically, the control of weapons and sensors has been the responsibility of the resident warfighter (Officer) in charge of the local platform (ship, aircraft, etc.). Maintaining this control authority is an important design consideration for IFC solutions. Each unit needs to implement decision aids that recommend tasking for all relevant warfare assets in the battle group. However, resident operators need to always have the ability to override resource taskings for local resources, and in many cases, approve resource taskings, such as launch decision, generated in an automated fashion.

**2.7 IFC Design Principles**

The following design principles are key to achieving IFC for aerospace operations:

- [1] Enable fire control functions to be performed locally or remotely
- [2] Utilize warfare resources from a Force-centric perspective
- [3] Shift fire control functions from specific weapon system methods to common processes
- [4] Design IFC into a decentralized architecture
- [4] Enable fire control functions to be performed in an automated-fashion
- [5] Perform IFC while enabling local Command Authority

**3.0 Proposed IFC Concept**

This section proposes a vision or concept for a system solution to enable future IFC operations. The concept is based on the guidance provided by the design principles laid out in the previous section.

The concept is to:

- [1] Implement an architecture that combines a network centric paradigm with automated intelligent management of sensors, weapons, and links to overcome individual system limitations and enable collaborative engagements; and
- [2] Provide automated engagement decision aids that use “common” algorithms and

shared tactical data to simultaneously produce identical engagement recommendations at each distributed unit.

The IFC concept is based on the following three fundamental system characteristics:

- Dynamically updateable doctrine;
- Decentralized architecture; and
- Synchronized information, doctrine, and decision aids

The approach enables each smart node to determine the optimum force-level resource management option and gain nodal agreement among distributed units prior to tasking local resources.

The envisioned concept for future IFC operations is based on a network-centric foundation achieved through implementing common processors on distributed units and enabling enhanced information sharing. Figure 12 provides a context diagram of the distributed units—each containing common processors. The common processors function collaboratively as a distributed system to produce a Single Integrated Air Picture (SIAP). One peer, or warfare unit hosting a common processor, is enlarged to show the processor’s interfaces with the unit’s resources.

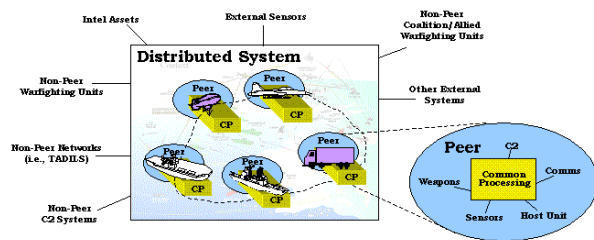

**Figure 12 – Distributed System**

Each processor contains common processing—identical computational and algorithmic methods. This supports the “Common Processing” philosophy, illustrated in Figure 13, upon which the SIAP concept is based. The philosophy, simply stated, is that identical processors provided with identical sets of data/information input will produce identical tactical air pictures.

This premise is carried one step further in support of future IFC. Equipping each

processor with common decision-making algorithms, which when fed identical track pictures (or data sets), allows each unit to produce identical resource tasking recommendations and engagement orders.

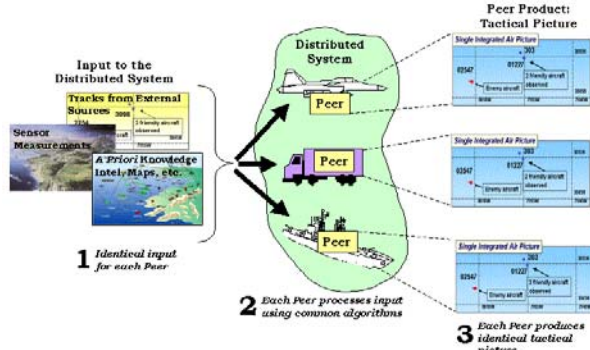

Figure 13 - Common Processing Philosophy

As Figure 14 illustrates, each unit can use “common” algorithms to produce identical Force-level engagement recommendations at each participating node. Therefore, each unit concurrently arrives at the same conclusion that a particular weapon has the best shot

and that a particular sensor (not necessarily collocated with the weapon) can best track and/or illuminate the target. This concept relies on incorporating common automated decision aids into each common processor and implementing an architecture that enables the sharing of common data sets and information among units.

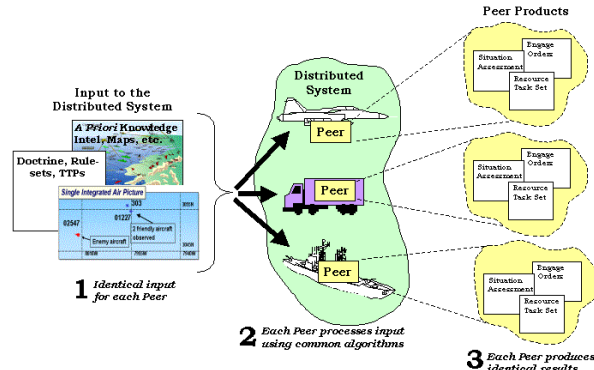

Figure 14 - IFC Common Processing

Figure 15 shows a diagram of the automated functions to be performed by each unit to

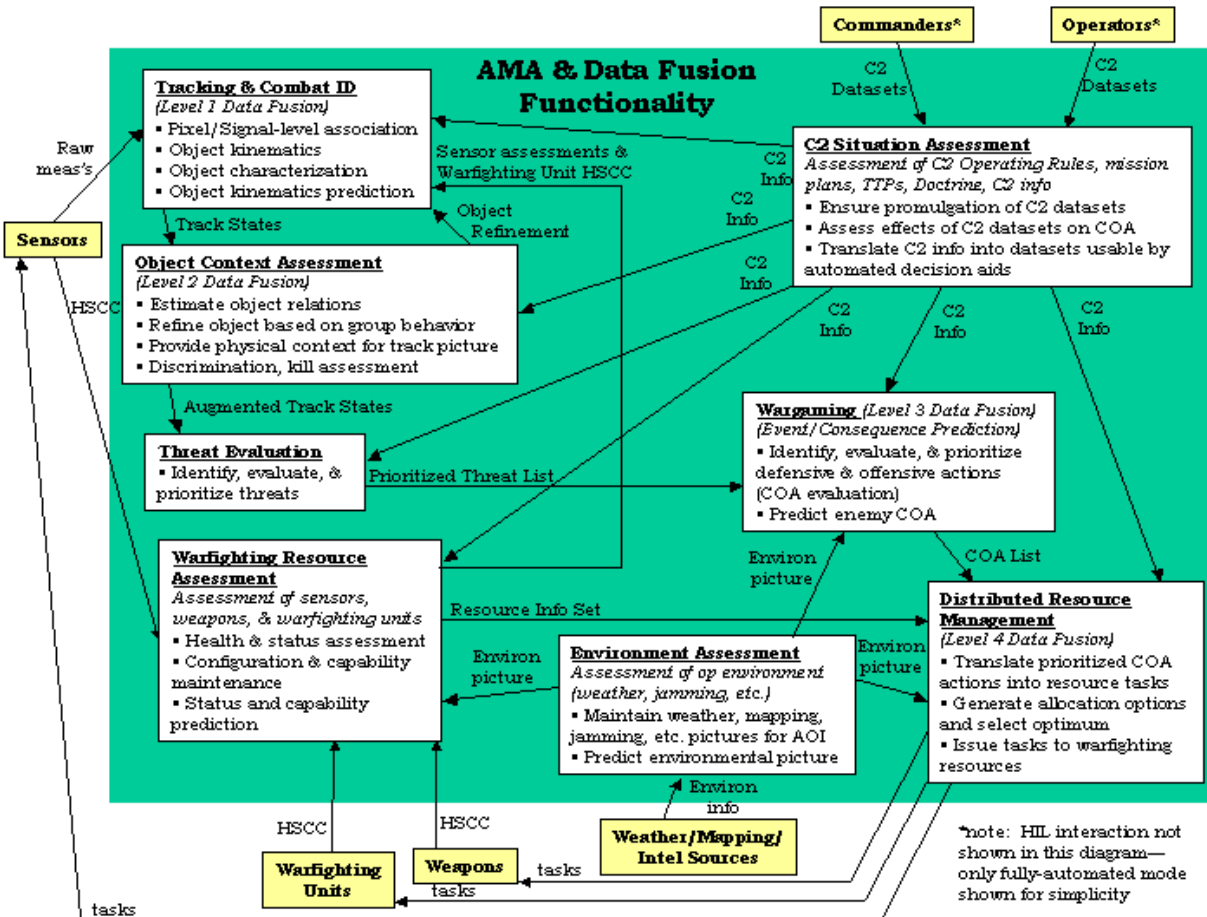

Figure 15 - Functional IFC Concept

produce identical decision recommendations and management aids. The functions are loosely based on the data fusion construct developed by the Joint Directors of Laboratories (JDL). Figure 15 identifies functional areas that align with the JDL levels of data fusion. The figure shows entities external to the peers such as sensors, weapons, decision-makers, Intel/weather data sources, and the warfighting units to which peers are resident. Figure 15 shows functional domains for fusing data and information to develop a representation of the real operational situation. These functional domains include: Tracking and Combat ID, Object Context Assessment, Threat Evaluation, Warfighting Resource Assessment and Environmental Assessment.

The Wargaming domain uses the situation awareness data (or picture) to develop and analyze hypotheses of enemy behavior and the effect of friendly defensive or offensive measures. From wargaming, a determination of the best Course of Action (COA) can be made and a set of resource tasks can be derived. The Distributed Resource Management (DRM) domain then pairs resources with tasks using optimization methods. Finally, the C2 Assessment domain keeps track of plans, procedures, doctrine, and other governing rule sets that are used to make assessments and resource pairing decisions. The functions shown in Figure 15 will be discussed in more detail in the next Section on Key IFC Capabilities.

Table 2 lists decision recommendation products of the processes shown in Figure 15.

**Table 2 – List of IFC Products**

<p><b>Products of IFC AMA and Data Fusion Process:</b></p> <ul style="list-style-type: none"> <li>• Preferred shooter determination</li> <li>• Weapon-Target Pairing</li> <li>• Sensor Support for Engagements</li> <li>• Engagement Control Strategy (i.e., forward pass)</li> <li>• Engagement Preferences (intercept geometry)</li> </ul>
--

In conclusion, a basic operational example of how this IFC concept would be realized is as follows. Each distributed unit uses “common” algorithms to produce identical Force-level engagement recommendations. Therefore, each unit arrives at the same

conclusion that a particular weapon has the best shot; that a particular sensor (not necessarily collocated with the weapon) can best track and/or illuminate the target; and that a particular unit should assume engagement control after missile launch.

**4.0 Key IFC Capabilities Required**

Based on the IFC introduction presented in section 1; the design principles for IFC established in section 2; and the vision for future IFC proposed in section 3; this section addresses the set of key capabilities required. In order to enable the IFC solution concept illustrated in Figure 15 and described in the previous section, the following capabilities are needed:

- Shared Situation Awareness
- Determination of Best Course of Action
- Distributed Resource Management
- Embedded IFC Planning

**4.1 Shared Situation Awareness**

Shared Situation Awareness (SA) is key for IFC because each unit needs identical, complete, accurate, & timely awareness (knowledge) of the operational situation. Shared SA is the ability of distributed units to gain a common understanding of the totality of the tactical situation, including the threat, the defended assets, the readiness of warfighting resources, and command and control constraints within which the systems must operate. Figure 16 illustrates the various data sets or “pictures” comprising SA.

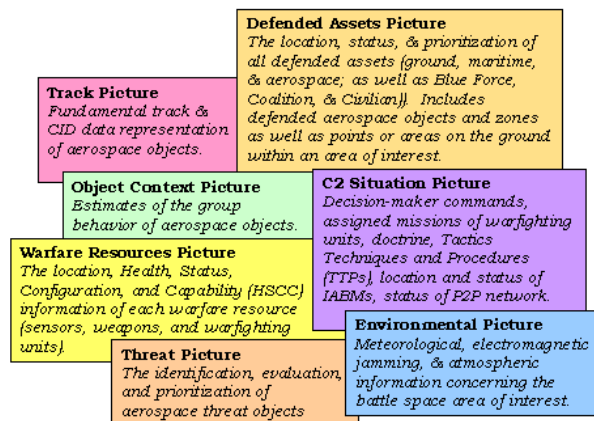

**Figure 16 – SA Pictures**

Each unit must create and maintain a “picture” of each of these aspects (shown in Figure 16) of the operational situation. The

pictures are really sets of information, updated on a continuous basis, that are products of the data fusion process.

**Data Fusion Processes**

Shared SA relies on common data processing and data fusion algorithms on each distributed unit to assess and develop a representation of the real situation. Table 3 describes each of the primary SA data fusion capabilities.

**Table 3 – SA Data Fusion Capabilities**

<b>SA Capabilities</b>	<b>Description</b>
<b>Tracking &amp; Combat ID</b>	<ul style="list-style-type: none"> <li>• Pixel/Signal-level association</li> <li>• Object kinematics</li> <li>• Object characterization</li> <li>• Object kinematics prediction</li> </ul>
<b>Object Context Assessment</b>	<ul style="list-style-type: none"> <li>• Object relations estimation</li> <li>• Refinement of object ID &amp; typing based on group behavior</li> <li>• Provision of physical context for track picture</li> <li>• Discrimination, kill assessment</li> <li>• Development &amp; maintenance of defended assets picture</li> </ul>
<b>Warfighting Resource Assessment</b>	<ul style="list-style-type: none"> <li>• Assessment of sensors, weapons, &amp; warfighting units</li> <li>• Health &amp; status assessment</li> <li>• Configuration &amp; capability maintenance</li> </ul>
<b>C2 Situation Assessment</b>	<ul style="list-style-type: none"> <li>• Assessment &amp; Adoption of Blue Force C2 inputs</li> <li>• Promulgation of commands within Community of Interest (COI)</li> <li>• Translation of C2 inputs into system operating rules, constraints, &amp; parameters</li> </ul>
<b>SA Certification</b>	<ul style="list-style-type: none"> <li>• Assessment of track quality</li> <li>• Assessment of track ID confidence</li> <li>• Certification of fire control quality SA</li> </ul>

<b>SA Capabilities</b>	<b>Description</b>
<b>Environment Assessment</b>	<ul style="list-style-type: none"> <li>• Development &amp; maintenance of environmental picture (weather, mapping, jamming, etc.) for AOI</li> </ul>
<b>Processor Evaluation</b>	<ul style="list-style-type: none"> <li>• Assessment of processor performance (SIAP state)</li> <li>• Processor health &amp; status assessment</li> </ul>
<b>Threat Evaluation</b>	<ul style="list-style-type: none"> <li>• Threat identification, evaluation, and prioritization</li> </ul>
<b>Force Readiness Assessment</b>	<ul style="list-style-type: none"> <li>• Fusion of assessments</li> <li>• Determination of overall readiness of warfighting forces</li> </ul>

The set of functions that develop SA are data fusion, association, and assessment processes that develop a description or interpretation of the current relationships among aerospace objects, events, and the context of the operational environment. This process estimates the operational situation and assigns quantitative confidence values to the estimates. Effectively, the functions seek to develop as accurate a representation of the real world as possible. Quantitative values are computed to allow decision-makers to know with what confidence a particular object is a threat or what the probability that a particular weapon system will engage a threat, as examples. The payoff of automating the situational assessment capability is that the complex and time-critical nature of operational situations for aerospace warfare can involve the assimilation of large amounts of information in time periods that are too narrow for manual assessment to support rapid and effective decision-making. Performing such assessments on distributed warfighting units to support collaborative operations compounds the challenge. Embedding common situational assessment functions in a network of distributed units that can share data and information is key to enabling IFC.

**Information Architecture**

Shared SA relies on an appropriate information architecture to enable data sharing among distributed units. While

individual warfare units provide organic capabilities, the real force multiplier is when they are netted together in a mutually supportive role—providing a battle space awareness that is greater than the sum of their individual awarenesses. Distributed unit collaboration to achieve shared SA and IFC capabilities is achieved through the establishment, maintenance, and management of Peer-to-Peer (P2P) networks that enable an adequate data dissemination capability.

The reality of warfare operations is that at any given time, warfighting units may be collaborating on various levels based on their collaboration needs as well as their ability to collaborate. Their collaboration needs may range from autonomous operations (or the complete lack of collaboration); to the sharing of tactical information and development of a single integrated air picture; to highly integrated IFC operations involving the commitment of warfare assets to a collaborative warfighting operation involving multiple distributed units. The ability to collaborate depends on adequate communications and data paths between distributed units as well as embedded processor functionality that manage the necessary distribution of data/information that enables automated decision-making capabilities and collaborations to occur.

Objectives for information sharing in support of IFC are as follows:

- [1] The information architecture must be based on Force-centric de-centralized architecture
- [2] The network must allow warfare resources to be managed according to Force-level needs (rather than unit-centric needs)
- [3] Network management must be flexible to enable special data distribution needs during engagements (higher data rate and/or throughput).

Required information dissemination functions are listed in Table 4. These functions need to be performed using common methods across warfare units.

**Table 4 - Information Dissemination Functions**

Information Dissemination Functions
• Determines needs of information-recipient

Information Dissemination Functions
users or decision nodes (data advertisements/ subscriptions)
• Tracks data availability
• Establishes routing paths & maintains connectivity
• Optimizes bandwidth usage
• Determines feasibility of transmission/checks link status
• Sends and receives commands to/from remote link managers to control, manage, & synchronize transmission
• Transmits data/information according to local/remote synchronized commands

Table 5 contains types of information that need to be exchanged among distributed units to support the IFC concept. In particular, it is necessary for units to exchange information concerning warfare resources in addition to the sensor data that is the usual focus of tactical information exchange efforts.

**Table 5 - IFC Information Exchange Requirements**

Information Exchange Required for IFC
• Associated Measurement Reports
• Resource information: Health, Status, Configuration, & Capabilities of Resources
• C2 Datasets (Doctrine, TTPs, plans, manual commands)
• Resource Tasking Requests
• Resource Commitment “Handshakes”

Table 6 lists characteristics of the data exchange that are critical to supporting the IFC concept. In a bandwidth-limited environment, it may become necessary to intelligently manage communication resources to support critical aerospace operations such as collaborative engagements.

**Table 6 - Data Exchange Characteristics**

Data Exchange Characteristics
• Supports real-time P2P exchange of sensor measurement data
• Broadcast/Multicast/Point-to-Point
• Non-real-time traffic for operations control
• Link monitoring
• Quality of Service delivery
• Data integrity and confidentiality
• Bandwidth allocation/monitoring
• Data dissemination prioritization (for time-

Data Exchange Characteristics
sensitive data or bandwidth constraints)
• Ad hoc nodal topology (nodes can easily join or leave network)
• Interfaces with Tactical Data Links (TDLs)

**4.2 Determination of Best COA**

Determination of the best Course of Action (COA) is key for determining that a threat requires defensive measures – taking into account possible ramifications. The ability to predict operational situations and hypothesize the effect of alternative COAs (Effects Based Operations), is a powerful aid in effective IFC decision-making. This section introduces the concept of automated wargaming in support of tactical aerospace operations.

The ability to predict enemy COAs provides great advantage to the warfighter. Assigning quantitative confidence values to potential COAs will support other advanced C2 capabilities such as collaborative planning and resource management. For example, based on the confidence level of a predicted enemy Theater Ballistic Missile (TBM) launch site, units may assign a priority level to the site as a possible future threat. This function then feeds the resource management capability by building a case for increased sensor surveillance of the region or a possible assigned strike mission. Examples of enemy COA attributes that can be predicted and assessed are described in Table 7.

**Table 7 – Enemy COA Attributes**

Enemy COA	Description
TBM Launch Site	Prediction of launch site locations and types based on launch point estimations of tracked TBMs.
TBM Launch	Prediction of future TBM launches (launch type, time, direction) based on known and estimated parameters and capabilities of the launcher (from previous launches, Intel, a priori knowledge, estimated time of mobility of the transport-launching container, etc.)
Enemy	Prediction that attributes a

Enemy COA	Description
Attribution	particular hostile event or object to a particular enemy. This is particularly important for terrorist activity—predicting which nation or terrorist group is responsible for a hostile action.
Enemy Intent	Determination of enemy intention based on actions, communications, and enemy doctrine.
Enemy Capability	Estimation of the size, location, and capabilities of enemy forces
Threat Opportunities	Identification of potential opportunities for enemy threat based on prediction of enemy actions, operation readiness analysis, of friendly vulnerabilities, and analysis of environmental conditions.
Enemy Scenarios	Develop a battlespace visualization of the national guidance and assigned regional area of responsibility to create enemy scenarios & enemy COA. From this visualization, at the component-level, targeting analysis, SA, target development and selection, target nomination, weaponeering, and Battle Damage Assessment can be accomplished.

In addition to predicting enemy COAs, automated wargaming methods can provide the ability to identify, evaluate and prioritize blue force COAs based on analyzing historical trends and projecting the performance of sensors and weapons based on their known capabilities.

The future concept is to embed units with common wargaming functionality that enables them to identify and evaluate tactical options for near real-time defensive responses or offensive actions; as well as plan blue force COAs for longer projected time periods such

as hours to weeks ahead. Thus, this future capability would bridge the gap between tactical operations and planning capabilities; enabling dynamic replanning and allowing warfighting resources to be used most effectively based on the most current knowledge of the operational situation.

Wargaming functionality includes multi-perspective analysis, which analyzes current and predicted operational situations from both red and blue perspectives. Offensive/defensive analysis predicts the results of hypothesized enemy engagements considering rules of engagement (ROE), enemy doctrine, and weapon models. The wargaming would take into account estimated weapons effectiveness based on projected weapon resource capabilities. Wargaming functions calculate effectiveness measurements such as: probability of kill, probability of raid annihilation, probability of survivability, and probability of munitions effectiveness. These projected measures of effectiveness would support the estimate of projected force readiness. Wargaming could enable units to support Effects-Based Operations (EBO) in which the effects of blue force actions on the enemy would be analyzed and assessed to support decision-making. The wargaming functionality produces prioritized blue force COAs that support the generation of missions and tasks for use by the DRM process.

Some additional prediction capabilities that can be integrated into the wargaming to enhance the decision process are listed in Table 8. These include environmental effects on possible COAs; the projection of resource capabilities; and an overall prediction of force readiness.

**Table 8 - Additional Prediction Capabilities**

Prediction Capabilities	Description
<b>Environment Prediction</b>	Prediction of environmental effects on hypothesized COAs: - Prediction of weather effects on specific munitions and sensor detection ranges - Prediction of environmental impacts from munitions employment.

Prediction Capabilities	Description
<b>Resource Projection</b>	Prediction of the capability and performance of sensors, weapons, & units given hypothesized COAs.
<b>Force Projection</b>	Prediction of Force Readiness - Prediction of overall force readiness & capabilities

Once a blue force defensive or offensive action is determined as the optimum COA, a list of tasks for warfare resources can be derived. This set of tasks feeds the DRM process described in the next section.

**4.3 Distributed Resource Management**

Distributed Resource Management (DRM) is key to enabling and optimizing the use of distributed resources for collaborative and integrated fire control. DRM is effectively the culmination of the data fusion processes performed for SA and determining the best COA. DRM is the capability that allocates the prioritized tasks to the optimum sensor and weapon resources.

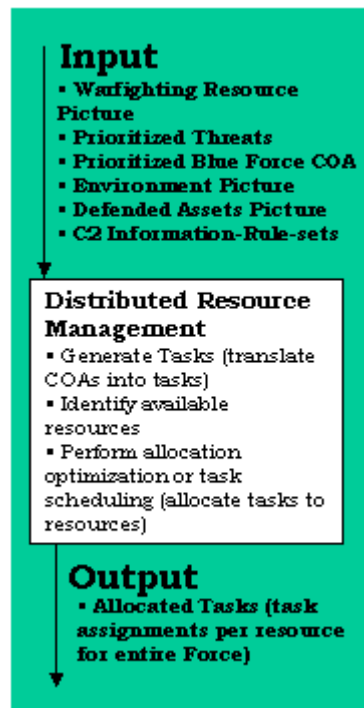

**Figure 17 - DRM Input and Output**

For input, the DRM capability requires results of situation assessment and situation prediction. The DRM must identify a running



list (that is continually being updated as the operational situation changes) of specific tasks (or resource missions) based on the identified and prioritized threats, best estimated blue force COA, and operational situation (i.e., environment, defended assets locations, etc.). Figure 17 shows DRM functions and the input and output to this function set.

The DRM uses optimization techniques to schedule tasks or allocate them to the most suitable warfighting resources. Based on the availability and capability of resources at any given time, the DRM may have to modify the list of tasks and determine that some cannot be performed or may be performed in a different order. The advantage of the DRM capability is that it enables each distributed unit to determine the best use of each resource in the “force” (or within a set of collaborating peers) and to make this determination in a near-simultaneous manner. In this way, resources can be used for force needs rather than just for the needs of an individual unit.

information embedded in the SIAP. Figure 18 shows the major functions involved in DRM.

Table 9 contains IFC functions performed by the DRM fusion and optimization engine. The functions in Table 9 indicate the detailed decision-making that needs to be performed to “determine the prioritized list of resource tasks” and “generate allocation options and select optimum”; as these fusion engine functions are shown in Figure 18.

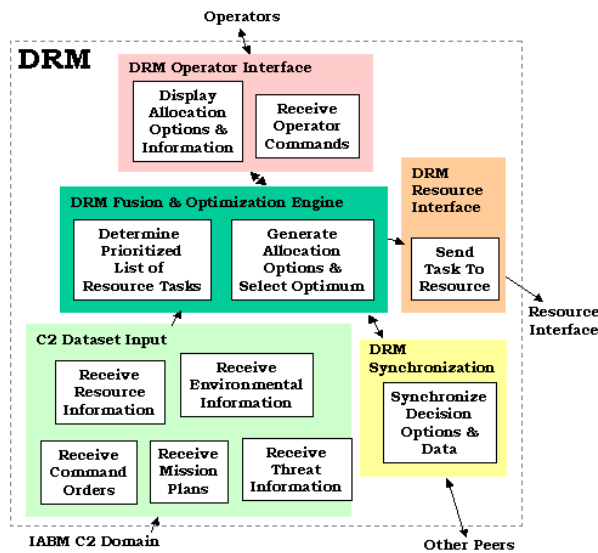

Figure 18 – DRM Functions

The basic concept for implementing DRM is the development of a set of processing algorithms, containing automated methods for optimization and decision aids, that will be replicated on each participating warfighting unit to effectively produce the same decision results given that each instantiation will be fed with the common

**Table 9 – DRM Fusion Engine Functions**

DRM Fusion Engine Functions for IFC
<p><b>Launch determination</b></p> <ul style="list-style-type: none"> <li>- Receive threat &amp; COA determination</li> <li>- Assess engageability of weapon options</li> <li>- Determine intercept probability</li> <li>- Decide to launch (or not)</li> </ul>
<p><b>Engagement support strategies</b></p> <ul style="list-style-type: none"> <li>- Threat detection/cue</li> <li>- FCQ data availability</li> <li>- Sensor tasking/commitment</li> <li>- Preferred sensor arrangement</li> </ul>
<p><b>Weapon-target pairing</b></p> <ul style="list-style-type: none"> <li>- Preferred shooter determination</li> <li>- Engageability of weapon options</li> </ul>
<p><b>Selective engagement</b></p> <ul style="list-style-type: none"> <li>- Selection of best option if multiple engagement options along the threat trajectory exist</li> </ul>
<p><b>Engagement support strategy after launch</b></p> <ul style="list-style-type: none"> <li>- Forward pass (preferred eng control option)</li> <li>- Remote guidance relay (preferred sensor arrangement)</li> <li>- Remote target illumination (preferred sensor support)</li> </ul>

An additional capability for effective DRM is a synchronization process that shares allocation results to compare and correct for discrepancies. This step may be necessary to ensure that distributed units compute identical decision results; especially when the commitment of distributed resources is critical, as is the case for IFC.

A bonus feature of DRM is that it distributes command authority to individual units. Historically, the control of weapons and sensors has been the responsibility of the resident warfighter (Officer) in charge of the local unit (ship, aircraft, etc.). Maintaining this control authority is a feature of DRM. Each unit would use the DRM capability to

formulate sets of tasking for all relevant warfare assets (both resident and nonresident) in the battle group. However, resident operators always have the ability to override resource taskings for local resources generated in an automated fashion by the DRM. Thus, command authority is upheld.

**4.4 Embedded IFC Planning**

Embedded IFC planning is key to the automated orchestration of IFC operations. Prior to deploying warfare units into operation, planners can establish doctrine to guide the automated systems that perform decision-making capabilities. Table 10 lists examples of built-in planning that can be performed and embedded into the systems prior to operations.

**Table 10 – IFC Planning**

<b>IFC Planning Functions</b>
• Predicting operational situations that require collaborative fire control
• Establishing prioritization schemes for missions, threats, defended areas, tactics
• Establishing rule sets to guide resource behavior for IFC operations
• Establishing parameters to control engageability calculations, target-weapon pairing, target identification/threat evaluation, & sensor tasking
• Establishing decision logic

Planning that is predetermined or established prior to operations is called deliberate Planning. Two levels of deliberate planning exist: defense planning and defense design. Defense planning refers to macro-level planning—establishing plans from a larger perspective. Defense design is planning at the micro-level—assigning TTPs and rule sets to specific resources and establishing parameters for computational systems. Examples of each are shown in Table 11.

**Table 11 – Defense Planning and Defense Design**

<b>Defense Planning - “Macro” Planning</b>
• Assigning resources to missions
• Allocating areas/zones within theater
• CINC priorities
• Identifying critical assets
<b>Defense Design – “Micro” Planning</b>
• Specific TTPs & Rule sets
• Initialization parameters
• Correlation Track Quality Values

Dynamic Planning is the modification of plans during operations. This capability is also referred to as dynamic replanning. This capability is useful because the reality of operational situations can rarely unfold exactly as predicted in a plan. Implementing a plan that reflects reality by updating is based on up-to-the-moment data as it becomes available becomes a necessary capability for IFC and automated decision aids. Implementing dynamic planning allows the systems to take resource changes into account—sometimes resources break or become unavailable. It also supports faster Blue Force reaction times by taking into account unexpected enemy COAs and threats. Table 12 lists examples of dynamic planning functions.

**Table 12 – Dynamic Planning Functions**

<b>Dynamic Planning Functions</b>
• Replanning – dynamic creation of new plan
• Refinement of plan
• Reassignment of resources
• Ad hoc operations
• Alteration of rule sets
• Reset of parameters
• Reestablishing prioritization

**5.0 IFC Development Strategy**

This section presents a strategy for developing the key capabilities required to enable the proposed IFC concept.

There are three levels of IFC capabilities<sup>4</sup> that development efforts should aim towards as objectives:

- [1] **Enhanced Air Picture:** cleaner/better/more complete/more common
- [2] **AMA for weapon/target & sensor/target pairing:** “best” weapon, “best” target, “best” kill location, “best” tactics
- [3] **Full AMA/DRM:** IFC competes with other mission areas for resources

The first level provides enhanced data for firing units. This level can be considered the NCW foundation of shared information gained by a network-centric environment; and upon

<sup>4</sup> Defined by Joint SIAP System Engineering Organization (JSSEO) Team; June 2004

which, advanced IFC capabilities can be built. Enhanced data shared among remote units provides enhancements for IFC. The second objective level includes the use of automated decision aids to recommend the best weapon and sensor pairings with targets. This level is effectively, the optimized management of distributed resources for fire control or engagement purposes. Finally, the third objective level broadens the scope of automated resource management to all applicable operational mission areas, of which fire control is one. Achieving this capability level allows resources to be optimally managed across mission areas. The development strategy presented in this paper addresses the achievement of the second level: managing resources within the IFC mission area.

The second strategy guiding the development approach is to build in increments or spirals that afford intermediate IFC capabilities. The rest of this section proposes development spirals based on grouping similar system capabilities into four spirals, with each consecutive spiral adding more functional sophistication.

The four spirals are identified as:

- [1] **The NCW Foundation**
- [2] **Common & Request-Based IFC**
- [3] **Semi-Automated & Force-Centric IFC**
- [4] **Fully Automated & Optimized IFC**

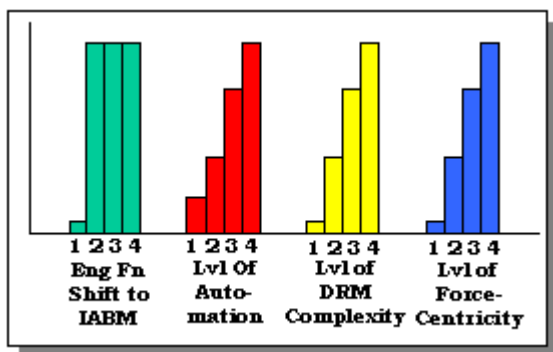

Figure 19 – Spiral Levels of Accomplishment

Figure 19 shows how each spiral provides increasing levels of IFC in terms of the IFC design principles. The green columns show that engagement functionality is performed by weapon systems in the first spiral, but shifts into a common process by the second spiral. The other three groups of colored

columns show incremental increases in levels of automation, DRM complexity, and Force-centricity (shifting from a unit perspective to a Force-level perspective).

**5.1 Spiral 1 – NCW Foundation**

The first IFC development spiral is the establishment of a NCW foundation—the ability to share high quality data for fire control. This spiral assumes a P2P network and the implementation of common processes across distributed units to generate a single integrated air picture. Spiral 1 IFC capabilities are focused on sharing Fire Control Quality (FCQ) data among distributed units and issuing automated requests to distributed sensors to provide additional data.

**System Capabilities Required:**

[1] **Track Certification**

The provision of a certification process, which determines track quality and certifies individual tracks for “engageability” due to the data quality, data latency, associated CID, and other appropriate criteria.

[2] **Shared Associated Measurement Data**

Enhanced networks for sharing measurement data with high rates and throughput

[3] **Sensor Tasking Requests**

The ability to determine in an automated fashion that additional data is required for a particular track or sector; and the ability to broadcast a request within the COI.

[4] **Sensor Request Prioritization**

The ability to prioritize received sensor tasking requests when multiple requests are received concurrently.

Example prioritization schemes include: first come, first serve; request urgency labeling (example levels may include: desired, urgent, critical, etc.); and prioritization according to the request source (some requesting units may have precedence over others).

[5] **Engagement Notification**

The ability to send weapon launch notifications to participating units within the COI. This capability places requirements on the network and network interfaces to handle the formatting and transmission of weapon launch notifications.

**IFC Capabilities Achieved:**

- **Precision Cue** – receipt of a remote “cue” or alert of a potential threat target

- **Engagement Notification** – notification to COI when a weapon fired
- **Request for Off-board Sensor Support** – request broadcast within COI for remote sensor data to provide precision cue (surveillance) or higher track accuracy.
- **Positive Interceptor Identification** – *very* high confidence identification of aerospace object within track picture that represents interceptor
- **Manual LoR** - engagement is prosecuted on the available filtered track state. However, the weapon system performs engagement functions and the local sensor must be capable of supporting the engagement after launch as a back up if the composite track state is not sufficient.
- **Manual EoR** - use of remote FCQ data to support EoR; however, remote sensor support tasking and commitment requires Operator (or manual) in the loop.

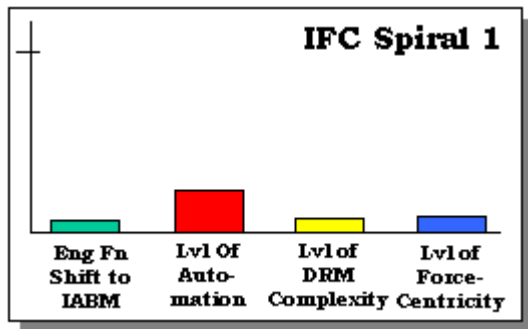

Figure 20 – Spiral 1 Accomplishments

Figure 20 shows the level of *integration* or *collaboration* that is achieved according to some of the IFC design principles that guide the IFC concept and development. The graphs illustrates that: the engagement functions still reside in the weapon systems and are not performed by common processes; processes are mainly manual but some automation exists; that DRM is very basic; and that the fire control focus is unit-centric.

**5.2 Spiral 2 – Common/Request-Based IFC**

The second IFC development spiral is primarily focused on the shift of fire control (or engagement) functionality out of weapon systems and into common processors. Additionally, spiral 2 includes the ability to issue requests among distributed units to engage a threat.

**System Capabilities Required:**

- [1] **Sharing Resource Information**  
Enhanced networks for sharing sensor resource information among distributed units
- [2] **Enhanced Sensor Scheduling**  
Enhanced scheduling/prioritization schemes for the optimal determination of sensor tasks.
- [3] **Self-monitoring**  
The ability to monitor/assess picture quality and the functioning of the common processes & networks to determine incomplete picture, low quality or latent track data, or other possible error sources.
- [4] **Weapon Tasking Requests**  
The ability to broadcast weapon task requests (requests that other units engage a particular threat) in an automated fashion within COI.
- [5] **Intelligent Processing**  
The ability to optimally apply the use of data fusion algorithms and filter out data to fuse only the optimal data to produce the highest quality track picture.
- [6] **Common Fire Control Functionality**  
Fire control functions performed by common processors (rather than by weapon systems).

**IFC Capabilities Achieved:**

- **Request-based EoR** – request broadcast within COI for remote sensor to provide FCQ data on threat throughout duration of engagement
- **Request-based Shooter Selection** - request broadcast within COI for remote weapons to intercept a particular threat
- **Automated LoR (or composite)** – launch decision computed for local weapon based on composite track picture or best available data & data fusion processes

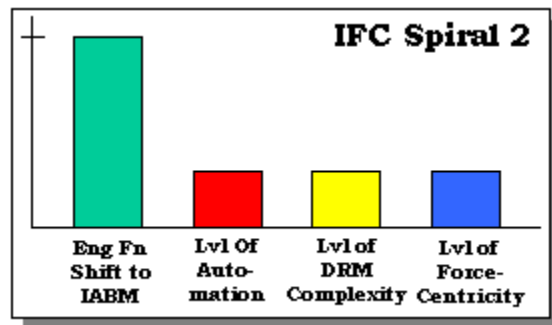

Figure 21 – Spiral 2 Accomplishments

Figure 21 illustrates that in Spiral 2: engagement functionality has shifted out of weapon systems and into common

processors; the level of automation and DRM complexity has increased (enhanced sensor schedulers and automated request-based engagements); and that using request-based weapons management enables an advancement in the ability to operate from a Force perspective.

**5.3 Spiral 3 – Semi-Automated & Force-Centric IFC**

The third IFC development spiral focuses on increasing automated processes for managing resources and on a Force-level determination of the preferred shooter.

**System Capabilities Required:**

- [1] **Request-based DRM** – generation and transmission of requests for engagement support (by weapon or sensor) to specific unit based on limited awareness of that unit’s resource capabilities. Ability to gain resource commitments in automated fashion.
- [2] **Basic AMA** – basic ability to determine collaborative engagement strategies involving local and remote resources; as well as evaluating distributed shooter-target pairings to select optimum.
- [3] **Basic Deliberate Planning** – basic embedded doctrine and rule sets to enable the automated evaluation of optimal engagement strategies and resource use.

**IFC Capabilities Achieved:**

**Enhanced Request-Based IFC** - Request-based IFC capabilities (such as EoR, selecting the best shooter, tasking sensors to enhance the picture) are enhanced because each distributed unit computes determinations of resource capabilities, instead of have to interact with the local and remote sensor and weapon systems. Thus, the determinations are enhanced and more rapidly made. Additionally, resources can be committed in an automated fashion.

- **Basic Preferred Shooter Determination** Distributed units simultaneously determine the optimum shooter for each threat based on their situation awareness of battlespace and weapon HSCC.

Figure 22 illustrates that in Spiral 3: levels of automation, DRM complexity, and Force-centricity have risen. The addition of AMAs and embedded planning enable distributed

resources to be managed with a more Force-level perspective.

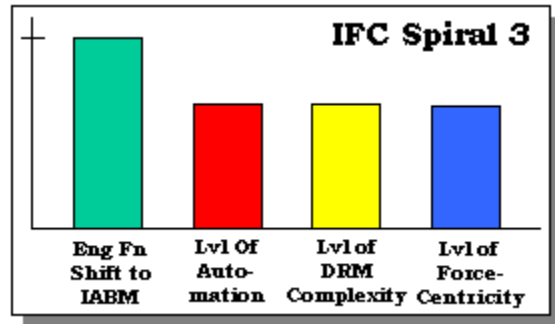

Figure 22 – Spiral 3 Accomplishments

**5.4 Spiral 4 – Fully Automated IFC**

The fourth IFC development spiral achieves the vision set forth in this paper for a proposed IFC concept. Spiral 4’s capabilities achieve the Level 2 IFC objectives of full automation for optimized DRM within the IFC mission area.

**System Capabilities Required:**

- [1] **Advanced Data Fusion and SA** Advanced COA determination (effects based operations) – units use enhanced SA and AMAs to perform wargaming functions to determine best COA based on estimated enemy COAs and the threat picture. From the COAs, a detailed sets of tasks are defined that need to be performed by the distributed resources.
- [2] **Fully Automated DRM** Participating PROCESSORs simultaneously compute the optimum use of the Force’s distributed resources to perform defined sets of tasks (determined from COA determination) within the IFC mission area. Each unit then tasks its local sensors based on the Force-level determination of optimized missions.
- [3] **Deliberate and Dynamic Planning** Embedded plans as well as dynamic planning capabilities provide rule sets and logic for AMAs to function and make decision recommendations in an automated fashion. Planning functions enable resources to be allocated to tasks according to planned rules.

**IFC Capabilities Achieved:**

- **Automated IFC** – distributed units simultaneously determine the optimum distributed resource engagement strategies

involving the best use of distributed sensors, weapons, and C2 resources; and then task local resources based on the Force-level determinations. Advanced IFC strategies achieved include:

- **Distributed sensor management**
- **Preferred shooter determination**
- **Automated EoR**
- **Forward pass**
- **Remote fire**

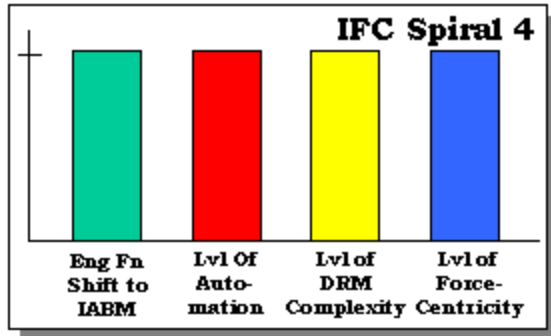

Figure 23 – Spiral 4 Accomplishments

Figure 23 illustrates that the IFC capabilities provided in Spiral 4 enable the design principles of common fire control functionality, full automation, envisioned DRM, and Force-level perspective are reached.

**6.0 Conclusion**

In conclusion, this paper set forth to define the IFC problem space; explore design principles to govern IFC solutions; propose a grand vision for future IFC operations; introduce capabilities required to achieve the proposed IFC concept; and discuss an incremental development strategy for achieving the vision.

The following list of “take-aways” conclude this paper:

- Performing fire control using distributed resources in an integrated and collaborative manner takes advantage of network-centric advances and is the key to future aerospace warfare advances.
- Design principles guiding IFC solutions include a de-centralized architecture, automating processes, using common fire control functions across the Force, and using a force-wide perspective in managing resources.

- The proposed IFC concept is based on automated engagement decision aids that use “common” algorithms and shared tactical data to simultaneously produce identical engagement recommendations at each distributed unit.

- Key capabilities required include: shared SA, determination of best COA, DRM, and embedded IFC planning.

- IFC development strategy is based on spiral builds that afford intermediate IFC capabilities while focused toward automated Force-centric IFC vision.

**References**

[1] Alberts, David S., et al., *Network Centric Warfare, Developing and Leveraging Information Superiority*, 2/e CCRP Publication Series, 2000.

[2] Alberts, David S., et al., *Understanding Information Age Warfare*, CCRP Publication Series, August 2001.

[3] Antony, Richard T., *Principles of Data Fusion Automation*, Artech House, Inc., 1995.

[5] *Capstone Requirements Document (CRD) for Theater Air and Missile Defense (TAMD) (S/NF) JROCM 056-01*, 1 March 2001.

[5] Crowe, Doug, et al., *Integrated Architecture Behavior Model (IABM) Configuration 05 Description Document Version x.xa (Working Copy)*, JSSEO, June 2004.

[6] Hall, David L., *Mathematical Techniques in Multisensor Data Fusion*, Boston: Artech House, Inc., 1992.

[7] Hall, David L. & McMullen Sonya A.H., *Mathematical Techniques in Multisensor Data Fusion, 2nd ed.*, Artech House, Inc., 2004.

[8] Johnson, Bonnie & Green, John M., *Naval Network-Centric Sensor Resource Management*, Command & Control Research & Technology Symposium, 2002.

[9] Johnson, Bonnie, Green, John M., & Canfield W., *Gaining Naval Battle Space Through Automation*, National Fire Control Symposium, 2001.

[10] Schroeder, Jerry, et al., *Single Integrated Air Picture (SIAP) Operational Concept Document*, JSSEO, 2002.

[11] Schroeder, Jerry, *White Paper on Integrated Fire Control (Advanced Engagement Concepts) for Joint Theater Air and Missile Defense*, SIAP Program, 1999.

[12] Schroeder, Jerry, *White Paper on Automated Battle Management Aids for Joint*

*Theater Air and Missile Defense*, SIAP Program, 1999.

[11] Smith, Edward A., *Effects Based Operations*, CCRP Publication Series, 2002.

[12] Steinberg, Alan N., Bowman, Christopher L., & White Franklin E., *Revisions to the JDL Data Fusion Model*.

[13] Young, Bonnie W., *A C2 System for Future Aerospace Warfare*, Command and Control Research and Technology Symposium, 2004.



**NORTHROP GRUMMAN**

DEFINING THE FUTURE

# Future Integrated Fire Control

ICCRTS 2005

June 2005

**Bonnie Young**

Senior System Architect  
Northrop Grumman Corporation  
Bonnie.Young@ngc.com  
703-407-4531

FROM UNDERSEA TO OUTER SPACE TO CYBERSPACE





# Future C2 Challenges:

- Information Dominance
- Most Effective Use of Joint/Coalition Assets & Forces
- Dynamic Force & C2 Tailoring

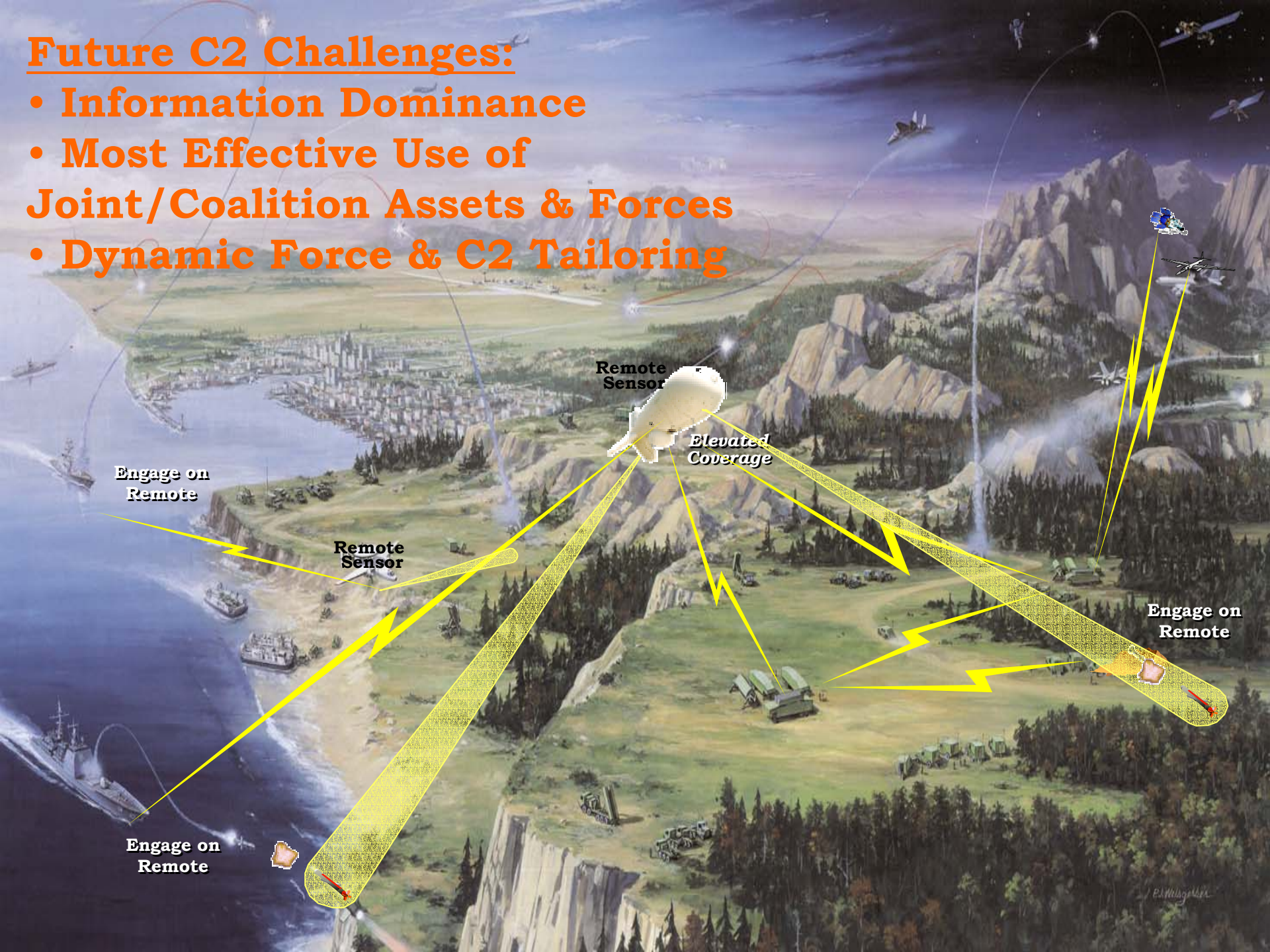

# C2 Challenges for Future Warfare

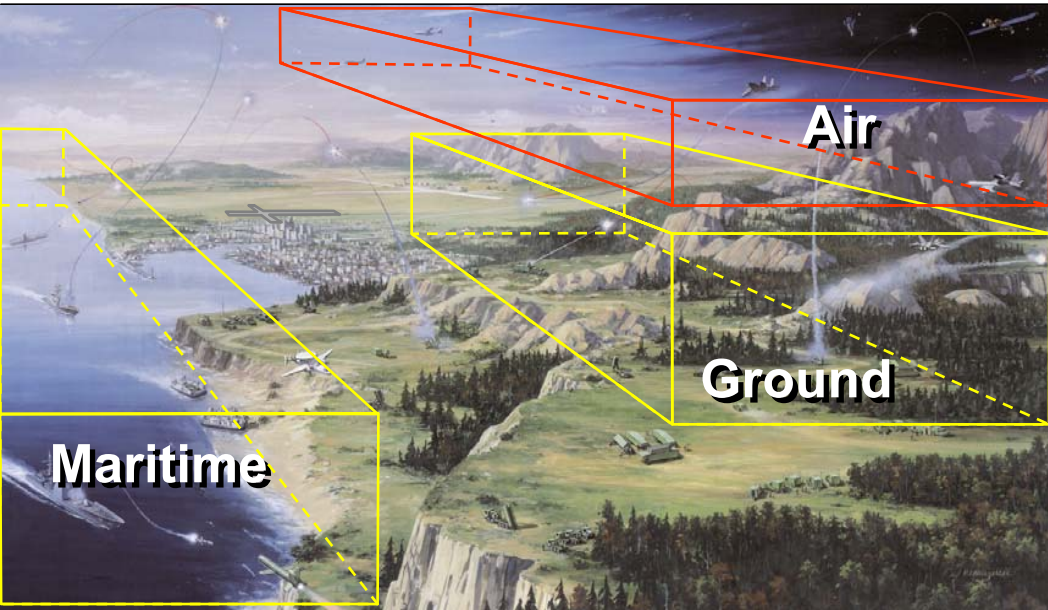

- Non-interoperable pictures: air, ground, maritime
- Non-interoperable units: ships, aircraft, land assets, etc.
- Uncoordinated C2/Decision-making: use of weapons & sensors is “platform-centric”

- JEZ: achieve ability for aircraft & interceptors to share airspace
- IFC: achieve ability to utilize non-located weapons & sensors to perform fire control
- Enhance C2 decision-making to support time-critical Joint (& Coalition) operations

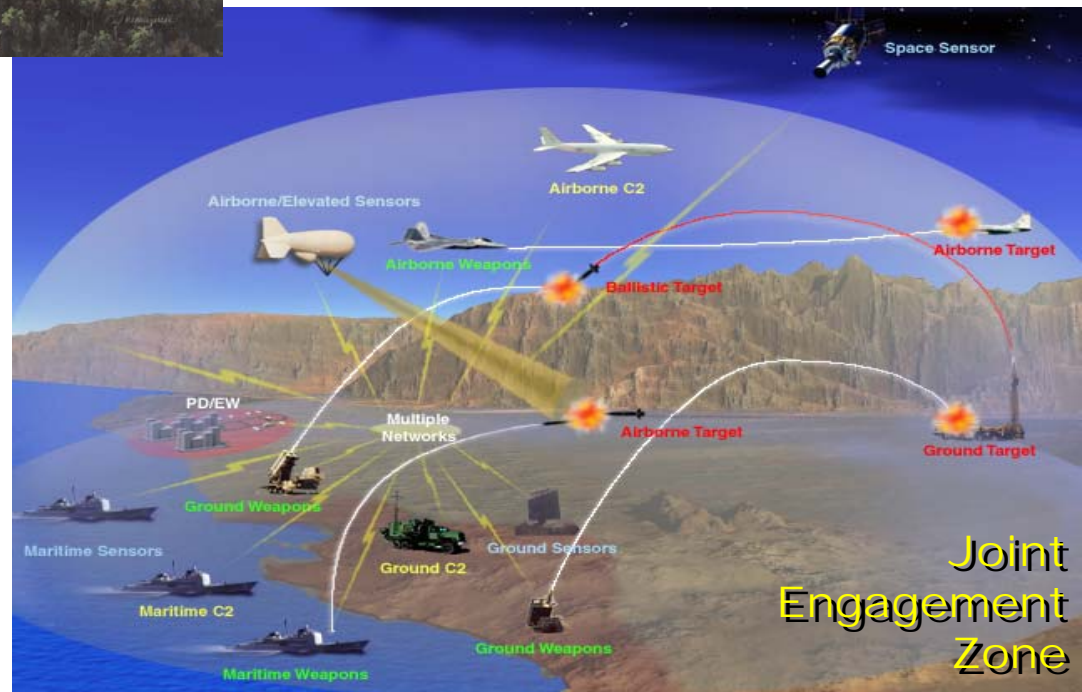

# The Role of C2

---

**The role of C2 in warfare operations is to optimize the use of offensive and defensive resources to combat enemy threats.**

Future advances in Joint C2 will rely on:

- Automated Decision-Making
- Advanced Data Fusion
- Enhanced Situational Awareness
- Distributed Resource Management
- Collaborative Time-Critical Missions
- Collaborative Planning & Dynamic Re-Planning
- Force-Wide Resource Optimization

# Background

---

## **Research Goal:**

To explore concepts and develop capabilities that achieve shared battlespace situational awareness among distributed forces and optimize the management of distributed warfare resources for Force-centric collaboration.

## **Sponsors:**

- Joint Single Integrated Air Picture (SIAP) System Engineering Org.
- Navy's Common Command and Decision (CC&D) System
- Johns Hopkins University Masters Program

## **Major Participants:**

- Mike Green, Naval Post Graduate School, Monterey, CA
- William Canfield, Lockheed Martin, Moorestown, NJ
- Ray Thornber, Galaxy Scientific, San Diego, CA
- Capt Jeff Wilson & JSSEO Staff, JSSEO, Arlington, VA

- 
- **Integrated Fire Control**
  - C2 Design Considerations
  - Future C2 Concepts
  - Key Capabilities Required
  - Conclusion

# IFC Definition

---

**Integrated Fire Control (IFC) refers to the participation and coordination of multiple non-collocated warfare assets in tactical engagements of enemy targets**

- IFC is the ability to develop fire control solutions from information provided by remote sensors
- IFC expands the weapon's effective kinematic range by removing dependency on range limits of the local sensors
- Future advances in aerospace warfare depend largely on IFC – the collaborative use of distributed warfare assets for time-critical aerospace engagements.

# ***Why Integrated Fire Control?***

---

**The ability to direct distributed warfare resources in a collaborative manner enables major enhancements for tactical fire control:**

- Selection of the best shooter from a set of geographically distributed weapons
- Improved chance of interception (by selecting the optimal engagement geometry)
- Improved economy of weapon resources (by reducing redundant shots)
- Earlier launch decisions are possible (remote detection/precision tracking)
- Decoupling of local sensor/weapon pairing constraint
- Sharing engagement control – forward pass
- Off-board engagement support for guidance relay and target illumination
- Enhanced defense against complex threat environments (sophisticated or significant numbers of aerospace targets) – IFC may be a necessity for victory

# IFC Variants

## Precision Cue

A cue is received from a remote source that represents a possible threat.

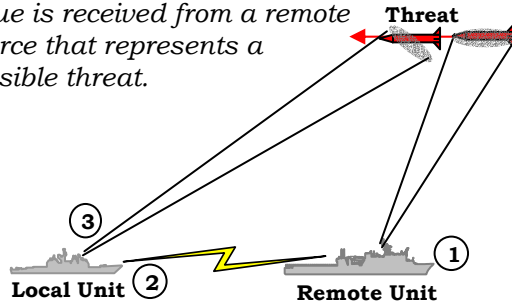

- ① Remote sensor detects threat.
- ② Local unit receives cue.
- ③ Local unit tasks local sensor to detect and track threat.

## Launch on Remote

Remote sensor data is used to initiate a missile launch without holding the track locally.

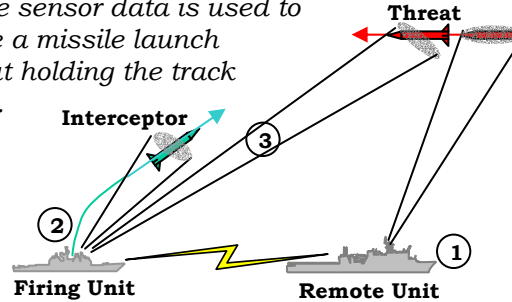

- ① Remote unit provides FCQ threat data.
- ② Firing ship launches interceptor based on remote threat data.
- ③ Local unit tasks local sensor to provide FCQ threat data for remainder of post-launch engagement cycle.

## Engage on Remote

One or more remote sensors provide data upon which all (or portions) of an engagement is conducted.

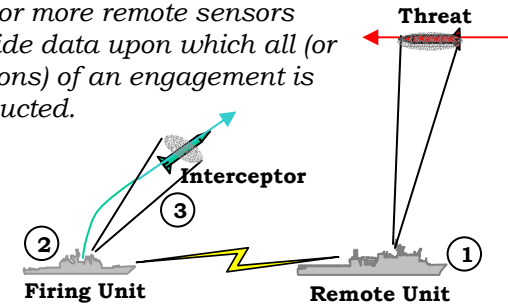

- ① Remote unit provides FCQ threat data.
- ② Firing ship launches interceptor based on remote threat data.
- ③ Remote unit continues to control engagement (compute & provide interceptor guidance, etc.) based on remote data.

## Forward Pass

Control of the in-flight missile is handed off (or forward passed) to another unit to complete the intercept.

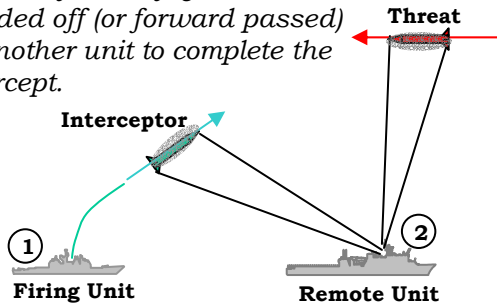

- ① Firing Unit launches interceptor & passes engagement control to Remote Unit
- ② Remote Unit takes over engagement control – tracks threat, passes guidance to interceptor, and illuminates threat when necessary

## Remote Fire

The decision to launch is made by a remote unit. Engagement Control can be local or remote.

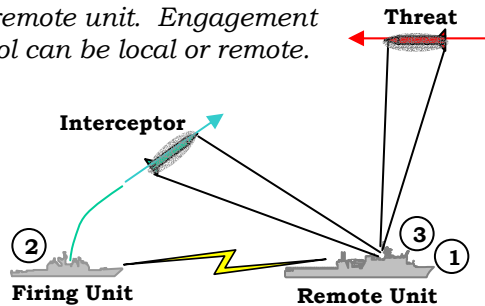

- ① Remote unit makes decision that firing ship should launch.
- ② Firing ship launches interceptor.
- ③ Remote unit (in this example) controls engagement (threat tracking, interceptor guidance, etc.).

## Preferred Shooter Determination

The optimum weapon from a group of warfare units is selected to intercept a threat.

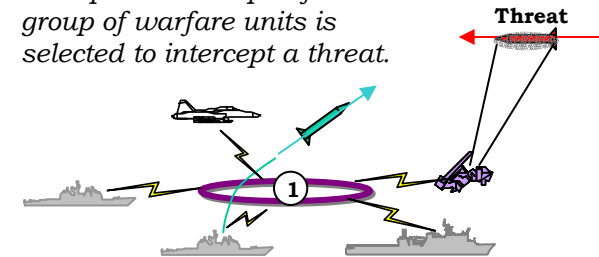

- ① The best shooter is selected based on optimum engagement geometry and engageability determination. PSD can be performed in conjunction with any of the other IFC variants. PSD is, in effect, Force-centric weapon-target pairing.



# Fire Control Functions

<b>Fire Control Function</b>	<b>Function Description</b>
<b>Object Observation</b>	Sensor(s) observes aerospace object.
<b>Object Tracking &amp; Identification</b>	Object is tracked and identified – sensor measurements are used to estimate an object’s location, kinematics, identity & intent
<b>Fire Control Quality Data Attainment</b>	Data is obtained with enough accuracy and update rate to support engagement (launch decision, guidance calculations, and engagement control). (May involve sensor tasking or managing data path (dedicated or increased bandwidth))
<b>Engagement Initiation</b>	Decision is made to initiate defensive measures against an air target of interest (includes: threat evaluation, engageability determination, shooter selection, sensor support selection).
<b>Guidance Calculation</b>	Calculation is made of the interceptor guidance required to intercept target.
<b>Engagement Control</b>	Warfare resources are managed during engagement: weapon control; tasking sensors & communication resources; ensuring resource commitment; monitoring resource performance; validating FCQ data; monitoring engagement support; and negating (terminating) engagement if necessary.
<b>Guidance Relay</b>	Sensor or communication data path provides guidance (in-flight target updates (IFTUs) or target object maps (TOMs)) to interceptor while in flight.
<b>Target Illumination</b>	Sensor illuminates target to support interceptor homing to target.

- 
- Integrated Fire Control
  - **C2 Design Considerations**
  - Future C2 Concepts
  - Key Capabilities Required
  - Conclusion

# Design Considerations

---

**The manner in which C2 functions are performed determines the degree of integration achievable and the ability to control Forces from a Force-centric perspective.**

The key to achieving *integrated* C2 or fire control is the realization that common command and decision functions can be performed in a variety of manners:

- [1] Locally or remotely
- [2] From a Unit-centric or Force-centric perspective
- [3] Using unique or common processing
- [4] Centralized or De-centralized control
- [5] Manually or in an Automated-fashion

# Local vs. Remote

	<b>PC</b> Precision Cue	<b>LoR</b> Launch on Remote	<b>EoR</b> Engage on Remote	<b>FP</b> Forward Pass	<b>RF</b> Remote Fire	<b>PSD</b> Preferred Shooter Determination
<b>Object Observation</b>	R	R	R	L or R	R	L or R
<b>Object Tracking &amp; Identification</b>	L & R	R	R	L or R	R	L or R
<b>Fire Control Quality Data Attainment</b>	L	R & L	R	L or R	R	L or R
<b>Engagement Initiation</b>	L	L	L	L	R	Force Perspective
<b>Guidance Calculation</b>	L	L	L	L or R	L or R	L or R
<b>Engagement Control</b>	L	L	L	L & R	L or R	L or R
<b>Guidance Relay</b>	L	L	L or R	L or R	L or R	L or R
<b>Target Illumination</b>	L	L	L or R	L or R	L or R	L or R



= Key function that, when performed remotely, distinguishes an IFC variant

# Shifting to Force Level Thinking

## Single Unit

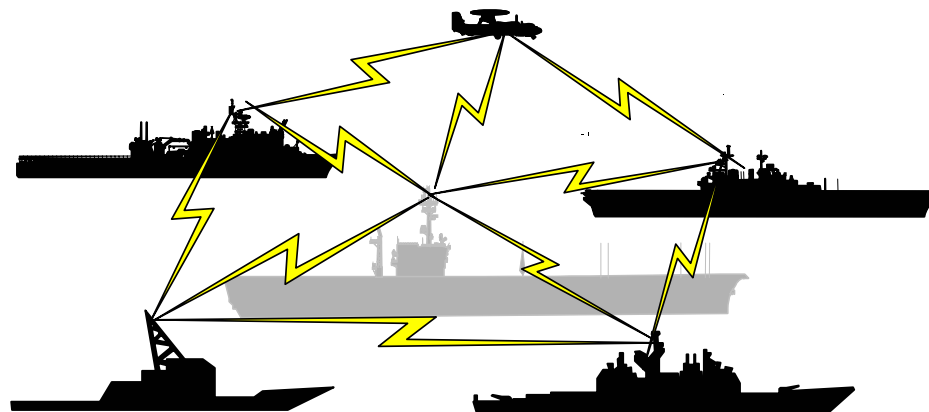
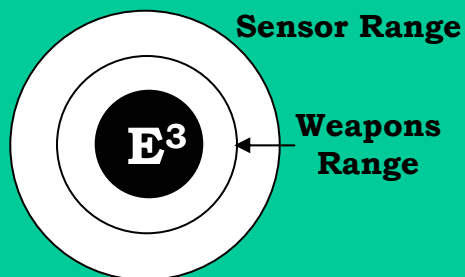

## Network Centric Collaboration

## Multiple Units (Non-collaborative)

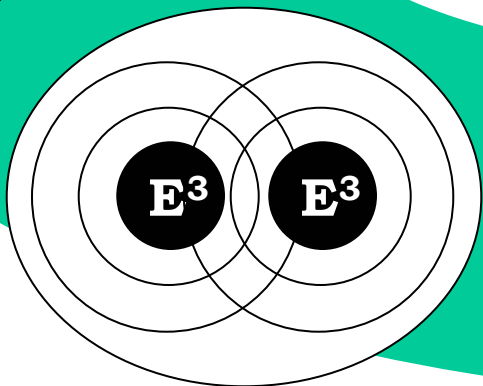

## Multiple Units (Collaborative)

Engagement Quality  
Tracking Information

Engagement Quality  
Typing & Tracking  
Information

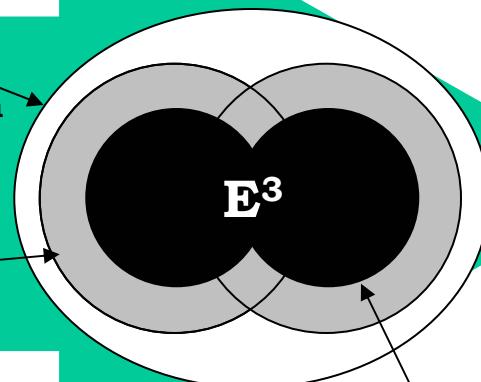

Effective Engagement  
Envelope (E<sup>3</sup>)

# Unique vs. Common Processing

**Another challenge lies in the necessary paradigm shift to performing C2 functions in an identical manner at each node. This difficult, yet necessary, shift is key to enabling more advanced forms of C2.**

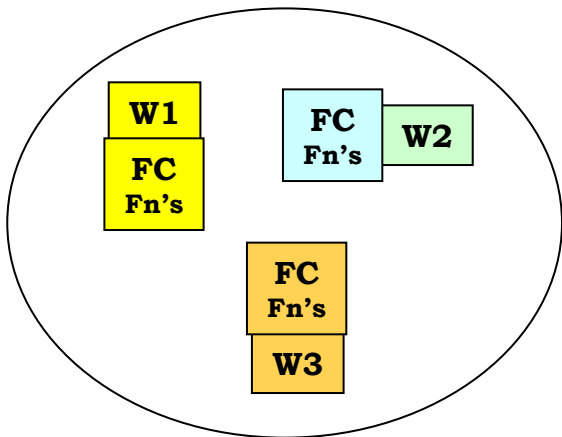

**Weapon/Target pairing  
Engageability determination  
Sensor support determination  
Launch decision  
Engagement initiation  
Engagement control  
Guidance computations**

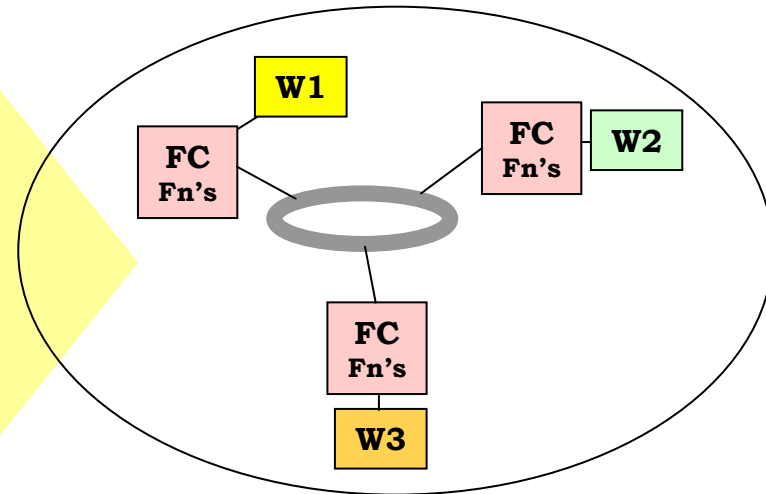

- The fire control focus is unit-centric
- Each weapon system is focused on its own engageability—whether its weapon will intercept the target
- Each weapon system cannot determine if it is the best shooter in the Force; and each will only consider local sensor support
- Forward Pass would be cumbersome if not impossible

- Fire control focus is Force-centric
- Requires access to information concerning all the relevant warfare resources within the Force
- Preferred shooter determination among Force's weapons is enabled
- Advanced forms of IFC requiring automation such as LoR and EoR are more effectively performed
- Performing fire control functions in an identical manner on each unit enables control of engagement to be more easily passed between units

# Centralized vs. De-centralized

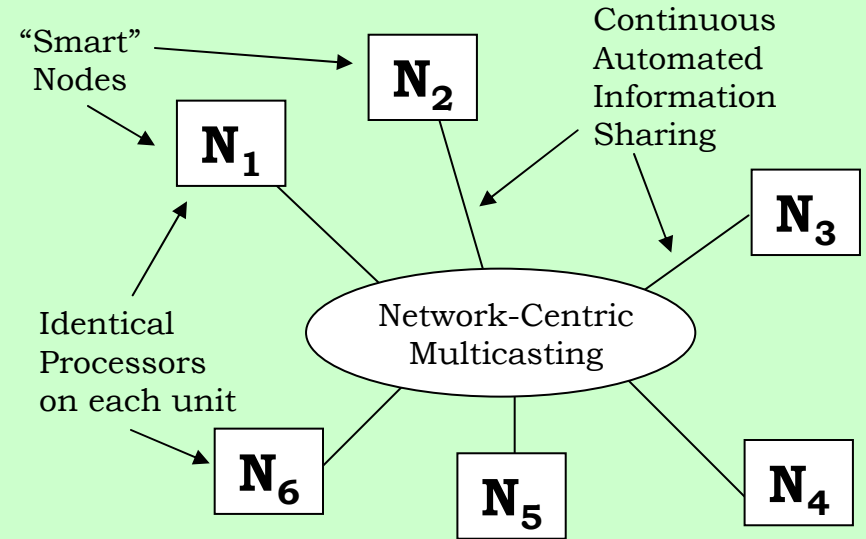
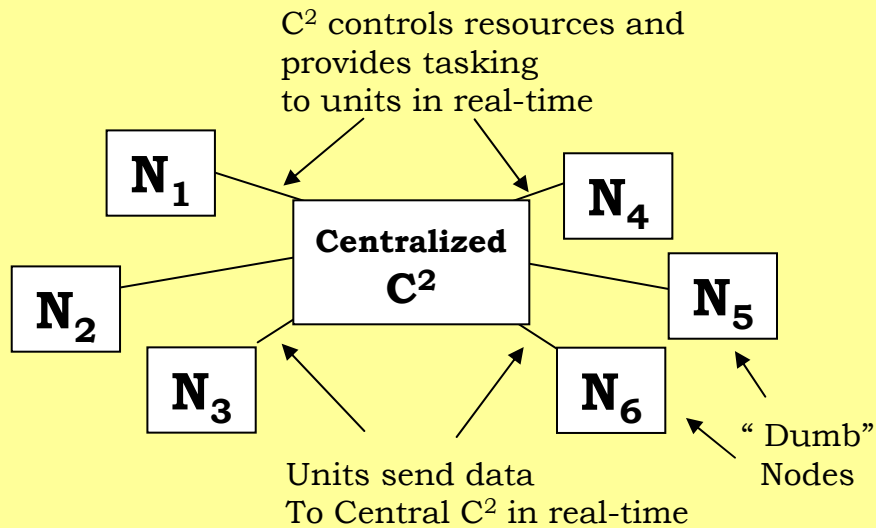

**C2 can be performed using a centralized decision node approach; however there are major advantages to adopting a decentralized approach:**

- The biggest factor is the latency involved in centralized C2. Aerospace warfare places high demands on rapid decision-making and responses - waiting for a launch decision to be made at a remote central decision node may not be an option.
- Distributing command authority for interceptor launch decisions to the unit level is a long-standing tradition and has its obvious merits.
- Equipping distributed units with common algorithms to produce identical engagement recommendations enables a decentralized, yet Force-centric approach and eliminates a single point of failure

# Manual vs. Automated

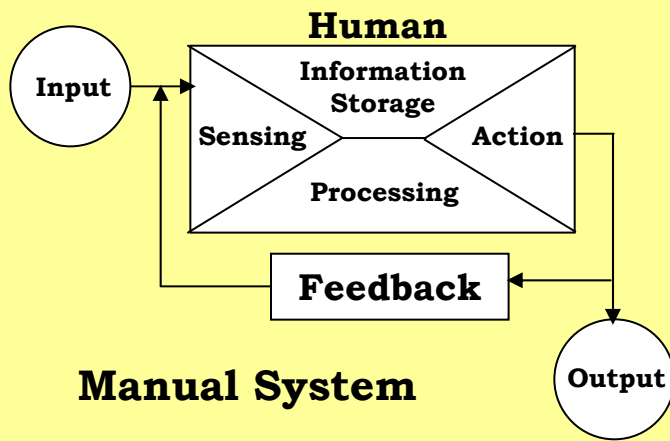

**Manual System**

## Manual Decision-making

- Humans make distributed collaboration decisions
- Humans communicate over voice communications or “intranet chat” to commit resources for IFC

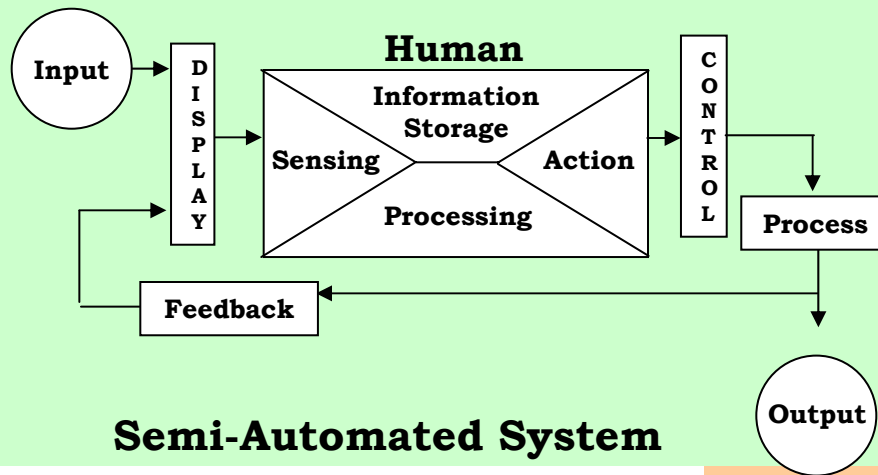

**Semi-Automated System**

## Semi-Automated Decision-making

- Humans make distributed collaboration decisions with aid of machine-fused & shared picture
- Resource control, tasking, and commitment performed using automated feedback and control processes

## Automated Decision-making

- Machines perform decision-making capabilities as well as feedback processing, information display, and control.
- Machine-generated decision options are presented to human for monitoring and command by negation (overriding automated decisions).

**Automated System**

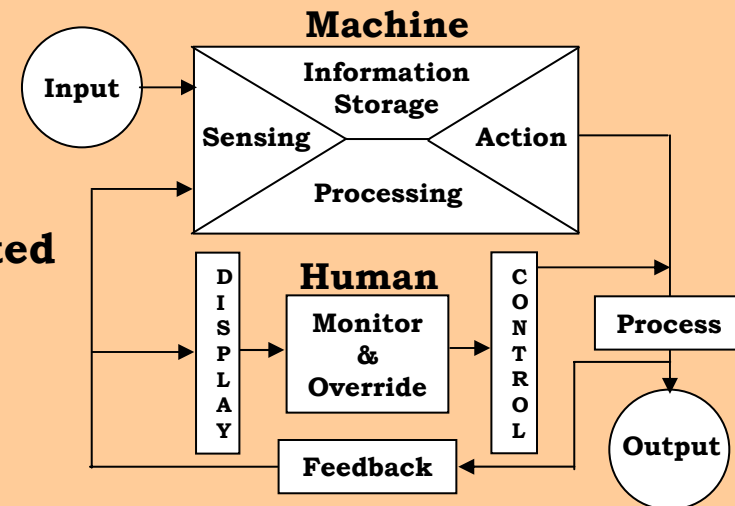



# Command Authority

---

**C2 must be designed to permit local control of warfare assets, thus maintaining organic command authority, while enabling Force-level optimized asset utilization, control, and collaboration across distributed warfighting units or hosts.**

- Perform launch decision locally
- Use common decision aids that recommend resource usage (e.g., weapon-target pairing) with Force-wide perspective
- Ensure local operators always have ability to override local resource taskings generated in an automated fashion
- Maintain operator ability to manage resources manually

# C2 Design Principles

---

**The following design principles are key to advancing future C2 capabilities:**

- [1] Enable fire control functions to be performed locally or remotely
- [2] Utilize warfare resources from a Force-centric perspective
- [3] Shift common command and decision functions from unique methods to common processes
- [4] Design C2 into a decentralized architecture
- [4] Enable C2 decision-making to be performed in an automated-fashion
- [5] Perform IFC while enabling local Command Authority

- 
- Introduction to IFC
  - IFC Design Considerations
  - **Future C2 Concepts**
  - Key Capabilities Required
  - Conclusion

# Future C2 Concepts

---

- [1] Implement an architecture that combines a network centric paradigm with automated intelligent management of sensors, weapons, and links to overcome individual system limitations and enable collaborative engagements; and
- [2] Provide automated engagement decision aids that use “common” algorithms and shared tactical data to simultaneously produce identical engagement recommendations at each distributed unit

## Characteristics:

- **Dynamically updateable doctrine**
- **Decentralized architecture**
- **Synchronized information, doctrine, decision aids**

**Each smart node determines optimum force-level resource management option & gains nodal agreement prior to tasking resources**

# Distributed System of Peers

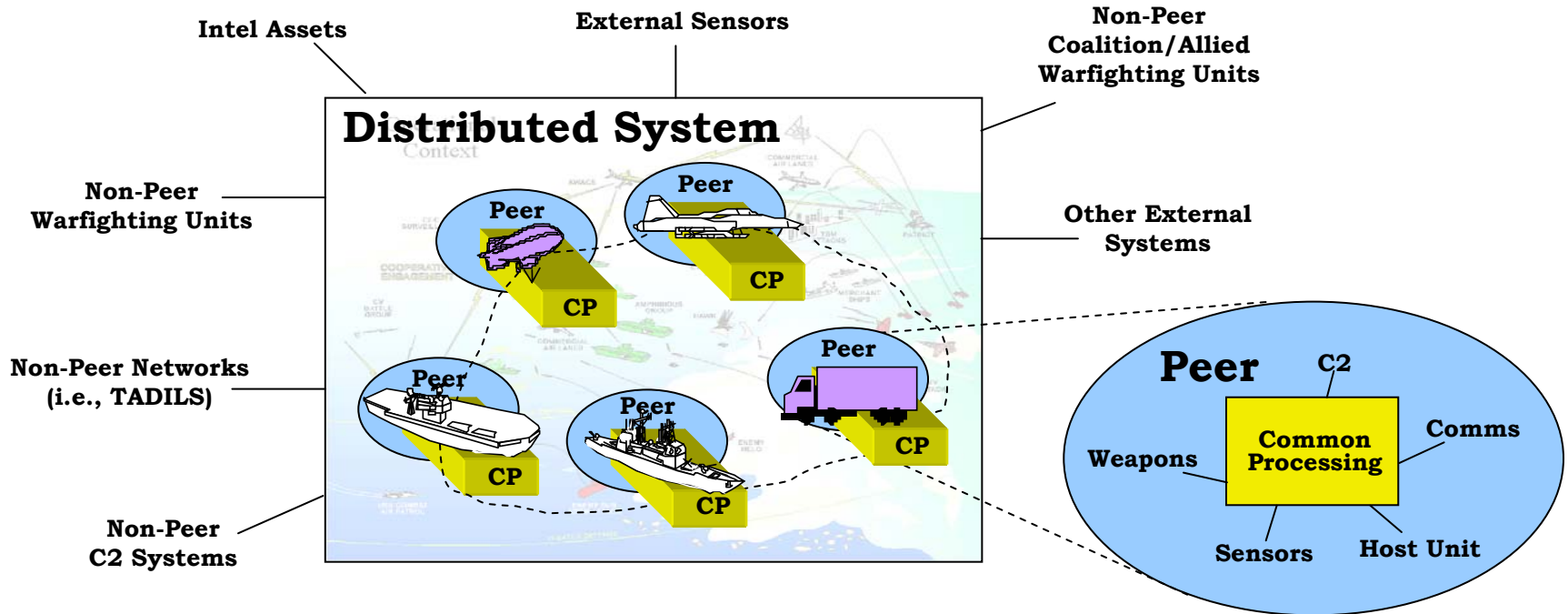

- **Each warfighting unit implements common processing algorithms to perform Joint tactical BMC2 functionality.**
- **A peer is defined as the common C2 processing integrated with a unit's warfare resources.**
- **A “system” of distributed peers interacts or collaborates by sharing information over a Peer-to-Peer (P2P) network.**

# Common Processing Philosophy

The philosophy, simply stated, is that common processing algorithms provided with identical data & information input will produce identical picture, assessment, and decision results.

## Peer Product: Tactical Picture

### Input to the Distributed System

Tracks from External Sources	
3098	2 friendly aircraft observed
2254	craft
	3045N
	7955W

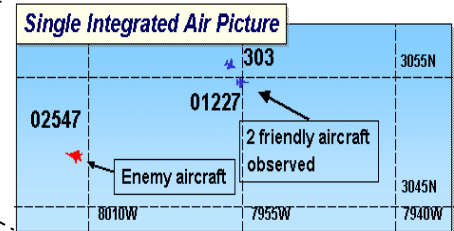
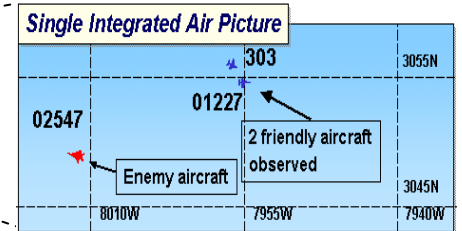
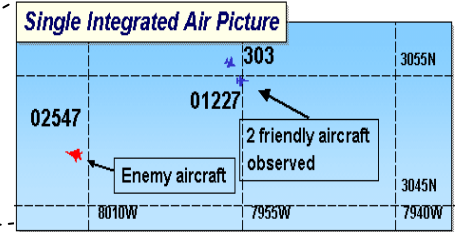
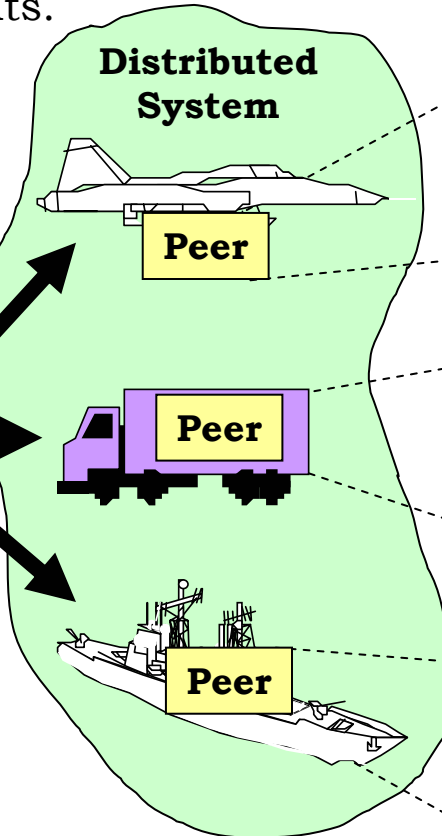

**1** Identical input for each Peer

**2** Each Peer processes input using common algorithms

**3** Each Peer produces identical tactical picture

# Common Processing for C2

**Take the “Common Processing” Philosophy One Step Further:**  
Equip each IABM with common decision-making and advanced data fusion algorithms, which when fed identical track pictures (or data sets), allows each to produce identical resource tasking recommendations.

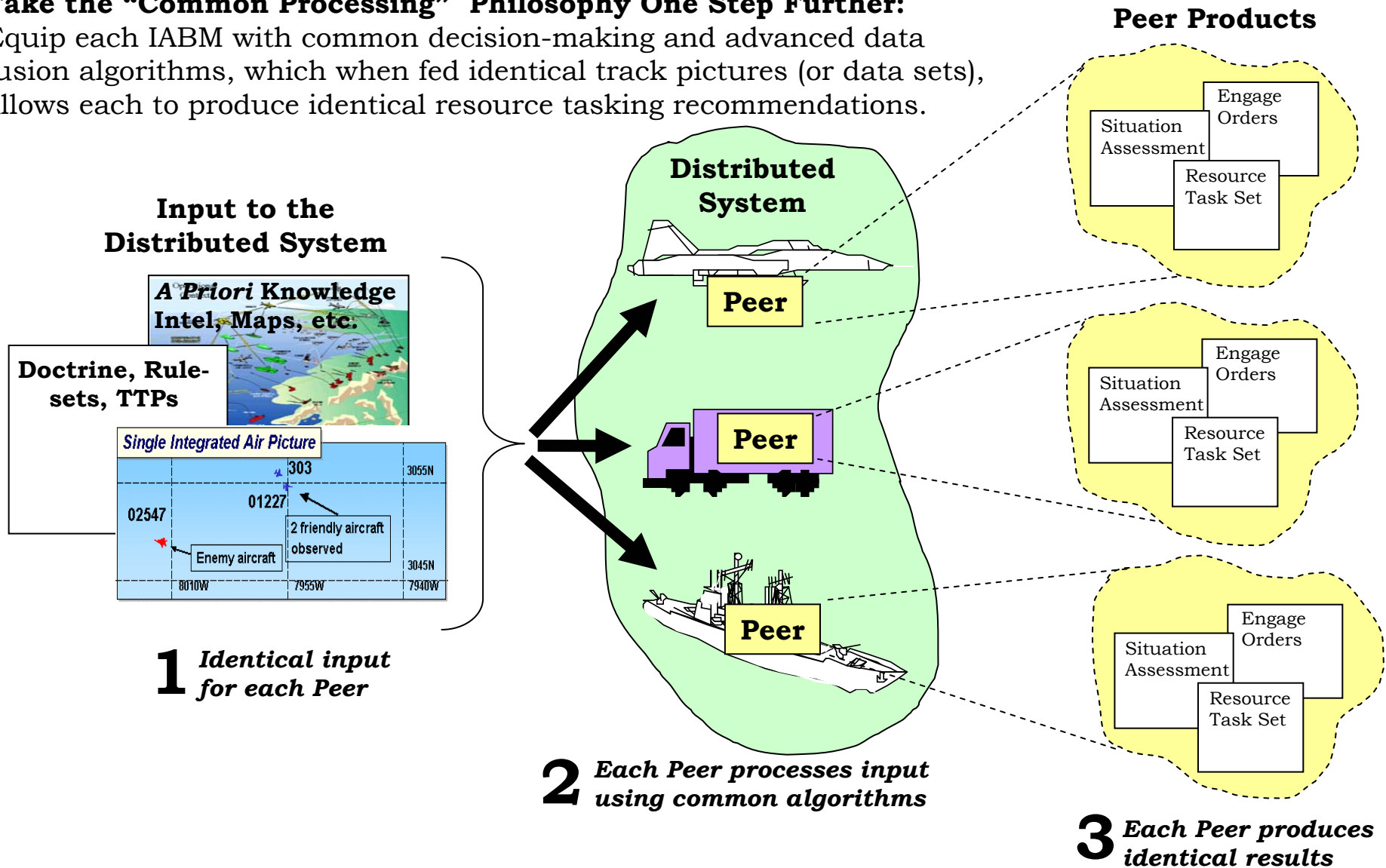

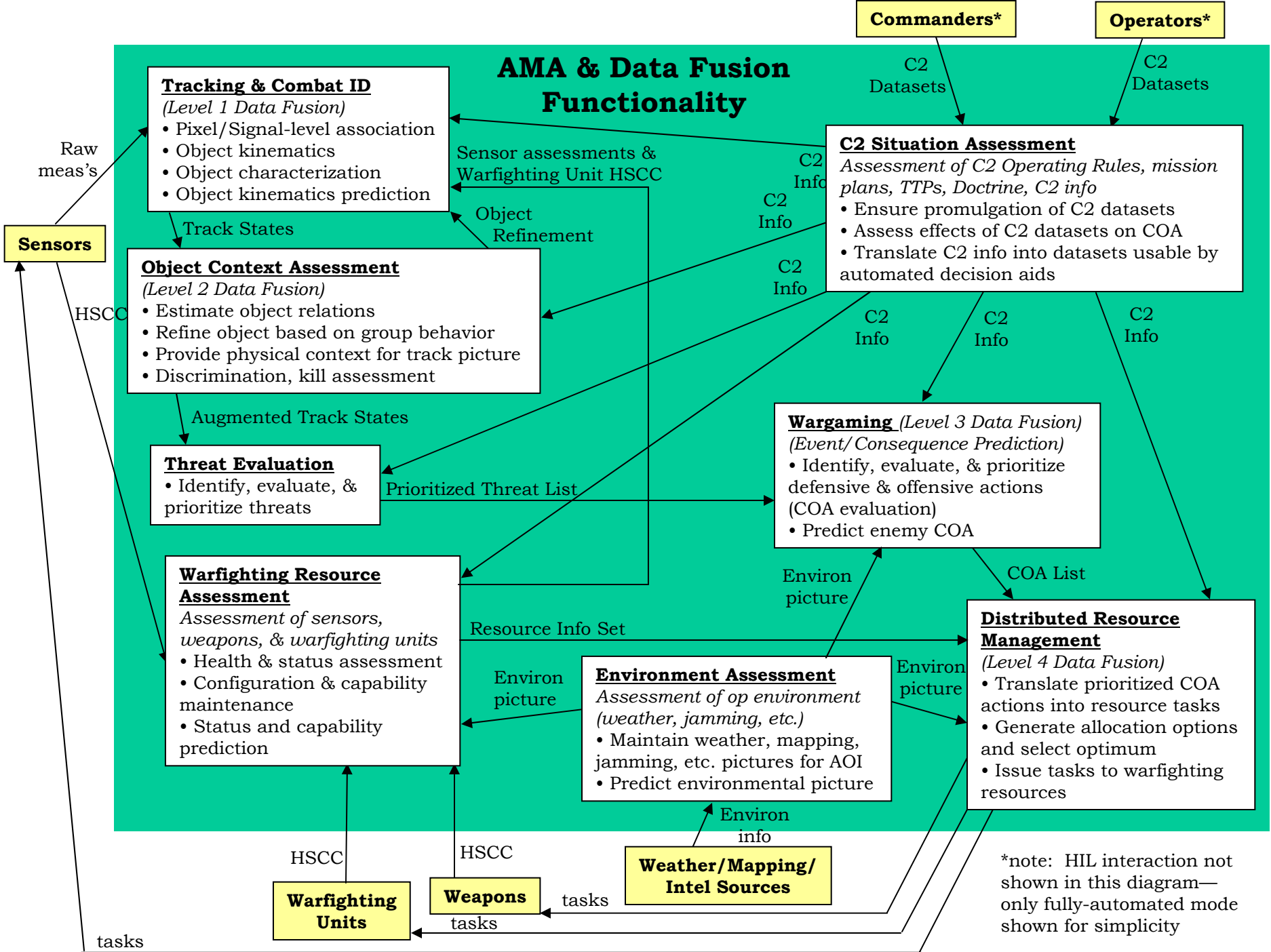



# Common C2 Processing Products

---

## **Products of AMA and Data Fusion Process:**

- Preferred shooter determination
- Weapon-Target Pairing
- Sensor Support for Engagements
- Engagement Control Strategy (i.e., forward pass)
- Engagement Preferences (intercept geometry)

**Example:** each distributed unit uses “common” algorithms to produce identical Force-level engagement recommendations. Therefore, each unit arrives at the same conclusion that a particular weapon has the best shot and that a particular sensor (not necessarily collocated with the weapon) can best track and/or illuminate the target.

- 
- Integrated Fire Control
  - C2 Design Considerations
  - Future C2 Concepts
  - **Key Capabilities Required**
  - Conclusion

# Key Capabilities Required

---

## **Collaborating units need to determine:**

- Preferred shooter
- Weapon-Target Pairing
- Sensor Engagement Support Strategy
- Engagement Control Strategy (i.e., forward pass)
- Engagement Preferences (i.e., forward pass)

## **What capabilities are needed?**

- Shared Situation Awareness
- Determination of Best Course of Action
- Distributed Resource Management
- Embedded C2 Planning

# Shared Situation Awareness...

... is key because each unit needs identical, complete, accurate, & timely awareness (knowledge) of the operational situation.

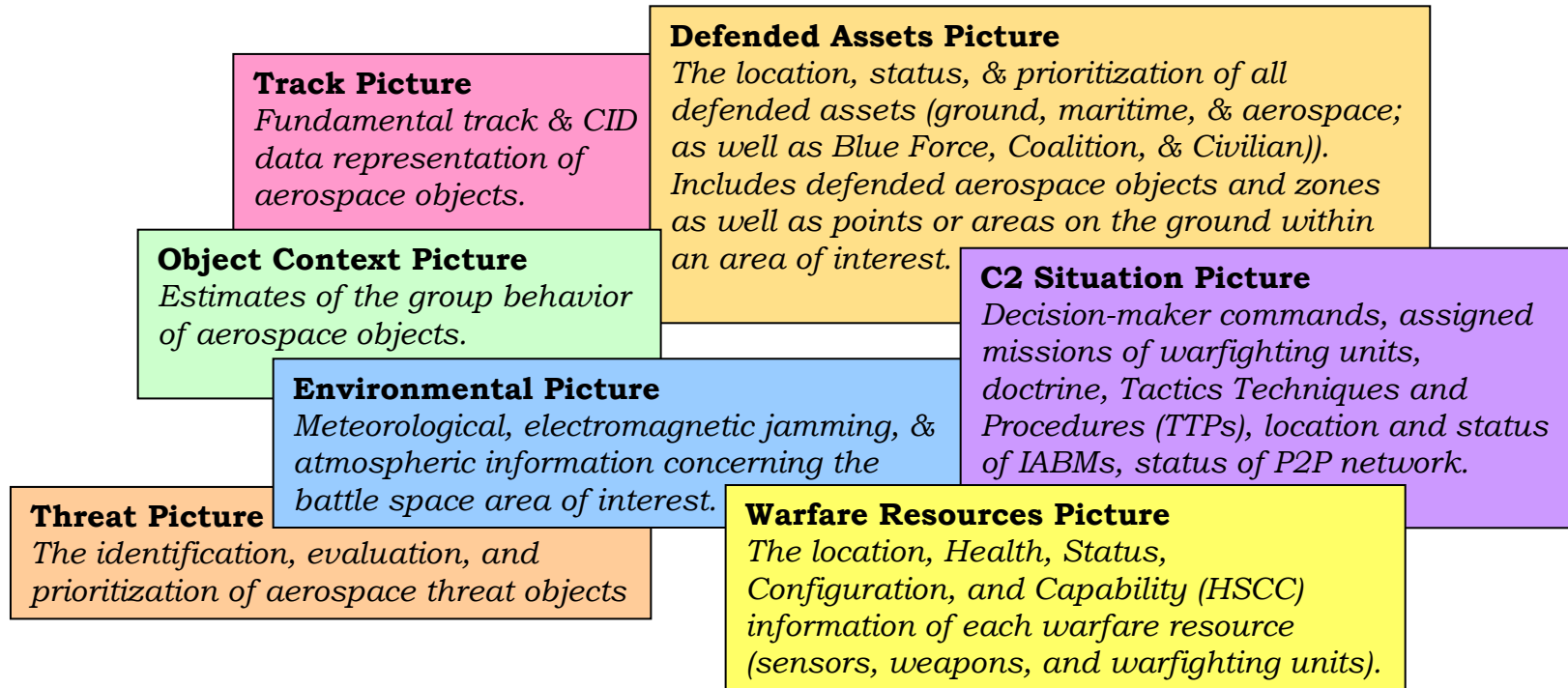

**Shared Situation Awareness (SA)** is the ability of distributed units to gain an understanding of the totality of the tactical situation, including the threat, the defended assets, the readiness of warfighting resources, and command and control constraints within which the systems must operate.

# Data Processing & Fusion

## Shared SA relies on:

Data processing and data fusion algorithms to assess and develop a representation of the real situation

### Situation Assessment Capabilities

#### Tracking & Combat ID

- Pixel/Signal-level association
- Object kinematics
- Object characterization
- Object kinematics prediction

#### C2 Situation Assessment

*Assessment & Adoption of Blue Force C2 inputs*

- Ensure peer promulgation of commands
- Translate C2 inputs into system operating rules, constraints, & parameters

#### SA Certification

- Assessment of track quality
- Assessment of track ID confidence
- Certification of fire control quality SA

#### Object Context Assessment

- Estimate object relations
- Refine object ID & typing based on group behavior
- Provide physical context for track picture
- Discrimination, kill assessment
- Maintain defended assets picture

#### Warfighting Resource Assessment

*Assessment of sensors, weapons, & warfighting units*

- Health & status assessment
- Configuration & capability maintenance

#### Environment Assessment

- Develop & maintain environmental picture (weather, mapping, jamming, etc.) for AOI

#### Peer Evaluation

- Assessment of Peer processing performance
- Peer health & status assessment

#### Threat Evaluation

- Identify, evaluate, & prioritize threats

#### Force Readiness Assessment

*Fusion of assessments*

- Determination of overall readiness of warfighting forces

# Information Architecture

## Shared SA relies on:

An appropriate information architecture to enable data sharing among distributed units.

### Peer-to-Peer (P2P) Network Capabilities

#### **Objectives for Information Sharing:**

Based on Force-centric de-centralized architecture

- Allows warfare resources to be managed according to Force-level needs (rather than unit-centric needs)
- Manages network to enable special data distribution needs during engagements. (higher data rate or throughput)

#### **Information Dissemination Capabilities:**

- Determines needs of information-recipient users or decision nodes (data advertisements/ subscriptions)
- Tracks data availability
- Establishes routing paths & maintains connectivity
- Optimizes bandwidth usage
- Determines feasibility of transmission/checks link status
- Sends and receives commands to/from remote link managers to control, manage, & synchronize transmission
- Transmits data/information according to local/remote synchronized commands

#### **Information Exchange Required:**

- Associated Measurement Reports
- Resource information: HSCC
- C2 Datasets (Doctrine, TTPs, plans, manual commands)
- Resource Tasking Requests
- Resource Commitment “Handshakes”

#### **Data Exchange Characteristics:**

- Supports real-time P2P exchange of sensor measurement data
- Broadcast/Multicast/Point-to-Point
- Non-real-time traffic for operations control
- Link monitoring
- Quality of Service delivery
- Data integrity and confidentiality
- Bandwidth allocation/monitoring
- Data dissemination prioritization (for time-sensitive data or bandwidth constraints)
- Ad hoc nodal topology (nodes can easily join or leave network)
- Interfaces with Tactical Data Links (TDLs)

# Determination of Best COA...

... is key for determining that a threat requires defensive measures—taking into account possible ramifications (Effects Based Operations)

## **Situation Prediction**

### Environment Prediction

- Predict weather for AOI
- Predict possible jamming/clutter

### Resource Projection

*Prediction of sensors, weapons, & unit performance*

- Availability & capability prediction

### Wargaming – Event/Consequence Prediction

*Prediction of sensors, weapons, & unit performance*

- Predict threat
- Predict & evaluate enemy COA & intent
- Identify, evaluate & prioritize blue force COA
- Evaluate effects of C2 inputs on blue force COA
- Analyze historical trends

### Force Projection

Prediction of Force Readiness

- Prediction of overall force readiness & capabilities

- Projects the current situation into the future to estimate the enemy COA and potential impact of the blue force's planned actions.
- Develops and assesses alternative futures or hypotheses concerning the current situation and possible COAs.
- Assigns quantitative confidence values to potential COAs
- Enables collaborative planning, effective resource management, and dynamic replanning

# Distributed Resource Management...

**... is key to enabling and optimizing the use of distributed resources for collaborative and integrated fire control**

## **Distributed Resource Management**

### **Engagement support strategy after launch**

- Forward pass (preferred eng control option)
- Remote guidance relay (preferred sensor arrangement)
- Remote target illumination (preferred sensor support)

### **Selective engagement**

- Selection of best option if multiple engagement options along the threat trajectory exist

### **Launch determination**

- Receive threat & COA determination
- Assess engageability of weapon options
- Determine intercept probability
- Decide to launch (or not)

### **Engagement support strategies**

- Threat detection/cue
- FCQ data availability
- Sensor tasking/commitment
- Preferred sensor arrangement

### **Weapon-target pairing**

- Preferred shooter determination
- Engageability of weapon options

- Based on the use of automated management (or decision) aids to determine and recommend optimum uses of warfare resources
- Using identical AMAs on distributed units enables decisions to be made in a timely manner to support time-critical engagement operations.
- Each distributed unit uses distributed resource management AMAs to determine tasks for all resources within the community of interest (COI)
- Resident operators always have ability to override resource tasking recommendations for local resources; thus command authority is upheld.



# DRM Capability

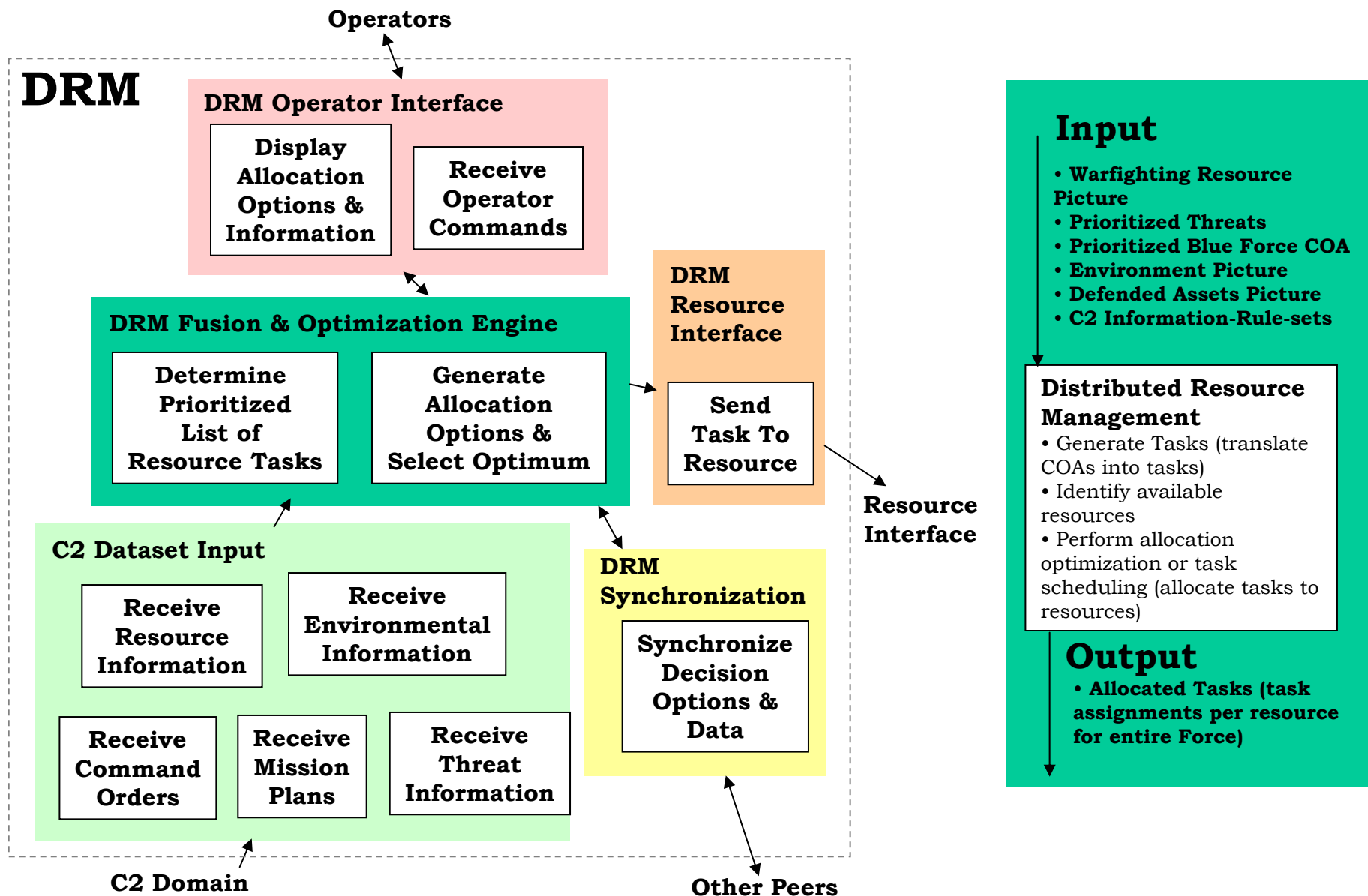

# Embedded IFC Planning...

**... is key to the automated orchestration of IFC operations**

## **Built-in planning prior to operations is a key enabler of AMAs:**

- Predicting operational situations that require collaborative fire control
- Establishing prioritization schemes for missions, threats, defended areas, weapons, tactics
- Establishing rule sets to guide resource behavior for IFC operations
- Establishing parameters to control engageability calculations, target-weapon pairing, target identification/threat evaluation, & sensor tasking
- Establishing decision logic

## **Deliberate Planning is the predetermination of resource utilization.**

### **Defense Planning - “Macro” Planning**

- Assigning resources to missions
- Allocating areas/zones within theater
- CINC priorities
- Identifying critical assets

### **Defense Design – “Micro” Planning**

- Specific TTPs
- Rule sets
- Initialization parameters
- Correlation Track Quality Values

## **Dynamic Planning is the modification of plans during operations**

### **Dynamic Planning Functions:**

- Replanning – dynamic creation of new plan
- Refinement of plan
- Reassignment of resources
- Ad hoc operations
- Alteration of rule sets
- Reset of parameters
- Reestablishing prioritization

### **Why Dynamic Planning is Useful:**

- Plan implementation needs to reflect reality
- Resources change (things break, resources become unavailable)
- Enemy prediction never 100% accurate (unexpected events, enemy COAs, & threats)

- 
- Integrated Fire Control
  - C2 Design Considerations
  - Future C2 Concepts
  - Key Capabilities Required
  - **Conclusion**

# Conclusion

---

- Using distributed resources in an integrated and collaborative manner takes advantage of network-centric advances and is the key to future air warfare and missile defense advances
- Design principles guiding advanced C2 solutions include a decentralized architecture, automating processes, using common fire control functions across the force, and using a force-wide perspective in managing resources
- The proposed strategy distributes C2 “power” to the edge: missile defense systems maintain self-contained command authority while also becoming full participants in force-centric family of systems
- Key capabilities required include: shared SA, determination of best COA, DRM, and embedded IFC planning.

---

**BACK UP CHARTS**

# Development Strategy

## Objective Capability Levels:

- [1] Enhanced Air Picture: cleaner/better/common
- [2] AMA for weapon/target & sensor/target pairing (“best” weapon, “best” target, “best” kill location, “best” tactics)
- [3] Full AMA/DRM: IFC competes with other mission areas for resources

## Development Strategy:

- Develop system capabilities to reach at least level [2] objective
- Build in increments or spirals that afford intermediate IFC capabilities

## Spirals:

- [1] NCW Foundation: Sharing high quality data for fire control
- [2] Request-based IFC & common engagement functionality
- [3] Basic semi-automated & force-centric IFC
- [4] Fully Automated & Optimized IFC

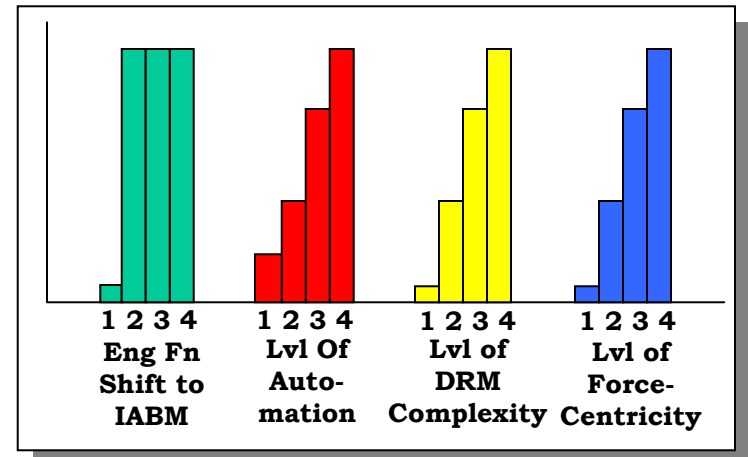

# 1<sup>st</sup> IFC Development Spiral

## ➤ NCW Foundation: Sharing high quality data for fire control

### System Capabilities Required:

- Track certification
- Enhanced networks for sharing measurement data with high rates and throughput
- Automated sensor task requests broadcast within COI
- Basic sensor request prioritization scheme (for when multiple requests are received)
- Engagement notification broadcast within COI

### IFC Capabilities Achieved:

- **Precision Cue** – receipt of a remote “cue” or alert of a potential threat target
- **Engagement Notification** – notification to COI when a weapon fired
- **Request for Off-board Sensor Support** – request broadcast within COI for remote sensor data to provide precision cue (surveillance) or higher track accuracy.
- **Positive Interceptor Identification** – absolute (100% confidence level) identification of aerospace object within track picture that represents interceptor
- **Basic Launch on Remote or Composite** - engagement is prosecuted on the available filtered track state. However, the weapon system performs engagement functions and the local sensor must be capable of supporting the engagement after launch as a back up if the composite track state is not sufficient.
- **Semi-automated EoR** - Use of remote FCQ data to support EoR; however, remote sensor support tasking and commitment requires Operator (or manual) in the loop

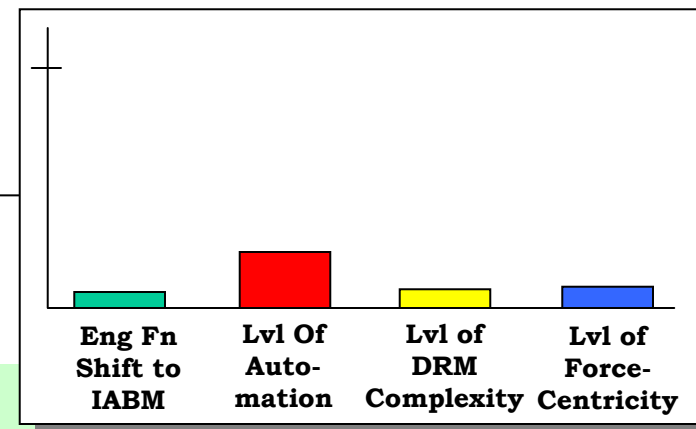

## 2<sup>nd</sup> IFC Development Spiral

### ➤ Request-based IFC & common engagement functionality

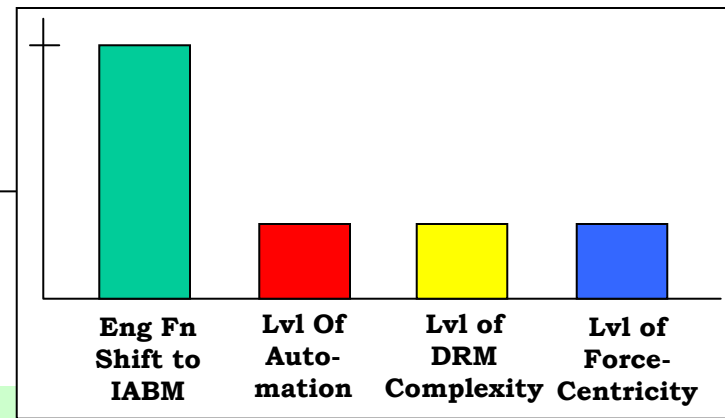

#### System Capabilities Required:

- Networks share sensor resource information (HSCC) among distributed units
- Automated sensor resource scheduling/prioritization schemes
- Self-monitoring (to determine incomplete picture or low quality track data)
- Automated weapon task requests broadcast within COI
- Intelligent application of best data fusion algorithms and best available data to produce most accurate target track
- Launch decision (engageability) functionality shifts from weapon system to IABM

#### IFC Capabilities Achieved:

- **Request-based EoR** – request broadcast within COI for remote sensor to provide FCQ data on threat throughout duration of engagement
- **Request-based Shooter Selection** - request broadcast within COI for remote weapons to intercept a particular threat
- **Automated LoR (or composite)** – IABM computes launch decision for local weapon based on composite track picture or best available data & data fusion processes



# 3<sup>rd</sup> IFC Development Spiral

## ➤ Basic semi-automated & force-centric IFC

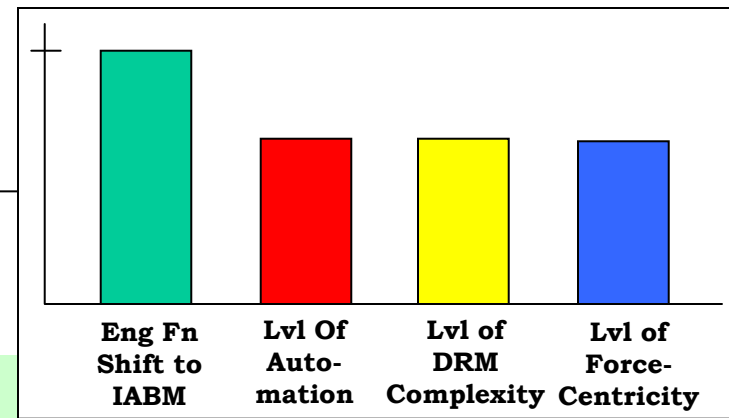

### System Capabilities Required:

- Enhanced automated sensor scheduling techniques
- Request-based distributed resource management
- Basic automated management aids
- Basic deliberate planning

### IFC Capabilities Achieved:

- **Enhanced Request-Based IFC** - All request-based IFC capabilities (such as EoR, selecting the best shooter, tasking sensors to enhance the picture) are enhanced because each distributed unit manages local sensors and weapons using automated common IABM processes (rather than having to interact with Operators or local sensor/weapon systems).
- **Basic Preferred Shooter Determination** - Distributed units simultaneously determine the optimum shooter for each threat based on their situation awareness of battlespace and weapon HSCC.

# 4<sup>th</sup> IFC Development Spiral

## ➤ Fully Automated & Optimized IFC

### System Capabilities Required:

- Advanced data fusion and situation assessment
- Advanced COA determination (effects based operations)
- Fully automated DRM
- Deliberate and dynamic planning

### IFC Capabilities Achieved:

- **Automated IFC** – distributed units simultaneously determine the optimum distributed resource engagement strategies involving the best use of distributed sensors, weapons, and C2 resources; and then task local resources based on the Force-level determinations. Advanced IFC strategies achieved include:

- **Distributed sensor management**
- **Preferred shooter determination**
- **Automated EoR**
- **Forward pass**
- **Remote fire**

