



**NAVAL
POSTGRADUATE
SCHOOL**

MONTEREY, CALIFORNIA

THESIS

UTAH WIRELESS INTEGRATED NETWORK (UWIN)

by

S. Camille Anthony

September 2006

Thesis Advisor:

Christopher Bellavita

Second Reader:

Edward McConkie

Approved for public release; distribution is unlimited.

THIS PAGE INTENTIONALLY LEFT BLANK

REPORT DOCUMENTATION PAGE			<i>Form Approved OMB No. 0704-0188</i>
Public reporting burden for this collection of information is estimated to average 1 hour per response, including the time for reviewing instruction, searching existing data sources, gathering and maintaining the data needed, and completing and reviewing the collection of information. Send comments regarding this burden estimate or any other aspect of this collection of information, including suggestions for reducing this burden, to Washington headquarters Services, Directorate for Information Operations and Reports, 1215 Jefferson Davis Highway, Suite 1204, Arlington, VA 22202-4302, and to the Office of Management and Budget, Paperwork Reduction Project (0704-0188) Washington DC 20503.			
1. AGENCY USE ONLY (Leave blank)	2. REPORT DATE September 2006	3. REPORT TYPE AND DATES COVERED Master's Thesis	
4. TITLE AND SUBTITLE Utah Wireless Integrated Network (UWIN)		5. FUNDING NUMBERS	
6. AUTHOR S. Camille Anthony		8. PERFORMING ORGANIZATION REPORT NUMBER	
7. PERFORMING ORGANIZATION NAME(S) AND ADDRESS(ES) Naval Postgraduate School Monterey, CA 93943-5000		10. SPONSORING/MONITORING AGENCY REPORT NUMBER	
9. SPONSORING /MONITORING AGENCY NAME(S) AND ADDRESS(ES) N/A		11. SUPPLEMENTARY NOTES The views expressed in this thesis are those of the author and do not reflect the official policy or position of the Department of Defense or the U.S. Government.	
12a. DISTRIBUTION / AVAILABILITY STATEMENT Approved for public release; distribution is unlimited.		12b. DISTRIBUTION CODE A	
13. ABSTRACT The state of Utah, like all states and the federal government, has had a long-standing need to improve communication capacity in its emergency response and public safety system. As government entities strive to meet this priority in the National Strategy for Homeland Security, it is crucial that communication systems be interoperable. Ironically, the groundwork for establishing an interoperable communication system nationwide is dependent upon effective human communication and coordination among policy makers, homeland security professionals, first responders and technologists. Accurate and complete information, in the right hands at the right time, can prevent, deter or mitigate a terror event or other mass casualty event. As hosts of the 2002 Winter Olympics, Utah understood that communication was critical to incident command and control and created a world-class 800 MHz communication system to support that mission. Since the 2002 Winter Olympics, with the leadership of former Governor Olene S. Walker and hard work and dedication from multiple agencies, Utah has developed that basic Olympic communications blueprint into the Utah Wireless Integrated Network (UWIN). It is the nation's first statewide, interoperable, wireless voice and data network and it is used every day by Utah's public safety professionals.			
14. SUBJECT TERMS Communication System, Interoperability, Information, Wireless, Voice and Data Network, 2002 Winter Olympics			15. NUMBER OF PAGES 69
			16. PRICE CODE
17. SECURITY CLASSIFICATION OF REPORT Unclassified	18. SECURITY CLASSIFICATION OF THIS PAGE Unclassified	19. SECURITY CLASSIFICATION OF ABSTRACT Unclassified	20. LIMITATION OF ABSTRACT UL

THIS PAGE INTENTIONALLY LEFT BLANK

Approved for public release; distribution is unlimited

UTAH WIRELESS INTEGRATED NETWORK (UWIN)

S. Camille Anthony
Coordinator, Criminal Justice Advisory Council, Salt Lake County, Utah
B.A., University of Utah, 1987

Submitted in partial fulfillment of the
requirements for the degree of

**MASTER OF ARTS IN SECURITY STUDIES
(HOMELAND SECURITY AND DEFENSE)**

from the

**NAVAL POSTGRADUATE SCHOOL
September 2006**

Author: S. Camille Anthony

Approved by: Christopher Bellavita, PhD
Thesis Advisor

Edward McConkie
Co-Advisor

Douglas Porch, PhD
Chairman, Department of National Security Affairs

THIS PAGE INTENTIONALLY LEFT BLANK

ABSTRACT

The state of Utah, like all states and the federal government, has had a long-standing need to improve communication capacity in its emergency response and public safety system. As government entities strive to meet this priority in the National Strategy for Homeland Security, it is crucial that communication systems be interoperable. Ironically, the groundwork for establishing an interoperable communication system nationwide is dependent upon effective human communication and coordination among policy makers, homeland security professionals, first responders and technologists.

Accurate and complete information, in the right hands at the right time, can prevent, deter or mitigate a terror event or other mass casualty event. As hosts of the 2002 Winter Olympics, Utah understood that communication was critical to incident command and control and created a world-class 800 MHz communication system to support that mission. Since the 2002 Winter Olympics, with the leadership of former Governor Olene S. Walker and hard work and dedication from multiple agencies, Utah has developed that basic Olympic communications blueprint into the Utah Wireless Integrated Network (UWIN). It is the nation's first statewide, interoperable, wireless voice and data network and it is used every day by Utah's public safety professionals.

THIS PAGE INTENTIONALLY LEFT BLANK

TABLE OF CONTENTS

I.	INTRODUCTION.....	1
II.	TECHNOLOGY: A TOOL AGAINST TERRORISM.....	5
III.	HISTORY OF WIRELESS COMMUNICATIONS IN UTAH	9
IV.	WHAT IS UWIN?.....	15
V.	THE UWIN PLAN.....	19
VI.	CHALLENGES TO ESTABLISHING STATEWIDE INTEROPERABILITY	23
VII.	SOLUTIONS FOR ESTABLISHING STATEWIDE INTEROPERABILITY...25	
VIII.	TECHNOLOGY TIES IT ALL TOGETHER.....	29
IX.	PAYING FOR UWIN.....	35
X.	THE PRACTICAL IMPACT OF VOICE AND DATA TECHNOLOGY	43
XI.	CONCLUSION	49
	LIST OF REFERENCES.....	51
	INITIAL DISTRIBUTION LIST	53

THIS PAGE INTENTIONALLY LEFT BLANK

LIST OF FIGURES

Figure 1.	Utah’s Statewide Voice Integration Plan (From: Douglas Chandler)	27
Figure 2.	New Equipment and Existing Communication Systems Work Together (From: Douglas Chandler)	30
Figure 3.	Statewide Voice Coverage (From: Douglas Chandler)	31
Figure 4.	Utah’s Mobile Data Network (From: Douglas Chandler)	34
Figure 5.	Interoperability in Utah.....	39
Figure 6.	Intelligence Flow During Operation Electric Storm.....	45
Figure 7.	Always Have a Backup Plan.....	47

THIS PAGE INTENTIONALLY LEFT BLANK

LIST OF TABLES

Table 1. Funding Plan for UWIN.....40

THIS PAGE INTENTIONALLY LEFT BLANK

ACKNOWLEDGMENTS

Former Governor of Utah, Michael O. Leavitt

Former Governor of Utah, Olene S. Walker

Utah Wireless Integrated Network Governing Board

Glenn H. and Sonja Ruth Anthony

Kenneth A. Hansen

THIS PAGE INTENTIONALLY LEFT BLANK

I. INTRODUCTION

The state of Utah, like all states and the federal government, has had a long-standing need to improve communication capacity in its emergency response and public safety system. Government officials across the nation have known for years that voice and data communication systems are in disrepair and lack compatibility between manufacturers and technologies. In spite of this knowledge, public safety communication issues simply have not found their way up to the top of the priority list for policy development, technology upgrades or funding. In the aftermath of the tragedies on September 11, 2001, when it became widely understood that many fire fighters lost their lives because they were unable to receive police radio warnings to evacuate the twin towers in New York City,¹ system improvements and interoperability began to attract attention at the highest levels of government. The radios did not work and people died as a result. Now that this operational defect has been exposed, policy makers and homeland security leaders must learn from it and do everything possible to prevent this failure from happening again.

In addition to establishing communication infrastructure at the local, state and federal levels to gather and disseminate incident management, intelligence and threat information, it is crucial that the communication systems be interoperable. That means disparate voice and data communication systems must be able to exchange and use information.² Information is useless unless it gets to the person who can take appropriate action regarding the information. Accurate and complete information, in the right hands at the right time, can prevent, deter or mitigate a terror event or other mass casualty event. The person most likely to receive information or detect a threat will be a local government worker. Local jurisdictions, most homeland security professionals agree, do not always have sufficient resources to disseminate threat information or respond on their own to major catastrophic events. Terror groups could easily exploit these vulnerabilities by carrying out an asymmetrical attack anywhere in rural or metropolitan America. The bombing of the Alfred E. Murrah Building in Oklahoma City taught us that local

1 <http://gao.gov/new.items/d04231t.pdf> [Accessed November 8, 2003].

2 [Hyperdictionary.com](http://www.hyperdictionary.com). <http://www.hyperdictionary.com> [Accessed November 2003].

government can very quickly become overwhelmed and compromise the coordination and response of a major terror event. Federal and state agencies must be able to step in to assist or assume control in these situations. It is imperative that such transitions be seamless and all responders able to communicate regardless of the agency they represent.

National homeland security planners understand the importance of interoperability and have placed it as a high priority in the National Strategy for Homeland Security:

Although American information technology is the most advanced in the world, our country's information systems have not adequately supported the homeland security mission. Today, there is no single agency or computer network that integrates all homeland security information nationwide, nor is it likely that there ever will be. Instead, much of the information exists in disparate databases scattered among federal, state, and local entities. In many cases, these computer systems cannot share information – either “horizontally” (across the same level of government) or “vertically” (between federal, state, and local governments). Databases used for law enforcement, immigration, intelligence, public health surveillance, and emergency management have not been connected in ways that allow us to recognize information gaps or redundancies . . . It is crucial to link the vast amounts of knowledge resident within each agency at all levels of government.³

Ironically, the groundwork for establishing an interoperable communication system nationwide is dependent upon effective human communication and coordination among policy makers, homeland security professionals, first responders and technologists. Traditionally, these diverse groups have developed silo systems to meet their specific communication needs but have failed to consider cross-disciplinary or standardized voice and data systems. As communication technology improves, that tradition is changing and interoperable, enterprise systems are preferable from a policy, technology and financial standpoint.

Among the many questions swirling around about how we as a nation can better respond in future emergency situations, inquiries regarding public safety communications actually have answers. The most fundamental aspect of emergency response is effective communication. Voice and data communications are critical to incident command and

³ Office of Homeland Security, “National Strategy for Homeland Security”, (Washington, D.C.: Government Printing Office, July 2002), 55.

control. The foundation of all first responder activity is the transfer of accurate, complete and timely information. In large catastrophic events, it is often necessary to add emergency response resources from multiple jurisdictions. In those circumstances, it is critical that communications equipment provide flawless interaction and interoperability among everyone deployed to the incident. By definition, risk is high in emergency situations and success is measured in human lives saved or lost. It is imperative that communications solutions provide faultless interaction as federal, state, local and military entities come together to manage major emergency events.

Utah learned this important lesson while hosting the 2002 Winter Olympics. Because Olympic security required resources from every branch and level of government to work seamlessly to ensure the safety of guests from around the world, the counties along Utah's Wasatch Front created a world class 800 MHz communication system. Since the Olympics, Utah has not only discovered more answers to the public safety communications dilemma, but is developing that basic Olympic blueprint into a world-class, statewide communication system. What may cause Utah to stand apart from other states is that top leaders in the state, most notably, former Governor Olene S. Walker, have made the improved system a top priority. The Utah Wireless Integrated Network (UWIN) is the nation's first statewide, interoperable, wireless voice and data network in the country.

In this thesis, I will argue that Utah needed a statewide, integrated, wireless voice and data network because: disparate legacy communication systems that law enforcement and first responders have been using for years cannot talk to each other; systems that are unable to talk to each other are incapable of deploying accurate and complete information in a timely fashion; in order to safely and effectively respond to and manage terror and other emergency events, law enforcement and first responders must have effective and efficient communication capabilities.

I will draw from my leadership experience and participation in creating UWIN as the research methodology for this thesis. Using my experience, I will engage in a discussion of the technical, funding and political problems associated with creating a statewide communication network, ie. no statewide interoperability, lack of statewide

coverage, lack of statewide backbone, frequency refarming, 700 MHz spectrum, lack of funding, lack of interest, geography, etc. I will also examine the opportunities associated with creating a statewide communication network, ie. upgrades to central electronic databanks (CEB), installation of OmniLink, 800 MHz statewide coverage, improved working relationships, etc. Finally, I will include a review of the pros and cons of the multi-disciplinary participation and partnership in the UWIN project.

II. TECHNOLOGY: A TOOL AGAINST TERRORISM

Technology is a valuable tool for law enforcement and other first responders when it works. It leaves those professionals and the public susceptible to increased danger when it does not work. In those circumstances, it is a liability that must be remedied. Understanding and conquering our vulnerabilities in the war on terror as well as the war on crime is equally, if not more, important as identifying and exploiting the enemy's weaknesses. One fact dominates all homeland security threat assessments: terrorists are strategic actors. They choose their targets deliberately based on the weaknesses they observe in our defenses and our preparedness.

Federal, state and local jurisdictions have made no secret of their inability to communicate effectively. This vulnerability is discussed openly and regularly. The terrorists are well aware of it. As a result, it would be a fairly logical step by a terror group to plan and execute an event that would require a diverse response (fire, law enforcement, emergency medical services, etc.) from several jurisdictions (federal, state and local or multi-city, multi-state). Once the initial event had erupted, a second, unrelated event could quickly follow in the same jurisdictions requiring the same responders. This type of asymmetrical tactic would have a debilitating impact on responders and create very real fear and helplessness for citizens. When citizens feel vulnerable and unprotected, government is criticized for being disorganized and ineffective. At that point, the terrorists are able to claim success. Government progress in terror prevention, interdiction, deterrence and education erodes and severe psychological and negative economic effects quickly follow.

It is absolutely unacceptable to allow the enemy another chance to take advantage of our technology frailties. Authors Daniel Benjamin and Steven Simon in their book, *The Age of Sacred Terror*, suggest that is exactly what occurred following the first World Trade Center bombing. They claim United States officials failed to act after being put on notice that "a new brand of terrorism that aimed at mass casualties had arisen."⁴ They explain their criticism of the government by stating:

⁴ Daniel Benjamin and Steven Simon, *The Age of Sacred Terror* (New York: Random House, 2002): 386.

It is true that between the understanding of that threat and the reality of four planes being used as missiles there is a chasm of incomprehension. But the government failed not because it did not foresee the exact mode of attack. It failed because it did not act against an opponent it knew would like to kill large numbers of Americans, and because it was not alert enough to the signs of an impending operation.⁵

It seems the only thing worse than not having information, is failing to use the information we have to prevent, deter or counter a terror event. The United States must vigilantly explore, discover and mend any other Achilles' heels that may exist within our strategy, operations and technology.

Not only is information technology critical to command and control of a terrorist, criminal or natural disaster event, it can be an efficient and secure method to communicate intelligence information. When one contemplates how they can obtain information about the operational and organizational dynamics of terrorist groups, it conjures up images of 007 hiding bugs in his nemesis' drinking glass and microscopic cameras on the lapels of unwitting co-conspirators. Today's technology makes that fiction very, very real. The collision of reality and fantasy, however, ends there. Technology gadgets are only useful if the information they collect will prevent, deter or allow a more effective response to a catastrophic event. We no longer have to imagine, for example, a doctor being able to see, evaluate and treat patients at the injury scene during the first critical hour following an accident. It is happening via real-time video.

Similarly, firefighters can now stream video and other types of information from inside a burning building or other hazardous environment. Incident commanders can monitor the environment around individual firefighters who, due to their protective gear, cannot recognize the dangers around them. Another benefit is the opportunity to monitor firefighter biometrics such as heart and respiration rates which may allow timely intervention to prevent or minimize serious injury or death.

While the examples above involve non-war applications, those technologies can easily be adapted to create video, voice and data communications in combat situations, in intelligence gathering and in threat identification and dissemination. The bonus is that

⁵ Benjamin and Simon, 386.

the technologies need not wait on a shelf until a catastrophic event demands its use. They are as vital to the life safety issues that we confront in our communities every day as they are to conquering terror activities.

Technology is also the tool by which we will infiltrate enemy communication systems. Without the appropriate technology tool, there is no hope of developing an ongoing understanding of the ever changing operational and organizational dynamics of terror groups and communicating the information learned. Without a fully interoperable information and communication network, terrorists will sense our weakness and strike. Without information, government officials at the local, state and federal levels of government cannot design effective measures to prevent, deter or respond to those terrorist attacks.

THIS PAGE INTENTIONALLY LEFT BLANK

III. HISTORY OF WIRELESS COMMUNICATIONS IN UTAH

Utah, like other states, has long faced a serious dilemma with respect to public safety communications system interoperability. In 1973, state public safety agencies migrated their radio communications systems to the very high frequency (VHF) 150-173 MHz band. Many local government public safety entities followed the state's lead and migrated to the VHF band. Salt Lake City and Ogden City decided against moving to the VHF band and shifted their public safety radio communications operations to the ultra high frequency (UHF) 450-470 MHz band instead. This decision created an interoperability dilemma that required public safety agencies along the Wasatch front to install and utilize two separate mobile radios to provide voice access to all of the dispatch centers.⁶

In the 1980s, public safety agencies utilized analog radio systems operating in the 150 MHz frequency range. The Federal Communications Commission (FCC) isolated this radio spectrum for use by governmental agencies to provide public safety communications. The state of Utah still holds licenses for common channels to provide limited interoperability for emergency responders statewide. As the channel capacity in radio equipment increased over time, agencies were able to cross program frequencies to further enhance interoperability.

In the mid 1980's through the early 1990's the 150 MHz spectrum became overused and congested in Utah's metropolitan areas. In response, several agencies along Utah's densely populated Wasatch Front moved to UHF systems operating in the 460 MHz spectrum to avoid congestion and gain better saturation.

In July 1993, then Governor, Michael O. Leavitt formed an intergovernmental task force comprised of more than fifty public safety communication and technology

⁶ Geographically, Utah is a large state but as of 2000, the population was estimated at only 2,246,553. Over seventy percent of Utah's live in four counties. This group of four contiguous counties, known as the Wasatch Front, consists of Salt Lake County (population 902,777), Utah County (population 371,894), Davis County (population 240,204), and Weber County (population 197,541). The remainder of the state is geographically much larger but contains a much smaller population base.

experts. He charged the task force with researching, evaluating and making recommendations regarding the technology needed to meet Utah's long-term public safety radio communications needs.

After months of study, the task force concluded that the governor's vision for a fully interoperable radio communications system could be best met with 800 MHz trunked radio technology. A trunked radio system dynamically assigns radio channels as requested by a radio user. The radio channels are not assigned to any users until they are needed. All radio users on the system monitor a control channel with one control channel per site. Instead of selecting a channel, the user selects a Talkgroup with the mode select switch. When a user wishes to talk, he or she presses the push-to-talk button and a radio channel is instantly assigned to the Talkgroup. All the users that are operating on the same Talkgroup can then communicate. When the conversation is over, the repeater is released; the radios are muted and again monitor the control channel. Five channels in a trunked system can handle dozens of Talkgroups. The task force recommended that 800 MHz be installed statewide in phases over a period of years and that the system serve local, state, and where feasible, federal, public safety agencies.

In 1997, the Utah State Legislature passed House Bill 187 entitled "State and Local Public Safety 800 Megahertz Project." This legislation established the Utah Communications Agency Network (UCAN) as a quasi-government entity and gave it responsibility to create a statewide communications network and provide governmental public safety communications services, facilities and equipment. In an effort to resolve the interoperability dilemma between incompatible VHF and UHF wireless communications systems in Utah, UCAN set a goal to migrate all public safety entities to a common, 800 MHz band. Unfortunately, the UCAN goal to install 800 MHz statewide is cost prohibitive and the state's interoperability dilemma has been exacerbated by an additional 800 MHz band of operation used only on the Wasatch Front. The relationship between the state and UCAN quickly became competitive as each entity struggled to build and maintain incompatible systems. The relationship eventually became adversarial and both entities lost focus of the original goal of improving public safety communications statewide.

In 1999, construction began on the 800 MHz radio system along the Wasatch Front. Before UCAN's inception, its member agencies used different frequencies, different bands, and different technologies. There was no common platform for communications, coordination, or situational control. Today, all UCAN agencies communicate with each other directly and in real time. During the 2002 Winter Olympics, when the Department of Defense's (DOD) radio system failed, the UCAN system was able to accommodate all of DOD's traffic at the last moment. As result, a total of 15,000 users were supported without interruption for seventeen days. Since November 2003, UCAN has provided two-way radio communications services for 109 public safety agencies in ten counties surrounding Salt Lake City. They include Salt Lake, Davis, Utah, Weber, Summit, Wasatch, Tooele, Morgan, Box Elder, and Cache Counties.

On July 1, 2003, Utah held a Summit on Interoperability. The Summit was the culmination of several discussions I had had with the Chair and the Executive Director of UCAN (I was serving on then Governor Michael O. Leavitt's Cabinet at the time as Executive Director of the Utah Department of Administrative Services). The discussions began as an effort to repair strained professional relationships between UCAN, the state's Division of Information Technology Services (ITS) in the Department of Administrative Services (DAS) and the Department of Public Safety (DPS). Candid discussions quickly led to the realization that all three entities shared a similar vision for public safety communications in Utah and that each had a better chance of accomplishing their individual goals by maximizing collective resources rather than competing for scarce resources. With an agreement to proceed as partners, we decided to invite other interested parties to participate in building a statewide wireless voice and data communications network. We agreed that the entire effort would be inclusive, not exclusive.

I co-chaired the July 1, 2003 Interoperability Summit with UCAN Chair, Gary Whatcott. Representatives from DAS, ITS, UCAN, DPS, Health, Criminal and Juvenile Justice, Corrections, Utah Education Network (UEN) and the Utah Sheriffs' Association were present. Gary and I explained that the purpose of the meeting was to establish cooperative working relationships between major voice and data network owners and

users and to leverage existing and future resources to build a statewide wireless, integrated, interoperable voice and data network. UCAN and ITS representatives presented information regarding technology resources and human resources available in their agencies. The presentations contained helpful history, maps of microwave and cellular tower locations, asset inventories and suggestions for the future direction of interoperability in Utah. Out of the ensuing discussion, an unlikely, but welcome, partner emerged.

Mike Peterson from the Utah Education Network (UEN) explained that the education network called EdNet relies on commercially provided circuits and fiber, but uses microwave where necessary. UEN's initial goal was to provide network connectivity to all high schools and colleges in the state. Having achieved much of that goal, EdNet and its auxiliary systems provide distance learning to 400 classrooms statewide. Mike expressed an interest in using UCAN and ITS networks to provide redundancy throughout the EdNet system and at the same time, indicated a willingness to make the education network available to other state and local agencies. As this offer was made, I watched each participant mull over the wide variety of potential uses of UEN's video conference, distance learning capabilities. From statewide training to managing a weapon of mass destruction (WMD) or other mass casualty event and everything in between, doors to virtually every community in the state had been opened to Utah's homeland security effort.

UEN's offer widened Utah's communication net, but it did not fix any of the holes. Utah still needed affordable voice and data communication solutions, especially in the rural areas of the state. As discussions and meetings continued over the next several weeks, additional partners became interested in the project and began to bring additional resources to the table. The Utah Department of Transportation (UDOT), for example, had been looking for a way to connect each of its maintenance stations throughout the state to the state's wide area network (WAN). Several state department directors were looking for facilities to locate 802.11 hotspots and mesh networking so troopers, local health and law enforcement officers, transportation workers and other government professionals could have wireless internet and WAN access from their vehicles through a

common secure interface as they work out in the field. This cooperative solution would also allow multiple agencies to share data access when responding to specific localized emergency incidents.

In addition to the UDOT project, Summit participants discovered that Utah National Guard (UNG) had been working on a wireless data solution in conjunction with the U.S. Forest Service. Their concept involved extending the wireless data hot spot range from 300 feet to three miles. The state immediately began a pilot project with the UNG and the Utah Highway Patrol (UHP) along the I-15 corridor to determine if this data solution could perform on a statewide basis.

As the weeks passed following the interoperability summit in July, a small subcommittee of the participants was researching and exploring technologies to close the holes that prevent interoperability between VHF, UHF, 800 and 900 MHz frequency bands as well as analog, digital and mixed mode system configurations. In the fall of 2003, the subcommittee reported back to the full Summit group that it had found a technology called OmniLink.⁷ OmniLink is a private trunking voice solution which enables large mission-critical users, such as state and national governments, utilities and other agencies, the ability to roam and operate seamlessly throughout vast geographic areas.⁸

On Friday, November 7, 2003, newly inaugurated Utah Governor Olene S. Walker signed her first Executive Order establishing the Utah Wireless Integrated Network (UWIN) Governing Board. Governor Walker had been aware of the need to have an interoperable communications system in Utah since the 1980's when she chaired the Utah Commission on Criminal and Juvenile Justice (CCJJ). While Chair of CCJJ, she experienced, first hand, the policy discussions surrounding disparate public safety communication systems before "interoperability" was a homeland security buzz word and before the concept of "homeland security" existed. As she prepared to become Utah's Chief Executive, I had the opportunity to review the outcomes of the Interoperability Summit and inform her that an atmosphere of cooperation and coordination was growing

⁷ OmniLink is a Motorola hardware and software package.

⁸ David Fletcher, "UWIN Handout" (n.p., December 2003): .

as discussions about the future of public safety communications in Utah continued and the goal of creating a statewide voice and data, wireless, integrated, interoperable network was taking shape. Governor Walker could not wait to be a part of the solution. And, she really didn't wait. Two days after she became Governor, she called a press conference, assembled the members of the new UWIN Governing Board, announced the project and signed the Executive Order.⁹ She also set a deadline. She announced that by July 1, 2004 the first phase of UWIN would be in place and emergency response professionals from one end of the state to the other would be able to communicate and their voice communication systems would be interoperable. The July deadline was not a planned part of the Governor's talking points that day, but it quickly became the centerpiece of the UWIN strategic plan. She was very excited about finally making unresolved, twenty-year-old public safety communication issues a top priority in the top office of state government.

With the support and challenge of the Governor and the new spirit of cooperation among the diverse members of the UWIN Governing Board statewide, interoperable, wireless voice and data were well on their way to becoming a reality in Utah. Still, there were significant challenges to move from a widely archaic and silo oriented communication arrangement to a state-of-the-art, fully integrated communication network.

⁹ See www.uwin.utah.gov to view video of Governor Walker's press conference and read the UWIN Executive Order.

IV. WHAT IS UWIN?

UWIN stands for Utah Wireless Integrated Network. It is a statewide, wireless, interoperable, voice and data network that leverages existing communications resources within the state of Utah. Those existing resources are being augmented with state-of-the-art technology in order to ensure a redundant, fully integrated state public safety communication system. It is a network that is overseen by the UWIN Governing Board which was established by Executive Order on November 7, 2003.¹⁰ The network provides seamless, coordinated and integrated communication for local, state, federal and interested military agencies operating in Utah.

Unlike many government boards, membership on the UWIN Governing Board is not defined. Instead, all interested parties are welcome to participate. The reason behind the open forum approach was to make the process of establishing a statewide wireless voice and data network inclusive, not exclusive. Over 23 individuals are participating. They represent a variety of state and local government agencies a few of which include: Utah National Guard, Utah League of Cities and Towns, Utah Association of Counties, Department of Public Safety, Department of Health, Department of Administrative Services, Division of Information Technology Services, Department of Agriculture and Food, Fire Chiefs' Association, Utah Chiefs of Police Association, Utah Sheriffs' Association and the Utah Education Network. Several Governing Board participants commented that they appreciated working together in an atmosphere of cooperation and coordination and value the cross-discipline interaction and relationship building that developed as a result of the UWIN project. Each member realized that they needed something someone else on the UWIN Board had, and, each agency represented on the UWIN Board had something someone else needed. For those components that did not exist in anyone's coffers, agencies pooled their resources to acquire the parts necessary to fill the holes. Coordination, cooperation, funding and leadership on the part of all interested parties propelled Utah into action with respect to the future of statewide public safety communications rather than locking it into the precarious reactive position of the past.

¹⁰ See Appendix for list of Governing Board member as of December 2004.

All states need a coordinated, comprehensive plan to build interoperable communication systems and effectively leverage the few federal, state and local dollars that are available. Our nation's leaders have recognized that homeland security is a shared responsibility among federal, state and local governments. Improving information sharing and information systems is the key to successfully fulfilling that collective stewardship. The National Strategy for Homeland Security states:

Information contributes to every aspect of homeland security and is a vital foundation for the homeland security effort. Every government official performing every homeland security mission depends upon information and information technology.¹¹

If information is the foundation of the homeland security effort, communication of information frames the structure and, effective action regarding information completes the structure.

Fortunately, the UWIN Board had a great foundation from which to begin its information sharing duties. Based on the coordinated and cooperative efforts of Utah Public Safety Commissioner Robert L. Flowers and the Utah Olympic Public Safety Command (UOPSC), Utah made significant advances in communications, intelligence gathering and analysis in preparation for and during the 2002 Winter Olympics. UOPSC also excelled in information and intelligence sharing but they were shared among a limited group of people and specific geographic area. Since the Games, Commissioner Flowers has continued that intelligence legacy by creating the Utah Criminal Intelligence Center (UCIC) which is co-located with Utah's Joint Terrorism Task Force (JTTF) in Salt Lake City, Utah.

While Utah's law enforcement community and the Utah National Guard do a stellar job with intelligence gathering and analysis, dissemination of that intelligence, statewide, to the right people at the right time continues to be a challenge. Utah's intelligence community can access necessary information from their desktops but, in the event of a catastrophe, when up-to-the-minute information and intelligence can mean the

¹¹ U.S. Office of Homeland Security, National Strategy for Homeland Security (Washington, D.C.: Government Printing Office, July 2002), 55.

difference between lives saved or lost, public safety professionals need to have access to critical information at the event sight, wherever that may be in the state and on any radio or data device available.

While government officials have recognized the importance of getting the right information to the right people at the right time in order to keep the homeland secure, they are quick to point out that there are fundamental problems with establishing an efficient government-wide information and communication system. First, information system acquisition is generally not coordinated and second, legal and cultural barriers prevent agencies from integrating information systems.¹² These two problems are not a surprise to anyone. Every government worker who has ever had to work with someone outside his or her agency has run into communication and information sharing problems. By establishing the UWIN Governing Board, Governor Walker provided a forum for discussing communication issues in Utah and set the expectation that those discussions would lead to tangible solutions.

¹² U.S. Office of Homeland Security, National Strategy, 56.

THIS PAGE INTENTIONALLY LEFT BLANK

V. THE UWIN PLAN

Once the UWIN Governing Board was in place, it acknowledged the key to successfully delivering the UWIN project on time and in working order was full cooperation and coordination among its members, steering committees and staff. Both the UWIN Vision Statement and Mission Statement were drafted to recognize and support that notion:

UWIN Vision Statement – UWIN is a wireless intergovernmental network that will leverage existing State resources. The network will provide seamless, coordinated, and integrated communication for local, state, and federal agencies. This will allow public safety agencies the flexibility to communicate on a wide variety of vendor products statewide.

UWIN Mission Statement – UWIN Governing Board’s mission is to plan for and foster coordination and integration among wireless networks on a statewide basis that meet the requirements of local, state, and federal public safety and other state agency needs.¹³

Using these statements as a guide, the Governing Board assigned staff to draft a strategic plan for the entire UWIN project. Throughout the drafting process, the Governing Board provided input and direction to shape the plan.¹⁴ Because funding was such a major obstacle, the Governing Board decided to carry out the UWIN plan in two phases. Phase I of the Plan focused on providing interoperable voice communication between 800 MHz radios and 150 MHz radios. Phase II centered on creating the first statewide mobile data solution in the country. Because there was no start-up or ongoing funding dedicated to the project, the Governing Board determined that interoperability in Utah would occur by leveraging federal grant funding with existing budgets for communication technology and infrastructure.

The Governing Board also determined that in order to create good will and buy-in among local and federal government agencies, it would build and fund the network with a statewide perspective rather than a solely state perspective. With that principle in mind, local units of government which had identified communication issues as a need in the

¹³ UWIN, <http://www.uwin.utah.gov> [Accessed September 28, 2005].

¹⁴ The current version of the UWIN Strategic Plan can be viewed at www.uwin.utah.gov.

state's homeland security regional planning process would have their communication needs addressed through the UWIN pool of money and be interoperable with their local, state and federal partners as well. The funding for local communications equipment was available through the Homeland Security grant, 80% pass-through funds. The Governing Board determined the state would fund the interoperability piece of the project with the Homeland Security 20% funding that is earmarked for state agency use.

In addition to creating a strategic plan to organize the UWIN project, the UWIN Governing Board organized itself by creating an Executive Committee and four Steering Committees. The Executive Committee was tasked with setting the agenda for the Governing Board meetings. In addition, the Governing Board members empowered the Executive Committee to make interim and emergency decisions regarding the UWIN project. The other committees included the Technical Steering Committee (TSC), Finance Steering Committee (FSC), Education Steering Committee (ESC) and Interoperability Steering Committee (ISC).

The Governing Board envisioned the TSC would be the most active Steering Committee and its sole focus was to ensure UWIN was a reliable, secure and state-of-the-art technology.¹⁵ Information technology experts from all agencies participating on the Governing Board were invited to participate.

The Finance Committee was made up of grant managers and technology finance staff from several state agencies. It was assigned to advise the Governing Board of grant opportunities and work on potential solutions for a permanent appropriation for the ongoing operation and maintenance costs associated with UWIN.¹⁶

The Education Steering Committee was asked to focus on both public and user education. The Governing Board wanted the ESC to provide information and accountability to the public and make certain all law enforcement and first responder professionals were appropriately trained on the new technology. DPS pledged a full-time

¹⁵ To read more about the UWIN Technical Steering Committee, go to <http://uwin.utah.gov/techcommittee/techcommittee.html#>

¹⁶ Members of the Finance Steering Committee include: Jennifer Hemenway – CCJJ, Laura Lewis – DPS, Dave Lamb – DAS, Brian Spencer – DAS/ITS, Kris Hamlet – DPS/DES, Renee Matsuura – Department of Agriculture and Food.

employee to direct both education efforts. In addition to that staff person, the Public Information Officers from all agencies participating on the Governing Board were invited to join.

The Interoperability Steering Committee was created by vote of the Governing Board at its August 6, 2004 meeting. Its purpose is to proactively define, standardize and furnish a process for ensuring interoperability. The ISC divided its responsibilities into two categories: 1) Policy and Training Issues and 2) Technical Issues. In other words, the policy and training responsibilities are like developing the owner's manual for interoperability and then ensuring the users know how to function in an interoperable environment. The technical responsibilities deal with understanding and organizing the parts and pieces of interoperability and determining exactly how to make disparate systems talk to each other. The Governing Board also assigned the ISC to provide a forum for questions and concerns regarding interoperability.¹⁷

¹⁷ The following individuals volunteered to serve on the ISC: Verdi White II – DPS, Ed McConkie – CCJJ, Lt. Mike Kelley – UNG, Mark Peck – SLCPD, Floyd Ritter – DAS/ITS, Chris Rueckert – DPS, Jake Hunt – UCAN, Brent Thomas DPS/DES, Jeff Dial – St. George Police Department.

THIS PAGE INTENTIONALLY LEFT BLANK

VI. CHALLENGES TO ESTABLISHING STATEWIDE INTEROPERABILITY

The most obvious challenge, at the outset, for the UWIN Governing Board was, while there were pockets of interoperability in the state, no statewide, integrated network existed. Twenty percent of public safety agencies are in rural Utah and have used 150 MHz spectrum to communicate during daily law enforcement activities and in more catastrophic emergencies. This, combined with the fact that most of the Utah National Guard uses frequencies other than 800 MHz, made statewide, direct communication among first responders, in real time, impossible in Utah.

The UWIN Governing Board's second challenge was that even if there had been a statewide network in place, there was no statewide radio coverage available to all first responders. Utah has statewide 150 MHz coverage provided by ITS but, this coverage only afforded rural agencies using 150 MHz radios a statewide solution for interoperability. Large, metropolitan agencies using 800 MHz, lacked coverage in rural areas. This was problematic because those larger agencies possess the assets that would be needed to augment rural resources in the event of a major catastrophe.

The third challenge was that no statewide communication backbone existed. Utah operated regional communication centers throughout the state. These centers lacked the ability to link or patch between one another. The inability to patch often resulted in officers and agencies being isolated and without backup. With UWIN complete, the connections between trunked and conventional radio systems provide the statewide backbone. The same backbone carries both interoperable data communication and voice communication.

The fourth challenge came directly from the federal government and involved frequency re-farming. In an effort to create more radio channels, the FCC is in the process of reallocating all spectrum below 512-MHz from 25 kHz channels to new 6.5 kHz spaced channels. This will force a change in the equipment utilized by rural agencies

that already are under funded. This remains a problem because many of the rural area radios were purchased prior to 1997 and are incapable of operating on anything other than 25 kHz spacing.

Another challenge presented by the federal government was that the FCC made the 700 MHz spectrum available for public safety communications by mandating the television industry move to a different spectrum. Utah is unique because its local television stations have completed their migration and the spectrum has been cleared. Utah's public safety community can begin using the new wide band spectrum as soon as it submits, and the FCC approves, the state plan.¹⁸ This spectrum will allow 64 kbps speeds in the 25 KHz channels and will double to 128 kbps with the addition of 50 KHz wide band channels. The FCC has indicated that it will allow the contiguous use of three 50 KHz channels creating a potential speed of 384 kbps, with this new found speed, users will be able to develop applications for photos and video.¹⁹

Funding is always a problem and created the sixth challenge for the UWIN Board as it endeavored to meet its goals. UCAN's 800 MHz trunked solution being used on the Wasatch Front is funded through rates paid by agencies using the system. In rural Utah the 150 MHz system has been subsidized by the state since its inception. As a result, rural agencies have become accustomed to "free" service and have minimal communications budgets as a result. UCAN has worked well for the urban areas of Utah and it provided stellar voice communication service during the 2002 Winter Olympic Games. Expanding the UCAN model into rural Utah, however, has been cost prohibitive. Rural counties cannot afford the infrastructure and even if they could, they would not be able to pay for the service. Current members of UCAN are unwilling to subsidize the rural areas by increasing the current service rates. This very real financial dilemma has prevented Utah government leaders from progressing toward adequate voice interoperability both vertically and horizontally.

¹⁸ Utah has completed its 700 MHz plan and as of September, 2005 is waiting for the required approval from surrounding states before submitting the plan to the FCC. To read more about Utah's 700 MHz planning process, go to www.uwin.utah.gov/700mhzrpc.

¹⁹ Philip Bates (Director Information Technology, Utah Department of Public Safety), interview with author, Salt Lake City, Utah, August 27, 2004.

VII. SOLUTIONS FOR ESTABLISHING STATEWIDE INTEROPERABILITY

The UWIN Governing Board was given the task of providing an interoperable communication solution statewide and developing a strategy to accommodate future communications needs. The Governing Board formed the TSC to carry out the technical requirements of the project. The TSC's first assignment was to research and explore technologies to close the holes that prevent interoperability between radios using VHF, UHF, 800 and 900 MHz frequency bands as well as analog, digital and mixed mode system configurations. The TSC quite quickly developed a solution to provide interoperability among existing systems and allow seamless migration to new solutions and spectrums as they become available.

The TSC's solution addressed the interoperability problems by resolving the following barriers to interoperable communications:

1. Provide a standards-based core system that allows any radio to be utilized and shared.
2. Upgrade existing communications equipment in regional centers so that it matches equipment used in metropolitan areas.
3. Provide training to all system users on resources and capabilities.
4. Provide 800 MHz and 150 MHz coverage statewide utilizing existing sites.

Each of these projects, aimed at achieving UWIN's goal of statewide voice interoperability, was launched using federal funding. In order to meet Governor Walker's July 1, 2004 deadline, the TSC recommendations needed immediate implementation.

First, the TSC worked with local UWIN partners to upgrade the regional communication centers. These upgrades consisted of installing two major technology components. They began with installing a central electronic bank (CEB) in each center. The CEB allows local radio channels to be shared regardless of frequency or type to any other dispatch or emergency operations center in the state. The CEB also enables dispatchers to patch any radio channel to any other radio channel anywhere in the state. Installing consoles was the second upgrade component. Consoles are the computer systems that interact with the CEB, allowing an operator to interface with the new

interoperable system. The consoles are located in dispatch centers and emergency operations centers. They also provide for an interface from conventional telephone to any radio on the system.

The cornerstone of Utah's interoperability project was the installation of OmniLink. The OmniLink technology has finally addressed the interoperability dilemma across incompatible systems. OmniLink is a switch that ties disparate radio systems together, providing interoperability. It allows users on one system to communicate directly with users on another system through a dynamic patch initiated at any participating dispatch center. In addition to OmniLink, conventional 800 MHz repeaters were installed in strategic rural locations to allow 800 MHz system users along the Wasatch front to communicate throughout rural Utah.

Another step recommended by the TSC to create statewide interoperability was to provide 800MHz access statewide. Conventional 800 MHz base radio equipment has been installed at existing 150 MHz sites, providing radio coverage to 800 MHz radio users statewide. These base units are tied to the nearest CEB located in the regional center allowing control from any console on the system. This provides interoperable public safety communications between the rural and metropolitan users.

Finally, two types of security have been incorporated into the OmniLink system. The first security element is authentication. Authentication is the process used to ensure that the radio attempting to attach to the network is in fact authorized to use the radio network. When a radio attempts to attach to the radio network, it is challenged for an identification code. The requested credentials must match the preset code in the database before access is granted. These credentials are also utilized to restrict and filter access to the system depending on access privileges granted to the requesting user.

The second type of security is called message privacy. This is a security technique used to ensure the content of each transmission remains confidential. The system is compliant with common air interface specifications for encryption. This means encrypting devices can be installed in radios that require the highest level of privacy.²⁰

²⁰ Philip Bates (Director Information Technology, Utah Department of Public Safety), Interview with author, Salt Lake City, Utah, August 27, 2004.

For a graphic representation of UWIN, please view Utah's Statewide Voice Integration Plan below:²¹

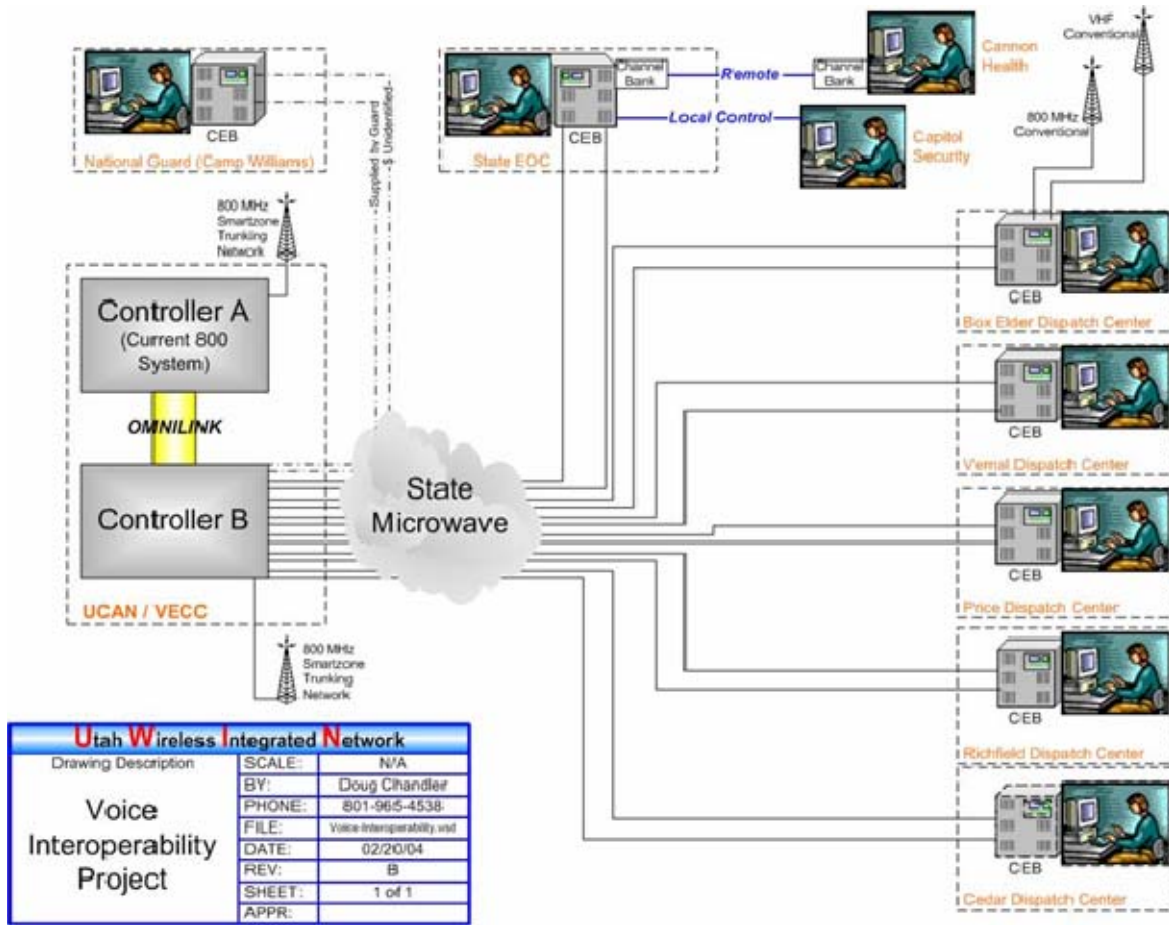

Figure 1. Utah's Statewide Voice Integration Plan (From: Douglas Chandler)

²¹ Chart by Douglas Chandler (Manager, ITS Wireless Services, Department of Administrative Services, State of Utah), Salt Lake City, Utah, February 20, 2004.

THIS PAGE INTENTIONALLY LEFT BLANK

VIII. TECHNOLOGY TIES IT ALL TOGETHER

In order to meet Governor Walker's July 1, 2004, deadline to have the country's first statewide, wireless communication voice network, the Governing Board issued a Request for Proposal (RFP) in accordance with state procurement practices to network the legacy voice systems that were in place throughout Utah. Three companies responded to the Request for Proposal (RFP), two of which proposed using Voice Over Internet Protocol (VOIP) as an interoperability solution. The VOIP approach was a problem, however, because it would force voice traffic to compete with data traffic. Motorola was the third respondent and had developed a new technology called OmniLink. OmniLink is a hardware and software package, also known as a switch, which ties disparate radio systems together, providing interoperability. In non-technical terms, OmniLink would be the equivalent of a device from which one could play and watch a film without respect to its mechanical genre. In other words, one could play a Beta, VHS or DVD film on a single machine.

OmniLink was also an attractive solution because it was dedicated solely to voice traffic and provided a very efficient mechanism for processing voice communication. OmniLink quickly became the \$2.7 million centerpiece of voice interoperability in Utah. The diagram below shows how the new equipment and existing communications systems work together.²²

²² Diagram by Douglas Chandler (Manager, ITS Wireless Services, Department of Administrative Services, State of Utah), Salt Lake City, Utah, 2004.



Figure 2. New Equipment and Existing Communication Systems Work Together
(From: Douglas Chandler)

The map below illustrates the statewide coverage available by utilizing OmniLink. The lavender shading indicates UCAN coverage area.

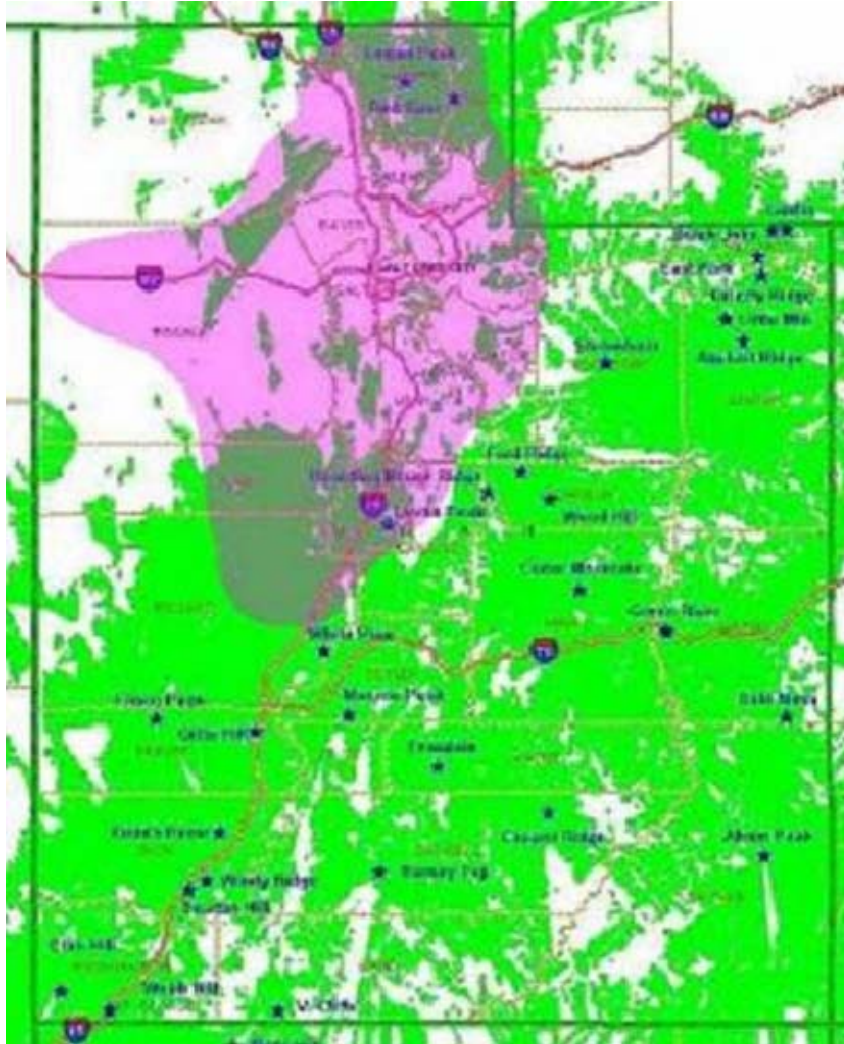

Figure 3. Statewide Voice Coverage (From: Douglas Chandler)²³

Like Phase I – Voice, an RFP process was used to procure the data component, Phase II – Mobile Data, of UWIN. That process, however, followed an extensive pilot project. The UWIN technology team tested data solutions using the UHF spectrum in Tooele County, Logan City and Park City. The locations were selected to ensure the product would function well in varied geography and weather conditions.

Upon overwhelming success with the pilots, the RFP was released and there were three respondents. Ultimately, IP Mobile Net was awarded the \$1.2 million contract and the statewide 700 MHz Mobile Data Network (MDN) build-out began immediately. As

²³ Map by Douglas Chandler, Manager ITS Wireless Services, Department of Administrative Services, State of Utah, Salt Lake City, Utah, 2004.

part of the award, IP Mobile Net agreed to upgrade the equipment at all the pilot locations upon acquisition of the contract to meet the FCC's long-term plan to force all government communications into the 700 MHz spectrum. Utah's television stations have already abandoned the 700 MHz spectrum so it is currently available for public safety communication within Utah's borders.

The UWIN TSC analyzed the MDN technology issues and made four recommendations to the UWIN Governing Board. The TSC's first recommendation to the UWIN Governing Board was to adopt data standards based on the global justice XML standards and use web services for information communication and data delivery. These data standards allow for messaging, attempts to locate, incident reports, arrest reports, accident reports, citations, and many other types of information to be shared between disparate systems. One element missing from the national XML standard is a defined web services component with defined transactions allowing information sharing. Currently, state and federal agencies wait for a phone call requesting assistance. With Utah's web-based mobile data network, state and federal agencies can visually monitor incidents as they occur and have operational awareness prior to receiving a call for assistance. Requests for escalated assistance will be met with better preparation and response times will be significantly shorter due to real time awareness of all information related to the incident.

The TSC's second recommendation was to overlay the wireless data network on the state's existing wide area network (WAN) and take advantage of the state microwave network. By utilizing existing infrastructure, equipment and installation costs were eliminated and operation and maintenance costs are shared among a greater number of users.

The TSC's third recommendation was to utilize the 700 MHz spectrum for the MDN. The Federal Communications Commission (FCC) has reserved that spectrum for first responder use.

The TSC's fourth recommendation was to develop security standards and a centralized authentication structure. Incorporating these elements in the data network allows any user to roam on any wireless infrastructure throughout the state. This means

highway patrol troopers, for example, are able to pick up and work off a signal from a Utah Department of Transportation maintenance shed, any local law enforcement data point or a variety of other owners and providers.

The UWIN Governing Board accepted all the TSC's recommendation and determined that Utah's wireless data network would be deployed on 25 KHz spaced channels and migrated through software upgrade to the wideband 50 KHz channels as the FCC approves them. In addition to creating a much needed statewide wireless data network, Phase II – Data also provides a roadmap for other states as they navigate through the 700 MHz migration process. Having incident information via mobile data applications dramatically reduces the volume of voice system usage; however, the data network is also capable of transporting voice communication in the event of a voice network failure.

The UWIN Governing Board set a phased implementation schedule, contingent on funding. If immediate funding was not available, the data component of UWIN would be built in stages as funding became available. When completed, the data system will provide seamless statewide coverage to all first responder agencies throughout the state. In a major incident, the state will have the ability to control the level and priority of access to the first responder community based on their needs. By implementing a dedicated, state data system, resources on the commercial systems will be freed up for citizen use.

The map below is color coded to show the status of MDN in Utah

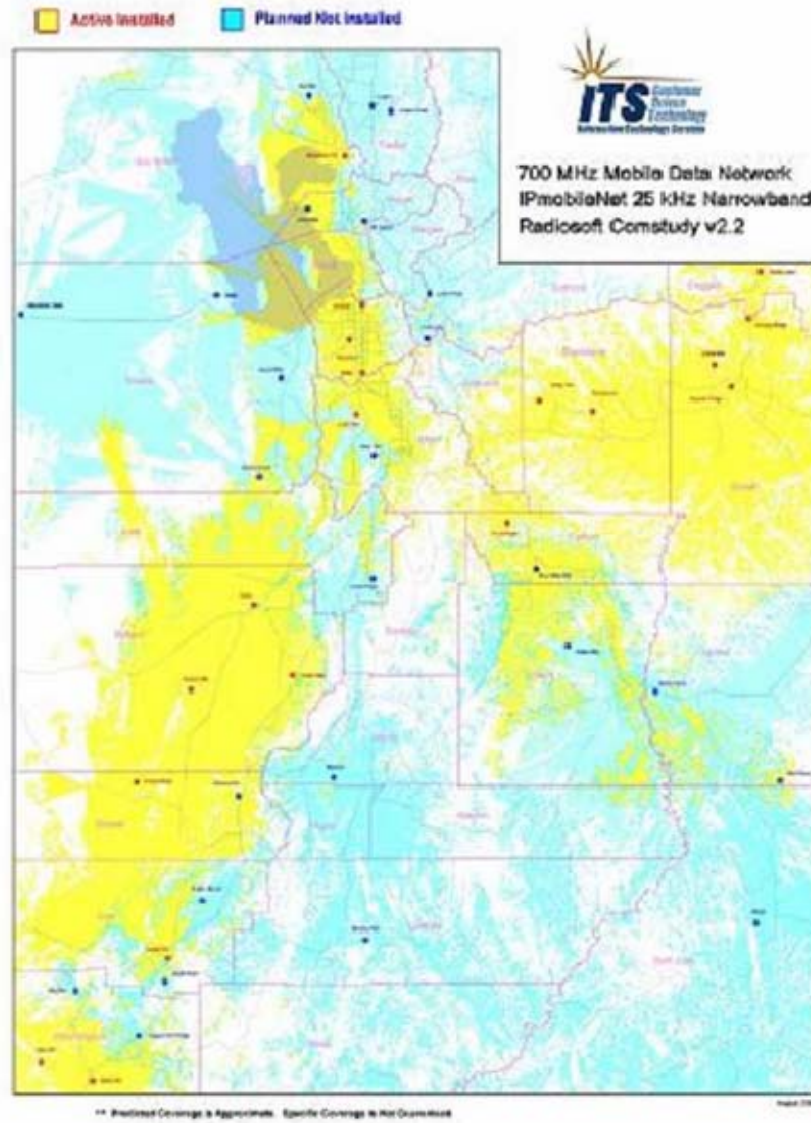

Figure 4. Utah's Mobile Data Network (From: Douglas Chandler)²⁴

²⁴ Map by Douglas Chandler, Manager, ITS Wireless Services, Department of Administrative Services, State of Utah, Salt Lake City, UT, August 2005. <http://uwin.utah.gov/mobiledata/mobiledata.html> [2 October 2005].

IX. PAYING FOR UWIN

Now that interoperability of public safety communication systems is more widely accepted as a top priority for policy development, the weak economy has generally prevented state legislatures from allocating dollars for a “new” communications programs. The Bush administration, on the other hand, has steadfastly encouraged Congress to provide additional resources to federal, state and local governments to support its *National Strategy for Homeland Security*. While a small amount of federal funding has trickled its way through the federal fiscal machine down to state and local government, more is needed.

UWIN would not be possible without the federal dollars that have been allocated to state and local government for homeland security and bioterrorism issues. While Utah does not get a lot of federal assistance, the help it does receive is much appreciated and Utah leverages every penny that comes its way.

An example of Utah’s thriftiness ties back to how the federal dollars are allocated within the state. Utah is divided into regions and each region is required to submit requests for funding to the Division of Emergency Services (DES) in DPS. Because so many of the initial regional requests included a communication system enhancement, DES, in cooperation with the UWIN Governing Board and the regions determined that all communication projects needed to meet the interoperability standards suggested by the UWIN TSC and ratified by the UWIN Governing Board in order to be eligible for funding. By setting communication standards and using a simple coordinating function, the state has prevented further fragmentation of our existing communication system and ensured that all future developments will be interoperable. The regions understand and appreciate the coordination effort because they are able to get the necessary system improvements and be interoperable with other entities for the same or lower cost.

While it is frustrating that the Utah State Legislature has not, to date, provided any new funding for homeland security in general or the UWIN project in particular, executive branch officials who want to see UWIN move forward have had to exercise patience because of the difficult economic conditions Utah has faced. In fact, state

executive branch departments have stepped up their efforts with existing resources to ensure that homeland security issues are addressed in spite of economic hardship.

At the December 5, 2003 meeting of the UWIN Governing Board, the members voted to purchase OmniLink. In order to fund the purchase, the collection plate was passed among the members of the Governing Board. The Utah Department of Health offered \$1.3 million from the federal bioterrorism grant. DPS contributed \$3.6 million homeland security grant dollars. UCAN included a \$500,000 credit they had with the OmniLink vendor. ITS and the UNG volunteered staff time for development and installation. On December 30, 2003, the OmniLink contract was signed. Engineers began configuring the software immediately and the installation was completed by June, 2004. Testing and evaluation were conducted so the system would be operating well in advance of the Governor's July 1, 2004 deadline.

The UWIN Governing Board made a decision at its inception that every effort would be made to provide interoperable communications to users at the lowest possible cost. As a result, all equipment purchases have been paid for up front to avoid including debt payments in the user rate. The biggest challenge to the success of UWIN is providing an affordable rate to the user and identifying an ongoing funding source to help with maintenance and operation costs.

On one of my trips to Washington, D.C., I attempted to address the ongoing costs issues with members of the Utah Congressional delegation and staff at the Office of Domestic Preparedness (ODP) in the Department of Homeland Security. I asked the delegation members to help get a \$20 million federal appropriation for the state of Utah to create the Public Safety Communications Fund. If the fund is established, the Utah State Treasurer will invest the \$20 million and use the income generated from the investments to reduce or eliminate rates charged to users. The rate is necessary to pay ongoing operation and maintenance costs for UWIN.

During my meeting with ODP staff we discussed the fact that grant recipients around the country have purchased essentially all the equipment they need with homeland security grant dollars. I explained to ODP staff that in a discussion with Secretary Ridge when he was visiting Utah, he agreed that the next logical development of the grant

would be to expand the funding purposes to include operation and maintenance of the equipment that has been purchased. As a result of that discussion, Commissioner Robert L. Flowers and I requested that Utah receive special permission to begin the practice immediately. I drafted the following letter of response for ODP authorization to formalize the request, hoping that it would be fully approved:

July 2, 2004

Mr. Robert L. Flowers, Commissioner
State of Utah, Department of Public Safety
4501 South 2700 West
Salt Lake City, UT 84119

Dear Commissioner Flowers:

As the SAA for the State of Utah, I would like to grant your request under the ODP Homeland Security Grants to utilize funding in the following ways to help achieve the interoperable communications goals that your state has identified in its most recent strategic plan:

Funding may be used to purchase service contracts.

Funding may be used to purchase existing communication equipment and infrastructure components.

Funding may be used to assist in retiring a loan, which was used to purchase equipment that qualifies under the existing ODP Homeland Security Grants.

In using funding under any one of these proposals, the SAA must adhere to all pass-through requirements that exist under the ODP Homeland Security Grant guidance. Additionally, both state and local agencies must agree to utilize their share of the grant dollars to carry out these proposed communication projects through written documentation. All reporting requirements will remain intact.

On August 16, 2004, the Grant Manager in Utah's Division of Emergency Services received the following email²⁵ from Marcelino Galvan, in the Office of Justice Programs at the United States Department of Justice in response to our inquiries:

²⁵ Marcelino Galvan, <GalvanM@ojp.usdoj.gov>, August 16, 2004.

Kris,

Here is the response for the Homeland Security Utilization Request:

#1 Service Contracts:

Maintenance contracts are allowed under the ODP FY 2003 SHSGP Part II and the FY 2004 SHSP and LETPP grant funds.

#2 Funding used to purchase existing communication equipment and infrastructure components:

This would be allowable under all ODP grant programs.

#3 Retiring existing loans:

This would not be allowable under any of the ODP grant funds.

Thank you, Marcelino

While ODP did not approve our concept in full, its response provided enough flexibility to state and local officials to begin using homeland security grant dollars for one-time operating costs associated with UWIN. In addition to \$4.4 million in Homeland Security grant funding, the Utah Department of Health gave \$1.3 million of its federal Bioterrorism grant dollars for central electron bank (CEB) and console upgrades at regional dispatch centers throughout Utah.

Between Homeland Security and Bioterrorism funds, Utah has dedicated a total of \$6.2 to the UWIN project. The Governing Board requested another \$600,000 in FY2006 Homeland Security funding to finish building out the data infrastructure and purchase additional radios, bringing the total investment to \$6.8 million. As a result of these expenditures, Utah is the first state in the nation that is fully interoperable between state and local agencies as well as with the Utah National Guard.

The diagram below illustrates the interoperability of the system:²⁶

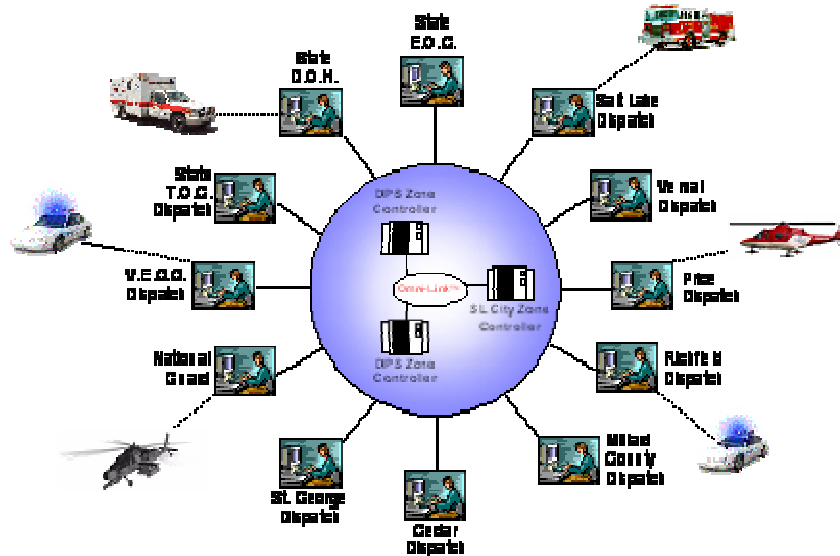

Figure 5. Interoperability in Utah

While grant dollars have been solely responsible for constructing UWIN to date, the Governing Board has known all along that ongoing maintenance and operation funding would be needed to sustain the system once it became operational. The projected ongoing annual costs total \$1,238,945. Understanding that state general fund dollars are very scarce, the Governing Board determined that a portion of the ongoing costs should be borne by the users. At the same time, the Governing Board did not want to compromise public safety, particularly in small, rural areas of the state simply because an agency was unable to bear its share of the costs to operate the network. Therefore, after much discussion as to the appropriate balance between user support and state or federal subsidization, Governor Walker included a \$755,000 ongoing general fund appropriation in her FY2006 Budget Recommendation to the Legislature. This meant that the Governing Board would have to generate \$483,945 in revenue through user rates. It chose to raise this revenue by recommending to the Rate Committee that the State Repeater System rate be increased for the first time in twelve years. That rate increase was expected to generate \$124,900. The Governing Board also proposed a new \$15 per

²⁶ Diagram by Douglas Chandler (Manager, ITS Wireless Services, Department of Administrative Services, State of Utah), Salt Lake City, Utah, 2004.

unit, per month rate for the data component to the Rate Committee. Estimates show that there is an immediate need for approximately 2000 data units between state and local agencies. Revenue from those units is estimated to generate \$359,045. The Rate Committee approved the Governing Board recommendations.

The approved rates were submitted to the 2005 Legislature and were approved. The projected costs and revenues are presented below:

Projected On-Going Costs	
Voice Circuit and Maintenance Costs	510,210
Mobile Data Network Maintenance Costs	228,735
Omni-Link Maintenance Costs	500,000
Total Projected Costs	1,238,945
Projected Billable Revenue	
State Repeater System Rate Increase	124,900
Mobile Data Network Billing	359,045
Total Projected Billable Revenue	483,945
Projected Appropriation Needed	\$755,000

Table 1. Funding Plan for UWIN

In addition to the projected billable revenues above, users of the system have invested and will continue to invest funds (including Homeland Security 80% pass through funds) to purchase equipment needed to use the network.

While it was a major victory to have the \$755,000 ongoing general fund appropriation in Governor Walker’s Budget Recommendation, the 2005 Legislature failed to fund it. This forced the Governing Board to use Homeland Security grant dollars to fund another year of operation and maintenance. The UWIN Governing Board resubmitted a request for \$750,000 ongoing general fund dollars to the 2006 Legislature.

In the meantime, public safety professionals, the Utah National Guard and other first responders are benefiting from what General Ralph Dewsnup referred to as the “magic”²⁷ of OmniLink in their day-to-day activities. Several of those agencies are working in different stages of pilots of the MDN and it will soon be fully operational.

²⁷ Bart D. Berry (Lieutenant Colonel, Utah National Guard, State of Utah), Salt Lake City, Utah, June 2004.

THIS PAGE INTENTIONALLY LEFT BLANK

X. THE PRACTICAL IMPACT OF VOICE AND DATA TECHNOLOGY

Basic data, received in a timely manner and appropriately acted upon can have a life-changing impact. Lieutenant Richie with the Utah Highway Patrol was sitting in his patrol car on Highway 40 near Park City, Utah, when an Amber Alert with an attempt-to-locate (ATL) on a vehicle with Minnesota plates scrolled across his in-car computer screen. He decided to use a mapping program on his computer to figure out the drive time from Minnesota to Provo, Utah. While waiting for the results, a vehicle passed matching the description of the ATL vehicle. He followed the vehicle, moved in closer and confirmed the license plate number with dispatch. He pulled the car over, arrested the male driver and recovered his young female kidnapping victim, unharmed. Lieutenant Richie reported that the ability to quickly access data on his in-car computer is a valuable tool for carrying out his duties and protecting the public. The program he used that day alerted him to significant important information. The information was fresh and easy to reference. The information came to him at the right place at the right time. It allowed him to act appropriately and intercept a crime.

Lieutenant Richie's positive experience with information technology in 2003 was far different than that of law enforcement in Marion, Utah, 15 years earlier during a 13-day siege at the ranch of deceased polygamist John Singer. On January 16, 1988, Addam and Jonathan Swapp, claiming to have received a revelation from God, blew up an empty church belonging to The Church of Jesus Christ of Latter-day Saints. The men believed the bombing would bring John Singer back from the dead. John Singer had been shot in 1979 when he drew a gun on police serving a warrant for contempt of court following his refusal to send his children to school. At the scene of the church explosion, authorities found a note "declaring the family's sovereignty from the United States and a holy war against the state and federal government for persecution of their family."²⁸ Since John Singer's death, Addam had married two of Singer's daughters and become close with his

²⁸ Mike Carter, "Vicki Singer Says Lawman Fired Shot" (Desert News, August 11, 1995.): B2.

widow, Vicki Singer. The 14-member family barricaded themselves in their little ranch house for thirteen days, believing that John Singer would be resurrected and return to end the standoff.

During that time, approximately 100 local, state and federal officers surrounded the ranch and used various tactics to urge the family to surrender. The standoff came to a bloody end when Lieutenant Fred House from the Utah Department of Corrections was releasing his police dog near the compound. Lieutenant House was killed by wheelchair-bound Timothy Singer who fired his rifle from inside the home. Officers from all agencies stormed the house and arrested Addam and Jonathan Swapp and Vicki and Timothy Singer.

The bizarre series of events that led to Lieutenant House's death and the arrest of the perpetrators captivated Utahns throughout the standoff, the criminal trials and the convictions. I first became interested in the incident from a professional level in 1992 when then Commissioner of the Utah Department of Public Safety, Douglas Bodrero, recounted the command and control problems that occurred during those 13 days. He attributed the length of the standoff and the associated problems with the inability and failure of the local, state and multiple federal agencies to communicate. Each agency was using a different radio frequency. As we brainstormed possible solutions back in 1992, former Commissioner Bodrero claimed that he was going to write a book about the Marion standoff and title it, *The Radios Don't Work*. He also expected to write a sequel and call it, *The Radios Still Don't Work*. To date, neither book has been written. I am hopeful that the first book will be a success when it finally finds its way to a publisher. I am equally hopeful he will not need to write the sequel.

If early indications hold, interoperable communication will not be a problem in Utah again. In June, 2004, we tested the UWIN Phase I – Voice in Operation Electric Storm. The objectives for the joint exercise were:

1. Successfully accomplish Phase I of Governor Walker's UWIN vision.
2. Solidify the JTTF Intelligence Fusion Cell.
3. Successfully conduct a Critical Infrastructure Mission/Quick Reaction Force.
4. Assess and validate the State and Joint Force Headquarters alternate Joint Emergency Operations Center at Camp Williams.

The After Action Report for Operation Electric Storm stated:

1. Governor Walker's vision for UWIN, Phase I was accomplished.
2. Interoperability was validated time and time again during Electric Storm
3. Millard County, DES/HS, JFHQ-UT (which included multiple units scattered throughout Utah) were able to talk across multiple radio systems.
4. Motorola's OmniLink technology was demonstrated as a versatile and effective tool for the entire public safety community.³⁰

Operation Electric Storm was carefully planned and executed to test the rigors of the UWIN system. Still, it is impossible to plan for every eventuality either in a staged exercise or in an actual emergency situation. It was raining during the operation. In the middle of the scenario, a lightning bolt struck the Millard County CEB and fried the card. Because of redundancies built into UWIN, technicians were able to transfer all voice traffic to the Emergency Operations Center at the State Capitol two hundred miles away in Salt Lake City. The transfer was seamless. Soldiers and law enforcement personnel using radios were unaware there had been a failure.³¹

³⁰ Bart D. Berry (Lieutenant Colonel, Utah National Guard, State of Utah), Salt Lake City, Utah, June 2004.

³¹ Photograph provided by Bart D. Berry (Lieutenant Colonel, Utah National Guard, State of Utah), Salt Lake City, Utah, June 2004.



Figure 7. Always Have a Backup Plan

THIS PAGE INTENTIONALLY LEFT BLANK

XI. CONCLUSION

Information and intelligence sharing is vital to fighting and winning the war on terror. Communication of that information and intelligence is critical to both day-to-day public safety responsibilities and major incident command and control. Establishing an interoperable communication infrastructure at the local, state and federal levels of government and among the military branches to ensure the accurate, complete and timely dissemination of information to first responders, incident management personnel and other public safety professionals is a top priority in the National Strategy for Homeland Security. Not only does the state of Utah agree with this priority, it has demonstrated leadership and innovation in creating UWIN, the nation's first statewide, wireless, interoperable voice and data communication network. Utah has proven that reliable public safety communication can be achieved with very little money and partners who are willing to work together. UWIN, and the process used to create it, is a model for other states to emulate.

THIS PAGE INTENTIONALLY LEFT BLANK

LIST OF REFERENCES

- Association of Public Safety Communication Officials. *APCO International – Homeland Security White Paper*. Daytona Beach, Fl.: The Association of Public Safety Communication Officials, August 2002.
- Benjamin, Daniel and Steven Simon. *The Age of Sacred Terror*. New York: Random House, 2002.
- Carter, Mike. “Polygamous Matriarch Claims Feds Shot Officer Slain in Utah Siege.” *Desert News* (August 11, 1995): E32.
- Chemical and Biological Arms Control Institute. *What Should We Know? Whom Do We Tell? Leveraging Communication and Information to Counter Terrorism and Its Consequences*. Washington, D.C.: Chemical and Biological Arms Control Institute, 2002.
- Fletcher, David. “UWIN Handout – Phase I”. UWIN Governing Board Meeting. State Office Building, Salt Lake City. December 5, 2003.
- Horiuchi, Vince. “Singer’s Conviction in Killing Will Stand.” *Salt Lake Tribune* (July 20, 1991): B2.
- M/A Com, Inc. *Refarming – Truths and Myths*. Lynchburg, Virginia; Tyco Electronics M/A Com, Inc., December 2002.
- NGA Center for Best Practices. *Volume Two: Homeland Security, A Governor’s Guide to Emergency Management*. Washington, D.C.: NGA Center for Best Practices, 2002.
- National Task Force on Interoperability. *Why Can’t We Talk, Working Together to Bridge the Communications Gap to Save Lives, A Guide for Public Officials*. Washington, D.C.: National Task Force on Interoperability, February 2003.
- PSWINS. “The State of Interoperability.” <http://www.publicsafetywins.gov> [Accessed March 18, 2004].
- U.S. Department of Homeland Security. *The SAFECOM Program: Statement of Requirements for Public Safety Wireless Communications & Interoperability*. Washington, D.C.: U.S. Department of Homeland Security March 2004
- U.S. Office of Homeland Security. *National Strategy for Homeland Security*. Washington, D.C.: U.S. Office of Homeland Security, July 2002.

Utah Wireless Integrated Network (UWIN). <http://www.uwin.utah.gov> [Accessed September 28, 2005].

INITIAL DISTRIBUTION LIST

1. Defense Technical Information Center
Ft. Belvoir, Virginia
2. Dudley Knox Library
Naval Postgraduate School
Monterey, California
3. Christopher Bellavita
Naval Postgraduate School
Monterey, California
4. Edward McConkie
Salt Lake City, Utah
5. S. Camille Anthony
Salt Lake City, Utah