

NOTES ON FIELD FORTIFICATION

PREPARED BY
THE ARMY FIELD ENGINEER SCHOOL
THE ARMY SERVICE SCHOOLS

*For Use of
Student Officers, Army School of The Line
1916*

Third Edition



FORT LEAVENWORTH:
Army Service Schools Press
1916

Report Documentation Page

Form Approved
OMB No. 0704-0188

Public reporting burden for the collection of information is estimated to average 1 hour per response, including the time for reviewing instructions, searching existing data sources, gathering and maintaining the data needed, and completing and reviewing the collection of information. Send comments regarding this burden estimate or any other aspect of this collection of information, including suggestions for reducing this burden, to Washington Headquarters Services, Directorate for Information Operations and Reports, 1215 Jefferson Davis Highway, Suite 1204, Arlington VA 22202-4302. Respondents should be aware that notwithstanding any other provision of law, no person shall be subject to a penalty for failing to comply with a collection of information if it does not display a currently valid OMB control number.

1. REPORT DATE 1916	2. REPORT TYPE	3. DATES COVERED -	
4. TITLE AND SUBTITLE Notes on field fortification, for use of student officers, Army School of the Line, 1916.		5a. CONTRACT NUMBER	
		5b. GRANT NUMBER	
		5c. PROGRAM ELEMENT NUMBER	
6. AUTHOR(S)		5d. PROJECT NUMBER	
		5e. TASK NUMBER	
		5f. WORK UNIT NUMBER	
7. PERFORMING ORGANIZATION NAME(S) AND ADDRESS(ES) Army Command & General Staff College, Combined Arms Research Library, 250 Gibbon Avenue, Fort Leavenworth, KS, 66027-2314		8. PERFORMING ORGANIZATION REPORT NUMBER	
9. SPONSORING/MONITORING AGENCY NAME(S) AND ADDRESS(ES)		10. SPONSOR/MONITOR'S ACRONYM(S)	
		11. SPONSOR/MONITOR'S REPORT NUMBER(S)	
12. DISTRIBUTION/AVAILABILITY STATEMENT Approved for public release; distribution unlimited			
13. SUPPLEMENTARY NOTES			
14. ABSTRACT According to whether they respond to strategical or tactical needs, fortifications may be classified as strategical fortifications and tactical fortifications and are most frequently constructed, in whole or in part, during times of peace, with all the resources of the technical arts and strengthen points whose strategical importance in the event of a war is clearly seen. Occasionally, however, the necessity for strategical fortifications arises only at the outbreak or during the progress of a war to strengthen points, the strategical value of which could not be foreseen. Their construction, more limited as to time, involves expedients less comprehensive than in the case of works built during times of peace, but still far in excess of those applicable in ordinary field worlds. The Army field engineer school prepared this educational handbook for use of student officers, Army School of the Line. It provides a foundation of knowledge on permanent and semi-permanent field fortifications that can be set up on a field of battle. It describes how to set up field fortifications as well as illustrating the principles behind their use in defensive operations			
15. SUBJECT TERMS			
16. SECURITY CLASSIFICATION OF:			17. LIMITATION OF ABSTRACT
a. REPORT unclassified	b. ABSTRACT unclassified	c. THIS PAGE unclassified	18. NUMBER OF PAGES 118
			19a. NAME OF RESPONSIBLE PERSON

1st Edition	-	-	-	-	-	1912.
2d Edition (Reprint)	-	-	-	-	-	1914.
3d Edition, Revised and Problems Added	-	-	-	-	-	1916.

Chapter I

GENERAL PRINCIPLES.—FIELD FORTIFICATIONS IN RELATION TO STRATEGY AND TACTICS.—SIMPLE RIFLE TRENCHES.—LOCATION OF TRENCHES.

IN all contests for the mastery, whether between individuals or between aggregations of individuals, there is an inevitable combination of offensive and defensive action. Neither contestant, however great be his superiority, can afford to neglect all defensive precautions. This applies with particular force to the game of war, in which the contestants are represented by armies, often of huge size, operating over vast areas.

In military operations the advantages sought by each side are, in the first instance, strategical; in the second, tactical. The attainment of either, or both, necessarily implies possession of the power of maneuver. The advantages attained by strategical maneuvers are generally realized only by winning the battle, which is their culmination, and for which ability to maneuver tactically must be maintained.

The power to maneuver, whether strategically or tactically, is essential to success. The side which, from any cause, loses the power of maneuver in strategical combinations will be at a disadvantage in the decisive battle. If it further loses the power of tactical maneuver, final defeat is inevitable.

As maneuver is necessary to success, troops should welcome orders to advance from the trenches. Changing conditions of the conflict have in the past frequently led to the construction of trenches without their being used, and officers must expect this

as a feature of campaigning, and accept cheerfully what at times may appear as unnecessary labor.

That offensive action alone can produce decisive results is clearly established by military history, and all military teachings are in complete accord on this point. "Troops dig because they are forced to halt, they do not halt to dig." (Normand.) But while acting generally offensively oneself, it is none the less necessary to guard against the enemy's offensive movements, and this can be most effectively accomplished by limiting his power to maneuver. The means most commonly employed to this end are fortifications, which have for their object the strengthening of the terrain at predetermined points in such manner as to permit relatively small forces to check the movements of the adversary while at the same time facilitating and increasing your own maneuver power. Only those fortifications, conceived and applied in this spirit, are really useful in the conduct of military operations.

According to whether they respond to strategical or tactical needs, fortifications may be classified as *strategical fortifications* and *tactical fortifications*. *Strategical fortifications* are most frequently constructed, in whole or in part, during time of peace, with all the resources of the technical arts, to strengthen points whose strategical importance in the event of war is clearly seen. Occasionally, however, the necessity for strategical fortifications arises only at the outbreak, or during the progress, of a war to strengthen points, the strategical value of which could not be foreseen. Their construction, more limited as to time, involves expedients less comprehensive than in the case of works built during time of peace, but still far in excess of those appli-

cable in ordinary field works. *Strategical fortifications* are also called *Permanent* and *Semi-Permanent* or *Provisional*, according to the time of their construction and the materials employed. The various existing* land fortifications in Europe are examples of permanent fortifications, while the defenses of Washington, D. C., in 1861-65, form a good example of provisional fortifications. Both permanent and provisional fortifications are constructed by military engineers, mainly with civilian labor, and will not be further considered in these "Notes."

Tactical fortifications are such as are generally constructed by the troops themselves to satisfy passing tactical needs. The time and materials available for their construction vary between wide limits, from the hasty intrenchment built with the portable tools of the troops, not infrequently under fire, to elaborately fortified lines of defense requiring days, weeks, or even months for their preparation, in which work the civilian population may sometimes be employed, as was done by the Russians in Manchuria and the Boers in South Africa.

Tactical fortifications being constructed in the field to satisfy temporary tactical needs are also properly called *field fortifications*. It is well to observe, however, that the various classifications of fortifications attempted by different authors are not always clearly defined. Strategy and tactics frequently blend into each other and so do the fortifications constructed to meet their needs. Similarly, classifications based on the time and materials of construction employed, imperceptibly merge into one another. Sometimes hasty works commenced on the

*Refers to those existing before the outbreak of the European War of 1914.

field of battle are gradually developed into stronger ones in response to the tactical situation, as occurred with both the Russian and Japanese lines on the Shaho and with the Turkish lines at Plevna.

These notes will deal mainly with tactical, or field fortifications, this being the type which most directly concerns combat officers of all branches of the service.

As previously stated, the object of all fortifications should be to check the adversary's power of maneuver, with relatively small forces, while at the same time facilitating our own maneuver. To surrender our own power of maneuver is either an admission of weakness justified only in the presence of superior forces and resorted to for the purpose of gaining time; or else, the result of the failure of the commander to appreciate the part played by fortifications in tactical operations. Unless, therefore, the adversary is overwhelmingly superior, field fortifications must be employed in a manner not to kill the offensive spirit.

The conception that field fortifications can, and should, play a part in offensive operations, although long recognized, was brought into great prominence in the recent campaign in Manchuria, especially on the part of the Japanese, who, while making free use of field fortifications of all kinds, never relaxed their aggressive spirit; on the one hand clinging desperately with the spade to what they had won with the rifle; and on the other hand checking with their rifle the Russian attempts to drive them from their works. Troops acting offensively cannot continue to advance constantly at all points of an extended battlefield where fighting is carried on for days. Halts will be inevitable from time to time at various points

to permit assembling forces for further efforts, to cover the mass of the attack, to choose the point of the attack, or to hold the enemy. At all these halts the offensive will wish to hold his ground, for which purpose the strengthening of the terrain is desirable and necessary.

To derive the maximum benefit of field fortifications, especially in offensive operations, requires a thorough understanding of their application in accordance with correct and definite principles. Too early, too extensive, and too frequent use of field fortifications are certain to injure the offensive spirit of leaders and troops, sacrifice the maneuver power and surrender tactical advantages to the adversary. On the other hand, a total neglect of the benefit to be derived from the employment of field fortifications will involve needless and heavy losses and, against a skillful adversary, will lead to disaster. Just where and to what extent to use field fortifications in tactical operations without impairing the offensive spirit is often a delicate and difficult matter to decide; for this reason the art of applying hasty field works is one of the most important and difficult branches of the entire subject of fortification. This is all the more so for the reason that, although all troops are now liberally supplied with tools for the construction of field works, it is a fact that little attention is devoted to this important subject in peace training. Duties illy learned in peace training will surely not be well performed under the stress of war.

The most recent wars have left no doubt as to the extensive part played by fortifications in field operations, fortifications which must be constructed by the troops themselves at all times and under a

variety of circumstances, requiring, therefore, good understanding on the part of all officers and training on the part of the enlisted men.

Since the object of field fortifications is to check the enemy's maneuver power with relatively small forces, it is pertinent to inquire just how this result may be accomplished. In any combat the primary object is to gain superiority of fire by means of which the enemy will be compelled to yield ground, either by the fire itself or by the bayonet in the hands of the troops whose advance has been rendered possible by this fire.

Superiority of fire depends upon many factors, such as the character of the fire arm, training of the troops, size, vulnerability and visibility of targets; but mainly on the relative number of weapons employed. It is obvious that advantage in numbers may be offset by some of the factors mentioned. Thus, troops firing from behind cover are decidedly less visible and less vulnerable than troops in the open. A man standing and facing to the front presents about nine square feet of vulnerable surface, while in the prone firing position he presents but little more than two square feet in the open. Firing from behind cover the vulnerable target of a rifleman becomes less than one square foot; so that, other things being equal, one rifle behind cover would roughly be able to cope with two rifles firing from the open. Other factors affecting the fire superiority of troops behind cover as compared with those in the open are the larger advantage of the former in the matter of ammunition supply, preparation of foreground, knowledge of ranges, better communications, measures for concealment, and possibility of reinforcing the firing line under cover.

By a scientific and skillful manipulation of all available means of fortification, troops behind cover can check the advance of an adversary many times their number.

It is therefore evident that superiority of fire is not only a question of relative number of weapons brought into action but also of their relative fire effect, and that fortifications afford the means for bringing about equality of fire effect between forces numerically unequal. Any device or artifice which lends itself to diminishing hostile fire effect therefore constitutes an element of fortification and may be employed either by the attack or the defense.

However, the advantages of fortification will accrue in a much greater degree to the troops on the defense, since they can select and prepare their field of fire so as to give the fullest effect to their weapons and prepare better cover for their lines and supports; while the troops of the attack, being necessarily on the move, must content themselves with such natural cover as the terrain affords or with the very hasty and limited works that can be constructed with their portable tools.

Unless fire superiority has been attained the attacking troops cannot advance and their intended tactical movement is checked. This is the time for the commander of the defensive troops to reap the advantages which his field fortifications have conferred and, if he correctly understands the game, he will pass to the offensive with his reserves, which he has been able to spare for this purpose, attacking vigorously, while the enemy is more or less exhausted and used up by his previous efforts. It is only by putting into execution such an aggressive action that he can avail himself of the benefits to be

derived from the employment of field fortifications on the battlefield of today. To continue a passive defense must certainly lead to defeat by an energetic enemy, who, failing in his efforts to dislodge the adversary from his fortifications, will maneuver him out of them, or avoid them in the first instance, if they appear too strong to attack. The latter consideration leads to the conclusion that it would be a mistake to prepare too strongly a battlefield position whereon a decisive action is sought, for the enemy will then simply maneuver and all preparation will have been in vain.

From the foregoing observations we may rightly deduce the following general principles regarding the employment of fortifications in connection with tactical maneuvers:

1. The employment of field fortifications implies a defensive attitude, but only a temporary one; they must never be permitted to impair aggressive action.

2. Field fortifications constitute a means, coordinate with maneuver power and fire effect, for the attainment of tactical ends; their correct employment therefore constitutes an essential part of the subject of tactics.

The mere construction of field fortifications is a comparatively simple matter, the knowledge of which is easily acquired. Their correct tactical application is an exceedingly difficult subject and calls for the exercise of the highest judgment on the part of troop leaders. In the modern battle, with its extended front and long duration, the ever-shifting phases of the combat will afford frequent opportunities for their application upon the part of all leaders, from the commander-in-chief down to the company

officers. Ordinarily, technical advice and technical assistance will be impracticable under the condition of the rapidly shifting events of the battlefield, and this fact requires that combat troops themselves be able to organize field works to suit the exigencies of the occasion. All combat officers should, therefore, possess a good understanding of the part played by field fortifications in military operations, know where and when to use them; and the troops themselves should be trained in their construction.

Simple Rifle Trenches

Superior fire effect being the primary object of all tactical operations, the fullest possible scope must be given to the weapons employed, which are the gun, machine gun, and rifle. Although of the greatest importance in diminishing hostile fire effect, cover must never be permitted to interfere with the fire effect of our own weapons. Perfect cover, while obtainable in practice, is therefore inadmissible since no fire can be delivered from it. The use of the weapon requires either that it should be capable of firing over the cover or through an opening made in it, either of which involves a certain area of vulnerability, which area should of course be made as small as practicable.

In the use of existing and specially constructed cover, the consideration of the free and unrestricted use of the weapon must always be kept in view, as this determines the organization of the cover. In field fortifications, natural topographical, or existing artificial features will be used, ordinarily, to secure cover, provided their location is suitable for good fire effect. They not infrequently offer better cover with less preparation than is possible with

specially constructed cover, and include such features as ridges of ground, banks of water courses, road embankments and cuts, walls, property inclosures of all kinds, quarries, etc. In thickly populated countries such features occur in great abundance and their employment largely reduces the necessity for specially constructed cover. In sparsely settled country the necessity for constructing cover is more frequent and the method of providing it will now be considered.

The requirements to be filled by any cover are readily deduced from a consideration of the objects to be attained. As already pointed out it must permit the most effective use of the weapons employed. In addition, it should afford the maximum material protection against the enemy's projectiles of every kind, should be as inconspicuous as possible, and, finally, should be capable of easy and rapid construction with the available means. Guns, machine guns and rifles require different forms of cover to suit their special dimensions and methods of use. We will consider, for the present, cover for riflemen only, the rifle being the main weapon of the offense and defense.

The form of cover best adapted for the riflemen and best fulfilling the requirements above specified is the result of experience and reasoning. This form will naturally be subject to variations, both in the manner of its execution and in its final dimensions, depending upon available time, tools, and material. Hasty cover prepared on the field of battle, in the immediate presence of the enemy and frequently under fire, will necessarily be more limited as to dimensions than cover constructed with more deliberation.

In order to permit the most effective use of the weapon the soldier should be able to adopt a comfortable firing position behind the cover. This requirement is fulfilled by a standing position with a firm support for the rifle and calls for about 4' 6" relief, between the top of the cover and the surface upon which the soldier stands. This relief may be secured by raising the top of the cover to a height of 4' 6" above the natural surface of the ground, or by lowering the surface upon which the soldier stands an equal distance below the surface of the ground, or by a partial combination of the foregoing methods. The consideration of being able to overlook the foreground dictates that the top of the cover should rise some distance above the surface of the ground, whereas the consideration of inconspicuousness dictates that the height of the cover above the natural surface of the ground shall be as small as possible. Considerations of speed and ease of construction dictate that the necessary difference of elevation between the top of the cover and the surface upon which the soldier stands shall be secured by a partial elevation of the former and partial depression of the latter. These considerations conflict more or less, with the result that the adopted forms are compromises.

The thickness of cover desirable is such as to secure protection against all projectiles of the enemy, and it therefore becomes a factor of the penetration of the projectiles in use. Experiment has shown that 3' thickness of ordinary earth is proof against all rifle and shrapnel bullets, but that to stop light field gun projectiles a thickness of from 9' to 12' is necessary and still greater thickness for the projectiles of heavy field guns.

The following table gives the penetration of the modern small arm rifle bullet, caliber 30, at 400 yards:

Material	Penetration in inches
Dry pine.....	34"
Dry oak.....	25"
Dry loam.....	40"
Gravel or broken stone.....	9"
Snow, lightly compacted.....	90"
Brick work.....	15"

It is manifest that it will generally be beyond the power of the troops to provide specially constructed cover of sufficient thickness to resist the penetration of artillery projectiles and this condition must be accepted. The danger from this source is, however, trifling, for cover constructed with due regard for inconspicuousness affords so poor a target that few hits will be secured. A well placed projectile will not destroy more than a yard of cover and will reach but a single man. According to French artillery officers, it is estimated that but one shot in ten, even in well regulated artillery fire, will produce a hit; and that 1,000 rounds would be required to destroy a simple infantry parapet 100 yards long. This would practically exhaust the entire ammunition supply of a field battery, and as there will be miles of cover on an extended battlefield, no such expenditure of artillery ammunition can be entertained. As aptly expressed by General Langlois, "firing against rifle trenches with artillery shell would be like trying to kill flies with a war club" and with all the chances of failure. Furthermore, the greater portion of the ammunition of a light battery consists of shrapnel, and the practicability of effective fire against trenches is thus largely reduced.

If, therefore, the cover provides protection against rifle and shrapnel bullets, little need be feared from artillery projectiles. The protection of rifle trenches depends far less upon their strength than on their slight command, good concealment, and dispersion of the targets. The parapets should, however, keep out rifle and machine gun bullets, which are responsible for 85 to 90 per cent of all casualties. Parapets that do not keep out rifle bullets only serve to deform them, making them capable of more serious wounds.

The simplest and most usual form of cover for the rifleman is the simple standing trench shown in Fig. 1, Plate I. It will be noted that the elevation of the cover, commonly designated as the parapet, is 1' above the natural ground surface and that the bottom of the excavation, called the trench, is 3' 6" below the ground surface, thus affording the requisite difference of elevation, or relief, for the convenient use of the rifle in a standing position. The area of the excavation is approximately equal to the area of the parapet, thus satisfying the requirement of the maximum rapidity of construction. The top of the parapet is practically horizontal for a distance of three feet, insuring protection against the penetration of rifle and shrapnel bullets, while its outer slope is quite flat, facilitating the harmless ricochet of artillery projectiles. The side slopes of the trench and the interior slope of the parapet are held as steep as the nature of the soil will permit, while a small berm, 1' wide and 1' high, is left between the parapet and trench to serve as an elbow rest for the riflemen and as a place to store ammunition. The trench is furthermore made as narrow as possible,

reducing the amount of excavation and diminishing the exposure.

This trench (Fig. 1) best fulfills all the requirements sought for in hasty cover for the rifleman and is the form generally adopted by all armies. It can be constructed in practically the same time as the kneeling trench, and, as it affords better facility for the use of the rifle and better cover for the man, should be followed in all normal cases. Slight modifications may at times be desirable or necessary; to secure a somewhat higher parapet, to better enable the foreground to be overlooked, to suppress the parapet for better concealment, or to provide for the contingency of difficult soils preventing a depth of trench as great as 3' 6". Modified forms of the simple rifle trench are shown in Figs. 2, 3 and 4, Plate I, and their construction is obvious from the figured dimensions.

The cross-sections of trenches as shown are called *profiles*. Although accurate dimensions are given, these need be adhered to only approximately in practice, especially in hasty work. It is important that the relief of the trench be suited to the stature of the individual rifleman, who should look out for this himself.

These simple trenches constitute the main elements of the defensive organization for infantry in situations calling for the execution of hasty cover. By resting his rifle on the parapet and his elbow on the elbow rest, the man need expose but little more than his head while in the act of firing, and by crouching down or sitting on the bottom of the trench he will be practically safe from ordinary shrapnel fire and shell fragments.

In average soil the trench can be constructed in

one and one-half hours with the portable entrenching tools. Slight as such trenches may appear, they afford a material increase of resisting power against troops in open terrain and are practically indestructible by artillery fire. Their very slightness is an element of strength, affording the smallest possible target, the inconspicuousness of which may be further increased by the use of artificial means as will be later considered.

The forms of simple rifle trenches shown may be regarded as normal types of hasty trenches applicable to passing tactical needs, and capable of being constructed by the infantry with their portable tools in a comparatively short time.

The main defect of the simple rifle trench is its total lack of lateral communication, rendering difficult the reinforcing of the fire line and the removal of the wounded. If it be likely that such a trench may be held for some length of time, it will pay to improve its profile in the manner shown in Fig. 5, Plate I. This profile affords a covered lateral communication without interfering with the delivery of fire, and also a more convenient cover against shrapnel for men sitting on the step with their backs against the parapet.

The types of profiles shown in the Figs. 1-5 represent the practical limit of trenches applicable to hasty works for use on the battlefield. In ordinary soils their construction can be effected in four hours or less. Still stronger profiles may be constructed by widening and deepening the excavation and by increasing the thickness of the parapet, giving better cover to the riflemen when not actually manning the parapet, as well as resistance to the

penetration of the projectiles of field and heavier guns.

A type of profile secure against the penetration of light field artillery projectiles is shown in Fig. 6, Plate I. Profiles of this type are too monumental and require too much work to be applicable to hasty field entrenchments. They belong rather to the type of provisional fortifications and would be employed for strategic rather than tactical purposes. Their construction is the business of technical, rather than non-technical troops, although situations may arise in which hasty field works may be developed until they reach the dimensions of the stronger types. The fortified lines of position on the Shaho and at Mukden on both the Russian and Japanese sides afford examples of such strengthening of hasty field works. Figs. 7 and 8, Plate I^a, show some of the profiles of strengthened trenches employed by the Russians and Japanese in the Manchurian campaign.

With regard to the location of rifle trenches with respect to the foreground, it is to be observed that in order to realize the full effect of the modern firearms a clear field of fire to the effective range of the weapons is extremely desirable. The experiences of the recent campaign in Manchuria have shown that sensible losses from infantry fire were incurred at distances as great as 2,000 yards and that at 1,000 yards this fire attained a tremendous power. But in order to fire effectively at the longer ranges the rifleman must have a clear view of the foreground. In perfectly flat terrain, whether level or sloping, the command afforded by the usual type of fire trenches is insufficient to afford a good distant view of targets so insignificant as those afforded by a skirmish line.

If it were merely a question of obtaining a good distant view the best location for fire trenches would unquestionably be on the military crests of heights with rather steep slopes, but such a location involves two disadvantages, first, the sacrifice of grazing fire which is so much more effective than plunging fire, and, secondly, exposure of the trenches to the enemy's view. If the slopes of the heights are too abrupt, there is the further danger of dead space at the shorter ranges.

Fire trenches located on prominent crests are on the whole disadvantageous, affording good targets to hostile artillery which will thereby be able to support the advance of the hostile infantry with good effect. Examples of the bad effects of locating rifle trenches on prominent crests are furnished by the Russian works in Manchuria as well as by the earlier trenches of the Boers in South Africa.

To secure the advantages of a good view and at the same time to minimize the exposure of the trenches, a location on gently rising ground having a concave slope is unquestionably the best. Unfortunately the terrain must be taken as we find it, and ideal positions, such as that of the French at St. Privat with its gently sloping glacis-like foreground, are not generally afforded.

The location of the fire trenches then resolves itself into a choice between the military crest of rising ground or some position further forward. The disadvantages of a conspicuous location on the crest have already been pointed out, and such locations are inadvisable unless the trenches be so strongly constructed that they can withstand ordinary artillery fire, such as the Russian trenches on 203 Meter hill. Positions forward of the crest sacrifice command and

limit distant view, but are less exposed to hostile fire. The chief disadvantage of a position forward of the crest is the difficulty of communicating with the fire trenches, either for reinforcing the same or for withdrawing. Such being the conflicting considerations, it is manifest that the location of rifle trenches with respect to the foreground must be a matter of compromise, to be determined by sound judgment on the part of officers responsible for the location.

In order to avoid the neutralizing effect of hostile shrapnel fire, some French authorities have advocated the abandonment of positions on or in advance of crests altogether and placing them on the counterslopes of elevated ground on or near the rear edges of plateaus. If the field of fire be not too restricted such locations may occasionally afford marked advantages. The Boer position on Spionkop was of this character: Ordinarily, positions on the counterslope afford a relatively short field of fire, permit the enemy to approach the covering crest with little loss, and to take up a covered position, at short ranges, for a further advance. In general, counterslope positions have little to recommend them, and the location of fire trenches will be on or in front of the military crest, so as to secure the best view of the foreground consistent with a reasonable amount of security from hostile artillery fire.

In rolling country, affording a succession of crests within rifle range of each other, it will often be difficult for the hostile artillery to bring a well regulated fire to bear upon the trenches. If a position for direct fire be taken upon the nearest crest in front, the hostile artillery will itself be exposed

to infantry fire from the trenches. If it seeks a defiladed position behind the crest, it may not be able to fire at angles of elevation sufficiently low to reach the trenches.

Besides the advantage of a better field of view and of fire afforded by occupation of high ground the additional advantages follow:

- (a) The crests will conceal our dispositions in depth from the enemy's view.
- (b) The enemy's assault will be made more exhausting by compelling him to ascend the slopes.
- (c) Good facilities will be afforded for launching a counter attack.
- (d) The possibility of providing several tiers of fire, will sometimes be offered.

In locating a trench upon a crest care must be taken that the trench be not outlined against a skyline. To avoid this it will be necessary at times to push the trench some distance down the forward slope. If the forward slope is convex in profile or consists of a succession of crests, it will sometimes be necessary to advance the trenches well forward in order to secure the best field of fire.

Fig. 9, Plate 1^a, shows the usual location of a trench on or near the crest of gently rising ground. Fig. 10, Plate 1^a, shows a location on the forward slope. The best location must be decided in each case on the ground itself by placing the eye at the elevation of the parapet and sighting over the foreground.

When trenches have to be located upon steep slopes some modifications of the profile are necessarily involved. To enable the rifleman to fire down hill conveniently the relief of the parapet should be less than in the normal case, as shown in Fig. 11,

Plate 1^a. The diminished relief does not necessarily imply a decrease of cover, for if the enemy must look up the hill, the plane of defilade will rise towards the trench and less height of cover will serve to protect men in the trench.

It has also been recommended to make the interior slopes less steep when firing down hill in order to avoid a weak angle at the interior crest. This is of doubtful utility for it involves more exposure to shrapnel fire.

Since trenches on crests and commanding slopes are more exposed to the enemy's view and fire, especial pains should be taken to secure concealment. This may be partly accomplished by locating the trench so as to take advantage of any existing natural screen or by artificial means such as covering the excavated earth with grass, sods, weeds or placing branches and twigs in its front. The short lengths of rifle trenches and their dispersion along the slopes, both in depth and laterally, contribute to conceal the works and to minimize the effect of hostile artillery fire.

Simple Standing Trench

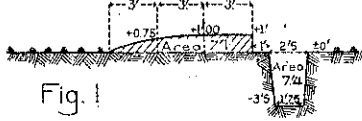

Fig. 1

Simple Standing Trench, 1 1/5 Command

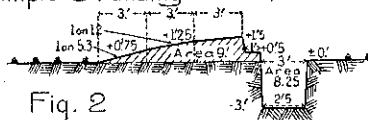

Fig. 2

Simple Standing Trench, Parapet Suppressed



Fig. 3

Simple Standing Trench, Rocky Ground

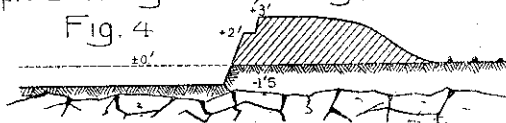

Fig. 4

Completed Standing Trench

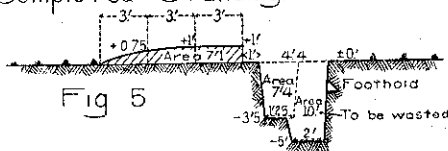

Fig. 5

Triangular Profile To Resist Field Guns

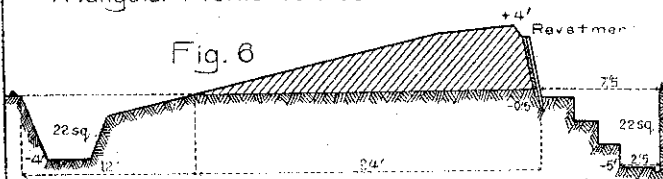
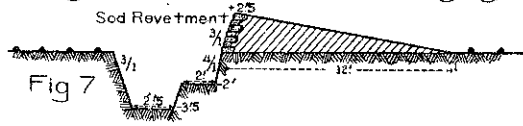
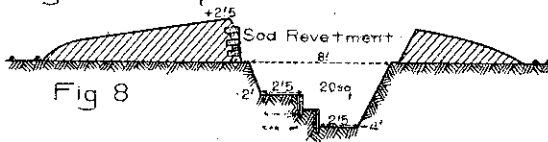

Fig. 6

Strengthened Russian Trench, Liaoyang



Strengthened Japanese Trench, Chinchiatun



Location of Trench on Military Crest

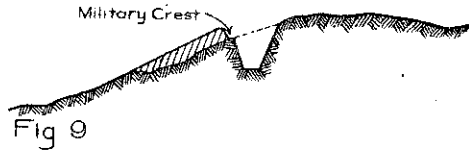

Location of Trench forward of Military Crest

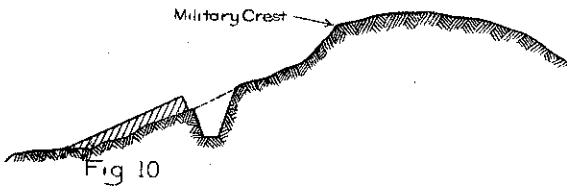

Modified Relief On Steep Slopes

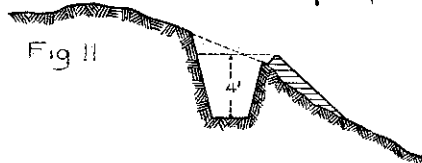

Chapter II

PRINCIPLES OF THE DEFENSIVE ORGANIZATION.—SUPPORTING POINTS.—ARTILLERY POSITIONS.—USE OF ENGINEER TROOPS.

IN taking up a position the intentions of the commander and the nature of the terrain govern. The location, choice and organization of the position are especially influenced by the object of the combat, that is, whether it is planned to make a purely passive defense for the purpose of gaining time or to seek a decisive action implying offensive conduct.

The general location of a position is influenced mainly by the strategical situation. It must lie favorably, not only to the direction of the enemy's line of march but also to ones own. In general it must be the natural result of the forward march without requiring extensive displacements of the troops.

The choice of the actual position results from the tactical situation in connection with the utilization of the advantages of the terrain, therefore tactical strength and security are sought. A position has value only when it compels the enemy to attack or when it permits the defense to gain the desired time, or favorable opportunities for his own offensive action in case the enemy undertakes a turning movement.

As the opposing forces become smaller the value of organized *defensive lines* diminishes, since the attack can readily maneuver the defense out of its position without great loss of time. In considering the defensive organization of lines, therefore, only fronts of some extent are in question—at least that

of a brigade—which cannot be turned without the sacrifice of considerable time, or without the incurrance of certain risks. Defense of a defile might involve a very limited length of line, but this is a special case.

In choosing a position the principal requirements to be satisfied are: a wide and clear field of fire; concealment; freedom of maneuver along, and in rear of the position; and security for the flanks. The extent of the position in frontage and depth must also be suited to the strength of the forces available for its occupation. Too extended a front may lead to a position being easily pierced, but may be justified: in order to gain secure points of support for the flanks; to deceive the enemy regarding the strength of the forces; and when there is an abundant ammunition supply. Too limited a depth increases the difficulty of covering the supports and reserves and their lateral movement. It may therefore lead to the disadvantageous occupation of advanced positions. Too restricted a front, implying excessive depth, will facilitate turning movements by the enemy and delay reinforcing the front line.

The increase in size of armies as well as the marked increase in fire effect of modern weapons and the more liberal equipment of intrenching tools, have all conduced to an extension of fronts since 1870. The French position at Gravelotte was occupied at the rate of about ten men per yard of front and similar densities obtained at Wörth, Mars la Tour and Sedan. The German lines of investment around Paris and Metz were, however, much less strongly occupied, counting but three to four men per yard of front. At Plevna, the Turkish position had a front of about 25 miles and was held with only

one and one half men per yard. In the South African war the Boers held their positions on the Tugela, 11 miles long, with some 7,000 men.

At Mukden the Russian position was something like 55 miles front and was occupied by a little more than three men to a yard.

It must be evident that no definite rules can be formulated for the necessary strength of occupation of a position, based either on experience or reasoning. So much depends upon the special circumstances, such as the terrain, strength of works, armament, and quality of troops that any figures are apt to be misleading.

It may, however, be safely assumed that, given good troops, a good field of fire, and cover, a strength of one and one half men per yard can hold a position for a reasonable length of time against greatly superior forces, but the defense will be purely passive.

As regards the organization of the position in its details, it is to be noted that there must be an intimate coöperation between the working of the infantry and the artillery. Before the perfection of indirect fire methods the number of artillery positions was very limited and the entire organization was based upon these as a framework. At the present time no such limitation as to artillery positions exists, and the organization is based upon the best disposition of the infantry trenches, to which the artillery conforms.

The positions for the field artillery should be so selected as to enable it: to combine its fire with that of the infantry upon the probable directions of attack up to the decisive moment; to combat the hostile artillery up to the nearest positions; and to meet possible flank attacks. The heavy artillery will be

posted in support of the field artillery at points where it can bring its fire to bear upon presumed lines of march and artillery positions of the enemy. This applies especially to heavy guns, like the 4.7-inch rifle whose great range and terrific shrapnel effect are useful against the enemy's reserves and combat trains. Heavy howitzers, like the 6-inch, are best held in a position of readiness near good roads until the direction of the enemy's main attack is developed.

Owing to the uncertainty as to the direction of the enemy's main attack, the artillery positions will necessarily call for a certain amount of dispersion, but as a rule the guns will be grouped by battalions or regiments in partial or completely defiladed gun epaulments. The infantry positions should ordinarily be so far to the front of the artillery positions as to protect the latter from hostile infantry fire as well as from attacks in flank or rear, while at the same time not exposing the infantry to loss from premature bursts. A distance of at least 600 yards is desirable. In addition, the infantry position must afford a good fire on the near foreground, and where the terrain does not permit of a frontal fire it must be replaced or supplemented by flanking fire. In broken terrain or on slopes with convex profiles, flanking fire will frequently afford the only means of covering the near foreground of a position.

Machine guns will be employed in carefully covered emplacements at points where a special reinforcement of the infantry fire is necessary, such as upon small portions of the terrain useful to the enemy, on the flanks of infantry units, and on the wings of the position.

The area of terrain within which the position

may be chosen is fixed, to a large extent, by the tactical situation. The nearer the enemy, the less the field for selection; and when contact has once been established and the fight has begun, the side electing to hold its ground must generally halt where it finds itself and strengthen the terrain as best it can. In prepared battlefield positions where as much as a day's march separates the combatants, beside electing to hold its ground for the time being will have more latitude in the choice of a position. It may advance or retire some distance to hold a stream, valley, ridge of heights, edge of plateau; or to take advantage of any other favorable topographical features.

The details of the defensive organizations depend upon the intentions of the commander, to which this organization must respond. Does he intend to seek a decisive action by an immediate and vigorous attack? If so, it is evident that there is no use, *a priori*, for defensive works on the particular portions of the front covered by the attacking troops. In such case, defensive organizations will be undertaken only on such parts of the line as are not for the time being involved in the attack. During the progress of the attack, many occasions will arise, especially in the long drawn-out battles of today, calling for the employment of defensive works for temporary purposes with a view to facilitating further progress, holding captured points, etc.; but the need for these cannot be foreseen, and their use is dependent upon the course of the fight.

Does the commander intend to receive the attack of the enemy on a position of his own choosing, with a view to wearing him out and making him disclose his intentions, in order then to pass to a resolute and

determined attack? If so, the original defensive organization must be more thoroughly planned and executed than in the first case. At the same time care must be exercised not to resort to such excessive strengthening of the position as may influence the enemy not to attack. For this will defeat the intentions of the commander and injure the morale of the troops who, experience has shown, are loth to quit elaborate fortifications constructed at the expense of much time and labor and affording them excellent cover.

Does the commander seek merely to hold his ground—in other words, to make a passive defense for the purpose of gaining time? Then his defensive organization must be still more comprehensive and elaborate and limited only by the time and resources available. Of this character were the several fortified positions of the Russians in Manchuria, which, while fulfilling their object so far as frontal attacks were concerned, nevertheless failed because their flanks were turned.

But whatever the object to be served by the defensive organization of lines, the same general principles are applicable. These principles may be summarized as follows:

1. The defensive position must have sufficient depth.
2. The defensive line is discontinuous laterally.

The defensive organization in depth is merely the adaptation of defensive measures to tactical formations. The attack will be made as a succession of efforts or impulses to which the defense will respond by a succession of resistances. The succession of resistances may take the form of a series of successive prepared lines, each offering resistance in

turn, or a single prepared line of resistance successively strengthened from the rear by the bringing up of the supports and reserves. The former method is represented by the French school of thought with its advanced posts, advanced combat line, main line and second line (*position de repli*), while the second method is represented by the German school of thought.

The method of successive prepared lines of resistance, while theoretically sound, is open to the objection that troops will not hold so long nor so well if they know that there are in rear other prepared defensive lines. This view of the effect of successive fortified lines is supported by the results of the Manchurian campaign in which the Russians frequently offered but feeble resistance from their advanced lines. This yielding and falling back of the foremost lines is injurious to the morale of the defense as a whole.

The concentration of all defensive measures on a single prepared line, relying upon mobile supports and reserves for the necessary organization in depth, is more conducive to the best morale of the troops and more in keeping with the maintenance of the offensive spirit. It is, therefore, on the whole, considered preferable.

The principle of the lateral discontinuity of the defensive organization is in compliance with the principle of the economy of forces, is better adapted to the tactical handling of organized units, and takes advantage of the long range of modern weapons. Its practical result is that the defensive organizations are grouped at certain points along the front, leaving intervals of greater or less extent which are defended by the cross and flanking fire of adjacent

organized points, as well as by the play of their supports and reserves. The interval between successive organized points is dependent upon the topographical features of the terrain and the necessity for reciprocal flanking fire, which limits this interval to 800 or 1,000 yards.

Such organized defensive points located along the front of a prepared position are called supporting points. Formerly it was deemed necessary that closed works, in the nature of forts or redoubts, should constitute the organization of supporting points; and this to a certain extent still obtains in the case of permanent fortifications and provisional works. The underlying idea of closed works is that, by virtue of their all round defense, they will be capable of maintaining themselves after the line is pierced and thus afford opportunity for the defense to reestablish itself. In field fortifications, especially in hasty works for use on the battlefield, closed works find little or no application. Such works are difficult to conceal, and, unless very strongly organized with bomb-proof shelters and interior communications (for which time is ordinarily lacking in field fortifications), they will become veritable shell traps, liable to subject their garrison to annihilation by artillery fire. To secure the fullest development of fire effect from modern weapons there is required a wide extent of trenches rather than the limited faces of closed works.

All the objects formerly sought by the use of the old types of closed works, with their massive profile and geometrical trace, can be better realized by a proper grouping of simple rifle trenches, either alone or in conjunction with some existing natural or artificial feature, such as a village, group of buildings,

or a clump of woods. If deemed necessary, such trenches can be so laid out, that, although discontinuous, they can bring fire in any and all directions; be entirely surrounded by obstacles; and, in connection with dispersed covers, perform all the functions of a closed work with far better concealment, better protection and infinitely less labor. In the rare cases where a closed work may be used, such as a support for a wing or behind or in a specially weak or dangerous portion of the front, it will ordinarily take the form of a simple ring trench enclosed by a continuous line of obstacles and will have a fixed garrison assigned to it. Fig. 2, Plate II, shows a form of ring trench with overhead cover as recommended for the German service.

Closed works of the character used by the Russians in their positions at Liaoyang and Mukden, although field fortifications, belong rather to the class of provisional fortifications and may find application under similar situations, that is, where there is abundant time and the works can be constructed with the assistance of civilian labor. But even here the same results can be obtained by the proper combination of rifle trenches, obstacles, covers, communications and their accessories. Fig. 1, Plate II, shows one of the Russian redoubts at Liaoyang, while Plate III shows a form of Japanese redoubt. The latter, approximating a ring trench in the simplicity and ease of its construction, is a decidedly better form for field fortification than the former.

The term *supporting point*, as now understood, refers to an *area* of ground organized defensively for a definite object by the troops themselves with the means usually available. Only very exceptional-

ly will it present a closed form with a continuous fire line and then generally only in the shape of a ring trench. Except for permanent and provisional works, supporting points in the nature of forts and redoubts of monumental construction will find no application. In Fig. 1, Plate IV, is shown the general layout of the Russian works on 203 Metre hill, the whole presenting an excellent example of a group of trenches constituting a strong supporting point. Fig. 2, Plate IV, shows the supporting point on Redoubt hill, a part of the outer Russian line at Liaoyang.

A prepared fortified line of resistance will, therefore, consist normally of a line of supporting points, the intervals being such that mutual defense by cross and flanking fires is assured. The supporting points themselves may be natural topographical or existing artificial features (villages, woods, etc.), organized defensively, groups of rifle trenches, or combinations. Each supporting point will be organized and defended by a tactical unit. The principle of discontinuity is not limited merely to the intervals between successive supporting points. In extended battlefield positions still larger intervals may be left between the larger tactical units, such as divisions and army corps, the object being to tempt the enemy to make an attack upon the interval and thus to expose himself to counter attacks behind the line. In the Russian outer line at Liaoyang there was an interval of one and one half miles between the positions of the I and III Siberian Corps, which the Japanese, however, refrained from attacking.

The flanks of a position will always be tempting points for the enemy's attacks, and should therefore be secured by resting them on impassable obstacles,

or if this cannot be done, by echeloning them to the rear and keeping strong reserves close at hand.

Long trenches are not desirable, even where the ground permits of their application, which it ordinarily does not. Any part of a long trench once found by the enemy easily leads to the disclosure of the remainder. A long trench penetrated at any point will generally become untenable. For these reasons it is considered preferable to limit the length of single trenches to that required for a company and if a greater development of fire is needed, additional trenches of company, platoon, or even squad length may be constructed. The several trenches of a group need not, and generally would not be on one line, but might be separated in depth as well as laterally. By this dispersion of works a certain flexibility is obtained, permitting the best adaptation to the ground and lending itself to concealment and protection.

The size of the tactical unit assigned to a supporting point depends upon the tactical importance of the supporting point and upon the intervals separating it from the adjacent supporting points. A battalion forms a very convenient tactical unit and will be most often used. A portion of the battalion will be employed in the firing line and the remaining portion as a support to reinforce the firing line.

For the conduct of the combat and to fix responsibility, the entire defensive front, if of any extent, will be divided into sectors, to each of which will be assigned a complete tactical unit. The division into sectors is influenced by the topography, the strength of the forces, and the intentions of the commander. With a large force the initial division into sectors will be made by the commander-in-chief, who will assign the larger tactical units, such as field armies

or divisions, to definite portions of the front and give to each its mission. The larger sectors are further subdivided into smaller sectors by the commanders of larger units down to brigades and even regiments. By this means responsibility is fixed and the exercise of command simplified.

Each sector, large and small, will ordinarily have a sector reserve at the disposal of the commander of the sector. The strength of this reserve will depend upon the tactical object in view. Where it is merely a question of holding ground the reserves will not be so strong as where a decisive issue is sought. In extended battlefields, portions of the front will be organized with a view to offensive action, and the strength and location of the reserves will be governed accordingly.

The practical method of organizing a defensive line depends upon the time available and requires the coöperation of all the arms of the service, including the technical troops. It will manifestly be impracticable for the commander-in-chief of a large force—say several field armies—to inspect personally the entire front and to decide upon the details of the position and of the works to be constructed. Only general directions, based upon the map and upon the military situation can be given by the commander of a large force. These directions will merely specify the fronts to be occupied by the larger units, their mission and designate the general reserves and their location.

Ordinarily the time available will permit no higher than division commanders to make a reconnaissance (either in person or by a designated staff officer) upon which to base the details of a defensive line. When such reconnaissance is made prior to

the issue of orders the division commander, or his delegated staff officer, should be accompanied by the commander of the artillery and engineers for the purpose of coördinating the work of the latter arms with that of the infantry. Not infrequently, a prior reconnaissance by the division commander is impracticable and it is then possible for him to make dispositions of a general character only, based on the map and the general situation, leaving to brigade and regimental commanders the decision as to details.

The necessity for a good understanding of the organization of defensive positions on the part of all line officers therefore becomes apparent. Without such uniformity of application, the use of field works to strengthen the terrain will produce no satisfactory results.

Covering Force

The security of troops engaged on the organization of defensive position must be provided for by throwing forward suitable covering detachments.

Use of Engineers

It is now accepted as a principle that all hasty field works must be constructed by the troops who are to defend them, and all troops, infantry, artillery, and cavalry are equipped with tools for this purpose. The need for hasty works under present day conditions is so frequent and so extensive that their construction cannot be delegated, as was formerly the case, to the engineers whose numbers will be quite inadequate for such a purpose. There are, however, many classes of works required in the organization of a position which demand operations for which the other troops are neither trained nor

equipped and which can be best carried out by the technical troops. Of this character are the following:

(a) Demolitions, calling for the use of high explosives in clearing the foreground, and obstructing the enemy's communications.

(b) Cutting down of heavy timber, for which the infantry tools are not adapted.

(c) Assisting in the organization of specially important supporting points involving the employment of artificial obstacles and substantial covers.

(d) Providing communications, especially bridges, in rear of and along the position.

(e) Executing special constructions such as observation stations, shelters for the wounded.

(f) Constructing works on the second line of defense, if such should be contemplated.

In general, the engineers will be employed on works of general interest not definitely assignable to any other combat unit, and on works requiring special technical skill and tools.

Since the proportion of engineers is small, any attempt to apportion them uniformly over an extended front must lead to such a scattering of personnel and material as to preclude any practical results. Undue subdivisions will render supervision by engineer officers impossible and will complicate the subsistence and administration of the engineer units. All considerations, therefore, point to the employment of the engineers in tactical units, viz., companies.

When a reconnaissance precedes the actual organization of a position the senior engineer officer will be able to furnish advice as to the best employment of the engineer troops to carry out the inten-

tions of the commander, and this would naturally be followed in assigning the engineer troops. Where no such reconnaissance can be made, the assignment of the engineers will have to be made more or less arbitrarily and their employment decided by the commander of the units to which they may be attached.

The engineer troops are auxiliaries to the other combat troops and can render valuable services in the organization of defensive positions as well as on the offensive. In the latter case, they will accompany the leading troops of the attack equipped with demolition and pioneer tools and high explosives, prepared to overcome or remove any obstacles interfering with the advance of the infantry, and to assist in the organization of captured points. To secure the best results from the employment of engineer troops on the battlefield it is incumbent that all combat officers should understand their functions, capacity for executing work, as well as their limitations.

Plate II

Sketch of a strongly constructed supporting Point for a company at war strength, 44 covers for 220 men.

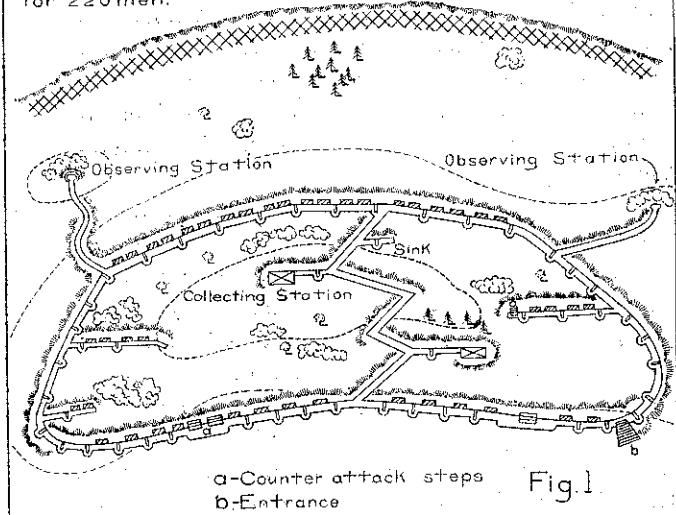

Russian Infantry Redoubt at Liaoyang

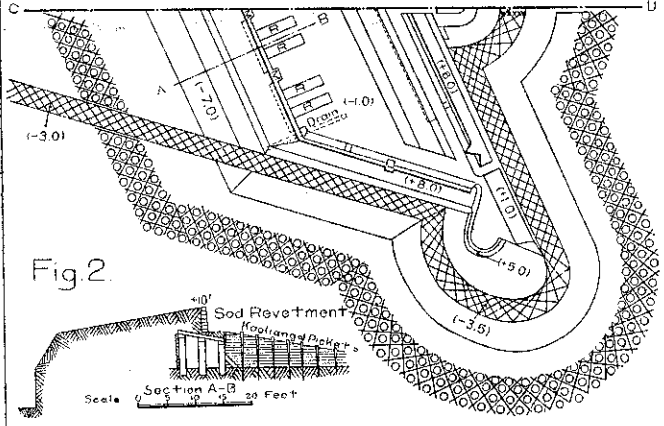

Legend
 Chevaux de frise... XXXX Wire entanglement ...XXXX
 Military Pits... °°°° R.....Ramp
 M.M.....Machine gun emplacement

J.H.

JAPANESE FIELD REDOUBT NEAR KANGPIENHSIEN.

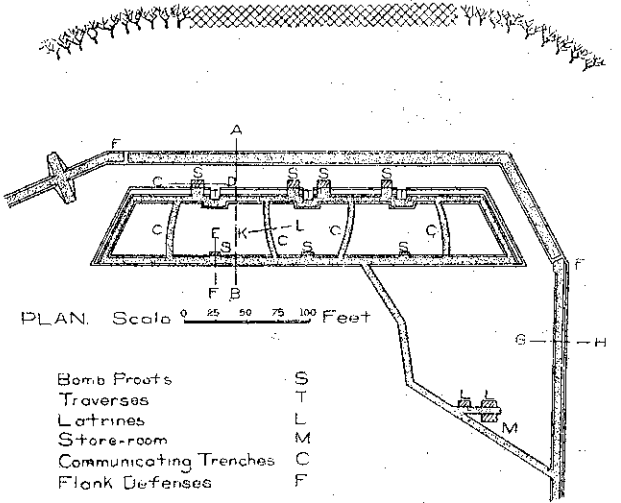

- | | |
|------------------------|---|
| Bomb Proofs | S |
| Traverses | T |
| Latrines | L |
| Store-room | M |
| Communicating Trenches | C |
| Flank Defenses | F |

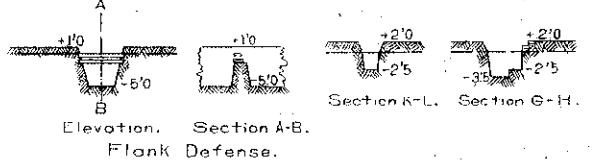
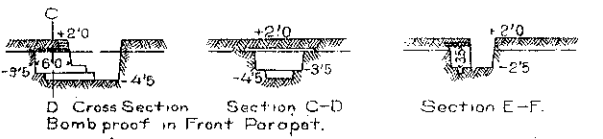
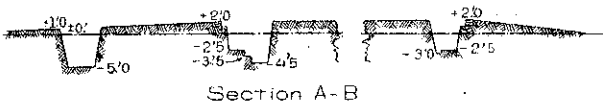

Scale for Sections 0 5 10 15 20 25 Feet

Note The dash and dot line represents the original ground surface.

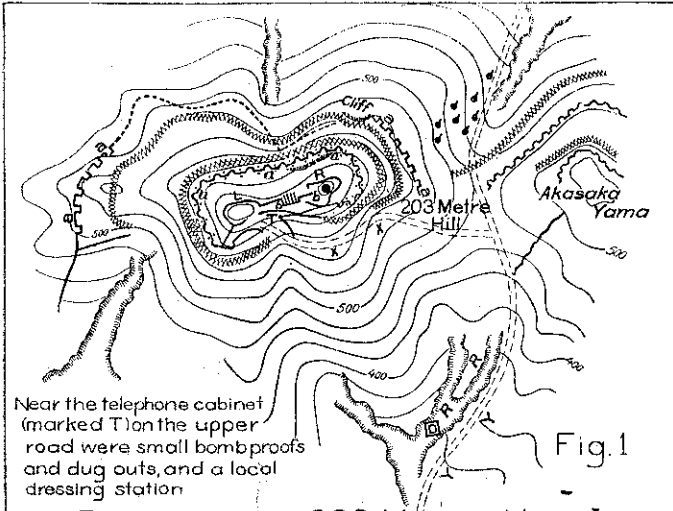

Near the telephone cabinet (marked T) on the upper road were small bombproofs and dug outs, and a local dressing station

Fig 1

DEFENSES OF 203 METRE HILL

- | | | | |
|-------------|--|-----|---|
| R | Right Redoubt | X X | Upper road |
| L | Left Redoubt | Y Y | Lower road |
| | Wire Entanglements | ● | Commandant's bomb proof |
| - - - - - | Trenches unoccupied | T | Telephone Cabinet |
| — — — — — — | Traversed trenches occupied | □ | Dressing Station |
| ○ | Lower (circular) trench | R R | Ravine where the reserves were usually kept |
| — — — — — — | Central Battery with connecting trenches | ◆◆ | Fougasses |
| b b | Trench on crest-line with communication trench to upper road | | |

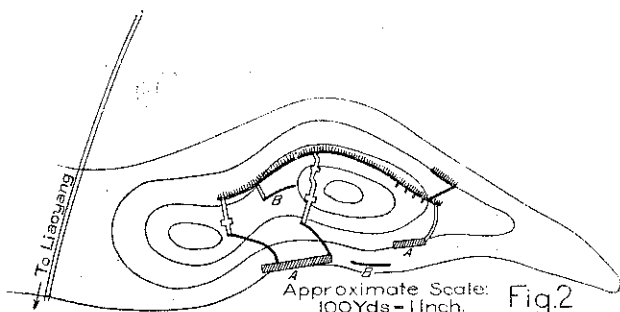

Approximate Scale: 100 Yds - 1 inch. Fig 2

SUPPORTING POINT ON REDOUBT HILL, RUSSIAN OUTER LINE AT LIAOYANG

- | | | | |
|-------------|---------------------------------------|-----------|---|
| A A | Splinter Profs | — | Communicating Trench (single Parapet) |
| B B | Open Cover Trenches | — — — — — | Traversed Fire Trench |
| | Simple Standing Trench | — — — — — | Traversed Communicating Trench (double Parapet) |
| — — — — — — | Communicating Trench (double Parapet) | □ | |

Chapter III

ACCESSORY FEATURES OF RIFLE TRENCHES.—HEAD COVER, TRAVERSES, SHELTERS, OBSERVATION STATIONS, MA- CHINE GUNS, DRAINAGE, WATER SUPPLY, NIGHT FIRING, AMMUNITION RECESSES, ETC.

IN the usual case, time for the organization of hasty battlefield fortifications will be very limited, even on the part of the defense, and the chances are that the simple standing trench will have to fulfill all requirements. However, it would be a serious mistake on the part of any commander not to endeavor, in the time at his disposal, to render his hasty fortifications as effective as possible. There are two considerations involved, more or less opposed, viz.:

(a) The fortifications should be made as effective as possible, but

(b) The troops must not be so exhausted by excessive work as to seriously impair their fighting power.

Fortunate is the commander who possesses the good judgment necessary to attain the happy mean between these two extremes.

The simple standing trench having been constructed, there are various accessory means of improving it. If it is evident from the first that there will be ample time, these accessory features should be embodied in the original plan; but, in the normal case this will not be practicable, and their consideration must be deferred until after a usable trench has been completed. These means of further improvement will now be discussed.

Head Cover

Head cover is obtained by either notching or loopholing the parapet. The simplest manner of doing the former is by placing small heaps of earth on the parapet, at intervals corresponding to the spacing of the riflemen; each man firing to the right of the heap immediately in his front (see Fig. 1, Plate V). This method is of questionable value, as the man does not get much protection and, at short ranges, the enemy is afforded an excellent aiming point. If mud or sods are available, the sides of the mounds can be made steep (see Fig. 2, Plate V), and the protection then becomes of real value. Any available material may be made use of to sustain the side slopes of the mounds at a greater angle of repose than the soil of which they are composed will naturally take. Notched parapets were frequently used by both Russians and Japanese in Manchuria.

Various forms of loophole are shown in Figs. 3 to 9, Plate V. Certain terms are used to define the various parts of a loophole, viz.: the bottom is called the *floor* or *sole*, the sides are called the *checks* and the narrow portion the *throat*. It is evident that the only essential difference between notches and loopholes is that the latter has a roof; therefore the same descriptive terms apply to the notch. Materials for loopholes will not generally be available for hasty works, but they should be employed whenever practicable as they materially increase the cover and contribute to greater accuracy in shooting.

The throat may be at the end of the loophole nearest to the rifleman, in which case he gets the best use of his rifle but not such good protection; or it may be at the end farthest away from the soldier, in which case he gets maximum protection but

must move about a pivot in order to change his aim; or the throat may be located at some intermediate point as a compromise. Various locations are indicated in the figures.

The Hopper Loophole, Fig. 5, Plate V, is a most effective form, especially if the throat is closed by a steel plate spiked to it. The plate should be about one half inch thick, of hard steel, and is pierced by a comparatively small opening for accomodating the rifle. Figures 6 and 7 show the forms of plates used by the Japanese and Russians in the late war.

If the material composing the loophole, or notch, is hard and resisting, the throat should always be placed to the front, or the cheeks in front of the throat should be stepped to prevent glancing in of projectiles.

Where the character of fire to be delivered involves a wide lateral and a small vertical angle, loopholes may take the forms of slits. Such a form will result from laying logs, or fascines, lengthwise on the parapet, supported at intervals by sods or other material, as shown in Figs. 8 and 9, Plate V. Various other materials, it is readily seen, may be used in constructing this form of loophole.

Head cover is valuable chiefly for neutralizing the effect of hostile shrapnel fire, thus enabling the riflemen to man the parapet at any and all stages of the combat. It, however, increases the visibility of the parapet and restricts the field of fire. At close range the notches and loopholes serve as aiming points to steady the fire of the enemy, especially if he can see light through them when unoccupied. In the latter case he waits until the light is obscured and then fires, knowing he has an animate target.

It is obvious that the defense must provide a proper background for the openings, or removable screens. Simple curtains made of empty sacks or sand bags will suffice.

Traverses

An unbroken, continuous trench would be exposed to enfilade fire, and also a shell or shrapnel bursting therein would have wide-spread effect. These difficulties are partially met by constructing the trenches in short lengths. It is, however, desirable, if time permits, to further subdivide each trench by means of traverses, the interval between adjacent traverses, not exceeding eight yards. Better defilade is thus secured, the material effect of any burst is confined to very narrow limits, and the moral effect upon the defenders of observing the destruction wrought by a successful burst is practically eliminated.

The traverses should be about two yards thick at the height of the interior crest. While their efficiency for defilade is a direct function of their height, it must be remembered that inconspicuousness of the trench is of prime importance. It is therefore inadvisable to carry them much, if any, above the general line of the crest, and in no case should this difference of level be greater than 18 inches.

When practicable, provision should be made for the traverses in the initial laying out of the trenches; failing this they can be constructed later. The excavation involved in the connection around a 2 yard traverse is equivalent to 12 lineal feet of simple trench. Figures 10 and 11, Plate V, show two methods of traversing a trench. If the first form is used,

the sides of the traverse should be made as steep as possible, in order that the reduction of space on the firing line may be a minimum. Traverses arranged as in Fig. 10 are called "attached" traverses and those arranged as in Fig. 11, "detached" traverses.

Shelters

In these days of accurate artillery fire it is essential that, if the trenches are to be occupied for any length of time, some sort of shelter be provided for the men when they are not actually manning the parapet. This shelter should be made as effective as time, materials, and the fitness of the troops for such work, permit. It will vary from the simplest form of splinter-proof to shelter proof against the heaviest siege artillery projectile. The overhead thickness of material for shelter will vary; 6 to 8 inches of earth on thin boards giving protection from shrapnel and splinters, 3 feet of earth on 6 inches of timber to resist light field guns, and 6 feet of earth on 12 inches of timber being the least that will afford protection when the fire of siege guns and howitzers is to be taken into account.

The great value of the shelters in the trench is that the men are protected in a position from which they can, in time of need, very rapidly man the parapet.

Various forms for these shelters are shown in the Figs. 12 to 18, Plates V and VI. In Figure 18, Plate VI, is shown a combination of head cover and shelter which is very effective. It will be noted that in some cases the shelter is closed to the rear by a sort of trapdoor or cover which, while not heavy enough to be unwieldy, will still offer considerable

resistance to small fragments and splinters. Timber will usually be the material used to sustain the roof, but railroad rails, or other forms of steel beams, are equally suitable.

Time being available for their construction, provision should be made for the shelters in laying out the trench, but they can also be readily constructed after the completion of the excavation of the trench, and on the field of battle this will be the usual order of procedure.

In determining the area of overhead cover to be provided, allow six square feet of floor space per man for temporary occupancy, and twelve square feet per man if the occupation is to be of long duration.

Observation Stations

Except when the garrison are actually required to man the parapet, they will all be under cover save a few lookouts whose duty will be to give timely warning of the movements of the enemy. These lookouts must be able, while well protected, to thoroughly observe the foreground. In the normal case there will be trees, or some artificial construction already existing, which may be made of use as a point of observation. Such facilities do not, however, always exist, and specially constructed observation stations must then be provided. These must afford the occupant the maximum amount of cover consistent with his being able to efficiently perform his duty as lookout. The two forms, furnishing basic ideas, are shown in Figs. 19, Plate VI^a, and 20, Plate VI. In the first form the bottom of the trench is lowered so that the man can just look over the superior slope; he must rely upon inconspicuous

headgear or a screen to shelter his head from view. In the second form he is given overhead cover.

In all cases observation stations must be so located and constructed that they will not disclose the location of the trenches. Where it is practicable they should always be placed in the trenches, but there will be many cases where they will have to be located in advance of or behind them.

Observation can be carried on by a man crouching below the parapet and making use of mirrors properly placed, but it is not believed that any great reliance should be placed on this method. The mirrors are too delicate for the rough handling incident to campaign and it would require a very high order of intelligence to employ them effectively.

Machine Guns

Machine guns are now an accepted and very potent factor in battlefield operations, and provision for their efficient use in the trenches must be made. Emplacements must be so constructed as to afford maximum protection to the gun detachment consistent with the free use of the weapon. Splinter-proof overhead cover is desirable and should be provided if practicable.

Shelter should be provided for both gun and detachment when not engaged in firing. The guns of a platoon should be spaced about twenty feet apart, and adjacent emplacements should be connected by a communicating trench.

Drainage

If a trench is to be occupied for any length of time, especially where much ground or falling water is to be encountered, drainage becomes of prime im-

portance. Many years ago a celebrated military authority asserted that "nothing so saps the courage of a soldier as to wet the seat of his trousers." This may be accepted as a true maxim, especially in cold weather, and the trench should therefore be made as dry as possible. The floor of the trench should be given a sufficient slope to the rear where an intercepting drain should collect the water and carry it to prepared sumps or to a point from which it can be disposed of by drainage. Provision should also be made for excluding surface drainage from the trenches.

Water Supply

A sufficient supply of good drinking water must be assured to the men occupying trenches. The arrangements to be made will, of course, depend principally upon the length of time the trench is to be occupied. Suitable vessels can be placed in the trenches and kept filled, or water for filling canteens can be distributed at stated intervals. In soils where water is easily reached, wells may even be dug in the trenches.

Night Firing

The successes of the Japanese in the Russo-Japanese war have given a wonderful impetus to night operations and they may be expected to play very important parts in the wars of the future. On the part of the defense this will necessitate provision for night firing. The best means, of course—and these will be employed by both attack and defense—are searchlights. Along an extensive defensive front it is not believed that sufficient searchlights will ever be provided, since it is necessary to illumi-

nate the entire extent of front, due to the fact that information is lacking as to the point which the enemy will select for attack.

If there is sufficient suitable material, bonfires can be prepared, to be lighted when the lookout reports the advance of the enemy. This also will seldom be practicable. Other means of illuminating the foreground are star shell rockets, such as were used by the Russians at Port Arthur, and illuminating pistols for firing cartridges of port fire which will burn for eight or ten seconds.

All means of night illuminations being uncertain, the only remaining expedient is to place during daylight rests such that the rifles, when placed upon them, will sweep a desired area without any aiming on the part of the soldier. These rests may be standards, to which the rifle is fastened by pins and which may be so constructed as to permit of adjustment for several ranges, or they may be simple battens placed lengthwise along the parapet so that rifles placed upon them are directed at the desired area. See Fig. 22, Plate VI-a.

General

No magazine arrangements are necessary. As noted in Chapter I, ammunition for immediate use may be placed upon the elbow rest. Recesses may be constructed in the parapet and in the shelters in which boxes of small arms ammunition may be placed.

As far as practicable, telephonic communication should be provided throughout the trenches.

In loose soils or sand great difficulty will be encountered in making slopes stand at the desired angles. Revetment should be resorted to if prac-

licable. Figs. 23 and 24, Plate VI^a, show a method of revetting with any available material, such as corn stalks, brush, etc. For more elaborate methods of revetment, see Engineer Field Manual, 1909, page 371 *et seq.*

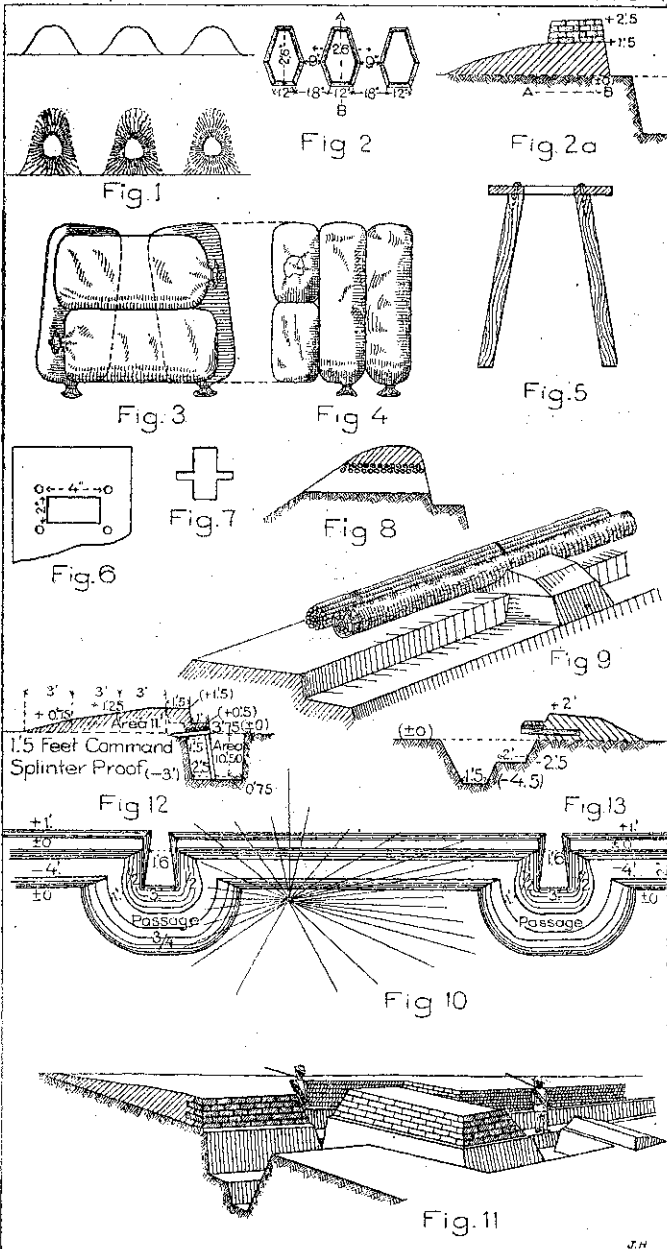

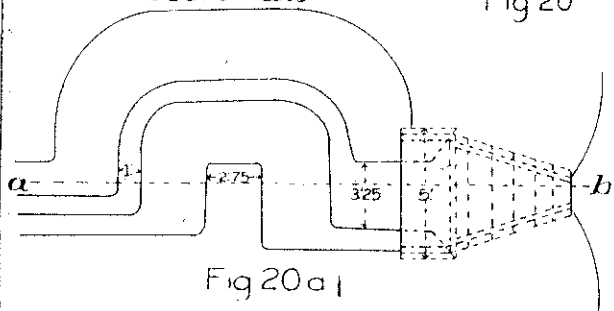
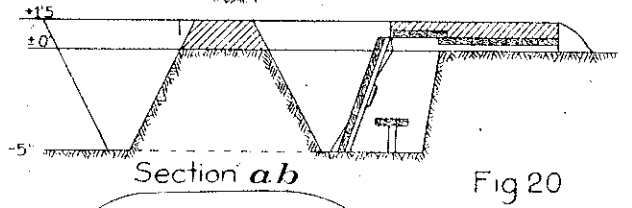
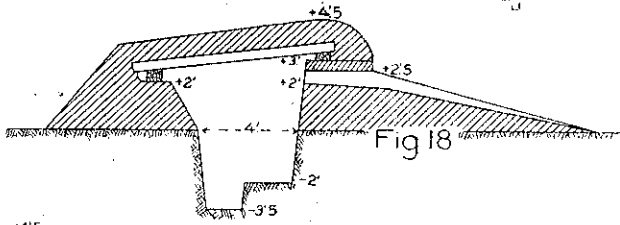
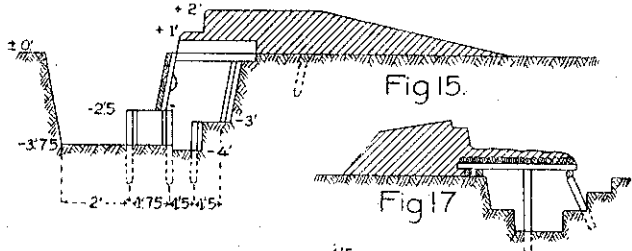
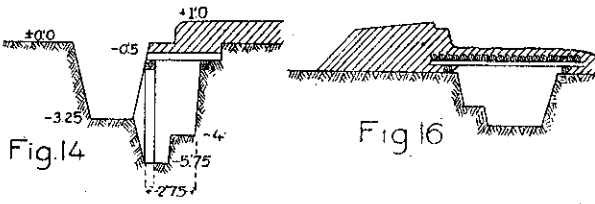

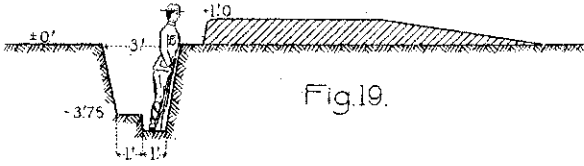

Fig. 19.

Machine Gun Emplacement.



Fig. 21.

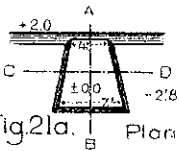

Fig. 21a. Plans

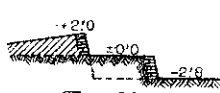

Fig. 21b. Section A-B

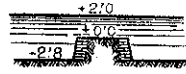

Fig. 21c. Section C-D

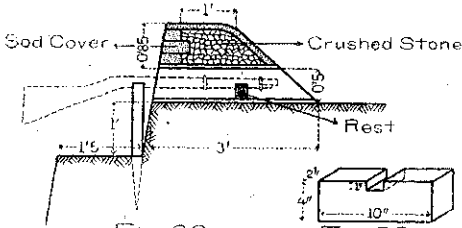

Fig. 22a.

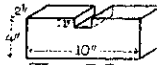

Fig. 22b.

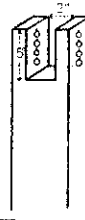

Fig. 22c.

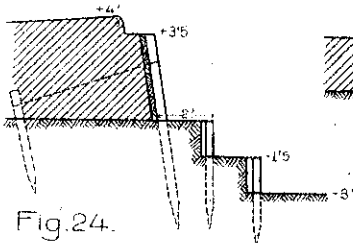

Fig. 24.

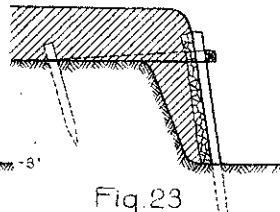

Fig. 23

Chapter IV

ACCESSORY FEATURES IN REAR OF THE FIRE TRENCHES.— SHELTERS FOR THE SUPPORTS AND RESERVES, COMMUNI- CATIONS, OBSERVATION STATIONS, EMBLEMMENTS FOR ARTILLERY, LATRINES, DRESSING STATIONS, ETC.

WE have seen that fortified positions must have sufficient depth, as otherwise the line is too easily pierced. This depth is secured by the location of the supports and the sector and the general reserves. This organization in depth calls for the employment of certain accessory features in rear of the fire trenches, and these we will now discuss.

It will frequently be the case that the character of the terrain is such as to afford natural or existing artificial cover for supports and reserves by which they are shielded from the view of the enemy, and, to a greater or less extent, protected from his fire. It may even be the case that ravines, folds in the ground and existing concealed roads furnish in addition covered approaches from the above concealed positions to the fire trenches. Such ideal conditions, however, do not by any means always exist, and lacking such natural cover and communications, troopers must be prepared to provide them for themselves.

Trenches for protecting supports and reserves are called *cover trenches*, and those connecting the fire and cover trenches are called *communicating trenches*. Fig. 1, Plate VII, shows the relation existing between the three classes of trenches.

Supports should be held so near to the fire line that they can readily reinforce it under all emergen-

cies. This may compel distances as small as fifty yards, notwithstanding the fact that the cover trenches then come inside the dispersion area of artillery fire directed at the fire trenches. The prompt reinforcement of the firing line at the critical moment is a delicate matter. The enemy's artillery fire, having supported his infantry at the decisive range, will be extended to cover the rear of the position. It is just at this moment that the supports will be wanted to reinforce the fire trench. If, therefore, the supports are placed too far to the rear they not only may not arrive in time, but to come up at all will need cross ground liable to be swept by artillery fire. Reserves, both sector and general, must be so located that they can reach all equally important parts of the fire line with equal facility, or that the length of time necessary for them to reach any point is an inverse function of the importance of that point. The reserves should generally be placed far enough to the rear to escape the effect of "overs" from hostile artillery; that is, not nearer than 300 yards.

Cover trenches for supports and reserves differ from fire trenches in that they are not ordinarily designed to deliver fire but are merely for protection of the soldier pending his taking an active part in the engagement. They should afford him the maximum of shelter and comfort, and give him a *ready means of egress*. To fulfill the latter requirement, trenches may be provided with sortie steps to permit the occupants to advance on a broad front and without loss of time. The amount of protection afforded is dependent upon time, materials, and the equipment and condition of the troops, varying from the simplest mound of earth to trenches with complete

overhead cover. Types are illustrated by Figures 2 and 3, Plate VII. There is no limit to the number of styles of cover behind the fire trenches, involving the existing or natural features, the work of the troops, and a combination of these two.

The cover trenches being provided, the next thing to do is to give the troops a safe passage from them to the fire trenches. *Communicating trenches* are intended merely for the concealment of the men while passing through them. Not being continually occupied, and it being impossible for the enemy to discover whether he is doing any real damage to them by artillery fire, there is not much chance of their being subjected to a regular bombardment, hence men passing through are exposed to chance shots only. Of course, the communicating trenches must not be enfiladed by the enemy, and, therefore, the trace of such trenches should make an angle with (i. e., not be parallel to) the enemy's fire. Where this cannot be done the communicating trenches may be defiladed by traverses, or they may be entirely covered over, as in the case of a communicating trench leading to a fire trench some distance down a forward slope. The earth excavated from the trench is usually piled up on the side toward the enemy; sometimes it is piled on both sides. Figure 4, and Figure 4^a, Plate VII, illustrate forms of communicating trenches.

As regards both cover trenches and communicating trenches, we must not lose sight of the fact that the usual time will not permit of their construction on the field of battle and we will, therefore, be limited to making the best of any natural, or existing artificial accidents of the terrain. Every effort should be made to improve these, however, without

imposing an exhausting amount of work upon the troops. The same necessity for concealment applies to these trenches as to the fire trenches, but in a somewhat lesser degree. Both cover and communicating trenches may sometimes overlook the foreground in portions of their length and may then be used to reinforce the firing line by providing a firing step on such portions.

Where the communicating trenches change direction, returns can be constructed and made use of for latrines and for the establishment of collecting stations, as shown in Fig. 1, Plate VII. These should of course be given the most effective cover possible, the collecting stations particularly demanding overhead cover. The construction employed will be in all respects similar to that used in the trenches.

Notwithstanding the many scientific adjuncts made use of in military operations, it must not be forgotten that war is in reality a very elementary affair, and that ruses will be as effective today, if well planned, as they were in earlier times. For this reason dummy trenches should, whenever practicable, be made use of. They deceive the enemy both as to the location and as to the number of the defenders. These trenches should be made to simulate, as nearly as possible, real trenches in every way, but should be somewhat more conspicuous. They should be located in rear, rather than in advance of the fire line, but at the same time, they should be so placed as not to subject either supports or reserves to chance shots. Much use was made of dummy trenches in the Boer War, and the Japanese, especially, made great and effective use of them in deceiving the Russians. Even a furrow run with a plow will at

long and mid-ranges present the appearance of a trench.

One of the most essential requirements of a fortified position is that easy communication must exist everywhere in rear of the firing line. To this end, roadways as good as practicable must be prepared, over which reserves can be moved very speedily in any desired direction. Streams must be bridged and ravines either bridged or the banks scarped down. Guide posts must be set up for day use, and lanterns for night, to insure troops taking the proper directions. The character of these works is so obvious that nothing more than a reference to them is deemed necessary.

Telephonic communication must be provided throughout in order that all operations may be properly coördinated.

If time suffices, covered stations must be provided for commanding officers. Nothing is so apt to demoralize a force as to be deprived at a critical moment of its directing genius. Any form of covered observation station such as shown in Figs. 19, and 20, Plate VI, Chap. III, will be suitable for the purpose. Very conspicuous hill tops are not so well adapted for stations for commanding officers as points which are less prominent but still afford a satisfactory view. The Commanding General of the Japanese XI Division was severely wounded at Port Arthur while in an observing station located on a conical hilltop.

No discussion of the accessory features in rear of the fire line would be complete without reference to the artillery positions. In many cases the guns can be placed in numerous positions concealed from view and employing indirect fire, and here no artifi-

cial cover is essential. In other cases the artillery will not be so fortunate, and artificial means of protection for both guns and men will be needed. This is especially necessary in so-called "dagger batteries," i.e., concealed guns placed well to the front, ready to open fire at critical moments on a line of advance or a restricted area.

The simplest protection that can be given is to fill in with earth the gap between the ground and the bottom of the shields. If more time is available, protection for the gun crew may be given as shown in Figure 5, Plate VII. In this case no shelter is provided for the gun, ammunition may be stored in the shelter for the men, and the caisson may be placed as shown. Any additional time will be utilized in completing the pit as shown in Figure 6, Plate VII, thereby rendering the gun fairly safe. If it is known from the first that time will be available, the gunpit shown in Figure 7, Plate VII, might well be built, the ammunition being stored as indicated and the limbers hauled back to a place of safety. Adjacent gun pits should be connected by communicating trenches arranged so that a continuous parapet will be presented, thus making it more difficult for the enemy to locate the exact positions of the guns. Overhead cover for the cannoneers is desirable and should be provided if practicable.

The above refers to light artillery guns. The heavy artillery will, as a rule be far enough to the rear not to require any work for its protection. Should exceptional circumstances render artificial constructions necessary, they would follow very closely the gun pits given, the dimensions being varied to suit and especial attention being paid to the protection of the ammunition, it being very

valuable and its destruction by a chance long range shell being possible.

Observation stations for the battery commanders, and the higher commanders of the artillery, must be provided. These should be covered if practicable, and provided with some means of inter-communication.

Dummy gun pits will be especially valuable in drawing the hostile artillery fire, and a simple mound of earth, rapidly thrown up with a log protruding over the crest will serve as such.

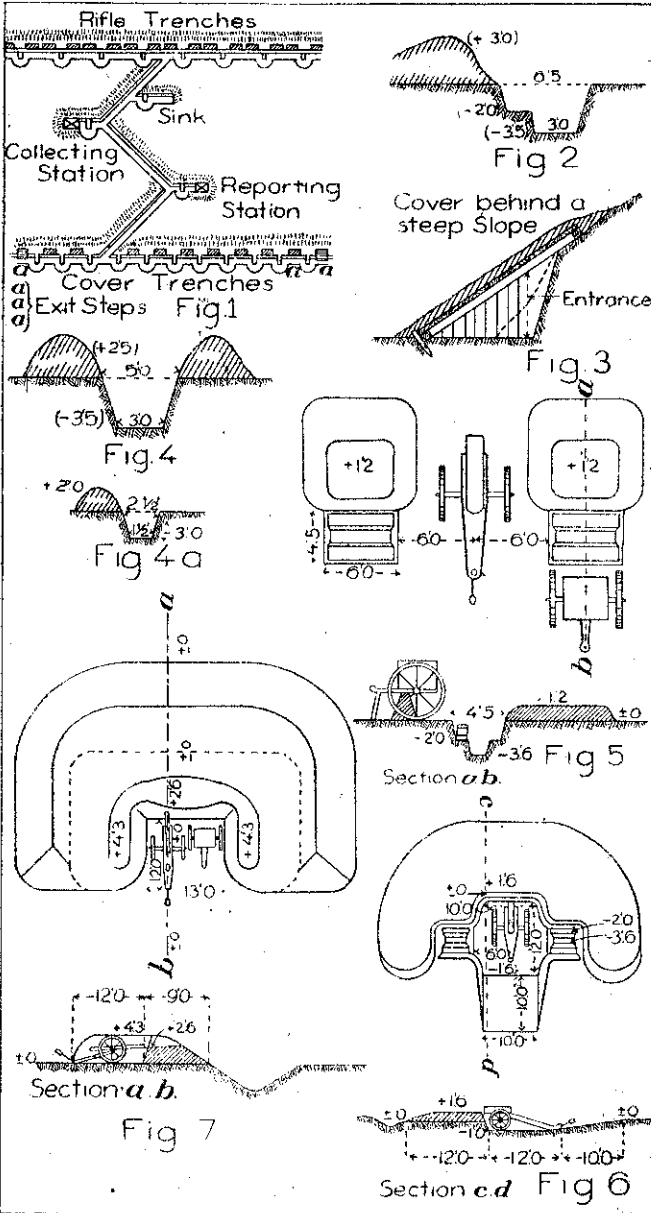

Chapter V

ACCESSORY FEATURES IN FRONT OF THE FIRE TRENCHES.—
CLEARING THE FOREGROUND.—DEMOLITIONS.—AD-
VANCED POSTS.—OBSERVATION STATIONS.—
RANGE MARKERS, ETC.

WE have seen that the most important requirement of a fortified position is a clear field of fire, extending, as nearly as practicable, to the effective range of the small arm. This means that everything in the foreground, not of use to the defense and which may be of use to the enemy, shall, so far as circumstances and resources permit, be destroyed or its character so altered as to remove this possibility of benefit to the enemy. This organization of the field of fire is known as "clearing the foreground," and includes clearing out or cutting down and removing woods, thickets and hedges; destruction of buildings, stone and brick walls; trampling down, or otherwise flattening out growing crops; the razing of earthen mounds, manure and stone piles, and the filling of depressions. The clearing of the foreground of all cover limiting the view and field of fire, coupled with the marking out of ranges, is more important than all other defense arrangements. Only with a clear view and unobstructed field of fire can one's own fire effect be fully developed.

In the felling of timber it must be remembered that it will be necessary to cut up and remove the trees, as if left on the foreground they may furnish excellent cover for the enemy. For this reason, owing to lack of time or facilities, it will often be best to clear a wood out, leaving the large trees

standing. This will especially be the case where the foreground has an uniform slope from the trenches, for with such a field of fire, standing timber, without undergrowth, will neither hinder the defense nor favor the attack.

Frame buildings, hay stacks and other combustible objects may be destroyed by fire, but this method must be used with caution, as the resulting smoke may obscure portions of the terrain and form a screen facilitating the approach of the enemy. Buildings and structures of all kinds may be destroyed by explosives, but care must be exercised in applying this method, since the resulting débris sometimes furnishes better cover for the enemy than would the buildings or structures if left standing.

Standing crops can best be leveled by some species of drag, operated by man or animal power. It is not infrequently the case, however, that standing crops, also hedges and thickets, constitute sufficiently formidable obstacles to render their destruction by the defense inadvisable, and the relative value of the better field of fire and the natural obstacle should be weighed before making decision as to the disposition to be made of such natural features. Crops like corn, sugar cane and kowliang, when in full growth, may be broken down about eighteen inches from the ground, as was done by the Russians in Manchuria. This treatment insures a clear field of fire as well as affording a natural obstacle.

Given a clear field of fire up to and including long range infantry fire, intrenched troops can with their fire alone, unaided by obstacles, stop the most determined attacks, provided the disparity of forces is not too great. Such an ideal field of fire will

rarely be found, and there will usually be portions of the line that, owing to the character of the terrain, the enemy can approach under cover. In this case, the enemy having approached to close quarters without appreciable loss, and his morale being consequently excellent, it is questionable whether even rapid and accurate fire will stop him in the short remaining distance he has to travel. However, the effectiveness of a field of fire is measured by a time interval, not a distance. It is therefore advisable to introduce something that will impede his progress and thus expose him for a longer time to this most effective fire of the defense. In cases such as this, as well as in cases where, because of great inferiority in numbers, a purely passive defense is contemplated, obstacles, if practicable, are an essential component of the defensive organization. Their object, as seen, is to protect works from surprise, to reduce the momentum of an attack by breaking up the enemy's formations, and to hold the enemy under the most effective rifle fire of the defense.

To accomplish these results the obstacles should not be more than about 300 yards from the fire trench, for if placed farther away, the enemy, while destroying them, will still be covered by the fire of his artillery. The obstacle, on the other hand, must not be closer to the fire trench than about seventy-five yards, for if the enemy gets within this distance before he is stopped, his too proximate position has a most disturbing effect upon the accuracy of fire of the defenders, and he would, in addition, be able to hurl hand grenades with considerable effect. Owing to the necessity of guarding obstacles at night, it is advisable to locate them as near the inferior limit as practicable.

If practicable, obstacles should always be concealed, naturally or artificially, since there is thus introduced a most disturbing element of surprise for the enemy, and the damage or destruction of the obstacles by artillery fire is reduced or eliminated.

Obstacles are sometimes used to deny to the enemy a certain line of approach which it will be difficult for the defenders to cover with their fire. In this case, they must be of such construction that they cannot easily be destroyed.

In the usual case of field fortification, the time available will permit nothing more than the marking out of ranges, digging of a trench and some clearing of the foreground; but the value of obstacles must be thoroughly appreciated and they must be made use of whenever possible, if the circumstances are such as to render their use desirable. In detached posts, where a stubborn defense is to be made against a probable all-around attack, a complete circle of obstacles is indispensable.

We will now proceed to a discussion of the usual types of obstacles, it being borne in mind that these are merely types, furnishing definite ideals which will be approached as nearly as time, materials, and other considerations will permit. The fact that a commander cannot construct obstacles of the types shown will scarcely be an acceptable excuse for not making the best possible use of the materials and resources of which he is possessed.

The most effective obstacle is the barbed wire entanglement, of which we have the *high* and *low* types shown in Figures 1 and 2, Plate VIII.

In the high wire entanglement the pickets are about four inches in diameter and about six feet long. They should be sunk in the ground about two

feet, the intervals between pickets and rows being about six feet, and the pickets in successive rows being staggered. The wire is then fastened to the pickets by wrapping or by wire fencing staples, or both, in such a fashion as to connect the top and bottom of each picket with the tops and bottoms of all adjacent pickets, and a few strands are run around irregularly. A regular barbed wire fence, when strongly built, will also serve as a good obstacle. It may be used alone or to reinforce a regular entanglement.

The low wire entanglement is constructed on the same general idea, the pickets being lighter and shorter and the wire connecting only the tops. The low wire entanglement is especially useful when it can be placed in low growing vegetation and thus be entirely concealed naturally. Another, and very excellent form of the low wire entanglement, when concealed by vegetation, is constructed by driving the pickets with their heads flush with the ground surface, and leaving considerable slack in the wire. Wire entanglements found extensive application in the South African and Manchurian wars: When there is an insufficient supply of barbed wire, it should be used for the front and rear horizontal wires, smooth wire being employed for the remainder.

It has been previously mentioned that growing crops, hedges and thickets may serve as obstacles. If interlaced with barbed wire, they become very effective.

Where wire is scarce, or stakes are difficult to obtain, much good can be accomplished by the use of wire nooses, placed in the grass and firmly pegged down. The advancing soldier catches his foot in the

noose, draws it tight around his leg when he endeavors to extricate himself. Considering the dangerous position in which he is placed, his efforts to free himself will take sufficient time to insure his being put out of action. See Fig. 3, Plate VIII.

Wire entanglements to be effective should have a depth of approximately thirty feet. The wires should not be strung very tightly, as this will facilitate cutting. This class of obstacle is practically exempt from damage by artillery fire, and will have very general application on account of the extensive use of barbed wire and the consequent ease of obtaining it.

Other forms of wire entanglements are shown in Figures 4 and 5, Plate VIII.

Special types of wire for obstacles have been developed in Europe during the present war.

An *abatis* is an obstacle presenting the sharpened ends of pronged timber to the enemy. In felling trees they may be dropped towards the direction of hostile approach, left attached to the stump, the foliage and smaller branches cleaned off and the ends of branches sharpened, thus forming a very efficient *abatis*. See Fig. 6, Plate VIII. Several rows of such fellings, the tops of successive rows overlapping the points of attachment of those in front, furnish as good an obstacle as can be desired, especially if interlaced with a few strands of barbed wire.

Abatis may also be constructed as shown in Figs. 7 and 8, Plate VIII^a, small trees or branches being used. Barbed wire will here too add much to the efficiency of the obstacle. *Abatis* can be seriously damaged, or even destroyed, by artillery.

Another form of obstacle is the *shallow and deep*

VIII.

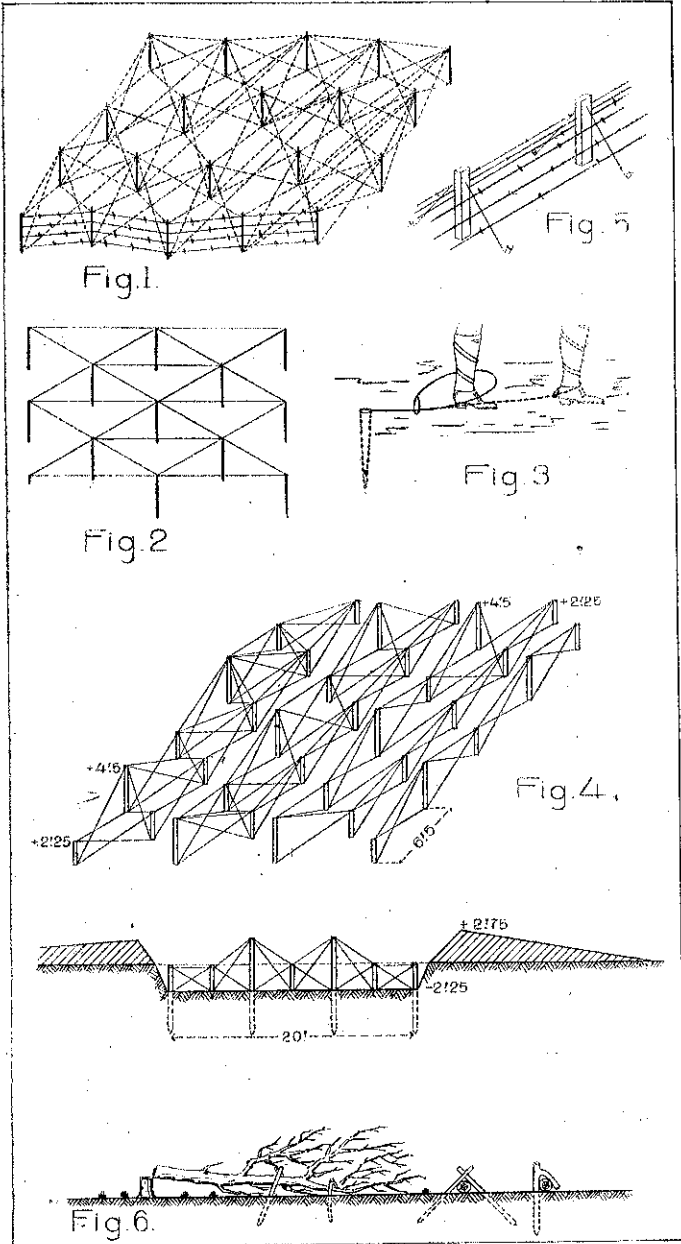

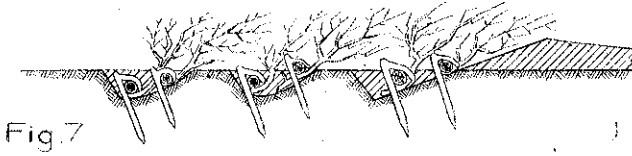

Fig. 7

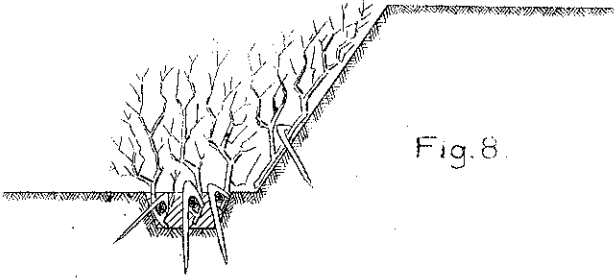

Fig. 8

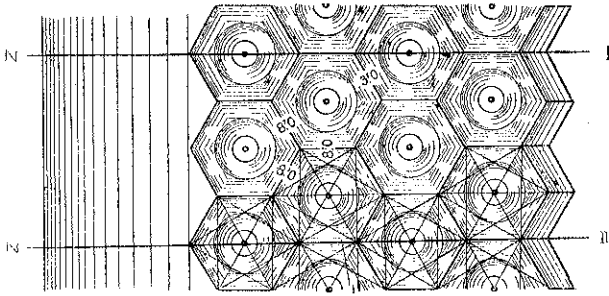
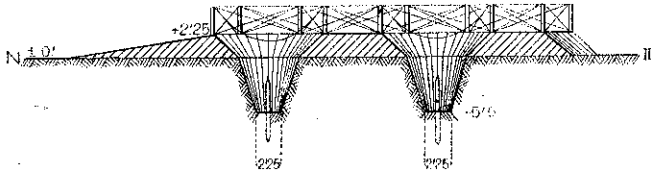
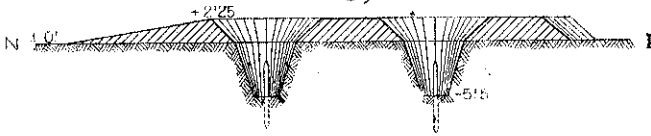

Fig. 9



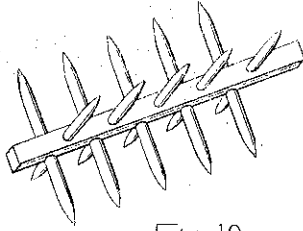

Fig. 10

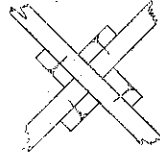

Fig. 11

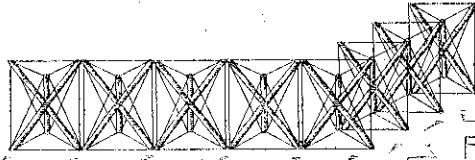

Fig. 12

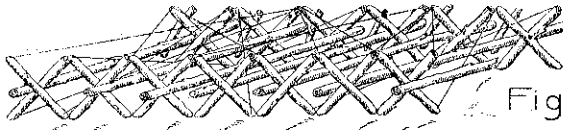

Fig. 13.

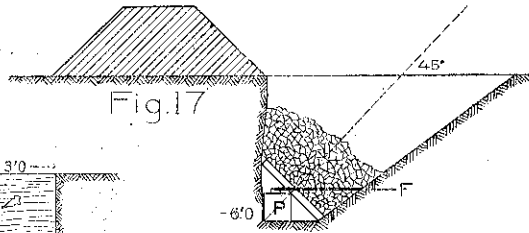

Fig. 17

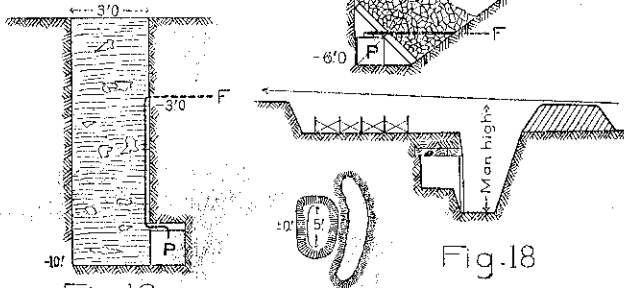

Fig. 16.

Fig. 18

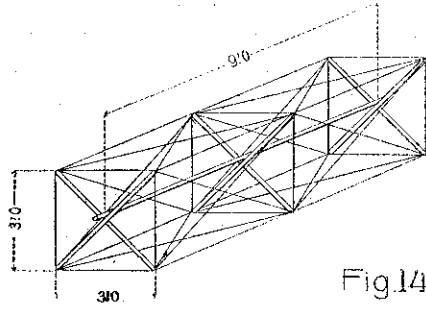

Fig 14

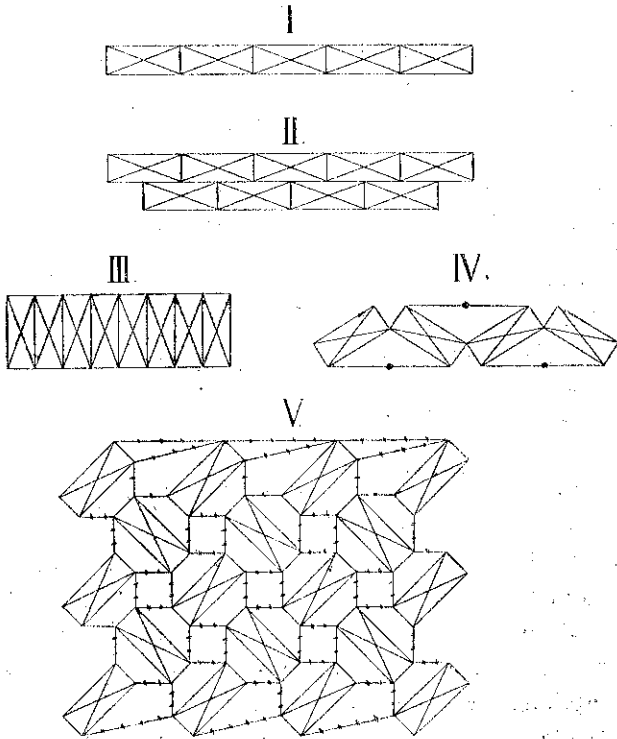

Fig 15

pit. While they have had much use in the past, and the Russians employed them uniformly in their defensive works during the Manchurian War, their value as obstacles is hardly sufficient to repay the expense of construction. A low wire entanglement is frequently constructed, covering the same area as the pits, and a somewhat more effective article is thus created. See Fig. 9, Plate VIII^a. The deep pit has the further disadvantage of furnishing close cover for the enemy if he succeeds in getting into them.

Two forms of *chevaux de frise* are shown in Figures 10 and 11, Plate IX. Any and all parts of them may be of metal or wood. The lances are ordinarily about six feet long. This obstacle is constructed in short lengths, for ease in transportation, the successive short lengths, when in opposition, being wired or chained together. This obstacle possesses the great advantage that it can be made under cover, can be held in reserve, and can at any time be used to rapidly close the hostile avenues of approach.

Figures 12 and 13, Plate IX, show similar obstacles which were used by the Japanese and Russians in their late war. The first consists of tripods formed by binding poles together at their middles with wire, these tripods being then placed abutting and secured together by wire. The Russian form consists of exaggerated saw bucks, similarly abutted and bound together. A form of wire *chevaux de frise* is shown in Figs. 14 and 15, Plate IX^a.

Land mines may be made use of as obstacles, and while they do not effect much actual damage, their moral effect, as was demonstrated in the Russo-Japanese War, is very great. The mines may be controlled, contact, or a combination, depending

upon whether their action is intended to be by judgment firing, automatic, or by either method at the will of the defender.

Figures 16 and 17, Plate IX, show simple land mines and *fougasses*, the latter being designed to throw a shower of stones or fragments in a predetermined direction. For the charges to be used in land mines and *fougasses*, see Engineer Field Manual, 1909, pp. 414-415.

The natural obstacle offered by a running stream may be rendered much more effective by damming the stream and causing an area of overflow. It may also be possible to divert some stream into the foreground and thus produce the same effect. Whether fordable or not, such an inundated area will be a very appreciable obstacle to the attack.

In placing obstacles, it must always be kept in mind that it may at any time be desirable to assume the offensive, and provision must be made enabling the defenders to do so without being impeded by their own constructions.

While *advanced posts* must be used with great caution, their use is at times necessary, for instance, to afford flanking fire over otherwise dead spaces, or to occupy some point which must be forbidden territory for the enemy. They are also valuable, when garrisoned by a few expert riflemen liberally supplied with ammunition, in bringing early upon the enemy so effective a fire that he will be compelled to deploy and disclose his strength and intentions. They must always be intrenched, but should be open to fire from the main line in rear, thus preventing their occupation by the enemy, and means must be provided for the safe withdrawal of the garrison to the rear. The construction of these advanced posts

differs in no way from the construction of ordinary intrenchments, except that they are usually of simpler construction, and, as mentioned, must be open to fire from the rear.

It may be desirable to have a few advanced *observation stations*, to give early information of the enemy's movements. These should be constructed as already set forth in Chapter III, and should have telephonic connection with the main position.

Illumination of the foreground has already been discussed in Chapter III. Where this is not practicable, men must be placed in observation to the front at night. These men are given as much shelter as practicable, but nothing must in any way interfere with their seeing and hearing in every direction. They must also be protected from the fire of their own side as it will be impracticable for them to fall back after giving the alarm. A form of cover for an advanced night sentry is shown in Fig. 18, Plate IX.

One of the great advantages of the defense is that the engagement takes place on ground which is more or less of his own choosing, and about the features of which he will have much better information than the enemy. Of especial value will be a determination of ranges, enabling him to bring an effective fire upon the advance as soon as perceived. This determination of ranges is second in importance to nothing else, and should be undertaken at once. There will usually be natural, or existing artificial features, which will serve sufficiently to identify ranges, but, lacking these, marks must be established which will convey the desired information to the defender without attracting the attention of the attack. Such marks may be whitewashed piles of

stone or stakes with markers attached. Every commander of a sector of the firing line, must take steps to insure the possession of sufficient information concerning ranges to enable his command to bring accurate fire on every portion of the foreground within effective rifle range.

In all hasty defensive organizations the time and means available will limit the amount of work that can be put on accessory features. Extensive clearing of the foreground involves much labor, as does also the construction of artificial obstacles. By care and judgment in locating the fire lines and by the utilization of natural obstacles, much can be accomplished towards securing a clear field of fire and impeding the enemy's advance without the expenditure of an excessive amount of labor, from which it is desirable to spare fighting troops as much as possible.

Chapter VI

EXECUTION OF FIELD FORTIFICATIONS BY TROOPS.—TOOL EQUIPMENT, TASKS, RELIEFS, ETC.

THE practical execution of field fortifications depends upon the tool equipment of the troops, their training, and upon the time available for work.

It is now the recognized practice to equip all troops with tools and appliances for the execution of different classes of works required in field and fortress warfare, in movements and in encampments, and the proper use of these tools and appliances should form part of their peace instruction.

The ability to prepare cover quickly and under all emergencies is now regarded as so important that work tools should form a part of the portable equipment of the troops, from which the soldier should never be separated and which is second in importance only to the rifle and ammunition.

In order to reduce weight and to admit of greater convenience in carrying, the portable tool equipment is considerably lighter and smaller than the corresponding commercial tools, which necessarily reduces the output of work. In addition to the portable tools, additional tools of larger size and of special patterns are carried in the combat and field trains for use in the more comprehensive organizations of the terrain.

As a result of the experiences of the South African and Manchurian campaigns, several nations, notably France, Russia and Japan, have materially increased the tool equipment of their infantry.

In 1914, the portable tool equipments of the leading military nations was as follows:

France, 1 tool per man.	Germany, 1 tool to 2 men.
Russia, 1 tool per man.	England, 1 tool to 2 men.
Japan, 1 tool per man.	Italy, 1 tool to 2 men.
Austria-Hungary, nearly one tool per man.	

The portable tool equipment of the United States Infantry is fixed by General Orders No. 42, War Department, 1913, as follows:

For each squad—1 pick mattock, with carrier.
1 wire cutter, with carrier.
3 shovels, with carriers.
1 cutting tool, with carrier.
Weight of shovel, 2 lbs.
" " carriers $\frac{3}{4}$ lb.

While it is not so specifically stated, it is understood that the cutting tools are to be one half hatchets and one half machetes.

The following is the recommendation of the Cavalry Equipment Board for the portable tool equipment of the United States Cavalry, which has not yet received the approval of the War Department:

"Each man carries a combination picket-pin and handle for intrenching tool, weight 1 lb. 9 oz., case 4 oz.; a pick head weight 9 oz.; an axe head, weight 1 lb. 4 oz.; a spade, weight 1 lb. 1 oz., and case (including case for pick head and axe head), weight 1 lb. The picket-pin serves as a handle for all three tools."

The proportion of cutting to intrenching tools varies between wide limits in the different armies, being 5 per cent in the German, 15 per cent in the French, and 50 per cent in the United States. The proportion of cutting to digging tools is influenced by the character of the country in which it is likely that war may be waged. European armies, operating in thickly settled and cleared terrain will have

less use for cutting tools than armies operating in tropical or sub-tropical countries with their dense forest and vegetable growths. Types of portable intrenching tools in use by different armies are shown in Figs. 1 to 6, Plate X.

In addition to the portable tools carried on the person of a soldier a further provision of park tools is made in the combat and field trains of the several infantry units.

This regimental equipment is carried on one field wagon furnished for the purpose. The tool wagons of a division will be consolidated into a park, under the charge of the chief engineer of the division.

The allowances of park tools for infantry and cavalry units and their method of transportation are given in War Department orders, Tables of Organization, and Unit Accountability Equipment manuals.

No special intrenching tools, either portable or park, are provided for the field artillery.

In the execution of field fortifications the available time, the training of the troops, and tool equipment are governing factors. In hasty works the portable tools of the infantry will usually be the main reliance of the troops, but may be supplemented by the large tools of the trains and tools requisitioned locally (from villages and farms close at hand).

In the construction of rifle trenches the company forms the normal working unit. The company commander, assisted by the platoon and squad leaders, marks out the line of trench, determines the height of the parapet and the location of the traverses. The location of the line of excavation is most

conveniently marked on the ground by the squad leaders laying their packs on the ground or by sticking their bayonets into it. The men provided with intrenching shovels are then deployed on the line and, after being properly posted, each man forces his intrenching tool into the ground close to his feet, thus marking the left (or right) limit of his task. The men then step back several paces, unsling and lay down their packs, pick up their rifles and a couple of cartridge clips and deploy anew on the line marked out. Each man lays down his rifle on the ground behind him and then commences work. If an attack is likely during the progress of the work, the first efforts should be directed towards securing a parapet of sufficient height to afford cover for the head and a support for the rifle in the lying down position, after which the trench is gradually deepened to the final requirements of a standing trench, the work being so regulated that the trench may at all stages be usable for defense. Men may be posted 5 feet apart by taking intervals with both arms extended and hands closed and 3 feet apart by taking intervals with one arm extended, hand closed. Dimensions of rifle trenches may be laid off with the intrenching tools, which are 22 inches long.

If actually under fire and unable to work in a standing position a rifle trench may still be constructed by the men working in pairs, one using his intrenching tool to excavate a shallow trench on his right side and heaping up the earth so obtained to gain cover for his head and a rest for his rifle while his comrade keeps on firing. Duties are exchanged from time to time by passing the intrenching tool back and forth, one man digging and the other firing until gradually a standing trench is secured. The

method of executing a trench under fire is shown in Fig. 7, Plate X.

If the ground be too hard to admit of the easy insertion of the intrenching shovel it will be advantageous to first loosen the earth with the pick. There being but one pick per squad, it will either have to be used in turn by each of the three shovelers or else one man may be detailed to do all the picking for the three shovelers, working from one end of their combined tasks to the other, each shoveler in turn stepping from the trench and resting while the man with the pick is employed in the limits of the shoveler's task.

Squad leaders supervise their squads, seeing that the work progresses as quickly as possible, that the desired dimensions are attained and that the trench is made as inconspicuous as possible. Platoon commanders see that the work of their squads proceeds uniformly, apportion assistance to any squads experiencing delay, see that squad leaders are familiar with the ranges determined to recognizable points of the foreground, cause observation of the foreground to be maintained if the enemy is close at hand and arrange for the occupation of the trenches when finished.

The company commander is responsible for the correct location of the trench or trenches and sees that important ranges are determined for the information of his company and arranges for the occupation of the trenches when completed.

The foregoing is the general method followed when intrenching must be carried out in the immediate presence of the enemy or under his fire.

When more time is available the portable tools will be replaced or supplemented by the tools of the

trains or requisitioned in the vicinity and more care can be taken in siteing the trenches and accurately posting the workmen.

The rate of progress depends upon the interval between workmen as well as on the character of the tools employed. The portable intrenching shovel is incapable of the same output of work as the larger tools of the train or regular commercial models, but its shorter handle permits of men working at smaller intervals than do the larger tools. For convenient working with the larger tools an interval of five feet between workmen is about as small as can be used, while with the portable tools men can work at interval of three feet (even two and one half feet being stipulated in the regulations of foreign armies). Roughly speaking, it may be assumed that the time necessary to complete a trench with the portable tools with the men at three foot intervals is about the same as with the larger tools with men at five foot intervals.

Since only a portion of the company is equipped with intrenching shovels, all the men cannot be put to work digging simultaneously. In the French service there are 160 intrenching shovels per company and with three feet intervals 486 feet of trench can be dug at once. This is sufficient for the entire company, allowing two feet of trench per rifleman, which experience has shown to be about the minimum for the most convenient use of the rifle, although tests carried out by the Maneuver Division at San Antonio, Texas, in 1911, show that men can be placed as close as eighteen inches apart and still fire satisfactorily.

The portable tool equipment of the United States service furnishes but three intrenching shov-

els and one intrenching pick to a squad of eight men. The length of trench to accommodate a squad should be about sixteen feet, which will necessitate intervals of five feet if each squad is to dig its own length of trench. So great an interval for the portable tool will entail a material increase of time in construction, which is permissible if the time can be spared. Otherwise two squads must combine to dig one squad length of trench. By doubling up squads a length of trench for half the company can be very quickly constructed. Whether the diggers shall be posted at the larger or smaller intervals and more or less length of trench in greater or less time be undertaken, must be determined by the requirements of the situation.

The progress of the work is also affected in no small degree by the question of tasks. With long continued exertion the output of work falls off rapidly. If, therefore, the workmen be relieved at frequent intervals better progress will be attained. For hasty works executed by troops under great pressure, perhaps also exhausted by marching and fighting, the tasks should be no greater than can be accomplished in two hours' time. This will conduce to a more rapid progress of the work and will conserve the marching and fighting powers of the troops. If double gangs be employed on each task, the gangs alternating every thirty minutes and working as rapidly as possible, a still faster progress will be attained without exhausting the men. This was the method employed by the Japanese in Manchuria, each gang relieving the other on a whistle signal.

Since but three men per squad will be equipped with intrenching shovels in our service, double gangs can readily be formed in each squad and the

work thus expedited. Other means sometimes available for expediting the hasty preparation of cover are afforded by the following:

(a) The use of the plow to run a few furrows and loosen the earth to a depth of six or eight inches. Plows may be occasionally found convenient to hand at nearby farms, to which, if other teams are not procurable, the teams of the combat train may be harnessed. In more deliberate works extensive employment of farm and road making machinery may be made with advantage. By suitably modifying the draft rigging a plow can be used to loosen the earth the full depth and width of rifle trenches.

(b) By incorporating into the parapet any available loose material such as fence rails, small logs, stones, etc. Such material can be gathered up and placed by the men not actually employed in digging.

If it is necessary to give the parapet considerable command, say anything over one and one half feet, it will be desirable torevet the interior slope of the excavated material. In hasty trenches this will ordinarily be limited to using the larger lumps and clods of earth and piling them up as steeply as they will stand. Provided the materials are available, a form of hurdle revetment may be made quite quickly by driving stakes at intervals of three or four feet and placing in front of them brush, branches, cornstalk, etc.

In the interest of concealment it is desirable to save the sod taken from the excavated area for covering the parapet. In hasty work this will not always be practicable and material for covering the parapet will then have to be procured by men not employed in digging. A convenient way of saving the

sod is to cut the turf into strips about one foot wide the full width of the parapet and then roll it up to the front. When the parapet is completed the sod is simply rolled back on the parapet.

In the organization of a supporting point formed of a group of trenches, only a portion of the tactical unit assigned to the defense of the supporting point will be employed in executing rifle trenches. The men not assigned to work on the fire trenches will be employed in clearing the foreground, constructing cover and communicating trenches for supports and reserves and in gathering material for head and overhead cover in case the latter is to be provided.

The time required for the execution of the different classes of work involved in hasty field fortifications depends upon the tools used. Experience has shown that the average output per hour for men working with large tools with two-hour reliefs is about twenty cubic feet for medium soils such as can be excavated without a pick, while the output per hour of the portable tool with two-hour reliefs is about twelve cubic feet. If the workmen be spaced at intervals of five feet the time required for constructing any type of trench, with reliefs not longer than two hours, in medium soil, will be the quotient of the number of square feet in the cross section of the trench divided by four. To execute the same work with the portable tools in the same time the men must be posted at intervals of three feet, or else a longer time will be required. The excavated area of the simple standing trench is 7.4 square feet, hence it can be constructed in ordinary soils in something less than two hours' time, provided men are posted at five-foot intervals when

working with large tools and at three-foot intervals when working with portable tools.

The character of the soil greatly influences the time required for constructing earth covers. In stony or rocky soil, the time will be very much increased and with portable tools may even be impracticable. For more massive profiles, such as occur in more deliberate organizations, the portable tools are of little use, their short handles making it impossible to throw excavated material any distance. Similarly the portable cutting tools of the infantry are suited only to light work. Any heavy work, such as cutting down of large trees, demolition of structures, etc., must be accomplished with the large tools of the combat trains or left to the engineers.

The most important fact for the line officers to remember is that a simple standing rifle trench of $1\frac{1}{2}$ linear feet per man can be constructed in two hours or less with the portable digging tools of the infantry and that two hours' additional work with the same tools will convert this into the complete standing trench shown in Fig. 5, Plate I.

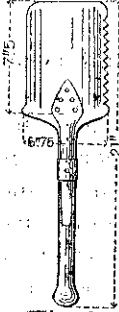

Fig. 1
French
Intrenching
Shovel.

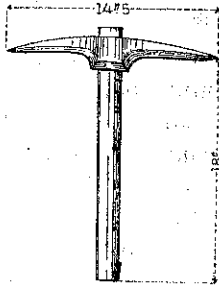

Fig. 2
French
Intrenching
Pick

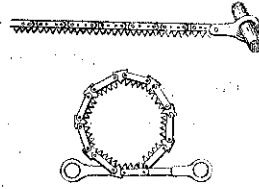

Fig 3
French Jointed Saw

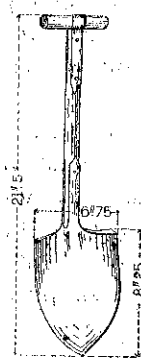

Fig. 4
U.S. Intrenching
Shovel

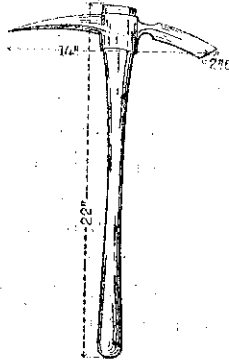

Fig. 5
U.S. Intrenching
Pick

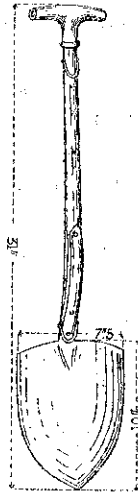
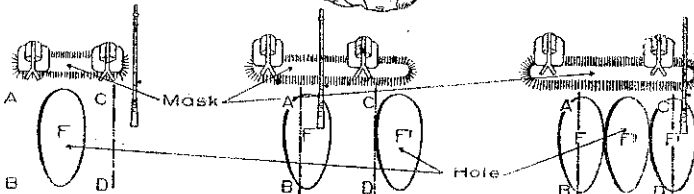

Fig. 6
U.S. Pioneer
Pack Shovel



Execution of a trench by two men in prone position.

The following table gives the approximate time required for the execution of the more usual classes of work which may fall to the infantry in campaign :

Works	Personnel	Tools	Time
Simple standing rifle trench—	1 man per yd.	Portable	2 hours.
Simple overhead covers	1 man per yd.	Park model	2 hours plus time for gathering & bringing up material.
Cutting down trees	6 in. diameter : 2 men.	2 axes or 1 jointed saw	3 minutes.
	12 in. diameter : 2 men.	1 2-man saw 2 axes	1 minute. 15 minutes.
	18 in. diameter : 2 men.	1 jointed saw 1 cross-cut saw 2 axes	10 minutes. 5 minutes. 30 minutes.
Clearing brush	20 men : 300 sq. yards	1 cross-cut saw 5 axes	12 minutes. 1 hr. or 30 sq. yds. per tool.
Abatis	6 men per 6 running yds. 3 rows trees deep	1 axe, 1 saw 1 bill hook	2 hours.
Wire entanglement	Preparing stakes : 3 men	2 axes, 1 saw	3 min. per stake.
	Placing wire : 6 men for 15 to 18 sq. yds.	1 maul, 3 cutt'g pliers, 2 hammers, staples	1 hour.

In prepared positions for which considerable time would be available, the works would be planned with care both as to trace and profile and laid out accurately by the engineers. The construction of such positions may often be effected wholly or partly by civilian labor and by the use of excavating machinery. Troops will, however, be frequently called upon to assist in construction, and, in such a case, their work would be supervised by overseers furnished from the engineers, whose functions will be limited to seeing that the workmen adhere to established lines and grades of the works. Officers commanding the troops employed as fatigue parties will alone be responsible for the conduct and efficient working of their men.

Chapter VII

UTILIZATION OF ACCIDENTAL FEATURES OF THE TERRAIN.
PRINCIPLES OF THE ORGANIZATION OF VILLAGES.
HOUSES, WOODS, ETC.

THE highest expression of the art of field fortifications consists in the utilization of the *natural* strength of the terrain in the most advantageous manner with the minimum means, including the avoidance of its disadvantages.

All natural screens, covers, obstacles and communications have a distinct advantage over artificial creations, not only in the relatively smaller amount of work required, but also in the fact that troops will, as a rule, advance from them more readily than they will from purely artificial works.

Existing features of the terrain may be utilized either as screens only, as covers, or as both. Some, like road and railroad embankments and cuts, afford better cover than any artificial construction practicable within the time and with the means available in the field.

Among the more ordinary features of the terrain which may be utilized as fortification may be mentioned walls, hedges and fences, buildings, villages, woods, road embankments and cuts, ravine and stream banks, quarries, etc. All these features are rarely represented on the ordinary small scale maps used in directing military operations, hence the question of their utilization requires a certain eye for terrain, skill and experience in utilization of its features for tactical purposes and the ability to

weigh the value of these features for use as screens and covers.

The utilization of existing features of the terrain for fire lines requires in general the preparation of a firing platform to permit the soldier to fire standing, with a good view of the foreground and a convenient rest for his rifle, with good communications along and in rear of the fire line.

Individual trees or bushes usually afford insufficient cover against the penetration of rifles and machine guns and must be strengthened by an earth cover. Dikes, roads, embankments and like features constitute excellent fire lines. If narrow, the fire line should be organized on the slope away from the enemy as shown in Fig. 1, Plate XI. If wide, it is better to construct a firing trench along the edge nearest the enemy, connected with the rear slope by communicating trenches shown in Fig. 4, Plate XI. If a railroad track occupies the top of the embankment the rails will make a good firing crest. The railroad embankment skirting the Shoushanpu ridge in the Russian defenses at Liaoyang formed part of the Russian fire lines and was strongly held. The same embankment was also used as cover by the Japanese in their attack against Shoushanpu.

Sunken roads, dry water courses, quarry walls and like features are organized according to their nature by arranging the slopes on the side toward the enemy to afford a firing position for the riflemen and access thereto. Scarping of banks, excavating steps, providing ramps and like work is called for.

Figs. 2 and 3, Plate XI, show methods of organizing a ravine bank and road ditch.

In case the feature constitutes a good obstacle, for instance, a wet ditch with muddy bottom, it will

be better to construct a rifle trench some distance to the rear. Long, straight and dry ditches with steep banks may also be arranged to be flanked by constructing short parapets across them at salient and reëntrant angles. Examples of the use of such features are afforded by the sunken road at Fredericksburg, the gravel pits at Gravelotte and numerous instances of dry water courses in the Manchurian campaign.

All classes of property enclosures may be made to serve as screens and covers as well as obstacles. Hedges make excellent screens and if of thorny growth, such as osage orange, a good obstacle, especially if interwoven with a few strands of barbed wire. For use as cover they require the addition of an earthen parapet on the side away from the enemy as shown in Fig. 5, Plate XI. Openings for firing through the hedge should not be spaced too regularly or made too clear cut as otherwise they would reveal the location of the fire line.

Board, picket, barbed wire and iron fences may be used as obstacles by moving them in sections bodily to suitable location, or else their material may be employed in providing accessory features in or in rear of the fire trenches. Close board fences also serve as masks and may be used as revetment for fire trenches by throwing up an earth parapet in their front.

Stone and brick walls afford good cover if sufficiently thick (15 to 18 inches for rifle bullets against brick walls). The provision for firing platform is regulated by the height of the wall, several forms of installation being shown in Figs. 6 to 9, Plate XI. High walls may be arranged for 2 tiers of fire. Stone wall have the disadvantage of giving a dangerous

splinter effect, to diminish which it is well to cover their tops with sod or sand bags. Stone walls are also comparatively easily breached by light field guns at medium and short ranges. When the wall is not too high an earthen parapet in its front as shown in Fig. 10, Plate XI, will afford reasonable protection against artillery fire.

Individual buildings have ordinarily only a limited value for defense. Unless of very solid construction their walls can be pierced by rifle bullets at mid and short ranges and demolished by artillery. Notwithstanding their disadvantages history affords numerous examples of stubborn defense from strongly constructed masonry buildings. Unless dangerously exposed to artillery fire, strongly constructed buildings like factories, public institutions, churches, etc., can be readily organized for a strong defense by a few men. The principal works to be carried out are the closing and barricading of all openings on the ground floor, including cellar openings, arranging windows and doors for delivery of fire, proper arrangements for flanking fire and guarding against conflagrations by removal of all readily combustible material and keeping a supply of water on hand.

Village and woods constitute the larger features of the terrain which frequently find application as a means of defense. Notwithstanding the increased fire effect of artillery due to the introduction of rapid fire guns and howitzers with improved ammunition, villages and woods still continue to serve as strong supporting points in extended lines of defense and have shown themselves capable of stubborn defense in the most recent wars. "All the explosive shell of an entire army corps will not suffice to demolish a village" says General Langlois and this contention is

supported by the experience of the recent campaign in Manchuria in which the adobe and brick villages of the Chinese were the scenes of many severe combats.

The importance of villages and woods depends essentially upon their location with respect to the battle lines, their nature as to size and character of construction or growth and the method of their organization. When favorably located they possess the advantage of threatening the enemy's line of advance, flanking our own defense lines and when suitably organized form supporting points in the whole defensive organization. Their disadvantages consist in the difficulty of directing their defense and the restriction of maneuvers for reinforcing fire lines or making counter attacks.

The outer edges of both woods and villages are easily distinguishable from a distance and afford good targets for artillery, hence the fire line should not, in the interests of better protection, be coincident with the edges.

In the organization of villages for stubborn defense their perimeters are sub-divided into tactical sections (companies, battalions) care being taken not to use main entrance roads as section boundaries. From $\frac{2}{3}$ to $\frac{3}{4}$ of the entire garrison is assigned to the section defenses, the remainder forming the general reserve for use in counter attacking the enemy in flank or for covering withdrawal. Each section keeps out a section reserve and organizes its front line into a firing line and supports. The strength of sector garrisons, including supports and local reserves, may be calculated at $1\frac{1}{2}$ men per yard of perimeter.

The front line of defense of a village is now or-

dinarily placed 50 to 100 yards to the front of the nearest buildings, using simple rifle trenches or utilizing any suitably located property enclosures organized as already indicated. Where the village is not exposed to artillery fire, for instance when located in a deep and narrow valley, the outer walls of the front building may be selected for the outer defense lines and these buildings prepared for defense. The main entrances of the village should be barricaded strongly and the main approaches held under heavy rifle and machine gun fire.

Cover for supports and reserves can ordinarily be found behind the walls of inner buildings. For the supports, which must be near the fire line, cover trenches may be required.

The interior communications are exceedingly important in the defense of a village. Since the main streets will ordinarily be fire swept and barricaded, other means must be provided for securing freedom of movement for supports and reserves. Openings must be made in inclosures and house walls to afford short and direct routes to the various points of the front, and these routes must be numerous and marked by sign boards.

As in all other cases, the front fire line must be located so as to command the foreground. Detached buildings in front of the main fire line are generally left standing if they do not limit unduly the field of fire.

Interior defensive lines may be organized, providing the village offers any good dividing line generally parallel to the front. A wide street or stream through the village may be employed for this purpose. In any event, it is well, always, to organize defensively one or more strong buildings in the in-

terior or towards the rear of the village, to serve as a place of final defense after the front line shall have been pierced. The retention of such a group of buildings as a keep greatly facilitates the recapture of the village by the outer reserves.

The general principles governing the organization of woods are much the same as the case of villages. The front line of defense may be placed some distance in advance of the outer edge or, if the woods be open, a short distance within. The latter location is especially favorable to concealment, but, owing to the roots of trees, digging is more difficult. If the woods be extensive, troops may be economized by providing abatis along portions of the edge and flanking these from fire trenches located at salient angles. Openings should be left between the abatis and fire trenches to permit of an advance.

Interior defense lines may occasionally be practicable in woods along the banks of a stream or on the edges of a clearing. Owing to the absence of buildings, keeps rarely enter into the defensive organization of woods.

The most important measure in organizing woods for defense is the preparation of interior communications. The organization of these should actually precede the construction of the lines, for without the former the latter will be of little value. Roads or paths parallel and perpendicular to the front in sufficient numbers to permit ready movement of supports and reserves must be constructed and will call for much labor if there be heavy undergrowth. If time permits the rear edge of a wood may be obstructed by slashings to delay the enemy breaking through and give them time for counter measures.

While woods and villages may be readily organized for a stubborn defense *per se*, their tactical value depends upon their location with respect to the remaining elements of the defensive line as well as upon the adjacent topography. Their value is sometimes reduced to that of mere screens for the shelter of sector or general reserves. Sometimes their location is such that, while not vital to the defense, they may be made to serve as attractions for the enemy and thus relieve the pressure against the real key points of a position.

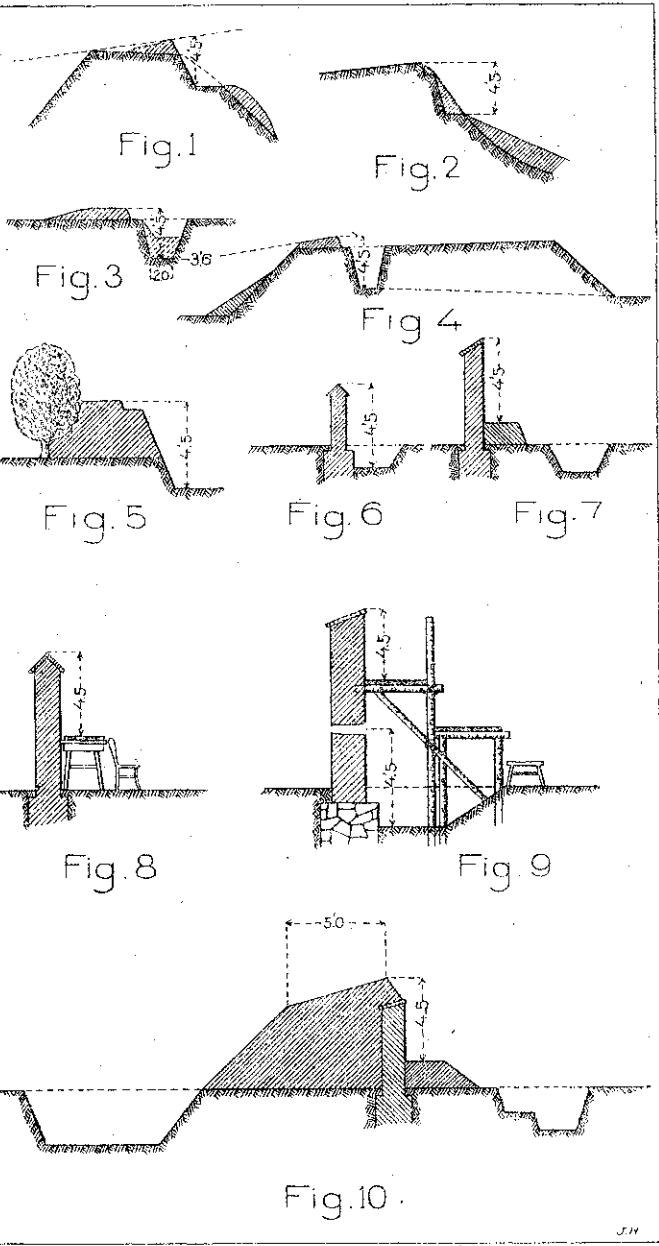

Chapter VIII

APPLICATION OF FIELD FORTIFICATIONS TO THE DEFENSE OF THE LINES OF COMMUNICATIONS.—BRIDGE HEADS.— BARRIER WORKS.

Defense of Lines of Communications

THE uninterrupted service of the lines of communications is of vital importance to the existence of an army in the field and their protection consequently a matter of deep concern to the commander-in-chief. The front of operations will, therefore, usually be such as to cover the lines of communications in the best possible manner, that is, normal or nearly so to these lines.

But when the lines of communication are long it will be impossible for the army to protect them by its own front and it becomes necessary to assign special troops for this duty. It will be manifestly impossible to protect adequately every foot of a long line without detaching an undue proportion of troops, nor is this necessary. Attacks on the lines of communications will ordinarily be made by raiding parties only, whose security will depend upon their mobility. If all vital points of the lines of communications, such as important bridges, viaducts, tunnels, locks, fuel and water supplies, etc., be guarded, the damages which a raiding party can bring about at other points will be relatively insignificant. The destruction of a mile of track (burning of cross-ties, bending or removal of rails, etc.) will engage the efforts of a fair-sized force for quite a time and yet such damage can be repaired within 24 hours, whereas a single man with a few pounds of high

explosives can, in a few minutes damage a bridge or tunnel so as to cripple the lines of communications for weeks or months.

A due regard for economy of forces therefore indicates that only vital points of the line of communications require guarding and that field fortifications can be usefully employed for this purpose.

The service of the lines of communication, including their protection, devolves upon the commander of the lines of communication and he is responsible for their defense against hostile enterprises. The troops detached for this purpose are under his orders and may comprise all arms of the service.

The considerations involved in the application of field fortifications to the protection of vital points on lines of communication are somewhat different from those applicable to fortified lines. Since the attack may come from any or all directions, it is evident that there must be an all round defense. Furthermore, since no prolonged systematic attack by artillery is to be feared, the importance of concealment for the defensive works is less, permitting the use of stronger profiles. Since the defense will be purely passive, closed works with ample obstacles will be in order.

As in all other defensive organizations, the works designed for a defense of a point on the lines of communication must be sited so as to give the greatest effect to the weapons of the defenders, mainly the rifle and machine gun. The topography will therefore dictate the location of the works and this may necessitate placing them on commanding ground at some little distance from the object to be defended. To insure the immediate protection of structures like tunnels, bridges, viaducts, etc., additional works will sometimes be needed to prevent access to the structures by individuals or small parties.

Since only a passive defense with minimum numbers is contemplated, the character of the works will be such as to permit of an all round defense. They will therefore consist of small redoubts, blockhouses, or even groups of trenches surrounded by a continuous line of obstacle. For the protection of an important bridge the defensive arrangements might consist of several closed defensive points on each bank, occupying commanding ground and a good all round field of fire with the addition of a trench or blockhouse at each end of the bridge. To prevent access to the bridge piers and abutments by boats, the piers and abutments should be held under fire from the works. A type form of defensive arrangements for the protection of a bridge by two companies of infantry is shown in Fig. 1, Plate XII. The defensive arrangements for tunnels would be made in a similar manner, consisting of several closed defensive points on heights adjacent to the portals with a blockhouse or field redoubt at each portal.

Blockhouses are small bullet-proof buildings roofed in to protect their garrisons from the weather. They may be constructed of timber, plate iron, rails, corrugated iron or combinations of materials. Timber alone will no longer stop bullets unless of extraordinary thickness and must be reinforced by earth and metal. A simple form of timber blockhouse with galvanized iron roof is shown in Fig. 2, Plate XII^a.

Another form used by the British in South Africa is shown in Fig. 3, Plate XII^a. This latter was constructed of corrugated iron drums made bullet-proof by stone and gravel packing as shown in the figure. When surrounded by a continuous obstacle and with entrances secured, blockhouses of

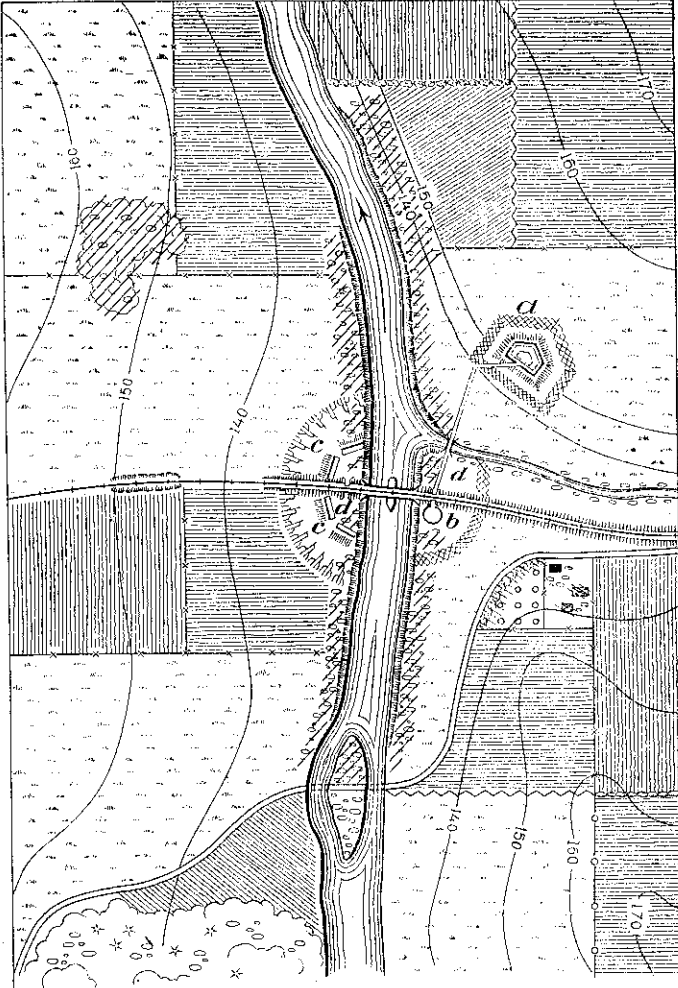

Fig 1

Scale 200 yds = in.

- a** Closed Field Work for $\frac{3}{4}$ Co
- b** Block House for $\frac{1}{4}$ Co
- c** Trench for 1 Co.
- d** Communicating Trench.

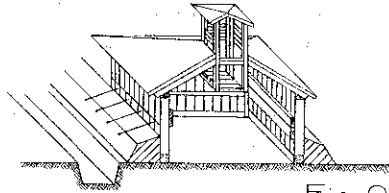
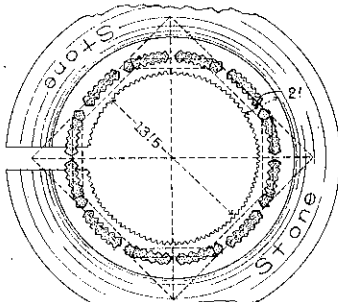
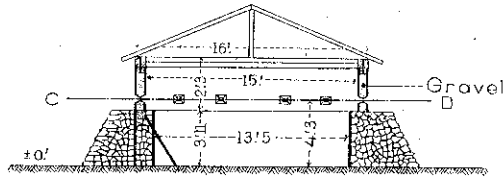

Fig 2



Section C-D

Fig 3

Block House
used by British in
South Africa

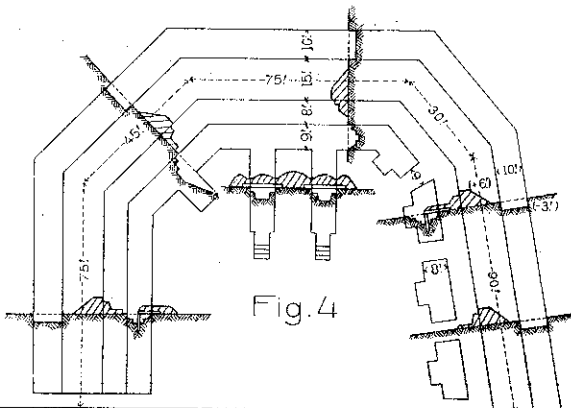

Fig 4

the type described enable their small garrisons, 12 to 20 men, to offer a stubborn resistance. They can be destroyed only by artillery with which only large raiding parties would be supplied.

When field redoubts are employed on the defense of the lines of communication they will be of small size (for garrisons of one half to one company) and may be simple ring trenches or have a somewhat stronger profile as shown in Fig. 4, Plate XII^a.

The defense of a line of communications involves not only the security of points vital to the line as discussed above, but also a service of information, which, in connection with mobile troops, will enable reinforcements to be hurried to threatened points. The wireless telegraph is especially valuable as a means of reporting the near presence of hostile raiding parties and is not subject to interruption like the ordinary telegraph or telephone lines. Whenever the latter are used, any interruption of the service must be taken as an indication of the presence of the enemy. Mobile columns held in readiness at convenient points along the line must be set in motion as soon as the enemy makes his appearance and endeavor to defeat his attempts at injuring the line. On railroads such mobile columns may be moved rapidly along the line on special armored trains, carrying machine guns and artillery. The country on either side of the line should also be observed and patrolled to some distance by sentinels and cavalry in order to give timely warning of the enemy's approach. A system of visual signals (heliograph or flags for daytime, rockets or signal fires for nighttime) should be established as a means of communication between sentinels and the garrisons of the defenses.

Bridge Heads

Bridges on the lines of communication over wide and deep streams are of such vital importance as to call for special treatment. Not only must the bridge structures themselves be protected from all possible damage but provision must also be made to cover the deployment of the army in an advance and its withdrawal in case of a retrograde movement. Field works constructed to meet the foregoing requirements are called bridge heads and consist of a line of works enclosing the bridge on the side of the enemy and located at such a distance therefrom as to protect the bridge structures from hostile artillery and to enclose sufficient ground to insure some manœuvring power to the army.

The principles governing the organization of a bridge head are the same as those governing the organization of defensive lines, except that the flanks of the bridge head, by resting on the stream above and below the crossing, are secure, whereas in defensive lines the flanks are frequently in air. Bridge heads, being intended for passive defense only, will consist of works more strongly organized with a view to economy of forces, and the supporting points may be closed works.

Stream crossings are in effect nothing but short defiles and a bridge head, therefore, is a form of the defense of a defile at its exit, that is, on the side of the enemy. If attacks are likely to be made on the stream crossing from the side of the stream away from the enemy, that is, on the entrance to the defile, a line of works should be constructed on this side also. When a stream crossing is thus defended on both sides the works constitute a double bridge head.

For large armies a single bridge would not afford sufficient means for crossing a stream and several bridges would be required, part of which would be military bridges specially built for the purpose. The several bridges, if not too far apart, would all be enclosed by the same bridge head, as was the case of the Russian bridge head at Liaoyang, which formed the arc of a circle of some $2\frac{1}{2}$ miles radius and covered 7 bridges, including the railroad bridge.

Barrier Works

Barrier works are such as are designed to close defiles, mountain passes or stream crossings to the enemy, usually on the flanks of a field army. Closure of defiles may be effected either at their exits or entrances, and in the case of mountain passes, in their interiors also. When it is a question of a purely passive defense the best location for barrier works will be at the entrance of the defile, that is, the side away from the enemy. If, however, an advance from the defile is held in view, the defense must be made at the exit and should enclose sufficient ground to permit of deployment.

The principles governing the construction of barrier works are similar to those governing the construction of bridge heads. The works in general will consist of a line of supporting points affording mutual support and organized in a manner similar to the supporting points in a defensive line. As the defense will usually be passive, only the supporting points will be strongly organized and may take the form of closed works with a belt of obstacles.

Chapter IX

UNLIKE chess, bridge whist, map problems and map maneuvers, field fortification is not an "indoor sport." While the fundamental principles of the game can be learned from books, nothing but hard practice on the ground will develop the ability to play fast and well.

Since the object of field fortifications is to economize men, a fortified position is most skillfully organized when, without excessive labor in preparation, a maximum of resistance can be made with a minimum of troops. But such results are attainable only by skillfully taking advantage of the natural and artificial features of the terrain.

It follows that every officer who may lead troops in campaign should cultivate that grasp of ground which enables him quickly to lay out field intrenchments. Fortunately such practice is possible in peace time. All that is necessary are varied ground and assumed tactical situations.

The course in topography and field fortification at The Army Service Schools has for its object the training of the student officer to quickly grasp the lay of the ground and to make the best use of it under a given tactical situation. It consists of a number of problems solved on the ground. Each fortification problem sets forth a tactical situation involving the organization of a defensive position. The student is conducted to the sector to be held by the organization he is assumed to command and on the ground he locates his fire trenches and makes his decisions as to accessory works necessary. He

submits his solution in the form of a topographical sketch showing the lay of the ground and all work he proposes.

A few typical problems are included in these "Notes". To the student at Fort Leavenworth they will be of value if he will study them on the ground. To readers at other stations they may be of assistance in getting up fortification problems on accessible terrain.

Conventional Signs. Course in Field Fortification

Open Fire Trench	
Open Traversed Fire Trench	
Head Cover	
Overhead Cover	
Open Cover Trench	
Cover Trench, Overhead Cover	
Communicating Trench	
One Field Gun	
Four Field Guns	
Field Gun Pits	
Machine Gun	
Machine Gun Pit	
Supports and Reserves	
Observing Station	
Redoubt	
Abatis (or Slashing)	
Entanglement	
Mines	
Headquarters	
Cavalry	
Clearings and Demolitions	
Roads and Paths	

Traversed

Problem No. 1

(See Plate XIII)

General:

1. Missouri, Blue and Kansas, Red.
2. A red regiment is holding the Western end of the Terminal Bridge. A strong red force of two infantry divisions and a cavalry brigade is advancing on Leavenworth from the vicinity of Kansas City, Kansas.

A Blue field army of three infantry divisions is attempting the invasion of Kansas from the vicinity of Platte City, Mo.

Special:

1. Early this morning a pontoon bridge was thrown across the Missouri River at the point of the Prison Flat. The 1st Blue Infantry Division began crossing at 6-00 A. M. with the mission of clearing the Reds out of Leavenworth and occupying a defensive line along Five Mile Creek to cover the crossing of the main body by the Terminal Bridge.

2. At 9-00 A. M. the Reds have been driven out of Leavenworth but not until they succeeded in destroying one span of the Terminal Bridge. The divisional cavalry supported by the 1st Infantry Brigade has encountered a strong Red force and has been forced back into the southern edge of Leavenworth. The 2d Infantry Brigade has just been halted on Grant Avenue, the head of the leading regiment, the 5th Infantry, being at the corner of Grant and Metropolitan.

3. You command the 1st Bn., 5th Infantry, and at 9-00 A. M. receive verbal orders from your regimental commander to organize and hold, as part of a defensive line running from the mouth of Corral Creek to the U. S. Penitentiary and thence generally west to Hund Station, the sector Missouri River-Grant Avenue, inclusive. You are informed that the 2d Bn. will hold the sector Grant Avenue exclusive-U. S. Penitentiary, exclusive, and that the 3d Bn. will constitute the reserve of the regimental sector and be posted behind the 2d Bn. in Corral Creek bottom.

Required:

A sketch, 6" equals one mile, with approximate 10-foot contours, showing the topography, the disposition of your force and the works you propose to construct.

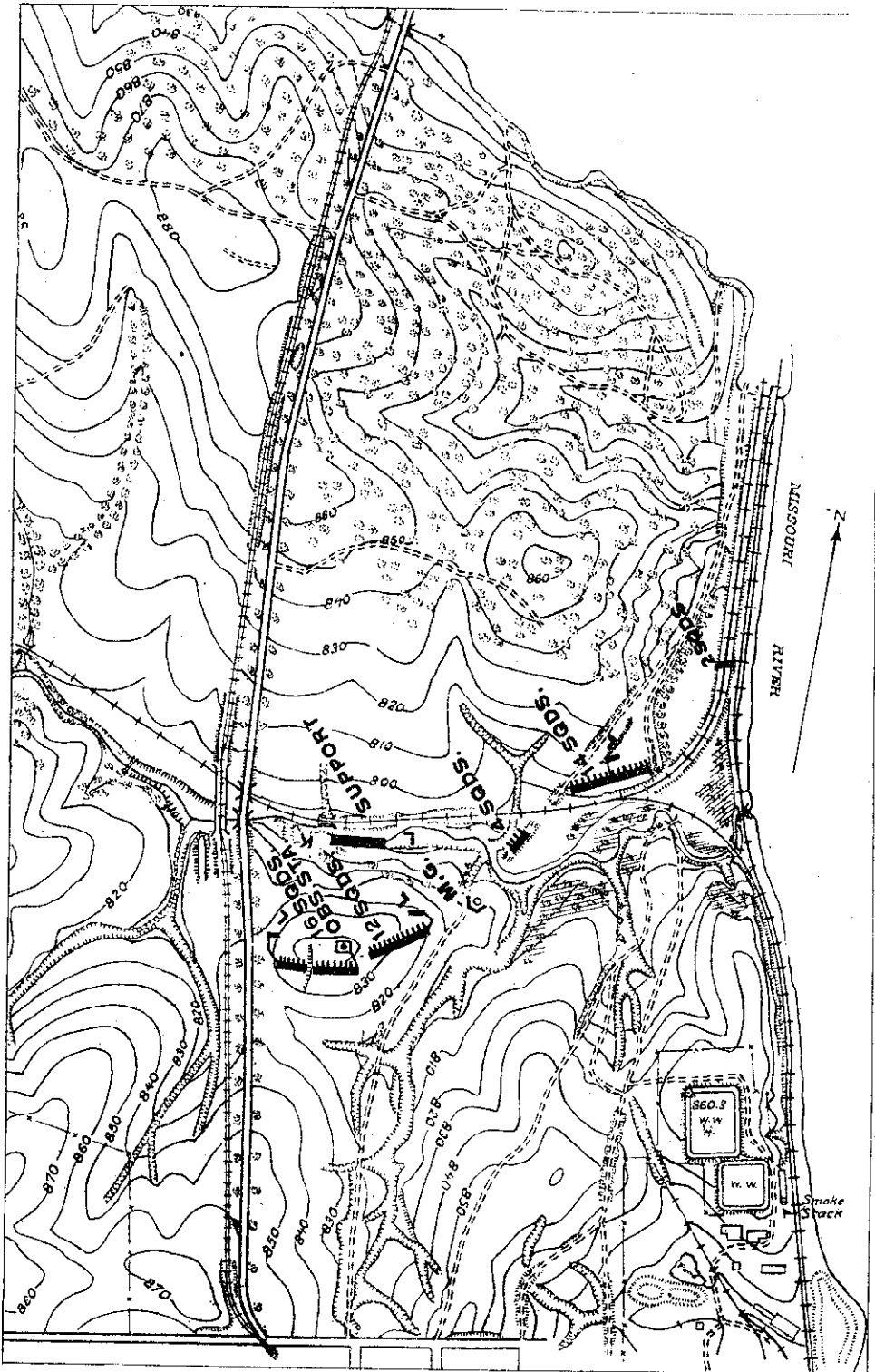

500

1000 YDS.

Problem No. 2.

(See Plate XIV)

Situations same as Problem 1, except that you command the 2d Bn., 5th Blue Inf., and at 9-00 A. M. receive verbal orders from your regimental commander to organize and hold, as part of a defensive line running from the mouth of Corral Creek through the U. S. Penitentiary and thence generally west to Hund Station, the sector Grant Avenue, exclusive-U. S. Penitentiary, exclusive. You are informed that the 1st Bn. will hold the sector Grant Avenue, inclusive-Missouri River, that the 3d Bn. will constitute the reserve of the regimental sector and be posted behind your battalion in Corral Creek bottom, and that the left of the 6th Infantry will be intrenched just south of the U. S. Penitentiary with machine guns covering the road in your front leading to the East Gate.

Required:

A sketch, 6" equals one mile, with approximate 10-foot contours, showing the topography, the disposition of your force and the works you propose to construct.

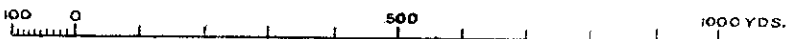
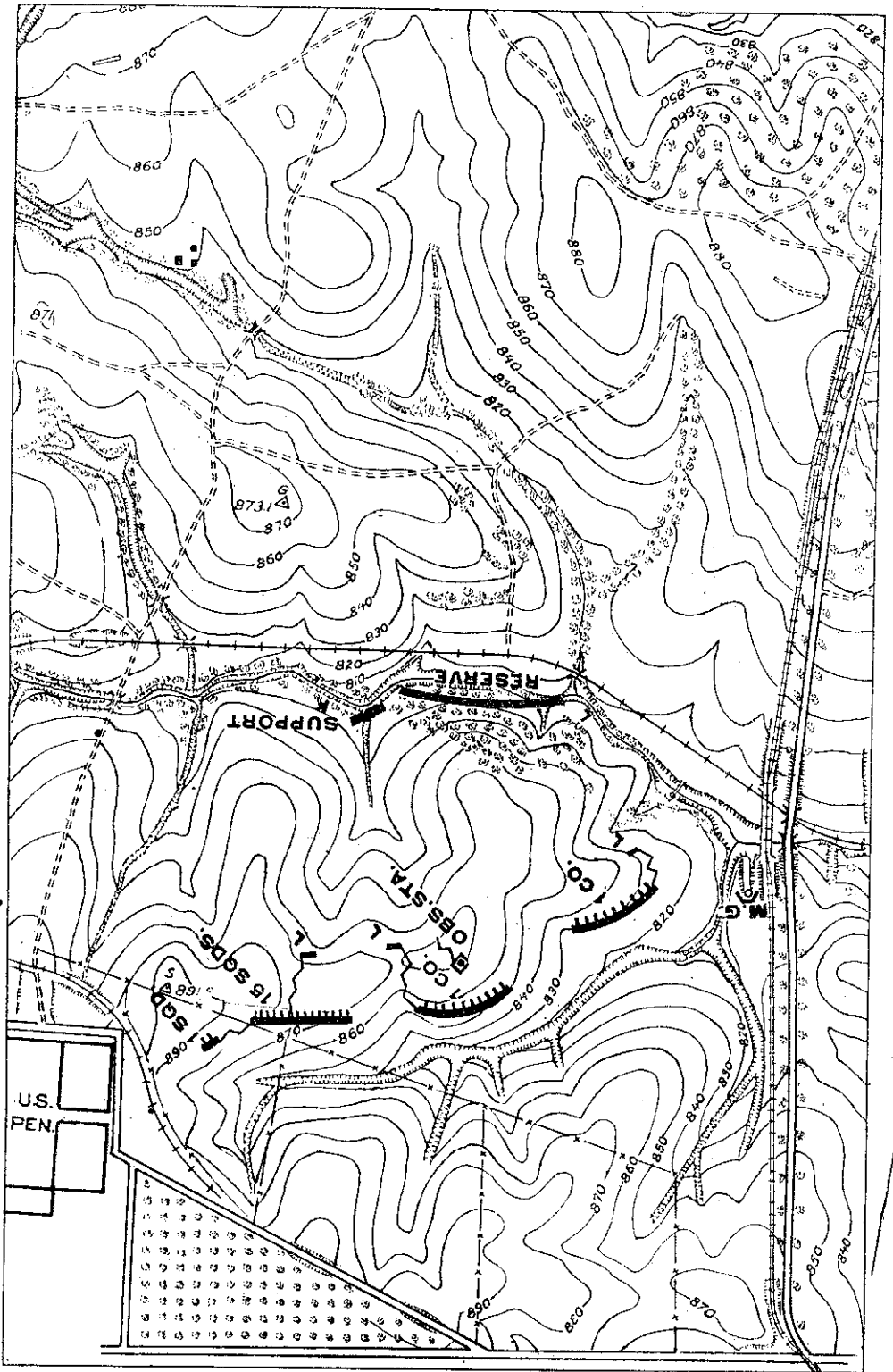

Problem No. 3

(See Plate XV)

General:

1. Kansas, Blue; Missouri, Red.
2. A Red field army is attempting to force a crossing of the Missouri River. A regiment of infantry (Blue) has been guarding the Terminal Bridge at Leavenworth while the main Blue force has been held in the vicinity of Kansas City, Kansas. Yesterday afternoon Reds were making preparations to bridge the Missouri River at the Point of the Prison Flat.

Special:

1. The 1st Brigade, 1st Blue Infantry Division, was entrained for Leavenworth at 10-00 P. M. last night and completed detraining in Leavenworth at 6-00 this morning. The balance of the division is following by marching.
2. At 6-30 A. M. the commander of the 1st Brigade learns that the Reds have completed their bridge and that cavalry has begun to cross. He orders the 3d Infantry through Fort Leavenworth to hold the Reds in check and the 1st and 2d Infantry to organize a defensive position from the Missouri River at the mouth of Corral Creek to Blue Cut.
3. You command the 1st Infantry and are ordered to organize and hold with your regiment the sector Missouri River-Prison Lane, exclusive.

Required:

A sketch, 6" equals one mile, with approximate 10-foot contours, showing the topography, the disposition of your troops and the works you propose to construct.

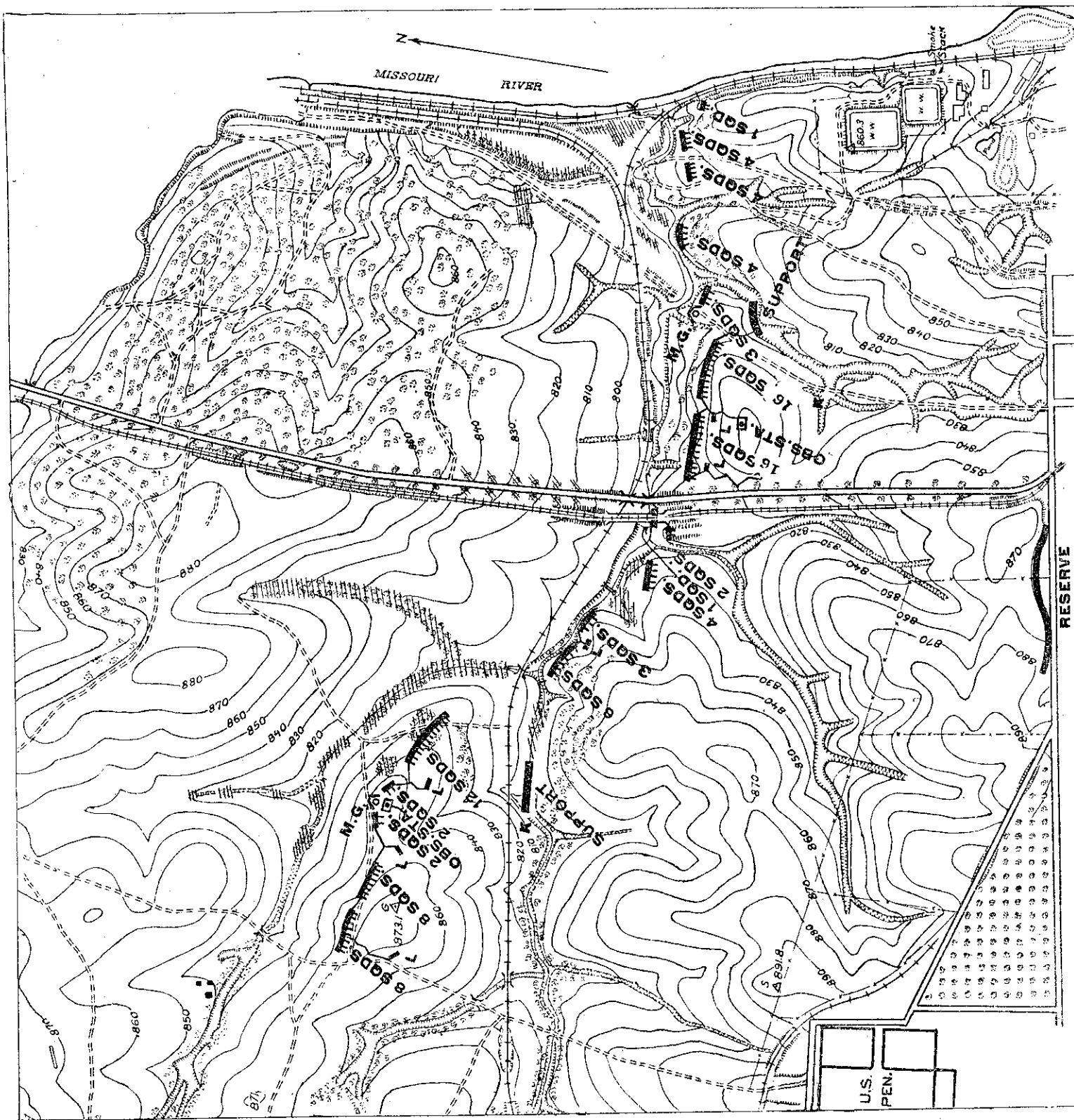

1000 YDS
500
0
100

U.S.
PEN.

