



**THE KC-135 WITH A MULTI-POINT REFUELING SYSTEM:  
INCREASED CAPABILITY WITH UNKNOWN COSTS**

GRADUATE RESEARCH PROJECT

James E. Dittus, Major, USAF

AFIT/GMO/ENS/03E-02

**DEPARTMENT OF THE AIR FORCE  
AIR UNIVERSITY**

***AIR FORCE INSTITUTE OF TECHNOLOGY***

---

---

**Wright-Patterson Air Force Base, Ohio**

APPROVED FOR PUBLIC RELEASE; DISTRIBUTION UNLIMITED

The views expressed in this graduate research paper are those of the author and do not reflect official policy or the position of the United States Air Force, Department of Defense or the United States Government.

THE KC-135 WITH A MULTI-POINT REFUELING SYSTEM:  
INCREASED CAPABILITY WITH UNKNOWN COSTS

GRADUATE RESEARCH PAPER

Presented to the Faculty

Graduate School of Engineering and Management

Air Force Institute of Technology

Air University

Air Education and Training Command

In Partial Fulfillment of the Requirement for the

Degree of Masters of Air Mobility

James E. Dittus, BS

Major, USAF

June 2003

THE KC-135 WITH A MULTI-POINT REFUELING SYSTEM:  
INCREASED CAPABILITY WITH UNKNOWN COSTS

James E. Dittus, BS  
Major, USAF

Approved:

\_\_\_\_\_  
Major Stanley E. Griffis, PhD

\_\_\_\_\_  
Date

## Preface

More than one research topic was initiated during this endeavor. Thankfully, my friend, and mentor, Lieutenant Colonel Lee DeRemer provided my initial vector toward AF/XORM where my topic originated. Colonel Robert Winston, Chief Global Mobility and Special Operations division needed to know the true costs of the KC-135 Multi-Point Refueling System (MPRS). To Col Winston I offer my thanks for agreeing to sponsor my research despite its eventual change in flavor.

I wanted to find the costs for the MPRS but I quickly discovered that a lack of use made it increasingly difficult to get the historical information I wanted. Falling back on the contract and the contractor, with the help of Robert Mengel, KC-135 MPRS Program Manager at the Aeronautical Systems Center, I learned there was little available to build on so I changed my vector. My research evolved into a snapshot of the system's capability to determine limit on the costs that should be paid to provide the added value.

This project would not be possible without extensive assistance and I offer my heartfelt thanks to each of the following individuals. First, Major Scott Vaughn, a fellow student, provided me the kick in the pants to really get started. Janice Missildine, the Air Mobility Warfare Center Librarian, provided me her time and expertise in research to help me with background material that saved me countless hours. Major Stan Griffis, my advisor, motivated me about reliability, offered me a sounding board for my ideas, and truly helped refine my rough work. Most importantly, I appreciate my wife and children for sacrificing time, dealing with stress, and supporting my efforts. Without them, this research, as with much else in my life, would not be possible.

James E. Dittus

## Table of Contents

	Page
Preface.....	iv
List of Figures.....	vii
List of Tables.....	viii
Abstract.....	ix
I. Introduction.....	1
II. Literature Review.....	5
Refueling Need.....	5
MPRS Capability.....	7
Contract Requirements.....	8
Life Cycle Costs.....	12
MPRS History.....	14
Drogue Refueling Analysis.....	15
System Problems.....	20
Refueling Planning.....	24
III. Methodology.....	26
Overview.....	26
Assumptions.....	27
Planning Considerations.....	32
Scheduling Art.....	34
IV. Results and Analysis.....	36
V. Conclusion.....	39
Areas for Further Study.....	39
Recommendations.....	40
Appendix A. Sample Refueling Requests.....	42
Appendix B. Basic Tanker Rainbow Sheet.....	44
Appendix C. Basic Tanker Schedule.....	55
Appendix D. MPRS Tanker Rainbow Sheet.....	57

Appendix E. MPRS Tanker Schedule.....	68
Glossary.....	70
Bibliography.....	71
Vita.....	73

## List of Figures

Figure	Page
1. KC-135R with MPRS (extended in trail).....	1
2. MPRS Drogue Refueling Envelope .....	10
3. Dents in Pod Outer Ring (rear view).....	21
4. Sample Airspace.....	30



## List of Tables

Table	Page
1. Hose Cycle Test Points.....	22
2. TPC Fuel Transfer Rates.....	25
3. System Reliability with Redundant Components.....	29
4. Fuel Burn Rates.....	33
5. Comparison of Schedules, KC-135R vs. KC-135R with MPRS.....	38

## Abstract

In 1994, the Air Force began development of a Multi-Point Refueling System to augment the refueling capability of the KC-135 Stratotanker. The system utilization has been extremely low since its purchase due to design problems. Despite the challenges, the value of the MPRS making the KC-135 a flexible refueling aircraft that can perform both boom and drogue refueling on the same mission cannot be overstated. This added mission capability gives planners the ability to plan refueling more efficiently and conserve refueling resources that are heavily tasked.

Now that the MPRS is fully operational and augmenting the KC-135 as planned, it is possible to quantify the value provided by the added capability of the system and compare it with the costs to make decisions about the future of the system. This research draws on technical manuals, operational testing, and expert opinion to determine appropriate planning factors to use for tactical refueling planning with MPRS capability. A sample set of refueling requests that are generated in the creation of an air tasking order (ATO) is evaluated. The refueling satisfied by KC-135Rs without MPRS capability is compared to the same requirements fulfilled by KC-135Rs equipped with MPRS to provide an evaluation of the system's value.

The MPRS provides increased capability for the KC-135 fleet. In a tactical employment refueling scenario, the MPRS increases efficiency of the theater-wide refueling mission 10-18%. This value range is contingent upon the assumptions of system reliability, desired mission success, and the type of tactical environment in which the system is employed. This system adds significant value in redundancy and mission capability without costing more than the savings achieved.

THE KC-135 WITH A MULTI-POINT REFUELING SYSTEM:  
INCREASED CAPABILITY WITH UNKNOWN COSTS

**I. Introduction**

In 1994, the Air Force began development of a system to augment the refueling capability of the KC-135 Stratotanker. The Multi-Point Refueling System (MPRS), shown in Figure 1, was envisioned as a commercial off-the-shelf purchase to increase the combat refueling capability of the KC-135 in a cost-efficient manner. Nearly 10 years later, the Air Force is wondering if these refueling pods are providing the cost-efficient performance that was desired.

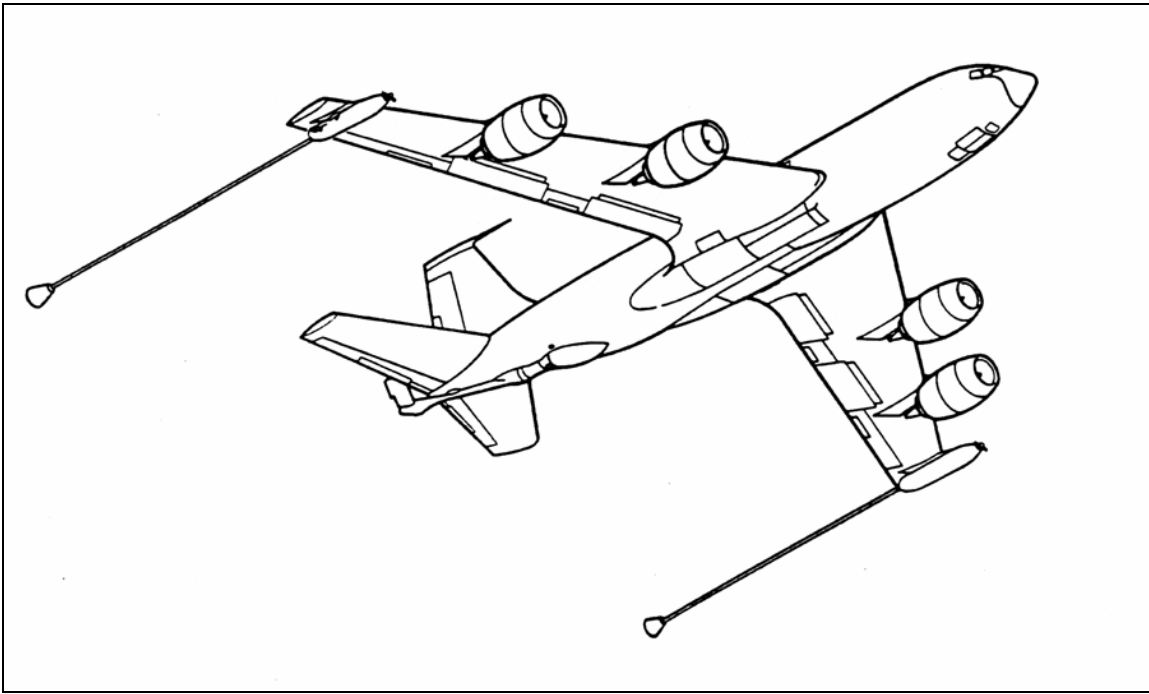

Figure 1. KC-135R with MPRS (extended in trail). (Sullivan et al, 1998)

Since the inception of the MPRS, it has been plagued with problems ranging from material defects in some of the parts to aerodynamic challenges that caused damage to its

host KC-135. These challenges caused the pods to remain mostly unused except for test and evaluation missions to identify corrective measures for the system. Now that corrective modifications have been made and procedures have been altered to provide acceptable system performance, the system is again cleared for operational use. The system has been used extensively in Operation IRAQI FREEDOM and this initial wartime usage may begin to provide the data necessary to determine if the benefits are worth the costs.

Through all the effort to get the system operational, its utilization has been extremely low. Any system that is purchased but goes unused will have a hard time being qualified as cost-efficient since an unused product produces no value, provides no capability, and saves no costs. In fact, during the production cycle, some contract options were not funded so the original purchase of thirty-three pod sets and forty-five aircraft modification kits was not achieved. The current, and apparently final, purchase plan stands at twenty pod sets and twenty aircraft modification kits. All twenty pod sets have been delivered and twenty aircraft modifications have been completed. The contract is closed currently so any future purchases will require a new contract (Mengel, 2003).

Despite the challenges, the value of a flexible refueling aircraft that can perform both boom and drogue refueling on the same mission cannot be overstated. With the MPRS, the KC-135 has the capability of boom and drogue refueling on the same mission. This added mission capability gives planners the ability to plan refueling more efficiently and conserve refueling resources that are heavily tasked. It also provides command and control elements the flexibility to respond to emergency refueling needs more easily.

Redundancy is another advantage of the MPRS. Probe-equipped aircraft predominantly flown by the United States Navy, the United States Marine Corps and many nations across the world do not require large amounts of fuel. A flight of four such aircraft can typically be refueled with the quantity of fuel available in a single KC-135. However, the failure of a single-drogue system, such as the KC-135 boom-drogue adapter (BDA), would prevent refueling. Redundancy would require a second KC-135, nearly doubling the cost of the refueling support. The MPRS provides this redundancy on a single airframe. If it experiences a single drogue failure, it could still accomplish the mission with a single aircraft.

Now that the MPRS is fully operational and augmenting the KC-135 as planned, it is possible to quantify the value provided by the added capability of the system. Then, a baseline for an acceptable operating cost will be available to compare with the operating costs once they are determined. Based on this future comparison, decisions about the future of the system can be made, including possible incorporation into the next generation refueling aircraft.

Existing planning documents used by air operations centers (AOCs) do not address the capability provided by the MPRS. This research will draw on technical manuals, operational testing, and expert opinion to determine appropriate planning factors to use for tactical refueling planning with MPRS capability. Based upon these factors, a sample set of refueling requests that are generated in the creation of an air tasking order (ATO) will be evaluated. The refueling requirements satisfied by KC-135Rs without MPRS capability will be compared to the same requirements fulfilled by KC-135Rs equipped with MPRS to provide an evaluation of the system's value.

This capability increase could be deceptively interpreted as an across-the-board increase but will only be applicable to tactical refueling of probe-equipped aircraft. To fully understand the benefits of the system, the advantages of the two-drogue system's redundancy must also be considered. This redundancy will also decrease tanker requirements for overwater deployments of probe-equipped aircraft although this is not specifically examined in this research.

With a defined capability increase, the true economic value of the MPRS can be determined. Additional costs will be incurred by the MPRS including training, decreased fuel efficiency, and maintenance/logistics. These costs must be offset by the increased capability to provide an economically valuable system.

## **II. Literature Review**

### **Refueling Need**

Since the end of the Cold War, the United States military has significantly reduced its forward-based presence around the world in favor of an expeditionary force that is predominantly based in the continental United States. In order to support the national security strategy of the United States, the military relies upon global reach. According to AFDD 2-6.2, "While air refueling has been the key element in modern airpower employment, force downsizing, a reduction in overseas presence, and increased global responsibilities have brought a need for robust, flexible, and versatile air refueling force" (Air Force Doctrine Center, 1999:2).

Air refueling assets act as both force enablers and force multipliers and are the backbone of global engagement. As a force enabler, refueling provides our initial response forces the opportunity to deploy or engage rapidly without having to delay at enroute bases for fuel. Additionally, avoiding enroute bases also avoids the political and diplomatic challenges that have caused challenges to military operations with increasing frequency in recent history. As a force multiplier, refueling increases combat effectiveness by increasing the range, payload, loiter time, and flexibility of a given aircraft (Air Force Doctrine Center, 1999). This capability is the highest priority for intratheater air refueling forces because combat aircraft may be based well outside enemy threats and requires refueling to give them the needed range to engage their targets (Air Force Doctrine Center, 1999).

History has shown the effectiveness and critical need of refueling capability. One of the most publicized examples was during the raid on Libya in 1986. Operation EL DORADO CANYON demonstrated the global attack capabilities of the United States military by launching a majority of strike aircraft from bases in the United Kingdom. The operation was impacted by diplomatic overflight restrictions that meant a significantly extended route of flight was needed to reach the target area and accomplish the mission objectives. The operation was made possible by aerial refueling (Air Mobility Command, 1998). Operation DESERT STRIKE on Iraq in 1996 is another example where two bombers were supported by twenty-nine tankers to accomplish the global strike mission (Air Force Doctrine Center, 1999).

In the future, refueling capability will likely be even more essential. As seen during Operation IRAQI FREEDOM, many locations for conducting air operations will be unavailable due to shifting political and diplomatic climates around the world. For operations in Iraqi airspace, the military had grown accustomed to the use of airfields and airspace in Turkey and the Kingdom of Saudi Arabia. The restricted availability of these resources during Operation IRAQI FREEDOM caused a major shift in the two-front war plan. On the eve of operations, quick adjustments had to be made. Since aircraft were based farther from the combat area in the north, increased refueling capability was required to avoid limits to combat capability. Unfortunately, refueling assets are not abundantly plentiful. According to retired Rear Admiral Stephen Baker, a senior fellow at the Center for Defense Information, "one major lesson for the Navy and Air Force [from Operation Iraqi Freedom] is that they need more aerial refueling tankers" (Whittle,



2003). Our refueling fleet must also be ready to satisfy the needs of the world's receiver aircraft, over half of which are equipped for drogue refueling (Sullivan et al, 1998).

### **MPRS Capability**

Aerial refueling is predominantly conducted by two delivery methods on the refueling tanker, boom and drogue. Air Force aircraft were designed predominantly for use of the boom refueling method because of the advantages of a significantly higher fuel transfer rate. The Navy and most other countries predominantly use drogue refueling. The MPRS consists of a single refueling pod mounted on each wing of a modified KC-135. Each pod has a drogue refueling system.

Although the KC-135 was designed to provide boom refueling, it is capable of providing drogue refueling through the use of the boom-drogue adapter (BDA). This adapter is installed prior to flight and limits the aircraft to only refueling with the drogue on any mission where it is installed. The use of the MPRS provides two drogue-refueling points at the KC-135's wingtips without affecting the centerline boom's capability. With the MPRS, the KC-135 can conduct both boom and drogue refueling on the same mission. Alternatively, the BDA can be installed on dedicated drogue missions to provide increased system reliability and a refueling capability if the MPRS malfunctions. The MPRS also offers the capability to refuel two aircraft simultaneously provided the wingspan of those aircraft does not exceed 68 feet (North Atlantic Treaty Organization, 2002).

Refueling two aircraft simultaneously may be the greatest advantage of the MPRS. Typically, aircraft that refuel with a drogue system are small fighter-type aircraft

that require smaller amounts of fuel. They require a large quantity of aircraft to receive fuel in the shortest time possible. This same need exists for the fighter-type aircraft refueling from a boom. However, the challenge is greater for an aircraft that requires drogue refueling because the refueling rates are significantly lower. Refueling rates through a boom can exceed 6,000 pounds per minute (ppm) while refueling through a drogue is roughly half of that: 2,800 ppm through a BDA and 2,680 ppm through the MPRS drogue (North Atlantic Treaty Organization, 2002). "Many European aircraft have relatively poor on-load rates and consequently require lengthy AAR [Air-to-Air-Refueling] time; this may make their use incompatible with single-point tankers" (North Atlantic Treaty Organization, 2002).

### **Contract Requirements**

Following a congressional directive in 1995, the Air Force began acquisition of the MPRS (Bowling, 2003). The contract was awarded to the Boeing Corporation which separated the production into Group A and Group B. Group A consisted of forty-five aircraft modification kits to alter the internal fuel plumbing in the KC-135 and provide control equipment for the MPRS. Group B consisted of thirty-three pairs of refueling pods and wing pylons to be mountable on the modified points of the KC-135 with a Group A kit installed (Aeronautical Systems Center, 1995). Currently, there have been twenty Group A kits purchased and installed and twenty Group B kits purchased. The total contract cost, including research, development, testing, and engineering (RDT&E), procurement, and installation, has been \$102.7M (Aeronautical Systems Center, 2002).

"The KC-135 MPRS will provide the capability to simultaneously and independently air refuel two probe equipped United States, NATO [North

Atlantic Treaty Organization], or allied aircraft up to a wing span of 68 feet allowing a minimum of one third wingspan separation using air refueling pods installed on the left and right wing of the KC-135R aircraft. (Boeing, 1995:1)

In addition to the overall system description, the contract included a very detailed set of specifications for the system capability and performance. The specifications detailed below are applicable to parts of this research.

In terms of aircraft performance, the general characteristics of the KC-135 are not significantly reduced by installation of the MPRS. In fact, the reductions in performance are extremely small. The contract requires the system to cause a degradation of the critical field length of not greater than 110 feet at maximum weight with the system installed (Boeing, 1995). The computed critical field length value for a KC-135 without MPRS is 11,777. The value with MPRS is 11,868 feet (Holt, 2003). The computed difference 91 feet for critical field length. This is within the contractual tolerance and less than one percent difference with the system installed. Therefore, this change is operationally insignificant. In the event this was a factor, it is probable that other mission adjustments could be made to compensate for the decreased takeoff performance.

The presence of the pods also limits the range of the aircraft due to increased drag. By contract, range cannot be degraded by more than six percent with the drogues/hoses stowed or thirteen percent with the drogues/hoses extended (Boeing, 1995). The aircraft technical manual shows a range degradation that averages 4.8% with the MPRS in the stowed position and approximately 13% with the drogues/hoses extended (Department of the Air Force, 2002). The technical manual computation was from flight test data so it indicates the contract was fulfilled in this area. This research will rely upon the technical manual values for any calculations.

Within the normal air refueling envelope, as indicated in Figure 2, each pod is required to provide a stable drogue for receiver aircraft and permit engagement with receiver closure rates in the range of 2-10 feet per second. Also, the system should not permit inadvertent disconnects from the drogue while the aircraft maintains a position between the maximum hose takeup distance and the hose full trail position (see Figure 2) less 7 feet while also maintaining a movement rate between 10 feet per second closure and 5 feet per second separation (Boeing, 1995).

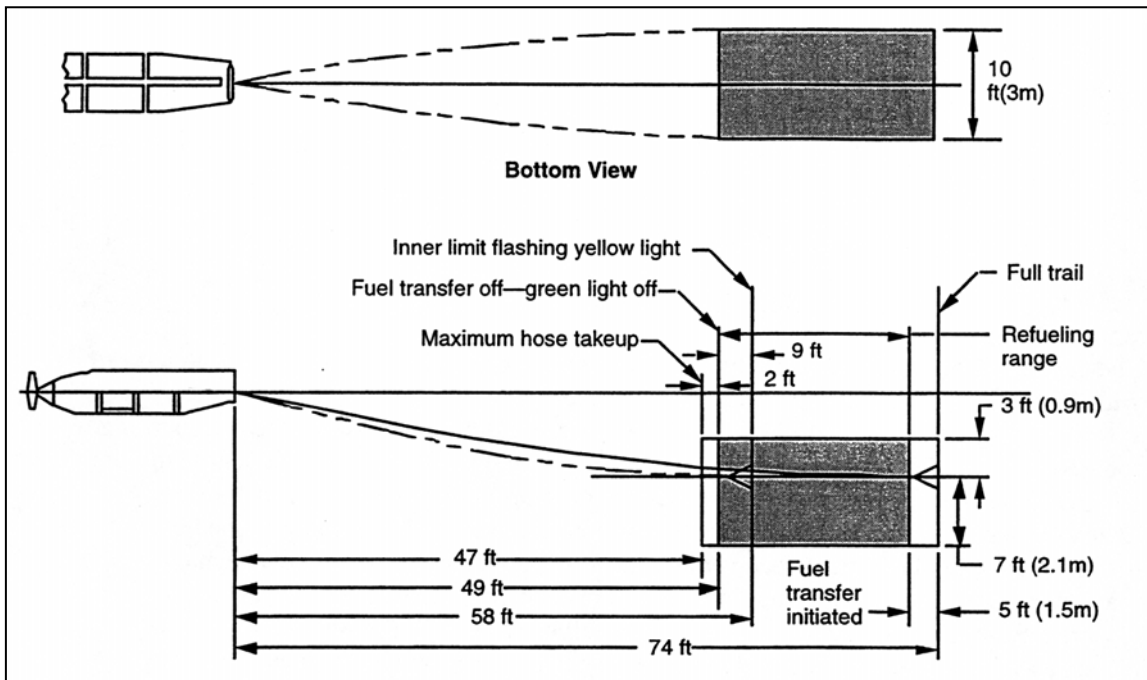

Figure 2. MPRS Drogue Refueling Envelope (Boeing, 1995)

To aid in maintenance efforts, the pods are required to have an elapsed time indicator, which shows the accumulation of operating time. Here, operating time is defined as the amount of time the hose is extended (Boeing, 1995). This indicator is useful for evaluating usage on some parts of the equipment. Other parts of the pod, such as the spinner on the nose of the pod, are operating throughout the time the aircraft is in flight. This variance in operation of the system requires a more complex model for

evaluation of the maintenance of the system since the two measures vary depending on the types of mission the KC-135 performs with the pods installed. If the tanker is based far from its refueling location, the spinner, and other parts operating throughout flight, will more rapidly complete their service life than components that are only in operation when the hose and drogue are extended. Therefore, the policy for basing and operations of the KC-135 can greatly alter the life-cycle costs of the MPRS.

The refueling pods are required to provide an offload rate of 355 gallons per minute (gpm) to receiver aircraft (Boeing, 1995). Most computations use JP-8 as a standard and a value of 6.7 pounds per gallon. This equates to a required offload rate of 2,378.5 pounds per minute (ppm). The NATO planning document for refueling, ATP-56(A), indicates the offload rate for the MPRS is approximately 2,680 ppm (North Atlantic Treaty Organization, 2002). This value exceeds the required performance value by approximately 300 ppm. Actual flight-testing accomplished in 1996 however yielded a transfer of 24,000 pounds over a 19 minutes period with both MPRS pods functioning, approximately 1,200 ppm (Sullivan et al, 1998). This number included transfer time for aircraft into refueling position and out of refueling position which does not coincide with the contractual requirements. However, it does indicate a possible planning factor for refueling aircraft from two operational drogues.

The MPRS is required to have a service life of 22,500 hours (Boeing, 1995). The service life value was not specifically qualified. It could mean hours of pod flight time or it could mean hours of pod usage with the hose extended. If it is assumed to be hours of pod flight time, coupled with an annual aircraft usage of 404 hours per year, each MPRS should last 55 years if the aircraft are used with the system installed at all times (Boeing,

1995). Any time operating the aircraft without the system installed will extend the life of the pods and pylons; the on-aircraft components will not experience any life extension benefits from lack of system use. Since the service life of the KC-135 will expire before the MPRS, this should not be a factor in pod operations in conjunction with the KC-135. However, the aircraft that replaces the KC-135 could utilize the MPRS but the remaining life in the MPRS might make costs of integration with a future tanker infeasible.

Reliability and maintainability requirements for the MPRS are also documented in the contract. The system is required to support an aircraft mission capable rate (MCR) of eighty-five percent. To support this, the mean time between failure (MTBF) for the MPRS is 180 pod-operating hours. This rate is valid following the service use of a "statistically significant number of pod systems" (Boeing, 1995). The mean time to repair (MTTR) the system is required to be 2 hours. Installation of the Group B components (pylons and pods) must be capable in a 6-hour period including an operational checkout of the system (Boeing 1995). Life cycle costs for the system were required to be evaluated with the Standardization Evaluation Program (STEP) 5.0 model as discussed below (Aeronautical Systems Center, 1996).

### **Life Cycle Costs**

"Logistics life cycle cost is the measurement of the price of an integrated logistics support program" (Carpenter, 1994:19). The cost is important to adequately design support requirements for a system, integrate support into the system design, identify the most cost-efficient means of support, and to ensure the support structure is developed and acquired. Often, logistics life cycle costs (LLCC) have taken a back seat to operational

design considerations and they have been traded for more immediate concerns when limited budgets are stretched (Carpenter, 1994:19)

The vast majority of expenses in any program are realized after the initial design phase and once full-scale development has begun. Unfortunately, most of these expenses are committed in the design phase and well before full-scale development. Therefore, increasing effort on early analysis of life cycle costs can yield tremendous benefits. Source selection can be more adequately assessed to save costs over the life of the system rather than just the initial acquisition. To this end Carpenter, in his 1994 article suggests the use of a LLCC matrix. The LLCC matrix is a spreadsheet that captures all the LLCC costs, broken down into categories, for easy analysis. (Carpenter, 1994).

Unfortunately for the MPRS, life cycle costs were not evaluated this way. As indicated in the contract requirements section earlier, life cycle costs required analysis by the STEP model. The STEP model was used to assess life cycle costs for avionics equipment and is no longer used. According to the KC-135 Program Manager at the Aeronautical Systems Center, and in consultation with Boeing, life cycle costs were never assessed for the MPRS program (Mengel, 2003). A report on LLCC was available in the minutes for the preliminary design review but the method for its generation was not indicated. It included STEP costs along with some other categories but the information for each year was aggregated so that only the total costs were available for the life of the system. Additionally, the cost was broken down to a cost per flight hour of \$350.81. Unfortunately, without knowing what information was used to calculate this data, it is difficult to use (Aeronautical Systems Center, 1996).

Now that the system is fielded, the life cycle costs should be easier to ascertain. However, with the systems limited use, there is a lack of statistically significant quantities of data to update existing life cycle costs. Reports from usage in the field from one unit during Operation IRAQI FREEDOM and its buildup period showed extensive use of the system. The mission capable rate was 100% with only two repairs required over a 5-month span. This indicates a significant improvement over previous years and results seen during testing.

### **MPRS History**

Drogue refueling has existed since 1949. "The system used was simple in its operation, and it is only reasonable that it was Flight Refueling Ltd., the most experienced company in the world in the field of air refueling, that should have been the one responsible for the development" (Byrd, 1994). Flight Refueling Limited is still making refueling systems today and is the manufacturer of the KC-135 MPRS.

Initially, the KC-135 was designed primarily to provide extended range to Strategic Air Command's fleet of intercontinental bombers for delivery of nuclear weapons. For this reason, one of the primary design considerations was passing large quantities of fuel in a short period of time. This enabled the bombers to proceed on their mission's optimum flight profile with a minimum disruption for the refueling. Other refueling needs were considered but this requirement dominated and led to the air refueling boom as the system of choice for the KC-135.

With the need for drogue refueling of all the other potential customers of the KC-135, a boom drogue attachment was also needed. This provides the required apparatus



for probe-equipped aircraft and satisfies the basic refueling needs. Other tankers including the KC-10A Extender and nearly all foreign refueling aircraft provide drogue refueling. Some, including the French KC-135FR even have a MPRS that is nearly identical to the United States' system.

***Drogue Refueling Analysis.***

In 1993, the General Accounting Office (GAO) published a report in response to a congressional request for an assessment of air refueling performance during Operation Desert Storm. This assessment was made to determine the relevance of a 1990 study by the Rand Corporation and the adequacy of the Department of Defense response to that study (General Accounting Office, 1993).

The original Rand study suggested the reconfiguration of all F-15 and F-16 aircraft to have probes installed and the integration of probes into future aircraft development. This modification would allow existing F-15s and F-16s to refuel from either boom or drogue equipped tankers to provide redundancy and flexibility. Also, the study suggested that 250 KC-135s could be modified by adding 2 multipoint drogue pods. The net result of this study would allow reduced operating and support costs while enhancing tanker efficiency allowing the retirement of twenty-six KC-135s. (General Accounting Office, 1993)

The Rand study showed the advantages based on increased efficiency, operational effectiveness, interoperability, and safety. The increased efficiency of the KC-135 fleet was to be achieved by accomplishing its refueling missions more quickly with two offload points and therefore spending less time loitering in the refueling area. Operational effectiveness was also a product of the decreased refueling time. Since a

group of aircraft could refuel more quickly, the aircraft that refueled early in the sequence would have more fuel available for mission accomplishment with less fuel used waiting for other aircraft in the mission package to complete refueling. Having both boom and drogue refueling available on the same aircraft on any single mission enhanced interoperability. Finally, safety was improved through redundancy of drogues for probe-equipped receivers on overwater deployments (General Accounting Office, 1993).

The Air Force analysis of the Rand study showed the performance tradeoffs for equipping the F-16 with a probe were unacceptable. After considering the lack of savings as a result of not equipping the F-16 with a probe, the Air Force determined the overall plan for aircraft modification was not cost effective and submitted this recommendation to the Secretary of the Air Force. Further rounds of analysis, each apparently omitting a significant factor from the original Rand study, eventually left the concept without any fighter aircraft modifications or future drogue capabilities (General Accounting Office, 1993)

A number of inaccuracies in the Air Force analysis were noted. The on-load rate through the boom, for both the F-15 and F-16, was overestimated by thirty percent. Additionally, the on-load rate for the F-16 through the drogue was underestimated by seventeen percent. The Air Staff analysis also showed a threefold increase in the amount of time to refuel aircraft from the drogue. The analysis was the result of interviews with Air Force pilots that had limited experience with drogue refueling. A more accurate analysis could have been accomplished with information from Navy refueling experiences (General Accounting Office, 1993).

Efficiency of the KC-135 was miscalculated by the Air Force. The Air Staff assumed increased drag for a multipoint refueling system but failed to consider the increased drag of the BDA in its comparison. Also, long loiter times, well in excess of refueling requirements were used in the calculations that exacerbated the error in the amount of drag assumed for the mission comparison (General Accounting Office, 1993).

Operational capability limitations for a probe-equipped F-16 were exaggerated. The installation of an internal probe would have required removal of the gun, an unacceptable proposition, so the external probe was the only option remaining. Problems were noted with the external probe arrangement but the F-16 program office later indicated that none of the problems were showstoppers. General Dynamics, the manufacturer of the F-16 indicated that flight testing was the only way to accurately assess the operational issues and this was not accomplished (General Accounting Officer, 1993).

The GAO study looked at Operation Desert Storm for evidence of the potential value of the multipoint refueling system. Officials from United States Central Command (USCENTCOM) said there were limitations on the single-point tankers that multipoint tankers would have alleviated. The Air Staff concluded that these limitations were the result of the intensive, time-compressed, operations found only during the first 3 days of the conflict. The remaining days would have benefited from the single-point tanker due to the decreased efficiency of the multipoint tanker. This was based on their previously flawed analysis of the results of drag on efficiency. The GAO concluded that the original benefits shown by the Rand study were accurate. Airspace efficiency was another

advantage of the multipoint system that would require fewer tankers to accomplish the same mission in the same limited airspace (General Accounting Office, 1993).

During Operation Desert Storm, single-point tankers met the refueling need but satisfied the need inefficiently. Special circumstances enabled the operational successes and this cannot be expected in future operations. "Plentiful bases and fuel allowed planners to assemble a very large tanker force" (General Accounting Office, 1993:16). Air supremacy was achieved early and maintained. This gave the Air Force freedom of operations. Without air supremacy, operations would have been compressed to fit within a window of localized air superiority and the compressed operations would have required an increase in efficient refueling capability (General Accounting Office, 1993).

RAND conducted a summary study of previous research into MPRS capabilities in 1996. In this study various factors were analyzed to determine the reason many previous studies had provided such varying results. Also, an ATO from one day in Operation DESERT STORM was analyzed to determine if refueling assets could have been used more efficiently. From this analysis, a number of conclusions were obtained (Killingsworth, 1996).

Multipoint refueling offered great advantages under certain operational conditions but offered no advantage for others. Great advantage was noted for high-intensity fighter operations, anchor area refueling, large percentage of probe-equipped receivers, and large fighter packages. All the studies analyzed by this RAND report indicated the benefits of multipoint refueling but differed on the amount of savings because of the different assumptions about the refueling needs of the forces and scenarios possible (Killingsworth, 1996).

All agree that multipoint is beneficial when the tempo of fighter operations is high enough to make the number of fuel-offload points in the air a limiting factor on the number of fighters flown. That is, boom-limited situations occur when there is a large number of planned fighter missions in a brief amount of time, and the high volume of combat air traffic requires that the number of aerial-refueling tracks and anchorpoints be limited. In addition, there simply may not be enough tankers to go around, because there are few bases at which to bed them down or because a second MRC [major regional conflict] commences. *The desirability of transitioning to probe/drogue technology depends both on the frequency of these situations and on the emphasis planners place on them.* (Killingsworth, 1996:34)

Killingsworth analyzed refueling needs on the first day of the ground offensive in Operation DESERT STORM to see how many tanker missions could have been avoided through use of a MPRS type system on the KC-135. He picked this day to capture because it was the highest tempo of the war other than the first three days. The analysis consolidated adjacent air refueling tracks and tried to combine receiver packages that were within 30 minutes of each other, consisted of speed compatible receivers, and whose tankers had enough extra fuel to service the new package. He tried to optimize usage of a fixed tanker schedule with slight modifications to fighter timing. As a result, he was able to reduce the 214 tanker missions required by 21 missions. Of these 21 missions, only 1 required multipoint refueling due to time limitations (Killingsworth, 1996). Apparently his advantages were achieved through more efficient scheduling of tanker resources.

Additional observations were noted in the RAND study and they still appear to be problematic today. First, retrofitting the existing fleet of fighter aircraft was not recommended due to the age of the fleet and the time it would take to implement such a program. It recommended an evolutionary approach to equip future fighter aircraft with dual capability for refueling from both boom- and drogue-equipped tankers. Second, tanker planners need additional tools to efficiently plan refueling campaigns and surplus

refueling capability, possible with MPRS, could find its greatest use in post-strike refueling after the fog and friction of war have had their impact on the plan. However, this requirement is more difficult to quantify than well-planned pre-strike refueling. Third, multipoint refueling is of the greatest advantage to the Navy but they have not defined their requirement for it nor advocated for its advancement (Killingsworth, 1996).

In conclusion, there is multipoint utility in high-intensity environments and substantial numbers of MPRS-equipped tankers would contribute to operational flexibility. The tanker savings range from seventeen to fifty percent depending on the analysis parameters used. In addition to high-intensity environments, multipoint refueling is advantageous when airspace is limited, receivers are based close to the combat area, post-strike adjustments are required, and a second regional conflict stretches refueling assets (Killingsworth, 1996).

#### ***System Problems.***

In 1996, the 33d Flight Test Squadron conducted the Qualification Operational Testing and Evaluation (QOT&E) to assess the effectiveness and operational suitability of the MPRS. That testing of the system showed early indications of the problems that have been experienced throughout the life of the program.

Early flights experienced hose oscillations during retraction of the last 15-20 feet of the hose. The severity of the oscillation was more significant when the aircraft speed was higher and the frequency of oscillation increased as the drogue assembly was retracted. As the retraction was completed, the aircrew members felt a light shudder in the aircraft and the drogue impacted the rear of the pod assembly causing several dents as shown in Figure 3 (Sullivan et al, 1998).



Figure 3. Dents in Pod Outer Ring (rear view). (Sullivan et al, 1998)

Continued observation of these oscillations showed the problem to be consistent and several hose retractions resulted in the drogue assembly striking the aircraft wing (Sullivan et al, 1998).

Turbulence also caused hose oscillations that made refueling more challenging. In light turbulence, receiver aircraft were able to effectively make contact with and refuel from the MPRS but required several attempts. In one encounter of moderate turbulence, the drogue assemblies became so unstable that the refueling was terminated (Sullivan et al, 1998).

Despite these incidents, the test report determined the MPRS was satisfactory for operational use on the KC-135. Some conclusions and recommendations were provided. Hose oscillation data was inconclusive due to the small sample size and the test limitation of only one KC-135 aircraft and one pod set. Further observation and collection of data

on hose oscillation was recommended. Due to the effects of turbulence, the report recommended that refueling with the pods be restricted in moderate or greater turbulence (Sullivan et al, 1998).

The Follow-on Operational Test and Evaluation (FOT&E) conducted by the 33d Flight Test Squadron in 2001 focused extensively on the hose oscillation problem. The test was conducted with two aircraft and two pod sets on three flights. On each flight hose oscillation was measured at a number of test points as indicated by Table 1. For each of these test points a complete cycle of each MPRS hose was accomplished to

Table 1. Hose Cycle Test Points (Davis and Romano, 2001)

<b>Gross Weight (pounds)</b>	<b>Altitude (flight level)</b>	<b>Angle of Attack</b>	<b>Airspeed (KIAS)</b>
220,000	<200	0.5	220
		0.4	260
		0.3	300
220,000	>260	0.5	220
		0.4	260
		0.3	300
250,000	<200	0.6	220
		0.4	260
		0.3	300
	>260	0.6	220
		0.4	260
		0.3	300
300,000	<200	0.5	260
		0.4	280
		0.4	300
	>260	0.5	260
		0.4	280
		0.4	300

evaluate hose oscillations in various aircraft conditions and determine if the hose could be successfully operated without the drogue striking the aircraft, causing damage, or causing excessive difficulty for the receiver in attempting to make or maintain contact. Only ninety-one percent of the attempts were judged to be successful and the test group



determined this to be inadequate. As a result of this problem and an analysis of the aircraft conditions during successful test points, Air Mobility Command (AMC) issued a flight restriction that limited the retraction of the hose to speeds of 220-260 knots when the aircraft was below 260,000 pounds (light to medium weight) and 260-300 knots when the aircraft was above 260,000 pounds (heavy weight) (Davis and Romano, 2001).

These flight restrictions present an operational impact. Some receivers, like the EA-6B and the S-3, may be performance limited and unable to remain with the KC-135 during retraction in the heavyweight high-speed retraction envelope. Therefore, the KC-135 may have to leave the hoses extended on deployment sorties when the receiver aircraft must stay with the tanker. This can increase drag by seven percent for the duration of the deployment sortie and cause significantly increased costs for operation (Davis and Romano, 2001).

Reliability for the MPRS was shown to be a significant problem during the 2001 tests. Only fifty-nine percent of the employment missions with the pods were completed with both pods functional and only ninety-two percent were completed with at least one pod working (Davis and Romano, 2001). Calculating the reliability for a single pod based on redundancy parallel components yields reliability between 64.8 percent and 71.4 percent. The mean time between failures (MTBF) was measured at 29.4 hours for the duration of the FOT&E. Statistical analysis conducted by the 33d Flight Test Squadron indicated with eighty percent confidence that the real MTBF is no greater than 41.3 hours. The maintenance actions required to keep the system operational resulted in a mean time between maintenance of 10 hours and a mean time to repair (MTTR) of 3.9

hours. These numbers indicate the MPRS advantage of redundancy is offset by its reliability and maintainability (Davis and Romano, 2001).

As a result of this testing, a number of recommendations were made. Two recommendations of great significance were focused on the reliability and the hose oscillations. To be a viable system, it must be reliable for use so the reliability must be improved. Linked with the reliability, but also safety and repair costs, the hose oscillation must be mitigated to increase operational usability and decrease maintenance efforts.

### **Refueling Planning**

The Air Mobility Warfare Center Detachment 1 conducts training for air refueling planners at Hurlburt Field Air Force Base. Originally it was called the Tanker Planner Course (TPC) but it has recently evolved into a part of the Air Operations Center training course. This course is responsible for all training for air refueling planners to work in an AOC. This course covers operations from the doctrinal perspective the way down to the tactical combat planning.

The big issues concerning tanker operation planning are operating locations (including logistical support), force structure requirements, airspace requirements, and combat planning. This research will only look at the combat planning. A reduced airspace requirement for tankers is an important gain from use of the MPRS but its advantages will be evident from the combat planning.

The TPC teaches the use of Air Force Pamphlet 10-1403. Unfortunately, the pamphlet only provides gross planning numbers to aid in sizing a generic force based on

mission distance and formulas for computing available fuel for a tanker to offload or fuel required for a receiver mission. The focus appears to be on deployment operations rather than employment operations (Department of the Air Force, 2003a).

For employment planning, instructors for the TPC provide some general planning factors. Offload rate is dependent on the number of refueling pumps applicable to the receiver as well as the type of refueling (see Table 2. Boom refueling provides the

Table 2. TPC Fuel Transfer Rates (Vellines, 2003a)

Refueling Type	# of Pumps	Fuel Transfer Rate (ppm)	Notes
Boom	1	1,500	Single Engine Aircraft (F-16)
Boom	2	3,000	Two Engine Aircraft (F-15)
Boom	3	4,500	
Boom	4	6,000	Heavy Aircraft (C-17, RC-135)
Drogue*	N/A	1,200	
MPRS* (1 pod)	N/A	1,200	
MPRS* (2 pods)	N/A	1,200	Rate is per pod. Two aircraft would get 2,400 ppm

\* Non-U.S. rate is 1,000 ppm

greatest transfer rate but is dependent on the receiver size. Heavy aircraft have large enough fuel lines to accept the maximum transfer rate of the KC-135 while smaller aircraft, like the F-16 carrying external fuel tanks, can only be refueled with a single air-refueling pump from the KC-135. Along with these rates, time is allotted for each aircraft package to prepare for refueling and to complete refueling operations. Small, fighter-type, aircraft are given 5 minutes for their refueling window on the front and back end of their actual fuel transfer time. Heavy aircraft are given 10 minutes on either end (Vellines, 2003a).

### **III. Methodology**

#### **Overview**

To assess the value of the MPRS, this research will demonstrate the system capability in a realistic scenario. The realistic scenario will be a sample set of refueling requests that covers a 24-hour period and comes from the Tanker Planner Course taught by the Air Mobility Warfare Center Detachment 1. The refueling requests are very similar to a typical set of requests from Operation ALLIED FORCE with some modifications to provide scheduling challenges for tanker planners (Vellines, 2003b). The refueling requests can be found in Attachment 1. With this set of requests, two refueling support schedules, one without MPRS-equipped KC-135s and one with the MPRS, will be generated. These two schedules can then be compared to determine the number of aircraft sorties required, the number of aircraft needed to fly the sorties, and the number of flight hours expended.

After the operational value of the MPRS has been assessed, ideally, it would be compared with the life cycle costs. Unfortunately, due to the lack of experience with the system, actual life cycle costs are not available. The only life cycle costs available are the hourly operating costs found during the design review for the system and they are not detailed enough to use effectively. However, this research will determine the cost difference for the two refueling support schedules (with and without MPRS) and provide a value for the increased operational capability. This value will also be compared to the present day value of the design review operating costs for the MPRS.

## Assumptions

To plan the refueling support schedule, the most important factor is the guidance from the Combined Forces Air Component Commander (CFACC). This guidance will tell the planners how to provide the refueling support. For purposes of this research, the primary concern is reliability. Most tactical refueling operations have a tanker scheduled to provide increased reliability for the air campaign. During Operation IRAQI FREEDOM, there weren't any reliability tankers scheduled due to a lack of available aircraft (McCaskill, 2003). This research will assume the CFACC wants his refueling operation to provide 99.5% reliability so additional tankers, some without scheduled refueling, will be scheduled to ensure this reliability.

Although mission capable rates are used for aircraft, no mission success rates are tracked. Mission success rate is the probability of accomplishing the assigned mission once the aircraft is successfully launched. For this research, mission success rate and reliability may be used interchangeably. Many units can report their mission success rates on specific operations or deployments but no rates are kept for aircraft fleets. The rate for the MPRS is even more difficult than the boom and BDA success rates without a history of operational experience. The QOT&E had a 100% mission-success rate while the FOT&E had rates of 92% for one pod operational and 59% for both pods operational. To determine the rate for an individual pod, the system can be considered to be two identical components operating in series. The system reliability can be expressed by formula 1 where R is the reliability of a single pod (Ebeling, 1997). Substituting 59% for

$$R_s = R^2 \quad (1)$$

$R_s$  and solving for R leaves us with  $R = 76.8\%$ . However, the system can be considered

as two components operating in parallel also. The system reliability can be expressed as seen in formula 2 (Ebeling, 1997). Substituting 92% for  $R_s$ , and solving for  $R$  leaves us

$$R_s = 1 - (1 - R)^2 \quad (2)$$

with  $R = 71.7\%$ . For the reliability calculations of the entire tanker schedule, it is more appropriate to think of this reliability in terms of  $k$  required components out of  $n$  available components. In terms of a reliability tanker, this is equivalent to three tankers scheduled to support a collection of refueling requests with one spare reliability tanker scheduled. Therefore, this would be three ( $k = 3$ ) required components (tankers) out of four ( $n = 4$ ) available components (tankers). For a MPRS-equipped tanker, there are two available pods ( $n = 2$ ) and individual pod reliability can be determined for either two pods required or only one. Formula 3 is used to determine system reliability for  $k$ -out-of-

$$P(k) = \left( \frac{n!}{k!(n-k)!} \right) R^k (1-R)^{n-k} \quad (3)$$

$n$  redundancy (Ebeling, 1997). With  $n = 2$  and  $k = 1$  (one of two pods functioning), a 92% probability of success is achieved with  $R = 71.7\%$ . With  $n = 2$  and  $k = 2$  (both pods functioning), a 42% probability of success is achieved with  $R = 64.8\%$ . Based on the FOT&E results it can be assumed that the reliability lies between 64.8% and 71.7%.

Recent results from Operation IRAQI FREEDOM showed a 100% success rate (Nelson, 2003).

The variance of these numbers indicates more study is needed into mission success rates for the MPRS. For this research, the success rate for an individual pod is assumed to be 95%. Based on anecdotal experience and a lack of recorded information, this research

will use a 99% mission-success rate for a basic KC-135, and a 98% mission-success rate for a KC-135 with BDA (OOMAC, 1969). These reliability figures, used with formula 3 above, provide us with the information in Table 3. These values determine how many

Table 3. System Reliability with Redundant Components

Number of Booms Available	Number of Booms Needed	Composite Reliability (R=.99)	Number of BDAs Available	Number of BDAs Needed	Composite Reliability (R=.98)	Number of MPRS Pods Available	Number of MPRS Pods Needed	Composite Reliability (R=.95)
5	5	95.1%	5	5	90.4%	8	8	66.3%
5	4	99.9%	5	4	99.6%	8	7	94.3%
5	3	100.0%	5	3	100.0%	8	6	99.4%
5	2	100.0%	5	2	100.0%	8	5	100.0%
5	1	100.0%	5	1	100.0%	8	4	100.0%
4	4	96.1%	4	4	92.2%	8	3	100.0%
4	3	99.9%	4	3	99.8%	8	2	100.0%
4	2	100.0%	4	2	100.0%	8	1	100.0%
4	1	100.0%	4	1	100.0%	6	6	73.5%
3	3	97.0%	3	3	94.1%	6	5	96.7%
3	2	100.0%	3	2	99.9%	6	4	99.8%
3	1	100.0%	3	1	100.0%	6	3	100.0%
2	2	98.0%	2	2	96.0%	6	2	100.0%
2	1	100.0%	2	1	100.0%	6	1	100.0%
						4	4	81.5%
						4	3	98.6%
						4	2	100.0%
						4	1	100.0%
						2	2	90.3%
						2	1	99.8%

= Insufficient Reliability ( < 99.5%)

reliability fuel offload points are required to achieve the 99.5% mission success rate desired for this analysis.

To successfully schedule reliability tankers, the area of operations must be considered. For purposes of this research, sample airspace has been generated that is designed to support the sample refueling requests. For planning purposes, all tankers are operating from bases that are two and a half hours flight time from the operational area. The refueling airspace is divided into four general areas. This area is shown below in

Figure 4. There are two linear refueling tracks, Bongo, and Mercury, and two other areas. Each of the other areas contains two anchor refueling tracks. The linear refueling tracks have only one assignable refueling level and the tracks are each isolated from all

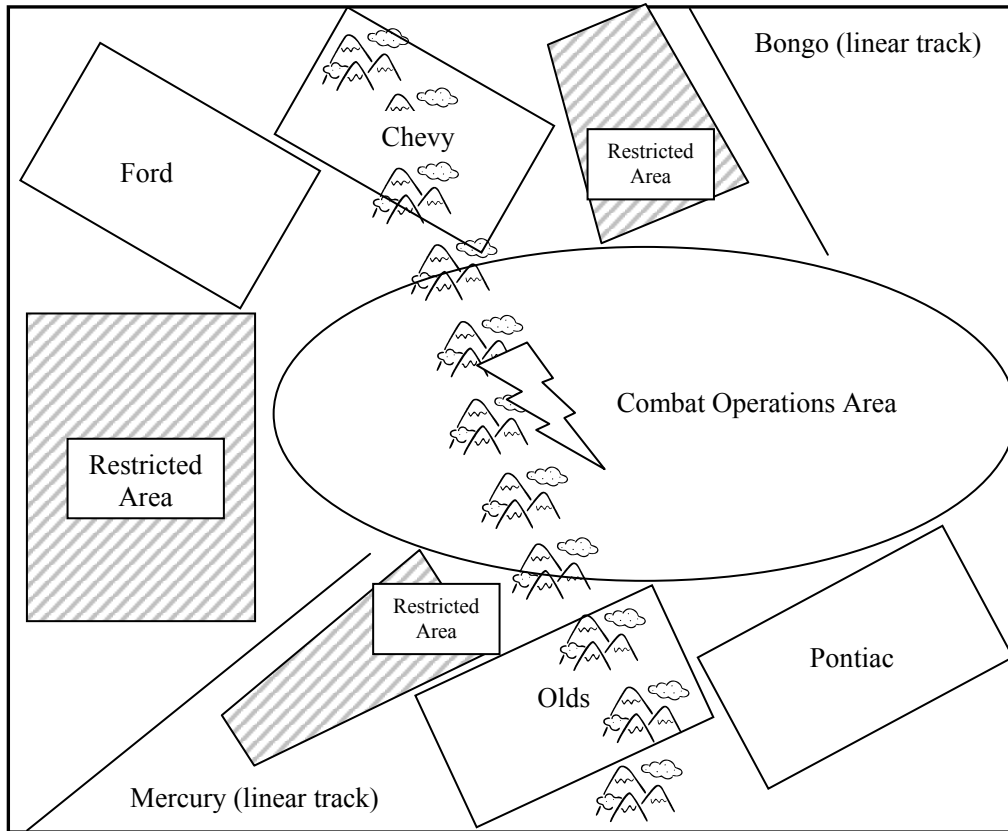

Figure 4. Sample Airspace

other refueling areas. Each of the anchor tracks has more than one refueling level. The anchor areas located over the mountains, Chevy and Olds have two assignable refueling levels, a high-level and a mid-level. The other two anchor areas, Ford and Pontiac, have the high- and mid-level refueling space in addition to a low-level refueling area. Each refueling level can support a single tanker mission that may be made up of as many as 3 tankers. Tankers may move between adjacent refueling anchors allowing 20 minutes for the transition and between refueling levels allowing 10 minutes for the transition.



Reliability tankers could be scheduled to support the linear refueling tracks but, for this analysis, they are unable to support any other refueling mission or refueling area and reliability tankers in other refueling areas are unable to support the linear tracks due to airspace limitations. Since refueling on linear tracks is usually accomplished with aircraft needing boom-type refueling, a reliability tanker only increases reliability by approximately 1%. Due to this limited increase and the significant cost in resources, 99% reliability provided by a single KC-135 on a boom refueling mission is adequate for this research. Reliability tankers scheduled in any anchor airspace may be used to support any refueling at any level in the anchor assigned or the adjacent anchor area.

Flexibility is allowed for in receiver refueling requests. In a typical operation, minor adjustments to refueling requests would be coordinated with the refueling requester but some general guidelines offer the opportunity to make changes to optimize refueling assets. For the purposes of this research, refueling requests must be kept within the same anchor refueling area but may be placed in a different altitude or adjacent refueling track. Some aircraft may not be able to refuel in all areas due to operational capability restrictions. These restrictions will be discussed in the next section.

As mentioned earlier, refueling transfer rates are available from numerous sources and vary drastically. It is likely that the rates used by the TPC instructors are the most reliable since they are constantly challenged to ensure mission success and maximize the efficiency of refueling resources. They are therefore prevented from using rates that are too high, causing combat mission delays due to increased refueling time, or rates that are too low, causing excess refueling resources to be wasted. This analysis will use the values shown earlier in Table 2. In addition to the actual fuel transfer time, additional

time is allowed for flights of receiver aircraft to maneuver into position with the tanker before and after the refueling as well as time for pre- and post-refueling checklists. Small aircraft are given 5 minutes on each end of the refueling window in addition to their fuel transfer time. Large aircraft are given 10 minutes extra on each end. With multiple refueling assignments for a single tanker, flights of receiver aircraft were allowed to overlap their 5 minute maneuvering time so long as the two flights of aircraft had similar refueling speeds. Refueling times are flexible to allow increased efficiency in scheduling but the flexibility is limited to ensure mission success for the receiver aircraft. Although any adjustment to refueling times necessitates coordination with the receiver aircraft's mission planner, assumptions were required for this research. End refueling times are typically more critical to ensure combat aircraft can utilize mass and surprise effectively so these times will not be adjusted by more than 5 minutes. Begin refueling times will not be adjusted by more than 11 minutes. Total refueling time for flights of aircraft in anchors was limited to 30.

### **Planning Considerations**

The biggest consideration when planning refueling missions is the amount of fuel that must be carried by the tanker. The fuel that is available to offload to receiver aircraft is the same fuel that the aircraft uses to fly. Air Force Pamphlet 10-1403 provides a formula for available offload from a tanker but it is not designed for the tactical refueling in anchor areas that is typical of combat operations. Some general assumptions can be made to compute fuel loads needed. KC-135Rs can usually takeoff with 180,000 pound fuel loads from the bases they are operated from. This research uses that value as a

maximum fuel load. The average KC-135R planner uses 10,000 pounds per hour (pph) as a fuel burn planning factor. Most refueling bases require approximately 25,000 pounds of fuel reserve upon arrival at the landing base but the aircraft is limited to approximately 80,000 pounds of fuel upon landing (assuming no cargo is carried). With 5 hours of flight time (2.5 hours in each direction) and an average fuel burn of 10,000 pph, the KC-135R will have approximately 105,000 pounds of fuel available for both offload and loiter time in an anchor area. To account for the added drag of the MPRS, this analysis will use the fuel burn rate published in Air Force Pamphlet 10-1403 of 10,718 pph (Department of the Air Force, 2003a). This fuel burn rate is applied to the 5 hours of flight time to and from the refueling area. If the aircraft has a BDA attached, there is a 3% range penalty in the cruise configuration. The MPRS averages a 4,8% range penalty. For calculations while on station in the anchor area, this analysis will assume the aircraft is configured for refueling with boom down, or MPRS hoses and drogues extended. Table 4 shows the resultant fuel burn with the various range penalties applied (Department of the Air Force, 2002).

Table 4. Fuel Burn Rates (Department of the Air Force, 2002)

Configuration	Penalty	Fuel Burn Rate (pph)
Boom Stowed	None	10,718
Boom Down	1,200 pph	11,918
BDA Stowed	3%	11,040
BDA Down	3% + 1200pph	12,240
MPRS	≈ 4.8%	11,232
MPRS Extended	≈ 8%	12,131

The type of receiver aircraft is a significant consideration when planning. As discussed earlier, some receiver aircraft require a boom system for refueling and some

require a drogue system. Airspeed, altitude, and tanker gross weight are also important considerations.

Aircraft with incompatible speeds for refueling cannot be refueled by the same group of tankers at the same time. If refueling speeds are dissimilar with other receivers, refueling times are not allowed to overlap. Fighter aircraft refuel at a speed of 315 knots. Naval aircraft have varying optimal speeds but usually refuel at a common speed to allow for flexibility in refueling packages. This analysis assumes 275 knots. A-10s refuel at 220 knots and C-130s refuel at 200 knots. This analysis assumes fighter aircraft are compatible with naval aircraft for overlap of maneuver times but will not be refueled simultaneously. A-10s and C-130s are compatible low speed receivers with each other but not with any other type receiver. Altitude is a limitation for many aircraft. For this analysis, only fighter aircraft can refuel in the high refueling areas. A-10s and C-130s are restricted to refueling in low refueling areas. A-10s and C-130s are also restricted from refueling with a tanker that is too heavy. The maximum tanker weight for refueling is 250,000 pounds so the maximum takeoff fuel weight of 180,000 pounds may be limited by the receiver aircraft and the refueling schedule.

### **Scheduling Art**

There is no automated tanker scheduling tool or even a defined procedure for accomplishing scheduling for tactical refueling. Scheduling is an art taught by the TPC that ensures successful refueling while attempting to optimize resources. The technique taught is the use of a 'rainbow chart' to display refueling requests in a visual organization by refueling area and time.

With a 'rainbow chart', tankers are scheduled from available assets to cover all the refueling requests. Careful consideration is given to ensuring tankers have enough fuel to accomplish the refueling mission and receivers receive enough fuel in the requested time to complete their assigned mission. After rough planning, more complete fuel computations are made and each mission is checked to ensure successful completion. Reliability tankers are then added to ensure the desired mission-success rate. In some cases reliability tankers will not have a refueling mission scheduled but other cases will allow refueling missions to be split between tankers when one is enough to accomplish the mission but requires the second for reliability. Also, some reliability tankers need to have a receiver to prevent them from returning home with too much fuel onboard the aircraft to land. This excess fuel would require dumping in order to land and this waste of fuel can be avoided. Once the schedule is complete it is once again reviewed to ensure all missions with fuel requests have been scheduled a tanker (or informed of a lack of resources).

#### **IV. Analysis**

The majority of the analysis is in the scheduling that was accomplished with 'rainbow charts.' The initial scheduling effort, basic tanker scheduling, satisfied all refueling requests with KC-135Rs that could be equipped with the BDA for probe-equipped receivers. The rainbow chart can be found in Attachment 2. Review of the chart shows most receiver requests were adjusted within the parameters given in chapter 3. The summary of tanker missions for this scheduling effort can be found in Attachment 3. To fulfill all the refueling requests and achieve a 99.5% reliability rate, seventy-six tanker missions are needed. Forty-four of the missions are boom missions that can be accomplished through the use of twenty-six tankers using 4 hours of ground time between missions. Thirty-two of the missions are scheduled with a BDA. These missions can be supported with twenty-one aircraft using the same 4 hours of ground time between missions. A fleet of forty mission-capable aircraft is sufficient to cover all the missions if the BDAs are selectively swapped between aircraft and 2 hours are allowed for either installation or removal. With an 85% mission capable rate, a fleet of thirty-one boom-configured tankers and twenty-five BDA-configured tankers, for a total of fifty-six tankers, is sufficient to support the refueling requests. With maintenance installation and removal of the BDAs, only forty-eight aircraft are required to support all the missions. A total of 467 flight hours are required to accomplish these missions of which 276 are boom hours and 191 are BDA hours.

The second scheduling effort, MPRS tanker scheduling, satisfied all refueling requests with KC-135Rs that could be equipped with the MPRS for probe-equipped receivers. The rainbow chart can be found in Attachment 4. Review of the chart shows

most receiver requests were adjusted within the parameters given in chapter 3. The summary of tanker missions for this scheduling effort can be found in Attachment 5. To fulfill all the refueling requests and achieve a 99.5% reliability rate, sixty-three tanker missions are needed. Thirty-seven of the missions are boom missions that can be accomplished through the use of twenty tankers using 4 hours of ground time between missions. Twenty-six of the missions are scheduled with the MPRS. These missions can be supported with twenty aircraft using the same 4 hours of ground time between missions. A fleet of twenty-seven aircraft is sufficient to cover all the missions if the MPRSs are selectively used on aircraft and 4 hours are allowed for either installation or removal. With an 85% mission capable rate, a fleet of twenty-four boom-configured tankers and twenty-four MPRS-configured tankers, for a total of forty-eight tankers, is sufficient to support the refueling requests. The current fleet of only twenty MPRS-capable aircraft is insufficient to satisfy this need. With maintenance installation and removal of the MPRS, only forty-three aircraft are required to support all the missions but twenty-four of these aircraft must be modified aircraft that can have the MPRS installed. A total of 390 flight hours are required to accomplish these missions of which 226 are boom hours and 164 are MPRS hours. Table 5 on the next page shows a comparison of the two options.

Flying costs for the KC-135R are \$2,704 per flight hour in fiscal year 2003 dollars (Department of the Air Force, 2003b). Applying this cost to the flight hours in each of the schedules shows the difference in costs that can be spent on the MPRS to increase capability without increasing cost per flight hour. Applying the flying hour cost to the scheduled flying time yields the results seen in the bottom of Table 5. Since the

Table 5. Comparison of Schedules, KC-135R vs. KC-135R with MPRS

	Without MPRS	With MPRS	Value Difference	Percentage Difference
Missions Needed	76	63	13	17.1%
Mission-Capable Aircraft Needed (w/o conversion)	47	40	7	14.9%
Mission Capable Aircraft Needed (with conversion)	40	36	4	10.0%
Total Aircraft Needed (w/o conversion)	56	48	8	14.3%
Total Aircraft Needed (with conversion)	48	43	5	10.4%
Total Hours Flown	467	390	77	16.5%
Boom Hours Flown	276	226	50	18.1%
Droge Hours Flown	191	164	27	14.1%
Cost of Flight Time (1,000s of \$)*	\$ 1,262.68	\$ 1,055.28	\$ 207.40	16.4%

\* Flight time cost does not include cost of MPRS

cost savings of \$207,400 must be compared to the unknown MPRS costs, it must be spread evenly over the MPRS hours to determine the threshold MPRS flying-hour costs. Spread over the 164 MPRS flying hours, the threshold cost is \$1,264,63. The design review flying hour cost was \$350.81 in 1996 dollars. Adjusting for inflation is extremely difficult without knowing the makeup of the design review costs. Each type of expenditure has a different inflation rate. With that in mind, the worst case inflation rate from 1996 to 2003 is 171% (Purvis, 2003). In 2003 dollars, the cost per flying hour is \$599.89 which is well below the threshold cost.



## **V. Conclusion**

The MPRS provides increased capability for the KC-135 fleet. In a tactical employment refueling scenario, the MPRS increases efficiency of the theater-wide refueling mission 10-18%, depending on your perspective. This value range is contingent upon the assumptions of system reliability, desired mission success, and the type of tactical environment in which the system is employed. Based upon the 16.4% savings in flight time, the MPRS can have an operating cost of \$1,264.63 per flight hour. Based upon the only cost figure currently available, the preliminary design review cost of \$350.81 per flight hour, this system adds significant value in redundancy and mission capability without costing more than the savings achieved.

This conclusion is limited to a tactical employment environment that is typical of recent combat operations supported by the refueling fleet. It does not provide an assessment for the required capability of the refueling fleet nor does it make any broad implications about the current or future force structure.

### **Areas for Further Study**

Reliability of the MPRS has experienced a wide range of results. Now that the system is experiencing increased usage for both training and combat operations, a model needs to be developed to accurately assess the reliability of the system. This reliability should be expressed as a mission capable rate to apply to the fleet. With this known reliability, accurate costs can be determined. Additionally, new reliability values are needed to show mission success. These values can be used to provide the assessment of a

refueling plan so that planners and leaders can know the level of service provided to the refueling customer. Also, with this information, the refueling customer can request a level of refueling support in terms of refueling requests and a desired mission success rate that can be supported.

A life cycle cost model needs to be developed to help make decisions about the future of this program. The future of the system will be decided on a cost-benefit analysis that cannot be accomplished without the known costs. Benefits can be analyzed in varying scenarios depending on the National Military Strategy but without the costs, decisions cannot be made.

Future tanker aircraft could benefit greatly from the MPRS. Early consideration must be given to this system since the increased value could alter the purchase decisions. Acquisition of a fleet of aircraft to replace the KC-135 without first considering the MPRS will most likely result in an adequate refueling capacity for a given price. It is unlikely that additional money would be spent to improve a system that already meets the needs of the Air Force. However, an early decision to add the MPRS could create more value for the money. It could lead to the purchase of a smaller fleet of aircraft to replace the KC-135 and saving money that can be better used on other needs.

## **Recommendations**

Planning tools need to be developed that will automate refueling scheduling, converting it from an art to a science. Our military can not afford to leave utilization of a high value, high demand asset to the risk of an artists skill with a paintbrush. In addition to automated planning tools for tanker scheduling, tanker planners need to be equipped

with better planning guidance than that found in AMCP 10-1403. This document fails to consider tactical tanker employment issues in favor of limited deployment refueling information and airlift on tanker aircraft.

The CFACC must have a well thought out reliability plan that is more extensive than a directive to ensure there are enough backup tankers and fuel aloft to support the loss of tanker support. Air Mobility Division planners need to be able to provide a designed reliability level in support of an air campaign. With automated planning tools, planners need to be able to program these tools with the CFACC's desired level of reliability.

Finally, as the primary user of drogue refueling, the Navy must identify its refueling requirements. Only these requirements can give the Air Force the foundation to acquire and maintain refueling assets that are capable of supporting the sizable drogue-refueling mission.

## Appendix A. Sample Refueling Requests

Mission Number	Number of Aircraft	Type of Aircraft	Refueling Type Required	Location	Altitude (x 100)	Begin Refueling Time	End Refueling Time	Offload (x 1000 pounds)
1326F	3	B-52H	Boom	Bongo	240	140030	140138	53
1331F	3	B-52H	Boom	Bongo	240	140910	141018	53
1655F	4	F-15C	Boom	Chevy HI	260	141622	141643	42
1425F	4	F-15C	Boom	Chevy HI	260	142106	142120	23
1661F	4	F-15C	Boom	Chevy HI	260	142122	142143	42
1525F	4	F-16C	Boom	Chevy MID	200	132324	132337	20
2401	4	F-16CJ	Boom	Chevy MID	200	132338	132348	15
1521F	4	F-16C	Boom	Chevy MID	200	132350	140003	21
1405F	4	F-15C	Boom	Chevy MID	200	140005	140016	20
1701F	4	F-15E	Boom	Chevy MID	200	140010	140028	29
1411F	4	F-15C	Boom	Chevy MID	200	140040	140048	15
1641F	4	F-15C	Boom	Chevy MID	200	140122	140133	41
1645F	4	F-15C	Boom	Chevy MID	200	140622	140643	41
1561F	4	F-16C	Boom	Chevy MID	200	141004	141017	20
2405	4	F-16CJ	Boom	Chevy MID	200	141016	141027	15
1705F	4	F-15E	Boom	Chevy MID	200	141035	141047	38
1651F	4	F-15C	Boom	Chevy MID	200	141122	141133	41
1571F	4	F-16C	Boom	Chevy MID	220	142140	142151	17
1575F	4	F-16C	Boom	Chevy MID	220	142145	142202	17
2415	4	F-16CJ	Boom	Chevy MID	220	142145	142223	16
1601F	4	F-16C	Boom	Chevy MID	220	142155	142211	17
2235N	4	F-14D	Drogue	Ford HI	280	141140	141152	23
2305N	2	EA-6B	Drogue	Ford MID	220	140205	140223	15
2515N	4	F/A-18D	Drogue	Ford MID	220	141105	141120	11
2525N	4	F/A-18D	Drogue	Ford MID	220	141120	141135	11
2511N	4	F/A-18D	Drogue	Ford MID	220	141140	141200	15
2302N	1	EA-6B	Drogue	Ford MID	220	141230	141238	7
2521N	4	F/A-18D	Drogue	Ford MID	220	141305	141333	23
2011F	4	A-10	Boom	Ford LO	160	140126	140140	24
1761F	4	A-10	Boom	Ford LO	160	140140	140155	26
2015F	4	A-10	Boom	Ford LO	160	140426	140440	24
1246F	1	EC-130	Boom	Ford LO	160	140455	140504	19
1765F	4	A-10	Boom	Ford LO	160	140540	140555	26
2021F	4	A-10	Boom	Ford LO	160	140726	140740	24
1771F	4	A-10	Boom	Ford LO	160	140940	140955	26
1261M	4	AV-8B	Drogue	Ford LO	160	141135	141151	28
1265M	4	AV-8B	Drogue	Ford LO	160	141150	141209	33
2307N	2	EA-6B	Drogue	Ford LO	160	141305	141312	9
1247F	1	EC-130	Boom	Ford LO	110	141335	141344	18
1775F	4	A-10	Boom	Ford LO	110	141340	141359	26
2001F	4	A-10	Boom	Ford LO	160	141740	141755	26
1250F	1	EC-130	Boom	Ford LO	160	142050	142058	15

Mission Number	Number of Aircraft	Type of Aircraft	Refueling Type Required	Location	Altitude (x 100)	Begin Refueling Time	End Refueling Time	Offload (x 1000 pounds)
2005F	4	A-10	Boom	Ford LO	160	142140	142155	26
2501F	1	RC-135V	Boom	Mercury	250	140335	140428	81
2136F	1	E-8	Boom	Mercury	250	140452	140545	63
1126F	1	E-3C	Boom	Mercury	250	140535	140628	62
2502F	1	RC-135V	Boom	Mercury	250	141135	141228	81
2137F	1	E-8	Boom	Mercury	250	141435	141528	41
1127F	1	E-3C	Boom	Mercury	250	141735	141828	62
2503F	1	RC-135V	Boom	Mercury	250	141935	142028	81
2140F	1	E-8	Boom	Mercury	250	142035	142128	42
2535N	4	F/A-18D	Drogue	Olds HI	260	141805	141813	12
2541N	4	F/A-18D	Drogue	Olds HI	260	141845	141856	16
2551N	4	F/A-18D	Drogue	Olds HI	260	141855	141906	16
2215N	4	F-14D	Drogue	Olds MID	200	140142	140153	40
2203N	4	F-14D	Drogue	Olds MID	200	140542	140553	40
2221N	4	F-14D	Drogue	Olds MID	200	140942	141002	40
2225N	4	F-14D	Drogue	Olds MID	200	141342	141402	40
2231N	4	F-14D	Drogue	Olds MID	200	141742	141802	40
2531N	4	F/A-18D	Drogue	Olds MID	200	141835	141846	17
2545N	4	F/A-18D	Drogue	Olds MID	200	141855	141906	17
2311N	2	EA-6B	Drogue	Olds MID	200	142025	142040	13
2213N	4	F-14D	Drogue	Olds MID	200	142142	142202	40
1415F	4	F-15C	Boom	Pontiac HI	280	141710	141724	24
1421F	4	F-15C	Boom	Pontiac HI	280	141815	141831	28
2201N	2	F-14D	Drogue	Pontiac HI	280	142005	142014	16
1165B	4	GR-1B	Drogue	Pontiac MID	220	141734	141750	28
1161B	4	GR-1B	Drogue	Pontiac MID	220	141750	141804	25
1171B	4	GR-1B	Drogue	Pontiac MID	220	141815	141832	31
1175B	4	GR-1B	Drogue	Pontiac MID	220	141855	141912	31
2300N	2	EA-6B	Drogue	Pontiac MID	220	142030	142042	20
1531F	4	F-16C	Boom	Pontiac LO	160	140136	140158	18
2061F	1	AC-130H	Boom	Pontiac LO	160	140225	140233	15
1535F	4	F-16C	Boom	Pontiac LO	160	140536	140558	18
2062F	1	AC-130H	Boom	Pontiac LO	160	140725	140733	15
1541F	4	F-16C	Boom	Pontiac LO	160	140936	140958	18
2063F	1	AC-130H	Boom	Pontiac LO	160	141225	141233	15
1545F	4	F-16C	Boom	Pontiac LO	160	141336	141358	18
2411	4	F-16CJ	Boom	Pontiac LO	160	141711	141722	15
2064F	1	AC-130H	Boom	Pontiac LO	160	141725	141733	15
1551F	4	F-16C	Boom	Pontiac LO	160	141736	141758	18
1565F	4	F-16C	Boom	Pontiac LO	160	141800	141814	24
1555F	4	F-16C	Boom	Pontiac LO	160	142136	142158	18
2065F	1	AC-130H	Boom	Pontiac LO	160	142155	142207	13

### Appendix B. Basic Tanker Rainbow Sheet

Time-->	23:15	23:20	23:25	23:30	23:35	23:40	23:45	23:50	23:55	0:00	0:05	0:10	0:15	0:20	0:25	0:30	0:35	0:40	0:45	0:50	0:55	1:00	1:05	1:10	1:15	1:20
<b>Location</b>																										
Bongo																	30M KC135/50K88									cont.
																	30B B32/23K88									cont.
Chevy HI				20M KC135M 70K67																						cont.
Chevy MID				22K KC135M 50K29																						cont.
Ford HI																										
Ford MID																										
Ford LO																										cont.
Mercury																										cont.
OBS HI																										
OBS MID																										
Pontiac HI																										
Pontiac MID																										
Pontiac LO																										

Time-->	1:25	1:30	1:35	1:40	1:45	1:50	1:55	2:00	2:05	2:10	2:15	2:20	2:25	2:30	2:35	2:40	2:45	2:50	2:55	3:00	3:05	3:10	3:15	3:20	3:25	3:30	
Location																											
Bongo																											
Chevy HI																											
Chevy MID																											
Ford HI																											
Ford MID																											
Ford LO																											
Marcury																											
ORSHI																											
ORSMID																											
Pontiac HI																											
Pontiac MID																											
Pontiac LO																											

Time-->	3:35	3:40	3:45	3:50	3:55	4:00	4:05	4:10	4:15	4:20	4:25	4:30	4:35	4:40	4:45	4:50	4:55	5:00	5:05	5:10	5:15	5:20	5:25	5:30	5:35	5:40		
Location																												
Bongo																												
Chevy HI																												
Chevy MID																												
Ford HI											274 KC18015CK44																cont.	
Ford MID																												
Ford LO											274 KC136M3CK06																cont.	
											274A1024K45																cont.	
Marcury																												cont.
																												cont.
																												cont.
ORS HI																												cont.
ORS MID																												cont.
Pontiac HI																												cont.
Pontiac MID																												cont.
Pontiac LO																												cont.





Time-->	7:55	8:00	8:05	8:10	8:15	8:20	8:25	8:30	8:35	8:40	8:45	8:50	8:55	9:00	9:05	9:10	9:15	9:20	9:25	9:30	9:35	9:40	9:45	9:50	9:55	10:00	
Location																											
Bongo																											
Chevy HI																											
Chevy MID																											
Ford HI																											
Ford MID																											
Ford LO																											
Mercury																											
ONB HI																											
ONB MID																											
Pontiac HI																											
Pontiac MID																											
Pontiac LO																											

Time-->	10:05	10:10	10:15	10:20	10:25	10:30	10:35	10:40	10:45	10:50	10:55	11:00	11:05	11:10	11:15	11:20	11:25	11:30	11:35	11:40	11:45	11:50	11:55	12:00	12:05	12:10
Location																										
Bongo	cont.																									
Chevy HI	cont.																									
Chevy MID	cont.																									
Ford HI	cont.																									
Ford MID	cont.																									
Ford LO	cont.																									
Mercury	cont.																									
ONS HI																										
ONS MID	cont.																									
Pontiac HI																										
Pontiac MID																										
Pontiac LO																										

Time-->	12:15	12:20	12:25	12:30	12:35	12:40	12:45	12:50	12:55	13:00	13:05	13:10	13:15	13:20	13:25	13:30	13:35	13:40	13:45	13:50	13:55	14:00	14:05	14:10	14:15	14:20
Location																										
Bondap																										
Chevy HI	e.ont.																									
Chevy MID																										
Ford HI																										
Ford MID	e.ont.																									
Ford LO	e.ont.																									
Marcury	e.ont.																									
Obs HI																										
Obs MID																										
Pontiac HI																										
Pontiac MID																										
Pontiac LO																										



Time-->	18:35	18:40	18:45	18:50	18:55	17:00	17:05	17:10	17:15	17:20	17:25	17:30	17:35	17:40	17:45	17:50	17:55	18:00	18:05	18:10	18:15	18:20	18:25	18:30	18:35	18:40	
Location																											
Bondo																											
Chevy HI																											
Chevy MID																											
Ford HI																											
Ford MID																											
Ford LO																											
Mercury																											
Obs HI																											
Obs MID																											
Pontiac HI																											
Pontiac MID																											
Pontiac LO																											



Time-->	20:55	21:00	21:05	21:10	21:15	21:20	21:25	21:30	21:35	21:40	21:45	21:50	21:55	22:00	22:05	22:10	22:15	22:20	22:25	22:30	22:35	22:40	22:45	22:50	22:55	23:00	23:05	
Location																												
Bongo																												
Chevy HI	cont.	47M KCI35M4B1W23																										
Chevy MID			06/8 KCI35M4B1K23																									
			06/4 F-523K20																									
				22/4 F-1542K43																								
Ford HI																												
Ford MID																												
Ford LO	cont.	47M KCI35M39K57																										
	cont.																											
	cont.																											
Mercury	cont.																											
	cont.																											
	cont.																											
	cont.																											
Clids HI																												
Clids MID	cont.																											
Pontiac HI																												
Pontiac MID																												
Pontiac LO																												





### Appendix C. Basic Tanker Schedule

Num A/C	Tnkr Config	Location	Fuel Load	Entry	Exit	Scheduled Offload	Sched. Land. Fuel	Missions Refueled
1	Boom	Bongo	150	0:30	1:38	53	29	1326F
1	Boom	Bongo	150	9:10	10:18	53	29	1331F
1	Boom	Chevy HI	170	23:22	1:59	29	56	1701F
1	BDA	Chevy HI	165	11:02	13:17	11	71	2515N
1	Boom	Chevy HI	145	20:47	22:23	0	72	
2	Boom	Chevy MID	145	23:22	0:28	76	40	1405F, 1521F, 1525F, 2401
1	Boom	Chevy MID	150	0:36	1:38	56	28	1411F, 1641F
2	Boom	Chevy MID	155	10:02	11:33	99	34	1561F, 1651F, 1705F
3	Boom	Chevy MID	140	21:06	22:23	132	27	1425F, 1571F, 1575F, 1655F, 1661F, 2145
1	Boom	Ford HI	150	4:27	6:44	0	69	
1	Boom	Ford HI	110	7:22	7:40	0	52	
1	Boom	Ford HI	160	9:38	11:33	15	68	2405
3	BDA	Ford HI	95	11:37	11:54	23	28	2235N
2	BDA	Ford MID	95	2:02	2:25	15	28	2305N
1	BDA	Ford MID	165	11:02	13:17	42	40	2302N, 2307N, 2511N, 2525N
1	Boom	Ford LO	140	1:24	1:57	50	29	1761F, 2011F
1	Boom	Ford LO	130	4:27	5:06	43	25	1246F, 2015F
1	Boom	Ford LO	110	5:38	5:57	26	26	1765F
1	Boom	Ford LO	160	6:20	7:40	65	25	1645F, 2021F
1	Boom	Ford LO	110	9:38	9:57	26	26	1771F
2	BDA	Ford LO	150	11:33	13:33	84	28	1261M, 1265M, 2521N
2	Boom	Ford LO	130	13:35	14:03	44	48	1247F, 1775F
2	Boom	Ford LO	170	16:20	17:57	68	63	1655F, 2001F
1	Boom	Ford LO	135	20:47	21:57	41	26	1250F, 2005F
1	Boom	Mercury	175	3:35	4:28	81	29	2501F
1	Boom	Mercury	155	4:52	5:45	63	27	2136F
1	Boom	Mercury	155	5:35	6:28	62	28	1126F
1	Boom	Mercury	175	11:35	12:28	81	29	2502F
1	Boom	Mercury	135	14:35	15:28	41	29	2137F
1	Boom	Mercury	155	17:35	18:28	62	28	1127F
1	Boom	Mercury	175	19:35	20:28	81	29	2503F
1	Boom	Mercury	135	20:35	21:28	42	28	2140F
1	BDA	Olds HI	140	17:41	19:11	0	66	
1	BDA	Olds HI	145	19:55	22:05	0	63	
3	BDA	Olds MID	110	1:31	1:58	40	36	2215N
3	BDA	Olds MID	105	5:36	5:58	40	32	2203N
3	BDA	Olds MID	110	9:38	10:05	40	36	2221N
3	BDA	Olds MID	110	13:38	14:05	40	36	2225N

Num A/C	Tnkr Config	Location	Fuel Load	Entry	Exit	Scheduled Offload	Sched. Land. Fuel	Missions Refueled
3	BDA	Olds MID	140	17:41	19:11	118	27	2231N, 2531N, 2535N, 2541N, 2545N, 2551N
2	BDA	Olds MID	120	20:24	21:07	53	30	2213N, 2300N
3	BDA	Pontiac MID	165	17:27	19:16	115	49	1161B, 1165B, 1171B, 1175B
1	BDA	Pontiac MID	130	19:55	20:47	36	28	2201N, 2311N
2	Boom	Pontiac LO	125	1:36	2:35	33	43	1531F, 1535F, 2061F
2	Boom	Pontiac LO	180	5:41	9:53	51	51	1541F, 2062F
2	Boom	Pontiac LO	135	12:22	13:58	33	46	1545F, 2063F
3	Boom	Pontiac LO	160	17:04	18:31	124	48	1415F, 1421F, 1551F, 1565F, 2411
2	Boom	Pontiac LO	120	21:32	22:08	31	44	1555F, 2065F

## Appendix D. MPRS Tanker Rainbow Sheet

Time	23:15	23:20	23:25	23:30	23:35	23:40	23:45	23:50	23:55	0:00	0:05	0:10	0:15	0:20	0:25	0:30	0:35	0:40	0:45	0:50	0:55	1:00	1:05	1:10	1:15	1:20	
Location																											
Bongo																	30M KC135/150/K38									cont.	
																	30V B52/63/K38										
Chewy HI																											
Chewy MID																											
Ford HI																											
Ford MID																											
Ford LO																											
Mercury																											
Oldis HI																											
Oldis MID																											
Portiac H																											
Portiac MID																											
Portiac LO																											



Time	1:25	1:30	1:35	1:40	1:45	1:50	1:55	2:00	2:05	2:10	2:15	2:20	2:25	2:30	2:35	2:40	2:45	2:50	2:55	3:00	3:05	3:10	3:15	3:20	3:25	3:30
Location																										
Borgo	cont.																									
Chevy HI	cont.																									
Chevy MID	cont. 144 F15/41K58																									
Ford H																										
Ford MID																										
Ford LO	cont. 242 KC1357150/K23																									
Mercury	cont. 244 K10/24K/42																									
Obis H	cont. 384 A 025 K57																									
Obis MID	cont. 311 KC1357301/K58																									
Pontiac H	cont. 311 KC13571801/58																									
Pontiac MID																										
Pontiac LO	cont. 384 KC135124/K55																									
	cont. 36/4 F16/18K58																									
	cont. 22 A C13015K55																									



Time	3:35	3:40	3:45	3:50	3:55	4:00	4:05	4:10	4:15	4:20	4:25	4:30	4:35	4:40	4:45	4:50	4:55	5:00	5:05	5:10	5:15	5:20	5:25	5:30	5:35	5:40	
Location																											
Bongo																											
Chew HI																											
Chew MID																											
Ford H												27 A KI 35/150/K44															cont.
Ford MID																											
Ford LO												27 A KI 35/130/K06															cont.
											27 A A10/24/K45																cont.
Mercury																											cont.
	35A KI 35/175/K28																										cont.
	35M RC 35/81/K28																										cont.
																											cont.
																											cont.
																											cont.
																											cont.
																											cont.
Obis H																											cont.
																											cont.
																											cont.
Obis MID																											cont.
																											cont.
																											cont.
																											cont.
Pontiac H																											cont.
																											cont.
Pontiac MID																											cont.
																											cont.
Pontiac LO																											cont.
																											cont.
																											cont.
																											cont.
																											cont.
																											cont.
																											cont.
																											cont.
																											cont.
																											cont.
																											cont.
																											cont.
																											cont.
																											cont.
																											cont.



Time	5:45	5:50	5:55	6:00	6:05	6:10	6:15	6:20	6:25	6:30	6:35	6:40	6:45	6:50	6:55	7:00	7:05	7:10	7:15	7:20	7:25	7:30	7:35	7:40	7:45	7:50	
Location																											
Bongo																											
Chewy HI																											
Chewy MID																											
Ford H																						22A KC133A10K90					
Ford MID																											
Ford LO																											
Mercury																											
Oldis H																											
Oldis MID																											
Pontiac H																											
Pontiac MID																											
Pontiac LO																											



Time	7:55	8:00	8:05	8:10	8:15	8:20	8:25	8:30	8:35	8:40	8:45	8:50	8:55	9:00
Location														
Bongo														cont.
														cont.
Chewy HI														cont.
														cont.
Chewy MID														cont.
														cont.
Ford H														cont.
Ford MID														cont.
Ford LO														cont.
														cont.
Mercury														cont.
														cont.
Oldis H														cont.
														cont.
Oldis MID														cont.
														cont.
Pontiac H														cont.
														cont.
Pontiac MID														cont.
														cont.
Pontiac LO														cont.
														cont.



Time	10:05	10:10	10:15	10:20	10:25	10:30	10:35	10:40	10:45	10:50	10:55	11:00	11:05	11:10	11:15	11:20	11:25	11:30	11:35	11:40	11:45	11:50	11:55	12:00	12:05	12:10
Location																										
Bongo	cont.																									
Bongo	cont.																									
Chevy HI	cont.																									
Chevy HI	cont.																									
Chevy MID	cont.																									
Ford H																										
Ford MID																										
Ford LO																										
Mercury																										
Oldis H																										
Oldis MID	cont.																									
Oldis MID	cont.																									
Pontiac H	cont.																									
Pontiac MID																										
Pontiac LO																										





Time	12:15	12:20	12:25	12:30	12:35	12:40	12:45	12:50	12:55	13:00	13:05	13:10	13:15	13:20	13:25	13:30	13:35	13:40	13:45	13:50	13:55	14:00	14:05	14:10	14:15	14:20
Location																										
Borgo																										
Chevy HI																										
Chevy MID																										
Ford HI																										
Ford MID																										
Ford LO																										
Mercury																										
Olds HI																										
Olds MID																										
Portiac HI																										
Portiac MID																										
Portiac LO																										





# REPORT DOCUMENTATION PAGE

Form Approved  
OMB No. 0704-0188

maintaining the data needed, and completing and reviewing this collection of information. Send comments regarding this burden estimate or any other aspect of this collection of information, including suggestions for reducing this burden to Department of Defense, Washington Headquarters Services, Directorate for Information Operations and Reports (0704-0188), 1215 Jefferson Davis Highway, Suite 1204, Arlington, VA 22202-4302. Respondents should be aware that notwithstanding any other provision of law, no person shall be subject to any penalty for failing to comply with a collection of information if it does not display a currently valid OMB control number. **PLEASE DO NOT RETURN YOUR FORM TO THE ABOVE ADDRESS.**

<b>1. REPORT DATE (DD-MM-YYYY)</b> xx - 06 - 2003	<b>2. REPORT TYPE</b> Graduate Research Project	<b>3. DATES COVERED (From - To)</b> Jun 2002 - Jun 2003
--	--	--

<b>4. TITLE AND SUBTITLE</b> The KC-135 With a Multi-Point Refueling System:  Increased Capability With Unknown Costs	<b>5a. CONTRACT NUMBER</b>
	<b>5b. GRANT NUMBER</b>
	<b>5c. PROGRAM ELEMENT NUMBER</b>

<b>6. AUTHOR(S)</b> Dittus, James E.	<b>5d. PROJECT NUMBER</b>
	<b>5e. TASK NUMBER</b>
	<b>5f. WORK UNIT NUMBER</b>

<b>7. PERFORMING ORGANIZATION NAME(S) AND ADDRESS(ES)</b> Air Force Institute of Technology Graduate School of Engineering and Management (AFIT/EN) 2950 P Street, Building 640 WPAFB OH 45433-7765	<b>8. PERFORMING ORGANIZATION REPORT NUMBER</b>  AFIT/GMO/ENS/03E-02
---	--

<b>9. SPONSORING / MONITORING AGENCY NAME(S) AND ADDRESS(ES)</b> Col Robert Winston Chief, Global Mobility and Special Operations Air Staff Pentagon DSN 227-4939	<b>10. SPONSOR/MONITOR'S ACRONYM(S)</b> AF/XORM
	<b>11. SPONSOR/MONITOR'S REPORT NUMBER(S)</b>

**12. DISTRIBUTION / AVAILABILITY STATEMENT**  
Approved for public release, distribution unlimited

**13. SUPPLEMENTARY NOTES**

**14. ABSTRACT**

The Multi-Point Refueling System augments the refueling capability of the KC-135. Its utilization has been low since purchase due to design problems. Despite the challenges, the value of the MPRS cannot be overstated. This mission capability gives planners the ability to plan refueling more efficiently.

Now that the MPRS is fully operational it is possible to quantify its value and compare it with the costs to make decisions about the future of the system. This research will draw on technical manuals, testing, and expert opinion to determine planning factors to use for tactical refueling planning with MPRS. A set of refueling requests will be evaluated. The refueling satisfied by KC-135Rs without MPRS capability will be compared to the same requirements fulfilled by KC-135Rs equipped with MPRS to provide an evaluation of the system's value.

MPRS provides increased capability for the KC-135 fleet. In a tactical employment refueling scenario, the MPRS increases efficiency of the refueling mission 10-18%. This value range is contingent upon the assumptions of system reliability, desired mission success, and the type of tactical environment in which the system is employed. This system adds significant value in redundancy and mission capability without costing more than the savings achieved.

**15. SUBJECT TERMS**  
Multi-Point Refueling System MPRS KC-135 tanker life cycle costs drogue planning scheduling

<b>16. SECURITY CLASSIFICATION OF:</b>			<b>17. LIMITATION OF ABSTRACT</b>  UU	<b>18. NUMBER OF PAGES</b>  83	<b>19a. NAME OF RESPONSIBLE PERSON</b> Lt Col Stephan P. Brady
<b>a. REPORT</b> U	<b>b. ABSTRACT</b> U	<b>c. THIS PAGE</b> U			<b>19b. TELEPHONE NUMBER (include area code)</b> (937) 255-6565 x4367