

*ARMY RESEARCH LABORATORY*



**Launch Dynamics of the XM1002 Cartridge, 120-mm Target  
Practice Multipurpose Projectile, TPMP-T**

**by James F. Newill, James Garner, Anthony Farina,  
Rollie Dohrn, and Dipak Kamdar**

**ARL-TR-3068**

**September 2003**

## **NOTICES**

### **Disclaimers**

The findings in this report are not to be construed as an official Department of the Army position unless so designated by other authorized documents.

Citation of manufacturer's or trade names does not constitute an official endorsement or approval of the use thereof.

Destroy this report when it is no longer needed. Do not return it to the originator.

# **Army Research Laboratory**

Aberdeen Proving Ground, MD 21005-5066

---

---

**ARL-TR-3068**

**September 2003**

---

## **Launch Dynamics of the XM1002 Cartridge, 120-mm Target Practice Multipurpose Projectile, TPMP-T**

**James F. Newill and James Garner  
Weapons and Materials Research Directorate, ARL**

**Anthony Farina  
U.S. Army Armament Research, Development, and Engineering Center,  
Picatinny Arsenal**

**Rollie Dohrn and Dipak Kamdar  
Alliant Techsystems Inc.**

## Report Documentation Page

*Form Approved*  
OMB No. 0704-0188

Public reporting burden for this collection of information is estimated to average 1 hour per response, including the time for reviewing instructions, searching existing data sources, gathering and maintaining the data needed, and completing and reviewing the collection information. Send comments regarding this burden estimate or any other aspect of this collection of information, including suggestions for reducing the burden, to Department of Defense, Washington Headquarters Services, Directorate for Information Operations and Reports (0704-0188), 1215 Jefferson Davis Highway, Suite 1204, Arlington, VA 22202-4302. Respondents should be aware that notwithstanding any other provision of law, no person shall be subject to any penalty for failing to comply with a collection of information if it does not display a currently valid OMB control number.

**PLEASE DO NOT RETURN YOUR FORM TO THE ABOVE ADDRESS.**

<b>1. REPORT DATE (DD-MM-YYYY)</b> September 2003		<b>2. REPORT TYPE</b> Final		<b>3. DATES COVERED (From - To)</b> October 2001–May 2002	
<b>4. TITLE AND SUBTITLE</b> Launch Dynamics of the XM1002 Cartridge, 120-mm Target Practice Multipurpose Projectile, TPMP-T				<b>5a. CONTRACT NUMBER</b>	
				<b>5b. GRANT NUMBER</b>	
				<b>5c. PROGRAM ELEMENT NUMBER</b>	
<b>6. AUTHOR(S)</b> James F. Newill, James Garner, Anthony Farina,* Rollie Dohrn,** and Dipak Kamdar**				<b>5d. PROJECT NUMBER</b> 1L162618AH80	
				<b>5e. TASK NUMBER</b>	
				<b>5f. WORK UNIT NUMBER</b>	
<b>7. PERFORMING ORGANIZATION NAME(S) AND ADDRESS(ES)</b> U.S. Army Research Laboratory ATTN: AMSRL-WM-BC Aberdeen Proving Ground, MD 21005-5066				<b>8. PERFORMING ORGANIZATION REPORT NUMBER</b> ARL-TR-3068	
<b>9. SPONSORING/MONITORING AGENCY NAME(S) AND ADDRESS(ES)</b>				<b>10. SPONSOR/MONITOR'S ACRONYM(S)</b>	
				<b>11. SPONSOR/MONITOR'S REPORT NUMBER(S)</b>	
<b>12. DISTRIBUTION/AVAILABILITY STATEMENT</b> Approved for public release; distribution is unlimited.					
<b>13. SUPPLEMENTARY NOTES</b> *U.S. Army Armament Research, Development, and Engineering Center, Picatinny Arsenal, NJ 07806 **Alliant Techsystems Inc., Arden Hills, MN 55112					
<b>14. ABSTRACT</b> This report details the launch performance of the experimental XM1002. The study compares the accuracy performance of candidate XM1002 designs to aid the development. The results show significant differences in launch characteristic of the two types of projectiles, which are related to their transverse moment of inertia.					
<b>15. SUBJECT TERMS</b> gun/projectile launch dynamics, HEAT projectile					
<b>16. SECURITY CLASSIFICATION OF:</b>			<b>17. LIMITATION OF ABSTRACT</b>  UL	<b>18. NUMBER OF PAGES</b>  20	<b>19a. NAME OF RESPONSIBLE PERSON</b> James F. Newill
<b>a. REPORT</b> UNCLASSIFIED	<b>b. ABSTRACT</b> UNCLASSIFIED	<b>c. THIS PAGE</b> UNCLASSIFIED			<b>19b. TELEPHONE NUMBER (Include area code)</b> 410-278-6097

Standard Form 298 (Rev. 8/98)  
Prescribed by ANSI Std. Z39.18

---

## Contents

---

<b>List of Figures</b>	<b>iv</b>
<b>List of Tables</b>	<b>iv</b>
<b>1. Introduction</b>	<b>1</b>
<b>2. XM1002 Projectile</b>	<b>2</b>
<b>3. Development Plan</b>	<b>2</b>
<b>4. GPDS</b>	<b>3</b>
4.1 What Are They? .....	3
4.2 How Are They Done?.....	4
<b>5. Versions of the XM1002 Projectile Used in This Report</b>	<b>7</b>
<b>6. Launch of the XM1002</b>	<b>7</b>
<b>7. Conclusions</b>	<b>12</b>
<b>8. References</b>	<b>14</b>

---

## List of Figures

---

Figure 1. The XM1002. ....	1
Figure 2. XM1002 performance specification risk levels.....	3
Figure 3. Components of the models. ....	4
Figure 4. Definition of projectile jump. ....	5
Figure 5. Projectile rates, and projectile motion relative to the bore. ....	5
Figure 6. Definition of projectile jump and variability for the simulations. ....	6
Figure 7. Description of the Plan A and Plan B projectile.....	7
Figure 8. Gun tube centerline shape. ....	8
Figure 9. Types of defects seen in gun tube centerlines. ....	8
Figure 10. Ideal tube shapes.....	9
Figure 11. Torturous path tubes (based on SN2658). ....	9
Figure 12. Results from ideal tube shapes. ....	10
Figure 13. Results from torturous path shapes.....	11
Figure 14. Relative jump vs. tube shape magnitude. ....	12

---

## List of Tables

---

Table 1. Physical properties of the projectiles. ....	7
---	---

---

## 1. Introduction

---

The XM1002 is the multipurpose, antitank (MPAT) training round being developed for use in the M1A1 Abram's 120-mm M256 gun system by the Project Manager for Tank and Medium-Caliber Armament Systems, Picatinny Arsenal, NJ. The projectile development program is low cost with an accelerated timeframe that uses less (Figure 1) firing than traditional training projectile development programs. In order to meet the demands of the program, Alliant Techsystems Incorporated (ATK)\* proposed a development plan using a mix of ballistic tests, wind tunnel tests, and high-fidelity aerodynamic range tests coupled with gun/projectile simulation. This report describes the approach used for the gun projectile simulation work along with typical results.

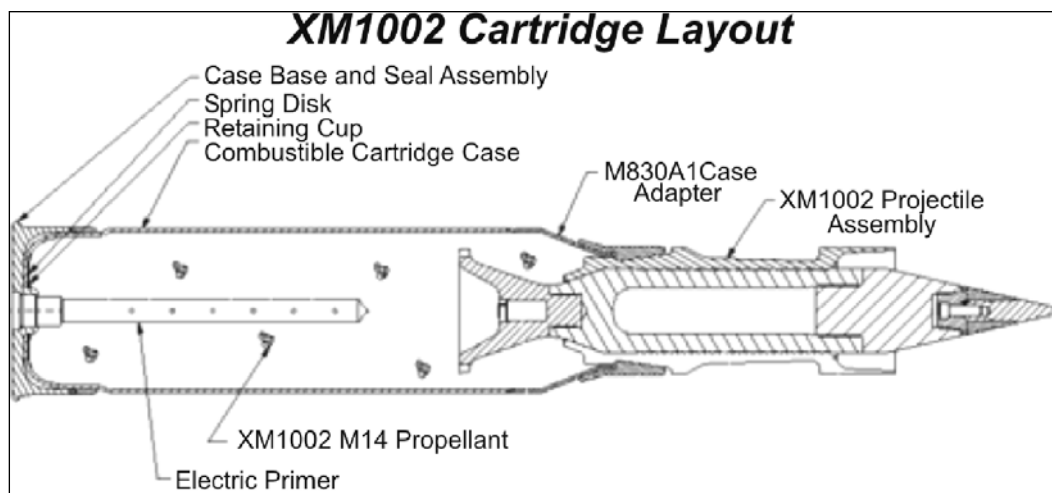

Figure 1. The XM1002.

In order to understand the launch performance of the XM1002 projectile, the U.S. Army Research Laboratory's gun/projectile dynamics simulation (GPDS) codes were used. This method relies on a numerical-experimental approach to design, where projectile changes are assessed for performance changes in projectile muzzle jump. The approach mimics traditional experimental development, which uses system performance to drive projectile design decisions. The projectile configurations are assessed through a range of theoretical gun centerline profiles and defects to show the design's sensitivity to the system. The performance characterization of the projectiles is an extension of the simulation work that has been accomplished on other tank ammunition.

The results describe the launch dynamics of the XM1002, which are compared to the kinetic energy (KE) and high-explosive antitank (HEAT) projectile counterparts. From these results, a

---

\* Alliant Techsystems Inc. (ATK), Arden Hills, MN 55112.

definition of performance will be developed and used in the comparison of different projectiles and the source of their performance differences.

---

## **2. XM1002 Projectile**

---

The requirements for the XM1002 projectile include a maximum range of  $\leq 8000$  m at  $10^\circ$  gun elevation, and a target impact dispersion of  $\leq 0.3$  mil. Additionally, the tracer, which must be a different color than other 120-mm training rounds, must be visible to a range of 3000 m. The design must be as low cost as possible. A unique fire control solution will be developed and incorporated into the M1 Abrams tank fleet.

The original concept, early designing, and testing were done by the Government at Picatinny Arsenal, NJ. This work included initial design studies, wind tunnel tests, and fabrication and gun firing of prototype projectiles (the firings took place at the U.S. Army Aberdeen Test Center, Aberdeen Proving Ground, MD). The results of this early work were provided to the contractor for information to be used in the full-scale engineering development of the cartridge.

The main challenges in designing the XM1002 lie in the conflicting requirements of having ballistic performance similar to a tactical design while having a restricted maximum range. These requirements drive tradeoffs in nearly all other performance and design areas. For example, through careful design, a conical stabilizing flare and boattail have been incorporated that provide adequate stability for good dispersion performance while adding enough drag to reduce the maximum range from  $>10$  km for the tactical projectile to  $<8$  km for the XM1002 at  $10^\circ$  gun elevation. This has been accomplished while having a wind sensitivity of just two times that of the tactical projectile (the current KE training projectile has a wind sensitivity of five times that of its tactical counterpart).

Of great importance to the on-target performance of the XM1002 is the in-bore behavior, the study and simulation of which are addressed in this report.

---

## **3. Development Plan**

---

The XM1002 performance specification has over 50 requirements. Most of the requirements are easily met using production and design methodology derived from previous training round experience (M865 and M831A1). Seventeen specifications were identified as potential risks that required special consideration. These specifications are identified in Figure 2 with an associated risk level.



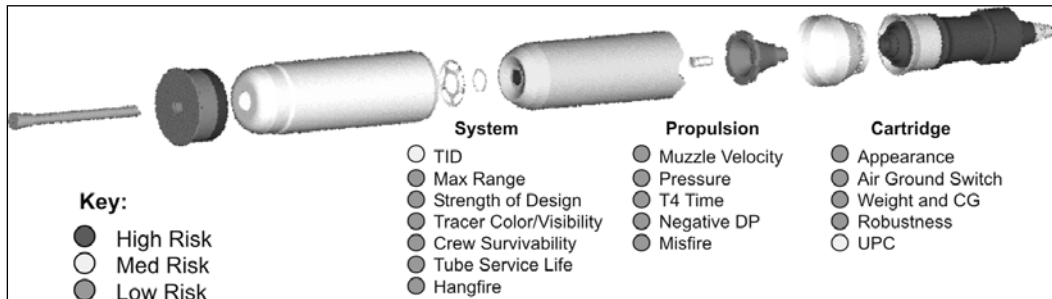

Figure 2. XM1002 performance specification risk levels.

As can be seen in the figure, target impact dispersion (TID) and unit production cost (UPC) provided the most risk to this program. Manufacturing methods and accurate understanding of key characteristics facilitate UPC. Physical understanding of launch and flight are required to obtain good TID.

Full-scale testing was prohibitively expensive. Therefore, ATK proposed a development plan that relied heavily on subscale testing and modeling. The plan uses three iterations. The first iteration included a wind tunnel, subscale spark range, and a full scale TID test. This iteration was primarily used to obtain reliable aerodynamic data and physical information to be used in modeling. The second iteration uses the iteration one information for modeling to narrow candidate designs. A TID test coupled with predicted performance would be used to identify a final design. The third iteration would provide confirmation of the final design through a final TID test, maximum range test and rough-handling tests. Modeling and laboratory testing are used in all iterations. Progressive iterations provided additional information to improve the fidelity and confirm the validity of the models.

Launch dynamics are a primary driver in TID performance and UPC is directly affected by key characteristics. The modeling described in this report provided information that allowed the XM1002 team to minimize both risk areas. Launch differences in candidate designs were recognized and identification of key characteristics to launch remains an ongoing task.

## 4. GPDS

### 4.1 What Are They?

The GPDS code uses a numerical-experimental approach to design, where projectile changes are assessed for their influence on projectile muzzle jump. The approach mimics traditional experimental development, which uses system performance to drive projectile design decisions. The projectile configurations are assessed through a range of theoretical gun centerline profiles and tube defects to show the design's sensitivity to the system.

## 4.2 How Are They Done?

GPDS use three-dimensional (3-D) finite element (FE) models of the M256 120-mm tank cannon launching projectiles. The method is described in references (1–6). The hydrocode FE formulation was chosen to allow investigation of stress wave propagation due to elements of launch. The models are 3-D to capture the asymmetric response of the projectile and gun system resulting from the nonlinear path of the projectile during launch, asymmetric boundary conditions, general lack of symmetry in the centerline profiles of the gun tube, and asymmetric gun motion.

The projectiles and gun systems are both built in similar manners. Models are developed for the components and then integrated (see Figure 3). Relative motion is obtained by defining the proper physics to allow interaction between the parts. Because this projectile is relatively simple, the nose, body, sabots, stabilizer, and obturator are welded together, and sliding interfaces are defined between the sabot, stabilizer, and the gun bore. One of the purposes of the study is to estimate tank fleet performance. In order to do this, the projectile model is integrated into (and fired from) a number of gun models that have unique tube centerlines (the centerlines are covered later in this report). The propellant pressure loading for the gun system and projectile is generated from IBHVG2 (7), which provides good quality interior ballistic prediction for production charges.

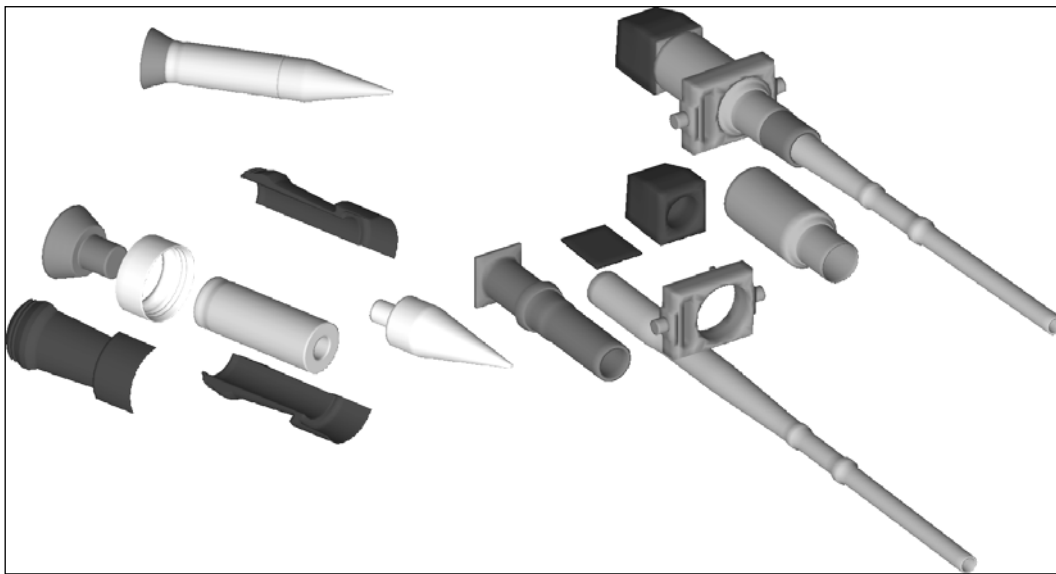

Figure 3. Components of the models.

Projectile performance is often defined in terms of jump (see Figure 4). Jump is fully defined in references (8, 9) and is also detailed in the previous references to GPDS, along with how the jump models have been adapted to the GPDS.

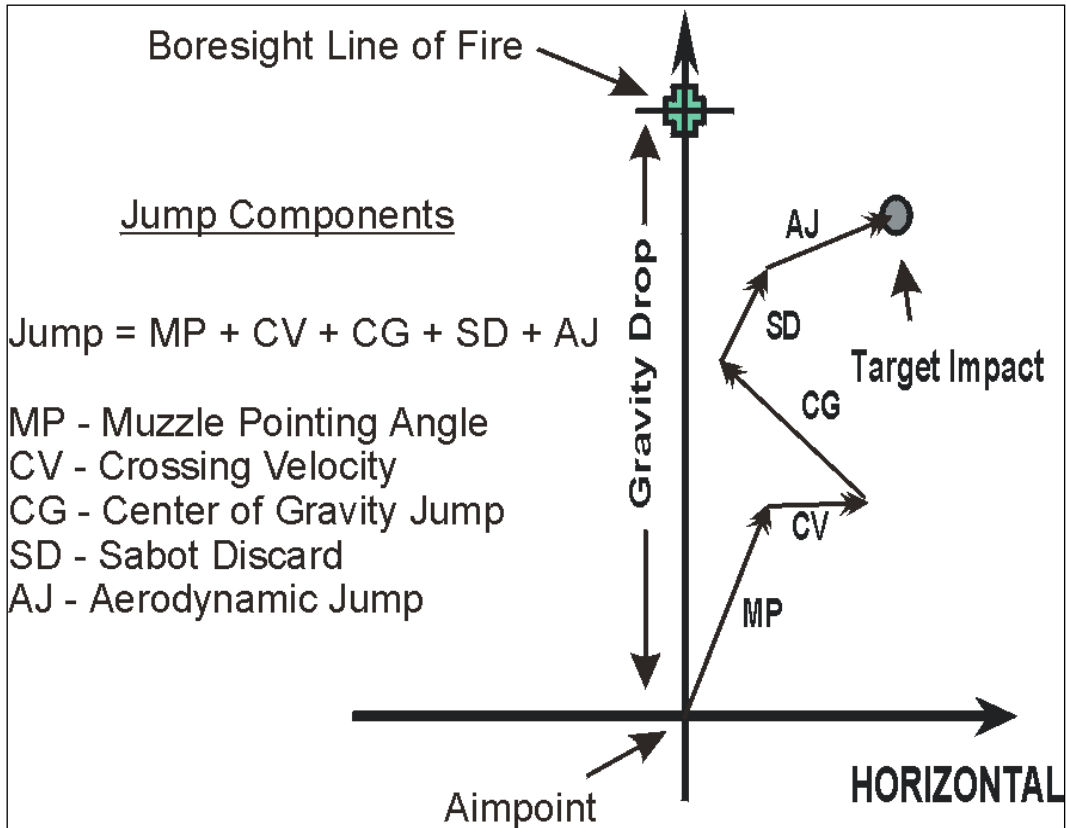

Figure 4. Definition of projectile jump.

A primary use of GPDS is to predict shot-exit conditions (i.e., the average transverse velocity component of the projectile and the average angular rate of the projectile around its center of gravity [CG]). The definition of these quantities is given in Figure 5. Modeling the small clearances between the projectile bourrelets and the inner diameter of the gun tube, as well as bourrelet deformation under launch and balloting loads, allows the projectile to move (somewhat) independently of the tube.

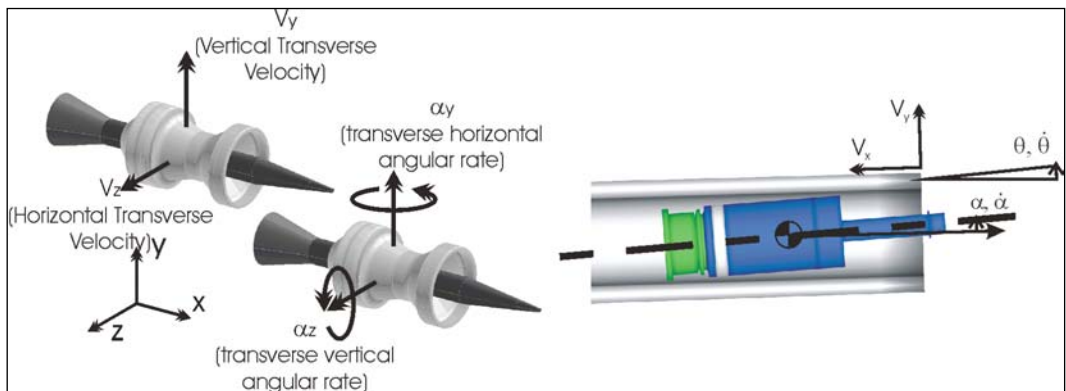

Figure 5. Projectile rates, and projectile motion relative to the bore.

Two of the jump vector components that are affected by the in-bore dynamics of the projectile are total CG jump and aerodynamic jump (AJ). Total CG jump is a combination of CG jump, crossing velocity (CV), and muzzle pointing angle (MP), as shown in Figure 6. Total CG jump is directly related to the transverse velocity of the projectile's CG at muzzle exit in the laboratory coordinate frame (see equation 1). AJ is directly related to the initial angular rate at muzzle exit, coupled with the angular rate imparted during sabot discard (see equation 2),

$$CG_{total} = \frac{V_{transverse}}{V_{muzzle}}; \tag{1}$$

$$AJ = -k_y^2 \frac{C_{n\alpha}}{C_{m\alpha}} \frac{d}{V_{muzzle}} \dot{\alpha}. \tag{2}$$

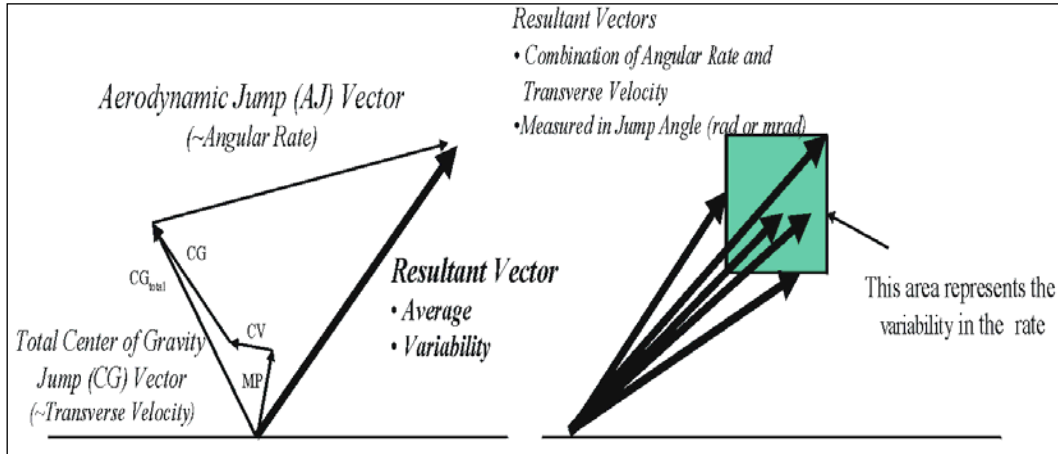

Figure 6. Definition of projectile jump and variability for the simulations.

In these equations,  $C_{n\alpha}$  is the coefficient for the aerodynamic normal force,  $C_{m\alpha}$  is the aerodynamic moment coefficient;  $d$  is the subprojectile reference diameter,  $V_{transverse}$  is the velocity in the transverse direction at the muzzle,  $V_{muzzle}$  is the velocity parallel to the axis of the tube at the muzzle,  $\dot{\alpha}$  is the angular rate at the point of entry into free flight, and  $k_y^2$  is the square of the transverse radius of gyration.

Jump variability is used in this report to determine good vs. poor shooting performance. Because initial conditions are not known precisely on a shot-by-shot basis, gun dynamic codes assume a range of initial conditions to predict an envelope of performance. Essentially, a range of initial projectile cocking angles (up, down, left, right, and straight) are chosen, and then a series of simulations is run to determine the jump variability.

---

## 5. Versions of the XM1002 Projectile Used in This Report

---

XM1002 has used a variety of flight projectiles during development. The two projectiles, Plan A and Plan B, that were used in the simulations work in this report are shown in Figure 7.

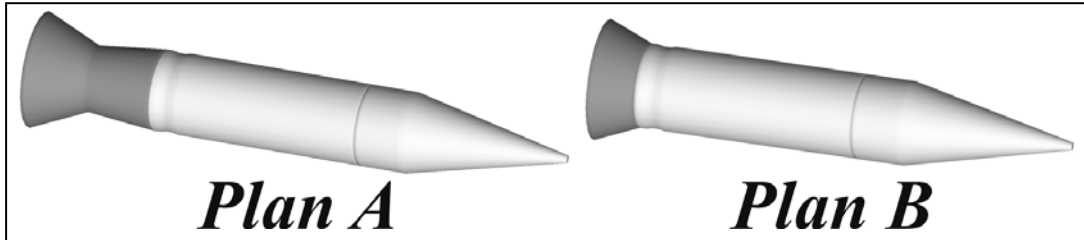

Figure 7. Description of the Plan A and Plan B projectile.

Plan A has an 80-mm-diameter body that transitions into a 6° boattail and a flare stabilizer (indicated by the dark shading). Plan B has an 80-mm cylindrical body with a flare stabilizer attached to the back. The primary difference in the two projectiles is the transverse moment of inertia and the aerodynamic coefficients. Two slightly different versions of the Plan A projectile will be used. The only difference in these projectiles is the diameter of the stabilizer. The first has a 114-mm flare and the second has a 110-mm flare.

The physical attributes of the two projectiles are listed in Table 1.

Table 1. Physical properties of the projectiles.

	<b>114 Plan B</b>	<b>114 Plan A</b>	<b>110 Plan A</b>
<b>CG (mm)</b>	219.610	247.080	245.490
<b>CG (cal)</b>	2.745	3.089	3.069
<b>Mass (kg)</b>	7.596	8.053	8.004
<b>I axial (kg mm<sup>2</sup>)</b>	5616	6091	5984
<b>I transverse (kg mm<sup>2</sup>)</b>	88740	138500	135100

---

## 6. Launch of the XM1002

---

The XM1002 projectile is relatively heavy (~22 lb), with a launch velocity of ~1400 m/s.

There are a number of influences on the projectile that result in its jump characteristics. Some of these influences are as follows: gun motion, gun tube centerline, projectile structure, flight characteristics, and propellant variability. However, this report will focus only on the effects of gun tube centerline for total projectile jump.

Gun tubes are described with a coordinate system originating at the rear face of the tube.

The x axis is along the tube with the y axis being vertical. The z axis is positive to the right (looking down the tube). The centerline is described as a displacement from a perfectly straight gun tube in the y and z directions as is shown in Figure 8.

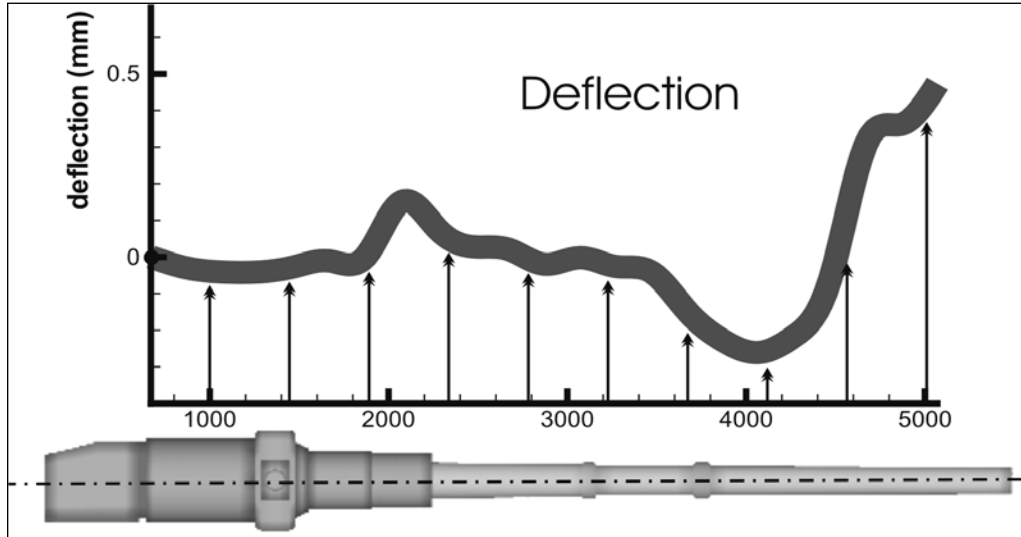

Figure 8. Gun tube centerline shape.

The guns are measured using a variety of systems. The original systems were optical and have been replaced by laser locating devices, which have improved both the speed and accuracy of the measurements. A large portion of the M256 gun system's tubes has been characterized and the analysis of the shapes has resulted in classification of types of defects. Figure 9 shows some of the important quantities that impact projectile jump.

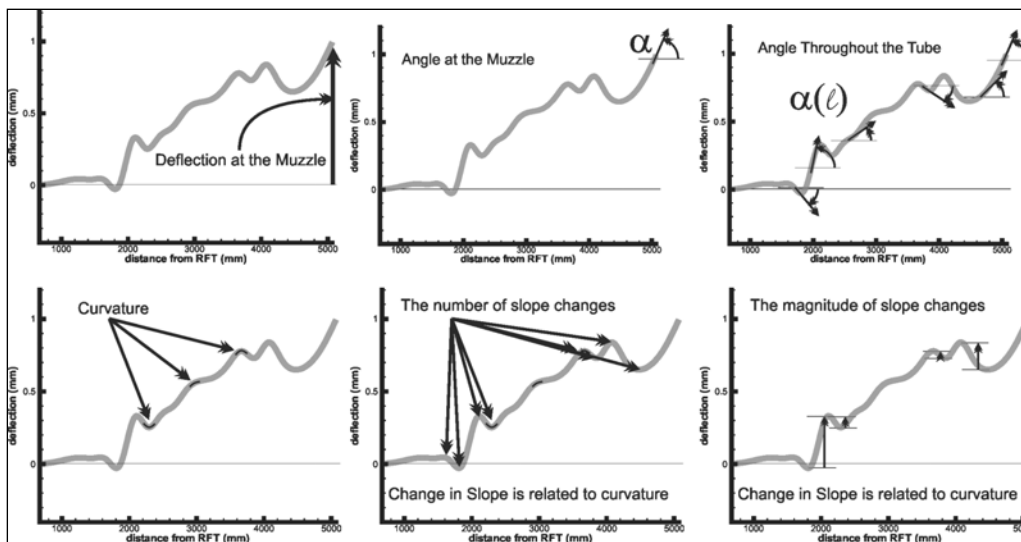

Figure 9. Types of defects seen in gun tube centerlines.

For this study, two types of theoretical tubes were selected to investigate the differences in the two projectiles' jump performance. The first set of tubes is a series of smooth bends that span the magnitude of tubes in the fleet (see Figure 10). It should be noted that the distributions of the magnitudes are not symmetric. The bends start at two different locations changing the relative velocity that the projectile navigates the direction changes. The starting locations of the bends are at 2 and 3.8 m. The tubes have been modified in either the vertical and horizontal directions. This set of tubes shows how a projectile responds to smooth changes in direction.

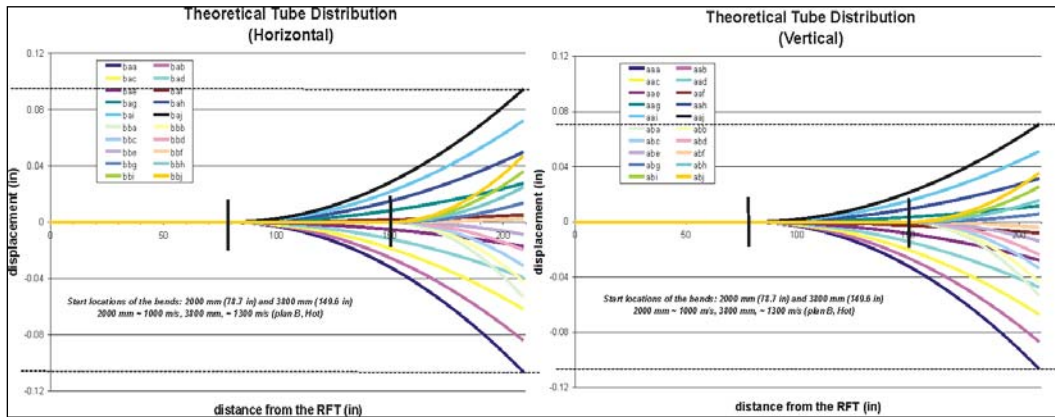

Figure 10. Ideal tube shapes.

The second set of tubes investigates performance from a more practical sense. These tubes are based on a tube which possesses many of the shape defects noted in Figure 11.

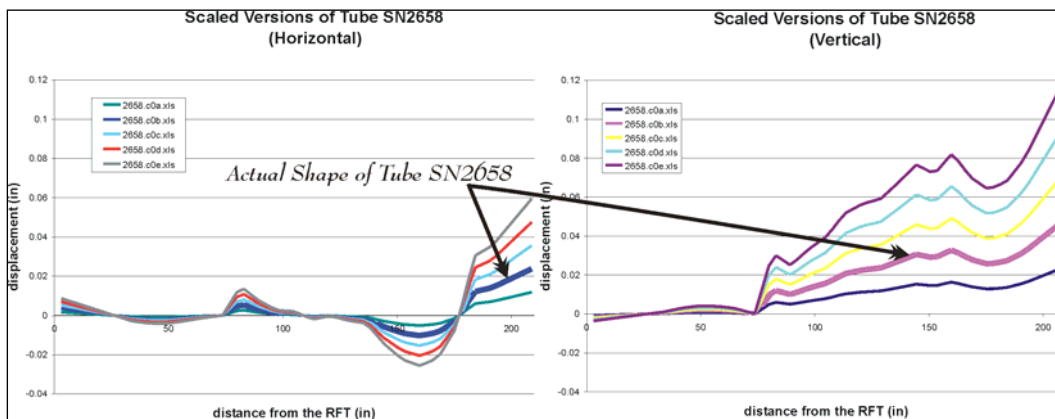

Figure 11. Torturous path tubes (based on SN2658).

These tubes were built by scaling the magnitude of a particular gun tube in the fleet, SN2659. These tubes are modified in both vertical and horizontal planes concurrently. Due to the nature and quantity of the defects, these tubes are denoted as the torturous path tubes. The purpose of including these tubes is to investigate more realistic performance due to nonideal tube centerline shapes.

The results from the simulations show jump at the muzzle, Figure 12, for the ideal tubes shapes. The first is that the area swept out by the two versions of the Plan A projectile is nearly the same. This is an expected result because the 4-mm change in stabilizer diameter has minimal impact on the projectile attributes, especially the transverse moment of inertia and mass. The second result seen in the figure is that the Plan A projectiles sweep out a larger area than the Plan B projectiles. Figure 12 shows the individual shots for the ideal tube shapes along with bounding boxes for each of the groups. The size of the area swept out by Plan B is 24% smaller than the size of the area swept out by Plan A. This is probably due to the mass differences in the projectiles. With Plan A, the higher mass of the two projectiles means more transverse energy is imparted to the projectile as it is forced to navigate the bend. The transverse energy manifests itself in jump.

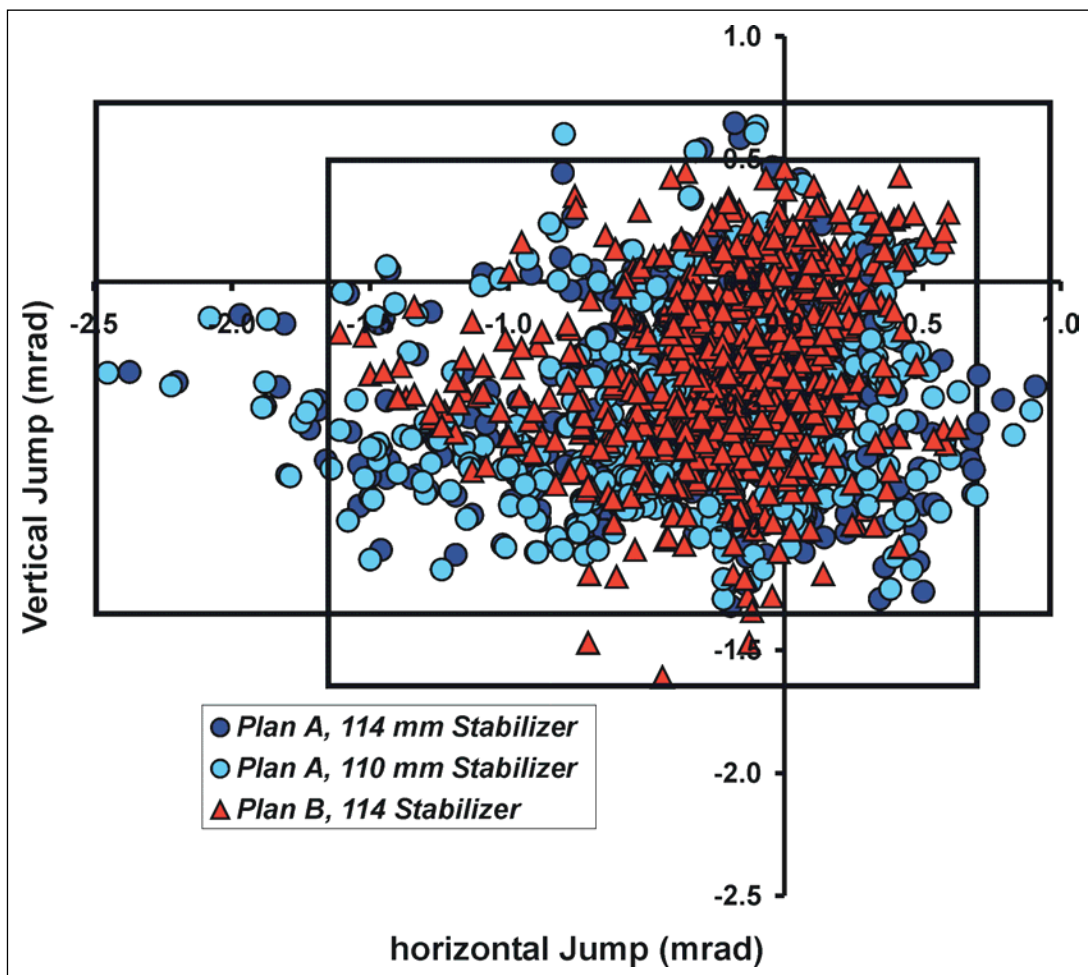

Figure 12. Results from ideal tube shapes.



Figure 13 shows the results from the torturous path tubes. There are several items to note from this figure. First, the magnitudes of the total jump are very high. This was caused by the large magnitude of the centerline shape scaling. This will be examined in a more realistic range at the end of this section. The second item is the similar performance of the two versions of the Plan A projectile. Again, this is an expected result because the differences in the projectile are minor. The third item is the relatively large magnitude of the area swept out by the Plan B projectile relative to the Plan A projectile. This is seen in more detail in Figure 13. In this figure, the area swept out by Plan A is 35% smaller than Plan B. The explanation for this is related to the moments of inertia for the two projectiles.

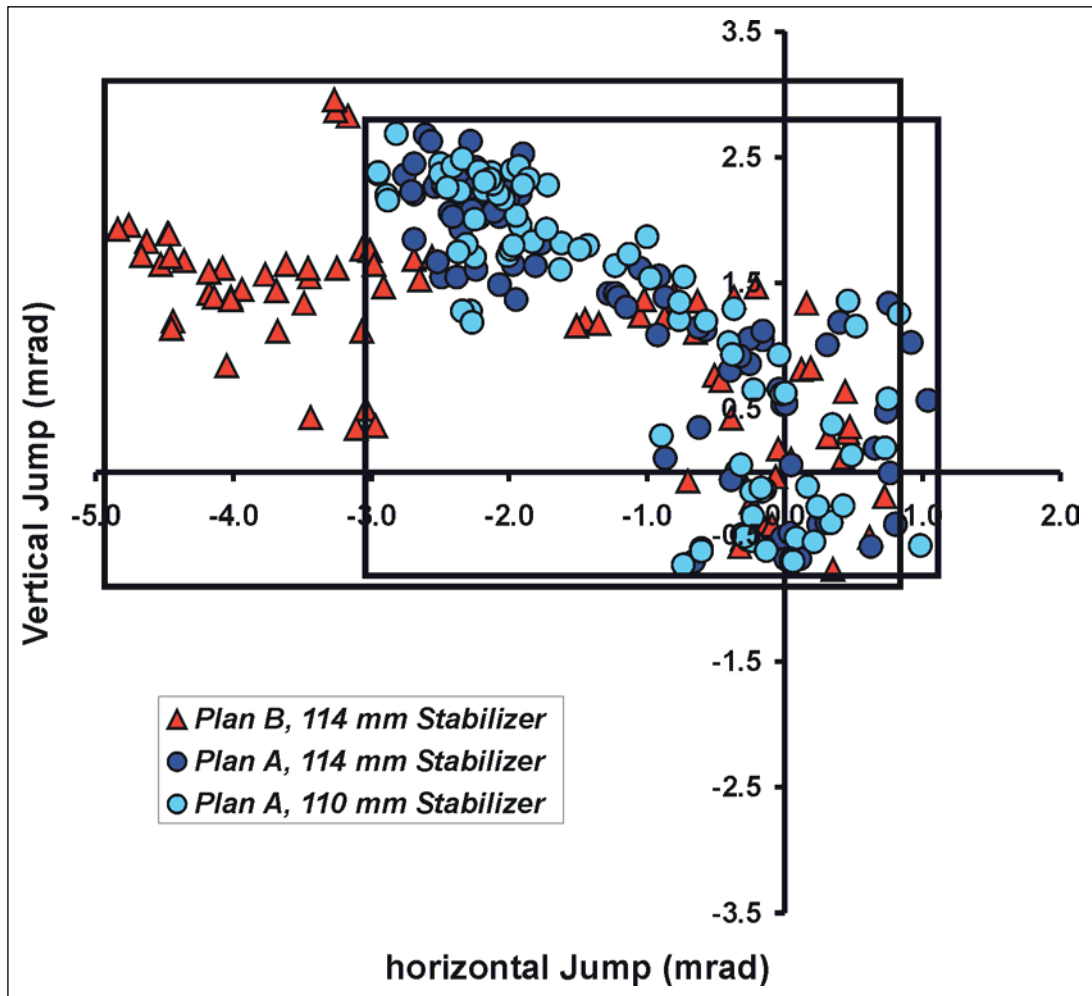

Figure 13. Results from torturous path shapes.

Plan A has a higher moment of inertia than Plan B due to its higher mass and longer length. As the tube forces Plan A to change direction, its higher moment of inertia resists these changes more than the Plan B projectile. Unlike the smooth tube shapes, the torturous path tube shapes force the projectile to navigate many changes during launch. The lower moment of inertia of Plan B makes it less resistant to the gun tube influence resulting in higher jump.

This is further illustrated in Figure 14. This figure focuses on scaling magnitudes of tube SN2658 from 0 to 1, well within the size and locations of defects in tubes in the fleet. The jump of the center of impact (COI) of each group is plotted vs. the magnitude of the tube shape. What is seen in this figure is that not only is the total area swept out by Plan B in Figure 13 larger than Plan A, but for each increment in the magnitude of the shape of SN2658, the jump for Plan B increases faster than Plan A.

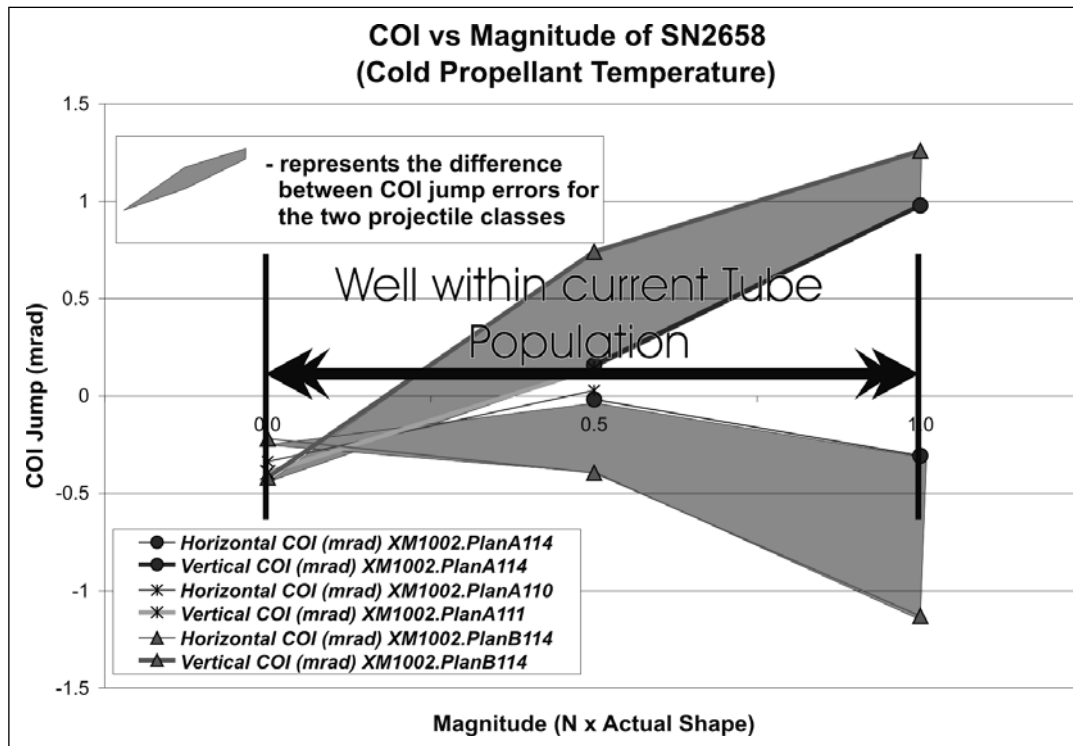

Figure 14. Relative jump vs. tube shape magnitude.

## 7. Conclusions

The simulation accomplished on the different versions of the XM1002 projectiles was able to show differences in the jump performance. The two variations of the Plan A projectile, 114-mm vs. 110-mm stabilizer, show very similar performance in both sets of tubes used in the study. This was an expected result because the stabilizer changes only slightly changed the mass and moment of inertia of the projectile. The results show significant differences between the Plan A and Plan B projectile. The Plan B projectile shows better jump variability (24%) in the ideal tube shapes when compared to the Plan A projectile. The difference is attributed to the lower mass of the projectile. When the projectiles were testing in the torturous path tubes, the Plan A projectile showed lower variability (34%) when compared to Plan B. Because the torturous path tubes require navigating a complex shape with many turns in both the horizontal and vertical

directions, the differences in performance are attributed to the differences in the projectile's moment of inertia. Because Plan B has a lower moment of inertia, it is not as able to resist the path changes imposed by the tube which results in higher jump variability. This result is very consistent regardless of the magnitude of the tube shape because Plan A always showed more jump. The difference in jump variability in both the ideal case and the torturous path case manifest themselves in accuracy through occasion to occasion error. In all, simulations were used to assess the theoretical accuracy of various XM1002 projectiles during development. This information was used to mitigate risk during down selection between the different designs. Validation of the results is planned in the next phase of development.

---

## 8. References

---

1. Burns, B. P.; Newill, J. F.; Wilkerson, S. A. In-Bore Projectile Gun Dynamics. *Proceedings of the 17th International Ballistics Symposium*, Midran, South Africa, 26 March 1998.
2. Newill, J. F.; Burns, B. P.; Wilkerson, S. A. *Overview of Gun Dynamics Numerical Simulations*; ARL-TR-1760; U.S. Army Research Laboratory: Aberdeen Proving Ground, MD, September 1998.
3. Newill, J. F.; Hoppel, C. P. R.; Kamdar, D.; Guidos, B.; Drysdale, W. H.; Livecchia, C.; Luciano, M. *Geometric and Material Changes to the Forward Bourrelet to Optimize Performance of KE Ammunition*; ARL-TR-2328; U.S. Army Research Laboratory: Aberdeen Proving Ground, MD, September 2000.
4. Newill, J. F.; Hoppel, C. P. R.; Soencksen, K. P.; Plostins, P. Simulation of the M865 Kinetic Energy Projectile With Experimental Validation. *Proceedings of the 18th International Ballistics Symposium*, San Antonio, TX, November 1999.
5. Newill, J. F.; Hoppel, C. P. R.; Drysdale, W. H.; Kamdar, D. S. *Effects of Bourrelet Stiffness on the Interior Ballistic Performance of Kinetic Energy Ammunition*; ARL-TR-2002; U.S. Army Research Laboratory: Aberdeen Proving Ground, MD, June 1999.
6. Newill, J. F.; Wilkerson, S. A.; Hoppel, C. P. R.; Drysdale W. H. Numerical Simulation of Composite Kinetic Energy Projectiles Launched by an M1A1 Abrams M256 Gun System. *Proceedings of the 30th SAMPE Technical Conference*, San Antonio, TX, 23 October 1998.
7. Anderson, R. D.; Fickie, K. D. *IBHVG2 – A User’s Guide*; BRL-TR-2829; U.S. Army Ballistic Research Laboratory: Aberdeen Proving Ground, MD, July 1987.
8. Bornstein, J.; Celmins, I.; Plostins, P.; Schmidt, E. M. *Techniques for the Measurement of Tank Cannon Jump*; BRL-MR-3715; U.S. Army Ballistic Research Laboratory: Aberdeen Proving Ground, MD, December 1988.
9. Guidos, B.; Plostins, P.; Webb, D.; Newill, J. F. *120-mm Tank Gun Accuracy Demonstrator (TGAD) Jump Test*; ARL-TR-2199; U.S. Army Research Laboratory: Aberdeen Proving Ground, MD, December 1999.

<u>NO. OF COPIES</u>	<u>ORGANIZATION</u>	<u>NO. OF COPIES</u>	<u>ORGANIZATION</u>
2	DEFENSE TECHNICAL INFORMATION CENTER DTIC OCA 8725 JOHN J KINGMAN RD STE 0944 FT BELVOIR VA 22060-6218		<u>ABERDEEN PROVING GROUND</u>
		2	DIR USARL AMSRL CI LP (BLDG 305) AMSRL CI OK TP (BLDG 4600)
1	COMMANDING GENERAL US ARMY MATERIEL CMD AMCRDA TF 5001 EISENHOWER AVE ALEXANDRIA VA 22333-0001		
1	INST FOR ADVNCD TCHNLGY THE UNIV OF TEXAS AT AUSTIN 3925 W BRAKER LN STE 400 AUSTIN TX 78759-5316		
1	US MILITARY ACADEMY MATH SCI CTR EXCELLENCE MADN MATH THAYER HALL WEST POINT NY 10996-1786		
1	DIRECTOR US ARMY RESEARCH LAB AMSRL D DR D SMITH 2800 POWDER MILL RD ADELPHI MD 20783-1197		
1	DIRECTOR US ARMY RESEARCH LAB AMSRL CS IS R 2800 POWDER MILL RD ADELPHI MD 20783-1197		
3	DIRECTOR US ARMY RESEARCH LAB AMSRL CI OK TL 2800 POWDER MILL RD ADELPHI MD 20783-1197		
3	DIRECTOR US ARMY RESEARCH LAB AMSRL CS IS T 2800 POWDER MILL RD ADELPHI MD 20783-1197		

<u>NO OF COPIES</u>	<u>ORGANIZATION</u>
1	DIRECTOR US ARMY RESEARCH LAB AMSRL CP CA D SNIDER 2800 POWDER MILL RD ADELPHI MD 20783-1197
3	DIRECTOR US ARMY RESEARCH LAB AMSRL OP SD TL 2800 POWDER MILL RD ADELPHI MD 20783-1197
1	DIRECTOR US ARMY RESEARCH LAB AMSRL SS SD H WALLACE 2800 POWDER MILL RD ADELPHI MD 20783-1197
2	DIRECTOR US ARMY RESEARCH LAB AMSRL SS SE DS R REYZER R ATKINSON 2800 POWDER MILL RD ADELPHI MD 20783-1197
1	DIRECTOR US ARMY RESEARCH LAB AMSRL WM MB A FRYDMAN 2800 POWDER MILL RD ADELPHI MD 20783-1197
1	DPTY ASST SECY FOR R&T SARD TT THE PENTAGON RM 3EA79 WASHINGTON DC 20301-7100
1	COMMANDER US ARMY MATERIEL CMD AMXMI INT 5001 EISENHOWER AVE ALEXANDRIA VA 22333-0001

<u>NO OF COPIES</u>	<u>ORGANIZATION</u>
4	COMMANDER US ARMY ARDEC AMSTA AR CC G PAYNE J GEHBAUER C BAULIEU H OPAT PICATINNY ARSENAL NJ 07806-5000
2	COMMANDER US ARMY ARDEC AMSTA AR AE WW E BAKER J PEARSON PICATINNY ARSENAL NJ 07806-5000
1	COMMANDER US ARMY ARDEC AMSTA AR FSE PICATINNY ARSENAL NJ 07806-5000
1	COMMANDER US ARMY ARDEC AMSTA AR TD C SPINELLI PICATINNY ARSENAL NJ 07806-5000
6	COMMANDER US ARMY ARDEC AMSTA AR CCH A W ANDREWS S MUSALLI R CARR M LUCIANO E LOGSDEN T LOUZEIRO PICATINNY ARSENAL NJ 07806-5000
1	COMMANDER US ARMY ARDEC AMSTA AR CCH P J LUTZ PICATINNY ARSENAL NJ 07806-5000

<u>NO OF COPIES</u>	<u>ORGANIZATION</u>
4	COMMANDER US ARMY ARDEC AMSTA AR FSF T T FARINA J GRAU C LIVECCHIA B WONG PICATINNY ARSENAL NJ 07806-5000
1	COMMANDER US ARMY ARDEC AMSTA ASF PICATINNY ARSENAL NJ 07806-5000
1	COMMANDER US ARMY ARDEC AMSTA AR QAC T C C PATEL PICATINNY ARSENAL NJ 07806-5000
1	COMMANDER US ARMY ARDEC AMSTA AR M D DEMELLA PICATINNY ARSENAL NJ 07806-5000
3	COMMANDER US ARMY ARDEC AMSTA AR FSA A WARNASH B MACHAK M CHIEFA PICATINNY ARSENAL NJ 07806-5000
2	COMMANDER US ARMY ARDEC AMSTA AR FSP G M SCHIKSNIS D CARLUCCI PICATINNY ARSENAL NJ 07806-5000
2	COMMANDER US ARMY ARDEC AMSTA AR CCH C H CHANIN S CHICO PICATINNY ARSENAL NJ 07806-5000

<u>NO OF COPIES</u>	<u>ORGANIZATION</u>
1	COMMANDER US ARMY ARDEC AMSTA AR QAC T D RIGOGLIOSO PICATINNY ARSENAL NJ 07806-5000
1	COMMANDER US ARMY ARDEC AMSTA AR WET T SACHAR BLDG 172 PICATINNY ARSENAL NJ 07806-5000
1	US ARMY ARDEC INTELLIGENCE SPECIALIST AMSTA AR WEL F M GUERRIERE PICATINNY ARSENAL NJ 07806-5000
11	COMMANDER US ARMY ARDEC AMSTA AR CCH B P DONADIA F DONLON J KOSTKA P VALENTI C KNUTSON G EUSTICE S PATEL G WAGNECZ R SAYER F CHANG K HENRY PICATINNY ARSENAL NJ 07806-5000
6	COMMANDER US ARMY ARDEC AMSTA AR CCL F PUZYCKI R MCHUGH D CONWAY E JAROSZEWSKI R SCHLENNER M CLUNE PICATINNY ARSENAL NJ 07806-5000

<u>NO OF COPIES</u>	<u>ORGANIZATION</u>
1	PM ARMS SFAE GCSS ARMS BLDG 171 PICATINNY ARSENAL NJ 07806-5000
1	COMMANDER US ARMY ARDEC AMSTA AR WEA J BRESCIA PICATINNY ARSENAL NJ 07806-5000
11	PM MAS SFAE GSSC TMA W SANVILLE D GUZIEWICZ E KOPACZ R ROESER R DARCY R KOWALSKI P CARDELL F STEINBERG C ROLLER J MCGREEN B PATTEN PICATINNY ARSENAL NJ 07806-5000
1	COMMANDER US ARMY ARDEC PRODUCTION BASE MODERN ACTY AMSMC PBM K PICATINNY ARSENAL NJ 07806-5000
1	COMMANDER US ARMY TACOM PM ABRAMS SFAE ASM AB 6501 ELEVEN MILE RD WARREN MI 48397-5000
1	COMMANDER US ARMY TACOM AMSTA SF WARREN MI 48397-5000

<u>NO OF COPIES</u>	<u>ORGANIZATION</u>
1	COMMANDER US ARMY TACOM PM BFVS SFAE GCSS W BV 6501 ELEVEN MILE RD WARREN MI 48397-5000
1	COMMANDER US ARMY TACOM CHIEF ABRAMS TESTING SFAE GCSS W AB QT T KRASKIEWICZ 6501 ELEVEN MILE RD WARREN MI 48397-5000
1	COMMANDER WATERVLIET ARSENAL SMCWV QAE Q B VANINA BLDG 44 WATERVLIET NY 12189-4050
3	ARMOR SCHOOL ATZK TD R BAUEN J BERG A POMEY FT KNOX KY 40121
3	HQ OSC TANK AMMUNITION TEAM AMSIO SMT R CRAWFORD B DAVIES D PORTERFELD ROCK ISLAND IL 61299-6000



<u>NO OF</u> <u>COPIES</u>	<u>ORGANIZATION</u>	<u>NO OF</u> <u>COPIES</u>	<u>ORGANIZATION</u>
14	BENET LABORATORIES AMSTA AR CCB R FISCELLA M SOJA E KATHE M SCAVULO G SPENCER P WHEELER S KRUPSKI J VASILAKIS G FRIAR R HASENBEIN AMSTA CCB R S SOPOK E HYLAND D CRAYON R DILLON WATERVLIET NY 12189-4050	3	ALLIANT TECHSYSTEMS INC J CONDON E LYNAM J GERHARD WV01 16 STATE RT 956 PO BOX 210 ROCKET CENTER WV 26726-0210
8	ALLIANT TECHSYSTEMS INC C CANDLAND C AAKHUS B SEE N VLAHAKUS R DOHRN S HAGLUND L NELSON D KAMDAR 4700 NATHAN LANE PLYMOUTH MN 55442	3	GENERAL DYNAMICS OTS B PERKINS P RADCZENKO L BUONODONO 10101 NINTH ST NORTH ST PETERSBURG FL 33702
9	ALLIANT TECHSYSTEMS INC T ROCKNE T TOMPSON T HUNGERFORD J PERSON R DOHRN L OSGOOD G BLACKMAN M TAYLOR J DAVID TCAAP BLDG 104 ARDEN HILLS MN 55112	3	GENERAL DYNAMICS OTS FLINCHBAUGH DIV E STEINER B STEWART T LYNCH PO BOX 127 RED LION PA 17356
1	SAIC M PALMER 1410 SPRING HILL RD STE 400 MS SH4 5 MCLEAN VA 22102	1	UDLP G THOMAS PO BOX 58123 SANTA CLARA CA 95052
1	APPLIED COMPOSITES W GRISCH 333 NORTH SIXTH ST ST CHARLES IL 60174	2	UDLP R BARRETT MAIL DROP M53 V HORVATICH MAIL DROP M53 328 W BROKAW RD SANTA CLARA CA 95052-0359
		3	UDLP GROUND SYSTEMS DIVISION M PEDRAZZI MAIL DROP N09 A LEE MAIL DROP N11 M MACLEAN MAIL DROP N06 1205 COLEMAN AVE SANTA CLARA CA 95052
		2	UDLP R BRYNSVOLD P JANKE MS 170 4800 EAST RIVER RD MINNEAPOLIS MN 55421-1498

<u>NO OF</u> <u>COPIES</u>	<u>ORGANIZATION</u>	<u>NO OF</u> <u>COPIES</u>	<u>ORGANIZATION</u>
1	GDLS DIVISION D BARTLE PO BOX 1901 WARREN MI 48090		AMSRL WM BA D LYON
2	US ARMY ARMAMENT RESEARCH DEVELOP & ENG CNTR A FARINA PICATINNY ARSENAL NJ 07806		AMSRL WM BC P PLOSTINS J NEWILL (5 CPS) M BUNDY J GARNER (2 CPS) D WEBB B GUIDOS (2 CPS) A ZIELINSKI
4	ALLIANT TECHSYSTEMS INC R DOHRN (2 CPS) D KAMDAR (2 CPS) ARDEN HILLS MN 55112		AMSRL WM BD B FORCH R FIFER R PESCE RODRIGUEZ B RICE
<u>ABERDEEN PROVING GROUND</u>			
2	US ARMY MATERIEL SYSTEMS ANALYSIS ACTIVITY AMXSX TD P DIETZ D NORMAN 392 HOPKINS RD APG MD 21005-5071		AMSRL WM BE C LEVERITT AMSRL WM BF J LACETERA AMSRL WM BR C SHOEMAKER J BORNSTEIN AMSRL WM M D VIECHNICKI G HAGNAUER J MCCAULEY
1	US ARMY ATC W C FRAZER CSTE DTC AT AC I 400 COLLERAN RD APG MD 21005-5059		AMSRL WM MA L GHIORSE S MCKNIGHT AMSRL WM MB B FINK J BENDER
1	DIRECTOR US ARMY RESEARCH LAB AMSRL OP AP L APG MD 21005-5066		W DRYSDALE C HOPPEL AMSRL WM T B BURNS M ZOLTOSKI
43	DIR USARL AMSRL CI AMSRL CI S A MARK AMSRL CS IO FI M ADAMSON AMSRL SL BA AMSRL SL BL D BELY R HENRY AMSRL SL BG AMSRL WM J SMITH AMSRL WM B A HORST		AMSRL WM TC R COATES