

**An Experimental Facility for
Imaging of Medium Scale
Underwater Explosions**

John M. Brett, Michael Buckland,
Terry Turner, Charles G. Killoh and
Peter Kiernan

DSTO-TR-1432

DISTRIBUTION STATEMENT A
Approved for Public Release
Distribution Unlimited

20031103 082



An Experimental Facility for Imaging of Medium Scale Underwater Explosions

John M. Brett, Michael Buckland, Terry Turner, Charles G. Killoh and Peter Kiernan

Maritime Platforms Division
Platforms Sciences Laboratory

DSTO-TR-1432

ABSTRACT

A new experimental capability for the study of underwater explosions has been developed. This is based on a unique facility that permits direct optical imaging of the detonation of medium scale (1-5 kg) explosive charges at PSL's Underwater Explosion Test Facility, Melbourne, Victoria. Imaging of UNDEX events in a field environment presents many technical challenges including protection of structures and sensitive equipment from high shock loads, attainment of optically clear water, high speed imaging in low light levels and experimental operation at significant water depths. The techniques employed to successfully overcome these challenges are described. The potential of this new capability is demonstrated by imaging and analysis of the detonation of a 0.5 kg explosive charge of Composition B.

RELEASE LIMITATION

Approved for public release

AQ F04-01-0025

Published by

*DSTO Platforms Sciences Laboratory
506 Lorimer St
Fishermans Bend, Victoria 3207 Australia*

Telephone: (03) 9626 7000

Fax: (03) 9626 7999

© Commonwealth of Australia 2003

AR-012-767

May 2003

APPROVED FOR PUBLIC RELEASE

An Experimental Facility for Imaging of Medium Scale Underwater Explosions

Executive Summary

Assessing the lethality of underwater weapons and the vulnerability of warships to their effects is of vital importance to the maintenance of a naval warfighting capability. These assessments must be based on a sound knowledge of underwater explosive (UNDEX) effects and the fluid-structure interaction associated with target response. DSTO has conducted research in this field, employing a variety of instrumentation such as pressure gauges, velocity meters, accelerometers and strain gauges. Much has been learnt from these studies but there can be no substitute for the powerful insight into UNDEX phenomena afforded by direct optical imaging. Accordingly, DSTO has developed a new experimental capability for the optical study of underwater explosions at the PSL Underwater Explosion Test Facility, Melbourne, Victoria.

Successful imaging of underwater explosions, particularly at medium scale in a field environment, is technically challenging. A number of difficulties must be overcome, including the protection of containment structures and equipment from high shock loading, attainment of high water clarity, high speed imaging with low light levels and experimental operation at significant water depth. The techniques used to successfully meet these challenges are described in this report. The potential of this new capability is demonstrated by imaging and analysis of the underwater explosive bubble generated by the detonation of a 0.5 kg explosive charge of Composition B.

This facility will be applied to meet a number of defence goals. It has already been employed to assess the underwater efficiency of a novel explosive mix of interest to the Australian Defence Force and further studies of this type are likely. Studies of target response to UNDEX effects are in progress with the key objectives of expanding our understanding of the phenomena of explosively driven fluid-structure interaction and providing experimental data for validation of predictive computer codes. The experimental capability that Australia now possesses will permit it to make a valuable contribution to important new TTCP (The Technical Cooperation Program) activities in this area.

Authors

John M. Brett

Maritime Platforms Division

John Brett was awarded a Phd in Astrophysics from the Australian National University in 1988 and subsequently spent five years engaged in postdoctoral research at universities in England, Sweden and Australia. He joined the Maritime Platforms Division (then SSMD) of PSL in 1993 and since then has been researching underwater explosive damage effects and associated aspects of submarine vulnerability

Michael Buckland

Maritime Platforms Division

Michael Buckland graduated BAppSc at RMIT 1984. He was employed with BHP prior to joining DSTO. He has worked in the area of weapon effects since 1987, and spent 15 months in Canada working on underwater explosive effects. He is currently working as a Senior Professional Officer within Maritime Platforms Division of PSL in the naval platforms survivability/vulnerability research field.

Terry Turner

Maritime Platforms Division

Terry Turner graduated BSc at Deakin University in 1989 and completed his MSc at the University of Melbourne in 1993. He joined Materials Division of AMRL in 1989. He currently works in the Naval Platform Survivability Section of Maritime Platform Division. Terry's research activities include the study of fluid structure interactions due to near field underwater explosions.

Charles G. Killoh
Maritime Platforms Division

Charles Killoh was employed with the Ammunition Factory Metallurgical Laboratory from June 1963 –August 1982. Since joining DSTO in August 1982 he has participated in the conduct of major investigations into the factors affecting the fragmentation and safety of high explosive ammunition and the behaviour of materials under explosive loading in general. He is currently working as a Technical Officer 4 in Maritime Platforms Division of PSL in survivability /vulnerability and underwater explosive damage effects.

Peter Kiernan
Maritime Platforms Division

Peter Kiernan joined DSTO in 1970 with six years previous experience in industrial chemical/metallurgical laboratories. Since then he has worked as a technical officer in a variety of investigations into munitions and explosives and their effects on targets including a number of bomb site analyses. He is currently a Technical Officer 4 involved in experimentation in the area of vulnerability of naval platforms to weapon effects.

Contents

1. INTRODUCTION	1
2. UNDEX BUBBLE THEORY	2
3. IMAGING TECHNOLOGY	3
4. ILLUSTRATIVE IMAGING RESULTS	14
5. SUMMARY	18
6. ACKNOWLEDGMENTS	18
7. REFERENCES	19

1. Introduction

The underwater detonation of an explosive warhead creates both a shock wave and a pulsating bubble of detonation product gases. The damaging potential of the shock wave is well known but it is less well appreciated that the fluid dynamics associated with the pulsating bubble are also capable of inflicting considerable damage. Indeed, for weapons detonated in close proximity to a target, it may well be that collapse of this bubble (possibly onto the target) is the dominant damage mechanism.

The mechanics of bubble collapse damage are not well understood but progress can be made with careful experimentation utilising modern sensitive instrumentation. Although much can be inferred from measurements of water pressure and from the response of the target itself (with accelerometers, velocity gauges etc), there can be no substitute for (in addition) imaging the behaviour of the bubble and the fluid structure interaction it produces.

The ability to observe and measure bubble behaviour is central to many studies of weapon effectiveness and warship vulnerability. For example, evaluating the potential of a new underwater explosive requires the measurement of its maximum bubble size and the assessment of submarine vulnerability and/or torpedo countermeasures requires an understanding of the role of bubble damage for close-in attack. For these reasons MPD has developed an underwater explosive (UNDEX) imaging facility. High speed imaging of any explosive event is technically challenging. However, performing this underwater introduces a new range of technical difficulties that must be overcome. These include camera operation in an extreme shock environment, water clarity and low light levels.

A small number of UNDEX imaging facilities exist overseas, though in the main these are small-scale tanks and test ponds limited to the study of smaller explosive masses. A small-scale test tank of this type will soon be commissioned at DSTO's Edinburgh laboratory. This report describes the underwater imaging facility developed by DSTO at the PSL Underwater Explosion Test Facility (UETF) near Melbourne, Victoria. Apart from being the first operational Australian UNDEX bubble imaging facility, it also represents a unique solution to the problem of imaging in open water, thereby permitting the study of medium-scale charge masses. The ability to study larger charge sizes is particularly important for novel multi-component explosives that may require larger diameters to achieve complete detonation. After a brief introduction to bubble dynamics, we describe the facility and the methodologies developed to permit effective UNDEX imaging. The capability is then demonstrated with images from the detonation of a charge of the explosive Composition B. Further applications are presented by Brett and Buckland [1] and Turner and Buckland [2].

2. UNDEX Bubble Theory

A brief introduction to UNDEX bubble dynamics is necessary to provide background to the design, implementation and application of the imaging facility. Ignition of a HE device generates a detonation wave which passes through the explosive converting it into high temperature and high pressure gas. Upon reaching the water interface, the detonation wave transfers into the water as a shock wave leaving behind a high pressure bubble of detonation product gases. The gas bubble expands, resisted by the hydrostatic pressure of the surrounding water. The momentum acquired by the water overexpands the bubble so that at its maximum diameter its internal pressure is less than the surrounding hydrostatic value. Consequently the bubble collapses and the momentum of the in-falling water compresses the bubble to an internal pressure well above the surrounding hydrostatic pressure. Thus, when it reaches its minimum diameter, the bubble is set to begin a new cycle of expansion and contraction. This pulsational behaviour can repeat a number of times, although energy losses limit the importance of subsequent cycles and the presence of fluid boundaries can disrupt the bubble.

A number of important damage mechanisms are associated with collapse of the bubble. The rapid compression of the bubble around the time of minimum diameter produces a pressure pulse in the surrounding water. Although the peak magnitude of this pressure pulse is less than that of the shock wave, its duration is longer so that its impulse can be comparable. Another significant damage mechanism occurs if the bubble collapses asymmetrically. This produces a high speed directional flow of water passing through the bubble in the direction of the asymmetry. The hydrostatic pressure gradient associated with increasing water depth produces such a jet directed towards the water surface. The obstruction of water flow due to the presence of a nearby structure also causes asymmetric collapse and the formation of a water jet directed towards the structure. A useful overview of underwater explosions has been presented by Snay [3] and for a more detailed account the reader is directed to Cole [4].

The volume of water displaced by the bubble and the time it takes for it to collapse are directly related to the damage potential of an explosive. Accordingly, the measurement of maximum bubble radius and pulsational period are central to the characterisation of an underwater explosive. Studies of bubble pulsation for different explosives have shown that simple empirical relationships exist for the dependence of pulsation period (T) and initial maximum radius (A_{max}) on both charge weight (W) and water depth (H). Much of this work is summarised by Swisdak [5] who gives

$$T = K \frac{W^{1/3}}{(H + H_0)^{5/6}} \quad (1)$$

and

$$A_{\max} = J \frac{W^{1/3}}{(H + H_0)^{1/3}} \quad (2)$$

where K and J are experimentally determined constants for a given type of explosive and H_0 is the atmospheric head (approximately 10 m). The constants K and J can be used to define the relative bubble energy of two explosives in the following manner; based on measurements of periods, the relative bubble energy (RBE) is defined as

$$RBE = \left(\frac{K_{\text{explosive1}}}{K_{\text{explosive2}}} \right)^3 \quad (3)$$

and based on measurements of maximum bubble diameter, the relative potential bubble energy (RPBE) is defined as

$$RPBE = \left(\frac{J_{\text{explosive1}}}{J_{\text{explosive2}}} \right)^3 \quad (4)$$

Thus using the constants J and K the bubble energy of an unknown explosive mix can be defined relative to that of a well-characterised one.

3. Imaging Technology

UNDEX experiments at small scale can be conducted in appropriately robust test tanks. If sufficient money is available, dedicated test ponds can be constructed for experiments at larger scale. The design of these purpose built facilities can be optimised (at a cost) for UNDEX imaging. However, to allow testing of larger explosive masses at reasonable cost we must turn to natural bodies of water and effective UNDEX imaging in these environments can be problematic.

High speed imaging of an underwater explosion poses serious technical challenges that must be overcome to obtain useful scientific data. These include provision of optically clear water, operation of equipment at considerable water depth, imaging of dynamic events in low light levels and exposure of the camera to a high shock environment. The DSTO imaging facility has been specifically designed to overcome these difficulties and to provide a practical working environment. The basic concept of the facility is an array of modular support rafts sitting atop a water enclosure. In essence the facility acts as a flexible tank immersed in a larger body of water.

3.1 The Test Site

The facility was developed to suit conditions at PSL's UETF (Fig. 1). This site on the outskirts of Melbourne consists of a flooded quarry of approximate dimensions 100 x 40 m with water depth varying from 12 m to 16 m. Water clarity is not ideal for imaging but the site has advantages of substantial water depth, an established infrastructure and proximity to the home laboratory.

Any fixed volume of water places limits on the size of the bubble that can be studied. Clearly at its maximum expansion the bubble must not be large enough to broach the surface or contact the bottom. Furthermore, the dynamics of a pulsing bubble are affected by the presence of nearby boundaries to the water body, such as the water surface and quarry floor. To prevent strong effects of this nature a minimum separation of two bubble radii between the edge of the bubble and these boundaries is desirable. This places definite limits on the maximum charge mass that can be usefully studied. For a charge detonated at the mid-depth point of the quarry (8 m depth), the maximum bubble diameter should be no larger than 5.3 m, which corresponds to a maximum charge size of approximately 8 kg for TNT.



Figure 1. The PSL Underwater Explosion Test Facility. The imaging facility is seen near the top left shore with the detachable filter section towards the camera. Support facilities are visible on the top right shore.

3.2 The Superstructure

The above-water structure of the facility consists of modular flotation units of dimension 2.5 m x 1.8 m, connected to form an array of flexible size that permits working access to the facility (Figure 2). Selected units are modified to perform specialised functions, such as camera support. Proximity to the detonation exposes the facility to potentially high shock loading, which could cause damage to the submerged portion of the flotation units. For this reason, buoyancy is provided by cylinders of closed cell polyethylene foam that provides shock resistance without the high weight penalty associated with heavy steel tanks.

3.3 The Water Enclosure

Existing water clarity at the test site was not adequate so remedial chemical treatment and filtration was required (see below). Treatment of the entire quarry water body was not of course possible, so a smaller volume had to be sectioned off with a suitable enclosure. To retain the potential of the large body of water in regards to maximum charge size the enclosure must have as little influence on the dynamics of the bubble pulsation and collapse phenomena as possible.

The installed enclosure consists of a cylindrical PVC tank liner with a diameter of 18 m and a height of 17 m. The base of the cylinder was closed off with a hemispherical cap. The top of the liner was supported with a ring of 1 m long rolls of flotation foam. The low density and thinness of the PVC material makes it almost transparent to the shock wave and consequently shock wave damage is not a concern. However, these characteristics make it vulnerable to damage from the fluid flow driven by rapid bubble expansion that could stretch and rupture the liner. This problem was avoided by ensuring that the flexible liner is not fully filled with water but rather is deployed in a partially collapsed state. By this means the liner can easily expand to accommodate the extra volume of the explosive bubble, in a manner analogous to inflation of a crumpled paper bag. The required expansion allowance can be estimated by equating it to the fluid displacement needed to accommodate the bubble at its maximum diameter. This expansion capability is designed into the facility; the liner that has a fully extended diameter of 18 m is positioned around the floating platform array that has an external dimension of 10.9 x 13.4 m, providing an overall radial wall expansion capacity of some 2 m. The bottom of the liner must also be protected against rupture and this is the function of its hemispherical base section. In water deeper than 17 m, floats attached to its centre, position it inside the cylindrical wall. This configuration will allow the base to move out under bubble expansion, once again preventing stretching of the liner. At present however this feature is not utilised, the current water levels at the test site are such that the base sits directly on the floor of the quarry, as shown in Fig. 3.

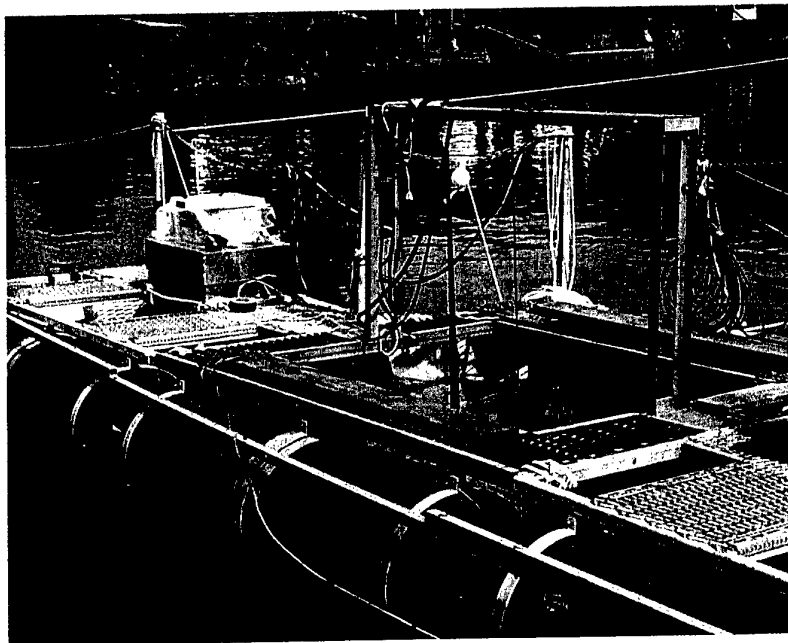
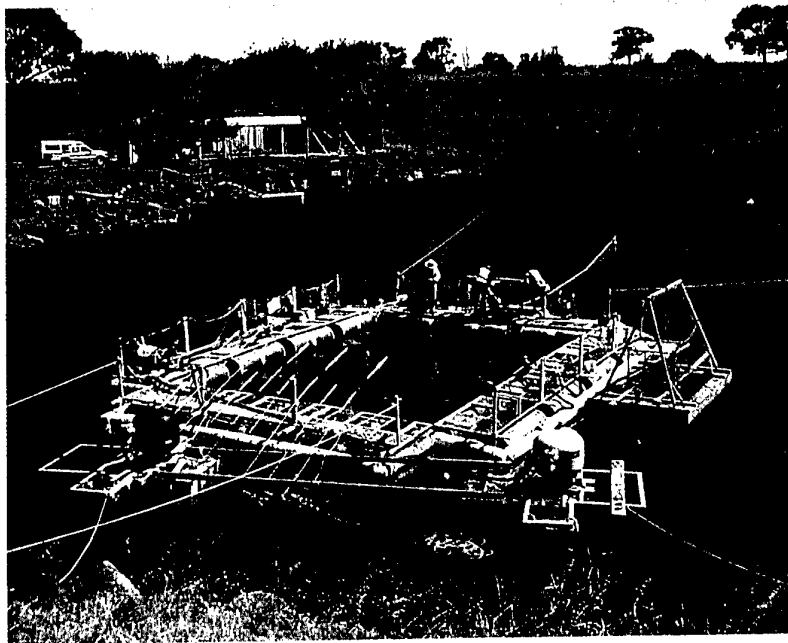

Figure 2. The imaging facility. The top view shows the overall arrangement of modular surface platforms together with the attendant filter 'barge' below and transport rig at right. The bottom view shows a close-up of the specialised camera handling platform. Note the foam filled rubber buoyancy tubes.

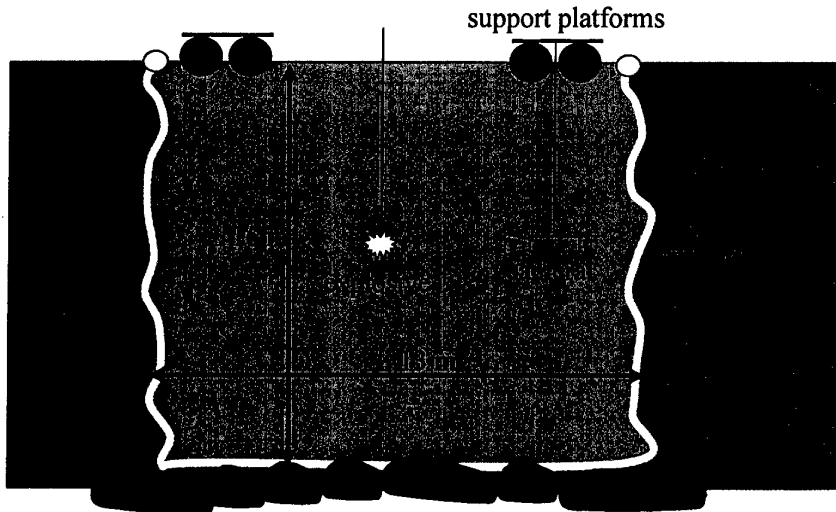

Figure 3. Schematic of the facility showing the positioning and dimensions of the water enclosure and the radial expansion capability of its wall.

3.4 Water Clarification Techniques

Even for small explosive charges, which can be observed at close range, poor water clarity seriously degrades image resolution. Heavier charge masses generate larger bubbles, which must be viewed from further away, through greater amounts of intervening water. Without reasonable water clarity these larger events become invisible to the camera. Effective clarification in natural bodies of water requires the removal of both biological material and suspended particulate matter and this was achieved using chemical treatment techniques coupled with filtration. Improvements in water clarity were assessed by use of a Secchi disk - a simple white disk lowered into the water until no longer visible from the surface (Fig. 4). This maximum depth can be used as a comparative measure of water clarity. Using the clarification techniques described below, the Secchi disk value was improved from 4 m outside the enclosure to 12 m inside.

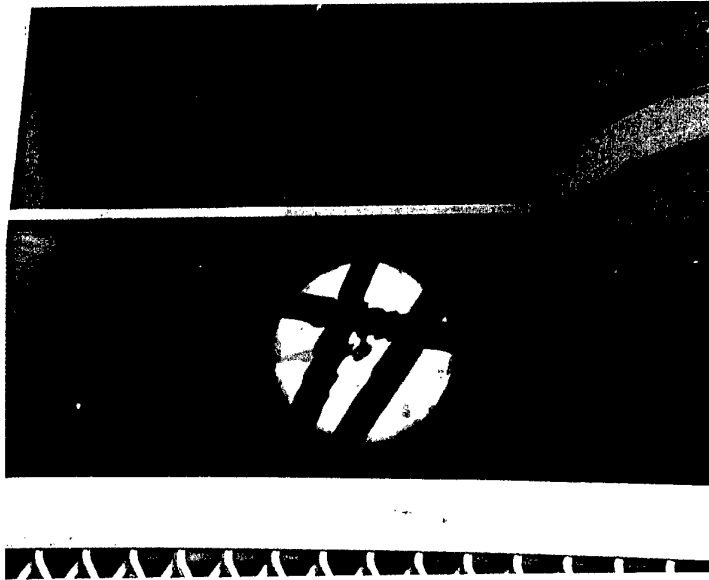

Figure 4. The Sechi disk used for comparative assessment of water clarity, seen suspended just below the water surface.

3.4.1 Chemical Treatment

Standard practices based on pool cleaning techniques were adopted, (Fig. 5) with modifications enforced by the large depth and volume of the imaging enclosure (16 m and approximately 2.5×10^6 l respectively). Biological contaminants such as algae and diatoms were found to be the major cause of turbidity at the UETF site. Tablets of trichloroisocyanuric acid, suspended in open mesh bags, were found to be an effective and long lasting treatment for this problem. Addition of liquid sodium hypochlorite was also tried but was found to be less effective.

Suspended material such as fine clays and detonation products can also be a problem in natural water environments and these can be removed by the use of chemical flocculants. These act by binding together the suspended material so that they either fall out or can be filtered more effectively. Aluminium Sulphate is a common and cheap chemical flocculant. An application of 25 kg, mixed with water and sprayed onto the water surface, was found to be sufficient to initiate the cleaning process. The effectiveness of flocculation is dependent on the pH of the water. The approximate ambient pH of the site is 9, which is too high for optimal chemical treatment. This was lowered by an initial treatment with sodium bisulphate. Cumulative addition of 400 kg of this chemical lowered the pH to a value of approx 7.4, which is within the optimal range for flocculation.

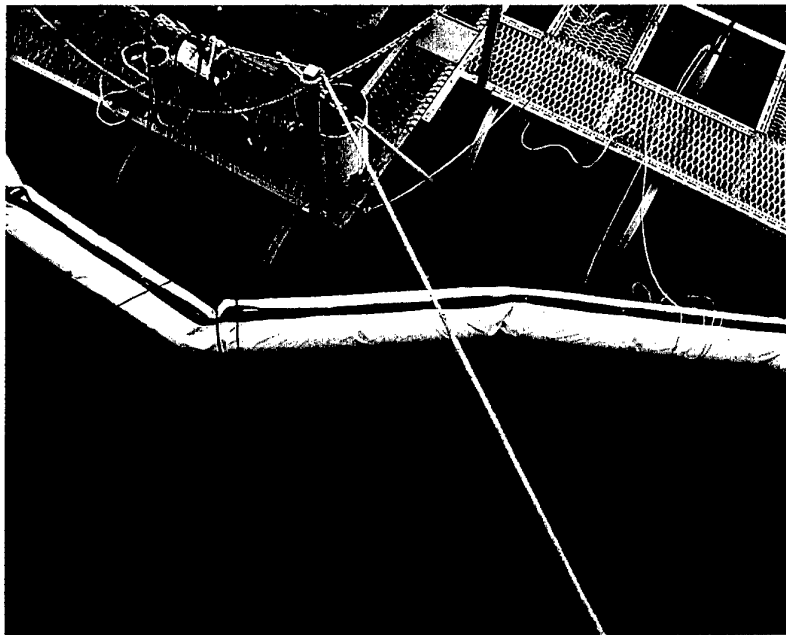
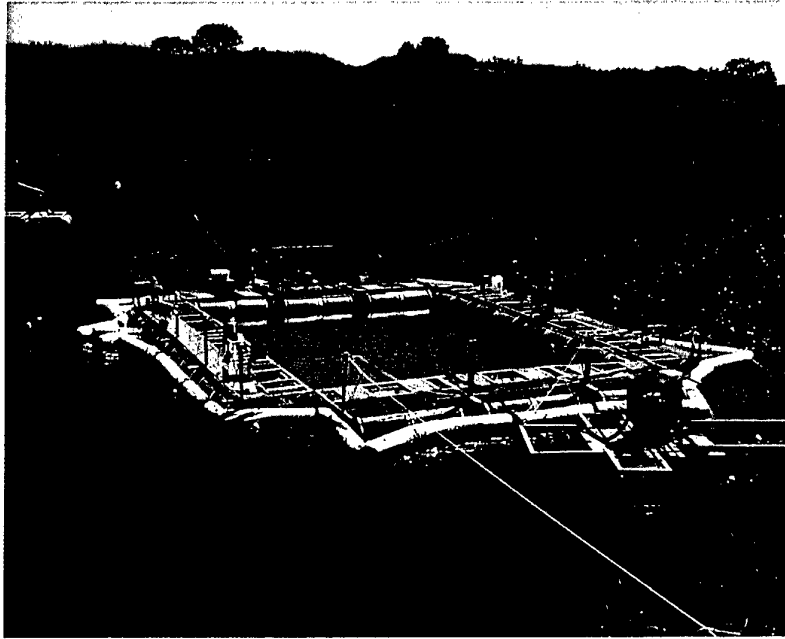

Figure 5. The facility after chemical water treatment. The bottom view illustrates the effectiveness of the enclosure at water separation.

3.4.2 Filtration

Although removal of the worst contaminants can be achieved with chemicals, experience has shown that filtration is also needed to achieve and maintain adequate water clarity. For this purpose the facility includes two pump-driven sand filters rated at 530 l/min that can turnover the total nominal volume of 2.5×10^6 l in 39 hours. However, the large depth of the enclosure makes it very difficult to obtain thorough mixing of the water and thus it is very unlikely that the total volume is being effectively filtered within this time. The filtering process is concentrated in the vicinity of the camera and experiment to maximise its effectiveness.

3.5 Camera

Video was selected over film as the recording medium. Whilst the faster framing rate of high-speed cine is necessary to record shock wave phenomena with time-scales of microseconds, the slower phenomena of bubble dynamics can be captured with high speed video. For example, the pulsation period for a 1 kg charge of TNT detonated at a depth 8 m is 190 ms. A high-speed video with a framing rate of 1000 frames/sec is more than adequate to record this event. The video system also has the considerable advantage of permitting immediate inspection of results. The current video camera is a Kodak EktaPro Hi-Spec motion analyzer (Fig. 6) capable of framing rates up to 1000 frames/sec with exposure times down to 10 μ s.

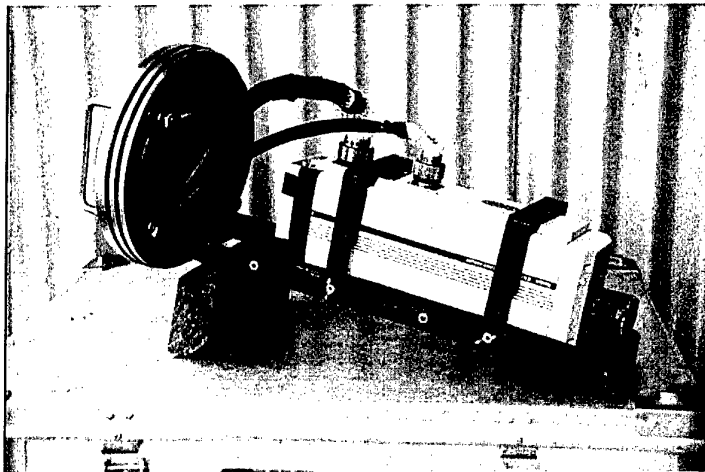

Figure 6. The EktaPro high-speed video camera mounted on its housing frame.

Although the EktaPro unit is sufficiently robust for use in air blast and impact testing, it had not been previously applied to UNDEX testing. In this application it must be positioned close to the detonation and consequently is subjected to high shock loading. Protection from this and from water ingress was provided by the camera housing unit shown in Fig. 7. This unit is a duplicate of the camera housing developed by DRES for its own program of UNDEX research and has been fully described by Rude et al [6].

For the purposes of the current report we list its major design features:

- Construction from 12.7 mm thick stainless steel to withstand the marine high shock load environment.
- Streamlined design to promote smooth diffraction of the shock wave around it.
- A tail-cone to prevent focussing of diffracted wave on the mounting base plate.
- Use of effective o-ring seals for water sealing.
- Use of neoprene mounting pads to dampen shock induced camera vibration.

During shock qualification tests conducted at DRES this camera housing design was subjected to and survived a peak pressure loading of 25.5 MPa and a shock factor loading of 0.5.

3.6 Lighting

Adequate illumination is a key factor in successful UNDEX experimentation. In many cases the ambient lighting from strong penetrating sunlight provides the best illumination. The brightness of this must of course be compatible with the sensitivity of the camera being used. For operation at the UETF, it was found that once water clarity had been improved then sufficient sunlight penetrated to the operating depth (8 m) for operation of the EktaPro camera.

In some circumstances, such as the imaging of small, possibly shadowed target structures, artificial lighting can be necessary. Specialised flash units for UNDEX imaging have been developed [6] but these have yet to be utilised at the Epping site.

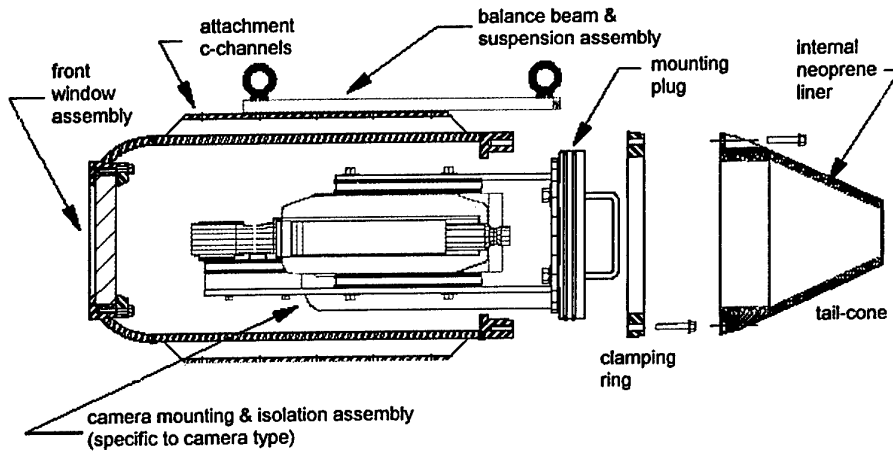
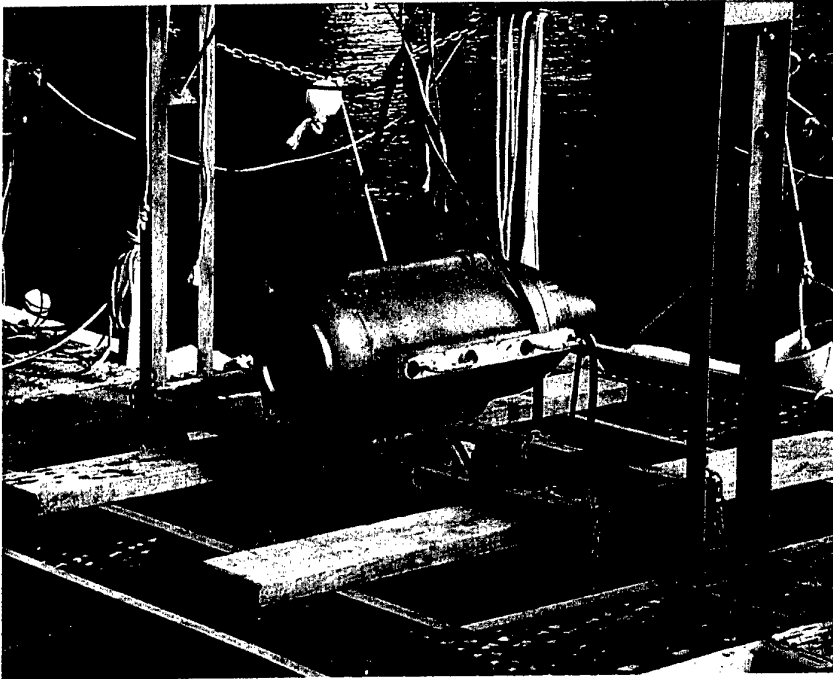

Figure 7. The shock resistant UNDEX camera housing. Schematic taken from [6]

3.7 Limitations

The facility is shown in use in Fig. 8. Surface effects due to shock wave reflection and venting of the bubble are apparent. Heavier explosive charges must be detonated near the centre of the enclosure to prevent damage to the superstructure from these effects. The need to accommodate the full bubble diameter within the camera's field of view places a limitation on the maximum charge weight that can be usefully detonated, and this will be dependent on the camera lens used. A lens with a large field of view of 52 degrees, as used in these experiments, limited the maximum charge mass to 5 kg of explosive.

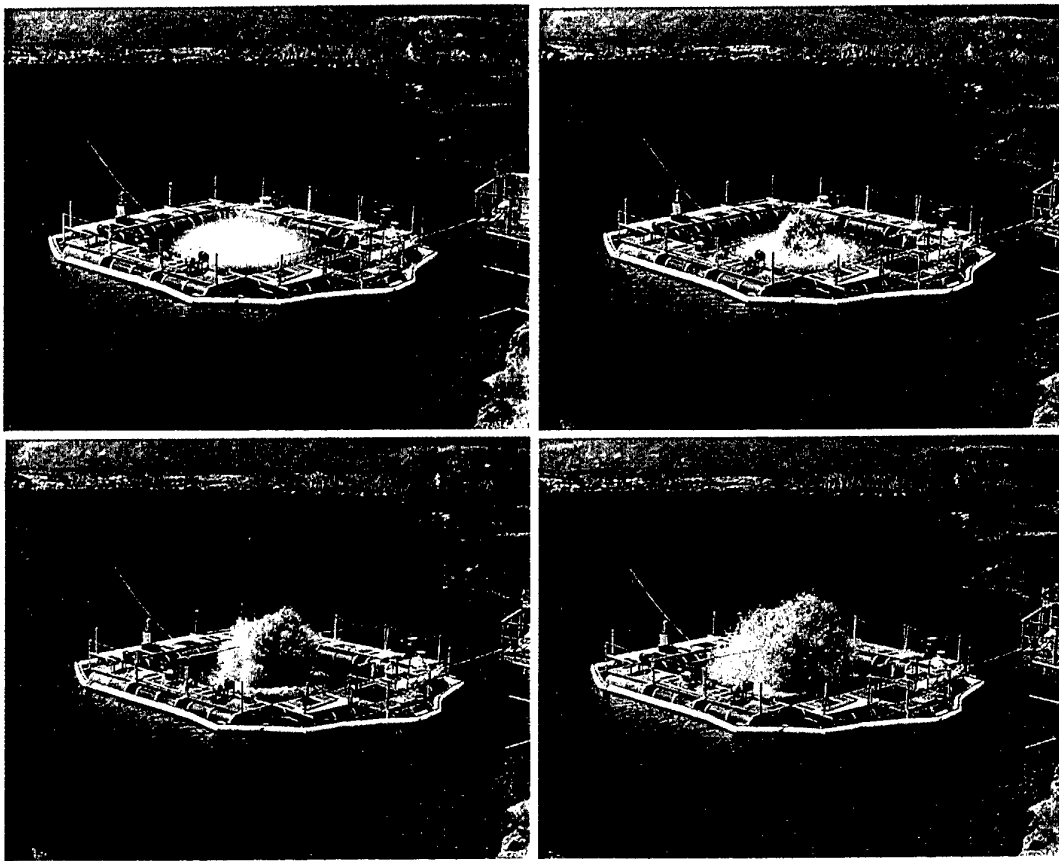

Figure 8. An earlier development version of the facility in action. Surface effects due to shock wave reflection and venting of the bubble can be seen.

4. Illustrative Imaging Results

This facility has been developed with two major purposes in mind – assessment of the underwater performance of explosives and the study of the complicated fluid-structure interaction associated with UNDEX attack on targets. Such work will be reported in future publications. For the purposes of this report we demonstrate the potential of this new experimental capability by presenting images from the detonation of the widely used explosive Composition B.

Video images were recorded at a framing rate of 1000 frames/s, giving a time resolution of 1 ms. This resolution is more than adequate for explosive charges of mass > 0.5 kg, which have an expected period in excess of 170 ms. Figure 9 shows selected frames from the video record of detonation of a 0.5 kg charge of Composition B. In each frame the bubble is seen near the centre of the circular field of view set by the window of the camera housing. The bubble can be seen throughout this sequence, with the exception of frame 4 (4 ms), for which a bubbly haze on the viewing window obscures the view. The time that this forms is consistent with the expected formation of shock wave induced cavitation on the viewing window.

The selected frames follow the event from detonation through the first pulsation into the beginnings of the 2nd expansion. During the initial expansion phase the bubble is seen to be remarkably smooth and spherical. Indeed sunlight can be seen reflecting off its upper surface around the time of its maximum diameter. However, during its contraction to minimum size the bubble becomes visibly asymmetric, developing a flattened base. This can be attributed to the variation in water pressure with depth. Vertical bubble migration around the time of minimum diameter is also apparent, with the bubble rising approximately 0.4 m. To obtain reliable measurements of bubble diameter, the raw video frames must be corrected for any optical distortions and then scaled. Optical distortion was removed by use of a calibrated imaging matrix positioned in front of the camera, so as to fill the field of view. Scaling was achieved with a graduated light frame positioned at the same distance from the camera as the explosive charge.

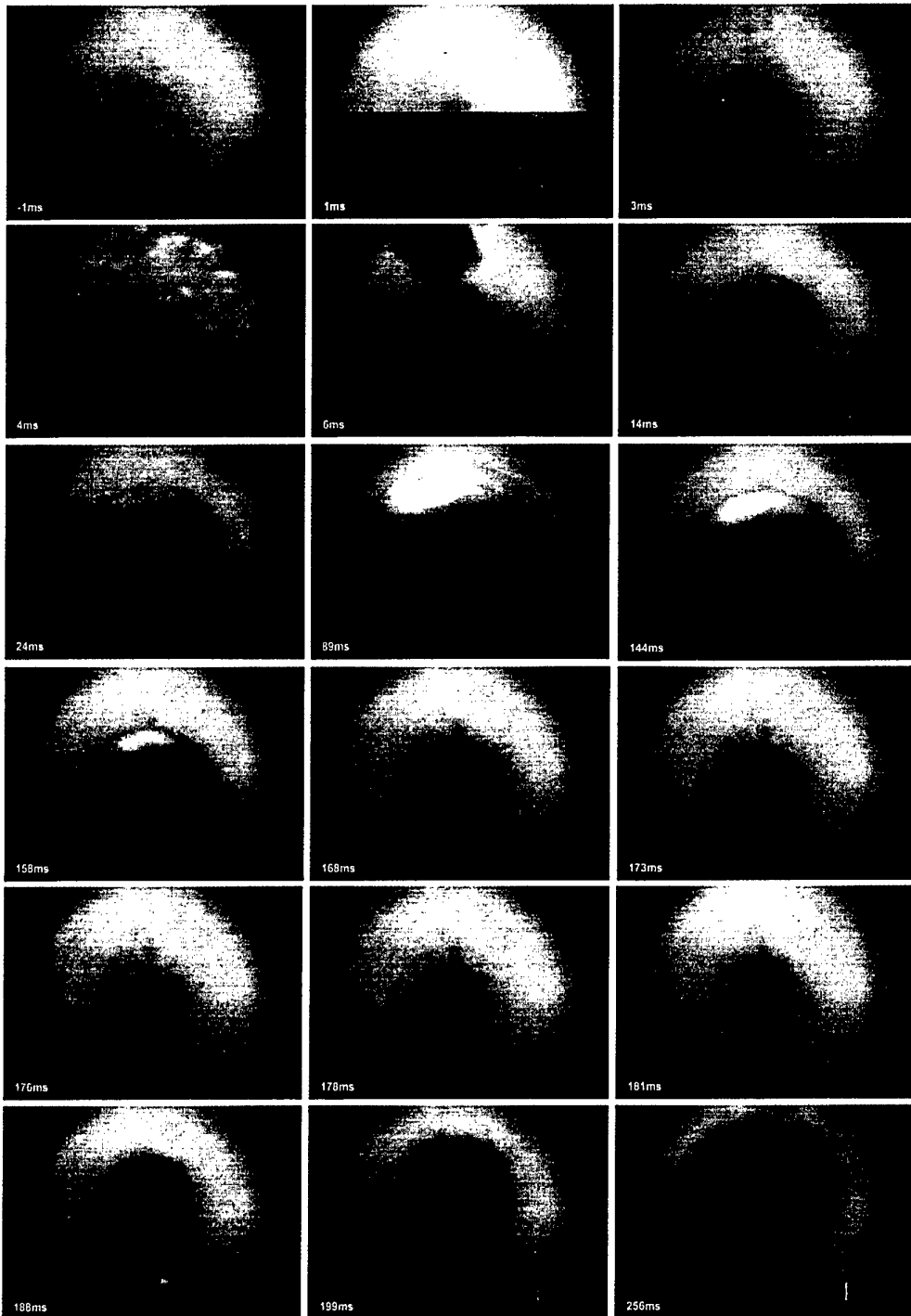

Figure 9. Selected frames from the detonation of 0.5 kg Composition B at a depth of 5 m. The time since detonation is given on each frame. The maximum bubble diameter is about 2.3m.

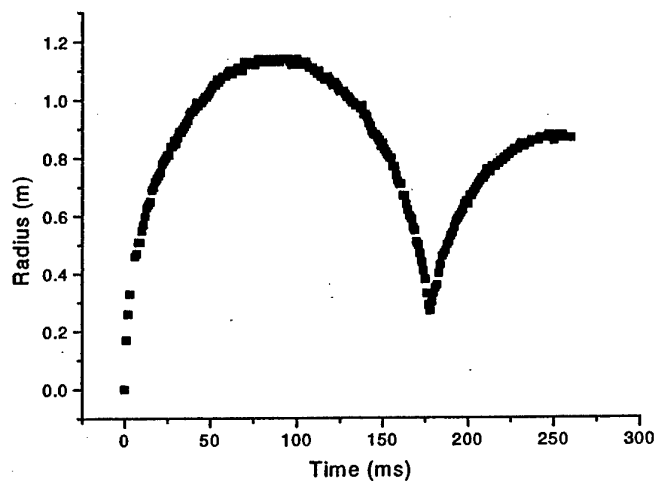

Figure 10. The variation of bubble radius with time measured for 0.5 kg of Composition B detonated at a depth of 5 m.

The corrected video frames can then be used to measure the radius of the bubble. Figure 10 shows the time dependence of radius measured for the 0.5 kg charge of Composition B. The overall characteristics of bubble pulsation can clearly be seen i.e. a rapid collapse/expansion near minimum radius and a relatively slow change around the time of maximum radius. An analysis of this experiment will serve to demonstrate the value of optical imaging in providing insight into underwater explosive phenomena. Figure 10 shows that the bubble collapses from a maximum radius of 1.14 m to a minimum radius of 0.27 m in an interval of 97 ms. Simple calculation shows that this collapse causes the in-fall of 6.1 m^3 of water in an interval of 0.09 s .i.e. 6 tonnes of water is moved in a tenth of a second. This clearly demonstrates the potential of bubble collapse to cause damage.

Underwater pressure is routinely measured for UNDEX experiments at the Epping trial site. Figure 11 shows the underwater pressure measured with a PCB138A05 transducer at a distance of 4.5 metres from the 0.5 kg Composition B charge. The pressure peaks associated with passage of the shock wave and the first bubble pulse pressure wave are clear and the timing of the bubble pulse is consistent with the recorded image of minimum radius shown in Fig. 10. The expanded view of the shock wave shown in Fig. 12 can be inspected for evidence of interaction of the UNDEX event with the test environment. The two major features of the shock wave tail can be attributed to surface reflection at 4.5 ms and reflection from the floor and walls of the quarry in the interval 13-19 ms.

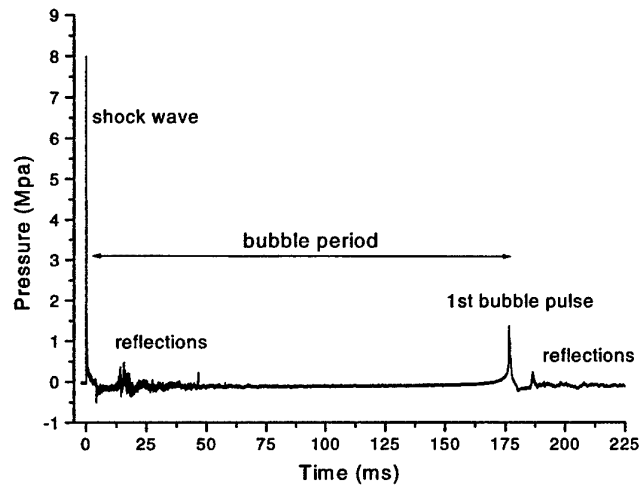

Figure 11. Pressure record measured 4.5 m from the detonation of 0.5 kg of Composition B.

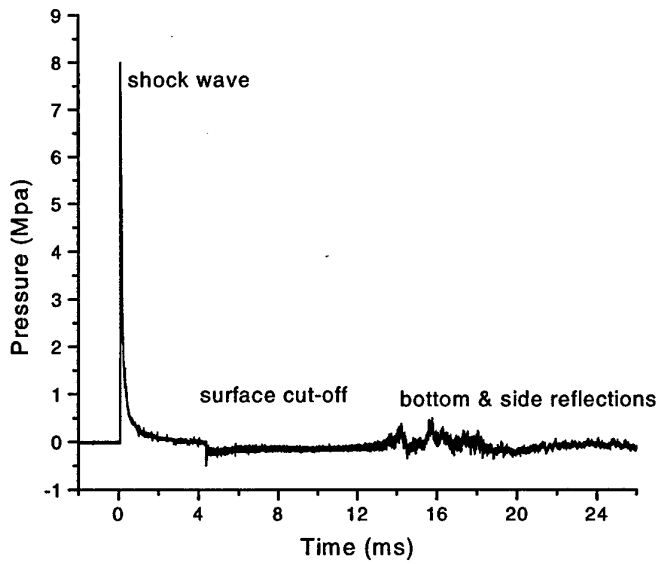

Figure 12. Expanded view of first 25 ms of Fig. 11 showing shock wave reflection features.

We see no clear evidence of reflection from the PVC walls of the water enclosure. If this occurred, it would be expected about 2 ms after the shock wave front.

Whilst these effects are not large, it is clear that the expanding bubble will see both reflected tension and compression waves and so the UNDEX environment of the imaging facility differs measurably from the free field environment. Accordingly, it is recommended that any assessment of bubble dynamics of new explosives be conducted in a comparative manner against a well-known explosive.

5. Summary

A new experimental capability for the study of underwater explosions at medium scale has been described. With this facility DSTO can perform optical studies of the complex gas and fluid dynamics generated by these events.

Successful imaging of underwater explosions, particularly at medium scale, is technically challenging. A number of difficulties must be overcome, including the protection of structures and equipment from high shock loading, attainment of good water quality in a 'open' water environment and high speed imaging with low light levels. Techniques to overcome these difficulties have been described.

This facility permits the assessment of the efficiency of underwater explosives and gives a penetrating insight into the complicated fluid-structure interaction responsible for damage to floating and submerged targets. The potential of this new capability was demonstrated by imaging and analysis of the UNDEX bubble behaviour generated by the detonation of a 0.5 kg charge of Composition B.

6. Acknowledgments

The conduct of this research would not have been possible without the efforts of a number of people who worked with us to develop the imaging capability. The enthusiastic support of the MPD trials team is acknowledged, in particular Phillip Box during initial installation of the facility at Epping and Frank Marian for competent handling of explosives. The Ektapro video camera was kindly loaned to DSTO by the Army Land Engineering Agency (LEA). Successful operation of this and other video equipment was crucial to our success and in this regard we were fortunate to have the expertise of Jim Nicholls (Boeing) and Terry Olson and Gary Durrant of LEA. John Slater and Gerry Rude from DRE Suffield, Canada, provided valuable advice during this project. Finally, it is a pleasure to thank Dave Ritzel and Norbert Burman for initiating the project and Joe Kiewlak, whose interest and support ensured that the needed resources were available.

7. References

- [1]. Brett, J. M. and Buckland, M., "An Assessment of the Underwater Performance of an Unusual Dual Component Explosive., DSTO Secret Report.
- [2]. Turner T., Buckland, M. "An Investigation of the Fluid-Structure Interaction Resulting from a Near Field 5g UNDEX Event ", DSTO Report in preparation.
- [3]. Snay, H.G. 1957, Hydrodynamics of Underwater Explosions. In: *Symposium on Naval Hydrodynamics*, Publication 515. National Academy of Science, National Research Council, Washington DC, 325-352.
- [4]. Cole RH (1948) Underwater Explosions, Princeton University Press, NJ.
- [5]. Swisdak, M (1978) Explosive effects and properties. II Explosive effects in water, NSWC/WOL/TR.76.116.
- [6]. Rude, G., Slater, J. S., Brett, J. M. and Buckland, M., "High Speed Photographic Technology for Examining Underwater Explosion Phenomena in Open Water", SAVIAC 1999

DISTRIBUTION LIST

An Experimental Facility for Imaging of Medium Scale Underwater Explosions

John M Brett, Michael Buckland, Terry Turner, Charles Killoh and Peter Kiernan

AUSTRALIA

DEFENCE ORGANISATION

S&T Program

Chief Defence Scientist
FAS Science Policy
AS Science Corporate Management
Director General Science Policy Development
Counsellor Defence Science, London (Doc Data Sheet)
Counsellor Defence Science, Washington (Doc Data Sheet)
Scientific Adviser to MRDC Thailand (Doc Data Sheet)
Scientific Adviser Joint
Navy Scientific Adviser
Scientific Adviser - Army (Doc Data Sheet and Distribution List only)
Air Force Scientific Adviser
Director Trials

} shared copy

Platforms Sciences Laboratory

Chief of Maritime Platforms Division
Dr David Saunders RLSPS
Dr John Brett, 5 copies
Michael Buckland
Terry Turner
Peter Kiernan
Charles Killoh

Systems Sciences Laboratory

Dr Norbert Burman
Dr Anna Wildegger-Gaissmaier
Tim Clarke

DSTO Library and Archives

Library Maribyrnong
Library Edinburgh, 1 copy
Australian Archives

Capability Systems Staff

Director General Maritime Development (Doc Data Sheet only)
Director General Aerospace Development (Doc Data Sheet only)

Knowledge Staff

Director General Command, Control, Communications and Computers (DGC4)
(Doc Data Sheet only)

Navy

SO (SCIENCE), COMAUSNAVSURFGRP, NSW (Doc Data Sheet and Distribution List only)

Army

ABCA National Standardisation Officer, Land Warfare Development Sector, Puckapunyal (4 copies)

SO (Science), Deployable Joint Force Headquarters (DJFHQ) (L), Enoggera QLD (Doc Data Sheet only)

Intelligence Program

DGSTA Defence Intelligence Organisation

Manager, Information Centre, Defence Intelligence Organisation

Defence Libraries

Library Manager, DLS-Canberra

Library Manager, DLS - Sydney West (Doc Data Sheet Only)

UNIVERSITIES AND COLLEGES

Australian Defence Force Academy

Library

Head of Aerospace and Mechanical Engineering

Serials Section (M list), Deakin University Library, Geelong, VIC

Hargrave Library, Monash University (Doc Data Sheet only)

Librarian, Flinders University

OTHER ORGANISATIONS

National Library of Australia

NASA (Canberra)

OUTSIDE AUSTRALIA**INTERNATIONAL DEFENCE INFORMATION CENTRES**

US Defense Technical Information Center, 2 copies

UK Defence Research Information Centre, 2 copies

Canada Defence Scientific Information Service, 1 copy

NZ Defence Information Centre, 1 copy

ABSTRACTING AND INFORMATION ORGANISATIONS

Library, Chemical Abstracts Reference Service

Engineering Societies Library, US

Materials Information, Cambridge Scientific Abstracts, US

Documents Librarian, The Center for Research Libraries, US

INFORMATION EXCHANGE AGREEMENT PARTNERS

Acquisitions Unit, Science Reference and Information Service, UK

Library - Exchange Desk, National Institute of Standards and Technology, US

SPARES (15 copies)

Total number of copies: 64

DEFENCE SCIENCE AND TECHNOLOGY ORGANISATION DOCUMENT CONTROL DATA				1. PRIVACY MARKING/CAVEAT (OF DOCUMENT)	
2. TITLE An Experimental Facility for Imaging of Medium Scale Underwater Explosions		3. SECURITY CLASSIFICATION (FOR UNCLASSIFIED REPORTS THAT ARE LIMITED RELEASE USE (L) NEXT TO DOCUMENT CLASSIFICATION) Document (U) Title (U) Abstract (U)			
4. AUTHOR(S) John M. Brett, Michael Buckland, Terry Turner, Charles G. Killoh and Peter Kiernan		5. CORPORATE AUTHOR Platforms Sciences Laboratory 506 Lorimer St Fishermans Bend Victoria 3207 Australia			
6a. DSTO NUMBER DSTO-TR-1432	6b. AR NUMBER AR-012-767	6c. TYPE OF REPORT Technical Report	7. DOCUMENT DATE May 2003		
8. FILE NUMBER 2002/48957/1	9. TASK NUMBER LRR 02/156	10. TASK SPONSOR DSTO	11. NO. OF PAGES 20	12. NO. OF REFERENCES 6	
13. URL on the World Wide Web http://www.dsto.defence.gov.au/corporate/reports/DSTO-TR-1432.pdf			14. RELEASE AUTHORITY Chief, Maritime Platforms Division		
15. SECONDARY RELEASE STATEMENT OF THIS DOCUMENT <i>Approved for public release</i>					
OVERSEAS ENQUIRIES OUTSIDE STATED LIMITATIONS SHOULD BE REFERRED THROUGH DOCUMENT EXCHANGE, PO BOX 1500, EDINBURGH, SA 5111					
16. DELIBERATE ANNOUNCEMENT No Limitations					
17. CITATION IN OTHER DOCUMENTS Yes					
18. DEFTEST DESCRIPTORS underwater explosions, images, explosion effects, detonation assessment, imaging techniques					
19. ABSTRACT A new experimental capability for the study of underwater explosions has been developed. This is based on a unique facility that permits direct optical imaging of the detonation of medium scale (1-5 kg) explosive charges at PSL's Underwater Explosion Test Facility, Melbourne, Victoria. Imaging of UNDEX events in a field environment presents many technical challenges including protection of structures and sensitive equipment from high shock loads, attainment of optically clear water, high speed imaging in low light levels and experimental operation at significant water depths. The techniques employed to successfully overcome these challenges are described. The potential of this new capability is demonstrated by imaging and analysis of the detonation of a 0.5 kg explosive charge of Composition B.					