

# SANDIA REPORT

SAND2003-1160  
Unlimited Release  
Printed April 2003

## Design of Largest Shaped Charge: Generation of Very Large Diameter, Deep Holes in Rock and Concrete Structures

Manuel G. Vigil

Prepared by  
Sandia National Laboratories  
Albuquerque, New Mexico 87185 and Livermore, California 94550

Sandia is a multiprogram laboratory operated by Sandia Corporation,  
a Lockheed Martin Company, for the United States Department of Energy's  
National Nuclear Security Administration under Contract DE-AC04-94AL85000.

Approved for public release; further dissemination unlimited.



**Sandia National Laboratories**

20030606 148

Issued by Sandia National Laboratories, operated for the United States Department of Energy by Sandia Corporation.

**NOTICE:** This report was prepared as an account of work sponsored by an agency of the United States Government. Neither the United States Government, nor any agency thereof, nor any of their employees, nor any of their contractors, subcontractors, or their employees, make any warranty, express or implied, or assume any legal liability or responsibility for the accuracy, completeness, or usefulness of any information, apparatus, product, or process disclosed, or represent that its use would not infringe privately owned rights. Reference herein to any specific commercial product, process, or service by trade name, trademark, manufacturer, or otherwise, does not necessarily constitute or imply its endorsement, recommendation, or favoring by the United States Government, any agency thereof, or any of their contractors or subcontractors. The views and opinions expressed herein do not necessarily state or reflect those of the United States Government, any agency thereof, or any of their contractors.

Printed in the United States of America. This report has been reproduced directly from the best available copy.

Available to DOE and DOE contractors from  
U.S. Department of Energy  
Office of Scientific and Technical Information  
P.O. Box 62  
Oak Ridge, TN 37831

Telephone: (865)576-8401  
Facsimile: (865)576-5728  
E-Mail: [reports@adonis.osti.gov](mailto:reports@adonis.osti.gov)  
Online ordering: <http://www.doc.gov/bridge>

Available to the public from  
U.S. Department of Commerce  
National Technical Information Service  
5285 Port Royal Rd  
Springfield, VA 22161

Telephone: (800)553-6847  
Facsimile: (703)605-6900  
E-Mail: [orders@ntis.fedworld.gov](mailto:orders@ntis.fedworld.gov)  
Online order: <http://www.ntis.gov/help/ordermethods.asp?loc=7-4-0#online>



# **Design of Largest Shaped Charge: Generation of Very Large Diameter, Deep Holes in Rock and Concrete Structures**

Manuel G. Vigil, Consultant  
Explosive Projects and Diagnostics Department  
Sandia National Laboratories  
P. O. Box 5800  
Albuquerque, NM 87185-1452

## **Abstract**

This report documents the design at Sandia National Laboratories (SNL) of the largest known conical shaped charge (CSC). This CSC was designed specifically to generate a very large hole diameter and a substantial jet penetration depth in hard rock and concrete structures as part of the Cruise Missile Program. The charge will fit in the existing volume between the missile body and the PEN-X penetrator weapon that it carries. The CSC jet produces a precursor hole in a hard rock or concrete target with a hole profile such that the penetrator deceleration loads are reduced sufficiently to allow the weapon components to function successfully at maximum penetration depth. Additionally, the precursor hole will allow substantially deeper penetration into the target to obtain good coupling at the rock or concrete interface, thus allowing the maximum shock or stress wave transmission into the target when the weapon is detonated. A parametric study was conducted using the Shaped Charge Analysis Program (SCAP) code to design this 28 inch outside diameter by 28.5 inch long CSC. The total charge weight was about 900 pounds. The total weight of Octol explosive was about 600 pounds.

Testing was conducted on schedule on November 23, 2002, at Myer's Ridge, Tonopah Test Range. The target was Sidewinder Tuff rock. The test was a complete success. Below the surface crater (below 15 inches), the hole diameter remained constant at 10 inches diameter (hole diameter predicted by SCAP was 11.3 inches) up to the maximum measured penetration depth of 19.5 feet (penetration predicted by SCAP was 18.9 feet).



## ACKNOWLEDGMENTS

I would like to acknowledge Ed Talbot, John Andersen, and Lloyd Bonzon, all of Sandia National Laboratories (SNL), for their support and guidance in the management of this program.

The steel support structures performed just as expected in accordance with Roy Dickey's mechanical designs. The hole-measuring system, including the threaded aluminum rods and disks, worked as expected. Once the SCAP code analyses were completed to establish the design of the shaped charge, Roy, with minimal information and guidance, performed the following tasks:

1. Generated the piece-part drawings and found a company to fabricate/manufacture the CSC hardware,
2. Found a company to fabricate the steel support structure for the CSC and penetrator at Tonopah Test Range (TTR),
3. Designed the steel platform to support the conical shaped charge (CSC) during shipment, explosive loading, and testing,
4. Designed the steel structure to support the CSC and penetrator during the test, and
5. Was the main contact at SNL/NM for coordinating the efforts to conduct the test at TTR.

Roy and I have been in this business for a long time, and this experience was constantly tested or challenged throughout Phase I of this program. We shared the enthusiasm and recognized the unique, challenging, and exciting tasks and requirements for the successful completion of this part of Phase I of the program.

The pressure and vacuum system provided by the TTR team to clean out the hole worked very well. The TTR team helped to make the post-test measurements of hardware fragment locations and was responsible for cleanup of the test site.

Thirty-four channels of data were successfully recorded during the TTR test. These data included pressure, acceleration, and strain measurements. Bill Kluesner and his crew spent long hours connecting the instrumentation lines to the transducers in the BLU-109 penetrator installed behind the shaped charge, repairing some accelerometer and strain gage transducer wirings, setting up all the electronic hardware including the expected recording levels and multi-recording channels at different frequencies, assisting with the penetrator installation on the steel support structure, assisting with the installation of the radiator hoses to protect the instrumentation cables, etc. Bill and his crew did an excellent job as usual.

Roger Smith, Dave Paul, Rod Shear, and Vern Hermansen teamed well to get the test plan, Safe Operating Procedure (SOP), SOP addendum, detonator tests including Tetryl pellets, and system checkouts using sugar loads, which were vital for successfully conducting this test.

Professor Michael Huerta, University of Texas at El Paso, conducted the CTH hydrocode modeling/simulation work as an independent check of the final charge design resulting from the SCAP code parametric study for the shaped charge jet penetration of the Sidewinder Tuff rock target. Ed Mulligan provided the arming and firing, firing set functioning, checkout, and system guidance in working with TTR personnel.

Thanks to John Andersen and Michele Steyskal for their review comments and help in getting this report published in a timely manner.

# CONTENTS

1. INTRODUCTION .....	11
2. REQUIREMENTS .....	12
2.1 Tuff Rock Target Hole Requirements .....	12
2.2 Shaped Charge Limitations/Requirements .....	12
2.3 Schedule Requirements .....	12
3. FIRST SHAPED CHARGE .....	14
3.1 Target Modeling .....	14
3.2 Explosive .....	14
3.3 Shaped Charge Liner .....	14
3.3.1 Liner Mechanical Impedance .....	14
3.3.2 Liner Density .....	15
3.4 Explosive Housing/Tamper .....	15
3.5 Liner Retainer Ring/Explosive Cover Plate .....	16
3.6 Conical Shaped Charge Assembly .....	16
3.7 Detonator .....	16
3.8 Booster Charge .....	16
3.9 Booster Pellets .....	17
4. SHAPED CHARGE MODELING/SIMULATION .....	18
4.1 SCAP Code Description .....	18
4.2 SCAP Code Parametric Study Analyses .....	19
4.2.1 Copper Liner .....	20
4.2.2 Aluminum Liner .....	20
4.2.3 Tungsten Liner .....	21
4.3 SCAP Code Final Design Output .....	21
4.4 Sidewinder Tuff Rock Parameters .....	21
4.5 Tuff Rock Penetration Predictions .....	22
5. SHAPED CHARGE FABRICATION AND TESTING .....	23
5.1 Shaped Charge Explosive Loading .....	23
5.2 First Shaped Charge Test at TTR .....	23
5.2.1 Assembly and Test Procedure .....	24
5.2.2 SCAP Code Predictions vs. TTR Test Results .....	24
5.3 Second Shaped Charge Design .....	26
6. SUMMARY .....	27
REFERENCES .....	29
Appendix A. Piece-Part and Assembly Drawings for the Final CSC Design Drawings .....	69
Appendix B. Conical Shaped Charge Assembly Photos .....	77
Appendix C. SCAP Code Parametric Study Data/Copper Liner .....	85

Appendix D. SCAP Code Parametric Study Data/Aluminum Liner .....	93
Appendix E. SCAP Code Parametric Study Data/Tungsten Liner .....	97
Appendix F. CSC Final Design Dimensions, Weights, and Volumes .....	101
Appendix G. Tonapah Test Range Test Fixtures/Structures .....	105

## Figures

Figure 1. Conical Shaped Charge Configuration.....	41
Figure 2. CSC Copper Cone/Explosive Side.....	42
Figure 3. CSC Copper Cone/Air Side .....	42
Figure 4. CSC Cone – Cylinder, Aluminum, Explosive Housing.....	43
Figure 5. Explosive Housing Inside View.....	43
Figure 6. Explosive Housing Outside View .....	44
Figure 7. CSC Cone Retainer Ring (Aluminum) .....	44
Figure 8. Aluminum, Explosive Cover Plate.....	45
Figure 9. CSC Steel Support Platform (0.5 x 40 x 40 in. Al, 269.2 lb).....	45
Figure 10. Assembled CSC .....	46
Figure 11. SCAP Code Model Geometry .....	47
Figure 12. Jet Formation at +75 Microseconds/Detonation Wave .....	48
at Base of Explosive.....	48
Figure 13. Jet Formation at +150 Microseconds .....	49
Figure 14. Jet Formation at +250 Microseconds .....	50
Figure 15. Jet Formation at +350 Microseconds .....	51
Figure 16. Jet Formation at +450 Microseconds .....	52
Figure 17. Jet Formation at +550 Microseconds .....	53
Figure 18. Jet Velocity Versus Dimensionless Distance.....	54
Figure 19. Explosive Housing/Tamper Velocity Versus Distance.....	55
Figure 20. Jet Penetration Versus Standoff .....	56
Figure 21. Jet Penetration Versus Hole Radius/Diameter Profile .....	57
Figure 22. Jet Penetration Versus Time.....	58
Figure 23. Jet Penetration Versus Jet Velocity.....	59
Figure 24. Accumulated Jet Mass Versus Jet Velocity .....	60
Figure 25. Accumulated Jet Momentum Versus Jet Velocity .....	61
Figure 26. Accumulated Jet Kinetic Energy Versus Jet Velocity .....	62
Figure 27. Jet Generated Hole Volume Versus Standoff .....	63
Figure 29. Overall Test Configuration .....	65
Figure 30. CSC Installed on Structure and Below Penetrator .....	65
Figure 31. Post-Test Hole in Tuff, Penetrator, and Support.....	66
Figure 32. Post-Test, Tuff Rock Surface Crater, and Hole .....	66
Figure 33. Penetrator Nose Area/Nose Piece Missing .....	67
Figure 34. Penetrator Nose Recovered Near Hole .....	67



## Tables

Table 1. Milestone Chart for Design of Shaped Charge .....	35
Table 2. Sidewinder Tuff Rock Parameters .....	36
Table 3. Octol Explosive Parameters .....	36
Table 4. SCAP Code Input File.....	37
Table 5. Parametric Study/Variable CSC Liner Materials.....	37
Table 6. CSC Hardware Weights .....	38
Table 7. SCAP Code Shaped Charge Jet Penetration in Sidewinder Tuff Predictions Versus Measured Test Data Comparisons .....	39
Table 8. 28 Inch Dia. Shaped Charge (SC) Jet Penetration and Hole Diameter Measurements in Tuff Rock.....	40

## NOMENCLATURE

AOLLC	American Ordnance LLC
CSC	Conical Shaped Charge
CTH	C to the Third power, SNL hydrocode
EBW	Exploding Bridgewire Detonator
HMX	Octahydro-1,3,5,7-tetranitro-1,3,5,7-tetrazocine
Octol	Explosive, 75% HMX, 25% TNT
PETN	2,2-bis[(nitroxy)methyl]-1,3-propanediol,dinitrate
Primasheet	PETN based plastic, sheet explosive/formerly Detasheet
RISI	Reynolds Industries, Inc.
SCAP	Shaped Charge Analysis Program
SNL	Sandia National Laboratories
SOP	Safe Operating Procedure
TETRYL	N-methyl-n,2,4,6-tetranitrobenzenamine
TNT	2-methyl-1,3,5-trinitrobenzene
TTR	Tonopah Test Range

## 1. INTRODUCTION

This report documents the design at Sandia National Laboratories (SNL) of the largest known conical shaped charge (CSC). The CSC design is shown in Figure 1, and the hardware is shown in Figures 2–10. This CSC was designed specifically to generate a very large hole and a substantial jet penetration depth in rock and concrete structures as part of the Cruise Missile Program. The charge fits in the existing volume between the missile body and the PEN-X penetrator weapon that it carries. The CSC jet produces a precursor hole in a hard rock or concrete target with a hole profile that has the following benefits:

1. The penetrator deceleration loads are reduced sufficiently to allow the weapon components to function successfully at maximum penetration depth,
2. It also helps prevent rebound of the penetrator from hard targets,
3. It may help reduce target uncertainties, and
4. The precursor hole will allow substantially deeper penetration to obtain good coupling at the rock or concrete interface, thus allowing the maximum shock or stress wave transmission into the target when the weapon is detonated.

A parametric study was conducted using the Shaped Charge Analysis Program (SCAP) code to design this 28 inch outside diameter by 28.5 inch long CSC. The total charge weight was about 900 pounds. The total weight of Octol explosive was about 600 pounds. This very large shaped charge was designed in a month and a half without any development testing, peer review, etc., as is customary for similar designs at SNL.

The requirements or goal for this CSC design was to generate an entrance hole of 12 to 15 inches diameter (below the surface crater) in tuff rock with a minimum jet penetration depth of 15 feet. The SCAP-predicted depth of jet penetration in tuff rock was about 19 feet. The SCAP-predicted diameter of the tuff entrance hole was about 11 inches.

The program requirements were for a fast-track program that relied heavily on previous SNL CSC design, computer codes modeling/simulation, fabrication, testing, and experience. References 1–63 document some of SNL's previous shaped charge design work.

The first test using the large CSC was conducted at Tonopah Test Range (TTR), Nevada, into a Sidewinder Tuff rock formation target on November 23, 2002. A second large CSC will be designed to generate a similar hole in about a 20-foot cubical concrete structure.

## **2. REQUIREMENTS**

### **2.1 Tuff Rock Target Hole Requirements**

The Sidewinder Tuff rock target requirements are as follows:

- a. Hole Geometry
  1. Depth: 15 ft minimum
  2. Diameter: 12–15 inches
  3. Profile: As close to cylindrical as possible
- b. Target Properties
  1. Design 1: Sidewinder Tuff rock (see Table 2)
  2. Design 2: Concrete: 5000 psi concrete with aggregate, no rebar

### **2.2 Shaped Charge Limitations/Requirements**

The shaped charge limitations and requirements are as follows:

- a. Standoff
  1. Optimum standoff to meet hole requirements
- b. Total Weight
  1. Less than or equal to 971 pounds
- c. Shaped charge geometry
  1. Diameter (including explosive housing/tamper):  
28 inches if integral with missile fuselage (would be limited to aluminum tamper if integral)
  2. Length:  $\leq 28.5$  inches
- d. Materials
  1. No limitations on liner or tamper materials or thickness

### **2.3 Schedule Requirements**

- a. Test CSC design 1 into Sidewinder Tuff rock target at Tonapah Test Range, Nevada, in November 2002.
- b. Test CSC design 2 into concrete target at SNL in 2003.

Table 1 lists the major milestones, and schedule for this project.

SNL explosive weapons components have typically taken several years for conceptual design, modeling, analyses, fabrication, development testing, peer review, final design, fabrication, testing, and final documentation.

The desired schedule and budget did not permit the normal procedures to be followed. This CSC was designed in a month and a half, the design drawings were completed in one week, the materials and fabrication source were obtained in about two weeks, the CSC hardware and TTR test support structures were fabricated in six weeks, and the explosive loading was completed in five weeks.

### **3. FIRST SHAPED CHARGE**

The design of the first large shaped charge was expedited and took the fast, higher risk path because no development work could be conducted with this project. The project started in July 2002, and its goal was to design, fabricate, load with explosive, and deliver the first shaped charge by November 2002.

#### **3.1 Target Modeling**

Initially, some Sidewinder Tuff rock parameters were available, and others were calculated or estimated in order to model this target material. Some of the Sidewinder Tuff rock parameters are listed in Table 2.

#### **3.2 Explosive**

Ideally, a high-density HMX-type explosive that can be cast, pressed, or machined was desired. Generally, for a secondary-type explosive, the higher the density, the better is the desired metal-driving ability for conical-liner collapse. The much lower performing COMP-C4 explosive could have been used as a last resort if time and budget would not allow the use of the higher density HMX-type explosive.

Pressed HMX explosive would yield the highest density (about 1.9 g/cc); however, the tooling, dies, etc., were too expensive to pursue. The HMX explosive is relatively more expensive than most other explosives.

Cast explosive (i.e., Octol) was next considered because it has a high enough density of about 1.8 g/cc and consists of 75% HMX and 25% TNT. Three explosive casting sites for loading the required 600 pounds were identified: American Ordnance LLC (Middletown, Iowa), New Mexico Institute of Mining & Technology (Socorro, NM), and Stanford Research Institute (Palo Alto, CA). All three sites could do the job, but only American Ordnance could do the job within the time and budget constraints. The Octol explosive parameters are listed in Table 3.

#### **3.3 Shaped Charge Liner**

Ideally, a high-density, ductile liner material would have been used to meet the 15-foot jet penetration depth requirement. However, the real challenge with this large shaped charge design was in generating the very large entrance hole diameter (12–15 inches) required.

##### **3.3.1 Liner Mechanical Impedance**

Theoretically, a material of relatively low impedance (density times sound speed) matching the mechanical impedance of Sidewinder Tuff would allow the maximum kinetic energy transfer from the penetrating jet material. This unproven concept makes a

lot of sense for generating large hole diameters in tuff, although if the jet density is too low, then the desired maximum jet penetration is harder to achieve.

### 3.3.2 Liner Density

The liner density is the dominant parameter for determining the jet penetration depth in the target material. Therefore, liner materials like tungsten, gold, platinum, depleted uranium, tantalum, etc., would be desired if maximum penetration were the most important requirement. Most of the above materials were immediately omitted because of expense, safety, or hazardous materials considerations. Bimetallic materials, a trumpet-shaped liner geometry, and variable thickness liners were also considered, but they were omitted in the design consideration because of added costs in fabrication. Finally, aluminum, copper, and tungsten liner materials were considered.

**Aluminum** – Aluminum 6061-T6 was one of the three materials considered for this CSC design. This aluminum is ductile (allows for jet to elongate considerably before particulation or breakup), common, and relatively inexpensive.

**Tungsten** – Tungsten was another of the liner materials considered. The mechanical impedance for this material is much higher than that of tuff. The maximum jet penetration depth could easily be obtained with tungsten. However, the desired large hole entrance diameters could not be obtained with reasonable or practical liner thickness. Additionally, material costs were beyond the program budget.

**Copper** – Copper was the final material considered, and it was chosen for the final design. The mechanical impedance of copper provides a compromise between the much higher impedance of tungsten and the much lower impedance of aluminum and allows the generation of relatively large diameter holes in tuff with sufficient jet penetration. Copper is ductile, common, and inexpensive relative to higher density materials. A spin-cast process was used to more economically fabricate the copper liner. Molds were made of the desired geometry of the liner. The copper was injected into the spinning mold. Ultrasonic methods were used to inspect the final liner configuration to assure that there were no voids or air pockets in the liner. The liner inside and outside surfaces were machined to the final dimensions. The design of the 28-inch outside diameter copper liner is shown in Figure 1, and the liner is shown in Figures 2 and 3.

### 3.4 Explosive Housing/Tamper

The explosive housing or tamper material selected was aluminum 6061-T6. Steel or a higher density material was desirable but would have caused the CSC total weight to exceed the limitation of 971 pounds. For structural considerations, the minimum aluminum thickness was 0.75 inch, which is the final thickness selected. The explosive housing is shown in Figures 4, 5, and 6.

### **3.5 Liner Retainer Ring/Explosive Cover Plate**

The threaded aluminum ring for retaining the conical copper liner in the explosive housing is shown in Figure 7. The 0.25 inch thick by 16 inch diameter aluminum explosive cover plate is shown in Figure 8. A 0.5 x 40 x 40 inch (plate only; fork lift tines are about 3 x 4 inches) steel platform supports and is permanently attached to the CSC (Figure 9).

### **3.6 Conical Shaped Charge Assembly**

The piece-part and assembly drawings for the final CSC design are shown in Figures A1–A6 in Appendix A. The CSC hardware assembly is shown in Figure 10. This is the configuration shipped to American Ordnance in Iowa for Octol explosive loading. Additional shaped charge hardware assembly photos are included in Figures B1–B10 in Appendix B.

### **3.7 Detonator**

One RP-1 Exploding Bridgewire Detonator (EBW) was used to initiate the explosives. This is a detonator produced by Reynolds Industries, Inc. (RISI) (ref. 64). The detonator output end is 0.405 inch in diameter. The detonator body length is 1.2 inches. The detonator contains 251 mg of PETN explosive initiating charge followed by 375 mg of RDX explosive main output charge for a total of 626 mg of explosive.

The detonator firing parameters are as follows (ref. 64):

1. Threshold bridgewire burst current: 190 amps
2. Threshold voltage: 500 volts
3. Function time: 2.75 microseconds  $\pm$  0.025 microsecond

### **3.8 Booster Charge**

The booster charge was used on this design only because no development tests were conducted prior to this one-of-a-kind full-scale test and therefore provided additional assurance of initiating the Octol main charge. The initial design included an inert material between this booster charge and the main charge to produce the wave shaping of the detonation wave initiating the main charge. This technique is used when a flatter detonation wave profile is desired, and generates higher jet tip velocities and longer jets, resulting in deeper penetrations in the given target. At the last minute, it was decided that the wave shaper technology was not necessary for this design, but the booster charge was left in the design anyway. The booster charge chosen was Primasheet 1000 (formerly Detasheet 1000) explosive. This a PETN-based explosive. The density is about 1.46 g/cc. The detonation velocity is 6.8 mm/microsecond. The composition is 80% PETN, 19% nitrocellulose, 0.5% dimethyl dinitro butane, and 0.5% ATC binder.



### 3.9 Booster Pellets

Two each 0.5 inch diameter by 0.5 inch long Tetryl explosive pellets were installed between the RP-1 detonator and the Primasheet booster charge. The Tetryl explosive density is about 1.71 g/cc. The detonation velocity is 7.85 mm/microsecond. The detonation pressure is about 260 Kb. The heat of formation is +4.67 Kcal/g. The atomic composition is  $C_7H_5N_5O_8$ .

## 4. SHAPED CHARGE MODELING/SIMULATION

The Shaped Charge Analyses Program (SCAP) (refs. 2 and 3), was used for the modeling/simulation analyses, including a parametric study of the CSC parameters for the first shaped charge design. This is an analytical code that can be used to economically conduct parametric studies for shaped-charge design. The more expensive CTH hydrocode (ref. 65) was used to model the final design from the SCAP analyses as an independent check on the final design. The CTH code predictions and comparisons with the SCAP code predictions data will be published separately in the near future.

### 4.1 SCAP Code Description

SCAP is an interactive modeling code developed at SNL to assist in the design of shaped charge components. Design requirements for SNL applications need not correspond to typical conventional weapon shaped charge requirements. Miniaturized components, specialized materials, and nonstandard designs open the way for possible unique modeling requirements. The need for an in-house SNL code with maximum modeling flexibility and ease of use has led to the development of SCAP.

SCAP is user friendly and very inexpensive to run. It is designed for flexibility in shaped charge device configuration, choice of competing modeling techniques, and implementation of new models for various parts of shaped charge jet formation and penetration phenomena. The code at present contains models for liner acceleration, jet formation, jet stretching and breakup, jet penetration, and confinement motion. Different models are available for some portions of the code and may be chosen via a menu format. Few *a priori* assumptions are built into the code with the intent that the program structure should allow the modeling of devices of nonstandard design. For example, derivatives needed in the analysis are computed via interpolation rather than from formulas based on geometric assumptions. The result is a code that is conceptually simple and well structured.

SCAP is written in FORTRAN 77 and is currently run on PC systems at SNL using Version 5.0 of Microsoft FORTRAN. The code produces both hardcopy output listings and graphical output. Plotting portions of the code allow creation of a movie of the jet formation process and utilize the high-level plotting package RSCORS, developed at Sandia. Any SNL-supported black-and-white or color plotting device may be used with SCAP. The code is most convenient to run on dual alphanumeric and graphics terminals. The code also accesses an ordinary differential equation solver in the SNL SLATEC mathematical subroutine library. Information and/or assistance relative to RSCORS and the SLATEC library may be obtained from the Computer Consulting and Training Division at SNL. However, the SCAP user need not be familiar with the details of these systems. The user must only obtain the appropriate device codes for his particular plotting output devices.

References 2 and 3 give background information on shaped charge phenomena and give the rationale behind the use of a shaped charge analysis code. Initialization and zoning formats for the code, liner acceleration and motion, jet formation, jet breakup and jet penetration models, and a short comparison of code results with experimental data are also discussed in these references.

For code validation, it was desirable to obtain any experimental data for shaped charge jets or projectiles penetrating tuff rock or any other similar geological material. The previous data (ref. 41) for shaped charge jets penetrating tuff rock formations at the TTR with much smaller CSCs were used to validate the SCAP code.

## 4.2 SCAP Code Parametric Study Analyses

The SCAP analytical code was chosen to conduct this parametric study because it was the only code that could be used to stay within the time and budget constraints of this program. SCAP runs the complete problem in less than 15 minutes for most configurations. Each run produces output data for 20–30 different standoffs. Using a hydrocode like CTH, which takes overnight computing times per two-dimensional run, to produce data for only one standoff would take an enormous amount of time and money to conduct a parametric study as was done here with SCAP. A SCAP code input file is shown in Table 4.

The CTH hydrocode was used to model the final SCAP-predicted CSC design in order to obtain an independent check on the final parameters. The CTH hydrocode should produce more accurate output data because it requires and uses Equation of State parameter input data for every different material in the CSC design and target. The CTH code was used to vary the following Sidewinder Tuff parameters: unconfined compressive strength, fracture stress, and Poisson's ratio.

The SCAP code was used to conduct a parametric study to evaluate the effects on hole profile (diameter versus depth) and penetration depth while varying the following parameters:

1. Charge diameter,
2. Liner material,
3. Liner apex angle,
4. Liner Thickness,
5. Explosive geometry,
6. Explosive type,
7. Explosive housing material, and
8. Explosive housing thickness.

Because of the tight schedule, this study was conducted with the limited tuff rock parameters that were available at that time. Some of the mechanical properties were for Antelope or Yucca Mountain Tuff. Other necessary parameters were calculated. Late in the study when more Sidewinder Tuff parameters became available, some of the SCAP models were rerun with the updated data.

The following summarizes the many SCAP runs conducted during this parametric study. These data are included in Appendices C through E for copper, aluminum, and tungsten conical liners, respectively.

#### **4.2.1 Copper Liner**

Appendix C includes the parametric study data for the copper liner. Table C1 lists the jet penetration and hole diameter data for the copper liner. This table lists the charge length, standoff (S.O.), liner apex angle, liner thickness, maximum jet penetration, entrance hole diameter, diameter of the hole at maximum jet penetration, jet tip velocity, and jet diameter. The charge length varied from 20.5 to 28.5 because the available length requirement was changed during this study. The table lists only a sample of the total SCAP runs during this study.

Table C2 lists the jet penetration, hole diameters, and jet tip velocity for varying primarily the liner apex angle from 60 to 100 degrees. Data for several liner thicknesses, charge lengths, and standoffs are included in this table. For Figures C1–C6, the points indicated by the symbols are data predicted by the SCAP code, and the solid lines are the least squares fit to the data. Figure C1 shows the jet penetration versus liner apex angle.

Table C3 shows the effect of varying the liner thickness at a constant 80° apex angle. In accordance with the data of Table C3, the entrance hole diameter increases for thicker liners, but the maximum jet penetration decreases. Figure C2 shows the jet penetration versus liner thickness.

Table C4 lists the jet penetration, and hole diameters for varying the CSC standoff from 0 to 145 inches for a 0.75-inch thick, 80° apex liner. The jet penetration increases with increasing standoff up to 83 inches, while the entrance hole diameter decreases from 18 to 9 inches. The bottom hole diameter remains about the same.

Figure C3 shows the entrance hole diameter versus liner apex angle. Figure C4 shows the diameter at the maximum jet penetration versus apex angle. Figure C5 shows the entrance hole diameter and jet penetration versus standoff. Figure C6 shows entrance hole diameter versus jet penetration for aluminum, copper, and tungsten liners.

#### **4.2.2 Aluminum Liner**

Table D1 lists the jet penetration, hole diameter, and jet velocity data for various aluminum liner apex angles from 60 to 90 degrees. For each apex angle, data for several liner thicknesses, and standoffs are included in this table. The main conclusion from these data is that the penetration is well below the desired 15 feet. Larger than 15-foot penetrations can be obtained with an aluminum liner, but the apex angle has to be decreased to about 45 degrees before the jet hole diameter is well below the 12-inch minimum requirement.

Table D2 lists the jet penetration and hole diameters for varying the CSC standoff from 0 to 669.3 inches. The jet penetration increases to 6.6 feet with increasing standoff up to 105.5 inches and then decreases while the entrance hole diameter decreases from 24 to 12 inches. The bottom hole diameter remains about the same.

### 4.2.3 Tungsten Liner

Table E1 lists the jet penetration, hole diameter, and jet velocity data for various tungsten liner apex angles from 60 to 90 degrees. For each apex angle, data for several liner thicknesses and standoffs are included in this table. The entrance hole diameters vary from 11.3 to 8.5 inches for apex angles from 60 to 90 degrees, respectively. The jet penetration can be more than twice the desired 15-foot depth.

Tungsten was dropped from consideration a liner material when we learned the material and fabrication of the liner would cost more than \$60,000.

## 4.3 SCAP CODE FINAL DESIGN OUTPUT

Table 4 shows the SCAP code input file. SCAP-code-predicted optimum standoff, jet penetration, entrance hole diameter, bottom hole diameter, and jet tip velocity data are listed in Table 5, comparing aluminum, copper, and tungsten liners. The input parameters in this table are described in detail in reference 2. Final calculated CSC component weights are listed in Table F1 in Appendix F. Figure 11 shows the SCAP code model geometry. The copper liner collapse and jet formation process is shown in Figures 12–17 for times after explosive initiation of 75, 150, 250, 350, 450, and 550 microseconds, respectively. The detonation wave in the explosive has just reached the base or end of the explosive at a time of 75 microseconds as shown in Figure 12. At 550 microseconds (Figure 17), the jet is 80.7 inches long. Figure 18 shows that the maximum jet tip velocity is 0.51 cm/microsecond in accordance with the top curve and the jet formation model used in this analysis. As shown in Figure 18, bottom curve, the slug velocity is about 0.05 cm/microsecond. Figure 19 shows a maximum aluminum explosive housing velocity of about 0.34 cm/microsecond.

Figure 20 shows the jet penetration into Sidewinder Tuff versus standoff (20 different standoffs). As shown in Figure 20, the optimum standoff for maximum jet penetration is about 74.8 inches or about 2.8 conical liner inside diameters. The finally selected standoff of 58.3 inches or 2.2 conical liner inside diameters is also indicated on Figure 20. Because generating the relatively large diameter hole was seen as the biggest challenge in the design of the CSC, the smaller standoff near the optimum was more desirable. The actual standoff for the test was 4 feet 6 inches or 54 inches (Figure 28). The slightly lower standoff was a result of having to use screw jacks in the support structure to correct for the uneven rock surface and also for intentionally tilting the fixture 2 degrees to ensure that the penetrator did not impact the crater generated by the CSC jet. Measured weights of all final design hardware, including shipping hardware, are listed in Table 6.

## 4.4 SIDEWINDER TUFF ROCK PARAMETERS

The Sidewinder Tuff rock parameters are listed in Table 2. Many of them were not available until the SCAP parametric study was almost completed. Therefore, most of the study was conducted using initial tuff properties that were calculated, assumed to be like other tuff rock (Antelope Tuff, Yucca Mountain Tuff, etc.), or estimated. A couple of SCAP runs were made with some of the current Sidewinder Tuff parameters.

Sidewinder Tuff coring samples were taken at the Myer's Ridge test site selected at TTR just before the test was conducted. Some of these core samples will be tested at a civil engineering laboratory to determine the material density, unconfined compressive strength, confined compressive stress, strain rate parameters, etc. When these data are available, and if the tuff properties differ significantly from the values used in SCAP and CTH modeling/simulation work, then additional runs will be conducted with these codes.

#### **4.5 TUFF ROCK PENETRATION PREDICTIONS**

The jet-generated hole profile in the tuff rock using the final CSC design is shown in Figure 21. The surface crater diameter is 21.3 inches. Below the surface crater, the entrance hole diameter is about 11.3 inches, which is close to the desired 12-inch minimum diameter. The diameter at the bottom of the hole is about 5.2 inches. The maximum jet penetration is about 18.9 feet, which is larger than the desired minimum of 15 feet.

The SCAP-code-predicted data are shown in Figures 22–27. The jet penetration depth versus time data are shown in Figure 22. The jet penetration as a function of jet velocity is shown in Figure 23. The accumulated jet mass versus jet velocity data are shown in Figure 24. The accumulated jet momentum versus jet velocity data are shown in Figure 25. The accumulated jet kinetic energy versus jet velocity data are shown in Figure 26. The jet generated hole volume versus standoff is shown in Figure 27.

## **5. SHAPED CHARGE FABRICATION AND TESTING**

The shaped-charge hardware was fabricated by Accurate Machine in Albuquerque, NM, and was completed on October 1, 2002. The shaped charge hardware was shipped to American Ordnance LLC (AOLL) for loading with Octol explosive in mid October 2002.

### **5.1 SHAPED CHARGE EXPLOSIVE LOADING**

Octol explosive was selected for this shaped charge. This is a high-density (1.8 g/cc), cast secondary explosive with good metal driving capability (for collapse of conical liner). It is a mixture of 75% HMX and 25% TNT explosives. The casting of this large amount of explosives is expensive, but it is still only a fraction of the amount for a 100% pressed HMX explosive (density of about 1.9 g/cc).

The explosive loading for this large CSC was performed at AOLLC in Middletown, Iowa, at the Iowa Army Ammunition Plant. AOLLC was the only company that could do the job in a cost-effective, timely manner for this program.

### **5.2 FIRST SHAPED CHARGE TEST AT TTR**

The first test with this large shaped charge was conducted on November 23, 2002 at the TTR, Nevada.

The shaped charge was positioned at about a 54-inch standoff (Figure 28) from the surface of a large Sidewinder Tuff rock formation (about 20+ feet diameter by about 22 feet deep) at the Myer's Ridge test site.

The CSC standoff and penetrator support structure is shown in Figure G1 in Appendix G. This steel structure weighs about 5,000 lb and stands about 16 feet high. The instrumented BLU-109 penetrator shell or body used in this test is about 96 inches long. The shaped charge is about 28.5 inches long.

A 30-inch inside diameter by 0.25-inch thick by 97.5-inch long steel cylinder was installed above the CSC and around the penetrator unit to simulate the Cruise Missile body as shown in Figures G1 (Appendix G). This is done to contain the blast wave as a Cruise Missile would, yielding more accurate blast environment on the penetrator. Figure G2 is a drawing of the steel support structure and the cylinder simulating the missile body.

A photo of the steel support structure is shown in Figure G3. The part of the steel structure that supports the shaped charge is shown in Figure G4. The cylinder simulating the missile body is shown in Figure G5. Figure G6 shows the steel plate that was bolted to the base of the penetrator as shown in Figures G7 and G8. The plate with penetrator and cylinder attached was then bolted on top of the steel structure.

### **5.2.1 Assembly and Test Procedure**

A very brief final assembly describing the procedure utilized is as follows:

1. The CSC/penetrator support structure was positioned on the surface of the tuff rock formation.
2. Screw jacks built into the four legs of the structure were used to level or orient the structure at about a 2-degree tilt relative to a normal or perpendicular orientation to the tuff rock surface to avoid having the penetrator impact the CSC-generated hole.
3. The penetrator was installed (using a large fork lift, cherry picker, or other heavy equipment) on the steel missile body simulation cylinder (8 each, 0.625-inch-diameter bolts were used to attach the penetrator to the cylinder) as shown in Figure G8.
4. The steel missile body simulation cylinder, including the penetrator, was then installed in the support structure as shown in Figure G1.
5. A small forklift was used to lift the shaped-charge assembly and slide it into the area of the support structure below the penetrator/cylinder assembly as shown in Figure G1.
6. The RP-1 detonator and two Tetryl pellets (about 0.5 inch diameter by 0.5 inch long) were then installed in the port on the top aluminum plate explosive cover.
7. Personnel were evacuated to the safe distance (predicted to be greater than 3,000 feet; personnel were actually located 9,890 feet from the CSC), and the CSC was initiated.

### **5.2.2 SCAP Code Predictions vs. TTR Test Results**

This section documents the test results from the first shaped charge test to complete this portion of Phase I of the PEN-X Program.

The SCAP code analyses to design this large CSC were started in the middle of June 2002. All tasks, including conducting the test, were conducted in about five and a half months. Developing an explosive component, the largest CSC ever, without development testing, peer review, etc., is an unprecedented accomplishment. Previously, the design, drawings, development, fabrication, explosive loading, testing, etc., typically took well over one year. The work of the Sandia California and New Mexico and Tonopah personnel was outstanding and allowed this portion of Phase I of this program to be accomplished in a timely manner.

The test was conducted on schedule on November 22, 2002, at Myer's Ridge, TTR, at 3:00 p.m. The test was a complete success. Figure 28 shows the penetrator, CSC, and measured post-test hole profile in the tuff rock. Table 7 compares the tuff rock hole parameters predicted by the SCAP code with the post-test measurements and the desired values of the PEN-X Program. As indicated in Figure 28 and Table 7, the generated hole profile in the Sidewinder Tuff rock is very close to the SCAP-code prediction and PEN-X Program desired profile. Figure 28 (side view) shows that the tuff surface spall diameter was about 87 inches on top, the actual crater diameter below the spall area was about 36 inches and narrowed to about 28 inches at a 7 inch depth. Below the surface crater (below



16 inches), the hole diameter remained constant at a diameter of 10 inches (the hole diameter predicted by the SCAP code was 11.3 inches near the entrance and tapering to 7.0 inches at the bottom) to the maximum measured penetration depth of 19.5 feet (SCAP-code-predicted penetration was 18.9 feet). Typically, hole diameter decreases with increasing depth, which suggests that the copper slug following the high-velocity jet or some other hard material may have plugged the hole at the 19.5 foot depth. Therefore, the actual jet penetration depth could be several feet deeper than was measured. A core rig will drill through the slug to determine the geology below the slug, and the total depth of penetration of the jet. From the three core samples taken around the jet impact area, this 20.5 foot by 24.6 foot, Sidewinder Tuff rock was about 20 to 22 foot deep. Below this depth, the core samples showed sandy type soil. The jet may have penetrated the entire depth of tuff.

Figure 28 also shows a top view of the tuff dimensions, the hole produced by the shaped charge, the location of the radial cracks in the tuff, and the locations of the three core samples taken in the tuff.

Table 8 lists some additional information that was not included in Table 7. This table includes summary information about the CSC, explosives, detonator, standoff (54 inches), test site location (Myer's Ridge), test date, ambient temperature, test time, fireset location from CSC, instrumentation trailer location from CSC, personnel location from CSC during test, etc.

Figure 29 shows the overall test configuration including the steel, CSC, and penetrator support structure in the center, missile simulation cylinder, radiator hose housing for the instrumentation cables, and the wire rope between two steel towers supporting the four radiator hoses. Figure 30 shows the CSC installed in the steel support structure. The installed RP-1 detonator, shaped charge, BLU-109 nose, steel cylinder simulating the missile body, and some of the steel support structure are shown in Figure G9.

Figure 31 shows the post-test configuration of the CSC jet-generated hole, penetrator, steel support structure, and other metal debris. The center of gravity of the penetrator landed 13 feet from the hole. The pre-test configuration, steel support structure, etc., was intentionally tilted about 2 degrees in this direction. The long, rectangular steel plate from the CSC support platform landed over the hole as shown in Figure 31. The section of the steel support structure below the level of the CSC landed about 20 feet from the hole as shown in Figure 31. The remaining steel plates, etc., in this figure were part of the steel CSC support platform. The surface area around the jet-generated hole is shown in Figure 32 after the tuff rock surface was cleaned.

Figure 33 shows the penetrator nose with the approximately 5-inch-long nose cone section (bolts to the penetrator main body) missing. Figure 34 shows the penetrator nose cone recovered tens of feet from the hole. The weld area of the nose cone piece failed during the test with the threaded part still attached to the penetrator.

All hardware located above the CSC was scattered over the test area between the hole and probably as far as 1,400 feet (predicted distance for aluminum explosive housing fragments). The smaller aluminum missile fragments from the explosive housing were

more difficult to find. Larger steel fragments were found as far as between 900 to 1,000 feet. Figure G10 shows the locations relative to the shaped-charge-generated hole of the BLU-109 penetrator steel support structure and other fragments located after the test.

### **5.3 SECOND SHAPED CHARGE DESIGN**

The second shaped charge will be designed in the near future and tested in about August 2003. The test site is unknown at this time. The design of this charge will require the same steps as for the design of the first charge except that the target will be concrete. The desired hole profile may be different.

A Davis Gun System at TTR will be used to fire an instrumented penetrator into the CSC-generated hole in the Sidewinder Tuff in January 2003. Acceleration measurements during this test will be used to determine whether a larger or smaller hole will be necessary in the concrete target for this second test. The deceleration level must be below a certain threshold for all components to function successfully.

## 6. SUMMARY

The design at Sandia National Laboratories of the largest known CSC has been presented. The CSC hardware was fabricated, loaded with Octol explosive, and successfully tested at TTR.

The SCAP code was used to conduct a parametric study to select the CSC geometry, explosive, liner material, explosive housing material, and CSC standoff from the Sidewinder Tuff rock to meet the program requirements. The final CSC design was selected from the SCAP predictions resulting from the parametric study. Table 5 compares SCAP code predictions for aluminum, copper, and tungsten conical liners.

The jet characterization parameters, jet penetration depth, and hole diameters in Sidewinder Tuff rock predicted by the SCAP code were presented. The hole profile predicted by the SCAP code agrees very well with the measured data from the TTR test as shown in Table 7.

The CTH hydrocode was used to model the final SCAP-predicted CSC design in order to obtain an independent check on the final parameters. The CTH hydrocode should produce more accurate output data because it requires and uses Equation of State parameter input data for every material in the CSC design.

The CTH code was used to vary the following Sidewinder Tuff parameters:

1. Unconfined compressive strength,
2. Fracture stress, and
3. Poisson's ratio.

The comparisons of the SCAP code, CTH code, and test results or data will be published in the near future.



## REFERENCES

1. Vigil, M. G., et al., "Spent Fuel Cask Sabotage Investigations," 2001 PATRAM (Package Transportation of Radioactive Materials) Symposium, Chicago, Illinois, September 3–7, 2001.
2. Robinson, A. C., *SCAP-A Shaped Charge Analysis Program - User's Manual for SCAP 1.0*, Sandia National Laboratories, NM, SAND85-0708, April 1985.
3. Vigil, M. G., *Optimized Conical Shaped Charge Design Using the SCAP Code*, Sandia National Laboratories, NM, SAND88-1790, September 1988.
4. Vigil, M. G., et al., *Consequence Analysis of Radiological Interests Involving the TRUPACT-II, Volume 1*, Sandia National Laboratories, NM, SAND98-1541, July 1998.
5. Vigil, M. G., et al., *Consequence Analysis of Radiological Interests Involving the TRUPACT-II, Volume 2*, Sandia National Laboratories, NM, SAND98-1542, July 1998.
6. Luna, R. E., K. S. Neuhauser, M. G. Vigil, *Projected Source Terms for Potential Sabotage Events Related to Spent Fuel Shipments*, Sandia National Laboratories, NM, SAND99-0963, June 1999.
7. Sandia National Laboratories memorandum, Manuel G. Vigil, consultant, to Richard Yoshimura, 6141, Dated October 3, 2002, Subject: SCAP CODE CALCULATIONS OF HEDD ATTACK ON SPENT FUEL CASKS.
8. Vigil, M. G., et al., "International Initiatives in Transportation Sabotage Investigations," 2001 PATRAM (Package Transportation of Radioactive Materials) Symposium, Chicago, Illinois, September 3–7, 2001.
9. Vigil, M. G., *Sabotage of Spent Fuel Casks using High Energy Density Devices*, Sandia National Laboratories, NM, SAND2001- , July 2001.
10. Vigil, M. G., Vigil et al., "Perspectives on Spent Fuel cask Sabotage," Waste Management 2001 Symposium, Tucson, AZ, February 25–March 1, 2001.
11. Vigil, M. G., et al., *Projected Source Terms for Potential Sabotage Events Related to Spent Fuel Shipments to a Yucca Mountain High Level Waste Repository*, Sandia National Laboratories, NM, SAND98-5685, December 1999.
12. Vigil, M. G., et al., *Explosive Technique for Cutting Bulk, Thick-Walled Steel and Reinforced Concrete Structures*, International Conference on High Pressure Science and technology, Honolulu, Hawaii, July 25–30, 1999.

13. Vigil, M. G., et al., *Projected Source Terms for Postulated HEDD attacks on Spent Fuel Shipments*, Sandia National Laboratories, NM, SAND98-5674, July 1999.
14. Vigil, M. G., *Precision Linear Shaped Charge Analyses for Severance of Metals*, Sandia National Laboratories, NM, SAND96-2031, August 1996.
15. Vigil, M. G., *Explosively-Driven Magnetohydrodynamic Generator: Phase II*, Sandia National Laboratories, NM, SAND96-1242, June 1996.
16. Vigil, M. G., *Conical Shaped Charge Pressed Powder Metal Liner Jet Characterization and Penetration in Aluminum*, Sandia National Laboratories, NM, SAND97-1173, May 1997.
17. Vigil, M. G., *Precision Linear Shaped Charge Analyses for Severance of Metals*, Sandia National Laboratories, SAND96-2031, August 1996.
18. Vigil, M. G., *Plane Shock Generator Explosive Lens*, Sandia National Laboratories, NM, SAND94-3206, May 1996.
19. Vigil, M. G., et al., "Explosively-Driven Magnetohydrodynamic (MHD) Generator Studies," Tenth IEEE International Pulsed Power Conference, July 10–13, 1995, Albuquerque, NM.
20. Vigil, M. G., B. Duggins, *Diagnostic Instrumentation System Development: Explosively Driven Magnetohydrodynamic Generator: Phase I*, Sandia National Laboratories, NM, SAND94-0116, September 1994.
21. Vigil, M. G., B. Duggins, *Explosively-Driven Magnetohydrodynamic Generator: Phase I*, Sandia National Laboratories, NM, SAND94-0045, August 1994.
22. Vigil, M.G., D. L. Marchi, *Annular Precision Linear Shaped Charge Flight Termination System for the ODES Program*, Sandia National Laboratories, NM, SAND94-1089, June 1994.
23. Vigil, M.G., "Shaped Charge Design and Performance," *Proceedings of the Near Wellbore Mechanics Conference*, Sandia National Laboratories, NM, April 7, 1993.
24. Vigil, M. G., *Precision Linear Shaped Charge Designs for Severance of Aluminum Materials*, Sandia National Laboratories, NM, SAND92-2449, December 1992.

25. Vigil, M. G., *Plane Shock Generator Explosive Lens: PH 13-8 Mo Stainless Steel Versus 4340 Steel Shock Wave Separators and LX-13 versus PBX-9501 Explosive Particle Velocity-time Profiles*, Sandia National Laboratories, NM, SAND92-2811, February 1992.
26. Vigil, M. G., *Fragment Hazard Zone Analysis for Explosive Test Facilities*, Sandia National Laboratories, NM, SAND92-0243, May 1992.
27. Vigil, M. G., "Precision Linear Shaped Charge Jet Severance of Graphite-Epoxy Materials", *Proceedings of NASA/DoD/DOE Pyrotechnic Conference*, Houston, TX, June 9-10, 1992., SAND92-0610C.
28. Vigil, M. G., *MC4043 Parachute Jettison Linear Shaped Charge Characterization and Development for the B90 Program*, Sandia National Laboratories, NM, SAND91-1316, July 1991.
29. Vigil, M. G., *Analysis of Terminal Flyer Plate Velocities for Various Cased Explosive Configurations*, Sandia National Laboratories, NM, SAND91-0578, April 1991.
30. Vigil, M. G., *C-H-N-O Detonation Properties for Explosives with Various Densities*, Sandia National Laboratories, NM, SAND91-0603, May 1991.
31. Vigil, M. G., *Explosively Driven Missile Trajectory Parameters for Various Fragment Materials and Velocities*, Sandia National Laboratories, NM, SAND91-0277, March 1991.
32. Vigil, M. G., *Explosive Shaped Charge Projectile Water Penetration and Cavitation (U)*, UCNI, Sandia National Laboratories, NM, SAND90-3241, March 1991.
33. Vigil, M. G., L. N. Kmetyk, *Large Conical Shaped Charge Jet Parameter Study Using the CTH Code*, Sandia National Laboratories, NM, SAND90-2603, January 1991.
34. Vigil, M. G., L. N. Kmetyk, *Unitary Shaped Charge Alternative to Tandem Shaped Charges*, Sandia National Laboratories, NM, SAND90-2650, February 1991.
35. Vigil, M. G., P. Yarrington, L. N. Kmetyk, *CTH Analyses of VIPER Shaped Charge Water Tunneling with Comparison to Experimental Data*, Sandia National Laboratories, NM, SAND90-2676, March 1991.
36. Vigil, M. G., P. Yarrington, L. N. Kmetyk, *CTH Analyses of VIPER Shaped Charges: Comparison to Test Data*, Sandia National Laboratories, NM, SAND90-2604, February 1991.

37. Vigil, M. G., *Design of Linear Shaped Charges Using the LESCA Code*, Sandia National Laboratories, NM, SAND90-0243, March 1990.
38. Vigil, M. G., *Graphical Analysis of Barrel-Tamped Explosively Accelerated Flyer Plates*, Sandia National Laboratories, NM, SAND90-0388, March 1990.
39. Vigil, M. G., "Design and Development of Precision Linear Shaped Charges," SAND89-0196C, *Proceedings of the 9th International Symposium on Detonation*, Portland, Oregon, August 28–Sept. 1, 1989.
40. Vigil, M. G., *Projectile Impact Hugoniot Parameters for Selected Materials*, Sandia National Laboratories, NM, SAND89-1571, July 1989.
41. Vigil, M. G., *Explosive Shaped Charge Penetration into Tuff Rock*, Sandia National Laboratories, NM, SAND88-2338, October 1988.
42. Vigil, M. G., *Optimized Conical Shaped Charge Design Using the SCAP Code*, Sandia National Laboratories, NM, SAND88-1790, September 1988
43. Vigil, M. G., *Spallation Criteria for Explosively Driven Steel Flyer Plates*, Sandia National Laboratories, NM, SAND87-2719, January 1988.
44. Vigil, M. G., A. C. Robinson, "An Analytical-Experimental Comparison of 150 and 220 Grain Per Foot Linear Shaped Charge Performance," *Proceedings of the Tenth International Symposium on Ballistics*, San Diego, CA October 27–29, 1987.
45. Vigil, M. G., D. L. Marchi, *MC3920 Converter Development for the Sea Lance/NDB Program (U)*, Sandia National Laboratories, NM, SAND87-1690, September 1987.
46. Vigil, M. G., D. L. Marchi, *MC3938 Flight Termination System for the Sea Lance/NDB Program*, Sandia National Laboratories, NM, SAND87-1528, September 1987.
47. Vigil, M. G., D. L. Marchi, *MC3991 Parachute Cutter Development for the Sea Lance/NDB Program*, Sandia National Laboratories, NM, SAND87-0876, May 1987.
48. Vigil, M. G., J. G. Harlan, *Optimal Design and Fabrication of Reproducible Linear Shaped Charges*, Sandia National Laboratories, NM, SAND87-0982, May 1987.
49. Vigil, M. G., "Explosive Initiation by Very Small Conical Shaped Charge Jets," *Proceedings of the Eighth International Symposium on Detonation*, Albuquerque, NM, July 15–19, 1985.



50. Vigil, M. G., "Penetration of Reinforced Concrete Storage Vaults with Explosively Driven Flyer Plates", *Proceedings of Eight Symposium on Vulnerability of Aerial and Surface Targets*, San Diego, CA, March 26–28, 1985.
51. Vigil, M. G., and R. P. Sandoval, *Development of a Method for Selection of Scaled Conical Shaped Explosive Charges*, Sandia National Laboratories, NM, SAND80-1770, March 1982
52. Vigil, M. G., *Full Scale M3 Military Conical Shaped Charge Tests on Nuclear Fuel Transport Cask Plate Models and Surrogate Fuel Rods (U)*, Sandia National Laboratories, NM, SAND79-2024, CNSI, October 1979.
53. Vigil, M. G., *Explosive Disablement Technology*, Ninth Explosive Device Technology Exchange Group Meeting, Eglin Air Force Base, Florida, July 24–25, 1984.
54. Vigil, M. G., *A Method for Penetration of Reinforced Concrete Barriers with High Velocity Impacting Plates*, Sandia National Laboratories, NM, SAND79-1254, August 1979.
55. Vigil, M. G., *A Scaling Law for the Penetration of Reinforced Concrete Barriers with Tamped Explosive Charges on the Surface*, Sandia National Laboratories, NM, SAND79-1256, August 1979.
56. Vigil, M. G., *Threshold Penetration of Reinforced Concrete Barriers with Tamped and Untamped Explosive Charges on the Surface*, Sandia National Laboratories, NM, SAND79-1255, August 1979.
57. Vigil, M. G., *Penetration of Layered Reinforced Concrete-Steel Barriers with Untamped Explosive Charges*, Sandia National Laboratories, NM, SAND79-1257, August 1979.
58. Vigil, M. G., *A Scaling Law Describing the Penetration of Reinforced Concrete Barriers by Explosively Driven Flyer Plates*, Sandia National Laboratories, NM, SAND79-1253, August 1979.
59. Vigil, M. G., *High Velocity Explosively Driven Flyer Plate Impact Test on a MK-4 Nose with a MC2984 Contact Fuze (U)*, CNSI, Sandia National Laboratories, NM, SAND75-0157, September 1975.
60. Vigil, M. G., *Development of Methods for Scaling Conical Shaped Charges for the WFRP Nuclear Fuel Transport Cask Test Program*, Sandia National Laboratories, NM, SAND80-0594, March 1980.

61. Vigil, M. G., *High Velocity Explosively Driven Lucite Flyer Plate Impact Test on Three MK-4 Noses with MC2984 Contact Fuzes (U)*," Sandia National Laboratories, NM, Secret, October 15, 1975.
62. Vigil, M. G., *Full Scale M3 Military Conical Shaped Charge Tests on Nuclear Fuel Transport Cask Plate Models and Surrogate Fuel Rods (U)*, Sandia National Laboratories, NM, SAND79-2024, CNSI, October 1979.
63. Vigil, M. G., et al., "An Experimental Source Term Data Base for Assessing the Safety of Spent Fuel Transportation," SAND81-1188C, *Transactions of the American Nuclear Society Transactions*, San Francisco, CA, Volume 39, TANSO39 1-1076 (1981), ISSN: 0003-018X, November 29-December 3, 1981.
64. Reynolds Industries Systems, Inc. (RISI), *Manufacturers of Secondary Explosive Initiators and Accessories Manual*, San Ramon, California.
65. McGlaun, J. M., S. L. Thompson, M. G. Elrick, *CTH User's Manual and Input Instructions*, Sandia National Laboratories, NM, SAND88-0523, April 1988.
66. Wawersik, W. R., M. E. Stavig, memorandum, K.R. Dunbar, 5165, dtg. : July 13, 1987, Subject: Mechanical Properties of Sidewinder Tuff," Sandia National Laboratories, NM, June 1987.
67. Patterson, W. J. , *Physical Properties and Classification of Seven Type of Rock Targets*, Sandia National Laboratories, NM, Report No.: SC-TM-68-621, September 1968.
68. Longcope, Jr., D. B., *The Prediction of Loads on Penetrators into Rock Via Spherical Cavity Expansion Approximation*, Sandia National Laboratories, NM, SAND87-0959, April 1990.

**Table 1. Milestone Chart for Design of Shaped Charge**

<b>MILESTONE DESCRIPTION</b>	<b>TIME (weeks)</b>	<b>DATE COMPLETED</b>
Planning	5	6/11/02
Kickoff Meeting (0)		
Target Penetration Requirements		
CSC Design Requirements		
Schedule		
Cost Estimate Plan		
Project Plan		
Explosive Selection		
No. of Full Scale Targets (1 Assumed)		
No. of Full Scale Tests (1 Assumed)		
SCAP Code Analyses	8	8/13/02
Target Parameters		
CSC Parameters		
Validation Runs		
Parametric Study		
CSC Design 1		
Conceptual Design Review Meeting		
Final CSC Design	1	8/20/02
Evaluation of SCAP Analyses		
Evaluation CTH Analyses		
Final CSC Design Selected		
Final Design Review Meeting		
CSC Fabrication (2)	5	9/27/02
Request for Quote for CSC Hardware		
Fabrication of CSC Hard/Assuming 1 CSC		
CSC Hardware Shipment		
Test Planning	4	10/15/02
Test Site Selection		
Target Site Selection		
No. of Tests		
Explosive Loading/Assuming 1 CSC		11/11/02
Memorandum Report/Design of Shaped Charge		11/13/02
Shipment of Loaded Charge to TTR		11/18/02
CTH Code Analyses (1)	4	11/19/02
CSC Design 1		
Testing at TTR (3)	2	11/22/02
Shipment of Hardware		
Test Setup Hardware Fabrication		
Shipment of Test Setup Hardware		
Test Setup		
Conduct Test		11/23/02
Documentation/Final Summary Report		12/30/02

- (0) Project work started about June 11, 2002
- (1) Includes computer time/work performed in Dept. 9231, 9232, or 5725.
- (2) Includes two sets of CSC and explosive hardware (explosive loading site to be determined depending on selected explosive)
- (3) Includes only Sandia personnel attendance at test site

**Table 2. Sidewinder Tuff Rock Parameters**

PARAMETER	VALUE	COMMENT
Dry Density	1.8–2.0 g/cc	Measure at TTR Site*
Total Porosity	23.6%	
Saturation	14.1%	
Air Voids	20.2%	
Young's Modulus	9.9 Gpa	Reference 66
Bulk Sound Speed	0.31 cm/us	
Unconfined Compressive Strength	0.0005 Mb	Measured
	0.0008 Mb	Calculated
	4420 psi	Reference 67
Confined Compressive Strength	100–200 Mpa	
Mean Failure Stress/Simple Tension	0.000033 Mb	Reference 68
Poisson's Ratio	0.21–0.27	Reference 68
Bulk Modulus	91 Kb	Reference 68
Tangent Modulus(50%)	0.80 x 10 <sup>6</sup>	Reference 67

\* Measured from core samples taken at TTR test site (data between 3.5 and 17 feet)

**Table 3. Octol Explosive Parameters**

PARAMETER	VALUE
1. Composition:	
HMX	75 WT.%
TNT	25 WT.%
2. Atomic Composition	
Carbon:	1.78
Hydrogen:	2.58
Nitrogen:	2.36
Oxygen:	2.69
3. Density: (g/cc)	
TMD:	1.843
Nominal:	1.81
4. Melting Temp.:	> 80 C
5. Detonation Energy:	
Calculated: H2O (l):	1570 cal/g (6.57 MJ/g)
Calculated: H2O (g):	1433 cal/g (5.98 MJ/g)
6. Heat of Formation:	+2.57 Kcal/mol (+11.9 KJ/mol)
7. Detonation Velocity:	8.48 mm/us (@ 1.81 g/cc)
8. Detonation Pressure:	342 kbar
9. Gurney Constant(cm/us) <sup>.5</sup>	0.281
10. Explosive Exponent	3.06
11. Oxygen Mass Balance (%)	-27.0
12. Gas Generation (mole/g)	0.0333

**Table 4. SCAP Code Input File**

```

GRAM      CM      MICROSEC      4      1      2      2      1      3      3
      2      30OCTOL7525      1.810E+00      8.480E-01      2.800E-01      3.000E+00
8.960E+00      3.940E-01      1.230E+00      7.000E+02      7.000E+02      4.800E-03      4 4.000E+00
4.000E+01      3.117E+01      4.000E+01      3.365E+01
2.770E+00      8
0.000E+00      3.365E+01      0.000E+00      3.556E+01      4.338E+01      4.339E+01      4.350E+01      4.350E+01
5.662E+01      6.350E-01      4.010E+01      0.000E+00      4.500E+02      20      1
1.780E+00      7.000E+02      1.200E-01      0.000E+00      5.000E-03      2.100E-01      3.100E-01      1.408E-02
NOPRINT      PLOT      NONE      NOMOVIE      5.235E+00-5.585E+00      3.175E+00      0.000E+00
PLOT      PLOT      PLOT      PLOT      PLOT      PLOT      PLOT      PLOT
ALL
SPECSNAP      6      7.500E+01      1.500E+02      2.500E+02      3.500E+02      4.500E+02      5.500E+02
    
```

**Table 5. Parametric Study/Variable CSC Liner Materials**

Liner: 1.0 in. thick, 80 degrees Apex Angle  
 Explosive: Octol (75% HMX/25% TNT), 1.843 g/cc, 0.848 cm/us,  
 Total Weight: 562 lb (including Primasheet booster)  
 Housing/Tamper: Aluminum, 0.5 in. thick  
 CSC Total Length: 28.5 in.  
 CSC Total Weight: 828 lb

LINER MATERIAL	STANDOFF (in.)	JET PENETRATION (ft)	ENTRANCE HOLE DIAMETER (in.)	BOTTOM HOLE DIAMETER (in.)	JET TIP VELOCITY (cm/us)
Aluminum	116 (4.4 CD)	10	11	6	0.67
Copper	62 (2.3 CD)	18.9	14.2	5.2	0.51
Tungsten	26.5 (1 CD)	30 ++	8.5	3.1	0.36

**Table 6. CSC Hardware Weights**

<b>CSC HARDWARE</b>	<b>MATERIAL</b>	<b>WEIGHT (lb)</b>	<b>TOTAL WEIGHT (lb)</b>
1. Conical Liner	Copper	187.7	187.7
2. Explosive Housing	Aluminum		
Cylinder		125.2	
Frustum of Cone		20.0	
Plate		5.0	
Retainer Ring		8.2	158.4
3. Explosives			
Main Charge	Octol	600.0	
Booster Charge	Primasheet	9.6	
Pellets (2 Each)	Tetryl	5.5 grams	
Rp-1 Detonator	PETN/RDX	626 grams	611.0
4. Total CSC Hardware			957.2
5. CSC Support Platform	Steel	269.2	269.2
6. Total CSC Hard. + Platform			1226.3
7. TTR Shipping Box	Plywood	40	40
8. Total Shipping Wt. to TTR			1266.3

Tetryl Pellets: 1.71 g/cc, V=1.61 cc, W=2.75 g per pellet, W=5.5 g per 2 pellets  
 Retainer Ring: 2.77 g/cc, V = 1337.8 cc, W = 3705 g = 8.17 lb

**Table 7. SCAP Code Shaped Charge Jet Penetration in Sidewinder Tuff Predictions Versus Measured Test Data Comparisons**

SOURCE	P JET PEN. (ft)	Dhe ENTRANCE HOLE DIA. (in.)	Dhb BOTTOM HOLE DIA. (in.)	Dct SURFACE CRATER TOP DIA. (in.)	Dcb SURFACE CRATER BOTTOM DIA. (in.)	Hct SURFACE CRATER DEPTH (in.)	Hcb SURFACE CRATER BOTTOM DEPTH (in.)	Dspall SURFACE CRATER SPALL DIA. (in.)
SCAP Code	18.9	11.3	7.0	21.0	14.2	9.8	36	None
Test Measure	19.5	10	10.0*	28.0	10	7.0	15.0	87
Prog. Desired	>15	12-15	12-15	None	12-15	None	None	None

\* - / + Copper slug may have plugged hole at this depth; hole in tuff could be several feet deeper.

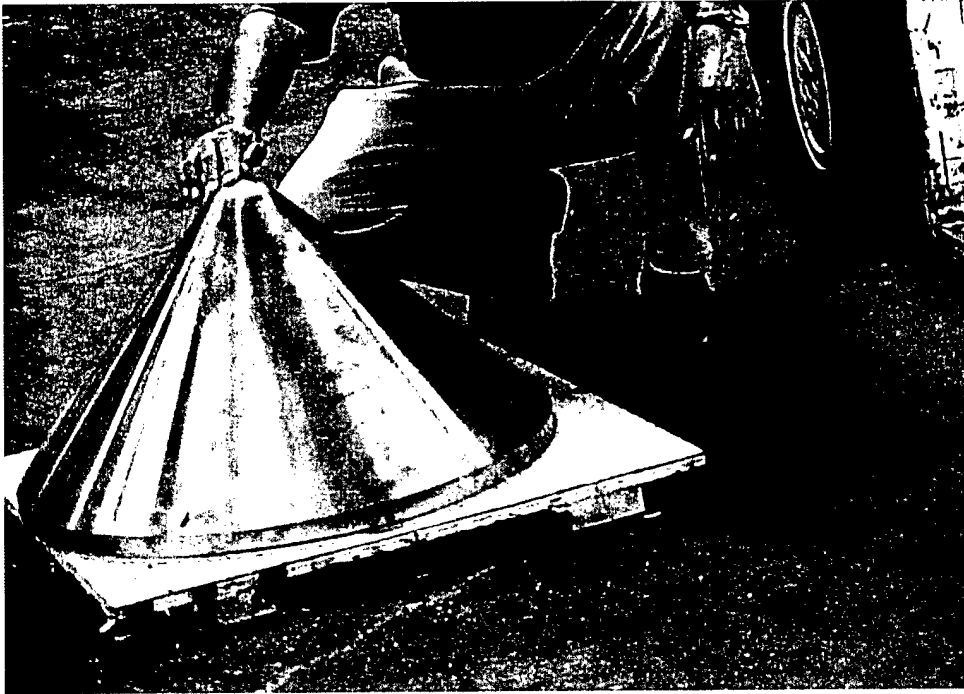
**Table 8. 28 Inch Dia. Shaped Charge (SC) Jet Penetration and Hole Diameter Measurements in Tuff Rock**

Conical Shaped Charge: 28 in. O.D., copper liner,  
 80 degree Apex Angle,  
 Al Housing, 923 lb tot. wt.  
 Explosive: Octol (75% HMX/25% TNT), 1.8 g/cc, Cast, 600 lb  
 Detonator: RP-1 (EBW), (252 g PETN, 375 g RDX), 626 g total  
 Booster Charge: Primasheet 1000, 80% PETN, 1.46 g/cc, 10.8 LB  
 Booster Pellets: Tetryl explosive, 2 each,  
 0.5 dia. x 0.5 inch long, 1.71 g/cc  
 Standoff: 54 inches  
 Target: Sidewinder Welded Tuff  
 SC, Penetrator & Support Structure Tilt Angle: 2°  
 Tonapah Test Range (TTR) Site: Myer's Ridge  
 Test Date: 11/23/02      Temp.: 55 ° F      Time: 3:00 p.m.

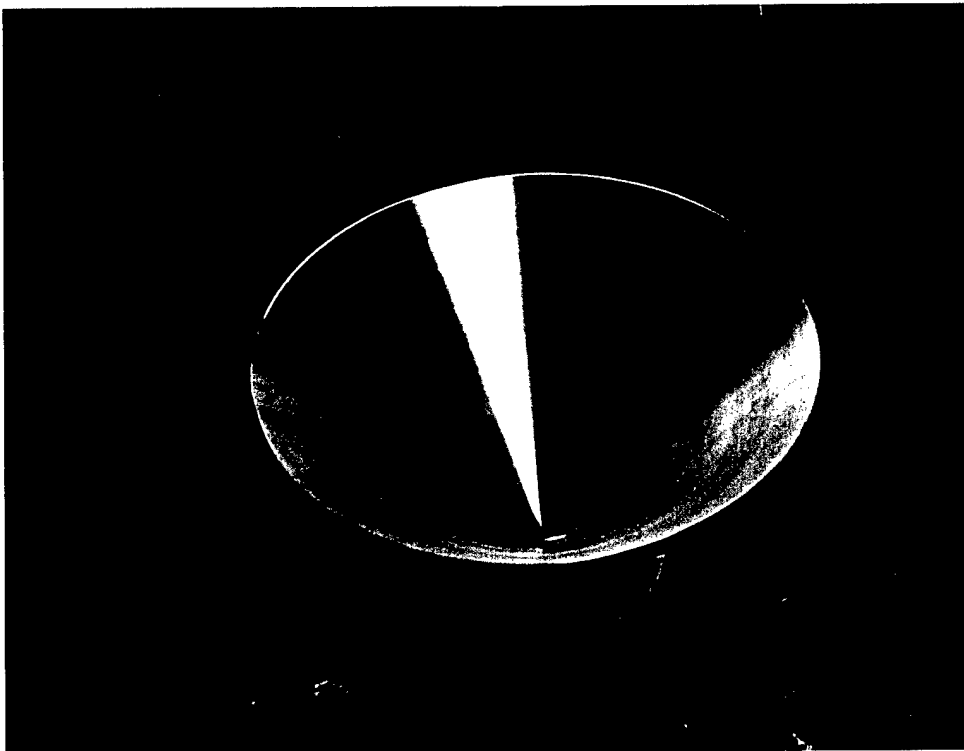
PARAMETERS	VALUE
1. Jet Penetration (P)	19.5 feet
2. Tuff Surface Spall Diameter	87 inches
3. Surface Crater Diameter	28 inches
4. Upper Surface Crater Depth	7 inches
5. Lower Surface Crater Total Depth	16 inches
6. Entrance Hole Diameter (De)	10 inches
7. Bottom Hole Diameter (Db)	10 inches
8. Distance/Nose-Shaped Charge	6.0 inches
11. Distance/Nose to Detonator	4.25 inches
12. Radiator Hose Vertical Length	10 feet
13. Radiator Hose Horizontal Length	50 feet
14. Fireset Distance from Charge	250 feet
15. Instrumentation Trailer Distance	1100 feet
16. Personnel Distance from Charge	9890 feet



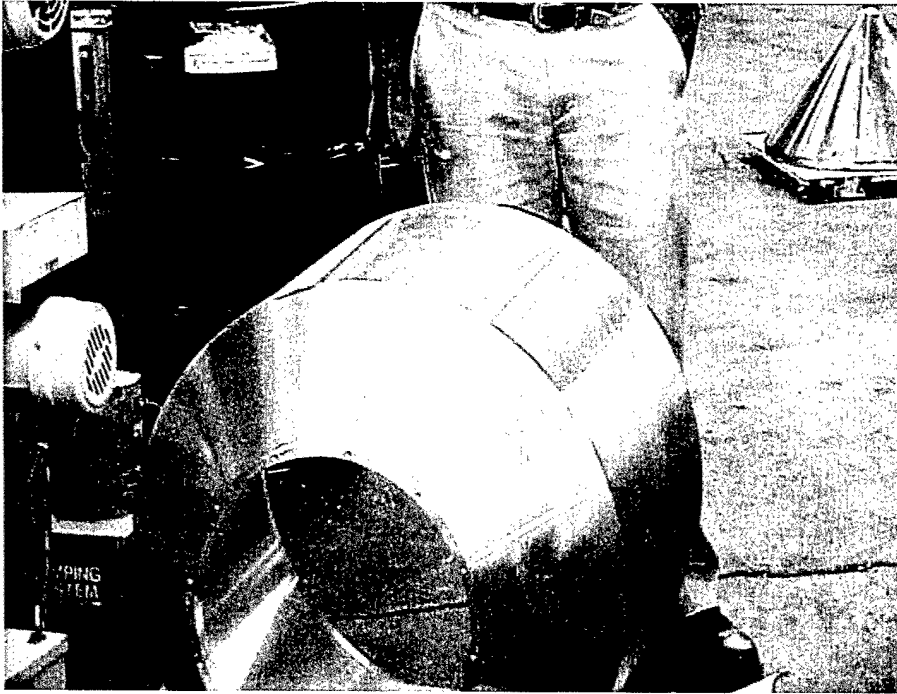




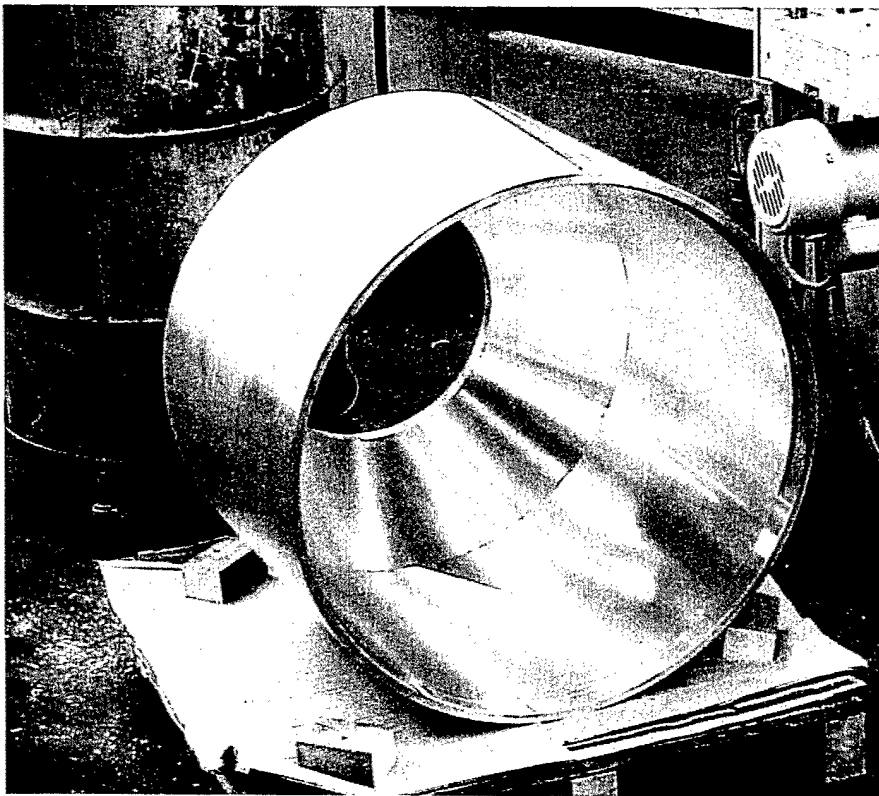
**Figure 2. CSC Copper Cone/Explosive Side**



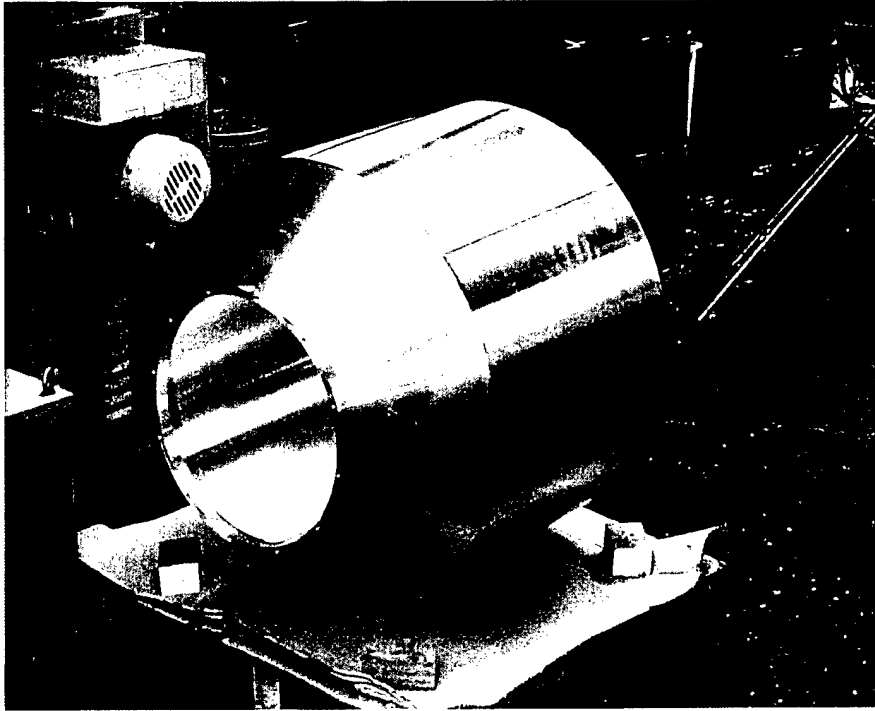
**Figure 3. CSC Copper Cone/Air Side**



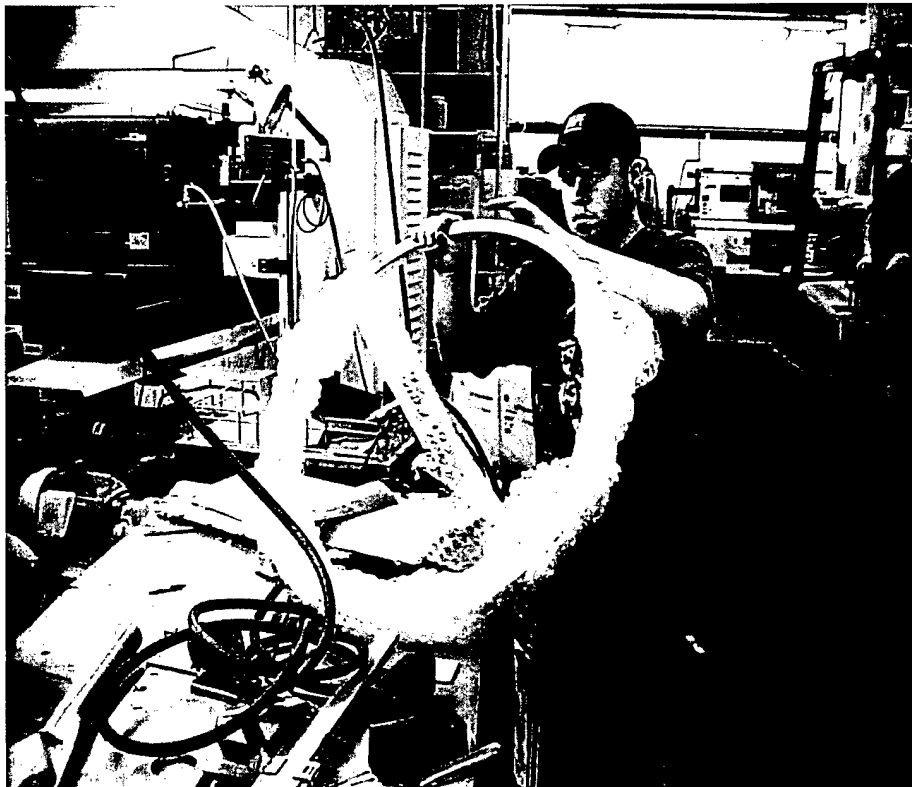
**Figure 4. CSC Cone – Cylinder, Aluminum, Explosive Housing**



**Figure 5. Explosive Housing Inside View**



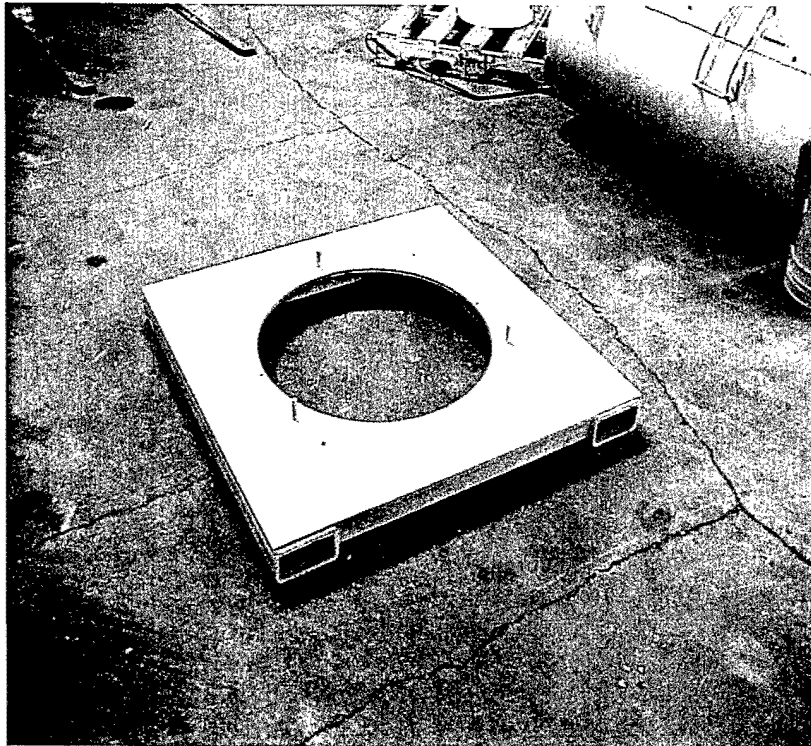
**Figure 6. Explosive Housing Outside View**



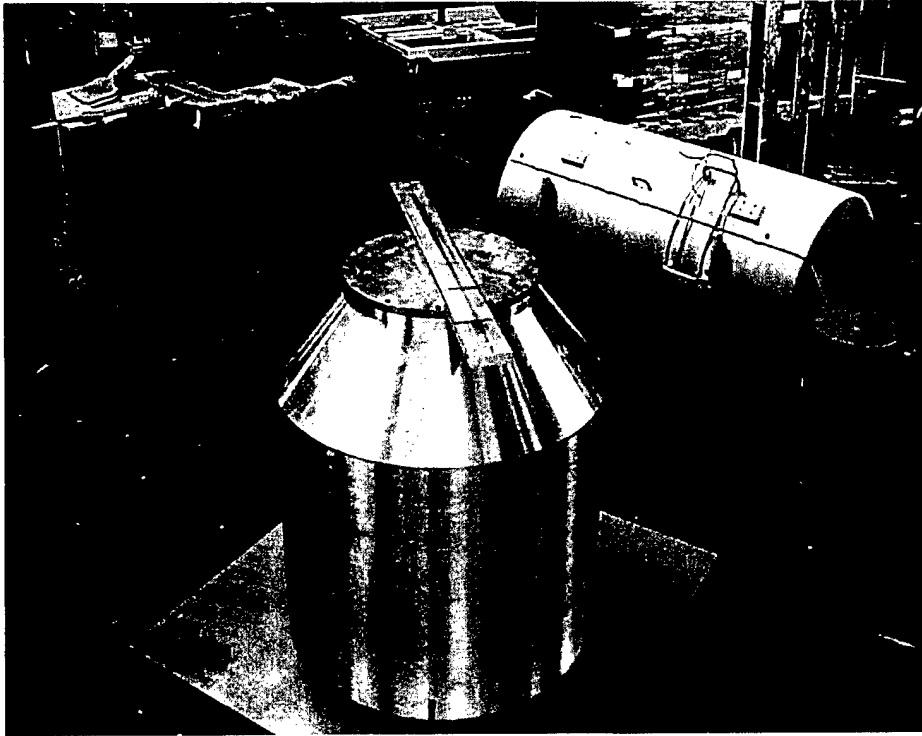
**Figure 7. CSC Cone Retainer Ring (Aluminum)**



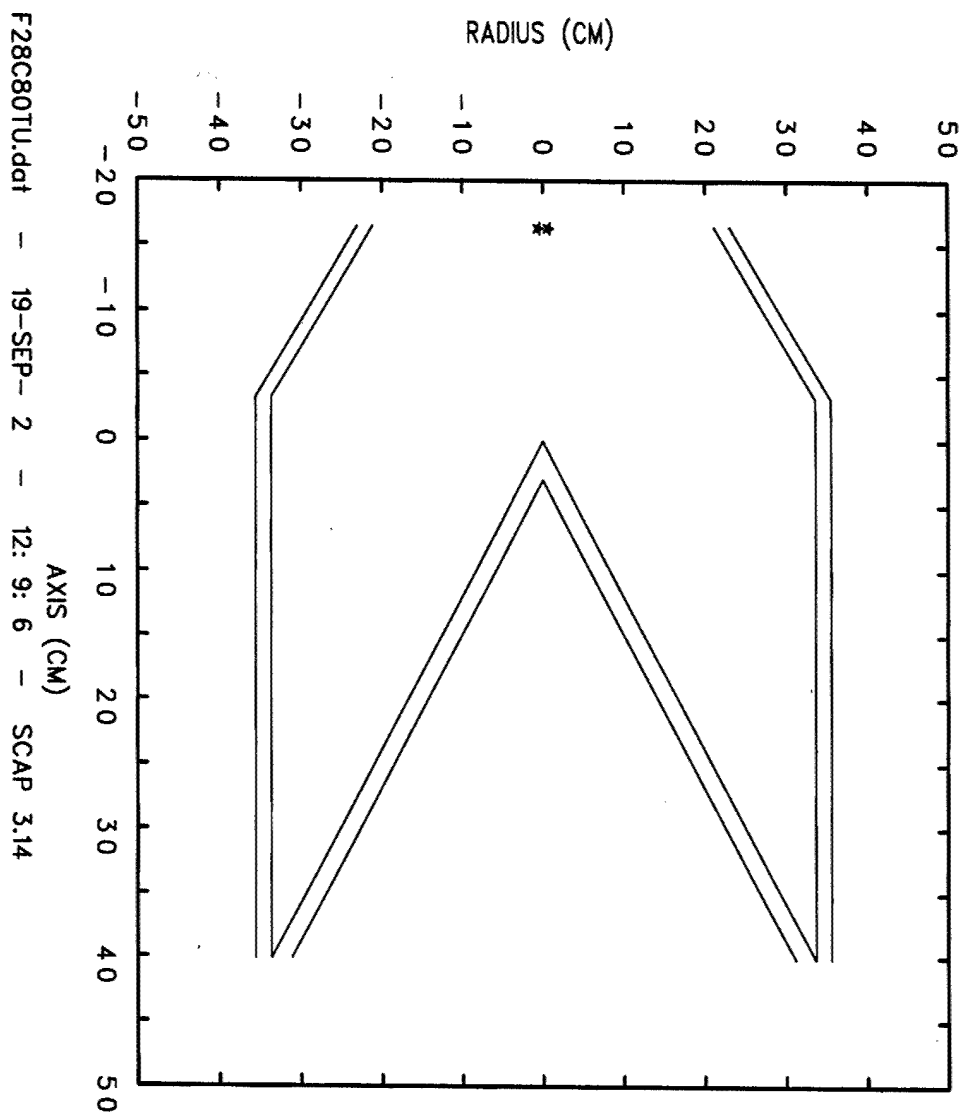
**Figure 8. Aluminum, Explosive Cover Plate**



**Figure 9. CSC Steel Support Platform (0.5 x 40 x 40 in. Al, 269.2 lb)**



**Figure 10. Assembled CSC**



F28C80TU.dat -- 19-SEP- 2 -- 12: 9: 6 -- SCAP 3.14

Figure 11. SCAP Code Model Geometry

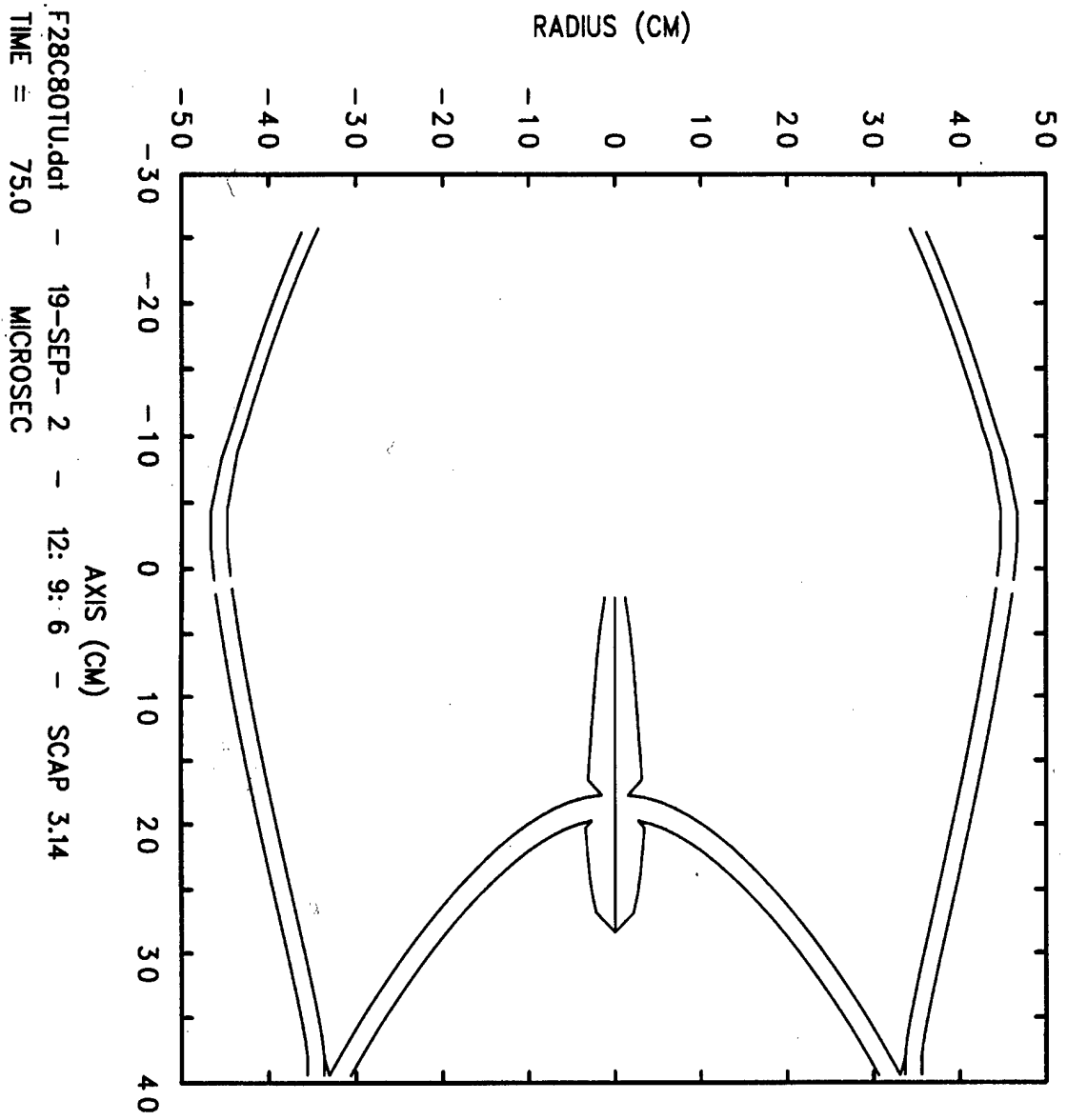


Figure 12. Jet Formation at +75 Microseconds/Detonation Wave  
 at Base of Explosive



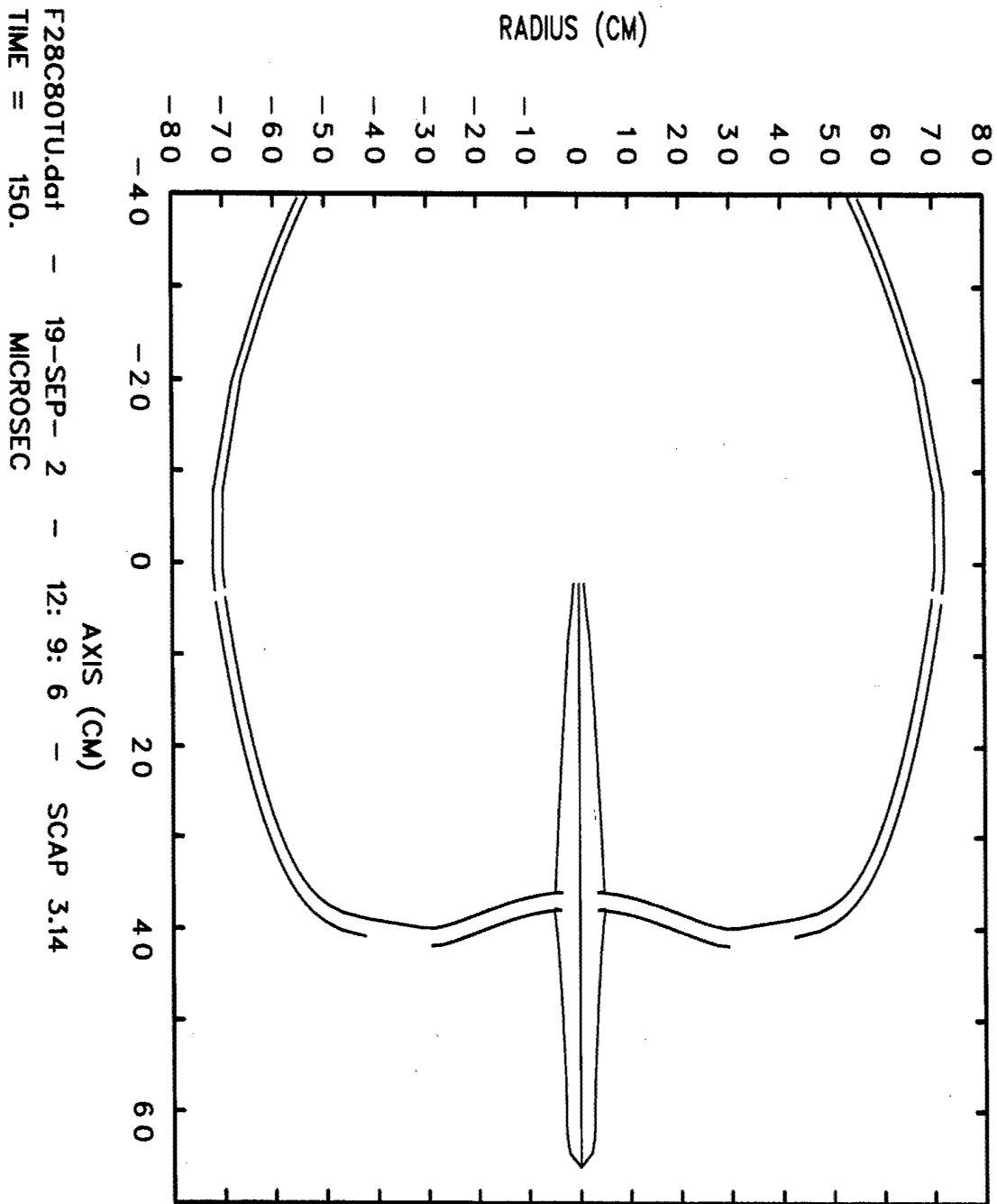


Figure 13. Jet Formation at +150 Microseconds

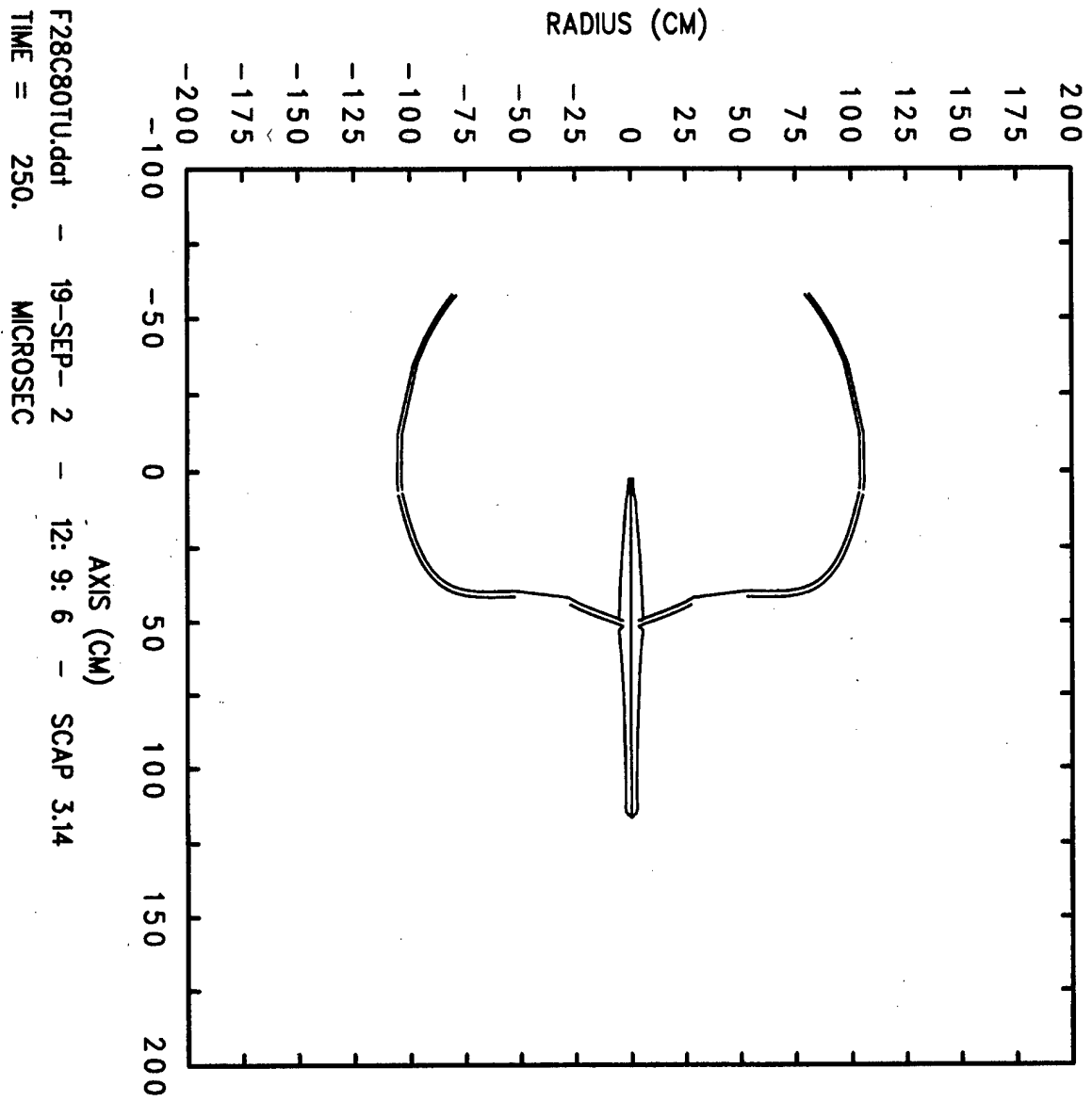


Figure 14. Jet Formation at +250 Microseconds

F28C80TU.ddt - 19-SEP- 2 - 12: 9: 6 - SCAP 3.14  
TIME = 350. MICROSEC

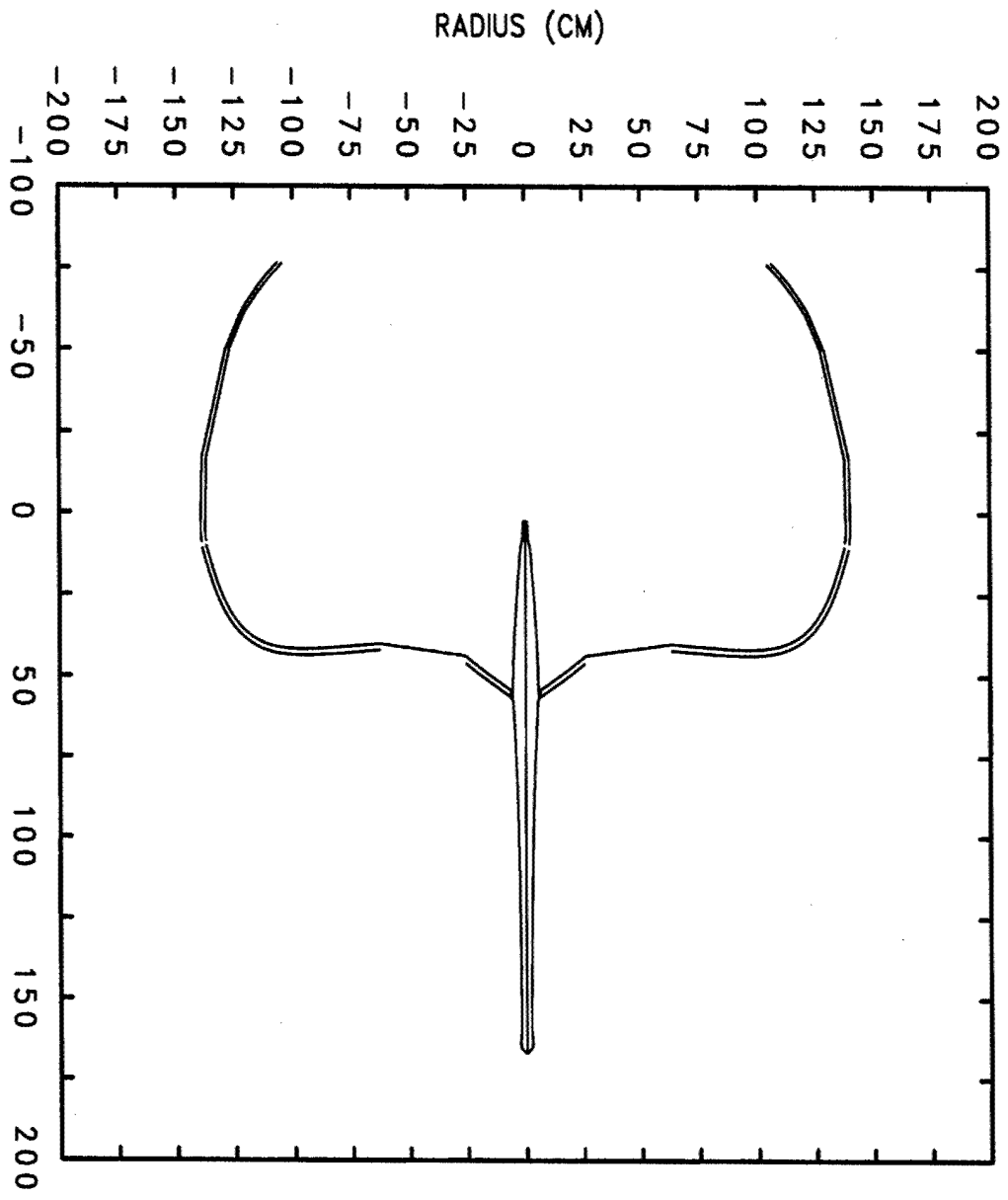


Figure 15. Jet Formation at +350 Microseconds

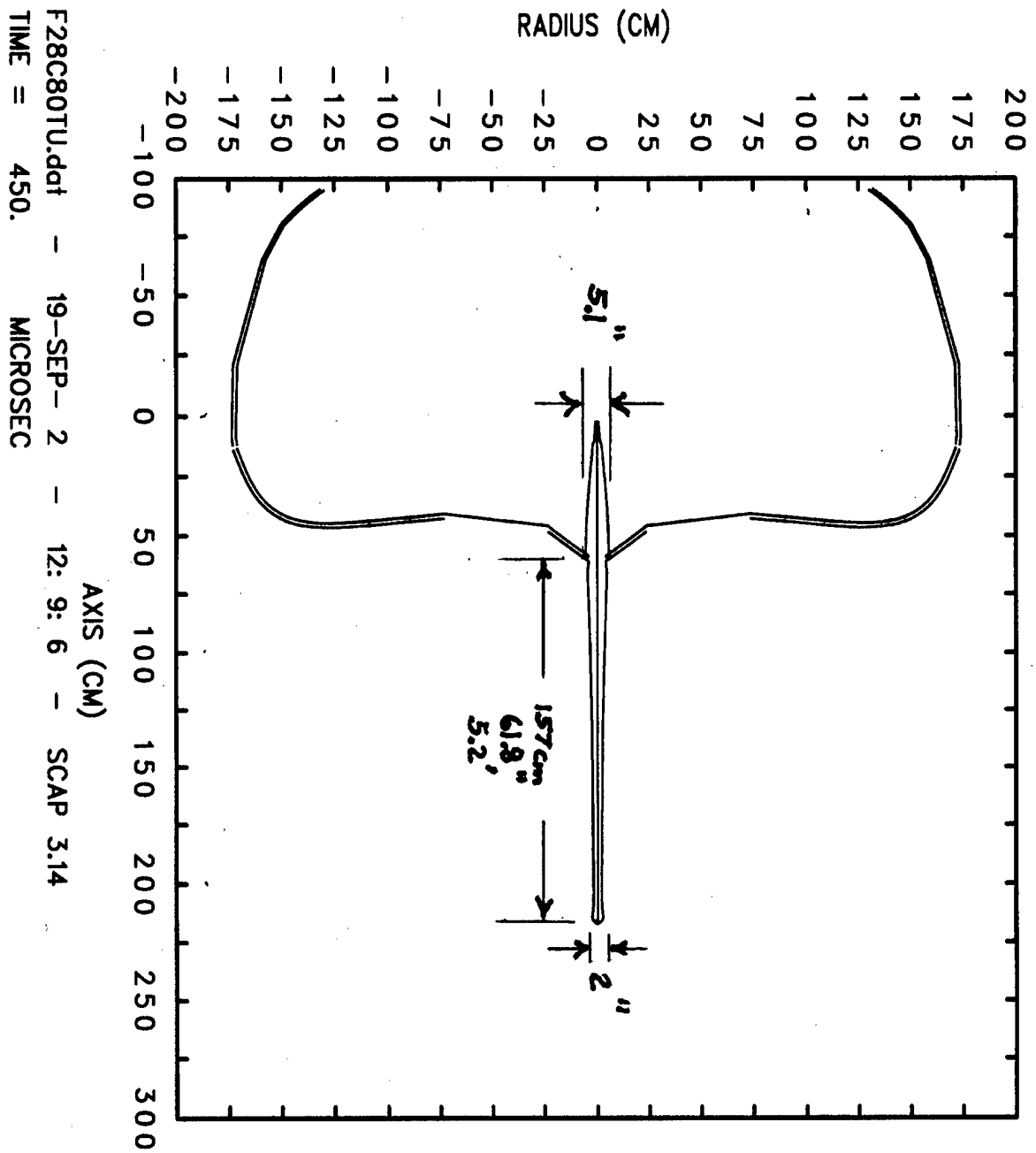


Figure 16. Jet Formation at +450 Microseconds

F28C80TU.ddt - 19-SEP- 2 - 12: 9: 6 - SCAP 3.14  
TIME = 550. MICROSEC

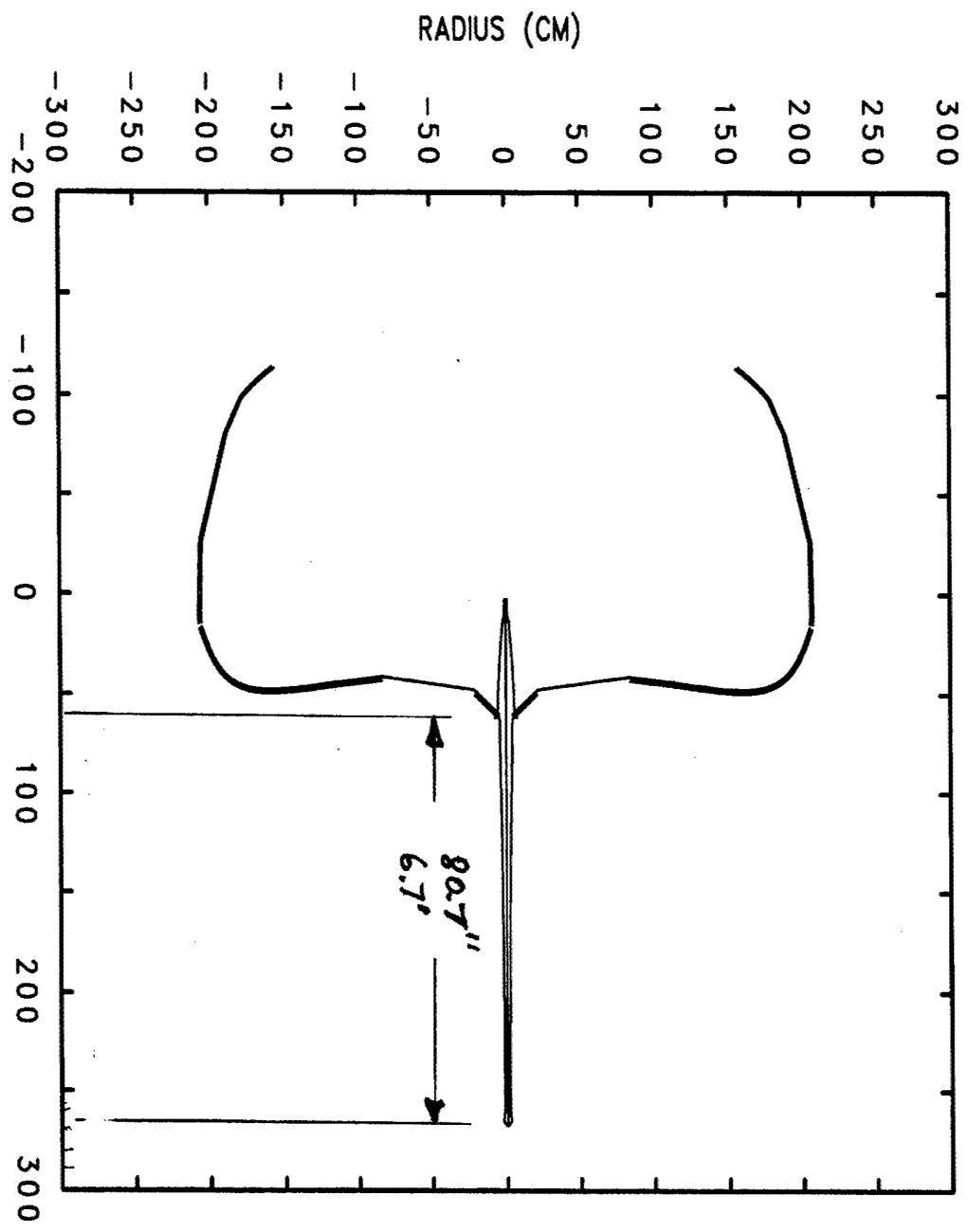
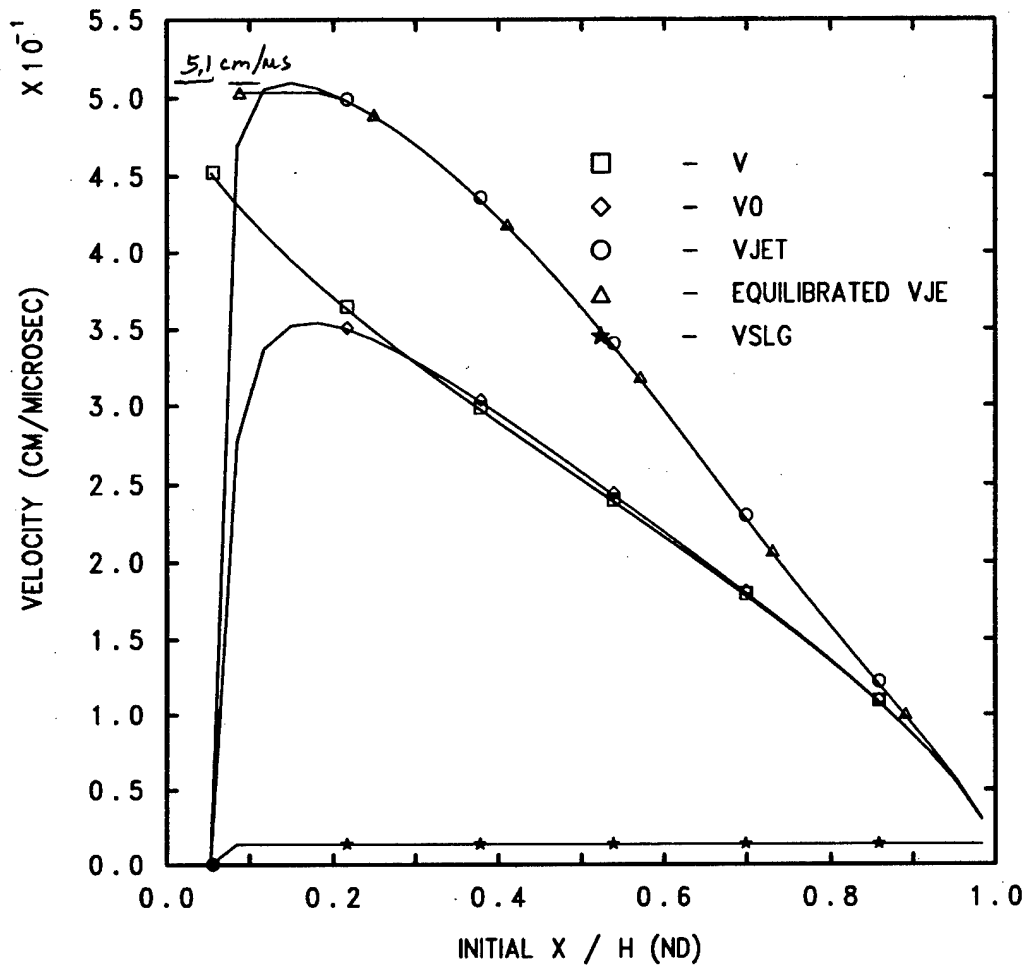
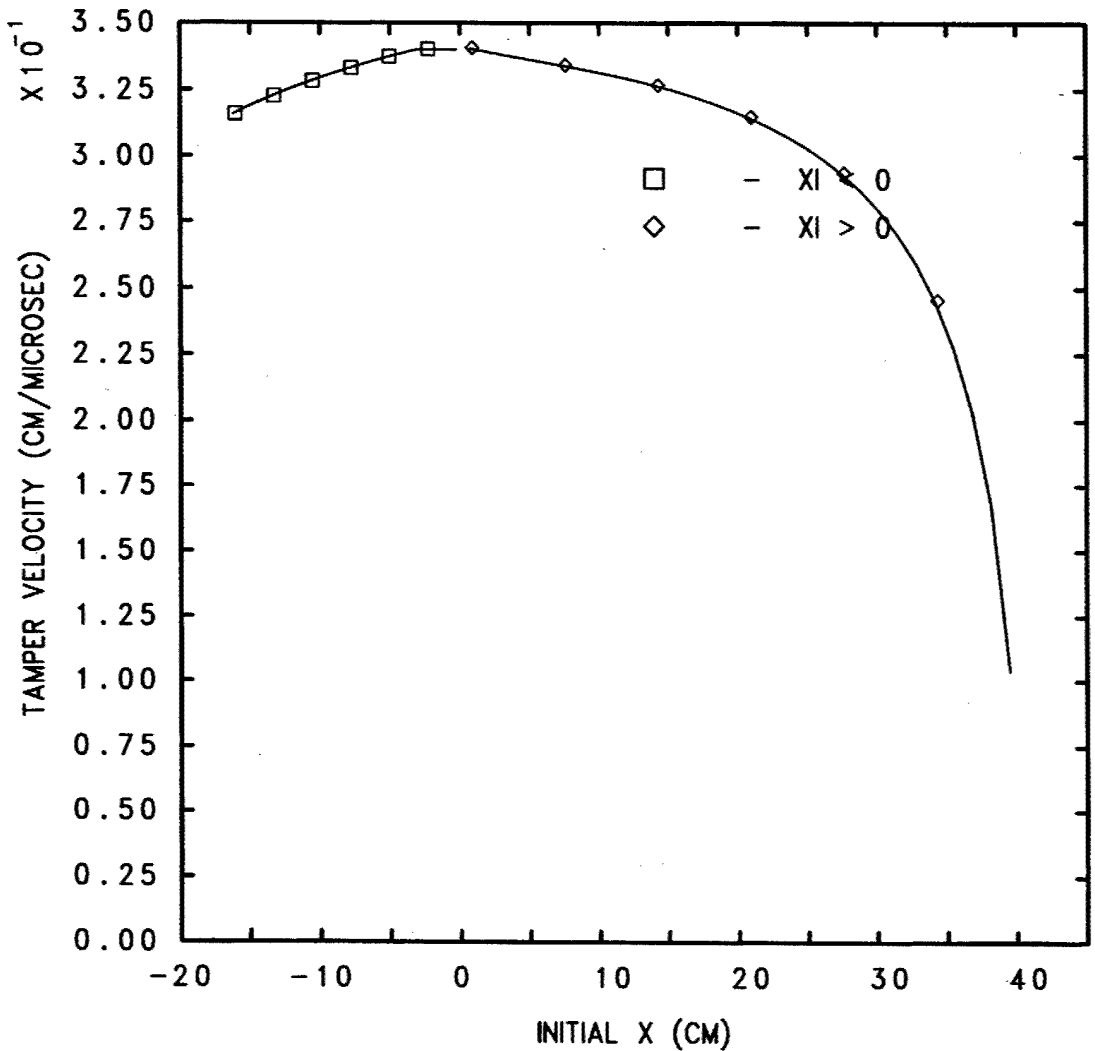


Figure 17. Jet Formation at +550 Microseconds



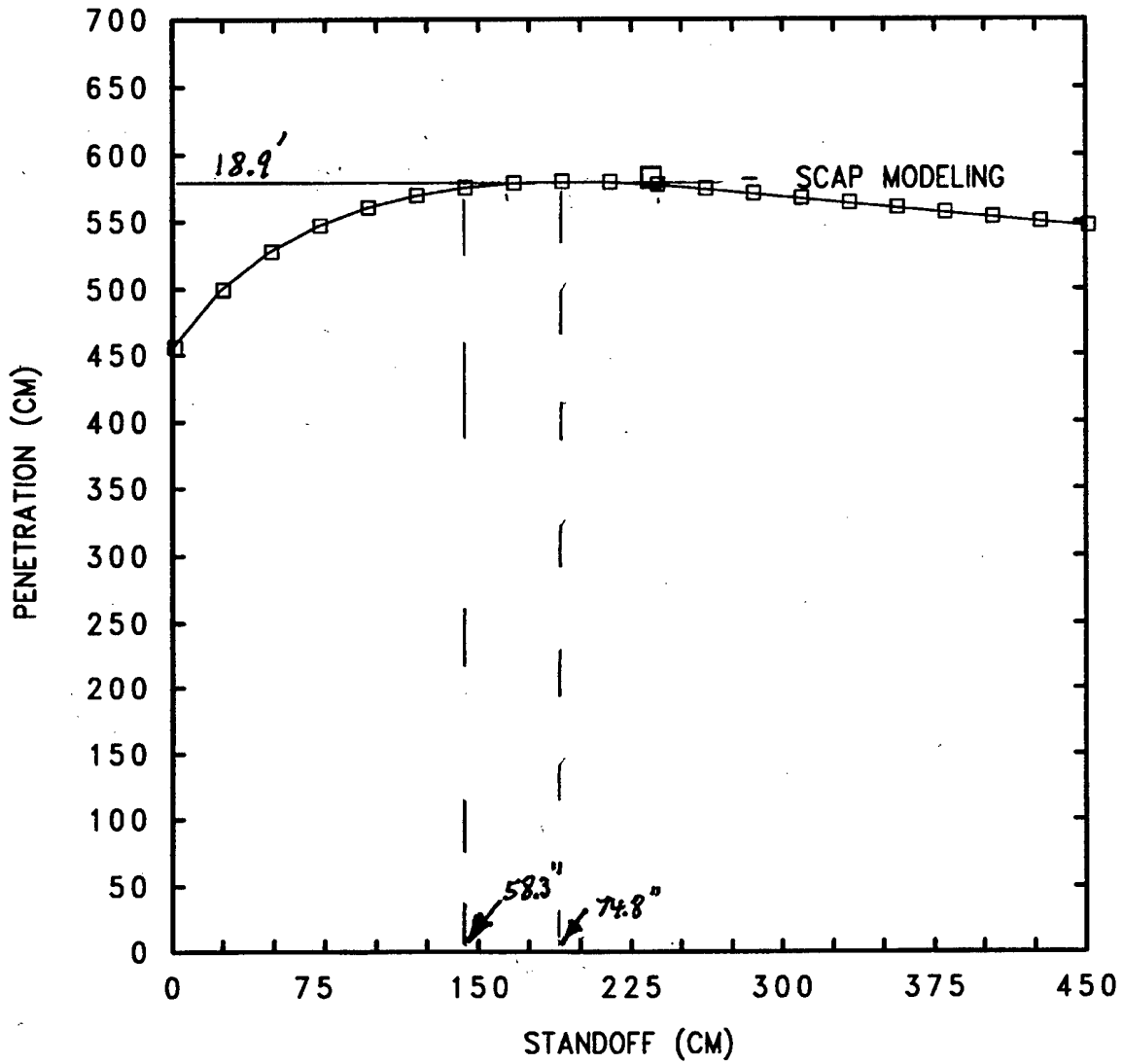
F28C80TU.dat - 19-SEP- 2 - 12: 9: 6 - SCAP 3.14

Figure 18. Jet Velocity Versus Dimensionless Distance



F28C80TU.dat - 19-SEP- 2 - 12: 9: 6 - SCAP 3.14

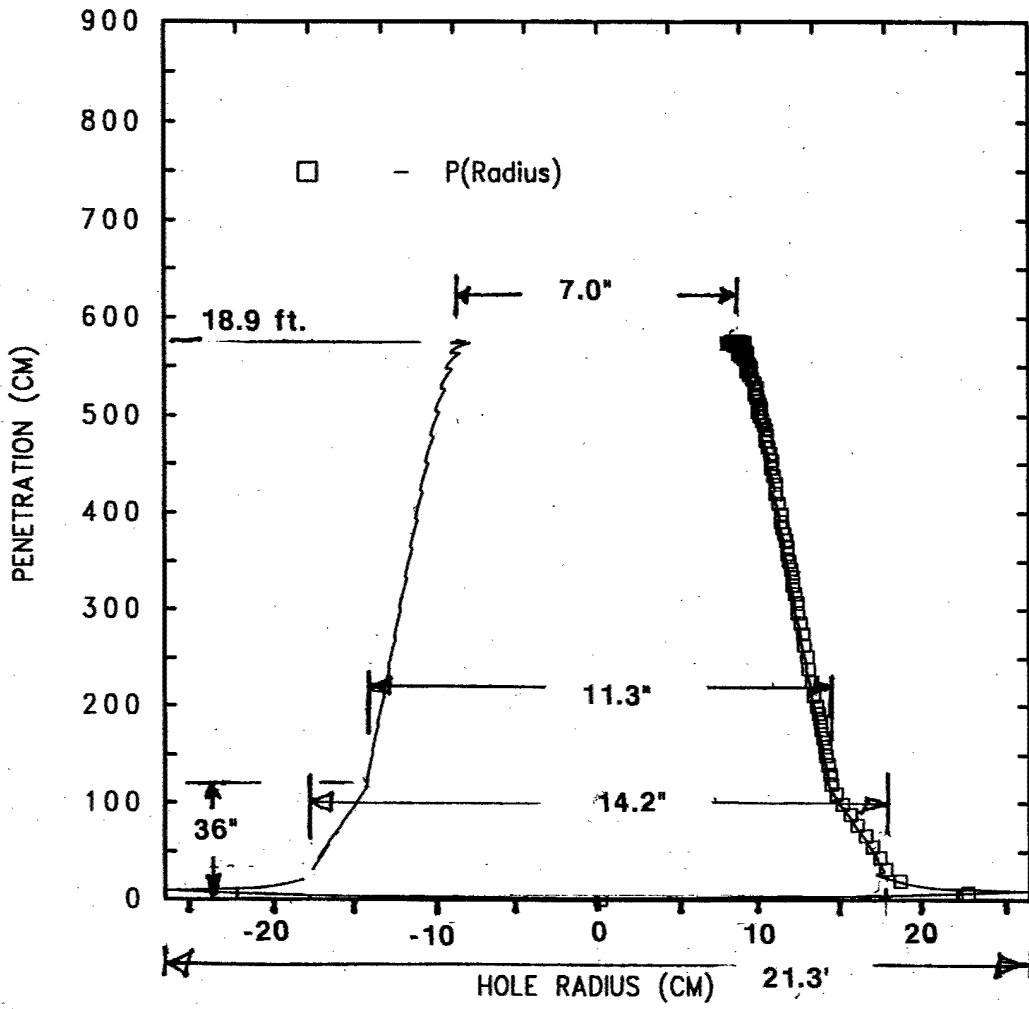
Figure 19. Explosive Housing/Tamper Velocity Versus Distance



F28C80TU.dat - 19-SEP- 2 - 12: 9: 6 - SCAP 3.14

Figure 20. Jet Penetration Versus Standoff





F28C80TU.dat - 19-SEP- 2 - 12: 9: 6 - SCAP 3.14  
 PENETRATION AT 142. (CM) STANDOFF

Figure 21. Jet Penetration Versus Hole Radius/Diameter Profile

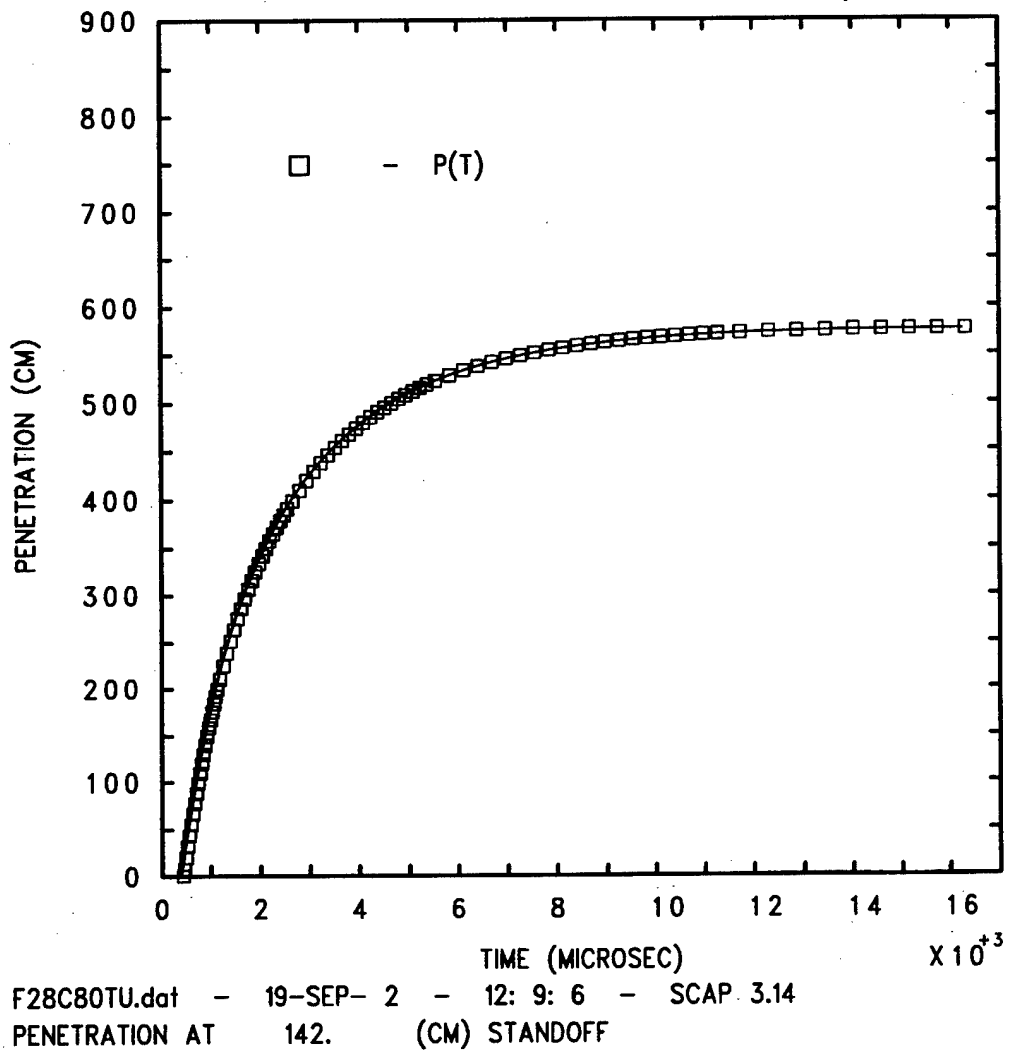


Figure 22. Jet Penetration Versus Time

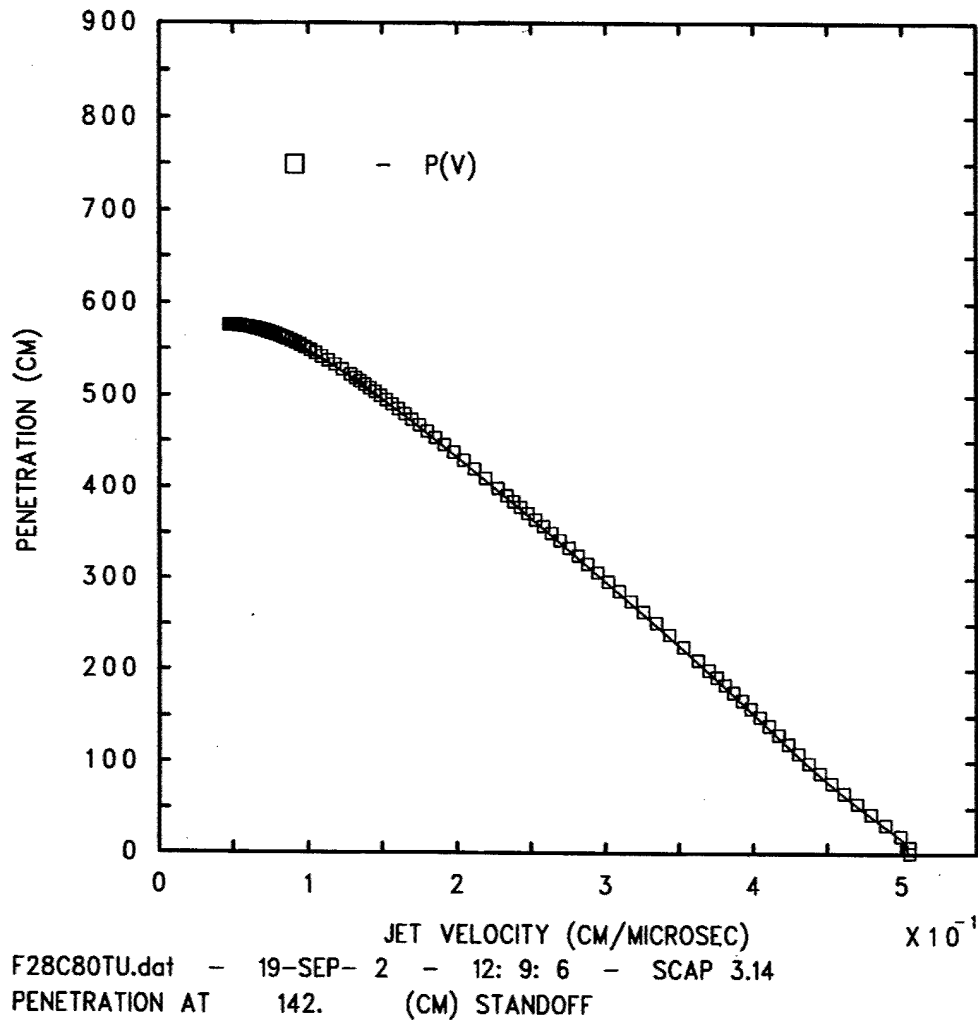
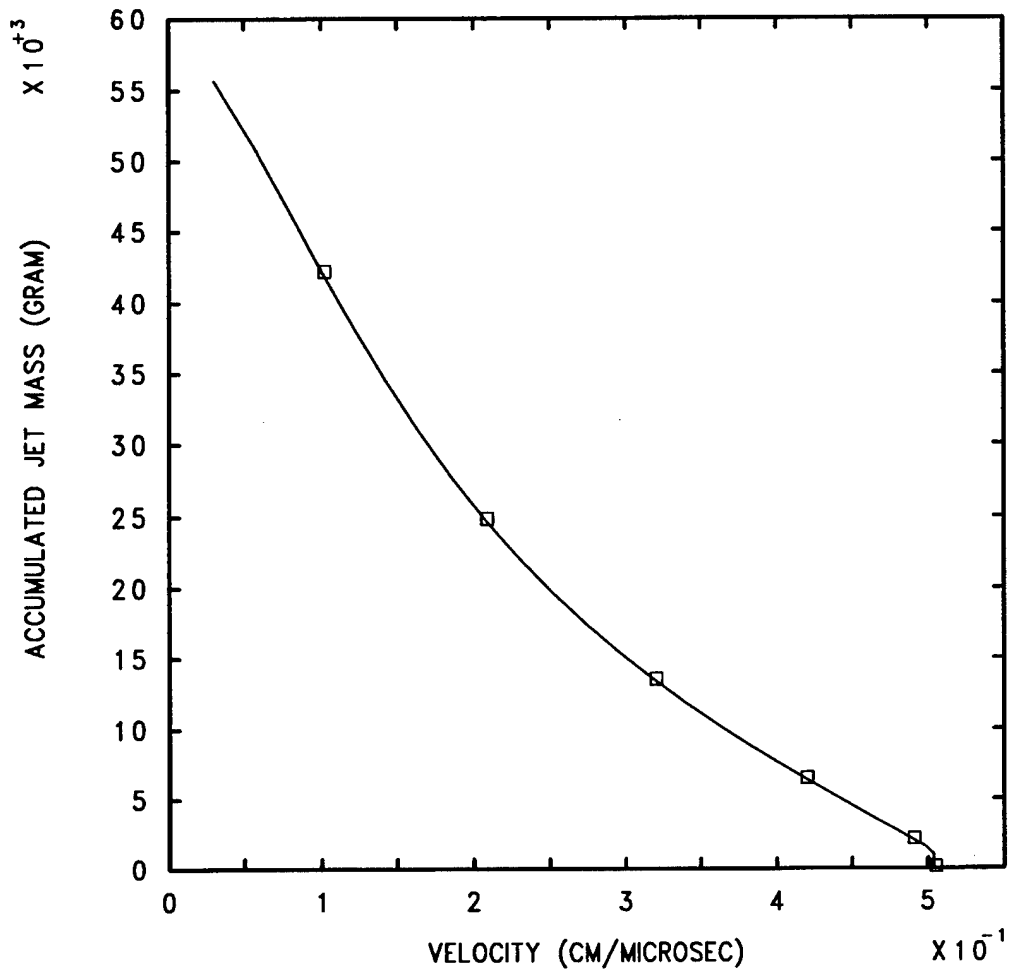
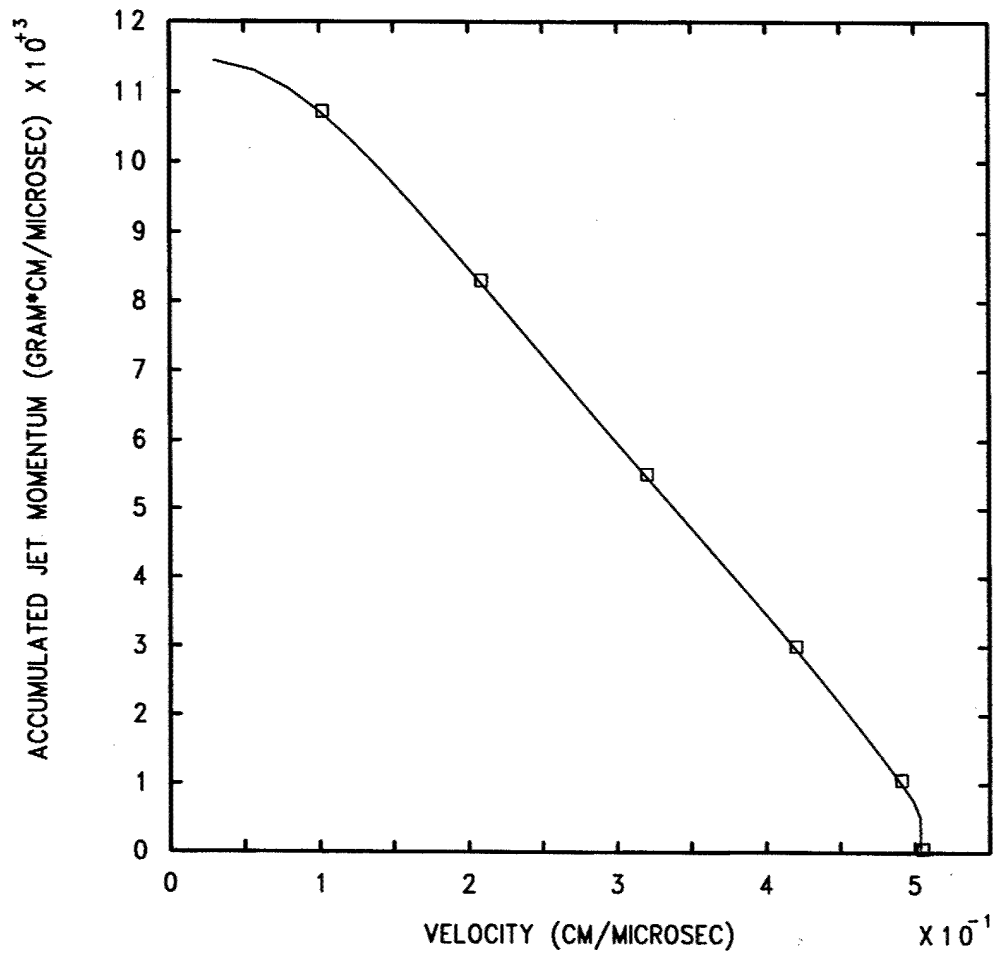


Figure 23. Jet Penetration Versus Jet Velocity



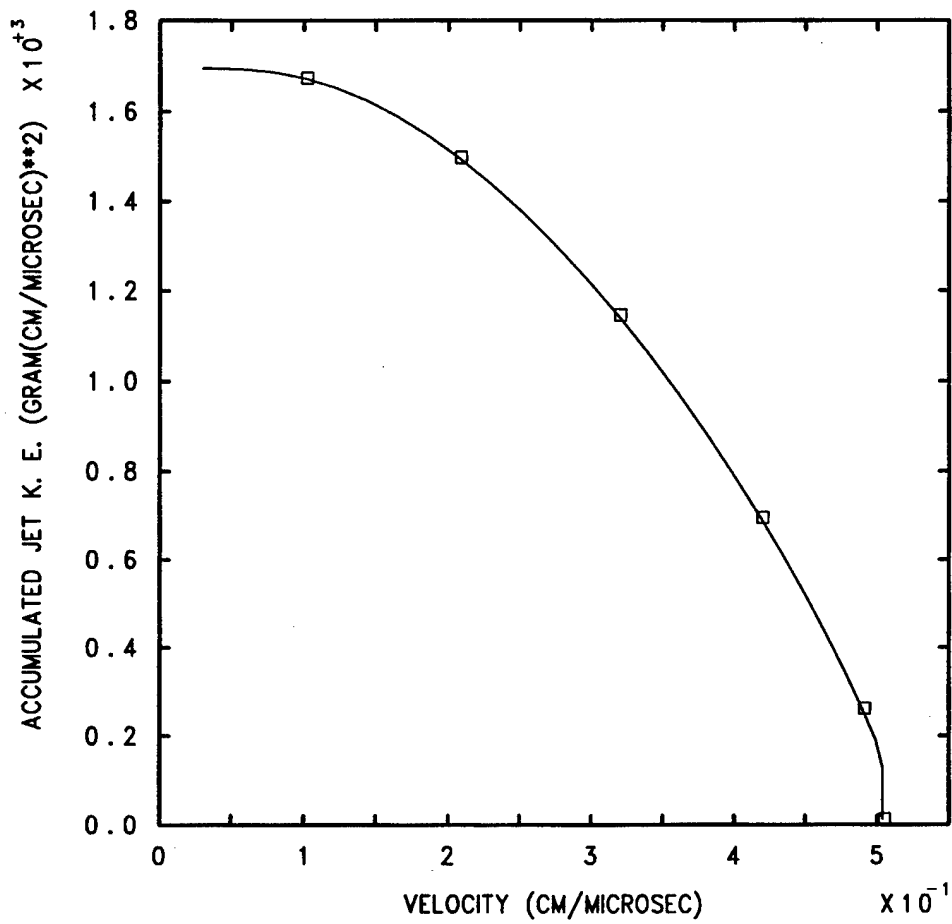
F28C80TU.dat - 19-SEP- 2 - 12: 9: 6 - SCAP 3.14

**Figure 24. Accumulated Jet Mass Versus Jet Velocity**



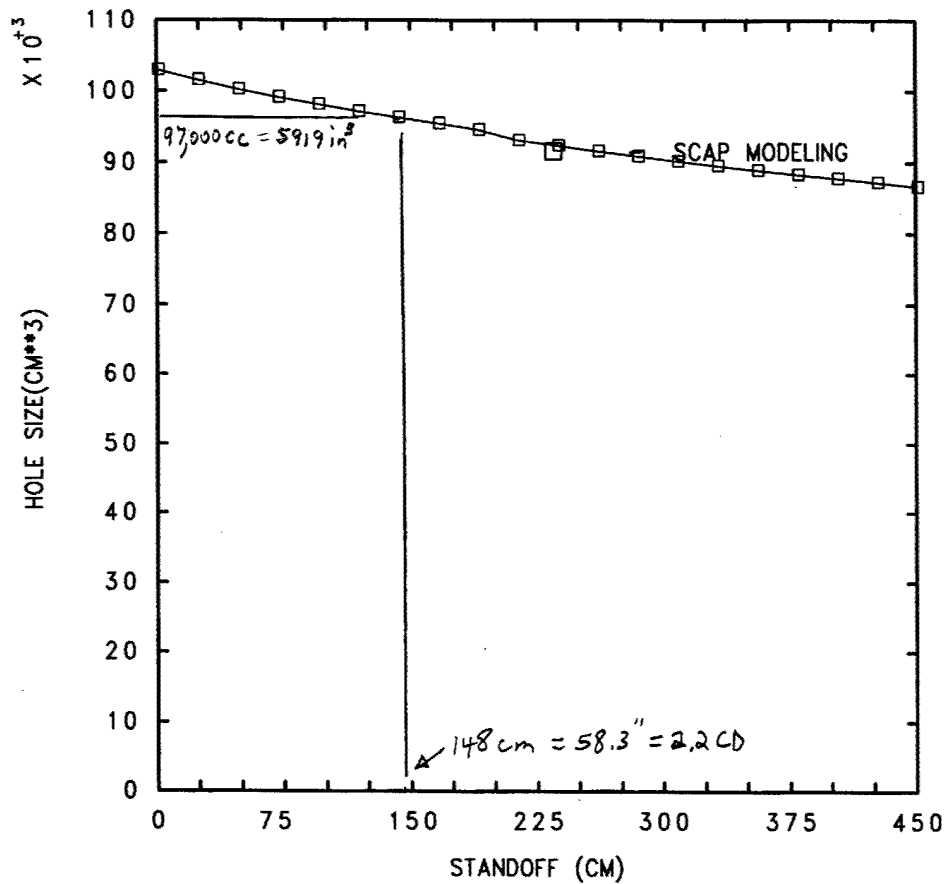
F28C80TU.dat - 19-SEP- 2 - 12: 9: 6 - SCAP 3.14

Figure 25. Accumulated Jet Momentum Versus Jet Velocity



F28C80TU.dat - 19-SEP- 2 - 12: 9: 6 - SCAP 3.14

Figure 26. Accumulated Jet Kinetic Energy Versus Jet Velocity



F28C80TU.dat - 19-SEP- 2 - 12: 9: 6 - SCAP 3.14

Figure 27. Jet Generated Hole Volume Versus Standoff

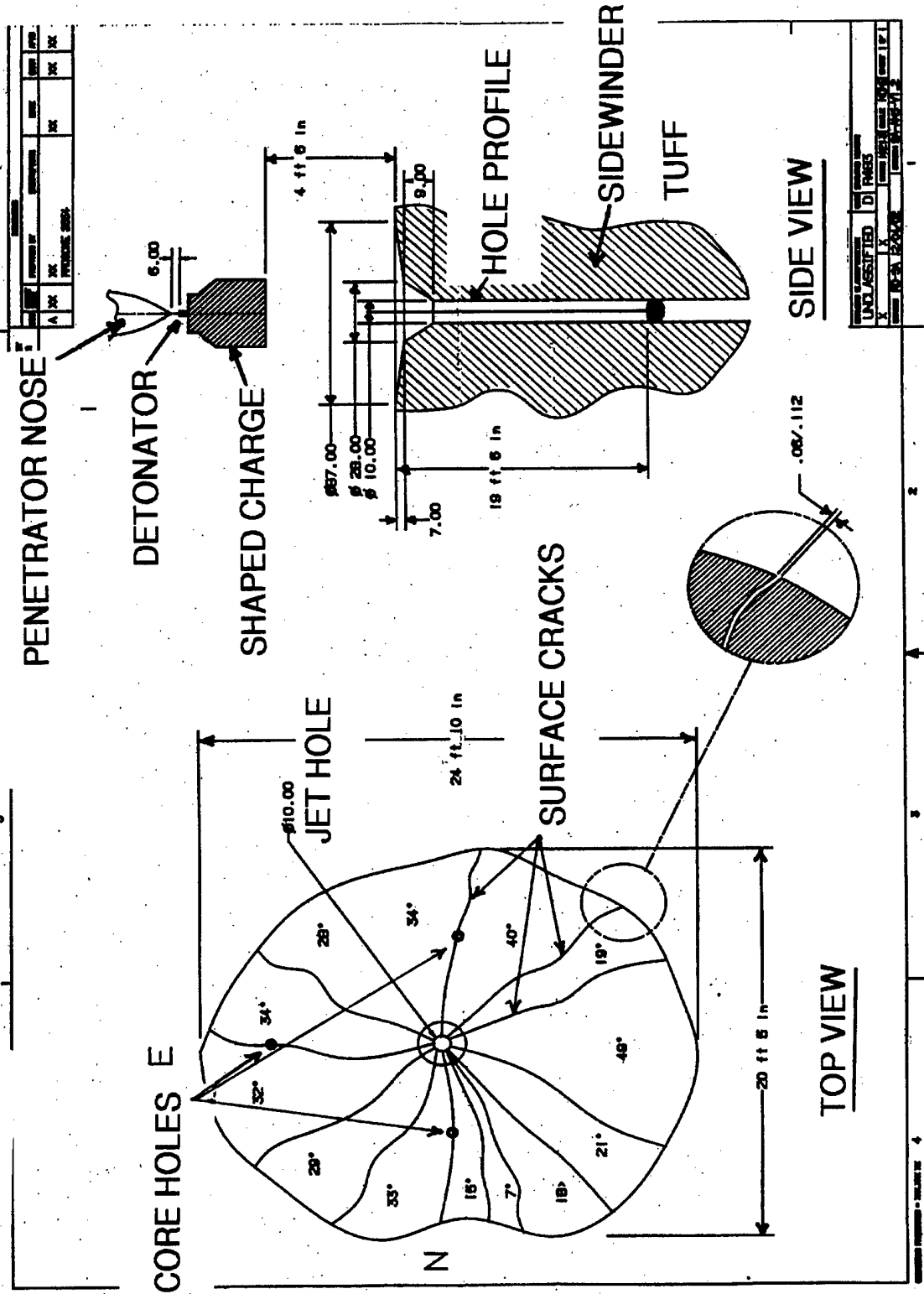
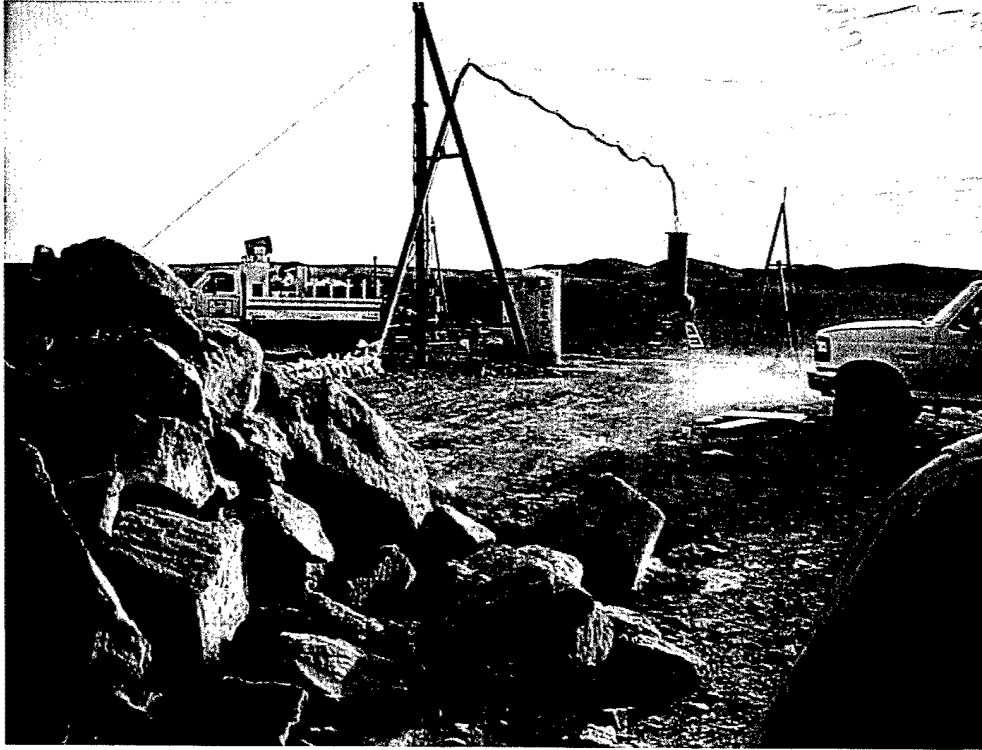
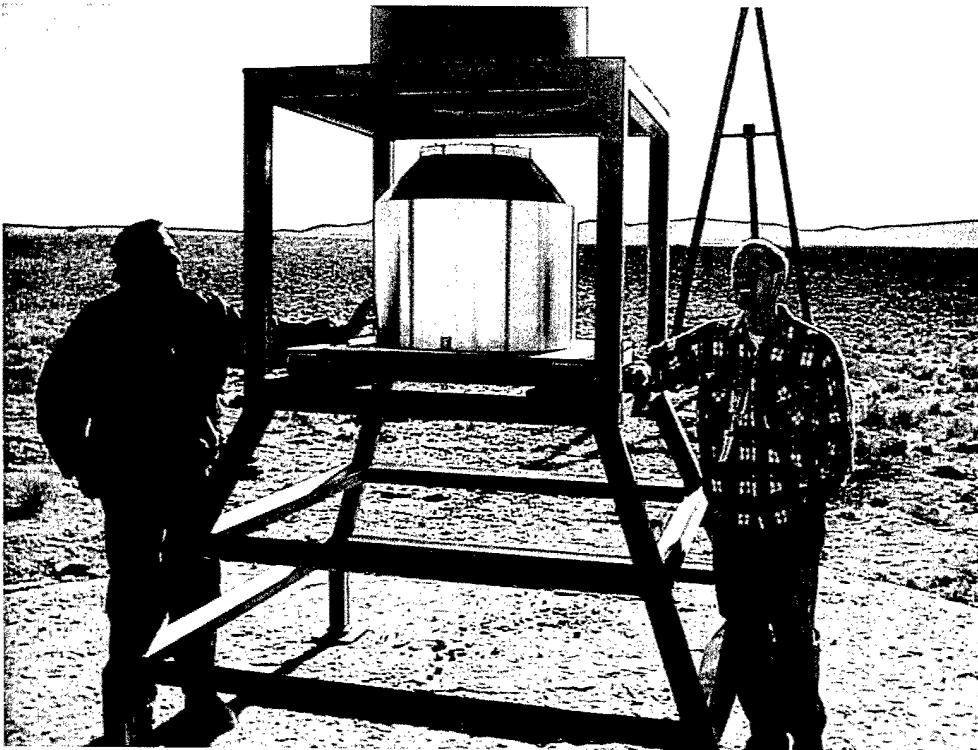


Figure 28. Penetrator, CSC, and Tuff Rock Hole Profile





**Figure 29. Overall Test Configuration**



**Figure 30. CSC Installed on Structure and Below Penetrator**



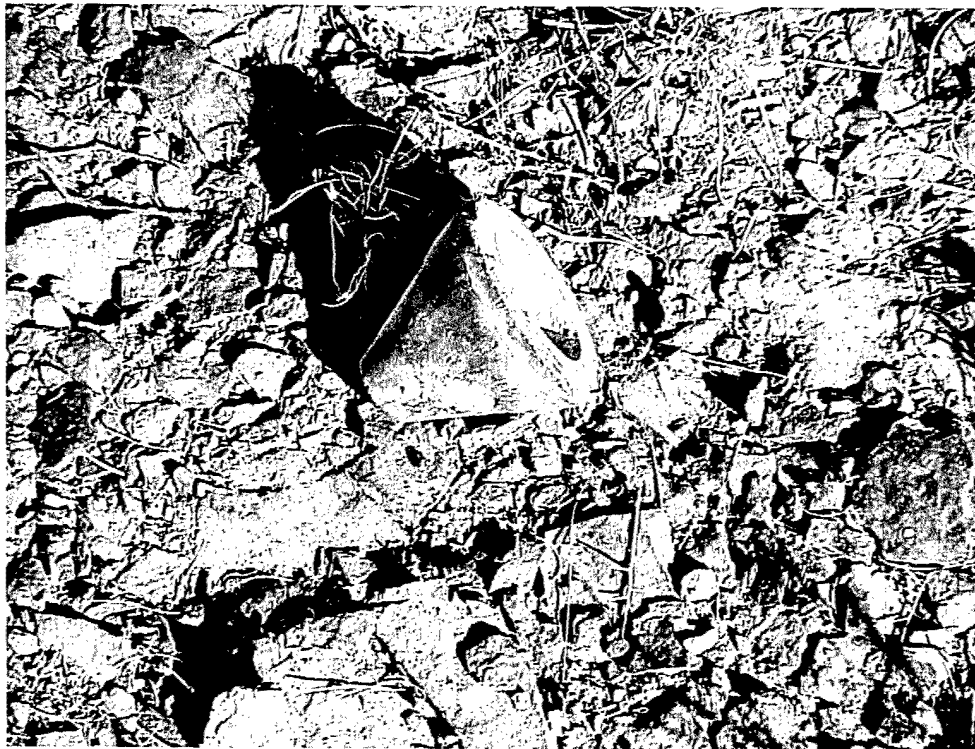
**Figure 31. Post-Test Hole in Tuff, Penetrator, and Support**



**Figure 32. Post-Test, Tuff Rock Surface Crater, and Hole**



**Figure 33. Penetrator Nose Area/Nose Piece Missing**



**Figure 34. Penetrator Nose Recovered Near Hole**



**APPENDIX A**

**PIECE-PART AND ASSEMBLY DRAWINGS FOR THE FINAL CSC  
DESIGN DRAWINGS**





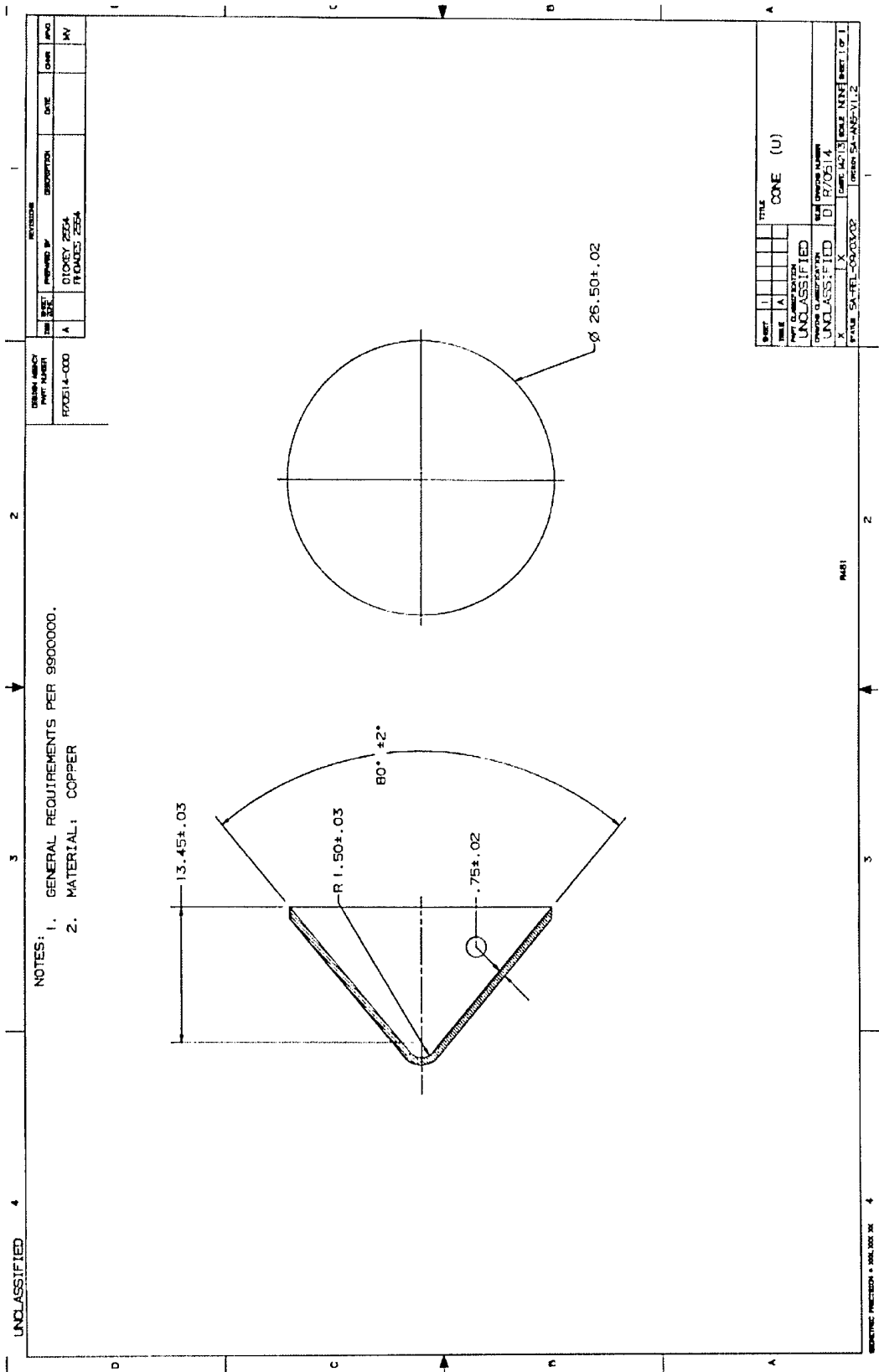


Figure A2. CSC Copper Cone



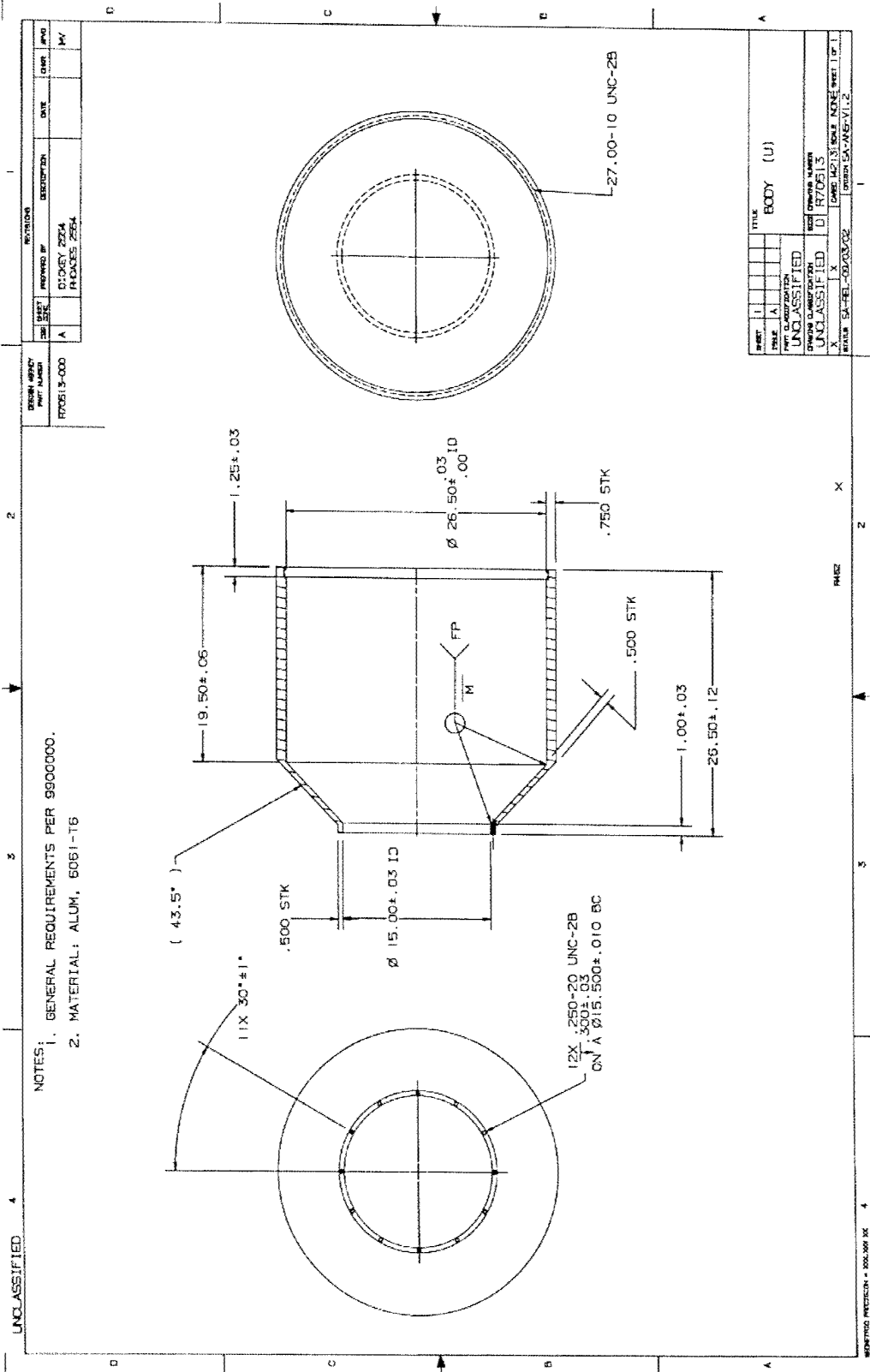
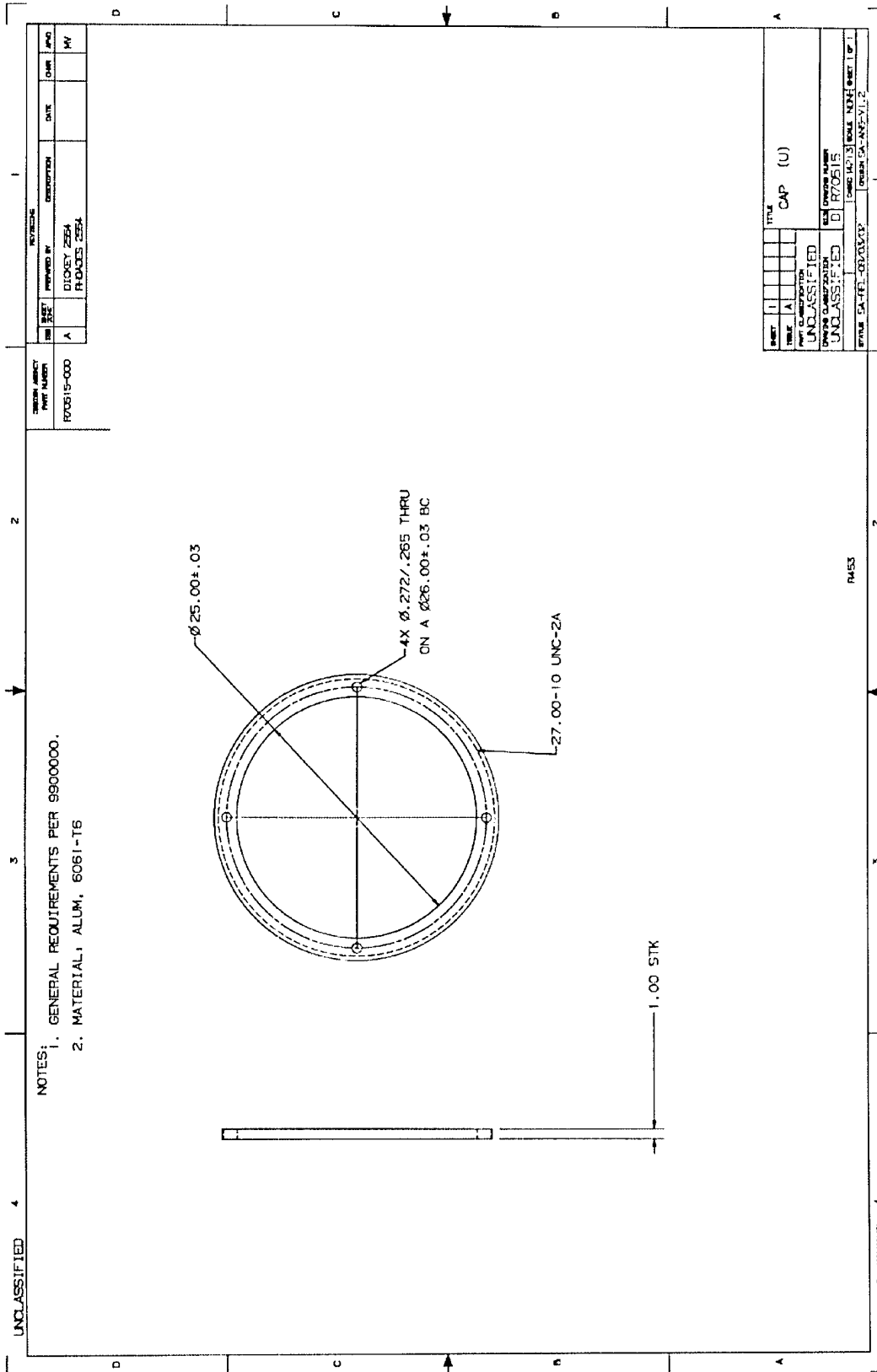


Figure A3. Explosive Housing



**Figure A4. Cone Retainer Cap/Ring**

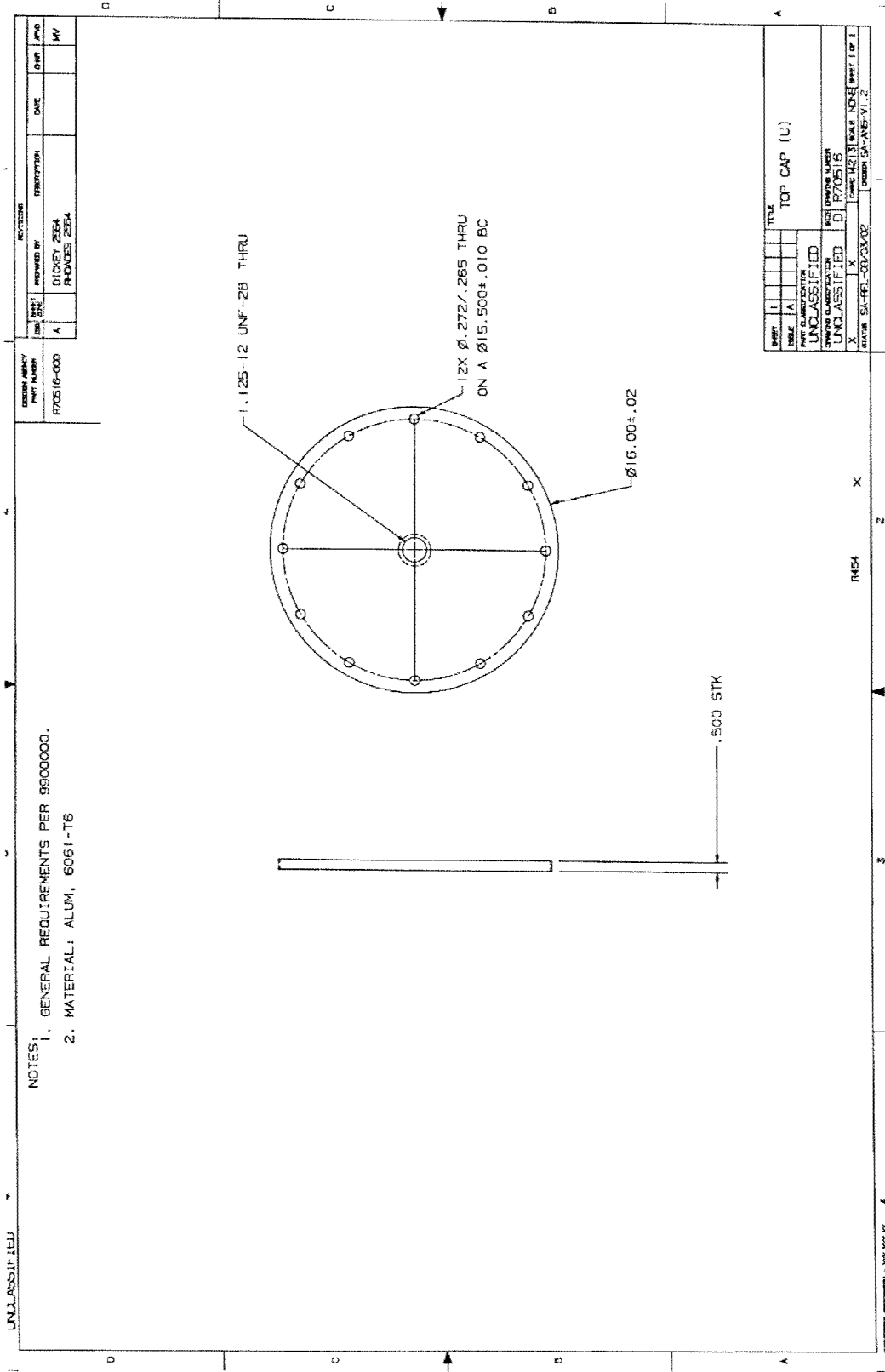


Figure A5. Explosive Cover Plate/Cap

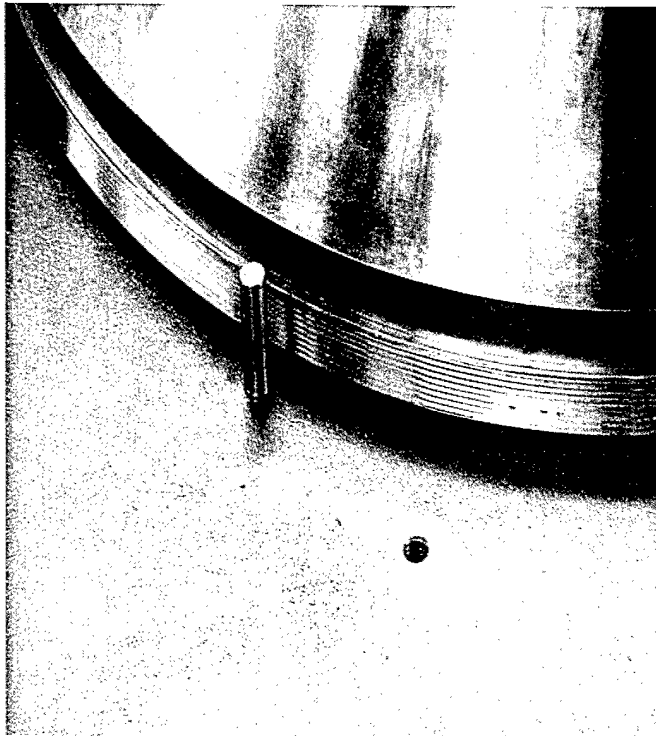


**APPENDIX B**  
**CONICAL SHAPED CHARGE ASSEMBLY PHOTOS**





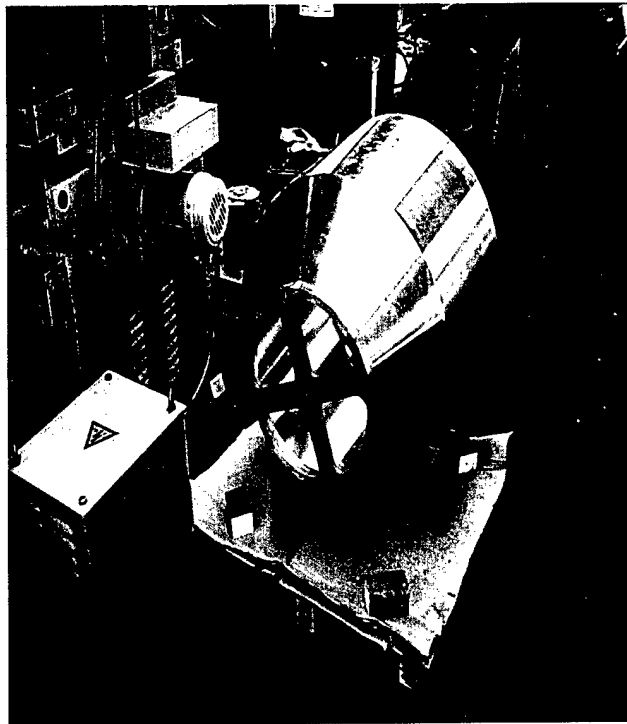
**Figure B1. Installation of Cone Retainer Ring on Support Platform**



**Figure B2. Retainer Ring Threaded Outer Perimeter**

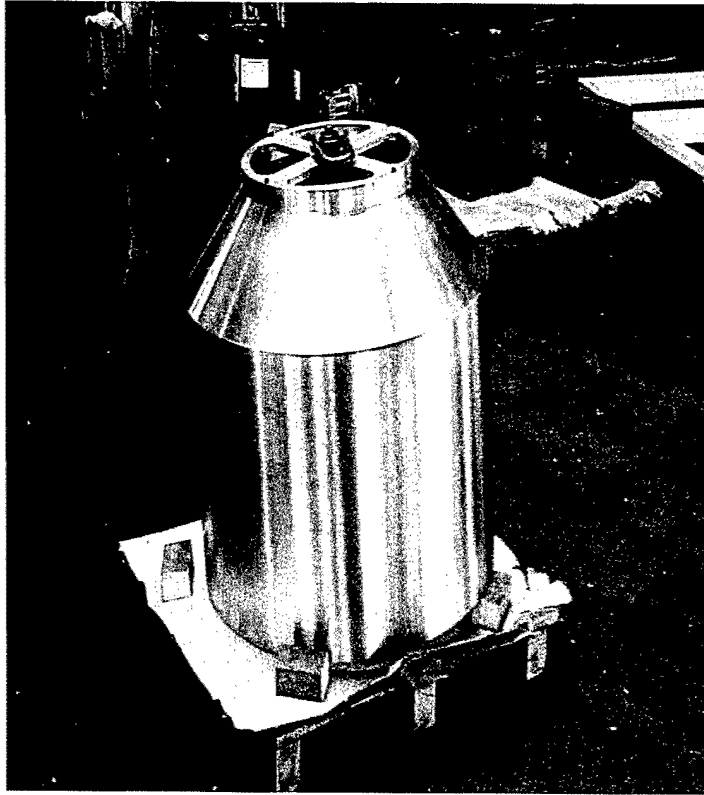


**Figure B3. Cone Installed in Retainer Ring and Support Platform**



**Figure B4. Aluminum Explosive Housing/Explosive Loading Fixture**





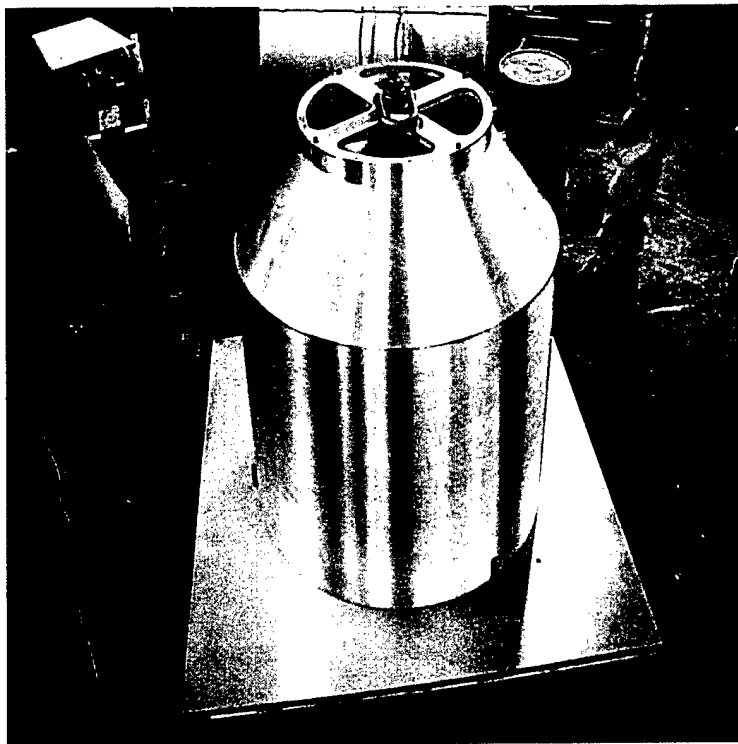
**Figure B5. Aluminum Housing/Loading Fixture/Lifting Eye Bolt**



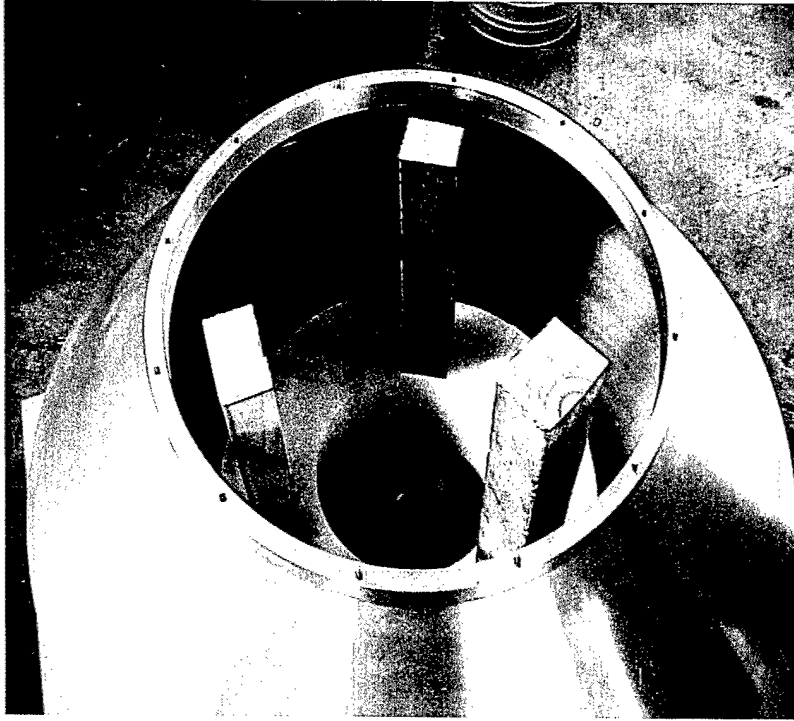
**Figure B6. Housing Being Assembled with Copper Cone and Ring**



**Figure B7. Ring, Cone, and Housing Assembly**



**Figure B8. Support Platform, Ring, Housing, and Loading Fixture**



**Figure B9. Wood Blocks, and Foam Ring for Hardware Shipping**



**Figure B10. Aluminum, Explosive Cover Plate on Aluminum Housing**



## APPENDIX C

### SCAP CODE PARAMETRIC STUDY DATA/COPPER LINER

Note: Data points indicated by symbols in Figures C1–C6 are predicted data using the SCAP code. The solid line is a least squares fit of the data. The least squares fit equation is also shown in the figures.



**Table C1. Copper Liner/28 Inch O.D. CSC/SCAP Predictions**

Liner: Copper, 26.5 inch I.D., 28 inch O.D.

Target: Sidewinder Tuff Rock

CHARGE LENGTH (in.)	S.O. (in.)	APEX ANGLE (deg)	LINER THICK (in.)	P JET PEN. (in.)	De ENTR. HOLE DIA. (in.)	Db BOTT. HOLE DIA. (in.)	Vj JET TIP VEL. (cm/us)	Dj JET DIA. (in.)
20.5	132	80	0.98	133	13.5	5.9	0.47	2.0
26.0	70	60	0.55	173	10.3	4.5	0.67	1.7
22.0	174	70	1.2	130	10.1	5.5	0.47	1.8
22.0	131	80	1.2	116	10.6	5.7	0.44	2.0
22.0	131	90	1.2	108	8.5	5.3	0.44	2.0
28.4	89.5	60	0.75	161	17.6	5.2	0.58	2.0
28.4	179.0	60	1.5	138	14.9	6.3	0.45	2.0
28.5	179	90	0.75	132	10.4	5.2	0.48	2.0
28.5	41	80	0.75	146	12.8	5.2	0.54	2.0
28.5	62	80	1.5	122	11/3	7.3	0.44	2.0
28.5	62	80	0.55	155	9.9	4.2	0.61	2.0
28.5	62	70	0.75	158	12.0	6.3	0.57	2.0
28.5	55.9	80	0.75	226.4	14.2	5.2	0.51	2.0

**Table C2. Parametric Study/Variable Apex Angle**

Liner: Copper, 26.5 in. I.D.

Explosive: Octol (75% HMX/25% TNT), 1.843 g/cc, 0.848 cm/us,

Total Weight: 562 lb (including Primasheet booster)

Housing/Tamper: Aluminum, 0.5 in. thick

CSC Total Length: 28.5 in.

CSC Total Weight: 828 lb

<b>APEX ANGLE (deg.)</b>	<b>LINER THICK. (in.)</b>	<b>CSC CHARGE TOTAL LENGTH (in)</b>	<b>S.O. (in.)</b>	<b>PEN. (in.)</b>	<b>PEN. (ft)</b>	<b>ENTR. HOLE DIA. (in.)</b>	<b>BOTT. HOLE DIA. (in.)</b>	<b>JET TIP VEL. (cm/us)</b>
60	0.55	26	70	173	14.4	10.3	4.5	0.67
60	0.75	28.4	90	161	13.4	17.6	5.2	0.58
60	1.50	28.4	179	138	11.5	14.9	6.3	0.45
70	0.75	28.4	62	158	13.2	12	6.3	0.57
70	1.2	22	174	130	10.8	10	5.5	0.47
80	0.55	28.4	62	155	12.9	9.9	6.3	0.57
80	0.75	28.5	62	189	15.7	11.3	5.2	0.52
80	0.75	28.5	55.9	226.4	18.9	14.2	5.2	0.51
80	0.75	28.4	41	146	12.2	12.8	5.2	0.54
80	1.00	28.4	62	178	14.8	12	5.5	0.48
80	1.20	22	131	116	9.7	10.6	5.7	0.45
80	1.50	28.5	62	122	10.2	11.3	7.3	0.44
80	2.00	28.5	41	124	10.3	14.2	9.6	0.37
90	0.75	28.5	104	181	15.1	8.5	5.2	0.49
90	0.75	28.5	179	132	11.0	10.4	5.2	0.48
90	1.2	22	131	108	9.0	8.5	5.3	0.44
100	0.5	28.5	62	173	14.4	9	4.4	0.47



**Table C3. Parametric Study/Variable Liner Thickness**

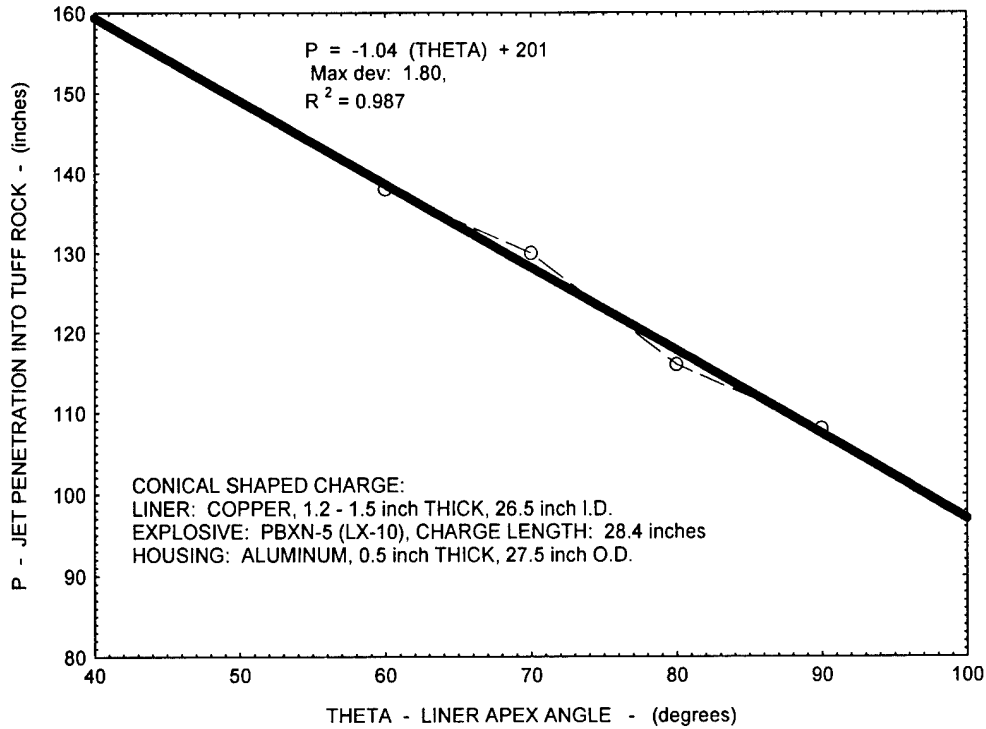
Liner: Copper, 80 degrees Apex Angle  
 Explosive: Octol (75% HMX/25% TNT), 1.843 g/cc, 0.848 cm/us,  
 Total Weight: 600 lb (including Primasheet booster)  
 Housing/Tamper: Aluminum, 0.5 in. thick  
 CSC Total Length: 28.5 in.

<b>COPPER LINER THICKNESS (in.)</b>	<b>STANDOFF (in)</b>	<b>JET PENETRATION (ft)</b>	<b>ENTRANCE HOLE DIAMETER (in.)</b>	<b>BOTTOM HOLE DIAMETER (in.)</b>	<b>JET TIP VELOCITY (cm/us)</b>
0.75	104 (3.9 CD)	16	10	5	0.52
1.00	62 (2.3 CD)	15	12	6	0.48
2.00	41 (1.5 CD)	10	14	10	0.37

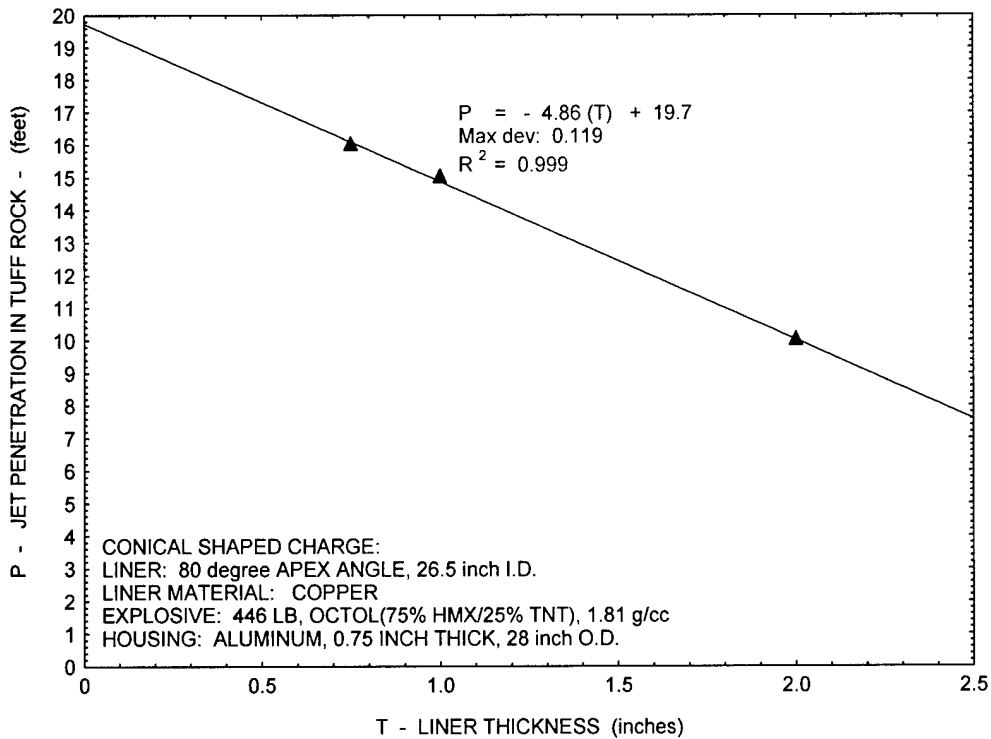
**Table C4. Parametric Study/Variable Standoff**

Liner: Copper, 0.75 in. thick, 80 degrees Apex Angle  
 Explosive: Octol (75% HMX/25% TNT), 1.843 g/cc, 0.848 cm/us,  
 Total Weight: 600 lb (including Primasheet booster)  
 Housing/Tamper: Aluminum, 0.5 in. thick  
 CSC Total Length: 28.5 in.  
 CSC Jet Tip Velocity: 0.52 cm/us

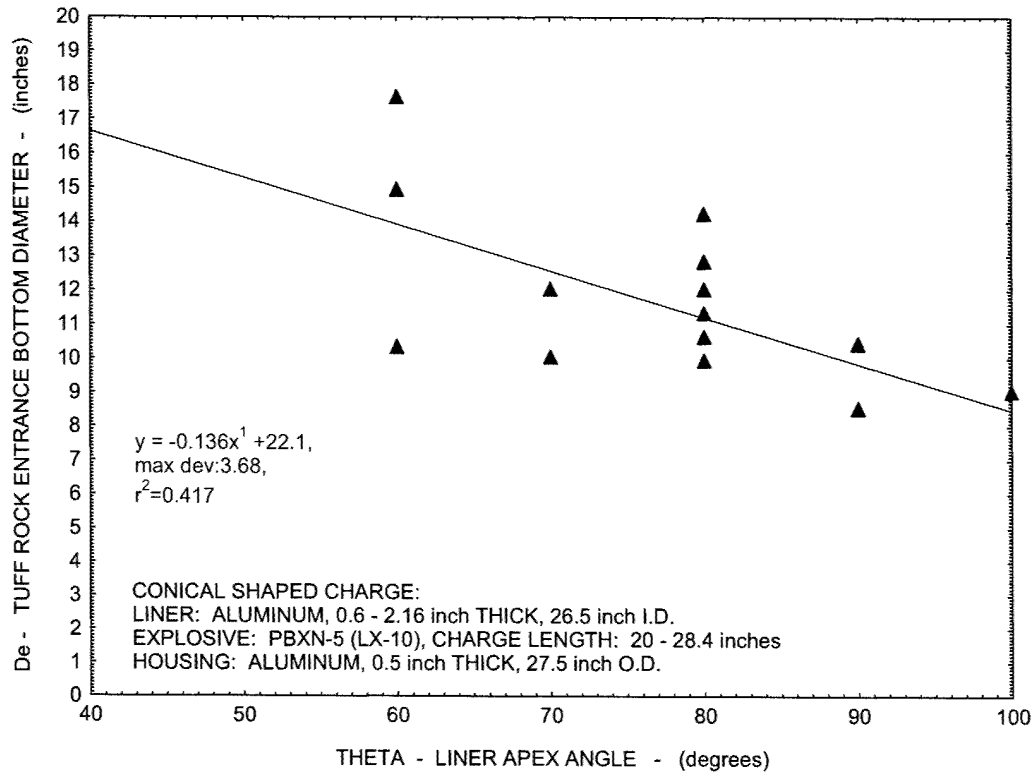
<b>STANDOFF (in.)</b>	<b>JET PENETRATION (ft)</b>	<b>ENTRANCE HOLE DIAMETER (in.)</b>	<b>BOTTOM HOLE DIAMETER (in.)</b>
0	10	18	5
21	13	16	5
41	15	13	5
83	16	11	5
104	16	10	5
124	16	9	5
145	16	9	5



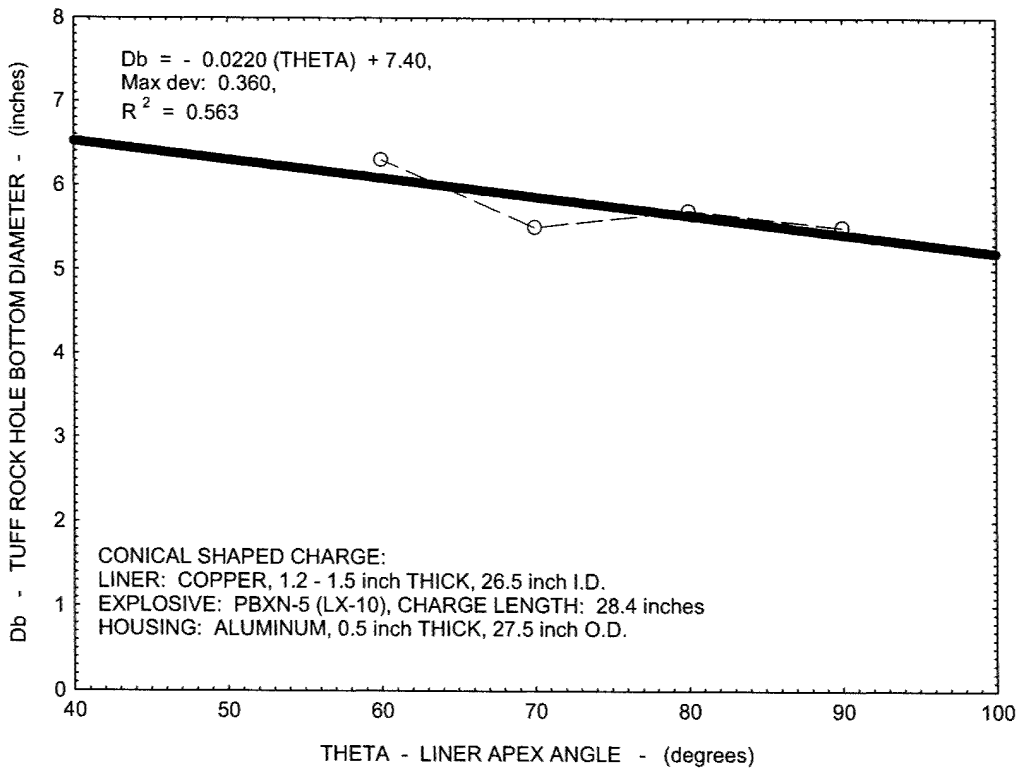
**Figure C1. Jet Penetration Versus Liner Apex Angle**



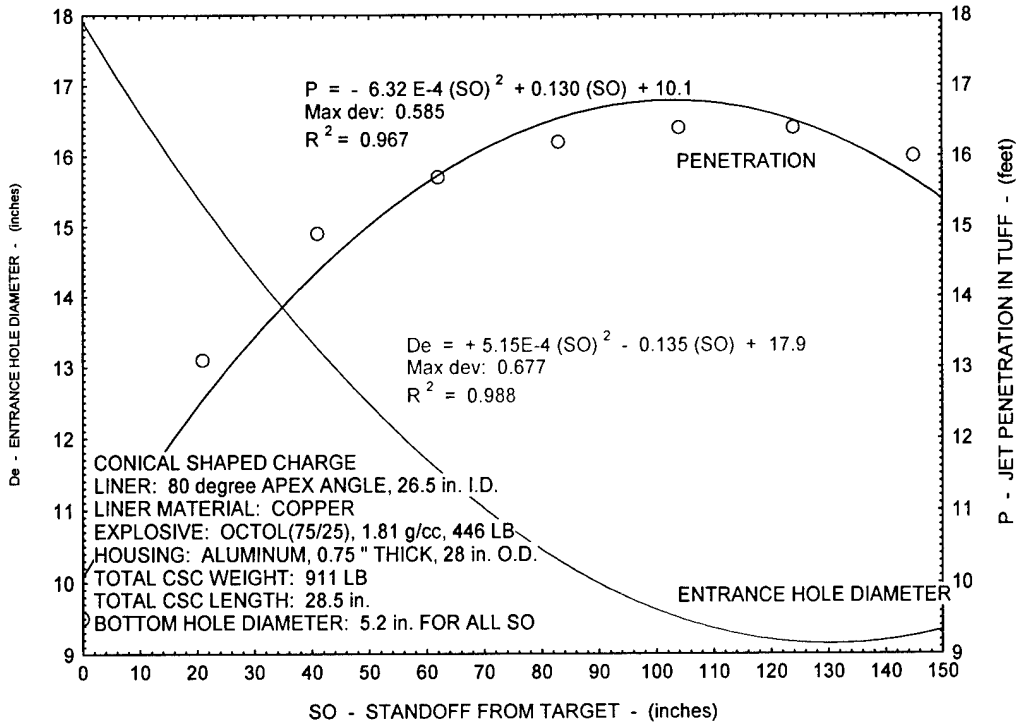
**Figure C2. Jet Penetration Versus Liner Thickness**



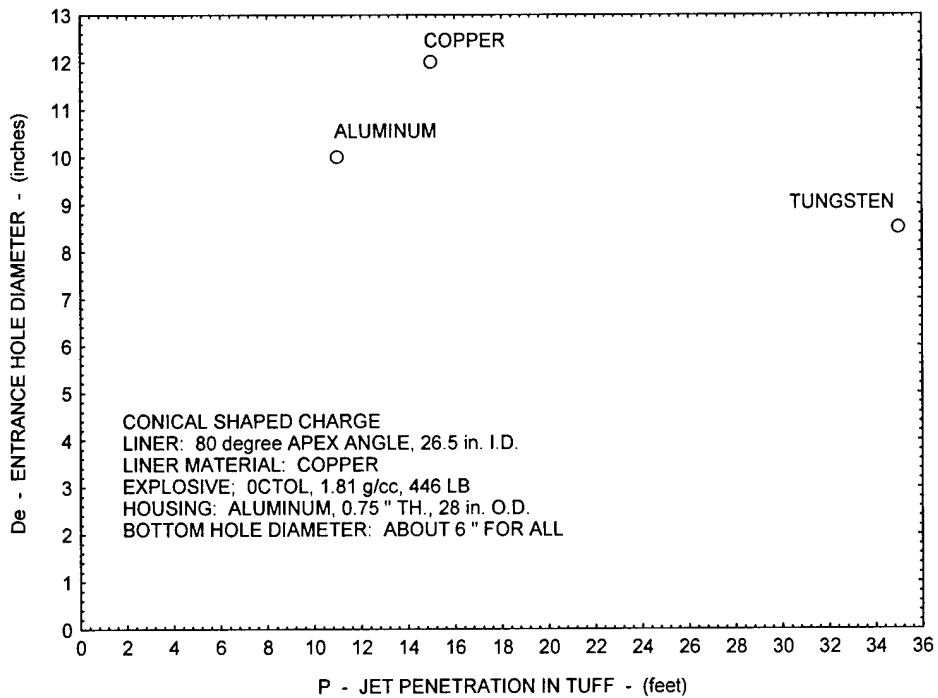
**Figure C3. Entrance Hole Diameter Versus Liner Apex Angle**



**Figure C4. Tuff Diameter at Maximum Penetration Versus Apex Angle**



**Figure C5. Entrance Hole Diameter and Jet Penetration Versus Standoff**



**Figure C6. Entrance Hole Diameter Versus Penetration/Al, Cu, and W**

**APPENDIX D**  
**SCAP CODE PARAMETRIC STUDY DATA/ALUMINUM LINER**



**Table D1. Parametric Study/Variable Liner Apex Angle**

Liner: Aluminum, 26.5 in. I.D.  
 Explosive: Octol (75% HMX/25% TNT), 1.843 g/cc, 0.848 cm/us,  
 Total Weight: 600 lb (Including Primasheet Booster)  
 Housing/Tamper: Aluminum, 0.5 in. thick  
 CSC Total Length: 28.5 in.  
 CSC Total Weight: 915 lb

<b>APEX ANGLE (deg.)</b>	<b>LINER THICK. (in.)</b>	<b>S.O. (in.)</b>	<b>PEN. (ft)</b>	<b>ENTR. HOLE DIA. (in.)</b>	<b>BOTT. HOLE DIA. (in.)</b>	<b>JET TIP VEL. (cm/us)</b>
60	0.6	70.5	8.5	14	4.7	0.8
80	0.5	83	9.8	10	4.2	0.76
80	0.75	106	7.5	12.2	5.2	0.58
80	1.00	116	9.8	11.3	5.6	0.67
80	2.16	71	6.1	16.7	7.3	0.54
90	0.76	106	6.9	10.4	5.2	0.65
90	2.16	106	5.9	13.1	4	0.53

**Table D2. Parametric Study/Variable Standoff/Aluminum**

Liner Apex Angle: 80 degrees  
 Target: Tuff rock  
 Explosive: PBXN-5, 1.84 g/cc  
 Liner Inside Diameter: 26.5 inches  
 Liner Thickness: Cu: 0.65 inch, Al: 2.0 inches

<b>STANDOFF (in )</b>	<b>ENTRANCE HOLE DIAMETER (in )</b>	<b>BOTTOM HOLE DIAMETER (in )</b>	<b>JET PENET. (in )</b>
0	16.1	9.5	19.7
35.2	11.8	5.5	57.1
70.5	9.3	5.5	72.3
105.5	8.3	5.5	78.7
140.9	7.8	5.5	72.3
176.0	7.4	5.5	68.9
352.4	7.4	5.5	64.9
421.3	7.4	5.5	49.2
527.6	7.4	5.5	47.2
669.3	7.4	5.5	39.4





**APPENDIX E**

**SCAP CODE PARAMETRIC STUDY DATA/TUNGSTEN LINER**



**Table E1. Parametric Study/Variable Apex Angle**

Liner: Tungsten, 26.5 in. I.D.  
 Explosive: Octol (75% HMX/25% TNT), 1.843 g/cc, 0.848 cm/us,  
 Total Weight: 600 lb (including Primasheet booster)  
 Housing/Tamper: Aluminum, 0.5 in. thick  
 CSC Total Length: 28.5 in.

<b>APEX ANGLE (deg.)</b>	<b>LINER THICK. (in.)</b>	<b>S.O. (in.)</b>	<b>PEN. (ft)</b>	<b>ENTR. HOLE DIA. (in.)</b>	<b>BOTT. HOLE DIA. (in.)</b>	<b>JET TIP VEL. (cm/us)</b>
60	0.76	100	30 ++	11.3	1.6	0.38
80	0.50	62	30++	8.6	2.4	0.47
80	0.76	100	30++	8.5	3	0.45
80	1.00	21	30++	8.5	3	0.36
90	0.76	102	30++	8.5	1.6	0.375

++ SCAP code was not run long enough to obtain maximum.



**APPENDIX F**

**CSC FINAL DESIGN DIMENSIONS, WEIGHTS, AND VOLUMES**



Table F1. Calculated CSC Final Design Dimensions, Weights, and Volumes

LINER: MATERIAL: COPPER

-----  
 D = DIAMETER (in) = 26.5  
 THETA=APEX ANGLE (degrees) = 40  
 H = CONE HEIGHT(HE SIDE) (in) = 15.7  
 HA = CONE HEIGHT(AIR SIDE) (in) = 14.95  
 T = THICKNESS (in) = .75  
 DENSITY (g/cc) = 8.96  
 VOLUME (in<sup>3</sup>) = 579.4388  
 WEIGHT (lb) = 187.7096

EXPLOSIVE BOOSTER CHARGE: TYPE: PRIMASHEET

-----  
 DIAMETER (in) = 15  
 DENSITY (g/cc) = 1.7  
 THICKNESS (in) = 1  
 TOTAL EXPLOSIVE WEIGHT (lb) = 10.84749

EXPLOSIVE MAIN CHARGE: TYPE: OCTOL (75% HMX/25% TNT)

-----  
 MAX. DIAMETER (in) = 26.5  
 MIN. DIAMETER (in) = 15  
 CYLINDRICAL LENGTH (in) = 18.5  
 FRUSTRUM OF CONE LENGTH (in) 6  
 ANGLE FROM VERTICAL (degrees) = 43.5  
 DENSITY (g/cc) = 1.81  
 TOTAL EXPLOSIVE WEIGHT (lb) = 585.3154

REAR TAMPER PLATE: ALUMINUM

-----  
 DIAMETER (in) = 16  
 THICKNESS (in) = .25  
 VOLUME (in<sup>3</sup>) = 50.20037  
 DENSITY (g/cc) = 2.77  
 WEIGHT (lb) = 5.027563

CYLINDRICAL TAMPER: ALUMINUM

-----  
 INSIDE DIAMETER (in) = 26.5  
 OUTSIDE DIAMETER (in) = 28  
 LENGTH (in) = 19.5  
 DENSITY (g/cc) = 2.77  
 VOLUME (in<sup>3</sup>) = 1250.4  
 WEIGHT (lb) = 125.2275

FRUSTRUM OF CONE TAMPER: ALUMINUM

-----  
 MINOR INSIDE DIAMETER (in) = 15  
 MINOR OUTSIDE DIAMETER (in) = 16  
 MAJOR INSIDE DIAMETER (in) = 26.5  
 MAJOR OUTSIDE DIAMETER (in) = 27.5  
 LENGTH (in) = 6  
 ANGLE FROM VERTICAL (degrees) = 43.5  
 DENSITY (g/cc) = 2.77  
 VOLUME (in<sup>3</sup>) = 200.0172  
 WEIGHT (lb) = 20.0317

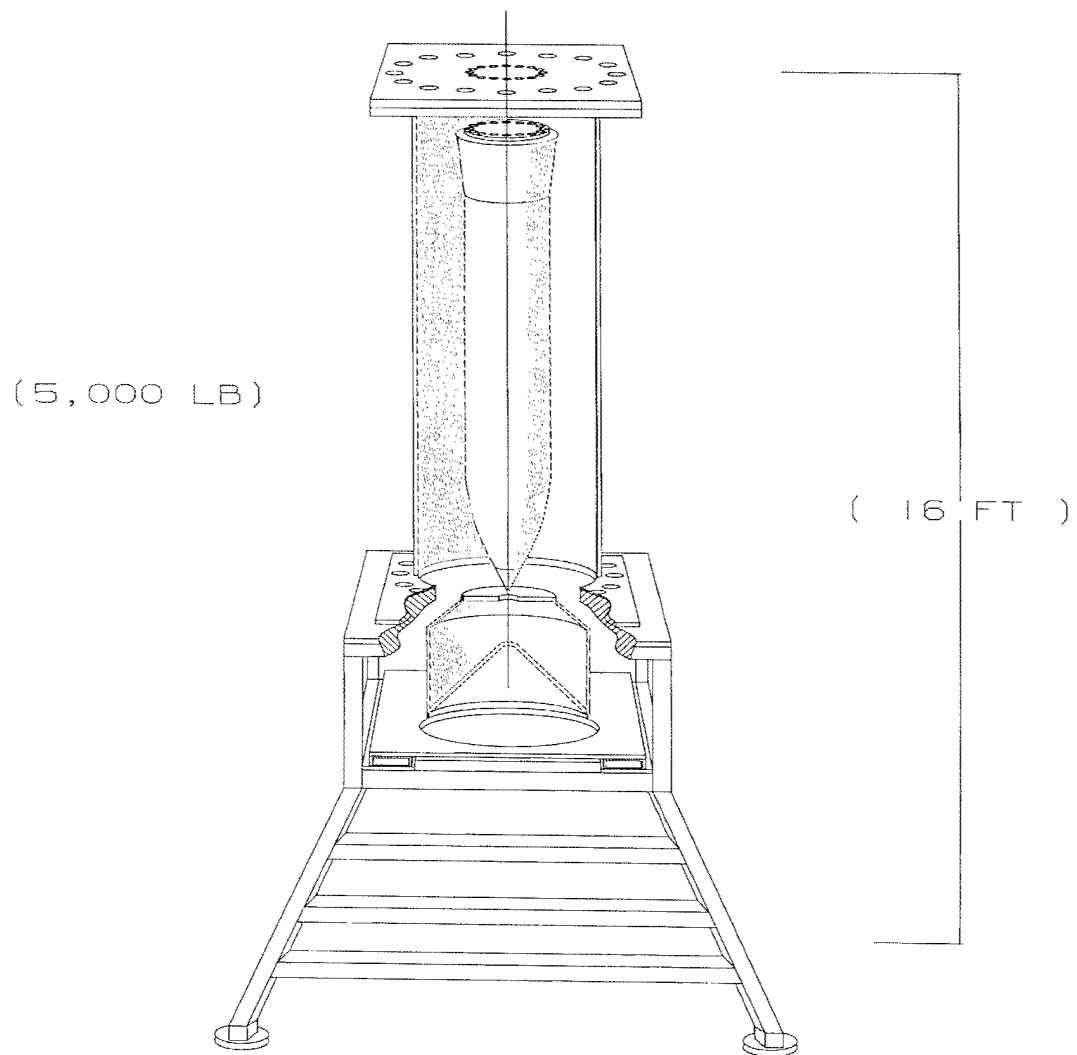
TOTAL LENGTH OF CSC (in) = 28.5  
 TOTAL CSC EXPLOSIVE WEIGHT (lb) = 596.1629  
 TOTAL SYSTEM OR DEVICE WEIGHT(lb) = 923.3117





**APPENDIX G**  
**TONAPAH TEST RANGE TEST FIXTURES/STRUCTURES**

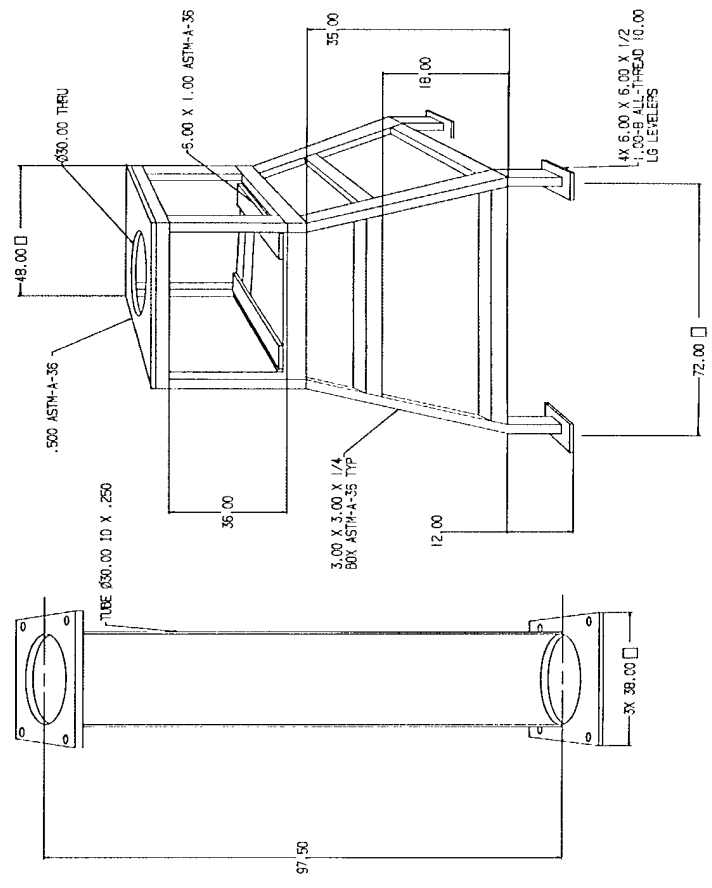
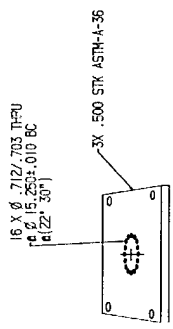




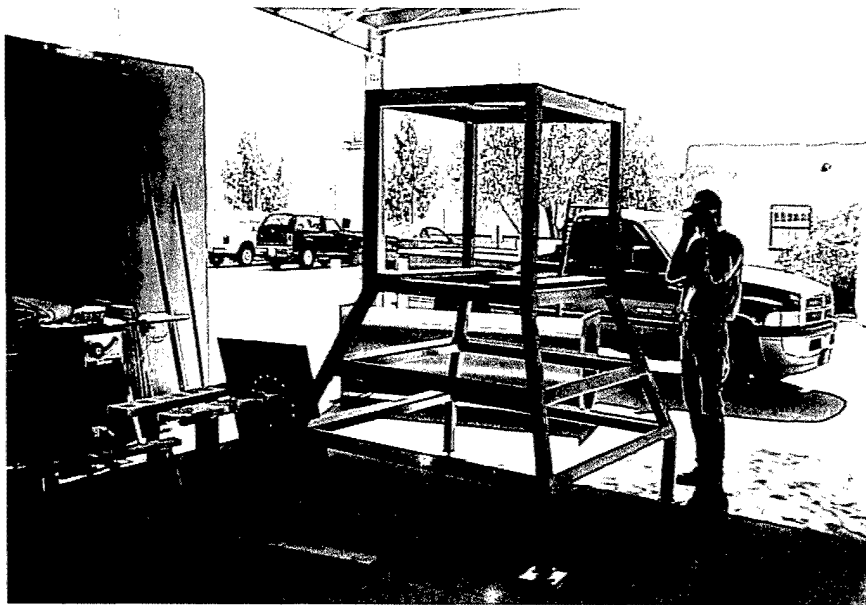
**Figure G1. CSC/Penetrator Weapon/Cruise Missile Body  
Cylinder/Steel Support Structure**

**Sandia National Laboratories**  
 Operated for the United States Department of Energy by  
 Lockheed Martin

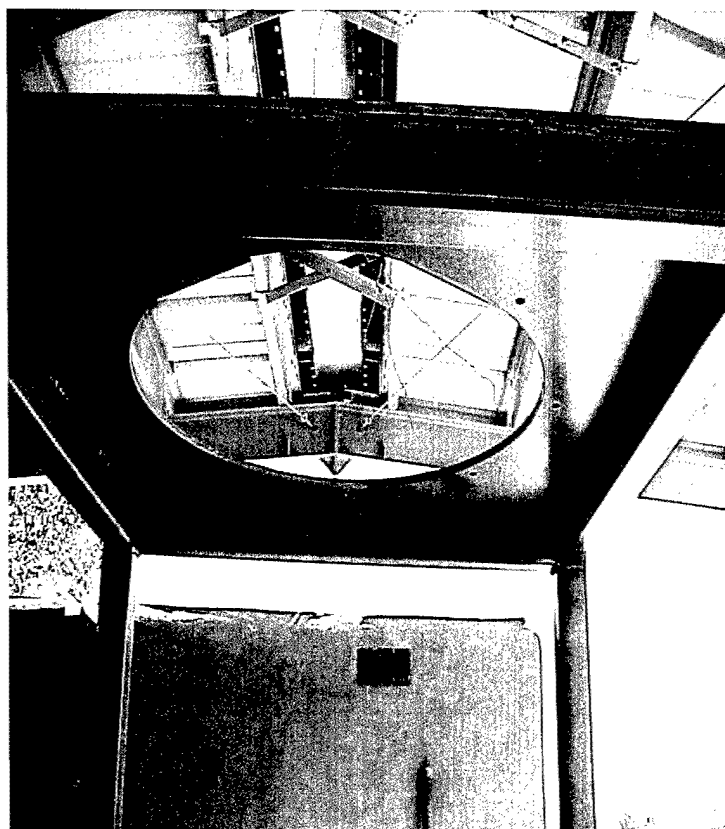
Roy R. Ditzler  
 Sandia National Laboratories  
 Corporate Mail Stop  
 1170  
 P.O. Box 5800, MS 1164  
 Albuquerque, NM 87124-5800  
 Telephone: (505) 844-1916 Fax: (505) 844-5301  
 E-mail: roy.ditzler@sandia.gov  
 Web: <http://www.sandia.gov>



**Figure G2. Cruise Missile Body Shell Simulator/Steel CSC and Penetrator Support Structure**



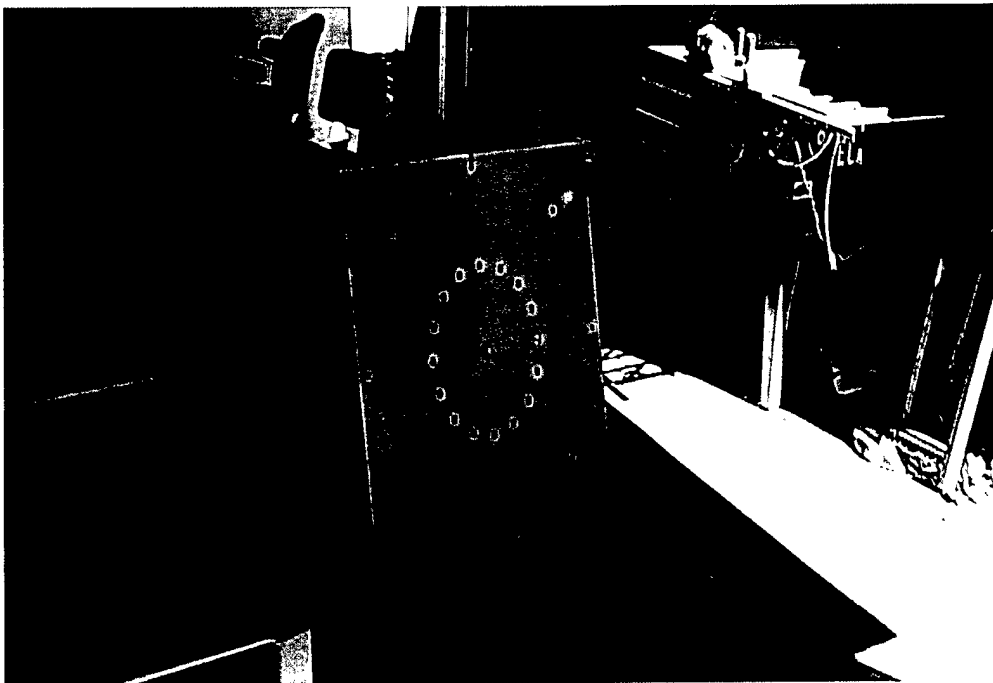
**Figure G3. Steel TTR Test Support Structure/16 Feet High**



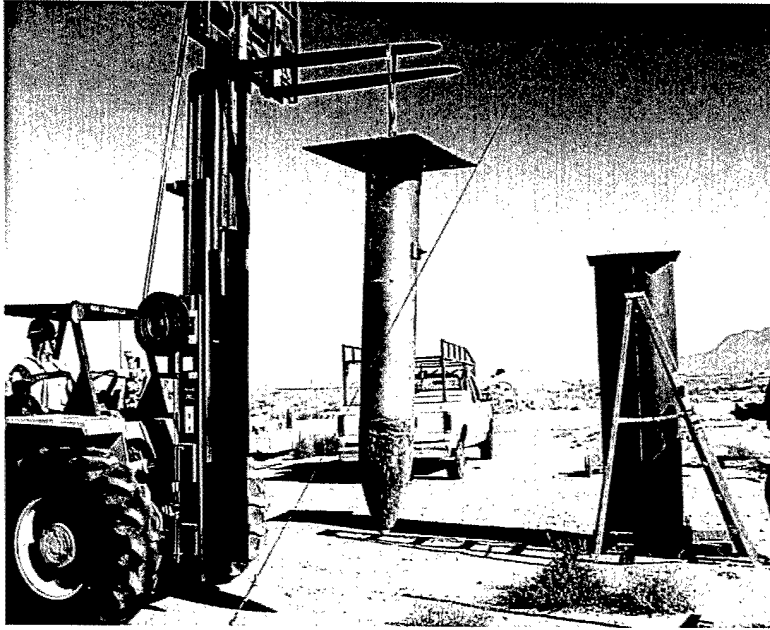
**Figure G4. Circular Opening at Top of Steel Support Structure**



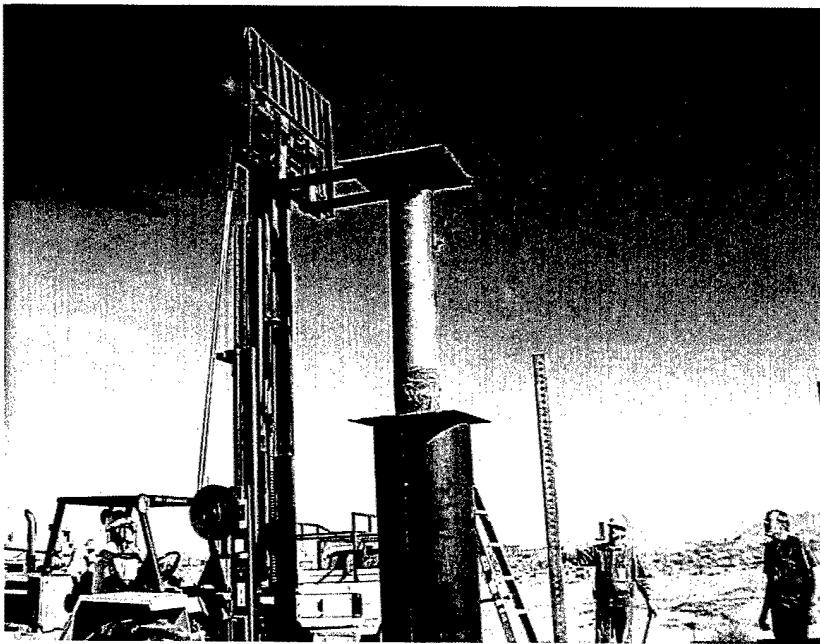
**Figure G5. Missile Body Simulator Cylinder**



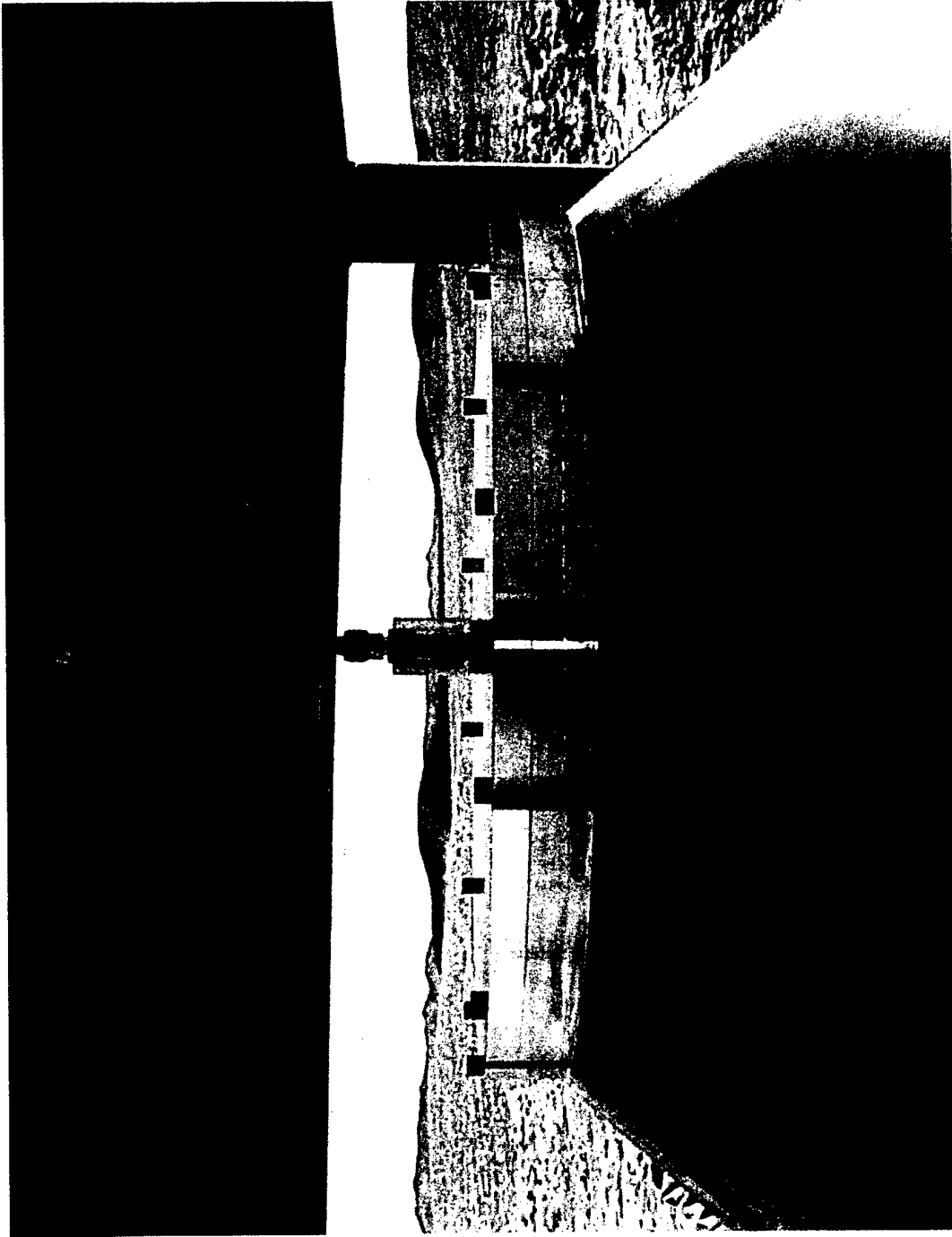
**Figure G6. Penetrator Steel Support Plate**



**Figure G7. Penetrator on Support Plate/Cruise Cylinder**

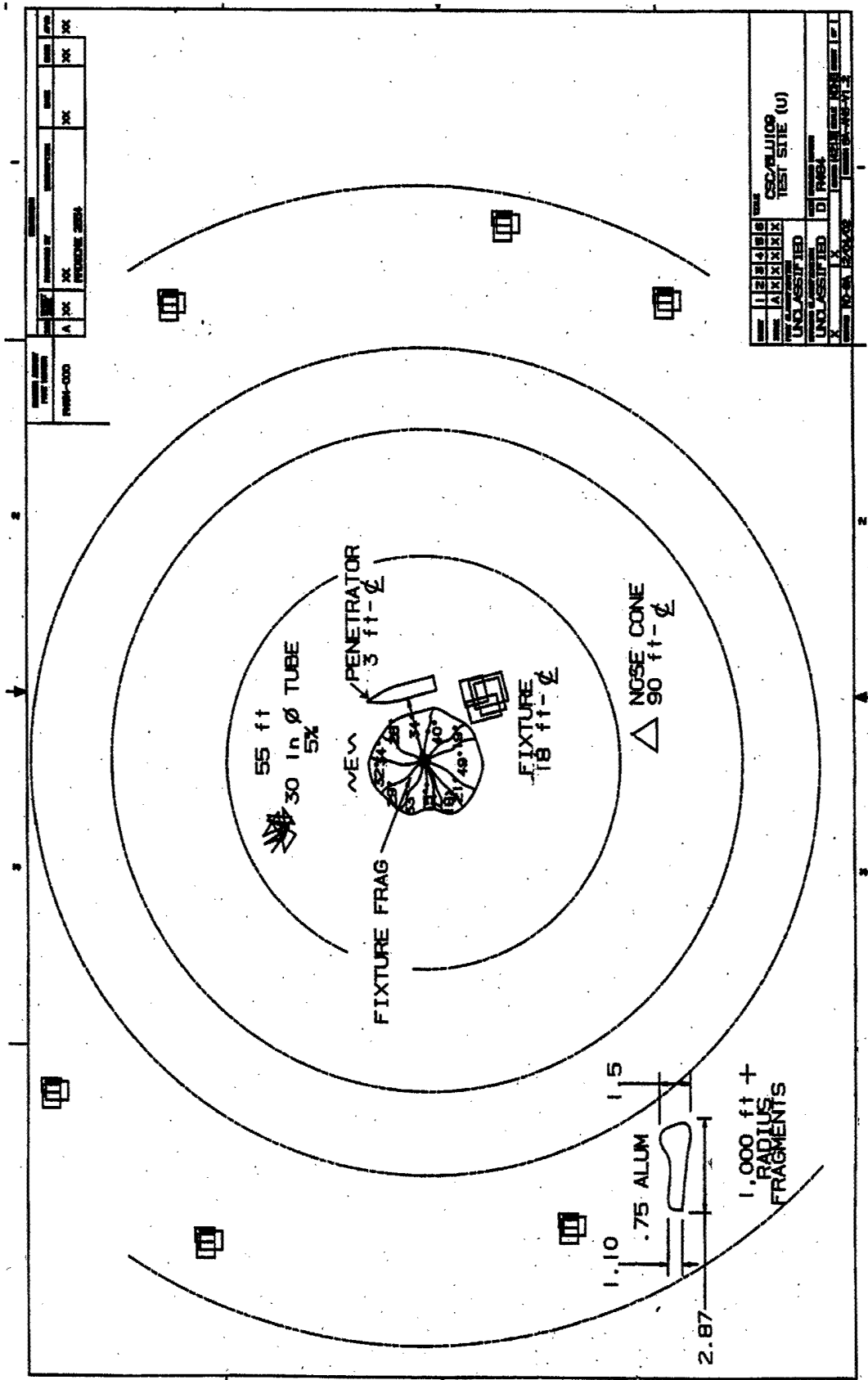


**Figure G8. Penetrator Being Installed in Cruise Cylinder**



**Figure G9. Pre-Test Configuration of RP-1 Detonator, Penetrator Nose, Shaped Charge, and Missile Simulation Cylinder**





FORM NO. 100	REV. 1	DATE	BY
100-100			
APPROVED BY	DATE	BY	DATE
A JAC		JAC	
PREPARED BY	DATE	BY	DATE
JAC		JAC	
PROJECT NO.	2000		

FORM NO.	REV.	DATE	BY
100-100			
CLASSIFICATION	UNCLASSIFIED		
CONTROL	UNCONTROLLED		
DATE	10-28-2008		
BY	D JAC		
TEST SITE	CSC/MJ/109		
TEST SITE	TEST SITE (U)		

Figure G10. Blu-109 Penetrator, Steel Support Structure, and Various Fragments/ Post-Test



## Distribution:

- 1 Commander  
US Army Material Command  
ATTN: AMCDRA-ST  
5001 Eisenhower Avenue  
Alexandria, VA 22333-0001
- 1 Commander  
US Army Armament, Munitions  
ATTN: SMCAR-ESP-L  
Rock Island, IL 61299-5000
- 4 Commander  
Naval Surface Warfare Center  
ATTN: Code DG-50  
W. Reed, R10A  
E. Johnson  
W. Bullock  
Code DX-21, Lib Br  
White Oak, MD 20910
- 3 Director  
DARPA  
ATTN: J. Richardson  
LTC Quinn  
T. Hafer  
1400 Wilson Blvd.  
Arlington, VA 22209-2308
- 1 US Army Harry Diamond Laboratories  
ATTN: SLCHD-TA-SS,  
Bob Christopherson  
2800 Powder Mill Road  
Adelphi, MD 20783-1197
- 3 Battelle-Columbus Laboratories  
ATTN: Technical Library  
Dr. L. Vescilius  
D. Trott  
505 King Avenue  
Columbus, OH 43201
- 1 Battelle  
Edgewood Operations  
ATTN: R. Jameson  
2113 Emmorton Park Road  
Suite 200  
Edgewood, MD 51040
- 1 Aerojet Electro Systems Company  
ATTN: Warhead Systems,  
Dr. J. Carleone  
1100 W. Hollyvale St.  
P.O. Box 296  
Azusa, Ca 91702
- 1 S-Cubed  
ATTN: Dr. R. Sedgwick  
P.O. Box 1620  
La Jolla, CA 92038-1620
- 1 Defense Technical  
Information Center  
DTIC DDA  
8725 John Kingman Rd.  
STE 0994  
Ft. Belvoir, VA 22060-6218
- 1 Director  
US Army Research Lab  
AMSRL D  
Dr. Smith  
2800 Powder Mill Road  
Adelphi, MD 20783-1197
- 5 Defense Nuclear Agency  
ATTN: Maj J. Lyon  
CDR K. Hunter  
T. Fredrickson  
R. J. Lawrence  
SPSP K. Kibong  
6801 Telegraph Road  
Alexandria, VA 22310-3398

- 3 Commander  
US Army ARDEC  
AMSTA AR FSA E  
ATTN: W. P. Dunn  
J. Pearson  
E. Baker  
Picatinny Arsenal, NJ 07806-5000
- 3 Commander  
US Army Aviation & Missile CMD  
AMSAM RD PS WF  
ATTN: S. Hill  
D. Lovelace  
M. Schexnayder  
Redstone Arsenal, AL 35898-5247
- 7 Air Force Armament Lab  
AFATL DLJW  
ATTN: W. Cook  
M. Nixon  
AFATL DLJR  
J. Foster  
AFATL MNW  
LTD Lorey  
R. D. Guba  
Eglin AFB, FL 32542
- 1 USAF Phillips Laboratory  
VTSI  
Robert Roybal  
Kirtland AFB, NM 87117-7345
- 6 Los Alamos National Laboratory  
ATTN: L. Hull, MS A133  
J. V. Repa, MS A133  
C. Wingate, MS D413  
E. J. Chapyak, MS F664  
P. Howe, MS P915  
J. Kennedy, MS P915  
P.O. Box 1663  
Los Alamos, NM 87545
- 4 Director  
Lawrence Livermore National Labs  
MS L35  
ATTN: R. E. Tipton  
D. Baum  
M. Murphy  
T. McAbee  
P.O. Box 808  
Livermore, CA 94550
- 5 Energetic Materials RSCH TSTNG CTR  
New Mexico Tech  
ATTN: J. Mason  
D. J. Chavez  
M. Leone  
L. Libersky  
F. Sandstrom  
Campus Station  
Socorro, NM 87801
- 4 Southwest Research Institute  
ATTN: C. Anderson  
S. A. Mullin  
J. Riegel  
J. Walker  
PO Drawer 28510  
San Antonio, TX 78228-0510
- 2 AEROJET  
ATTN: J. Carleone  
S. Key  
PO Box 13222  
Sacramento, CA 95813-6000
- 1 Boeing Houston Space Station  
R. F. Graves  
PO Box 58747  
Houston, TX 77258
- 1 Computational Mechanics  
J. A. Zukas  
PO Box 11314  
Baltimore, MD 21239-0314

- 3 DYNA East Corporation  
ATTN: P. C. Chou  
R. Ciccarelli  
W. Flis  
3620 Horizon Drive  
King of Prussia, PA 19406
- 1 Explosive Technology  
M. L. Knaebel  
PO Box KK  
Fairfield, CA 94533
- 1 RAYTHEON MSL SYS CO  
T. STURGEON  
BLDG 805 M/S D4  
PO Box 11337  
Tucson, AZ 85734-1337
- 1 Lockheed Missile & Space Co.  
R. Hoffman  
Santa Cruz Facility  
Empire Grade Rd.  
Santa Cruz, CA 95060
- 1 McDonnell Douglas  
Astronautics Company  
B. L. Cooper  
5301 Bolsa Avenue  
Huntington Beach, CA 92647
- 1 SAIC  
M. W. McKay  
10260 Campus Point Dr.  
San Diego, CA 92121
- 5 SRI International  
ATTN: J. D. Colton  
D. Curran  
R. Kloop  
R. L. Seaman  
D. A. Shockey  
333 Ravenswood Avenue  
Menlo Park, CA 94025
- 1 Zernow Technical Services Inc.  
L. Zernow  
425 W. Bonita Avenue Suite 208  
San Dimas, CA 91773
- 6 ABERDEEN PROVIDING GROUND  
AMSRL WM TB  
ATTN: R. Frey  
P. Baker  
AMSRL WM TC  
ATTN: M. Lampson  
D. Scheffler  
R. Summers  
W. Walters  
Aberdeen Proving Ground, MD 21005-5069
- 1 U.S. Department of Energy  
ATTN: Michael Wangler, EM-70  
Washington, DC
- 1 U.S. Department of Energy  
Yucca Mountain Project Office  
1551 Hillshire Drive  
Las Vegas, NV 89134  
Attn: Jozette Booth
- 1 U.S. Department of Energy  
Albuquerque Operations Office  
National Transportation Program  
Attn: Steven Hamp
- 6 U.S. Nuclear Regulatory Commission:  
Office of Nuclear Safety and Safeguards  
Spent Fuel Project Office  
ATTN: John Cook (4)  
Earl Easton  
Skip Young

2 U.S. Department of Transportation  
Research and Special Programs  
Administration  
RM 8108, DHM-60  
400 Seventh St., SW  
Washington, DC 20590  
ATTN: Richard C. Hannon  
Thomas McNamara

1 Michael Huerta, Ph.D., P.E.  
The University of Texas at El Paso  
Associate Professor  
Department of Mechanical and Industrial  
Engineering  
El Paso, Texas 799968-0521

1 U.S. Department of Commerce  
National Technical Information Service  
5285 Port Royal Road  
Springfield, VA 22161

1 Steven Maheras  
SAIC  
655 Metro Place South, Suite 745  
Dublin, OH 43017

1 MS 0100 Mail Services, 102631  
1 MS 0310 P. Yarrington, 06115  
1 MS 0439 D. Longcope, 09127  
1 MS 0482 K. D. Meeks, 02131  
1 MS 0482 R. Baty, 022131  
1 MS 0482 W.J. Patterson, 02131  
1 MS 0718 D.J. Ammerman, 6141  
1 MS 0718 H. R. Yoshimura, 06341  
1 MS 0718 J. L. Sprung, 06141  
1 MS 0718 M.A. Molecke, 6141  
1 MS 0718 R. E. Luna, 06130  
1 MS 0820 P. Taylor, 09232  
1 MS 0820 M. Kipp, 09232  
1 MS 0835 J. M. McGlaun, 09140  
1 MS 0836 E. S. Hertel Jr., 09116  
1 MS 0980 L. N. Kmetyk, 09127  
1 MS 1156 R.M. Tachau, 15322  
1 MS 1156 D. Preece, 15322  
1 MS 1157 P.W. Cooper, 15322  
1 MS 1157 J.H. Stofleth, 15322

1 MS 1174 W.H. Rutledge, 15414  
1 MS 1174 R.G. Lundgren, 15414  
1 MS 1174 M. Forrestal, 15414  
1 MS 1452 C. Gresham, 02552  
1 MS 1452 B. Melof, 02552  
5 MS 1452 M. Steyskal, 02552  
1 MS 1453 G. Scharrer, 02553  
1 MS 1453 E. Hafenrichter, 02553  
1 MS 1453 S. Harris, 02553  
1 MS 1453 G. Rivera, 02553  
1 MS 1453 W. Tarbell, 02553  
1 MS 1454 L. Bonzon, 02554  
1 MS 1454 R. Dickey, 02554  
1 MS 1454 M. Kaneshige, 02554  
1 MS 1454 D. Johnson, 02554  
1 MS 1454 D. Paul, 02554  
10 MS 1454 Manuel G. Vigil, 02554  
1 MS 9035 W.G. Wilson, 08230  
1 MS 9036 E.B. Talbot, 08222  
5 MS 9036 J.R. Andersen, 08222  
1 MS 9036 A.F. Baker, 0822  
1 MS 9018 Central Technical Files, 8945-1  
2 MS 0899 Technical Library, 9616  
1 MS0 612 Review and Approval Desk, 9612  
for DOE/OSTI

