

ERDC TR-01-13

Engineer Research and
Development Center



US Army Corps
of Engineers®

Strategic Environmental Research and Development Program

Distribution and Fate of Energetics on DoD Test and Training Ranges: Interim Report 2

Judith C. Pennington, Thomas F. Jenkins,
Guy Ampleman, Sonia Thiboutot, James M. Brannon,
Jason Lynch, Thomas A. Ranney, Jeffrey A. Stark,
Marianne E. Walsh, Jeff Lewis, Charolett A. Hayes,
June E. Mirecki, Allen D. Hewitt, Nancy Perron,
Dennis Lambert, Jay Clausen, and Joseph J. Delfino

October 2002

20021231 154

The contents of this report are not to be used for advertising, publication, or promotional purposes. Citation of trade names does not constitute an official endorsement or approval of the use of such commercial products.

The findings of this report are not to be construed as an official Department of the Army position, unless so designated by other authorized documents.



PRINTED ON RECYCLED PAPER

Distribution and Fate of Energetics on DoD Test and Training Ranges: Interim Report 2

by Judith C. Pennington, James M. Brannon, June E. Mirecki

Environmental Laboratory
U.S. Army Engineer Research and Development Center
3909 Halls Ferry Road
Vicksburg, MS 39180-6199

Thomas F. Jenkins, Thomas A. Ranney, Jeffrey A. Stark, Marianne E. Walsh,
Allen D. Hewitt, Nancy Perron, Dennis Lambert

Cold Regions Research and Engineering Laboratory
U.S. Army Engineer Research and Development Center
72 Lyme Road
Hanover, NH 03755-1290

Guy Ampleman, Sonia Thiboutot, Jeff Lewis

Defence Research Establishment Valcartier
2459 Pie XI Blvd. North, Val-Bélair, Québec,
Canada, G3J 1X5

Jason Lynch, Joseph J. Delfino

Environmental Engineering Sciences Department
College of Engineering
University of Florida
Gainesville, FL 32611

Jay Clausen

AMEC Earth and Environment
110 Littleton Road, Suite 1B
Westford, MA 01886

Charolett A. Hayes

DynTel
3530 Manor Dr., Suite 4
Vicksburg, MS 39180

Interim report

Approved for public release; distribution is unlimited

Prepared for U.S. Army Corps of Engineers
Washington, DC 20314-1000

Contents

Preface	ix
Abbreviations	xii
1—Introduction.....	1
Background	1
Related On-Going and Leveraged Studies.....	7
Scope of Project CP1155.....	9
Objectives.....	10
Summary of Previous Year Results (FY00)	10
References	11
2—Characterization of Explosives Contamination at Military Firing Ranges: Yakima Training Center, Washington; Camp Guernsey, Wyoming	17
Introduction	17
Yakima Training Center, Washington	19
Camp Guernsey, Wyoming.....	34
Materials and Methods	41
Results and Discussion	44
Camp Guernsey, Wyoming.....	60
Comparison of Results from Discrete and Composite Surface Soil Samples from Yakima and Camp Guernsey	68
Surface Water Springs, Camp Guernsey	70
Historical Firing Records, Yakima Training Center	70
Summary and Recommendations	73
References	74
3—Assessment of CFB Shilo Training Areas.....	79
Introduction	79
Sampling Strategies	81
Parameters Monitored and Analytical Methods.....	86
Magnitude of Study	86
Results	87
Conclusion.....	89
4—Transport Parameters for Firing Range Residues.....	90
Background	90
Objectives.....	91
Materials and Methods	91

Results and Discussion	99
Summary and Conclusions	120
References	121
5—Conclusions.....	125

SF 298

List of Figures

Figure 1.	Location of Yakima Training Center	20
Figure 2.	Antitank Range at Yakima Training Center soil sampling near an armored personnel carrier target	21
Figure 3.	Soil sampling locations around armored personnel carrier target at Yakima Antitank Range	22
Figure 4.	Ruptured LAW Rocket at Yakima Antitank Range	22
Figure 5.	MPRC tank firing range at Yakima Training Center	23
Figure 6.	Soil sampling locations at tank firing point on MPRC Range at Yakima Training Center.....	24
Figure 7.	Soil sampling locations at the firing point of 155-mm howitzers at Yakima Training Center	26
Figure 8.	Soil sampling locations at a direct fire 155-mm howitzer firing point, Yakima Training Center.....	27
Figure 9.	Soil sampling locations at a firing point for 81-mm mortars at Yakima Training Center.....	28
Figure 10.	Soil sampling locations in Central Impact Area, Yakima Training Center. Samples were collected within a bomb crater that also had a 155-mm crater within	29
Figure 11.	Soil sampling locations around a 155-mm crater at the Central Impact Area, Yakima Training Center	30
Figure 12.	Sampling location in an area of the Central Impact Area, Yakima Training Center. Composite sample collected around a 155-mm crater	31
Figure 13.	Sampling locations in an area of the Central Impact Area, Yakima Training Center, samples collected around a 155-mm crater and next to an illumination round	32

Figure 14.	Soil sampling locations in front of location where Claymore mine had been detonated at Yakima Training Center.....	33
Figure 15.	Map of artillery impact area at Camp Guernsey, Wyoming	35
Figure 16.	Artillery target at Camp Guernsey	35
Figure 17.	Soil sampling locations around truck target at artillery impact area at Camp Guernsey.....	36
Figure 18.	A 500-lb bomb that had undergone a low-order detonation, Central Impact Area, Camp Guernsey.....	37
Figure 19.	Soil sampling locations around low-order 500-lb bomb at Camp Guernsey.....	38
Figure 20.	Soil samples collected in a wheel pattern at the artillery impact area at Camp Guernsey.....	39
Figure 21.	Soil sampling locations in front of firing point for 155-mm howitzers at Camp Guernsey	40
Figure 22.	40-mm HE grenade found on antitank range at Yakima Training Center	47
Figure 23.	Surface soil concentrations for NG for samples collected at the MPRC tank firing range at Yakima Training Center.....	50
Figure 24.	Surface soil concentrations for 2,4DNT samples collected at the MPRC tank firing range at Yakima Training Center.....	51
Figure 25.	Linear sampling used in battleruns for soils sampling	83
Figure 26.	Circular sampling around target in battleruns for soils and biomass sampling	83
Figure 27.	TNT, RDX, and HMX molecular structures	92
Figure 28.	Surface area comparison of explosives at 150 rpm and 10°C.....	99
Figure 29.	Mixing speed comparison of middle-size surface area explosives.....	101
Figure 30.	Comparison of HMX multiple regression, multiple variable dissolution rate correlation to the HMX single regression, multiple variable dissolution rate correlation.	105
Figure 31.	Rate comparisons of TNT study data to multiple regression-multiple variable regression line and the Levins and Glastonbury regression line	106

Figure 32.	Comparison of TNT solubility literature to this study.....	109
Figure 33.	Comparison of RDX solubility literature to this study	110
Figure 34.	Comparison of HMX solubility literature to this study	111
Figure 35.	Composite explosive solubility prediction correlations.....	112
Figure 36.	Comparison of explosive dissolution rates at three pH values	113
Figure 37.	Comparison of TNT dissolution rates from pure TNT, Octol, and Composition B at 20 °C and 150 rpm.....	114
Figure 38.	Comparison of HMX dissolution rates from pure HMX, LX-14, and Octol at 20 °C and 150 rpm	115
Figure 39.	Comparison of RDX dissolution rates from pure RDX and Composition B at 20 °C and 150 rpm	115
Figure 40.	Adsorption kinetics of nitroglycerine in LAAP-D, Picatinny, and Yokena Clay soils.....	116
Figure 41.	Adsorption kinetics of MNX in LAAP-D, Picatinny, and Yokena Clay soils	117
Figure 42.	Adsorption kinetics of DNX in LAAP-D, Picatinny, and Yokena Clay soils	117
Figure 43.	Adsorption kinetics of TNX in LAAP-D, Picatinny, and Yokena Clay soils	118
Figure 44.	Partitioning coefficients for MNX, DNX, and TNX in LAAP-D soil.....	118
Figure 45.	Partitioning coefficients for nitroglycerine in LAAP-D and Picatinny soils	119
Figure 46.	Desorption kinetics of TNT, RDX, and HMX in Fort Lewis soil.....	120

List of Tables

Table 1.	Explosives Detection Limits for Soil and Water	43
Table 2.	Explosives Concentrations in Soils from Yakima Antitank Firing Range, $\mu\text{g kg}^{-1}$	45
Table 3.	Explosives Concentrations in Soils near a Tank Firing Point at Yakima Multipurpose Range Complex, $\mu\text{g kg}^{-1}$	49

Table 4.	Explosives Concentrations in Soils at Two 155-mm Howitzer Firing Points, Yakima Training Center, $\mu\text{g kg}^{-1}$	53
Table 5.	Explosives Concentrations in Soils at Direct Fire 155-mm Firing Point near Central Impact Area, Yakima Training Center, $\mu\text{g kg}^{-1}$	54
Table 6.	Explosives Concentrations in Surface Soil at an 81-mm Mortar Firing Point, Yakima Training Center, $\mu\text{g kg}^{-1}$	55
Table 7.	Explosives Concentrations in Soils Collected at Yakima Central Impact Area Range 261, $\mu\text{g kg}^{-1}$	56
Table 8.	Explosives Concentration in Soil from a Claymore Mine Detonation Area, Yakima Training Center, $\mu\text{g kg}^{-1}$	59
Table 9.	Soil Geochemistry, Yakima Training Center	59
Table 10.	Geochemistry of Water Samples, Yakima Training Center, mg L^{-1}	60
Table 11.	Explosives Concentrations in Soils at the Artillery Impact Area at Camp Guernsey, $\mu\text{g kg}^{-1}$	61
Table 12.	Explosives Concentrations in Soils Near a Ruptured 500-lb Bomb, Camp Guernsey, $\mu\text{g kg}^{-1}$	62
Table 13.	Explosives Concentrations in Soils near UXO Items before and after Detonation with C4, Camp Guernsey, $\mu\text{g kg}^{-1}$	65
Table 14.	Comparison of Reproducibility Using Discrete and Composite Samples.....	69
Table 15.	Geochemistry of Groundwater at Camp Guernsey Springs, mg/L^{-1}	70
Table 16.	Firing Record of the Most Commonly Fired Munitions for 1999-2001 at Yakima Training Center.....	71
Table 17.	Firing Record of the Most Commonly Fired Munitions for 1996-2001 at Guernsey Training Center	71
Table 18.	High Explosive Load Carried by Munitions Items Commonly Fired at Yakima Training Center and Camp Guernsey	72
Table 19.	Mean Dud and Low-Order Detonation Rates for Munitions Items Commonly Used at Yakima Training Center and Camp Guernsey	73
Table 20.	Properties of Soils Used in Adsorption and Desorption Testing	98

Table 21.	Dissolution Rates as a Function of Surface Area at 150 RPM and Different Temperatures	99
Table 22.	Dissolution Rates as a Function of Temperature at 150 RPM and Different Explosive Surface Areas.....	100
Table 23.	Dissolution Rates, r (mg min^{-1}) as a Function of Mixing Rate, m (rpm), Using Middle Value Surface Areas and Specified Temperatures.....	101
Table 24.	Zero-Order pH-Related Explosive Dissolution Rates Measured at 30 °C, 150 rpm, and Normalized Solid Explosive Surface Area.....	104
Table 25.	Average Percent Difference Comparisons between Data from This Study, the Multiple-Regression Multiple-Variable Equation, the Single-Regression Multiple-Variable Equation, and the Levins and Glastonbury (1972a) Correlation for RDX Dissolution Rates	107
Table 26.	Solubilities of High Explosive Compounds at Specified pH and Temperature	108

Preface

This report was prepared by the U.S. Army Engineer Research and Development Center (ERDC), Environmental Laboratory (EL), Vicksburg, MS, in partnership with ERDC, Cold Regions Research and Engineering Laboratory (CRREL), Hanover, NH, and the Defence Research Establishment Valcartier (DREV), Quebec, Canada; the University of Florida; and AMEC Earth and Science, Inc., Westford, MA. The research was sponsored by the Strategic Environmental Research and Development Program (SERDP), Arlington, VA, Mr. Bradley P. Smith, Executive Director, and Dr. Jeff Marqusee, Technical Director, under Compliance Project Number CP1155. The principal investigator was Dr. Judith C. Pennington, Research Biologist, Environmental Processes and Engineering Division (EPED), EL, ERDC, Vicksburg. Co-principal investigators were Dr. Thomas F. Jenkins, Research Chemist, Environmental Sciences Branch (ESB), CRREL, ERDC, Hanover; Dr. James M. Brannon, Geochemist, EPED, ERDC, EL; Drs. Guy Ampleman and Sonia Thiboutot, DREV; LTC Jason Lynch, University of Florida, Gainesville; and Mr. Jay Clausen, AMEC.

Range soil characterization research reported in Chapter 2 was conducted by Dr. Jenkins, Ms. Marianne E. Walsh, Research Chemical Engineer, Mr. Alan D. Hewitt, Research Physical Scientist, ESB; Mr. Jeffrey A. Stark, Physical Sciences Technician, Civil Engineering Research Branch; Ms. Nancy Perron, Physical Sciences Technician, Snow and Ice Branch, and Mr. Dennis Lambert, Mechanical Engineering Technician, Engineering Resources Branch, ERDC, CRREL; Dr. Pennington and Dr. June E. Mirecki, Geochemist, ERDC, EL; Mr. Thomas A. Ranney, Staff Scientist, Science and Technology Corporation, Lebanon, NH; and Ms. Charolett A. Hayes, Staff Scientist, DynTel, Vicksburg. Characterization of Canadian ranges reported in Chapter 3 was conducted by Drs. Ampleman and Thiboutot, and Mr. Jeff Lewis, DREV. Research on soil partitioning and explosives dissolution reported in Chapter 4 was conducted by Dr. Brannon, LTC Lynch, and Dr. Joseph J. Delfino, University of Florida, and Ms. Hayes.

The authors gratefully acknowledge the assistance provided by Mr. Dale Tadewald, Range Manager, and Mr. Lawrence B. Fain, Environmental Compliance Manager, Yakima Training Center (YTC). This study could not have been conducted without their active support and assistance. The authors also acknowledge SSG Michael Terhorst and John Szillinsky, 53rd Explosive Ordnance Disposal (EOD), for identifying the munitions responsible for creating various craters within the artillery impact area and for providing overall EOD

support. In addition, we thank LTC Robert E. Kempfe, Commander, YTC, for his support in conducting this research.

The authors acknowledge the active participation of COL Joe Michaels, Facility Manager, Mr. Frank Seifert, Hazardous Waste Manager, and MSG Danny Moss, Environmental Engineer, Wyoming National Guard, and Mr. John A. Moser, Geohydrologist, U.S. Army Center for Health Promotion and Preventive Medicine, Aberdeen Proving Ground, Maryland, who assisted in soil and water sample collection during the sampling activity at Camp Guernsey, Wyoming. In addition, we would like to thank CW4 David Beach and MSG Brad Boyer from 3rd BN 10th SFG (A), Fort Carson, Colorado, and SFC Guy Mosier and SGT Tim Walker from HQ STARC, Wyoming National Guard, who conducted detonations of UXO items in support of this study. COL Michaels and MSG Moss are specially acknowledged for collection of the firing point soil samples at Camp Guernsey.

This report was reviewed by Drs. Terry Sobecki and Jeff Davis, ERDC, EL. The study was conducted under the direct supervision of Dr. Richard E. Price, Chief, EPED, EL; Dr. Edwin A. Theriot, Director, ERDC, EL; Dr. J. C. Tatinclaux, Chief, ESB, CRREL; and Dr. Barbara Sotirin, Director, ERDC, CRREL.

At the time of publication of this report, Director of ERDC was Dr. James R. Houston. Commander and Executive Director was COL John W. Morris III, EN.

This report may be cited as one document or by chapters as follows:

Complete report:

Pennington, J. C., Jenkins, T. F., Ampleman, G., Thiboutot, S., Brannon, J. M., Lynch, J., Ranney, T. A., Stark, J. A., Walsh, M. E., Lewis, J., Hayes, C. A., Mirecki, J. E., Hewitt, A. D., Perron, N., Lambert, D., Clausen, J., and Delfino, J. J. (2002). "Distribution and fate of energetics on DoD test and training ranges: Interim Report 2," ERDC TR-01-13, U.S. Army Engineer Research and Development Center, Environmental Laboratory, Vicksburg, MS.

Chapter 1:

Pennington, J. C., and Clausen, J. (2002). "Introduction," Chapter 1, Distribution and fate of energetics on DoD test and training ranges: Interim Report 2, ERDC TR-01-13, U.S. Army Engineer Research and Development Center, Environmental Laboratory, Vicksburg, MS.

Chapter 2:

Jenkins, T. F., Pennington, J. C., Ranney T. A., Stark, J. A., Walsh, M. E., Hayes, C. A., Mirecki, J. E., Hewitt, A. D., Perron, N. M., and Lambert, D. (2002). "Characterization of explosives contamination at military firing ranges: Yakima Training Center, WA, and Camp Guernsey, WY," Chapter 2, Distribution and fate of energetics on DoD test and training ranges: Interim Report 2, ERDC TR-01-13, U.S. Army

Engineer Research and Development Center, Environmental Laboratory,
Vicksburg, MS.

Chapter 3:

Ampleman, G., Thiboutot, S., and Lewis, J. (2002). "Assessment of CFB Shilo Training Areas," Chapter 3, Distribution and fate of energetics on DoD test and training ranges: Interim Report 2, ERDC TR-01-13, U.S. Army Engineer Research and Development Center, Environmental Laboratory, Vicksburg, MS.

Chapter 4:

Brannon, J. A., Lynch, J., Hayes, C. A., and Delfino, J. J. (2002). "Transport parameters for firing range residues," Chapter 4, Distribution and fate of energetics on DoD test and training ranges: Interim Report 2, ERDC TR-01-13, U.S. Army Engineer Research and Development Center, Environmental Laboratory, Vicksburg, MS.

Chapter 5:

Pennington, J. C., Jenkins, T. F., Ampleman, G., Thiboutot, S., Brannon, J. A., and Lynch, J. (2002). "Conclusions," Chapter 5, Distribution and fate of energetics on DoD test and training ranges: Interim Report 2, ERDC TR-01-13, U.S. Army Engineer Research and Development Center, Environmental Laboratory, Vicksburg, MS.

The contents of this report are not to be used for advertising, publication, or promotional purposes. Citation of trade names does not constitute an official endorsement or approval of the use of such commercial products.

Abbreviations

AC	Arca composite
AcN	Acetonitrile
ADNTs	Aminodinitrotoluenes
2ADNT	2-amino-4,6-dinitrotoluene
4ADNT	4-amino-2,6-dinitrotoluene
2A4NT	2-amino-4-nitrotoluene
4A2NT	4-amino-2-nitrotoluene
APC	Armored personnel carrier
CBF	Confined burn facility
CFB	Canadian Force Base
CG	Camp Guernsey, Wyoming
CRREL	Cold Regions Research and Engineering Laboratory
3,5DNA	3,5-dinitroaniline
1,3DNB	1,3-dinitrobenzene
2,4DNT	2,4-dinitrotoluene
DREV	Defence Research Establishment Valcartier (Canada)
EL	Environmental Laboratory
EOD	Explosive ordnance disposal
ERDC	Engineer Research and Development Center
GC-ECD	Gas chromatography-electron capture detection
HMX	Octahydro-1,3,5,7-tetranitro-1,3,5,7-tetrazocine
LAW	Light Antitank Weapon
MMR	Massachusetts Military Reservation
3-NA	3-nitroaniline
NG	Nitroglycerin
RDX	Hexahydro-1,3,5-trinitro-1,3,5-triazine
RP-HPLC-UV	Reversed-phase high performance liquid chromatography ultraviolet detection
SARM	Standard Analytical Reference Materials
TNB	1,3,5-trinitrobenzene
TNT	2,4,6-trinitrotoluene
UXO	Unexploded ordnance
YTC	Yakima Training Center, Washington

1 Introduction

Background

Testing and training ranges are essential to maintaining the readiness of the Armed Forces of the United States. Recently, concerns have arisen over potential environmental contamination from residues of energetic materials at impact ranges. The current state of knowledge concerning the nature, extent, and fate of contamination is inadequate to ensure sound management of ranges as sustainable resources. The potential for environmental impacts, including contamination of drinking water supplies, mandates that the DoD demonstrates responsible management of these facilities in order to continue testing and training activities.

Regulatory precedent

In January, 2000, the U.S. Environmental Protection Agency (EPA) Region I issued an Administrative Order for Response Action in the matter of "Training Range and Impact Area, Massachusetts Military Reservation" to the National Guard Bureau (NGB) and the Massachusetts National Guard under authority of Section 1431(a) of the Safe Drinking Water Act, 42U.S.C. § 300i(a) (USEPA 2000). The purpose of the Order was to require the respondents to "undertake Rapid Response Actions and Feasibility Studies, Design and Remedial Actions to abate the threat to public health presented by the contamination from past and present activities and sources at and emanating from the Massachusetts Military Reservation (MMR) Training Range and Impact Area." This is an important precedent for suspension of military training as a result of environmental contamination of soils and groundwater.

The MMR is a 21,000-acre installation located on Cape Cod, Massachusetts. The Training Ranges and Central Impact Area is approximately 14,000 acres located on the Camp Edwards portion of the installation. The Central Impact Area, approximately 2,000 acres, has artillery and mortar targets and is surrounded by firing ranges, artillery and mortar positions, and training areas (AMEC 2001). The Cape Cod Aquifer, a sole source aquifer for western Cape Cod, lies directly beneath the Training Ranges and Central Impact Area. Based on the findings of lead, explosives, explosives-related compounds, pesticides and other organic contaminants in soils, and RDX, TNT, HMX and some organics in groundwater, the USEPA ordered the respondents to conduct feasibility studies at several MMR areas including the Central Impact Area (USEPA 2000). The order

also required rapid response actions for contaminated soils at several gun positions, target positions, and a wetland site for contaminated sediments.

MMR Update

The following is a brief summary of the last 5 years of work conducted at the Massachusetts Military Reservation. The goal of the Impact Area Groundwater Study Program (IAGWSP) is to assess and clean up the impacts of certain types of historic training activities conducted at the Camp Edwards' Impact Area and Training Ranges. These areas lie directly over the Sagamore Lens, the most productive part of the Cape Cod Aquifer. The National Guard Bureau is required by EPA to conduct the project and is overseen by both the EPA and the Massachusetts Department of Environmental Protection (MADEP).

Administrative Order No. 4 (AO4) was issued on January 4, 2001, under the Resource Conservation and Recovery Act (RCRA) to the National Guard Bureau. This order requires that munitions found subsurface or in burial pits be properly stored and disposed of in a Contained Detonation Chamber (CDC), or by other means which prevent the release of explosives, metals, and other contaminants into the environment. As of June 2001, as many as 1,703 items had been destroyed using the CDC with additional items awaiting disposal.

More than 170 monitoring wells have been installed and over 300 soil samples collected throughout the 15,000-acre training ranges and Impact Area as part of the program. As a result of the investigation, several sites/areas of Camp Edwards are being more closely examined to assess the nature and extent of contamination from past military activities. The following major sites are under investigation:

- Demolition Area 1
- Southeast Corner of the Ranges
- Central Impact Area
- Gun and Mortar Firing Positions
- Chemical Spill-19

For each major site, a feasibility study must be prepared to evaluate potential alternatives for conducting groundwater and soil cleanup. A feasibility study evaluates technologies and alternatives to be used for the containment, treatment, and/or removal of contamination from a site. In addition, the IAGWSP is conducting an investigation and a feasibility study to address potential environmental impacts from unexploded ordnance throughout Camp Edwards.

Demolition Area 1. Soil and groundwater investigations have been conducted at Demolition Area 1 to identify the nature and extent of contamination at the site. Investigations began in June 1997 and continue. For groundwater, the contaminants of concern (COCs) are the explosive compounds – RDX, TNT, HMX, 2ADNT, 4ADNT, 2,4DNT, and perchlorate.

RDX and perchlorate have migrated the farthest in the groundwater. Plumes of these compounds as currently defined extend about 5,500 ft west of Demo Area 1 and are about 400 ft wide and 100 ft deep in the aquifer. The maximum measured groundwater contamination found is 370 parts per billion (ppb) for RDX and 300 ppb for perchlorate. The lifetime health advisory for RDX in drinking water is 2 ppb (USEPA 1988). No Federal or state drinking water standard has been set for perchlorate, but the EPA has calculated that a safe exposure level in drinking water for perchlorate is in the range of 4 to 18 ppb. A detailed evaluation of six remedial technologies for these constituents is currently under discussion with the regulatory agencies.

The 12 COCs for soil are under review by the regulatory agencies. They are primarily explosives and propellants, but also included are several other contaminants such as metals, semi-volatile organic compounds (SVOCs), and dioxin. Once approved by the agencies, the selected COCs will form the basis for evaluating the cleanup alternatives for the soil contamination.

Southeast corner of the ranges. Explosives have been detected in groundwater and soil southeast of the Impact Area and north of Snake Pond. This area lies at the top of the groundwater mound of the Sagamore Lens of Cape Cod's sole source aquifer. Groundwater flows out radially from this area. This area contains three former defense contractor test ranges (the "J" Ranges) and one Massachusetts Army National Guard range (the "L" Range). The U.S. Army - from the 1930s to the 1950s - extensively used this entire area for training. Existing documentation on defense contractor activities at the J Ranges suggests that bulk explosives were disposed of, ground surface as well as below ground, into holding tanks. Open burn/open detonation disposal of munitions also occurred in numerous locations throughout the J Ranges. In addition, buried caches totaling approximately 1,700 mortar rounds have been exhumed from locations since 1998. Also, various test firings and research and development activities by numerous contractors occurred in this area. The L Range was utilized for training with high explosives during the 1940s and from the 1970s to the 1980s.

Central Impact Area. Detections of explosives at various depths and locations in the aquifer track back to, or originate from, the Central Impact Area where mortar and artillery rounds were fired for many years. To date, an area of groundwater containing primarily RDX and HMX has been delineated as extending as far as 11,000 ft northwest from its probable source. The groundwater contamination underlies an area of approximately 621 acres with approximately 880 million to 1.3 billion gal of water having been affected above the 2-ppb health advisory for RDX. The main source for the explosives in groundwater appears to be an area along Turpentine Road and Tank Alley, which coincides with the location of the targets for the Central Impact Area. The source likely covers about 440 acres of land within the Central Impact Area.

Gun and mortar firing positions. Camp Edwards contains approximately 36 current and former locations from which artillery and mortar rounds were fired. EPA requested that NGB conduct detailed evaluations of these positions based on detections in soil of elevated levels of the propellant and explosive compound

2,4DNT, in addition to several metals, SVOCs, and pesticides. The IAGWSP is evaluating contamination at these positions and will begin developing remedial alternatives for cleanup in the near future.

Chemical Spill-19 (CS-19). The CS-19 site is a small area in the west-central region of the Impact Area. The area was used for the burial and burning of ordnance. The highest concentration of RDX detected in groundwater at this location was 20 ppb in the central area of CS-19. Elevated levels of explosives, metals, and SVOCs have also been found in soils at this location. Groundwater contamination in this area, which is currently known to extend 2,500 ft west and is underlain by contamination originating farther up gradient in the Central Impact Area, is currently being addressed by the Air Force under the Installation Restoration Program (IRP) through a Remedial Investigation/Feasibility Study.

Administrative Order No. 3 identified several rapid response actions required to protect the groundwater at Camp Edwards. The first round of rapid response actions has been completed. The areas included contaminated soils at the:

- KD range firing points and target areas.
- Gun position 7.
- Armored Personnel Carrier.
- J-3 Wetland.
- Study Area 2 of the Impact Area.

These areas are located within the training ranges and Impact Area and have been investigated as part of the ongoing IAGWSP. The results of these investigations have identified explosives, metals, propellants, and pesticides in soil and sediment. Several of the areas had concentrations of contaminants detected above Massachusetts Contingency Plan (MCP) Reportable Concentration Soil-1 (RCS-1) levels. The RCS-1 levels are concentrations that, when exceeded, require notification of MADEP and may require further investigation and remediation of contamination.

A soil-sampling program was conducted to determine the extent of soil contamination within five rapid response areas that exceeded the proposed soil cleanup goals. Results of the sampling program identified approximately 810 cu yd of contaminated soil that exceeded the Rapid Response Action (RRA) soil cleanup goals.

The RRA addressed the following requirements:

- Elimination of current and potential sources of contaminants to the aquifer from soils and sediment in the areas.
- Development and implementation of a monitoring plan to assess compliance with the cleanup goals for source control measures.
- Excavation, treatment and/or disposal of contaminated sediments, soils, debris and other materials generated during the RRA.

- Restoration of areas disturbed by the removal actions, particularly vegetation and habitat.

A second round of RRA to address contamination at Mortar Target 9 and the former H Range is currently underway.

An extensive Munitions Survey Project (MSP) has been underway since July 1998, in addition to the investigation and remediation of soil and groundwater contamination at Camp Edwards. The MSP was designed to locate buried munitions at locations on Camp Edwards. Phase I of the project was intended to investigate selected sites by conducting geophysical surveys to detect subsurface metallic objects (anomalies or targets). Phase II of the MSP will involve investigations of other sites at Camp Edwards. To verify the geophysical surveys, a limited number of subsurface validations have been performed during Phase I of the MSP. Before field investigations for the MSP began, several sites, locations, and functional areas were selected for investigations. Those areas included selected gun and mortar positions, Demolition Area 1, Central Impact Area, the High Use Target Area, a slit trench, selected water bodies, and portions of the J Ranges.

The MSP was designed to acquire data that could be used to support the groundwater study. In particular, it was intended to fill significant gaps in data relevant to the issue of ordnance, buried munitions, and burial pits at Camp Edwards. The intention of the MSP was to provide to stakeholders information about the current condition of the ranges and locations at Camp Edwards. The original set of tasks drafted in mid-1999 has been refined and modified as new information about buried ordnance at Camp Edwards has been discovered and analyzed.

The survey focuses on locating large burial pits or disposal sites, because such sites were assumed to be potential sources of explosive chemicals detected in groundwater. Preliminary findings suggest that smaller burial sites or even individual unexploded ordnance can be located using geophysical techniques. All of the information gathered as part of the MSP will be utilized to support the UXO Feasibility Study required by the EPA Administrative Order No. 3.

Characterization investigations prior to project CP1155 initiation

Antitank ranges. Extensive range characterization research has been conducted by the Canadian Force Base (CFB) Valcartier, Quebec (Thiboutot et al. 1997, 1998, 2000; Ampleman et al. 2000; Dubé et al. 1999). Light antitank weapon (LAW) rocket ranges at Fort Ord, California, and at CFB Valcartier have also been studied by U.S. scientists (Jenkins et al. 1997, 1998). Results of chemical analyses at the LAW rocket sites indicated explosives residues deposited on the surface soils as a result of high use of the rocket. The main charge in the LAW rockets is octol, which is composed of 60 percent HMX and 40 percent TNT (proportions may vary up to 75 percent HMX). Accumulations of HMX near tank targets were as high as 1,640,000 $\mu\text{g kg}^{-1}$ in surface soils at Valcartier, and as high as 587,000 $\mu\text{g kg}^{-1}$ in surface soils at Fort Ord. However, TNT

concentrations were only about one one-hundredth that of HMX concentrations at both sites.

Thiboutot et al. (1998) sampled four antitank ranges in addition to the range at Valcartier, two at Western Area Training Center, Wainwright, Alberta, and two at Canadian Force Ammunition Depot (CFAD), Dundurn, Quebec. Results were similar to those reported for Valcartier, i.e., relatively high levels of HMX in surface soils, but much lower levels of TNT. The highest concentration of HMX detected at these ranges was $3,700,000 \mu\text{g kg}^{-1}$ at Range 13, Wainwright. HMX concentrations were much lower at the other ranges because of much lower usage.

Heavy artillery ranges. Thiboutot and Ampleman (2000) collected 87 composite soil samples at Canadian Force Training Range Tracadie, New Brunswick. The range had been used for artillery, gun and mortar firing, and was heavily contaminated with unexploded ordnance (UXO). Nevertheless, no explosives residues were detected in soils by Standard Method 8330 analysis (USEPA 1994). Ampleman et al. (2000) collected soil samples at several ranges at Canadian Force Base Chilliwack, British Columbia. Soils associated with craters were sampled at the Slesse Range, and concrete, steel, and woodcuttings were sampled at another area. Low concentrations of TNT and RDX were found in both areas. Low levels of RDX and HMX were also found at the Vokes Grenade range. However, visual observation at a propellant burning area at CFAD, Rocky Point, indicated that the site was littered with partially burned propellant grains. These propellant grains contain nitroglycerin, nitrocellulose, and/or nitroguanidine. The U.S. Army Center for Health Promotion and Preventative Medicine (CHPPM) conducted a study at the artillery impact area at Camp Shelby, MS (U.S. Army Center for Health Protection and Preventative Medicine, in press). Analysis of surface soil samples collected in a grid pattern over a large area using Method 8330 (USEPA 1994) (detection limits of about $250 \mu\text{g kg}^{-1}$) indicated very little detectable residues of explosives-related contaminants.

Previous fate and transport studies

Important processes affecting environmental fate and transport of explosives include dissolution rate and soil adsorption and desorption. Studies to define dissolution of explosives have been confined to individual explosives compounds (Taylor and Rinkenbach 1923; Spangford et al. 1983; Hale, Stanford, and Taft 1979; Ro et al. 1996). These studies have limited applicability for dissolution of explosives residues on ranges, because such explosives are typically formulated with binders, waxes, stabilizers, and other compounds when they are added to munitions. Dissolution of these formulations is likely to proceed more slowly than anticipated on the basis of the pure compound solubility. Extensive studies have been conducted on soil adsorption and desorption (Haderlein, Weissmahr, and Schwarzenbach 1996; Pennington and Patrick 1990; Ainsworth et al. 1993; Xue, Iskandar, and Selim 1995; Comfort et al. 1995; Leggett 1985; Selim and Iskandar 1994; Myers et al. 1998; Price, Brannon, and Yost 1998; Brannon, Price and Hayes 1997), transformation (McCormick, Feeherry, and Levinson 1976; Kaplan and Kaplan 1982; Townsend, Myers, and Adrian 1995; Price, Brannon, and

Hayes 1997; Comfort et al. 1995; Selim, Xue, and Iskandar 1995; Xue, Iskandar, and Selim 1995; Haderlein, Weissmahr, and Schwarzenbach 1996; Myers et al. 1998; Riefler and Smets 2000), degradation (McCormick, Feeherry, and Levinson 1976; McCormick, Cornell, and Kaplan 1981, 1985; Lewis et al. 1996; Funk et al. 1993; Crawford 1995; Pennington et al. 2001; Regan and Crawford 1994; Coleman, Nelson, and Duxbury 1998; Kaplan 1993; Hawari et al. 2000; McCormick, Cornell, and Kaplan 1985; Spangord et al. 1983) and chemical reactions with soil components (Kaplan and Kaplan 1982; Caton, Williams, and Griest 1994; Pennington et al. 1995, 1997, 1998; Thorne and Leggett 1997; Thorn 1997; Haderlein, Weissmahr, and Schwarzenbach 1996).

The studies just cited have been focused on the explosives contamination typically resulting from manufacturing and from loading, assembling, and packaging (LAP) of explosives into casings. The primary difference between fate and transport of explosives residues on ranges and contamination associated with LAP facilities is the integrity of the delivery system, the transport of explosives from the munitions, and the environment (aquatic, terrestrial, wetland, etc.) in which the delivery system comes to rest. Instead of solubilized explosives concentrated in lagoons and washout areas as has been observed at LAP facilities, firing ranges present more diffuse sources that are less readily characterized. In addition to contaminated soil, explosives are also present in munitions at various states of integrity (solid formulations) that may completely or partially confine the explosives. Since fate and transport processes have not been studied in the context of range contamination, data for process descriptors are incomplete or lacking for some relevant explosives compounds, propellants, and detonation by-products.

Related On-Going and Leveraged Studies

Range characterization

U.S. Army Alaska Public Works. The U.S. Army Engineer Research and Development Center, Cold Regions Research and Engineering Laboratory (ERDC-CRREL) has an agreement with the U.S. Army Alaska Public Works to conduct site investigations at four firing ranges, Range Alpha and Stuart Creek at Fort Wainwright, and Washington and Delta Creek Ranges at Fort Greeley. These site investigations will be leveraged to provide additional data on concentrations of explosives residues in surface soils resulting from training range activities.

Army Environmental Center. The Army Environmental Center (AEC) is conducting a Strategic Environmental Research and Development Program (SERDP) sponsored project, CP 1226 "UXO Corrosion – Potential Contamination Source," to identify the type, character, and rate of perforations in casings of UXO underlying soil at U.S. military installations. The goal of the corrosion project is to examine approximately 200 pieces of ordnance during the study. Soils collected in proximity to UXO will be analyzed at ERDC. Data will be leveraged with data amassed in CP 1155. The AEC is also conducting a "Range Sustainment Program" to proactively ensure access to ranges and to protect drinking water sources on active ranges. Project CP 1155 has been coordinated with this project and will share site access with this project whenever possible to benefit both

efforts. Coordination with the AEC firing points emissions study, which will define airborne emissions from firings of various munitions, has also been achieved.

Confined Burn Facilities Projects. Efforts have been made over the last several years to find alternatives to incineration, or open burning and open detonation, of unnecessary munitions and explosives. Unlike SERDP Project CP1155, which focuses on postblast residues of munitions under active firing, these studies are focused primarily on air quality when disposing of unneeded munitions by burning or detonating. The Tooele Army Depot, Tooele, UT, has used various incineration technologies including a furnace capable of burning 140 to 180 kg of energetics material per hour, and the so-called "bang box" configurations for confined burning to capture air emissions for further treatment. A 1,000-cu m "bang box" that can test 227 g of explosives or 2.27 kg of propellants has also been used at the Dugway Proving Ground, Utah. The box, formally known as the Propellant, Explosive, and Pyrotechnic Thermal Treatment Evaluation and Test Facility, is instrumented to measure emissions. The Naval Sea System (NAVSEA) Surface Warfare Center Division, Indian Head, Maryland, also has a Confined Burn Facility (CBF) where they are conducting a project, "Confined Burn Facility Open Burning Ground Replacement Technology," sponsored by the Environmental Security Technology Certification Program (ESTCP) the goal of which is to develop an environmentally acceptable, economical, and proven alternative to open burning of munitions.

Fate and transport studies

Army Environmental Quality Technology Program. Two studies are currently under execution at the Environmental Laboratory (EL), ERDC, Vicksburg, concerning fate and transport processes for explosives. The studies are funded under the Installation Restoration Research Program (IRRP), Army Environmental Quality Technology Program. One work unit, A835/301X/UX001, "Characterization and Mobilization of Unexploded Ordnance," is quantifying chemical signatures emanating from UXO under various environmental and geophysical conditions. The purpose of the study is to provide the technical basis for chemical sensor development, for discrimination between UXO and innocuous clutter, and for refinement in the classification of detected UXO. The other work unit, A835/309E/RE004, "Fate and Transport of Explosives Contaminants," is developing screening level and comprehensive fate and transport models and process descriptors for UXO in soil, aquifer, and aquatic environments for use in the exposure assessment phase of risk assessments. These work units are concerned with explosives from UXO rather than from the more diffuse and diverse explosives residues that exist at firing ranges. However, transport parameters developed under these work units will be used in this project to ensure a comprehensive and unified database. Approximately 10 percent of the funds for defining fate and transport parameters will be contributed by the SERDP project.

UXO in marine environments. The Naval Facilities Engineering Service Center, Port Hueneme, California, and the Space and Naval Warfare Systems Center, San Diego, CA, are conducting a study in conjunction with the ERDC,

EL, to determine toxicological and geochemical interactions of ordnance and explosives in marine environments. Geochemical studies will determine dissolution, adsorption, and transformation rates of explosives in marine environments. Process descriptors determined in freshwater will be compared with those determined in salt water to determine what descriptors are affected by salinity. Process descriptors for any explosives unique to marine activities will also be determined. The toxicology studies will focus on toxicity, bioaccumulation, trophic transfer, and tissue concentrations of explosives in marine environments and the toxic effects of mixtures of explosives on marine organisms.

Scope of Project CP1155

Project CP1155 was designed to develop techniques for assessing the potential for environmental contamination from energetic materials on testing and training ranges. Techniques will be developed to define the physical and chemical properties, concentration, and distribution of energetics and residues of energetics in soils and the potential for transport of these materials to groundwater. Other issues, such as off-site transport in surface runoff, or as a component of airborne dust, are also important but are beyond the scope of the project.

The project encompasses the following principal tasks:

- a.* Characterization of surface soil contamination associated with impact areas and firing points of heavy artillery and hand grenade ranges.
- b.* Determination of transport process descriptors for residues of high explosives, their formulations and by-products, including soil partition coefficients, adsorption/desorption kinetics, and dissolution rates.
- c.* Association of residues from low-order detonations with characteristics of the blast such as energy yield and intensity of the fire ball.
- d.* Comparison of residues from various charges used in demolition of unexploded ordnance to determine which produces the least potential for environmental contamination.

Ultimately, project data from various sites and tests will be integrated with climate and geological data and site historical firing records to produce guidance for estimating an explosives contamination source term suitable for use in groundwater fate and transport models and in the exposure component of risk assessments. The data will also be compared with data available for the Massachusetts Military Reservation to assess how typical/atypical are the conditions at MMR. This report addresses progress to date on tasks *a*, *b*, and *d* above. Task *c* has been initiated, but data are currently incomplete.

Objectives

The primary objective of the study is to provide the DoD with techniques to assess the potential for groundwater contamination from residues of high explosives (TNT, PETN, RDX, and HMX) at testing and training ranges. Results of the project will facilitate informed management decision making, minimize environmental impacts of testing and training, and contribute to continued operation of ranges.

Specific objectives include the following:

- a. Provide a unified database system that will include:
 - (1) A listing of the energetic materials used in current and past munitions systems that are known or expected to be present in UXO items on testing and training ranges and whose use may have resulted in diffuse low-level contamination of soils; and
 - (2) A specific protocol that can be used to determine the nature and extent of surface soil contamination around impact areas to include the sampling strategy and analytical methods best suited to this application.
- b. Provide source term estimates for postblast residues based on the extent of surface soil contamination and the attributes of dissolution and release to fate and transport processes.
- c. Provide new data for the relevant environmental processes controlling the fate and transport of residues of high explosives on ranges.

Summary of Previous Year (FY00) Results

Two tasks were initiated during the first year of the study: (a) characterization of explosives contamination at military firing ranges, and (b) filling data gaps on environmental fate and transport parameters of explosives residues. To address the first task, three training areas, a hand grenade range, firing points for 105-mm howitzers, and a heavy artillery and mortar range, were sampled at Fort Lewis, Washington. Ground- and surface water around the heavy artillery range were also sampled. To expand the database, a hand grenade range at Fort Richardson, Alaska, was sampled. The second task was addressed by reviewing existing data for explosives pertinent to the range environment. Data gaps were filled by empirical determinations in the laboratory.

Results of the first task demonstrated that RDX was common in surface soils at the grenade ranges, while 2,4DNT, a propellant component, was found at the howitzer firing points. On the artillery/mortar range, highest concentrations of TNT and RDX in surface soils were found in the vicinity of low-order detonations. Low concentrations of RDX (<1 ppb) were also detected in several ground- and surface water samples. Results suggest that contaminant distribution

is highly heterogeneous and that low-order detonations may be significant point sources for contamination of groundwater.

Examination of existing environmental transport parameter data for task (b) showed that process information was almost totally lacking on nitrobenzene, tetryl, nitroglycerin, and PETN. Process information on 2,4DNT, 2,6DNT, 1,3,5DNT, 1,3DNB, 3,5DNA, and picric acid were incomplete. Process information for 2,4DNT, 2,6DNT, 1,3,5DNT, and 1,3DNB were obtained during this and the IRRP studies. Results for transformation rate and adsorption coefficients indicate that 2,4DNT, 2,6DNT, 1,3,5TNB, and 1,3DNB disappear faster and adsorb more in surface than in aquifer soils.

Dissolution kinetics showed that the surface area estimation procedures used during this study were reproducible and accurately estimated the surface area of different amounts of explosives. Increased temperature and stir rate resulted in increased dissolution rates for TNT, RDX, and HMX. Dissolution rates for TNT, RDX, and HMX decreased in the order TNT>HMX>RDX at 10 °C and 150 rpm. This indicates that TNT will be mobilized faster than RDX and HMX. However, this does not mean that higher concentrations of TNT than RDX or HMX will be observed in groundwater. That will depend on the relative stability of the compounds once they are exposed to soils. TNT is less stable in soil than is RDX or HMX.

Results of the first year of the study suggest a complex distribution of surface soil contamination on DoD ranges that is related to the kinds of munitions fired. The relatively slow dissolution rates and low partition coefficients suggest that these residues potentially serve as a long-term source of low-level explosives contamination to groundwater and surface water.

References

- AMEC. (2001). "Impact Area Groundwater Study Program (IAGWSP)," Technical Team Memorandum 01-6, Central Impact Area Groundwater Report (in preparation), AMEC Earth and Environment, Inc., Westford, MA.
- Ainsworth, C. C., Harvey, S. D., Szecsody, J. E., Simmons, M. A., Cullinan, V. I., Resch, C. T., and Mong, G. H. (1993). "Relationship between the leachability characteristics of unique energetic compounds and soil properties," Final Report, Project Order No. 91PP1800, U.S. Army Biomedical Research and Development Laboratory, Fort Detrick, Frederick, MD.
- Ampleman, G., Thiboutot, S., Désilets, S., Gagnon, A., and Marois, A. (2000). "Evaluation of the soils contamination by explosives at CFB Chilliwack and CFAD Rocky Point," DREV Report TR-2000-103, Defence Research Establishment Valcartier, Quebec.
- Brannon, J. M., Price, C. B., and Hayes, C. A. (1997). "Abiotic and biotic TNT transformations," Technical Report EL-97-3, U.S. Army Engineer Waterways Experiment Station, Vicksburg, MS.

- Caton, J. E., Ho, C. -h., Williams, R. T., and Griest, W. H. (1994). "Characterization of insoluble fractions of TNT transformed by composting," *Journal of Environmental Science and Health A29*(4), 659-670.
- Coleman, N. V., Nelson, D. R., and Duxbury, T. (1998). "Aerobic biodegradation of hexahydro-1,3,5-trinitro-1,3,5-triazine (RDX) as a nitrogen source by a *Rhodococcus* sp., strain DN22," *Soil Biology and Biochemistry* 308/9, 1159-1167.
- Comfort, S. D., Shea, P. J., Hundal, L. S., Li, Z., Woodbury, B. L., Martin, J. L., and Powers, W. L. (1995). "TNT transport and fate in contaminated soil," *Journal of Environmental Quality* 24, 1174-1182.
- Crawford, R. L. (1995). "Biodegradation of nitrated munitions compounds and herbicides by obligately anaerobic bacteria." *Biodegradation of nitroaromatic compounds*. J. C. Spain, ed., Plenum Press, New York, 87-98.
- Dauphin, L., and Doyle, C. (2000). "Study of ammunition and dud and low order detonation rates," Report number SFIM-AEC-ET-CR-200049, prepared for U.S. Army Environmental Center, Aberdeen Proving Ground, Maryland, by U.S. Army Defense Ammunition Center, McAlester, OK.
- Dubé, P., Ampleman, G., Thiboutot, S., Gagnon, A., and Marois, A. (1999). "Characterization of potentially explosives-contaminated sites at CFB Gagetown, 14 Wing Greenwood and CFAD Bedford," DREV Report TR-99137, Defence Research Establishment Valcartier, Quebec.
- Funk, S. B., Roberts, D. J., Crawford, D. L., and Crawford, R. L. (1993). "Initial-phase optimization for bioremediation of munition compound-contaminated soils," *Applied and Environmental Microbiology*, 597, 2171-2177.
- Haderlein, S. B., Weissmahr, K. W., and Schwarzenbach, R. P. (1996). "Specific adsorption of nitroaromatic explosives and pesticides to clay minerals," *Environmental Science and Technology* 30, 612-622.
- Hale, V. Q., Stanford, T. B., and Taft, L. G. (1979). "Evaluation of the environmental fate of munition compounds in soil," Final Report AD-A082874, U.S. Army Medical Research and Development Command, Fort Detrick, Frederick, MD.
- Hawari, J., Halasz, A., Sheremata, T., Beaudet, S., Groom, C., Paquet, L., Rhofir, C., Ampleman, G., and Thiboutot, S. (2000). "Characterization of metabolites during biodegradation of hexahydro-1,3,5-trinitro-1,3,5-triazine (RDX) with municipal anaerobic sludge," *Applied and Environmental Microbiology* 66, 2652-2657.
- Jenkins, T. F., Walsh, M. E., Thorne, P. G., Thiboutot, S., Ampleman, G., Ranney, T. A., and Grant, C. L. (1997). "Assessment of sampling error associated with the collection and analysis of soil samples at a firing range contaminated with HMX," Special Report 97-22, U.S. Army Cold Regions Research and Engineering Laboratory, Hanover, NH.

- Jenkins, T. F., Walsh, M. E., Thorne, P. G., Miyares, P. H., Ranney, T. A., Grant, C. L., and Esparza, J. (1998). "Site characterization at the inland firing range impact area at Fort Ord," Special Report 98-9, U.S. Army Cold Regions Research and Engineering Laboratory, Hanover, NH.
- Kaplan, D. L. (1993). "Biotechnology and bioremediation for organic energetic compounds," *Organic Energetic Compounds*. Paul Marikas, ed., Nova Science Publishers, Inc., NY.
- Kaplan, D. L., and Kaplan, A. M. (1982). "Thermophilic biotransformations of 2,4,6-trinitrotoluene under simulated composting conditions," *Applied and Environmental Microbiology* 44(3), 757-760.
- Leggett, D. C. (1985). "Sorption of military explosive contaminants on bentonite drilling muds," CRREL Report 85-18, U.S. Army Cold Regions Research and Engineering Laboratory, Hanover, NH.
- Lewis, T. A., Goszczynski, S., Crawford, R. L., Korus, R. A., and Admassu, W. (1996). "Products of anaerobic 2,4,6-trinitrotoluene (TNT) transformation by *Clostridium bifermentans*," *Applied and Environmental Microbiology* 62, 4669-4674.
- McCormick, N. G., Cornell, J. H., and Kaplan, A. M. (1981). "Biodegradation of hexahydro-1,3,5-trinitro-1,3,5-triazine," *Applied and Environmental Microbiology* 42(5), 817-823.
- McCormick, N. G., Cornell, J. H., and Kaplan, A. M. (1985). "The anaerobic biotransformation of RDX, HMX, and their acetylated derivatives," Technical Report 85-007, U.S. Army Natick Research, Development, and Engineering Center, Natick, MA.
- McCormick, N. G., Feeherry, F. E., and Levinson, H. S. (1976). "Microbial transformation of 2,4,6-trinitrotoluene and other nitroaromatic compounds," *Applied and Environmental Microbiology* 31(6), 949-958.
- Myers, T. E., Brannon, J. M., Pennington, J. C., Townsend, D. M., Davis, W. M., Ochman, M. K., Hayes, C. A., and Myers, K. F. (1998). "Laboratory studies of soil sorption/transformation of TNT, RDX, and HMX," Technical Report IRRP-98-8, U.S. Army Engineer Waterways Experiment Station, Vicksburg, MS.
- Pennington, J. C., Brannon, J. M., Gunnison, D., Harrelson, D. W., Zakikhani, M., Miyares, P., Jenkins, T. F., Clarke, J., Hayes, C., Ringleberg, D., Perkins, E., and Fredrickson, H. (2001). "Monitored natural attenuation of explosives," *Soil and Sediment Contamination* 10(1), 45-70.
- Pennington, J. C., Hayes, C. A., Myers, K. F., Ochman, M., Gunnison, D., Felt, D. R., and McCormick, E. F. (1995). "Fate of 2,4,6-trinitrotoluene in a simulated compost system," *Chemosphere* 30, 429-438.

- Pennington, J. C., Honeycutt, M. E., Li, A. Z., Thorne, P. G., Felt, D. R., Allersmeier, D. R., Jarvis, A. S., Marx, K. A., Leggett, D. C., Hayes, C. A., McFarland, V. A., Walker, J., Porter, B. E., Kaplan, D. L., Gunnison, D., Fredrickson, H., and Thorn, K. A. (1997). "Explosives conjugation products in remediation matrices," Technical Report SERDP-97-7, U.S. Army Engineer Waterways Experiment Station, Vicksburg, MS.
- Pennington, J. C., and Patrick, W. H., Jr. (1990). "Adsorption and desorption of 2,4,6-trinitrotoluene by soils," *Journal of Environmental Quality* 19, 559-567.
- Pennington, J. C., Thorn, K. A., Gunnison, D., McFarland, V. A., Thorne, P. G., Inouye, L. S., Fredrickson, H., Leggett, D. C., Ringleberg, D., Jarvis, A. S., Felt, D. R., Lutz, C. H., Hayes, C. A., Clarke, J. U., Richmond, M., O'Neal, B., and Porter, B. E. (1998). "Explosives conjugation products in remediation matrices: Interim Report 2," Technical Report SERDP-98-12, U.S. Army Engineer Waterways Experiment Station, Vicksburg, MS.
- Price, C. B., Brannon, J. M., and Hayes, C. (1997). "Effect of redox potential and pH on TNT transformation in soil-water slurries," *Journal of Environmental Engineering* 123, 988-992.
- Price, C. B., Brannon, J. M., and Yost, S. (1998). "Transformation of RDX and HMX under controlled Eh/pH conditions," Technical Report IRRP-98-2, U.S. Army Engineer Waterways Experiment Station, Vicksburg, MS.
- Regan, K. M., and Crawford, R. L. (1994). "Characterization of *Clostridium bifermentans* and its biotransformation of 2,4,6-trinitrotoluene (TNT) and 1,3,5-triaza-1,3,5-trinitrocyclohexane (RDX)," *Biotechnology Letters* 1610, 1081-1086.
- Riefler, R. G., and Smets, B. F. (2000). "Enzymatic reduction of 2,4,6-trinitrotoluene and related nitroarenes: Kinetics linked to one-electron redox potential," *Environmental Science and Technology* 34, 3900-3906.
- Ro, K. S., Venugopal, A., Adrian, D. D., Constant, D., Qaisi, K., Valsaraj, K. T., Thibodeaux, L. J., and Roy, D. (1996). "Solubility of 2,4,6-trinitrotoluene (TNT) in water," *Journal of Chemical Engineering Data* 41, 758-761.
- Selim, H. M., and Iskandar, I. K. (1994). "Sorption-desorption and transport of TNT and RDX in soils," CRREL Report 94-7, U.S. Army Cold Regions Research and Engineering Laboratory, Hanover, NH.
- Selim, H. M., Xue, S. K., and Iskandar, I. K. (1995). "Transport of 2,4,6-trinitrotoluene and hexahydro-1,3,5-trinitro-1,3,5-triazine in soils," *Soil Science* 160, 328-339.
- Spanggord, R. J., Mabey, W. R., Mill, T., Chou, T. W., Smith, J. H., Lee, S., Robert, D. (1983). "Environmental fate studies on certain munitions wastewater constituents," LSU-7934, AD-A138550, SRI International, Menlo Park, CA.

- Taylor, C. A., and Rinkenbach, W. H. (1923). "The solubility of trinitrotoluene in organic solvents," *Journal of the American Chemical Society* 45, 44-59.
- Thiboutot, S., and Ampleman, G. (2000). "Characterization of an UXO impacted range (Tracadie Range) for potential contamination by energetic materials." *Proceeding of the fifth international symposium and exhibition on environmental contamination in Central and Eastern Europe, Prague, Czech Republic, Sept 2000.*
- Thiboutot, S., Ampleman, G., Dubé, P., Hawari, J., Spencer, B., and Paquet, L. (1997). "Protocol for the characterization of explosives-contaminated sites," DREV-R-9721, Defence Research Establishment Valcartier, Quebec.
- Thiboutot, S., Ampleman, G., Gagnon, A., Marois, A., Jenkins, T. F., Walsh, M. E., Thorne, P. G., and Ranney, T. A. (1998). "Characterization of antitank firing ranges at CFB Valcartier, WATC Wainwright and CFAD Dundurn," DREV-R-9809, Defence Research Establishment Valcartier, Quebec.
- Thiboutot, S., Ampleman, G., Gagnon, A., and Marois, A. (2000). "Characterization of an unexploded ordnance contaminated range (Tracadie Range) for potential contamination by energetic materials," DREV Report TR-2000-102, Defence Research Establishment Valcartier, Quebec.
- Thorn, K. A. (1997). "Covalent binding of the reductive degradation products of TNT to humic substances examined by N-15 NMR," *American Chemical Society Abstracts* 37, 305-306.
- Thorne, P. G., and Leggett, D. C. (1997). "Hydrolytic release of bound residues from composted soil contaminated with 2,4,6-trinitrotoluene," *Environmental Toxicology and Chemistry* 16(6), 1132-1134.
- Townsend, D. M., Myers, T. E., and Adrian, D. D. (1995). "2,4,6-Trinitrotoluene (TNT) transformation/sorption in thin-disk soil columns," Technical Report IRRP-95-4, U.S. Army Engineer Waterways Experiment Station, Vicksburg, MS.
- U.S. Army Center for Health Protection and Preventative Medicine. Geohydrologic Study No. 38-EH-8879-99, "Training range site characterization and risk screening, Camp Shelby, MS," 7-23 September 1999 (in press), Aberdeen Proving Ground, Maryland.
- U.S. Environmental Protection Agency. (1994). "Nitro aromatics and nitramines by HPLC," 2nd update, SW846, Method 8330, Office of Solid Waste and Emergency Response, Washington, DC.
- _____. (2000). "Administration Order for Response Action EPA Docket Number SDWA-1-2000-0014, USEPA Region 1, in the Matter of Training Range and Impact Area, Massachusetts Military Reservation, January, 2000," Washington, DC.

- U.S. Environmental Protection Agency. (1988). "Health advisory for RDX," U.S. Environmental Protection Agency, Criteria and Standards Division, Office of Drinking Water, Washington, DC.
- Verscheuren, K. (1983). *Handbook of Environmental Data on Organic Chemicals*. 2nd ed., Van Nostrand Reinhold Co., Inc., New York.
- Walsh, M. E., and Ranney, T. A. (1999). "Determination of nitroaromatic, nitramine, and nitrate ester explosives in soils using GC-ECD," CRREL Report 99-12, U.S. Army Cold Regions Research and Engineering Laboratory, Hanover, NH.
- Xue, S. K., Iskandar, I. K., and Selim, H. M. (1995). "Adsorption-desorption of 2,4,6-trinitrotoluene and hexahydro-1,3,5-trinitro-1,3,5-triazine in soils," *Soil Science* 160, 317-327.

2 Characterization of Explosives Contamination at Military Firing Ranges: Yakima Training Center, Washington; Camp Guernsey, Wyoming

Introduction

Background

In the first year of this project, training ranges at Fort Lewis, Washington, were sampled to assess the potential for contamination of groundwater with explosives-related contaminants on military training ranges (Jenkins et al. 2001, Pennington et al. 2001). This included surface (0-5 cm) soil samples collected at three functional areas within the Fort Lewis range complex; a hand grenade range impact area, a firing point for 105-mm howitzers, and a portion of the artillery and mortar impact area. Groundwater was sampled from monitoring wells and seepage areas around the periphery of the artillery range. Historical firing records from an electronic database were reviewed to determine the types of munitions items that had been fired on the heavy artillery range over time. Surface soil samples were also collected from a second hand grenade range at Fort Richardson, Alaska. All of these samples were analyzed for the presence of explosives residues using a new GC-ECD method (SW-846 Method 8095, USEPA 1999; Walsh and Ranney 1999) that provides detection limits about two orders of magnitude lower than SW-846 Method 8330 (USEPA 1994), the method commonly used for the analysis of explosives in soil and water. Method 8330 has been adequate for characterization of explosives contamination at Army ammunition plants and depots, where concentrations were much higher, but these limits may be inadequate to delineate contamination at many areas within training ranges.

RDX was detected in all of the soil samples, both surface (0-5 cm) and shallow subsurface at both hand grenade ranges (depths as great as 30 cm at Fort Lewis and 45 cm at Fort Richardson). Concentrations in surface soils ranged

up to 51,200 $\mu\text{g kg}^{-1}$ at Fort Lewis, and 518 $\mu\text{g kg}^{-1}$ at Fort Richardson. TNT and HMX were also detectable in most soils from these two grenade ranges with maximum concentrations of 40,600 and 5,220 $\mu\text{g kg}^{-1}$, respectively. Recent results from detonations of hand grenades on a snow-covered range suggest that these residues were not due to high-order detonation of grenades that functioned as engineered, but to the relatively few low-order detonations of grenades that did not detonate when thrown and were subsequently detonated by Explosive Ordnance Disposal (EOD) personnel. Overall, concentrations of explosives-related contaminants were an order of magnitude higher at the Fort Lewis grenade range than at the Fort Richardson grenade range, probably because of higher usage of the Fort Lewis range. While RDX concentrations were moderate, removal of the contaminant to prevent potential groundwater contamination should not be difficult, because the size of ranges, particularly compared with the artillery range impact areas, are quite small.

At the Fort Lewis artillery range, surface and near surface soil samples were collected at a 105-mm howitzer firing point and in the main impact area. At the firing point, samples were collected in front of two howitzers that had each fired about 600 rounds from the same position. Samples were collected at distances out to 10 m and 20 m for the two guns. Overall, 2,4DNT, a component of single-based propellant was found at concentrations as high as 237,000 $\mu\text{g kg}^{-1}$ in surface soil.

At the Fort Lewis artillery range impact area, soil samples were collected in and around craters formed by detonation of various artillery and mortar rounds. Concentrations of explosives residues associated with these high-order detonations were very low, often below a detection limit of 1 $\mu\text{g kg}^{-1}$ (1 part-per-billion). RDX, the analyte of most concern for groundwater contamination, was always less than 100 $\mu\text{g kg}^{-1}$ in these soil samples.

Soil samples were also collected under and adjacent to a 155-mm round that had undergone a low-order detonation. In this case, the concentration of TNT was extremely high in the surface soil under the round (1.5 percent) and was still substantial in soils collected at 5- and 10-cm depths. Residues of explosives resulting from low-order detonations are many orders of magnitude higher than residues that result from high-order detonations.

Water samples obtained from five monitoring wells and five seeps that border the artillery range at Fort Lewis contained low concentrations ($<1 \mu\text{g/L}$) of RDX (Jenkins et al. 2001, Pennington et al. 2001). The source of this contamination was not determined. Results of soil analyses from Fort Lewis and Fort Greeley indicate that very low concentrations of explosives residues are more widely spread at testing and training ranges than observed previously (Jenkins et al. 2001, Pennington et al. 2001, Walsh et al. 2001). The use of an analytical method that has lower detection limits than the current standard method for explosives residues, SW846 Method 8330 (USEPA 1994), detection limit of 250 $\mu\text{g kg}^{-1}$, allowed delineation of contamination at training ranges. The GC-ECD method developed recently by Walsh and Ranney (1999) has detection limits near 1 $\mu\text{g kg}^{-1}$ for many explosives residues and is particularly appropriate for use in range characterization studies.

The distribution of explosives residues at all the ranges investigated was spatially very heterogeneous. Concentrations of explosives-related compounds in soils collected less than a meter apart at hand grenade ranges differed by over two orders of magnitude. At artillery firing points, concentrations of propellant residues differed by as much as an order of magnitude over the same distance. At artillery impact areas, the spatial heterogeneity was large as well, although it is difficult to define numerically since many of the concentrations were below detection limits. Concentrations of explosives residues for soils collected in areas that were visibly free of craters, however, often had explosives concentrations as high or higher than soils collected from the rim of a fresh crater. Thus, site characterization using discrete samples does not provide representative samples even over fairly small areas, and a sampling strategy employing multi-increment (or composite) samples will be used to reduce variability and provide a more reliable estimate of mean concentrations.

Objectives

The overall objective of the range characterization portion of this project was to assess the potential for contamination of groundwater with explosives-related contaminants on military training ranges. Objectives for the FY 2001 study were to sample two additional installations with various types of range activities. This was to include both firing points and impact areas for artillery and mortars, and an antitank firing range. A specific objective was to test the use of composite sampling as a means of collecting samples that can be used to provide a more reliable estimate of the average concentrations in areas with various sources of contamination. An additional objective was to determine whether surface intact and ruptured UXO items act as localized sources at the various ranges. The FY2001 studies will also be used to determine if the conclusions obtained at the Fort Lewis artillery ranges can be generalized to other sites.

Yakima Training Center, Washington

Location

Yakima Training Center (YTC) occupies most of the land between the Columbia River and Interstate Highways 90 and 82, in central Washington state (Figure 1). The 510-square-mile facility includes one of the two largest unaltered shrub-steppe habitats in Washington state (the other is the Hanford Reservation). Shrub-steppe in Washington is characterized by generally dry areas of sagebrush and bunchgrass. Military training has taken place at the center since 1942. The climate is arid with an annual rainfall of 7.9 in., measured in the city of Yakima.

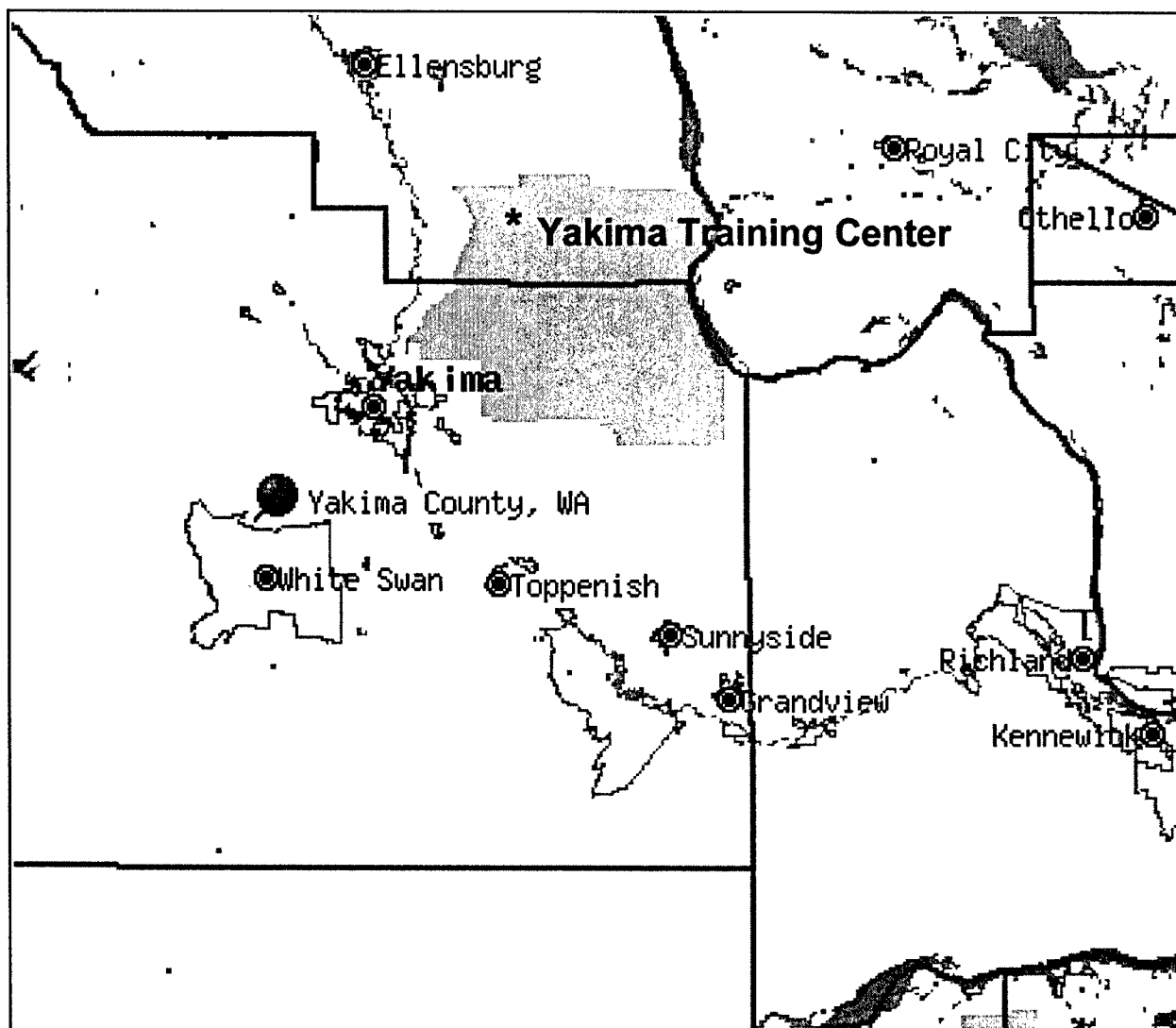

Figure 1. Location of Yakima Training Center

Approach

Surface soils (0-1 cm) were sampled at several different types of ranges at YTC in May 2001. Sampling was conducted at a firing point and an impact area at an antitank range, firing points and impact areas for 155-mm howitzers, a firing point for the 120-mm main tank gun, and the detonation point for a Claymore mine. Surface water samples were collected at several points where surface streams were found either in or on the boundary of the Central Impact Area. Several potable water wells were also sampled.

Antitank range

Initial sampling was conducted at Range 7, which is used for training with light anti-armor weapons (LAW), AT-4 antitank rockets, and 40-mm grenades, including those filled with high explosives (HE). Soil sampling at this site

included 30-increment surface composite samples and discrete samples from the surface to depths as deep as 15 cm. Surface composite samples were collected from 0-1 cm.

The area around one of the most heavily impacted targets, an armored personnel carrier (APC), was selected for intensive sampling (Figure 2). Duplicate surface composite samples were collected around the perimeter of this target within distance intervals from the edge of the APC of 0-2 m, 2-5 m, 5-10 m, and 10-15 m (Figure 3). Discrete surface and shallow subsurface samples (to 10 cm) were also collected at several points within this area. Discrete and shallow subsurface samples were also collected next to an intact 40-mm (HE-filled) grenade, and a cracked HE-filled LAW rocket (Figure 4). Duplicate surface composite soil samples were collected in an area 5-10 m in front of the firing point for LAW and AT-4 rockets at Range 7.



Figure 2. Antitank Range at Yakima Training Center soil sampling near an armored personnel carrier target

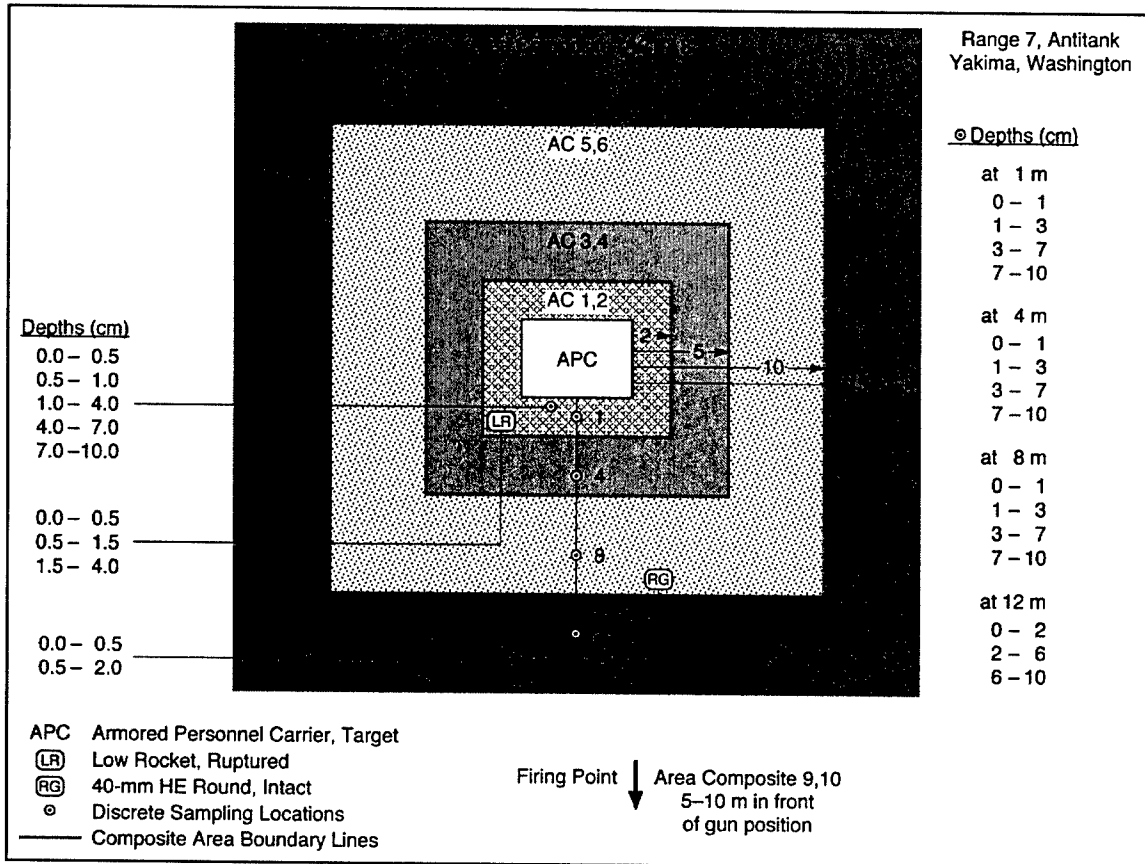

Figure 3. Soil sampling locations around armored personnel carrier target at Yakima Antitank Range

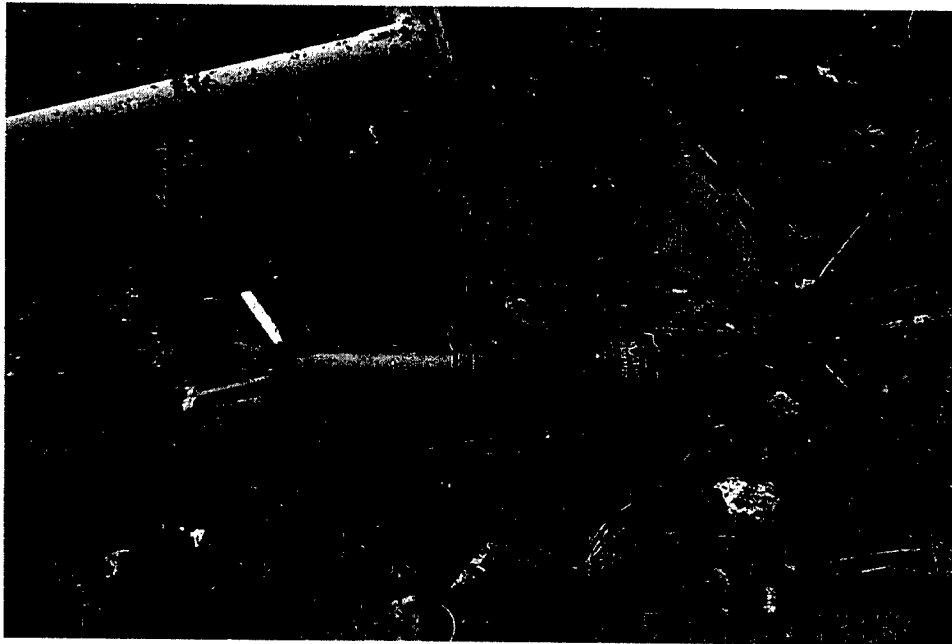

Figure 4. Ruptured LAW Rocket at Yakima Antitank Range

Multi-Purpose Range Complex, 120-mm tank firing point

The Multi-Purpose Range Complex (MPRC) is set up as a battle run for tanks. The main tank gun (120-mm) was fired at several fixed positions against an array of moving targets (Figure 5). One of the fixed firing points at this range was sampled as shown in Figure 6. Surface composite (0-2.5 cm), surface discrete (0-2.5 cm), and several shallow subsurface discrete samples (2.5-5 cm) were collected for this firing point, up to 75 m from the muzzle position.

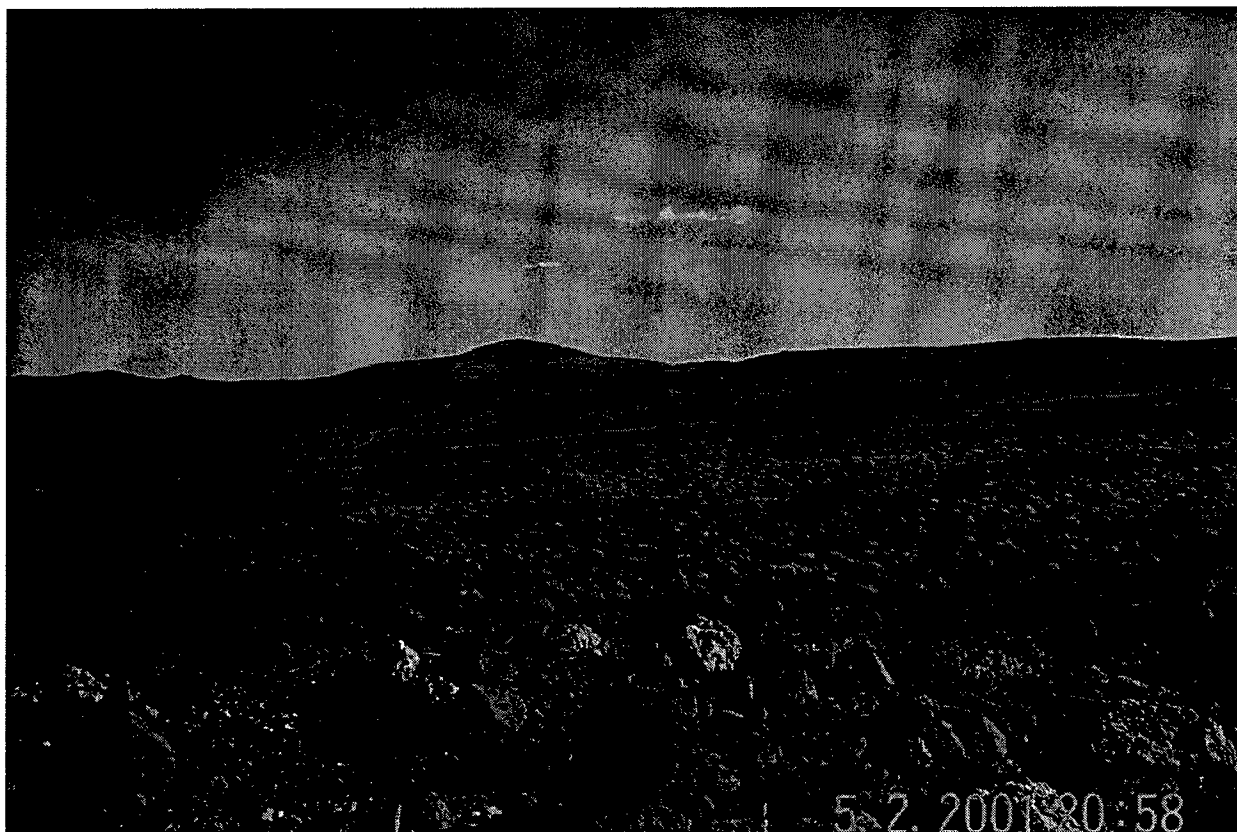

Figure 5. MPRC tank firing range at Yakima Training Center

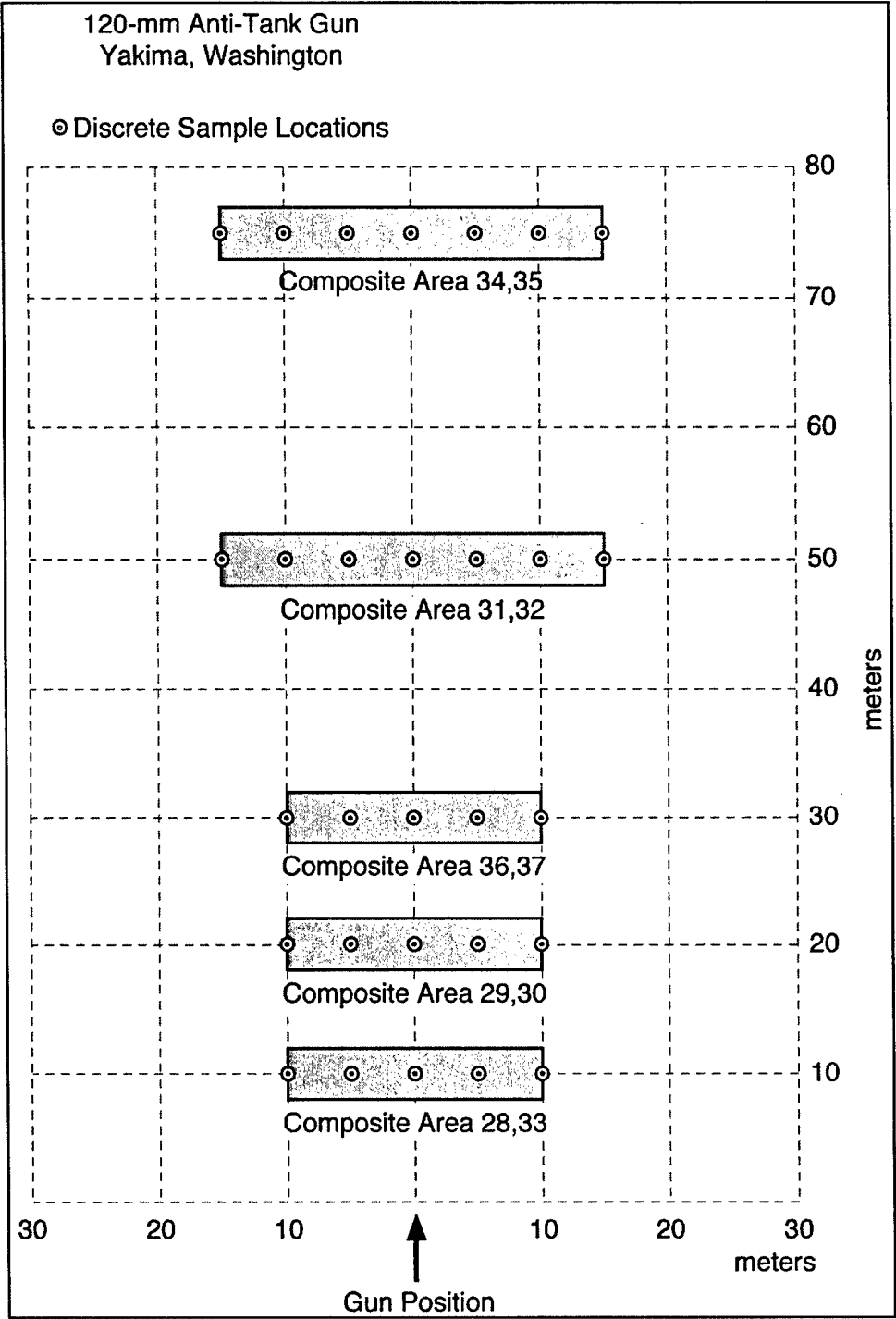

Figure 6. Soil sampling locations at tank firing point on MPRC Range at Yakima Training Center

155-mm howitzer firing points

Several firing point positions used within the past several months for practice firing of 155-mm howitzers were visually inspected. The gun positions used at these firing points were located by finding the disturbed soils resulting from the rear spades that are used to absorb the gun recoil. Several of these gun positions were clearly identifiable by the deep indentations in the soil. Based on the dimensions of the howitzers, the position of the muzzle and the direction of fire were estimated.

Surface composite samples were collected in four zones at distances of 5, 10, 20 and 50 m for one gun position as shown in Figure 7. Discrete surface and shallow subsurface samples (as deep as 5 cm) were also collected as shown. Duplicate surface soil composites were collected in an identical pattern at a second gun position, but no discrete samples were collected. A set of composite and discrete samples were also collected at the recently used firing point of a M 198 (155-mm) direct fire gun. Four (4) composite and 12 discrete surface samples were collected as shown at distances as great as 32 m from the firing pad (Figure 8).

Both single- and triple-based propellant are used for 155-mm howitzers. The major component of single-based propellant is nitrocellulose, while 2,4DNT is used as a plasticizer. The major components of triple-based propellants are nitrocellulose, nitroglycerine (NG), and nitroguanidine.

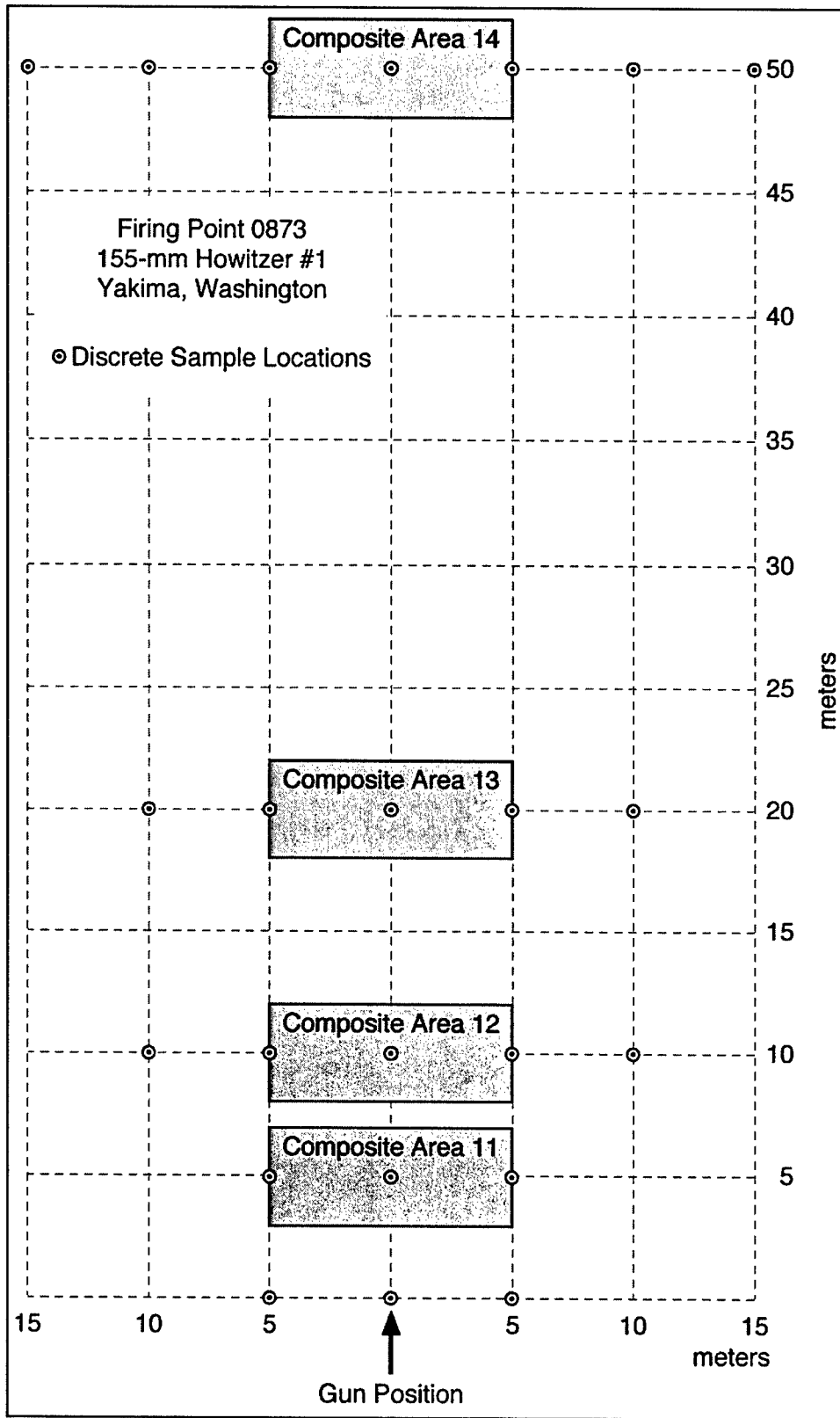

Figure 7. Soil sampling locations at the firing point of 155-mm howitzers at Yakima Training Center

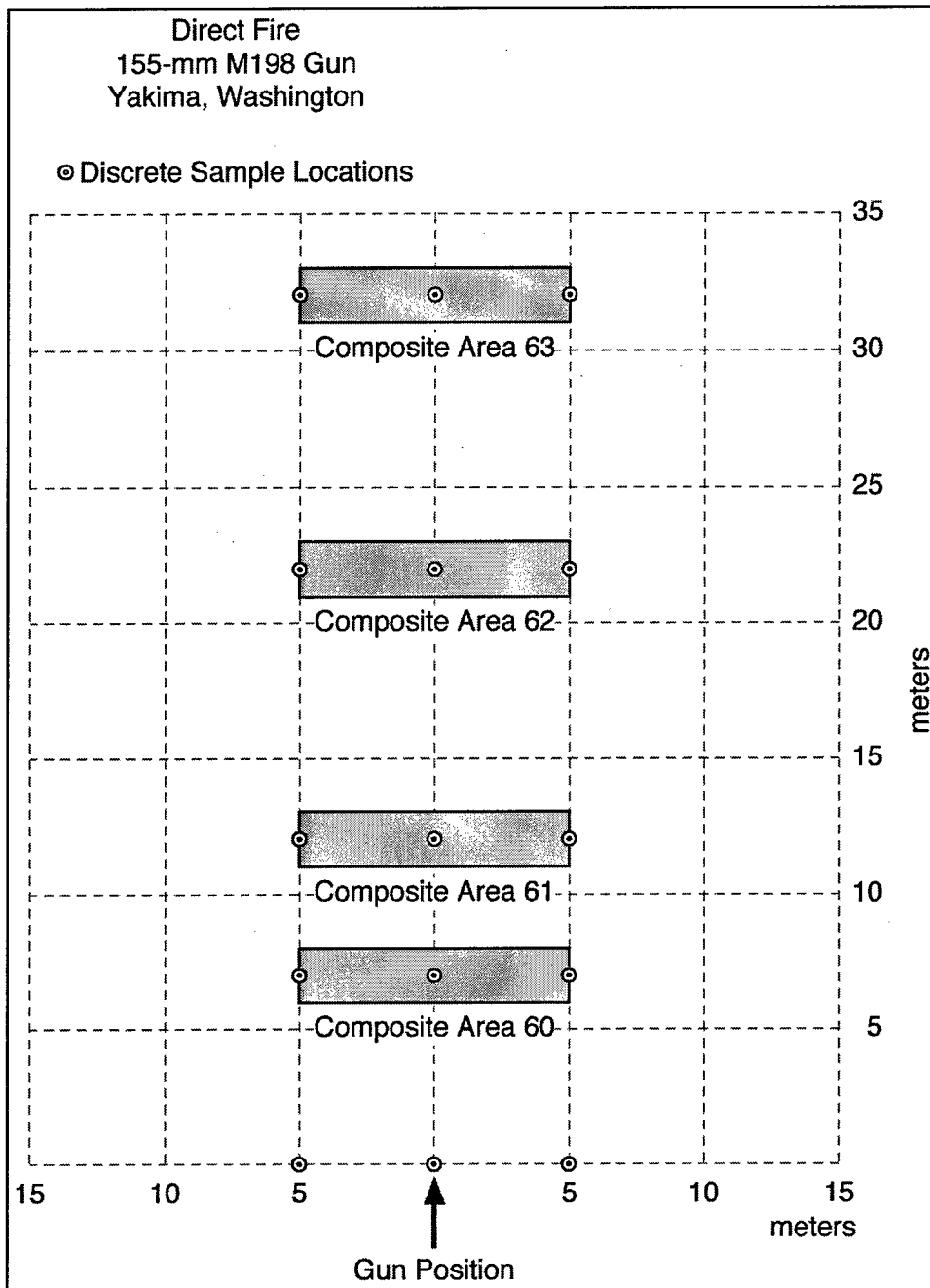

Figure 8. Soil sampling locations at a direct fire 155-mm howitzer firing point, Yakima Training Center

Mortar firing point

A portion of the range used for practice firing of various types of mortars was sampled. As with the artillery firing points, the exact positions of individual mortars were unknown. Visual reconnaissance was used to locate and identify an individual position, which appeared to be a firing position for an 81-mm mortar. Figure 9 shows the exact layout for surface composite and discrete samples collected at this site. The double-based propellant for 81-mm mortars is composed of 57.75 percent nitrocellulose, 40.0 percent NG, 1.5 percent potassium nitrate, and 0.75 percent ethyl centralite (diethyldiphenyl urea).

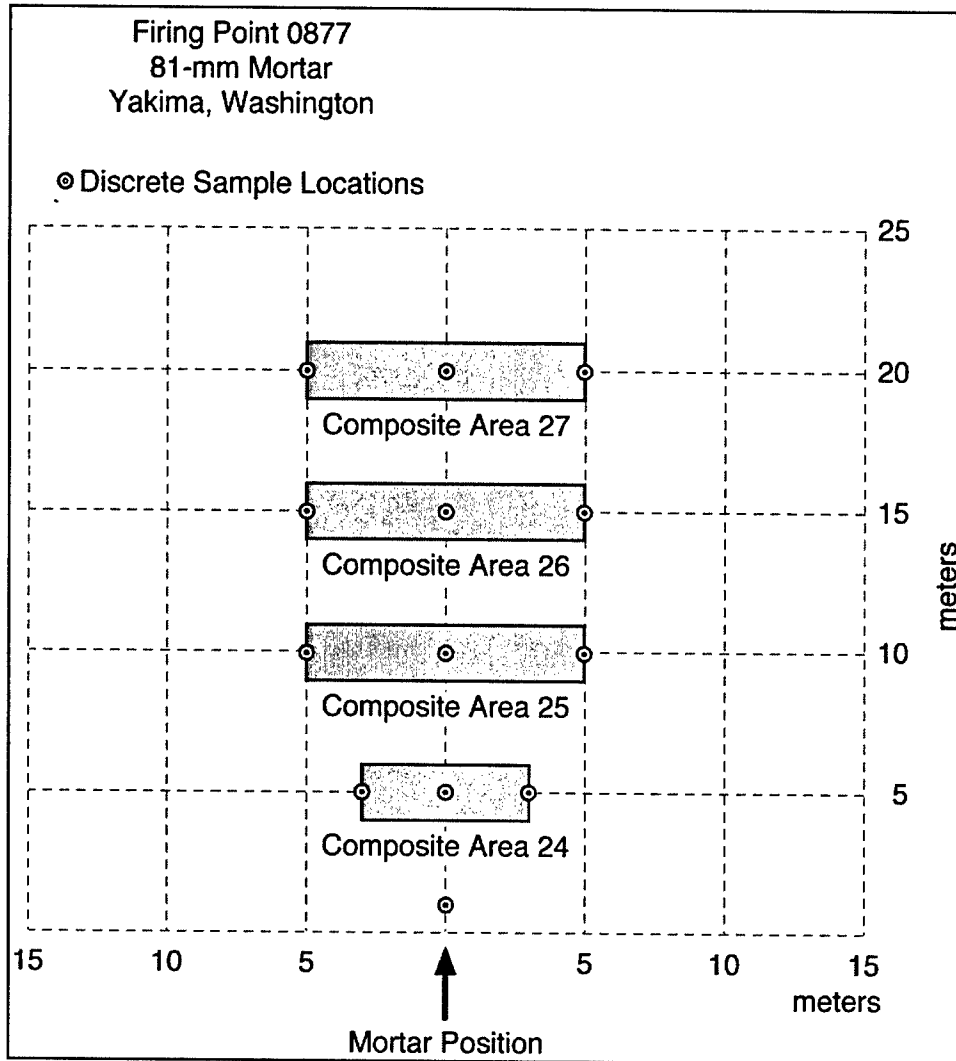

Figure 9. Soil sampling locations at a firing point for 81-mm mortars at Yakima Training Center

HEP 105-mm round

Two discrete samples were collected under a high explosive plastic (HEP) 105-mm round that was found between OP-1 (observation point 1) and OP-2. The first sample was collected directly under the round (0-1 cm) and the second

was collected at the 1- to 2-cm depth. It appeared that the round had been blown in place using C4 but was not totally destroyed.

Central impact area

Several sets of samples were collected in locations that had recently been targeted with 155-mm howitzer fire in the Central Impact Area. The first area was within an old bomb crater and around a recent 155-mm crater that was 9 m from a tank target (Figure 10). Four discrete samples were collected around the crater rim at the cardinal directions. Duplicate surface composites were collected around the perimeter of the crater, 1 m from the edge of the rim.

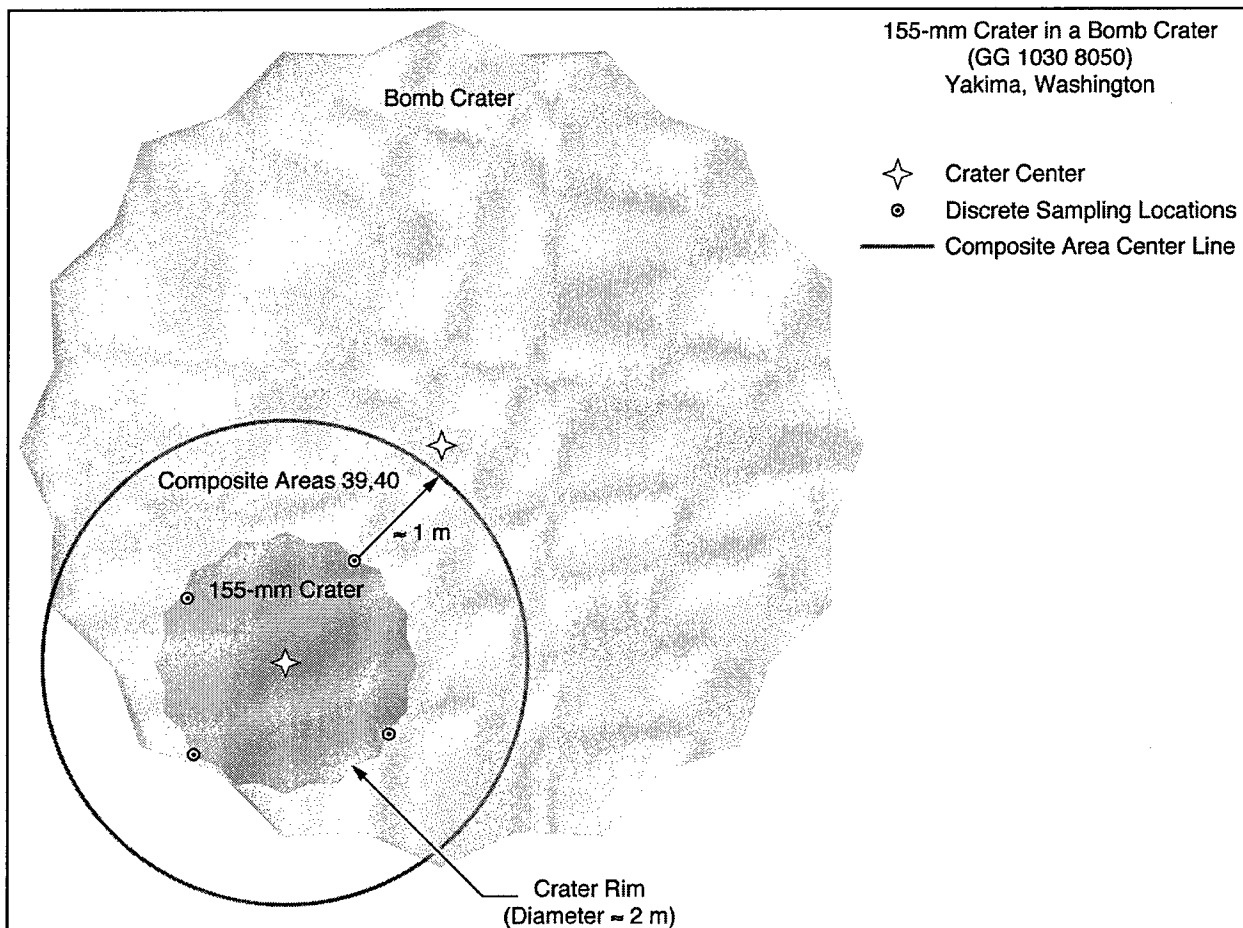

Figure 10. Soil sampling locations in Central Impact area, Yakima Training Center. Samples were collected within a bomb crater that also had a 155-mm crater within

A second set of samples was collected around the rim of a single 155-mm crater. Four discrete surface samples were collected as discussed above. Four composite samples were also collected at distances as far as 8 m from the center of the crater (Figure 11).

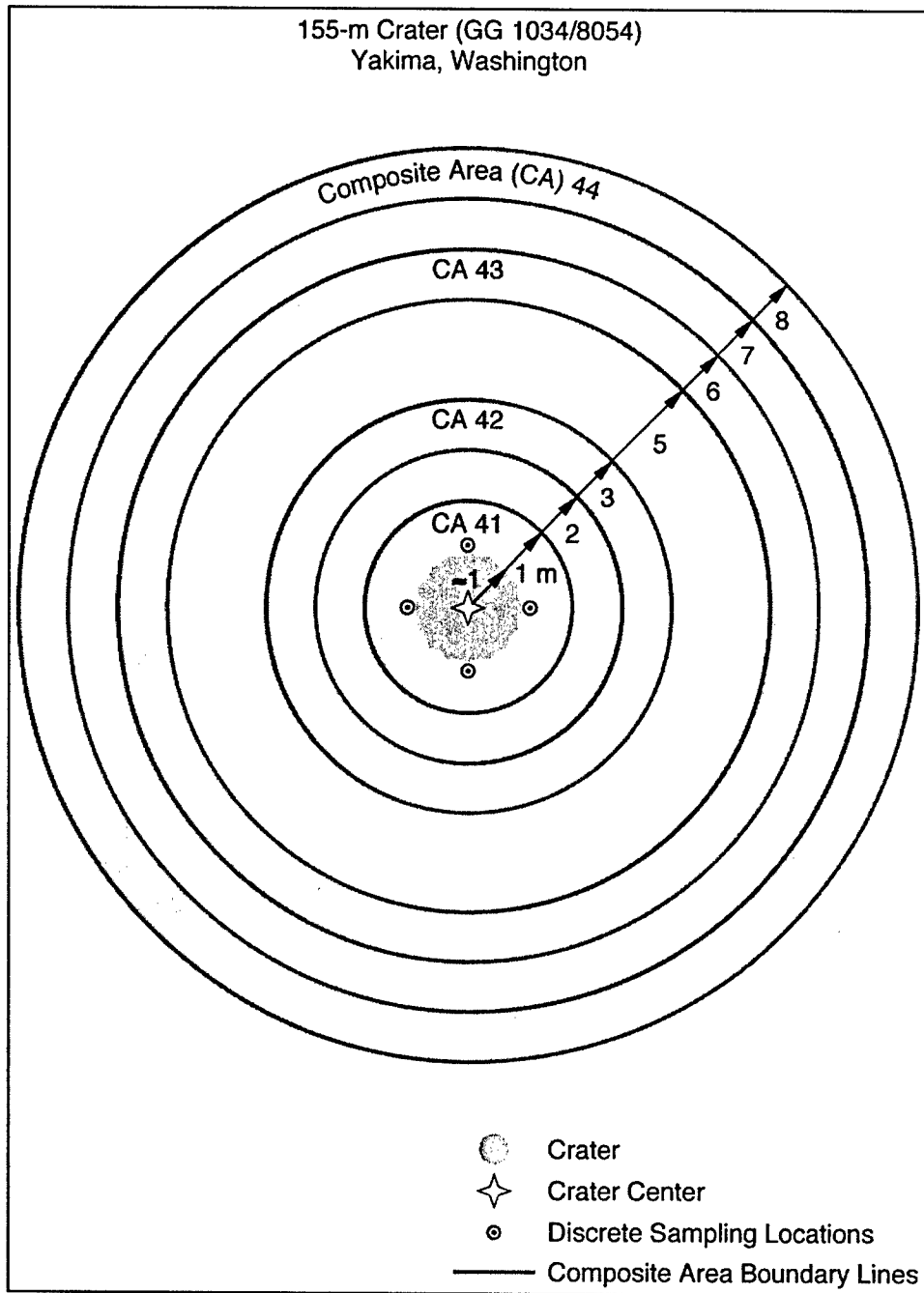

Figure 11. Soil sampling locations around a 155-mm crater at the Central Impact Area, Yakima Training Center

Several discrete samples were collected near a 155-mm white phosphorus (WP) dud and near a new 155-mm HE (intact) round. A discrete surface soil sample and two depth samples (as deep as 5 cm) were collected in the area of a 155-mm low-order illumination round. A corroded 105-mm dud was also observed in this area as well and two discrete samples were collected next to the nose and tail of this round.

A discrete sample was collected in the center and four discrete samples were collected around the rim of a 155-mm crater. Two discrete surface samples were collected next to an illumination round located next to the 155-mm crater (Figure 12). Five discrete samples were collected around a second crater in an identical manner. One composite sample was collected in a 1-m perimeter around this second crater (Figure 13).

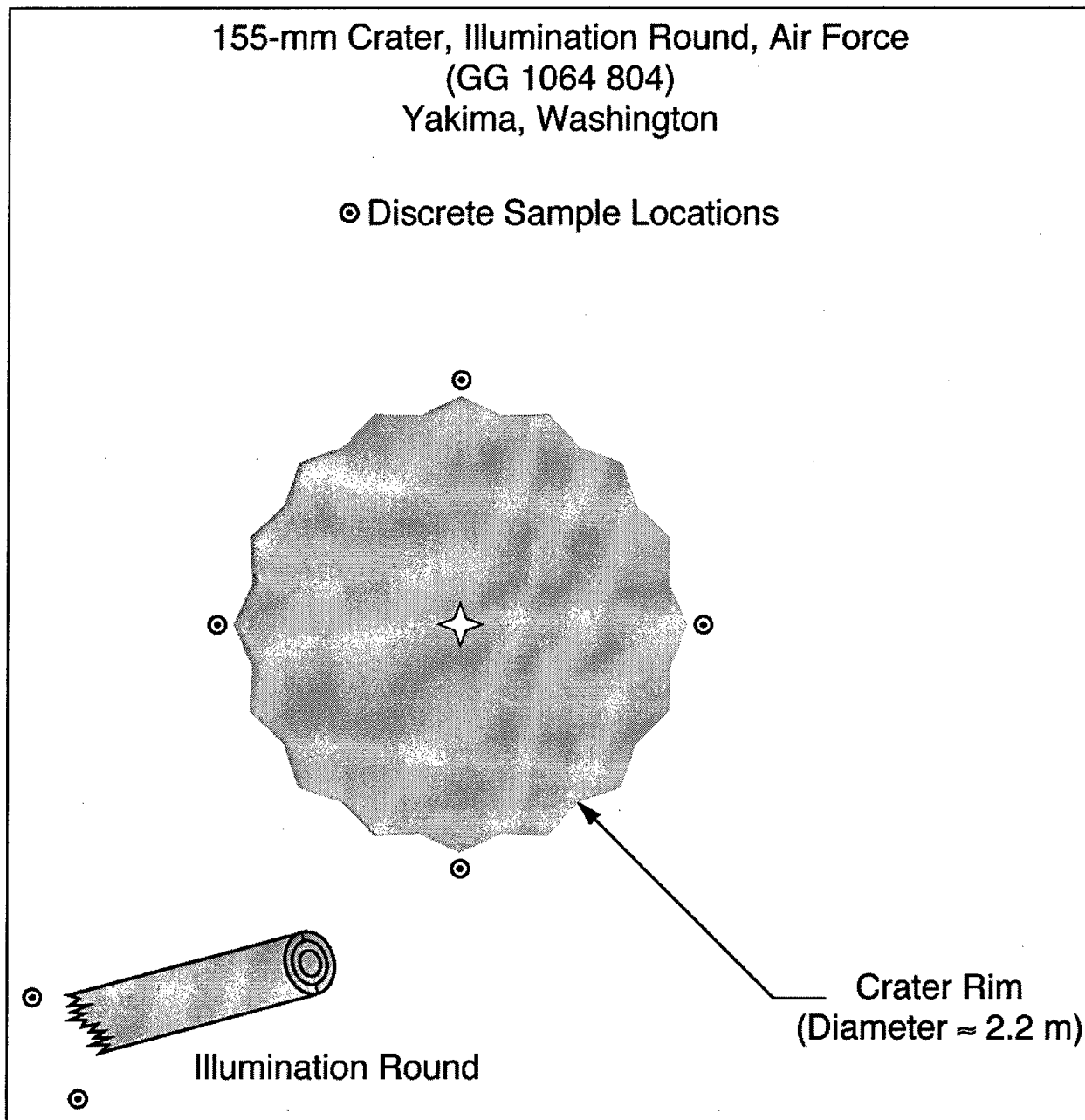

Figure 12. Sampling location in an area of the Central Impact Area, Yakima Training Center. Composite sample collected around a 155-mm crater

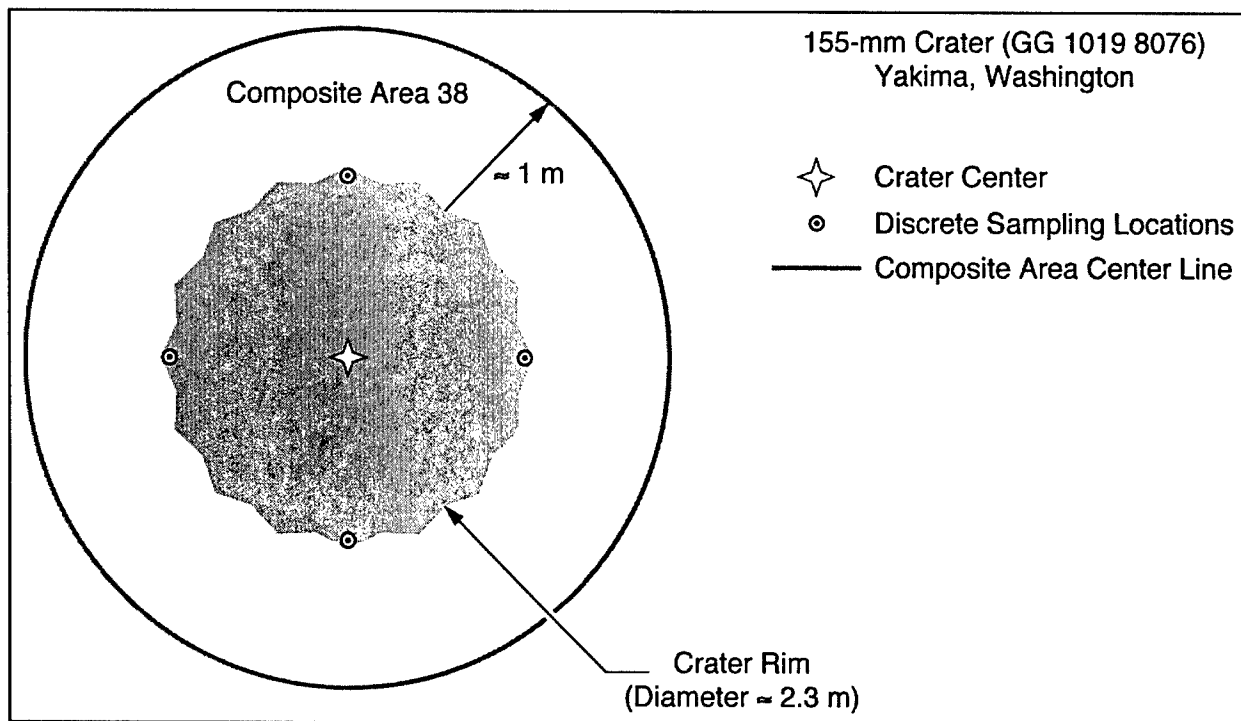

Figure 13. Sampling locations in an area of the Central Impact Area, Yakima Training Center. Samples collected around a 155-mm crater and next to an illumination round

Four discrete surface samples and a single composite sample were collected near a ruptured 81-mm illumination mortar round in a crater. One surface sample was collected under the round.

Claymore mine detonation area

The final area sampled at YTC was on the edge of the central impact area where a Claymore mine had been detonated within the previous week. Four (4) composite and 12 discrete surface samples were collected at distances as great as 30 m from the point of detonation (Figure 14).



Figure 14. Soil sampling locations in front of location where Claymore mine had been detonated at Yakima Training Center

Water sampling

Three potable water wells and three surface water locations were sampled. The potable water wells included one inside the pump house near Yakima Research Station, one at the intersection of Training Areas 2A and 3B, and one at the intersection of Training Areas 8B and 11B. These were sampled by tapping the spigots. Surface water was sampled at Selah Creek in Range 10, in Lmumma Creek just off the road at the northwestern edge of Range 19, and in Lmumma

Creek on the Central Impact Area near the lowest point on the range in a stand of willows and reeds. Surface water was sampled by placing the sample container into the stream. Samples were collected in a single 4-L brown glass bottle, thoroughly mixed, and subdivided into separate bottles already containing appropriate preservatives for the specific analyses (analytical chemistry described under Materials and Methods). The subsamples were distributed as follows: two 1-L samples for explosives; a 500-mL sample for nitrate/nitrite, total organic carbon, total iron, calcium, magnesium and manganese; and a 100-mL sample for sulfate and chloride.

Camp Guernsey, Wyoming

Location and sampling

Camp Guernsey (CG) has been a Wyoming National Guard installation since 1939. It is located in Southeastern Wyoming on the North Platte River about 90 miles north of Cheyenne where the elevation ranges from 4,300 to 5,280 ft. It encompasses about 34,000 acres of which 31,360 acres are available for training. The climate in the summer is generally dry with warm days and cool nights. The total annual precipitation is 9 in. with 70 percent of that falling during the growing season. The terrain consists of rolling hills covered with blue gramma, buffalo grass, and sagebrush, and the soil is predominantly sandy loam.

Soil sampling at Camp Guernsey was concentrated at the artillery impact area and was conducted the week of September 17, 2001 (Figure 15). An artillery firing point where 155-mm howitzers were fired was sampled on October 1, 2001, just after firing was completed. Surface water samples were collected on September 24, 2001.

Prior to our sampling activities, the artillery range had been used for training by various units with 155-mm howitzers using HE, WP, and illumination rounds. Several unexploded 155-mm rounds of various types were found and identified by EOD personnel from the Wyoming National Guard.

Artillery impact area

Several individual targets are present in the artillery impact area at Camp Guernsey. These targets are vehicles of various types (trucks, armored personnel carriers, etc.) and were used primarily for target practice using 155-mm howitzers and various types of mortars. A typical truck target was selected which appeared to have been used to about the same degree as others within the area, based on debris and target damage (Figure 16).

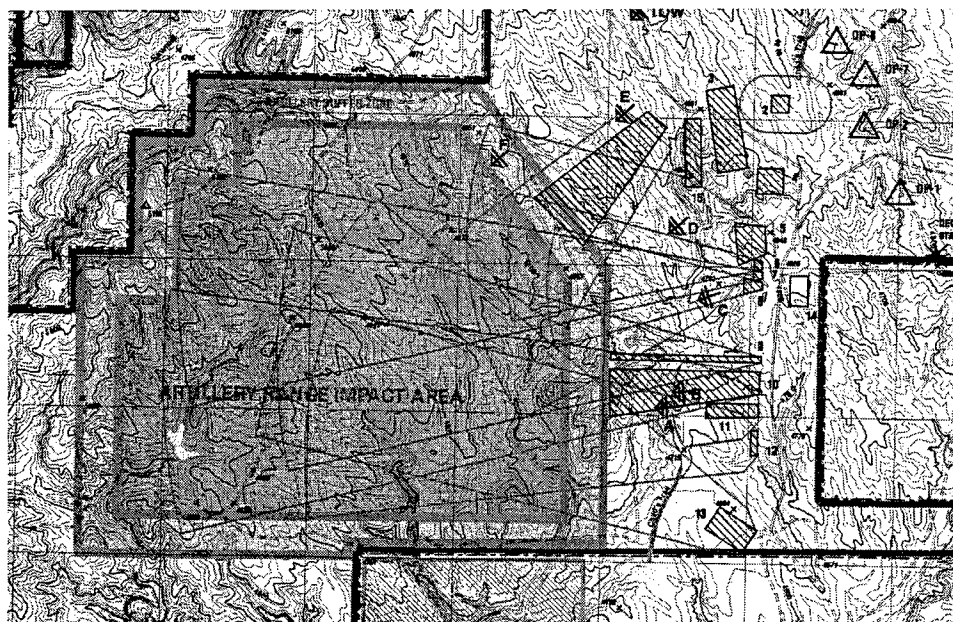

Figure 15. Map of artillery impact area at Camp Guernsey, Wyoming



Figure 16. Artillery target at Camp Guernsey

Duplicate surface composite samples were collected around the perimeter of the target at distances averaging 1, 5, 10, and 15 ± 1 m from the truck target (Figure 17). Each composite sample was made up of 30 individual increments collected within the top 1.0 cm of soil. Discrete surface and shallow subsurface soil samples were also collected at 1, 5, 10, and 15 m from the target. The depths of individual samples were in most cases 0-1 cm, 1-5 cm, 5-10 cm, and 10-15 cm.

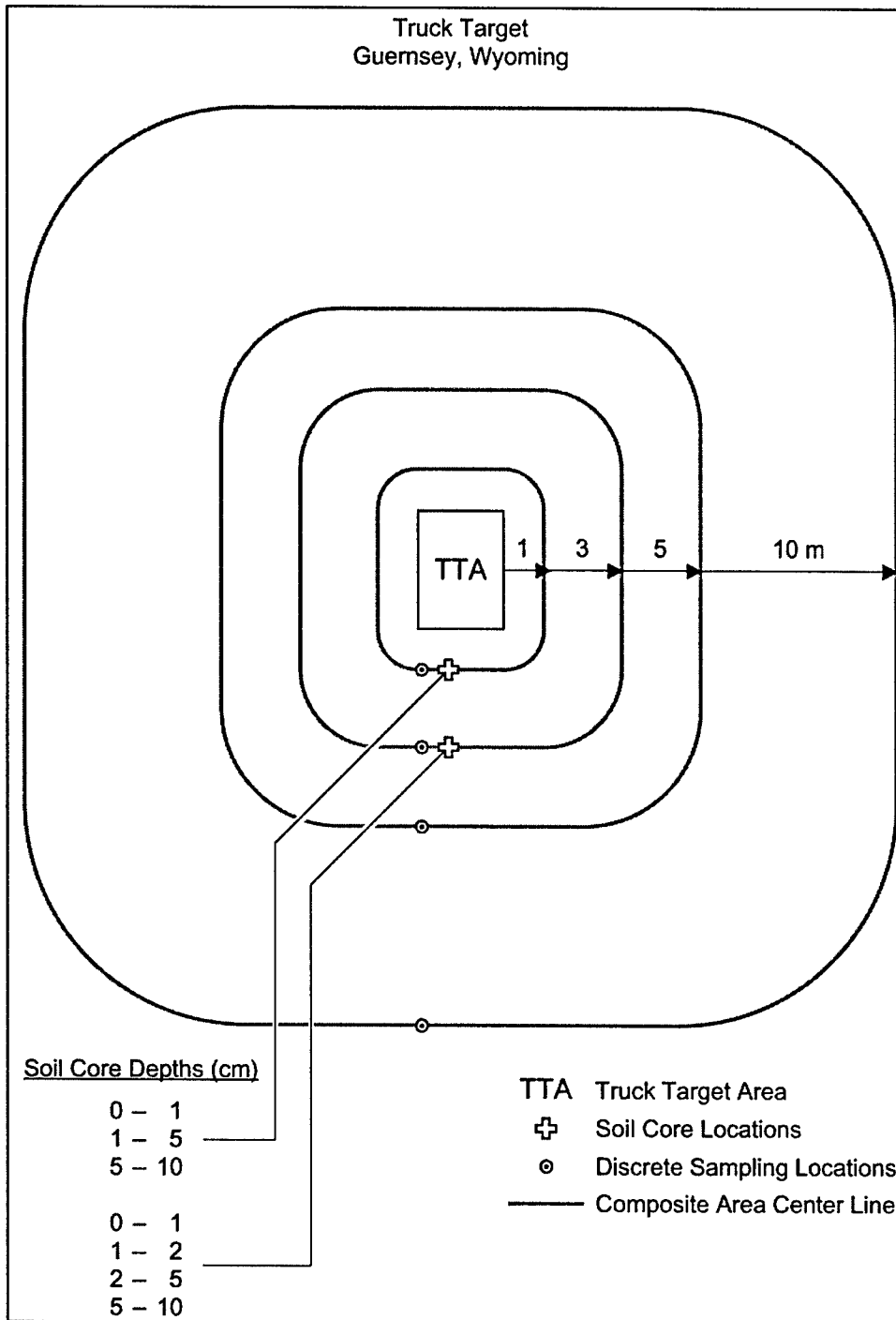

Figure 17. Soil sampling locations around truck target at artillery impact area at Camp Guernsey

A set of core samples was collected at depths from the surface to 16 cm adjacent to a broken 155-mm round.

Low-order rounds and a low-order 500-lb bomb

Perimeter composite samples were collected as described at distances of 3, 5, and 10 m from an unexploded 155-mm HE round (UXO 1). Duplicate discrete samples were also collected at 3, 5, and 10 m from the round; duplicates were collected 1 m apart.

Discrete and composite samples were collected in an identical manner around a second unexploded 155-mm round (UXO 2) and around an unexploded 81-mm mortar round and a 155-mm round lying together (UXO 3).

Soil samples were collected around a low-order 500-lb bomb (Mark 82) estimated by personnel from the Wyoming National Guard to have been on site for at least 2 years (Figure 18). The explosive that remained in the bomb (estimated at 50 lb) had turned red in the sun suggesting that the main charge was TNT. Reddish colored surface soil was observed in several locations at distances as far as 4.7 m from the bomb. Discrete surface and subsurface soil samples were collected in areas where the reddish colored soils were observed. Composite soil samples were also collected around the perimeter of this low-order detonation at 3, 5, and 10 m from the bomb (Figure 19).



Figure 18. A 500-lb bomb that had undergone a low-order detonation, Central Impact Area, Camp Guernsey

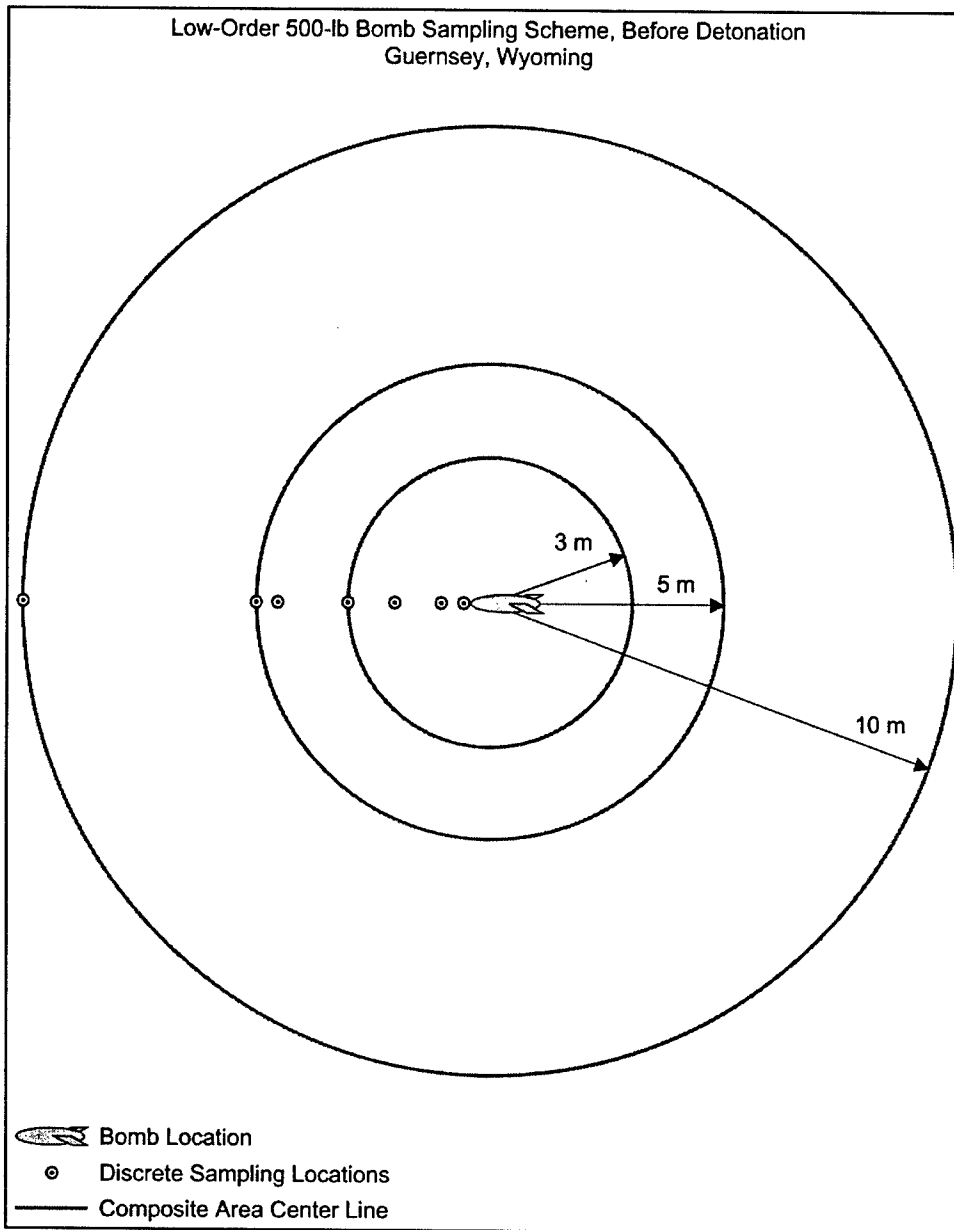

Figure 19. Soil sampling locations around low-order 500-lb bomb at Camp Guernsey

Blow-in-place of UXO items and low-order 500-lb bomb

After the soil samples were collected around these items, a team of personnel from the Wyoming National Guard and Special Forces 3rd BN 10th SFG (A) detonated UXO 1, 2, and 3 and the low-order 500-lb bomb on the afternoon of 19 September. For UXO 1 and 2, two 1.25-lb blocks of C4 were used. For UXO 3, four C4 blocks were used, and for the 500-lb bomb, three C4 blocks were used.

The following morning duplicate composite and discrete soil samples were collected in and around the craters formed from these detonations. At each of

these locations, duplicate surface composites were collected around the perimeters of the craters at distances of 3, 5, and 10 m; duplicate surface discrete samples were also collected south or southwest of the centers at the same distances. For the crater formed from the detonation of the bomb, surface discrete samples were collected at the center of the crater and around the rim in the four cardinal directions. Duplicate discrete samples were also collected at 3, 5, and 10 m south of the crater. A set of seven discrete samples was collected using a wheel pattern (4-ft diameter) centered at 3.5 m southeast of the crater (Figures 19, 20) (Jenkins et al. 1997a).



Figure 20. Soil samples collected in a wheel pattern at the artillery impact area at Camp Guernsey

Artillery firing points

Since no firing activity took place during the week of sampling at Camp Guernsey, COL Joe Michaels, Facility Manager at Camp Guernsey, volunteered to collect soil samples before and after firing of 155-mm howitzers using our sampling design (Figure 21). This activity was conducted 2 weeks after the primary sampling event.

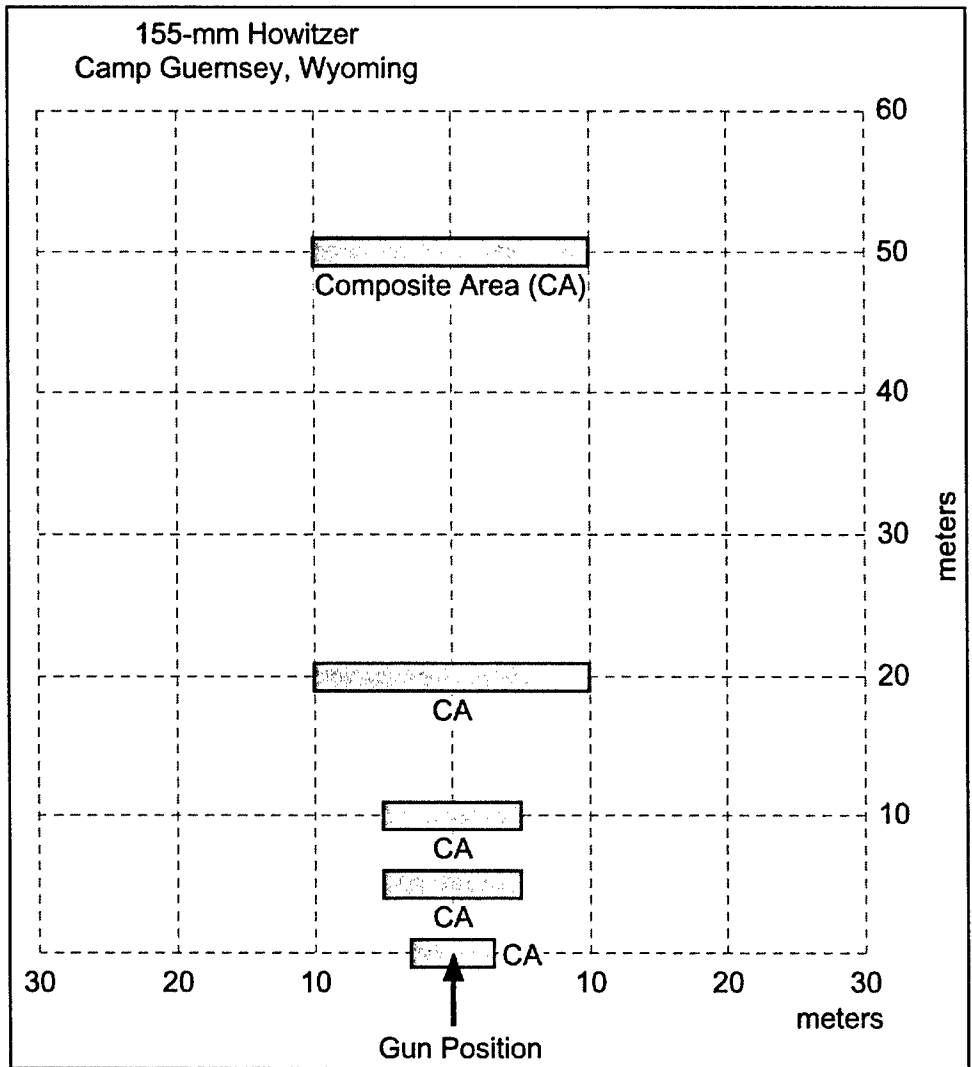

Figure 21. Soil sampling locations in front of firing point for 155-mm howitzers at Camp Guernsey

To collect firing point samples, two gun positions were set and center lines established from the muzzle in the direction of fire. A set of duplicate composite surface soil samples were collected for each gun position, prior to firing, perpendicular to the center line at distances 0, 5, 10, 20, and 50 m from the muzzle. The 0-m samples were collected at a distance of 3 m on both sides of the center line. The 5- and 10-m samples were collected 5 m on both sides of the center line, and the 20- and 50-m samples were collected 10 m on both sides of the center line. At least 30 increments were collected per sample.

After the three 155-mm howitzer batteries had fired 43 rounds, samples were collected in an identical manner in front of the two outside guns. All rounds fired used green bag charge 3 (D540 M3), single-based propellant. Samples were shipped on ice to CRREL by overnight carrier.

Surface water sampling

Surface water samples were collected at the same sites included on the facility routine monitoring plan. These included the following springs: Deer Corn and Ryan Springs in the North Training Area, Sawmill Springs in Sawmill Canyon just northwest of the Artillery Range Impact Area, and Pet Springs just south of the Artillery Range Impact Area (Figure 15).

Materials and Methods

Soil sample collection and shipment

All surface composite soil samples at YTC and CG were collected using stainless steel hand shovels, which were carefully wiped with clean towels, washed with acetone, and air-dried between samples. Each sample was composed of at least 30 individual increments collected randomly within the area sampled from the top 0-1 cm. Individual increments were placed into polyethylene plastic bags, which were sealed with twist ties once all increments for a given composite were collected. Each bag was placed in a zip-lock bag and shipped to the laboratory in ice filled coolers (FedEx overnight). Upon arrival at CRREL the samples were frozen at -30 °C until extracted and analyzed.

Surface discrete samples were collected in an identical manner as individual increments for the composites. Depth samples were collected using a 3/4-in. stainless steel soil corer. Sampling devices were cleaned as described above between samples. Discrete samples were placed into glass jars, enclosed within a zip lock bag, shipped to CRREL on ice, and frozen as described above.

Soil extraction

Soil samples were allowed to warm to room temperature and air-dried. Dried soils were either homogenized within the laboratory, or ground using a Lab Tech ESTA Vibratory Ring Mill (grinding was conducted by Charles Ramsey, EnviroStat, Fort Collins, Colorado) prior to subsampling. Whether soils were ground or not, subsampling was conducted by spreading the soil into a thin layer in an aluminum pie pan, mixing thoroughly, and randomly collecting at least 10 individual portions using a stainless steel spatula to create a 10-g subsample. Each subsample was placed into a 40-mL glass vial and a 20-mL aliquot of acetonitrile (AcN) was added. The vials were then individually placed on a vortex mixer for 30 sec to suspend the soil particles, and the vials were placed in an ultrasonic bath for 18 hr. The temperature of the bath was maintained at less than 25 °C with cooling water. The vials were removed from the bath and allowed to stand undisturbed for at least 30 min. For samples analyzed by gas chromatography (GC), the extracts were filtered through a 25-mm Millex-FH (0.45 µm) disposable filter, discarding the first milliliter and collecting the remainder in a clean autosampler vial. For samples analyzed by reversed-phase high performance liquid chromatography (RP-HPLC), a 1.0-mL portion of the

filtered extract was mixed with 4.0 mL of reagent grade water. These processed extracts were refrigerated until analyzed. Most samples from YTC and CG were analyzed by GC. High concentration samples were analyzed by RP-HPLC. The decision on which type of analysis to conduct first was made based on our knowledge of the concentrations of analytes that would likely be present for a given type of sample. For instance, results from previous investigations indicated that concentrations of HMX in soil samples from antitank rocket ranges were often in the 10,000 to 100,000 $\mu\text{g kg}^{-1}$ range (Jenkins et al. 1997b; Jenkins et al. 1998). This is well above the linear range of the gas chromatographic-electron capture detector (GC-ECD) detector but easily analyzed by RP-HPLC-UV. For artillery ranges, however, results from the work at Fort Lewis indicated that the concentrations of explosives in most samples are below 50 $\mu\text{g kg}^{-1}$ (Jenkins et al. 2001; Pennington et al. 2001), too low for RP-HPLC-UV analysis, but measurable using GC-ECD.

GC-ECD analysis

The autosampler vials containing acetonitrile soil extracts were placed into GC autosampler trays that were continuously refrigerated by circulating 0 °C glycol/water through the trays. The samples were injected into an HP-6890 GC equipped with a micro cell Ni^{63} micro-electron capture detector (GC- μECD). Results were obtained according to the general procedure outlined in EPA SW846 Method 8095 (EPA 1999). Direct injection of 1 μL of soil extract was made into a purged packed inlet port (250 °C) equipped with a deactivated Restek Uniliner. Primary analysis was conducted on a 6-m \times 0.32-mm ID fused-silica column, with a 1.5- μm film thickness of 5 percent-(phenyl)-methylsiloxane (RTX-5 from Restek, Bellefonte, PA). The GC oven was temperature programmed as follows: 100 °C for 2 min, 10 °C/min ramp to 260 °C, 2-min hold. The carrier gas was helium at 10 mL/min (linear velocity approximately 90 cm/sec). The ECD makeup gas was nitrogen flowing at 40 mL/min. If a peak was observed in the retention window for a specific signature compound, the extract was reanalyzed on a confirmation column, 6 m \times 0.53-mm ID with a 0.1- μm film thickness of 50 percent cyanopropylmethyl and 50 percent phenylmethyl-polysiloxane (RTX-225 from Restek). If analyte concentrations were within the linear range of the ECD, concentrations reported were taken from the determination on the primary column, unless there appeared to be co-elution with another compound. In such cases, reported concentrations were taken from the determination on the confirmation column. Estimated detection limits for the GC-ECD analysis are given in Table 1.

Analyte	Soil, $\mu\text{g kg}^{-1}$		Water, $\mu\text{g L}^{-1}$
	RP-HPLC	GC-ECD	GC-ECD
HMX	26	26	0.004
RDX	34	3	0.004
TNB	16	3	0.007
TNT	16	1	0.01
2,6DNT	19	0.8	0.003
2,4DNT	28	0.8	0.009
2ADNT	38	2.5	0.003
4ADNT	32	1.6	0.003
TNB	20	2	0.007
NG	20	22	0.2
DNA	Co-elutes with NB	2	
DNB	100	0.7	0.004
Tetryl	600	20	0.009
PETN		16	0.2

RP-HPLC analysis

High concentration extracts were also analyzed by RP-HPLC according to the general outline provided in SW846 Method 8330 (USEPA 1994). When samples were analyzed by both GC-ECD and RP-HPLC, concentrations above $500 \mu\text{g kg}^{-1}$ were taken from the HPLC analysis which had a higher range of linearity. RP-HPLC analysis was conducted on either a SpectraSystem AS3000 set at 254 nm, or a modular system composed of a Spectra-Physics Model SP8800 ternary HPLC pump, a Spectra-Physics Spectra 100 variable wavelength UV detector set at 254 nm (cell path 1 cm), a Dynatech Model LC241 auto sampler equipped with a Rheodyne Model 7125 sample loop injector, and a Hewlett-Packard 3396A digital integrator set to measure peak heights. Separations were conducted on a 15-cm \times 3.9-mm NovaPak C-8 column (Waters, Milford, MA) eluted with 85/15 water/isopropanol (v/v) at 1.4 mL/min. Samples were introduced by overfilling a 100- μL sampling loop. Concentrations were estimated against a multianalyte standard. Estimated detection limits for the RP-HPLC method are presented in Table 1.

Soil geochemistry

Selected composite soil samples were analyzed for pH (Mehlich 1984), total Kjeldahl nitrogen and total organic carbon (TOC) (American Public Health Association 1985), particle-size distribution (Day 1956 as modified by Patrick 1958, Gee and Bauder 1986), cation exchange capacity (CEC) (Rhoades 1982), and total iron (Olson and Ellis 1982).

Analyses of water

Laboratory analyses for geochemical parameters included total iron, calcium, magnesium and manganese (Method 6010, USEPA 1988a), nitrate-nitrite nitrogen

(Method 353.2, USEPA 1982), sulfate (Method 375.2, USEPA 1982), and chloride (Method 325.2, USEPA 1979). Samples for total iron, calcium, magnesium, and manganese, total organic carbon, and nitrate-nitrite nitrogen were preserved with 0.4 g NaHSO₄ to 250 mL of water. Samples for sulfate and chloride were not preserved.

Analysis of water samples for explosives was conducted by GC-ECD according to SW846 Method 8095 (USEPA 1999), after solid phase extraction and elution with acetonitrile. Extracts were analyzed by GC-ECD as described for soil extracts. Analytes and method detection limits are provided in Table 1.

Results and Discussion

Yakima Training Center, Washington

Antitank range

Analytical results from discrete and composite soil samples collected at the antitank firing range at Yakima Training Center are presented in Table 2. HMX was the analyte found at highest concentration in nearly every soil sample collected near the armored personnel carrier (APC) target. Mean HMX surface concentrations in the composite samples collected at distances from the APC decreased from about 47,000 $\mu\text{g kg}^{-1}$ at 0-2 m, to 16,000 $\mu\text{g kg}^{-1}$ at 2-5 m, to 6,300 $\mu\text{g kg}^{-1}$ at 5-10 m, and to 3,600 $\mu\text{g kg}^{-1}$ at 10-15 m. Concentrations of HMX in soils as high as 1,900,000 $\mu\text{g kg}^{-1}$, and 479,000 $\mu\text{g kg}^{-1}$ have been measured for samples from antitank ranges at Canadian Force Base Valcartier (Jenkins et al. 1997b, Thiboutot et al. 1998) and at Fort Ord (Jenkins et al. 1998), respectively. The presence of HMX as the major contaminant at antitank ranges is consistent with the use of LAW and AT-4 rockets on these ranges. High concentrations in surface soils are thought to arise as a result of the high incidence of rupture of these rockets without detonation, spreading the explosive fill onto the soil. These have been observed on the surface at two antitank ranges that we have characterized in previous studies (Jenkins et al. 1997b, 1998). The dud rate for M66 Law rockets has been estimated at 4.52 percent (Dauphin and Doyle 2000). The explosive fill for these rockets is octol, which is 70 percent military grade HMX and 30 percent military grade TNT. According to specification, RDX in military Grade A HMX cannot exceed 7 percent; in Grade B HMX, RDX cannot exceed 2 percent (Headquarters, U.S. Army Corps of Engineers 1994).

Table 2
Explosives Concentrations in Soils from Yakima Antitank Firing Range¹, $\mu\text{g kg}^{-1}$

Sample Number	Munitions/Target	Sample Location ²	Sample Depth, cm	HMX	RDX	TNT	NG	2,4DNT	2ADNT	4ADNT
Discrete Samples										
Y1	40-mm grenade	near intact	0-0.5	6,380	8,210	<16	102	<28	<38	<32
Y2	40-mm grenade	near intact	0.5-2.5	1,440	563	<16	7,850	150	<38	<32
Y3	Target	50 cm NE	Surface	75,000	90,400	<16	<20	<28	<38	<32
Y4	Target	50 cm NE	0.5-1.0	17,900	13,100	<16	<20	<28	<38	<32
Y5	Target	50 cm NE	1.0-4.0	19,900	4,290	<16	<20	<28	<38	<32
Y6	Target	50 cm NE	4.0-7.0	19,400	3,540	<16	<20	<28	<38	<32
Y7	Target	50 cm NE	7.0-10.0	20,500	7,070	<16	<20	1,510	<38	<32
Y8	Target	1 m N	Surface	53,500	4,070	<16	<20	<28	<38	<32
Y9	Target	1 m N	1.0-3.0	18,200	6,060	<16	<20	<28	<38	<32
Y10	Target	1 m N	3.0-7.0	26,700	6,800	<16	<20	<28	<38	<32
Y11	Target	1 m N	7.0-10.0	1,180	315	<16	<20	<28	<38	<32
Y12	Target	4 m N	Surface	19,000	215	<16	200	<28	17.5	100
Y13	Target	4 m N	1.0-3.0	4,240	125	<16	175	<28	47.5	25
Y14	Target	4 m N	3.0-7.0	4,530	97.5	<16	<20	<28	<38	<32
Y15	Target	4 m N	7.0-10.0	1,120	80.0	<16	<20	<28	<38	<32
Y16	Target	8 m N	Surface	1,900	775	55.0	13,000	480	20.0	72.5
Y17	Target	8 m N	1.0-3.0	338	293	<16	<20	<28	<38	<32
Y18	Target	8 m N	3.0-7.0	298	62.5	<16	<20	800	<38	<32
Y19	Target	8 m N	7.0-10.0	27.5	27.5	<16	<20	<28	<38	<32
Y20	Target	12 m N	0-2.0	2,940	<34	37.5	4,120	208	72.5	75
Y21	Target	12 m N	7.0-10.0	153	195	<16	10,600	163	<38	<32
Y22	Target	12 m N	7.0-10.0	43	87.5	<16	<20	<28	<38	<32
Y23	Ruptured Law Rocket	Next to	0-0.5	10,400,000	45,700	358,000	<20	1,770	17,700	24,700
Y24	Ruptured Law Rocket	Next to	2.0-6.0	1,020,000	4,760	41,700	1,260	483	4,380	5,580
Y25	Ruptured Law Rocket	Next to	6.0-10.0	49,300	1,530	1,720	895	183	1,700	1,820
Composite Samples										
YC1	Target	0-2m	Surface	35,600	3,130	<16	<20	<28	<38	<32
YC2	Target	0-2 m	Surface	58,000	736	61.4	270	52	333	459
YC3 ³	Target	2-5 m	Surface	11,700	259	73.1	1,100	148	114	133
YC4 ³	Target	2.5 m	Surface	20,800	344	35	1,300	88	118	152
YC5	Target	5-10 m	Surface	1,760	115	<16	92	<28	<38	<32
YC6	Target	5-10 m	Surface	10,800	196	47	467	<28	93	78
YC7	Target	10-15 m	Surface	6,510	83	117	<20	<28	32	27
YC8	Target	10-15 m	Surface	771	92	<16	2,750	98	<38	<32
YC9	Rocket Firing Position	Front 5-10 m	Surface	<26	<34	<16	1,840	<28	<38	<32
YC10	Rocket Firing Position	Front 5-10 m	Surface	<26	<34	<16	3,630	<28	<38	<32

¹ The following undetected analytes were excluded from the table: 2,6DNT, 1,3DNB, 1,3,5TNB, 3,5DNA, PETN. All shaded data were generated using RP-HPLC analysis. All other data were generated using GC-ECD.

² Upper case abbreviations indicate cardinal directions relative to munitions or target; numerals indicate distance from munitions or target.

³ These samples were mechanically ground before subsampling.

The concentration of HMX in shallow subsurface soils is also presented in Table 2. At a distance of 1 m from the APC, for example, HMX concentrations at depths of 0-1 cm, 1-3 cm, 3-7 cm and 7-10 cm were 53,500, 18,200, 26,700, and 1,180 $\mu\text{g kg}^{-1}$, respectively. Except for samples collected very close to the APC (0.5 m), concentrations generally decline substantially in going from the surface to depth. HMX concentrations in soil collected next to a broken LAW rocket were much higher, ranging from 10,400,000 $\mu\text{g kg}^{-1}$ in surface soil, 1,020,000 $\mu\text{g kg}^{-1}$ in soil at 2- to 6-cm depth, and 49,300 $\mu\text{g kg}^{-1}$ at a 6- to 10-cm depth.

Mean RDX concentrations in the surface composite samples decline regularly from 1,930 $\mu\text{g kg}^{-1}$ at a distance of 0-2 m from the target to 88 $\mu\text{g kg}^{-1}$ at a distance of 10-15 m. RDX concentrations also decline with depth. For example, the concentration of RDX in a core sample collected 1 m from the target decline from 7,070 $\mu\text{g kg}^{-1}$ in the surface soil to only 315 $\mu\text{g kg}^{-1}$ at a depth of 7-10 cm (Table 2). Similarly, RDX declines from 45,700 $\mu\text{g kg}^{-1}$ at the surface, to 4,760 $\mu\text{g kg}^{-1}$ at the 2- to 6-cm depth, and to 1,530 $\mu\text{g kg}^{-1}$ at the 6- to 10-cm depth for samples collected next to a broken LAW rocket. While RDX concentrations are generally much lower than HMX, RDX may be of greater concern since RDX has a higher reported toxicity than HMX and is the contaminant of most concern in the ground water at MMR (USEPA 1988b, 2000).

In the mean composite samples, RDX concentrations range from 1.9 to 6.6 percent of the HMX present. These values are within the range expected if the RDX originated as an impurity in military grade HMX. However, results from the discrete samples indicate that the percentage of RDX relative to HMX ranges as high as 121 percent for surface samples collected about 50 cm from the target. This implies that there must be another source of RDX, perhaps 40-mm grenades, which are also fired on this range, or the use of C4 to dispose of duds. Many 40-mm practice rounds were found on the site as well as one live, intact 40-mm HE filled grenade (Figure 22). In addition, the percent of RDX relative to HMX generally increases at depth. This may be a result of the higher solubility of RDX relative to HMX (about 60 mg/L for RDX and about 5 mg/L for HMX) (Burrows et al. 1989), and a more rapid rate of dissolution. (Lynch et al 2001).

Despite the high concentration of TNT in octol (30 percent), concentrations of TNT, and the major TNT transformation products (4ADNT and 2ADNT), were much lower than either HMX or RDX in the antitank range soils. The exception was for a soil sample collected next to a ruptured LAW rocket where TNT was present at 358,000 $\mu\text{g kg}^{-1}$, and the HMX/TNT ratio was only slightly lower than that in octol. Generally, the concentrations of TNT, 4ADNT, and 2ADNT were below RP-HPLC detection limits that ranged from 16 to 38 $\mu\text{g kg}^{-1}$. These antitank range soils were not analyzed by GC-ECD because of the very high HMX and RDX concentrations, which could contaminate the injector and electron capture detector, and result in excessive instrument down time. The much lower TNT concentration in these soils, relative to HMX, is consistent with results from the Arnhem antitank range at CFB Valcartier (Jenkins et al. 1997b) and the antitank range at Fort Ord (Jenkins et al. 1998). This is likely because of its more rapid dissolution (Lynch et al. 2001), environmental transformation of TNT into its mono amino derivatives (4ADNT and 2ADNT), and subsequent humification of these compounds (Thorne and Leggett 1997; Thorn, Pennington, and Hayes in press). Under the geochemical conditions generally present in surface soils in the arid environment at Yakima (aerobic), HMX and RDX are not typically subject to biotic degradative processes. In addition, HMX and RDX have lower water solubilities and dissolve much slower into water than TNT, hence a greater percentage remains at the surface where they were deposited (Lynch et al. 2001).



Figure 22. 40-mm HE rifle grenade found on antitank range at Yakima Training Center

Relatively low concentrations of 2,4DNT (generally less than $100 \mu\text{g kg}^{-1}$) were detectable in composite and discrete samples collected near the target. Concentrations were higher than those found for TNT in many of these samples. Initially, its source was attributed to single-based propellant where it is used as a plasticizer. However, the concentrations of 2,4DNT in surface composites near the firing point were either below or just above the detection limit (about $1 \mu\text{g kg}^{-1}$). Therefore, it does not appear that rocket propellant can be the source of 2,4DNT in these antitank range soils. 2,4DNT is also an impurity in military grade TNT, where it is present at less than 1 percent. The absence of high TNT concentrations in these samples also argues against this source as well. It is possible that 2,4DNT is originating from less commonly fired ordnance, but the source remains uncertain.

Nitroglycerine (NG) was also found in all of the composite and in several discrete samples collected near the target area of the antitank range. However, the NG was distributed differently than the HMX with no apparent concentration decrease as sample distances from the target increase. Unlike 2,4DNT, the source of the NG is probably the propellant used for the antitank rockets which is triple based and contains about 20 percent NG. In previous studies of antitank ranges, data were not reported for NG (Jenkins et al. 1997b, Thiboutot et al. 1998). However, when GC-ECD chromatograms for samples from the Arnhem range at CFB Valcartier were reexamined, peaks for NG were observed. Therefore, NG may be present at other antitank ranges as well.

Two composite surface soil samples were also collected 5-10 m in front of the LAW and Rocket firing points (Table 2). This location was at least 100 m from the impact area; hence, any compounds detected should be associated with firing activities rather than detonations. NG was the only target analyte detected in these samples. The mean concentration of NG in this region was $2,740 \mu\text{g kg}^{-1}$. The most probable source of NG at the firing points is the triple-based propellants used in these munitions.

Duplicate composite samples were collected at several distances from the tank target and at the firing point. This was done to evaluate the ability to replicate surface samples using a 30 increment composite sample collection protocol. For one pair of samples (YC3 and YC4, 2-5 m from the target), the samples were mechanically ground for 60 sec using a LabTectonics ring mill at Mineral Stats, Inc., Broomfield, CO. For samples collected near the tank target that were not ground prior to subsampling, mean relative standard deviations (RSD) for HMX, RDX, TNT, and NG were 82.4, 43.9, 63.9, and 78.5 percent, respectively. The standard deviation for the pair of samples near the target that were mechanically ground prior to subsampling were 39.6, 19.9, 49.8, and 11.8 percent, respectively, a substantial improvement in the ability to replicate analyses for three of the four analytes. Thus, it appears that the grinding step was useful in reducing subsampling error and improves the overall ability to provide replicate samples for analysis.

Multipurpose Range Complex (MPRC), 120-mm tank firing point

Analytical results for soil samples collected in front of the tank firing position on the MPRC are presented in Table 3 and the results for NG and 2,4DNT are shown in Figures 23 and 24. Two components of gun propellants, NG and 2,4DNT, were found 10 m in front of the firing position at concentrations as high as $17,000 \mu\text{g kg}^{-1}$ and $33,000 \mu\text{g kg}^{-1}$, respectively. Concentrations of both analytes were still detectable 75 m from the firing point, the farthest distance sampled. These analytes were detected over the width sampled, which was 30 m (15 m to either side of our center line drawn from the firing point to the nearest target). Based on these results, two types of propellant were used at this firing point, single-based propellant in which 2,4DNT is used as a plasticizer, and triple-based propellant which is composed of NG, nitrocellulose, and nitroguanidine. These residues were deposited over an area of at least $2,250 \text{ m}^2$, at this fixed firing position.

Table 3
Explosives Concentrations in Soils near a Tank Firing Point at Yakima Multipurpose Range Complex,¹ $\mu\text{g kg}^{-1}$

Sample Number	Sample Location ²	Sample Depth, cm	RDX	TNT	NG	2,4DNT	2,6DNT
Discrete Samples: 120-mm Tank Gun							
Y95	10 m F, 10 m R	Surface	<34	<16	1,540	8,620	138
Y96	10 m F, 5 m R	Surface	142	34	17,000	30,500	376
Y97	10 m F, C	Surface	25	27	5,370	30,400	552
Y98	10 m F, 10 m L	Surface	113	29	6,560	33,000	392
Y99	10 m F, 5 m L	Surface	<34	<16	1,600	3,280	16
Y100	20 m F, 10 m R	Surface	<34	<16	6,610	2,530	16
Y124	20 m F, 10 m R	2.5-5	<3	<1	972	149	2
Y101	20 m F, 5 m R	Surface	<34	<16	4,050	6,160	32
Y125	20 m F, 5 m R	2.5-5	<34	<16	1,400	5,300	60
Y102	20 m F, C	Surface	<3	<1	442	660	<0.8
Y126	20 m F, C	2.5-5	<34	<16	448	904	14
Y103	20 m F, 5 m L	Surface	<34	<16	646	4,180	63
Y127	20 m F, 5 m L	2.5-5	<34	<16	342	668	7
Y104	20 m F, 10 m L	Surface	<34	<16	2,070	9,360	162
Y128	20 m F, 10 m L	2.5-5	<3	<1	62	344	6
Y105	30 m F, 5 m R	Surface	<34	<16	862	1,340	20
Y106	30 m F, 10 m R	Surface	<3	<1	356	280	4
Y107	30 m F, C	Surface	<3	<1	880	216	<0.8
Y108	30 m F, 5 m L	Surface	<3	<1	668	698	7
Y109	30 m F, 10 m L	Surface	<3	<1	270	157	1
Y110	50 m F, 15 m, R	Surface	<3	<1	547	114	1
Y111	50 m F, 10 m R	Surface	<34	<16	1,110	2,150	7
Y112	50 m F, 5 m R	Surface	<3	<1	280	356	2
Y113	50 m F, C	Surface	<3	<1	308	54	<0.8
Y114	50 m F, 5 m L	Surface	<34	<16	568	1,340	3
Y115	50 m F, 10 m L	Surface	<3	<1	56	40	<0.8
Y116	50 m F, 15 m L	Surface	<3	<1	320	56	<0.8
Y117	75 m F, 15 m R	Surface	<34	<16	2,650	801	8
Y118	75 m F, 10 m R	Surface	<34	<16	2,250	258	<0.8
Y119	75 m F, 5 m R	Surface	<3	<1	1,090	130	2
Y120	75 m F, C	Surface	<3	<1	860	442	5
Y121	75 m F, 5 m L	Surface	<3	<1	114	3	<0.8
Y122	75 m F, 10 m L	Surface	<3	<1	152	8	<0.8
Y123	75 m F, 15 m L	Surface	<3	<1	16	<0.8	<0.8
Composite Samples: 120-mm Tank Gun							
YC28	10 m F	Surface	<100	<100	6,030	26,500	392
YC33	10 m F	Surface	<100	<100	3,090	22,200	418
YC29	20 m F	Surface	<100	<100	1,890	5,550	32
YC30	20 m F	Surface	<100	<100	705	10,900	230
YC36	30 m F	Surface	<34	<16	604	480	2
YC37	30 m F	Surface	<100	<100	669	3,860	<19
YC31	50 m F	Surface	<34	<16	306	14	<19
YC32	50 m F	Surface	<100	<100	348	1,350	<19
YC34	75 m F	Surface	<34	<16	496	56	<19
YC35	75 m F	Surface	<34	<16	513	319	<19

¹ The following undetected analytes were excluded from the table: TNB, PETN, 4ADNT, 2ADNT, HMX, DNA, DNB, Tetrl. All shaded data were generated using RP-HPLC analysis. All other data were generated using GC-ECD.

² Sample location is relative to munitions or target; F = Front, R = Right, C = Center, L = Left

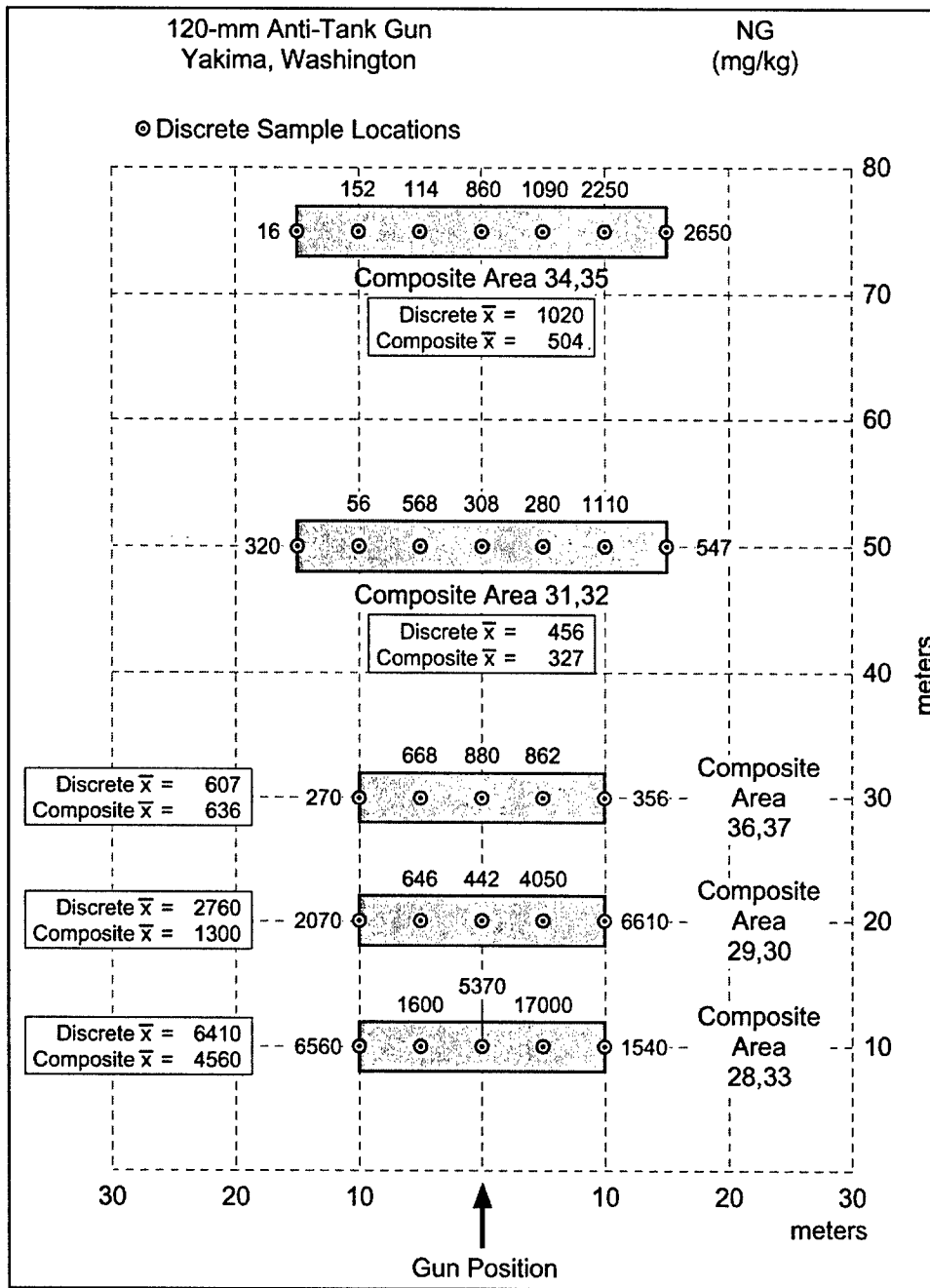

Figure 23. Surface soil concentrations for NG samples collected at the MPRC tank firing range at Yakima Training Center

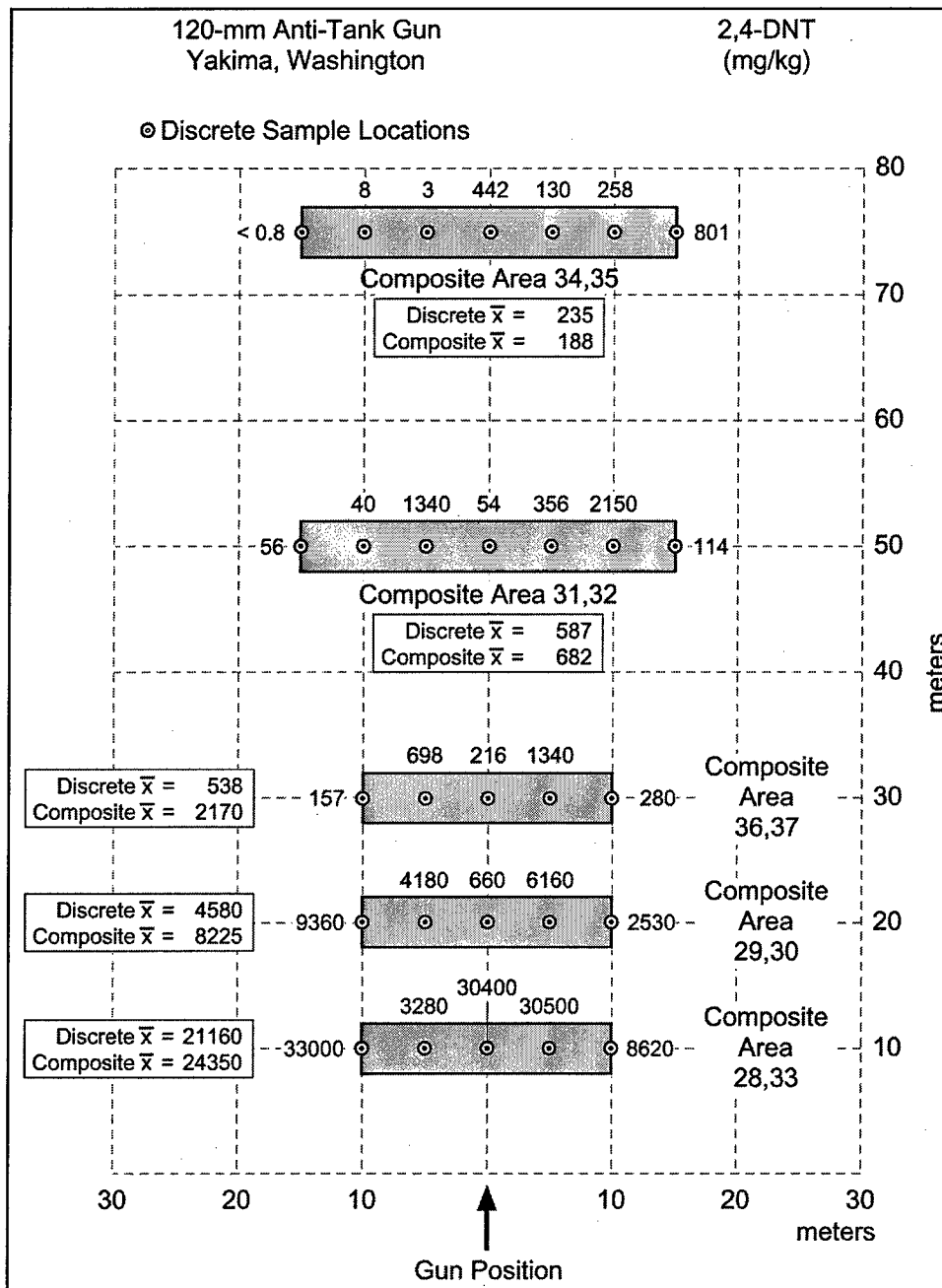

Figure 24. Surface soil concentrations for 2,4DNT samples collected at the MPRC tank firing range at Yakima Training Center

2,6DNT was also detected in most of the samples collected at this firing point. 2,6DNT is an impurity in military grade 2,4DNT. The mean ratio of 2,4 to 2,6DNT in the five discrete samples where the 2,6DNT was present above $100 \mu\text{g kg}^{-1}$ was 68. Recent results from biodegradation studies by Spain (personal communication)¹ indicate that 2,6DNT does not degrade to any extent when 2,4DNT is present, and the ratio of 2,4 to 2,6DNT may be indicative of the

¹ Dr. James Spain, U.S. Air Force Research Laboratory, Tyndall Air Force Base, Florida, personal communication, 2001.

degree to which biodegradation has taken place. Thus far, we have been unable to obtain information on the initial ratio of 2,4DNT to 2,6DNT to assess whether much degradation has taken place, but once this information is available, these ratios should provide a useful insight into the rate of transformation of 2,4DNT in surface soils.

Concentrations of NG in the surface soils (0-2.5 cm) 20 m from the firing position ranged from 442 to 6,610 $\mu\text{g kg}^{-1}$ for NG with a mean value of 2,760 $\mu\text{g kg}^{-1}$. NG concentrations for samples collected at the 2.5-5 cm depth ranged from 62 to 1,400 $\mu\text{g kg}^{-1}$ with a mean of 645 $\mu\text{g kg}^{-1}$. Likewise for 2,4DNT, concentrations in the top 2.5 cm ranged from 660 to 9,360 $\mu\text{g kg}^{-1}$ with a mean of 4,580 $\mu\text{g kg}^{-1}$, while at the 2.5-5 cm depth they ranged from 149 to 5,300 $\mu\text{g kg}^{-1}$ with a mean of 1,470 $\mu\text{g kg}^{-1}$. Thus, some downward transport of these compounds has occurred even at this arid site. Deeper samples were not collected because of concerns about the possible presence of UXO.

The mean 2,4DNT to 2,6DNT ratio in the five subsurface soil samples was 76. This ratio indicated that very little change in the ratio of the 2,4 to 2,6DNT had occurred in the subsoil relative to that at the surface at the time these samples were collected. If Spaine's conclusions are correct, this indicates that little biotransformation of 2,4DNT had occurred in the subsurface at this location.

The only other energetics-related compounds detected at the MPRC were in a few samples, generally near the firing point, where low concentrations of TNT and RDX were detected. The samples where TNT was detected generally had 2,4DNT concentrations in excess of 3,000 $\mu\text{g kg}^{-1}$, indicating that the TNT ($<50 \mu\text{g kg}^{-1}$) was possibly an impurity in the military grade 2,4DNT. The source of the low levels of RDX in a few of these soil samples is unknown, but these were the samples nearest the firing point and the same samples in which TNT was detected.

155-mm howitzer firing points

Results from the analysis of discrete and composite soil samples from two 155-mm howitzer firing points are shown in Table 4. No target analytes were detected in composite samples collected at Gun Position 1. From the Gun Position 2, composite 2,4DNT was found in five of the eight samples. This included both duplicates at distances of 5 and 10 m from the muzzle, and one of the two duplicates collected at 20 m from the muzzle. Concentrations of 2,4DNT in these samples ranged from 11 to 94 $\mu\text{g kg}^{-1}$. No NG or other explosives-related analytes were detected in any of these composites.

Table 4
Explosives Concentrations in Soils at Two 155-mm Howitzer Firing Points, Yakima Training Center¹, $\mu\text{g kg}^{-1}$

Sample Number	Sample Location ²	Sample Depth, cm	RDX	2,4DNT
Discrete Samples: Howitzer Firing Point # 1				
Y26	5 m W	Surface	<3	24
Y27	At muzzle	Surface	9	<0.8
Y28	5 m E	Surface	<3	<0.8
Y29	5 m W	Surface	<3	<0.8
Y30	C, 5 m out	Surface	<3	<0.8
Y31	5 m E, 5 m out	Surface	<3	24
Y32	10 m W, 10 m out	0.0-2.5	<3	<0.8
Y33	10 m W, 10 m out	2.5-5.5	<3	<0.8
Y34	5 m W, 10 m out	0.0-2.5	<3	<0.8
Y35	5 m W, 10 m out	2.5-5.5	<3	<0.8
Y36	C, 10 m out	0.0-2.5	<3	<0.8
Y37	C, 10 m out	2.5-5.5	<3	<0.8
Y38	5 m E, 10 m out	0.0-2.5	<3	<0.8
Y39	5 m E, 10 m out	2.5-5.5	<3	<0.8
Y40	10 m E, 10 m out	0.0-2.5	5	5
Y41	10 m E, 10 m out	2.5-5.5	<3	<0.8
Y42	10 m W, 20 m out	Surface	<3	<0.8
Y43	5 m W, 20 m out	Surface	<3	5
Y44	C, 20 m out	Surface	<3	185
Y45	5 m E, 20 m out	Surface	<3	<0.8
Y46	10 m E, 20 m out	Surface	<3	<0.8
Y47	15 m W, 50 m out	Surface	<3	<0.8
Y48	10 m W, 50 m out	Surface	<3	<0.8
Y49	5 m W, 50 m out	Surface	<3	6
Y50	C, 50 m out	Surface	<3	<0.8
Y51	5 m E, 50 m out	Surface	<3	<0.8
Y52	10 m E, 50 m out	Surface	<3	<0.8
Y53	15 m E, 50 m out	Surface	<3	<0.8
Composite Samples: Howitzer Firing Point # 1				
YC11	5 m	Surface	<3	<0.8
YC12	10 m	Surface	<3	<0.8
YC13	20 m	Surface	<3	<0.8
YC14	50 m	Surface	<3	<0.8
Composite Samples: Howitzer Firing Point # 2				
YC16	5 m	Surface	<3	19
YC17	5	Surface	<3	11
YC18	10 m	Surface	<3	65
YC19	10 m	Surface	<3	16
YC20	20 m	Surface	<3	94
YC21	20 m	Surface	<3	<0.8
YC22	50 m	Surface	<3	<0.8
YC23	50 m	Surface	<3	<0.8

¹ The following undetected analytes were excluded from the table: HMX, TNT, NG, 2,6DNT, 2ADNT, 4ADNT, TNB, PETN, DNA, DNB, Tetryl. All data were generated using GC-ECD analysis.
² Sample location is relative to the Howitzer muzzle; W = West, E = East, C = Center.

2,4DNT was detected in 6 of the 23 discrete samples collected at Gun Position 1. The highest concentration was $185 \mu\text{g kg}^{-1}$ for a sample collected 20 m from the muzzle. Concentrations of 2,4DNT in the remaining five samples ranged from 5 to $24 \mu\text{g kg}^{-1}$ with these positive samples located randomly over the

sampled area and as far as 50 m from the muzzle position. There was no detection of 2,4DNT in the five shallow subsurface samples.

NG was detected in none of the discrete or composite samples. RDX was detected in two discrete samples, but the concentrations were only 5 and 9 $\mu\text{g kg}^{-1}$, respectively.

Overall, the concentrations of explosives and propellant residues at the 155-mm firing point were very low and often undetectable using Method 8095. This result agrees with that found at Camp Shelby, MS (CHPPM 2001), where almost all results were below the detection limit of the analytical method used (RP-HPLC Method 8330 (USEPA 1994). The fact that 2,4DNT was detected at the Yakima firing points and NG was not indicates that the propellant used at these firing points was probably single-based.

The final firing point sampled at YTC was used for direct fire of 155-mm howitzers. This position is within 100 m of the central impact area and had recently been used for firing activity. Composite samples collected at distances ranging from 7 to 32 m from the firing pad indicated the presence of NG and 2,4DNT, but the deposition pattern suggests independent deposition of the two propellant-related analytes (Table 5). For NG, the concentrations decline at increasing distance from the firing pad; for 2,4DNT, the concentrations are only detectable at distances of 22 and 32 m from the pad. Thus, it appears that triple-based propellant was used for the direct fire of the 155-mm howitzers and that some other firing activity also took place at this location, depositing 2,4DNT.

Table 5
Explosives Concentrations in Soils at Direct Fire 155-mm Firing Point near Central Impact Area, Yakima Training Center,¹ $\mu\text{g kg}^{-1}$

Sample Number	Sample Location ²	Sample Depth, cm	NG	2,4DNT	2,6DNT
Discrete Samples					
Y153	7 m, 5 m R of C	Surface	1,220	52	<0.8
Y154	7 m C	Surface	45	3	<0.8
Y155	7 m, 5 m L of C	Surface	75	<0.8	<0.8
Y156	12 m, 5 m R of C	Surface	1,250	<0.8	<0.8
Y157	12 m, C	Surface	2,610	<0.8	<0.8
Y158	12 m, 5 m L of C	Surface	20,100	<0.8	<0.8
Y159	22 m, 5 m R of C	Surface	5,900	<0.8	<0.8
Y160	22 m, C	Surface	9,430	11	<0.8
Y161	22 m, 5 m L of C	Surface	11,800	8250	190
Y162	32 m, 5 m R of C	Surface	1,160	10	<0.8
Y163	32 m, C	Surface	9,660	240	<0.8
Y164	32 m, 5 m L of C	Surface	12,300	12	<0.8
Composite Samples					
YC60	7 m	Surface	25,700	<28	<19
YC61	12 m	Surface	2,952	<28	<19
YC62	22 m	Surface	6,012	3225	50
YC63	32 m	Surface	1,852	266	<19

¹ The following undetected analytes were excluded from the table: HMX, RDX, TNT, 2ADNT, 4ADNT, TNB, PETN, DNA, DNB, Tetryl. All shaded data were generated using RP-HPLC analysis. All other data were generated using GC-ECD.

² The sample location is relative to the firing pad. The first number is out from the firing pad and the next number is the cardinal direction from the firing pad; R = Right, L = Left, C = Center.

Results from analysis of the 12 discrete samples collected at this area are consistent with the composite sample results. NG and 2,4DNT were detected in many of these samples with the highest 2,4DNT concentrations for samples collected at 22 and 32 m from the firing pad. The concentration gradient for NG, as a function of distance from the pad, was not identifiable in the discrete samples. In fact, the lowest NG concentration was found for samples collected 7 m from the firing point, while mean concentrations for samples collected at 12, 22, and 32 meters were very similar. Both analytes exhibited extreme spatial heterogeneity in the discrete samples.

Mortar firing point

The results from analysis of surface soil samples from the 81-mm mortar firing position are presented in Table 6. Four composite samples were collected 5, 10, 15, and 20 m from the position of the base plate. NG was detected in the composite sample collected 10 m from the base plate position at a concentration of 246 $\mu\text{g kg}^{-1}$. No other target analytes were detected. The presence of NG is consistent with the composition of the double-based propellant used with 81-mm mortars.

Table 6
Explosives Concentrations in Surface Soil at an 81-mm Mortar Firing Point, Yakima Training Center,¹ $\mu\text{g kg}^{-1}$

Sample Number	Sample Location ²	NG
Discrete Samples		
Y58	1 m F	<22
Y59	3 m L, 5 m out	45
Y60	C, 1 m out	<22
Y61	3m R, 5 m out	32
Y62	5 m L, 10 m out	40
Y63	C, 10 m out	26
Y64	5 m R, 10 m out	<22
Y65	5 m L, 15 m out	<22
Y66	C, 15 m out	<22
Y67	5 m R, 15 m out	40
Y68	5 m L, 20 m out	<22
Y69	C, 20 m out	23
Y70	5 m R, 20 m out	<22
Composite Samples		
YC24	5 m	<22
YC25	10 m	246
YC26	15 m	<22
YC27	20 m	<22

¹ The following undetected analytes were excluded from the table: HMX, RDX, TNT, 2,4DNT, 2,6DNT, 2ADNT, 4ADNT, TNB, PETN, DNA, DNB, Tetryl. All data were generated using GC-ECD analysis.

² Sample location is in reference to the base plate of 81-mm mortar firing point; F = Front, L = Left, C = Center, R = Right.

A set of 13 discrete samples was also collected within the same area. NG was detected in 6 of the 13 at distances as far as 20 m from the base plate location, but concentrations were always less than 45 $\mu\text{g kg}^{-1}$. NG was detected in some samples at a given distance, but not in others from the same distance. The lack of a discernable pattern to this deposition indicates that the deposition was spatially random. As with the composite samples, no other target analytes were detected in any of these discrete samples.

Central impact area

Several target analytes were detected in composite samples collected in two of the four detonation craters at the artillery range impact area. However, concentrations of these target analytes were always less than 26 $\mu\text{g kg}^{-1}$ (Table 7). RDX was detected in four of these samples with a maximum concentration of 17 $\mu\text{g kg}^{-1}$. 2ADNT and 4ADNT were detected in one. Results for the discrete samples collected around the same four craters, plus a fifth one, confirm that target analyte concentrations are very low. RDX was detected at 8 $\mu\text{g kg}^{-1}$ in 1 of the 22 crater samples. No other target analytes were detected in these samples.

Table 7
Explosives Concentrations in Soils Collected at Yakima Central Impact Area Range 261,¹
 $\mu\text{g kg}^{-1}$

Sample No.	Munitions/ Target	Sample Location ²	Sample Depth, cm	HMX	RDX	NG	2,4DNT	2,6DNT	2ADNT	4ADNT	PETN
Discrete Samples											
Y71	81mm IR ³ Ru ⁴		Surface	<26	<3	<22	<0.8	<0.8	<2.5	<1.6	<16
Y72	155-mm #1	E	Surface	<26	<3	<22	<0.8	<0.8	<2.5	<1.6	<16
Y73	155-mm #1	N	Surface	<26	<3	<22	<0.8	<0.8	<2.5	<1.6	<16
Y74	155-mm #1	W	Surface	<26	<3	<22	<0.8	<0.8	<2.5	<1.6	<16
Y75	155-mm #1	S	Surface	<26	<3	<22	<0.8	<0.8	<2.5	<1.6	<16
Y76	155-mm #2	E	Surface	<26	<3	<22	<0.8	<0.8	<2.5	<1.6	<16
Y77	155-mm #2	S	Surface	<26	<3	<22	<0.8	<0.8	<2.5	<1.6	<16
Y78	155-mm #2	N	Surface	<26	<3	<22	<0.8	<0.8	<2.5	<1.6	<16
Y79	155-mm #2	W	Surface	<26	8	<22	<0.8	<0.8	<2.5	<1.6	<16
Y80	155-mm #3	N	Surface	<26	<3	<22	<0.8	<0.8	<2.5	<1.6	<16
Y81	155-mm #3	W	Surface	<26	<3	<22	<0.8	<0.8	<2.5	<1.6	<16
Y82	155-mm #3	S	Surface	<26	<3	<22	<0.8	<0.8	<2.5	<1.6	<16
Y83	155-mm #3	E	Surface	<26	<3	<22	<0.8	<0.8	<2.5	<1.6	<16
Y92	155-mm #4	C	Surface	<26	<3	<22	<0.8	<0.8	<2.5	<1.6	<16
Y93	155-mm #4	W	Surface	<26	<3	<22	<0.8	<0.8	<2.5	<1.6	<16
Y94	155-mm #4	N	Surface	<26	<3	<22	<0.8	<0.8	<2.5	<1.6	<16
Y129	155-mm #4	W	Surface	<26	<3	<22	<0.8	<0.8	<2.5	<1.6	<16
Y130	155-mm #4	S	Surface	<26	<3	<22	<0.8	<0.8	<2.5	<1.6	<16
Y133	155-mm #5	C	Surface	<26	<3	<22	<0.8	<0.8	<2.5	<1.6	<16
Y134	155-mm #5	N	Surface	<26	<3	<22	<0.8	<0.8	<2.5	<1.6	<16
Y135	155-mm #5	E	Surface	<26	<3	<22	<0.8	<0.8	<2.5	<1.6	<16
Y136	155-mm #5	S	Surface	<26	<3	<22	<0.8	<0.8	<2.5	<1.6	<16
Y137	155-mm #5	W	Surface	<26	<3	<22	<0.8	<0.8	<2.5	<1.6	<16

(Continued)

Table 7 (Concluded)

Sample No.	Munitions/ Target	Sample Location ²	Sample Depth, cm	HMX	RDX	NG	2,4DNT	2,6DNT	2ADNT	4ADNT	PETN
Y84	New 155-mm, dud	Under Nose	Surface	26	719	<22	7	3	49	58	<16
Y85	155-mm, WP	FR	Surface	1,770	6,720	<22	22	0.8	0.8	2.5	<16
Y86	155-mm, WP	BR	Surface	5,240	53,500	<22	22	0.8	0.8	2.5	<16
Y87	155-mm, IR Broken HE charge in sample	F	Surface	<26	<3	<22	<0.8	<0.8	<2.5	<1.6	<16
Y88	155-mm, IR Broken HE charge in sample	F	1.0	<26	<3	<22	<0.8	<0.8	<2.5	<1.6	<16
Y89	155-mm, IR Broken HE charge in sample	F	5.0	<26	<3	<22	<0.8	<0.8	<2.5	<1.6	<16
Y90	105-mm, HE filled, Rusty	Nose	Surface	<26	8	<22	144	3	9	5	115
Y91	105-mm, HE filled, Rusty	Tail	Surface	<26	7	<22	<0.8	<0.8	<2.5	<1.6	<16
Y131	AFI ⁵ Broken	Casing	Surface	<26	<3	<22	<0.8	<0.8	<2.5	<1.6	<16
Y132	AFI Broken	Casing	Surface	<26	<3	<22	<0.8	<0.8	<2.5	<1.6	<16
Y56	105-mm	Under HEP	Surface	<26	<3	<22	<0.8	<0.8	<2.5	<1.6	<16
Y57	105-mm	Under HEP	2.5	<26	<3	<22	<0.8	<0.8	<2.5	<1.6	<16
Sample No.	Munitions/ Target	Sample Location, ⁶ m	Sample Depth, cm	HMX	RDX	NG	2,4DNT	2,6DNT	2ADNT	4ADNT	PETN
Composite Samples											
YC38	155-mm #1	0-1.0	Surface	<26	17	<22	<0.8	<0.8	3	4	<16
YC39	155-mm #2	1.0	Surface	<26	<3	<22	<0.8	<0.8	<2.5	<1.6	<16
YC40	155-mm #2	1.0	Surface	<26	<3	<22	<0.8	<0.8	<2.5	<1.6	<16
YC41	155-mm #3	1.0	Surface	<26	<3	<22	<0.8	<0.8	<2.5	<1.6	<16
YC42	155-mm #3	2.0-3.0	Surface	<26	14	<22	<0.8	<0.8	<2.5	<1.6	<16
YC43	155-mm #3	5.0-6.0	Surface	<26	15	<22	<0.8	<0.8	<2.5	<1.6	<16
YC44	155-mm #3	7.0-8.0	Surface	<26	15	<22	<0.8	<0.8	<2.5	<1.6	<16
YC50	155-mm #5	1.0	Surface	<26	<3	<22	<0.8	<0.8	<2.5	<1.6	<16

¹ The following undetected analytes were excluded from the table: TNT, TNB, DNA, DNB, Tetryl. All data were generated using GC- ECD analysis.

² Sample location is relative to crater of particular munitions; E = East, N = North, W = West, S = South, C = Center, FR = Front of Round, BR = Back of Round.

³ Illumination round.

⁴ Ruptured.

⁵ Air Force illumination round.

⁶ Sample location is in reference to crater.

Samples were also collected in the impact area around various types of objects that we observed during range reconnaissance. Surface soil that was sampled under the nose of a relatively recent in-tact 155-mm howitzer round contained RDX at 719 $\mu\text{g kg}^{-1}$. In addition, 2ADNT and 4ADNT, transformation products of TNT, were found at 49 and 58 $\mu\text{g kg}^{-1}$, respectively. The presence of the environmental transformation products of TNT demonstrated that while TNT was not detected, it had been present at some point in the past.

Surface soil samples from under the front and back of a corroded 155-mm dud, tentatively identified by EOD personnel as a WP round, contained RDX at

6,720 and 53,500 $\mu\text{g kg}^{-1}$, respectively. RDX is used in the burster charge for this round. Water had apparently entered the round and leached RDX into the soil beneath. HMX, a manufacturing impurity of RDX, was also present.

No target analytes were detected in the set of surface and shallow subsurface soils beneath a 155-mm illumination round.

Several target analytes were detected in two surface soil samples collected next to a very corroded 105-mm HE dud that was sitting on the surface. These included RDX; 2,4 and 2,6DNT; 2 and 4ADNT; and PETN. The highest concentration was for 2,4DNT at 144 $\mu\text{g kg}^{-1}$ in one of the samples. 2,4DNT is not a major component of the explosive in 105-mm howitzer rounds and was probably deposited from a different source, such as propellant. The RDX concentrations in these two samples were 7 and 8 $\mu\text{g kg}^{-1}$. The concentrations of 2ADNT and 4ADNT were 9 and 5 $\mu\text{g kg}^{-1}$ in one of the two samples, respectively. TNT was not detected, but the presence of the monoamino transformation products indicates that it had been present at one time. The low concentrations of RDX and the TNT transformation products could have originated from Composition B in the 105-mm dud, but this is only speculation. Nevertheless, the very low concentrations indicate that the round is not a significant source of explosives residues to the site at present.

No target analytes were detected next to an Air Force illumination round or in the surface or subsurface soil next to a 105-mm HEP round.

Claymore mine

The results for the four surface composite samples collected in front of the detonation point for a Claymore mine are presented in Table 8. The only target analytes detected in these samples were NG and 2,4DNT. Concentrations of NG in the 5-, 10-, and 15-m samples were 1,270, 66, and 96 $\mu\text{g kg}^{-1}$, while the concentration at 20 m was less than the detection limit. For 2,4DNT, the concentration found at 10 m was 4 $\mu\text{g kg}^{-1}$, while at 15 m it was 3 $\mu\text{g kg}^{-1}$.

Nearly identical results were found from analysis of the 12 discrete samples collected in this same area. Mean NG concentrations declined from 851 $\mu\text{g kg}^{-1}$ at 5 m, to 151 $\mu\text{g kg}^{-1}$ at 10 m, to 132 $\mu\text{g kg}^{-1}$ at 15 m, and to 72 $\mu\text{g kg}^{-1}$ at 20 m. 2,4DNT was detected in 7 of the 12 samples with concentrations randomly varying from 4 to 18 $\mu\text{g kg}^{-1}$.

The Claymore mine that was detonated was placed along the fence line separating the impact area of the range from the maneuver and firing point area. Since Claymore mines do not contain NG or 2,4DNT, their presence in these samples was not a result of the detonation of the Claymore. Rather, these compounds were undoubtedly deposited from propellants from artillery and mortars fired over the fence line into the impact area.

Table 8 Explosives Concentration in Soil from a Claymore Mine Detonation Area, Yakima Training Center,¹ $\mu\text{g kg}^{-1}$				
Sample Number	Sample Location ²	Sample Depth, cm	NG	2,4DNT
Discrete Samples				
Y139	5 m from, 3 m RC	Surface	1,050	<0.8
Y140	5 m from, C	Surface	1,340	18
Y141	5 m from, 3 m LC	Surface	163	<0.8
Y142	10 m from, 3 m RC	Surface	175	7
Y143	10 m from, C	Surface	128	<0.8
Y144	10 m from, 3 m LC	Surface	153	5
Y145	15 m from, 3 m RC	Surface	49	<0.8
Y146	15 m from, C	Surface	199	14
Y147	15 m from, 3 m LC	Surface	147	17
Y148	20 m from, 3 m RC	Surface	67	4
Y149	20 m from, 3 m RC	Surface	16	<0.8
Y150	20 m from, 3 m LC	Surface	137	9
Composite Samples				
YC64	5 m from	Surface	1,270	<0.8
YC65	10 m from	Surface	51	4
YC66	15 m from	Surface	96	3
YC67	20 m from	Surface	<22	<0.8
¹ The following undetected analytes were excluded from the table: HMX, RDX, TNT, 2,6DNT, 2ADNT, 4ADNT, TNB, PETN, DNA, DNB, Tetryl. All data were generated using GC-ECD. ² Sample location is relative to detonation point; RC = Right of Center, C = Center, LC = Left of Center.				

Soil geochemistry

Soils at the Yakima Training Center are loam to sandy loam with a slightly acid pH (Table 9). TOC and CEC are moderate, averaging less than 2 percent and 20 meq 100 g⁻¹, respectively. Soils are generally typical of the region.

Table 9 Soil Geochemistry, Yakima Training Center								
Site	TOC ¹ percent	CEC ² meq/100 g	Total Iron percent	pH	Particle Size			TKN ³ mg kg ⁻¹
					Clay percent	Sand percent	Silt percent	
YC 34,35	1.91	15.7	1.89	6.6	18.3	51.6	30.1	805
YC 11,13,14	1.46	16.7	2.05	6.6	16.4	44.4	39.2	1,000
YC 41,42,43,44	2.0	19.6	2.14	6.2	20.1	48.5	31.4	1,115
YC 24,25,226,27	1.72	17.2	2.12	6.2	23.0	56.5	20.5	1,318
YC 9,10	2.31	16.3	2.7	6.7	20.2	50.9	28.9	1,644
¹ Total organic carbon. ² Cation exchange capacity. ³ Total Kjeldahl nitrogen.								

Potable and surface water

Ground and surface water is generally soft (sum of Ca and Mg <50 mg L⁻¹ (Table 10)). Total iron was less than the EPA drinking water standard of 0.3 mg L⁻¹, except in surface water from Lmumma Creek on the impact area where it was only slightly higher (0.62 mg L⁻¹). All other parameters were low and typical of the environment. No explosives or degradation products of explosives were detected.

Sample Location	Ca	Fe	Mg	Mn	NO ₂ /NO ₃	SO ₄	Cl
YRS Well	23.3	<0.120	14.2	<0.004	0.13	14	7.8
Lmumma Creek	40.9	0.070	19.4	0.0082	<0.10	30	21
Range 55	18.8	0.150	9.30	0.0043	0.91	15	6.4
Selah Creek	21.4	0.250	10.8	0.0308	<0.10	12	7.1
Range 19	32.8	<0.120	17.2	0.0083	0.33	23	16
Lmumma Creek Impact Area	27.1	0.620	14.6	0.0828	0.24	15	10

Camp Guernsey, Wyoming

Artillery impact area

Results for the surface composites around the truck target selected on the artillery range at Camp Guernsey (Figure 17) indicate that the concentrations of explosives residues are quite low (Table 11). The highest concentrations were for HMX in the samples nearest the target (1-m samples) with a mean concentration for duplicates of 151 $\mu\text{g kg}^{-1}$. 2ADNT and 4ADNT were detected in most of these samples at concentrations at or below 54 $\mu\text{g kg}^{-1}$. TNT and RDX were also detected in several of these samples, but the concentrations were below 20 $\mu\text{g kg}^{-1}$ and 4 $\mu\text{g kg}^{-1}$, respectively.

Concentrations in the discrete samples collected at this site were also very low, always below 30 $\mu\text{g kg}^{-1}$ except for a sample in the depth interval 5-10 cm collected 5 m from the target. In this samples, the concentrations of TNT, 2ADNT, 4ADNT, and TNB were 22,700, 1,080, 1,080, and 200 $\mu\text{g kg}^{-1}$, respectively. Concentrations for the other depth intervals for this sample, including those above and below this sample, were below 15 $\mu\text{g kg}^{-1}$ in all cases. The reason why one subsurface sample had a much greater concentration than any other is unclear, and the sample may have been contaminated in some way with a small particle of explosive from the surface.

Overall, concentrations of explosives-related analytes in these samples were very low. In fact, if Method 8330 (USEPA 1994) were used exclusively for these samples, almost all values would have been below analytical detection limits. These results agree with those from Yakima, those obtained by Walsh et al. (2001) for Fort Greely, Alaska, and those obtained by CHPPM (2001) for samples collected at the Camp Shelby, Mississippi, artillery range, and show that explosives residues in most areas at artillery impact areas sampled to date are in the low $\mu\text{g kg}^{-1}$ range or below, even near targets.

Table 11
Explosives Concentrations in Soils at the Artillery Impact Area at Camp Guernsey,¹
µg kg⁻¹

Sample No.	Sample Location ²	Sample Depth, cm	HMX	RDX	TNT	2ADNT	4ADNT	TNB
Discrete Samples								
G1	1 m	Surface-1.0	<26	<3	<1	11	10	<3
G2	1 m	1.0-5.0	<26	<3	<1	<2.5	<1.6	<3
G3	1 m	5.0-10.0	<26	<3	<1	<2.5	<1.6	<3
G4	5 m	Surface-1.0	<26	<3	<1	7	10	<3
G5	5 m	1.0-2.0	<26	4	<1	5	9	<3
G6	5 m	2.0-5.0	<26	<3	<1	11	14	<3
G7	5 m	5.0-10.0	<26	<34	22,700	1,080	1,080	200
G8	5 m	10.0-17.0	<26	<3	<1	4	5	<3
G41	1 m, D	Surface	<26	13	<1	8	12	<3
G42	1 m, D	Surface	<26	<3	<1	<2.5	<1.6	<3
G43	5 m, D	Surface	<26	8	<1	6	10	<3
G44	5 m, D	Surface	<26	<3	<1	11	18	<3
G45	10 m, D	0.0-1.0	<26	<3	<1	6	10	<3
G46	10 m, D	1.0-5.0	<26	<3	<1	5	9	<3
G47	10 m, D	5.0-10.0	<26	<3	<1	6	10	<3
G48	10 m, D	10.0-15.0	<26	<3	<1	<2.5	<1.6	<3
G49	15 m, D	0.0-1.0	<26	<3	<1	11	15	<3
G50	15 m, D	1.0-5.0	<26	<3	<1	15	17	<3
G51	15 m, D	5.0-10.0	29	<3	<1	10	19	<3
G52	15 m, D	10.0-15.0	25	12	<1	3	6	<3
Composite Samples								
GC1	1 m	Surface	116	<34	<16	<38	<32	<16
GC2	1 m	Surface	186	<34	<16	<38	<32	<16
GC3	5 m	Surface	<26	3	6	11	19	<3
GC4	5 m	Surface	<26	4	<1	8	11	<3
GC5	10 m	Surface	<26	3	13	40	54	<3
GC6	10 m	Surface	<26	<3	13	14	23	<3
GC7	15 m	Surface	<26	<3	<1	6	11	<3
GC8	15 m	Surface	<26	3	<1	7	13	<3

¹ The following undetected analytes were excluded from the table: 2,6DNT, 2,4DNT, TNB, PETN, DNA, DNB, Tetryl. All shaded data were generated using RP-HPLC analysis. All other data were generated using GC-ECD.
² Sample location is relative to truck target; D = Down slope.

Characterization of area near low-order 500-lb bomb prior to detonation

During exploration of the artillery impact area at Camp Guernsey, we noticed a large munitions item that had apparently undergone a low-order detonation (Figure 18). The item was subsequently identified by EOD personnel as an Air Force 500-lb bomb (Mark 82). The bomb contained a large amount of residual explosive, perhaps as much as half (about 40 kg) of the original explosive charge. The explosive had been exposed to the light and had turned red in the sun, indicating that at least a portion of the explosive fill was TNT. Analysis confirmed that it was TNT with about 0.2 percent of TNB (Table 12), a major photochemical degradation product of TNT. Because no Air Force bombing had occurred in the last several years (according to EOD team), this ruptured bomb had been on site for a minimum of 2 years.

Table 12
Explosives Concentrations in Soils Near a Ruptured 500-lb Bomb, Camp Guernsey,¹
 $\mu\text{g kg}^{-1}$

Sample Number	Sample Location ²	Sample Depth, cm	HMX	RDX	TNT	2,4DNT	2,6DNT	2ADNT	4ADNT	TNB	DNA
Discrete Samples: Low-Order 500-lb Bomb Prior to Detonation with C4											
G66	ES	Surface	<10,000	<10,000	9,440,000	<10,000	<10,000	<10,000	<10,000	50,000	<10,000
G67	ES	1.0-3.0	4,200	600	240,000	<1,000	<1,000	<10,000	<10,000	3,200	<1,000
G68	ES	4.0-7.0	1,280	<1,000	42,000	1,960	<1,000	19,400	15,960	960	<10,000
G63	4.7 m	Surface	<10,000	<10,000	8,050,000	<10,000	<10,000	<10,000	<10,000	48,000	<10,000
G64	2 m D	Surface	204	38	4,660	98	138	2,980	4,532	274	206
G65	1 m D	Surface	<2,000	<2,000	467,000	<2,000	<2,000	9,200	8,000	3,600	<2,000
G19	Piece of explosive in 500-lb bomb		<0.1 percent	<0.1 percent	99+ percent	<0.1 percent	<0.1 percent	<0.1 percent	<0.1 percent	<0.2 percent	<0.1 percent
Discrete Samples after Bomb Detonated with C4											
G24	Center	Surface	<2,000	<2,001	66,700	<2,000	<2,000	7,400	2,900	1100	<2000
G69	NR	Surface	178	<34	7,400	<28	<19	10,700	9,190	202	
G70	ER	Surface	<26	<34	45,500	<28	<19	4,360	2,160	<16	
G71	SR	Surface	<26	128	20,500	246	98	5,031	4,040	340	142
G72	WR	Surface	<26	28	3,980	<28	<19	1,000	808	68	20
G90	3 m S	Surface	<2,000	160	68,000	<2,000	<2,000	2,600	1,360	560	<2,000
G91	3 m S	Surface	<5,000	<5,000	150,000	<5,000	<5,000	<5,000	<5,000	1,200	<5,000
G92	5 m S	Surface	<1,000	<1,000	29,000	<1,000	<1,000	2,160	1,560	220	<1,000
G93	5 m S	Surface	<1,000	<1,000	24,100	<1,000	<1,000	1,160	1,860	200	<1,000
G94	10 m S	Surface	<26	80	820	<28	<19	210	390	98	
G95	10 m S	Surface	<26	14	482	<28	<19	<100	<100	<16	
G96	WS, 3.5 m SW of C	Surface	<1,000	120	28,000	<1,000	<1,000	960	1,160	160	<1,000
G97	WS, 3.5 m from Edge	Surface	<2,000	<2,000	64,350	<2,000	<2,000	2,920	1,920	600	<2,000
G98	WS 3.5 m from Edge	Surface	<1,000	<500	30,200	<1,000	<1,000	3,840	3,320	220	<1,000
G99	WS 3.5 m from Edge	Surface	<1,000	140	34,400	<1,000	<1,000	1,960	1,340	260	<1,000
G100	WS 3.5 m from Edge	Surface	<2,000	<2,000	61,500	<2,000	<2,000	1,080	1,240	360	<2,000
G101	WS 3.5 m from Edge	Surface	<5,000	<5,000	61,500	<5,000	<5,000	<5,000	<5,000	600	<5,000
G102	WS 3.5 m from Edge	Surface	<10,000	<10,000	206,000	<10,000	<10,000	<10,000	<10,000	1,400	<10,000
Composite Samples Prior to Detonation of Bomb											
GC27	10 m from	Surface	<26	<34	602	<28	<19	34	60	8	
GC28	10 m from	Surface	<26	<34	10	<28	<19	53	63	6	
GC29	5 m from	Surface	<26	<34	320	<28	<19	270	348	<16	
GC30	5 m from	Surface	<26	4	199	<28	6	180	254	9	
GC31	3 m from	Surface	18	134	4,170	20	<19	808	990	98	48
GC32	3 m from	Surface	44	36	21,900	42	54	2,070	2,720	228	

(Continued)

Table 12 (Concluded)

Sample No.	Sample Location ³	Sample Depth, cm	HMX	RDX	TNT	2,4DNT	2,6DNT	2ADNT	4ADNT	TNB	DNA
Composite Samples after Bomb Detonation with C4											
GC51	3 m from	Surface	<26	<34	118,000	146	96	1,560	1,730	878	120
GC52	3 m from	Surface	<26	<34	28,000	<28	<19	740	840	220	<DL ⁴
GC53	5 m from	Surface	<26	<34	13,300	<28	<19	354	368	108	20
GC54	5 m from	Surface	<26	118	7,010	<28	<19	246	704	84	16
GC55	10 m from	Surface	<26	<34	1,120	<28	<19	50	44	<16	<DL
GC56	10 m from	Surface	<26	64	760	<28	<19	60	82	<16	<DL

¹ The following undetected analytes were excluded from the table: NG, PETN, DNB, Tetryl. All shaded data were generated using RP- HPLC analysis. All other data were generated using GC-ECD.

² Sample location is in reference to low-order 500-lb bomb; D = Down slope, ES = Edge of shell.

³ Sample location is in reference to crater; C = Center, NR = North Rim, ER = East Rim, SR = South Rim, WR = West Rim, S = South, WS = Wheel Sample, SW = Southwest.

⁴ Less than detection limit. Co-elutes with NB; therefore, detection limits are uncertain.

Several areas of reddish stained soil were observed, as far as 4.7 m from the bomb. Subsequent analysis of these soils indicated that this reddish stain was a result of the deposition of TNT, either when the bomb partially detonated, or when rainfall eroded and spread the explosive fill downslope.

Surface soil collected next to the ruptured bomb contained 9,440,000 $\mu\text{g kg}^{-1}$ or 0.944 percent TNT (Table 12). The TNT concentrations at the 1- to 3-cm, and 4- to 7-cm depths at this location were 240,000, and 42,000 $\mu\text{g kg}^{-1}$, respectively. Surface soil samples at 1, 2, and 4.7 m down slope were 467,000, 4,660, and 8,050,000 $\mu\text{g kg}^{-1}$, respectively. The major biotic, abiotic, and photochemical transformation products of TNT (2ADNT, 4ADNT, and TNB) were also found in these samples. Clearly the ruptured bomb has caused substantial localized contamination with TNT.

The mean concentrations of TNT in the duplicate surface composite samples collected at 3, 5, and 10 m from the bomb were 13,000, 260, and 306 $\mu\text{g kg}^{-1}$, respectively. Mean concentrations of 2ADNT and 4ADNT ranged from 34 to 2,720 $\mu\text{g kg}^{-1}$ in these same samples. TNB was also detected in these samples. The mean RSD for the three pairs of duplicates for TNT was 88.7 percent, but was considerably lower at 40.4 and 30.5 percent for 2ADNT and 4ADNT, respectively. The lower RSD for the TNT transformation products relative to TNT may be because of the fact that these compounds originate from TNT that dissolved from the crystalline material and was redeposited in a more homogeneous distribution. The mean ratio of TNT/2ADNT for these composite samples was about 6. This indicated that a substantial portion of the TNT that was deposited had been subject to environmental transformation.

Characterization of area near low-order 500-lb bomb after it was blown in place

After the area around the 500-lb bomb was sampled, the EOD team destroyed this bomb using a blow-in-place technique. Analysis of duplicate surface composites indicated that the mean TNT concentrations after the detonation were

74,600, 10,200, and 943 $\mu\text{g kg}^{-1}$ at 3, 5, and 10 m from the crater (Table 12). These values increased from 13,000, 260, and 306 $\mu\text{g kg}^{-1}$, respectively, prior to detonation. The mean ratio of TNT to its microbial degradation product, 2ADNT, increased in these samples from about 6 prior to detonation to about 33 after detonation, confirming that much of the TNT found after detonation was deposited by the blow-in-place detonation of the low-order bomb.

Concentrations of TNT in the discrete samples collected near the crater varied from 66,700 $\mu\text{g kg}^{-1}$ in the center of the crater to 3,980 $\mu\text{g kg}^{-1}$ on the west rim of the crater. The mean ratio of TNT to 2ADNT for these samples averaged about 6, indicating that much of the TNT found in the crater area had been deposited prior to the blow-in-place detonation.

The concentrations of TNT in discrete samples that were collected in the sampling wheel pattern, centered a distance of 3.5 m from the crater, varied from 28,000 to 206,000 $\mu\text{g kg}^{-1}$. The mean TNT concentration (\pm standard deviation) for these seven samples was $72,300 \pm 62,300 \mu\text{g kg}^{-1}$. The mean ratio for TNT/2ADNT for the five samples where 2ADNT was quantified was 27, an indication that the bulk of the TNT found at a distance of 3.5 m from the crater was freshly deposited, rather than being present prior to detonation.

Overall, these results indicate that the blow-in-place detonation of this ruptured 500-lb bomb resulted in TNT contamination at distances at least as far as 10 m from the location of the detonation. Higher concentrations of TNT were found in surface soil at a distance of 3.5 m from the crater than within or on the edge of the crater. This may be indicative of the so-called "halo" effect, where deposition beyond a certain radius is higher than within that radius.

Soil samples collected before and after demolition of 155-mm duds

A series of both discrete and composite samples were collected in the impact area at Camp Guernsey at distances ranging from 3 to 10 m from several 155-mm surface duds and one 81-mm dud. The area sampled was not heavily cratered, and these samples could serve as typical background level samples for this impact range. After these soil samples were collected, the rounds were detonated by EOD personnel with C4 and a second set of discrete and composite surface samples were collected in an identical manner. Results of these analyses are presented in Table 13.

Table 13

Explosives Concentrations in Soils near UXO Items before and after Detonation with C4, Camp Guernsey, ¹ µg kg⁻¹

Sample No.	Munitions /Target	Sample Location ²	HMX	RDX	TNT	2,4DNT	2,6DNT	2ADNT	4ADNT	TNB
Discrete Surface Samples Prior to Detonation with C4										
G29	UXO 1, 155-mm ³	3 m	<26	<3	6	<0.8	9	279	316	<3
G30	UXO 1, 155-mm	3 m	<26	<3	14	15	20	445	520	4
G31	UXO 1, 155-mm	5 m	<26	<3	15	<0.8	<0.8	84	106	<3
G32	UXO 1, 155-mm	5 m	<26	<3	7	<0.8	<0.8	36	58	<3
G33	UXO 1, 155-mm	10 m	<26	<3	<1	<0.8	<0.8	6	12	<3
G34	UXO 1, 155-mm	10 m	<26	<3	<1	<0.8	<0.8	9	16	<3
G35	UXO 2, 155-mm	3 m	<26	6	<1	<0.8	<0.8	<2.5	<1.6	<3
G36	UXO 2, 155-mm	3 m	<26	47	<1	<0.8	<0.8	<2.5	<1.6	<3
G37	UXO 2, 155-mm	5 m	4	<3	<1	<0.8	<0.8	4	7	<3
G38	UXO 2, 155-mm	5 m	<26	<3	<1	<0.8	<0.8	<2.5	<1.6	<3
G39	UXO 2, 155-mm	10 m	<26	<3	<1	<0.8	<0.8	<2.5	<1.6	<3
G40	UXO 2, 155-mm	10 m	2	<3		<0.8	<0.8	5	6	<3
G57	UXO 3, 155-mm, 81-mm	3 m	134	45	21	<0.8	<0.8	34	47	<3
G58	UXO 3, 155-mm, 81-mm	3 m	86	34	4	<0.8	<0.8	52	77	<3
G59	UXO 3, 155-mm, 81-mm	5 m	51	330	4	<0.8	<0.8	38	64	<3
G60	UXO 3, 155-mm, 81-mm	5 m	43	29	8	<0.8	<0.8	40	59	<3
G61	UXO 3, 155-mm, 81-mm	10 m	41	20	3	<0.8	<0.8	33	45	<3
G62	UXO 3, 155-mm, 81-mm	10 m	9	26	3	<0.8	<0.8	15	23	<3
Sample Number	Munitions/ Target	Sample Location ⁴	HMX	RDX	TNT	2,4DNT	2,6DNT	2ADNT	4ADNT	TNB
Discrete Surface Samples after Detonation with C4										
G79	UXO 1, 155-mm	70 cm N	24,200	173,000	38,600	<0.8	<0.8	<2.5	<1.6	<3
G80	UXO 1, 155-mm	70 cm E	20,800	184,000	50,200	<0.8	<0.8	<2.5	<1.6	<3
G81	UXO 1, 155-mm	70 cm S	13,000	118,000	29,700	<0.8	<0.8	<2.5	<1.6	<3
G82	UXO 1, 155-mm	70 cm W	32,400	225,000	84,700	<0.8	<0.8	<2.5	<1.6	<3
G83	UXO 1, 155-mm	C	82,800	541,000	294,000	<0.8	<0.8	<2.5	<1.6	<3
G84	UXO 1, 155-mm	3 m SW	19,400	124,000	84,800	<0.8	<0.8	<2.5	<1.6	<3
G85	UXO 1, 155-mm	3 m SW	2,120	19,100	9,620	<0.8	<0.8	<2.5	<1.6	<3
G86	UXO 1, 155-mm	5 m SW	10,600	77,800	25,600		<0.8	<2.5	<1.6	<3
G87	UXO 1, 155-mm	5 m SW	8,840	46,300	17,200	<0.8	<0.8	<2.5	<1.6	<3
G88	UXO 1, 155-mm	10 m SW	3,240	22,000	11,700	<0.8	<0.8	<2.5	<1.6	<3
G89	UXO 1, 155-mm	10 m SW	6,000	36,200	17,600	<0.8	<0.8	<2.5	<1.6	<3
G20	UXO 2, 155-mm	50 cm N	<26	<3	7	<0.8	<0.8	<2.5	<1.6	<3
G21	UXO 2, 155-mm	50 cm E	2	9	<1	<0.8	<0.8	2	6	<3
G22	UXO 2, 155-mm	50 cm S	33	<3	101	<0.8	<0.8	6	6	<3
G23	UXO 2, 155-mm	50 cm W	55	5	26	<0.8	<0.8	4	6	<3
G73	UXO 2, 155-mm	3 m	<26	<34	2,040	102	<19	<38	<32	<16
G74	UXO 2, 155-mm	3 m	<26	<3	<1	<0.8	<0.8	<2.5	<1.6	<3
G75	UXO 2, 155-mm	5 m	<26	<3	<1	<0.8	<0.8	<2.5	<1.6	<3
G76	UXO 2, 155-mm	5 m	<26	4	281	<0.8	<0.8	56	50	<3
G77	UXO 2, 155-mm	10 m	<26	<3	<1	<0.8	<0.8	<2.5	<1.6	<3
G78	UXO 2, 155-mm	10 m	<26	<3	<1	<0.8	<0.8	<2.5	<1.6	<3
G9	UXO 3, 155-mm, 81-mm	NR	708	540	518	<28	<19	202	156	50

(Continued)

Table 13 (Continued)

Sample Number	Munitions/ Target	Sample Location ¹	HMX	RDX	TNT	2,4DNT	2,6DNT	2ADNT	4ADNT	TNB
G10	UXO 3, 155-mm, 81-mm	ER	111	928	78	<0.8	<0.8	<2.5	<1.6	<3
G11	UXO 3, 155-mm, 81-mm	SR	91	180	153	<0.8	<0.8	145	163	<3
G12	UXO 3, 155-mm, 81-mm	WR	304	155	35	<28	<19	59	75	<16
G13	UXO 3, 155-mm, 81-mm	3 m	500	120	24,700	<28	<19	1,680	1,720	240
G14	UXO 3, 155-mm, 81-mm	3 m	254	158	1,340	<28	<19	1,480	1,540	28
G15	UXO 3, 155-mm, 81-mm	5 m	173	356	111	<0.8	<0.8	90	98	<3
G16	UXO 3, 155-mm, 81-mm	5 m	278	204	5,740	<28	<19	332	456	48
G17	UXO 3, 155-mm, 81-mm	10 m	101	41	296	<0.8	<0.8	72	91	<3
G18	UXO 3, 155-mm, 81-mm	10 m	762	98	18	<0.8	<0.8	114	190	<3
Sample Number	Munitions/ Target	Sample Location ²	HMX	RDX	TNT	2,4DNT	2,6DNT	2ADNT	4ADNT	TNB
Composite Surface Samples Prior to Detonation with C4										
GC9	UXO 1, 155-mm	3 m	<26	3	8	5	<0.8	194	267	<3
GC10	UXO 1, 155-mm	3 m	<26	<3	76	<0.8	5	145	179	<3
GC11	UXO 1, 155-mm	5 m	<26	16	10	<0.8	<0.8	250	268	5
GC12	UXO 1, 155-mm	5 m	<26	<3	18	5	<0.8	118	145	<3
GC13	UXO 1, 155-mm	10 m	<26	<3	7	<0.8	3	67	89	<3
GC14	UXO 1, 155-mm	10 m	<26	<3	210	<0.8	4	154	177	<3
GC15	UXO 2, 155-mm	3 m	<26	<3	<1	<0.8	<0.8	4	6	<3
GC16	UXO 2, 155-mm	3 m	<26	3	<1	<0.8	<0.8	4	6	<3
GC17	UXO 2, 155-mm	5 m	<26	4	<1	<0.8	<0.8	9	12	<3
GC18	UXO 2, 155-mm	5 m	193	<3	<1	<0.8	<0.8	8	6	<3
GC19	UXO 2, 155-mm	10 m	<26	<3	<1	<0.8	<0.8	5	7	<3
GC20	UXO 2, 155-mm	10 m	<26	<3	<1	<0.8	<0.8	7	7	<3
GC21	UXO 3, 155-mm, 81-mm	3 m	173	103	4	<0.8	<0.8	58	70	<3
GC22	UXO 3, 155-mm, 81-mm	3 m	66	39	29	<0.8	<0.8	43	61	<3
GC23	UXO 3, 155-mm, 81-mm	5 m	176	89	20	<0.8	<0.8	119	161	<3
GC24	UXO 3, 155-mm, 81-mm	5 m	530	299	551	4	3	222	436	11
GC25	UXO 3, 155-mm, 81-mm	10 m	216	70	128	<0.8	<0.8	84	119	6
GC26	UXO 3, 155-mm, 81-mm	10 m	324	92	40	<0.8	<0.8	111	147	<3
Sample Number	Munitions/ Target	Sample Location ³	HMX	RDX	TNT	2,4DNT	2,6DNT	2ADNT	4ADNT	TNB
Composite Surface Samples after Detonation with C4										
GC45	UXO 1, 155-mm	3 m	17,200	121,000	60,800	98	<0.8	110	98	<3
GC46	UXO 1, 155-mm	3 m	9,800	159,200	23,500	84	<0.8	<2.5	112	<3
GC47	UXO 1, 155-mm	5 m	9,000	72,800	39,150	64	<0.8	178	195	<3
GC48	UXO 1, 155-mm	5 m	8,300	92,300	19,400	46	<0.8	162	22	<3
GC49	UXO 1, 155-mm	10 m	11,530	1,010	15,741	<0.8	<0.8	<2.5	<1.6	<3
GC50	UXO 1, 155-mm	10 m	11,870	8,940	3,060	<28	<19	54	80	26
GC39	UXO 2, 155-mm	3 m	3	3	145	8	3	10	12	<3

(Continued)

Table 13 (Concluded)

Sample Number	Munitions/ Target	Sample Location ³	HMX	RDX	TNT	2,4DNT	2,6DNT	2ADNT	4ADNT	TNB
GC40	UXO 2, 155-mm	3 m	10	2	77	5	<0.8	5	6	<3
GC41	UXO 2, 155-mm	5 m	<26	<3	92	5	<0.8	7	10	<3
GC42	UXO 2, 155-mm	5 m	<26	<3	73	3	<0.8	6	10	<3
GC43	UXO 2, 155-mm	10 m	<26	<3	<1	<0.8	<0.8	<2.5	<1.6	<3
GC44	UXO 2, 155-mm	10 m	<26	<3	<1	<0.8	<0.8	<2.5	<1.6	<3
GC33	UXO 3, 155-mm, 81-mm	3 m	520	1,000	844	<28	<19	286	290	34
GC34	UXO 3, 155-mm, 81-mm	3 m	152	174	29,400	<28	<19	586	550	<16
GC35	UXO 3, 155-mm, 81-mm	5 m	3,200	5,480	6,200	<28	<19	478	514	74
GC36	UXO 3, 155-mm, 81-mm	5 m	602	113	93	<28	<19	100	139	<16
GC37	UXO 3, 155-mm, 81-mm	10 m	180	80	38	<28	<19	57	85	<16
GC38	UXO 3, 155-mm, 81-mm	10 m	79	77	40	<28	<19	65	93	<16

¹ The following undetected analytes were excluded from the table: NG, TNB, PETN, DNA, DNB, Tetryl. All shaded data were generated using RP-HPLC analysis. All other data were generated using GC-ECD.

² Sample location is relative to the round.

³ The 155-mm is an artillery round; the 81-mm is a mortar round.

⁴ Sample location is relative to crater after detonation; N = North, E = East, S = South, W = West, C = Center, SW = Southwest.

Analytes present at the highest concentration in the composite samples collected around UXO 1, a 155-mm howitzer dud, were 2ADNT, 4ADNT, and TNT, which were present in all six of the samples collected. Concentrations ranged from 67 to 268 $\mu\text{g kg}^{-1}$ for the individual ADNTs with a mean of 171 $\mu\text{g kg}^{-1}$, and from 7 to 210 $\mu\text{g kg}^{-1}$ for TNT with a mean of 55 $\mu\text{g kg}^{-1}$. Concentrations just above analytical detection limits were observed for RDX, 2,4DNT and 2,6DNT in a few of these samples. The concentrations of none of these analytes were correlated in any way with their position relative to the 155-mm dud, and hence the source of these residues is unknown.

An identical set of surface composites were collected around UXO 2, also a 155-mm dud. 2ADNT and 4ADNT were again detected in all six samples, but the concentrations ranged from 4 to 12 $\mu\text{g kg}^{-1}$. No TNT was detected in these samples, but RDX was detected in the range of 3 to 16 $\mu\text{g kg}^{-1}$ in four of the samples, and HMX was detected in one sample at 193 $\mu\text{g kg}^{-1}$.

A third set of six surface composites were collected in an area containing a 155-mm dud and an 81-mm dud, in an identical pattern as for UXO 1 and 2. HMX, RDX, TNT, 2ADNT, and 4ADNT were detectable in all six samples at concentrations ranging from 4 to 551 $\mu\text{g kg}^{-1}$. Mean concentrations for HMX, RDX, TNT, and the individual ADNTs were 248, 115, 129, and 136 $\mu\text{g kg}^{-1}$, respectively. Again, the source of these residues was not obvious.

Results for composite samples collected the following day after all these rounds were destroyed by detonating them in place using C4 are also presented in Table 11. For the area around UXO 1, there was a dramatic increase in the concentrations of RDX, TNT, and HMX. For example, the mean concentration of

RDX increased from $<10 \mu\text{g kg}^{-1}$ prior to the detonation to $65,600 \mu\text{g kg}^{-1}$ after the detonation. Likewise, the mean concentration of TNT and HMX increased from $55 \mu\text{g kg}^{-1}$ and $<26 \mu\text{g kg}^{-1}$, respectively, to $25,300$ and $7,900 \mu\text{g kg}^{-1}$. The relative concentrations of RDX, TNT and HMX in soil, after the blow-in-place operation, were about the correct proportion for deposition of Composition B. While the concentrations of RDX, TNT, and HMX were much higher than prior to detonation, the concentrations of 2ADNT and 4ADNT did not increase, indicating that these compounds are not formed during detonation.

Analytical results for UXO 2 were quite different. Concentrations of RDX, TNT, and HMX were generally below detection limits prior to the blow-in-place operation and only TNT appears to have increased to about $100 \mu\text{g kg}^{-1}$ because of the deposition from the detonation. For UXO 3, mean concentrations of RDX, TNT, and HMX before the item was blown in place were 115, 129, and $248 \mu\text{g kg}^{-1}$, respectively, and 1,150, 6,100, and $789 \mu\text{g kg}^{-1}$ after the blow-in-place operation.

Therefore it appears that the degree of deposition of explosives residues resulting from blow-in-place operations is quite variable. Sometimes minimal deposition occurs and results in barely detectable changes in concentrations of residues, and other times it results in surface soil concentrations as high as $100,000 \mu\text{g kg}^{-1}$ for the major explosive compounds such as TNT and RDX.

Artillery firing point, Camp Guernsey

Analytical results for soils collected at the firing point of 155-mm howitzers indicated that no propellant residues above the analytical detection limits for GC-ECD Method 8095 were found in any of these samples, either before or after firing. Thus it appears that very little propellant residues were deposited from this firing activity.

Comparison of Results from Discrete and Composite Surface Soil Samples from Yakima and Camp Guernsey

Both discrete and composite samples were collected at a number of locations at YTC and CG. The reason both types of samples were collected at a given location was to assess whether there was a difference in the representativeness that was achievable using the two approaches. Previous work has demonstrated that there is large spatial heterogeneity in distribution for explosives residues in soil at a variety of explosives-contaminated sites (Jenkins et al. 1997a, 1997b, 1998, 2001; Walsh et al. 2001).

Figures 23 and 24 show the concentrations found for NG and 2,4DNT for discrete and composite surface soil samples collected at the YTC tank firing range. Individual values for discrete samples collected at a fixed distance from the muzzle vary substantially for both NG and 2,4DNT. For example, at a distance of 10 m from the muzzle, values of $17,000$ and $1,540 \mu\text{g kg}^{-1}$ were

obtained for NG for samples collected 5 m apart; similarly for samples 20 m from the muzzle, individual discrete samples were 4,050 and 442 $\mu\text{g kg}^{-1}$, only 5 m apart.

The mean relative standard deviation (RSD) for NG and 2,4DNT for the samples collected at the YTC tank firing range (MPRC) are shown in Table 14. For NG, the reproducibility of values is much improved for composites (RSD = 25.8 percent) compared with that for the discrete samples (RSD = 83.4 percent). However, this is not true for 2,4DNT, where RSDs are similar at 81.3 percent and 100.9 percent for composite and discrete samples, respectively. In this case, the NG and 2,4DNT originate from different propellant formulations, and hence are distributed from different firing events.

Table 14 Comparison of Reproducibility Using Discrete and Composite Samples			
Tank Firing Point Yakima MPRC Range			
	Mean percent Relative Standard Deviation		
	NG	2,4DNT	
Discrete Samples	83.4	100.9	
Composite Samples	25.8	81.3	
Blow-in-place area of 155-mm howitzer round Camp Guernsey			
	Mean percent Relative Standard Deviation		
	HMX	RDX	TNT
Discrete Samples	56.2	58.0	56.3
Composite Samples	19.7	15.5	51.1
Blow-in-place area of 500-lb bomb Camp Guernsey			
	Mean percent Relative Standard Deviation		
	TNT		
Discrete Samples	34.3		
Composite Samples	52.7		

A similar comparison was made for discrete and composite soil samples collected at CG in an area where a 155-mm howitzer round was blown in place using C4 (Table 14). For HMX and RDX, substantially lower RSDs were obtained for composite samples compared with discrete samples (for RDX the RSD for composites was 15.5 percent and for discretetes was 58 percent). There was no such improvement for TNT, however, in the same samples (RSD for composites was 51.1 percent; RSD for discretetes was 56.3 percent). While these residues originated from the same event, the TNT came from the main HE charge within the 155-mm round, whereas, the HMX and RDX came from the C4 used to initiate the detonation. This could be the difference in the results obtained, but this is not certain.

The final comparison of this type was made for surface soil samples collected at CG at an area where a 500-lb bomb was blown in place using C4 (Table 14). For this case, the RSD for TNT was slightly lower for discrete samples (RSD = 34.3 percent) than it was for the composite samples (RSD = 52.7 percent). The reason for this behavior for TNT is unclear, although it could be an artifact of the subsampling used. Walsh, Ramsey, and Jenkins (in press) have found that it is

necessary to mechanically ground a large (>1 kg) sample in order to obtain representative subsamples for analysis.

Overall, the RSDs appeared to be slightly improved for composite samples relative to discrete ones, although the improvement obtained was less than expected. One of the reasons for only a small improvement in reproducibility may be the difficulty in obtaining reproducible subsamples from bulk composite samples as indicated by Walsh, Ramsey, and Jenkins (in press). An initial test where composite samples were mechanically ground indicates that the standard deviation for subsamples taken from a composite were reduced by a factor ranging from 3 to 10. Thus it is possible that an improvement in representativeness by using composite samples was partially lost because of inadequate subsampling. Additional experiments will be conducted to explore this possibility.

Surface Water Springs, Camp Guernsey

Groundwater geochemistry is typical of the geographic area (Table 15). Groundwater is generally slightly hard (sum of calcium and magnesium greater than 50, but less than 100 mg L⁻¹). One sample, Ryan Springs, slightly exceeded the drinking water standard for total iron (0.3 mg L⁻¹) and for manganese (0.05 mg L⁻¹). Nitrate/nitrite values were well within the range for natural waters (0.1 to 10 mg L⁻¹ (Driscoll 1987)). Although two samples contained chloride levels greater than typical for groundwater (about 6 mg L⁻¹ (Tardy 1971)), levels were not sufficient to cause concern. Sulfate levels were generally normal (less than 100 mg L⁻¹ (Davis and DeWiest 1966)). No explosives or explosives degradation products were detected in Camp Guernsey springs.

Sample Location	Ca	Fe	Mg	Mn	NO ₂ /NO ₃	SO ₄	Cl
Deer Corn Springs	55.3	<0.120	25.2	<0.004	1.1	28	6.8
Ryan Springs	56.4	0.400	22.5	0.058	0.03	9.4	6.5
Sawmill Springs	56.9	0.130	25.8	<0.004	0.96	18	5.1
Pet Springs	49.7	<0.120	24.3	<0.004	0.98	27	5.3

Historical Firing Records, Yakima Training Center

Firing records at YTC for the most heavily used high explosives rounds over a 33-month period indicated that the 155-, 81-, 120-, and 105-mm were fired most extensively (Table 16). These rounds were also commonly fired at Fort Lewis (Pennington et al. 2001) and at Camp Guernsey (Table 17). A total of 6,388 81-mm mortar rounds were fired at YTC during the last 3 years (Table 16). These rounds contain Composition B which is composed of 60 percent RDX, 39 percent TNT and 1 percent wax (Table 18). Each 81-mm round contains about 571 g of RDX. The mean low-order rate and dud rate for 81-mm rounds has been estimated at 0.06 and 2.24 percent, respectively (Table 19, Dauphin and Doyle (2000)). If 0.06 percent of the 6,388 rounds fired produced a low-order detonation, this computes to about four low-order detonations over this 3-year

period. If we assume that about half of the initial mass of RDX present in these rounds is deposited when a round goes low order, this computes to about 1.14 kg of RDX deposited. In addition, about 140 of the 81-mm rounds are estimated to be duds which are often destroyed by blow-in-place operations using C4. The mean mass of residue deposited when 81-mm rounds are blown in place using C4 has been estimated at 42 mg per round (Jenkins et al. 2000). If all 140 rounds were destroyed using this procedure, we estimate that about 6 g of RDX would be deposited by the blow-in-place destruction of 81-mm duds.

Table 16
Firing Record of the Most Commonly Fired Munitions for 1999-2001 at Yakima Training Center¹

Round	DODIC Number ²	1999	2000	2001 ³	Total
60-mm HE M720	B642	1,049	116	1,552	2,717
66-mm rocket HE M72	H557	448	100	-- ⁴	548
Sum 81-mm HE	C228, C236, C256	2,634	1,850	1,904	6,388
Sum 84-mm HE	C382, C383, C995	418	227	238	883
90-mm HE	C280, C282	165	--	--	165
105-mm HE M1	C445	1,413	2,534	1,918	5,865
106-mm HE AT M344A1	C650	36	--	--	36
Sum 107-mm (4.2-in.) HE	C697, C699	412	--	77	489
Sum 120-mm HE	C379, C623, C787, C788	2,663	1,385	1,923	5,971
Sum 155-mm HE	D510, D544, D563, D579	3,530	2,866	2,686	9,082

¹ Records include data from the RFMS database acquired from January 1999 through September 2001 as provided by SFC Antonio Felix.

² Department of Defense Identification Code.

³ Data through September 2001 only.

⁴ Indicates no record of firing this ammunition type during this year.

Table 17
Firing Record of the Most Commonly Fired Munitions for 1996-2001 at Guernsey Training Center¹

Round	DODIC Number ²	1996	1997	1998	1999	2000	2001 ³	Total
Sum 60-mm HE	B632, B642	204	368	453	250	72	-- ⁴	1,347
81-mm HE M374	C256	46	373	191	300	184	300	1,394
90-mm HEAT M371A1	C282	--	413	--	--	--	--	413
105-mm HE M1	C445	1,250	2	--	--	2,060	--	3,312
107-mm (4.2-in.) HE M392A2	C697	1,842	240	800	2,175	--	--	5,057
Sum 155-mm HE	D510, D544	6,681	2,540	2,573	5,447	5,684	2,713	25,638
8-in. HE M106	D680	1,201	--	--	1	1	--	1,203

¹ Records include data provided by Mr. Guy Mosier, Camp Guernsey Training Center.

² Department of Defense Identification Code.

³ Data through October 2001 only.

⁴ Indicates no record of firing this ammunition type during this year.

Table 18
High Explosive Load Carried by Munitions Items Commonly Fired at Yakima Training Center and Camp Guernsey¹

Round	DODIC ²	Main Charge (g)		Supplemental Charge		Pellet Booster		Pellet Auxiliary Booster		Main Charge Total, g
		RDX	TNT	HE ³	Wt, g	HE	Wt, g	HE	Wt, g	
M72	H557	(213 HMX) ⁴	90.7	-	-	Tetryl or RDX	5.60	-	-	
M106	D680	-	16,465	TNT	134	-	-	-	-	16,465
60-mm	B632	-	156	-	-	Tetryl	259	Tetryl	4.76	188
60-mm	B642 ⁵	114	74	-	-	RDX	7.9	HMX	144	354
81-mm	C236 ⁵	571	372	-	-	-	-	-	-	943
81-mm	C256 ⁵	571	372	-	-	RDX	23	RDX	0.14	943
84-mm	C382	-	-	-	-	-	-	-	-	-
84-mm	C383	-	-	-	-	-	-	-	-	-
84-mm	C995	-	-	-	-	-	-	-	-	-
90-mm	C280	-	934	-	-	Tetryl	351	Tetryl	3.8	934
90-mm	C282 ⁵	467	304	-	-	Tetryl	7.9	Tetryl	0.95	771
105-mm	C445	-	2,086	TNT	136	-	-	-	-	2,086
105-mm	C4455	1,251	814	TNT	132	-	-	-	-	2,086
106-mm	C6505	759	494	-	-	RDX	8.0	-	-	1,253
107-mm	C6995	1,565	1,017	TNT	136	-	-	-	-	2,582
107-mm	C6975	1,565	1,017	TNT	136	-	-	-	-	2,582
120-mm	C6235	1,790	1,170	? ⁶	?	RDX	7.9	HMX	1.89	2,990
120-mm	C787 ⁷	?	-	-	-	-	-	-	-	?
120-mm	C788	-	2,100	-	-	RDX	12.5	-	-	2,100
155-mm	D510 ⁵	4,014	2,609	-	-	-	-	-	-	6,623
155-mm	D544 ⁵	4,191	2,725	TNT	136	-	-	-	-	6,916
155-mm	D544	-	6,622	TNT	136	-	-	-	-	6,622
155-mm	D563	2,805	-	-	-	-	-	-	-	2,805
155-mm	D579 ⁵	4,082	2,653	TNT	136	-	-	-	-	6,735

¹ Sources of data are the Munitions Items Disposition Action System (MIDAS); personal communication Mr. Mark Serben, Office of the Product Manager for Mortar Systems, TACOM, Picatinny Arsenal, NJ, March 19, 2000; (Headquarters, U.S. Army Corps of Engineers 1994).

² Department of Defense Identification Code.

³ High explosive.

⁴ HMX, not RDX.

⁵ Main charge is Composition B, which is typically composed of 60 percent RDX and 39 percent TNT.

⁶ Unable to determine presence or quantity.

⁷ Composition A3 (91 percent HE, RDX, and 9 percent wax). Mass of the HE was unavailable.

Table 19
Mean Dud and Low-Order Detonation Rates for Munitions Items
Commonly Used at Yakima Training Center and Camp Guernsey¹

Round	DODIC ²	Items Tested	DUDs, percent	Low Orders, percent
M72	H557	2,722	4.52	0.04
M106 ³	D680	160	0	0
M720	B652	3,838	1.07	0
60-mm ⁴	B632	7,792	3.35	0
60-mm	B642	3,838	1.07	0
81-mm ⁵	C228	16,435	2.28	0.08
81-mm ⁵	C236	16,435	2.28	0.08
81-mm ⁶	C256	9,122	2.16	0.02
84-mm	C382	U ⁷	U	U
84-mm	C383	U	U	U
84-mm ⁸	C995	658	0	0.15
90-mm	C280	838	13.8	0
90-mm	C282	870	2.76	0.80
105-mm ⁹	C445	10,003	4.39	0.07
106-mm	C650	1,065	3.66	0
107-mm	C699	1,518	2.24	0.02
120-mm	C379	U	U	U
120-mm	C623	U	U	U
120-mm	C787	U	U	U
120-mm	C788	270	2.59	0
107-mm	C697	U	U	U
155-mm	D510	U	U	U
155-mm	D544	6,216	2.75	0.02
155-mm	D563	U	U	U
155-mm ¹⁰	D579	1,152	0	0

¹ Values based on test data acquired by U. S. Army Defense Ammunition Center, McAlester, OK (Dauphin and Doyle 2000).

² Department of Defense Identification Code.

³ Dud and low-order rates depend upon kind of fuze. With the M582 fuze the dud rate was 5.11 percent (9 fired), and the low-order rate was zero. With other fuzes the dud and low-order rates were zero.

⁴ Three models were tested. Values are derived from combining data for all models.

⁵ This specific DODIC numbered item was not tested. Values are derived from sum of all 81-mm mortars tested.

⁶ Four models were tested. Values are derived from combining data for all models.

⁷ Data were unavailable.

⁸ Two models were tested. Values are derived from combining data for both.

⁹ One model was tested with nine fuzes. Values are derived from combining data for all.

¹⁰ Various models and fuzes were tested. Values are derived from combining data for all.

These estimates of residue deposition suggest that low-order detonations, while not posing a large explosion hazard, should be managed rather than being ignored, because they are a potential source for groundwater contamination. In addition, they indicate the importance of using a technology that results in complete detonation when conducting range clearance for duds.

Summary and Recommendations

Various types of military testing and training ranges are quite different with respect to their potential for contaminating underlying groundwater resources with

residues of explosives (CHPPM 2001, Jenkins et al. 1997a, 1997b, 1998, 2001, Pennington et al. 2001, Thiboutot et al. 1998, Walsh et al. 2001). For example, at antitank rocket ranges, surface soils near targets have been found to be contaminated with HMX residues at concentrations in the tens to thousands of parts-per-million (mg/kg). In contrast, soils near targets at artillery ranges have concentrations of RDX and TNT in the low parts-per-billion range ($\mu\text{g kg}^{-1}$). In both cases, though, soil concentrations of explosives-related residues can be 1 percent or more next to ruptured ordnance or low-order detonations. For artillery ranges, the nonpoint source of explosives residues for potential groundwater contamination is quite low, but there are more significant point sources randomly located across these ranges.

Adequate characterization of explosives contamination at artillery ranges is very difficult. These ranges are very large and the use of discrete samples to represent even small geographical areas results in large uncertainty. Some success in improving the representativeness has been achieved using various composite-sampling strategies (Jenkins et al. 1997a, 1999), but the improvement offered using 30-increment composite samples was less than anticipated at YTC and CG (Table 14). The reproducibility between duplicate composite samples may have been compromised by inadequate subsampling prior to analysis. This problem has been documented for composite soil samples from other ranges (Walsh et al. in press) and additional research is underway to evaluate the possibility of improvement using mechanical grinding prior to subsampling. A major reason why adequate subsampling has been difficult is that the explosives contamination in these samples may be present as small particles of the explosives, rather than low concentrations of residues sorbed to soil particles.

The results of this study indicate that the practice of detonating dud rounds using C4 sometimes leads to substantial contamination with explosives residues. The degree of contamination is quite variable, and the size of the contaminated areas is currently poorly defined. The use of C4 can result in incomplete detonation, and C4 is composed of 91 percent RDX, a potentially significant groundwater contaminant. Groundwater contamination with RDX has resulted in the suspension of live fire training at the Massachusetts Military Reservation (USEPA 2000), and has been found at low levels in groundwater at Fort Lewis (Jenkins et al. 2001, Pennington et al. 2001). Increased consideration should be given to improving the efficiency of detonation for blow-in-place operations and the use of more environmentally benign demolition charges.

References

- American Public Health Association. (1985). *Standard Methods for the Examination of Water and Wastewater*, 16th ed., Washington, DC.
- Burrows, E. P., Rosenblatt, D. H., Mitchell, W. R., and Parmer, D. L. (1989). "Organic explosives and related compounds: Environmental and health consideration," TR-8901, USA Biomedical Research and Development Laboratory, Fort Detrick, Maryland.

- Center for Health Protection and Preventative Medicine (CHPPM). (2001). "Geohydrologic study no. 38-EH-8879-99, Training range site characterization and risk screening, Camp Shelby, Mississippi," 7-23 September 1999.
- Dauphin, L., and Doyle, C. (2000). "Study of ammunition and dud and low order detonation rates," Report Number SFIM-AEC-ET-CR-200049, prepared for U.S. Army Environmental Center, Aberdeen Proving Ground, MD, by U.S. Army Defense Ammunition Center, McAlester, OK.
- Davis, S. N., and DeWiest, R. J. M. (1966). *Hydrogeology*. Wiley, NY.
- Day, P. R. (1956). "Report of the committee on physical analyses, 1954-1955," *Proceedings, Soil Science Society of America*, 167-169.
- Driscoll, F. G. (1987). *Groundwater and wells*. 2nd ed., Johnson Division, St. Paul, MN.
- Gee, G. W., and Bauder, J. W. (1986). "Particle-size analysis." *Methods of Soil Analysis, Part I-Physical and Mineralogical Methods*. 2nd ed., A. Klute, ed., American Society of Agronomy, Inc., Madison, WI.
- Headquarters, U.S. Army Corps of Engineers. (1994). "Army ammunition reference sheets for artillery ammunition: Guns, howitzers, mortars, recoilless rifles, grenade launchers and artillery fuzes," Technical Manual TM 43-0001-28, Armament Research, Development and Engineering Center, Picatinny Arsenal, NJ.
- Jenkins, T. F., Grant, C. L., Brar, G. S., Thorne, P. G., Schumacher, P. W., and Ranney, T. A. (1997a). "Sampling error associated with collection and analysis of soil samples at TNT contaminated sites," *Field Analytical Chemistry and Technology*, 1, 151-163.
- Jenkins, T. F., Walsh, M. E., Thorne, P. G., Thiboutot, S., Ampleman, G., Ranney, T. A., and Grant, C. L. (1997b). "Assessment of sampling error associated with the collection and analysis of soil samples at a firing range contaminated with HMX," Special Report 97-22, U.S. Army Cold Regions Research and Engineering Laboratory, Hanover, NH.
- Jenkins, T. F., Walsh, M.E., Thorne, P. G., Miyares, P. H., Ranney, T. A., Grant, C. L., and Esparza, J. (1998). "Site characterization at the inland firing range impact area at Fort Ord," Special Report 98-9, U.S. Army Cold Regions Research and Engineering Laboratory, Hanover, NH.
- Jenkins, T. F., Grant, C. L., Walsh, M. E., Thorne, P. G., Thiboutot, S., Ampleman, G., and Ranney, T. A. (1999). "Coping with spatial heterogeneity effects on sampling and analysis at an HMX-contaminated antitank firing range," *Field Analytical Chemistry and Technology* 3, 19-28.
- Jenkins, T. F., Ranney, T. A., Walsh, M. E., Miyares, P. H., Hewitt, A. D., and Collins, N. H. (2000). "Evaluating the use of snow-covered ranges to estimate

the explosives residues that result from detonation of army munitions,” ERDC/CRREL Technical Report TR-00-15, U. S. Army Engineer Research and Development Center, Cold Regions Research and Engineering Laboratory, Hanover, NH.

- Jenkins, T. F., Pennington, J. C., Ranney, T. A., Berry, T. E., Jr., Miyares, P. H., Walsh, M. E., Hewitt, A. D., Perron, N., Parker, L. V., Hayes, C. A., and Wahlgren, E. (2001). “Characterization of explosives contamination at military firing ranges,” ERDC Technical Report TR-01-05, U. S. Army Engineer Research and Development Center, Cold Regions Research and Engineering Laboratory, Hanover, NH.
- Lynch, J. C., Myers, K. F., Brannon, J. M., and Delfino, J. J. (2001). “Effects of pH and temperature on the aqueous solubility and dissolution rate of 2,4,6-trinitrotoluene (TNT), hexahydro-1,3,5-trinitro-1,3,5-triazine (RDX), and octahydro-1,3,5,7-tetranitro-1,3,5,7-tetrazocine (HMX),” *Journal of Chemical and Engineering Data* 46, 1549-1555.
- Mehlich, A. (1984). “Mehlich 3 soil test extractant: A modification of Mehlich 2 extractant,” *Communications in Soil Science and Plant Analyses* 15(12), 1406-1416.
- Olson, R. V., and Ellis, R., Jr. (1982). “Iron,” *Methods of Soil Analysis, Part 2-Chemical and Microbiological Properties*, 2nd ed., A. L. Page, R. H. Miller, and D. R. Keeney, ed., American Society of Agronomy, Inc., Madison, WI.
- Patrick, W. H., Jr. (1958). “Modification of method of particle size analysis,” *Proceedings, Soil Science Society of America* 22, 366-332.
- Pennington, J. C., Jenkins, T. F., Brannon, J. M., Lynch, J., Ranney, T. A. Berry, T. E., Hayes, C. A., Miyares, P. H., Walsh, M. E., Hewitt, A. D., Perron, N., and Delfino, J. J. (2001). “Distribution and fate of energetics on DoD test and training ranges: Interim report 1,” ERDC Report TR-01-13, U. S. Army Engineer Research and Development Center, Environmental Laboratory, Vicksburg, MS.
- Rhoades, J. D. (1982). “Cation exchange capacity,” *Methods of Soil Analysis, Part 2-Chemical and Microbiological Properties*. 2nd ed., A. L. Page, R. H. Miller, and D. R. Keeney, ed., American Society of Agronomy, Inc., Madison, WI.
- Tardy, Y. (1971). “Characterization of the principal weathering types by the geochemistry of waters from some European and African crystalline massifs,” *Chemical Geology* 7, 253-271.
- Thiboutot, S., Ampleman, G., Gagnon, A., Marois, A., Jenkins, T. F., Walsh, M. E., Thorne, P. G., and Ranney, T. A. (1998). “Characterization of antitank firing ranges at CFB Valcartier, WATC Wainwright and CFAD Dundurn,” Report # DREV-R-9809, Defence Research Establishment Valcartier, Quebec.

- Thorn, K. A. "N-15 NMR investigations of the covalent binding of reduced TNT amines to soil humic acid, model compounds and lignocellulose," *Environmental Science and Technology* (in press).
- Thorn, K. A., Pennington, J. C., and Hayes, C. A. "N-15 NMR investigations of the reduction and binding of TNT in an aerobic bench-scale reactor simulating windrow composting," *Environmental Science and Technology* (in press).
- Thorne, P. G., and Leggett, D. C. (1997). "Hydrolytic release of bound residues from composted soil contaminated with 2,4,6-trinitrotoluene," *Environmental Toxicology and Chemistry*, 16(6), 1132-1134.
- U.S. Army Center for Health Protection and Preventative Medicine. (2000). "Geohydrologic Study No. 38-EH-8879-99, Training range site characterization and risk screening, Camp Shelby, MS," 7-23 September 1999.
- U.S. Environmental Protection Agency. (1979). *Chemistry laboratory manual for bottom sediment and elutriate testing*. Region V, Central Regional Laboratory, Chicago, IL.
- _____. (1982). "Methods for chemical analysis of water and wastes. EPA 600/4-79-020, March 1979, and EPA 600/4-82-055 Dec 1982," Environmental Monitoring and Support Laboratory, Cincinnati, OH.
- _____. (1988a). "Test methods for evaluating solid waste," SW-846 Method 6010, 3rd ed., November 1986 with December 1988 Revisions, Office of Solid Waste and Emergency Response, Washington, DC.
- _____. (1988b). "Health advisory for RDX," U. S. Environmental Protections Agency, Criteria and Standards Division, Office of Drinking Water, Washington, DC.
- _____. (1994). "Nitroaromatics and nitramines by HPLC," Second Update SW-846 Method 8330, Office of Solid Waste and Emergency Response, Washington, DC.
- _____. (1999). "Nitroaromatics and nitramines by GC-ECD," Fourth Update SW-846 Method 8095, Office of Solid Waste and Emergency Response, Washington, DC.
- _____. (2000). "Administration Order for Response Action EPA Docket Number SDWA-1-2000-0014 USEPA Region 1 In the Matter of Training Range and Impact Area, Massachusetts Military Reservation," Boston, MA.
- Walsh, M. E., and Ranney, T. A. (1999). "Determination of nitroaromatic, nitramine, and nitrate ester explosives in soils using GC-ECD," CRREL Report 99-12, U. S. Army Cold Regions Research and Engineering Laboratory, Hanover, NH.

Walsh, M. E., Collins, C. M., Racine, C. H., Jenkins, T. F., Gelvin, A. B., and Ranney, T. A. (2001). "Sampling for explosives residues at Fort Greely, Alaska: Reconnaissance visit July 2000," Technical Report ERDC/CRREL-01-15, U.S. Army Engineer Research and Development Center, Cold Regions Research and Engineering Laboratory, Hanover, NH.

Walsh, M. E., Ramsey, C. A., and Jenkins, T. F. "The effect of particle size reduction on subsampling variance for explosives-residues in soil," *Chemosphere* (in press).

3 Assessment of CFB Shilo Training Areas

Introduction

A comprehensive environmental assessment was conducted at Canadian Forces Base (CFB) Shilo during the month of September 2001 (Phase II). Soil, biomass, groundwater, and surface water were all tested for a wide variety of contaminants. This report outlines the work performed and provides the reader with an understanding of the methodology of the sampling campaign, and the historical context of the contamination.

Range history

CFB Shilo was established in 1910 when the rapid influx of settlers onto the prairies persuaded the Militia Department (now the Department of National Defence) to secure areas of the prairies for military exercises. Initially called Sewell Camp, Shilo was established about 200 km west of Winnipeg on 96,000 acres of rolling prairie. Its size and location were carefully chosen to be appropriate for use as an artillery training range, as well as for all combined arms maneuvers.

World War I saw the camp growing in size, reaching a peak of 30,000 people including all ranks in 1917. However, following the war it was reduced in size and again became seasonal. It was only in 1940 that a permanent camp was constructed in preparation for the renewal of hostilities, and the base as it exists today began to take shape. Following World War II, Shilo became the permanent home to the Royal Canadian Artillery. The Royal Canadian School of Artillery was established in 1960.

In 1965 and 1966, a West German artillery unit carried out cold weather trials on their equipment at Shilo. This marked the beginning of a long relationship with the German military. In 1974 mechanized troops from the Federal Republic of Germany began training at Shilo under the German Army Training Exchange Shilo (GATES) agreement. The closure of GATES in 2000 prompted an environmental study, conducted by DREV, to assess the impact that 25 years of intensive armored training had on the prairie ecosystem. Of particular concern were the MILAN missiles used by the Germans. These missiles contained

Thorium-232 (^{232}Th), a radioactive element used as a tracer in the guidance system.

The ammunition expended since 1910 is significant and gives an excellent idea of the magnitude of the Unexploded Ordnance (UXO) challenge. Canadian expenditures are estimated at 2,185,000 rounds, and German expenditures at 299,000 rounds for a total of nearly 2.5 million rounds. If a conservative dud rate of 5 percent is assumed, 125,000 rounds of dud munitions are left over an area of 96,000 acres (a dud rate as high as 40 percent can be observed with some ammunition). The majority of the ammunition that has been fired is either 105- or 155-mm artillery rounds and 105-mm tank rounds. These munitions contain several kilograms of explosive fill. Even if level one clearance is done on a regular basis, the casual observer at Shilo will find several unexploded munitions in the course of a day. As it is reasonable to assume that most of the dud rounds are buried, the potential environmental impact is obvious. Therefore, the potential for the contamination of the soils, biomass, or groundwater by explosive is considered relatively high.

It should also be pointed out that prior to 1970, records were not kept with the same accuracy as they are today and, in fact, the numbers could be even higher than quoted here. As well, experimental trials have been conducted at CFB Shilo by both the Canadian and German military. These secret trials left no record of either the number or the type of rounds that were fired.

A legacy of 90 years of military training left UXO problems at CFB Shilo. The goal of the present study was to identify the environmental impacts these munitions are causing, including the potential for explosive contamination of the training ranges and their surroundings.

Environmental assessment

In 2000, an environmental assessment of CFB Shilo was tasked to Defence Research Establishment Valcartier by Director General Environment (DGE), prior to the GATES closure. The Phase I characterization of the Shilo battleruns was accomplished in the fall of 2000, following the departure of the Germans, in order to establish the impact of the past training activities on the environment. This initial work was done under considerable time and funding constraints and indicated that a more extensive and detailed assessment was necessary. This Phase II of the characterization of Shilo training ranges was conducted in September 2001 and is the subject of this report. Drs. Guy Ampleman and Sonia Thiboutot, and Messrs. Jeff Lewis and André Marois, DREV, were on site and led the characterization work. Dr. Richard Martel, Messr. Jean-Marc Ballard and Ms. Catherine Gauthier, Institut National de la Recherche Scientifique (INRS), led the hydrogeological characterization work. Eight Defence Construction Canada employees were on site to assist in the field work and to lead the subcontractors involved in the drilling of piezometers, proofing of the drilling locations by electromagnometers (EM-61), and the analysis of samples for geochemical parameters.

Distinguishing between an environmental assessment and environmental remediation is important. The work done was purely to measure the contaminants present in the environment at CFB Shilo. Prior to any cleanup, the problem must be identified. The purpose of this work was simply to identify the problem. While assessments can be done in weeks or months, remediation efforts usually require years. This environmental evaluation was initiated primarily to determine Germany's share in any cleanup or remediation activities. Presently, the goal is more oriented to understanding and sustaining the training activities as well as understanding the fate of explosives in the training area environment.

This assessment addressed four areas of concern: the contamination of surface soils, aquifer soils, biomass, groundwater, and surface water. The contamination patterns of surface soils around targets and in the battleruns were evaluated. The unconfined aquifer underlying the training area was assessed (hydrostratigraphy, hydraulic conductivity, groundwater flow direction), and groundwater quality was evaluated. The extent of biomass contamination in the worst-case scenario locations (around targets) and in battleruns was assessed and finally, the surface water quality was evaluated.

Previous DREV studies revealed that surface soils were contaminated by energetic materials and metals in training ranges, especially in antitank ranges. Characterizing the groundwater quality is also critical, especially on such a large range. Metals and energetic materials are both mobile in sandy environments and may, therefore, migrate with the groundwater, thus presenting a threat to human health and the environment. Moreover, combined with groundwater quality, groundwater flow had to be carefully assessed to determine its velocity and direction to evaluate the amplitude of a potential problem. This groundwater serves as a drinking water source for the base, is used to sustain aquatic ecosystems, and also serves for irrigation. Consequently, any contamination could impact human health, the irrigated crops, and the aquatic ecosystems. In fact, groundwater flowing under CFB Shilo discharges into surface water in many springs southeast of the range discharging into the Assiniboine River and into the Marsh Creek to the north of the range. Both are highly sensitive areas since they support wildlife and humans receptors. Epinette Creek to the north is also used for irrigation. Biomass, such as prairie grass, has proven to bioaccumulate both metals and energetic materials. Therefore, the grasses could represent a high potential intake source of these compounds for wildlife. Finally, the surface water quality had to be verified since wildlife has access to it and it can also be used for irrigation purposes.

Sampling Strategies

Soil and biomass sampling was conducted under DREV's supervision while surface water and groundwater sampling was conducted with the guidance of INRS. DREV and INRS have both developed expertise in the characterization and the environmental fate of energetic materials in Canadian Forces training ranges and open detonation ranges. For this particular sampling campaign, Defence Construction Canada (DCC) was responsible to support DREV and INRS during Phase II by hiring the drillers, all the necessary personnel, supplying

materials, etc. Funding was provided mainly from Defence Land Force Requirement (DLFR) for the hydrogeologic portion of the study and from the Strategic Environmental Research and Development Program (SERDP) for the surface soil and biomass sampling portion of the study. Phase I of the Shilo characterization was performed during September-October 2000 following Germans' departure; Phase II was performed during September 2001.

Soils

The Germans conducted most of their training at five battleruns at CFB Shilo. Three of these battleruns were sampled during Phase I (Berlin, Deilinghofen, and Essen). These battleruns were the focus of the soil and biomass sampling campaigns. During Phase II, the two remaining battleruns, Aachen and Cologne, rifle ranges, grenade ranges, and a small part of Essen named Klein Essen were sampled for biomass and soils. Since a pattern of contamination was observed around targets in the battleruns during Phase I, Phase II emphasized biomass and soil sampling around targets. A battlerun is a loosely defined area, approximately 5 km long and up to 2 km wide, where tanks and other armoured vehicles conduct mounted exercises. Various types of targets were used, most of them pop-up targets not designed to stop the rounds. Therefore, these rounds could land just about anywhere. If live firing leads to the accumulation of contaminants in soils, higher levels should be found at the end of battleruns since the ammunition fired should land toward the far end. Therefore, the sampling involved the collection of linear composite samples at 20, 40, 60, 100, and 120 percent of the length of each range as illustrated in Figure 25. The start point for each of the linear composite samples was pinpointed using a global positioning system (GPS), cross-referenced with a topographic map of the base. From the start point, small amounts of soil were collected randomly while walking perpendicularly across the battlerun. Each sample was normally approximately 1 kg and was composed of a minimum of 20 discrete samples. A large effort was also dedicated to the identification of potential hotspots such as broken UXO. Soil and biomass samples were then collected around these potential hotspots. Few such hotspots were found. This can be explained by the type of training conducted in battleruns. Pop-up targets do not stop rounds, which is quite different from the situation on antitank training ranges.

Antitank rocket ranges usually use static targets – often WW II vintage tanks – and these massive targets often cause dud rounds to break open on impact. The situation with pop-up targets is arguably better than that on antitank ranges, because the explosive content of the shell is not spread into the environment. A circular sampling strategy used around targets to collect biomass and soils samples consisted in building composite samples out of 20 subsamples of soils or biomass collected at specific distances such as 0 to 1, 1 to 3, 3 to 5, 5 to 10 m as illustrated in Figure 26.

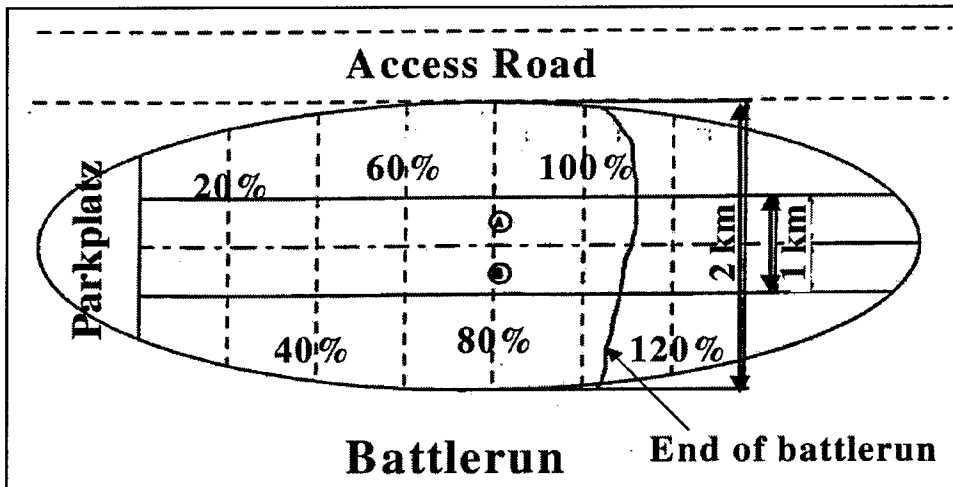

Figure 25. Linear sampling used in battleruns for soils sampling

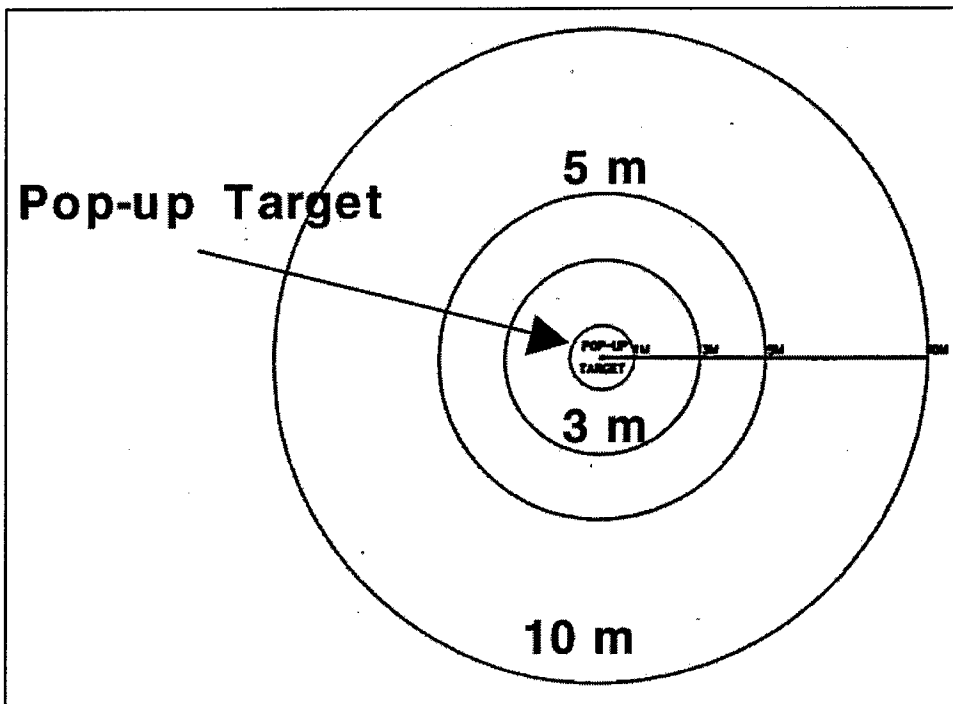

Figure 26. Circular sampling around target in battleruns for soils and biomass sampling

Finally, specific soil samples were collected for ^{232}Th analyses in suspected areas where MILAN missile debris was found. In these instances, missile debris was used as sources for the circular sampling strategy. When soils were taken as background samples, they were collected in a random manner, in a circular pattern of approximately 20 m. A minimum of 30 subsamples was collected to form each background sample.

Biomass

As mentioned earlier, biomass samples were composite samples of different plant species. Given the prairie ecosystem at Shilo, most of the plants collected were grasses or small shrubs. Only the aboveground parts of the plant were sampled, and no roots were included. Each composite sample was composed of many different discrete samples taken in a roughly 10-m-diam area. One composite sample was generally about 1 L in volume of compacted biomass. During Phase II, no biomass sample was collected in the battleruns using the linear sampling strategy, since no pattern of contamination was observed during Phase I. Our efforts for biomass sampling during Phase II were concentrated in background areas, around hotspots, around targets in battleruns, and in rifle and grenade ranges.

The contaminant that is available in vegetation for grazing by herbivores is a good indicator of the potential for contaminants to enter the food chain. Herbivores can ingest contaminants by eating plants that are contaminated either in their cellular structure or on their surfaces. These contaminants may bioaccumulate and be passed on to carnivores, subsequently moving the contamination to higher trophic levels. A classic example of bioaccumulation of an organic contaminant is the case of the peregrine falcon, which was pushed to the brink of extinction because of extremely high tissue levels of the pesticide DDT. Data concerning how explosives are incorporated into tissues after ingestion or dermal contacts are limited and effects of explosives on survival and reproduction are uncertain. The explosives may be accumulated or simply excreted. A small study was conducted at DREV to assess the potential explosives toxicity hazard to EOD personnel handling explosives in the field. Rats exposed to TNT excreted 75 percent of the dose within 24 hr. Similar data for other explosives are limited or unavailable. However, the low log K_{ow} values of most of the explosives suggest that they will be excreted rather than accumulated in animal tissues. For example, RDX, which is readily bioaccumulated by vegetation (Price et al. 2002),¹ is also likely to be readily excreted. Nevertheless, concentrations of explosives in vegetation on live-fire ranges are an indicator of the potential for food chain impacts.

Metals can be bioaccumulated in plants. Soluble metals tend to bioaccumulate in the stem or leaves, while less soluble metals tend to bioaccumulate in the roots of the plants. Thorium-232 was found at higher concentrations in the root system of plants at CFB Shilo, while no, or very low concentrations were detected in upper part of the plant. Since most herbivores graze only on aboveground vegetation, only upper portions of plants were sampled. However, the simple presence of a contaminant in plant tissues gives a reasonable indication that the contaminant may be introduced into the food chain, and cause damage if it bioaccumulates in higher trophic level animals. Certain metals are known to be very toxic and can concentrate in body tissues.

¹ Price, R. A., Pennington, J. C., Larson, S. L., Newman, D., and Hayes, C. A. (2002). "Uptake of RDX and TNT by agronomic plants," *Soil and Sediment Contamination* 11, 307-326.

Since metals could be either inside the plants, e.g., following phytoremediation, or on the plants, accumulated by deposition of dust containing metallic particles, both compartments were evaluated. The biomass samples were analyzed before and after leaching in distilled water. Results indicated no distinct pattern of contamination. Therefore, no discrimination of metals in or on the plants was made during Phase II. Since the animals would ingest the contaminant by eating both internal and surface contamination on the plants, analysis of the whole plant is appropriate. For energetic materials, lyophilisation of the entire biomass material was done so the concentrations represent the total amounts in and on the plants.

Groundwater

Monitoring wells were installed according to the American Society for Testing and Materials (ASTM)-D5092-90.¹ These wells were placed according to available groundwater flow data obtained during Phase I and were located throughout the base to complete the piezometric map. Prior to sampling, each well was thoroughly developed. Development involves the removal of the fine sedimentary particles in the soil that are present at the level of the aquifer and would otherwise contaminate the sample. Once developed, water samples were taken to test for explosive residues and ²³²Th as well as more common contaminants such as heavy metals and solvents.

Slug tests were performed on all developed wells to estimate the hydraulic conductivity of the sand formation. This was done by injecting compressed air into the well in order to drop the water table between 30 and 70 cm below its natural static level. After an instantaneous pressure release, the rise in water table was recorded with a Level Logger pressure gauge (from Solinst). Data interpretation by the Bower Rice method evaluated the hydraulic conductivity. The horizontal component of groundwater velocity and direction was measured *in situ* with a flowmeter (*Geoflo 40L*). The *Geoflo 40L* is a probe with eight thermistors placed around a heat source. The instrument measures the propagation and the deformation of a heat pulse in the groundwater. In dynamic systems like an aquifer, the heat pulse propagates with an elliptic shape and the long-axis is oriented in the groundwater flow direction.

Water level measurements were made after well development. An electronic measuring tape (RST) with a precision of ± 0.5 cm was used to record the water depth in every well in relation to the top of the PVC tubing. The pH, conductivity, and redox potential were measured electronically at each well. The position and elevation of the top of each well PVC casing was determined using the two-GPS technique. The GPS locations (northing and easting) of monitoring wells and the elevations of the top of the PVC tubing served to construct the piezometric map. The error associated with GPS location is ± 2 m whereas the precision on elevation was ± 0.01 m (0.39 in.) with this technique.

¹ American Society for Testing and Materials. (1990). "Standard practice for design and installation of groundwater monitoring wells in aquifers," ASTM D5092-90, Philadelphia, PA.

Surface water

Surface water was sampled from streams, rivers, and springs, both on the base and outside its boundaries as background samples. Surface water from these sources is replenished largely from subsurface sources. Therefore, they can provide useful information without having to drill and develop monitoring wells. In addition, samples can be taken in areas that otherwise could not be sampled – such as on private land when the owners would be unlikely to authorize the drilling of a well. Conductivity, redox potential, and pH were measured at each site. The same series of samples were taken for surface water as for subsurface groundwater to allow the same testing.

Parameters Monitored and Analytical Methods

Soil and biomass samples were analyzed for metals, energetic materials, and for ^{232}Th using a different technique. Groundwater and surface water samples were analyzed for metals, most common anions, ^{232}Th , energetic materials, and other more common contaminants and parameters, such as dissolved solids. Unlike Phase I, no parkplatz was sampled, so soils and groundwater were not analyzed for petroleum, VOCs, and benzene, toluene, ethylbenzene, and xylene (BTEX). Metals were analyzed by Inductively Coupled Plasma Mass Spectrometry (ICP/MS). All the parameters available by this method were included in the study. Energetic materials for soils and groundwater were analyzed at DREV by Gas Chromatography/ Electron Capture Detector, a method that leads to a 1-ppb detection limit for explosives in soils. INRS conducted the following onsite groundwater measurements: pH, electrical conductivity, temperature, dissolved oxygen, and Eh. Furthermore, water level measurements, in situ permeability tests, and groundwater flow direction and velocity measurements were also conducted. Thorium-232 was analyzed by the Geological Survey of Canada using ICP/MS with a detection limit of 5 ppt for aqueous samples. All the results coming from these analyses are presently being compiled and analyzed.

Magnitude of Study

During Phase I of the characterization accomplished in September 2000, a total number of 83 soil (8 background), 34 biomass (4 background), 34 groundwater (3 background), and 11 surface water (2 background) samples were collected. Background soil samples are critical for establishing the anthropogenic contribution versus the natural contribution for all parameters. A total of 18 background soils samples were initially planned for collection. However, because of the same limiting factors mentioned earlier, only eight background samples were collected, all in the southern part of the Shilo training area. All of the samples collected during Phase I, except for the background samples, were collected mainly in three battleruns and in parkplatz. Some soils were sampled at each of the five battleruns for traces of volatile organic compounds (VOCs) and BTEXs. Two composite samples were randomly collected at each parkplatz and named samples A and B. Composite samples included a minimum of 20 subsamples. For ^{232}Th , the target areas for the MILAN missiles were identified

and the approach using the circular pattern was applied to collect soil samples. Forty-one boreholes were drilled, and observation wells were installed. Because of bad weather, only 36 wells were developed and groundwater was collected from only 34 wells.

Results

Soil sample results were compared to Canadian Council Ministers of Environment (CCME) soil threshold criteria and to the mean value of background sample results for some representative metals. None of the soil samples exhibited contamination levels higher than any of the CCME threshold criteria, even for agricultural soils. This indicated no major soil contamination at either surface or subsurface levels.

The analytical results obtained for the parameters tested in all types of samples demonstrated that no major contamination could be related to the training activities. In soils, the accumulation of some metals associated with munitions was observed around pop-up targets but did not reach levels of concern. Neither surface soil nor the subsurface soil samples showed levels of metals higher than agricultural CCME criteria. Our study clearly demonstrated that no major problems are associated with soil contamination. The fact that higher levels of contaminants were encountered around targets proved that the firing activity caused an accumulation of contaminants locally, but not at levels of concern. However, radioactive thorium accumulated near targets in both soils and groundwater and presents a concern. Soil samples near targets presented statistically higher results for ^{232}Th , while results for groundwater showed ppb levels of the radioactive compound, close to identified MILAN missiles impacted areas. Concentrations are still very low, both in soils and groundwater, but considering the very long half-life of this particular contaminant, it is still of high concern to find measurable traces of this element. ^{232}Th has accumulated around target impact area and even if this element has a very low solubility, it is found at trace levels in the groundwater and it might migrate off range in a long-term scenario. Therefore, discontinuation of MILAN missile firings at CFB Shilo was recommended. It was also recommended that MILAN missile debris should be collected and disposed according to an existing procedure for radioactive materials.

All the analyses for explosives revealed no contamination in soils, groundwater, and biomass samples. Analyses showed only traces (below our quantification limits) of energetic residues in some water samples. This will be confirmed when a 1-ppb detection and quantification level is obtained. The 1-ppb detection limit will allow the certification that no trace-level of explosives are found in the Shilo groundwater. Confirmation of the absence of energetic residues in groundwater is still very important and will be completed in Phase II. Results obtained from the biomass samples, both for metals concentrations in plants (extracts) and the metals dust on the plants (leachates), showed no increased level of concern in the battleruns when compared to the biomass background mean values. Only five hits were encountered in the Berlin range where some metals showed concentrations higher than background samples. These hits were not

considered critical. Higher levels of chromium and aluminum were found in the 80 and 120 percent transects of Berlin where the highest concentrations of UXO were expected. No hits were observed in the Essen or in the Deilinghofen battleruns.

No biomass samples were collected around targets for which systematic soil sampling was carried out. This decision was based on discussions with range controllers who believed that the targets should not present the highest levels of UXO concentration. Since the targets were pop-up targets, more than 90 percent of the munitions fired at them did not stop, but continued toward the end of the battleruns. The fact that we did not collect plants around targets is unfortunate, since a trend in accumulation of metals was observed for soils and could have also been observed for the biomass. This was corrected in Phase II where many biomass samples were collected around targets.

For some groundwater and surface water samples, Al, Mn, Fe, Cr, Ag, and Se exceeded CCME threshold criteria. However, iron and manganese were found in background samples at high concentrations and, therefore, were not considered as threats to the environment. Aluminum was found in trip blanks (empty container sent along with the other samples to evaluate any contamination occurring during transportation of the samples to the laboratory) and field blanks at level as high as 60 ppb. Therefore, levels lower than 60 ppb should be considered insignificant. Silver was detected in some samples at high levels, but field replicates showed no traces of silver, indicating that it was not significant at the levels measured. Chromium and selenium were detected at low levels exceeding the lower limit interval of the aquatic life threshold criteria and, therefore, should not be considered a threat in groundwater media.

At the end of Phase I, further work was recommended to fully characterize this very large site. One should keep in mind that this study was made at a regional scale and that the sampling was, therefore, not representative of the whole area. Point sources at the local scale could still be found in the future. The training area can be considered as a weak source with various modes of transportations for contaminants with no measurable impacts on environmental receptors outside of the range.

Phase II was dedicated mainly to complete the work initiated during Phase I. This resulted in more background sampling, more soil and biomass sampling around the targets to better assess the pattern of contamination, more ^{232}Th sampling in suspected areas, sampling soils and biomass in rifle and grenade ranges, and completing the sampling of the two remaining battleruns. During this phase, 162 soils samples, including 23 as backgrounds, and 64 biomass samples, including 18 as backgrounds, were collected. Forty supplementary wells were drilled and installed to complete the piezometric map of the base. All the 80 wells were sampled for groundwater analyses and more surface water samples were collected around the base. A total of 132 groundwater samples, including 12 as background, were collected. Surface water samples were also collected to evaluate what is going out of the ranges. All these results are being compiled and analyzed.

Conclusion

The task of environmentally assessing a large area is enormous. This effort represents one of the first efforts worldwide to comprehensively assess an active training base. It is seen that the situation in battleruns using pop-up targets is completely different from the one encountered in antitank training. No energetic materials were detected in soils, biomass, and groundwater. Metals were detected in soils, in biomass, and in groundwater at low concentrations. ²³²Th was detected in soils and groundwater at some locations in Deilinghofen. No problems were identified related to petroleum products, VOCs and SVOCs. During Phase II, the efforts will be directed to acquiring more data on specific areas to complete the analysis of the situation at CFB Shilo.

The enormous density of unexploded ordnance presents a huge environmental challenge, both in the immediate physical danger of unexpected detonations, and in the longer-term, environmental damage caused as the explosive and metallic components of the munitions enter the environment. During Phase II, efforts will be directed to assessing the contamination at hotspots to verify if the contamination increased around broken UXOs. It should also be noted that the nature of munitions as contamination point sources makes it extremely difficult to identify all contaminated sites. The task of assessing military sites is challenging but must be done in the interest of sustaining the training activities in the long term.

4 Transport Parameters for Firing Range Residues

Background

Dissolution of explosives residues from free product contained in cracked or partially fragmented munitions is the primary method by which nonvolatile explosives contaminate firing ranges. Yet, dissolution rates of explosives components of munitions have not been measured (Brannon et al. 1999). Soils analyses show concentration gradients for HMX and TNT that are consistent with kinetic limitations on solubilization (Jenkins et al. 1997). However, the information available on dissolution kinetics of explosives residues is limited to a small amount of unpublished data by Jenkins that show pronounced differences in the rates of TNT, RDX, and HMX movement into solution over time. Thiboutot et al. (1998) show that for octol, the dissolution rates of TNT and HMX differ substantially. Gilcrease, Murphy, and Reardon (1996) reported that surface area and mixing rate affects TNT dissolution rate. Accurate dissolution rate kinetics for explosives and the main explosives formulations used in munitions are key parameters for describing the fate and transport of explosives residues from firing ranges into groundwater.

The main factors affecting fate and transport of explosives residues after they dissolve from solid phase residues are adsorption, transformation, and irreversible soil binding (Brannon and Myers 1997). The primary fate and transport process descriptors that are required for modeling the movement of explosives residues through soil and into groundwater are the adsorption coefficient and the transformation rate coefficient. Process descriptors mathematically depict the impacts of interactions between soil and water on explosives concentrations in water and soil. The adsorption coefficient is a mathematical expression that describes the distribution of a chemical compound between soil and water when they are at equilibrium. When transformation or irreversible sorption is significant, equilibrium is not attained and the transformation rate coefficient is used to describe the fate and transport of an explosive contaminant. The transformation rate coefficient is a kinetic parameter that describes the removal of a compound from solution by transformation and sorption. The transformation rate coefficients generally follow first-order kinetics (Brannon and Myers 1997). The amount of available data on fate and transport process descriptors for explosives residues varies greatly. Most studies have been directed at TNT and its transformation products, RDX, and to a lesser extent, HMX.

This chapter reports progress on development of environmental fate and transport parameters for selected energetic residuals for which data are currently lacking or that have been detected on firing ranges. Fate and transport parameters are used to evaluate the migration of explosives residues from the solid phase residue into solution during rainfall events (dissolution kinetics) and the interactions of explosives residues in solution with firing range soils that then occurs. This chapter presents new process data leveraged with the Army Installation Restoration Research Program (IRRP) work unit titled "Fate and Transport of Explosives Contaminants" (A835/309E/RE004) which provided 90 percent of the funding for this effort. When completed, the dissolution data will be published as a separate "thesis" ERDC report.

Objectives

The objectives of this study were (a) to evaluate dissolution kinetics for the explosives formulations Composition B, octol, and LX-14, (b) to determine dissolution kinetics and solubility for TNT, RDX, and HMX, and (c) to determine process descriptors for selected explosives residues for which data are lacking. Fate and transport process parameters were determined for nitroglycerine and the mono-, di-, and tri-nitroso transformation products of RDX (MNX, DNX, TNX). In addition, site specific process descriptors were determined for TNT, RDX, and HMX in Fort Lewis soils.

Materials and Methods

Explosives dissolution: Kinetics

Three military grade explosives selected for this study were 2,4,6-trinitrotoluene (TNT), hexahydro-1,3,5-trinitro-1,3,5-triazine (RDX), and octahydro-1,3,5,7-tetranitro-1,3,5,7-tetrazocine (HMX). TNT is a nitroaromatic explosive, while RDX and HMX are classified as nitramines (Figure 27). The TNT used in this study is identified as Type I flake, the RDX is Type II, Class 3 crystals, and the HMX is Grade B, Class 2 crystals. Military grade high explosives were used to replicate the nature of explosives expected in a field environment (i.e., age, composition) and were deemed more representative than pure individual compounds. These explosive compounds were used separately and in the preparation of the nonbound explosive mixtures to compare with the explosive compounds in the formulations Composition B, octol, and LX-14.

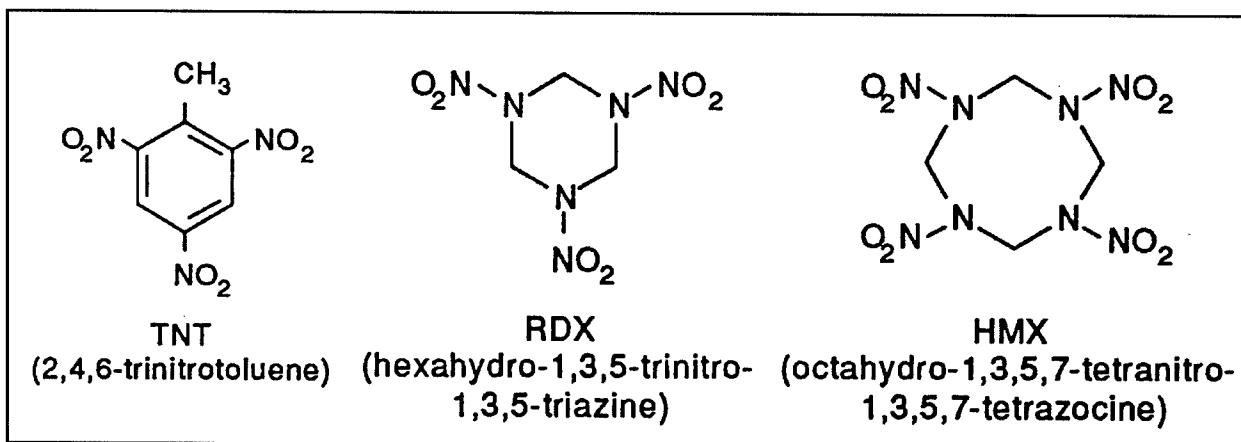

Figure 27. TNT, RDX, and HMX molecular structures

Environmental variables. The choice of experimental variables was based on key terms in Fick's First Law.

$$V \frac{dC}{dt} = \frac{D}{h} a(C_s - C_b) \quad (1)$$

where

dC/dt = the change in concentration over time ($\text{mg s}^{-1}\text{L}^{-1}$)

V = volume of solvent (L)

D = diffusion coefficient ($\text{cm}^2 \text{s}^{-1}$)

a = surface area (cm^2)

C_s = solubility (mg cm^{-3})

C_b = concentration in bulk liquid (mg cm^{-3})

h = stagnant layer thickness (cm)

This expression can be reduced to a zero order equation where the approximation of the $\frac{D}{h}$ term under different environmental conditions is possible. To approximate a zero order equation, several of the variables in Equation 1 were assumed constant. In dilute solutions, C_b is small with respect to C_s and is assumed negligible. Sampling intervals were therefore arranged to be complete before the predicted C_b/C_s ratio reached 0.2. Experiments were also controlled so that changes in solvent volume (averaging a 1-percent loss from total sampling) and explosive compound surface areas (averaging a 5-percent loss from dissolution) would be negligible. The need to maintain a dilute solution affected run times, ranging from 4.3 min for HMX at 30 °C (solubility less than 3 mg L^{-1}) to 120 min for TNT at 10 °C (solubility greater than 70 mg L^{-1}).

The three temperatures selected for this study (10, 20, 30 °C) are representative of the range of ambient conditions where unexploded explosive compounds might be found in the environment.

Approximation of explosive surface areas was necessary because of the heterogeneity of particle sizes and shapes (ranging from less than a 0.04-mm-diam for HMX crystals to greater than 4-mm length for TNT flakes). Surface areas for RDX and HMX were estimated using mass-to-surface area ratios for each explosive based on military specifications for acceptable granulation distribution. These nominal surface areas do not account for surface roughness that was seen microscopically on the explosives. Based on a desired separation of approximately 20 percent among the three sample surface areas (to provide sufficient separation yet fit within the conditions of this study), RDX quantities that produced sample surface areas of approximately 8, 10, and 12 cm² were measured using an estimated RDX surface area-to-mass ratio of 100.4 cm² g⁻¹. Similarly, sufficient HMX was used to produce sample surface areas of approximately 5, 6, and 7 cm² based on an HMX surface area-to-mass ratio estimate of 598.5 cm² g⁻¹. Surface area effects on dissolution rate were normalized by dividing the dissolution rate (mg min⁻¹) by the nominal explosive surface area used in the run (cm²), resulting in a rate with units of mg min⁻¹ cm⁻².

Measuring TNT flake areas under a microscope and then weighing these sets of flakes on a balance yielded a reproducible surface area-to-mass ratio. This method yielded a surface area to mass estimate of 23.28 cm² g⁻¹. Sufficient TNT was used to produce sample surface areas of approximately 5.8 cm², 7.3 cm², and 8.7 cm².

The stagnant layer thickness represents the gradient zone in the solution between the surface of the solid explosive (where the solution concentration is at the solubility limit) to a point in the solution where the concentration equals that of the rest of the bulk solution. Since dissolution is affected by the rate of transport from the surface of the explosive compound to the bulk solution, rates would increase if the layer were thinner and the gradient steeper (Stumm and Morgan 1996). This condition can be achieved by energy input in the form of agitation or stirring. Mixing rates of 90, 150, and 250 rpm were selected to examine effects of mixing rate on dissolution rates.

Experimental design. To determine the impact of each variable on dissolution rate, one of the variables was allowed to change while the other two were held constant. To limit TNT photolysis (Townsend and Myers 1996), experiments were performed under limited light conditions and samples were stored in the dark. The experimental design is based on dissolution tests described in the United States Pharmacopeia Convention, Inc. (1990).

Initially, 500 mL of demineralized (reverse osmosis) water in 600-mL beakers were covered with aluminum foil and allowed to equilibrate for 15 hr to temperature in a water bath. The water temperature was regulated using a Fisher Scientific Isotemp Refrigerated Circulator and insulated by a floating layer of 20-mm hollow plastic balls.

Stirring propellers from overhead mounted Yamato Scientific StedFast Digital Lab Stirrers were centered and lowered into the beakers, adjusted to the desired rpm, and raised to a height of 2.5 cm above the beaker bottom. Once these conditions were achieved, the desired amount of dry explosive compound was

added to each beaker. While continuing to stir, five 1-mL samples were periodically pipetted from a zone midway between the surface of the solution and the top of the stirring propeller and midway between the beaker wall and the propeller shaft.

Analytical methods. Pipetted 1-mL samples were immediately filtered using a disposable 3-mL Luer-Lok syringe with attached Millex Millipore Filter unit (0.45- μm pore size). The filtrates were combined with an equal volume of 45- μm filtered acetonitrile, and capped in a 4-mL vial. The vial was vortexed for 5 sec and then stored quiescently for at least 25 min. Samples were analyzed using a Waters High Performance Liquid Chromatograph (HPLC) following EPA SW846 Method 8330 (U.S. Environmental Protection Agency (USEPA) 1994a).

Effects of pH on explosives solubility and dissolution

The Holston Army Ammunition Plant, Kingsport, TN, provided experimental quantities of TNT and the explosive formulations octol and composition B. Picatinny Arsenal, Picatinny, NJ, provided experimental quantities of LX-14, RDX, and HMX. Demineralized water (reverse osmosis with a pH of approximately 5.7) was used with the pH adjusted lower by addition of H_2SO_4 and HNO_3 , or higher by the addition of Na_2CO_3 and NaOH . These chemicals were selected to replicate acid rain and basic conditions expected in the natural environment.

Environmental variables. Environmental factors such as temperature and pH can affect solubility and therefore chemical fate and toxicity (Huang et al. 2000). If ideal conditions are assumed, solubility can be estimated using the equation (Atkins 1982):

$$\ln x_B = -\left(\frac{\Delta_{fus}H}{R}\right)\left(\frac{1}{T} - \frac{1}{T^*}\right) \quad (2)$$

where

- x_B = mole fraction of solute
- $\Delta_{fus}H$ = enthalpy of fusion of solute
- R = ideal gas constant
- T = absolute temperature
- T^* = solute melting temperature

Aqueous solutions of explosive compounds are not ideal, but the general equation remains similar following the form

$$\ln S = A - \frac{B}{T} \quad \text{or} \quad S = A * \exp\left(\frac{-B}{T}\right) \quad (3)$$

where

S = solubility
A and B = arbitrary constants
T = absolute temperature

Taylor and Rinkenbach (1923) conducted one of the earliest studies on TNT aqueous solubility over the temperature range 0 to 100 °C but did not evaluate the effect of pH. Spanggord et al. (1983) reported expressions for TNT and RDX solubility based on measurements at 10, 20, and 30 °C, but also did not investigate pH. Ro et al. (1996) reported aqueous solubilities for TNT at differing pH levels and temperatures. They proposed a solubility correlation and found that temperature had the greater impact on solubility and that solubility varied widely at higher pH. Phelan and Barnett (2001) reported TNT pH independent aqueous solubility values that agree with those reported by Spanggord et al. (1983). None of the predictive solubility correlations were similar to the others. Townsend and Myers (1996) and Gibbs and Popolato, ed. (1980) list solubilities from the literature for TNT, RDX, and HMX as a function of temperature and independently of pH. These values will be shown later in figures compared with results from this study. Here we reevaluate TNT solubility as a function of temperature and pH, and add evaluations of RDX and HMX solubility as a function of these same variables.

Dissolution is the primary mechanism allowing for transformation and transport of nonvolatile explosive compounds. Dissolution rate and solubility control the persistence of the explosive at the source and the degree of contamination at some distance away from this source. Fick's Law can be used to predict the concentration of explosive compounds dissolved in water as well as the time required to reach solubility limits.

$$\frac{dC}{dt} = K_L a (C_s - C_b) \quad (4)$$

where

dC/dt = dissolution rate
K_La = overall mass transfer coefficient
C_s = solubility
C_b = concentration in bulk liquid

If the dissolution rate is known, Equation 4 (Tchobanoglous and Schroeder 1987) can be integrated to identify the concentration, C_t, at any time:

$$C_t = C_s (1 - e^{(-K_L a)t}) \quad (5)$$

Information on high explosive dissolution rates is sparse. Gilcrease, Murphy, and Reard (1996) reported that increasing stirring rate increased dissolution of TNT and surface area by grinding of the particles during mixing. The effects of

pH have not been addressed. The zero-order, multivariable dissolution rate (dC/dT) equations (in units of mg dissolved per minute) are

$$\begin{array}{c} \text{TNT} \\ \frac{dC}{dt} = \left(9.82E - 6 \left[\frac{mg}{\min - C - cm^2 - rpm} \right] * temp[C] - 4E - 5 \left[\frac{mg}{\min - cm^2 - rpm} \right] \right) * sa[cm^2] * rpm \end{array} \quad (6a)$$

$$\begin{array}{c} \text{RDX} \\ \frac{dC}{dt} = \left(1.49E - 6 \left[\frac{mg}{\min - C - cm^2 - rpm} \right] * temp[C] - 6.1E - 6 \left[\frac{mg}{\min - cm^2 - rpm} \right] \right) * sa[cm^2] * rpm \end{array} \quad (6b)$$

$$\begin{array}{c} \text{HMX} \\ \frac{dC}{dT} = \left(4.46E - 6 \left[\frac{mg}{\min - C - cm^2 - rpm} \right] * temp[C] - 7.8E - 7 \left[\frac{mg}{\min - cm^2 - rpm} \right] \right) * sa[cm^2] * rpm \end{array} \quad (6c)$$

where

temp = temperature
 sa = nominal surface area
 rpm = stirring rate in the experimental design

Experimental design. Aqueous solutions with pH values of 4.2, 5.7, and 6.2 were used as the solvent for the solid explosive dissolution experiments. An excess amount of solid explosive was added to 200 mL of pH adjusted water in a 250-mL Erlenmeyer flask wrapped in aluminum foil to minimize photolysis (Townsend and Myers 1996).

A magnetic stir bar was added to the flask, which was then sealed with parafilm. The solution was stirred on a magnetic stirrer at a rate sufficient to maintain a deep vortex. Experiments were performed in duplicate and at temperatures of 3.1 ± 0.8 , 21.1 ± 1.4 , and 33.3 ± 3.0 °C. Samples were taken in replicate seven and 14 days after stirring began. Samples were immediately passed through a 0.45- μ m pore size membrane filter and combined with an equal volume of 0.45- μ m filtered acetonitrile. Procedures for dissolution rates, equipment, and analytical methodologies were as previously described.

Dissolution rates of military formulations

Experimental quantities of weapons grade RDX, HMX, and TNT were provided by the Environmental Processes and Engineering Division, Environmental Laboratory (EL), U.S. Army Engineer Research and Development Center (ERDC), Vicksburg, MS. These explosive compounds were used separately and in the preparation of the nonbound explosive mixtures for comparative purposes with the explosive compounds in the formulations.

Three samples of TNT and eight samples each of Composition B and octol were melt-poured at the Holston plant into 5.5-cm-diam disk-shaped molds with an average thickness of $0.88 \pm 0.08 \text{ cm}^2$. Octol is the formulation name given to a mixture of HMX and TNT (Gibbs and Popolato, ed. 1980). The octol consisted of 70 percent HMX and 30 percent TNT by weight. Composition B is a mixture of TNT and RDX that might also include a wax desensitizer (Gibbs and Popolato, ed. 1980). Composition B consisted of 59.5 percent RDX, 39.5 percent TNT, and 1 percent wax by weight. Both octol and Composition B are prepared by stirring the other components of the formulation into melted TNT and, after mixing, allowing the resulting formulation to solidify. LX-14 is a plastic-bonded explosive consisting of 95.5 percent HMX and 4.5 percent polyurethane by weight (trademarked as Estane). The components of LX-14 are bonded together using a pressurization process.

The procedure for the dissolution rate experiments were as outlined previously for the pure compounds with one modification. The width of the formulation disks required that the mold be added first to the beaker and the 500 ml of water subsequently added at time zero while the stirring propellers were turning.

Explosives partitioning

Adsorption kinetics. An aquifer soil, LAAP -D, and two surface soils with different physical characteristics, Yokena Clay (a Sharkey clay) and Picatinny (Ridgebury Soil Series), were used to measure adsorption kinetics (Table 20). The tests were conducted under nitrogen in a glove box to simulate anaerobic aquifer conditions. Sufficient soil (4 g) and distilled, deionized, deoxygenated water (16 mL) were added to 25-mL glass centrifuge tubes to make a soil-to-water ratio of 1:4. For nitroglycerine testing, the distilled water added to the soil contained 1.47 mg L^{-1} nitroglycerine. The transformation products of RDX (MNX, DNX, and TNX) were spiked by adding 16 mL of a solution of either TNX or a mixture of MNX and DNX. The solution for MNX and DNX was a mixture of the two compounds, because they cannot be chemically separated at this time. The initial concentration of TNX was 3 mg L^{-1} , while the initial concentration of the mixture of MNX and DNX was 1.01 mg L^{-1} MNX and 1.71 mg L^{-1} DNX. Samples were placed on a reciprocating shaker at 180 excursions per minute. At predetermined sampling times (0.5, 1, 6, 12, 24, 72, 120, and 168 hr for nitroglycerine and 1, 6, 24, 48, 72, 96, and 120 hr for MNX/DNX and TNX), triplicate tubes were removed and centrifuged at 8,288 RCF for 30 min. Two mL of the aqueous sample was removed and 2-mL acetonitrile was added. The diluted samples were analyzed by HPLC using EPA SW846 Method 8330 (USEPA 1994).

Soil	TOC, percent ¹	CEC ² , meq 100 g ⁻¹	pH	Clay, percent	Sand, percent	Silt, percent
LAAP D	0.02	5.5	5.5	7.5	85	7.5
Yokena Clay	2.4	38.9	6.4	48.75	13.75	37.5
Picatinny	0.634	9.8	6.1	5	62.5	32.5
Fort Lewis	0.26	6.8	6.8	9.9	82.3	7.8

¹ Total organic carbon
² Cation exchange capacity

Adsorption partitioning. Adsorption partitioning was conducted with LAAP D, Yokena Clay, and Picatinny soils in a 1:4 ratio of soil to water in 25-mL glass centrifuge tubes. TNX samples were spiked at concentrations of 1.1, 2.8, 5.6, 8.3, and 11.1 mg L⁻¹. The DNX/MNX samples were spiked at 0.4, 1, 2, 3, and 4 mg L⁻¹ DNX and 0.2, 0.5, 1.1, 1.6, and 2.1 mg L⁻¹ MNX. Nitroglycerine was spiked at concentrations of 1, 1.5, 2.0, 2.5, and 2.0 mg L⁻¹. Triplicate samples for nitroglycerine testing were shaken for 72 hr for LAAP D soils and 120 hr for Picatinny soils on a reciprocating shaker at 180 excursions/min, centrifuged at 8,288 RCF for 60 min, and the aqueous phase was removed and analyzed for nitroglycerine as previously described for the kinetics tests. Yokena clay soil was not tested because steady-state nitroglycerine solution concentrations were not attained. Triplicate TNX and DNX/MNX samples were shaken for 1 hr on a reciprocating shaker at 180 excursions/min prior to centrifugation, preparation, and analysis as previously described.

Desorption kinetics. Fort Lewis soil (Table 20) from the hand grenade range contained 2.6 mg Kg⁻¹ TNT, 22.5 mg Kg⁻¹ RDX, and 3.5 mg Kg⁻¹ HMX. Tests were prepared by loading 2.5 gms soil into 25-mL centrifuge tubes and adding 10 mL of water. Samples were placed on a reciprocating shaker at 180 excursions per minute. At sampling times (0.5, 1, 6, 24, and 48 hr), duplicate tubes were removed and centrifuged at 8,288 RCF for 30 min. Two mL of the aqueous sample was supplemented with 2 mL acetonitrile, then analyzed by HPLC for TNT, RDX, and HMX using EPA SW846 Method 8330 (USEPA 1994).

Desorption partitioning. Soil from the hand grenade range at Fort Lewis (2.5 g) was loaded into two 25-mL centrifuge tubes. Ten (10) mL of water was added to the centrifuge tubes, shaken on a reciprocating box shaker at 180 excursions/min for 24 hr and centrifuged at 8,288 RCF for 30 min. A 2-mL aqueous aliquot was removed, 2 mL of acetonitrile were added to the aqueous aliquot and the samples were analyzed for TNT, RDX, and HMX as previously described. Excess water was removed and replaced by 10 mL of fresh water, and the shaking and analytical procedures were repeated three more times.

Results and Discussion

Dissolution of explosives

Analysis of the dissolution data showed that linear regression adequately described explosives dissolution. The mean r^2 and standard deviation from the mean for each explosive dissolution rate experiment was 0.986 and 0.008 for TNT, 0.989 and 0.014 for RDX, and 0.746 and 0.096 for HMX, respectively. Ten individual runs each were analyzed at 10 and 30 °C. Six individual runs were analyzed at 20 °C for each explosive.

If the surface area approximations were reproducible, an evaluation of dissolution rate normalized for surface area ($\text{mg min}^{-1} \text{cm}^{-2}$) should yield similar rates if performed under the same conditions. To check this premise, dissolution rates for the three explosives are shown in Figure 28. Results indicate that the surface area estimation procedures were similar and reproducible. Dissolution rates as a function of surface area at 150 rpm and 10, 20, and 30 °C are summarized in Table 21.

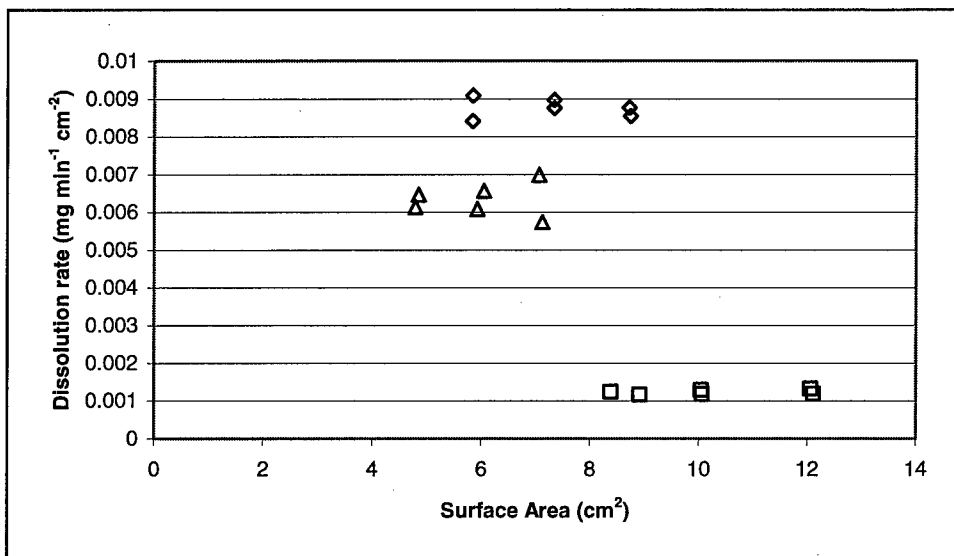

Figure 28. Surface area comparison of explosives at 150 rpm and 10°C (\diamond = TNT, \square = RDX, Δ = HMX)

	10°C		20°C		30°C	
	$\text{mg min}^{-1} \text{cm}^{-2}$	r^2	$\text{mg min}^{-1} \text{cm}^{-2}$	r^2	$\text{mg min}^{-1} \text{cm}^{-2}$	r^2
TNT	0.009	0.996	0.014	0.908	0.041	0.958
RDX	0.001	0.988	0.003	0.718	0.006	0.992
HMX	0.006	0.999	0.013	0.995	0.020	0.992

Dissolution rates as a function of temperature ($\text{mg min}^{-1} \text{ } ^\circ\text{C}^{-1}$) at 150 rpm and at specified explosive surface areas are summarized in Table 22. Changes in temperature have the greatest effect on TNT and the smallest effect on RDX dissolution rates. Dissolution rate increases with increases in temperature, suggesting that dissolution of these explosives is an endothermic process.

	cm^2	$\text{Mg min}^{-1} \text{ } ^\circ\text{C}^{-1}$	r^2	cm^2	$\text{Mg min}^{-1} \text{ } ^\circ\text{C}^{-1}$	r^2	cm^2	$\text{Mg min}^{-1} \text{ } ^\circ\text{C}^{-1}$	r^2
TNT	5.800	0.008	0.955	7.300	0.009	0.964	8.700	0.012	0.953
RDX	8.000	0.0015	0.961	10.000	0.0018	0.960	12.000	0.0023	0.957
HMX	4.800	0.003	0.996	6.000	0.004	0.999	7.100	0.005	0.998

The activation energies of dissolution were calculated using a form of the Arrhenius equation (Henry and Heinke 1996):

$$E_a = \frac{R \ln\left(\frac{k_1}{k_2}\right)}{\left(\frac{1}{T_1} - \frac{1}{T_2}\right)} \quad (7)$$

where

- E_a = activation energy
- $k_{i=1,2}$ = dissolution rate at conditions $_1$ and $_2$
- R = universal gas constant
- $T_{i=1,2}$ = temperature in $^\circ\text{K}$ at conditions $_1$ and $_2$

Activation energies for TNT, RDX, and HMX were calculated to be 55.6, 55.4, and 40.7 kJ mol^{-1} , respectively. In agreement with the Arrhenius prediction, that dissolution rate doubles with a 10 $^\circ\text{C}$ increase in temperature, the experimental dissolution rates increased by approximately 2.2 times for TNT and RDX and 1.8 times for HMX.

Dissolution rates as a function of mixing rpm at 10 and 30 $^\circ\text{C}$ and an explosive compound surface area equal to 7.3 cm^2 for TNT, 10 cm^2 for RDX, and 6 cm^2 for HMX are shown in Figure 29. Dissolution rate correlations as a function of mixing rate are presented in Table 22. Given that zero agitation equates to diffusion, linear regression trend lines of the data were not forced through zero. These y-intercepts in Table 23 allow comparison of the "relative" diffusion rates of the three explosive compounds, with TNT having the apparent slowest diffusion rate followed by RDX and HMX with the highest diffusion rate. Changes in stirring rate have the greatest effect on TNT and the smallest effect on HMX dissolution rates.

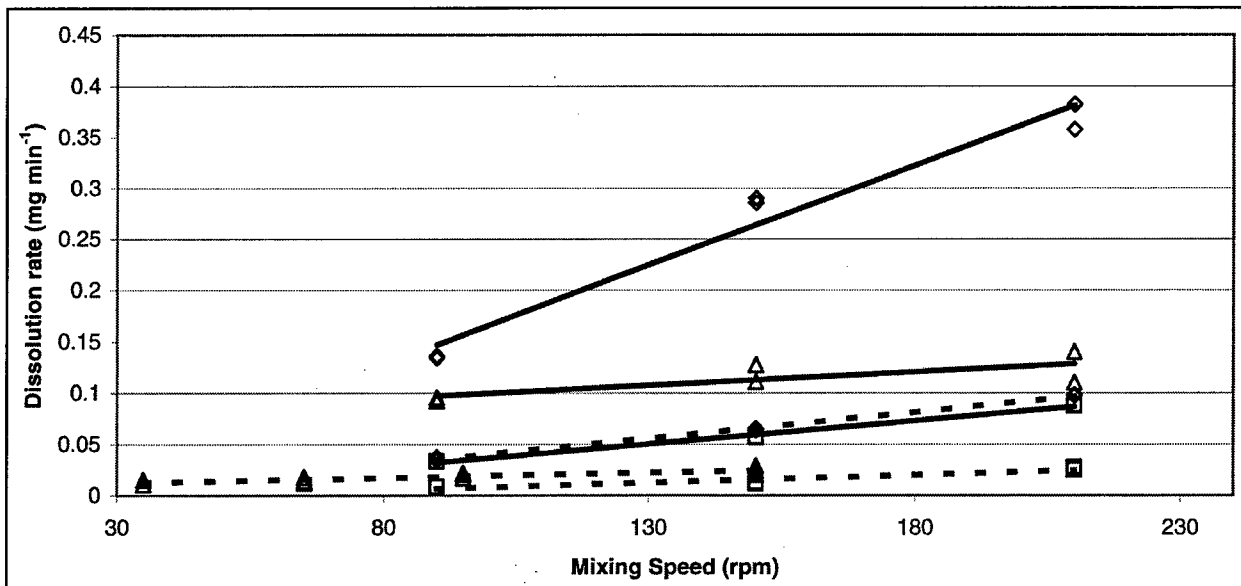

Figure 29. Mixing speed comparison of middle-size surface area explosives (\diamond = TNT, \square = RDX, Δ = HMX, — = 30 °C, --- = 10 °C)

Table 23
Dissolution Rates, r (mg min^{-1}) as a Function of Mixing Rate, m (rpm),
Using Middle Value Surface Areas and Specified Temperatures
(Note how selection of study rpm values affects correlation r^2 for
HMX)

	10 °C		30 °C	
	Correlation	r^2	Correlation	r^2
TNT	$r = 5.0\text{E-}4 * m - 1.1\text{E-}2$	0.99	$r = 2.0\text{E-}3 * m - 2.9\text{E-}2$	0.96
RDX	$r = 1.0\text{E-}4 * m - 6.7\text{E-}3$	0.89	$r = 5.0\text{E-}4 * m - 8.5\text{E-}3$	0.99
HMX	$r = 1.0\text{E-}4 * m + 8.7\text{E-}3$	0.97	$r = 3.0\text{E-}4 * m + 7.4\text{E-}2$	0.58

Using the mixing rates of 90, 150, and 210 rpm for HMX resulted in a linear regression trend line with an r^2 of only 0.58. This nonlinearity suggested that increases in mixing speed over the experimental range had reduced effects on increasing HMX dissolution rate. In theory, there should be a limit to how much the stagnant layer thickness can be decreased as a result of increased energy input. A second experiment using mixing rates of 35, 65, 95, and 150 rpm at 10 °C and a surface area of 6 cm^2 for HMX was performed to test this theory. The resulting r^2 for this correlation improved to 0.97 and is included in Figure 29.

To relate rpm-based dissolution rates in a beaker to terms that are used in a process or natural setting, mixing speed was correlated to two different terms. The first is the ε term (a mass normalized energy dissipation rate) in the Levins and Glastonbury (1972b) correlation

$$\varepsilon \approx \frac{N^3 D_s^5}{D_T^2 H} \quad (8)$$

where

N = stirrer speed
 D_s = stirrer diameter
 D_T = tank diameter
 H = height of liquid

This term has been used in tank reactors and is relevant in an equation to be presented later when comparing TNT dissolution rate results of this study to that of Gilcrease, Murphy, and Reardon (1996).

The second correlation relates the power-driven mixing rate to the "R" term (rainfall erosivity index) in the Revised Universal Soil Loss Equation (RUSLE) (U.S. department of Agriculture (USDA) 2001). The reason for pursuing this relationship was to relate rainfall energy impinging on explosives in the field to the energy input variable in the experimental design. This would permit the calculation of dissolution rates and contaminant persistence resulting from rain falling on explosive compounds exposed on the soil surface. The R term, a yearly average, is in units of hundreds foot tons-force inch acre⁻¹ hour⁻¹ year⁻¹, or energy times a rainfall rate over an area (Simanton 2000).¹ The experimental design has similar units with power input (energy/time) over an area (beaker area) in a certain depth (height of liquid in beaker). Mixing power requirements assuming turbulent flow were estimated using the equation (Tchobanoglous and Schroeder 1987):

$$p = k\rho n^3 d_i^5 \quad (9)$$

where

p = power requirement
 k = arbitrary constant estimated as 1 (Borsella 2000)²
 ρ = liquid density
 n = rotational speed
 d_i = diameter of mixer impeller

After equating units, R-values in the RUSLE program (ranging from the 20s in Nevada to the 350s in Florida) were similar to the experimental energy input values selected for this study. For example, an R-value of 250 hundred foot tons-force inch acre⁻¹ hour⁻¹ year⁻¹ (representative of Tennessee) from the RUSLE compares well to a mixing speed of approximately 120 rpm in the experimental design using the equation

¹ Simanton, R. 17 July 2000. Agricultural Research Service, Tucson, AZ.

² Borsella, J. July, 2000. Yamato Scientific America, Inc., Orangeburg, NY.

$$\text{rpm} = 60 \left(R * \frac{1.182 \times 10^{-6} \frac{\text{Watt} \cdot \text{cm}}{\text{cm}^2} \Pi D_T^2}{\text{kpd}_i^5 H} \right)^{1/3} \quad (10)$$

where

$$\begin{aligned} R &= 100 \text{ foot-ton-force inch acre}^{-1} \text{ hour}^{-1} \text{ year}^{-1} \\ D_T &= \text{cm} \\ d_i &= \text{m} \\ \rho &= \text{kg m}^{-3} \\ H &= \text{cm} \end{aligned}$$

Besides evaluating individual variable effects on explosive dissolution rates, the combination of temperature, surface area, and mixing speed into a single correlation was investigated using three different approaches. The first approach built on the single variable dissolution rate approach and involved a series of linear regressions incorporating an additional variable at each regression, ultimately yielding an expression for dissolution rate with units of $\text{mg min}^{-1} \text{cm}^{-2} \text{rpm}^{-1} \text{ } ^\circ\text{C}^{-1}$. Of the possible combinations, the sequence of variables addition and regressions used in this study was from dissolution rate expressed as mg min^{-1} to $\text{mg min}^{-1} \text{cm}^{-2}$ to $\text{mg min}^{-1} \text{cm}^{-2} \text{rpm}^{-1}$ to $\text{mg min}^{-1} \text{cm}^{-2} \text{rpm}^{-1} \text{ } ^\circ\text{C}^{-1}$. All regressions except the last forced the y-intercept to zero. Other sequences for variable addition did not yield a multivariable equation that closely fit the experimental data. With respect to the variables employed in this study, ranking from greatest to least impact on dissolution rate is temperature ($^\circ\text{C}$), followed by surface area (cm^2), and then mixing speed (rpm). The multiregression, multivariable equations, whose solutions yield a dissolution rate in units of mg min^{-1} , are presented below. The average percent difference between raw data dissolution rates expressed as mg min^{-1} and those calculated by the multivariable equation averaged less than 10 percent for TNT and RDX and less than 15 percent for HMX.

$$\begin{aligned} &\text{TNT} \\ \frac{dm}{dt} &= \left(1.0E-5 \frac{\text{mg}}{\text{min} - \text{cm}^2 - \text{rpm} - ^\circ\text{C}} * T - 4.3E-5 \frac{\text{mg}}{\text{min} - \text{cm}^2 - \text{rpm}} \right) * a * m \quad (11a) \end{aligned}$$

$$\begin{aligned} &\text{HMX} \\ \frac{dm}{dt} &= \left(4.75E-6 \frac{\text{mg}}{\text{min} - \text{cm}^2 - \text{rpm} - ^\circ\text{C}} * T - 2.4E-6 \frac{\text{mg}}{\text{min} - \text{cm}^2 - \text{rpm}} \right) * a * m \quad (11b) \end{aligned}$$

$$\begin{aligned} &\text{RDX} \\ \frac{dm}{dt} &= \left(1.49E-6 \frac{\text{mg}}{\text{min} - \text{cm}^2 - \text{rpm} - ^\circ\text{C}} * T - 6.5E-6 \frac{\text{mg}}{\text{min} - \text{cm}^2 - \text{rpm}} \right) * a * m \quad (11c) \end{aligned}$$

A second approach avoided the multiple regressions in favor of a single linear regression of normalized dissolution rates and one variable. Dissolution rates were normalized by dividing initial mg min^{-1} rate of each run by two of the variable conditions used in that particular run (i.e., surface area and rpm). These normalized rates were then regressed against the remaining variable (in this case temperature). These linear regressions were not forced through zero. The first row in Table 24 identifies the dissolution rate equation for the example given. This process was then repeated two more times, once for rpm as the last included variable (row 2, Table 24) and again using surface area as the independent variable (row 3, Table 24). Again, those correlation trend lines where temperature served as the independent variable had the best fit to the data. This indicates that temperature has the greatest impact on dissolution rate employing the units used in this study. The means of the average percent difference between the described correlations and the experimental data for all the explosive compounds with temperature as the independent variable was 10 percent, for surface area it was 15 percent, and for mixing speed it was 450 percent.

Table 24			
Zero-Order pH-Related Explosive Dissolution Rates Measured at 30 °C, 150 rpm, and Normalized Solid Explosive Surface Area			
Method	Dissolution rate/ $\text{mg/cm}^2 \text{ s}^{-1}$	R ²	Av percent diff ^a
TNT			
Eq 5	= 0.00063	n/a ^b	9.1
Composite	= 0.00069	0.984	
HMX			
Eq 5	= 0.00032	n/a ^b	9.8
Composite	= 0.00029	0.628	
RDX			
Eq 5	= 0.000097	n/a ^b	1.0
Composite	= 0.000096	0.991	

Results from the multiple linear regression methodology for determining a correlation with multiple variables are very similar to the single linear regression approach. Two validation runs were performed for each explosive compound using different temperatures (15 and 25 °C), surface area (6 cm^2), and mixing rate values (180 and 120 rpm) from those generating the correlations. The single regression correlation line is included with the multiple regression correlation line for comparison with experimental HMX data in Figure 30 as are the validation data points. All TNT (not shown) and HMX data and validation points fell within the 99-percent confidence bands, while all RDX data (not shown) and validation points fell within the 95-percent confidence bands.

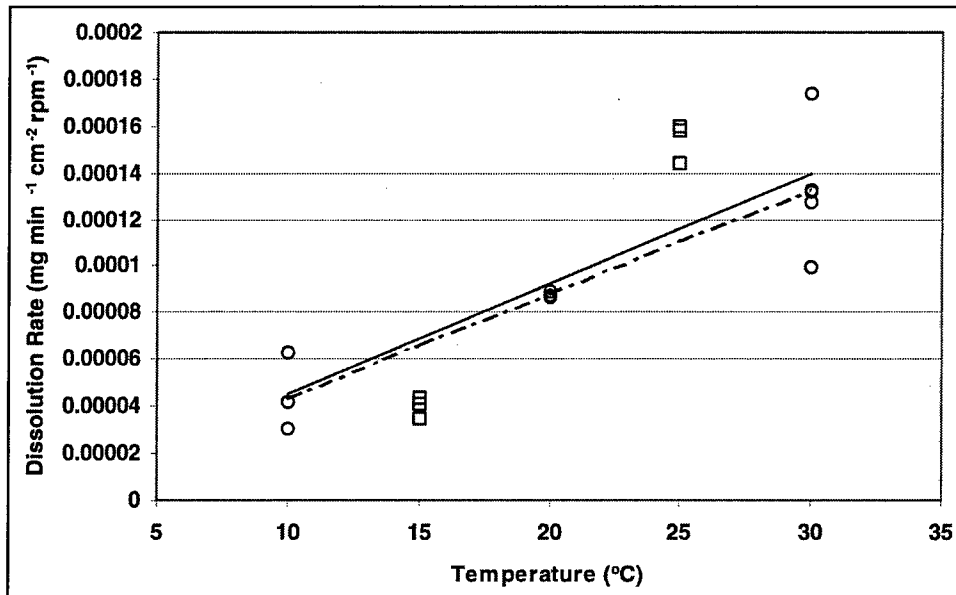

Figure 30. Comparison of HMX multiple regression, multiple variable dissolution rate correlation (—) to the HMX single regression, multiple variable dissolution rate correlation (---). Note: Correlation data points (○) and validation points (□)

The last method for determining a multivariable dissolution rate expression used a correlation developed by Levins and Glastonbury (1972a) describing spherical particle-liquid hydrodynamics and mass transfer in a stirred vessel

$$\frac{kd_p}{D_v} = 2 + 0.47 \left(\frac{d_p^{4/3} \varepsilon^{1/3}}{\nu} \right)^{0.62} \left(\frac{D_s}{D_T} \right)^{0.17} \left(\frac{\nu}{D_v} \right)^{0.36} \quad (12)$$

where

- k = mass transfer coefficient
- d_p = particle diameter
- D_v = diffusivity
- ε = energy dissipation rate/unit mass
- ν = kinematic viscosity
- D_s = stirrer diameter
- D_T = tank diameter

Gilcrease, Murphy, and Reardon (1996) used this method in their evaluation of TNT dissolution in reactors containing either water or a water/Teflon bead slurry.

Comparisons between the Levins and Glastonbury (1972a) correlation and the experimental data obtained in this study can be made by expressing the “k” term in Equation 12 in milligrams dissolved per minute and comparing it to the rate determined from the data of each run. The dissolution rates for data from this study, rates predicted by the multivariable equation derived in this study, and rates

predicted by the Levins and Glastonbury (1972a) correlation for TNT mixed at 150 rpm and 10 °C (lower set of data) and 30 °C (upper set of data) are compared and presented in Figure 31. The average percent difference between actual rates and those predicted using the Levins and Glastonbury correlation are slightly greater than those based on the multivariable equation.

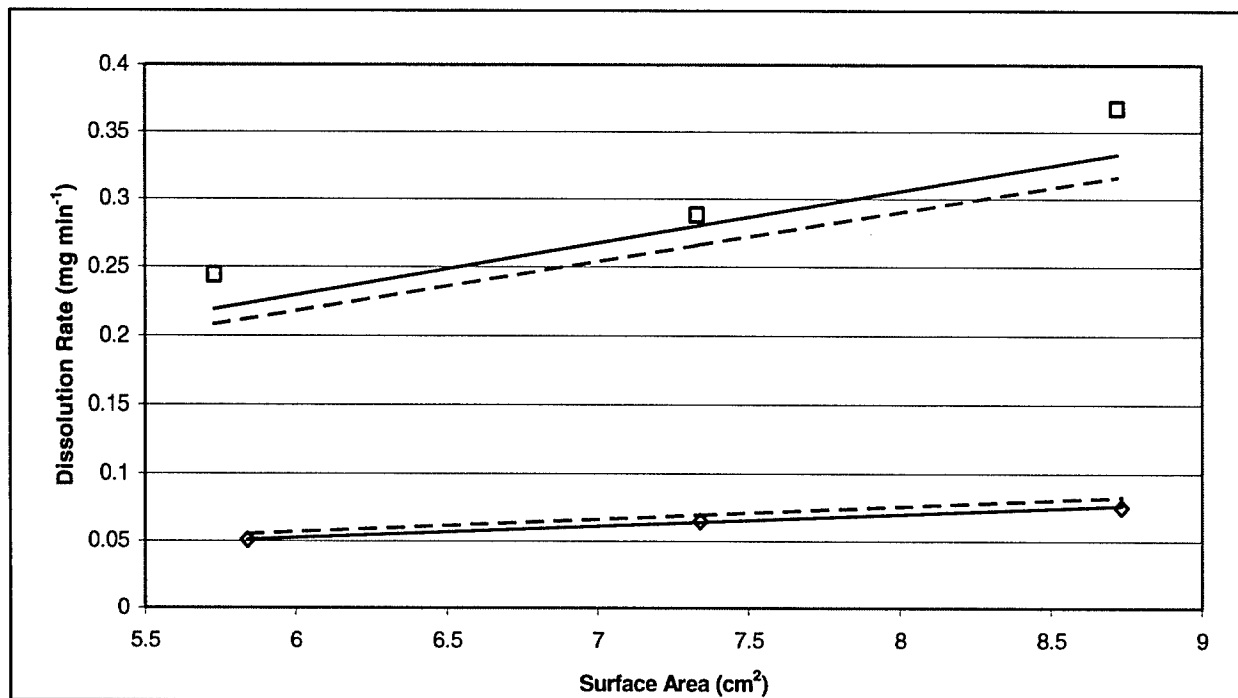

Figure 31. Rate comparisons of TNT study data (\square = 30 °C data, \diamond = 10 °C data) to multiple regression-multiple variable regression line (—) and the Levins and Glastonbury (1972a) regression line (---)

Gilcrease, Murphy, and Reardon. (2001) noted that the effectiveness of the k term in Equation 12 depended on selecting an appropriate effective diffusivity value. Gilcrease, Murphy, and Reardon (1996) successfully used the Levins and Glastonbury (1972a) approach in describing the dissolution of solid TNT in both deionized water and in a Teflon chip/water slurry. For the best fit to their experimental design, Gilcrease, Murphy, and Reardon (1996) selected a TNT diffusivity of $7.4\text{E-}6 \text{ cm}^2 \text{ s}^{-1}$ at 25 °C. For our study, a diffusivity of $6.71\text{E-}6 \text{ cm}^2 \text{ s}^{-1}$ at 25 °C (Townsend and Meyers 1996) was used.

The Levins and Glastonbury (1972b) correlation did not prove as accurate in predicting dissolution rates for either RDX or HMX compared to the multivariable equations developed in this study. Average percent differences between prediction and actual rate exceeded 20 percent for each explosive compound, even after modifying diffusivity values from those reported in the literature. Best-fit diffusivity values at 25 °C were $2.2 \text{ E-}6 \text{ cm}^2 \text{ s}^{-1}$ and $1.5\text{E-}4 \text{ cm}^2 \text{ s}^{-1}$ for RDX and HMX, respectively (vs $7.15 \text{ E-}6$ and $6.02 \text{ E-}6 \text{ cm}^2 \text{ s}^{-1}$, reported by Townsend and Meyers (1996) at 25 °C). The “relative diffusivities” in Figure 29 show similar orders of separation among explosives as those presented here.

Estimating a single-particle diameter for RDX and HMX from a heterogeneous mix of crystal sizes may have had a major impact on the applicability of the Levins and Glastonbury (1972a) correlation. A comparison of rates among our experimental data, the temperature-based multivariable equation, and the Levins and Glastonbury correlation k term is shown in Table 25. Use of an estimated single-particle size may also account for the discrepancies in the best-fit diffusivities.

Table 25
Average Percent Difference Comparisons between Data from this Study, the Multiple-Regression Multiple-Variable Equation, the Single-Regression Multiple-Variable Equation, and the Levins and Glastonbury (1972a) Correlation for RDX Dissolution Rates

Run ID	Surface Area/rpm/°C ¹	Dissolution Rate mg min ⁻¹			Dissolution Rate mg min ⁻¹		Dissolution Rate mg min ⁻¹	
		Study Data	Multiple Variable Eqn	Avg percent Diff	Single Variable Eqn	Avg percent Diff	Levins Glastonbury Correlation	Avg percent Diff
M	S/150/10	0.010	0.011	-6.3	0.011	-10.5	0.014	-29.2
O	M/150/10	0.012	0.013	-3.5	0.013	-7.6	0.016	-26.4
P	L/150/10	0.015	0.015	-2.1	0.016	-6.2	0.019	-25.16
R	M/90/10	0.008	0.008	9.1	0.008	4.9	0.012	-34.0
S	M/210/10	0.026	0.018	38.4	0.019	34.3	0.020	28.8
R1	S'/150/20	0.015	0.014	4.0	0.014	2.5	0.015	-2.5
R2	M'/150/20	0.015	0.018	-13.6	0.018	-15.1	0.019	-20.1
R3	L'/150/20	0.019	0.021	-8.7	0.021	-10.2	0.023	-15.1
R8	S/150/30	0.047	0.046	1.6	0.047	0.6	0.055	-15.0
R6	M/150/30	0.057	0.058	-1.0	0.058	-2.0	0.068	-17.6
R9	L/150/30	0.071	0.069	2.2	0.070	1.2	0.082	-14.4
R4	M/90/30	0.034	0.035	-2.9	0.035	-3.9	0.050	-39.4
R5	M/210/30	0.088	0.081	8.9	0.081	8.0	0.083	5.5

¹ S = 8, M = 10, L = 12, S' = 4, M' = 5, L' = 6 cm²

Dissolution rates for TNT, RDX, and HMX as a function of temperature, surface area, and power input are best represented by the first row of equations in Table 24 where temperature was the final variable in rate determination. These equations can provide insight to expected changes in explosive dissolution rates given changing seasonal temperatures and remaining explosive surface area. To predict rainfall affects on expected dissolution rates, use Equation 10 which relates the RUSLE "R" term to mixing rpm. Equation 8 can be used to relate study rpm to stirred reactors.

Limits exist for the use of these correlations, however. First, dissolution rates cannot exceed the solubility limit of the explosive. Second, extrapolation outside the limits of the study boundaries is not recommended. Third, as demonstrated by the HMX results, a point is reached where increased power input results in only minimal changes in dissolution rate.

Effects of pH and temperature

Solubility. The temperature range studied (3.1 °C to 33.3 °C) is representative of ambient conditions in most areas of the Continental United States where explosives residues are typically found. The pH range was based on maximum and minimum pH values reported for rainfall in the Continental United States (National Atmospheric Deposition Program 1998). The experimental solubility data for the three high explosives at three pH values and temperature are summarized in Table 26. To conform to the format in Equation 3, data were plotted as $\ln[S]$ vs $1/^\circ\text{K}^{-1}$ and linearly regressed. Solubility of TNT, RDX, or HMX at different pH values did not differ significantly ($p < 0.05$).

Table 26
Solubilities of High Explosive Compounds At Specified pH and Temperature

TNT						RDX						HMX					
pH 4.2		pH 5.7		pH 6.2		pH 4.2		pH 5.7		pH 6.2		pH 4.2		pH 5.7		pH 6.2	
Tmp ¹ °C	Sol ² mg L ⁻¹	Tmp °C	Sol mg L ⁻¹	Tmp °C	Sol mg L ⁻¹	Tmp °C	Sol mg L ⁻¹	Tmp °C	Sol mg L ⁻¹	Tmp °C	Sol mg L ⁻¹	Tmp °C	Sol mg L ⁻¹	Tmp °C	Sol mg L ⁻¹	Tmp °C	Sol mg L ⁻¹
2.3	49.5	2.3	54.5	2.4	55.9	2.7	13.5	2.5	12.6	2.1	13.1	2.7	0.81	2.5	0.77	2.1	0.77
2.3	50.5	2.3	54.2	2.4	56.4	2.7	13.0	2.5	12.8	2.1	13.5	2.7	0.80	2.5	0.77	2.1	0.77
2.6	54.9	2.3	47.5	2.4	54.9	2.7	13.3	2.6	13.8	2.6	12.9	2.7	0.76	2.7	0.77	2.6	0.60
2.6	55.7	2.3	47.3	2.4	55.4	2.7	13.2	2.6	13.7	2.6	13.3	2.7	0.78	2.7	0.78	2.6	0.65
4.2	57.6	4.1	47.9	4.7	56.7	2.8	13.5	2.7	13.2	2.9	13.7	3.6	0.92	3.6	1.01	3.6	0.98
4.2	57.7	4.1	48.2	4.7	57.4	2.8	12.9	2.7	13.2	2.9	13.9	3.6	0.91	3.6	0.95	3.6	0.93
4.2	45.7	4.6	58.1	5.2	56.7	3.2	13.9	3.5	13.6	3.9	14.1	3.6	0.89	3.7	0.90	3.6	0.93
4.2	48.4	4.6	59.1	5.2	56.1	3.2	14.0	3.5	13.9	3.9	13.5	3.6	0.91	3.7	0.99	3.6	0.94
20	100.7	20	96.7	20	99.6	20.1	38.9	20	37.7	20	37.5	22.6	3.82	22.7	3.84	22.5	3.88
20	99.0	20	98.7	20	100.2	20.1	36.8	20	37.8	20	37.6	22.6	3.84	22.7	3.82	22.5	3.88
20	99.2	20.1	98.9	20.1	99.5	20.1	38.6	20.2	38.0	20	38.2	22.8	3.68	22.8	3.88	22.7	3.80
20	101.7	20.1	100.6	20.1	96.3	20.1	38.3	20.2	38.0	20	38.8	22.8	3.68	22.8	3.89	22.7	3.79
20.1	96.3	20.2	98.8	20.1	99.5	20.2	35.8	20.4	35.4	20.4	35.5	23.1	3.87	23	3.94	23.4	3.93
20.1	95.9	20.2	99.8	20.1	99.8	20.2	35.7	20.4	35.6	20.4	35.3	23.1	3.85	23	3.95	23.4	3.72
20.1	96.0	20.2	97.5	20.2	94.6	20.2	36.0	20.4	35.1	20.4	36	23.7	3.94	23.5	3.90	23.7	3.75
20.1	97.8	20.2	100.4	20.2	97.2	20.2	36.3	20.4	35.6	20.4	36.1	23.7	3.97	23.5	3.94	23.7	3.89
36	211.7	35.7	208.5	35.9	216.5	31.6	65.1	31.7	62.5	31.7	67.6	28.5	5.35	28.5	5.40	28.5	6.21
36	213.1	35.7	213.5	35.9	213.9	31.6	65.4	31.7	62.2	31.7	68.1	28.5	5.55	28.5	5.43	28.5	6.10
36	208.5	36	215.2	36	212.2	31.9	46.5	32	60.6	32	58.7	28.6	5.74	28.6	5.96	28.6	6.13
36	211.6	36	214.3	36	215.3	31.9	48.5	32	61.8	32	59.8	31.2	7.58	28.6	6.02	28.6	6.66
37.7	219.6	37.7	229.7	37.6	229.4	32.1	65.9	34	73.4	34.1	85.2	31.2	7.74	31.7	7.25	32.3	7.67
37.7	219.4	37.7	230.6	37.6	231.4	32.1	66.3	34	87.8	34.1	86.5	32	7.41	31.7	7.19	32.3	7.75
37.8	218.2	37.7	226.2	38	234.4	32.1	65.6	34.1	86.8	34.2	85.7	32	7.47	32.2	7.39	32.3	7.60
37.8	214.8	37.7	228.3	38	235	32.1	64.1	34.1	85.7	34.2	81.8	ND3	ND	32.2	7.39	32.3	7.63
							34.9		92.5								
							34.9		89.95								

¹ Temperature; ² Solubility; ³ Not Done

Solubilities for TNT compare favorably with those reported by Spangord et al. (1983) and Phelan and Barnett (2001) (Figure 32). Solubilities for TNT were less than those reported by Taylor and Rinkenbach (1923), but higher than those reported by Ro et al. (1996). Solubilities for RDX (Figure 33) again compare favorably with Spangord et al. (1983) though generally less than those values reported in the literature. Solubilities for HMX agree well with those

values reported by Townsend and Meyers (1996) (Figure 34). A correlation was made for solubilities reported by Spanggord et al. (1982) and cited in Townsend and Meyers (1996) and plotted in this figure for comparative purposes. Composite correlations that utilize all TNT, RDX, and HMX data to predict solubility are presented in Figure 35.

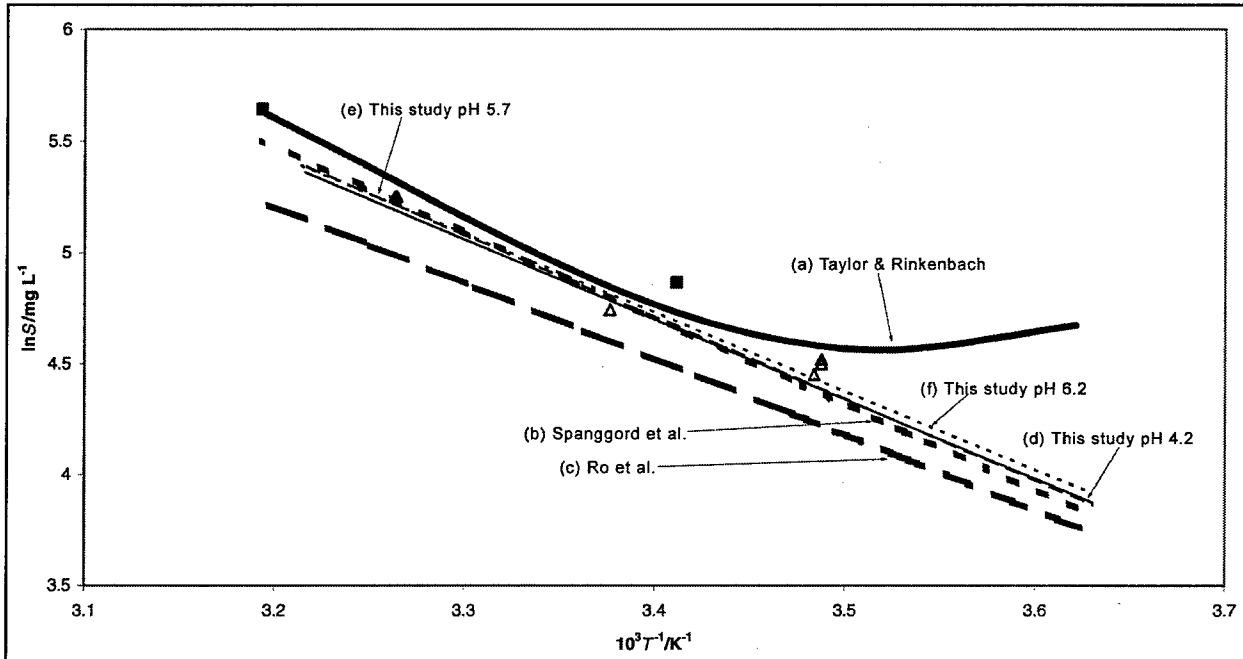

Figure 32. Comparison of TNT solubility literature to this study. (a) Taylor and Rinkenbach (1923); (b) Spanggord et al. (1983); (c) Ro et al. (1996); ■ Gibbs and Popolato (1980); Δ Phelan and Barnett (2001); (d) this study pH 4.2 [$\ln(S/\text{mg L}^{-1}) = 16.895 - 3,586.4 K/T$, $R^2 = 0.9822$]; (e) this study pH 5.7 [$\ln(S/\text{mg L}^{-1}) = 17.263 - 3,691.3 K/T$, $R^2 = 0.9837$]; (f) this study pH 6.2 [$\ln(S/\text{mg L}^{-1}) = 16.777 - 3,542.5 K/T$, $R^2 = 0.9785$]

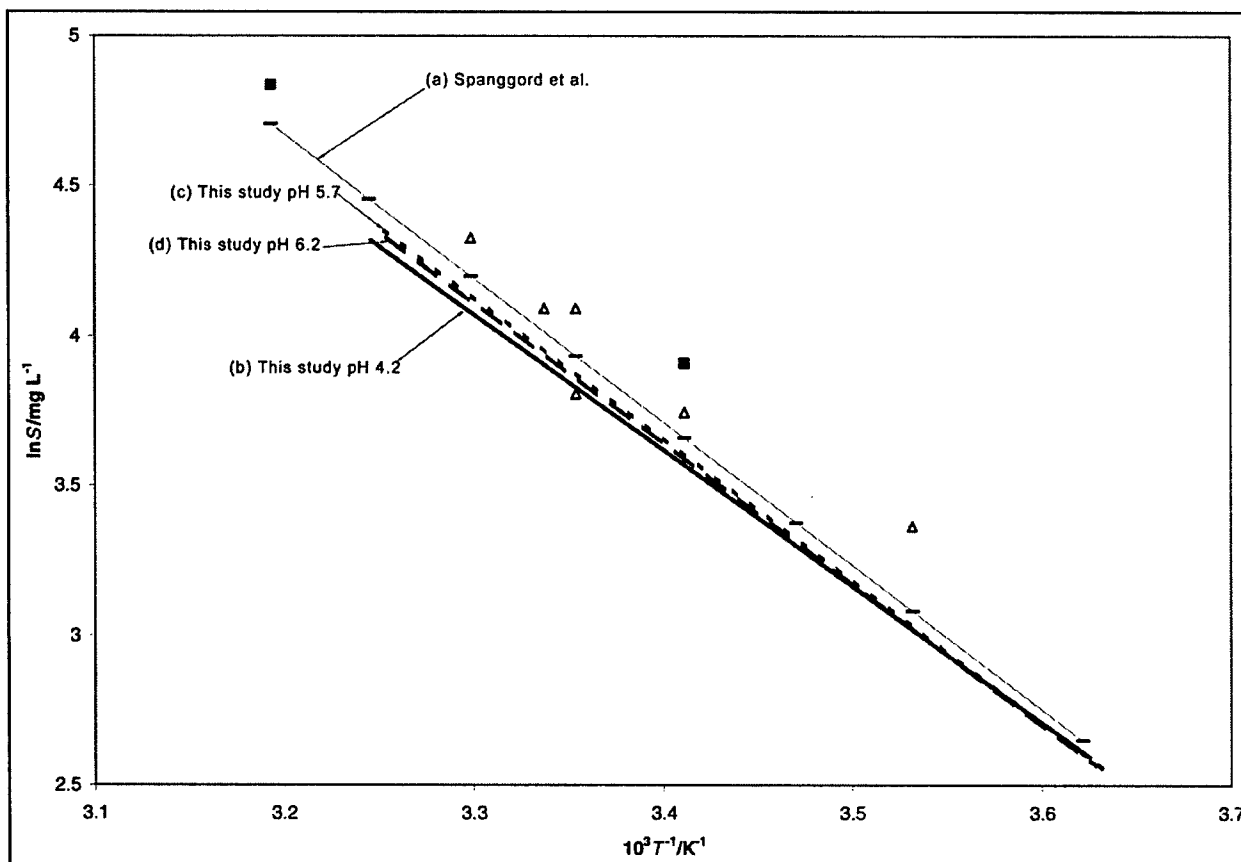

Figure 33. Comparison of RDX solubility literature to this study. (a) Spangord et al. (1983); ■ Gibbs and Popolato (1980); Δ Townsend and Meyers (1996); (b) this study pH 4.2 [$\ln(S/\text{mg L}^{-1}) = 19.087 - 4,549.1 K/T$, $R^2 = 0.987$]; (c) this study pH 5.7 [$\ln(S/\text{mg L}^{-1}) = 19.718 - 4,727.8 K/T$, $R^2 = 0.995$]; (d) this study pH 6.2 [$\ln(S/\text{mg L}^{-1}) = 19.818 - 4,753.2 K/T$, $R^2 = 0.995$]

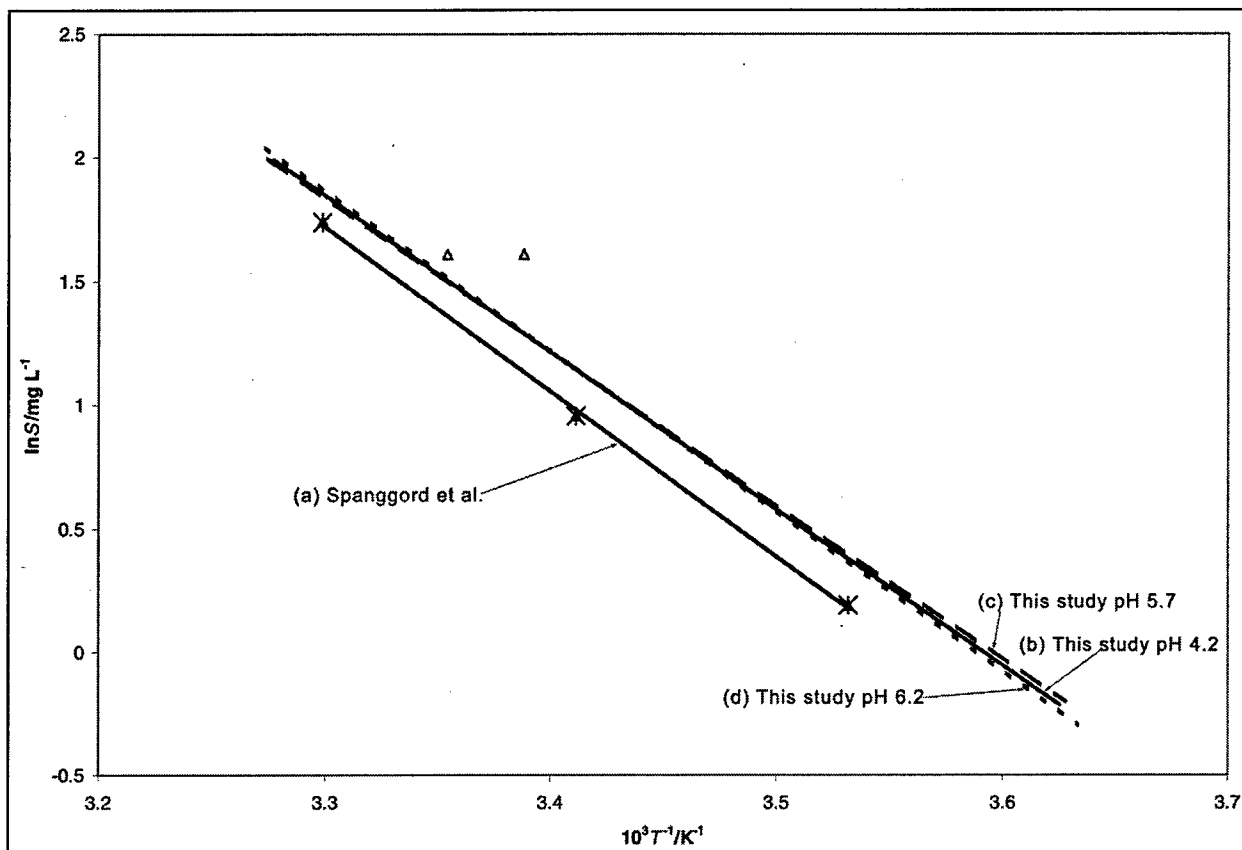

Figure 34. Comparison of HMX solubility literature to this study. (a) Spanggord et al. (1982) (from Townsend and Meyers 1996); Δ Townsend and Meyers (1996); (b) this study pH 4.2 [$\ln(S/\text{mg L}^{-1}) = 22.741 - 6,332 K/T$, $R^2 = 0.9974$]; (c) this study pH 5.7 [$\ln(S/\text{mg L}^{-1}) = 22.399 - 6,230 K/T$, $R^2 = 0.9968$]; (d) this study pH 6.2 [$\ln(S/\text{mg L}^{-1}) = 23.344 - 6,506.8 K/T$, $R^2 = 0.9901$]

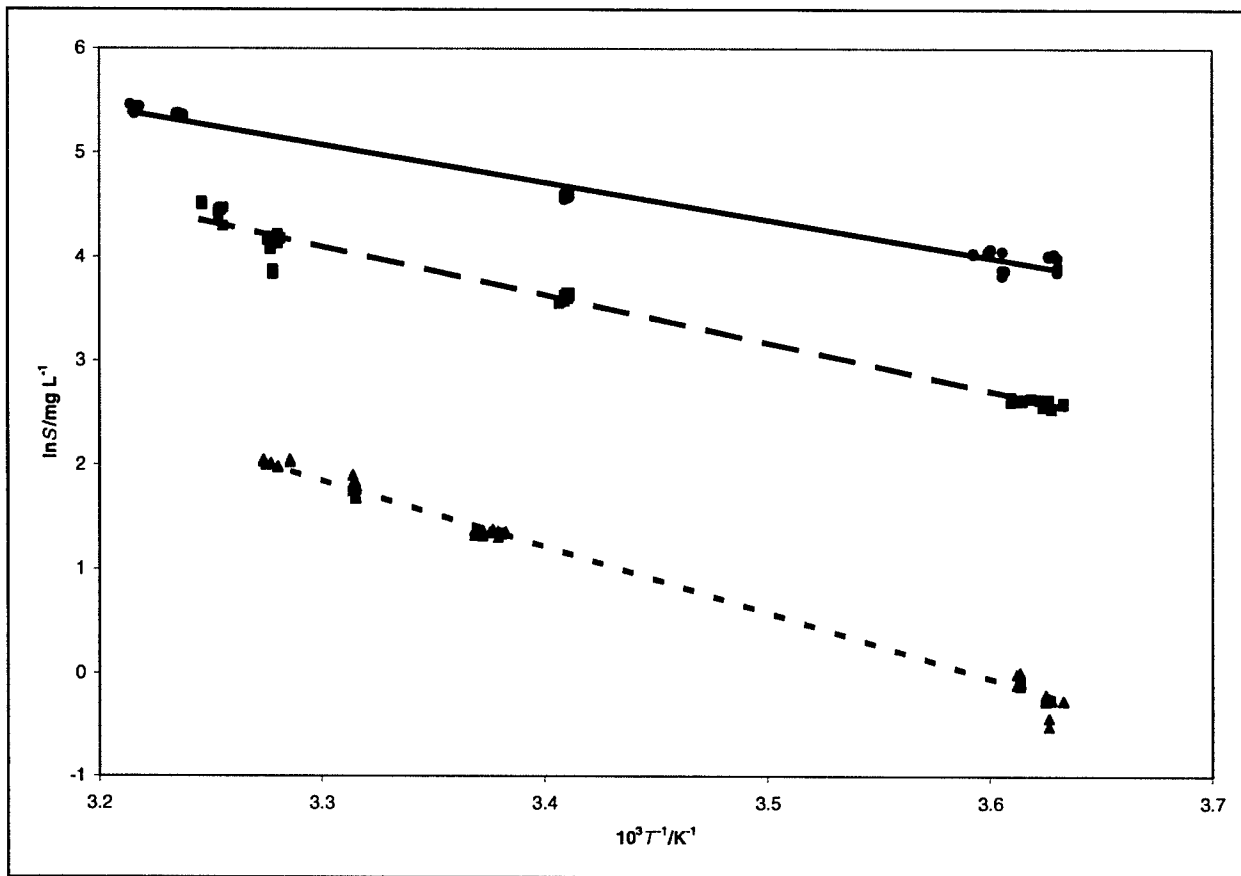

Figure 35. Composite explosive solubility prediction correlations. —● TNT [$1n(S/mg L^{-1}) = 16.981 - 3,607.5 K/T, R^2 = 0.990$];▲ HMX [$1n(S/mg L^{-1}) = 22.825 - 6,358.2 K/T, R^2 = 0.997$]; --■ RDX [$1n(S/mg L^{-1}) = 19.52 - 4,670.9 K/T, R^2 = 0.992$]

Dissolution. Evaluation of pH effects on dissolution rate was conducted at 30 °C because of higher solubility values for each explosive at this temperature. Samples were taken at a rate and over a time period selected so that sample concentrations would be well below solubility maxima, hence keeping the solution dilute. The pH did not affect the dissolution rate of TNT, RDX, or HMX (Figure 36). In general, TNT had the fastest dissolution rate, followed by HMX and RDX. Composite dissolution rates incorporating all pH data for TNT, HMX, and RDX (Table 24) compared well to those predicted by Equation 10.

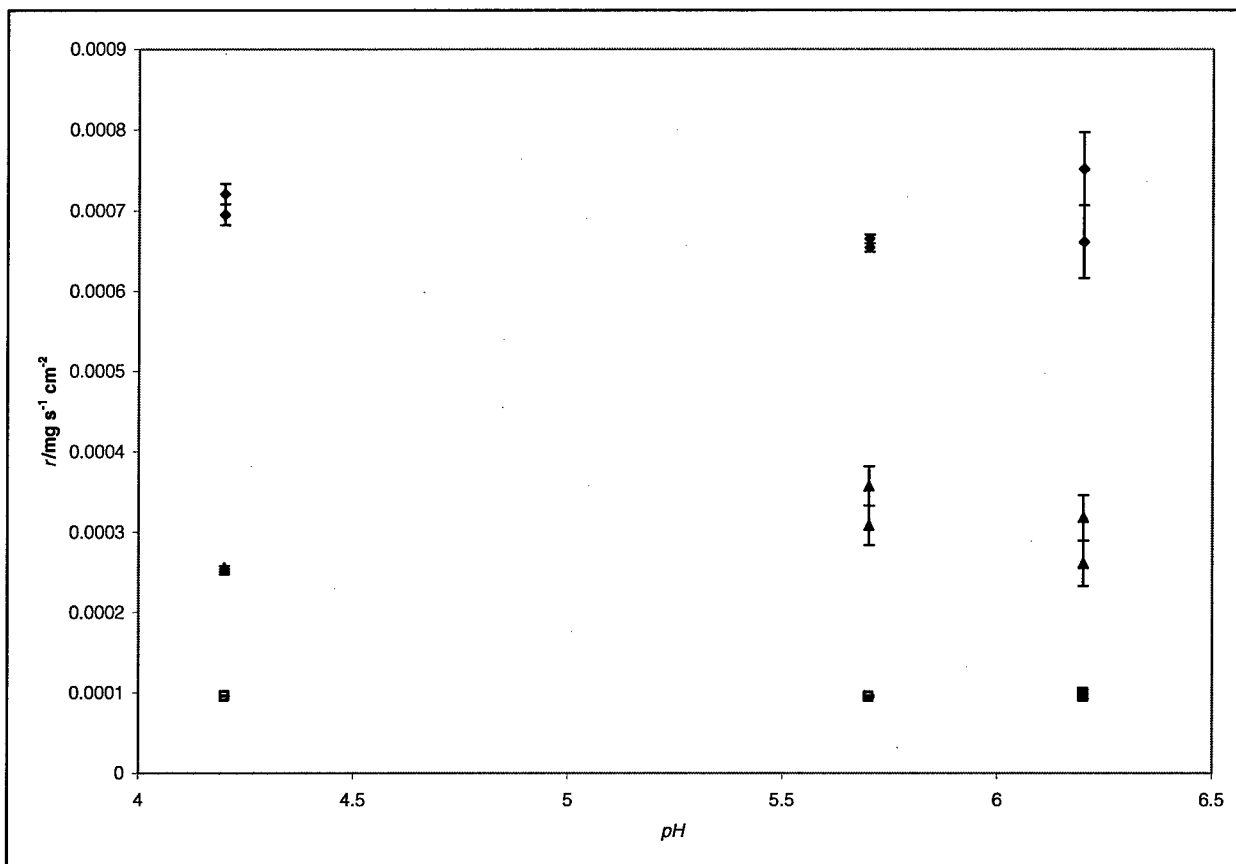

Figure 36. Comparison of explosive dissolution rates at three pH values: \blacklozenge TNT, \blacktriangle HMX, \blacksquare RDX. Vertical bars are standard deviations from the mean

A reducing environment at pH 7 had a pronounced impact on TNT, RDX, and HMX stability in soil (Price, Brannon, and Hayes 1997; Price, Brannon, and Yost 1998). Remediation strategies that rely on high alkalinity (Heilmann, Wiesmann, and Stenstrom 1996) may be related to a reducing environment by the Nerst equation where an increase in pH corresponds to a decrease in redox potential (Stumm and Morgan 1996), but the pH required ($pH \geq 10$) exceeds those normally encountered in the environment.

The combined ability to predict solubility and dissolution rate at a given temperature permits the prediction of solution concentration at any given time using Equation 5. This equation was used here to confirm that solubility had been reached prior to the seventh day of stirring. Using a conservative mixing rate of 210 rpm and 30 °C, HMX attained saturation in less than half a day, RDX in less than 5 days, and TNT was 99.996 percent of saturation in 7 days.

Dissolution rates of formulations

The dissolution rates for all analytical runs were recorded in units of $mg\ cm^{-2}\ sec^{-1}$ to normalize for the variations in solid surface area. TNT, RDX, and HMX were run independently in addition to the formulations and mixtures to serve as a

basis for dissolution rate comparison. The dissolution rates for the formulations at 150 rpm and 20 °C are presented in Figures 37, 38, and 39 for TNT, HMX, and RDX, respectively. Both the melt-pour process used in the preparation of octol and composition B and the pressure binding process used in the production of LX-14 appear to have caused the inherent explosive compounds to dissolve at rates lower than those of the pure compounds. TNT dissolution rates from octol and Composition B molds were lower than those from a pure TNT mold (Figure 37). HMX dissolution from LX-14 and octol were orders of magnitude lower than dissolution rates from pure HMX (Figure 38). RDX showed a more than 50 percent decrease in dissolution rate from composition B compared to the pure compound (Figure 39).

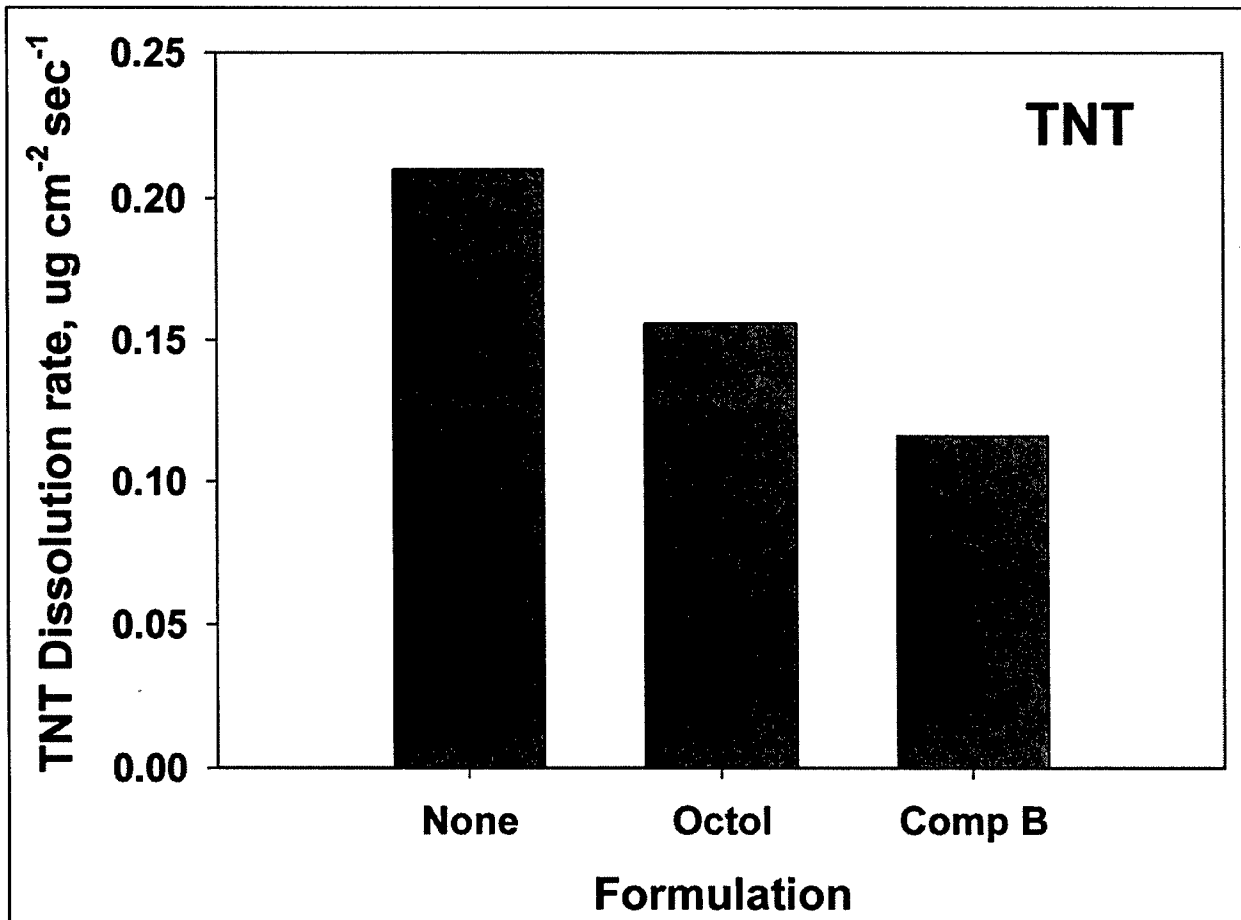

Figure 37. Comparison of TNT dissolution rates from pure TNT, octol, and composition B at 20 °C and 150 rpm

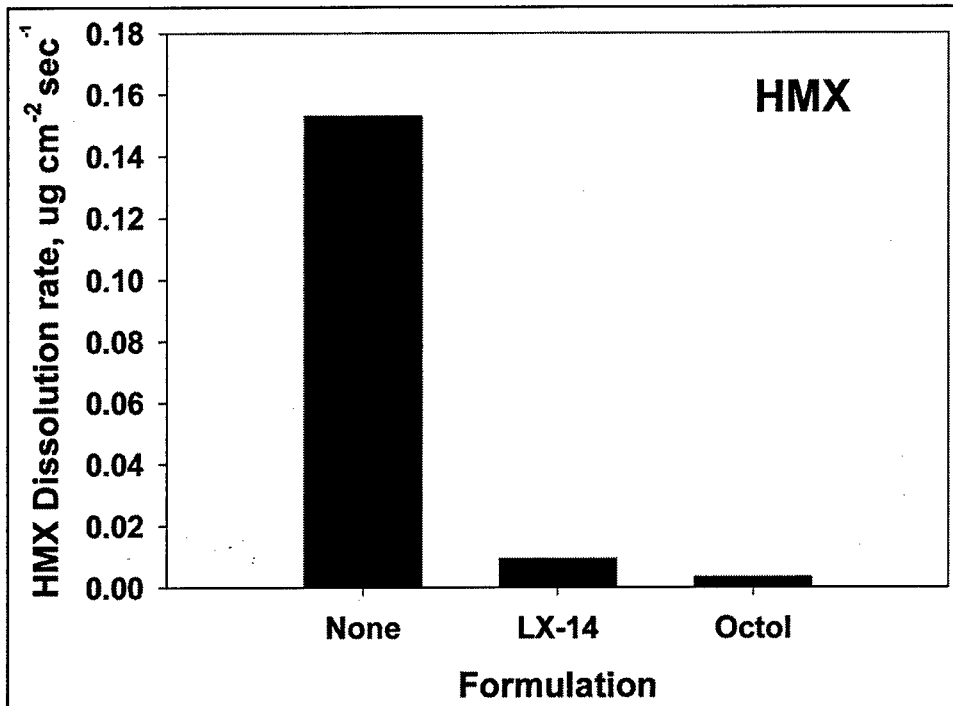

Figure 38. Comparison of HMX dissolution rates from pure HMX, LX-14, and octol at 20 °C and 150 rpm

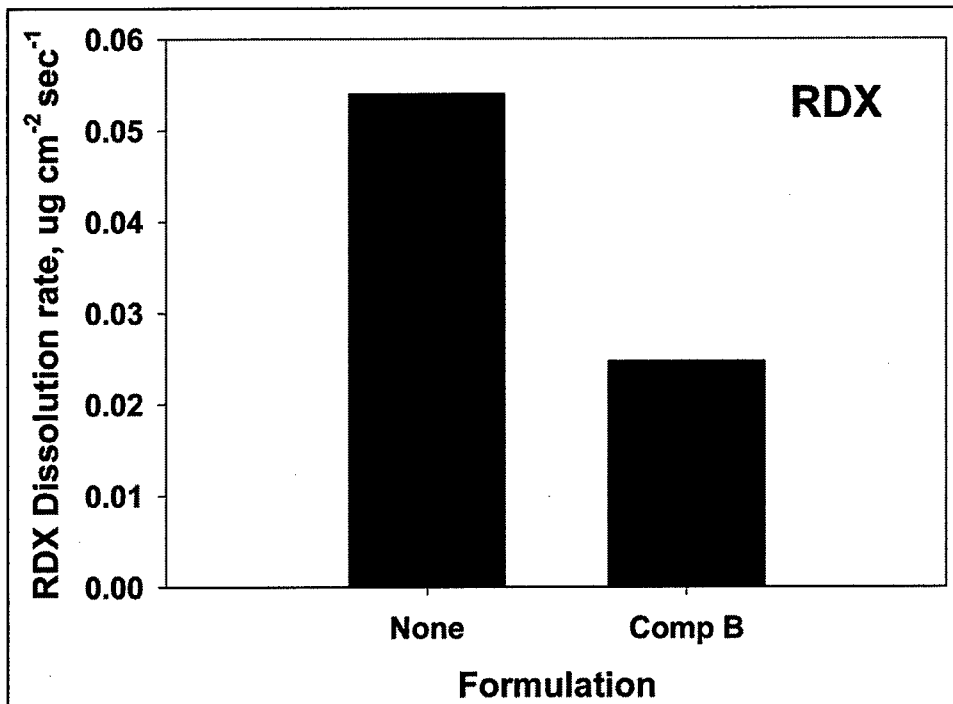

Figure 39. Comparison of RDX dissolution rates from pure RDX and composition B at 20 °C and 150 rpm

Explosives partitioning

Adsorption kinetics and partitioning. Solution nitroglycerine concentrations decreased over time when exposed to all tested soils (Figure 40). Partitioning coefficients are not provided for Yokena Clay because steady-state conditions did not develop. Half lives for nitroglycerine were 335 hr, 84 hr, and 7.3 hr for LAAP D, Picatinny, and Yokena Clay soils, respectively. Results suggest that nitroglycerine will be degraded and strongly adsorbed in both aquifer and surface soils.

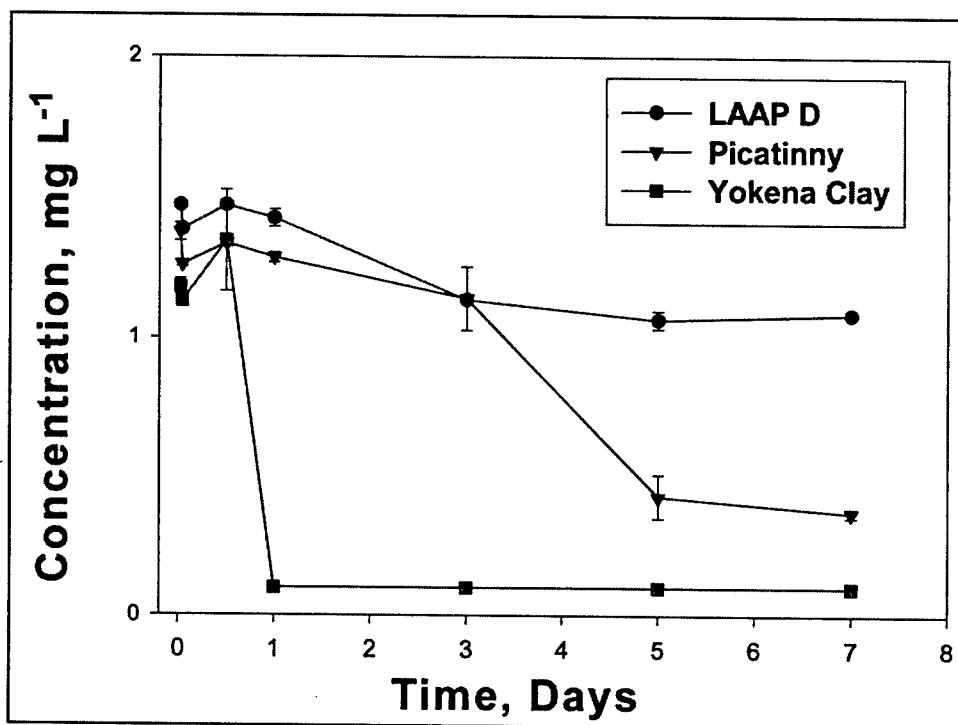

Figure 40. Adsorption kinetics of nitroglycerine in LAAP-D, Picatinny, and Yokena Clay soils

Concentrations of the RDX transformation products MNX (Figure 41), DNX (Figure 42), and TNX (Figure 43) were generally stable in all three soils. Notable exceptions were MNX and DNX in Yokena Clay soil. The half-lives shown in Figures 41 and 42 for Yokena Clay reflect first-order transformation coefficients of 0.225 h^{-1} ($r^2 = 0.754$) and 0.333 h^{-1} ($r^2 = 0.76$) for MNX and DNX, respectively. Partitioning coefficients for LAAP D soil ranged from 0.29 to 0.85 L Kg^{-1} for MNX, DNX, and TNX (Figure 44). This compares to a value of 0.33 L Kg^{-1} for RDX in LAAP D soil (Pennington et al. 1999). These results indicate that adsorption coefficients for the major RDX transformation products are similar to that of the parent compound. Partition coefficients for nitroglycerine were similar in the two soils for which K_d s could be determined (Figure 45).

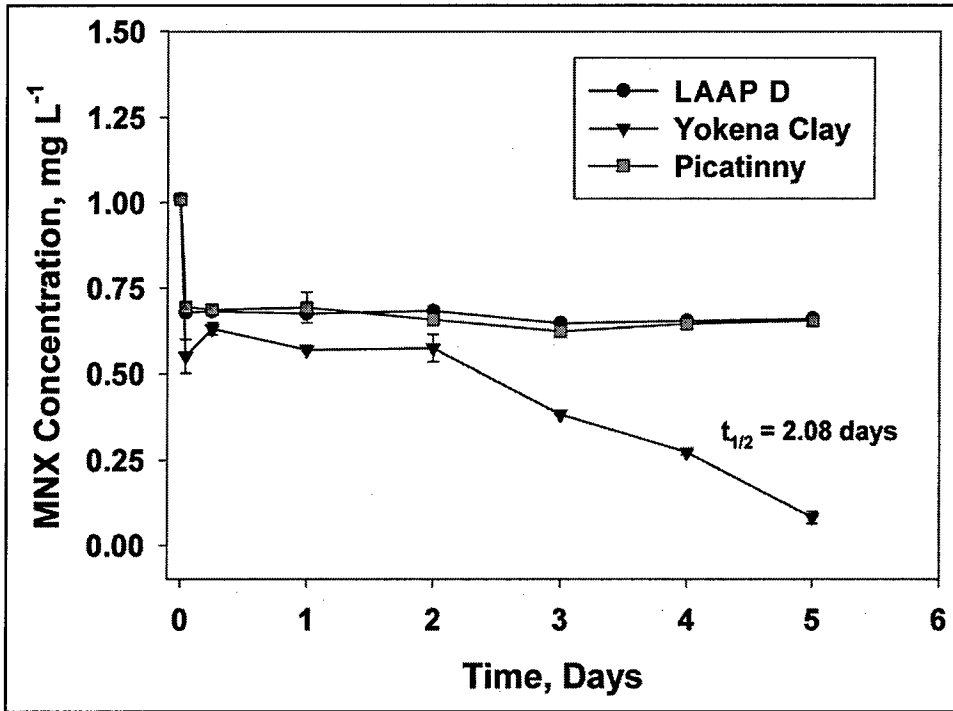

Figure 41. Adsorption kinetics of MNX in LAAP-D, Picatinny, and Yokena Clay soils

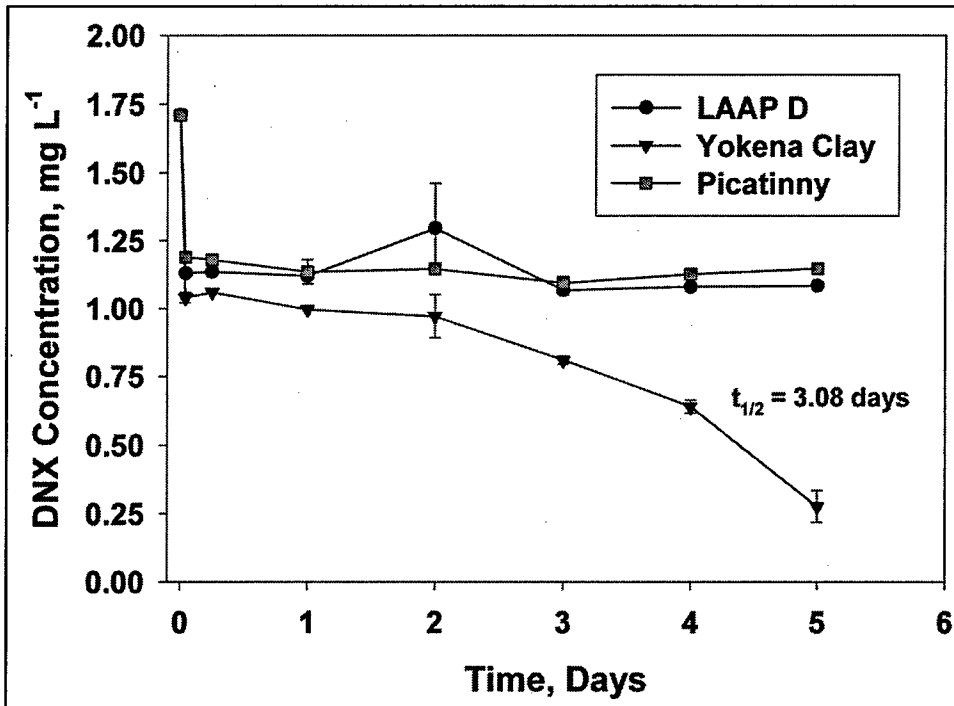

Figure 42. Adsorption kinetics of DNX in LAAP-D, Picatinny, and Yokena Clay soils

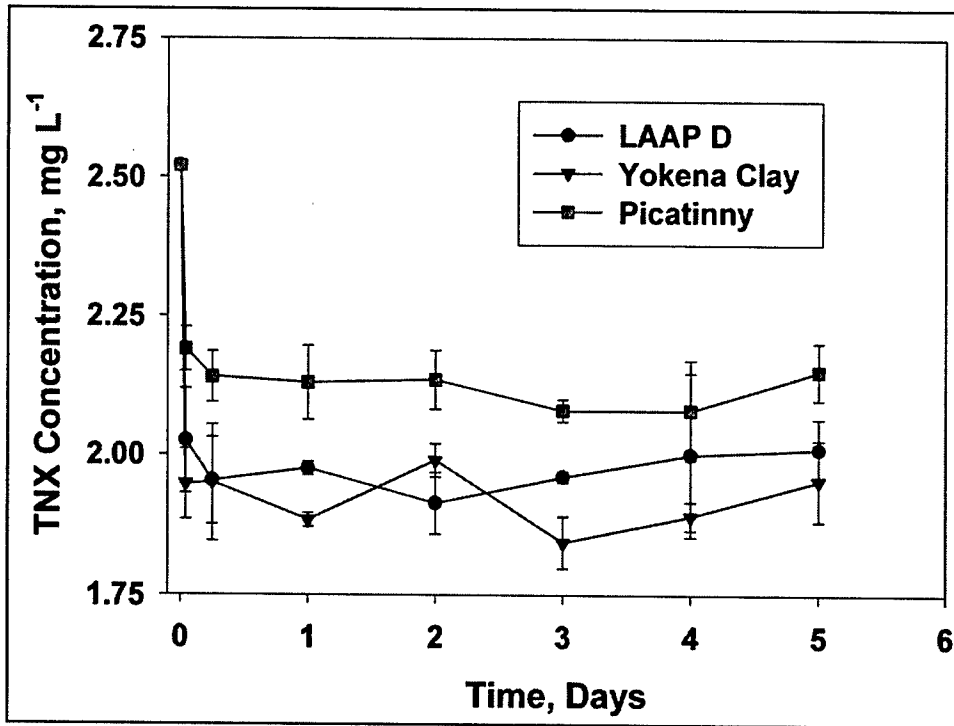

Figure 43. Adsorption kinetics of TNX in LAAP-D, Picatinny, and Yokena Clay soils

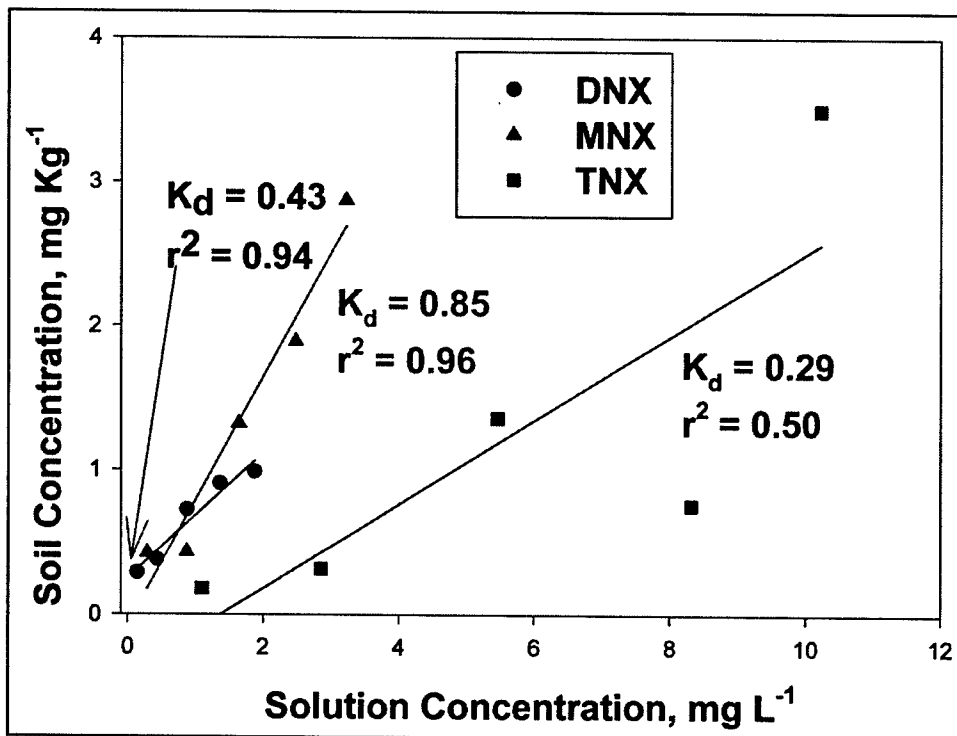

Figure 44. Partitioning coefficients for MNX, DNX, and TNX in LAAP-D soil

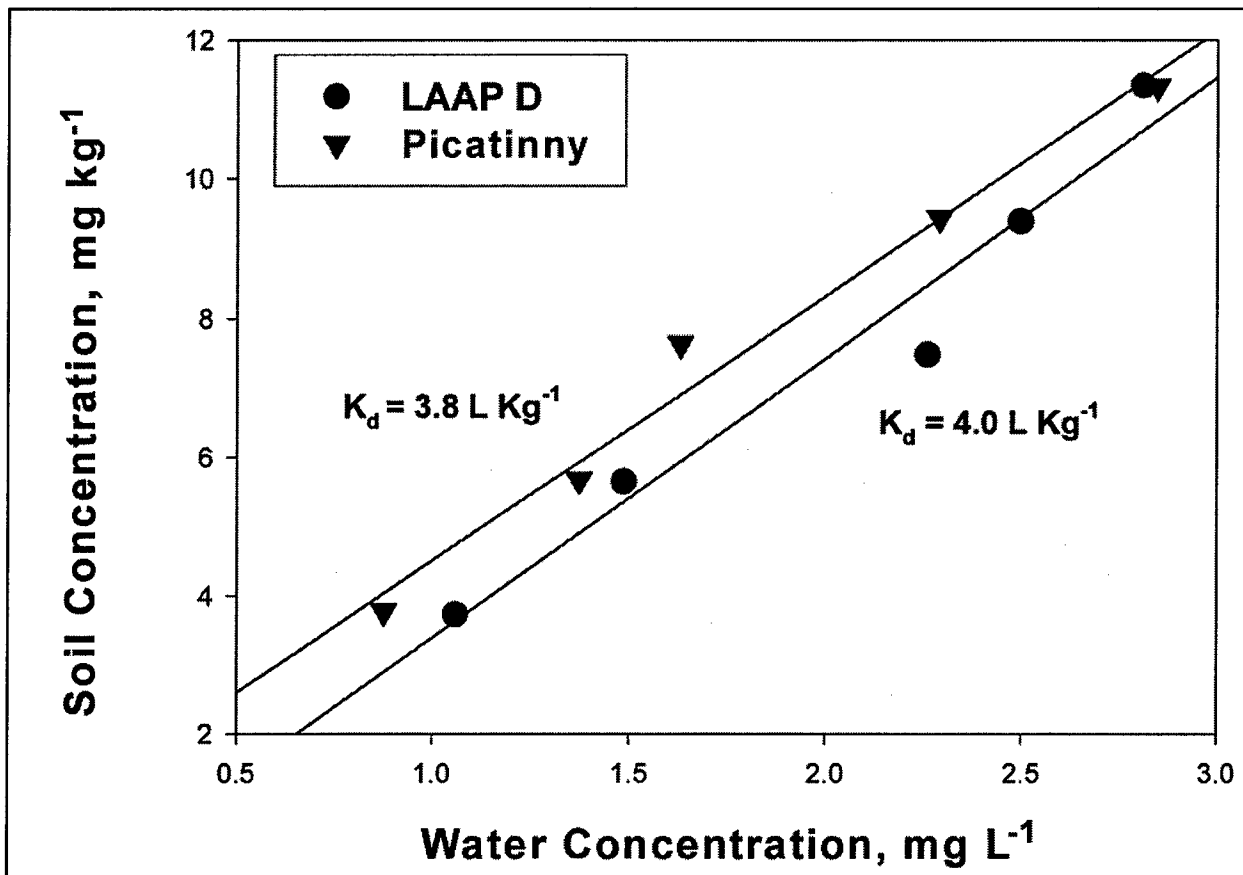

Figure 45. Partitioning coefficients for nitroglycerine in LAAP-D and Picatinny soils

Desorption kinetics and partitioning. Concentrations of TNT, RDX, and HMX desorbed from the Fort Lewis soil reached steady-state concentrations in 6 hr (Figure 46). These results indicate that TNT, RDX, and HMX are rapidly desorbed and mobilized from the soil. No decrease in solution concentrations was observed over the course of 2 days following establishment of steady-state concentrations.

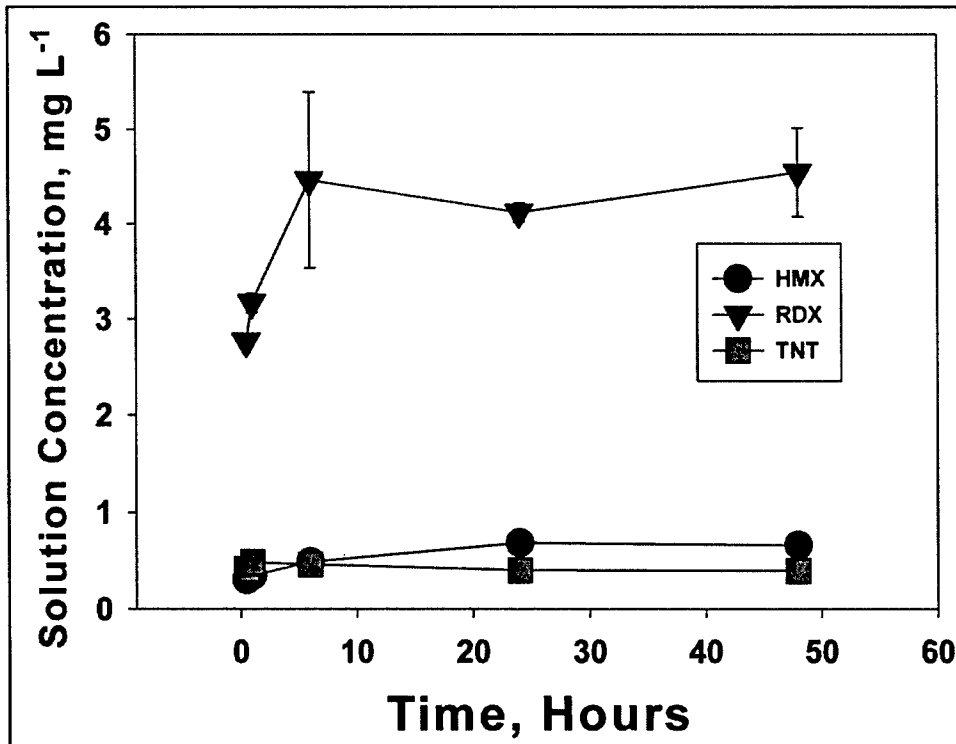

Figure 46. Desorption kinetics of TNT, RDX, and HMX in Fort Lewis soil

Partitioning coefficients were highest for HMX ($3.5 \pm 0.6 \text{ L Kg}^{-1}$), intermediate for TNT ($1.6 \pm 0.8 \text{ L Kg}^{-1}$), and lowest for RDX ($0.6 \pm 0.2 \text{ L Kg}^{-1}$). These results indicate that transport will be greatest for RDX in this soil.

Summary and Conclusions

Dissolution rates of explosives increase with increases in surface area, temperature, and mixing rate. Under the same experimental conditions, the order of dissolution rate (fastest to slowest) was TNT, HMX, and RDX. Calculated activation energies for dissolution of TNT, RDX, and HMX in kJ mol^{-1} were 55.6, 55.4, and 40.7, respectively. Dissolution rates approximately double with every 10°C increase in temperature. Surface area estimates were reproducible and the RUSLE “R” values and experimental energy input were comparable. At 25°C and using the Levins and Glastonbury (1972b) correlation, diffusivities were estimated at $6.71 \text{ E-}6 \text{ cm}^2 \text{ s}^{-1}$ for TNT, $2.2\text{E-}6 \text{ cm}^2 \text{ s}^{-1}$ for RDX, and $1.5\text{E-}4 \text{ cm}^2 \text{ s}^{-1}$ for HMX.

The use of combined variable equations, such as those presented in Table 24 and Equation 10, are representative of observed dissolution rates under various environmental conditions. Predicting dissolution rates by performing multiple regressions of data was no improvement over normalizing these data into the appropriate units for dissolution and performing a single regression. Regressing dissolution in units of $\text{mg min}^{-1} \text{ cm}^{-2} \text{ rpm}^{-1}$ vs temperature in $^\circ\text{C}$ provides the best multivariable equation fit to experimental data. The Levins and Glastonbury correlation was a viable method of estimating dissolution rates when diffusivities

were known and explosives were of uniform particle diameter. The relationships developed in this study will serve as a first/worst case approximation of expected dissolution rates in a field environment.

Solubilities and dissolution rates of TNT, RDX, and HMX were not significantly affected by pH over the pH range (4.2 to 6.2) but were significantly affected by temperature over the range (3.1 to 33.3 °C) studied. TNT was the most soluble and had the highest dissolution rate, while RDX had the second highest solubility but exhibited the slowest dissolution rate. Composite correlations incorporating all pH data were presented to predict explosive solubility as a function of temperature and to identify dissolution rates using specified variables. These equations can be used to predict the solubility of TNT, RDX, and HMX, their dissolution rates, and solution concentrations over time.

The production process affects dissolution rates of the explosive compounds in the formulations. Dissolution rates of explosives compounds are suppressed in LX-14, composition B, and octol.

Adsorption kinetics and partitioning studies showed that nitroglycerine was degraded and strongly adsorbed in both aquifer and surface soils. Therefore, it is not expected to persist in the environment. The RDX transformation products, MNX, DNX, and TNX, were generally stable in all tested soils. Adsorption coefficients for the RDX transformation products were similar to that of the parent compound. Desorption partitioning with Fort Lewis soil showed that steady-state solution concentrations of TNT, RDX, and HMX were reached within 6 hr. RDX partitioned to this soil less than TNT and HMX, indicating that RDX transport would be greatest.

References

- Atkins, P. M. (1982). *Physical Chemistry 2*. W. H. Freeman, San Francisco, CA.
- Brannon, J. M., Deliman, P. N., Gerald, J. A., Ruiz, C. E., Price, C. B., Hayes, C., Yost, S., and Qasim, M. (1999). "Conceptual model and process descriptor formulations for fate and transport of UXO," Technical Report IRRP-99-1, U.S. Army Engineer Waterways Experiment Station, Vicksburg, MS.
- Brannon, J. M., and Myers, T. E. (1997). "Review of fate and transport processes of explosives," Technical Report IRRP-97-2, U.S. Army Engineer Waterways Experiment Station, Vicksburg, MS.
- Gibbs, T. R., and Popolato, A., ed. (1980). "LASL Explosive Property Data." University of California Press, Berkeley, CA.
- Gilcrease, P., Murphy, V., and Reardon, K. (1996). "Bioremediation of solid TNT particles in a soil slurry reactor: Mass transfer considerations." *Proceedings of the HRSC/WERC Joint Conference on the Environment, May 1996, Albuquerque, NM*.

- Gilcrease, P., Murphy, V., Reardon, K. (2001). "Simultaneous grinding and dissolution of TNT solids in an agitated slurry," *American Institute of Chemical Engineering Journal*.
- Headquarters, Department of the Army. (no date). Military Specification RDX, MIL-DTL-398D, Washington, DC.
- _____. (no date). Military Specification HMX, MIL-DTL-45444C, Washington, DC.
- Heilmann, H. M., Wiesmann, U., and Stenstrom, M. K. (1996). "Kinetics of the alkaline hydrolysis of high explosives RDX and HMX in aqueous solution and adsorbed to activated carbon," *Environmental Science and Technology* 30, 1485-1492.
- Henry, J. G., and Heinke, G. W. (1996). *Environmental Science and Engineering*. 2nd ed, Prentice Hall, New York, 193.
- Huang, G., Xiao, H., Chi, J., Shiu, W., MacKay, D. (2000). "Effects of pH on the aqueous solubility of selected chlorinated phenols," *Journal of Chemical Engineering Data* 45, 411-414.
- Jenkins, T. F., Walsh, M. E., Thorne, P. G., Thiboutot, S., Ampleman, G., Ranney, T. A., and Grant, C. L. (1997). "Assessment of sampling error associated with the collection and analysis of soil sample at a firing range contaminated with HMX," Special Report 97-22, U.S. Army Cold Regions Research and Engineering Laboratory, Hanover, NH.
- Levins, D., and Glastonbury, J. (1972a). "Particle-Liquid hydrodynamics and mass transfer in a stirred vessel, Part I – Particle-Liquid motion," *Transactions of the Institution of Chemical Engineers* 50, 32-41.
- Levins, D., and Glastonbury, J. (1972b). "Particle-Liquid hydrodynamics and mass transfer in a stirred vessel, Part II – Mass transfer," *Transactions of the Institution of Chemical Engineers* 50, 132-146.
- National Atmospheric Deposition Program. (1998). "Hydrogen ion concentration as pH from measurements made at the field laboratories," Available from URL: <http://nadp.sws.uiuc.edu/isopleths/maps1998/phfield.gif> [Accessed 5 May 2000].
- Pennington, J. C., Gunnison, D., Harrelson, D. W., Brannon, J. M., Zakikhani, M., Jenkins, T. F., Clarke, J. U., Hayes, C. A., Myers, T., Perkins, E., Ringelberg, D., Townsend, D. M., Fredrickson, H., and May, J. H. (1999). "Natural attenuation of explosives in soil and water systems at Department of Defense sites: Interim report," Technical Report EL-99-8, U.S. Army Engineer Waterways Experiment Station, Vicksburg, MS.
- Phelan, J. B., and Barnett, J. L. (2001). "Solubility of 2,4-dinitrotoluene and 2,4,6-trinitrotoluene in water," *J. Chem. Eng. Data* 46, 375-376.

- Price, C. B., Brannon, J. M., and Hayes, C. A. (1997). "Effect of redox potential and pH on TNT transformation in soil-water slurries," *Journal of Environmental Engineering* 123, 988-992.
- Price, C. B., Brannon, J. M., and Yost, S. L. (1998). "Transformation of RDX and HMX under controlled Eh/pH conditions," Technical Report IRRP-99-1, U.S. Army Engineer Waterways Experiment Station, Vicksburg, MS.
- Ro, K. S., Venugopal, A., Adrian, D. D., Constant, D., Qaisi, K., Valsaraj, K. T., Thibodeaux, L. J., and Roy, D. (1996). "Solubility of 2,4,6-trinitrotoluene (TNT) in water," *Journal of Chemical and Engineering Data* 41, 758-761.
- Spanggord, R. J., Mabey, R. W., Chou, T. W., Haynes, D. L., Alfernese, P. L., Tse, D. S., and Mill, T. (1982). "Environmental fate studies of HMX, screening studies, Final report, Phase I – Laboratory study," SRI Project LSU-4412, SRI International, Menlo Park, CA, for U.S. Army Medical Research and Development Command, Fort Detrick, Maryland.
- Spanggord, R. J., Mabey, W. R., Mill, T., Chou, T. W., Smith, J. H., Lee, S., and Robert, D. (1983). "Environmental fate studies on certain munitions wastewater constituents," LSU-7934, AD-A138550, SRI International, Menlo Park, California.
- Stumm, W., and Morgan, J. (1996). "Kinetics at the solid-water interface: Adsorption, dissolution of minerals, nucleation, and crystal growth." In *Aquatic Chemistry Chemical Equilibria and Rates in Natural Waters*. 3rd ed., Wiley, New York.
- Taylor, C. A., and Rinkenbach, W. H. (1923). "The solubility of trinitrotoluene in organic solvents," *Journal of the American Chemical Society* 45, 44-59.
- Tchobanoglous, G., and Schroeder, E. D. (1987). "Water quality characteristics, modeling, modification," Addison-Wesley, Reading, MA.
- Thiboutot, S., Ampleman, G., Gagnon, A., Marois, A., Jenkins, T. F., Walsh, M. E., Thorne, P. G., and Ranney, T. A. (1998). "Characterization of antitank firing ranges at CFB Valcartier, WATC Wainwright and CFAD Dundurn," DREV-R-9809, Defence Research Establishment, Valcartier, Quebec.
- Townsend, D., and Myers, T. (1996). "Recent developments in formulating model descriptors for subsurface transformation and sorption of TNT, RDX, and HMX," Technical Report IRRP-96-1, U.S. Army Engineer Waterways Experiment Station, Vicksburg, MS.
- United States Pharmacopeia Convention, Inc. (1990). *The United States Pharmacopeia, The National Formulary*. 22nd rev., 17th ed., Rockville, MD.
- U.S. Department of Agriculture. (2001). "Revised universal soil loss equation," [Online], Available from: URL <http://www.sedlab.olemiss.edu/rusle/> [Accessed 14 July, 2000].

U.S. Environmental Protection Agency (1994). "Nitroaromatics and nitramines by HPLC," Second Update SW-846 Method 8330, Office of Solid Waste and Emergency Response, Washington, DC.

5 Conclusions

Results of range characterization studies indicate that various types of military testing and training ranges differ in the contaminants present. For example, surface soils near targets on antitank rocket ranges are contaminated with extremely high concentrations (ppm) of HMX, while soils near targets on artillery ranges exhibit extremely low concentrations (ppb) of RDX and TNT. The contamination associated with battle runs using pop-up targets is completely different from those associated with fixed antitank targets. Consistently high concentrations (percent levels) of explosives residues were found near ruptured ordnance. Artillery ranges are a potentially very low nonpoint source of explosives residues with higher point sources randomly scattered across the site. A multi-increment composite sampling strategy is essential to adequately characterize the distribution of contaminants on artillery ranges. Combining 30 individual increments into a composite sample in these studies resulted in adequate reproducibility. The ability to reproduce data with an acceptable level of uncertainty provides confidence that the sample is representative of the area.

The degree of contamination associated with detonation of dud rounds using C4 is a potential concern. The use of C4 can result in incomplete detonations that scatter RDX across the soil. Since RDX is an undesirable groundwater contaminant, consideration should be given to improving the efficiency of blow-in-place disposal of dud rounds.

Dissolution rates of TNT, HMX, and RDX increased with surface area, temperature, and mixing rates. TNT dissolved fastest, followed by HMX and RDX, respectively. Solubility and dissolution rates were unaffected by pH, but increased slightly with temperature. Solubility and dissolution rates were not always consistent with each other for a given analyte. Specifically, of the three primary explosives, TNT, RDX, and HMX, TNT was the most soluble and had the highest dissolution rate, while RDX had the second highest solubility but exhibited the slowest dissolution rate. Dissolution rates of individual explosives were suppressed in their formulations, i.e., LX-14, composition B, and octol. Therefore, explosives formulations would persist longer in surface soils than the parent compounds.

Nitroglycerine degraded rapidly in all soils tested; therefore, it is not expected to persist in surface soils. The RDX transformation products, MNX, DNX, and TNX, were generally stable in all soils tested. These compounds exhibit transport potential consistent with RDX. Transport parameters used to model potential

groundwater contamination and to evaluate environmental or human health risk should reflect formulations of the explosives present and the dissolution rates as well as solubilities.

REPORT DOCUMENTATION PAGE

Form Approved
OMB No. 0704-0188

Public reporting burden for this collection of information is estimated to average 1 hour per response, including the time for reviewing instructions, searching existing data sources, gathering and maintaining the data needed, and completing and reviewing this collection of information. Send comments regarding this burden estimate or any other aspect of this collection of information, including suggestions for reducing this burden to Department of Defense, Washington Headquarters Services, Directorate for Information Operations and Reports (0704-0188), 1215 Jefferson Davis Highway, Suite 1204, Arlington, VA 22202-4302. Respondents should be aware that notwithstanding any other provision of law, no person shall be subject to any penalty for failing to comply with a collection of information if it does not display a currently valid OMB control number. PLEASE DO NOT RETURN YOUR FORM TO THE ABOVE ADDRESS.

1. REPORT DATE (DD-MM-YYYY) October 2002		2. REPORT TYPE Interim Report 2		3. DATES COVERED (From - To)	
4. TITLE AND SUBTITLE Distribution and Fate of Energetics on DoD Test and Training Ranges: Interim Report 2				5a. CONTRACT NUMBER	
				5b. GRANT NUMBER	
				5c. PROGRAM ELEMENT NUMBER	
6. AUTHOR(S) Judith C. Pennington, Thomas F. Jenkins, Guy Ampleman, Sonia Thiboutot, James M. Brannon, Jason Lynch, Thomas A. Ranney, Jeffrey A. Stark, Marianne E. Walsh, Jeff Lewis, Charolett A. Hayes, June E. Mirecki, Allen D. Hewitt, Nancy Perron, Dennis Lambert, Jay Clausen, Joseph J. Delfino				5d. PROJECT NUMBER	
				5e. TASK NUMBER	
				5f. WORK UNIT NUMBER	
7. PERFORMING ORGANIZATION NAME(S) AND ADDRESS(ES) See reverse.				8. PERFORMING ORGANIZATION REPORT NUMBER ERDC TR-01-13	
9. SPONSORING / MONITORING AGENCY NAME(S) AND ADDRESS(ES) U.S. Army Corps of Engineers Washington, DC 20314-1000				10. SPONSOR/MONITOR'S ACRONYM(S)	
				11. SPONSOR/MONITOR'S REPORT NUMBER(S)	
12. DISTRIBUTION / AVAILABILITY STATEMENT Approved for public release; distribution is unlimited.					
13. SUPPLEMENTARY NOTES					
14. ABSTRACT Testing and training ranges are essential to maintaining the readiness of the Armed Forces of the United States and Canada. Recently, concerns have arisen over potential environmental contamination from residues of energetic materials at impact ranges. The current state of knowledge concerning the nature, extent, and fate of contamination is inadequate to ensure sound management of ranges as sustainable resources. This project was designed to develop techniques for assessing the potential for environmental contamination from energetic materials on testing and training ranges. Techniques will be developed to define the physical and chemical properties, concentration, and distribution of energetics and residues of energetics in soils, and the potential for transport of these materials to groundwater. The approach included characterization of two U.S. installations, Yakima Training Center, Washington, and Camp Guernsey, Wyoming, and one Canadian installation, Canadian Force Base Shilo. Postblast residues from various heavy artillery munitions were characterized by sampling surface soils associated with firing positions and with craters from both high- and low-order detonations. Where possible, ground- and surface water associated with the ranges was also sampled. Vegetation was characterized on the Canadian					
<i>(Continued)</i>					
15. SUBJECT TERMS See reverse					
16. SECURITY CLASSIFICATION OF:			17. LIMITATION OF ABSTRACT	18. NUMBER OF PAGES	19a. NAME OF RESPONSIBLE PERSON
a. REPORT UNCLASSIFIED	b. ABSTRACT UNCLASSIFIED	c. THIS PAGE UNCLASSIFIED			19b. TELEPHONE NUMBER (include area code)
				139	

Block 7. (Continued)

U.S. Army Engineer Research and Development Center, Environmental Laboratory, 3909 Halls Ferry Road, Vicksburg, MS 39180-6199

U.S. Army Engineer Research and Development Center, Cold Regions Research and Development Laboratory, 72 Lyme Road, Hanover, NH 03755-1290

Defence Research Establishment Valcartier, 2459 Pie XI Blvd. North, Val-Bélair, Québec, Canada, G3J 1X5

Environmental Engineering Sciences Department, College of Engineering, University of Florida, Gainesville, FL 32611

AMEC Earth and Environment, 110 Littleton Road, Suite 1B, Westford, MA 01886

DynTel, 3530 Manor Dr., Suite 4, Vicksburg, MS 39180

Block 14. (Continued)

range. The study also included determination of transport parameters for RDX transformation products, MNX, DNX, and TNX, and for nitroglycerin. Dissolution rates and solubilities of TNT, RDX, and HMX were determined on the compound and on three explosives formulations, LX-14, composition B, and octol.

Results of range characterization studies indicate that various types of military testing and training ranges differ in the contaminants present. Consistently high concentrations (percent levels) of explosives residues were found near ruptured ordnance. Artillery ranges are a potentially very low nonpoint source of explosives residues with higher point sources randomly scattered across the site. A multi-increment composite sampling strategy is essential to adequately characterize the distribution of contaminants on artillery ranges. Contamination associated with demolition detonation of dud rounds using C4 is a potential concern. The use of C4 can result in incomplete detonations that scatter RDX across the soil. Since RDX is an undesirable groundwater contaminant, consideration should be given to improving the efficiency of blow-in-place disposal of dud rounds.

Dissolution rates of TNT, HMX, and RDX increased with surface area, temperature, and mixing rates. Nitroglycerine degraded rapidly in all soils tested; therefore, it is not expected to persist in surface soils. The RDX transformation products, MNX, DNX, and TNX, were generally stable in all soils tested. These compounds exhibit transport potential consistent with RDX. Transport parameters used to model potential groundwater contamination and to evaluate environmental or human health risk should reflect formulations of the explosives present and the dissolution rates as well as solubilities.

Block 15.

Detonation residues
Dinitrotoluene
Explosives
HMX
Partition coefficients
RDX
Test ranges
TNT
Training Ranges
Transformation rates