

NASA TECHNICAL
REPORT



NASA TR R-180

NASA TR R-180

PROPERTY OF:

AMPTING BOARD

56920

Reproduced From
Best Available Copy

DISTRIBUTION STATEMENT A
Approved for Public Release
Distribution Unlimited

REACTIVITY OF TITANIUM
WITH OXYGEN

by W. A. Riehl, C. F. Key, and J. B. Gayle
George C. Marshall Space Flight Center
Huntsville, Ala.

20020110 093

REACTIVITY OF TITANIUM WITH OXYGEN

By W. A. Riehl, C. F. Key, and J. B. Gayle

George C. Marshall Space Flight Center
Huntsville, Ala.

NATIONAL AERONAUTICS AND SPACE ADMINISTRATION

For sale by the Office of Technical Services, Department of Commerce,
Washington, D.C. 20230 -- Price \$2.75

Acknowledgement

The study described in this report was the result of a "team" effort involving primarily the General Chemistry Section, to which the authors are assigned, and the Corrosion and Physical Chemistry, Metallurgy, and Engineering Research Sections of the Engineering Materials Branch. In addition, assistance was provided by the Experimental Mechanics Section of the Propulsion and Mechanics Branch, the Development Shop Section of the Engineering Materials Branch, and the Test Division of this Center.

TABLE OF CONTENTS

	Page
SECTION I. INTRODUCTION	1
SECTION II. LITERATURE REVIEW	2
A. Reaction with Flowing LOX	2
B. Pressure Bottle Failure	2
C. Rupture of Titanium in LOX	3
D. Effect of Bullet Puncture	4
E. Galling or Frictional Reactions	4
F. Reaction in Flowing Gaseous Oxygen	5
G. Reactions in Gaseous and Oxygen-Containing Mixtures	5
H. Miscellaneous	5
I. Summary for Section II	6
SECTION III. IMPACT SENSITIVITY	6
A. Comparative Sensitivity of Titanium and Other Materials	7
B. Nature of Impacting Surfaces	11
C. Effect of Various Titanium Alloys	15
D. Effect of LOX-LN ₂ Mixtures	15
E. Effect of Thickness	16
F. Effect of Grit	18
G. Effect of Weldments	22
H. Surface Treatments	22
I. Coatings	32
J. Summary for Section III	40
SECTION IV. SHOCK SENSITIVITY OF TITANIUM IN CONTACT WITH LIQUID AND GASEOUS OXYGEN	41
A. Preliminary Considerations	42
B. Test Procedures and Results	43
C. Summary for Section IV	56
SECTION V. EFFECT OF CONDITIONS ASSOCIATED WITH SPACE VEHICLES	57
A. Impacts	57
B. Vibration	62

TABLE OF CONTENTS (Concluded)

	Page
C. Pressure Cycling	67
D. Acoustic Energy	67
E. Thermal Effects	72
F. Orifices or Mechanical Failure	77
G. Fatigue Fracture	77
H. Spark Sensitivity	83
I. Puncture	86
J. Summary for Section V	107
SECTION VI. COMPARISON OF RELATIVE MATERIALS REACTIVITY RATINGS USING DIFFERENT TEST METHODS	107
SECTION VII. SUMMARY	109
REFERENCE	111

LIST OF ILLUSTRATIONS

Figure	Title	Page
1	LOX Impact Sensitivity of Conditionally Acceptable Materials	9
2	LOX Impact Sensitivity of Titanium Alloys and Typical Unacceptable Materials	10
3	Effect of 5 Kg-M Impact on Titanium Specimen in LOX	13
4	Details of Striker, Sample Cup, and Sample (Impact Sensitivity Tester).	14
5	Impact Sensitivity of Various Titanium Alloys . .	17
6	Effect of Grit on LOX Impact Sensitivity.	21
7	Effect of Deburring on LOX Impact Sensitivity. .	24
8	Effect of Vacuum Annealing on LOX Impact Sensitivity.	29
9	Effect of Pickling After Vacuum Annealing	31
10	Effect of Electroless Nickel Coatings on LOX Impact Sensitivity.	37
11	Effect of Electroless Copper on LOX Impact Sensitivity.	39
12A	Shock Sensitivity Test Method No. 1	44
12B	Shock Sensitivity Test Method No. 2	51
12C	Shock Sensitivity Test Method No. 3	53
13	Test Setup for External Impacts	59
14	Model Test Tanks (for LOX Puncture Tests) . . .	61

LIST OF ILLUSTRATIONS (Continued)

Figure	Title	Page
15A	Titanium Tank Vibration Test.	63
15B	LOX Fill Tanks Vent and Purge System (Schematic) for Vibration Test	64
16	"Rotap" Vibration Test	66
17	Schematic Diagram of Pressure Impulse Cycling Apparatus	68
18	Aluminum Tank Failure in Pressure Test.	69
19	Pressure Cycles	70
20	Ultrasonic Energy Test Setup	71
21	Acoustic Test Setup	73
22	Overall Values and Frequency Spectra of Acoustic Energy Tests	74
23	Direct Impingement of Hydrogen/Air Flame on Titanium	76
24A	Insulated Titanium LH ₂ Tank Before Puncture	78
24B	Titanium LH ₂ Tank After Puncture and Burning of H ₂	79
25	Interior of Titanium LH ₂ Tank After Test. .	80
26	Titanium Vessel Failure	81
27	"Burnt" Spots on Fatigue Fractured Titanium.	83
28	Apparatus for Spark Sensitivity Tests	85

LIST OF ILLUSTRATIONS (Concluded)

Figure	Title	Page
29	Test Setup for External Gas Phase Puncture.	88
30	Puncturing Tools	89
31	Typical Appearance of Titanium After Puncture Tests	91
32	Typical Appearance of Aluminum and Stainless Steel Diaphragm After Puncture. .	92
33	Test Setup for External Liquid Phase Puncture.	97
34	Tank Puncture Apparatus (M-1 Rifle).	100
35	Remains of Titanium Tank After Puncture . .	101
36	Tank Puncture Apparatus - Pin Type	103

LIST OF TABLES

Table	Title	Page
1	Comparative LOX Impact Sensitivity of Various Materials	8
2	Comparative LOX Impact Sensitivity of Titanium, Aluminum Alloys, and Stainless Steel	12
3	Effect of Nature of Impacting Surfaces	15
4	Relative Impact Sensitivity of Various Titanium Alloys	16
5	Effect of LN ₂ Dilution on LOX Impact Sensitivity	18
6	Effect of Thickness on LOX Impact Sensitivity.	19
7	Effect of Grit on LOX Impact Sensitivity	20
8	Effect of Welding on LOX Impact Sensitivity of Titanium	22
9	Effect of Deburring.	23
10	Effect of Hand Polishing on LOX Impact Sensitivity.	25
11	Effect of Electropolishing on LOX Impact Sensitivity of Titanium Alloys.	26
12	Effect of Annealing on LOX Impact Sensitivity of Titanium Alloys	28
13	Effect of Pickling on LOX Sensitivity of Titanium Alloys After Vacuum Annealing	30
14	Effect of Passivation on LOX Impact Sensitivity	32

LIST OF TABLES (Continued)

Table	Title	Page
15	Phosphate Coated Titanium (5Al-2.5Sn)	33
16	Effect of Anodizing on LOX Impact Sensitivity of Titanium	33
17	Effect of Teflon Coatings on LOX Impact Sensitivity of Titanium	35
18	Effect of Ceramic Coatings on LOX Impact Sensitivity	36
19	LOX Impact Sensitivity of Electroless Nickel Plated Titanium	38
20	LOX Impact Sensitivity of Electroless Copper Coated Titanium.	38
21	Effect of Repetitive Impacts on Electroless Coated Specimens	41
22	Summary of Shock Sensitivity Results Obtained by Method I.	46
23	Shock Sensitivity Results - Method II.	52
24	Summary of Shock Sensitivity Results Obtained by Method III.	55
25	Resonant Points in Vibration Tests	65
26	Fatigue Testing of Ti-5Al-2.5Sn Under GOX Pressure	82
27	Summary of Diaphragm Puncture Tests (Gaseous Phase).	90
28	Miscellaneous Diaphragm Puncture Tests (Gaseous Phase).	93

LIST OF TABLES (Concluded)

Table	Title	Page
29	Effect of Pressure on Titanium Diaphragm Reactivity on Puncture	95
30	Effect of Coatings on Puncture Sensitivity.	96
31	Summary of Diaphragm Puncture Tests (Liquid Phase)	98
32	Effect of Liquid Nitrogen Substitution for LOX. .	99
33	Summary of Tank Puncture Tests	104
34	Comparison of Relative Reactivity of Materials With Oxygen Based on Different Test Methods .	108

NATIONAL AERONAUTICS AND SPACE ADMINISTRATION

TECHNICAL REPORT R-180

REACTIVITY OF TITANIUM WITH OXYGEN

By

W. A. Riehl, C. F. Key, and J. B. Gayle

SECTION I. INTRODUCTION

Titanium alloys are attractive for construction of LOX/LH₂ containers for space vehicle systems because of their high strength-to-weight ratios at cryogenic temperatures.

Consideration of the physical and chemical properties of titanium indicate that it should be more reactive to oxygen than most other metals, including aluminum and steel. Its lower specific heat results in a higher temperature per unit heat input and its lower thermal conductivity makes heat dissipation more difficult. In addition, titanium has a relatively low ignition temperature in oxygen. Thus, one would expect that it should be considerably easier to initiate a reaction of oxygen with titanium than with aluminum or steel. Another factor strengthening this judgment is the solubility of O₂ and TiO₂ in titanium which results in dissolution of protective surface oxide films in the high temperature or molten metal.

This study was undertaken to develop information on which a knowledgeable decision could be based concerning the use of titanium for construction of thin walled LOX tanks. The primary goals were to

1
p 2

investigate the reactions of titanium alloys with oxygen under a variety of conditions associated with space vehicles, and to determine if the titanium could be treated or coated in some fashion to eliminate such hazards.

See also 51518 and 50003

SECTION II. LITERATURE REVIEW

NOTE: This literature review was restricted to laboratory and service experiences with titanium in oxygen systems.

A. REACTION WITH FLOWING LOX*

In 1959, Aerojet-General (refs. 1 and 2) designed a test to simulate actual conditions of LOX flow through a stainless steel loop containing a 2 1/2-foot section of 3/16-inch-wall, 2-1/2-inch-ID-Titanium-75A tubing. The intent was to impact the titanium section by a drop-weight method. Before the system was completely instrumented and while the system was unattended, a reaction took place that destroyed part of the system, some burning of both titanium and stainless steel occurring. The cause of this reaction could not be established, because of the many variables. However, LOX was flowing at the time, and the pressure of the system was approximately 700 psi.

B. PRESSURE BOTTLE FAILURE

In 1959, Rocketdyne (ref. 3) experienced a failure of a 24-inch pressure bottle constructed of Ti-6Al-4V. The vessel previously had been hydraulically tested to 5000 psi, dried, degreased in trichloroethylene, and then cycled several times with LOX to 4500 psi. A violent reaction occurred after LOX again was added. Burning of some of the fractured edges occurred, but indications were that this began

* Much of the information in this section was obtained from a literature survey reported in WADD Tech. Report No. 60-258, "A Study of the Titanium Liquid Oxygen Pyrophoric Reaction," 1960. Numbers in parentheses delineate the references appended to this report.

after the tank exploded. Some burning took place also at a boss and at weld areas that were not fractured. It was concluded that the most probable cause of failure was a reaction of oxygen with contaminant in the boss area. For example, small amounts of contamination similar to that found in the trichloroethylene used for flushing were found on the threads of the boss. It is also possible that the pressure vent closed accidentally. However, this should only have resulted in a pressure of approximately 750 psi which would not have caused failure of the bottle. Since the evidence was not conclusive, the exact cause of failure was not established.

Stanford Research Institute reported that when titanium capsules containing high pressure oxygen (500 psia) were ruptured, the metal ignited even though the original surface had been previously oxidized (ref. 4). An explosive shock wave, inherent in this test, may have been a contributing factor.

C. RUPTURE OF TITANIUM IN LOX

Four investigators have reported reactions between titanium and LOX on tensile or stress rupture:

1. Menasco Manufacturing Company made stress rupture tests with 1/4-inch round tensile bars of 4340 steel, 304 stainless steel, 7075 aluminum, and Ti-6Al-4V (refs. 5 and 6). The titanium specimens were machined and then degreased in acetone; the steel and aluminum specimens were grit blasted, water rinsed, and then degreased in acetone. A stainless steel cylinder was silver soldered to the specimen grip to contain the LOX. After cooling to LOX temperature, the specimen was pulled at about 0.015-inch per inch per minute in a standard universal testing machine. Each material was pulled under LOX; one specimen of Ti-6Al-4V also was pulled in the vapor phase just above the LOX. Only the titanium specimen pulled in LOX reacted, with burning occurring at the fractured ends, and to a lesser extent at the threaded ends.

2. The Martin Company also investigated the tensile rupturing of titanium specimens (0.063 by 3/8 inch) under LOX using a standard universal testing machine (ref. 6). A small flash of light occurred at failure of every specimen at strain rates in the range of 4 to 100 inches per inch per minute but no burning of the fractured face was reported.

3. Aerojet-General fractured ten end-supported titanium specimens in LOX. One ignition was reported.

4. Battelle Memorial Institute made stress rupture tests on Ti-6Al-4V in LOX (ref. 7). Light flashes occurred at the fracture, and burnt spots were almost always present at support locations.

On the other hand, Titanium Metals Corporation of America ruptured a small piece of Ti-6Al-4V under LOX in conjunction with a program on the resistance of titanium to gaseous and liquid fluorine (ref. 8). Oxygen was condensed in a pressure bomb by liquid nitrogen, and the specimen was pulled apart. No reaction was observed, and the freshly ruptured surface was bright.

D. EFFECT OF BULLET PUNCTURE

The Bendix Corporation fired a caliber .50 incendiary bullet into a titanium-LOX tank (ref. 9). A huge flash was observed and a violent reaction occurred, resulting in fragmentation of the vessel. Fusion and burning were noted on the fracture faces of some of the pieces. Similar tanks of type 304L stainless steel apparently failed to react and did not shatter unless they were faulty or had defects at the grain boundaries.

E. GALLING OR FRICTIONAL REACTIONS

The Martin Company conducted tests on galling effects by rotating the end of a stainless steel rod on a titanium specimen in an aluminum cup filled with LOX (ref. 6). The rod was mounted in a drill press and operated at peripheral speeds of up to 40 inches per second (200 feet per minute) and pressures up to 1600 psi. The reaction, as indicated by the intensity of a light flash, increased with increase in speed and/or pressure. The temperature generated was estimated to be about 1000°F, as observed from the color of the stainless steel rod.

Battelle Memorial Institute reported reactions upon rotating Ti-6Al-4V or Ti-75A alloys on stainless steel in LOX, as evidenced by brilliant flashes of light and burnt spots on post examination (ref. 7).

F. REACTION IN FLOWING GASEOUS OXYGEN

Bendix Aviation (ref. 9) investigated the effect of passing gaseous oxygen at high velocity through a titanium orifice. A freshly prepared titanium orifice was made by quickly drilling a hole with a dull drill to form a large burr. The burr was forced back into the hole and high-pressure oxygen was forced through. In one instance, ignition occurred, but the reaction could not be duplicated.

G. REACTIONS IN GASEOUS AND OXYGEN CONTAINING MIXTURES

The Stanford Research Institute investigated the reactions of titanium and oxygen-containing atmospheres (ref. 10). A freshly formed titanium surface reacted rapidly with oxygen, and the energy released by this reaction resulted in ignition of the titanium sample, which then continued to burn until either the metal was consumed or the supply of oxygen was exhausted. Under static conditions at room temperature, at least 350 psi of 100 percent oxygen was necessary to initiate the reaction, whereas, with 45 percent by volume of oxygen, a pressure of 2000 psi was required. Under dynamic conditions, as in the case of a ruptured pressure disc, much less stringent conditions were needed. With pure oxygen, 50 psi pressure would initiate the reaction. Once the reaction began, it would propagate at high pressures with as little as 2 percent oxygen in steam. About 10 percent oxygen was required for propagation at atmosphere pressure.

Battelle Memorial Institute investigated the effect of low temperature on the ignition of titanium in gaseous oxygen (ref. 11). At room temperature, titanium 75A alloy required 75 psi of oxygen to initiate reaction upon the freshly formed metal surface (by tensile testing). With the same alloy and test conditions, but at -123.3°C (-190°F), 100 psi of oxygen were necessary for reaction. Similar tests with the Ti-6Al-4V alloy showed 100 psi necessary at room temperature and 125 psi at -123.3°C (-190°F).

H. MISCELLANEOUS

Jackson, et al., reported some studies on minimizing the reaction of titanium and oxygen under rupture conditions by gaseous additions and by coatings (ref. 11). Two percent HF, or five percent

argon, raised the threshold pressure for reaction of Ti-75A alloy from 75 to 200 psig. Fluorine additions increased the reactivity.

Two coatings were tried; one produced by a fluoride-phosphate treatment, and another of aluminum (by vapor decomposition from tri-isobutyl aluminum). Neither coating decreased the reactivity upon tensile rupture in pressurized oxygen. Very limited tests indicated that the fluoride-phosphate treatment might afford some reduction, but not elimination, of the impact sensitivity in LOX. Only one aluminum coated sample was impact tested in LOX, with no reaction occurring.

I. SUMMARY FOR SECTION II

While it may be true that the causative factor in some of the adverse incidents described above cannot be ascribed definitely to chemical reactivity of titanium and LOX, and in some cases the titanium/LOX reactions was a post-failure phenomenon, careful attention to the literature available at the beginning of this program seemed to justify extreme caution in considering titanium for use in LOX systems.

SECTION III. IMPACT SENSITIVITY

This organization probably was the first to note the impact sensitivity of titanium in contact with LOX. In April 1957, results of preliminary tests indicated that titanium 125A alloy did not satisfy the usual criteria for use in LOX systems. Since that time, several other alloys have been tested and found sensitive.

At MSFC, all materials to be used in LOX systems are evaluated for compatibility by the impact sensitivity method described in several reports (refs. 12, 13, and 14) and specified in MSFC-SPEC-106, "Testing Compatibility of Materials for Liquid Oxygen Systems." Materials are classed in three categories. Acceptable materials must produce no reactions, or "fires," in twenty individual trials, or no more than one in 60 trials at an impact energy of 10 Kg-M*

*1 Kg-M = 7.2 ft-lb.

delivered by a 20-pound plummet through a 1/2-inch diameter striker pin. In the latter case, the maximum allowable frequency of reactions at 10 Kg-M is 1.6 percent. Materials which produce reactions at this level, but not at half the impact energy (5 Kg-M), are classed as "conditional." Such materials may generally be used in indirect applications in LOX systems where the possibility of contact with oxygen is remote. Those materials which are sensitive at 5 Kg-M impact force are classed as "unsatisfactory" and not recommended for any applications in or near LOX systems. All of the impact sensitivity tests described in this report were made in strict accordance with MSFC-SPEC-106.

At least six other investigators have since reported that titanium alloys are sensitive to impact in LOX. These include:

Aerojet-General Corporation
Battelle Memorial Institute
General Dynamics/Astronautics
Martin Company
Reaction Motors, Inc.
WADD

A. COMPARATIVE SENSITIVITY OF TITANIUM AND OTHER MATERIALS

The impact sensitivity of various materials and titanium alloys are shown for comparative purposes in Table 1. The sensitivity of "conditional" materials is shown graphically in FIG 1. The frequency of reactions between those materials and LOX is generally below 33 percent at 10 Kg-M.

The impact sensitivity of titanium alloys and several others of comparable reactivity is depicted in FIG 2. With these materials, the reaction frequency at 10 Kg-M generally ranges from 20 to 75 percent. FIG 2 clearly shows that, based upon the most widely accepted method for evaluating the compatibility of materials in LOX (impact sensitivity), titanium alloys provide essentially the same degree of hazard risk as such materials as Nylon, Buna-N, Rectorseal, Styrofoam, cotton, and polyethylene. It is understood that several years ago an explosion which caused the death of two employees, and severely burned four more, was traced to use of Buna-N and Nylon in a LOX system.

Table 1. Comparative LOX Impact Sensitivity of Various Materials

<u>Material</u>	<u>No Fires/No. Tests</u>				<u>Insensitivity Level* (Kg-M)</u>
	<u>At 10 Kg-M</u>		<u>At 5 Kg-M</u>		
	<u>No.</u>	<u>%</u>	<u>No.</u>	<u>%</u>	
<u>Acceptable Materials</u>					
Teflon based materials inorganic composites (26 various types)	0/520	0			Over 10
Fluorotrichloroethylene based materials (12 types)	0/380	0			Over 10
Aluminum - 5052	19/1480	1.3			Over 10
Aluminum - 2014 T6	0/400	0			Over 10
<u>Conditionally Acceptable</u>					
Mg-Li Alloy - CA91	2/3	66	0/20		5
Seal-Rite	2/30	6.6	0/20		9
DC-33	2/11	18	0/20		5
<u>Unacceptable</u>					
Nylon (twine)**	2/2		1/2		1
Buna-N**	2/3		1/18	6	5
Rectorseal 15**	2-5/20	10-25	1-3/20	5-15	2-3
Apiezon-M	2/2		0/18	6	-
Cotton (twine)	2/2		2/7	28	-
Polyurethane Foam	1/1		1/10	10	2
Polyethylene	2/5	40	1/10	10	1
Styrofoam	3/6	50	2/5	20	2
Ti-A-110	12/20	60	7/20	35	1
Ti-6Al-4V	12/20	60	7/20	35	1
* - 0/20 or 1/60 level.					
** - Explosions have been attributed to the use of these materials in LOX Propulsion/GSE systems.					

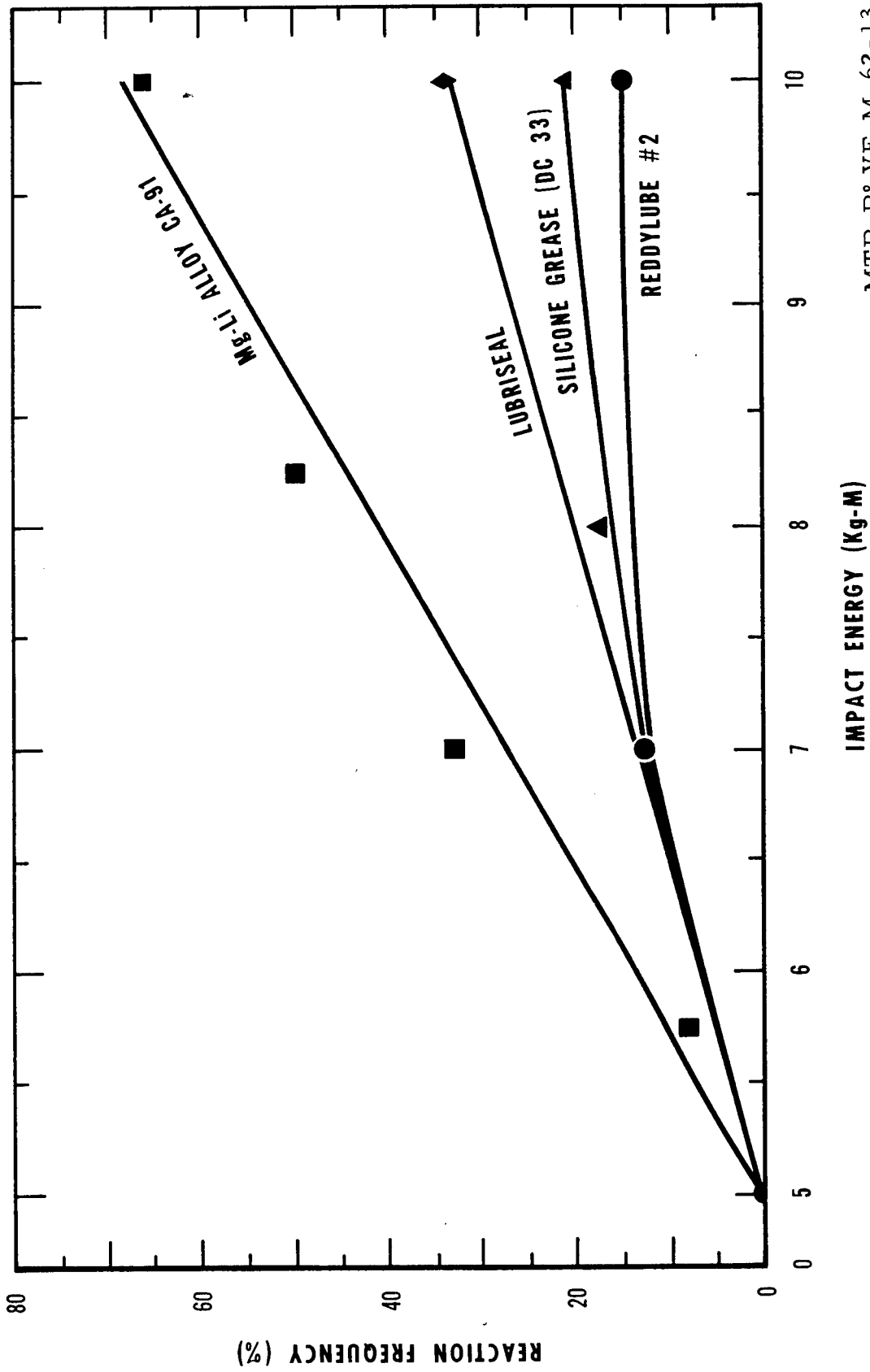

MTP-P&VE-M-62-13

FIGURE 1. TYPICAL LOX IMPACT SENSITIVITY OF CONDITIONALLY ACCEPTABLE MATERIALS.

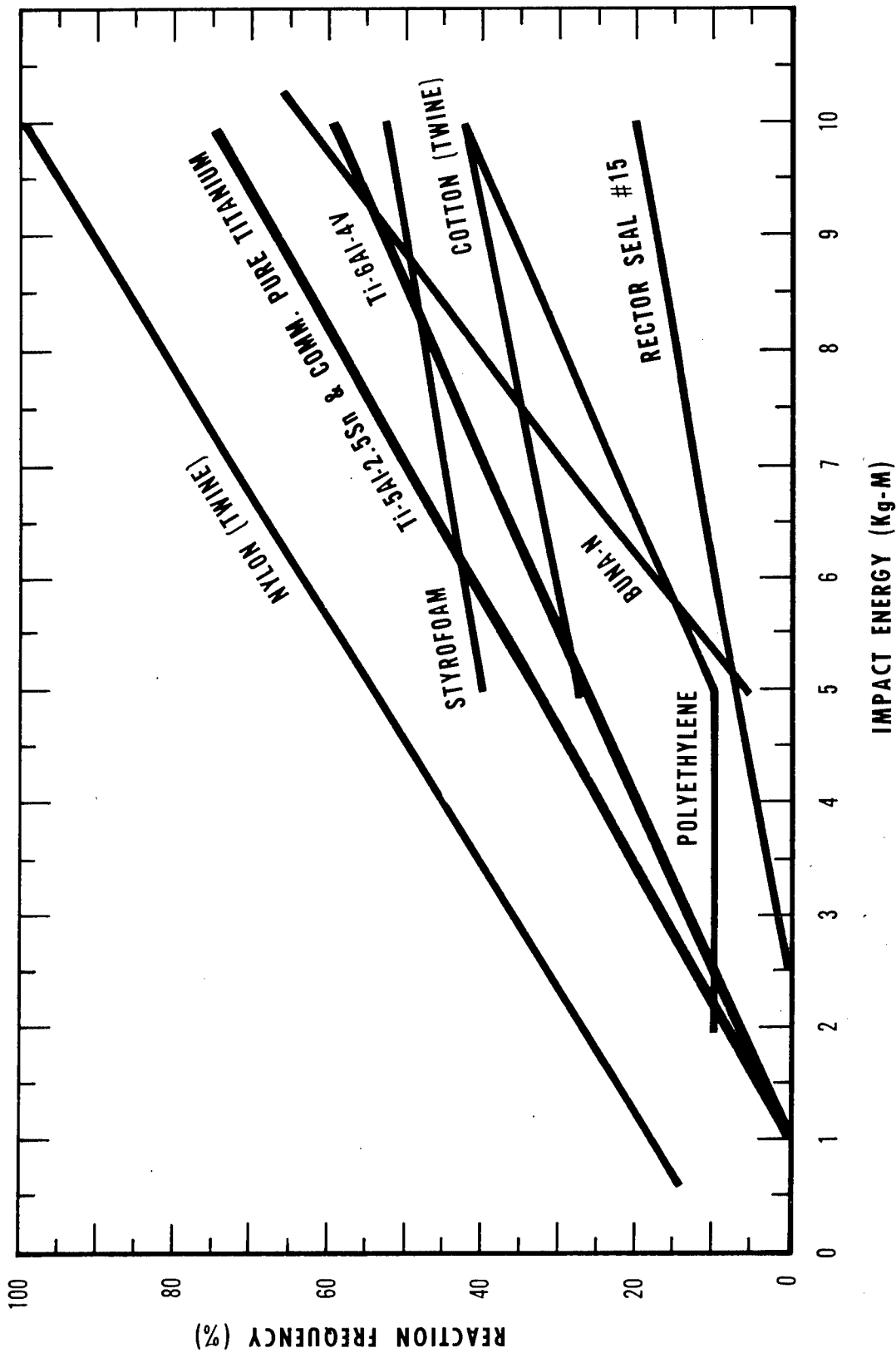

MTP-P&VE-M-62-13

FIGURE 2. LOX IMPACT SENSITIVITY OF TITANIUM ALLOYS AND TYPICALLY UNACCEPTABLE MATERIALS.

More detailed comparison of the LOX impact sensitivity of titanium with that of aluminum and steel alloys commonly used for space vehicle tank and skin construction are shown in Table 2. Only the titanium alloy was reactive in these tests. The typical appearance of titanium specimens before and after impacting in contact with LOX is shown in FIG 3.

Tests also were made to study the behavior of the different materials under repeated impacting of the same sample at a relatively low impact energy. In a set of 100 samples of 5Al-2.5Sn (0.010 inch thick) subjected to 3 Kg-M impact energies, the following results were obtained:

Number of Reactions on First Impact	- 11
Number of Reactions on Second Impact	- 60
Number of Reactions on Third Impact	- 26
Number of Reactions on Fourth Impact	- 2
Number of Reactions on Fifth Impact	- 1
Total	<u>100</u>

The average number of impacts required for reaction was 2.2.

Two samples each of 0.010 inch stainless steel (type 301) and aluminum (type 2014-T6) were similarly tested. No reactions occurred in 50 repetitive impacts on any of the four samples.

B. NATURE OF IMPACTING SURFACES

FIG 4 shows the details of the striker pin, sample cup, and sample placement for the impact sensitivity tester. Because it was suspected that the various metal combinations present therein might have introduced spurious effects, such as different hardnesses and/or electromotive potential couples, tests were made in which the compositions of the striker pins, sample cups, and samples were interchanged. The results listed in Table 3 showed that appreciable reactivity occurred only when titanium was present. Thus, it was concluded that the nature of the mating surfaces did not significantly affect the impact sensitivity of titanium in LOX.

Table 2. Comparative LOX Impact Sensitivity of Titanium, Aluminum Alloys, and Stainless Steel

All samples were tested as 1 1/16 inch diameter discs in the "As Received" and hand deburred condition.

	10 Kg-M No. Reactions/ No. Tries	% Frequency	5Kg-M No. Reactions/ No. Tries	% Frequency	Repetitive Impacting (Average No. of Drops to Ignite at 3 Kg-M Impact Energy)
<u>0.063 inch thickness</u>					
5Al-2.5Sn Ti	47/120	39	19/100	19	2.7
5456 Al	1/100	1	0/100	0	-
2014-T6 Al	0/100	0	0/100	0	-
301 Stainless Steel	0/100	0	0/100	0	-
<u>0.010 inch thickness</u>					
5Al-2.5Sn Ti	28/145	19	34/100	34	2.2
2014-T6 Al	0/100	0	0/100	0	> 100
301 Stainless Steel*	0/100	0	0/100	0	> 100

*Actually 0.012 inch thick.

*2 Average number of repetitive impacts on sample to cause ignition at 3 Kg-M impact energy.

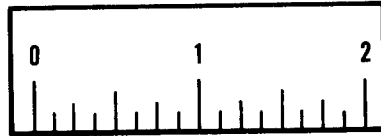

NO REACTION



TYPICAL APPEARANCE OF SAMPLES WHICH REACTED

**0.010 IN. THICK 5Al-2.5Sn TITANIUM AS RECEIVED
HAND DEBURRED & VAPOR DEGREASED AFTER IMPACT TEST**

MTP-P&VE-M-62-13

FIGURE 3. EFFECT OF 5Kg-M IMPACT ON TITANIUM SPECIMENS IN LOX

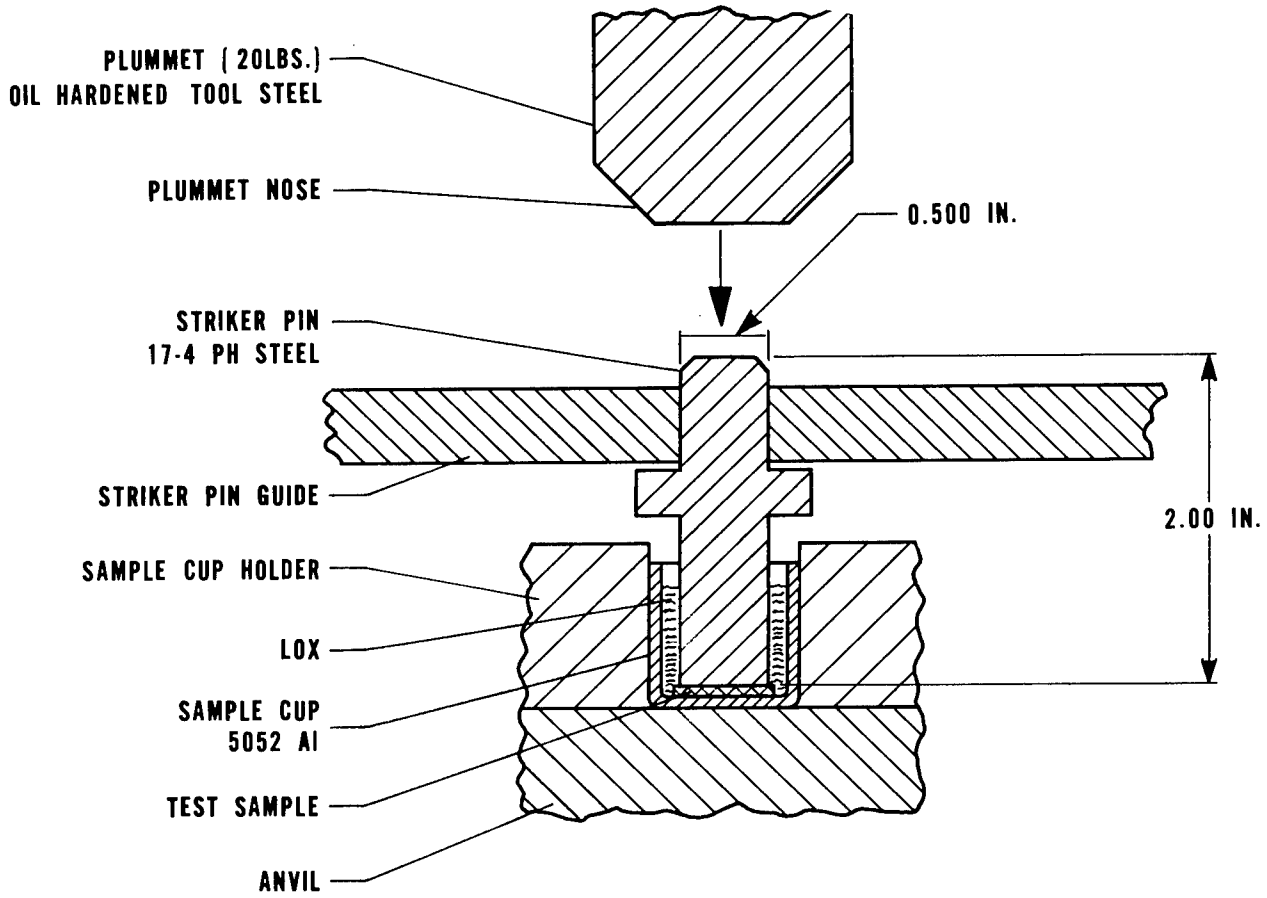

FIGURE 4. DETAILS OF STRIKER, SAMPLE CUP, AND SAMPLE (IMPACT SENSITIVITY TESTER)

Table 3. Effect of Nature of Impacting Surfaces
On Ti/LOX Sensitivity

All samples of cups 1/16 inch thick - As Received, deburred and degreased

Cup	Composition		Results	
	Sample	Pin	No. Reactions/ No Tests	% Reaction Frequency
Ti-A-110 ^a	None	Ti-A-110	9/20	45
Al-5052	5Al-2.5Sn Ti	St. Steel (17.7PH)	47/120	39
S. St. (301)	5Al-2.5Sn Ti	St. Steel (17.7PH)	36/80	38
Al-5052	None	St. Steel (17.7PH)	19/1480	1.3
Al-5052	Al-2014-T6	St. Steel (17.7PH)	0/100	0
Al-5052	St. Steel (301)	St. Steel (17.7PH)	0/100	0
S. St. (301)	None	St. Steel (17.7PH)	0/100	0
S. St. (301)	Al-2014-T6	St. Steel (17.7PH)	1/100	1

C. EFFECT OF VARIOUS TITANIUM ALLOYS

Data on the impact sensitivity of four common titanium alloys are presented in Table 4 and FIG 5. All have an impact insensitivity level in the same range, i. e., 1-3 Kg-M. The reaction frequency of the 5Al-2.5Sn and RC-55 alloys are equivalent. The frequency of the 13V-11Cr-3Al alloy may be somewhat lower as a result of the smaller amount of titanium in the alloy (approximately 73 percent). An explanation of the still lower reaction frequency of the 6Al-4V alloy is not present.

These results show that, in general, the overall impact sensitivity of titanium does not vary greatly with these alloys. (While the reaction frequency of the 6Al-4V alloy is less, its insensitivity level is still very low.)

D. EFFECT OF LOX-LN₂ MIXTURES

In order to investigate the variation in impact sensitivity with LN₂ dilution of the LOX, tests were made with approximately 50, 60, 70, and 100 percent (by weight) LN₂ in LOX. The liquids

Table 4. Relative Impact Sensitivity of Various Titanium Alloys

All samples in "As Received" condition - 11/16 inch diameter discs, punched from 0.063 inch sheet, barrel deburred, and vapor degreased.

No. Reactions/No. Tests At X Impact Energy (Kg-M)	Alloy				
	5 Al - 2.5 Sn	6 Al - 4 V	Comm. Pure	4 Al - 3 Mo - IV	13 V - 11 Cr - 3 Al
10	11/20	7/40	15/20	2/2	15/36
8.3		1/2			
8		1/2			
7.2		2/3			
7					5/20
5	3/20	2/60		1/1	2/20
3	1/20		1/20	2/5	0/20
2	1/20	0/20	2/20	1/3	0/20
1	0/20		0/20	0/4	

were mixed in a Dewar flask and used within thirty minutes, the duration of the test series. Chemical analyses showed that the nitrogen content did not decrease more than four percent during this time.

All specimens were 0.063 inch thick by 11/16 inch diameter discs of 5Al-2.5Sn titanium, which were deburred and vapor degreased prior to test.

The results showed that titanium was still relatively sensitive to impact at 60 percent LN₂ dilution (Table 5). At 70 percent and 100 percent LN₂, it was insensitive. Thus, titanium is not impact sensitive in liquid air (79 percent N₂ - 21 percent O₂). However, liquid air (and LN₂ evaporating in air) becomes enriched with LOX on evaporation, and only a relatively small amount of such enrichment would result in impact sensitivity of titanium in contact with the fluid. Such a condition probably could occur on titanium surfaces exposed to air at temperatures below the boiling point of oxygen (-183°C, -297°F at 1 atm.).

E. EFFECT OF THICKNESS

MSFC-SPEC-106 (paragraph 4.3) specifies that "sheet materials up to 1/4 inch in thickness shall be tested as 5/8 inch diameter discs in the thickness intended for actual use Only materials, such as greases and fluids, whose thicknesses are not

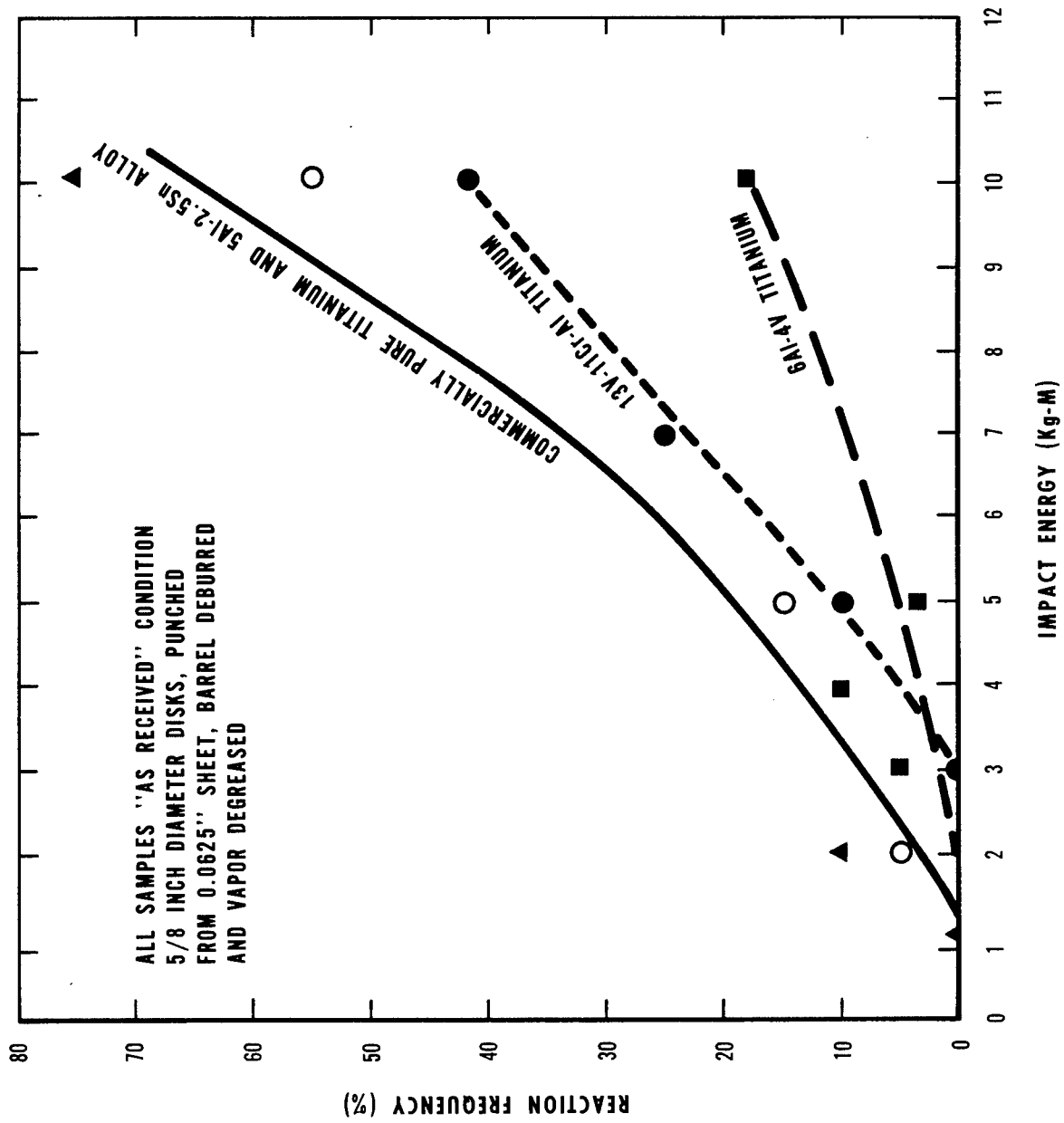

FIGURE 5. IMPACT SENSITIVITY OF VARIOUS TITANIUM ALLOYS

Table 5. Effect of LN₂ Dilution on LOX Impact Sensitivity of
of 5Al-2.5Sn Titanium (0.063 in. Thick)

All Samples "As Received" Deburred and Vapor Degreased,
11/16 in. diam. discs

LN ₂ Dilution (by weight)	Results (No. Reactions/No. Tests)							
	10 Kg-M	9 Kg-M	8	7	6	5	3	1
0	11/20	-	-	-	-	3/20	1/20	0/20
50	1/20	3/20	3/20	0/20	0/20	-	-	-
60	2/20	-	-	2/20	1/20	0/20	-	-
70	0/20	0/20						
100	0/20							

dictated by conditions of use shall be tested as 0.050 (plus or minus 0.005) inch layers in test cups." (The latter thickness was based upon experimental work reported by Lucas and Riehl (refs. 2, 12, and 13).

The effect of thickness upon the impact sensitivity of the 5Al-2.5Sn titanium alloy is shown in Table 6. All thicknesses from 0.010 inch to 0.125 inch reacted in more than 10 percent of the tests. If it is assumed that the 34 percent frequency of the 0.010 inch material at 3 Kg-M is anomalous, there is a general trend toward increasing reactivity with greater thicknesses. This is opposite to the usual behavior of materials such as greases and lubricants in impact sensitivity testing and suggests that with metal specimens, bending or deforming of the thinner materials may absorb part of the impact energy. However, this trend cannot be readily confirmed from the repetitive impact data for which there was no great difference in results with varying sample thickness.

F. EFFECT OF GRIT

It is well known that hydrocarbon contamination must be avoided in LOX systems. Lucas and Riehl reported that inorganic contamination must be minimized also (refs. 12 and 13). They found

Table 6. Effect of Thickness on LOX Impact Sensitivity of 5Al-2.5 Sn Titanium Alloy

All samples tested as 11/16 inch diameter discs in the "As Received" and hand deburred condition

Thickness (in.)	10 Kg-M Impact Energy		5 Kg-M Impact Energy		Repetitive Impacting Average No. of Drops to Ignite at 3 Kg-M Impact Energy
	No. Reactions No. Tries	Frequency %	No. Reactions No. Tries	Frequency %	
0.125	94/100	94	74/100	74	1.8
0.063	47/120	39	19/100	19	2.7
0.032	34/100	34	14/100	14	2.7
0.025	40/100	40	11/100	11	2.6
0.010	28/145	19	34/100	34	2.2

that by placing a few small hard particles, such as sand, alundum, or silicon carbide, in the bottom of an aluminum test cup the reaction frequency was markedly increased upon impact in LOX. It is believed that when particles are abraded or driven into the aluminum, the heat liberated at microscopic contact points frequently is sufficient to trigger a reaction between the fresh metal surface and the LOX.

To investigate this phenomenon, standard impact sensitivity tests were made on titanium alloys contaminated with a small amount of silicon carbide in an aluminum test cup. Data are listed in Table 7. The graphical comparison of results with and without grit (FIG 6) shows that while the insensitivity level is not affected, the frequency of reactions at higher impact energies is very greatly increased, attaining 100 percent reactivity at only 5 Kg-M.

The above tests were made using 0.063 inch thick samples of 5Al-2.5Sn titanium with the standard aluminum test cup. In order to differentiate between those reactions which may have been caused by aluminum, rather than titanium, a second set of tests was made in which aluminum and titanium cups were used without sample inserts. The results (Table 7) clearly showed that the titanium is far more reactive than the aluminum under such conditions. The

Table 7. Effect of Grit on LOX Impact Sensitivity

Impact Energy (Kg-M)	5Al-2.5Sn Ti Alloy Specimens* (Without Grit)		5Al-2.5Sn Ti Alloy Specimens* (With Grit**)		5Al-2.5Sn Ti Alloy Test Cups † (With Grit**)		5052 Al Alloy Test Cups † (With Grit**)	
	No. Reactions	Reaction Frequency (%)	No. Reactions	Reaction Frequency (%)	No. Reactions	Reaction Frequency (%)	No. Reactions	Reaction Frequency (%)
10	11/20	55	20/20	100	4/4	100	0/20	0 †
5	3/20	15	20/20	100	4/5	80	0/20	0 †
3	1/20	5	11/20	55	-	-	-	-
2	1/20	5	9/20	45	2/3	67	-	-
1	0/20	0 ‡	0/20	0 ‡	0/20	0 ‡	-	-

* All Specimens 0.063 Inches Thick

** Approximately 0.5g of 150 Mesh SiC in Each Test Cup

† No Specimen Inserted - Cup Alone Subjected to Impact

‡ Reaction Frequency Uncertain Because of Limited Tests

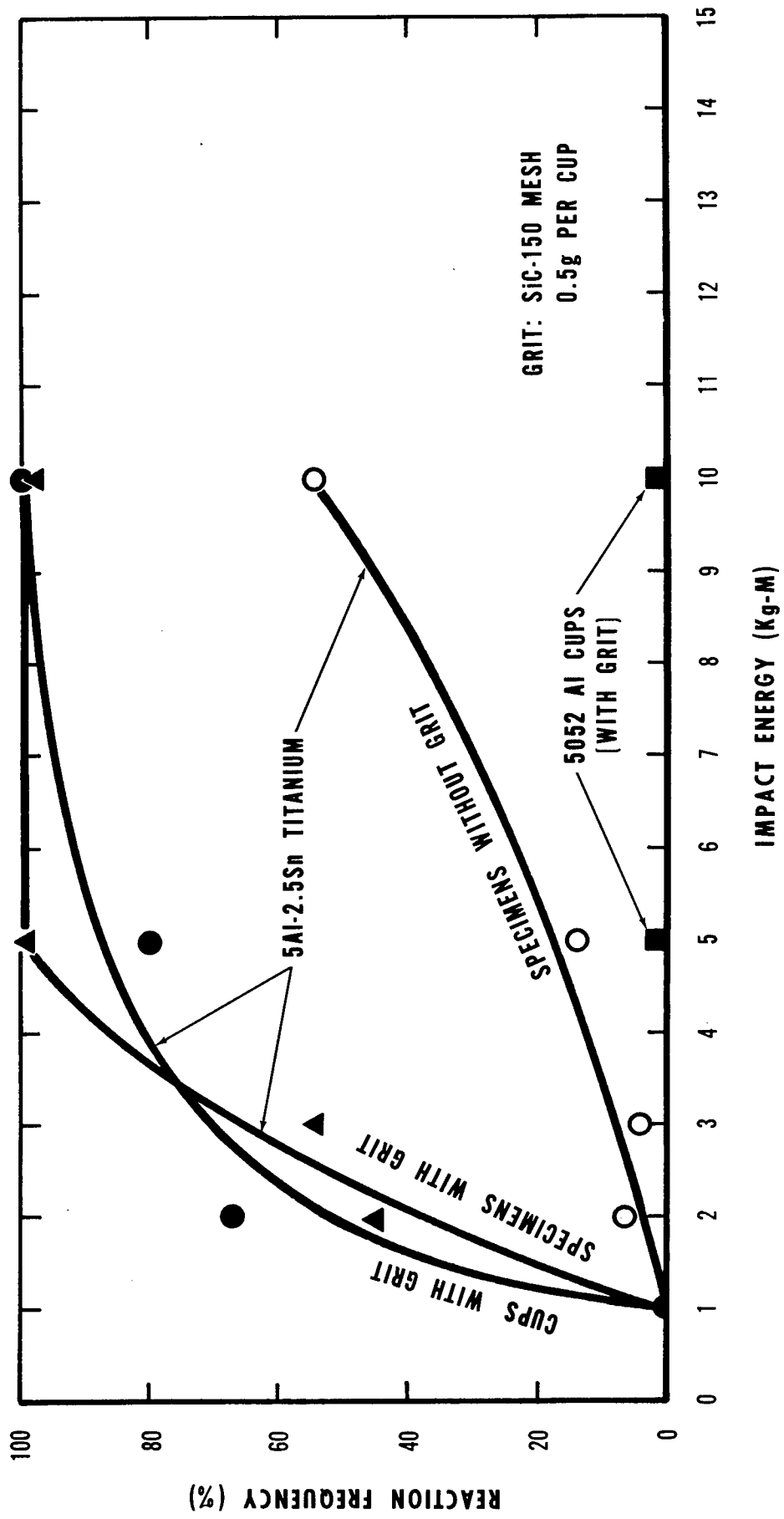

FIGURE 6. EFFECT OF GRIT ON LOX IMPACT SENSITIVITY

lack of any reactions with aluminum in the data listed is not considered anomalous in view of the very low degree of reactivity of this material with LOX.

G. EFFECT OF WELDMENTS

In order to determine whether weldments affect the reactivity of titanium and oxygen, 5Al-2.5Sn titanium sheets (0.063 inch thick) were welded together with 75A alloy rod. Based on radiographic examination, sets of samples were prepared from both high and low porosity areas. Samples also were taken immediately adjacent to, but not including, the weld bead to represent the heat affected zone, and farther away to be representative of the sheet.

Impact sensitivity tests did not show significant difference in the reactivity of any of the various sets of samples (Table 8).

H. SURFACE TREATMENTS

Deburring. Samples were prepared for impact sensitivity testing by punching 5/8 inch diameter discs from the sheet stock. This operation produced somewhat rough edges, frequently accompanied by slivers and burrs. Because it would be expected that such a condition would enhance reactivity, all samples were deburred by tumbling the samples in a drum, containing 1/4 to 1/2 inch porcelain balls, for several hours ("Barrel" deburring). The effect of this treatment was confirmed by experimental tests of 6 various sets of samples

Table 8. Effect of Welding on LOX Impact Sensitivity of Titanium

Tested Area of Titanium Alloy 5Al-2.5Sn Welded With 75A Rod	Number of Reactions At Given Impact Energy				
	10 (Kg-M)	5 (Kg-M)	3 (Kg-M)	0.42 (Kg-M)	0.28 (Kg-M)
Crown of Low Porosity Weld Bead	1	4	0		
Crown of High Porosity Weld Bead	3	1	0		
Area Adjacent to Weld	4	12		1	0
Parent Metal	11	3	1	0	

NOTE: All samples 1/16-inch thick (except weld bead).

Table 9. Effect of Deburring

Alloy	Thickness	Condition	No. Reactions/No. Tests at X Kg-M	
			Deburred	Not Deburred
6Al - 4V	.063	As Received	7/40 @ 10	12/20 @ 10
			1/2 @ 8.3	7/20 @ 5
			1/2 @ 8	1/20 @ 2
			2/3 @ 7.2	0/20 @ 1
			2/60 @ 5	
			0/20 @ 2	
6Al - 4V	.063	Vacuum Annealed	4/20 @ 10	1/20 @ 10
			1/20 @ 8	2/20 @ 8
			1/4 @ 7	2/23 @ 6
			2/16 @ 6.5	3/20 @ 5
			0/20 @ 6	2/20 @ 3
6Al - 4V	.063	Electropolished Prior to vacuum Annealing	2/45 @ 10	2/23 @ 10
			2/20 @ 9.9	1/20 @ 9.2
			0/20 @ 9.2	4/20 @ 8.7
				1/20 @ 8.3
				0/20 @ 8
5Al - 2.5Sn	.063	As Received	11/20 @ 10	12/20 @ 10
			3/20 @ 5	9/20 @ 8
			1/20 @ 3	7/20 @ 5
			1/20 @ 2	1/20 @ 2
			0/20 @ 1	0/20 @ 1
13V-11Cr-3Al	.063	As Received	15/36 @ 10	12/20 @ 10
			5/20 @ 7	5/20 @ 5
			2/20 @ 5	4/20 @ 3
			0/20 @ 3	2/20 @ 1
			0/20 @ 2	1/20 @ 0.5
5Al - 2.5Sn	.010	As Received	2/40 @ 10	6/20 @ 10
			2/20 @ 5	1/20 @ 5
			0/20 @ 4	1/20 @ 4.5
			0/20 @ 3	0/20 @ 4

with and without deburring (Table 9). In all cases, the deburring treatment slightly decreased the reaction frequency and/or raised the level of insensitivity. Typical results with the 0.063 inch thick 5Al-2.5Sn alloy are plotted for illustration in FIG 7.

Polishing. Since it was shown that deburring of samples slightly decreased the reactivity with LOX, it would be expected that

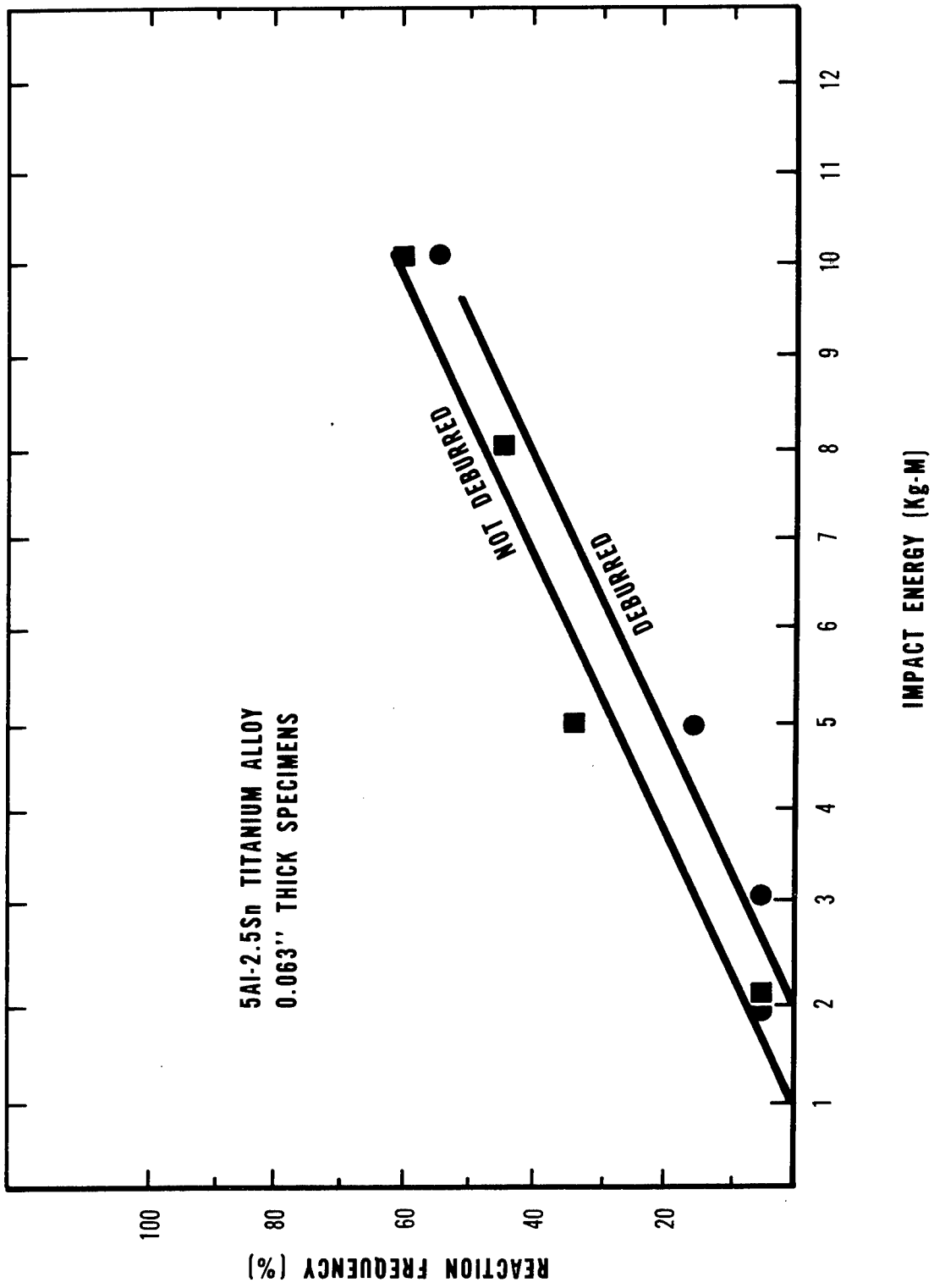

FIGURE 7. EFFECT OF DEBURRING ON LOX IMPACT SENSITIVITY

polishing of the surface would be even more beneficial. The effectiveness of hand and electropolishing were therefore investigated.

Hand polishing was done by using emery paper down to grade 4/0 on both sides and the edges. Because of the time consumed in this operation, the number of samples was held to a minimum. The comparative impact sensitivity of samples with and without hand polishing after deburring is shown in Table 10. The results indicated that polishing tended to increase the sensitivity and reaction frequency, possibly by removing much of the oxide film from the surface.

Electropolishing after deburring was accomplished at a current density of 8-11 amps/dm² for several minutes in a solution of 80 parts (by volume) ethylene glycol, 6 parts hydrofluoric acid, and 6 parts water. Tests on five sets of samples showed that the

Table 10. Effect of Hand Polishing on LOX Impact Sensitivity of Titanium Alloy 6Al - 4V

All test specimens were 5/8 inch diameter discs punched from 0.063 inch sheet stock		
Impact Energy (Kg-M)	No. Reactions/No. Tests	
	Barrel Deburred	Barrel Deburred and Hand Polished
10	7/40	3/3
8.3	1/2	
7.9	1/2	
7.2	2/3	
5	2/60	
3		1/13
2	0/20	
1		1/26

Table 11. Effect of Electropolishing on
LOX Impact Sensitivity of Titanium Alloys

Alloy	Thickness	Condition	No. Reactions/No. Tests at X Kg-M	
			Deburred	Deburred Electropolished
5Al - 2.5Sn	0.063	As Received	11/20 @ 10	15/20 @ 10
			3/20 @ 5	11/20 @ 5
			1/20 @ 3	1/20 @ 2
			1/20 @ 2	0/20 @ 1
			0/20 @ 1	
5Al - 2.5Sn	0.063	HF-HNO ₃ Pickled before, and vacuum annealed after polishing	4/20 @ 10	6/20 @ 10
			1/20 @ 8	1/3 @ 8
			3/21 @ 7	0/20 @ 5
			1/15 @ 5	
			3/21 @ 3	
			4/20 @ 2	
			1/6 @ 1	
0/14 @ 0.5				
6Al - 4V	0.063	Vacuum annealed* ¹	4/20 @ 10	2/45 @ 10
			1/20 @ 8	2/20 @ 9.8
			1/4 @ 7	0/20 @ 9
			2/16 @ 6.5	
			0/20 @ 6.0	
4Al-3Mo-IV	0.063	Vacuum Annealed* ¹	1/20 @ 10	2/21 @ 10
			4/20 @ 8	2/20 @ 9.2
			3/20 @ 6.89	3/20 @ 8.6
			2/20 @ 6.2	0/20 @ 8.3
			0/20 @ 5.23	0/20 @ 8
13V-11Cr-3Al	0.063	Vacuum annealed* ¹	2/20 @ 10	2/20 @ 10
			3/20 @ 8.3	0/20 @ 9.0
			1/20 @ 8	0/20 @ 8.0
			3/17 @ 7.3	
			0/20 @ 7	

*¹After Electropolish

reactivity under impact in LOX was not greatly different with or without electropolishing after deburring (Table 11). The reactivity of the 5Al-2.5Sn alloy samples which were not annealed was slightly increased. Electropolishing apparently lowers the sensitivity if the samples are

subsequently annealed in an inert atmosphere. In the annealing operations for these samples (as discussed separately later) the samples were allowed to cool in air, and thus formed a heavy oxide coating on the surface. This phenomena was proven by reflection electron diffraction studies. It is probable that by electropolishing prior to annealing a chemically cleaner surface was present during annealing and consequently afforded conditions for a thicker and/or more tenacious oxide film to form.

Annealing. Samples of five various titanium alloys were annealed in accordance with manufacturer's recommendations in a vacuum furnace at 705°C (1300°F) for one hour and allowed to cool in air. Impact sensitivity test results on seven sets of annealed and "as received" samples are listed in Table 12. A plot of typical results is shown in FIG 8. While annealing did not decrease the reactivity of any set to an acceptable level, i. e., maximum of one reaction in 60 trials at 10 Kg-M, significant effects resulted. In all seven cases, the insensitivity level was raised appreciably and the reaction frequency decreased markedly. As mentioned in the discussion on electropolishing, this is believed due to the formation of a more effective oxide film on the surface during the cooldown from annealing.

Effect of Pickling. Samples of four alloys were vacuum annealed to obtain uniform grain size and etched in a nitric acid-hydrofluoric acid solution to study the effect of the initial surface film on "as received" titanium (Table 13). An interesting phenomenon was noted while testing the etched samples. The violence of the reaction was greater than those detected in the "as received" condition, and the frequency of reaction increased. Furthermore, the insensitivity level was lowered. This phenomenon is exemplified by tests made on 0.063 inch thick 5Al-2.5Sn (FIG 9). The "as received" material exhibited sensitivity to 1 Kg-M impact energy. However, when the material was annealed, the insensitivity level was raised to 7.5 Kg-M. After etching, the material was still sensitive at 0.5 Kg-M. Considering that titanium should be chemically cleaned prior to welding, the etched state represents a condition which may occur easily in service applications.

Passivation. Stainless steel and aluminum alloys commonly are "passivated" to concentrated peroxide by degreasing the surface, pickling, and then exposing it to concentrated peroxide for several

Table 12. Effect of Annealing on LOX
Impact Sensitivity of Titanium Alloys

Alloy	Thickness	Condition	No. Reactions/No. Tests at X Kg-M	
			As Received	Vacuum Annealed
6Al - 4V	.063	Not Deburred	12/20 @ 10	1/20 @ 10
			7/20 @ 5	2/20 @ 8
			1/20 @ 2	2/23 @ 6
			0/20 @ 1	3/20 @ 5
				2/20 @ 3
6Al - 4V	.063	Deburred	7/40 @ 10	4/20 @ 10
			1/2 @ 8.3	1/20 @ 8
			1/2 @ 8	1/4 @ 7
			2/3 @ 7.3	2/16 @ 6.5
			2/60 @ 5	0/20 @ 6
				0/20 @ 2
4Al-3Mo-1V	.063	Deburred	2/2 @ 10	1/20 @ 10
			1/1 @ 5	4/20 @ 8
			2/5 @ 3	3/20 @ 7
			1/3 @ 2	2/20 @ 6.2
			0/9 @ 1	0/20 @ 5.2
5Al - 2.5Sn	.063	Not Deburred	12/20 @ 10	2/20 @ 10
			9/20 @ 7.2	2/18 @ 9.2
			7/20 @ 5	1/20 @ 8.3
			1/20 @ 2	1/20 @ 8
			0/20 @ 1	0/20 @ 4.5
5Al - 2.5Sn	.010	Deburred	2/40 @ 10	2/50 @ 10
			2/20 @ 5	
			0/20 @ 4	
			0/20 @ 3	
RC - 55	.063	Deburred	15/20 @ 10	3/20 @ 10
			1/20 @ 3	4/20 @ 8
			2/20 @ 2	3/20 @ 7
			0/20 @ 1	2/20 @ 6
				0/20 @ 5
13V-11Cr-3Al	.063	Deburred	15/20 @ 10	2/20 @ 10
			5/20 @ 5	3/20 @ 8.3
			0/20 @ 3	1/20 @ 8
			0/20 @ 2	3/17 @ 7.4
				0/20 @ 7

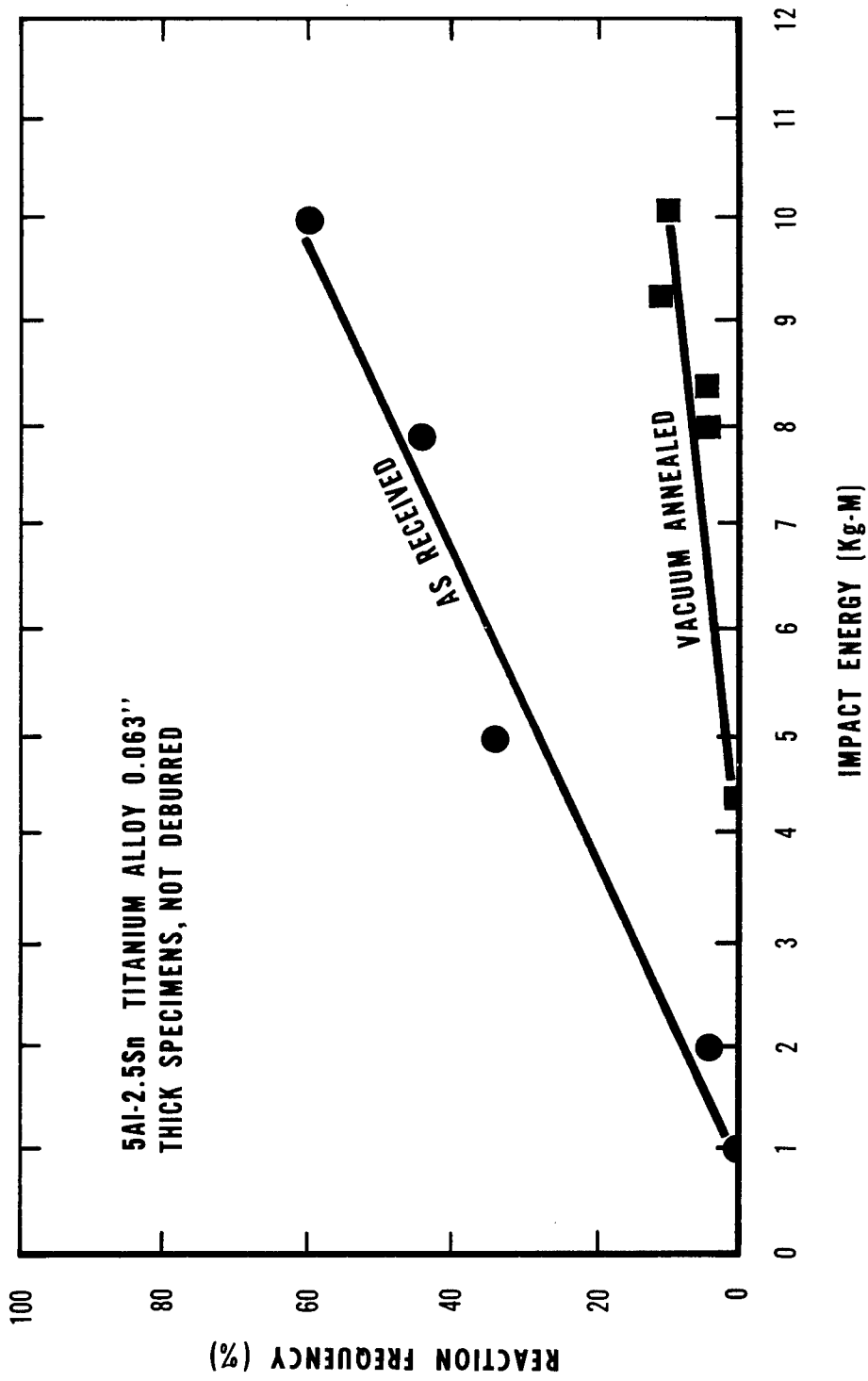

FIGURE 8. EFFECT OF VACUUM ANNEALING ON LOX IMPACT SENSITIVITY

Table 13. Effect of Pickling on LOX Sensitivity of Titanium Alloys After Vacuum Annealing

Alloy	Thickness inches	Condition	No. Reactions/No. Tests at X Kg-M		
			As Received	Vacuum Annealed Only	Pickled After Vacuum Annealing
6Al - 4V	.063	Deburred	7/40 @ 10	4/20 @ 10	8/21 @ 10
			1/2 @ 8.3	1/20 @ 8	4/20 @ 8
			1/2 @ 8	1/4 @ 7	2/20 @ 5
			2/3 @ 7.2	2/16 @ 6.5	3/20 @ 2
			2/60 @ 5	0/20 @ 6	0/20 @ 1
4Al-3Mo-1V	.063	Deburred	2/2 @ 10	1/20 @ 10	11/20 @ 10
			1/1 @ 5	4/20 @ 8	3/6 @ 9.2
			2/6 @ 3	3/20 @ 7	12/20 @ 8
			1/3 @ 2	2/20 @ 6	14/20 @ 5
			0/4 @ 1	0/20 @ 5	3/20 @ 2
Comm. Pure	.063	Deburred	15/20 @ 10	3/20 @ 10	1/3 @ 7
			1/20 @ 3	4/20 @ 8	1/3 @ 6
			2/20 @ 2	3/20 @ 7	1/5 @ 5
			0/20 @ 1	2/20 @ 6	1/4 @ 4
				0/20 @ 5	3/13 @ 3
5Al - 2.5Sn	.063	Not Deburred	12/20 @ 10	2/20 @ 10	4/20 @ 10
			9/20 @ 8	2/18 @ 9.2	3/20 @ 7.3
			7/20 @ 5	1/20 @ 8.3	1/15 @ 5
			1/20 @ 2	1/20 @ 8	3/21 @ 3
			0/20 @ 1	0/20 @ 7.2	4/20 @ 2
5Al - 2.5Sn	.010	Deburred	2/40 @ 10	2/50 @ 10	11/20 @ 10
			2/20 @ 5		4/20 @ 4
			0/20 @ 4		1/20 @ 2
			0/20 @ 3		0/20 @ 1

hours. To investigate whether such a treatment would produce a protective coating on titanium, samples of the 6Al-4V alloy were prepared in this manner. Impact sensitivity test results of untreated and "passivated" samples are shown in Table 14. The treatment increased the reactivity under these test conditions.

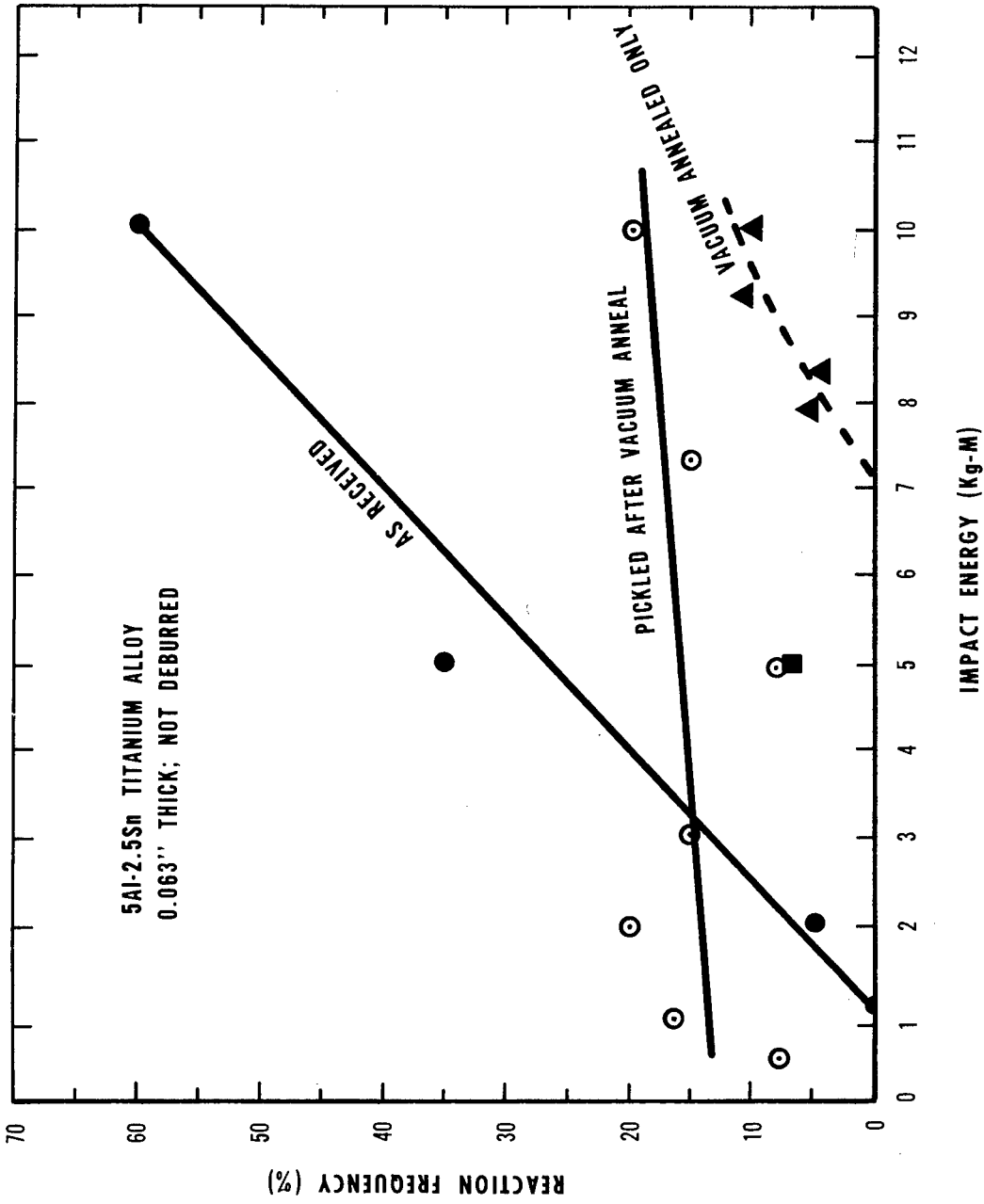

FIGURE 9. EFFECT OF PICKLING AFTER VACUUM ANNEALING

Table 14. Effect of Passivation on LOX Impact Sensitivity
 6Al-4V Titanium - 0.063 inch Thick
 Treated with 30% H₂O₂ for several hours (after degreasing and pickling)

Impact Energy (Kg-M)	Reactivity	
	Untreated No. Reactions/No. Tests	Passivated No. Reactions/No. Tests
10	7/40	1/3
5	2/60	1/5
3	1/20	1/17
2	0/20	1/8
1	-	1/2
0.5	-	0/10

In another attempt to produce a passive surface, separate sets of samples of the 5Al-2.5Sn alloy (0.063 inch thick) were treated with boiling acid and alkali and impact tested. Those samples boiled in concentrated nitric acid for 30 minutes produced 13 reactions in 20 trials at 10 Kg-M, thus exhibiting no improvement. Samples boiled in concentrated potassium hydroxide for 20 minutes were somewhat less reactive, i. e., only two fires in 20 trials at 10 Kg-M, but still were not acceptable.

I. COATINGS

Phosphate. Phosphate coating would be a comparatively simple treatment to apply to space vehicle tanks. Consequently, considerable tests were made in an attempt to find or develop a phosphate treatment capable of desensitizing titanium to an acceptable degree in the impact test. A total of 24 various phosphate coating treatments were tried. These consisted of 13 types of manganese phosphate treatments, four types of iron phosphate treatments, and seven other types. None of these reduced the impact sensitivity to an acceptable level (Table 15).

Anodizing. Three types of anodizing were tried on two titanium alloys. Details and data are provided in Table 16. None of

Table 15. Phosphate Coated Titanium (5Al-2.5Sn)
 10 Kg-M Impact Energy
 0.063 inch Thick Samples

<u>Sample Treatment</u>	<u>No. Reactions/20 Tests</u>
Manganese Phosphate - 13 various treatments and modifications tried	2-12
Iron Phosphate - 4 types of treatment	2-8
7 Other Phosphate Coatings - using NH ₄ HF ₂ , pyrophosphate, Na ₃ PO ₄ , etc. combinations	3-12

Table 16. Effect of Anodizing on LOX Impact Sensitivity of Titanium
 All samples - 0.063 inch thick

<u>5Al-2.5Sn Alloy - Results</u>			
<u>Impact Energy (Kg-M)</u>	<u>No. Reactions/No. Tests As Received</u>	<u>No. Reactions/No. Tests Chromic Acid Anodized</u>	
10	11/20	1/1	
5	3/20	1/1	
3	1/20	1/13	
2	1/20	1/8	
1	0/20	1/5	
0.5		0/13	
<u>6Al-4V Alloy - Results</u>			
<u>Impact Energy (Kg-M)</u>	<u>No. Reactions/No. Tests As Received</u>	<u>No. Reactions/No. Tests NaOH Anodized</u>	<u>No. Reactions/No. Tests Cyanide Anodized</u>
10	7/40	2/2	9/20
8.6	1/2	1/1	
8	1/2	5/17	
3	1/20		2/3
2	0/20		2/20
1			0/20

these treatments was beneficial. On the contrary, the results indicate that the material was rendered somewhat more reactive.

Nitriding. Forty 5Al-2.5Sn titanium specimens were exposed to a nitrogen atmosphere for three hours at 816°C (1500°F). Only two faint flashes were noted when all of these samples were impact sensitivity tested. It may well be that by further refinements nitriding could provide acceptable protection. However, since such a process would be quite difficult to control on large thin walled tanks and could result in embrittlement of the alloy, it was not followed up in this study.

Teflon. Because of their wide and satisfactory use in LOX systems, as well as favorable low temperature properties, it was thought that Teflon coatings might afford desensitization of titanium to impact in LOX. Three types of commercial Teflon based coatings were tried on two alloys (Table 17). Although the coatings apparently afforded some protection, the resulting sensitivity was still much higher than could be considered acceptable.

Flame Sprayed Metal. In an attempt to produce a protective coating, samples of the 6Al-4V alloy were flame sprayed with commercially pure aluminum to a thickness of 0.010 inch, the minimum thickness necessary to obtain a uniform coating by this process. The impact sensitivity of such samples was not appreciably decreased in comparison with uncoated samples. On the other hand, flame spraying with Metco 43C, an 80 percent Ni - 20 percent Cr composition afforded some protection to 5Al-2.5Sn titanium (0.063 inch thick). The reaction frequency was lowered and the insensitivity level raised from 1-2 Kg-M to 7 Kg-M. However, such a coating would be very difficult to apply to thin sheets without producing warpage, and would impose a significant weight penalty.

Ceramic Coatings. The effect of four ceramic enamel type coatings upon the impact sensitivity of titanium is shown in Table 18. None of these significantly affected the reactivity under these test conditions.

Electroplated Coatings. Electroplated coatings, one mil thick, of nickel or copper satisfactorily desensitized titanium (6Al-4V) to impact. With only 0.5 mil of copper, two minute flashes were

Table 17. Effect of Teflon Coatings on LOX Impact Sensitivity of Titanium

All samples 1 1/16 in. diam. x 0.03 in. thick
(except as noted) deburred, coated on both sides and edges

Alloy	Coating	Approximate Coating Thickness	Results					
			No. Fires/No. Trials at X Kg-M					
5A1-2.5Sn	None		<u>10Kg-M</u> 11/20	5 3/20	3 1/20	2 1/20	1 0/20	1/2
5A1-2.5Sn	DuPont Primer # 850-201 and DuPont Clear Finish # 852-202 0.010 in. thick specimen	0.8 mils	5/40	-	-	-	-	-
5A1-2.5Sn	None		28/145	-	11/100	-	-	-
5A1-2.5Sn	DuPont Primer No. 850-201 and Primer No. 852-202	0.5 mils	2/20	-	-	-	-	-
6A1-4V	None	-	7/40	2/60	-	0/20		
6A1-4V	DuPont Primer # 850-201 and Clear Finish # 852-201	1 1/2 mils	2/5	0/15				
6A1-4V	DuPont Primer # 850-202 DuPont Clear Finish #852-202 Layer of fiberglass cloth bonded in with 3 more coats of Clear Finish.	3 mils	2/2	2/6	1/1	1/9	0/20	

observed in 20 trials at 10 Kg-M, and none in 20 trials at 8 Kg-M. These coatings thus offered a solution to the impact sensitivity of titanium in LOX. However, in addition to being difficult to apply internally to large tanks, they also presented an appreciable weight penalty when applied to tanks of only 0.010 inch wall thickness.

Electroless Coatings. Electroless type coatings are much more easily applied internally to tanks than electroplated coatings. Consequently, tests were made with electroless nickel and copper coatings. Only 0.2 mil of electroless nickel was needed to desensitize 0.063 inch thick 5A1-2.5Sn titanium to impact in LOX. This required only five minutes plating time. The effect of coating thickness and

Table 18. Effect of Ceramic Coatings on LOX Impact Sensitivity of Titanium

Ti Alloy	Sample Thickness (in.)	Coating	Impact Energy (Kg-M)	Results	
				No. Reactions/No. Uncoated	No. Tries Coated
6Al-4V	0.063	Gold	10	7/40	6/47
			5	2/60	3/20
			3		0/20
			2	0/20	-
5Al-2.5Sn	0.063	Silver	10	7/40	9/20
	0.010	T-1*	10	7/40	9/42
		1 T-4*	10	4/20	13/20

* Enamel Coating Developed for Titanium at MSFC

plating time upon the reaction frequency (at 10 Kg-M) of such samples is shown in FIG 10. In order to obtain confirmation of these results, several sets of 20 samples each were tested at various thicknesses. Detailed data are provided in Table 19. A slightly thicker coating was necessary to reduce the reactivity of the 0.010 inch thick alloy (5Al-2.5Sn) to an acceptable degree. The main disadvantage to this coating was its comparatively poor adhesion. Severe flaking and/or cracking of the coatings occurred frequently on impact. As would be expected, this effect was much more pronounced with the 0.010 inch than with the 0.063 inch thick samples and probably could be overcome by heating to fuse the nickel coating. However, such treatment would affect the physical properties of the alloy and would be difficult, if not impractical, to apply to large thin walled tanks.

It was found that electroless copper coatings also could desensitize titanium to impact in LOX. A 0.25 to 0.30 mil thickness of this coating was sufficient to reduce the reaction frequency of 0.063- or 0.010-inch 5Al-2.5Sn titanium to an acceptable level (Table 20

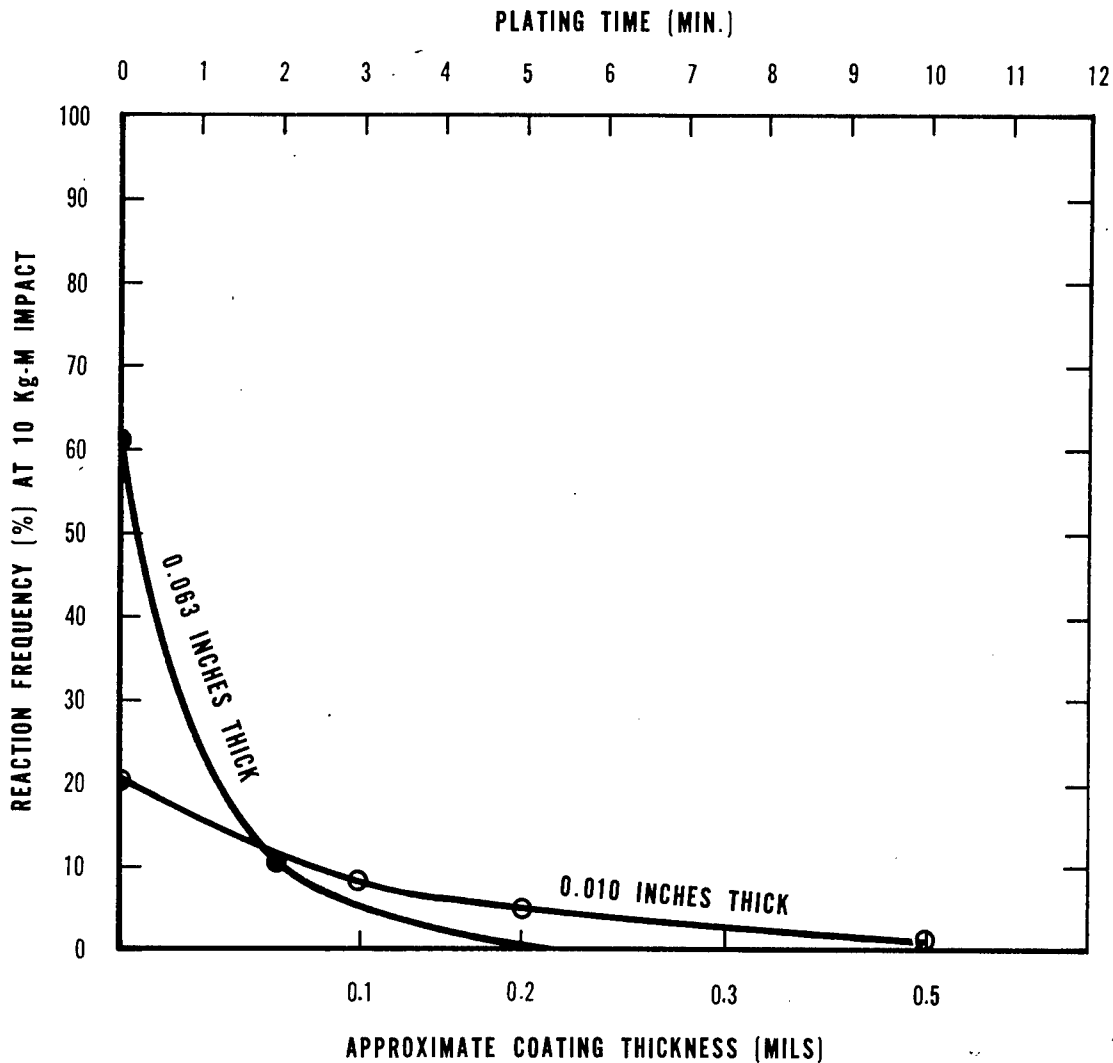

FIGURE 10. EFFECT OF ELECTROLESS NICKEL COATINGS ON LOX IMPACT SENSITIVITY OF 5Al-2.5Sn TITANIUM ALLOY

and FIG 11). There was no evidence of spalling or cracking of this coating after impact. Furthermore, in those cases where reactions occurred, only minor flashes were observed and the reaction did not propagate, the point at which reaction occurred being barely distinguishable from the remainder of the surface. The reactions

Table 19. LOX Impact Sensitivity of Electroless Nickel Plated -
5Al-2.5Sn Titanium Alloy

At 10 Kg-M Impact Energy Level				
Samples - As Received and Barrel Deburred Before Coating				
Sample Thickness (in.)	Treatment Time (min.)	Coating Thickness (mils)	No. Reactions/No. Tests	% Reactions
0.063	0	0	12/20	60
	2	<0.1	2/20	10
	3	0.1	2/80	2.5
	5	0.2	0/40	0
	10	0.4	0/80	0
0.010	0	0	28/145	19
	2	<0.1	2/20	10
	3	0.1	7/100	7.0
	5	0.2	4/130	3.0
	10	0.4	1/108	0.9

Table 20. LOX Impact Sensitivity of Electroless Copper Coated -
5Al-2.5Sn Ti-Alloy

All samples barrel deburred before coating by Shipley Process and tested at 10 Kg-M impact level				
Sample Thickness (in.)	Treatment Time (min.)	Coating Thickness (mils)	No. Reactions/No. Tests	% Reactions
0.063	0	0	12/20	60
	20	0.05	25/80	31.3
	60	0.1	7/60	11.7
	120	0.25 to .30	1/60	1.6
0.010	0	0	28/145	19
	20	0.05	4/60	6.7
	25	0.05	2/20	10
	50	<.1	1/20	5
	65	0.1	3/80	3.7
	80	>.1	3/100	3.03
	120	0.25 -0.3	1/60	1.6

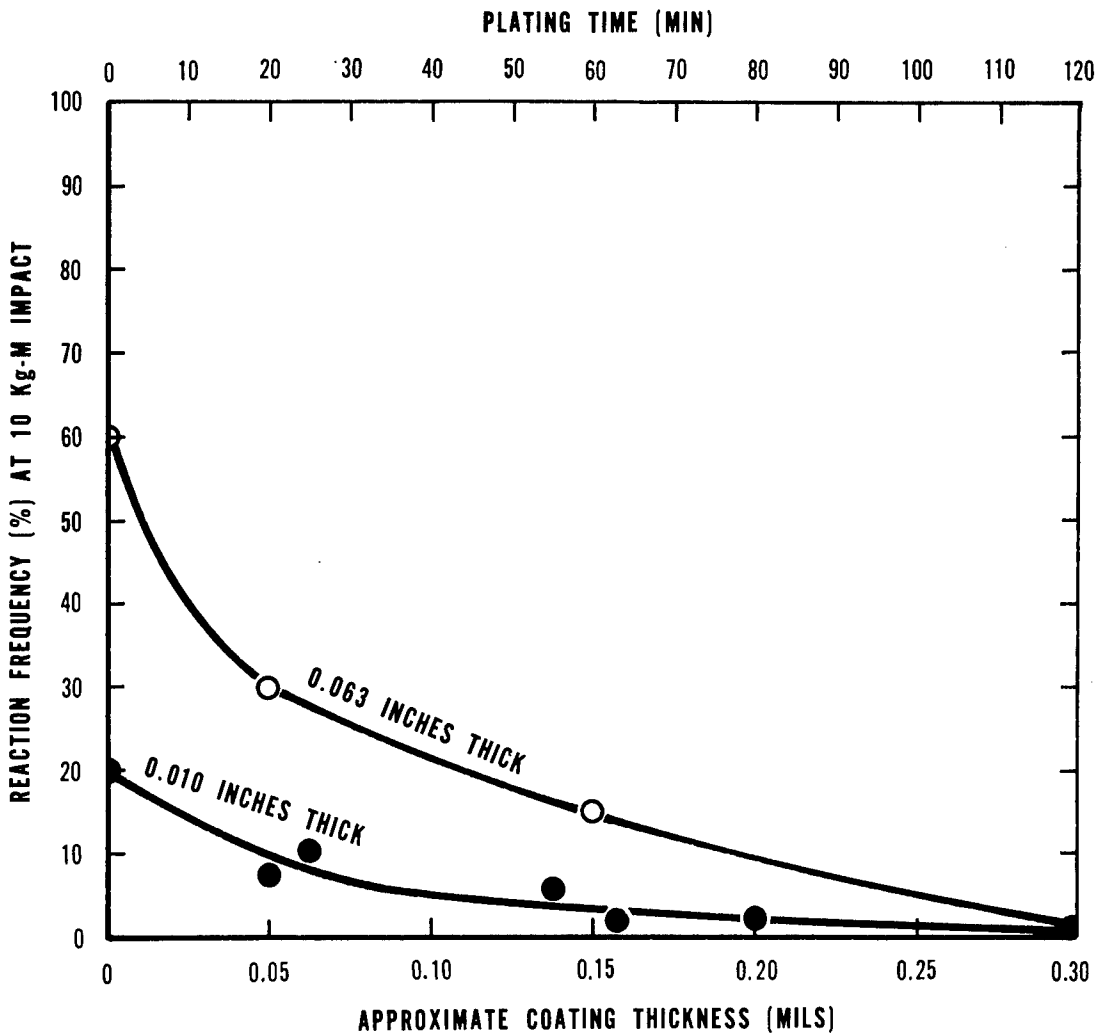

FIGURE 11. EFFECT OF ELECTROLESS COPPER COATINGS ON LOX IMPACT SENSITIVITY OF 5Al-2.5Sn TITANIUM ALLOY

occurring with the nickel coated samples were comparatively more violent than that with the copper coating and the reaction zone frequently propagated and consumed an appreciable portion of the test sample. The copper coating process requires considerably more time (two hours) than that of the nickel (5-10 minutes). However,

this could be advantageous in that it would allow better process control during internal application to large tanks.

The effectiveness of these coatings also was confirmed by repetitive impacting. Individual samples with and without the coating were subjected to repeated impacts at a very low energy level, i. e. , 1 Kg-M, until a reaction occurred. The average number of impacts to accomplish a reaction was very greatly increased by the coatings (Table 21).

J. SUMMARY FOR SECTION III

Although occasional variations may occur, the influence of a number of factors on the impact sensitivity of titanium in LOX, and consequently, on the reactivity of titanium and oxygen may be inferred from the preceding test results. These are summarized as follows:

Neutral (Or No Significant Effect)	Beneficial (Degreased Reactivity)
Nature of Mating Surfaces	Electroless Copper Coating (0.2 - 0.3 mil)
Various Alloys	Electroless Nickel Coating (0.2 - 0.3 mil)
Weldments	Electroplated Copper or Nickel (1 mil)
Electropolishing	Deburring
Hand Polishing	Annealing (Oxide Coating)
Phosphate Coatings	Nitride Coating
Anodized Coatings	Teflon Coatings
Ceramic Coatings	
	Detrimental (Increased Reactivity)
	Grit
	Pickling
	Passivation
	(Increasing Thickness)

Table 21. Effect of Repetitive Impacts on Electroless Coated Specimens

All Tests by Repetitive Impacting at 7.1 Kg-M Impact on 5Al-2.5Sn Titanium				
Sample Thickness (in.)	Sample Condition	No. of Drop That Fired	Range	Average
0.063	No Coating	2, 2, 3, 3, 3, 2, 3, 3, 2	2-3	3rd
	Electroless Cu (90 min.) 0.2 mil	Over 55, Over 55, 9, 37, 36	9-over 55	Over 38
0.010	No Coating	5, 5, 8, 3, 5, 11, 7, 5, 5, 5	3-11	6th
	Electroless Ni 0.4 mil	4, 8, 16 16, 29, 62	4-62	23rd
	Electroless Cu (90 min.) >0.1 mil	11, 26, 27, 46	11-46	28th

SECTION IV. SHOCK SENSITIVITY OF TITANIUM IN CONTACT WITH LIQUID AND GASEOUS OXYGEN

The results of the extensive investigations of the LOX-impact sensitivity of titanium alloys might appear to constitute overwhelming evidence for rejection of titanium for the suggested application. However, it has been argued that this method of testing fails to duplicate conditions to which a flight or test vehicle would be subjected and the results are therefore of questionable applicability. Although it is recognized that this same argument could be applied to many of the traditionally accepted methods of materials testing, the mission payload gain possible by use of titanium was sufficiently attractive that it was decided to conduct additional investigations using several methods of testing prior to reaching a final conclusion.

One of the supplementary methods selected for testing was determination of the sensitivity of the titanium/oxygen system to initiation by shock stimuli. Although the question of duplication of flight or test conditions again arises, the two factors tend to support the relevancy of the test method for the suggested application:

1. Vehicles may be subjected to shocks resulting from engine ignition and/or rough combustion; explosive bolts, valves, and similar devices; explosion of gaseous propellants leaking from valves, flanges, and other locations; and aerodynamic phenomena.

2. Shock testing is probably the most widely accepted method for determining the relative sensitivity to detonation of solid propellants.

The following sections describe the apparatus and procedures developed for this investigation and present results obtained for titanium/oxygen and for several reference systems.

A. PRELIMINARY CONSIDERATIONS

A survey of the literature yielded little information of direct value since no reference was found to studies of two phase mixtures having a relatively limited interface for reaction.

In general, information derived from sensitivity tests on a particular system must be compared with similar information for selected reference systems to be useful. For the current application, extensive experience using aluminum and stainless steel for constructing vehicle LOX tanks virtually dictated selection of aluminum/oxygen and stainless steel/oxygen systems for reference purposes; obviously any system found to be equally safe would be considered acceptable.

To obtain an indication of the relative ranges of response for titanium/LOX and aluminum/LOX, preliminary tests were carried out by placing strips of titanium or aluminum into stainless steel cups filled with LOX and detonating a short length of Primacord taped to the outside of the cup. The results indicated that the titanium/LOX/reaction was very easy to initiate whereas aluminum/LOX was very difficult, the difference being large enough to indicate that relatively crude methods of testing would permit valid comparisons of results. Furthermore,

the exigency of the program and lack of electronic instrumentation for measuring detonation characteristics precluded development of a sophisticated test method.

B. TEST PROCEDURES AND RESULTS

On the basis of the preliminary results mentioned above, three methods of testing were devised employing the donor-acceptor technique. The first method involved variable donors with fixed donor-acceptor spacing and the other two involved fixed donors with variable spacing. The three methods are illustrated graphically in FIG 12.

Of the various features common to the three test methods, two may be noted at this point. First, whenever feasible, both the samples and test containers were alkaline cleaned and vapor degreased prior to testing. Second, the Bruceton method of sensitivity testing was used whenever the range of applicable stimuli and detectable responses permitted. By this procedure, an initial sample is exposed to a given stimulus level and the response noted. If a reaction (flash or explosion) occurs, a second sample is subjected to a stimulus one increment smaller than the first. If on the other hand the first sample fails to react, the second sample is subjected to a stimulus one increment larger than the first. The sequence is continued in this manner, each sample being subjected to a stimulus one increment larger or smaller than the previous depending on the previous response, until the scheduled number of tests have been completed. All calculations are carried out by established procedures which have been described by previous investigators (ref. 15).

Although in a strict sense the acceptor consists of those portions of both the metal and medium (oxygen) in contact at the interface, for convenience, the metal or other solid reference material is generally referred to as the acceptor. The 5Al-2.5Sn alloy was used in all tests involving titanium acceptors.

Method I - Variable Donor. This method provides an indication of the sensitivity of a given acceptor to variations in the size of the donor charge for a fixed donor-acceptor spacing (FIG 12A). The container for the acceptor and medium was a 1-1/2-inch diameter X 18-inch X 0.035-inch stainless steel (type 304) tube with a 1/8-inch stainless steel welded to it for a bottom. The acceptor consisted of

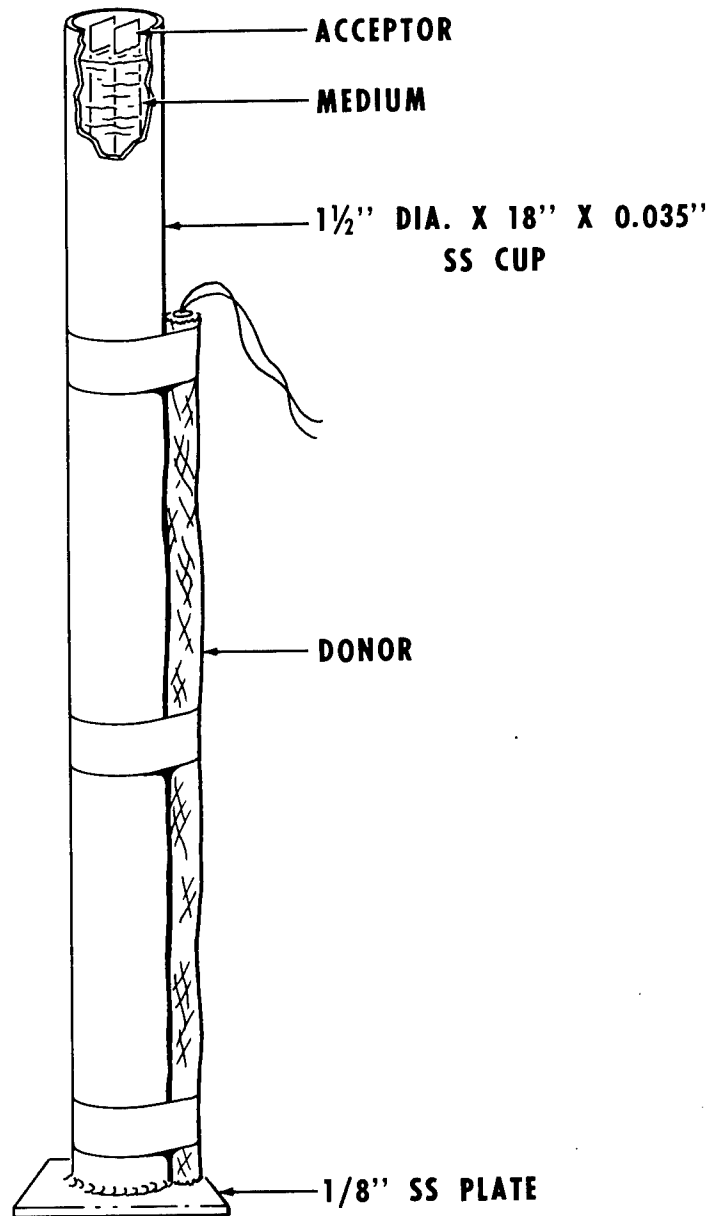

FIGURE 12A. SHOCK SENSITIVITY TEST METHOD NO. 1.

two 1-inch X 18-inch strips of the material to be tested fastened together with small welded spacers of the same material so that their 1-inch X 18-inch faces were parallel and separated from each other by approximately 1/2 inch. The donor, either a length of Primacord with an M36A1 detonator, or an M36A1 detonator alone, was taped to the outside of the tube. The donor was varied by changing the length of the Primacord (up to 12 inches) or by using Primacord of various sizes (50 to 400 gr/ft). No attempt was made to hold the acceptor fixed in the tube so there was a slight random variation in the donor-acceptor spacing, the mean being approximately 1/4 inch which includes the 0.035-inch stainless steel tube wall.

This method was more adaptable than the other two and therefore was applied to the largest number of different acceptors. Test results are summarized in Table 22.

a. Titanium. Titanium alloy was used as the acceptor for these tests. The sensitivity was such that the only size of Primacord usable for a donor was 40 gr/ft, the smallest size which would propagate reliably in the test configurations used. By varying the length of the Primacord in increments of approximately 1 inch, the average stimulus for each of the three thicknesses tested (0.063, 0.035, and 0.010 inch) was found to be very close to one detonator (zero inch of Primacord) when either LOX or GOX was used as the medium.

A few tests were made to insure that the observed sensitivity did not result from the welding of the spacers to the strips by substituting Teflon spacers with mechanical fasteners. The results (not included) did not differ significantly from those for the welded spacers.

Visual observation indicated that in some instances the reaction took place in the form of an explosion immediately upon initiation of the donor charge. In other instances, the reaction appeared to take place as an initial burning which lasted roughly one second followed by an explosion. Inspection of the titanium strips after reaction had ceased indicated that burning had proceeded uniformly over most or all of the surface, the corresponding decrease in thickness usually amounting to roughly 0.01 inch. For the 0.010-inch thick samples, very little titanium was recovered from those tests in which a reaction occurred.

Table 22. Summary of Shock Sensitivity Results Obtained by Method I

Material	Acceptor* ¹		Number of Tests	Average Stimulus (Donor)* ²	Primacord		Standard Deviation	
	Thickness, Inches	Medium			Detonator	Inches	gr/ft	% of Average Individual
Ti 5A1-2.5Sn	0.063	LOX	12	M36A1	0.84	40	14	7
Ti 5A1-2.5Sn	0.035	LOX	18	M36A1* ³	0	-		
Ti 5A1-2.5Sn	0.010	LOX	5	M36A1* ³	0	-		
Ti 5A1-2.5Sn	0.063	GOX	10	M36A1* ³	1.5	40		
Ti 5A1-2.5Sn	0.010	GOX	5	M36A1* ³	0	-		
Al 5052-H34	0.063	LOX	9	M36A1	12	238	27	17
Al 5052-H34	0.035	LOX	7	M36A1	12	224	31	24
Al 5052-H34	0.063	GOX	6	M36A1* ³	12	283		
Al 5052-H34	0.035	GOX	7	M36A1	12	224	33	28
Stainless Steel - 301	0.035	LOX	4	M36A1* ³	>>12	400		
Allpax # 500	0.063	LOX	4	M36A1* ³	>12	400		
Johns Manville # 76	0.063	LOX	4	M36A1* ³	>12	400		
Mg-HK31XA-H-24	0.063	LOX	10	M36A1	12	189	35	18
200 gr/ft Primacord	*1	Water	11	M36A1* ³	12	400		
400 gr/ft Primacord	*1	Water	7	M36A1* ³	12	283		
Ti, Cu Plated	0.010	LOX	8	M36A1	12	100	37	20
Ti, Ni Plated	0.010	LOX	10	M36A1	12	84	29	15

*1 For these tests, all acceptors consisted of 1 x 18 inch strips of material of the given thickness except for the Primacord acceptors which were rod shaped lengths 18-inches long with diameters of 0.3 and 0.4 inch respectively for the 200 and 400 gr/ft sizes.

*2 This refers to the stimulus (donor) required for 50 percent reaction, i. e., a 50-50 probability of occurrence.

*3 Estimated - procedure did not follow Bruceton method.

b. Aluminum. Aluminum alloy (5052 H34) was used as the acceptor for these tests, the donor being a 12-inch length of Primacord (plus one M36A1 detonator) in each instance. The size of the donor charge was varied in equal logarithmic increments using 50, 100, 200, and 400 gr/ft sizes of Primacord. By proceeding in this manner, the average stimulus for each of the thicknesses tested (0.063- and 0.035-inch) was found to be close to 250 gr/ft Primacord in 12-inch lengths when either LOX or GOX was used as the medium. Visual observations indicated that the reactions were similar to those for titanium except that no initial delays were noted and burning did not proceed uniformly over the surface, appearing instead to be confined to certain areas or puddles.

c. Stainless Steel. Because the test containers were made of type 304 stainless steel, each test, in effect, involved a potential acceptor of this material. Observation of the containers recovered from the various tests yielded no evidence of reaction of the container material except in those instances when titanium also reacted. For these tests, it appeared that the heat liberated by the burning titanium was so great that it caused some burning to the stainless steel. To confirm the conclusions based on observations of the test containers, a few tests were made using 1-inch X 18-inch strips of 0.035-inch thick stainless steel with two 12-inch lengths of 400 gr/ft Primacord taped to the container as the donor. Also, in one instance, the two lengths of Primacord were placed inside the container with the strips. Although the test strips were torn and badly distorted, no evidence of reaction was noted and it was concluded that the required stimulus was very much greater than 12 inches of 400 gr/ft Primacord.

d. Gasket Materials. To obtain comparisons with other materials individually qualified for LOX service by impact testing, three tests each were made using Allpax No. 500 and Johns Manville No. 76 gasket materials (both 1/16-inch thick and pre-impregnated with a fluorocarbon oil) with a 12-inch length of 400 gr/ft Primacord donor. Once a trace reaction was noted for one sample of Johns Manville No. 76. It was therefore concluded that the average stimulus necessary for initiation was much greater than 12 inches of 400 gr/ft Primacord.

e. Magnesium. This material was selected for testing because its well-known property of burning in air indicated a relatively high reactivity with oxygen. A magnesium thorium alloy (HK31XA-H24)

was tested at 0.063-inch thickness in LOX. The results indicated that an average stimulus of 12 inches of approximately 200 gr/ft Primacord was necessary, which is intermediate between those for titanium and aluminum.

f. Primacord. Because of the much greater sensitivity of titanium than that of the reference materials discussed above, it was considered desirable to obtain a comparison with a conventional explosive. Primacord was selected because of its availability, and common usage in destruct systems of flight vehicles.

Because PETN, the explosive ingredient of Primacord, is approximately oxygen-balanced, there was no need to use LOX, so water was selected as the medium. In carrying out the tests, 18-inch lengths of 200 and 400 gr/ft Primacord were taped to lengths of 1/8-inch welding rod fitted with spacers at the top and bottom to approximately center the test material in the container. The donor charges, consisting of 12-inch lengths of Primacord, were taped to the outside of the tube and initiated in the usual manner. The results indicated average donor sizes of approximately 400 and 300 gr/ft Primacord (in 12-inch lengths) respectively for the 200 and 400 gr/ft Primacord acceptors. The greater sensitivity of the 400 gr/ft Primacord may be partly due to its greater diameter which resulted in a smaller donor-acceptor spacing.

In any event, the average stimulus did not differ markedly from that for the aluminum/LOX system which confirms the safe handling characteristics of this explosive.

g. Copper and Nickel Plated Titanium. As with the impact investigations discussed previously, consideration was given to the possibility of alleviating the sensitivity problem by plating to eliminate the titanium/LOX interface, the plating material being copper or nickel for which the resulting interfaces are insensitive to impact in LOX. Accordingly, electroless procedures were used to plate 1-inch \times 18-inch \times 0.010-inch titanium strips from the same alloy as used previously. The pair of strips constituting an acceptor were held by Teflon spacers to preclude damage to the coatings by welding. The results indicated that the average stimulus was increased from approximately one detonator to 12 inches of 100 gr/ft and 12 inches of 84 gr/ft Primacord (each with a detonator) respectively for the

copper and nickel plated samples. Although these increases are appreciable, the average stimuli are still less than those required for aluminum.

h. Blank Tests. To indicate the effects of various donor charges on the structural integrity of the test containers, each sample for which no reaction occurred was visually inspected. Also, blank tests were made in which LOX was used alone with the various acceptor materials excluded, or for which LN₂ was substituted for LOX with the various acceptor materials being included.

These tests indicated that a single detonator made only a small dent, sometimes accompanied by a 1/8-inch tear in the tube wall, the titanium or other reference material not being visibly affected.

Similar tests with 12 inches of 100 to 400 gr/ft Primacord yielded containers that were dented the length of the Primacord, the depth of the indentation varying with the size of the donor. For the 100 gr/ft Primacord, the indentation was slight and the test strips were not visibly affected. For the 400 gr/ft Primacord, the indentation was marked, and the test strips were bent such that they were not easily removed from the tubes. In some instances, small tears or cracks, usually 1 to 2 inches long, were noted in the sides of the tube.

i. Summary of Results Obtained with Method I. The following is a listing of the results using this test method on various materials in order of increasing stimuli required for initiation:

Material Tested	Approximate Size of Primacord Needed for Ignition, gr/ft
Titanium	0*
Cu or Ni Plated Titanium	100
Magnesium	200
Aluminum	250
400 gr/ft Primacord	300
200 gr/ft Primacord	400
Fluorocarbon Impregnated Gaskets	>400
Stainless Steel	>>400

*Detonator alone.

Method II - Variable Spacing. Method II employed the same container and acceptor configurations as Method I but the purpose in this case was to obtain the acceptor sensitivity as a function of the donor-acceptor spacing (FIG 12B). The donor, either 2 inches of 400 gr/ft Primacord with an M36Al detonator or the detonator alone, was held in a stainless steel cannon below the bottom of the container. The spacing thus included the 1/8 inch stainless steel plate which formed the bottom of the containers. The cannon used with Primacord was simply a 5/8 inch diameter \times 2-1/2 inch hole drilled in one face of a 6-inch diameter \times 3-1/2 inch stainless steel block. A 3/16-inch diameter hole was drilled through to the other face from the bottom of the 5/8-inch diameter hole to enable wiring to be brought to the detonator. The cannon used with the detonator alone was similar except that the face of the detonator was held flush with the face of the cannon.

Acceptors tested with this method were titanium, aluminum, and Primacord from the same stock used for Method I. Data from the Method II tests are listed in Table 23.

a. Titanium. Titanium was tested only in LOX by this method. A 2-inch length of 400 gr/ft Primacord with an M36Al detonator was used with 0.063-inch acceptors, and an M36Al detonator alone was used with the 0.010-inch strip acceptors. An average spacing of 2.75 inches was determined for the Primacord donor, and a value of 0.23 inch for the detonator alone.

b. Aluminum. Aluminum (5052-H34) acceptors were tested in both LOX and GOX, 0.063-inch strips in LOX and 0.035-inch strips in GOX. The donor in each case was 2 inches of 400 gr/ft Primacord with an M36Al detonator. The mean spacings observed were 0.48 inch for LOX and 0.16 inch for GOX.

c. Primacord. A 3-inch length of 400 gr/ft Primacord was used as the acceptor and a 2-inch length of 400 gr/ft Primacord was the donor. Both air and water were used for the medium. The acceptor was held against the bottom plate inside the cup and the donor was placed flush against the bottom plate on the outside. Ten tests were conducted with no reaction of the Primacord acceptors being noted. Thus, the 1/8-inch stainless steel plate served as a sufficient gap to preclude initiation.

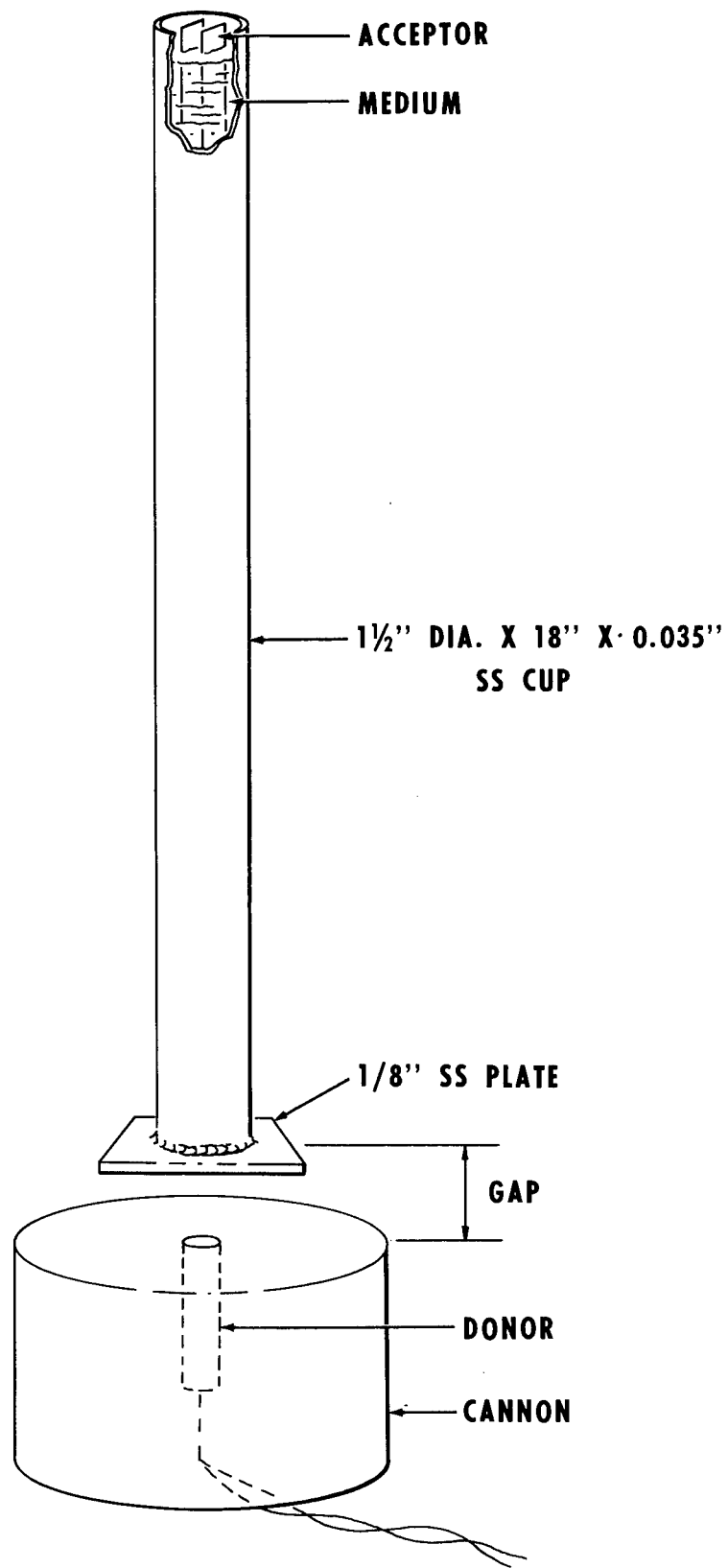

FIGURE 12B. SHOCK SENSITIVITY TEST METHOD NO. 2.

d. Stainless Steel. Although no specific tests were made with stainless steel acceptors, as with the previous method, the test container was made of type 304 stainless steel. In no instance was any indication of reaction of the container material with LOX observed except when a reaction with titanium also occurred. As noted for Method I, the heat generated by the titanium/LOX reaction appeared to be sufficient to cause some burning of the container.

e. Blank Tests. With this method, no instance of penetration of the test container was noted. However, in a few instances with the Primacord donor and a very small spacing, the bottom of the container was distorted sufficiently that the weld fastening the plate to the tube was split. The detonator donor caused only a perceptible dent in the plate even with zero spacing.

Method III - Variable Spacing. A different configuration was used for Method III (FIG 12C). The purpose in this case was to obtain an estimate of sensitivity as a function of the donor-acceptor spacing as in Method II but without the 1/8 inch stainless steel plate included in the spacing. A sheet of the material of interest formed the bottom

Table 23. Summary of Shock Sensitivity Results Obtained by Method II

Acceptor *1		Medium	Number of Tests	Donor		Average Stimulus*2 (gap) Inches	Standard Deviation % of Average *3 Individual Average		
Material	Thickness, Inches			Detonator	Primacord Inches gr/ft				
Ti 5Al-2.5Sn	0.063	LOX	10	M36A1	2	400	2.88	13	6
Ti 5Al-2.5Sn	0.010	LOX	13	M36A1	0	-	0.36*4		
Al 5052-H34	0.035	LOX	11	M36A1	2	400	0.61	23	12
Al 5052-H34	0.035	GOX	10	M36A1	2	400	0.46	25	11
400 gr/ft Primacord	*1	Air	5	M36A1	0	-	<0.13*4		
400 gr/ft Primacord	*1	Water	5	M36A1	0	-	<0.13*4		

*1 For these tests, all acceptors consisted of 1 x 18 inch strips of material of the given thickness except for the Primacord acceptors which were rod shaped lengths 3 inches long with a diameter of 0.4 inch.

*2 This refers to the stimulus (gap) required for 50 percent reaction, i. e., a 50-50 probability of occurrence. A 1/8-inch thickness of stainless steel plate is included in each gap; the remainder being air.

*3 Calculations for percentages are based on that portion of the average total gap which is air.

*4 Estimated - procedure did not follow Bruceton method.

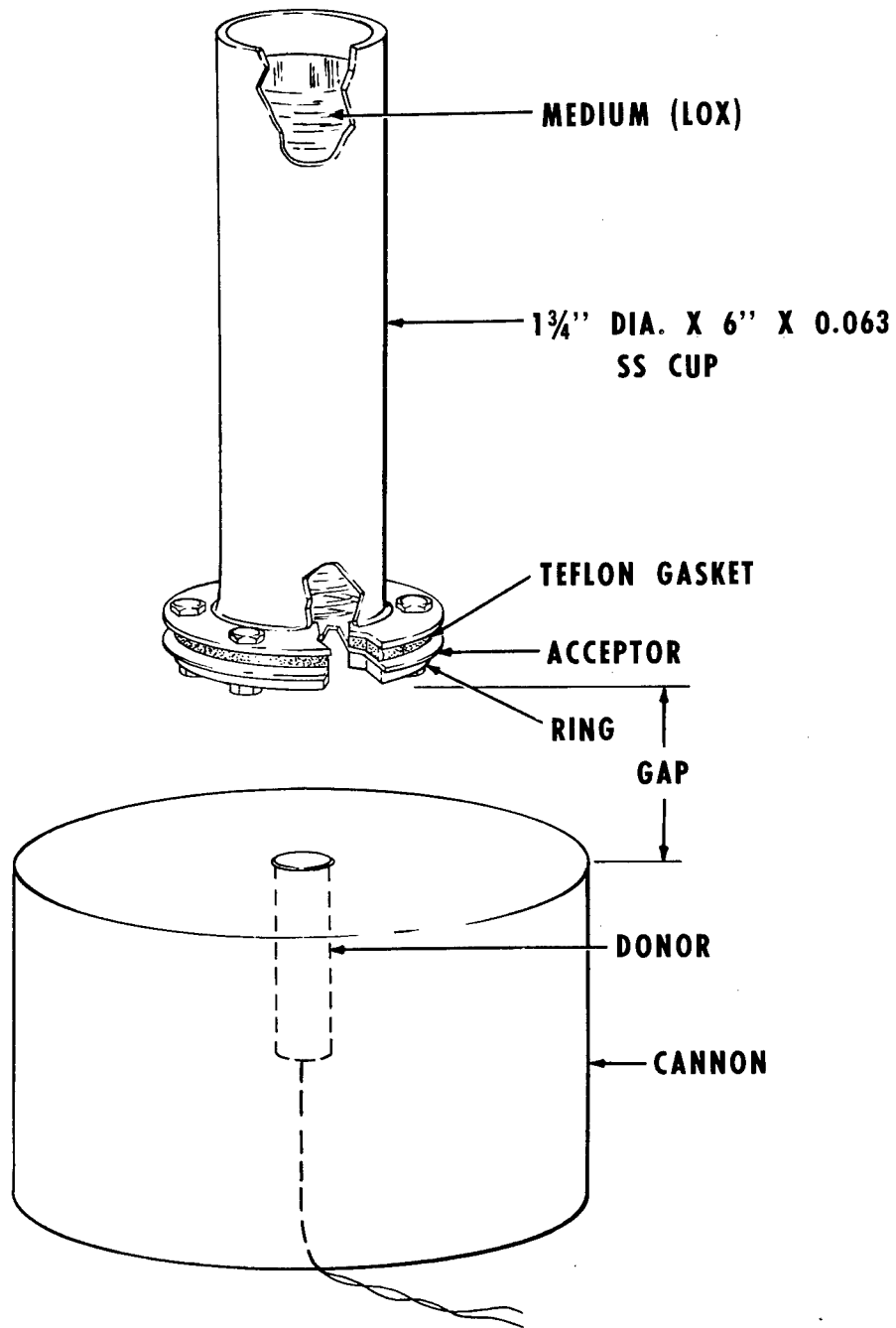

FIGURE 12C. SHOCK SENSITIVITY TEST METHOD NO. 3.

of the container resulting in the acceptor-medium interface being removed from the donor at zero gap only by the thickness of the acceptor itself. A 1-3/4 inch O.D. × 6 inch × 0.063 inch stainless steel tube formed the wall of the container. As in Method II, the donors were held in stainless steel cannons.

With this configuration, the acceptors subjected to test were titanium, aluminum, Primacord, copper plated titanium, and nickel plated titanium. In the series with Primacord, the container itself was eliminated and the donor and acceptor were held at the desired spacing by a slightly different arrangement. Test results obtained by this method are given in Table 24.

a. Titanium. Titanium acceptors of 0.063-inch and 0.032-inch thickness were tested with LOX and GOX, and 0.010-inch acceptors with LOX only. Donors were 2 inches of 400 gr/ft Primacord with an M36A1 detonator except for one series with 0.063-inch material in which the detonator alone was used. Several series of tests were made with 0.063-inch titanium/LOX and the results demonstrated the reproducibility of this method of testing. The mean spacings obtained for the three series were 2.92, 2.50, and 3.00 inches. Series of tests employing the other thicknesses of titanium also gave results in this range.

b. Aluminum. Aluminum acceptors of thicknesses of 0.063 and 0.032 inch were tested with the lesser thickness being tested only with LOX, the larger with both LOX and GOX. Results with these acceptors gave mean gaps of 0.95 inch for 0.063-inch aluminum/LOX, 2.10 inches for 0.032-inch aluminum/LOX, and 1.37 inches for 0.063-inch aluminum/GOX. Thus aluminum is significantly less sensitive than titanium with this test configuration.

c. Primacord. One series of tests was made with a Primacord acceptor in air. As indicated before, the container was eliminated and the Primacord acceptor was held at the desired spacing by taping it to a welding rod positioned vertically immediately above the cannon holding the donor. The resulting mean gap was 1.55 inches which is in the range of values determined for aluminum/LOX, and corresponds to a much greater stimulus than that required for titanium/LOX.

Table 24. Summary of Shock Sensitivity Results Obtained by Method III

Acceptor *1		Medium	Number of Tests	Donor			Average Stimulus *2 (gap) Inches	Standard Deviation, % of Average	
Material	Thickness, Inches			Detonator	Inches	Primacord gr/ft		Individual	Average
Ti 5A1-2.5Sn	0.063	LOX	10	M36A1	0	-	1.55	35	15
Ti 5A1-2.5Sn	0.063	LOX	6	M36A1	2	400	2.92 *3		
Ti 5A1-2.5Sn	0.063	LOX	4	M36A1	12	400	3.00	16	13
Ti 5A1-2.5Sn	0.063	LOX	10	M36A1	12	400	2.50	9	6
Ti 5A1-2.5Sn	0.032	LOX	18	M36A1	12	400	2.44	25	9
Ti 5A1-2.5Sn	0.010	LOX	12	M36A1	12	400	3.90	45	17
Ti 5A1-2.5Sn	0.063	GOX	11	M36A1	12	400	2.13	65	33
Ti 5A1-2.5Sn	0.032	GOX	9	M36A1	12	400	2.75	16	18
Al 5052-H34	0.063	LOX	10	M36A1	12	400	0.95	23	13
Al 5052-H34	0.032	LOX	11	M36A1	12	400	2.10	21	11
Al 5052-H34	0.063	GOX	7	M36A1	12	400	1.37 *3		
400 gr/ft Primacord	*1	Air	14	M36A1	12	400	1.55	43	15
Ti, Ni Plated	0.010	LOX	11	M36A1	12	400	2.50 *3		
Ti, Cu Plated	0.010	LOX	5	M36A1	12	400	2.50 *3		

*1 For these tests, all acceptors consisted of 1.9 inch diameter discs of the given thickness except for the Primacord acceptor which consisted of a 6-inch length of Primacord in the arrangement described in the text.

*2 This refers to the stimulus (gap) required for 50 percent reaction, i. e., a 50-50 probability of occurrence.

*3 Estimated - procedure did not follow Bruceton method.

d. Blank Tests. Blank tests with the detonator donor indicated that small fragments (up to approximately 200 u) from the aluminum detonator case tended to penetrate the thinner diaphragms (0.010 to 0.035 inch). Also, the Primacord donor produced some fragments from the cannon which behaved similarly, although not to such a marked extent. The results with this configuration therefore are considered less reliable than those obtained with Methods I and II, since ignition may have been associated with penetration rather than shock.

e. Copper and Nickel Plated Titanium. Titanium discs having a thickness of 0.010 inch were plated with 0.2- to 0.3-mil thicknesses of copper and titanium by an electroless procedure and tested as acceptors with LOX. The average response for each coating was approximately the same as that determined for the uncoated titanium. The contrast between results obtained by this method and those reported earlier for Method II are consistent with the observation that penetration by fragments occurred frequently with Method III. Thus, sensitivity to any mode of ignition for which penetration of the metal is involved would not be greatly affected by coatings. However, it was noted that with the coated samples burning was not as extensive, suggesting that the coatings effected some decrease in the tendency to propagate under these conditions.

C. SUMMARY FOR SECTION IV

Taken together, these data indicate that titanium in either LOX or GOX requires a much smaller stimulus for shock initiation than any of the reference systems selected for testing. Whereas plating with either copper or nickel tends to reduce the sensitivity of titanium, this technique is not effective when the initiating stimulus causes penetration of the protective plating. Even when the plating is not penetrated, the sensitivity of the plated metal is greater than that for aluminum. The relative order of shock sensitivity of the various materials tested is shown below in decreasing order of sensitivity based on results by all three test methods (where applicable):

Titanium >> nickel plated titanium \approx copper plated titanium > magnesium > aluminum > Primacord > fluorocarbon impregnated gasket material or stainless steel.

These data indicate that any use of titanium in contact with either liquid or gaseous oxygen tends to decrease the safety and reliability of the vehicle to an extent dependent on the nature and severity of forces to which the vehicle is subjected during testing and flight.

SECTION V. EFFECT OF CONDITIONS ASSOCIATED WITH SPACE VEHICLES

As mentioned before, impact sensitivity testing is the most widely accepted method for evaluating the compatibility of materials for LOX service. As such, it is undoubtedly a valuable, and usually the only, "screening" type of test which can be rather simply applied to a wide variety and large number of materials. It is an empirical and not an absolute test.

In order to fully assess the compatibility of a material with LOX on an absolute basis, it would have to be tested under all of the exact conditions to which it may be exposed in service applications. For space vehicles, the ultimate tests would be successful use in the particular LOX service intended in a statistically meaningful number of flights. Obviously this would not be an economical or feasible method of testing new materials.

Although all of the conditions associated with flight cannot be duplicated exactly in ground testing, many can be partially or closely simulated. Furthermore, those conditions to which vehicles may be exposed in test stand operations and/or ground handling can be fairly well duplicated when desired.

Consequently, titanium in contact with oxygen was tested under a wide variety of conditions associated with space vehicles. Test specimens included coupons, discs, and in view of the application intended, small model tanks pressurized with LOX.

A. IMPACTS

Referring again to FIG 3, it is seen that in the standard impact sensitivity test, the striker pin face rests directly on the sample, and both are submerged in LOX. There will almost certainly be a thin, and probably discontinuous, film of LOX between the two faces. Because of natural microprojections occurring on both

surfaces, localized microscopic point contacts exist between the pin face and sample. It is suspected that the mechanism of reaction in this test is such that when impact occurs, high local temperatures are generated at these contact points. Furthermore, because the mating faces are being driven together, some of the LOX (or GOX) entrapped therein will be subjected to adiabatic compression. The combination of heat (from both friction and adiabatic compression) as well as probable exposure of fresh surfaces at these micro contact points may initiate a reaction between the sample and oxygen. In any case, whether or not a reaction is evidenced by a flash, an audible report, and/or charring of the sample, is dependent upon the degree of propagation of the reaction. Propagation is favored by an increased degree of chemical reactivity. Thus, the comparative degree of chemical reactivity of materials with oxygen can be inferred by impact sensitivity testing.

While it is apparent that the comparative degree of reactivity of materials with LOX may be inferred from impact sensitivity tests, such test conditions do not, and cannot, represent the gamut of those which are associated with space vehicles. Conditions which most nearly simulate the impact sensitivity test may occur in space vehicles as a result of closure of poppet valves or chattering of flanges or other connections. Other impacts could result from many sources, as on pump impeller blades, mechanical or accidental impacts, etc. In a tank application, it is reasonable to assume that impacts on the outside of the wall may result from inadvertent collision with other objects, such as a worker dropping a tool, a moving crane, shrapnel from a nearby catastrophic vehicle explosion, dropping or bumping of the vehicle in handling, etc. Impacts also could occur inside the tank from chattering of mating parts, or in small clearance areas under vibration, as well as from parts of components inside the tank breaking loose.

Tests were made to obtain information on the reactivity of titanium in contact with oxygen when subjected to external impacts. The test fixture is shown in FIG 13. A 0.063-inch thick disc of titanium* was sealed into the top of the test fixture with the Teflon

*Unless otherwise stated, all further experimental tests with titanium reported hereafter were made with the 5Al-2.5Sn alloy.

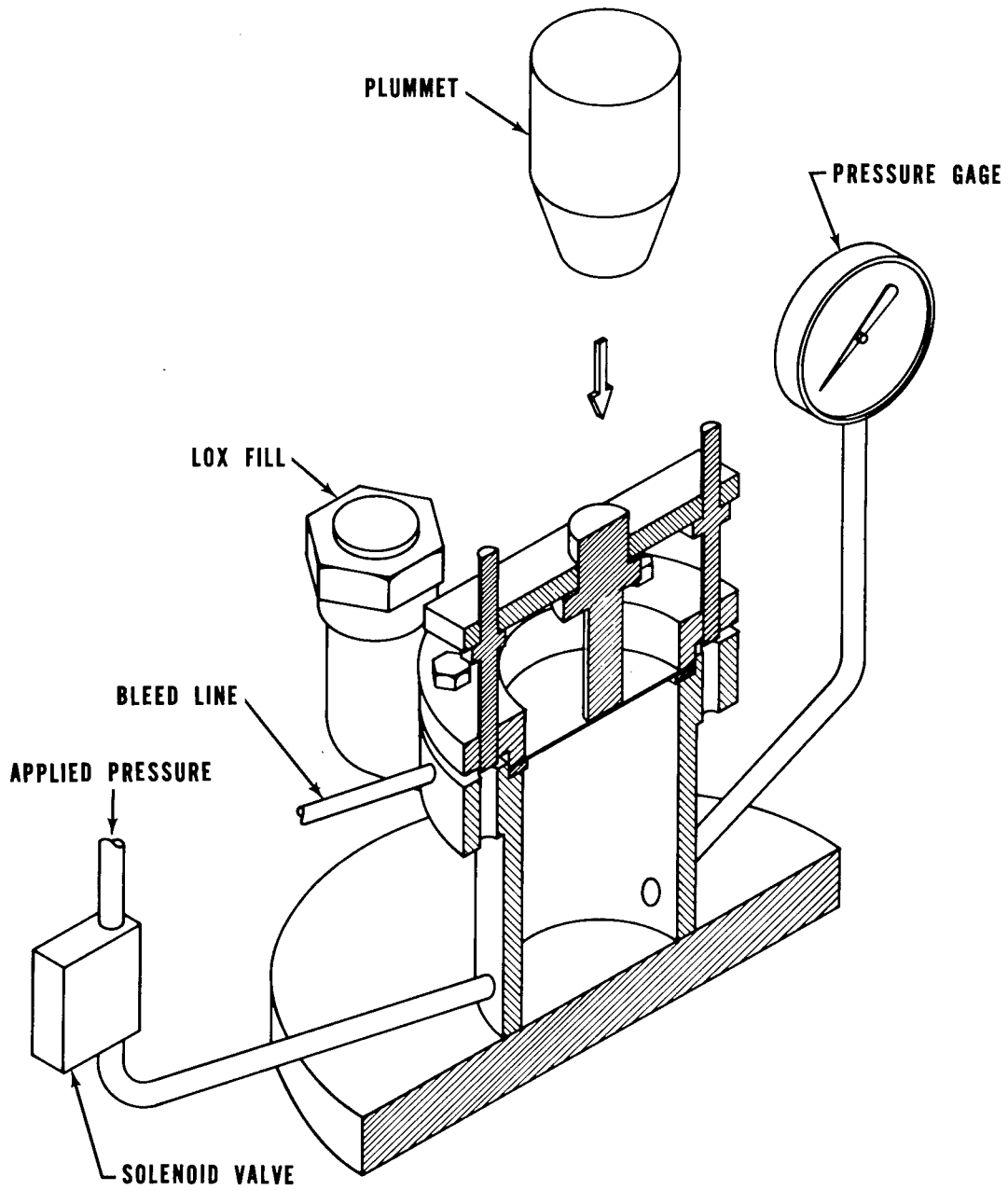

FIGURE 13. TEST SETUP FOR EXTERNAL IMPACT

gasket. The container was pressurized to 50 psig with oxygen at room temperature. The 1/2-inch diameter flat faced striker pin was placed on top of the titanium and subjected to a 20 Kg-M impact (by use of a 40-pound plummet). No reactions occurred in four individual tests.

Tests also were made with LOX. In an attempt to provide liquid contact with the titanium, a small overflow line was placed at the gasket surface and LOX passed through the container until only liquid overflowed through the vent. Under the same impact conditions as above, no reactions occurred in four trials.

In an attempt to partially simulate the effect of component parts breaking loose in the vehicle LOX tank and being rattled around from the vibration environment in flight, a steel cube was placed inside a titanium tank containing LOX and vibrated. The tank was constructed from 0.010-inch material to the configuration shown in FIG 14, except that a 2-inch cube of 321 stainless steel was inserted prior to welding of the second head. The edges and corners of the cube were cut with a power hacksaw. The test tank was placed in a "Rotap" machine* then filled with LOX and pressurized to 35-40 psig. Vibration was continued until all of the LOX had evaporated (approximately 15 minutes) leaving the cube to rattle in a GOX environment. Although the surface was peppered with minute dings, no detectable reactions occurred. The tank was not punctured or split by these conditions. Tests also were made in the same manner except that vibration was accomplished on a mechanical shake table at up to 20 G's*. No reactions occurred in this case either.

At first impression, one might infer that these results are in contradiction to those obtained in the standard impact tests, since both are internal type impacts. However, as explained previously, it is strongly suspected that a fresh metal surface and/or adiabatic compression are major factors in initiation of the reaction in the standard sensitivity test method. The edge of a cube striking a curved surface is not expected to present conditions which would be nearly

*Further details on these vibration environments are presented in the next section of this report.

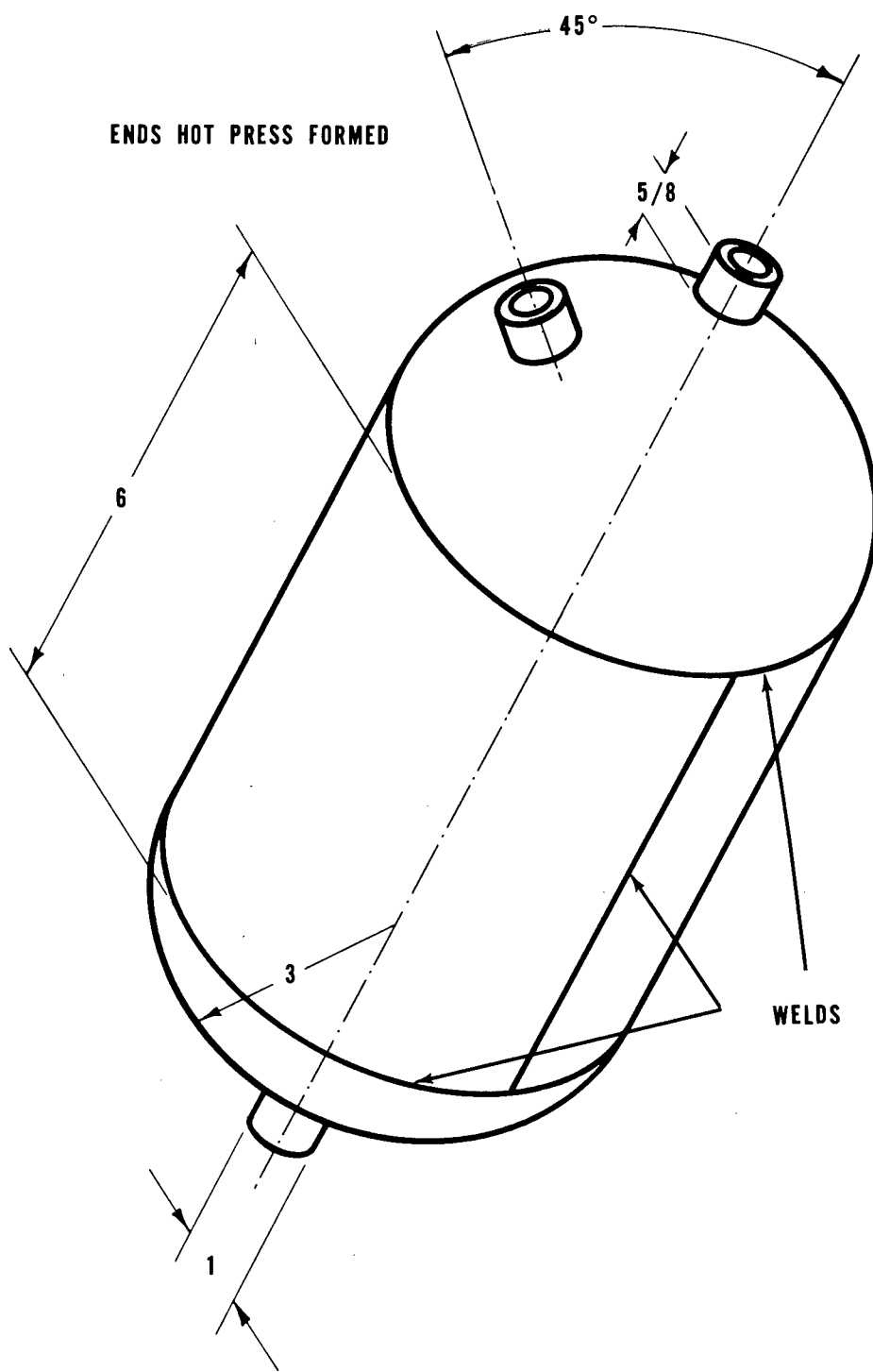

FIGURE 14. MODEL TEST TANKS (FOR LOX PUNCTURE TESTS)

as conducive to adiabatic compression as that of a 1/2-inch diameter flat face on a flat sample. The former consists of point contact, while, the latter, an appreciable area of contact. Thus these results lend additional support to the importance of adiabatic compression in the standard impact sensitivity test.

B. VIBRATION

High Frequency, Low Amplitude. Since high vibration levels are associated with space vehicles, the reactivity of titanium to oxygen under such conditions was investigated.

Three titanium tanks (FIG 14) were tested with a 1/16-inch wall thickness and another with a 0.010-inch wall thickness and containing a 2-inch cube (see paragraph VI. A). The test setup is shown in FIG 15A. The tanks were subjected to vibration with the tank longitudinal axis both vertical and horizontal. The system used to fill the tanks with liquid oxygen, pressurize, and purge is shown in FIG 15B. After the tanks were approximately one-half full of liquid oxygen, the inlet valve was closed and the vent valve was partially closed, allowing self-pressurization to 50 psig. The vibration tests consisted of a five minute scan covering the following conditions: 20 to 50 cps at 5.0 G's, 55 to 110 cps at 0.03-inch double amplitude, 110 to 200 cps at 20 G's. At the conclusion of each test, the test tank was purged with helium. The first tank (0.063-inch gauge) was subjected to a vibration sweep from 20 to 200 to 20 cps. The tank was then rotated 90° about the Z-Z' axis and tested again in the same manner. The remaining tanks were tested from 20 to 200 cps, rotated 90° about the Z-Z' axis and 90° about the X-X' axis, and the vibration test repeated. Resonant dwell tests were conducted immediately after each vibration test according to the resonant points recorded. These points were determined by accelerometers and are presented in Table 25. There was no reaction during any of the vibration or resonant dwell tests.

Low Frequency, High Amplitude. In order to attempt a partial simulation of the sloshing type of vibration, experimental tests were made also in a "Rotap" machine (FIG 16). In this equipment, the tanks were subjected to approximately 3 cps through a circular displacement pattern of approximately 2-inch diameter. Each test duration was normally ten minutes. The tanks were loaded with LOX

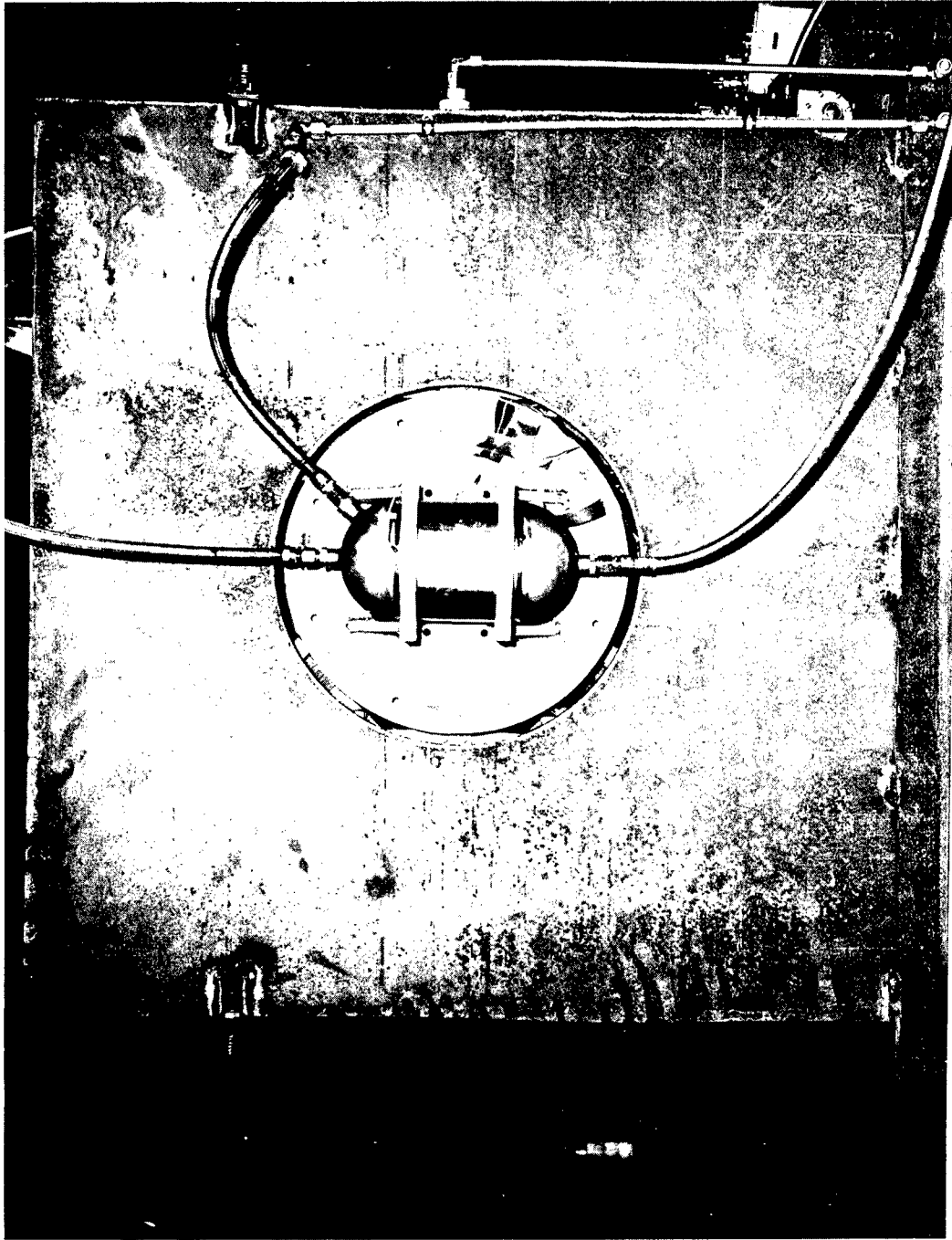

FIGURE 15A. TITANIUM TANK VIBRATION TEST (HIGH FREQUENCY, LOW AMPLITUDE)

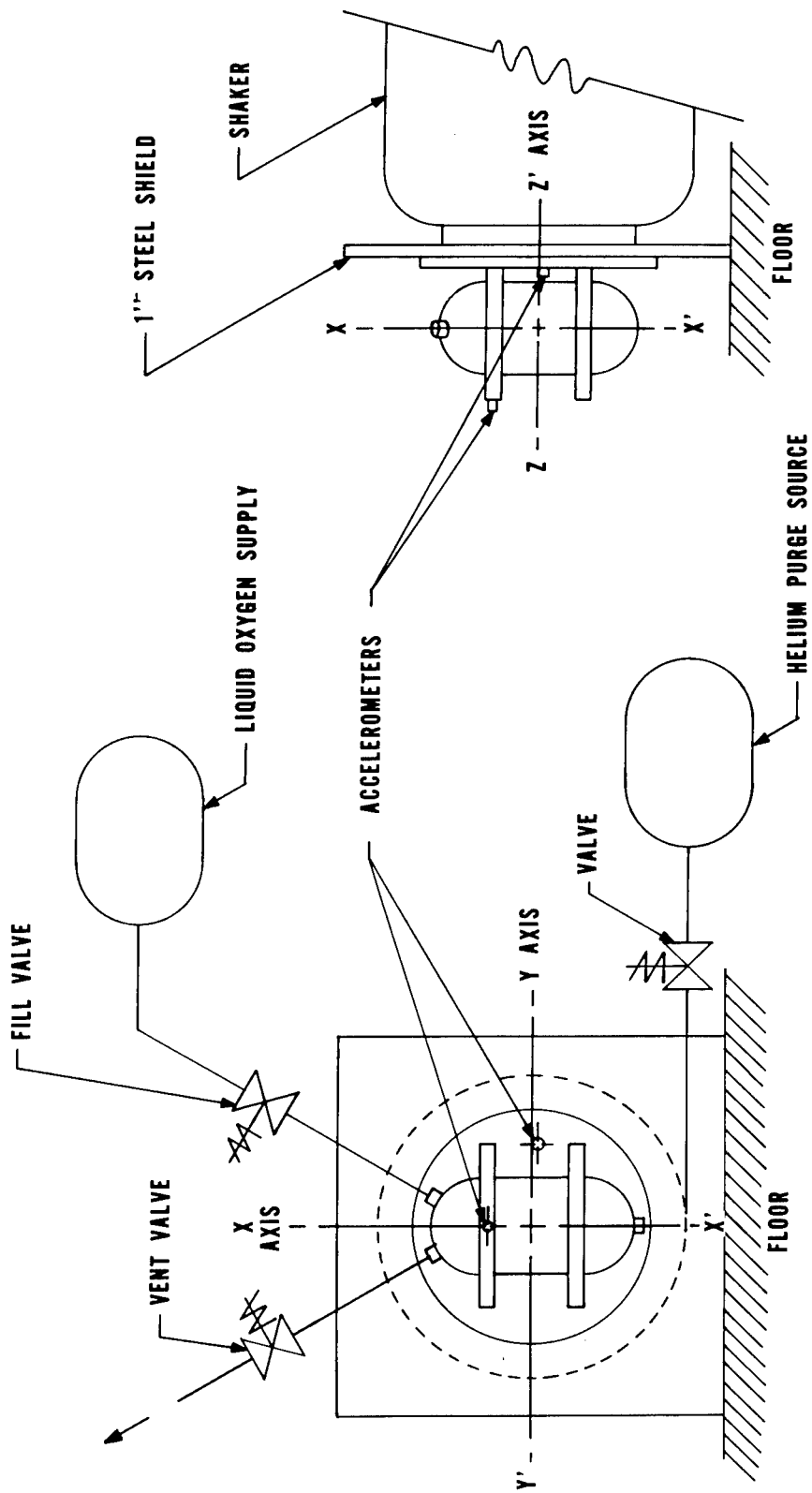

FIGURE 15B. LOX FILL, TANK VENT & PURGE SYSTEM (SCHEMATIC)
FOR HIGH FREQUENCY, LOW AMPLITUDE VIBRATION TESTS

Table 25. Resonant Points in Vibration Tests
on Titanium Tanks (.063" Gauge) Containing LOX

<u>Tank Longitudinal Axis Vertical</u>						
FREQUENCY (cps)	TANK "A" ACCEL. G'S		TANK "B" ACCEL. G'S		TANK "C" ACCEL. G'S	
	A ₁	A ₂	A ₁	A ₂	A ₁	A ₂
1810	50	250				
1920			30	200	30	125
<u>Tank Longitudinal Axis Vertical</u>						
FREQUENCY (cps)	TANK "A" ACCEL. G'S		TANK "B" ACCEL. G'S		TANK "C" ACCEL. G'S	
	A ₁	A ₂	A ₁	A ₂	A ₁	A ₂
1800	30	250				
1890					30	150
1970			30	190		
TITANIUM TANK (.010" GAUGE)						
<u>Tank Longitudinal Axis Vertical</u>						
FREQUENCY (cps)	TANK 1 ACCELERATION G'S			TANK 2 ACCELERATIONS G		
	A ₁	A ₂		A ₁	A ₂	
1900	30	125		40	130	
<u>Tank Longitudinal Axis Horizontal</u>						
FREQUENCY (cps)	TANK 1 ACCELERATION G'S			TANK 2 ACCELERATIONS G		
	A ₁	A ₂		A ₁	A ₂	
1960	No Record	No Record		40	125	
RESONANT POINTS						
TITANIUM TANK (.010" GAUGE) with 2" STEEL CUBE						
<u>Tank Longitudinal Axis</u>						
FREQUENCY (cps)	Vertical			Horizontal		
	TANK ACCELEROMETERS G'S			TANK ACCELEROMETERS G'S		
	A ₁	A ₂		A ₁	A ₂	
1870	125	350		100	300	

and pressurized in the same manner as with the previous vibration tests. Five tests were made on one 1/16-inch wall titanium tank and 200 on the 0.010-inch thick tank containing the 2-inch steel cube. No reactions occurred in any of the tests.

In another test in the "Rotap" machine, the top vent port in the tank (1/16-inch wall) was left open and light impacts were produced on the titanium boss during shaking. This was accomplished with the tapping fixture which is provided for this purpose when this

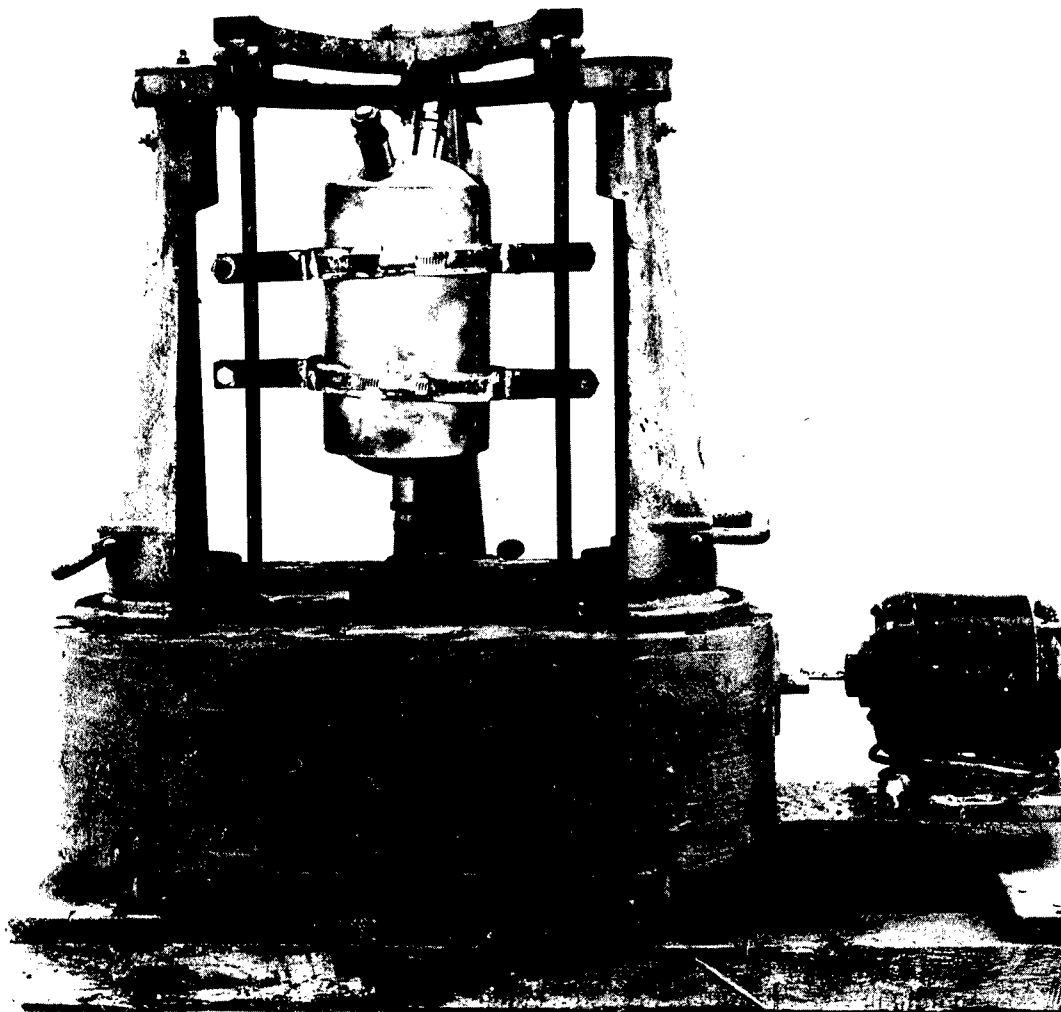

**FIGURE 16. "ROTAP" VIBRATION TEST TITANIUM TANKS
(LOW FREQUENCY, HIGH AMPLITUDE)**

machine is used for its intended function, i. e., sieve shaking to separate particles or crushed materials into various size ranges. No reactions occurred in 10 minutes of such a test, even though dense oxygen vapors continually were passing over the impacting surfaces. These results show that the vibration conditions employed in these tests will not induce a reaction between titanium and oxygen.

C. PRESSURE CYCLING

Experimental tests also were made to investigate whether the mechanical surges produced by rapid pressurizing of LOX in titanium tanks could initiate a reaction.

A schematic diagram of the apparatus used for these tests is shown in FIG 17. One aluminum tank (0.049-inch gauge) and one stainless steel tank (0.049-inch gauge) were used in place of the test specimen in order to adjust the pressure cycling device. The aluminum tank, filled with and surrounded by liquid nitrogen, was installed first and failed during the first pressure cycle at 1000 psig. This failure occurred in a weld seam and progressed through the lower hemisphere to the welded fitting (see FIG 18). There was no reaction involved in this failure. The aluminum tank was replaced by a stainless steel tank, which withstood approximately 200 cycles during adjustment of the cycling device. This tank was also surrounded by and filled with liquid nitrogen. After the desired pressure cycle was obtained (FIG 19) two titanium tanks (0.063-inch wall) were tested. Each tank, filled with liquid oxygen and surrounded by liquid nitrogen, successfully withstood 250 pressure cycles with no failures or reaction. A third tank, duplicate in construction and material, was installed in the pressure cycling device and filled with liquid oxygen but surrounded by ambient air. This tank also withstood 250 cycles with no failure or reaction. The pressurizing medium for the aluminum and stainless steel tanks was high pressure air; for the titanium tanks, gaseous oxygen.

D. ACOUSTIC ENERGY

Ultrasonic. Liquid level detectors in LOX systems frequently are of a type employing an ultrasonic probe. It is known that ultrasonic cleaning can erode holes through thin aluminum foils. Furthermore, it is understood that theoretically the pressure and temperature in the cavitation bubbles are very high. Thus a cursory test was

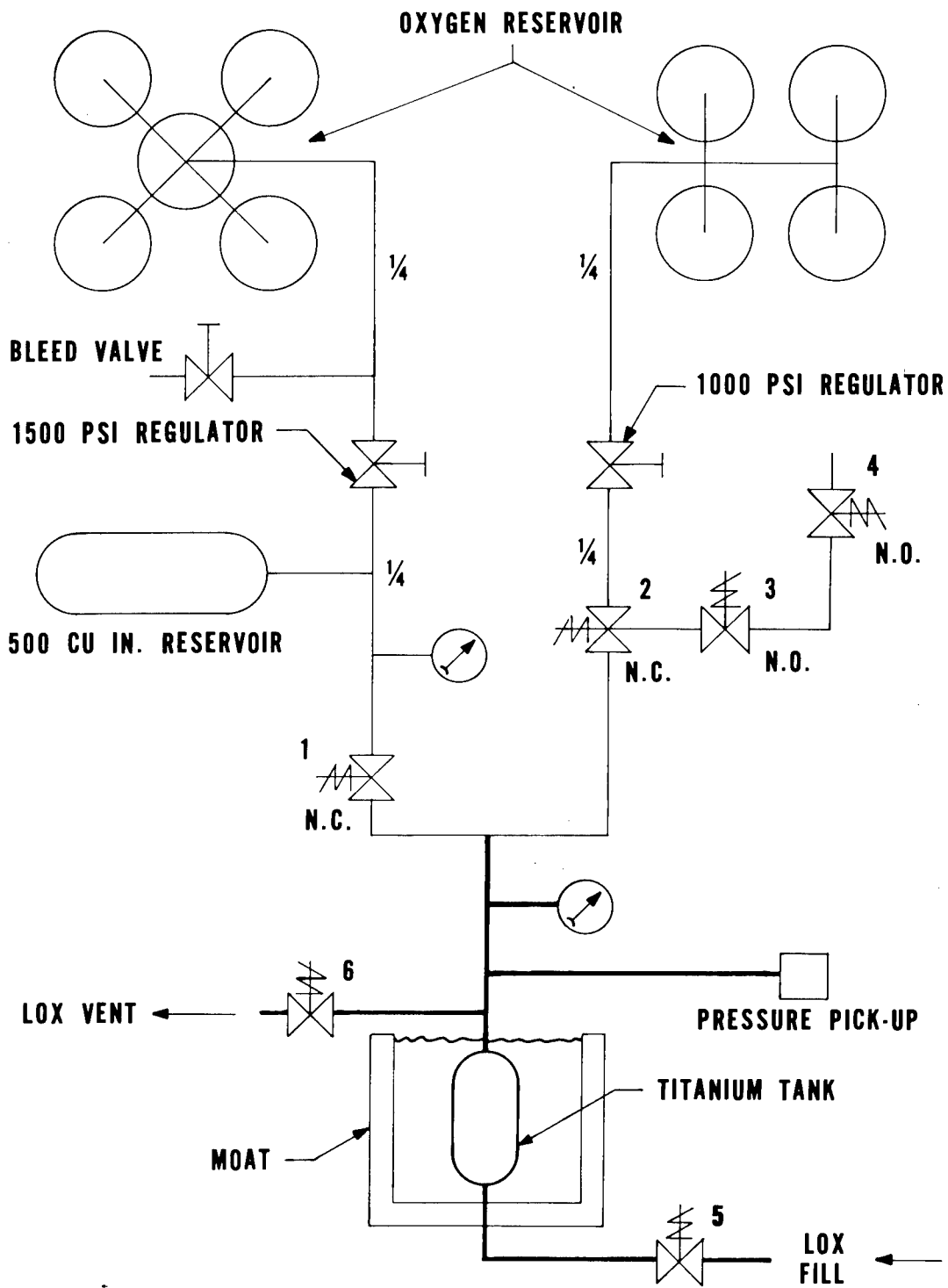
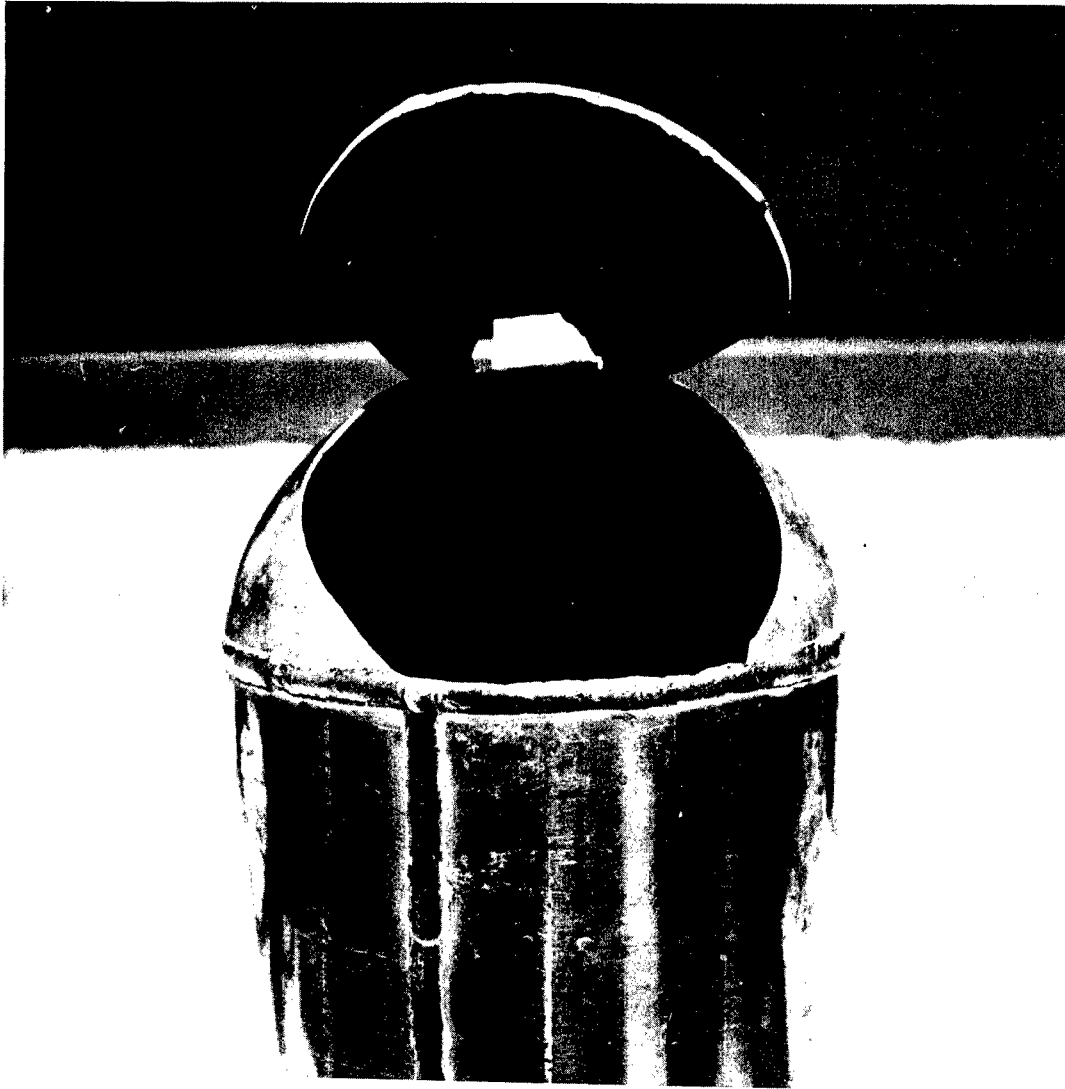

FIGURE 17. SCHEMATIC DIAGRAM OF PRESSURE IMPULSE CYCLING APPARATUS



**FIGURE 18. ALUMINUM TANK FAILURE
IN PRESSURE TEST-0.063 IN. WALL**

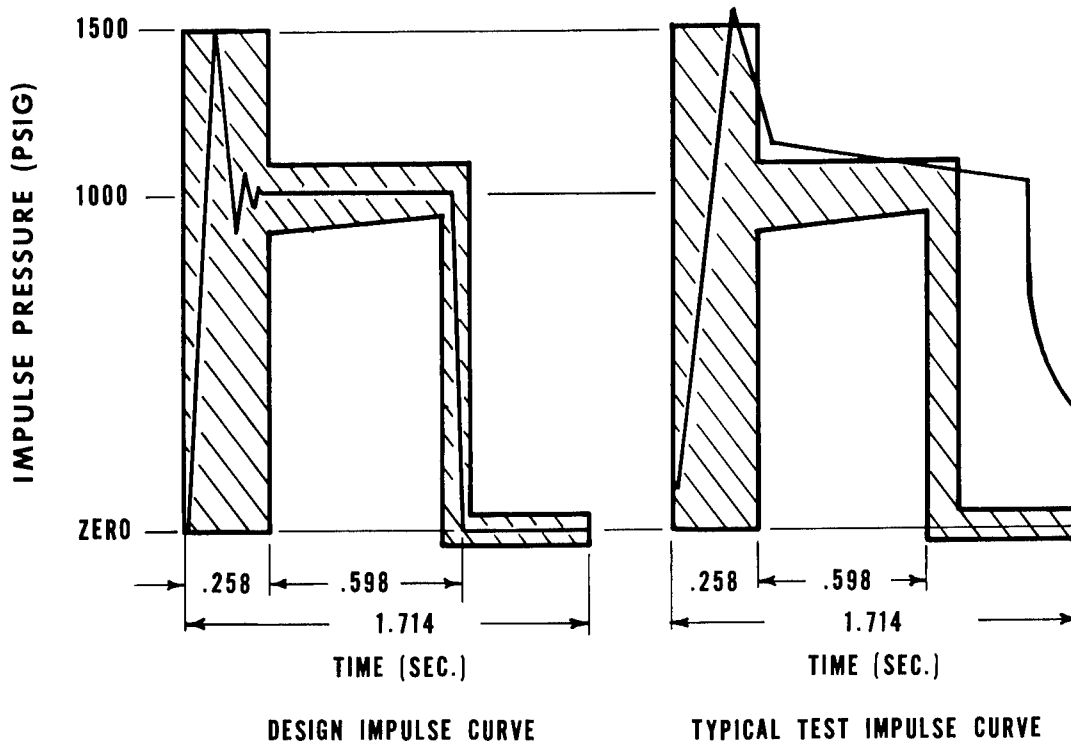

FIGURE 19. PRESSURE CYCLES

made in order to obtain limited information as to whether such an environment could initiate a reaction between titanium and LOX.

Titanium coupons were placed in LOX and subjected to ultrasonic energy (FIG 20). Commercial ultrasonic cleaning equipment was used for this purpose. At a maximum power the generator output was 400 watts, and was coupled to a 25 kc magneto strictive transducer. A dummy run was made with only LOX in the stainless steel container to obtain the evaporation time (i. e. , 10-15 minutes). Three runs then were made with two inch diameter test discs; one each of 0.010, 0.025, and 0.063 inch thickness for 15 minutes duration. No reactions occurred.

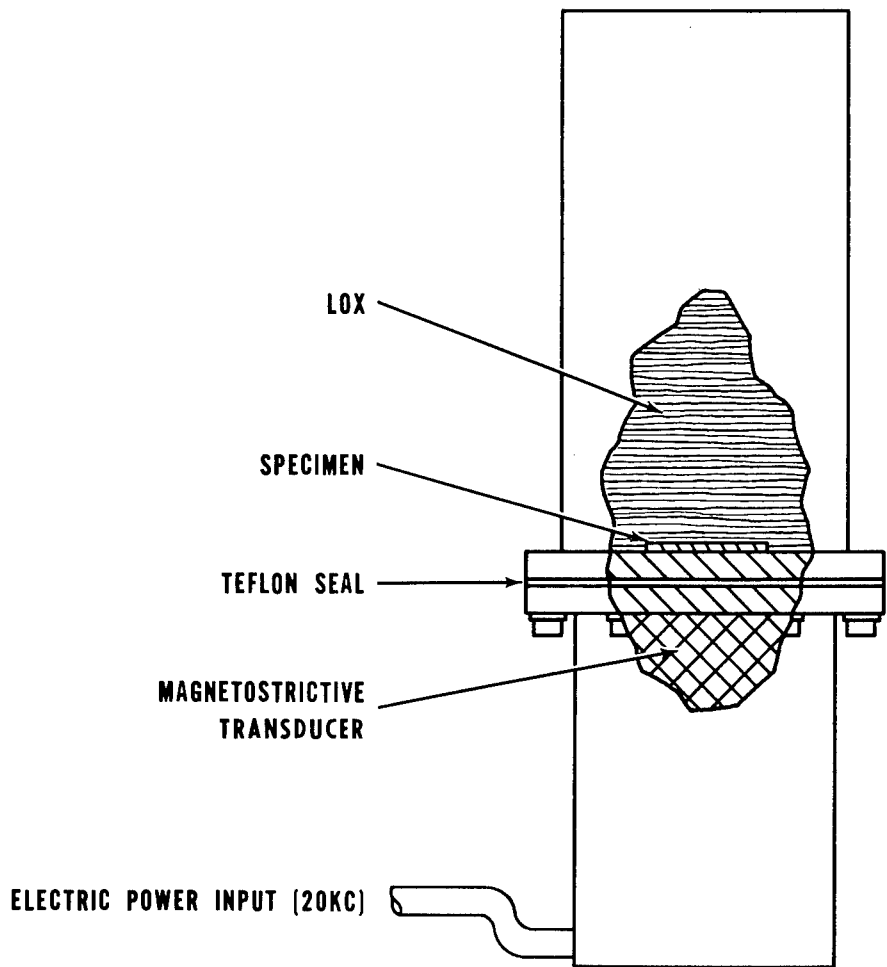

FIGURE 20. SCHEMATIC OF SET UP FOR DETERMINING EFFECT OF ULTRASONIC ENERGY ON LOX SENSITIVITY OF MATERIALS.

The ultrasonic energy levels under these test conditions undoubtedly are far higher than those used in liquid level detectors, and thus it might be inferred that ultrasonic level detectors are safe for use in titanium-LOX systems. While the test results are indicative, the sonic frequencies of cleaning and detector instruments are understood to be quite different and could affect the capability to initiate a

reaction. Thus, before actually employing an ultrasonic liquid level detector in LOX systems containing titanium, it would be advisable to make a simple test of the particular detector proposed for use in the intended service application before assuming that no appreciable hazard is present.

Sonic. Limited tests were made in order to investigate whether the sonic energy levels or other environmental conditions associated with close proximity to a rocket engine firing could initiate the titanium-oxygen reaction.

Two 0.010-inch wall titanium tanks filled with LOX were located about 8 feet from a rocket motor (FIG 21). A 4000-pound thrust liquid oxygen-kerosene rocket engine was fired to produce a 150 db acoustic pressure level. The titanium tanks were filled with LOX prior to each test and LOX evaporation was utilized to maintain a pressure of approximately 50 psig in the tanks.

Four tests were conducted with the LOX filled titanium tanks exposed to a nominal sound pressure level of 150 decibels. Three of these tests were of 60 seconds duration and one was of 30 seconds, for a total test time of 210 seconds. FIG 22 depicts the average sound pressure level for all of the tests at the two microphone positions shown in FIG 21. The tanks were not affected by these conditions.

E. THERMAL EFFECTS

Titanium in contact with oxygen in the space vehicle tanks could be exposed to elevated temperatures from a number of sources, such as aerodynamic heating, or proximity to retro and/or ullage rocket exhausts. In addition, if a leak occurs in a LH₂ tank fabricated from titanium, ignition of the ensuing gas (which is highly probable from spurious sources) will result in heating of the wall. Based on chemical considerations, it is not expected that this could result in a reaction between the titanium and hydrogen. However, as the liquid hydrogen supply diminishes the exterior surface of the titanium will become exposed to elevated temperatures in contact with air.

Literature sources on the thermal ignition of titanium are inconsistent. Dean and Thompson reported that titanium ignited at approximately 920°C (1700°F) in a 300 psia oxygen environment and 1315°C (2400°F) at 50 psia (ref. 16). Titanium was far more reactive

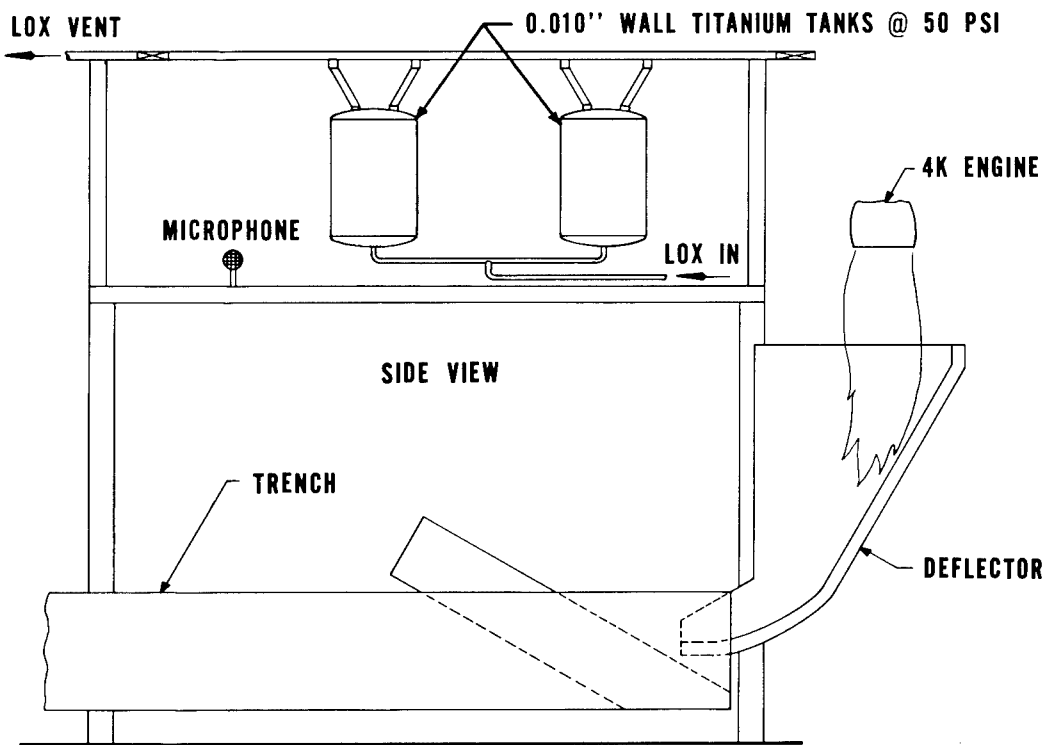
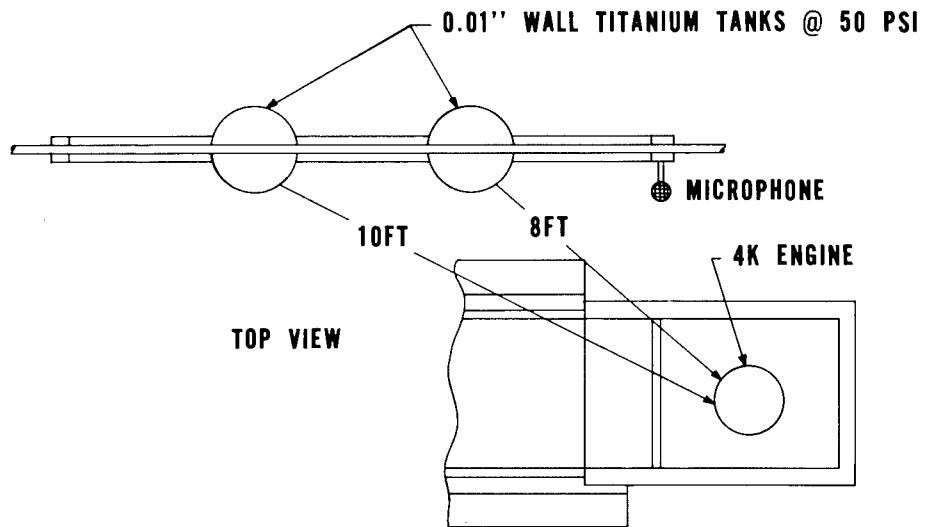

FIGURE 21. ACOUSTIC TEST SETUP (TITANIUM LOX TANK)

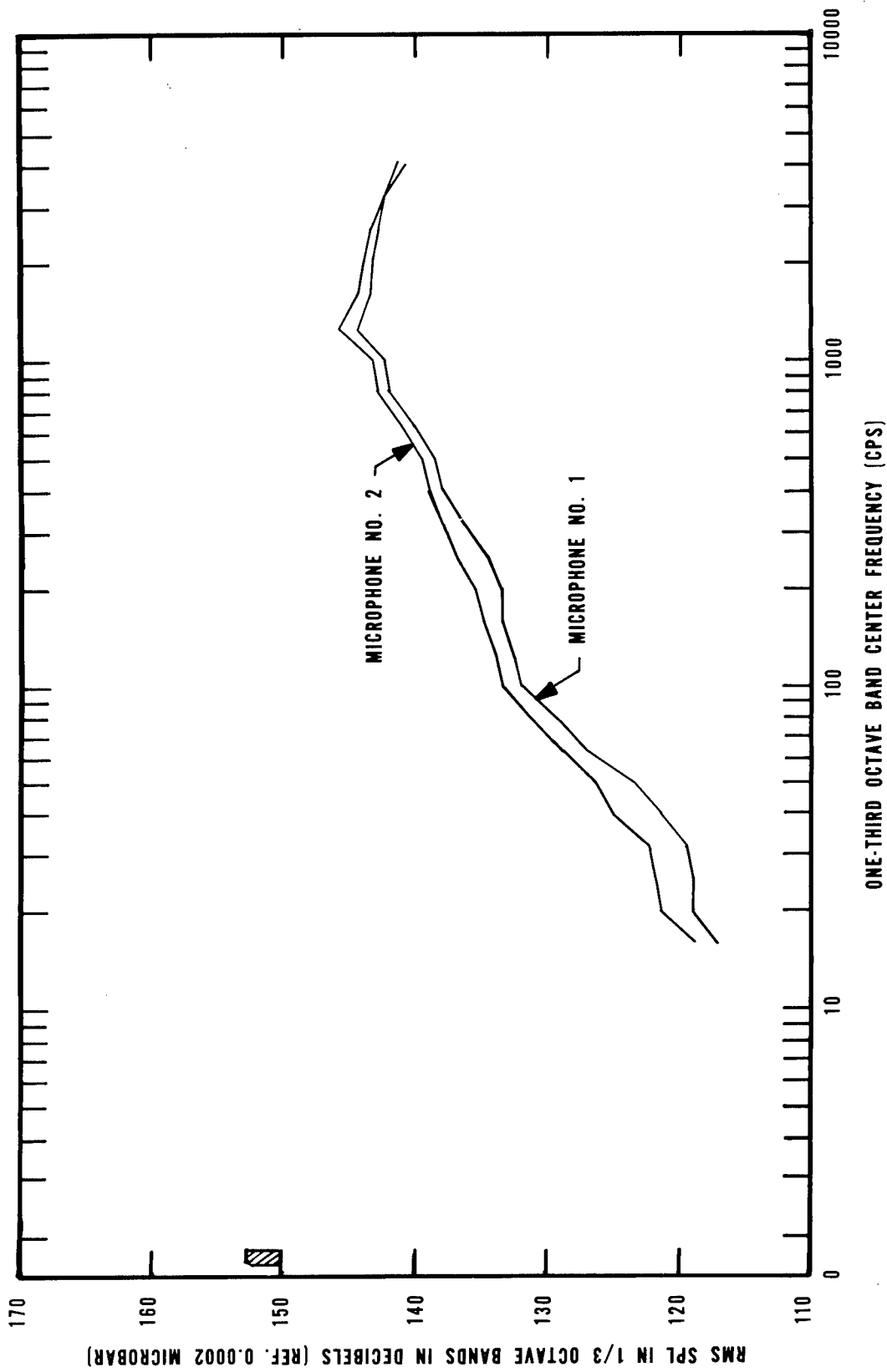

FIGURE 22. OVERALL VALUES AND FREQUENCY SPECTRA ON EITHER SIDE OF TITANIUM TANKS IN ACOUSTIC ENERGY TESTS

in an oxygen atmosphere than any of the metals they tested, which included aluminum, stainless steel, cobalt and nickel alloys, and copper. Ignition of titanium occurred 200°C (250°F) to 800°C (1000°F) below the melting point (1800°C, 3272°F, for elemental titanium) and the test specimens were completely destroyed. On the other hand, Hill, Adamson, Foland, and Bressette reported spontaneous ignition of titanium in oxygen at 500 psia at 1150°C (2100°F), 320°C (400°F) higher than that reported by Dean and Thompson at 300 psia (ref. 17). Hill, et al., also reported that titanium spontaneously ignited in air at approximately 1600°C (2900°F).

Tests were made to investigate whether direct impingement of hydrogen/air flames would ignite titanium in air. Laboratory type tests were made by modifying the titanium disc container fixture shown previously in FIG 17. A small hole (0.010-inch diameter) was drilled in the 0.010-inch titanium disc and a similar disc without a hole was placed parallel to the lower one and several inches directly overhead. A flow of gaseous H₂, sufficient to maintain a pressure of 5-10 psig in the container, was begun and the escaping gas ignited by a spark. Upper surface temperatures of both discs were monitored by thermocouples (FIG 23). Four tests of approximately 10 minutes duration each were made, in which the spacing between the titanium plates were varied to obtain the highest temperatures. Under these test conditions, a spacing of one inch resulted in attainment of 1200°C (2200°F) on the top plate, and 980°C (1800°F) on the lower plate. The titanium was severely embrittled by these conditions, as would be expected, and a thin white powder coating formed on the surface (undoubtedly titanium dioxide). However, the metal did not ignite. Similar tests with 2014-T6 aluminum rather than titanium, produced melting (as expected) without appreciable reaction.

These results indicated that deleterious effects on titanium by a hydrogen/air flame are much more likely to be structural weakening, i. e., embrittlement, than ignition.

In order to more nearly simulate service conditions, burning tests were made on two small titanium tanks (0.010-inch wall) insulated externally with one inch of polyurethane foam and filled with LH₂, and pressurized to 35 psig. The tanks were punctured with a 1/8-inch diameter pointed pin, and the ensuing gas ignited by a spark. The test continued until all of the hydrogen was consumed. In the test on the second tank, some additional LH₂ was allowed to flow into the tank

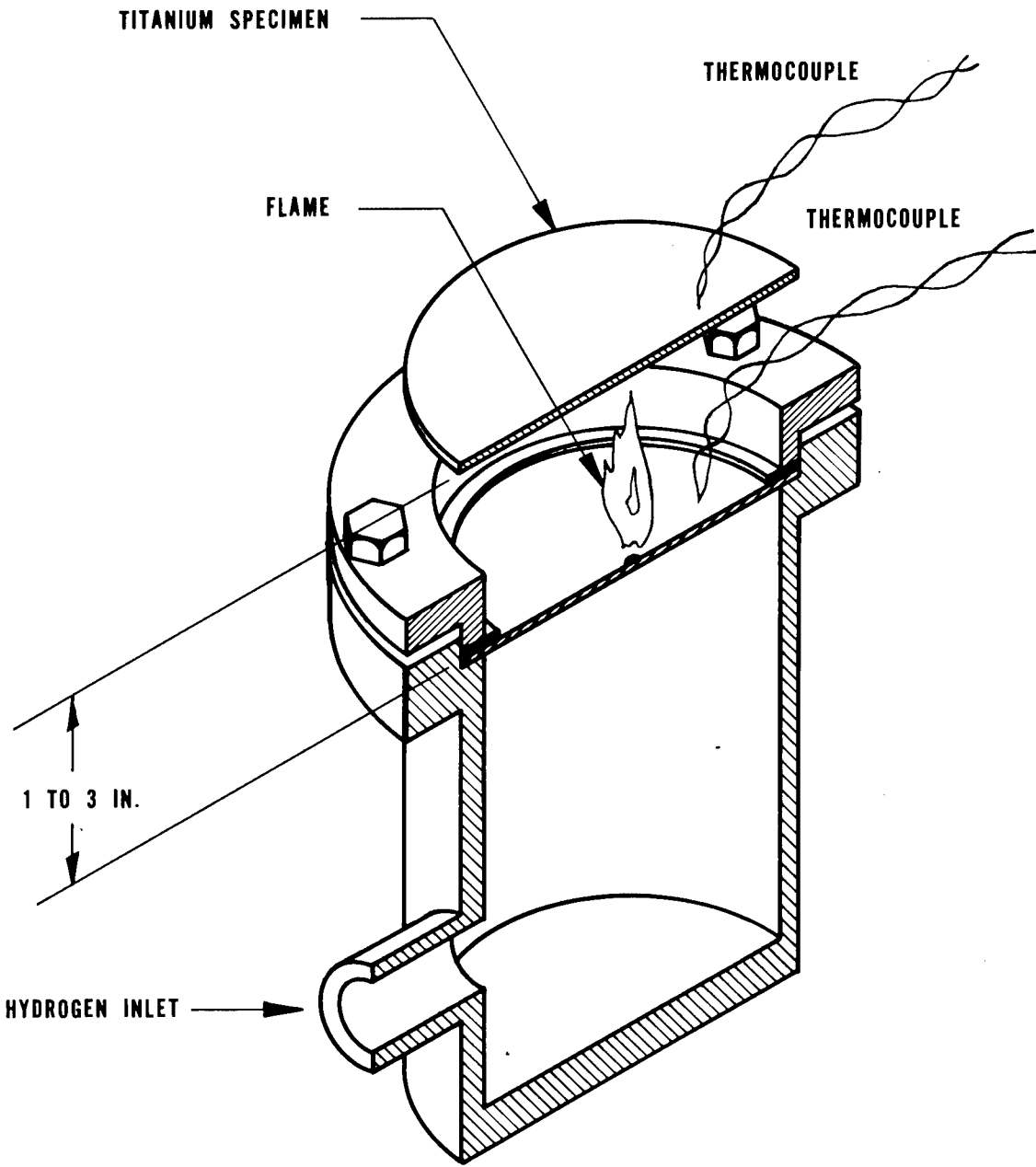

FIGURE 23. DIRECT IMPINGEMENT OF HYDROGEN/AIR FLAME ON TITANIUM

during burning. All of the insulation was burned off the tanks in both tests. Camera coverage showed that relatively intense flames occurred, which occasionally were localized to produce very severe hot spots. However, the titanium did not react with either hydrogen or the air. FIG 24A and 24B show the appearance before and after test, and FIG 25 shows an internal view of the puncture and crack.

These results, coupled with those reported in the literature, indicate that while thermal initiation of a reaction between titanium and oxygen (or air) occurs far more readily than stainless steels, the necessary temperatures are higher than would normally occur in space vehicle tank applications, or be permissible for maintenance of structural integrity.

F. ORIFICES OR MECHANICAL FAILURE

A limited number of tests was made to investigate whether some flaws or defects in fabrication of titanium tanks would serve to initiate a reaction on subsequent use in oxygen systems. A sample disc containing a minute orifice, which resulted from a patch weld on 0.025-inch thick titanium, was pressurized twice to 100 psig with gaseous oxygen to allow a stream of gas to pass through. No reaction occurred. Another sample with a minute crack in a 0.025-inch thick disc was pressure flexed with 100 psig oxygen until the crack propagated from 1/4 to approximately 1-1/4 inches. No reactions occurred in this instance either.

A test tank which was being fabricated from 0.010-inch titanium showed minute leakage at a weld adjacent to the boss. In order to obtain a low temperature crack propagation test, the tank was filled with liquid oxygen and all fill vent ports were closed to allow build-up of pressure. The maximum internal pressure recorded was 57.0 psig, which was insufficient to rupture the vessel. An external oxygen pressure source, which had been attached to an inlet port on the vessel, was used to increase the internal pressure to 125 psig, at which point the tank ruptured at the weld seam (FIG 26). A clean break, without any evidence of reaction, occurred.

G. FATIGUE FRACTURE

It is believed that fracture of a metal from fatigue is the culmination of a process which begins at a microcrack in the surface,



**FIGURE 24A. LH₂-TITANIUM TANK TEST
BEFORE PUNCTURE AND H₂ BURNING**

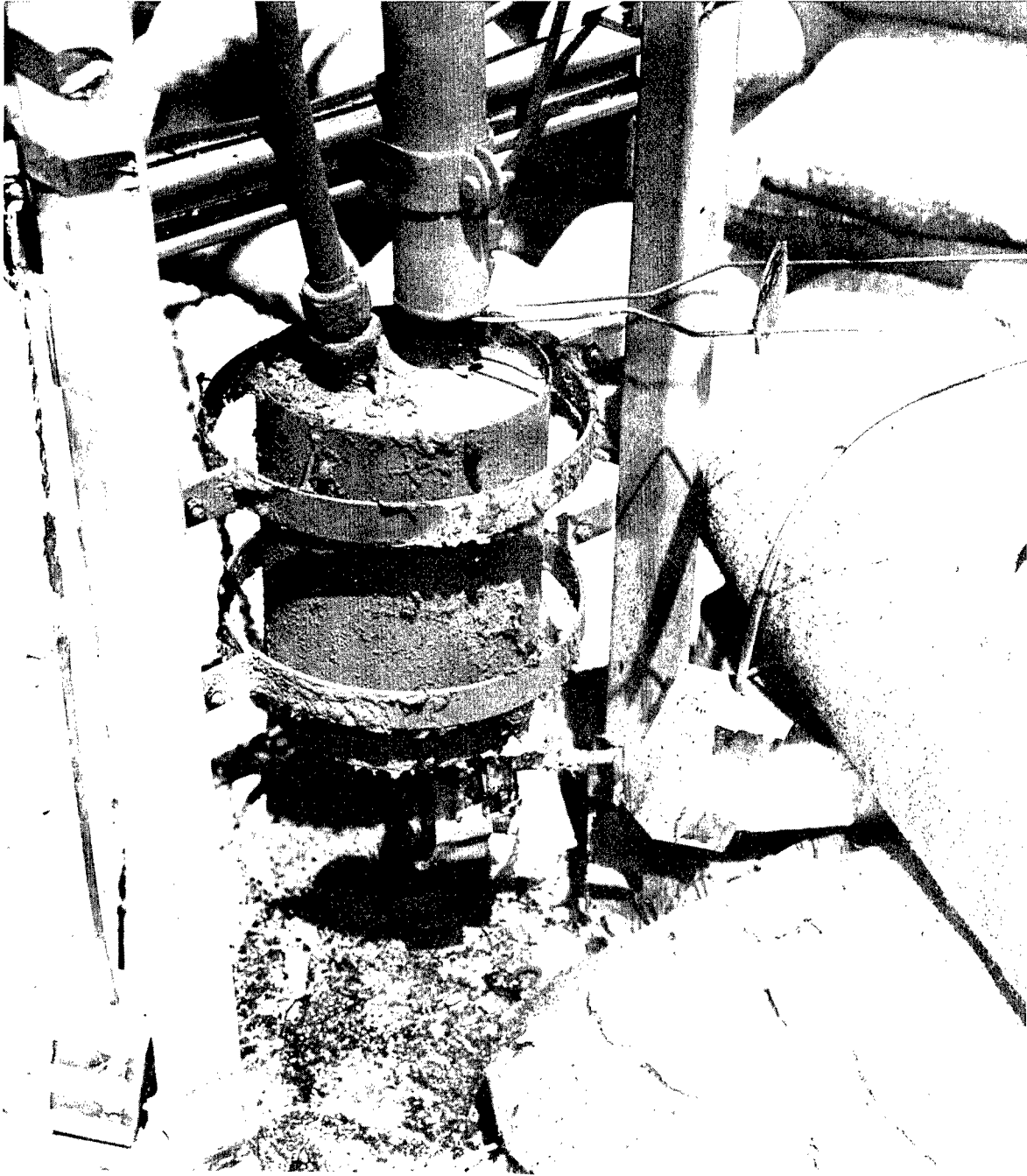

**FIGURE 24B. LH₂-TITANIUM TANK TEST
AFTER PUNCTURE AND H₂ BURNING**

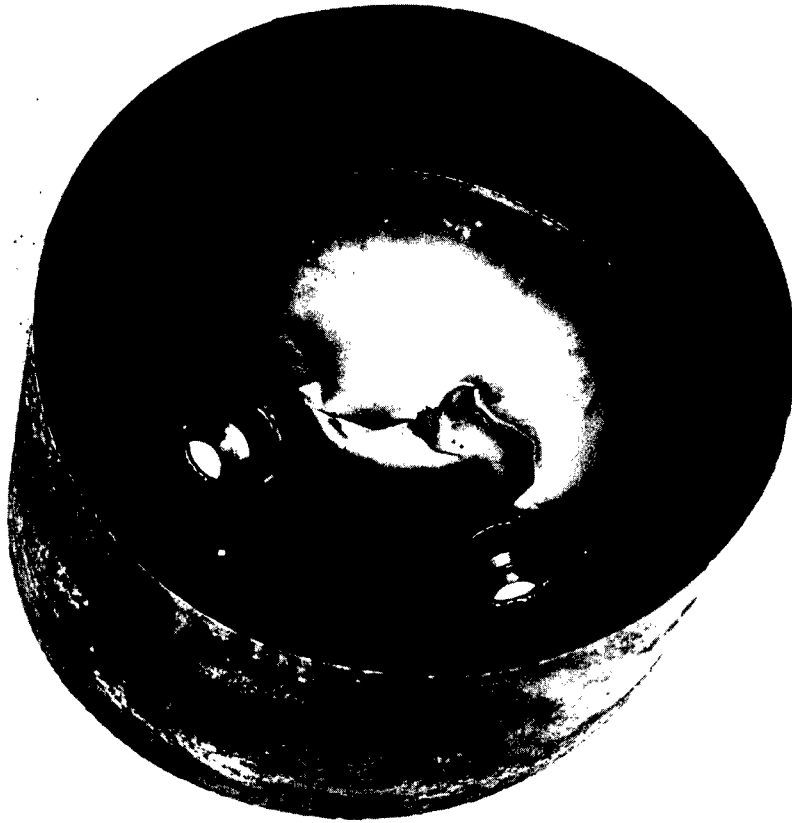
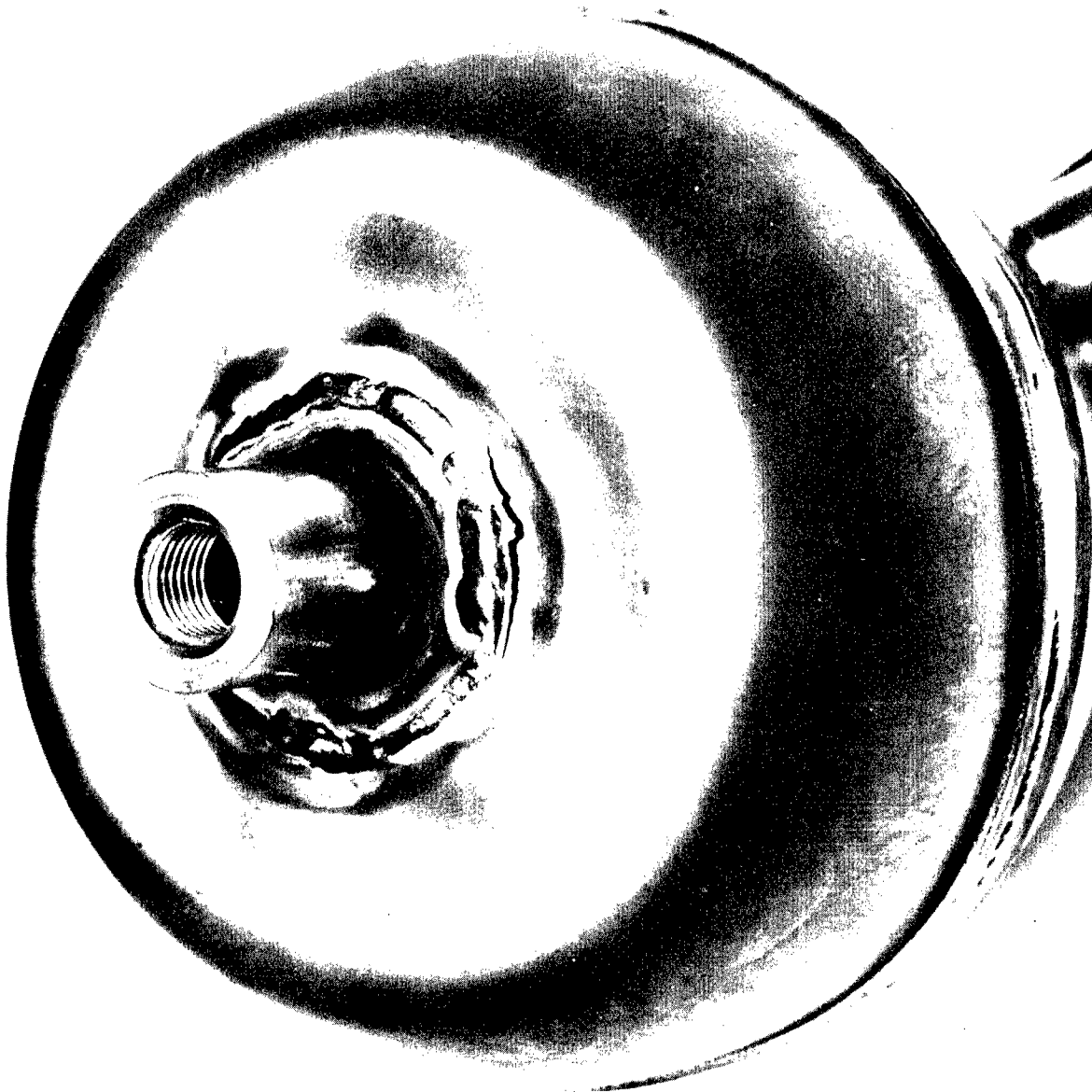

FIGURE 25. INTERIOR OF LH₂-TITANIUM TANK AFTER PUNCTURE AND H₂ BURNING

and with flexure, propagates eventually to failure. Others have reported in the literature that stress or tensile rupture of titanium in an oxygen environment has resulted in only small flashes and/or minute visible burnt spots on the fracture faces (see Section II. C.). However, it was suspected that under fatigue, oxygen gas entrapped in the microfissures could undergo adiabatic compression during flexure and initiate a violent reaction with titanium. Consequently, experimental studies



**FIGURE 26. TITANIUM VESSEL FAILURE
AT 125 PSIG O₂-0.010 IN. WALL**

were made to investigate whether fatigue of titanium specimens would initiate a violent reaction in an oxygen environment.

The apparatus used was a Sonntag Fatigue Testing Machine, which was modified by placing a brass bellows closure around the flexure fixture. This area was thoroughly flushed with gaseous oxygen and pressurized prior to test. In order to achieve the correct functions of the machine, it was necessary to "stack" at least three of the specimens of 0.032-inch thickness and less, in the test fixture. These thin specimens also were scored lightly with a file in order to achieve fracture within a reasonable test duration (up to ten hours).

A total of 19 specimens was fractured (Table 26). Violent reactions or sustained burning did not occur in any case with 0.010- to 0.125-inch thick 5Al-2.5Sn titanium specimens, and oxygen pressures from 20 to 60 psig. The six reactions noted in eight trials of the 0.025-inch thick material at 50-60 psig were observed only as minute "burnt" spots on the fracture faces. These results were very similar to those reported by Jackson, Miller, Boyd, and Fink from tensile rupturing of commercially pure titanium at 60 psig oxygen (ref. 11). A typical "burnt" spot is shown in FIG 27. Flashes may

Table 26. Fatigue Testing of Ti-5Al-2.5Sn Under GOX Pressure

<u>Material Thickness (in.)</u>	<u>Oxygen Pressure Psig</u>	<u>No. Tests</u>	<u>Results</u>
0.125	60	1	No Reaction
0.125	50	3	No Reaction
0.125	40	1	No Reaction
0.125	30	1	No Reaction
0.125	20	1	No Reaction
0.032	50	2	No Reaction
0.025	60	1	1 Reaction
0.025	50	7	5 Reactions
0.010	50	2	No Reaction

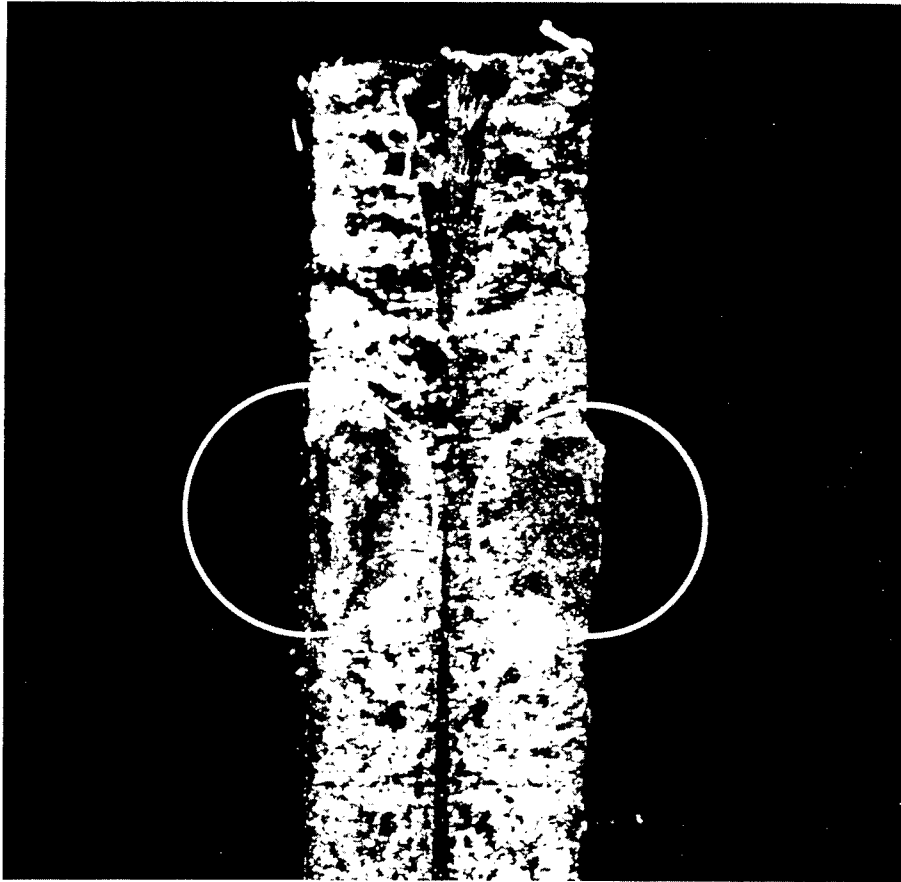

BOTH EDGES OF SAMPLE SHOWN IN FOLDED OVER POSITION

**FIGURE 27. "BURNT" SPOTS OF FATIGUE
FRACTURED SPECIMEN**

have accompanied rupture of this specimen; however, visual observations were not possible in this test apparatus.

These results indicate that initiation of a reaction between titanium and oxygen due to fatigue cracking is not a serious hazard.

H. SPARK SENSITIVITY

Electrical devices (level detectors, etc.) frequently are used inside space vehicle LOX tanks. Furthermore, the accumulation of

electrostatic charges as a result of fluid flow is well known. Because the results of the various tests described above indicated a relatively high reaction sensitivity of titanium/oxygen systems to various stimuli, consideration was given to the possibility of accumulating a sufficient charge (due to electrical components or to vibration and sloshing of the liquid) to constitute a spark type ignition source.

To examine this possibility, an apparatus capable of subjecting a sample to a wide range of spark energies was constructed and used to determine the relative ease of ignition of titanium and aluminum in gaseous oxygen. Some information also was obtained relative to steel.

Apparatus and Procedure. The apparatus used for this investigation (FIG 28) was essentially that used for testing explosives in the partly confined condition by Brown, Kusler, and Gibson (ref. 18).

Two modifications were used. In the first modification, the sample consisted of a 0.25- by 0.5-inch rectangular sheet of metal of the desired thickness. The sample was placed on end in the glass tube sample holder, the air displaced from the tube by gaseous oxygen entering through a small hole in the stainless steel base. A spark of known energy discharged from a steel phonograph needle which was brought into close proximity with the sample and immediately removed by means of a single stroke plunger. In the second modification, the sample was prepared in the form of a long strip, 0.01 by 1-inch, with a 45-degree point on one end. This strip was substituted for the phonograph needle and the spark allowed to discharge from the point of the sample to the steel base plate inside the glass sample holder when the plunger was activated.

Results. Tests using the first modification were directed primarily toward ascertaining the effect of metal thickness on the spark energy required for ignition.

Results for titanium indicated that very low spark energies sufficed for ignition of samples of 0.005-inch thicknesses with somewhat larger energies required for thicknesses of 0.007 and 0.010 inch. The results were extremely variable, however, and appeared to depend on the extent of confinement, oxygen flowrate, point of impingement of the spark, and other variables. The results are therefore regarded as semiquantitative and only the range of spark energies for which ignitions were obtained (one to ten joules) is regarded as significant.

*Joules = 1.2 RT
1.2 joules = 10⁷ ergs
= 0.738 ft. lb.*

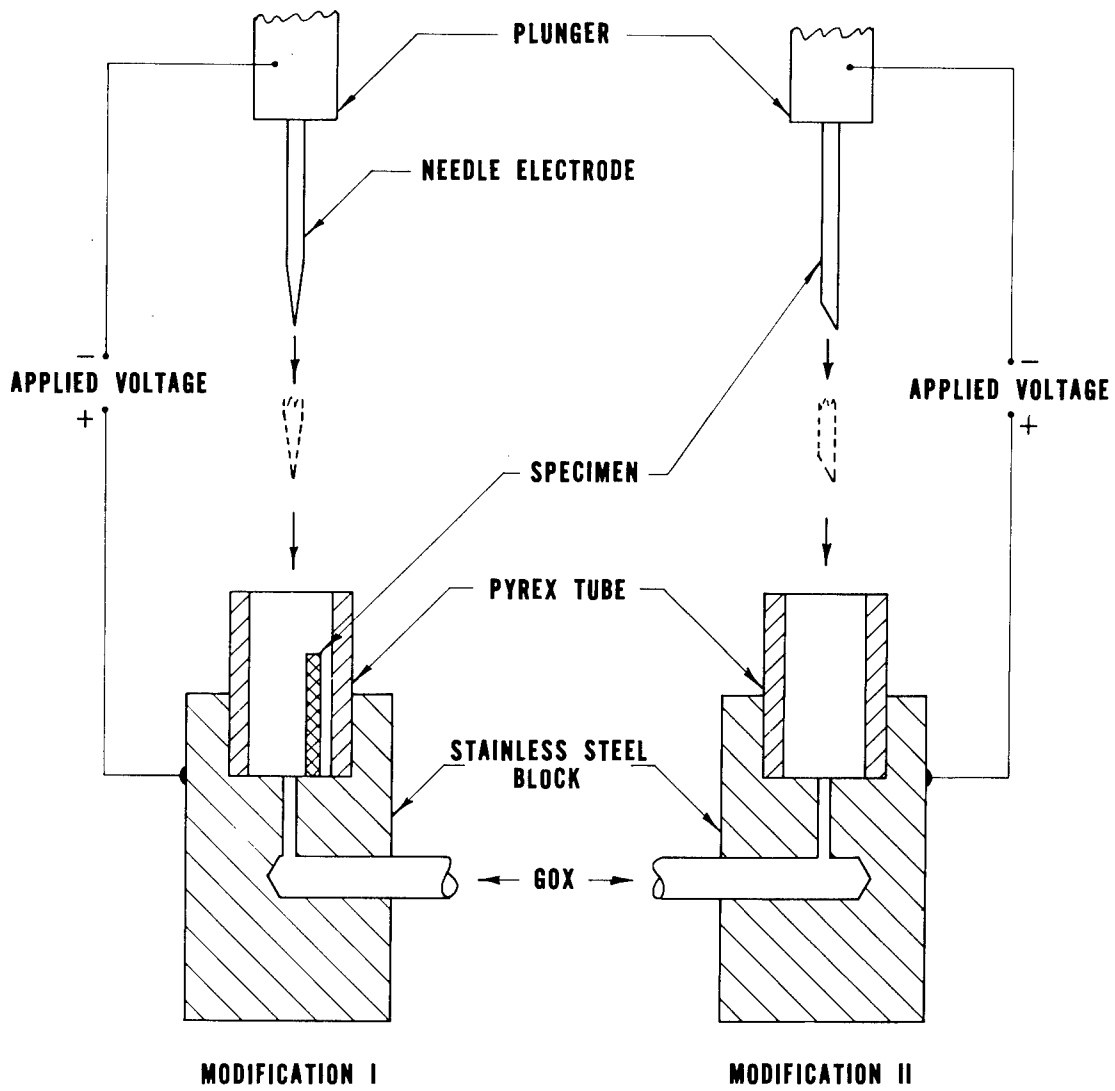

FIGURE 28. APPARATUS USED FOR SPARK SENSITIVITY TESTS

Aluminum failed to ignite with spark energies up to the maximum capacity of the apparatus (10 joules).

The second modification of the test procedure was used in an attempt to obtain further indication of the effects of the several operating variables on the ignitibility of titanium. The results, however, did not differ greatly from those obtained with the first modification, and the investigation was discontinued.

It should be noted that the steel phonograph needles used in the first modification were subjected to stimuli comparable to those to which the titanium samples were subjected in the second modification. Inasmuch as these needles were substantially unaffected by the test, it was concluded that the spark energies possible with this apparatus were insufficient for ignition of steel.

It should be noted that in these tests ignition of titanium took place without an explosion; burning usually proceeded rapidly until the oxygen supply was cut off or the sample consumed.

These semiquantitative results indicate that far lower spark energies are required for ignition of titanium than for aluminum or steel in gaseous oxygen.

I. PUNCTURE

Puncture of space vehicle tanks may result from spurious, as well as environmental conditions (meteoroids), and the probability of such an occurrence is enhanced greatly with wall thicknesses of approximately 0.010 inch, rather than those commonly employed in non-pressure stabilized structures.

Spurious sources of puncture could include worker errors, and/or shrapnel from a catastrophic explosion on another test stand. Environmental puncture could result from meteoroid punctures in space flight.

As cited earlier (paragraph II. D.), the Bendix Corporation obtained a violent reaction on firing an incendiary bullet into a titanium tank containing LOX. Since no tests were reported with ordinary bullets, the importance of the incendiary nature of the projectile in initiating the reaction could not be evaluated.

Littam and Church reported tests in which a 0.005-inch thick titanium diaphragm was pressurized with gaseous oxygen and punctured with a knife edge (ref. 4). Only two tests were made at 50 psig in oxygen, and one at 10 psig. Violent and sustained burning occurred with both tests at the higher pressure, and no reaction occurred in the third test. These results strongly suggested that puncture of 0.010-inch titanium diaphragms containing 50 psig, or slightly less, of oxygen might produce violent reactions.

Diaphragm Tests -

a. Gaseous Phase. The fixture for these tests is shown in FIG 29. A 2-inch disc of the sample to be punctured was used as a diaphragm to seal the gas in the lower container. Normally, the container was flushed and pressurized to 35-40 psi from a cylinder of compressed oxygen. For low temperature testing, a quantity of liquid oxygen was placed in the container and self-pressurization was used.

In the preliminary phases of these tests, several shapes of puncturing tools were employed, as shown in FIG 30. Since no important differences in results were noted, the 1/8-inch pointed rod was arbitrarily selected as a standard, and used in all subsequent disc puncture tests (except the darts, which are specifically cited later). The puncturing tool was held in position by a collar and the fixture placed in the impact sensitivity tester. The plummet and guide rail of the tester were used simply to deliver sufficient force to drive the pin through the test disc. Furthermore, this operation could be done in the existing test facility, and with remote controls.

Test results of diaphragm puncture tests in the gaseous phase are summarized in Table 27. These included various sample thicknesses, materials, as well as ambient and low temperature gas. From the overall standpoint, reactions were obtained in a total of 49 times in 57 trials, or 86 percent of the time, with titanium - from 0.010- to 0.032-inch thick and various puncturing tools.

Furthermore, the reactions on puncture were usually extremely violent and spectacular, producing significant detonations

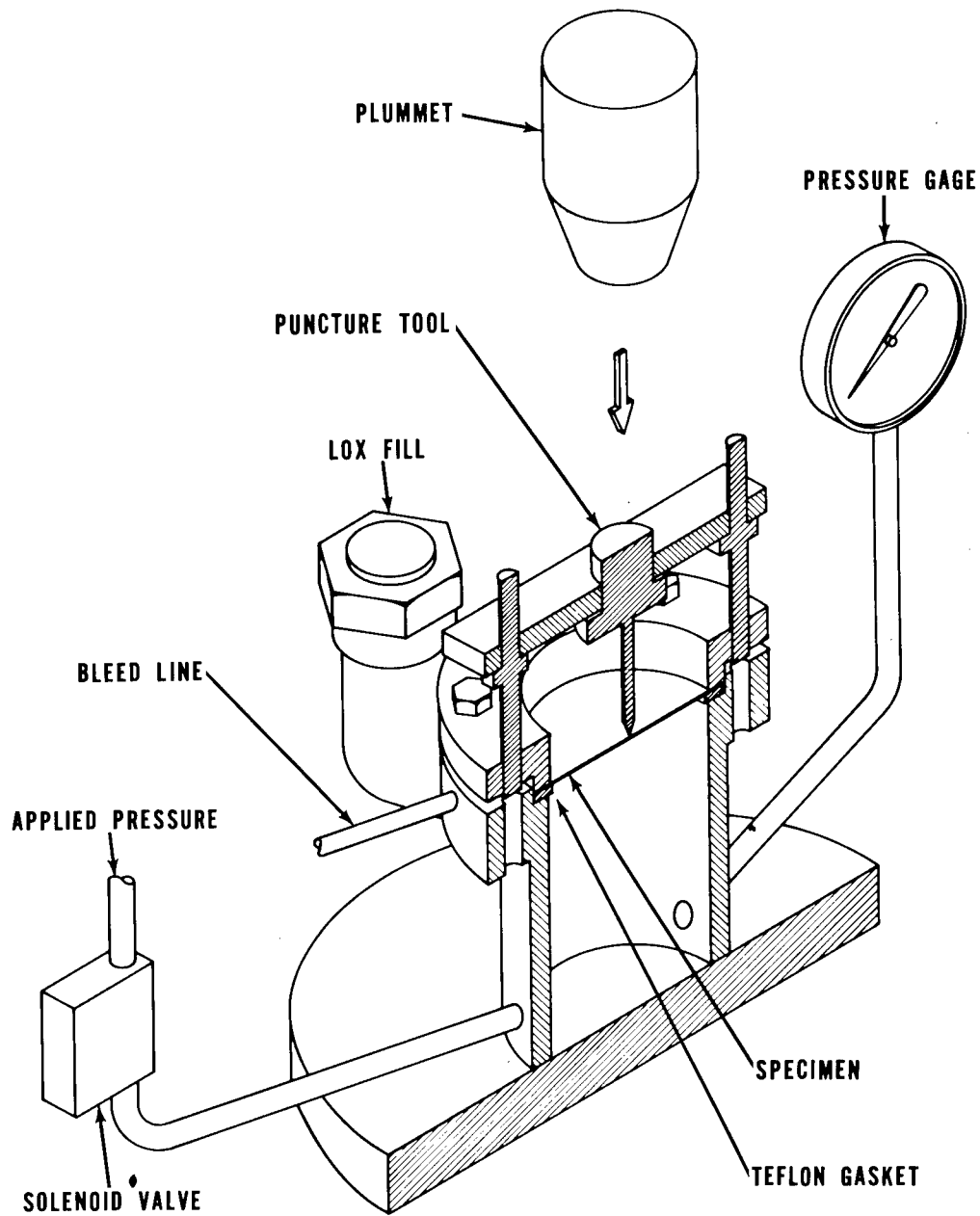
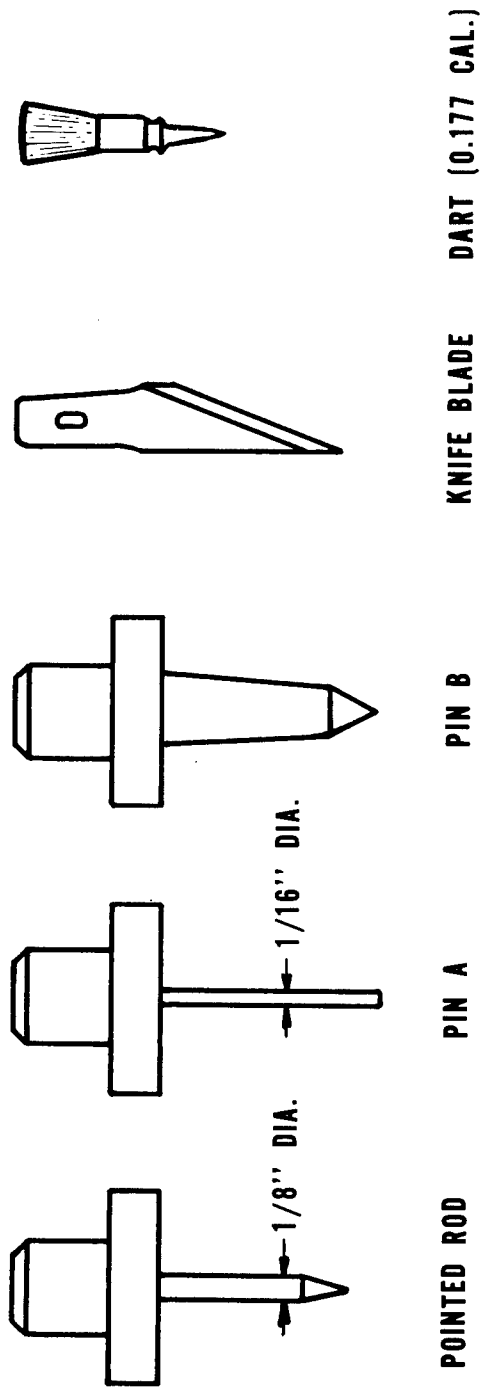

FIGURE 29. TEST SETUP FOR EXTERNAL GAS PHASE PUNCTURES



ACTUAL SIZE

FIGURE 30. PUNCTURING TOOLS

Table 27. Summary of Diaphragm Puncture Tests Gaseous Phase

With Internal Pressure of 35-40 psig

Thickness (in.)	Puncturing Tool	5A1-2.5Sn Titanium				LOX Temp.			2014-T6 Aluminum		6061-T6 Aluminum		
		D*	SB*	F*	Total No.	D	SB	F	Total No.	Room Temp.	LOX Temp.	Room Temp.	LOX Temp.
0.010	1/8 in. pointed rod			3	6	1		7	8				
	Pin A			5	6								
	Pin B					2	1	1	4		0/4		
	Knife Blade	1	1		4		1	2	3	0/5			
0.025	1/8 in. pointed rod			10	10	7	3	2	14		0/10	0/5	0/9
0.032	1/8 in. pointed rod			2	2								
0.063	1/8 in. pointed rod									0/2	0/12		
Sub-Totals		1	13	8	28	10	5	12	29	0/7	0/26	0/5	0/9
Totals		22/28				27/29				0/33	0/14		
						49/47				0/47			
						86%							

* - Detonations, Sustained Fast Burning, Flashes.

or rapid combustion of all of the exposed titanium (FIG 31). The detonations were accompanied by a very loud explosion which usually blew open the door of the test cell (friction latch). Detonations were much more frequent in the low temperature than in the room temperature tests. This may be due to a higher concentration of oxygen present.

No reactions were obtained in 47 trials with two aluminum alloys (2014-T6 and 6061-T6) under a similar variety of test conditions. Comparative tests were made also with a type 301 stainless steel diaphragm (0.012-inch thick) at low temperatures. No reactions occurred in ten trials (FIG 32). Similar puncture tests with thin (0.006-inch) commercially pure aluminum at room temperature also failed to produce any reactions in four trials (Table 28).



ORIGINAL SPECIMEN

NO COATING

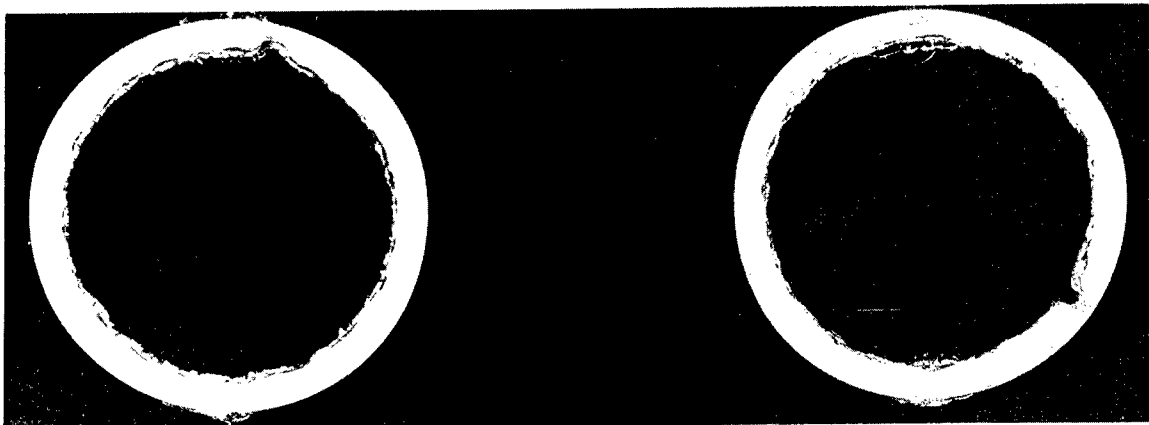

ELECTROLESS NICKEL COATED

ELECTROLESS COPPER COATED

**ALL SAMPLES - 0.010 IN. THICK X 2 $\frac{3}{4}$ IN O.D.-5Al-2.5Sn TITANIUM
PRESSURIZED TO 35-40PSI. INTERNALLY WITH LOX & GOX &
PUNCTURED IN GAS PHASE BY 1/8 IN. DIAM. POINTED ROD.**

**FIGURE 31. TYPICAL APPEARANCE OF TITANIUM DIAPHRAGMS
AFTER PUNCTURE TESTS**

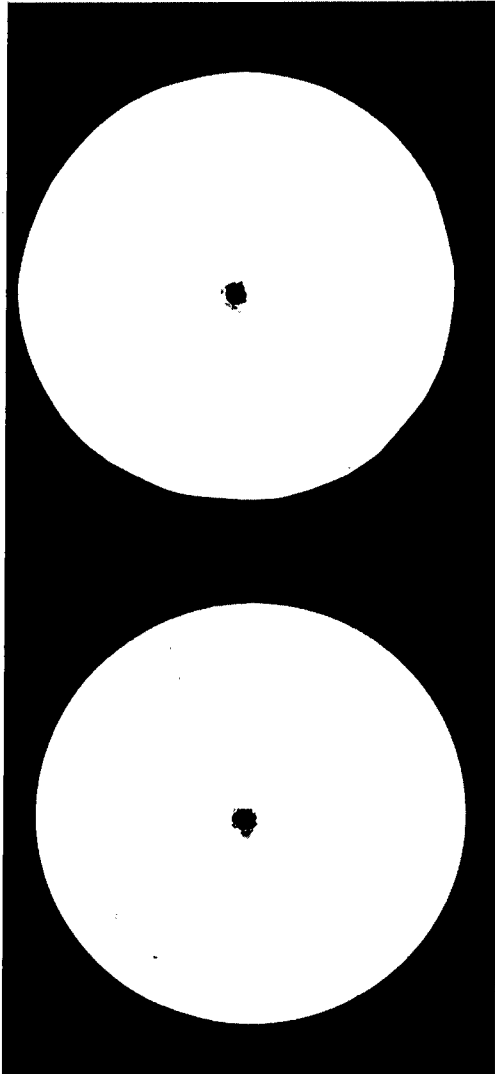

**2014-T6 ALUMINUM
0.010 IN. THICK**

**301 STAINLESS STEEL
0.012 IN. THICK**

**PRESSURIZED TO 35-40PSI. INTERNALLY WITH LOX & GOX,
AND PUNCTURED IN GAS PHASE BY 1/8 IN. POINTED TOOL**

**FIGURE 32. TYPICAL APPEARANCE OF ALUMINUM AND
STAINLESS STEEL DIAPHRAGMS AFTER PUNCTURE**

Table 28. Miscellaneous Diaphragm Puncture Tests
 Gaseous Phase
 1/8" Pointed Pin - 35-40 psig O₂

	HK31 Magnesium	1100 Al	301 S. S.	Allpax 500 Fluorolube	Titanium 13V-11Cr-3Al
Thickness (in.)	0.063	0.006	0.012	0.063	0.025
Temperature	Room	Room	LOX	LOX	Room
Results	1/20 ^{*1}	0/4	0/10	0/5	4/6 ^{*2}
*1 1 Faint Flash in 20 trials, 2 at 40 psig, and 9 each at 60 and 100 psig.					
*2 3 Sustained burnings and 1 flash					

Because of the lower degree of reaction frequency in impact sensitivity testing of the 13V-11Cr-3Al titanium alloy (as compared with the 5Al-2.5Sn alloy) six 0.025-inch thick discs were punctured while exposed to gaseous oxygen at room temperature. Three burned violently to complete sample consumption, and one produced a flash. Thus, this alloy was not significantly less reactive than the 5Al-2.5Sn alloy upon penetration in contact with oxygen.

In order to obtain further comparisons of the relative reactivity of these materials with oxygen on the basis of impact and puncture sensitivity testing, puncture tests were made on HK31 magnesium alloy, and an organic material, Allpax 500. The latter is rendered acceptable in the impact sensitivity test by impregnating with a fluorocarbon oil and is widely used as a gasket material in MSFC LOX systems. One faint flash was observed in 20 puncture tests on the magnesium (0.025-inch thick) at room temperature, and no reactions occurred in five trials with the Allpax (0.063-inch thick) at low temperature. These limited tests indicated that the relative rating of materials based on puncture tests apparently correlates well with the rating based on impact sensitivity tests.

The results clearly prove that penetration of titanium diaphragms pressurized with oxygen usually will produce a detonation or violent and rapid combustion of the metal. Similar results were obtained with two titanium alloys. Three common aluminum alloys, one stainless steel, and a LOX compatible (based on impact tests) organic gasket material were tested and produced no reactions under the same test conditions. Magnesium produced only very slight evidence of any reactivity on puncture.

(1) Effect of Gas Composition. Five 0.025-inch thick titanium diaphragms were punctured while exposed to 100 psig air internally. Two flashes resulted. Two flashes also were observed in three similar tests with 0.010-inch thick titanium. Thus, it appears that while puncture of titanium pressurized with air will produce a reaction, it probably will not propagate to yield an explosion. Control tests also were made with gaseous nitrogen at 35-49 psig on the reverse side of titanium diaphragms. Two samples each of 0.010-inch and 0.025-inch thick titanium were punctured with the 1/8-inch diameter pointed tool. No reactions occurred in any of these tests.

(2) Effect of Pressure. Fifteen puncture tests were made using gaseous oxygen at pressures from 20 to 0 psig (Table 29). The latter value was obtained with only a trickle flow of oxygen through the container to an open vent. Four reactions still occurred in five trials at atmospheric pressure, two of which sustained burning to sample consumption.

(3) Effect of Coatings. The effectiveness of those coatings which protected titanium from reacting in the impact sensitivity tests was investigated under puncture conditions (Table 30). Electroless nickel and electroless copper plated titanium diaphragms were punctured at ambient and LOX temperature. The coatings did not provide protection from reaction on penetration. Because of the inherent exposure of the fresh surface of the base material on penetration, it is doubtful that any surface coating could prevent the titanium from reacting under such conditions.

Only one of the six tests with coated samples failed to produce sustained burning, and in this case, the pin penetrated the diaphragm but the puncture accidentally sealed before appreciable gas escaped. This result suggests that a gas flow across the fresh surface is necessary to initiate the reaction on puncture.

Table 29. Effect of Pressure on Titanium Diaphragm Reactivity on Puncture

Using 1/8 in. diam. pointed tool and 0.010 in. thick 5Al-2.5Sn Titanium, and gaseous oxygen at room temperature.

Pressure psig	Total No. Tests	REACTIONS	
		Sustained Burning	Results No. Flashes
25	1	1	-
20	1	1	-
15	4	2	2
10	2	1	1
5-6	2	1	1
0	5	2	2

b. Liquid Phase. Studies also were made to investigate the effect of penetrations with liquid oxygen on the reverse side. In these tests, the test diaphragm was placed in the bottom of the container and punctured from below. This was accomplished by using the plummet of impact sensitivity tester to deliver the puncturing force through a "see-saw" lever arm as shown in FIG 33.

Reactions occurred twenty times in twenty-one trials, 15 with 0.010-inch thick, and 5 with 0.025-inch thick titanium (Table 31). In the single instance where no reaction occurred, the puncture self-sealed, as occurred once previously in the gas phase puncture tests. Of the twenty reactions, eight were explosions and seven consisted of violent sustained burning of the sample.

In order to obtain some insight as to whether microscopic punctures with a low energy driving force would initiate a reaction, several tests were made using a dart as the puncturing tool. A caliber 0.177 steel dart was fired from a commercial air pistol

Table 30. Effect of Coatings on Puncture Sensitivity of Ti/O₂

All Samples 5A1 2.5Sn Titanium 0.025 inch thick					
Diaphragm Punctures - Internally pressurized to 30-35 psig and tested in gaseous phase, punctured with 1/8 inch diameter pointed rod. Coating Thickness - 0.2 to 0.3 mil per side.					
RESULTS					
	<u>D</u>	<u>SB</u>	<u>.F</u>	<u>Total No.</u>	<u>Summary</u>
<u>Ambient Temperature -</u>					
No Coating		10		10	10/10
El. Cu both sides		1		1	} 2/2
El. Ni both sides		1		1	
<u>LOX Temperature -</u>					
No Coating	2	1	1	4	4/4
El. Cu both sides		1		1	} 3/4
El. Cu one side		1		1	
El. Ni both sides		1		2*	
*2nd test punctured, but sealed					

into the 0.010-inch thick titanium diaphragm. One "sustained burning" reaction, and three flashes resulted in four trials. A control test in which the darts were fired into a diaphragm in air showed that the punctures were only several hundred microns in diameter.

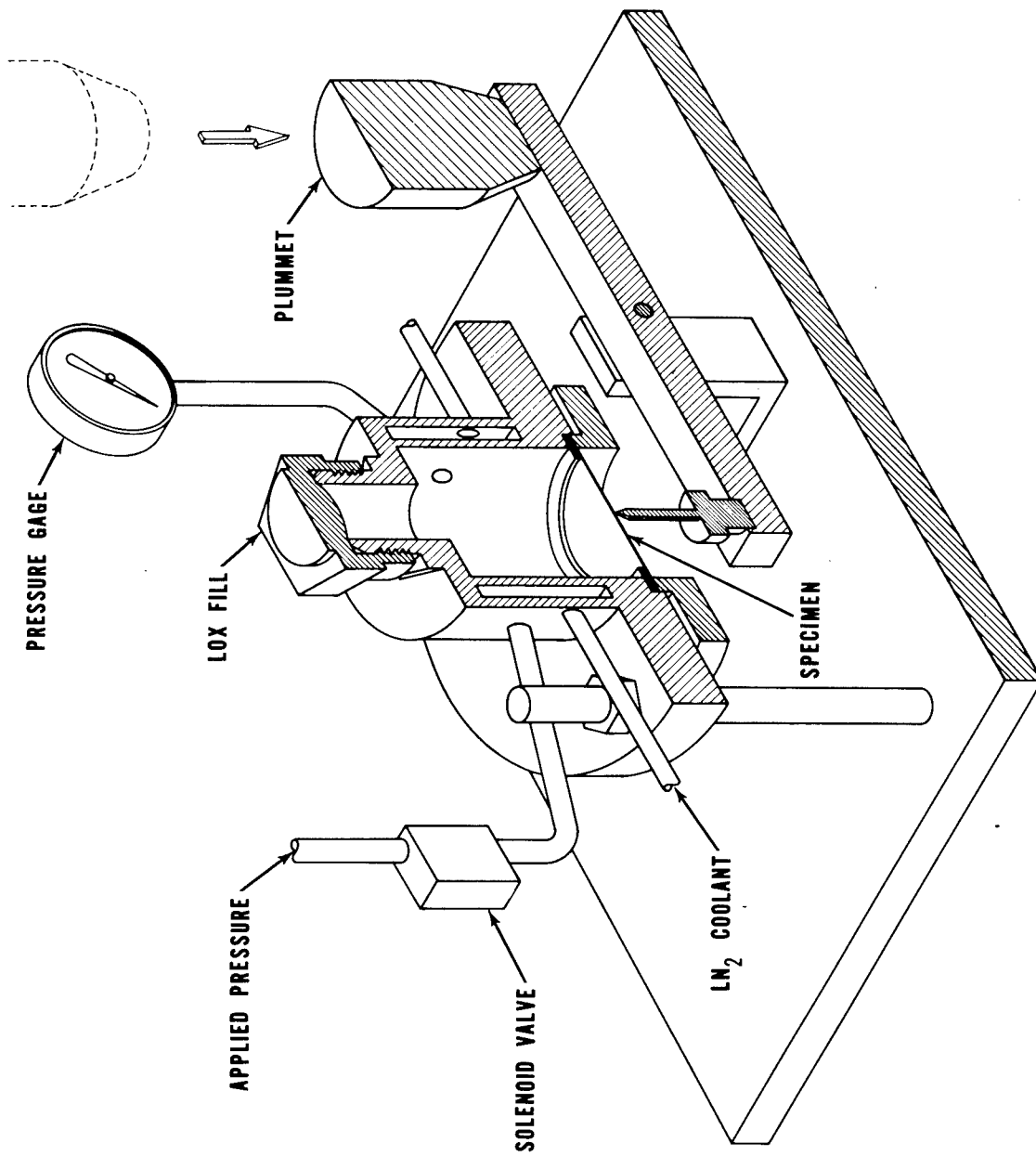

FIGURE 33. TEST SETUP FOR EXTERNAL LIQUID PHASE PUNCTURES

Table 31. Summary of Diaphragm Puncture Tests

<u>Liquid Phase - 35-40 psig</u>							
Using 1/8 inch diameter pointed puncturing tool (unless otherwise noted)							
<u>Titanium (5Al-2.5Sn)</u>					<u>Aluminum</u>	<u>St. Steel</u>	
Thickness (In.)	Det.	SB	F	Total No. Tries	(2014-T6)	(301)**	Remarks
0.010	4	6	1	12*	0/10	2 very weak Flashes/10	0.177 cal. Dart Punctures
0.010		1	3	4			
0.025	4	0	1	5			

* One Puncture - but sealed and held pressure.

** Actually 0.012" thick

In comparative tests, neither 0.010-inch nor 0.025-inch aluminum (2014-T6) reacted in ten puncture trials each under the same test conditions. Two very weak flashes were noted in 10 trials on 0.012-inch thick 301 stainless steel. It is suspected that the latter minor flashes probably were either from the puncturing pin (17-4 PH steel) and diaphragm, or from the mild steel lever arm striking the test fixture. However, this could not be easily discerned because the "upside down" mode of test prevented direct view of the puncturing process.

Control tests also were made by substituting LN₂ for LOX (Table 32). No reactions occurred in ten trials each with 0.010-inch and 0.025-inch titanium.

Tank Tests. In order to more nearly simulate service conditions, five model tanks were filled with LOX, pressurized to 35-40 psig, and punctured. All tanks were of similar shape and size as shown in FIG 14 and initially were made with 0.063-inch thick walls. Three were made of 5Al-2.5Sn titanium and two of 2014-T6 aluminum. When it was found to be difficult to puncture the round

Table 32. Effect of Liquid Nitrogen
Substitution for LOX

On Diaphragm Puncture Sensitivity - Using Ti-5Al 2.5Sn Alloy, 1/8" diam. pointed puncturing tool Liquid Phase Punctures, 35 - 40 psig internal pressure.

Thickness In.	<u>Liquid Oxygen</u>				<u>Liquid Nitrogen</u>
	Det.	SB	F	Total No. Tries	
0.010	4	6	1	12	0/10
0.025	4	0	1	5	0/10

head of these tanks with the 1/8-inch diameter pins (because of mechanical limitations of the puncturing device, i. e., the pin generally slid down the side), the puncture areas were milled down to 0.025- to 0.032-inch thick on one titanium and one aluminum tank. On one of the titanium tanks, the upper head was removed and replaced with flat 0.025-inch sheet.

The most drastic puncture test used was penetration by a standard M-1 rifle bullet, i. e., caliber .30-06 bronze jacketed lead slug. The test setup is shown in FIG 34. The first test was made with the aluminum tank. No reaction occurred. The bullet penetrated both sides of the tank, leaving clean holes.

The titanium tank exploded under the same conditions. Remains of the tank are shown in FIG 35. High speed motion pictures disclosed that fast and violent combustion occurred immediately on penetration, showering the area with flying particles of burning titanium. These burning particles subsequently exploded in flight. The reaction appeared to be subsiding somewhat when, several tenths of a second after initial penetration, a detonation occurred. The test was not provided with blast instrumentation; however, the blast was very powerful.

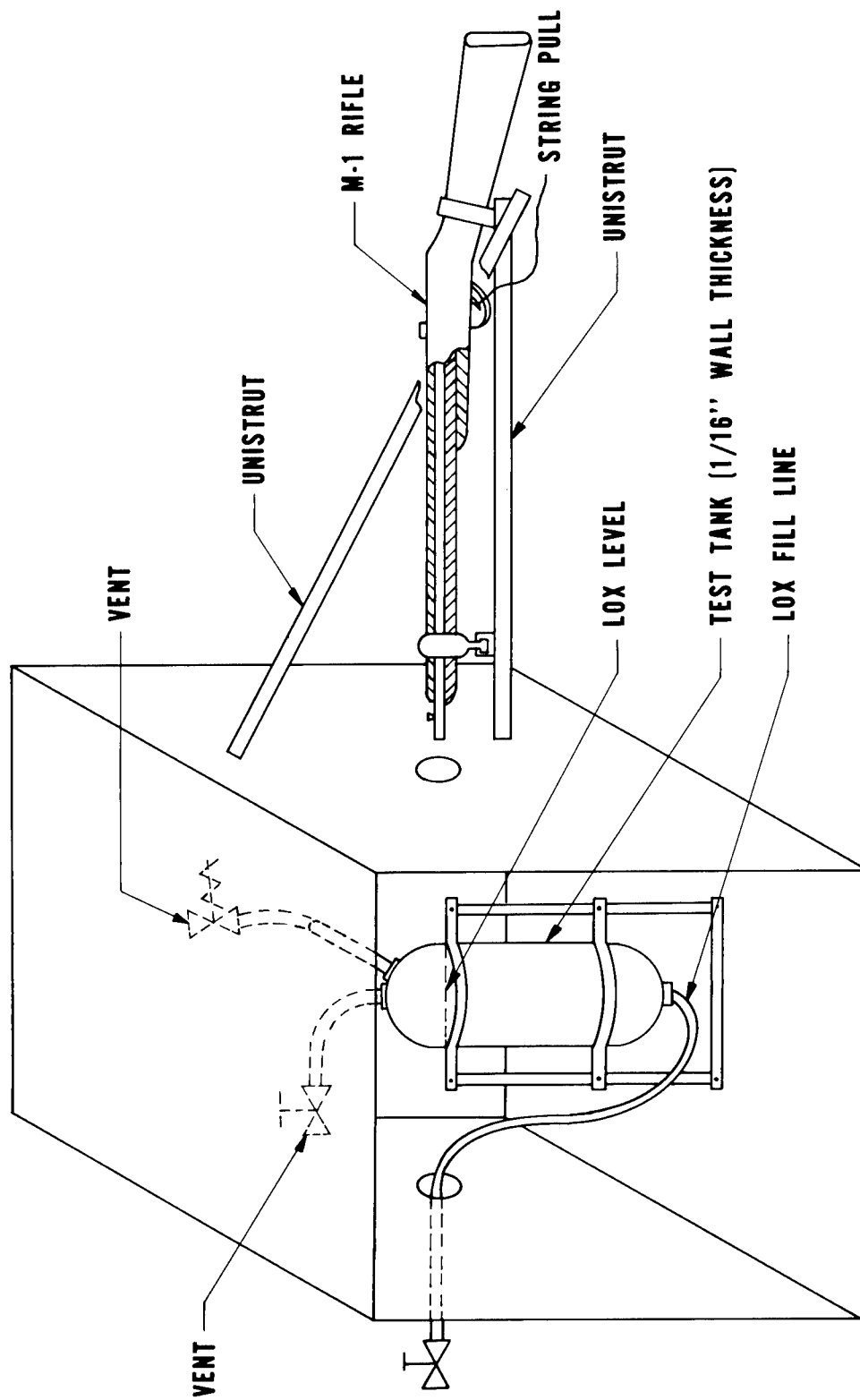

FIGURE 34. TANK PUNCTURE APPARATUS (M-1 RIFLE SETUP)



**FIGURE 35. REMAINS OF TITANIUM TANK AFTER PUNCTURE
(CONTAINED LOX PRESSURIZED TO 35-50 PSIG,
PUNCTURED WITH 1/8" PIN)**

Tests also were made with the milder pin type punctures used in the diaphragm tests. The two milled head tanks were used for these. The test setup and puncturing mechanism are shown in FIG 36.

An aluminum tank was tested first and again failed to react on puncture. In the first pin test on the titanium tank, the puncture self-sealed and no reaction occurred. In order to provide some information on the initiation of reactions in tanks by shock conditions, a 10-inch length of 40 gr/ft Primacord was taped to the side of this container. (None of the previous shock sensitivity tests were made with tanks.) The tank was refilled with LOX and was being pressurized when an explosion occurred spontaneously. The Primacord had not been set off at the time. It is suspected that the pin may have been jarred loose during pressurization and the escaping gas ignited the titanium. High speed camera coverage of this explosion disclosed the same delayed detonation process as occurred in the bullet puncture. The explosions from both tanks were of the same relative degree of blast intensity. The remains of this tank were similar to those of the previous test.

Another pin puncture test was made using a titanium tank in which the top head was replaced by a 0.025-inch flat sheet. An explosion and delayed detonation again occurred.

Results of these tests are summarized in Table 33. The titanium tanks exploded in all three trials on puncture. Neither of the two aluminum tanks reacted under the same conditions.

Concurrent with these tests at MSFC, the Lewis Research Center fired steel and Nylon pellets (7/32-inch diameter) into a 0.025-inch thick titanium diaphragm, which was exposed to LOX internally (ref. 19). Violent explosions resulted with both types of projectiles.

Meteoroid Simulation Tests. The nature of the problem incurred by meteoroid impacts in space flight is ill defined. Although much work has been reported in this field, there still exists a very high degree of uncertainty of predictions of meteoroid impacts and their effects on space vehicles. For example, the range of meteoroid distribution curves published by Whipple indicates that the probability

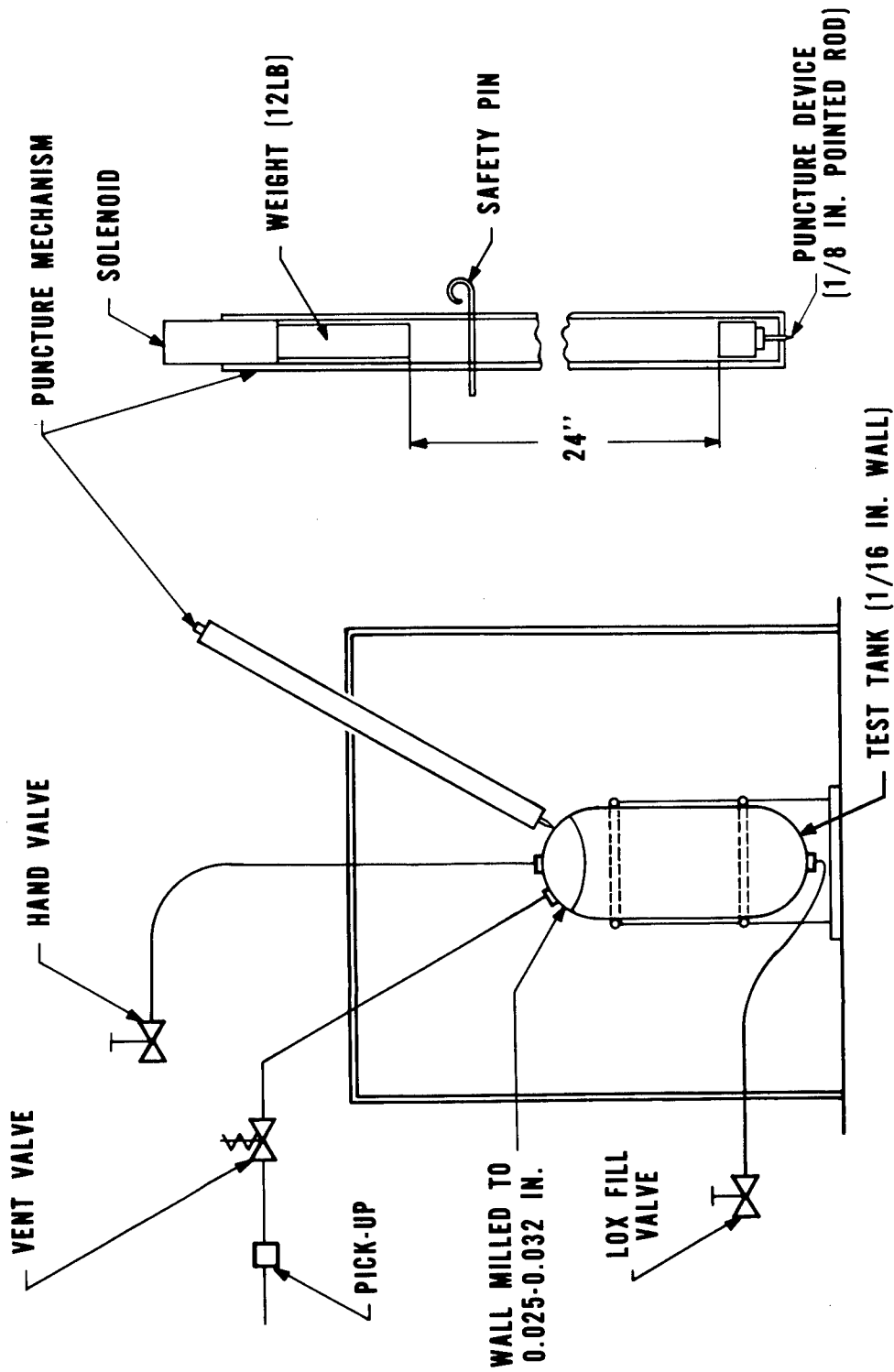

FIGURE 36. TANK PUNCTURE APPARATUS-PIN TYPE TEST SETUP

Table 33. Summary of Tank Puncture Tests
Containing LOX and GOX at 35-40 psig

<u>Tank</u>	<u>Puncturing Implement</u>	<u>5Al-2.5Sn Titanium</u>	<u>2014-T6 Titanium</u>
1/16 inch wall	Bronze Jacketed Slug from M-1 Rifle	Fast Burn, then Detonation	No Reaction
1/16 inch wall with head milled to 0.025-0.032 inch thick	1/8 inch pointed rod	Puncture sealed Re-pressurized-Primacord-Unexplained explosion	No Reaction
1/16 inch wall with flat 0.025 inch head	1/8 inch pointed rod	Fast Burn, then Detonation	-----

of meteoroid particles capable of penetrating to a 0.010-inch depth in aluminum varies from 10 in 24 hours to one in three years (10^{+1} to 10^{-4}) per square meter of surface (ref. 20).

The results of the previous puncture tests strongly indicated that penetration of titanium tanks containing LOX by a single meteoroid encountered in space flight could result in a catastrophe.

Consequently, it was decided to investigate the behavior of titanium diaphragms, pressurized with LOX, upon simulated meteoroid punctures. Since meteoroid simulation facilities were not available at MSFC, the work was done under contract by two independent companies.

The General Dynamics/Aeronautics (GD/A) Corporation fired 0.1 to 0.2 g steel projectiles through air at velocities from

9,100 to 15,900 ft/sec into titanium, aluminum, and stainless steel diaphragms, internally pressurized with LOX (ref. 21).

In this study, two diaphragms were tested simultaneously by use as front and back closures for a cylinder lying along the path of the projectile. Using titanium discs, the back diaphragm ignited and burnt violently 15 times in 16 tests. Test conditions included both the 5Al-2.5Sn alloy and the 6Al-4V alloy, in thicknesses of 0.025, 0.016, and 0.014 inch, gaseous oxygen at room temperature or LOX, and pressures of 20 and 60 psig. The front diaphragm reacted less often, but still in over one-half of the tests.

Control tests using 60 psig N₂ or zero psig air with titanium diaphragms produced no reactions. Eight trials with 0.016-inch thick 2024-T3 aluminum discs (60 psig - GOX and LOX), and seven trials with 0.010-inch thick 301-XFH stainless steel also failed to react. However, slight oxidation was noted around some of the penetrations in aluminum.

GD/A also investigated whether sandwiching of the titanium between aluminum or stainless steel plates would diminish the reactivity. Diaphragms consisting of 2014-T3 aluminum, then 6Al-4V titanium, then 2014-T3 aluminum (all 0.016-inch thick) were placed on both ends of the test cylinder and punctured. Both ignited and burnt violently. Furthermore, the titanium reaction ignited the aluminum, which also burnt violently.

Similar results were obtained with sandwich diaphragms of 0.016-inch 6Al-4V titanium encased in two layers of 0.010-inch 301 XFH stainless steel. The steel also was burned extensively.

Results from these sandwich tests show that cladding of titanium with aluminum or stainless steel not only will not prevent titanium from reacting with oxygen upon puncture, but the titanium reaction will trigger burning of the "protective" material.

In the preceding tests, the particles were fired through the air. At such high velocities the particles probably were heated by friction in flight. Because it was suspected that ignition may have been triggered by the hot particle reacting with the air, titanium, and/or oxygen, experimental work also was done by firing the particles through a vacuum. This work was done by the Utah Research and Development Company (ref. 22).

The same type of test fixture was employed as previously, i. e., a horizontal cylinder with diaphragms of the test material in both ends, except that the front face formed the barrier between the oxygen (inside the cylinder) and the vacuum chamber. The pressure in the vacuum chamber was approximately 250 μ Hg, and the oxygen pressure was 60 psig in all tests.

Several types of guns were fired. Using a powder gun and spray technique, 5 to 15 micron size particles were accelerated to 25,000 to 29,000 ft/sec. However, the particles did not penetrate the target diaphragms (titanium) and no reaction occurred in four trials. By using a light gas gun, 1/16-inch diameter steel spheres were accelerated to 10,000 to 17,700 ft/sec. Three tests were made using both 5Al-2.5Sn and 6Al-4V titanium alloy diaphragms (2 per run) at thicknesses of 0.016 and 0.025 inch. Two were run with GOX (room temperature) and one with LOX. All six diaphragms burned upon puncture. Both of the diaphragms were completely consumed in the LOX test. Burning was not as extensive in the gaseous phase tests, due perhaps to depletion of the oxygen supply.

Using either GOX or LOX, no reactions occurred upon puncture of 301-XFH stainless steel (0.010-inch thick) or 2024-T3 (0.016-inch thick) diaphragms under the same test conditions as above. However, in both (aluminum and steel) tests in the liquid phase, the diaphragms were ruptured mechanically. No burning occurred. It is suspected that this was caused by hydrodynamic pressures following impact of the high velocity particle with the liquid, and/or a localized reaction of the pellet and the oxygen upon frictional heating in passage through the liquid. Tests also were made using the 1/16-inch diameter steel spheres at velocities of only 610 to 650 ft/sec. Four titanium diaphragms were penetrated using LOX internally. In these tests, the projectiles did not have sufficient energy to penetrate the rear diaphragm. No reaction occurred in one case. However, the other three diaphragms exploded and burned violently, consuming roughly sixty percent of the metal.

For comparative purposes, gaseous hydrogen at 60 psig was substituted for the oxygen inside the cylinder. Two tests were made in which 1/16-inch steel spheres at 16,000-17,000 ft/sec penetrated 0.016-inch titanium diaphragms. No reactions occurred.

J. SUMMARY FOR SECTION V

Based upon considerable experimental work at MSFC, and additional tests by four other laboratories, it is concluded that titanium tanks, or diaphragms, containing oxygen will almost always react violently, and frequently explode, upon puncture. Ignition of the reaction apparently is independent of composition of the penetrating particle or tool, or mode of puncture. Coatings which reduced the shock or impact sensitivity of titanium with oxygen were not protective under these conditions.

Aluminum or stainless steel alloys did not react under the same test conditions.

SECTION VI. COMPARISON OF RELATIVE MATERIALS REACTIVITY RATINGS USING DIFFERENT TEST METHODS

In the preceding sections, four major types of conditions were found capable of causing titanium to react with oxygen, i. e., impact, shock, puncture, and spark. The investigation along each of these lines constituted a different type of "sensitivity" test method. In addition to titanium, aluminum also was tested by all four methods, and stainless steel, magnesium, and organic gasket materials were tested by three of the methods. Ratings of the relative reactivity of these materials with oxygen based on all four methods are shown in Table 34. All of the ratings correlate with each other very well, and are in agreement with the relative reactivity based on chemical considerations. Furthermore, the corroboration of ratings based on the impact sensitivity test method by all of the other three methods lends considerable support to the validity of the former method and its respective criteria for acceptance of materials for LOX service. This is the test method most widely used in the space vehicle industry to evaluate the compatibility of materials with LOX.

Table 34. Comparison of Relative Reactivity of Materials with Oxygen
Based on Different Test Methods

TEST METHOD	MATERIAL TESTED			FLUOROCARBON IMPREGNATED ALLPAX
	TITANIUM	MAGNESIUM	ALUMINUM	
	(5 Various Alloys)	HK31	(1100, 6061, 2014)	301
#1 Impact Sensitivity Relative Reactivity Rating	Very High	Very Slight	Very Slight	Unreactive
Basis - Reaction Frequency At 10 Kg-M Impact	19-60%	0% (0/40)	1.6%	1.6%
Insensitivity Level In Kg-M	1-3	Over 10	Over 10	Over 10
#2 Shock Sensitivity Relative Reactivity Rating	Very High	Slight	Very Slight	Unreactive
Basis: Cylindrical Cup Test Method Average length of Primacord for Ignition	0 (Detonator Cap only)	200 gr/ft	250 gr/ft	Over 400 gr/ft Over 400 gr/ft
#3 Puncture Sensitivity Relative Reactivity Rating	Very High	Slight	Very Slight*	Unreactive
Basis: 1/8 inch Pin Tests Gas Phase No. Reactions/No. Tests	49/57	1/20	0/51	0/10 0/5
#4 Spark Sensitivity Relative Reactivity Rating	Very High	-	Unreactive	Unreactive
Basis: 0.05 to 0.010 inch thick Sheets tested in GOX at Spark Energies of 1-10 Joules				

* Slight oxidation occurred around edges in some meteoroid simulation tests

SECTION VII. SUMMARY

This study was made to investigate whether titanium reacted with oxygen under a variety of conditions associated with space vehicles, and if the titanium could be treated or coated to eliminate such hazards.

The impact sensitivity test method was used to investigate the effect of various alloys, weldments, surface treatments, coatings, and other factors upon the reactivity of titanium with oxygen. Those factors which generally did not significantly affect the impact sensitivity of titanium in LOX included polishing, the nature of the mating surfaces, or phosphate and anodized or ceramic coatings. Impact sensitivity also was essentially independent of the type of titanium alloy, and weldments did not affect the sensitivity. Pickling or passivation of the metal, or the presence of grit, markedly increased the reactivity. Deburring of edges, the oxide layer formed by annealing, "Teflon" coatings, or nitriding decreased the reactivity but still did not sufficiently desensitize the material to render it acceptable. Electroless or electroplated copper or nickel coatings did satisfactorily protect the titanium from impact sensitivity in LOX if the former type of coatings were 0.2-0.3 mil thick, and the latter 1 mil thick. Since adhesion of the nickel coatings generally is poor, the copper coating is preferred.

The following environmental conditions failed to induce reaction of titanium with oxygen (in the particular tests employed):

Vibration - high frequency, low amplitude - to 20 G's
- low frequency, high amplitude - "Rotap" machine

Pressure Cycling - to 1500 psig

Acoustic Energy - 27 kc ultrasonic vibrations
- 150 db sonic level near rocket motor

Heating in Air - to 1200°C (2200°F) with a H₂/air flame

Small orifices or pressurization to rupture (limited tests)

External Impacts - up to 144 ft/lb energy through a 1/2 inch diameter area (limited tests)

Although comparatively high spark energies (several joules) were necessary to ignite 0.010 inch thick titanium in oxygen, this combination was far more susceptible to spark initiation than aluminum or steel in oxygen.

The shock stimuli produced by small detonator caps alone were sufficient to initiate explosive reaction of titanium in contact with oxygen. Under the same test conditions, an extremely heavy shock, i. e., 250 gr/ft Primacord plus detonator caps, were required to initiate reaction of aluminum in oxygen. Stainless steel could not be made to react with oxygen under the most drastic shock conditions tried (400 gr/ft Primacord).

Titanium ^Atanks containing ^{Ti}LOX and/or GOX will almost always react violently, and frequently detonate, upon puncture. This occurred whether penetration was accomplished by pins, darts, bullets, Nylon or steel pellets, or simulated meteoroids fired through air or a vacuum. Aluminum or stainless steel tanks or diaphragms did not react under these same test conditions. Violent reactions occurred whether the container was pressurized or not. However, when air was substituted for the oxygen, only flashes resulted without appreciable propagation of the reactions.

Electroless copper or nickel coatings (0.2-0.3 mil thick) decreased the shock sensitivity in LOX, but the composite material was still more sensitive than aluminum. These coatings did not appreciably decrease the reactivity upon puncture.

On the basis of the findings of these studies, titanium is not recommended for construction of thin walled LOX tanks for space vehicles.

The reactivity of titanium with oxygen upon punctures, impacts, or shock stimuli should be thoroughly considered prior to use in other applications in space vehicles.

Handwritten notes:] [LOX-LN] [Surface Treatment] [Fatigue Cracks]

[See DMIC 51318] end

REFERENCES

1. Cawthorne, E. W., LOX-Titanium Reaction at Aerojet-General Corporation, Defense Metals Information Center Memorandum, February 20, 1959.
2. Butler, C. K., LOX-Titanium Reaction at Aerojet-General, private communication, July 15, 1959 to Battelle Memorial Institute, Columbus, Ohio.
3. Brennen, W. J., Failure of Titanium Helium Bottle, Rocketdyne, Canoga Park, California, Letter 59RD9330 to Battelle Memorial Institute, Columbus, Ohio.
4. Littman, F. E., and Church, F. M., A Study of Spontaneous Ignition of Metals, Stanford Research Institute, Menlo Park, California, AEC Final Report, Contract No. AT(04-3)-115 (August 15, 1960).
5. Boyd, W. K., and Cawthorne, E. W., ARTC Committee Meeting on LOX-Impact Testing, Project 18-48, October 20, 1959, Defense Metals Information Center Report on Travel, November 4, 1959.
6. Funck, J. J., Defense Metals Information Center Memorandum, August 3, 1959.
7. Jackson, J. D., Miller, P. D., Boyd, W. K., and Fink, F. W., A Study of the Titanium Liquid Oxygen Pyrophoric Reaction, WADD Tech. Report 60-258, June 1960.
8. Millaway, E. E., and Covington, L. C., Resistance of Titanium to Gaseous and Liquid Fluorine, Titanium Metals Corporation of America, Report No. 3, March 1959.
9. Jackson, J. D., Titanium-LOX at Bendix Aviation Corporation, Pioneer Central Division, Davenport, Iowa, Defense Metals Information Center Memorandum, February 15, 1960.
10. Littman, R. E., and Church, F. M., Reactions of Titanium With Water and Aqueous Solutions, Stanford Research Institute, Final Report, June 15, 1958.

REFERENCES (Continued)

11. Jackson, J. D., Miller, P. D., Boyd, W. K., and Fink, F. W., A Study of the Mechanism of Titanium-Liquid Oxygen Explosive Reaction, Battelle Memorial Institute, ASD Tech. Report 61-479, September 1961.
12. Lucas, W. R., and Riehl, W. A., An Instrument for the Determination of Impact Sensitivity of Materials in Contact With Liquid Oxygen, DSN-TR-2-58, October 15, 1958.
13. Ibid. - ASTM Bulletin, February 1960 (TP-33).
14. Curry, J. E., and Riehl, W. A., Compatibility of Materials With Liquid Oxygen, Marshall Space Flight Center, MTP-M-S&M-M-61-7, March 21, 1961.
15. U. S. Naval Ordnance Laboratory, Statistical Methods Appropriate for Evaluation of Fuze Explosive-Train Safety and Reliability, NAVORD Report 2101, White Oak, Maryland, 13 October 1953.
16. Dean, L. E., and Thompson, W. R., ARS Journal, July 1961, pp. 917-923.
17. Hill, P. R., Adamson, P., Foland, D. H., and Bressette, W. E., NACA Research Memo No. RML53L23b, High Temperature Oxidation and Ignition of Metals.
18. Brown, F. W., Kusler, D. J., and Gibson, F. C., Sensitivity of Explosives to Initiation by Electrostatic Discharges, U. S. Department of the Interior, Bureau of Mines Report of Investigations 5002, September 1953.
19. Private communications from Messrs. W. Brown and J. Shannon of Lewis Research Center, to the authors of this report.
20. Whipple, F. L., American Rocket Society, Report No. 2253-61, October 9-15, 1961.

REFERENCES (Concluded)

- (27)
21. Rolsten, R. F., Hunt, H. H., and Wellnitz, J. N., Hypervelocity Impact on Pressurized Structures, J. N., Report No. AE-62-0207, General Dynamics/Aeronautics Corporation, January 31, 1962.
 22. Data received in tabular form from Utah Research and Development Company, Salt Lake City, Utah, communication to authors via Mr. A. Hurlich of General Dynamics/Aeronautics Corporation, January 1962.

NASA TR R-180

stainless steel failed to react on impact or puncture. The shock stimuli produced by small detonator caps alone were sufficient to initiate explosive reaction of titanium in contact with oxygen. An extremely heavy shock was necessary to cause aluminum to react under the same test conditions, and stainless steel did not react under the most drastic shock conditions employed. The titanium/oxygen combination is considerably more susceptible to spark initiation than aluminum/oxygen. A comparatively high energy spark was necessary for reaction of 0.010-inch-thick sheets of titanium with oxygen. Under the particular test conditions used, titanium was insensitive to reaction with oxygen when subjected to vibration, pressure cycling, or to rupture with pressurization of thin walled tanks containing LOX.

NASA

NASA TR R-180

stainless steel failed to react on impact or puncture. The shock stimuli produced by small detonator caps alone were sufficient to initiate explosive reaction of titanium in contact with oxygen. An extremely heavy shock was necessary to cause aluminum to react under the same test conditions, and stainless steel did not react under the most drastic shock conditions employed. The titanium/oxygen combination is considerably more susceptible to spark initiation than aluminum/oxygen. A comparatively high energy spark was necessary for reaction of 0.010-inch-thick sheets of titanium with oxygen. Under the particular test conditions used, titanium was insensitive to reaction with oxygen when subjected to vibration, pressure cycling, or to rupture with pressurization of thin walled tanks containing LOX.

NASA

NASA TR R-180

stainless steel failed to react on impact or puncture. The shock stimuli produced by small detonator caps alone were sufficient to initiate explosive reaction of titanium in contact with oxygen. An extremely heavy shock was necessary to cause aluminum to react under the same test conditions, and stainless steel did not react under the most drastic shock conditions employed. The titanium/oxygen combination is considerably more susceptible to spark initiation than aluminum/oxygen. A comparatively high energy spark was necessary for reaction of 0.010-inch-thick sheets of titanium with oxygen. Under the particular test conditions used, titanium was insensitive to reaction with oxygen when subjected to vibration, pressure cycling, or to rupture with pressurization of thin walled tanks containing LOX.

NASA

NASA TR R-180

stainless steel failed to react on impact or puncture. The shock stimuli produced by small detonator caps alone were sufficient to initiate explosive reaction of titanium in contact with oxygen. An extremely heavy shock was necessary to cause aluminum to react under the same test conditions, and stainless steel did not react under the most drastic shock conditions employed. The titanium/oxygen combination is considerably more susceptible to spark initiation than aluminum/oxygen. A comparatively high energy spark was necessary for reaction of 0.010-inch-thick sheets of titanium with oxygen. Under the particular test conditions used, titanium was insensitive to reaction with oxygen when subjected to vibration, pressure cycling, or to rupture with pressurization of thin walled tanks containing LOX.

NASA

"The aeronautical and space activities of the United States shall be conducted so as to contribute . . . to the expansion of human knowledge of phenomena in the atmosphere and space. The Administration shall provide for the widest practicable and appropriate dissemination of information concerning its activities and the results thereof."

—NATIONAL AERONAUTICS AND SPACE ACT OF 1958

NASA SCIENTIFIC AND TECHNICAL PUBLICATIONS

TECHNICAL REPORTS: Scientific and technical information considered important, complete, and a lasting contribution to existing knowledge.

TECHNICAL NOTES: Information less broad in scope but nevertheless of importance as a contribution to existing knowledge.

TECHNICAL MEMORANDUMS: Information receiving limited distribution because of preliminary data, security classification, or other reasons.

CONTRACTOR REPORTS: Technical information generated in connection with a NASA contract or grant and released under NASA auspices.

TECHNICAL TRANSLATIONS: Information published in a foreign language considered to merit NASA distribution in English.

TECHNICAL REPRINTS: Information derived from NASA activities and initially published in the form of journal articles.

SPECIAL PUBLICATIONS: Information derived from or of value to NASA activities but not necessarily reporting the results of individual NASA-programmed scientific efforts. Publications include conference proceedings, monographs, data compilations, handbooks, sourcebooks, and special bibliographies.

Details on the availability of these publications may be obtained from:

SCIENTIFIC AND TECHNICAL INFORMATION DIVISION
NATIONAL AERONAUTICS AND SPACE ADMINISTRATION

Washington, D.C. 20546