

AEC-tr-6777

~~DI~~

AEC-tr-6777  
(PNE-3004)

**TRANSLATION SERIES**

**UNDERGROUND NUCLEAR EXPLOSIONS**

Problems of Industrial Nuclear Explosions

By  
B. I. Nifontov  
D. D. Protopopov  
I. E. Sitnikov  
A. V. Kulikov

*[Handwritten signature]*

Translated from a publication of  
Atomizdat, Moscow, 1965.

**DISTRIBUTION STATEMENT A**  
Approved for Public Release  
Distribution Unlimited

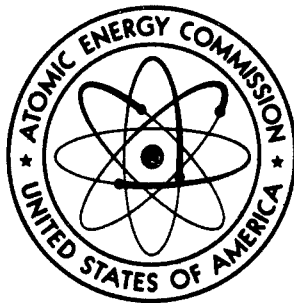

20011108 100

**UNITED STATES ATOMIC ENERGY COMMISSION**  
Division of Technical Information

Reproduced From  
Best Available Copy

LOVELACE FOUNDATION  
DOCUMENT LIBRARY

24892  
FEB 14 1967

A translation of: Podzemnye Yadernye Vzryvy. Problemy Promyshlennykh Yadernykh Vzryvov. B. I. Nifontov; D. D. Protopopov; I. E. Sitnikov; and A. V. Kulikov. Atomizdat, Moskva, 1965. 160p.

Translated by the U. S. Joint Publications Research Service, New York, a federal government organization established to service the translation and research needs of the various government departments.

In the interest of expeditious dissemination this publication has been reproduced directly from copy prepared by the translating agency.

Printed in USA. Price \$5.00. Available from the Clearinghouse for Federal Scientific and Technical Information, National Bureau of Standards, U. S. Department of Commerce, Springfield, Virginia. 22151

Issuance date: October 1966

AEC-tr-6777  
(PNE-3004)  
NUCLEAR EXPLOSIONS - PEACEFUL  
APPLICATIONS (TID - 4500)

UNDERGROUND NUCLEAR EXPLOSIONS

Problems of Industrial Nuclear Explosions

by

B. I. Nifontov, D. D. Protopopov,  
I. E. Sitnikov, and A. V. Kulikov

Atomizdat  
[State Publishing House for Atomic Science  
and Engineering]

Moscow, 1965

## TABLE OF CONTENTS

	<u>Page</u>
PREFACE.....	2
INTRODUCTION.....	4
CHAPTER 1. CONDITIONS UNDER WHICH EXPERIMENTAL UNDER- GROUND NUCLEAR EXPLOSIONS ARE SET OFF.....	7
General Information.....	7
Location and Geology of the Sections Where Explosions Were Set Off and the Properties of the Rocks	9
Approach Workings, Charge Chambers, and Packing of the Galleries.....	15
CHAPTER 2. NUCLEAR SHOTS FOR EXTERNAL EFFECT.....	20
Experimental Shots for Blast Effect Using Nuclear and Chemical Explosives.....	20
Parameters of Craters.....	22
The Efficiency of Nuclear and Chemical Explosives.....	33
CHAPTER 3. NUCLEAR EXPLOSIONS FOR INTERNAL EFFECT.....	36
Experimental Explosions for Internal Effect.....	36
Zones of Destruction of the Rocks.....	41
Zones of Prolonged Temperature Effect.....	46
Phases of the Effect of a Nuclear Explosion on the Surrounding Rocks.....	49
CHAPTER 4. SEISMIC AND AIR-COMPRESSION EFFECTS OF UNDERGROUND NUCLEAR EXPLOSIONS.....	57
Methods of Observations of the Seismic Effects and Recording Apparatus.....	57
Seismic Effect on Underground Galleries.....	62
Parameters of Seismic Explosive Waves in the Rock Massif	65
Seismic Effect and Parameters of Seismic Explosion Waves at the Surface of the Earth.....	67
Magnitudes of Underground Nuclear Explosions.....	78



TABLE OF CONTENTS (continued)

	<u>Page</u>
Seismically Dangerous Zones.....	81
Air-Compression Wave [i.e., shock wave].....	83
CHAPTER 5. RADIATION EFFECT OF UNDERGROUND NUCLEAR	
EXPLOSIONS.....	85
Zones of Radioactivity Distribution Underground.....	85
Discharge of Radioactive Products into Galleries and to the Surface.....	88
Nature of the Radioactivity in a Nuclear Explosion.....	89
Radioactive Contamination of Ground Waters.....	96
Radioactive Contamination of the Atmosphere and Radioactive Precipitation [i.e., fallout].....	98
Method of Reducing the Radiation Effect of Nuclear Explosions.....	100
CHAPTER 6. THE USE OF NUCLEAR EXPLOSIONS IN THE DEVELOPMENT OF DEPOSITS OF SOLID MINERALS.....	
	101
CHAPTER 7. THE USE OF NUCLEAR EXPLOSIONS IN THE CONSTRUCTION OF LARGE CIVIL-ENGINEERING STRUCTURES....	
	123
Introduction.....	123
The Construction of Harbors for Seagoing and River Vessels.....	123
The Construction of Canals for Seagoing or River Vessels	128
The Construction of Earth-Filled Dams (Dikes).....	129
Regulation of Surface and Underground Waterflows.....	132
Creation of Underground POL and Gas Storage Tanks.....	135
CHAPTER 8. THE USE OF NUCLEAR EXPLOSIONS FOR THE EXTRACTION OF PETROLEUM.....	
	140
Project Oilsand.....	140
The Project for an Experimental Explosion in the Colorado Oil Shales.....	148
CHAPTER 9. THE USE OF NUCLEAR EXPLOSIONS FOR THE GENERATION OF POWER.....	
	152
CHAPTER 10. THE USE OF NUCLEAR EXPLOSIONS FOR SCIENTIFIC PURPOSES.....	
	158
CHAPTER 11. EXPERIMENTAL EXPLOSIONS UNDER THE FLOWSHARE PROGRAM.....	
	162
The Gnome Experiment.....	162
The Sedan Experiment.....	181
BIBLIOGRAPHY.....	185

## PUBLISHER'S NOTE

In the book Podzemnye Yadernye Vzryvy (Underground Nuclear Explosions), data on the experimental underground nuclear explosions (shots) set off in the USA from 1951 to 1962, as published in the foreign press, and also information available in the literature concerning projects for the use of underground nuclear shots for industrial purposes, are generalized and systematized.

The first five chapters of the book are devoted to problems of the effect of underground nuclear explosions. The conditions under which the experimental shots of 1951--1958 were conducted are described, the results of experimental shots, of total internal effect, excavation, and ejection are generalized, the mechanical and thermal effects of the shots on the rocks are characterized, and an analysis is given of the seismic effect of underground nuclear explosions, and the results of observations of the radiation effect of the experimental shots are described.

In Chapters 6--11, information concerning the American projects of nuclear shots for industrial purposes (the "Plowshare" program) is generalized. Proposals and projects of foreign specialists for the use of underground nuclear explosions in the mining of solid and liquid (petroleum) minerals and in the construction of large structures, such as earth-fill dams, underground reservoirs and other storage spaces, canals, and harbors, are considered. Proposals for the use of nuclear explosions to obtain heat, and in certain fields of science, are also given. A description of the first experiments in the Plowshare program, the Gnome and Sedan shots, is given.

The book is intended for the general reading circle of engineering and technical workers.

## PREFACE

The Moscow Treaty prohibiting nuclear bursts in the atmosphere, in outer space, and under water, was the first step toward a goal that is the desire of all progressive mankind -- the total prohibition of nuclear bursts and the outlawing of the most destructive weapon that has ever been created on the earth.

However, although having signed the Moscow Treaty, the United States of America has not freed the world of test bursts of nuclear devices. Underground nuclear shots, renewed by the USA at the Nevada test area in September of 1961, are being conducted even at the present time. The example of the USA is followed by its junior partners, Britain and France.

In trying to justify the continuation of nuclear tests, American propaganda, as one of its arguments, advances the special program of the U.S. Atomic Energy Commission (AEC), concerning problems of the use of nuclear bursts for industrial and scientific purposes, the so-called "Plowshare" program.

However, with relationship to the well-developed American program for further development and accumulation of nuclear weapons, the Plowshare program looks more than modest. Thus, while more than 100 shots were set off for purposes of testing nuclear weapons at the Nevada testing area from September 1961 to January 1964, as was reported in the American press, in the same period, in connection with the Plowshare program, only three experiments were made.

A comparison of the expenditures of the U.S. Atomic Energy Commission, which is primarily the governmental organ for the development of the U.S. nuclear arsenal, with expenditures for the Plowshare program (the latest data are given in the report of Johnson and Higgins at the Third International Conference on the Peaceful Uses of Atomic Energy, Geneva, 1964), demonstrates that all expenditures of this program, from the beginning of its approval in 1957, amount to only 2% of the annual expenditures of the AEC.

Nevertheless, the engineering ideas of the use of powerful nuclear shots for industrial purposes (in mining, in the petroleum-production industry, in the construction of hydraulic-engineering structures and various types of earth structures, etc.), developed by the American specialists in accordance with the Flowshare program, appear, in our view, to be of definite interest.

The book Podzemnye Yadernye Vzryvy (problems of the industrial use of nuclear explosions), presented here for the attention of the reader, contains general information relative to the American projects for industrial and scientific use of nuclear explosions, the economic effectiveness expected in this case, fields of possible application of the explosions under consideration for scientific purposes, and also concerning the real difficulties and dangers in this path. The book systematizes the data published in the foreign (basically American) scientific and technical literature, as of the state of the art at the beginning of 1963.

In spite of a number of undoubtedly questionable provisions contained in the American literature, in this book we have not set ourselves the purpose of making a critical analysis of them. This must be the object of special work.

For the reasons indicated, the exposition of the materials in the book is given basically in accordance with the primary sources (books, articles, reports, and others). Obvious inaccuracies, to which the authors considered it necessary to call the attention of the reader, are referred to in the footnotes.

The authors express their gratitude to Corresponding Member of the Academy of Sciences USSR M. A. Sadovskii, for the valuable advice given by him during the writing of the book. The authors are also grateful to Z. I. Efimova, who rendered us great assistance in the preparation and formulation of the manuscript.

## INTRODUCTION

At the beginning of 1957, the U.S. Atomic Energy Commission approved a special program for the study of the possibilities of applying nuclear explosions for industrial and scientific purposes, which was given the name of "Plowshare"<sup>1</sup>).

This program provides for:

- 1) theoretical and experimental investigations of the phenomena accompanying nuclear bursts in different media, for the accumulation of data necessary in the use of nuclear explosions for the purposes indicated;
- 2) the designing and testing of special nuclear charges for industrial and scientific purposes;
- 3) the study of possible fields of use of nuclear explosions in industry and science;
- 4) the compilation and realization of projects of nuclear explosions for purposes of industry and science.

The U.S. Atomic Energy Commission exercises general supervision of work in accordance with the Plowshare program. More than 40 governmental and private institutions and research organizations have been brought in for the fulfillment of work in accordance with this program. The Lawrence Radiation Laboratory of the University of California plays a leading part among them. This laboratory, which accomplishes general coordination of the work, has issued a number of reports on the given program in the past period. The Argonne, Brookhaven and Oak Ridge National Laboratories, the U.S. Bureau of Mines (with its affiliates), the Colorado Mining Research Institute, and a number of private companies (Sandia Corporation, Dow, General Electric, and others) are also participating in this work to a great degree.

Scientists from different branches of science have been brought in to study problems of the peaceful use of nuclear explosions. Three special symposia (in 1958, 1959, and 1964) have been held in the USA in accordance with the

---

<sup>1</sup>) "Plowshare" -- Coulter, plow.

Plowshare program. Problems of the industrial application of nuclear explosions were discussed by American specialists at the Second International Conference on the Peaceful Uses of Atomic Energy (Geneva, 1958), in two papers (Brown and Johnson, "The Use of Nuclear Explosions for Peaceful Purposes," and Porzel, "The New Approach to the Production of Thermal and Electric Power by Means of Underground Nuclear Explosions"), and at the Third Conference (Geneva, 1964) in one paper (Johnson and Higgins, "Engineering Application of Nuclear Explosions in Accordance with the Plowshare Program").

Some projects in the Plowshare program are beginning to go beyond the national framework of the USA. Thus, Project Oilsand, for producing petroleum by means of nuclear explosions in the bituminous sands of Athabasca, it is proposed, will be accomplished with the permission of the Government of Canada, using the facilities of the petroleum companies of that country.

The basic problems on which the American specialists are working at the present time are as follows:

1. Development of minerals: a) removal of overburdens by means of nuclear explosions (primarily ejection explosions) and mass mining of minerals in large quarries; b) fragmentation of a mineral by nuclear charges (in case of necessity, also fragmentation of the overlying rocks) in the underground development of large deposits of lean ores by the system of forced caving in by levels. A variation of underground leaching of the ore is also possible, after its fragmentation by nuclear explosion; c) the extraction of almost inaccessible petroleum by means of reducing its viscosity by heating the rocks with the energy of a nuclear explosion, and by means of destroying structures (the development of additional cracks in the collecting stratum). It is intended to accomplish some of these methods in combination with the underground sublimation of the petroleum.

2. The construction of large structures: a) construction of earth-fill dams and dikes by means of nuclear explosions; b) the construction of canals (channels) and harbors for seagoing and river shipping, with the use of nuclear explosions intended to eject and scatter the material; c) the development of artificial storage tanks for the storage of petroleum and gas, in appropriate geological conditions, by means of nuclear charges laid at a great depth from the surface (through drilled wells); d) regulation of flows of surface, and ground waters by the formation of artificial water-carrying structures (aquifers) by means of nuclear explosion.

3. The generation of power: a) the creation of sources of thermal energy by means of underground explosions of nuclear charges of great power and heating the

appropriate rocks in a localized volume, with subsequent bleeding and channeling of the heat by pipes, by means of a coolant; b) obtaining electric power by means of the heat liberated by means of a powerful nuclear explosion under the earth (a development of the previous idea).

4. Scientific ideas: a) the production of trans-plutonium elements as a result of underground nuclear explosions, in the appropriate media; b) the formation of valuable mineral components by means of underground nuclear explosions, in particular obtaining diamonds from graphite or other carbon-containing materials; c) investigation of the structure of the earth and study of problems of seismology by means of powerful underground nuclear explosions (artificial earthquakes).

The problems listed are in different stages of solution; with respect to some of them, theoretical and calculation and planning developments are being conducted (in many cases very questionable and based on shaky assumptions) while with respect to others specific experimental projects have been compiled, and preparatory work for their accomplishment is being performed. One of the projects, named Gnome, is an underground nuclear burst in a salt stratum near the city of Carlsbad (in the state of New Mexico), which was accomplished in December of 1961. Besides this, experiment Sedan was conducted at the Nevada test area in July of 1962, and is also part of the Plowshare program.

The solution of the problems advanced by the Plowshare program is based on the investigation of various sides of the effect of underground nuclear shots. Nine shots set off in the period from 1951 to 1958 at the Nevada test area in accordance with nuclear weapons tests programs were studied in detail, and also the two experimental shots mentioned above (Gnome and Sedan) accomplished in accordance with the program named. At the present time, in the USA the results of some of the shots from a series of military tests begun in 1961 are being studied.

According to available reports, the experiments in the Plowshare program for the present are basically associated with the tests at the Nevada test area. During the next few years, it is proposed to set off nuclear shots both for scattering material and explosions for a camouflet effect. In the literature, eight such explosions have been named (five for scattering material (ejection) and three of an entirely camouflet effect). As a result of the setting off of experimental shots, they propose to develop a theory of crater formation and a technology for making industrial experiments in accordance with the available projects.

In this book, an exposition of accumulated data concerning the effects of nuclear shots, which compose the basis of the program named, precedes the consideration of projects and other developments under the Plowshare program.

## CHAPTER 1

### CONDITIONS UNDER WHICH EXPERIMENTAL UNDERGROUND NUCLEAR EXPLOSIONS ARE SET OFF

#### GENERAL INFORMATION

The beginning of the setting off of underground nuclear (atomic) explosions by the United States of America dates back to 1951, when at the U.S. Atomic Energy Commission (AEC) test area in the state of Nevada, during the test of the effect of a nuclear weapon, under the name Operation Jangle, one shot was accomplished with the charge located directly on the day surface (a contact burst), and the second with the charge buried in the ground to a depth of 5 m. In 1955, one more such shot was set off, with the charge placed in an alluvial stratum at a depth of 20 m.

Considering the fact that the testing of nuclear weapons underground at a great depth increases secrecy of testing and reduces radiation danger, the U.S. AEC in 1957--1958 performed a series of 13 experimental underground nuclear explosions at the Nevada test area.

Out of the underground contact experiments made in the period 1951 to 1958, in the literature nine underground explosions and one contact burst are considered, having greater powers of the charges in comparison to other explosions: in 1951 Jangle-S (19 November) and Jangle-U (29 November); in 1955 Teapot-Ess (23 March); in 1957 Rainier (19 September); in 1958 Mars (28 September); Tamalpais (8 October); Neptune (14 October); Logan (16 October); Evans (28 October); and Blanca (30 October). The power of the nuclear charges<sup>1)</sup> in the experiments indicated varied from

---

<sup>1)</sup> Here and in the future the power of a nuclear charge (power or energy of the blast) is expressed in units of trotyl (trinitrotoluol) (TNT) equivalent - tons (T) or kilotons (KT).



**Table 1**  
**Data Concerning Basic Underground and Contact Bursts Set Off in the USA [5]**

Series of explosions	Name of experiment	Place held	Date held (Greenwich time)	Time of day (Greenwich)	Type of explosion	Power of charge, KT	Depth at which charge lay from the day surface, m	Elevation of charge above sea level, m	Nature of explosion
Operation Jangle	Jangle-S	Test area, state of Nevada	19.11.1951	17	Contact	1,2	-1,1 (above surface)	1285	Blast effect
	Jangle-U	The same	20.11.1951	20	Underground	1,2	5,2	1310	"
Operation Teapot	Teapot-Ess	"	23. 3.1955	20,5	"	1,2	20,4	1290	"
Operation Plumb Bob	Rainier	"	19. 9.1957	17	"	1,7	210	2018	Camouflet
	Mars	"	28. 9.1958	00	"	0,0135	38	2048	"
Operation Hardtack, phase II	Tamalpais	"	8.10.1958	22	"	0,072	100	2017	"
	Neptune	"	14.10.1958	18	"	0,115	30	2048	Blast effect
	Logan	"	16.10.1958	06	"	5	253	1873	Camouflet
	Evans	"	28.10.1958	00	"	0,055	256	2020	"
	Blanca	"	30.10.1958	15	"	19	255	1872	Excavation
	Sedan	"	6.7.1962	19	"	100	194	1300	Blast effect
Project Gnome	Gnome	State of New Mexico	10.12.1961	21	"	3	365	—	Camouflet

1) Without any possible deviation from nominal values. [Footnote missing in table]

13,500 to 19,000 T. The depth at which the charges lay in the underground experiments varied from a shallow depth (5.2 and 20.4 m), in which the formation of blast craters occurred, to depths providing an entirely internal effect of the shot (complete camouflet).

In 1954--1958, the USA also set off several contact bursts of great power on the islands of the Pacific Ocean. The results of these experiments, with respect to the formation of explosion craters on the surface of the earth, are analyzed in detail in the work of Viale [1]. Since contact bursts are a field outside the scope of this work, data concerning these tests are not considered in the future.

In the autumn of 1961 the USA renewed underground nuclear explosions at the Nevada test area. Here, from September 1961 to 1 January 1963, 58 underground shots were set off. Among these tests the Sedan experiment, conducted on 6 July 1962, is of outstanding interest; it was an explosion of a thermonuclear charge with a power of 100 KT and a depth of 193 m, with the formation of a blast crater. This experiment was conducted as part of the Plowshare program. A description of the Sedan shot is given in Chapter 11. Besides this, one experimental underground nuclear shot (Project Gnome) in accordance with this same program was accomplished in salt strata in the state of New Mexico, near the city of Carlsbad, on 10 December 1961. The preparations and result of this experiment are expounded in detail also in Chapter 11.

The basic information concerning the experimental shot at the Nevada test site in 1951--1958, and also the Sedan and Gnome shots, are given in Table 1 [2--4].

#### LOCATION AND GEOLOGY OF THE SECTIONS WHERE EXPLOSIONS WERE SET OFF AND THE PROPERTIES OF THE ROCKS

Section where basic blast-effect (ejection) shots were set off. The Jangle-S, Jangle-U, and Teapot-Ess experiments, conducted with the formation of a blast-effect crater, were accomplished in section 10 of the Nevada test area, located in a valley at an elevation of approximately 1300 m above sea level [6], and having level relief of the surface. The charges were placed in alluvial deposits, typical for the desert, which Nordyke [7] characterizes as a friable mixture of sand and gravel, with a density of the average of from 1.5 to 1.7 g/cm<sup>3</sup>, and a water content at the depth of about 10%. Johnson and others [2] call the rocks weakly cemented alluvium. The Sedan shot, for blast effect, was set off in the same section of the Nevada test area, not far from the site where

the Jangle-U and Teapot-Ess shots were set off, in rocks represented as weakly cemented sand and gravel alluvial deposits [3, 8].

Section where shots were set off in Operations Plumb Bob and Hardtack, phase II. The basic underground explosions -- Rainier, Mars, Tamalpais, Neptune, Logan, Evans, and Blanca -- which were accomplished (with the exception of the

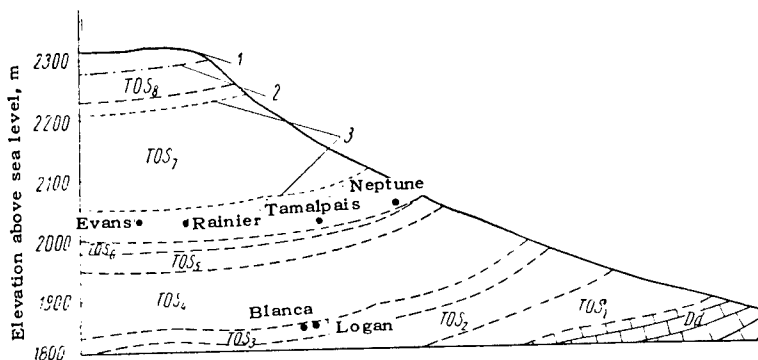

Figure 1. Geological cross section of the area where the basic nuclear shots were set off, and the positions of the charges:

TOS<sub>8</sub> -- fused tuff; rhyolites to quartz latites;  
TOS<sub>7</sub> -- brittle tuff, for the greater part weakly cemented and interbedded with sand, color grey to greyish-brown; TOS<sub>6</sub> -- fused tuff, color light grey to brownish-grey; TOS<sub>5</sub> -- stratified tuff, well cemented, color light yellow to green; TOS<sub>4</sub> -- stratified tuff, well cemented, color light grey to dark yellow, sometimes rose-pink; TOS<sub>3</sub> -- stratified tuff, well cemented, color red on top and bottom, rose-pink to dark yellow between layers; TOS<sub>2</sub> -- stratified tuff, color for the most part light grey to dark yellow; TOS<sub>1</sub> -- stratified tuff, color purple to rosy red; Dd -- massive limestone, hard, crystalline, color grey to dark grey; 1 -- summit of mountain above charges Blanca and Logan; 2 -- summit of mountain above charges Rainier, Evans, Tamalpais, and Neptune; 3 -- approximately upper and lower boundaries of weakly cemented grainy tuff.

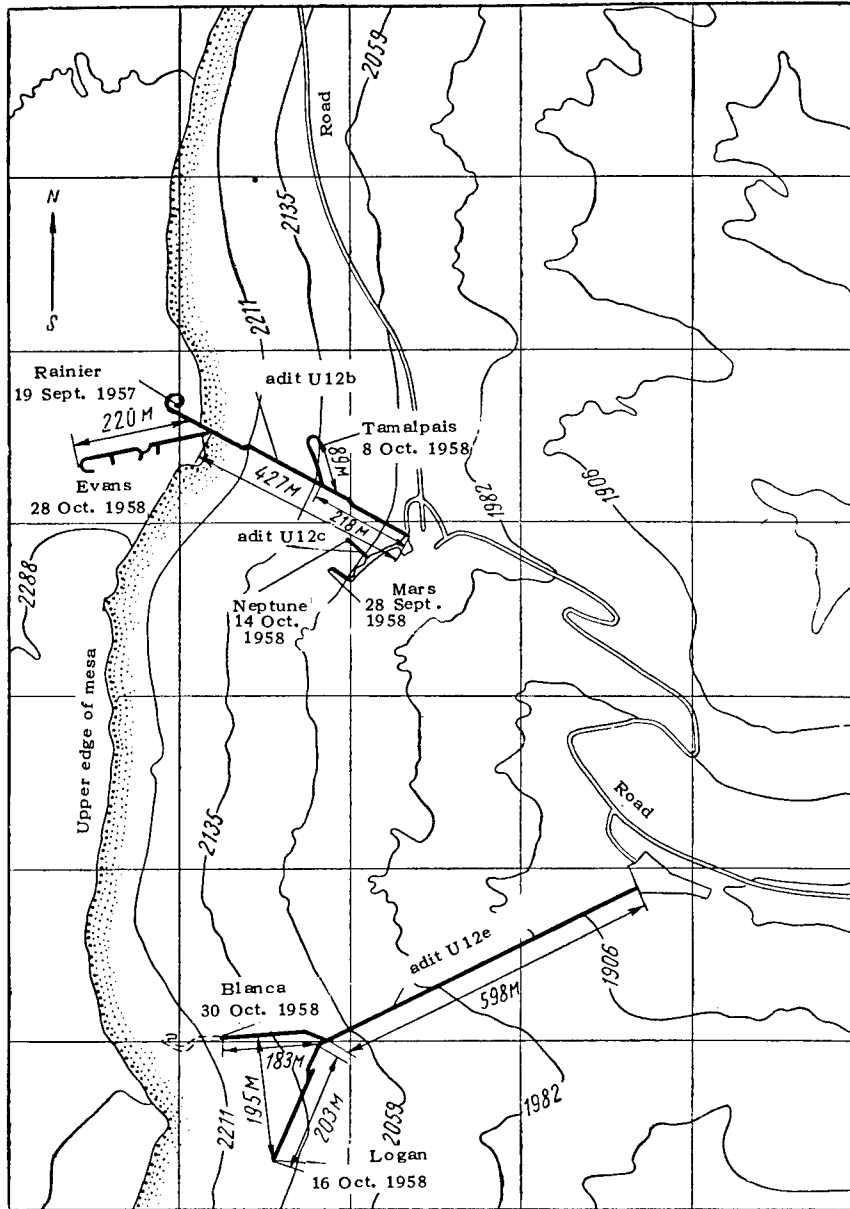

Figure 2. Location of adits for placement of charges in section 12 of the Nevada test area (contours are given in meters).

Neptune experiment) with total hermetic sealing of the products of the explosion underground, were conducted in section 12 of the Nevada test area. This section is the slope and upper plateau of a table (flat) mountain (i.e., a mesa) in the northwestern part of the Yucca highland (i.e., Yucca Flat), with elevations from 2000 to 2300 m above sea level. The experiments were grouped at three points in the given section, which were located at short distances (of the order of 300--1000 m) from each other. The site of shots Blanca and Logan were located further south of the other shots, and lower along the slope of the mesa (the elevation at the point where the charges were planted is about 1872 m). The point where experiments Rainier, Evans and Tamalpais were held is located north of the first section, and higher up along the slope (the charges were at the level 2017 m). Alongside the point where these shots were set off, somewhat to the southeast and slightly higher (the elevation of the point where the charges were planted was 2048 m), shots Neptune and Mars were set off.

The location of the sections where the basic experiments were conducted is apparent in Figure 1 [2] on a vertical projection and in Figure 2 [9] as a plan (i.e., a map).

The geological description of the sections and the characteristics of the rocks are given in the work by Johnson et al. [2] who used data from the U.S. Geological Survey. Details of the geological structure of the Neptune section are given by Nordyke [7]. The rocks in section 12 are represented by tuffs consisting chiefly of volcanic glass with large crystals of quartz and orthoclase. The geological section is given in Figure 1. The upper part of the mesa, at a depth of approximately 175 m, is composed of fused tuff (stratum TOS<sub>8</sub>). Below this lie seven horizons (from TOS<sub>7</sub> to TOS<sub>1</sub>) of stratified tuff, with a total thickness of approximately 500 m. Individual horizons are divided into several sub-horizons, with different characteristics of the tuff.

From the standpoint of the results of the experiment, horizon TOS<sub>7</sub>, having a zone of weakly cemented tuff, the tentative boundaries are represented in Figure 1, is of importance.

In experiments Rainier, Evans, Tamalpais and Neptune, the explosions involved the weakly cemented zones, hence the charges were located in horizon TOS<sub>7</sub>, approximately 30 m below this zone. In shots Blanca and Logan, the charges were located in the TOS<sub>3</sub> horizon, at a distance of 180 m from the boundary of the weak zone.

The basic characteristics of the physical and chemical properties of the rocks near the places where charges Rainier, Logan and Blanca were placed, according to Johnson et al. [2] are given in Tables 2--5.

Table 2

Average Values of Density, Porosity, and Moisture Content of the Rocks

Indices	Sections where experiments were held		
	Rainier	Logan	Blanca
Density in a dry state, g/cm <sup>3</sup> .....	1,7±0,2	1,8±0,3	1,6±0,2
Density in a natural state, g/cm <sup>3</sup> .....	2,0±0,2	2,1±0,2	1,9±0,2
Density of grains, g/cm <sup>3</sup> .....	2,3±0,2	2,6±0,1	2,4±0,1
Porosity, %.....	24,4±7,0	30,6±7,4	33,2±6,0
Moisture content, % by weight.....	15,3±3,5	14,5±3,5	17,5±3,5

Table 3

Average Chemical Composition of the Rocks

Components	Content in air-dried samples in sections where experiments were held, % by weight	
	Rainier	Logan
SiO <sub>2</sub>	66,9	71,5
Al <sub>2</sub> O <sub>3</sub>	12,3	13,0
CaO	2,3	0,7
Fe <sub>2</sub> O <sub>3</sub>	2,2	1,8
MgO	1,0	0,4
Na <sub>2</sub> O	1,3	1,3
K <sub>2</sub> O	2,2	6,6
H <sub>2</sub> O	10,6	4,5
Остаток	1,2	0,2

Table 4

Thermophysical Properties of the Rock

Properties	Rainier section	Logan section
Specific heat content, cal/(g · °C), at 100°C, and water content with relationship to weight of dry sample, %:		
0 . . . . .	0,21	—
15 . . . . .	0,31	—
20 . . . . .	0,53	—
30 . . . . .	0,36	—
Thermal conductivity, cal/(cm · sec · °C):		
dry rocks.....	0,0011	0,0014
moist rocks.....	0,0016	0,0020
Melting point, °C.....	850—1500	850—1500
Latent heat of melting (at 1500°C), cal/g.....	700	700
Latent heat of vaporization (at 3000°C), cal/g.....	3000	3000
Heating temperature (°C) for water loss, %:		
80 . . . . .	110	—
98 . . . . .	600	—
100 . . . . .	1000	—

Table 5a

Average Indices of Strength and Elasticity of the Rocks in Section Rainier

Index	Static tension in an air-dried state	Static compression			Dynamic characteristics (calculated)
		In an air-dried state	In a natural state	In a natural state at a hydrostatic pressure of 70 atm	
Strength, kg(force)/cm <sup>2</sup> .....	11,55	329	84	357	—
Young's modulus E, kg(force)/cm <sup>2</sup>	0,32 · 10 <sup>5</sup>	0,77 · 10 <sup>5</sup>	0,13 · 10 <sup>5</sup>	0,26 · 10 <sup>5</sup>	75 · 10 <sup>5</sup>
Poisson ratio, σ.....	0,12	0,11	—	—	0,09
Modulus of shear G (calculated), kg(force)/cm <sup>2</sup> .....	0,15 · 10 <sup>5</sup>	0,35 · 10 <sup>5</sup>	—	—	0,35 · 10 <sup>5</sup>
Modulus of all-sided compression, kg(force)/cm <sup>2</sup> .....					
without a shell.....	—	3,36 · 10 <sup>5</sup>	3,99 · 10 <sup>5</sup>	—	—
with a shell.....	—	0,29 · 10 <sup>5</sup>	0,38 · 10 <sup>5</sup>	—	—
Decrease in porosity (%) at pressure, kg/cm <sup>2</sup> :					
70 . . . . .	—	—	6	—	—
140 . . . . .	—	—	8	—	—
210 . . . . .	—	—	10	—	—
280 . . . . .	—	—	12	—	—

Table 5b

Velocity of Seismic Waves in Section  
of Shot Rainier

Depth from surface of the earth, m	Distance along the vertical from place where charge was located, m	Velocity of waves in stratum, m/sec
70—82	202—190	2190
82—94	190—178	4180
94—120	178—152	2030
120—160	152—112	2160
160—205	112—67	2190
205—235	67—37	1780

Note. The velocities of the seismic waves were measured directly in the massif before the shot was set off.

The region of the Gnome experiment. The section where the experimental industrial shot was set off in accordance with Project Gnome was located in the state of New Mexico, at a distance of 40 km to the southeast of the city of Carlsbad, in flat terrain. The shot was set off in strata of rock salt of the Solado formation, having interbeddings of anhydrite and aleurite. Above the salt stratum lie strata of anhydrite and aleurolite, which are covered at the surface by weak sandstone and sand (for more details see Chapter 11).

#### APPROACH WORKINGS, CHARGE CHAMBERS, AND PACKING OF THE GALLERIES

In the experiment Jangle-U and Teapot-Ess, when the charges were located at a shallow depth (5.2 and 20.4 m, respectively), they were placed in vertical mine shafts. In the Jangle-U shot, the charge was placed in a concreted charge chamber, with a cross section of 3 x 3 m in plan, and a height of 2.4 m. The chamber had concrete reinforcement and was drilled from a prospecting pit with a depth of 4 m, which, after the charge was laid, was entirely filled with sandbags [7].

In the Teapot-Ess experiment, the charge was placed in a well with a diameter of 3 m, drilled from the lower level of a mine shaft, which had a depth of about 20 m and a



diameter 9 m. The charge was covered by sandbags, after which the well and the shaft were filled with dirt, to the level of the earth's surface [7].

In the Sedan shot, a charge with a power of 100 KT was placed in a vertical well with a depth of about 200 m and a diameter of 914 mm, reinforced by pipes. After this the well was filled with dry sand [3, 10].

In the 1957--1958 experiments, the charges were placed through adits, excavated in the slope of the mesa, and in this case the following were used: adit U12b for shots Rainier, Tamalpais, and Evans; adit U12c for shot Neptune; and adit U12e for shots Logan and Blanca. The charges were placed inside chambers, dug from the adits. The Rainier shot was an exception, in which the charge was placed at the end of the basic adit. The arrangement of the adits, the side excavations, and the locations where the charges were placed is apparent in the plan in Figure 2.

In the Gnome experiment, the vertical mine shaft and a horizontal gallery drilled from it were the approach galleries (see Chapter 11). Horizontal approach galleries were made without any supporting and had a small cross section: in the tuffs at the Nevada test area 2.1 x 2.4 m to 2.7 x 2.7 m [2]; and in the rock salt in the Gnome shot, 2.4 x 3 m [12].

The nuclear charges in the Rainier, Tamalpais, Neptune and Evans experiments were placed in special chambers. The chambers in the shots, in all experiments except the Rainier experiment, had such dimensions in which a considerable free interval remained between the charge and the wall. The chamber in the Evans shot had especially large dimensions. In the Neptune experiment the walls of the chamber were faced with blocks of rock salt for the purpose of obtaining the data needed for the subsequent experiments in accordance with Project Gnome. In the experiments indicated, and also in the Gnome shot, the chambers were so arranged relative to the adit as to provide for movements of the walls of the adit and its plug before the product of the explosion would penetrate through the stopper<sup>1)</sup> into the adit. For this purpose, the end part of the adit was given either a helical shape (Rainier) or the shape of a hook (Tamalpais, Neptune, Evans, Gnome). In the Logan and Blanca shots, straight blind passages of the approach adits served as charge chambers (in the Blanca shot, initially it was planned to have a hook-shaped end of the adit (see Figure 2), but this section was never excavated).

---

1) Corresponds to the terms stemming and packing.

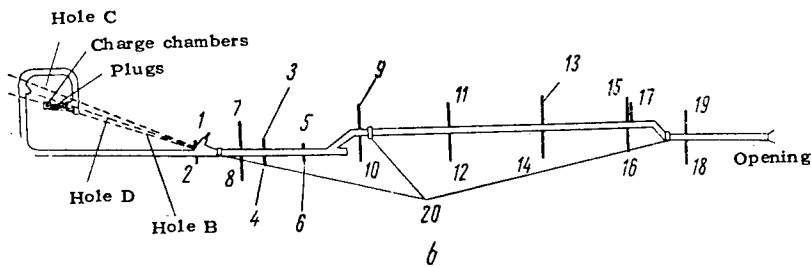
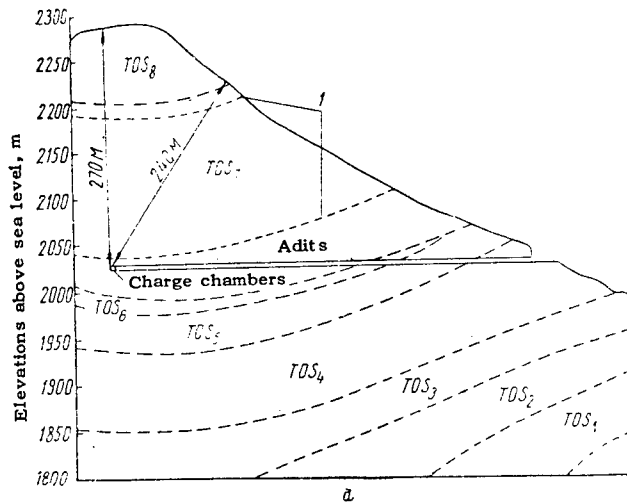

Figure 3. Placement of charge and plan of approach galleries in the Rainier shot.

a -- geological section: 1 -- upper and lower boundaries of weakly cemented tuff; b -- plan of adit U12b and position of drill holes: 1-19 -- drill holes for measuring temperature of the surrounding rocks; 20 -- shockproof doors.

In all the adits in the Nevada test area, sandbags served as the stopper material, and in the Gnome shot, bags filled with salt were used. In those cases when the adit had a "self-plugging" configuration, one section of plugging (Rainier, Evans, Gnome) or two sections (Tamalpais, Neptune)

were used. In a case of straight adits (Logan, Blanca) the stopper consisted of three or four sections, separated by air gaps. We should note the short length of the stopper section in all cases. The total maximum length of the four-section stopper in a straight adit during the Logan shot (5 KT) amounted to a little more than 30 m. In a subsequent shot with a straight adit (Blanca, 19 KT), the number of stopper sections was reduced to three, and its total length to 21 m, in spite of the considerably greater power of the charge.

In all experiments, one or two metal doors in concrete frames were fitted out in the adit, calculated for the pressure of the airborne shock wave, amounting to several kilograms per  $\text{cm}^2$  (5.25 kg(force)/ $\text{cm}^2$  for the Rainier shot, 3.5 kg(force)/ $\text{cm}^2$  for the Tamalpais shot).

Table 6

Data Concerning Approach Galleries and Charge Chambers

Name of experiment	Power of charge, KT	Workings for placement of charge	Length of galleries from charge to opening on earth's surface, m	Shape of end part of gallery	Stopper		Dimensions of charge chamber, m
					Number of sections	Total length, m	
Rainier	1,7	Adit U12b	630	Helical	1	4	1,8×1,8× >2,1
Tamalpais	0,072	" U12b02	328	Hook-shaped	2	12,2	6,4×4,6× >3,7
Evans	0,055	" U12b04	675	"	1	6	6×6×4,6
Neptune	0,115	" U12c03	80	"	2	10,7	5×3×3,7*
Logan	5	" U12c02	830	Straight	4	30,5	9,3×2,7× ×2,7
Blanca	19	" U12c05	780	"	3	21	6×2,4× ×2,1
Gnome	3	Shaft and drift	665	Hook-shaped	1	7	4×3,1× ×2,43

\* Chamber faced on all sides with blocks of salt having a thickness of 0.6 m; internal dimensions of chamber after facing are given.

Some data on the approach galleries and charge chambers for the basic shots from 1957--1958 and the Gnome experiment are given in Table 6 [2, 9, 12, 13, 14].

The plan of the approach adit and charge chamber for the Rainier shot, and also the geological section at the location of the charge, are given in Figure 3 [14].

## CHAPTER 2

### NUCLEAR SHOTS FOR EXTERNAL EFFECT

#### EXPERIMENTAL SHOTS FOR BLAST EFFECT USING NUCLEAR AND CHEMICAL EXPLOSIVES

Out of a series of experiments at the Nevada test area in 1957--1958, four nuclear shots were set off with the formation of blast craters on the surface (blast-effect shots). Three experiments -- Jangle-S, Jangle-U, Teapot-Ess -- were made in friable sediments (alluvium) on a level surface with charges of the same power (1.2 KT), but with them lying at different depths, beginning with a contact burst and ending with a depth of 20.4 m. The fourth experiment, Neptune, was made in tuffs with the charge (0.115 KT) placed on the slope of a mountain with a surface slope of  $30^{\circ}$ . Shot Blanca is an intermediate one between external-effect shots (for blast effect) and complete internal effect (complete camouflet) shots. This experiment is described in Chapter 4.

A fifth nuclear shot for blast effect is experiment Sedan, conducted on 6 July 1962. In distinction from the four shots for blast effects, which were conducted in accordance with military test programs, the Sedan shot was conducted as an experiment under the Plowshare program. In this experiment, in friable rocks at a depth of 193 m, a thermonuclear charge with a power of 100 KT was detonated. A detailed description of experiment Sedan is given in Chapter 11, and here only the basic results of this shot are given.

Aside from nuclear shots, experimental shots for blast effect were set off using charges of high-brisancy chemical explosives (TNT), in order to establish the quantitative relationship of the formation of craters needed and to obtain data for a comparison of the effect of a shot for blasting purposes by means of nuclear and chemical explosives. These experiments were conducted both in parallel with the first underground nuclear explosions, and after 1958 in accordance with the Plowshare program [1, 15--17].

The majority of the experiments with chemical explosives were performed in alluvial sediments in section 10 of the Nevada test area, where shots were made from the Jangle and Teapot-Ess series. Experiments were also made with chemical explosives (TNT) in basaltic rocks. In these experiments (the Backboard series), 10 shots were made with charges weighing 456 kg each and three shots with charges weighing 18,200 kg each. Experiments were made with simultaneous explosion of a TNT charge weighing 3.6 kg in dry lake sediments of the Nevada test area for establishment of the effect of the combined action of charges.

The information concerning shots for blast effect using chemical explosives, in alluvium, the data from the results of which were used for comparison with the results of nuclear explosions, and also information concerning the explosions of the Backboard series, are given in Table 7 [15].

A view of section 10 of the Nevada test area, with craters caused by the explosions of Jangle-U and Teapot-Ess, Scooter, Stagecoach, and other smaller shots with chemical explosives is shown in Figure 4 [7].

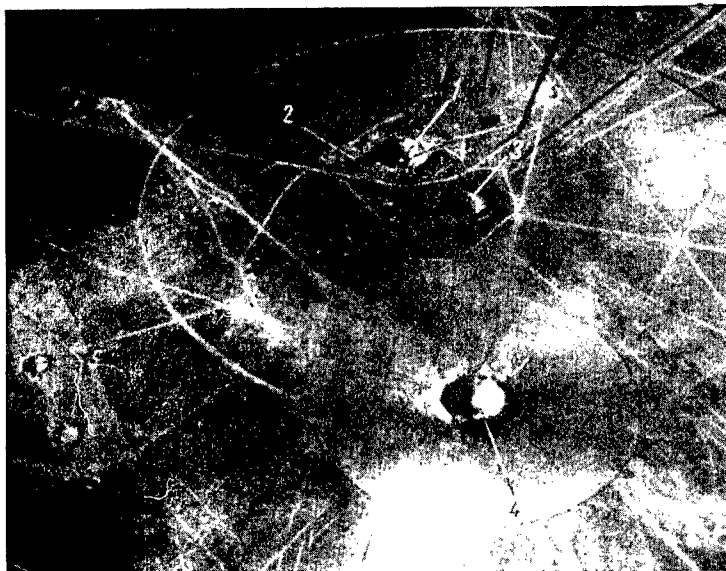

Figure 4. View of section 10 of the Nevada test area:

1 -- crater from the Teapot-Ess shot; 2 -- trench, showing the crater; 3 -- crater from the Jangle-U shot; 4 -- crater from the Scooter shot (chemical explosives); 5 -- three craters from Operation Stagecoach (chemical explosives).

Table 7

**Basic Data Concerning Experimental Explosions  
for Blast Effect of Chemical Explosives at the  
Nevada Test Area**

Name of project and series of experiments	Year	Rocks	Weight of charge, kg	Number of explosions	Depth of place of charge, m	
					Least	Greatest
Operation Jangle-S, chemical explosives.....	1951	Alluvium	100	2	0,2	1,0
			1160	6	-0,6	2,0
			18 150	1	1,6	
Project Mole.....	1953	"	116	7	-0,2	1,9
Project Hurdle.....	1953	"	116	6	0,2	1,9
Plowshare program	1959	"	116	10	1,9	7,8
			116	13	0	9,1
	1960	"	18 150	3	5,2	24,5
			454 000	1	38	
	1960	Basalt	453	10	7,8	18,2
			18 150	3	7,7	18,0

Note. The depth of placement of the charge with a minus sign indicates the height of placement of the charge above the day surface.

The analysis of the use of nuclear blast-effect shots given was made by American specialists on the basis of four nuclear blasting shots, detonated in 1951--1958, and the experiments with chemical explosives mentioned above. The data obtained in experiment Sedan agree to an adequate degree with the conclusions made concerning these explosions.

#### PARAMETERS OF CRATERS

In nuclear explosions of external effect, the blast craters are formed under the effect of a complex of physico-mechanical factors: the vaporization, blasting, and compression of the ground in the region of the explosion. A cross section and the relative dimensions of a typical crater are shown in Figure 5 [14, 18, 19]. The elements of the craters and the spheres of effect of the shot for blasting purposes are: the apparent crater 1 -- the visually apparent crater, formed after the explosion, resembling a parabola in the

vertical section of its boundary; the true crater 2, limited by a surface which characterizes the free volume initially formed by the blast, before partial filling of it by the material that fell into the crater after the explosion; the ground surrounding the true crater may be fragmented or destroyed; the crater lip 3, formed by the material 4 that fell in after the explosion and by the destroyed ground surrounding the crater; the zone of destruction 5, directly adjoins the true crater, characterized by a high degree of cracking and crumpling of the ground; the zone of plastic deformation 6, directly surrounding the zone of destruction, which is the region where the initial ground has been irreversibly displaced, but without apparent cracks or destruction; in hard rocks, the zone of plastic deformation is entirely lacking, or almost lacking.

The most characteristic shape for explosions set off for blast effect is shown by the crater from the Teapot-Ess explosion, although its volume is less than the maximum possible for the given power of the charge, because the charge was placed at a depth which was less than optimum. The crater from the Teapot-Ess explosion, with all its elements, is shown in Figure 6 [7]. In this explosion, the most detailed investigations were made, for the purpose of determining the contours of the blast crater. Before the explosion, along a line passing through the center of the future crater, in test holes with a depth 15--60 m, 21 columns of colored sand were placed. After the explosion, a trench was dug along this line, making it possible, by the part of the sand columns which had been preserved, to establish accurately the boundaries of the true blast crater and/or the zone of destruction (see Figure 6). The trench dug is visible in the photograph of the section where the explosions were detonated (see Figure 4).

In shots Jangle-U and Jangle-S, as a consequence of the shallow depth at which the charges were placed, a great scattering of the blown-up ground occurred, with a shallow depth of the craters.

In the Neptune shot, the charge was placed at a depth greater than the optimum figure, from the standpoint of the formation of a crater of maximum dimensions. The section of the mountain slope was uplifted in the form of a semicircular dome, to a height of 7.5--10.5 m, and then destroyed by the gases that broke through it, breaking it into large pieces, which were thrown to a height of 20--30 m. The slope of the surface also influenced the shape of the crater. A large number of fragments rolled down the slope, forming a mass of material with a length of 250 m, beginning at the downslope edge of the crater.



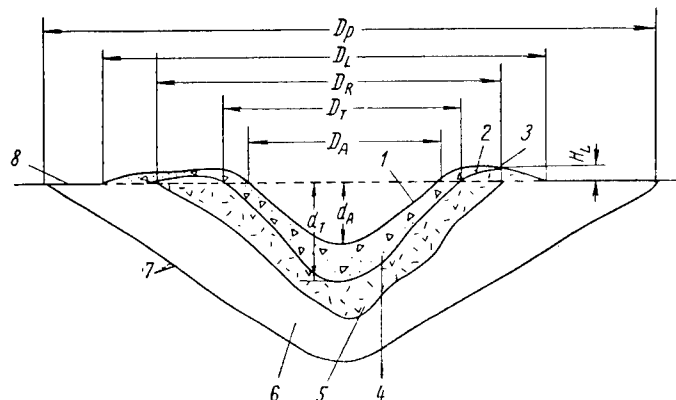

Figure 5. Elements of a crater caused by a nuclear explosion of external effect:

1 -- apparent crater; 2 -- true crater; 3 -- pile of ejected material; 4 -- ejected material that fell back into the crater; 5 -- zone of destruction; 6 -- zone of plastic deformation; 7 -- zone of elastic deformations; 8 -- surface of the earth.  $D_A$  -- diameter of apparent crater;  $d_A$  -- depth of apparent crater;  $D_T$  -- diameter of true crater;  $d_T$  -- depth of true crater;  $D_L$  -- diameter of material around crater lip equal to  $2.0 D_A \pm 25\%$ ;  $H_L$  -- height of fill around crater lip equal to  $0.25 d_A \pm 50\%$ ;  $D_R$  -- diameter of zone of destruction, equal to  $1.5 D_A \pm 25\%$ .  $D_P$  -- diameter of zone of plastic deformation equal to  $3 D_A \pm 50\%$ ;  $V_C$  -- volume of apparent crater, equal to  $(D_A^2 d_A)/8$  (calculated as a paraboloid).

After the Neptune shot, for determination of the physico-chemical state of the rocks, and for determining the contours of the zones of destruction and the distribution of radioactivity, 11 test holes were drilled in the zone of the explosion, seven of which were drilled from the surface (for this surface it was required that the blast crater be

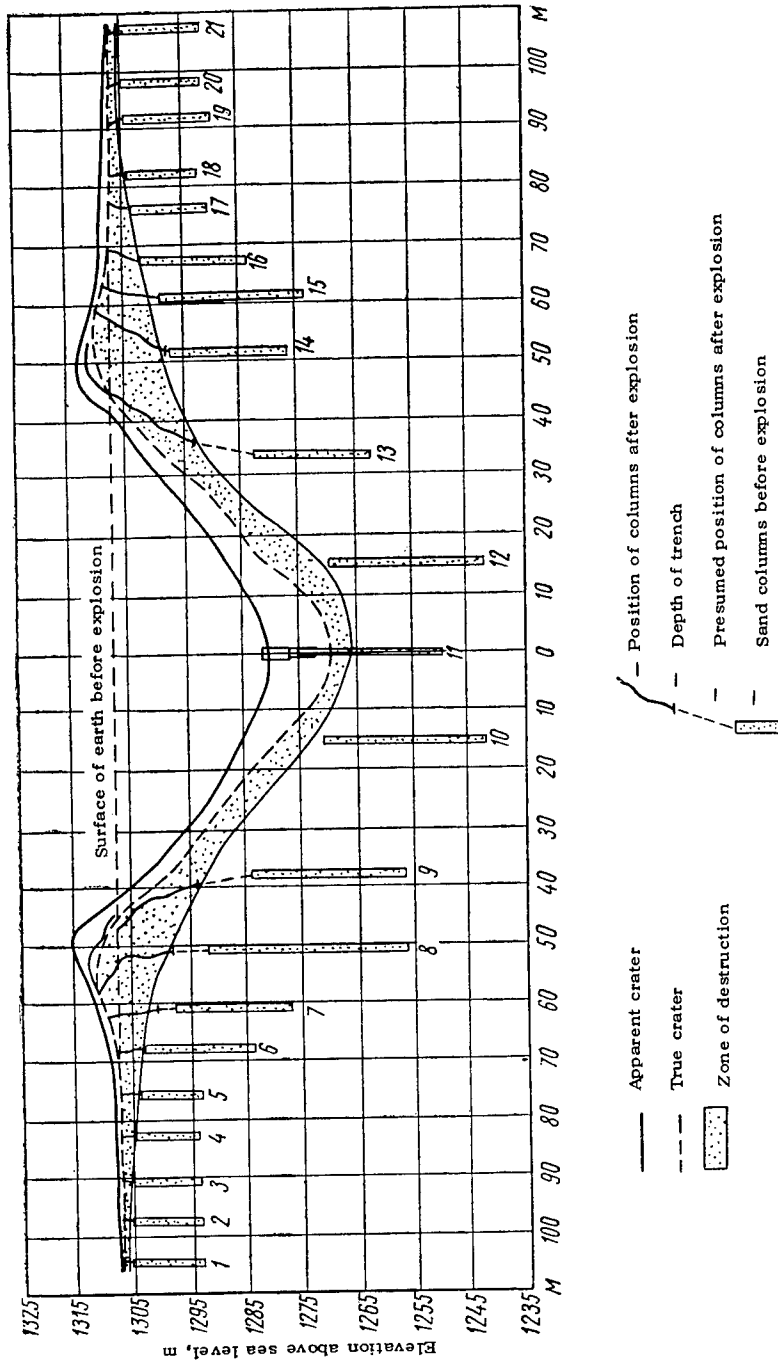
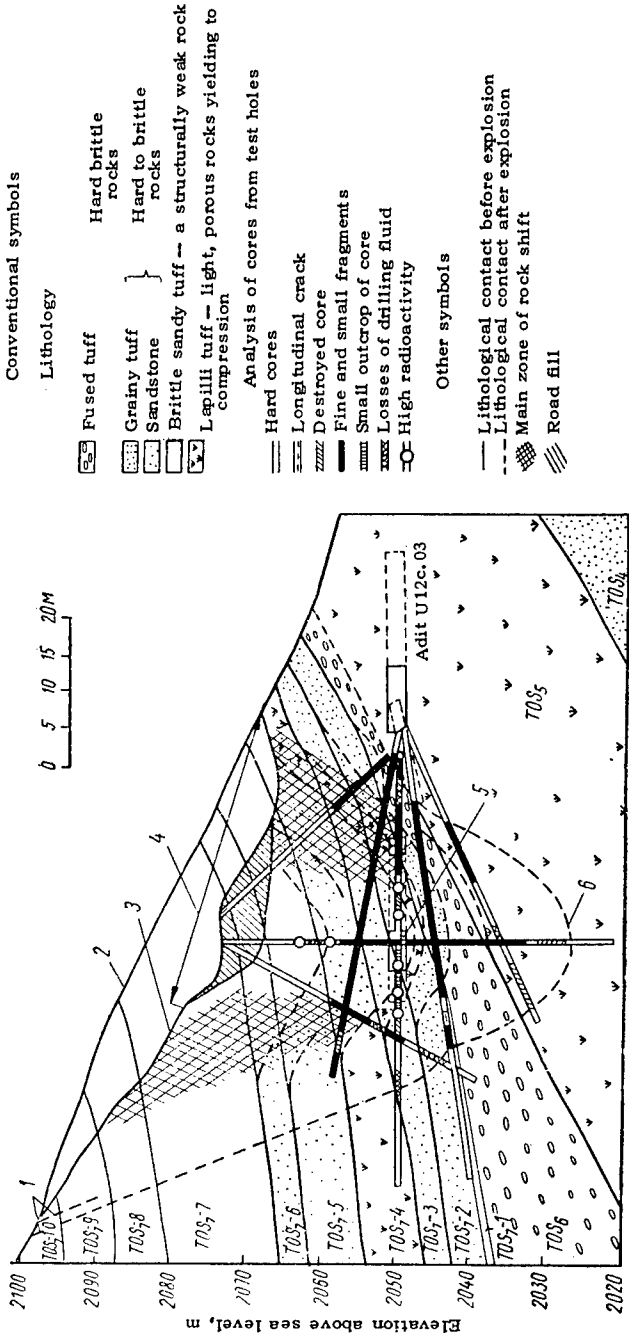

Figure 6. Section of crater caused by shot Teapot-Ess and position of control sand columns.



partly filled), and four from the approach adit (Figure 7). By means of these test holes, the contours of the various zones of the effects of the explosion were entirely determined [7].

The shape of the blast crater from the Neptune shot and the zones of the underground effect of the explosion, and also the detailed geological structure of the section, are shown in Figure 7 [7].

Data concerning nuclear explosions for external effect and the parameters of the craters are given in Table 8 [3, 7, 16, 20]. The profiles of the apparent craters, reduced to charges with a power of 1 KT, are represented in Figure 8 [7].

Table 8

Data Concerning Nuclear Explosions for External Effect, in Different Rocks, and the Parameters of the Craters

Parameter	Name of experiment and rock blasted				
	Jangle-S (alluvium)	Jangle-U (alluvium)	Teapot-Ess (alluvium)	Neptune (tuff)	Sedan (alluvium)
Power of charge W, KT.....	1,2	1,2	1,2	0,115*	100
Depth of setting of charge, line of least resistance, d, m.	-1,1**	5,2	20,4	33	193
Reduced depth of setting of charge, m/KT <sup>1/3</sup> .....	1	4,8	19	68	42
Radius of apparent crater R, m.....	13,7	40	44,5	33	185
Depth of apparent crater D, m.....	6,4	16,2	27,5	10,5	97
Volume of apparent crater V, m <sup>3</sup> .....	1260	28 250	73 300	16 800	5 million
R/D ratio.....	2,15	2,45	1,62	2,86	1,9
Blast index n <sup>2</sup> = R/d.....	—	7,7	2,2	1,0	0,95
Radius of true crater, m.....	—	—	46	—	—
Depth of true crater, m.....	—	—	38,5	—	—
Height of crater lip, m.....	—	2,4	5,8	—	30
Height of lift of rock column, m.....	—	1800	1600	25-30	600

\* According to other sources, 0.09 KT [2].

\*\* Height above surface of the ground.

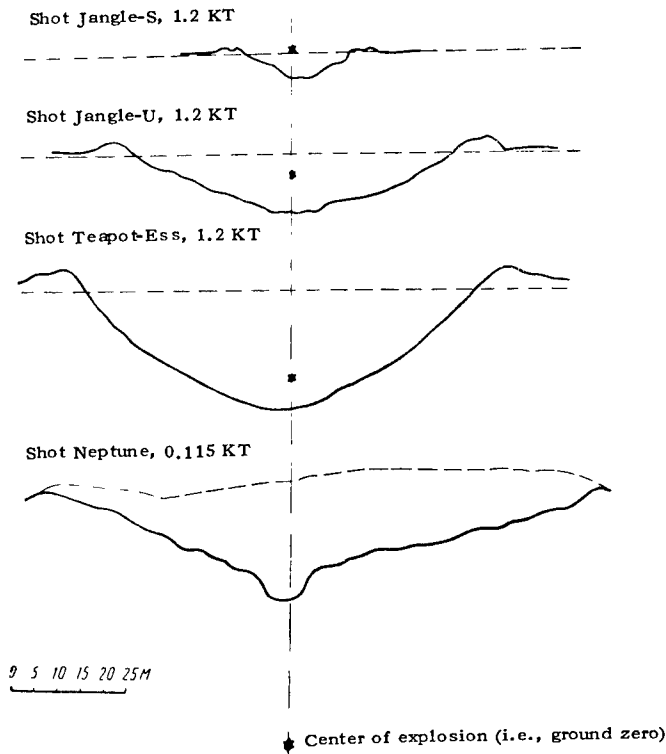

Figure 8. Profiles of apparent craters from nuclear explosions for external effect (reduced to charge with power of 1 KT).

Considerable attention is devoted in many works [1, 7, 15--17, 20] to establishment of a law of similarity (in the American literature the term "law of reduction" or "scale of reduction" is generally accepted). This law determines the dependence of the change in linear dimensions (radius and depth) of the blast crater upon the change in the power of the charge, and also makes it possible to reduce the results of explosions conducted at different depths to one depth of setting of the charge.

In a general form, the law of similarity is written in the following manner:

$$\frac{d_1}{d_2} = \left(\frac{W_1}{W_2}\right)^{Pd} ; \frac{R_1}{R_2} = \left(\frac{W_1}{W_2}\right)^{PR} ; \frac{D_1}{D_2} = \left(\frac{W_1}{W_2}\right)^{PD}, \quad (1)$$

where  $d_1$  and  $d_2$  are the depth of setting of charges with a power  $W_1$  and  $W_2$ ;  $R_1$  and  $R_2$  are the radii of the apparent craters caused by explosions with a power of  $W_1$  and  $W_2$ ;  $D_1$  and  $D_2$  are the depths of the apparent craters caused by explosions with a power  $W_1$  or  $W_2$ ;  $W_1$  and  $W_2$  are the powers of explosions 1 and 2;  $P_d$ ,  $P_R$ , and  $P_D$  are exponents with the charge power determining the law of similarity for the depth of placement of the charge, the radius and the depth of the apparent crater.

In recent years the majority of specialists [4, 15, 20] have arrived at the conclusion that the application of a reduction scale (law of similarity) with an exponent, with a power of the charges  $P$  equal to  $1/3$  ( $P = P_d = P_R = P_D$ ), as is accepted for charges intended for internal effects (see Chapter 4), in a case of blast explosions leads to considerable inaccuracies in the calculation. The cause of this is the fact that the reduction with a power of  $1/3$  does not consider the effect of the force of gravity of the rocks or the force of internal friction of the medium<sup>1)</sup>.

On the basis of experiments for blast effect with chemical explosives and a comparison of their results with the parameters of craters from nuclear explosions, in recent times a majority of the investigators (Nordyke [7, 15, 16], Viale [1], Murphey and Vortman [17]) consider that the linear parameters of the craters formed and the depth of placement of the charge, both for chemical and for nuclear explosions, are proportional to the power of the charge to the degree of  $1/3.4$ , i.e.,

$$\frac{d_1}{d_2} = \left(\frac{W_1}{W_2}\right)^{1,3,4}; \quad \frac{R_1}{R_2} = \left(\frac{W_1}{W_2}\right)^{1,3,4}; \quad \frac{D_1}{D_2} = \left(\frac{W_1}{W_2}\right)^{1,3,4}. \quad (2)$$

Violet [20], assuming the same dependence for the radius and depth of a crater, believes that for a depth of placement of the charge the following ratio gives a lower error (5%):

---

1) In the USSR this conclusion was made in 1952--1956. Soviet specialists, at this time, developed methods of calculating the charges of chemical explosives, with a consideration of the forces indicated.

$$\frac{d_1}{d_2} = \left(\frac{W_1}{W_2}\right)^{1,3,6} \quad (3)$$

The magnitude of the radii and depth of the blast craters obtained in all four nuclear explosions and in shots of chemical explosives in alluvium are reduced to the scale  $W^{1/3.4}$  (formula (2)) to a charge with a power of 1 KT, and plotted on the graph in Figures 9 and 10 [7]. From the graph it is apparent that the data on nuclear explosions coincide satisfactorily with the data on shots of chemical explosives (with the exception of the contact burst Jangle-S). Consequently, the craters formed in the nuclear explosions indicated may be compared with the craters formed by chemical explosives.

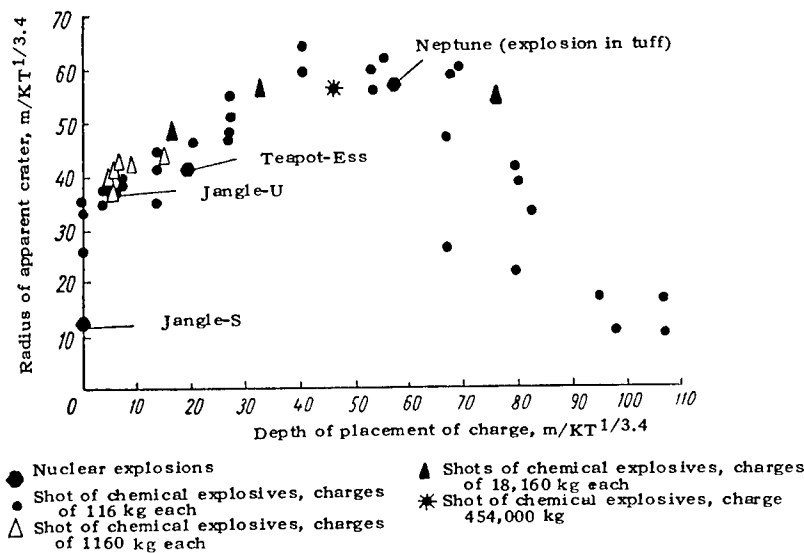

Figure 9. Dependence of the radius of the apparent crater upon the depth of placement of the charge, in alluvium, for nuclear and chemical explosives (reduced to a charge with a power of 1 KT).

The correspondence of the points with respect to the Neptune shot, which was conducted in tuff, with the points referred to explosions in alluvium, is explained by Nordyke [7] by the increase in the dimensions of the crater in tuff

in comparison to what was expected because of the considerable slope of the day surface.

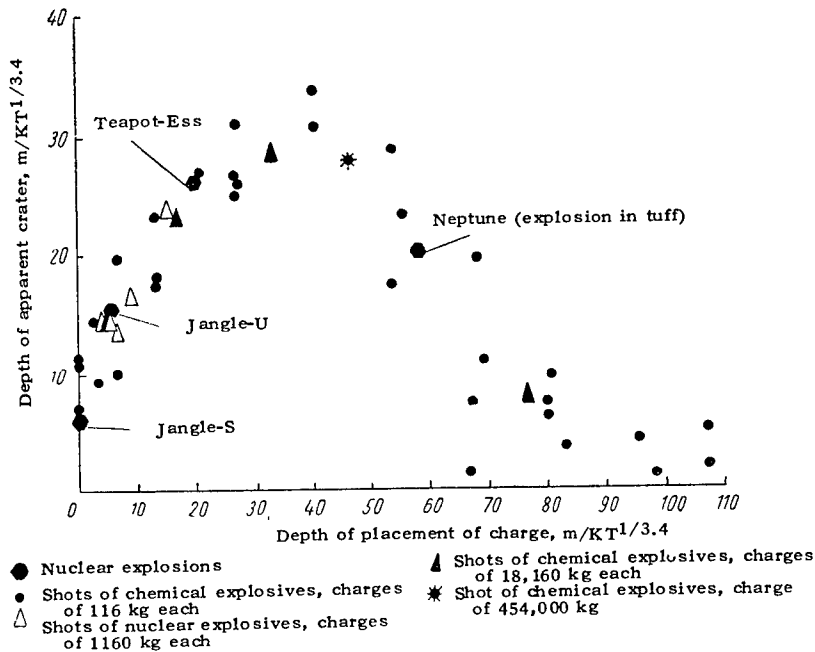

Figure 10. Dependence of the depth of the apparent crater upon the depth of placement of the charge, in alluvium, for nuclear and chemical explosives (reduced to a charge with a power of 1 KT).

A graph of the dependence of the radius and depth of an apparent crater upon the depth at which a charge with a power of 1 KT was set, constructed according to the points in Figures 9 and 10, and the corresponding degree of scale reduction  $1/3.4$  is represented in Figure 11 [7, 15].

For determination of the parameters of a crater when the charge has a power that is greater or less than 1 KT, it is necessary to: a) determine the reduced depth of placement of the charge of the given power  $W$  according to the dependence  $d_{red} = d/W^{1/3.4}$ ; b) find, by the graphs in Figure 11, the reduced radius  $R_{red}$  and depth  $D_{red}$  of the crater, corresponding to  $d_{red}$ ; c) determine the actual parameters of the crater according to the dependences  $R = R_{red} \cdot W^{1/3.4}$  and  $D = D_{red} \cdot W^{1/3.4}$ .



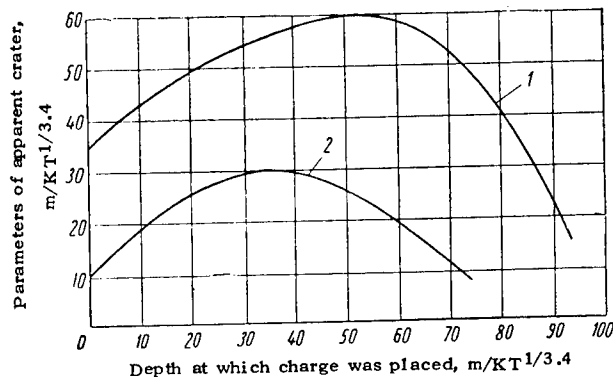

Figure 11. Dependence of the parameters of the apparent crater upon the depth at which a charge is laid, in alluvium (reduced to a charge with a power of 1 KT):

1 -- radius of crater; 2 -- depth of crater.

In calculation of the parameters of a crater for a medium that differs from dry alluvial sediment, it is recommended [5] that the following correction factors be introduced (as a multiplier): in strong rocks (granite, limestone, sandstone, etc.) 0.8 for the radius and depth of the crater; in ground saturated with water, 1.7 and 0.7, respectively<sup>1)</sup>.

On the basis of experiments with chemical explosives, Nordyke [19] considered it possible to conclude that in the majority of types of hard rocks the depth of the crater is reduced by 20--30% in comparison to the depth in alluvium, and in wet ground the dimensions of the craters are 20--50% greater than in dry alluvium.

A graph of the expected dimensions of a blast crater and the depth of placement of the charge necessary for the formation of a crater of maximum diameter, in the case of charges with a power of up to 10,000 KT, is given in Figure 12 [18]. The graph was compiled on the basis of an extrapolation of data from shots of chemical explosives with a power of up to 500 T, in alluvium. From the graph it follows that the optimum depth of placement of the charge for blasting away the ground, in alluvium, is

<sup>1)</sup> These recommendations of Nordyke and his subsequent conclusion need experimental confirmation.

$$d = 50 w^{1/3.4} \text{ m.}$$

(4)

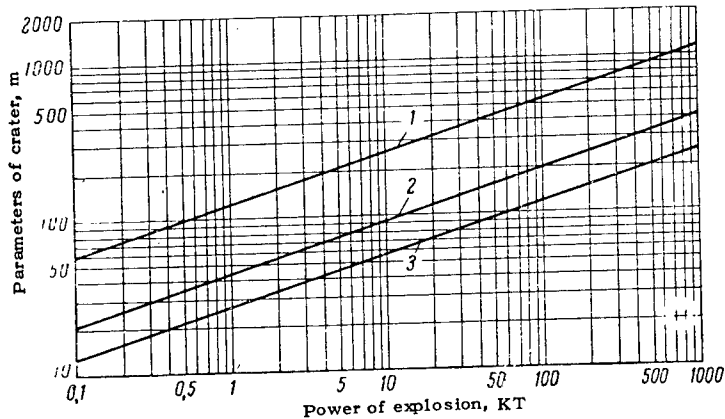

Figure 12. Parameters of a crater in alluvium, as a function of the power of the explosion, with the depth of placement of the charge providing the maximum diameter:

- 1 -- diameter of apparent crater ( $122 w^{1/3.4} \text{ m}$ );
- 2 -- depth of placement of the charge ( $50 w^{1/3.4} \text{ m}$ );
- 3 -- depth of apparent crater ( $27 w^{1/3.4} \text{ m}$ ).

With such a depth of placement of the charge, the dimensions of the apparent blast crater amount to:

$$\text{diameter } 122 w^{1/3.4} \text{ m;} \quad (5)$$

$$\text{depth } 27 w^{1/3.4} \text{ m.} \quad (6)$$

#### THE EFFICIENCY OF NUCLEAR AND CHEMICAL EXPLOSIVES

The problem of the relative efficiency of the explosions for blast effect made by means of nuclear and chemical explosives occupies an important place in the literature. In this case, in recent times, the majority of authors have drawn an analogy between the efficiency of nuclear explosions and shots of chemical explosives for such

a medium as alluvial sediments, with a moisture content of 10--15%. Thus, Nordyke [7] on the basis of data from Figures 9 and 10, concludes that the dimensions of craters formed by nuclear explosives are similar to the dimensions of craters caused by shots of chemical explosives.

The comparative effect of the formation of craters in bursts by nuclear and chemical explosives is characterized by the efficiency factor, which is expressed as the ratio of the powers of charges of chemical and nuclear explosives giving the same parameters of the apparent blast crater. The efficiency factor has different values, depending upon what parameter of the crater is used in the comparison of the explosions: radius, depth, or volume of crater. These factors are designated as  $\epsilon_R$ ,  $\epsilon_D$ ,  $\epsilon_V$ , respectively [15, 20].

In Table 9 the efficiency factors are given for each of the parameters indicated, calculated by Nordyke according to experimental data [15].

Table 9  
Efficiency Factors for Nuclear Blast Explosions  
in Alluvium

Name of experiment	$\epsilon_R$ , %	$\epsilon_D$ , %	$\epsilon_V$ , % (calculated)
Jangle-S.....	3,5±0,1	17±1	6±1
Jangle-U.....	87±22	135±22	103±22
Teapot-Ess.....	45±20	132±22	68±22
Average of Jangle-U and Teapot-Ess.....	68±15	134±15	85±15

Note.  $\epsilon_V$  is determined from the volumes of craters calculated as  $R^2D$ .

The difference between  $\epsilon_R$  and  $\epsilon_D$ , as given in Table 9, is significant and is explained by the mechanism of formation of the craters (compaction of the earth, recoil effect, gas structure) and the difference between the dimensions of the nuclear charges and the charges of chemical explosives. The mechanism of the formation of the crater, which plays the principal part in the given conditions, affects the radius and depth of the crater differently. Low efficiency factors in the Jangle-S contact burst are explained by the great loss of energy in a nuclear burst on the surface of the earth.

The difference in efficiencies of the Jangle-U and Teapot-Ess shots, expressed in a low value of  $\epsilon_R$  for the second shot and, as a consequence of this, a low  $\epsilon_V$ , can be explained by the conditions of the placement of the charge. In shot Teapot-Ess the charge was placed in the hole firmly against its walls, while in the Jangle-U shot the charge was placed in a chamber with a considerable gap between the charge and the walls of the chamber.

On the basis of the average efficiency factors given, the radius and depth of craters in nuclear explosions may amount to 90% and 110%, respectively, of the dimensions of the craters formed in similar conditions by shots of chemical explosives, in the opinion of Nordyke [15]<sup>1)</sup>.

---

<sup>1)</sup> For establishment of the relative effect of nuclear and chemical explosives with respect to the formation of craters in other rocks (especially when the charges are placed at a great depth and the medium is of low moisture content), the data are inadequate.

## CHAPTER 3

### NUCLEAR EXPLOSIONS FOR INTERNAL EFFECT

#### EXPERIMENTAL EXPLOSIONS FOR INTERNAL EFFECT

Out of six basic experiments in the tuffs of the Nevada test area, five explosions were set off without the formation of a blast crater. Experiments Rainier, Logan, Tamalpais, and Evans, in which the day surface was not destroyed, are explosions of completely internal effects (complete camouflet). In experiment Blanca the zone of destruction reached the surface of the earth, as a consequence of which this experiment must be considered as a shot of incomplete internal effect (a shot for the purpose of fragmentation of the massif).

Basic data on explosions for internal effect, together with data on the Neptune explosion, in which, together with a blast crater, a large zone of destroyed, but not ejected, rocks, was formed, are given in Table 10 [2, 7]. Here also is given information concerning the experimental-industrial camouflet shot Gnome, conducted in a massif of rock salt [4]. The experimental explosions at the Nevada test area are indicated in order of increase of the reduced line of least resistance ( $llr$ )<sup>1)</sup> which is determined from the expression

$$d_{red} = d/w^{1/8} \text{ [sic]}, \quad (7)$$

---

1) In the American literature they usually use the term "depth of placement of charge" (or "depth of explosion, shot depth") and "reduced depth of placement of charge" (or "reduced shot depth"), having in mind the  $llr$  and reduced  $llr$ .

Table 10

Data Concerning the Destructive Effect of Nuclear Explosions of the Complete Camouflet Type, Fragmentation and Partial Blast Effect in Tuff and in Rock Salt

Name of experiment	Characteristics of effect	Power of charge, KT	Depth of placement of charge along the vertical, m	Line of least resistance (11), m	Reduced 1/r, m/KT <sup>1/3</sup>	Volume of rock destroyed, thousands of m <sup>3</sup>		Dimensions of zone of fragmentation of the rock, m			
						Altogether	Per kiloton	Radius below charge	Radius at level of charge	Radius at surface or in upper part of cave-in zone	Height above charge
Nephere	Partial blast effect	0,115±0,02	36,5	30,0	67	65*	550	12	15	40	to the surface
Blanca	Fragmentation	19±1,5	290	255	95	11.500 (22 million tons)	600 (1,15 million tons)	—	—	150	to the surface
Logan	Complete internal effect (complete camouflet)	5 <sup>+0,2</sup> <sub>-0,4</sub>	284	253	147	—	—	—	—	—	—
Rainier		1,7±0,1	274	240	202	Minimum 350	Minimum 200	40	40	18	118
Tamalpais		0,072±0,01	125	100	238	—	—	—	—	—	—
Evans		0,055±0,03	280	256	675	—	—	—	—	—	—
Gnome		3±0,5	365	365	254	—	—	20	40	—	—

\* Calculated in accordance with Figure 7.

where  $d$  is the actual line of least resistance, i.e., the distance from the center of the charge to the nearest point on the surface of the earth,  $m$ ;  $W$  is the power of the charge in its TNT equivalent,  $KT$ .

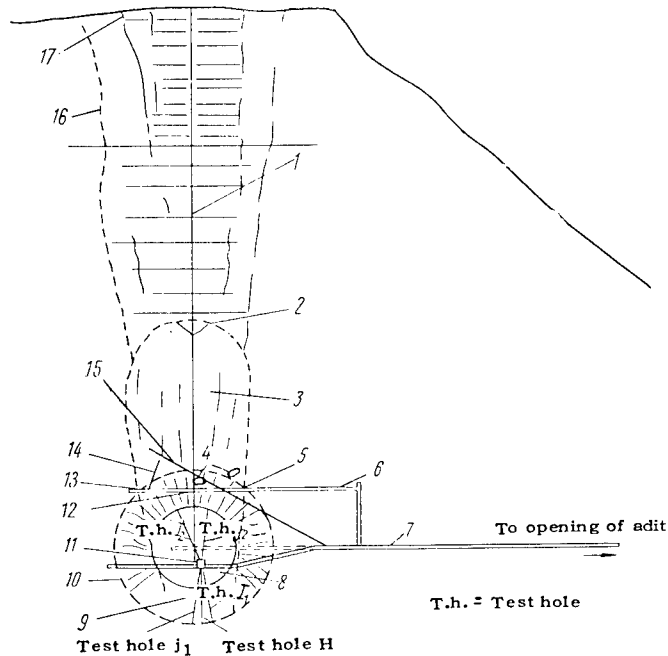

Figure 13. Zones of deformation of the rock in the Rainier shot and diagram of the survey galleries and holes:

- 1 -- vertical hole  $R = 6$  m, depth 278 m; 2 -- cavity at 156 m from the surface, 118 m above the point of the explosion; 3 -- zone of fragmented rock (cave-in); 4 -- cavities; 5 -- zone of shift of rock; 6 -- survey gallery; 7 -- basic adit U12b; 8 -- initial explosion cavity; 9 -- zone of material compacted by the explosion; 10 -- boundaries of zone of destruction; 11 -- place where charge was set; 12 -- section of drift 41 m long in destroyed rock; 13 -- zone of shift of rock; 14 -- perforated drill hole 14 m deep in soft sandstone material; 15 -- drill hole E; 16 -- overlying rocks of hard rhyolite tuff, 68 m; 17 -- small cracks at surface.

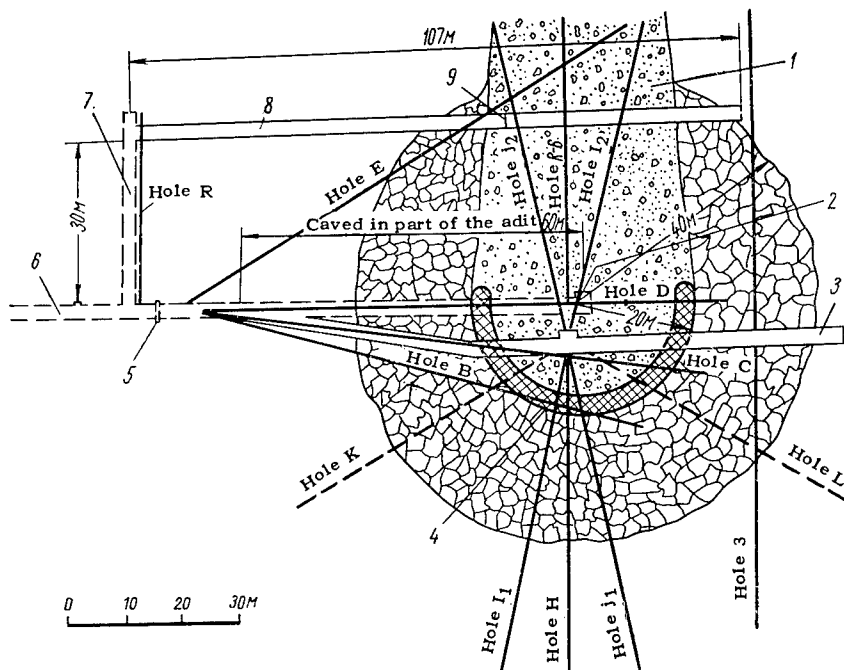

Figure 14. Galleries and drilled holes made in the zone of the Rainier shot:

1 -- cave-in zone; 2 -- location of the placement of the charge; 3 -- survey drift; 4 -- radioactive zone; 5 -- shockproof door; 6 -- basic adit U12b; 7 -- survey side gallery; 8 -- upper survey drift; 9 -- position of cut on 20 June 1959.

Note. Holes  $j_1$ ,  $j_2$ ,  $I_1$ , and  $I_2$  were cut at an angle of  $45^\circ$  to the vertical and lie on a plane perpendicular to the given section. The position of the given holes on the drawing is conventional. Hole 3 was drilled before the explosion.

Out of the experiments performed in 1957--1958, the Rainier shot was most completely studied from the standpoint of underground effect. In this experiment, the investigation of the zone of effect of the shot was conducted by means of test holes and galleries. A diagram of the survey holes and galleries is given in Figures 13 [21] and 14 [2].

They began to drill the first survey hole (R-6) several days after the explosion, on the surface of the mesa, at the epicenter of the explosion. In view of the danger of



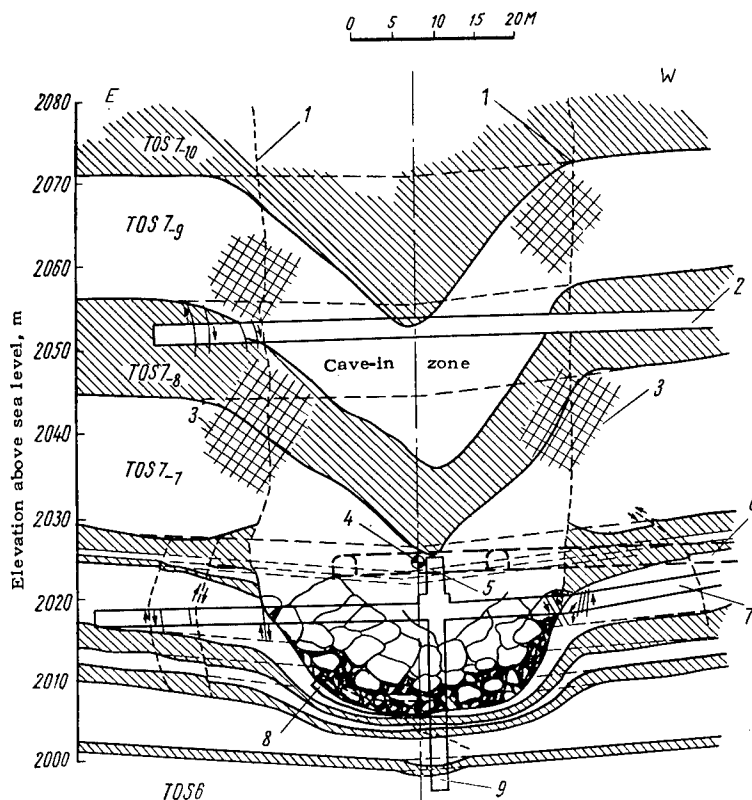

Figure 15. Stratigraphic section of the central zone of experiment Rainier after the explosion and diagram of the surveying of the lower part of the explosion cavity:

- 1 -- boundary of cave-in zone; 2 -- upper survey drift, cut from the side drift; 3 -- main zone of displacement (shift); 4 -- center of explosion; 5 -- short side gallery; 6 -- adit for placement of the charge; 7 -- survey drift; 8 -- lower survey cut; 9 -- blind cut with diameter of 2 m.

encountering a cavity with a high pressure, the drill was remotely controlled. Test hole R-6 passed through a small cavity in the upper part of the fragmentation cone, the zone of destruction, and reached the level where the charge was placed, 5.2 m from the center of the explosion. The depth of the hole was 278 m. Other survey holes were drilled from

underground galleries. From a cross cut in the wall of the basic adit, located at a distance of 63 m from the center of the explosion, three holes were drilled through the zone of fragmentation, in a fan-shaped arrangement: hole D horizontally through the center of the explosion; holes C and B, respectively, 8 and 17 m below (see Figures 3 and 14). Later, for determining the contours of the zone of effect of the explosion, 12 more holes were drilled from the survey galleries (see Figure 14).

Two survey galleries were tunneled into the central zone of the Rainier shot several months after the explosion (basically in the first half of 1958) from adit U12b. One survey drift was cut 7.5 m below the place where the charge was set, and the second 30 m higher. Both drifts intersected the zone of fragmentation of the rock by the explosion [2]. Later a small-sized side gallery was cut from the lower drift to the place where the former charge chamber was located, and also a vertical gallery from which, along the boundary corresponding to the bottom of the initial explosion cavity, a curved survey drift was cut. This stage of the survey of the central zone is represented in Figure 15 [18].

The zone of the underground effect of the Neptune shot was investigated by means of seven test holes, drilled from the surface, and four holes drilled from the underground galleries (see Figure 7). In other explosions for internal effects, survey holes were also drilled. The cores removed in the drilling of the survey holes were subjected to analysis and investigations for the physical, chemical, and radioactive properties of the rocks. The test holes also served for measurement of the temperature of the rocks after the explosion.

A description of the zones of deformation of the massif and the zones of a prolonged temperature effect is given below, and also the physical processes of the effect of a nuclear explosion on the surrounding rocks are described for the explosions intended for internal effect and for the Neptune experiment. The seismic and air-compression [mining] effects, and also the radiation effect of explosions intended for internal effect, are discussed in Chapters 4 and 5.

#### ZONES OF DESTRUCTION OF THE ROCKS

It was established by means of the survey holes and galleries that the region of destruction in explosions of entirely internal effect has the shape of a sphere, with its center at the place where the charge was located to which, from above, a zone of destroyed rock adjoins, in the form of a truncated cone or cylinder. The shape and dimensions of the zone of destruction after the Rainier shot are represented in Figures 13--15.

The majority of the authors [2, 14] assume the shape of the upper zone of the destroyed rock is in the form of a truncated cone (see Figure 14). The upper boundary of the zone of destruction in the Rainier shot is a small cavity with a height 7.5 m, located at a distance of 156 m below the surface of the earth and 118 m above the place where the charge was set (see Figure 13). The cavity had a roughly conical shape (it was investigated by means of photography).

With respect to the nature of the destruction of the rock, two clearly expressed zones are distinguished, coinciding basically with the spherical and conical zones described above. The first zone is permeated by water, and begins somewhat below the center of the explosion and extends to the upper boundary of the zone of destruction (upper cavity). It is created by the layers of rock lying above falling into the cavity initially formed by the explosion. The second zone, which consists of water-impermeable material (there were no losses of drilling water) has the form of a sphere, which surrounds the lower part of the cave-in zone. This zone is formed as a consequence of the direct destructive effect of the shock wave from the explosion of the charge on the rock massif. In the Rainier shot, the zones indicated have the following dimensions: the height of the cave-in zone amounted to 118 m above the place where the charge was set, with a diameter of 20--23 m in the first 30 m above the center of the explosion; the diameter of the cave-in zone above a point 30 m above the center of the explosion was not determined; this same zone continues below the center of the explosion, occupying a hemisphere with a radius of approximately 17 m; the zone of destroyed water-impermeable material had a radius of approximately 40 m [2].

In the Rainier shot, the distribution of pieces of rock, with respect to size, in the cave-in zone was as follows: in the lower survey drift the diameter of the pieces varied from approximately a decimeter in the peripheral part of the zone to a meter in sections located under the place where the charge was set; the intervals between pieces of rocks were filled with material pulverized to powder, which had succeeded in hardening, since the uncovering of the zone was done a year after the explosion (secondary cementation is not uncommon for material with a high content of clay particles). A survey gallery cut 30 m above the center of the explosion entered a region of fragmented rock at a distance of 23 m from the vertical axis passing through the center of the detonation. At this distance, the rock fragments had a diameter of from a decimeter to a meter and were broken by open cracks; then the size of the pieces gradually decreased, reaching a state of finely pulverized powder at a distance of 20 m from the vertical axis. As is apparent from

Figure 15, in the section of the cave-in zone located above the center of the explosion, the lithological horizons can be traced adequately clearly even in the fragmented material.

In the zone of destruction that is impermeable to water, warped and compacted material is located, formed as a result of the destruction of the tuff by the shock waves, with subsequent compacting in the expansion of the initial cavity. The degree of compaction of the tuff in this zone differs; in the lower section of the zone the material is more highly compacted than in the upper part, adjoining the cave-in zone.

Zones of cracks (jointing) lie in the interval of the radial distances from 40 to 90 m. Beyond the limits of distances of more than 90 m from the charge, a zone of elastic deformation began [22].

Johnson et al. [2] consider that the total quantity of rock destroyed amounts to a minimum of 700,000 T, of which 200,000 T is fragmented material of the cave-in zone and 500,000 T destroyed compacted material of the zone of fragmentation. By working from these figures, in explosions of an entirely camouflet type in the tuff massifs, the volume of rocks destroyed per kiloton of power of the charge would amount to: 300,000 T ( $135,000 \text{ m}^3$ ) in the zone of fragmentation; and 120,000 T ( $53,000 \text{ m}^3$ ) in the cave-in zone.

From Table 10 it is apparent that the complete internal effect of the explosion (a complete camouflet) was reached with a value of the reduced llr equal to  $146 \text{ m}/\text{KT}^{1/3}$ , while with a magnitude of the reduced llr equal to  $95 \text{ m}/\text{KT}^{1/3}$ , considerable destruction of the surface was already observed (in shot Blanca).

Johnson et al. [2], and later Parkinson [14], consider that the value of the reduced llr providing for a total internal effect of the explosion in tuffs is the quantity  $120 \text{ m}/\text{KT}^{1/3}$ . From this, the minimum value of the llr for an explosion of an entirely camouflet effect would be

$$d = 120 W^{1/3}, \text{ m} \quad (8)$$

where  $W$  is the power of the charge, in kilotons.

A graph of the dependence of zones of fragmentation and the cavity of the explosion upon the power of the charge for explosions of an entirely internal effect is given in Figure 16 [21]. The graph was compiled by calculations, on the basis of data on the Rainier shot, working from the following principles: 1) for charges of different power the

relationship between the diameter of the zone of fragmentation and the diameter of the explosion cavity is the same as in the given explosion; 2) linear dimensions (diameter or radii) of the zone of effect of the explosion are directly proportional to the power of the charge to the power

$1/3$ , i.e.,  $\frac{d'_R}{d'_x} = \left(\frac{W_R}{W_x}\right)^{1/3}$ , (where  $d'_R$  and  $d'_x$  are the diameters of

zones of deformations in the Rainier shot and an explosion of another power and  $W_R$  and  $W_x$  are the corresponding powers of the charges).

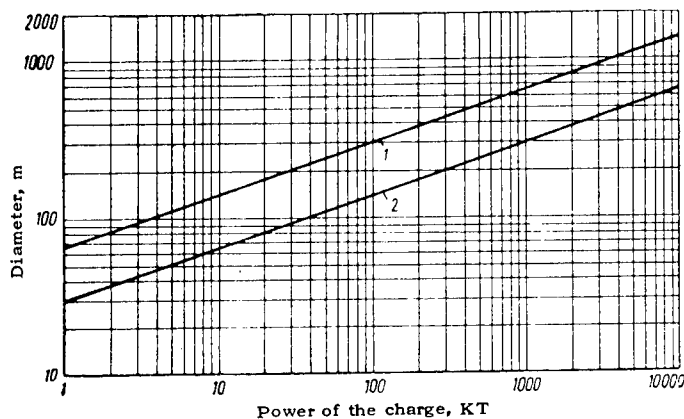

Figure 16. Diameters of the explosion cavity and zone of fragmentation as a function of the power of a nuclear charge:

1 -- diameter of fragmentation zone; 2 -- diameter of explosion cavity.

In the Blanca shot, an uplifting of a dome-shaped part of the mesa occurred, in a region with a diameter of approximately 500 m. This uplifting was fixed at the moment of the explosion by motion picture photography. It was chiefly the Mitchell motion picture camera that was used, with a rate of 100 frames per second (a more detailed description of the motion picture photography stations and apparatus is given in Chapter 4). The greatest uplifting was noticed on a section of the mountain slope located in the vicinity of the epicenter of the explosion.

The first movement of this section fixed by motion picture photography occurred 3.5 seconds after the explosion of the charge. The height of uplifting of the rocks reached a maximum of 7.6 m, 5.2 seconds after the explosion. The graph of the height of uplifting of the surface of the mountain slope, as a function of time, in the vicinity of the epicenter is given in Figure 17 [9]. The uplifting of the surface at a radial distance from the epicenter of 230 m amounted to about 0.75 m, and at a distance of 275 m about 0.45 m [9]. At 15.9 seconds after the explosion, a crack was formed on the slope of the mountain in the section of maximum uplifting of the surface, through which a column of gaseous explosion products was discharge.

In drilling into the zone of shot Blanca it was observed that the initial cavity which was formed in the explosion had a radius of 40 m. The cave-in (collapse) of this cavity, which, probably, began almost immediately after the explosion, reached the surface and led to the discharge of a certain quantity of radioactive explosion products to the surface of the earth.

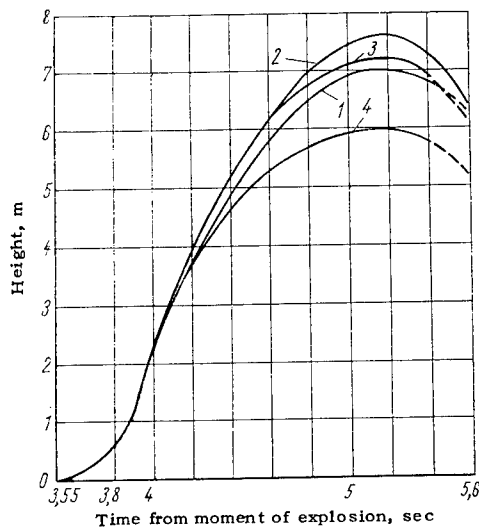

Figure 17. Change in the vertical displacement of the surface of the earth in time during shot Blanca:

1 -- reference mark 1; 2 -- reference mark 2; 3 -- reference mark 3; 4 -- reference mark 4.

Although the shape of the cave-in zone is not precisely known, the total volume of fragmented rock may be calculated, in approximation, on the basis of the dimension of the zone of destruction at the surface and the dimension of the initial cavity of the explosion. The volume of fragmented rock, calculated from the assumption that the zone of destruction had the approximate shape of an inverted cone, with a base radius of 150 m and a height of 335 m, amounts to 11.4 million m<sup>3</sup>, or about 22,000,000 T.

As is apparent from Table 10, the magnitude of the reduced l/r for shot Blanca, which gave the fragmentation of the massif without the formation of a blast crater, amounted to 95 m/KT<sup>1/3</sup>, while with a value of the reduced l/r equal to 67 m/KT<sup>1/3</sup> an external effect of the explosion is observed, with a considerable blasting of rock (experiment Neptune).

The underground effect of the Neptune shot was briefly considered in a work by Nordyke [7]. By means of test holes drilled after the explosion, it was established that the layers of tuff partly above the charge chamber collapsed into the initial cavity, but were only insignificantly displaced, and therefore individual lithological elements could easily be differentiated. Fragmentation extended 12 m downwards along the vertical and 15 m along the horizontal from the place where the charge was set. A zone of cracking (fracturing) below the level of location of the charge was in the shape of a hemisphere, with a radius of 20 m. The boundaries of the zone of fragmented and warped tuff at the day surface lie beyond the limit of the apparent blast crater. The zones of the underground effect of the Neptune shot are apparent in Figure 7.

#### ZONES OF PROLONGED TEMPERATURE EFFECT

The temperature distribution in the central zone of the Rainier shot, measured along test holes D, C and B (see Figure 13) five months after the explosion is shown in Figure 18 [2]. The heat content within the boundaries of different isothermal contours, calculated by working from the specific heat content of 0.3 cal/g · °C, are given in Table 11 [2].

The maximum temperature measured within the zone bounded by the 80°C isotherm was 94°C, i.e., it corresponded to the boiling point of water at the elevation of the explosion. The center of highest temperatures turned out to be displaced to the left of the place where the explosion occurred, by approximately 6 m. It is possible that the initial motion of the gases proceeded in this direction

along a large open crack, formed on this side, which led to the phenomenon indicated.

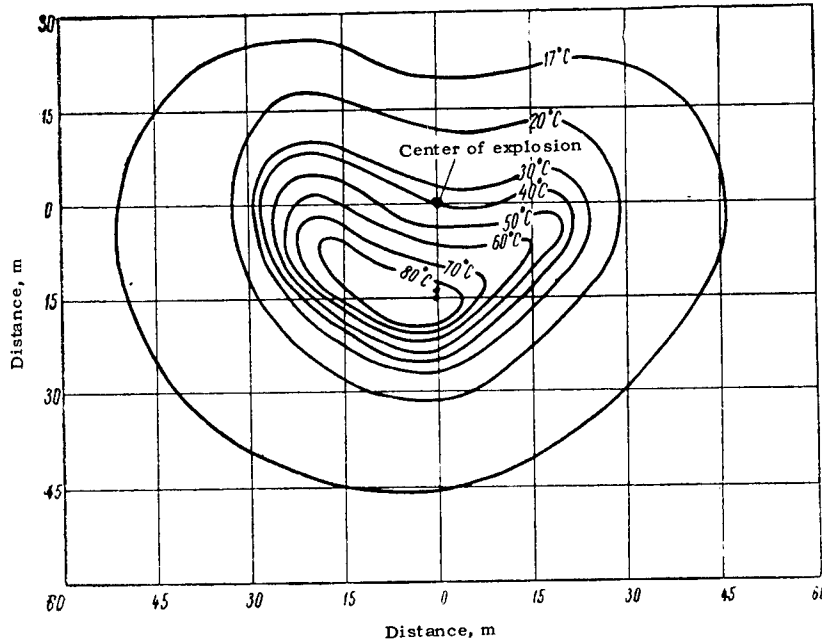

Figure 18. Temperature distribution in rocks during experiment Rainier five months after the explosion (isotherms on the vertical plane). Temperature of surrounding rocks 16.6°C.

Table 11

Distribution of Thermal Energy during the Rainier Shot

Isotherm, °C	Average radius, m	Total energy, accumulated within boundaries of isotherm*	
		x 10 <sup>6</sup> , kcal	In comparison with total energy momentarily liberated during the explosion, %
20	30,0	1000	60
40	24,0	700	40
60	16,7	300	17
80	9,1	60	3

\*Temperature distribution is assumed to be symmetrical with relationship to the axes.



The temperature distribution in other explosions was studied with less completeness than in the Rainier shot, but, however, in each case measurements of the temperature were made along one or several test holes. The general nature of the distribution, and precisely the geometry of the isotherms and maximum fixed temperatures were the same as in the Rainier shot. Great asymmetry in the temperature distribution and radiation distribution in the Logan and Blanca shots testified to the fact that at the first instant after the explosion a motion of part of the gases along the crack and in the direction of the approach galleries also occurred.

The approximate radii at which different temperature levels were recorded are given in Table 12 [2].

Table 12

Average Radius of Isotherm for Different Explosions, m

Isotherm, °C	Blanca	Logan	Rainier	Tamalpais*
20	73**	57**	30	—
40	36,5	30	24,3	—
60	—	24,3	16,7	—
80	—	21,3	9,1	—
$R_T$	64	42,6	28,2	15,2
$\frac{R_T}{W^{1,3}}$	24	25	24,6	36,6

**Note.**  $R_T$  is the radius at which the first sharp rise in temperature is observed, in comparison to the temperature of the surrounding rocks.

\*The charge was exploded in a large chamber.

\*\*Natural temperature of the rock in the Blanca and Logan shots was, respectively, 20 and 18°C.

According to the data in Table 12, the magnitude of the radius  $R_T$  in which we should expect a rise in the temperature of the rocks may be expressed by the following empirical formula [4]:

$$R_T = 24.6 W^{1/3}, \text{ m.} \quad (9)$$

## PHASES OF THE EFFECT OF A NUCLEAR EXPLOSION ON THE SURROUNDING ROCKS

Parkinson [14] and Johnson [23, 24] divide the entire process of the effect of a nuclear explosion for complete camouflet effect on the surrounding rocks into four stages: phase of nuclear reaction, phase of hydrodynamic effect, phase of static effect, and phase of thermo-radiation after-effect.

During the phase of nuclear reactions, in a time of less than 1  $\mu\text{sec}$ , the liberation of almost all the energy of the nuclear explosion occurs. The energy of the explosion of a fission charge is defined as the product of the number of nuclei fissioning, measured by the radiochemical method, multiplied by the magnitude of the energy momentarily liberated in the fission of one nucleus (179 MeV, or  $2.86 \cdot 10^4$  ergs), which is the sum of the kinetic energy of the fission fragments and the energy of the fast neutrons and the momentary  $\gamma$  radiation. The delayed liberation of energy associated with radioactive decay gives an additional 22 MeV per fission. About 15 MeV of this energy, in the final analysis, is converted to heat, and about 7 MeV is liberated during the first 20 min [2].

The initial temperatures and pressure in the charge chamber [2] may be calculated according to the following equations, compiled on the basis of the equation of the density of energy:

for temperature

$$E = 1,25 \cdot 10^8 \frac{\rho}{M} T + 7,65 \cdot 10^{-15} T^4, \quad (10)$$

for pressure

$$p = 0,83 \cdot 10^8 \frac{\rho}{M} T + 2,55 \cdot 10^{-15} T^4 \text{ dynes/cm}^2, \quad (11)$$

where E is the energy density equal to the energy density of the particles plus the radiation energy density, in ergs per  $\text{cm}^3$ , M is the molecular weight;  $\rho$  is the density of the material in the charge chamber,  $\text{g/cm}^3$ ; and T is the temperature of the explosion,  $^{\circ}\text{K}$ .

In the Rainier shot, energy amounting to  $7.2 \cdot 10^9$  ergs was instantaneously liberated. Since the mass of the material in the chamber amounted to about  $10^6$  g (the weight was approximately equal to 1 T), and the volume of the chamber was  $7 \cdot 10^6$  cm<sup>3</sup>, the average density was 0.14 g/cm<sup>3</sup>. At very high temperatures, almost all the nuclei were freed of their electrons, and since the atomic weight is approximately equal to two atomic numbers, the effective molecular weight amounts to approximately two. From the formulas given, it follows that the temperature a few microseconds after the shot was about 1,000,000°C, and the pressure was 7000 kilobars (about 7,000,000 atm). The radiation pressure at such a temperature amounts to 2.5 kilobars (2500 atm).

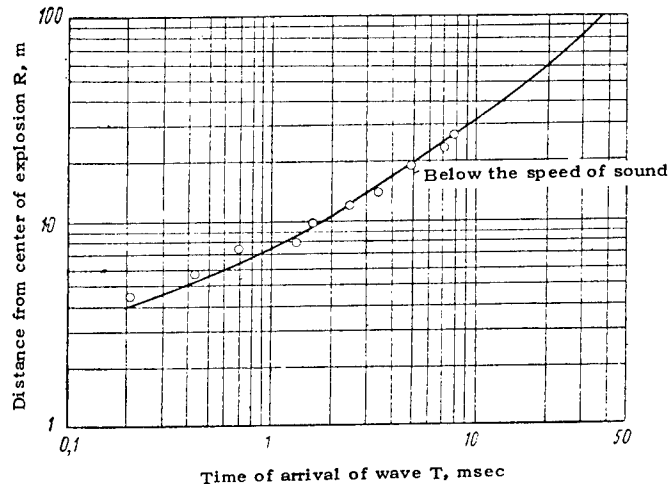

Figure 19. Rate of propagation of a shock wave during the Rainier shot:

o -- Porzel data; — -- calculated curve.

In the phase of the hydrodynamic effect, the vaporization and fusing of the rocks surrounding the charge occur, and a cavity is formed as a consequence of the compression of the fused rocks. The shock waves fragment the rocks in a zone adjoining the cavity, and cause seismic oscillations in a more distant zone.

Calculation of the dynamic processes in the medium [2] from the moment from several microseconds after the

nuclear reaction (ending of the first phase) up to 100 msec was performed by Nackels, who expanded Pelsor's previous calculations. In this case it was assumed that tuff has only an insignificant resistance to fracturing and behaves like a linear-elastic solid until such time as the tensile stress exceeds the compression stress caused by the rock pressure. The constants of elasticity were the measured values of the modulus of volumetric compression, modulus of shear, and the speed of sound.

The calculation data concerning the time of arrival of the shock wave at a point located at various distances from the charge, together with the result of the measurement of the actual arrival time as performed by Porzel, are given in Figure 19 [2]. The calculated dependence of the peak pressure of the shock wave upon the distance to the point of the explosion is shown in Figure 20 [2]. In a radius of up to 10 m, the pressure decreases as a function of distance, according to the law  $R^{-2.35}$ .

In a radius of up to 2.3 m, under the effect of the shock wave, the peak pressure of which (see Figure 20) reached 1,000,000 bars in 0.2 msec, the tuffs were transformed into vapor, and in a radius of up to 3.3 m, where the pressure amounted to 400,000 bars, the tuff fused.

In the first 4.6 m the shock wave had adequate energy to fuse all the tuff within the limits of this radius (660 T). Radiochemical analyses after the Rainier shot indicated that this magnitude actually amounted to about 800 T. The total quantity of fused tuff is equal to the sum of tuff fused under the effect of the shock wave (600 T) plus that fused because of the energy of decay of the fission products. It must be approximately 1.2 times as much as the magnitude of the fused tuff caused only by the effect of the shock wave. The coefficient 1.2 is the quotient of the division of the percentage of instantaneously liberated energy in the medium, gas + liquid + products of decay, by the percentage of instantaneously liberated energy in the medium, gas + liquid.

The shock wave fragmented the medium within a radius of 40 m, where the pressure was equal to 1400 bars, i.e., it was twice the resistance of the rock to static compression. At a distance of from 40 to 87--93 m, a gradual transformation of the shock wave into a seismic elastic wave occurred. From the calculations it is apparent that the zone of purely elastic deformations began at a distance from the center of detonation at 87 m along the vertical and 93 m along the horizontal.

Under the effect of high pressure, because of compaction of the fused material and the rocks destroyed by the shock wave, the formation of a central spherical cavity occurred until that moment when the pressure in the cavity

became equal to the pressure of the overlying rocks. The fused tuff covered the internal surface of this cavity with a layer having a thickness of 4--10 cm. The calculated rate of expansion of the cavity is shown in Figure 21 [2]. As is apparent from the curve, the radius of the cavity reaches its maximum magnitude equal to 18.9 m, in 80 msec. The actual radius of the cavity caused by the Rainier shot corresponded to this magnitude.

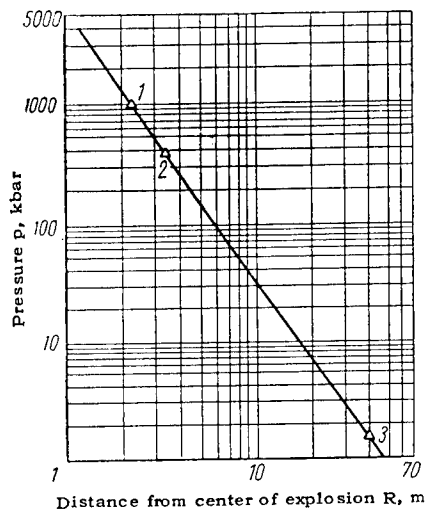

Figure 20. Dependence of maximum shock-wave pressure upon distance during the Rainier shot:

- 1 -- shock-wave pressure, 1 Mbar at a distance of 2.3 m;
- 2 -- pressure 0.4 Mbar at a distance of 3 m;
- 3 -- pressure of 1.4 kbar at a distance of 39.6 m.

The distribution of energy 90 msec after the explosion according to Nackels' calculation is given in Table 13 [2]. At this moment, less than 0.5% of the energy falls to the share of kinetic energy, and therefore the system was almost static.

At the phase of the static effect, because of the pressure drop in the cavity, the walls cave in and a cave-in cone above the cavity is formed. The phenomena occurring in the cavity after the Rainier shot, from the moment of its formation to its collapse, in general features are the same

[2, 14]. The cavity existed from 30 sec to 2 min. In this time the fused tuff flowed along the walls and dropped from the roof of the cavity. The lack of any hollows in the drops of congealed glassy material testifies to the fact that the temperature in the cavity decreased rapidly and sharply, as a consequence of which hardening occurred "on the wing," before the drops reached the bottom of the cavity.

Table 13

Distribution of Energy in the Rainier Shot

Zone	Radius, m	Instantaneously liberated energy, %
Vaporization.....	0—18,9	8,2
Fusion.....	18,9—19,0	19,1
Fragmentation.....	19—40	47,0
Crack formation.....	40—85	21,2
Elastic deformations.....	>85	4,5

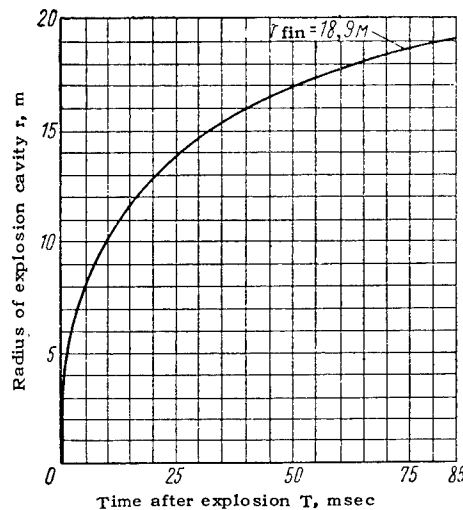

Figure 21. Rate of increase of cavity during Rainier shot.

The sharp decrease in temperature in the cavity, the considerable leakage of short-lived volatile radioactive products (krypton and xenon) from the cavity, and the marked asymmetry of the distribution of thermal energy after the explosion (see Figure 18) prove that a rapid decrease in

pressure, from 40 atm to only a few, occurred as a result of the propagation of the gases along the cracks that had no outlet to the surface (no radioactivity at the surface was detected). Judging by the asymmetry of the temperature distribution after the explosion, the ventilating crack was located on the side of the cavity opposite to the adit. The calculated temperature distribution at the moment when the cavity ceased to expand, but had not yet caved in, is shown in Figure 22 [2].

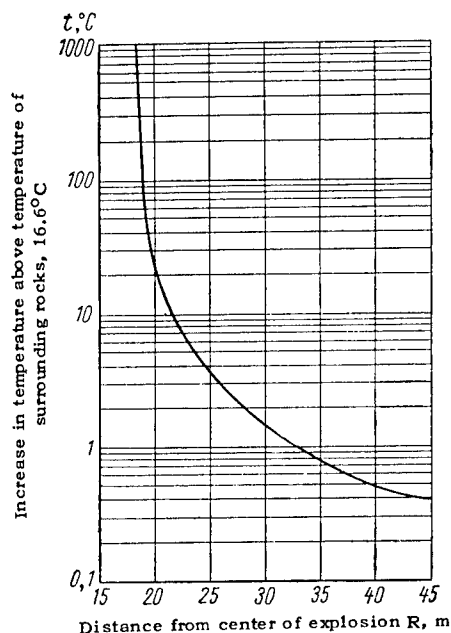

Figure 22. Initial temperature distribution in the Rainier shot.

Working from the melting point of tuff, the conclusion was made that the fused material at this moment had a temperature of 1200--1500°C. For heating 800 T of tuff with a moisture content of 15% up to this temperature, about  $5.7 \cdot 10^8$  kcal would be required, which amounts to 32% of all the energy liberated (instantaneous + thermal energy of the products of decay) in the Rainier shot ( $1.8 \cdot 10^9$  kcal). According to Nackels' calculations (see Table 13), 27% of the instantaneously liberated energy ( $1.7 \cdot 10^9$  kcal) is consumed in vaporization and fusion. Thus, the energy of the decay of the fission products must amount to 3--4% in addition to

the instantaneously liberated energy. The vapor pressure in the cavity, with the assumption that all the moisture from the fused and vaporized rock remains in it in the form of steam and that its temperature is approximately the same as the fused rock (1500°C), is calculated to be equal to 40.8 atm. This may be compared with the magnitude of the pressure of the overlying rocks, which is equal to 51--56 atm.

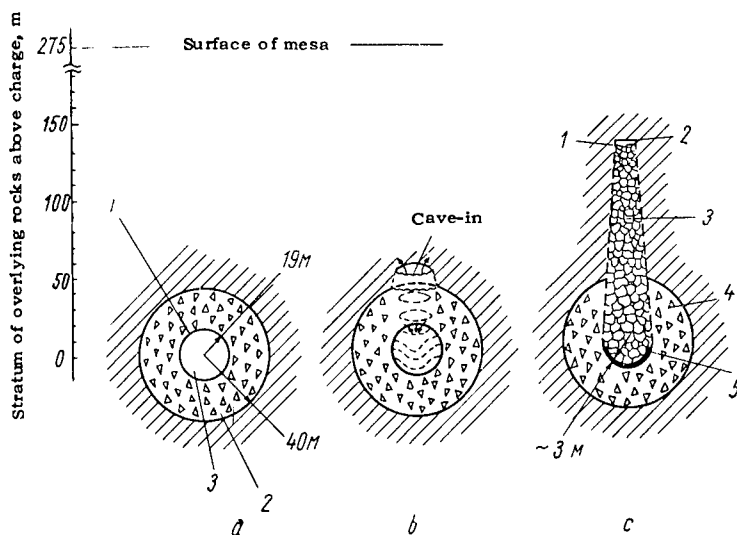

Figure 23. Development of the cave-in of the cavity in the Rainier shot:

a -- explosion cavity before cave-in (1 -- spherical layer of fused radioactive rock with a thickness of 10 cm, 2 -- zone of destruction, 3 -- explosion cavity); b -- development of the cave-in; c -- end of cave-in (1 -- cavity in upper part of cave-in zone, 2 -- depth from surface 156 m, distance from charge 118 m, 3 -- fragmented material, permeable for water, 4 -- destroyed material, impermeable for water, 5 -- main zone of radioactivity).

Johnson et al. [2] consider that the linear dimensions of the central cavity are subordinate to the law of similarity that is common for charges intended for an internal effect, i.e., they are proportional to the power of the charge to the power  $1/3$ , and they recommend that the



radius of the cavity be determined in accordance with the dependence

$$R = 15 W^{1/3} \text{ m}, \quad (12)$$

where  $W$  is the power of the charge, in kilotons.

Johnson [24] assumes that the temperature and pressure in the cavity decreased as a consequence of the propagation of vapors through the cracks during the cave-in of the cavity. The cave-in of the cavity, after the pressure in it decreased, occurs as a consequence of the reverse movement of the walls in a radial direction under the effect of the pressure of the water vapor formed from the water enclosed in the tuff, during the transfer to the rock from the fused layer. This cave-in occurred throughout the entire surface of the cavity and began before the fused mass had entirely flowed to the bottom. Then, at the end of this phase, a cave-in of the layers of rock lying above the roof of the cavity occurred, with the filling in of the latter by the fragmented material. A diagram of the development of the cave-in zone during the Rainier shot is given in Figure 23 [14, 25].

In the phase of thermal radiation aftereffects, the cave-in of the rocks lying above the cavity is completed, with complete formation of a cave-in zone, and a slow scattering of the heat and decay of the radioactive products occurs. The duration of the phase, as a function of some type or other of effect, is measured in days, months, or years [14, 24].

## CHAPTER 4

### SEISMIC AND AIR-COMPRESSION EFFECTS OF UNDERGROUND NUCLEAR EXPLOSIONS

#### METHODS OF OBSERVATIONS OF THE SEISMIC EFFECTS AND RECORDING APPARATUS

Observation of the seismic effect of underground nuclear explosions of the Plumb Bob and Hardtack, phase II, series was accomplished in accordance with an extensive program, with the participation of a number of state organizations and private companies (Stanford Research Institute, the Sandia Corporation, Laboratory of Engineering Research and Development, U.S. Coast and Geodetic Survey, the Edgerton, Hermeshausen, and Grier Company, and the Laboratory of Ballistic Research). The seismometric apparatus most frequently recorded the accelerations and displacement of the soil and the rock massif. The velocity of the particles, stresses and deformations were recorded in individual explosions conducted in 1958.

During the Rainier shot, accelerations of the motion of the rocks in the massif were recorded in test holes, drilled from the summit of the mountain in the direction of the charge chamber, in the approach adit, and at the surface of the mountain along a profile passing through the epicenter of the explosion. Observation of the movement of the surface of the earth in this experiment was performed at epicentral distances from 300 m to 15 km by the U.S. Coast and Geodetic Survey by seismographs for strong earthquakes, with direct optical recording. Part of the seismographs were accelerometers (period of natural oscillations of the pendulum  $T_0 = 0.03\text{--}0.15$  sec) calculated to record accelerations from 0.001 g to 3 g, and the other part ( $T_0 = 2\text{--}3$  sec) served for recording displacements with a maximum magnitude of up to 15 cm. Nine stations were established at distances (along

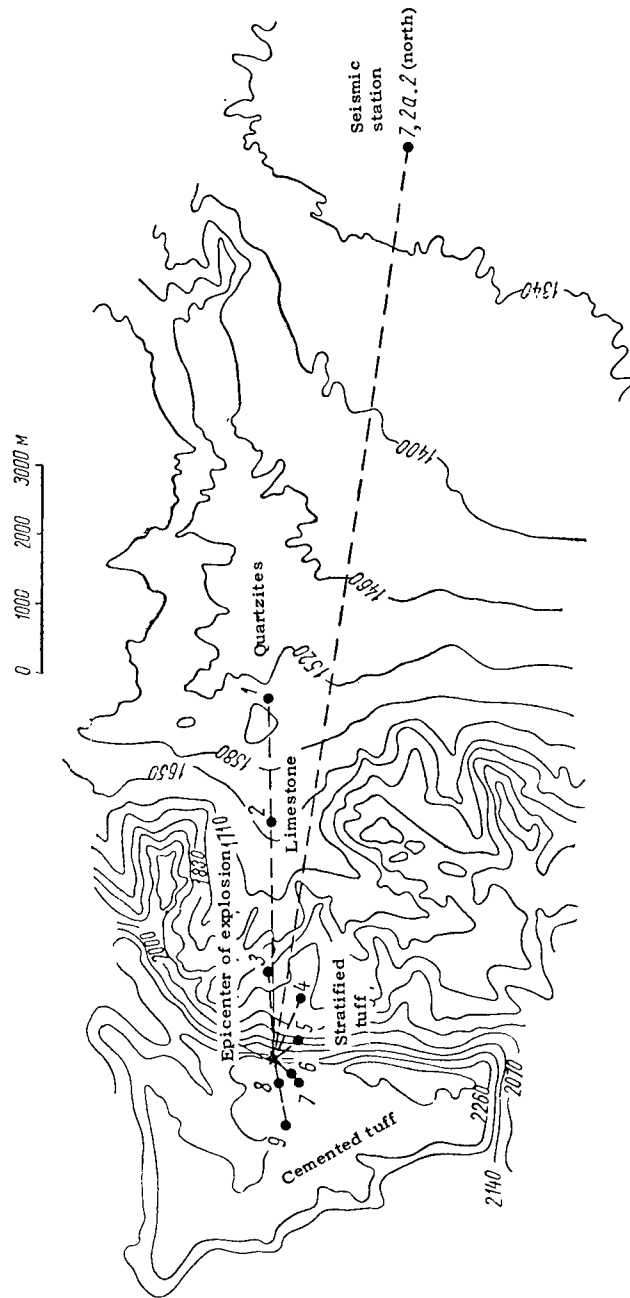

Figure 24. Arrangement of seismic stations on the day surface in the short-range zone during the Rainier shot (contour lines are shown in meters):

1-9 -- temporary seismic stations.

the surface of the earth) of from 370 m to 4.8 km from the center of the explosion. In the Rainier shot, one of the stations was located at a distance of 13.6 km from the point of the explosion, on alluvial soil, and in explosions of the Hardtack II series, at approximately the same distance on hard rock. The arrangement of the seismic stations during the Rainier shot is shown in Figure 24 [26].

In the Tamalpais, Logan, Evans, and Blanca experiments, 12 stations were installed in the zone from 600 m to 15 km from the point of the explosions, for recording strong oscillations (accelerations at displacement of the surface were recorded). Besides this, fixation of the acceleration of the surface was performed at shorter distances during the Tamalpais, Evans, and Blanca shots with Vianco accelerographs. At the epicenter of the Evans shot, three test holes were drilled, with depths of 225, 185, and 100 m. In these test holes the acceleration, velocities, stresses, and deformations were recorded during the Evans shot, and also the accelerations and velocities from the Blanca shot (Figure 25). Measurement of the displacement and stresses during the Tamalpais shot was also performed in the layer of rocks adjoining the approach adit. Large vertical upliftings of the surface of the earth were fixed during the Neptune, Blanca, and Evans shots, and also later during the Gnome experiment, by means of motion picture photography.

In the experiments of the Hardtack II series, two motion picture photography stations were placed on the slope of the mountain (combined station 1203) with a view both toward the epicenter of the Blanca shot and also toward the Evans and Neptune shots (see Figure 25). At these stations, there were two high-speed 35-mm Mitchell motion picture cameras each (filming 100 frames per second), one standard 35-mm camera taking 24 frames per second, and one 70-mm camera. The surface of the mesa was photographed by two distant motion picture photography stations (1204, and the station with a Dow camera), located to the northwest of the explosion section.

In the more distant zone, the seismic waves during the Rainier shots were fixed at stationary seismic stations operated by different organizations (University of California, California Institute of Technology, and others) within the limits of an epicentral distance of up to 3700 km.

Carder and Cloud [26] use for their analysis the data from seven permanent stations (Tinemaha, Hoover Dam, Mount Hamilton, Palo Alto, Pasadena, San Francisco, and Berkeley) located at distances of from 180 to 556 km from the epicenter, and equipped chiefly with Wood-Anderson seismographs.

In the explosions of the Hardtack II series, detailed observations in the long-range zone were performed by means

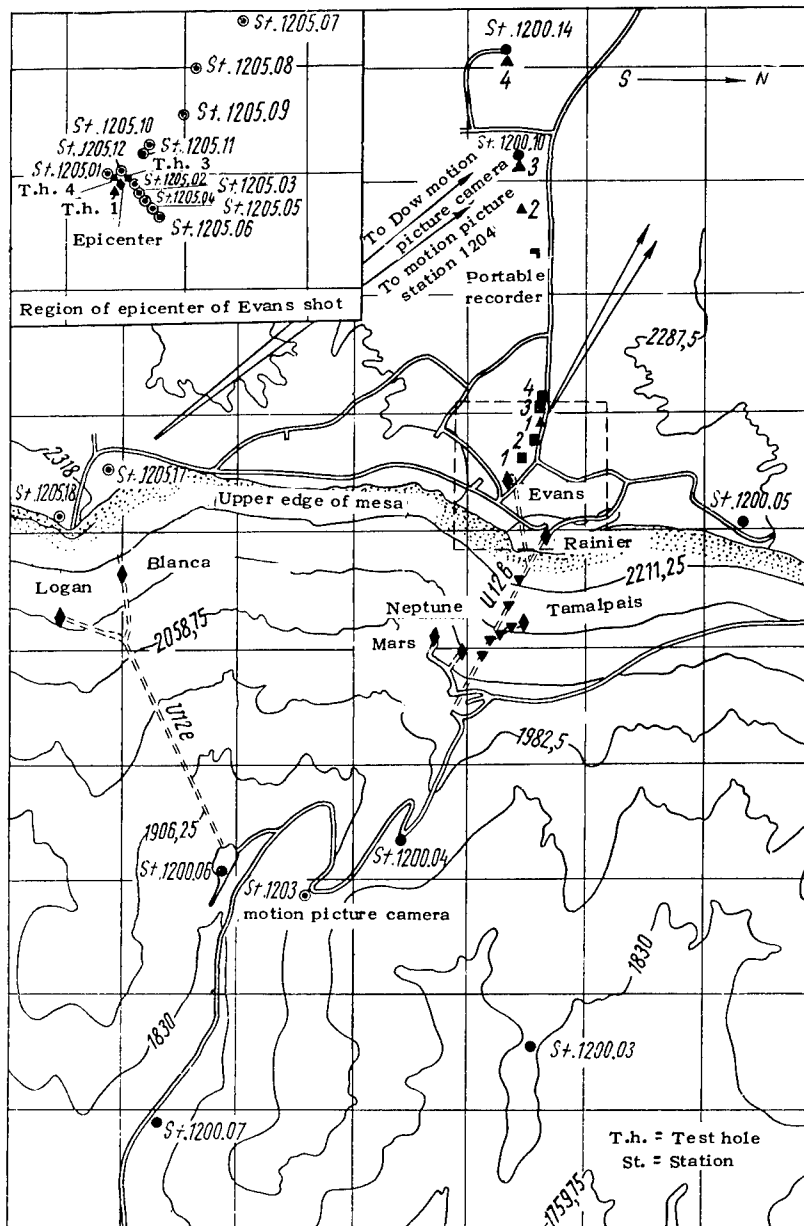

Figure 25. Arrangement of the seismic recording apparatus in the short-range zone during explosions of the Hardtack II series (contour lines are shown in meters).

- ◆ -- epicenters of explosions. Seismic recording stations:
- -- Stanford Research Institute; ▲ -- Sandia Corporation;
- -- U.S. Coast and Geodetic Survey; ▼ -- Laboratory of Engineering Research and Laboratory of Ballistic Research;
- ◎ -- motion picture photography stations of the Edgerton, Hermeshausen, and Grier Company and the Sandia Corporation.

of temporary seismic stations (operated by the Geotechnical Corporation), located along a line extending from the test area to the east as far as the state of Arkansas, and then to the northeast as far as the state of Maine [27]. The eight stations were left on the spot, and the position of the ninth station was changed in the interval between the Logan and Blanca shots. Recordings were obtained for 29 points, located at distances of from 80 to 4000 km from the location of the explosion. At distances of up to 2300 km the interval between the stations amounted to 100 km, and at greater distances, to 250 km. A diagram of the arrangement of the stations is given in Figure 26 [27].

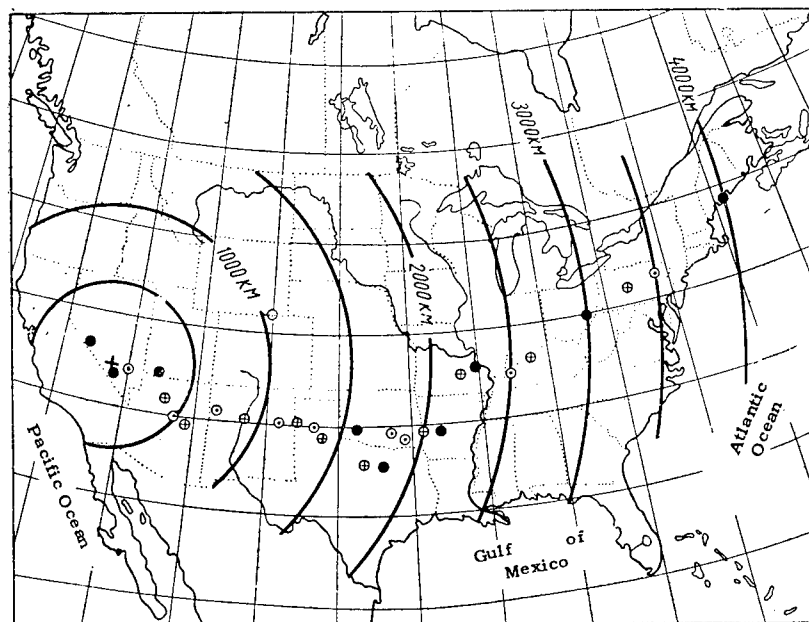

Figure 26. Arrangement of seismic stations in the long-range zone during explosion of the Hardtack II series:

+ -- region of nuclear explosions; ● -- permanent stations; + -- temporary stations during Blanca shot; ⊙ -- temporary stations during Logan shot.

The temporary stations were equipped with short-period vertical seismographs of the Benioff system ( $T_0 = 1$  sec; damping  $D_1 = 0.7$ ; natural period of galvanometers

$T_{galv} = 0.2$  sec; damping of the galvanometers  $D_2 = 1$ ). At the majority of the stations there were also two horizontal seismographs each (for the longitudinal and the transverse components). Recordings of the permanent seismic stations in the USA and Canada, which are equipped for the most part with Wood-Anderson torsion seismographs, were also used.

#### SEISMIC EFFECT ON UNDERGROUND GALLERIES

Data concerning the seismic effect of nuclear explosions on underground galleries basically contain information concerning the effect on approach galleries leading to nuclear charges. Data concerning the zones of destruction of the galleries are given in Table 14, the nature of damages to adit U12b during the Rainier shot in zones of continuous destruction and partial damage being shown in Figure 27 [14].

Table 14

Zones of Apparent Deformation of Approach Adits during Nuclear Explosions of Different Power in Tuff [2, 7, 14]

Deformation	Blanca 19 KT	Logan 5 KT	Rainier 1.7 KT	Neptune 0.115 KT	Tamalpais 0.072 KT
Continuous obstruction of the adit, m.....	260	250	60	21	—
Falling of pieces from the roof and walls, m.....	—	—	150	47	42
Displacement along fractures or flaking off of individual pieces, m.....	—	—	335	—	—

From the table it is apparent that the dimensions of sections of apparent deformation in the galleries increased as the power of the charge increases. The lack of correspondence of zones of destruction of adits in the Blanca and Logan shots calls attention to itself. In accordance with the law of similarity, we should expect that during the Blanca shot the destroyed part of the adit would be approximately 1.6 times as long as in the Logan shot:

( $\sqrt[3]{19} \approx 1.6$ ). Actually, this ratio amounts to  $260 \text{ m}/250 \text{ m} = 1.04$ . Such an inconsistency in the dimensions of zones of damages is explained by McKeown and Dickey [28] by the

features of the geological structure of the rocks, through which the shock waves from the Logan and Blanca shots were propagated.



Figure 27. Damage to approach adit U12b during the Rainier shot, at the following distances from the center of the explosion: 120 m (a) and 60 m (b).

Parts of adits U12e and U12e.05 (Figure 28), which received the greatest damage during the Logan shot, are within limits or near the sub-horizon A of the tuff horizon TOS<sub>3</sub>. In this sub-horizon the tuff is harder (density 2.11 g/cm<sup>3</sup>, porosity, 30.6%) than in the others (average value of density is 1.95 g/cm<sup>3</sup> and porosity 32.9%), and therefore the attenuation of the compression wave in the sub-horizon A is less, and the kinetic energy transmitted by the wave is greater than in the surrounding rocks.

Besides this, during the Logan shot the path of the wave along the direction to the end of the caved-in part of the adit was parallel to one system of natural fractures and perpendicular to another, while during explosion Blanca the path of the waves intersected both systems of fractures and 17 faults at an angle of about 45° (see Figure 28) [28], which caused a great degree of attenuation of the energy of the wave in the following explosion.

On the basis of experimental data for explosions in tuffs, the following dependencies have been derived [22]: the distance at which cave-in of the galleries occurs is,

$$D = 100 W^{1/3} \text{ m}, \quad (13)$$



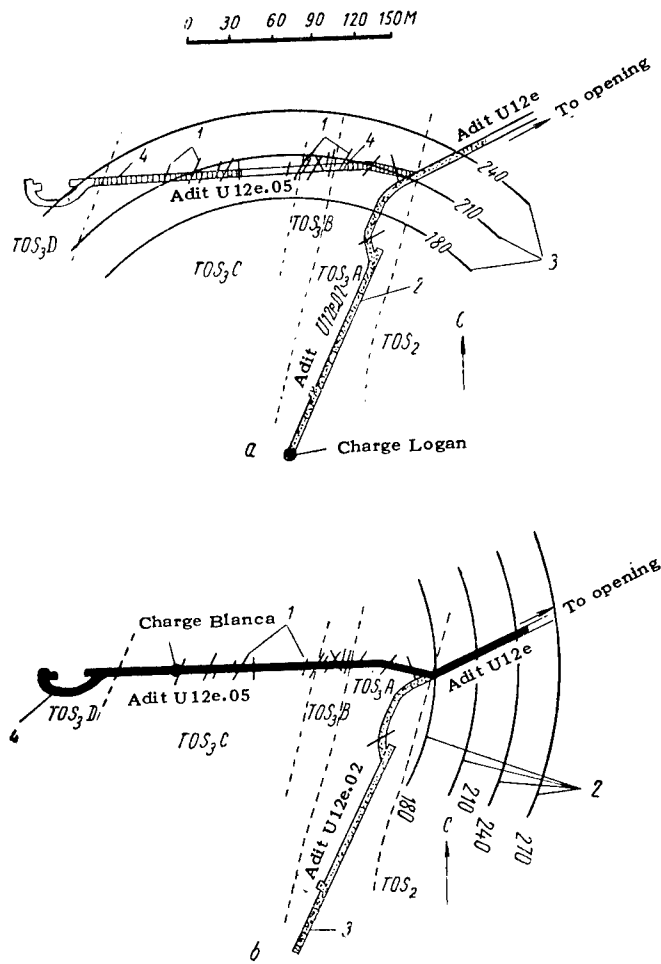

Figure 28. Destruction of approach adits:

a -- in the Logan shot (1 -- faults, 2 -- cave-in of adit, 3 -- lines of equal distance from the center of Logan shot, 4 -- damages to adit-- moderate to heavy); b -- in Blanca shot (1 -- fault, 2 -- lines of equal distance from the center of Blanca shot, 3 -- cave-in of adit during Logan shot, 4 -- cave-in of adit during Blanca shot).

the distance beginning at which damages to the galleries are lacking is,

$$D = 200 W^{1/3} \text{ m.} \quad (14)$$

### PARAMETERS OF SEISMIC EXPLOSIVE WAVES IN THE ROCK MASSIF

The recording of the acceleration in test holes located above the charge chamber in the Rainier shot showed a decrease in the magnitude of acceleration as the distance

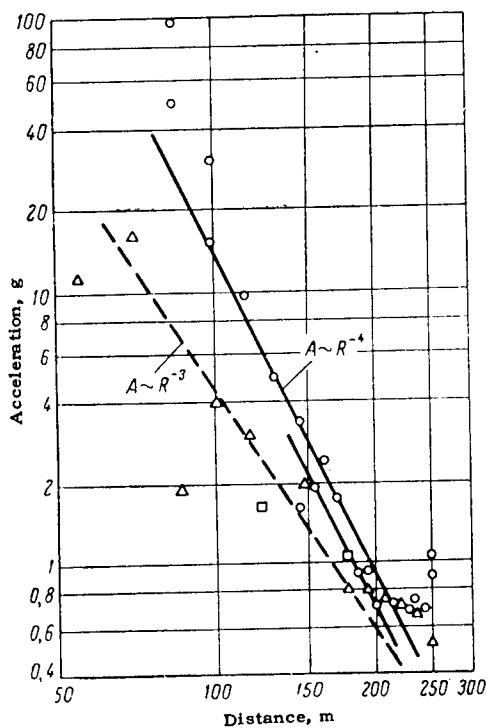

Figure 29. Dependence of accelerations in the massif upon the radial distance:

$\Delta$  -- data from Stanford Research Institute, Evans shot, vertical component;  
 $\circ$  -- data from Sandia Corporation, Evans shot, vertical component;  $\square$  -- data from Laboratory of Engineering Research and Development, Tamalpais shot, horizontal component.

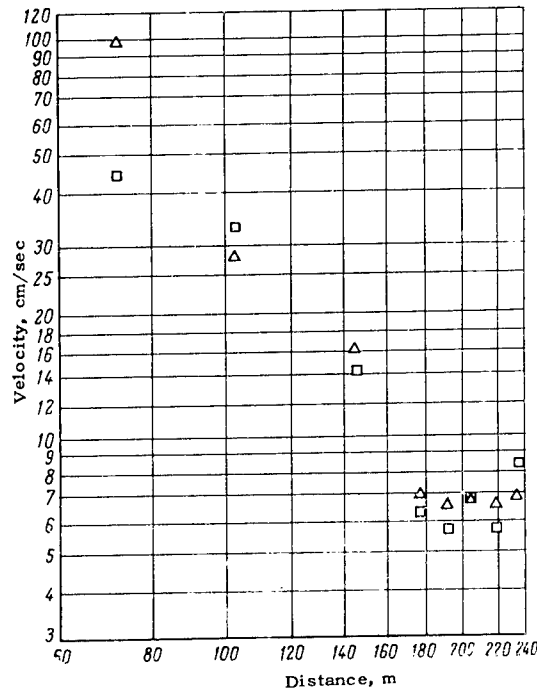

Figure 30. Dependence of vertical velocity of particles upon distance during the Evans shot:

□ -- measured values; △ -- calculated values.

from the charge increased, to the fourth power of the distance, i.e.,  $a \approx R^{-4}$ . At a depth of 60 m below the surface of the earth the acceleration was 1 g, after which it increased, reaching a magnitude of 5.8 g, at the surface at the epicenter.

Data from measurement of the maximum accelerations in the Evans (in test holes drilled from the surface) and Tamalpais (in bore holes drilled in the adit) shots are given in Figure 29 [9], from which it is apparent that at a distance of up to 180 m from the charge the acceleration is attenuated proportionally to the fourth power or cube of the distance; near the day surface the same phenomenon as was found during the Rainier shot is observed -- an increase in the maximum accelerations.

The maximum values of the velocity of rock particles at the depth measured in the test holes during the Evans shot and calculated according to the accelerations recorded

at these same points, are given in Figure 30 [9]. The maximum velocity is attenuated in proportion to the distance, to the power of from 2 to 3.

The stresses were fixed at several points during the Tamalpais shot (in bore holes with a depth of 2.8 m in adit U12b.02). At a distance of 30.5 m, the radial and tangential stresses were equal, respectively, to 70 and 50 kg/cm<sup>2</sup>. Apparently, both components of the stress vary in inverse proportion to the cube of the radial distance [9]. Displacement of the galleries in the rock layer adjacent to the surface (at a depth of less than 1 m from the wall of the gallery) during the explosion of the Tamalpais charge, measured at a distance of 90 m from the detonation point (reduced distance  $195 \text{ m}/KT^{1/3}$ ) amounted to 1.5--1.75 cm (duration of the positive impulse in the displacement wave was 90--180 sec) [9].

#### SEISMIC EFFECT AND PARAMETERS OF SEISMIC EXPLOSION WAVES AT THE SURFACE OF THE EARTH.

The greatest seismic effect on the surface in the vicinity of the epicenter was observed during the Blanca shot. The surface of the mesa being located directly above the charge, received a vertical displacement with an amplitude of approximately 0.75 m in a time of about 0.4 sec, and in this case the vertical maximum of the accelerations at the surface were stable in exceeding the accelerations in the horizontal direction [2]. Further uplifting of the slope of the mesa by 7.6 m occurred under the direct pressure of the explosion products as was described in Chapter 3.

In the Rainier shot, the upper part of the mesa separated from the massif and was displaced over a period of 146 msec upward, with the maximum amplitude at the epicenter of about 0.3 m. Then the block that had separated fell back into place. It is assumed that the detachment of the summit of the mesa from the massif occurred at a depth of a minimum of 30 m and a maximum of 90 m below the surface of the earth [2]. The acceleration of the motion of the surface at the epicenter reached a maximum value of 5.8 g 186 msec after the detonation. The maximum vertical displacement of the surface of the earth (sand and friable sandstone) in the Gnome shot near the epicenter of the explosion amounted to 1.8 m.

The result and analysis of observations of the motion of the earth's surface during the Rainier shot in a wide range of distances from the explosion point (from 0.3 to 700 km) were most completely discussed by Carder and Cloud [26].

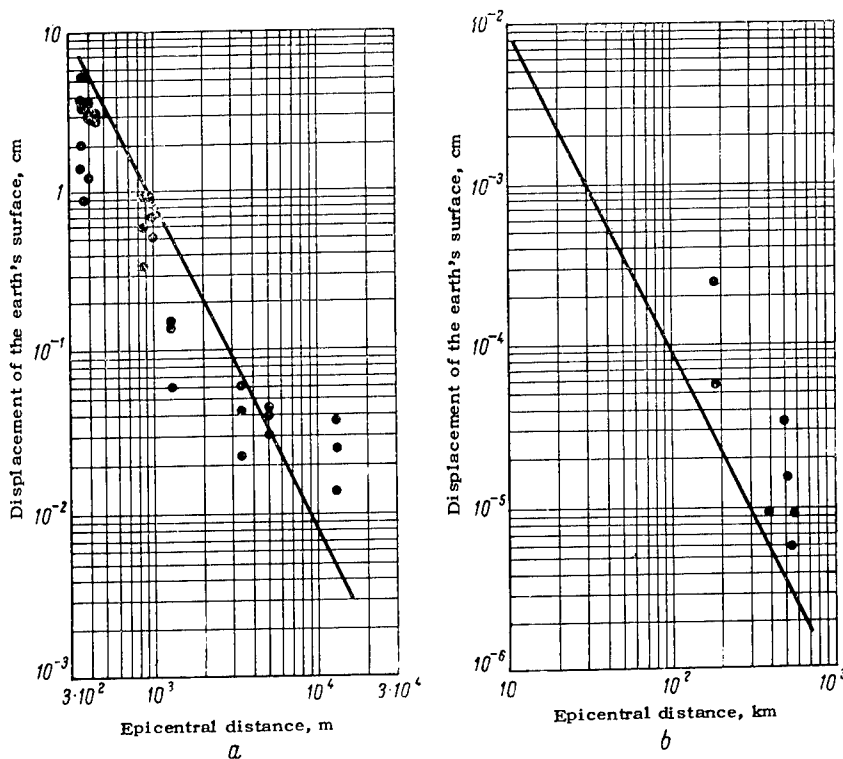

Figure 31. Displacements of the earth's surface during the Rainier shot:

a -- data from temporary stations with seismographs for recording strong earthquakes; b -- data from permanent seismic stations; — -- displacement calculated according to formula (16).

In a work by Adams et al. [9], the summary data and conclusions on the seismic observations made during the underground explosions of the Hardtack II series at epicentral distances of up to 15 km are discussed. During the preparation of the seismometric apparatus for the Rainier shot, near the section where this experiment was made in the tuffs two preliminary explosions of chemical explosives (TNT) were set off, with the charges weighing 10 and 50 T. On the basis of recordings of these experiments, and also seismograms on the 1945--1946 explosions at the U.S. Navy test area (in the state of Idaho), set off to test the serviceability of ammunition, formulas were compiled for preliminary calculation of the seismic effect of the Rainier shot.

$$a = 0,87 \frac{W^{0,75}}{R^2} 10^3 \text{ g}, \quad (15)$$

$$A = 3,4 \frac{W^{0,75}}{R^2} 10^3 \text{ cm}, \quad (16)$$

where  $a$  is the acceleration of the earth's surface, g;  $A$  is the amplitude of displacement of the earth's surface, cm;  $W$  is the power of the charge, tons;  $R$  is the distance to the location of the explosion, m.

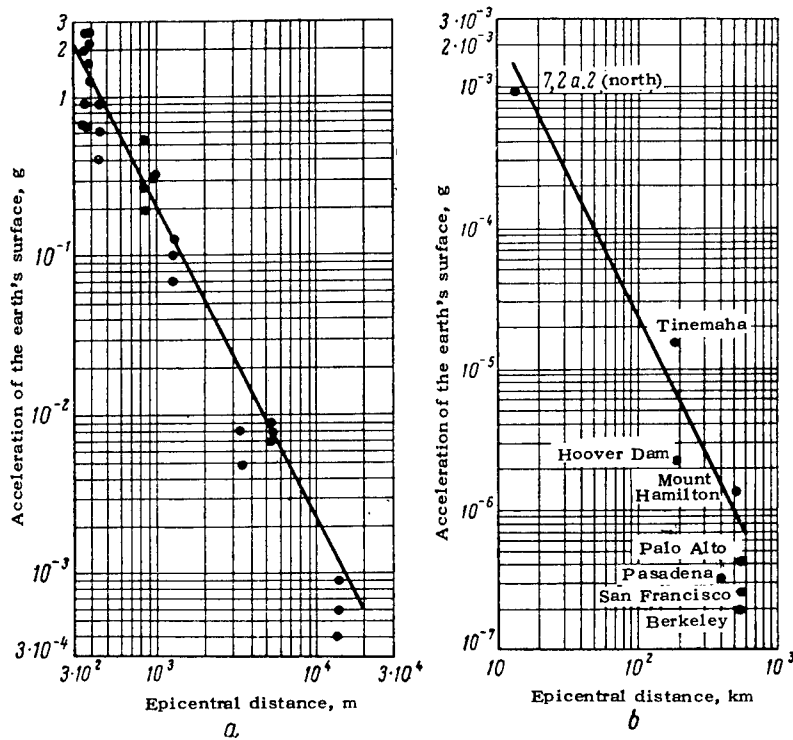

Figure 32. Accelerations of the earth's surface during the Rainier shot:

a -- data from temporary stations with seismograph for recording strong earthquakes; b -- data from permanent seismic stations; — -- acceleration calculated according to formula (15).

Formula 15 is valid for waves with an oscillation period of more than 0.05 sec, and formula (16) for waves with a period of more than 0.5 sec. Displacements and accelerations of the day surface due to the Rainier shot, recorded at 10 temporary stations located at epicentral distances of from 284 to 13,580 m, and at seven permanent stations in the long-range zone (180--556 km), are given in Figures 31 and 32 [26]. The heavy lines in the drawing correspond to displacements and accelerations calculated according to formulas (16) and (15). The period of the waves to which the maximum accelerations are referred at distances of up to 5.3 km for tuffs, limestones and quartzites, amounted to 0.1--0.2 sec in the overwhelming majority of cases. The period of the waves according to which the displacements in this same zone were determined amounted to 0.8 sec on the average for tuffs, limestone and quartzite, and 1.3 sec for sediments at a distance of 13.6 km. In the long-range zone at distances of 180 km or more, the maximum amplitude, in the opinion of Carder and Cloud [26], may be referred to the transverse waves S or the wave trains of the surface waves, with a duration of 20 sec, with a period of the individual wave of 1 sec.

The graph of the dependence of the amplitude of displacement upon the distance, for nuclear charges with a power of 1.7 KT, constructed on the basis of data obtained in the Rainier shot, is given in Figure 33 [26]. On the same graph are plotted data obtained from explosions of chemical explosions (50 T at the Nevada test area and 613 T at South Holston in the state of Tennessee, reduced to a charge with a power of 1.7 KT).

From Figure 33 it is apparent that the attenuation of the amplitude of displacement varies according to a curve (upper and right-hand part of the graph) which, in the range of distances from 3 to 150 km, is described by the dependence

$\frac{0.32}{R} 10^{-0.006R}$  and at distances of more than 150 km by the

dependence  $\frac{0.0075}{\sqrt{R}} 10^{-0.0025R}$ . At distances of less than 3 km from

the explosion, the attenuation of the amplitude of displacement is determined by the dependence  $0.7/R^2$  (the dotted line in the left-hand part of the drawing). Because of the different degree of attenuation of the amplitude of displacement of the waves as a function of distance, we may use formula (16) in an unaltered form only for distances of up to 1.5--3 km.

Thus, according to Carder and Cloud [26], in nuclear explosions in rocks similar to tuff, the amplitudes of displacement of the waves representing the greatest danger for

surface structures are determined according to the dependences as follows: at distances 0.3--3 km from the location of the explosion

$$A = 3,4 \frac{W^{0,75}}{R^2} 10^3 \text{ cm}, \quad (17)$$

at distances of 3--150 km

$$A = 13 \frac{W^{0,75}}{R} 10^{-4-0,003R} \text{ cm}, \quad (18)$$

at distances of 150--1000 km

$$A = 2,5 \frac{W^{0,75}}{\sqrt{R}} 10^{-5-0,0025R} \text{ cm}, \quad (19)$$

Here W is expressed everywhere in tons, R in formula (17) is in meters, and in formulas (18) and (19) in kilometers.

The amplitude of displacement may also be determined from Figure 33, aside from calculations according to these formulas. The values of the amplitude found according to the solid curve or the dotted straight line must be multiplied

by the expression  $(W/1.7)^{0.75}$  (where W is the power of the charge, in kilotons). The amplitude of the displacement of the surface in a case of great thickness of the sediment will be approximately twice the calculated values, which was also observed during the Rainier shot.

A joint analysis of data from seismic observations at the surface obtained during explosions of the Hardtack II series and data from the Rainier shot leads to the dependencies below, for accelerations and displacements in the zone at a distance of up to 15 km from the epicenter [9]. The accelerations at the earth's surface, recorded during the Tamalpais, Evans, Blanca and Logan shots at distances of 0.2--15 km from the location of the explosion and referred to a charge with a power of 1 KT, are shown in Figure 34. The data on the Rainier shot are also plotted there. We will give the equations for individual components:

vertical

$$a_z = 10^{5,41} \frac{W^{0,70}}{R^{2,04}} g; \quad (20)$$



radial

$$a_R = 10^{5,56} \frac{W^{0,69}}{R^{2,11}} g; \quad (21)$$

tangential

$$a_T = 10^{5,45} \frac{W^{0,67}}{R^{2,07}} g, \quad (22)$$

here W is in kilotons and R in meters.

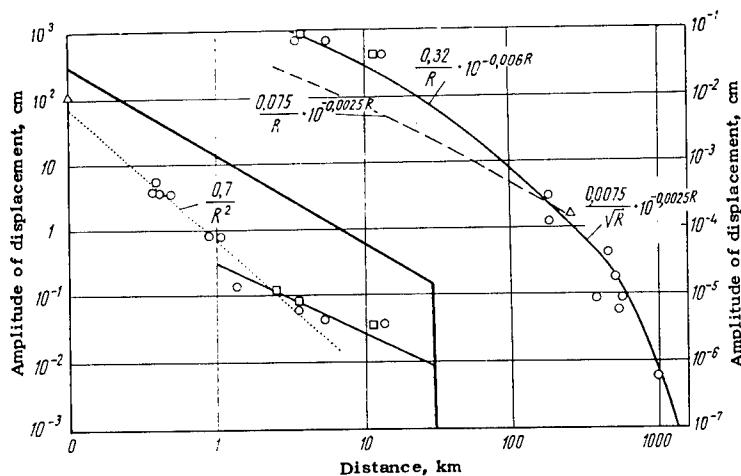

Figure 33. Refined dependence of the amplitude of displacement upon distance for the Rainier shot:

- o -- displacement in the Rainier shot:
- -- displacement in shot of chemical explosives South Holston, multiplied by 2;
- Δ -- displacement of shot of 50 T of chemical explosives, multiplied by 14.

The dependencies of displacements (vertical component) upon the distance to the source, according to data from explosions of the Hardtack II series and the Rainier shot, are given in Figure 35 [9].

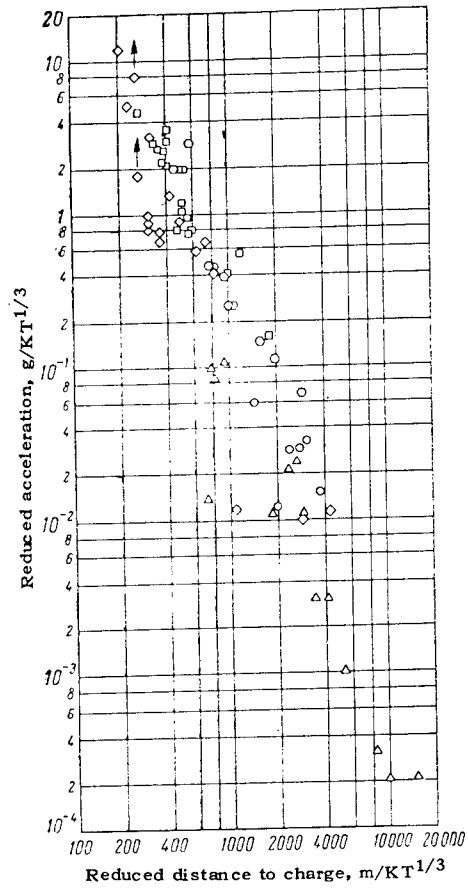

Figure 34. Dependence of the accelerations of the surface in radial components upon distance:

o -- data according to Tamalpais shot;  $\Delta$  -- Evans;  $\square$  -- Blanca;  $\diamond$  -- Logan;  $\square$  -- Rainier.

The displacements are expressed by the following equations for the individual components:

vertical

$$A_z = 10^{2.87} \frac{W^{0.69}}{R^{1.14}} \text{ cm}; \quad (23)$$

radial

$$A_R = 10^{4.75} \frac{W^{0.94}}{R^{1.68}} \text{ cm}; \quad (24)$$

tangential

$$A_T = 10^{4.84} \frac{W^{0.82}}{R^{1.73}} \text{ cm}, \quad (25)$$

here W is in kilotons and R is in meters.

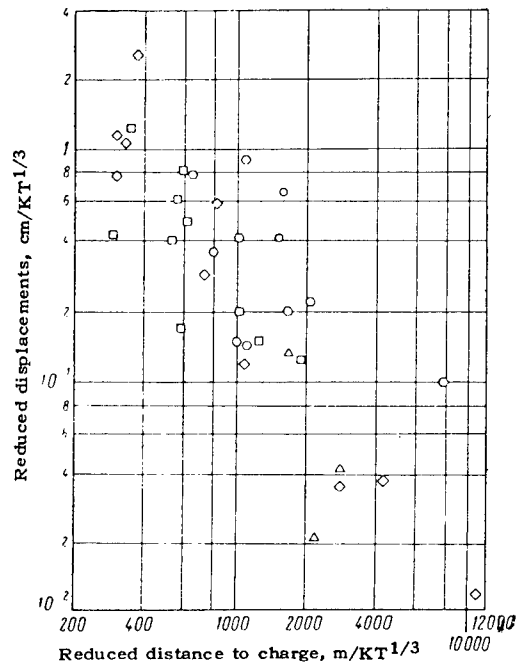

Figure 35. Dependence of vertical displacement of the surface upon distance:

□ -- data according to Blanca shot; ◇ -- Logan;  
 ◻ -- Rainier; ○ -- Tamalpais; △ -- Evans.

The result of seismic observations in the long-range zone during the explosions of the Hardtack II series (basically during experiments Blanca and Logan) which are of interest chiefly from the standpoint of seismology, are described in the work of Romney [27]. Since the pulse of Benioff's seismographs in the range of 0.5--1 sec, which is characteristic for the majority of the waves recorded, is more proportional to the velocity of motion than to displacement, Romney assumes the ratio  $A/T$  for the amplitude of the waves, where  $A$  is the recorded amplitude and  $T$  is the period of the wave. This quantity is not a measure of the true velocity.

The volumetric waves of group P with a predominating period of 1 sec or somewhat less than 1 sec were reliably determined only for the Blanca, Logan and Rainier shots at distances exceeding 300 km.

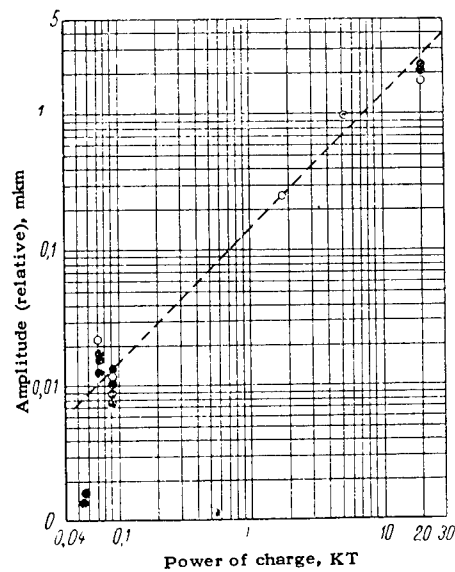

Figure 36. Dependence of the amplitude ( $A/T$ ) of the P waves upon the power of an underground nuclear explosion.

● -- data from temporary stations; ○ -- data from the Tinemaha seismic station.

The dependence of amplitudes of P waves upon the power of the explosion is represented in Figure 36 [27], where the amplitude for the Blanca shot, by division by the coefficient 2.36, which is the average ratio of the amplitudes of these explosions for equal distances, is reduced to the amplitude of the Logan shot. From the graph the approximately directly proportional dependence between the amplitude of the P waves and the power of the explosion is apparent. Without giving any explanation for this phenomenon, the author indicates that the law of directly proportional dependence cannot be applied for predicting the amplitudes of very large explosions, since the energy of the seismic waves will unavoidably exceed the total energy of the explosion. For a comparison, in the same drawing are plotted the amplitudes recorded by the Wood-Anderson seismograph at the Tinemaha station. They reflect the maximum amplitudes for displacement waves, but not for the group P waves. As is apparent from the drawing, the amplitude of the displacement waves at the Tinemaha

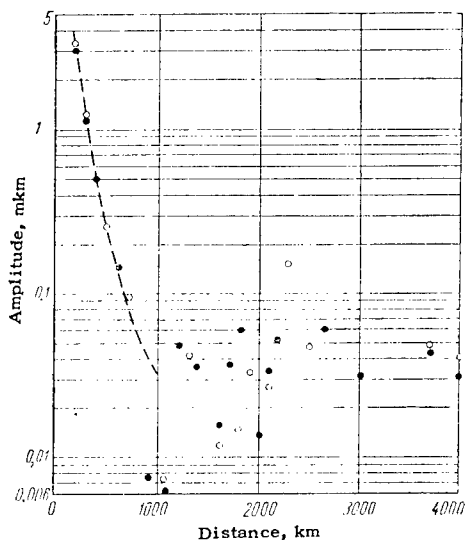

Figure 37. Dependence of the amplitude (A/T) of P waves upon distance for an underground nuclear explosion with a power of 19 KT:

● -- data from Blanca shot; ○ -- data from Logan, multiplied by 2.36.

station are in almost the same dependence upon the energy of the explosion as the amplitude of the P waves.

The dependence of the amplitude of the P waves upon the distance to the location of the explosion is represented in Figure 37 [27], and in this case the amplitudes for the Logan shot, by multiplication by the coefficient 2.36, are reduced to the amplitude of the Blanca shot.

At distances of from 200 to 1000 km, the amplitudes of the  $P_n$  waves are inversely proportional to the cube of the distance (the dashed line in Figure 37).

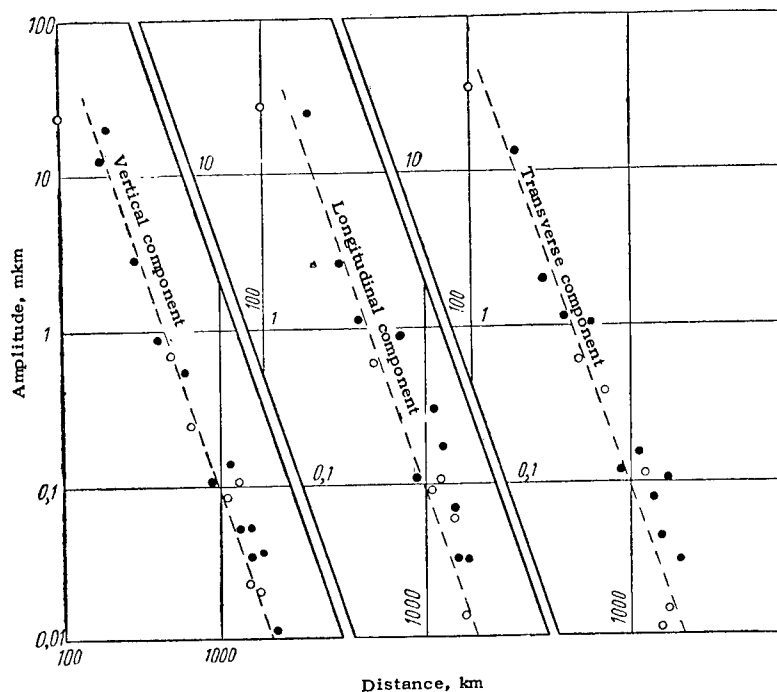

Figure 38. Dependence of amplitude (A/T) of displacement waves upon distance of underground nuclear explosions with a power of 19 KT:

● -- data according to Blanca shot; ○ -- data from Logan shot, multiplied by 2.25.

At distances of more than 1000 km, the  $P_n$  waves are reduced to such small amplitudes that the majority of the stations cannot detect them. However, the strong waves were observed several seconds after the expected arrival of the  $P_n$

waves. The sharp variation in the dependence of the amplitude upon the distance, the longer period, higher velocity, and the gap in the curve of the running all testify to the appearance of a new phase of the P waves. Beyond the limit of 2000 km, the amplitude decreased in almost the same manner as was expected on the basis of studies of earthquakes, with the exception of the fact that in the 3300--3500-km region, there is an area of low amplitude. The systematic dependence of the duration of the first motion (compression or rarefaction) was not established, with the exception of the rule that at distances of less than 700 km the first motion is compression and has a considerable intensity. Romney [27] explains this by the fact that at distances of from 1000 to 3000 km, because of the high level of microseismic interferences, it is not precisely known whether the first recorded wave corresponded to the first recorded motion or not.

Displacement waves (or  $L_g$ ) with a short period (1--1.5 sec), having a velocity of about 3.5 km/sec, were observed at a distance of about 2000 km. In these waves all three components of the motion are approximately equal to each other. The amplitudes of the  $L_g$  waves for different distances are given in Figure 38 [27], where the amplitudes for the Logan shot, by multiplication by the coefficient 2.25, are reduced to the amplitude of the Blanca shot. The coefficient 2.25 corresponds to the mean ratio of the amplitudes observed at the permanent stations. From this it is apparent that  $L_g$  varies inversely proportional to the cube of the distance from the explosion. The vertical amplitude of the displacement waves is three times as great as the vertical amplitude of the  $P_n$  waves. Long-period Rayleigh and Love surface waves (the latter with a period of 10 to 15 sec) were recorded at a number of the permanent stations.

#### MAGNITUDES<sup>1)</sup> OF UNDERGROUND NUCLEAR EXPLOSIONS

The problem of the magnitude of nuclear explosions has been very completely discussed in the work of Romney<sup>2)</sup> [27] and he has also calculated the magnitudes in the short-range

---

1) The magnitude is a certain generalized characteristic of the focus of a seismic phenomenon, making it possible to compare the foci with each other.

2) Yu. V. Riznichenko [29] considers these problems in detail, and indicates some errors made by Romney.

zone (local magnitudes<sup>1)</sup>) and in the long-range zone (teleseismic magnitudes<sup>2)</sup>). The local magnitudes, determined from measurements of the amplitudes of the waves by Wood-Anderson torsion seismographs and stations located at epicentral distances of from 180 to 580 km, amount to the following figures for the explosions indicated: Blanca,  $4.8 \pm 0.4$  (according to 10 stations); Logan  $4.4 \pm 0.4$  (according to 10 stations); and Rainier  $4.25 \pm 0.2$  (according to seven stations).

The magnitude for the Rainier shot, determined by the difference between magnitudes of the Logan and Blanca shots, turns out to be equal to 4.25 not 4.05. Romney considers that the first value was exaggerated, since data from three seismic stations were not considered. Carder and Cloud [26] in determining the magnitude for the Rainier shot from the energy of the waves calculated on the basis of seismograms from stations in the zone from 0.38 to 5.4 km, also, in the final analysis, give a value of the magnitude equal to 4 for this explosion. The teleseismic magnitudes, calculated with the use of parameters of the waves fixed at great distances, amount to  $4.8 \pm 0.4$  for the Blanca shot (according to eight stations), and  $4.4 \pm 0.5$  for the Logan shot (according to six stations).

Thus, the local magnitudes coincide with the teleseismic magnitudes. Romney assumes that, although according to Gutenberg at magnitude 4.5 the diversion between the scales reaches one, the calculated magnitude should be considered as reliable, and accepts a  $M = 4.8 \pm 0.1$  for the Blanca shot, and a  $M = 4.4 \pm 0.1$  for the Logan shot, where 0.1 is the mean square deviation from the average value.

The magnitudes for other explosions may be calculated on the basis of the established magnitude of the Logan shot, if we know the amplitudes  $A$  and the periods  $T$  of the waves:

$$M_l - M_x = \lg \left( \frac{A}{T} \right)_l - \lg \left( \frac{A}{T} \right)_x, \quad (26)$$

where the parameters with the subscript  $l$  refer to the Logan shot, and those with the subscript  $x$  to the explosion under consideration.

---

<sup>1)</sup> Local magnitudes are determined in the zone from the epicenter to 1000 km.

<sup>2)</sup> Teleseismic magnitudes are determined in a zone beginning at a distance of 1700 km.



The magnitudes determined according to formula (26) amount to the following<sup>1)</sup> for the Rainier shot  $M = 4.1$ ; for Neptune  $M = 2.4$ ; and for Tamalpais  $M = 2.6$ .

Romney, working from the basic formula for the determination of magnitudes

$$M = \lg \left( \frac{A}{T} \right)_d - \lg \left( \frac{B}{T} \right)_d,$$

where  $(A/T)_d$  is the amplitude at the distance  $d$ ;  $(B/T)_d$  is the amplitude of the explosion with a zero magnitude at the same distance, and with a directly proportional dependence between the amplitude and the power of the explosion (see Figure 36)  $(A/T)_d = K_d Y$ , recommends the following formula for the calculations, as a function of the power of the explosion<sup>2)</sup>:

$$M = 3,65 + \lg W, \quad (27)$$

where  $W$  is the power of the explosion, in kilotons.

Equation (27) is applicable for explosions in the tuffs of the Nevada test area. The Evans shot does not fall under the given dependence.

Carder and Cloud note that the magnitude of a nuclear explosion calculated according to the Gutenberg-Richter formula with respect to the energy of the source ( $E$ )

$$\lg E = 9,4 + 2,14M - 0,054M^2, \quad (28)$$

---

<sup>1)</sup> According to the determination of Yu. V. Riznichenko [29], the magnitudes of the nuclear explosions have the following value: for the Blanca shot  $5.2 \pm 0.1$ ; for Logan  $4.95 \pm 0.1$ ; and for Rainier  $4.7 \pm 0.1$ .

<sup>2)</sup> The dependence of the magnitude upon the power of the explosion expressed by the formula [29]  $M = 4.6 + 0.5 \lg W$ , gives more accurate results.

exaggerates the intensity and range of the destructive effects due to underground nuclear explosions. This is explained by the liberation of the energy of the explosion at a shallower depth and in a highly localized region.

#### SEISMICALLY DANGEROUS ZONES

Violet [30] proposes to calculate the zone that is dangerous to surface structures because of the seismic effect by means of the possible accelerations at the surface of the earth, using a dependence similar to formula (15),

$$a_{\max} = 0,154 \frac{W^{3/4}}{R^2} g, \quad (29)$$

where  $W$  is in kilotons and  $R$  is in kilometers.

Since earthquakes with an intensity of four (acceleration of the surface of the earth 0.016 g) do not cause any damages to buildings, we may assume that structures may withstand an acceleration of up to 0.1 g without any damage.

Working from dependence (29), the radius of the seismically dangerous zone for nuclear explosions intended for internal effect is

$$R = 1,54 \sqrt{W^{3/4}} \text{ km}, \quad (30)$$

where  $W$  is in kilotons.

Carder and Cloud [26] consider it possible to accept a high critical magnitude of acceleration. Assuming that since the maximum acceleration in the Rainier shot amounted to 0.13 g at a distance of 1.3 km, the radius within the limits of which damages may occur is limited to approximately 1.6 km for explosions analogous in power (1.7 KT). In the Logan shot (5 KT) and Blanca shot (19 KT) the main recording station with electronic apparatus and the ventilating plant located at the opening of adit U12e, 760 m along a straight line from the charges, did not receive any damages during the explosion [2].

Violet [30], in recommending formula (29) for calculating the acceleration in an explosion, considers that it may give an error by a factor of two or three to one side or the other. He gives a comparison of the seismic effects from a nuclear explosion with a power of 10 KT with the intensity of earthquakes (Table 15) when the oscillations from explosions of such a power need not cause any harmful

effect at epicentral distances of more than 8 km. Violet also notes that the seismic effect on underground galleries is less than that on surface structures at the same distance. Measurements show that accelerations at a displacement under the earth are usually reduced to half the degree in comparison to the same quantities at the surface.

Table 15

Oscillations of the Earth's Surface in an Underground Nuclear Explosion with a Power of 10 KT

Distance, km	Maximum acceleration, g	Intensity of earthquake (according to altered Mercalli scale), balls [i.e., intensities on a scale at which 10 is the maximum]	Seismic effect
1,6	0,34	8	Light damages to special design buildings, considerable damages to ordinary buildings in a good state of repair.
8	0,014	4	Windowpanes rattle and moving objects are damaged. Oscillations felt by many people indoors, and by some people outdoors.
16	0,003	3	Oscillations felt indoors, similar to oscillations from a passing train.
24	0,0015	1-3	Oscillations felt by sensitive people.
40	0,00054	—	Oscillations not perceived.

The data given in Table 15 agree quite well with the intensity of oscillations of the surface of the earth according to the perceptions of personnel engaged in setting off the explosions, and also persons living in the adjacent regions. The estimate of the intensity of the oscillations at various distances was as follows [2, 13]:

1. Shot Blanca (19 KT): 3.2 km from the epicenter, strong oscillations, shaking motor vehicles; 8 km, easily perceived oscillations; 26 km, weak oscillations; 32 km, oscillations not perceived.
2. The Logan shot (5 KT): at a distance of 8 km, weak but clearly perceptible oscillations; 11.3 km, oscillations not perceived.
3. Rainier shot (1.7 KT): at 4 km, weak oscillations.
4. Tamalpais shot (0.072 KT): at 4 km, oscillations were not perceived.
5. Gnome shot (3 KT): in rock salt: at 7 km from the epicenter there were clearly perceptible oscillations.

## AIR-COMPRESSION WAVE [i.e., shock wave]

The effect of an air-compression wave depends strongly upon the depth at which the charge is placed. In experimental explosions with a reduced depth of placement of charges of more than  $60 \text{ m}/\text{KT}^{1/3}$ , i.e., in all the experiments in tuffs, the effect of the shock wave and the sound effects were insignificant. Although sound waves were also fixed by microbarographs, at a distance of 4 km they were not audible at all to the human ear [2].

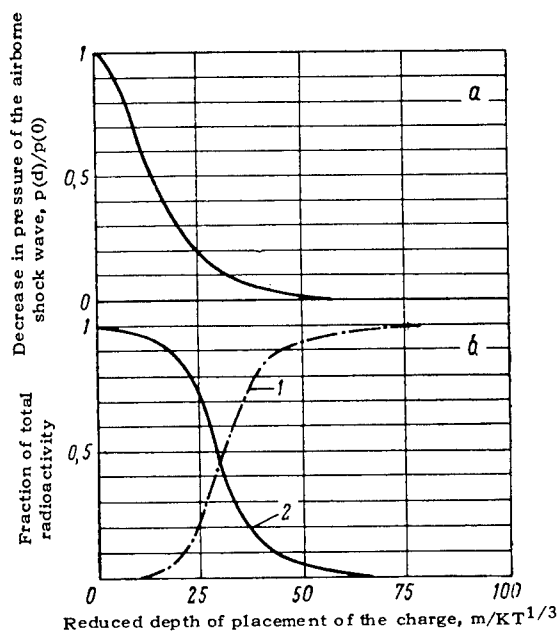

Figure 39. Expected effect of a nuclear explosion with a power of 1 KT as a function of depth of placement of the charge:

a -- air-compression wave:  $p(d)$  -- pressure of the shock wave for an explosion at the given reduced depth,  $p(0)$  -- pressure of the shock wave for a surface burst;  
 b -- distribution of radioactivity (1 -- radioactivity trapped underground, 2 -- radioactive fallout at the surface), and active products scattered to the atmosphere.

Violet [30] gives a graph of the dependence of the magnitude of relative pressure of a shock wave upon the depth of placement of the charge (Figure 39) from which it follows that in the Jangle-U and Teapot-Ess shots (the reduced depth of placement of the charges was  $5 \text{ m/KT}^{1/3}$  and  $19 \text{ m/KT}^{1/3}$ ), the pressure of the shock wave amounts to 85 and 30%, respectively, of the pressure in a burst at the surface. Thus, even in the case of blasting explosions, a considerable weakening of the airborne shock wave occurs in comparison to the surface bursts. Besides the depth of placement of the charge, such factors as the wind, inversion layer, density of the air, and other atmospheric conditions existing at the moment of the explosion also influence the air-compression effect. Secondary shock waves reflected from the ozonosphere reach the surface of the earth at a definite distance from the location of the explosion, and at shorter distances zones of "calm" are observed. The distances indicated, also the force of the reflected wave, depend upon the meteorological conditions at the moment of the explosion. When the explosion is set off at a moment of the most favorable meteorological conditions, we may ensure that the necessary regions fall within the zone of "calm."

In the opinion of Violet [30], underground explosions with a power of several megatons may be set off at a distance of 80 km from centers of population without any harmful effect of the airborne shock waves or sound waves. This distance must be refined in the process of further experimental nuclear explosions.

## CHAPTER 5

### RADIATION EFFECT OF UNDERGROUND NUCLEAR EXPLOSIONS

#### ZONES OF RADIOACTIVITY DISTRIBUTION UNDERGROUND

The study of the radioactivity of the rocks after the Rainier shot by means of survey holes and galleries, demonstrated that the zone of radioactive material had acquired the shape of a cup, located below the horizon where

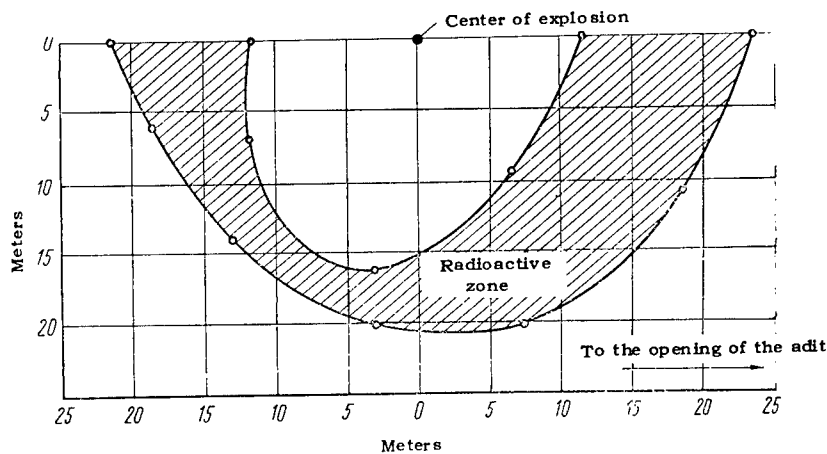

Figure 40. Shape and dimensions of zone of radioactive material in the Rainier shot (vertical section).

the charge was placed. The center of the external hemisphere approximately coincided with the place where the charge was located. The thickness of the layer or radioactive rocks amounted to several meters. The zone of radioactive material is shown in Figure 40 [2]. The change in the level of radioactive radiation in the region adjoining the center of

detonation, according to measurements in test holes 146 days after the explosion, is given in Figure 41 [14]. From this drawing it is apparent that the radioactive regions on both sides of the point of the explosion are divided into two zones: the first, from the center of the explosion to a distance of 22.8--18.2 m, with a dose of  $\gamma$  radiation equal to 200--400 mr/hr, and the second, a narrow zone to a distance of 16.1--13 m, with a maximum dose of 800 mr/hr. From test holes B and C, drilled below the level of placement of the charge, individual samples were obtained with a very high activity. In test hole B the dose reached 137 r/hr, and the activity was  $3.4 \cdot 10^{14}$  fissions/g (the total number of fissions in the explosion was  $2.5 \cdot 10^{23}$ ). The part of the samples having radioactivity in external appearance was a glassy mass with bubbles and numerous inclusions of grainy tuff, fused to different degrees. The density of the samples was  $1.8 \text{ g/cm}^3$ , which differs somewhat from the density of the rocks before the explosion ( $2 \text{ g/cm}^3$ ). The radioactivity level changed very rapidly as a function of distance. At a distance of from 0 to 11 m from the center of the explosion, the activity of the pulverized rocks only slightly exceeded the natural background. Beginning at a distance of 25 m from the charge, the activity dropped sharply and at a distance of 40 m became insignificant [31].

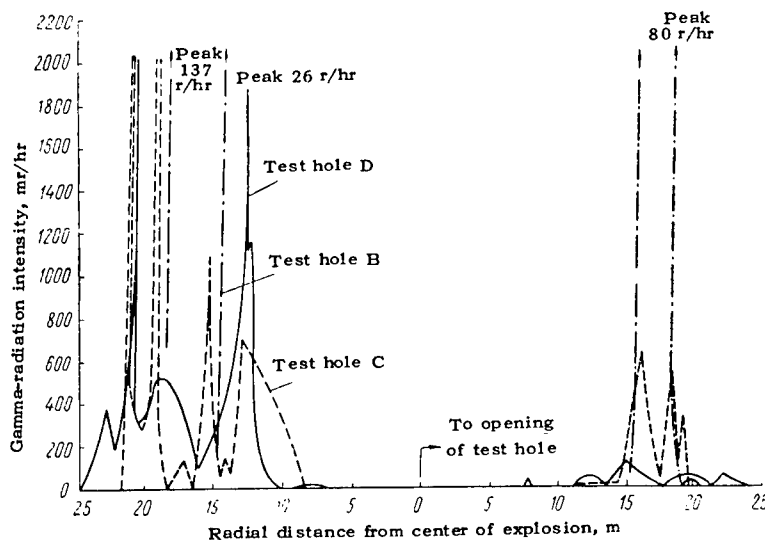

Figure 41. Levels of  $\gamma$  radiation in the central zone from the Rainier experiment, 146 days after the explosion

Eight months after the explosion, in excavating a survey gallery, where it reached the radioactive zone the dose at the drift surface amounted to 300 mr/hr, and at a distance of 1 m from the drift, 20 mr/hr. Pieces of broken radioactive rock were loaded manually by the workers (with shovels), and during transportation the radioactive rock from the gallery was adequately shielded by sandbags [32]. The dose in the upper cavity above the cave-in cone (117 m above the charge) did not exceed the natural background -- 0.04 mr/hr.

Table 16

Data Concerning the Radiation Effect of Underground Nuclear Explosions

Name of experiment	Reduced 11r, m/KT <sup>1/3</sup>	Radius of radioactive hemisphere, m	Reduced radius of radioactive hemisphere, m/KT <sup>1/3</sup>	Radio-activity of fallout product at the surface of the earth*, %	Distribution of radiation throughout the adit
Jangle-U	4,8	No data	—	>80	—
Teapot-Ess	19,2	No data	—	90	—
Neptune	67,6	6,4	14,3	1-2	—
Blanca	95,4	40,0	14,7	0,3-0,5	Small
Logan	146,5	26,0	15,3	0	None
Rainier	201,4	19,0	16	0	None
Tamalpais	237,7	9,2	22	0	Considerable quantity of gaseous radioactive fission products
Evans	675,0	No data	—	0	

\*The percentage of total activity of the explosion is indicated.

Similar to the Rainier shot, the general quantitative relationship of radioactivity distributions was also established in other experiments in tuff. The average radii of the outer contours of the radioactive zones for these explosions are given in Table 16 [2]. Working from the values of the reduced radii of the radioactive zones (hemispheres) with respect to the three largest explosions -- Blanca, Logan, and Rainier (see Table 16) -- the following empirical dependence was derived for determination of the radius of the radioactive zone [21]

$$R = 15 W^{1/3} \text{ m}, \quad (31)$$



where  $W$  is the power of the charge, in kilotons.

The formula obtained is analogous to formula (12) for a determination of the radius of the initial cavity.

The radioactive hemispheres [2] are formed as a result of the cave-in of the initial central cavity, covered with fused tuff, where a great part of the fission product is concentrated. The hardened fused material, in the form of a glassy mass, during the cave-in of the walls of the cavity is partially mixed with the rocks that caved in and is located along the peripheral part of the lower half of the cavity in a zone of cup-shaped form (see Figures 14 and 23). The central part of the cavity is filled to only a slight degree by the active material from the cave-in of the rocks located above the cavity.

#### DISCHARGE OF RADIOACTIVE PRODUCTS INTO GALLERIES AND TO THE SURFACE

The configuration of the adits, which provide their "self-plugging" or the application of a multi-section drift, prevented the propagation of the products of the explosion along the adits during the Rainier, Logan, and Blanca shots [2]. In these experiments, no noticeable penetration of radioactive products into the mining passages beyond the drift sections was established. In the restoration of the sections of the adits caved in by the explosion, a discharge of active products into the adits was observed at a distance of 180 m from the charge chambers in the Blanca shot and at a distance of 58 m in the Logan shot. In the Tamalpais experiment, radioactive gases penetrated into the adit in considerable quantities. In the Evans experiment, a great part of the radioactive products was discharged into the adit, because of disruptions of the drift during the explosion. Their leakage through the adit to the day surface was observed. Data concerning the discharge of radioactive products to the surface as a result of the destruction of the rock massif are given in Table 16.

In explosions of an entirely internal effect -- Logan, Rainier, Tamalpais, and Evans -- the radioactive products did not penetrate to the surface through the rock stratum.

In a case of an explosion with fragmentation of the surface layer of rocks -- Blanca -- the discharge of radioactive products amounted to less than 0.5% of the total activity of the charge. The maximum measured dose of  $\gamma$  radiation at the surface amounted to 50 mr/hr. The height of rise of the radioactive products was low -- 300 m.

In an explosion with partial blasting of the rock -- Neptune -- 1--2% of all the fission products were discharged to the surface. The radioactive products reached an altitude

of 3000 m, and then fell to the ground, extending 20 km downwind from the epicenter. The maximum  $\gamma$ -radiation dose an hour after the explosion amounted to 1200 r/hr in a section with a radius of 20 m from the epicenter. A dose of more than 50 mr/hr was observed in a section with a length of 9 km and a width of up to 1.5 km. From Table 16 it is apparent that in a blasting explosion in alluvial sediments, with the charge placed at a shallow depth (experiment Teapot-Ess), up to 90% of all the radioactive products were discharged to the surface. Some decrease in the activity measured at the surface during the Jangle-U shot, apparently, is explained by the fact that the charge exploded at a shallower depth than in the Teapot-Ess experiment, and therefore the scattering of the active products in the atmosphere was great.

First, for experiments in tuff, the discharge of radioactive products to the surface, with a magnitude of reduced llr of  $95 \text{ m/KT}^{1/3}$  (the Blanca shot) was very small, and with a magnitude of the reduced llr  $145 \text{ m/KT}^{1/3}$  (the Logan shot) it was entirely absent.

Johnson et al. [24] assume the average of these two values --  $120 \text{ m/KT}^{1/3}$  -- as the value of the reduced llr, providing for complete burial of the radioactive product under the ground in tuff or rock similar to them in properties; for determination of the llr (depth of placement of the charge) at which the discharge of radioactivity to the surface is exploded, they recommend that the same dependence [10] be used as in finding the depth of placement of a charge for a total camouflet effect, i.e.,  $d = 120 W^{1/3}$ , in meters, where  $W$  is the power of the charge, in kilotons.

#### NATURE OF THE RADIOACTIVITY IN A NUCLEAR EXPLOSION

Radioactivity of the fission products. The energy instantaneously liberated in a fission reaction (179 MeV per fission) includes the kinetic energy of the fission fragments, the momentary  $\gamma$  radiation, and the neutrons. A charge

with a power of 1 KT corresponds to  $1.46 \cdot 10^{23}$  fissions. From the additional energy (on the average, about 22 MeV per fission) liberated as a result of the decay of the fission products, about 50% is manifested in the form of  $\gamma$  radiation, about 17% as the energy of decay of the  $\beta$ -particles, and the other 33% as the neutrinos formed in the process of  $\beta$ -decay. Approximately 7 MeV of the energy of decay ( $\beta + \gamma$ ) is liberated in the first 20 min after the explosion [33]. At a temperature in the cavity surrounding a charge of the order of several million degrees, the chemical properties of the

fission products play no part, since the matter is transformed into incandescent gases or diffused atoms and electrons. Under the effect of the shock waves on the walls of the cavity, the layer of rock surrounding the charge is vaporized (about 1 m in an explosion with a power of 1 KT), and the vapors mixed with the incandescent gases which contain the fission products. As the incandescent gases cool to a temperature of about 5000°C, their condensation occurs, and then they are precipitated on the walls of the cavity, as part of the fused layer. The period of condensation ends basically in a few hundred milliseconds [21].

In nuclear explosions for internal effect, in rocks with a considerable silicon content, such as, for example, in tuff deposits, the fused rocks covering the walls of the cavity consist of a relatively insoluble glassy mass, in which a great part of the fission product is enclosed [30]. The glassy material traps from 60 to 85% of all the fission products. That part of the radioactive fission products which, in the cave-in of the cavity, is still in a gaseous state, is not trapped, but penetrates from the cavity into the destroyed rocks.

Table 17

Fraction of Active Elements in Percentages of Total Radioactivity

Elements	Time after explosion, min					
	0,166	0,5	1	5	30	60
Kr	3,8	5,0	5,8	4,3	2,5	4,2
Xe	2,6	3,8	4,6	9,0	5,0	3,5
Y	11,0	9,0	8,0	4,6	7,0	5,0
Zr	12,0	7,0	3,5			
Ba	7,0	2,6	2,4	8,0	9,0	8,0
Sr	6,0	4,0	5,0	11,0	4,0	3,7
Cs	7,0	7,0	7,0	8,0	8,0	8,0
Rb	7,0	8,0	8,0	11,0	7,0	4,8
La	9,0	8,0	4,0	2,8	9,0	10,0
Nb	10,0	12,0	11,0	8,0	5,0	6,0
Ce	4,7	3,0	1,0	2,5	5,0	4,4
Br	3,3	5,0	6,0	2,2	—	1,0
I	4,0	6,0	7,0	3,5	3,5	7,0
Mo	3,0	6,0	6,0	5,0	7,0	3,0
Te	2,7	2,5	2,0	3,5	9,0	14,0
Se	1,5	1,0	—	—	—	—
Pr	1,7	3,7	5,0	4,6	3,7	5,0
Sn	1,1	—	—	—	—	—
Tc	1,2	4,0	8,0	5,0	9,0	7,0
Sb	1,0	2,3	3,7	5,0	2,3	2,0
Nd	—	—	—	—	—	1,0

Note. Elements with a fraction of radioactivity of less than 1% are not indicated.

A list of the radioactive elements is given in Table 17 [32], with an indication of the fraction of total radioactivity which they constitute in different periods of time after the explosion.

From Table 17 it is apparent that a considerable part of the radioactive particles exists in the form of inert gases or volatile elements in a period of time comparable to the time during which the cave-in of the cavity occurs. Isotopes in the form of inert gases will not condense until decay into other elements has occurred, and the more volatile substances will not decay until the temperature decreases, or they decay into less volatile elements [33]. As the process of radioactive decay continues after the explosion, the relative distribution of gaseous and non-volatile isotopes changes.

The decay chains, before the appearance of certain isotopes detected by radiochemical analyses, are indicated in Table 18 [2]. A great part of the  $\text{Sr}^{90}$  is formed during fission in the form of inert  $\text{Kr}^{90}$  (about 80%), with the exception of small quantities of directly formed  $\text{Br}^{90}$  or  $\text{Rb}^{90}$ . Thus, if the cavity caves in in a period which may be compared with the half-life of  $\text{Kr}^{90}$  (33 sec), a great part of the final  $\text{Sr}^{90}$  is not trapped by the fused material, but is liberated from the cavity with the other gases.

The results of radiochemical analyses after all explosions set off in tuffs are given in Table 19 [2], from which the effect of volatile and gaseous predecessors on the excess of certain isotopes in the glassy mass and on the enrichment of them in the gas-permeable destroyed material is clearly apparent.

On the basis of data from Tables 17--19, it has been established [2, 30, 33], that even in explosions of an entirely internal effect and in the formation of an insoluble glassy mass, in which the basic parts of the products of decay are enclosed, a large fraction of the  $\text{Sr}^{90}$  and  $\text{Cs}^{137}$ , existing during the cave-in of the cavity in the form of inert gases ( $\text{Kr}^{90}$  and  $\text{Xe}^{137}$ ), will not be enclosed in the glassy mass, but propagated together with the other gases. Thus, quite significant quantities of  $\text{Sr}^{90}$  and other isotopes, the predecessors of which were gaseous or volatile elements, precipitate at quite considerable distances from the zone of high radioactivity and are distributed in the destroyed medium. With a temperature of 1000--1500°C in the explosion cavity, certain other products of decay also become volatile, which leads to a leakage of them from the glassy material. It is thus that arsenic, caesium, and uranium behave.

Table 18

Chains of Decay Leading to Isotopes Which  
Were Detected in the Products of Underground  
Nuclear Explosions

Mass number	Element, half-life, and isotope detected (underlined)			
85	As $\xrightarrow[sec]{0,43}$	Se $\xrightarrow[sec]{0,40}$	Br $\xrightarrow[sec]{30}$	<u>Kr</u>
89	Kr $\xrightarrow[min]{3,2}$	Rb $\xrightarrow[min]{1,5}$	<u>Sr</u>	
90	Kr $\xrightarrow[sec]{33}$	Rb $\xrightarrow[sec]{2,7}$	<u>Sr</u>	
91	Kr $\xrightarrow[sec]{9,8}$	Rb $\xrightarrow[min]{2}$	Sr $\xrightarrow[hr]{9,7}$	<u>Y</u>
95	Rb $\xrightarrow[kp]$	Sr $\xrightarrow[kp]$	Y $\xrightarrow[min]{10}$	<u>Zr</u>
99	Zr $\xrightarrow[sec]{30}$	Nb $\xrightarrow[min]{2,5}$	<u>Mo</u>	
137	I $\xrightarrow[sec]{22}$	Xe $\xrightarrow[min]{3,8}$	<u>Cs</u>	
140	Xe $\xrightarrow[sec]{16}$	Cs $\xrightarrow[sec]{66}$	<u>Ba</u>	
141	Xe $\xrightarrow[sec]{1,7}$	Cs $\xrightarrow[kp]$	Ba $\xrightarrow[min]{18}$ → La $\xrightarrow[hr]{3,7}$	<u>Ce</u>
144	Cs $\xrightarrow[kp]$	Ba $\xrightarrow[kp]$	La $\xrightarrow[kp]$	<u>Ce</u>

**Note.** kp = brief half-life (in comparison to seconds).

The lower content of Sr<sup>90</sup> and Cs<sup>137</sup> in the samples of glassy material from the Blanca and Logan shots in comparison with samples from the Rainier shot testifies, in the opinion of Higgins [34], to the shorter existence of the cavity before the moment of its cave-in for the first of the explosions indicated. In explosions of an incomplete internal effect, the fraction of radioactive fragments which are discharged into the atmosphere is enriched by the mobile gases and the volatile products of decay. This leads to an increase in the concentration of the isotopes Sr<sup>90</sup> and Cs<sup>137</sup> in comparison to their distribution in the fission products. The relative concentration of Sr<sup>90</sup> in samples of ejected rock

fragments in the Blanca shot, when 15 sec after the explosion from 0.3 to 0.5% of the total radioactivity of the fission products was discharged to the surface, increased by a factor of 5. Thus, about 2% of the total quantity of the Sr<sup>90</sup> formed in this explosion was actually discharged to the surface. During the Neptune shot, when 1--2% of the radioactive fission products was discharged to the surface, the concentration of the discharged Sr<sup>90</sup> as a result of five-fold enrichment because of the Kr<sup>90</sup>, increased to 5--10% of the total quantity formed during the explosion.

Table 19

Summary Data of the Radiochemical Series  
with Respect to Underground Explosions

Isotopes	Fraction of initial content in glassy material, %	How many times the content increased	
		In the cave-in zone	In the ejected material*
Kr <sup>85</sup>	< 1	~ 0	All in the gaseous products
Sr <sup>86</sup> , As	3-10	> 2	~ 10
Sr <sup>90</sup> , Cs <sup>137</sup> Y <sup>91</sup> , Ba <sup>140</sup>	20-40	> 2	~ 5
Cs, Ce <sup>141</sup>	30-60	> 2	> 2
U, Mo <sup>99</sup>	50-100	< 2	< 2
Pu, actinoids Pa, Hf Ta, Ce <sup>144</sup>			
Nd <sup>147</sup>	~ 100	1	1

\* Observed in the Neptune and Blanca experiments.

Violet [30] indicates that in the air the atoms of Sr<sup>90</sup> and Rb<sup>90</sup> rapidly precipitate on the surface of individual rock particles, which are discharged together with the gas from the explosion crater and, consequently, are removed from the atmosphere as these particles fall to the ground.

Induced radioactivity<sup>1)</sup>. Batzel [33] and Violet [30] note that in underground explosions, in essence, all the neutrons are absorbed by the rocks surrounding the charge within a radius of 1 m. Thus, the activity of the material in vaporization and fusing zones is composed of the activity of the fission product and the induced radioactivity. Batzel [33], working from the assumption that in a nuclear explosion about  $1 \cdot 10^{23}$  neutrons are liberated for each kiloton of power, and all these neutrons are captured by the medium, gives the calculations of induced radioactivity in the medium shown in Table 20 (the tuffs of the Nevada test area have a chemical composition given in Table 21).

Table 20

Radioactive Isotopes Formed in the Capture of Neutrons by the Medium

Element of the medium	Isotope formed	Half-life	Energy of gamma-radiation, MeV	Ratio of the capture of neutrons leading to the formation of the isotopes, %	Number of curies per kiloton of the charge	(curies) x x (energy of gamma radiation)
Na	Na <sup>24</sup>	15 hrs	4,0	3,7	$1,3 \times 10^6$	$5,2 \times 10^6$
Al	Al <sup>28</sup>	2.3 min	1,8	2,6	$3,5 \times 10^8$	$6,3 \times 10^8$
Mn	Mn <sup>56</sup>	2.6 hrs	1,8	1,3	$2,6 \times 10^6$	$4,7 \times 10^6$
Fe (0,33% Fe <sup>58</sup> )	Fe <sup>59</sup>	45 days	1,3	0,015	$\sim 10^2$	$\sim 1,3 \times 10^2$
Co	Co <sup>60</sup>	5.2 years	2,5	0,09	$\sim 10$	$\sim 25$

Table 21

Characteristics of the Composition of the Medium

Elements	Si	Al	Fe	Ca	H	Na	K	Mg	Tl	P	Mn	Co
Content by weight, %	50	14,5	9	6,4	5,1	4,9	4,7	3,7	0,6	0,18	0,18	0,0042

<sup>1)</sup> Radioactivity associated with the radiation of isotopes which are formed in the capture of neutrons by substances surrounding the charge is called induced radioactivity.

The oxygen content is not given, since it adsorbs considerably less than 1% of the neutron, and the water content in the medium amounts to 20% by weight.

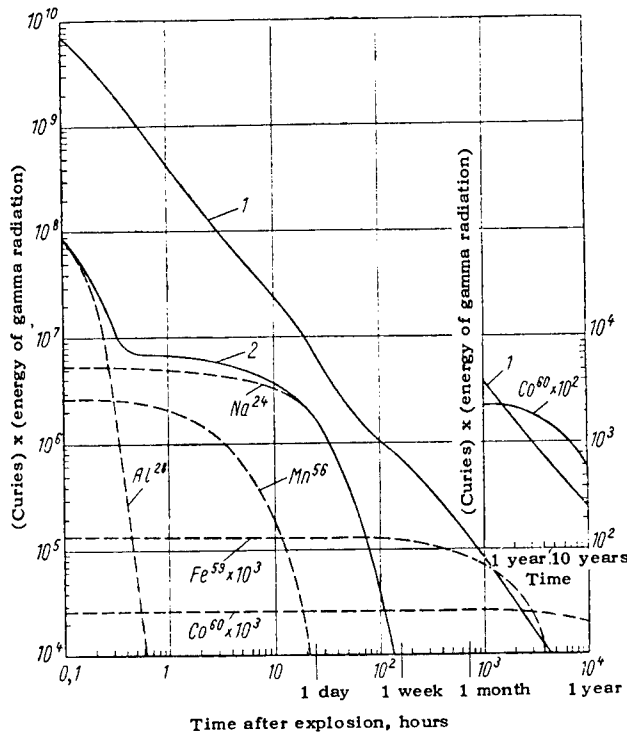

Figure 42. Comparison of the induced radioactivity with the radioactivity of the fission products in a nuclear explosion with a power of 1 KT:

1 -- fission products; 2 -- total induced radioactivity.

The neutrons captured by the medium are distributed in accordance with the percentage content of the element present and with the capture cross section of the thermal neutrons. If the water content in the medium amounts to 20% by weight, a great part of the neutrons is thermalized (retarded to thermal energies), before capture occurs, and about 60% of the neutrons are captured by the hydrogen in the water.

Data concerning isotopes producing  $\gamma$  radiation which are formed as a result of neutron capture are given in



Table 20 [32]. The number equal to the product of (curies) x x (energy of  $\gamma$  radiation) is a measure of the relative biological effect of the  $\gamma$  radiation.

In Figure 42 [33], a comparison is given of the induced activity and the activity of the fission products in an explosion equivalent to 1 KT with respect to instantaneously liberated energy. The induced radioactivity amounts to 20--25% of the activity of the fission products a day after the explosion, and 1% in a period of time of the order of one week. After 45 days, this radioactivity is reduced to 0.1%. As a result of the presence of  $\text{Co}^{60}$ , in the period from 3 to 15 years the induced radioactivity rises to 2%.

In the calculations given, the isotopes which do not produce  $\gamma$  radiations of high energy and do not intensify the external field of this radiation, but may have important significance from the biological standpoint, were not considered. Such isotopes include  $\text{Ca}^{45}$  (half-life 164 days), which radiates  $\beta$ -particles and is formed in the quantity of about 200 Ci per kiloton of energy of the explosion.

Violet [30] notes that the  $\text{Sr}^{90}$  and  $\text{Cs}^{137}$  are not formed in the effect of neutrons on the rocks surrounding the nuclear charge. He considers that the radiological danger from the induced radioactivity is insignificant in comparison to the radioactivity of the fission products from an atomic explosion.

#### RADIOACTIVE CONTAMINATION OF GROUND WATERS

The problem of the danger of radioactive contamination of ground waters in underground nuclear explosions is analyzed in detail by Higgins [34], on whose data the work of Batzel [33] is also based. If the medium in which the explosion occurs contains aluminum and silicon in adequate quantities, with a lack of an excess of sodium and potassium, the glassy mass formed in the fusion of the rocks, and containing a large part of the radioactive fission products, is practically immune to leaching. Higgins, citing the experiment of Amphlet and Warren, notes that 99.5% of all radioactive particles will not be leached from a glassy mass by ground waters during several centuries. In an explosion in carbonate rock, the fused material is less resistant to leaching, since the oxides of calcium and magnesium react with water.

A zone of finely divided unclassified material, formed during the explosion, may act as an effective watertight barrier between a possible flow of ground waters and the radioactive products.

The distribution of radioactive products of the explosion not trapped by the glassy mass by means of flows of ground waters may be estimated in the following manner. The ions  $\text{Sr}^{90}$  and  $\text{Cs}^{137}$  are selectively adsorbed from the ground waters by the majority of the minerals encountered in nature, and are distributed between the water and the minerals in accordance with the law

$$K_d = \frac{A_s M_w}{A_w M_s}, \quad (32)$$

where  $K_d$  is the distribution factor;  $A_s$  and  $A_w$  represent the radioactivity of the mineral and the water, respectively;  $M_w$  and  $M_s$  represent the masses of the water and the mineral, respectively.

The average rate of motion of the radioactive particles in ground waters is determined from the expression

$$F_A = \frac{F_w}{1 + K_d q}, \quad (33)$$

where  $F_A$  is the rate of motion of radioactivity;  $F_w$  is the velocity of the flow of ground waters;  $K_d$  is the distribution factor;  $q$  is the ratio of the mass of the mineral to the mass of the water per unit volume of the aquifer; in the majority of cases  $q = 4-5$  (according to Higgins) or  $q = 10$  (according to Violet).

The distribution factor for minerals varies from 40 (in limestone) for  $\text{Sr}^{90}$  to 100,000 for  $\text{Ce}^{144}$  (a table with values of  $K_d$  is given in the work of Higgins [34]). In water-bearing formations that have been surveyed, from which water was obtained via test holes, the natural rate of motion of the ground waters, as a rule, amounts to not more than 1.5 m per day and not less than 1.5 m per year.

Batzel [33], assuming that  $F_w = 1$  m/day,  $K_d = 300$  and  $q = 1$ , determines the rate of transfer of  $\text{Sr}^{90}$  as 0.003 m/day in accordance with formula (33). In a time equal to the half-life (28 years), this corresponds to the transfer of  $\text{Sr}^{90}$  to a distance of 30 m. Higgins, assuming that  $F_w = 3$  m/day,  $K_d = 416$  (ground) and  $q = 1$ , obtains a figure of  $F_A = 0.07$  cm/day for  $\text{Cs}^{137}$  and for  $\text{Pu}^{239}$ , in pure pulverized quartz, ( $K_A = 82$ ) -  $F_d = 3.8$  cm/day.

In experimental explosions, the charges in the Blanca and Logan experiments were made below the ground-water level [i.e., the water table]. The water collected in the survey holes and galleries near the location of the explosion had a radioactivity of from  $1 \cdot 10^{-9}$  to  $1 \cdot 10^{-8}$  Ci/l, which is approximately equal to the natural radioactivity of the ground waters in Southern Nevada and much less than the norm [34].

As a result of hydrogeological investigations for the determination of  $K_d$  and the velocity of the flow of ground waters, it has become known that in the majority of cases there will be practically no contamination of ground waters [30, 33].

#### RADIOACTIVE CONTAMINATION OF THE ATMOSPHERE AND RADIOACTIVE PRECIPITATION [i.e., fallout]

The problem of radioactive contamination of the atmosphere and the fallout of radioactive precipitation on the surface of the earth arises basically in explosions for the purpose of blasting earth or rock (reduced depth of placement of the charge is less than  $60 \text{ m/KT}^{1/3}$ ) and only to a small degree in explosions with fragmentation of the surface of the earth (reduced depth 90 to  $60 \text{ m/KT}^{1/3}$ ). The nature of radioactive precipitation in underground explosions for an external effect differs essentially from fallout in contact bursts or bursts in the atmosphere. As a consequence of the considerably lower altitude of the radioactive cloud [mushroom] the fission products do not reach the stratosphere, and therefore radioactive precipitation will not fall on the entire surface of the earth. The Neptune and Blanca experiments indicate that underground explosions for an external effect are associated with local (near-by) precipitation which may fall out at a distance of 40--170 km downwind from the location of the explosion [30].

It is known that the rising of pieces and particles of rock into the air when discharged from a crater facilitates the removal of the greater part of the radioactive products from the atmosphere [30, 33]. From 90 to 99% of the radioactive products are adsorbed on the surface of pieces of rock and dust particles and are carried away by them when they fall to the earth, and therefore the region of the propagation of this matter and the time of this fallout are reduced. Basically all the radioactive products, including 90--99% of the  $\text{Sr}^{90}$  and  $\text{Cs}^{137}$ , fall out within a few hours after the explosion. Since the fallout of  $\text{Sr}^{90}$  is dangerous from the biological standpoint as a consequence of its

absorption by plants, explosions for an external effect should be set off with a consideration of this feature.

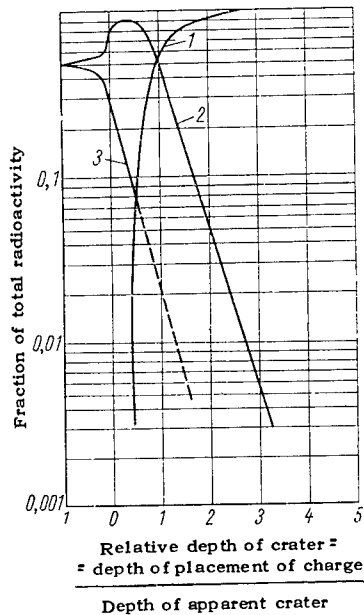

Figure 43. Distribution of radioactivity in a nuclear shot, as a function of the relative depth of the crater:

- 1 -- radioactivity trapped in the glassy mass and in rock fragments;
- 2 -- radioactivity of precipitation in the short-range zone;
- 3 -- radioactivity located in the air for a prolonged period of time.

The decrease in the radiation level at the surface, as a function of the time passed since the explosion, is described by the function  $t^{-1.2}$  (where  $t$  is time). Under the influence of meteorological conditions, a decrease in the activity may occur considerably faster. In the Teapot-Ess shot, a short interval of time after the explosion the measured radiation levels at the brow of the crater amounted to 60% altogether of those calculated according to the dependence  $t^{-1.2}$ . Thus, the radiation level at the surface of the earth is

$$R_t = FR_1 t^{-1.2}, \quad (34)$$

where  $R_t$  is the radiation level after  $t$  hours;  $R_1$  is the initial radiation level 1 hour after the explosion;  $t$  is the period of time that has passed since the measurements of the initial radiation level, in hours;  $F$  is the coefficient of meteorological conditions (a variable index, depending upon the specific conditions).

The effect of the depth of placement of the charge on the percentage of activity discharged to the surface and, consequently, the quantity of radioactive fallout, is clearly shown in Table 16.

A graph of the distribution of activity as a function of the relative depth of the crater, compiled basically according to the result of four nuclear explosions with the formation of craters, is given by Nordyke (Figure 43) [19]. Violet [30] gives a graph of the quantity of radioactive products in precipitation at the surface as a function of the reduced depth of placement of the charge (see Figure 39).

#### METHOD OF REDUCING THE RADIATION EFFECT OF NUCLEAR EXPLOSIONS

Foreign specialists [24, 34, 35] propose the following measures which may limit the harmful effects of radiation in nuclear explosions.

1. The application of nuclear charges in which the synthesis [i.e., fusion] reaction (thermonuclear reaction) is 95% used, and only 5% of the yield comes from the fission reaction, for purposes of reducing the quantity of radioactive products obtained during the explosion.

2. The use of materials containing boron (neutron reflectors) as shells for the nuclear charges, for purposes of absorbing the neutrons liberated in the nuclear explosion.

3. The application of a lining of quartz sand to the surface of the charge chamber in explosions in carbonate rocks, for the purpose of trapping the radioactive fission products in the glassy silicate fused material.

4. The use of the time factor for a natural decrease in the radioactivity level.

5. Setting off explosions for an external effect in favorable meteorological conditions, for purposes of reducing the zone of radioactive contamination of the surface.

6. Placing the charges at a depth providing for the maximum possible burial of radioactive products underground in the given conditions of the useful work of the explosion.

## CHAPTER 6

### THE USE OF NUCLEAR EXPLOSIONS IN THE DEVELOPMENT OF DEPOSITS OF SOLID MINERALS

The exposition of the ideas of industrial and scientific application of nuclear explosions should begin with the problem of using nuclear charges for developing solid minerals [11, 14, 21, 25, 31, 35, 36]. On the basis of the experimental underground explosions described above, which show the ability of nuclear explosions to break down large volumes of rock [11, 21, 36], American scientists consider that in the appropriate field of operations the application of nuclear explosions in the mining industry may be justified.

Brown and Johnson [11] indicate three interconnected problems of the industrial application of the energy of nuclear explosions:

- 1) selection of ore bodies of adequate size, in which it would be effective to use the enormous energy of the nuclear explosion. The presence of such powerful sources of energy makes it possible to accomplish work of such a scale and such a nature which would be entirely impossible in the use of ordinary methods;

- 2) the technical feasibility of purposefully directed nuclear explosions which are, at the same time, practically safe for the living organisms surrounding them. The problems associated with this will vary as a function of the specific task of the explosion. Among them include control of the magnitude and direction of the effect of the energy liberated in the explosion, the physical and chemical state of the surrounding medium after the explosion, the suppression or localization of the dangerous phenomena of a nuclear explosion -- radiation, seismic, airborne shock wave, and thermal. The latter problem must be solved in the future by the appropriate design of the nuclear charge and selection of

the appropriate medium and conditions for setting off the explosion;

3) the economic feasibility of nuclear explosions. The given problem depends upon the cost of the charge, and also upon the expenditures required for its placement in the proper position, its explosion, and measures for suppressing the dangerous phenomena.

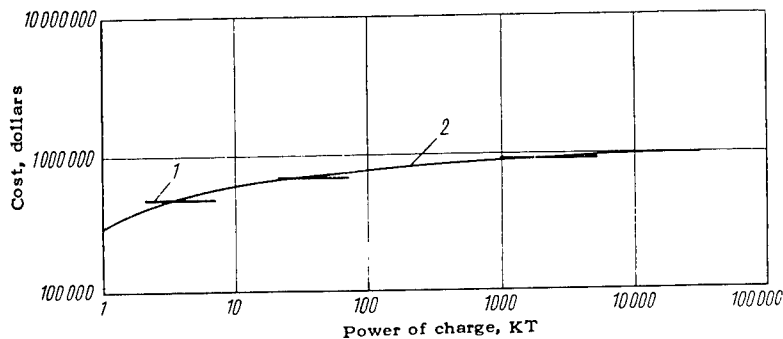

Figure 44. Cost of nuclear charges as a function of power:

1 -- cost of charges according to data published by the U.S. AEC; 2 -- cost according to further interpolation.

A comparison of the cost of nuclear charges and two types of chemical explosives, according to Hoy's data [18], is given in Table 22.

Nuclear charges with a power of the order of 1--2 KT are atomic bombs entirely based on the fission reaction; charges with a power of the order of megatons are thermonuclear bombs, and 95% of their energy is based on the fusion reaction and 5% on the fission reaction.

The cost of nuclear charges with intermediate values of power with relationship to those indicated in the table may be estimated by using the graph in Figure 44 [21].

As is apparent from Table 22, the increase in the nuclear charge reduces the relative cost per unit of its power and consequently at large scales reduces the cost of blasting operations.

The American scientists consider that the most probable field of application of industrial nuclear explosions [36] is the development of deposits of solid minerals that are large in reserves, but lean in quality, lying at a considerable depth in remote desert regions.

It is proposed [31, 36] that the following operations may be accomplished by nuclear charges: 1) fragmentation and removal of the overburden by explosions for blast effect, before the beginning of the working of the deposit by the open-pit method; 2) fragmentation of the mineral to prepare it for mining by the open-pit method; 3) fragmentation of the mineral and the overlying rocks in underground development of deposits by means of systems of forced cave-in by stages; 4) fragmentation of the mineral (ore) for subsequent removal of the valuable components by the method of underground leaching at the place where the ore body lies; 5) fragmentation and combustion of hard coal for underground gasification of it at the place where the coal bed lies.

The last proposal is analogous to the fragmentation of oil shales and underground distillation of the petroleum by means of nuclear explosions, which will be described in detail in Chapter 9, and therefore proposals concerning the application of nuclear explosions for mining solid minerals by the open-pit and underground methods will be expounded further.

Table 22

Comparative Cost of the Energy Liberated by Nuclear and Conventional Charges of Different Power

Power of charge, KT	Cost of $2.5 \times 10^5$ kcal* of energy liberated by different charges, dollars		
	Nuclear	Ammonium nitrate	TNT
1	115	85	250
5	25	85	250
50	3,75	85	250
1 000	0,25	85	250
10 000	0,025	85	250

\*  $10^6$  British Thermal Units [BTU].

In the evaluation of these proposals, the American specialists [11] arrive at the conclusion that adequate bases exist for calculating on the use of nuclear charges in the future for fragmentation (breaking of rocks). However, before the application of nuclear explosions in this field becomes a reality, it is necessary to do an enormous amount of experimental work.



Until knowledge has been accumulated for adequately precise control and precalculation of the results of the effect of underground nuclear explosions, it is not recommended that we experiment on specific ore bodies, as this might lead to an unjustified risk, considering the value of the surveyed mineral resources. Therefore, it is proposed to conduct the experiments in gangue rocks, having modes of occurrence and physical properties similar to the ore bodies. Special attention is devoted to the selection of the appropriate section for experimental explosions. It is emphasized that to obtain essential results from such an investigation, a prolonged period of time is required.

In the final analysis, the application of nuclear explosions for the development of solid minerals will become possible only if the given method will provide for cheaper mining, with the same magnitude of leanness of the ore, as is achieved by existing methods, and in the absence of a practical danger of radioactive contamination of the ore.

The performance of open-pit mining operations by means of nuclear explosions attracts the attention of researchers primarily by its opportunity of moving enormous volumes of earth and rock by explosions for a blast effect.

The parameters of craters formed in alluvial soils by nuclear charges, and also expenditures for each cubic meter of excavation created by nuclear explosions for a blast effect, are given in Table 23.

Table 23

Parameters of Craters from Nuclear Explosions for a Blast Effect and the Cost of Excavation<sup>1)</sup>

Power of charge, KT	Parameters of drill holes for placement of charge, m		Expenditures on the explosion, thousands of dollars				Parameters of crater			Expenditures for each m <sup>3</sup> of excavation, dollars
			Cost of charge	Expenditures for placement of charge	Operational expenditures	Total	Diameter, m	Depth, m	Volume, million m <sup>3</sup>	
	Diameter	Depth								
1	0,9	50	500	100	500	1100	120	30	0,16	6,90
10	0,9	100	500	150	750	1400	210	55	1,22	1,19
100	1,8	190	750	300	1000	2050	490	110	9,15	0,22
1000	1,8	370	1000	600	2000	3600	980	210	73,0	0,05

<sup>1)</sup>Recent data from the Sedan shot show some deviations from the parameter of the craters given in this table (see Chapter 11).

As is apparent from Table 23, a thermonuclear explosion with a power of 1000 KT theoretically may form an enormous open pit with a volume of the order 70--75 million m<sup>3</sup>. Such volumes may have large quarries in their final contours, after the removal of the debris and working of the ore reserves, which are measured in tens of millions of tons. In distinction from the conventional technology of open-pit operations, which include two independent processes -- the fragmentation of the rocks by chemical explosives and the removal of the broken rock from the quarry by loading and transporting machines and mechanisms, a nuclear explosion for blast effect solves in these problems in one operation.

As is apparent from Figure 44, according to data from the U.S. Atomic Energy Commission, the cost of a nuclear charge increases only insignificantly with a sharp increase in its power (for example, less than by a factor of three when the power is increased by a factor of 1000). These data refer to the first experimental explosions; in the industrial use of megaton nuclear charges we may calculate that their cost will be only half as much [21]. Consequently, the economic advantage of nuclear charges in large volumes of excavation of earth is considered to be unquestionable; to the contrary, however, in full volumes of excavations conventional methods of open-pit operations will be cheaper. In connection with this it is proposed to use nuclear charges for a blast effect for uncovering large deposits of lean ore, located in regions have a scanty population, which are unprofitable to develop by conventional methods and with the existing equipment. Such an opportunity is schematically illustrated in Figure 45. A steeply dipping bed of iron ore with a thickness of 120 m, outcropping at the surface at the summit of a mountain, is uncovered on the hanging side by a nuclear explosion for scattering the rock of the corresponding slope. As is apparent from Figure 45, an excavation with a volume of up to 15 million m<sup>3</sup> is formed, which, in view of the favorable relief of the surface, is done by a single nuclear charge with a power of 100 KT. The cost of a cubic meter of excavation will be of the order of 10--15 cents, while in the use of conventional methods it would be 30--35 cents.

In one of these works [14] considerations are expounded concerning the gradual uncovering of an ore deposit by nuclear explosions intended for blast effects. Nuclear charges of relatively small power (5--10 KT) are placed in the rocks of the overburden in a rectangular grid or in staggered settings, with the interval between the charges being 79--90 m. It is considered that the depth of placement of the charges of the first level from the surface

of the overburden in which it is possible to use this method must be a minimum of 15 m. The overburden is removed by successive explosions of these levels, beginning with the upper one. In direct proximity to the ore, the remnant of the overlying rock is removed by machinery. By such a method, in particular, it is recommended oil shales in the western states be uncovered for open-pit mining of this resource. The economics of the nuclear explosions in the given case will be less favorable as a consequence of the relatively small power of the charges.

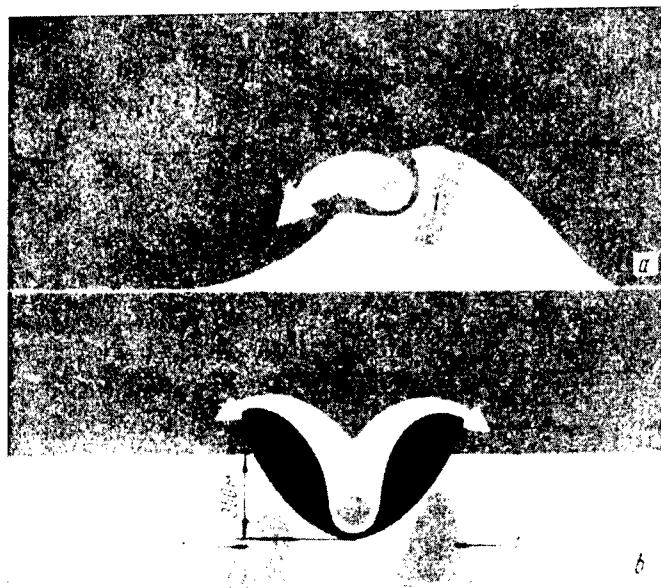

Figure 45. Diagram of the removal of the overburden above an ore deposit by a nuclear explosion for blast effects:

a -- vertical section; b -- plan;  
1 -- ore.

From another work [31] it is known that it is possible to quarry building stone and crushed rock by the open-pit method, and to fragment it to the necessary size, in one operation by means of nuclear explosions.

The application of nuclear explosions is also considered economical in the open-pit mines of the Anaconda Chile Company in South America, where the overburden factor at the present time is equal to 10:1 and in the near future

an increase in it is expected. The remoteness of the region, which is located in a thinly populated desert, favors the application of nuclear explosions in this deposit. It is proposed that the energy of nuclear explosions could also be used in the working of the Steep Rock iron-ore deposit in the province of Ontario (Canada), 65 km north of the U.S. border [37]. The ore bodies lie under a lake with an area of 18 km<sup>2</sup>, at a depth of 25--90 m; the thickness of the layer of silt on the lake bottom is 90 m; directly above the deposit lies the layer of rubbly gravel 30 m thick. The total thickness of the five ore deposits reaches several hundred meters. Before the beginning of the development of the deposits, after the water had been pumped out of the lake, it would be necessary to do a great amount of work in the removal of the silt and clay lying above the ore bodies, with the application of dredges and excavators. By means of nuclear explosions, these operations could be performed faster and cheaper.

In the USA, the reserves of taconite ores in the north of the state of Minnesota are enormous. The reserves of these ores with an average iron content of 30% amount to 56 billion T. At the present time, the difficulty of developing the taconite is associated with the great amount of oversized rock fragments produced, because of the inadequate power of modern chemical explosives. Subsequent crushing of the viscous and abrasive material in rock crushers is a labor-consuming and costly process. It is considered that this problem might be solved by the application of nuclear explosives [14].

In the USA the working of open-pit mines by modern methods is considered economical if up to 50 T of gangue [i.e., barren rock] is removed for each ton of ore. A higher ratio of overburden, even in the development of valuable ores, makes open-pit operations disadvantageous. In the use of nuclear explosions in open-pit operations such factors as the depth of the deposits, strength of the ore, thickness and nature of the overburden, and relatively small value of the mineral raw material, cease to play the primary role.

Thus, in the opinion of American researchers [3, 35, 36] the application of nuclear explosions in open-pit mining operations:

- 1) essentially simplifies the technological process of mining a mineral by combining several operations into one process;
- 2) makes it possible to increase considerably the depth of open-pit operations and the maximum ratio of overburden;
- 3) reduces the cost of mining a mineral to a tenth or less of the comparative cost with contemporary methods;

4) creates conditions for bringing into exploitation large deposits of lean and low-grade ores that are unprofitable for development at the present time.

In practice, the application of nuclear explosions in open-pit operations depends primarily upon the suppression of their harmful effects, and especially the radioactive contamination of the body being developed and of the surrounding terrain. Basic measures for safety provisions were expounded above (see Chapters 5 and 6). For a case of open-pit operations, they can be reduced to the creation of charges with a low fraction of the fission reaction in the explosion, the development of neutron-proof shells, the selection of the safest depths for the placement of the charges, and the consideration of the meteorological factors before the explosion, and the use of the time factor for natural deactivation (decay of the radioactive products) in the region of the explosion. Together with this, a number of specific problems arise which must be studied in the solution of the problem of the industrial application of nuclear explosions in open-pit operations. Some of them have been formulated by Boyd [36].

1. Methods of drilling and explosive operations and its equipment used at the present time make it possible to develop the planned contours of the quarries more precisely. In a case of nuclear explosions for a blast effect, the volume of unneeded "excess" rocks beyond the limits of the planned contours of the crater remains unknown, as well as the stability of the sides of the crater, the nature of operations and expenditures on their dismantling for safe mining of the ore located below.

2. Existing methods of open-pit operation provide for separate removal of barren rock and mining of the minerals, and make it possible to work different grades of ore or large inclusions of barren rock in ore bodies selectively. In nuclear explosions it is assumed that after removal of the overburden, another nuclear charge may be planted, which will blast the ore to the surface of the barren rock. In that case, a mixing of the ore and the rock is possible, thus creating an impoverishment of the mineral.

3. Existing methods of drilling and blasting operations in a quarry make it possible to control the size of pieces of the broken ore and the yield of oversized pieces to the degree required. In nuclear explosions, such a possibility is not clear. The formation of large blocks of ore, requiring considerable effort for secondary pulverization, is not excluded.

For a study of these problems and other questions of the safe and effective application of nuclear explosions in open-pit mining operations, further research is proposed in

the USA, including experimental explosions at special test areas and in thinly populated desert regions [25].

Proposals for the use of nuclear explosions in the underground development of solid minerals also are based upon the new opportunity for fragmentation and breaking of unusually large masses of rock.

The most complete concept of the development and result of an underground nuclear explosion for internal effect is given by the Rainier experiment, described in detail in Chapter 3. In very unfavorable conditions of operation of the charge, in practically an absolute pinch, an explosion with a power of 1.7 KT broke up 90,000 m<sup>3</sup> of tuff; besides, as a result of the cave-in of the overlying rock into the spherical explosion cavity, up to 225,000 m<sup>3</sup> of water-permeable (broken) rocks were formed.

By working from the laws of similarity, we must expect that more powerful nuclear explosions will break up enormous volumes of rock.

Not to mention a charge of 10 MT, the application of which in mining practice is scarcely probable, an explosion with a power of 1 MT could theoretically break up, in one explosion, a large ore body with reserves of 300--400 million T, if it had the appropriate shape. The optimum depth of planting of such a charge from the surface would be somewhat within limits of 1300--1500 m. The data given are a very tentative estimate of the possible results of the explosion, and do not so much characterize the absolute quantitative indices as the possible scales of fragmentation of the rocks by the nuclear shot.

In a case of the creation of more favorable operating conditions for the charge, the effect of the explosion, from the sense of fragmentation of the rock, might be considerably improved. An important circumstance, therefore, is control over the destructive effects of the nuclear explosion in the rocks. American researchers [36] are considering ways and means to obtain a directed effect for an underground nuclear explosion. For example, the optimum distance of a nuclear device placed in an underground chamber from the exposed surface of the surrounding rocks, in which the maximum shock effect of the explosion is achieved, has been established. Another possible, but as yet far from proven, effect is the effect of the shape of the chamber. In the explosion of a charge in an underground chamber of definite shape, we may expect a concentration of the explosion effect in one given direction. Besides this, cases of the energy distribution of a nuclear explosion are being studied: along one underground gallery; in four directions, along two intersecting galleries of limited length, and uniformly throughout the entire

surface of the massif being tapped. In all cases, conditions are being sought for direction of the energy of the explosion in a given direction, so that its fragmentation effect would be stronger than in the effect of an explosion in an unlimited massif, with the formation of an expanding sphere.

By means of appropriate preliminary preparation of the ore massif by mining workings, for a directed effect of the energy of the explosion, its useful effect may be increased, from the sense of the fragmentation of the ore, in comparison to the indices from the Rainier shot. The technique of forced mass cave-in by nuclear explosions may be advanced as far as it makes it possible to process adequately large ore bodies without dividing them into blocks.

The problem of the application of nuclear explosions for underground mining of ore is being considered by American specialists primarily because of the reduction in the reserves of rich ore deposits, in particular copper ores, that lie at a shallow depth. Boyd [36] indicates that at the beginning of the twentieth century the USA was developing ores with a content of 2.5% copper, completely satisfying the domestic market of the country for this metal, and even exporting it to many countries. At the present time, the average copper content in the ores extracted at American mines amounts to less than 1%, and the USA is obliged to import copper. In the future, the discovery of new deposits at great depth with a low metal content may be expected, and expenditures on their development will unavoidably increase, if new methods of underground mining are not found. Among these methods we may include the application of nuclear charges for cutting the ore, which is the basic costly operation in underground mines.

As yet no specific proposals or plans for underground working of definite deposits with the application of nuclear explosions have been published in the U.S. literature. The lack of such projects is probably explained by the complexity of underground fragmentation of rocks by this method, and the fact that the method has been little studied. However, quite a few ideas and planning proposals with reference to conditional ore bodies do exist, which may be divided into two groups: 1) the application of nuclear explosions in systems of forced cave-in by stories, with the removal of the ore and its delivery to the surface; 2) the application of nuclear explosions for breaking up ore, with subsequent leaching of it on the spot where it lies and delivery of solutions [i.e., concentrates] enriched in metal to the surface.

A possible variation of forced cave-in by stories, by means of nuclear charges with a power of 1.7 KT, which would be laid below the ore body, in order to prevent radioactive contamination of the ore, is given in Figure 46 [18].

The dimensions of the zone of effect of the charge and the cave-in zone of the ore are assumed by working from the assumption that the rocks have properties similar to tuff. In this case, the quantity and power of the nuclear charges, and the given dimensions, may be determined by using Figure 16. The basic shortcoming of the proposed scheme for the placement of the charges is the necessity of cutting and shoring up the galleries in a massif destroyed by the explosion [18].

After the explosion, it is necessary to do a certain amount of work to remove the fragmented ore, in analogy to mass cave-in systems. Great attention in this case is devoted to the preparation of the ore body before the explosion, to increase its efficiency, the creation of a definite shape and volume of the fragmentation zones, and also to protect the rocks in which the collecting shaft will be cut from the destructive effect of the charges.

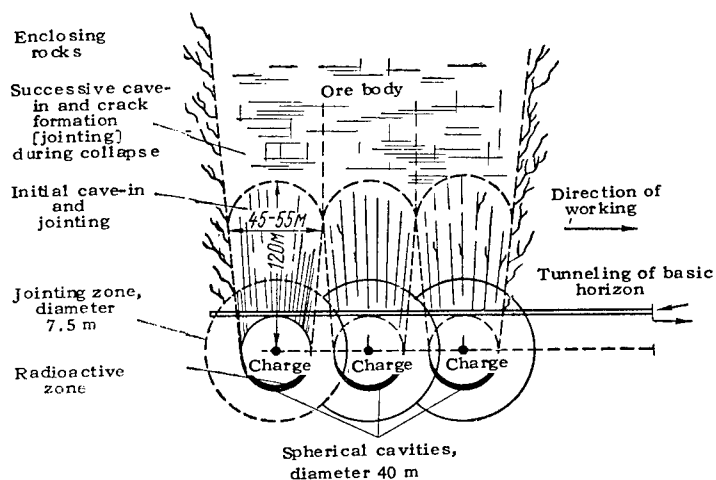

Figure 46. Diagram of the fragmentation of an ore body by nuclear charges in a system of forced cave-in, story by story.

In a case of the explosion of a single nuclear charge, in an intact massif, judging by the example of the Rainier experiment the fragmentation zone probably will be bounded below by a spherical segment of slightly disturbed rock. The tunneling of the outlet galleries in it may be accomplished in accordance with two schemes: 1) by means of finger rises of the same height, at different levels of the ore-removal horizon, or 2) with finger rises of different lengths, from



one level of the ore-removal horizons (Figure 47). In control of the effect of the nuclear explosion by the method of preliminary horizontal cutting of the massif that is to be collapsed, the fragmentation zone may be given a flat surface on its lower side, and the rocks under it may remain undisturbed. Then we may apply the simplest preparation of the gallery, with scraper drifts, and short finger rises (Figure 48).

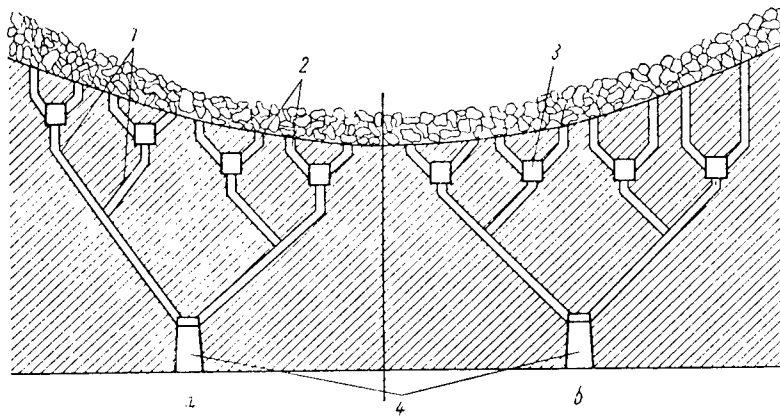

Figure 47. Preparation of the bottom of the block:

- a -- arrangement of drift of the ore-extraction horizon at different levels;
- b -- arrangement of the drift of the ore-extraction horizon on one level, with different lengths of finger risers;
- 1 -- communicating risers;
- 2 -- finger risers;
- 3 -- drift of the ore-extraction horizon;
- 4 -- ore-removal drift.

The basic advantage of the method of forced cave-in of the ore stage by stage, by means of nuclear explosion, is considered to be the possibility of developing the most diverse deposits, including those that are structurally disturbed, where ordinarily systems with mass cave-in can be applied with difficulty, or where it is impossible to apply them at all. Thus, nuclear explosions, as it were, would expand the field of application of high-capacity mining systems, with story-by-story cave-in of the ore.

The peculiarity of such mining systems lies in bringing out the ore under the enclosing overburden rocks. If the

latter are stable and difficult to cause to cave in, in the withdrawal large overhangs of rock are possible, with subsequent sudden cave-in of them, which may cause air-compression shock. This phenomenon is associated with danger to the lives of the workers engaged at the ore-extraction horizon. It is recommended that possible overhangs be avoided by preliminary fragmentation of the overlying rocks by means of nuclear explosion. Cave-in of the overlying rocks by the given method may be applied both in conventional systems for cave-in story by story by inertia, and forced cave-in, story by story, with blasting out of the ore by means of chemical explosives, and in a case of the method using forced cave-in, with nuclear explosions.

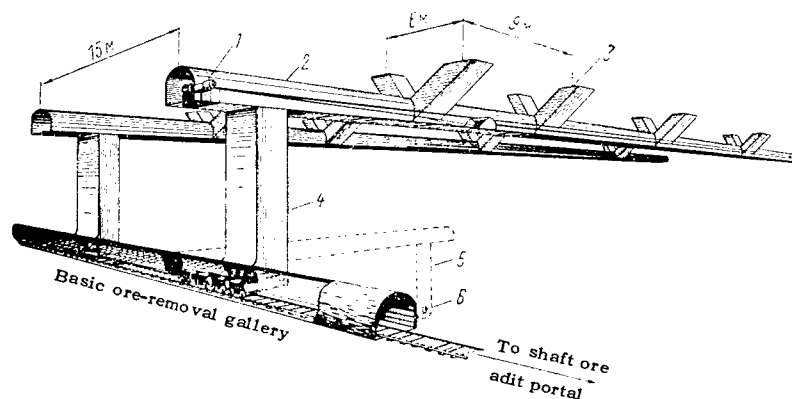

Figure 48. Preparation of the ore-removal horizon for ore caved in by a nuclear explosion:

- 1 -- scraper winch; 2 -- scraper drift; 3 -- outlet ramp
- 4 -- ore hopper 9 m long; 5 -- blind pit for placement of nuclear charge;
- 6 -- nuclear charge.

Rock removal, underground transport, and lifting of the broken ore to the surface are made highly complicated because of the radioactive phenomenon and residual heat of the nuclear explosion. Problems of seismic safety are solved in the same way as in ordinary underground explosions. It is recommended that the radius of the zone beyond the limits of which the seismic oscillations caused by the nuclear explosion will not present any danger to surface and underground structures be determined as indicated in Chapter 4.

From a vertical section of the fragmentation zone formed by the Rainier shot (see Figure 14), where the black arc marks the location of the basic concentration of radioactive products, it is apparent that at the first stage of removal of the ore to the system of galleries cut under the fragmentation zone, radioactivity will not present any special danger. However, after a definite time the radioactive ore will appear in the outlet ramp. Therefore, besides control of the ore removal, which makes it possible to predict to some degree when and through what ramp radioactive ore will pass, it is necessary to organize a constant and thorough radiometric control at the ore-removal horizon. If the radiation levels are higher than the permissible norm, American researchers propose the following protective measures for the personnel: a) automation of the operation of the scraper winch for its remote control, with the installation of a hermetically sealed screen having a window in the scraper drift; b) active dust suppression in the withdrawal and scraping of the ore by means of intensive spraying and purifying the outcoming air jet of radioactive materials by filtration through the appropriate absorbents; c) deactivation of the scraper drift after cessation of the removal of the radioactive ore, for which, for example, it must be intensively washed with water; d) stowage of the broken ore contaminated by radioactive products for a definite time, during which natural decay of the radioactive isotopes will occur.

The possibility of working near the zone of radioactive material and removal of the ore from this zone is confirmed by the experiment of cutting survey galleries in the vicinity of the Rainier shot.

According to a communication by Johnson et al. [2], in the cutting of a survey gallery from an approach adit (see Figure 14) the radiation level at the surface of the drift intersecting the zone of radioactive material amounted to 300 mr/hr, which made it possible to remove the pieces of rock manually and transport them in dump cars, with a simple shielding made of sandbags.

One of the possible variations of the working of deposits by means of nuclear explosions is a proposal for caving in the ore in individual sections or throughout the entire ore body, with isolation of the reserve of broken ore contaminated by radioactive products for a prolonged period of time for purposes of the natural decay of the short-lived radioactive isotopes. Removal of the ore from such sections may be accomplished after 15 years or more.

The heat created by nuclear explosion will be absorbed by the enormous volume of relatively cold ore that has caved in, and the average temperature in fragmentation zones is

expected to be comparatively low. However, in individual sections the temperature of the ore arriving at the ore-removal horizon may turn out to be increased, and create abnormal working conditions in the scraper drift. The heated ore is cooled by water, which is fed into the cave-in zone in large quantities, with multiple recirculation. The galleries of the ore-removal horizon must be ventilated by air, artificially cooled by stationary or portable cooling plants. In spite of the problems with this, in the opinion of American researchers, no insurmountable technical or economic reasons exist because of which it would be impossible in the future to apply nuclear explosions successfully in the underground working of deposits of ore, with the haulage of the mineral to the surface. A system of story-by-story forced cave-in by means of nuclear charges would make it possible to mine ores which at the present time are considered to be nonindustrial.

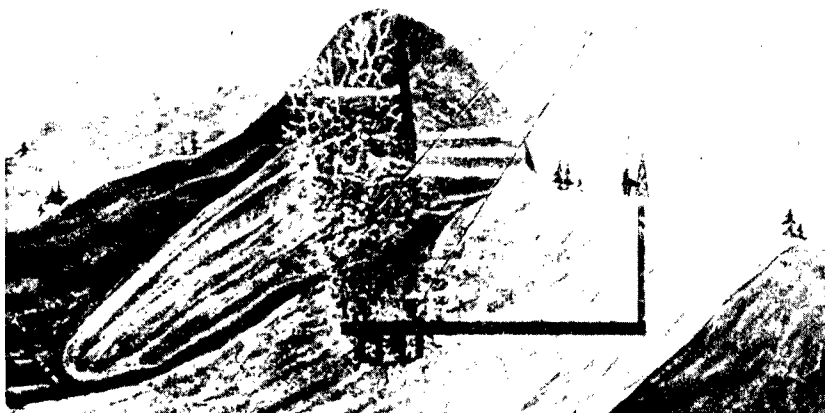

Figure 49. Underground leaching of ore after fragmentation by nuclear explosion:

1 -- feeding of leaching solutions; 2 -- old quarry; 3 -- ore broken up by nuclear explosion; 4 -- drainage gallery for collection of enriched solutions; 5 -- pumping station.

A first attempt to remove a mass of rock broken up by a nuclear explosion is known [25]. The experiment indicated was made in the section where the Rainier shot was set off

approximately 2--3 years after the detonation of the charge. In a survey gallery cut in 1959 from a riser 30 m above the approach adit (see Figure 14), four ramps were made in the zone where the rock was caved in by the explosion, to remove the broken rocks. A scraper winch installed in the drift delivered the rock to a raise stope from whence, through a hatch, it was loaded into dump cars and rolled out to the mouth of the adit. All operations were accomplished basically in the same way as in ordinary mining by block-by-block cave-in. The removal of the broken mass of rock was successful. However, the given experiment was of a purely demonstrative significance, since the rock mass removed was only barren rock.

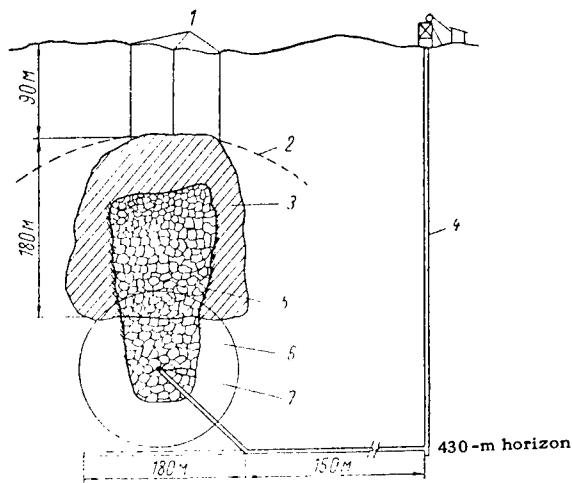

Figure 50. Fragmentation of ore by a nuclear explosion for subsequent underground leaching:

- 1 -- drilled holes for feeding in solution [solvents];
- 2 -- boundary of jointing;
- 3 -- ore body;
- 4 -- shaft;
- 5 -- cave-in zone;
- 6 -- fragmentation zone;
- 7 -- position of nuclear charge.

The principle of underground leaching of ores (Figures 49 [25] and 50 [21]) lies in the following: the ore deposit, as a rule, with a low content of valuable components, being impermeable to water in the massif, is broken up by one or several nuclear charges, with subsequent feeding of leaching

solutions through holes drilled from the surface. The uncut massif, which is impermeable to water, surrounding the fragmentation zone, creates, as it were, an enormous natural vessel, in which the process of underground leaching will occur. The solutions being pumped through the ore will remove the element needed (selectively, if necessary), be collected under the fragmentation zone in drainage galleries, and pumped out to the surface for subsequent reprocessing (precipitation of the valuable components).

The advantages of the given variations of the use of nuclear explosions for working ore deposits, in comparison to the first group of proposals, is obvious. In the given case, the necessity of removal of the ore no longer arises, nor is the underground transportation or lifting to the surface needed, which considerably simplifies the exploitation of the deposits, and reduces its cost. However, as Boyd mentions [36], in this case new problems arise, which as yet have found no answer because of our inadequate knowledge and experience.

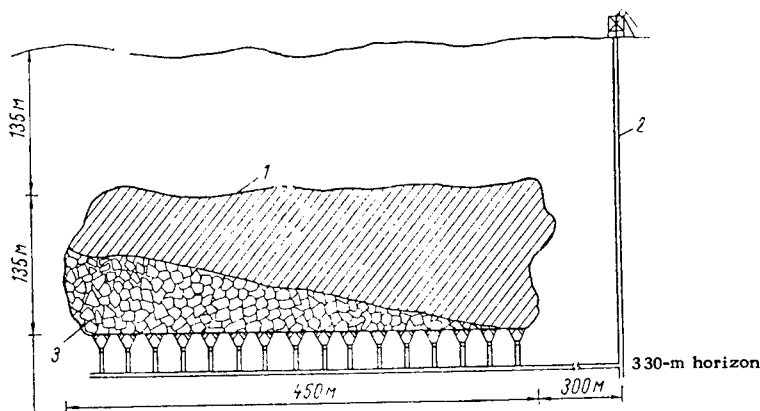

Figure 51. Development of deposits (with ore reserves of 50 million T) by the system of story-by-story cave-in by inertia:

1 -- ore bodies; 2 -- shaft; 3 -- collapsed ore.

1. It is quite apparent that the given process is of industrial interest only with adequate pulverization of the ore by the explosions, since the extraction factor of the valuable components depends upon this. At the same time, for

economic considerations the application of nuclear charges of great power is required, probably measured in hundreds of kilotons. The degree of fragmentation of the rocks composing the ore deposit in this case is unknown.

2. It is not known if nuclear explosions will create adequate and uniform permeability of the fragmentation zone to water (this is primarily associated with the first problem) for continuous and effective pumping of the leaching solution.

3. It is not known if the ore massif will be broken up to such a degree that the excavation of drainage galleries under it for collection of the enriched solutions will be hampered, or even made impossible, and it is also not known what the state of the underlying rocks (the bottom of the block) must be to prevent losses (leakages) of the valuable solutions.

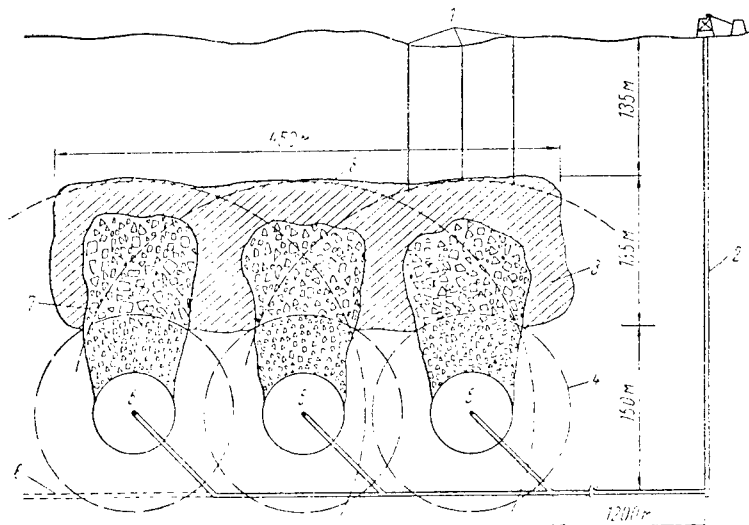

Figure 52. Development of a deposit (with ore reserves of 50 million T) by the method of fragmentation of the ore by nuclear explosion, with underground leaching. Vertical section:

- 1 -- wells for feeding in solution;
- 2 -- shaft; 3 -- ore bodies; 4 -- fragmentation zone; 5 -- nuclear charges; 6 -- drainage drift; 7 -- cave-in zone; 8 -- boundary of jointing.

4. It is not known if the indices of underground leaching (speed of the process, extraction factor of the valuable components) will be adequately high in order to justify expenditures for the mining preparatory operations and the necessary structures and other devices.

5. It is not known to what degree the leaching solution will be contaminated by the radioactive products of the nuclear explosion and the broken ore contaminated by them, as it is circulated.

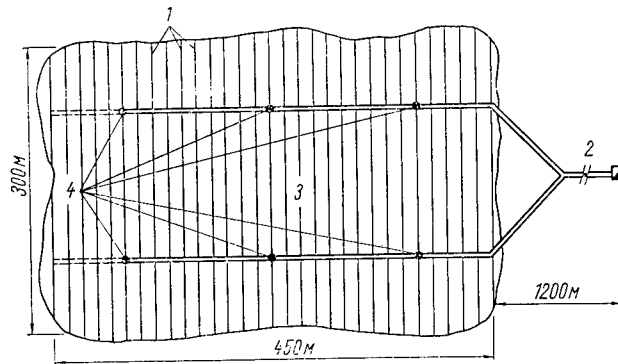

Figure 53. Development of a deposit (for reserves of 50 million T) by the method of fragmenting the ore with nuclear explosions, and with underground leaching. Plan of the drainage horizon:

- 1 -- drainage galleries; 2 -- shaft;
- 3 -- ore bodies; 4 -- nuclear charges.

The overwhelming majority of the radioactive products of an explosion, as the Rainier experiment demonstrated, will be trapped in a limited volume of glassy rock that is only slightly soluble, which, as it were, will reduce the danger of radioactive contamination of the solution. However, only experimental work can give a confirmation of this assumption, and only in such a way can we obtain the answers to the previous questions.

The Colorado Institute of Mining Research has made an interesting investigation on determining the profitability of the development of a conditional deposit of lean copper ores (with an average content of 0.5% copper) by different methods, including the application of nuclear explosions [37]. Technical and economic calculations were made for



deposits of ore reserves of 1.5 million T, 10 million T, and 50 million T, according to three variations for obtaining the copper: 1) story-by-story cave-in of the ore by inertia, with subsequent hydrometallurgical processing of it at the surface; 2) story-by-story cave-in of the ore by inertia, with subsequent floatation concentration of it at the surface; 3) breaking up the ore by nuclear explosions, underground leaching on the spot where the ore body lies, and pumping the enriched solution to the surface for precipitation of the copper.

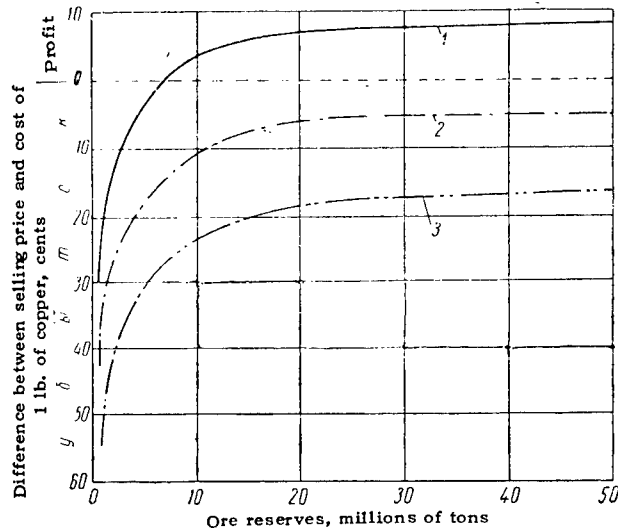

Figure 54. Profitability of extraction of copper as a function of the size of reserves and method of working the deposits:

- 1 -- fragmentation by nuclear explosions, with leaching of the ore on the spot where the ore body lies;
- 2 -- story-by-story cave-in by inertia, with subsequent floatation of the ore at the surface;
- 3 -- story-by-story cave-in by inertia, with subsequent hydrometallurgical processing of the ore at the surface.

A diagram of the working of a deposit with reserves of 50 million T in accordance with variations 1 and 2 is shown in Figure 51 [37]. The working of such a deposit by

Table 24

Comparative Efficiency of the Development of a Copper Deposit by Conventional Methods and by Means of Nuclear Explosions with Underground Leaching [14, 37]

Variation of copper extraction process	Ore reserve in deposits, millions of tons	Expenditure per ton of ore, dollars			Yield of copper from 1 T of ore*, kg	Cost of mining concentration per kilogram of copper, dollars	Cost of hydro-metallurgical processing per kilogram of copper, dollars	Total cost of extraction of 1 kg of copper, dollars	Profitability at a copper price of \$0.66 per kilogram, - profit, + loss, dollars
		On amortization of capital and preparatory operations	On mining	On concentration					
1	1,5	1,81	1,35	0,08**	3,24	1,59	0,25	1,84	-1,18
	10,0	0,53	1,35	0,08**	1,96	0,96	0,25	1,21	-0,55
	50,0	0,27	1,25	0,08**	1,60	0,79	0,25	1,04	-0,38
2	1,5	3,02***	1,35	0,90	5,27	1,61	—	1,61****	-0,95
	10,0	0,71***	1,35	0,90	2,96	0,91	—	0,91****	-0,25
	50,0	0,55***	1,25	0,90	2,70	0,82	—	0,82****	-0,16
3	1,5	1,68	—	—	1,68	0,93	0,41	1,34	-0,68
	10,0	0,40	—	—	0,40	0,22	0,41	0,63	+0,03
	50,0	0,20	—	—	0,20	0,11	0,41	0,52	+0,14

\*Depending upon extraction, determined by type of processing.

\*\*Expenditures on fragmentation (crushing) of the ore.

\*\*\*Amortization increases in comparison to first variation because of the amortization expenditures deducted for the concentrating mill.

\*\*\*\*Not counting expenditures for smelting the copper concentrate.

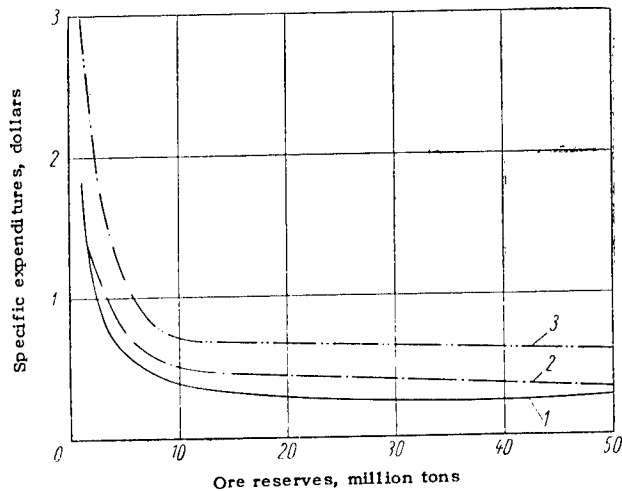

Figure 55. Change in specific expenditures per ton of ore with respect to capital and preparatory operations in different methods of working the ore body:

1 -- fragmentation by nuclear explosion, with leaching of the ore on the spot where the ore body lies; 2 -- story-by-story cave-in by inertia, with subsequent floatation of the copper ore at the surface; 3 -- story-by-story cave-in by inertia, with subsequent hydrometallic processing of the ore at the surface.

means of nuclear explosions and underground leaching is shown in Figures 52 [18] and 53 [37]. The results of the calculations are given in Table 24 and are shown in Figures 54 and 55 [37]. In the consideration of the results, we may conclude that in conditions in the U.S. the exploitation of deposits with a 0.5% copper content in the ore may be profitable only with the use of the first variation and in deposits whose reserves are more than 10 million T of ore. Thus, from the economic standpoint the fragmentation of the ore by nuclear explosions with subsequent underground leaching may in the future turn out to be the most acceptable method of working deposits of lean ores that are capable of being leached.

## CHAPTER 7

### THE USE OF NUCLEAR EXPLOSIONS IN THE CONSTRUCTION OF LARGE CIVIL-ENGINEERING STRUCTURES

#### INTRODUCTION

The next field of industrial application of nuclear explosions may be the construction of large civil-engineering (primarily hydraulic-engineering) structures. In this case, a nuclear charge may also be used for the instantaneous destruction and movement of enormous masses of rocks. The given problem is discussed by many American researchers [3, 11, 19, 23, 25, 31, 35, 38, 39], and also in Rougeron's book [40].

It has been proposed to use nuclear explosions for the solution of the following specific problems: 1) the construction of harbors for seagoing and river shipping; 2) the construction of canals for seagoing and river vessels; 3) the construction of earth-filled dams and dikes; 4) the regulation of surface and underground water courses; 5) the creation of underground storage tanks for POL and gas.

Aside from general ideas, there are already specific proposals and projects in existence in the given direction of the industrial use of nuclear explosions, and also a special experiment (the Sedan experiment) has been carried out at the Nevada test area.

#### THE CONSTRUCTION OF HARBORS FOR SEAGOING AND RIVER VESSELS

The essence of the given idea lies in the application of nuclear explosions for a blast effect, for the formation of sheltered harbors on the coast of a sea or the bank of a river. The explosion of a thermonuclear bomb with a power of 14 MT at the location of the coral reef of Elugolab (on Eniwetok atoll), set off by the USA, formed a unique "harbor."

The birth of the project on an industrial scale in the USA was a project for the construction of an enclosed seaport with an entrance channel at the northwest extremity of Alaska, known under the code name of Project Chariot. This project was conceived in 1958 and, aside from its applied significance, provided for the following basic goals: 1) the expansion of data concerning the results of nuclear explosions for a blast effect in rocks of different characteristics (in the given case, in the hard rocks of a seacoast); 2) the detonation of a simultaneous group explosion of nuclear charges; 3) the procurement of new information concerning the distribution of the radioactive products of nuclear explosions in the surrounding territory and in the atmosphere; 4) the study of the effect of the airborne shock waves at various distances from the point where the nuclear charges for an external effect were set, planted at a considerable depth.

The site of the future harbor is located 160 km north of the Arctic Circle, south of Point Hope and Cape Thompson, at the mouth of the little Ogotorok River. In the vicinity of Point Hope, the shore is not clear of the polar pack ice, which even in summer never moves far away from the land. Seagoing vessels can pass north of this point during only one month of the year. In the vicinity of the future harbor, the sea is free of ice three months in the year. Nearby there are deposits of coal and fields of petroleum, which could be developed in the presence of a good shelter for shipping.

The project proposed the placement of three charges of 20 KT each at a depth of 120 m and two of 200 KT each at a depth of 210 m, having arranged them in the plan as shown in Figure 56. As a result of the simultaneous explosion of these charges, it is proposed to form an entrance channel 550 m long and 250 m wide and a landlocked harbor 840 m long and 420 m wide (Figures 56 and 57). The minimum depth of the harbor will be 9 m. The volume of rock scattered by the energy of the nuclear explosions will amount to 20 million T according to the plan. Later on, the possibility of additional widening of the harbor to dimensions of 900 x 1500 m and increasing the width of the channel to 360 m is provided for.

To carry out the experiment, a deserted coast was selected, working from considerations of reducing the hazard due to radioactive contamination of the terrain. Besides this, for the minimum discharge of radioactive products into the atmosphere and at the surface of the earth, the burial of the charges at a considerable depth, as indicated above, was accepted. In the project it was assumed that the energy of the explosion will scatter only the surface rocks and the greater part of the radioactive products (80--90%) will

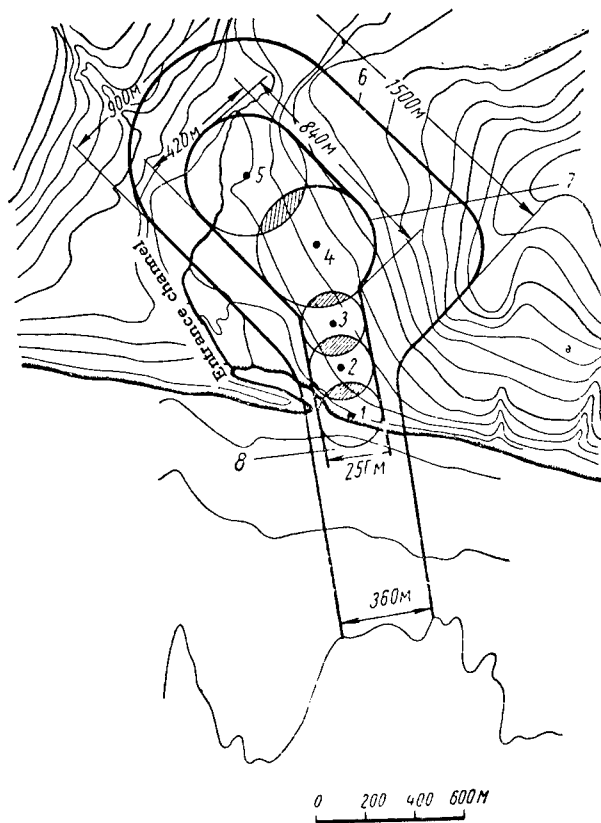

Figure 56. Arrangement of the charges for Project Chariot:

1, 2, 3 -- charges with a power of 20 KT each; 4, 5 -- charges of 200 KT each; 6 -- contour of the harbor after additional widening; 7 -- contour of the channel formed after the explosion; 8 -- entrance channel.

remain stored in the rocks that surrounded the nuclear charges. After the explosion, it was proposed to measure the radioactivity within a radius of 160 km and renew operations in the vicinity of the location of the explosion after two weeks.

Beginning in the middle of 1959, in the vicinity of the future harbor, geological, meteorological, ecological and oceanographic investigations were conducted. At individual periods up to 140 specialists from the AEC and other governmental institutions of the USA were engaged in this work.

Initially it was proposed to carry out Project Chariot in 1960. But as the surveys continued, doubts arose about the possibility of accomplishing it safely for the surrounding biosphere, and the time of its accomplishment was repeatedly delayed. In the summer of 1962 the AEC decided to delay the conduction of the given experiment for an indefinite period because of the protests of the local inhabitants (Eskimos), who considered that nuclear explosions represent a hazard for the population, fauna, and flora of the given region of Alaska [39]. Expenditures on Project Chariot by this time had amounted to about \$4 million.

The Sedan experimental nuclear explosion, set off in July 1962 at the Nevada test area, in the opinion of American researchers, made it possible to obtain an adequate quantity of data on the excavation of the soil and the creation of large diggings. As a consequence of this, the setting off of the Project Chariot explosions now is of lesser significance from the standpoint of studying the effects of nuclear explosions of great power for blast effect.



Figure 57. Overall view of the Project Chariot harbor for seagoing vessels.

A detailed description of the Sedan experiment is given in Chapter 11. According to a communication by Kelly [3], a nuclear charge with a power of 100 KT was exploded in the Sedan experiment (with the fraction of the energy obtained by the fission reaction being less than 30%, and that obtained from the fusion reaction being more than 70%),

placed at a depth of 193 m from the surface, in alluvial rocks, through a drilled hole with a diameter of 914 mm. The actual parameters of the blast crater formed by the explosion in comparison with those calculated in accordance with two variations of the dependence W of the power of the charge are given in Table 25.

Table 25

Calculated and Actual Parameters of the Apparent Blast Craters in the Sedan Shot

Parameters of crater after explosion	Calculated		Actual
	Variation I $(d,h)=f(W^{1/3})$	Variation II $(d,h)=f(W^{1/4})$	
Diameter d, m . . . . .	425	365	365
Depth h, m . . . . .	90	52	97

The rocks discharged fell within a radius of 4 km from the epicenter of the explosion, and the height of the rock pile around the crater varied from 60 to 30 m.

The Sedan experiment was very successful from the standpoint of the blast effect: the explosion removed 5.1 million m<sup>3</sup> of earth. From this index, the technical possibility of the construction of harbors (or canals) by means of nuclear explosions was proven. Later on, it will be necessary to refine the calculated sizes of the craters in soils and rocks of different characteristics, and also to solve the major problem of the given method of harbor construction -- safety from the standpoint of radiation effect. A comparison of expenditures of the creation of a harbor in hard rock by conventional methods and with the application of nuclear explosions [14] will make it possible to judge the economical nature of the method proposed.

Let us assume that a harbor must have a maneuvering basin with a diameter of 800 m and an entrance channel 1400 m long and 370 m wide. By the explosion of a charge with a power of 1 MT, laid at a depth of 50 m, a basin of the indicated diameter is formed, with a depth of 150 m. An explosion of four charges with a power of 100 KT each, laid at a depth of 20 m, would create a channel of the dimensions indicated, with a depth of 70 m. Altogether, the nuclear explosions would remove 100 million m<sup>3</sup> of rock. The cost of



these operations, according to calculations, would amount to 5 million dollars, i.e., each cubic meter of earth removed would cost 5 cents.

In a case of the performance of the operation by conventional methods, the total volume of a cut with a depth of 20 m would amount to 20 million  $m^3$ . However, the fragmentation of the rocks by means of drilling and blasting and removing them with excavators would cost considerably more than in the first case. The total expenditure would amount to \$2 per cubic meter of rock, or 40 million dollars for the entire volume. In more remote regions the cost indices would be several times as much. Thus, the creation of a harbor by nuclear explosions would be much cheaper than in a case of its construction by conventional methods.

#### THE CONSTRUCTION OF CANALS FOR SEAGOING OR RIVER VESSELS

With the arrangement of several nuclear charges intended for external effect in one line under the earth, as a result of their combined explosion for a blast effect, a channel may be formed for seagoing or river vessels. Johnson and Brown [35] indicate that nuclear charges with a power of 100 KT each, arranged in one row at intervals of 360 m, at a depth of 15 m from the surface, would form a canal 360 m wide and about 1.5 km long during the explosion.

In the USA several specific plans for the construction of canals by means of nuclear explosions are being studied. Among them we may mention first of all the entrance channel to the harbor for seagoing vessels at Cape Thompson in accordance with Project Chariot. There is a proposal for the construction of a river canal in the south of the USA, with the application of nuclear charges, which is to connect the Tennessee River with the Tombigbee River, emptying into the Gulf of Mexico. As a result of eight explosions with a power of the order of several kilotons each, it is supposed to remove about 70 million  $m^3$  of earth and to form a canal 56 km long<sup>1)</sup> passing through thinly populated terrain of Tishomingo County between Eromori in the state of Missouri and Pickwick Pool in the state of Alabama. It has been calculated that the use of nuclear charges would make it possible to save 20--30 million dollars in the construction

---

<sup>1)</sup> We have in mind the total length of the canal, including sections of existing routes, where the application of nuclear explosions is not foreseen.

of the canal, and to reduce the total cost of the work to 240 million dollars.

After the Sedan experiment was carried out, in the USA interest in the use of nuclear explosions in the construction of large hydraulic-engineering structures, especially new canals, rose considerably. In the American Senate, a proposal was introduced to study the problem of the construction of a second canal across the Isthmus of Panama with the use of nuclear explosions. It is expected that already by 1975, because of the growth of marine transportation, the existing Panama Canal will not be able to provide for the passage of all vessels even with continuous traffic in two directions. According to preliminary calculations, the construction of a second canal by means of nuclear explosions will make it possible to finish it in half the time and at a third of the cost required by conventional methods. It is proposed to route the new canal along the border between Panama and Colombia: either on the territory of Panama (the Sasardi-Morti route), or on the territory of Colombia (the Atrato-Truano route). In both cases, the mountainous relief of the terrain in the central part makes a transition to a swampy plain at the seacoast [41]. The reality of the accomplishment of such a project, again, depends upon a guarantee of the safe detonation of underground nuclear explosions in the given region.

The Atomic Energy Commission, together with the Corps of Engineers of the U.S. Army, is studying the possibility of the construction of other canals to connect navigable waterways, by means of nuclear explosions. In this case they have in mind a reduction in the expenditures on the work indicated in comparison to conventional methods.

In 1963 it was planned to conduct a new experiment at the Nevada test area to obtain data concerning the possibility of the construction of canals and harbors in group explosions of underground nuclear charges, arranged in the appropriate manner. However, the experiment was put off because of the danger of contaminating the atmosphere with radioactive fragments.

It is considered that nuclear explosions also may be applied to eliminate underwater obstacles for the purpose of improving navigation facilities: the elimination of rapids, deepening the beds of rivers, etc.

#### THE CONSTRUCTION OF EARTH-FILLED DAMS (DIKES)

The given type of structures differs from all the others described in this chapter, since these are not an excavation or an underground cavity, but a fill, formed by means of nuclear explosions. In the USA they are now

studying the following possibilities of the application of nuclear explosions in the construction of large earth-filled dams:

1) for fragmenting the hard rock, with subsequent laying of it in the body of the dam (dike or levee) by the conventional method or for the construction of weirs by explosions for a blast effect.

2) for construction of a dam by a direct fall (landslide) of rock (or soil) of which the steep banks of a watercourse are composed, when it is proposed to dam up the watercourse.

In the first case the problem can be reduced to the working of the construction material (stone or rubble) or to the construction of the route of a weir or spillway (channel) with the use of nuclear explosions. In the second case, it is necessary to solve the problem of directed explosion of the underground charge intended for external effect, or the problem of the given calculated seismic effect of the nuclear explosion, which will cause an earth slide.

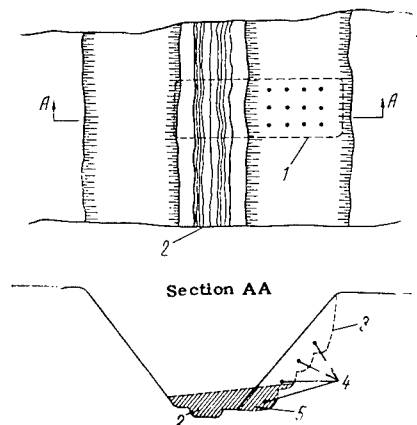

Figure 58. Formation of an earth-filled dam by means of nuclear explosions:

1 -- boundaries of the blasting zone; 2 -- river bed; 3 -- outlines of landslide; 4 -- nuclear charges; 5 -- earth-filled dam.

The construction of dams by the second method is especially feasible because of the high cost of materials

brought in for the body of the dam. The basic condition in this method lies in the fact that the material used (earth, hard rock) must be located above the upper datum level of the future dam, in direct proximity to it.

In their consideration of the problem of constructing dams by nuclear explosions for the purpose of creating landslides, the American specialists are using the practice of the Soviet Union in the construction of earth-filled dams by the use of powerful charges of chemical explosives. In analogy with this practice, it is proposed to use single-row or multi-row placement of the nuclear charges on one of the steep banks of the watercourse as indicated in Figure 58, with the bridging of the river bed by the collapsed rock after the explosion. In the opinion of American researchers, the creation of earth-filled dams with the use of the energy of nuclear explosions for simultaneous breaking up and moving of the rocks is most feasible.



Figure 59. Landslide in the canyon of the Madison River.

However, in the USA proposals also exist for the use of a nuclear explosion as a seismic shock only, which, in turn, would cause the movement of a landslide at the place desired and in the direction desired for the formation of the dam. The given idea arose in connection with the natural landslide which bridged the Madison River near Yellowstone

Park in the state of Montana, in August 1959 (Figure 59 [25]). An earthquake, whose epicenter was located at a distance of about 11 km away, was the cause of the landslide. It has been calculated that a similar landslide could be caused artificially by the explosion of a nuclear charge with a power of 190 KT. Since the main problem for the practical use of nuclear explosions in the construction of dams is the danger of radiation contamination of the surrounding terrain, the latter variation has definite advantages. The application of nuclear charges for initiating a landslide only would reduce the danger of radiation phenomena to a minimum. However, this method cannot provide adequately effective fragmentation or movement of the rock in comparison with directed explosions of charges laid directly in the bank slope.

For practical solution of the problem of the construction of earth-filled dams with the use of nuclear explosions, a program of additional research has been proposed, including experiments with conventional chemical explosives. As the probable region for the construction of the first experimental dams, the hydrographic network of Alaska is proposed, in which up to 15 specific points have been recommended (Lakes Cooper, Grant, Ptamiken, and the Yukon, Copper, Lewis Rivers, etc.). Aside from the construction of earth-filled dams, a proposal has been considered for the elimination of natural landslide dams, or obstructions, which may threaten catastrophic consequences, by means of nuclear explosions.

#### REGULATION OF SURFACE AND UNDERGROUND WATERFLOWS

Underground nuclear explosions create an entirely new opportunity in the field of the regulation of surface and underground waterflows by means of the formation of artificial underground reservoirs and water-carrying structures for the accumulation of water, flood control, and the tapping of aquifers [25, 35].

A thermonuclear charge is evaluated as a powerful and relatively cheap tool of the future, making it possible to construct reservoirs of considerable volume in the places needed. Rougeron [40] reports that the construction of the highest dam in Europe, on the upper reaches of the Nest River (France) lasted for seven years. In this case, a reservoir with a volume of 65 million  $m^3$  was formed. A crater of such a volume could be created by the underground explosion of a nuclear charge with a power of 700 KT, in considerably shorter periods of time and with lower expenditure.

The construction of artificial underground water-accumulating zones by means of nuclear explosions may pursue different goals:

1) the regulation of the regimes of rivers by means of an artificial underground reservoir for the diversion of the water in a case of flooding. Water from this reservoir can move along the aquifers (Figure 60) [35] or be accumulated for further use (irrigation or the generation of hydroelectric power);

2) providing hydroelectric power-generating systems with cheaper reservoirs instead of costly reservoirs created by conventional methods. In this case, the explosion crater can be used as a new variation of water system, when the generation of electric power will be accomplished along the entire route of the fall of the water to a level that is considerably lower than the river level or sea level. Rougeron [40] considers that hydroelectric-power stations in absorption craters, where the water head will reach several hundred meters, can be considered among the most profitable;

3) creation of water-permeable sections for feeding aquifers with surface waters (Figure 61) or with the ground waters from neighboring geological structures (Figure 62) [25]. We may, for example, destroy a river bed so that the water can seep into a collector stratum. By means of such artificial collectors, located at various depths from the surface, we may remove potable water from the region where it is used to a region that is short of water. In another case, an underground collector may serve for removing brackish or contaminated river water to a region where it will not pollute potable water.

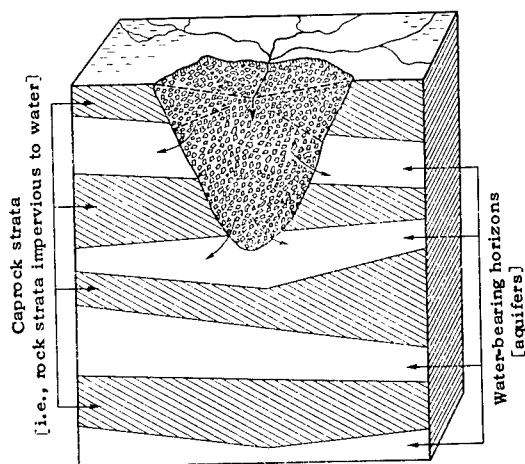

Figure 60. An underground reservoir formed by a nuclear explosion.

In the opinion of American researchers, the application of nuclear explosions may have a considerable effect on increasing the water resources of the USA, and providing for the better use of them. Simultaneously, they note the shortcomings in the application of nuclear explosions for purposes of water supply, which, aside from the harmful factors of such explosions, include the difficulty of the selection of appropriate territories for carrying out these operations, with a consideration of the effects of the explosions, and also the limited sphere of their effects in comparison to the dimensions of natural geological structures.



Figure 61. Creation of a water-permeable section for feeding an aquifer with surface water:

1 -- caprock; 2 -- aquifer; 3 -- place where nuclear charge is planted.

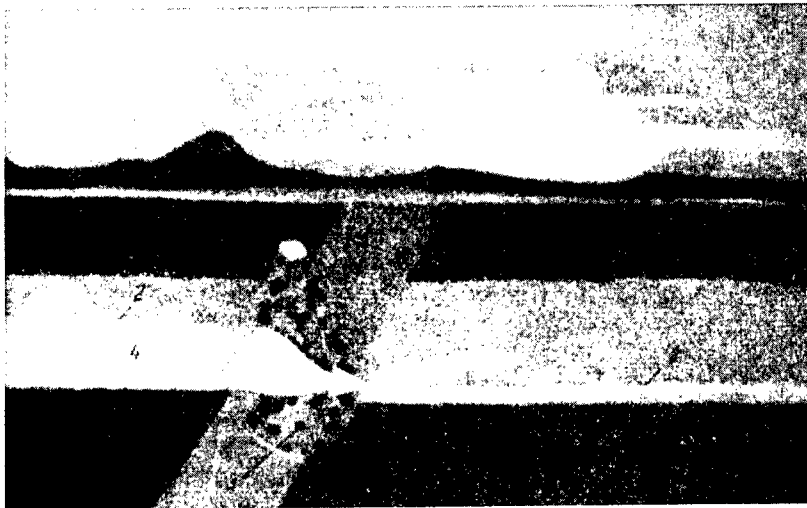

Figure 62. Destruction of a watertight barrier for permeation of an aquifer with ground waters from an adjacent structure:

- 1 -- watertight barrier; 2 -- water table;
- 3 -- place where nuclear charge is planted;
- 4 -- underground flow.

#### CREATION OF UNDERGROUND POL AND GAS STORAGE TANKS

The problem of the use of nuclear explosions for the construction of underground POL and gas storage tanks is considered in detail by Carlson [38]. In recent years, underground storage of petroleum and gaseous hydrocarbons has become more and more widely distributed in the USA because of the simplicity and economy of the given method. Thus, for example, the total volume of underground petroleum and gas storage tanks increased from 1.1 million  $m^3$  in 1952 to 4 million  $m^3$  in 1956, and in subsequent years the expansion of underground storage areas has continued.

Two types of underground petroleum and gas storage tanks exist in the USA, which are of interest from the standpoint of the use of nuclear explosions in their construction:

- 1) underground reservoirs in rocks that are impermeable to water -- with dimensions of 4000 to 40,000  $m^3$ . The total volume of such types of storage tanks has reached 240,000  $m^3$ . In most cases, they are used for propane and butane.



These gases must be stored under high pressure (up to 17--18 atm), because of which the operation of external storage tanks for these purposes costs several times as much as the use of underground storage areas;

2) surface tanks, which are closed by floating metal covers. Leakage of petroleum from them is prevented by regulating the ground-water level (i.e., the water table) under such a consideration that the pressure head of the latter exceeds the pressure head of the petroleum.

An example of such a storage tank is the petroleum storage reservoir built by the Standard Oil Company in an abandoned shale quarry with a volume of the order of 160,000 m<sup>3</sup> and an area of 3.3 hectares for the floating metal cover.

Besides the low cost of construction, underground storage tanks have the following advantages in comparison to external ones: 1) their construction does not require a large consumption of metal; 2) a change in the ambient temperature has practically no effect on the product being stored; 3) the operation of such storage facilities requires only small expenditures; 4) the probability of fires and accidents is reduced; 5) the camouflage is good, which increases the safety of the storage facility in a wartime situation.

In the opinion of American researchers, the use of nuclear explosions for the formation of petroleum and gas storage facilities of both types mentioned is possible, and would allow a considerable saving in comparison to conventional methods. A diagram of an underground storage tank of the first type, constructed by means of a nuclear explosion, is represented in Figure 63 [38]. The nuclear charge, exploded underground in rocks that are impermeable to water, initially formed a spherical cavity; then the arch of this cavity began to collapse, and a reservoir filled with broken rock was obtained. The free intervals between the pieces of rock create the necessary storage capacity for the storage of petroleum or gas. The filling of the reservoirs and loading of tankers are performed by means of two independent pipe lines, placed in the drilled holes.

With a high degree of pulverization of the rock by the explosion and collapse of the arch, the cavity will be filled with fine material, which sharply reduces the volume of the storage tanks, and hampers or makes impossible the withdrawing of the petroleum from it, because of the effect of capillaries and surface tension. In this case, it is necessary to remove the rock that has collapsed into the cavity, which, in turn, is possible only with an external effect of the nuclear charge, i.e., in the formation of petroleum storage facilities of the second type.

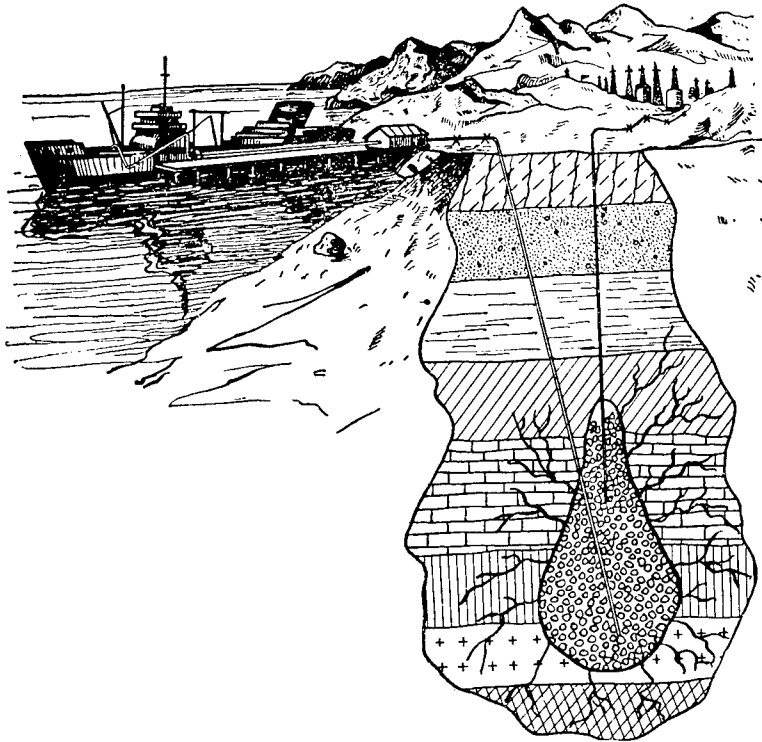

Figure 63. Diagram of an underground petroleum storage facility, created by a nuclear explosion.

In the construction of petroleum and gas storage facilities by means of nuclear charges, as in other cases of their industrial use, special attention must be devoted to the problem of radiation hazard. Explosions for blast effect will be used only in the formation of the crater-shaped storage tank of the second type; in the construction of underground petroleum storage facilities, charges for an internal effect will be used, which excludes radioactive contamination of the earth's surface. For protection against the harmful effect of radioactive products of a nuclear explosion, formed underground, special methods must be developed. Among them Carlson [38] includes: 1) a thorough washing out of the cavity with water under high pressure, for the purpose of removing the greater part of the radioactive products; 2) storage of the petroleum in a contaminated cavity, with subsequent decontamination of it as it is withdrawn from the storage tank; the radioactive particles are removed when passing the petroleum through a system of filters; 3) decontamination of the petroleum during its subsequent

refinement at the refinery, where the radioactivity may be removed together with the bitumen remaining after distillation. The methods listed are proposed as tentative measures. Other, possibly more effective, methods are not excluded.

As a consequence of the flammability of petroleum and petroleum products, attention must be paid to the temperature regime in the cavity. Data from the Rainier shot indicate that in a medium with a high moisture content the temperature falls rapidly (in the Rainier shot the temperature in tuffs with a water content of 15--20% by weight rapidly decreased from 1300 to 100°C). In a medium with a low moisture content, such as granite, for example, high temperatures, probably, will be preserved during a more prolonged period of time. Nevertheless, this problem is not especially serious. The ignition and vaporization temperatures of the product being stored are known precisely, and therefore the operation of the storage facility must begin after the temperature in the cavity has decreased to safe values. If the temperature in the cavity is very high, or the time factor is of decisive significance, the cavity can be cooled by feeding water into it.

Table 26

Volumes and Cost of Construction of Underground Petroleum and Gas Storage Tanks as a Function of the Power of the Nuclear Charge, in Kilotons

Indices	10	100	1000	10 000
Cost of nuclear charge, including expenditures for its planting, millions of dollars.....	0,9	1,25	1,75	2,0
Volume of storage tank, millions of m <sup>3</sup> .....	0,11	1,1	11,0	110,0
Expenditures on the construction of a similar storage tank by the conventional method, millions of dollars.....	2,8	28,0	280,0	2800,0
Calculated saving by the use of a nuclear charge, millions of dollars.....	1,9	26,75	278,25	2798,0

It is proposed to set nuclear charges for the formation of underground petroleum and gas storage facilities by means of drilled holes [38]. For a preliminary economic evaluation of the method of constructing underground petroleum and gas storage facilities by means of nuclear explosions, some calculations were performed, the results of which are given in Table 26 [38].

As is apparent from Table 26, the construction of underground petroleum and gas storage facilities by the use of nuclear charges may produce a very great saving, especially when their volumes are increased.

## CHAPTER 8

### THE USE OF NUCLEAR EXPLOSIONS FOR THE EXTRACTION OF PETROLEUM

#### PROJECT OILSAND

The problem of the application of nuclear explosions for the extraction of petroleum occupies an important place in the Plowshare program. In this case, it is proposed to use both the effect of the destruction and fragmentation of the rocks to increase their permeability, and the effect of the heating of large volumes of fragmented rock to reduce the viscosity of the petroleum enclosed in it. In published material, two proposals from the given field are both fully discussed: the experimental explosion in the bituminous sands [tar sands] of Athabasca (Canada), called Project Oilsand [42], and the extraction of petroleum from the Colorado oil shales in the USA [43, 44].

The tar sands of Athabasca, lying in an enormous area, of the order of 40--45 thousand km<sup>2</sup>, and having potential petroleum reserves approximately equal to the world's explored reserves, are not considered to be an industrial field, since so far no profitable methods of working them have been found. Altogether, about 2% of the area indicated is occupied by sections where the overburden rocks are relatively thin, where the development of the sands is possible by means of the open-pit method. The exceptionally high viscosity of the petroleum makes its extraction through wells practically impossible. Out of the many proposals of methods of extracting the petroleum up to the present time, not one has been considered satisfactory.

The Richfield Petroleum Company in 1958 proposed to set off an experimental underground explosion of a nuclear charge, placed under the tar sands in the McMurray horizon, in order to determine whether it was possible to reduce the

viscosity of the petroleum by heating it to an adequate degree for subsequent pumping of it out of zones of broken rocks through drilled wells. The region of the proposed experiment is shown in Figure 64 [42]. The precise coordinates of the site where the well is to be made by placing an explosive charge must be selected after a detailed topographic survey, since they have in mind providing a survey sector of the order of 3--3.5 km, in order to facilitate taking motion pictures of the movement of the earth's surface during the explosion.

A typical geological section in the vicinity of the shot site is given in Table 27 [42] and in Figure 65.

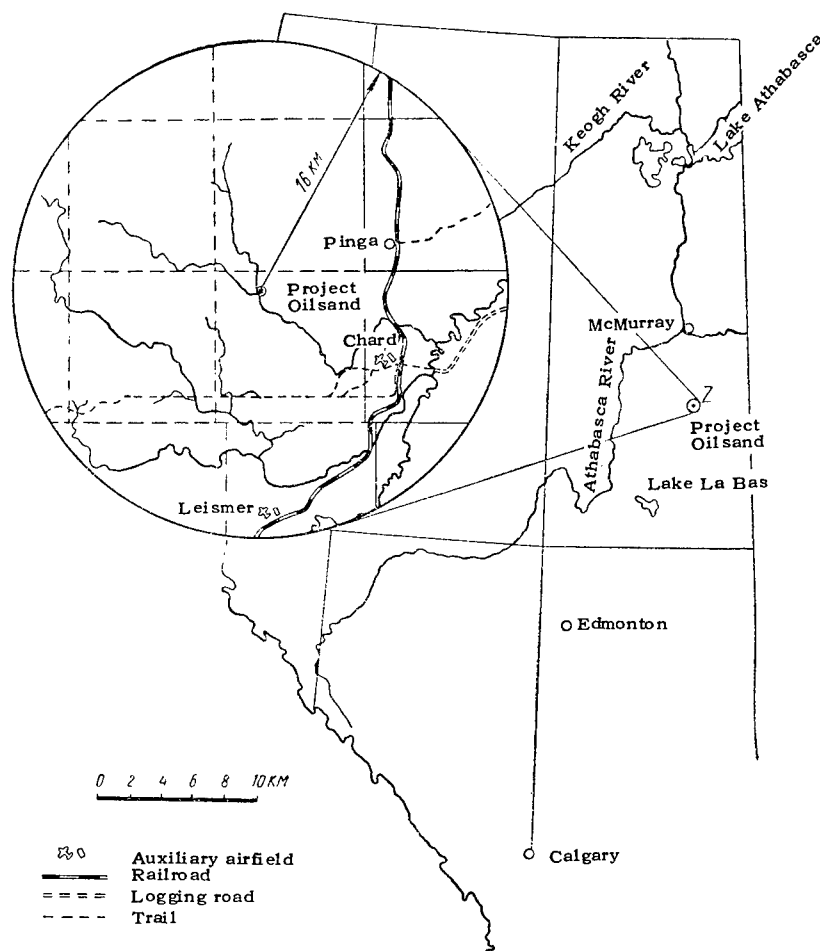

Figure 64. Location of the detonation of a charge in accordance with Project Oilsand.

Table 27

Stratigraphic Column of Rocks of the Shot Site

Depth from surface, m	Rocks (and their age)
0—65	Glacial deposits [drift], chiefly boulders, clay, and uncemented sand (Quaternary)
65—150	Shale and sandstone (Cretaceous)
150—240	Sandstone (Grand Rapids formation)
240—315	Shale and aleurolite (Clear Water formation)
315—365	Oil-bearing sand, aleurolite and shale (McMurray formation)
365—490	Limestone and shale (Beaverhill Lake formation)
490—690	Rock salt, anhydrite shale, and dolomite (Elk Point benches)
690—760	Dolomite (Metsi formation)
760—860	Red shale, rock salt, dolomite (Devonian)
860 and over	Granite and granite gneiss (Precambrian)

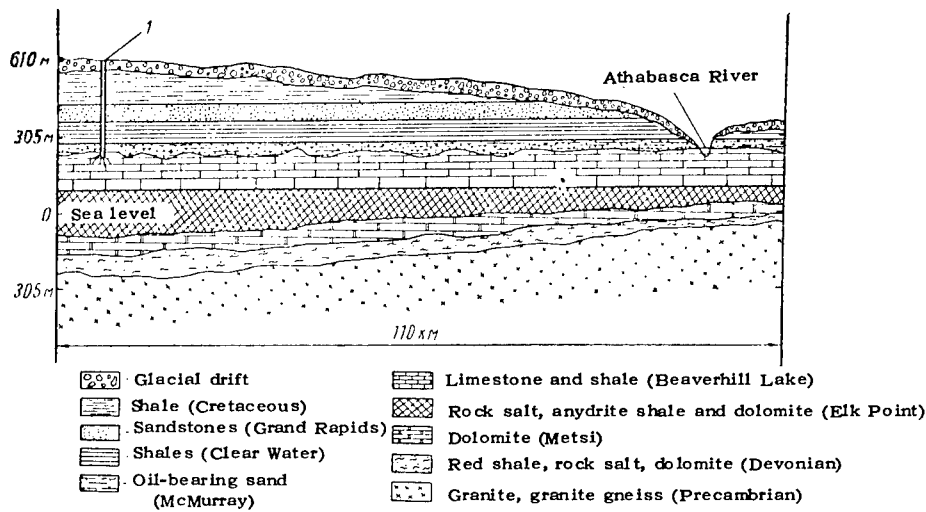

Figure 65. Geological section of the oil-bearing region of Athabasca:

1 -- well for placement of nuclear charge in accordance with Project Oil-sand.

The thickness of the tar sands amounts to 45--50 m, on the average, and in places it varies considerably because of the irregular hypsometry of the underlying limestone.

The sands of the McMurray horizon contain approximately 81% silica, 8% petroleum, 8% water and 3% clay, plus traces of other minerals. Four aquifers are expected: glacial sediments, the Grand Rapids formation, McMurray formation, and Beaverhill Lake formation, with a relatively small flow of ground waters.

According to the project, a nuclear charge with a power of 9 KT is to be lowered into its shot position through a well drilled approximately 15 m below the base of the McMurray formation into the Beaverhill Lake formation. The well would be lined with pipes having a diameter of 965 mm, cemented around the outer perimeter from the mouth to the bottom. The charge would be placed 6 m below the contact between the McMurray and Beaverhill Lake formation. After this, the well would be thoroughly stemmed with the calculation that it would collapse after the detonation of the charge. The stemming would consist of wooden plugs and drilling slurry, alternating with each other.

The limestones of the Beaverhill Lake formation, in which the nuclear charge would be placed, are characterized by the following average chemical content:  $\text{SiO}_2$  -- 13.5%;  $\text{Al}_2\text{O}_3$  -- 3%;  $\text{Fe}_2\text{O}_3$  -- 1%;  $\text{CaO}$  -- 40%;  $\text{MgO}$  -- 0.7%;  $\text{K}_2\text{O}$  and  $\text{Na}_2\text{O}$  -- 1%; and  $\text{CO}_2$  -- 39%.

In a natural state, the moisture content is 6--7% by weight.

On the basis of data from experimental underground explosions, especially Rainier, the following development of the phenomena in an explosion in accordance with Project Oilsand is expected (Figure 66) [42].

Immediately after the explosion of the charge, the temperature around it will increase to several million degrees Celsius and the rocks will vaporize, thus having formed the initial cavity, with a diameter of the order of 2.5 m and a vapor pressure of the order of 30 million atm. Around this cavity a zone of fusion of the rocks will originate, with a radius of about 6 m from the center of the charge. The cavity, expanding radially as a result of the enormous compression of the rocks in the direction of the motion of the shock wave, will reach its maximum dimensions approximately 0.1 sec after the explosion, with a radius of the order of 35 m. The shock explosion wave, propagating further in all directions, will produce disruptions in the rocks within a radius of 120--140 m. The final compression cavity as formed will be filled with gases, and its surface will be



coated with a layer of fused rocks with a thickness of the order of 75--80 mm. The pressure within the cavity will become less than the pressure of the overlying rocks (of the order of 85 atm), and the temperature will be close to the melting point of the complex carbonate medium of the surrounding rocks (1500--2500°C). The lower part of the cavity will be located in the carbonate rocks, and the upper part (approximately the top 30 m) in the oil-bearing shales.

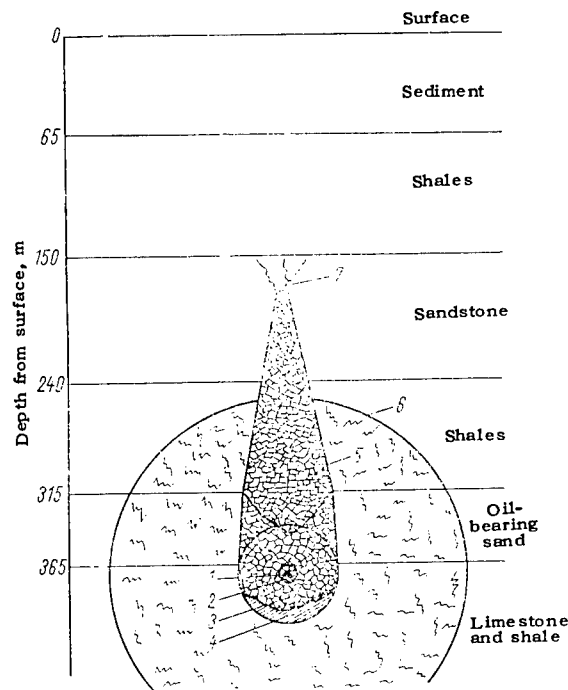

Figure 66. Proposed zone of rock fragmentation by a nuclear charge with a power of 9 KT according to Project Oilsand:

- 1 -- center of nuclear explosion;
- 2 -- initial cavity,  $r \approx 6$  m;
- 3 -- final spherical cavity,  $r \approx 34.5$  m;
- 4 -- cup-shaped zone of sintered and hardened glass-like rock;
- 5 -- tubular cave-in zone;
- 6 -- outer boundary of zone of destruction of the rock,  $r \approx 130$  m;
- 7 -- joints above cave-in zone.

As a result of chemical reactions between the components of the rocks, the shell of the cavity, apparently, will be a mixture of the following compositions (by weight): calcium silicate minerals 36--38%; calcium carbonate, with traces of magnesium carbonate, 28--30%; aluminum oxide and ferric oxide, carbonates and silicates, 28--30%; and other substances 2--4%. Approximately 1 sec after the explosion of the charge, approximately 40% of the total radioactivity of the fission products will be trapped in the gas-filled cavity, and the other 60% in the fused crust. The fused rock will flow downward to the bottom of the cavity, and after congealing will trap within itself the main fraction of the radioactive products. This congealed glassy material, the zone of distribution of which has the shape of a cup, will be located considerably below the McMurray stratum, which will produce the petroleum.

Under the pressure of the overlying rocks, the final spherical cavity, several seconds or minutes after the explosion, will collapse, and will be filled with the fragmented material; the cave-in will gradually extend upward, until such a time as a cone of fragmented rock is formed with a height equal to 2.5--3.5 times the diameter of the final cavity (175--250 m). In the cave-in of the overlying rocks within the cavity, exceptionally high initial temperatures will rapidly decrease, since the water-saturated broken material, because of the redistribution of heat, will provide a general cooling of the zone of the explosion to the boiling point of water.

The heat of the explosion will cause the decomposition of the hydrocarbon gases (to carbon) from that part of the petroleum of the lower bench of the McMurray formation, which is located directly above the initial cavity caused by the explosion. Beyond the limits of the cavity, the petroleum will be subjected to thermic cracking. We may assume that as soon as the oil-bearing sand collapses into the cavity and is heated as a result of heat transfer, the petroleum, heated up to 100°C, will acquire the necessary fluidity and can be pumped out through wells drilled into the collapsed cavity by the ordinary method (Figure 67). According to calculations, in the temperature distribution in a caved-in zone similar to experiment Rainier, a charge with a power of 9 KT will make it possible to remove 12,000 to 14,000 T of petroleum [40]. In this case, it is assumed that out of the total quantity of energy (900 million kcal), up to 50% is liberated in the form of heat, with a temperature of more than 100°C; 40% of the energy will be accumulated in the zone with a temperature below 100°C; and the remaining part of it will be scattered in a low-temperature form.

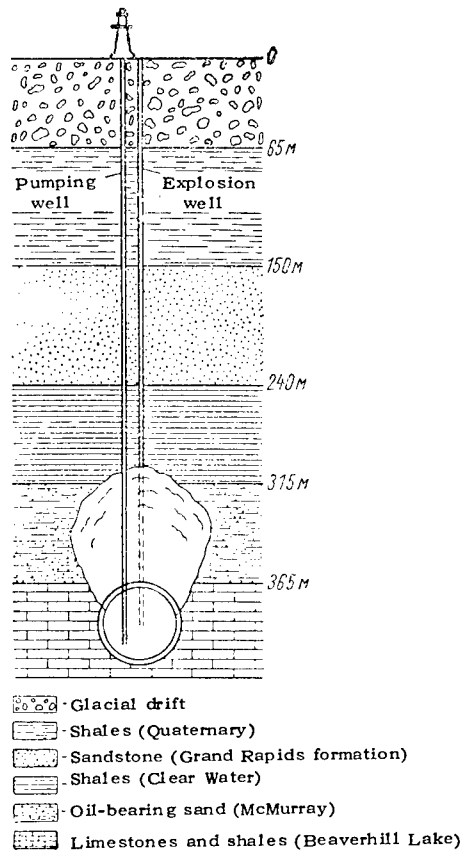

Figure 67. Diagram of the extraction of petroleum from the oil-bearing sands in accordance with Project Oil-sand.

The project provides for measures to eliminate the harmful effects of the nuclear explosion, or to suppress them to the maximum degree. First of all, the depth of placement of the charge is calculated for its internal effect, in order to prevent collapse from extending to the surface, and ensuring that the radioactive products of the explosion will be entirely buried (stored) underground. For this purpose, the depth of placement of the charge must exceed the maximum height of the collapse contour and the vertical joints, developing from its upper end in the direction of the earth's surface. Determination of the safe depth of placement was performed according to an empirical formula (8), as given in Chapter 4,

$$d_{\text{safe}} > 120 W^{1/3} \text{ m,}$$

where  $d_{\text{safe}}$  is the safe depth of placement, m;  $W$  is the power of the charge, KT.

According to this formula, for Project Oilsand,  $d_{\text{safe}}$  must be not less than 250 m. According to the project, the charge is to be placed at a depth of more than 365 m.

The shock waves, having reached the surface of the earth, are expressed in the form of considerable vertical oscillations of the surface. The observers will be able to perceive the explosion at a distance of up to 25 km; at a greater distance, the shock waves can be fixed only by a seismograph. It is assumed that the given explosion will not be able to serve as the impulse for a natural earthquake, since the region where the experiment is to be made is a very stable section of the earth's crust. The radioactivity of the petroleum and the ground waters in the region of the experiment will be a potential hazard. From this standpoint a commission of experts on Project Oilsand considers that [42]: 1) the natural decrease in the initial radioactivity (1 sec after the explosion) will occur quite rapidly, according to the function  $f(t^{-1.2})$ , after 1 min it will decrease to  $1/36$  of its initial value, and after a year by a factor of  $137 \cdot 10^6$ ; 2) no significant contamination of the petroleum by radioactive products can be expected, since they are distributed chiefly in the congealed fused rocks, pieces of fragmented rock, and the gaseous phase, and can be dissolved in the petroleum in small quantities only; 3) the radioactive materials leached from the congealed fused rocks and the fragmented rock, together with those remaining in the gaseous phase, will, in the final analysis, enter the ground water. The migration of the latter, according to data from surveys in the region of the shot, will occur at a rate of about 1 m per year.

Since the radioactive materials dissolved in the water tend to enter into an ion-exchange process with the minerals of the surrounding rocks, as the underground flows of water move, the rate of movement of radioactivity will be considerably less than the rate of migration of the water. Project Oilsand provides for a widespread program of surveys and observations before the experimental nuclear explosion, during it, and after the explosion. The appropriate samples and measurements will be taken through a series of drilled wells in the vicinity of the experiment.

## THE PROJECT FOR AN EXPERIMENTAL EXPLOSION IN THE COLORADO OIL SHALES

A second proposal for the use of nuclear explosions for the extraction of petroleum concerns the development of the oil shales of the Green River formation, lying in the states of Colorado, Utah and Wyoming. In a natural state, the organic part of the oil shales, called kerogen, consists of amorphous solid particles, practically filling all the pores, and reducing the permeability of the shales to nil. In the heating of the shales to a temperature of 450°C, the organic material decomposes, and above 66% of it by weight is converted to petroleum, 9% to gas, and 25% to coke. The enormous potential reserves of petroleum in the shale have remained almost unused up to the present time, since there are no profitable methods of extracting it. The shales have been developed to an insignificant degree by conventional methods of mining, and a dense waxy kerogen is extracted from it by distillation, which is then used as a fuel.

Specialists of the U.S. Atomic Energy Commission and the Bureau of Mines have proposed the application of nuclear explosions for underground fragmentation of the shales and their distillation on the spot where they lie for the extraction of the petroleum and gas. A project has been compiled for the first experimental explosion in the vicinity of the city of Rifle, in the state of Colorado. This section is located in the south of a large regional deposit of oil shales, known under the name of the Piceance Creek Basin, with an area of more than 3000 km<sup>2</sup> (dimensions approximately 65 x 50 km). Along the southern edge of the deposit lie the shale strata -- Mahogany Ledge -- that are richest in petroleum, and have a thickness of from 24 to 60 m. The content of organic matter in this stratum varies from 8 to 40% by weight, which is equivalent to a petroleum content of from 58 to 285 % per ton of shale. Directly over the point where the nuclear charge would be planted, the yield of petroleum would exceed 90 % per ton of shale. A silicon content of the order of 35% in the shales makes it possible to calculate on the capture of the greater part of the radioactive products of the explosion by the fused silicate rocks. The water saturation of the shales is very low. The resistance of the shales to compression amounts to 1050--1750 kg/cm<sup>2</sup> (the tuffs of the Nevada test area have a strength of 350--700 kg/cm<sup>2</sup>).

It is proposed to explode the nuclear charge in a chamber made in a blind adit, having a length of about 450 m and cut into the stratum of shales from the rocky slope on the surface. The charge will be covered by a stratum of

rocks of about 275 m along the vertical and, considering the considerably greater strength of these rocks than that of the tuffs of the Nevada test area, a complete camouflet effect is calculated. In rocks analogous to tuffs in properties, the zone of destruction must have a radius of the order of 60--90 m. Considering that the shales are twice as strong as the tuffs, the U.S. Bureau of Mines considers that the radius of the zone of destruction of the shales will amount to 30--60 m. Working from the least magnitude of this radius and from the assumption that the cave-in cone will have a slope at an angle of 45° to the horizontal, the probable volume of the destruction of shale is calculated to be of the order of 300,000 T. More than half of this fragmented mass will be located above the center of the explosion, and these shales will be highly permeable to water. However, it is impossible to calculate the degree of fragmentation in advance, because of the lack of data.

According to the calculations, the thermal energy of a 10-KT explosion will provide for heating the shales up to the melting point of the organic matter (about 450°C), and more than 20,000 T of petroleum and of the order of 280,000 m<sup>3</sup> of gas will be obtained by means of this factor. After the explosion, by drilling survey wells the geometry of the zone of fragmentation and destruction of the shale will be determined, the nature and dimensions of the joints will be fixed, and core samples and samples of petroleum and gas will be obtained for laboratory analyses.

When the contours of the zone of destroyed shale are refined, the authors of the project expect to propose the final method for underground distillation of the petroleum. In principle, this process will consist of the following: several wells will be drilled, and some (or one) of them will serve later on for forcing in air, in order to maintain the underground combustion, and others (or another) for pumping out the petroleum and gas. Then, as a result of artificial ignition a combustion front will be created in the fragmented shale; the part of the shale containing carbon will be used as a fuel, and also, partially, the gas and petroleum. The underground flame front thus originating will be maintained and controlled by the air pumped in and by the gaseous products of the petroleum. The combustible gases formed in the burning of the petroleum will force the liquid fraction (petroleum and water) out to the production wells. It is assumed that by means of distillation up to 25,000 T of petroleum may be obtained from the region of an experimental 10-KT explosion (besides 23,000 T obtained from the heating of the shale directly by the heat of the explosion).

The experts of the U.S. Bureau of Mines consider that the extraction of petroleum in this experimental section, and also on an industrial scale if the results of the experiments are favorable, may be accomplished by three methods of underground distillation: 1) ignition of the shales in the upper part of the zone destroyed by the explosion, with petroleum forced under it and forced out from the lower part, through wells of the appropriate depths, or through underground galleries excavated under the zone; 2) the ignition of the shales in the lower part of the zone destroyed by the explosion, with the forcing of the petroleum upward and by means of pumping it out through wells drilled from the surface into the upper part of the zone; 3) the ignition of shales in the center, with the petroleum forced out to wells drilled around the periphery of the zone destroyed by the explosion. Total expenditures to make the experiment are estimated by the project planners at 2.6 million dollars.

In a case of favorable results of the given experiment, it is proposed to use more powerful nuclear explosions for extraction of the petroleum from the shales. Thus, for example, it is calculated in the explosion of a 1-MT charge set at a depth of 900 m from the surface, up to 50 million T of shale may be broken up and more than 4.5 million T of petroleum extracted. Such a scale of extraction is comparable to the productivity of contemporary large petroleum fields of the USA.

We should note that some American specialists sharply criticize the idea of using nuclear explosions for extracting petroleum from bituminous shales. President Huntington of the RNB Corporation protested to the Atomic Energy Commission against the project for exploding a 10-KT charge and the idea of exploding a 1-MT charge [45]. He based his objections on the fact that at a temperature of more than 760°C from each ton of petroleum up to 60 kg of carbon dioxide gas is liberated, and if the petroleum obtained from the shales is rapidly heated up to 1100°C, it will entirely decompose, and the pressure of the gases formed would be of the same order of magnitude as it would be after an explosion of dynamite, i.e., of the order of 3500 kg/cm<sup>2</sup>. With a consideration of this, an explosion at a depth of 300 m would lead to a considerable discharge of rock and radioactive products. In this case, no petroleum would be obtained in industrial quantities. In the opinion of Huntington, to prevent an external effect of the explosion of a charge with a power of 1 MT, intensified by the effect of the gases from the decomposition of the petroleum, it would be necessary to place the charge at a depth of approximately 16 km. The AEC did not consider that Huntington's fears were well-founded.

In spite of the fact that since the discussion of the project for the extraction of petroleum from the shales by the explosion of a 10-KT charge more than 6 years have passed (the meeting was held with participation of the AEC, the Lawrence Radiation Laboratory, and the petroleum companies, and was held in January 1959), up to the present time no practical steps have been taken for the accomplishment of this experiment.



## CHAPTER 9

### THE USE OF NUCLEAR EXPLOSIONS FOR THE GENERATION OF POWER

The enormous quantity of heat liberated by a nuclear explosion at super-high temperatures, in the opinion of American specialists, could be used for the industrial generation of thermal and electric power [35]. There are several electric power stations in the world operating on natural underground thermal energy. The largest of them is located at Larderello (Italy) and has been operating on volcanic thermal energy since 1940. The capacity of this electric power station has been brought up to 300,000 kW. In New Zealand, at a natural hot spring in the volcanic region of Wairakei, an electric power station and a steam plant for production purposes have been built.

It is proposed to use industrial experience in electric power stations operating on natural underground heat in the generation of electric power from nuclear explosions. If we create a large hermetically sealed cavity underground, the energy of a nuclear explosion may be used to generate steam, with a high pressure and temperature.

Two methods have been proposed for bleeding off the heat: 1) setting off nuclear explosions underground with subsequent bleeding of the heat from the fragmented rocks; 2) setting off nuclear explosions in special capsules, localizing the energy of the explosion in a small volume, with the heat bled from the surface of the capsule.

In the first case it is considered very important that the rocks in the zone of the explosion be practically free of water. It has been calculated that the energy liberated in an explosion of a 1-KT charge in the salt formations of the Colorado plateau can heat 3000 T of salt to a temperature of 655°C. At such a temperature salt fuses. A charge of 1 MT can fuse 3 million T of salt in a sphere with a diameter of 180 m. The heat from such a thermal reservoir could be

extracted by forced circulation of a liquid or gaseous coolant, such as water or carbon dioxide, for example, and used to generate electric power at the surface. In an explosion in limestone or dolomite, an enormous quantity of carbon dioxide may be formed, and this gas can serve as a direct coolant [i.e., heat carrier]. Besides this, additional thermal energy may be obtained from calcium oxide during its reaction with water.

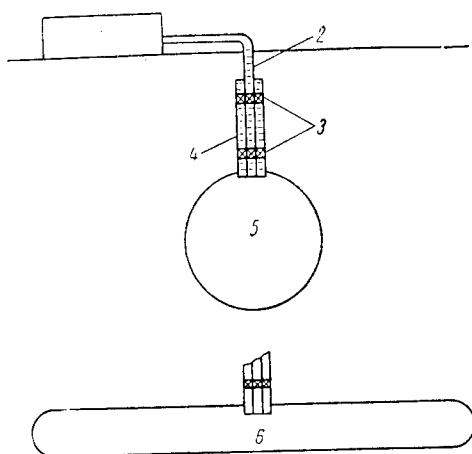

Figure 68. Diagram of an underground nuclear power station:

1 -- turbo-generator; 2 -- inner pipe line; 3 -- cut-off valves; 4 -- outer pipe line, filled with water; 5 -- spherical cavity formed by nuclear explosion; 6 -- cylindrical cavity formed by nuclear explosion (possible variation).

On the basis of the study of methods of designing the closed systems of reactors and investigations of the properties of soil, Porzel [46] has made hydrodynamic calculations according to which the pressure zone developed by a charge with a power of 1 KT may be limited in a sphere with a radius of 300 m. The fact that almost all the energy is enclosed in the relatively thin layer of rock surrounding the explosion cavity is of great interest. About 99% of the energy is stored in the cavity and shell with a thickness of  $3.3 W^{1/3}$  m, where  $W$  is the power of the charge, in kilotons;

from this fact, two conclusions were made: 1) the energy (power) is stored in a relatively small volume and it may be used for practical purposes; 2) the seismic energy amounts to an insignificant fraction of the total energy of the explosion.

The principle of generating steam by means of the energy of a nuclear explosion, for generating electricity, is illustrated in Figure 68. A pipe line serves as a channel for bleeding heat from the cavity. It is filled with water before the explosion is set off. We may assume that because water is practically incompressible (in comparison to rocks) the pipe line will not be ruptured during the explosion. The energy of the explosion, at the moment of the passage of the shock wave along the column of pipes, will strive to discharge the water. The pipe line consists of two columns -- an outer one and an inner one. The water plays the part of a protective jacket for the inner column. Such a design makes it possible to maintain a high pressure. The outer column protects the system against any mechanical effect from the side of the walls of the well.

In order to prevent water from getting into the cavity formed at the moment of the explosion, cut-off valves are built into both columns. After the explosion, the cut-off valves are opened, and the water from the inner column is released. The column of pipes is lowered to the explosion cavity. Water is fed through the inner column, which has a diameter of 25 mm, at a definite rate, and this water is transformed into steam in the explosion cavity. The steam formed is fed to the surface through the outer column, which has a diameter of 150 mm. At the surface the steam passes through a special heat exchanger and is used for operating a steam drive (turbine) for an electric generator. A condition of the creation of a thermal station in accordance with the given principle is the preservation of the cavity after the explosion, which, in practice, is especially difficult to accomplish.

As a result of the pressure drop at the walls of the cavity, stresses are created that considerably exceed the limits of strength of the rocks. Radial joints and the weight of the overlying rocks lead to the destruction of the roof and walls of the cavity. Porzel [46] considers the possibility of the formation of a cylindrical (elongated) explosion cavity, which is more stable than a cavity of spherical shape. An attempt to accomplish the idea of using the thermal energy of the explosion was made in Project Gnome.

Porzel [46] considers a method of obtaining heat in capsules localizing the energy of the explosion. On the basis of an investigation of hydrodynamic principles it was established that the energy of an explosion may be enclosed in a

container (capsule) of finite dimensions, filled with the appropriate material: an absorbent. The least dimensions, and at the same time the most feasible dimensions, of the capsule would be those in which almost all the material enclosed within the limits of the containing shell would make the transition to a gaseous phase in vaporization. The liberation of energy in a larger quantity than would be required for vaporization would cause superheating of the steam, which leads to a sharp increase in the hydrostatic pressure. Porzel [46] defines the minimum spherical volume necessary for localization of the energy from the expression

$$\frac{4}{3} \pi R^3 \rho H,$$

where R is the radius of the capsule;  $\rho$  is the

density of the absorbent; H is the total heat of fusion, heat of boiling, or latent heat of vaporization.

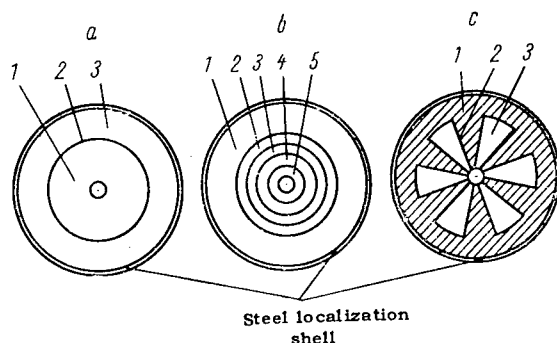

Figure 69. Diagrams of capsules for localization of the energy of a nuclear explosion (central circle is the nuclear charge):

- a) 1 -- dense materials; 2 -- boundary of vaporization; 3 -- porous materials; b) 1 -- sand; 2 -- water; 3 -- concrete; 4 -- glass; 5 -- steel; c) 1 -- porous material; 2 -- dense material; 3 -- expansible cavities.

For filling the capsule, materials with a high density and a high heat of vaporization are necessary. For this purpose, a number of known materials may be used, such as, for example, a glassy silicate mass, or steel. However,

graphite appears to be most appropriate because of its properties. The total heat of vaporization of graphite amounts to 13,000 cal/g, of which an amount of the order of 10,800 cal/g is the latent heat of vaporization. With a strong degree of heating, graphite accumulates considerable quantities of heat: in a case of an increase in the temperature from room temperature (20°C) to its boiling point (4000°C), of the order of 2000 cal/g, and if it is heated up to the melting point (3500°C), of the order of 1600 cal/g.

With the thermophysical quantities indicated, and with graphite's density of  $2.25 \text{ g/cm}^3$ , the minimum possible radii of localization of  $10^{12}$  cal of energy liberated by a 1-KT explosion, excluding the shock waves, according to Porzel's calculations come out to the following for the zones indicated: vaporization of graphite 2 m; fusion of graphite with a temperature close to the boiling point 3.8 m; with a temperature close to the melting point of graphite, 4.1 m.

Models of capsules are shown in Figure 69. In the model represented in Figure 69,a, only one type of material is used, analogous to graphite in its properties: around the charge the material is dense, and beyond this level it is porous. The model given in Figure 69,b is made up of different materials (steel, glass, concrete, water, sand), which are arranged in accordance with pressure levels. In the model represented in Figure 69,c, a method is shown of scattering the gas bubble in the dense material for a case when the dimensions of the capsule are decreased to the critical dimension. A simple scheme for bleeding heat from a capsule is shown in Figure 70.

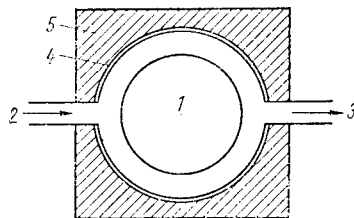

Figure 70. Capsule heat exchanger of an electric power station (thermal station):

1 -- capsule (radius of several meters); 2 -- cold liquid; 3 -- heated liquid; 4 -- hermetically sealed casing; 5 -- insulating block.

The transformation of the energy of a nuclear explosion into thermal energy in an insulated capsule has the following advantages in comparison to other methods of obtaining heat from nuclear power: 1) the radioactive fragments trapped and insulated in the rigid sphere rapidly decay, are almost entirely self-absorbed by the capsule, and directly facilitate the development of thermal power; 2) the capsules may be exploded underground or in a special area, excluding the risk of accidents and disasters at thermal stations and providing for localization of the first flare-up of radioactive fission products; 3) no strong pressure is developed in the capsule, and a short time after the explosion the outer shell is not even necessary; 4) the capsules may be transported and stored for a relatively long period of time, before the energy is bled from them; 5) with the exception of the charge itself, there are no moving parts in the capsule, or electronic devices or other complicated fittings, which simplifies the designing of the source of thermal energy; 6) the high temperatures and pressures originating during the nuclear reactions are a special advantage in the use of a thermonuclear charge as the source of energy in the capsules; 7) for the creation of a source of energy, no great capital expenditures are required (as would be needed in a case of a power reactor).

The shortcomings of the method of explosions in capsules include: 1) probably it would be required that pure thermonuclear charges with powers in the kiloton range be used in capsules, if they are used in distant regions or at temporary sites; 2) each capsule may be used only once, and the material contained in it must be considered as burning fuel; 3) the hermetic sealing shell of the capsule requires great expenditures.

## CHAPTER 10

### THE USE OF NUCLEAR EXPLOSIONS FOR SCIENTIFIC PURPOSES

The possibility of the use of nuclear explosions for performing scientific experiments is discussed in several works [6, 11, 23, 24, 47]. Experiments have been proposed for the investigation of cosmic space and the structure of the earth, obtaining isotopes, in particular the trans-plutonium elements, measurement of neutron resonances, etc. Some experiments have already been accomplished during the tests of nuclear weapons. It is proposed to perform others in the Plowshare program.

First of all, nuclear charges may be used for the production of transplutonium isotopes [23, 47].

Atomic explosions based on the fission reaction form  $2 \cdot 10^{23}$  neutrons per kiloton of the charge and create a flux that may be used for the activation of internal targets,  $10^{23}$  neutrons/(sec  $\cdot$  cm<sup>2</sup>). In thermonuclear shots, approximately 10 times as many neutrons are formed, and internal fluxes with an intensity of 10--20 times as much as in the explosion of a charge based on the fission reaction. Such fluxes are many orders of magnitudes higher than may be obtained at the present time by laboratory methods.

The discovery of einsteinium (atomic number 99) and fermium (atomic number 100) is associated with the first thermonuclear explosion, detonated in 1952 over the Pacific Ocean. This explosion was intended for military tests, and the samples of new isotopes were obtained in small quantities.

In applying a specially designed system in an underground explosion, in one explosion we may produce and extract milligrams of californium-252. At the contemporary state of nuclear engineering, several years would be required to obtain such a quantity of this rare isotope in a reactor. The effective half-life of californium-252 is 2.2 years (97% alpha-decay and 3% spontaneous fission) and the half-life of the portion due to spontaneous fission is 66 years. This

property makes the given isotope the only laboratory source of fission neutrons and fission fragments of its kind. Besides, with the appropriate design measurable quantities of an isotope with the mass number of 270 may be produced and determined, which as it is proposed, will be stable with an atomic number of element 104.

Nuclear explosions may also be used in investigations in neutron physics. Over the past 10 years, the measurements of neutron resonances, associated chiefly with the development of theory of the nucleus, have made it possible to obtain fundamental data on the neutron cross sections for the designing of reactors. In experimental techniques in the USA, various sources have been used for the production of neutrons. Hughes [47] has compared several methods of obtaining neutron fluxes used in the past with a nuclear explosion, which may also be used as a neutron source.

The largest designed reactor for continuous operation in a subcritical regime will produce  $3 \cdot 10^{20}$  neutrons per year. Such a powerful source must operate for 3000 years in order to produce the quantity of neutrons formed as the result of one nuclear explosion of 10 KT in power.

Similar results are obtained in the comparison of nuclear explosions with the productivity of a fast neutron selector. A nuclear explosion, forming  $10^{24}$  neutrons, with the appropriate moderation will create a flux of the order of  $4 \cdot 10^{10}$  neutrons/(sec  $\cdot$  cm<sup>2</sup>) in the interval of energy of from 1 to 10 electron-volts at a distance of 100 m. According to calculations it has been established that at Chalk River in the new NRU reactor, with the Brookhaven fast-neutron selector, we may, in the same interval of energy, and at the same distance, obtain  $10^7$  neutrons/cm<sup>2</sup> per year. Thus, the fast neutron selector at Chalk River must operate continually for 4000 years in order to provide the flux originated in one nuclear explosion.

Working from these considerations, Hughes [47] compiled a plan for an experiment on the basis of the use of a 5-KT explosion in accordance with Project Gnome as a source for the measurement of neutron resonances. Some information concerning the design of the installation and the first data obtained are given in the description of the Gnome experiment (Chapter 11).

In the process of accomplishment of a series of nuclear tests in 1959, Cowen, in one of the explosions, measured the effective fission cross section of uranium-235 nuclei as a function of the neutron energy. He used the following device: a ring made of uranium-235 was placed on a flywheel rotating at a high speed behind a collimator slot during the



explosion. The flight trajectory of the particles amounted to 30 m. After the explosion the flywheel was removed and the radioactivity of the ring was measured by radiometric and radiochemical methods. The quantities of the corresponding isotopes, such as  $\text{Ag}^{111}$  and  $\text{Mo}^{99}$ , obtained were compared with the ratio of these elements calculated as a function of the energy. A comparison of the results of both methods made it possible to obtain accurate data about the effective cross section of the atomic nuclei of certain elements. Having performed this experiment successfully, Cowen proposed that a similar experiment be made with a higher resolution during the Gnome shot, using a flight trajectory in a vacuum with a length of 300 m.

By a similar method, Lindner proposed to measure the capture cross section of neutrons of various isotopes during the accomplishment of Project Gnome.

In the study of the internal structure of the earth, a great part of the information is based on the analysis of signals caused by earthquakes. Proposals have been made to use nuclear explosions, conducted for the purpose of weapons tests, as a source of seismic signals [48]. In 1955 Bullen proposed that several nuclear explosions be set off for seismic purposes. The explosions of four bomb tests held in Central Australia in 1956 were used to obtain the first valuable information concerning the depth of the Mohorovičić discontinuity.

The possibilities of the application of nuclear explosions for seismic purposes are very wide. The principal uncertainties of conventional seismology, which depends upon earthquakes, are time, the source of the energy, and also the location and depth of the focus of the generating source. In a nuclear explosion, as a source of seismic signals, the location and time of the explosion and the quantity of energy liberated can be accurately controlled. The instruments needed may be reliably installed and calibrated before the explosion and after it. An analysis of the time curves of the run (hodographs) can provide more detailed information concerning the structure of the earth, since the source of the signals is precisely known. Recording installations may be placed in the proper places, and the seismologist will be able to depend on other sources than the natural signals arising from active seismic regions.

Antarctica is a region in which a nuclear explosion may be effectively used as a source for obtaining valuable information. This region is aseismic. A nuclear explosion, set off in the ice of Antarctica at a depth adequate to prevent the discharge of radioactivity into the atmosphere, would provide data concerning the average distribution of the

thickness of the ice, the distribution of the land under the ice, and the thickness of the earth's crust. With an adequately powerful explosion (100 KT) the signals would be propagated throughout the entire globe. This would make it possible to obtain information concerning the structure of different sections of the earth.

## CHAPTER 11

### EXPERIMENTAL EXPLOSIONS UNDER THE PLOWSHARE PROGRAM

#### THE GNOME EXPERIMENT

The first underground nuclear explosion in accordance with the Plowshare program -- Project Gnome -- was set off in the USA on 10 December 1961. This project provided for the explosion of a 5-KT nuclear charge (at first a charge with a power of 10 KT was planned) at a depth of 365 m in the salt beds of the Solado formation in a section located 40 km to the southeast of the city of Carlsbad (in the state of New Mexico).

The salt bed in which the nuclear charge was placed was reached by a vertical shaft having a depth of 365 m. From the base of the shaft, a horizontal approach gallery was cut, with a length of about 350 m, ending in a chamber for the placement of the charge. A diagram of the Gnome experiment and a geological section of the rocks in the region of the explosion are shown in Figure 71 [49].

According to the calculations it was assumed that in the explosion of a nuclear charge in a salt massif, a cavity would be formed, in the shape of a sphere, with a diameter of 33.5 m. About 6000 T of fused salt, with a temperature of 780°C and a thickness of the layer equal to 10.6 m, would be contained in the lower part of the cavity. The cavity formed would be filled with gas (a small quantity) and water (120 T) in the form of superheated steam. The source of the steam would be the water contained in the salt bed. According to estimated data, about 1% of the water, out of the total quantity of it contained in the salt beds in the zone of the effect of the explosion, would be expended in the formation of steam. The collapse of the cavity probably would not occur for a prolonged period of time [12, 13, 50].

The following goals were set in Project Gnome: 1) to study the possibility of the transformation of energy released as a result of the explosion of a nuclear charge into latent

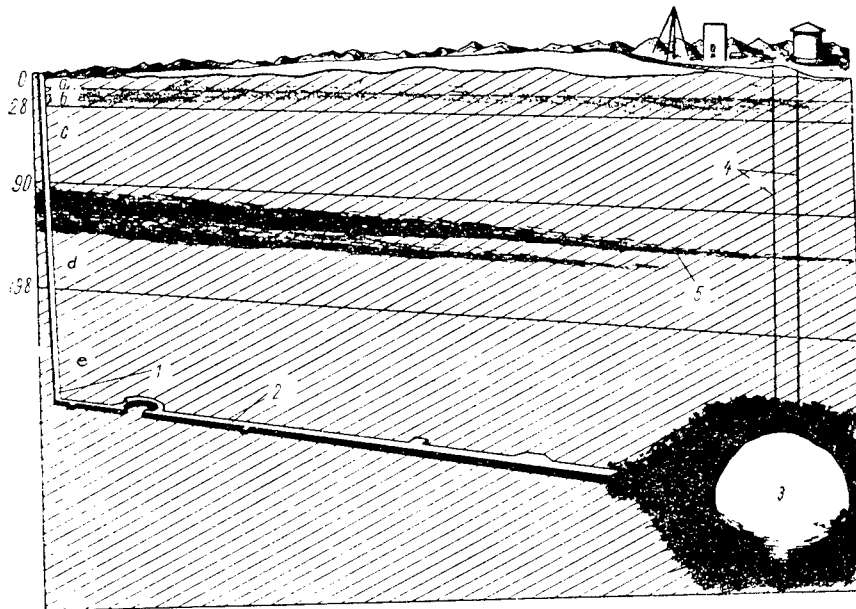

Figure 71. Schematic vertical section of the Gnome experimental section:

a -- sediments; b -- Pleistocene deposits of aleurite [silt] and sand; c -- red-colored deposits of aleurite, sandstone, and Triassic shales; d -- anhydrite, dolomite, limestone, and sandstone, Permian; 3 -- halite (rock salt) of the Solado formation (Permian); 1 -- shaft; 2 -- horizontal galleries at a depth of 365 m; 3 -- cavity formed by the nuclear explosion; 4 -- pipe lines for removal of steam and isotopes; 5 -- aquifer.

heat, with subsequent removal of the water vapor for the generation of electric power; 2) -- to investigate the practicability of the extraction of the radioactive isotopes formed as a result of the underground nuclear explosion, so that they might be used for scientific and industrial purposes; 3) to perform measurements of the neutron cross sections, which would make a considerable contribution to science and would facilitate the accomplishment of the nuclear reactor development program; 4) to establish in what way the effect of a nuclear explosion detonated in a salt bed differs from the effects of nuclear explosions accomplished in tuffs at the test area in the state of Nevada; 5) to obtain data for designing nuclear charges intended for explosions for industrial and scientific purposes [12, 13, 51].

The program for investigating the possibilities of the use of the thermal energy from a nuclear explosion was developed by the Lawrence Radiation Laboratory of the University of California. This program provided for both the determination of the magnitude and distribution of the thermal energy of the explosion in the central cavity and the rocks surrounding it and the study of the problems associated with the extraction of heat from the cavity for the generation of electric power. The injection of water into the explosion cavity was provided for (if this proved to be necessary), in order to bring the steam pressure up to  $8.75 \text{ kg(force)/cm}^2$ , with subsequent controlled generation of steam and its delivery to the surface. The power plant for obtaining electric current by means of steam has not been designed. The experiment was to be limited to a thorough study of the characteristics of the steam (pressure, flow velocity, the contaminants contained in it). It was proposed to collect the contaminated liquids arriving with the steam from the explosion cavity and to return them to the cavity again [12, 48].

It was assumed that in the explosion gaseous radioactive isotopes and solid radioactive isotopes associated with the salt would be formed. It was planned to obtain samples with the isotope content through wells drilled from the surface in the explosion section. One of these wells, with the apparatus for removing the radiochemical samples, was to be sunk directly into the charge chamber.

Samples of gas and salt were to be investigated for the isotope content in them. In addition to the samples that the Lawrence Radiation Laboratory proposed to collect, the Oak Ridge National Laboratory, which had been engaged in the separation of isotopes in a pure form for many years, proposed to collect samples from each gas individually, and also general samples, to evaluate the different methods proposed for extraction of the gases [4, 12, 13, 49, 52].

During the Gnome shot, for 1  $\mu\text{sec}$  a neutron flux of such power that it could not be contained in any laboratory equipment would originate. The Los Alamos Scientific Research Laboratory compiled an extensive program for the study of the neutron fluxes, with the use of a vacuum pipe line 300 m long, laid along the gallery from the charge chamber to the shaft. Neutrons with energies of different levels have different velocities. To record them, two measuring sets were installed in the vacuum pipe lines: one at a distance of 150 m from the beginning of the pipe, and the other at a distance of 300 m.

The mission of the experiment also included the determination of the running time of the neutrons and the study of the effect of neutrons with different energy levels

by means of a flywheel rotating at a high speed in the neutron beam. One experiment was intended for studying the fission process of the neutrons with different energy levels, in order to gain a better understanding of the difference between asymmetrical and symmetrical fission. It was proposed to measure the capture cross sections of the neutrons of several elements by the rotating flywheel method [12, 49, 52].

The scientific program of Project Gnome also provided for obtaining data concerning other phenomena characteristic for an underground nuclear explosion. It included the measurement of the pressure and velocity of the shock waves, measurement of the pressure in the cavity, investigation of the nature of the increase in the volume of the cavity, study of the seismic effects, study of the radiation temperature and intensity, measurement of the displacement of the surface after the explosion, study of the disruption of the stratification of the salt beds, and the investigation of other phenomena.

The Gnome experiment was made by the U.S. Atomic Energy Commission, which includes a section on the use of nuclear explosions for industrial purposes.

The development of the technical part of the project was performed by the Lawrence Radiation Laboratory of the University of California in accordance with a contract with the AEC. This same laboratory carried out the management of work in the fulfillment of the research program. Higgins and Randolph headed the technical management of the project. Aside from the Lawrence Radiation Laboratory, the Los Alamos Scientific Research Laboratory, the Oak Ridge National Laboratory, Stanford Research Institute, Sandia Corporation, U.S. Geological Survey, U.S. Bureau of Mines, U.S. Coast and Geodetic Survey, the Edgerton, Hermeshausen and Grier Company, and other organizations participated in the fulfillment of the research program. The Albuquerque Regional Administration of the AEC (at the city of Albuquerque, in the state of New Mexico) was responsible for management of field work in the accomplishment of the project, as the region of the experiment was located in its territory.

Many governmental organizations and private companies participated in the operations in the preparation and accomplishment of the experiment. The basic construction, mining and drilling operations were performed by 13 private firms, together with the U.S. Geological Survey, Bureau of Mines, and the engineer troops of the Albuquerque District.

The Sandia Corporation, the Edgerton, Hermeshausen and Grier Company, Federal Service, U.S. Public Health Service, and the U.S. Weather Bureau performed work in the detonation of the explosion. The cost of operations in the preparation and accomplishment of the Gnome experiment amounted to 5.5 million dollars [13].

Preparations for the experiment were begun in 1958. In the spring and summer the U.S. Bureau of Mines made a selection of the section for the conduction of the experiment, working from the following requirements: the salt beds must be adequately pure and must lie no deeper than 250 m from the surface, and the region must be thinly populated and must not be under private ownership. A location in the basin of the Delaware River [i.e., Delaware Creek], not far from the city of Carlsbad, in the state of New Mexico, was selected. In the autumn of 1958 the Geological Survey made a topographic survey of the site of the forthcoming explosion [12].

The region of the experiment was located 40 km to the southeast of the city of Carlsbad and approximately 55 km to the west of Carlsbad Caverns (Figure 72) [53]. The largest settlement near the site of the explosion was the city of Malaga, located at a distance of 19 km away, and there was a small ranch located 7 km from the site of the explosion. At a distance of approximately 10 km several gas and oil wells were functioning (the nearest gas well was 9.6 km away), and at a distance of 13 km away was an operating potash mine [18]. The surface relief is a plain.

In August--September 1959, the drilling of a survey hole for obtaining core samples was completed, which had been conducted for the purpose of studying the geological conditions. The stratigraphic section of the explosion site from the surface of the earth is as follows [23]: sandy limestone deposits 0--13 m, sand and weak sandstone 13--28 m, sandstone and shales 28--90 m, anhydrite and gypsum, including a dolomite aquifer and intercalations of aleurite 90--198 m; anhydrite and aleurite 198--216 m; rock salt of the Solado formation with interbeddings of clayey shales of anhydrite and polyhalite 216--457 m. The aquifer was located 195 m above the level of the placement of the charge (365 m) [18], i.e., it was located at the contact of the anhydrite and sandstone strata (see Figure 71).

The physical properties of the rock salt of the Solado formation are as follows: density in a natural state  $2.16 \text{ g/cm}^3$ , porosity 2.7%, Poisson's ratio 0.25, rate of propagation of a longitudinal wave 4300 m/sec. The water content in the salt is about 1% by weight.

A consultative group, consisting of specialists in hydrogeology, geophysics, and seismology, studied the possible dangers associated with the project and arrived at the conclusion that its accomplishment would not cause any harmful effects on the population or industrial enterprises, and would not lead to any radioactive contamination of the ground waters. In February 1959, a preliminary estimate of the seismic effects which might be expected in the explosion

of a nuclear charge was made. For this, three charges of chemical explosives were exploded. As a result of these investigations, data were obtained demonstrating that the enterprises of the chemical, petroleum and gas industries located in the zone adjacent to the Gnome experiment would not receive any damage from the seismic effect of the explosion.

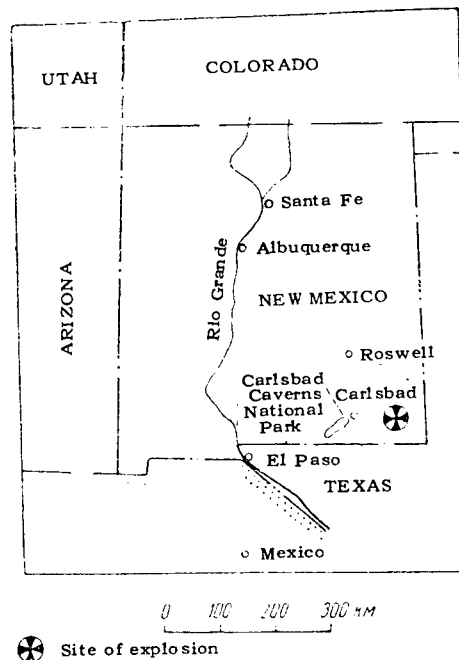

Figure 72. Region of the Gnome experiment.

For placement of the nuclear device in the center of the section selected, a vertical mineshaft was excavated, having a diameter of 3 m and a depth of 370 m. At the 365-m level, a horizontal gallery (later on this will be conventionally called a drift) with a section of 2.45 x 3.1 m was excavated from the shaft in a southwesterly direction. The full length of this drift was 340 m. The end section of the drift was made in the form of a hook, for purposes of self-isolation of the cavity after the explosion. The distance from the place where the charge was planted to the mine shaft, along a straight line, amounted to 300 m, and there was a distance of 365 m to the day surface. The mine shaft and the drift are shown in Figure 71. The configuration of the end part of the drift is represented in



Figure 73. The chamber for placement of the nuclear charge was the end of the drift, and the volume of the charge chamber was  $31.5 \text{ m}^3$  [12]. The drift was plugged after the placement of the charge in the chamber, but only to the length of the straight section (7--8 m) adjoining the charge chamber to the place where it made its transition to the curvilinear section. The plug was made of bags filled with salt.

To reduce the airborne shock wave, the section of the drift not far from the shaft had the shape of a knee, at the outlet of which was built a reinforced concrete bulkhead with a shockproof door [26]. Besides this, in the shaft two hermetically sealed covers were installed, one of which, located at the conjunction of the shaft and the drift, was calculated for a pressure of  $70 \text{ kg}(\text{force})/\text{cm}^2$  [4].

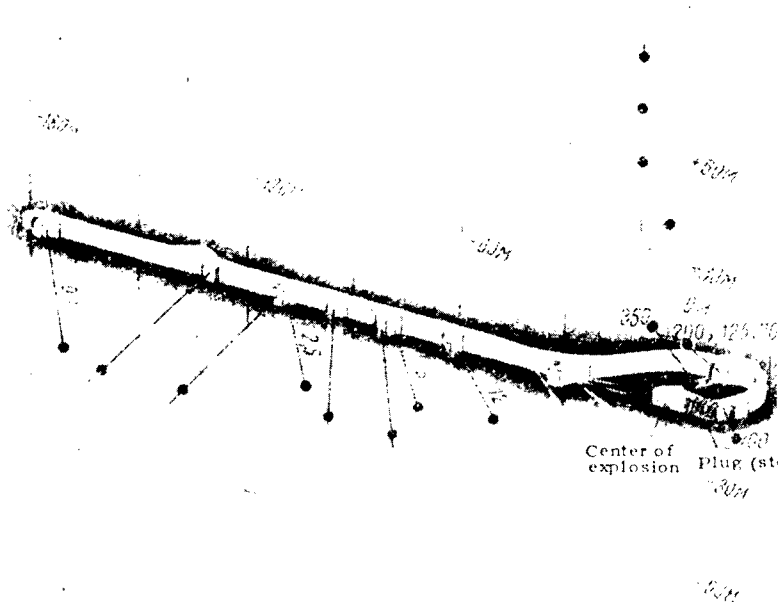

Figure 73. Configuration of the end section of the drift and arrangement of the pressure and temperature pick-ups:

—●— -- temperature pick-up; - - ● - -  
pressure pick-up (numbers given in  
kilobars).

Since the basic task of the experiment was to establish in what way the effect of an explosion in the new medium (in salt) differs from the effect of the previously conducted

explosions in tuff rocks, the apparatus fixing the motion of the massif, the pressure from the explosion, temperature of the rock, and other physical processes was installed at different distances from the point of the explosion [12]. The arrangement of the test wells and pressure and temperature pick-ups underground in the zone close to the explosion is shown in Figure 73.

The measuring instruments (chiefly seismic pick-ups) were also installed in wells drilled from the surface. The U.S. Geological Survey drilled hydrogeological wells with a depth of 0.3--4 km for observation of the water table and the migration of radioactivity [4]. Six seismic stations were constructed on the surface of the earth. In order to solve other problems in the research program, before the explosion special operations were conducted, and special equipment was installed.

From the surface, in the vicinity of the epicenter of the explosion, a well was drilled to a depth of 150 m. Casings with expanding connections were installed, permitting the vertical displacement of the reinforced concrete slab at the mouth of the well up to a distance of 2.5 m. It was assumed that after the explosion the drilling of the well would be continued until the explosion cavity was reached [49]. The steam extracted from the cavity through this well was to be fed to a device for the measurement of its parameters. This device was located on a platform near the shaft and included the following equipment: a preventer at the mouth of the well for prevention of sudden discharges of steam and gas, a steam-flow regulator, a heat-exchanger, tanks for acidic neutralizers, gas filters with a collection tank, filter traps to catch the exhaust steam, a clean-water tank, and a storage tank for purified water [12]. The plant was calculated to generate 3.6 tons of steam per hour at a steam temperature of 910°C and a pressure of 8.75 kg(force)/cm<sup>2</sup>. In a case where the parameters indicated were exceeded, the pressure would be reduced by a system of valves, and the temperature by adding water to the steam arriving from the well. The water formed from the steam as a result of condensation was again to be directed into the explosion cavity.

For extraction of the radioactive isotopes formed at the moment of the explosion, a well was drilled from the surface into the charge chamber. A completely hermetically sealed pipe line, in which a vacuum was created, was installed in the well.

The lower end of the pipe entering the charge chamber was closed by an aluminum disk, which was vaporized in the explosion. Immediately after the explosion, it was expected that the gases would be ejected through the pipe line. At

the upper end of the pipe several paper filters and a gas collector were installed. Automatic removal of the isotopes in the gaseous phase, it was proposed, would be performed in the following intervals of time: 1--40; 40--75; 60--90; 75--150; 150--1000 msec and 1--10 sec. The arrangement of the pipe for instantaneous removal of the gaseous isotopes in the charge chamber is visible in Figure 74 [49].

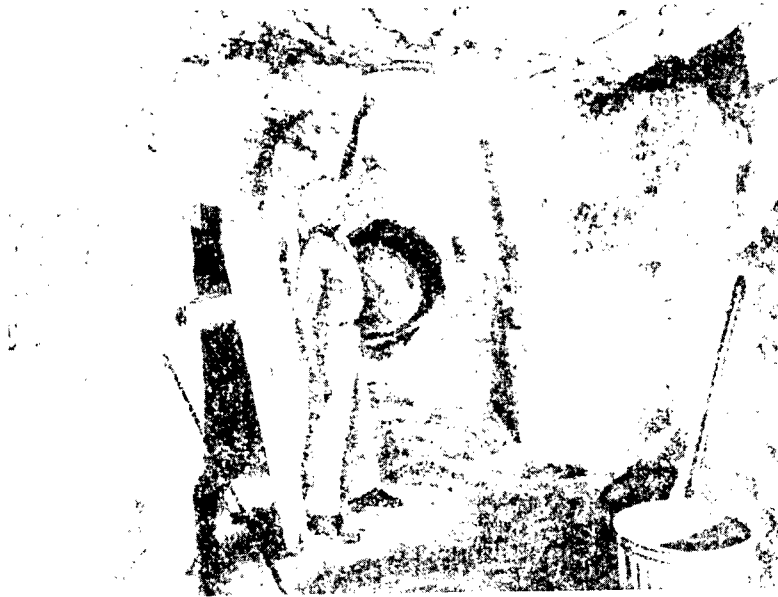

Figure 74. Chamber for the charge in the Gnome experiment: in the roof of the chamber is a well leading to the surface, for removal of samples of gaseous isotopes; on the rear wall of the chamber is a vacuum pipe for measurement of neutron fluxes.

In the explosion it was assumed that three classes of isotopes would be obtained: isotopes having an industrial significance (such as curium-244 and polonium-210 for electric power generators, for example), fissionable isotopes (plutonium, in particular), and transplutonium isotopes (both known and unknown ones) [13]. It was proposed to study the radioactive isotopes of more than 20 chemical elements obtained under the effect of the neutron flux in the explosion [25].

Before the explosion, different materials necessary for the formation of the isotopes were placed in the charge

chamber. Silver, gold, and uranium-235 were contained in these materials [4]. It was proposed to extract the solid isotopes from the explosion cavity and the surrounding rocks by drilling core wells from the surface and from the underground galleries [12].

A diagram of the arrangement of the equipment for investigation of the neutron fluxes is given in Figure 75 [25].

For investigation of the neutrons by the time-of-flight method in the drift beginning at the charge chamber, a high-vacuum pipe (tube) with a diameter of 56 cm and a length of 300 m was installed along a straight line. The front part of the pipe line was led directly into the charge chamber (see Figure 74). Since neutrons with an energy of the order of 1--900 eV are the ones that are chiefly of interest, at the entry of the vacuum tube into the chamber, a neutron moderator was installed, consisting of a block of a layer of polyethylene and a layer of lead (thickness of each layer 5 cm). At the entrance to the chamber, at the point where the neutron tube narrowed, two neutron counters were installed, which fixed the moment that the neutrons flew by.

At a distance of 275 m from the charge, at the end of the vacuum tube, two neutron flywheels were installed, one over the other [13]. The neutron flywheel was a wheel driven by an electric motor, and on the surface of this wheel turned toward the charge, strips of foil of the material intended for irradiation were fastened [49]. The collimator slot in the concrete shield before the flywheel made it possible for the neutrons to strike only a small part of the flywheel. Neutrons of different energy and different time of flight fall on different parts of the rotating flywheel, behind the collimator slot [52]. Here two neutron counters were installed: a silicon crystal detector, and an  $\text{He}^3$  counter. The neutron flywheels were shielded by a wooden casing, covered by caemanite (a boron mineral that absorbs neutrons).

The upper neutron flywheel, fabricated by the Los Alamos Scientific Laboratory, had a layer of foil made of uranium-235 and was intended chiefly for measuring the fission effects, and not neutron capture.

The lower neutron flywheel, fabricated by the Lawrence Radiation Laboratory, was complex in construction. Almost 1000 pieces of foil made of uranium, thorium, gold and hafnium were fastened on it. The uranium and thorium foils were intended for measuring the neutron-capture cross sections. These data can be used in the calculation of reactors. The foils made of gold, hafnium and uranium were

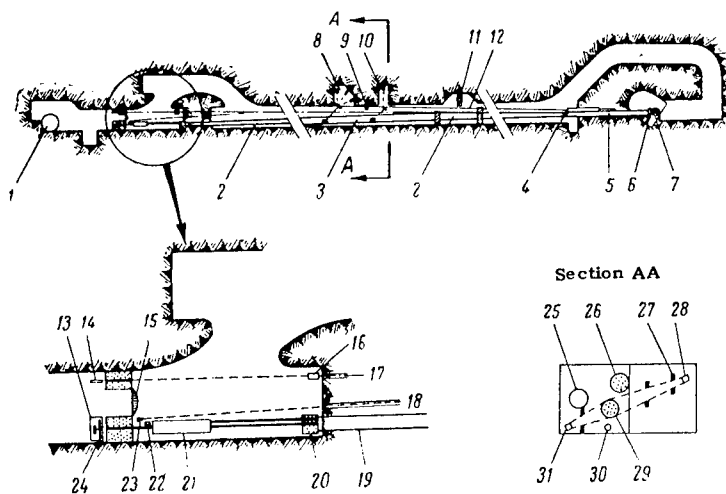

Figure 75. Diagram of the arrangement of the equipment for the investigation of the neutron fluxes in the Gnome shot:

1 -- vertical shaft; 2 -- vacuum pipe  $\phi$  56 cm; 3 -- vacuum pipe  $\phi$  86 cm; 4 -- lead attenuator; 5 -- stepped vacuum pipe; 6 -- moderator; 7 -- location of explosion; 8 -- location of installation of carbon targets; 9 -- detector for investigation of the section; 10 -- location of installation of beryllium targets; 11 -- concrete collimators; 12 -- beam of fast neutrons; 13 -- slide rails for removal of neutron flywheels; 14 -- neutron emulsion camera; 15 -- shockproof door; 16 -- detector for investigation of the spectrum of the Cherenkov glow; 17 -- neutron channel; 18 -- channel for  $\gamma$  rays; 19 -- vacuum pipe  $\phi$  56 cm; 20 -- neutron spectroscopic detectors; 21 -- vacuum pipe  $\phi$  56 cm; 22 -- neutron flux recorder; 23 --  $\gamma$ -ray detector; 24 -- neutron flywheels; 25 -- vacuum pipe  $\phi$  86 cm; 26 -- carbon transformer; 27 -- collimators; 28 -- Cherenkov  $\gamma$  detector; 29 -- beryllium transformer; 30 -- detector for investigating the radiation spectrum; 31 -- Cherenkov detector.

intended for measuring the effective cross sections of the neutron flux, which are of significance for theoretical physics. The velocity of rotation of the flywheels was 3000 rpm, and the duration of the experiment was 17 msec. In

this time the flywheels were to make a little more than half a revolution.

Signals from the apparatus installed underground were transmitted by special cables to the surface, to the recording instruments [49]. The station for recording the fast neutrons was located in a drift at a distance of approximately 150 m from the charge. Here carbon and beryllium targets and a detector for investigating the spectrum were installed [25, 52].

During the explosion, precautionary measures were taken: all persons associated with the explosion and present as observers (altogether, 400 persons were present) were located at an observation point placed 7.2 km from the site of the explosion [12]; entry to Carlsbad Caverns (55 km away) was temporarily closed; the cattle were removed from a region of large size; traffic of motor vehicle transport and aircraft flights in the region of the explosion were prohibited; mining operations at the potash mine (13 km away) were stopped [13]; and a gas well located 9.6 km away was filled with clay pulp [18].

For the explosion, an atomic charge with a nominal power of 5 KT was used. However, the actual power of the explosion was estimated to be equal to  $3 \pm 0.5$  KT.

It was proposed to detonate the explosion at 0800 local time. However, because of the fog that covered the region of the epicenter, and the wind that was blowing in the direction of Carlsbad, the explosion was delayed and was set off about 12 hours after favorable weather set in. From the observation point and from helicopters that took off at the moment of the explosion, a rise of the ground in the vicinity of the epicenter was clearly observed [12, 13]. Water vapors (100--200 T) and gaseous fission products were discharged from the mine shaft in the form of dense white smoke, which began to be carried away by the strong wind. A premature explosion of a charge of chemical explosives, located at the surface and intended for calibrating the barographic instruments, created the impression of the breakthrough of gases from the nuclear charge to the surface of the earth through some fissures. As a matter of fact, such a breakthrough did not occur, and the explosion was entirely an explosion of internal effect.

Some time (apparently 1 hour) after the explosion, parties were sent to the vicinity of the shaft platform to collect air samples, perform dosimetric measurements, and to inspect the surface of the explosion zone. Almost all the equipment on the surface remained undamaged. This made it possible, already on the day of the explosion, to commence preparations for drilling from the surface, and two days later they began to drill two wells toward the explosion

cavity [12]. At the end of December the drilling of these wells was completed. One well with a diameter of 304 mm, drilled at the epicenter of the explosion and intended for removing steam from the cavity, reached the upper part of the cavity at a depth of 332 m from the surface on 22 December 1961; the second well, with a diameter of 244 mm, calculated for feeding water into the cavity, was drilled through the cavity at a distance of approximately 18 m from the center of the explosion to a depth of 361 m, i.e., it reached a level lying 5 m above the bottom of the charge chamber [4, 13]. The drilling of this well was completed on 28 December.

In the second half of January and in February 1962, the U.S. Geological Survey drilled a vertical exploration well for removal of a core near the central zone of the explosion. The well had a diameter of 89 mm, a depth of 450 m, and passed at a distance of 45 m from the center of the explosion. A view of the region of the epicenter of the explosion and the site where the wells were drilled from the surface is shown in Figure 76 [4].

The investigation of the mine shaft as far as the place where it joined the drift ascertained that it was in a good condition, although this investigation was made six days after the explosion, when the neutron flywheels were removed from the near-by section of the drift [55]. In March 1962, they began to cut a new survey drift from the shaft in the direction of the central zone of the explosion. It was located on the same level (365 m) as the old drift, but 12 m south of the latter.

Underground wells were drilled from a distance of 60 m from the location of the placement of the charge toward the cavity, to determine the contours of the cavity and remove core samples from the cavity and the surrounding massif.

On 17 May 1962 the surveyors in the survey drift penetrated to the explosion cavity. The explosion cavity and the underground survey wells are shown in Figures 77 and 78.

The study of the central region of the explosion demonstrated that the initial explosion cavity had a diameter of 30--33 m. This cavity was formed partially because of vaporization and fusion of the salt, and partially because of the displacement of the surrounding salt bed. The zone of destruction was very small (2--4 m of the rocks adjoining the walls of the cavity).

Just as in tuff, the sides and the walls of the cavity collapsed, but in distinction from tuffs this collapse was limited, so that a stable cavity of large volume was formed, not entirely filled with the rock that had collapsed.

The total volume of the cavity, including the part filled with rock fragments, was determined to be equal to approximately 25,000 m<sup>3</sup>.

A year after the explosion, the dimensions of the cavity were: maximum diameter on the horizontal plane in the center part 52 m; diameter of the lower hemisphere 34 m; diameter of the upper hemisphere 45 m; maximum height of the free space 27 m.

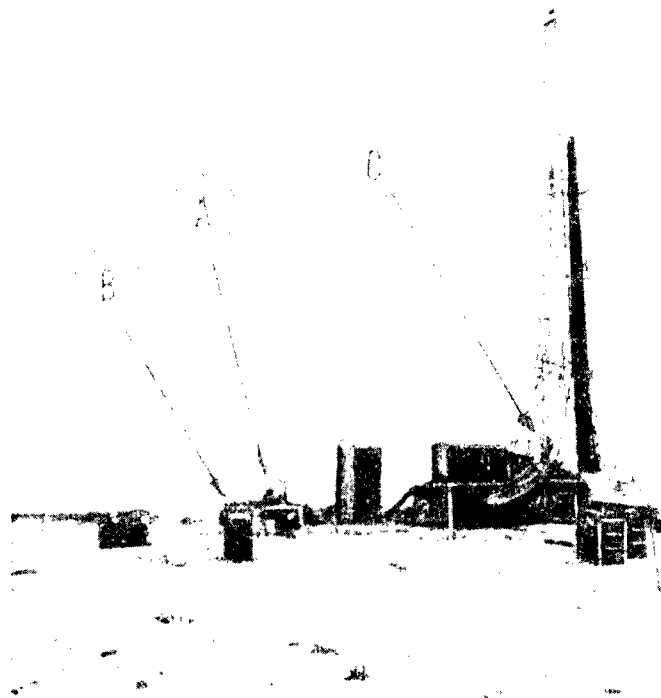

Figure 76. Region of the epicenter of the Gnome shot after the experiment was completed:

A -- ventilator for feeding air to the explosion cavity; B -- mouth of drilled well through which the steam was extracted; C -- site of drilling of the well with a diameter of 80 mm [sic, probably error for 89 mm], located at a distance of 45 m from the epicenter.



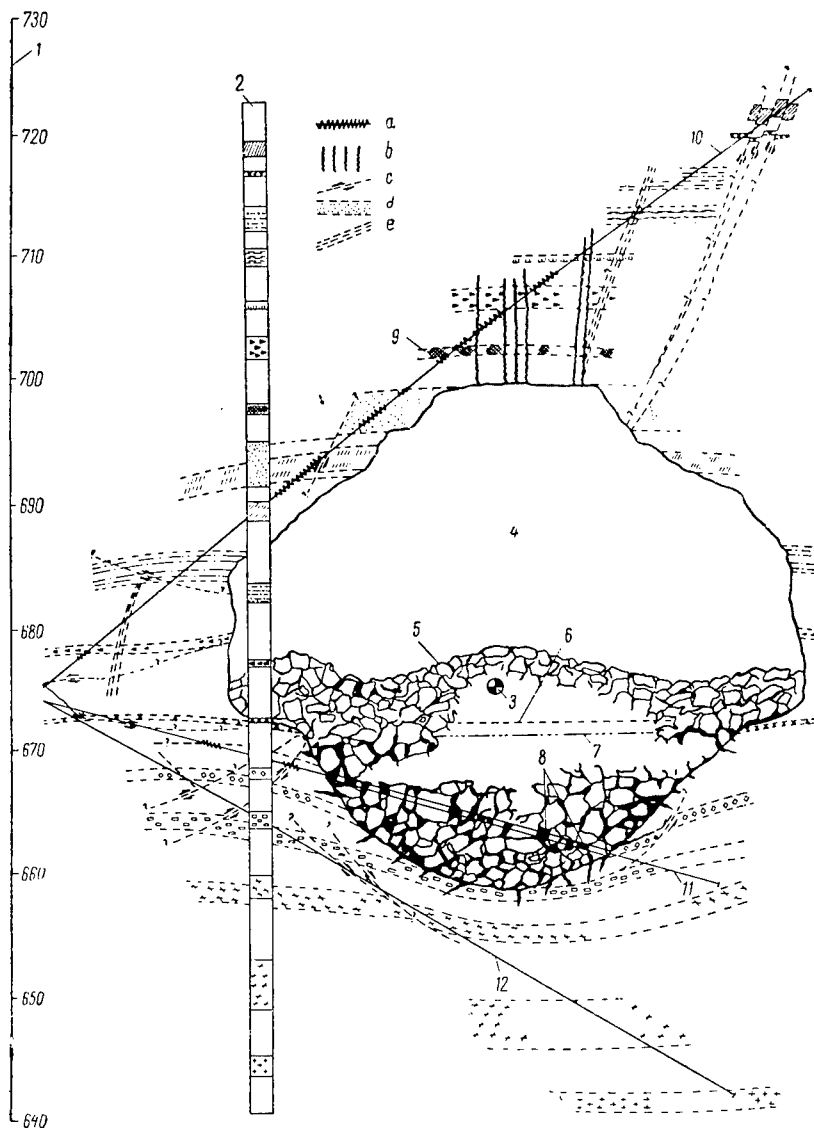

Figure 77. Vertical section of the Gnome explosion cavity:  
 1 -- elevation above sea level, m; 2 -- position of stratum before explosion; 3 -- center of explosion; 4 -- free space of the cavity; 5 -- pile of fragmented rock; 6 -- level of the water fed into the cavity through wells drilled from the surface; 7 -- approximate upper boundary of hardened fused salt; 8 -- distribution of hardened fused salt in well B; 9 -- strata exposed at the roof of the cavity (see Figure 78); 10 -- well A; 11 -- well B; 12 -- well C; a -- salt changed under the effect of the radiation and observed in the wells; b -- slightly radioactive hardened fused salt, forced into fractures; c -- displacement of strata; d -- contact of bedding planes; e -- zones of fractures.

The lower hemisphere of the cavity was filled with a mixture of solidified fused salt with unfused pieces, that caved in from the walls and roof. This mixture was coated with a 6-m layer of rock that had collapsed from the upper hemisphere of the cavity. No liquid fused salt was observed in the cavity [4].

According to calculations by the American researchers, the quantity of fused salt amounted to 2400 T, the total quantity of material that caved in from the roof and sides of the cavity was 28,000 T, including 13,000 T of material mixed with fused salt, and 15,000 T of material lying on top of this mixture.

The fractures of the salt massif were propagated chiefly from the roof side of the cavity. The maximum length of fractures from the center of the explosion in this direction was 60 m. A well for the removal of a core sample, drilled at a distance of 45 m from the center of the explosion, entered the zone of fractures [4, 57].

Basically all the radioactive products in a solid state were captured by the fused salt and concentrated in the mixture of this fusion with the material that collapsed, located in the lower part of the cavity. A great part of the gaseous radioactive products, as a consequence of the disruption of the hermetic seal of the cavity at the place where the vacuum pipe for neutron measurements was passed into it, escaped from the cavity through the drift and the mine shaft into the atmosphere.

Although the escape of active vapor from the mine shaft continued for several days, the yield of the basic part of the activity occurred during the first hour after the moment of the explosion. The radioactive vapors were carried away by the wind in a north-northwesterly direction at a speed of 25 km/hr.

The activity of the vapors issuing from the mine shaft at first was very high. Then the radioactivity of the vapor issuing from the cavity amounted to the following figures: 10 days after the explosion (in the mine shaft) 100 mr/hr; after 15--20 days (in the well for extraction of the steam) 5 mr/hr; after 1.5--2 months (in the well for removal of the core sample) 1--2 mr/hr [66].

Measurements of the  $\gamma$  radiation, performed through the well, indicated that 26 days after the explosion the dose amounted to 0.2--0.4 r/hr in the free part of the cavity and 5--20 r/hr in the zone of fragments in the lower part.

Because of the shielding effect of the layer of fragments formed from the salt beds that collapsed, covering the radioactive mass, the activity in the free part of the cavity was not great by the moment that it was opened by the gallery. The dose at the surface of the rock pile amounted

to: 6 months after the explosion 50--60 mr/hr, and after a year 5 mr/hr (there were sections with a larger dose).

In the joints (cracks) in the rock solid radioactive products were encountered at a distance of the order of several meters from the walls of the cavity (the greatest distance was 12 m).

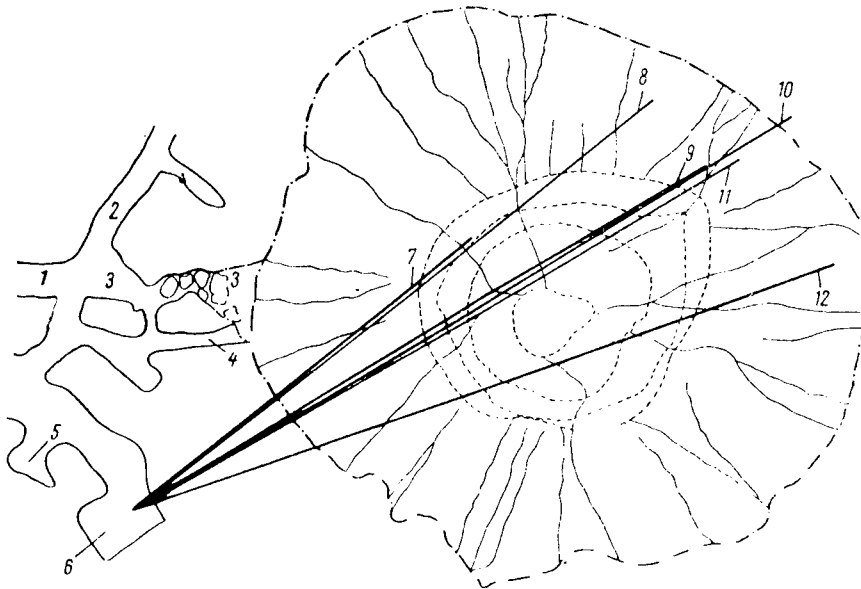

Figure 78. Gnome explosion cavity in plan (section through central zone):

1 -- drift for placement of the charge; 2 -- restored part of drift for placement of the charge; 3 -- escape route for gaseous radioactive products of the explosion from the cavity; 4 -- gallery for drilling well No 25 before the explosion; 5 -- recess for drilling well 6 before the explosion; 6 -- recess for drilling wells after the explosion; 7 -- well D; 8 -- well F; 9 -- well B; 10 -- well A; 11 -- well C; 12 -- well E. —·—·— -- contour of cavity along maximum dimensions; — — — -- boundaries of salt beds in roof of cavity; - - - - - -- radial cracks in the roof of the cavity.

Total collapse of the drift occurred at a distance of 40 m from the center of the explosion (14 m from the wall of the cavity at the present time) [59]. At a distance of up to 270 m from the charge, a collapse of the walls and roof

of the gallery was observed, of various intensity, in the form of large blocks of salt, fragments of medium size, and dust [51, 57]. At the conjunction of the enlarged part of the drift near the mine shaft, there were fallouts of large pieces of rock from the roof. The mine shaft remained practically undamaged. Only individual falls of rock were observed [4, 18].

According to the data from motion pictures taken at the moment of the explosion, it was established that at the epicenter of the explosion the rocks rose to a height of approximately 1.3 m, and then fell, having formed a fill with a height of about 0.7 m above the surface level before the explosion. A maximum rise (1.8 m) was observed 55 m from the epicenter of the explosion [51, 59]. The residual displacement at a distance of 100--150 m from the epicenter decreased to 0.12 m, and at a distance of 300 m entirely disappeared. A concrete platform (1.6 m<sup>2</sup>) with equipment for taking radiochemical samples, located at the epicenter, sank partially into the ground. The equipment continued to operate. Almost all the other equipment at the surface remained undamaged [12].

An aquifer located 195 m above the charge was little disrupted [18]. Filtration of the water into the shaft from the aquifer remained the same as it was before the explosion (570 l per week) [55]. Oscillations of the surface during the explosion were clearly perceptible at the observation point [13].

The seismic observation program was successfully fulfilled. The seismic signal was recorded in the greater part of the territory of the USA and at many individual stations in other countries, such as Uppsala (Sweden), for example. The fact that many well-equipped stations, in particular certain stations located within a radius of 125 km from the center of the explosion, did not record the signal may be explained by differences in the wave-propagation conditions, in connection with the features of the structure of the rocks near the site of the explosion [12, 51, 58].

The temperature in the cavity was measured through the well drilled from the surface. On 22 December 1962 the temperature in the free part of the cavity was about 100°C and the temperature in the zone of rock fragments varied from 50 to 650°C [59]. No fused salt (melting point 710°C) was observed. Sections with a temperature of 650°C were of a sporadic nature. It was assumed that the fine friable "fleecy" material was an insulating layer, through which small "geysers" penetrated, causing a sporadic rise in the temperature.

At the moment of the explosion, the hermetically sealed cover installed in the shaft at the junction with the drift was damaged. As a result of this, and also as a

consequence of the formation of channels connecting the cavity with the drift and the shaft, a leakage of steam from the cavity occurred [53, 60]. To obtain steam, water was forced into the cavity, in the zones of rock fragments, through the wells (435,000  $\lambda$  of salt water and 95,000  $\lambda$  of fresh water). As a consequence of the fact that during the time that it took to drill the wells the cavity had cooled considerably, the steam had very low pressures and temperatures. To use the steam to generate electric power, a pressure of 14 kg(force)/cm<sup>2</sup> was necessary. By forcing air into the cavity through one well and the mine shaft, the pressure of the steam coming from the well was increased to

3 kg(force)/cm<sup>2</sup> at a temperature of 65°C. This made it possible to test the equipment for the extraction of the steam for corrosion and to test the operation of the instruments for deactivation of the steam coming from the radioactive cavity [4, 50, 59]. Since the steam did not have the properties needed, investigations on the extraction of steam from the cavity were ceased on 19 January 1962 [59].

The removal of gaseous samples from the explosion chamber at the moment of the explosion was not successful, as a consequence of the fact that the pipe line for removing the samples was damaged by the explosion. On the basis of available data it is assumed that all the gaseous isotopes were contained in the steam which was discharged through the shaft. The fact that the gaseous isotopes were separated from the solid ones is important. Thus, the extraction of gaseous isotopes from the free cavity will be possible upon condition that the cavity is hermetically sealed, and, consequently this method may serve for obtaining gaseous isotopes [59]. It has been established that a great part of the tritium was contained in the water vapor. Consequently, we may also obtain and separate the radioisotopes of krypton, argon, and other gases [13, 58].

The removal of core samples for analysis for solid radioactive isotopes was successfully performed near the cavity.

Almost all (99%) of the isotopes of the solid substances were trapped in the fused salt. This material can be dissolved in hot water. At the Lawrence Radiation Laboratory a method was developed for separating the isotopes, based on conventional methods of chemical concentration. In this case the plutonium, americium, and curium behaved almost the same within the first concentration cycles. Investigations for the extraction of radioactive isotopes are continuing.

Although the neutron flywheels were rotating at a speed of 2600 rpm instead of the proposed 3000 rpm at the moment of

the explosion, the experiment in neutron physics was successful. The neutron flywheels were removed from the drift six days after the explosion. On the basis of known resonances in uranium, the neutron flux in the flywheels was determined, and it amounted to  $10^{12}$  neutrons/(sec · cm<sup>2</sup>). Several important resonances were observed in the range from 10 to 60 eV in the elements studied: gold, uranium, hafnium, and thorium [59].

#### THE SEDAN EXPERIMENT

Project Sedan -- an underground explosion of a 100-KT thermonuclear charge -- was carried out by the U.S. Atomic Energy Commission for determination of the technical possibility of the application of nuclear explosions in the excavation of rocks in construction and in mining. The conditions under which the experiment was carried out and its basic results are expounded by Kelly [3], and in other works [8, 10, 61--65], published soon after the experiment was made.

The experiment was carried out at the Nevada test area on 6 July 1962, at 1000 Pacific Standard Time. The charge was exploded at a depth of 193 m in a well with a diameter of 914 mm, which had been drilled and cased in weakly cemented alluvial deposits of Yucca Flats. Dry sand was used as the stemming.

A thermonuclear charge was used for the first time in an underground experiment. Less than 30% of the total energy liberated fell to the share of the fission reaction, and the other 70% was derived from the fusion reaction. According to preliminary calculation, the deviation of the power of the charge from the calculated magnitude amounted to about 10%.

For purposes of determining the flight trajectory and distribution of the pieces of earth and dust ejected, reference markers, measuring rods, pieces of canvas, and pans were placed near the site of the explosion. The measurement of the parameters of the apparent effect of the explosion and the oscillations of the earth's surface was also made by five motion picture cameras.

In the first three seconds after the explosion, a rise of the surface of the earth occurred, in the form of a dome of hemispherical shape, with a diameter of 180--240 m, to a height of 90 m. Then the incandescent gases broke through, which was observed by the representatives of the U.S. Atomic Energy Commission from a distance of 19 km as a bright flash of light. In the explosion, no formation of a fireball was noticed, in spite of the initial flash, although a rupture of the surface did occur in this case. The enormous mass of

ejected rock rose to a height of 600 m and fell to the earth; a pile of fragmented rock was formed on a considerable area. The burning gases and fine fractions of the rock separated from the shower of ejected rock, rose to an altitude of 3.5 km in the form of a dirty white cloud of gas and dust, and began to move toward the north. The dust cloud, visible from the city of Las Vegas, located at a distance of 105 km southeast of the test area, initially had the shape of a bubble, and then assumed a shape resembling enormous bulging rubber tubes.

As a result of the explosion, a crater was formed, partially filled with rocks. The diameter of the apparent crater was 365 m, and its depth 97 m. Around the crater a pile of ejected rock was located, in a radius of 1.5--2 km, with a thickness of from 6 to 30 m around the edge of the crater. The volume of the apparent blast crater amounted to 5 million m<sup>3</sup>.

The dimensions of the crater, calculated by working from the proportionality of the linear dimensions of the crater to the power of the charge, to a power of 1/3 (with a great degree of simplification, this may be assumed for charges with a power of the order of a kiloton), must amount to the following: diameter 425 m, depth 90 m. Upon condition of proportionality of the linear dimensions to the power of the charge by a power of 1/4, which is considered most probable for the given depth of placement of the charge and its power, a crater with a diameter of 365 m and a depth of 52 m should be formed. In comparing the calculated dimensions of the crater with the actual one, Kelly [3] considers that with an explosion having a power of 100 KT the linear dimensions of the apparent crater are proportional to the power of the charge to a power of 1/4 for diameter and to a power of 1/3 for the depth of the crater<sup>1)</sup>.

The reduced depth of placement of the charge, determined with a power of reduction of 1/3.4, for the Sedan shot amounts to

$$d_{\text{red}} = \frac{193}{100^{1/3.4}} = 51,$$

---

1) The radius and depth of the crater from the Sedan shot correspond to the function  $f(W^{1/3.4})$  adequately satisfactorily.

which is less than the magnitude  $d_{red} \approx 45 \text{ m/KT}^{1/3.4}$ , in which the volume of rocks blasted out, according to Figure 11, is the maximum. Thus, the charge in the Sedan experiment was placed at a somewhat greater depth than it should have been from the standpoint of the optimum blast effect.

In preparation for and in conducting the experiment, a great amount of attention was devoted to the study of the possibility of reducing the quantity of radioactive products of the explosion and to problems of radiation safety. The application of a thermonuclear charge with a power of 100 KT, in which less than 30% of the total power of the explosion fell to the share of the fission reaction, made it possible, by working from the calculations, to obtain less radioactivity than would be produced in an explosion at the surface of a charge with a power of 2 KT based on the fission reaction. Measures were also taken to reduce the radioactivity caused by the neutrons (induced radioactivity).

In the entire territory where it was assumed that there would be a fallout of radioactive precipitation, pans and collectors were placed; the territory was divided into small individual sections, depending upon their biological nature, for the purpose of studying the radiation effect. A large part of the radioactive fission products formed during the explosion were trapped underground and only about 5% of these products, according to estimate data, fell out to the surface within the short-range zone.

The dust cloud carrying a small part of the radioactive products that were not trapped underground, and did not fall in direct proximity to the crater, were carried by the wind in a submeridional direction to the north at a speed of 35 km/hr. According to the initial calculations, the radioactivity of the cloud at the moment of its slow passage over the evacuated region to the north of the test area amounted to about 1.5 r/hr. In moving to the north, the dust cloud crossed the main highway of the state of Nevada, which had been closed by the police. According to a report by the Commission, the dose measured at the main highway after 20 days at a distance of 50 km, amounted to 0.8 mr. Small white clouds that appeared over the city of Las Vegas several days after the explosion, according to a statement by the U.S. Weather Bureau, were ordinary, nonradioactive clouds.

Quite heavy radioactive particles fell in direct proximity to the crater, at a distance of up to 3.2 km from the site of the explosion, in the windward direction, and at a distance of up to 6.4 km downwind. The dose at the edge of the crater, measured by workers in a period of up to four weeks after the explosion, turned out to be no higher than 0.5--0.7 r/hr. The maximum radiation dose actually received



by anything beyond the limits of the test area amounted to 0.3 r which is less than the permissible level, equal to 0.5 r/year, established by the Federal Council on Radiation for cases of the peaceful use of nuclear energy.

On the basis of an analysis of the radioactivity as recorded by dosimeters and the network of control and measuring instruments installed beyond the limits of the test area, as made by the U.S. Public Health Service, it was possible to conclude that only a small part of the iodine-131 observed in cows' milk in the state of Utah may be the result of the Sedan shot. The Sedan experiment, in the opinion of officials, also caused an initial rise in the radioactivity noted on 13 July in the vicinity of Great Salt Lake, but they consider that the subsequent rise in radioactivity was due to the two tests of atomic weapons held at the Nevada test area: one on 11 July at a shallow depth, and a second on 14 July several meters above ground.

The seismic effect in the Sedan shot was considerably weaker than the effect precalculated according to the results of previously conducted explosions in tuff and alluvium. Accelerations of 0.1 g were fixed at a distance of 2.4 km from the epicenter of the explosion. Observers watching the experiment from the nearest hills, located several kilometers from the site of the explosion, did not feel any tremors of the ground.

The Sedan shot was recorded by seismic instruments at a distance of 480 km, at the University of California in Berkeley and at the California Institute of Technology at Pasadena, and, in the opinion of seismologists, could have been recorded by sensitive instruments over the entire surface of the globe.

Stations for recording the airborne shock waves, located within a range of distances of 130--240 km, recorded a maximum pressure of 0.83 mbar at China Lake, California, approximately 220 km to the southwest of the epicenter of the explosion. The study of the results of the Sedan shot is being continued.

## BIBLIOGRAPHY

1. Viale R. B. J. Geophys. Res., 66, 10, 3413 (1961).
2. Johnson G. W., Higgins G. H., Violet C. E. "Underground Nuclear Detonation," J. Geophys. Res., 64, 10, 1457 (1959).
3. Kelly J. S. Science, 138, 3536, 50 (1962).
4. Du Temple O. J. Nucl. News, 5, 4, 53 (1962).
5. The Effects of Nuclear Weapons. Revised Edition, Samuel Glasstone, Editor, Washington, April 1962.
6. "The Plowshare Program," Mech. Engng., 11, 86 (1960).
7. Nordyke M. D. J. Geophys. Res., 10, 3439 (1961).
8. "Hydrogen Explosion Set Off Underground in Nevada," The New York Times, July 7, 1962.
9. Adams W. M., Preston R. C. et al. J. Geophys. Res., 66, 3, 903 (1961).
10. "More Data on Sedan," Wash. Atomic Energy Report, 8, 10 (1962).
11. Brown H. and Johnson G. W. Report No 2178 (USA), Presented at the Second International Conference on the Peaceful Uses of Atomic Energy, Geneva, 1958.
12. Dehon W. N. "Project Gnome," Nucl. News, 5, 1, 3 (1962).
13. "First Peaceful Nuclear Explosives Test Was Substantial Success," Nucleonics, 20, 2 (1962).
14. Parkinson L. J. "Possible Applications of Nuclear Energy to Mining," Kings Coll. Mining Soc. Univ. Durham, S. A., 28, 1959, pp 71-80; Bergbauwissenschaften, 1960, No 12, pp 289-292.
15. Nordyke M. D. "An Analysis of Cratering Data from Desert Alluvium," J. Geophys. Res., 67, 5, 1965 (1962).
16. Nordyke Milo D. "Experiment of Explosion for Blast Effect, with the Use of Nuclear and Chemical Explosives, with Reference to the Plowshare Program," Translation from the English in the Collection Razrushenie i mekhanika gorn'yx porod (Construction and Mechanics of Rocks), Tr. In-ta gorn. dela AN SSSR (Transactions of the Institute of Mining of the Academy of Sciences USSR), 1962.
17. Murphey B. F. and Vortman L. J. J. Geophys. Res., 66, 10, 3389 (1961).
18. Hoy R. B. Mining Engng., No 9, 49 (1962).

19. Nordyke M. D. New Scientist, 15, 5, 294 (1962).
20. Violet Ch. E. J. Geophys. Res., 66, 10, 3461 (1961).
21. Clausen C. F. Pit and Quarry, June, 96 (1961).
22. A Study of Mine Examination Techniques for Detecting and Identifying Underground Nuclear Explosions, By the Staff, Bureau of Mines, Information Circular 8091, 1962.
23. Johnson G. W. Bull. Atomic Scientists, 16, 5 (1960).
24. Johnson G. W. Nucleonics, 18, 7, 49 (1960).
25. Lombard D. B. "Plowshare, a Program for the Peaceful Uses of Nuclear Explosives," Phys. Today, 14, 10 (1961).
26. Carder D. S. and Cloud W. K. J. Geophys. Res., 64, 10, 1471 (1959).
27. Romney C. J. Geophys. Res., 64, 10 (1959).
28. McKeown F. A. and Dickey D. D. Geol. Surv. Profess. Paper 400-B, B415 (1960).
29. Riznichenko Yu. V. "On the Seismic Magnitudes of Underground Nuclear Explosions," Tr. In-ta fiz. zemli im. O. Yu. Shmidta (Transactions of the Institute of Physics of the Earth imeni O. Yu. Shmidt), No 15 (182), (1960).
30. Violet Ch. E. Mining Congr. J., March, 79-83 (1960).
31. Crawford J. E. "Destruction," Ind. Rev. (Africa), 10, 5 (1959); Atomic Energy, 3, 11 (1958).
32. Johnson G. W. Mining Congr. J., 11, 78 (1958).
33. Batzel R. E. J. Geophys. Res., No 9 (1960).
34. Higgins G. H. J. Geophys. Res., 64, 10, 1509 (1959).
35. Johnson G. W. and Brown H. Scient. Amer., 199, 12, 49 (1958).
36. Boyd J. Mines Mag., No 10 (1961).
37. "Atomic Blasting for Mining," Mining World, 21, 8, 31 (1958).
38. Carlson R. H. "Constructing Underground Storage Facilities with Nuclear Explosions," Petrol. Engr. Management Ed., XXXI, 9, 1332 (1959).
39. "Chariot in Phase-Out," Wash. Atomic Energy Report, 8, 35, August 27 (1962).
40. Rougeron K. The Use of the Energy of a Thermonuclear Explosion (Russian Translation), Edited by S. I. Azarev, Translation from the French, Moscow, Izd-vo inostr. lit., 1957.
41. "Nuclear Excavation of Second Panama Canal to Be Studied," Nucleonics Week, 3, 28 (1962).
42. Govier G. M. Oil in Canada, September 28, 36 (1959).
43. Anderson C. C. "Awesome Recovery Promise," Petrol. Engr. Management Ed., XXXI, 9, 1328 (1959).
44. "Can Underground Blast Make Shale Oil Competitive?" Oil and Gas J., 12, January, 57 (1959).
45. "Underground Nuclear Explosions and Hazards," Appl. Atomics, January 14, 172, 18 (1958).

46. Porzel F. B. "A New Approach to Heat and Power Generation from Contained Nuclear Explosions," A/Conf., 15/P/178, 1958.
47. Hughes D. J. Nucleonics, 18, 7, 54 (1960).
48. Burke-Gaffney T. N., Bullen K. E. J. Phys., 11, 3, 318 (1958).
49. Balligand P. Nucleonics, 20, 2 (1962).
50. "Gnome Report No 3," Wash. Atomic Energy Report, VIII, February 5, 6 (1962).
51. "Project Gnome Observers Enter Area of Underground Nuclear Blast," Atomic Industry Reporter, No 361, May 2, 1962.
52. "Project Gnome," Atomic Industry Reporter, (By the Bureau of National Affairs, Inc., 1961, November).
53. "Underground Atom Blast Planned by U.S. for 1961," The New York Times, March 17, 1960.
54. "Report on Gnome," Wash. Atomic Energy Report, 8, 4 (1962).
55. "Drilling Company Gets Contract for Gnome Test Holes," Atomic Energy Clearing House, 8, 3, 27 (1962).
56. "Project Gnome. AEC Plans to Enter Cavity Made by Underground A-Shot," Atomic Industry Reporter, No 352, February 28 (1962).
57. "Gnome Mystery," Wash. Atomic Energy Report, 8, 17 (1962).
58. "Gnome Disappointment (Practicability of Underground Nuclear Shots for Power Production Unproved)," Wash. Atomic Energy Report, VIII, January 2, 1 (1962).
59. "Gnome Results Reviewed," Wash. Atomic Energy Report, VIII, 33 (1962).
60. Nucleonics Week, 2, 51 (1961).
61. "Atomic Earth Mover," Newsweek, LX, 3 (1962).
62. Finney J. W. "Largest A-Blast in Ground Mapped. Nevada Device Would Test Earth-Moving Power," The New York Times, June 27 (1962).
63. Miles M. "First H-Test in U.S. Fired in Nevada," The Washington Post, July 7, 1962.
64. "Project Sedan," Appl. Atomic, 354 (1962).
65. "Sedan Results Encouraging," Wash. Atomic Energy Report, VIII, 27-28 (1962).

## ADDITIONAL LITERATURE

1. Pasechnik I. P. et al. "Result of Seismic Observations in Underground Nuclear and TNT Explosions," Tr. In-ta fiz. zemli im. O. Yu. Shmidta, No 15 (182), (1960).
2. "A-Bomb Recovery of Shale Oil Proposed," Rocky Mt. Oil Reporter, March, 1959.
3. Antonides L. "Atomic Blasting, Mining Practice, Part 1," Engng. and Mining J., February, 159 (1959).
4. "Atomic Blast, Alberta Okays Oil Sand Explosion," Oil in Canada, 21, September, 14, 15 (1959).
5. Bertin L. The Financ. Post, No 44, 23 (1958).
6. Carder D. S. and Bailey L. F. Bull. Seismol. Soc. America, 48, 4, 377 (1958).
7. Carder D. S. and Mickey W. V. Bull. Seismol. Soc. America, 52, 1, 67 (1962).
8. Diment W. H. et al. Geol. Soc. America, 70, 12 (1959).
9. "Extraction of Minerals by Atomic Blasting," Mining J., 6439, 55 (1959).
10. Grossling B. F. Bull. Seismol. Soc. America, 49, 11 (1959).
11. Haskell N. A. J. Geophys. Res., 66, 9, 2937 (1961).
12. Herbst R. F. et al. J. Geophys. Res., 66, 3, 959 (1961).
13. Hess W. N. and Nordyke M. D. J. Geophys. Res., 66, 10, 3405 (1961).
14. Lasky S. G. Mining Congr. J., January, 48 (1960).
15. Latter A. L. et al. J. Geophys. Res., 66, 3, 943 (1961).
16. Latter A. L. et al. Phys. Fluids, 2, 3, 280 (1959).
17. "Plowshare Accelerated," Wash. Atomic Energy Report, VII, 36 (1961).
18. "Plowshare May Dig Canal in South," Nucleonics, 20, 6, 86 (1962).
19. "The Plowshare Program," Appl. Atomics, July 4, 353 (1962).
20. "Project Chariot to Be Held in 'Abeyance'," Atomic Energy Clearing House, 8, 35 (1962).
21. Rabb D. D. Mining Congr. J., 44, 11, 79 (1958).
22. Rinehart J. S. "How to Predict the Effects on Spalling When Caused by Large Blasts," Engng. and Mining J., August, 98 (1960).
23. Rougeron C. Le Petrole Thermonucléaire, Paris, 1959.

24. Simons H. "AEC, Pleased by Test, Plans for Two More," The Washington Post, July 7, 1962.
25. Teller E. "We're Going to Work Miracles," Popul. Mech., 3, 97, 278, 280, 282 (1960).
26. "To Help Develop the Necessary [Knowledge] for Using Nuclear Explosives," Atomic Energy Clearing House, 8, July 9, 28 (1962).
27. Wright J. K. et al. J. Geophys. Res., No 3 (1962).