

U.S. DEPARTMENT OF COMMERCE
National Technical Information Service

N76-15015-15073

PROCEEDINGS OF THE INTERAGENCY
WORKSHOP ON LIGHTER THAN AIR VEHICLES

Joseph F. Vittek

January 1975

DISTRIBUTION STATEMENT A
Approved for Public Release
Distribution Unlimited

Reproduced From
Best Available Copy

20011022 059

KEEP UP TO DATE

Between the time you ordered this report—which is only one of the hundreds of thousands in the NTIS information collection available to you—and the time you are reading this message, several *new* reports relevant to your interests probably have entered the collection.

Subscribe to the **Weekly Government Abstracts** series that will bring you summaries of new reports *as soon as they are received by NTIS* from the originators of the research. The WGA's are an NTIS weekly newsletter service covering the most recent research findings in 25 areas of industrial, technological, and sociological interest—invaluable information for executives and professionals who must keep up to date.

The executive and professional information service provided by NTIS in the **Weekly Government Abstracts** newsletters will give you thorough and comprehensive coverage of government-conducted or sponsored re-

search activities. And you'll get this important information within two weeks of the time it's released by originating agencies.

WGA newsletters are computer produced and electronically photocomposed to slash the time gap between the release of a report and its availability. You can learn about technical innovations immediately—and use them in the most meaningful and productive ways possible for your organization. Please request NTIS-PR-205/PCW for more information.

The weekly newsletter series will keep you current. But *learn what you have missed in the past* by ordering a computer **NTISearch** of all the research reports in your area of interest, dating as far back as 1964, if you wish. Please request NTIS-PR-186/PCN for more information.

WRITE: Managing Editor
5285 Port Royal Road
Springfield, VA 22161

Keep Up To Date With SRIM

SRIM (Selected Research in Microfiche) provides you with regular, automatic distribution of the complete texts of NTIS research reports *only* in the subject areas you select. SRIM covers almost all Government research reports by subject area and/or the originating Federal or local government agency. You may subscribe by any category or subcategory of our WGA (**Weekly Government Abstracts**) or **Government Reports Announcements and Index** categories, or to the reports issued by a particular agency such as the Department of Defense, Federal Energy Administration, or Environmental Protection Agency. Other options that will give you greater selectivity are available on request.

The cost of SRIM service is only 45¢ domestic (60¢ foreign) for each complete

microfiche report. Your SRIM service begins as soon as your order is received and processed and you will receive biweekly shipments thereafter. If you wish, your service will be backdated to furnish you microfiche of reports issued earlier.

Because of contractual arrangements with several Special Technology Groups, not all NTIS reports are distributed in the SRIM program. You will receive a notice in your microfiche shipments identifying the exceptionally priced reports not available through SRIM.

A deposit account with NTIS is required before this service can be initiated. If you have specific questions concerning this service, please call (703) 451-1558, or write NTIS, attention SRIM Product Manager.

This information product distributed by

NTIS

U.S. DEPARTMENT OF COMMERCE
National Technical Information Service
5285 Port Royal Road
Springfield, Virginia 22161

T N76-15015-15073
PROCEEDINGS

OF THE INTERAGENCY
WORKSHOP ON

LIGHTER THAN AIR VEHICLES

M.I.T. FLIGHT TRANSPORTATION LABORATORY

FTL Report R75-2
January, 1975

Edited by
Joseph F. Vittek, Jr.

710P
[Massachusetts Inst. of Tech.]

COPIES SUBJECT TO CHANGE

REPRODUCED BY
**NATIONAL TECHNICAL
INFORMATION SERVICE**
U. S. DEPARTMENT OF COMMERCE
SPRINGFIELD, VA. 22161

OCT 29 1976

CHAIRMAN'S MESSAGE

On behalf of the sponsoring agencies, NASA, Navy, DOT and FAA, I extend our thanks to all those who contributed to a successful LTA Workshop at Monterey, California, in September, 1974. Well beyond our expectations, the magnitude and breadth of representation was gratifying. Our purpose for sponsoring the workshop was to provide a timely forum for the exposition and discussion of current views, ideas, and activities on all aspects of LTA. With no intent to develop an advocacy position, either for or against LTA, we wanted to objectively survey those facts and speculations which abound amid the recent revival of interest. This we accomplished, and more. Through the confluence of opinions, prejudices, and ideas, often diverse but always in the spirit of camaraderie, this intense week focusing on LTA established a watershed from which future activities will flow. And, indeed, much work lies ahead. If the full potential of LTA is to be realized, it will require the collective efforts of industry, government and the universities. To assist in this effort, the Workshop Report and Proceedings provide an extension of a memorable week in Monterey.

Alfred C. Masy
General Chairman
NASA Ames Research Center

This report was prepared under joint NASA/ Navy/DOT/FAA Grant No. NSG-2024. The views expressed herein are not necessarily the official opinions of the sponsoring agencies: The Systems Study Division, NASA Ames Research Center; Naval Air Development Center, U.S. Navy; Office of Aviation Policy, FAA; and Office of the Assistant Secretary for Systems Development and Technology, DOT.

Portions of this report may be quoted without permission when credited unless noted differently in individual papers.

**FLIGHT TRANSPORTATION LABORATORY
MASSACHUSETTS INSTITUTE OF TECHNOLOGY
CAMBRIDGE, MASSACHUSETTS 02139**

TABLE OF CONTENTS

Chairman's Message Alfred C. Masey iii

Preface Joseph F. Vittek, Jr. ix

Exhortation Where Do We Go From Here? — Charles E. Rosendahl xiii

Economic and Market Analysis

Basic Relationships for LTA Economic Analysis — Raymond A. Ausrotas 1

Preliminary Estimates of Operating Costs for Lighter Than Air Transports — C. L. Smith, M. D. Ardema 7

Comparative Airship Economics — Robert Harthoorn 21

Effect of Present Technology on Airship Capabilities — Robert T. Madden, Frederick Bloetscher 31

Airship Economics — Richard D. Neumann, L. R. "Mike" Hackney 41

Some Economic Tables for Airships — Richard D. Neumann 53

A Study of Design Trade-Offs Using a Computer Model — Stephen Coughlin 63

An Economic Comparison of Three Heavy Lift Airborne Systems — Bernard H. Carson 75

An Approach to Market Analysis for Lighter Than Air Transportation of Freight — Paul O. Roberts, Henry S. Marcus, Jean H. Pollock 87

Market Assessment in Connection with Lighter Than Air — John E. R. Wood 111

Technical and Design Considerations

Basic Relationships for LTA Technical Analysis — Raymond A. Ausrotas 123 *D11*

The Effects of Selected Modern Technological Concepts on the Performance and Handling Characteristics of LTA Vehicles — Carmen J. Mazza 133 *D12*

Boundary Layer Control for Airships — F. A. Pake, S. J. Pipitone 147 *D13*

Airship Stresses Due to Vertical Velocity Gradients and Atmospheric Turbulence — Duncan Sheldon 157 *D14*

An Aerodynamic Load Criterion for Airships — Donald E. Woodward 169 *D15*

The Planar Dynamics of Airships — Frank J. Regan 177 *D16*

Preceding page blank

Floating vs. Flying, A Propulsion Energy Comparison — Fendall Marbury	187	D17
Long Fluid Filled Bags Suspended by Line Forces — M. L. Mullins, J. L. Duncan	199	D18
Computer Aided Flexible Envelope Designs — Ronald D. Resch	209	D19
LTA Application of a Long Trailing Wire High Speed/Low Weight Reeling System — D. F. Werb	217	D20

Materials, Manufacturing and Operations

LTA Structures and Materials Technology — Norman J. Mayer	223	D21
Potential Contribution of High Strength, High Modulus Aramid Fibers to the Commercial Feasibility of Lighter Than Air Craft — D. L. G. Sturgeon, T. K. Venkatachalam	243	D22
Airship Construction — John Roda	257	D23
Operational Considerations for the Airship in Short-Haul Transportation — Charles D. Walker	261	D24
Design Aspects of Zeppelin Operations from Case Histories — Walter P. Maersperger	267	D25
Lighter Than Air: A Look at the Past, A Look at the Possibilities — William F. Shea	285	D26
Mooring and Ground Handling Rigid Airships — Hepburn Walker, Jr.	297	D27
A New Concept for Airship Mooring and Ground Handling — John C. Vaughan	311	D28

Modern Airship Design Concepts

The Slate All Metal Airship — Claude C. Slate, Richard D. Neumann	323	D29
State of the Art of Metalclad Airships — V. H. Pavlecka, John Roda	331	D30
The Aerospace Developments Concept — John E. R. Wood	351	D31
Method for Transporting Impellent Gases — Hermann Papst	359	D32
The Design and Construction of the CAD-1 Airship — H. J. Kleiner, R. Schneider, J. L. Duncan	369	D33
A LTA Flight Research Vehicle — Fred R. Nebiker	395	D34
The Airfloat Heavy Lift Project — Edwin Mowforth	405	D35

Hybrid Airship Design Concepts

The Basic Characteristics of Hybrid Aircraft — J. B. Nichols	415	D36
A Semibuoyant Vehicle for General Transportation Missions — C. Dewey Havill, Michael Harper	431	D37

The Dynairship — William McElwee Miller, Jr.	441	D38
Some Aspects of Hybrid-Zeppelins — Paul-Armin Mackrodt	457	D39
Ultra-Heavy Vertical Lift Systems—"The Hell-Stat" — Frank N. Piasecki	465	D40
The Variable Density Aircraft Concept — A. C. Davenport	477	D41

Airship Applications

Roles for Airships in Economic Development — George J. Beier, Gerardo Cahn Hidalgo	485	D42
The Application of the Airship to Regions Lacking in Transport Infrastructure — Stephen Coughlin	499	D43
Military Applications of Rigid Airships — Ben B. Levitt	509	X
Potential ASW Missions for Lighter Than Air Ships — Richard S. Stone, Bernard O. Koopman, Gordon Raisbeck	517	X
Antisubmarine Warfare (ASW) — A Specific Naval Mission for the Airship (Abstract Only) — Louis J. Free, Edwin E. Hanson	527	X
The Surveillance Airship (Abstract Only) — L. E. Mellberg, R. T. Kobayashi	529	X
Airship Logistics? The LTA Vehicle: A Total Cargo System — L. R. "Mike" Hackney	531	D44
The Transport of Nuclear Power Plant Components — S. J. Keating, Jr.	539	D45
Airships for Transporting Highly Volatile Commodities — Miles Sonstegaard	551	D46
Using Lighter Than Air Vehicles (Dirigibles) in Housing Construction — E. E. Shamis, V. B. Moorychev	559	X
Environic Implications of Lighter Than Air Transportation — Patrick Horsbrugh	563	D47

Unmanned and Tethered Systems and Applications

Aerocrane—A Hybrid LTA Aircraft for Aerial Crane Applications — Russel G. Perkins, Jr., Donald B. Doolittle	571	D48
Unmanned Powered Balloons — Arthur O. Korn	585	D49
Special Problems and Capabilities of High Altitude Lighter Than Air Vehicles — P. R. Wessel, F. J. Petrone	595	D50
A Practical Concept for Powered or Tethered Weight-Lifting LTA Vehicles — M. Alain Balleyguier	605	D51
A Revolutionary and Operational Tethered Aerostat System Illustrating New LTA Technology — James A. Menke	613	D52
Technology Update—Tethered Aerostat Structural Design and Material Developments — Robert G. Witherow	623	D53

Two Lighter Than Air Systems in Opposing Flight Regimes—An Unmanned Short Haul, Heavy Load Transport Balloon and a Manned, Light Payload Airship — R. A. Pohl	637	D52)
Balloon Logging with the Inverted Skyline — C. Frank Mosher	651	D55
“LOTS” of LTA Applications — Jay S. Brown	667	D54
Remotely Piloted LTA Vehicle for Surveillance — Gerald R. Seemann, Gordon L. Harris, Glen J. Brown	679	D57

Appendices

LTA Bibliography — Richard D. Neumann	685	D58
Authors	689	

PREFACE

In the past few years there has been much discussion both in the United States and abroad of the ability of Lighter Than Air vehicles to meet future transportation needs. Many of the proposed uses and missions seem promising. However, Lighter Than Air is not without its problems. Although modern technology may be able to overcome these problems, the ultimate issue could be the economic feasibility of Lighter Than Air.

The Potential of LTA

The airship has certain advantages over alternate modes of transportation. Like a ship or barge, it can move large bulk and weight shipments over long distances. Unlike a ship or barge, it need not follow established waterways. Nor does it require terminal facilities other than at its home base. The airship offers these same advantages over railroads and has considerably greater capacity than trucks. Even though a high-cargo-capacity airplane could be developed that might match an airship's payload, it would require large runways at both ends of its trip. Thus, the airplane lacks the airship's flexibility.

Because of the inherent advantages, several LTA missions can be identified. One often mentioned is the use of LTA in developing nations to move bulk commodities and crops out of otherwise inaccessible areas. Another mission is the transportation of bulky machinery (such as nuclear power generation equipment) too large to move over normal highways or rail right-of-ways. Large capacity, coupled with the ability to hover, makes LTA a candidate for construction tasks—the proverbial “sky hook”. These same characteristics could be used for disaster relief when normal transport facilities are damaged.

Other uses such as spraying crops, geological surveying, archeological expeditions, military reconnaissance and anti-submarine missions are also feasible.

For passenger travel, the airship could revive an era of elegance no longer available. Although some feel the airship might compete for city-center to city-center short haul traffic, its true role would probably be the “cruise liner” of the air.

All these uses, coupled with the airship's potential for low pollution, low noise and energy efficient flight, have rekindled public interest and imagination.

The Problems of LTA

The promise of LTA is not without its problems. Most are directly related to the large size of a Lighter Than Air craft.

GROUND OPERATIONS

Although LTA vehicles may hover while transferring cargo, etc., they still have a requirement for home bases for maintenance, repairs and re-

furbering. The least this will require is an open area and a mooring mast or other tethering device. For some of the larger airships proposed, the clear area needed for maneuvering, particularly in response to wind shifts, could be quite extensive.

Ground handling techniques present a second problem. By the mid-1930s the hundreds of ground handlers required in earlier days had been reduced through mobile masts and winches, although many ground personnel were still needed. Refinements introduced by the Navy during the 1940s and 1950s reduced blimp ground crews to three or four men. But even today, about 10 ground handlers are needed to land a Goodyear blimp, a relatively small Lighter Than Air craft, at sites not equipped with mobile equipment.

An additional operational problem occurs when payload is taken on board or discharged from a Lighter Than Air vehicle. Under normal operating conditions, an airship has approximately neutral buoyancy. When the airship is loaded or unloaded, its weight changes, destroying the equilibrium condition. Normally, ballast is also loaded or unloaded to retain the neutral state (although reducing the amount of lifting gas would have the same effect). This means that if the airship is delivering or picking up cargo at some undeveloped site, there must also be provisions at the site for ballast and transferring that ballast. Alternatively, some on-board system is needed to change the gas volume. But such a system may be too heavy to justify.

AIR OPERATIONS

The replacement of hydrogen with non-flammable helium as the lifting gas has shifted the major danger of an airship catastrophe from fire to structural failure in violent weather. Undoubtedly, better structures can be designed today than 40 years ago. And modern materials can provide increased strength with decreased weight. But as the size of proposed airships increases so do the bending and twisting forces that may arise during operations. The structures required to meet the dynamic forces encountered by the large airships proposed by many may impose weight penalties due to safety considerations and decrease payloads, even if modern materials and techniques are applied.

Another structural problem is maintainability. Minor ground handling errors may damage the skin or interior bracing leading to substantial downtime for repairs. Questions of damage susceptibility, structural integrity and maintainability raise doubts as to the reliability of airships and their ability to reach the degree of utilization needed for commercial success.

Technological Solutions

Technology available today or in the foresee-

able future can alleviate many of these problems. Perhaps the most useful technological innovations would be the application of modern sensors and variable thrust and direction engines to both stabilize position and perform precise maneuvers. As in the Apollo spacecraft, inertial sensors that detect directional and rotational forces can be coupled through a computer to active control systems. This would allow rapid detection of undesired motion and the application of corrective forces to counter the motion before it becomes too severe, improving ground handling and air operations.

Television cameras could be used to monitor the parts of the airship not directly observable. They would also provide the crew with extra eyes during precise maneuvers such as docking. Radar altimeters would provide better knowledge of altitude. Better radio and navigation equipment would provide considerably more information than an old and experienced zeppelin captain would have ever thought possible.

Modern weather prediction techniques and frequent forecast updates would allow the safe circumvention of storms, as would airborne weather radars.

Computerized structural design techniques would permit more accurate analyses of the stresses and strains an airship would have to endure. This, coupled with today's knowledge of storm intensities and shear forces, would lead to structures designed to withstand the worst weather possible. And the application of titanium and composite fiber materials would minimize the weight of these structures. New synthetics are available to make stronger while lighter-weight coverings.

In short, the technology is available to address many of the problems of Lighter Than Air. An unanswered question is whether the demand for Lighter Than Air services is sufficient to offset the costs of this technology.

Economic Issues

For any new method of transportation to gain acceptance, it must offer an improvement over existing systems in terms of performance or cost or both. Therefore, to be a success, Lighter Than Air must capture traffic from an existing mode of transportation by offering a better service or generate new traffic by offering services not currently available. In a military context, LTA must be able to perform missions better or cheaper than at present, or offer a capability desired but not currently available.

GENERAL DEMAND

Although one can hypothesize what new markets or types of traffic might be developed if commercial airships did exist, the demand for such applications is limited. It is doubtful whether a potential airship manufacturer would commit corporate funds for LTA development based on such speculation alone. Therefore, for the private sector to take the lead in airship development, there must be sufficient general demand for airships

based on current transportation patterns to justify the investment risk of a manufacturer.

LTA's ability to lure traffic from other modes will depend on the cost and speed of the service it can offer as compared to the competition's. These characteristics can easily be determined for current methods of transport. Likewise, reasonable estimates of airship speeds and payloads are available. But to date, the cost of airship service is largely unknown because few accurate data points exist.

SPECIAL MISSIONS AND MARKETS

It is possible that a potential user could have a specific mission so suited to LTA and so expensive or impossible by other means that he would be justified in paying the manufacturer's development cost as well as paying for the airship itself. But because the development cost may run into the hundreds of millions of dollars, there are few potential users who could afford the initial investment. In some cases, an industry as a whole might be able to raise sufficient capital, but competitive pressures or anti-trust laws might prevent cooperative ventures.

The only customers that can clearly satisfy the criteria of specific missions suited to LTA and sufficient funds to underwrite development are governments, particularly their military branches. But, at least in the United States, the cost effectiveness of LTA must first be proven without a doubt to military leaders, the Defense Department and the Congress before funds will be released.

In a broader context, governments would be justified in supporting the LTA development if society as a whole would benefit from its introduction. Because the private sector is rarely rewarded for reducing the social costs of pollution, noise and energy consumption, corporate cost-benefit analysis may indicate that an investment is not worthwhile for the company alone. But that same investment might be very worthwhile for society collectively. In such a case, the government should act. Unfortunately for LTA, this concept of total social costs, though often discussed, is rarely the basis of government action unless associated political pressures are brought into play. And LTA has a small lobby at this time.

Institutional Constraints

A final set of problems is that imposed by government regulation, union contracts and the like. How will airships be certified? The Federal Aviation Administration has been attempting to develop standards for STOL aircraft for several years, although the differences between STOL and conventional aircraft are not that dramatic. How long will it take to develop standards for commercial airships? How will airships be tested? What safety standards will apply?

How will airships be handled by the air traffic control system? At the least, because of their relatively low speeds and altitude restrictions, special procedures of some type will be needed.

Will airships be operated by airlines? By ship-

ping companies? Will certificates of public convenience and necessity be required?

Will the aviation or the maritime unions have jurisdiction? Will the Civil Aeronautics Board or the Federal Maritime Commission have jurisdiction? What of our international bilateral agreements? Will they apply or will new negotiations be needed?

Although these issues are currently overshadowed by the technical and economic questions, they must at least be considered.

The Lighter Than Air Workshop

As a first step toward resolving some of these questions, NASA, along with the Office of the Secretary of Transportation, the Federal Aviation Administration and the United States Navy, contracted with the Flight Transportation Laboratory of the Massachusetts Institute of Technology to conduct a week-long workshop on Lighter Than Air in September, 1974.

Workshops have been used for many years to bring together a group of people knowledgeable on a particular subject for an intensive period of discussion and interchange of ideas. The approach used for the Lighter Than Air workshop was to have three days of papers and presentations on the current state-of-the-art followed by two days of working sessions to analyze the materials presented. The papers presented at the workshop are documented in FTL Report 75-2, *Proceedings of the Interagency Workshop on Lighter Than Air Vehicles*. The outputs of the working groups are documented in FTL Report 75-1, *An Assessment of Lighter Than Air Technology*.

The goals of the Lighter Than Air workshop were to establish what facts are known about LTA's potential, what are the unknowns and, in turn, what are the programs that could resolve some of the unknowns. No less important was the assembling of Lighter Than Air experts for face-to-face discussions for the first time in over forty years.

The workshop did accomplish these limited goals. It did not begin to answer all the questions concerning LTA. Rather, it pointed the way to answering the questions and provided a platform for further research to separate fact from speculation once and for all.

*Joseph F. Vittek, Jr.
Editor and Workshop Director
Assistant Professor
M.I.T. Dept. of Aeronautics
and Astronautics*



EXHORTATION

The dean of rigid airshipmen living today, Vice Admiral Charles E. Rosendahl began his Lighter Than Air career in 1923. He was navigator and senior surviving officer of the first American-built large rigid airship Shenandoah which crashed in a storm over Ohio on September third, 1925, with the loss of fourteen of her crew of forty-three. Commanded by Rosendahl, several of the Shenandoah's crew free-ballooned the front half of the ship for over an hour before coming safely to earth.

Subsequent to the Shenandoah crash, Admiral Rosendahl commanded the Los Angeles from May, 1926, to June, 1930. During that period, he participated in the trials of the Graf Zeppelin in Germany and was onboard for its first westward crossing of the Atlantic in October, 1928. As the U.S. Navy observer, he also made the Graf Zeppelin's historic around-the-world flight in 1929.

After commanding the Los Angeles, Rosendahl served in the Bureau of Aeronautics preliminary to assembling the flight test crew of the Akron, then nearing completion. He commanded the flight trials of that airship and delivered her to Lakehurst where he assumed command after her commission in October, 1931, and so served until June, 1932.

After two years at sea, Rosendahl was commanding officer of the Lakehurst Naval Air Station from 1934 to 1938. He was present during the Hindenburg's 1936 use of Lakehurst as its western North Atlantic terminal and flew on her many times. He was commanding officer at Lakehurst when the Hindenburg burned there on May 6, 1937.

Several more years were spent at sea, with a brief return to LTA in 1940 when then Commander Rosendahl was ordered to the Naval Department to activate the Navy's blimp program. During these sea years, Rosendahl was promoted to Captain and commanded the Minneapolis in several South Pacific engagements.

As of May, 1943, Captain Rosendahl was made Chief of Naval Airship Training and Experimentation and Special Assistant for LTA to the Deputy Chief of Naval Operations (Air) and promoted to Rear Admiral. In this position, he continued to play a major role in the outstanding success of the Navy blimp program during World War II.

Although he retired from the Navy in 1946 with the rank of Vice Admiral, his career in aviation was far from over. He served for nine years as Executive Director of the National Air Transport Coordinating Committee, is an Elder Statesman of Aviation (National Aeronautic Association); Past President and Life Honorary Member of both the Wings Club and the John Ericsson Society; and a Quiet Birdman.

Admiral Rosendahl was winner of the Harmon International Award (Aeronaut Class) in 1927 and 1950; a member of the Harmon Advisory Committee, 1948-1972; and Harmon Trustee, 1968-1972. He also holds the Navy Cross, Navy Distinguished Flying Cross and Navy Distinguished Service Medal.

After publishing two books and numerous articles on airships, Admiral Rosendahl has taken a less active public posture for several years, enjoying his retirement at Flag Point, New Jersey. Thus, it was to everyone's great enthusiasm that Admiral Rosendahl agreed to be the honored guest and special luncheon speaker at the workshop. The text of his talk is reproduced below.

WHERE DO WE GO FROM HERE?

VAdm. C.E. Rosendahl, USN (Ret.)

From the sidelines, I have been hearing and reading so much miscellaneous matter relating to airships that this seemed a propitious occasion for someone with actual operating experience in the large types to come in as a free-lance critic and discuss some of the pertinent topics with you. Let me assure you that my comments and criticisms are not intended to be discouraging, for I too believe in the revival of airships and a successful, useful hereafter for them in the fields for which they are suited.

There are today very few of us ancient mariners still around who, some years ago, participated in the *first* chapter of the story of the *rigid airship*. So it is comforting to see here, in this day and age, some new personalities scanning this subject in which we still believe. Though most of you are interested primarily in technical aspects of the airship picture, we trust you will not overlook the *operational* side, for the vehicles discussed won't operate themselves.

It is particularly pleasing to me to see again

such experienced airship pilots as Admiral Carl Seiberlich, Admiral Dick Andrews, Captain George Watson, Commander Ben Levitt, Professor "Red" Layton, Dr. Jack Harris, Bill Langen, Bob Ashford, Walt Collins, Lyn May, James Sejd, and that staunch airshipman Hepburn Walker. George Watson and I sweat out many a situation together in the big ships, but the others were too young, of course, to have served in the large or rigid airships of yesteryear. But they all typify a number of similarly qualified men who possess the basics derived from actually operating non-rigid airships, to qualify them for valuable participation in the next chapter in which modernized aircraft of the rigid airship type will star.

But at the same time, we cannot afford to lose sight of the non-rigid airships, "blimps" as you may call them.

It is fortunate that Admiral Seiberlich has his eye on blimps too, for such craft, modernized and equipped up to date, have capabilities for a variety of necessary defense tasks. Two of these are anti-submarine warfare and the protection of shipping. By way of quick illustration, in World War II our naval blimps escorted some 89,000 ships at sea, laden with troops, equipment, munitions, supplies, raw materials, without loss of a single vessel to enemy submarines. A good half of this record was made in areas where hostile undersea craft were known to be present.

The current official functions of the Navy include: "To organize, train, and equip Naval forces for...antisubmarine warfare and protection of shipping." Yet, sad to say, for untenable reasons the Navy currently has no blimps at all.

But so important are these tasks considered by defense authorities that: "To train forces...to conduct anti-submarine warfare and to protect shipping" is a designated task *also* of the U.S. Air Force, albeit as a function termed "collateral".

I sense, of course, that your primary interest here today is in the much larger or rigid airships. Yet, you must surely recognize that the avalanche of inspired airship publicity—some people would no doubt style it obvious "propaganda"—has sprung ajar the gates to discussion so widely that in my allotted time it is possible for me to touch upon only relatively few of the tempting topics available.

As a necessary preliminary, we should first review a few aeronautical terms to insure that we all speak the same airship language and understand what the other fellow is talking about.

The field of aeronautics, of course, embraces both heavier than air aircraft and lighter than air aircraft. The former derive their lift *aerodynamically*, the latter *aerostatically* from displacement of air by some gas which weighs less than air. HTA aircraft have only their aerodynamic lift. However, LTA aircraft have not only their buoyancy, but by flying at an inclination generate an aerodynamic lift increment which is very helpful.

In the HTA division we have "fixed wing" and "rotary wing" specialists. In the LTA field, the simplest forms are "free" and "captive" balloons, with buoyant lift only. But when we give balloons

propulsion and guidance, they are "steerable" or "dirigible" balloons or "airships". The word "dirigible" began life as an adjective which basically it still is despite its semantically corrupt use as a noun to denote only the "rigid" airship. Actually, in its defiled usage as a noun, "dirigible" could apply to a rigid, a semi-rigid, or a non-rigid (blimp) airship. Some folks even call them "zeppelins", whereas zeppelin is a particular type of rigid airship manufactured by the Zeppelin Company, as is the renowned 747 airplane a *Boeing* 747. So if we are talking about rigid airships, let's say so unmistakably.

There is a reason for this review of certain airship terms. Recently, airship publicists have embraced, and glorified unstintingly, something from the dream world in various configurations labeled "hybrid" and imagined to be almost everything to everybody, even though not a single form of one has yet been designed, let alone been built.

Of course, there is already under active consideration a purely heavier than air hybrid to result from mating the helicopter with the airplane to permit the resultant craft to take off and land almost vertically as well as to hover for a while. Cited in the ancestry of such rotatable propellers are those of the rigid airships Akron and Macon which with reversible engines could produce thrust up or down, astern or ahead. But let us hope today's version of such variable thrust installations are considerably better than those of the airship Akron days.

Genealogically, the heralded buoyant hybrid would be part lighter than air and part heavier than air. But no one knows yet whether the parts and performance inherited from the two progenitors would be the good ones, the mediocre ones, or the worst. So far they are only awesome "artist's conceptions" on flat paper, revealing nothing of what may be inside their cavernous carcasses. Looked at coldly and calmly, the real intention might well be just to graft onto an HTA vehicle some LTA buoyancy.

This situation reminds me somewhat of a letter the Navy Department received in the early days when transport airplanes were losing an occasional conflict with the laws of gravity. A Congressional source urged the Navy to share its airship helium supply so that airplanes could be made safer by putting helium in their wings. And then too there was the publicity-seeking gent who took the precaution of putting ping-pong balls in the wings of the plane he used in crossing the North Atlantic.

But, thank goodness, the buoyant hybrid idea would first have to be scrutinized by engineers and technologists, men to whom the slip stick and the computer are a lot more convincing than the eye-catching illustrated printed page and the siren songs of the television talking picture.

Thus far at least, the idea of the buoyant hybrid, heralded as of almost universal capability, has led to little except possibly some diminution of interest in the real airship. In my humble opinion, the buoyant hybrid should not be classed as an "airship". Rather, the cognizant authorities over

such matters should designate the HTA hybrid clearly as a member of the HTA aeronautical family, but at the same time create a distinct additional category in the field of aeronautics for the "neither fish nor fowl" buoyant hybrid. Then, if qualified technologists consider that the type has potential worthwhile value, by all means go ahead and explore it, but don't thereby stymie the modernized airship.

Admittedly, the world will always need imagination that can be translated into useful reality. It is furthermore granted that the flood of general airship publicity has generated a great deal of interest in the broad airship subject. But laudable as this is, one might wish it had been geared more to operational realities, so as not to put in jeopardy the credibility of *all* its representations.

For example, it has been said that "...on the ground, all the dirigible [meaning airship, one assumes] requires is a flat clearing—a grassy field will do". Also, to make airship moorings where needed, it has been proclaimed, the airship's own crew could tie the ship down by two or three "tether" points, run lines out and hammer stakes in the ground. Would that life in the airship world could be so simple!

Should these examples render suspect the degree of accuracy permeating *other* publicized dreamboat concepts? Recent airship propaganda has contended that after its losses in rigid airships the Navy gave up that type in favor of the smaller, less costly blimps. In more ways than one, that statement is highly inaccurate.

First, the Navy has *never* definitely and clearly announced its dropping of rigid airships, but rather sneaked that in as an implication when announcing the termination of blimps.

The Navy did not "give up" rigid airships in favor of blimps. The two types are not even in the same league. Their functions differ widely; one could not substitute for the other. And, we did have some blimps at the same time we had the rigids.

Additionally, the propagandist said, blimp operations were discontinued "as an economy measure". Wrong again. Airships of both types were exterminated with "malice aforethought", as I will sustain at length in a coming book.

But even though airships must suffer such indignities as just quoted, perhaps we should be thankful for the apparent disappearance of certain other fallacious items.

For example, rarely these days do we hear about mooring an airship atop the Empire State Building in New York or to other tall buildings elsewhere. There seems to have vanished also the once-touted city-to-city pick-up-and-delivery service by airships using midtown roof tops as landing platforms.

Also, in my opinion there will join those ideas, on the back shelf, the speculative use of large airships to take repeated rough air beatings and exposures to sandstorms, to sneak their great length and bulk through high and turbulent mountain passes not infrequently obscured by clouds and thunderstorms in order to pick up popular

garden products, then reverse the procedure and distribute them over the continent.

Yet, I am aware of the brief intimations that in flight an airship's helium might be alternately vaporized or liquified to help control buoyancy, "something done in the past by dropping ballast and valving off gas".

Helium in the liquid states requires heavy storage facilities as well as heavy facilities for changing it from gaseous to liquid form. Could the airship afford the diversion of useful lift to such weights plus the energy cost for helium liquification? Why introduce such complications at this point of revival of the airship, when they are not necessary in the airship's proper field of employment?

As to "valving off gas" for buoyancy control, with a little research the publicist could have learned that "valving off gas" was practiced only by hydrogen-inflated airships. There have been extremely few occasions when airships ever valved off helium. In the rigids, the weight of fuel consumed was compensated for by "water recovery apparatus" which condensed and collected water from engine exhaust gases, with an efficiency of over 100% at times. Must we assume that this particular airship publicist was unaware of "water recovery" while writing so authoritatively on other airship technical matters, and recommending much more costly, cumbersome, still unproven apparatus for buoyancy control?

Still another of the propagandist's eye-catchers in the dream world, in my opinion also headed for the back shelf, is the simple sounding but highly speculative proposition of having an enormous-sized airship stand still as a statue and make a "spot drop" with necessary "jeweler's precision" of extremely heavy indivisible mechanical assemblies. That operation would require not only heavy, expensive, complicated equipment for the airship, but of even more importance, very unusual cooperation of Mother Nature.

As to the suggested complete 100-bed hospital aboard an airship moored in a clearing in a continental interior to a simple stick mast brought in by the airship itself, one marvels at the great imagination its proposer must possess. What a workout this proposed project would be not only for the isolated airship's personnel, but also for the airship itself in rain, snow, sleet, thunderstorms, frontal passages, etc., as well as not being able to replenish its consumable necessities. Must we resort to such fantasy to try to establish that the airship can be a useful thing? From the practicability standpoint, ambition should be made of sterner stuff. From almost every standpoint, it would seem far better and cheaper simply to build an earth-bound hospital for "people-to-people" sake. About the only use for airships not conjured up so far seems to be carrying "coals to Newcastle".

Another publicized candidate for the back shelf is the suggested craft to be formed by the mating of three small hulls horizontally because, one reads, that "could ease construction and handling". First, aren't the craft's *flying considerations*

the primary concern?

Next, it is a well recognized adage that putting a given volume in three smaller containers rather than in one larger one, in the aggregate requires more container area and therefore more weight.

As for "ease in handling", have we already forgotten that on Aereon's first attempt to take its three-hulled craft out of the hangar, an ill-mannered gust of wind flipped it over on its back, hastening the decision to abandon the whole project?

And as for the published idea of mating three large blimp hulls pyramidically into one huge assembly, inquiry has revealed no enthusiasm and only great doubt from several of the most experienced airship pilots I know.

From the pen of a publicist one reads that: "A dirigible [apparently meaning a rigid airship] of the 1970's would not simply be an improved larger version of the Hindenburg or other pre-World War II rigid airships, such as America's Akron and Macon or Britain's R-100." Is that so? Is that pronouncement made as a consensus of informed opinion, or is it only its author's representation? Whatever thinking it is supposed to represent, I do agree with its author about there never being another R-100, nor, for more than one reason, another of the Akron-Macon design. But with the declaration that a modernized Hindenburg will not be built, I am in total disagreement.

It cannot be denied that the Hindenburg was the best rigid airship ever built, and a successful one, and never came up with any structural deficiencies. Yet her learned critics would have us believe that to her fundamental design there could *not* be applied "remarkable advances in propulsion, materials, guidance and control, navigation, aerodynamic theory, electronic data management," etc. To this has been added the statement that the Hindenburg was *underpowered*; by whose standards was she underpowered? I should like to know—certainly not those of the designers and builders of the ship. The critics have added the enigmatic impression that the Hindenburg "had to have a crew continually adjusting and repairing the craft". Doesn't every ship have a crew on watch to operate mechanisms, take readings and report them, etc.? Does the subject commentator believe that all the crew did was to go along for the ride? The quoted inference could have been only some layman's clumsy planted attempt to denigrate a fine airship.

Nuclear propulsion admittedly is an enchanting goal. But realistically, and regardless of the extent of its pre-installation tests and trials, in any first-time airborne installation, "bugs" which cannot be anticipated will creep into its adaptation and make unwise immediate total dependence upon it. Thus, it would seem only prudent to have as "insurance" a pair of additional propellers conventionally driven. Furthermore, who knows but that use of airborne nuclear power overland may be forbidden?

As for passenger traffic, there has been nothing but high praise for transoceanic travel by airship. But during the airship's recuperative period after so many years of neglect, passengers would con-

stitute a most demanding payload.

So let's face some realities and lay aside the exotic proposals conjured up for buoyant hybrids. The airship may achieve a modest increment in operating altitude, but basically it is a low altitude craft. As such, great ocean expanses beckon to the airship, and offer the utmost in meteorological or "weather map" navigation.

At sea, we find waterborne freighters of very low speeds. At the other end of the spectrum are fast and ever-faster airborne freighters. This ever widening speed gap is open to the airship freighter, even if airships never become any faster than the Hindenburg. The airplane provides the fastest transport of cargo, the waterborne freighters the slowest. At a speed of even only 4 to 5 times that of the latter, the airship can provide an additional useful type of service. From contacts with them, I know that Zeppelin designers and operators felt that a cruising speed of about 100 knots was about all they saw any need for in airships.

An authority like Aerospace Engineering Professor Francis Morse says the airplane needs cargo weighing around eleven pounds per cubic foot for economical use of its capacity. "Morse thinks his airship," says Fortune Magazine, "could outperform airplanes in carrying cargoes of fairly high value but fairly low density, which includes most manufactured products." Waterborne freighters haul cargoes for which speedy delivery is of least concern. Airplanes can carry certain cargoes for which speedy delivery is mandatory or at least essential, but at a correspondingly high cost. And Morse has pointed out the general type of intermediate cargoes which it is widely believed would bring the airship plenty of patronage. So that's the field in which the revived airship should resume its place in the world.

So what should be done to modernize the Hindenburg design? There are numerous readily attainable modifications for achieving the goal in addition to the simple conversion of passenger spaces and accommodations into freight stowage. And when there is some agency or authority set up to go into that subject on a serious basis, I shall be glad to pass on my ideas on such updating. But at this point, I will state my firm conviction that the modernized Hindenburg is the proper basis for revival of the rigid airship in the fields in which rigid airships belong.

But there are specific features which deserve adequate attention now in anybody's airship thinking, and here are a few. Boundary layer control has long been a topic of conversation, with general agreement that it is a potential aid of great value. Counter-rotating stern propellers fit into the scheme. Vectored thrust is another worthy goal. The maritime world has long known the value of and is using the "bow thruster" for maneuvering around docks without tug boats.

Jet Assisted Take-Off—JATO—once employed by early flying boats, should not be overlooked. In the airship world, the Italian airship designer Forlanini, in 1932 published information on a novel and interesting maneuvering system he had just installed in a small airship of his. In the bow he

had a centrifugal blower, and a similar one in the stern, each with five outlets or valves for effecting air streams. Thus, compressed air jets could be directed at both ends of the ship, to give thrust ahead or astern, upward or downward, or to starboard or to port. It was claimed that by the operation of these valves, independently or in combination, extreme maneuverability of the airship could be obtained—it could revolve horizontally about its center of gravity, rise or fall vertically or climb or descend at a steep angle, and even move sideways, without discharging ballast.

It should be remembered that the LZ-127, the old Graf Zeppelin, operated throughout her long lifetime on a gaseous fuel called "blau-gas" of density of about 1.0. Since she was inflated with hydrogen, the danger from the gaseous fuel could be accepted. If a helium ship could perfectly insulate a gaseous fuel with its already contained lift helium, the combination would have great advantages.

There is obvious great infatuation with metal hulls for modern large airships or buoyant hybrids, seemingly traceable to the ZMC-2, a very small metal-hulled airship purchased by the Navy some years ago. My advice to such enthusiasts is to "Stop, Look, and Listen" before they go overboard with this idea.

One must indeed admire the development of technique and equipment for literally stitching or sewing together thin metal sheets to form the hull of the ZMC-2. But there are other considerations of transcending importance which must be weighed, and the most important of all is the transmission of heat by the metal hull.

To maintain its shape, the metal hull of the ZMC-2 depended partly on the pressure of the helium within it, so the metal hull served also as the helium container. This is contrary to the conventional rigid airship wherein the helium cells and the ship's outer cover are separate, the space between them also serving to ventilate the hull.

Without burdening this paper with the technical details, let me say simply that because of the very rapid transmission of heat to and from the ZMC-2's helium, sudden fluctuations in altitude to prevent loss of helium and great changes in her buoyancy made the operation of this craft very "tricky". Indeed, the pilots regarded the ZMC-2 as a "bucking bronco" of the air. Even while docked in the hangar there could sometimes be heard metallic "cries" of the hull in response to rapid temperature-pressure changes.

Yes, I hear comments about the "large ground crews" the Hindenburg personnel wanted. But let me assure you, our Naval airship personnel had made great pioneering strides in the mechanizing of airship ground handling of our own rigid airships, improvements that unquestionably the Germans would have adopted in time.

Providing whatever ground manpower the Hindenburg desired was no problem whatsoever. There were always plenty of volunteers who regarded the arrivals and departures of that ship as awe-inspiring events in international history that they didn't want to miss. Furthermore, our per-

sonnel found these occasions of great value in keeping current their knowledge of airships such as we all thought would some day return in our own inventory.

There seems to be floating around an impression that the Germans themselves evidenced being through with airships when they dismantled the LZ-130, next in the Hindenburg series, early in WW II. Actually, they intended, after winning the war, to go into rigid airships on a big scale, but in WW II airships would have been of no value to them. So they scrapped the LZ-130 and the still existing old Graf Zeppelin (LZ-127) and of course made use of the fine alloys with which those two airships had been constructed.

But behind this was their decision to get rid of the two large airship hangars at Frankfurt which were easy for approaching enemy bombers to spot and use for position finding. Even more important to the Germans was the hazard these two huge structures on a totally blacked out field presented to Luftwaffe pilots taking off and landing there at night.

Sincerely, I am enjoying all the papers and presentations being made here. As for my own paper, it is realized that not every question in *your* minds could possibly be answered on this single occasion. But let's hope it has brought realization that more than enthusiasm is required to effect revival of the airship.

Airship history becomes more and more confused as author after author bemoans and pyramids our pioneering losses, and presents his own versions of the loss of the Shenandoah, the burning of the Hindenburg, etc.,—events of nearly half a century ago. What is needed is clarification, not more confusion.

Just a loose confederation of "interested" parties can't hope to re-establish the airship. The game isn't played by the cheer-leaders and the rooting section. So, in my way of looking at the situation, by far the most important decision to be arrived at is that of authoritative cognizance over airships and airship matters. Until that is attained, there may not be any "party platform" on airships. But pending the establishment of such cognizance, perhaps we shall have to look elsewhere for help.

No doubt you remember from Greek mythology of your school days that the stalwart and renowned Greek hero Hercules was assigned to perform a number of tasks that were considered very formidable ones. Frequently mentioned is the "fifth task" which consisted of cleansing the Augean stables which for 30 years had been occupied by thousands of cattle without ever having been cleaned out. But Hercules wasn't awed for a moment. He simply joined two rivers together and with their combined streams got the flushing-out job done in a single day!

So please, Mr. Hercules, wherever you are—over the Island of Cyprus or elsewhere—and whatever you are doing, please drop the bricks and come on down and help us clean up and straighten out the airship situation.

ECONOMIC AND MARKET ANALYSIS

Basic Relationships for LTA Economic Analysis — Raymond A. Ausrotas

Preliminary Estimates of Operating Costs for Lighter Than Air Transports — C. L. Smith,
M. D. Ardema

Comparative Airship Economics — Robert Harthorn

Effect of Present Technology on Airship Capabilities — Robert T. Madden, Frederick Bloetscher

Airship Economics — Richard D. Neumann, L. R. "Mike" Hackney

Some Economic Tables for Airships — Richard D. Neumann

A Study of Design Trade-Offs Using a Computer Model — Stephen Coughlin

An Economic Comparison of Three Heavy Lift Airborne Systems — Bernard H. Carson

An Approach to Market Analysis for Lighter Than Air Transportation of Freight — Paul O. Roberts,
Henry S. Marcus, Jean H. Pollock

Market Assessment in Connection with Lighter Than Air — John E. R. Wood

XVII

BASIC RELATIONSHIPS FOR LTA ECONOMIC ANALYSIS

Raymond A. Ausrotas*

ABSTRACT: Operating costs for conventional lighter than air craft are presented, based upon data of actual and proposed airships. An economic comparison of LTA with the B-747F is shown. A brief discussion of possible LTA economic trends concludes the paper.

INTRODUCTION

In the field of Lighter Than Air, there is a wealth of performance data and a dearth of economic data. Thus it is not surprising that most discussions about the potential of LTA end in agreement that an airship of a given size could carry out some specific mission, but in disagreement as to how much it would cost. Since commercial airship operations have not been undertaken for almost forty years, this paucity of data is not surprising, and any new proposal for LTA--as far as its economic viability--runs into immediate suspicion. It is not the intent of this paper to review the overall economics of LTA, but rather simply to present the supply (cost) side of the equation.

*Associate Director, Flight Transportation Laboratory, Massachusetts Institute of Technology, Cambridge, Massachusetts 02139

AIRSHIP ECONOMICS

The unit cost of an airship is the first in a series of unknowns in an economic analysis of LTA. This cost is determined by four basic variables: total development cost (non-recurring costs), the anticipated airship production run (required to allocate the development cost to each airship), the construction cost (recurring costs), and engine cost. Engine costs would be known before construction was undertaken--the other variables are largely unknown. (Also unknown are such operational factors as need for hangars, mooring masts, terminal buildings, as well as airspace utilization problems, etc.). Estimates of development costs vary from \$50 million to \$500 million; the number of airships needed ranges from 1 to 200; and construction cost estimates range from \$0.50 per cubic foot to \$4.00 per cubic foot. Clearly no definitive answer can be given to the question of "How much will an airship cost?"

Given some purchase price, the airship will be depreciated by the operator over its useful life. If the price of the ship is \$20 million and assuming a life of 10 years, straight line depreciation results in annual ownership costs of \$2 million. In U.S. scheduled airline operations depreciation typically amounts to 10% of total operating costs (direct and indirect). A possible annual operating cost of the airship could be \$20 million. However, consider ocean tanker operations; here depreciation is typically 50% of direct operating costs, resulting in direct operating costs of \$4 million. Adding 50% for indirect costs, total annual airship operating costs amount to \$6 million. Until airships have been in commercial operation for some time, it is hard to judge whether airships will be more like shipping fleet or airline operations.

However, it is possible to take a look to the past when transport airships were in operation. This perspective should provide at least an outline of the likely cost structure should LTA become a commercial possibility.

Table 1 presents a detailed breakdown, in CAB Form 41 style (1931 dollars), of the pro forma costs for a metalclad airship of about the same size as the Navy's Akron/Macon¹. Depreciation was projected to be 20% of total costs, about in line with airline costs; indirect operating cost was 50% of DOC; about the same as current freight airline experience.

The total projected costs of the MC-72 were probably unduly conservative. They were higher than those experienced by three commercial transports, the Bodensee, Graf Zeppelin and the Hindenburg, as is shown in Table 2^{1,2,3,4,5}. The Hindenburg was practically a twin for the MC-72, and achieved about 16¢/available seat mile, compared to the projected 36¢/asm for the MC-72.

Figure 1 shows the improvement in productivity and decrease in costs achieved by the Zeppelins as their capacity increased. The Goodyear

airship design of 1945 appeared to be a realistic follow-on to the Zeppelin line.

Table 1

Projected Operating Costs - Airship MC72 (1931 Dollars)
 Based on: Block Speed 68 mph; Payload 20 tons; Utilization 3,000 hours; Available Seats 50; Volume 7.26M cu.ft.; Average Stage Length 3,300 miles; Airship Cost \$5m.

Airship Operating Expenses (Per Block Hour)

Flying Operations	
Crew	59.0
Fuel and Oil	11.0
Helium (at \$0.40/cu.ft.)	100.0
Insurance	204.0
Other	58.0
Total Flying Operations	432.0
Maintenance-Flight Equipment	135.0
Depreciation	
Airframe	170.0
Engines	79.0
Total Depreciation	249.0
<u>Total Airship Operating Expenses</u>	<u>816.0</u>
Per Airship Mile (\$)	12.0
Per Available Ton Mile (¢)	60.0
Per Available Seat Mile (¢)	24.0
Indirect Operating Costs (Per Hour)	408.0
Total Operating Costs (Per Hour)	1,224.0

Figure 1

Productivity and Operating Costs of Commercial Dirigibles

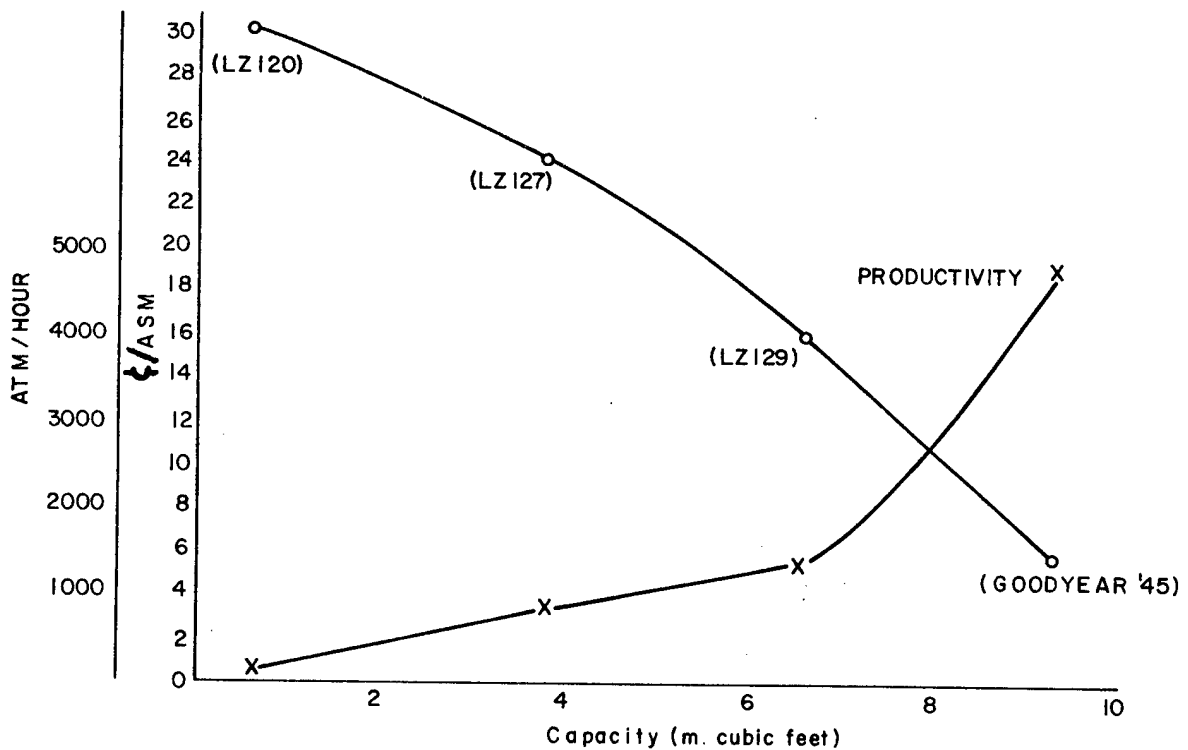

TABLE 2

Economic Comparison of Various Airships, Actual and Proposed (*)

Airship	LZ 120 Bodensee	LZ127 Graf Zeppelin	LZ 129 Hindenburg	MC-72* (Metalclad)	Goodyear* '45 Dirigible	SCACI* AMC 7.4
Gas Volume (M cu.ft.)	0.812	3.708	7.062	7.26	10	7.4
Max. Payload (tons)	3.2	14.8	20.4	20	70	60
Block Speed (mph)	61	61	68	68	68	100
Available Seats	30	20	50	50	112 - 288	250 (est.)
Av. Stage Length (miles)	400	3,000	3,500	3,500	4,000	2,000
Money Value (Dollars)	1935	1935	1935	1931	1946	1974
Total Operating Costs:						
1. ¢/available seat mile	30	24	16	36	9 - 4	3 (est.)
2. ¢/mile	9.0	4.8	8.0	18.0	10.0	7.1
3. ¢/hour	549	292	544	1,224	680	707
4. ¢/available ton mile	282	32	39	90	14	13
5. ¢/seat hour	18.3	14.6	10.9	24.5	6.1 - 2.4	2.8 (est.)

Moving forward some forty years to Table 3, a similar breakdown of costs is shown for two of the Southern California Aviation Council, Inc. proposed airships⁴. The AMC-7.4 is about the same size as the MC-72, and it is interesting to note that although the dollar's value has decreased by a factor of about 3 since the mid-thirties, the operating expenses for the airship are assumed to have gone down while the unit price of the airship has more than doubled. Depreciation of the newer airships is about 30% of total operating costs, somewhat closer to ship operations, while indirect costs are assumed to average only about 10% of DOC.

Table 4 provides the operating expenses for a B-747 freighter flying in the United States⁶. A comparison of the airship and aircraft operating cost indicates that the aircraft costs are below those anticipated for all the 7 million cu. feet airships shown in Table 2- only at the super-airship sizes do costs become competitive with the B-747. Then the insurance premiums of the large airships become the dominating operating expense.

Although Table 2 shows the costs at current dollars, the actual value of the dollar has deflated by 300-400% from the mid-thirties. However it is not totally unreasonable to assume that airship expenses would in fact decrease. The average U.S. scheduled airline cost per available seat mile in 1938 was 5.5¢,⁷ while in 1970 it had decreased to 3.6¢/asm. However, the available seat miles during this period grew from 1,067,793,000 to 264,903,850,000, and the economics of scale, operating experience and increased safety which the airlines gained during this period of 30 years have all contributed to reducing costs. Clearly airships have not had the benefit of a similar learning period, and it is not quite correct to extrapolate directly from airline data. Only after some years of actual airship operations will it be possible to determine if similar trends will hold.

Table 3

Projected Operating Costs - SCACI Airships (1974 Dollars)

Based on: Airborne Speed 100 mph; Stage Length 2,000 miles, Utilization 4,000 hours.

<u>Airship Operating Expenses</u> (Per Airborne Hour)	AMC-7.4 (Cost \$13M, Payload 60 tons)	AMC-42 (Cost \$74M, Payload 804 tons)
Flying Operations		
Crew	143.0	154.0
Fuel and Oil	52.0	163.0
Helium	0.0	0.0
Insurance	189.0	1,125.0
Other	0.0	0.0
Total Flying Operations	384.0	1,442.0
Maintenance	58.0	95.0
Depreciation	167.0	903.0

Total Airship Operation Expenses	609.0	2,440.0
Per Airship Mile (\$)	6.0	24.0
Per Available Ton Mile (¢)	10.0	3.0
Indirect Operation Costs (Per Hour)	98.0	206.0
Total Operating Costs (Per Hour)	707.0	2,646.0

Table 4

Estimated B-747F Operating Costs (1972 Dollars)

Based on: Block Speed 500 mph; Stage Length 2,000 miles; Utilization 3,000 hours; Payload 100 tons.

Aircraft Operating Expenses (Per Block Hour)

Flying Operations	
Crew	300.0
Fuel and Oil	400.0
Insurance	50.0
Total Flying Operations	750.0
Maintenance	500.0
Depreciation	500.0
Total Aircraft Operating Expenses	1,750.0
Per Airship Mile (\$)	3.5
Per Available Ton Mile (¢)	3.5
Indirect Operating Costs (Per Hour)	900.0
Total Operating Costs (Per Hour)	2,650.0

REFERENCES:

1. Carl B. Fritsche, The Metalclad Airship, The Royal Aeronautical Society, London (1931) Aeronautical Reprints No. 61.
2. Peter Brooks, "Transport Airships," Flight International, (December 25, 1959) p. 780.
3. P.W. Litchfield and Hugh Allen, Why Has America No Rigid Airships, Corday and Gross Co., Cleveland, Ohio (1945).
4. Southern California Aviation Council, Inc., Committee on Lighter than Air, "Technical Task Force Report" Pasadena, California: SCACI, (May 15, 1974).
5. Bureau of Aeronautics, Department of the Navy, Rigid Airship Manual, 1927, U.S. Government Printing Office, Washington, D.C. (1928).
6. Bureau of Accounts and Statistics, Aircraft Operating Cost and Performance Report for Calendar years 1969 and 1970, Civil Aeronautics Board, Washington, D.C. (August 1971).
7. Research and Statistics Division, Handbook of Airline Statistics, 1961 Edition, Civil Aeronautics Board, Washington, D.C. (December 1961).

PRELIMINARY ESTIMATES OF OPERATING COSTS FOR
LIGHTER THAN AIR TRANSPORTS

C. L. Smith*
M. D. Ardema*

ABSTRACT: Presented is a preliminary set of operating cost relationships for airship transports. The starting point for the development of the relationships is the direct operating cost formulae and the indirect operating cost categories commonly used for estimating costs of heavier than air commercial transports. Modifications are made to the relationships to account for the unique features of airships. To illustrate the cost estimating method, the operating costs of selected airship cargo transports are computed. Conventional fully buoyant and hybrid semi-buoyant systems are investigated for a variety of speeds, payloads, ranges, and altitudes. Comparisons are made with aircraft transports for a range of cargo densities.

INTRODUCTION AND SUMMARY

Much of the present confusion over the viability of modern airships can be traced to the assumptions and methods used in the estimations of operating costs. For example, recent estimates of the direct operating costs (DOC) of airship cargo transports range from 0.5 to 15.0¢/available ton-statute mile. This paper will discuss a methodology of airship cost estimation and present a preliminary set of operating cost relationships for airship transports.

The starting point for development of the cost relationships are the DOC formulae of the Air Transport Association¹ and the indirect operating cost (IOC) categories developed jointly by Boeing, Lockheed, and Douglas². These methods are commonly used for estimating operating costs of commercial aircraft and are founded on extensive operating experience and a vast data base. They are adopted in the present

*Aerospace Engineer, NASA Ames Research Center, Moffett Field, CA.

paper because of the many similarities between modern airships and aircraft. The formulae are examined element by element to assess the applicability to airships. Modifications are made where appropriate, and areas of uncertainty are pointed out. Additional elements required for airships, such as those associated with procurement and maintenance of the buoyant gas, are formulated.

An airship performance model is necessary to define the airship configurations for input into the cost model. Such a performance model suitable for conceptual design has been developed expressly for the cost model used in this paper. The methods of performance analysis are discussed in the next section.

To illustrate the cost estimating relationships, the operating costs of selected airship transports are computed. A conventional fully buoyant, and a hybrid semi-buoyant airship are defined and discussed. The effects on operating costs of changes in cruise speed, gross takeoff weight, range, and cruise altitude are investigated. Comparisons are made with aircraft transports. The effect of cargo density on aircraft operating costs is assessed. The two airship configurations and the aircraft are illustrated in Figure 1.

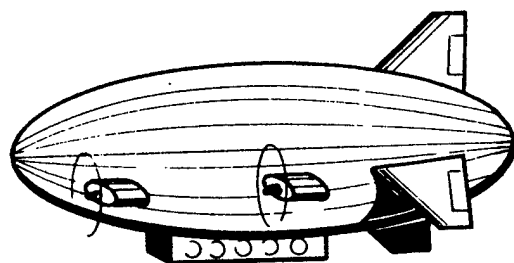

FULLY BUOYANT

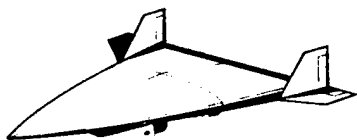

HYBRID



AIRCRAFT

Figure 1
Study Configurations

Any airship costing methodology must be regarded as highly speculative at the present time. It is hoped that the cost relationships developed in this paper will provide a temporary means for estimating airship costs as well as providing a starting point for developing more definitive relationships.

METHODS OF ANALYSIS

Performance

The airship performance analysis begins with the calculation of gas volume, V_{GAS} , and envelope volume, V_{ENV} , in terms of the specified buoyant lift, L_{BUOY} , as follows

$$\left. \begin{aligned} V_{GAS} &= \frac{L_{BUOY}}{K_G} \\ V_{ENV} &= \frac{\rho_{S.L.}}{\rho_{ALT}} V_{GAS} \end{aligned} \right\} \quad (1)$$

where $K_G = .06$ for Helium and $\rho_{S.L.}$ and ρ_{ALT} are the atmospheric densities at sea level and cruise altitude, respectively. Once V_{ENV} is known, the airship geometry can be determined.

The aerodynamic analysis follows Appendix A of reference 3. After the Reynolds number, R_N , has been computed, the skin friction coefficient, C_f , is determined from⁴

$$C_f = \frac{.03}{R_N^{1/7}} \quad (2)$$

The bag drag coefficient is⁴

$$C_{D_{BAG}} = C_f \left[4 \left(\frac{\ell}{d}\right)^{1/3} + 6 \left(\frac{d}{\ell}\right)^{1/2} + 24 \left(\frac{d}{\ell}\right)^{2.7} \right] \quad (3)$$

where (ℓ/d) is the fineness ratio. The drag coefficient is then

$$C_D = C_{D_{BAG}} + C_{D_F} \quad (4)$$

where C_{D_F} accounts for the fin and other miscellaneous components of drag and is taken as equal to .005 in the present study. The vehicle zero-lift drag is determined from

$$D_0 = q C_D S_{REF} \quad (5)$$

where

$$S_{REF} = V_{ENV}^{2/3} \quad (6)$$

The lift coefficient is taken from reference 2 as

$$C_L = (0.5\pi AR \sin\alpha + K_L \sin^2\alpha \cos\alpha) \frac{S_p}{S_{REF}} \quad (7)$$

where AR is the aspect ratio, α is the angle of attack, S_p is the platform area, and

$$K_L = 1.7 AR e^{1-AR} \quad (8)$$

The drag due to lift coefficient, C_{D_i} , is obtained from reference 5 as

$$C_{D_i} = C_L \tan \alpha \quad (9)$$

For the hybrid airship, the angle of attack is selected by setting $C_{D_0} = C_{D_i}$. The vehicle dynamic lift and drag due to lift are

$$\left. \begin{aligned} L_{DYN} &= \rho C_L S_{REF} \\ D_i &= \rho C_{D_i} S_{REF} \end{aligned} \right\} \quad (10)$$

respectively. The fully buoyant airship is assumed to fly at zero angle of attack. Thus, the gross takeoff weight, W_{GTO} , and total drag, D , are given by

$$W_{GTO_FULLY\ BUOYANT} = L_{BUOY} \quad (11)$$

$$D_{FULLY\ BUOYANT} = D_0$$

For the hybrid,

$$\left. \begin{aligned} W_{GTO_HYBRID} &= L_{BUOY} + L_{DYN} \\ D_{HYBRID} &= D_0 + D_i \end{aligned} \right\} \quad (12)$$

The structural weight, W_{STRUC} , defined to be the empty weight minus the propulsion system weight, is obtained from

$$W_{STRUC} = K_{S1} V_{ENV} + K_{S2} L_{DYN} \quad (13)$$

where the second factor is zero for the fully buoyant airship. The first factor results from the "cube-cube" law governing scaling of airship empty weight and lift. The historical value of K_{S1} is .0325 but a value of .0250 is used in the present study, reflecting about a 25% improvement in structures and materials technology over the historical base. This is probably a conservative assumption when the great increases in structural and material efficiencies in the past 40 years are considered.

The horsepower required for cruise is determined from the fundamental relationship

$$HP_{CR} = \frac{S D}{550 \eta_p} \quad (14)$$

where S is the cruise speed in feet per second and $\eta_p = .82$ is the propulsive efficiency. The rated horsepower is

$$HP_{RATE} = \frac{P_{S.L.}}{P_{ALT}} \sqrt{\frac{T_{S.L.}}{T_{ALT}}} \frac{HP_{CR}}{K_T} \quad (15)$$

where P and T are the atmospheric pressure and temperature, respectively, and K_T is the throttle setting, taken as .60 in the present study. Both diesel and turboprop engines were investigated, and it was found that the former gave superior performance in both the fully buoyant and hybrid airships. The weight of the diesel engines is

$$W_{ENG} = K_E \frac{HP}{RATE} \quad (16)$$

where K_E was taken as 1.0. The weight of the rotors and drivetrains, W_{DRV} , was estimated from empirical data and added to the engine weight to obtain the propulsion system weight, W_{PROP} .

The mission fuel requirements are determined from

$$W_{FUEL} = HP_{CR} \frac{SFC}{S} R \quad (17)$$

where SFC is the specific fuel consumption and R is the range. Finally, the payload may be determined from

$$W_{PAY} = W_{GTO} - W_{STUC} - W_{PROP} - W_{FUEL} \quad (18)$$

Cost

The development of a costing methodology for airships may follow one of two paths. First, there is the methodology based on past airship costs and past operating experience. This data base, however, is so old that it has limited use in the modern context. The economic situation and manufacturing techniques of today cannot be reflected accurately in a model based on historical airship data.

The second possibility is to use techniques that have been developed for estimating costs in the air transport industry. This approach is natural since aircraft and airships have many characteristics in common. Both have a need for light weight and high performance to obtain optimum operational efficiency. In order to minimize the labor requirements, both will include sophisticated flight control and avionics systems. Minimum operating costs require a high degree of dependability and high utilization factors. Also, airships and aircraft will have to meet the same institutional and operational constraints since both will be performing their tasks under the jurisdiction of the same regulatory agencies. Therefore, the costing techniques based on air transport experience were used in this study since they were considered to be more applicable in predicting the economic characteristics of the airship.

The vehicle costs were derived using equations which compute cost as a function of weight. The equations compute separate costs for body structure, propulsion, avionics, crew station controls and panels, and final assembly. These are then summed to derive a first unit cost. Learning curve factors are applied next to arrive at the cost per unit for the production quantity. Airship unit costs were estimated from the same equations that were used for conventional aircraft. This assumption is probably conservative since there possibly are reasons why airship unit costs per pound of structure may be lower than those of aircraft.

The operating cost is divided into two parts — direct and indirect. The DOC's were computed using the Air Transportation Association (ATA) equations.¹ The indirect costs were derived using the equations developed jointly by Boeing, Lockheed, and Douglas² with a modification to include the gas replenishment needed for airships. Table 1 is a listing of the items in DOC's and IOC's.

A preliminary examination indicated that the land requirements for the aircraft and airships would be equal so those costs were not included in the study. Aircraft

Table 1
Operating Cost Elements

• **DIRECT OPERATING COST (ATA METHOD)**

- CREW
- FUEL
- INSURANCE
- MAINTENANCE
- DEPRECIATION

• **INDIRECT OPERATING COST (LOCKHEED-BOEING-DOUGLAS METHOD)**

- MAINTENANCE OF GROUND PROPERTIES AND EQUIPMENT
- VEHICLE SERVICING
- CARGO TRAFFIC SERVICING
- RESERVATIONS, SALES, ADVERTISING
- GENERAL AND ADMINISTRATIVE
- GAS REPLENISHMENT

actually require more land for the runways, but the hourly utilization of the land is quite high whereas an airship when moored does not allow the land it occupies to be utilized for other airships. Due to their large sizes, fully buoyant airships may have an adverse effect on air traffic congestion. The hybrid airship would be superior to the fully buoyant airship in terms of land utilization and air traffic congestion.

The block time is very important to the productivity of the vehicle. The block times were computed by the following equations

$$\left. \begin{aligned}
 t_{\text{AIRSHIP}} &= \frac{R + .5 S}{S(1 - \frac{25^2}{S^2})} \\
 t_{\text{AIRCRAFT}} &= \frac{R + .5 S}{S(1 - \frac{75^2}{S^2})} + \frac{1}{2}
 \end{aligned} \right\} \quad (19)$$

where t = block time, hr; R = range, nautical miles; and S = cruise speed, knots.

The time to climb to and descend from cruising altitude is accounted for by the factor $.5 S$. In the denominator, the fractional quantity accounts for the effect of winds which are assumed to be 25 and 75 knots for the airship and aircraft, respectively. The correction is derived by assuming that the vehicle encounters a headwind over half the range and a tailwind of the same velocity over the other half. The aircraft block time also includes a half hour of ground maneuver time which is not necessary for the airship.

Table 2 lists the assumptions for the cost study. The utilization rates of airships will be considerably higher than those of aircraft due to the higher trip times. Further, it may be possible to do almost all maintenance in flight. Achievement of high utilization is important for airships due to their inherently poor productivity. It is assumed in the present study that ground time is only necessary for freight loading and unloading. The airship requires two crews for the long flights, but salaries were assumed to be paid only while the crew was actually working. The utilization and crew salary assumptions should be regarded as optimistic. The airships will require an annual total gas replenishment equal to about 25% of their volume. The price of Helium was taken as 10¢ per cubic foot.

Table 2
Economic Assumptions

	AIRCRAFT	FULLY BUOYANT & HYBRID
CREW SIZE	3	3
UTILIZATION (HR/DAY)	11.67	23.40
FUEL COST (\$/GALLON)	.25	.25
DEPRECIATION PERIOD (YRS)	15	15
RESIDUAL VALUE (%)	15	15
INSURANCE RATE (%)	2	2
GAS REPLENISHMENT (%/YEAR)	0	25

RESULTS

The study configurations are shown in Figure 1. The fully buoyant airship is of conventional ellipsoidal shape. The hybrid configuration has an elliptic cone forebody and an afterbody which tapers to a straight line trailing edge. The cross-sections are elliptical. The hybrid configuration represents an arbitrary choice of shape since the performance optimization model is not sufficiently detailed to account for all the interactions necessary for a configuration optimization. Thus, there may well be superior hybrid configurations to that considered here.

Table 3 shows the characteristics of the fully buoyant and the hybrid airship sized for 1,000,000 pounds of buoyant lift. Also shown for reference are the characteristics of a cargo aircraft of 500,000 pounds gross takeoff weight. The cruise speeds of the airships were selected to maximize the productivity-to-empty weight ratio and were found to be 100 knots in both cases. Due to the severe penalties associated with designing airships for high cruise altitudes, sea level altitude was assumed. Cruise altitude capability is then obtained by preheating the buoyant gas to fill the envelope at takeoff. The dimensions of the airships are large compared with those of the aircraft, with the hybrid being somewhat more compact than the fully buoyant. The horsepower of the hybrid airship is considerably higher than that of the fully buoyant due to the higher drag of the former. The hybrid airship has 724,000 pounds of dynamic lift at cruise in addition to its 1,000,000 pounds of buoyant lift. Both airships have 16.7×10^6 ft³ of He.

The weight statements on Table 3 show that the fully buoyant airship and the cargo aircraft have about the same payload fractions and that that of the hybrid airship is somewhat lower. Consideration of the ratio W_{FUEL}/W_{PAY} indicates that the fully

Table 3
Vehicle Characteristics

	FULLY BUOYANT	HYBRID	AIRCRAFT
WGTO, 1000 lbs.	1000	1724	500
WSTRUC	417	652	163
WPROP	43	90	50
WFUEL	195	497	116
WPAY	345	484	171
CRUISE SPEED*, knots	100	100	462
CRUISE ALTITUDE, ft.	0**	0**	35,000
LIFTING GAS	He	He	—
GAS VOLUME, ft. ³	16.7 x 10 ⁶	16.7 x 10 ⁶	—
LENGTH, ft.	1032	658	160
RATED HORSEPOWER	27,700	70,640	—
RANGE, n.mi.	2700	2700	2700

*CHOSEN TO MAXIMIZE PRODUCTIVITY-TO-EMPTY WEIGHT RATIO
**ALTITUDE CAPABILITY OBTAINED BY PRE-HEATING GAS

buoyant is the most fuel conservative of the three, followed by the cargo aircraft. It appears that the extra lifting capability of the hybrid airship as compared with the fully buoyant airship is cancelled by its higher drag.

The operating cost breakdowns for the three vehicles are shown on Figure 2. Considering DOC first, the elements of depreciation, maintenance, and insurance are seen to be about the same for all three vehicles. The fuel cost is lowest for the fully

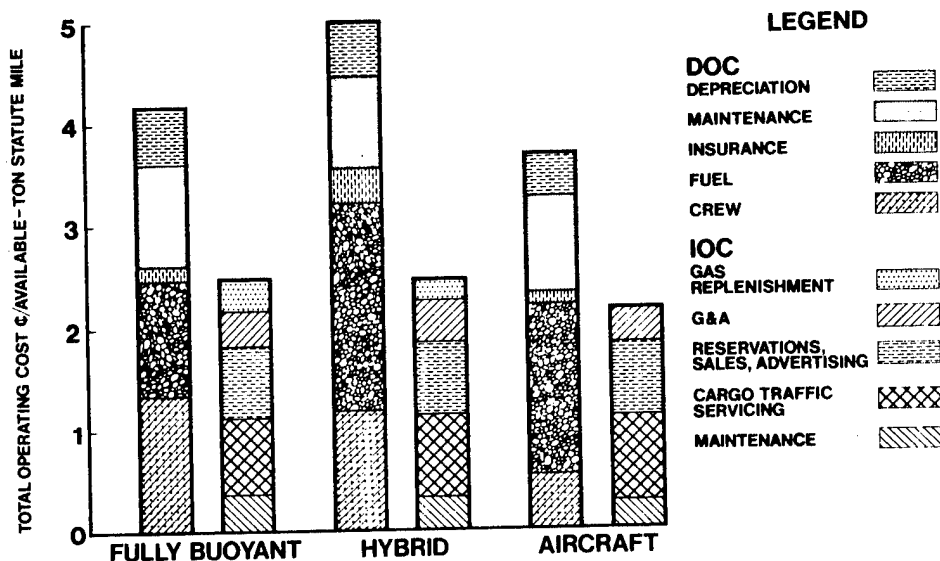

Figure 2
Operating Cost Comparison

buoyant airship and highest for the hybrid airship, reflecting the fuel economies of the three vehicles. The crew costs are high for the airships due to their relatively low speed and productivity. As mentioned earlier, the economic assumptions used to compute the airship DOC's must be regarded as optimistic. Most important of these assumptions are the high utilization rate and number of crew members (see Table 2). Use of the cargo aircraft utilization rate and the assumption of continuous pay for all crew members would give airship DOC values of twice those shown on Figure 2.

The IOC's of the airships are similar to those of the cargo aircraft except for the requirement for lifting gas replenishment. This results in slightly higher IOC's for the airships. Adding the DOC's and IOC's to get the total operating cost (TOC) gives values of 6.6, 7.4, and 5.8¢/available ton-statute mile for the fully buoyant airship, hybrid airship, and cargo aircraft, respectively. Although the depth of analysis is insufficient to draw conclusions based on small differences, it would seem that airships are at best marginally competitive with aircraft for the mission under consideration.

As is commonly believed, airships become more efficient as they become larger, as demonstrated in Figure 3. The tick marks denote the nominal vehicles of Table 3.

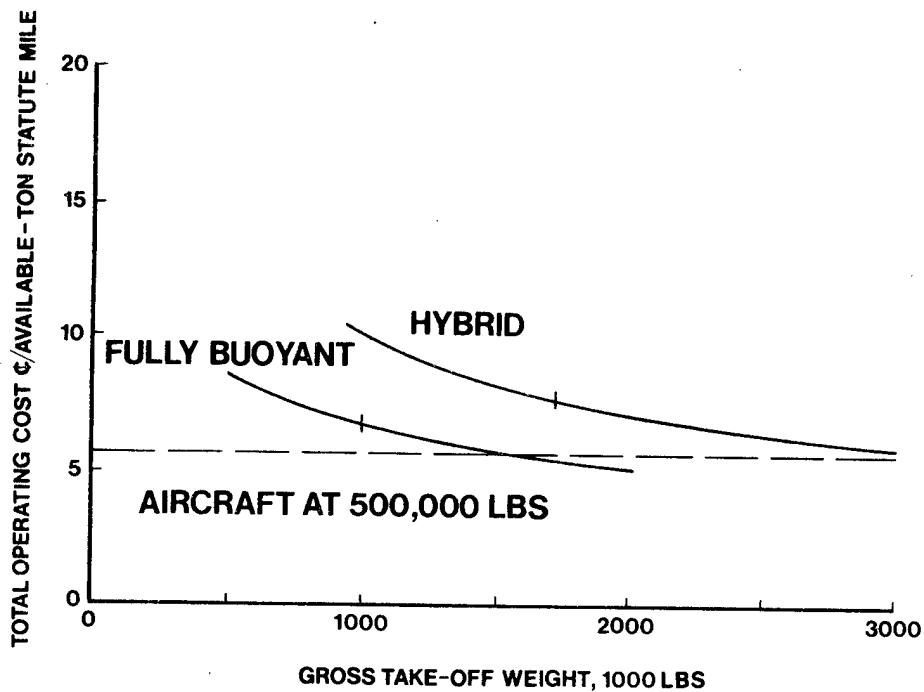

Figure 3
Effect of Take-Off Weight

The reason for this trend is not that the empty weight fraction decreases as is often stated (in fact, the "cube-cube" law implies a constant empty weight fraction), but rather that the skin friction decreases and the aerodynamic efficiency increases at the larger sizes. Figure 3 shows that the fully buoyant airship has the same TOC as the 500,000 pound cargo aircraft at a gross takeoff weight of about 1,400,000 pounds. The hybrid airship TOC only approaches that of the cargo aircraft at extremely large values of gross takeoff weight. At the large airship gross takeoff weights, a point of diminishing returns is reached beyond which further reductions in TOC are small.

The fully buoyant airship is superior to the hybrid airship at all values of gross takeoff weight and both are noncompetitive with the cargo aircraft at values below 1,000,000 pounds.

The sensitivities of TOC to cruise speed for the two airships are shown in Figure 4.

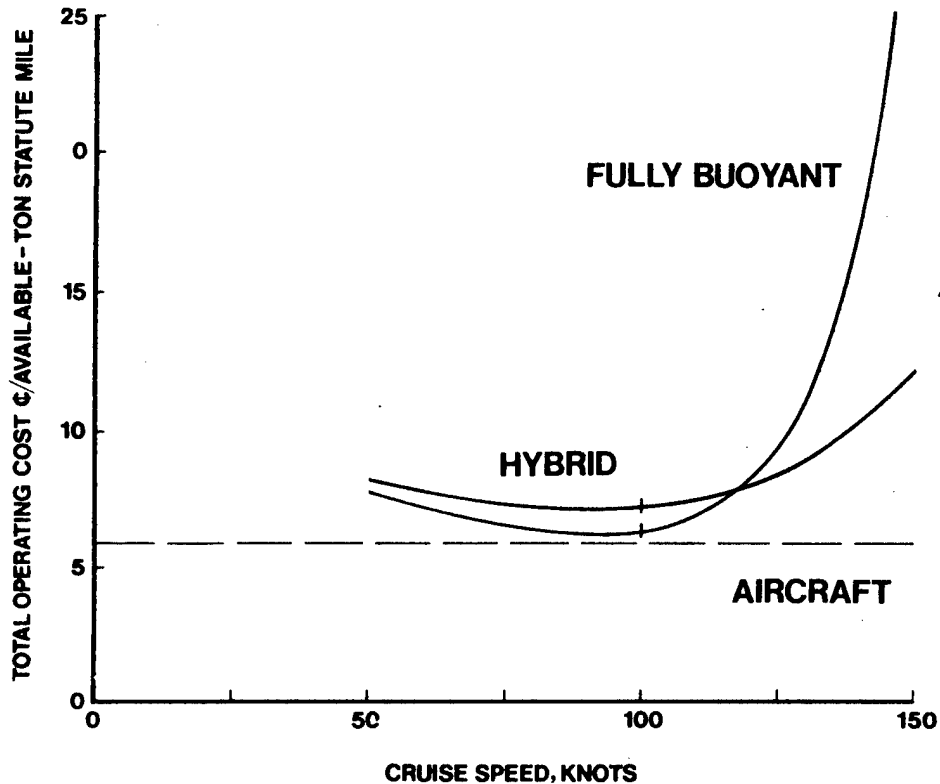

Figure 4
Effect of Cruise Speed

Also shown for reference is the TOC of the cargo aircraft which cruises at 462 knots. At lower airship speeds, around 50 knots, the fuel consumption is low and the payload fraction is high. The productivity, however, is very low. At higher speeds, around 150 knots, the drag becomes prohibitively high and the payload fraction becomes low. The result of these trends is that minimum TOC is achieved at around 100 knots for both airships, thus justifying the original choice of this cruise speed. The figure shows that the hybrid airship is much less sensitive to cruise speed than is the fully buoyant airship.

There is a severe penalty for flying at cruise altitudes appropriate for transcontinental flights as shown in Figure 5. If the requirement is for a 10,000 foot altitude, the TOC is approximately double that of the sea level case. At 20,000 foot, both airships have negative payloads. (Reducing the cruise speed or the range would give positive payloads at 20,000 feet.) To avoid venting gas, it is desirable to preheat the buoyant gas to expand it to the envelope volume prior to takeoff.

The effect of range on the total operating cost of the two airships and the aircraft is shown in Figure 6. The TOC of the fully buoyant airship and the cargo aircraft increases slightly with increasing range. The TOC of the hybrid airship increases

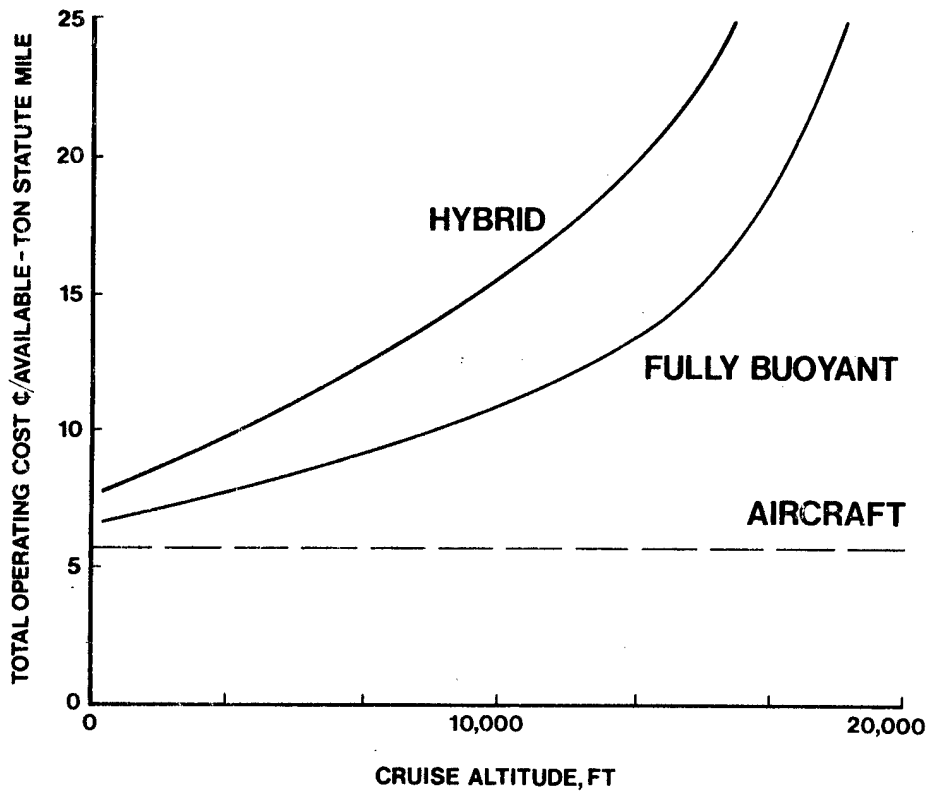

Figure 5
Effect of Cruise Altitude, No Preheat

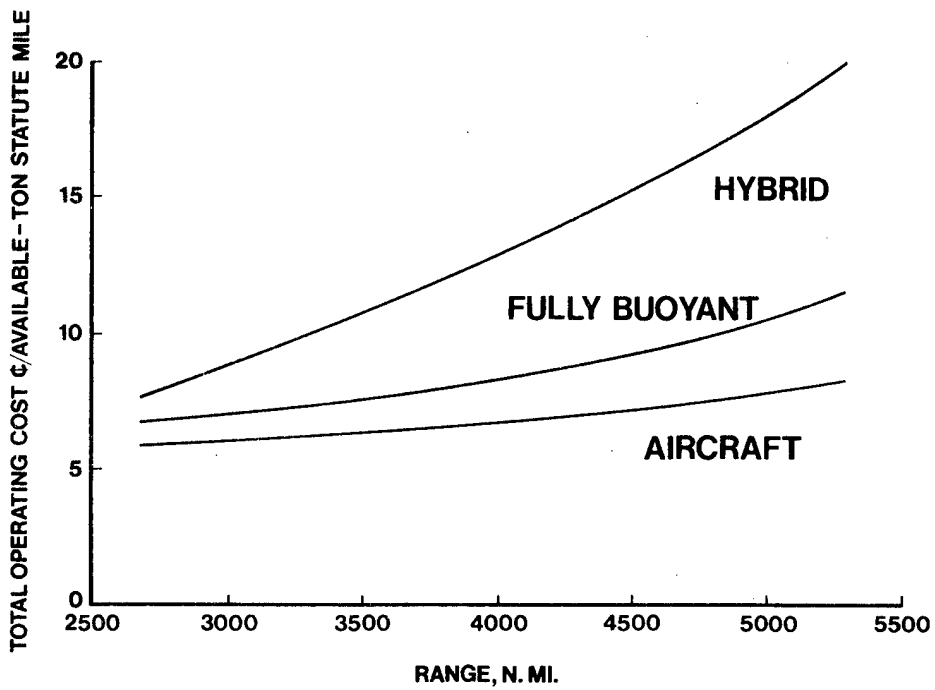

Figure 6
Effect of Range

more rapidly due to the relatively high fuel fraction and low payload fraction of this vehicle. At the longer intercontinental ranges of 5000 n. mi., the hybrid airship is not competitive with the fully buoyant airship or the cargo aircraft.

Current cargo transport aircraft are frequently limited not by cargo weight but by cargo density. Cargo aircraft are designed for a cargo density of about 10 lb/ft³. For cargos of lesser density, the full payload weight cannot be carried. The effect on TOC is shown in Figure 7, where it is assumed that the airships are not limited by cargo density constraints. The effect on the cargo aircraft TOC is severe, and at a cargo density of 5 lb/ft³ the cargo aircraft TOC is double that of the airships. Therefore, it may be concluded that airships are more attractive than aircraft for transport of low density cargo.

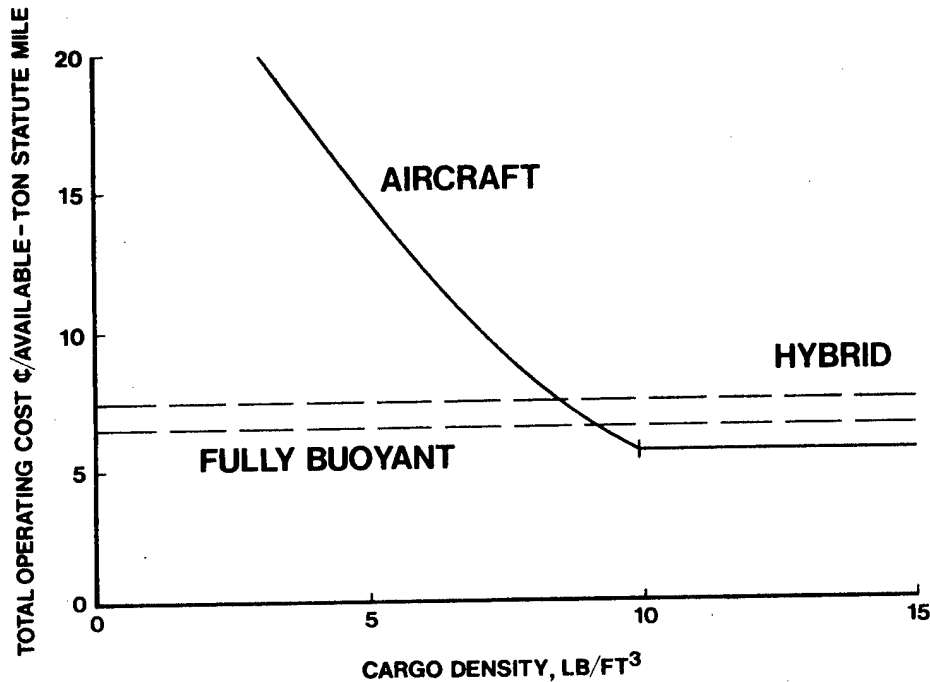

Figure 7
Effect of Cargo Density

CONCLUDING REMARKS

The results have shown that airships are marginally competitive with aircraft on established freight routes. Using somewhat optimistic assumptions for airship economic analysis gives airship total operating costs which are slightly higher than those for aircraft. There are, however, several categories of missions which are potentially attractive for airships, many of which were not considered in this study. Among these are: (1) transport of low density or indivisible bulky cargo (examples of the latter would be modular housing or nuclear reactor components); (2) transport to or from undeveloped sites (examples are transport of agricultural crops from sites which have no road or runway access and supply of developing nations); (3) missions in which the unique features of airships are of use (these features are high endurance and hover and V/STOL capability; the missions include surveillance and intra-urban transportation); (4) use as special purpose vehicles (examples are an oil/gas transporter in which the gas serves as the buoyant gas, and a hospital ship for disaster relief); and (5) military missions.

The parametric results show that airships are highly sensitive to cruise speed and altitude selection. It is important to select the optimum cruise speed correctly. It is highly desirable to preheat the buoyant gas in order to minimize the effects of altitude requirements.

The fully buoyant and hybrid aircraft designs were found to have about the same economic performance. The extra lifting capability of the hybrid is counteracted by its greater drag. The operating costs being equal, there are some operational factors favoring the hybrid. The hybrid would have less sensitivity to cruise speed, superior low speed control characteristics, and greater ease of ground handling as compared with a fully buoyant design.

REFERENCES:

1. Air Transport Association, Standard Method of Estimating Comparative Direct Operating Costs of Turbine Powered Transport Airplanes (December 1967).
2. Lockheed-Georgia Company, A Proposed Standard Method for Estimating Airline Indirect Operating Expense, Report No. LW70-500R (May 1970).
3. Havill, C. D. and Williams, L. J., Study of Buoyancy Systems for Flight Vehicles, NASA TMX-62, 168 (December 1972).
4. Hoerner, Dr.-Ing S. F., Fluid-Dynamic Drag, Hoerner (1965).
5. Durand, W. F., Aerodynamic Theory, Volume VI, Julius Springer, Berlin (1936).



COMPARATIVE AIRSHIP ECONOMICS

Capt. Robert Harthoorn*

ABSTRACT: As future LTA vehicles will be doomed right from the start if they do not fill a real need, some differences in transport philosophy between design engineers on the one hand and freight forwarders on the other are discussed. Watching rising costs of energy necessary to transport our cargo from A to B, and realizing that this price of energy is always included in the product's selling price at B, the apparent correlation between installed specific tractive force per unit of cargo weight and pure freighting cost are contemplated. Very speedy and progressive Airship designs are mistrusted by the author, because the key to any low cost transport tool is to design it for its given task only, without any unnecessary sophistication.

THE BEE AND THE PHYSICAL DISTRIBUTION SYSTEM

It is said that in order to collect one kilogram of honey, the bee flies an average corresponding distance of twice the equator's length, and thanks to his faultless computerized communication and balanced stock-and-distribution systems, not one bee ever flies one meter too far, and not one gram of honey is lost. Related to our present pattern of transport, this example teaches us in a nutshell how we ought to perform the so-called Physical Distribution System, which is up to the present still far away from this ideal situation. As a good excuse for our human and technological shortcomings in this field, we may remark that our bee is not tied down to the most numerous and complicated national and international laws governing commercial aviation, nor the very complex freight rate structures set by the (I)nternational (A)ir (T)ransport (A)ssociation, delaying customs formalities, political barriers, feeder ground transport, etc.

*General Manager, Equipment Control, Holland America Line, Rotterdam, The Netherlands

PRECEDING PAGE BLANK NOT FILMED

Having all the freedoms of the air, instead of the five freedoms embodied by the Chicago Convention; and in his own area, not bothered by other competitive means of transport, the bee flies and lands wherever he chooses and always ships the same commodity from production center to final destination at only one computed flat through-rate.

Coming to the Airship concept, I took this example because, when I read or listen to the promotion arguments of some Airship designers, I get the slight impression that the freight forwarder and/or the operator has to take it for granted that the Airship, figuratively speaking is going to substitute the bee, and solve all of our transport problems accordingly.

It is quite human and understandable that any designer, as a specialist, likes to take pride in a new and sophisticated design, but initially one has to realize that the Airship is not the only competitive way to transport paying loads, and secondly, one has to realize that the shipper or the paying passenger is the ultimate customer, and it is essential that these points of view are borne in mind when talking about the re-introduction of the Airship concept. Original thinkers who want to break some old habits of transport are badly needed, but it should be appreciated that there can be only one valid reason for accepting the Airship concept, and that is if Airship services can perform a profitable and useful function.

LAMINAR AIR-FLOWS OR "LAMINAR CASH-FLOWS"?

The varying Airship cost figures supplied up to the moment are rather frustrating. On this basis one cannot blame the investors' reluctance to invest a reasonable amount of capital, because he is neither interested in the difference between laminar and turbulent airflows, nor in propeller efficiency, but only in "laminar cash-flows" and returns on capital. This statement may sound a bit unsympathetic in some circles, but if one accepts that the profits of any businesslike undertaking are the lifeblood necessary for investments in the future, one has to realize that the investor wants a sound and reliable cost figure.

THE CAPITAL RETURN FACTOR

The economical crux of the whole matter concerning comparative Airship economics is embodied in one simple formula. This formula measures the profitability of an investment in terms of gross net income per unit of invested capital, called the Capital Recovery Factor Formula, viz.,

$$\frac{\text{AFR} - (\text{DOC} + \text{IOC})}{\text{Total Invested Capital}} = \geq 0.15 \quad \text{or} \quad 15\%$$

In this formula, the total annual freight revenue (AFR) represents the product of (average actual loadfactor) x (maximum payload capacity) x (average blockspeed) x (number of operational hours/year) x (freight rate per ton/nautical mile). Taking into account the later deduction of state taxes and stockholders' dividends, we assume that the desired outcome of this C.R.F. Formula gives the investors the reasonable figure of at least 0.15, equal to 15%. The designer's responsibility now is to supply, within the limits of the given specifications, a valid and controllable breakdown of the direct building and technical operating cost figures, which are important parameters in the given formula.

DETERMINING AIRSHIP'S SHADOW FREIGHT RATE

Presuming that the Airship's shadow freight rate is more or less determined by the direct competitor in this field, viz., the present aircraft carrier, it is essential that the Airship's freight rate be determined at a price which is preferably at least 30% less than the average actual airfreight rate applying to the same transport distances.

Taking a very average specific airfreight rate from Amsterdam to New York, viz., \$0.45 per short ton/nautical mile, the average Airship shadow freight rate will be determined at, let us say, \$0.30 per ton/nautical mile. Considering a long-haul designed Airship, having a trans - N. Atlantic payload capacity of 300 short tons, and presuming that the accepted break-even load factor of 0.5 (50%) provides no capital return at all--which means that total freight revenue equalizes total costs--we demand a capital return of at least 15%, obtainable at an average annual load factor of 75%.

Presuming 3,000 operational hours per year, and an average blockspeed of 80 knots, one may now reach the conclusion that after applying the C.R.F. formula, the total maximum admissible capital investment may not exceed the amount of 36 million dollars.

$$\frac{16.2 - 10.8}{y} = 0.15$$
$$y = 36$$

This system of approach may be a bit unconventional, but it serves perhaps the purpose in which way one may assess the commercial viability of Airship services.

SPEED AFFECTS THE CAPITAL RETURN FACTOR

I am aware that the notion of speed in Airship circles leads to a lot of disputes; however, to obtain an optimal economical speed for any given transport device is a rather complicated and tricky business. Mentioning rigid Airships, sailing up to 150 to 300 knots and more, the unhappy operator may find himself caught in the financial speed-trap if he neglects in what way this speed increment is going to affect the Capital Return Factor.

In other words, taking into consideration that extra fuel to be carried displaces payload capacity, the total ton/n.m. production may initially increase to a certain limit, but the question remains to what extent this particular speed does affect the several other parameters of the C.R.F. formula. It has to be appreciated that "speed boosting" negatively affects the maintenance labor and material costs, utilization hours, depreciation period, engines building costs, fuel consumption, and consequently, the Direct Capital Investment.

The positive or negative outcome of the balance will be determined by the return on capital, after having fed all the known parameters into this formula; however, some dimensionless parameters will always remain, such as service, goodwill, marketing policy, etc. We can appreciate that the Airship's minimum technical speed is determined by the average prevailing atmospheric conditions. A reasonable increase of speed, however, may be justified if the Airship, by offering increased sailing frequencies, also improves her average load factor. Marketing policy, however, is subject to the operator's responsibility, because the appreciation of speed depends upon the freight-forwarder's philosophy.

WHAT PRICE, WHAT FRICTION?

Technically speaking, one easily can increase the power of any small Volkswagen engine, so as to provide a speed of 100 mph and more, but the small Volkswagen was not designed and not intended as a very speedy automobile. The same remark applies to the bulky Airship, which ought to have a relatively low specific resistance coefficient at cruising speed, which means a favorable, relatively high lift-to-drag ratio number. It would be an unrealistic approach to presume that the Airship provides such a high L/D ratio number because she is such a fine aerodynamically shaped piece of machinery; the simple reason to keep in mind, however, is that only the heavy Airship is able to sail the sky with a relatively low service speed, and any thoughtless speed increment weakens her economical strength.

Let us please not take any given commercial transport device out of its natural, technical and economical area of environment within which it can operate. If we want to ship relatively high valued cargo, we do not object to paying for a low L/D ratio number, but in this particular case we would prefer the present pure freighter Boeing 747, which provides, for a given price, at least a real good speed.

A rather strange sense of humor is needed to believe in very speedy Airships having competitive freight rates combined with L/D ratio numbers which lie in the range between seagoing Hovercraft and the sleek, supersonic, payloadless Concorde.

IMPROVING L/D RATIO NUMBER ONLY BY ECONOMY OF SCALE

After doubling the original cruising speed of the pre-war Airship "Hindenburg" from 68 knots to 136 knots, the very favorable L/D ratio number of about 44 will drastically decrease to the rather poor ratio number of 11. This is even 6 points less than the L/D value of the Boeing 747, which flies at about 520 knots at normal cruising speed, even without the so-called miraculous boundary layer control system.

By applying some elementary formulae determined by nature, one now has to enlarge the original volume 64 times in order to obtain a sun eclipse, cause by a nearly 13 million cubic meter Airship with sufficient propulsion power to develop 136 knots; but now having regained the original L/D ratio number of 44; or in other words, having the same specific resistance coefficient of the original "Hindenburg."

$$\text{At 68 knots} \dots \dots \dots \frac{L}{D} = 44$$

$$\text{At 136 knots} \dots \dots \dots \frac{L}{4D} = \frac{1}{4} \times \frac{L}{D} = 11$$

$$\text{At 136 knots/volume} \times 64 \dots \dots \dots \frac{64 \times L}{(\sqrt{64})^2 \times 4D} = \frac{L}{D} = 44$$

L/D RATIO NUMBER AS A PARAMETER OF THE CAPITAL RETURN FACTOR FORMULA

Pointing to the thesis that the L/D ratio number is inversely proportional to the fuel consumption and directly proportional to the maximum payload capacity, it will be appreciated that in reference to the C.R.F. formula, this ratio number has a certain economical significance, if one considers the (L)ift as representing the incoming dollars and the (D)rag representing the outgoing dollars.

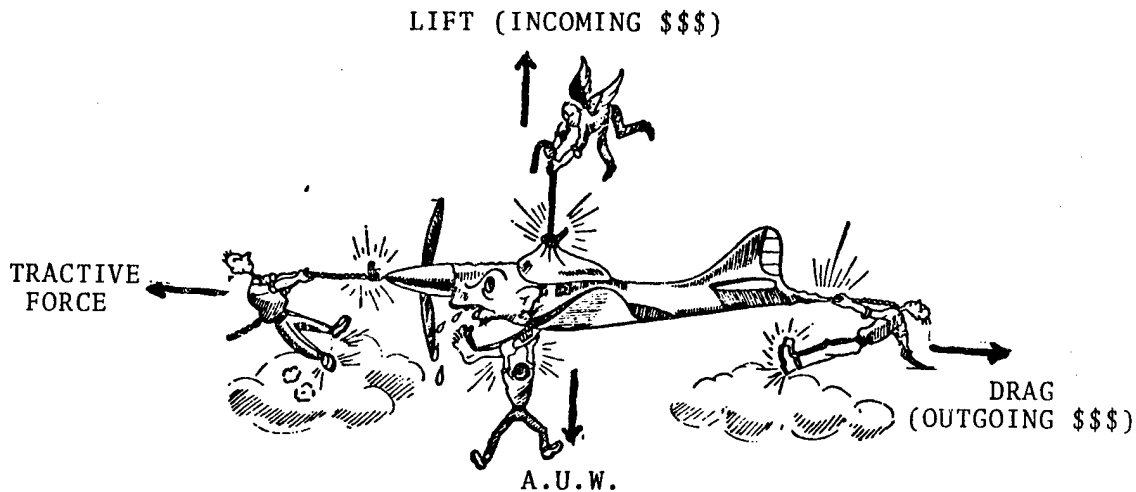

SURFACE TRANSPORT SYSTEMS

As a consequence of our welfare growth and increasing world population, many types of transport craft with specific designs have to become available to deal with the growing variety of commodities which have to be transported in the most efficient way.

If one observes the development of surface transport systems, the future Airship has to find her place among Ro-Ro-Ships, gigantic 50 knot container ships, gasturbine-driven freight blocktrains, powerful roadtrailers combined with computer guided traffic systems, waterjet-propelled fast Hover and Hydrofoilcraft, etc., offering within their own speed ranges, very competitive freight and/or passenger tariffs.

Now, one may object by arguing that present types of motor vehicles and trains are relatively slow and that the speed advantage of fast aircraft, serving European travelling distances, is wiped out by the time losses caused by too long distances to the airports and waiting times. Watching the future development of tracked aircushion and/or linear induced magnetic trains (Advanced Passenger Trains), running up to 270 mph, one may conclude that the now existing speed gap between the conventional train and the aircraft at travelling distances between 200 miles and 1,000 miles can be filled by future A.T.P.'s.

In view of the Modal Split assumption regarding proposed regular passenger services by Airships in Western Europe, it is of some interest to realize that before the introduction of the Tokaido "Bullet Train" running from Tokyo to Osaka and vice versa, 26% of the travellers between these towns went by plane, which percentage rapidly dropped to a bare 6% after the introduction of this Tokaido Line.

Summarizing those competitive services offered by surface transport in Western Europe, it seems evident that unless considerable door-to-door time and total transportation costs can be saved, the regular short haul freight Airship has small prospect of success in competition with the relatively cheap surface transportation systems.

Where the journey in W. Europe involves a seacrossing, Airship services might have certain advantages in saving handling and transferring times and costs. These advantages, however, are partly offset by the fast

growing number of Ro-Ro-Ferries operating in the North Sea, Mediterranean and Baltic Area, etc.

COMPARING DIFFERENT TRANSPORT DEVICES; THE DANGER OF CONVINCING FIGURES

If one wants to sell a special piece of transport machinery, it is not too difficult to find convincing arguments, accompanied by even more convincing figures; the danger with figures, however, is that one can sweep them together under all kinds of carpets to meet the required qualifications. Comparing overall efficiency in terms of transport capability between different commercial transport devices might be a useful mental exercise, but only in order to reach some general conclusions. Generally speaking, those comparisons do not produce real economical usefulness if one omits the Total Cost Concept from door-to-door, which is the ultimate and decisive marketing factor. Trying to prove that the building cost per ton structure weight of an Airship having the same transport potential as the freight Boeing 747 has to be considerably cheaper than the comparative cost per ton of that particular aircraft does not impress any investor unless, of course, he wants to sell this craft for scrap value. In terms of horsepower per ton All Up Weight (A.U.W.), the average private motorcar needs an installed engine power of about 100 h.p. per ton and is in this respect more efficient than the Boeing 747. However, in terms of installed h.p. per seat/mile it is good to realize that the private automobile is in this respect one of the most expensive ways of transporting yourself from A to B, but as we have already stated, there are a lot of other factors to be taken into account.

By neglecting the total transportation costs, including door-to-door saving time for a given transportation distance, one may easily jump into a financial trap, if somebody convinces you to purchase his train tickets, arguing that the number of installed h.p. per seat/mile as well as his tariff are considerably less than the comparative figures of your private motorcar.

Comparing direct operating costs of two modes of transport, even if both are operating in the same environmental area, often gives no clear picture either. One may, for instance, easily draw the wrong conclusion that the full container ship in comparison with the conventional dry cargo ship, is so expensive that she could never be operated on a competitive basis, if one neglects the total transportation cost concept.

PROFIT EARNING PAYLOAD, DRAGGING UNPROFITABLE TARE WEIGHT

Accepting the philosophy that the only profitable work done by any commercial transport vehicle is the overcoming of the resistance of the payload in its motive container consequently means in reverse that each ton of motive payload has to drag a certain amount of unprofitable resistant deadweight.

To overcome this unprofitable resistance, one can imagine that figuratively speaking, each ton of motive payload has to be provided with a certain amount of tractive force. If we further accept the reality that the main reason cargo commodities are shipped from seller to buyer is to make a profit, then this consequently means that any shipper wants to transport each ton of cargo at the greatest possible speed, combined with the lowest price for tractive force, which price of energy is related to the product's selling price.

As high speeds are usually in contrast to relatively low specific resistance coefficients, the following comparison between several modes of transport (past, present and future) may be of some interest.

THRUST COSTS - DOLLARS

Total installed specific thrust in kilograms to move one ton of pure profitable payload at service speed, arranged in rising sequence of their respective resistance coefficients, based on a 100% loadfactor and taking into account the deadweights of fuel, lubes, stores, equipment, and empty containers, etc.

MODE OF TRANSPORT	TOTAL INSTALLED SPEC. TRACTIVE FORCE IN KG/TON PAYLOAD	KNOTS/HR SERVICE SPEED
1. Super Tanker "Esso Deutschland" (Europe - Pers. Gulf Trade)	2.484 kg	17
2. Dry Cargo Ship "Hamburg" (Trans N. Atlantic Trade)	8.10 kg	19
3. Average Container Freight Train	23.57 kg	38
4. Full-Container Ship (Sea-Land Galloway)(Trans N. Atlantic Trade)	29.40 kg	31
5. Road Truck (Mercedes Benz LPB/2224	63.36 kg	38
6. <u>Large Airship</u> (Future) Airfloat Trans- ¹ port Ltd.)(Trans N. Atlantic Trade)	175.00 kg	100
7. Future Sidewall Surface Effect Ship ² (C.A.B. System)(S.E.S.)(Tr.N.Atl.)	229.00 kg	100
8. Freight Hovercraft,,type Voyageur I '73 (Bell Aerospace)(300 km range)	464.00 kg	35
9. Airship "Hindenburg" (1936/37) (Trans North Atlantic)	518.00 kg	68
10. Boeing 747 F. (Freighter) (Trans N. Atlantic)	1,002.00 kg	514
11. Heavy Lift Helicopter Sikorsky S64E (70 km range)	1,534.00 kg	95
12. Supersonic Concorde (Trans North Atlantic)	5,449.00 kg	1,160

*Captured Air Bubble

GENERAL CONCLUSION

One cannot force the laws of nature, but one can balance them against each other.

Now one may draw a lot of conclusions, but as far as land - surface transportation is concerned, the freight train makes in this respect a very efficient mode of transport.

Realizing that the propeller efficiency of the pre-war "Hindenburg" was about 67%, it is obvious that she would provide a slightly better figure, if I had taken the presently accepted efficiency of 85%, combined with current building materials and construction methods, which provide in turn a more favorable payload weight to structure weight ratio.

Further it may be noticed that the "Economy of Scale" does really pay off, if one compares the figures of the large Trans North Atlantic Airship with the relatively small Trans Atlantic "Hindenburg," which economy applies also to the surface displacement ships.

In sequence of specific motive forces on a ton payload basis, the large Airship ranks as number 6 on the list, but arranged in sequence of increasing service speeds, this large Airship has to be listed between helicopter and transatlantic aircraft.

In other words, the large Airship needs for each ton of shipped payload a relatively small tractive force, combined with a relatively good speed.

Since the Concorde is designed as a pure passenger carrier, it is, of course, not fair to compare this aircraft with pure freight carriers.

Looking at the heavy lift helicopter, one is inclined to believe that nobody can afford to transport loads with this very expensive carrier, but the comparison with regular freight carriers is also a bit misleading, if one does not judge the helicopter on her proven merits as a very specialized transport tool.

AN IMAGINARY HEAVY AIRCRAFT, HAVING A L/D RATIO NUMBER OF 40?

If it were possible to scale down the speed of the Boeing 747 ("F") to about 130 knots the specific motive force per ton payload would drop to the comparative value of the Sea-Land Full-Containership. As every type of aircraft is designed for their own speed, this example of wishful thinking is of course a bit of theoretical nonsense; flying close to stalling speed with extended flaps makes economics relatively worse than they are; but what if one reverses this problem by putting forward the question, "Will it be possible to construct a heavy plane, carrying 200 tons of payload with a speed of 130 knots and having an overall lift-to-drag ratio number of 30 and over?"

The expected answers which I got from some aeronautical engineers were that this trick could not be done, because the very low loaded wings would introduce increased frictional drags, structural problems and weight penalties, etc.

If we accept that the "curse" which lies upon heavy aircraft is that it has to induce its own lift by considerable forward speed, we have to accept the Airship as the only natural way to solve this L/D ratio problem, which consequently means a mechanical, as well as an economical, restriction as far as the transporting of less valuable commodities by air is concerned.

THE (DESIGN) DENSITY STORY

In view of the relatively roomy cargo space of the Airship, one may safely presume that an Airship is practically always weight-restricted, which means that if the Airship is loaded to her full permissible take-off weight, she usually has some cargo space left, regardless of the average densities of the shipped cargoes.

Referring to several density studies concerning airfreight commodities, one may draw the conclusion that present aircraft often have a problem with their cargo design density, which statement also applies, but to a lesser extent, to the 747 pure freight Boeing. This density problem often causes aircraft to cube out before they are loaded to their maximum permissible payload weight, which causes in turn a loss in revenue potential.

The reason is that any transport device is essentially a compromise; building aircraft with lower density design specifications involves structural weight penalties, or as it is said: "Aircraft cannot afford to carry air inside their belly holds."

As 9 lbs. per cubic foot is the limiting figure set by present aircraft between weight and volume tariff (dimension weight rule), this figure is an important key regarding the economics and freight tariff structures of future Airship freight services.

COMPETITIVE FREIGHT RATES - LOW DENSITY FREIGHT MARKET

Even if the future Airship cannot provide a reasonable gain in pure freighting costs regarding high density commodities, she is nevertheless highly competitive with present airfreighting, regarding voluminous commodities weighing less than 9 lbs. per cubic ft. In spite of the fact that the average "on dock" density for aircargo lies roughly in the neighborhood of 13 lbs. per cubic ft., there still exists a huge market of very low density commodities weighing less than 9 lbs. per cubic ft.

These low density commodities represent about one third of the total world number of air freight parcels forwarded at present by air, which amounts roughly to nearly half of the total world air freight package volume. As there is no economical need for the Airship to punish these lower density commodities by applying the volume tariff, it is of some interest to be keenly aware of the fact that the future trend inclines to lower densities of air freight commodities.

TRANSPORTING OWLS TO ATHENS?

Coming to the end of this paper, the dominating factor is the very competitive services offered by other means of transport. However, we believe in the Airship concept as a basically sound concept, and I fully agree with other speakers that the Airship, as a specialized tool has many useful applications, such as transporting heavy and/or indivisible loads, etc., in which case the Airship gets paid for the specialized job to be performed.

If the Airship can decrease the present airfreight rates in order to reach the commodities on the upper limit of the median value group, she may indeed have some prospects as a regular long haul freight carrier, not by trying to transport owls to Athens, but only by carrying selected commodities over wisely selected routes and distances.

RECENT DEVELOPMENTS IN RUSSIA

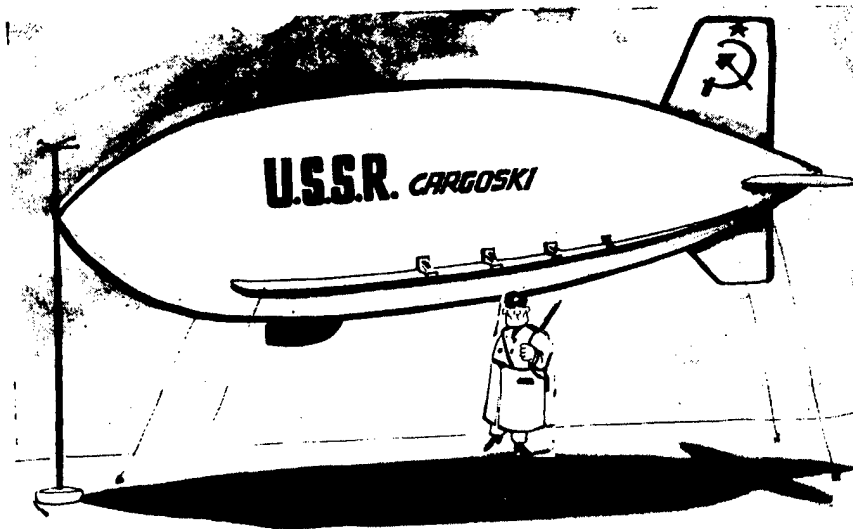

It will revolutionize cargo transportation--
She runs on vodka!

REFERENCES:

1. Mowforth, E., Dr., Airfloat Project, Royal Aeronautical Society, London (Sept. 20, 1971).
2. Decker, J.L., High Speed Marine Vehicles - A Design Outlook, Isle of Wight Branch of the Royal Aeronautical Society (Oct. 19, 1972).
3. International Freighting Weekly, London (1973).
4. Baton, Jean, The Place of Transport in Modern Society, International Air Cushion Engineering Society (Feb. 17, 1971).
5. Plesman, A., Exploitatie Van Vliegtuigen, De Ingenieur, No. 33 (August 14, 1936).
6. O'Hara, Clifford B., Moving Freight in the Future, Society of Packaging and Handling Engineers, San Francisco (Oct. 28, 1969).
7. Liberatore, E.K., American Surface Effect Ship Activities, Jane's Freightcontainers (1969).
8. Harthoorn, R., Naar een "Come-back" van het Luchtschip, Beta, Nos. 11, 12, 13, 14, and 15, Amsterdam (1971)
9. U.S. War Department, Technical Manual Aerostatics, TM 1-325, Washington D.C. (Oct. 1, 1940).

EFFECT OF PRESENT TECHNOLOGY
ON AIRSHIP CAPABILITIES

Robert T. Madden*
Frederick Bloetscher**

ABSTRACT: This paper presents the effect of updating past airship designs using current materials and propulsion systems to determine new airship performance and productivity capabilities. New materials and power plants permit reductions in the empty weights and increases in the useful load capabilities of past airship designs. The increased useful load capability results in increased productivity for a given range, i. e., either increased payload at the same operating speed or increased operating speed for the same payload weight or combinations of both.

Estimated investment costs and operating costs are presented to indicate the significant cost parameters in estimating transportation costs of payloads in cents per ton mile. Investment costs are presented considering production lots of 1, 10 and 100 units. Operating costs are presented considering flight speeds and ranges.

INTRODUCTION

As the result of many inquiries, Goodyear Aerospace Corporation (GAC) conducted studies relative to the projected costs for operating basic airships as transportation system vehicles. Past designs, a larger size of past designs, and the direct substitution of present materials and propulsion systems for past materials and propulsion systems were considered in the studies. The studies attempted to be conservative by not considering heavy take-offs in calculating useful load capabilities or redesigns of the airship to obtain: lower empty weights, aerodynamic lift, or greater flight speeds. Background on past GAC airship designs, the effect of substituting present technology on airship performance capability, and a simplified cost analysis considering investment costs and operating costs of airships as transportation vehicles are presented.

*Manager, Marketing, Goodyear Aerospace Corporation, Akron, Ohio, U. S. A.

**Senior Aeromechanical Systems Engineering Specialist, Goodyear Aerospace Corporation, Akron, Ohio, U. S. A.

SUMMARY OF UNITED STATES AIRSHIPS

As part of the studies GAC reviewed past airship designs and their characteristics. Goodyear has been involved with design, construction, testing and operation of most of the United States non-rigid and rigid airships. A listing of these airships is presented in Table I.

Table I - U. S. Navy/GAC Airships*

Dates In Use	Airship Class	Number Produced	Mission
1931-33**	Akron/Macon	2	U.S. Navy Patrol And Aircraft Carrier
1931-45	K Class	135	Patrol And Escort
1955	ZPG-5K	18	Patrol And Escort
1951-58	ZPG-2(2W)	17	ASW And AEW Patrols
1956-61	ZPG-3W	4	AEW Patrols
1941-47	L Class	150	Convoy/Escort
1947-1972	GZ-(L) Class	10	Goodyear Advertising

*Above listing represents about 75 percent of all U. S. airships built
 **Rigids - others are non-rigid or pressurized structures

Goodyear's non-rigid airship production experience versus the characteristic airship length is presented in Figure 1.

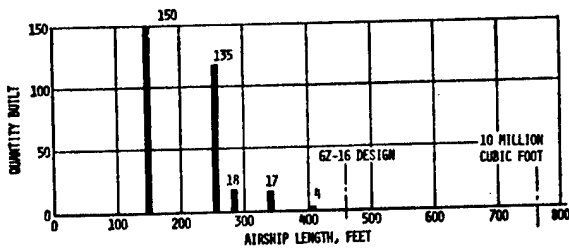

Figure 1
GAC Non-Rigid Airship Experience

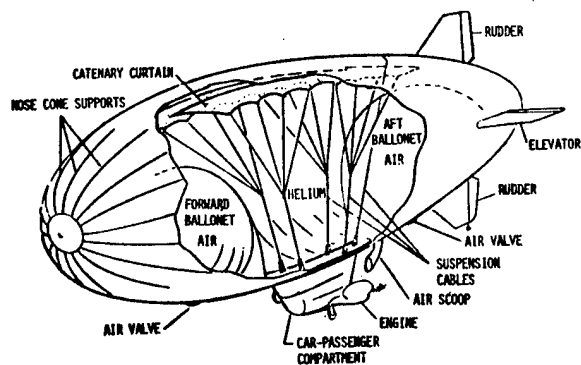

Figure 2
Typical Airship Design

The quantities of each size built indicates that most of the experience is with airships 150 to 260 feet in length. The GZ-16 design represents one of the large non-rigid designs completed by Goodyear for government consideration. Also indicated is the length of an airship with a volume of 10 million cubic feet. A typical non-rigid airship design is presented in Figure 2. The airship envelope group is basically a foldable assembly including the basic envelope, catenary attachments, cables and ballonet. Components and subassemblies, such as, the nose cone supports, valves and fans are rigid structures attached to the envelope. The car group is a rigid assembly of such items as the car structure, engines, controls, pilot station, cargo bay, etc. The car group is attached to the envelope through use of external and internal catenary curtains. Assembly of the airship-car to envelope, etc. - is accomplished in a hangar. The envelope is inflated with helium and a weighted net placed over the envelope controls the envelope distance above

the floor. The rigid structures are attached to the envelope and corresponding cable adjustments are made while the lifting envelope is restrained. Once the car is attached and the ballonnet filled with air, the net can be removed. The functions of the ballonnet are shown in Figure 3.

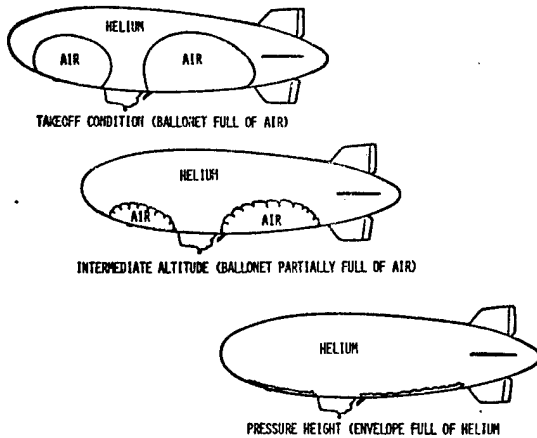

Figure 3
Airship Ballonet Operation During Flight

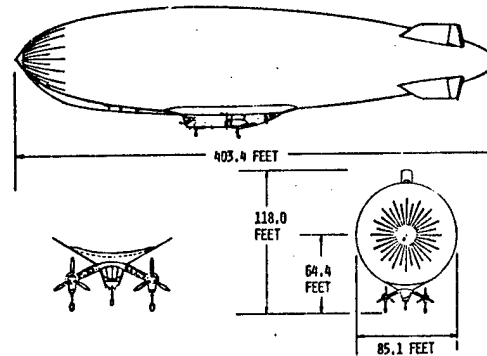

Figure 4
Goodyear ZPG-3W Airship

The ballonnet controls the buoyancy and attitude of the airship from takeoff to pressure height or maximum flight altitude. The air in the ballonnet is discharged automatically as the airship ascends to allow expansion of the helium gas and the ballonnet maintains a constant envelope pressure during flight. The ballonnet is essentially empty at the pressure height altitude condition. Flying higher than pressure height results in envelope pressures above design conditions. The ballonnet can also provide static trim in pitch during operations of the airship.

The largest non-rigid airship to become operational with the Navy is presented in Figure 4. Exceptional performance was attained by the U. S. Navy using the Goodyear ZPG-3W despite bad weather during long endurance station keeping/reconnaissance missions. Advanced ground handling equipment and methods were developed for the ZPG-3W airship that reduced ground crew manpower requirements during landing, takeoff and mooring. Goodyear believes that large non-rigid airships should be considered for cargo transportation. The rationale includes:

- o Rigids had to be used initially for large sizes because high strength envelope fabric did not exist for non-rigids.
- o New and efficient envelope materials are available for large non-rigid airships.
- o New materials are:
 - . Twice as strong as steel for same thickness.
 - . Six times as strong as steel for same weight.
- o Not one non-rigid airship has been lost due to structure or mechanical failure.

EFFECT OF TECHNOLOGY ON AIRSHIP PERFORMANCE CAPABILITIES

The cargo capacity of airships is based on the amount of air they displace, their

empty weight, the propulsion requirements for cruising speed, and the fuel requirements for the operating distances and speeds. One approach for indicating their capability is the gas unit-static lift per cubic foot as presented by the horizontal upper curve in Figure 5.

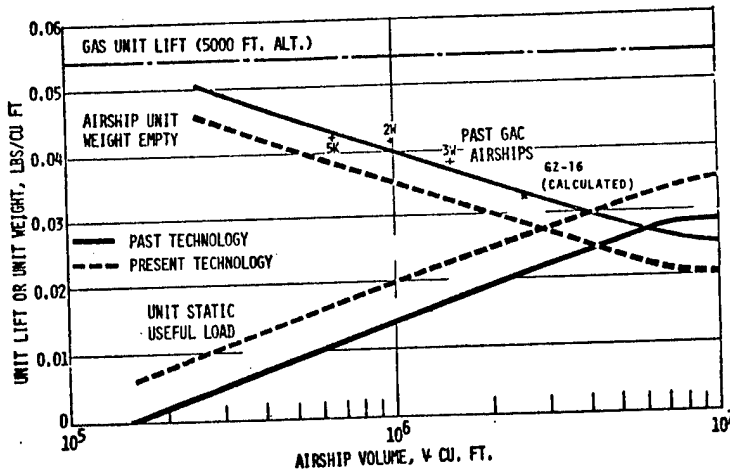

Figure 5
Airship Unit Weight And Static
Lift Characteristics

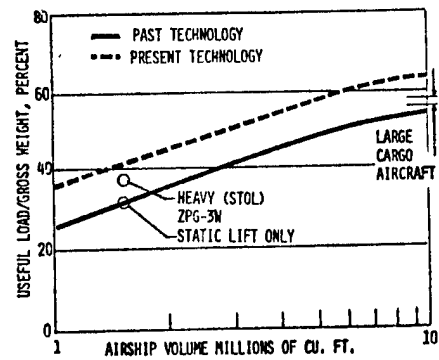

Figure 6
Airship Useful Load Efficiency

Its value is the difference between air and helium weights at a nominal helium purity value at 5,000 feet (0.0545 lbs/cu. ft.). The next lower solid curve presents the calculated empty unit weight (weight of airship empty/volume of air displaced by airship) of airships using past materials and engines. Past and present operational GAC airships are indicated on the curve for reference. The lowest solid curve is the difference between the gas unit lift and the airship unit empty weight. This difference is useful load for a neutrally buoyant airship and is available for fuel and cargo. The dashed curves present the same information for airships using present envelope materials and turboprop engines. These newer materials and power plants offer a significant increase in useful load compared to past materials and engines.

Another method of presenting vehicle efficiency is to plot the percentage of useful load to gross vehicle weight. Values of this parameter are presented for airships displacing 1 to 10 million cubic feet of air in Figure 6. The solid curve represents airships made using past materials and engines. The dashed curves represent the same designs using present materials and engines. Both curves are based on take-off with a neutrally buoyant airship. The ZPG-3W Airship value and that for a large cargo aircraft are presented for reference. The effect of "taking off" heavy (STOL) also can increase the value of the parameter. For example the value increased from 31 to 38.6 percent as indicated by symbols on the figure when the ZPG-3W Airship operated in the heavy condition.

From the useful load values, the payload can be calculated versus range for the different size airships. Payload values at 75 knots cruising speed and 5,000 feet altitude were calculated for airships ranging in size from 1.5 to 10 million cubic feet. The results are presented in Figure 7 using past and present technology considering only static lift.

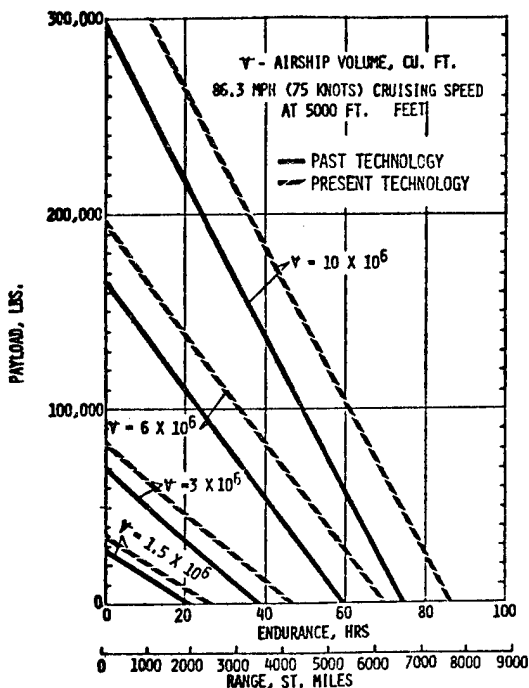

Figure 7
Payload Weight Capabilities Versus
Range For Airships Cruising At 75 Knots

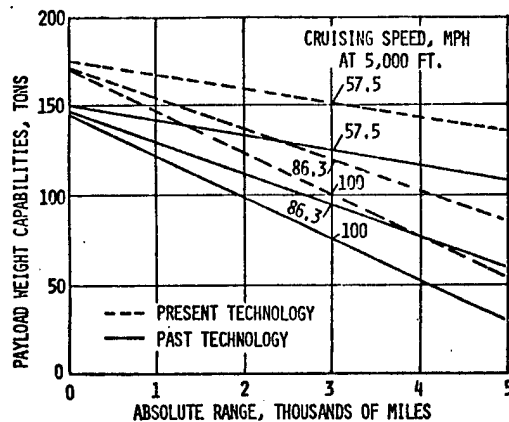

Figure 8
Payload Weight Capabilities Versus
Range For 10 Million Cu. Ft. Airships
At Different Cruising Speeds

From the useful load capabilities of the airships, presented in the past curves, the payload capacities of 10 million cubic feet displacement airships were calculated for 3 different cruising speeds and for ranges to 5,000 miles. The results are presented in Figure 8. Zero range represents a zero fuel condition. The reduction in payload weight capability with increasing range is directly related to increasing fuel weight requirements. For ranges of approximately 2,500 miles and a reserve of 500 miles, the payload capability can be determined from the 3,000 mile absolute range values. Payload capabilities from 75 to 150 tons are available, depending on the cruising speed and whether past or present technologies are used in the airship's construction. For ranges of approximately 1,500 miles and a 500 mile reserve, the payload capability can be determined from the 2,000 mile absolute range values. Payload capabilities of nearly 100 to 160 tons are available.

The value of payload transported in ton-miles per gallon of fuel is of interest from a fuel conservation standpoint. The values for several cruising speeds were calculated for a single size airship. The results are presented in Figure 9.

Values from 10 to 50 ton-miles per gallon are available on flights with an absolute range of 3,000 miles. Values from 13 to 62 ton-miles per gallon are available on flights with an absolute range of 2,000 miles. The values are greatest at the lowest speeds and shortest ranges.

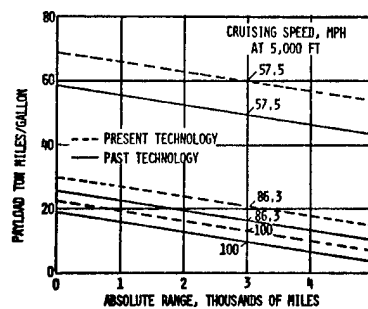

Figure 9
Payload Ton Miles/Gallon Vs
Range And Speed For 10 Million
Cu. Ft. Airships

SIMPLIFIED COST ANALYSIS

A simplified cost analysis was made to determine the costs per ton-mile for delivering cargo 2,500 and 1,500 miles using airships of 10 million cubic feet displacement flying at 5,000 feet altitude.

The characteristic dimensions for the 10 million cubic feet displacement airship based on design considerations used with the ZPG-3W and GZ-16 Airships are presented in Figure 10. No new design innovations and only proven fabrication, dimensional and operational practices using present day materials and engines were considered for calculating performance and costs. The costs are grouped as investment and direct operating costs in Table II. The annual investment costs are presented as a portion of initial airship costs for ease of presentation. The direct operating costs are grouped into labor and material costs per hour of flight.

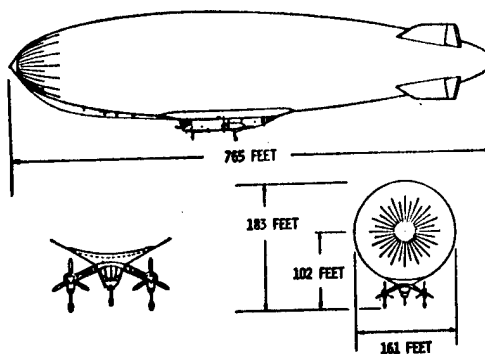

Figure 10
Typical 10 Million Cubic Feet
Displacement Airship

Table II - Preliminary Airship Transportation Cost Model

<p>Investment Costs</p> <ul style="list-style-type: none"> Annual Costs Depreciation Of Investment Interest On Investment Insurance Initial Investment Costs Non-Recurring - 1st Unit, 10 Units, 100 Units 	<p>Direct Operating Costs</p> <ul style="list-style-type: none"> Labor Costs/Flight Hour Flight Crew Maintenance Technicians Ground Service Crew Material Dollars/Flight Hour Fuel/Oil Helium Spares/Equipment
--	---

User investment costs are presented in Table III.

Table III - Annual Investment Costs

Annual Costs (As A Portion Of Initial Investment Costs)

1. Depreciation = $\frac{\text{Initial Cost} - 0.20 \text{ Initial Cost}}{10 \text{ Years}}$	= 0.080 Initial Investment Costs Per Year
2. Interest = (Average Over 10 Years)	= 0.040 Initial Investment Costs Per Year
3. Insurance = 0.03 (Average Depreciated Cost For 10 Years)	= 0.018 Initial Investment Costs Per Year
Total	= 0.138 Initial Investment Costs Per Year

Initial Investment Costs - Single, Average Of 10, Average Of 100 Units - 2500 Mile Operating Range

Airship Performance*		Cargo Tons	Unit Costs** Millions		
			1st Unit	Average For 10	Average For 100
Speed, MPH	Range, Miles				
57.5	2500	151	27.6	19.7	13.8
86.3	2500	120	28.1	20.1	14.0
100	2500	101	28.6	20.4	14.3

*Differences In Cargo Capacity Reflect Propulsion System And Fuel Weights For The Same Size Airship At Operating Flight Speeds To A Maximum Range Of 3,000 Miles.

**Differences In Costs Reflects Propulsion System Costs For The Operating Flight Speeds.

Annual Investment Costs Per Ton Mile - 2500 Mile Operating Range

Airship Performance		Cargo Tons	Productivity* Ton Miles Each Year	Costs/Ton Mile, Cents	
				Average For 10 Airships	Average For 100 Airships
Speed, MPH	Range, Miles				
57.5	2500	151	3.47×10^7	7.84¢	5.5¢
86.3	2500	120	4.15×10^7	6.68¢	4.65¢
100.0	2500	101	4.04×10^7	6.98¢	4.88¢

*Productivity Based On 4,000 Flight Hours Per Year.

Annual investment costs consider depreciation, interest and insurance costs. Taxes on the user's investment, profit on the user's investment, or initial non-recurring costs to build and certify the first airships were omitted. The initial investment costs are dependent, mostly on the airship costs. The average recurring costs for 10 airships (based on 1973 dollars) were used to determine the recurring costs of the first production unit and for the average costs of 100 production units. The differences in price between airships with different cruising speeds are related to the differences in propulsion systems and nose stiffening costs. The investment costs per ton-mile were determined from the annual investment costs and airship productivity in ton-miles for 4,000 flight hours per year. The flight period is similar to that used for commercial airplanes. Productivity ranges from 30 million to 40 million ton-miles per year per airship for flights of 2,500 miles. The investment costs per ton-mile range from approximately 4.65 to 7.84 cents per ton-mile depending on the airship's cruising speed and the number of airships produced.

Direct operating costs are further defined in Table 1V and are based on the costs of labor and materials. The cost of labor is calculated from the labor hours per trip and the hourly rate for the three general classes of labor. The labor costs per ton-mile are obtained by dividing the labor costs per trip by the ton-miles of cargo carried per trip. The direct operating labor costs run from 1.87 cents to 2.16 cents per ton-mile.

The direct operating costs for materials consumed by the airship include: the fuel and oil, based on the horsepower required for the cruising speed, the cost of replacing helium lost due to operations and some leakage, and the cost of spares based on the hours of flight per year and the airship's initial cost. The costs of materials per ton-mile are from 3.03 to 5.75 cents. The lowest value is related to the lowest speed airship which requires the least fuel and also has the greatest payload capacity.

The totals of investment and direct costs per ton-mile for 2,500 mile and 1,500 mile flights are presented as total operating costs in ton-mile in Table V. The investment costs are approximately one-half the total costs per ton-mile at the lowest cruising speed. Increasing the cruising speed reduces the investment costs per ton-mile and increases the direct operating costs per ton-mile. The optimum cruising speed for least cost per ton-mile appears to be between 57.5 and 100 MPH as the value for 86.3 MPH is less than either. The total costs per ton-mile run between 10.5 cents and 14.7 cents depending on how many airships are produced and their cruising speeds for trips of 2500 miles. The total costs per ton-mile run between 9.27 and 13 cents depending on how many airships are produced and their flight speeds for trips of 1500 miles.

A similar study was conducted using past airship designs including their original materials and engines. Their costs are presented as solid lines in Figure 11 in cents per ton mile versus their productivity per year. Both single airships and fleets of ten airships are presented. The curves indicate the desirability of selecting airships of increasing size over selecting many airships of the same size for increasing productivity. The operating costs presented earlier of the single airships using present materials and propulsion systems also are indicated for reference by the dashed curve.

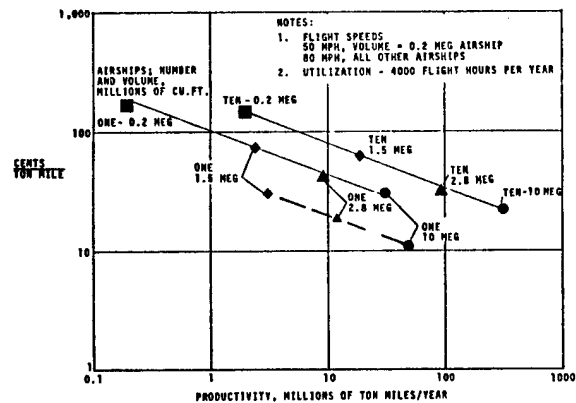

Figure 11
Effect Of Airship Size On Ton-Mile Costs

Table IV - Direct Operating Costs - 2500 Mile Trip

Labor Hours And Labor Costs

Labor Hours Per Trip

Flight Crew (5) = 5 (Flight Hours + 2 Hours)

Maintenance Technicians = 10 (Flight Hours)

Ground Service Crew = 60 Man Hours, Loading-Unloading - Services

Labor Costs Per Trip And Per Ton Mile

Operating Speed MPH	Flight Crew @\$15/hr. av.	Maintenance @\$10/hr. av.	Ground Service @\$7/hr. av.	Total \$ per trip	Ton Mi. per trip	Cost Ton Mile	Cents
57.5	3410	4350	420	8180	378,000	2.16	¢
86.3	2320	2900	420	5640	300,000	1.87	¢
100	2020	2500	420	4940	252,500	1.95	¢

Material Dollars - Average For 10 Units

Flight Speed MPH	Fuel Costs*, ¢ ton mile	Helium Costs**, ¢ ton mile	Spares Costs***, ¢ ton mile	Total Materials, ton mile
57.5	0.71 ¢	1.0 ¢	1.89 ¢	3.6 ¢
86.3	2.00 ¢	0.85 ¢	1.62 ¢	4.47 ¢
100.0	3.20 ¢	0.87 ¢	1.68 ¢	5.75 ¢

Material Dollars - Average For 100 Units

Flight Speed MPH	Fuel Costs, ¢ ton mile	Helium Costs, ¢ ton mile	Spares Costs, ¢ ton mile	Total Materials, ton mile
57.5	0.71 ¢	1.00 ¢	1.32 ¢	3.03 ¢
86.3	2.00 ¢	0.85 ¢	1.13 ¢	3.98 ¢
100.0	3.20 ¢	0.87 ¢	1.18 ¢	5.25 ¢

*Fuel & Oil = 42¢/gallon. **Helium = 1 Volume/Yr. At \$35 Per 1000 Cu. Ft. ***Spares Per Hr. = X 10⁻⁵ Initial Cost

Table V - Total Costs Per Ton Mile

2500 Mile Trips

Average Based On 10 Units

Flight Speed MPH	Investment Costs, ¢ Ton Mile	Direct Costs Ton Mile, ¢		Total Costs, ¢ Ton Mile
		Labor	Material	
57.5	7.84 ¢	2.16 ¢	3.60 ¢	13.6 ¢
86.3	6.68 ¢	1.87 ¢	4.47 ¢	13.02 ¢
100.0	6.98 ¢	1.95 ¢	5.75 ¢	14.7 ¢

Average Based On 100 Units

Flight Speed MPH	Investment Costs, ¢ Ton Mile	Direct Costs Ton Mile, ¢		Total Costs, ¢ Ton Mile
		Labor	Material	
57.5	5.5 ¢	2.16 ¢	3.03 ¢	10.7 ¢
86.3	4.65 ¢	1.87 ¢	3.98 ¢	10.5 ¢
100.0	4.88 ¢	1.95 ¢	5.25 ¢	12.0 ¢

1500 Mile Trips

Average Based On 10 Units

Flight Speed MPH	Investment Costs, ¢ Ton Mile	Direct Costs Ton Mile, ¢		Total Costs, ¢ Ton Mile
		Labor	Material	
57.5	7.40 ¢	2.16 ¢	3.41 ¢	12.97 ¢
86.3	5.84 ¢	1.75 ¢	3.89 ¢	11.48 ¢
100.0	5.69 ¢	1.72 ¢	4.48 ¢	11.89 ¢

Average Based On 100 Units

Flight Speed MPH	Investment Costs, ¢ Ton Mile	Direct Costs Ton Mile, ¢		Total Costs, ¢ Ton Mile
		Labor	Material	
57.5	5.20 ¢	2.16 ¢	2.87 ¢	10.23 ¢
86.3	4.06 ¢	1.75 ¢	3.46 ¢	9.27 ¢
100.0	3.98 ¢	1.72 ¢	4.07 ¢	9.77 ¢

One method of determining whether a vehicle is competitive for transporting cargo in a new region is to compare its transportation costs versus the costs of developing an all weather highway and using standard highway vehicles. A short road, 100 kilometers, was chosen for comparison. All the costs for the road were charged against the transportation system. As can be seen by the curves in Figure 12 the annual investment costs for the road alone exceed the vehicle associated costs until 100 million ton-miles of cargo are transported per year. Airship costs using past and present materials and engines are indicated by solid and dashed curves respectively. For productivity rates of less than 100 million ton miles per year the airship is candidate transportation vehicle because of the annual road costs.

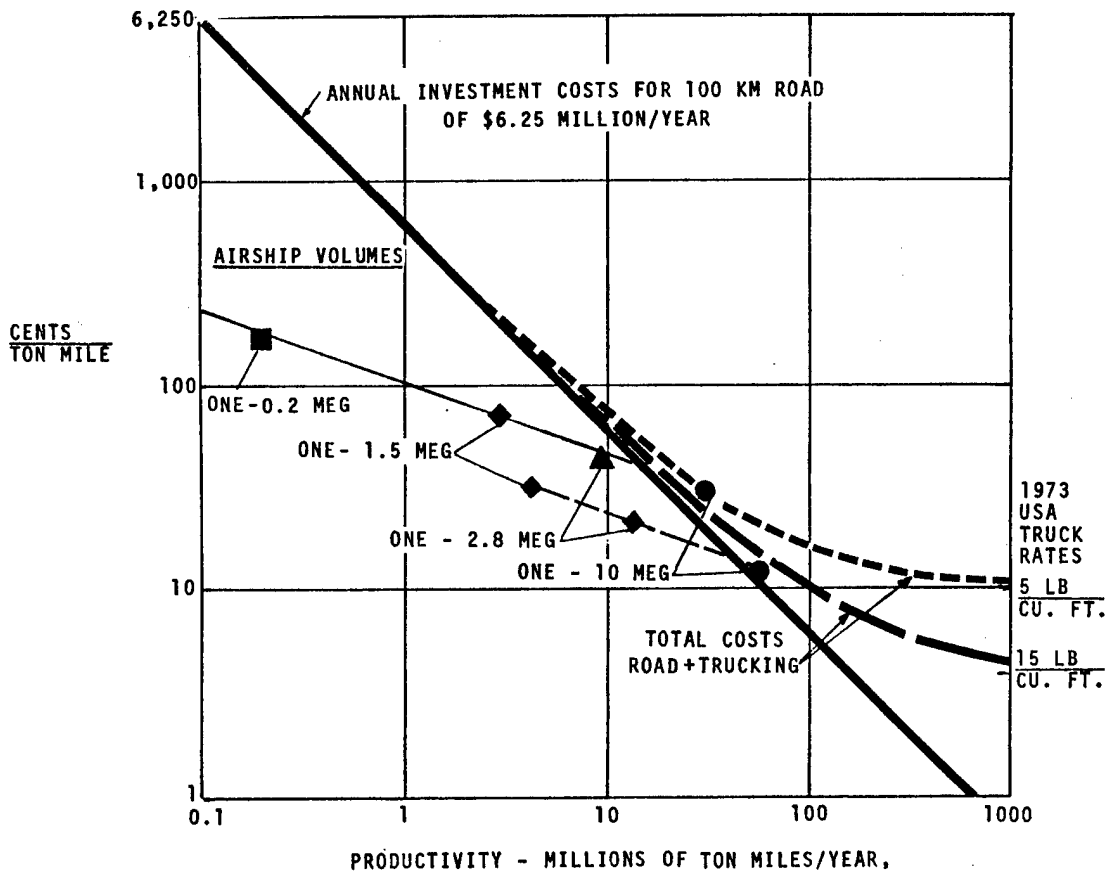

Figure 12
Comparison Of Transportation Costs Considering Investment Costs

CONCLUSIONS

The following conclusions were drawn from the results of the studies:

1. Present materials and propulsion systems can meet the requirements of all the basic airship designs investigated.
2. Use of present materials and power plants in these conventional airship designs increases their productivity and makes them attractive candidates for transportation missions, i. e. ,
 - all sizes are attractive where the regions infrastructure is undeveloped
 - the largest size airship is attractive for transporting low density cargo even where the regions infrastructure is developed

N76-15020

AIRSHIP ECONOMICS

Richard D. Neumann*
L. R. "Mike" Hackney**

ABSTRACT: This paper will deal with projected operating and manufacturing costs of a large airship design which is considered practical with today's technology and environment. It will be based on data and information developed during an 18-month study by the Southern California Aviation Council, Inc. as to the question of feasibility, engineering, economics and production problems related to a large metalclad type airship. It will provide an overview of other classic airship designs and explain why metalclad was selected as the most prudent and most economic design to be considered in the 1970-80 era. Crew operation, ATC and enroute requirements will be covered along with the question of handling, maintenance and application of systems to the large airship.

Few of man's contrivances have held the continued capacity to awe people as have the airships. Even today in the era of the C5A and 747, blimps are a main attraction in the sky. It is unfortunate that our national approach for bigness is equated with expense and often makes us lose sight of the economic advantages as experienced with the supertankers, jet aircraft and industry.

It is well known that supertankers of 200,000 tons are more cost productive in movement of oil than a 20,000 ton tanker. In aeronautics, aircraft were sold by economics and reliability starting with the DC-3 which cost 5 cents per passenger mile, the DC-6 which cost 2.5 cents per passenger mile, to the present wide bodies which currently operate at costs of 1.5 cents per passenger seat mile.

*Chairman, Lighter Than Air Committee, Southern California Aviation Council, Inc., Technical Task Force, Pasadena, California, U.S.A.
**President, Hackney & Associates, and member Southern California Aviation Council, Inc. Technical Task Force, Pasadena, California, U.S.A.

The airships left us almost 40 years ago, yet continually are proposed on a cyclic basis. The span between those cycles becomes progressively shorter and commences with vast claims for its unique abilities or economics. The massive problems of the past are eliminated with the stroke of a pen and the all encompassing words "New Technology." While in some respects this may be true, claims are damaged by half vast science fiction approaches to technology. As the cycle advances, glowing magazine and news media reports issue forth exclaiming in expansive phrases the benefits soon to accrue to mankind, transportation, manufacturers, ecology, environment and pure science.

There is perhaps no other man-made and conceived machine so capable of generating such loyal support, boundless enthusiasm, deep emotion and the utter lack of common sense of what it is and what it is not. No other form of transportation has received so little financial interest as the airship, except commercial sailing ships of recent years.

In Germany Graf von Zeppelin, a man who had an idea and put it to work, is the classic of achievement in the face of adversity. Initially putting his own capital into his idea, something few will do today in the most prosperous nation in the world, he gained some limited success and ran out of money which is a common end to most dreams. Two lotteries later, courtesy of the King of Wurtemberg, he developed his first successful military financing. We may well wonder if Las Vegas might not become the future financing empire for our aerospace industry. It has certainly applied more imagination to attracting things and doing things than many of our other sources.

Airships of the days gone by were victims of a variety of maladies created as a byproduct of the violation of natural laws and planning without adequate foresight. The airship holds a distinctive safety record throughout its history totaling 758 dead, of which 497 were military combat fatalities. It is symptomatic of our society that today we will spend 9 million dollars to burn the "Hindenburg" all over again for a motion picture, to continue the myth that airships are unsafe, while funding for any aspect of airship technology cannot obtain first class postage financing.

The world rose in outrage over environmental problems that affected the health of all. It was a different story when it affected their autos, fuel and pocketbooks. The airship appears to offer many unique benefits in the environmental area without creating a cavity in the national pocketbook. Railroads in the northeast were granted 2 billion dollars and it was recognized as being too little too late. Safety in rail transport is almost non-existent with continued accidents, fatalities and losses of property.

Within ten years almost 50 percent of all United States existing rail trackage will be abandoned at the request of the Federal Department of Transportation. Most of this will be in the agricultural sector of the nation. Truckers are planning to pick up the slack at a prohibitive price tag to all of us who use the highways.

Plans have gone forward to build trucks which will comprise two or three units, expanded from 12 to 14 foot widths and over 120 feet long. In a very few years of this event, our national highway system will be a sea of broken concrete from coast to coast. We will be forced to fight for available roadway with these giants. Air traffic and aircraft have little to go before saturation points are reached and which have already caused a high degree of public disaffection with security checks, lack of parking, baggage losses and traffic delays at overcrowded airport facilities.

Similar to a truck traveling fixed highways that reach New York, Chicago or Cleveland in the rush hours, airplanes must compete for available air traffic roadways into the airport, or in reality the funnel. It is here that most major accidents take place, both on the road and in the air, and our system breaks down. It is here where unimaginable future traffic jams will occur. It is here that the imagination of America's genius of industrial and scientific expertise must concentrate. Additional airports can be built at a major inconvenience to passengers and at a 1974 cost of 1.5 billion dollars for an intercontinental and 500 to 700 million dollars for a regional airport. Additional freeways and expressways will be built with their related massive population dislocations and at a cost of several million dollars per mile of concrete.

Compare this to the potentials possible if we think in terms of airships. Safety, a most important consideration, would seem to be answered by the past record of airships when hydrogen was not involved. With helium one must consider the dramatic effects of a collision between two feathers.

Engineering, design, construction, all questions continually raised about the airship, are expanded upon to a degree that is not consistent with reason and logic as related to problems. Supertankers today are larger than what we would consider big in the average airship. Costs certainly will be consistent with what is required to engineer tankers of 200,000 tons or less.

Ability to serve and perform within economic and safety requirements is possible. Have we lost our touch in the United States? Until the airship we never let anything deter us from being a success. Significantly the challenge could be picked up by other nations and credit will go to their ingenuity and engineering. Germany, which proved the concept, lost out only because of a little man who set the world on fire.

Ask yourself, are the risks worth the gamble and do they justify the development of the airship? Are arguments made by many proponents and opponents valid? Does the airship have the capacity to make the quantum jump that is expressed so often? If it does, to what degree does real potential exist?

Since the time the airplane has shown promise, California has been interested in aviation and has helped develop it as a useful transport means. The introduction by independent airlines of low cost coach service has resulted in air transportation being our primary transport industry after the private auto.

Concurrent with the airplane, California was also the home of Lighter Than Air development which commenced with Captain Thomas Scott Baldwin and Roy Knabenshue's pioneering experiments with dirigibles in Pasadena and the San Gabriel Valley. Their efforts resulted in a lightweight aero engine being pioneered and a variety of dirigibles were built, flown and tested on what is now the site of the Rose Bowl. The relationship between aerospace and the military can be traced to Captain Baldwin's sale of his airship "The Signal Corps" to the U. S. Army a year before the Wright Brothers managed a similar purchase.

In 1911, Calbraith P. Rogers completed the first transcontinental flight in a Wright flyer, the Vin Fiz, specifically making a landing in Pasadena to collect a \$10,000 award at the site of Tournament Park, the present location of Cal Tech. It was to California that Lindbergh came to buy a Ryan monoplane specifically redesigned for the flight to Paris.

In California the DC-3 gave birth to a long line of Douglas transports and provided the competitive incentive that shrunk the world from weeks and days to hours. It was from California that man started his first steps to the moon and space.

It seems, therefore, that after the years of controversy over the airship, and its unique capabilities, that Californians will look into it. They will determine that it was something that was overlooked much like the gattling gun of 100 years ago, only to become a major weapon again.

Based on the era of the airships and their successors, the blimps, it appeared that the answers should be forthcoming and that a plentiful supply of data and detail would be available. The Southern California Aviation Council, Inc. founded in 1958, has pioneered major studies to determine both the adequacy of existing airports, future needs and regional considerations. It is a quasi-official volunteer organization based in Pasadena and is funded by county governments of Southern California. Its charter is broad and permits it to act and engage in any and all aspects of aviation which affect Southern California.

In 1971 SCACI commenced a program to seek better methods of moving perishable products. The Lighter Than Air Committee was a direct result of the impasse in this area, to evaluate the vast claims being made for the airship. Its purpose was to determine what data was available and whether the airship holds a potential to solve California's transportation problems.

Early in the study it was apparent that much emotion as well as a lot of misinformation was involved in any effort to examine Lighter Than Air objectively. Federal interest in the subject was non-existent to a surprising degree. Many comments made by federal officials indicated a complete ignorance of the subject and characterized an attitude that anyone investigating LTA was an immediate candidate for the lock-up. One official characterized LTA engineering and development with a bland, "Everything there is to know about Lighter Than Air was known in the first 50 years of this century," and accordingly "It's a matter for the Air Transport Association and the private sector." Many officials have indicated substantial interest, but ask that they not be mentioned for what are obvious reasons. There is, however, government

interest which could surface with efforts to provide sound and intelligent approaches. As the effort continued adverse attitudes diminished and genuine interest and outside help was gained. Many organizations are interested in the subject.

The consistent factor associated with this interest is the wide divergence of backgrounds that are represented and the lack of nostalgia as an attraction, but rather commercial and scientific interest. Among this group are people who had backgrounds on the rigid airships, the Navy blimps and indeed a few associated with the R-100 and R-101 of England, a former German pilot of World I who served several hundred hours on the Bomber Zeppelins, military officers on active duty, along with some very distinguished people in aerospace.

One immediate result was access to private files and obtaining data that could well have been lost forever. Long forgotten papers and designs were located. Films of airships were salvaged and materials and artifacts catalogued for future examination. A reasonably firm foundation to examine the engineering, design, economic and practical aspects of the airship has been obtained.

Pertinent to any such examination, many claims by proponents are ill conceived and unsupported by factual record and factual data. Many problems associated with airships are products of imagination as well as fact. There are other aspects of the airship overlooked and/or glossed over by proponents, that have limited foundations which require more examination. Expansive claims for pollution elimination, fuel conservation and ultra heavy lift must be subject to critical questioning though there is some credibility to many of the claims.

Before any honest evaluation of a program can be conceived and advanced there must be determinations of the economics. SCACI produced a major study on the subject and economics involved. Taking 18 months overall, conclusions support further exploration of the airship concept. The question of whether the airship will be developed must be founded on the basis of its economic viability and operational capabilities as a transport, military or logistics mode.

A conclusion reached by the Lighter Than Air Committee of SCACI is that further feasibility studies are not required to substantiate additional studying of the airship concept. It is SCACI's conclusion that future activity must be directed to a moderately sized research vehicle investigation. SCACI believes a moderately sized vehicle of at least 3.8 million cubic feet in displacement will provide the basic criteria. This vehicle's development should be, it is suggested, a joint government/industry program to explore and develop the concept.

There are many factors related to the development of safe, efficient and economically feasible airships. The factors relate not to the airship itself, but to the systems applications which must be applied to make it practical.

DECIDING ECONOMIC FACTORS

To provide a foundation for basic economics of airships, certain factors are known. There are classic type airships and advanced concept types. Adding lately to the confusion is the addition of the hybrid. The latter will not be covered for a variety of reasons, but mainly it is suggested if you are going to build an airplane put wings on it and fly it like an airplane. If it is to be an airship, efforts to place wing and lifting foils are counterproductive, if one assumes that all other problems have been overcome relating to gas expansion, size and altitude.

The development of airships and their history will be presumed to have been well covered. It should be noted that anyone interested in Lighter Than Air must become well versed in the history of the subject as well as the past engineering accomplishments and mistakes. We allude to girder/fabric airships of the 20's and 30's as evolved from the basic Zeppelin concepts, the pressure ships of fabric and the ZMC-2 and SMD-100 metalclads.

The Graf Zeppelin was without question the most successful airship. American efforts ended in disaster, mitigated to some extent by the use of helium, but nevertheless resulting in the loss of 3 of the 4 rigid airships. One, a German commercial design, ZR-3, was surveyed for a combination of political and economic reasons well in advance of its lifetime, long before being broken up.

The second most singularly successful rigid type airship was the metalclad ZMC-2. It is given little credit for its achievements because of its diminutive size and lack of general knowledge that it was the first and only airship designed specifically for experimental reasons. It developed necessary criteria and data for future larger metalclad designs.

Early in the SCACI LTA Study it was apparent that to develop airships on the basis of engineering of the 20's and 30's is doomed to failure. Lying in wait are the same causes that eliminated the airship concept. Examination of the fabric pressure ships indicates similar potentials for failure with large sizes and indeed further examination disclosed that this was a primary cause of the cancellation of fabric pressure airships by their single customer. Elimination of semi-rigid airships is based on fabric ships if application of metal hulls was applied.

Any transport system's acceptance is controlled by the degree of safety of the system and this applies to the airship. No airline passenger would willingly board a flight if the known odds were 8 to 1 against reaching the desired destination. As long as odds remain one in 10 million in favor of his getting there, he will fly. This standard is applicable to auto, rail, ship or bicycle.

The history of the rigid commercial airship lends confidence to potential voyagers whether as crew or as passenger. The history of pressure airships has a record of safety not achieved by any other form of transport. There is an added factor, speed or the time and distance factor. Sightseeing from a blimp is a desire of many people, more than there is capacity to carry.

Flying a continent or ocean is another matter, when measured in days compared to hours by jet. The fabric airship is speed limited with its maximum speed well under 100 miles per hour. The girder/fabric rigid airship has the capability to reach 100 mph sustained speeds, but its safety is questionable, and is sustained by results now recorded for history. How does technology overcome these factors which are supported throughout transportation history?

One of the very early determinations by the LTA Committee is that regardless of design technology the rigid classic airship will retain complete vulnerability to the elements. It was further indicated that in spite of the excellent capabilities of Dr. Eckener and his associates, very capable training and excellent ability to handle airships, that they were aware of this failing. Every effort was made to avoid major frontal conditions or risk destruction and potential accidents. The fabric airship offers a better safety factor in this regard, with some hard data remaining of very extensive Navy efforts in 1958 to prove, and they did conclusively, that airships were not fair weather vehicles.

SCACI efforts are now directed toward examination of all metal airships, capabilities, safety and ruggedness. The ZMC-2 fully supports the theory of metalclad airships. For general purposes it was small and experimental. Unfortunately no civilian use was made to examine its unique capabilities. It proved, however, the soundness of the concept.

One man who sought to seek out and prove some of its rugged capabilities, Captain Bill Kepner, later Lt. General Kepner of the USAF, in 1930 requested permission to operate the ZMC-2 in storm conditions of the nature that destroyed the Shenandoah. Captain Clark, USN, then in command of Lakehurst Naval Air Station, denied permission. Even today General Kepner states that the ZMC-2 was the strongest airship ever built and certainly capable of taking on any major storm without fear of destruction.

SCACI recognizes that there are many who will take umbrage at the suggestion that rigid airships and fabric airships are limited and cannot fulfill the claims, illusions or science fiction approaches of many airship proponents. We recognize that a few will scoff at the all metal airship as being impractical and not being in conformance with their ideas and proposals. Be that as it may, we can only suggest that they study the subject further.

To SCACI metalclad construes plastic and other space age materials of lightweight and substantial strength. We have selected this path because speed is a major criteria and the fabric ships cannot match the speed demanded in modern day transportation. Life span is important and fabric cannot exceed an 8 to 10 year life at which point its deterioration extends to a high danger point. Fabric is size limited as was evidenced in the SPG-3W series. If airships are to become viable they must be large by a factor of 20 over the SPG-3W types.

Girder/fabric airships consist of an internal structure which is designed to carry all the aerodynamic, stress, torsional and payload distribution. It was conceived to carry internal gas cells. Externally, a fabric covered airship required both constant attention and replacement and must be made taut after or during each trip.

W. A. Klikoff in his paper "Pressure Airships," presented at the Fifth National Aeronautic Meeting of the ASME in Baltimore, Maryland, May 1931 says it better than SCACI can.

"Design Conditions and Factors of Safety" -- In the present design of rigid airships a rather peculiar system of factors of safety is adopted. Factors of safety of 4 and higher are used for static loads, but when the aerodynamic loads are superimposed, then the designers do not increase the structural strength in proportion to the increase of load, but increase the structural strength only to some extent which causes decreasing of the factors of safety. This practice is justified by the fact that conditions of superimposing both types of loading occur less often and the effects of higher loads on the structure will be less. For this reason airship designers are satisfied to drop their factors of safety to as low as 2, and sometimes even smaller for the worst loading conditions. This method of design may give the operating personnel a false sense of security, making them overconfident in the strength of airships under normal flying conditions, and in case of emergency they may treat the airship without due caution, causing perhaps a breakage of structure and severe disaster. Several airship accidents were traced to this cause by some of the experts.

AND

This hogging bending moment and this longitudinal force due to gas head pressure are present in all airships. In rigid airships there exists another factor due to gas pressure. Whereas in non-rigid types the transverse component of pressure produces uniform transverse tension in the covering, in rigid airships this transverse component acts as a side load on longitudinals, complicating their design by loading them with side load combined with direct stresses due to the bending of the whole airship. This loading condition of longitudinals tends to explain why gas pressure is often called a liability in the case of conventional rigid airships.

AND

The gas-head pressures due to the properties of lifting gas produce forces and moments reaching such magnitudes that the airship designer should undoubtedly try to utilize them as much as possible to his advantage. The longitudinal force is the most helpful one because it tends to produce a uniform tension throughout the structure, and all materials used in airships can carry much higher tensile loads than compression loads."

While Mr. Klikoff presented that paper over 43 years ago his analysis is still correct. All metal airships offer some unique advantages to the airship concepts operationally and have substantial economic advantages in manufacture.

All metal airship designs are simple compared with others. Metal airships will pay a penalty if sized too small. As they grow in displacement and size, advantages start to outstrip those of other types. Metal is capable of resisting higher pressures and high loadings. Fabric is limited. Metal such as aluminum applied to the large metal airship costs 85 to 95 cents per square yard, while fabric costs at least \$10.00 per square yard.

Fabric airships must approach the investment and development depreciation costs on the basis of 8 to 10 years, while the metal airship has no assigned minimum life span at this date. If the DC-3 is used as a comparative, the metal airship could take on eternal connotations. The major advantage of the metal airship is that it can uniquely be developed for high speed flight at speeds of 200 mph and higher.

A favorable economic aspect is that in aerospace we are metal workers with resources, knowledge and capability to fabricate shell type structures economically through mass production techniques. One factor of the metal airship is that its size, while posing some problems also permits simplification of construction methods.

The conclusions drawn by SCACI are that airship design, manufacture and life-span if predicated upon metal designs, will be practical from the economic, manufacturing and operational requirements. To follow classic methods of the past will be to place impossible burdens in the path of development and costs beyond comprehension.

ECONOMIC FACTORS OF AIRSHIP DESIGN, MANUFACTURE AND OPERATION

Design

While it is not readily available to researchers there is more than adequate design and engineering material available to eliminate the necessity of starting from scratch on airship engineering. Substantial detailed analysis of the ZMC-2 and follow-on engineering projects for larger sized metalclads has been compiled and upgraded at SCACI. Obviously each group that creates a design idea will incorporate their individual identity and engineering concepts. Some diligent investigative and exploratory research will provide a bounty of material. It is for the investigator to determine his path to follow as SCACI and its people have followed the path of the metal airship.

Approaching the subject with the large amount of excellent data available will permit reasonable approaches to determining projected costs. Whether interested parties can obtain their objectives at reasonable cost will be determined by their interest, persistence and ingenuity.

Manufacture

It has been the style recently to seek funding for programs based on double the estimated cost while hoping that it will not end up costing triple the estimate. It is anticipated that some organizations may use this approach. We would like to make, however, some suggestions which we believe are valid with respect to manufacturing costs.

Airships were built for almost 40 years. The primary cost was for engineering and design, not fabrication or manufacture. A comment was long ago made that airplanes breed like rabbits while airships breed like elephants. History does not support such a conclusion. Count Zeppelin and his organization produced airships in World War One at a faster rate than we can produce 747's or C5A's, time and facilities taken into account. The later history of airship manufacture and fabrication after World War One indicated that every airship built was constructed, erected and inflated in what must amount to record time for the small working crews involved. Goodyear employed fewer than 140 people, including engineers, when the ZR-4 and ZR-5 were being built. Slate Airship employed a group of 40 people and construction time was less than 100 days. The Zeppelin works employed some people who were engaged in a variety of other tasks, as well as airship construction. ZMC-2 was built with less than 40 people.

Methods exist and the investigator will find them if he looks. New methods are being developed at present with indications of great promise of short fabrication times and economies of mass production.

Airship Tooling

Metal working tools are available in quantity which can readily be applied to airship construction. Tooling is available at what amounts to scrap metal prices. The airship does not require complicated and sophisticated tooling set-ups. Tool and die makers will be necessary for basic metal tooling and are competent to do the job. Expensive R & D tooling development programs are not required. Even the hull itself will not require excessive expense in special tooling. Special jigs will be fabricated by the erection crews and engineering task force from common materials. In short, the process of building and maintaining airships requires far simpler tooling than required by fixed wing aircraft.

Airship Operations

There are known quantities in the airship which relate to operational costs. Powerplant requirements and fuel consumption charts can be developed with a reasonable degree of accuracy and be directly related to costs per mile, per hour and per ton mile. Past practices of employing massive engineering crews will be eliminated in design planning. Flight crew complements are suggested to consist of 2 men on small units and 3 men on large units. Additional crew members would be added as determined by flight time planning to serve as relief crew members, as is done in current Air Carrier services today.

The compacting of control consoles will relieve crew and pressure, a major determining factor in fixed wing operations. Addition of current navigational and communications electronics simply reduce pilot pressure. The use of closed circuit monitoring systems allows the flight engineer far more reliable systems operation and control than is possible with on-board service personnel. Crew costs can be projected accurately, taking into account time aloft, duty time, pay raises and inflation.

Landing fees, facilities, ground support equipment, mooring and handling equipment are all determinable quantities and only the exercise of judgment is required. Future expense measured against presently known expense will provide an index. The above are calculable with reasonable accuracy.

UNKNOWN ECONOMIC FACTORS OF OPERATION

At present even with the best of educated guesses certain cost factors will enter the picture, from commercial and military aspects that are not projectable with a high degree of accuracy.

The cost of manufacture is directly related to depreciation schedules and the cost of engineering. This cost while projectable if using airframe manufacturers as an example, can vary considerably from design discussion to actual delivery. Educated guesses are possible but remain to be proven conclusively. They will be a major factor in determining the economic viability of airships.

Major overhaul and servicing requirements may remain a partial unknown until actual operations and several hundred thousand hours are accumulated to provide basic data. Known factors relating to powerplants are projectable with a high degree of accuracy. There may be some unknowns related to hull overhaul and major section replacements as a result of metal fatigue in some structures. Much of this can be accurately estimated prior to manufacture, but there remains the potential for error.

Airships, if commercial operation is considered, will pose some very unusual insurance considerations. A projection was made based on the experience of the Hindenburg. The SCACI projections may provide at least a long needed starting point.

Helium Gas and Hydrogen Gas

Helium is recognized as being the safer alternative, although it is believed that metal airships can operate with both gases with almost equal safety. Helium currently costs \$35.00 per 1,000 cubic feet, FOB Kansas. Hydrogen can be obtained commercially in bulk at 65 cents per 1,000 cubic feet at present. The lift factor, while a major inducement to consider hydrogen is not as substantial an inducement as the wide disparity between the costs of the gases. The fast breeder reactor poses a potential to produce substantial amounts of helium as a by-product. A cost determination to separate helium from natural gas as opposed to the cost to separate it from radioactive particles as a by-product has not been studied and is needed. It may prove that helium will be abundant and cheap, a major consideration for future airship economics.

Hydrogen is a major economic consideration if it in part becomes a fuel source for future airships. Consideration of such use has been made, but not as related to costs and economics of airship operations. It is another area of study currently underway at SCACI.

Carriage of ballast is a restriction pertinent to airships. Most sea-going ships must operate in ballast after discharging their cargo. This does not appear to pose a problem which cannot be eliminated from operational considerations. It does not appear as significant a problem as it has sometimes been represented. Considerable efforts are being directed to this question. The primary question is economic and carriage of ballast does not seem to pose major economic restraints on the airship.

The Purpose of Economics

For 40 years the arguments have raged and they show no signs of diminishing or of being proven or disproved. Evidence exists that the airship can meet the economic tests necessary to include them in our transportation system in day to day activity. Evidence also exists that airships have proven less than durable in the face of adverse weather.

In the United States every airship built differed significantly from every other and the results ended in disaster. In Germany, airships were built in series and achieved a high degree of success both operationally and economically. To continue to study the airship as a concept will only further add to the confusion about what they are and what they are not, what they can do and what they cannot do, what they will cost and what a waste it would be to develop the concept. In recent months indications are that several small airship designs of impractical payload considerations may be constructed. This, while a step in the proper direction, does not mitigate the many other problems associated with airship potential or problem areas, if indeed it does not further damage the image of airships conclusively.

SCACI believes the airship deserves development in the form of a series of prototypes which can be adequately flight tested and can be developed for special purposes. The design must be simple and utilize the vast knowledge gained from the past combined with proven technical developments of the last 40 years.

Some interesting hybrids have been proposed and may hold some promise for future research but the prototype we propose has got to work and that means maximum utilization of things we know right now.

Prototype development will be essential to a program to establish learning curves of management, manufacture, design, systems development, training and operational procedures and standards. Prototypes must be considered as an expendable item to apply modifications and newly gained knowledge and not be expected to solve all the problems upon the first flight. This has too often been the case in the past. This objective is the present goal of the SCACI Lighter Than Air Committee and its Technical Task Force. We hope the near future will bring a realization of this goal.

N76-15021

SOME ECONOMIC TABLES
FOR AIRSHIPS

Richard D. Neumann*

ABSTRACT: During the course of the Southern California Aviation Council study on Lighter Than Air it was determined that some form of economic base must be developed for estimation of costs of the airship. The tables are part of this paper.

During the course of the first study on Lighter Than Air by the Southern California Aviation Council, Inc. it was determined rather quickly that little material was available to make a proper economic determination of the airship. What does exist is fragmentary, or ancient and not applicable.

Application of construction techniques and manpower, materials, power-plants and personnel if considered in current technology, would leave the airship as only an anachronism. It was, therefore, essential to determine some of the characteristics of the airship as it will be in the immediate future and its method of manufacture, operation, and administration.

*Chairman, Lighter Than Air Committee, Southern California Aviation Council, Inc., Lighter Than Air Technical Task Force, Pasadena, California, U.S.A.

The following tables were developed and used as guides to the overall study of the airship's economics. We have not provided the entire study since it is weighted by many conclusions of the SCACI group that others may not agree with. In determining manufacturing costs the use of cubic displacement was applied rather than cost per pound and ton of airframe. The latter may also be acceptable and use of both could provide an excellent cross check of the manufacturing economics.

Crew costs were not included because SCACI operations and flight people have very definite ideas of what would comprise a crew and what would not and these estimates would certainly not agree with what has been past practice or suggested by airship proponents of late. GSA and general operational practices are considered closer to seagoing operations than to air transport, but this too may not agree with pre-conceived ideas, and was not included.

We hope that these tables will act as a guideline and permit further efforts to go forward to truly provide a reasonable economic basis upon which the airship can be viewed objectively. One need only remember that air transportation and global access in hours has only existed for the 16 years since the jet transport.

We have a long way to go in aviation and it may be fitting that the airship will be among those future advances. Future passenger exposure to the airship will certainly have a bearing on its future, as profoundly as the ability of the jet to eliminate vibration and give the feeling of living-room comfort at 450 mile per hour speeds.

It has been man's dream and also his major necessity to develop transportation and communications as vital to his well being and survival. The airship appears to offer massive gains if it can be adequately managed to reduce transportation costs measurably and at the same time provide greater operating freedoms and access to cargo or passengers than any other form we use today, airplanes, truck, ships, helicopters and barges.

Arguments over the questions of the handling, mooring survivability and applications of the airship belie that innate ability that lies within the aerospace industry worldwide to solve problems of immense magnitude and achieve great advances which have led to space, the moon and now the galaxies. If the economics are correct or within reason then it is necessary to get on with the job and prove it by an operating product on which further refinements can be made and determined.

AIRSHIP GROSS LIFT/USEFUL LIFT

<u>SERIES</u>	<u>Helium Volume (@ 95% Purity) Cubic feet</u>	<u>Gross Lift in Tons @ 95% purity. (61.5Lbs per 1000CF)</u>	<u>Percent Gross Lift weight to Hull weight (%)</u>	<u>Useful Payload Lift-Tons</u>
MC-7.4	7,400,000	220.14	48%	114.4
MC-15	15,000,000	461.25	40%	276.75
MC-22	22,000,000	676.5	38%	419.43
MC-35	35,000,000	1,076.5	37%	667.4
MC-42	42,000,000	1,291.5	35%	839.4
MC-52	52,000,000	1,599.0	33%	1,071.4
MC-55	55,000,000	1,691.25	31%	1,167.15

AIRSHIP CHARACTERISTICS WHICH
DETERMINE COSTS

ITEM:	MC-7.4	MC-15	MC-22	MC-35	MC-42	MC-52	MC-55
Length:(feet)	712.7"	902"	1,024.8"	1,196.4"	1,271.3"	1,365.6"	1,390.7"
Diameter:	142.5"	180.4"	204.9"	239.2"	254.2"	273.1"	278.1"
Volume-Hellum(10) ⁶	7.4	15	22	35	42	52	55
Fineness ratio:	5	5	5	5	5	5	5
Horsepower 0 - 50 MPH	2,500	4,000	7,500	10,000	13,500	18,000	21,000
Horsepower 51 - 100 MPH	5,000	7,500	9,000	12,000	16,000	23,000	27,000
Horsepower 101 - 200 MPH	30,000	71,000	84,000	95,000	118,000	130,000	144,000
Fuel Consumption - 50 MPH @ Gallons/Hour	125	188	188	250	335	415	530
Pounds/Hour $\frac{1}{2}$	750	1,128	1,128	1,500	2,010	2,490	3,180
.20¢ per gallon(\$)	25.00	37.60	37.60	50.00	67.00	83.00	166.00
.30¢ per gallon	37.50	56.40	56.40	75.00	100.50	124.50	159.00
.40¢ per gallon	50.00	75.20	75.20	100.00	134.00	166.00	212.00
Fuel Consumption - 100 MPH Gallons/Hour	125	188	229	310	407	582	655
Pounds/Hour	750	1,128	1,374	1,860	2,442	3,992	3,930
.20¢ per gallon	25.00	37.60	45.80	62.00	81.40	116.40	131.00
.30¢ per gallon	37.50	56.40	68.70	93.00	122.10	194.60	196.50
.40¢ per gallon	50.00	75.20	91.60	124.00	162.80	232.80	262.00
Fuel Consumption - 200 MPH Gallons/Hour	750	2,000	2,125	2,375	2,937	3,250	3,600
Pounds/Hour	4,500	12,000	12,750	16,250	17,622	19,500	21,600
.20¢ per gallon	150.00	400.00	425.00	475.00	587.40	650.00	720.00
.30¢ per gallon	225.00	600.00	637.50	712.50	881.10	975.00	1,080.00
.40¢ per gallon	300.00	800.00	850.00	950.00	1,174.80	1,300.00	1,440.00

$\frac{1}{2}$ Specific Fuel consumption is projected at 25 percent higher than currently obtainable with current powerplants.
 $\frac{1}{2}$ Fuel weight is computed at 6 pounds per gallon rather than at actual weight of 5.8 pounds/gallon.

AIRSHIP

DEPRECIATION SCHEDULE

ASSUMPTIONS: The depreciation schedule applies a 15 per cent (15%) and a 5 per cent (5%) residual value at 16 years and at 25 years. The utilization schedule A and D column allow for the highest depreciation costs and lowest depreciation costs based on speeds of 100 and 200 Miles Per Hour. Estimated life of a metal type Airship Hull based on physical experience is set at 25 to 30 years. Residual value may be considered the scrap value of the metal content and component systems values.

AIRSHIP SERIES	Residual Value		Full Depreciation		Full Depreciation		16 Year Depreciation		25 Year Depreciation	
	15% Value (O)3	5% Value (O)3	15% residual (O)3	5% residual (O)3	15% residual (A Column)	5% residual (D Column)	15% Residual - Annual Charge off Schedule - (15%)	5% Residual - Annual Charge off Schedule - (5%)	15% Residual - Annual Charge off Schedule - (15%)	5% Residual - Annual Charge off Schedule - (5%)
MC-7.4	1,890	630	10,710	11,970	669,300	748,125	428,400	477,200	892,500	997,500
MC-15	3,937	1,312	22,312	24,937	1,394,531	1,558,593	1,310,080	1,463,000	2,082,500	2,324,752
MC-22	5,775	1,925	32,575	36,575	3,253,906	3,636,750	2,491,000	2,799,000	3,094,000	3,458,000
MC-35	9,187	3,062	52,062	58,188	3,892,187	4,367,187	5,118,513	5,720,812	3,275,900	3,661,320
MC-42	11,225	3,675	62,275	69,875	4,209,375	5,403,125				
MC-52	13,650	4,550	77,350	86,450						
MC-55	14,450	4,817	81,897	91,533						

AIRSHIP UTILIZATION VERSUS DEPRECIATION COST

AIRSHIP SERIES	4000 Hours Annual Utilization		6000 Hours Annual Utilization		A Column M.P.H. (\$ per Mile)		D Column M.P.H. (\$ per Mile)	
	Cost/Hour 16Year/15%	Cost/Hour 25Year/5%	Cost/Hour 16Year/15%	Cost/Hour 25Year/5%	100 - 200	100 - 200	100 - 200	100 - 200
MC-7.4	167.30	187.03	107.99	119.30	1.115	.557	1.115	.795
MC-15	348.62	398.64	223.12	249.37	2.324	1.162	2.324	1.162
MC-22	511.52	571.48	327.50	365.75	3.408	1.704	3.408	1.704
MC-35	813.47	909.18	526.25	581.88	5.423	2.711	5.423	2.711
MC-42	903.04	1,091.79	622.75	699.75	6.486	3.243	6.486	3.243
MC-52	1,052.34	1,350.78	773.50	864.50	7.015	3.007	7.015	3.007
MC-55	1,279.64	1,430.23	818.97	915.43	7.314	610.22	7.314	610.22

REPRODUCIBILITY OF THE ORIGINAL PAGE IS POOR

AIRSHIP INSURANCE ANALYSIS
(Hull, Public Liability & Property Damage)

ASSUMPTION: The calculations expressed herein are based on typical airframe costs of fixed wing aircraft using a higher value to qualify the experience rate applied to new operations. It is significant to note that German Commercial Airship insurance rates of the 1930's era were less than One per cent (1%) of hull value based on performance and safety. A probable rate will be in the 2.5 to 3 per cent range.

AIRSHIP SERIES	Hull Value	Hull Value	Hull Value	Hull Value	Cost @	Cost @	Cost @	Cost @	Cost @
	@ \$1.75 CF. 1/ (A) (0)3	@ \$1.50 CF (B) (0)3	@ \$1.25 CF (C) (0)3	@ \$1.00 CF (D) (0)3	6% of A (A-1) (0)3	6% of B (A-2) (0)3	4% of A (A-3) (0)3	4% of D (A-4) (0)3	2% of A (A-5) (0)3
MC-7.4	12,600	10,800	9,000	7,400	756	432	504	288	252
MC-15	26,250	22,500	18,750	15,000	1,575	900	1,070	600	525
MC-22	38,500	33,000	27,500	22,000	2,310	1,320	1,540	880	770
MC-35	61,250	52,500	43,750	35,000	3,675	2,100	2,450	1,400	1,225
MC-42	73,500	63,000	52,500	42,000	4,410	2,520	2,940	1,680	1,470
MC-52	91,000	78,000	65,000	52,000	5,460	3,120	3,640	2,080	1,820
MC-55	96,350	82,500	68,750	55,000	5,781	3,300	3,854	2,200	1,927

UTILIZATION COST BREAKDOWN-INSURANCE

AIRSHIP SERIES	4000 Hours - cost per hour		6000 Hours - cost per hour		COST PER MILE @ 100 & 200 MPH		
	Based on Columns		Based on Columns		Based on Columns		
	A-1	A-6	A-1	A-6	A-1	A-6	A-1
MC-7.4	189.00	36.00	126.00	24.00	1.890	.240	.945
MC-15	393.75	75.00	262.50	50.00	3.937	.50	1.968
MC-22	577.50	110.00	385.00	73.33	5.77	.733	2.887
MC-35	918.75	175.00	612.50	116.66	9.187	1.166	4.593
MC-42	1,125.00	210.00	735.00	140.00	11.250	1.400	5.625
MC-52	1,365.00	260.00	910.00	173.33	13.655	1.733	6.825
MC-55	1,445.25	275.00	963.50	183.33	14.45	1.833	7.226

1/ C.F. = Cubic foot displacement of vehicle

Assumptions: Fossil fuels of JP-4,
Karo base for turbine operation.
As at 5-10-74, domestic cost per gallon
average .19¢ per C.A.B. Monthly report.

FUEL/PAYLOAD/COST/RANGE
Without Boundary Layer

200 M.P.H. = 174 Kts
100 M.P.H. = 84 Kts

AIRSHIP SERIES:

	Cost per Hour \$	Cost per mile-St.	Fuel Weight-lbs 2,000 Mile Range: 100MPH-20Hrs 200MPH-10Hrs	Fuel Weight-Tons	Crew Weight Pounds	Reserve Fuel Weight Pounds	Crew, Fuel & Res. Fuel weight-Tons Miles	Payload 2000 St. Ton Mile	Cost per Assuming a 100% error-	Cost per mile/Ton
<u>MC-7,4</u>										
High Speed -200MPH	150.00	.75	90,000	45	5000	18,000	56.5	60	.0215	.025
@ .20¢ per gallon	225.00	1.15	"	45	"	"	"	"	.091	.038
@ .30¢ " "	300.00	1.50	"	45	"	"	"	"	.025	.050
@ .40¢ " "										
Low Speed -100 MPH	25.00	.15	15,000	7.5	"	5,000	12.5	101	.00148	.00296
@ .20¢ per gallon	37.50	.375	"	"	"	"	"	"	.00375	.00750
@ .30¢ per " "	50.00	.50	"	"	"	"	"	"	.0050	.010
@ .40¢ per " "										
<u>MC-15</u>										
High Speed - 200 MPH	400.00	2.00	120,000	60	"	24,000	74	202	.0099	.0198
@ .20¢ per gallon	600.00	3.00	"	"	"	"	"	"	.0148	.0296
@ .30¢ " "	800.00	4.00	"	"	"	"	"	"	.0193	.0386
@ .40¢ " "										
Low Speed - 100 MPH	37.60	.376	22,560	11.3	"	5,000	16.3	260	.00151	.00302
@ .20¢ per gallon	56.40	.564	"	"	"	"	"	"	.00261	.00522
@ .30¢ " "	75.20	.752	"	"	"	"	"	"	.00289	.00578
@ .40¢ " "										
<u>MC-22</u>										
High Speed - 200 MPH	425.00	2.125	127,500	63.75	"	25,500	79	340	.00625	.0125
@ .20¢ per gallon	637.50	3.185	"	"	"	"	"	"	.00936	.0187
@ .30¢ " "	850.00	4.25	"	"	"	"	"	"	.0125	.0250
@ .40¢ " "										
Low Speed - 100 MPH	45.80	.458	27,480	13.74	"	5,496	19.	400	.00145	.0029
@ .20¢ per gallon	68.60	.687	"	"	"	"	"	"	.00171	.0034
@ .30¢ per gallon	91.60	.916	"	"	"	"	"	"	.00229	.00458
@ .40¢ per gallon										

FUEL/PAYLOAD/COST/RANGE - Sheet 2:

MC-35												
High Speed - 200 MPH												
@ .20¢ per gallon	475.00	2,375	162,500	81.25	"	32,500	100	567	.00118	.00836		
@ .30¢ " "	712.50	3.56	"	"	"	"	"	"	.00627	.01254		
@ .40¢ " "	950.00	4.75	"	"	"	"	"	"	.00837	.01674		
Low Speed - 100 MPH												
@ .20¢ per gallon	62.00	.62	37,200	18.60	"	7,400	24.82	642	.000965	.00193		
@ .30¢ " "	93.00	.93	"	"	"	"	"	"	.001448	.00289		
@ .40¢ " "	124.00	1.24	"	"	"	"	"	"	.00193	.00366		
MC-42												
High Speed - 200 MPH												
@ .20¢ per gallon	587.40	2,937	176,220	88.11	10,000	35,244	110.73	728	.00403	.00806		
@ .30¢ " "	881.10	4.405	"	"	"	"	"	"	.00605	.01210		
@ .40¢ " "	1,174.80	5.874	"	"	"	"	"	"	.00806	.01612		
Low Speed - 100 MPH												
@ .20¢ per gallon	81.40	.814	48,840	24.42	10,000	9,768	34.30	804	.00101	.00202		
@ .30¢ " "	122.10	1.221	"	"	"	"	"	"	.00151	.00302		
@ .40¢ " "	162.80	1.628	"	"	"	"	"	"	.00202	.00404		
MC-52												
High Speed - 200 MPH												
@ .20¢ per gallon	650.00	3.25	195,000	97.5	"	39,500	122	949	.00342	.00684		
@ .30¢ " "	975.00	4.875	"	"	"	"	"	"	.00513	.01026		
@ .40¢ " "	1,300.00	6.50	"	"	"	"	"	"	.00684	.01368		
Low Speed - 100 MPH												
@ .20¢ per gallon	116.40	1.164	79,840	39.92	"	15,968	52.90	1,018	.00114	.00228		
@ .30¢ " "	194.60	1.946	"	"	"	"	"	"	.00191	.00382		
@ .40¢ " "	232.80	2.328	"	"	"	"	"	"	.00227	.00454		
MC-55												
High Speed - 200 MPH												
@ .20¢ per gallon	720.00	3.60	216,000	108	"	43,200	134.6	1,032	.00348	.00696		
@ .30¢ " "	1,080.00	5.40	"	"	"	"	"	"	.00523	.01046		
@ .40¢ " "	1,440.00	7.20	"	"	"	"	"	"	.00697	.01394		
Low Speed - 100 MPH												
@ .20¢ per gallon	131.00	1.31	78,600	39.3	"	15,720	52.15	1,114	.00117	.00234		
@ .30¢ " "	196.50	1.965	"	"	"	"	"	"	.00176	.00352		
@ .40¢ " "	262.00	2.62	"	"	"	"	"	"	.00235	.00470		

BOUNDARY LAYER CONTROL-ECONOMIC EFFICIENCY

Assumptions:

Boundary Layer Control is believed applicable to large airships without the attendant penalties that are imposed on fixed wing aircraft. This study believes that BLC will improve the efficiency by 50 per cent (%). NASA estimates indicate BLC on a cylindrical airform will increase the efficiency by 58 per cent(58%). The study may therefore be as much as 20% understated as to BLC efficiency.

<u>AIRSHIP SERIES:</u>	<u>Horsepower:</u>		<u>Horsepower/ BLC Design 200 M.P.H.</u>	<u>Fuel in</u>		<u>Fuel in Pounds/Gals BLC Design</u>	<u>Cost Per hour @ 200 M.P.H.</u>	
	<u>Conventional Design 200 M.P.H.</u>	<u>Conventional Design 200 M.P.H.</u>		<u>Pounds/Gals Conventional</u>	<u>Pounds/Gals BLC Design</u>		<u>204PG \$</u>	<u>304 PG \$</u>
MC - 7.4	30,000	30,000	15,000	4,500/750	2,250/375	75.00	112.50	150.00
MC - 15	71,000	71,000	35,500	12,000/2000	5,310/885	177.00	265.50	354.00
MC - 22	84,000	84,000	42,000	12,750/2,125	6,360/1060	212.00	318.00	424.00
MC - 35	95,000	95,000	47,500	16,250/2375	7,122/1187	237.40	356.10	478.80
MC - 42	118,000	118,000	59,000	17,622/2937	8,100/1350	270.00	405.00	540.00
MC - 52	130,000	130,000	65,000	19,500/3250	9,750/1625	325.00	487.50	650.00
MC - 55	144,000	144,000	72,000	21,600/3600	12,300/2050	410.00	615.00	820.00

A STUDY OF DESIGN TRADE - OFFSUSING A COMPUTER MODEL

Stephen Coughlin*

ABSTRACT: The paper is an extension of previous work undertaken by the author. It studies the interaction between the efficiency of the structural design and the cost of the structure used; and shows that future effort is best directed at producing a low cost structure of medium efficiency, but with the ability to withstand normal service wear. The paper then goes on to study the trade-off between aerodynamic drag and structure weight in selecting a length to diameter ratio for the hull, and to evaluate the implications of power plan type and fuel cost on the economics of the airship. As a final study the choice of lifting gas is considered.

Introduction

The development of technological research into vehicles such as large airships is in itself a complex problem. Whilst working on "new" vehicles of this type, the design engineer is unable to fall back upon the benefits of past development and operational experience. This means that those responsible for directing the research effort have a problem in separating those areas of airship technology requiring extensive effort from those that can be considered of little or no importance.

In order to surmount this problem a cost model was developed at Cranfield, which allowed us to study the impact of varying key design parameters. It permitted sensitivity analysis to be undertaken in order to produce a simple ranking of problem areas.

* Research Officer, Cranfield Institute of Technology, Cranfield, England

PRECEDING PAGE BLANK NOT FILMED

The results produced from the initial model were published in a previous paper (ref 1), a summary of which is given in table 1.

Parameter	Initial Assumption	% change in operating cost	
		-50%	+50%
Altitude	3,000 ft	-4%	+4%
L/D	6.	-22%	+22%
s.f.c	.47 lb/HP/hour	-4%	+7%
s.w	.5 lb/HP	-1%	+0%
min t _e	.06 inches	-47%	+70%
F	1.27	+108%	
Transmission efficiency	.85	-10%	+12%
Max Speed/ Cruise Speed	1.1	-5%*	+27%
Utilisation	5,000 hrs	+55%	-14%
Interest on Capital	10%	-15%	+17%
Vehicle life	10 years	+46%	-14%
Structure cost	£20,000/ton	-40%	+42%
Gas cost	£30/1000 ft ³	-4%	+3%
Power plant cost	£20/HP	-½%	+½%
Fuel cost	£20/ton	-3%	+5%
Crew wages	£140,000	-4%	+4%
Maintenance	4% first cost	-9%	+9%
Insurance	1% first cost	-3%	+2%

* Ratio taken as 1

TABLE 1
A SUMMARY OF THE SENSITIVITY ANALYSIS PRODUCED IN REF 1

Structure of the Model

The earlier model has now been improved in those areas shown to be critical in the previous study in order to provide greater clarity, with the hope that it will show where future research would be best directed. It must be stressed at this point that, although the philosophy of the model is based upon a conventional design process, the results produced here are intended to illustrate critical areas and Key variables rather than suggest an ideal design.

A simplified diagram of the model is shown in figure 1. The model is structured to allow all the individual variables to be varied independently or jointly, to cater for "trade-offs" to be studied. The input to the model, once it has been set-up, is the route capacity in tons/year, range in miles and the flight altitude in feet. The speed is then determined for the lowest operating cost within the constraints applied.

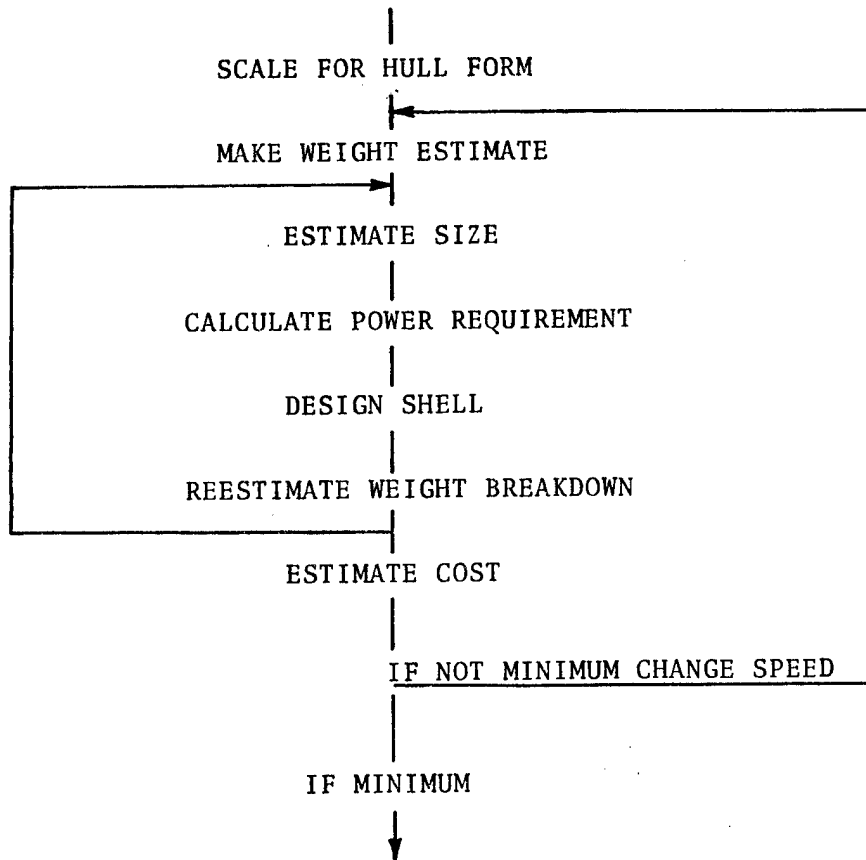

FIGURE 1 - MODEL STRUCTURE

Decision Criterion

The criterion chosen for the evaluation was that of minimum fare level for a set rate of return. This was chosen on the grounds that a freight system is purely commercial, social inputs being small, and the ultimate decision would therefore be on commercial possibilities.

Method of Analysis Used

As all parts of the system are as yet undefined, it was necessary to consider it in a mathematical form, representing each component as an input to the operating cost. The form of the mathematical model so

produced was then optimised for minimum operating cost as follows:

A technology assessment technique based upon Net Present Value
 The net present value (NPV) of any project is given by

$$NPV = \sum_{\ell=1}^{\ell=n} \left[C_{f_{\ell}} \times (1+r)^{-\ell} \right] - C_0$$

where

- ℓ is a year in the projects life
- n is the life of the project
- C_f is the net cash flow
- C_0 is the first cost
- r is the interest on capital

If the cash flow is assumed smooth (ie there are no discrete payments all are smoothed throughout the project's life then the equation can be simplified to give

$$NPV = C_f \left[\frac{1 - (1+r)^{-n}}{r} \right] - C_0$$

Putting $C_f = C_r - C_c$

and $C_r = T \times F$

where

- C_r is the cash revenue/year
- C_c is the cash cost/year
- T is the system capacity/year
- and F is the charge per unit capacity/trip

gives

$$NPV = (T \times F - C_c) \left[\frac{1 - (1+r)^{-n}}{r} \right] - C_0$$

as an optimum it can be taken that $NPV = 0$, allowing the relationship

$$F = \frac{1}{T} \left[\frac{C_o}{\left[\frac{1 - (1 + r)^{-n}}{r} \right]} + C_c \right]$$

This now provides a simple relationship between the cost of a system in terms of its total first cost (C_o), its operating cost (C_c) and its fare level (F). (This is easily modified for systems that have components with different book lives, but for simplicity in this example, they have all been assumed constant).

Evaluation of C_o and C_c

a) Considering the vehicle only;

The major first cost (C_o) components are

- 1) Structure Cost
- 2) Lifting Gas Cost
- 3) Power Plant Cost

and the major annual cash costs (C_c) were assumed to be

- 4) Fuel
- 5) Crew Pay
- 6) Repairs
- 7) Insurance

Table 1 shows how these may be described in terms of vehicle parameters

	Function Of	Major Parameters
Structure Cost	Weight of structure	W, u
Lift Gas Cost	airship volume	V
Power Plant Cost	installed power	S, u
Fuel Cost	fuel used	S, u
Crew Pay	assumed constant	
Repairs	assumed to be a	} C_o
Insurance	percentage of first cost	

where W = size of airship

u = speed of airship

V = volume of airship = $f(W)$

S = surface area of airship = $f(W)$

Hence all components of the vehicle are some function, in this simple case, of vehicle size and speed.

Analysis of Vehicle only

Using this theory and inserting the necessary engineering relationships, it was possible to derive an iterative technique (fig 1) that gave a solution for the optimum design where

$$\frac{dF}{du} = 0$$

The Datum Situation

It is impossible in a paper like this to cover the full range of options available. For this reason a single specification has to be chosen to act as the datum situation and, unless otherwise stated, the assumptions should be taken as given in table 2.

The following is a list of the basic assumptions used in the assessment, together with the justification for these assumptions.

Assumption	Value
Tons/year	150,000
Range	1000 miles
Life	10 years
Operational altitude	5,000 ft
Length/diameter ratio	6.
Specific fuel consumption	.47 lb/hp/hr
Specific weight of power plant	.5 lb/hp
Minimum practical value of t_e	.06"
Reserve fuel	33%
Power plant cost	£20/HP
Fuel cost	£100/ton
Crew wages	£140,000
Maintenance cost	4% first cost
Insurance cost	1% first cost
Interest on capital	20%

TABLE 2 ASSUMPTIONS USED IN STUDY

STRUCTURE

As a first step in the study a totally unconstrained analysis was undertaken. Structures of various efficiencies and ranges of costs were studied, the results of which are shown in figure 2. The structural efficiency is reflected by the equivalent shell thickness

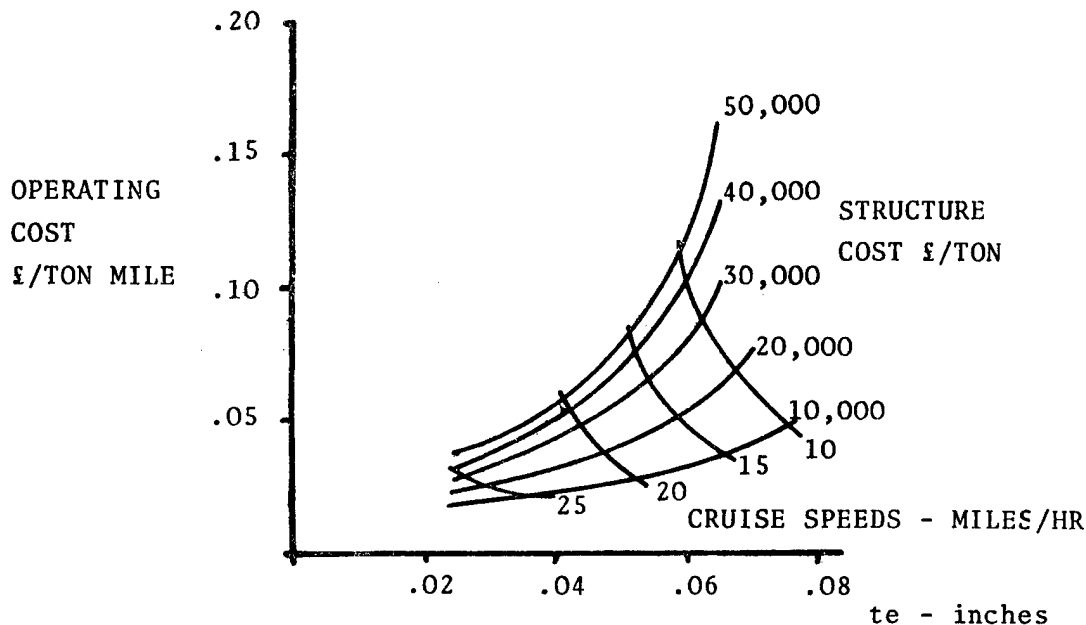

FIGURE 2 UNCONSTRAINED SOLUTION

which is given by

$$te = \frac{\text{Total Structure Weight} \times 12}{\text{Density of Duraluminium} \times \text{Surface Area}}$$

te is in inches and other units in pounds and feet

From figure 2 it can be seen that in the unconstrained situation the results produced are trivial. The low equivalent thickness would not have any resistance to hail impact or bird strikes of the lowest magnitude. Those shells that do have higher equivalent thicknesses are discounted by the low optimum cruise speeds associated with them, which are incapable of providing an acceptable level of aerodynamic stability.

The study was repeated with the solutions constrained to a minimum speed of 50 miles/hour and a minimum equivalent shell thickness of .06 inches. This resulted in a set of solutions all of which lie along one of the applied constraints. The results of this study are shown in figure 3.

Analysis of figure 3 shows a number of designs all above the .06 inch constraint, but with speeds of 50 miles/hour. When these solutions were studied in greater depth the structural efficiencies which related to the designs were found to be so low as to make them trivial solutions to the problem. This implies therefore that all the useful solutions lie on the minimum equivalent thickness constraint had optimum speeds increasing from 50 miles/hour to 70 miles/hour. The speed increased linearly as the structure was used more efficiently from 50 miles/hour to some constant value, dependent upon the structure cost assumed, the higher the structure cost the higher the

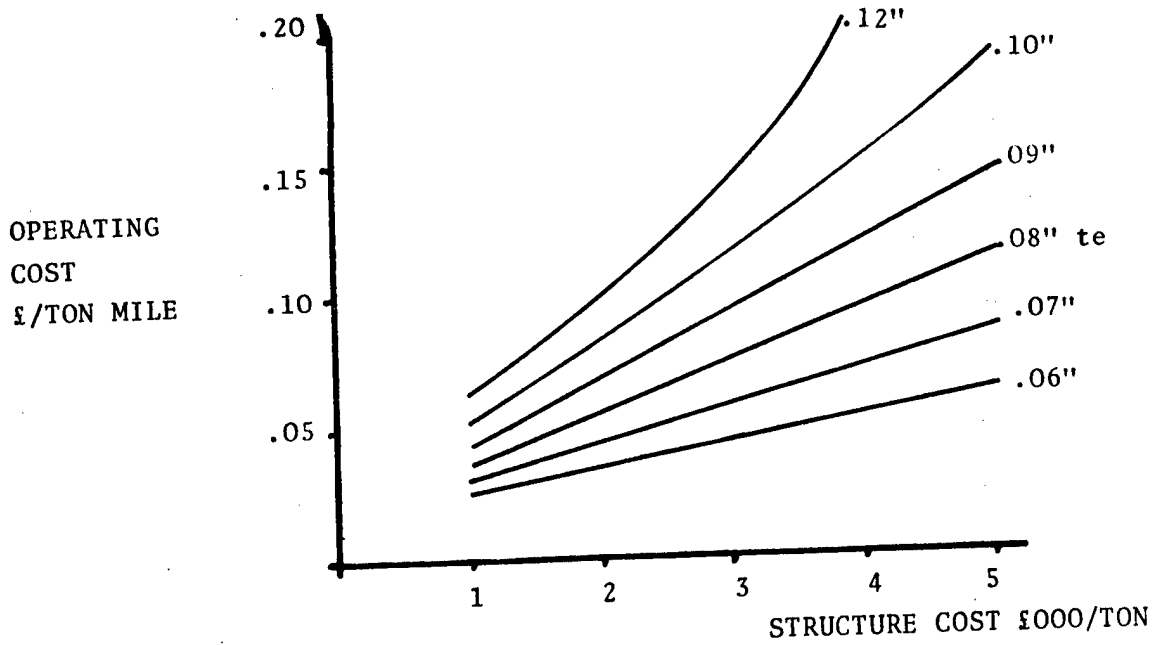

FIGURE 3 CONSTRAINED SOLUTION

the steady state value of the optimum speed. The reason for this is that for cost effectiveness the more expensive structures have to be used more efficiently. Hence, to off set the increased cost of the structure the design becomes smaller and faster, as structure cost increases. Figure 4 shows the value of these steady state results for optimum cruise speed.

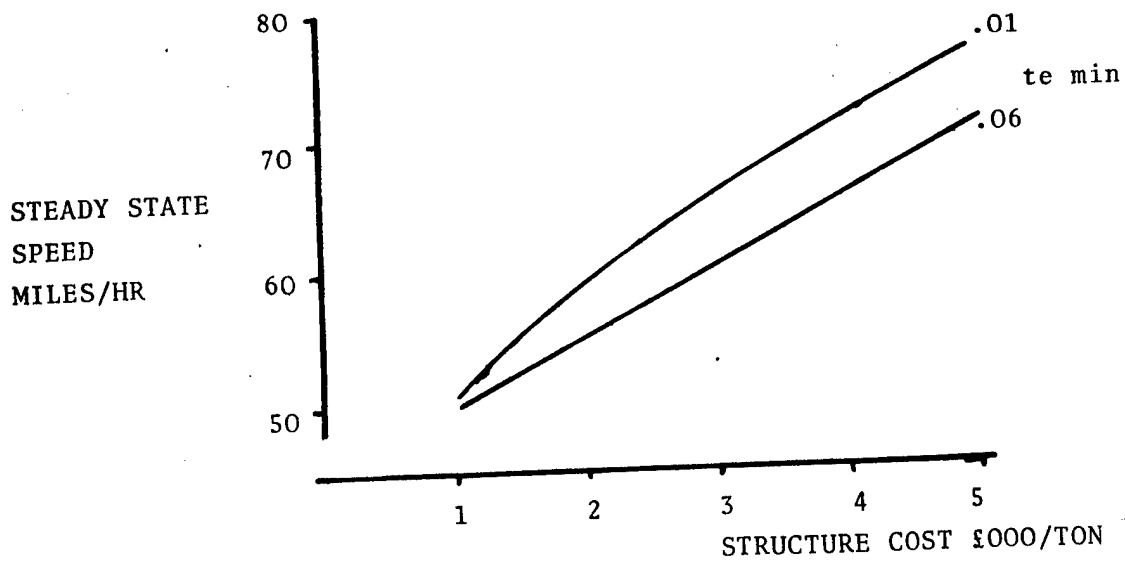

FIGURE 4 STEADY STATE SPEEDS

The Minimum Equivalent Thickness Constraint

From the results already produced, it becomes apparent that the equivalent thickness constraint is a key area. The production of a light weight design which is also resilient enough to withstand

rigorous service conditions is difficult. Experience in structures of this type is completely lacking and the possibility of achieving a minimum value of .06" is unknown. A value of .1" has also been considered, therefore, and the results are included in figures 3 and 4.

Implications of the Structure Study

This study illustrates the unique problems of designing airship structures. It shows quite clearly that high efficiency structures have no major role to play in the shell design of conventional airships, and the need is for practical structures, the major constraint being the ability of the structure to withstand general in-service knocks. The future lies, therefore, in producing low cost structures of medium efficiency, weight being a second order problem.

This lies in contradiction to present aircraft design philosophy, where weight saving is a major criterion, and the use of materials such as titanium and carbon fibre reinforced structures is commonplace. In designing an airship shell there is a need for low density structures, not to reduce weight but to allow greater thicknesses to be used in order to increase resilience to damage. At the same time, however, costs should be low whilst strength is a problem of the second order. Structures that provide possible solutions to this requirement are glass fibre structures or foam supported structures. Thought must also be directed towards varying the design of the conventional rigid airship in order to introduce some of the requirements already outlined.

The same problems are also relevant to the production of the hull. The structure should be robust enough to allow simple handling during construction, since any special requirements will only increase production costs. This could lead to a situation where even the simplest of structures could be highly expensive due to high handling cost.

In conclusion to this section, it would seem that, with the relatively small variation in operating cost for changes in equivalent thickness at the low structure costs, as shown in figure 3, a weight penalty could be accepted provided the use of heavier structures assist in reducing production costs. With this in mind, it is recommended that future research should be directed at producing a structure with a low equivalent thickness but with the major constraints of being able to be easily and cheaply produced and to undergo normal handling in service and during production.

LENGTH/DIAMETER RATIO

Closely related to the previous problem is the choice of length/diameter ratio of the hull. The selection of the optimum value requires a trade-off between the structure weight and the skin friction drag.

Drag

In order to relate the drag to the length/diameter ratio the following drag relationship was used:

$$\text{Drag} = q S_D C_D$$

where q is the dynamic pressure

S_D is the wetted drag area

$$\text{and } C_D = \frac{.03}{R_E^{1/7}} \left[1 + \frac{1.5}{\left(\frac{l}{d}\right)^{3/2}} + \frac{7}{\left(\frac{l}{d}\right)^3} \right]$$

(Source - Ref 2)

The results of this study are shown in figure 5.

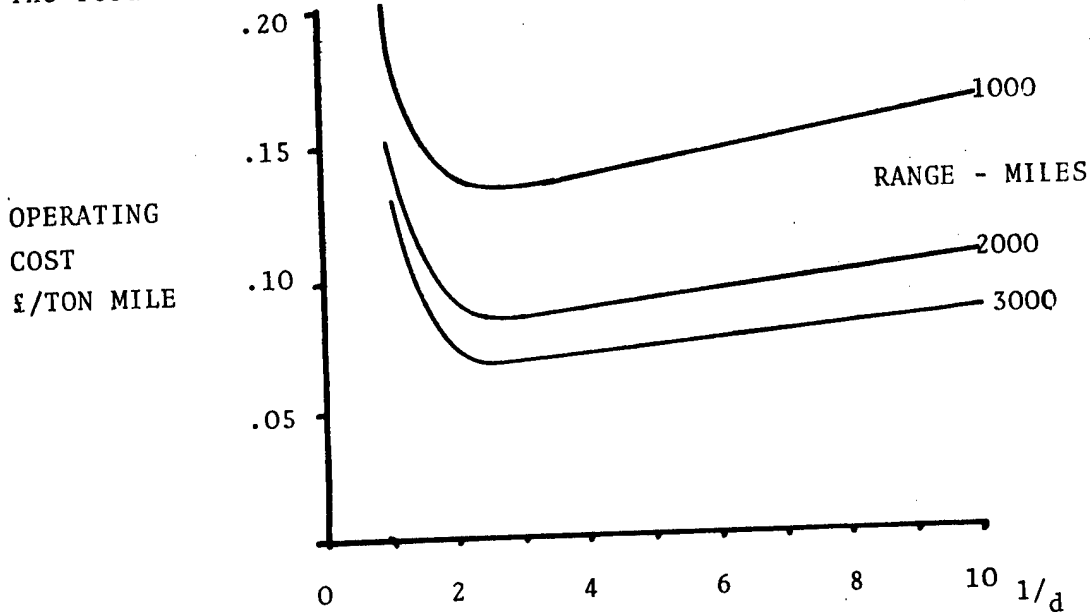

FIGURE 5 VARIATION OF LENGTH/DIAMETER

From this it can be seen that the optimum ratio of length to diameter is 2.5, and that this value is independent of range. This optimal value is based on a trade-off of fuel cost and structure cost and gives no consideration to stability. In selecting the final value it will be necessary to consider the requirements of directional stability, which is likely to increase the value.

FUEL AND POWER PLANT

Although it was shown previously (Ref 1) that the choice of power plant and the cost of the fuel were not critical areas in terms of airship economics, it was decided that, with the rapid increase in fuel prices that has occurred, the problem should be reassessed.

Fuel Cost

In order to study the effects of fuel cost on cost effectiveness, two designs were undertaken to fulfill the same requirements. Each design had a different fuel cost; the first £20/TON, a typical value for two years ago, and the second £100/TON, a value representative of present high fuel costs. The major characteristics of the designs are given in table 3.

FUEL COST	£20/TON	£100/TON
OPTIMUM MAX LIFT	1170 TONS	1490 TONS
OPTIMUM CRUISE SPEED	77 MILES/HR	51 MILES/HR
OPERATING COST	£.026/TON MILE	£.03/TON MILE

TABLE 3 EFFECT OF FUEL COST

The results illustrate how rapid changes in costs can modify past results. Fuel cost has increased from a minor variable to a major variable, and has caused a marked decrease in the optimum speed.

Power Plant Choice

The importance of the fuel cost is also reflected in a study of power plant characteristics. The importance of specific fuel consumption is clearly seen from figure 6, the specific weight of the power plant having very little importance by comparison, (values of specific weight from .5 to 5 fall on the same curve).

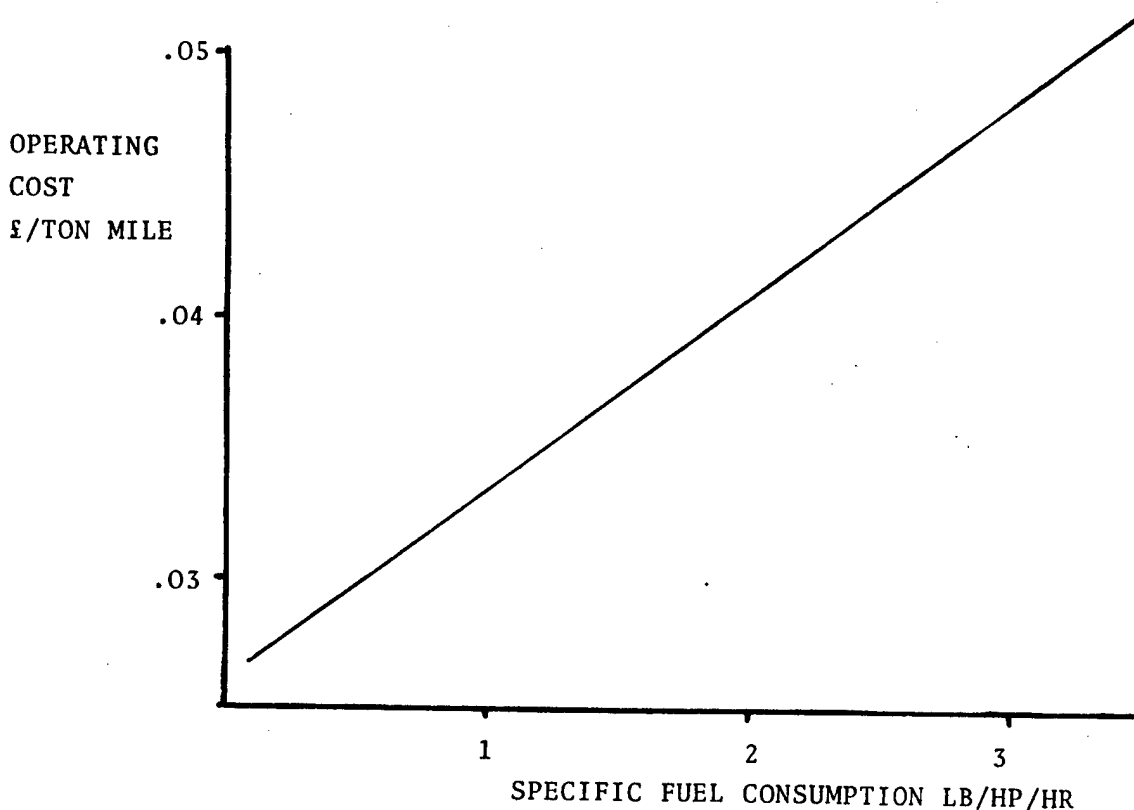

FIGURE 6 EFFECT OF POWER PLANT

REFERENCES:

1. Coughlin S., An Appraisal of the Rigid Airship in the UK Freight Market, Cranfield CTS Report 3, Cranfield Institute of Technology, England. (March 1973).

N76-15023

AN ECONOMIC COMPARISON OF
THREE HEAVY LIFT AIRBORNE SYSTEMS

Bernard H. Carson*

ABSTRACT: Current state of art trends indicate that a 50-ton payload helicopter could be built by the end of the decade. However, alternative aircraft that employ LTA principles are shown to be more economically attractive, both in terms of investment and operating costs for the ultra-heavy lift role. Costing methodology follows rationale developed by airframe manufacturers, and includes learning curve factors.

In this country, we have about a decade of experience with helicopters designed for the heavy lift role; at present, ten tons of payload can be transported from one random point to another and this capability has already made an impact in military operations, and the construction and logging industries, to name a few more notable applications. A wide variety of other uses have been found that, taken together, assure us that the heavy lift helicopter has become an acceptable, and in some cases a unique solution to some of our complex transportation requirements. But, as experience is gained, payload limitations are becoming rapidly apparent, and it is logical to look beyond the present in an effort to identify the options that exist in advancing current heavy lift technology.

This paper deals with the economics of heavy lift systems, but in a sense, it may be viewed as a technology assessment presented in an

*Professor of Aerospace Engineering, U. S. Naval Academy, Annapolis, Maryland, U.S.A.

economic framework; economics and technology appear to be somewhat inseparable. It is also fair to point out that the subsequent text deals with direct economics of design, development, construction and operation of heavy lift systems, and makes no attempt to address the indirect economic benefits that will almost certainly accrue in a variety of future heavy lift applications; that aspect is left to other authors whose efforts, appearing concurrently with this one, will treat this subject in some depth.

For this study, we have chosen three such systems. The first is an extrapolation of current, or near-timeframe heavy lift helicopter technology to a fifty-ton payload machine. The second is the hybrid Aerocrane as proposed by All American Engineering Corporation, also of fifty ton payload capacity. The last is a device that is an admixture of Lighter Than Air technology and existing helicopters, as proposed by Piasecki Aircraft. None of these systems exist, or are likely to in the next few years, even if work were to be begun at once on some or all of them. In economic forecasting, a "few years" may be an unacceptably long time, considering present inflationary trends; nevertheless, conclusions reached on the basis of comparative costs should be relatively immune to this effect.

Baseline Lifting Capability

Mostly as a matter of convenience, but with some rationale, the payload to be held common to these three systems is established at fifty U.S. tons (100,000 lb). All American Engineering Company has effectively sized such a machine (F-1) and conducted a comprehensive design study during the course of their general feasibility efforts, and it thus seems appropriate to view this effort as a logical beginning for purposes of comparison. From a military standpoint, a fifty ton sling load is an all inclusive capability, except for the main battle tank and the heaviest mobile artillery pieces. In commercial applications, a fifty ton payload seems also to satisfy most requirements excepting large nuclear reactor components, and very large tree harvesting operations. Other baseline parameters will be developed subsequently, appropriate to the aircraft under consideration.

50-Ton Heavy Lift Helicopter Point Design

Since the best U.S. production helicopter to date has a design payload of 12.5 tons, it is necessary, before becoming greatly exercised about a 50-ton HLH, to establish that such a machine is technically feasible within the constraints imposed by near-time airframe and engine technology. It is to this end that the following assessment is made.

Much effort has gone towards the advancement of helicopter technology in the past thirty years or so, but remarkably few helicopters have been designed from the outset with the heavy lift role in mind; whatever else may be said, the Soviets have been completely dominant in this field (see Table I) although the first ultra-heavy lift

2
 1
 helicopter appears to be the Hughes prototype YH-17 (1952) (called the Sky Crane¹) which had a design gross weight (DGW) of 52,000 lb., and a lifting ability of 27,000 lb. Subsequently, in the U.S., we have developed helicopters having payloads in excess of 10 tons (the CH-53, 54 series) while in the USSR, the Mil-series designs, which started in 1957, appear to have peaked out as long ago as 1969, when the MI-12 set a world payload record by lifting 34.2 tons to an altitude of 2,000 meters. Present on-going efforts here are centered about the U.S. Army-sponsored Heavy Lift Helicopter, the Boeing-Vertol prototype presently under schedule to fly in 1975. This aircraft has a design payload of 22.5 tons and features a great deal of advanced materials applications as a means of keeping the structural weight fraction within bounds².

TABLE I

F.A.I. Heavy Lift Helicopter Records:
 Greatest Payload Carried to 2,000 Meters

Date	Aircraft	Load
17 Dec 1955	YAK-24 (USSR)	4,000 Kg (8,818 lb.)
11 Oct 1956	HR2S-1 (USA)	6,010 Kg (13,249 lb.)
30 Oct 1957	Mil-6 (USSR)	12,004 Kg (26,464 lb.)
23 Sep 1961	Mil-10 (USSR)	15,103 Kg (33,296 lb.)
13 Sep 1962	Mil-6 (USSR)	20,117 Kg (44,350 lb.)
6 Aug 1969	Mil-12 (USSR)	40,205 Kg (88,636 lb.)

It is in fact the growth of structural weight fraction which stands alone as a chief concern when contemplating large aircraft of any description. For baseline estimates, the square-cube law may be invoked. But in practice, this produces an overly-pessimistic picture since many aircraft components (e.g., flight instruments and avionics) do not scale up with aircraft size, and other major components such as engines have not historically followed this scaling law due to continuous improvements in state of art.

It is interesting, and as it turns out, highly instructive, therefore, to examine what sparse data exists on "scratch-built" heavy lift helicopters as a first attempt to determine the trend of empty weight fraction as a function of design gross weight.

F-2 summarizes this effort, revealing what appears to be a remarkably simple picture of structural weight growth for large helicopters. Two distinct trends are evident, one for the Soviet and the other for U.S. efforts. Study of these trends indicates some significant aspects. First, it can be seen that the Soviets gave high priority to the development of large helicopters as far back as twenty years ago. The Mil-6, which first flew in 1957, has a design gross weight of 93,000 lb. and a payload in excess of 30,000 lb., both figures roughly double the best U.S. effort to date. Then followed the Mil-8 and the Mil-10, which first flew in 1966. With this technological base, they were thus evidently encouraged in 1965 to begin the

development of an ultra-large machine. This resulted in the Mil-12, which first flew in 1969, and, after a series of improvements, established the payload record mentioned above.

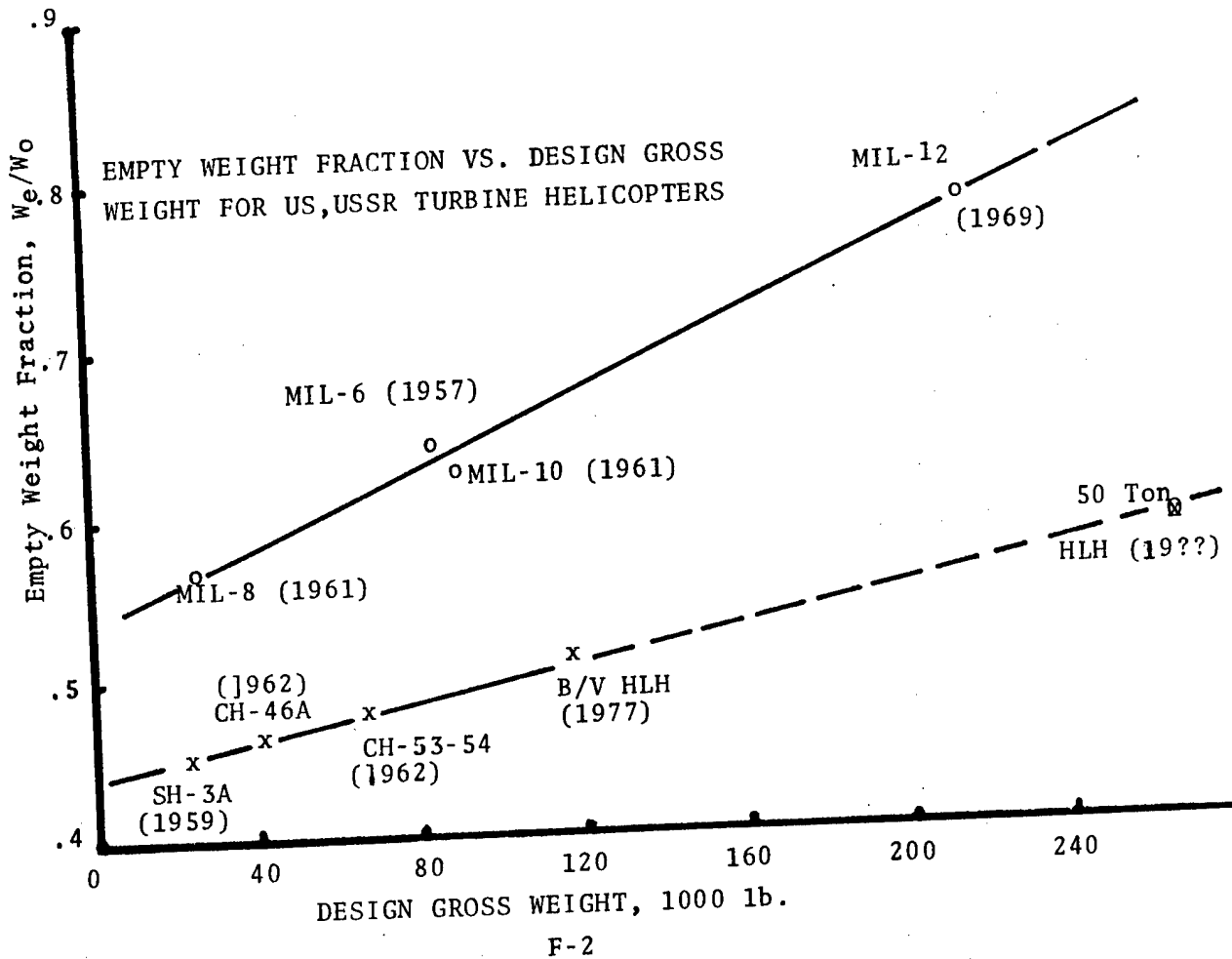

Of greater significance than its impressive size, however, is the indication that the Mil-12 is, or rather was, the largest helicopter payload configuration that could be developed within the constraint of their structural weight growth trend. To see this, it is only necessary to translate this trend into an approximate analytical expression, i.e.,

$$W_e/W_o = 0.54 + 0.10W_o/10^5$$

where W_e , W_o are the empty and design gross weights; and defining "payload" to include not only useful payload, but crew and fuel weights, then $W_p/W_o = 1 - W_e/W_o$, and there results

$$W_p = 0.46W_o - 0.10W_o^2/10^5$$

which shows that there is a value of W_o that will produce the maximum payload. This simple model predicts that payload to be 53,000 lb, corresponding to a design gross weight of 230,000 lb. This may be compared with data taken from Ref. 2, which lists the DGW for the Mil-12 at 213,000 lb. and a design payload of 55,000 lb. It is thus tentatively suggested that the Soviets had, in 1969, designed the ultimate load-lifting helicopter allowable within their technology. In keeping with their structural weight growth trend, a 50 ton payload helicopter would have been quite out of the question.

The U.S. experience in heavy lift helicopter design shows a better structural weight fraction trend than the Soviets, probably because the early lack of comparably large shaft engines demanded that greater attention be given to detailed structural design. This has also had the effect of providing incentives to develop weight saving materials (e.g., composites) for secondary structural applications. In any event, whether this trend can be maintained (or better yet, reduced) for U.S. helicopters of arbitrary size is a question that cannot be answered at the present. Assuming that this trend were maintained, however, we find, by application of the above rationale, that the maximum payload is about 78.5 tons, at a DGW of 560,000 lb.

Thus, while we have not "proved" that there is an upper limit to a U.S. helicopter payload, we have, through this exercise, been encouraged to believe that a 50-ton payload helicopter is not a technical impossibility, at least according to current U.S. structural weight growth trends.

For present purposes, then, it is assumed that this trend well represents a technically feasible configuration in the 50 ton payload range, and, with a 10% payload allowance for fuel, sizes out nominally to be a 260,000 DGW helicopter having a payload (including fuel) of 110,000 lb. This gives a structural weight factor of 0.577. With this as a base, the 50 ton HLH sizes out fairly rapidly by using fixed component weight fractions and disk loadings for the Boeing Vertol HLH as a reference. Assuming a 22% rotor overlap, a 228' length emerges for a tandem rotor configuration, based on a 128' rotor diameter. This was determined³ by assuming a rotor figure of merit of 0.78. A total of 30,000 SHP is required for this aircraft, allowing for a mechanical transmission efficiency of 0.95. Four engines of the Allison T701-AD-700 type, or its derivatives, should suffice. This engine is rated at 8,075 SHP, and is currently under development for the Boeing Vertol HLH. F-3 illustrates the composition of empty weight fraction for the two aircraft.

A- Airframe P- Powerplant
P/F- Payload & Fuel M- Miscl.

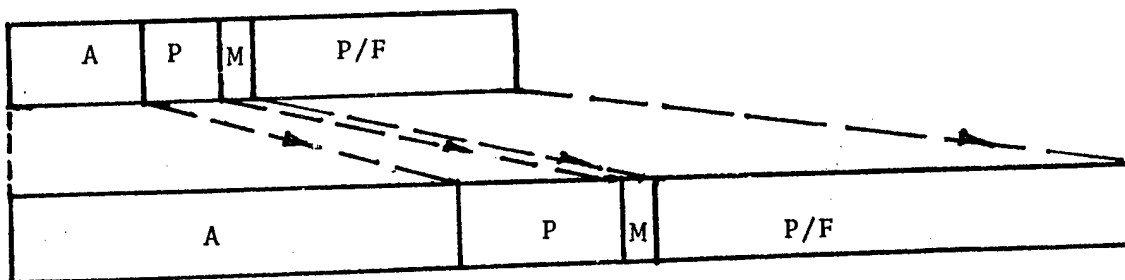

Weight Stretch Factors for 50 Ton HLH Based on
Boeing/ Vertol XCH-64

F-3

The Aerocrane concept as proposed by All American Engineering Company is described elsewhere, but for completeness, a brief description is included here.

As shown in F-1, the Aerocrane consists of an aerostatic sphere that supports a set of equatorially mounted, cruciform wings. In operation, this assembly is rotated by wing-mounted engines and propellers. With this arrangement, aerodynamic lift is developed on the wings that adds to the aerostatic force so that lift can be controlled in the hovering mode. Control is directed from a non-rotating cab supported by the main structure. In the proposed fifty-ton version, the useful load divides in a roughly equal way between aerodynamic and aerostatic lift. In addition, all structural weight of the aircraft is supported by the aerostat, which has been sized for that purpose. Wing (or rotor) incidence is both cyclically and collectively controllable, so the aircraft hovers and translates in much the same fashion as a helicopter, except when the overall buoyancy of the system is positive; in this case forward flight is obtained by tilting the aircraft backwards, and using negative lift to propel the craft at constant altitude. For system parameters used in this study, the reader is referred to Ref. 4.

"Gargantua" (see F-4) is the name adopted by the Piasecki Aircraft Corporation to describe a heavy lift device that is engagingly simple; it places no demands on state of art, and could presumably be built almost immediately with relatively low technological risk. As can be seen, it consists of a large rigid airship hull built along the lines of the Akron/Macon design, except that all engines, controls and other subsystems have been transferred from the hull to four helicopters attached to the lifting envelope by two crossover, or "saddle" beams. In principle, the aerostatic lift of the hull com-

pensates for the entire dead weight of the system, which includes the basic hull and saddle weights, and the fully-fueled helicopter weights as well. The total helicopter lift (equal to the DGW of the four helicopters) can then be used for lifting and propelling the system. In the configuration shown, this would amount to about 84 tons, corresponding to four CH-53D's.

As with the Aerocrane, a separate paper on this subject appears concurrently with this one, to which the reader is referred for additional details⁵.

Cost of Gargantua - Since no rigid airships have been built for about 40 years, there is no relevant experience base whatever on which to draw in terms of unit airframe costs. The AKRON, having a gross weight of 460,000 lb., cost \$5.3 million, about half of which went into tooling and hangaring costs, since her sister ship, the MACON, cost only about \$2.6 million. During construction of these craft, vast amounts of hand labor were employed at rates that were cheap even by the standards of the era, since the depression was then in full swing. It seems fairly certain that this construction philosophy would not prove profitable, or perhaps even possible in the present age. A comprehensive study, performed by a task force of design engineers, manufacturing specialists, and costing experts, is probably required to determine the optimum capital investment in airframe fabrication machinery, as weighed against labor costs as can be foreseen in the 1980 timeframe. On the other hand, the traditional rigid airship structure is highly parts-redundant, suggesting that a diverse subcontracting approach that made use of the excess capacity of major airframe manufacturers might be a productive option. If this were done, a reasonable first estimate for unit airframe costs might be \$10-\$20/lb. (typical "low technology," i.e., light aircraft figures) the higher figure probably the more appropriate one initially, with costs tending toward the lower figure as experience was gained. This would put the cost of the basic Gargantua airship hull at somewhere between four and eight million dollars.

As for the helicopters, it may be supposed that surplus military aircraft (if they exist) would be used on a "proof of concept" prototype, but a serious commercial or military venture would surely require new aircraft, probably in the \$3-8 million cost category, depending on the extent of modification required to existing designs, and whether they were intended to operate in the helicopter (as opposed to the completely captive) mode part of the time. Allowing for fail-safe interconnects, winching equipment and other auxiliary gear, initial production Gargantuas might cost as little as \$20 million, and as much as \$40 million, or thereabouts. Until the Gargantua proposal moves past the concept and into the preliminary design phase, more energetic attempts to pinpoint its development, production, and operating costs appear to be futile.

Costing Methodology

The remainder of this paper is concerned with the generation of esti-

mates for the costs associated with the acquisition and operation of the remaining two aircraft.

In general, aircraft costing methodology follows an application of established trends based upon mission requirements, cost analyses of existing designs, historical trends, state of art potentials, and complexity factors. The actual process of generating total costs for a given configurational design then depends on the "order of estimate" appropriate to the study phase. To clarify, first order estimates of acquisition costs can be obtained from relatively simple microscopic cost trends. Independent variables appropriate to this order are speed, range, payload, gross weight, installed horsepower, number of aircraft produced, and so forth. As the design evolves, individual components and subsystems begin to crystallize in terms of size and weight, and second-order estimating rationale can be applied (with liberal amounts of computer time) to provide a more refined estimate of total costs. Table II indicates an example of the informational detail necessary to proceed with this costing phase. In the terminal design phase, estimates become interwoven with reality (mostly as a result of prototype experience) and cost estimating is confined to design change practices.

In a paper of this scope, it is obviously not possible to develop cost figures much beyond the first order level of estimation, although an attempt has been made to apply second-order rationale for the Aerocrane and the 50-ton HLH where possible. The data base used for this study derives from studies conducted by several airframe manufacturers^{6,7} for the U.S. Navy, but it necessary to point out that neither these data, nor the conclusions thus reached in the present study represent the official policies of the Department of the Navy.

TABLE II

Typical Second-Order Cost Estimating Factors
(shown for illustration only)

Component	Dollars Per Pound
1. MAIN ROTOR GROUP	81.3
2. WING GROUP	99.5
3. TAIL ROTOR	100.0
4. TAIL SURFACES	24.7
5. BODY GROUP	99.5
6. ALIGHTING GEAR	46.5
7. FLIGHT CONTROLS	115.0
8. PROPULSION GROUP	TREND
etc.	

Effect of Production Numbers on Manufacturing Costs - In proposing new aircraft, major airframe companies speak of a learning curve, or a price-quantity relationship that accounts for the fact that, during

a production run, many cost-reducing factors will materialize that act to steadily decrease the unit aircraft cost. As an example, the first production aircraft (actually the tenth actual aircraft, allowing for preproduction prototypes) might cost \$10 million, a figure that historical trends and other data might predict to be halved at the 100-aircraft mark. According to a linear-logarithmic relationship, this predicts that the tenth production aircraft should cost about \$8 million, hence the term "80% learning curve" that would be cited in this instance. The production rate influences this figure significantly, mostly due to the effect of fixed costs that must be written off during production⁸; a half-rate might change this figure to 85%. But the important aspect to note here is the profound effect that production numbers have on average unit costs. With an 80% learning curve, the average cost is about 64% of the tenth aircraft cost, if 100 aircraft are produced; this figure further diminishes to 35% if the total production is increased to 1000. Another beneficial effect of production numbers is, of course, in the unit amortization of development costs.

Since it is difficult to envision heavy lift aircraft of whatever description being produced in numbers greater than several hundred, the basis for estimating production costs has been set at runs of one hundred and two hundred aircraft, in an attempt to illustrate this effect. In so doing, we have assumed an 80% learning curve. Current trends indicate this figure to be on the low side.

Development Costs - Airframe manufacturers' data⁶ and a study of current trends indicate a development cost of \$380M (1973 dollars) for the 50-ton HLH. This assumes the use of developed engines and avionics. For purposes of comparison, a separate study (1971) performed under U.S. Army contract estimated development costs for a 24-ton HLH at \$535M, which included \$90M for engine development, \$60M for a new rotor test facility, and \$30M for avionics development. Therefore, our figure appears to be the correct order of magnitude. For the Aerocrane, a figure of \$163M has been developed, which includes allowances for developmental problems in engine installation, and the design and development of propellers that will be required to match engine performance with the low speed environment. This figure is considerably in excess of that predicted by All American Engineering.

Flyaway and Investment Costs - For this study, the flyaway cost is taken as 110% of the production cost, which includes net profit and marketing costs, such as ferrying and crew training. To this is added another 20% which, to the order of accuracy sought here, represents the initial spares allocation, which is comprised of 50% of the basic engine cost, and 25% of the basic airframe and equipment costs. Both the Aerocrane and the HLH appear to be well represented by this approximation.

Table III summarizes the total acquisition costs for the two aircraft, as a function of production run.

TABLE III

Acquisition Costs vs Production Run,
80% Learning Curve, 1973 M\$

	Aerocrane (100/200 A/C)	50-Ton HLH
R&D	163/163	378/378
Mfg Cost (tot.)	364.3/614.3	1570/2648
Unit Cost	5.27/3.89	19.46/15.13
Flyaway Cost ¹	5.80/4.28	21.41/16.64
Invest. Cost ²	6.85/5.06	25.30/19.67

1. Flyaway Cost = 110% Unit Cost
2. Invest. Cost = 130% Unit Cost

Operating Costs - In developing operating costs, the following rationale was employed: a) Specific fuel consumption is taken nominally to be 0.5 lb-fuel/HP-hr, and fuel costs \$150/per ton. b) Maintenance hours per flight hour (both scheduled and unscheduled) is estimated to be 7 hrs for the HLH vs 5 hrs for the Aerocrane, diminishing linearly to 3 hrs after two years of operational experience, and costs \$8 per hour. c) Crew costs are \$90 per hour, which includes overhead. d) Non-productive flight time (e.g., ferrying, training) represents 20% of total utilization. e) Hangaring and insurance costs are not included. f) Initial cost includes 20% for spares, which are replenished annually at a rate of 3% of the original flyaway price. g) True interest rate on the debt is 5% after allowances are made for depreciation and interest tax deductions. With these assumptions, the following average annual operating costs were developed (Table IV) based on 10 years life cycle.

TABLE IV

Average 10 yr Hourly Operating Costs
for 600/1200 flight hours per year
(1973 dollars, 1974 fuel prices)

Prod. run/Aircraft	Aerocrane	50-Ton HLH
100	\$1805/1385	4605/3065
200	1580/1270	3920/2720

Conclusions: In this paper, the attempt has been to combine reasonable technological projections with representative, current costing rationale as a means of determining, to first order, the costs associated with heavy lift capability. While the exactitude of numbers developed in a study of this scope is always open to question, it is felt that they are of the correct order of magnitude, and almost certainly of correct relative magnitude in the comparisons that have been made. In all phases of development, manufacture, and operation, the Aerocrane emerges as considerably more cost effective than the 50-Ton HLH, underscoring the savings that might be expected in a

heavy lift device, where part of the lift is gotten for free, so to speak. Costs, like weight, have a way of "snowballing" in advanced, state of art aircraft, which the 50-ton machine represents. Part of this escalation derives from obvious physical causes, such as the necessity to develop better materials, to keep empty weight fractions within bounds. Somewhat less obviously, there is a "cost-risk" spiral that has become ever-increasingly a dominating cost element in new aircraft development; whether this can be avoided in the development of LTA technology would make an interesting study in itself.

As remarked earlier, lack of details argued against the comparable cost analysis of Gargantua, and it is hoped that this paper will be useful for comparative purposes, when this information is forthcoming.

Acknowledgements: This work was sponsored by the Assistant Commander for Research and Technology, Naval Air Systems Command, whose support is gratefully acknowledged. Special acknowledgement is also made for the many valuable and substantive contributions of Mr. R.H. Krida, and in particular, Mr. R. Perkins, both of NASC, during the course of this effort.

REFERENCES:

1. Lambermont, P., Helicopters and Autogyros of the World (revised), A.S. Barnes and Company, New York, New York (1970).
2. Jane's Yearbooks, Jane's All the World's Aircraft, 1973-74, London, England (1973).
3. Gessow, A., and G. Meyers, Jr., Aerodynamics of the Helicopter, Fredrick Ungar Publishing Company, New York, New York (1967).
4. Perkins, R.G., and D. Doolittle, Aerocrane - A Hybrid LTA Aircraft for Aerial Crane Applications, Proceedings, LTA Workshop, Monterey, California (1974).
5. Piasecki, F., Ultra-Heavy Vertical Lift, The Heli-Stat, Proceedings, LTA Workshop, Monterey California (1974).
6. Herrick, G.E., and R.J. Flemming, Rotary Wing Concepts for Navy/Marine Corps Medium VTOL Applications, Sikorsky Aircraft Report Ser-80856 (January 1974).
7. Clark, R.D., et al, Navy Medium VTOL Design Study, Vol. 2, Contract No. N00019-73-C-0443, Boeing Vertol Company (February 1974).
8. Spangenberg, G., High-Low Mix-Solution or Problem, Aeronautics and Astronautics, Vol. 12, 9 (September 1974).



N76-15024

AN APPROACH TO MARKET ANALYSIS
FOR LIGHTER THAN AIR
TRANSPORTATION OF FREIGHT

Paul O. Roberts*
Henry S. Marcus**
Jean H. Pollock***

ABSTRACT: This paper presents an approach to marketing analysis for Lighter Than Air vehicles in a commercial freight market. After a discussion of key characteristics of supply and demand factors, a three-phase approach to marketing analysis is described. The existing transportation systems are quantitatively defined and possible roles for Lighter Than Air vehicles within this framework are postulated. The marketing analysis views the situation from the perspective of both the shipper and the carrier. A demand for freight service is assumed and the resulting supply characteristics are determined. Then, these supply characteristics are used to establish the demand for competing modes. The process is then iterated to arrive at the market solution.

The possibility of a revival of Lighter Than Air (LTA) vehicles results in numerous suggestions for possible missions. While LTA enthusiasts revel in the unique performance characteristics of large payload and extremely long flight range, some of the popularly suggested missions do not utilize these features with any degree of economy. Transport of outsized, bulky cargo such as reactor or machinery parts is frequently among the first missions associated with LTA. Hovering and lowering preassembled structures is also suggested.

Memories of the Hindenberg also apparently prompt ideas of passenger transport. To name a few: ferry service for passengers and cars across the English Channel, leisure cruises to the Caribbean, hotels for remote areas, as well as flying laboratories and dormitories for teams of scientists, researchers, surveyors or salvagers. Rescue

* Professor of Transportation, and Director of the Center for Transportation Studies, Massachusetts Institute of Technology, Cambridge, Mass.

** Assistant Professor of Marine Systems, and Executive Officer of the Commodity Transportation and Economic Development Laboratory, Massachusetts Institute of Technology, Cambridge, Mass.

*** Graduate Student, School of Business Administration, Babson College, Babson Park, Mass.

missions after natural disasters are also mentioned.

Another suggestion makes the airship the candidate to introduce trade into the underdeveloped and inaccessible regions of Africa, South America, and Asia. Crop dusting, insect control, oil spill cleanup and mobile hospitals have also been entertained as LTA missions. Finally, military missions such as troop and supply carriers, weather and intelligence observation stations, and a platform for ocean surveillance are all considered as possibilities.

All of these proposed LTA missions share several salient features which should cause one to carefully consider the appropriateness of LTA use at all. These features include 1) a lot of "one-shot job" suggestions as to missions -- movement of reactor pieces and natural disasters are not everyday occurrences; 2) the availability of much less expensive alternatives, such as large cranes, crop-dusting planes and stationary hotels and laboratories; 3) lack of a high volume, intense commercial base over which a rational allocation of the extremely high capital costs could be made, such as in many instances of trade development of underdeveloped areas with minimal trade volume.

In short, intense use must be made of an LTA in order to spread the high capital costs over as wide a usage base as possible as we will show subsequently. In addition, if the LTA is to become a success, mass production is desired. To meet these high volume requirements, commercial freight is the largest potential market for LTA's. In fact, commercial freight may be the only market large enough to support such a mass production process.

AN APPROACH TO MARKETING ANALYSIS

The market for Lighter Than Air craft depends necessarily on the market for their services. Although this paper concerns primarily the latter, it is necessary to consider the former to the extent that the size of the market for the craft influences the cost of the individual vehicles. This occurs in two ways: the amortization of the initial research and development cost over the vehicle fleet and the economies of scale in manufacture. The importance of the research and development costs can be demonstrated by considering the impact on aircraft cost of various fleet sizes. With an overall development cost of 100 million dollars, a fleet of 5 vehicles would have a share of 20 million each. For 25 vehicles, this cost would drop to 4 million, or if a fleet of 300 could be counted upon, the amortized cost would drop to almost \$330,000 per vehicle. Thus, the financial viability of the concept could depend importantly on the fleet size initially planned for.

Supply Determinants

A first step in any analysis would be to determine for a given technology of transport what the costs of owning and operating the equipment are and what prices or tariffs would have to be charged in order to

offer transport service. This depends on a number of factors which are well known and conceptually straightforward yet sometimes ignored in practice. These are:

- Annual corridor volume in tons
- Consolidation and deconsolidation possibilities
- Shipment size distribution
- Required frequency of service
- Seasonality
- Directionality

These factors all influence the choice of vehicle size and payload and the ability to maintain a given market share and equipment utilization. See Figure 1.

The overall volume of flow is obviously one of the most important factors since it directly influences the economies of scale which can be attained by the use of large equipment at big load factors. A single 5000 pound shipment being carried by truck incurs costs in the range of twenty cents per ton mile. If the truck were carrying 70,000 pounds, as many tractors hauling double trailers can, the cost drops to around a cent and a half a ton mile.

Large corridor volumes tend to beget even larger corridor volumes since greater volume means more frequent service, greater possibility for consolidation and deconsolidation and more opportunity to smooth out the irregularities caused by seasonality or directional movement. This tends to be especially true for those modes which carry big payloads such as rail and ocean shipping. Instead of shipping direct from origin to destination using the high cost mode, it may be worthwhile to use a feeder service to consolidate loads. See Figure 2.

Measuring Cost and Performance

The question is in the final analysis how much cargo can be attracted? This depends of course on the relative cost and performance of the modal offerings and how they are perceived by the shipper. The performance of a particular service is measured implicitly or explicitly by the shipper in his choice of mode and size of shipment. Included in this list of performance measures are:

- waiting time
- travel time
- time reliability
- probability of loss and damage
- special services such as refrigeration or in-transit privileges
- transport cost or tariff

Waiting time is that period from the time that a request for transport has been registered to the time the vehicle is in place ready for loading. Waiting time, along with travel time and time reliability, make up what the shipper may view as a lead time distribution in his inventory process. Because it is variable it must be protected

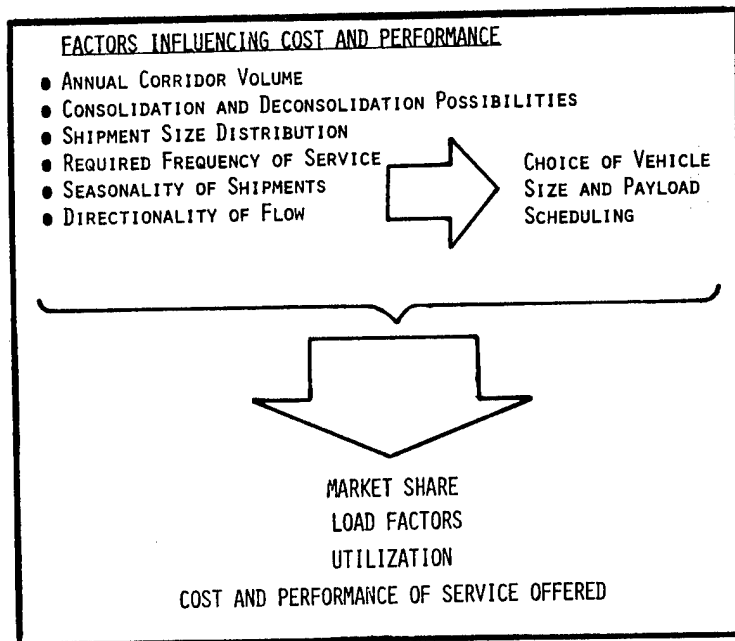

FIGURE 1. FACTORS INFLUENCING THE COST AND PERFORMANCE OF SERVICES OFFERED

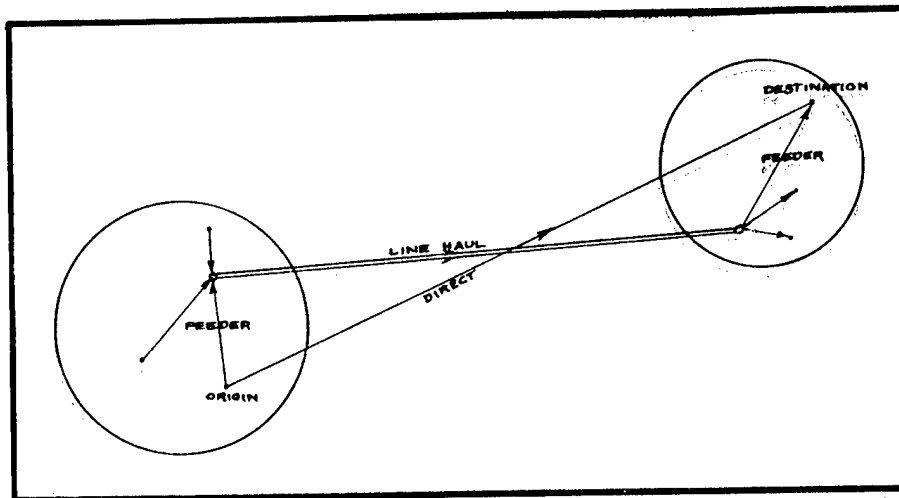

FIGURE 2. CONSOLIDATED SERVICE VERSUS DIRECT SHIPMENT

against by safety stock, ordering ahead or by fast shipment. Minimum shipment size and transport tariff combine to form the shipper's view of the size-rate schedule. See Figure 3.

Demand Characteristics

The way in which a shipper values specific elements of the performance achieved by a particular mode in routine shipment depends upon the characteristics of the commodity to be shipped. High value goods perceive travel time and travel time variability differently than do low value goods or goods for which there is no cost associated with stock-out. The more important factors in the valuation of transport performance appear to be:

- value per pound
- density
- shelf life
- inventory stockout characteristics
- annual use volume and variability
- need for special environment, handling or services

These factors are used by the shipper in a subjective evaluation of the costs of transport. This evaluation whether performed explicitly using carefully derived costs by trial and error or by pure intuition and judgment results in a choice of shipment size, mode and frequency of shipment. See Figure 4. Obviously, the minimum shipment sizes and the transport tariffs found on the size-rate schedule of offerings influences this choice.

Supply-Demand Equilibrium

Thus, there is a supply-demand equilibrium process at work in the real world. The supply of transport services with certain costs and performance or level of service characteristics elicits a demand by shippers through their decisions on choice of mode, shipment size, and frequency of service. In the aggregate this demand is seen by the transport system as an annual corridor volume with a certain level of consolidation of shipments, weight size distribution, seasonality, and directionality of flow. See Figure 5. As changes occur there are adjustments first on one side of the supply demand system, then on the other. The process tends to be incremental and changes occur relatively slowly.

The analysis of this system can be accomplished by formalizing the decision processes and the costing procedures on a step-by-step basis following the flow shown in the diagram. The costing procedure is not trivial as many of the papers at this conference demonstrate. But, it is done on a day to day basis for existing modes and can be done for a potential new mode with some allowances for uncertainty. Note that the costing process does require a more or less complete design of facilities, personnel, procedures, etc., for a system whose extent can only be guessed at the outset. There are, however, more conceptual problems on the demand side.

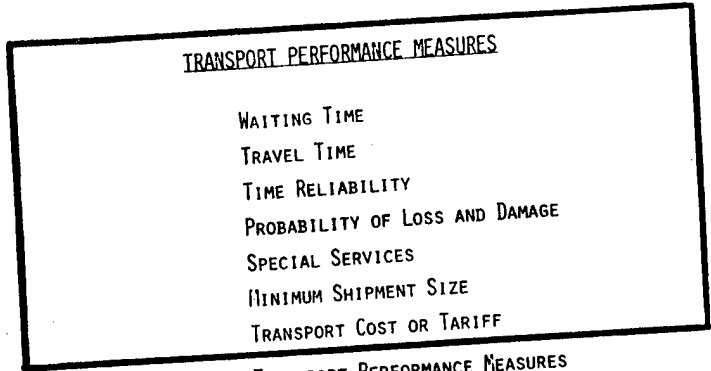

FIGURE 3. TRANSPORT PERFORMANCE MEASURES

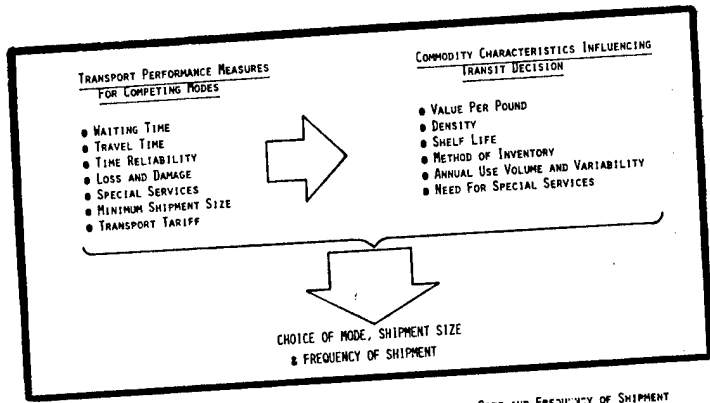

FIGURE 4. FACTORS INFLUENCING THE CHOICE OF MODE, SHIPMENT SIZE AND FREQUENCY OF SHIPMENT

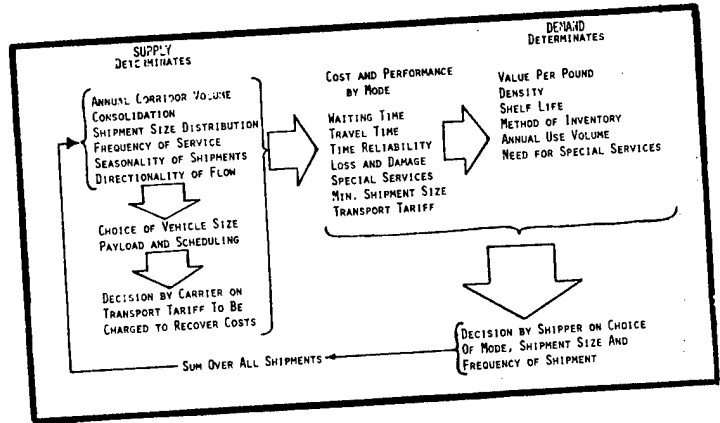

FIGURE 5. THE SUPPLY-DEMAND EQUILIBRIUM SYSTEM FOR FREIGHT TRANSPORT

Demand Modelling

Demand modelling for freight is still in its infancy. There are well-formulated models for urban passenger demand and the expectations are for usable models for freight in the not distant future. It is also possible to proceed item by item (or more realistically, market segment by market segment) to examine the choices open to a shipper and to decide on a rational basis what mode the shipper will choose. A problem always exists in deciding upon the makeup of the market segments and the definition of their commodity characteristics, but this can and has been done and our efforts to perform market demand analysis for a variety of market segments useful to our purposes here will be described later in this paper.

In attempting to apply this process to the case of Lighter Than Aircraft which is more of a revolution than an incremental change, there is the question of how to "break into" the analysis circle. Should costs and performance be assumed and the demand analysis performed initially to determine volumes which are then used in the supply side analysis? Or should market volumes be assumed and used as input to the design and costing out of the supply side? Both should probably be done. Another problem is the markets to be addressed. It is difficult to start with the whole world. Some idea of market corridors and/or types of commodities to attempt to serve are needed as a point of beginning.

As a way into the problem and in an attempt to gain some pragmatic insights into what the possible freight markets are, it is useful to search for short-cuts that will reveal markets in which Lighter Than Aircraft can offer superior service by all (or at least most) of the level of service performance measures stated previously. That is, we are looking for some markets that Lighter Than Aircraft can steal. Some possibilities include those offered by classical modes such as container-ships, rail piggyback, truck, or air. There are also commodity markets such as dry bulk, neobulk, perishables, etc., that could be explored. In the next section we will examine some of these possibilities.

A THREE-PHASE APPROACH

In order to analyze potential markets for LTA vehicles, a three-phase procedure is used. The first phase provides an overview of line-haul costs and characteristics of competing modes of transport in the commercial freight market and then does the same for LTA with what figures there are available. The basic market position of LTA vehicles is then apparent.

Phase two presents a computer simulation model of the total origin to destination costs and times for competing modes. The ability to vary distance and commodity to be shipped provide cost data for a wide range of shipments and it is possible to compare LTA costs with those of the competition on many routes.

Phase three examines the shipper's demand side of the market analysis with another computer simulation model which reflects shippers' con-

cerns in choosing a transport mode. The conditions under which LTA will be chosen can be analyzed for a number of market segments.

Phase 1 - Line-Haul Cost and Performance

Commercial freight markets are large and well-established; consequently the LTA vehicle will face immediate heavy competition. It is important to remember that aside from any annual growth of the market that an LTA vehicle can capture, the bulk of LTA business must be wrested away from the competition. For this reason, an analysis of the line haul, terminal costs and performance of the various modes will be presented.

If we consider the transcontinental U.S. market, a distance of 2500 miles, we see in Table 1 that there is a wide spread between the available revenue ton-mile costs of shipments by air, rail TOFC (trailer on flat car), and truck.

Research by the Southern California Aviation Council, Inc., shows that as the size of LTA vehicles increases, their unit costs decrease, as one might suspect. The largest LTA vehicle studied by the Council has a payload of 1,114 tons at 100 mph, and 1,032 tons at 200 mph. The construction cost of such a vehicle is estimated at \$96.25 million. If we assume a 25 year life and a 4 percent residual value, a net present value system of representing the time value of money at an opportunity of 10 percent results in an annual equivalent capital cost of \$10.56 million. (The Council calculates annual capital cost by a different method. Note also that the tax shelter of such an investment should also be considered.) Using the Council's data for all other cost data, the costs per revenue ton-mile figure for the LTA vehicle over a 2000 mile distance becomes 4.4¢ for the 100 mph craft, and 3.5¢ for the 200 mph craft. Consequently, adjusting for travel segments of equal distance (and varying definitions of costs), it would appear at first glance that the LTA vehicle costs place it lower than air or truck but higher than rail TOFC.

Since a listing of the modes by speed is identical to the one by costs, the LTA vehicle does not appear to dominate any existing mode in terms of both cost and speed. Therefore, the LTA vehicle will not simply replace an existing mode and take over its current market. The LTA market will, rather, depend on how the shipper trades off cost and speed and other factors in his analysis.

Phase 2 - Total Door to Door Performance

In Phase 2, a computer simulation is used to attempt to account for many of the factors omitted from the simple overview of Phase 1, such as varying distances, densities, cargo values, inventory carrying costs, or load factors in the calculation of total origin to destination costs and times.

The computer program calculates the following component costs:

- Pickup and delivery
- Inventory and warehouse

TABLE I
 RANGE OF LINE HAUL PLUS TERMINAL
 COSTS PER REVENUE TON-MILE*
 SURFACE VS. AIR TRANSPORTATION
 1975

	LINE HAUL**	TERMINAL***	RANGE	TOTAL	
				Most	Likely
TRUCKING	2.67-4.23¢	.97-1.39¢	3.64-5.62¢	4.9¢	
RAIL TOFC	1.17-1.38	.34-.40	1.51-1.78	1.8	
AIR FREIGHT					
707	5.25-6.98	2.7-3.1	8.0-1-.08	8.8	
DC-8-63	4.90-6.51	2.3-2.7	7.2-9.21	8.0	
747	3.70-4.92	1.0-2.0	4.70-6.92	5.4	

* COSTS REPRESENT THE DEFINITION OF OUT OF POCKET COSTS BY THE REGULATORY AGENCIES.

** TRUCK PLUS AIR BASED ON 100% LOAD FACTOR (WEIGHT BASIS). RAIL BASED ON 70,000-POUND SHIPMENTS.

*** RAIL TERMINAL EXCLUDES PLATFORM HANDLING. AIR TERMINAL INCLUDES ONLY TRAFFIC SERVICE EXPENSE.

SOURCE: THE FUTURE OF THE U.S. DOMESTIC AIR FREIGHT INDUSTRY, LEWIS M. SCHNEIDER, HARVARD UNIVERSITY, 1973, PAGE 133.

- Inland line haul
- Transoceanic or transcontinental line haul
- Terminal handling
- Packaging
- Cargo insurance
- Documentation

Importance of Cost Components - The density of cargo has a large impact on air freight costs, and all modes are sensitive to their design densities. Phase 1 data assumed that each mode carried cargo at its design density. The design densities of a truck or container is 20 lbs/cu.ft. and the design density of a containership is 43 lbs/cu.ft. The design density of a 747 is 10.9 lbs/cu.ft., while the average cargo density was 8.6 lbs/cu.ft. and ranged from 5.3 to 20.0 pounds. The difference between the design density and the average actual cargo density results in an increase of 27 percent in the effective cost per available ton-mile. The greater the deviation of the average cargo density from the design density, the greater the effective cost per available ton-mile, as borne out by the computer simulation.

The very nature of the commodities involved is a significant aspect of the market. Ocean carriers and railroads are generally thought to carry "low" value commodities for which delivery time is not generally critical and even the increased inventories necessitated by the time lag and additional warehouse costs involved still total far less than the cost of air shipment.

To better evaluate the differences in transit times of different modes, the computer simulation in Phase 2 assumes that the shipper incurs an inventory carrying cost equal to an annual charge of 10 percent of the value of the product. While air modes, including LTA vehicles, would appear to be natural carriers for high value cargo, it should be noted that only 18 out of 402 commodity groupings analyzed by the Transoceanic Cargo Study have average values more than \$5.00 per pound. See Table 2.

While data in Phase 1 assume 100 percent load factors, and a 2500 mile distance, the computer simulation in Phase 2 allows these figures to vary. Rather than looking only at the costs and times of the line-haul mode, the computer simulation analyzes the total origin to destination costs and times, including those to perform consolidation and deconsolidation, showing the situation as it appears to the shipper.

For the sample computer runs shown in this paper, four commodities were used: meat, fruit, computers and leather goods, to give a wide range of densities and values. See Table 3. The airplane used in the computer program is a wide-bodied jet aircraft of the Lockheed L-500 or Boeing 747 class, which operates at a 70 percent load factor. The vessel is an 800 unit containership which operates at a 69 percent load factor. (The program is a modification of that presented in the Transoceanic Cargo Study by Planning Research Corporation, Los Angeles, California, 1971. Characteristics of the various modes of transportation are also taken from this study.) The authors feel that costs for the plane are biased

TABLE 2

TRANSOCEANIC COMMODITIES WITH VALUES IN EXCESS OF \$5.00 PER POUND

DOTTO NUMBER	DESCRIPTION	DENSITY (POUNDS PER CUBIC FOOT)	VALUE PER POUND
864 I	WATCHES AND CLOCKS, INCLUDING PARTS	27	\$11.80
681 E	SILVER, PLATINUM, & PLATINUM GROUP METALS, UNWROUGHT OR PARTLY WORKED	360	19.31
515 E	RADIOACTIVE & STABLE ISOTOPES, THEIR COMPOUNDS, MIXTURES, & RADIOACTIVE ELEMENTS EXCEPT URANIUM, THORIUM ORES, CONCENTRATES	NA	11.66
681 I	SILVER, PLATINUM, PLATINUM GROUP METALS, UNWROUGHT OR PARTLY WORKED	360	438.00
212 E	FURSKINS, UNDRESSED	34	12.16
714 E	OFFICE MACHINES & PARTS, INCLUDING COMPUTERS	30	9.41
736 E	ELECTRIC APPARATUS FOR MEDICAL PURPOSES, RADIOLOGICAL APPARATUS, & PARTS	21	5.22
861 E	SCIENTIFIC, MEDICAL, OPTICAL, MEASURING & CONTROLLING INSTRUMENTS, & APPARATUS, EXCEPT ELECTRICAL	30	5.63
614 E	FURSKINS, DRESSED, INCLUDING DYED	11	7.73
726 E	STEAM ENGINES, TURBINES, INTERNAL COMBUSTION, JET AND GAS TURBINES, AIRCRAFT & MISSILES, & PARTS	21	9.62
746 E	AIRCRAFT & SPACECRAFT, & PARTS	8	9.82
734 E	TELECOMMUNICATION APPARATUS & PARTS, INCLUDING RADIOS, TV SETS, NARAIIDS	15	7.73
842 E	FUR CLOTHING & OTHER ARTICLES MADE OF FURSKINS EXCEPT HEADGEAR, ARTIFICIAL FUR ARTICLES THEREOF	NA	25.50
212 I	FURSKINS, UNDRESSED	34	6.27
614 I	FURSKINS, DRESSED, INCLUDING DYED	11	6.74
746 I	AIRCRAFT AND SPACECRAFT, & PARTS	8	10.02
842 I	FUR CLOTHING & ARTICLES MADE OF FURSKINS AND FUR, EXCEPT HEADGEAR	NA	6.14
1 I	LIVE ANIMALS, EXCEPT ZOO ANIMALS, DOGS, CATS, INSECTS, AND BIRDS	6	9.30

SOURCE: U.S. DEPARTMENT OF TRANSPORTATION, ASST. SECRETARY FOR POLICY & INTERNATIONAL AFFAIRS, OFFICE OF SYSTEMS ANALYSIS & INFORMATION, TRANSOCEANIC CARGO STUDY-FORECASTING MODEL & DATA BASE, VOL. 1, PREPARED BY PLANNING RESEARCH CORPORATION (WASHINGTON, 1971), PP. 111-60 THROUGH 111-65.

TABLE 3

COMMODITY CHARACTERISTICS USED IN SAMPLE COMPUTER RUNS

COMMODITY	VALUE (\$/LB.)	DENSITY (LB./CU.FT.)
MEAT	.28	51
FRUIT	.13	34
COMPUTERS	9.41	30
LEATHER GOODS	1.72	8

downward, since no commercial aircraft that large exists and the costs for the ship are biased upward, because many containerships are much larger than the size chosen. Consequently, the choice of numbers should narrowly define the costs of the "market niche" to be sought after by LTA vehicles.

First Scenario - Results from the computer simulation of two scenarios moving cargo from an inland point in the U.S. across the ocean to an inland point in a foreign country have been developed. In the first scenario, cargo moves by truck from an inland U.S. origin 200 miles to either a seaport or airport, 3000 miles across the ocean by either ship or plane, and 200 miles inland to its foreign destination by truck. Figure 6 shows the total origin to destination cost in dollars per pound for air and ocean freight as the inland truck portions remain constant at 400 miles and the transoceanic distance increases from 500 miles to 6000 miles. The figure shows that the competition between air and containerships is most severe for high value-low density commodities (i.e., computers, leather goods, etc.) The cents per ton-mile costs for the plane and ship over transoceanic distances from 500 miles to 6000 miles are given in Figure 7. A key point discerned from this figure is that while the vessel costs per ton-mile decrease over the entire distance, the air costs per ton-mile increase, showing the tradeoffs being made by the plane between payload and fuel capacity.

Sample data for one particular ocean distance (3000 miles) for meat and computers are shown in Tables 4 and 5. In comparing modes of transportation for the same commodity, two key factors are inventory carrying costs, which reflect total transit times, and transoceanic line-haul costs. In comparing costs between commodities, the key factors are cargo insurance and inventory carrying costs, which both reflect the value per pound of each commodity.

If we hypothesize how an LTA vehicle will fit into this scenario, let us assume a 150 mph speed and a direct origin to destination trip with no feeder services. In by-passing all feeder services as well as pick-up and delivery, the LTA vehicle can make the trip in 0.94 days. The cost should be lower than that of air but higher than that of ocean. What we see here is that waiting times and inland feeder service times can have a major effect on the overall transit time, particularly for airlines. To the extent that LTA vehicles can by-pass terminals and travel directly from the origin to destination, they can save both time and money for the shipper.

In comparison with ocean, while the LTA vehicle will probably not ever be able to match the line-haul costs of containerships, for high value cargo the time differential may be more than enough to make the shipper choose the LTA vehicle. For extremely high value cargo, the large transit time using a vessel line-haul service may actually make it less expensive because of the inventory carrying costs involved to use the LTA vehicle in the cost framework shown.

Second Scenario - The second scenario compares a rail-ocean-rail trip with a truck-air-truck trip. The rail-ocean-rail trip is made up of a

TABLE 4

TOTAL 1975 ORIGIN TO DESTINATION COSTS*

OCEAN VS. AIR
 COMMODITY: MEAT
 DISTANCES: DOMESTIC INLAND TRUCK - 200 MILES
 FOREIGN INLAND TRUCK - 200 MILES
 TRANSOCEAN - 3000 MILES FOR BOTH
 PLANE AND SHIP

COST COMPONENTS (\$/LB.)	OCEAN	AIR
PICKUP & DELIVERY COST	.00118	.00118
INVENTORY CARRYING COST	.00479	.00176
INLAND LINE-HAUL	.00449	.00449
TRANSOCEAN LINE-HAUL	.00120	.09825
TERMINAL HANDLING	.00251	.01772
PACKAGING	.00657	.00437
INSURANCE	.00081	.00198
DOCUMENTATION	.00024	.00024
TOTAL (\$/LB.)	.02179	.12999
TOTAL \$/TON-MILE	.01282	.07646
TOTAL # DAYS	16.9	6.2

*COST COMPONENTS (I.E., INVENTORY CARRYING COST, PACKAGING, ETC.) ARE TOTALS OF THE INLAND AND TRANSOCEAN SEGMENTS.

TABLE 5

TOTAL 1975 ORIGIN TO DESTINATION COSTS*

OCEAN VS. AIR
 COMMODITY: COMPUTERS
 DISTANCE: U.S. INLAND TRUCK 200 MILES
 FOREIGN INLAND TRUCK 200 MILES
 TRANSOCEAN 3000 MILES FOR BOTH
 PLANE AND SHIP

COST COMPONENTS (\$/LB.)	OCEAN	AIR
PICKUP & DELIVERY	.00118	.00118
INVENTORY CARRYING COST	.06424	.02362
INLAND LINE-HAUL	.00619	.00619
TRANSOCEAN LINE-HAUL	.00204	.09825
TERMINAL HANDLING	.00437	.01772
PACKAGING	.01115	.00743
INSURANCE	.00789	.02611
DOCUMENTATION	.00024	.00024
TOTAL (\$/LB.)	.09730	.18074
TOTAL \$/TON-MILE	.06487	.10632
TOTAL # DAYS	16.9	6.2

*COST COMPONENTS ARE TOTALS OF THE INLAND AND TRANSOCEAN SEGMENTS.

FIGURE 6

TOTAL ORIGIN TO DESTINATION COSTS
 (INCLUDING 400 MILES OF INLAND TRUCKING)

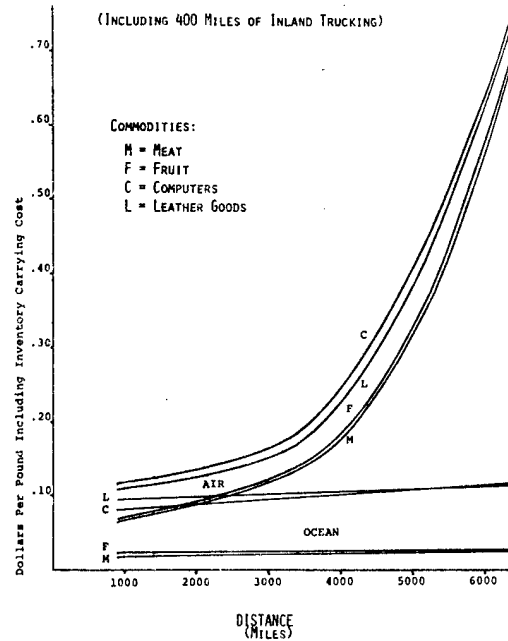

DISTANCE (MILES)

FIGURE 7

COSTS PER TON-MILE
 FOR OCEAN AND AIR MODES

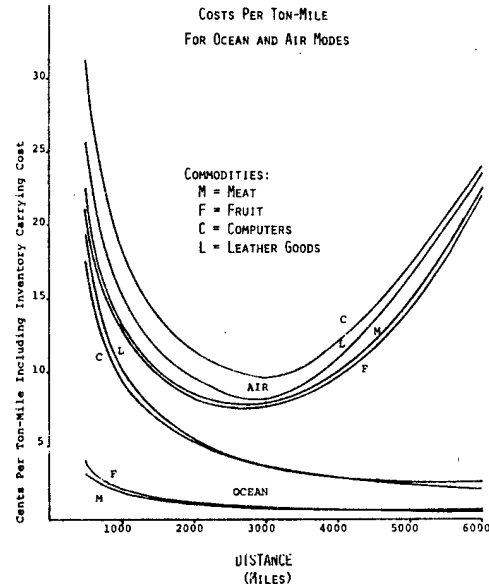

DISTANCE (MILES)

REPRODUCIBILITY OF THE ORIGINAL PAGE IS POOR

1000 mile rail feeder service to the port, a 3000 mile ocean voyage, and a 1000 mile rail segment to the inland foreign destination. The truck-air-truck trip between the same origin and destination is composed of a 200 mile truck segment to the airport, a 4500 mile air trip, and a 200 mile inland segment to the foreign destination. This comparison is similar in concept to the situation shown in Figure 2, where the shipper has to decide whether to use surface inland feeder services over rather long distances to bring his cargo to a consolidation point for a particular carrier, or whether to ship by air in a manner more nearly resembling an origin to destination trip. A key factor in this decision is whether the shipment size is large enough relative to the mode of transportation to take the origin to destination alternative.

Sample data from computer runs of this scenario are shown in Tables 6 and 7. For a low valued good (i.e., meat), the cost of air freight over such a long distance may well be prohibitive. Even for a high value good, the costs may make air freight undesirable to the shipper. However, it should be noted that the difference between ocean and air becomes less for the higher value commodity. Again, the shipper is faced with the problem of cost versus time. For computers, this trade-off becomes \$.105 per pound versus 12.6 days. An LTA vehicle going directly from the origin to destination at 150 mph could make the 4900 mile trip in 1.4 days; this time is considerably faster than the truck-plane-truck situation because of the time associated with the inland feeder systems. However, such a direct origin to destination trip requires the shipper to be able to fill most, if not all, of the LTA vehicle.

In many cases, the shipper is again left with the problem of trading off cost with time. While Phase 2 has included inventory carrying cost as one way to quantify the time involved, factors such as service reliability by mode and stockout costs are necessary to complete an analysis that would allow the shipper to directly choose the mode he wants. Phase 3 describes the demand characteristics which make such an analysis possible.

Phase 3 - An Analysis of the Transcontinental Surface Markets

Here, the emphasis will shift to the demand side. How does a shipper make the decisions concerning mode choice, size of shipment, and frequency of ordering? One way to approach the behavior of the shipper is to assume that he is a rational individual responsible in a fiscal sense for the ordering, transport, storage, and inventory control of a single item. This is a simplification of the actual world since for many items, multiple item inventory management is more realistic. But, for our purposes, it is useful to demonstrate in an uncomplicated way how he might reason to ship by one mode or another and how he goes about selecting the appropriate shipment size.

To simulate the decision making process of the shipper we used a computer program written to perform single item inventory management. The program develops optimum inventory strategies for a commodity defined by its use, rate and economic characteristics by selecting the order

TABLE 6

TOTAL 1975 ORIGIN TO DESTINATION COSTS*

OCEAN-RAIL VS. AIR-TRUCK		
COMMODITY: MEAT		
DISTANCE:	OCEAN-RAIL	{ U.S. INLAND 1000 MILES FOREIGN INLAND 1000 MILES OCEAN 3000 MILES
	AIR-TRUCK	{ U.S. INLAND 200 MILES FOREIGN INLAND 200 MILES AIR 4500 MILES
COST COMPONENTS (\$/LB.)	OCEAN-RAIL	AIR-TRUCK
PICKUP & DELIVERY	.00118	.00118
INVENTORY CARRYING COST	.00535	.00176
INLAND LINE-HAUL	.06022	.00449
TRANSOCEAN LINE-HAUL	.00120	.18167
TERMINAL HANDLING	.00251	.01772
PACKAGING	.00657	.00437
INSURANCE	.00114	.00198
DOCUMENTATION	.00024	.00024
TOTAL (\$/LB.)	.07841	.21341
TOTAL \$/TON-MILE	.03136	.08711
TOTAL # DAYS	18.9	6.3

*COST COMPONENTS ARE TOTALS OF THE INLAND AND TRANSOCEAN SEGMENTS.

TABLE 7

TOTAL 1975 ORIGIN TO DESTINATION COSTS*

OCEAN-RAIL VS. AIR-TRUCK		
COMMODITY: COMPUTERS		
DISTANCES:	OCEAN-RAIL	{ U.S. INLAND 1000 MILES FOREIGN INLAND 1000 MILES OCEAN 3000 MILES
	AIR-TRUCK	{ U.S. INLAND 200 MILES FOREIGN INLAND 200 MILES AIR 4500 MILES
COST COMPONENTS (\$/LB.)	OCEAN-RAIL	AIR-TRUCK
PICKUP & DELIVERY	.00118	.00118
INVENTORY CARRYING COST	.07186	.02363
INLAND LINE-HAUL	.06022	.00619
TRANSOCEAN LINE-HAUL	.00204	.18167
TERMINAL HANDLING	.00437	.01772
PACKAGING	.01115	.00743
INSURANCE	.00789	.02611
DOCUMENTATION	.00024	.00024
TOTAL (\$/LB.)	.15895	.26417
TOTAL \$/TON-MILE	.06358	.10782
TOTAL # DAYS	18.9	6.3

*COST COMPONENTS ARE TOTALS OF THE INLAND AND THE TRANSOCEAN SEGMENTS.

quantity, Q, the reorder point, R, and the mode of shipment, M, so as to minimize total logistics costs over a one-year time period. These costs include:

- ordering,
- transporting,
- storing,
- capital carrying, and
- stockout

The innovation in this program is in the way in which stockout is related to the lead time performance of the transport system and stockout costs are traded off against transport costs. Transport performance is defined using a schedule of minimum shipment sizes with their corresponding rates, loss and damage probabilities and out of pocket costs. It is important to note that the choices open to the inventory manager are all expressed in his decisions on Q, R, and mode once the annual use rate and its variability are known.

This approach of simulating the decisions of the inventory manager should allow us to gain a feeling for the mode choice and shipment sizes that will be made in a given transportation market for various commodities over a range of useage rates. However, there are too many commodities to approach the problem that way. It would be better to divide the entire universe of goods into commodity groups or market segments and treat each market segment individually. There is still a problem with multidimensionality. From the list of commodity attributes which are important in the selection of mode, which are the key 2 or 3 which best define a market segment?

- value per pound
- density
- shelf life
- inventory stockout characteristics
- annual use volume and variability
- need for special services

On this first round of the analysis, we have chosen value per pound and useage rate along with inventory stockout characteristics as the three descriptors to be varied. Other variables will have an average value, but will not be changed.

It is useful to digress a moment to clarify what is meant by inventory stockout characteristics. There is a period after the reorder point in the inventory cycle for which the inventory level is subject to chance. There is variability in both the useage rate and the lead time of the transport vehicle carrying the replenishment stock. If useage spurts up or transport is delayed, or both, there will be a stockout. During each reorder cycle there is a probability of stockout which can virtually never be eliminated though it can be minimized by reordering at a higher reorder point or by using a faster or more reliable mode. By inventory stockout characteristics we mean the nature of the costs that will be incurred.

There are a variety of possible stockout situations. For some commodities, there is an immediate loss of sale once a stockout has occurred. The vendor for ice cream in Central Park on a hot day experiences these stockout costs. He doesn't lose the value of the stock, but merely the contribution to overhead and profit. For other commodities there is not an immediate loss of sale since the customer may accept the excuse that the part which is currently out of stock has been backordered and that it is due to be in on Monday. Thus, there is a probability of sale loss which increases with number of days out. Still another situation is that which occurs in manufacturing when an item important in the assembly line causes the whole line to stop and the plant to be closed down. Each can be handled by varying the makeup of the stockout cost matrix as between number of items out of stock and number of days this condition has existed. This cost matrix is multiplied by the probability of being in each of these states to obtain the expected value of a stockout.

The total logistics costs associated with ordering, storing, carrying the invested capital and transporting by the various modes must be determined for each inventory strategy tried. A scheme for proceeding mode by mode to examine each break point on the transport size rate tariff schedule is used. For that break point the best reorder point is determined by a short search of possible R's and the selection of the one with the lowest total logistics cost. This procedure was used here to examine a four by four matrix of market segments for three different inventory stockout conditions on a transport corridor of 2500 miles. For this example, air, truck, and rail TOFC service was available.

Each market segment was defined by the value per pound, which ranged from \$0.01 per pound to \$10.00 a pound; by the annual usage rate, which ran from 10,000 pounds per year to 100 million; and by a probability distribution on the usage rate. See Figure 8. The unit cost of a stockout, the interest rate on the carrying cost of capital, the storage space per item, and a host of lesser variables were also employed.

The performance measures for each of the transport modes, their size-rate schedule and the transport lead time distributions used in the computations for each market segment are shown in Figure 9. The attempt here was to select transport tariffs and break points which were broadly representative of cost-based freight rates found in practice.

The computer runs were made for three separate inventory stockout situations. There were:

- No stockout costs
- Stockout results in immediate sales loss
- Stockout increases probability of plant closedown

For each market segment, the computer printed the optimum inventory policy by giving the shipment size, Q , the reorder point, R , the mode, M , the total logistics cost per pound, $\$$, and the number of orders per

Input Data for Market Segment

- 507.4 \$/item - value/item
- 507.4 lbs/item - weight/item
- 16 ft²/item - storage space
- 50.7 \$/item - unit stockout cost

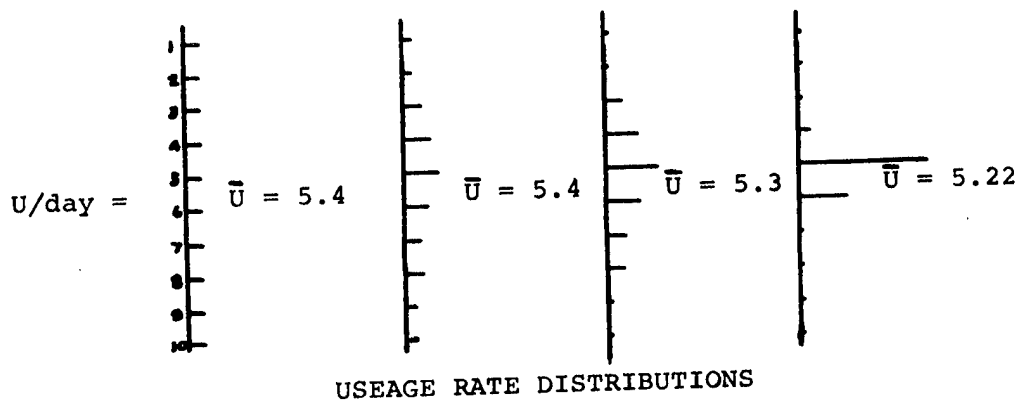
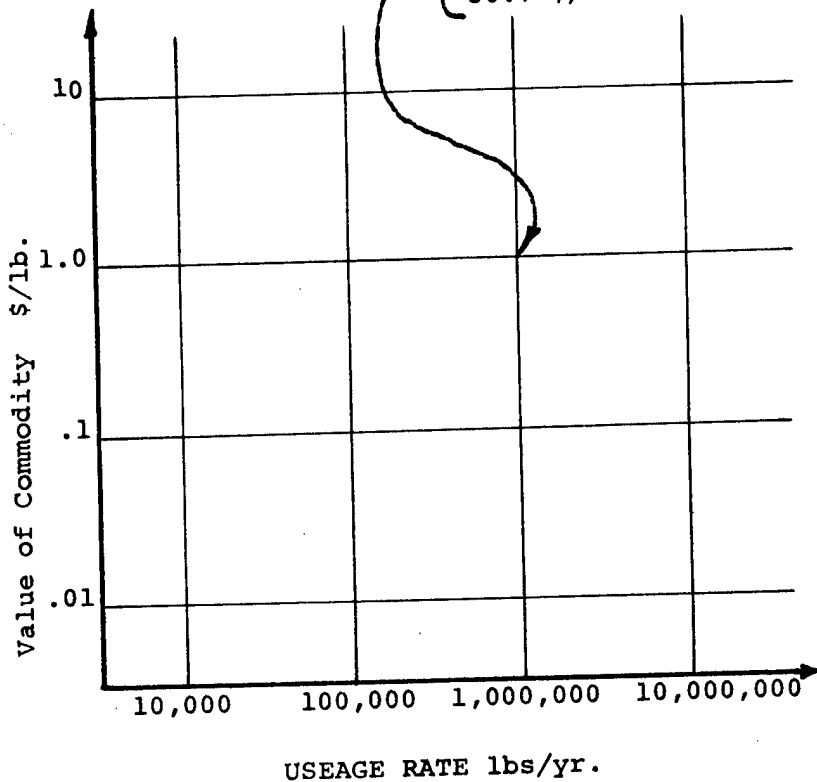

FIGURE 8. Market Segment Definition

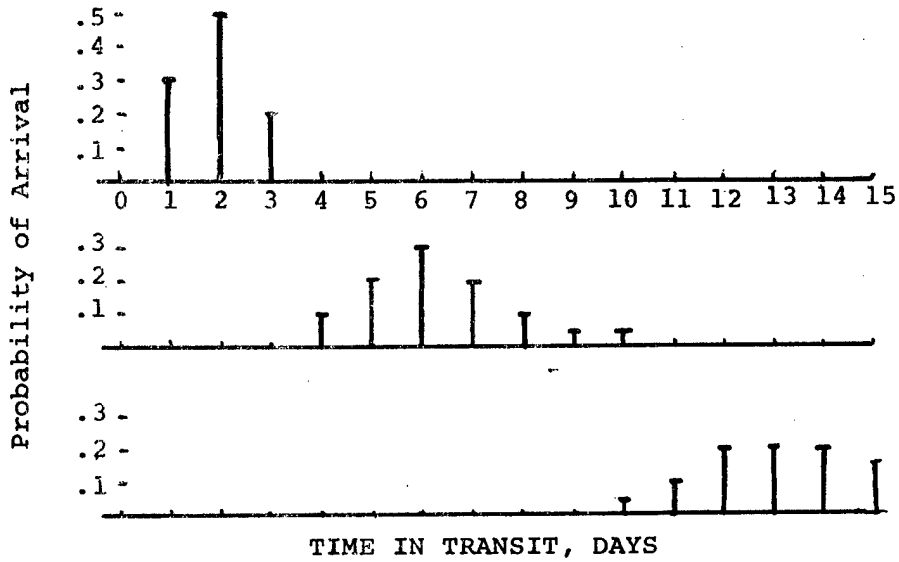
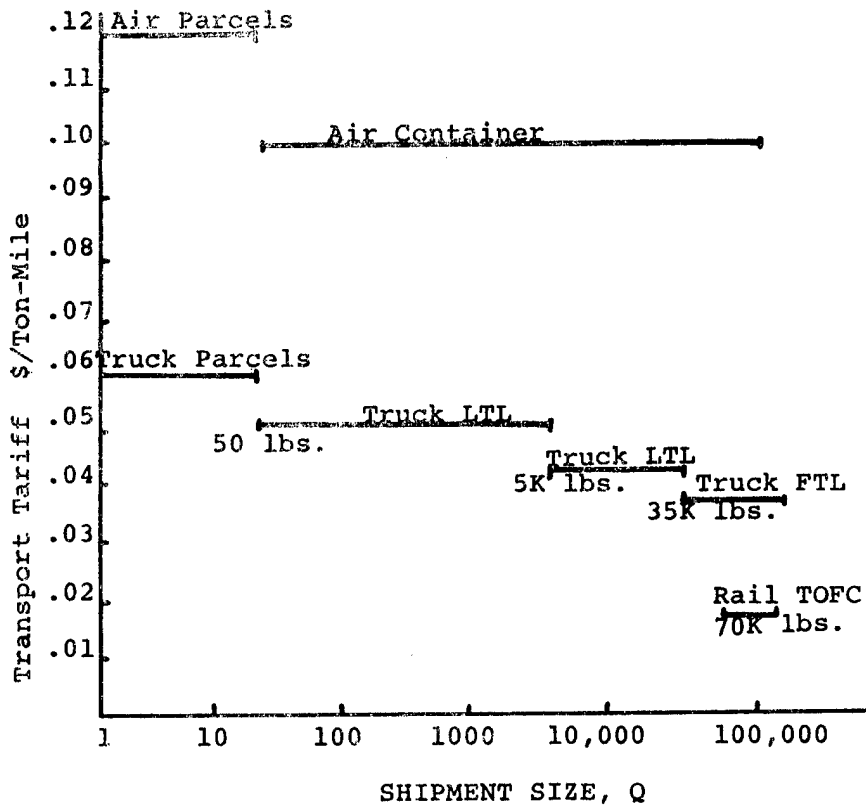

FIGURE 9. Transport Size Rate Tariff Schedule and Lead Time Distributions by Mode

year, 0. Close examination of the pattern of optimum policies reveals a pattern to the strategies which tends to shift as the cost of stockout changes.

For the case of no stockout cost, the reorder point is extremely low. See Figure 10. Since there is no cost of stockout there is no penalty for using slower modes so rail TOFC is used for the larger shipments. Full truckload is discontinuous, but this may be because of discreteness in the definition of market segments. Air freight has captured only the high value, low volume shipments.

For stockout with immediate sale loss, much the same pattern emerges; but truck has encroached on rail TOFC. See Figure 11. Also reorder points are high, especially for the less reliable modes amounting to more than half the quantity ordered in some cases. This causes total logistics costs to be slightly higher to reflect the higher capital carrying cost of the additional inventory.

For the case where the probability of plant closedown exists, air freight shipments have taken over one market segment from what was full truckload shipments in the previous case. See Figure 12. Surprisingly, this is the only change in mode though there has been an increase in reorder point especially for the slower modes.

Overall, the results look much as one might expect, though the stability is somewhat surprising. With higher order costs and higher interest rates on capital carrying there might be more switchover to air or truck from rail TOFC for the high value goods. Nevertheless, the results look reasonable with respect to mode choice and inventory strategy.

To get a feel for the viability of Lighter Than Air services introduced into this market, an additional computer run was made. For this run an assumption about lead time variability and size rate transport rates had to be made. It was reasoned that the lead time distribution for Lighter Than Air should be slower than air and faster than truck. The rate was placed at \$.04 per ton-mile between LTL truck rates and FTL truck rates, and higher than rail TOFC, with a minimum shipment size of 35,000 pounds. In other words, the service offered was to be a fast "piggyback" service.

The results of this run are interesting. See Figure 13. Lighter Than Air service captured only the market segment previously served by FTL truck and by air freight. This seems to indicate that to compete effectively in this market, transport costs would have to be lower than FTL truck. Certainly lower costs would have increased the markets for Lighter Than Air.

This computer run considered only a 2500 mile transcontinental shipment. A complete analysis would have to look at shorter markets. In addition such an analysis would investigate the sensitivity of such factors as interest rates on capital carrying and higher storage charges.

FIGURE 10. Optimal Inventory Strategies for the Case -
NO STOCKOUT COSTS

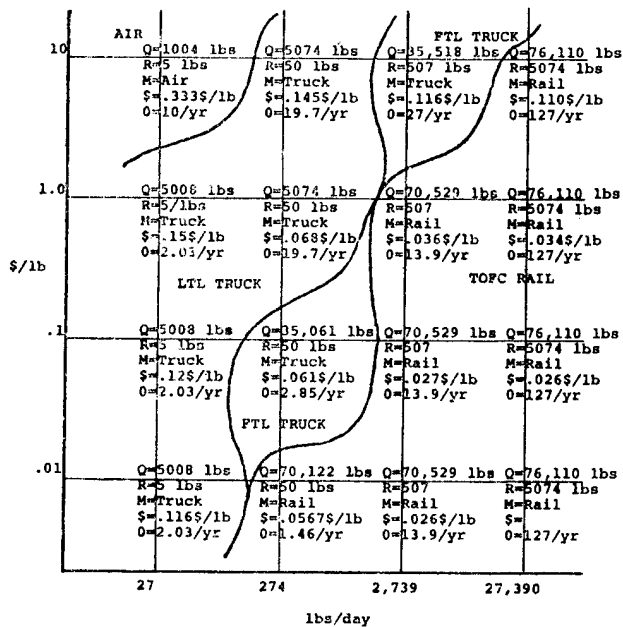
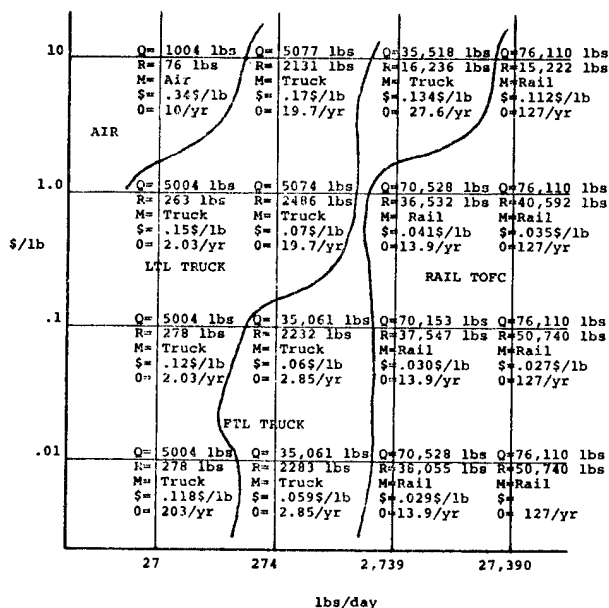

FIGURE 11. Optimal Inventory Strategies for the Case -
STOCKOUT RESULTS IN IMMEDIATE SALE LOSS



REPRODUCIBILITY OF 11.
ORIGINAL PAGE IS POOR

FIGURE 12. Optimal Inventory Strategies for the Case -

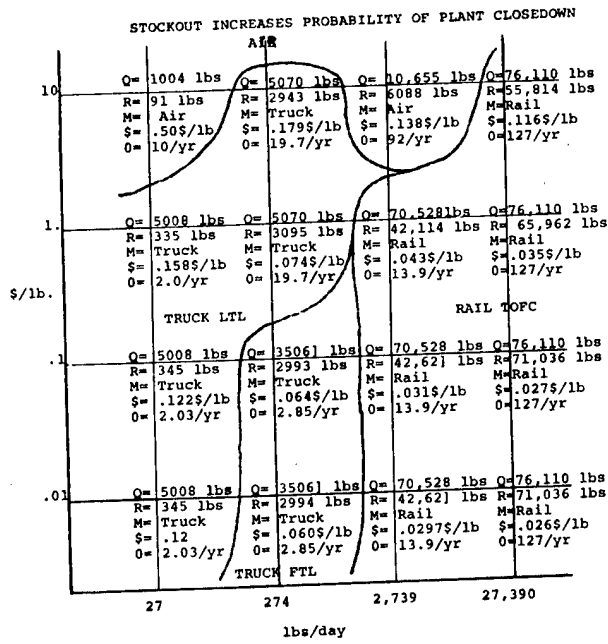
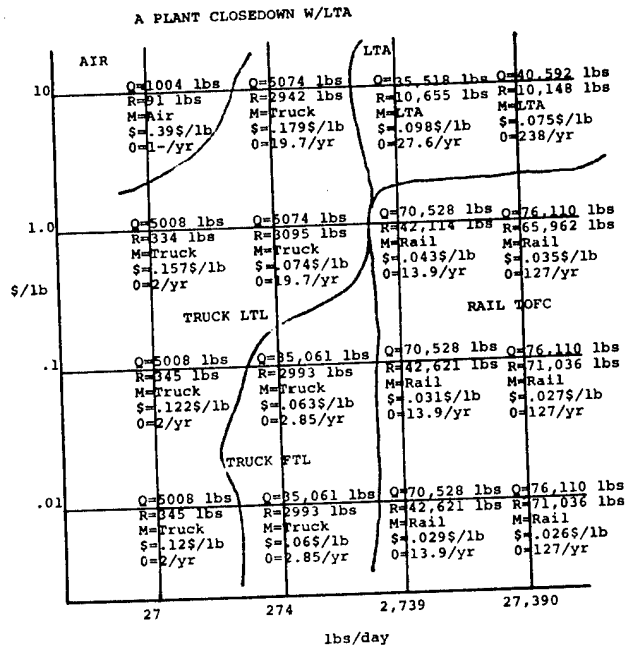

FIGURE 13. Optimal Inventory Strategy for the Case -



To complete this analysis, the size of each market segment must be known. Without the size of each market segment, it is impossible to sum up the flows to determine overall tonnages by shipment size. In this case the market is a hypothetical one that might be compared with the one between New York and Los Angeles in distance, travel time, and transport rates. To get the sizes of each market segment some empirical work would need to be done. This would require more time and accessibility to data than we had available but should not be an impossible task.

CONCLUSIONS

Concept Viability

At this time it is difficult to conclude whether Lighter Than Aircraft have a future or not. Certainly, lower costs per available ton-mile than those we have assumed here would make a stronger case for them. But, the terminal costs and performance are also important. They will closely reflect the care put into the design of an overall network. The problems associated with raising capital and obtaining hull insurance, et., will also be important. If a profitable concept can be found there will be a variety of environmental, institutional, and regulatory questions that will need to be addressed. There could well turn out to make or break the concept.

Thoughts for Further Marketing Research

The previous analysis has indicated that the LTA vehicle will perform best when the situation has the following characteristics: large annual volume resulting in relatively large LTA vehicles, relatively constant demand and directional balance causing high utilization, and origin to destination movements minimizing the use of feeder services. Existing modes of transportation have established markets with many of these characteristics. Further research, in part relying on the type of marketing approach described here, could determine which specific markets could be diverted to LTA vehicles.

In the maritime industry, neobulk shippers possess many of these characteristics. These shippers have too much volume per shipment to make it economical to use normal common carriers, yet do not possess enough cargo to make chartering an entire ship economically feasible. Specialized ships call on a network of such neobulk shippers offering them lower than normal prices on a contract basis with reliable service.

In the airline industry, shippers who charter entire airplanes for their freight on a regular basis could form potential markets for LTA vehicles. Agricultural products, especially fresh fruits and vegetables, are a possibility.

In the railroad industry unit trains of containers, either trailer-on-flat car (TOFC) or container-on-flat car (COFC) should be analyzed for

possible diversion to LTA. The rail shipments differ from the air and water movements described above in that railroad (or the shipper using the railroad) normally provides a consolidation function prior to shipment.

Within these established markets, LTA vehicles could attempt to direct the higher value cargo from the ships and railroads and the lower value cargo from the airlines. If LTA vehicles were able to put together a network of customers, each shipping full LTA vehicle-load lots of cargo on a scheduled contracted basis (possibly on a direct origin to destination basis), the full economic potential of the LTA vehicle could be realized.

Analysis Needed

The type of analysis that must be conducted to determine the marketability of the concept is clear, however. It must address both supply and demand elements. It should start from a marketing concept to define the performance specifications for the system as a whole including terminal organization and operation. From this a detailed set of equipment costs and costs per ton-mile must be developed and translated into a rate structure. The concept can then be tested by using demand models to determine the choice of mode and size and frequency of shipment for each market segment. The market segments are then factored up to give the overall market share, revenues, costs, and overall profitability.

Once available the market analysis can be used with incremental changes to adjust the marketing concept to make it more profitable or attempt to find a concept that will be profitable.

REFERENCES:

1. Schneider, Lewis M., The Future of the U.S. Domestic Air Freight Industry, Harvard University, Graduate School of Business Administration, Boston, Mass. (1973).
2. Planning Research Corporation, Transoceanic Cargo Study, Los Angeles, Calif. (1971).
3. Southern California Aviation Council, Inc., Committee on Lighter-Than-Air Technical Task Force Report, Pasadena, Calif. (May 15, 1974).
4. Hunt, Jack R.; Levitt, Ben B.; Morse, Francis; Stehling, Kurt R.; and Vaeth, J. Gordon, "The Many Uses of the Dirigible," Astronautics and Aeronautics (October 1973).
5. Marcus, Henry S., "The Emerging Battle Between Containerships and Jumbo Jets," presented at the International Transportation Research Conference, Bruges, Belgium (June 1973).
6. Roberts, Paul O., "The Logistics Management Process as a Model of Freight Traffic Demand," prepared for the International Symposium on Freight Traffic Models, Amsterdam (May 1971).
7. Roberts, Paul O.; Hattock, Brock A.; and Collins, T. Jay, "Trains: A Computerized Transportation and Inventory System," Division of Research, Graduate School of Business Administration, Harvard University (June 1971).

N 76 - 15 0 25

John E. R. Wood *

ABSTRACT: Given no constraints on size, the airship could carry almost anything almost anywhere. Economics and practical difficulties arise of course, and the problem then becomes one of relative assessment of the problems and prospects involved in any area of possible application. This must then be integrated with an economic evaluation of the selected project area. A review of the marketability of the airship is given, and the relative energy consumption and speed potential of the airship is compared to other modes and guidelines to areas of initial development are also provided, together with a brief historical review.

GENERAL INTRODUCTION

A Convention such as this represents a long awaited opportunity to examine objectively and critically the problems and prospects of what is, after all, a totally new concept of transport. The term "totally new" will no doubt provoke a certain amount of protest, but it is in fact perfectly justifiable, although it is of course true that an established hierarchy of airships, differing not only in size but also in payload, range and indeed all the other factors which are normally associated with logical series of craft, operated over a period of some forty years. But the operation of these craft must not be interpreted as having been conceived along lines of assessment remotely similar to those that must be considered today.

The airship may have been conceived as a vessel of peace, but it owes much of its early impetus of development to the demands of war. In a period of growing international rivalry between Britain and Germany, at a time when powered heavier than air flight was a thing of the future this was hardly surprising. The period 1900 - 1920 saw a continuous, steady development of the airship with a natural acceleration of this development, as the Great War approached. The great majority of this development was concentrated in Germany, in a Germany that was nationalistic enough, probably justifiably, to feel that it had little to learn from other countries, and that had even less desire to communicate this information abroad.

* Director, Aerospace Developments, London, England.

The partial success, more evident in the manpower it kept 'tied up' in Great Britain for defensive purposes than by any damage they caused would probably have encouraged the Germans to have continued development immediately after the cessation of hostilities, but the hand of retribution was still firmly in place, and anything that smacked of a rebirth of German industry was heavily curtailed.

In these circumstances, the hand, if not of friendship, then at least of partnership, which was advanced by the U. S. A. was too good to miss albeit at the cost of much injured pride. Thus, in the early 20's the Goodyear-Zeppelin consortia came into being.

Let us recap the situation so far. The initial development of these craft took place against a background of Nationalism, at a time when no other form of powered flight existed. Against this background it is easy to understand how a situation developed whereby the design of these craft came to be based upon constraints of money available, and the limitations, or expected limitations of the technology available. It was naturally assumed that development of larger, faster 'better' ships was an economically desirable aim. Market analysis as we know it was virtually unheard of, and the question of designing for overall profitability was hardly considered.

After the war the interest shown in these craft was still based upon the simple fact that civil operation over Trans-Oceanic distances at speeds greater than a liner was unachievable. Therefore speed being an obviously desirable factor, anything that could decrease this time must capture a market! The holes in this logic, even then, should be fairly obvious, how much more so today, with a plethora of alternative transport modes, and opportunities for investment available. (Unfortunately, recent aeronautical experience, particularly in the U. K. indicate that lessons from the past are difficult to learn properly).

Again, designers and manufacturers, anxious to develop what was at the time a unique transport mode, were, to put it kindly, optimistic about the difficulties of maintenance, mooring, running costs, the development potential of these craft, and a whole host of other areas of critical importance to profitability. In the earliest stages, when few craft were operating, and when little or no 'feedback' information could be obtained, this was understandable. When the operating results of these craft were staring these people in the face, it was perhaps less so. Even so, one must not be too damning. There is always a dichotomy between the potential of a mode, and the ability of any particular marque of craft to meet that potential. Then, as now, the dictum was "wait until you see the next one". This problem was aggravated by the fact that much design work carried out by the Germans in the early part of the War was only just being evaluated by other nations (notably, Great Britain) some seven or eight years afterwards. Nowhere was development proceeding from a current 'base level' and administrative failures (and rivalry) meant that much needed information was often not crossing company, let alone country boundaries. A number of small concerns, primarily in the U. S. displayed commendable technical ingenuity in producing airships displaying novel construction techniques. But again one is left with the feeling that many of the originators were not over cautious about minimising the difficulties involved in 'scaling up' such craft to a practical size, and, with the number of craft available to them, the limited financial backing, and the lack of much in the way of 'sophisticated' data logging devices, the claims made for the ease with which such craft could be up-graded must be regarded with caution.

On the military side, the development of the Akron and Macon must rank foremost in the developments of the inter war years. Anyone who has read Richard Smith's extraordinarily fine book cannot fail to be surprised and heartened by the enthusiasm and progress that was achieved, nor can they ignore the lack of administrative liaison, the funding difficulties, and

the vague feeling that many elements within the project had differing ideas about what function the craft were in fact, designed for. One would venture a guess that far too little planning was done, especially in determining the operational requirements of the craft, at the pre-construction phase. That is conjecture, what is not, is that these craft were, at best, a limited success, and all the while, waiting in the wings and growing larger, more powerful, more potent, was the aeroplane, destined to overshadow the airship almost completely. That this was so was due far less to the undoubted technical failures of the large airship, than to the economic profitability and ease of reaching diverse markets, coupled with the wider throughput, and greater reliability of service which the aeroplane offered at the time.

PRESENT DAY ASSESSMENT TECHNIQUES

Why such a long introduction, simply because many of the basic criteria contained have not been recognised by many of those that support the introduction of the airship as a transport service device. The use of the word 'introduction' rather than 're introduction' is intentional, for reasons which I hope have been made obvious.

The world has come a long way, politically, socially and economically since those far off days. It may be argued that it has not gone the right way, but what is certain is that critical assessment of high cost technology, or of technology that may have wide ranging implications has grown up, fast.

We live in a world of extensive communications, of multi-national corporations indulging in a multitude of differing activities, of rapidly developing markets, and of rapidly escalating costs.

We have reached a stage where the travelling public think little of travelling in an aircraft costing thirty million dollars, which is, as near as dammit, perfectly constructed, and is operated by an organisation massive in its support, training and maintenance facilities. That aircraft is not simply an established part of our transport infrastructure, it is the development not of a single company, but of fifty years of overall aeronautical development, a development which, in recent times at least, has become coordinated internationally in all aspects of its operation to an unprecedented, and uncompleted degree; specifications and safety requirements, of unheard of severity are laid down for everything from a glider to a Jumbo jet by international organisations, and design standards are established long before the first nut and bolt have been put together. In simple terms, everything that flies today, other than the simplest light aircraft, is the high cost product of a high cost, large scale operation, not the smallest of these costs, naturally enough, are due to the heavily increased administrative costs which accompany operations of this scale.

And yet, into this 'new arena' of cost estimation, came a strange body of men, enthusiasts one and all and, in many cases, simply not appreciating the cost of developing the points made above. This is by no means a total observation, but it does apply to a dishearteningly large number of people who are now waving the flag for airships. One of the main reasons for this strange state of affairs is almost certainly due to the fairly distinct division which at present exists within the fledgling airship movement, on the one hand, the engineer, obviously unlikely to have been professionally connected with Lighter Than Air for any considerable period of time, or indeed likely to have been involved in anything approaching a large investment programme of research into L. T. A. and on the other, the marketing man, who is obviously keen on drumming up interest in what is, potentially at least, a very large area for investment. In many cases it must be obvious that each, although passionately enthusiastic, often has little contact with the other, and neither appears to take account of

the other transport modes available, and of the effect the reaction of these other modes to the project would have on the overall potential of the scheme.

There is a bewildering array of designs at present available, ranging from the conventional to the unlikely, with round, flat, double hulled and other hull forms, and power units ranging from diesel engines to atomic reactors. But a question which must be asked is what were the design considerations that produced these ideas? If one sees a 400 ton payload craft for example, why not a 500 or 800, or 200 ton ship. Have the advantages, and difficulties involved in designing for higher speeds and larger sizes been sufficiently appreciated from the vital economic as well as the technical aspects, and to what extent is current aircraft data concerned with areas such as handling characteristics been extrapolated in order to provide even technical justification for the various craft. Most important of all, what markets and products have these craft been designed to cater for? In many cases it would seem that this question has been left alone. The assumption being that, if a craft of a certain size and transport capacity exists, then the market will gravitate towards it. This is a false premise, and represents a classic case of putting the cart before the horse. Without a knowledge of the market then no design can claim proper viability.

The results of this present attitude may be summed up as follows:

1. The majority of the largest, most ambitious designs originate from the smaller design concerns. Many of whom are operating on a part-time, unfunded basis.
2. Many of the 'failure areas' of previous rigid airships have not been properly considered. Most notable amongst these areas being the structural inadequacy, high maintenance, and high manpower requirements of the conventional Zeppelin design.
3. There is a tendency to assume that a particular type of construction is "the best" rather than realising that the type of construction which represents an optimum is dynamic and varies with, size, speed, and market.
4. In general, and for a variety of reasons, the unit costs, development costs, and administrative costs of running such a project have been underestimated, in some cases to a ludicrous extent.
5. Very little attention has been paid to "off vehicle" costs, those associated with terminal facilities, maintenance etc.
6. Many organisations have presented the "final model" of their craft, without giving any indications of the cost and extent of the pre-production and prototype programme.
7. The time to in service operation is often so little that it must be considered that in many cases, the design process is assumed to be complete. If the total funding and manpower inputs are examined this will be an unlikely situation.
8. Little attention has been paid to the fact that no airship building infrastructure exists. Hindenburg for example was the end product of an organisation that had been in existence for forty years. (With a very large proportion of the original staff still employed.) The loss of these indefinable advantages which result from the existence of such a 'worked up' organisation are assumed to

be catered for by the rather nebulous term "advances in material technology". These advantages, certainly in many areas, are less than is generally supposed, and often will impose a high cost disbenefit on the craft, which is usually ignored.

Most of the above reads like a roll-call of horror. It might reasonably be inferred that the purpose of this report is to dampen the rapidly growing interest in L. T. A. Nothing could be further from the truth. The airship appears to offer a number of very promising areas for investment and development. The purpose of the foregoing has been to ensure that these areas of development are examined from a suitably critical viewpoint.

ANALYSING THE MARKET

It has already been stressed that there is no single optimum type of airship. It is unlikely at this stage that any single agency is going to finance a world survey in order to evaluate the potential application of virtually all freight movements to the airship. Indeed such an exercise would be purely academic. Reasonably enough, most interest in the use of airships will continue to centre around those market areas that are not providing good enough economics at present, or are failing to meet the demand that is present. This failure may be due either to a lack of availability of the present transport mode or to certain inherent deficiencies in the mode (high running costs, labour intensive etc.) or it may simply be that the market has expanded greatly, and the mode has been unable to expand with it, whilst retaining its initial profitability. There is a second area of very great importance, where markets have developed without the associated ground based transport infrastructure having been developed. This often occurs in areas that have experienced rapid economic growth in recent years, and that have extraordinarily difficult topographical problems (mountains, forests, etc.).

It is likely therefore that the market that will require investigation will be a victim of one or more of the above constraints, and that the market will be suggested by an outside source. The problem that then presents itself is one of comparing the likely costs of meeting demand using an airship with the costs involved using an alternative system.

BASIC CONSIDERATIONS OF THE AIRSHIP

Initially, having decided on an area of investigation, some form of "first pass" estimate must be obtained to determine whether there is any hope whatsoever of using the craft profitably. To this end it may be useful to state some fairly safe assumptions.

1. The conventional airship is slower in airspeed than an aircraft.
2. The trip end facilities required for an airship are less than for any aircraft, and for airships with payload ranges of 2 - 20 tons or thereabouts they are a lot less than for an aircraft of similar capacity.
3. An airships running costs (in terms of fuel costs) increase rapidly with speed, and relatively slowly with size.
4. The annual utilisation of a small airship should be as good as that of a small aircraft.
5. The initial utilisation of a large craft would be unlikely to be even as good as a large aircraft.

6. The first costs of a small airship (payload range 2 - 20 tons) would, or rather should, be less than for an aircraft of similar size.
7. The first costs of a large airship would be unlikely to be substantially less than for a large airliner.
8. A small to medium size airship would be capable of a far quicker time to in service use than a large craft.
9. The degree of investment required to produce facilities for building and maintaining a large airship would be disproportionately high in comparison to the sums required for a small craft.

With the previous statements in mind, let us now examine the basic steps necessary to evaluate any particular potential area of application.

Historically, there has always been a relationship between the various sizes of craft and the type of construction which represented an optimum for each size range. These were approximately as follows:

Simple "Blimp" type	=	<1000, 000 Cu. Ft.
Semi Rigid Type	=	200, 000 - 2000, 000 Cu. Ft.
"Zeppelin" Type Rigid	=	1000, 000 - 8000, 000 Cu. Ft.

Nowadays it is suggested that improvements in technical design capability have not only resulted in the coming into being of several new types, but have increased the size range for the craft very considerably.

Simple "Blimp" type	=	<1000, 000 Cu. Ft.
Internally Supported "Blimp"	=	1000, 000 - 25, 000, 000 Cu. Ft.
"Zeppelin" Type Rigid	=	1000, 000 - 50, 000, 000 Cu. Ft.
Monocoque (Supported) Type Rigid	=	2, 000, 000 - 200, 000, 000 Cu. Ft.

These are generalisations, and do not represent the thoughts of all connected with L. T. A. (Notable exceptions would include the Blimp designs of Argyropoulos and Sonstegaard, which are larger than any sizes here considered) But, in general, they are a fair example of current design trends.

With these basic classifications in mind, the basic steps involved in evaluating "an airship" against any selected market may be considered as follows.

ANALYSING A MARKET. NINE FUNDAMENTAL STEPS

1. Analyse data relative to existing and projected commodity flows for selected markets.
2. Examine the topographical and meteorological data to obtain payload and utilisation figures for a craft.
3. Based on information obtained so far (tons/year and utilisation) construct a graph of number of craft/size of individual craft.
4. Modify this information to take account of a network transport system (i. e. on-going goods with separate pick-up points) if this is required.
5. Examine trade offs between increased speed (greater fuel consumption, different power requirements etc.) and size (trip end facilities, mooring facilities, assembly and difficulties, construction costs, control problems, etc.) relate results obtained to Item 4.
6. Having ascertained size and number of craft required (based on 'conventional' airship types and speeds, determine capital costs for craft, together with costs for trip end facilities.
7. Determine annual cash outgoings for the operation including maintenance, insurance, return on capital, fuel and manpower costs, to provide a total cost/year.
8. Divide total costs/year by tons/year to be operated to give a costs/ton.
9. Compare costs so obtained with costs/ton obtained by existing or projected alternative modes, conduct a risk analysis on this figure, and, based on the results obtained Go/No Go.

The reason for evaluating designs based on conventional theory, moving at conventional speeds, is based solely on the philosophical principle known as "Hackmans Razor", that is Investigate the most likely answers first, a simple enough concept, and one that is frequently forgotten.

MARKET ANALYSIS FOR MILITARY APPLICATIONS

Nothing has been said so far about the potential of L. T. A. to military applications. This is solely because the criteria for evaluation are so very different to those normally applied to civil applications. Much will doubtless be said about military applications during this workshop, and it is an area which Aerospace Developments has investigated at length. Within the confines of this paper, all that may be said is that the inherent qualities of long range, high speed, and good station keeping combined with good payload ability, suggest applications in both A. E. W. and A. S. W. with perhaps less attractive applications for heavy assault craft.

MARKETING

The basic physical parameters which require investigation when assessing the economic viability of the airship have been outlined. There are, however, a number of factors which are somewhat subjective, which determine with equal importance the degree of success which the project will ultimately achieve. These "saleable" qualities may be regarded as "marketing".

PROJECT EVALUATION (Figure 1.)

"The Whole World's a Stage" as Shakespeare said, and likewise what one sees depends very much upon where one sits. In any airship operation there are likely to be three main "characters" and the prime requirements that each will have in the project, in isolation, are shown in the illustration. There are other factors which may well be advantageous to the project, yet which have nothing to do with the basic requirements of either the customer, the operator, or the manufacturer. A prime example of this is the degree to which current aircraft designs are being factored around "environmental" considerations. (Quietness, low pollution, etc.) Such factors may actually decrease the attraction for the operator (higher running costs), the manufacturer (higher development costs) and the customer (higher freight charges) and yet, the degree to which the craft can meet these external constraints can significantly improve the market penetration of the type. It is the function of the marketing aspect of such a project, as defined here, to make the main partners in any such venture aware of the importance of these external factors.

It must also be remembered that the development of any new transport mode provides a great opportunity in terms of marketing simply because it is a new mode, especially if it appears that this new mode may be established at a relatively low cost.

The financial climate is also likely to have an effect on any military development. It is easy to see that, if funding overall is fairly tight, then a project stands a far greater chance of receiving financial support if it can be cross justified across civil applications as well. The basic design of "an airship" is remarkably similar for any application, be it carrying cargo or Sonar gear. It would, for example be a very difficult job to justify the B.1. bomber as being suitable for use by the Timber Industry also. It is not likely to be so difficult for an airship!

THE "TRANSPORT EFFICIENCY" OF THE AIRSHIP

The functions of illustrations 2, 3 and 4 (Ref. 1) is simply to show that we are living in a world where fuel costs are likely to rise, and where oil fuel is likely to continue to be required in ever increasing quantities for transport use. Figure 5 shows the dramatic increase that has occurred in air transport which suggests that the "marketability" of air transport is based on subjective as well as objective appraisal and that the decision to go by air is influenced by powerful advertising pressure. As fuel costs increase so the trade off between the fuel costs involved and the speed (often perceived rather than real) and charisma of "air travel" will be examined even more critically. The prospect of the airship, with its low fuel consumption, its lower initial cost, and its ability to use low grade fuels effectively must inevitably be considered further. Figure 6 is an attempt to rate this efficiency in relative terms, based on information collated by Bouladon of the Battelle Institute. It reveals a craft with transit speeds of an express train, or double that of heavy ground transport operating under idealised conditions, with a fuel consumption barely greater than the lorry, yet without the necessity for the massive investment in roads and railways that conventional

systems demand. It is an aircraft in the true sense of the word, offering good access capabilities, with the possibility of remarkably low fuel costs and, at least in the smaller sizes, low trip end costs, surely a concept worthy of further consideration.

CONCLUSION

This has been a brief discourse, couched in general terms for a general public, but I hope that it has shown that much time, effort and money has already been spent on examining the application of L. T. A. to a wide variety of operational areas. There is no such thing as an "ideal" airship. Each case, and each application MUST be considered in its own individual light. There are many areas of such evaluation that will remain subjective, at least for a considerable time, but the ability to interpret these areas, and to ascribe to each of them their relative importance does exist, and should be utilised. The Chinese have a proverb, "The Flower must Grow from the Seed". It will require very little investment to ensure that this first small seed is well planted, and from this, and this alone, will the true potential of this exciting phase of transport development be discerned.

REFERENCES

1. Bouladon G. Raes Review (May, 1974)
-

PROJECT EVALUATION: THE FOUR VITAL FACTORS

FIG. 1

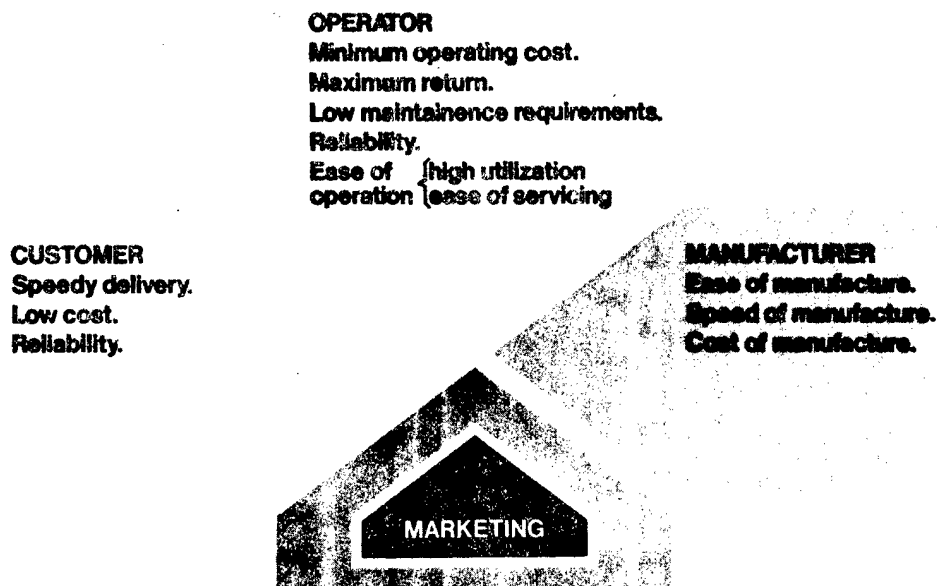

TRANSPORT IN TERMS OF ENERGY CONSUMPTION

FIG. 2

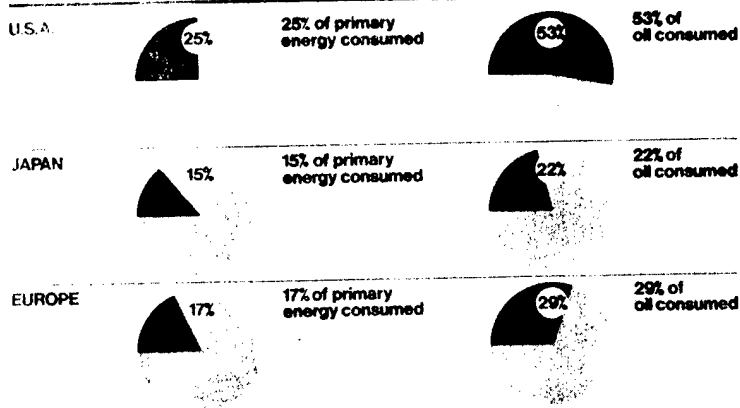

(N.B. only direct consumption is considered here)

IMPORTED ENERGY DEPENDENCE

FIG. 3

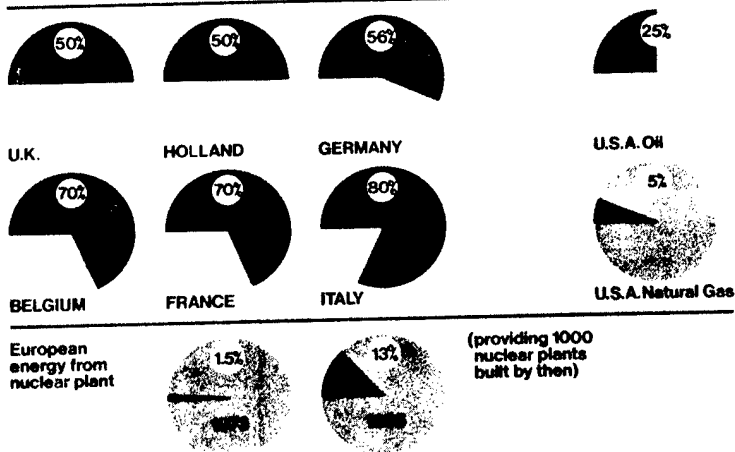

AVAILABLE OIL SUPPLIES

FIG. 4

Maximum oil production is likely to occur around 2000 A.D. and should be approximately 5 milliard tons/year

Non substitutable oil requirements (mainly in the petrochemical industry) will total 2 milliard tons/year

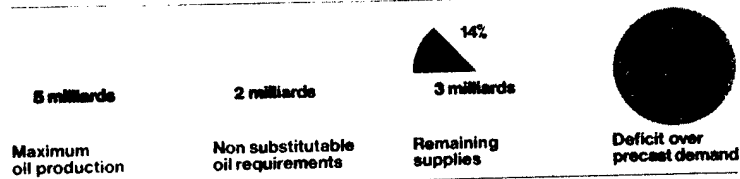

Therefore, remaining supplies will be 3 milliard tons/year. This represents only 14% of world energy consumption and is a deficit of 1.5 milliards over precast demand, PROVIDED THAT

ALL OTHER CONTRIBUTIONS TO ENERGY SUPPLY ARE DEVELOPED AS OUTLINED ABOVE. This is, to say the least, unlikely.

GROWTH OF WORLD TRAFFIC 1953-1973

FIG. 5

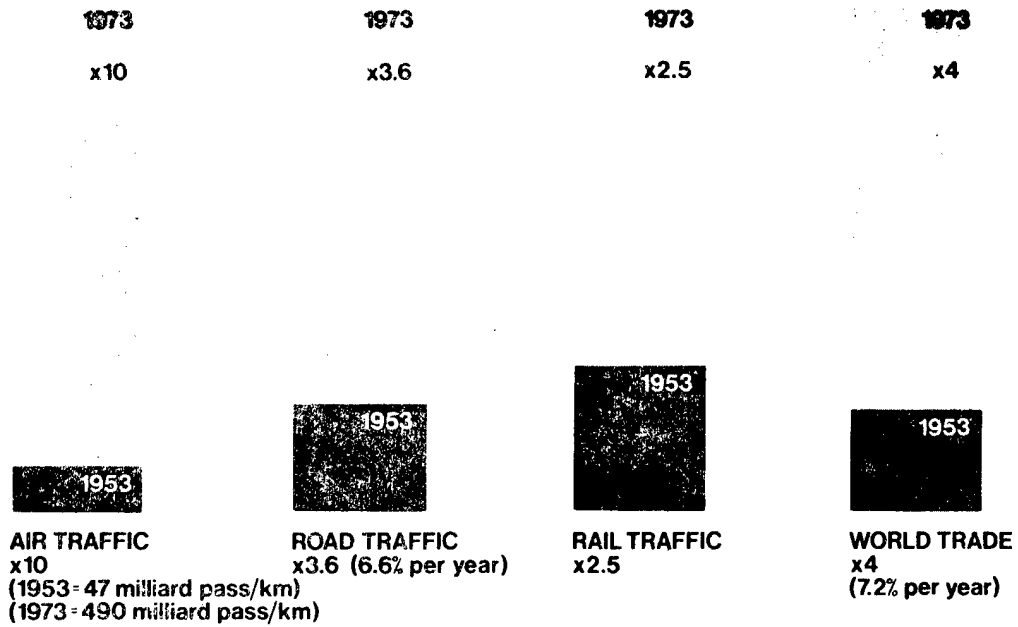

SPEED AND ENERGY CONSUMPTION TRADE-OFFS

FIG. 6

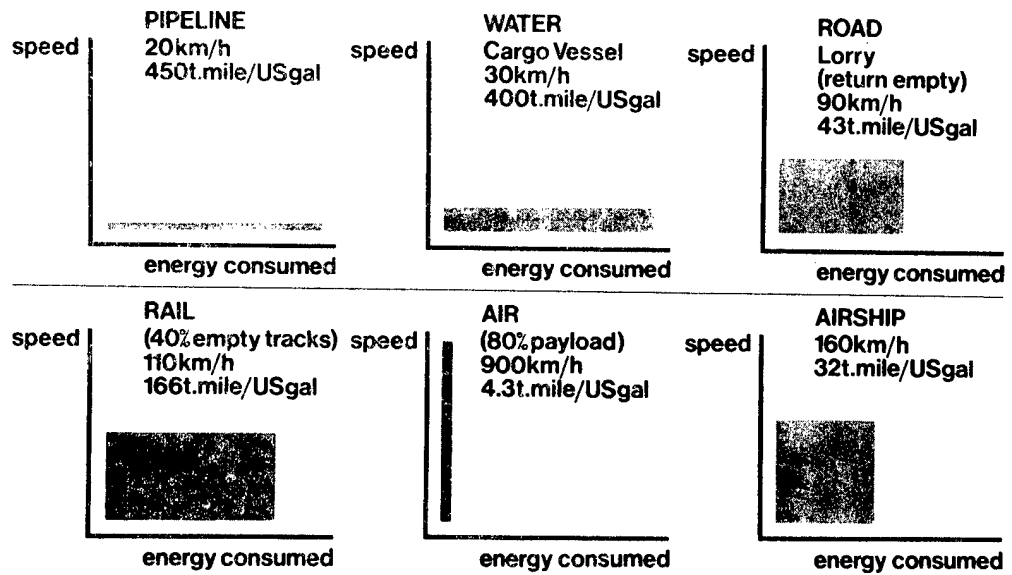

BOULADON/BATELLE

TECHNICAL AND DESIGN CONSIDERATIONS

Basic Relationships for LTA Technical Analysis — Raymond A. Ausrotas

The Effects of Selected Modern Technological Concepts on the Performance and Handling Characteristics of LTA Vehicles — Carmen J. Mazza

Boundary Layer Control for Airships — F. A. Pake, S. J. Pipitone

Airship Stresses Due to Vertical Velocity Gradients and Atmospheric Turbulence — Duncan Sheldon

An Aerodynamic Load Criterion for Airships — Donald E. Woodward

The Planar Dynamics of Airships — Frank J. Regan

Floating vs. Flying, A Propulsion Energy Comparison — Fendall Marbury

Long Fluid Filled Bags Suspended by Line Forces — M. L. Mullins, J. L. Duncan

Computer Aided Flexible Envelope Designs — Ronald D. Resch

LTA Application of a Long Trailing Wire High Speed/Low Weight Reeling System — D. F. Werb

11/17

BASIC RELATIONSHIPS FOR LTA TECHNICAL ANALYSIS

Raymond A. Ausrotas*

ABSTRACT: An introduction to airship performance is presented. Static lift equations are shown which, when combined with power requirements for conventional airships, allow parametric studies of range, payload, speed and airship size. It is shown that very large airships are required to attain reasonable speeds at transoceanic ranges.

INTRODUCTION

The performance equations for airships are presented as a basic introduction to the technology of LTA. The lift equations are based upon aerostatic lift principles; the drag equations assume airship fineness ratios (length to diameter) of past airships and conventional fuel sources and engines. It is shown then that the Lift-to-Drag ratio is proportional to $C^{1/3}/V^2$, where C is capacity and V is the velocity of the airship, indicating that to maintain the same L/D ratio while increasing speed calls for a huge expansion of airship size.

*Associate Director, Flight Transportation Laboratory, Massachusetts Institute of Technology, Cambridge, Mass. 02139

AIRSHIP PERFORMANCE

Lift

Aerostatic lift is the basic means of carrying a payload in LTA craft. According to Archimedes' principle a body immersed in fluid is bouyed up with a force equal to the weight of the displaced fluid. The object of the airship game is to displace a large weight of air--the bouyant force obtained being equal to the weight of the air displaced. Although the ideal airship would be a vacuum vessel, obvious structural problems inhibit this solution, and some lighter than air gas is used to maintain the structural integrity of the airship. Thus the gross lift capability of an airship is equal to the bouyant force minus the weight of the ship, or

$$L_{\text{gross}} = \rho_{\text{air}} V_{\text{body}} - \rho_{\text{body}} V_{\text{body}} \quad (1)$$

or, neglecting structural weight,

$$L_{\text{gross}} = (\rho_{\text{air}} - \rho_{\text{gas}}) V_{\text{body}} \quad (2)$$

Since $\rho_{\text{air}} = 0.077 \text{ lb/ft}^3$ and $\rho_{\text{helium}} = 0.011 \text{ lb/ft}^3$, a thousand cubic feet of helium "lift" about 66 lbs.

This is at standard air temperature and pressure conditions. Corrections are usually made for water vapor and impurity of the lifting gas, as well as percentage of inflation of the gas cells at liftoff.

At 5,000 feet the density of air is about 86% of sea level density, and at this altitude one thousand cubic feet of helium lift only 54 lbs. (Changes in temperature and barometric pressure at any height also affect lift, sometimes producing the condition of "false lift.") The ship will continue to rise until the altitude at which the bouyant force of air will just support the total weight of the airship (including the weight of the helium). This is the operational static ceiling.

"Pressure height" is reached when the gas cells of the airship are completely full; as the ship rises, reduction in barometric pressure permits the helium to expand; flight at a higher altitude produces helium loss, either by purposeful venting or destruction of the gas cells. In the past, airships have cruised at about 2,000 feet with a pressure altitude of about 6,000 feet. While this procedure saved helium, it reduced the payload and resulted in routing problems in mountainous areas.

"Superheat" is another common lifting phenomenon in LTA. Positive superheat exists when the temperature of the lifting gas is greater than the ambient air temperature; negative superheat is the reverse. An increase in gas temperature results in decreased density of lifting gas and increased gas volume. A superheat of +4.3°F results in a 1% increment of lift when the airship is lower than its pressure height^{1,2}.

In addition to static lift, an airship can obtain a certain amount of dynamic lift from the engines. This varies depending on the power of the engines and the shape of the airship. Dynamic lift in the past has been about 10% of static lift. Dynamic lift can allow an airship to "take off heavy" from a runway similar to heavier than air vehicles, but it also requires additional power and fuel, negating some advantages of LTA.

The payload that an airship can lift, then, depends upon the "capacity" of the airship (the cubic feet of volume of the lifting gas), the structural (fixed) weight of the airship (hull, engines, coverings, instruments), plus ballast, crew, equipment and fuel. Airships have had a 50/50 ratio of useful payload to structural weight; the weight of the hull alone for rigid airships has been approximated as¹

$$W_{\text{hull(tons)}} = 11C \quad (3)$$

where C = capacity in millions of cubic feet. Assuming the 50/50 ratio to hold and further assuming that the hull accounts for the great majority of the structural weight, the useful lift available for payload and fuel is, in tons,

$$L_{\text{net}} = 11C \quad (4)$$

This formula agrees approximately with the experience of the past, where the useful payload has been about 30% of the gross lift, since assuming incomplete inflation, gas impurities, etc., gross lift of a helium airship is about 60 lbs per 1,000 cubic feet, or, in tons

$$L_{\text{gross}} = 30C \quad (5)$$

Given technological improvements in structures, an airship designed today would probably have a higher payload/structure ratio and hence lift a somewhat greater useful load.

Power

The drag for an airship can be formulated similarly to that of HTA craft. For airplanes

$$D = C_D \rho/2 S V^2 \quad (6)$$

where D = drag
 ρ = density of air
 V = airspeed
 S = area
 C_D = dimensionless drag coefficient

For airships, then

$$D = K_A \rho/2 C^{2/3} V^2 \quad (7)$$

where K_A = whole ship drag coefficient
 C = capacity of airship ($C^{2/3} = S$)
 V = velocity of airship

The power required to overcome the airship drag is

$$P = \text{Drag} \times \text{Velocity} \quad (8)$$

or, defining a new "drag" coefficient, k_a , ($k_a = K_A/550$),

$$\text{Maximum Horsepower} = k_a C^{2/3} V^3 \quad (9)$$

where V = maximum airspeed

Equation (9) allows trade-offs between horsepower, speed and capacity to be made, once k_a is known.

From the data on actual airships built, k_a can be determined. Table 1 shows the characteristics of past airships 3,4,5.

Table 1

Principal Characteristics of Past Airships

Airship	Fineness Ratio	Capacity (m.cu.ft.)	Horsepower	Max. Speed (mph)	k_a
LZ126 Los Angeles	7.3	2.5	2,000	73	2.79×10^{-3}
LZ 127 Graf Zeppelin	7.8	3.7	2,650	80	2.17×10^{-3}
R.100	5.4	5.6	3,960	82	2.28×10^{-3}
ZRS 4/5 Akron/Macon	7.9	6.5	4,480	84	2.17×10^{-3}
LZ 129 Hindenburg	4.4	7.1	4,100	88	1.63×10^{-3}

As an approximation (for large airships) k_a is assumed to be 0.002. Thus, from equation (9),

$$HP = 0.002 C^{2/3} V^3 \quad (10)$$

For range estimation, the specific fuel consumption must be known. This can be taken as 0.5 lb. per BHP hour.^{1,6} The weight of fuel used per hour at any speed, converting to tons/hour, is:

$$W(\text{fuel}/\text{hour}) = 0.00025 HP \quad (11)$$

The maximum endurance of the airship, E (in hours), will come about when the payload consists totally of fuel.

Assuming that total net lift is used for fuel, from equation (4),

$$11C = (0.00025 HP)E \quad (12)$$

or

$$E = \frac{11C}{0.00025 HP} \quad (13)$$

or, substituting equation (10)

$$E = 2.2 \times 10^7 C^{1/3} / V^3 \quad (14)$$

Then the maximum range of the airship is (excluding headwinds)

$$R_{\max} = E \times V \quad (15)$$

or

$$R_{\max} = 2.2 \times 10^7 C^{1/3} / V^2 \quad (16)$$

One item neglected in this discussion is the cruise altitude--it is assumed that an airship operator would choose the lowest altitude possible since there is a sharp loss in range with increased operating altitude, independent of all other factors.

Figures 1-5 present a parametric study of large airships based upon the given assumptions. It can be seen that exceedingly large airships are required to reach oceangoing ranges at higher speeds: an airship of 30 m.cubic feet capacity is needed to cross the Atlantic at speeds above 125 mph, given some fuel reserve requirements. An airship of 7.5 m.cubic feet can carry a payload of 25 tons at 80 mph 5,000 miles. If the speed is increased 50% to 120 mph the range that the same payload can be carried drops to 2,000 miles. To be able to achieve the same payload-range combination at the higher speed, an airship capacity of more than 30 m.cubic feet is required.

It is also interesting to look at the lift to drag ratio for airships. From equations (5) and (7),

$$L/D = K C^{1/3} / V^2 \quad (17)$$

This provides another illustration of the penalty of high speed in airships. If the cruising speed were to be doubled and the designer wished to maintain the same L/D ratio, the capacity of the airship would have to be expanded by a factor of 64. If the same gas volume is maintained, on the other hand, the L/D ratio drops by a factor of 4.

FIGURE 1
Horsepower vs. Capacity
 (Velocity (max.) in mph)

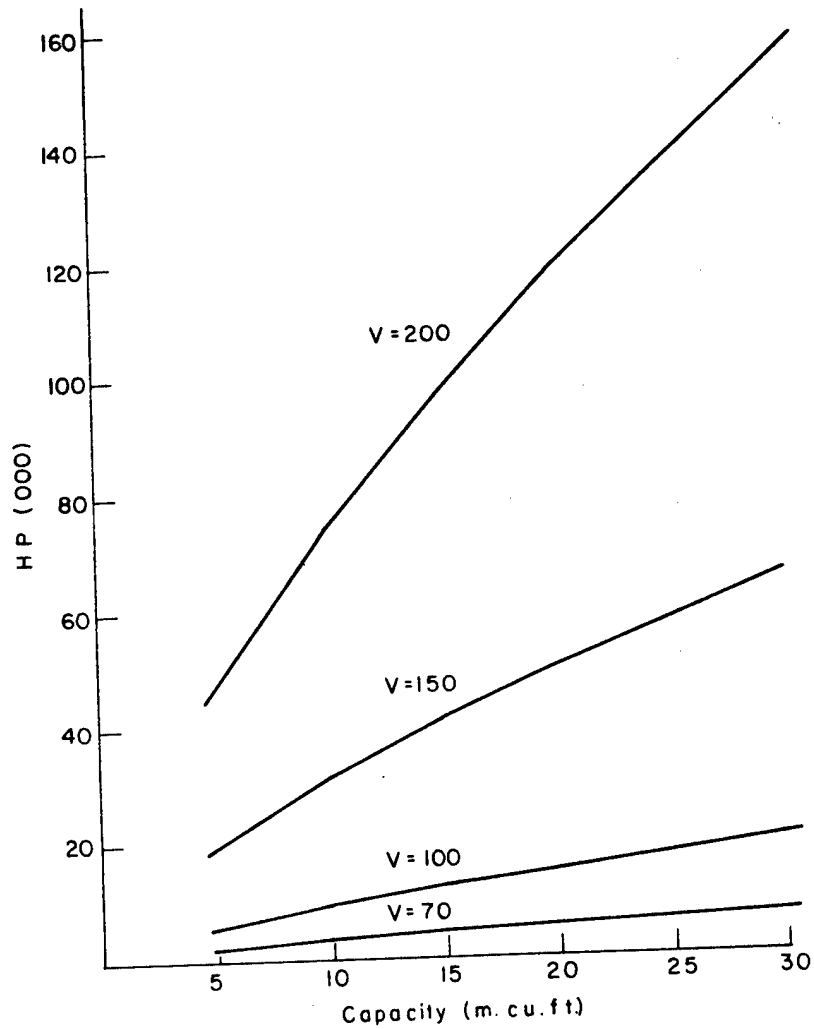

FIGURE 2
Maximum Range Capacity
(Velocity in mph)

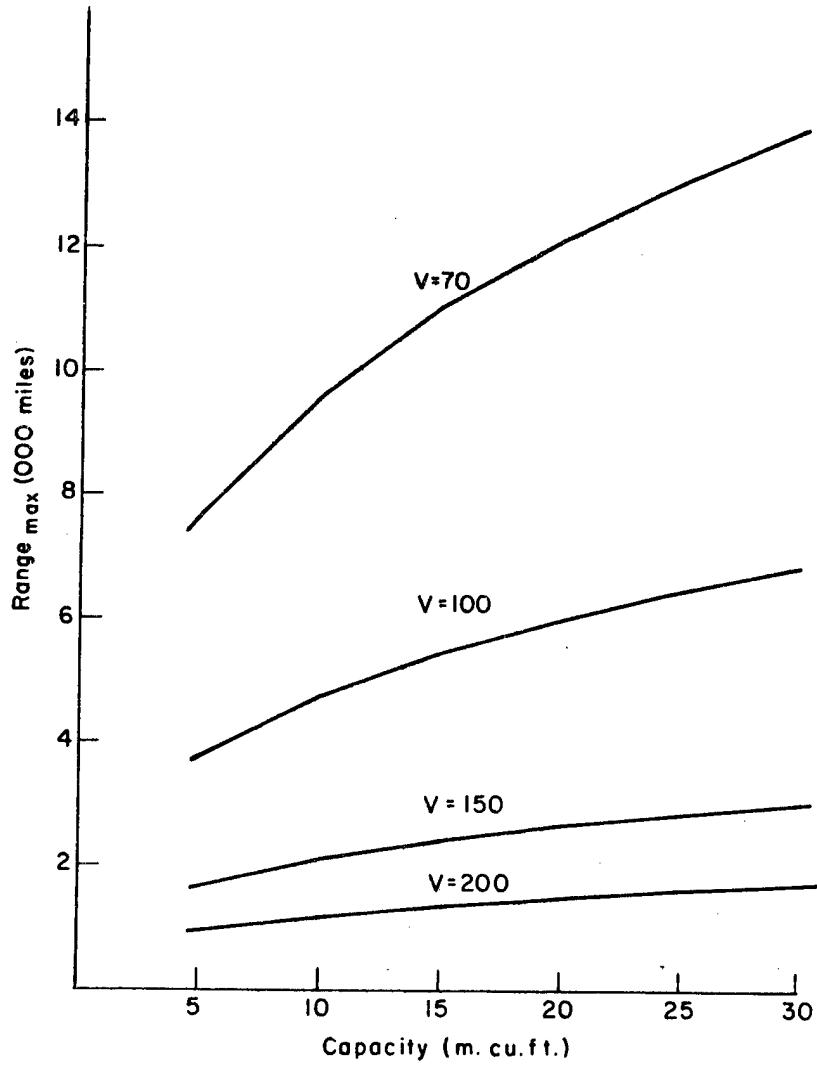

FIGURE 3
Payload vs. Range
 (7.5 m. cubic feet airship)

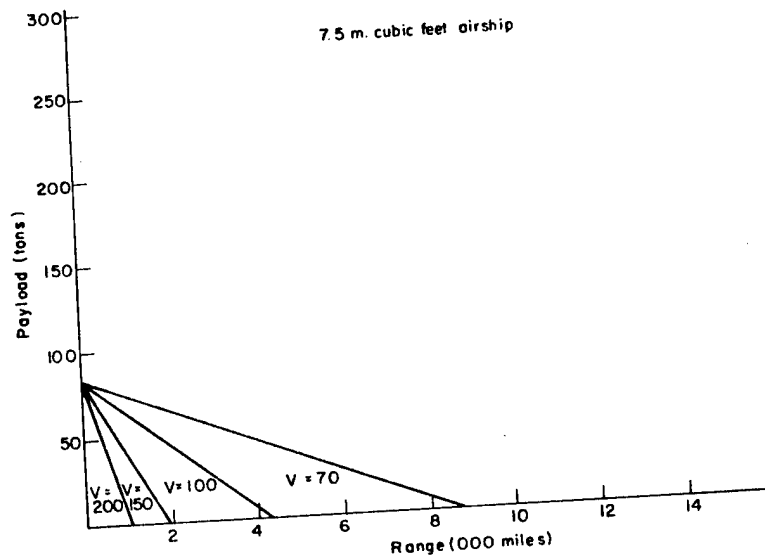

FIGURE 4
Payload vs. Range
 (10 m. cubic feet airship)

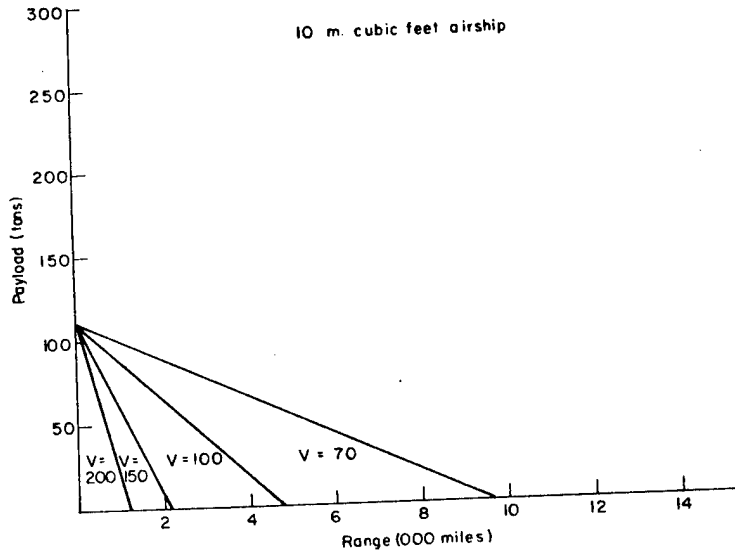
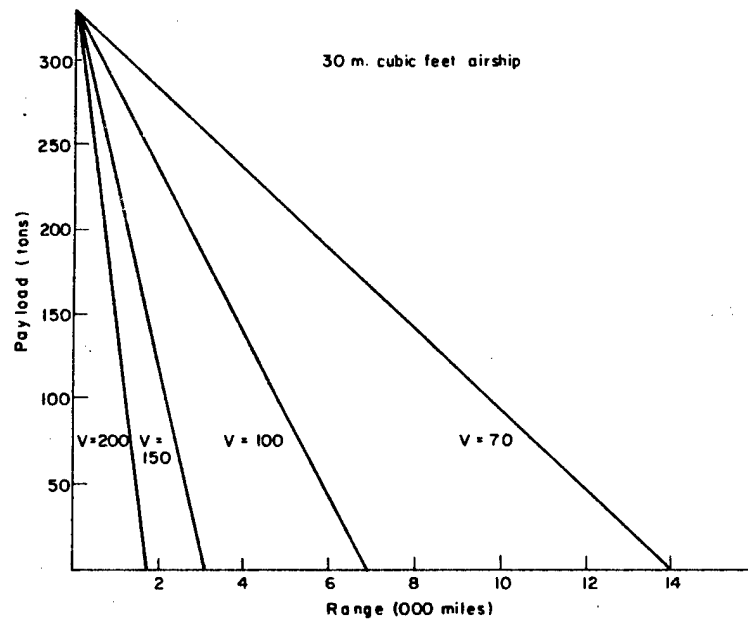

FIGURE 5

Payload vs. Range
(30 m. cubic feet airship)



REFERENCES:

1. E.H. Lewitt, The Rigid Airship, Sir Isaac Pitman & Sons, Ltd., London (1925).
2. Bureau of Aeronautics, Department of the Navy, Rigid Airship Manual, 1927, U.S. Government Printing Office, Washington, D.C. (1928).
3. Peter Brooks, "Transport Airships," Flight International, (December 25, 1959) p. 780.
4. Anon., Building the World's Largest Airships, The Goodyear-Zeppelin Corporation, Akron, Ohio (1929?).
5. Carl B. Fritsche, The Metalclad Airship, The Royal Aeronautical Society, London (1931) Aeronautical Reprints No. 61.
6. E. Mowforth, "A Design Study for a Freight-Carrying Airship," The Aeronautical Journal of the Royal Aeronautical Society, Vol. 75, No. 723 (March 1971) p. 166.

THE EFFECTS OF SELECTED MODERN
TECHNOLOGICAL CONCEPTS ON THE
PERFORMANCE AND HANDLING CHARACTERISTICS
OF LTA VEHICLES

Carmen J. Mazza*

ABSTRACT: The results of an airship design sensitivity study, a prelude to a more in-depth, impending follow-on analysis is presented. A wide variety of airship design concepts, including the classical and high aero-lift augmented-hybrids are examined with regard to specific technological improvements and consequent gains in performance, stability and control and flying qualities. Variations in size, payload, power required and airspeed are quantitatively analyzed for airships representing aero-to-buoyant lift ratios of zero to 3.0 over a range of technology improvements implying reduced drag, reduced structural weight fractions and lighter, more efficient propulsion systems. Qualitatively, future airships are discussed in terms of stability, control and flying qualities requirements dictated by projected demands for vastly improved operational effectiveness and ease of handling. Such topics include stability augmentation systems, load-alleviation systems and total computer state-sensing and controls management systems. It has been shown that, for the most part, highly refined conventional designs offer attractive gains in both performance and ease of handling. Hybrid airships represent a good potential for missions requiring the transport of heavy payloads at higher airspeeds over shorter ranges without the capability for sustained hover and vertical flight.

NOMENCLATURE

A	=	Aspect ratio
C_D	=	Drag coefficient
C_L	=	Aerodynamic lift coefficient
d	=	Maximum diameter of airship (ft)
D	=	Vehicle air displacement (lbs)
HP	=	Horsepower ($550 \frac{\text{ft lbs}}{\text{sec}}$)
k	=	Burgess "inverse drag factor"
	=	$\frac{2 \sqrt{2/3}}{C_D S_{\text{ref}}}$ (for drag non-dimensionalized in conventional aircraft terms)
L_a	=	Aerodynamic total lift = $C_L q S$ (lbs)
L_b	=	Buoyant lift (lbs)
l	=	Overall length of airship (ft)
p_{C_D}	=	Percentage change in drag coefficient
p_{w_f}	=	Percentage change in w_f
p_{w_p}	=	Percentage change in w_p

* Head, Flight Dynamics Branch, Naval Air Development Center, Warminster, Pennsylvania, U.S.A.

q = Dynamic pressure = $1/2 \rho_{\text{air}} v^2$ (lbs/ft²)
 R = Range (naut. miles)
 S_w = Main lifting surface area of hybrids (ft²)
 t_m = Mission duration (hrs.)
 V = Total volume of airship (ft³)
 V_{GAS} = Volume of buoyant gas (ft³)
 v = Airspeed (ft/sec)
 W_1 = Weight of air and gas (lbs)
 W_2 = Weight of structure (inner and outer) (lbs)
 W_3 = Weight of ballast, crew and misc. (lbs)
 W_4 = Weight of propulsion system (inclgd. engines, fuel, etc.) (lbs)
 W_5 = Weight of payload (lbs)
 W_n = Component weight fraction = $\frac{W_n}{D}$
 w_f = Specific fuel consumption (lbs/HP hr)
 w_p = Propulsion system weight per unit power (lbs/HP)
 ρ = Mass density (slugs/ft³)
 ρ' = Weight density = g (lbs/ft³)

FOREWORD

The material contained in this paper has been drawn, in part, from a current Naval Air Development Center Study entitled, "Advanced Technology Airships: Feasibility for Naval Application", tasked by the Naval Air Systems Command H.Q., Washington, D.C. (AIR-03P3). The scope of the Center study includes the examination of LTA vehicles for military applications with emphasis on the Naval ~~escort~~/surveillance mission as a tentative design reference. Included as a final output of this year's effort will be a technical parametric data base for a variety of LTA concepts, associated cost projections and an analysis of several other candidate Naval missions for Lighter-than-Air Vehicles.

Despite the interest in the feasibility aspects of the study, a position will not be adopted until late in the investigative period. Therefore, a smaller but nonetheless interesting segment of the Center study has been selected for this LTA Workshop paper.

BACKGROUND

Airships compiled an impressive record commercially and militarily, both for scope of endeavor and safety during their operations; first by Germany during WWI, through the commercial years of the twenties and thirties and finally by the United States Navy, which terminated airship operations in the early sixties. Throughout a period of over thirty-five years of development the airships evolved from the fragile and short-lived LZ.1 of Count Zeppelin in 1900 to the magnificent LZ.127 Graf Zeppelin of 1928 and finally the ill-fated LZ.129 Hindenburg, representing the pinnacle of airship technology, which exploded and burned at her mooring mast at Lakehurst on 6 May 1937. The Hindenburg disaster signifies for many the unequivocal end of the rigid airship as a practicable airborne vehicle. However, it is more realistic to recall that Germany, which contained by far the strongest nucleus of airship technology, was forced to exclude the airship from further development because of a lack of helium and because of pressing commitments to develop her heavier-than-air power for the impending WWII. Having built 138 airships, most of which were technologically highly successful, Germany brought an abrupt halt to the technology by destroying the Hindenburg's sister ship the LZ.130 Graf Zeppelin II, the facilities and all peripheral airship equipment then based at Friedrichshafen. Until recently no nation with the potential capability to follow through with a major airship program has attempted seriously to assume responsibility to carry on the development of a modern rigid airship.

The airship has long been seen, although somewhat skeptically, as an attractive Anti-Submarine Warfare (ASW) platform because of its long endurance and considerable payload capability. However, considerations of low speed, vulnerability and all-weather performance have in the past offset these assets. Today, however, with the application of modern technologies in materials, avionics systems, propulsive systems, structural design, stability and control and meteorology the airship is again being considered because its potential for sustained and effective surveillance appears to be well-matched to today's threat. In fact, the ASW Search and Surveillance Program Advisory Board sponsored by NAVMAT 03, concluded in November 1972, in their summary report that "Airships warrant another look in light of current trends in sensors, operating missions, and the threat".

The U. S. Navy, as in the past, is once more considering the rigid airship as a means of potentially satisfying a number of future mission roles. In 1968 a parametric study of conceptual LTA vehicles was completed by the Goodyear Aerospace Corp. for the Naval Air Development Center (reference 1). The conclusions arrived at in the work of reference 1 still stand as an indication of the technical feasibility and operational attractiveness of the modern LTA vehicle and further, point out the need for serious research and development to achieve more nearly optimum and operationally effective airships.

INTRODUCTION

There are a number of technologies which, during the past forty years since airship design has been laid to rest, have advanced to a point of offering a modern dirigible "obvious" benefits. Such technologies as structural mechanics, materials and even meteorology belong in this category. Another technological branch which has grown very rapidly within the same period which offers perhaps less obvious benefits is aerodynamics; including stability, control and handling qualities. Several aerodynamic concepts have evolved from development work in low-speed boundary layer control alone which could be applied to reduce drag and render control surfaces more effective on a future airship. Likewise, developments in the field of airborne real-time digital flight control systems can potentially provide not only direct control of an LTA vehicle but could be of great benefit in presenting the pilot and crew with a continuous, up-dated status of the location and amount of ballast and valving gas available for retrimming the ship at any time.

This paper reviews the advantages of the following specific aerodynamic and stability and control concepts and/or considerations with regard to performance and overall handling qualities of future airships.

- a. Optimal Aerodynamic Shapes; including the classical symmetrical/cylindrical shape, a derivative thereof and the lifting body/hybrid configurations.
- b. Augmented Lift and Maneuvering Devices; i.e., the use, primarily, of thrusting devices for augmenting buoyant lifting and aerodynamic controls.
- c. Boundary Layer Control; as a means for improving the aerodynamic efficiency of the vehicle and for improving the effectiveness of aerodynamic control surfaces.
- d. Automatic Flight Control and Stability Augmentation Systems; including automatic trimming functions, load-alleviation functions, stability augmentation and total computer state-sensing and controls management systems.

Although limited in scope quantitatively (primarily due to the short span of time since this study was initiated but certainly also due to a lack of hardened experience in the, perhaps lost, art of airship design), the objectives of this paper are to; 1, point out the advantages of the more practicable, least-risk

modern technological wares and concepts afforded to the rigid airship now, 2, communicate the U. S. Navy's commitment to ascertain the feasibility of LTA for future mission roles and 3, stimulate the thinking and communication among those who will comprise the new airship technological community.

CONCEPTUAL DESIGNS

Four generically different design concepts have been chosen for analysis. These are illustrated in Figure 1 and are identified as: A. Classical, B. Modified Classical, C. Delta and D. Wing-Augmented.

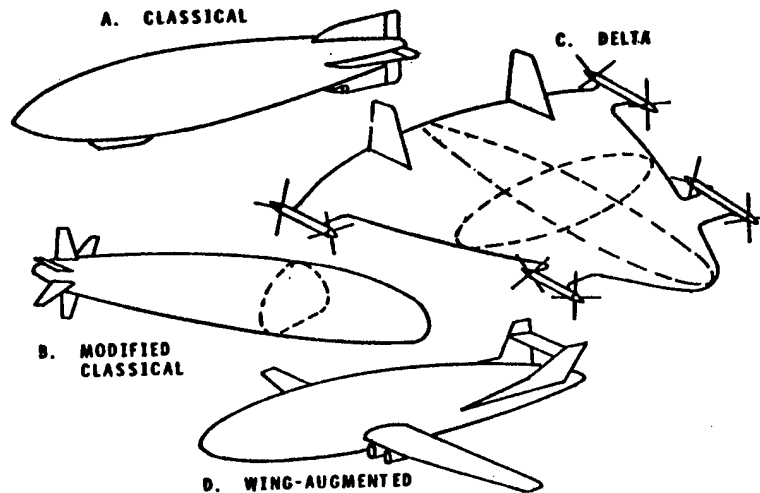

FIGURE 1. AIRSHIP DESIGN CONCEPTS: CONVENTIONAL TO HYBRID

Designs A through D represent a reasonable cross-section of the spectrum of both old and recently discussed and proposed concepts. They range from the neutrally-buoyant ($L_a/L_b = 0$), optimum fineness ratio cylindrical type to the high lift-augmented ($L_a/L_b = 2$ to 3) "Megalifter" (see reference 2) hybrid type.

The aerodynamic characteristics of concepts C and D are as significantly different from either the classical or modified-classical designs as are the missions to which such progressive designs might be usefully applied. In general, the power requirements for the high lifting body and hybrid classes of airships rise rapidly with increasing departure from the classical form thereby tending to reduce significantly the range over which reasonably large payloads may be carried. Such designs as the delta and wing-augmented types invariably preclude a VTOL and hover capability as well; a characteristic long considered highly useful in conventional airships. However, the comparison of these characteristics (and others as well) among concepts A through D will be presented in more explicit terms below.

Since the primary objective of this paper is to determine the advantages of applying improved technology to the airship, a reference classical design was chosen about which to perturbate the design parameters and the consequent improvements in performance.

An airship of circular lateral cross-section with parallel mid-body and assumed elliptical nose and aft-body longitudinal cross-sections was chosen and sized to a total volume of $10,000,000 \text{ ft}^3$. This airship, referred to herein after as the

"basic design", is intended to represent approximately a 1930 state of technology. Figure 2 presents a two-view drawing of the basic design and a summary of its characteristics.

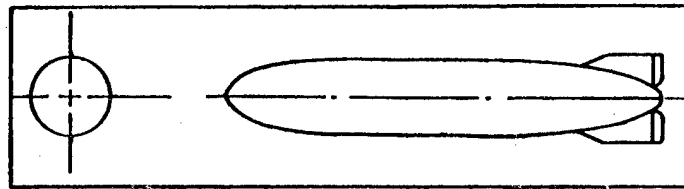

$V = 10,000,000 \text{ ft}^3$
 $D = 763,500 \text{ lbs}$
 $V(\text{cruise}) = 63.5 \text{ kts}$
 $\text{Payload (W}_5) = 100,000 \text{ lbs}$
 $\text{HP} = 3900$
 $\text{Range} = 1900 \text{ nautical miles}$
 (out and return)
 = 3800 nautical miles
 (out only)

$V_{\text{GAS}} = .85V \text{ (at S. L.)}$
 Gas: Helium
 $\text{Gas weight fraction (W}_1) = .288$
 $\text{Structural weight fraction (W}_2) = .300$
 $\text{Crew, Ballast and Misc. weight}$
 $\text{fraction (W}_3) = .055$
 $l = 836.4 \text{ ft}$
 $d = 139.4 \text{ ft}$

FIGURE 2. TWO-VIEW DRAWING AND GENERAL CHARACTERISTICS OF REFERENCE CONVENTIONAL AIRSHIP DESIGN.

PERFORMANCE AND SIZING TRENDS

In order to show the potential advantages of reducing drag, structural weight and propulsion system weight (regardless of means) the basic (conventional) design was perturbed using a range of improvements believed to be representative of the current technology. Volume, power, airspeed and range are indicated over the assumed range of improvements in drag and component weights.

To provide some insight into the possible advantages afforded by severe shape changes it was decided to examine, as a class, those airships which employ either lifting bodies or surfaces to derive a significant percentage of their total lifting capability. Such airships can be considered to be represented by a range of designs varying from concepts B to D previously introduced.

Trends in Conventional Airships

All performance calculations for this and the following section on lift-augmented airships were made to preliminary design levels of accuracy. Several assumptions were made to "lump", respectively, drag contributions, propeller efficiencies, variations in power output and propulsion system factors and weight components in order to facilitate rapid calculation of the trends. It is believed that the results arrived at are in no way significantly compromised by the assumptions made. On the contrary, the simplistic approach taken in these calculations is necessary to gain a quick, quantitative feel for the design sensitivities in order to plan for more effective follow-on analyses.

One of the limitations of airships, viewed as serious by many, is airspeed. Airspeeds were usually in the 50 to 70 kts range; very slow by comparison with today's aircraft standards. In attempting to increase the speed, for instance, of a $10,000,000 \text{ ft}^3$ conventional airship from 70 to 90 kts we see in figure 3 that the total horsepower required more than doubles; and for yet another 10 kts the power more than triples. However, additional speed attained through increased power

yields quickly to diminished returns with regard to payload since, in this case, a one to one tradeoff must be made between every pound of additional propulsion system and fuel weight and the payload.

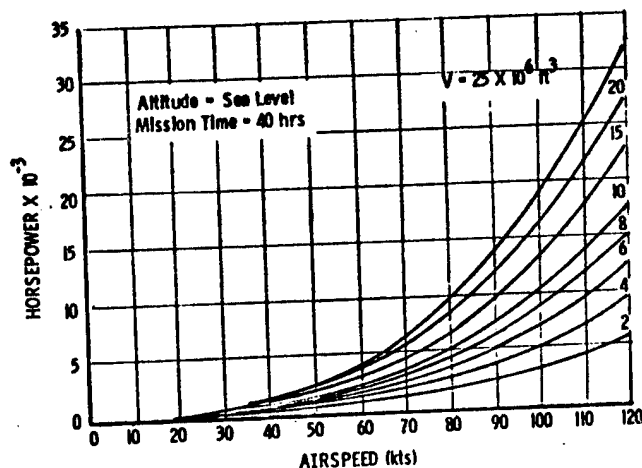

FIGURE 3. SIZING TRENDS OF CONVENTIONAL AIRSHIPS

The payload would have suffered greater still because of the increased weight of a stronger structure and outer covering to compensate for the greater loads imposed on the airship. Today more practical tradeoffs in power, speed and volume may be possible through significant reductions in drag and structural weight and through improvements in propulsion system characteristics.

Equation (1), below, was obtained from reference 3. It provides a convenient form to relate the design factors of drag airspeed, power and propulsion system characteristics to the sizing factors of volume, displacement and payload.

$$\left. \begin{aligned} (1-W_1'-W_2'-W_3') D &= (w_p + w_f t_m) \frac{D^{2/3} \rho_{air} v^3}{99K} + W_5 \\ V &= \frac{D}{\rho_{air}} \end{aligned} \right\} \quad (1)$$

Exercising equation (1) about the characteristics of the basic design (figure 2) the sensitivity of diminishing drag on volume airspeed, payload and power was determined. Percentage changes in the drag coefficient C_D (relating to K) of -5, -10, -15 and -20 percent were conservatively chosen to represent drag reductions which might be readily achieved through body design changes (submersed protuberances and re-shaping to minimize base drag).

Figure 4 (a through d) presents the results of first reducing drag (figure 4 (a)), reducing W_2' , w_p and w_f (figure 4(b)), increasing power (figure (c)) and finally, in figure (d), effecting all improvements. A total mission duration of 60 hrs. was kept constant. Only modest gains in airspeed are seen to be realized. Even with a 20 percent reduction in drag only 5 kts additional speed is gained. Sacrificing payload 50 percent only yields a total gain in airspeed of 8.5 kts. Considering improvements in both structural weight and propulsion system a total

airspeed increase of over 11 kts or an improvement of 18 percent in airspeed can be realized. Doubling the power to overcome the drag, the best airspeed that can be achieved (under the present assumptions) for a 10,000,000 ft³ airship would be 87 kts (an improvement of almost 40 percent), but for this, 20,000 lbs of payload would have to be sacrificed.

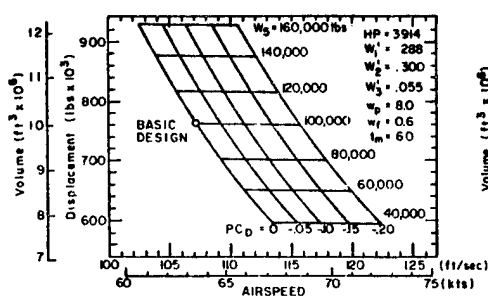

FIG. 4(a) REDUCING HULL DRAG ONLY

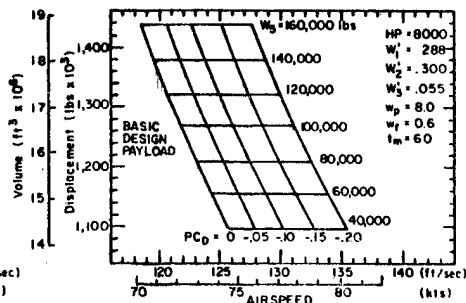

FIG. 4(b) REDUCING HULL DRAG, STRUCTURAL WEIGHT FRACTION, IMPROVING ENGINE CHARACTERISTICS

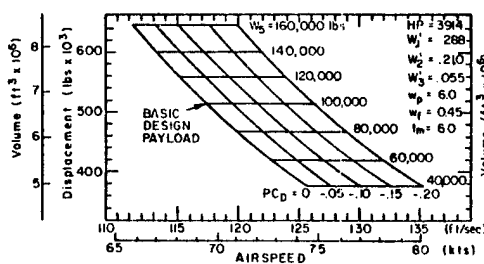

FIG. 4(c) REDUCING HULL DRAG, INCREASING POWER

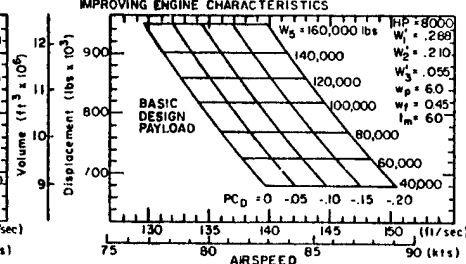

FIG. 4(d) ALL MAJOR TECHNOLOGY IMPROVEMENTS

Table I below presents a summary of the technology perturbations and the percentage improvements in airspeed.

TABLE I
SUMMARY OF AIRSPEED IMPROVEMENTS
(CONVENTIONAL AIRSHIP)

Figure	Drag	Structural Fraction (W_2')	Propulsion (w_p, w_f)	Power (HP)	Payload (W_5)	Airspeed (v)	$\frac{\Delta v}{v}$
4(a)	Basic					63.5 kts	-
4(a)	-20%	Basic				68.6 kts	8.0%
4(b)	-20%	-30%	-25%	Basic		75.3 kts	18.6%
4(d)	-20%	-30%	-25%	+100%	-20%	87.0 kts	37%

The most significant reductions in the drag of a conventional rigid airship can be achieved through boundary layer control. Experiments conducted on non-rigid (pressure) airships have indicated a reduction of approximately 15 percent in, primarily, base drag for small ($V < 1,000,000$ ft³) designs employing propulsion units within a circular shroud located at the approximate normal flow separation point on the aft section of the airship. The use of a large, active boundary layer control system on a non-rigid airship is limited to external design implementations. Such external systems can introduce significant drag components in themselves. It appears that if boundary layer control is to be accomplished effectively the system must be designed within the hull envelope. It is believed that such "submerged" systems for rigid airships could yield drag improvements approaching 25 to 30 percent if designed in

conjunction with aerodynamically cleaner hulls.

One such design is conceptually shown in figure 5.

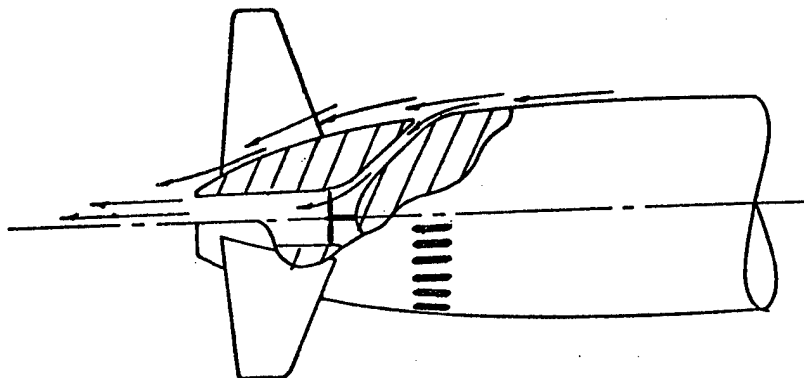

FIGURE 5. BOUNDARY LAYER DESIGN CONCEPT COMPRISING SUCTION AND STERN PROPULSION

Depicted is a boundary layer control system comprising suction in the region of normal flow separation and stern propulsion which, in-turn, aids in maintaining the momentum of the flow near the base of the airship. If feasible with regard to other considerations, i.e., weight distribution, structural design and duct losses this system affords considerable attraction in that it also improves the flow in the vicinity of the high aspect ratio tri-tailed empennage shown also in the illustration. Higher energy flow which is less disturbed in the region of the fins could yield higher control powers with reduced tail areas as well as improved static stability.

Maintaining the 10,000,000 ft³ "basic design" volume and payload it is projected that the speed of conventional airships utilizing the above new technology or its derivatives could well surpass 100 kts.

Trends in Aero-Lift-Augmented Airships

A new class of airships have been proposed in recent years which combine aerodynamic lifting with buoyant lifting in an attempt, primarily, to gain airspeed and improve payload capacity. Such aero-lift-augmented airships derive aerodynamic lift either integrally through high-lifting hull designs or externally through the addition of lifting surfaces on an otherwise classical appearing hull (fuselage). This class of airships may be generally represented by design concepts ranging from B to D previously shown in figure 1.

To examine the sensitivity of sizing and performance factors of aero-lift-augmented airships the parameter L_a/L_b (the ratio of aerodynamic to buoyant lift) was introduced into equation (1) along with other terms reflecting induced drag, increased structural weight fraction and hull/lifting-surface interference drag. Equating the total weight of the hybrid to the lift we obtain

$$W_1 + W_2 + W_3 + W_4 + W_5 = L_a + D \quad (2)$$

where $D = L_b$ is the displacement of the airship portion of the hybrid, exclusive of the displacement of lifting surfaces which are considered negligible. In expanding equation (2) a number of useful relationships emerge in addition to the final expression sought for $L_a/L_b = f$ (Sizing + Performance Factors). A short derivation is given below.

Expanding (2) and dividing by L_b :

$$W_1' + W_2' + W_3' + \frac{(w_p + w_{ftm})HP}{D} + W_5' = \frac{L_a}{L_b} + 1 \quad (3)$$

The power required is assumed equal to the basic airship drag plus the induced drag of the main lifting surfaces. In addition, a 20 percent increase in basic hull drag was assumed to account for the zero-lift drag of the lifting surfaces and the wing/hull interference drag. Induced drag was optimistically assumed equal to the theoretical minimum through the expression

$$\text{Induced drag} = \frac{L_a}{q\pi A} \frac{L_a}{S_w} \quad (4)$$

The horsepower can then be expressed as,

$$HP = \frac{v}{550} \frac{6.67 D^{2/3} \rho_{air} v^2}{k} + \frac{L_a \left(\frac{L_a}{S_w}\right)}{\pi \frac{1}{2} \rho_{air} v^2 A} \quad (5)$$

Substituting (5) into (3) and rearranging we obtain the final sizing equation,

$$W_1' + W_2' + W_3' + (w_p + w_{ftm}) \frac{v}{550} \left[\frac{6.67 \rho_{air} v^2}{\sqrt[3]{D} k} + \frac{\left(\frac{L_a}{L_b}\right) \left(\frac{L_a}{S_w}\right)}{\pi \frac{1}{2} \rho_{air} v^2 A} \right] + W_5' = \frac{L_a}{L_b} + 1 \quad (6)$$

The aero-lift augmented airships were examined over a range of augmentation ratios (L_a/L_b) of zero to 2.0. A wing loading (L_a/S_w) for the hybrids of 35 lbs/ft² and an aspect ratio (A) of 8.0 was assumed constant throughout the calculations. An overly optimistic specific fuel consumption of 0.45 was assumed to represent an average modern technology engine of unspecified type. However, the **powerplant** weight factor, w_p , was conservatively chosen at 6.0 lbs/HP and may offset the low specific fuel consumption. The structural weight fraction was varied linearly from 0.2 to 0.4 over an L_a/L_b range of zero to 3.0 i.e.,

$$W_2' = 0.2 + .065 \left(\frac{L_a}{L_b}\right) \quad (7)$$

to account for an increase in the structural weight of these airships with increasing **aero-lift** augmentation ratio. A nominal zero lift hull drag factor of $k = 70.6$ (corresponding to a $P_{CD} = -10\%$) was assumed.

In order to select a reasonable mission duration for the bulk of this brief analysis the payload and augmentation ratio was computed for $t_m = 10, 20$ and 30 hrs over a range of L_a/L_b of zero to 3.0. The airspeed and hull volume assumed were, respectively,

150 kts and 7,000,000 ft³. Figure 6 shows the resultant plot.

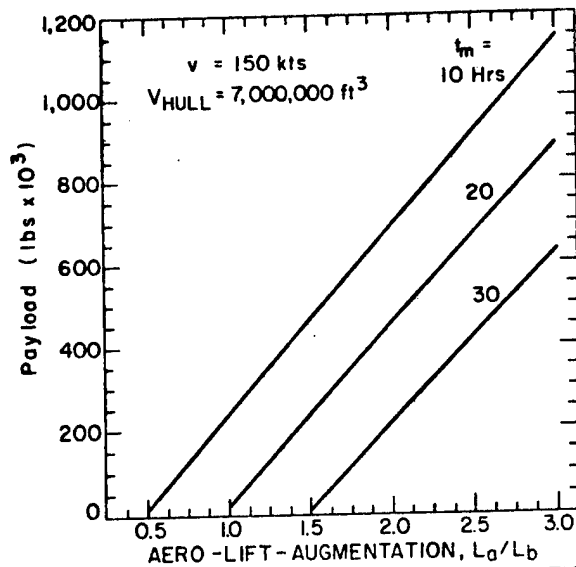

FIG. 6 VARIATION OF AERO-LIFT-AUGMENTATION RATIO AND MISSION TIME ON PAYLOAD CAPACITY FOR HYBRID AIRSHIPS

The payloads obtainable for the assumed conditions are seen to be sizeable and are sensitive to both L_a/L_b and mission time. It was decided to choose a $t_m = 20$ hrs despite proposed mission times approaching 50 hrs for the pure hybrids (the larger mission times being selected undoubtedly to gain economic cargo-carrying feasibility).

Figure 7 (a through c) presents the trends in payload, size and power for varying L_a/L_b and for each of three assumed airspeeds, i.e., 75, 100 and 150 kts. Referring once again to a "basic" hull volume of 10,000,000 ft³ at 75 kts (figure 7 (a)) and an $L_a/L_b = 1.0$ the payload capability is indicated to be 750,000 lbs; almost 10 times the payload capability of a conventional airship at 75 kts.

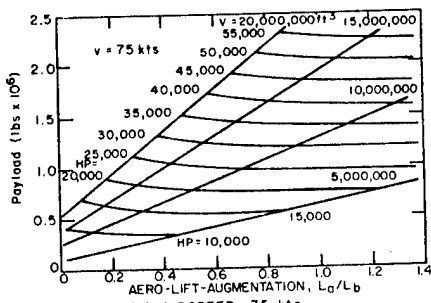

FIG. 7(a) AIRSPEED = 75 kts

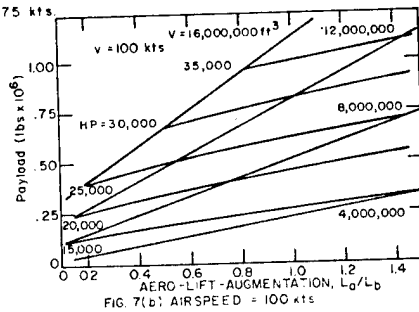

FIG. 7(b) AIRSPEED = 100 kts

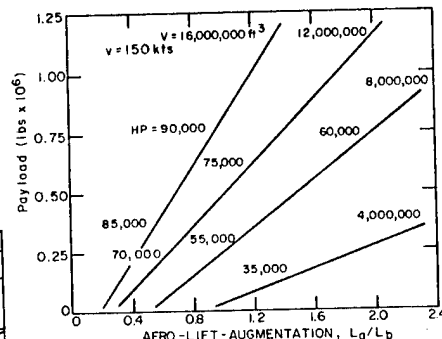

FIG. 7(c) AIRSPEED = 150 kts

However, as higher speeds are demanded of the hybrid greater hull volumes and/or larger augmentation ratios are required to maintain equally impressive payloads. The drag rise incurred at the greater airspeeds is reflected in the additional power (fuel and power plant weight rising) required and consequently higher hull volumes. The trends, it will be recalled are similar for conventional airships but are of an order of magnitude less. This analysis gives no accurate indication of an optimum augmentation ratio for hybrid airships however, for payloads neighboring a half-million pounds an L_a/L_b of 1.7 and a hull volume no greater than $10,000,000 \text{ ft}^3$ are indicated. Figure 8 clearly shows that to maintain payload capability at increased airspeeds the lift augmentation ratio must rise.

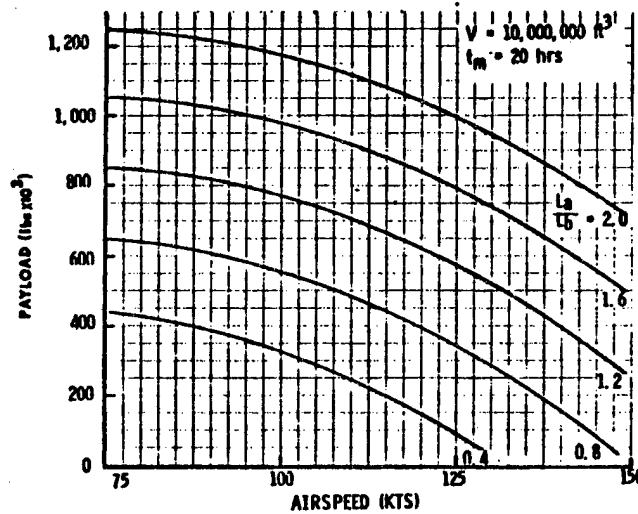

FIGURE 8 - VARIATION OF AUGMENTATION RATIO AND AIRSPEED ON PAYLOAD FOR A FIXED VOLUME HYBRID AIRSHIP

STABILITY, CONTROL AND HANDLING CHARACTERISTICS

A quotation from reference 4 by Max M. Munk addressing the topic of airship maneuvering reminds us clearly of the fundamental necessity for stability in airships.

"Bare airship hulls are immaneuverable, and bare spindle shaped arrows have been known since time immemorial to fly unsatisfactorily. The remedy has likewise been known since before the dawn of history - the spindle is provided with fins near its rear end, flexible feathers for arrows, and more substantial ones for airship hulls."

In this section various topics in stability, control and handling qualities will be considered with regard to the impact modern technology may have on them. No quantitative data has been provided with which to support the projections postulated. Considerable attention is yet to be directed toward the "maneuvering" of a modern Naval airship as this is a topic which bears heavily on the future operational success of all Lighter Than Air vehicles.

Basic Stability and Control

The airship, regardless of the actual shape or size to which it may someday evolve, will always be a slow-responding and fundamentally difficult vehicle to maneuver without stability augmentation/anticipatory devices. The bare hull characteristics of the classical (conventional) airship are unstable but easily "remedied" with suitably designed fins. Reference 4 and others relate the absence of good

theoretical techniques with which to design the fins for minimum drag and acceptable levels of static stability. We can assume that if little theory was available for designing the fins even less was available for designing optimum control power into the control surfaces. Nothing was known back in the 1920's and 30's concerning the design of dynamic systems using pilot/vehicle closed-loop systems analysis; giving rise to much empiricism in design (some of which continues today). The introduction of higher lifting bodies for the hulls of future airships will undoubtedly be accompanied by additional problems in static stability. The delta airship (concept c in figure 1) is usually severely unstable in pitch and requires careful mass distribution in order to achieve acceptable static margins. The hybrid airship should be more design manageable with regard to providing good static stability since there is some freedom in locating the center of pressure of the wing relative to the hull's center of buoyancy and the overall vehicle's center of gravity.

Direct Thrust Maneuvering

It appears almost certain that future airships will not employ ballasting as a means for providing attitude trim. It is desirable to eliminate the use of ballast entirely but this may not be possible due to its role, along with gas valving, in providing altitude trim as well. To insure more positive, faster responding control for both trimming and maneuvering direct, vectorable thrust control will undoubtedly emerge as a practicable control design. Direct, vectorable thrust control can provide active control throughout the entire flight envelope of the airship but will be especially useful in ground proximity operations such as takeoff, landing and off-loading/on-loading cargo. The most efficient manner by which to effect such control would be to incorporate it with the main propulsion system, vice an auxiliary system. Much has been learned throughout the past 20 years of VSTOL aircraft development which can be directly transferred to airship control technology. Deflected slipstream, tilt-propellor, vectored jet-thrust and many more concepts common to the great variety of VSTOL aircraft can be considered in searching for available airship control systems. The necessity and operational attractiveness of automatic flight control systems in airships will do much to force the use of vectorable controls because of their response compatibility (transferring ballast is a slow-to-respond process and not a reliably repeatable one).

Computer State Sensing and Automatic Management of Controls

Dr. H. Eckner, in his written piloting instructions for the flight personnel of the airship "Delag" (reference 5) often cites the awesome consequences of "inattentiveness" on the part of the airship captain and the flight crew. The successful operation of airships required the highly skillful sensing of crucial airship/environment states and management of controls. All records, it is certain, are not clear concerning the loss of airships due to pilot/crew error but it can be reasonably assumed that a large percentage of airship accidents were primarily due to such causes.

At the nucleus of an airship automatic flight control system will be a modest, real-time, airborne digital computer (within the current state of technology). The computer will serve to receive all data related to (1) trim state, (2) fuel and gas states, (3) translational and angular motion states, (4) environmental states, (5) structural load states, and (6) pilot control commands. All of these and more (such as navigational, meteorological, etc. data) will be sensed at frequencies up to and possibly greater than 20 times each second. The information will be processed and signals continuously outputted to drive (1) stability augmentation systems, (2) flight-director displays, (3) crew-station monitors, (4) altitude and attitude hold modes, (5) load alleviation systems, (6) gust alleviation systems and (7) specific flight path maneuvering (for approaches to landing, docking, etc.). All of the above automatic functions are available for use in the modern airship. Some,

and probably most, will become an absolute necessity. Figure 9 provides a functional diagram of a conceptual automatic flight control system for a modern airship.

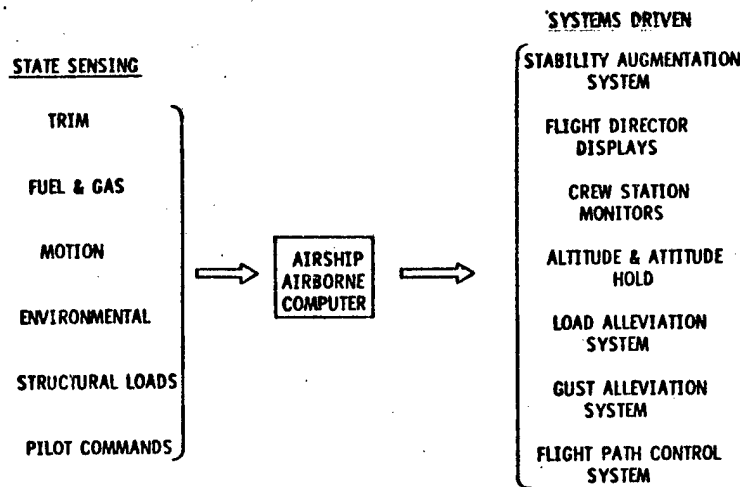

FIGURE 9. FUNCTIONAL DIAGRAM: AIRSHIP STATE SENSING AND CONTROLS MANAGEMENT SYSTEM

Simulation and Handling Qualities Requirements

Another beneficial advantage which the designers of modern airships will enjoy in comparison with their 1930 predecessors will be the use of piloted simulation. Flight simulation has advanced over the past decade to the point where its use has become an indispensable aid in the development of all of today's aircraft. The statics and dynamics of airships are no less complicated than is the static and dynamic behavior of a modern airplane. It is interesting to note that the flight simulation of airships will, in all probability, require far less sophistication with regard to visual outside-world displays and motion displacement. Modest display systems and motion bases of only limited angular and translational displacement and speed of response will be required.

It is expected that serious simulation efforts will soon get underway to begin providing designers with the guidance, now totally lacking, concerning stability, control and handling qualities requirements for a range of airship classes. The cost and time required for the successful development of an airship more than warrants serious attention to the systematic development of flight dynamics design requirements.

CONCLUSIONS

This paper clearly represents only the bare beginning of a vast amount of research and eventually development which must be undertaken by government and industry alike in order to build up an airship technology base which has been neglected now for over thirty-five years.

Airships representing a drastic departure from the classical form have been examined (albeit briefly) and found to promise attractive performance characteristics for equally non-classical missions. The effect of a radical change in shape (typified by the aerodynamic lift-augmented hybrids) has been found to add to the design problems normally associated with the conventional airships all of the problems (and

more) associated with the design of heavier than air aircraft as well. Aero-lift augmentation ratios in the vicinity of 1.7 for a ten million cubic foot hull volume were found to yield a hybrid airship capable of carrying half-million pound payloads at speeds of over 150 kts. Concepts such as these and many others which were not discussed in this paper offer potential advantages to both the military and commercial communities and as such should be regarded as serious candidates for future Lighter Than Air vehicles.

By far, the least risk, shortest development time and highest payoff airship for Naval applications appears to be a highly modified form of the classical design. This position, though admittedly premature, is founded principally on the basis of the necessity for very lengthy mission durations, an acceptance of modest improvements in speed ($v \leq 120$ kts), respectable improvements in payload ($\geq 100,000$ lbs) and reliance on an established operational experience base with this class of airships. It has been shown that modern technological improvements can readily yield such airships without the necessity of assaulting entirely new technological problems.

REFERENCES:

1. Anon., Parametric Study of Dynamic Life Aerostats for Future Naval Missions, Goodyear Aerospace Corp., Akron, Ohio, 1968.
2. Fink, D. E., Hybrid Heavy-Lift Vehicle Under Study, Aviation Week and Space Technology, pages 49 to 51, 29 July 1974.
3. Burgess, C. P., Airship Design, The Ronald Press Company, New York, 1927.
4. Durand, W. F., et al, Aerodynamic Theory, Vol. VI, Division Q and R, Aerodynamics and Performance of Airships, Durand Reprinting Committee, 1943.
5. Eckner, H., Dr., Brief Instructions and Practical Hints For Piloting Zeppelin Airships For the Flight Personnel Of The "Delag", a revised extract appearing in D. H. Robinson's LZ. 129 Hindenburg, Arco, Publishing Co., Inc., New York, 1964.

BOUNDARY LAYER CONTROL
FOR AIRSHIPS

N76-15028

F. A. Pake*
S. J. Pipitone**

ABSTRACT: This paper summarizes an investigation of the aerodynamic principle of boundary layer control for non-rigid LTA craft initiated under the Office of Naval Research, Contract NONr1412(00)LI. The project included a wind tunnel test on a BLC body of revolution at zero angle of attack. Theoretical analysis is shown to be in excellent agreement with the test data. Methods are evolved for predicting the boundary layer development on a body of revolution and the suction pumping and propulsive power requirements. These methods are used to predict the performance characteristics of a full-scale airship. The analysis indicates that propulsive power reductions of 15 to 25 percent and endurance improvements of 20 to 40 percent may be realized in employing boundary-layer control to non-rigid airships.

INTRODUCTION

The investigation of the application of boundary-layer control to non-rigid LTA craft was initiated by Goodyear Aerospace Corporation in March, 1954 under Office of Naval Research Contract NONr1412(00)LI. The project stretched over a 3 1/2 year period primarily because of a 20-month delay during which all effort was suspended while awaiting the availability of the 7' x 10' transonic wind tunnel at NSRDC (then called the David Taylor Model Basin). The scope of the study included the evaluation of the drag characteristics of an airship hull which employed either suction slots or an auxiliary air foil as a means of preventing turbulent boundary layer separation. The drag results were predicted by theoretical methods presented in References 1 and 3. Comparative drag values were obtained for one body configuration in the wind tunnel tests reported in Ref. 2.

*Flight Dynamics Section, Goodyear Aerospace, Akron, Ohio 44315

**Technical Staff Goodyear Aerospace, Akron, Ohio 44315 U.S.A.

BOUNDARY LAYER CONTROL

This discussion of boundary layer control will be limited to bodies of revolution with flow at high Reynolds numbers. Therefore, turbulent flows are assumed. With fluid flow about a body the friction occurring on the forward portion consumes much of the initial energy of the fluid adjacent to the body. The fluid so affected is termed the boundary layer. When this relatively low energy fluid reaches the stern, the fluid is confronted with an unavoidable region of increasing surface pressures due to the increasing static pressure of the fluid external to the boundary layer being impressed upon it. If the rate of pressure increase is relatively large, the boundary layer fluid will not contain sufficient energy to flow against such a high "back pressure," so to speak. This then results in considerable thickening of the boundary layer with possible flow separation.

Although it is possible to design a body of revolution having a favorable pressure gradient over essentially the entire length of the body, generally such a body must have a relatively blunt after end. This design produces a correspondingly adverse pressure gradient that tends to cause boundary-layer separation and consequent drag losses.

This problem can be approached passively by lengthening the body (increasing the fineness ratio) thereby reducing the adverse pressure gradient and delaying boundary layer thickening so that the area affected by the reduced pressure is small and hence tend to reduce the pressure drag. For bodies of constant volume, however, an increase in fineness ratio is accompanied by an increase in friction drag due to the consequent increase in surface area. Altering the pressure drag by varying the fineness ratio gives rise to a change in friction drag of opposite and approximately equal magnitude for the common airship fineness ratios. When the pressure drag is efficiently reduced, accompanied by a lower fineness ratio, the total drag can be significantly reduced as illustrated in Figure 1.

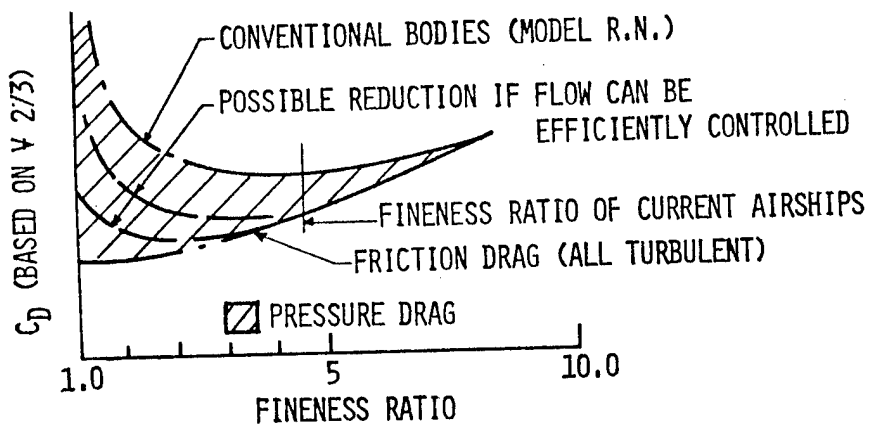

Figure 1
Pressure Drag Versus Fineness Ratio

However, through proper body-contour design, the adverse gradient can be located at one longitudinal body station or for a short longitudinal body station or for a short longitudinal distance to produce a favorable pressure gradient extending to the 100-percent body station. By applying the air-flow suction at this longitudinal body station (or area of velocity and pressure discontinuity), energy will be supplied to stabilize the boundary layer and prevent air-flow separation. A drag economy can be realized if the reduction in the external drag of the body is greater than the equivalent suction drag.

Configuration Selection:

The first decision to be made in the selection of a boundary-layer control airship configuration was the suction system. The distributed type suction systems made up of many perforations or slots were discarded as not feasible for the non-rigid airship application. Thus the single slot system was chosen and it remained to choose an airfoil shape. The available selection could be categorized in two groups - the conventional airfoil and the Griffith type airfoil. The Griffith shape has several advantages for BLC applications. Although designed for laminar flow, it possesses the favorable pressure gradients necessary to any type of boundary layer control. The localized adverse pressure gradient is compatible with the single slot control system. Also, the slot location is well aft for the lower fineness ratios. The Griffith type airfoil was therefore chosen. The specific contour used in the study was a 34 percent thick Lighthill shape. This was selected on the basis of the potential flow characteristics as determined by a series of electrostatic tank tests. The selected airfoil shape and velocity distribution are shown in Figure 2. As can be seen the adverse flow region is quite local between $X/l = 1.6$ and 1.7 . This shape was used in the theoretical drag estimates, the wind tunnel test and the full-scale performance studies.

Drag Estimates and Wind-Tunnel Tests:

A method of calculation was evolved to predict skin friction, equivalent suction drag, and propulsive efficiency of this type of airship hull. Local skin-friction coefficient values were determined for the forward stagnation region, the laminar boundary-layer region under a favorable pressure gradient before the suction slot, and the turbulent boundary-layer region under a favorable pressure gradient behind the suction slot.

Equivalent suction drag was based on the mean total-head loss in the boundary-layer suction flow at the slot entry. This did not include duct losses since such losses can be evaluated only after the preliminary design of a specific ducting system. Hence, the suction drag was evaluated for an idealized system where duct losses were small compared with boundary-layer losses.

The wind-tunnel tests were carried out in the 7' x 10' transonic tunnel. The Reynolds number was varied from 4.4×10^6 to 10^7 . Due to the model size restriction and the relatively high test Reynolds numbers, a powered model with force measurements was not possible and therefore drag quantities were determined from the momentum deficit in the wake. Artificial stimulation at 10 percent of the model length

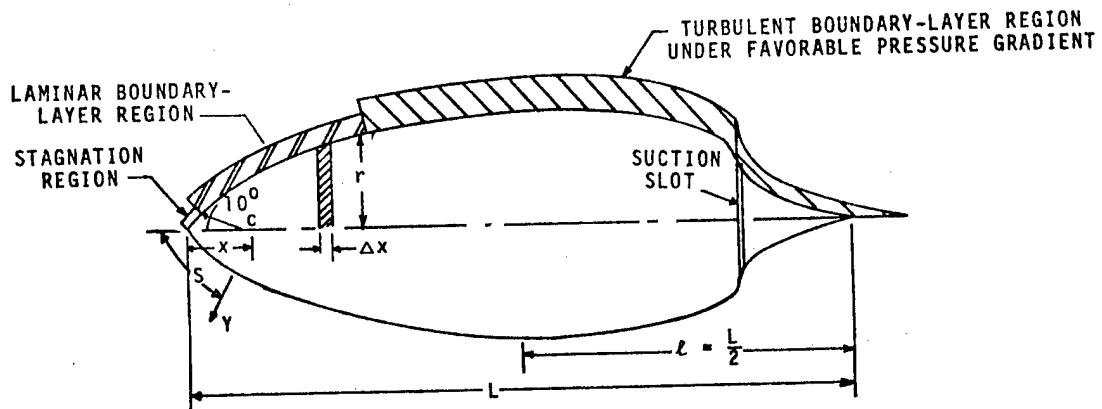
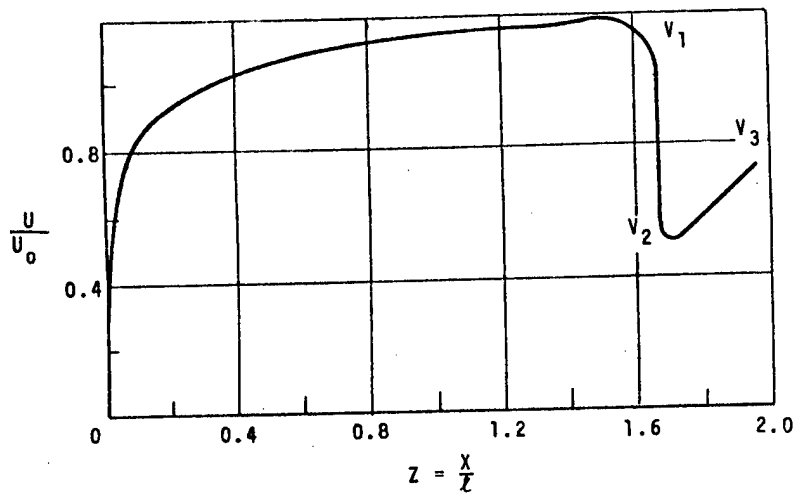

Figure 2
Favorable Velocity Distribution and Corresponding
Regions over a Boundary-Layer-Controlled Airship

was utilized to obtain turbulent flow. The final test consisted of one BLC configuration at zero angle of attack with the sole objective being whether or not the theory predicted the reduction in drag realistically. A model of ZP2G-1 airship hull was also tested under the same environment to ensure a true comparison of drag change between the conventional and BLC airships. The actual comparison of the experimental and test data is shown in Figure 3. The drag coefficients of the body are plotted versus the suction quantity coefficient. The plots shown are for a Reynolds number of 4.2×10^6 . The wake drag and suction drag are plotted separately. They are then added together and plotted as total drag. The experimental data is presented in the same manner. It can be seen that good agreement exists between the theoretical and experimental work. This agreement is further borne out by the pressure distribution. The measured pressure coefficients are plotted with the theoretical values in Figure 4 for a Reynolds number of 10×10^6 .

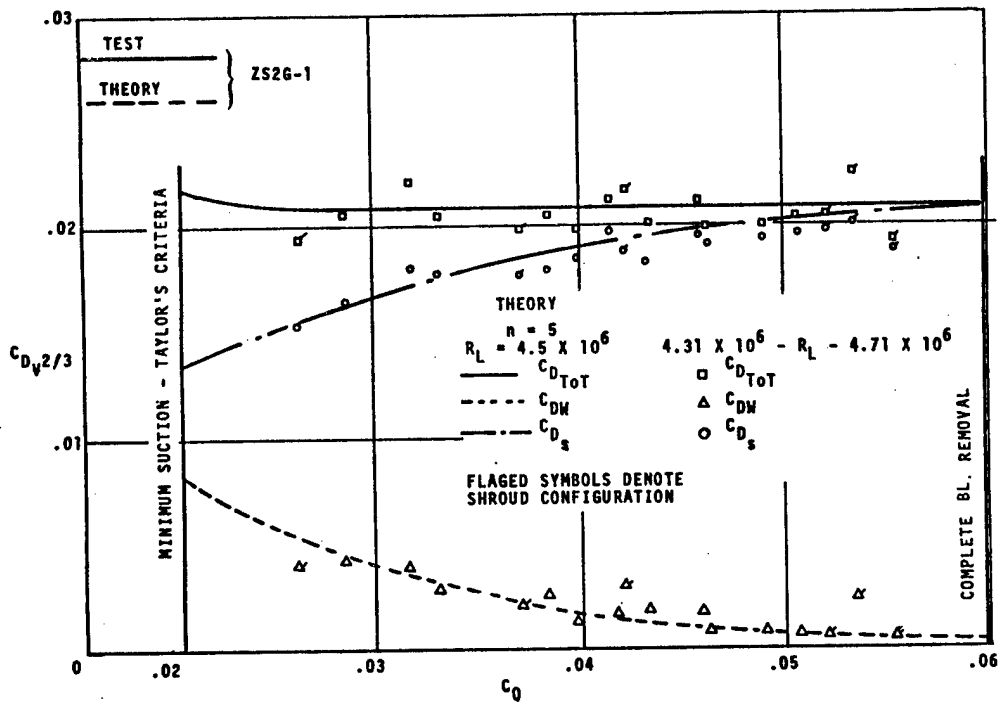

Figure 3
 Test & Theoretical Drag Comparison
 BLC Model - $R_L = 4.5 \times 10^6$

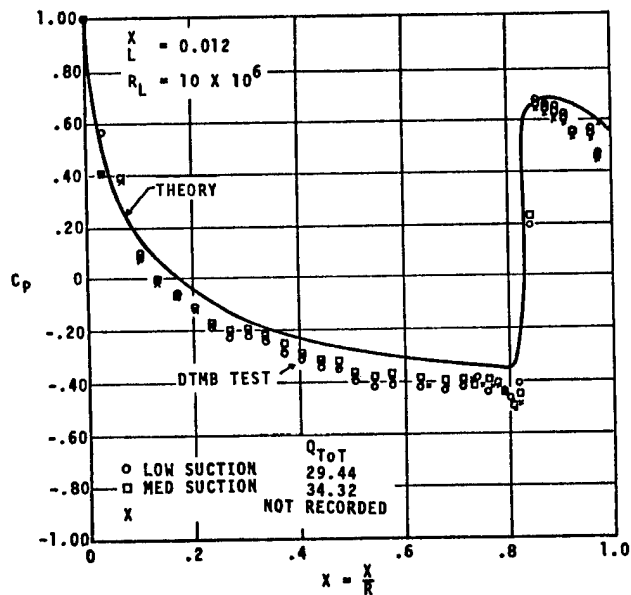

Figure 4
 Pressure Distribution Comparison Test
 and Theoretical BLC Body

The drag of the BLC airship at all Reynolds Numbers and slot widths, as determined from the rake, were in excellent agreement with the theoretically predicted values. The ideal suction drag also indicated close agreement although theory appears to be somewhat greater than the measured values. Other comparisons of BLC test parameters with theory also showed excellent agreement. These preliminary tests validated the drag reduction predicted by theory. The tests not only showed this excellent agreement with theory, but also demonstrated this agreement over a sufficient range of Reynolds Numbers to give credence to full-scale theoretical estimates.

Comparison of Full Scale Performance

In order to compare the performance of a BLC airship with that of a conventional (ZP2N) airship, a preliminary design was required in order to consider the impact of all the features associated with each type that had a bearing on drag besides the hull drag alone. The scope of this program does not permit comparing airship sizes and the associated power requirements based on missions but does compare mission capability based on an airship size of one million (10^6) cubic feet. Figure 5 compares the total power requirements for the two configurations. A 10 percent reduction in component drag for the BLC configuration can be attributed primarily to the fact that outriggers, nacelles and empennage cables (fins are cantilevered) are not required.

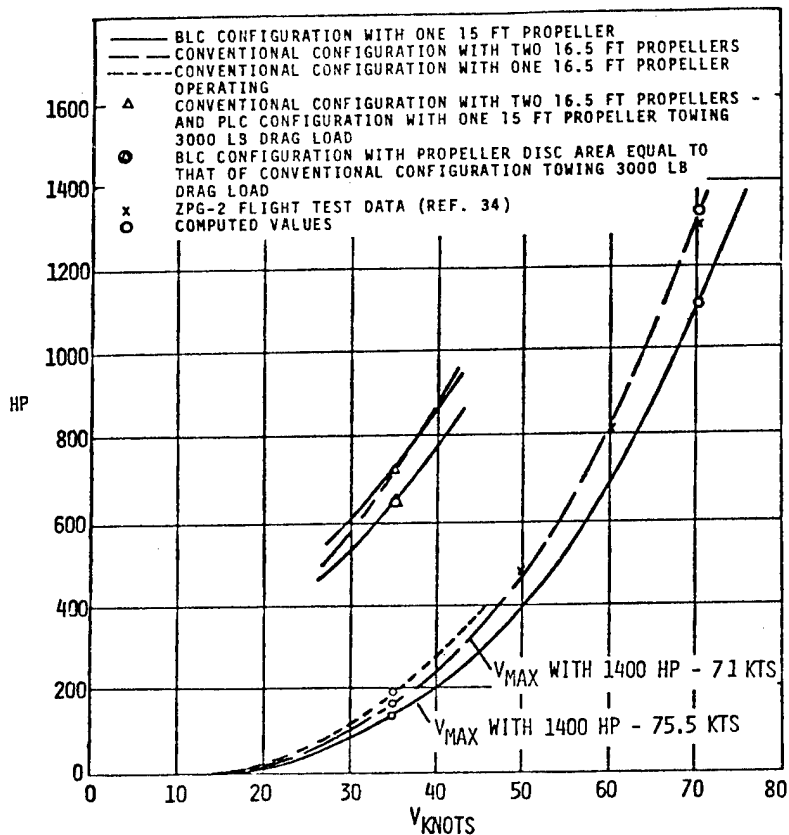

Figure 5
Horsepower Requirements vs Flight Velocity
For BLC & Conventional Airships $\Psi = 10^6$

When considering various operational conditions such as single engine cruise (normal conventional airship operation) with the corresponding differences in SFC and propeller efficiencies, the BLC airship would offer an endurance improvement of between 20 and 40 percent at most operating velocities. With a propeller comparable in size to those used on conventional airships, the improvement in endurance for ASW towing would be 10 percent when the tow drag is 3000 pounds or 25 percent if the tow load was 100 pounds.

A complete evaluation of the advantages of a BLC airship must encompass many factors including a comparison of the general operational characteristics of each configuration and the weight allowable for fuel. Although such an evaluation was beyond the scope of this study, it is of interest to briefly discuss some of the major BLC operational characteristics as they differ from the conventional airship's characteristics.

(1) Static instability of an airship is due almost entirely to the hull and is a function of fineness ratio; $C_{M\alpha}$ decreases with decreasing fineness ratio and consequently will require less in the way of a stabilizing system. As shown in Figure 6 the tail length is substantially the same and due to structural considerations the aspect ratio can be considerably greater.

(2) Low speed control is a prime consideration for airships and with the BLC airship it can, to a considerable degree, be obtained by vectoring the outlet air from the duct. This would have its greatest effect during a towing operation such as sonar array towing.

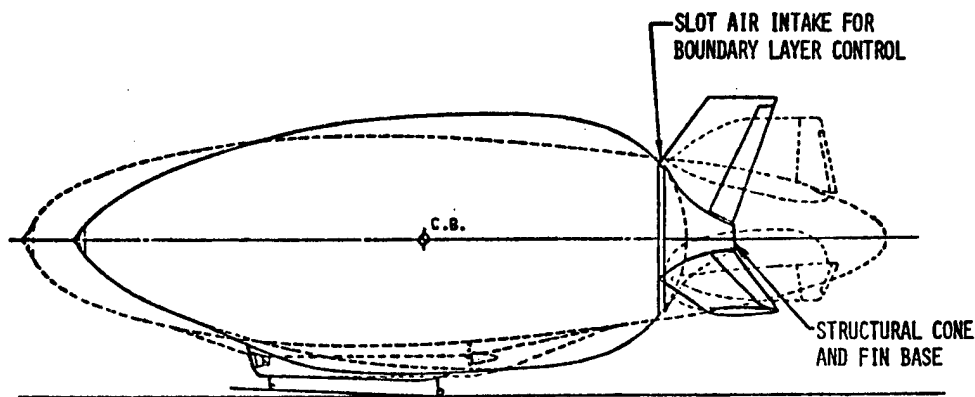

Figure 6
Comparison of BLC Airship with Conventional
For Equal Volume

(3) Propeller and engine noise interferes not only with crew comfort but also with the effectiveness of the mission equipment; sonar operations as an example. The BLC configuration is inherently conducive to quiet operation; the propeller is shrouded and the distance between the propulsion unit and the crew is considerably greater than is the case with the conventional design. The aft location of the BLC power plant also represents a noise reduction to the crew.

(4) Other advantages of the BLC configuration are in the areas of elimination of variable pitch protection from physical damage.

CONCLUSIONS

The findings of this limited investigation into the boundary-layer-control airship show sufficient increase in the airship performance to warrant further study. The following conclusions are offered:

(1) The NSRDC wind tunnel tests confirm the ability of the theoretical methods described in this report to predict the boundary layer control of a body of revolution at zero angle of attack.

(2) The theory confirmed by the NSRDC wind tunnel tests together with allowance for inlet and duct losses predicts that the bare hull power requirements for a full scale BLC airship hull of fineness ratio 3.0 at zero angle of attack can be expected to be 10 to 20 percent less than the power requirements of a conventional airship hull of equal volume.

(3) The differences in the components other than the hull associated with the two configurations, offers an additional 5 to 10 percent reduction in power requirements for the BLC non-rigid airship configuration.

(4) A BLC configuration of fineness ratio 3.0 can be expected to reduce the total propulsive power requirements of a conventional non-rigid airship of equal volume 15 to 25 percent.

(5) If both configurations have equal fuel quantities available, BLC can be expected to increase the endurance 20 to 40 percent.

(6) Indications exist that the fineness ratio of 3.0 selected for this investigation may not be optimum for a BLC airship.

The predicted theoretical increase in performance, together with the operational advantages, indicated a significant advance in airship design and led to the initiation of the BLC program. This program, although limited in scope, has confirmed the validity of the predicted performance improvement. To take full advantage of the results thus far and fully exploit the potential of the BLC configuration, this contractor recommends the following program to continued effort be initiated:

(1) To refine the merits and limitations of applying boundary-layer control to airships, the following investigations should be initiated:

a) Theoretical power requirement studies for bodies with fineness ratios less than 3.0 which necessitate further electrostatic tank testing.

b) Wind tunnel testing to determine the effect of angles of attack.

c) Preliminary design studies to define an operational configuration would, in conjunction with items (a) and (b) above, permit the selection of an optimum and practicable configuration.

(2) To obtain data for the design and fabrication of a BLC airship, a wind tunnel test of a self-powered model at reasonable, large Reynolds numbers should be conducted upon completion of Item 1 above.

REFERENCES:

1. Goodyear Aerospace Corporation, A Theoretical Aerodynamic Analysis of a Boundary-Layer Controlled Airship Hull, GER-6251, Akron, Ohio (14 September, 1954).
2. Cerreta, P. A., Wind Tunnel Investigation of the Drag of a Proposed Boundary Layer Controlled Airship, Navy Dept., David Taylor Model Basin Aerodynamics Laboratory, Aero Report 914 (March, 1957).
3. Horshe, M. L., Pake, F. A., and Wasson H. R., Air Investigation of a Boundary Layer Controlled Airship, GER 8399, Goodyear Aerospace Corporation, Akron, Ohio (15 October, 1957).

AIRSHIP STRESSES DUE TO
VERTICAL VELOCITY GRADIENTS
AND ATMOSPHERIC TURBULENCE

Duncan Sheldon*

ABSTRACT: Munk's potential flow method is used to calculate the resultant moment experienced by an ellipsoidal airship. This method is first used to calculate the moment arising from basic maneuvers considered by early designers, and then expended to calculate the moment arising from vertical velocity gradients and atmospheric turbulence. This resultant moment must be neutralized by the transverse force of the fins. The results show that vertical velocity gradients at a height of 6000 feet in thunderstorms produce a resultant moment approximately three to four times greater than the moment produced in still air by realistic values of pitch angle or steady turning. Realistic values of atmospheric turbulence produce a moment which is significantly less than the moment produced by maneuvers in still air.

INTRODUCTION

At one time airship design was a highly organized and systematic activity, and hundreds of papers have been written on the subject. The period of greatest activity was from 1910 to 1938. However, in spite of careful efforts several notable disasters occurred. Some were at least partly the result of political considerations; examples are the American ship Shenandoah and the British ship R-101. The most spectacular of all, the Hindenburg disaster, was of course due to the use of hydrogen as lifting gas. With the exception of the inadvisable use of hydrogen and the deterioration of the hull of the R-101, most well-known dirigible disasters were connected either with atmospheric turbulence or vertical wind currents in storms or above mountains¹.

* President, Transportation Technology Inc. Marblehead, Massachusetts

The British ship R-38 buckled in the middle and broke in two because of a strong wind gust (1922). At the time the airship was already experiencing significant stresses arising from a sharp turning maneuver. The Shenandoah perished in a 70 mph squall (1924). As the result of a navigational error the Akron was drawn into the center of a storm. While maneuvering upward to offset a downdraft, its lower rudder hit the ocean and the airship fell into the sea (1933). The Macon lost its top rudder during a squall and was also lost at sea (1935).

As a result of the R-38 crash the Royal Aeronautical Society established the R-38 Memorial Prize. In response to this competition three exceptionally detailed airship design papers were published²⁻⁴. This was in 1923, and taken together they constitute probably the most detailed airship design analyses available in English. Most later work was a refinement of methods discussed in these articles. One can even view the design of the Graf Zeppelin and her sister ships (1928-1938) within the context of the methods presented by these British and American authors. Of course the principal ingredient missing from these relatively early papers is the practical experience and full-scale data obtained by the German designers. However, there were no basic changes in the relevant technology in the years from 1923 to 1938.

An important part of the early design work was the highly ingenious description of the aerodynamic forces on airship hulls devised by Munk⁵⁻⁶. His theory is based on an ideal (non-viscous) fluid and Kelvin impulses. Under most conditions Munk's theory is in surprisingly close agreement with full-scale experiments².

As pointed out in several recent articles⁷⁻⁹, the technology relevant to airship design has undergone an extraordinary expansion along with all other aerospace activity. Modern computers and modern knowledge of structural dynamics permit analyzing the airship's structure as a whole. It is essential to apply our current knowledge of atmospheric turbulence and vertical wind currents to these structural calculations. Safety is the overwhelming design consideration applicable to future airships, and relating atmospheric hazards to structural integrity holds the greatest promise of assuring safe operation. It might be argued that damaging atmospheric effects can usually be avoided, particularly during non-scheduled flights. The record of the German pilots serves to establish this to some degree. But the importance of scheduled operations also requires that atmospheric hazards be given careful consideration.

The purpose of this paper is to show how our present knowledge of the atmosphere can be combined with Munk's equations to calculate the resultant moment on an airship arising from vertical currents and atmospheric turbulence. Approximate results are given for the resultant moment experienced by a 1,000 foot long ellipsoidal airship with a fineness (length-to-diameter) ratio of 5. This is the shape suggested for a "basic" airship considered in a recent design study by Mowforth¹⁰. These results are compared with the moments arising from pitch angles and steady turning rates in still air which were taken into consideration by the early designers.

AERODYNAMIC CONSIDERATIONS

Munk's Equations

The motion of airship hulls gives rise to an air flow that is well approximated by potential flow. There may be a large resultant moment of the aerodynamic forces, but only a comparatively small lift and drag. With wings the conditions are different as there is considerable lift. Since the momentum of the flow is not necessarily in the direction of motion of the hull, a principal axis problem presents itself. Strictly speaking, we should distinguish between the momentum of the flow and the Kelvin impulse of the flow, but Munk himself disregarded this difference and we have no need to make the distinction here. The net resultant moment is expressed in terms of the volumes of the apparent additional masses of the hull. The apparent additional mass of a solid moving through a fluid along one of its principal axes is simply a proportionality constant expressing the resistance to accelerations along the axis offered by the fluid itself. Note that it is not a measure of the inertia of the solid, because the solid need not have any mass at all. In this case all of the energy is stored in the flow, and the apparent additional masses along each principal axis are equal to the apparent masses. The effect of the fluid surrounding the solid is, however, fully described by assigning to the solid an apparent additional mass in addition to its original or actual mass. The apparent mass of a circular cylinder in a uniform two-dimensional stream is $\rho\pi r^2$; and for a sphere in a three-dimensional uniform stream its value is $\frac{1}{2}(4\pi r^3)\rho$. Here r and ρ are radius and density. Apparent volume is obtained from apparent additional mass by dividing by the density.

Munk shows that an airship hull, flying steadily under an angle of attack α and with the velocity of flight V experiences a resultant couple of the magnitude

$$M = \frac{\rho}{2} V^2 (K_2 - K_1) \sin 2\alpha \quad (1)$$

where K_1 and K_2 denote the apparent volumes with respect to the longitudinal and transverse principal axes of the hull. This moment is unstable, consequently fins are required for stabilization. Munk also calculates the transverse force on an airship (with circular cross section) turning under an angle of yaw:

$$\begin{aligned} dF = dx \left[(k_2 - k_1) \frac{dS}{dx} v^2 \frac{\rho}{2} \sin^2 \phi \right. \\ \left. + k_1' v^2 \frac{\rho}{R} \cos^2 \phi + k_2' v^2 \frac{\rho}{R} x \frac{dS}{dx} \cos^2 \phi \right] \quad (2) \end{aligned}$$

where

- dF = Transverse force acting over a differential length along the longitudinal axis
- dx = Differential length along the longitudinal axis
- k_1 = (Hull volume)/ K_1

$$k_2 = (\text{Hull volume})/K_2$$

k' = Ratio of the apparent hull moment of inertia about the aerodynamic center to the moment of inertia of the displaced air

x = Position on the longitudinal axis relative to aerodynamic center

S = Area of circular cross section at x

ϕ = Yaw angle

R = Turning radius

v = Airship velocity

ρ = Density of air

This expression of course does not contain the air forces on the fins. Munk's theory also yields a closed form expression for the pressure distribution over any ellipsoid inclined at an arbitrary angle to the flow. The first term on the right-hand side of Equation 2 can be used to calculate the longitudinal distribution of forces resulting from a vertical gust. In this case the yaw angle in Equation 2 is identified with the angle of attack

$$\phi = \tan^{-1} \frac{u}{V} \quad (3)$$

where u is the transverse velocity and V is the forward velocity. Munk assumes the airship has a variable effective angle of attack along its axis. The magnitude of the superposed angle is $\tan^{-1}(u/V)$, where u generally is variable. The momentum produced at each portion of the airship is the same as the air force at that portion if the entire airship had that particular angle of attack. Consequently, Equation 2 can be used to determine the moment experienced by an airship as it moves through a vertical velocity gradient. In this case we assume the pilot is able to hold the airship on a straight course in inertial space without yaw or pitch. Equation 2 will also be used to calculate the moment resulting from a turning maneuver. Equation 1 provides a direct method of calculating the bending moment when the only disturbing force is due to pitch.

Moment Response Function

Munk's theory can be extended to calculate the transverse forces caused by atmospheric turbulence. It is assumed the pilot is able to hold the airship on a straight course in inertial space without yaw or pitch. We begin by attributing to a circular cross-section of area S the virtual mass ρdx just as if the cross-section were part of a circular cylinder immersed in two-dimensional flow. The transverse force acting on this cross section as a result of the velocity perturbation $u = u_0 e^{i\omega t}$ is

$$f = \rho S dx (i\omega) u_0 e^{i\omega t} \quad (4)$$

Now

$$\omega = 2\pi f = 2\pi \frac{V}{\lambda} = k_p V \quad (5)$$

where ω is the angular frequency of the perturbation, f is the cyclical frequency, V is the forward velocity of the airship, λ is the wavelength in the forward direction, and k_p is the propagation constant for a particular wavelength. It is convenient to take the geometric center of the ellipsoid as the origin of our coordinate system. Then the moment experienced by the airship, per unit velocity perturbation, is given approximately by

$$\frac{M}{u_0} = v \rho k_p \int_{-L/2}^{+L/2} S(x) e^{i(\omega t + kx)} x dx \quad (6)$$

where L is the length of the airship.

Uniform S is not a candidate hull shape, but this case leads to the simplest form of the moment response function. If S is uniform, the result is

$$\left| \frac{M}{u_0} \right| = v \rho S L \left(\frac{\sin(\pi \zeta)}{\pi \zeta} - \cos(\pi \zeta) \right) \quad (7)$$

where $\zeta = L/\lambda$. This is the long wavelength approximation, and approaches zero as ζ approaches zero. For short wavelengths, $\zeta \gg 1$, the bending moment at the longitudinal positions of maximum transverse velocity is the important consideration. In this case

$$\left| \frac{M}{u_0} \right| = \frac{SPV}{k_p} \left(\frac{\pi}{2} - 1 \right) \quad (8)$$

For an ellipsoidal airship with a fineness ratio of 5 we set

$$S(x) = \frac{\pi}{25} \left\{ (L/2)^2 - x^2 \right\} \quad (9)$$

and use Equation 6 to obtain

$$\left| \frac{M}{u_0} \right| = \frac{\pi}{50} L^3 \rho v \left\{ \frac{\sin \hat{k}}{\hat{k}} + \frac{3 \cos \hat{k}}{\hat{k}^2} - \frac{3 \sin \hat{k}}{\hat{k}^3} \right\} \quad (10)$$

where $\hat{k} = Lk_p/2$, again this is the long wavelength approximation, and the right-hand side of Equation 10 tends to zero as \hat{k} tends to zero. The short wavelength approximation, Equation 8, still applies provided

$$\frac{dS}{dx} \frac{\lambda}{S} \ll 1 \quad (11)$$

METEOROLOGICAL CONSIDERATIONS

Vertical Wind Gradients in Thunderstorms

Using Munk's equations we can calculate the force at each section of the hull of a representative airship for vertical wind currents known to exist in the atmosphere. Typical values for a thunderstorm are considered. Taken together Figures 1-3 enable us to obtain a good approximation of the vertical currents and horizontal scale of thunderstorms. Figure 1 shows information which was obtained to describe the atmospheric effects an airplane experiences as it flies through a thunderstorm. Figure 2 suggests that the vertical velocity profile given in Figure 1 is applicable above about twenty thousand feet. With the help of Figure 3, we can construct a similar thunderstorm profile for an altitude of approximately 6,000 feet, which is a typical operational altitude. These diagrams give no information about the severity of the turbulence; they can only be used to study the airship stresses arising from vertical currents. However, we can observe that the region of "violent turbulence" extends much further than the region of severe vertical currents. Figure 1 represents the vertical velocity profile in the plane of travel of the thunderstorm; the updraft usually has a fairly uniform cross section of about 10 miles transverse to its line of travel. Figure 3 shows that below about ten thousand feet the vertical flow is not quite as constricted as at higher altitudes. Let us therefore make the approximation that at 6,000 feet the horizontal scale of the currents is twice as large as shown in Figure 1. Accordingly, the magnitude of the vertical current distribution is cut in half (due to the transverse extent of the storm the flow is treated as two-dimensional). This means that the more severe vertical velocity gradients in the horizontal direction are of the order of 0.2 ft./sec./ft.

Atmospheric Turbulence

It is possible to describe the energy distribution of atmospheric turbulence as a function of wavelength by the same relatively simple formula for the following three forms of turbulence¹¹:

- (i) clear air turbulence near the ground,
- (ii) turbulence near and in cumulus clouds,
- (iii) thunderstorms.

The distribution of energy density $S_w(k)$ at different wavelengths $(1/k)$ of the vertical component of the turbulence may be given by

$$S_w(k) = 2L_s \sigma_w^2 \frac{1 + (8/3) (L_1 k)^2}{[1 + (L_1 k)^2]^{1/2}} \quad (12)$$

where

σ_w = Root mean square vertical velocity

L_s = Scale of turbulence

$L_1 = 1.339 (2\pi L_s)$

for each patch of turbulence. Twice the total energy per unit mass of air equals the mean square of the turbulence velocity so that

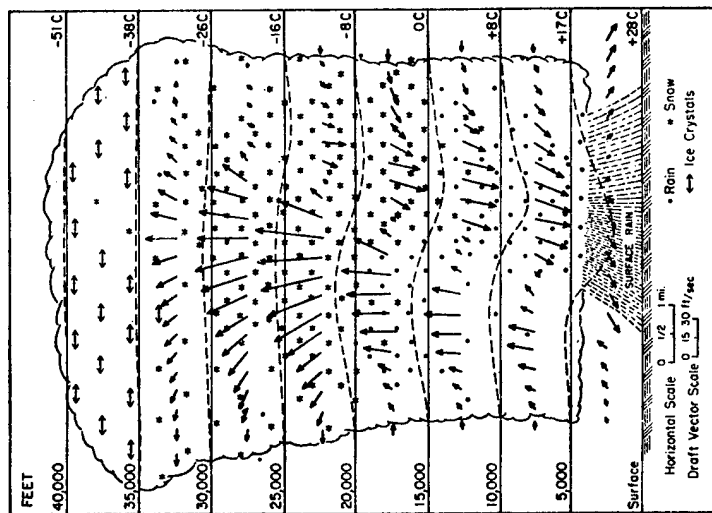

Figure 2. Mature Thunderstorm (Ref. 12)

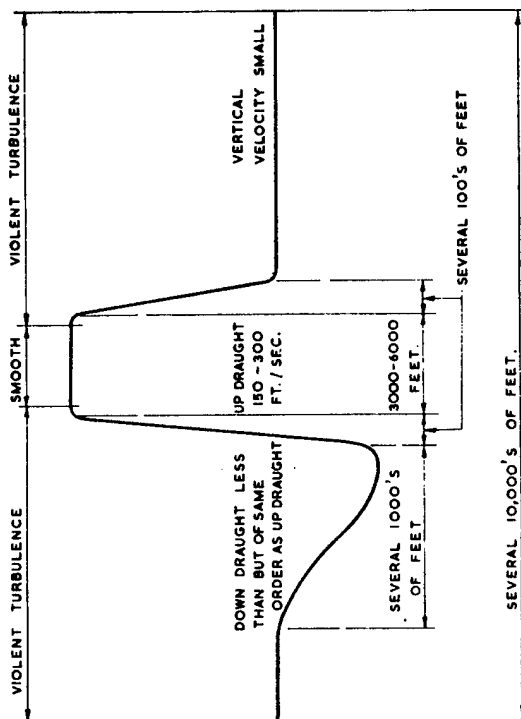

Figure 1. Variation of mean vertical velocity in line of travel of a thunderstorm a few thousand feet below tops of clouds (Not to scale, Ref. 11)

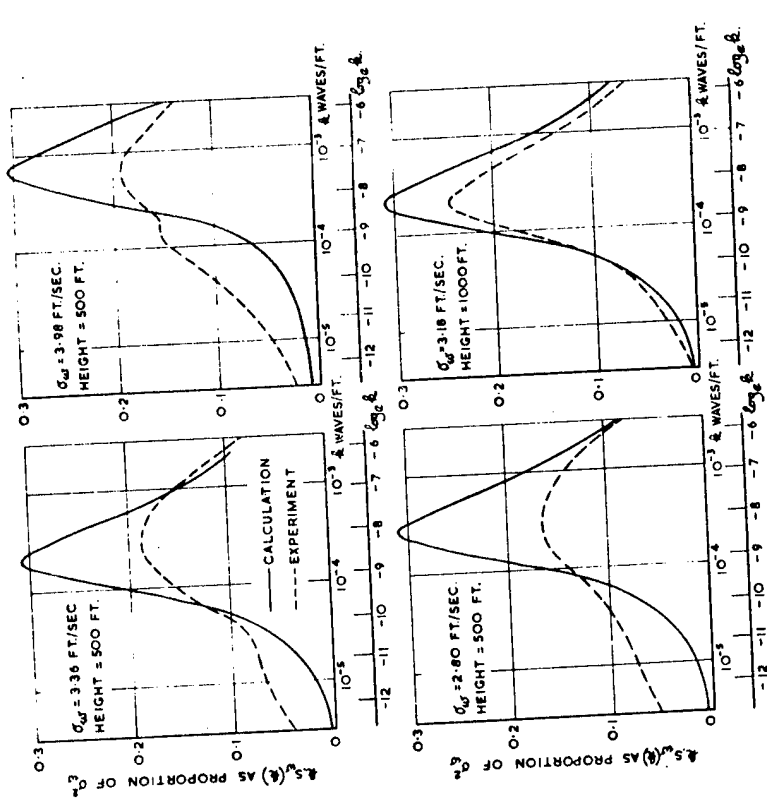

Figure 4. Distribution of energy per unit mass of air $[L_1 S_w(k)]$ at different wavelengths $(1/k)$. Measurements on balloon cables deduced from F.B. Smith (1961) and compared with

$$S_w(k) = 2L_s \sigma_w^2 \frac{[1 + (8/3)(L_1 k)^2]^{11/6}}{[1 + (L_1 k)^2]}$$

where $L_1 = 1.339(2\pi L_s)$; $\sigma_w = \text{R.M.S. vertical velocity}$. L_s is chosen so that calculated and experimental distributions have $k \cdot S(k)$ a maximum at the same k .

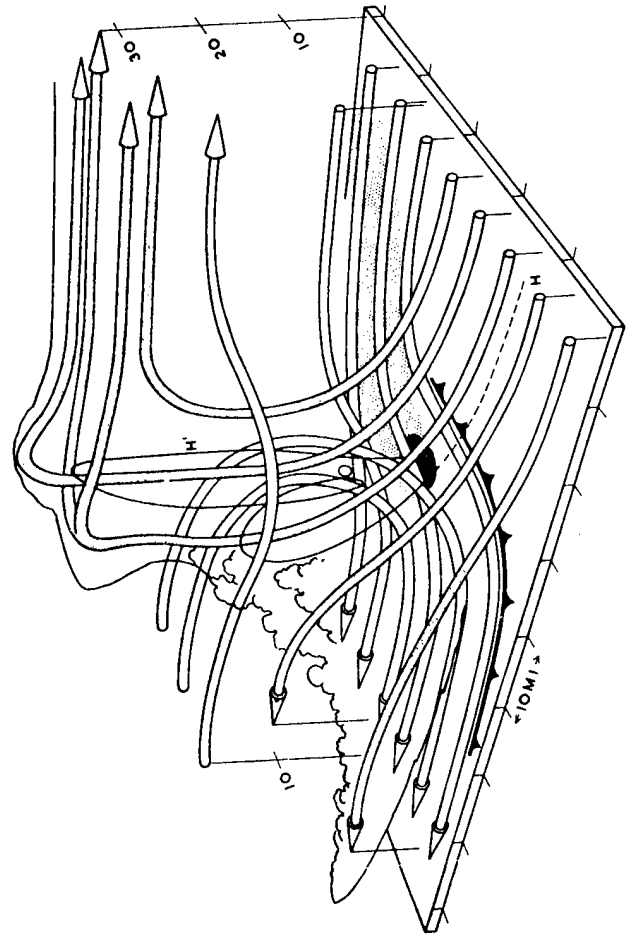

Figure 3. Model of air flow in a severe storm cumulonimbus. Stream lines are drawn of the motion relative to the storm, which moves from left to right, and are shaded where condensation has occurred. A schematic outline is drawn of the anvil cloud and of a squall front (marked on the trailing edge of the squall front) marked on the ground as a cold front). Heights are marked in thousands of feet. (Reproduced from "Air Flow in Cumulonimbus" by F.H. Ludlam, Atmospheric Turbulence and its relation to Aircraft, H.M. S.O., 1963)

$$\sigma_w^2 = \int_0^{+\infty} S_w(k) dk = \int_{-\infty}^{+\infty} k S_w(k) d(\log_e k) \quad (13)$$

Thus, twice the total energy per unit mass of air is given by the area under the curve of $k S_w(k)$ against $\log_e k$ and the area under the curve $k S_w(k) / \sigma_w^2$ is unity. Usually Equation 12 is adjusted to fit experimental data by selecting L_s so that the calculated and experimental distributions $k S_w(k)$ have a maximum at the same value of k . A comparison of theoretical and experimental distributions is shown in Figure 4¹³. We shall follow the common practice of referring to $S_w(k)$ as a power spectral density even though in reality it is a mean-square-value-density spectrum.

NUMERICAL RESULTS

Wind Velocity Gradients

The resultant moment experienced by the airship is evaluated from

$$M = \int_{-L/2}^{+L/2} \left(\frac{dF}{dx} \right) x dx \quad (14)$$

by using Equations 2 and 3 and setting $u = (du/dx) (L/2 - x)$. The results are shown in Table I for $(du/dx) = 0.01, 0.1, 0.2,$ and 0.3 .

Atmospheric Turbulence

If $H(k)$ is the response function describing the resultant couple when the airship is subjected to a transverse velocity wave of unit amplitude, then the mean square value of this moment is given by

$$M_{r.m.s.}^2 = \int_0^{+\infty} |H(k)|^2 S_w(k) dk \quad (15)$$

if $S_w(k)$ is a stationary function. Using $dk = d\hat{k} / (\pi L)$ and $d\hat{k} = \hat{k} d(\log_e \hat{k})$ Equation 15 becomes

$$M_{r.m.s.}^2 = \frac{1}{\pi L} \int_{-\infty}^{+\infty} |H(\hat{k})|^2 S_w(\hat{k}) \hat{k} d(\log_e \hat{k}) \quad (16)$$

After setting

$$\left| H(k) \right|^2 = \left| \frac{M}{u_c} \right|^2 \quad (17)$$

Equation 16 was used to evaluate $M_{r.m.s.}$ in response to the atmospheric power spectral density function given by Equation 12. Two cases were

considered¹¹: (1) Captive balloon data taken at a height of 1,000 feet with $\sigma_w = 3.54$ fps, and (2) Data obtained from an airplane flight at 40,000 feet in a thunderstorm. The results are shown in Table I.

Summary

The resultant moments obtained by the various methods discussed in this paper are compared in Table I. Dashes are used where an entry is not applicable. These moments are an important measure of the airship's stress because they must be neutralized by the transverse force of the fins. The first five cases, which include rectilinear motion at a constant pitch angle and steady turning without pitch, are conditions in still air which were considered by the early designers. The angle of yaw corresponding to the turning radius R was obtained by Munk⁵

$$\phi = \frac{L}{2R} \frac{1}{k_2 - k_1} \quad (18)$$

Equation 1 was used in Case 1, and Equation 2 was used in Case 2. Agreement of these two cases serves as a check on the numerical methods and also confirms, with remarkable accuracy, the approximations Munk used in deriving Equation 2.

Cases Six through Eleven correspond to situations where our current knowledge of the atmosphere was used. When a uniform vertical velocity gradient was considered, the vertical velocity was assumed to be zero at the tail and increase in the direction of flight. The resultant moment for Case Nine is less than Case Eight because the sine of the angle 2ϕ contained in Equation 2 decreases as ϕ increases beyond 45° . The data for the thunderstorm¹¹ were obtained at 40,000 feet and are not fully satisfactory for our purpose. However, the density was adjusted to this height, and the result corresponding to a direct application of the power spectral density equations is included. These results show that the values of atmospheric turbulence found in the literature produce a moment which is significantly less than the moment produced by realistic maneuvers in still air. However, the vertical velocity gradients at an altitude of 6,000 feet in a thunderstorm produce a moment which is three to four times larger than the moment produced by maneuvers in still air.

Table I. Numerical Results

Case Number	1	2	3	4	5	6	7	8	9	10	11
Pitch Angle, degrees	6	6	0	0	0	0	0	0	0	0	0
Yaw Angle, degrees	0	0	3.4	6.9	13.8	0	0	0	0	0	0
Uniform Vertical Velocity Gradient, fps/ft	0	0	0	0	0	0.01	0.1	0.2	0.3	-	-
Turning Radius, 10 ³ ft	∞	∞	10.	5.	2.5	∞	∞	∞	∞	∞	∞
Scale of Turbulence, ft	-	-	-	-	-	-	-	-	-	890.	5600.
R.M.S. Vertical Velocity, fps	-	-	-	-	-	-	-	-	-	3.54	9.40
Resultant Moment, 10 ⁶ ft-lbs	36.1	36.2	19.0	37.8	80.1	17.2	106.	112.	106.	*2.45	*3.08
Equations Used	1	2,14	2,14,18	2,14,18	2,14,18	2,14,18	2,14,3	2,14,3	2,14,3	10,12,16	10,12,16

Conditions Applicable to All Cases Unless Otherwise Noted

* R.M.S.

Forward Velocity of Airship = 100 fps

Density = 0.001988 slugs/ft³ (Standard Atmosphere at 6000 ft)

In Case 11, Density = 0.000582 slugs/ft³ (Standard Atmosphere at 40,000 ft)

Fineness Ratio = 5

Coefficients of Additional Mass of Ellipsoid: $k_1 = 0.059$, $k_2 = 0.895$, $k' = 0.701$

REFERENCES:

1. Kirschner, E. J., The Zeppelin in the Atomic Age, University of Ill. Press, Urbana (1957).
2. Burgess, C. P., Hunsaker, J. C., and Truscott, S., "The Strength of Rigid Airships", Jour. of the Royal Aeronautical Society, Vol. XXVIII, No. 162 (June, 1924) pp. 327-448.
3. Jones, M. A., "The Aerodynamical Characteristics of the Airship as Deduced from Experiments on Models, with Applications to Motion in a Horizontal Plane", Jour. of the Royal Society, Vol. XXVIII, No. 157 (June, 1924) pp. 88-150.
4. Scott, G. H., and Richmond, V. C., "A Detailed Consideration of the Effect of Meteorological Conditions on Airships", Jour. of the Royal Aeronautical Society, Vol. XVIII, No. 162 (June, 1924) pp. 189-221.
5. Munk, M. M., Fundamentals of Fluid Dynamics for Aircraft Designers, Ronald Press, New York (1929).
6. Munk, M. M., "The Aerodynamic Forces on Airship Hulls", NACA TR No. 184 (1924).
7. Morse, F., O'Hare, G. J., Pavlecka, V. H., Stehling, K. R., and Vaeth, J. G., Aeronautics and Astronautics, Vol. 10, No. 11 (November, 1972) pp. 32-40.
8. Hunt, J. R., Levitt, B., Morse, F., Stehling, K. R., and Vaeth, J. G., "The Many Uses of the Dirigible", Aeronautics and Astronautics, Vol. 11, No. 10 (October, 1973) pp. 58-65.
9. Seeman, G. R., Harris, G. L., Brown, G. J., and Cullian, C. A., "Remotely Piloted Mini-Blimps for Urban Application", Aeronautics and Astronautics, Vol. 12, No. 2 (February, 1974) pp. 31-35.
10. Mowforth, E., "A Design Study of a Freight Carrying Airship", Aeronautical Journal, Vol. 75, No. 723 (March, 1971) pp. 166-174.
11. Taylor, J., Manual on Aircraft Loads, Pergamon Press, Oxford (1965) Chapter 2.
12. Petterssen, S., Weather Analysis and Forecasting, Vol. II, McGraw-Hill, New York (1956) p. 159.
13. Smith, F. B., "An Analysis of Vertical Wind Fluctuations at Heights Between 500 and 5000 Feet", Quart. Jour. of the Royal Meteorological Society, Vol. 87, No. 372 (April, 1961).

N76-15030

AN AERODYNAMIC LOAD
CRITERION FOR AIRSHIPS

Donald E. Woodward*

ABSTRACT: This paper derives a simple aerodynamic bending moment envelope for conventionally shaped airships. This criterion is intended to be used, much like the Naval Architect's "standard wave," for preliminary estimates of longitudinal strength requirements. It should be useful in trade-off studies between speed, fineness ratio, block coefficient, structure weight, and other such general parameters of airship design.

INTRODUCTION

The longitudinal, or beam, strength of an airship is obviously of fundamental importance to its design. It would be of great convenience to the designer, therefore, to have an envelope of the maximum bending moment distribution over the airship's length. This paper derives such an envelope from theories and experiments in the literature, and attempts to show that it is neither uneconomically severe nor rashly lenient.

In the early days of airships, speeds and dynamic pressures were low, and static loads were the major ones to be resisted by the hull beam. By the end of World War I, however, performance had improved so that aerodynamic loads were as important as, or even preponderant over, static loads. This was made dramatically evident by the succession of large airships which were lost as the result of aerodynamic over-

* Consultant

CS
loading of their longitudinal strength. R-38 in 1921 focused attention on circling flight and sudden extreme control maneuvers. Shenandoah in 1925 emphasized the hazards of strong vertical gusts. Finally, although Macon had been designed with gust effects in mind, her loss by fin failure in 1935 led to a critical review of airship design and construction by the Durand Committee. This review concluded that there was insufficient understanding of the effects of gust loads, both as regards overall structural loads and local fin loads.

At the recommendation of the Durand Committee, the Navy contracted with the Daniel Guggenheim Airship Institute (DGAI) to conduct a broadly based study of this problem. The results of this study up to 1940 are summarized in Reference 1; they comprise wind tunnel, whirling arm, and water tunnel experiments on airship models, and a meteorological investigation of atmospheric gustiness.

The essential elements of a correct theoretical approach had already been established in 1935 (References 2 and 3). But the actual work of setting up the equations, obtaining a solution, and finding quantitative results was not completed and published until 1958, when Calligeros and McDavitt reported work they had performed at M.I.T. under contract to the Bureau of Aeronautics.⁴

The larger part of this paper will consist of a description of the Calligeros-McDavitt theory and its numerical results, and of the DGAI experiments, with a comparison and reconciliation of the two. From the joint theoretical and experimental results, an overall gust moment envelope is constructed. Examples of the other types of aerodynamic loads -- circling flight, abrupt control reversal, and lifting dynamically a static overload -- are presented from the literature. They are shown all to fall within the gust moment envelope, which to some extent justifies the scant attention paid them here. This result also establishes the gust moment envelope as the aerodynamic load criterion advertised in the title.

Bending moments are generalized in the usual way, as a dimensionless coefficient defined by:

$$\text{Bending Moment} = C_m q (\text{Vol})^{2/3} L \quad (1)$$

where (Vol) is air volume, L length, and q dynamic pressure.

A discussion in terms of a discrete gust seems somewhat outmoded in comparison with the methods of spectral analysis common in airplane and missile aerodynamics, but is made necessary by the nature of the DGAI experiments. The powerspectral analysis would seem particularly appropriate for large airships, the lengths of which approach the commonly accepted value of the scale of turbulence in the free atmosphere. Happily, Reference 4 embraces both methodologies, and the agreement which is found between the discrete-gust formulation and the DGAI experiments lends confidence to the turbulent-spectrum approach.

THEORY

The theory develops the equations of motion of the airship in the usual manner. The physical situation is as pictured in Figure 1. The airship, at some angle of pitch θ and velocity V_0 is encountering a gust characterized by a spatial distribution of transverse velocities W which can be specified quite generally. In the worked numerical example, the gust form is taken as a full cycle $1 - \cos$ with peak velocity W_0 any specified fraction of V_0 and wavelength any given fraction of the ship length. The aerodynamic forces and moments acting on the airship are resolved into longitudinal, lateral, and rotation components, and the amount by which each set is unbalanced is equated to the acceleration multiplied by the apparent mass (or apparent moment of inertia).

The typical small-displacement linearizations of aerodynamics are then assumed, i.e., that transverse and rotary components are independent and their coefficients are directly proportional to angle of attack, angular velocity, etc. Both local aerodynamic forces and integrated aerodynamic stability derivatives are based on a modification of slender-body theory applied to the apparent cross-section distribution (i.e., including added-mass effects) taking as the base area the apparent cross-section of hull-plus-fins at the trailing edge. The equations can then be put into a dimensionless form suited to numerical solution, for any given airship form and gust assumption.

As part of the determination of the equations of motion, the local aerodynamic loads are found; these, together with the inertial reactions of the distributed airship mass, are treated as loads on a free beam, integrated to obtain shears, and again to find the bending moment curve of the beam. This theory yields, for selected stations along the airship beam, a history of the bending moment at that station as a function of the position of the airship with respect to penetration of the gust. The envelope of the maxima of the moments at these various stations would then be the design bending moment criterion we seek, if the theory were complete and exact. Other information obtainable from the theory includes the envelope of shear maxima, the lateral and angular positions of the airship and the derivatives of these quantities, and the local angle of attack and transverse acceleration at the fin center of pressure.

Reference 4 also derives transfer functions for the airship responses and loads which, applied to an assumed or empirical random gust spectrum, yield RMS values of the displacements, velocities, accelerations, shears, moments, etc.

The theoretical calculations just outlined were carried out for an airship approximating to the ZPG-2W class of million-cubic-foot nonrigids. It was found that C_m is directly proportional to W_0/V_0 , the ratio of peak gust velocity to forward velocity. The history of moment at any station is dependent on the ratio of the gust development length to the length of the airship, and peaks for a ratio of 1/2, although this maximum does not vary greatly between 1/4 and 3/4. Reference 4 only calculates the case of zero rudder angle.

The full-line curve in Figure 2 is the envelope of peak values of $\frac{C_m}{W_0/V_0}$ for the example airship.

DGAI EXPERIMENTAL PROGRAM

The DGAI tests measured the motions and resultant stresses which occur when an airship moves freely under the influence of gusts. These tests were made with self-propelled models in a water tank, a transverse current of controlled velocity profile simulating the gust. The gust profile approximated a one-minus-cosine transition over a scale length of 400 feet, followed by a steady region at the full transverse velocity W_0 . Model dimensions, and moments of inertia about all three axes, were scaled directly from the Akron.

The experiments reported in Reference 1 were made with "Mark II" control surfaces, scaled directly from those actually used on the Akron. Later experiments^{5,6} used other sizes and shapes of surfaces. Except in one case the maximum gust moments measured with these other surfaces all fell within the envelope established by the Mark II surfaces. The exceptional fins were of very high aspect ratio (for airship fins) and placed very far aft; their high moment values were only slightly above the Mark II envelope over the rear quarter of the model, and will be ignored for our simple design rule-of-thumb.

In addition to the measurements of 6:1 fineness ratio, a few results are available on a model of equal displacement and similar profile, scaled to a 4:1 fineness ratio.

COMPARISON AND RECONCILIATION

The results of the water tunnel experiments are plotted in Figure 2. The zero-rudder bending moments for the 4:1 model are shown as crosses, and those for the 6:1 model with Mark II fins as circles. The small dots are moments on the 6:1 model when the rudder was not at zero, or was changing, during the test. Also plotted in this figure is the moment envelope of Calligeros and McDavitt's example airship, also with rudder fixed at zero.

Several observations can be made. First, there is good agreement between the measured coefficients for the 4:1 model and the theoretical curve for the nonrigid. Second, although the envelope of moments over the forebodies is virtually the same for all three airships, the coefficients over the afterbodies are markedly higher for the two rigid airships' models in comparison with the theory. Furthermore, this difference is more marked for the 6:1 model than the 4:1 model. Third, use of rudders during the gust encounter is seen to increase negligibly the envelope over the forward two-thirds of the ship, and in fact may greatly reduce the moments over this part of the ship. Only just forward of the fins does the use of the rudders increase the moment significantly, by up to 40 per cent. On the other hand, reductions of as much as 50 per cent may also result even at this far-aft station.

The agreement between theory and experiment increases confidence in both, but it is still necessary to explain the discrepancies. Three factors suggest themselves: inadequacies of theory, differences between nonrigid and rigid airships, and differences in the assumed gust shapes.

The approximations mentioned in discussing the theory are, of course, inadequacies. The small displacement linearization of the equations is significantly in error, because the displacements are not small and the aerodynamic coefficients are not constant; the rotary derivatives, for example, have been shown to have a strong dependence of angle of attack.⁷ The use of modified slender-body theory, although a good approximation for obtaining the airship motions, is quite incapable of expressing the generation of distributed lift over the afterbody and the downwash of the hull upon the empennage, i.e., the local dynamic loading in the area where theory differs most from experiment.

The only notable difference between the theoretical nonrigid and the rigid models is in mass distribution, which in the nonrigid is highly peaked in the vicinity of the center of buoyancy. This might make the nonrigid more quick to respond in pitch and thus accelerate away from the gust more rapidly, before the fins were in the transverse flow. However, the difference in terms of the ratio of radius of gyration to length is only about ten per cent between nonrigid and the 6:1 model, so this effect is probably not a major one.

A third explanation of the envelope differences is found in the gust forms. The theoretical calculation assumes a full-cycle 1-cosine profile, while the profile actually achieved in the water tank approximated a half-cycle; both were about equally proportioned to ship length. Thus, when the theoretical airship had penetrated a full ship length from the entry to the gust, its lateral velocity had almost peaked and was rapidly damped out thereafter, while the rigid models at the same stage had not yet achieved their final lateral velocity, but were still accelerating in a cross-flow. This would cause the same aerodynamic loading on the rigid models as in nonequilibrium pitched flight, resulting in a bending moment in the same sense as the transient moment cause by the gust.

These physical arguments give qualitative assurance, at least, that the sign of the difference between theory and experiment is correct. On these bases, a safe envelope for gust bending moment coefficients, in terms of $C_m/W_0/V_0$, will be bounded by straight lines starting at 0 at the nose of the airship, increasing to 0.065 at 0.3 length, then to 0.10 at 0.5 length, constant to 0.65 length, and then decreasing linearly to 0 at the stern.

EXAMPLES

In order to compare the gust bending moment with other hull bending moments, it is necessary to adopt some definite value for the maximum gust velocity. The DGAI summary report, considering all available published data on gustiness as well as fresh information obtained by DGAI, concluded: "It is suggested that 35 ft/sec cross wind should be considered as a maximum value which might occur in weather conditions whose severity is not necessarily recognized even by a skilled pilot." More recent data do not seem to require much change.

The remaining two figures plot some examples of the bending moment envelope derived here against various measured or calculated airship aerodynamic moments. Figure 3 groups a number of such results for the U.S.S. Shenandoah, for which fairly extensive data are available in the literature. The Shenandoah's top speed was 91 ft/sec, which with 35 ft/sec maximum gust velocity gives W_0/V_0 equal to 0.385, so the peak of the moment coefficient envelope is 0.0385. At an altitude where atmospheric density is 0.0021 slugs/cubic ft, the corresponding bending moment is 3,950,000 lb-ft.

Curve L is a dynamic lift case, taken from Burgess' Airship Design.⁸ It results in about 50 per cent greater moments than were actually ever contemplated in the Shenandoah design.⁹ Curve A represents a modification of L, following a suggestion by Arnstein¹⁰ that the maximum bending envelope could be derived from that for maximum dynamic lift by multiplying by a load factor increasing elliptically from 1 at mid-length to 3 at the ends. Curve C represents circling flight at full speed at a radius of 3,000 feet, based on curved model tests.⁷ Curve R is for sudden rudder reversal, based on a control surface normal-force coefficient of 0.4, which is probably as much as can be obtained by deliberate maneuvers. The curve labeled N is a rule-of-thumb due to Naatz¹¹ that the maximum value of C_m is approximately 0.01; presumably this will fall off to zero at the ends according to some curve such as shown. Curve G results from a Goodyear report¹² which states that gust loads "for conventional airships" have long been calculated by using an effective angle of attack of twice the arc tangent of W_0/V_0 , on the basis of two exceptional measurements of such high angles in the DGAI water tank tests. Curve X is that calculated by Burgess⁹ as possibly corresponding to the conditions which broke the Shenandoah's hull at Frame 125. Point LW represents a maximum-power turning moment on a theory due to Lewitt.¹³ Point B is an actual measurement by Burgess while the Shenandoah was flying over the Alleghenies in rough weather.⁹

Figure 4 collects together data on four airships, together with their bending moment criteria as derived here. Points labeled LA-T, LA-R (which are indistinguishable) and LA-G are, respectively, moments measured on the Los Angeles in steady turning, sudden rudder reversal, and flight through gusty weather. (14) Point RS-1 is a measured moment at the midpoint of the keel of the U.S. Army semirigid RS-1,¹⁶ when encountering a gust which caused pitching through $+25^\circ$. A curve is presented for moments due to rudder reversal calculated by Schwengler for a 7,000,000 cubic foot paper design.¹⁵ Finally, the design bending moment curve for the Akron¹ is shown, the only one which anywhere exceeds the proposed moment criterion.

The weight which ought to be given to these examples differs widely in the various cases. However, the fact that virtually all lie completely within the gust moment criterion derived here, and that the most severe of the examples approach rather closely that criterion, does give some credibility to the contention that the simple

envelope given is a useful rule-of-thumb for determining the preliminary longitudinal strength requirements of new airship designs.

REFERENCES:

1. T. von Karman and T. Troller, Summary Report of the Investigations of Gust Effects on Airships, Daniel Guggenheim Airship Institute, Akron, O. (1941?).
2. K. Arnstein and W. Klemperer, Performance of Airships, Div. R.IV of Aerodynamic Theory, W. F. Durand (Ed.), Springer, Berlin (1935), pp. 115-120.
3. W. B. Klemperer, Airships in Gusts, DGAI Pub. No. 3, Report on Airship Forum, Akron, O. (1935), pp. 104-116.
4. J. M. Calligeros and P. W. McDavitt, Response and Loads on Airships Due to Discrete and Random Gusts, MIT Aeroelastic and Structures Research Lab Tech. Rpt. 72-1, Cambridge, Mass. (Feb. 1958).
5. D.G.A.I., Report on Influence of Fin Form on the Flight Path and Bending Moment of an Airship Model in Free Flight, Akron, O. (May 1941).
6. D.G.A.I., (same title), Akron, O. (April 1943).
7. R. M. Smith, Curvilinear Dynamics of Airships Based on Bowed Model Tests, Proc. 5th Int'l. Congress for Applied Mechanics, Cambridge, Mass. (1939).
8. C. P. Burgess, Airship Design, Ronald Press, N.Y. (1927), p. 91.
9. Am. Soc. Naval Eng., Technical Aspects of the Loss of the U.S.S. Shenandoah, Jnl. A.S.N.E., XXXVIII No. 3 (August 1926).
10. K. Arnstein, The Development of Large Commercial Rigid Airships, Trans. Am. Soc. Mech. Eng. (Aeronautics), Vol. 50 (1928), p. 1.
11. H. Naatz, Recent Researches in Airship Construction II - Bending Stresses on an Airship in Flight, NACA TM No. 276, Washington, D.C. (1925).
12. Goodyear Aerospace Corp., Parametric Study of Dynamic Lift Aerostats for Future Naval Missions, Report GER 13564, Akron, O., (1968).
13. E. H. Lewitt, The Rigid Airship, Pitman, London (1925), pp. 61-69.
14. C. P. Burgess, Flight Tests on U.S.S. "Los Angeles" Part II - Stress and Strength Determination, NACA Rpt. No. 325, Washington, D. C. (1928).
15. J. Schwengler, Der Bau der Starrluftschiffe, Springer, Berlin (1925).
16. R. E. Robillard and R. A. Miller, Full Scale Tests of the Semirigid Airship RS-1, U.S. Army, Air Corps Information Circular, v. 7, n. 619 (1928).

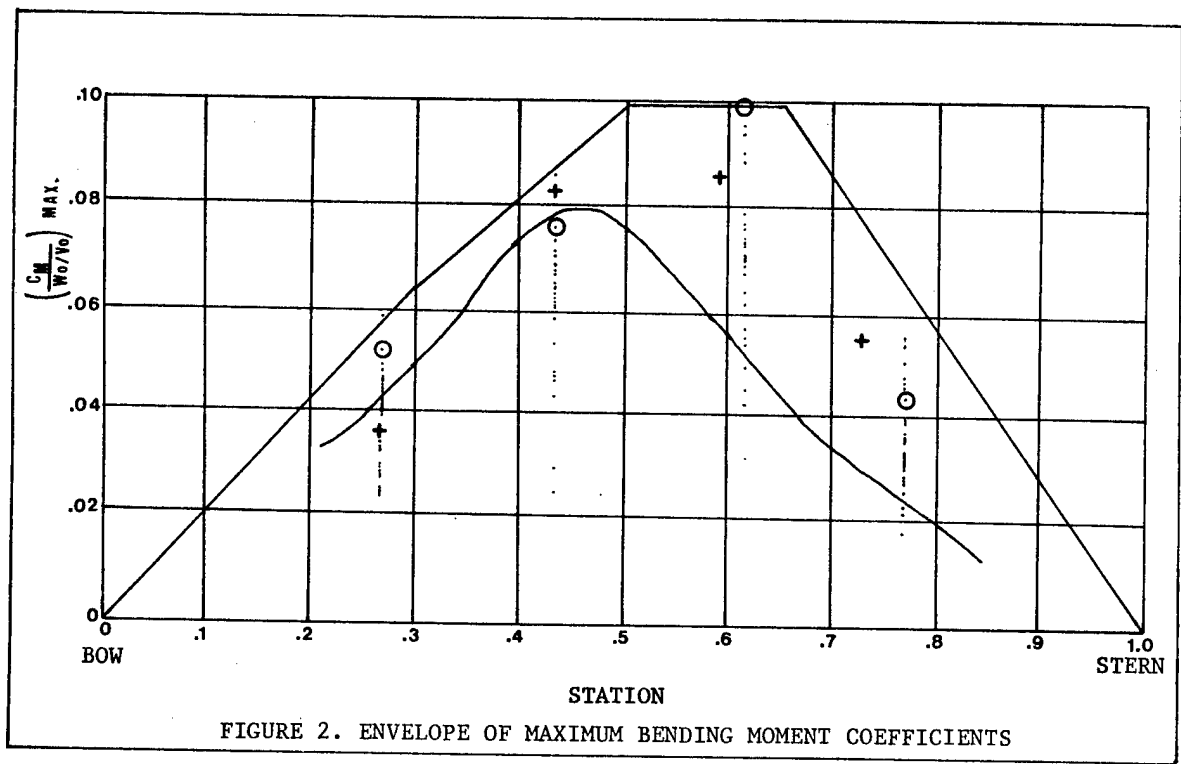
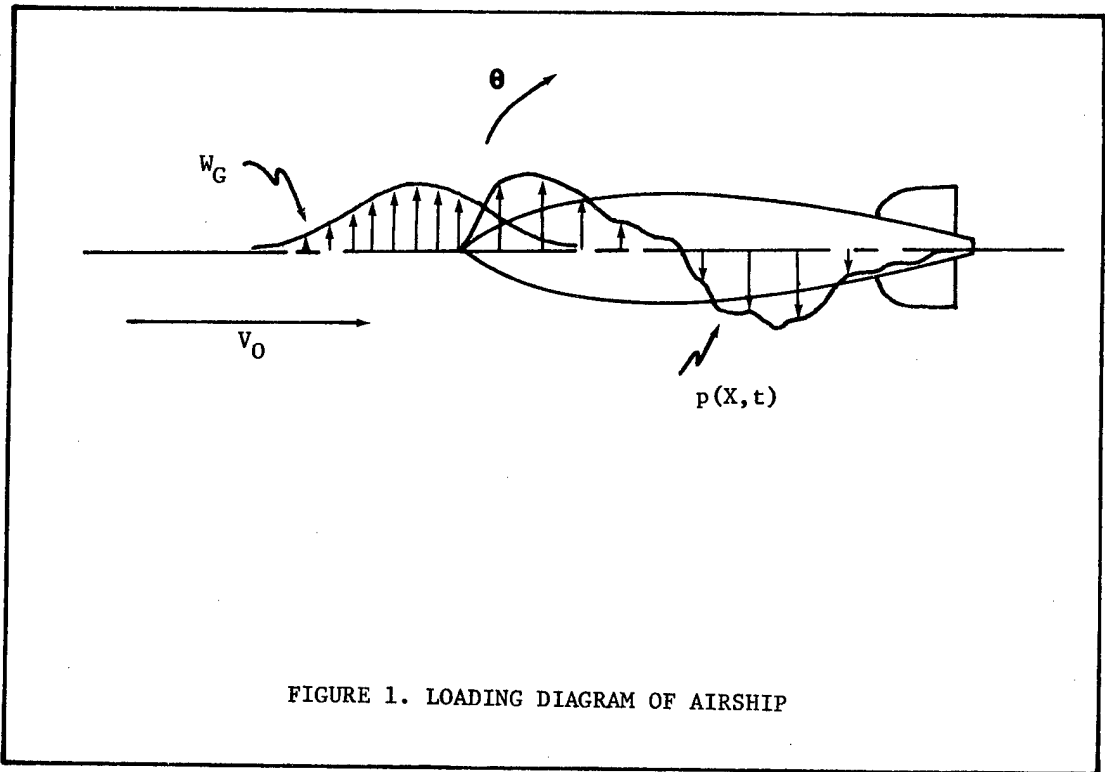

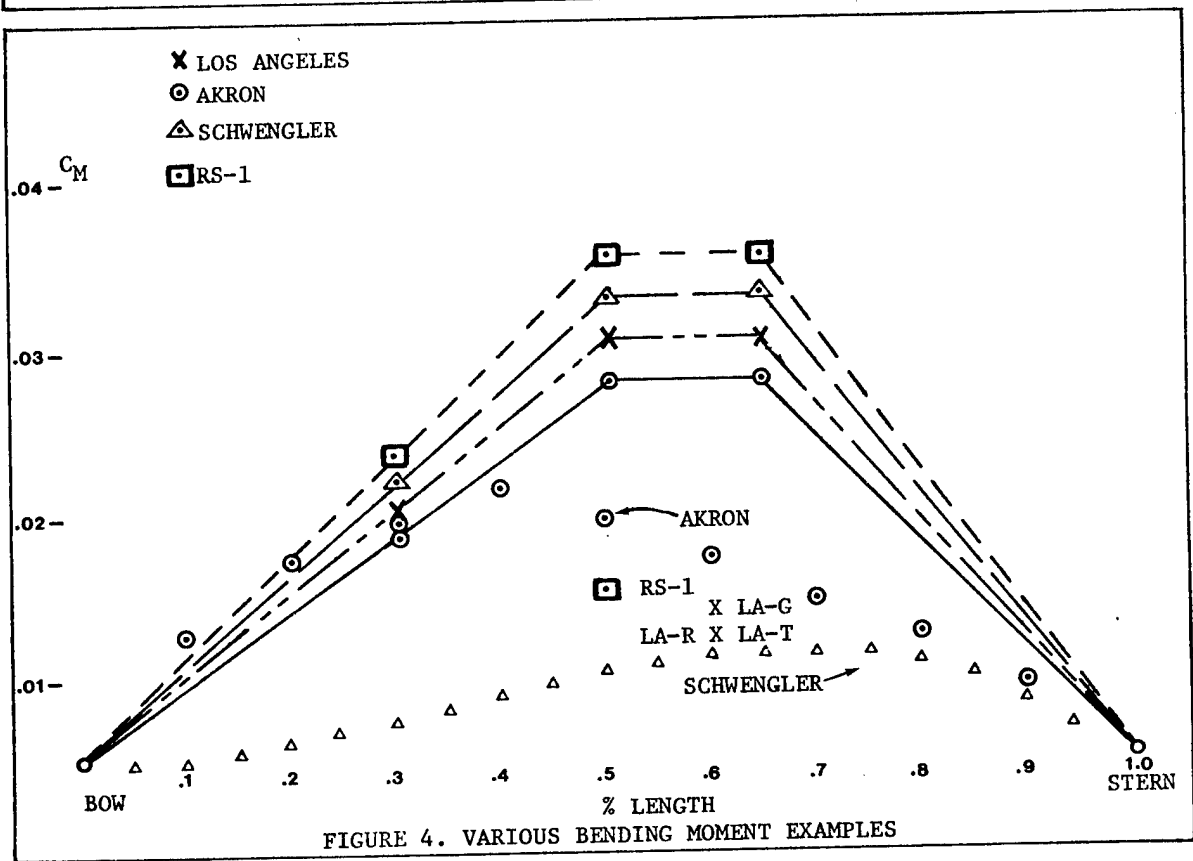
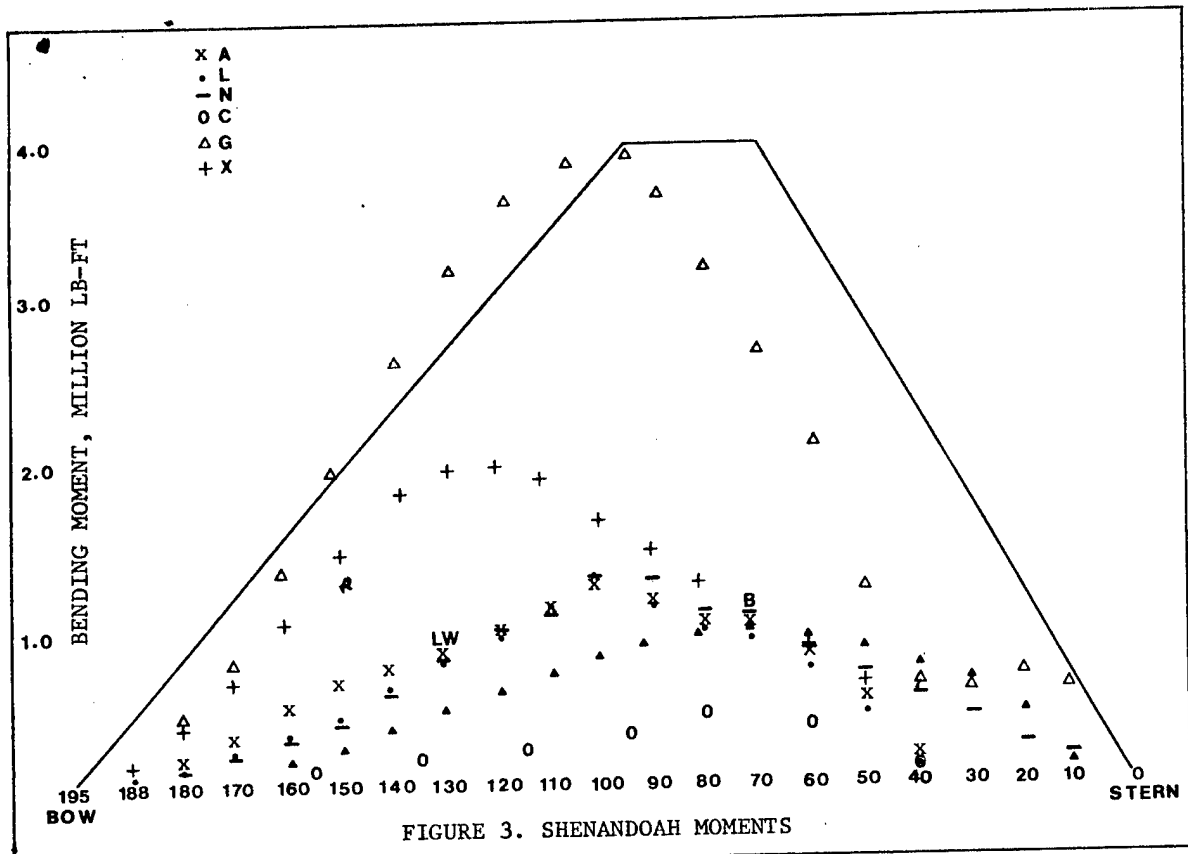

THE PLANAR DYNAMICS OF AIRSHIPS

Frank J. Regan*

ABSTRACT: This paper will consider the forces and moments acting upon a LTA vehicle in order to develop parameters describing planar motion. Similar expressions for HTA vehicles will be given to emphasize the greater complexity of aerodynamic effects when buoyancy effects cannot be neglected. A brief summary is also given of the use of virtual mass coefficients to calculate loads on airships.

SYMBOLS

C_D	Drag coefficient
C_m	Pitching moment coefficient, $M_y/QS\ell$
C_{mq}	$\partial C_m/\partial (q\ell/2V)$
$C_{m\dot{q}}$	$\partial C_m/\partial (\dot{q}\ell^2/2V^2)$
$C_{m\alpha}$	$\partial C_m/\partial \alpha$
$C_{m\dot{\alpha}}$	$\partial C_m/\partial (\dot{\alpha}\ell/2V)$
C_z	Normal force coefficient, F_z/QS
C_{zq}	$\partial C_z/\partial (q\ell/2V)$
$C_{z\dot{q}}$	$\partial C_z/\partial (\dot{q}\ell^2/2V^2)$
$C_{z\alpha}$	$\partial C_z/\partial \alpha$
$C_{z\dot{\alpha}}$	$\partial C_z/\partial (\dot{\alpha}\ell/2V)$
D	Drag force
g	Gravitational acceleration

* Supervisory Aerospace Engineer, U. S. Naval Ordnance Laboratory
Silver Spring, Maryland

\bar{g}	$g (1 - 1/S)$
I_y	Transverse moment of inertia
K_y	Transverse radius of gyration, $\sqrt{I_y/m\ell^2}$
L	Body length
ℓ	Reference length, body length
M_y	Pitching moment
m	Body mass
Q	Dynamic pressure, $1/2\rho V_o^2$
S	Reference area, $v^{2/3}$
s	Airship density to medium density, ρ_b/ρ
V_o	Airship speed
V	Airship volume
X_e, Y_e, Z_e	Inertial axes
X, Y, Z	Body axes
Z	Normal force
α	Angle of attack
θ	Angle of pitch
ϕ	Velocity potential
ρ	Density

INTRODUCTION

In studies of the dynamics of Heavier Than Air (HTA) vehicles, effects due to buoyancy are almost invariably neglected. Sustaining force is the result of relative motion existing between the HTA vehicle (or at least some portion of the vehicle) and the surrounding air mass. In short, the lift or sustaining force associated with HTA craft is entirely dynamic.

A somewhat reverse situation exists in the case of Lighter Than Air (LTA) craft. The principal sustaining force comes from buoyancy, with perhaps a small additional force (about 10 percent) available under some conditions from dynamic lift. To put the comparison between LTA and HTA craft on at least a semiquantitative basis, it is convenient to define a relative density parameter, s , as

$$S = \frac{\rho_b}{\rho} \quad (1)$$

It may be seen that s is of $O(1)$ for a LTA vehicle, while for a HTA s is no less than $O(10^{+2})$ and for most cases $O(10^{+4})$.

In addition to buoyancy playing an essential role in LTA dynamics, there are in addition dynamic effects which for convenience might be lumped in the terms virtual mass. Such dynamic effects are taken to mean forces and moments arising from (and hopefully linear with) angular rate or linear acceleration. These virtual mass effects are essentially reactive forces and moments caused by imparting an angular velocity and a linear and angular acceleration to the surrounding air. Like buoyancy these virtual effects are usually neglected for HTA

craft; for LTA vehicles, however, such effects form an essential part of the loads acting on the craft. Thus such effects enter prominently into any considerations of stability.

No originality is claimed in the following development of either the mathematical model of planar dynamics or the subsequent load calculation methods. The equations of planar motion originated with ballisticians such as Murphy (1). However, because of the negligible effect of buoyancy, great simplifications are possible in the aeroballistic formulation. As will be shown, the airship equations are far more complex. The load calculation techniques follow from Bryson (2) originally and have been presented by Nielson (3). Again these methods are applied to LTA vehicles rather than the HTA missiles which were the original motivation for Bryson's work.

DYNAMICS OF PLANAR MOTION

Consider an airship undergoing planar motion as illustrated in Figure (1) below

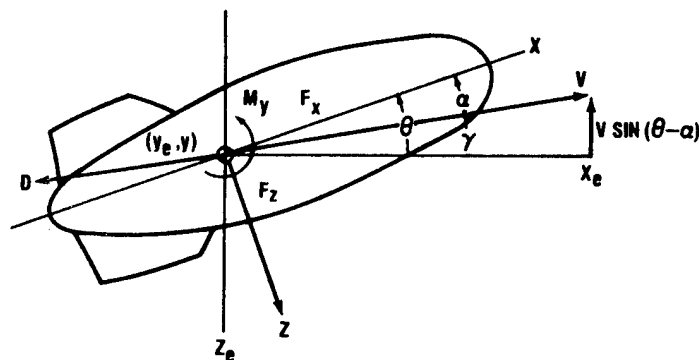

FIG. 1 FORCES AND MOMENTS ACTING ON AIRSHIP

The axes X_e, Y_e, Z_e are the inertial axes, while X, Y, Z are body-fixed axes. The equations of planar motion are the forces along axes X_e, Z_e and the moment about axis Y_e . Note that because of the definition of planarity axis Y_e is identical to axis Y .

The moment and two force equations may be written as

$$mV \cos(\theta - \alpha) = F_x \cos \theta - D \quad (2a)$$

$$m \ddot{x}_e = F_z \cos \theta - F_x \sin \theta + mg \left(1 - \frac{1}{s}\right) \quad (2b)$$

$$I \ddot{\theta} = M_y \quad (2c)$$

where s is the relative density parameter of equation (1). In addition to the three load equations above, figure (1) also provides the following kinematic relationship:

$$\dot{x}_e = -V \sin(\theta - \alpha) \quad (3a)$$

which gives upon differentiation

$$\ddot{x}_e = -\dot{V} \sin(\theta - \alpha) - V \cos(\theta - \alpha) [\dot{\theta} - \dot{\alpha}] \quad (3b)$$

Under the assumption that the X axis does not greatly vary from the horizontal, X_e , it is possible to restrict θ and α to small angles. Subject to such small angle restrictions equations (2) and (3) become:

$$m \dot{V} = -D = F_x \quad (4a)$$

$$m \ddot{x}_e = F_z - F_x \theta + mg \left(1 - \frac{1}{s}\right) \quad (4b)$$

$$I_y \ddot{\theta} = I_y \dot{\alpha} = M_y \quad (4c)$$

$$\dot{x}_e = -V(\theta - \alpha) \quad (4d)$$

$$\ddot{x}_e = -\dot{V}(\theta - \alpha) - V(\dot{\theta} - \dot{\alpha}) \quad (4e)$$

A first step might be the substitution of equation (4e) into equation (4b) to give:

$$-m[\dot{V}(\theta - \alpha) + V(\dot{\theta} - \dot{\alpha})] = F_z - F_x \theta + mg \left(1 - \frac{1}{s}\right) \quad (5)$$

Equation (4a) may now be used to eliminate \dot{V} in the above expression resulting in:

$$D(\theta - \alpha) - mV(\dot{\theta} - \dot{\alpha}) = F_z + D\theta + mg \left(1 - \frac{1}{s}\right) \quad (6)$$

The above expression may be altered by introducing the following non-dimensional force coefficients

$$C_D = D \left(\frac{1}{2} \rho V_0^2 S\right)^{-1} \quad C_z = F_z \left(\frac{1}{2} \rho V_0^2 S\right)^{-1} \quad (7)$$

The coefficient C_z may be expanded in a Taylor series as

$$C_z = C_{z_0} + C_{z_\alpha} \alpha + C_{z_{\dot{\alpha}}} \left(\frac{\dot{\alpha} l}{2V}\right) + C_{z_g} \left(\frac{gl}{2V}\right) + C_{z_{\dot{g}}} \left(\frac{\dot{g} l^2}{2V^2}\right) \quad (8)$$

Equation (6) may now be written in terms of C_z and C_D as

$$\left(\frac{\rho S l}{2m}\right) C_D (\theta - \alpha) - \left(\frac{gl}{2V}\right) + \left(\frac{\dot{\alpha} l}{2V}\right) = \left[C_{z_0} + C_{z_\alpha} \alpha + C_{z_{\dot{\alpha}}} \left(\frac{\dot{\alpha} l}{2V}\right)\right] \frac{\rho S l}{2m} \quad (9)$$

$$\frac{\rho S l}{2m} \left[+ C_{z_g} \left(\frac{gl}{2V}\right) + C_{z_{\dot{g}}} \left(\frac{\dot{g} l^2}{2V^2}\right) + C_D \theta \right] + g \left(1 - \frac{1}{s}\right) \frac{l}{V^2}$$

It is now possible to simplify equation (9) somewhat by the following redefinitions:

$$C_z^* = C_z \left(\frac{\rho S l}{2m}\right); \quad C_D^* = C_D \left(\frac{\rho S l}{2m}\right); \quad \bar{g} = g \left(1 - \frac{1}{s}\right) \quad (10)$$

Equation (10) now allows equation (9) to be rewritten and then rearranged as

$$\left(\frac{g\ell^2}{2V^2}\right)C_{zg}^* + \left(\frac{g\ell}{2V}\right)[1+C_{zg}^*] = \left(\frac{\alpha\ell}{2V}\right)[1-C_{zg}^*] - \alpha(C_D^* + C_{z\alpha}^*) - C_{z_0}^* - \bar{g}\ell V^{-2} \quad (11)$$

Equation (4c), the moment equation, may be written as:

$$\bar{g} = \left(\frac{\rho S l V^2}{2I_y}\right)C_m = \left(\frac{V}{\ell}\right)^2 \left(\frac{\rho S l}{2m}\right) \left(\frac{m\ell^2}{I_y}\right)C_m \quad (12)$$

where M_y has been replaced by C_m ($\rho S l V^2/2$). Again replacing C_m by a Taylor series in α , $\dot{\alpha}$, q , and \dot{q} and using the starred quantities gives for equation (12):

$$\left(\frac{g\ell^2}{2V^2}\right)[1 - k_y^{-2}C_{m\dot{g}}^*] - \left(\frac{g\ell}{2V}\right)k_y^{-2}C_{m\dot{g}}^* - \left(\frac{\alpha\ell}{2V}\right)k_y^{-2}C_{m\dot{\alpha}}^* - \alpha k_y^{-2}C_{m\dot{\alpha}}^* = k_y^{-2}C_{m_0}^* \quad (13)$$

Equations (11) and (13) are now the basic equations of planar motion. The final goal remains to eliminate one of the variables between these simultaneous equations. For the present purposes the variable q will be eliminated and a single differential equation of motion in α will be written. As might be expected, this single equation is quite complicated. Before presenting this dynamic equation in a tractable form, an outline of the procedure will be given. A fairly straightforward approach is to eliminate \dot{q} between equations (11) and (13). The resulting equation containing q , α , and $\dot{\alpha}$ is then differentiated to give an expression in \dot{q} , α , $\dot{\alpha}$, and $\ddot{\alpha}$. Returning to equations (11) and (13), eliminating this time q between them now provides a second expression \dot{q} , α , $\dot{\alpha}$, and $\ddot{\alpha}$. Elimination of \dot{q} between these equations gives the single dynamic equation in α , $\dot{\alpha}$, and $\ddot{\alpha}$. In carrying out the above manipulation it is necessary to perform the differentiation of (ℓ/V) . This operation may be written as,

$$\frac{d}{dt} \left(\frac{\ell}{V}\right) = \ell \frac{d}{dt} V^{-1} = -\frac{\ell}{V^2} \frac{dV}{dt} = -\frac{\ell}{V^2} \left(-\frac{C_D \rho S V^2}{2m}\right) = C_D^* \quad (14)$$

The single equation in α that will represent dynamic planar motion will be written as:

$$\ddot{\alpha} + H_1 \left(\frac{V}{\ell}\right)\dot{\alpha} - M_1 \left(\frac{V}{\ell}\right)^2 \alpha = A_1 \left(\frac{V}{\ell}\right)^2 + G_1 \quad (15)$$

where

$$H_1 = \left[\frac{[1 - k_y^{-2}C_{m\dot{g}}^*][C_D^* + C_{z\alpha}^*] + (1 + C_{zg}^*)k_y^{-2}C_{m\dot{\alpha}}^* + (1 - C_{z\alpha}^*)k_y^{-2}C_{m\dot{g}}^* + k_y^{-2}C_{zg}^*C_{m\dot{\alpha}}^*}{k_y^{-2}C_{zg}^*C_{m\dot{\alpha}}^* - (1 - C_{z\alpha}^*)[1 - k_y^{-2}C_{m\dot{g}}^*]} \right] \quad (16a)$$

$$M_1 = \left[\frac{\{[1 - k_y^{-2}C_{m\dot{g}}^*][C_D^* + C_{z\alpha}^*] + k_y^{-2}C_{m\dot{\alpha}}^*C_{zg}^*\}C_D^* + (C_D^* + C_{z\alpha}^*)k_y^{-2}C_{m\dot{g}}^* - (1 + C_{zg}^*)k_y^{-2}C_{m\dot{\alpha}}^*}{k_y^{-2}C_{zg}^*C_{m\dot{\alpha}}^* - (1 - C_{z\alpha}^*)[1 - k_y^{-2}C_{m\dot{g}}^*]} \right] \quad (16c)$$

$$A_1 = \left[\frac{\{k_y^{-2}C_{zg}^*C_{m_0}^* + C_{z_0}^*[1 - k_y^{-2}C_{m\dot{g}}^*]\}C_D^* + k_y^{-2}C_{m\dot{g}}^*C_{z_0}^* - (1 + C_{zg}^*)k_y^{-2}C_{m_0}^*}{k_y^{-2}C_{zg}^*C_{m\dot{\alpha}}^* - (1 - C_{z\alpha}^*)[1 - k_y^{-2}C_{m\dot{g}}^*]} \right]$$

$$G_1 = \left[\frac{\bar{g} [K_y^2 C_{m\dot{y}}^* - C_D^* [1 - K_y^2 C_{m\dot{y}}^*]]}{K_y^2 C_{m\dot{\alpha}}^* C_{m\dot{y}}^* - [1 - K_y^2 C_{m\dot{y}}^*] [1 - C_{L\dot{\alpha}}^*]} \right] \quad (16d)$$

Before attempting to simplify equations (16) it is necessary to reduce equation (15) to an equation with constant coefficients as the presence of (V/l) introduces time into the coefficients. This may be accomplished by writing

$$\dot{\alpha} \equiv \frac{d\alpha}{dt} = \frac{d\alpha}{dx} \frac{dx}{dt} = \frac{d\alpha}{d(x/l)} \frac{1}{l} \frac{dx}{dt} = \alpha' \left(\frac{V}{l} \right) \quad (17a)$$

where differentiation has been changed from time, t , to a non-dimensional arc length, (X/l) . In a similar fashion $\ddot{\alpha}$ may be written in terms of (X/l) as

$$\ddot{\alpha} = \left(\frac{V}{l} \right)^2 \alpha'' - \left(\frac{V}{l} \right)^2 C_D^* \alpha' \quad (17b)$$

By replacing time derivatives by arc-length derivatives, equation (15) now becomes a second order constant coefficient equation:

$$\alpha'' + (H_1 - C_D^*) \alpha' - M_1 \alpha = A_1 + G_1 \left(\frac{l}{V_0} \right)^2 \quad (18)$$

Admittedly, equations (16) are quite complex; for certain applications such as aeroballistics, great simplifications may be made.

However, before considering this aspect of the problem, the conditions for stability of motion will be examined.

STABILITY CONSIDERATIONS

Equation (18) may be rewritten as

$$\alpha'' + 2\lambda \alpha' + \omega_n^2 \alpha = \omega_n^2 \alpha_0^A + \omega_n^2 \alpha_0^g \quad (19)$$

where

$$\lambda = \frac{H_1 - C_D^*}{2} \quad (20a)$$

$$\omega_n^2 = -M_1 \quad (20b)$$

$$\alpha_0^A = -\frac{A_1}{M_1} \quad (20c)$$

$$\alpha_0^g = -\frac{G_1}{M_1} \left(\frac{l}{V_0} \right)^2 \quad (20d)$$

The term, λ , is the damping factor of the airship, the term, ω_n , is the undamped natural frequency. Only for small values of λ does the body oscillate at this frequency; in the presence of a significant amount of damping the planar oscillatory frequency, ω_d , is less than the undamped frequency, ω_n . The damped planar frequency, ω_d , can be expressed in terms of λ and ω_n as

$$\omega_d = \sqrt{\omega_n^2 - \lambda^2} \equiv \omega_n \sqrt{1 - \lambda^2/\omega_n^2} \quad (21)$$

The term α_0^A in equation (20c) is the trim angle of attack due to aerodynamic asymmetries, while α_0^g in equation (20d) is the trim angle of attack due to gravitational path curvature. With regard to the term α_0^g , it might be of interest to note that if the airship is neutrally buoyant, i.e. $s = 1$, then from equation (10) $\dot{g} = 0$ and hence from

equation (20d), α_0^g must be zero.

There are two conditions for oscillatory motion. These are:

$$\lambda < \omega_n \quad (22a)$$

and

$$\omega_n^2 > 0 \quad (22b)$$

The former condition allows us to write for the equality $\lambda = \lambda_c = \omega_n'$,

$$\omega_d = \omega_n \sqrt{[1 - (\lambda/\lambda_c)]} \quad (23a)$$

where (λ/λ_c) is often called the damping ratio.

The condition for oscillatory motion given in equation (22b) is that ω_n is real which, in turn, from equation (20b) requires that

$$M_1 < 0 \quad (23b)$$

Under the condition where equations (22b) and (23b) are satisfied, stability (subsident motion) requires that

$$2\lambda = [H_1 - C_D^*] > 0 \quad (24a)$$

$$\omega_n^2 = -M_1 > 0 \quad (24b)$$

Thus to assess dynamic and static stability (equations (24a,b) respectively) it is necessary to assign numerical values to the derivatives contained in equations (16a) and (16b). Numerical values for these terms are contained in Table I. While these values may vary with airship dimensions, they have been computed for the airship shown in Figure (2) below. An outline of the computational technique is given subsequently.

$$2\lambda = [H_1 - C_D^*]$$

$$\frac{[1 - k_y^{-2} C_{m\dot{y}}^*][C_D^* + C_{z\dot{\alpha}}^*] + (1 + C_{z\dot{\beta}}^*) k_y^{-2} C_{m\dot{\alpha}}^* + (1 - C_{z\dot{\alpha}}^*) k_y^{-2} C_{m\dot{y}}^* + k_y^{-2} C_{z\dot{y}}^* C_{m\dot{\alpha}}^*}{k_y^{-2} C_{z\dot{y}}^* C_{m\dot{\alpha}}^* - (1 - C_{z\dot{\alpha}}^*) [1 - k_y^{-2} C_{m\dot{y}}^*]} - C_D^*$$

Inserting values from Table I gives,

$$\frac{[1 + 2.98][.044 + .049] + (1+0)(-2.31) + (1+2.30)(2.31) + (22.36)(-.119)}{(-2.31)(-.119) - (1 + 2.297)(1 + 2.98)}$$

$$-.0437$$

$$-.234 - .0437 = -.278$$

Quite obviously the inequality of equation (24a) is not met so the airship is not dynamically stable.

In considering the oscillatory frequency relationship for static stability (equation (24b)) we may write:

$$M_1 = \frac{\{(1 - K_y^2 C_{m\dot{g}}^*) (C_D^* + C_{z\alpha}^*) + K_y^2 C_{z\dot{g}}^* C_{m\alpha}^*\} C_D^* + (C_D^* + C_{z\alpha}^*) K_y^2 C_{m\dot{g}}^* - (1 + C_{z\dot{g}}^*) K_y^2 C_{m\alpha}^*}{K_y^2 C_{m\alpha}^* C_{z\dot{g}}^* - (1 - C_{z\alpha}^*) [1 - K_y^2 C_{m\dot{g}}^*]}$$

It can readily be shown that since the term in the braces is multiplied by C_D^* it is rather small. This allows the above expression to be numerically evaluated as

$$M_1 = 1.73$$

Obviously the second condition of equation (24b) is not met.

It might be expected that numerical values of the stability derivatives would vary from airship to airship. However, it would appear that no general simplifications may be made in the H_1 and M_1 coefficients except to omit terms multiplied by C_D^* . The results seem to indicate that for a satisfactory description of planar dynamics it is necessary to calculate the eight stability derivatives of Table I. Drag, as we have noted, is relatively unimportant for estimating the planar dynamics.

In passing it might be of interest to examine the equivalent expressions for H_1 , M_1 , A_1 , and G_1 , which are satisfactory for an HTA vehicle. If quantities such as $C_{m\dot{q}}^*$, $C_{z\dot{q}}^*$, $C_{z\dot{g}}^*$, and $C_{z\dot{\alpha}}^*$ are ignored along with the product of starred quantities one, has

$$H_1 = - [C_{z\alpha}^* + K_y^2 (C_{m\alpha}^* + C_{m\dot{g}}^*)] \quad (25a)$$

$$M_1 = K_y^2 C_{m\alpha}^* \quad (25b)$$

$$A_1 = K_y^2 C_{m\dot{g}}^* \quad (25c)$$

$$G_1 = - \left[\frac{g}{l} K_y^2 C_{m\dot{g}}^* \right] \quad (25d)$$

Quite clearly the criteria of equations (24) are met when $C_{m\dot{q}}^* + C_{m\alpha}^*$ and $C_{m\alpha}^*$ are negative for the HTA vehicle. An examination of equations (16a) and (16b) quickly show that dynamic stability cannot depend upon such simple criteria in the case of an LTA vehicle: stability considerations are far more complex for the LTA vehicle.

For a typical airship we have seen that the motion consists of one exponentially undamped mode and one exponentially damped mode since from equation (19)

$$\lambda_{1,2} = -\lambda \pm \sqrt{\lambda^2 - \omega_n^2} = -\lambda \pm \sqrt{\lambda^2 + M_1} \quad (26)$$

and using $\lambda = -.139$ and $M_1 = 1.73$ we obtain

$$\lambda_1 = .479 \quad \lambda_2 = -1.18$$

As is well known, the fixed-wing HTA vehicle usually evidences two damped oscillatory modes.

CALCULATION OF AERODYNAMIC LOADS

A fairly straightforward method of calculating static and dynamic loads on an airship is the method of virtual mass. While this technique has its origin in the work of nineteenth-century hydrodynamicists, it has been applied with some success by Bryson⁽²⁾ to HTA vehicles. Since space limitations do not permit even an outline of the derivation, reference should be made to either Bryson's work⁽²⁾ or the more readable treatment of Nielson⁽³⁾.

Through the use of this virtual mass technique it may be shown that the derivatives used in the previous expressions for H_1 and M_1 are given as,

$$C_{z\ddot{x}} = 2BC_D^* - 2A_{11} \quad (27a)$$

$$C_{z\dot{x}} = -4B_{11} \quad (27b)$$

$$C_{z\ddot{y}} = 4\bar{A}_{11} \left(\frac{x}{\ell}\right)_b \quad (27c)$$

$$C_{z\dot{y}} = 4C_{11} \quad (27d)$$

$$C_{m\alpha} = -2C_{11}C_D^* + 2\left(\frac{x}{\ell}\right)_b \bar{A}_{11} + 2B_{11} \quad (27e)$$

$$C_{m\dot{\alpha}} = 4C_{11} \quad (27f)$$

$$C_{m\dot{q}} = -4\left(\frac{x}{\ell}\right)_b \bar{A}_{11} - 4C_{11} \quad (27g)$$

$$C_{m\ddot{q}} = -4D_{11} \quad (27h)$$

where

$$A_{11} = \pi \bar{a}(x)^2 / S \quad (28a)$$

for body-alone and that

$$A_{11} = \bar{1} \bar{s}(x)^2 \left[L - \frac{\bar{q}(x)^2}{\bar{s}(x)^2} + \frac{\bar{a}(x)^2}{\bar{s}(x)^2} \right] \quad (28b)$$

for the body in the presence of fins. $a(x)$ is the body radius as a function of body station and $s(x)$ is fin span (center-line to tip) as a function of body station. In addition B_{11} , C_{11} and D_{11} are defined as

$$B_{11} = \int_{(x/\ell)_b}^{(x/\ell)_n} A_{11} \left(\frac{x}{\ell}\right) d\left(\frac{x}{\ell}\right) \quad (29a)$$

$$C_{11} = \int_{(x/l)_b}^{(x/l)_n} \left(\frac{x}{l}\right)^n A_{11} d\left(\frac{x}{l}\right) \quad (29b)$$

$$D_{11} = \int_{(x/l)_b}^{(x/l)_n} \left(\frac{x}{l}\right)^2 A_{11} d\left(\frac{x}{l}\right) \quad (29c)$$

when "n" and "b" refer to nose and base respectively.

The above integrals have been evaluated numerically for the airship shown in Figure (2) from tabular values of $a(x)$ and $s(x)$. The calculations of equations (27) were carried out to give the results shown in Table I.



LENGTH (FT)	DIAMETER (FT)	VOLUME (FT ³)	MOM. OF INERTIA (SLUG-FT ²)
517	120	4.4 X 10 ⁶	1.42 X 10 ⁸

FIG. 2 REPRESENTATIVE AIRSHIP

TABLE I

C_{Zd}	$C_{Z\dot{d}}$	$C_{Z\ddot{d}}$	C_{Zg}	$C_{m\dot{d}}$	$C_{m\ddot{d}}$	C_{mg}	$C_{m\dot{g}}$
.03165	-1.458	10 ⁻⁹	-0.0756	.7305	-0.0756	+0.0756	-0.09725

Also calculated in the program is the airship volume $V = 4.4158 \times 10^6$. Assuming neutral buoyancy it can be shown that $(\rho SL/2m)$, equals 1.57, which together with values in Table I allows the starred derivatives (equation (10)) to be calculated.

CONCLUSION

This paper has taken a brief look at the hydrodynamic complexities of planar dynamics of airships. It has been shown that the equations of motion for a LTA vehicle are far more complex than the corresponding equations of a HTA vehicle. A method has been presented for calculating all loads (except drag) acting on a moving airship.

REFERENCES:

1. Murphy, C. H., "Free Flight Motion of Symmetric Missiles," BRL Report 1216, Ballistic Research Laboratories (July 1963).
2. Bryson, A. E., "Stability Derivatives for a Slender Missile with Application to Wing-Body-Vertical-Tail Configurations," Journal of the Aeronautical Sciences, Vol. 20, No. 5, pp. 297-308 (1953).
3. Nielson, J. N., Missile Aerodynamics, McGraw-Hill Publishing Co. (1960).

FLOATING vs. FLYING,
A PROPULSION ENERGY COMPARISON

Fendall Marbury*

ABSTRACT: Floating craft are compared to those that fly. Drag/weight for floaters is shown to be proportional to v^2/L , while for flyers it is independent of size and speed. The transportation market will therefore assign airships to lower speeds than airplanes, and will favor large airship sizes. Drag of an airship is shown to be only 11 percent of submarine drag at equal displacement and speed, raising the possibility that airships can compete with some types of ships.

INTRODUCTION

Excitement over airships is again on the rise, and many expect their second coming, including this author. As a result of this ferment, the air is already full of proposals, some alleged to float, others in part to fly, all claiming to be advantageous.

Nor are floating and flying confined to airship proposals. When airships reenter the transportation business, they will be in direct competition with ships that float in water, airplanes that fly in air, and a growing variety of craft that fly on water.

This therefore seems to be the right time, and this Workshop a suitable occasion, at which to take stock of floating and flying in air and in water. The groundwork has already been done, and all that remains is to organize the data so that useful comparisons can be made. Hopefully the results will be helpful both in sorting out airship proposals and in steering airships towards their proper place in the future transportation picture.

* Naval Architect, Ketron, Inc., Arlington, Virginia, U.S.A.

DRAG PER UNIT DISPLACEMENT AS A CRITERION OF COMPARISON

The general standard of comparison in this paper will be the ratio of drag to displacement, both being measured in the same units, or its equivalent for flying machines, drag per unit weight. This is in effect a craft's friction coefficient, the best single index of its energy consumption, and one of only a few important determinants of its economic performance.

Consider for instance a craft traveling a distance E from one place to another, having drag D and displacement or weight W . Then,

$$Q = D E \quad (1)$$

Q being the energy consumed by the trip, and

$$T \sim W E \quad (2)$$

T being the amount of transportation produced or producible by the trip. It follows that the ratio R of energy consumed to transportation produced is

$$R = \frac{Q}{T} \sim \frac{D}{W} \quad (3)$$

Other things equal, a craft burns fuel in direct proportion to its drag-to-weight ratio. Besides having to be bought, the fuel must also be carried, detracting from the ability to carry a payload in all but nuclear-propelled craft. It follows that, as the drag-to-weight ratio goes up, the upper limit on endurance comes down.

The market for transportation has imposed a selection process on the various types of craft and their particular designs. The market will accept higher drag-to-displacement only if it gets something in return. What it usually gets is more speed, which has value on the market. As a result, if the craft which coexist at any time are ranked in order of ascending drag/weight, most of them will also be in order of ascending speed. The exceptions, many of them watercraft, will be found to have something else to offer, often a combination of lower first cost and access to more numerous or cheaper terminals.

Compared to other craft, airships have never come at a low price per pound, nor are they known for easy handling at terminals. If airships can have any fundamental advantage over competing craft, it is probably a lower drag per ton. It will be shown that this advantage can indeed be substantial, but that proper choices of both size and speed are required to realize it.

FLOATING

Floating Itself

Craft that operate in air or water must be sustained from sinking to the ground, and floating is the most popular method of doing this. In this application, it has two notable characteristics:

Floating in the usual steady state consumes no energy. This no doubt accounts for its widespread use and is part of the reason that boats were already well developed

at the dawn of recorded history.

The second feature of floating is that it ties craft volume to craft weight. The buoyant force results from the higher static pressure on the bottom of the craft than on the top, and by Archimedes' principle it is equal to the weight of fluid displaced. The buoyant force on a floating craft must equal its weight. In the usual notation, this requirement is:

$$W = \rho g V \quad (4)$$

where W is craft weight, ρ the mass density of displaced fluid, g the acceleration of gravity, and V the immersed volume. With airships as with submarines, V is constant. If anything is brought aboard, something else of equal weight must be taken off. During the first airship era, this nearly inflexible requirement cost substantial amounts of time, money and lift gas¹. The classic Zeppelin cannot actually remain much Lighter Than Air; it has always to be about the same weight.

Drag/Weight for Floating Craft

The weight-volume relationship (4) has an effect on the drag/weight ratio of floating craft, which will now be developed.

Drag - With hulls as with most other objects, the drag due to motion through a fluid is most conveniently expressed as:

$$D = C \frac{\rho}{2} S v^2 \quad (5)$$

where v is the velocity of the motion, S is some characteristic area of the object, and C is a dimensionless coefficient. When the object's shape is such as to deflect the flow or to induce strong turbulence, most of the drag is in the form of pressure differences across the object, and C is constant. As $(\rho/2)v^2$ is the stagnation pressure of the flow, it is the custom to take S as the object's cross-sectional area normal to the flow and to think of C as the average fraction of stagnation pressure which acts on the object. Drag of this type is called "pressure drag".

Hulls, however, are designed specifically to minimize pressure drag. They do not as a rule deflect the flow, nor are many turbulence-inducing objects allowed to stick out of them. The passing flow remains attached to a good hull far aft, with the result that the pressure buildup around the bow is balanced by similar pressures on the stern. Net pressure drag can be and often is quite low, in the sense that C is much less than unity.

What hulls cannot be designed to avoid is frictional drag. Be they never so smooth, it is still substantial and is the largest single drag component of ships at low speeds, and of airships and submarines at all speeds. As friction acts tangentially on the hull's envelope, it is customary to use the wetted surface, or area of the envelope, as S when equation (5) is used on a hull. For C_f , the frictional resistance coefficient, one uses the value for a flat plate having the hull's length and speed.

C_f is not quite constant; it diminishes slowly as the Reynolds number vL/ν rises. If frictional resistance were fitted to an equation like (5) with C constant, the exponent of v would be in the range 1.8 to 1.9, slightly less than 2. To simplify the

following discussion, it will be assumed for a while that equation (5) holds for turbulent friction with a constant drag coefficient.

Drag/Weight - For geometrically similar hulls, V is proportional to L^3 and S to L^2 . Calling the constants of proportionality C_V and C_S , and using (5) and (4),

$$\frac{D}{W} = \frac{C_t(1/2) \rho C_S L^2 v^2}{\rho g C_V L^3} = \frac{C_t C_S}{2 C_V} \frac{v^2}{g L} \quad (6)$$

Drag/Weight for a hull is seen to be directly proportional to v^2/L . The non-dimensional quantity v^2/gL happens to be the square of the Froude number, a common speed parameter for surface ships. Two geometrically similar surface hulls will have the same value of wavemaking R/W when run at the same Froude number. Its appearance here, where no wavemaking is involved, is coincidental.

Equation (6) is important, because it points out clearly the direction in which to seek transport efficiency for ships, including airships. Ships should be large and not too fast. A small, fast ship or airship is apt to be a technical tour de force and an economic disaster.

Air vs. Water Performance

At present, nearly all floating craft operate in water. Here in this Workshop we are studying the proposition that more of them should operate in air. It will therefore be in order to make a couple of air/water drag comparisons.

Same Object at Same Speed - Assuming pressure drag for this simple case, every quantity on the right-hand side of (5) is the same for air as for water, except the mass density. Typical values of mass density are $0.00238 \text{ lb-sec}^2/\text{ft}^4$ for sea-level air and $1.99 \text{ lb-sec}^2/\text{ft}^4$ for sea water at 59°F . Using these values, with subscripts a and w for air and water, respectively,

$$\frac{D_a}{D_w} = \frac{\rho_a}{\rho_w} = 0.00120 \quad (7)$$

As anyone who has gone wading can testify, air drag is negligible compared to water drag, on the same object. This result explains the typical appearance of ships, clean on the bottom and cluttered on top. In fact, ships have little to fear from wind, while it ranks as a major threat to airships.

Same Displacement at Same Speed - While (7) may be interesting, it is hardly a fair basis on which to compare air and water craft. In this section an airship will be compared to a geometrically similar submarine. Both will have the same displacement, as well as the same speed, making the ratio of their drags an estimate of their relative fuel consumptions to produce the same amount of transportation. Drag will be assumed frictional, though in fact it has a pressure component.

Using (4) with $W_a = W_w$ and with the density ratio in (7) the hull size ratios are first obtained:

$$\frac{v_a}{v_w} = \frac{\rho_w}{\rho_a} = 836 \quad (8)$$

$$\frac{L_a}{L_w} = 836^{1/3} = 9.42 \quad (9)$$

$$\frac{S_a}{S_w} = 836^{2/3} = 88.7 \quad (10)$$

showing that the airship is enormously larger than a submarine of equal displacement. The ratio of their Reynolds numbers will now be computed using for dynamic viscosities, $\nu_a = 1.56 \times 10^{-4}$ ft²/sec for air at sea level, and $\nu_w = 1.28 \times 10^{-5}$ ft²/sec for sea water at 59°F.

$$\frac{R_{na}}{R_{nw}} = \frac{L_a}{L_w} \frac{\nu_w}{\nu_a} = 0.77 \quad (11)$$

To use (11), let $R_{nw} = 10^9$, which is entirely possible. That makes $R_{na} = 7.7 \times 10^8$. From the table of Schoenherr flat-plate friction coefficients²

$$\frac{C_{fa}}{C_{fw}} = \frac{1.58 \times 10^{-3}}{1.53 \times 10^{-3}} = 1.03 \quad (12)$$

With little difference between air and water frictional drag coefficients, and no difference between the two pressure drag coefficients, the drag ratio that is about to be obtained will be a robust approximation, insensitive to the proportions of frictional and pressure drag, and therefore valid for a wide variety of hull forms, appendages, etc.

Using (12), (10), and (7) in (5), the desired drag ratio is obtained:

$$\frac{D_a}{D_w} = 0.11 \quad (13)$$

The airship has only 1/9th the drag of a submarine of equal displacement at the same speed! It follows that the airship could go from port to port about three times as fast as the submarine without burning any more fuel.

The writer, a card-carrying naval architect, was at first unsettled by result (13), which makes it appear that airships might put ships totally out of business. Further reflection made this appear less likely.

For one thing, many ships can carry two or three times their light weights, while the navigable classes of Lighter Than Air craft do well to carry loads equal to their light weights. For an airship to be competitive with tankers in energy consumption, it would have to be more than 7000 feet long by 1000 feet in diameter, while operating

at less than 50 knots. Winds being what they are, such a low-powered behemoth would be unsafe.

Airships look much better for some of the marine express trades. Container ships, Roll-on, Roll-off (RoRo) ships, seagoing ferries and passenger ships operate at much higher values of D/W than tankers, often five or six times as high. All of them are lighter than the big tankers, and in many cases their payloads are less than half of full-load displacement. Moreover, as is not the case with tankers, many of these ships' customers wish they were faster and would be willing to pay a premium for more speed.

All this adds up to the possibility of a large commercial market for airships. They are more difficult and costly to build than water ships, but in the matter of fuel costs, equation (13) leaves airship designers plenty of room for maneuver.

FLYING

Flying as an Escape from Hull Drag

Where cheap transportation or long distance endurance is called for, a floating hull at low speed is unbeatable. As equation (6) makes clear, however, the same hull will encounter rapidly increasing, arbitrarily high drag as speed is increased. To make a craft go faster without becoming much bigger or heavier, one must do something drastic to decrease the drag of the hull.

In airplanes (and in land vehicles, for that matter) the strategy is to shrivel the hull, making it much denser than the air it passes through, so that its "wetted" surface is far smaller than that of an airship of the same weight. This approach fails underwater, because only solid lumps of metal have the required density, and they do not make useful hulls. The system used by high-speed marine craft is to lift the hull out of water, or almost out of water, so as to achieve the type of drag reduction illustrated by (7).

Whatever is done, the result is a hull which cannot float while operating at design speed and must be supported by other means. The simplest and most popular such means, for aircraft at least, is a wing fixed to the hull which generates the needed lift. This method, called "flying", will be used for illustration here.

Induced Drag, the Price of Flying

Wing performance data can be condensed by the use of expressions analogous to (5).

$$C_L = \frac{L}{1/2 \rho S v^2} \quad (14)$$

$$C_D = \frac{D}{1/2 \rho S v^2} \quad (15)$$

where the symbols the same as before, except that L is the lift force, at right angles to the flow, and S is the wing's planform area, slightly less than half its "wetted" surface. For a flying craft, $L = W$, the craft's weight.

Both lift and C_L are directly proportional to the wing's angle of attack. The drag has frictional and pressure components, as with a hull, but its characteristic component is the induced drag, the drag due to lift. For a wing of elliptical planform (the most efficient planform), the drag coefficient is³:

$$C_D = c_d + \frac{C_L^2}{A} \quad (16)$$

where c_d is the coefficient of the hull-like drags and A is the aspect ratio, defined as b^2/S , where b is the wingspan. Using (14), (15) and (16), it is possible to write an expression for D/W while flying:

$$\frac{D}{W} = \frac{D}{L} = \frac{C_D}{C_L} = \frac{c_d + \frac{C_L^2}{A}}{C_L} \quad (17)$$

Bearing in mind that C_L is determined by the wing section, angle of attack and A , all geometric properties of the wing or the flow past it, (17) has a remarkable property. Speed, size and weight all are absent. To this first-order approximation, flying may be done at any speed (and size) with equal efficiency. At craft design stage, more speed merely produces a smaller wing, leaving the product Sv^2 unchanged.

Proof that flying D/W is indeed approximately constant can be found in what has happened to commercial aircraft since World War II. As soon as suitable engines became available, their speeds tripled. The cost of this advance was low in drag and fuel consumption. In fact, the new jet airlines showed better overall economy than their slower predecessors.

FLOATING COMPARED TO FLYING

The behaviors of D/W in floating and flying craft contrast strongly, the former varying as v^2/L , the latter scarcely changing over a wide speed range. From this it is clear that low speed and large size favor airships over airplanes. This section presents the results of some rough airship performance calculations compared to typical flying performance. One result is estimates of the speeds and weights at which both have the same drag, and would therefore burn about the same amounts of fuel.

For the airship hull, DTMB Model number 4165 was used. This is the best member of Series 58, a related group of bodies of revolution that were tested underwater at what is now the Naval Ship Research and Development Center, Carderock, Md. Its ratio of length to diameter is 7.0 and its prismatic coefficient 0.60. It looks suitable as an airship hull, and tests⁴ indicated its residuary resistance coefficient (pressure drag coefficient) to be 0.00037, based on wetted surface and using the Schoenherr friction line.

Experience with past airships⁵ indicates that a generous allowance should be made for the drag of control surfaces and other protrusions, which often had drag comparable to that of the bare hull. In the calculations presented here, residuary resistance coefficient is taken as 0.0004, and the allowance for non-hull drags

as 0.0016, for a total non-frictional drag coefficient of 0.0020, based on wetted surface. For comparison, the friction drag coefficients ranged from 0.0019 to 0.0013, and were taken from the Schoenherr line². This makes the sum of the non-frictional drags greater than the frictional drag at all speeds. It is intended to represent an airship performance level that can be achieved easily.

Calculations were made at displacements of from 200 to 2000 tons in sea-level air and at speeds to 200 knots. The dimensions of the different-sized airship hulls are given in Table 1, while D/W is plotted vs. speed in knots on Figure 1.

Table 1.

Dimensions of Geosim Airships

Displacement, Long Tons	Length, Feet	Diameter, Feet
200	847	121
500	1149	164
1000	1449	207
1500	1658	237
2000	1825	261

For comparison to the airship results, figure 1 also shows two levels of flying performance, lines of constant D/W at 0.05 and 0.10. The former represents very good flying performance, well above average for flying generally but closer to a par performance for an airplane that might compete with airships. Many sailplanes can do better, reaching D/W's in the neighborhood of 0.03, but a great majority of powered aircraft operate above the 0.05 line.

The other line, at D/W = 0.1, is closer to typical performance for airplanes generally, but most planing hulls and many hydrofoils have higher D/W than this. Taken together, these two lines bracket most of the flying competition for airships.

The speeds below which airships consume less energy than nearly all airplanes can be read directly from figure 1, ranging from about 90 knots at airship displacement 200 tons to 135 knots at 2000 tons. Airship speeds at D/W = 0.1 range from 125 knots at 200 tons to just over 180 knots at 2000 tons. Higher speeds than these are unlikely to make sense, unless justified by special conditions.

At the intermediate speeds, for instance 90 to 125 knots at 200 tons or 135 to 180 knots at 2000 tons, airships will have flying competition. The flying competition will probably operate at higher speeds, because, once enough drag is incurred to make flying possible, increase of speed is relatively cheap. An airship, on the other hand, always has the choice of operating more slowly, thereby achieving greater economy and longer range. Many water ships are doing this right now, the practice having become widespread about a year ago, when ship fuel first became scarce, then tripled in price. This feature of floating craft has both commercial and military survival value, and no flying machine can do likewise.

To conclude, figure 1 suggests the speculation that, within a generation or so, air transportation will have come to resemble the existing marine system. The heavy

hauling will be done by large, floating ships, while most passengers and some freight of high intrinsic or time value will still fly.

Figure 2 is provided for direct comparison of airships to craft for which readers may have data, being a plot of effective horsepower vs. speed in knots for the five displacements tried. Those displacements were, as it happens, chosen with our co-host the Navy in mind. Several hydrofoil and military planing-hull craft have displacements in the neighborhood of 200 tons, while 2000 tons matches both pre-World War II destroyers and the prototype Surface Effect Ships (SES's) now in development.

Those destroyers made about 36 knots on 70,000 shaft horsepower. Their effective horsepowers must therefore have been around 40,000, possibly higher. Had they been airships, that much effective horsepower would have been good for about 100 knots.

Winged airships have been proposed, which partly float and partly fly. A major motive behind these proposals is apparently to replace the balky buoyancy controls of past airships with something more accurate and faster-acting. This analysis shows, however, that such a mixed-lift craft will incur a drag penalty.

Suppose, for instance that such a craft has a hull of 500 tons displacement and a wing that supports another 500 tons, and that it operates at about 105 knots, where according to figure 1 both hull and wing have D/W of 0.05. As also shown by figure 1, the same lift and speed could be achieved by a 1000-ton pure airship at D/W of about 0.04, burning 20 percent less fuel.

This is not to say that mixed lift is wrong, because the problems it could solve are substantial. However, the cost in added drag inclines the author to think that dynamic lift for airships should be used in moderation, much as it is in submarines. If only enough is provided to give the buoyancy controls time to respond to emergencies, then safety will be enhanced at small cost in fuel.

CONCLUSIONS

To recapitulate, the foregoing investigation suggests the following conclusions:

Airships should be large, but not too fast.

Bigger is better, just as with ships. Large airships can have an operating speed which is, at the same time, high enough to stem head winds and avoid storms, and low enough to make them more economical to operate than airplanes. For displacements under 2000 tons, this analysis suggests 80 to 120 knots as about the right speed range. The upper limit could be increased a few tens of knots by careful design.

For small airships, the demands of safety and economy conflict. If made fast enough for all-weather operation, they become non-competitive with airplanes through higher fuel consumption.

Airships may become competitive with the faster types of ships.

Compared to such ships, airships appear to offer the possibility of more speed

without more fuel consumption, while carrying the same payloads for the same distances.

Wings on airships cause added drag.

Small wings may well be worth having as fast-acting backstops for the buoyancy control systems, but large wings are suspect. Wings improve airship drag-weight only at speeds so high that pure flying would be better yet.

REFERENCES:

1. Hook, T., Shenandoah Saga, Air Show Publishers, Annapolis, Maryland (1973)
2. Gertler, M., A Reanalysis of the Original Test Data for the Taylor Standard Series, David Taylor Model Basin Report 806, Washington, D.C. (March 1954), Appendix 6.
3. Abbott, I. H., and v. Doenhoff, A.E., Theory of Wing Sections, Dover Publications, Inc., New York, N.Y. (1959), pages 1-8.
4. Gertler, M., Resistance Experiments on a Series of Streamlined Bodies of Revolution - for Application to the Design of High-Speed Submarines, David Taylor Model Basin Report C-297 (April 1950)
5. Hoerner, S. F., Fluid-Dynamic Drag, published by the author, New Jersey (1965), page 14-1.

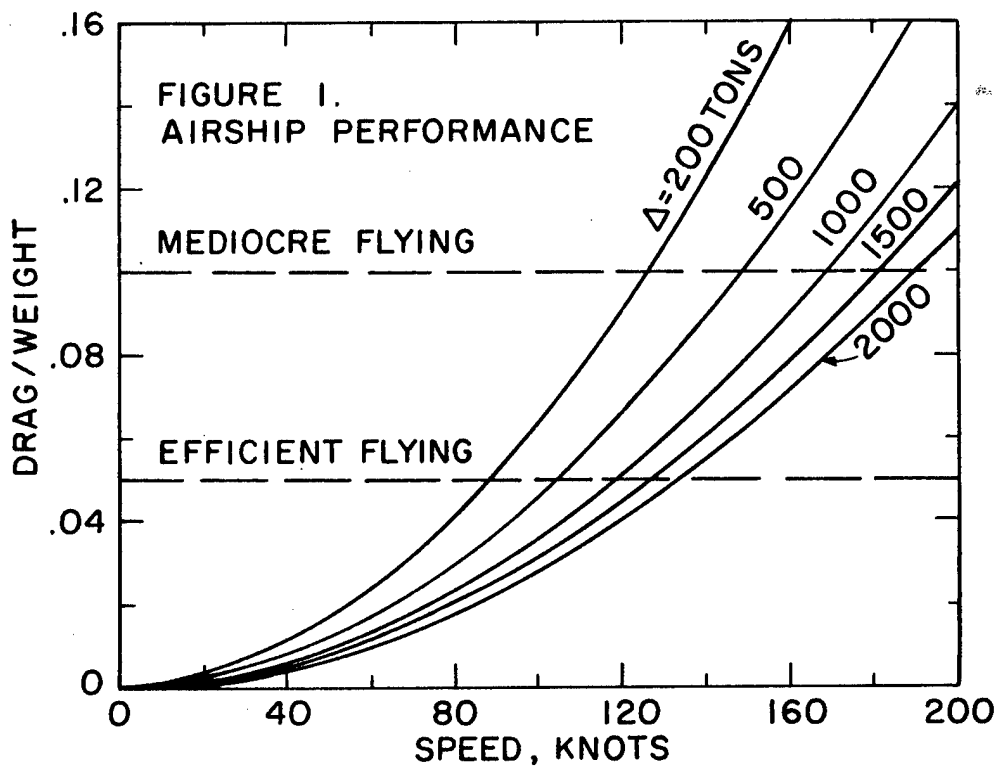

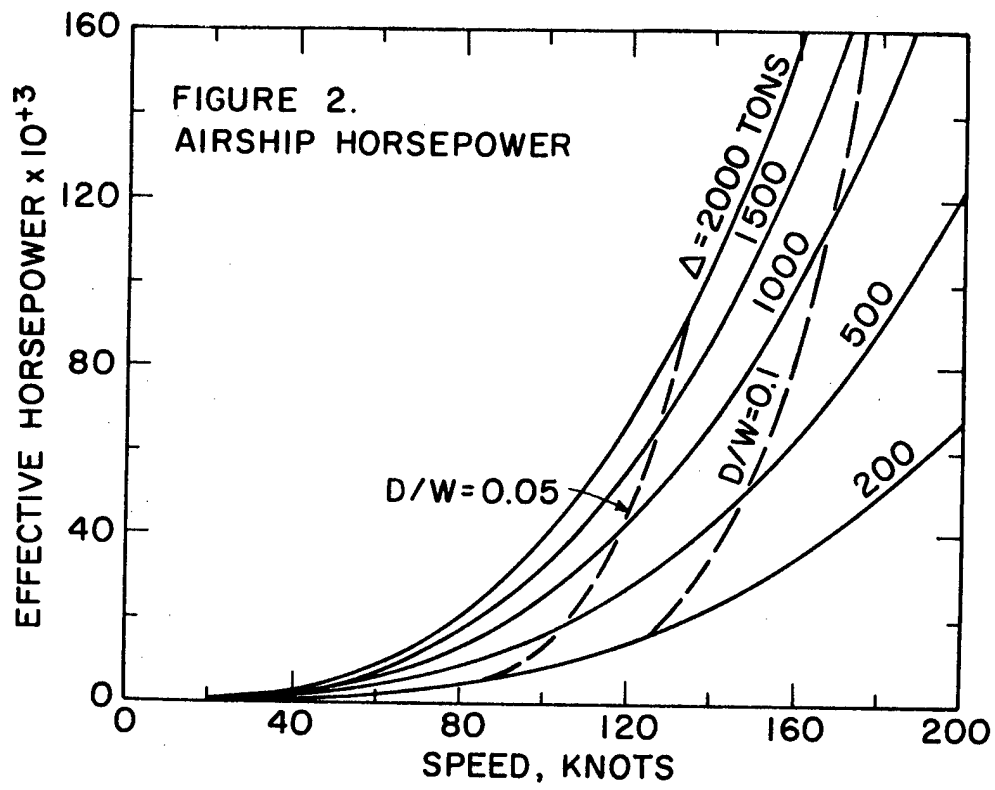

LONG FLUID FILLED BAGS
SUSPENDED BY LINE FORCES

H. L. Mullins*

J. L. Duncan**

ABSTRACT: A previous analysis of fluid filled storage bags is extended to the case of a long fluid filled cylindrical membrane supported by uniform line loads. Cross-sectional shape, stiffness of the support system and stress resultants in the membrane are determined. The application of the numerical results to problems arising in the design of non-rigid airships is discussed.

INTRODUCTION

Long fluid filled bags are used for a variety of purposes and examples which have been studied include sausage-like storage bags for oil ⁽¹⁾, portable silos ⁽²⁾, inflatable structures including life-rafts ⁽³⁾, suspended cylinders ⁽⁴⁾ and a variety of non-rigid pressure airships, "blimps", and semi-rigid dirigibles ⁽⁵⁾.

The long filled cylinder resting on a horizontal flat base was considered by Demiray and Levinson. ⁽¹⁾ They obtained a solution for the stress resultants and the shape of the bag in repose. In this present work, their analysis is employed and extended

*Graduate Student, Dept. of Mechanical Engineering, McMaster University, Hamilton, Ontario, Canada.

**Professor, Dept. of Mechanical Engineering, McMaster University.

to apply to the case in which the long bag is supported by concentrated loads applied to the membrane along lines parallel to the bag axis. It is shown that the results can be summarized by functional relationships of non-dimensional parameters and some numerical results are presented.

The solutions are relevant to the design of non-rigid pressure airships. In these vehicles the principal fixed weight, the car, is attached to the fabric envelope by a so-called "catenary" suspension system inside the envelope as shown in Fig 1.

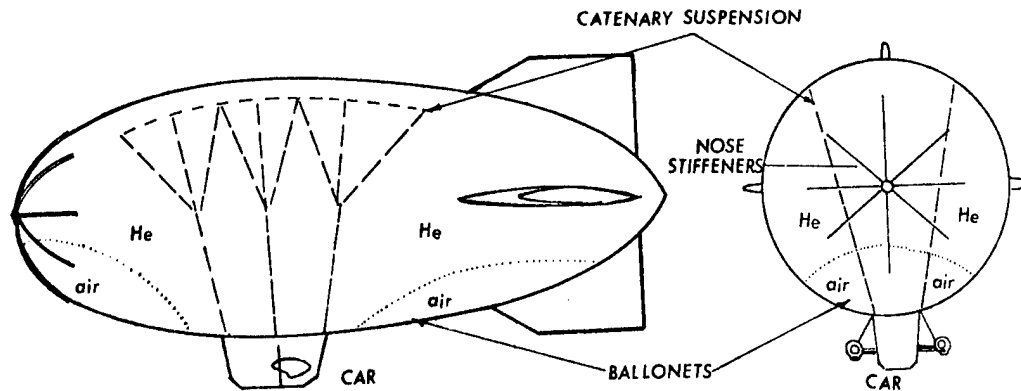

Fig 1 General arrangement of a non rigid pressure airship

The envelope is maintained at a constant differential inflation pressure by pumping air into the ballonets shown. The fabric is reasonably light and woven in such a way as to resist both direct and shear strains. The inflation pressure is sufficient to maintain the shape of the envelope under static and aerodynamic loads. The application of the numerical results of the two dimensional analysis to the case of airship envelopes is discussed.

THE ANALYSIS

The membrane is assumed to be inextensible in all directions, to have zero flexural rigidity and to be weightless. We consider a normal section of an infinitely long uniform bag. Under equilibrium conditions, the cross section is represented by the curve,

$$\begin{aligned} x &= x(s) & x(0) &= 0 \\ y &= y(s) & y(0) &= 0 \end{aligned} \quad (1)$$

where (x,y) is a set of rectangular cartesian coordinates and s is the arc length measured from the lowest point, the origin, in Fig 2.

The stress resultant in the membrane is T , which is constant between loads, and the angles between the tangent to the membrane and the horizontal is $\theta(s)$. For the cases to be considered here, the hydrostatic pressure or more strictly the differential pressure across the membrane, is $p(s)$ which is taken as,

$$p(s) = p_o + wy \quad (2)$$

where p_o is the inflation pressure at the lowest point, $y = 0$, and w is the difference in specific weight between the fluids inside and outside the membrane. In general w may be either positive or negative and in the problems considered, it is constant i.e. the fluids are incompressible.

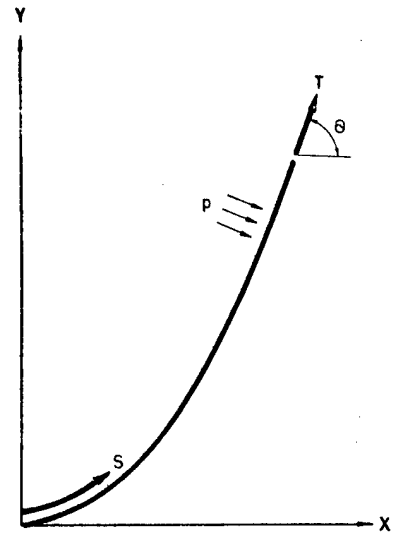

Fig 2 Membrane Coordinates

The general solution to the problem for $w < 0$ is given by Demiray and Levinson⁽¹⁾. Define R as $1/2\pi$ times the perimeter of the membrane cross-section. The following dimensionless groupings will be used:

$$\frac{x}{R}, \frac{y}{R}, \frac{s}{R}, \frac{p_o}{Rw}, \frac{T}{p_o R}$$

For convenience in writing the following equations define

$$k^2 = \frac{4Tw}{p_o^2} = 4 \frac{(T/p_o R)}{(p_o/Rw)} \quad (3)$$

For $(4Tw/p_o^2) > 0$, Ref (1) obtains

$$\frac{y}{R} = \frac{p_o}{Rw} \{ \sqrt{[1+k^2 \sin^2(\theta/2)]} - 1 \} \quad (4)$$

$$\begin{aligned} \frac{x}{R} = & 2 \frac{T}{p_o R} \frac{\sin \theta}{\sqrt{[1+k^2 \sin^2(\theta/2)]}} \\ & - \frac{p_o}{Rw} \sqrt{(1+k^2)} E \left[\alpha, \frac{k}{\sqrt{(1+k^2)}} \right] \\ & + \left(2 \frac{T}{p_o R} + \frac{p_o}{Rw} \right) \frac{1}{\sqrt{(1+k^2)}} F \left[\alpha, \frac{k}{\sqrt{(1+k^2)}} \right] \end{aligned} \quad (5)$$

$$\frac{s}{R} = 2 \frac{T}{p_o R} \frac{1}{\sqrt{(1+k^2)}} F \left[\alpha, \frac{k}{\sqrt{(1+k^2)}} \right] \quad (6)$$

where $F[\alpha, \rho]$ and $E[\alpha, \rho]$ are the elliptic integrals of the first and second kind

respectively, and α is defined by

$$\alpha = \arcsin \left[\frac{\sqrt{(1+k^2) \sin(\theta/2)}}{\sqrt{1+k^2 \sin^2(\theta/2)}} \right] \quad (7)$$

Previous work did not consider the case for $w < 0$. It may be shown ⁽⁶⁾ that for $-1 < (4Tw/p_o^2) < 0$,

$$\frac{x}{R} = 2 \frac{T}{p_o R} \left[\left(1 - \frac{2}{k^2}\right) F \left[\frac{\theta}{2}, k \right] + \frac{2}{k^2} E \left[\frac{\theta}{2}, k \right] \right] \quad (8)$$

$$\frac{s}{R} = 2 \frac{T}{p_o R} F \left[\frac{\theta}{2}, k \right] \quad (9)$$

For $(4Tw/p_o^2) < -1$,

$$\frac{x}{R} = 2 \frac{T}{p_o R} \frac{1}{k} \left[2E \left[\beta, \frac{1}{k} \right] - F \left[\beta, \frac{1}{k} \right] \right] \quad (10)$$

$$\frac{s}{R} = 2 \frac{T}{p_o R} \frac{1}{k} F \left[\beta, \frac{1}{k} \right] \quad (11)$$

where

$$\beta = \arcsin [k \sin(\theta/2)] \quad (12)$$

For both of these cases,

$$\frac{y}{R} = \frac{p_o}{Rw} \{ \sqrt{[1 - k^2 \sin^2(\theta/2)]} - 1 \} \quad (13)$$

Boundary Conditions

Demiray and Levinson considered the case of the bag resting on a flat surface. In this work, we consider the membrane acted upon by loads uniformly distributed on a line which is perpendicular to the (x,y) plane. In the first case, we consider a central line load as shown in Fig 3. The perimeter of the membrane has a total length $2\pi R$ and the membrane is filled with a buoyant fluid. The load intensity is Q per unit length. Taking Q/R^2w as the dimensionless load per unit axial length of bag and setting this equal to the buoyancy force per unit length we obtain

$$\frac{Q}{R^2w} = \int_A \frac{dA}{R^2} \quad (14)$$

The equilibrium equation at the point of application of the force i.e. at $s/R = \pi$ is

$$\theta = \arcsin(Q/2T) = \arcsin \left[\frac{(Q/R^2w)/2}{(T/p_o R)(p_o/Rw)} \right] \quad (15)$$

in terms of the above dimensionless groups.

Equations (6), (7) and (15) may be solved simultaneously on a digital computer by an iterative process.

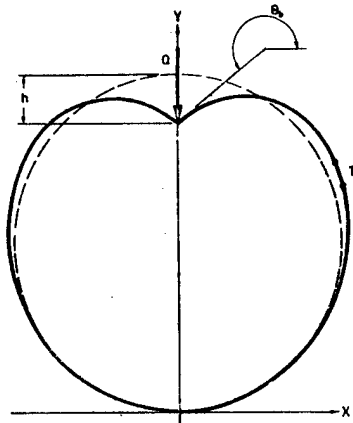

Fig 3 Central Suspension Case

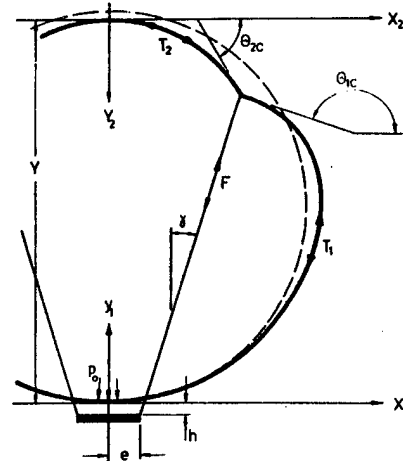

Fig 4 Twin Suspension Case

In the second case, we consider two equal line loads symmetrically disposed about the centreline as shown in Fig 4. The force intensity F arises physically from a set of inextensible cables which pass through sliding seals at the bottom of the membrane and anchor to a rigid frame of width $2e$. For convenience it is assumed that if the membrane were circular, the lower anchor point would be in the plane $y = 0$; under equilibrium conditions with the membrane deformed, the anchor point has fallen a distance h . The angle of inclination of the suspension cables in the undeformed state is designated by γ . In Fig 4, variables with the subscript 1 refer to the lower portion of the membrane below the point of application of the load; variables with the subscript 2 refer to the upper section. For the upper section axis y_2 is directed downwards as shown and w is now negative. The differential pressure at $y_2 = 0$ is $p_0 - wY$.

The boundary conditions arising from continuity of the membrane are

$$\begin{aligned} x_{1c} / R &= x_{2c} / R, & y_{1c} / R + y_{2c} / R &= Y / R \\ \phi_{1c} / R + \phi_{2c} / R &= \pi \end{aligned} \quad (16)$$

The equilibrium equation at the point C yields the further condition

$$\frac{(x_{1c} / R) - (e / R)}{(y_{1c} / R) + (h / R)} = \frac{-(T_2 / p_0 R) \cos \theta_{1c} - (T_1 / p_0 R) \cos \theta_{1c}}{(T_2 / p_0 R) \sin \theta_{2c} - (T_1 / p_0 R) \sin \theta_{1c}} \quad (17)$$

where e/R is the dimensionless cab frame width and h/R is the dimensionless suspension deflection.

NUMERICAL RESULTS

Central Support Case

Membrane shapes and stress resultants were obtained for typical conditions which might apply to a small non-rigid airship, i.e. diameter = 40 ft, inflation pressure in the range 5 to 15 lbf/ft² and $w = 0.0696$ lbf/ft³ which is the lift of pure helium at 0°C (this is a conservative value, 0.0625 lbf/ft³ often being taken for airship calculations⁽⁵⁾). The results are presented with dimensions for convenience. Fig 5 shows the deflected shapes and Table I the stress resultants and deflections of the suspension point from the position for a circular membrane.

Table I

p_o (lbf/ft ²)	T (lbf/ft ²)	h (ft)	Q (lbf/ft)
5	112.3	5.233	85.6
10	212.9	2.727	86.6
15	313.3	1.831	87.0

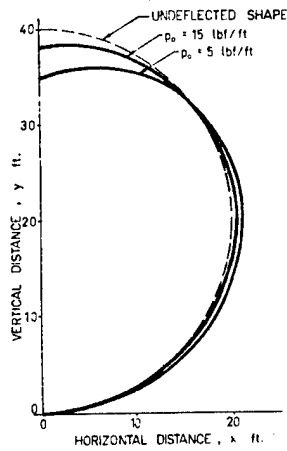

Fig 5 Cross-sectional Shapes for various inflation pressures for the central suspension case

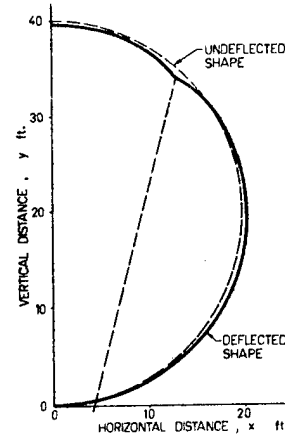

Fig 6 Cross-sectional Shape for an inflation pressure of 10 lbf/ft² for twin suspension

Two Support Case

This case, shown in Fig 4, is the more usual situation in airships and is considered further. Results were obtained for the particular geometry $\gamma = 15^\circ$ and $e/R = 0.2$. Fig 6 shows the deflected shape for a membrane of nominal diameter 40 ft and an inflation pressure $p_o = 10$ lbf/ft². Fig 7 shows the non-dimensional deflection h/R versus the non-dimensional pressure parameter p_o/Rw . Fig 8 shows the non-dimensional membrane stresses $T/p_o R$ versus p_o/Rw .

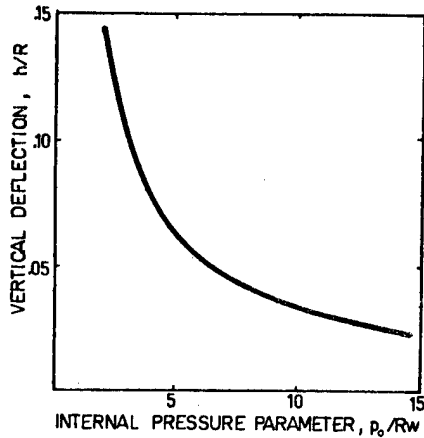

Fig 7 Suspension Deflection, h/R , versus p_o/Rw for the case shown in Fig 4; $e/R=0.2$, $\gamma=15^\circ$

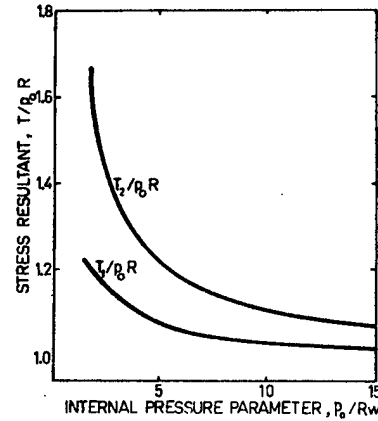

Fig 8 Stress Resultants, $T/p_o R$ versus p_o/Rw for the case shown in Fig 4; $e/R=0.2$, $\gamma=15^\circ$

THE DYNAMIC CASE

We consider the case in which the bag and the air surrounding it are subject to a vertical acceleration ng upwards. If we assume that the differential pressure at $y = 0$ is p_o as before, it may easily be shown that for the dynamic case, the differential pressure at any other point is

$$p' = p_o + (n+1)wy \quad (18)$$

The buoyancy force per unit length will be

$$Q' = w(n+1) \int_A dA \quad (19)$$

We consider that the suspension is attached to a mass which under static conditions gives rise to a vertical force per unit length $Q = w \int_A dA$ (from equation 14). Under dynamic conditions the vertical component of the suspension force will now be $Q(1+n)$ and clearly this is equal to Q' . Thus the dynamic case may be obtained from the preceding results by replacing the relative specific weight w by w' where

$$w' = (1+n)w \quad (20)$$

DISCUSSION

The analysis provides membrane shapes and stress resultants for the two-dimensional problem of the fluid filled bag and these can be applied to both the static and dynamic cases.

In a non-rigid airship, the inflation pressure p_o must be sufficient to maintain the shape of the structure under both static and dynamic loads. As an example, we consider an airship designed for a 75 mph maximum speed. Allowing for a frontal

gust of 15 mph, the maximum stagnation pressure at the nose would be 22 lbf/ft². Usually the nose contains a stiffening structure, which permits lower inflation pressures of, for example, 60% of the stagnation pressure or 13 lbf/ft² in this case. For a helium filled bag of 40 ft diameter, the non-dimensional pressure parameter would have the value of 9.3. From Figs 7 and 8, we obtain values for the vertical deflection of 8.4 inches and for the stress resultants of $T_1 = 270$ lbf/ft and $T_2 = 292$ lbf/ft. The stress resultant due to pressure only, i.e. $p_0 R$ is 260 lbf/ft so the effect of the suspension on the envelope stresses is quite small.

In the design of airships, it is customary to consider the effect of a transverse gust of about 30 ft/sec⁽⁷⁾. A vertical gust of this magnitude could give rise to accelerations in excess of 1g. In the example chosen, the parameter p_0/Rw would be halved for an upward acceleration of 1g and the deflection would be 16.6 inches i.e. approximately doubled.

There are important differences, however, between the problem formulated and the real case of an airship. These are:-

1. The analysis is for a two dimensional system. Airships will have a fineness ratio (overall length to maximum diameter) of between 3 and 5, thus curvature in the axial plane will significantly diminish the stress resultants and probably increase the overall stiffness.
2. It is not possible to arrange the suspension system in such a way that the suspension force F in Fig 4 exactly balances the buoyancy at that section. Consequently bending moments arise in the axial plane and the associated shear forces are transmitted through the membrane. These will give rise to deformations of the section which differ from those in the two-dimensional case.
3. It is customary to have a secondary suspension system in the form of a skirt or fairing between the cab and the envelope as shown in the schematic diagram in Fig 9. This will be considerably stiffer than the upper suspension system so that under dynamic loading the additional loads will be transferred to the envelope by

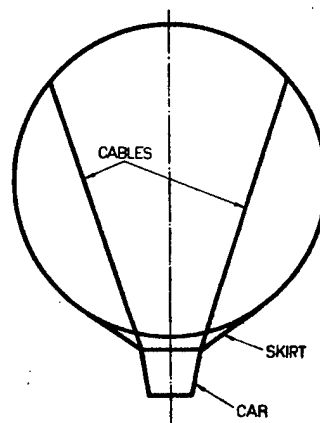

Fig 9 Schematic Illustration showing the skirt location

the skirt rather than by the cables.

4. Below the ceiling altitude of the airship, not all of the envelope is filled with helium. Up to 10% of the internal volume can be taken up by air in ballonets as shown in Fig 1. These serve to maintain the inflation pressure and allow for expansion of helium at higher altitudes i.e. on ascending air is bled off from the ballonets and this prevents loss of helium. These ballonets may have a significant effect on the deformed shape at a section.
5. The dynamic case assumes that the surrounding fluid has the same acceleration as the bag. This is not truly representative of the situation in a vertical gust where there will be an aerodynamic pressure distribution on the section due to the relative transverse velocity of the surrounding air. This problem, as well as the effect of the pressure distribution due to forward velocity are outside the scope of this work.

Other factors give rise to stress distributions and deformations in airship envelopes which have not been considered here. These include instantaneous and creep strains in the fabric, improper rigging and the effects of the empennage. It is considered, however, that the analysis and numerical results presented will assist the designer in the preliminary investigation of envelope and suspension performance in non-rigid airships.

ACKNOWLEDGEMENTS

The authors would like to thank the National Research Council for their support of the research at McMaster University and Mr. R. Schneider N.A., President of the Canadian Airship Development Corporation and Mr. E. DeAssis and Mr. D. Epps of Hoverjet Inc., for their help and advice in this work.

REFERENCES:

1. H.Demiray and M. Levinson, Int. J. Mech. Sci. 14, p431 (1972).
2. F. Otto, Tensile Structures Vol. 1, MIT Press, Cambridge,Mass.(1967).
3. G.H. Wu, J. Appl. Mech. 71, p615 (1971).
4. J.L. Duncan and A.R.Ragab, Trans CSME 1, p135 (1972).

5. C.P. Burgess, Airship Design, Ronald Press, New York (1927).
6. I.S. Gradshteyn and I.M. Ryzhik, Table of Integrals Series and Products, Academic Press, New York (1965).
7. Ministry of Transport, Civil Aeronautics Provisional Airworthiness Requirements, Airships (Canadian Government) (derived from FAR.25)

COMPUTER AIDED FLEXIBLE ENVELOPE DESIGNS

Ronald D. Resch*

ABSTRACT: This paper will deal with two computer aided design methods for the design and construction of strong, lightweight structures which require complex and precise geometric definition. The first, flexible structures, is a unique system of modeling folded plate structures and space frames. In the latter it is possible to continuously vary the geometry of a space frame to produce large, clear spans with curvature. The second method deals with developable surfaces where both folding and bending are explored with the observed constraint of available building materials and what minimal distortion would result in maximum design capability. We are developing alternative inexpensive fabrication techniques to achieve computer defined enclosures which are extremely lightweight and mathematically highly precise.

Folded Plate Systems

My discovery of kinematic folded plate systems, which I term folded mosaic structures, began some twelve years ago with a curiosity about the dynamic behavior of a crumpled wad of paper. An extended observation led me to develop an operational procedure for diagramming the bounding edges of what appeared to be the essential plates involved in the formation of an individual wrinkle. I have created diagrams of folded plate patterns which I subsequently integrated into continuous patterns by the use of symmetry operations.

Hundreds of these patterns have been made and investigated. The unique property of each is that, by allowing only folding of the sheet along the lines of the pattern, a flat sheet may be transformed into a variety of three dimensional shapes, Figure 1. These include domes, warped surfaces, and complex shells involving both. It is also possible to create structures which envelope a space by closing back on themselves. An additional feature of each pattern is that the entire system is composed of the repetition of a small number of non-identical plates. For example, the pattern shown has as few as two unique triangles generating the entire system, Figure 2.

* Associate Research Professor, Computer Science, University of Utah, Salt Lake City, Utah, U.S.A.

Although there has been some formal study in the area of kinematics -- namely, mechanics and the kinematics of machinery -- there has rarely been an exploration of geometric systems of the type and to the extent of those I have conducted. This work is unique in its discovery, and in its development of new kinematic systems. My initial interest was only to examine what sort of total system behavior results when a specific configuration of geometry is brought together.

Early investigation was directed toward discovery of new patterns and observations of how each moved. This was done simply by folding up large sheets of paper on which a pattern had been scribed. The model was then moved by hand to change it from one shell form into another, Figure 3. The inherent beauty of these forms, and the facility with which one could directly change them at will, immediately gripped the imagination. The design potential for creating lightweight architectural shells, or other three dimensional enclosures, was more than apparent.

Larger and larger models were made, first of paper and then of cardboard, and scored and folded by hand. As study progressed I began to use computers, and to develop computer aided design techniques for observing the behavior of three dimensional structures, by creating simulated images, developing shading techniques, and investigating structural analysis.

We can now fold these patterns in such a way that almost any surface shape, that a designer can specify as an enclosure, can be constructed as a precise folded plate shell form. While this was always possible to demonstrate empirically, a precise calculation of the three dimensional geometry was not possible until 1971 when I collaborated with Professor Hank Christiansen, a structural analyst, who wrote a kinematic analysis program for this purpose. The computer aided design techniques achieve a series of versatile structural systems which are capable of producing an infinite variety of enclosure shapes.

Computer Aided Structural Analysis

Initial work in computer simulated structural analysis is complete on these systems. We are able to show, by computer simulated color photographs, the stress distribution throughout the structure. We have developed these versatile geometric systems by producing drawings, diagrams, and three dimensional models using computer assisted design techniques. Under computer simulation one can continuously change the plate geometry, Figure 6, make a selection of a specific arrangement of plates, and then continuously fold them for study and selection of some desired form of single curvature, Figure 7. The plates may also be folded to achieve an approximation to a doubly curved, or warped surface, Figure 8. An arrangement of a series of these folded structures would be suitable for creating the envelope of a rigid airship. As well as being both lightweight and strong, the modular foldings would lend themselves to economic mass production techniques.

Curved, Plate Truss Structures

The folded plate systems can also produce space frame structures. With these it is possible to continuously vary the geometry of the space frame to produce structures other than the usual flat, or occasional geodesic, types. Structures which require large, clear spans, such as airport hangers, are usually accommodated by the standard flat octet space truss, to which current methods of design and construction are limited.

There is an obvious need for clear span trusses which have some curvature. To achieve flexibility in the design and the construction of such structures, we have completed a working computer program which allows the specification of any surface of revolution. It will then construct a truss on top of that surface, the depth of which may also be specified, and it will output a control tape for the creation of all the plates of the given structure. Figure 9 is a photograph of actual models, showing the standard truss at the bottom, with two trusses of increasing curvature above.

The Developable Surface Program

The aerospace industry has brought a growing need for strong, lightweight structures which require complex and precise geometric definition. The usual solution has been by costly numeric controlled milling of solid blocks to achieve these required structures. Our work is attempting to develop alternative inexpensive fabrication techniques to achieve computer defined space forms.

It is well understood that to fold a metal plate along a straight line strengthens it; and that bending it to some radius of curvature will increase its structural stability. I have observed that one can combine these two structural properties by introducing a curved, folded edge to a plate. From this basic structural observation we have created a Developable Surface computer program to allow completely general design freedom. It was not at all apparent at the outset, however, that one could generalize a folded edge to any space curve. A thorough mathematical analysis revealed that such a generalization was possible. With this determined, we developed the program.

From this research we have developed generic systems and construction techniques which have the following potential applications, and are beginning to produce numeric controlled engraving and fabrication of folded metal prototypes for same:

1. Airship envelopes
2. Curved, clear span structures
3. Solar energy reflectors
4. Liners for liquid natural gas tankers
5. Lightweight gas tanks for airplane wings
6. Concrete formwork for space curve structures
7. Lightweight guideways for rapid transit monorails
8. Lightweight complex bridge interchanges

A controlled, curved surface, or pathway, can be achieved by declaring the space curve to be a folded edge defining two developable surfaces. This program makes the ordinarily difficult task of physical construction of a precise, complex space curve, relatively simple and direct, while using flat sheet materials and requiring limited joining. Figures 10 and 11 are photographs of an actual model of a complex structure defined by the Developable Surface program. Additional typical forms created with this program can be seen as a part of the film presentation of this paper as computer simulated color video pictures.

Ruled Surface Program, An Approximation to Warped Surfaces

This program constructs a triangular network in a zig-zag manner between the alternate points on two space curves. The curves are definable in the same ways as the curve in the developable surface program. The triangular network may be flattened out to form a flat network, and numeric controlled tapes and pictures of this are available, as well as plots and display pictures of the three dimensional objects. Several networks may also be found and displayed at the same time.

Hyperbolic paraboloids have been extensively used in architecture, for example, because they are both elegant and structurally efficient. They suffer, however, from demanding difficult and expensive formwork. The ruled surface program allows us to directly build any hyperbolic paraboloid by triangular approximation.

These are a few of a number of techniques we have developed for the definition and construction of extremely lightweight and mathematically controlled surfaces and enclosures.

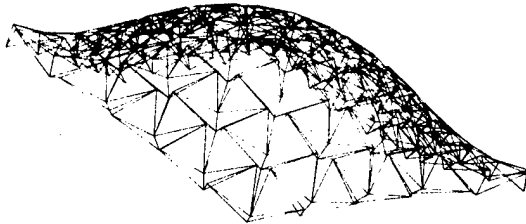

FIG. 1

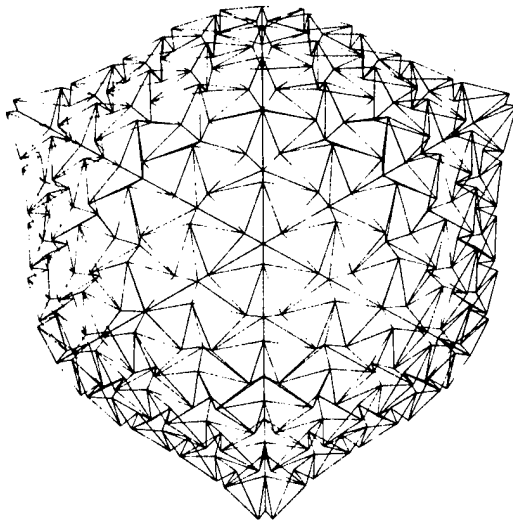

FIG. 2



FIG. 3

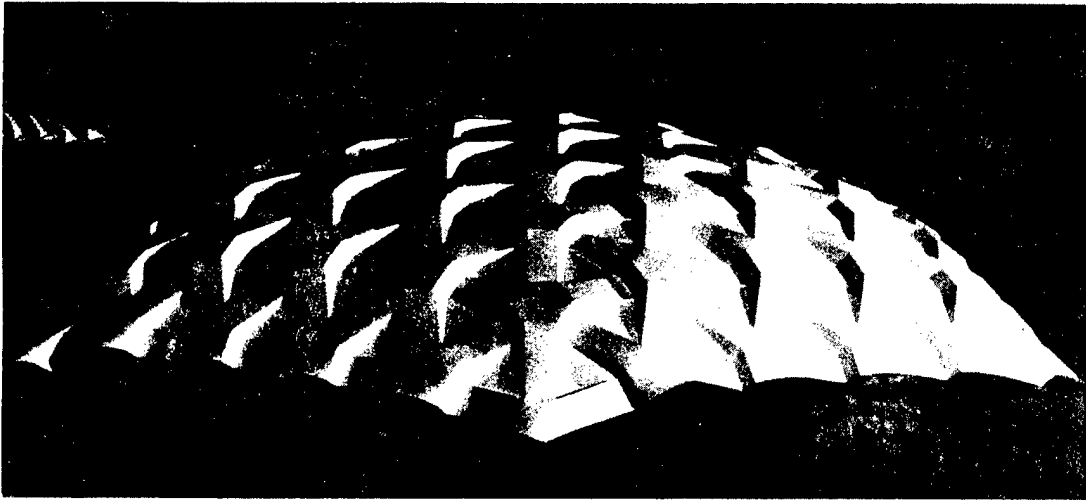

FIG. 4

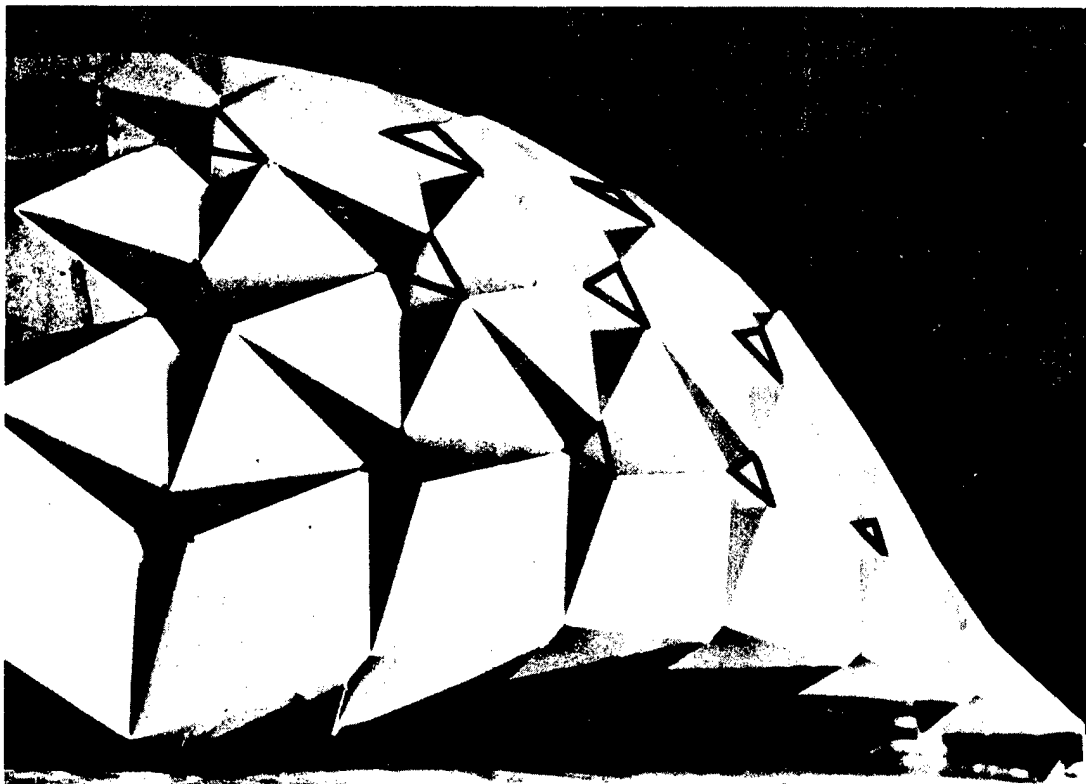

FIG. 5

REPRODUCIBILITY OF THE
ORIGINAL PAGE IS POOR

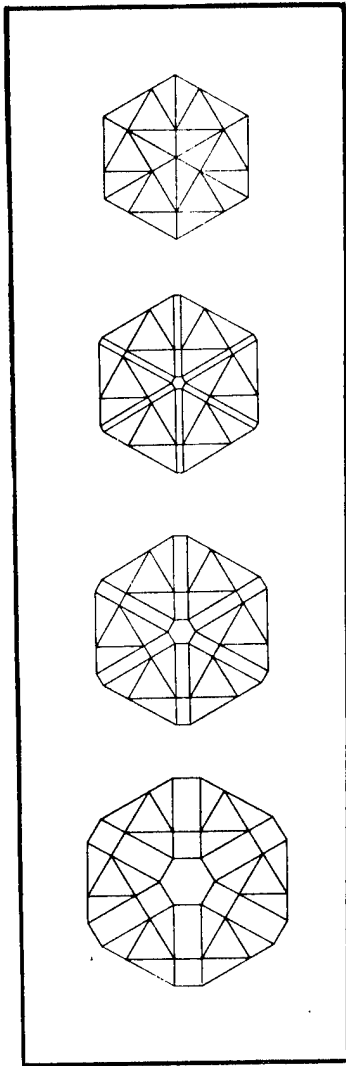

FIG. 6

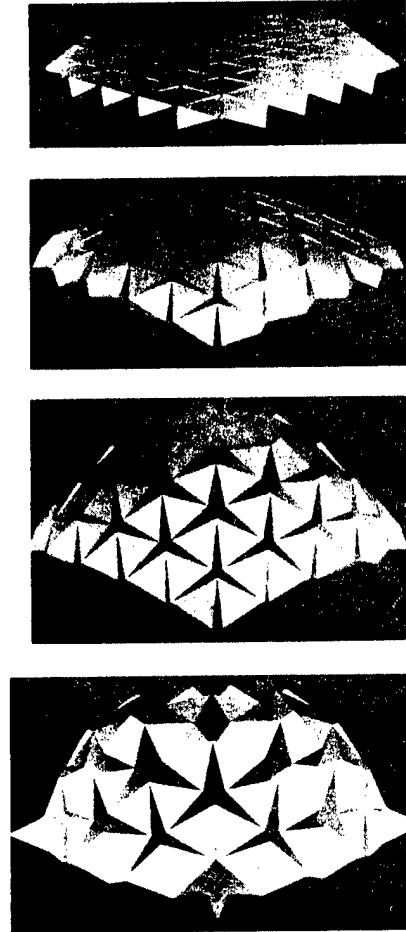

FIG. 7

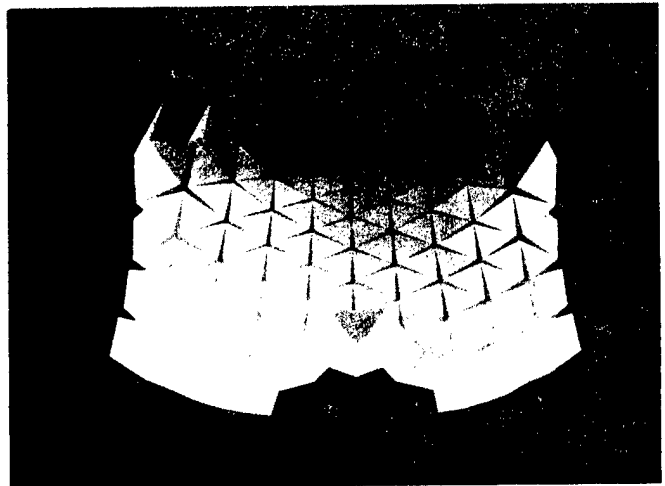

FIG. 8

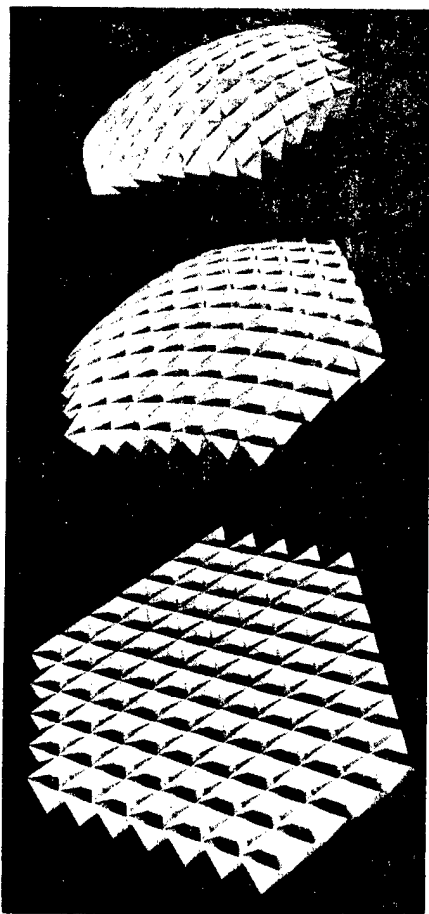

FIG. 9

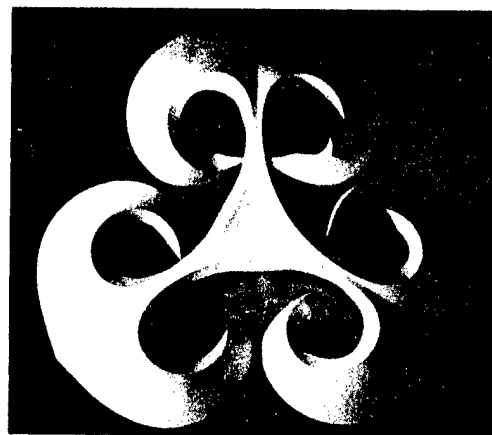

FIG. 10



FIG. 11

REPRODUCIBILITY OF THE
ORIGINAL PAGE IS POOR.

N76-15035

LTA APPLICATION OF A LONG TRAILING WIRE
HIGH SPEED/LOW WEIGHT REELING SYSTEM

D. F. Werb *

ABSTRACT: This paper is presented to acquaint the LTA community with the successful development of a unique yet simple reeling system for handling long trailing tensile members at high speeds. This high speed when combined with the system simplicity, low weight and effective motive power consumption should make this reeling system particularly attractive to LTA planners and designers for numerous LTA missions.

Renewed widespread interest in potential applications of Lighter Than Air (LTA) vehicles has been generated by both military and civilian missions that may involve raising/lowering, towing, transferring, laying, mooring or radiating by use of trailing tensile members. Such trailing tensile members generally would be metal cables, nylon hawsers, coaxial multi-strand electrical wires, fiber-optic communication lines, slender hoses for both liquid and gaseous fluids, and very-low-frequency trailing antenna cables.

This paper addresses the application of a significantly improved method of "winching" a long metal stranded antenna cable from a LTA vehicle; however, this "winching" method could well have numerous military/civilian applications involving the combination of a LTA vehicle and a reeling system for one and/or two-way movement of long trailing flexible and semi-flexible filaments of any nature.

* Senior Aerospace Design Engineer (3051)
Air Vehicle Technology Department
Naval Air Development Center
Warminster, Pennsylvania

PRECEDING PAGE BLANK NOT FILMED

LTA REELING SYSTEM DESIGN FACTORS

The paramount requirements of most airborne reeling applications involve at least one or all of the following considerations:

1. High speed payout/retrieval of trailing tensile member.
2. System simplicity.
3. Low system weight.
4. Low system motive power.
5. Various mechanical form factor constraints.
 - (a) low profile
 - (b) low center of gravity
 - (c) crash loading integrity

Certain previously classified airborne missions have required trailing an Airborne Very-Low-Frequency (AVLF) antenna cable that places emphasis on all the aforementioned design factors plus one entirely peculiar requirement; handling of a fragile semi-rigid tensile member.

AVLF REELING SYSTEMS

Recent AVLF reeling systems have been applications of a common winch which apply all the trailing antenna cable tensile load onto the rotating drum. Thus the drum had to be "oil-well rig" design rather than tailored to air vehicle design.

Structural support and motive power were adversely constrained by this approach. Unrelieved tensile load and fragile tensile member handling requirements forced including unnecessarily precise cable wrapping procedures. All of these design constraints combined to produce a reeling system that was complex, extremely heavy and slow, handling almost quarter inch diameter copper covered cable at less than 500 feet per minute (FPM) rates. Minor basic design approach changes resulted in a 13,000 pound (lb) mechanical system that handled more than 15,000 feet of cable at no better than 2,000 FPM payout and 500 FPM reel-in respectively.



FIGURE 1 - AVLF REELING SYSTEM

Several design iterations have fine tuned these systems to reach 5,000 FPM payout and 1,500 FPM reel-in rates, and 4,000 pound system weight development limit.

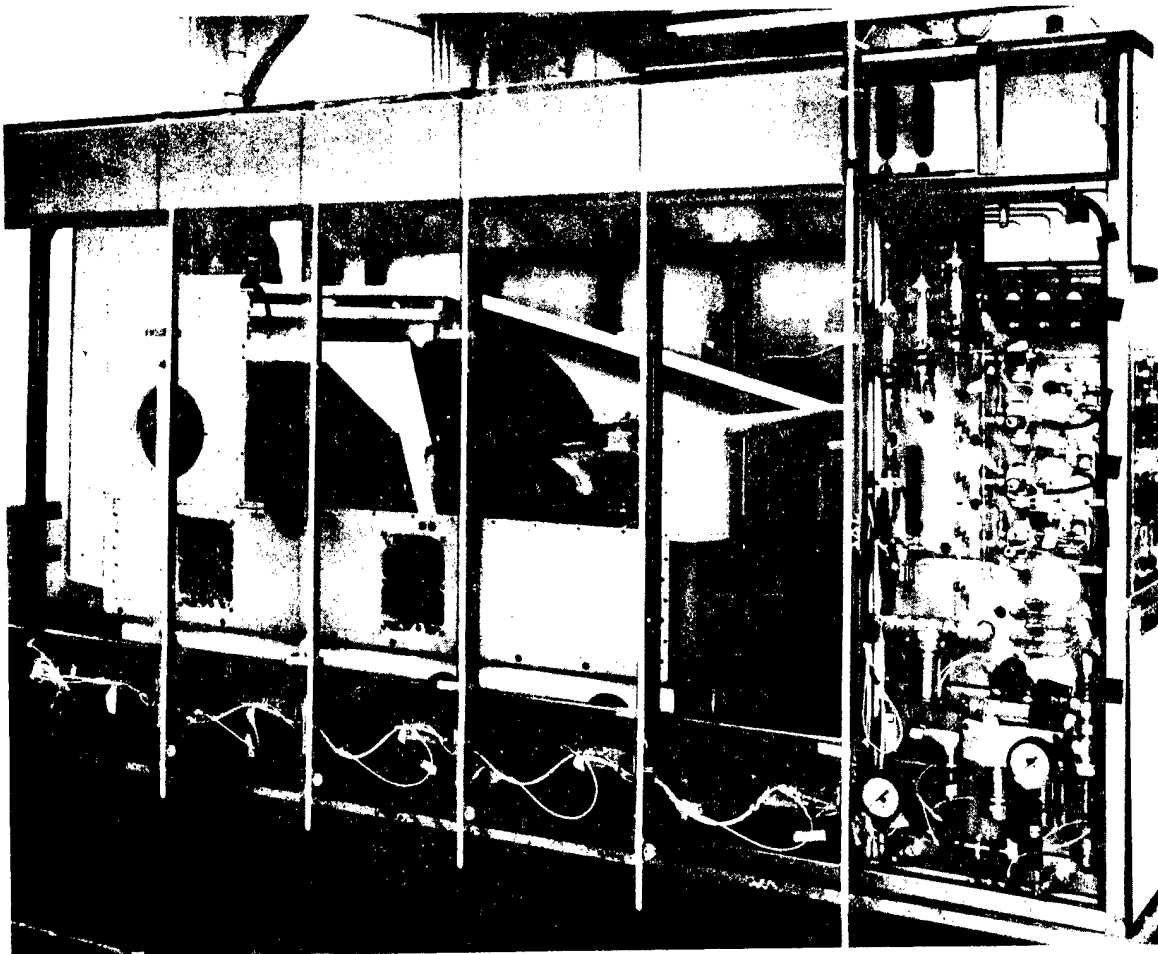

FIGURE 2 - AVLF REELING SYSTEM

However, high rotational speeds, heavy equipment weight, motive power inefficiency, unrelieved tensile loads, precise wrapping/vibration sensitivities, high mass inertia shortcomings and system complexity have not been alleviated.

MOTIONLESS COIL STORAGE/REELING SYSTEM

The Naval Air Development Center, which has an extensive history in airborne towing system development, was tasked to explore new cable handling approaches free of aforementioned shortcomings. Several years of laboratory experimentation and state-of-the-art reviews produced a full scale working model of a Motionless Coil Storage/Reeling System which points the way to alleviation of all the addressed shortcomings.

Motionless Coil Storage (MCS) is a method to store cable in the shape of a coil without constantly continuing to rotate the coil as each successive foot of cable is brought aboard and wrapped. An artist's

sketch of the laboratory model is shown in figure 3.

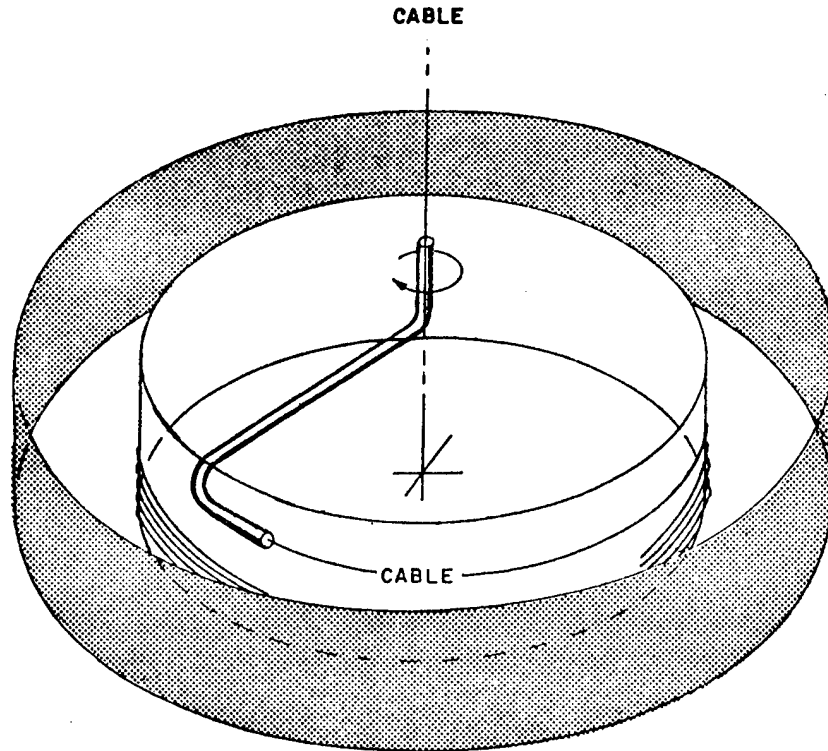

FIGURE 3 - MOTIONLESS COIL STORAGE

The most simple description is to say that it is a significant variation of the sport fisherman's "spinning reel" that has become so popular in recent years. MCS employs one very light low speed rotating member which, in laboratory full scale test setup, reliably demonstrated 6,000/2,500 FPM cable handling rates and successfully performed the reel out of 24,000 feet of a copper covered quarter inch diameter (.65 lbs/ft) tensile member in the total elapsed time of just under 5 minutes (4 min., 42 sec.). Laboratory simulation has indicated that reel-in rates can equal payout rates if sufficient power is available.

Testing began with a concept of pushing and pulling cable into and out of an open cylindrical container. Progressive changing/testing led variously to laying cable inside an annular cavity and finally around to the present concept of freely wrapping the cable about a large-diameter, low-profile vertical stationary drum with a cable distributing spinner. The spinner is extremely light in weight and rotates at a very slow speed while handling cable faster than a mile a minute. The full potential of the inherent high speed capability has not been able to be demonstrated yet; however, design synthesis conservatively indicates a 8,000/5,000 FPM system should total no more than 1,300 pounds.

Key to attaining these high handling speeds with such a low weight, low profile mechanical system is the inherent simplicity of the overall system design. The spinner requires a simple hydro or electro-

mechanical drive to maintain low cable tension (5 to 25 pounds) when reeling-in. Design simplicity for reeling-out is assured by taking advantage of a unique physical phenomenon discovered in laboratory testing described as a "reverse loop". The MCS when reeling-out forms a "reverse loop" at a threshold speed which acts as a stabilizer against the MCS outer wall, thereby permitting these high speeds without complex control devices.

ILLUSTRATION OF MOTIONLESS COIL "REVERSE LOOP"

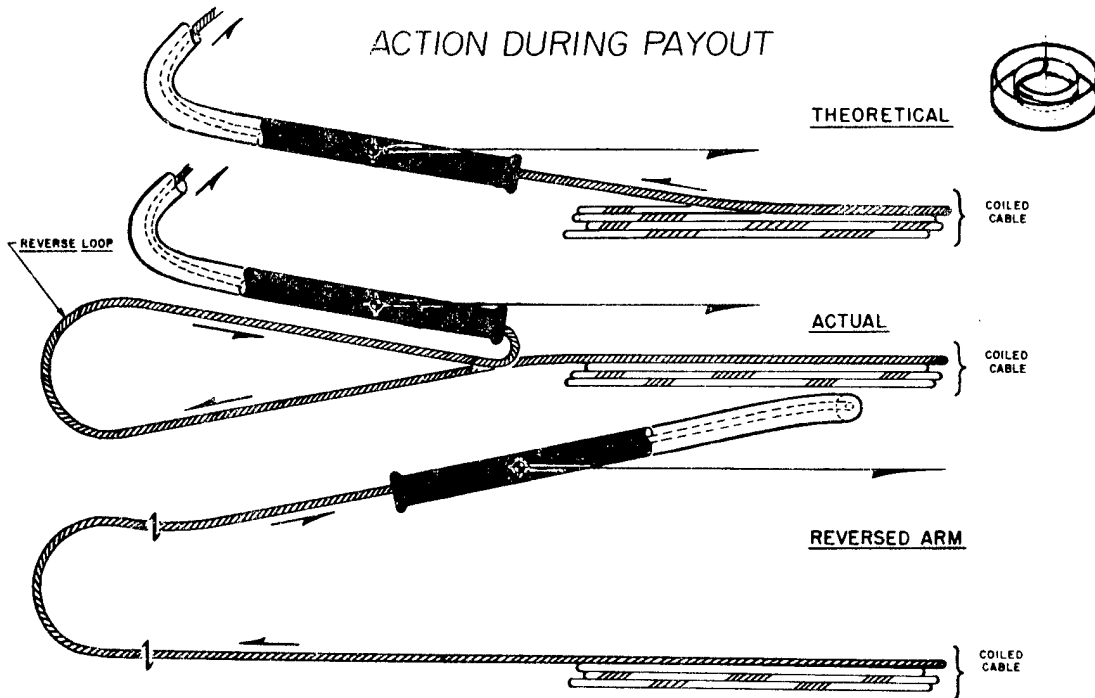

FIGURE 4

The spinner is not dynamic balance sensitive and does not require weighty support structure as does a rotating drum and cable combination. Low mass movement of inertia is inherently more safe and more easily meets "g" loading structural requirements for crash conditions.

Reliability and maintainability are assured since the system is a model of simplicity which requires correspondingly simple control and drive mechanisms.

The MCS has a cable torsion sensitivity threshold which is easily established by laboratory simulation to finalize engineering preliminary design parameters.

Although this paper has addressed the MCS in a VLF trailing antenna application, the MCS can be combined with cable driving/pulling devices such as multiple capstans, pinch rollers, linear transport devices or "free fall" methods and integrated with LTA vehicles or even stationary groundborne applications to fulfill limitless missions.

Expanding the laboratory facilities would permit demonstration of

higher speeds with longer length cables but the NAVAIRDEVCEEN has completed sufficient ground testing of the MSC concept to conclude that the next most economical step is the design and installation of an airborne prototype.

This paper is presented to acquaint the LTA community with the successful development of this technology for whatever applications community members can devise for their particular needs.

MATERIALS, MANUFACTURING AND OPERATIONS

LTA Structures and Materials Technology — Norman J. Mayer

Potential Contribution of High Strength, High Modulus Aramid Fibers to the Commercial Feasibility of Lighter Than Air Craft — D. L. G. Sturgeon, T. K. Venkatachalam

Airship Construction — John Roda

Operational Considerations for the Airship in Short-Haul Transportation — Charles D. Walker

Design Aspects of Zeppelin Operations from Case Histories — Walter P. Maersperger

Lighter Than Air: A Look at the Past, A Look at the Possibilities — William F. Shea

Mooring and Ground Handling Rigid Airships — Hepburn Walker, Jr

A New Concept for Airship Mooring and Ground Handling — John C. Vaughan

LTA

LTA STRUCTURES AND MATERIALS TECHNOLOGY

Norman J. Mayer*

ABSTRACT: The state-of-the-art concerning structures and materials technology is reviewed. It is shown that many present materials developments resulting from balloon and aircraft research programs can be applied to new concepts in LTA vehicles. Both buoyant and semi-buoyant vehicles will utilize similar approaches to solving structural problems and could involve pressurized non-rigid and unpressurized rigid structures. System designs common to both and vital to structural integrity will include much of the past technology as well. Further research is needed in determination of structural loads, especially in future design concepts.

INTRODUCTION

History records that the Western civilized world discovered the principle of balloon flight when Joseph Montgolfier fashioned a cubical container from an innkeeper's skirt of silk taffeta in November 1782 to capture the smoke and heated air of the fireplace and watched the device rise to the ceiling.

It was common sense on the part of Joseph and Ettiienne Montgolfier that the container or envelope holding the gases had to be a light-weight material. Later versions of Montgolfier balloons were made of paper or lined with it. Varnished silk was selected for hydrogen balloons and was a favorite among balloonists many years. As with most successful inventions, the specialized industries soon became

*NASA Headquarters, Washington, D.C.

interested enough to apply their particular knowledge and skills to the production of more suitable materials, such as high quality cotton fabric and rubber coatings.

The development of the airship forced the injection of engineering into the subject. The inefficiency of propulsion systems accounted for such a great portion of the available lift for power plants that designers (be they professional or amateurs) were compelled to utilize lightweight structural design techniques to achieve any useful lift at all. When airships passed from the category of inventor's brainchild and from sport vehicles to transportation or military vehicles of useful potential, funds and personnel became available to incorporate engineering approaches into designs. Likewise, as with balloons, the input of other specialists and industries also began to be a part of improving the vehicle and increasing its efficiency. Much can be written concerning the historical aspect of the development itself. However, this paper will primarily confine itself to a review of current technology and specifically to the state of the art in two major disciplines - materials and structures.

MATERIALS AND STRUCTURES TECHNOLOGY

These two disciplines are so interrelated that it is difficult, if not impossible, to clearly separate one from the other. Structural design techniques vary according to the materials chosen or available. Materials are chosen depending on the structural design approach to be used. Modern design practices produce synergistic effects when structures and materials are properly related.

Recent thought on the subject of airships indicates that future vehicles could consist of configurations vastly different from vehicles present or past. It has been shown by various studies (Ref. 1, 2, 3, and 4) that airships which combine dynamic and static lift (hybrids) may offer an improvement in efficiency in certain speed ranges. It has also been proposed that either conventional or hybrid airships employing heated air or other gases may also show advantages for certain missions (Ref. 4, 5, and 6).

As long as such vehicles require buoyancy or static lift for any part of their mission, there will be certain features common to all in terms of structural and material requirements. These stem from the fact that buoyancy of any usable amount requires large displacement. Thus, all LTA aircraft or their variations will be large vehicles always exceeding in size any of their HTA counterparts by at least several factors.

Large size or volume is accompanied by large surface area on which unit air loads are low and much lower than normal airplane surfaces carry. Ultra-lightweight structural design is required to provide the external contours of such vehicles without sacrificing lifting efficiency. Thus, the need for fabrics, lightweight high-stiffness structural members, etc. is well established. Minimum material gage is often a problem in design and construction.

The containment of any gas requires use of pressure control systems capable of handling high rates of gas flow in order to preserve structural integrity. Such requirements are reflected in sub-system development of valves, blowers, and in the design of gas shafts, air ducts, etc., which require application of special materials and design techniques.

AIRSHIP STRUCTURAL TYPES

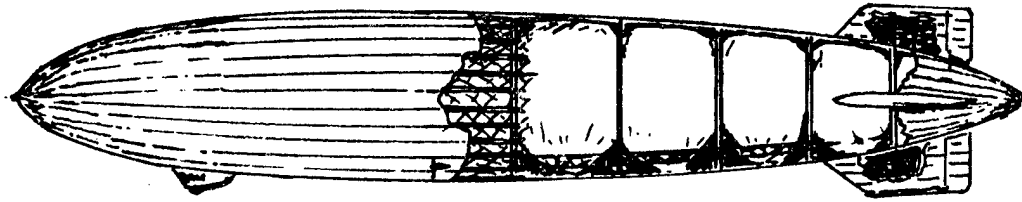

Non-pressure rigid

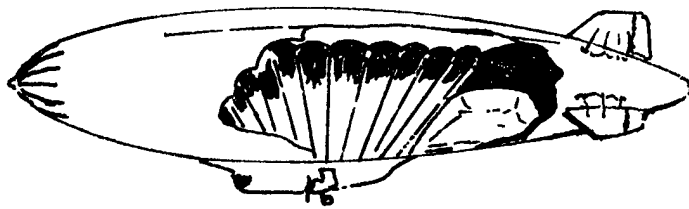

Pressure non-rigid

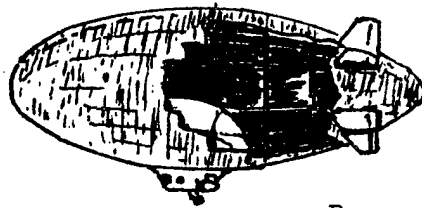

Pressure rigid

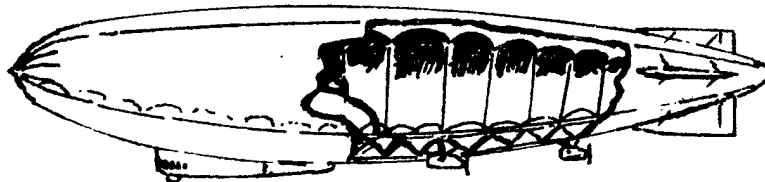

Pressure semi-rigid

Figure 1

Regardless of vehicle type (conventional or hybrid), the designer has to choose whether to maintain an aerodynamic configuration by means of pressure or by means of a non-pressurized external skin supported by an internal rigid structure, or by a combination of both. Figure 1 illustrates airships which are examples of the various types.

These common characteristics distinguish LTA vehicles from their HTA contemporaries and require application of a considerable amount of past knowledge as well as new technology.

Materials

Pliant Materials - As noted above, airships are pressure sensitive vehicles. Therefore, there is usually a need for at least part of the gas container to be capable of volume changes and be constructed of a pliant material.

An ideal material in this category would be a film with extremely low permeability, high tensile strength, high tear strength, a linear stress-strain curve to the yield point, reasonable Young's tensile modulus, good ductility, isotropic character, and stable properties under expected environmental conditions. Thus far no such material exists.

High altitude scientific balloons have used films alone for envelopes. Such balloons are an example of the interdependence of structures and materials. During the 1950's a balloon form was developed known as the natural shape. The contour of the envelope was determined by the gas head pressure and resulted in all stresses being carried in the vertical direction such that theoretically there would be zero circumferential (parallel to equator) tension. Such design enabled use of oriented polyethylene and later use of vertical load tapes.

One parameter peculiar to balloons of this type, which does not necessarily apply in the case of airships, is that of the high altitude environment. In such an environment, the envelope is directly exposed to very low temperature and high ultraviolet radiation.

Higher strength films are obtained by reinforcing with some kind of filament, usually bonded to the film and oriented in a quasi-orthotropic pattern. Table 1 lists a few examples of films and their characteristics for balloons and gas cells. For comparison, older film and gas cell materials are also listed.

Table 1

BALLOON FILMS AND GAS CELL MATERIALS

<u>FILM</u>	<u>Reinforcement</u>	<u>Weight</u>	<u>Tensile Strength</u>	<u>Permeability</u>
		<u>Oz./Yd.²</u>	<u>Lbs./In. Warp</u>	<u>L/m²</u>
Polyethylene	None	0.3	15	1.00
2 Ply Mylar	None	1.6	30	0.30
Mylar	Dacron Scrim	1.6	45	1.75
Nylon	Nylon Cloth	1.9	50	2.00
Rubber	Cotton	5.5	45	3.00
Coating				
Gold Beater's Skin	Cotton	4.5	40	2.00

Many of these materials are of interest for airship applications. One significant characteristic sometimes not considered at the outset, is that of resistance to manufacturing and handling damage and resistance to tearing. Films tear easily. Reinforced films are much more difficult to tear once the damage reaches the reinforcing filaments.

If the material is to be used as a gas container primarily, its required strength would be determined by the amount of superpressure it would have to endure and the method of transferring the lift of the gas to the structure. These requirements would combine with the anticipated cyclic variations of pressure and flexing, atmospheric conditions, and the above mentioned resistance to accidental damage. It is anticipated that future airship gas cells would be similar to the reinforced balloon films now in use.

When material is required to serve as hull structure as well as gas container, as in a non-rigid airship, strength and other requirements are considerably more severe. The stresses are higher, the environmental effects are a major factor, and gas retention becomes a serious problem. These parameters combine to exceed the properties of films alone and thus far, only the higher efficiencies obtainable from closely spaced filamentary materials such as textiles, appear to be satisfactory.

Textiles have been conventionally woven as two sets of threads crossing each other in an orthogonal pattern. Such weaves are effective in transmitting stress in their respective directions, but not in any diagonal direction, i.e. on the bias. Therefore, the usual solution is to bond two or more plies of cloth together such that one is oriented 45° to the other. Most two-ply envelopes are constructed in this fashion.

A recent patented textile development, known as "Doweave", provides for this function by having three thread sets intermeshed in a single fabric to provide quasi-isotropic properties and eliminate the need for bonding two or more plies together, therefore making possible single ply envelopes.

Woven fabrics must be coated with an elastomeric material or bonded to a film of sufficient thickness to prevent high gas loss. All non-rigid airships built to date have employed the first method - namely a coating as the gas barrier. For two or more ply construction, the bonding of the fabrics is also accomplished by an elastomeric coating. An outer coating, often of different material from the inner, is applied to the surface exposed to the airstream to provide resistance to and control of environmental effects. The net result of such construction is a material which consists of about half cloth and half elastomer.

If a Doweave type material is used, there is a weight saving of one thread set plus the additional inter-ply elastomer or adhesive. However, since the total elastomeric thickness provides the gas barrier, and a certain minimum amount is required to achieve a given rate of permeability, only specific testing would determine how much could be eliminated totally.

Another approach which theoretically provides more efficiency is to combine the best properties of two materials - namely film and cloth. Thin film can be manufactured to provide a much less porous surface than can be obtained by an equal weight of elastomer. Research programs for improved balloon films have progressively enabled film

manufacturers to achieve unusually thin gages of high quality. For applications where the film is only a gas barrier, the minimum gage theoretically would only be limited by that required to eliminate microscopic holes, and obtain a given rate of permeability. Thus, a weight saving is possible by bonding a film to one or more plies of cloth, and ideally could consist of a combination of the three ply Doweave with a thin film gas barrier.

Fabrics which function as structures undergo a considerable number of cycles of flexing which consists of elongation of the yarns, an interaction of the yarns due to crimp through the interstices, and ply deformation due to shear stresses. All of this flexing has an effect on the bonds between the elastomer or films and the yarns in the cloth. In the case of the former, microscopic paths for gas escape are developed. In the case of films, localized debonding can occur which eventually leads to leaks.

Since envelopes (and gas cells) are manufactured, shipped, and handled many times during both processes, they are subjected to wrinkling, creasing, scuffing, or abraiding conditions. Both elastomeric coatings and films are adversely affected by this treatment. Again, the elastomer can be damaged by the local flexing and the film can be debonded. A number of tests simulating such conditions are usually necessary to evaluate particular candidate materials.

Pliant materials which function as both gas cells and airship hulls must have, in addition to good gas retention, and the other characteristics noted previously, sufficient resistance to creep-rupture under both constant and varying stress. Most materials will creep under constant stress above certain temperatures. Fibers made from either natural or synthetic materials creep at temperatures within the normal operating ranges. The rate of creep varies with the stress level. For a given stress level, a fiber or cloth made from it will fail after a period of time of sustained stress. Envelope materials are chosen on the basis that the failure point is beyond the planned life of the envelope. Since these characteristics vary considerably among various materials, data must be developed or available for each candidate material.

The stress-strain curve for most of the candidate organic fibers shows a linear portion at lower stresses and non-linear portions at higher stresses. Materials which show no linearity are not acceptable for airship envelopes. Uncontrolled stretch results in distortion of the envelope shape which affects the aerodynamic performance of the airship. It also produces severe problems with the rigid components which are attached to the envelope such as nose stiffening, suspension systems, cars, fins, and control systems. This is the reason why nylon has not been used, although it possesses good tensile strength. Polyester fabrics, such as Dacron, on the other hand, do demonstrate satisfactory elongation and creep, and are standard for most airships (and tethered balloons) at present.

In recent years, a new polymeric fiber has been developed by DuPont which appears to be ideal for airship applications. This is called Kevlar-49. It possesses a tensile strength of about 400,000 p.s.i. and higher (580,000 p.s.i. in short lengths). Ref. 7. In addition to its high tensile strength, it has a tensile modulus about double that of aluminum, and a linear stress-strain curve. It is already being applied to aircraft structures as a composite material as will be noted later. As a textile replacement for present airship fabrics, it appears to be a promising candidate. Table 2 compares various natural and synthetic fibers for pressure airship envelopes.

As noted, the concept of using heated gas in certain future vehicles has been proposed. The lifting efficiency of such vehicles varies with the temperature of the gas. If envelope fabrics are required to operate at sustained high ΔT values, these parameters must be factored into the selection and evaluation of the material, particularly with regard to creep and operating life.

Table 2

FIBERS FOR PRESSURE AIRSHIP ENVELOPES

<u>Fiber</u>	<u>Specific Tensile Strength</u>	<u>Specific Tensile Modulus</u>
KEVLAR 49	8×10^6	380×10^6
POLYESTER	2×10^6	20×10^6
NYLON	2.8×10^6	20×10^6
COTTON	0.8×10^6	19×10^6
SILK	1.0×10^6	21×10^6

Metals - Modern aluminum alloys have about double the tensile strength of the alloys used during the early 1930's for large airships. While such difference can be translated into weight saving, the percentage is strongly dependent on the application. When applied to a rigid pressure airship design, such as a metalclad, the full improvement in strength may be utilized over the major sections of the hull, provided the airship is large enough. In rigid designs, where girders and frames were employed with a non-structural covering, an 18% weight improvement due mostly to improved girder design has been estimated (Ref. 8).

A significant feature of conventional airship structure is the fact that large portions operate at very low stress. As discussed later, both the Zeppelin types and the pressure types tend to behave as monocoque cylinders in bending and are much more sensitive to the maintenance of adequate structural stiffness against both local and general buckling. Unfortunately, although tensile strength has improved for aluminum alloys, the modulus of elasticity has not. This factor points to the need for localized stiffening of structural members such as may be obtained through application of selective composite reinforcement as discussed later.

Other Metals - The combined requirements for high modulus, good fatigue life, and low corrosion were recognized in design of large airships in the past, and as recently as 1939 stainless steel girders were considered as candidates for airship structural members (Ref. 9). Today, they would continue to be examined, especially in combination with some of the structural design approaches discussed later. Titanium alloys could also provide some of the structure for certain airship hulls. Both stainless steel and titanium would represent higher cost as compared with aluminum, and neither would represent much gain in weight savings, especially in a minimum gage application.

Composite Materials - Fortunately, much of the technology presently being developed and available in connection with the use of composite materials in airplanes can be applied to airships. Table 3 lists the properties available from composites as compared with metals.

Table 3

PROPERTIES OF STRUCTURAL MATERIALS

<u>Material</u>	<u>Specific Tensile Strength</u>	<u>Specific Tensile Modulus</u>
7075 ALUMINUM	0.8×10^6	100×10^6
6Al 4V TITANIUM	1.1×10^6	100×10^6
KEVLAR/EPOXY	3.2×10^6	220×10^6
GRAPHITE/EPOXY	3.5×10^6	$350-700 \times 10^6$

In this regard, two approaches are possible. The first involves the use of composites to provide local strengthening and stiffening of conventional metal structures. This process is described in Ref. 10. Essentially, it consists of bonding laminates made of advanced composite materials (boron or graphite/epoxy) to the surface of structural members, usually stiffeners or flanges located at the maximum radii of gyration in a section of structure. Laminates are manufactured from standard tapes of composite materials. This process could be applied to light alloy members of airships with very effective results.

The second approach would be use of an all-composite structure where all structural members are manufactured from fibrous composite materials. As will be discussed later, the maximum values of weight savings could be obtained from this approach.

Structures

One of the most controversial aspects of past designs and present airship proposals stems from an evaluation of their structural adequacy. In some respects, much of this controversy is the result of comparing past technology in airships with present technology in other aircraft. It is a matter of record that in the period represented by early Zeppelin construction through that of the U.S. rigid airship program (1900-1935) that some of the best aeronautical engineering talent available was associated with airship technology development. The airship structure particularly represented a challenge to the theoretician and analyst and the airship itself was a very advanced aeronautical development. Structural design, therefore, was at its best when applied to the airship. In particular, this refers to the rigid types, since in the case of the pressure types the sizes were smaller, and the problems simpler.

A survey of the state of the art can be made concerning three aspects: loads, structural analysis, and testing.

Loads - Airship hull loads resulting from aerodynamic forces consist of maneuvering loads, gust loads, and ground handling loads.

For airships flying at speeds approaching 100 mph, the hull bending moments produced by flight through gusts by far exceed those from maneuvering. Generally, a thorough analysis of this condition would include determination of loads for the hull itself for a maximum design velocity gust transit, and other conditions which would produce maximum loads on the empennage and other components.

The response of an airship to such conditions is dependent on its configuration and its accompanying dynamic and control characteristics.

Up to and following the design of the Akron and Macon rigid airships, a substantial amount of research was performed to determine maximum gust conditions and airship flight characteristics in gusts. These were limited to the ellipsoidal hull shapes employed for all airships up to the present.

During the 1930's, a special airship research facility became available in Akron, Ohio which contained, among other things, whirling arms, a vertical wind tunnel, and a water channel. These three pieces of apparatus were used in combination with scale models to investigate gust effects on rigid airships. Figures 2 and 3 illustrate two methods used.

The difficulties and uncertainties of relating such tests to full scale results can be appreciated. More significant, however, is the necessity of building a step-by-step base of technology which eventually is proven sound enough to furnish confidence for future design approaches. Since gust response is configuration sensitive, a period of learning and confidence would be necessary for new concepts which represent significant departures from the ellipsoidal form.

Another approach to this problem can be taken by means of a computerized analysis to simulate flight in turbulence. Such studies were initiated in 1958 as part of the U.S. Navy airship structures research program (Ref. 11). Figure 4 shows a typical set of curves obtained in this manner for a large non-rigid airship.

Ground handling of airships has always represented a critical part of the operational cycle. A good case can be made for never hangaring or docking airships because the records show more losses or damage occurred in this part of the operation than from any flight accident. The main reason, of course, is the fact that the maximum hull forces used for design are derived from flight conditions as discussed above. Ground forces are only permitted to develop loads which do not exceed flight values. This results in maximum cross winds of about 20 knots against which the airship may be held. If provisions were made for higher winds, the ground condition would become the dominant hull design condition and would result in excess strength (and weight) for flight. Designers have been unwilling to accept this penalty for a non-flight condition.

During ground handling operations, lines are designed to slip (if on winches) or part to avoid hull overstress and resultant structural damage. If this should occur in the vicinity of a hangar, the result is a collision and severe damage to the airship.

A number of tests using towed models in water have been run to investigate both the static and dynamic conditions involved. One series of tests actually simulated the complete docking/undocking operation, including the weathervaning motions while moored (Ref. 12).

Newer proposed concepts for airships would include hull shapes resembling oblate spheroids, deltoids, or other flattened configurations. These shapes in combination with a large portion of static heaviness may effectively eliminate or reduce the limitation of the ground conditions.

Analysis - The complexity of analysis of the structure of a rigid airship can be illustrated by a statement by C. P. Burgess (Ref. 13).

Figure 2

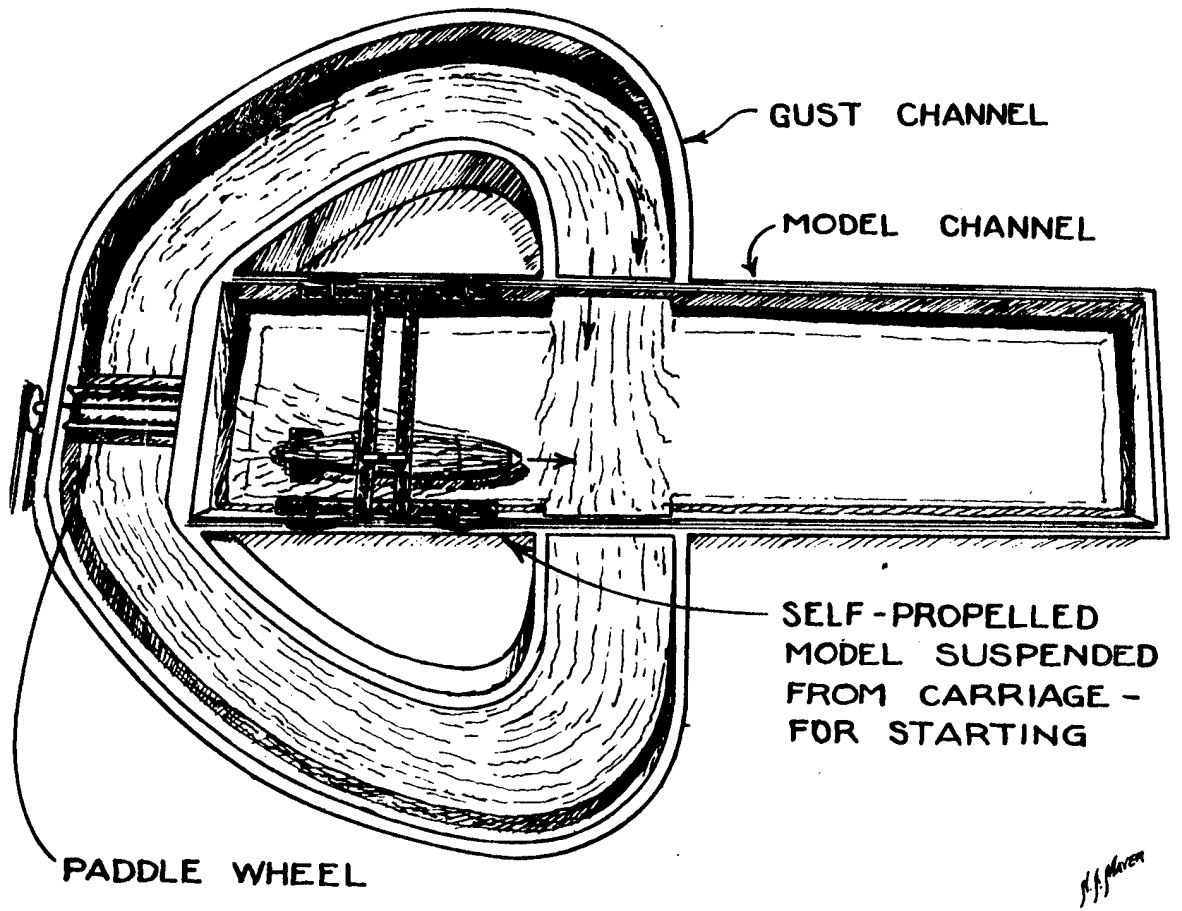

Sketch of Water Channel

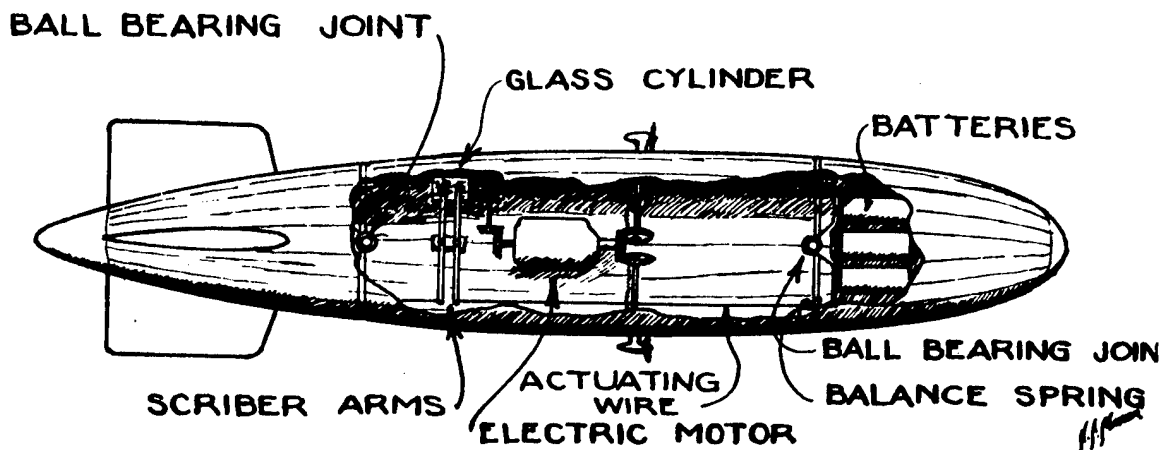

Sketch of Water Channel Model

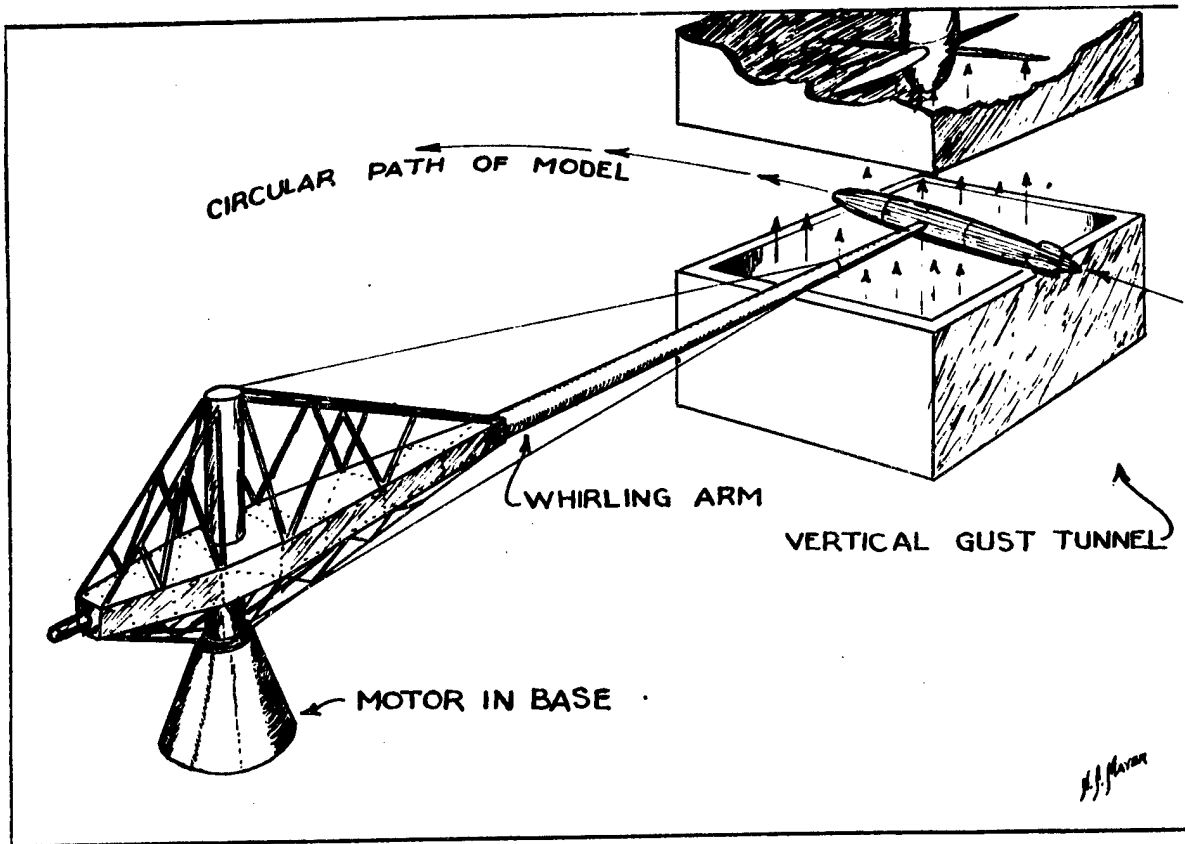

Sketch of Whirling Arm.
Figure 3

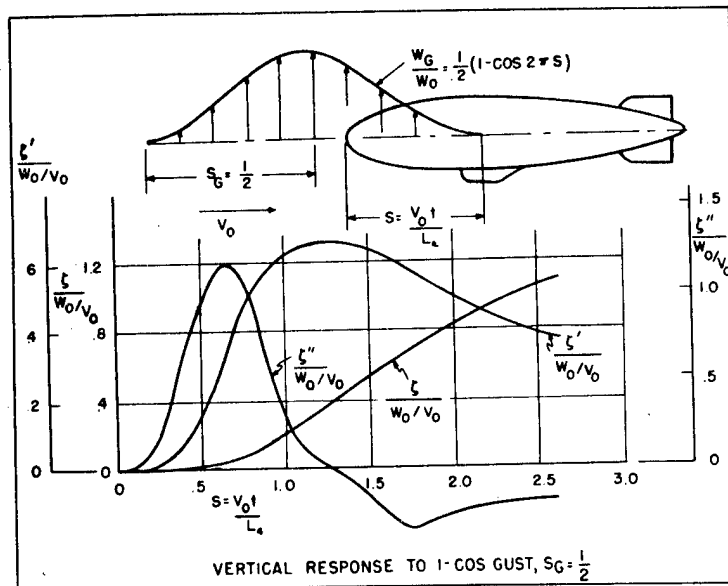

Figure 4

"Even the exact calculation for the simple case of a hexagonal braced structure, five frame spaces in length, and with symmetrical loading, requires the solution of ten simultaneous equations --- with the work carried out to six or seven significant figures".

Of course, no rigid airship was ever built with only six sides so that exact solutions of structural analyses were never feasible for these more complex structures. Approximate methods were developed, however, which have shown remarkable accuracy when compared with later test results (Ref. 14).

Among the contributors to analytical development was Professor William Hovgaard of MIT, who in 1922 developed a method to reconcile two separate approaches involving a bending moment approach and a transverse shear approach (Ref. 15). Later contributions were made by L. H. Donnell, R. V. Southwell, Upson and Klikoff, and Burgess (Ref. 16).

All of these analyses suffered from the inability of the analyst to visualize or separate overall deformation from local effects resulting from the flow of stresses in the structure. An ingenious method for achieving this, using scale structural models, was developed by the Goodyear Zeppelin Corporation based on principles described originally by L. H. Donnell (Ref. 16). This method was applied to both complete and partial models of rigid airships. The essential element in such models was a model girder which scaled down the axial, radial bending and torsional stiffness of the major component members of the prototype. In addition, members also incorporated sensitive means of measuring the corresponding strains and stresses.

The use of these models allowed analysts for the first time to evaluate the existing methods of structural analysis, and separate effects of local from general loads. The design of members was varied according to the type of condition to be investigated. Figure 5a shows a typical member. Figure 5b shows the method of measuring deflections of the model.

These techniques are essentially represented in modern computerized finite element structural analyses. These programs contain libraries of various types of elements such as plates in shear and bending, membranes, rods, beams, rings, etc. whose behavior under various loading conditions are predetermined and their mathematical expressions entered as a permanent part of the computer program. The analyst then represents the actual structure as accurately as possible, using the available elements in the library. A very complex structure can be represented in this fashion, using several thousand elements. The computer program then combines these elements and performs the required structural analysis yielding stresses and deflections for a given load condition, static or dynamic. It also produces mode shapes and frequencies, frequency response or other structural data for which it was designed. The results can be displayed by CRT's or by computerized plotters enabling the engineer to actually see the calculated deformations (Ref. 17). These complex analyses were impossible to perform in the 1930's and it was not until the early 1960's that the high speed digital computer rendered practical solution times ranging from minutes to hours, depending on the problem.

Figure 6 shows a modern aerospace vehicle structure graphically represented in finite element form.

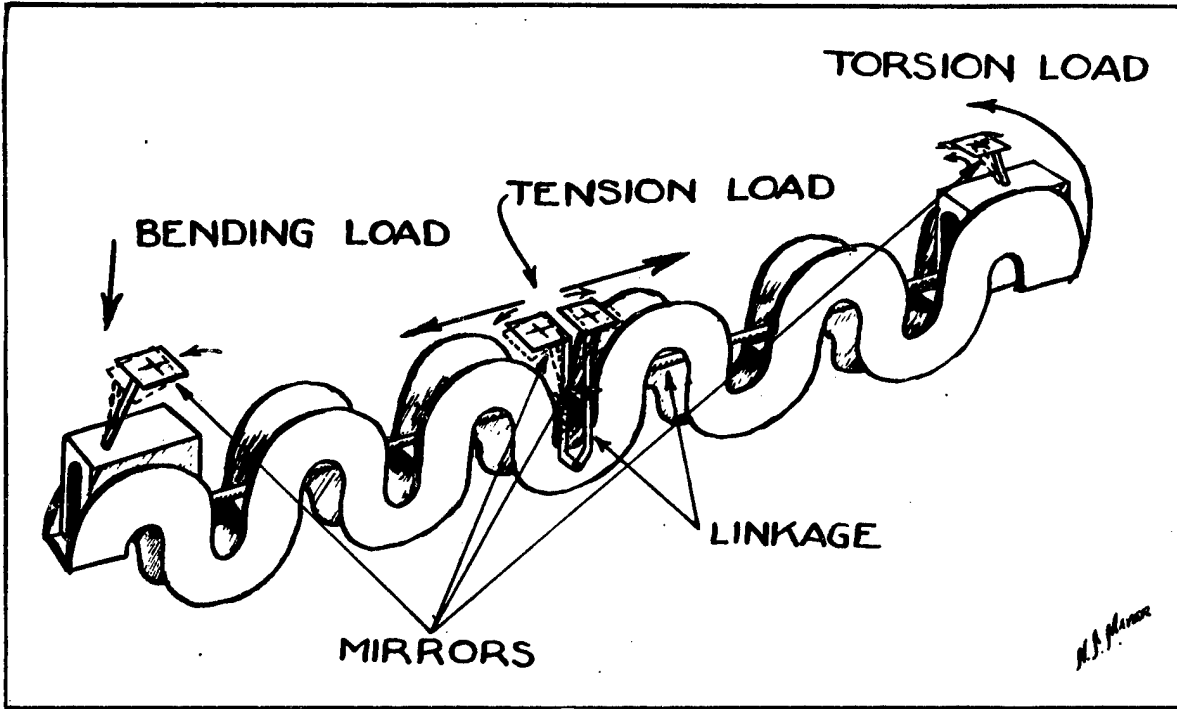

Figure 5a

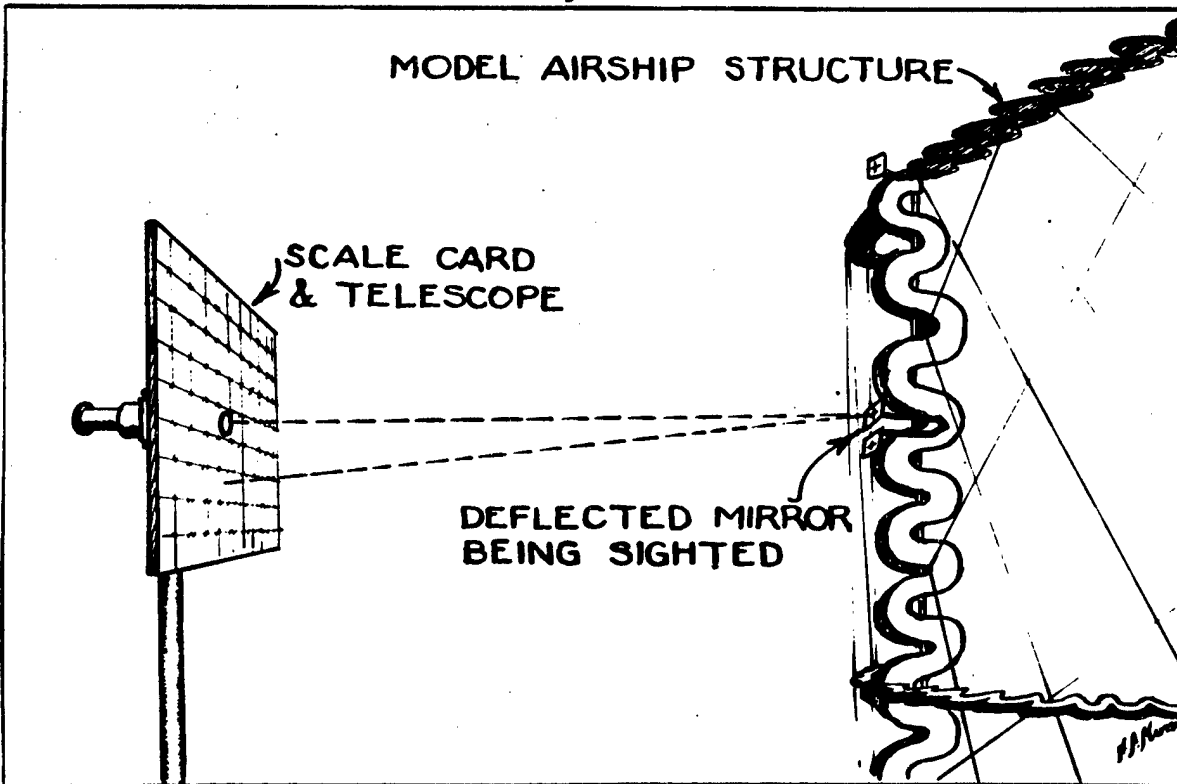

Figure 5b

Testing - There are several categories of tests which all aircraft undergo during development. The first of these is part of a process sometimes called engineering development. In this process, complex structural elements such as joints, typical sections, and members or portions of structures containing advanced manufacturing processes such as bonding are tested to validate the design and analysis approach and the reliability of the manufacturing process. New material combinations are also evaluated to develop, if necessary, design allowables (values of strength and elastic characteristics) which can be relied upon for design. This type of testing would be necessary for any new design.

A second category of testing is the static test, wherein the complete structure, or portions of it, representing the production design are subjected to various load levels up to design limit and finally ultimate or failing loads. While portions of the structure may be tested this way, usually realistic tests of this kind are impractical for large airships. In the past, static bending tests were performed, but only low percentages of the limit could be obtained due to limitations in applying load to the structure.

A similar circumstance was found in dynamic testing of large launch vehicles for spacecraft. Although such tests were conducted, they were limited to input loads of low values. The costs of such testing, which was performed outdoors, was so great as to stimulate R&D programs for developing scaled dynamic test models with sufficient accuracy to replace full scale tests.

Models such as described previously might be adapted for simulating large airship tests as well.

A number of special tests may always be required to check out structural and design characteristics peculiar to airships. Full scale flight tests, of course, will always be required to provide full flight condition check-out for all systems.

DESIGN APPROACHES

Today, there is considerable speculation concerning novel approaches to improved LTA vehicles. These range from proposals for modernized versions of Akron-Macon-Hindenburg designs to types which combine airplane-helicopter-airship features. Much of the technology discussed in the foregoing sections would apply to all types. Improved materials would naturally benefit any aircraft, and may be critical to the success of some. An example of this is the solitary, but significant development of the ZMC-2, an all metal hulled airship. This design was critically dependent on the development of alclad aluminum which provided the difference between achieving a hull where corrosion would have quickly accounted for its integrity and one which remained airworthy for over 10 years, despite its .008 gage skin.

Modern structural design and analysis techniques also apply to all types of future airships. However, there are many distinctions possible among various types proposed and their accompanying structural features and efficiency. The two major classes would include buoyant types and semi-buoyant types.

Buoyant Types

Practically all LTA vehicles built thus far fall into this class. The results of a study by the author made in 1960 showed the rigid non-pressure type to be about 25 - 35 percent more efficient structurally than the non-rigid pressure airship.

Against such efficiency must be weighed other factors such as cost and operational flexibility. Non-rigid envelopes can be fabricated at any suitable facility and shipped anywhere. Navy non-rigid envelopes represented about 10% of the total cost of the airship. Large rigid hulls, on the other hand, must be constructed at the final assembly point with much special equipment and manpower. The structure and the fabrication represent a major portion of the total cost.

Operational flexibility is obtained from the non-rigid by virtue of its envelope being able to temporarily sustain higher than design loads (within limits, of course) without damage. This increases the overall safety of the aircraft and allows for much parameter uncertainty.

Not all of these differences obtain without qualifications. Various methods have been proposed to reduce fabrication costs for rigid types. Composite materials, for example, offer a possibility here due to lower tooling costs. They also would result in further weight reductions over those obtainable from modern metals. Recent NASA studies of transport aircraft have shown structural weight savings up to 30% (Ref. 18). Also, methods may be available to perform the complete assembly of a hull only as a final step (Ref. 19).

While a pressure airship may seem inherently safer, the penalty of assuring an adequate means of sustaining pressure and the need of adjusting and monitoring this pressure almost constantly during flight is an additional operational complexity. The use of compliant materials for structure is definitely a weight penalty as reflected in the study. However, the comparison does not include application of recently developed fibers. Compartmentation of gas space in a non-rigid does not produce the same advantages as available to rigid. A high rate of pressure reduction is an unacceptable hazard to non-rigids.

The metal-clad airship would show an improvement over the values for the non-rigid. Modern versions of this type (in large sizes) constructed of high strength aluminum, stainless steel, or titanium might equal the rigid in structural efficiency, although other design trade-offs might auger against the choice.

A design concept which combines a rigid/non-rigid concept was invented by C. P. Burgess, but never applied in practice (Ref. 20). The main structure consists of four longitudinal keels connected by widely spaced transverse frames and diagonal shear wires. Only the shear wires are inside the gas space. The gas is contained in a combination envelope-cover similar to a non-rigid airship. The keels are external to this envelope and are faired over by a light cloth cover. The combination envelope-cover is terminated by semi-hemispherical or concave ends with the space between cells also filled with gas. Ballonets are used to pressurize the gas sufficiently to maintain a stiff outer shape. These features are shown in Figure 7. As pointed out by the inventor himself (Ref. 21), there are a number of advantages and disadvantages to this concept.

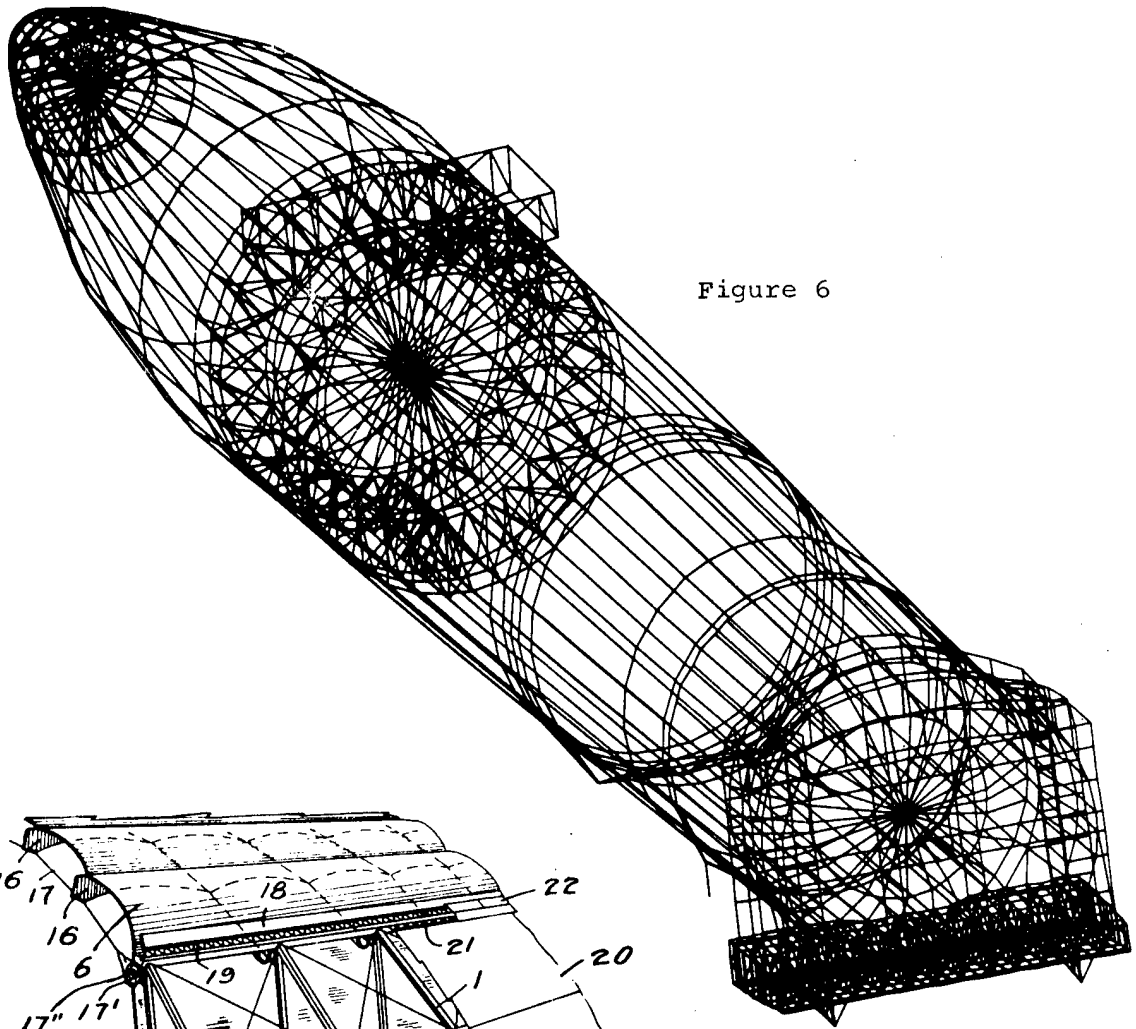

Figure 6

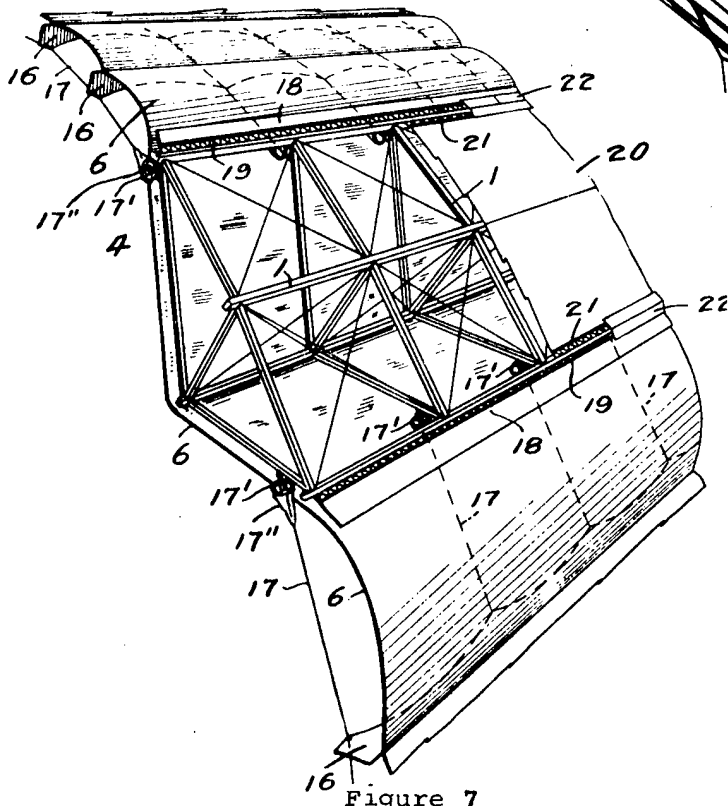

Figure 7

Semi-Buoyant Types

Although semi-buoyant LTA aircraft would acquire some of the characteristics of airplanes or helicopters, they will have structural indices (Ref. 22) considerably below ordinary HTA aircraft. Therefore, they will not be entirely free of the need to utilize ultra-lightweight structure. Single skin construction would appear to be limited to pressurized hulls unless the permissible operating speed ranges are significantly high enough to allow skin gages or semi-monocoque construction of sufficient stiffness to avoid local buckling. Perhaps the higher modulus composite materials would provide the answer here.

As noted in the introduction, gas retention will require consideration of the same factors as were necessary for buoyant types. Thus, most of the materials technology can be applied.

There is a substantial base technology for the aerodynamics of ellipsoidal hulls. A similar technology might be extrapolated from tests of certain aircraft body shapes such as lifting bodies and re-entry shapes. The size difference could produce serious discrepancies in drag and stability estimates, but should not be too serious for loads determination.

PROBLEM AREAS

Materials

Fortunately, the high altitude free balloon and the tethered balloon have continued to develop a technology in materials which can be applied to future airships. This includes the art of design and fabrication of pliant materials. A similar development does not really exist for rigid structures. Ultra-lightweight metal design and fabrication has not been needed for aircraft and only to a limited extent for spacecraft. Whatever technology is available in this regard may well come from the latter engineering activity, however. Composite materials offer a distinct possibility for improvements, but most of the research and design activity has been directed toward airplane application. Only recently has there been recognized a need for large area structures with low unit loads for space application. This is an area requiring a combination of advanced structural concepts and new materials applications and could represent a fairly large technology effort in LTA.

Structures

The area of structural analysis has received sufficient attention in recent years such that much of it is applicable to the most complex airship structure and should be no great problem for the future. The area of weakness, however, is in the determination of loads. This was never satisfactorily achieved for conventional airships, even though progress was made as previously noted when gust transit criteria became predominant in design. Much more needs to be accomplished here, particularly in relating realistic conditions to loads in very large vehicles. An important part of this relationship is the response of the airship to the air load condition in terms of the overall vehicle dynamics and control activity. Practically no technology base exists in this category. Likewise, a technology program would have to be established for new configurations.

The success or failure of either buoyant or semi-buoyant vehicles will be dependent on their overall efficiency and cost. Both elements will be strongly influenced by conceptual innovation and application.

of superior design techniques. As was true in the 1920's and 30's, the best engineering talent may be required to achieve feasibility and ultimate success in new future vehicles.

CONCLUSIONS

1. Both buoyant and semi-buoyant airships have common materials and structures requirements in terms of needs for pliant materials, pressure control, and lightweight structural design.
2. Pliant materials technology can be applied from present balloon development to design of gas cells and envelopes and should result in higher efficiency components.
3. Improved metals and composite materials both offer reductions in overall weight for future airships.
4. Loads determination in large airships represent a critical technology need for structural design.
5. Modern computer techniques will provide a significant improvement in analysis of complex airship structures.
6. Testing of large scale airship structures will probably require use of models.
7. New design concepts are needed for most effective combination of structures and materials technology.

REFERENCES:

1. Arnstein, Karl, "Research and Development Problems Arising in Airship Design", Daniel Guggenheim Airship Inst. Publication No. 1, 1933.
2. Goodyear Aerospace Corp. Report GER 13564 "Parametric Study of Dynamic Lift Aerostats for Future Naval Missions", Jan. 1968.
3. Miller, W.M., "The Dynairship" Colloque Aerall, Nov. 1973.
4. Havill, C.Dewey, "A Lifting Body Dirigible for Air Transport Missions", NASA Working Paper MA-72-3, Dec. 1972.
5. Raven Corp. Data.
6. Cameron Balloons, LTD. Data.
7. E. I. DuPont deNemours & Co. Data.
8. Burgess, C.P., Design Memo 345, 1942.
9. Burgess, C.P., Design Memo 318, 1939.
10. Brooks, Wm., et al, "Application of Composites to the Selective Reinforcement of Metallic Aerospace Structures", AGARD Conference Paper, No. 112, 1973.
11. Calligeros, J.M., McDavitt, P.W., "Response and Loads on Airships Due to Discrete and Random Gusts", M.I.T. Technical Report 72-1, 1958.

12. Boldt, T.R., "Towed Model Tests of 1/75 scale ZPN Airship", General Development Corp. Report No. R50-8-2, 1954.
13. Burgess, C.P., "Airship Design", Ronald Press, 1927.
14. Arnstein, Karl, Shaw, E.L., "On Methods of Calculating Stresses in the Hulls of Rigid Airships", Fifth International Congress of Applied Mechanics, 1938.
15. Hovgaard, William, "The Longitudinal Strength of Rigid Airships", S.N.A.M.E. Transactions, Vol. 30, 1922.
16. "Report on Airship Forum", Daniel Guggenheim Airship Institute Publication No. 3.
17. Butler, T.G., Michel, D., "NASTRAN", NASA SP-260, 1971.
18. NASA Advanced Transport Technology Studies.
19. Chaffe, R.C., Mayer, N.J., "The Bay Assembly Airship Production System", Unpublished, 1946.
20. U.S. Patent No. 1,925,133, 1931.
21. Burgess, C.P., Design Memo 198, 1935.
22. Shanley, F.R., "Mechanics of Materials", McGraw-Hill, 1967.

POTENTIAL CONTRIBUTION OF HIGH STRENGTH, HIGH MODULUS
ARAMID FIBERS TO THE COMMERCIAL FEASIBILITY
OF LIGHTER THAN AIR CRAFT

D. L. G. Sturgeon*
T. K. Venkatachalam**

ABSTRACT: This paper reviews Kevlar® aramid fiber, fabric, rope and cable performance, and economics relevant to the material, structural, and reliability aspects of lighter than air craft.

I. INTRODUCTION

Kevlar® 29 and Kevlar® 49 are two high strength, high modulus, and low density organic fibers recently introduced by Du Pont. These unique aramid fibers offer for the first time textile processibility combined with the highest specific strength (tensile strength/density) available commercially for any material, and a specific Young's modulus (modulus/density) intermediate between fiberglass, steel and aluminum on the low side, and the more exotic graphite and boron fibers on the high. The excellent tensile properties of "Kevlar" have generated extensive trade development programs and commercial sales into rubber and plastic reinforcement uses, many of which have requirements similar to those anticipated for the construction, operation and maintenance of lighter-than-air craft.

*Research Supervisor, E. I. du Pont de Nemours & Co., Wilmington, Del.
**Senior Research Chemist, E. I. du Pont de Nemours & Co., Wilmington, Delaware.

A. Tensile Properties

The basic "Kevlar" characteristics are summarized in Table I. Organic fibers such as nylon and Dacron® polyester have long been used successfully in many industrial applications; but their properties limit their ability to perform in end uses requiring very high strength and low stretch (e.g., wire rope and electromechanical cables). "Kevlar" 29 and "Kevlar" 49 aramid fibers with their combination of high strength (400×10^3 psi), high modulus (9 to 19×10^6 psi), or low stretch (2.4 to 4%) that approach steel (Figure 1), combined with light weight (~ 1.45 g/cc) permit the realization of systems not practical with steel or other synthetic fibers. The yarn properties of "Kevlar" are compared to those of steel, nylon and "Dacron" polyester in Table I. A comparison of the strength and stiffness per unit weight, also called specific strength and specific stiffness, versus other fibers and metals is shown in Figure 2. Note that "Kevlar" offers the highest specific strength of any known commercial material, and a specific modulus intermediate between conventional fibers and metals on the one hand, and more exotic fibers such as graphite and boron on the other.

B. Temperature Effects

The high level of room temperature strength and modulus versus more conventional textile fibers is retained at elevated temperatures as shown in Fig. 3 and 4. In addition, low temperatures that could be encountered in polar service do not reduce the strength or unduly embrittle the fiber, Table II. More extreme lower temperatures, as those required for the containment of liquified gases are also innocuous to the fiber. Work by NASA has shown that "Kevlar" 49 fiber that had a room temperature (75°F , 297°K) tensile strength of 425×10^3 psi, only decreased in strength to 386×10^3 psi when tested at liquid H_2 temperatures (-423°F , 20K), Ref. 1.

C. Creep

A further design consideration for inflatable structures, such as the skins of balloons, is that they must remain in tension for long periods of time without excessive creep. The high crystallinity of "Kevlar" 29 and 49 make creep negligible up to significantly high percentages of the ultimate tensile strength (UTS) of the fiber, Fig. 5. Comparison of the creep rates of "Kevlar" 29 and "Dacron" polyester, measured by the slopes of the curves in Fig. 6, gives further indication of the superiority of the aramid in this respect.

D. Creep Rupture

Strong but brittle materials have difficulty sustaining high percentages of their ultimate tensile stress for useful periods of time due to their creep-rupture behavior. This causes cracks that initiate at some point in the material to rapidly propagate, leading to the collapse of the entire item. The substantial advantage over glass of the fibrous polymeric structure of "Kevlar" in preventing this brittle fracture has been documented elsewhere (Ref. 2). This characteristic could be of value in the design of pressure vessels required for vehicle altitude control and/or ground storage of helium.

E. Ultra-Violet Stability

Precaution should be taken to protect "Kevlar" ropes, cables and fabrics from degradation due to prolonged UV exposure. Because "Kevlar" is self-screening, if degradation of the outer perimeter of a rope, or the outer plies of a coated fabric, can be tolerated, they will protect the interior plies from damage. More economically, ropes and cables can be jacketed with UV resistant braids (e.g., "Dacron"), or an extruded pigmented thermoplastic. A pigmented film as the outer layer of a coated fabric lamination is also an effective UV screener.

III. FLAMMABILITY

Flammability characteristics can be crucial in the selection of material for the applications of interest to this audience. The Limiting Oxygen Index (LOI) is an accepted method of ranking the relative flame retardance of textile fabrics, Table III. Note that the performance of "Kevlar" 29 and "Kevlar" 49 is similar to high temperature resistant Nomex® aramid. Table IV compares the flame and smoke characteristics of "Kevlar" 49 fabric reinforced resin laminates with identical glass fiber reinforced configurations, where precaution has been taken to select a halogenated epoxy as the matrix. Data show "Kevlar" 49 to meet stringent specifications in effect for commercial aircraft interiors.

IV. ELECTRICAL PROPERTIES

The dielectric constant of a "Kevlar" laminate is about one unit lower, and the loss tangent equivalent, to that of a glass fiber reinforced item that uses the same resin. Thus, "Kevlar" is transparent to electromagnetic radiation and can be used advantageously as radome material. Both electrically and thermally it is an insulator, Table V. Its good dielectric properties also make it an ideal material for antenna guy wires that do not interfere with signal transmission.

V. COST

Presently, "Kevlar" sells on a dollars per pound of breaking strength basis at 20 to 40% premium over improved galvanized plow steel wire. The very significantly higher strength per unit weight of "Kevlar" vs. steel compensates for the difference in cost per unit weight. At realistic projected prices, the cost for equivalent strength with "Kevlar" 29 and 49 should be lower than for steel wire.

VI. APPLICATIONS

We will now describe applications for "Kevlar" which take advantage of its properties described above, and which have relevance to material, structural and reliability aspects of lighter-than-air craft. We will purposely exclude "Kevlar" reinforced plastics applications in the aircraft, missile, marine and recreational equipment field that are well-documented elsewhere in the literature (Refs. 4-7). We have specifically selected for review "Kevlar" uses in high performance ropes and cables, coated fabrics, and industrial hose. The relevance of the performance demonstrated by "Kevlar" in these uses to the anticipated requirements of materials for lighter than air craft should become clear in what follows.

A. Ropes and Cables

1. Advantages

The primary advantage of "Kevlar" fibers is an excellent strength-to-weight ratio in very long cables such as those used in oceanographic and aerospace markets. Fig. 7 illustrates the "free" length "Kevlar" will support in both air and water as compared to steel. With the highest specific strength of any material known, "Kevlar" offers increased payloads and permits easier handling with smaller, lighter, and more economical systems.

In addition to the high strength-to-weight ratio, "Kevlar" also offers the following advantages:

- High modulus (resistance to stretch)
- Corrosion resistance
- Non-conductivity
- Flexibility

These characteristics are advantageous in many applications where "Kevlar" is now under evaluation. These include:

Mechanical Lines -

- Oil well rig mooring lines
- Buoy mooring lines
- Tug boat towing lines
- Running and standing rigging
- Helicopter hoist lines
- Balloon tether lines
- Antenna guys
- Parachute shrouds
- Leader lines

Electromechanical Cables -

- Data and sonabuoy mooring cables
- Air and sea towed antenna cables
- Deep ocean work system cables
- Subsea television cables
- Balloon tether cables

Data developed to date in these applications confirm the anticipated strength-to-weight advantages of "Kevlar". In mooring lines, now being developed for offshore oil rigs, a mechanical line of "Kevlar" with 1 million pounds breaking strength exhibits an 80% weight savings in air versus steel. Deep ocean electromechanical cables being developed by the Navy have also shown the high strength-to-weight ratio allows

higher payloads in water (20X) at the same safety factor as an equal size steel cable. In addition to the easier handling of these lighter lines and cables, the corrosion resistance provides safer, longer lasting systems, with no significant strength loss occurring after one year in sea water.

Also, the non-conducting characteristic of "Kevlar" provides added safety in lines, and prevents the strength member from shorting out conductors in electromechanical cables, or interfering with the reception of antennas. High altitude meteorological balloon tethering cables have been deployed and are performing satisfactorily. Pultruded "Kevlar" 49 reinforced plastic guy wires have been operational since 1972 on the radio telescope of the Arecibo Observatory, Puerto Rico (Ref. 7).

A further benefit, confirmed in hydroplane work by the Navy and Woods Hole Oceanographic Institute, is that cables of "Kevlar" are much quieter in operation than steel cables.

2. Forms

"Kevlar" 29 and "Kevlar" 49 can be used either as "soft" yarns (like nylon and "Dacron" polyester) on conventional textile twisting, stranding or braiding equipment, or as resin impregnated strands which may be handled like steel wire on wire stranding, cabling and braiding equipment.

Types of rope and cable structures which have been demonstrated include: 3-strand, 8-strand, plaited, single and double braids, parallel strands, 1x7, 1x19, 7x7, 7x19, 19x7 ropes, and center core and contra-helically wound cables. Typical properties of some rope constructions are shown in Table VI. The construction is chosen to achieve the optimum balance of strength, modulus and flexibility required for specific application. Notice that the strengths of the "Kevlar" items are equal or better than for steel at about one-fifth the weight of cable.

3. Cost

Cost comparison of "Kevlar" and nylon or polyester ropes, Table VII, shows "Kevlar" to be comparable in cost at equal breaking strength.

B. Coated Fabrics

Table VIII shows Hypalon® coated nylon fabric (5.1 oz/yd²), intended as air supported shelter material, compared to a "Kevlar" analog that utilizes fabric of less than half the basis weight (2.1 oz/yd²). The "Kevlar" item is 20% lighter, stronger and more tear resistant. We are currently evaluating fabrics coated with other elastomers.

Work by Sheldahl Advanced Products Division in tethered balloons (Ref. 8) has shown that ply laminates of "Kevlar" offer significant strength-to-weight improvements, are less permeable, and have equal or better abrasion resistance than conventional "Dacron" reinforced counterparts (Tables IX-XI).

C. Industrial Hose

Small diameter industrial hoses (3/16"-1/2") with thermoplastic resin inner liners braided with "Kevlar" and covered with PVC have been shown to support internal pressures up to 40×10^3 psi. Such industrial hoses are now commercial. "Kevlar" is expected to offer considerable advantage in automotive radiator and heater hoses with temperature capabilities up to 300°F.

Gates Rubber Company has recently reported (Ref. 9) use of "Kevlar" in anhydrous ammonia hose with high burst, low volumetric expansion and superior chemical resistance than incumbent products; and in high pressure hose which is nonconductive and more flexible than their steel reinforced counterparts.

VII. CONCLUSIONS

"Kevlar" in its regular (9×10^6 psi) and high (19×10^6 psi) modulus forms offers a combination of physical properties heretofore unavailable among man-made fibers. In spite of its superior performance, "Kevlar" retains the handleability normally associated with more conventional textiles. This allows processing using existing equipment and techniques that result in high performance products of attractive economics.

The high level of tensile strength per unit weight of "Kevlar" combined with its balance of other properties has allowed the reduction to practice of systems concepts in mechanical and electromechanical applications not possible with other materials. The new dimensions in design and economics available with "Kevlar" we think can help improve the performance/cost effectiveness of the lighter than air craft concept.

REFERENCES:

1. Hanson, M. P., "Effect of Temperature on Tensile and Creep Characteristics of PRD-49 Fiber/Epoxy Composites", NASA Technical Note, NASA TND-7120, November 1972.
2. Chiao, T. T., et al., "Filament Wound Kevlar® 49/Epoxy Pressure Vessels", NASA CR-134506, November 9, 1973.
3. Moore, J. W. and Sturgeon, D. L. G., "High Modulus Organic Fiber Composites in Aircraft Applications", Composites, Jan. 1973, pp. 34-38.
4. Stone, R. H., "Advanced Organic Fibers for L-1011 Interior Structures", 17th National S.A.M.P.E. Symposium & Exhibition, pp. V-A-SIX-1 to 19, Los Angeles, California, April 11-13, 1972.
5. Wooley, J. H., Paschal, D. R., and Crilly, E. R., "Flight Service Evaluation of PRD-49/Epoxy Composite Panels in Wide Bodied Commercial Transport Aircraft", Final Report NASA CR-11-2250, March 1973.
6. Sturgeon, D. L. G., et al., "Kevlar® 49 Composites for Sporting Goods and Recreational Equipment", 19th National S.A.M.P.E. Symposium & Exhibition, Vol. 19, pp. 304, April 23-25, 1974.
7. Scala, E., "High Strength Filaments for Cables and Lines", Analysis of the Test Methods for High Modulus Fibers and Composites, ASTM STP-521, pp. 390-409, 1973.

8. Niecum, R. J. and Munson, J. B., "Investigation of "Kevlar" Fabric Based Materials for Use with Inflatable Structures", Sheldahl Advanced Products Div., NASA Contract NAS1-11694, April 1974.

9. Rohlfig, R. A., "New High Strength Reinforcing Fibers", Rubber and Plastics News, p. 8, July 1, 1974.

TABLE I - YARN PROPERTIES

	<u>"Kevlar" 29</u>	<u>"Kevlar" 49</u>	<u>GIPS*</u>	<u>Nylon</u>	<u>"Dacron"</u>
Tenacity, gpd**	21	21	2.9	9.8	9.5
" psi	400,000	400,000	285,000	143,000	168,000
Modulus, gpd	500	1000	200	55	115
" psi (10 ⁶)	9	19	29	0.8	2.0
Specific Modulus, in., 10 ⁸	1.7	3.6	1.0	0.3	0.6
Density (g/cc)	1.44	1.45	7.86	1.14	1.38
Elongation, %	4	2.4	2.0	18.3	12.0
Cost (\$/lb)	7.50	8.50	0.80	0.80-1.00	0.75-1.05
" (\$/lb Break Force x 10 ⁻⁸)	99	112	80	25	27

*Galvanized Improved Plow Steel

**gpd = grams per denier

TABLE II - "KEVLAR" 29* PROPERTIES AT ARCTIC TEMPERATURE

	<u>75°F</u>	<u>-50°F</u>
Tenacity, gpd	19.1	19.8
Elongation, %	4.1	3.9
Modulus, gpd	425	521
Loop Tenacity, gpd	8.3	7.7
Loop Elongation, %	2.0	1.8

*4500 Den.

TABLE III - LIMITING OXYGEN INDEX

T-728 Nylon	0.20	Nomex®	0.28
Virgin Wool	0.25	"Kevlar" 29	0.29

TABLE IV - FLAME AND SMOKE PROPERTIES IN EPOXY* RESIN

	<u>"Kevlar" 49</u>	<u>Glass</u>
Flammability FAA 25.853 Test		
Burn Length (in.)	5.5	7.75
Time to Extinguish (min.)	0.70	0.75
National Bureau of Standards Smoke Chamber		
Max. Specific Optical Density flame ignition	148	197
Max. Specific Optical Density radiant ignition	54	77

*Flame retardant

TABLE V - ELECTRICAL PROPERTIES OF "KEVLAR" 49 AND GLASS
FABRIC LAMINATES IN FR-4 EPOXY RESIN

	<u>"Kevlar" 49</u>	<u>Glass</u>
Dielectric Constant (ASTM D-150, 10 ⁶ Hz)	4.12	5.15
Dissipation Factor (ASTM D-150, 10 ⁶ Hz)	0.0239	0.0210
Dielectric Strength, volts/mil (ASTM D-149)	957 (29.7 mils)	793 (36.1 mils)
Volume Resistivity, ohm/cm (ASTM D-257)	5 x 10 ¹⁵	2 x 10 ¹⁵
Surface Resistivity, ohm/square (ASTM D-257)	5 x 10 ¹⁵	3 x 10 ¹⁵
Arc Resistance, seconds	125	123
Volume % Fiber	48	44

Conditions: Tests at R.T. after samples had
been conditioned at 73°F for 24
hours at 50% R.H.

TABLE VI - TYPICAL ROPE CONSTRUCTIONS

	<u>Diameter</u> <u>(in.)</u>	<u>Lbs/100 Ft</u>	<u>Break</u> <u>Strength</u> <u>(lbs)</u>
<u>3-Strand</u>			
"Kevlar" 29	1/2	-	14,300
"Dacron"	1/2	-	6,900
Nylon	1/2	-	8,000
<u>Braid</u>			
"Kevlar" 29 (med. pick)	9/16	10.8	34,000
"Dacron"	9/16	10.0	16,000
"Kevlar" 29 (long pick)	3/16	1.5	6,500
<u>8-Strand Plaited</u>			
"Kevlar" 29	1/2	8.6	17,500
"Dacron"	1/2	7.0	6,400
Nylon	1/2	6.8	7,100
<u>H.B.L. Plaited</u>			
"Kevlar" 29 w/"Dacron" cover	23/23	13.2	31,500
Nylon w/"Dacron" cover	1	18.9	24,600
<u>Wire Rope</u>			
<u>1x7:</u> "Kevlar" 29	1/8	0.8	2,500
Galv. Aircraft Strand	1/8	3.5	2,100
<u>1x19:</u> "Kevlar" 29	3/16	1.4	4,700
Stainless Steel Galv. Aircraft Strand	3/16	7.7	4,700
<u>7x7:</u> "Kevlar" 29	5/16	3.5	12,000
Galv. Aircraft Strand	5/16	16.7	9,200
<u>7x19:</u> "Kevlar" 29	1/2	8.0	25,000
Galv. Aircraft Strand	1/2	45.8	22,800

TABLE VII - COST* COMPARISON IN ROPES

	<u>"Kevlar" 29</u>	<u>Nylon or Polyester</u>
Breaking Strength, lbs		
1 1/4"	153,000	64,000
2"	302,000	164,000
Weight, lbs/100 ft		
1 1/4"	61	53-60
2"	156	135-135
Cost/Foot, \$		
1 1/4"	4.78	1.83
2"	12.42	4.64
Cost/Lb Breaking Strength (\$ x 10 ⁻⁵)		
1 1/4"	3.12	2.86
2"	3.17	2.82

*Wall Rope "Uniline" price list May 1974.

TABLE VIII - AIR SUPPORTED SHELTER MATERIAL

	<u>Nylon</u>	<u>"Kevlar" 29</u>
<u>FABRIC PROPERTIES</u>		
Weight, oz/yd ²	5.1	2.1
Tensile Strength	380 x 375	215 x 230
Grab Method (WxF), lbs		
Burst - Mullen, psi	800	930
<u>COATED* FABRIC PROPERTIES</u>		
Weight, oz/yd ²	15.0	11.3
Tensile Strength	300 x 300	380 x 335
Grab Method (WxF), lbs		
Tongue Tear Strength (WxF), lbs	20 x 20	20 x 25
Burst - Mullen, psi	840	900

TABLE IX - TENSILE STRENGTH OF "KEVLAR" 29
COATED FABRIC LAMINATES (Ref. 8)

Test Temp. °C	1-Ply "Dacron" 3.8 oz/yd ²		2-Ply "Dacron" 2.25 oz/yd ²		1-Ply "Kevlar" 1.8 oz/yd ²		2-Ply "Kevlar" 2.7 oz/yd ²	
	MD	TD	MD	TD	MD	TD	MD	TD
	(lb/in)		(lb/in)		(lb/in)		(lb/in)	
60	230	220	173	148	257	300	331	303
22	262	263	184	154	269	330	394	420
-51	258	261	216	210	321	334	460	457

MD = Machine Direction
TD = Transverse Direction

TABLE X - HELIUM PERMEABILITY DATA (Ref. 8)

1/m²/24 hr @ 300 N/m² Pressure

Single-Ply		Two-Ply	
"Dacron"	"Kevlar" 29	"Dacron"	"Kevlar" 29
0.4	0.3	0.7	0.5

TABLE XI - ABRASION DATA* (Ref. 8)

	Cycles
1-Ply "Dacron"	40,000
1-Ply "Kevlar"	69,000
2-Ply "Dacron"	21,000
2-Ply "Kevlar"	21,000

*Number of cycles required to expose the fabric when abraded against themselves.

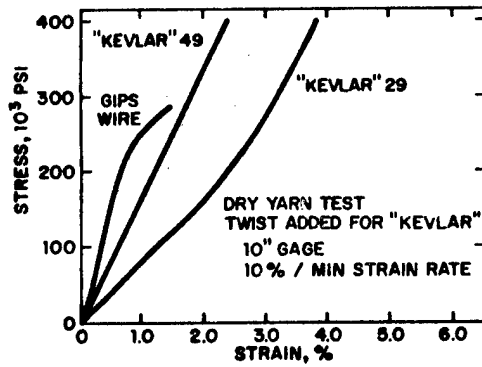

FIG. 1 - STRESS-STRAIN CHARACTERISTICS

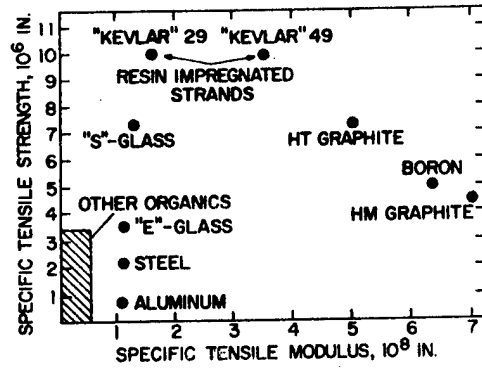

FIG. 2 - SPECIFIC TENSILE STRENGTH AND TENSILE MODULUS

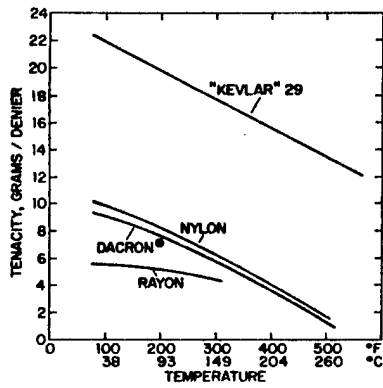

FIG. 3 - EFFECT OF TEMPERATURE ON TENACITY

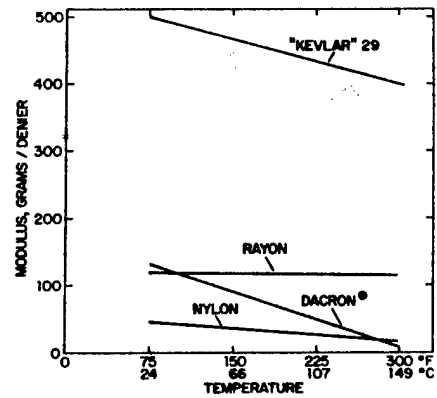

FIG. 4 - EFFECT OF TEMPERATURE ON MODULUS

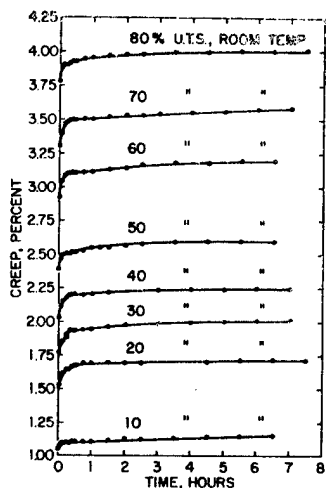

FIG. 5 - CREEP OF "KEVLAR" 29

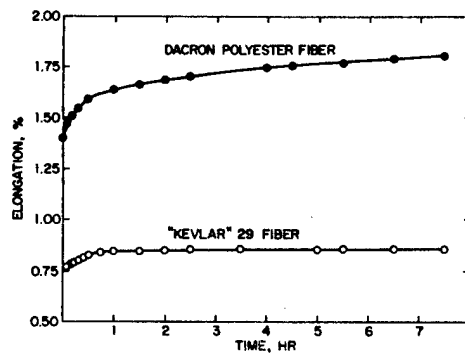

FIG. 6 - COMPARATIVE STRESS-CREEP OF "KEVLAR" 29 AND "DACRON" FIBER TESTED AT 10% OF ULTIMATE TENSILE STRENGTH

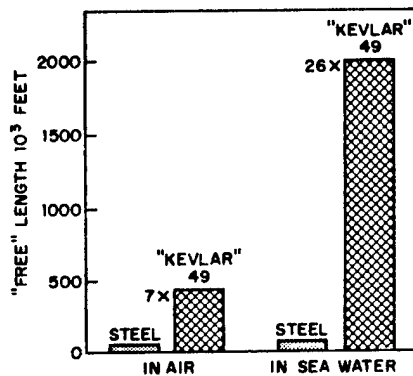
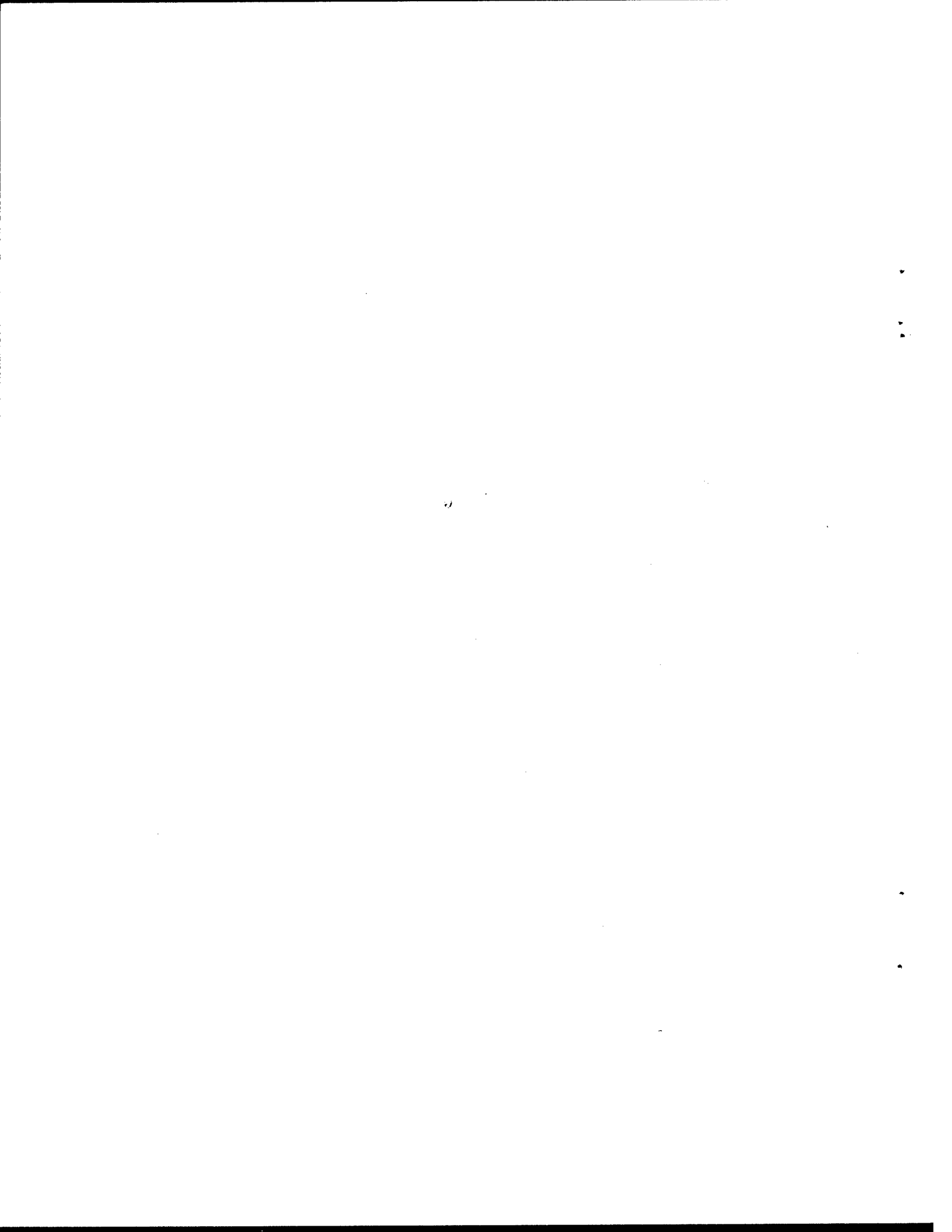

FIG. 7 - "FREE" LENGTH COMPARISON

(LENGTH AT WHICH STRENGTH MEMBER BREAKS OF ITS OWN WEIGHT = TENSILE STRENGTH/DENSITY)



AIRSHIP CONSTRUCTION

John Roda*

ABSTRACT: Forty-four years ago the first successful metal airship was completed and delivered to the United States Navy, the ZMC-2. Between those years and the present, very little effort or serious consideration has been given to the manufacture, design, construction, or economic impact of airships. It is important that we retain and exploit the small but continually diminishing pool of airship talent that will expedite the success of the United States in what is now a pioneering venture. The relative simplicity of airship construction, utilizing the tremendous technical advances of the last 44 years, leads to the conclusion that this form of transportation holds great promise for reducing costs of military missions and improving the international competitive position of the United States in commercial applications.

The design concept for our all metal airship directed the utmost consideration toward manufacturing feasibility. The design is such that existing fabrication and assembly methods can be applied.

Extensive sub-assembly of the airship's structure components into large module segments will substantially reduce the elapsed time required to complete each airship in the assembly dock.

Modular assembly methods in various forms are presently being used in aerospace and modern shipyards to increase productivity, insure quality and reduce costs.

When necessary to accelerate production, a subcontracting program will be negotiated with existing aircraft builders, also their sub-contractors and material suppliers. Thereby we will avail ourselves of additional facilities and skilled personnel.

*Director, Turbomachines, Inc., Irvine, California, U.S.A. and member, Southern California Aviation Council, Inc., Lighter Than Air Committee Technical Task Force, Pasadena, California, U.S.A.

The technical skills required to fabricate and assemble metal airships are comparable to those presently employed to construct all metal airplanes. For the foreseeable future these skills are readily obtainable.

Certain special tooling and new assembly methods, as they relate to our metal airship construction are being designed and developed during the initial research and development phase. During these early stages of research and development, close coordination between engineering, manufacturing and tooling personnel is very essential.

The team concept is a must on an airship development program. You cannot departmentalize. Time and cost will not permit an elaborate organization.

A delivery schedule commitment applies to all involved on any complex project. A schedule is no more or less than a timetable, or time allotment. It is very important that all functions committed to a "Promise to Deliver" complete their responsibility on time.

A behind schedule condition frequently leads to cost overruns. This is usually caused by expending excessive overtime and resorting to other forms of heroics to make up for lost time. The excessive use of overtime on a fixed price contract can become a bottomless pit inasmuch as a fatigue factor limits output, and not the hours expended. Also, quality is endangered as mental fatigue and discoordination occur.

There are many factors involved in scheduling and they are all of utmost importance and deserving of full consideration before making a contractual delivery commitment.

QUALITY CONTROL

The quality of aircraft starts with the initial design layout. Quality must be designed and manufactured into a craft with each operation performed within approved standards.

Quality cannot be inspected into an aircraft or in any way compromised. There can be only one standard applied as to the degree of quality acceptance. Skill requirements for airship craftsmanship must be above levels acceptable for routine aircraft production line work.

Airship mechanics will require diversified experience and a capability to perform a variety of skills with a minimum amount of supervision.

CONSTRUCTION FACILITIES

Existing airship construction facilities in America are limited and whether any of these could be obtained for an airship development program is being investigated.

If existing facilities are not available, a new and completely modern structure with overhead cranes, elevators, adjoining fabrication facilities and engineering department should be constructed. If such a structure were approved, serious facility design consideration must be given for future growth in size of airships up to thirty million cubic feet or larger. Modern production layout would be taken into account.

For the initial research and development program, present United States government owned facilities exist in Southern California. This property includes two large airship hangars. It is a former Navy Airship Base, now being used as a helicopter repair and storage depot. A close inspection would be required to determine whether they are adequate, or if they are obtainable for a prototype airship development program.

The location, climate and other considerations make this facility desirable.

Information from knowledgeable sources indicates that much government owned surplus machinery of all categories and sizes are stored in various depots. If this equipment could be leased for an airship program, much valuable time could be saved with a considerable reduction in total budget requirements.

In conclusion I would like to share this thought with you. At this late hour we still have access to a diminishing store of technical knowledge and experience relating to modern all metal airship engineering and construction.

This knowledge and experience is a valuable and irreplaceable national asset and should be exploited to strengthen our national defense.

The dirigible also has the potential for resolving our rapidly deteriorating national transport system and thus insuring our future economic well-being.

There is an urgent need in many areas of this world for a modern airship transport system to provide transportation and cargo service where none exists. These multiple needs will insure the economic viability of this transportation medium, a medium which is capable of establishing an entire new industry and sustaining itself on its own merits.

N76-15039

OPERATIONAL CONSIDERATIONS FOR THE AIRSHIP
IN SHORT-HAUL TRANSPORTATION

Charles D. Walker*

ABSTRACT: This paper surveys the airship's problems and the possibilities for their solution in a short-haul transportation environment. The problems are derived from both past experience and envisioned operation. Problems relative to both fully buoyant and semi-buoyant configurations are considered and their origins in principle discussed. Also addressed in this paper are the state-of-the-art technologies with the potential of providing answers to the airship's operational difficulties.

The airship as a mode of short-haul transportation appears among the long list of potential applications for the modern operational vehicle. But there is, at present, no operational transport airship. The anticipated problems of operation, a necessary element of the concept evaluation for any new system, must then be based upon any pertinent past operation. This operational experience is, however, limited in its direct correlation to modern demands. It is limited not only in the scope of applications but also in time base (as compared to span of operations for Heavier Than Air) and level of technology. Virtually all inputs keyed to large rigid airships originated prior to 1939. Military and limited commercial (mainly advertising) experience continued to the early 1960's in the form of non-rigids. Only limited commercial application is on going. Current research and development is almost nonexistent.

So the present day planner, wishing to determine the applicability of a modern airship to the short-haul air transport market, must either ignore the labors of his technological forebearers and start from scratch or he can build on the past. He has the ability to survey, filter and assimilate the facts and figures of the airship's operational history. Determining the operations and the problems that are now relevant to a short-haul role, he can make swifter, less costly and less risky system design decisions. This paper will make a beginning in this direction.

*Manager, Aerling, Bedford, Indiana, U.S.A.

PRECEDING PAGE BLANK NOT FILMED

REQUIREMENTS OF THE MODERN AIRSHIP IN SHORT-HAUL TRANSPORTATION

Eventually, a set of criteria will be required to evaluate the engineering solutions of the airship's operational shortcomings. These criteria can be extrapolated from the general requirements of a short-haul system.^{1, 2}

Requirements of Short-Haul Transportation

The general requirements of the short-haul system are no different than those of any large transport system: safety, convenience and comfort, comparable cost, and community benefit. From these general requirements, the technical requirements of a short-haul mode aircraft may be drawn. These are shown in Table 1.

Table 1
Technical Requirements of an Aircraft Short-Haul Mode

- | | |
|--|---|
| ● Reliability at Least Equal to Fixed-Wing Aircraft | ● Accessible to the Traveler/Shipper |
| ● Navigational and Flight Path Control Aids to Provide All Weather Operation | ● Compatible with the Traveler/Shipper |
| ● Internal Noise Vibration, Sensitivity to Atmospheric Conditions at Levels Attractive to the Traveler/Shipper | ● External Noise at Acceptable Levels |
| ● Competitive Payload Capacity | ● Low Air Pollution |
| ● Competitive Block Speed | ● Low Energy Consumption |
| | ● Minimize Utilization of Land and New Facilities |

The short-haul aircraft will be operating over travel distances of up to 500 miles and in low, medium and high density markets.

OPERATIONAL PROBLEMS OF THE MODERN AIRSHIP

It can be assumed that in this operational environment the modern airship will encounter many of the same difficulties as its ancestors during the first third of this century. There will also be new problems spawned by market demand, institutions, and modern technology. The list of problems that follows contains those difficulties that appear to be most nearly associated with the short-haul operating mode.

Slow Speed Aerodynamic Control

This problem is not one peculiar to the airship. It is common to all aerodynamically controlled bodies. Basically it is the control surfaces' inability to provide an adequate resultant force due to lack of sufficient flow velocity. The upper threshold for loss of aerodynamic control is generally 15 mph. It was found that a kind of control reversal also occurs at these low speeds. This has been investigated and procedural remedies can be instituted.³ This problem is particularly hazardous during landing maneuvers when positive control is required for mooring operations, as well as for the welfare of the ship itself.

Trim Control

The balance adjustment of an airship in flight has two inputs - aerodynamic and static.

Aerodynamic trimming is done by deflection of the elevators. Again, this is a common point for controlled aerodynamic bodies. But static trimming is more obvious in a buoyant vehicle. Static trim is accomplished by adjusting the center-of-gravity longitudinally. The medium of static trim adjustment has usually been ballast movement, ballonnet inflation control, valving of lifting gas, or even shifting on-board personnel. Obviously, the principle is positional control of mass. Adequate control of static trim can effectively minimize the demand for aerodynamic trim.⁴

Buoyancy Control

This problem area can be basically described as the requirement to maintain a level of static lift. Control is a function of vehicle altitude and lifting medium temperature.

Gas Valving

The valving of lifting gas is intimately tied to buoyancy control. In fact, it is a means of control. Gas will be valved if the airship exceeds its pressure altitude and the gas cell or envelope is at maximum volume condition. There is the potential of a catastrophic failure of the envelope, so gas is released to reduce the pressure differential. Gas may be valved to control ascent and descent, although it is the most expensive and risky means.

Ballast Management

Again, this is a means of buoyancy control and also potentially a trim control technique. Ballast is mass and has consisted of such innocuous items as sand, lead, and water. The inefficient use of ballast (and gas valving) in flight can lead to a condition called "exhaustion" by the Germans. It is the condition of an airship that has lost its means of buoyancy (and possibly trim) control.

Manpower (Ground Crew)

The bulk of the airship required many personnel actively engaged in holding her down when the ship was not flying. Being a buoyant body, the airship was generally at the mercy of some of the elements and people were the most easy means of active control. Today, this kind of labor intensive activity is a problem.

Weathervaning

Another ground problem, weathervaning is actually a result of the vehicle being a buoyant body and subject to any sufficiently large disturbing motion of the surrounding medium - wind. With a streamlined configuration and airfoils aft, the airship continually tries to point into the wind. Mooring and ground handling equipment and operations must be adaptable accordingly.

Weather

Perhaps potentially the greatest problem, weather has many facets. Gusting near the ground may cause a vehicle/ground collision. Turbulence at altitude can produce structurally damaging shear forces. Thermals can produce an undesirably rocky ride-trim control problems. Precipitation and condensation provide buoyancy problems through mass accumulation on the vehicle's surface and possible cooling of the lifting gas, reducing displacement. Temperature variations result in changes of lifting gas and thus affect buoyancy. The control surfaces can easily be jammed if ice is allowed to accumulate. This problem is common to all aircraft. Loss of visibility is not as great a problem for an airship as it is for a heavier than aircraft because an airship can reduce its velocity to zero in obstacle avoidance without losing lift. It will be more of a danger in congested airspaces. Lightning strikes are not a great

problem because even a large puncture of the gas container doesn't mean a catastrophic loss of lift. And the use of helium, rather than hydrogen as the lifting gas, means that combustion is negated.

Human Error

This problem is all pervasive and, as long as man remains in the operational system, this problem area will, to some degree, be present.

Air Traffic Control

This heading refers to a category of problems derived from the interaction of air vehicles within a limited volume of airspace. An air transport system brings these problems of congestion upon the airship.

Useful-Load Transfer

The transfer of payload to or from the airship, both on the ground and hovering, is seen as presenting some tough engineering and procedural problems. Problems of positive load positioning, vehicle control, and buoyancy control are foremost in this new area.

Landing Impact Control

Because airships were originally constructed of girder and wire frames overlaid with fabric skins, any impacting contact with the earth could cause structural damage. Impact loading would still be a problem with rigid structures of this type.

Interface With Ground Handling/Support Equipment

Problems of equipment/systems interfacing will become a larger concern when the design complexity of the airship escalates to meet the problems touched on previously. Both active and passive ground support will be important to a moored or docked airship.

POSSIBLE TECHNOLOGICAL APPROACHES

All of the previously discussed problem areas must be evaluated to determine their basic nature. Only then can effective, detailed approaches to solving the problem be programmed. In the paragraphs to follow, however, a start is made at isolating state-of-the-art concepts and techniques that may be able to evolve solutions.

Vectored/Lift Thrust

Producing vectored thrust by swiveling propulsors and by reversing propellers is possible. Both methods are either in operation today or in the prototype stage.⁵ Another approach that is in operation is the use of the directed thrust jet of a turbine engine; an application of blown flap technology.

Improved Control Surface Response

Several current control systems appear to be applicable. Control Augmentation System, fly-by-wire, and Active Control Technology would provide an attractive coupling of digital/electrical/hydraulic/mechanical systems for the increasingly complex control requirements of the modern airship.^{6, 7} Boundary Layer Control would go far toward solving the principle cause of surface control loss.

Improved Static Trim

The approach to improving static trimming may be the positional control of mass in the form of a liquid. Aircraft are currently utilizing on-board fuel for this purpose by controlling its location in the fuel tanks. Additionally, the concept of a semi-buoyant airship would provide mass for an inertial keel that is inherently trim stabilizing.

Thermodynamic Lifting Gas Management

Suggestions for artificial means of super heating the lifting gas to increase lift on one hand and cool, compress or liquify the gas to decrease lift on the other, have obvious merit. The means of compression and liquification may prove too massive, however.

Mechanical/Thermal Icing Prevention

Proven means of applying thermal energy to aerodynamic surfaces to prevent icing are available. The heat produced by a thermodynamic gas management system would also prove helpful. Hydraulic and mechanical means of releasing the ice are practical.

Increased Speed Capability

This improvement has many benefits including economic competitiveness and weather avoidance. It may be accomplished by use of laminar flow control to reduce drag, better aerodynamic design, and turboprop/turbofan propulsors.

Avionics

The wide range of systems available and programmed can provide aids to solve the weather and air traffic control problems. Instrument Landing System and Area Navigation are two systems in existence. Micro-wave landing and discrete-address beacon systems are projected aids of importance. Weather forecasting provided to the systems user will go far to assist the operational airship.

Improved Flight Crew Training

Simulators, currently an indispensable part of flight crew training should improve the airships' efficiency and safety.

Ground Handling/Material Handling Equipment

In a competitive transport market, the airship cannot ignore the existing containerized/bulk cargo handling systems. In addition, consideration to adapting conventional general purpose equipment such as vans and flat-bed trucks should be given. This could assist in opening new markets.

Improved Mooring Methods

The problems of mooring and handling airships will not soon be gone. But innovative devices such as turntables for mooring and direct mooring to the airship's undercarriage structure could ease them.

Further study and clarification of the semi-buoyant lift concept may in itself prove the most important solution to the modern airship's problems. The successful adaptation of the safest form of air travel with the best understood and utilized form could mean a more efficient complete transportation system.

REFERENCES:

1. Vittek, J. F., Problems and Issues For Short-Haul Air Transportation, Society of Automotive Engineers, New York, New York (May, 1972).
2. Coty, U. A. and Kasling, P. H., V/STOL and STOL For Short-Haul Transportation, AIAA Fourth Annual Meeting and Technical Display, New York, New York (October, 1967).
3. Fisher, R. R. and Ross, R. S., Recent Airship Developments and Applications, Proceedings, Sixth AFCRL Scientific Balloon Symposium, Bedford, Massachusetts (27 October, 1970).
4. Airship Aerodynamics, U. S. War Department Technical Manual TM 1-320, Washington, D. C. (11 February, 1941).
5. Stepniewski, W. Z., VTOL Aircraft and Short-Haul Transportation, AIAA Student Journal, New York, New York (December, 1972).
6. Fraser, D. C. and Felleman, P. G., Digital Fly-By-Wire, Astronautics & Aeronautics, New York, New York (July/August, 1974).
7. Goodmanson, L. T. and Gratzner, L. B., Recent Advances in Aerodynamics For Transport Aircraft, Astronautics & Aeronautics, New York, New York (January, 1974).

N76-15040

DESIGN ASPECTS OF ZEPPELIN OPERATIONS
FROM CASE HISTORIES

Walter P. Maiersperger*

ABSTRACT: This paper deals with some widely held beliefs concerning the practicability of rigid airships in air carrier operations. The paper shows, by a review of past operational experience, and some basic aerostatic theory, their actual record and the reasons for their demise. Problems of atmospheric density and temperature variations, meteorological factors, aerodynamic stability and control, and mooring difficulties are discussed and related to actual case histories. Structural and flight efficiencies are compared to airplane efficiencies for airplanes contemporary with the zeppelin as well as modern designs. The difficulty of supporting new, commercial airship developments on an economic basis is made clear.

"In the development of human flight the zeppelin episode could only have been a very brief one". So wrote the master mariner of airships, Hugo Eckener, with respect to air carrier operations. Because reference books, semi-professional journals and current airship enthusiasts have published a great deal of mis-information about bouyant aircraft, it is the purpose of this paper to put on the record of this workshop some physical laws and design factors that establish the truth of Eckener's observation.

Ship Analogy - Sir George Cayley appears to have started the analogy with surface ships by suggesting that airship lift be subdivided into multiple compartments for greater safety. C. P. Burgess wrote that because rigid airships had this feature, they could lose one or more lifting cells without endangering the airworthiness of the ship.

*Lt. Col. USAF-Ret

Actually, this feature only helps prevent instant catastrophe. To remain aloft the airship must jettison weight in equal proportion to the lift it lost. The weight dropped must leave the airship in satisfactory trim, or it will experience extreme difficulty in maintaining control of any forward speed, and thus, its chances of reaching a safe haven. Therefore, any loss of lift jeopardizes the airworthiness of any airship.

The SHENANDOAH and the R-33 both escaped disaster after being torn from their mooring masts and thereby suffering the loss of forward lifting cells. On the other hand the ITALIA and the MACON were both lost after suffering deflation of their aft cells. The disparity in the analogy is that surface ships have an immense reserve buoyancy. No airship ever had any while on a design mission. A ship with a flooded compartment sinks deeper into the water, all of its hull above water constituting reserve buoyancy. The airship with deflated cell sinks all the way to earth, unless it drops weight, as stated above. This ship analogy is one of the most basic and persistent myths, so it was treated first.

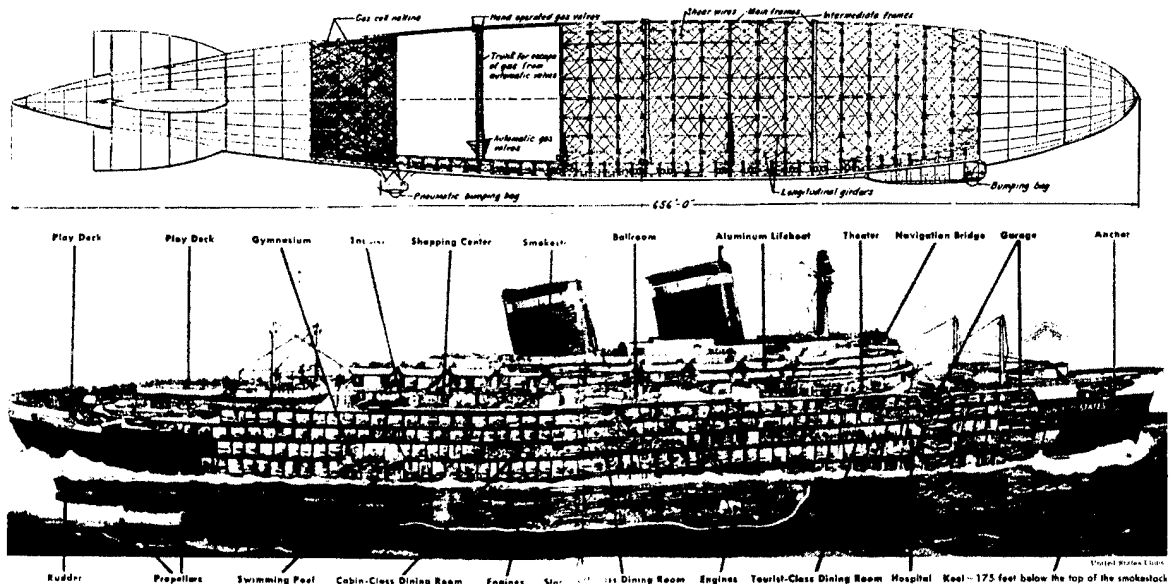

Figure 1. Ship and Airship cross-sections

Shipping is the cheapest and best mode of long distance transportation known to man. It does not follow that because airships are also buoyant vessels, they are equally as attractive. Because water is more than 800 times as dense as air, there is a striking difference between

the utilization of volume aboard a ship and an airship. In Fig. 1 it is seen that it is almost impossible to overload a ship with most industrial products, -only solid materials and ore can do that. Generally, the stability of the ship becomes the limiting factor, not the load which may be placed aboard. In contrast, the passenger and cargo space on the airship is so small as to be almost unrecognizable. As an Englishman has put it, "The wisdom is questionable, of creating an airship as large as the MAURETANIA for a load only so large as a lorry can carry".

Before leaving this analogy, it is necessary to point out that only captive balloons operate lighter than air. In normal operation, an airship is not lighter than air. Like a ship, it is equal in weight to the weight of the fluid it displaces. Balloons, and all airships, which are really dirigible balloons, should be called bouyant aircraft, and the term 'lighter than air' eliminated as part of the myth surrounding the subject.

AEROSTATICS

Eckener reminds one that every airship landing is essentially a balloon landing. Misunderstanding concerning the nature of balloon flight began with the first public notice, the 23 August Proclamation of the French Government, issued, "so that alarm be not occasioned to the people". It spoke of balloon experiments than in progress and revealed the operating principle as "filled with inflammable air" a balloon will "rise toward heaven till it's in equilibrium with the surrounding air". Ever since, most people believe that a balloon will rise until it is in equilibrium with less dense air at higher altitude, and conversely, that a descending balloon will sink until it is in equilibrium with lower, more dense air. In fact, aerostatic lift is unstable lift. A light balloon will continue to go up and a heavy one down, until the pilot valves gas or drops weight, or the balloon, on its way up, passes the height at which its bag is full, known as pressure height, and either blows-off gas through its overpressure valves, or bursts. This physical fact is responsible for the expenditure of both gas and ballast on every flight. In operation, an airship must sacrifice almost 1% of its gross lift for every 100 ft rise in altitude, and must carry a minimum of 3% of its gross lift in the form of ballast to prevent inadvertent descent at inopportune times. In practice, its lifting gas is assumed to be about 95% pure (ie., diffused 5% by air). Thus, a commercial airship must sacrifice about 13% of its cargo capacity to fly at minimum altitude (1500 ft) with minimum safe ballast. No other vehicle ever seriously considered for commerce is so inherently handicapped.

Altitude - Fig. 2 shows the aerostatic effect on design if an airship

were considered for transcontinental flight. For scheduled, instrument flight over eastern USA, the FAA requires a minimum cruising altitude of 8000 ft, and over western USA 16,000 ft. The figure shows the increases in diameter, frontal area, and volume necessary to achieve various cruise altitudes, compared to a sea level balloon having the same lift capability. Alternately, the lower block shows the effect on lift capability if the volume is kept constant and the design is used at the various altitudes. This block explains the extreme difficulty all airships have had in crossing the United States in the past, as they were all sea level designs. The SHENANDOAH flew so low she knocked off her trailing wire antenna 'fish' at 2200 hrs near El Paso. The GRAF did the same thing near Tours on the return maiden flight, also at night, and carrying passengers! The AKRON, eastbound, had to jettison 6 tons of fuel and her onboard airplanes to proceed beyond Phoenix, and was then so short of fuel she couldn't make it back to Lakehurst non-stop.

None of the historic airship flights would have been sanctioned under modern airways regulations, yet these flights are recalled by current enthusiasts to extoll the capabilities of zeppelins. It should be noted that the figure represents static lift effects only. A larger airship would require still greater volume increase to carry the larger engines and greater fuel and ballast load of the larger, high level design.

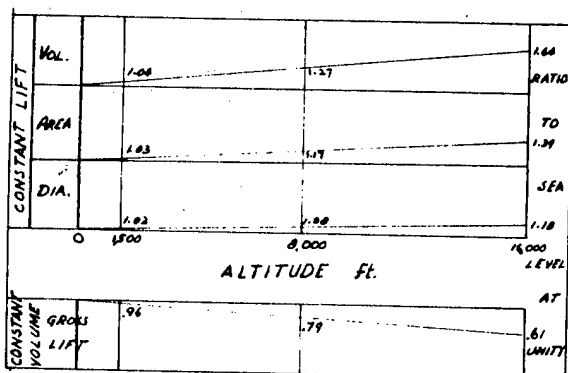

Figure 2. Static Effect of Altitude

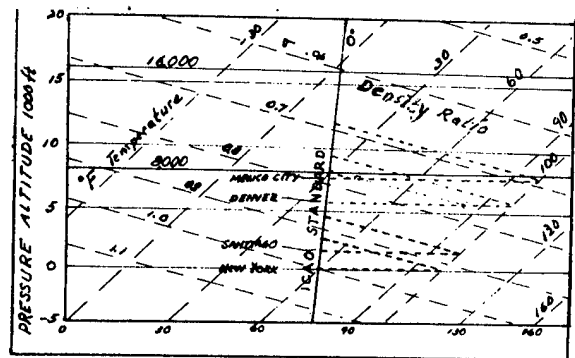

Figure 3. Atmospheric Effects

The real world has a variable atmosphere and cities are located at various altitudes and climates. Fig. 3 is a standard air chart which has certain selected cities spotted on it at their respective altitudes. It is seen that an airship designed for eastern USA (8000 ft design altitude) could not operate into Denver, at design gross weight if the ground temperature exceeded 85°F, although Denver's altitude is but 5280 ft. The same would be true at Mexico City, elevation 7347 ft,

whenever the temperature exceeded 42°F. Only the 16,000 ft design would be practical for both places, even though the Rocky Mountains would not have to be crossed from the eastern seaboard, for either destination.

Superheat - This is the amount of increase of gas temperature above ambient air. Superheat develops most noticeably when the airship is moored out on the field on a sunny day. Even at Santiago, elevation 1675 ft, the airship will be at 7,400 ft density altitude if 40° of superheat is allowed to develop on a 100°F day. A sea level design airship with full cells will blow off gas equivalent to 18% of its gross lift under such conditions. This happened to the GRAF at Los Angeles. As the field had no refilling facilities, the GRAF was so heavy at take-off, she left without ballast and made it over the telephone wires at the end of the field with 3 ft to spare. Eckener mentions a 'cat-walk' crew, whose duty it was to step off, or back onto a moored zeppelin, depending on changing superheat as clouds or rain showers went by. Larger zeppelins will require that the field have gas, water and fuel pumping facilities to maintain the airship at correct equilibrium under changing conditions. The AKRON experienced this situation at Parris Is. Marine Base, and the MACON at Opa-Locka. In both episodes, alternate rain and sun aggravated the troubles, as rain soaked covers may add 10% to the gross weight of the ship.

Rain, Snow and Ice Loads - If extra gas is added to permit take-off with a load of rain, snow or ice on the cover, this gas will be blown-off when the ship reaches design altitude. Cold weather will normally allow take-off, whereas in hot weather the gas cells may become full before the extra lift to carry the load is obtained. While moored, snow and ice may cause high local structural stresses at the horizontal fin attach points. Nobile recounts brooming for two days to prevent snow accumulations from buckling his hull at these points. Andree's log books show his balloon suffered acutely from snow and ice loads in flight, and they leave the recommendation that means be developed to heat the cover and prevent such accumulations. Nobile's controls froze tight on his return from the North Pole. His tragic crash is attributable indirectly to having to stop the ship while the jammed controls were freed. However glorious the record of the German passenger zeppelins, they never attempted a North Atlantic crossing in the winter season. Only a few years later, green crews flew combat planes over this route year 'round. De-icing remains a development of large proportion facing those who would resurrect the zeppelin.

AERODYNAMICS

Knut Eckener claimed that airships flew naturally, unlike airplanes

which depended on some trick to keep it in balance. The force center comparisons, shown in Fig 4, indicate the airship may be the trickier of the two. In airplane configuration terms, the airship is a 'tail-less' design, meaning the tail control surfaces are carried on the wing itself, -the wing being the hull of the airship. While the center of pressure (c.p.) and the center of gravity are virtually coincident on an airplane, the c.p. is far forward of the c.g. on the airship when it enters a gust. The airship has a third force center, the center of bouyancy (c.b.) located high, but directly above, the c.g. This arrangement provides a stable restoring moment whenever the hull develops lift. It is seen that the low slung engines of the airship always produce a pitch-up. C.P. movement on an airplane is expressed as a percentage of the length of the wing cord. On an airship, it is a percentage of the length of the entire hull. Tailless airplanes cause design control difficulties; so does the airship. The inter-relationship of forces about these three centers apparently require a great deal of experience for the pilot to assess correctly. For instance, a heavy ship will be flown dynamically in a nose up attitude. But an airship at neutral bouyancy, trimmed statically nose heavy, will appear to fly in the same attitude. Consumption of the fuel and water ballast causes the c.g. to rise, thus reducing its power to provide stable restoring moments. A light ship flies and handles differently than a heavy ship.

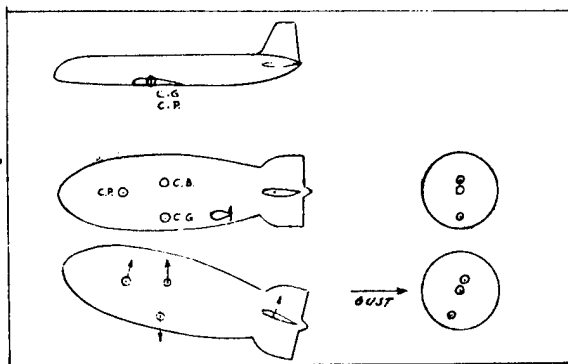

Figure 4. Force Center Comparisons

Controls - The destabilizing force always produced by gusts on the forward hull is countered by the large control surfaces. Their movement has been a field for development of design philosophy, if not for satisfactory solution of the problem they present. The problem is that rapid movement of the surfaces tends to produce forces so high as to endanger the integrity of the hull. On the other hand, slow motion produces very sluggish control response.

It sounds incredulous to learn that it took 25 seconds to move the LOS ANGELES elevator through full travel, and that Norway was proud of his solution for the R-100 which only permitted the full strength of the helmsman to move the control 30° initially. Then, as the ship responded, additional deflection could be applied. Full deflection took about 30 seconds! Norway recalls passing thru a squall at night, near Montreal, when the ship was tossed upward 3200 ft into the clouds, spun 92° in direction, and

pitched nose down 35°, all in less than a minute. Actually, Norway's statement proves the ship was actually uncontrollable under certain conditions. Both the SHENANDOAH and MACON experienced moments when the rudder was applied one way and the nose moved initially in the other. The SHENANDOAH just missed a mountain at night. On the MACON, the forces produced under this action carried away her upper fin. Because the airship has a very low thrust to weight ratio, and is sluggish in response to its controls, it can hardly avoid being carried above pressure height in a developing thunderstorm. It then blows-off its gas, or overpressures and bursts its gas cells, leaving the airship heavy as it encounters the corresponding down current. Either the structure fails, as it did in the case of the SHENANDOAH and the DIXIE or the ship is left short of fuel and ballast with which to reach its destination. Because the trim of the airship and the forces developed are so interrelated the pilot may easily make an error of judgement. The MACON was 'light' when her fin ripped off and deflated her aft cells, due to the action of a violent down and side gust. Without steering control and hanging tail low, the pilot dumped ballast heavily. The MACON then rose above pressure height to 4850 ft and stayed there 16 minutes, blowing off gas. When it finally grew 'heavy' and started down, it went all the way down into the sea.

Airships driven into warmer air tend to sink until their gas temperature normalizes with the ambient air. The reverse is true when driven into colder air. Under such conditions, the airship may at first balk at climbing into warmer air, or descend into colder air. The AKRON spent several hours cooling off her gas before she would descend into the cool air overlaying San Diego on her first trip west. Because of such 'tricks' airship schedules may only be set to the day, steam ship schedules to the early or late tide, while airline schedules may be set to the hour, as Scandinavian Airlines demonstrated when pioneering the North Polar route from western USA to Europe.

Systems have been proposed to eliminate the valving of gas, by various means, or to recover the weight of fuel consumed by water recovery systems placed in the engine exhaust. None of these systems would answer the control requirement for successful penetration of violent atmospheric conditions. The glib answer is to avoid such conditions. If the incident of violent weather coincides with the arrival of the ship at her destination, the answer is no longer satisfactory. Alternate bases, criminally lacking in the past, must be provided in any serious plan of the future.

MOORING

A previous section discussed mooring problems associated with changing

lift due to temperature variations and precipitation. This section will touch on mooring problems connected with wind. The problem dates back to the first involuntary free flight of a Montgolfier balloon, their second of 600 cu ft capacity, when the wind tore loose the tethering lines. A few days later it destroyed their 23,000 cu ft balloon, prepared for a demonstration before the Royal Academy. Both Eckener and Lehman had their mooring accidents. The mooring system developed by the US Navy appears to represent the highest state of development of any, but it is desired to question one feature of this development, the stern beam car. Fig. 5 shows this car in position. It rode out of the dock athwartships, then transferred to the rails of the mooring circle, until the airship was headed into the wind. Then it was replaced by a lighter 'riding-out' car which allowed the airship to rotate into the wind with her nose secured to the mast at the center of the mooring circle. The operation was reversed for docking the airship.

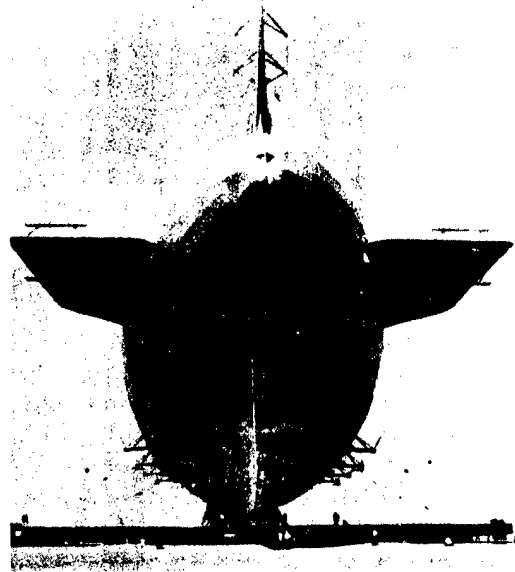

Figure 5. Stern Beam Car

The stern car was in use in February 1933, when it was noted that strong cross winds were heeling the AKRON 6° from vertical. An instant later the lines tore sections of Frame 35, 17 and Zero out of the ship. Frame 17 was damaged on the MACON from thermals while crossing Texas on a sunny day, and is also the frame from which the upper fin of the MACON separated, the day the MACON was lost. With this restraint system the wire stays from the stern car do not pass into the center line of the ship, while the nose is restrained at the center line. How much strain did Frame 17 absorb during the undocking and docking operation, and to what degree was this system of docking responsible for the successive failures of Frame 17? Perhaps the floating hangar system originally used was the optimum system.

STRUCTURE

Fig. 6 shows the differences in frame design used on the German and American airships. Fig. 6a shows the radial, wire braced Zeppelin Co. type frame. Fig. 6b shows the Goodyear design, an integrally braced, deep triangular section, built-up girder ring. The fins of the AKRON-

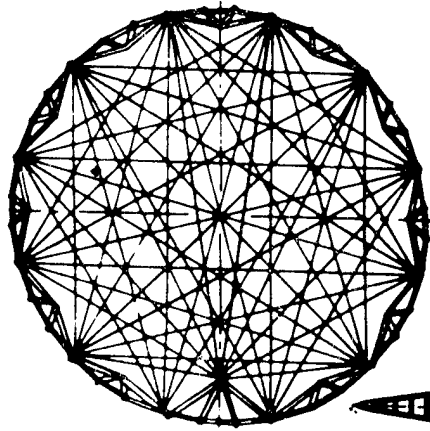

Figure 6a.
Wire Braced

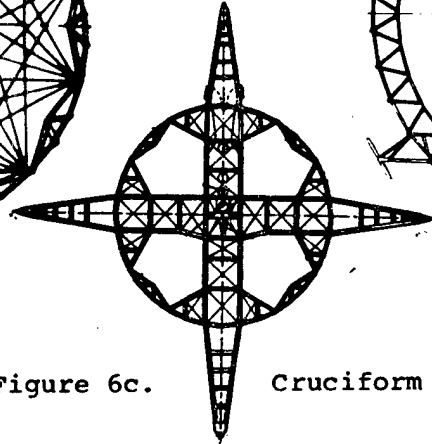

Figure 6c. Cruciform Tail

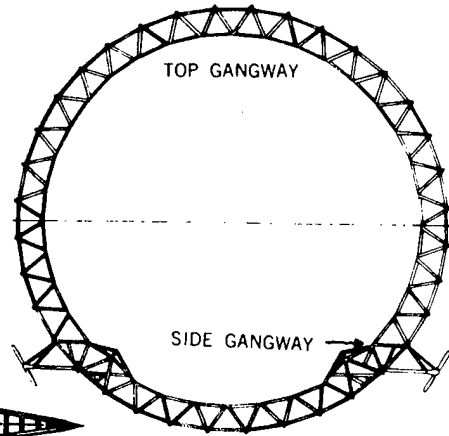

Figure 6b.
Integrally Stiff

MACON were cantilevered from such rings. The side loads developed by the fins due to cross winds while mooring would be transferred thru these rings to the wire stays of the stern beam car. In contrast, the fin spars on Zeppelin designs passed right thru the hull, in what is called 'cruciform' design. Fig 6c shows how well braced the Zeppelin fins were into the frames. The difference in design has occupied many words of testimony, and any new design would revive the discussion all over again.

METEOROLOGY

The original French Proclamation of 1783, prophesied that the taffeta and paper machines "will some day prove serviceable to the wants of society". So they have, particularly in the field of meteorology, which has reciprocated by serving all aviation. In WWII, the air transport command adopted 'pressure pattern' navigation, said then to have been developed by the Zeppelin Company. It is astonishing to discover that in 1831 an American mechanical engineer, William Redfield, published a paper entitled "The Law of Storms" and in 1836, gave a set of rules for determining the path of a hurricane and how to avoid sailing into the center of it. An English museum curator, Henry Piddington in Calcutta, read Redfield's papers and soon marketed a "Sailor's Horn Book" enclosing in cover pockets, celluloid guides for the Northern and Southern hemispheres. With these, the knowledgeable ship's captain

could locate on his chart, the center of a storm, whether to run before the storm or detour behind it, and what his sailing time would be. Fig. 7 shows Eckener's use of this knowledge on his delivery flight with the LOS ANGELES, and the maiden flight to the USA in the GRAF ZEPPELIN. His long detours by way of the Madiera, Azores and Bermuda Islands are plain to see. Of particular interest is his return journey in the GRAF, when he deliberately penetrated a front off the east coast of the United States, and based on clear weather reports, planned a great circle route from there all the way home. Instead, his 1,000 extra miles of zigs and zags indicate the kind of weather he actually ran around.

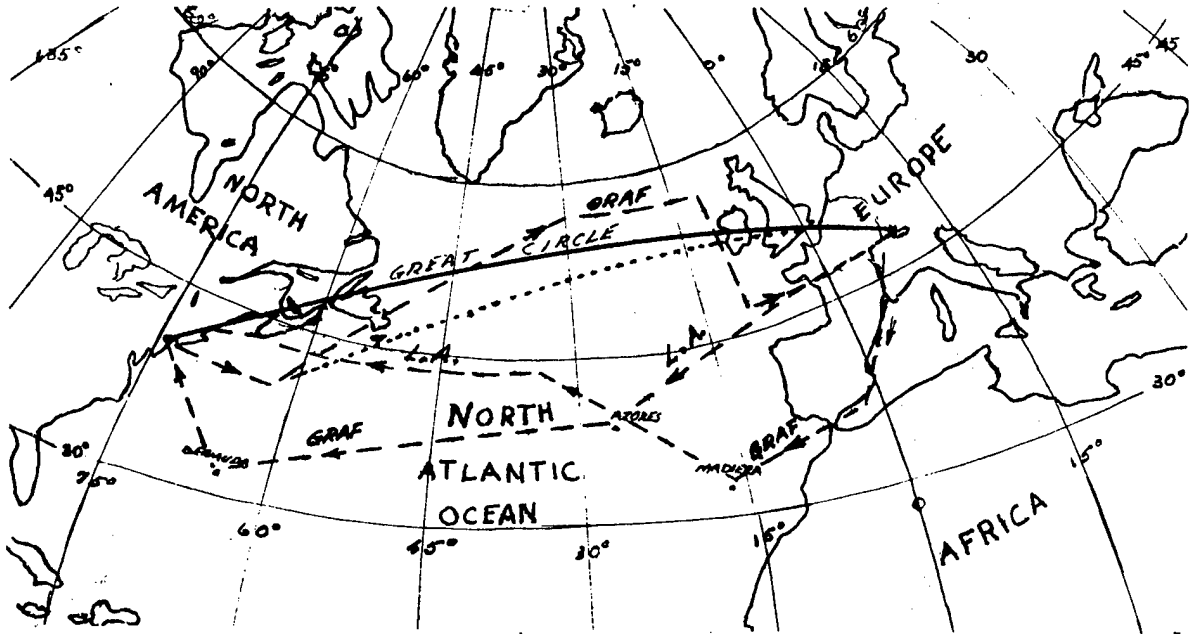

Figure 7. Actual Routes vs Great Circle

In January 1933, the captain of the AKRON detoured around the Great Lakes to land the following day behind a storm that had confronted him the night before when he had tried to land at Lakehurst. American airship captains also learned meteorology, but were guided more by radio reports than by the "Law of Storms". In April 1933, that same captain made several course reversals before choosing one that took him straight into the center of a storm, and eternity. On that night, static had partially blocked his reception of a full weather report. The literature suggests the airship was mishandled on the fatal night. It might be more accurate to admit that zeppelins cannot survive some storms.

There seem to be only two kinds of turbulence particularly dangerous to airships. One is a single violent gust not visibly associated with a frontal passage, or any widely ranging thermals. It is undetectable and experienced before the pilot can do anything. Such a gust appears to have torn the wing off a jet airliner climbing to altitude past Mt. Fuji, and on 12 Feb 1935, one tore the upper fin off the MACON, three miles off Pt. Sur, over the Pacific Ocean on a generally overcast day when violent updrafts are least expected. Another kind of turbulence is associated with frontal passage and air mass thunderstorms. The principal currents are up and down, in clear air or in precipitation, at any altitude, and occasionally, strong horizontal gusts are encountered at the same time. The sequence of zeppelin failure under these conditions has been mentioned previously. Munk, a contemporary of the WWI zeppelin age, analyzed a sample gust of 6 ft per second and concluded that gusts are no more dangerous than turns, certainly a now outdated judgement. One wonders if anyone has designed a zeppelin to modern gust data and found that it could be built light enough to carry a viable payload?

PERFORMANCE AND ECONOMY

Economic cost formulations are published by governmental regulating agencies, although each manufacturer and user has his own rules as well. When government engages in a vast new engineering project it tends to make its own, new set of rules. It seems adequate at this time to make comparisons based on the weight of metal need to produce a given design, and the performance in terms of payload and range obtained by this investment.

TYPE	LZ-24	LZ-85	LZ-99	LZ-104	STAAKEN	LINKE	LZ-129	AKRON	DC-6	BRISTOL
	● S.L. & H	● H	● 100% purity		VI	HOFFMAN	MACON			BRITANNIA
DATE	1914	1916	1917	1917	1917	1919	1936	1931	1947	1960
VOL. M cu ft	0.795	2.0	2.04	2.42	-	-	7.06	6.85	-	-
We M lbs	36.8	-	51.0	51.5	18.0	17.6	260.2	242.4	49.8	90.6
Wto M lbs	56.6	142.5	145.0	166.0	26.5	32.1	419.0	403.0	106.2	185.0
% We/Wto	65.2	-	35.2	31.1	68.0	54.7	62.6	60.3	46.8	49.0
PAYLOAD M lbs	0.7	5.0	9.9	26.5	2.2	-	36.4	30.0*	8.0	34.0
%PAYLOAD/Wto	1.24	3.51	6.83	16.0	8.24	-	8.01	-	7.5	18.4
CEILING M ft	1.5	15.0	19.0	1.5	19.4**	10.5	1.5	1.5	-	-
PASSENGERS							50		70	
CREW							50		7	

*Estimated Airplane contingent **Adjustable pitch propellers H = million

Figure 8. Design Data Comparisons

Fig. 8 shows data for a reasonable sample of airplanes and zeppelins from WWI forward. Because the data is obtained from so many different

sources, no real accuracy is claimed. It is felt that the figures are sufficiently representative for the task at hand. WWI data, with two exceptions, applies to bombing missions over England. Post WWII data applies to a minimum New York to Paris capability.

At first glance, it becomes apparent that there never was a 25 ton payload zeppelin, despite the almost daily assurances of Enthusiasts that such payloads are 'small' for zeppelins. The Enthusiasts and certain reference books alike, seem confused by the difference between "useful lift" and 'payload'. Next, the payload to gross lift ratio is little if any better than airplanes of the past, inferior to more recent airplanes and getting more inferior all the time.

The five WWI zeppelins show the influence of design altitude on the payload and range capabilities of a zeppelin. The first zeppelins were sea level designs. Antiaircraft fire soon drove them higher. The bomb loads peaked at 9,900 lbs with the LZ-99 of 1917, which had a design ceiling of 19,000 ft. The next example is the famed Bulgaria to Khartum and return zeppelin, LZ-104 (L-59) which carried 26,500 lbs of supplies. The LZ-104 was a specially prepared LZ-99 type, with an extra lift bay added, increasing its volume by 18%. The great increase in payload and range was not due to extra lifting bay but that it flew a sea level route, while the LZ-99 at 19,000 ft was operating at a density ratio of .55. At that height LZ-99's lift was only 75,600 lbs, and her bomb load 13.5% of that. The LZ-104 with the same structure, was operating at sea level gross lift, -that is to say, grossly overloaded, for a one time flight.

The above possibly explains the tragedy of the L-72 (LZ-117?), of a class designed to operate at 26,400 ft (5000 meters), the peak development of German WWI zeppelins. Seized by France for 'reparations', named the DIXMUDE, she was used to surpass Germany's feat with the LZ-104, to impress the French African colonies by flying around them. The DIXMUDE was destroyed on the second such political exploit near Sicily, probably by structural failure in the vicinity of a storm, though she also burned in the air.

Designed to airline structural standards, the HINDENBURG (LZ-129) required 7 million cu ft to slightly exceed the feat of the LZ-104 with 2.4 million cu ft. To cross the United States in accordance with airline standards will require airships that many times larger again, to carry the same payload as the LZ-104.

Two WWI airplane designs appear in the figure. The Staaken VI bomb load in percentage of gross weight (% Payload/Wto) exceeded that of the Zeppelins. The Linke-Hoffman II, completed only after the war, is

shown in an overload condition. Its 54.7% empty to gross weight ratio (We/Wto) is the harbinger of airplane structural efficiency to come, - 20 years later. The Staaken Co. was a division of the Zeppelin Co., created by Count Zeppelin to produce bombing airplanes for the Army, because he never had any faith in the zeppelin employed as a bomber.

The figures presented for the HINDENBURG are not the more favorable ones representing hydrogen filling, but less favorable ones for helium at 95% purity and 1500 ft cruise altitude, which is the basis for the AKRON-MACON figures. The relatively small DC-6 is seen to be far superior in terms of structural ratio and almost matching the HINDENBURG in payload to weight ratio. The BRITTANIA surpasses the HINDENBURG in both categories. The crew to passenger ratio alone may spell the difference between profit and loss for airline operations. The record is discouraging for any mode of transportation which demands a high level of manpower to operate.

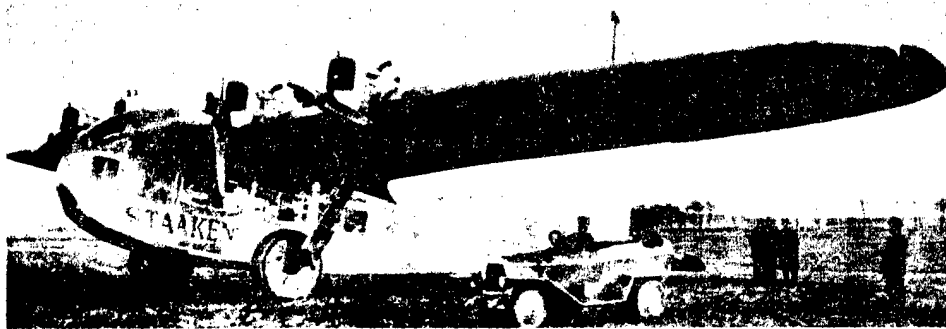

Staaken E.4/20 all-metal airliner of 1920



Armstrong Whitworth ATALANTA class of 1932

Figure 9. Airplane Development Delay

Airplane-Airship Competition- Enthusiasts like to indulge in a theory that airplane interests conspired to delay the zeppelin progress. Figure 9 shows that an outstanding airplane development was seemingly suppressed for more than the number of years Germany was prohibited

from building large commercial zeppelins. The upper photo shows a Staaken passenger plane built of aluminum, equivalent in construction to the Boeing 247 and DC-3's of the 1930's, flown in 1921 before being ordered destroyed by the Allied Control Commission. The same design apparently resurfaced 12 years later on Imperial Airways, lower photo. So much for the conspiracy theory.

RANGE/PAYLOAD

The range payload curves of Fig. 10 complete the story. The BRITTANIA at 185,000 lbs almost encompasses the performance of zeppelins weighing $2\frac{1}{2}$ times more. The 707-320, three quarters as heavy as the HINDENBURG, completely surpasses it. Because airplanes shown are 4 to 7 times faster than any airship ever built, and return of investment is dependent on productivity, the product of payload and speed, it is unnecessary to even show the relative speed or productivity of the airplane and the airship. This figure indicates the magnitude of the improvement necessary to produce zeppelins that will be economically viable, were they to ever overcome their operational difficulties.

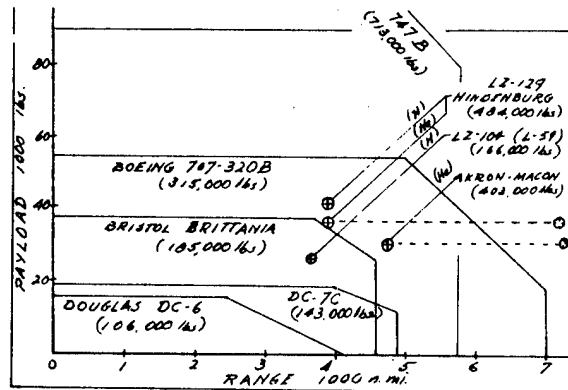

Figure 10.
Range-Payload Comparisons

CONCLUSIONS

The Enthusiast recites like catechism that the advantage of the airship is that it requires no power to develop lift (unlike an airplane) and that this feature is its great advantage in economy and fuel savings over the airplane. This rote ignores the extreme weight empty penalty and high drag associated with the enormous gas filled structure required to produce bouyant lift, which inevitably defeats the airship in any comparison with the airplane in air commerce. But for the technological accident that large volumes of hydrogen became available to lift transatlantic payloads in bouyant aircraft a generation before large and reliable engines became available to lift those payloads in airplanes, the airship would never have been developed. It follows that when the engines became available the airship faded from the scene, and there appears no valid reason for ressurecting them as air carriers.

REPRODUCTION OF THIS PAGE IS POOR

REPRODUCTION OF THE ORIGINAL PAGE IS POOR

The cathedral-like hangars which remain at Lakehurst and Moffett N.A.S. for one of man's most beautiful creations, the zeppelin, give pause for reflection of a brief chronicle of bouyant flight:

"The French Government of 1783, 'It is only a machine... which will some day prove serviceable to the wants of society'.

Sir George Cayley, in 1816, explaining why he was pursueing flight by means of inclined planes, '...my object was to leave out the unwieldy bulk of balloons altogether.'

Adm Wm A Moffett, USA, testifying before Congress, 'I would willingly sacrifice the purchase of one cruiser for two airships of the same cost, but would not sacrifice any airplane funds and transfer them to the airship fund...'

Sir Dennistoun Burney (in 1922 originator of the British Government's 'Burney Scheme' which resulted in producing the R-100 and R-101) writing in 1929, 'As a result of the last seven years investigation and work upon R-100, I am firmly convinced that airship enthusiasts not only overstated their case, but failed to realize that a vessel that could neither make a landing without elaborate extraneous aid, nor be housed or rigidly secured in rough weather, must always remain a doubtful value for commercial purposes.....'.

Hugo Eckener in his 1949 book, '...the role of this aerial vehicle in commerce seems to have ended after a brief period of glory.....for speed and time saving are trump cards'".

Frank Lloyd Wright reportedly shook his head when he looked at St. Patrick's cathedral. Asked why he shook his head he answered that he approved of the design but not its purpose. That about sums up the case against the commercial carrier zeppelin.

REFERENCES:

1. Burgess, C.P., Airship Design, The Ronald Press, New York (1931)
2. Munk, M.M., Fluid Dynamics For Aircraft Designers, Ronald Press, New York (1929).
3. Jones, B., Elements of Practical Aerodynamics, Wiley & Sons, New York (1936)

4. USAF, The Thunderstorm, U. S. Weather Bureau (1949).
5. Spanner, E.F., This Airship Business, privately published, London (1927).
6. Spanner, E. F., Gentlemen Prefer Aeroplanes, privately published, London (1928).
7. Spanner, E.F., The Tragedy of the R-101, 2 vols, privately published, London (1931).
8. Eckener, H., My Zeppelins, Putnam, London (1958, orig 1949).
9. Eckener, H., Around The World Flight Address, National Geographic (June 1930).
10. Lehman, E., Zeppelin, Longman, Green & Co., New York (1937).
11. Robinson, D.H., L Z 129 Hindenburg, ARCO Publishing Co., New York (1964).
12. Mooney, M.M., The Hindenburg, Dodd, Mead & Co., New York (1972).
13. Norway, N.S., Slide Rule, Wm. Morrow & Co., New York (1954).
14. Higham, R., The British Rigid Airship, G. T. Foulis & Co., (1961).
15. Leasor, J., The Millionth Chance, Hanish Hamilton, London (1957).
16. Kirschner, E.J., The Zeppelin in the Atomic Age, Univ. of Illinois Press, Urbana (1957).
17. Smith, R.K., The Airships AKRON and MACON, U S Naval Institute, Annapolis, Maryland (1965).
18. Toland, J., Ships In The Sky, Holt & Co., New York (1957).
19. Glines, C.V., Lighter Than Air Flight, Franklin Watts, Inc., New York (1965).
20. Nobile, U., My Polar Flights, F. Muller, Ltd., London (1961).
21. Jewett, R.L., The Tin Bubble, AIRPOWER magazine, (Sept 1974).
22. Weiss, D.A., The Saga of the Tin Goose, Crown Publishers, Inc., New York (1971).

23. Allen, H., The Story of the Airship (Non Rigid), Donnelley & Sons, Chicago (1942).
24. Dixon, P.L., Ballooning, Ballantine Books, New York (1972).
25. Harper, H., The Evolution of the Flying Machine, Hutchinson & Co., London (1930).
26. Grierson, J., Challenge To The Poles, Archon Books, Conn. (1964).
27. Rolt, E.T.C., The Aeronauts, Walker & Co., New York (1966).
28. Haddow, G.W. & Grosz, P.M., The German Giants, Funk & Wagnalls, New York (1962).
29. Higham, R., Britain's Imperial Air Routes, Foulis & Co., London (1960).
30. Gibbs Smith, C.H., The Aeroplane, H.M.S.O., London (1960).
31. Rand Corp., Controversy In Soviet Research And Development: The Airship Case Study, Distr: Nat Tech Info Serv, US Dept Commerce, AD-769 910 (October 1972).
32. Plaignaud, J., Airships of the Past and Lightened Aircraft of the Future for Commercial Aviation, Institut Du Transport Aerien, Paris (1973?7-E).
33. Maiersperger, W.P., Airships? Not Again, Aero & Astro, AIAA (Feb. 1974).
34. Jane's, All The Worlds Aircraft, various editions.
35. Swanborough, E.G., Military Transports and Training Aircraft of the World,
36. Laing, A., American Sail, Dutton & Co., New York (1962).

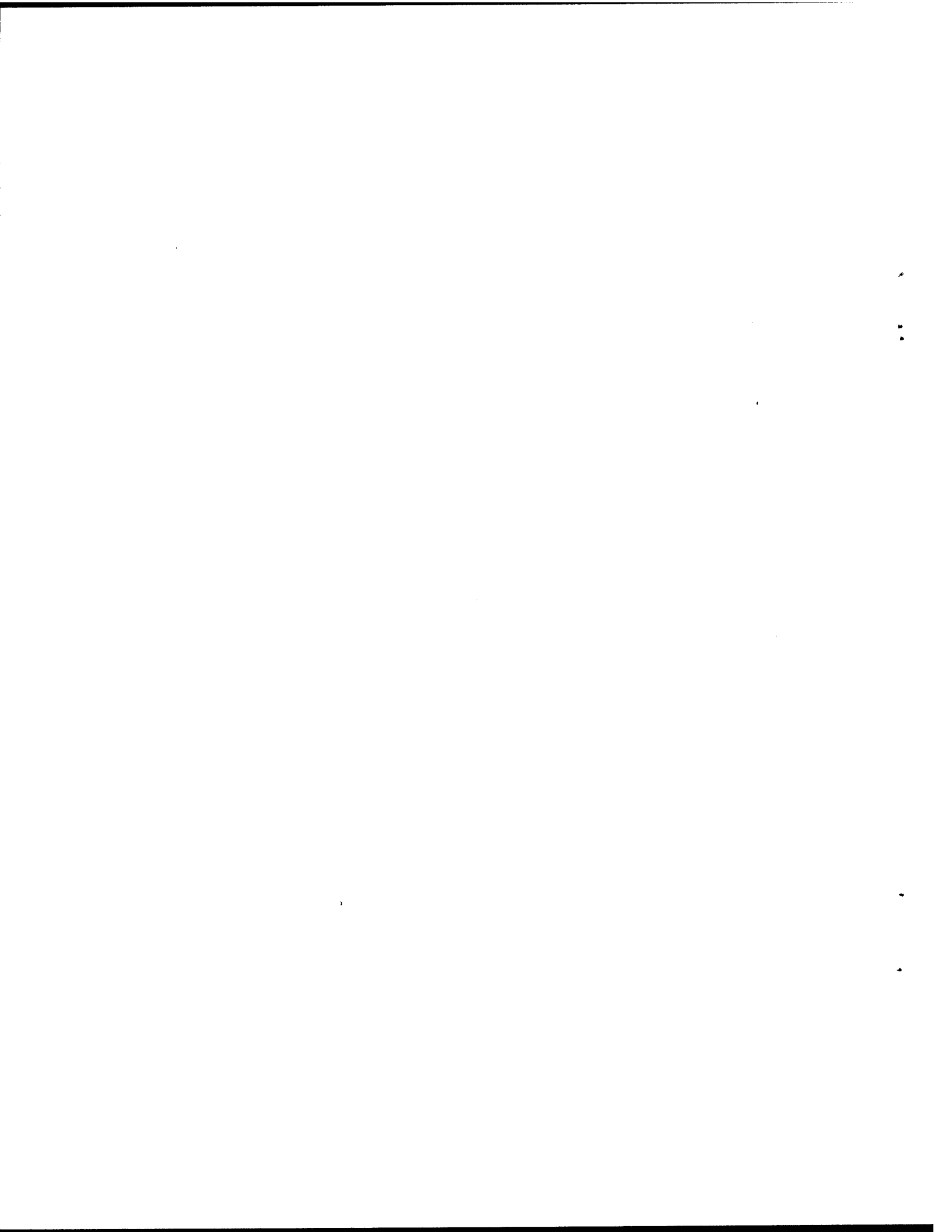

LIGHTER THAN AIR: A LOOK AT THE PAST, A LOOK AT THE POSSIBILITIES

William F. Shea*

In these days of energy concern and the rising cost of all types of fuel, it is not surprising that eminent authorities are casting about for an economical method of flight - inexpensive to operate, causing small noise interference to others, and offering the possibility of great payloads. It is also not too surprising that in the search for economical flight, lighter-than-air aircraft are once again receiving serious consideration as one of the feasible alternatives.

Ever since the first free flight of men, on November 21, 1783, when Pilatre de Rozier and the Marquis d'Arlandes arose from Paris in a "Montgolfiere" or hot-air balloon, lighter-than-air flight has waxed and waned in popularity. Their balloon had a volume of some 60,000 cubic feet of hot air - which was generated by the burning of straw and wool in a brazier suspended under the open neck of the balloon. 1/ Today's modern hot-air balloons typically range from about 77,000 cubic feet to one monster nearly 300,000 cubic feet in size, and instead of burning wool and straw, the modern balloonist burns propane or butane. Although that first free flight of man lasted only about 25 minutes and covered a distance of only five miles, it encouraged others to venture into the age of flight. In January 1793, Jean Blanchard conducted the first free balloon flight in America at Philadelphia. History records that that flight was witnessed by George Washington and his cabinet. 2/

As early as 1794, balloons were used for military purposes. On June 26, 1794, a gas-filled balloon was used by the French to direct fire of artillery onto enemy ranks.

In 1861, during our Civil War, a Professor Lowe introduced balloons into our own military operations for the Union Army. He was cited as influencing a German military attache, Count Ferdinand von Zeppelin, who later designed and built many rigid airships or dirigibles. 3/

The first true airship flight was made in 1852 by Henri Giffard, a Frenchman. Other pioneers included Charles Renard and Captain A. C. Krebs in 1884, and Alberto Santos-Dumont, a Brazilian working in Paris in 1901.

* Chief, Division of Aeronautics, California DOT, Sacramento, CA. U.S.A.

PRECEDING PAGE BLANK NOT FILMED

The first rigid airship, with an interior framework for shape, was constructed in 1895 in Petrograd by David Schwartz, an Austrian. A second ship, all metal (aluminum) was constructed by Schwartz in Berlin in 1898.

On July 2, 1900, Count Ferdinand von Zeppelin and a crew of four others launched the first "Zeppelin" from Lake Constance and in 1908 the Schutte-Lanz Company launched its first airship.

In 1915, Schutte-Lanz and Zeppelin combined forces (resources and patents) to develop the L-30 class of dirigible or "super Zeppelins". They were used during World War I for raids on Allied cities and war vessels. France and Great Britain also built airships for war use, and one of these - the British R-34 - crossed the Atlantic twice shortly after WW I in 1919 - the first airship to accomplish that feat. The United States Navy operated a non-rigid airship on a number of evaluative flights in 1917 and in the same year the Zeppelin L-59 flew a 4,000-mile nonstop round trip from Jamboli, Bulgaria to South Africa.

As part of the reparations following WW I, the United States Navy acquired the German-built Los Angeles, which it operated from 1924 to 1939.

The Germans continued with their successes in dirigibles, and the LZ-127 Graf Zeppelin operated from 1928 through 1937, carrying more than 14,281 passengers and traveling more than a million miles.

The largest airship ever built, the German LZ-129, or Hindenburg, was completed in 1936. It was 811 feet long, and had a gas volume of 7,063,000 cubic feet. Its cruising range at 78 miles per hour was 8,750 miles, and was powered by four 4,000-horsepower diesel engines. Unable to obtain helium, the Hindenburg was lifted by highly-flammable hydrogen. In May 1937, at the end of its 37th Atlantic crossing, the Hindenburg was racked by explosions and crashed at Lakehurst, New Jersey. Essentially, this was the end of the airship era, except for some non-rigids operated since. The Germans began to construct the LZ-130 and LZ-131 as successors to the Hindenburg, but these were abandoned when the Germans decided to concentrate on heavier-than-air aircraft for their WW II venture. One of the oddities of the era was the ZMC-2, a metalclad blimp constructed for the U.S. Navy in 1929. Known as the "Tin Bubble", it had a 202,000 cubic foot hide of 0.0095 Alclad alloy. It was dismantled in 1942 at Lakehurst. Another all-metal airship was the "City of Glendale". Airship engineering for rigid types ended in 1935 in the United States and in 1938 in Germany. The Navy operated a WW II K-class, non-rigid blimp in Air Sea Warfare (ASW) operations. These blimps were twin-engined, and ranged in size from 416,000 to 456,000 cubic feet. The final Navy non-rigids were 1.5 MILLION cubic feet - ZPG-3 ASW airships of the late fifties. The U.S. Navy abolished its Lighter Than Air program in 1960. Other than hot-air balloons, about the only lighter-than-air craft still in use today are the Goodyear blimps. Goodyear constructed 244 blimps for the Navy and Army under contract - 55 more for commercial uses, and a 300th for use as a commercial vehicle in Europe. Besides Goodyear, Wallenkamper has produced some in Germany and delivered one to Japan.

The Goodyear blimps are most famous for their advertising. The smallest of the three in use today is the Florida-based "Mayflower" built in 1968, which is 160 feet long, 58 feet high, and 51 feet wide, with a capacity of 146,300 cubic feet of helium, powered by twin 175-horsepower, 6-cylinder aircraft engines. The Los Angeles-based "Columbia" and Houston-based "America" are sister ships, constructed by Goodyear in 1969. They are 192 feet 1 inch long, 59 feet 5 inches high, and 50 feet wide, with a capacity of 202,700 cubic feet of helium, and are driven by twin 210-horsepower, 6-cylinder fuel injected, pusher-type aircraft engines. These normally operate between 1,000 and 3,000 feet altitude. Goodyear's most recent airship, a sister to the Columbia and America, was constructed in Carington, England, and is known as the Europa. It was put in service in June of 1972 and has performed public relations and public service assignments in 11 countries.

In a series of public information releases, the Goodyear Corporation has given many facts on its nonrigid blimps. One of those releases contains the following:

Safety is the primary factor in the overall airship operation. Although it is possible to fly in some types of adverse weather, the Columbia remains moored to her mast when there is rain and/or wind in excess of 20 miles per hour. 4/

Quite obviously, this severely limits utilization of the blimps at certain times of the year, and more specifically, in certain areas of the world. The blimps, when they travel cross-country, must be accompanied by a ground party with vehicles for mooring, service, radio control, and ground assistance. There just aren't airports or other ground facilities capable now of accommodating the blimps - hence, the extensive support convoy for cross-country flights.

"It sounds preposterous, but some enthusiasts believe dirigibles will make economic sense in the seventies", says Tom Alexander in an article entitled "A New Outbreak of Zeppelin Fever". Alexander presents some rather interesting facts in his article and states that the Hindenburg:

...was so lightly poised in the ocean of air that a child could shove it about. Loaded with seventy passengers and thirteen tons of cargo, it could cross the Atlantic on \$500 worth of diesel fuel...

Alexander also speaks of modern day uses for lighter-than-air vehicles in reporting that Goodyear has a \$35,000 contract from the city of Tempe, Arizona to work up a preliminary design for a small, two-place police blimp that might replace the "noisy, fatiguing helicopter". He also discusses the Boston University's proposed passenger Zeppelin, which might possibly be nuclear powered. 5/

Alexander also discusses some limitations on airships. He says:

...They will never be particularly fast; because of the air resistance to their huge bulk, the practical upper limit on airship speed appears to be somewhere in the vicinity of 100 to 120 miles per hour...

But Mr. Alexander isn't all condemnatory of dirigibles. He describes Gordon Vaeth as the principal activist for the "airship underground" and cites that what

...lighter-than-air craft have going for them is the 'square-cube' law - which simply says that if you double the radius of a sphere, the surface area (and therefore weight) will quadruple while the volume increases eight-fold. Applied to airships, what this means is that as they get bigger, they should get better and better in lifting capacity and operating economics. By now, few people in the movement are much interested in airships smaller than the Hindenburg. Vaeth and several others seem to think that dirigibles containing around 20 million cubic feet of helium - or around three times the volume of the Hindenburg - would be about right for starters. 6/

Alexander also credits John Norton, president of J. R. Norton, Co., which is headquartered in Phoenix, with interest in shipping produce by lighter-than-air. He says that Norton ships the equivalent of 10 to 12 carloads of lettuce around the nation daily, but is at the point of despair over conventional transportation.

The Southern California Aviation Council, Inc. (SCACI), has a Lighter-Than-Air Committee which has done prodigious work in exploring the possibilities for future uses of airships. The committee even urged, in a resolution, that research should be conducted into the possible use of dirigibles to help solve some of the nation's transportation problems. 7/ In their unpublished Technical Task Force Report of May 15, 1974, SCACI discusses airships ranging in size from 7,400,000 cubic feet to 55 MILLION cubic feet and with payloads ranging from 114.4 tons to 1,167.15 tons. 8/ The same report speaks glowingly of speeds ranging up to 200 miles per hour (174 knots), and dimensions from 712 feet 7 inches to 1,390 feet 7 inches in length. Diameters range from 142 feet 5 inches to 278 feet 1 inch.

Power is another question entirely. The report indicates that for speeds up to 50 miles per hour, from 2,500 to 21,000 horsepower will be required. Between 51 and 100 miles per hour, the horsepower range is from 5,000 to 27,000. To achieve speeds of 101 to 200 miles per hour, however, the report predicts horsepower requirements of from 30,000 horsepower for the smallest airship to 144,000 horsepower for the largest. Neumann states that engines are available which can generate 1 horsepower for each 1/2 pound of weight. Even if that is achievable, it would take a 72,000 pound engine to generate 144,000 horsepower, not including the weight of fuel. It is conceivable that nuclear power could be developed for use in airships, but problems of shielding and gearing would have to be considered. Safety considerations would also have to be fully brought into any study aimed at nuclear uses for propulsion. The lifting capacity of the airship, naturally, would have to be adequate and it goes without saying that cost considerations would be paramount. Estimates have ranged from 50 million to 500 million to create the first prototype modern airship. In these days of the commonplace cost-overrun, however, it would be conceivable that the cost for the first airship - on the scale envisioned - could easily reach 1 billion dollars.

Although some of the modern visionaries of the airship speak in glowing terms of huge passenger loads, most of the realists in their number devote their efforts to the area of cargo movement. As to the "airlift" capacity of the airship, some of the authorities in the field are talking about payloads of more than 500 tons:

Let it be clearly stated and understood that the current technology exists within the U.S. to produce an airship capable of carrying payloads in the 250- to 500-ton range. The potential use of a nuclear power plant is technically possible but is politically unacceptable at this time, therefore conventional power plants would have to be considered. 9/

It is also readily conceded by all of the airship advocates that the lifting gas used would be helium. Even though a cubic foot of hydrogen can lift about 10 percent more weight than a cubic foot of helium, the flammability of the hydrogen makes it unacceptable.

Critics of the airship concept are quick to point out the time lag between conceptual design and actual fabrication of any air vehicle, but the airship defenders point out that the Slate Metal Airship and the ZMC-2 - the Navy's "Tin Bubble" - were completed in less than six months after completion of the detailed engineering and construction of hangar facilities.

There are a number of constraints inherent in airship operations. One of these is the tremendous expenditure of power needed to achieve useful speeds. Forward movement of an airship is calculated to require approximately 10 horsepower per ton of airship weight - and this is at low speeds of 50 to 90 miles per hour. On the other hand, dynamic lift can increase gross loads from 8 to 13 percent. In the past there was a 50/50 ratio of structural weight to payload, but new design criteria call for a ratio of 35/65. The SCACI report 10/ also states that an airship applies a lift ratio of 65 pounds for every 1,000 cubic feet of helium gas. Applying that lift ratio to the 55 million cubic foot monster envisioned in the report, we find that the total lift capacity would be 3,575,000 pounds - and at a ratio of 65/35 (payload to structural weight), the payload computes to 2,323,750 pounds - or more than 1,161 tons. It appears that the engineers have adequately done their homework.

The SCACI report 11/ also accepts the metalclad concept for the airship of the future and indicates that using laser welding equipment now available, aluminum sheet can be welded at a speed of 500 inches per minute - 2,400 feet per hour. Technicians and scientists are currently evaluating the need for heat treating the welds produced by the laser technique.

Another of the constraints less susceptible to solution is the problem of a construction facility capable of housing and sheltering the airship during its construction. West Coast shipping yards have been exploring the possibility of using some of their docking capacity for just such a purpose, and some have even speculated on using the Rose Bowl at Pasadena for a construction port. Perhaps the major constraint, however, is overcoming the inertia and lack of any real interest in investing the massive amounts of capital needed for airships.

Researchers have estimated that the supply of helium available is adequate:

Finally, in recent weeks, as word that the U.S. Government has ended its helium conservation program, the question has arisen whether there is enough helium available to support an airship revival program on a long-term basis. Helium that has been extracted from natural gas and stored underground now totals about 30 billion cubic feet. 12/ A careful analysis of long-term helium reserves (raw helium), particularly that found in natural gas which is not well suited for heating, shows that lack of helium should not be a problem and that a major airship effort can go forth without concern over this point. 13/

We note quickly that the 30 billion cubic feet now stored is considerably more than needed for a fleet of 55-million-cubic-foot airships, even those of the monster proportions spoken of in the SCACI report. It is more than enough, even, for several airships of the proportions envisioned by William Kitterman, a member of the Atomic Energy Commission's Division of International Security Affairs. Kitterman contemplates a 75-million-cubic-foot airship, 10 times the size of the Hindenburg, and nearly a quarter of a mile in length. It could carry a 750-ton payload. 14/

SCACI has been in contact with a number of congressional leaders, including Senators Barry Goldwater, Warren G. Magnuson, Charles H. Percy, and Herman E. Talmadge. They have also contacted airline people and representatives of NASA and the office of the U.S. Navy's Chief of Naval Operations (Air Welfare). Some of the responses have been lukewarm acknowledgements, while others might be construed as half-hearted endorsements of the uses of airships to solve our transportation problems.

In most of the material available on the subject, there is precious little in the way of discussion of the ground-handling facilities necessary to accommodate the huge and ungainly airships of the size discussed. True enough, some of the writers speak of cargo delivery without landing of the airship, but there still has to be a large enough cleared area for maneuvering space.

In "The Helium Horse", Stehling and Vaeth report some interest has been evinced at the working levels within the U.S. Navy - for anti-submarine warfare - and within the U.S. Air Force - for strategic airlift. Almost everyone knows of the role played by "barrage balloons" in guarding strategic installations during WW II, and the use of blimps for convoy escort during that same conflict. Let us, for the moment, concede that there are many uses for which the airship or dirigible might be readily adaptable. Let us also concede that construction of large airships is feasible - in the light of present day technology. Are there enough peacetime and/or wartime uses of airships to warrant the infusion of huge amounts of capital into construction, and if so, what will be the source of that capital? Research and development costs would surely be expected to be underwritten by the U.S. Government - at least, that is the expectation voiced by the airship advocates. Who, then, would be the expected users or operators of these giant airships? The only existent airships today (not counting the hot air balloons) are used in public

relations and advertising - or for an occasional sight-seeing trip. It would seem to this writer that there is much work yet to be accomplished by the airship advocates if they are to persuade the public that airships are a feasible answer to public transportation problems. It would also seem that power plants must be designed and constructed with a capacity to generate the tremendous horsepower required to propel the huge airships conceived by airship advocates. Fuel considered to be useful for the airship must be lightweight, readily available, and low in cost. Our truckers now know that diesel fuel is no longer inexpensive. With all the opposition to nuclear power plants evidenced today, it hardly seems reasonable that the public will readily accept an atomic power plant which might conceivably fall on them. Cooling an atomic reactor would present a logistic problem of mammoth proportions to handle the coolant liquid, and shielding of the crew and passengers would be a small problem when compared to protecting those on the earth below.

This writer also finds it difficult to readily accept the predictions of speeds approaching 150-200 miles per hour, or of airships nearly a quarter-mile in length. It is equally difficult to accept predictions that airships will be capable of carrying 2,000 passengers. When passengers can cross the Atlantic in a matter of hours by airplane, how many will be content to fly at speeds of 90-100 miles per hour by airship? Even with radar, storm penetration is not always easy for the modern airliner - operating at altitudes 30,000 to 40,000 feet, above most storms. But some storms tower to even those heights. When compact aircraft are occasionally damaged by clear-air turbulence, how will an airship - rigid or otherwise - cope with CAT or jet streams? Will they only be able to travel from west to east? With rising fuel costs, will the airship be able to compete with, say, a fleet of Boeing 747s or Lockheed 1011s, or DC-10s in hauling produce from, say, California, or Europe, or New York? With all the pressure brought to bear on airports today, where is the land to come from for airship handling facilities? (Although little land would be required for airships.) When the Goodyear blimps are grounded in the presence of rain or winds of 20 knots, will not the airships also suffer in times of storms? It is enough of a problem today to create the hangars and ground equipment to facilitate maintenance on the Boeing 747 and DC-10. How is the cost for such facilities to be borne for handling and maintaining airships? The true test of the airship concept, of course, can only come with time. The research has been beneficial in resurrecting little-known facts of the past, but little Federal support appears to be forthcoming. Nostalgia is not an acceptable substitute for pragmatism or true cost/benefit analysis.

Maybe the future isn't all gloomy for the airship enthusiasts, though. NASA is reportedly looking at lighter-than-air:

Three major aircraft manufacturers with no previous experience in building large lighter-than-air craft have revealed in-house study efforts on their part to determine the applicability of airships to modern transport needs. The American Institute of Aeronautics and Astronautics (AIAA), responding to the increasing

professional interest in the subject, scheduled a special panel session on airships on January 29 (1974) as part of its annual meeting. This special session drew one of the largest crowds of the overall meeting. During that session, a NASA representative announced a forthcoming Request for Proposals for a feasibility study of potential applications of buoyant and semi-buoyant aircraft. Further, NASA and MIT are planning a jointly-sponsored summer workshop on airships and their uses.

The airship has a potential for peacetime uses, such as transporting whole hospitals to remote areas; transporting heavy construction equipment; hauling large volumes of produce cross-country at acceptable speeds, but passenger movements will not be as readily acceptable. Even some of the airlines have grounded their Boeing 747s because of a poor load factor, and there is no assurance that a large passenger capacity would be used on airships. The airship has been proven in certain war or military (and naval) operations, but their vulnerability is something else with which we would have to cope. It would have to be accepted that certain meteorological conditions would contra-indicate the utilization of the airship, and harboring an airship in the face of oncoming storms would be a mammoth problem not easily soluble. LTA research will undoubtedly contribute to the "Megalifter", a project about to begin by NASA Ames.

In a paper of this brevity, we have only touched the surface of the uses of airships, and the admittedly sketchy treatment of the subject should only be enough to whet the appetite of the reader for more knowledge on the subject. We commend the interested reader to our very brief bibliography, and we give full credit to all the authors we have cited in this work.

REFERENCES:

1. N. D. Smith, Discovering Flight, Dufour Editions, Inc., Chester Springs, Pennsylvania, 1966. Library of Congress Catalog Card #67-23286.
2. Ted G. Misenhimer, Aeroscience, Aero Products Research, Inc., Culver City, California, 1970.
3. Ibid., p. 634
4. Goodyear Airship Operations, Columbia, Goodyear News Bureau, Akron, Ohio, 1970, a News Release.
5. Tom Alexander, "A New Outbreak of Zeppelin Fever", Fortune, December 1973.
6. Ibid.
7. Marvin Miles, "Aviation Group Urges Study of Dirigibles", Los Angeles Times, September 24, 1973.
8. Richard D. Neumann, Technical Report of the Committee on Lighter Than Air, Southern California Aviation Council, Inc., May 15, 1974 (Pasadena).

9. F. H. Gerring, Sales Engineer, Aero-Mechanical Division, Goodyear Aerospace Corporation, Akron, Ohio, in a Letter to Richard D. Neumann (of SCACI), June 29, 1973.
10. Neumann, Op. Cit.
11. Ibid.
12. Kurt R. Stehling and J. Gordon Vaeth, "The Helium Horse", Naval Aviation News, May 1974.
13. Ibid.
14. Tom Alexander, Op. Cit.

BIBLIOGRAPHY:

- Alexander, Tom, "A New Outbreak of Zeppelin Fever", Fortune, December, 1973.
- Anonymous, "Ballooning", National Aeronautics, Spring, 1973.
- , "Russia Held Developing Nuclear-Powered Blimp", Los Angeles Times, January 24, 1974.
- , Portfolio on Blimps, Goodyear News Bureau Releases, Akron, Ohio, September and October, 1970. "Goodyear Airship Operations - Columbia", "Europa - A New Airship for Europe", "Blimp Briefs - The Goodyear Airship, Columbia", "Origin of the Word 'Blimp'", "Lighter-Than-Air History, Columbia", "Super Skytacular - Night Sign, Columbia", "Airship Night Sign History, Columbia".
- , M.L.H., "Balloon, Navigating the Air", American Peoples Press Encyclopedia, Vol. II, p. 907-917, Chicago, 1955. This article cites an additional bibliography, as follows:
- Allen, H., "Story of the Airship", 1942.
- Davy, M. J. B., "Aeronautics: Lighter-Than-Air Craft", 1950.
- Holland, R. S., "Historic Airships", 1938.
- Lehman, E., and H. Mingus, "The Zeppelins", 1927.
- Sinclair, J. A., "Airships in Peace and War", 1934.
- Wilkinson, S. F., "Lighter-Than-Air", 1939.
- Federal Air Regulations, Part 31, and Part 101, U.S. Government Printing Office, Washington, D.C., 1970.
- Gerring, F. H., Sales Engineer, Aero-Mechanical Systems Division, Goodyear Aerospace Corporation, Akron, Ohio, June 29, 1973, in a Letter to Richard D. Neumann (of SCACI).
- Hayes, Dr. Will, et al., Balloon Digest, for the Federal Aviation Administration, a booklet, 1974.
- Metzger, Ray, Jr., "The Immovable Feast", a series of papers prepared for the Committee on Agriculture and Forestry, United States Senate, November 20, 1973.
- Miles, Marvin, "Aviation Group Urges Study of Dirigibles to Solve U.S. Transportation Problems", Los Angeles Times, September 24, 1973.
- , "1,000 Foot Giants May Move Cargo Through the Skies", Los Angeles Times, October 28, 1973.
- Misenhimer, Ted G., Aeroscience, Aero Products Research, Inc., Culver City, California, 1970.

Neumann, Richard D., Technical Task Force Report, Southern California Aviation Council, Inc., Committee on Lighter Than Air, Pasadena, California, May 15, 1974.

Smith, Murlin Gene, "First World Hot Air Balloon Championships", National Aeronautics, Summer, 1973.

Smith, N. D., Discovering Flight, DuFour Editions, Inc., Chester Springs, Pennsylvania, 1968.

Stehling, Kurt R., and J. Gordon Vaeth, "A Compelling Case for the HELIUM HORSE", Naval Aviation News, May 1974.

Swaim, Dave, "Airships Seen Filling Cargo Gap", Pasadena Star News, January 27, 1974.

MOORING AND GROUND
HANDLING RIGID AIRSHIPS

Hepburn Walker, Jr.

ABSTRACT: This paper will deal with the problems of Mooring and Ground Handling Rigid Airships. A brief history of Mooring and Ground Handling Rigid Airships from July 2, 1900 through September 1, 1939 is included. Also a brief history of ground handling developments with large U. S. Navy non-rigid airships between September 1, 1939 and August 31, 1962 is included wherein developed equipment and techniques appear applicable to future large rigid airships. Finally recommendations are made pertaining to equipment and procedures which appear desirable and feasible for future rigid airship programs.

Today proposals for construction and operation of very large rigid airships for both COMMERCIAL and GOVERNMENTAL purposes are actively being considered. These plans envision conventionally configured rigid airships dependent on static lift ranging in volumes up to 100,000,000 cubic feet displacement. These huge specialized cargo rigids would have a length of some 1,800 feet, and a maximum diameter of 300 feet.

Mooring and ground handling these very large airships presents problems, but none of the problems are insurmountable. During the first rigid airship era, which spanned some forty years from July 2, 1900 through September 1, 1939 and the outbreak of WWII, great strides were made in developing mechanical equipment and ground handling techniques. During this forty year period approximately 160 rigid airships were built and operated in Germany, Great Britain, France, Italy and the United States of America. Rigid airships increased in displaced volume during this time span from about 400,000 cubic feet to over 7,000,000 cubic feet. As these volumes increased obviously the mooring and ground handling problems increased also, but fortunately linear dimensions and surface areas of airships do not increase at the same ratio as volumes increase. In fact with the eighteen fold increase in volume from the 400,000 cu. ft. LZ-1 of 1900

PRECEDING PAGE BLANK NOT FILMED

to the 7,000,000 cu. ft. volumes of LZ-129 and LZ-130 we find the length had merely doubled from a little over 400 feet to 804 feet. Diameters rose from 38'6" for LZ-1 to 135'1" for LZ-129 and LZ-130.

During the first nine years of rigid airship flight operations from July 2, 1900 to October 27, 1909 Count Zeppelin concentrated construction activity and flight operations of the Bodensee, or Lake Constance, at Mansell on the shoreline at the western outskirts of Friedrichshafen. LZ-1 made her first flight from the floating construction shed on the Lake on July 2, 1900. The ship was secured to a float inside the hangar and towed out on the lake by small boats acting as tugs. The LZ-1 then made her takeoff from the deck of the float and a short time later landed on the surface of the lake on her two cars which were designed to float on water. She was then spotted on her barge and towed back inside the hangar, or rather maneuvered into the hangar, by the launches. The term ground handling is an obvious misnomer during this period as it was strictly water handling. The significant point is that by using the boats as tugs mechanical handling was first used for undocking and docking rigid airships.

Count Zeppelin had decided on water based operations for two reasons;

1. He felt that takeoffs and landings could be accomplished more easily and safely from and to the surface of the lake.
2. He was of the opinion that a floating hangar moored at one end and free to weathervane would solve any problems with cross hangar winds.

The water takeoffs and landings created no problems in themselves. In fact water landings by rigid airships continued infrequently through the Arctic flight by the Graf Zeppelin in 1931. It is felt that water landings and moorings are perfectly feasible for any future airship program on the surfaces of large protected bodies of water such as bays, lakes and wide rivers. Loading and off-loading cargo to boats and barges can be accomplished easily, and water landings are ideal from the standpoint of ease in ballasting airships as unlimited amounts of water ballast are immediately available.

The problems Count Zeppelin faced with his Lake Constance construction and operation efforts were due to the two floating hangars, and the original floating hangar relocated on pilings on the shoreline at Manzell. On one occasion a severe winter storm damaged the second floating hangar and badly damaged the airship housed inside. Another time a storm tore the hangar from its moorings and drove it ashore. On top of all this it proved extremely difficult to tow the airships back into the hangars in any real wind, and on one occasion a ship was severely damaged redocking. In 1908 Count Zeppelin decided that his operation should be relocated on a flying field on land. A site at Friedrichshafen was obtained on a long term lease and in 1909 he transferred his construction and flight activities to this base.

On March 16, 1909 the first deliberate landing on land was made by LZ-3 on the field at Friedrichshafen. May 9, 1909 LZ-3 was first

docked in the temporary tent hangar, and on October 27, 1909 LZ-6 made the final flight from the floating hangar at Manzell. All construction and flight operations by the Zeppelins subsequent that date were from land based hangars.

From May 9, 1909 until May 16, 1911 Zeppelins routinely docked and undocked from their new hangars on land using manpower alone without serious incidents. On May 16, 1911 LZ-8, the commercial "Deutschland II", was undocked at Dusseldorf in a strong cross hangar wind with a ground crew of about 300 men. The wind carried the ship away from the ground crew and stranded her on top of the wind screen, damaging the ship so severely that she had to be dismantled.

Dr. Hugo Eckener took the accident to LZ-8 to heart and he quickly developed a system of docking rails and docking trolleys for the hangar at Baden-Oos in the summer of 1911. These proved so successful that they were soon installed at all German airship bases, and were later copied in Great Britain, France, Italy and the United States for their rigid airship bases.

The docking rails and trolleys were the first mechanical aids devised for docking and undocking the land based rigid airships. They marked a vast improvement in maneuvering the ships in and out of their hangars. The ships were secured by lines, port and starboard abreast the ships for much of their lengths, to the trolleys which ran on small wheels or rollers in two tracks recessed in concrete extending from inside the hangars several hundred feet out on the field. After undocking, the aft cables would be slacked off and disconnected and the ship would be held by the ground crew until takeoff. The reverse procedure was used after landing into the hands of a ground crew for docking. Docking rails and trolleys continued in use in Germany until flight operations ceased September 1, 1939.

For any future rigid airship program the docking rails and trolleys should probably continue to be considered as an alternate docking aid, particularly at construction hangars where docking and undocking would be a very infrequent occurrence. The reason for this is that the trolley-rail system is a relatively inexpensive system as compared to the more sophisticated docking and undocking equipment which will be discussed later in this paper.

Between August 1, 1914 and the Armistice on November 11, 1918 Germany completed some 106 rigid airships, while the British completed 8 rigids. It seems almost incredible that with all the technical skill and ingenuity of the Germans that they were unable to devise any system to moor their ships out, either on the ground or in the air. They had only two alternatives; fly them or dock them. Their ships were frequently hangar bound by high winds when they were needed for scouting or bombing missions. Often on returning from long flights of 24 hours or more high winds were encountered at their bases that prevented the ships from being docked.

Very large ground crews were required to handle the German army and navy airships. In 1916 large 2,000,000 cu. ft. ships were introduced, five times the volume of LZ-1. In 1917 ships as large as 2,400,000 cu. ft. were completed, six times the volume of the earliest ships. While the smaller pre-war passenger ships of the DELAG, all well under 1,000,000 cu. ft., were operated only in fair weather, the much larger military airships of WWI operated in extremely unfavorable weather. It was not unusual for ground crews of as many as 700 men being used to land and dock one of the larger ships in adverse weather, and using the docking trolleys to assist in getting the ship into the hangar. At the height of WWI North Sea operations the number of men assigned to the ground crews at the two largest bases were 1,293 men at Nordholz, and 1,299 at Ahlhorn.

The German navy did make one very expensive attempt to solve the ground handling problem. In 1914 a revolving double hangar was completed at Nordholz to lick the problem of cross hangar winds. This hangar, later lengthened to accommodate larger ships, remained in service until November, 1918, but it could house only two ships of the 26 operational. High costs, plus the problem of revolving the hangar with snow on the ground, precluded other revolving hangars from being completed.

Great Britain, although she only operated 8 rigid airships during WWI, grasped the need for some method to moor the airships outside their hangars. In April, 1917 rigid #9 was accepted and operated at Howden testing sea anchors, and operated at Howden and Pulham testing the "three-wire system" for mooring out through October, 1917. A triangle some 550 feet on each side with ground anchors at each corner and tied together with three wires of greater length forming a bridle to the airship at her mooring point midway between the nose and control car was the essence of the system. The R-9, ballasted light, rode at a fairly safe altitude above the ground. The 3-wire system was never a satisfactory solution to the mooring problem, but at least it was an attempt to find an answer.

In 1919 R-26 experimented further with this system. R-34 used the 3-wire arrangement at Mineola during her American stay in July, 1919, but it gave considerable trouble. The 3-wire system was last used at Howden in January, 1921 when R-34 rode out to it and was so badly damaged on the field that she had to be dismantled. It does not appear that the 3-wire mooring out system has anything to offer for future rigid airship programs, with the possible exception that a variation of this arrangement might prove practical for mooring on the surface of protected bodies of water.

But the British deserve full credit for developing the high mooring mast for rigid airships, a solution to the mooring out problem that was extremely successful, if not quite the ultimate answer. In 1911 they had tried a floating mast at Barrow with the "Mayfly", but that particular approach, while of historical interest, was not made in

England for a high mooring mast for rigid airships. In March, 1918 an 120' high mast was ordered from Vickers. In May, 1919 the mast was completed at Pulham and on July 11, 1919 R-24 was moored to the high mast for the first time. She remained moored for nearly three weeks. From Sept. 1, 1919 until Oct. 15, 1919 she again rode out on this mast. Her final mooring out was from Nov. 7th to about the middle of December, 1919. In late December, 1919 R-24 was dismantled at Pulham as she was obsolete. A satisfactory solution to the mooring out problem had been developed. Now rigid airships finally had three alternatives; they could fly, they could remain in their hangars, or they could ride out for extended periods on the high mast.

The original procedure with R-24 at Pulham was first to walk the ship to the vicinity of the mast from the hangar, or after landing to a ground crew, connect the mooring wire from the ship to a wire from the mast head, allow the ship to rise statically, and then have the mast winch pull the ship into the mast connection. Later in 1919 the ship was able to make flying moors to the high mast using a ground crew of only half dozen men to connect the wires and operate the winch. Static takeoffs from the mast could be made with even fewer men. Riding out to the mast only one man was needed to operate the ballast pump, and two men aboard to attend the elevator and ballast the ship.

In February, 1921 high mast mooring experiments resumed with R-33. On February 7, 1921 she made her first static takeoff from the high mast and on the same date she made her first flying moor to the mast. She continued to use the Pulham high mast until July or August when she was decommissioned. From April to June, 1921 R-36 also used the mast. During this period yaw guys were added to the equipment to control lateral movement of the nose and to prevent the airship from overriding the mast while being pulled into the cup. British experiments were suspended Sept. 20, 1921 when R-80 arrived at Pulham to be decommissioned.

While the temporary close down of the British airship program was unfortunate, the U. S. Navy has been very favorably impressed with the high mast experiments by R-24 in 1919 and with R-33 and R-36 in 1921 at Pulham. The U. S. Navy had bow mooring provisions included in the design of ZR-1 and insisted that the LZ-126 design by the Zeppelin Co. include a strengthened bow for nose mooring, a nose spindle and a nose cone.

The ZR-1, or USS Shenandoah, between Sept. 4, 1923 and Sept. 3, 1925 made 26 high mast moorings, plus 7 to the mast on the airship tender "Patoka".

The procedure for a high mast flying moor follows. The airship approaches the mast slowly headed into the wind at an altitude of about 200'. The mooring wire from the mast has previously been laid out on the ground some 500' to leeward from the mast. As the nose of the airship reaches a point above this mast wire she lowers her main

wire to the ground where it is connected with a special coupling to the mast wire. The airship is allowed to rise statically taking the slack out of the mooring wire. The two yaw guy wires are then sent down to the mast head on messenger blocks and connected by couplings to the two yaw winch wires which have already been led from the winches at the base of the mast to fairlead snatch blocks located about 60 degrees to each side of the mast on a 500' radius circle. One of these fairlead block anchorages is located every 7 1/2 degrees around this 500' circle so that the ship can moor headed into a wind coming from any direction. The slack is taken out of the yaw lines and all three winches controlled remotely from the mast head pull the airship slowly into the mast until the airship cone is locked in the mast cup. This procedure is an easy one and can be accomplished with a ground and mast crew of less than a dozen men. The ship can remain moored to the high mast for any desired length of time.

Aside from the very high costs for the permanent type high masts there are other disadvantages. The fact that an airship must continually be literally "flown" while moored to a high mast is the main disadvantage. A complete section of the flight crew must remain aboard at all times to man the elevator and rudder controls and keep the ship properly ballasted. Also they must be prepared to slip the mast in an emergency and fly the ship. Suitable tail drags to prevent the airship from kiting were a problem and the crew had to be alert that sudden rain or snow would not cause the tail to contact the ground.

The ZR-3 was delivered in October, 1924 and between that date and her final high mast mooring in October, 1929 she made 47 high mast moorings. She also made 44 moorings to the mast on the "Patoka" during her career. On August 25, 1927 the Los Angeles made her famous nose stand on the Lakehurst high mast when a cool sea breeze swept in from the Atlantic. The ship had tremendous superheat when suddenly immersed in the cool air. The ship kited to almost a vertical position with the 180 degree shift in wind coupled with the sudden drop in air temperature. She soon regained her normal horizontal attitude and suffered no damage, other than to her dignity. But officers at Lakehurst were convinced that a better method of mooring had to be devised, and in fact they were already at work on this project. This was the low, or stub, mast.

But before going into the low mast development, let us put the high mast to bed. In 1925 and 1926 the R-33 was put back in commission for mooring experiments to the old mast at Pulham and the new permanent 200' mast completed in 1926 at Cardington for R-100 and R-101. The R-100 used the Cardington mast and the one at Montreal for flying moors on all her flights, and R-101 made all her flights from and to the very expensive Cardington high mast. It does not appear that the high mast has any real future for a rigid airship program based primarily on the excessive cost of permanent type high masts.

On October 5, 1927 history was made at Lakehurst when the Los Angeles was first moored to an experimental 60' high stub mast. This mast was a pole braced by wire cables and proved entirely successful. A taxi-wheel carriage was clamped on #1 power car so that the stern of the ship was free to roll in azimuth around the mast on a 10' wide smooth path on a circle with a radius of 438'. The ship was ballasted heavy on the taxi-wheel to prevent kiting.

This mast was shipped to Panama early in 1928 and the Los Angeles moored to it at France Field, Canal Zone February 28, 1928. The stub mast became so popular with the commanding officers of the Los Angeles that only four more moorings were made to high masts after 1-1-28, and none after October, 1929. The Los Angeles moored to a low mast at the 1929 Cleveland National Air Races. In early 1930 a low mast was erected at Parris Island, South Carolina as a regular advance or alternate base. The Los Angeles moored at Parris Island on numerous occasions throughout 1930 and 1931. Another stub mast was erected for the Los Angeles at Guantanamo, Cuba early in 1931. Between February 4, 1931 and March 2, 1931 the Los Angeles was away from her Lakehurst hangar for a month for operations with the fleet at Panama. She operated from the mast at Guantanamo Bay as well as from the mast on the tender Patoka, mooring at Parris Island also during her return to Lakehurst.

Between October 5, 1927 and her decommissioning for reasons of economy on June 30, 1932 the Los Angeles made a total of 185 moorings to various low masts, and 26 moorings to the Patoka. The stub mast had been a complete success and high masts were no longer used by U. S. Navy airships, except for the mast on the airship tender Patoka.

Static takeoffs from the stub masts were routine for the Los Angeles from October, 1927 on, but moorings were another matter. For the first year or so the Los Angeles would make a conventional trailrope landing to the regular ground crew and the crew would "walk" the Los Angeles to the mast where the main mooring wire winch would slowly pull the nose cone into the mast cup. In July, 1928 a railroad track on a 438' radius from the center of the mast was installed at mooring out circle #1 at Lakehurst. On this track a rideout flat car was provided equipped with rail clamps, but no brakes, upon which #1 power car was secured. This marked an improvement over the taxi-wheel on a path system as, between the ballast on the rideout car and the hold-down clamps on the track, the ship was positively prevented from kiting, even in the severest gust and superheat conditions.

In addition to the rideout car, two yaw guys cars equipped with hold-down clamps and brakes also ran on the same track. While the first flying moors to the stub mast were made with the ground crew handling the yaw lines with the main winch pulling the nose into the cup, the addition of the track and yaw guy cars made mechanical flying moors to the stub mast a reality.

As any future rigid airship program will almost certainly involve some

type of low mast mooring, a detailed description of the procedure seems appropriate. The mooring mast is located in the exact center of the riding out circle. At Lakehurst two tracks were provided at circle #1, one on a 438' radius for the Los Angeles and her rideout car and yaw guy cars, and a second track on a 643' radius for the Akron and Macon. Making a flying moor to a low mast is a relatively easy maneuver. The main wire is laid out on the ground 500' to leeward from the mast cup with the coupling eye located at the landing flag. The two yaw guy anchor cars are spotted forty degrees to right and left of the landing flag, or about sixty degrees right and left from the mast cup on the railroad track.

The two yaw lines are led from the winches at the mast to the fairlead blocks on the two yaw guy cars anchored on the circle, and back to the landing flag. The landing flag is kept directly downward from the mast cup with a smoke candle leeward from the flag. The yaw guy cars and gear are shifted relative to any shift in the wind as indicated by the flag. The airship slowly approaches the mast at an altitude of around 200 feet. When the nose of the airship is over the landing flag the port and starboard trailropes are dropped and the two yaw lines are coupled to the two trailropes, and slack is taken out of the lines quickly in order to control the ship without delay. As soon as the yaw guys have tension the main wire is lowered and coupled to the main mast wire and slack taken out. Four forces are now involved; the positive buoyancy of the airship acting upwards, the main mooring winch pulling the nose cone towards the cup, and the two yaw guy winches supplying lateral control as well as preventing the ship from overriding the mast. Once the nose cone is locked in the cup the water ballast line is hooked up and the stern of the airship is pulled down and secured to the rideout car on the track.

Low masts were used by six rigid airships between October, 1927 and Sept. 1, 1939. The U.S. Navy rigid airships Los Angeles, Akron and Macon used both the fixed stub masts and the mobile low masts developed for mechanical docking. The German commercial airship Graf Zeppelin used the fixed stub masts regularly during her seven years of service between Germany and Brazil, and also used mobile masts for docking at bases with hangars. The Hindenburg and Graf Zeppelin II used the mobile type of low mast only, but Hindenburg rode out at circle #1 at Lakehurst regularly in 1936 with the mobile mast anchored and dogged down, so in effect it served as a fixed mast for most of her flights to Lakehurst. It is to be noted that of all 160 rigid airships built to date, but six of them had the great operational advantage of being able to operate from either stub masts, or from the mobile masts.

After the tremendous success with low mast mooring in October, 1927 at Lakehurst bids were asked for a mobile mast at Lakehurst in November, 1927. This first mobile mast for rigid airships was completed in the summer of 1929 and revolutionized rigid airships ground handling. This mast had a triangular base and was mounted on

crawler treads. It was towed by a heavy duty tractor. The mast had a minimum height of 60', but the top was telescopic so that ships larger than the Los Angeles could also moor. The procedure for mooring to the mobile mast was identical with that for a fixed low mast.

In September, 1929 the Los Angeles made her first static takeoff from the mobile mast. Also in September, 1929 the Los Angeles made history by using the mobile mast for the first time for docking in the Lakehurst hangar. By using the mast to handle the bow of the ship and for towing into the hangar, the ground crew was substantially reduced as manpower was only needed to handle the stern of the airship in docking and undocking maneuvers. In November, 1929 the Los Angeles made her first flying moor to the mobile mast. Finally in January, 1930 the Los Angeles first docked with the mobile mast in conjunction with four docking trolleys on each side of the ship connected to one another and a taxi-wheel under the aft car. A system, presumably with bridles, was used whereby the trolleys were towed by the airship, while the tractor towed the mast, airship and trolleys. The ground crew for docking the Los Angeles was now reduced to 60 men, where previously several hundred were required to dock and undock the ship in moderate winds. Two larger railroad mobile masts on square bases were built in 1931 and 1933 respectively for the Akron and Macon. Also a large telescopic railroad mast was constructed at Sunnyvale for the Macon.

The first mobile railroad mast was completed at Lakehurst in 1931 for use by the Akron of 6,500,000 cu. ft. volume, nearly 3 times that of Los Angeles. The railroad mast was heavier, ran more smoothly on the tracks and was towed by a railroad locomotive. The larger telescopic RR mast completed in 1933 had a self contained power plant and was almost identical with the Sunnyvale mobile RR mast.

In 1930 officers at Lakehurst had devised a heavy stern beam to handle the tails of the Akron and Macon for docking and undocking at the class A bases, Lakehurst and Sunnyvale. It was assumed that the side load on the Akron would be on the order of 63,000 lbs. in docking and undocking in a cross wind. The stern beam was designed to run in and out of the hangar on the two existing 64 1/2 ft. gage railroad tracks. The stern beam built by Wellman Engineering Co. for Lakehurst weighed around 178,000 lbs. The length was 186'6". Traveling in and out of the hangar the beam rolled on two four-wheeled trucks towards each end of the beam on the existing tracks. For traveling on the circular hauling up track in front of the hangar the beam was supported by one truck at each end of the beam. The trucks for the circle are jacked down eight inches lifting the hangar track trucks 4" above the track.

Originally the Akron was towed in and out of the Lakehurst hangar by the mast with the ship towing the beam along under the lower fin. This was felt to be risky and early in 1932 a spreader gear arrangement between the railroad mast and beam was adopted so that the

mast towed the stern beam, and there were no compression forces, or tension forces, acting on the airship.

For hauling the beam and ship against the wind on the circular hauling up track a special locomotive was built 266,000 lbs. in weight and with a drawbar pull of 63,000 lbs.

Sunnyvale and Lakehurst each had hangars, mobile masts, spreader gear, yaw guy cars and rideout cars. At Sunnyvale the two mooring out circles at each end of the hangar served a dual purpose, they were both mooring out circles and hauling up circles.

The six class B bases for the Akron and Macon ideally each had a stub mast with a rideout RR track on a 643' radius, winches, two yaw guy cars and a rideout car. Opa-Locka, Florida; Camp Kearney, Cal.; Ewa, Hawaii; and Guantanamo, Cuba were so equipped. Parris Island had a mast and path only and Fort Lewis was in process when the program ended.

Germany had rail type mobile masts for LZ-127, LZ-129 and LZ-130 at Frankfurt, Lowenthal and Rio. Hauling up circles were at the above bases, but it is not known what mechanical hauling up equipment was used, if any, to secure the ships to docking trolleys. But all three airships used their mobile masts regularly for docking and undocking.

Since September 1, 1939 all significant improvements in airship ground handling have been developed by the U.S. Navy. Mobile masts mounted on balloon tires at each corner of the triangular masts and towed by tractors were built for the L, G, K and M airships during WWII. Stick masts were also used at advance bases. All docking and undocking of the non-rigids was done with a tractor and mobile mast handling the bow and manpower on the stern of the ships.

After WWII 55 new airships were purchased through April, 1960. Sizes of some of these new AEW and ASW non-rigids increased dramatically. Eighteen of these new airships were of 1,000,000 cu. ft. volume, while the largest WWII non-rigid was 725,000 cu. ft. Four of the new airships were huge non-rigids of 1,500,000 cu. ft. with a length of 403'. It became absolutely imperative that new methods and mechanized equipment be developed to help land, moor, dock and undock these large airships.

The largest mobile mast we had during WWII was the KM mast weighing 39,000 lbs. Types weighing from 44,200 lbs. to 55,900 lbs. were produced to handle the 1,000,000 cu.ft. airships. But much larger masts were needed to handle the huge 1,500,000 cu.ft. ZPG-3W AEW airships. The Type V mast with hydraulic controls was developed, and the 1-14-58 Ground Handling Manual listed its weight at 150,000 lbs., but the 1-15-61 Manual revised its weight down to 128,670 lbs. In any event these masts were by far the largest ever built to moor a non-rigid. Jacked and secured at a mooring out circle with a 3W moored a Type V mast was designed for 90 knot winds.

The towing tractors also became heavier and more powerful. The 1-1-54 Manual lists two tractors in use; the Type I-9 Tractor weighing 10,500 lbs. with a drawbar pull of 7,500 lbs. and the Buda HA-120 weighing 16,800 lbs., with a drawbar pull of 12,000 lbs. The I-9 is being phased out at this time. The 1-14-58 Manual lists 3 types of tractors for towing the heavier masts and larger airships. The Buda HA-120 mentioned above is now being phased out in favor of the MC-2 Airship Spotting Tractor weighing 23,500 lbs., with a drawbar pull of 15,000 lbs. The ultimate towing tractor for the program was the Mobile Winch Type MC-3 weighing 30,000 lbs., and with a drawbar pull of 24,000 lbs.

The greatest breakthrough and most significant advance in ground handling airships, since the mobile railroad masts and stern beams for the rigid airships of the 1930s, was the development of the ground handling "mules" in the mid-1950s at Lakehurst. The 1-1-54 Navy ground handling manual makes no reference to mobile ground handling mules, but the 1-14-58 Manual features their use. Obviously at some time between these two dates the mobile winches were developed and adopted for regular service use. The Mobile Winch Type MC-3 was the first mobile winch developed. This MC-3 mobile winch served several purposes and proved to be invaluable. First of all they were by far the most powerful towing tractors to be used with the large mobile masts. But their other designed uses were far more important, even vital. The MC-3 winches, working in pairs, were used to handle the tails of the airships in undocking and docking maneuvers, while the Type IV and Type V masts, towed by MC-3 tractors, handled the bows. Ground crews were greatly reduced. MC-3 mules held the nose of an airship stationary while the mast was towed close and the winch pulled the nose cone into the mast cup completing the mooring. It was found it was better to bring the mast to the ship than vice versa. A MC-3 tractor towed the mast and ship to a mooring out circle. Pairs of MC-3 mules were used for unmasting the ships, and were also used to launch the airships. With the versatile MC-3 mules at last the ground handling of the largest non-rigids had achieved the ultimate in mechanical ground handling and mooring. Landing a ZPG-3W using a pair of mules was accomplished regularly with a ground crew of only 18 men. Docking was done with a crew of 12. Unmasting and launching with a pair of mules was accomplished with only 12 men.

Later MC-4 mules were introduced. They were lighter and more maneuverable, consequently they were not usually used for handling the tail during docking or undocking, but they were used for landing, masting, unmasting and launching airships where their greater agility came into play.

In ending this paper I should like to make some observations and offer a few opinions.

I feel that future conventionally configured large rigid airships

should operate as true VTOL aircraft. They should make static takeoffs, perhaps aided by vectored thrust, from low type mooring masts.

Large rigid airships should make flying moors to low masts, again making them VTOL vehicles.

Rigid airships should moor out on circles, preferably equipped with railroad track for yaw guy cars and a rideout car.

Nearly 100% of large rigid airship operations should be to and from fixed low mooring masts. Loading and off-loading cargo can be accomplished easily.

Future rigid airships should only need to dock once a year for a few weeks of annual, overhaul. Thus only one maintenance hangar should be required for every dozen or so airships. The maintenance hangar servicing these dozen ships would require a mobile mast, and a stern beam and spreader gear. Ideally the mooring out circle and hauling up circle would be combined as at Moffett Field in the 1930s.

Construction hangars, in my opinion, will always be required for large airships. A mobile mast, docking rails and manpower should suffice at these sites as docking and undocking operations will be few and far between.

Mooring on large protected bodies of water is feasible, and loading and off-loading cargo on barges can be accomplished easily.

A small training rigid airship should be built and operated before going into large rigids. This small ship could be ground handled with mobile masts like the Navy Type V mast, and with ground handling mules similar to the Navy MC-3 Type. This training ship should be from 1,000,000 cu.ft. to 2,000,000 cu.ft. in volume.

The sheer size and length of very large rigid airships, plus the large area landing mat that would be required, plus structural considerations indicate that heavy takeoffs using aerodynamic lift should not be considered for conventional circular cross section rigid airships. For large rigids a static takeoff from a mast is best. Additional payload up to 10% of the gross static lift of the airship can easily be flown aboard by hook-on plane once the airship is at cruising altitude and speed.

Airships larger than 5,000,000 cu.ft., to use an arbitrary figure, should be ground handled with a railroad type mobile mast and beam at maintenance bases.

The metal-clad pressure rigid airships would be moored and ground handled by the same methods and equipment as conventional rigid airships.

For the near future we should only consider rigid airships up to 15,000,000 cu.ft., as that represents the size ship that can be built in our largest existing hangar. After the 15,000,000 cu.ft. ships prove their worth we can go to larger hangars and larger airships.

We have the basic answers for ground handling any size airship, and equipment and techniques will continue to improve with a new airship program.

REFERENCES:

1. RIGID AIRSHIP MANUAL 1927. U.S. Govt. Printing Office 1928.
2. Rosendahl, C. E., The Mooring and Ground Handling of a Rigid Airship, Aeronautical Engineering, (January-March, 1933).
3. Bolster, C. M., Mechanical Equipment for Handling Large Rigid Airships, Aeronautical Engineering, (July-September, 1933).
4. Operational Post Mortem, 1935, USS Macon, National Archives. (1962).
5. Lakehurst NAS, Blue Jacket's Airship Manual 1940.
6. Handbook. Airship Ground Handling Instructions. (November 1, 1958).
7. Robinson, Douglas H., Giants in the Sky, GT Foulis & Co. Ltd. Oxfordshire, England (1973).

PHOTOGRAPHS:

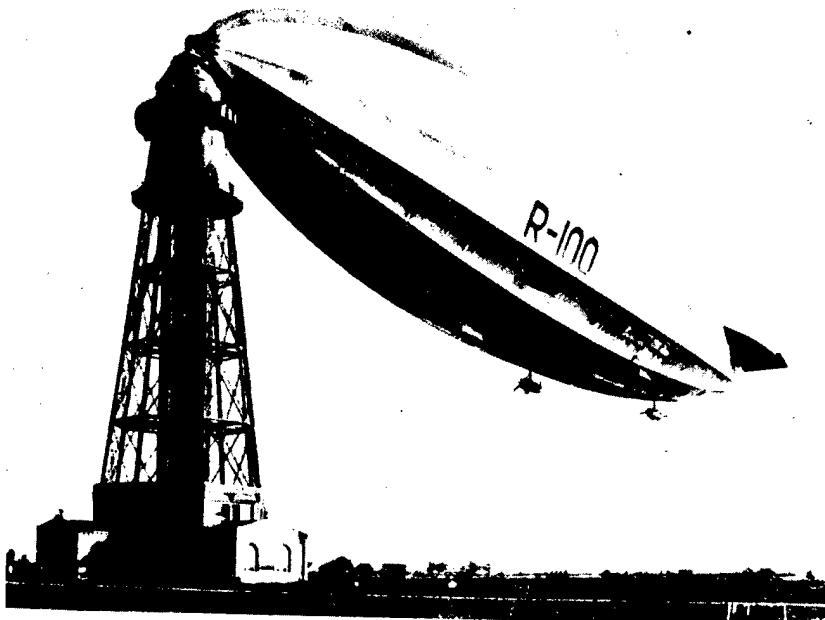

1. R-100 moored to permanent type high mast. Montreal, Canada (1930)

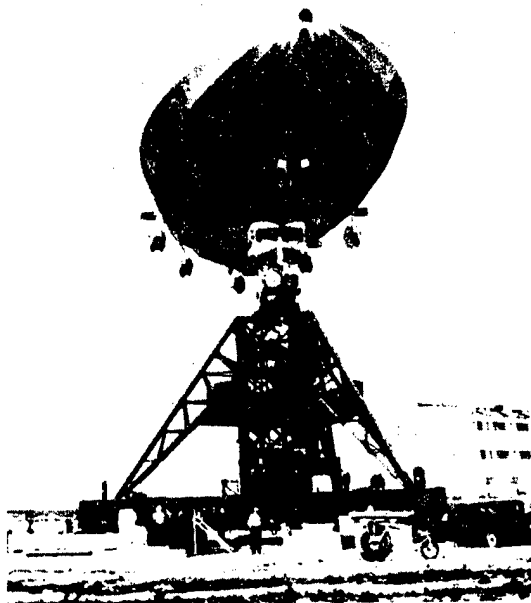

2. USS Los Angeles making a flying moor to mobile mast. Lakehurst (1931)

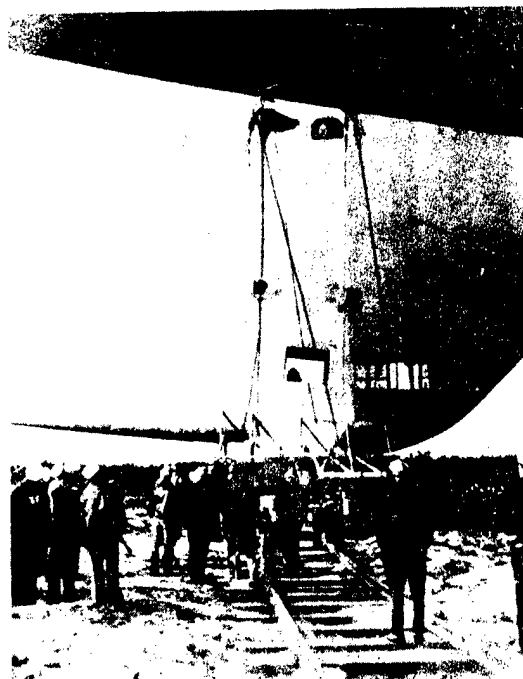

3. USS Akron lower fin moored at circle with rideout RR carriage and taxi-wheel. Lakehurst (~1932)

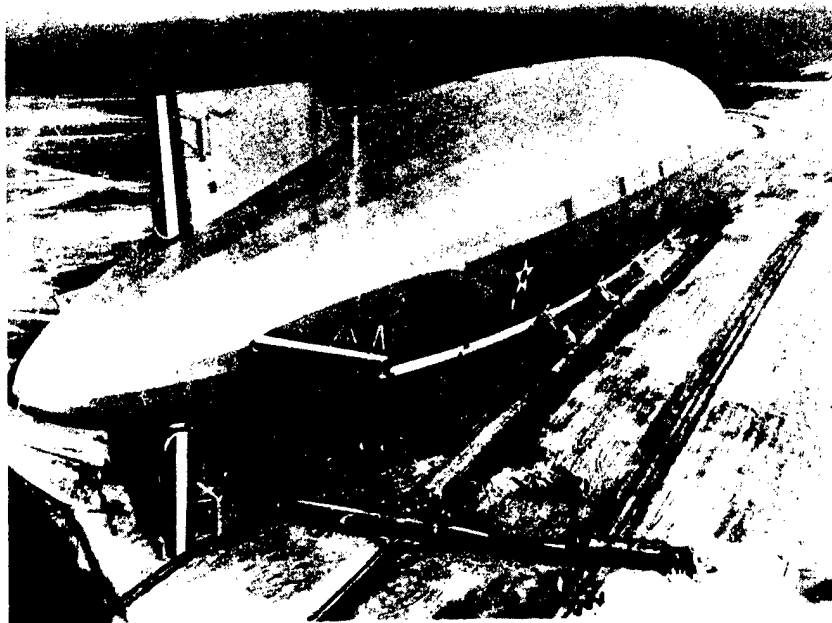

4. USS Macon being docked with mobile railroad mast, stern beam and spreader gear. Lakehurst (1933)

A NEW CONCEPT FOR
AIRSHIP MOORING AND GROUND HANDLING

John C. Vaughan*

ABSTRACT: Calculations have been made to determine the feasibility of applying the Negative Air Cushion (NAC) principle to the mooring of airships. Pressures required for the inflation of the flexible trunks are not excessive and the maintenance of sufficient hold down force is possible in winds up to 50 knots. Fabric strength requirements for a typical NAC sized for a 10-million cubic foot airship were found to be approximately 200 lbs./in. Corresponding power requirements range between 66-HP and 5600-HP. No consideration has been given to the internal airship loads caused by the use of a NAC and further analysis in much greater detail is required before this method could be applied to an actual design, however, the basic concept appears to be sound and no problem areas of a fundamental nature are apparent.

INTRODUCTION

Recent publications have pointed out some potential advantages possessed by airships in certain mission areas and have advocated the construction of large airships employing modern technology and materials. If the airship is indeed to stage a "comeback," then in addition to the application of new materials and technology in the vehicle itself, some quantum jump in the area of mooring and ground handling must also be accomplished. It is the purpose of this paper to suggest a means by which this quantum jump might be made.

For several years, development work has been proceeding which is aimed at applying the basic principles of Air Cushion Vehicles (ACV) to aircraft takeoff and landing systems. (Ref. 1, 2, 3 and 4.) A schematic of a typical system is shown in Figure 1. A flexible

* Operations Research Analyst, Naval Air Systems Command,
Washington, D. C., U. S. A.

toroidal shaped trunk of rubberized fabric is located on the bottom of the aircraft and its shape is maintained by pressurizing it to a pressure (P_t) greater than atmospheric. Air is allowed to flow through holes (A) and (B) to maintain the cushion pressure (P_c) and to provide lubrication between the trunk and the ground. The cushion pressure is greater than atmospheric (but less than trunk pressure) and supports the weight of the aircraft by acting over the bottom portion of the aircraft enclosed by the trunk.

DESCRIPTION OF CONCEPT

Figure 2 is a sketch illustrating a Negative Air Cushion (NAC) as applied to a large somewhat conventionally shaped airship. The major departure from a conventional airship shape stems from the employment of a large flat bottom rather than the usual rounded extension of the hull body of revolution. A flat airship bottom is not essential to the concept, however, a rounded hull bottom would require a slightly more complex trunk design and construction. The two NAC trunks shown may, in general, assume any planform shape, but for the analysis to follow, they are assumed to be circular. The trunk material itself may be either elastic or inelastic non-porous fabric. A pump (M_1) is used to inflate the trunk to a pressure (P_2) greater than atmospheric pressure (P_0). Another pump (M_2) evacuates the space enclosed by the trunk, the ground and the airship bottom so that a cushion pressure (P_1) is maintained less than P_0 . The pressure difference ($P_0 - P_1$) acting over the airship bottom produces a force acting to hold the airship down to the ground. Obviously, the pump (M_2) might, through the use of appropriate valves and lines, supply the air to pressurize the NAC trunk, thus obviating the need for separate pumps for trunk and cushion pressure. Operation in this manner might not be practical, however, in view of the differing pressures and air flow rates associated with the NAC cushion and a trunk which utilized bleed air lubrication. This paper will not consider design details to this depth.

In order to satisfy the condition that the airship will weathervane two alternative methods may be proposed. One involves special installations on the airship itself while the other would utilize permanently installed ground equipment. Some representative turntable schemes are illustrated in Figure 3. In the methods depicted in 3A and 3B, the entire forward NAC trunk would be mounted on rollers (R) so that it could rotate about its vertical axis of symmetry. The arrangement of 3B requires a seal in order to prevent atmospheric air from leaking into the cushion volume. It can be seen that with arrangements 3A and 3C, no seals are required, since solid structure effectively separates regions of differing pressures. In the first two designs, the NAC trunk remains stationary with respect to the ground while the airship hull is free to swivel as the wind direction changes. (It should be noted that the air station real estate required to permit 360° airship rotation is considerably less than if the conventional mooring mast is located at the airship nose.) The second method of swiveling would employ a NAC trunk fixed to the airship (Figure 3C) but a flat turntable permanently mounted flush with ground at the air station would provide the swiveling action.

The methods mentioned above represent alternative means of obtaining airship weathervaning. The first method, wherein the forward NAC

is connected to the airship through a swivel, will permit operation at virtually any suitable remote site. The second method could be used only at an established site equipped with the appropriate turntable. The obvious advantage to the second method lies in the simplified airship installation. A third possibility, applicable to the fixed site, is the use of a ground based pump to supply the forward cushion suction. Since the forward NAC trunk need only be inflated initially and then sealed, no airship borne power need be expended to provide the airship hold down. The ground-based cushion pump could be mounted directly on the turntable or connected to the turntable through suitable rotary seals.

Regardless of the method used to allow weathervaning, the horizontal shear force between the airship and the ground, which resists the wind force, is a function of the friction coefficient between the trunk and the ground and the force pressing the trunk to the ground. This force must be supplied entirely by the forward trunk, since the aft trunk can furnish none while the airship is turning.

The aft trunk might be operated in two different ways. In the first mode, air would be supplied continuously to the trunk and be allowed to bleed out through lubrication holes located where the trunk is tangent to the ground. This method of operation would require a continuous power output to drive the pumps. However, the ability to reduce the horizontal friction between the trunk and the ground by this method is not certain. The second method of operating the aft trunk would entail the use of sensors on the airship which would detect the presence of crosswinds requiring airship weathervaning. The aft trunk would be identical to the forward trunk, that is, it would have no bleed holes and could be sealed after inflation. When the sensors determine that the crosswind has reached some predetermined value, the cushion pressure would be released, reducing the ground contact force and permitting the hull to rotate around the forward trunk. While this rotation is taking place, all external horizontal and vertical forces and moments applied to the airship would be resisted by the forward trunk alone.

All of the previous comments have considered only airship mooring on a solid surface. Figure 4 illustrates the NAC in use on a water surface. Since it is not possible to develop horizontal shear forces with the water, the airship could tie up to an anchored buoy or, alternatively, could carry its own anchor. In either case, the weathervaning problem is solved automatically if a single anchor near the nose is used. A variation to the water based mooring concept is the use of a raft anchored at a single point so as to be free to swivel. If the raft were large enough to receive both trunks, the airship would have complete freedom to weathervane with essentially a dry land interface.

ANALYSIS OF CONCEPT

In the following analysis, it will be assumed that the airship is ballasted to produce a condition of neutral buoyancy. Additionally, the airship is assumed to be a rigid body and internal loads caused by the externally applied loads are not considered.

Axial Horizontal Forces

The drag force on the airship along its axis is given by

$$D_x = C_{D_x} q S_o \quad (1)$$

The magnitude of the force holding the airship down to the ground is given by

$$H = (P_o - P_i) A_o \quad (2)$$

In order to restrain the airship while facing into the wind, equation (3) must be satisfied.

$$D_x = \mu H \quad (3)$$

Combining equations (1), (2) and (3), and assuming that $A_o = a^2 S_o$.

$$C_{P_{ix}} = \frac{C_{D_x}}{\mu a^2} \quad (4)$$

where $C_{P_1} = (P_o - P_1)/q$.

Lateral Horizontal Forces

Similarly, an equivalent pressure coefficient related to a crosswind is given by

$$C_{P_{iy}} = \frac{C_{D_y}}{\mu a^2} \quad (5)$$

Vertical Forces

In addition to increased drag (in the lateral direction) and rolling moment, a crosswind can also result in an aerodynamic lift on the airship hull. In order to relate the lift and lateral drag force to the same reference area, it is assumed that the airship is a cylinder with an arbitrary length/diameter ratio. Thus,

$$S_y/S_o = 1.274 l/d \quad (6)$$

The magnitude of the lift force is given by

$$L = C_L q S_o \quad (7)$$

and the pressure coefficient required to counteract this aerodynamic lift is shown in equation (8).

$$C_{P_{iL}} = \frac{C_L}{a^2} \quad (8)$$

Vertical Ground Reaction

In order to balance the down load produced by the NAC, a ground reaction force is transmitted through the trunk over the shaded areas shown in the trunk plan views of Figure 5. Two conditions are indicated, one with no wind and the other with enough wind to raise the upwind trunk contact area to a line.

First considering the no wind case,

(ground reaction force) = (hold down force)

$$\frac{\pi}{4}(P_2 - P_o)[(a + 2f)^2 d^2 - a^2 d^2] = \frac{\pi}{4}(P_o - P_i) a^2 d^2$$

$$(P_2 - P_0) = \frac{a^2 (P_0 - P_1)}{4f(a+f)} \quad (9)$$

For the case with maximum crosswind,

(ground reaction force) = (hold down force) - (lift force)

$$C_{P_2} = \frac{a^2 C_{P_1} - C_L}{4f(a+f)} \quad (10)$$

where $C_{P_2} = (P_2 - P_0)/q$.

Rolling Moments

The ability of the NAC to resist the overturning moment caused by a crosswind condition is analyzed in the following manner. If it is assumed that the trunk bleed holes are completely effective in reducing the horizontal friction force between the trunk and ground to zero, then all of the horizontal wind force must be resisted by the forward trunk alone but both trunks are capable of furnishing a counter rolling moment to resist overturning. Figure 5 indicates the forces being considered along with their geometric relationships. Taking moments about point X, we consider first that moment produced by the difference between the hold down force and the aerodynamic lift which is assumed to act through the vertical centerline. Next is the moment produced by the drag force which is assumed to act a distance $d/2$ above the ground. Finally, there is the moment produced by the ground reaction force which acts on the shaded area of Figure 5. All of these moments are combined as follows.

$$\begin{aligned} & (\text{hold down} - \text{lift}) + (\text{drag}) - (\text{ground reaction}) = 0 \\ & 2(P_0 - P_1)A_0 \left(\frac{ad}{2}\right) - L \left(\frac{ad}{2}\right) + D_y \left(\frac{d}{2}\right) - 2 \left[(P_2 - P_0)A_1 \frac{(a+2f)d}{2} - (P_2 - P_0)A_0 \left(\frac{ad}{2}\right) \right] = 0 \end{aligned}$$

Substituting appropriate terms and dividing by q we have

$$C_{D_y} = a C_L + 2 C_{P_2} [(a+2f)^3 - a^3] - 2 a^3 C_{P_1} \quad (11)$$

Equation (11) indicates the maximum value of the lateral drag coefficient (based on airship cross sectional area) at which an overturning moment can be resisted.

Trunk Fabric Loads

The tension in the trunk fabric can be computed by considering the trunk pressures which are required to hold the airship in a given wind condition. If the trunk is attached to the airship bottom as sketched in Figure 6, then the fabric tension is given by,

$$\begin{aligned} T &= \frac{(P_2 - P_0) \left[\frac{\pi}{4} (w+2u)^2 d^2 - \frac{\pi}{4} w^2 d^2 \right]}{\pi (w+2u)d + \pi wd} \\ T &= \frac{1}{2} C_{P_2} q d u \end{aligned} \quad (12)$$

Power Requirements

The horsepower required to maintain a given air flow over a specified

pressure drop is given by

$$HP = \frac{Q(\Delta P)}{550 \eta} \quad (13)$$

Assuming that the cushion air flow is equal to the leakage area times the square root of twice the pressure differential divided by the air density, we have

$$Q_c = \pi h a d \sqrt{\frac{2(P_0 - P_1)}{\rho}} \quad (14)$$

The power required to maintain the aft NAC would be considerably greater than the above value. At a minimum, this same power would be required to maintain the same air leakage from the atmosphere to the cushion area. In addition, power is required to maintain the trunk pressure while supplying the lubrication air through the trunk bleed holes. The aft NAC power requirement becomes,

$$HP = \frac{1}{550 \eta} [Q_c (P_0 - P_1) + Q_T (P_2 - P_0)] \quad (15)$$

The airflow Q_T is based upon a pressure drop equivalent to the difference between trunk pressure and a pressure half way between atmospheric and cushion.

$$Q_T = \pi h a d \sqrt{\frac{2[(P_2 - P_0) + \frac{1}{2}(P_0 - P_1)]}{\rho}} \quad (16)$$

Operation Over Water

The essential features of a NAC operating over a water surface are shown in Figure 4. In order to maintain vertical equilibrium (airship ballasted to neutral buoyancy), the weight of water displaced by the trunks plus the aerodynamic lift generated on the hull is equal to the weight of water drawn up into the cushion chamber above the free water surface. Figure 4(A) illustrates the static situation with no wind. The shaded volumes above and below the free surface are equal. The weight of water above the free surface is numerically equal to the hold down force. Figure 4(B) shows the effect of wind. In this case, the weight of water in the similarly shaded volumes above and below the free surface level are equal to the hold down force minus the lift force. The weight of the oppositely shaded volume is equal to the lift force. It can be seen, qualitatively, that roll stability is maintained by the trunk sinking to a greater depth on the down wind side which produces a greater vertical reaction force on that side and thus, is a function of the trunk geometry. No quantitative analysis of roll stability on water has been made at this time.

Cushion Pump-Down Time

The cushion pump-down time is calculated on the basis of Equation (13). The airflow out of the cushion volume is calculated as a function of the pressure drop across the pump. Since, by this equation, the airflow approaches infinity as the pressure drop approaches zero, an arbitrary maximum airflow is assumed for cushion pressures less than 16 psf. Air is assumed to leak into the cushion volume in accordance with Equations (14) and (16). Thus, combining the results of these two equations and Equation (13) permit a determination of the net flow out of the cushion. Integration of this net flow provides an expression of cushion pressure as a function of time, that is,

$$P_i = P_o - \frac{gRT}{V} \int_0^t (\dot{M}_{OUT} - \dot{M}_{IN}) dt \quad (17)$$

NUMERICAL EXAMPLE

To illustrate the application of the NAC concept to an airship design, a sample calculation will be made to indicate the characteristics of a NAC as applied to an airship of ten-million cubic feet displacement. The basic airship layout is as shown in Figure 2 with other pertinent details listed in Table I. Equations (4) and (5) determine the NAC pressure coefficient required to withstand axial and lateral wind, respectively. It can be seen that the lateral force

$$C_{P_{IX}} = 0.81 \quad (A)$$

$$C_{P_{IY}} = 17.06 \quad (B)$$

is about twenty times the axial force for any given wind velocity. If weather conditions and local topography are such that wind directions can be accurately predicted, then operation of the NAC can be based upon axial winds. For the purpose of this example, the worst case will be assumed, that is, lateral winds at the maximum expected velocity will be considered.

Equation (8) can be used to determine the NAC pressure coefficient which will counteract the lift produced on the airship hull by a crosswind. The total pressure coefficient required is the sum

$$C_{P_{IL}} = 2.13 \quad (C)$$

of Equations (B) and (C). Thus

$$C_{P_I} = 17.06 + 2.13 = 19.19 \quad (D)$$

Equations (9) and (10) show the relationship between cushion pressure, trunk pressure, lift coefficient in crosswind, trunk diameter and trunk ground contact area. From Equation (10),

$$C_{P_2} = \frac{(.50)^2(19.19) - (.533)}{4f(.5+f)} \quad (E)$$

Values of C_{P_2} as a function of f are plotted in Figure 7.

If the flattened portion of the trunk (f) is taken as 0.05 of the nominal inside trunk diameter (a), the allowable CD_y which can be tolerated before the airship will begin to roll over is given by Equation (11). Substituting appropriate values yields

$$CD_y = (.533)(.5) - 2(40)[(.5+2(.05))^3 - (.5)^3] - 2(19.19)(.5)^3$$

$$CD_y = 2.75 \quad (F)$$

This allowable value of CD_y is less than the estimated value.

The fabric loads in the trunk are computed from Equation (12) using a design crosswind of 50 knots.

$$T = (.5)(40)(8.47)145(.10) = 2450 \text{ lbs/ft}$$

$$T=205 \text{ lbs/in}$$

(G)

The NAC power requirements will now be calculated using Equations (13) through (16). From Equation (14),

$$Q_c = \pi(.001)(.5)(145)(.10) \sqrt{\frac{2(162.3)}{0.002376}} = 84 \text{ ft}^3/\text{SEC} \quad (\text{H})$$

where; $(P_0 - P_1) = C_{p1} = 19.19(8.47) = 162.3 \text{ lbs/ft}^2$

From Equation (13), the horsepower requirement of the forward NAC trunk is

$$\text{HP} = \frac{84(162)}{550(.75)} = 33.1 \quad (\text{I})$$

If the aft NAC trunk utilizes bleed holes for lubrication, Equation (16) is used to compute the airflow requirement based upon bleed hole area fifty times the forward trunk leakage area. This area would allow 10 rows of 0.25 in. diameter bleed holes spaced approximately 0.8 inches apart.

The horsepower requirement of the aft trunk utilizing bleed air is given by Equation (15).

$$\text{HP} = \frac{[84(162.3) + 677(339)]}{550(.75)} = 5598 \quad (\text{K})$$

This high power requirement for the aft trunk, when bleed hole lubrication is employed, indicates that the alternative scheme, which would utilize interrupted suction when crosswinds of a certain magnitude are exceeded, might be a more attractive means to provide for airship weathervaning.

If operation from a water surface is anticipated, the cushion pressure of 162.3 lbs/ft² would result in water rising in the cushion volume to a height of 2.6 feet above the free surface.

The cushion pumpdown time of the forward NAC trunk is computed by performing a numerical integration of Equation (17). A maximum value of \dot{M}_{out} of 10 times the steady state value of the design cushion pressure is assumed.

The approximate volume of the NAC cushion chamber is,

$$V = \frac{\pi}{4} (.5)^2 (145)^3 \cdot \frac{10}{2} = 29,930 \text{ ft}^3 \quad (\text{L})$$

The initial mass of air in the cushion (at sea level standard conditions) is,

$$M = \rho V = .0023769(29930) = 71.14 \text{ slugs} \quad (\text{M})$$

The flow out of the cushion is given by Equation (13).

$$\dot{M}_{out} = 34.45/\Delta P \text{ slugs/sec} \quad (\text{N})$$

The flow into the cushion is given by

$$\dot{M}_{in} = 0.0157 \sqrt{\Delta P} \text{ slugs/sec} \quad (\text{O})$$

These flows are plotted in Figure 8.

A numerical integration of Equation (17) was performed using the flow rates of Figure 8. Two curves are shown, the first which assumes a single pump with 33.1-HP input, the second which assumes the addition of another identical pump. When two pumps are used, it is assumed that one pump is shut down when the steady state pressure is reached.

REFERENCES:

1. Bell Aerosystems Company, Air Cushion Landing Gear Feasibility Study, Technical Report AFFDL-TR-67-32, Buffalo, New York (May, 1967).
2. Bell Aerospace Company, Preliminary Design, Analysis and Development Data for an Air Cushion Landing System Applied to a High-Performance Aircraft, Report 7414-950001, Buffalo, New York (October, 1971).
3. The Boeing Company, Navy A-4 Air Cushion Landing System Preliminary Design Study, Report D162-71046-1, Seattle, Washington (November, 1971).
4. San Diego Aircraft Engineering, Inc., Preliminary Design Study of an Air Cushion Landing System on a High-Performance Aircraft, Report No. SAE 71-044, San Diego, California (December, 1971).

GLOSSARY OF TERMS:

Symbols

A_0	Area within trunk-to-ground inner tangent line. (ft ²)
a	Diameter of NAC inner ground tangent line as fraction of airship diameter (See Figure 5).
C_D	Drag coefficient in ground proximity.
C_L	Lift coefficient in ground proximity.
C_p	Pressure coefficient.
D	Aerodynamic drag in ground proximity. (lbs)
d	Nominal diameter of airship (See Figure 2). (ft)
f	Radial dimension of trunk in ground contact as fraction of airship diameter (See Figure 5).
g	Acceleration due to gravity. (ft/sec ²)
H	NAC hold down force. (lbs)
h	Equivalent gap between NAC trunk and ground. (ft)
L	Aerodynamic lift in ground proximity. (lbs)
l	Length of airship. (ft)
\dot{m}	Mass flow. (slugs/sec)
P	Pressure. (lbs/ft ²)
Q	Airflow. (ft ³ /sec)
q	Dynamic pressure. (lbs/ft ²)
R	Universal gas constant. (ft-lb/lb/°F)
S	Area. (ft ²)
T	Temperature. (°R); tension in trunk fabric. (lbs/ft)
u	Radial dimension between inner and outer trunk attachment as fraction of airship diameter (See Figure 6).
V	Volume of NAC chamber. (ft ³)
μ	Coefficient of friction between trunk and ground.
η	Overall pump efficiency.
ρ	Density of air. (slugs/ft ³)

Subscripts

0	With pressure, ambient. With area, airship cross section normal to x axis.
1	With pressure, air cushion chamber. With area, airship cross section in x-y plane.
2	With pressure, air cushion trunk pressure.
C	Air cushion.
T	Trunk.

TABLE I

NUMERICAL EXAMPLE AIRSHIP CHARACTERISTICS

Volume = 10,000,000 ft³

$C_L = 0.10 (S_1/S_0) = 0.5333$	$a = 0.50$
$C_{Dy} = 0.20 (S_1/S_0) = 1.066$	$\mu = 0.25$
$C_{Dx} = 0.05$	$u = 0.10$
$l = 606 \text{ ft}$	$\eta = 75\%$
$d = 145 \text{ ft}$	$h = 0.001 \text{ ft}$

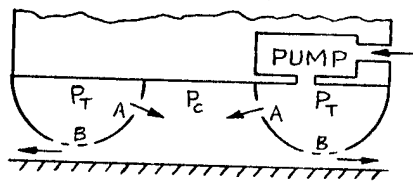

TYPICAL ACLS
Figure 1

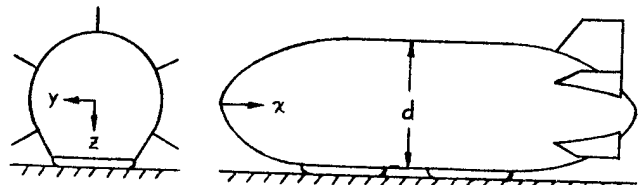

TYPICAL AIRSHIP NAC INSTALLATION
Figure 2

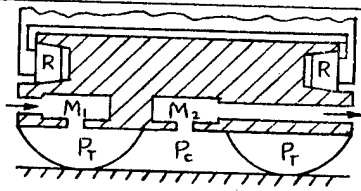

Figure 3A

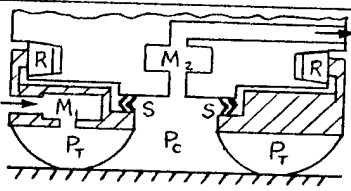

Figure 3B

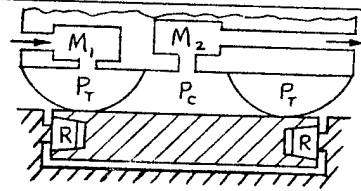
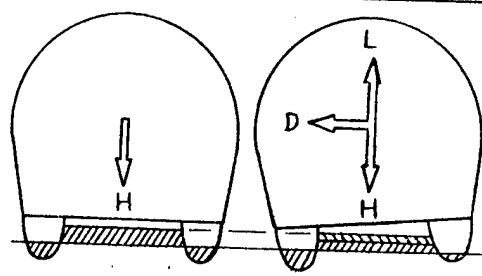
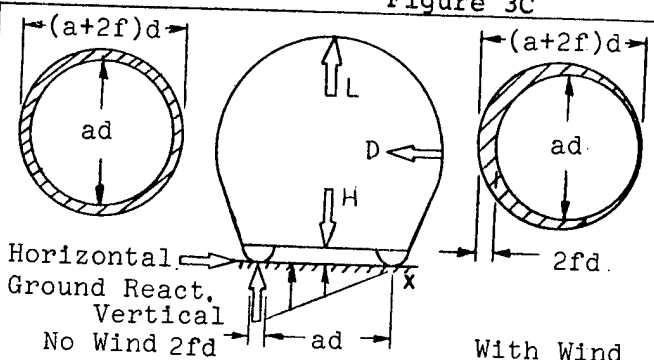

Figure 3C



No Wind
With Wind
NAC ON WATER
Figure 4A
Figure 4B



NAC GROUND REACTIONS AND FOOTPRINT
FIGURE 5

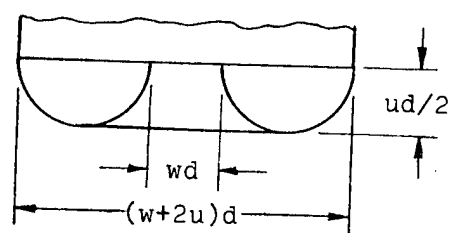

FREE AIR TRUNK CONFIGURATION
Figure 6

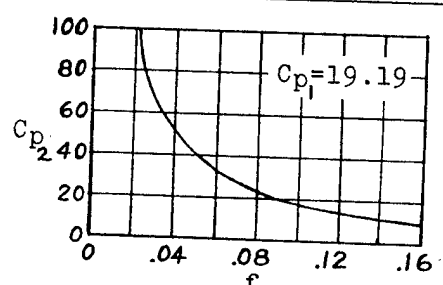

TRUNK FLATTENING VS TRUNK PRES.
Figure 7

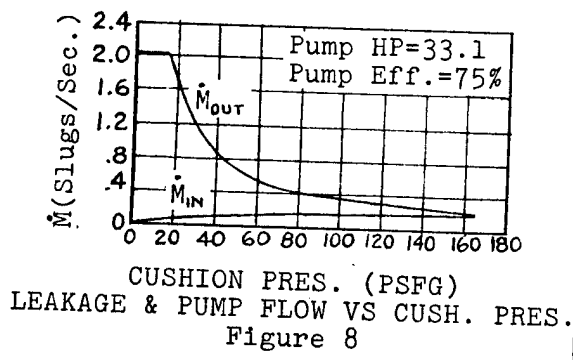

LEAKAGE & PUMP FLOW VS CUSH. PRES.
Figure 8

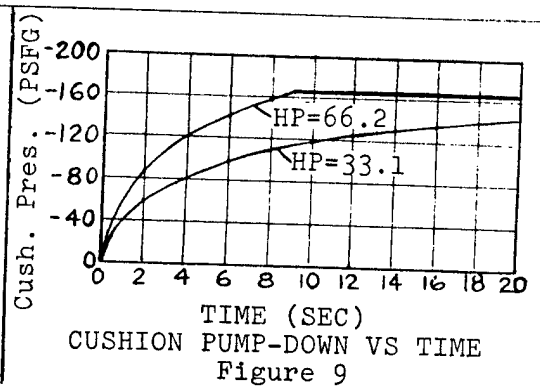

CUSHION PUMP-DOWN VS TIME
Figure 9

REPRODUCIBILITY OF THE ORIGINAL PAGE IS POOR

MODERN AIRSHIP DESIGN CONCEPTS

The Slate All Metal Airship — Claude C. Slate, Richard D. Neumann

State of the Art of Metalclad Airships — V. H. Pavlecka, John Roda

The Aerospace Developments Concept — John E. R. Wood

Method for Transporting Impellent Gases — Hermann Papst

The Design and Construction of the CAD-1 Airship — H. J. Kleiner, R. Schneider, J. L. Duncan

A LTA Flight Research Vehicle — Fred R. Nebiker

The Airfloat Heavy Lift Project — Edwin Mowforth

977

N76-15044

THE SLATE ALL

METAL AIRSHIP

Claude C. Slate*
Richard Neumann**

ABSTRACT: This paper will cover the development of the Slate all metal airship "City of Glendale" built and completed in 1930. A brief discussion of the airship facilities accompanied by slides will be covered. Pertinent data which led to other engineering accomplishments for aviation will be covered and shown. The paper will deal with the SMD-100 concept, along with a brief commentary on the costs and problems involved in such an airship design and the application of the hoisting and elevator facilities to airship development.

In 1928, in the city of Glendale, California, the Slate family, headed by Captain Benton Slate funded, designed, constructed and inflated the airship "City of Glendale." It was one of the four all metal airships built in the Lighter Than Air era. Unlike the ZMC-2 metalclad, the Slate was financed by a family group and considerable attention to cost was required with limited availability of outside sources.

The Slate design incorporated a gore panel structure which was formed on the world's largest stretch and form press and in the process corrugated for additional strength. The gores were placed along the hull longitudinally, while the hull was rotated with slings and counterweights to maintain the work area at a specified platform height.

* President, Slate All Metal Dirigible Company, Glendale, California, U.S.A. and member Southern California Aviation Council, Inc. Lighter Than Air Committee Technical Task Force, Pasadena, California, U.S.A.
**Chairman, Southern California Aviation Council, Inc. Lighter Than Air Committee, Pasadena, California, U.S.A.

On completion, the hull was inflated with natural gas and floated to a second hangar facility where mating of the gondola was carried out. In this facility the hull was purged of the natural gas and inflated with hydrogen. Metal was German manufactured duraluminum in sheet form and imported to the United States. The second facility was also to be used for the installation of the powerplants and related modification work.

As with many aircraft, the Slate airship was taken out of the hangar for purposes of promotion and publicity, at which time it was to be turned around and brought back into the hangar to complete the installation of powerplants and flight controls. The person assigned to the control car to maintain the pressure controls was talked into leaving it for a few moments to have his picture taken. While this was happening, hull pressure expanded due to the hot California sunlight and caused the rupturing of a seam.

The hull gores were joined with a crimping process similar to that used on conventional food cans today. Internal ring structure of very light weight was riveted to the gores. So despite the sudden heavy pressure surge and the opening of a seam, damage was confined to a very small area and the airship was returned to the hangar with adequate time to spare for repairs. This alone was testimony to the ability of metal airships to sustain damage without catastrophic results. Had the same accident happened in flight, there would have been sufficient time to land and unload passengers.

The Slate design offered novel and significant changes in airship thinking, many of which have been adopted today by airship proponents. Passengers, fuel, crew and cargo were taken aloft by an elevator or hoisted aboard. The corrugation gave the hull unprecedented longitudinal strength.

The powerplant, which consisted of a high speed rotor, operated in such a manner as to cavitate air in front of the airship and pull it forward into what amounted to a vacuum. It also acted to redistribute the boundary layer and this permitted use of smaller control surfaces. As a result of tests the powerplant initially reached an effectiveness of 68.2 percent. Later refinements are reported to have increased this figure to almost 80 percent.

The Slate program required that they not only design and innovate, but become manufacturers of hydrogen gas, engineer the world's largest stretch and form press, and develop new ideas on the handling of cargo and passengers. Our film clips and slides will show these aspects.

In 1958, Claude C. Slate decided to follow in the family interest in airships and produced the Slate All Metal Dirigible SMD-100. This design has been copied in the USSR and was reported extensively in the 1960's by the Soviet press. The description and slides on the SMD-100 which follow are based on the design and engineering of a 7 million cubic foot airship and missions to which it is applicable.

The original design would have involved costs including the building of facilities, of 9 million dollars. With inflation and the way costs have gone up, the same design is estimated to cost now between 14 and 15 million dollars which includes the facilities.

The Slate airship like the ZMC-2 was an accomplished fact. Unlike the ZMC-2 which was designed from the start as an experimental prototype for the Navy, the Slate was for commercial application. In 1930 the depression was in full sway and funds planned for the development by the Slate family dried up. Within an 18-month period all work was abandoned on the airship and demands for the removal of the facility at Grand Central Airport were made, resulting in the scrapping of the uncompleted airship.

With the technology that exists today, the Slate airships could be manufactured and operating for unit costs of approximately 6 million dollars after a series of three to four were developed and facilities constructed.

A metal airship was recognized as the only answer to the many perils of the airships of the 20's and 30's. The Slate family contributed to our knowledge of airships and designs. More than any other organization they willingly gambled their own funds on development and would have succeeded except for the financial crash that shook not only the United States, but the world.

SLIDES PRESENTED AT WORKSHOP

Slide #1

The Slate Aircraft Company was formed in the middle 20's. After an unsuccessful attempt to lease the blimp hangar at Ross Field in Arcadia, California, property was leased in the city of Glendale. Hangars were erected to produce the Slate All Metal Passenger Carrying Airship. The initial financing was by private capital and it wasn't until construction was well underway that stock was available to the general public. These ships were to be used strictly for carrying passengers and cargo.

Slide #2

The small hangar was for the construction of the hull and the larger hangar was for the final assembly of the cabin and powerplant.

Slide #3

The all metal monocoque ship was 212 feet long, 58½ feet in diameter, with a total displacement of 330,000 cubic feet. Initially, it was to be powered by a 500 horsepower steam turbine. Total weight of the ship was under 14,000 pounds, and payload was approximately 8,000 lbs.

Slide #4

Airborne ship shown during one of the many tests for checking the powerplant, ballast, and elevator systems.

Slide #5

The first longitudinal sheet in place. The ship was made up of continuous longitudinal sheets and circular rings. The rings were produced on a yoder type roll. At the time the ship was started, 18-inch wide coiled aluminum in 200 foot lengths was the largest size available. It required splicing at the nose and tail sections. All work was performed on the horizontal centerline of the ship.

Slide #6

Hull approximately 75% complete. Note end of stretch and form press.

Slide #7

Hull approximately 90% complete. All riveting was performed with hand operated rivet sets.

Slide #8

Front end of hull showing work platform and splice of longitudinal sheet.

Slide #9

The hull work crew putting the last sheet in place. 158 formed sheets made up the hull. The last sheet fit perfectly.

Slide #10

Internal view of the hull. Note the simplicity of construction.

Slide #11

Cabin under construction and ballonnet undergoing inflation tests.

Slide #12

Hull moving from small hangar to larger hangar for cabin attachment. Natural gas was used to initially purge the ship. At this point natural gas was used as a means of buoyancy.

Slide #13

Hull suspended in a large hangar for cabin installation.

Slide #14

In 1953 a larger ship of approximately 900,000 cubic foot displacement was proposed to the Navy. Complete design and structural analysis was furnished to the Navy.

Slide #15

Performance data on the ship.

Slide #16

Cabin arrangement, with live-on provisions for crew and submarine surveillance equipment.

Slide #17

In 1960, lighter than air, as a means of moving missiles and related equipment was investigated by the government. The design of the 8,600,000 cubic foot ship with a 100 ton payload and a 2,400 mile range was started.

Slide #18

The primary task was for moving the new Saturn booster and other out-sized cargo.

Slide #19

Performance data on the ship.

Slide #20

Payload and operational data.

Slide #21

The cargo bay was sized to carry the first stage of the Saturn booster.

Slide #22

The ship would have the capability of moving three Minuteman missiles.

Slide #23

Further studies brought about the SMD-100 and primary effort was directed to the Air Force and NASA.

Slide #24

The ship was configured to accomodate practically any size cargo. Two hoist bays were provided in place of the large cabin. The flight deck and crew quarters were in the lower fin.

Slide #25

Live-on accomodations for forty men were provided.

Slide #26

Specifications of the ship.

Slide #27

Performance of the ship.

Slide #28

Ten hoists in each bay are capable of picking up 300,000 pounds. Maximum height of pickup is 250 feet. The hoists are mounted on rails in each hoist bay and move fore and aft to handle cargo up to 160 feet in length. Auxiliary power is provided on the tips of the horizontal stabilizers. The powerplants swivel 360 degrees making it possible to turn the ship in twice its length.

Slide #29

Carrying the first stage of the Saturn booster.

Slide #30

Hoisting three Minuteman missiles.

Slide #31

Moving bridges and out-sized cargo.

Slide #32

Moving housing and emergency hospital.

Slide #33

Installation and servicing of remote radar installations.

Slide #34

Salvaging of aircraft.

Slide #35

Container loading or unloading without the use of conventional dock cranes. The ship would handle ten 40-foot sea-land containers, with each container weighing up to 30,000 pounds.

Slide #36

Container handling from ship to shore for remote areas without harbor facilities.

Slide #37

Moving, erecting, and servicing of oil well equipment.

Slide #38
Servicing of off-shore oil drilling platforms.

Slide #39
Transporting pipe line with prefabricated lengths up to 160 feet.

Slide #40
Transporting and servicing of remote housing and construction equipment.

Slide #41
Maintenance and servicing of remote mining operations.

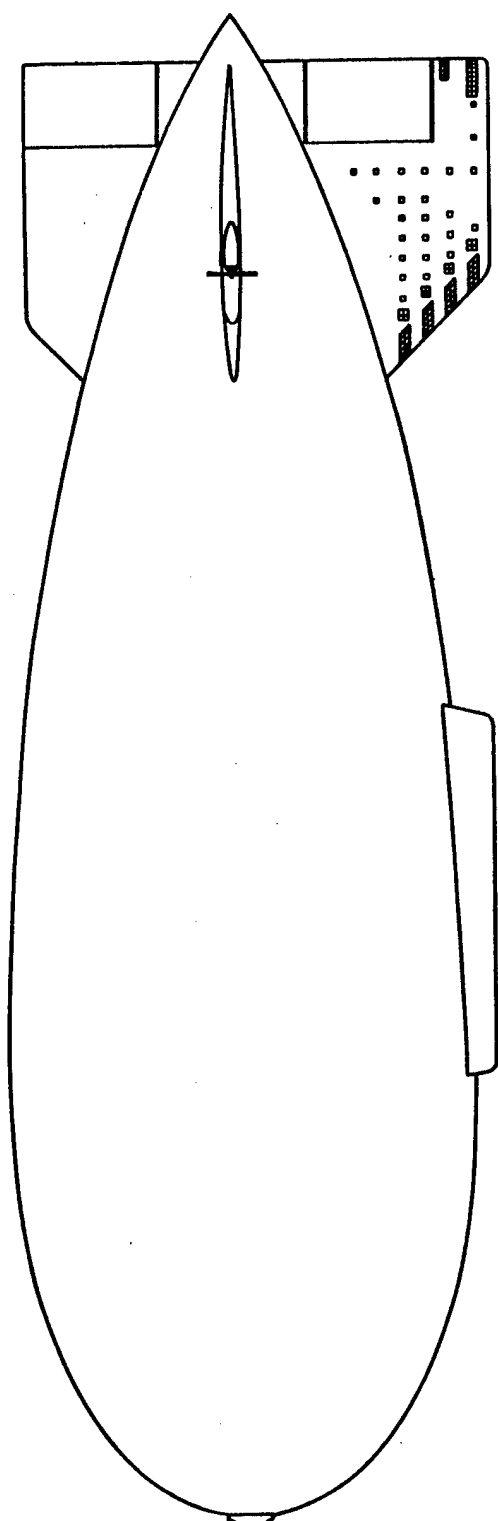

SLATE ALL-METAL DIRIGIBLE

Normal Take Off Helium Capacity	7,804, 133 Cu. Ft.
Gross Lift At Normal Take Off	491,652 LB.
Weight Empty	206,494 LB.
Useful Load	285,158 LB.
Crew 25 Men	5,250 LB.
Fuel and Oil	73,420 LB.
Ballast	9,005 LB.
Cargo Static Take Off	197,483 LB.
Cargo Dynamic Take Off	244,518 LB.
Range With 73,420 LB. of Fuel	2,400 MI.
Maximum Fuel or Ballast Capacity	340,000 LB.
Maximum Speed At 4672 S.H.P.	100 M.P.H.
Cruising Speed at 3836 S.H.P.	80 M.P.H.
Auxiliary Power Plants. 2 @ 250 H.P. each	500 H.P.
Service Ceiling	7500 FT.

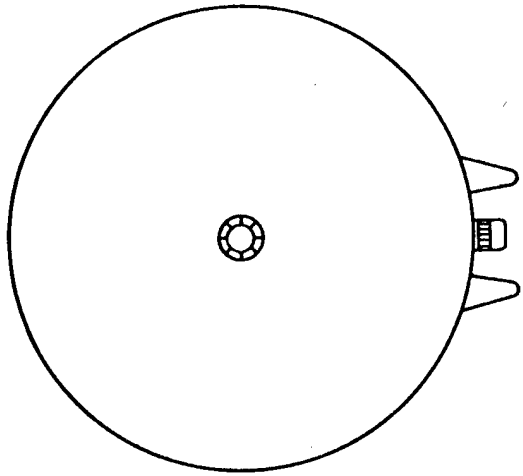

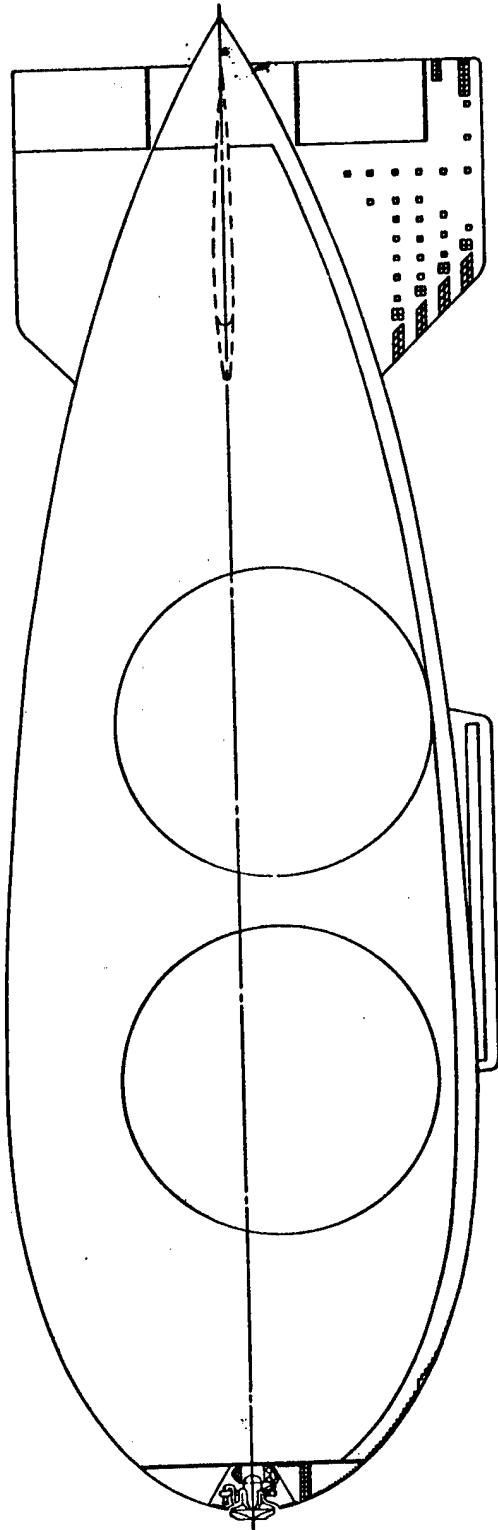

SLATE ALL-METAL DIRIGIBLE

Length of Hull	570 FT.
Diameter of Hull	177 FT.
Maximum Height Over Hull and Cabin	186 FT.
Fineness Ratio	3.22
Displacement of Hull	8,671,258 CU. FT.
Total Ballonet Displacement	1,734,251 CU. FT.
Ratio Ballonet Volume to Hull Volume	20%
Thickness of Aluminum Alloy Skin	.014
Width of Cabin	8 Ft.
Capacity of Cabin	44 Men
Number of Air Valves	2
Number of Gas Valves	4
Main Power Plant; Allison Model 510-H2	5000 H.P.
Maximum Area Covered by Cargo Hoist	33.5 Ft. x 120 Ft.
Passenger Elevator Capacity	12 Men

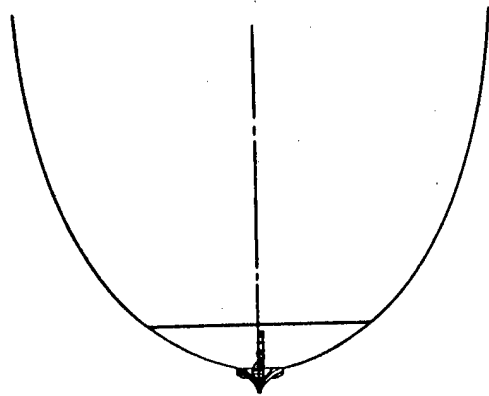

N76-15045

STATE OF THE ART OF
METALCLAD AIRSHIPS

V. H. Pavlecka*
John Roda**

ABSTRACT: This paper will deal with metalclad airship development of the past history and with the immediate prospects for continuation of the development of these airships. The metalclad airships promise high safety even in highly inclement weather, are capable of high speeds, while lifting high useful loads. Metalclad airships which in first cost would compare favorably with the costs of sea-going ships and in operating costs promise to be lower than airplanes.

HISTORY

First flight by man was in a balloon. It was inevitable that as soon as a prime mover was available, man would install it under an elongated balloon, now called an airship or a dirigible, and drive it directionally. At the time of the first flight in an airplane, the airship was well understood and for that time, daring prospects were already under way, in sizes that dwarfed the small airplanes. The historically unforgettable names of these pioneers, Zeppelin, Parseval, Schutte-Lanz in Germany; Forlanini in Italy; Clement-Bayard, Lebaudy and Santos-Dumont in France; Welman and Baldwin in the United States, etc., will always live in the mythology of airship development. One of them was Schwartz, an Austrian army officer, who succeeded in building an all aluminum, cylindrical airship, which at least floated in the air. Ultimately, Zeppelin, a master industrialist, besides a daring and imaginative inventor, organizer and engineer, brought the

*Technical Director, Turbomachines, Inc., Irvine, California, U.S.A.

** Director, Turbomachines, Inc., Irvine, California, U.S.A.

rigid airship to a high state of perfection. A parallel development arose in Germany, headed by Professor Schutte and financed by the known firm of Lantz, makers of farm implements. This group was even more daring and innovative than Zeppelin. They built their first three ships of plywood, as the aluminum alloys were still being developed; later on of tubular steel girders; their ships were aerodynamically least resistant bodies, with many innovations, later considered indispensable to airship concepts.

In the early 1920s, with Zeppelin returning back to civil aviation and resuming the highly successful passenger transport service by Delag and Schutte-Lantz terminating their existence under the limitations of the Versailles Treaty, two men emerge in the United States, from different directions but with a common interest - all-metal dirigibles; Carl B. Fritzsche and Ralph H. Upson.

Each one was unlike the other, and in fact each complemented the other. Carl was a pragmatic, outgoing man; a man of immense energy and vision, dedicated to purpose, ingenious in finding roads to those in power, convincing and enthusiastic, not above removing persistent obstacles with impatient gusto. Ralph was a rare product of American culture; a practical idealist, intellectual of profundity, in the class of Adlai Stevenson, highly educated and intelligent. To us, young ones, it was a delight to be daily exposed to these two men, who so well provided indispensable and different talents to the development of metalclad airships. Due to their cultural diversities, each vaguely and subtly distrusted the other with a solidly built in, but never admitted mutual plea of, "Please do not leave me, I need you".

Ralph laid down the principles of all metal hull design in the days when the great majority of the aircraft industry doubted that all metal airplanes were feasible. Carl worked the intricate paths to the powers of decision; somehow obtained private money from many sources in what still must be one of the best examples of free enterprise, and eventually found all doors of established agencies in Washington closed to any hopes for contract money. In this situation, he did what must be equivalent to climbing of Mt. Everest; he went directly to the U. S. Congress and with his persuasion he managed a rider to the Naval Appropriations Bill for the funds to build the ZMC-2, an experimental all-metal airship.

It is most proper to commence this talk with a sincere tribute to these two men, no longer with us; to their genius in the services of humanity, their attractive human qualities and their vision, which welded us all into a unique group of workers. I am sure that they had in mind what we shall talk about now. It is the ultimate egalitarianism of nature that singular men do not live longer than others. We now must do the utmost to take up the slack due to their absence and continue, and I am certain that both, Ralph and Carl, imagined this day might sometime come, when airships would continue.

The results of efforts of Carl and Ralph was the ZMC-2, (Picture No. 1). The primary objective was to demonstrate the all-metal or metalclad

hull principle; the secondary objective was to use the ZMC-2 in training airship pilots. It was delivered in August, 1929 to Lakehurst by then Captain W. E. Kepner, the test pilot of the ZMC-2 and it served at Lakehurst for twelve years, until 1942, when it was decommissioned to gain space for larger airships. It had a length of 149 ft. 5 in.; diameter of 52 ft. 8 in.; displacement of 202,200 cubic feet of which 151,600 cubic feet was lifting and originally was fabricated from a .006 inch thick 17ST alloy. This alloy corroded so badly in spite of anodic treatment that soon after commencing the fabrication of the hull, it appeared wasteful to go any further and our Navy was asked to pressure the aluminum industry to develop either an effective protection against corrosion or to come up with a noncorrosive alloy. Alcoa did just that, developing the Alclad sheet from which also most airplanes have been made since 1933. Alclad was developed for the ZMC-2.

The Alclad plating was .095 inches thick, riveted by a wire-rivet automatic machine developed by E. Hill; and the plating was cut in frustum cone envelope sheets and was riveted in peripheral and staggered longitudinal seams. Mr. Roda, who was deeply involved in the fabrication and assembly of the ZMC-2 will tell you more about its construction as well as the construction of modern metalclad airships to come.

The ZMC-2 hull was inflated with Helium and the hull was kept under a pressure of approximately 2.5 inches of water by two ballonets, used also for pitch trim. Throughout all twelve years of service, no seam leakage of Helium has been recorded and the experience is that a lifting gas can be contained inside a metal hull indefinitely with minimal additions from time to time. The external metal surface in the highly salty air of Lakehurst, shows pitmarks of corrosion after twelve years, some of it caused by impact erosion by grains of sand. The aluminum layer of the .095 inch thick Alclad is extremely thin and this is probably the main factor. The internal surface appeared still as bright as when it left the mill, even inside the ballonets where too, it was exposed to salty air. In large ships, the electrolytically protective external aluminum layer will be thicker due to the thicker gages of the sheet, and possibly, Alclad sheet can be rolled for large all metal ships with one side, the external side, having a greater thickness of aluminum than the internal side. The fineness ratio of the ZMC-2 was 2.83, yet the hull was still stable and maneuverable. The sheet thickness was excessively great, for reasons of facilitating fabrication and it was planned that the ship be overweight for this reason although the final weight met the estimates with some 270 lbs. underweight. Such a limitation will not again arise in larger hulls. To countermand this penalty, the fineness ratio was selected low, in order to obtain a low surface-volume ratio. Another influence on this decision was the desire to secure as high a hull curvature longitudinally as possible; more than sufficient thickness of the hull plating permitted high-hoop loads at still low-hoop stresses.

In Figure 2 is shown the inside of the hull of the ZMC-2, inflated with air under a low pressure. The hull plating under pressure was taut and smooth without wrinkles. When the pressure was released, the plating buckled, entirely elastically and the hull was then supported

in its general shape by the frame and longeron structure, as a rigid airship hull. The lifting gas was contained by the plating, while two separate ballonets were attached to the plating by cemented shoe strips. The pressure inflation-deflation cycle was repeated many times before the ship flew and it must have been repeated very frequently during the lifetime of the ship without any notice of fatigue.

The ZMC-2 hull was inflated first with carbon dioxide, from the bottom, displacing the air toward the top and out. Subsequently the carbon dioxide gas was pushed out from the top to the bottom by Helium, until the gas volume of the hull was full with Helium. This method of inflation resulted in a very thin interface layer of mixed gases, air-carbon dioxide and subsequently carbon dioxide-Helium. In larger hulls it will not be necessary to resort to this process of inflation, as we shall see further on.

The fundamental principle of a metalclad hull was and remains the use of the lifting gas pressure and of the inflation pressure for strength and rigidity of the hull. The fabric-covered rigid airship hull also is subject to the forces of the lifting gas pressure of the cells. But this pressure, in a rigid airship hull, has to be contained by the wire and girder structure and contributes only very little to the strength of the hull as a beam, while loading adversely the girders in bending, in addition to compressive loads imposed on them by bending moments of the hull. In rigid airships, the gas pressure or the lift, generates unwanted and high secondary loads which the structure has to contain without any gain in strength for the carrying of basic hull loads. The lift forces in rigid airships require additional weight in longitudinal girders and frames. In Figure 3 is shown the Zeppelin L-129 airship. At the top of the drawing can be seen the gas-cell fabric supported by a planar network of wires anchored to the longitudinal girders and frames, which in turn take the lift forces by bending to the transverse frames. The girders of the frames are also loaded in bending by the forces from the retaining wire network. The lifting structure, the cells and the girders with wire netting between adjacent members, are then covered by external fabric whose sole purpose is to streamline the whole hull structure. This is the original concept of the Zeppelin rigid airships and in spite of its defects, it has served well. In Figure 4 is shown a number of transverse sections of the L-129 hull, illustrating well the sequences of the transfer of the lift forces to the longitudinal girders in bending. The peripheral space between the cells and the outer fabric surface is filled with air and is ventilated to the outside at numerous stations.

This space of course, is lost to the lift; in Hydrogen airships of this type, this peripheral volume always was the greatest hazard to the safety of the hull because at times, it was filled with a mixture of leaked-out Hydrogen and air. It is a credit to the discipline of operating crews of rigid airships that in only one, the last case, an airship was lost by fire in peacetime operation; R-101 ran into ground and burned afterward.

The metalclad hull principles, as laid down by Upson before SAE in 1926, are now classical to the modern airship design. These principles

recognize that an airship hull must be an all-metal, gas-containing body, simply, a shell. The presence of the lifting gas pressure is not a nuisance but a design asset that automatically can benefit the strength and rigidity of the hull. It is not necessary to design it out, at the cost of complexity and weight, but rather it is desirable to design it in, with a gain in safety, simplicity and improved structural quality. The metal hull of the Upson airship was to be rigid, noncollapsible, so even if gas were to be lost from a cell, the hull still would retain its form, not collapse, and get the airship home at reduced speed.

To this end, he went further and specified that the hull be held under pressure by air in the gas dilatation volume or volumes that we call ballonets. Upson outlined a principle that may be considered a hybrid between the rigid ship and a collapsible hull nonrigid or semirigid airship and, advanced this concept, by making the self-supporting hull completely of metal. Hybrids often, but not always, are superior to the original individual components; this definitely is the case in metal-clad airships, although we see proposals for some hybrids combining airships and airplanes which make one wonder.

Upson's concept not only utilizes the lift forces for strength and rigidity but also uses additional pressure to keep the whole hull skin under tension and imparts to it a high capability to support shear stresses as well as high compressive loads due to bending. The use of pressure provided by nature as well as by the designer in an all-metal hull, has opened wide the prospect of constructing all-metal airships of very large sizes and flight capabilities, especially speed, heretofore not possible even of consideration. Upson's system has given us means to create airships of high speed which will be reliable, strong and powerful to ride out storms if need be, that non-pressurized rigid airships should not dare to come near.

One important advance in the control of airships was introduced also by Upson in the form of multiple fins. All airship hulls in motion build up a thick boundary layer along the length of the hull. The classical cruciform fins are largely submerged in this boundary layer on the hull of high fineness ratio, also partly due to their low aspect ratio. The multiple fins can have a higher aspect ratio and therefore, are more effective and can be smaller. Furthermore, the multiple fin loads, being individually smaller and more numerous, are better distributed into the hull structure, and the stern structure weight can be markedly reduced. All rigid airships of the past suffered from low lift in the stern, due to the hull slenderness, still further aggravated by high structural weights and consequent high bending moments. This limitation has now been either reduced or done away with at no increase in drag. The multiple fins of the ZMC-2 were successful and did not have to be reworked as is often the case with airplane tail surfaces. ZMC-2 suffered in flight from a swinging roll, which can be analyzed as originating from the swirling slip-stream of the propellers, both rotating in the same sense. This should not occur again.

ZMC-2 was the first airship of this system. After its completion, we continued working on a larger ship, the ZMC-38, a 3,800,000 ft.³ dis-

placement with lifting gas volume of 3,500,000 ft.³, Fig. 5, of 1930, which, while still of a small scale would have incorporated all features of a working airship of much larger size. ZMC-38 was projected for 100 mph top speed. It had a fineness ratio of 4.5; at this fineness ratio, the hull already reaches its minimum drag coeff., which does not change significantly toward higher fineness ratios.

The hull form was arrived at with highest diligence and desire to obtain a high prismatic coefficient (.63) at low drag and therefore, the maximum practical surface/volume ratio. It also provided high lift in the stern. The envelope curve, so called E-H curve, Fig. 6, is a combination of an ellipse from the bow to the maximum diameter station with a hyperbola from approximately 40% length to 80% length and finally a second hyperbola in the stern for the remaining 20% of the hull length. At all stations of change from one geometrical curve to another, the first derivatives are on a smooth curve as anywhere else on the whole hull. Also, the second derivatives, the rate of change of the slope are on a smooth, continuous curve at all longitudinal stations. The hull plating was to be approximately .018 inches thick 2024 ST Alclad, although the thickness was to vary over the hull, according to the local needs. Fig. 7 shows the wind-tunnel model of the ZMC-38.

The main frames were deep only in those segments where transverse bending moments are high. The main frames had everywhere sufficient depth for free movement of a man, one or more, but at the low side of the hull, the depth was large enough for spacious habitation. The intermediate frames and longerons were to be made of lattice girders, as of course were the main frames. The design you see is now 44 years old, an immense age in the aviation history; yet today, as we apply modern technology to this effort, nothing needs to be altered in principle, although the influences of technical advancements on the design as it might be constructed now, are many as we shall see. The λ ratio (weight empty/total lift) of ZMC-38 was $\lambda = (.6838)$, a rather high figure, compared to the Hindenburg, adjusted for Helium gas, $\lambda = (.5991)$, until we consider the scale of the two hulls and also that the ZMC-38 was to be a 100 mph ship, compared to Hindenburg's 77.7 mph. In general, these numbers have changed noticeably now, in view of modern technology.

Since 1930, the project year of the ZMC-38 several other metalclad airships were design-studied, among them MC-59, MC-72 and in 1939, Upson studied MC-11.9. In late times, we have been exploring parameters of metalclad airships of as much as (50-55) X (10⁶)ft³ hull displacement and up to 200 mph top speed.

MODERN METALCLAD AIRSHIP POSSIBILITIES

The resumption of metalclad airship design and construction cannot, at this time, be focused on a large ship. Such a program would be too demanding on the designers, builders and operating crews. Instead a rational program has to be considered which would resume at where we stopped 40 years ago and bring the art as rapidly as possible to a useful state with larger and larger ships to follow.

Historically, this procedure has been followed by the Portuguese King, Henry the Navigator in his most farsighted program for sea voyages to discover the rest of the world and in our times by the NASA in the Apollo program. A metalclad airship of $(3-4) \times 10^6$ ft³ displacement appears to be highly justified for this purpose as the next ship to build; this initial class could even be named the "Caravelle" class. Not only one ship but several, will be needed before all participating in the return of airships would be ready for large airships.

The purpose of this new MC-38 is to organize an imaginative and productive design group with the responsibility for designing successful large and fast ships; to establish a dedicated construction group, reliable and trustworthy, and to train operating crews, first on simulators, as the assembly of the first ship commences and later by actual flight experience and overall, to continue the further development of airship technology in all completeness.

One of the first ships should continue to be experimental, heavily instrumented and should be for some time, in a never-ending state of rebuilding for trying new structures, power plants, boundary layer control, computerised operation, thrusters, thermodynamic management of lift, ground handling, etc. An MC-38 airship has approximately 100 tons gross lift with Helium and should be useful for several tasks of Naval as well as Coast Guard and civilian nature, so it would not be a waste any more than many other devices we operate as a nation for our collective benefit or protection.

In Fig. 8, is shown a sketch of such an airship, the MC-38 of the vintage of 1974. The hull contour curve is the same as that of the ZMC-38, shown before, as is its fineness ratio; possibly, the stern hyperbola could be made still fuller, but only wind tunnel tests could decide this. The only striking difference is that six instead of five fins are projected. We shall come to the reason for this later on. In the design of the hull, we shall have the luxury of computer programs for shells and it will be possible to determine precisely the thickness of the plating locally, based on wind-tunnel pitch and yaw test, with notable saving of weight.

First of all, let us orient ourselves with respect to areas in which significant gains have been made since 1930, in an itemized arrangement as follows:

Materials

The first significant gain is in materials now available to us, in aluminum and other metal alloys. Alclad is to be used again, with 7075 or 7178 series for hull plating, frame structures and longitudinalals. For forgings, excellent aluminum and also magnesium alloys are available. Titanium alloys may be used in some applications, although Titanium will be appreciated more in bigger ships to come. Similar advancements have been made in steels, superalloys, fabrics, synthetics, bonding materials, etc., even in cables, all tending toward lower weights.

Structure

The structural configuration is markedly different in detail. No longer the intricate, embroidery-like girders of the past. The basic structural element will be the honeycomb components, solid panel surfaces, with minimum of joints. A joint in any structure is a liability; it makes for a structural discontinuity, has to restore the elemental strength and is usually the first part to fail; it is always heavy and expensive without contributing to the structure. The honeycomb panel frames and structures in general, do not have point concentration of forces and where concentrated loads enter the structure, the local reinforcing structure is easy to fabricate and low in weight and cost.

The honeycomb structure will be used all over the bow hull surface, without framing and longitudinals, with suitable doublers, as well as at other parts of the hull and over the fins, particularly at all locations loaded with concentrated shears, such as valve openings and hull cut-outs for any purpose. All transverse frames will be peripherally continuous (Fig. 9) circular, not polygonal, without individual joints except for reinforcements where local loads enter. To further carry out the policy of structural integrity and light weight and low cost, all longitudinals will be external, on the outer surface of the hull. Aerodynamically, this is a minimal compromise with a small aerodynamic penalty but a vast gain in strength, rigidity, lower weight and also cost. The longitudinals also will be designed as internal honeycomb structures, most likely of semicircular sections, riveted over the plating seams. The structure inside the hull will be everywhere circumferential, while outside the hull, it will be exclusively longitudinal. There will be no specific joints between them, except as they cross, one inside the other with the hull plating between them.

Hull Plating

The ZMC-2 hull was assembled from straight-sided frustum cone envelopes of thin sheet as rings. For large hulls, long and deep thinking concludes, it is more practical and also aerodynamically perfect, to assemble the hull out of gores, as Mr. Roda will describe later on. We already have facilities in the aerospace industry for stretch-forming panels of the maximum sheet sizes. This system requires a minimum of length of seams on the hull surface, the large panel gores can be lifted and manipulated by vacuum pads and in the quality of surface of finished hull, it is doubtful that a more aerodynamically perfect structure can be fabricated; this is important in view of the high speeds at which future metalclad airships will sail.

Not the least important of the structural components are the means of joining the structure. While the first ships will be riveted, we are intensively thinking of EB welding, Laser welding, thermoplastic bonding and we shall consider any other method that may yet come to notice. We know from experience that sealing will not be a problem; all hull seams will be in the immediate proximity of rigid structures, eliminating possibilities of local flexure. All hull seams will be made of flush 100° rivets, not so much for reasons of low surface roughness although that too, is important, but for reasons of high fatigue resist-

ance. These rivets are driven in with one pneumatic hammer blow and fill the dimpled hole cavity in the sheets by plastic flow of the rivet metal to a tight, prestressed fit. They are not only stronger but also highly fatigue resisting; people flying airplanes do not realize when they look at the flush rivets along a door jamb as they enter, that they are catching a glimpse of one of the most powerful, yet lightest fasteners.

The honeycomb light structures are well developed in a multitude of configurations and their use in the metalclad airship construction is one example of modern technology making available for airships most useful means for the purpose of achieving light, rigid and strong structures. In the history of airships, it has usually been the other way around.

Fig. 10 is a picture of a tanker. Two of these are being built by Camel-Laird in England. It is a 55,000 tonner and as tankers go, it is therefore a baby tanker. It is 680 ft. long, fully 151 ft. longer than MC-38. Its beam is about the same as the MC-38 diameter. The two structures, MC-38 and this tanker are comparable in size but designed for different elements; the airship for sailing in the air space and the tanker on the interface between oceans and atmosphere, the roughest and most hostile boundary on the earth. The purpose of showing this picture is to compare these two structures. The tanker structure is obviously highly complex compared to the metalclad airship structure and it has to be. The amount of fitting and welding of elemental components in the tanker hull, compared to the simplicity of the metalclad airship structure, is simply staggering. The tanker has four longitudinal, full depth bulkheads; without them it would come apart. The design and the labor in thousands of joints connecting the structure into a force-resisting shell, is in startling contrast to the continuity of structure of a metalclad hull, requiring only seams for joining. This has a direct bearing on the cost and weight of the two structures. This may at least allay some apprehensions about the cost of fabrication of metalclad hulls. The comparison goes further in contrasting the mechanical equipment in the tanker hull; the main engine room and its ancillary facilities, the pump room in midships and the electric and pipe lines not completely visible. In this respect also, the airship is either simpler and at worst, not as complicated as the machinery of a tanker. It is constructive to keep this in mind when considering costs in particular.

The airship hull as well as the fin structure, will be provided on all metalclad ships with permanent strain sensing transducers which will report at all times to the flight engineer's panels and will inform the captain during storms. The hull will be equipped with orthicon transducers observing the cell fabric, functioning of valves, and of movable surfaces, of power plants and any other strategic elements. The flight engineer will know local gas temperatures as well as the surface temperatures of the hull; after all, he is managing not only an aerodynamic but also thermodynamic engine. He will also learn quickly of any internal leakage; in fact, the airships will be thoroughly instrumented for continuing surveillance of strains in the structure and state of the lifting gas as well as of the controlling air.

Propulsion

If the available materials and structural concepts, useful for metal-clad airships are spectacular in their merits, the contribution of turbomachines to airships is even more dramatic. Here it is best to itemize the possibilities, as follows:

- A. Forward and reverse propulsion.
- B. The control of the boundary layer in flight.
- C. Thrustors for the automatic as well as the manual control of airships in the proximity of the ground, without any laboring crew.

Forward and Reverse Propulsion

The airships of the foreseeable future will be propelled by gas turbines. These are the lightest, most reliable and durable power plants available now; any talk about Stirling engines, Diesel engines, or for that matter any reciprocating engines, is sheer retrogression. Gas turbines even in the small size projected for the MC-38, have a fuel consumption now of $(.40)^{lb}/SHPH$ and by the time the first ship will be ready for them, this should diminish to approximately $(.35-.36)^{lb}/SHPH$.

The MC-38 uses three power plants, approximately 2,000 HP maximum capability, and without BL control of the hull, although even for 100 mph it may be less. Two power plants are one on each side, driving CR, CP propellers, the 100 mph speed being still too low for turbofans. The third unit is in the main frame supporting the fins, driving air through a tunnel toward the stern exit end. With all three power plants running, the speed is 100 mph; with two side power plants running at full fuel input, the speed is 87 mph, while the central unit is at standstill. With the central unit only running, the speed is 63 mph. Thus we have three modes of operation, obtaining three high economy cruising speeds with lower economy speeds in-between. The latter case, propelling by the stern power plant alone, is particularly suitable for exploration of oceans at 60 mph and lower speeds, with a silent driving engine inside the hull, surrounded by acoustically impermeable lifting gas. The central turbine may have a lower maximum output than the side turbines.

Reversing is to be done by propellers in either all three power plants, or preferably only in the two side power plants. All propellers are specified as CR, to eliminate the wake swirl, not only for neutral approach toward the fins, but also for efficiency reasons. All power plants are telecontrolled from the bridge, no crew is needed for on the spot supervision.

The problem of weight-lift equilibrium with respect to fuel cannot anymore be solved by exhaust vapor condensation. For one reason, it is difficult to condense moisture from gas turbine exhaust, but most importantly, it is a clumsy method, dirty in its product, with resistance to flight and heavy. The most suitable and acceptable way to deal with this necessity is to burn Hydrogen gas as a supplementary fuel to the liquid fuel. Hydrogen is to be contained in balloons, in Helium cells, completely isolated from air, Fig. 11. Their volumetric content is just right for lifting the fuel and it is to be consumed at the corres-

ponding rate to the liquid fuel consumption so that there is maintained a continuing lift-weight equilibrium at all times. For complete equilibrium of lift-weight, the Hydrogen has to contribute 17.73% of the total heat input into the turbines, based on one pound of liquid fuel requiring 14.22 ft³ of Hydrogen for lift. Only the three main power plants will run with supplementary Hydrogen; all others, in thrusters and boundary layer control units, will run exclusively with liquid fuel and the figures just noted will increase above 20% of the total heat input to the main turbines. The volume of Hydrogen for a 25-hour trip at full power in MC-38, is 11.85% of the total displacement. The supplementary use of Hydrogen as fuel is the ultimate solution of the lift equilibrium problem with our present means. It is safe and dependable, simple and efficient, does not involve any increase in drag and very little if any additional weight. The reduced tankage for the liquid fuel should compensate for the fabric weight of the Hydrogen cells in the Helium compartments.

The gas turbine is of tremendous value to airships. Not only is its specific weight low, but the structure supporting it from the hull can be also much lighter than with piston power plants. Furthermore, it requires no major cooling and complexities associated with it. It is the most reliable power plant requiring low maintenance we could have dreamed of and in a honeycomb structure cell, it is not excessively noisy; two side power plants are provided to give the Captain an additional freedom of horizontal directional control. The power plants are so small and compact that mounting them inside the hull is not justified for the side units.

The Control Of The Boundary Layer In Flight

The MC-38, as in fact the metalclad shell principle at last makes possible effective boundary layer control. Boundary layer control is now an old technology, discovered already in 1904 and developed in the 1920's to a point of usefulness but not applied to aircraft generally, because at the speeds the heavier-than-air vehicles fly, it requires a considerable power plant to energize. For MC-38, it is projected that each of the seven main frames will be provided with surface orifices to remove the boundary layer that grows in the longitudinal direction between the main frames, by suction. The expectations are that a large reduction of the mean thickness of the BL along the length of the hull will be achieved, an approach toward the goal of a thin and constant BL thickness all over the hull. Similarly, the fixed parts of the fins will also be provided with suction slits or orifices to reduce the BL build-up on them. The prior work on this control is most encouraging and in our experiments with advanced turbomachine cascades, we have achieved extraordinary results in preventing separation of flow with only negligible expenditure of energy.

Each main frame will have a suction power plant for this purpose; a suction compressor driven either electrically or by a small gas turbine. It is a fact that no known dynamic compressor system can attain as high a negative (suction) entry pressure, as the centripetal contra-rotating compressor. It will be mandatory to use these compressors for

the removal of the BL. Their energy consumption will be small, particularly in relation to the fuel amount that would be needed without the reduction of drag by the boundary layer removal. These little suction power plants, if gas turbines, will run only on liquid fuel, without Hydrogen admixture. The electrical load in a modern metalclad airship will be high, due to the automation of controls, orthicon cameras of the closed TV system in the hull, power pressurizing system (no scoops), computer load and also the transient de-icing demands by electrofilmed surfaces over known strategic areas. Electricity generating power plants will also be gas turbines.

It is known that drag can be reduced by removal of the BL on a body of revolution to less than one half of that with BL. We have attained similar results on compressor cascades with only one station of suction; to begin with, it appears reasonable at this time to expect that with seven stations along the length of the hull, it should be possible to reduce the drag, on a metalclad, pressurized airship hull to at least 66% of the drag without the BL control; the drag coefficient therefore would be approximately .043, with fins, controls gondola and two-sided turbines. This expectation could not be realized on a fabric-covered rigid airship hull, even if the fabric were to be pressurized to a low pressure to prevent flapping of the surface. The fabric instability of the surface of rigid airships is a source of high drag. I have seen fabric waves on the R-100 dirigible which must have been at least four feet crest-to-crest. Metalclad hull surface is stable with almost perfect curvature when at atmospheric pressure, will not exhibit deep buckles in the ship of the size of the MC-38 and larger.

One incidental benefit of the BL control will be the reduction of the size of the fins, due to the thin BL at their bases, as compared to the relatively large part of their span made ineffective by a thick noncontrolled BL. This gain manifests itself in two ways. First of all, it is possible to rely on only six fins, with dual elevators and single rudders, on the top and bottom dorsal fins. The second gain is in the increased aspect ratio of the fins, compared to eight surfaces.

The fact is that without BL control, it would be prohibitive to operate even low drag hulls of metalclad airships at high speeds. The metalclad airship hull has even in the case of the ZMC-2, a very smooth surface. With the projected gore construction, the smoothness of surface and the correctness of shape, will be the ultimate that can be reached with any hull, non-deformable by aerodynamic forces, unlike with fabric pressurized hulls. With hulls of this precision of form and low surface friction, it is effective to practice BL control and reduce the virtual drag to a minimum attainable within the practicality of the means. The fuel requirements for doing this will be very modest, because the powers involved are low. Also, the weight of the turboblowers for this purpose will be low, of the order of .20lb/lb of T. Gas turbines have an excellent record of reliability of starting; statistics of our Navy for instance, are completely reassuring on this and there is no doubt, that the BL control power plants, as well as the thrusters will be similarly reliable in response to the starting switch.

Thrustors for the Control Of Airships

The third power plant system on board the MC-38 will be the thrustors. This is a fairly recent technology, developed first for docking of large ocean ships and now also used in spectacular manner on drilling rig platforms on high seas, for example in the North Sea, one of the roughest oceans.

What has been accomplished already and is being used on an increasing scale with drill rigs and ocean liners, can be duplicated with airships of the highly rigid metalclad hull system. The MC-38 is to be provided with turbine thrustors in the bow and in the stern. In the bow, on top of a hull main frame will be a vertical, downward thrustor of approximately 1000 lb. maximum thrust, although the final thrust size will be determined by extensive consultations with the captains of the past airships and by wind-tunnel tests. On each side of the hull is to be located also one thrustor, for starboard thrust and port thrust.

On the bottom of the hull but closer to the center of buoyancy, will be a group of three thrustors in the bow and three on the stern, for vertical upward thrust. The vertical positive lift thrustors are projected in triplicate in the bow as well as in the stern, in order to secure a high vertical lift for a heavy lift-off. All thrustors will be identical in size and in positive vertical lift which is the only critical direction, there is a safety factor of 3 on response to starting and availability. All will be operated by a computer with captain's override, through accelerometers sensors.

There arises a new and peculiar problem associated with aerodynamic thrustors. Similar thrustors are being manufactured and several firms produce them. They are used for vertical lift platforms and in all present applications their long time speed response lag is not highly important.

In the airship control, the long time lag in speed response of the aerodynamic thrustors is extremely important. The hydraulic thrustors in ships have a short lag, because they are low-speed machines. In high-speed aerodynamic machines, the time lag is a function of the cube of speed of rotation and is too long for this control method with single-rotating thrustors, which would have to be run up beforehand and left running at full speed, or near-full speed, while the airship is under their control; the forces of control would have to be derived from opening and closing of gates. This is a complex, heavy, fuel consuming method.

However, contra-rotating thrustors are capable of alleviating this lag because for the same output, their time lag is eight times shorter on thrust delivery either rising or decreasing. This is a promising use and it should satisfy the requirements for high responsiveness even for airship control without structural complexities of gating. The thrustor control is an indispensable means for airship handling near land and during approach to the mast and taking over the anchoring by heavy land tractors, a method initiated by Zeppelin works already in 1935.

The concept of control of airships by thrusters completely changes the experiences and preconceptions of the past and requires the abandonment of the insecurity and unpredictability of handling of airships near and on the ground. This concept, now available and in fact indispensable to all future airships, is contingent on a rigid hull; without this quality of structure, thrusters would actually be dangerous - again the metalclad pressurized airship meets this prerequisite condition and will be capable of making use of thrusters from the first ship to come.

Hull Cells and Pressure Control (Thermodynamic Management of Lift)

The ZMC-2 was a single cell lifting gas hull. In larger ships, the problems arise with containment of the lifting gas. One is the inflation with lifting gas. The second is the problem of division of the hull into individual lifting compartments. The third one is the pressure and lift control. In Fig. 12 is shown a practical solution of the problem of inflation and subdivision of the hull. The upper half diametral area of each main frame contains a semicircular curtain of reinforced fabric, which separates two adjacent cells. At a station a short distance from the center line of the hull is attached to the horizontal edge of this curtain, a semicylindrical cell, with a half-circle fabric wall at each end and a half-perimeter cylindrical fabric wall connecting the two semicircular ends. The upper part of the metalclad hull and the walls of the main frames are the remaining containing walls of each cell. After installation, the cells, one by one, will be deflated by pumping the air out at the top of a main frame. The pumping will continue until a low vacuum is reached, to draw all air out in order to reduce the contamination of the lifting gas.

Next step will be the inflation of the cell space, at this time reduced to zero, with the lifting gas, with the lower, fabric-cylindrical curtain of the cell ultimately floating above the bottom part of the hull, thus creating a control air space below each cell. At two specific main frames will be provided reinforced fabric, separating the hull into three individual air spaces for hull trim control.

The cell fabric is considered to be silk, with Mylar films on each side. The silk industry is in a depressed state and it should not be difficult to obtain this strongest fabric for highly flexible, internal walls. Rapid and noncontaminating inflation and deflation of the metalclad airship hulls is therefore no problem whatever. Both, the air space as well as the gas space will be provided with blow-off valves. For containing the Hydrogen-fuel gas in a Helium-filled hull, one of several possible schemes is to provide a semicircular cell, shown before, from all internal walls of the hull, which would be located between two intermediate frames and piped into the main frames.

So far, we have been talking about Helium filled airships. The first metalclad airships will have to be filled with Helium for reasons which are obvious to all. Yet, we are and always have been aware that the metalclad hull is safe for holding Hydrogen gas; even in case of puncture of the plating, air will not enter the hull, only gas will

escape and even if it should burn externally, it cannot burn internally. The lift of Helium is almost 10% less than that of Hydrogen. This reduced lift cannot come from the weight empty of the ship, it has to come from the useful load; in terms of useful load, the 10% difference grows to 25-30% of the useful load of a small airship and this cruel fact would make the Helium airships economically unattractive.

If the airships are to be a factor in transportation they must use Hydrogen for lifting gas. The metalclad hull is safe for containing Hydrogen, but the cell system in Fig. 12 is not. If it were to be used to contain Hydrogen, the leakage through fabric and possibly also at the seams would contaminate the control air volume and we would have the same dangerous situation as in the peripheral interspace of fabric-covered airships. In fact, worse because in the fabric covered hull, the mixture of air and leaked gas eventually and in a short time escapes, but in a metalclad hull, it could remain for a relatively long time. Solution of this problem leads to the concept of using Helium as a separating or shielding gas between Hydrogen and the control air volumes. This is shown in Fig. 13, where we again see a similar cell-fabric structure as with Helium only inflation, but now the cells contain Hydrogen. The space between the fabric cells and the bottom of the metal hull, is containing Helium, completely enveloping all facilities, habitable spaces, controls, and power plants, the Hydrogen cell fabric never coming in contact with the air space. Even the seams on the sides of the main frames are covered with Mylar films to contain possible leakage in spite of seam seals.

The controlling air is contained in ballonets between the Helium volumes and accessible air spaces; the fabric of these inflatable volumes is the only additional weight required, not a great weight.

This containment of Hydrogen is feasible, would be safe and light in weight. The volume of Helium would be no more than 10-15% of the Hydrogen volume at most, therefore, the Hydrogen lift would be reduced only very little. It is inevitable that metalclad airships of the immediate future will fly with Helium but after experience and confidence will set the minds at ease the Hydrogen-Helium metalclad airship is inevitable. In this respect the experience gained with Hydrogen fuel will be reassuring and valuable.

The MC-38 will use blowers for the control of air pressure; this is a simple means, without additional scoops. Of course, the control will be automated and capable of holding the pressure to extremely small tolerances with means that have been available and in use for a long time already in the central power plant stations. There is no fixed value of operating pressure to be set as the optimum. An optimum can be based on speed, on the diameter or on the maximum expected bending moment due to turbulence or a number of other criteria. In MC-38 with 7075-T6 Alclad plating of .018 thickness, with a minimum factor of 2 on Y.P. and seam efficiency of only 75%, the hull could sustain an air gage pressure of $.54 \text{ lb/in}^2$ in a Hydrogen filled hull at sea level. In terms of water column, this amounts to 15.77 inches of water. With altitude, this pressure would be reduced by controls. The operation of a

metalclad airship will probably take advantage of the continuously controllable hull pressure, raising it to a safe limit during approach to the ground and during flight in rough weather. The hull pressure will become a variable not only as a function of altitude but also of flight conditions, of speed and also during ground approach. The elevated pressure is desirable at high flight speeds as well as during rapid changes of temperature.

This last observation gets us to the consideration of what has come to be known as the thermodynamic management of lift. It started actually from the desire to control lift without wasting Helium, but instead liquefy it and store it in Dewar containers as the fuel was consumed. This proved to be impractical due to high energy consumption required for liquefying Helium and also due to the lightness of the liquid Helium. Next, we explored liquefied air and discarded that too for similar reasons. There is no hope for either one of these cryogenic methods of lift control. However, this thinking then leads into two different directions; one, to use Hydrogen as supplementary fuel for main turbines, which we mentioned already and the second one, to consider heating and cooling of the lifting gas; the thermodynamic control of lift by addition or removal of heat has considerable merit and will be one of the programs for experimentation with the MC-38.

It requires much less energy for a given volumetric change, to manipulate Helium than Hydrogen and this is part of the attraction for applying this method to Helium airship operation. Also, in the Hydrogen ship with Helium barrier, this is convenient; although in the Hydrogen ship the required energy will be greater and the Helium volume will have to change more to control the broader Hydrogen volumetric changes. Obviously, it is much more efficient to heat Helium than to cool it by refrigeration, due to the low thermal efficiency of all refrigerating cycles. The Carnot ratio is always low in refrigeration. It is really fortunate that heating is so efficient, because it is more important in controlling the lifting gas than refrigeration, since it reduces or prevents sinking motion. For this reason, the cooling of the lifting gas will be only a large fraction of the heating capability; during a rising motion, the Captain has also valving besides thrustors at his disposal, whereas during the sinking motion valving is denied him, and for this reason among others, the thrustors for countermanding the sinking motion are more numerous and therefore, more powerful than the thrustors for providing sinking motion.

The overall purpose is to eliminate the need for carrying water ballast. The ultimate decision not to carry ballast at all will be arrived at gradually; the first airship definitely will still carry some ballast water, although perhaps not as much as without thrustors and thermodynamic control of lift.

FINAL COMMENTS

The MC-38 and larger airships of the future, should be constructed as load carriers, with exchangeable containers, locked into the structure, so that their bodies will integrate into the airship hull and contribute to its flight strength and rigidity; although these containers

will be of the same size, their conceptual design will be diverse. One type may be insulated and refrigerated; another may be constructed for carrying liquids; a number of them would be made similar to mobile homes, for habitation, with built-in sanitary facilities, cabins or seats, galley, interconnected social spaces between containers, etc. By carrying different containers, the ship will be capable of conversion into a freighter, or a laboratory, or a passenger ship by selecting loading alone.

There exists a wide speed gap between surface vehicle or sea vessel speeds and the today normal aircraft speeds. This speed gap is at least 450 mph, within which there is no transport means of intermediate speed now available to us. This wide-speed gap will be corrected by airships with speed ranging from say one hundred knots to two hundred knots within five years from the commencement of the airship program. This comparison illustrates how sorely needed airships are, particularly on intercontinental routes, overseas. Equally as much but in a different way, for the surveillance of the oceans.

Small airships of the MC-38 size inevitably have high weight empty/gross lift ratio or λ ratio, and cannot afford a relatively large fraction of their total volume for the compensation of lifting gas dilatation. This means that they are low ceiling airships. The MC-38 air-control space would have to be approximately 12% of the total gas volume of the ship for 5,000 ft. ceiling. At this ceiling the MC-38 would still have a useful lift of 30,000 lb with Helium, not bad for a small, purely experimental and training class of ships.

The λ ratio changes, at first rapidly, with increasing displacement. At approximately $(12.825) \times 10^6$ ft³ hull displacement, the value of $\lambda = .396$, instead of $\lambda = .594$ of the modern MC-38, a gain of 50% in favor of useful load to total displacement. This is a law, one of the laws governing the airship engineering. Therefore, larger ships will be able to reach and stay at higher ceilings without any problems and without excessive limitations of useful load capability. This is an indication of how powerful airships can be in larger displacements, over approximately 10^7 ft³, and also what broader freedoms of operation are open to them with increasing size.

The favorable decline of λ with increasing size of airship hulls has two other consequences, both desirable and welcome. One is the prospect of very large Helium-lifted airships in which the reduction of the useful lift would be less than the (25 - 30)% characteristic of small ships and the load carrying capability would still be within economically attractive limits. The probable consequence might be that large passenger airships would be lifted with Helium, while the naval ships and freighters, both of which will very likely travel at higher speed, will be lifted with Hydrogen-Helium gases.

The second consequence of the declining λ with size, is the freedom of large airships to afford a larger gas dilatation control air volume and therefore, gain in their ceiling capability, without serious limitations on their useful lift. In other words, ceilings of 15,000-20,000 ft. will be economically feasible, if required. This would

apply to overland airships; intercontinental airships should have no need of ceilings over 8,000 to 10,000 feet.

Still another conclusion emerges with increasing size of airships. It is the fact that past the MC-200, (20,000,000) ft.³ size, the λ ratio declines only slowly and in view of this, it appears doubtful that airships larger than (20-30) (10⁶) ft.³ total displacement will offer economically more than this maximum size. The impression is that the optimum size of an airship may be approximately MC-250, (25)(10⁶) ft.³ airship. This size is larger than fabric covered airships should attempt to reach. The λ value of the MC-250 would be approximately = .320. Dimensionally this ship would have a diameter of 224 ft. and a length of 1,008 ft., which is fully 300 ft. shorter than a 300,000 ton tanker of which over 150 are being built now, all over the world. This could well be a 200 knot ship, capable of 20,000 ft. ceiling, if needed and it could well afford both of these performance figures, whether lifted with helium or with hydrogen-helium combination.

With hydrogen it would have a total lift of approximately 747 tons; with helium, the total lift would be approximately 682 tons. The useful lift of the helium ship would be approximately 464 tons; the hydrogen-helium ship would lift approximately 500 tons of useful load. The difference in total lift due to the specific lifts, has declined to a little over 7% from (25-30%) of useful load in a small ship.

Modern airships will be more complex in detailed facilities and equipment than forty years ago. This is unavoidable and is in fact necessary to achieve as high perfection as possible. We have seen the airplane grow from a simple device into a sophisticated and incredibly reliable transport in spite of its also incredible complexity. In fact it is thanks to this complexity that it has become a safer, dependable and viable transport vehicle. Similar comparison with what used to be holds true also with seagoing ships, power stations or even a locomotive, and it will also be true for airships. Functional complexity imparts desirable and indispensable qualities to every dynamic engine and it will make metalclad airships also highly reliable, safer and trustworthy economical transport ships compared to all our past experience.

ILLUSTRATIONS AND SLIDES TO BE PRESENTED

Figure 1	ZMC-2
Figure 2	Inside of ZMC-2
Figure 3	L-129 -- Longitudinal
Figure 4	L-129 -- Transverse
Figure 5	ZMC-38 -- 1930
Figure 6	E-H Curve for Hulls
Figure 7	Wind Tunnel Model of ZMC-38
Figure 8	MC-38 -- 1974
Figure 9	Perspective view of the MC-38 (1974) Structure
Figure 10	Picture of a Tanker
Figure 11	Cell Diaphragm for helium only
Figure 12	Hydrogen cells in helium
Figure 13	Hydrogen-Helium cell

REFERENCES:

1. Upson, R. H., Metalclad Rigid Airship Development, A.S.M.E. Transactions, New York, New York (1926).
2. Metalclad Airship Corporation, World's First Metalclad Airship, Detroit, Michigan (1929).
3. Fritsche, C. B., The Metalclad Airship, The Royal Aeronautical Society, Reprint No. 61, London, England (1931).
4. Klikoff, W. A., Pressure in Airships, A.S.M.E. Transactions, New York, New York (1931).
5. Fritsche, C. B., Some Economic Aspects of the Rigid Airship, A.S.M.E. Transactions, New York, New York (1930).
6. Upson, R. H., The General Problem of the Stressed-Skin Airship Hull, Daniel Guggenheim Airship Institute (1935).
7. Burgess, C. P., Some Airship Problems, Daniel Guggenheim Airship Institute (1935).
8. Whale, George, British Airships, Past, Present and Future (1920).

THE AEROSPACE DEVELOPMENTS CONCEPT

John E.R. Wood *

ABSTRACT: For the last three years, Aerospace Developments have been under contract to Shell International Gas. Their brief has been to assess the viability of using airships for the transport of natural gas, and to complete the initial design of such a system, the airship and its associated sub-systems together with a continuing economic analysis of the project. Investigations, on a funded basis, have also been carried out into the application of the airship for A.S.W. and A.E.W. uses, and a further investigation into the transport of mineral concentrates for an Australasian mining concern has recently been completed.

INTRODUCTION

The present day method of transportation for Natural Gas has several major disadvantages. It is a high cost operation, which demands considerable investment both in surface vessels and in fixed ground plant. Briefly, the system in use at present is as follows:

1. The gas is piped from the well (or wells) to a central liquefaction plant. This is usually located at, or near, the coast.
2. From the liquefaction plant the gas is piped aboard liquid Natural Gas (L. N. G.) carriers. It is stored at -161°C throughout the voyage.
3. On arrival at the home port the gas is stored in a liquefied state, and is then

* Director, Aerospace Developments, London, England

PRECEDING PAGE BLANK NOT FILMED

re-gasified and passed into gaseous pipe storage for subsequent distribution to consumers.

Both the tankers and the liquefaction plant are enormously expensive. A large L. N. G. carrier costs, at present day prices, in excess of \$100 million, and a large liquefaction plant with its associated tankers, demands an investment approaching \$2 billion. Much of this investment has to be concentrated in ground plant located in areas of high political instability (Algeria, Libya, etc.). These assets may be sequestered by the parent countries at any time, and without any notice. The liquefaction plant consumes approximately 20% of the energy it produces in the liquefaction process and the scale of investment required means that a very large market must be assured before any deliveries can be contemplated. Small wonder then that the need for a cheaper, less politically susceptible, more flexible system has been recognised for a long time.

THE AIRSHIP AS A GAS CARRIER

Because the gas methane (the prime constituent of Natural Gas) is lighter than air, with a lifting force of approximately 45 lbs/1000 cubic feet, there is an obvious attraction in using a Lighter Than Air craft for transporting the material, since the payload will also provide the ascensional force (at least on the outward voyage). Even if the gas is assumed to contain its maximum possible concentration of contaminants (sulphur, CO₂ etc.) it is still no heavier than air. The main problem centred around the fact that, because the volume of the gas is increased in the ratio of 645:1 over its liquefied state when it is expanded to atmospheric pressure and ambient temperature, and because hoop stress considerations demand that the gas be carried under these conditions in order to carry a sensible amount of gas, the craft has to be a very large one indeed.

CHOICE OF TYPE OF CRAFT

An initial examination of the economic considerations, together with the knowledge that, within the bounds of technical competence (and certain construction costs) "The Bigger the Better" at least from the point of view of ultimate costs/cubic feet, led to the requirement for a craft approaching 100,000,000 cubic feet, which, in dimensional terms, is very large indeed!

For craft even approaching this size there appears to be only one answer, the Supported Monocoque type of construction. Supported because at some point in the journey the gas will have to be removed from the craft, and therefore gas pressure will not be available to stabilize the outer skin, and Monocoque because this is the only type of construction that is sufficiently amenable to the present day demands of quality control and rapid assembly whilst retaining adequate margins of strength. The "Zeppelin" type of construction is often still held to be the best type of construction, and the reasons for this advocacy are very difficult to ascertain. A fairly rudimentary analysis of craft of this type will show that this system of construction was inadequate to meet the demands on strength grounds alone for the sort of annual utilisations that must be achieved in order to make the system profitable. Even when used for the sort of craft that were constructed forty years ago, the rigid girder construction was not safe enough, by modern standards, and was demanding in terms of in-flight maintenance, and yet many people are still advocating the use of such construction methods for craft far larger than those of old, and they are intending to use these craft in applications far more demanding than any that have been required in the past. There is a great deal of evidence to suggest that even such staunch advocates of conventional airship practise as Charles Burgess were convinced of the need for a "stressed skin" type structure. Had the initial design for such an airship resulted in a much smaller size of craft, then it is possible that a different approach might have been adopted (probably an internally

supported "BLIMP") but for a craft of the size required, we are confident that the type of construction system adopted represents an optimum.

THE CRAFT ITSELF (Figure 1)

As may be seen from the illustration, the craft represents a fairly conventional approach to airship aerodynamics. It has a length/diameter ratio of 6:1 which represents a reasonable compromise between controllability and cost of materials (it is interesting to note that recent economic analyses show that, as far as material costs are concerned, there are advantages in reducing the length/diameter ratio to as little as 2:1. These analyses do not take account however of the control and mooring difficulties associated with craft of this type.).

The craft itself is approximately 1,800 feet in length with a maximum diameter of 300 feet. This entails considerable difficulties as regards a construction facility, and the methods used to overcome this problem are described later in this report.

The use of a considerable degree of cylindrical midship section is a sensible one, there is little, if any, advantage in resistance terms in adopting a fully streamlined form, and the advantages in terms of jiggling and construction costs militate heavily in favour of the type of design which has been adopted.

THE BASIC SYSTEM OF CONSTRUCTION (Figure 2)

The primary unit of construction is the "unitary panel" which is 20 feet in length by 10 feet in height. Since there is a very definite need to conserve weight, and because the primary mode of failure is in compressive buckling of the top skin, it was decided to develop a material which combined the best of both worlds. It was decided to utilise a "sandwich" form of construction, using stainless steel outer and inner skins, which are adequate for the tensile loads that will be imposed, together with a Keflar fibre inner core, the purpose of which is to increase the "I" value of the matrix. The result is a material which combines light weight with exceptional strength albeit at a fairly high unit cost. The decision to use a polyamide fibre rather than a metal such as aluminium as the infill for the matrix was based on two major considerations.

1. The need to obviate, as much as possible, the risk of corrosion due to the ingress of water under the outer skin.
2. The necessity to avoid the possibility of electroxytic action between the infill and the outer skins.

In order to minimize the weight of the infill, a honeycomb type of structure has been used for stabilizing the outer and inner skins.

The basic method of the assembly is outlined in Figure 2. Storage is provided for the steel, the honeycomb and the epoxy type adhesive (refrigerated). The honeycomb panels are pre-profiled to an accurate curvature, and the panels are then bonded to the outer and inner skin by an autoclave process, the completed panel then moves to a final finishing bay (edge profiling etc.) before being passed to a completed materials stockyard. This system enables the latest methods of quality control (ultrasonics, radiation, backscatter etc.) to be employed to ensure continuously high standards of material integrity. When one considers that one airship alone of this size will require approximately $1\frac{1}{2}$ million square feet of

honeycomb and 3 million square feet of skin material, the necessity for proper quality control will be apparent.

A comprehensive stress analysis, based on "finite element techniques" developed by Professor Argyris, has been carried out on the craft, together with an analysis of likely gust loads that will be imposed on the craft during in service operations, and the results indicate that an overall safety factor approaching 3 is likely to be achieved. (This analysis takes account of the maximum aerodynamic loads likely to be encountered.) These safety factors are considerably in excess of those required for current civil aircraft applications, and augur well for future development.

POWERING REQUIREMENTS FOR AIRSHIPS

As part of the current programme, a comprehensive examination of the powering requirement has been carried out. This programme, carried out under the supervision of Professor Young of Queen Mary College, has entailed a detailed evaluation of the boundary layer conditions obtaining around an airship of the size contemplated. There is an obvious advantage in using a power plant that has already been developed, even though the lower speed of advance of the airship when compared to conventional aircraft may reduce the efficiency of the unit. It is desirable to keep the number of power units to a minimum, in order to reduce the number and complexity of associated sub systems, and to ease problems concerned with cockpit control.

A summary of the powering requirements is given below.

<u>Hull Volume</u>	=	<u>50 million cubic feet</u>	
		<u>Speed (m. p. h.)</u>	<u>S. H. P.</u>
		40.	951.
		70.	4, 558.
		100.	12, 246.
		140.	33, 305.

<u>Hull Volume</u>	=	<u>100 million cubic feet</u>	
		<u>Speed (m. p. h.)</u>	<u>S. H. P.</u>
		40.	1, 433.
		70.	6, 906.
		100.	19, 265.
		140.	50, 230.

It can be readily appreciated that the powering disbenefit from increased speed is far larger than that imposed by increasing size. Since the economic cruise speed for the craft lies in the range 90 - 100 kts. it is possible to use existing power plants for the smaller craft. In the prototype programme two proteous engines, driving Hovercraft type (i. e. large blade area) prop sets will be adequate. The proteous, which will be of the marine type, has accumulated over 500,000 operative hours, has a high mean time between overhauls, and is already available shafted to a B. H. Y. type Hovercraft propellor. For the larger

5
1
ships it is possible to utilize a multiple (4 or 6) proteous arrangement, but it is rather more likely that an exhaust turbine, connected to a high by-pass fan unit such as the RB-211 would represent a more sensible approach. In the gas carrying application the craft would use a certain amount of gas to fuel the engines, and this further reduces the maintenance requirements.

It is not intended to install these engines in any type of vectoring mounting, this is usually a much more expensive exercise than most people imagine, and often entails major redesign of the power plant itself. As may be seen from the first illustration, the engine units are "podded", this is not an attempt to improve propellor efficiency, but rather an effort to reduce blade tip noise. In the prototype craft it will be possible to mount the engines above the wing section, and to use the wing to further improve the noise attenuation characteristics of the craft.

Because of the thickness of the fin root, it is possible to provide access to the engine pods in flight. It is unlikely, however, that licensing authorities would look kindly on anything other than emergency repairs being carried out whilst the craft is in flight. All electronic and mechanical interfaces have been designed to be as modular as possible, and any major servicing would be carried out on a replacement basis.

Attention has also been focussed on the decision to place the engines on the tail surfaces. It is pointed out (correctly) that this entails an increase in the loading on the tail surfaces. The weight penalty, at least for a gas-turbine engine is, however, small and the control surfaces have to be designed to absorb high aerodynamic forces anyway. In addition, placing the engines at the tail has the following major advantages:

1. The engines are installed well clear of the boundary layer, thus there is little boundary layer interaction, with consequent power savings.
2. When fully pitchable propellers are fitted, the transverse separation of the engines enables a high turning moment to be applied, even at very slow airspeeds, this is particularly useful when approaching or leaving the mast.
3. Because the power units are situated at the mid height of the elevators, rather than on the underside of the hull (common practice on many early airships) there is far less chance of the engine being driven through the hull and into the methane gas in the event of a grounding.

THE BUILDING FACILITY FOR THE CRAFT

One of the major cost areas in the development of this craft, will undoubtedly be the provision of a suitable facility within which the airship may be built. There are those who advocate building the airship in the open, using everything from a roofed over clay pit to a lake, or who suggest that by using turntables etc. a large airship may be constructed without any protection from the elements. This we have always regarded as fanciful. Although the prototype craft are sized to fit inside the facilities still in existence in the U.K., the full scale ships will require a shed some 2,000 feet in length by 400 feet high. Comparative studies of conventional and inflatable structures, which have been commissioned both in the U.S.A. and the U.K. have resulted in the decision to use an air stabilized structure, in which the prime loads are taken by a supporting steelwork and cable system, with inflation being used to stabilize the building against gust loads. A ground plan, showing the existing sheds at Cardington, England, together with the new "super shed"

superimposed upon them, is shown in Figure 3. The total cost of such a facility is estimated to be approximately \$40 million at present day prices.

GASSING AND DE-GASSING THE SHIP

The ship will almost certainly be gassed through a fairly conventional "Stub" type tubular mast. The gas, fed in through a central connection, is led to individual compartments by four "Box Keels" at 90° to each other within the ship. A "Top Hat" membrane system is used to keep air and gas separate within the craft. At the discharge terminal the gas is forced back through the box keels by purging the ship with a carrier gas. On the other side of the membrane, the gas is passed to ground storage for future distribution. Various systems for returning the craft to the gas field have been under consideration, and the version shown uses an internal helium annulus to provide sufficient buoyancy to lift the craft in the "light ship" condition, the excess buoyancy being counteracted by ballast being taken aboard.

THE PROTOTYPE PROGRAMME

It is regarded as being impossible to construct a full size craft without a comprehensive prototype programme. In addition to a large number of static rigs, a series of craft ranging from 2 million - 30 million cubic feet are intended to be built before work on the 100 million cubic feet ship can commence. These craft will be built using the same techniques and panel sizes intended for the fleet size ships, in order to optimize the assembly techniques and to provide feedback operational information. Because of this, these craft will not be as efficient in terms of their payload/total lift ratio as vessels built by alternative means, nevertheless, these craft still have enough lift to provide a useful payload and illustration 4 shows the 8 million cubic feet ship in an anti submarine role.

CONCLUSION

The work being carried out for Shell is part of an on going process. All being well it is hoped to complete the construction of a prototype craft by the beginning of 1979, and for a full size craft to be operational by 1984. This exercise is by no means a low key area of financial activity, precise costs are classified by Shell, and indeed are as yet not finalized in many areas. But a unit cost of \$60 million/ship may confidently be expected. It has been the purpose of this necessarily brief paper to emphasize the fact that at least one major industrial company has seen fit to initiate, and to continue to support, on a significant financial scale, a thorough investigation into the possibility of utilising Lighter Than Air craft on a major scale. It would perhaps be pertinent to add that due to obvious considerations of commercial confidentiality much of the information given has necessarily been of a superficial nature. Should more detailed information on the project be required, it is respectfully suggested that initial approaches should be made to Shell International Gas themselves.

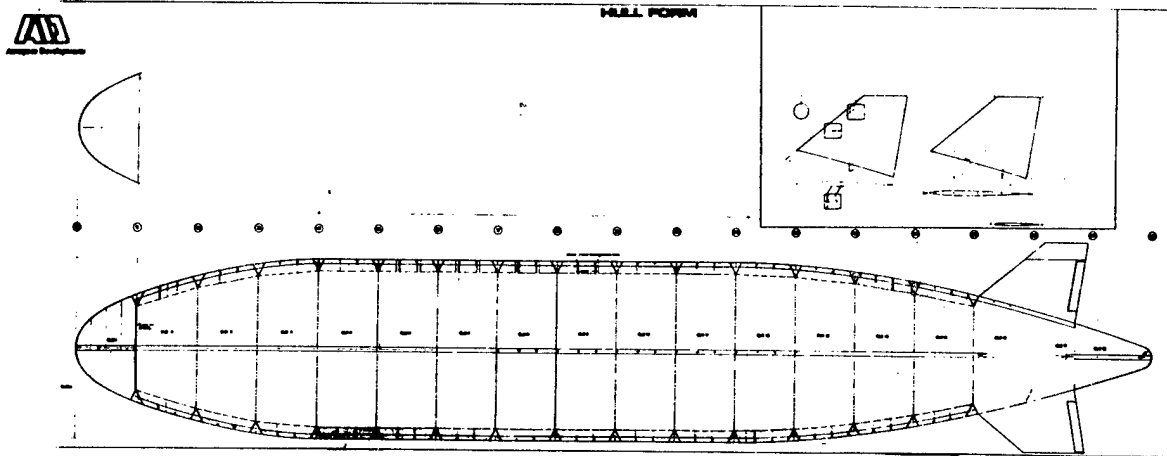

Figure 1

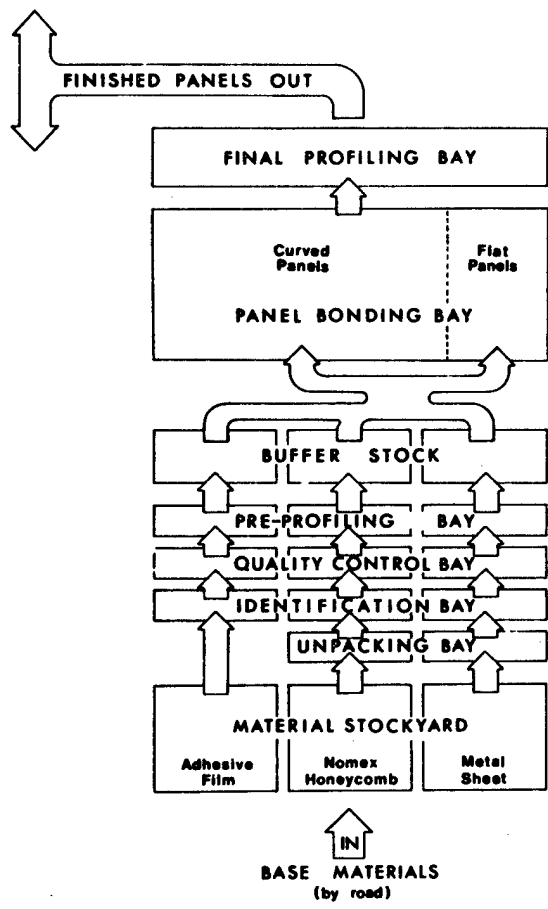

Figure 2

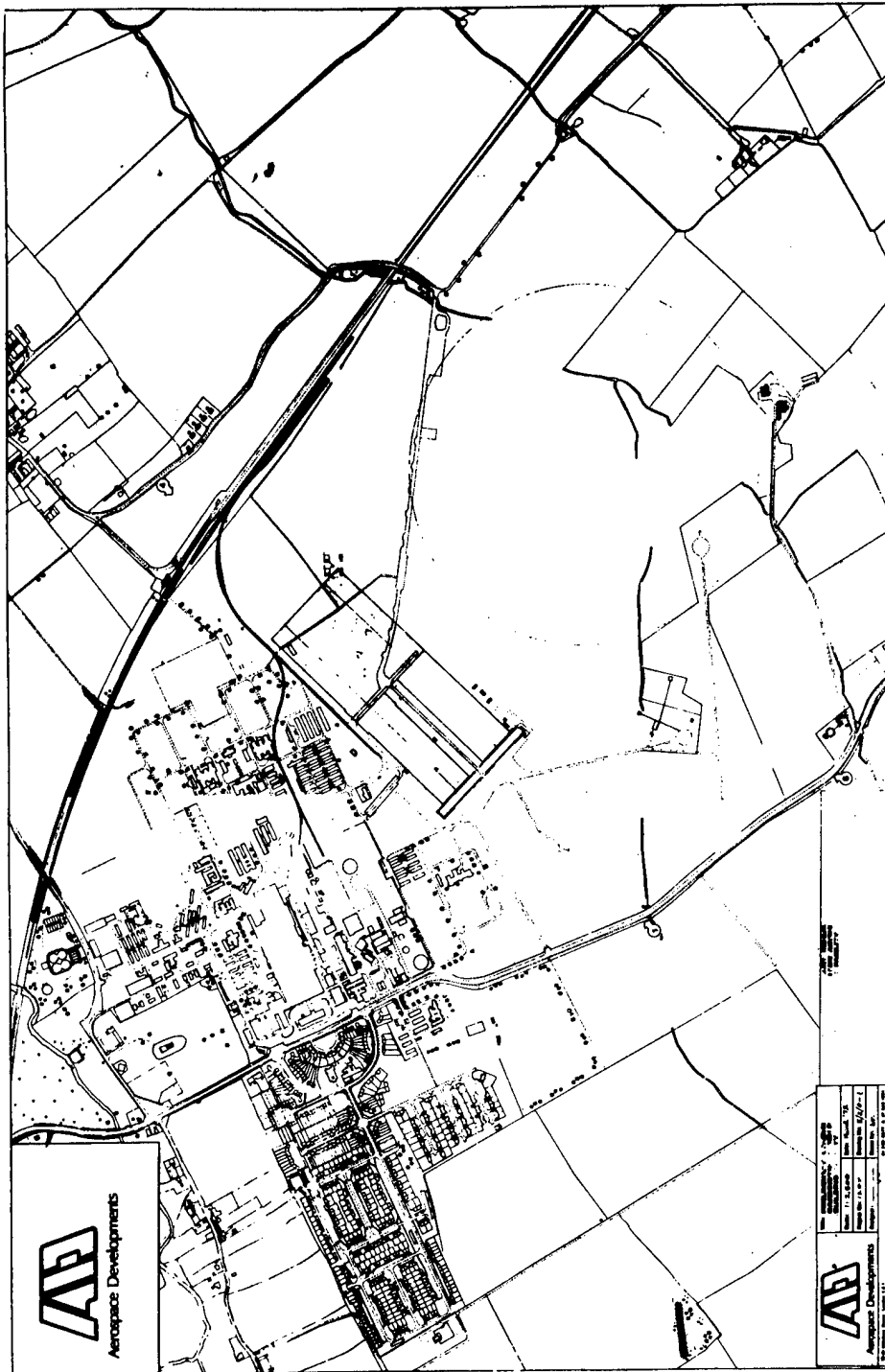

Figure 3

METHOD FOR TRANSPORTING
IMPELLENT GASES

Hermann Papst *

ABSTRACT: The described system DAL comprises a method and a device for transportation of buoyant impellent gases, without the need for expensive pipes and liquid tankers. The gas is self air-lifted from its source to a consignment point by means of voluminous, light, hollow bodies. Upon release of the gas at the consignment point, the bodies are filled with another cheap buoyant gas (steam or heated air) for the return trip to the source. In both directions substantial quantities of supplementary freight goods can be transported. Requirements and advantages are presented.

THE PROBLEM AND ITS SOLUTION CONCEPT

The Situation

More than 90 % of the presently known finds of natural gas can not yet be used economically as supplies of energy. Annually, billions of cubic meters of natural gas are being burned off at the heads of oil wells. Systematic exploitation and utilization of natural gas fields is by no means fully developed.

Conventional Transport Systems

Contrary to the situation that prevails in the case of transporting oil, pipelines and tankers are not economical for transporting natural gas and must therefore be seen as intermediate solutions. Investments

*President, Papst-Motoren KG, St. Georgen, Black Forest, W.-Germany

for both these modes are extraordinarily high. Even an interconnected system of tankers and pipelines is not flexible enough. Moreover the tanker mode requires refrigeration (-258°F) and loading and unloading while the gas is liquid. Liquefaction cost approximately \$ 8 per 1000 norm cubic meters (Nm³). Thus pipeline and tanker are not economically optimal solutions for the transportation of natural gas.

The Solution Principle

Reflections on a better solution of this problem center on a specific property of natural gas: it is lighter than air. Compared to the earth atmosphere, natural gas has a much lower specific weight which thus makes it possible to transport it through the air in large containers which are able to fly. At the place of delivery of the natural gas, these containers can be filled with another light gas that is cheaply and abundantly available there, in order to make the flight return to the natural gas source. Both steam and hot air are possibilities here.

Special Requirements and Possibilities for Realization

The weight of the containers plus power plant and thrusters, with the necessary accessories, must be less than the lift that is generated by a load of steam or hot air. A lightweight and heat insulated sandwich skin for the containers will be required to guarantee the necessary temperature stability for the steam or other gases. To supply the necessary heat to keep the temperature at prescribed levels, the heat of the engine exhausts is used. The steam or hot air is forced out by natural gas in the loading process. Mixing of the gases is prevented by moveable separating walls in the individual cells.

Comments

The most significant advantages of gas transport by "lighter than air ships" compared to pipelines have been indicated in an expert opinion from Professor Alfred Walz (Technical University of Berlin, Institute for Supersonic Flow). Also Mr. Miles Sonstegaard of the University of Arkansas has determined, for his system, that the transportation of liquid natural gas (LNG) in "lighter than air ships" is decisively more advantageous than fixed pipeline systems.

Patents and Acronym

Detailed construction considerations and calculations form the basis for patent applications in over 40 countries, some of which have already been granted. These patent applications cover construction and mode of operation of the DAL transport system, which requires no hanger or special landing facility. The acronym DAL represents the german conceptual description

"Dampf/Erdgas Austausch Lufttransporter"
(Steam/Natural Gas Exchange Cargo Airship)

In the following section, the concept described above is explained in greater detail via an example of typical airship of the kind mentioned before. The explanation indicates further advantageous construction features.

DESCRIPTION OF THE SYSTEM

Structure Characteristics

The natural gas air transport system DAL is designed around large, dynamically stable self propelled flying bodies. It is technically

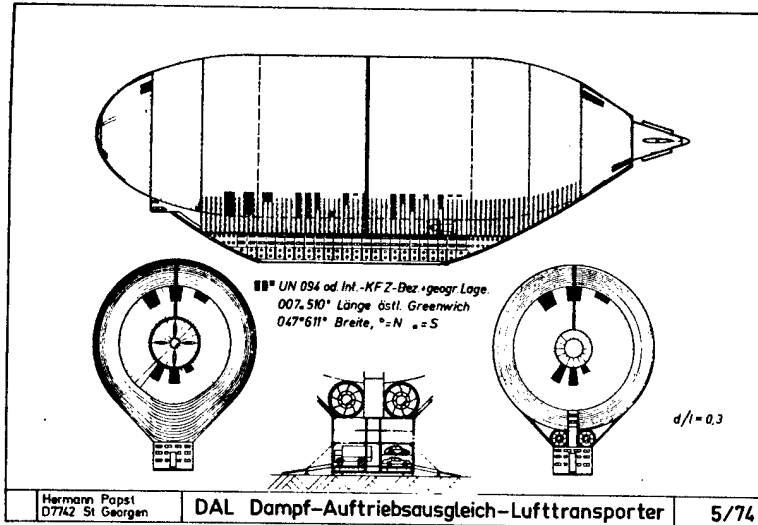

feasible, for example, to consider a ship of 364 m (1100 ft) length and 104 m (317 ft) diameter with a volume of 2,300,000 cubic meters (63,000,000 cubic feet) and which consists of a pressurized skin made of fiber-reinforced plastics. A rigid integrated cabin structure and keel, 130 meters long, 26 meters wide, and 18 meters high, is attached to the pressurized balloon via circumferential bands. The cabin houses the crew, passengers, freight containers, all equipment necessary for driving the vessel, and approximately 150 flexible tanks for ballast water or liquid freight (e. g. oil). In the interior of the airship, flexible bulkheads (dividing walls) are installed to allow separation of the total space into gas compartments of variable size. Figure 10/74 shows the distribution of different gases within the interior of the ship during a single transport journey.

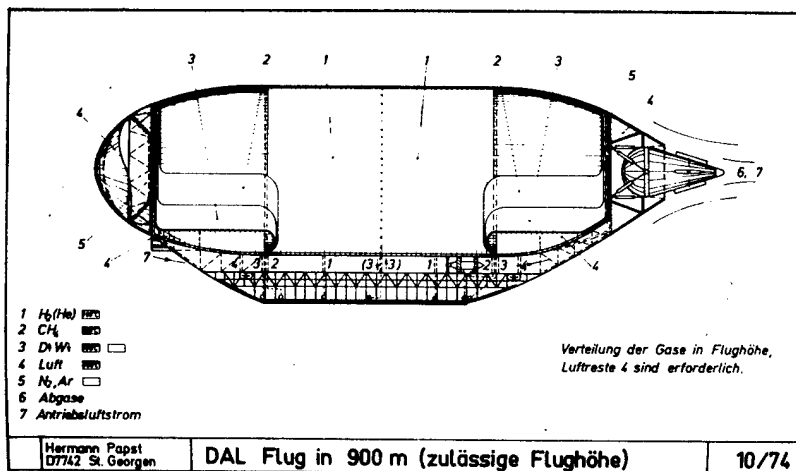

Technical Data

The average speed is planned to be 150 km/hour at 1000 m (3000 ft) altitude. The required power of the engine is assumed to be 8000 hp. The volume of natural gas that can be transported over the distance North-Slope New York (that is 5250 kilometers) for instance is about 2,1 million cubic meters of methane, assuming 90 % of full load and 4 % fuel consumption. The extra available cargo space when heating the methane to 100°C is about 1200 tons. The action radius with full load is only limited by economics. This means that circumnavigation of the earth without intermediate stops is feasible (possible). On the flight back to the source of the natural gas the payload with steam as buoyant gas is about 800 tons, with hot air of 100°C, 200 tons, and with preponderantly hydrogen buoyant gas at 100°C, 2000 tons.

Propulsion and Steering Mechanism

Motive power is produced by a thruster with a ring slot at the stern of the airship. Steering of the jet stream is performed by excentric regulation of the inner cone of the thruster. Thus an effective maneuvering capability at low air speeds and low noise levels is provided.

Double-Walled Skin

For this concept, the skin of the airship body is the decisive component. It must be light and strong, gas tight and heat insulating, aging resistant and weather resistant.

Weight and Strength - The skin must carry the aerodynamic loads during flight. The external pressure distribution on the flying body (fig.1/74)u shows, that significantly less strength is sufficient over the large surface area of the middle part.

The gas pressure P can be reduced to a quarter of the T stream pressure Q .

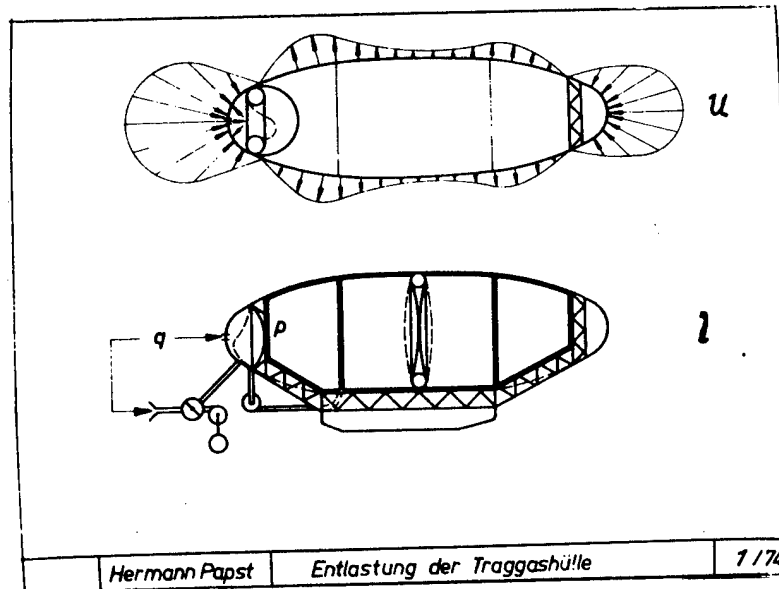

Use of small spherical cells of higher strength in the bow and stern, f.i. realized by means of the highly pressurized tube ring element

shown on the left in fig. U, drastically reduces the skin weight via such divisions of the total skin surface. Fig. I indicates alternative solution. Foil and polyester fabric are intended as skin materials for a maximum strength to weight ratio.

Temperature Insulation - This tensile fiber polyester fabric hull consists of two separate walls with a heat insulating protective gas maintained under pressure in between, thus making it temperature resistant to 100° C.

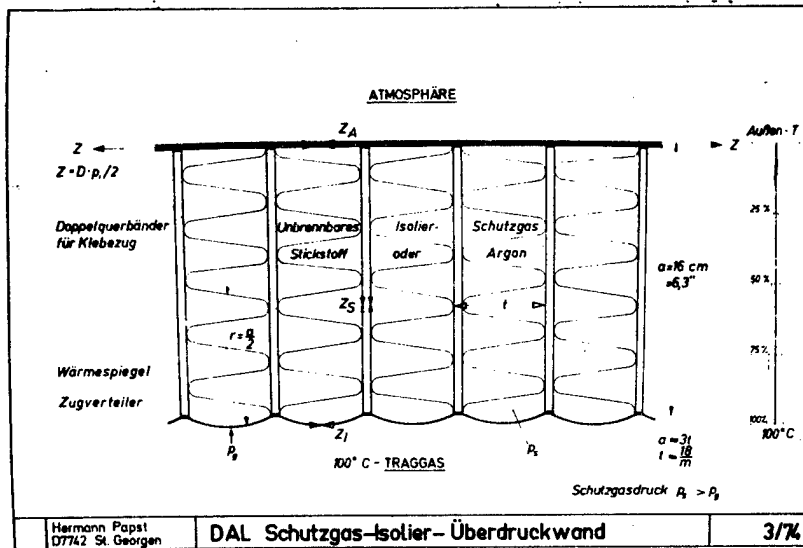

The double-walled skin is pumped full with nitrogen or argon and is maintained under a permanent pressure of approximately 20 Torr. For the wall, about 16 centimeters (6 inches) thick, there exists a heat-loss value of approximately 20 Kcal/m²h, i. e., approximately 240 Norm-m³/h of natural gas is required to cover the heat loss for the above-mentioned large flying body with 96,000 m² surface area. This is about 8,000 m³ or .4 % of the natural gas volume for a flight distance of 5,000 km and a cruising speed of 150 km/h. The heat of the exhaust gases of the motors can cover this heat loss with considerable reserve. The structure of the double walled skin is characterized by the arrangement of tensile loaded bands between the high strength exterior wall and the interior wall of the skin. Between these tensile bands, folded zig zag form aluminium vapor plated foil serves to substantially prevent heat radiation. The skin walls are completely covered inside as well as outside with aluminium foil, so that diffusion is prevented. The aluminium is, in turn, covered with a fluoride resin or similar water repellent material. The protective gas is completely dry. Also light has no effect on the skin material. Thus the greatest possible resistance to aging is provided. The skin covering is also immune to radiation, lightning, rain, and ice formation.

NATURAL GAS SHIPMENT

The medium that provides the lift for the vessel on the way to the natural gas source is either hot air or steam. Figure 12/74 shows the DAL filled with steam shortly before departure to the natural gas source.

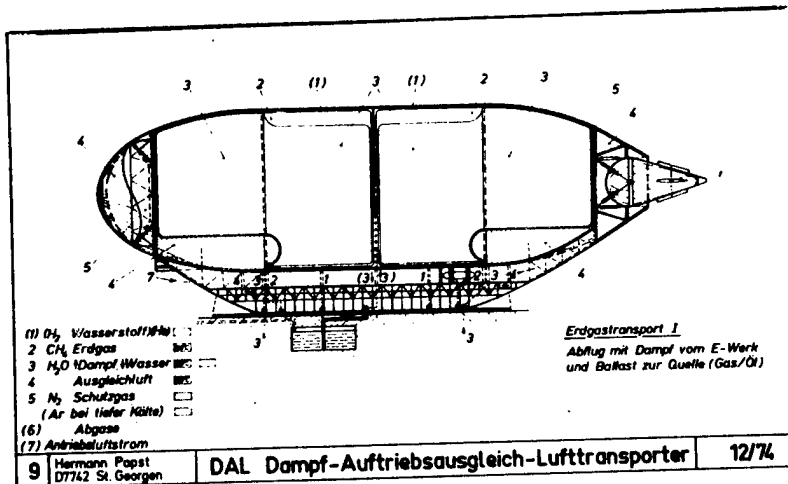

The problem of heat loss is solved technically via regulated additions of heat from the exhaust heat of the motors. The exhaust heat from the axial piston, natural-gas-driven motors keeps the lifting gas at 100°C via a closed steam circulation. Axial piston motors with novel swash-plate power plant are being developed by Papst-Motoren KG.

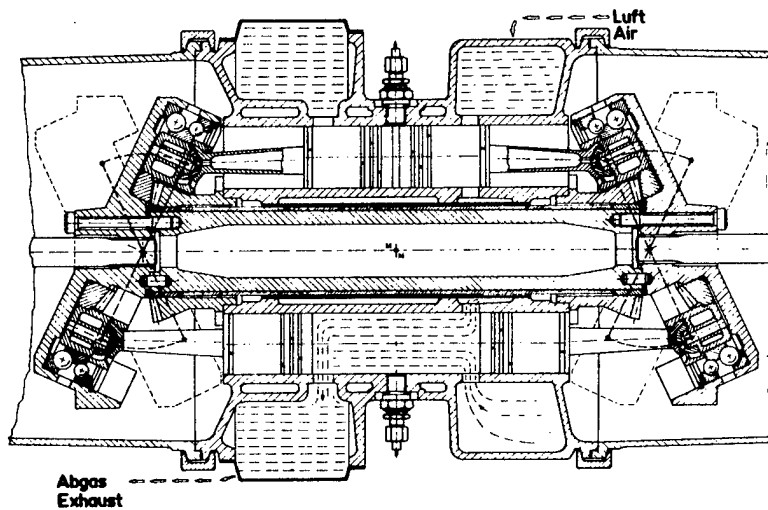

Because 400 tons of payload are attainable with warm air filling, it is possible to carry even the heaviest drilling rigs, together with the necessary equipment and personnel, directly into regions where oil and natural gas are found, even if they are difficult to reach by way of surface transportation (arctic lands, deserts, continental shelves, tundra, dunes).

Figure 13/74 indicates how steam or warm air is forced out by pumped-in natural gas at the gas source.

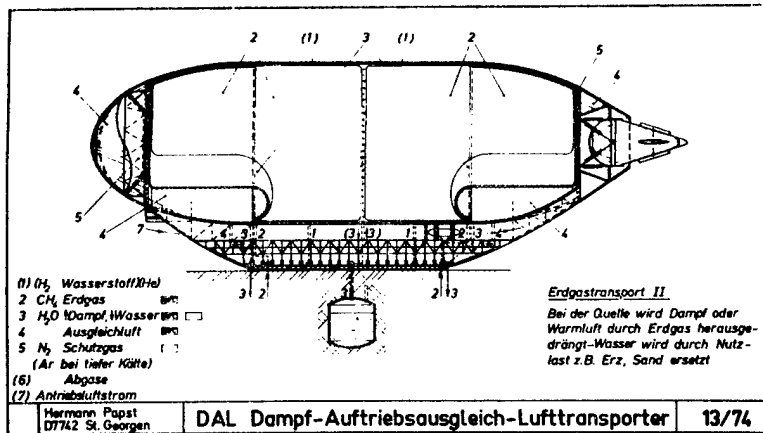

At this point nearly the entire body has been filled with natural gas. Only small leftover spaces are available for vapor and warm air to balance lift. This is the departure condition at the gas source. The total lift is 1683 tons, if a buoyant volume of 2,3 million cubic meters is assumed, divided as follows:

2 100 000 m³ natural gas
200 000 m³ balancing air

All gases are heated to 100°C. For an assumed unloaded weight of the airship of 570 tons including keel frame, skin, crew, passengers, supplies, and auxiliary ballast water, a lift of 1,100 tons is available for payload, e. g., LNG or oil. At departure from the natural gas source, the total lift is composed of:

1 613 tons natural gas
70 tons warm balancing air

After traveling the example distance of 5 250 km the natural gas component is reduced to 1565 tons. This equalized by a steam lifting component of 53 tons and a reduction of the air lifting component to 65 tons. The total departure lift of 1,683 tons is thus maintained.

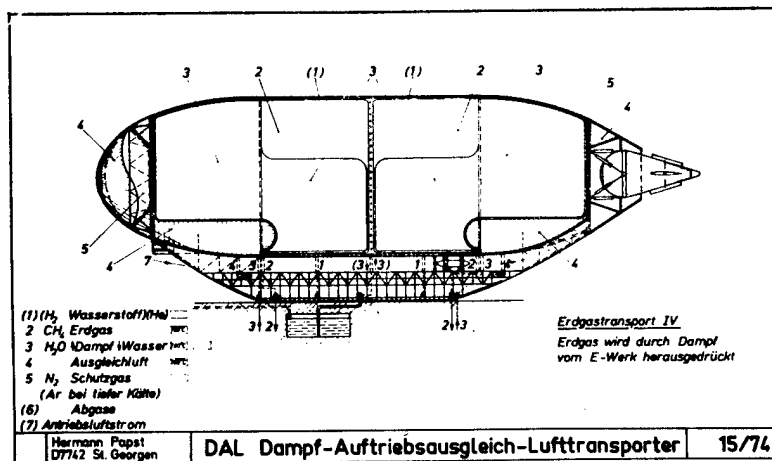

After arrival at the delivery destination, steam is pumped into the cells intended for it and the natural gas is thereby forced out. Steam is abundantly available as a byproduct at electric power plants. Thus the cycle is completed! Landing is achieved by setting the DAL against the wind, driving to maintain position, and descending. After landing, the ship is held on the ground via suction. The keel frame is kept airtight against the ground by an inflated tube skirt which encircles the bottom perimeter. Unevenness up to one meter can be equalized by this means. The landing surface can thus lie near the gas source. Small auxiliary suction pumps reduce the pressure under the tube-skirt structure to approximately 300 mm water-column, so that the DAL can also be held fixed in storms with winds up to 150 km/h.

SAFETY CONSIDERATIONS

The life expectancies of the double sheath covering made of highly impact-resistant fiber-reinforced polyester and other plastics as well as the foil gaskets and the aluminium-foil protective covering are very large indeed. The protective gas between the double sheath in the absence of oxygen, moisture or light guarantees maximum lifetime. The danger of ignition of the natural gas is largely controlled by the pressurization of the heat insulated double-sheath with a non flammable gas (e.g. nitrogen). After a puncturing of the exterior wall the protective gas escapes and the neighboring bands and the inner wall attach themselves automatically to the outer wall, thereby sealing the leak. The strength of the outer skin (about 40 000 kp/m) and the seams is eight times the normal load during flight at full speed. The entire double sheath covering remains filled with gas during operation. Arrangement, control and checking of the power plant are based on the fail-safe principle. Even loss of 50 % of the power allows full maneuverability of the ship. The DAL may remain afloat for months without the engines running. Liquid fuel is not needed/used, i.e. higher safety.

COST AND ECONOMIC FEASIBILITY

One natural gas transport vessel with a capacity of 2,3 million cubic meters (63 million cubic feet) of natural gas and 1,200 tons of oil can be built today for about \$ 20,000,000 if 50 units are to be manufactured. Cost of operation per year is estimated at \$ 1,300,000. On 100 round trips, covering a distance of 5 250 km (3,260 miles) each, a heat equivalent of about 280,000 tons of oil can be transported. Comparing the cost of transportation by air shipment and by pipeline, you find at presumed 68 billions of cubic meter per year and a distance of 5,250 km a demand of 237 DALs. An investment of \$ 20,000,000 per DAL means 7 cent per cubic meter transport capacity; out of which result about 0,7 cent per cubic meter gas as transport costs. These conditions will by far not be reached with the pipeline mode. The costs of transporting for one barrel of gasoline would amount to \$ 1,6. These cost figures could be reduced by hauling additional freight or passengers. About 1 % of the transported volume are used up for propulsion and buoyancy per 1 000 kms.

For loading and unloading freight, the bottom of the cabin of the DAL contains special containers for water, capable of holding up to 2,420 tons. Water is pumped out while freight is taken on and the reverse takes place when freight is unloaded. For an exchange of 110 tons of

load the pumping costs amount to approximately 50 cents.
Loading and unloading would usually be done by this gradual process

The annual revenue from goods transported by one DAL of 364 m length and 104 m diameter, assuming a 70% utilization of freight capacity and 70% utilization in time, is illustrated in the following table:

Lift generated by	Net cargo capacity	\$ Million
Steam	880 t	9.6
Natural Gas	1100 t	11.55
Hydrogen	2200 t	23.10

For 50 round trips over a Distance of 6,215 miles each, this corresponds to an annual mileage of 621,500 miles. (Base 3 cts/ton.mile)

SUMMARY

Compared to pipeline or pipeline ship - pipeline systems of transporting natural gas, the proposed natural gas air transport system DAL shows the following advantages:

Independence from geographic and climatic hazards. One means of transportation only for both land and sea routes, door-to-door transportation even over great distances.

Independence from locally changing political situations. Quick shifting to alternative sources maximum of flexibility.

Lower investments of reduced risk.

The possibility of large-scale coordination of supplying even remote natural gas sources. Thus additional optimization and rationalization is feasible.

Lower cost for transporting natural gas via freight and passenger revenue.

Even small finds will be economically attractive.

CONCLUSION

The DAL-Airship-System in principle can be used:

for transportation of high volume and heavy goods

in aero-crane applications

for passenger transportation purposes with maximum comfort.

for transporting impellent gases and thus puts a big question mark over natural-gas-pipeline systems.

THE DESIGN AND CONSTRUCTION OF THE
CAD - 1 AIRSHIP

H. J. Kleiner*
R. Schneider**
Dr. J. L. Duncan***

ABSTRACT: This paper will deal with the background history, design philosophy and Computer application as related to the design of the envelope shape, stress calculations and flight trajectories of the CAD-1 airship, now under construction by Canadian Airship Development Corporation.

It will also outline a three-phase proposal for future development of larger cargo carrying airships.

INTRODUCTION

McMaster University's interest in airship technology and development extends back to September 1972, when three senior mechanical engineering students began a feasibility study to determine the possible use of airships to help expand Canada's northern frontiers. The three students, H. J. Kleiner, E. G. Smith, and J. Douglas, with the aid of their supervisors, Dr. J. L. Duncan, Prof. W. R. Newcombe and Dr. J. H. T. Wade, produced a four volume report. This work received fairly extensive publicity and eventually drew the attention of Mr. R. Schneider, President of Hoverjet Inc., to the abilities of McMaster University's Mechanical Engineering Department in this area.

* McMaster University, Hamilton, Ontario

** President, Canadian Airship Development Corporation, Thornhill, Ontario

*** Professor, McMaster University, Hamilton, Ontario

Mr. Schneider had done extensive research and studies in the field of airships since 1968, and felt that it would be possible to design and construct airships in Canada.

By the time of the first meeting between Mr. Schneider and the McMaster Group, only Mr. Kleiner, who had started work on his M.Eng. degree, and the three supervisors remained.

During the first meeting between these two groups in early February 1973, it was decided that the McMaster group would provide the engineering required to set-up the specifications for the preliminary design of a "minimum Airship" of the non-rigid type, and Mr. Schneider and his team would arrange for financing that would allow the construction of this airship at Hoverjet Inc.

Three basic objectives were envisaged as being achieved by this course of action:

- (i) Commercial employment in the role of a research platform, aerial filming, and TV work, survey and S.A.R. work and aerial advertising.
- (ii) Training of Air and Ground crews for future larger airships.
- (iii) Provide a basis for developing Canadian design and Manufacturing skills and capabilities for larger airship projects.

To encompass the various and widely scattered groups and individuals who had expressed their willingness to provide their knowledge and services to the project, a non-profit interest group known as the Canadian Airship Study Group was formed and Mr. Schneider appointed as Co-ordinator.

By June 1973, initial financing was secured and the bulk of the design work was completed, allowing a construction start to be made in the Fall of 1973.

The airship design that emerged has no novel or radical design features, but follows established design and construction principles for pressure airships. From the design point of view, it is intended primarily to gain experience and competence in the various aspects of airship design.

The airship is 120 ft. long, with a 40 ft. maximum diameter, powered by two CONTINENTAL O - 200 aircraft engines of 100 hp each and a cruising range of 300 miles. Payload capacity of 1575 lbs. which will enable a flight crew of two and four passengers, or an equivalent cargo load to be carried.

Although the design follows conventional and established practices, advanced methods of design analysis have been employed. In addition, techniques of envelope manufacture and the materials used will embody recent developments in synthetic fibres, weaving, coating and joining methods.

As the construction of the (then) CAS - 1 progressed, it was felt that a company should be incorporated to take over from CASG and Hoverjet Inc., and oversee the construction of the present airship and lay the framework for future airship designs. Thus, early in 1974, the Canadian Airship Development Corporation was incorporated to take the functions of the CASG. The airship was re-designated as CAD-1.

This paper will describe the analysis which led to the design specifications of the CAD-1, the techniques employed in the computer aided analysis of the flight performance and loads, and the economic assessment of the present airship. Further work to be done by C.A.D.C. will also be reviewed.

DESIGN PHILOSOPHY

The preliminary studies performed were based on computer outputs which, for various fineness ratios, allowed evaluation of such parameters as:

- (i) Weights and displacement (Fig. 1)
- (ii) Power and velocity for constant shape (Fig. 2)
- (iii) Power and displacement (Fig. 3)
- (iv) Power and shape for a constant velocity
- (v) Displacement and control surface areas

Initial evaluation of these parameters and the performance specifications which had been set, led to the selection of a shape with a fineness ratio of $F = 2.25$ and a volume of 70,000 cu. ft.

The shape chosen was developed from a polynomial expression originated by General Mills (*4) which allows the generation of an infinite number of shapes. The final body shape can then be chosen on a performance and aesthetic basis. The expression used for the body shape was:

$$y = \frac{[n+m]^{n+m}}{2 f n^n m^m} \cdot \frac{x^n}{L^{n+m-1}} (L-x)^m$$

where: n and m are parameters which may be altered to produce varying shapes,

f is the fineness ratio desired,

L is the overall airship length in feet,

x is the distance from the bow in feet.

The versatility of this expression is illustrated by 2.1 and 2.2 which show the relationship between the shapes generated and several known shapes.

The very low fineness ratio caused considerable worry as to possible stability problems. In order to ascertain the degree of stability of the design, a computer program was developed to calculate the pressure distribution over any airship body in both level flight and flight at varying angles of attack. The only inputs required are data relating to velocity, angle of attack and body shape. This program was derived from, and is an extension of Theodor von Karman (*1) on airship pressure distributions. The type of output produced by the programmer is shown by Fig. 3.1, the pressure distribution for the CAD-1 shape in level flight. As a result of this investigation, the fineness ratio was increased to 3.00, while at the same time the volume was raised to 90,000 cu.ft., in order to offset the weight escalation by this change and other developments. Figures 3.2 and 3.3 show the initial and final shapes that were decided upon.

It was originally intended to power CAS-1 by means of two 2-stroke inboard engines driving swivelling, ducted fans. Although this was a very light and simple arrangement, the Canadian Ministry of Transport (M.O.T.) requirements for licensing the craft and the lack of funds for a large scale certification program led to the temporary abandonment of this vectoring power system. In its place, two light aircraft engines of sufficient power, mounted in a conventional configuration, are used. This caused a substantial increase in weight.

At the same time, several discussions took place as to the Gondola (Car) design. Based on manufacturing facilities and skilled labour available, the decision was made to use a welded tubular steel structure over a fabricated aluminum structure, which, in turn, caused a further increase in weight.

The gondola load structure consists of lightweight 4130 chrome-moly aircraft tubing in a conventional design arrangement. However, it was decided that the gondola design and strength was to be sufficient to provide for the possibility of future development of various propulsive methods, such as the one previously mentioned, and also allow for the testing of other systems. In addition, the use of the airship for training purposes suggested a rugged structure as the possibility of heavier than normal impact on the main wheel, which must be absorbed by the gondola structure, was high.

All these considerations made the volume increase mandatory in order to maintain the initial specified payload and performance specifications. The engineering required to design the gondola was provided by the McMaster group while the actual application engineering and construction was carried out by a group at Hoverjet under the supervision of Mr. Schneider. The primary gondola structure is illustrated in various stages of construction in Figures 4.1 and 4.2.

FLIGHT TRAJECTORY CALCULATIONS

The question of how an airship will behave when required to perform certain manoeuvres has always been one of the uncertainties of airship design. Wind tunnel experiments and model studies have been inconclusive (*5).

During the period of quantity construction of airships, designers based their decisions upon empirical data that had been gathered from previous designs. However, recent airworthiness regulations require that the forces acting during various manoeuvres be calculated and taken into account at the structural design stage. The calculations involved in this task would be very tedious and time consuming if done by hand; the problem is tractable, however, using the high speed digital computer.

The requirements that must be met are given in the "Ministry of Transport, Civil Aeronautics, Provisional Airworthiness Requirements, Airships" subpart C, Structure, sections SC. 4 (a) through SC. 4 (e) (*3).

"Manoeuvring Load Conditions.

The airship structure shall be designed to withstand the limit loads resulting from the following manoeuvring conditions, conducted at airspeed of V_D , critical statically-heavy weight, and at the centre-of-gravity location critical for each manoeuvre:

- (a) In level flight, application of full rudder, applied at the maximum control rate attainable, until a heading of 75° off the original heading is attained, followed by immediate application of full opposite rudder, applied at the maximum control rate attainable to original heading. The effects of overcontrol shall be taken into account.
- (b) In level flight, maintain a steady-state turn with rudder fully deflected in the direction of turn.
- (c) The manoeuvres of SC. 1(a) through SC. 1(b) combined with full-up elevator, applied at the maximum control rate attainable, and alternatively, with full-down elevator, similarly applied.
- (d) In level flight, apply full-down elevator at maximum control rate attainable until the specified maximum rate of descent is obtained followed immediately by full-up elevator at maximum control rate until rate of descent equals zero. The effects of overcontrol shall be taken into account.
- (e) The manoeuvres of SC.4(d) combined with alternatively a left and right steady-state turn."

The theory needed to provide the trajectories dictated by these manoeuvres was examined and a user-oriented computer package which has been developed will be described.

This work constituted a major part of Mr. Kleiner's M.Eng. thesis (*2).

Once the required trajectories have been achieved the resulting loads on the airship are calculated by the programme. The theory used in developing the programme was based mainly on empirical equations. The programme does not simulate the exact conditions that prevail in the airship. To simplify matters, the ballonets were considered to be fully deflated at all times. Thus, center of gravity shifts, due to various degrees of inflation, were neglected as were axial shifts of the center of gravity due to the fore-and-aft of the air in the ballonets. The results achieved by the programme are illustrated by Figures 5.1 through 5.5. Only a portion of the manoeuvres required are illustrated here, however, the results achieved are readily apparent.

The manoeuvres presented are:

- (1) Fig. 5.1 Graphical illustration of the programme output-take-off trajectory.
- (2) Fig. 5.2 Graphical illustration of the programme output-full rudder until a 75° turn has been achieved.
- (3) Fig. 5.3 Graphical illustration of the programme output-full opposite rudder until the original heading regained.
- (4) Fig. 5.4 Graphical illustration of the programme output-full up elevators and a steady state turn from 0 - 180 degrees.
- (5) Fig. 5.5 Graphical illustration of the programme output-full down elevators until maximum descend rate achieved and then full up elevators until descend rate equals zero.

It is also hoped that these results will provide a basis on which to check the output of the work presently being carried out by Mr. H. Sharpe of the University of Toronto Aerospace Institute for CAD/C, on modern stability analysis and control systems evaluation for airships.

The computer design package previously mentioned is very simple to operate and requires only that the designer input the physical characteristics of the design. The trajectories and the loads incurred will be the resultant output. This package has been tested for several designs and has performed satisfactorily.

ENVELOPE MATERIAL

The selection of the envelope material presented several interesting alternatives. Initially, it was hoped that the envelope could be built of metal, a la ZMC-2, or perhaps a plastic-foam laminate.

Whatever the advantages of these materials, one major obstacle prevented their use, cost. The term "cost" includes both the large amount of engineering time required as well as the actual costs of material and construction. The use of the more established airship envelope material as used on the Goodyear airships was felt to be a last resort as cost and weight were felt to be much too high. Also, construction of an envelope of this type and material required skilled labour, not presently available. Hence, after surveying the alternative materials available, a decision was made in favour of the new Dupont "Kevlar-29" fibre. The material is woven in a "Trigon" (triaxial) fabric, polyurethane coated and UV retardant added in the process. Material weight is 8.5 oz. per square yard.

Induction sealing of all envelope seams will replace conventional sewing. Seams are taped inside and outside. This process provides a major saving in labour.

So far, no major obstacles have been encountered, neither in the engineering or construction of the airship. Work progresses very well with the construction of the envelope and control surfaces as the next step.

FUTURE PROGRAM

Based on the work so far, a future development program has been worked out between McMaster University and Canadian Airship Development Corporation and submitted to the Canadian Government and potential future users of large cargo carrying Airships.

PROPOSAL

This proposal has been prepared in the anticipation that the LTA vehicle technology so far developed will be recognized as a sound contribution to a method of Cargo Transportation capable of servicing the northern areas of Canada.

A consortium of interests is proposed so that the contributions of expertise in the technical, operational and economic areas can be included in the overall project development besides providing some financial support for the project.

In view of the developments in LTA vehicle technology in the USA and Europe, it is considered that Canada does have both the potential and technical capability to develop its own LTA vehicles especially for areas where there are a wide range of natural resources and climatic and terrain conditions which make normal modes of transportation extremely difficult.

DEVELOPMENT PROGRAM

Since the formation of CADC work has started on what could be a three phase program; the program will start with the current small scale activities and move toward the larger scale, potentially economic vehicles and actual freight operations. The program will be directed at developing the technological expertise to design and build airships which are not only reliable but efficient (in their design) and at the same time provide real data on operations from which better operating forecasts can be made.

The program has three identifiable phases:

- (1) The first can be planned and costed in detail immediately.
- (2) Financial requirements for the second phase can only be determined by the work done in the first phase, although an approximate estimate has been prepared.
- (3) No attempt is made to determine the cost of the third phase, but the general objectives and some of the possible means are stated.

Before detailing the three phases, an outline is given of the groups who might be interested in forming a consortium to develop LTA vehicle technology and then establish an operating organization as a transportation function in Canada.

ECONOMICS

The economics using Lighter Than Air transportation vehicles has not been developed as there is no reliable history on which to base manufacturing and operating costs.

There are, however, some interesting comparisons on the costs of:

- (a) very large aircargo aircraft, and
- (b) the costs of LTA vehicles.

In the case of (a), the initial manufacturing costs are extremely high. Under normal operating conditions large airstrips, navigation systems, refuelling facilities and maintenance support must be provided. There is sufficient data available to at least estimate costs per mile in the aircraft mode of cargo movement.

In the case of (b), the manufacturing costs are much less, and will not require the complicated design inherent in aircraft. LTA vehicles will not require the extensive runways with their continual maintenance expense, will operate with a less sophisticated navigation system and the turn around maintenance will be much less. It is also anticipated that development into full service would be accelerated through LTA vehicles.

Comparison of fuel and other secondary costs would also appear to be in favour of the LTA vehicles.

It is recognized that the speed difference between the two vehicles is a big factor but against this could be considered the possibility of intermediate staging posts which could readily be established for LTA Cargo Carriers.

The economics of the LTA operations would be part of the consortium study.

THE CONSORTIUM

The eventual scale of the venture, and its inherent risks are such that the total program should involve a consortium of interests. For the sake of brevity in this proposal, these are identified in the following manner.

Government Agencies

It is suggested that the Department of Industry, Trade and Commerce would invite the appropriate Branches in other relevant Departments such as the Ministry of Transport, the Ministry of Indian and Northern Affairs and the Ministry of State for Science and Technology to evaluate their interests in supporting the project. The Science Council and the National Research Council should also be invited to participate in discussions.

Discussions have already been held with the Canadian Transport Commission and the Transport Development Agency who have encouraged continuation of the project since it was first introduced to them.

Carriers

The two principal Canadian carriers with extensive transportation experience, Canadian National and Canadian Pacific Railways, would be invited to contribute their own proposals for the operation and economic assessments of airships related to transportation demands in areas of Canada not serviced by their own systems. Additional freight carriers both surface and air, specializing in northern transportation could also be invited to contribute in long range planning, i.e. Air Canada, C.P. Air, Nordair, Transair, Wardair.

Aircraft Manufacturers

Such companies as DeHavilland, Canadair & Douglas could be involved in the future design and fabrication of the airship and companies like CAE, Aviation Electric interested in the flight instrumentation and controls.

Constructors

The Canadian Airship Development Corporation (CADC) has designed and is constructing an airship - CAD-1 which is 120 feet long to carry a payload of 1,500 lbs. and be operational by the Spring of 1975.

The CAD-1 would be used for initial training and operations and is committed by CADC for their own evaluations. A second model using the same design and configuration could be built and be operating by the Summer of 1975 for use by the consortium.

It is inevitable that other developments for larger airships with carrying capacities of 300 - 500 tons will require other aircraft manufacturers to be part of the consortium for engineering, design and construction of the larger airships.

The Centre for Applied Research and Engineering Design, Incorporated (CARED) at McMaster University would provide the project management and administration to coordinate the activities of the Consortium in Phase I and prepare the estimates for Phase II at a negotiated contract cost.

THE PROJECT

Phase I

This Phase can be conveniently divided into three sections:

Operating and Training

The purpose is to obtain experience with a small, pressure type airship (blemp) operating in various areas of Canada. A nucleus of both ground and air crews would be developed which would be sufficient size to man operations in the next phase of the program. The airship would be of the CAD-1 type:

120 ft. long, 1,500 lbs. payload

The first airship of this type will be ready for operations early in 1975, however, it is fully committed in another area under an existing operating contract with the Canadian Airship Development Corporation. It is suggested that a second airship of this type be constructed and purchased as part of this project and this could probably be available by the Summer of 1975. This would then be operated for a period of 18 months in this phase of the program.

Application Assessment

Investigations of the applications, economic assessments and feasibility of transportation development for a larger airship to be constructed in Phase II would be carried out jointly by the government and the consortium. The developed data would be continuously fed into the third activity in Phase I.

Engineering Design

A detailed design and cost estimate would be produced for an airship to be constructed in Phase II. This would still be a pressurized type of about 300 ft. overall length with a payload of 15 to 20 tons. For convenience, this type would be called CAD-2. The design activity for CAD-2 will be headed by Canadian Airship Development Corporation (CADC). The objective will be to complete the design by the end of 1975, so that Phase I can be completed by the middle of 1976 with detailed plans, targets and cost estimates prepared for Phase II.

An estimate of costs in Phase I is as follows:

Purchase of CAD-1 type airship	\$ 600,000.
Cost of operating and crew training for 18 months	300,000.
Applications investigation and transport systems evaluation	80,000.
Design of CAD-2 and associated research projects	160,000.
Project administration costs	<u>96,000.</u>
TOTAL PROJECTED COST:	<u>\$ 1,236,000.</u>

Phase II

The detailed program would be proposed as the result of the experience gained in Phase I. However, it is intended that operating tests and training with the CAD-1 type airship would continue while the large CAD-2 type was being constructed.

This Phase would include the operating of the larger airship (CAD-2) with some time spent on scheduled freight movements. It is unlikely this airship would be an economic carrier except in exceptional circumstances, but it would enable realistic operational trials to be made which could influence the economics in the next Phase of the program.

No detailed estimate of the cost of Phase II is attempted, although, the CAD-2 airship would probably cost approximately \$3 million and the overall cost of Phase II would be about \$5 million. The CAD-2 airship should be operating by the end of 1976 and Phase II concluded at the end of 1977.

The design team would continue during Phase II on the preliminary design of an economically feasible commercial vehicle.

Phase III

The objective in Phase III will be to complete the detail design and to construct a prototype of an economical commercial carrier based on the experience and data obtained in Phases I and II.

The configuration and method of manufacture cannot be determined at the present time, although it seems likely that this would have a payload of about 300 to 500 tons. (It will be observed that in each successive type of airship in the program, the payload increases by a multiplication factor of between 10 and 20, and this is thought to be the maximum jump which is reasonable to make).

The eventual prototype could be a metal-skinned airship, but it is anticipated that many of the features in the vehicle itself and in ground handling and operating will have evolved naturally (as is normal in sound engineering projects) from what has been developed in the earlier Phases.

REFERENCES:

- (*1) Von Karman, T., "Calculation of Pressure Distribution on Airship Hulls", NACA Technical Memorandum No. 574, (1927).
- (*2) Kleiner, H.J., "Aspects of Airship Design", M. Eng. Thesis, McMaster University, (1974).
- (*3) Ministry of Transport, Civil Aeronautics, Provisional Airworthiness Requirements, Airships.
- (*4) Anderson, A.A., Erickson, M.L., Frochlich, H.E., Henjum, H.E., Schwoebel, R.L., Stone, V.H., Torgeson, W.L., "Lighter-than-Air Concepts Study", Final Report Nonr 1589 (07), General Mills, Inc., Minneapolis, Minnesota (1960).
- (*5) Hecks, K., "Pressure Airships: a review", Aeronautical Journal, November (1972), pp. 647-656.

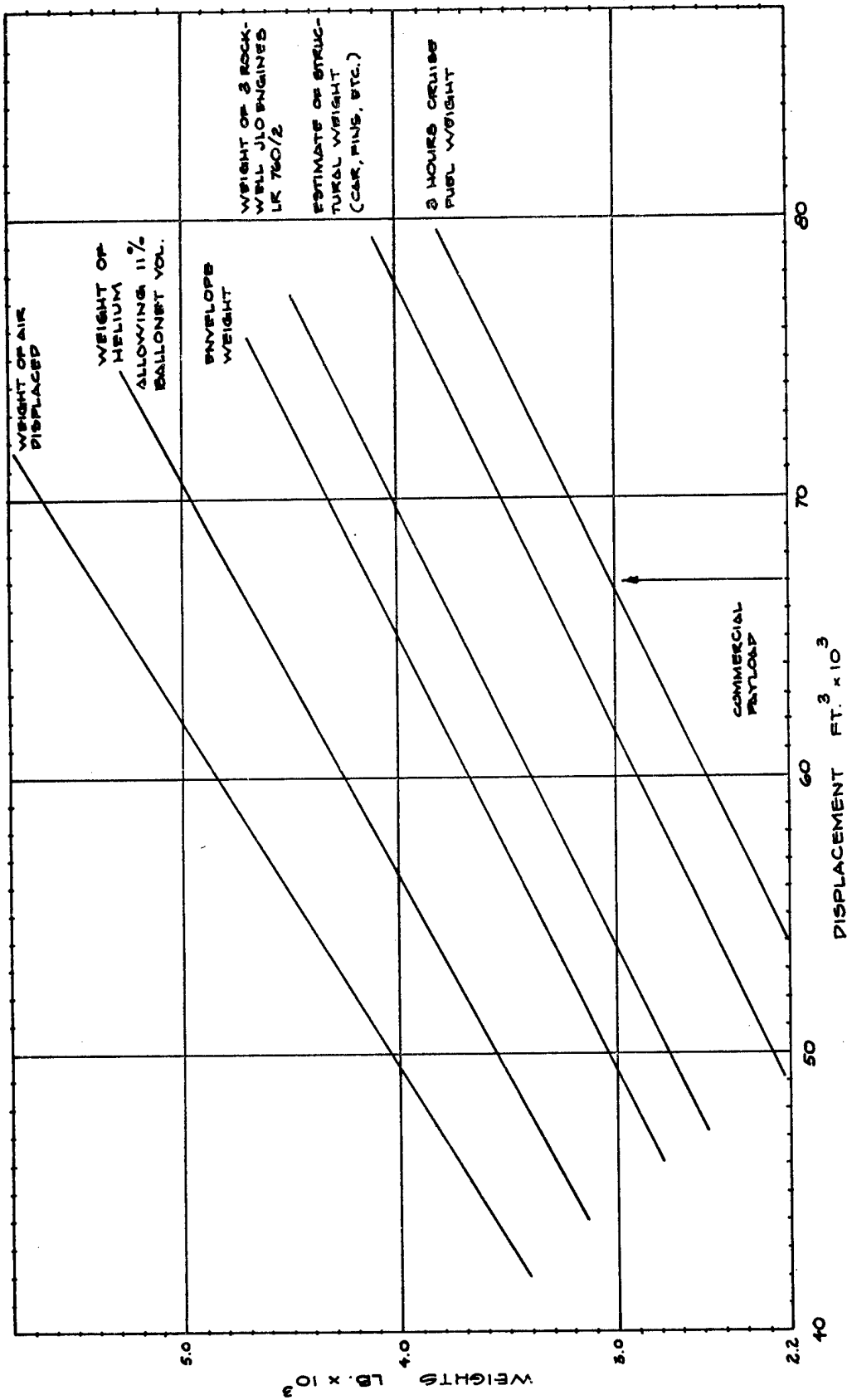

FIG. 1 WEIGHT v. DISPLACEMENT
 F = 2.50 V = 60 MPH
 N = 0.2 M = 0.6

REPRODUCIBILITY OF THE ORIGINAL PAGE IS POOR

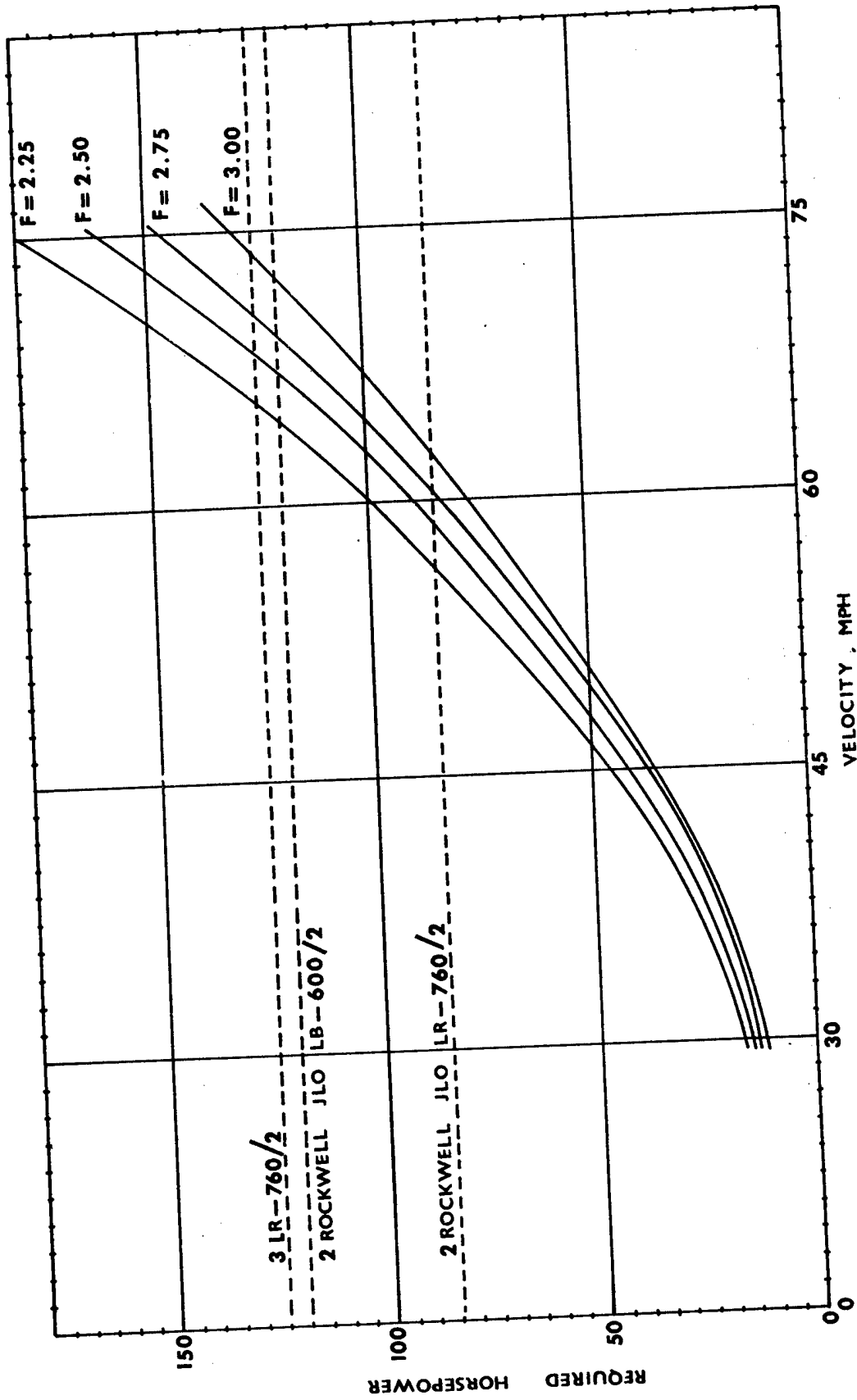

FIG. 2 REQUIRED ENGINE HP V. MAXIMUM VELOCITY
 VOLUME = 70,000 CUBIC FEET
 N=0.2 M=0.6

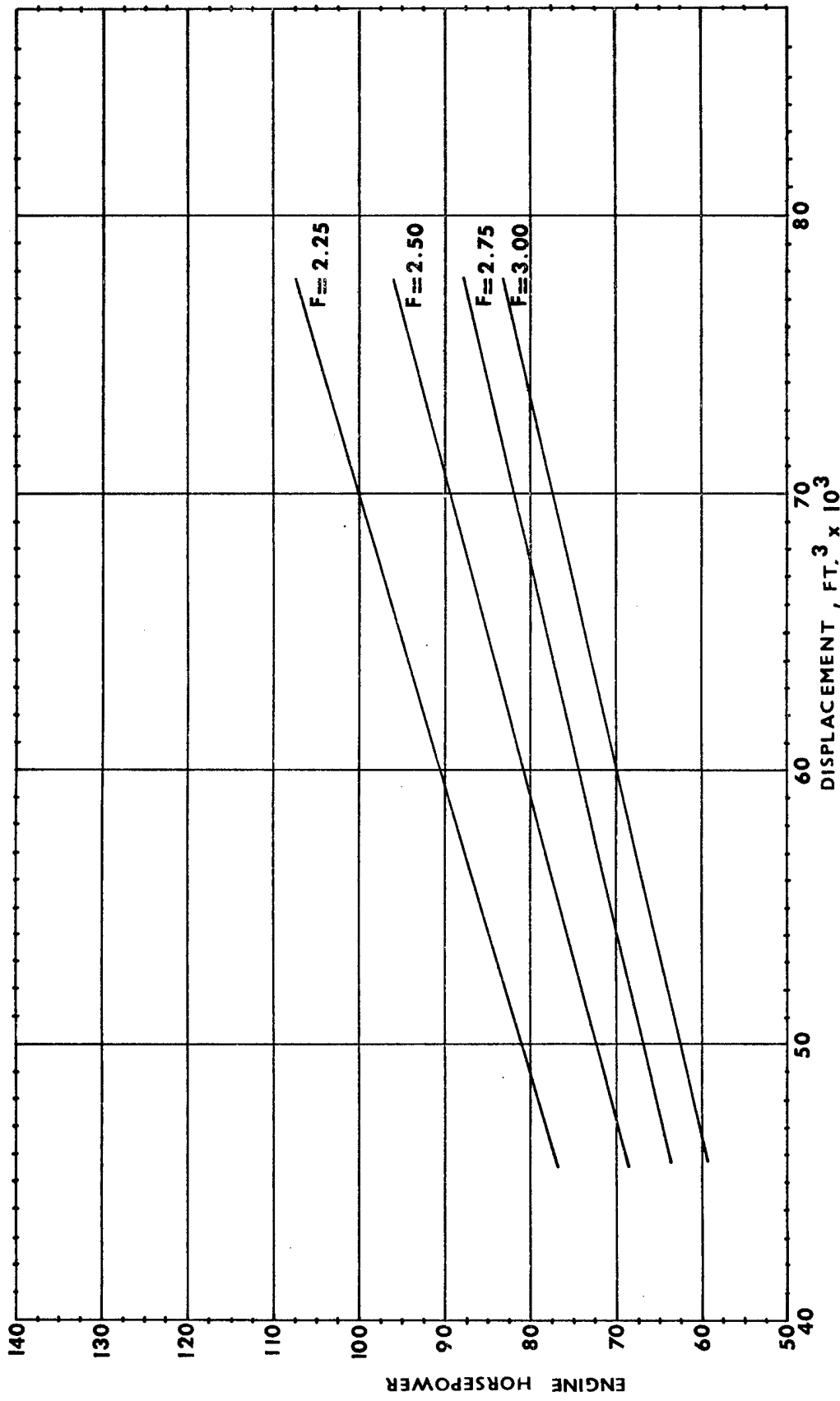
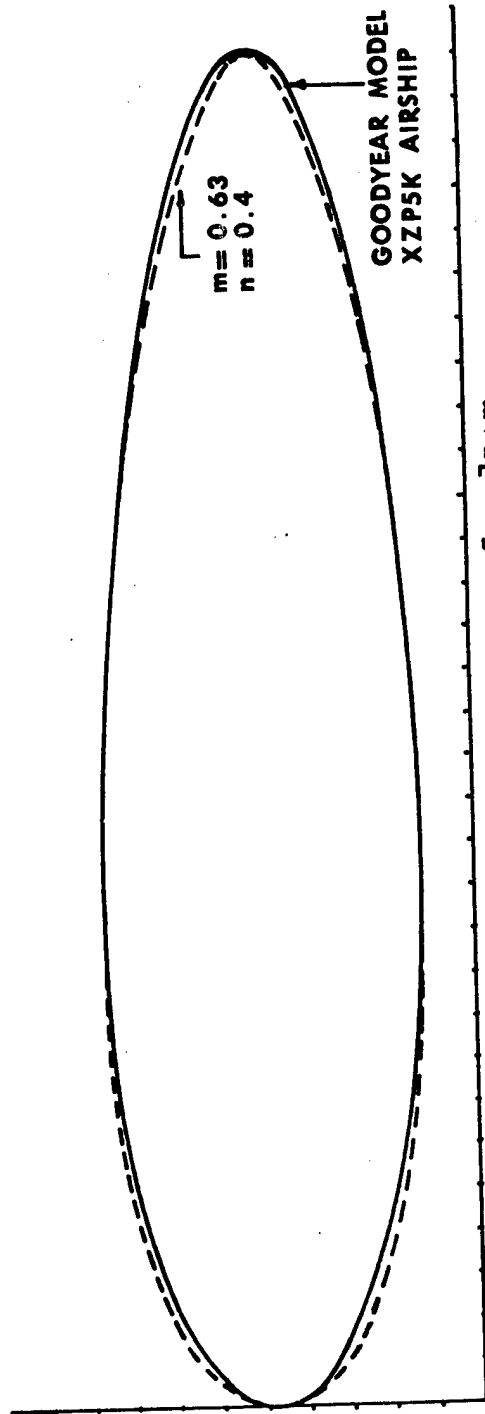

FIG. 3 REQUIRED ENGINE HORSEPOWER V. DISPLACEMENT
 V = 60 MPH N = 0.2 M = 0.6



$$Y = \frac{[i+m]^{n+m}}{2 f n^m} \cdot \frac{x^n}{L^{n+m-1}} [L-x]^m$$

FIG. 2.1 APPROXIMATE COMPARISON OF EQUATION Y = $\frac{[i+m]^{n+m}}{2 f n^m} \cdot \frac{x^n}{L^{n+m-1}} [L-x]^m$ TO GOODYEAR MODEL XZPSK AIRSHIP, $f = 4.17$

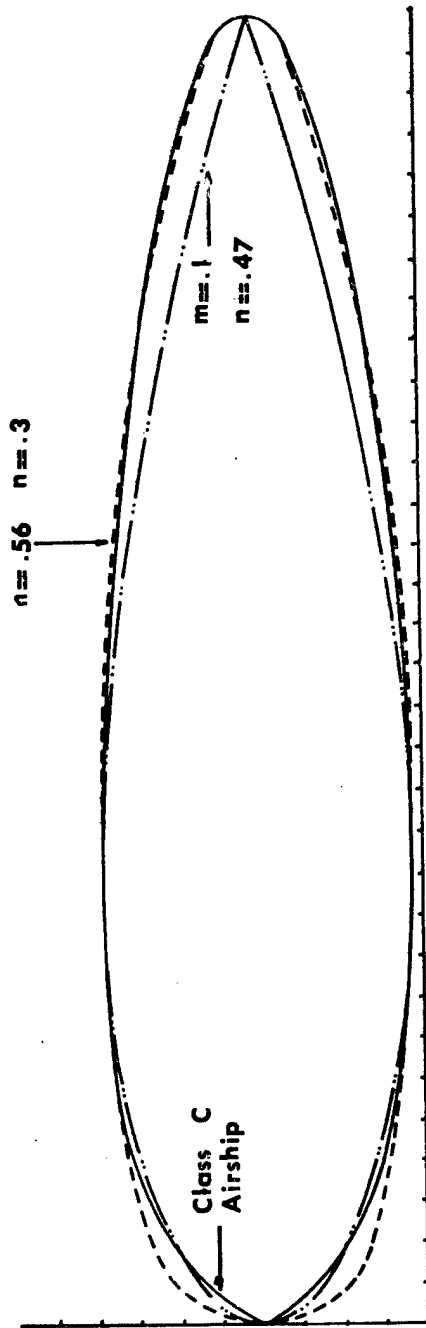
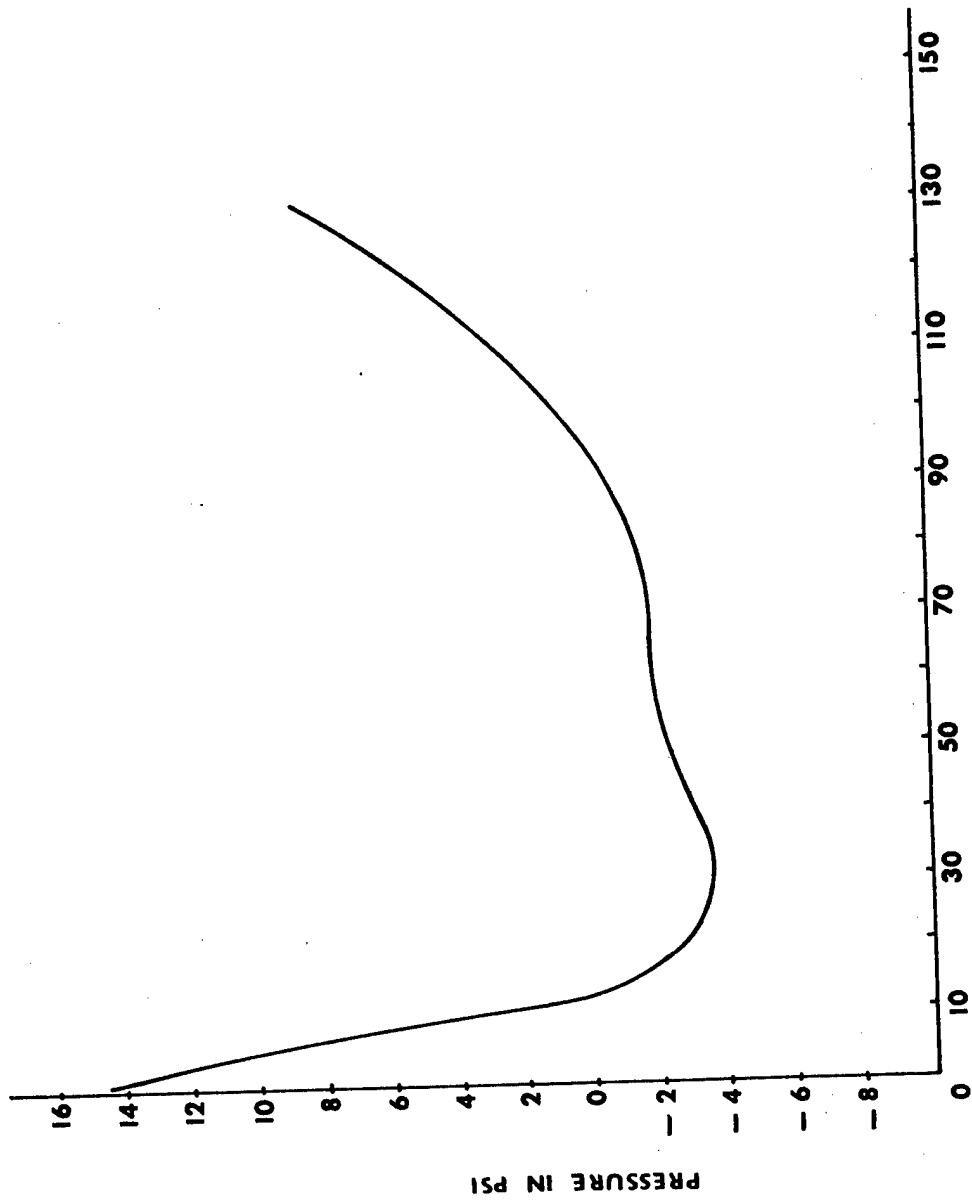
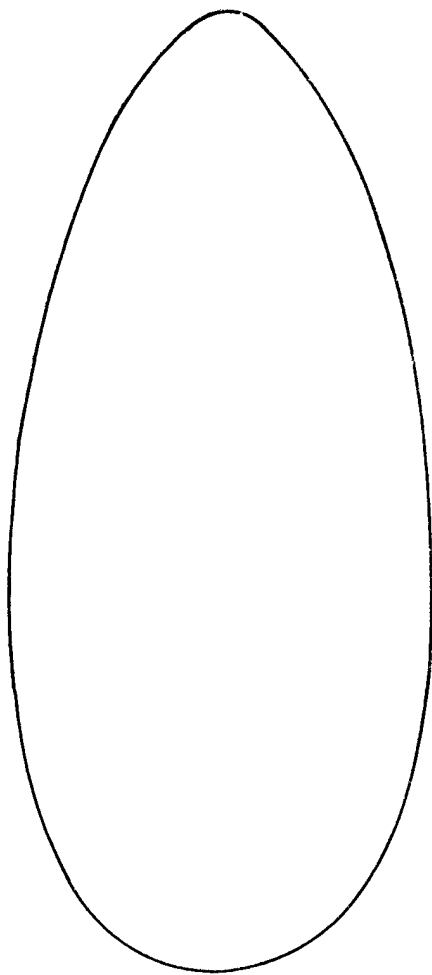

FIG. 2.2 APPROXIMATE COMPARISON OF EQUATION $Y = \frac{[n+m]^{n+m}}{2 f n^m} \cdot \frac{x^n}{L^{n+m-1}} [L-x]^m$

TO CLASS C AIRSHIP , $f = 4.19$



DISTANCE ALONG HULL IN FT.
FIG. 3.1 PRESSURE DISTRIBUTION FOR AN AIRSHIP IN LEVEL FLIGHT
 $m = 0.6$
 $n = 0.4$
 $V = 110 \text{ fps}$
 $f = 3.00$



$m = 0.6$
 $n = 0.4$
 $f = 2.25$

FIG. 3.2 INITIAL SHAPE OF ENVELOPE

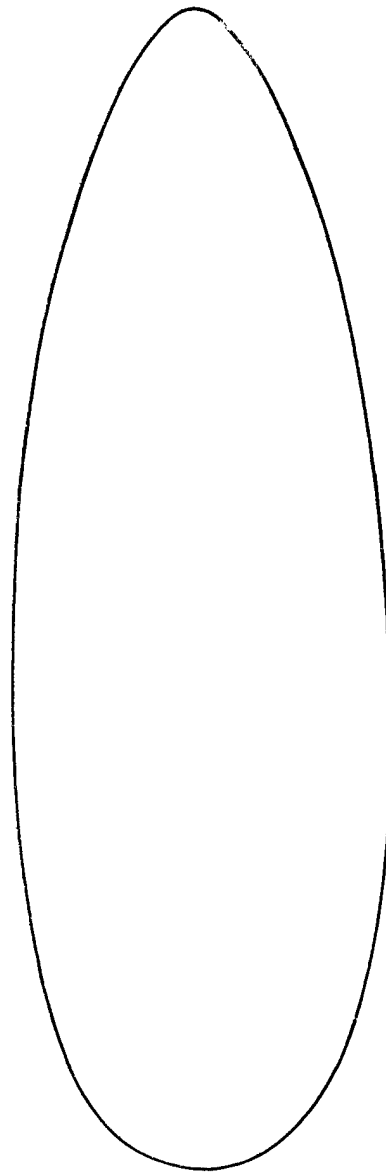

$m = 0.6$
 $n = 0.4$
 $f = 3.00$

FIG. 3.3 FINAL SHAPE OF ENVELOPE

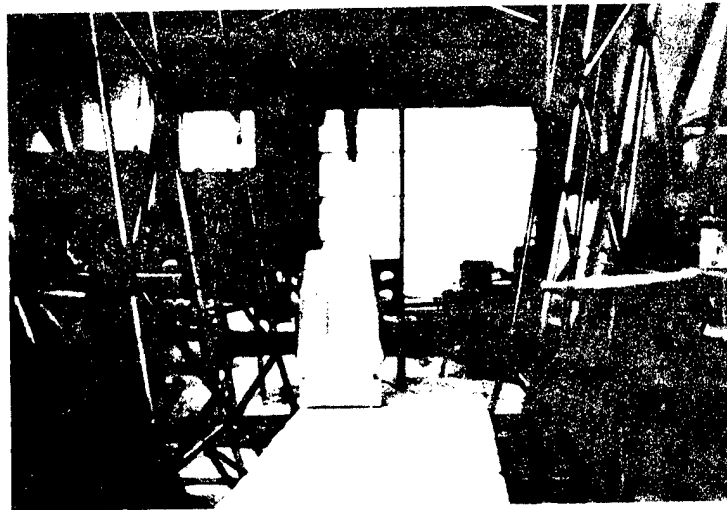
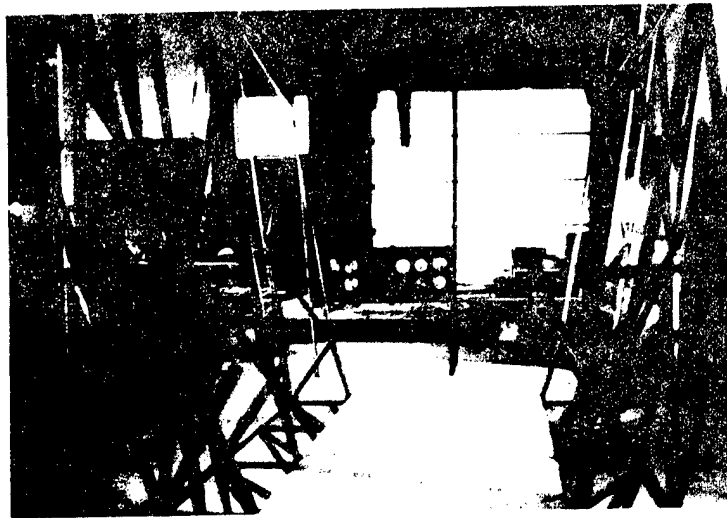
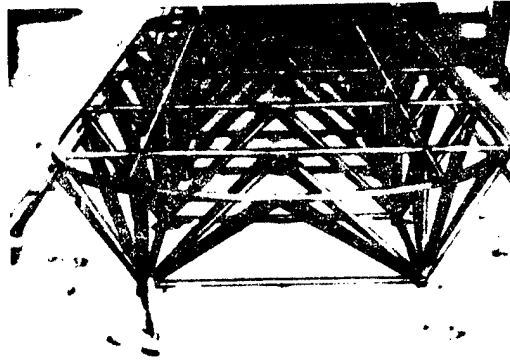

Figure : 4.1 Cabin Structure During Construction

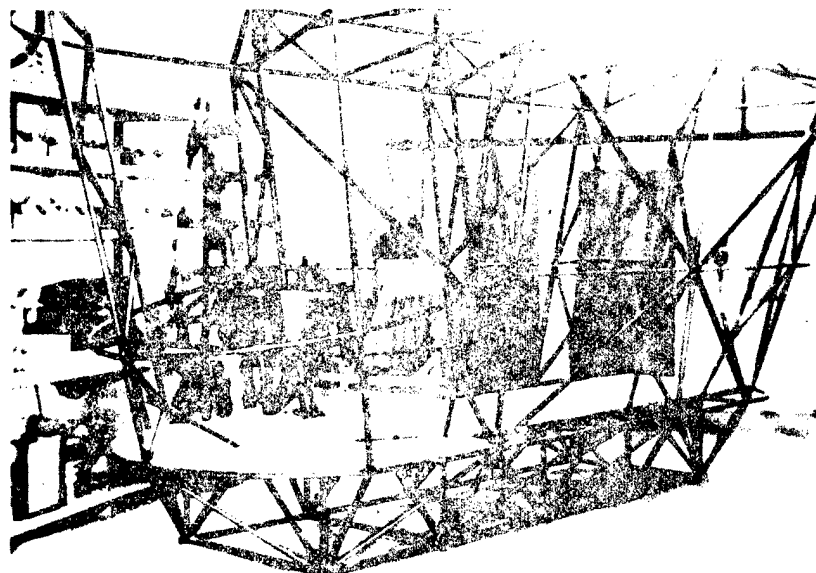
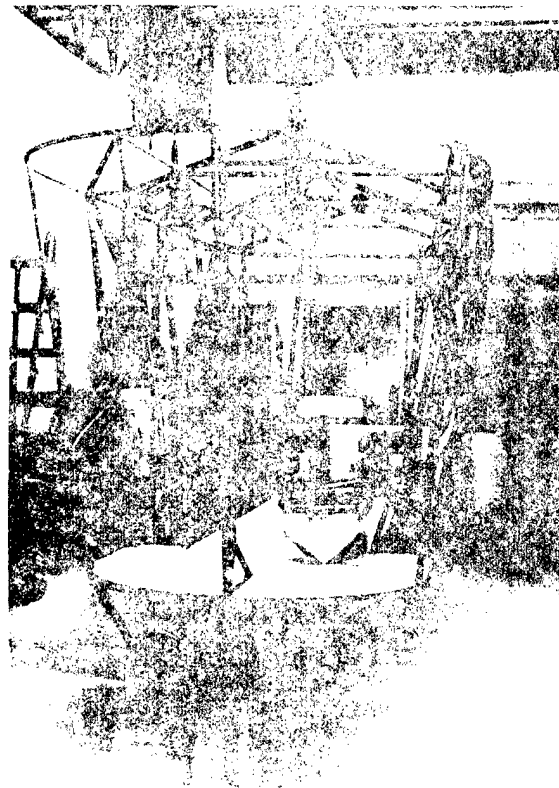

Figure: 4.2 Cabin Structure as Completed

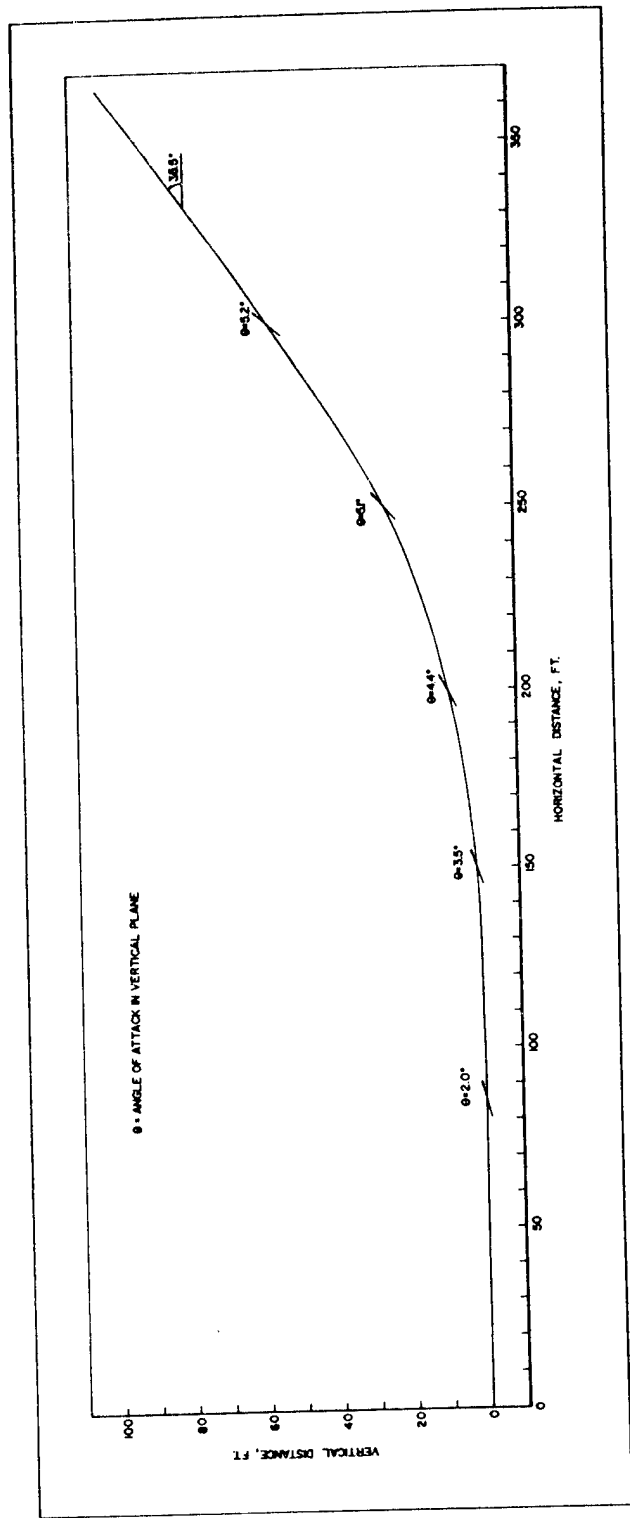

FIG. 5.1 TAKE-OFF TRAJECTORY

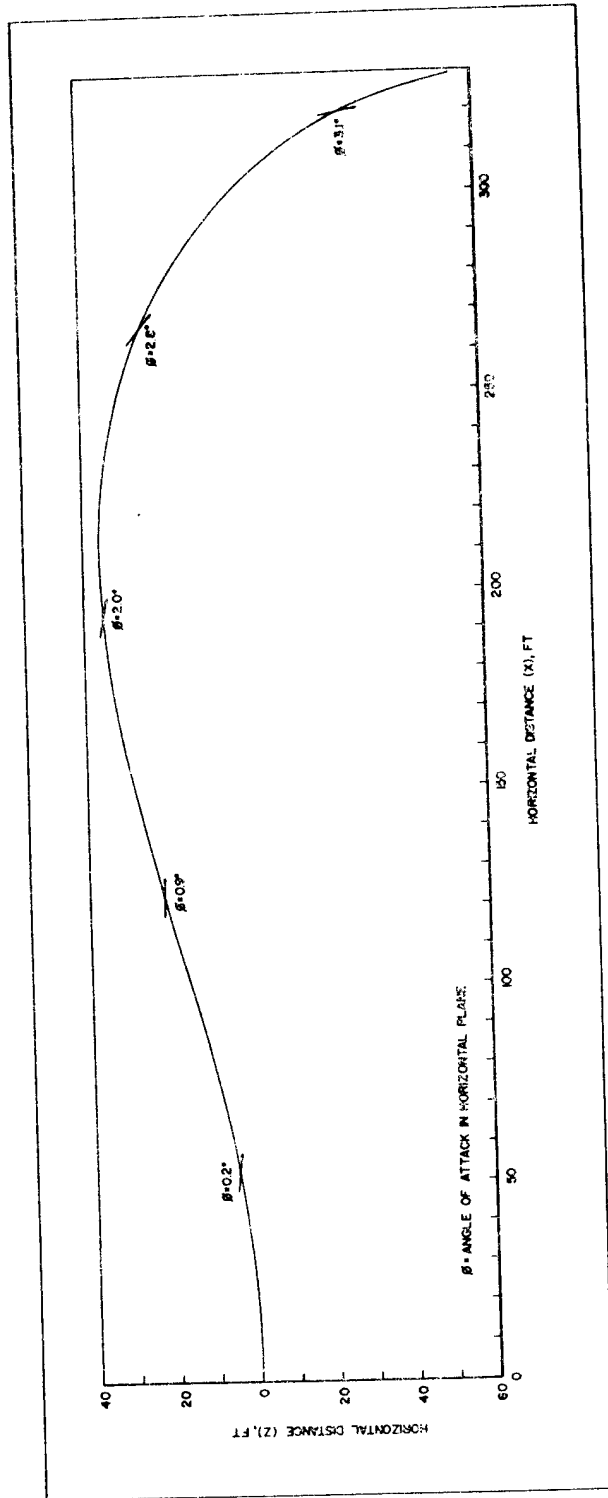

FIG. 5.2 FULL RUDDER UNTIL A 75° TURN HAS BEEN ACHIEVED

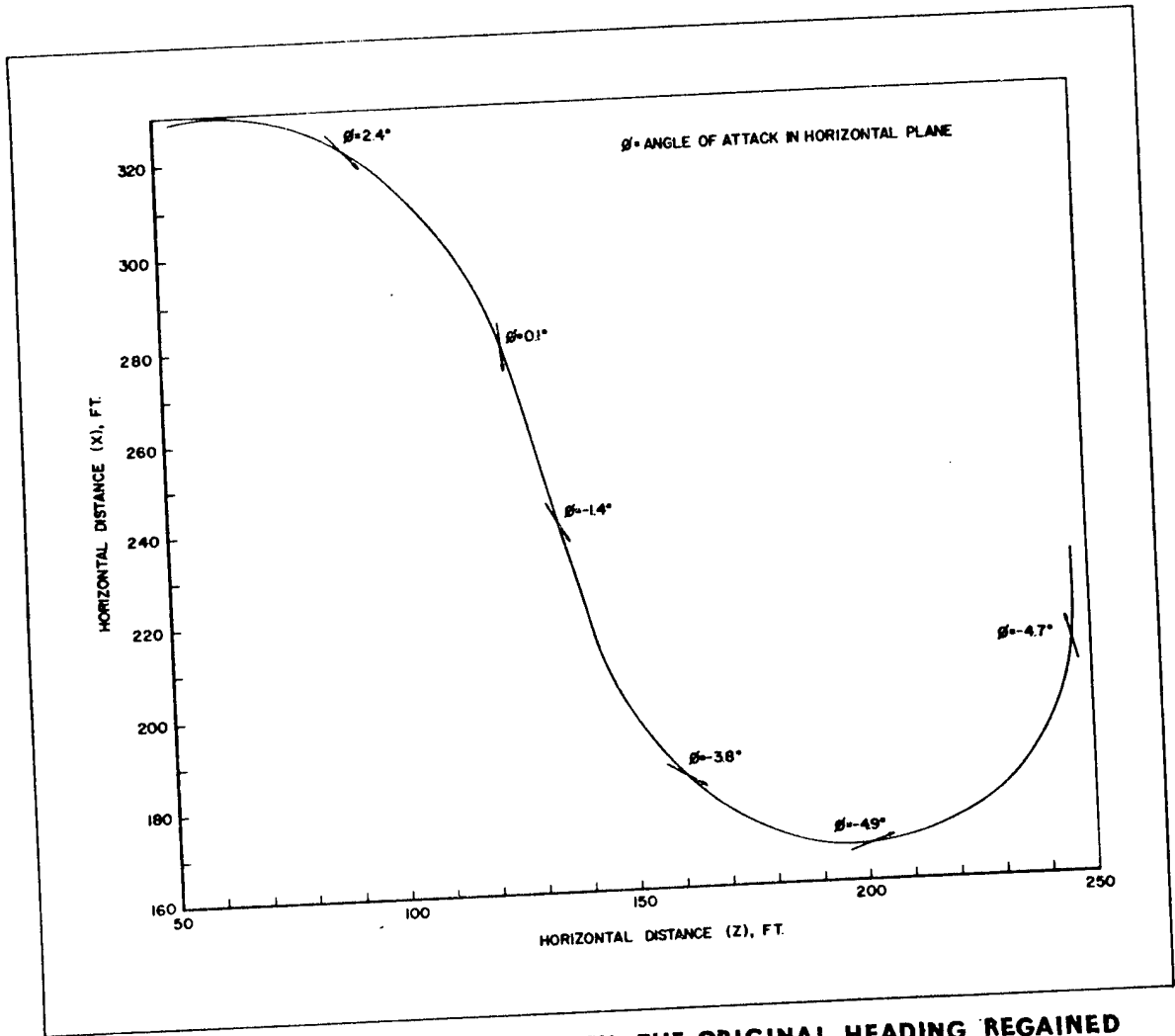

FIG. 5.3 FULL OPPOSITE RUDDER UNTIL THE ORIGINAL HEADING REGAINED

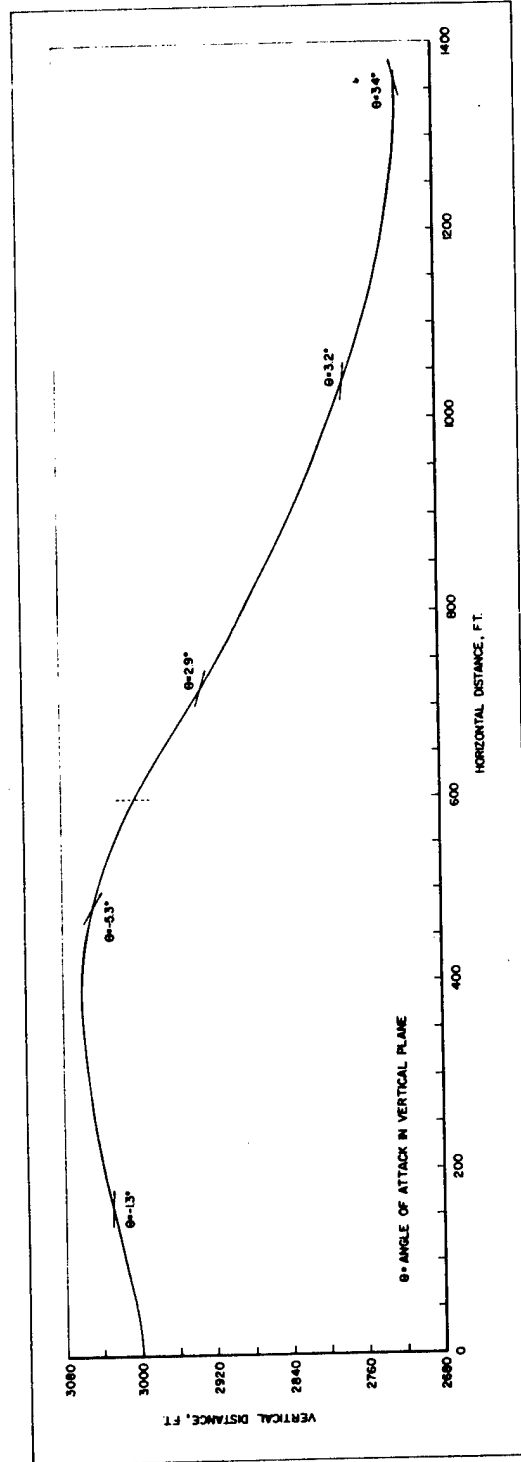

FIG. 5.5 FULL DOWN ELEVATORS UNTIL MAXIMUM DESCENT RATE ACHIEVED AND THEN FULL UP ELEVATORS UNTIL DESCENT RATE EQUALS ZERO

A LTA FLIGHT RESEARCH VEHICLE

Fred R. Nebiker*

ABSTRACT: A LTA Flight Research Program is proposed. Major program objectives are summarized and a Modernized Navy ZPG-3W Airship recommended as the flight test vehicle. The origin of the current interest in modern airship vehicles is briefly discussed and the major benefits resulting from the flight research program described.

INTRODUCTION

The renewed interest in LTA vehicles can be attributed to four major factors:

- 1) A growing awareness of the ecological and energy problems associated with current transportation systems, 2) the realization that the operational characteristics and capabilities of airships are either not available or available only to a limited extent in other transportation systems, 3) the conviction that the quantum advancements in aerospace and aviation systems technology can place modern airships on the same level of safety, economy, and performance capability as alternate transportation systems, and 4) the identification of many conventional and unique missions that modern airship vehicles could potentially perform cost effectively.

In contrast to these factors, certain limitations and purported deficiencies are often defined as also characteristic of airships. These broadly can be grouped in

* Manager, Marketing, Goodyear Aerospace Corporation, Akron, Ohio, U.S.A.

three major areas: technical limitations, economic uncertainties, and institutional uncertainties. Each of the four sources of interest, the technical limitations, and economic and institutional uncertainties are briefly discussed.

A LTA Flight Research Program, similar to the joint Army-NASA Rotor Systems Research Aircraft and Tilt Rotor Research Aircraft Programs is discussed as one approach to resolving many of the technical, economic and institutional uncertainties which must be investigated in order to insure realization of the full potential of modern airships.

A Research Vehicle, consisting of a Modernized Navy ZPG-3W is described and its performance presented.

ECOLOGICAL AND ENERGY FACTORS

The recent oil embargo and the resulting concern over the energy crisis has resulted in an increased awareness of the dependency of our existing forms of transportation on the ever decreasing supply of petroleum. Commercial aircraft, one of the most severely affected transportation modes during the embargo, join private automobiles at the head of every list in terms of fuel energy consumed per passenger mile or per cargo ton mile. In contrast, modern-airship vehicles, because no fuel is expended in overcoming gravity, offer an extremely fuel efficient transportation mode.

A second area of increased public concern is the ecological and environmental aspects of air transportation. Demand projections for air transportation indicate that many major airports will be considerably overloaded in the near future. Acceptable locations for the construction of major new airport facilities and STOL-port facilities present an increasingly difficult environmental and land use problem. Also, the ground level noise environment in areas immediately adjacent to airport facilities, as well as the air pollution associated with commercial aircraft-ground operations, are significant considerations in the introduction and operation of future air transportation systems. In each of these areas, the potential operational characteristics of modern airships, such as vertical takeoff, low power requirements, operational flexibility, and safety, offer potential advantages as an alternate transportation mode for cargo and personnel.

The lower power requirement results from the use of buoyant lift rather than aerodynamic lift. The decreased power requirements result in reduced operational noise, decreased air pollution and potentially reduced costs, through reduced fuel consumption per unit productivity.

MODERN AIRSHIP CAPABILITIES

Although the unique capabilities of airship vehicles compared with existing aircraft are fairly well recognized, they will be briefly identified:

1. Safety, resulting from their relatively low takeoff and landing speeds and the fact that airships cruise at low altitudes, usually well below conventional aircraft traffic.
2. Carry bulky and heavy payloads, either internal in specially designed, containerized cargo bays, or suspended externally beneath the hull.
3. Virtually all-weather operational capability, with ground handling in severe weather further aided by vectorable thrust.
4. Exceptional endurance capability unparalleled by any air transportation vehicle.

5. Operate where no airports or roads exist, unhampered by land-water interfaces.
6. Hover for extended periods of time, particularly in the hybrid mode, combining buoyant lift with propulsive lift achieved through vectored thrust.
7. From an environmentalist's point of view, airships offer one of the most attractive transportation modes available. Both reduced air pollution and lower noise levels result from the lower power requirements.
8. Finally, from an energy conservation point of view, airships offer an extremely fuel-efficient transportation mode in terms of cargo ton miles or passenger seat miles per pound of fuel.

APPLICATION OF CURRENT TECHNOLOGY TO AIRSHIPS

Significant advances in structures, materials, and aerospace technology have occurred since the last detailed airship design effort was conducted. A few of the developments that could provide the highest payoff to airship technology include:

1. Extensive knowledge of weather patterns via Space Age weather forecasting and on-board weather radar.
2. More reliable propulsion systems with improved fuel consumption and power to weight ratios.
3. Higher strength-to-weight ratio materials: fabrics, metals and composites.
4. Improved permeability plastics that will greatly improve helium retention.
5. Tremendously improved capability for the analysis and design of large rigid and semi-rigid airship structures resulting from the advent of modern high-speed computers and the developments of large-scale generalized structural dynamics analysis programs developed for Apollo and other NASA related programs.
6. Better insulation and high-temperature material capability to capitalize on the potential performance improvements resulting from super heating the lifting gas.

MODERN AIRSHIP MISSIONS

Perhaps the most significant factor contributing to the revived interest in modern airship vehicles is the identification of many promising conventional missions and several rather unique missions for modern airships. The missions most frequently discussed have arisen from a combination of the factors above: ecological and energy considerations, unique airship capabilities, and the promise of new technology. They may be loosely grouped into five general classes: commercial, public service, space related, AEC related, and military. Some of the most promising missions are listed below.

Commercial Missions: short haul passenger, oversized cargo, bulk (agricultural) cargo, natural gas transportation. **Public Service Missions:** police surveillance, environmental surveillance, disaster relief. **Space Related Missions:** shuttle transportation, solid rocket motor and external tank transportation. **AEC Missions:** radioactive fuel/waste transportation, delivery of large power plant components for remote plant site construction. **Military Missions:** Open ocean ASW surveillance with towed sonar arrays, sonar buoy field-deployment, monitoring repair and retrieval, mine sweeping vehicles, airborne command and control, cargo delivery,

anti-ship missile defense.

MODERN AIRSHIP PROBLEMS AND TECHNICAL LIMITATIONS

With the many promising missions identified for modern airships, it is worthwhile to address the technical limitations and purported deficiencies often cited as limiting airship applications.

In the military area, airships appear to be ideal platforms, particularly for Naval ASW missions. Since airships served as excellent ASW vehicles during WW I and WW II, the question arises why they were phased out of these missions.

The reasons most often cited include (1) insufficient speed, (2) increasingly sophisticated submarine technology relative to detection equipment capability, and (3) vulnerability.

As submarine performance and speed improved, the pressurized airships were unable to maintain the required 30- to 40-knot ground speed under severe sea-state conditions: 60-knot head winds. With today's propulsion and design technology, improved pressurized, semi-rigid or rigid airships could easily provide the performance capability required to overtake the fastest enemy submarine or maintain station abreast of a convoy or task force in virtually any weather.

The second factor that contributed to the airship's retirement from naval service was unrelated to airship capability. Submarine technological and operational improvements outstripped detection equipment capability, particularly the sonar detection range. Sophisticated advancements during the recent decade have resulted in quantum improvements in ASW detection equipment. ASW airships could utilize extremely large towed array sonar systems, large area sonobuoy fields, new magnetic anomaly detection gear and improved radar equipment, as well as supporting systems, including onboard data processing, readout analysis, localization, attack and data link systems developed for the S-3 and P 3C aircraft and SH-3H and LAMPS helicopter ASW vehicles.

The final factor often cited in the demise of naval airships is their vulnerability. This topic seldom fails to arise when military applications of airships are discussed. In fact, recent developments in Soviet surface-to-air missile systems and anti-aircraft artillery systems often leads to doubts about the survivability of even our least vulnerable attack aircraft. For airships, however, acceptable levels of survivability can be achieved by employing the airship in missions and tactical environments compatible with their unique design and operational characteristics. Potentially airships could be equipped with self-defense systems, early warning and fire control radar, anti-air and anti-missile missiles, and various electronic countermeasures to further enhance their survivability.

In the nonmilitary mission area, other problems often cited limiting airship applications include low speed handling and control, ground handling, ballast requirements during load transfer, control of buoyancy and trim, and airship response to severe gusts and turbulence. None of these areas constitute unsolvable technical problems or limitations utilizing existing technology and operational procedures. However, airship performance and operational capability could certainly be improved by dedicated engineering design and development effort utilizing Apollo-era technology.

Ground handling of the latest and largest Navy airship, the Goodyear ZPG-3W, was considerably improved by the use of motorized "mechanical mules". Addition of vectorable thrust capability could also appreciably improve airship low-speed control and handling characteristics during landing and ground handling. Vectored-thrust capability was employed by the Goodyear Akron and Macon rigid airships in

the early 30's and could be appreciably improved utilizing 1974 technology in conjunction with a developmental flight test program. Small amounts of aerodynamic lift and vectored thrust could also be utilized for control of buoyancy and trim. Water recovery from fuel combustion products have been successfully applied for reclaiming ballast as fuel is consumed and warrants further investigation for modern propulsion systems. Initial heating of the lifting gas or intermediate, enroute ballast recovery are also promising avenues to buoyancy control.

Problems associated with airship response to severe turbulence can be minimized utilizing modern weather forecasting, navigation, and avionics to avoid severe turbulence. Modern computerized structural analysis and design capabilities would result in airship designs as air worthy as any modern aircraft.

Load transfer of massive cargo loads is an area that can benefit by actual flight experience and research and development efforts. Cargo/ballast load transfer approaches have been defined utilizing both water and solid ballast containers that simultaneously transfer the cargo to the ground and the ballast to the airship. Other approaches that offer promising solutions to on ground handling and cargo transfer include small reversible bow and stern-mounted ducted propellers and internally suspended cargo transfer platforms free to rotate independently of the airship's response to ground winds. For many airship applications, cargo transfer actually presents no major problem not previously solved in airship operations. This area would require appreciable research and development only for the transfer of large indivisible loads characteristic of some modern airship missions.

Thus, none of the major technical problems or limitations often associated with airship applications to either a military or nonmilitary missions represent problems that have not been adequately solved in the past and could not be appreciably improved upon via modern technology. While some modern applications might require airships of unprecedented size - 20 million, 40 million, perhaps even 100 million cubic feet - compared with the 6.5-million-cubic-foot Goodyear-built Akron and Macon, their development can be achieved by an orderly evolution from historical technology and experience.

The successful evolution will benefit significantly from the technology advancements of the last few decades and could be further enhanced by a research aircraft approach, not necessarily at full scale, aimed at investigations and improvements of airship technology and operations, particularly in the areas of low speed control, improved handling qualities, ground handling, cargo transfer, and advanced buoyancy control and ballast recovery systems.

ECONOMIC UNCERTAINTY

The fundamental problem that has deterred the revival of airship utilization is economic uncertainty. Research and development cost estimates for large rigid airships have ranged from zero dollars by Airfloat Transport Limited of England to half a billion dollars. Cost estimates of pressurized airships similar to these last employed by the Navy can also be misinterpreted. Historical cost data generally reflect extensive engineering and design efforts to meet rigid performance specifications and achieve significant technological advancements in performance capability. Sophisticated military equipment, and airship design characteristics for its utilization, resulted in specialized design features and costs.

These uncertainties in the R&D costs and production costs for unknown production quantities directly affect the operating costs estimates via indirect operating cost charges to amortization, interest charges, insurance, fees, taxes, etc. Uncertainties in the ground facilities and personnel costs associated with performance of the many different mission applications further confuse operating cost estimates, which will ultimately determine the economic viability of airship applications.

INSTITUTIONAL UNCERTAINTIES AND CONSTRAINTS

The third problem area that will affect the development of modern airship transportation systems for commercial applications may be defined or broadly grouped under the heading of institutional constraints. These include government regulations, state regulations, economic regulations, and so on.

The Federal Aviation Act of 1958 specifically requires the safety regulation of air-space, air navigation facilities, aircraft, aircraft parts, airmen, carriers, and certain airports. Historically, aviation safety policies have been issued and delineated through safety regulations issued under those requirements through the regulatory process. Furthermore, economic regulation cover transport of mail, persons, and property. Policy guidance in the Federal Aviation Act is broad, primarily looking toward the development of a safe and economically sound air network. Twenty-nine states have promulgated safety regulations applicable to intrastate operations. The range from simple registration and investigation of accidents to elaborate assurances of compliance with federal regulations.

Some of the major questions which arise in considering commercial applications include - How will airships be certified by the FAA? How will the airships be tested and how long will it take to develop commercial operation and safety standards? Who will operate modern airship vehicles? What International and National regulations and agreements will apply? Questions such as these must be considered in the successful introduction of modern airship transportation systems. Availability of an operational vehicle to investigate LTA operations within the existing commercial aviation network could contribute appreciably to the early resolution of many of the institutional uncertainties.

PROPOSED FLIGHT RESEARCH PROGRAM

Many of the technical, economic and institutional uncertainties can be resolved by a LTA Flight Research Program. The program objective would be to conduct a flight research program using a LTA flight research vehicle with sufficient versatility to provide economical flight evaluation and "proof of concept" verification of: 1) Advanced Technology Applications and Theoretical LTA Analysis, Design and Performance Methodology, 2) Improved Operational Concepts, 3) Research On Promising Mission Applications. The program would also identify areas where advanced technology developments could significantly improve modern airship operations.

The major development areas of interest to the flight research vehicle program are presented below.

Low Speed Control and handling qualities of modern airships may be appreciably improved by utilization of vectorable thrust propulsion systems for vehicle control at speeds below the minimum speed required for aerodynamic stability. Promising vectorable propulsion concepts include - A) stern mounted propulsion with gimbaling capability, B) fin mounted tractor propulsion, and C) tilt-rotor type propulsion. Canard control surfaces could also be employed to further improve aerodynamic control authority at low speeds. Each of the above concepts has been investigated either analytically, experimentally in wind tunnel programs or in modified full-scale vehicles and judged to be generally acceptable for improving low speed handling characteristics. The flight research program would further explore and develop these alternatives utilizing quantitative experimental flight test data correlated with theoretical predictions.

The research program objectives closely related to the area of low speed control and handling qualities include, A) Initial assessment of handling qualities and definition of safe operational envelope, B) verification of dynamic stability and control

over the entire operational envelope, C) investigation of gust sensitivity, D) Investigation of gust and load alleviation systems, E) investigation of noise effects in hover or near hover mode of operations. Other technology evaluations could include A) improved ballonet/envelope pressure control systems, B) improved buoyancy management techniques, and C) high altitude cruise vehicles.

The second major area of investigation of the flight research vehicle program is improved operational concepts. Research projects would include, A) investigation of improved ground handling equipment and procedures, B) operation with large heaviness ratios, C) investigation of cargo/ballast transfer systems, D) in flight ballast recovery systems, D) investigation of terminal area guidance and navigation systems, and F) integration of LTA vehicles with existing aviation/air traffic control systems.

The third major area of investigation is research and evaluation of promising mission applications for modern LTA vehicles. These investigations would include the mission peculiar characteristics and requirements for the missions identified, as well as general requirements and characteristics of many promising missions. For example, investigations would include A) external carriage of bulky objects, B) passenger ingress/egress techniques, C) systems and techniques for transporting fluid cargos, and D) extremely low speed (hover or near hover) operations.

The high development costs which might be predicted or expected of the "first" airship or vehicle for the Flight Research Program can be avoided by utilizing an existing, flight-proven vehicle design.

FLIGHT RESEARCH VEHICLE

A "modernized" version of the Navy ZPG-3W pressurized airship is proposed for the Flight Research Vehicle.

The ZPG-3W was developed for the Navy by Goodyear Aerospace in the late 1950's. The primary mission of this airship was all weather Airborne Early Warning (AEW) patrols of long endurance in open ocean areas at an altitude of 5,000 feet. The original ZPG-3W configuration is illustrated in Figure 1.

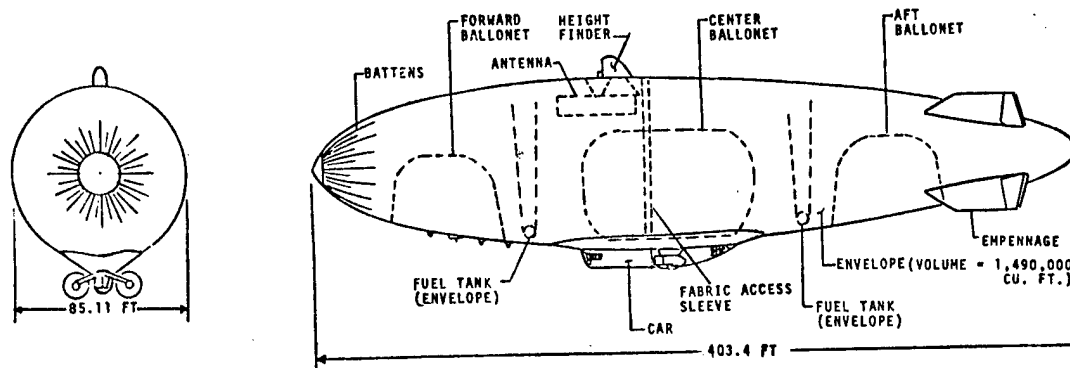

Figure 1
Original ZPG-3W Configuration

The ZPG-3W volume is 1,490,000 cubic feet. The distinguishing configuration features of the airship are twin engines mounted on outriggers which also function as a ram air intake scoop for the ballonets, an "X" tail for obtaining ground clearance, an internal antenna installation with a height finder and a tricycle landing gear for improved ground management. The engines are Wright Model R-1820-88 equipped with a cooling fan and a special gear box to obtain a lower propeller rpm.

The ballonets are connected by ducts from a plenum chamber for the egress of the air. The ballonet air is exhausted through pressure regulated "pop" valves. Air is supplied by electric blowers and ram air through ducts in the leading edge of the outriggers. The entire ballonet air system is automatic with manual override.

The battens are structurally designed to withstand the flight dynamic pressure and the mooring loads. The envelope which is constructed of two ply neoprene coated dacron fabric functions as a radome for the antenna. A vertical fabric shaft is installed for crew access to the antenna and height finned. The empennage and car are conventional airplane structures with the former fabric covered.

The interior of the car provides the pilot compartment, CIC compartment, ward room, galley, sleeping quarters and an aft equipment section. The latter section accommodated such items as tanks for fuel and ballast water, a crew relief station, hydraulic equipment, ballast provisions, APU, etc. Jettisonable fuel tanks are provided in the keel space below the floor for emergency ballast conditions.

The flight controls are similar to airplane arrangements in that they consist of a column and wheel. Rudder pedals are eliminated in lieu of directional control being obtained by actuating the wheel. Elevation is obtained by actuating the column in the conventional airplane manner. An autopilot and an automatic pressure system with manual overrides are provided. Demonstrated performance of the original ZPG-3W is presented in Table I.

Table I - Demonstrated ZPG-3W Performance

Operating Altitude	5,000 ft
Design Ceiling	10,000 ft
Maximum Speed	76 knots, EAS
Rate of Ascent	2,400 ft/min
Rate of Descent	1,200 ft/min
Endurance	75 hours with military equipment and 21 man crew
Gross Weight	93,485 (10,500 lbs heavy at takeoff)
Empty Weight	67,566
Envelope	33,115
Car	30,750
Empennage	3,701
Useful Load	25,919
Crew & Provisions	7,204
Fuel	19,712
Mission Equipment	(Included in Weight Empty)

A recent study has been completed by Goodyear Aerospace to define the performance potential of a "Modernized" ZPG-3W type vehicle suitable for use in the LTA Flight Research Program. The original design would be stripped of the AEW and other military mission equipment. Neoprene impregnated Kevlar with a strength to weight ratio twice that of dacron fabric would be used for the envelope material and the basic propulsion would consist of two GE T64-GE-10 or GE T64/P4C engines. This configuration would have the same outward appearance as the original ZPG-3W and a top speed of 100 knots. The performance characteristics of this LTA Flight Research Vehicle candidate is presented in Table II.

Further investigations are required to define the structural requirements of the car to accommodate the various propulsion system options to be investigated for low speed control improvements.

The proposed research vehicle would provide a flexible and economical research test bed which could be utilized for the LTA Flight Research Vehicle Program.

Table II - "Modernized" ZPG-3W LTA Research Vehicle Characteristics

Maximum Speed	100 knots
Gross Weight*	97,030**
Empty Weight	47,342
Envelope	17,018
Car	26,623
Empennage	3,701
Useful Load*	49,688

*10,500 lbs heavy

**3,000 ft pressure altitude, Kevlar fabric without stretch factor

SUMMARY

The renewed interest in modern airship vehicles is based on several well founded facts: 1) Airships are an environmentally desirable and energy efficient alternative to existing transportation modes, 2) airships have distinct advantages over existing transportation modes due to their unique operational capabilities, 3) Application of 1974 technology can significantly improve the capabilities of modern airships compared with vehicles of the past, and 4) because of the three facts above, many promising missions have been identified.

Three major areas must be investigated in order for the full potential of modern airships to be realized: technical limitations or uncertainties, institutional uncertainties and constraints, and economic uncertainties.

In the technical area, the successful revival of modern airship vehicles can be achieved by an evolutionary program based on airship technology of the past, upgraded to reflect the technology of today. With the possible exception of transfer of large indivisible cargos and incorporation of vectorable propulsion systems, technical problems do not exist that have not been solved in the past and could be significantly improved upon by the application, testing, and proving of equipment and operating techniques using 1974 technology.

The area of institutional constraints and uncertainties does not present any insurmountable problems but will require further investigation. Airship certification for commercial applications could be aided significantly by the availability of a research airship for actual flight-test programs.

Economic uncertainty is the major problem retarding the development and successful introduction of modern airship transportation systems. Cost uncertainties arise from unknown production quantities and unknown costs. These uncertainties in turn actually result from unknown market size (i. e., how many missions could airships cost effectively perform) and what characteristics (speed, payload, range, etc.) the airship should possess to perform these missions and the costs required to develop such a vehicle. The number of missions that airships can perform is uncertain because actual flight testing and operational investigations have not been conducted due to lack of a research or test bed airship. A research or test bed airship is not available because of the uncertainty in what size airship should be developed and the cost to develop such an airship.

One approach to eliminating the development cost/applications dilemma is through a Flight Research Program. The program would utilize a Research Airship, based on an existing ZPG-3W design, to serve as a flying test bed for evaluation of improved technological and operational approaches. Flight evaluation of a broad spectrum of mission applications would be performed.

RECOMMENDATIONS

Many of the applications being considered for LTA vehicles are practical and potentially economically viable. Unfortunately most of the applications taken alone do not justify the investment necessary to develop the required modern airship vehicle. Goodyear Aerospace believes that the country's military and civil interests would be best served by government support of an LTA Flight Research Program. The program would allow flight test evaluation of advanced technology applications and improved operational procedures as well as investigations of promising mission applications.

By utilizing a modernized version of the existing Navy ZPG-3W Airship, the Flight Research Program could be implemented at modest cost within two to three years.

In conclusion, Goodyear Aerospace is confident that the field of Lighter Than Air is an untapped resource with significant potential for current mission applications.

The sooner a practical, success oriented hardware program can be implemented, the sooner the payoff will occur for our nation.

N76-15050

THE AIRFLOAT HL PROJECT

Edwin Mowforth *

ABSTRACT: This paper describes a design study for a large low-cost rigid airship intended primarily for the movement of large indivisible loads between unprepared sites. A survey of the ship and its overall performance is followed by accounts of the operational procedures for the above function and for an alternative application to unit module transfer between fixed terminals. A final section indicates the estimated costs of construction and operation.

Objectives

The Airfloat HL (Heavy Lift) project was initiated late in 1970 as a design study for an airship to carry large indivisible loads over moderate distances - typically, 400 tonne over 2 000 km - between unprepared and possibly congested industrial sites. The associated requirement of minimum cost has dictated a 'low technology' design policy making the greatest practicable use of currently accessible materials, installations, techniques and experience in order to bypass, wherever possible, expensive involvement in research and development programmes. The outcome is a vehicle lacking sophistication and falling somewhat short of optimum technical efficiency, but offering the facilities of rapid manufacture and of immediate commercial effectiveness even if only one ship is built.

* Design Director, Airfloat Transport Limited, and Lecturer in Mechanical Engineering, University of Surrey.

General Description

Hull - The hull is seen from Fig 1 to be of conventional form, 400 m long and 85 m in diameter; it comprises a light alloy framework covered by a textile skin and divided internally by radially-braced transverse frames into 27 cells, each containing a reinforced Mylar gasbag to give a total helium capacity of 1 342 000 m³.

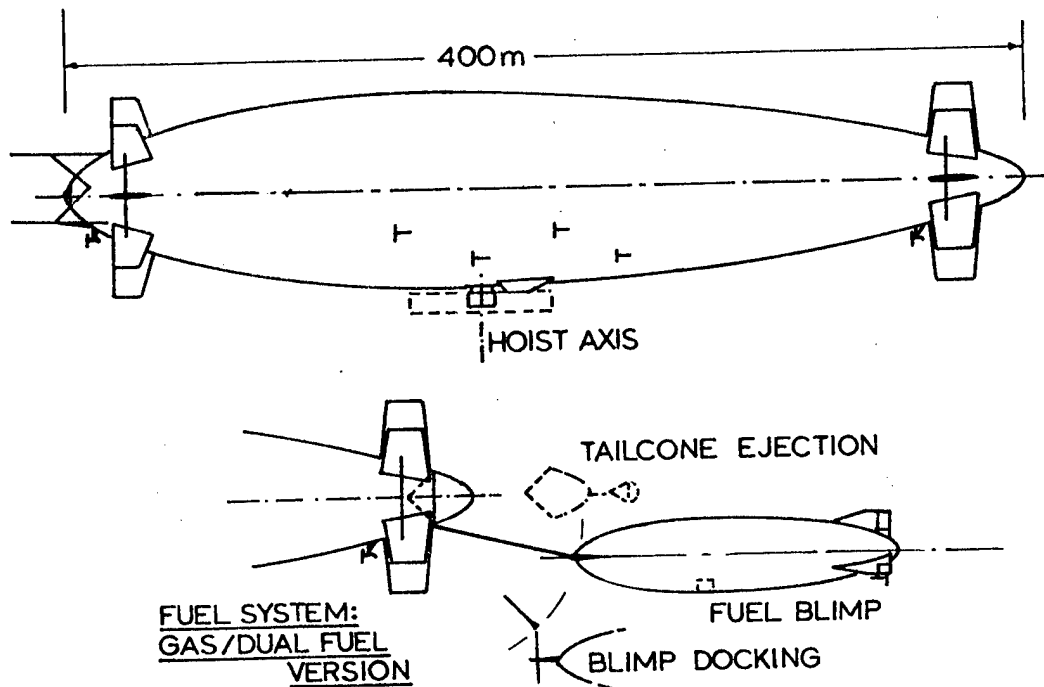

Fig.1. GENERAL ARRANGEMENT OF AIRFLOAT HL AIRSHIP

Propulsion - The ship carries 10 Rolls-Royce Marine Proteus dual fuel gas turbines, each driving a 6.4 m diameter Hawker Siddeley propeller. 2 units are mounted at nose and tail and can be vectored for lateral thrust, while 6 of the 8 disposed along the lower flanks can vector the propellers for vertical thrust. The ship normally cruises at 145 km/h using 4 engines when alone or 5 when towing a fuel blimp.

Control - To achieve the necessary position control in hovering flight there are 8 radially disposed fully-floating fins at either end of the hull, hydraulically powered through independent pump and motor sets driven electrically by duplicated gas turbine generator sets in the nose. Hovering and normal cruise control are automatic, gusting being sensed by the forward probes and compensated by control operation under the direction of a master control unit.

Fuel - The ship may operate on aviation kerosine, on natural gas or on dual fuel, a combination of both.

Kerosine operation uses 2 fixed 20-tonne tanks, topped up in flight from 10-tonne transfer tanks picked up and carried with the payload or ballast. The cruising weight loss of 4 tonne/h is met by routing journeys over free water surfaces from which water may be raised at intervals of up to 1 000 km through suspended pumps and hoses with the ship trimmed in hovering flight by vertical thrust. Between stops the discrepancy is met by dynamic lift, and the interval may occasionally be extended by the use of a rain water collection system.

On natural gas operation the HL airship tows a blimp, 135 m long, which carries 59 000 m³ of fuel gas; this offers an effective stage length of about 1 200 km. The blimp has its own propulsion unit and control system and can fly independently under radio control, so that refuelling may be effected by detaching the empty blimp and docking a full one with the HL ship flying at 60 km/h. While the blimp is detached the HL ship runs on a bridging supply of 5 000 m³ of fuel gas housed in a tailcone which may be ejected in case of fire; a further reserve of kerosine extends the operating period in an emergency.

Natural gas from European sources is lighter than air, so that the blimp becomes heavier as fuel is consumed. In the above system the blimp carries water ballast which is progressively discharged to balance the lift loss; in the alternative dual fuel system this water is replaced by kerosine which is pumped forward and consumed at the necessary rate to maintain trim. The Proteus engines of the HL ship may all run on either gas or kerosine, and the necessary dual fuel ratio is maintained by alternating between different combinations of gas and oil burning units. The effective stage length using the 135 m blimp is then 2 000 km.

Loading System - Loads are picked up in hovering flight by attachment to a frame suspended from a swivelling hoist mounted in the hull. The hoist is driven electrically, being powered by two gas turbine generator sets; it can be rotated to align the frame with the load axis regardless of wind direction, and has a compensation system for pitch and roll of the hull during load transfer. The use of the system in Open Site and in Module Operation will be described in a later section.

Accommodation - The control deck and crew accommodation are in two offset nacelles adjacent to the hoist. A cruising crew of 3 is envisaged, with a nominal load exchange handling crew of 4. In 24-hour operation on extended circuits 3 full crews and 3 cabin staff may be carried, totalling 24. A transfer lift between the nacelles permits the exchange of personnel and small stores with the ground while hovering.

Performance

Under ISA conditions and assuming 5% air contamination of the lifting helium, the gross disposable lift values corresponding to pressure heights of 500, 1 000 and 1 500 m become respectively 520, 460 and 400 tonne for the oil-burning version, reduced by 8 tonne for the gas and dual fuel versions with tailcone gas storage. With a 10-tonne reserve of kerosine and 20% excess range allowance, the range-payload relationships are indicated in Fig 2 for cruise at 145 km/h close to the pressure height, using 4 engines on the kerosine version and 5 on the blimp-towing types.

In all cases the payload corresponding to a given pressure height will fall by about 10 tonne for every 3^oK rise in atmospheric temperature, and vice versa.

The nose engine is not suitable for axial propulsion, but flight is possible on any symmetrical combination of the remaining 9 units; on 9 engines at economical cruise (3 000 hp) the airspeed in ISA conditions becomes 205 km/h for the kerosine ship and 190

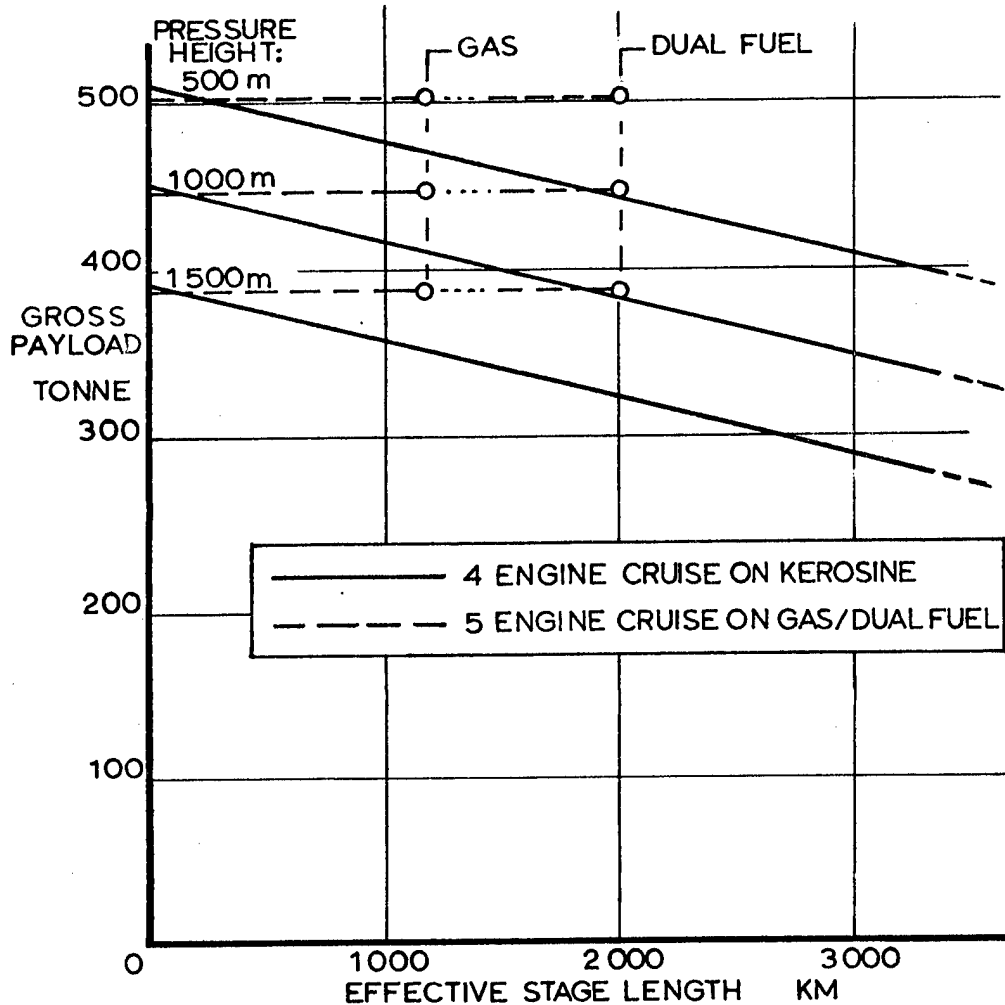

Fig. 2. PERFORMANCE OF AIRFLOAT HL AIRSHIP (ISA)

when towing a blimp; the corresponding 'idling' speeds on one engine only are 75 and 70 km/h. All quoted speeds refer to axial flight and may fall by 2 or 3 km/h when the hull axis is pitched for dynamic lift.

Open Site Operation

For the movement of large indivisible loads between industrial sites the hoist frame is coupled as in Fig 3 to a load frame which has ballast frames suspended from electric winches at its ends. Latches on the load frame bottom booms correspond with pickups on simple sub-frames which have been built onto the load prior to its proposed transportation date.

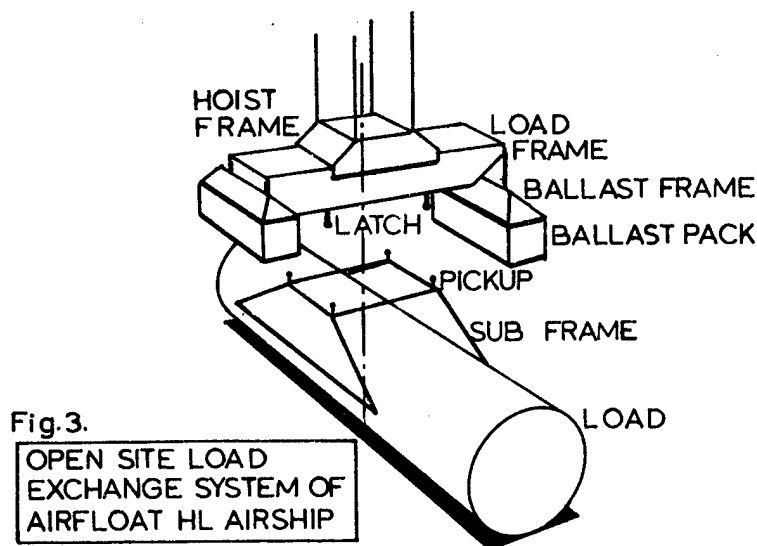
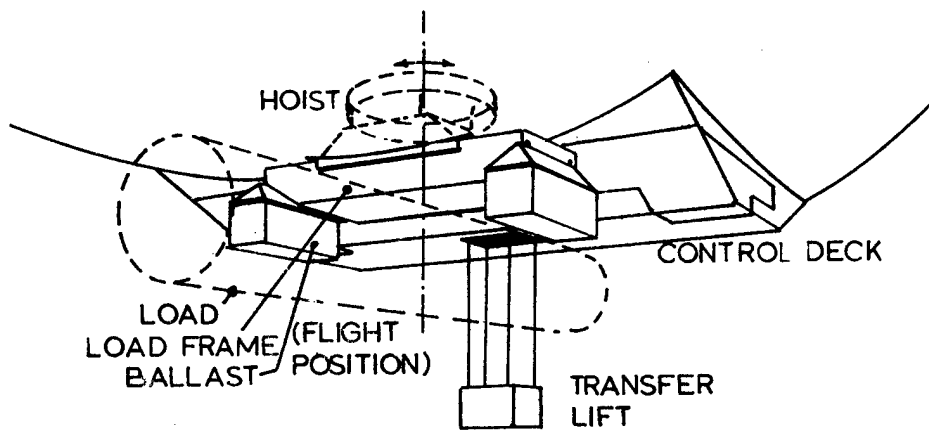
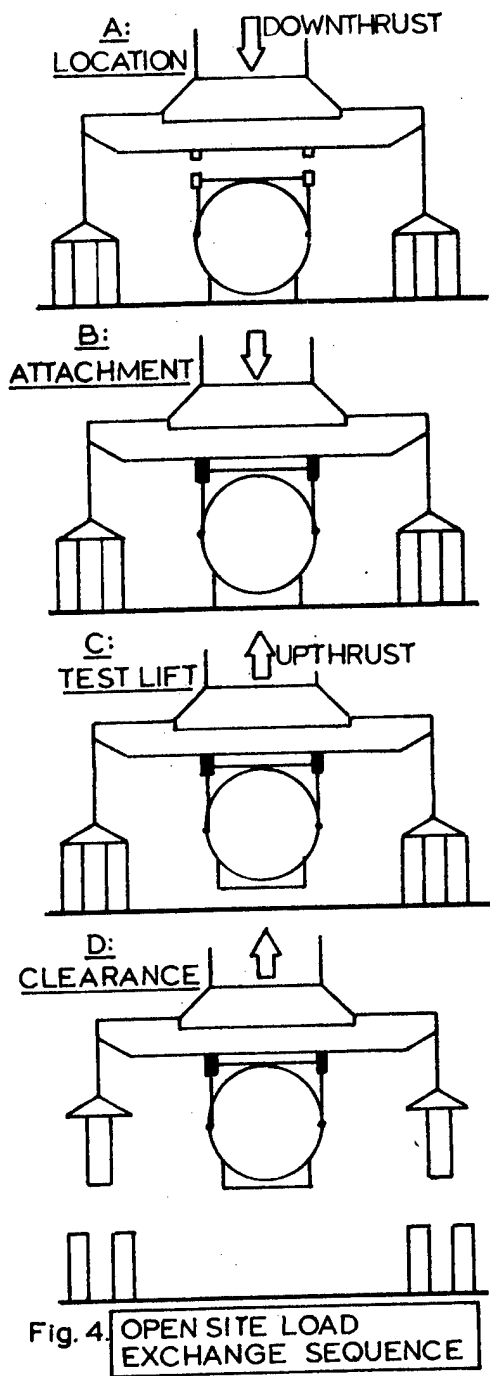

Fig.3.
OPEN SITE LOAD EXCHANGE SYSTEM OF AIRFLOAT HL AIRSHIP

To pick up a load, the airship arrives 'in ballast', i.e. with packs of 15-tonne water containers suspended from the ballast frames, and takes up a controlled hovering position 15 to 50 m above the load according to local conditions. As the load frame is being lowered by the main hoist it is aligned with the load and the ballast packs are let down relative to the load frame so that they will touch ground first with about 1 m clearance between latches and pickups, as in Stage A of Fig 4. The ballast packs are manoeuvred into position and grounded by downthrust of the vectored propellers while the ballast winches on the load frame draw it down onto the sub frames; the latches are then engaged to attach the load (Stage B). Upthrust is now applied and the ballast winches reversed, allowing the load to rise from the ground; in this position (Stage C) the load security and c.g. may be checked before finally detaching an appropriate number of ballast units so that the airship may rise bodily with the load (Stage D), which is then hoisted up and secured in the flight position. After departure of the airship the ballast containers are emptied and taken away by ground service vehicles, which also have the



task of providing containers and setting up ballast packs at delivery sites for exchange with incoming loads; the delivery sequence is then the reverse of the pickup process outlined above. The oil-burning version of the HL ship uses further ground vehicles to supply fuel in 10-tonne fibreglass transfer tanks which are incorporated into the ballast packs in place of ballast containers; the gas versions detach and dock fuel blimps in flight wherever these may be conveniently flown into the operating circuit.

The weight of the load frame and attachments, estimated to be 30 tonne, must be deducted from the gross payloads of Fig 2 to obtain the permissible weight of the payload and its sub frames.

Module Operation

Operation between fixed bases permits the use of permanent transfer installations through which loaded modules of similar weight may be rapidly exchanged without the involvement of external ballast systems. Fig 5 indicates the components of the module system; there is now no intermediate load frame, the hoist frame engaging the upper booms of lifting beams running across the module. The permissible weight of the loaded module then becomes the gross payload plotted in Fig 2.

A standard module has been designed, 60 m long, 25 m wide and 10 m deep, which with different internal arrangements can accommodate for example 250 cars and 1 000 passengers; or 3 000 foot passengers; or 15 loaded vehicles averaging 24 tonne apiece. Smaller modules may be postulated for bulk grain and fluids, perishables and containers, though there are few applications in the latter categories where the airship may be expected to show a decisive commercial advantage over existing systems.

Different module exchange mechanisms are under consideration; the one in Fig 5 uses two transfer pools separated by a causeway which carries a ballast block, equivalent in weight to a loaded module, on a frame of adjustable height. The incoming module is lowered into its pool and held down by vectored thrust while tracking bollards move it into the exchange position, the airship following in response to control signals from a

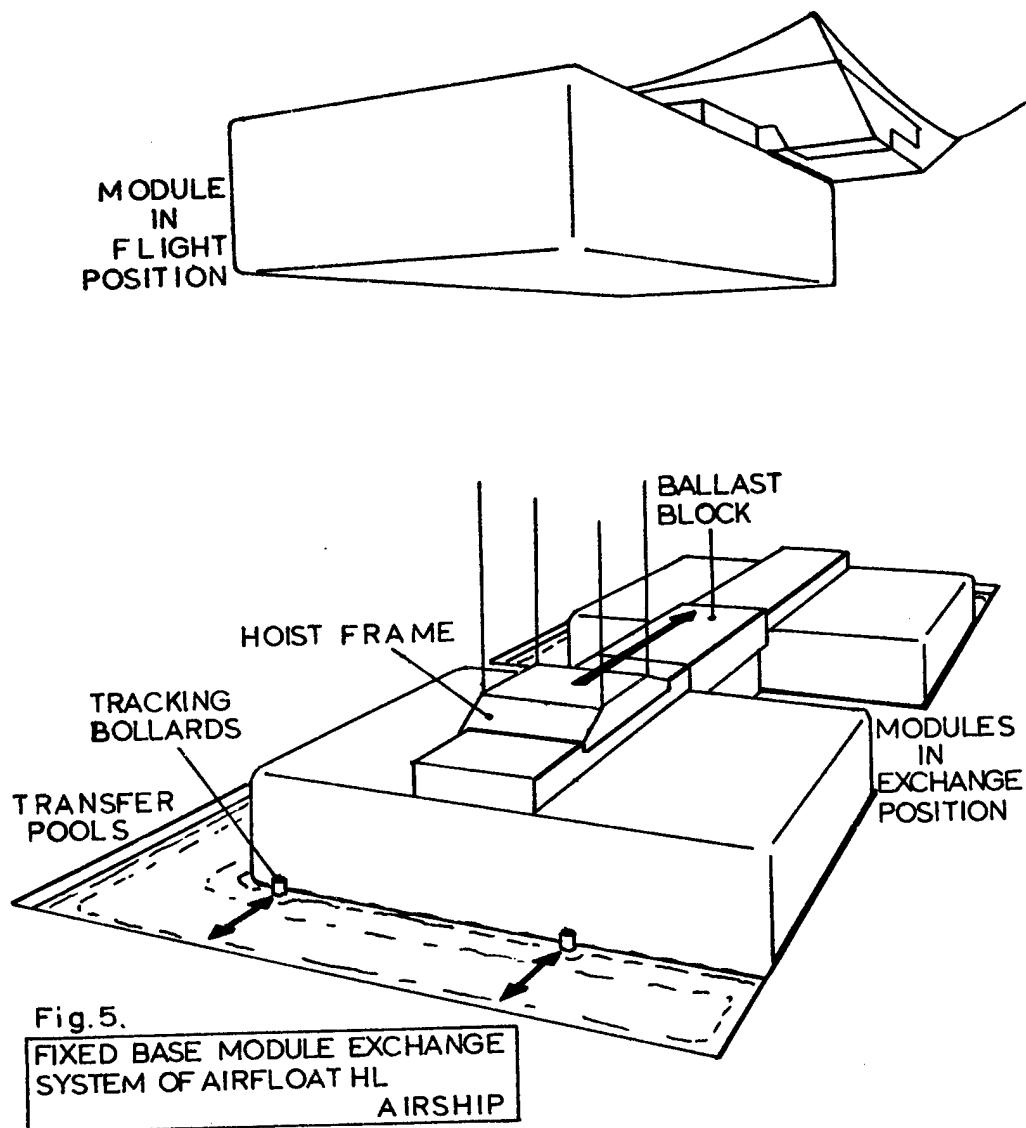

Fig. 5.
FIXED BASE MODULE EXCHANGE
SYSTEM OF AIRFLOAT HL
AIRSHIP

position gyro in the load frame. In the exchange position the module is coupled to the ballast block, which moves vertically to hold the module level while the hoist frame is tracked across the module and onto the block. At this stage the ballast block may, in an emergency or for some other reason, be lifted out in place of a module; in the normal transfer sequence, however, the block is now disconnected from the incoming module, coupled to the outgoing one, and again used to control the level of the latter while the hoist frame is moved onto its suspension beams. Finally the module is disconnected, moved out into the centre of its pool, and lifted clear.

Maintenance and Construction

The size of the HL airship precludes accommodation in a hangar of reasonable cost, and it must therefore live permanently in the open. For maintenance the airship is clamped

to a base turntable through its load frame and through additional stays to the engine mountings; the turntable is rotated through a control unit responding to signals from wind sensors surrounding the base, so that wind loads on the hull are kept within acceptable limits.

Construction must be carried out on the same turntable. The hull comprises an assembly of prefabricated units, each composed of two or three gas cells complete with shell structure, covering and gasbags; the latter are partially filled to reduce handling weight and to check for leaks and valve function. The units incorporating the hoist are first set up on the turntable, and further units are then added at either end so that the structure cantilevers towards nose and tail and can be turned to suit wind conditions. The hull units are lifted into place by hoists travelling along a temporary dorsal girder mounted along the top of the hull.

Safety

The most critical operating conditions arise during load transfer, and this phase has therefore received more attention than any other in the design of the HL system. The Open Site sequence allows the airship to lift either the load or the ballast clear of the site at any moment during the exchange period; an equivalent facility is offered by the ballast block in the module system, though here a critical condition arises while the hoist frame is tracking between lifting stations and the system is therefore being further examined. The failure during load exchange of any one engine will modify the control envelope, but will not require immediate withdrawal from the sequence except in severe turbulence. Flying control and computer systems are duplicated against electrical or mechanical failure.

In moving flight the principal danger, particularly when manoeuvring close to the ground, is that of structural damage and gasbag rupture due to collision with ground obstacles or light aircraft; larger commercial and military aircraft will tend to operate at higher altitudes and under stricter traffic control. The shell structure is diffuse and highly redundant, and may be expected to absorb appreciable damage in most areas without significant immediate loss of airworthiness; gasbag rupture, however, requires more attention. Each gasbag in the HL airship is divided internally by an annular membrane into two compartments, so that rupture of the outer skin cannot release more than half the gas content. In addition, 62 tonne of emergency water ballast carried in tanks at nose and tail permit balancing both of lift loss and of pitching trim loss arising from the collapse of any one gasbag or of any two half-bags.

The fire hazards inherent in gaseous fuels are met by the controlled separation techniques which have already been indicated. A burning fuel blimp may be towed on an extended cable until it burns out or can be released over a 'safe' area. Similarly, if the airship's tailcone becomes ignited the fuel blimp may be cast off and the tailcone 'trailed' on a cable until it can be safely jettisoned, running meanwhile on the kerosine reserve while the fuel blimp follows under its own power. The blimp is then reattached for continued flight.

Costs

Estimation of the capital cost of the HL airship is based upon the assumption that no initial facilities exist; the final figure, referred to current U.K. averages, therefore includes the cost of the construction site, of the accommodation, materials and personnel

for design, research, construction and crew training, and of one base turntable. A large item in the cost is a flight simulator system, to be used initially for control system development and later for crew training; the nature of the project renders simulator training more appropriate than flight training in a small airship, and no specific allowance has been made for the construction of a small vessel within the HL programme. Some use may, however, be made of any small airship which becomes available, such as one of the Goodyear or WDL blimps, or the larger Airfloat GP airship which forms the basis of a parallel project.

Exact costing is inhibited by unstable economic conditions; a comprehensive costing exercise was, however, carried out by Airfloat in 1972, and subsequent application of a suitable spectrum of inflation factors and known cost increases has led to a current estimate of about £9 000 000 (\$23 000 000) for one basic airship, using kerosine alone. There are then additional items for airship and mission variants; 3 fuel blimps and a refuelling base for the gas burning versions, ground service vehicles and facilities for open site work, 3 modules and 2 exchange terminals for module operation, leading to the following approximate capital costs:

	Open Site Operation	Module Operation
Oil-burning HL airship	£10 000 000 (\$25 000 000)	£11 000 000 (\$28 000 000)
Gas-burning HL airships	£12 000 000 (\$30 000 000)	£13 000 000 (\$33 000 000)

These costs refer to one airship; subsequent ships and their associated facilities would be expected to cost about £3 000 000 (\$7 000 000) less than the above totals.

The annual operating cost is found not to differ greatly between Open Site and Module systems, the running cost of the ground services for the former balancing that of the module terminals for the latter; there are, however, significant differences between the running costs of alternative fuel versions, and at current U.K. fuel prices the annual operating cost for a 46-week working year in a 15-year depreciation period becomes about £5 200 000 (\$13 000 000) on kerosine, £4 000 000 (\$10 000 000) on dual fuel and £3 300 000 (\$8 000 000) on natural gas alone. These figures refer to a single airship recovering the whole of its capital cost.

On Open Site work the annual capacity of one HL airship is about 450 000 000 tonne-km on kerosine and 470 000 000 tonne-km on dual fuel or gas; the corresponding figures for module operation with a module of 100 tonne tare weight are respectively 350 000 000 and 370 000 000 tonne-km. The unit capacity rates are then found to be:

	Kerosine	Dual Fuel	Gas
Open Site Operation:			
pence/capacity tonne-km	1.2	0.9	0.7
cents/capacity U.S. ton-mile	4.1	3.1	2.5
Module Operation:			
pence/capacity tonne-km	1.5	1.1	0.9
cents/capacity U.S. ton-mile	5.4	3.9	3.2

It should be emphasised that these are capacity rates estimated for construction in the U.K. and operation in Europe; their relationship with true rates will depend upon the area of operation and upon the load factors which can be achieved in the selected traffic category.

HYBRID AIRSHIP DESIGN CONCEPTS

The Basic Characteristics of Hybrid Aircraft — J. B. Nichols

A Semibuoyant Vehicle for General Transportation Missions — C. Dewey Havill, Michael Harper

The Dynairship — William McElwee Miller Jr.

Some Aspects of Hybrid-Zeppelins — Paul-Armin Mackrodt

Ultra-Heavy Vertical Lift Systems—"The Hell-Stat" — Frank N. Piasecki

The Variable Density Aircraft Concept — A. C. Davenport

4/17-a

THE BASIC CHARACTERISTICS
OF HYBRID AIRCRAFT

J. B. Nichols *

ABSTRACT: A number of missions or capabilities associated with LTA technology have not been accomplished by Heavier Than Air craft. Among these are the transportation of very heavy or very bulky loads and the ability to carry out extended duration flights at low speeds and low cost.

LTA technology appears capable of contributing to the solution of these problems; however, there are strong indications that the ideal solutions will not arise from the rebirth of LTA technology in the classical form of Zeppelins and blimps but in the form of hybrid aircraft which exploit the advantages of both aerostatic and aerodynamic techniques while avoiding the primary disadvantages of each. This paper establishes the basic characteristics of hybrid aircraft.

INTRODUCTION

The entire rationale of hybrid vehicles is based on the fact that LTA elements are less sensitive to the size and weight problems which are characteristic of aerodynamically supported vehicles. Figure 1 (From reference 1) illustrates this dominating characteristic of LTA elements. A typical hybrid aircraft is very insensitive to weight variations and thus exhibits different basic characteristics than the airplane and helicopter upon which our existing aerospace industry is established.

* President, United Technical Industries, El Segundo, California

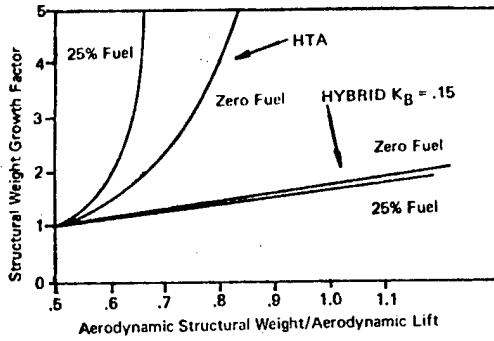

Figure 1
Structural Weight Growth
for a Constant Payload

The generalized structural weight equation for a hybrid machine is given by:

$$\frac{EW}{PL} = \frac{K_B(1-K_p+K_p K_S) + K_p K_S(1-K_F)}{1-K_F-K_B} \quad (1)$$

Where:

$$K_B = \frac{\text{Structural weight of LTA element}}{\text{Lift of LTA element}}$$

$$K_p = \text{Fraction of Payload carried by Aerodynamic Element}$$

$$K_F = \text{Fuel Weight/Gross Weight}$$

$$K_S = \frac{\text{Structural Weight of HTA element}}{\text{Lift of HTA element}}$$

For a Pure HTA vehicle, $K_B = K_S$, $K_p = 1$, and the above reduces to:

$$\frac{EW}{PL} = \frac{K_S}{1-K_F-K_S} \quad (2)$$

A typical value of K_B is .15 or less and remains almost constant regardless of size while K_S is seldom less than .50 and grows as size increases. The advantage of

adding an LTA element is illustrated by Figure 2 for the case of a hybrid with a $K_B = .15$ vs an HTA craft. For both aircraft the aerodynamic element weight/lift ratio, K_S , is allowed to grow. For the HTA craft the EW/GW ratio is identical to K_S , while for the Hybrid the EW/GW ratio is considerably less than K_S and remains in a practical range even when the Aerodynamic lifting structure far exceeds the lift produced by that structure. The overall vehicle weight (EW) required to carry a given payload (PL) is considerably less for the Hybrid than for the HTA craft and while the Hybrid machine should offer a significant cost saving over the HTA machine, the primary advantage of the Hybrid is that it makes very large sizes practical.

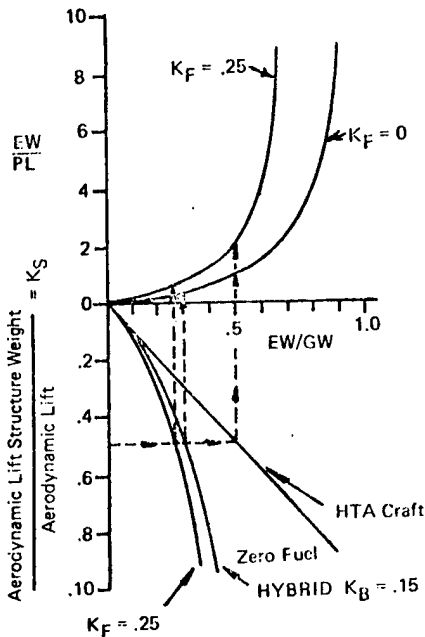

Figure 2.
Structural Weight Comparisons
HTAs vs HYBRIDS

REPRODUCIBILITY OF THE
ORIGINAL PAGE IS POOR

THE GENERALIZED AIRCRAFT CONCEPT

The complexity of the problem can be appreciated from the following minimum list of factors which must be considered merely to categorize a hybrid vehicle:

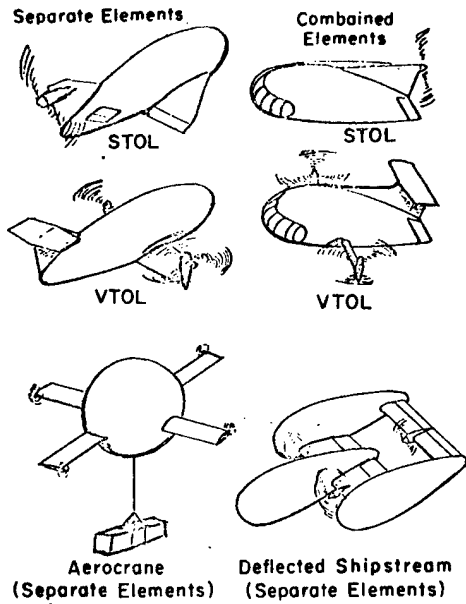

Figure 3
Hybrid Configurations

- o Airplane or "fixed wing" based hybrids vs helicopter or "rotary wing" based hybrids.
- o VTOL hybrids vs STOL hybrids.
- o Ballasted vs unballasted operation.
- o Separate static and dynamic lifting elements vs combining static and dynamic lift in one element. (Figure 3)

A very effective approach to isolating the important areas of hybrid vehicle interest is to define a totally generalized aircraft in which the fuselage, or working space, is identical for each aircraft, but the lifting means can be a wing (airplane), a rotor (helicopter or autogiro), a pure LTA system (Blimp), in Figure 4. The methodology can also be applied directly to a "rotary wing" as desired.

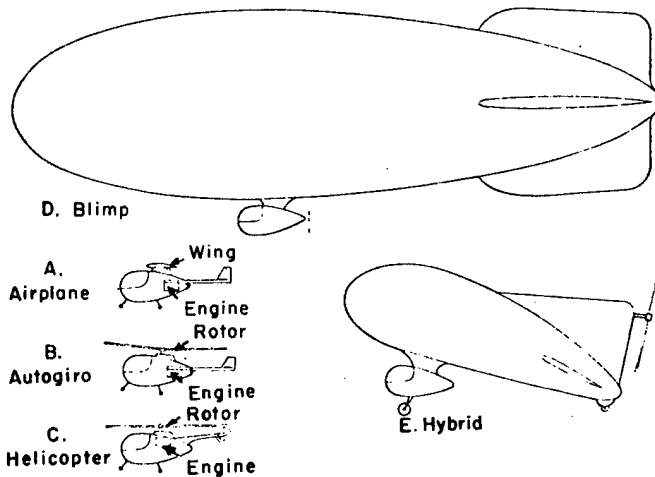

Figure 4
Generalized Aircraft

The hybrid machine thus can be treated as a generalized aircraft whose total lift capacity (i.e. gross weight) is provided by "p," the fraction of static lift; plus "1-p," the fraction of dynamic lift. For the case of combined elements, the volume of the "wing" is dictated by p; but with any given volume, the wing parameters (area, aspect, ratio, thickness, etc.) can be varied widely to produce a large family of surfaces with different dynamic lift characteristics.

There is a bit of irony involved in the hybrid aircraft of the type employing combined elements since the area available for the wing increases as the static lift percentage, p , increases. Maximum area is available for dynamic lift just when it is needed least, i.e., when the gas volume is enough to do the whole job. Nevertheless, this does not suggest a return to the pure LTA. Static lift elements still

appear to be best applied in combination with wings (or rotors) to allow them to fly slower, longer, or to carry larger loads. This is somewhat like adding a flap to a wing, but one which decreases rather than increases power requirements as speed is reduced. The enhancement of low-speed flight by the addition of LTA elements is paid for by large volumes, large frontal areas, and high drag which extracts a large power penalty at the higher-speed end of the spectrum. It also involves a handling and hangaring problem, when the vehicle is on the ground.

BUOYANT GAS LIFT CONSIDERATIONS

Light Gases

The buoyancy of a gas is simply the difference in density between air and the lifting gas. Several of the lighter gases are listed below with their densities and the ideal lift provided per 1000 ft³ of the gas.

Gas	Density	Cp	γ	Lift per 1000 ft ³ (lbs)
Air	.0765	.24	1.4	0
Hydrogen	.0053	3.41	1.41	71
Helium	.0106	1.25	1.66	66
Neon	.0533	.246	1.64	23
Ammonia	.0451	.52	1.32	31
Methane	.0423	.59	1.3	34
Natural Gas	.0514	.56	1.27	25

A perusal of the above table makes it quite evident why the most common lifting gases are hydrogen and helium. Nothing else compares. The 7% lift loss of helium also seems a small price to pay for its non-flammability compared to hydrogen. The other non-flammable gas, neon, is poor in performance. The other flammable ones are all commercial gases and while they provide little useful lift capability for payload they can easily lift themselves and thus suggest aerial transportation by LTA vehicles.

Hot Air

One other gas, hot air, is commonly employed for lift, particularly in sport balloons. Its use is popular for the obvious reason that it is easily available. While not a factor in its choice, the low Cp of air also makes it cheaper to heat than, say, methane or helium. The lifting capability of air is directly proportional to the density difference between the hot lifting air and the outside free air.

As shown in Figure 5, a temperature increase of 152° (to a gas temperature of 212°F = boiling water) will produce a lift of 17.3 lbs for each 1,000 cubic feet of air. A 1000°F temperature rise will yield a lift of approximately 50 lbs. while a 2000°F rise is required to provide 61 lbs. A temperature of approximately 3400°F would be required to obtain 66 lbs., the lift of helium.

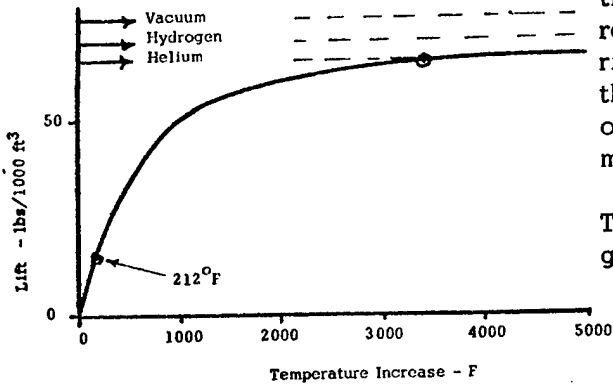

Figure 5
Lift Obtainable from Heating Air

Figure 5 shows considerable curvature in the lift characteristics indicating a severely reduced pay-off after 1000°F temperature rise. This is somewhat fortuitous because the lift obtainable by temperature rise is obviously limited by the capabilities of materials to contain the hot air.

The energy required to heat this air is given by:

$$\text{Btu/lb lift.} = T_o C_p \quad (3)$$

This remarkably simple relationship states that each pound of lift costs the same in energy input regardless of the temperature level. For air at sea level standard temperature and $C_p = .24$, Eqn. 3 yields:

$$\text{Btu/lb lift} = 520 (.24) = 125$$

If we are to assume that this heating is obtained by burning a liquid hydrocarbon of 18550 Btu/lb costing 9¢ per lb (54¢/gallon) then the cost of lift by hot air is $9¢ \times \frac{125}{18550} = .06¢$ per lb lift.

Helium therefore costs $\frac{1.06}{.0006} = 1770$ times as much as a charge of hot air for the same lift.

Dry steam exhibits similar characteristics to air and the use of steam as a lifting gas could prove interesting depending upon the propulsion system employed and the possibility of condensing and recycling the steam in an integrated lifting-propulsion cycle.

LIFTING VOLUME GEOMETRY

The choice of geometry for a lifting volume is a compromise between minimizing surface area and weight and maximizing the favorable external aerodynamic characteristics one wishes to exploit. Surface area, or weight, to contain any given volume of gas is minimized, obviously, by the use of a spherical container. Free balloons approximate spherical shapes.

Non-Lifting Shapes

In the case of true LTA vehicles (Zeppelins and blimps) the departure from a sphere is made in the direction of ellipsoids to reduce the frontal area and drag in the forward flight direction. The ellipsoid shapes of LTAs, which attain all or most of their lift statically, vary from the classically streamlined "Tear Drop" blimps to the Barrage Balloon "Sausages" and "Cigar Shaped" Zeppelins.

In the case of a hybrid aircraft, which obtains dynamic lift from its static lifting element, the lifting volume must be shaped to provide a more effective dynamic lifting surface since the static lifting force is less than the gross weight of the aircraft. Instead of "squashing" the meat ball into the sausage shape of a classical dirigible it is now more beneficial to flatten it into a hamburger or perhaps even into a true wing shape which has a longer span than chord. (Figure 6)

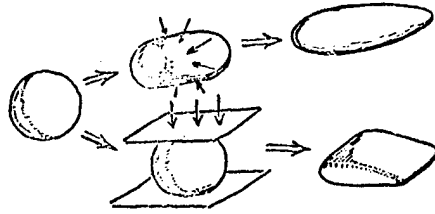

Figure 6
Various Shapes with the Same Volume

Departing from a sphere by increasing span (lateral stretching) while simultaneously reducing the thickness causes surface area and weight penalties more severe than longitudinal stretching but it does add dynamic lifting capability at a rapid rate.

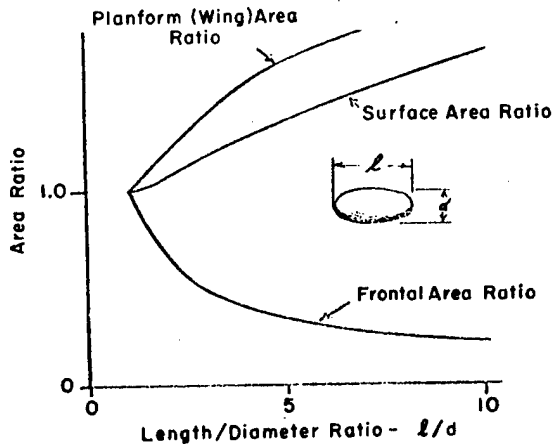

Figure 7
Area Ratios of Ellipsoid Compared to Sphere of the Same Volume

This is illustrated in Figure 7 which shows the area ratio relationships of an ellipsoid as compared with a sphere. Note that the frontal area can be reduced very much but one pays for this with considerable more surface area and structure to contain the gas volume. On the other hand, one also generates planform area which can act as a wing to provide dynamic lift.

Lifting Shapes

The shapes defined in Figure 7 are representative of pure LTAs but do not provide as effective dynamic lift surfaces as those which have a greater span as is typical of airplane wings.

It is still desirable from a structure and weight viewpoint to depart as little from a sphere as possible while aerodynamically it is best to have a long span wing. Intuitively one might expect an optimum vehicle shape somewhat like a hemisphere. For the same volume as a sphere, the hemisphere would have 1.26 times the diameter or 1.59 times the wing area. Even the hemisphere is not a good airfoil shape and its frontal area/volume relationship is poor, being identical to that of the full sphere.

The area of a wing in terms of its volume is given by an equation of the form:

$$A_{\text{wing}} = K \frac{AR^{1/3}}{t^{2/3}} \times V \quad (4)$$

Where: AR = Aspect Ratio
 t = Thickness ratio
 V = Volume
 K = Constant defined by the basic shape

Equation 4 is plotted for one value of K in Figure 8.

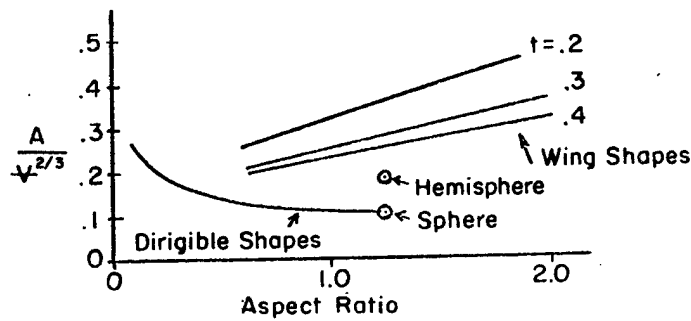

Figure 8
 Effect on Aspect Ratio and
 Thickness on Wing Platform Area

"AIRPLANE" HYBRIDS

For all practical purposes we can define a hybrid aircraft "wing" as being an airplane wing with a high-lift device which allows it to maintain full lift at lower speeds. In this case the high lift device is not a flap or slat which deflects the airstream but it is simply a device which relieves the wing of part of its burden. The amount of burden removed is defined by "p" which is the fraction of the gross weight carried by static lift.

A given wing volume relative to total aircraft weight establishes the value of "p," but for this same value of "p" the volume can be arranged into an infinite variety of wing geometries. For example, for any given fixed aspect ratio, a decrease in thickness will increase wing area. Obviously this will affect performance more than the thickness alone.

Drag and power curves were calculated and computer-plotted for 60 combinations of variables:

Static lift fraction of total: $p = 0.2, 0.4, 0.5, 0.6, 0.8$
 Aspect ratios: $AR = 0.5, 1.0, 1.5, 2.0$
 Thickness ratios: $t = 0.2, 0.3, 0.4$

Figure 9 is a plot of drag and power curves for the case of $AR = 1.0, t = 3, p = 0.5$. It should be noted that they are quite similar to typical airplane curves, except that the power required at low speeds is much lower than for airplanes since a significant fraction of the lift is supplied by the static lift element.

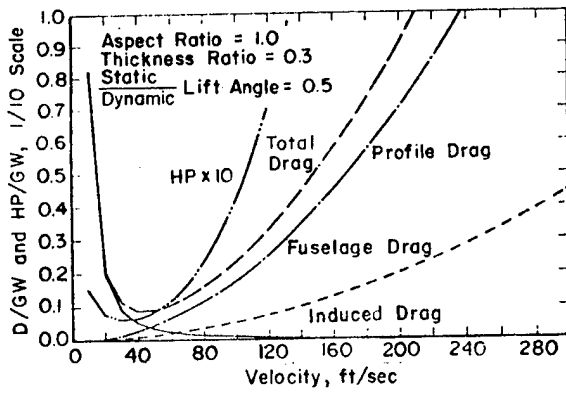

Figure 9
Drag and Power Curves for
a Hybrid Vehicle

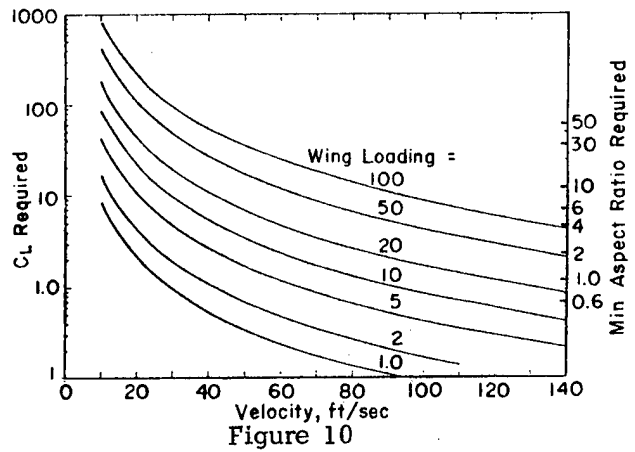

Figure 10
Wing Requirements
for Low Speed Flight

The minimum speed capability of an aerodynamically supported vehicle is a function of the wing loading and maximum lift coefficient, (Figure 10). The wing loading and lift coefficient are, in turn, functions of wing geometry (area, aspect ratio, etc). In the case of those airplane hybrids which employ their aerostatic lifting volumes also as aerodynamic surfaces, the aspect ratio and p factor both have a direct effect on the wing loading (Figures 8 and 11). The aspect ratio also has a direct effect on the maximum lift coefficient. Figures 11 and 12 illustrate the variation in wing loading and minimum velocity as affected by the p factor and aspect ratio.

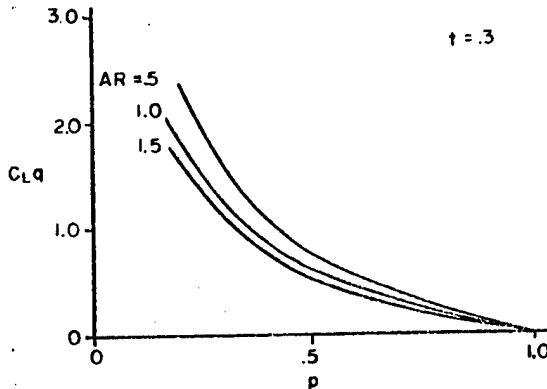

Figure 11
Hybrid Aircraft Dynamic
Wing Loading

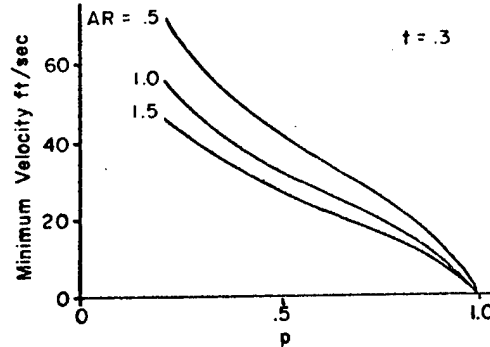

Figure 12
Hybrid Aircraft Minimum
Flying Speed

Several cases have been selected to illustrate the effect of the various parameters on vehicle power requirements. Rather than a display of the entire 480 computer plots, curves for 160 ft/sec (110 mph) and 50 ft/sec (35 mph) have been selected as basic indicators. Two additional curves were also chosen to illustrate the STOL characteristics: the power at 10 ft/sec (less than 7 mph), and the minimum power values. The speed at which minimum power occurred generally fell below the 50 ft/sec checkpoint, thus illustrating the ability of a very simple hybrid aircraft to provide very low loiter speeds without flying on the back side of the power curve.

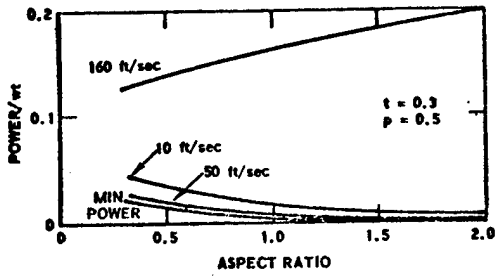

Figure 13
Effect of Aspect Ratio

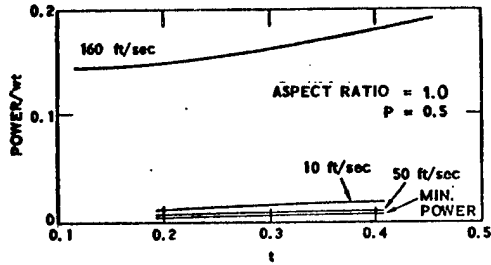

Figure 14
Effect of Thickness

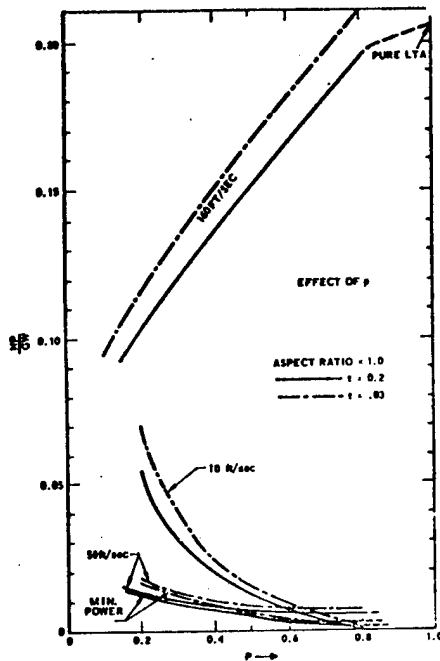

Figure 15
Effect of p

Figure 13 illustrates the effect of aspect ratio when t and p are held constant at 0.3 and 0.5 respectively. Wing area increases with aspect ratio for a constant volume and thickness ratio. One would, therefore, expect this increased wing area at higher aspect ratios to manifest itself in improved low-speed performance but at the expense of drag during high speeds. Such is the case.

Figure 14 illustrates the effect of thickness ratio. The effect of thickness ratio on power required is surprisingly small, at least for the particular conditions assumed ($AR = 1.0$, $p = 0.5$). The conclusion drawn from this trend is that factors other than power requirements would dictate the choice of thickness ratio. For example, structural weight and ground-handling conditions might both benefit from increased thickness. The former is obvious in that thick wing structures can be built lighter than thin ones for the same loads.

It is less obvious, however, that the increased thickness ratio increases the wing loading. This is due to the fact that for a given p the volume is fixed, and an increase in thickness ratio shows up as a decrease in wing area. This tends to reduce gust sensitivity and ground handling problems, which would be expected in aircraft with low wing loadings such as these. Even with modest values of p , the wing areas are much larger than for airplanes, and anything which can relieve the gust sensitivity would be beneficial.

Other things being equal, a thick airfoil would appear to be desirable. However, while the drags of these thick airfoils probably have been adequately accounted for in this study, there is some question as to the actual efficacy of these thick sections as lifting elements in a practical situation. Section thicknesses of much over twenty-five percent may leave much to be desired, particularly if they involve unknown side effects such as erratic

pitching moments or other poor handling characteristics. For this reason, before any decisions are made regarding the use of airfoils of over a 30 percent thickness ratio, it is recommended that considerably more study be given to the matter than was possible in this effort.

As would be expected, the most critical parameter is p , the fraction of the lift carried by the static lifting element. This is the primary parameter that differentiates the hybrid from a conventional aircraft. The effect of p has been plotted in Figure 15, with the aspect ratio held constant at 1.0. Thickness ratios of 0.2 and 0.3 are shown.

The primary performance penalty for the hybrid aircraft, as with its cousin the pure LTA, lies in the high-speed drag and power requirements. The high-speed power problem is clearly illustrated by the upper curve. This curve has been extended by a dotted line to the estimated performance for a machine of $p = 1.0$. (There is a break in the curve because there would be no reason to maintain an $AR = 1.0$ wing shape for a 100 percent state lift machine, and the best configuration would revert to a blimp shape of AR of 0.3 or less.)

With modern structural techniques it appears that a hybrid aircraft employing a mixture of static and dynamic lift can meet a number of mission requirements and provide long endurance at low-loiter speeds more economically than helicopters, airplanes, or autogiros. The problem is the power requirement at higher speeds. Obviously if extensive periods of loiter are required, p should be larger; while if high speed is required, p should be small. Recognizing that the one asset LTA elements offer is economical low-speed flight, it would not be too logical to incorporate LTA elements in a design and then prevent their effective exploitation by making p too small.

At this point, without a further mission-oriented guide to detail design, it would appear that a hybrid vehicle will attain most of the advantages hoped for it with values of p between 0.4 and 0.6, AR s of approximately 1.0 and thickness ratios representing the best compromise between aerodynamic performance and structural weight. Regarding the structural weight, one would expect the weight of any gas filled structure to minimize as it approaches spherical shape. It is, therefore, fortunate that the aerodynamics of hybrids tend to favor AR s near 1.0, as this is about as close to a sphere as a wing can be made.

AIRFRAME WEIGHT

General

There is no parameter more significant to the performance of an aerial vehicle than airframe weight. For any given aircraft class and size, the empty weight/gross weight ratio is a direct measurement of design refinement and structural efficiency. The empty weight represents the actual flying hardware purchased. Where the useful load (UL) represents the job to be done, the empty weight represents the initial investment made to get it done. It should be minimized, of course, and the value of the practical minimum is a function not only of the aircraft type and size but of the state of the art in materials and structure. All aircraft types are trending toward an EW/GW ratio of 0.50, with several isolated examples already below this value.

Figure 16 shows the linear relationship between UL and EW. For a given gross weight, a pound added to one obviously requires a pound subtracted from the other.

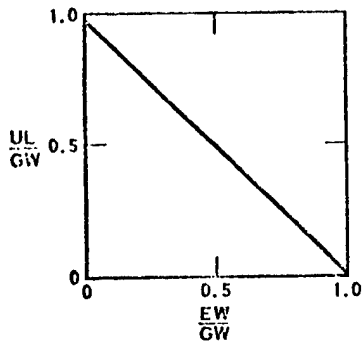

Figure 16
Useful Load - Empty
Weight Relationship

The significance of weight control for HTA craft is dramatically illustrated by plotting the EW/UL ratio. (Figure 17.) What appeared to be a rather innocuous increase in the EW/GW ratio now is seen to result in an extreme economic penalty when it is realized that a 30 percent increase in the EW/GW ratio from 0.50 to 0.67 results in doubling the size of the aircraft to carry the same useful load. This fact provides much of the incentive for employing LTA elements in the larger sizes rather than HTA elements (Ref. 1).

Heavier Than Air craft

The EW/UL ratio of several hundred aircraft of all Heavier Than Air types were plotted to determine the trends.

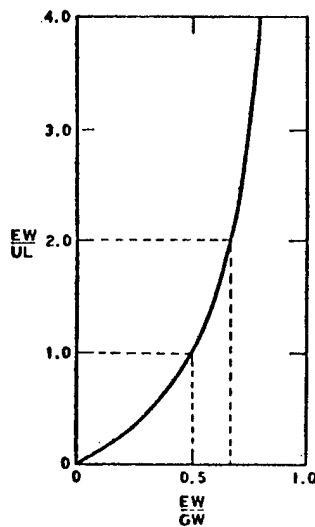

Figure 17
Empty wt/Useful
Load Ratio

A combination of statistical, design study, and analytical approaches has been employed to develop a weight and cost rationale which is accurate for each aircraft type and consistent between types, both HTA and LTA. By the use of computer correlated statistical data, certain insights were gained in both the weight and cost pictures which led to a novel approach towards determining weight and costs which appears to be more accurate and consistent than previously existing approaches, however space does not permit covering this material in this paper.

For actual aircraft types the EW/UL ratios vary from 0.8 to almost 4.0. In other words, for the lighter designs the purchase of only 0.8 pound of airframe is required to lift 1 pound of useful load, while at the other extreme the purchase of 4 pounds of airframe is needed to lift 1 pound of useful load. The EW/UL ratio is obviously the more meaningful one in pricing an aerial vehicle to accomplish a particular mission.

The zones for a number of aircraft types are illustrated in Figure 18.

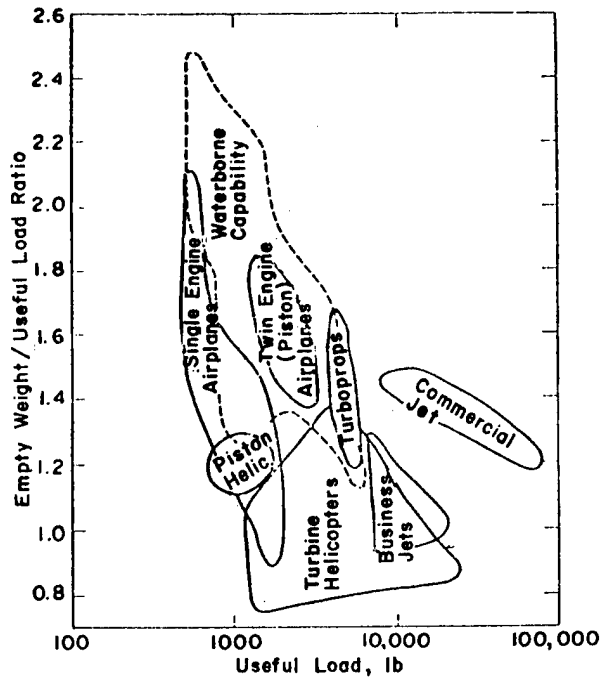

Figure 18

Typical Values of Empty Weight Ratio (HTAs)

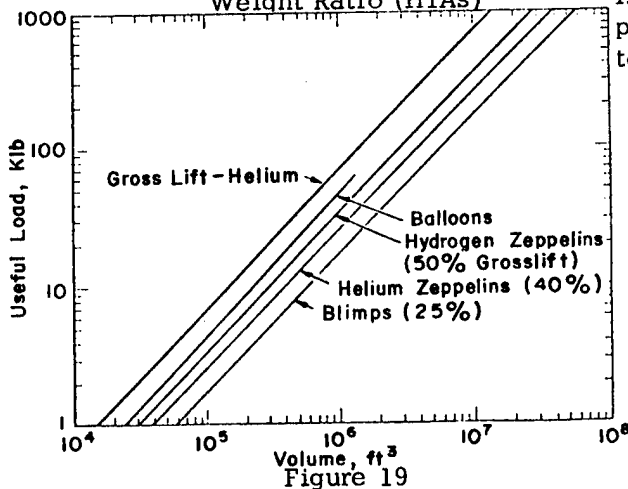

Figure 19

Useful Load Capabilities of LTA Craft

Lighter Than Air Craft

The Heavier Than Air types represent the overwhelming preponderance of aircraft. Their number and variety present a large base for statistical weight analyses but the Lighter Than Air (LTA) types are so few in number that a statistical analysis could be misleading particularly when most examples of the art represent obsolete practices. On the other hand, in some respects, the LTA types are simpler to analyze. For example, while the Heavier Than Air types are subject to the cube-square law, the static lift of an LTA type increases as the cube of its size right along with its empty weight, so that the efficiency of a giant machine should be no less than that of a small machine. Indeed, a plot of the limited data available (Figure 19) confirmed the linear (cube-cube) relationship to such a remarkable degree that it suggests more confidence in the ability to develop a weight rationale than was originally expected. The scatter of data points was so little for each discrete type of LTA as to provide certain insights regarding LTA potential on the basis of these observations:

- o The useful load ratio of rigid types of LTAs (Zeppelins) is considerably higher than for the nonrigid types (blimps). Useful-to-gross weight ratios of 40 to 50 percent are typical for Zeppelins, while blimps seldom exhibit ratios of better than 30 percent. (Blimps were not found inherently cheaper than rigid types either.)
- o The higher (50 percent) useful weight fraction for Zeppelins is associated with the hydrogen-filled types, while the 40 percent value is associated with the helium-filled types. The

difference cannot all be accounted for by the 7 percent increased lifting ability of hydrogen. A small remainder is probably due to a somewhat more conservative design practice on the later American (helium-filled) models versus the earlier European (hydrogen-filled) models.

- o Nonvehicular-type LTAs (weather balloons, logging balloons, tethered Aerostats, etc.), manufactured with more modern materials and engineering than found in present blimps, attain useful load fractions of approximately 70 percent. To obtain a fair comparison with Zeppelins and blimps, of course, it would be necessary to add a propulsion system, fuel, and a "car" which would reduce the useful load values below those of Zeppelins but probably above existing blimps.

For the purposes of this study it was necessary to obtain representative weights of LTA elements. Furthermore, the LTA elements for hybrid types are not like conventional shapes for dirigibles or blimps but are of shapes closer to that of airplane wings. While structural shapes of almost any configuration can be attained with

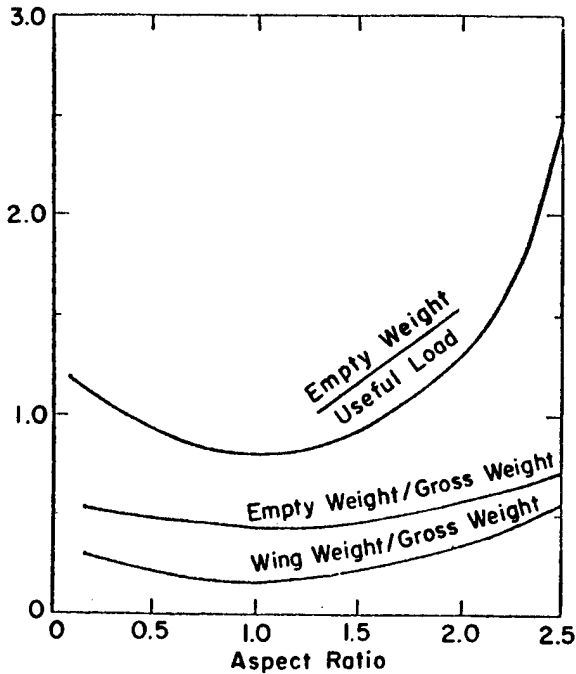

Figure 20
Typical Weight Characteristics of Hybrid Aircraft (Fixed 'Wing' - Combined Elements)

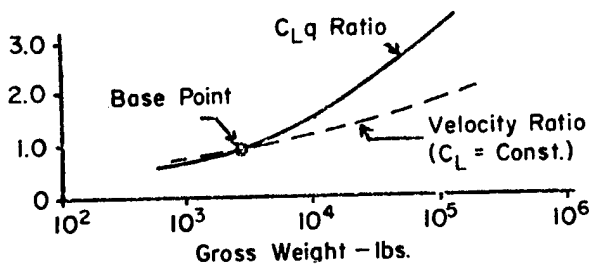

Figure 21
Size Effect on Hybrid Aircraft

be increased to obtain a larger C_L margin. Both of these approaches would tend to increase "wing" weight. As size increases, there would appear to be less incentive to combine dynamic and static lift elements and favor separate elements. This is dramatically illustrated by Figure 22 and 23 which show, respectively, wing loadings

inflated structures, nothing was discovered that would indicate their superiority in weight, performance or cost except for the simpler (spherical) shapes. Since more data was available on metallic structure than on fabric, the weight was estimated as if the structure were rigid. Figure 20 illustrates the weight picture for "Fixed Wing" combined element hybrids.

EFFECT OF SIZE

While airplanes follow a cube-squared law and become less efficient as size increases, dirigibles follow a cube-cube law and tend to maintain a constant useful load/gross weight ratio, regardless of size variations. The hybrid exhibiting certain of the characteristics of each, would be expected to fall between the two.

The wing area ratio between two geometrically similar hybrid machines (i.e., those with identical values of p , AR , and t) varies as the $2/3$ power of their volume ratio. In other words, as the size increases, the wing area grows only as the $2/3$ power of the buoyant (static) lift and the dynamic wing loading of the larger machine is greater than for the smaller machine. Either its minimum flying speed or its lift coefficient must be increased. (See Figure 21.)

Alternately, instead of maintaining similarity, the wing area could be increased (at the same volume) by decreasing the thickness ratio; or the aspect ratio could

for a fixed wing hybrid and disk loadings for a rotary wing hybrid.

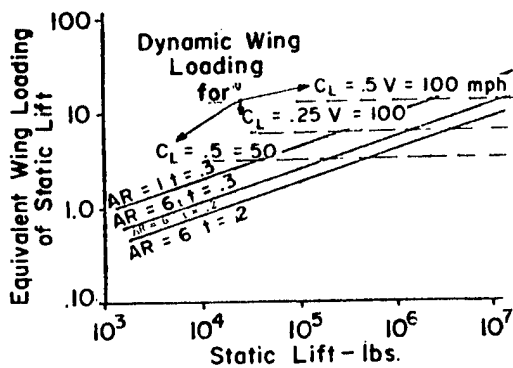

Figure 22

Equivalent Wing Loadings of Static Lift

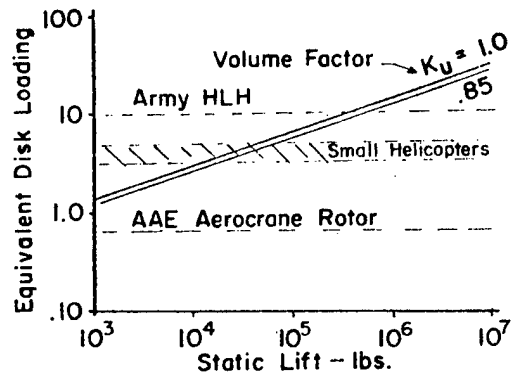

Figure 23

Equivalent Disk Loadings of a Spherical LTA Lifting Body

In the first figure, the static lift equivalent wing loadings are shown in solid lines for several combinations of aspect ratio and thickness ratio. Superimposed (in dotted lines) are the dynamic wing loadings corresponding to the lift coefficients and forward velocities indicated. Note that as the static lift capability approaches a million pounds that the static "wing loadings" become equal to the dynamic wing loadings. In other words, the LTA elements become as "compact" (planform wise) as the HTA elements.

The same characteristic is illustrated in the second figure for a rotary wing hybrid. In the case of All American's "Aerocrane," the rotor system (the dynamic element) for a 50 ton payload model has a disk loading of only 0.6 lbs/ft² but the center balloon has an equivalent disk loading of approximately 5.5 which is higher than most existing helicopters (the Army's heavy lift helicopter had a specific design limit of 10 lbs/ft²).

The planform densities of both fixed wing and rotary wing versions of the hybrid increase with the 1/3 power of the Static Lift, L_s:

$$\text{Fixed Wing Static Loading} = f\left(\frac{t^{2/3}}{AR^{1/3}}, L^{1/3}\right) \quad (5)$$

$$\text{Rotary Wing Static Disk Loading} = f(L^{1/3}) \quad (6)$$

The thickness ratio and aspect ratio obviously drop out of the rotary wing case, at least for configurations where the static lifting element is an essentially spherical balloon as in the "Aerocrane."

PROPULSION SYSTEMS

The combination of LTA elements and large size has a devastating effect on the propulsion problem. The problem can be appreciated by an examination of the equation for the torque requirement for a rotor (or propeller) per lb of thrust.

$$Q/T = \sqrt{T} \left(\frac{K_1}{V_T} + \frac{K_2}{\sqrt{DL}} \right) \quad (7)$$

Note that this equation is not non-dimensional but includes the thrust (i.e., size) to the 1/2 power. Typical cases have been plotted on Figure 24.

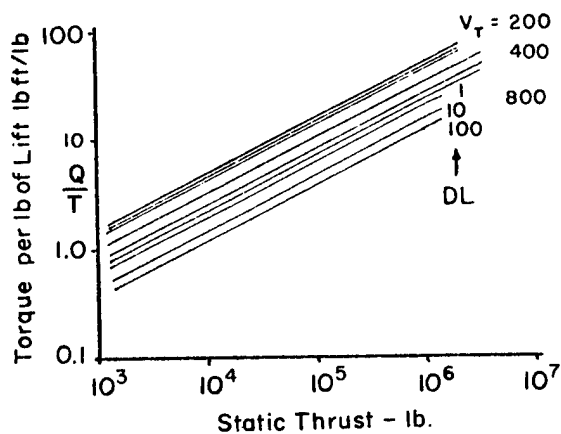

Figure 24
Rotor Torque Requirements

Note that as the thrust requirements increase from, say, 3,000 lbs to 300,000 lbs, the torque increases from approximately 1 lb-ft/lb thrust to 10! Torque requirements can be reduced slightly by increasing the tip speed (V_t) or the disk loading (DL) but these are second order effects. The basic size problem predominates! This torque problem has such severe effect on gear box weight that there is a real incentive to consider non mechanical drive systems particularly in the larger sizes. Reaction drive systems (pressure jets, tip engines, etc.) have been studied for years for heavy lift helicopters, but the large sizes of LTAs

and hybrids indicates a need to examine such drives for forward propulsion as well. In light of the characteristic speed spectrum, the forward thrust element most pertinent to LTAs and hybrids is the basic, open propeller (or rotor, in the case of the helicopter types).

For certain configurations, particularly fixed wing VTOL hybrids, ducted propellers or fans appear to offer many attractive features and must, of course, be considered. Ducting does lead to some size reduction, which improves compactness, particularly if the ducting represents an integral part of the airframe structure. As with disk loading or tip speed, however, ducting has only a second order effect on torque requirements and ducted propulsion or lifting systems cannot be expected to provide any significant weight saving over unducted systems. Their primary advantage is involved in the degree to which ducting contributes to the attainment of a practical integration of elements into a desirable overall configuration.

The severe torque problem of driving very large rotors, propellers and fans places the propulsion system right at the forefront of required technological improvements. In the case of the "Aerocrane" Heavy Lift System, tip mounted turboprops presently appear to solve the problem very effectively. For "Fixed Wing" Hybrids, no such obvious solution is available. Most LTA hybrid configurations merely suggest multiples of a conventional power pod driving conventional propellers, or, perhaps in the case of VTOL hybrids, multiple ducted fans.

Configurations which more fully integrate the propulsion and lift functions must be explored to determine if the problems of very large size are alleviated by such integration as opposed to maintaining separate functions.

The simplest integration objective would be to employ the propulsion system on a basic dirigible to reduce the aerodynamic drag by its effect on the boundary layer. Figure 25a illustrates the simplest case of a single conventional (though large) propeller or rotor in the pusher mode so that it tends to prevent boundary layer separation over the aft portions of the vehicle.

Figure 25b illustrates a configuration inversion in which the propeller is ducted and employs drastic diffusion to attain good propulsion efficiency from a small, light-weight propeller. A judicious choice of inlet location allows effective boundary layer management and the lack of external diffusion on the afterbody is also favorable toward maintaining a stable boundary layer. This configuration should also

provide inherent directional and pitch stability without tail surfaces. Also, the larger internal gas volume aft result in a rearward shift of the center of life compared to conventional shapes. This is good.

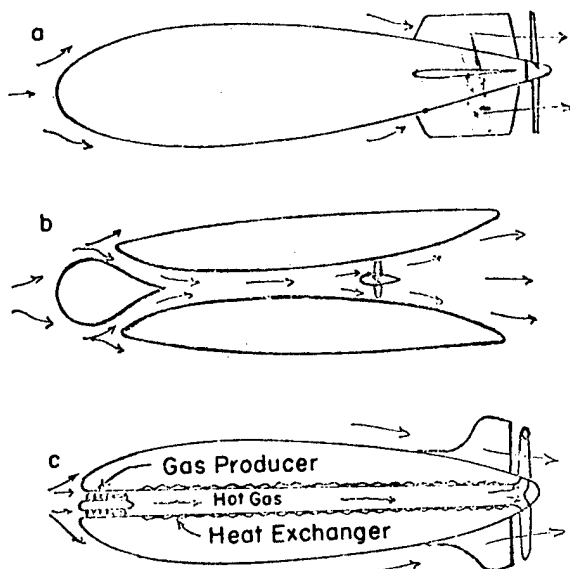

Figure 25
Aero/Propulsion Integration
Systems for Dirigibles

Finally, of course, one can consider exotic cycles. Figure 25c illustrates a system in which lightweight turbine gas generators produce the hot air which heats the lifting air or gas by a heat exchanger and then, after partial cooling, provides the propulsion at a high propulsive efficiency with a warm cycle pressure-jet driven propeller.

Alternately, steam cycles can be envisioned in which the steam first provides propulsion via a turbine and then passes to the lifting "bag" (cell or shell) where it produces lift and then condenses to return to the "boiler."

Of course, one can even speculate on the possibility of envelope materials attaining a $1,000^{\circ}\text{F}$ temperature capability thus making hot air as economically attractive for commercial operations as it has been for sport ballooning.

CONCLUSIONS

The very nature of a hybrid aircraft defines them as "light" aircraft and regardless of their size or configuration they may be synthesized from rather simple state-of-the-art elements which are well enough defined as to allow accurate overall parametric and detailed performance estimates.

The two primary problems involved in exploiting hybrid aircraft are: to define otherwise impractical missions and operations which become economically viable on the basis of applying LTA technology and then to tailor optimum hybrid aircraft around such missions. It is most important to fully appreciate the operational handicap associated with any vehicle which requires the use of ballast and how the elimination of ballast narrows the choice of configuration to those very few which can attain a suitable loading and efficiency balance between aerodynamic, aerostatic and propulsive elements.

REFERENCES:

1. Nichols, J.B. and Doolittle, D.B., Hybrid Aircraft for Heavy Lift, AHS Paper #814. (May 1974).
2. Nichols, J.B., Advanced Logging Concepts, Aerospace Report ATR-72 (57266)-2. (21 Mar. 1972).
3. Nichols, J.B., Evaluation of All American Engineering Co. "Aerocrane" - A Hybrid Aircraft Heavy Lift System. Aerospace Report ATR-74 (7291)-1. (Oct. 1973).
4. United Technical Industries - Series of Unpublished Reports on Hybrid Aircraft. (1971-1974).

N76-15052

A SEMIBUOYANT VEHICLE FOR GENERAL TRANSPORTATION MISSIONS

C. Dewey Havill*
Michael Harper**

ABSTRACT: The concept of small, semibuoyant, lifting-body airships is discussed. Estimates of important performance characteristics are made and compared with other flight vehicle systems.

INTRODUCTION

This paper discusses the concept of a small, semibuoyant, lifting-body airship with either a disposable or nondisposable buoyant fluid. Estimations of fuel consumption, payload capability, power requirements and productivity are made and compared to other flight systems. Comparisons are made on the basis of equal cost vehicles. The assumption is made that, to a first-order approximation, the costs of developing, procuring, and operating a commercial air transport vehicle are proportional to vehicle empty weight. It must be noted that no historical cost data exist for the lifting-body airship and therefore these comparisons must be considered preliminary.

VEHICLE CONFIGURATION

The vehicle configuration that was studied is shown in Figure 1. It is the NASA M2/F2 space reentry vehicle, which has been flight-tested in a gliding mode and

*Aerospace Consultant, formerly with NASA-Ames Research Center, Moffett Field, CA.
**Aerospace Engineer, NASA-Ames Research Center, Moffett Field, CA.

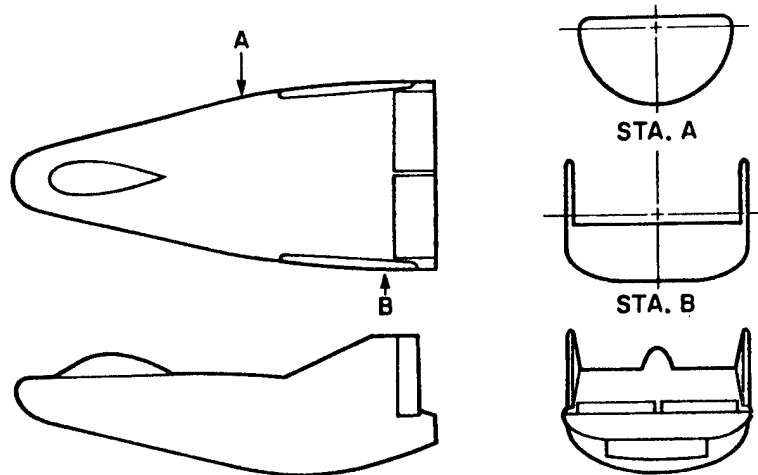

Figure 1
M2/F2 Lifting Body

extensively tested in wind tunnels. It was chosen because of the extensive amount of aerodynamic data available, but as an airship it may be inferior to a different configuration optimized for that purpose.

VEHICLE SIZE

The vehicle that has been studied most thoroughly has a length of 200 ft and a volume of 373,000 ft³. This is quite small relative to airships in general and would seem to contradict the widespread belief that airships become more efficient as their sizes increase. However, this belief is not borne out in Figure 2, which shows data for 75% of all commercial rigid and nonrigid airships ever built. These data indicate no change in structural efficiency with size for more than an order-of-magnitude size change with nonrigid airships, and almost an order-of-magnitude size change with rigid airships. The dashed lines in this figure indicate the three-halves scaling law. Therefore, the penalty associated with small vehicles does not appear to be real. This is important to the small vehicle concept because the smaller capital investment costs, compared to those of large dirigible concepts, allows a broad range of operational experience to be obtained without excessively high economic risk.

BUOYANT FLUID

The choice of a disposable or nondisposable buoyant fluid must be made on the basis of the vehicle operation at cruise. If a vehicle must fly around storms instead of over them, and around mountains instead of over them, then severe limits are placed on scheduling and mission flexibility, especially at shorter ranges. However, when using a costly nondisposable buoyant fluid such as helium, introducing altitude capability results in reduced payload since only a fraction of the vehicle volume can be filled with helium at takeoff. The variation of useful lift as a function of altitude capability is shown in Figure 3. The lower curve corresponds to inert weight fractions of dirigibles of the 1930s, while the upper curve represents possible weight ratios that might be achieved with current or future technology. The severe payload reduction is apparent, as appreciable altitude capability is built into such airships.

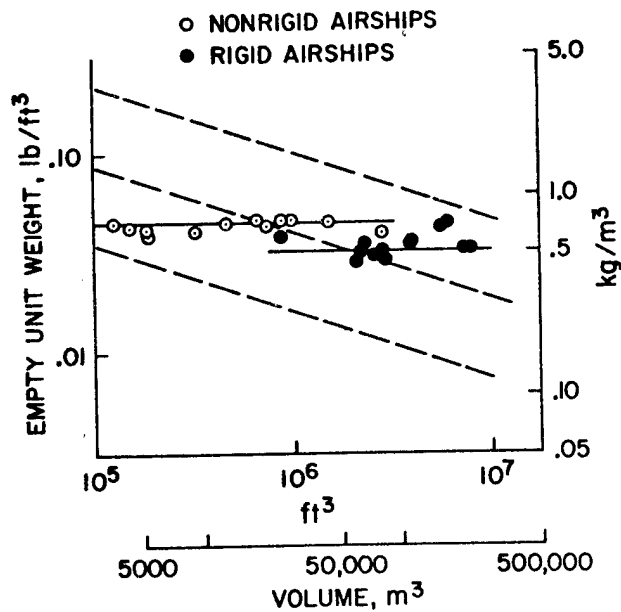

Figure 2
Empirical Weight Characteristics of Dirigibles

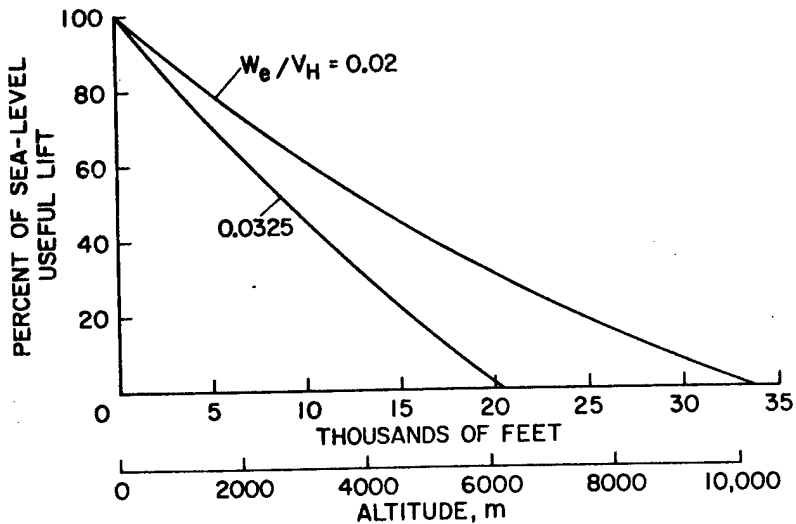

Figure 3
Lift Variation with Design Maximum Altitude

For a disposable fluid such as hot air, the unit lift at reasonable temperatures is less than helium, but regardless of altitude capability the vehicle is completely filled with fluid at takeoff. Therefore, if air is heated to a temperature at which its unit lift is half that of helium, and if an altitude capability is desired that limits the helium volume at sea level to one-half the vehicle volume, then takeoff lift for the two fluids is equal. Data are presented in Figure 4 showing the required temperature for hot air at which it has equal takeoff capability. It is obvious that if appreciable altitude capabilities are required, hot air at feasible temperatures can be equal or superior to helium in its lifting capacity. Also shown

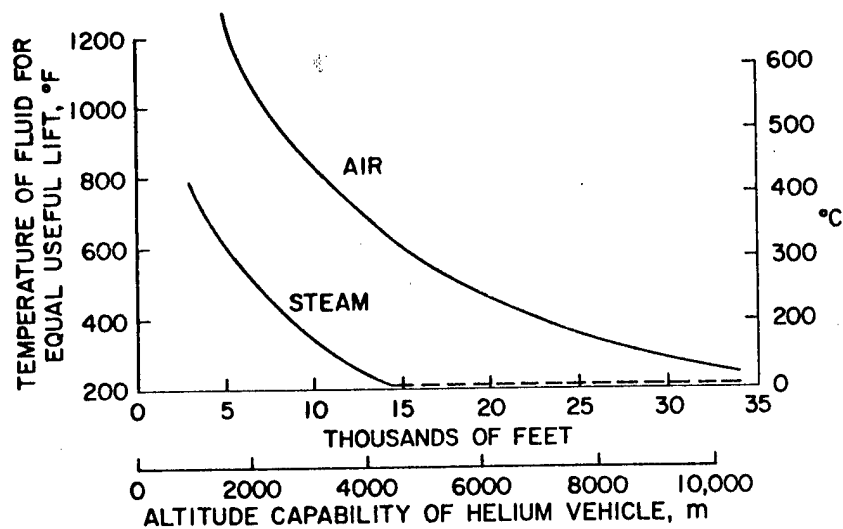

Figure 4
Temperature of Buoyant Fluid for Equal Takeoff Lift

in Figure 4 is the potential value of superheated steam as a buoyant fluid. At 600° F steam has greater lifting capacity than helium if altitude capabilities greater than 5000 ft are required.

It should be noted that generally the maintenance of heat in the fluid following takeoff might not be desirable, thus causing a reduction in buoyant lift at cruise. Furthermore, even if fluid temperature is maintained there is an appreciable reduction in buoyant lift at high cruise altitudes. This requires that additional lift be supplied aerodynamically during cruise, and since conventional airship configurations are very inefficient, aerodynamically, they are unsuited to the use of heated disposable fluids. Lifting-body configurations are suitable to such use since their aerodynamic lift-drag ratios can be as much as two-thirds that of conventional aircraft. The aerodynamic advantage of lifting-body ships may be somewhat offset by the structural weight penalty associated with their noncircular cross section.

FUEL CONSERVATION

Airships are considered desirable because of their good conservation and pollution-free characteristics. The best measure of these characteristics is the quantity of fuel used to transport a given payload through a given distance. In Figure 5, the proposed vehicle is compared to a number of other approximately equal cost air transport vehicles in terms of pounds of fuel per ton-mile of payload transported. The identification key for these vehicles is shown in Table I. It is apparent that if sufficiently low flight speeds are used, conventional dirigibles are appreciably superior in this respect. This is of questionable value since the speed range for such superiority is in the range where surface transportation systems can be used, and surface transportation systems should have lower fuel consumption. For speeds higher than practical ground transportation limits, the proposed hybrids are far superior to all other vehicles. Furthermore, while the hot-air vehicles are not quite as good as the helium vehicles, the difference might be easily outweighed by other performance characteristics.

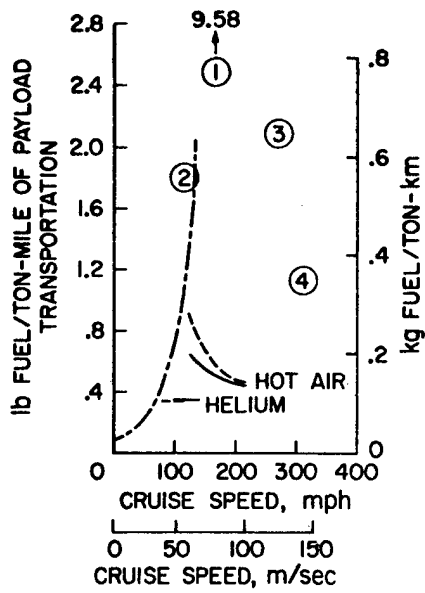

Figure 5
Fuel Consumption

TABLE I

Key for Figures 5 through 8

<u>Symbol</u>	<u>Vehicle type</u>
<u>HELICOPTER</u>	
1	Boeing-Vertol M114
2	Siskorsky S-64E
<u>TRANSPORT AIRCRAFT</u>	
3	Fairchild-Hiller FH-227D
4	G.D. Convair 600
<u>HYBRIDS</u>	
- - - - -	300° F Hot Air
_____	600° F Hot Air
<u>DIRIGIBLE</u>	

PAYLOAD

Another advantage commonly attributed to conventional dirigibles is an extremely high payload capacity. However, such payloads are a result of assuming extremely large vehicles. If approximately equal cost vehicles are again assumed, the results in Figure 6 are obtained. Here, payload for conventional airships is at best about equal to most Heavier Than Air vehicles. The data also indicate that, at higher cruise speeds, the payload capacity of the hybrid vehicles is superior to all other vehicles.

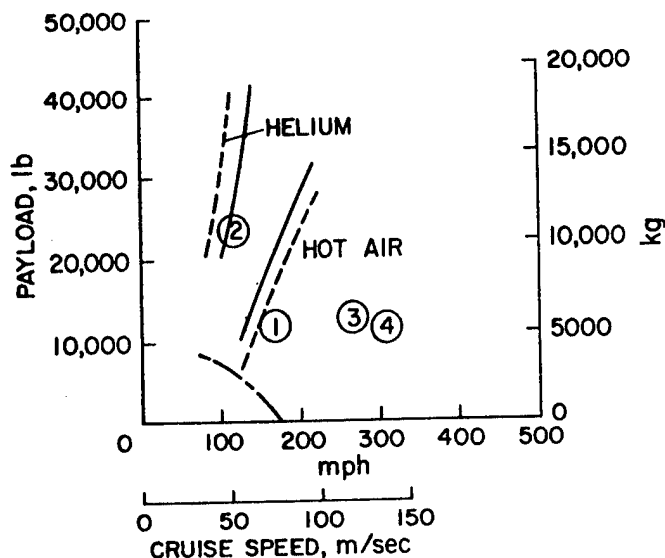

Figure 6
Payload Capability

POWER REQUIREMENTS

Since the hybrids being considered in these comparisons have a buoyant lift equal to only about 30% of their gross weight, 70% of the gross weight is lifted on takeoff by the propulsive system acting as a helicopter. One might conclude from this that power requirements for such vehicles are excessive. A comparison of the required horsepower per ton of payload (see Figure 7) shows that the power requirements for hybrids are less than or about equal to those for Heavier Than Air vehicles.

PRODUCTIVITY

While fuel conservation, pollution, payload capability, and power requirements have some significance generally, if economic factors or commercial viability are considered, the important factor is the quantity of payload transported over some distance in a given time. This quantity, called productivity, is shown in Figure 8. Herein lies the basic reason for many people resisting the return of airships. Heavier Than Air vehicles with about the same capital investment costs carry three to four times as much payload through a given distance in an hour, and thus have three to four times as much revenues. With such a large deficiency in productivity, dirigibles cannot hope to compete commercially with HTA vehicles in any mission that HTA vehicles can perform. However, the proposed hybrids have about twice the productivity of any other vehicle. Thus, their ratio of revenue to capital investment allows them to compete with HTA vehicles in conventional air transportation missions.

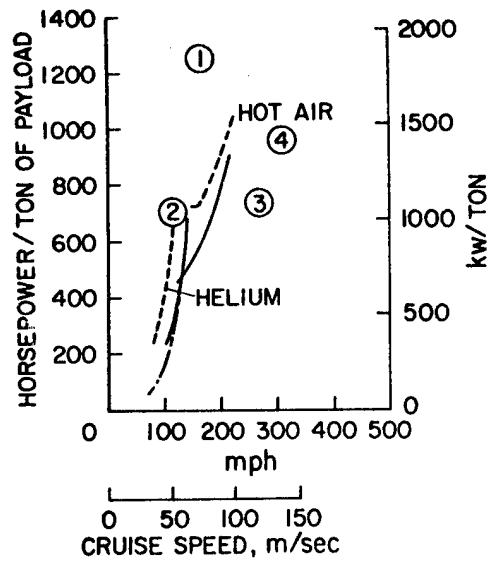

Figure 7
Power Requirements

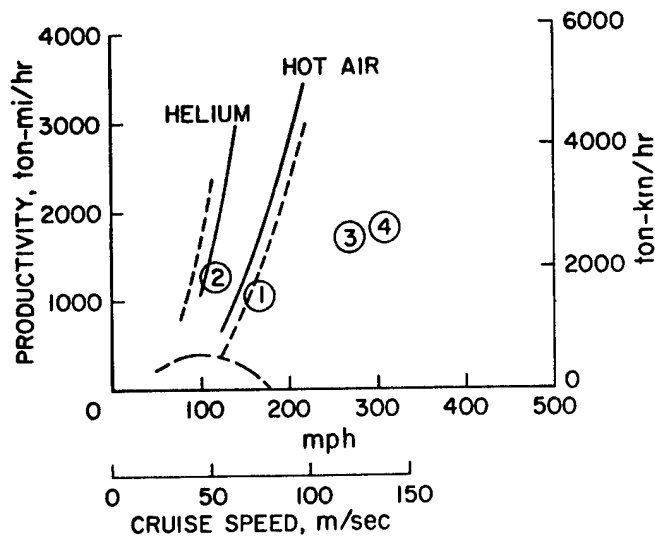

Figure 8
Productivity

In addition, their VTOL capability permits them to perform missions not possible for fixed-wing aircraft.

SPECIAL CONSIDERATIONS

Some other characteristics of LTA vehicles that are of significance in their evaluation are airfield requirements, unique missions, safety, and ride quality. Airship proponents claim that a dirigible, unlike commercial aircraft, only requires a level clearing with a mooring mast at the center. One should first consider the area

required. With reasonable safety requirements, the land area required for a 1000-ft-long dirigible is equal to the area of eight landing strips, 10,000 ft long. Furthermore, the eight landing strips will handle about 100 aircraft per hour, while only one dirigible can occupy this area during its time on the ground. Secondly, a simple cleared area is not sufficient since it must have a base to support cargo and cargo handling vehicles and any required ballast. Finally, except for the landing strips, commercial airport facilities are required for the handling of passengers and cargo, and there is no reason to suppose that such facilities would not also be required for passengers and cargo being transported by airship. However, reduced airport facilities might easily be factual where semibuoyant vehicles weighing three to four times as much as equal sized dirigibles are used. Such vehicles would not require mooring masts and would taxi from landing to loading area, leaving the former for use by other vehicles, as is the case with aircraft.

DEVELOPMENT FOR SPECIAL PURPOSE

Since conventional airships cannot compete economically with other commercial transportation systems, proposals have been made for their use in unique missions such as transporting power generators or transformers from factory to remotely located dam sites. While such proposals represent interesting solutions to some difficult transportation problems, it is difficult to support them if one examines capital investment costs and operating problems. Furthermore, it is difficult to envision enough unique missions to support any appreciable airship industry.

On the other hand, if conventional or hybrid airships were developed for some commercial purpose, they might have great utility in emergency situations as a rescue vehicle. In conditions generated by fire, flood, hurricane, or earthquake, one of the most severe problems is the loss of transportation routes. Frequently, the only way to provide rescue services when they are most needed is to use a VTOL air transporter with a high payload capacity. If airships are economically competitive and can be developed for conventional missions, then their availability during emergencies would be an additional value.

SAFETY

Probably the most significant advantage of LTA vehicles over HTA vehicles is their superior safety characteristics, and hybrid vehicles appear to be safer even than conventional airships. The hybrid, with its greater operational flexibility, can avoid the severe weather conditions that caused previous airships to come to grief. Even with complete power failure, impact speeds would be low. Without any great expense, completely safe systems could be developed for such impact speeds.

RIDE QUALITY

Due to the square cube law, motion stability and ride comfort improve as size increases. It was reported that the Hindenburg, with $7\frac{1}{2} \times 10^6$ ft³ volume, provided a more comfortable ride than any other transportation system in existence. It should not be concluded, though, that the proposed hybrids will have undesirable characteristics because they are small. The reason for increased ride comfort at larger sizes is the higher ratio of inertial mass to surface area. Since hybrids have three to four times the inertial mass of dirigibles, with the same surface area, such vehicles should have comparable ride quality with smaller sizes.

CONCLUSIONS

If the foregoing comparisons are valid, and hybrids will be economically competitive with HTA vehicles, then it is no longer necessary to invent unique or novel missions to justify their development. If the comparisons are correct, then such vehicles will be immediately useful in the broad spectrum of missions shown in Table II.

These estimates of general aviation aircraft indicate the use of 149,755 fixed-wing aircraft and 2,550 helicopters in 1975. If hybrids are economically superior, then most of the missions shown would be more effectively performed by them.

TABLE II
 Predicted General Aviation Aircraft in 1975

Use	Number of aircraft		Comments
	Fixed wing	Rotary wing	
Aerial application	6,200	350	Crop dusting, seeding and fertilizing, restocking fish, cloud seeding, etc.
Industrial/special use	1,900	400	Pipeline and highway patrolling, aerial surveying, emergency rescue, advertising, photography, helicopter hoist, firefighting, etc.
Air-taxi	12,100	900	Scheduled air-taxi, nonscheduled air-taxi, charter services
Business	31,250	900	Motives for justifying the acquisition of corporate aircraft are: Save valuable executive time Make own schedules Reliability, safety Reach off-airline cities Prestige
Personal	88,450		
Instructional	6,855		
Other uses	3,855		
Totals	149,755	2,550	

N76-15053

THE DYN AIRSHIP

William McElwee Miller, Jr.*

ABSTRACT: A brief history of Aereon Corporation and its research and development of hybrid aircraft, with preliminary projections of the advantages represented by a deltoid aerobody configuration, the "Dynairship".

Aereon Corporation has invented an "aerobody" which is a blend of two concepts:

- A buoyant-lift airship,
- A dynamic-lift lifting-body.

Historically, Dr. Solomon Andrews coined the name "aereon" (air age). A New Jersey inventor, he built and flew America's first directionally maneuverable aircraft over 100 years ago. It was a 3-hulled balloon, propelled first by gravity and then by buoyancy as he alternated the inclination of the hulls together with changes in the buoyancy. He also flew a second one before the company failed in the 1860's.

The present company--founded in 1959--took the name--Aereon--and built Aereon III during the early 1960's. A 3-hulled rigid airship,

* President, Aereon Corporation, Princeton, New Jersey

PRECEDING PAGE BLANK NOT FILMED

85' long, this vehicle demonstrated simple ground-handling. It was dismantled in 1967 after studies indicated a deltoid aerobody would be a superior configuration for a hybrid vehicle. It is a "lifting-body-airship," which we call the Dynairship.

Aereon has been innovating--with private funds, in an abandoned sector of aeronautical research for 14 years--that of airship development.

THE CONCEPTUAL BASIS

If the abandonment and subsequent neglect of airships was in part due to poor economics and operational problems, then innovation would be required, in technology, to overcome these. A more efficient and competitive airship could be developed; specifically:

1. There would need to be an advance in economics by:
 - a) an increase in the productivity of the vehicle, in payload and in speed;
 - b) a decrease in the man-machine interfaces, with a resulting lower labor cost.
2. There would need to be advancement in the art of airship operations, in several areas:
 - a) (Easy) Ground maneuvering and docking.
 - b) (Internal) Loading of bulky cargo and container-freight.
 - c) (Compatible) Flight operations within the existing airport and airways system and facilities.
 - d) (Maneuverable) Flight activity under adverse weather conditions.

Others previously had done work in areas suggestive, especially Dr. Solomon Andrews 100 years before; and N.A.S.A. had developed lifting-bodies for reentry from space, very compact fast vehicles.

THE AEREON APPROACH

Aereon III (Fig. 1), built 10 years ago, was a very ambitious attempt to combine many innovations at once. No wind-tunnel tests were done. The goal was to demonstrate all the innovations in the belief that resulting publicity would bring desired support. An accident to the aircraft cut short these hopes; but already Aereon III was superceded.

Aereon 26 (Fig. 2 - 5), the first "aerobody," evolved by a different philosophy, one which sought to achieve modest and limited goals in a series of steps; so that the greatest risk was assumed at least cost. Progressively larger costs were incurred as more became known about the aerobody. This was the sequence:

1. Parameters for an optimum hybrid aircraft were selected.
2. An optimization computer-search was done, to define the "aerobody" geometry.
3. Research and development then began with the plan to

proceed in 2 stages, consecutively:

- a) aerodynamics
 - b) aerostatics.
4. Aerodynamic research has centered on a series of ever-larger models of the "aerobody" leading to the smallest feasible manned experimental aircraft: Aereon 26.
- a) A balsa and paper model with rubber-band (20 cm.) was flown in a hangar in January 1968; A series of gas-engine powered 4' long radio controlled models were built and tested from spring 1968-1969; 7' model (R.C.) was tested in mid 1970.
 - b) A series of Wind-Tunnel tests during 1968-late 1969; Analog-computer simulation of Aereon 26.
 - c) AEREON 26 - heli-arc welded aluminum structure, aircraft cloth, aluminum sheet, strength-analysis (simple).
 - d) In late 1970 and early 1971 we moved the experimental aerobody to National Aviation Facilities Experimental Center (NAFEC) in New Jersey. Manned flight tests were conducted to obtain--not demonstration; but documentation as to stability and control, and performance.

This Program we called Project Tiger (Test Implementation Group Evaluation Report). It is the principal achievement of our company. It has been recorded accurately in "The Deltoid Pumpkin Seed"--a book which appeared first in New Yorker Magazine in 3 parts in February and which a large book club in the U.S. has recommended recently. This was the first public announcement of our flight tests. The book was not done for, or by, Aereon, however.

A 16mm. film of portions of these tests will be presented to this conference. It is the first such presentation to a professional audience. The exact data, however, is proprietary, and may not be released.

Significant findings include the following:

1. Performance was as had been predicted from previous analytical and experimental work. Phototheodolite recordings (at the National Aviation Facilities Experimental Center (NAFEC) a facility of the F.A.A.) verified performance.
2. Stability and control and handling qualities were good. A SFIM recorder on-board obtained precise data.
3. The pilot found the "aerobody" a docile and acceptable aircraft, within the limited scope of the tests.
4. In summary: --the "aerobody" is aerodynamically a feasible concept, and a basis exists for realistic studies of much larger such aircraft. The next step (and major milestone) will be the development of the Dynairship aerobody,

operationally to prove the concept of adding aerostatic lift to this aerodynamically proven configuration.

The final stage for translating the hybrid concept to reality will require the following general sequence, which Aereon is seeking to implement at this time.

1. Seek mission-definition for a (preferably) small hybrid aerobody, as a first step in a long-term plan to scale-up gradually (i.e.--in size of vehicle, cost incurred, development time) so as to control risk, gain from learning-curve benefits, and to develop economically the technology base for larger vehicles, and gradually to develop a market for hybrid aircraft generally.
2. Perform conceptual study of the suitability of the aircraft for performing a stipulated mission.
3. Analytical study of the structure weight and other questions basic to operating economics.
4. Design, build and test (evaluate) a prototype hybrid to determine operational suitability for the mission.

THE MAIN FEATURES OF THE DYNAIRSHIP

The Dynairship is half-way between the airplane and the airship (Fig. 6 - 10). It has much more aerodynamic lift than a comparable airship while, in exchange for this, it could not hover (by buoyant lift), which means it would operate from existing airfields normally and would be compatible with all (but high-speed) airplane traffic. Of course exceptionally large Dynairships (400 - 1,000' long) would require larger facilities. It would carry much more tonnage than the same-sized airship. Dynairship would be more maneuverable in air traffic and general operations including encounters with adverse weather. Dynairship would require smaller groundcrews and would land and taxi like an airplane. There would be a large gain in productivity over classical airship concepts for commerce of non-specialized loads. It would be less sensitive to wind-conditions for schedule-reliability and loading and unloading.

The Dynairship should be more energy-conservative than typical transport airplanes, with a lower ton-miles per hour productivity, but less thrust horse-power will be required and large cube-capacity for low-density cargoes or low-density fuels is available at no penalty to cargo space. Operating cost as well as acquisition-cost benefits may be realized were diesel engines to be made available.

In contrast to many airplanes, a hybrid aircraft offers a long-loiter capability at low fuel consumption while it could also have a top speed twice that of blimps. This combination is useful for patrol tasks, whether over cities or ocean spaces.

Aereon, lacking any widely-recognized criterion for estimation of airship structure weights (a basic element in cost estimates as well as operating economics), has assumed a structure-weight growth law following that of airplanes (Fig. 11). However, increases in size cause acquisition-cost benefits (Fig. 12) due to the growth of buoyant lift as a percentage of total lift and, at design-speeds of 150-200 mph, diesel engines substantially lower acquisition costs (theoretically). Such engines are not now in service.

Does the Dynairship configuration represent a specially effective design for a hybrid aircraft? Aereon's invention is based on the fact that it does. The significance is that the aerodynamic center occurs, in a highly-swept delta-body, near the 50% chord where the center of buoyancy also occurs, and where the "CG" is placed; and there is a minimum of trim control devices, therefore since there is a minimum disturbance to the stability of the deltoid Dynairship with speed changes, it is possible to carry a full range of tonnages at various speeds without major trim requirements. Maximum control authority is maintained under all normal flight maneuvers. Certain other planform shapes do not offer these inherent advantages but require energy-consuming, drag-creating means to provide trim. In sum, features of the Dynairship which represent capabilities of value are:

1. Improvement in performance over airships.
2. Improvement in energy-conservation over airplanes.
3. Potential benefits in acquisition cost.
4. Improvement in operational-efficiency over other hybrid concepts.

HYPOTHETICAL DYN AIRSHIPS (Fig. 13 - 14)

A Small Patrol Aircraft

Length: 50'	50 mph cruise; mission = 8 hour loiter with crew of 3 men and a speed range of 40 - 120 mph for aerial observation at low noise level and low fuel consumption with high crew efficiency and stable flight.
Gross (N): 4,000 lb.	
Power: 300 h.p.	

A Medium-Size Cargo Aircraft*

Length: 200'	150 mph cruise: mission = 90 tons of freight for a 1000 mile range, using medium to small fields, at energy-conserving levels of operation.
Gross (N): 270 T	
#200 = \$3,000,000.	

2-6
A Logistic Carrier*

Length: 1,000'

Gross: 4,200 T

#200 = \$65,000,000.

150 mph cruise; mission = 3,300 tons of bulk cargoes, or natural resources, from (or to) remote areas, under various weather conditions, to special airfields, where both large volumes and tonnages are required, at lowest effective acquisition cost per vehicle.

*Low confidence attached to preliminary estimates.

SUMMARY

With historical roots which are over 100 years old, Aereon Corporation, founded 14 years ago, has since then existed for the goal of developing aircraft which most effectively combine aerodynamic lift with aerostatic lift. Since 1967, the "aerobody" concept has been the means. (This could be described as an L.B.A.--a "Lifting Body Airship"--since it has no wings yet would develop substantial aerodynamic lift over the body.)

At first intuitively, then analytically and experimentally, the aerobody has been developed. Having determined--through a series of model tests and manned flight test--that it is aerodynamically and technically a feasible concept, the next major technical milestone is to develop and evaluate the aerobody in a larger size, in which buoyant lift would be significant.

Economic feasibility has not been established and must be investigated for a variety of missions, to which the capabilities of the conceptual aircraft-family may be suited. The helium-filled, delta aerobody we call the Dynairship, (or dynamic-lift airship). Its special features include:

1. Flight operations compatible with airplanes.
2. Economies in energy-consumption like airships.
3. Maneuverability improvement over airships and long-loiter improvement over airplanes.

Aereon's business is advanced airship-technology. We have, with our private funds, demonstrated our commitment. We have, alone in the world, flight-tested an optimized aerodynamic pre-prototype of the lifting-body-airship. Next, the Dynairship.

NOTE: All photographs and drawings copyrighted by Aereon, Inc. and may not be reproduced without permission.

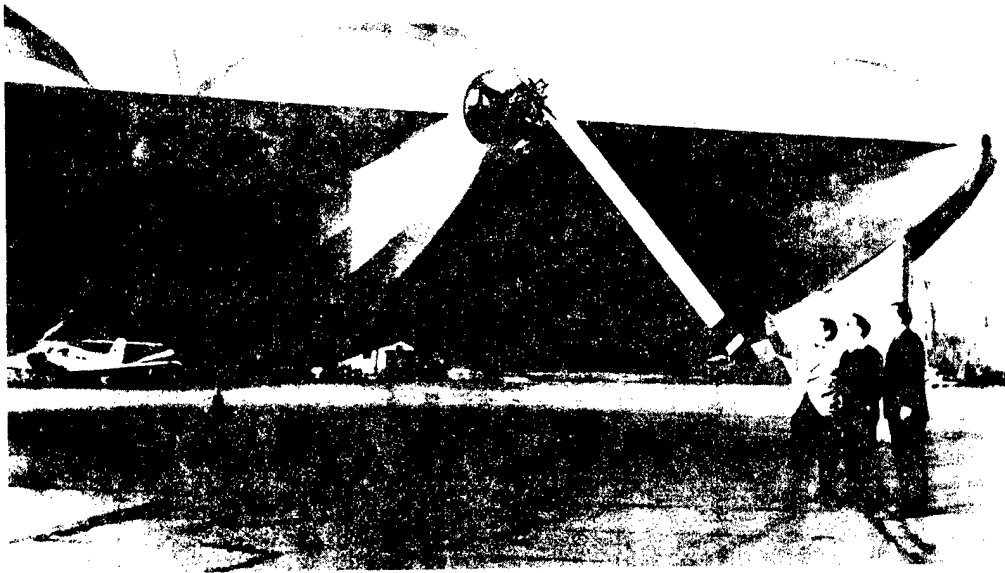

Figure 1. Aereon III, Mercer Co. Airport, Trenton, N. J.,
C. A. Beck, J. R. Fitzpatrick, M. Drew, Jr. (l.-r.), 1964

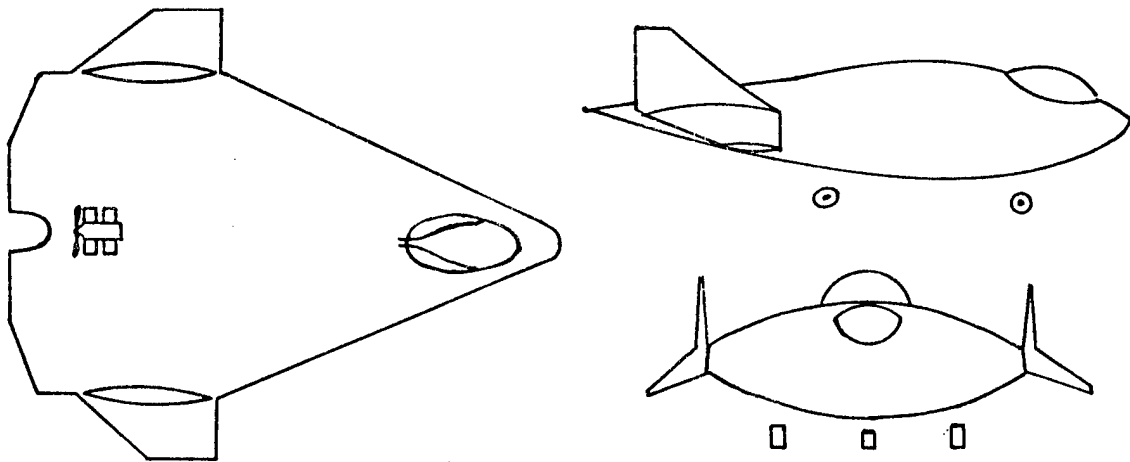

Figure 2. Aereon 26 Schematic

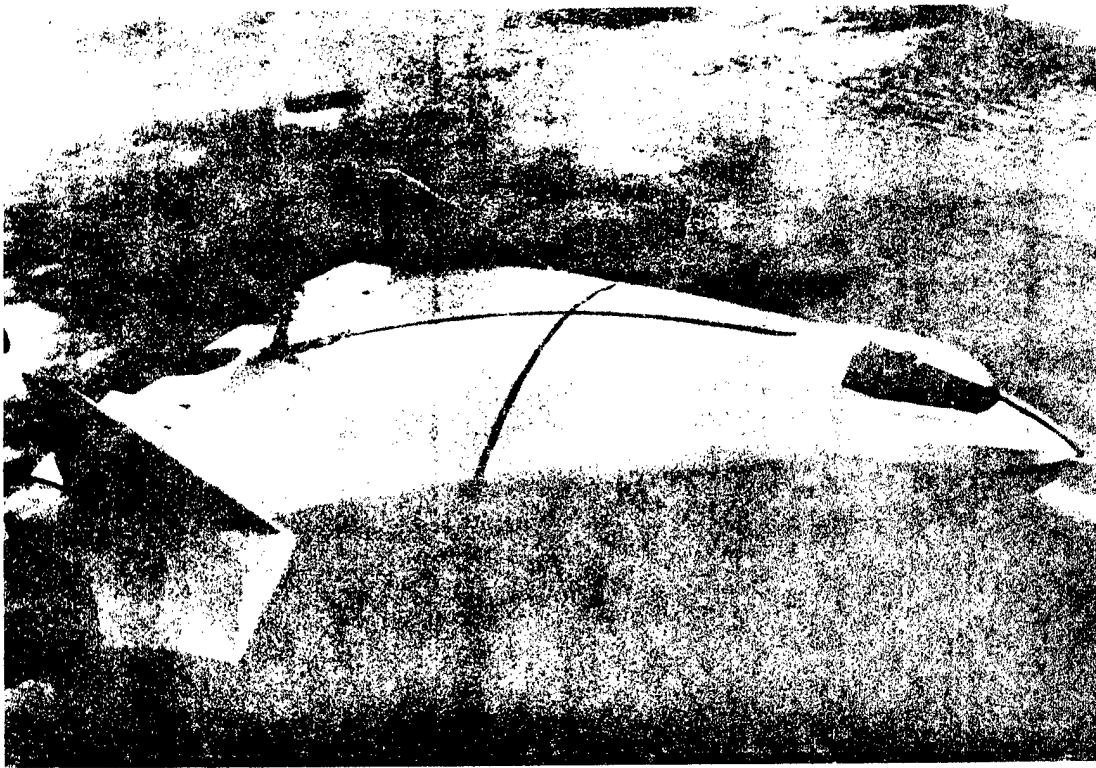

Figure 3. Aereon 26 During Ground Tests, Red Lion, N. J., 1969

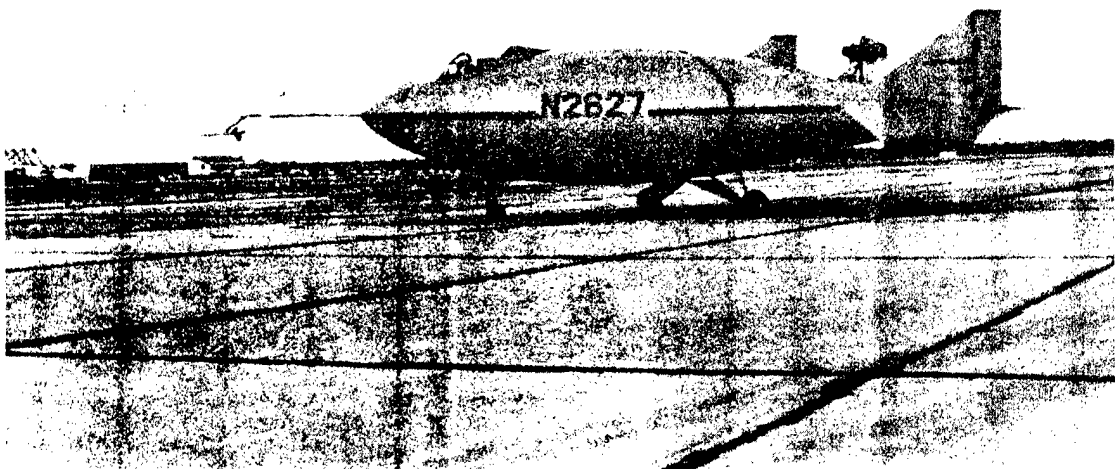
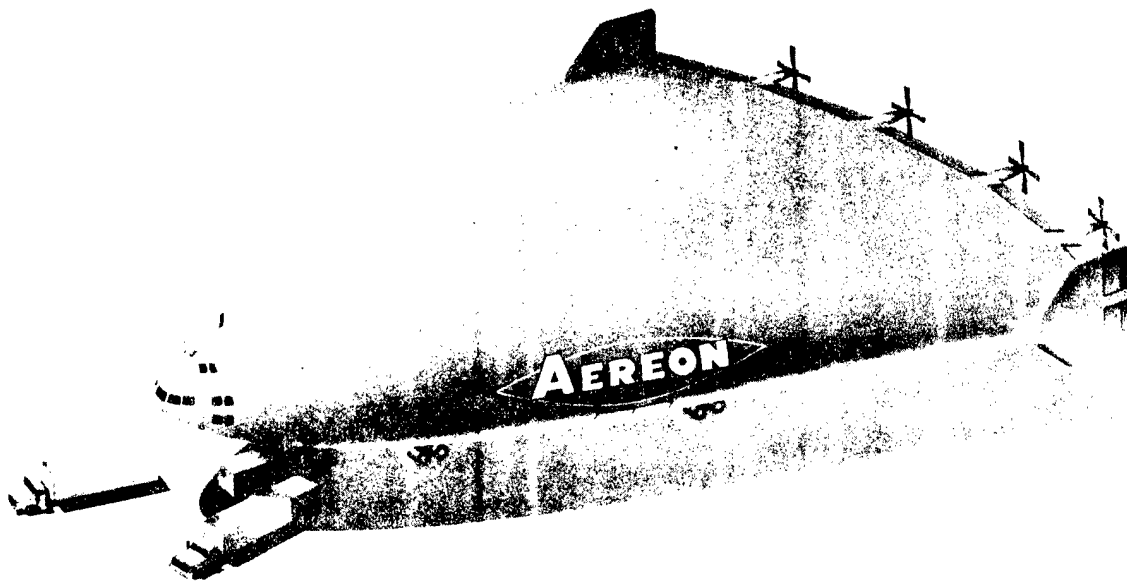

Figure 4. Aereon 26 Taxi Tests, NAFEC, Atlantic City, N.J., 1971



Figure 5. Aereon 26 in Flight, NAFEC, Atlantic City, N.J., 1971



" DYNAIRSHIP "

— AEREON, 1967

Figure 6. The Dynairship

THE APPROACH USED IN PREPARATION OF DISPLAYS
WHICH FOLLOW

- I. Assumptions made in range calculations of large Dynairships, i.e. 200 - 1,000 feet long.
- A. RANGE:
1. A Breguet range of 1,000 miles is assumed. This means that the quantity $\frac{1}{\text{SFC}} (L_D/D)$ remains constant throughout mission.
 2. The Breguet range is optimized by setting the cruising speed equal to the speed for max (L_D/D) , i.e.
 $V_{\text{cruise}} = V (L_D/D)_{\text{max}}$. This assumption defines the cruise lift coefficient.
 3. Fuel reserves of 15% of required fuel are assumed.
- B. AERODYNAMIC CONFIGURATION:
1. The basic aerobody shape is (optimally) cambered for maximum (L_D/D) , the condition of optimality being that the basic lift (due to camber) is equal to the additional lift (due to angle of attack). This implies different amounts of camber for different dynamic lift coefficients.
 2. All the effects of the camber variation on items such as volume, wetted area and structural weight have been neglected as a first approximation.
 3. The static lift, L_S , is assumed constant during the mission.
The static lift equation is $2.26 \times 10^{-3} \times \lambda^3$.
 4. An operating (mid-range) altitude of 10,000' assumed.
- II. Method used for calculation of Dynairship characteristics
- A. Cruising speed and overall size (V_{cruise} and ℓ) are independently assigned.
 - B. Static lift is calculated from the size (and volume).
 - C. Dynamic lift is calculated from speed and size. (C_{L_D} is determined from assumption I, A, 2 above)
 - D. The required cruise HP is then estimated for the aerobody optimum (L_D/D) .
 - E. The weight of the power plants (diesel and turbo-prop) is calculated given average PowerPlant Weight ratios.
SHP Installed
 - F. The required fuel is calculated from the S.F.C. of turbo-prop and diesel powerplants.
 - G. Structural weight is evaluated from the Structural Weight Growth Law.
 - H. Payload is calculated using mid-range fuel (half fuel + 15% reserve).
 - I. Powerplant and structural costs are estimated from average $\frac{\$}{\text{HP}}$, and $\frac{\$}{\text{lbs. of structure}}$ ratios.
Structural costs are based on 200th aircraft.
 - J. Finally, Energy-Effectiveness and Acquisition-Cost Effectiveness are estimated for the Dynairship.

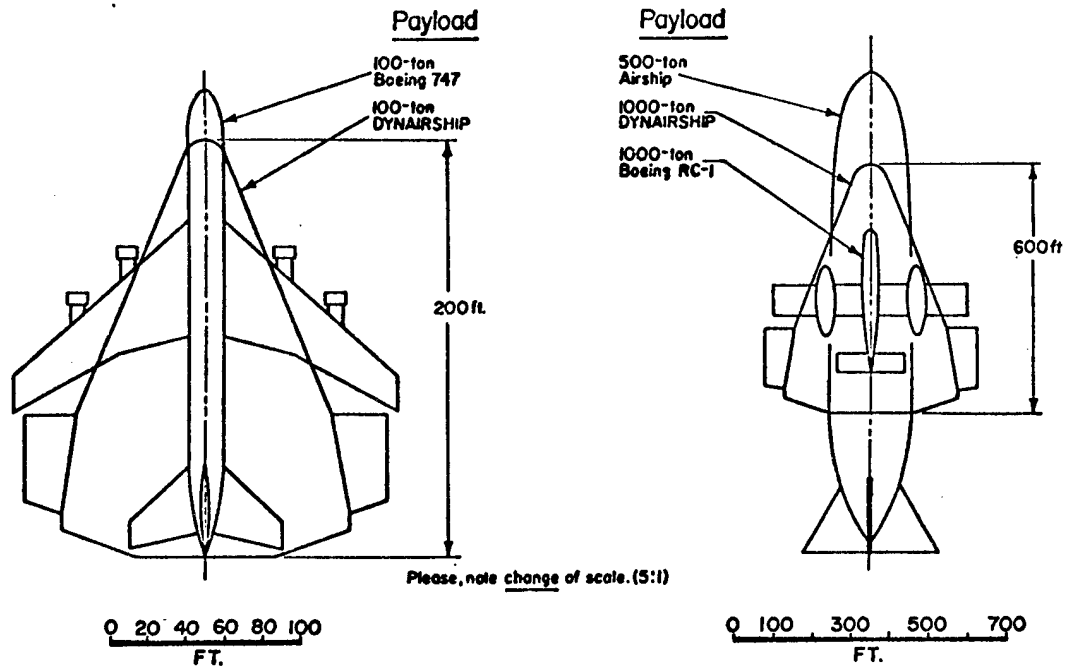

Figure 7. Dynairship Size and Payload Comparisons

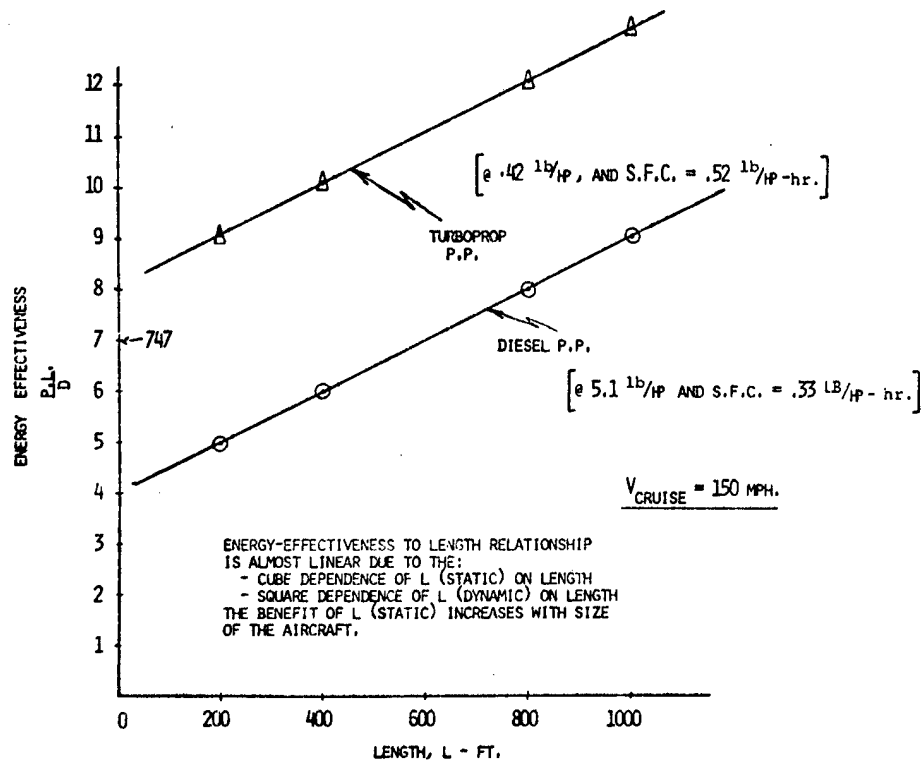

Figure 8. Dynairship Energy Effectiveness

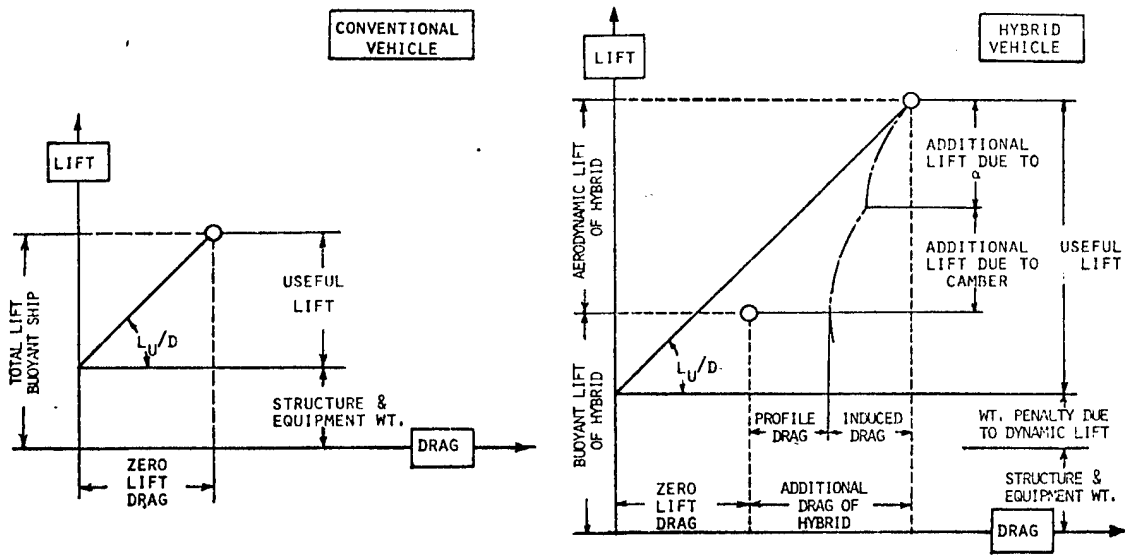

Figure 9. Useful Lift and Drag for Conventional and Hybrid Airships

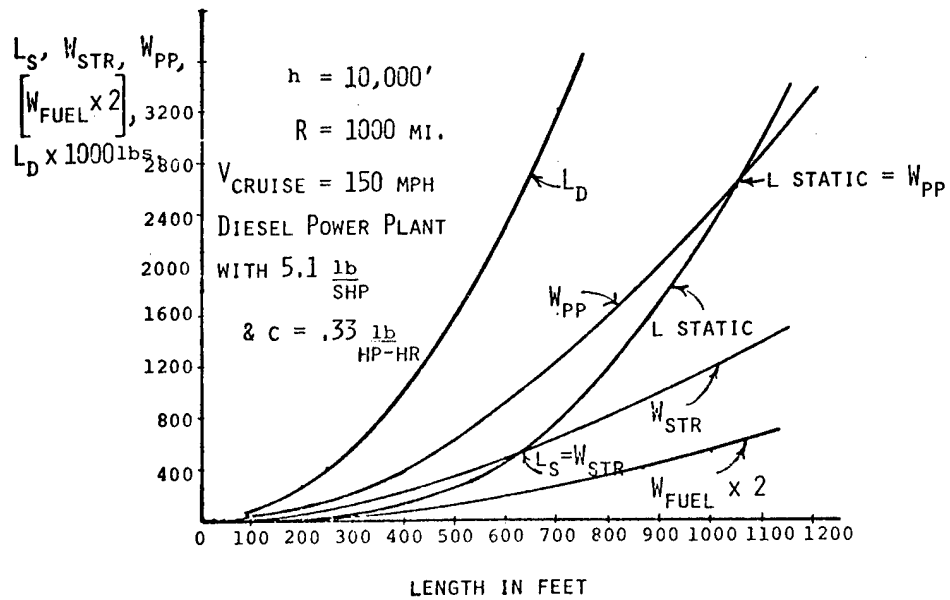

Figure 10. Dynairship Weights and Lifts vs. Size

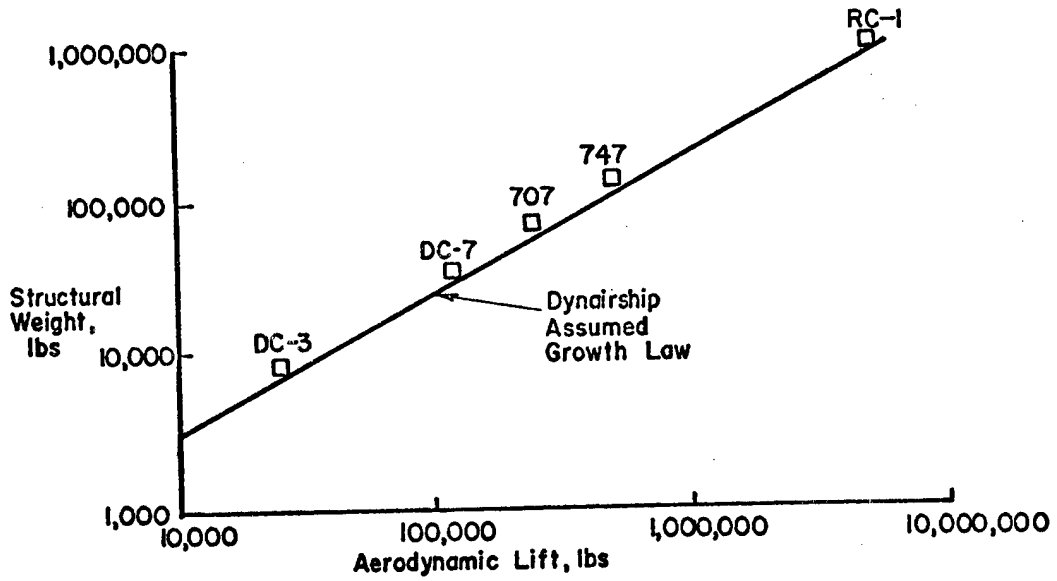

Figure 11. Structural Weight Growth Law

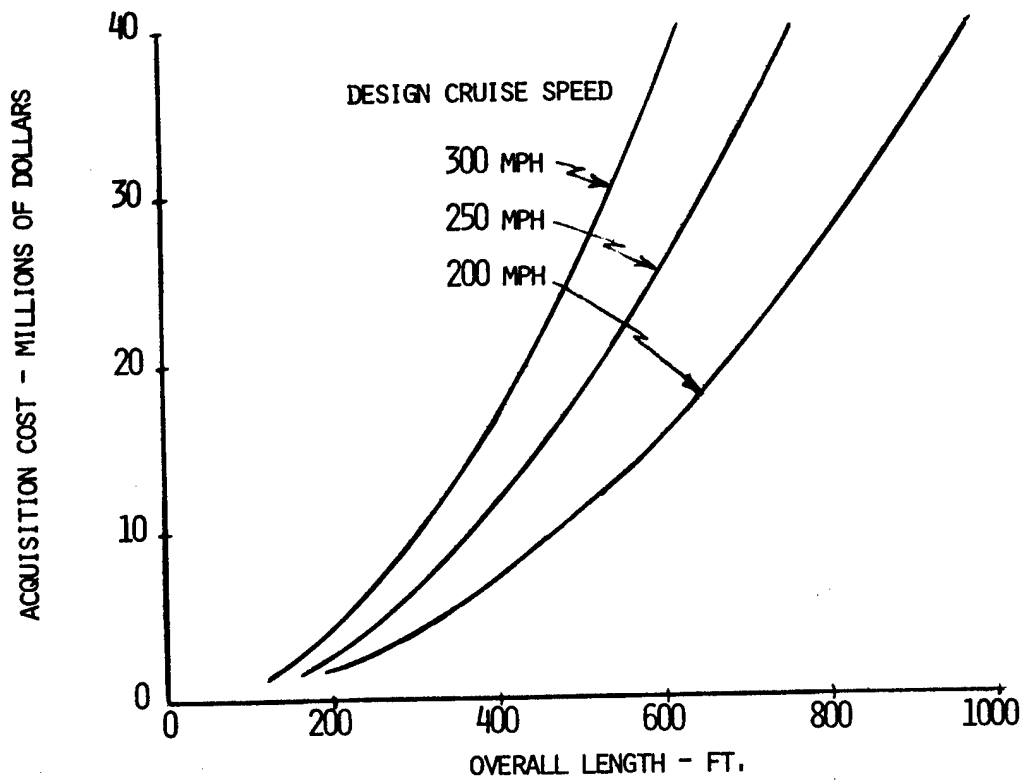
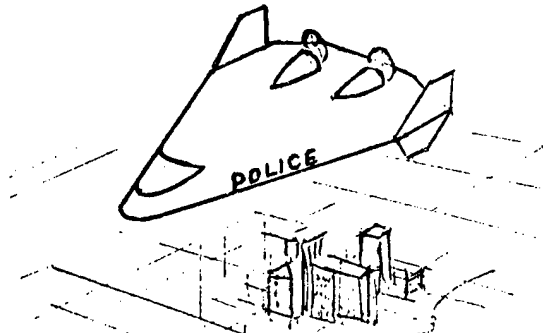

Figure 12. Dynairship Acquisition Cost (200th Aircraft)

PHASE I



- RESEARCH
- SURVEILLANCE

PHASE II

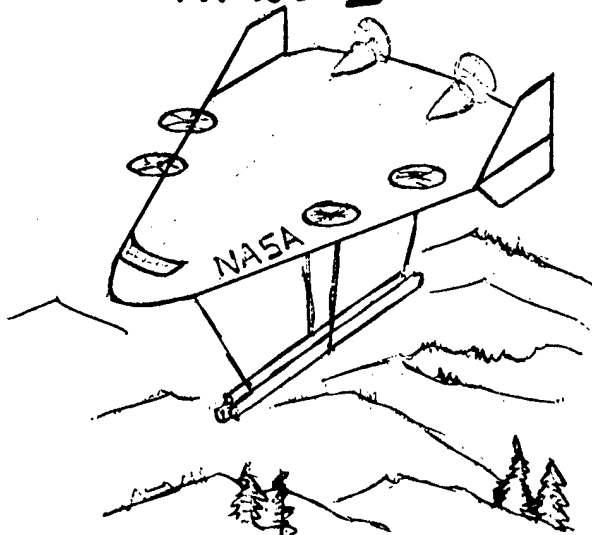

- RESEARCH
 - SYSTEMS (V/STOL)
 - ECONOMICS
- COMMERCE
 - BULK LIFTER
 - MASS TRANSPORT

PHASE III

REMOTE AREA LOGISTICS

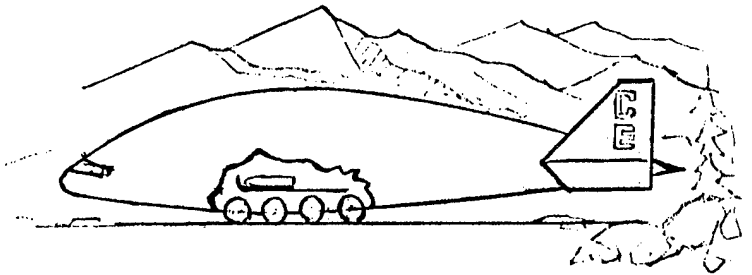

OCEANIC SURVEILLANCE

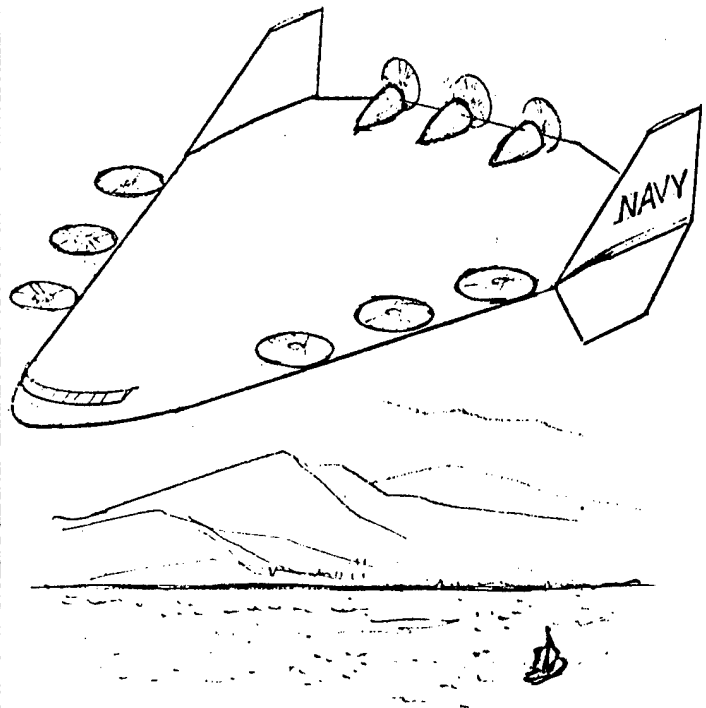

Figure 13. Phased Development for Dynairships

Figure 14
A PATROL AEROBODY

What is the 'aerobody' and how is it innovative?

1. A hybrid, a mix of aerostatic with aerodynamic lift, the 'aerobody' is a lifting-body of deltoid planform, elliptical cross-sections, and a fineness ratio of 4:5. Body geometry was derived from a computer-assisted optimization-search program. Several patents covering key aspects of this invention have been issued to Aereon both in the United States and abroad.
2. In operation, it is stable with acceptable handling qualities. Characterized by a low body-loading, it is capable of very low-speed flight and STOL. As a partially buoyant vehicle it is sure, however, to be much more maneuverable than a blimp. (It would require powered-lift for hover, at lower loadings than for heavier-than-air craft.) It would operate much like a STOL airplane in lower speed flight, but with considerably less fuel consumption, being capable of protracted loiter at speeds of 30 - 50 mph. Dash speeds comparable to or faster than helicopters now in service (reciprocating), and certainly faster than blimps, are normal expectations for the 'aerobody.' This combination of features would permit shorter response-time from its loitering station to any urgent call to counter a threat due to a high state of readiness. A loiter-time of 8 hours is assumed.
3. Below are presented two representative STOL 'aerobody' configurations, not the result of experimental work but based on the projections made from analytical and experimental test data. The aircraft are basic, not adorned with lift-augmenting refinements. Therefore feasibility and preliminary design studies are in order, fully to apply the 'aerobody' concept to Police missions.

	SMALL	LARGE
OVERALL LENGTH	- 50 ft.	100
OVERALL WIDTH	- 40 ft.	80
NORMAL GROSS WEIGHT ¹	- 3,990 lb.	7,610
CARGO AND CREW	- 1,600 lb.	3,700
LOITER SPEED	- 50 mph	30
MAX. LEVEL FLIGHT SPEED	- 130 mph	75
INSTALLED POWER	- 290 HP	210
TAKEOFF DISTANCE OVER 50'	- 770	300

¹Gross Wt. is defined as Gross Mass x g.

SOME ASPECTS OF
HYBRID-ZEPPELINS

Paul-Armin Mackrodt*

ABSTRACT: To increase an airship's maneuverability and payload capacity as well as to save bouyant gas it is proposed to outfit it with a slender delta-wing, which carries about one half of the total take-off weight of the vehicle. An optimization calculation based on the data of LZ 129 (the last airship, which saw passenger-service) leads to an Hybrid-Zeppelin with a wing of aspect-ratio 1.5 and 105 m span. The vehicle carries a payload of 40 % of it's total take-off weight and consumes 0.8 t fuel per ton payload over a distance of 10 000 km.

INTRODUCTION

For the economical transportation of large payloads aerostats must have huge dimensions. The last german Zeppelin used for transatlantic passenger service LZ 129 "Hindenburg" from 1936 for example, had a length of 247 m (820 ft) and 41 m (135 ft) diameter and could carry 19 t of payload. Airships of such dimensions are in the air difficult to manœuvre and would therefore heavily impede the air traffic in the crowded air-space of industrial countries. They require sophisticated and expensive take-off and landing procedures (ground crews!) and are on the ground difficult to handle because of their extreme wind sensitivity. Most of these disadvantages can be avoided if a wing is added to the airship, which compensates a considerable part of the unbalanced weight of the vehicle by aerodynamic lift. So

* Dr. rer. nat., Flugwissenschaftliche Fachgruppe Göttingen e. V.
34 Göttingen, Germany

PRECEDING PAGE BLANK NOT FILMED

can not only be avoided the necessity of carrying a water ballast as maneuvering aid of more than twice the payload - 38.5 t in the case of LZ 129 - but also the let off of buoyant gas (usually helium) to compensate the loss of weight by consumption of fuel or in landing maneuvers.

Because such a vehicle is thinkable only as a rigid airship, I call it Hybrid-Zeppelin (abbreviated HZ in the following).

GENERAL CONSIDERATIONS

In order to keep the HZ easy to handle on the ground, the wing span should be small; for example 1/2 the length or less. Furthermore the structural weight of the wing should be low, in order to generate substantial more lift than it's own weight at the relatively low speed and therefore low wing loading of an airship. These two conditions are easily to meet with a slender wing, especially with a slender delta-wing. The poor lift to drag ratio of the delta-wing is slightly increased in the case of the HZ, because the thick body covers a large part of the whole wing area and only the relatively small exposed surfaces of the wings contribute to the frictional drag. The glide path angle ϵ of the vehicle is given by:

$$\epsilon = \frac{C_{Do} + C_{Di}}{C_L} \quad (1)$$

(Here are C_{Do} and C_{Di} the coefficients of friction drag and induced drag, respectively, C_L is the lift-coefficient). With the following three well known relations:

$$C_{Di} = \frac{C_L^2}{\pi A} \quad (2)$$

(A is the aspect ratio of the wing)

$$C_{Do} = C_F \cdot \frac{S_{WW}}{S} \quad (3)$$

(C_F is the friction coefficient, S the total wing area, S_{WW} the wetted wing surface):

$$S_{WW} = 2 \frac{(b-d)^2}{A} \quad (4)$$

(b is the span, d the main-spar diameter) and with the constant:

$$K = \frac{L_D}{q \pi \frac{d^2}{4}} \quad (5)$$

(L_D is the dynamic lift, q the dynamic pressure) one obtains:

$$\epsilon = \frac{C_L}{\pi A} + 2 \frac{C_F}{C_L} \left(1 - \sqrt{\frac{C_L}{\pi A K}} \right)^2 \quad (6)$$

The second term in equation (6) decreases with decreasing A , which is important especially at low C_L .

To calculate the performance of a possible HZ one has to start with the simple and well known conditions

$$L_D = C_L \cdot q \cdot S \quad (7)$$

$$\frac{N_C \cdot \eta}{V_C} = \left(\frac{C_L^2}{\pi A} + C_F \frac{S_W}{S} \right) q S \quad (8)$$

(N_C is the continuous power output of the engines, η the propeller efficiency, V_C the cruising speed, S the total wing area and S_W the wetted surface of the whole vehicle). Though the friction coefficient C_F is well known (see e. g. Ref. 1):

$$C_F = \frac{0.455}{(\log Re_l)^{2.58}} \quad (9)$$

(Re_l is the Reynoldsnumber based on body-length l) we have still only two equations and four unknowns. A third equation is obtained from the optimization condition, which requires ϵ to be a minimum with respect to the geometry of the vehicle. The connection with the geometric arrangement is given by Spreiter (Ref. 2):

$$C_L = \frac{\pi}{2} A \alpha \left[1 - \left(\frac{d}{b} \right)^2 + \left(\frac{d}{b} \right)^4 \right]^* \quad (10)$$

(α is the angle of attack, b the wing span)

The derivative of equation (4) with respect to $\frac{d}{b}$ leads to the minimum condition

$$\frac{C_L^2}{\pi A} = C_F \cdot \frac{S_W}{S} \quad (11)$$

*) This relation is strictly valid only for a slender wing-body combination with cylindrical tail. The negative lift of the conical tail of the HZ is, however, compensated by the horizontal stabilizers.

Now we have the three conditions (7), (8) and (11) for the four unknowns C_L , S (or b), N_C and V_C , which means, that one of them can or must be chosen free.

CALCULATION OF AN EXAMPLE

The following calculation of a practical example is based on the data of LZ 129 (Table 1, left column, Ref. 3, 4).

	LZ - 129	HZ
length	247.2 m	247.2 m
diameter	41.2 m	41.2 m
span	—	105 m
aspect ratio	—	1.5
static lift	214 t	198 t
dynamic lift	—	250 t
cruise speed	125 km/h	230 km/h
range	14000 km	10000 km
cruise power	3600 PS	20500 PS
<u>weights:</u>		
body	86.5 t	74 t
engines	5.0 t	18 t
fuel	65.0 t	149 t
ballast	38.5 t	—
wing	—	27 t
payload	19.0 t	180 t
take off	214.0 t	448 t

Table 1

Technical data of LZ 129 and HZ

To carry out the optimization, some of these figures are changed. Cruising speed was chosen according to a time-table that provides two weekly roundtrips Frankfurt - New-York - Frankfurt which yields $V_C = 64 \text{ m/s} = 230 \text{ km/h}$ (= 124 kn) in 3000 m (= 10 000 ft) altitude. A range of $R = 10\ 000 \text{ km}$ (= 5500 nm) is at this speed sufficient. It was also assumed that by use of modern materials and technologies the weight of the body in spite of the higher loads due to the higher speed can be reduced by 15% to 74 t. The calculation of the weights of engines and fuel is based on the technical state at the end of World War II (Junkers "Jumo 205 D", Ref. 5). The weight per horsepower was assumed to be 0.9 kp/PS and the specific fuel consumption 0.168 kp/PS h. (Use of 75% lighter gas-turbines is still prohibited because of their 35 - 40% higher specific fuel consumption).

Furthermore it should be regarded that the aerostatic lift of the body is reduced by 7.5% to $L_{St} = 198$ t when helium rather than hydrogen is used. For the calculation of wing weight, it was supposed, that the expected low wing-loading permits a lightweight construction wing, the weight of which is not greater than 10 kp/m^2 (related to the exposed wing area). Finally should be regarded, that for the calculation of friction drag the surface of the body was approximated by that of a rotational ellipsoid.

On the basis of these figures an optimizing computation was performed in the range $0.5 L_{St} \leq L_D \leq 2 L_{St}$.

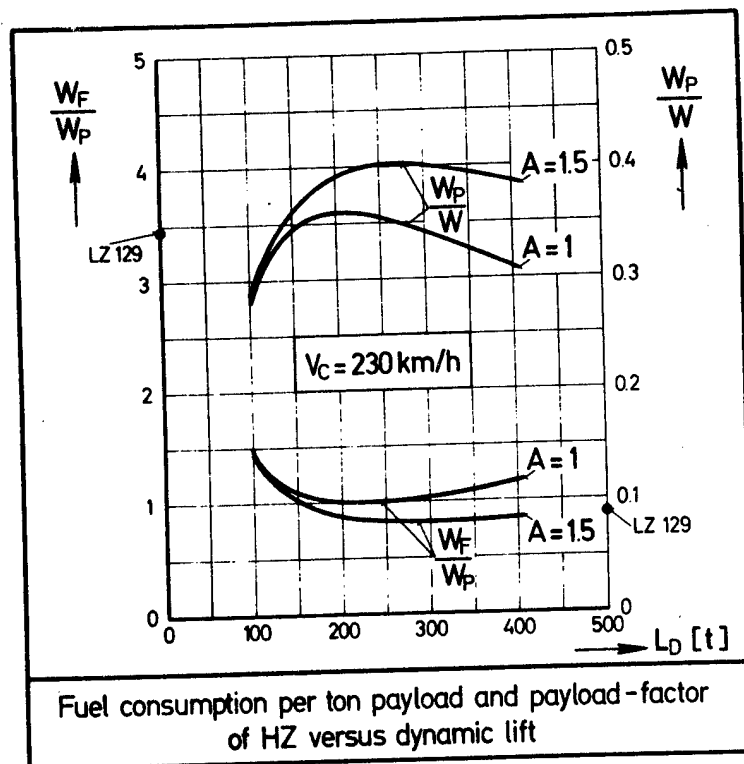

Figure 1

The computed results (Fig. 1) show, that the payload factor W_P/W (W_P is the weight of payload, W the total take-off weight) for $A = 1$ has a noticeable maximum of 36% at $L_D = 200$ t and the fuel consumption per ton payload W_F/W_P has a flat minimum of 1 at about 225 t dynamic lift. For $A = 1.5$ the optimum values are even more favourable and both met at $L_D = 275$ t, but the extrema are much less distinct. Furthermore for the two intermediate values of dynamic lift $L_D = 225$ t and $L_D = 250$ t the payload factor and the fuel consumption per ton

payload were calculated at $A = 1$ and $A = 1.5$ in dependence of the cruising speed V_C in the range $125 \text{ km/h} \leq V_C \leq 350 \text{ km/h}$.

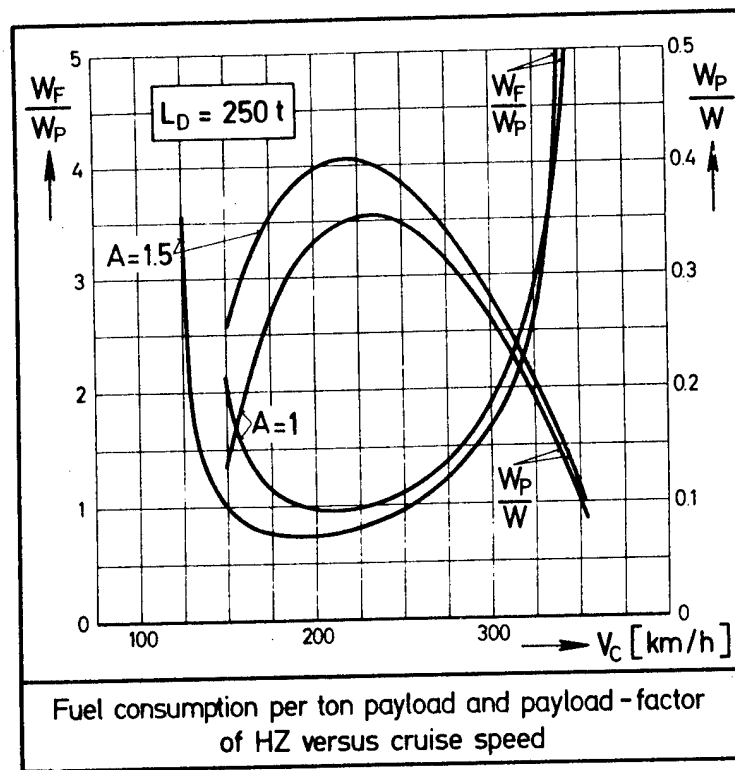

Figure 2

It can be seen clearly, that the heavier HZ (Fig 2) meets the optimum values at slightly higher speeds than the lighter one (Fig. 3), and that the payload factor of the HZ with $A = 1.5$ is at all speeds considerably higher (and the fuel consumption per ton payload lower) than the corresponding figures of the HZ with $A = 1$. The wing-loadings are $L_D/S = 25 \text{ kp/m}^2$ at $A = 1$ and 35 kp/m^2 at $A = 1.5$ and, therefore, confirm our expectations.

The general arrangement of a possible HZ with $L_D = 250 \text{ t}$ shows Fig. 4. The dorsal fin (and rudder) is considerably enlarged compared with that of LZ - 129 to gain lateral stability even if the ventral fin is deleted to provide ground clearance during take-off at high angles of attack. Possibly it can become necessary to apply small canard wings (eventually retractable) to improve take-off performance. The arrangement of propellers (engines will be hidden in the body) is not depicted, because the HZ is supposed to demonstrate only an aerodynamic concept and not a concrete project.

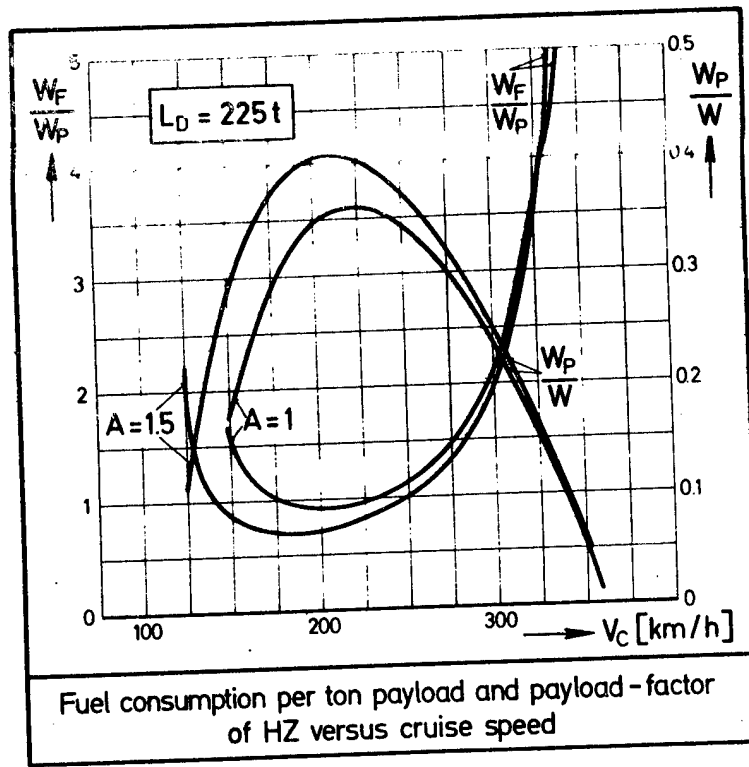

Figure 3

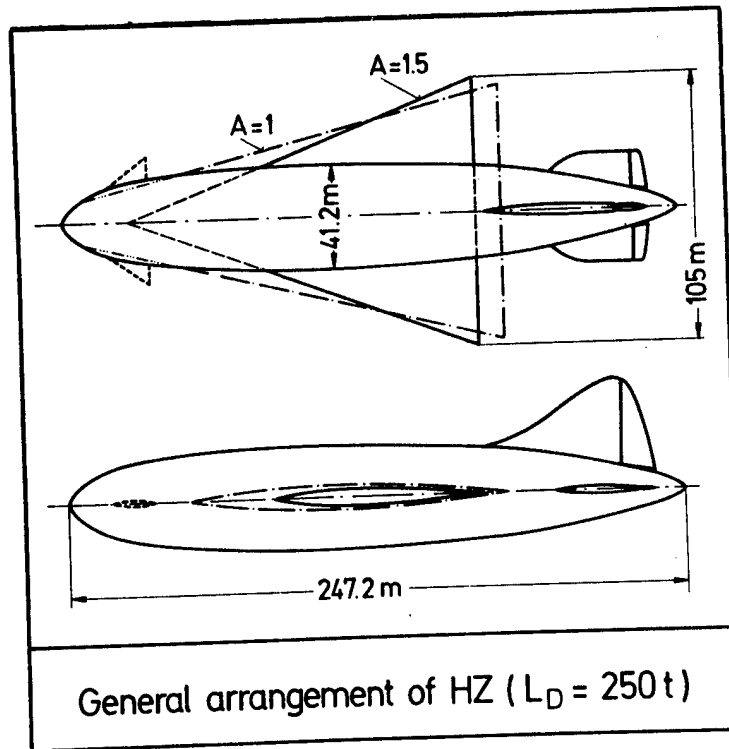

Figure 4

The technical data of the HZ are given in Table 1 , right column.

The figures show that a considerable progress in efficiency can be achieved compared to present aircraft. The payload factor of the described HZ on 10 000 km distance is 40 % whereas that of a modern jet-freighter on the same distance is about 11 % . Similar relations apply for the fuel consumption: the HZ consumes about 0.8 t fuel per ton payload for the given distance; a jet-freighter at the same conditions nearly 4.5 t ! Moreover, the fuel consumption of the HZ is rather an upper limit since it was not considered, that the weight of the HZ is continuously reduced while the fuel is being consumed. Finally, considering the acceptability with regard to the environment (less pollution and noise) and the high passenger-comfort, which the HZ offers, its rentability is likely to be very good. Whether passengers and air-freight expeditors are willing to pay for these advantages with a four times longer travel time (33 h) must be investigated by marked analysis.

REFERENCES :

1. Schlichting, H., Boundary layer theory , 6. Edition, Verlag G. Braun, Karlsruhe, Mc Graw Hill, New York, (1968)
2. Spreiter, J. R., The aerodynamic forces on slender plane- and cruciform-wing and body combinations, NASA Rep. 962 (1950)
3. Das Zeppelin-Luftschiff LZ - 129 "Hindenburg" , Deutsche Luftwacht-Luftwissen 3 (1936), S. 66
4. Jane's All the World's Aircraft , (1936), S. 5 c, S 63 d
5. Jane's All the World's Aircraft , (1945), S. 54 d
6. Jane's All the World's Aircraft , (1973/74), S. 364/365

N76-15055

ULTRA-HEAVY VERTICAL LIFT SYSTEM
"THE HELI-STAT"

Frank N. Piasecki*

ABSTRACT: The Heli-Stat is a novel hybrid VTOL vehicle comprised of an aerostat combined with helicopters. The static lift of the aerostat supports approximately the full empty weight of the entire assembly. The helicopter rotors furnish the lift to support the payload as well as the propulsion and control about all axes. Thus existing helicopters, with no new technology required, can be made to lift payloads of ten times the capacity of each one alone, and considerably more than that of any LTA built so far.

A vehicle is described which has a 75-ton payload, based on four existing CH-53D helicopters and an aerostat of 3,600,000 cu. ft. The method of interconnection is described along with discussion of control, instrumentation, drive system and critical design conditions. The vertical lift and positioning capabilities of this vehicle far exceed any other means available today, yet can be built with a minimum of risk, development cost and time.

INTRODUCTION

Considerable interest is currently evident in the potentiality of airships as a means of lifting and transporting heavy cargo. The interest in lighter than air (LTA) ships is being revived with national attention being focused on energy conservation and recognition of potential heavy lift missions for the LTA. Some of the areas of the overall transport spectrum which favor the airship as a transport vehicle are logging operations, pipe laying, power-transmission-line tower erection, building construction, and transportation of large oversize non-roadable equipment.

The heavy lift helicopter is already being employed on a short-haul basis to transport and position loads up to 12.5 tons in the above mentioned transport areas.

*President, Piasecki Aircraft Corp., Philadelphia, Pa. U.S.A.

One of the design arrangements that shows promise of alleviating many of the shortcomings of conventional LTA's is the semi-buoyant, hybrid vehicle. This type of LTA vehicle does not generate complete lift from buoyancy. Vertically oriented thrust from powered rotors is employed for total lift augmentation and for providing maneuver control forces. Additionally, aerodynamic lift is generated in forward flight due to the vehicle envelope shape and airfoil surfaces.

The design referred to is called the "Heli-Stat" system and is a hybrid LTA system which utilizes four large existing helicopters in combination with an LTA vehicle. The ratio of displacement vehicle lift to helicopter lift is proportioned such that the "Heli-Stat" is deliberately flown "heavy". Thus the thrust from the helicopter rotors is the dominant means of control and stabilization. The ground handling requirements are greatly simplified, and true precision hovering over a point on the ground becomes practical. Such hybrid vehicles may have 10 or more times the payload capability of one of the helicopters used in the Heli-Stat.

The employment of existing helicopters as integrated lift, propulsion, and control units offers low technical risk, cost, and development time. The latter is especially significant in view of the immediate application requirements for heavy air-lift capability in nuclear powerplant and other public construction programs.

DESCRIPTION OF THE HELI-STAT

The aerostat dimensions are sized such that the static lift provided by the aerostat will support all weight-empty components, including the helicopters. The helicopter rotor thrust is then available for useful load and maneuvering control forces, providing a hovering air-lift capability many times that of the largest crane helicopter of the predictable future. The designs described following are based on characteristics from existing helicopter and aerostat designs. Fig. 1 shows a layout of four CH-53E helicopters attached to an aerostat of 5,700,000 cu.ft. displacement. This is the size and shape of the "Macon" envelope, less one section and less the upper vertical fin. A payload of 140 tons can be carried.

Fig. 2 shows a version based on four existing CH-53D helicopters. This system has a payload of 75 tons, as shown in Fig. 3.

SELECTING THE AEROSTAT CONFIGURATION

Semi-rigid pressure envelopes or rigid envelopes can be adapted to the Heli-Stat concept. The longitudinal and lateral support beam structure which serves to attach the helicopters and support the payload can be tied structurally to the structural frames of the rigid envelope. In the case of the semi-rigid, the helicopter attachment and load-support beams can be made integral with the fore-and-aft keel structure.

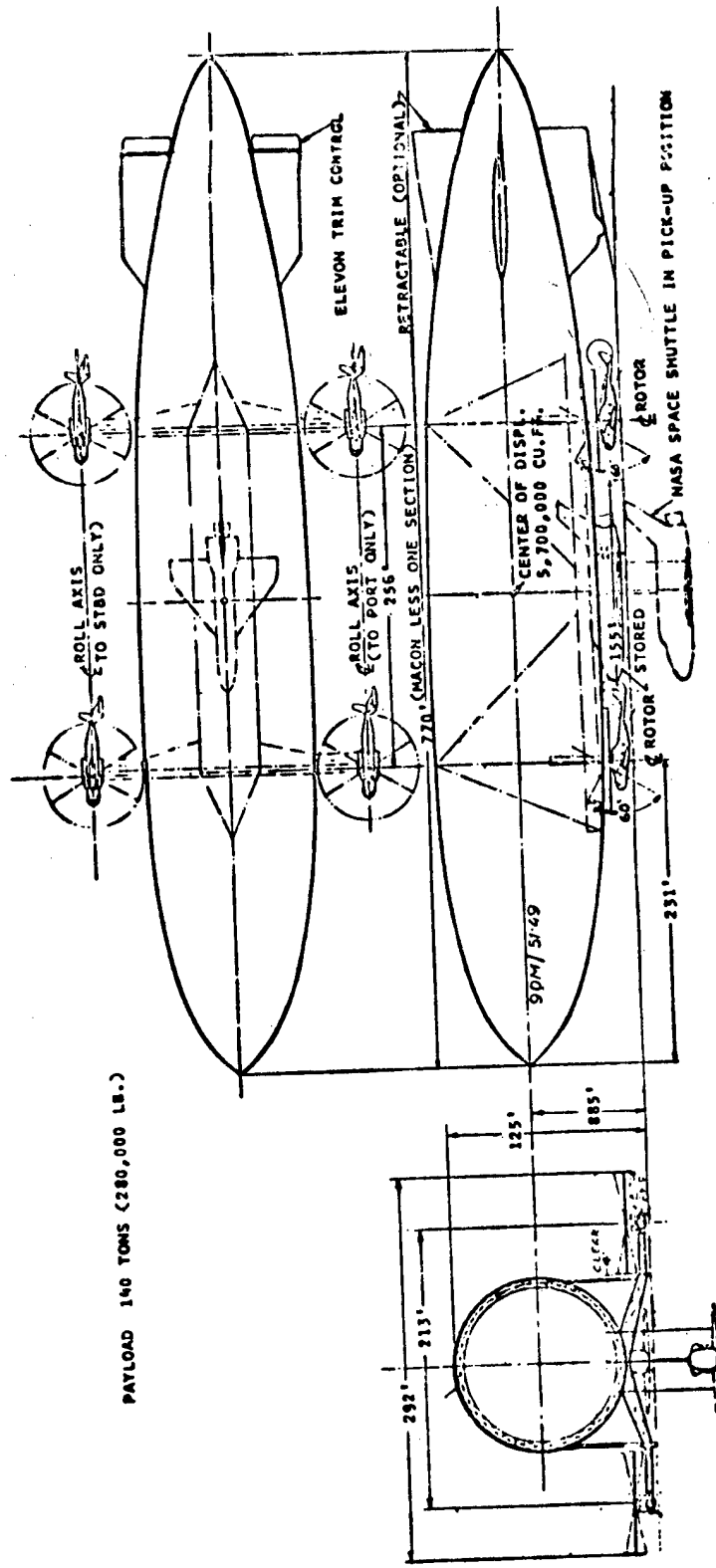

DWG. 97-X-0011. "GARGANTUA" HELI-STAT, MACON AND FOUR CH-53E'S
 FIGURE 1

REPRODUCIBILITY OF THE ORIGINAL PAGE IS POOR

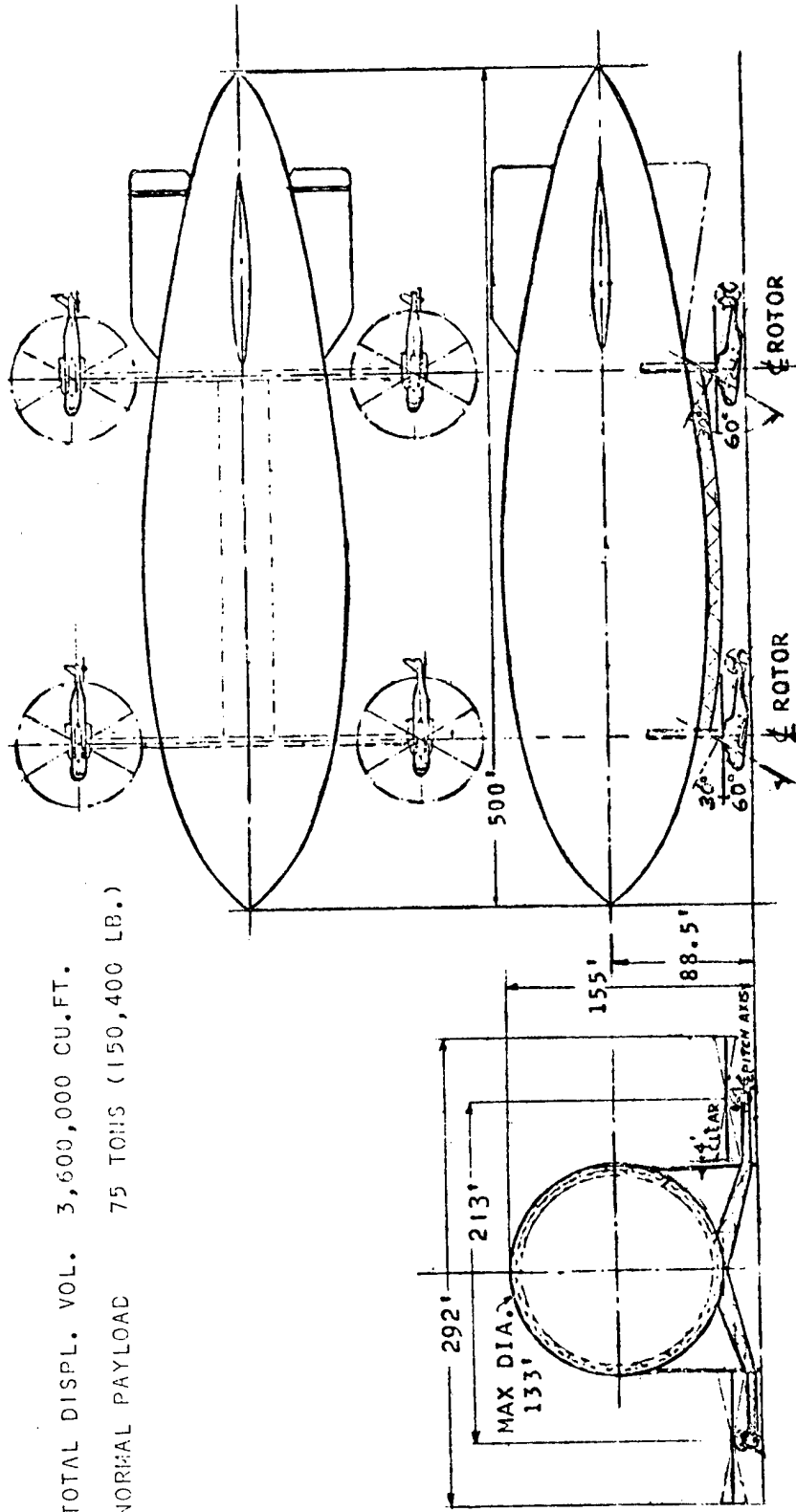

TOTAL DISPL. VOL. 3,600,000 CU.FT.

NORMAL PAYLOAD 75 TONS (150,400 LB.)

DWG. 97-X-0004. HELI-STAT WITH FOUR CH-53D'S

FIGURE 2

Figure 3. HELI-STAT WEIGHTS AND PERFORMANCE SUMMARY, MODEL 97X0004

<u>WEIGHTS</u>	<u>UNITS</u>	
Heli-Stat	Lb.	345,940
Weight Empty	Lb.	177,540
Helicopters (4) CH-53D's	Lb.	86,560
Aerostat Envelope and Structure and Inter-connecting structure (3,600,000 cu.ft.displ.)	Lb.	90,980
Useful Load	Lb.	168,400
Crew (6) at 200	Lb.	1,200
Fuel and Oil	Lb.	16,800
Payload	Lb.	150,400

PERFORMANCE, STANDARD ATMOSPHERE (59 DEGREES F. AT S.L.)

	<u>UNITS</u>	
Cruise Speed	MPH	100
Landing & Take-off Speed	MPH	0
Altitude	FT.	10,000*
Hover Ceiling	FT.	6,000
Climb, Vertical	FPM	500
Climb, Fwd. Flt.	FPM	2,000
Range (Non-Refueling)	ST.MI.	160**
Ferry Range (Non-Refueling)	ST.MI.	2,000

*FERRY
 **RANGE CAN BE EXTENDED BY TRADING PAYLOAD FOR FUEL.

No machinery or facilities are carried in the aerostat except those required by the aerostat's own requirements, that is, multiple air-pressure pumps, servo systems for multiple valve operation, ballast tanks, plumbing, and ballast-shifting pumps, etc.

Two crew stations are provided in the aerostat, for the winching and stowage of cargo.

The size of the aerostat is largely a function of the size and capability of the helicopters selected. From the list of large helicopters in Fig. 4, it is apparent that military-qualified or Federal Aviation Agency certified helicopter units can be economically procured. In a dedicated vehicle the helicopter units can be without many components such as the tail cone, drive, tail rotor, landing gear, cabin accommodations, etc., thus reducing the cost significantly yet providing the essential powerplant, transmission and control for the integrated lift, propulsion and control. Alternatively each of the helicopters in the Heli-Stat assembly can be a completely flyable unit, with detachable umbilical cords that interconnect the automatic flight control system and instrumentation between helicopters.

All controls and instrumentation of the assembly of helicopters are integrated into one pilot control station. Complete cockpit instrumentation and Comm/Nav equipment would be required in only one helicopter, except for intercommunication between crew members and stand-by emergency instruments for the alternate control station.

FIG. 4. LARGE U. S. HELICOPTERS

ITEM HELI/MODEL	UNITS	HLH	CH-53E	CH-47C	CH-54B	CH-53D	V-107	S-61
Manufacturer		B-V	Sik.	B-V	Sik.	Sik.	B-V	Sik.
Gross Weight	Tons	63	34	23	23.5	21	11.5	10.5
Certification (Availability)		1st Flt '76	1st Flt '74	ARMY	ARMY & FAA	NAVY	NAVY & FAA	NAVY & FAA
Turbines Number Model		3 GM T701- AD-700	3 G.E. T64 GE-415	2 Lyc. T55- L11	2 P&W JFTD- 12-5A	2 G.E. T64 GE-413	2 G.E. T-58 GE-10	2 G.E. T-58 GE-10
Rating (Each)								
Max. (Emerg.)	HP	8079	4330			3925		
T.O. (5 Min.)	HP			3750	4800		1400	1400
Mil. (30 Min.)	HP			3400				
Continuous	HP	7305	3665	3000	4430	3230	1250	1250

INTERCONNECTION OF HELICOPTERS TO AEROSTAT

Structural

Each helicopter is supported at the extremity of a lateral cantilever beam which joins the inboard fuselage structure of the helicopter to the bulkhead or keel structure of the aerostat. The flight loads acting on this beam are those supplied by each helicopter, including both aerodynamic and inertia loads. The lateral connecting beams are also designed to take the landing loads.

The structural design of the lateral connecting beams is necessarily influenced by rotor blade clearance considerations and the desirability of minimizing the rotor down-flow obstruction area. External struts or bracing tie-rods are utilized for minimizing structural weight and to achieve the necessary rigidity. The beam is a tubular truss structure having an airfoil fairing, with a passage-way provided between the two spars. The helicopter landing gear can be retained as a ground contact point, however, a main landing gear of longer travel is carried on the lateral beams at four points, with all its wheels steerable.

The port and starboard cantilever beams are interconnected through the centerline keel structure of the aerostat. The two lateral beams are structurally continuous from helicopter to helicopter, but have disconnect joints at the keel structure.

The longitudinal keel structure is composed of two central "keel" beams from which the payload is supported. This will permit the carriage of certain payload sizes internally, providing a centerline access hatch to accommodate cargo loading and unloading by hoist, for missions requiring internal storage.

Control System

The helicopters' control systems are interconnected so that they respond to one set of controls in the aft, port helicopter which is designated the master control station. This interconnection is accomplished through the use of the existing automatic flight control system which is already an integral part of the large helicopters contemplated for use in this assembly. The connecting electrical wires are fed into a mixing control box which actuates the required control of each helicopter servo control system to provide the desired control required by the commander of the assembly. The master helicopter, and its lateral mate, have a complete set of aerostat controls and instrumentation.

A qualified pilot is located in each cockpit and serves as a manual instrument-monitoring system with override in case of failure of any component. In addition to the master pilot, a co-pilot is stationed in the master cockpit with an engineer(s) to monitor the sensors and controls of the aerostat. Thus, a total crew of six to eight is carried aboard the airborne assembly. Walkways are provided for the crews to go to any helicopter and the aerostat during flight.

The primary rigging of the assembly for flight must be calculated for the fuel weight, basic weight of the individual helicopters including their crew, and ballast being carried. This will determine the weight to be balanced by the aerostat gas volume displacement lift at the altitude and temperature of the operation. Ordinarily, ballast will not be needed, since the same objective can be achieved by appropriately reducing the thrust of the various helicopter rotors.

The helicopters are free to use their cyclic pitch in all directions, approximately 11 degrees. In addition, they can be made to rotate about a transverse axle in longitudinal pitch 60 degrees forward and 30 degrees aft but are normally locked in a trim position. In the lateral direction, in addition to the rotor's lateral cyclic control of approximately 11 degrees the helicopter can be made to tilt out-board approximately 11 degrees.

In the yaw direction, the helicopters are rigidly fixed to the aerostat structural keel. For yaw moments, the port and starboard helicopters can differentially incline their longitudinal cyclic.

For lateral roll control, differential rotor collective pitch on one side, versus the opposite side, is utilized.

Pitching attitude of the assembly is via differential collective pitch of the forward rotors versus the aft.

Propulsion is achieved from the forward cyclic pitch of all rotors. Inclination of the helicopters can be utilized as the dynamic lift of the aerostat develops with forward speed. The aerostat angle of attack, and hence its lift, can be independently adjusted by the use of its longitudinal trim elevators. Retardation is accomplished by tilting the rotors aft.

Instrumentation

Each helicopter contains its own internal instrumentation, communication and navigation equipment. Additional sensors for the aerostat are distributed throughout the gas cells, interconnecting structure and controls with their readout in the master helicopter and its backup unit. A computer unit with memory circuits of basic weight data, balance and external environmental conditions provides immediate read-outs for the master pilot, his deputy and the flight control system.

Drive System

With a single power failure in one helicopter under any flight condition, the diagonally opposite helicopter must reduce its rotor thrust to match, in order to maintain longitudinal and lateral trim. The two helicopters with the reduced power can maintain rotor rpm by decreasing their rotor blade pitch and adjusting to a compatible shaft angle. The other two diagonally opposite helicopters, which have been operating with a reserve of power and thrust, must now increase their thrust to pick up the load from the failed helicopter and its mate. The central control mixing computer would automatically adjust for these conditions since the power levels of each turbine are continuous inputs into the computer.

In forward flight, the dynamic lift on the aerostat envelope can help balance the lift lost by these two helicopters. However, dynamic lift is zero at zero speed, and thus will not balance this loss in hovering. Therefore, either sufficient change in fuel weight, ballast dumping, altitude or temperature changes, etc. must occur or the Heli-Stat must carry a reserve hover lift.

An alternative balancing method can be supplied by mechanical interconnection of all helicopters as detailed in our work on the Multi-Helicopter Heavy Lift System, Refs. 1 and 2. This involves the interconnection of the rotor-drive systems of all the helicopters "downstream" of the engine free-wheel units, and requires appropriate modification to the drive system. However, the power of each engine is then available to all the rotors, and if one engine fails, the diagonally opposite helicopter is not forced to reduce power. The rotor in the partially disabled helicopter "borrows" power from the other three. However, this feature will increase the weight empty and cost.

CRITICAL DESIGN CONDITIONS

A design condition for the Heli-Stat would be the partial loss of rotor thrust in one helicopter resulting from a failure of one of its turbines. In the FAA airworthiness requirements for Category "A" rotorcraft (multi-engine with completely separate, dual power-plant systems) failure of more than one engine is considered so remote that there are no requirements for that condition.

A power failure in one unit would normally be a loss of part of the thrust of that helicopter unit plus the reduction of an equal amount about the center of total lift. If it is necessary to make a hovering landing in this emergency, the gross weight must be sustained by the buoyancy of the aerostat at the landing altitude

and temperature plus the thrust produced by one-half maximum power in the disabled helicopter and its opposite mate, and full power in the two unaffected helicopters.

If a run-on type landing can be made, for example at 50 mph air-speed, then the dynamic lift of the aerostat body can be counted on to augment the other sources of lift. In addition, all four helicopters can produce substantially more thrust, for a given power, at 50 mph than at zero speed. The Heli-Stat could then, with equivalent safety, carry 20% additional payload compared to the limitation of a hovering landing.

The above discussions all deal with an emergency situation in which two of the four helicopters were supplying only half power. It is clear then, that in the normal situation, when all four helicopters are fully operational, each will be operating at approximately $3/4$ of its maximum level of thrust and power. Thus, to allow for the emergency condition, there is inherently a large reserve lifting capacity in each helicopter, which can be called on for high temperature/altitude combinations, or loss of up to 20% of the helium in the aerostat.

It is for this reason that, ordinarily, the use of ballast will not be necessary. In a fully buoyant LTA, loss of helium can be compensated only by dumping or shifting ballast. In the Heli-Stat, however, a far more rapid response can be achieved by changing collective pitch on one or more of the helicopter rotors using the power reserved for emergencies. Moreover, the saving in ballast weight results in either a smaller aerostat or in lower rotor loadings on the helicopters, with consequent savings in helium, fuel and maintenance.

For purposes of (certification) design, it is proposed to use the FAA criteria for category A rotorcraft, Ref. 4.

- A. Take-off. After failure of one engine, make a safe landing on the take-off area or continue in flight.
- B. Anywhere else. Continue in flight to an area where a safe landing can be made.

(With no dumping of fuel or payload).

These criteria are more severe than those under which current crane-type helicopters are operated. The latter are not capable of hovering at full gross weight with one engine out, and a heavy payload must be dropped. This is not considered to be economically feasible with the very large and costly payloads anticipated for the Heli-Stat, and thus the design criteria should require the ability to hover with full payload, with one engine out. Ref. 5 states, "No pilot in command

of a civil aircraft may allow any object to be dropped from that aircraft in flight that creates a hazard to persons or property. However, this section does not prohibit the dropping of any object if reasonable precautions are taken to avoid injury or damage to persons or property".

As mentioned above, failure of more than one engine is considered so remote that the FAA has no requirements on the subject for multi-engine Category A helicopters. Nevertheless, should a complete power failure occur in one helicopter of the Heli-Stat during cruise, it can be put into autorotation and supply a portion of its normal thrust. The lift and propulsive forces must then be redistributed among the remaining helicopters, augmented by dynamic lift on the aerostat, and a landing with some forward airspeed would be necessary.

MOORING SYSTEM

Present aerostats have been moored from a nose point to a mast, and thence attached to a car, truck or gondola with wheels that are behind the center of buoyancy with sufficient weight to resist the vertical forces, yet free to rotate on the ground or on a track whilst the aerostat weather-cocks into the wind.

It is important that the aerostat be allowed to position itself into the wind. At large angles of yaw the total wind force can be thirty or more times the zero-degree magnitude. On an airship the size of the Akron a wind of 60 m.p.h., striking broadside, would exert a force of about 400 tons (800,000 lb.). Not only would such a large force involve a substantial ground anchor system, but even more important, it would require a multitude of mooring lines in order to distribute the loads into the balloon without severe stress concentrations which could rupture it.

On the other hand, allowing the aerostat to swing about the nose preempts a sizeable amount of clear land for mooring purposes. For the 75-ton Heli-Stat this would be a 1000-ft. diameter circle, which is nearly 20 acres. This circle can be reduced in area by 50% or more by mooring the Heli-Stat in such a way that it pivots around a point aft of the nose, but ahead of the most forward position of the center of pressure.

One method of accomplishing this is to actually attach the aerostat at a mooring fitting located at the desired pivot point. For many applications, however, it would be advantageous for this area of the Heli-Stat to be accessible, as in loading cargo, for example, or boarding passengers.

CONCLUSION

From previous helicopter crane operational experience and regulatory criteria, and performance characteristics of aerostats, and helicopters, a viable precision hovering air-lift system can be designed and constructed with the minimum of risk and development costs.

The resulting vehicles will provide a unique service of heavy vertical lift and positioning far exceeding the capabilities of any other means available today, and extend man's orderly development of his environment.



MODEL OF HELI-STAT BASED ON SHORTENED MACON ENVELOPE
FIGURE 5

REFERENCES

1. Piasecki Aircraft Corp., Report 39-X-11, Multi-Helicopter Heavy Lift System, Philadelphia, Pa.
2. U.S. Patent No. 3,656,723, Multiple Helicopter Lift System, Piasecki et al (April 18, 1972).
3. U.S. Patent No. 3,008,665, Helicopter and Balloon Aircraft Unit, Frank N. Piasecki (November 14, 1961).
4. Federal Aviation Agency, FAR Part 29, Airworthiness Standards, Transport Category Rotorcraft.
5. Federal Aviation Agency, FAR Part 91, General Operating and Flight Rules.

THE VARIABLE DENSITY AIRCRAFT CONCEPT

A.C. Davenport*

ABSTRACT: In the variable density aircraft concept the aircraft's density is varied by varying its volume. This is accomplished by combining a variable volume hull, which I call a dynapod, with intrinsic means for the controlled variation of a mass of working fluid or substance within the aircraft. The dynapod is a hinged structure and follows the volumetric variations of the working fluid. The result is a variable density hull, which with the attachment of power plants, etc., becomes a variable density aircraft.

THE AIRSHIP'S DILEMMA

Its fixed mass concept is the airship's dilemma. Part of the concept of airships is fixed geometry and weight maintenance through the use of ballast. This fixed mass concept is illustrated by: 1) U.S. airships using the water recovered from engine exhaust gases to replace the weight of consumed fuel; and 2) German airships using gaseous fuel whose consumption had little effect on the weight of the airship as its own weight was very near that of the air by which it was replaced. These systems were developed in an effort to provide a means of maintaining a selected density altitude. Let us review the operational penalties of the fixed mass concept.

* President, Dynapods, Inc., New Orleans, La., U.S.A.

Operational Penalties of the Fixed Mass Concept

Inertial - The greater the mass accelerated the greater the energy required. In the above examples energy is wasted in the acceleration, positive and negative, of ballast. Ballast is weight carried only for the sake of its own weight. The magnitude of this penalty is indicated by the realization that an airship developing 5,000 hp and having a specific fuel consumption of .6 lbs/hp/hr will consume 72,000 lbs of fuel in 24 hours. The replacement of the weight of this consumed fuel, whether by air or water, means that the airship, in a 24 hour flight, will carry an average excess load of 36,000 lbs. At any reasonable speed this translates into a lot of ton miles of useless effort. Fixed mass airships do not, as do other aircraft, benefit from reduced load operations.

Dynamic - Floating objects are in buoyant equilibrium. They float only when they are displacing that amount of the surrounding fluid exactly equal to their own weight. Floating objects require substantially less power to propel horizontally than do super- or sub-buoyant objects because no energy is wasted in the production of positive or negative lift. Fixed mass airships, because of the difficulty of maintaining buoyant equilibrium, routinely fly "heavy" or "light" thereby wasting energy in aerodynamic lift production.

Volumetric - The amount of energy required to propel a floating object through the air is largely due to its size and shape. The size and shape of the object govern its displacement. Heavy floating objects require more energy to propel them, not only because of their inertia, but also because they displace more of the surrounding air than do lighter floating objects.

The displacement of airships is also affected by the geography of the earth which requires that long range aircraft be capable of rising above mountain ranges or rising above most of their area and circumnavigating the rest. This practical requirement means that an airship has to be designed to operate at reasonable altitudes. If an airship's "pressure" altitude is 10,000 feet, for example, the LTA gas which it contained at sea level will have expanded 35% when the airship reaches its pressure altitude under standard temperature and pressure lapse rates. Airships are designed and built oversized to accommodate for this expansion. Airships normally fly at much lower levels, 3,000 feet or below, where the expansion of the LTA gas is 9% or less, and routinely pay a 26 to 32% excess volume tribute to the fixed mass concept.

In the operational modes the fixed mass concept wastes energy as it requires the lifting, acceleration and steady state propulsion of hulls whose weights and displacements are excessive because they carry such large amounts of ballast. The fixed mass concept is in diametric opposition to the purpose for which the airship was conceived.

THE VARIABLE DENSITY AIRCRAFT'S SOLUTION

The variable density aircraft solves the airship's dilemma by combining a dynapod with an intrinsic means for its expansion and contraction.

What is a Dynapod?

A dynapod is an articulated, variable volume, variable geometry, zero differential pressure, constant surface area hull. It is a hull of square cross section the sides of which are hinge-joined to allow the figure to vary its geometry and volume. Special pyramidal variable volume/geometry end sections complete the hull.

Since the dynapod can follow the volumetric variations of a working fluid the density of the assembly, that is the dynapod and the equipment attached thereto, can be controlled by varying the volume of the contained working fluid. By attaching the apparatus of propelled flight such a variable density hull becomes a variable density aircraft.

Expansion and Contraction

The volume of the contained working fluid is controlled by the addition and subtraction of the "wasted energy", heat, of the exhaust gases of the power plants. The expansion rate provided by this basic system can be augmented by auxiliary burners or other means when desirable. The addition and subtraction of heat in the basic system is through a heat exchanger of conventional design.

A single power plant, such as a UAC PT-6 developing 900 shp, has a mass air flow of 6.5 lbs/second. This air becomes part of the combustion products when burned with the fuel. These combustion products, as gases and vapors, are exhausted at a temperature of 613 degrees C. By transferring this heat into the working fluid via a heat exchange system it can be made to perform a useful service in the variable density aircraft by providing a substantial part of the energy needed to lift and carry loads. When heat extraction from the working fluid is desired the exhaust gases are diverted to the atmosphere and ambient air is channeled through the heat exchanger.

Intrinsic Expansion - The intrinsic expansion of the working fluid results in an 100% gain of the weight of the displaced air as useful lift. Father Francesco de Lana, in the 17th century, conceived the idea of using evacuated metal spheres to produce aerostatic lift. Only a weightless sphere containing a perfect vacuum could match the performance of intrinsic expansion as employed in the variable density aircraft concept.

DESIGN CONSIDERATIONS

Since the heat input required to expand the variable density aircraft from a semi-buoyant to a buoyant state depends upon the density differential of the two states, it is best to design the aircraft so that it is only slightly heavier than air in its minimum operational configuration. A slight increase in the temperature of the working fluid over ambient temperature will then result in positive buoyancy.

Effective control of the heat level of the working fluid requires control of the heat transfer from the hull. The use of low heat transfer materials and lightweight insulation in the construction of the hull establishes this control.

Major cost factors in the transportation of an object are the initial fabrication and routine maintenance costs of the carrier. These factors are elevated by design complexity. The design simplicity of the dynapod allows minimum facility, engineering, fabrication, and maintenance costs. No oversized, unorthodox buildings are required in their fabrication. Production in meaningful quantities can be economically achieved. The zero differential pressure feature of the dynapod allows the use of lightweight materials without substructure as the contents of the hull support the panels used in its construction. Since the dynapod is completely articulated, stresses are dissipated through out the hull as soon as they are applied.

A SIMULATED FLIGHT

Figure 1 on page 5 shows a cross section of the dynapod hull, the four panels of which are indicated by p. The flexible diaphragm, d, in the interior of the hull separates the fuel, f, from the LTA gas, g. The fuel gas, following the German system of using Blau gas, has a density equivalent to that of the surrounding air. The temperature of the LTA gas, g, is controlled by channeling either exhaust gases from the power plant, P, or air through the heat exchanger, h.

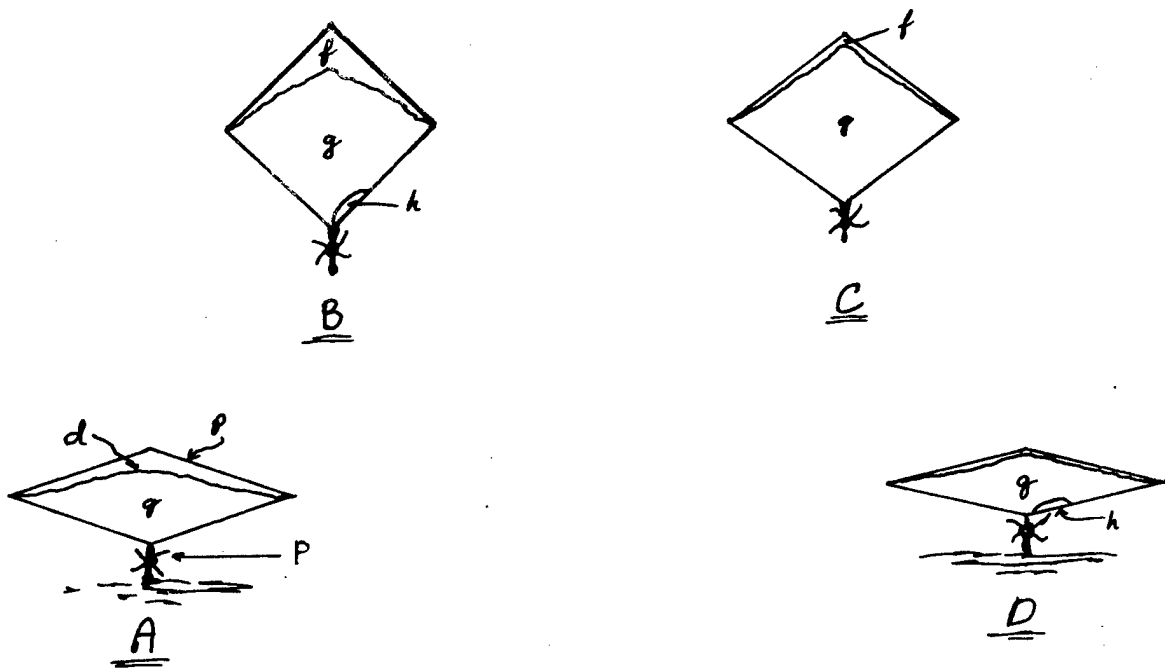

Figure 1
Cycle of Operation

A - The vehicle is on the surface in neutral buoyancy.

B - Heat energy has been added, via the heat exchanger, h, to the LTA gas, g, causing it to expand. As the dynapod expanded concurrently it displaced more air and the vehicle became LTA.

C - As fuel is consumed in flight the extraction of the fuel from the interior of the dynapod causes it to contract thereby reducing its volume and frontal area. As the fuel weight is equivalent to that of the air no change in density occurs. A proportional change in total volume and mass occurs.

D - Over destination heat energy is extracted from the LTA gas, g, by channeling ambient air through the heat exchanger, h. This decrease in volume without a decrease in mass results in an increase in the density of the vehicle and it settles to the surface.

VERSATILITY

Vehicle vs Load Size - A major factor in determining the cost of transporting an object is how well the carrier is matched to the load. Dynapods are clusterable and can be matched to exceptionally large or heavy loads without paying the penalty of exceptional load capability when carrying routine loads. Two different ways to cluster four dynapods are shown in Figure 2. More dynapods can be added to these.

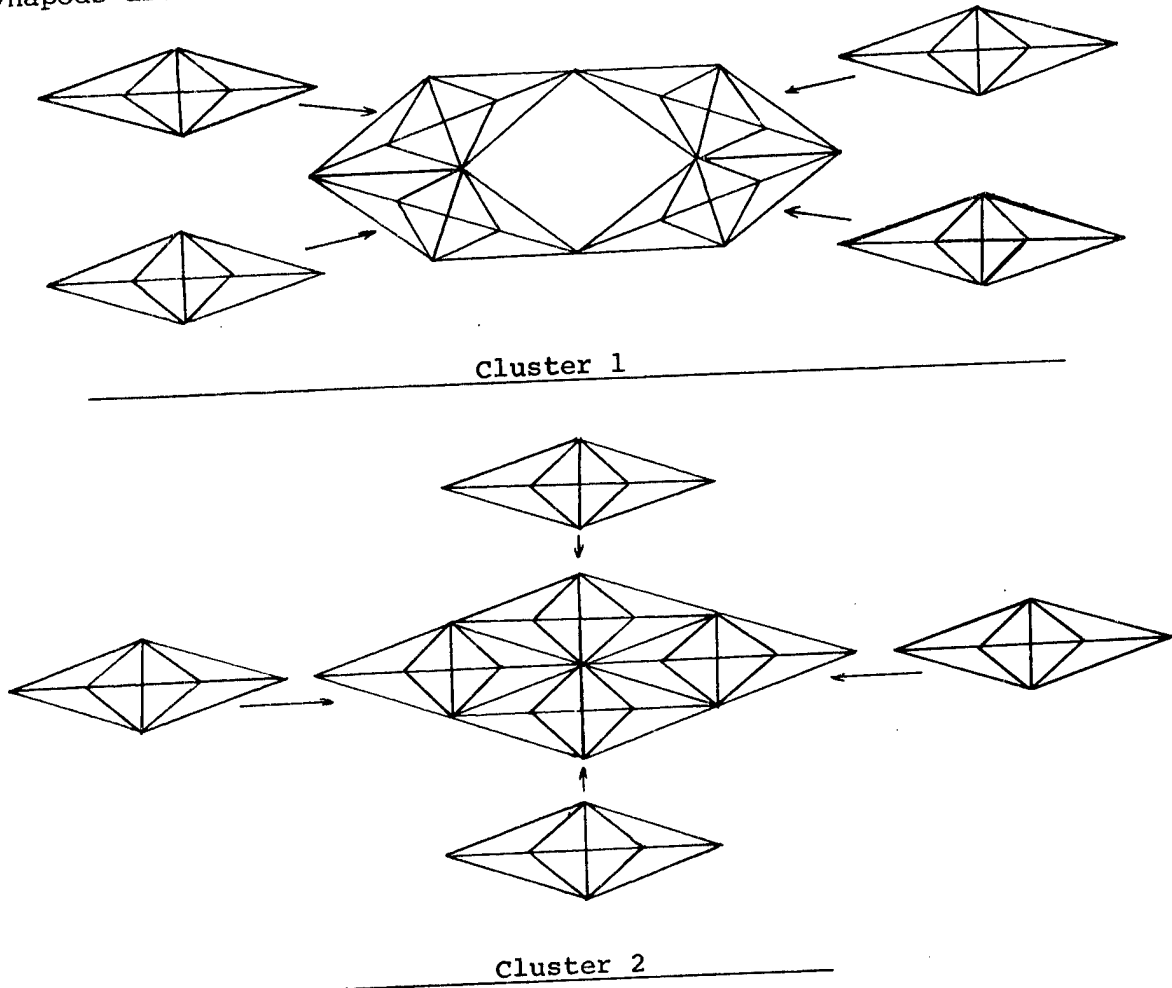

Figure 2
Clusterability

Low Profile - In the semi-buoyant configuration dynapods are relatively low in profile and are therefore less affected by gusts and wind changes. This assures easier ground movement and handling operations. When not in use dynapods are collapsible providing near perfect compact storage.

WHY A VARIABLE DENSITY AIRCRAFT?

Because it is a simplified, energy conserving transportation system. Practically all of mankind lives within that narrow band of air between sea level and 10,000 feet. The key factor in man's success as a species has been his ability to transport himself and his goods within that limited space. Transportation is movement, movement requires energy, and man today, because of his dependence on depletable energy sources, is suffering from an energy crisis. Stagnation is not the answer. It is not even an acceptable intermediate solution. We must develop energy conserving transportation systems to use until science can introduce non-depletable energy sources.

It is axiomatic that the more complex the system the more energy required in its operation. Complexity is introduced into surface transportation systems by the size and weight restrictions imposed by tunnels, bridges, transfer steps between terrain and water systems, etc. The use of our air ocean removes all of these restrictions provided that the same vehicle used to pick up a load at point of origin can also deliver it non-stop to its final destination. This implies a vehicle that can hold position over a load and pick it up or take off and land vertically with a load and carry that load long distances. The vehicle that can do these things economically and with minimal adverse ecological effect will serve man well. That vehicle is the variable density aircraft.

AIRSHIP APPLICATIONS

- Roles for Airships in Economic Development** — George J. Beier, Gerardo Cahn Hidalgo
- The Application of the Airship to Regions Lacking in Transport Infrastructure** — Stephen Coughlin
- Military Applications of Rigid Airships** — Ben B. Levitt
- Potential ASW Missions for Lighter Than Air Ships** — Richard S. Stone, Bernard O. Koopman, Gordon Raisbeck
- Antisubmarine Warfare (ASW)— A Specific Naval Mission for the Airship (Abstract Only)** — Louis J. Free, Edwin E. Hanson
- The Surveillance Airship (Abstract Only)** — L. E. Mellberg, R. T. Kobayashi
- Airship Logistics—The LTA Vehicle: A Total Cargo System** — L. R. "Mike" Hackney
- The Transport of Nuclear Power Plant Components** — S. J. Keating, Jr.
- Airships for Transporting Highly Volatile Commodities** — Miles Sonstegaard
- Using Lighter Than Air Vehicles (Dirigibles) in Housing Construction** — E. E. Siamis, V. B. Moorychev
- Environic Implications of Lighter Than Air Transportation** — Patrick Horsbrugh

404

N76-15057

ROLES FOR AIRSHIPS
IN ECONOMIC DEVELOPMENT

George J. Beier*
Gerardo Cahn Hidalgo**

ABSTRACT: This paper attempts to demonstrate that airships of known and tested technology could, in some cases, perform routine transport missions more economically than conventional transport modes. If infrastructure for direct surface transport is already in place or if such infrastructure can be justified by the size of the market and there are no unusual impediments to constructing it, then the airships of tested technology cannot normally compete. If, however, the surface routes would be unusually expensive or circuitous, or if they involve several transshipments, or if the market size is too small to spread infrastructure costs of conventional transport, the airships of tested technology present a workable alternative. The paper argues from a series of special cases. The cases, though unusual, are not unique; there are several similar possible applications which, in total, would provide a reasonably large market for airships.

INTRODUCTION

The World Bank has a substantial interest in transport development. Through fiscal year 1973 the Bank had lent over \$6,788 million for various transport projects. Although roads and railroads account for the bulk of this total the Bank also lends for pipelines, ports, and aviation. Our transportation loans have financed investment in virtually all the developing countries of Africa, Asia and Latin America.

The Bank, through its country oriented economic work, transport sector studies and project appraisal, including the analyses of possible alternative investments, attempts to expand the context of countries' plans for transport development. Within the general requirement that a project must have an acceptable payoff in development, the Bank has really unlimited freedom to finance a project using any technique.

* Economist, International Bank for Reconstruction and Development, Washington, D.C., U.S.A.

** Engineer, economist.

The "final product" of the Bank is simply a loan to a developing country to make an investment. Virtually all of our operations are aimed at helping the country to choose wisely among the alternatives available and to complement the investments with sound development policies. Thus our primary interest in studying airships is to decide whether this form of transport should be recommended to a country for study as a realistic and viable alternative.

The ideas that we present in the rest of this paper are aimed at stimulating discussion among airship experts of possible applications of airships, in special cases, to solve the immediate transport problems of less developed countries. We attempt to demonstrate that, using existing technology, the airship apparently has a series of possible development missions.

In the section that follows we will present extended examples of possible uses of airships of more or less well-known and tested technologies. In each case we attempt to show that there is a prima facie case for applying known technology to a new task.

CASE STUDIES

Two cases of completely different nature will be analyzed, the application of large airships of over 100 ton load capacity for long distance transportation; the utilization of small airships to haul small cargoes for short distances.

Cost Characteristics of the Airships

In order to proceed with a cost comparison of the airships against the conventional modes of transport several assumptions are necessary. For the most part these are implied in Table I or are specifically identified in the footnotes, but a few crucial assumptions should be discussed before turning to the Table.

(a) Cost of Construction: We have no recent direct evidence on capital cost for a large airship. Research and development, however, are very minor cost elements; we are simply attempting to estimate how much the cost of construction has increased over the years. The basic design and operating characteristics are well-known. Dr. Eckener, in 1952, estimated the cost of a new Hindenburg at \$7.7 to \$12.5 million, i.e. from \$68 to \$110 per kg empty weight. We have assumed a present construction cost of \$200 per kg empty weight for the large airship--about three times Dr. Eckener's low estimate. This seems about an adequate allowance for increased cost since 1952. For the smaller airships (2 tons and 15 tons), we assumed a construction cost of \$300 per kg empty weight, in accordance with the average cost estimates given by manufacturers for airships in this size range. Since they are intended for use in more difficult terrain, with many take-off operations, these airships will have to be more maneuverable and have a higher power weight ratio than the larger ship.

(b) Interest and depreciation: Throughout the paper we assume a 10% interest rate for all alternative transport investments. We assume a 20 year life for the large airship and a 10 year life for the smaller airships, in recognition of the rougher job envisioned for the small ship. A 20 year life may be near the outer limit of reasonable assumptions for the large ship but it is not clear that successful airships in this class, e.g., the Graf Zeppelin, were anywhere near

the end of their useful life when they were scrapped for want of helium.

(c) Flight time: We assume that the large airship could fly 6,000 hours a year. By way of comparison, the Hindenburg flew 2,810 hours in its first nine months of service, an annual rate of 4,215 hours. The use we are considering is a regular, shuttle type operation and the 6,000 hours assumption should not be too optimistic in these circumstances. For the smaller airship, in rougher terrain with irregular loadings, we assume a 3,000 hour per year performance--roughly, a day-time only schedule.

(d) The large airship would operate at nearly ideal altitudes and temperatures in the main use considered. The smaller airships would operate out of a set of bases about 700 meters above sea level, conducting most of their operations over territory of about that altitude.

The large airship is patterned on the Hindenburg, one of the largest airships ever in operation. It was a rigid dirigible with a gas volume of 216,000 cubic meters, a static gross lift of 206,400 kg, empty weight of 113,000 kg and useful lift of 93,000 kg. S.L.T.A. Inc. has made a series of estimates on the characteristics of a modernized Hindenburg (which we shall call the "H2"). The H2 is similar in design to the Hindenburg, incorporates no radical technological change, but is increased linearly in dimensions by 10%. This increases the volume of the H2 to 266,000 m³, and the gross lift to 266,000 kg. Incorporating modern structural materials, lighter engines, and modern advances in gearing, the H2 should be able to achieve a slightly better static efficiency; we have assumed a useful lift equal to empty weight, 133,000 kg, using helium as the lifting gas.

On these assumptions, the cost estimates of Table 1 were prepared.

TABLE I
COST CHARACTERISTICS OF VARIOUS AIRSHIPS

	133 ton airship	15 ton airship	2 ton airship
Airspeed (km hr)	129	130	130
Ground Speed (km hr)	113	110	110
Stage length studied (km) ^{a/}	1,290	220	220
Flight duration (hours)	11.4	2	2
Horsepower required	4,937	1,700	1,000
Fuel required ^{b/} (kg per trip)	11,256	680	400
Payload (metric tons)	121.7	11.25 ^{c/}	1.50 ^{c/}
Productivity in ton km per hour	13,752	1,238	165
Personnel and Maintenance cost (\$/hr)	150	83	43
Personnel and Maintenance cost (¢/ton km)	1.09 ^{d/}	6.7 ^{e/}	26.1 ^{e/}
Fuel cost (¢/ton km)	.84 ^{d/}	2.7 ^{e/}	12.1 ^{e/}
Direct operating cost (¢/ton km)	1.93 ^{f/}	9.4 ^{g/}	38.2 ^{h/}
Yearly capital recovery charge (\$million)	3.12 ^{f/}	.68 ^{g/}	.31 ^{h/}
Yearly payload (million ton km)	82.51	3.71	.50
Capital charge (¢/ton km)	3.78	18.3	62.0
Total Cost (¢/ton km)	5.71	27.7	100.2

- a/ Average stage length of the main comparison study included below.
b/ 0.2 kg per hp per hour.
c/ Assumed 75% load factor.
d/ Price per kg, April 1974 price FOB Matadi.
e/ Price per kg \$0.10.
f/ Cost \$26.6 million, depreciated over 20 years at 10% interest.
g/ Cost \$4.20 million, depreciated over 10 years at 10% interest.
h/ Cost \$1.89 million, depreciated over 10 years at 10% interest.

Source: Based on data furnished by Studiengruppe Luftschiffbau und Anwendungs Bereiche.

Use of the H2 in the Zaire export/import trade

The cost calculation for the H2, shown in Table 1, was derived to approximate the cost per ton km of the shuttle service of copper from the Katanga to an Atlantic port, Lobito, and the return of general cargo to Katanga, a stage length of about 1,290 km. Adequate balanced bulk cargo traffic is generated on this route to insure a virtually continuous full load operation. Hence the 100% load factor implied in the Table 1 calculations. The operating conditions on this route are nearly ideal: moderate temperatures and low land elevation.

To compare the cost of the H2 against conventional modes of transport, we calculated the cost per ton via airship over the 1,290 km stage length from Katanga to Lobito: \$73.6 per ton (5.71¢ per ton km times 1,290 km).

The first set of costs against which to evaluate the performance of the H2 are the short run costs of conventional transport modes: the direct operating cost of vehicles (railroad rolling stock and river fleets); the costs of administration repair and maintenance of infrastructure that vary with use of the infrastructure; the depreciation and interest cost of the vehicle fleet.

Specifically excluded are any construction or capital charges for infrastructure, or any charge for fixed administration or maintenance.

The present transport route we are considering is composed of three parts: the Kinshasa-Dilolo-Lubumbashi Railroad (KDL), from the copper areas of the Katanga to Port Francqui (1,430 km); a river barge portion from Port Francqui to the Port of Kinshasa (800 km); and a further railroad, the Chemin de fer de Matadi Kinshasa (CFMK), 366 km from Kinshasa to Matadi, the port on the Congo river with access to the Atlantic.

ZAIRE COPPER TRAFFIC - Conventional versus Airship Route

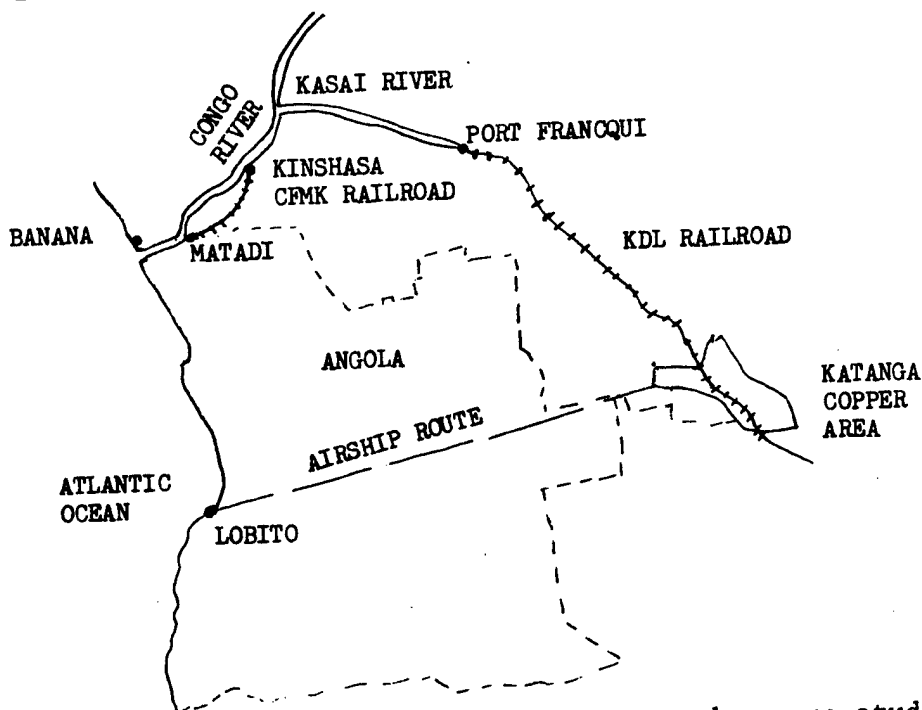

The cost characteristics of the present modes were studied in a major work published in 1971 by the French consulting firm BCEOM. Without updating for the inflation since then, except to take account of the increase in fuel prices, we obtain the following cost estimates:

TABLE II

OPERATING COSTS OF MATADI-KATANGA TRIP-CONVENTIONAL MODES

	US¢/ton km	KM	\$/ton
Katanga-Port Francqui (rail)	2.86 ^{a/}	1,430	40.89
Port Francqui Trans-shipment			5.95
Port Francqui-Kinshasa (river)	0.92	800	7.36
Kinshasa Trans-shipment			5.95
Kinshasa-Matadi (rail)	1.75 ^{a/}	366	6.40
Total Operating Costs			<u>66.33</u>
Inventory Cost of Goods in Transit ^{b/}			<u>5.04</u>
Total transit cost exclusive of infrastructure investments costs (per ton/trip)			<u>71.59</u>

Source: BCEOM, Etude de Transport de la Voie National, October 1971.

^{a/} To update the fuel price changes, the fuel component in marginal cost for the two railways was multiplied by a factor of 3.715, the latter being the ratio of gas oil prices in 1974 (\$117 per metric ton CIF Matadi) and 1971 (estimated at \$31.50 per metric ton CIF West African ports).

^{b/} An interest rate of 10%, a copper price (FOB Matadi) of \$1,624 per ton, and a bulk goods price (backhaul cargo) of \$200 per ton, were used to calculate the inventory cost for 20.2 days (the average trip time from Katanga to the port).

A comparison of the two modes shows that there is a very slight difference between the costs (less infrastructure costs) of conventional modes of transport (\$71.6 per ton) and the total costs (including construction costs) of the H2 (\$73.6 per ton). Turning the analysis on its head, we calculate that the H2 would just break even against conventional modes for the trip from the copper fields to an Atlantic Port if the H2 could be built for about \$25.5 million instead of the \$26.6 million which we assumed.

The inclusion of a reasonable allowance for infrastructure investment would make the airship's cost advantage very striking. Relying again on BCEOM data, the cost per ton for the trip Katanga-Matadi, on a full cost basis, would be about \$20-25 per ton higher than shown in the comparison. In other words, on a total cost basis for both modes, the airship is about 25% cheaper (\$73 per ton vs \$95 per ton).

The full cost comparison is not very precise; the BCEOM estimate refers to full cost of past investment rather than the full cost of future investment which might be avoided by use of airships, but it is not unreasonable to assume that the BCEOM estimate is less than full future cost. The list of conventional investments required to handle increments to traffic is indeed impressive, totalling from \$148 million to \$266 million, at 1971 prices, for the period to 1990 depending on the assumption concerning use of foreign routes. The bulk of this investment might be avoided or postponed for many years by use of airships. ^{1/}

A few other features of the comparison of costs between conventional modes and the H2 seem worthy of special note. The competitiveness of the airship against conventional modes without infrastructure cost depends on the much longer surface route. This suggests that at the present state of the arts the airship will not be generally competitive for bulk loads in cases where surface infrastructure is adequate and the trip is fairly direct, but that the flexibility of routes may tip the scales in favor of the airship when the surface route is indirect. Second, higher fuel prices make airships more competitive rather than less so. Fuel costs are only about 15% of total airship cost; the bulk of the cost is the capital charge. At 1974 prices fuel is in the neighborhood of 35% of operating costs for the competitive modes. Our comparison will hence be more favorable as oil prices increase, less favorable for a decline in oil prices. Third, inventory costs, even for a commodity as expensive as copper, do not turn out to be very important relative to other transport cost items.

We have made this comparison only to the Atlantic ports because we have no basis for a comparison of port costs for the H2 and conventional modes. No airship has ever undertaken this type of commercial freight operation. But it is generally believed that port costs could be lower for the H2. Using the airships ability to operate from a sheltered water base, the H2 might lighter onto a special purpose barge, and pick up return cargo, without ever using the normal port facilities. It seems quite clear that this will always give the airship a decided advantage over other air transport because conventional airplanes with a landing site away from the port require at least one more transshipment and a short surface haul. In normal circumstances, transshipment to ships from the H2 would probably be cheaper than transshipment from rail.

Use of H2 for Exports of Horticulture Products from Kenya

An often mentioned possible mission for airships is the intercontinental shipment of fresh produce. For our example, we investigated the possibility of increasing the vegetable and fruit shipments from East Central Africa to Europe--specifically the shipment of such goods from Nairobi to London. At Nairobi to London backhaul rates ranging from \$.48 per kg (IATA rate) to \$.35 per kg (the most favorable contract rate) the transportation of produce by air has increased from just over one thousand metric tons in 1969 to 6.5 thousand metric tons in the first nine months of 1972. The 1972 traffic experienced shortages of cargo space at backhaul rates, and the growth of this traffic is expected if transport at these rates can be expanded. Sufficient volumes already exist to employ an H2, and traffic can be expected to expand.

The cost per ton km at backhaul rates (for comparison to Table I) ranges from 7.08¢ (IATA rates) to 5.16¢ (contract rates). As Table I shows, the cost per ton km for the H2 in virtually ideal conditions is 5.71¢. Increasing costs by about one-half to compensate for less favorable operating conditions the H2 could still deliver at rates in the general neighborhood of the 1973 IATA backhaul rates.

The H2 presents a transport alternative, not very much more costly than the backhaul rates which have fostered rapid expansion of the Kenya-London vegetable and fruit trade, and well below the costs of transport at ordinary rates, which at the beginning of 1973 were about 18¢ per ton km from the Nairobi Region to Europe. It would appear therefore that the H2, or eventually a more advanced airship, may be important in breaking the backhaul bottleneck that now impedes further horticulture development in Kenya.^{2/}

However, the H2 faces special problems not encountered by backhaul traffic. First, the bulking requirements (100 tons) would be much more demanding at the point of origin. Second, the low speed would make the H2 less flexible in meeting the timing requirement at markets than is backhaul traffic. Finally, the airship is barely competitive with conventional airplanes on a cost basis for handling the traffic once volumes are large enough (say 15,000 tons per year) to justify a cargo plane devoted to this use. Costs, calculated on the same basis as those for the H2 ranged from 3.5¢ to 5.5¢ per ton km for conventional aircraft in 1972. For comparable planes the cost increase has been about 60% since that time, mainly on account of fuel cost increases which have more than doubled. Costs for conventional aircraft would thus be in the 6 to 8 cent range, per ton km, at this point in 1974, roughly competitive with the H2. Ground cost advantages of the H2 would probably be minimal in this situation where the infrastructure for planes is already highly developed.^{3/ 4/}

The H2 as an Alternative to Infrastructure Development, a Burundi Case

Another possible use of the H2 is to fill the (often discussed) transport vacuum in the case where a clearly important potential traffic faces a lack of some of the required infrastructure components for conventional transport. The economic choice is between the three options: not developing the resource; infrastructure development for surface or cargo plane transport; and shipment by airship. The particular case we shall summarize is the movement of nickel deposits from an area in Burundi to the seaport of Dar es Salaam.

A large and rich nickel deposit lies very shallow (susceptible to open gap mining), near Rutava in Central Burundi. The potential output of the mine is not precisely known, but 30,000 tons per year of metal (perhaps 45-50,000 tons of concentrates if it is shipped in that form) is the expected output of the mines once they are established.

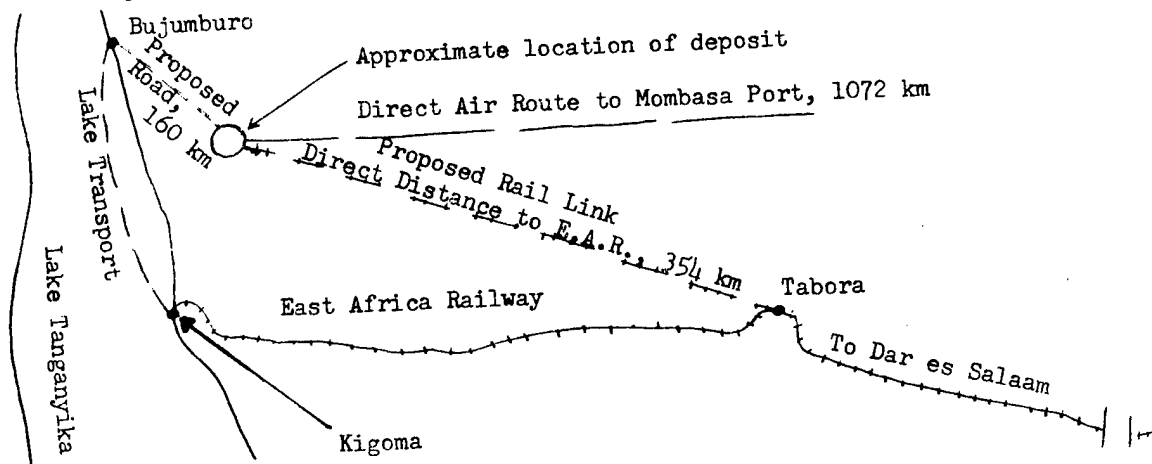

The conventional transport alternatives can be briefly summarized:

(a) A road can be built (or existing roads upgraded) between the Rutava region and Bujumbura, a distance of about 160 km. From Bujumbura (a lake port on Lake Tanganyika) the metal or concentrate could go by barge to Kigoma (about 320 km), and from there to Dar es Salaam aboard the East African Railroad (about 1,200 km). This long, indirect route (1,680 km), with two trans-shipments, and inevitably long stage time (say, 20-25 days) would be similar in direct cost to the Zaire traffic discussed above, but it would require a new road link and improvement in infrastructure for the Lake traffic. Our previous analysis in the case of Zaire would suggest that the H2 would roughly be competitive with this mode even without capital costs on the surface route. The airship needs to fly only a little over 1,000 km to reach the port of Mombasa (Kenya) where sheltered water areas are available for loading to ships, compared to the 1,680 km journey by surface. The capital cost of surface transport infrastructure by this route is comparatively modest--perhaps \$45-50 million for the needed investment in roads, rolling stock, barges and tugs, and lake ports, but this cost difference would appear to be decisive.

(b) A second alternative which has been discussed is to build a rail link directly to Tabora for a continuous rail journey from the mines, to Tabora, hence to Dar es Salaam aboard East African Railway. Costs for the new link have been estimated as high as \$300 million, since the railroad would have to traverse very difficult swampy areas. Once in place, the railway would have reasonably low variable costs for the entire trip length--about 1,200 km in a route nearly as direct as an air route. The relative costs of this alternative compared to the airship will depend, crucially, on the anticipated traffic volume. At relatively low volumes (such as 30,000 to 50,000 tons per year) the capital cost of the rail link would clearly be prohibitive, annual interest on the railroad investment being about three times the total annual cost of moving the traffic by airship.

(c) The third alternative would be to build a large enough airport at the mining area to fly the metal to Dar es Salaam or Mombasa aboard efficient cargo planes. On an operating cost basis, the H2 could compete almost equally with a large jet cargo plane, but the low traffic volumes would not employ even one medium sized cargo aircraft. The infrastructure advantage of the H2, and the cheaper trans-shipment at the port, would also seem to make the H2 preferable even at traffic volumes large enough to employ a plane.

Clearly the Burundi nickel export is a special case. In some cases (perhaps in this one) the additional development impact of a conventional mode would offset the airships advantages. But this and similar cases command attention for more detailed study.

Using Small Airships in the Region East of the High Andes in Peru

In the use of airships in the Andean region, the development program is considered in two basic steps: the use of a small airship, with useful load capacity of about 2 tons; the use of a 15-ton capacity dirigible to replace the small airship in a particular area once the

technical aspects of the use of an airship in the area have been proven, experience has been gained with its developmental impact and crews have received adequate training. Because the crew will generally not have good ground support, they will need skill in maintenance and unassisted landings, as well as for operating in difficult terrain. From the economic point of view, only the larger dirigible will be competitive, as shown below. But to gain experience with maximum safety, the smaller high-powered, easily handled ship will be used. The cost characteristics of both airships were presented in Table 1. The general zone that we are considering for use of these airships is east of the Andes mountains in Peru. The region reaches from the mountain side called "ceja de montana" in Peru, to the Amazon valley. A zone with similar geographic characteristics reaches into Ecuador and Colombia to the north and into Bolivia in the south. The altitude varies from 1,500 m in the mountains to 700 m in the east into uncharted country, forests, and eventually into tropical jungles through which run the head waters of the Amazon. The valleys are sparsely populated, and the area is, for the most part, undeveloped. These areas could potentially support a much larger population if better transportation and communications are supplied and if agriculture production is improved. Peru is now a large importer of food, over \$230 million per year, in spite of having large unutilized areas for agriculture.

In these regions, roads are costly to construct and hard to maintain, and may be impassable in many periods of the year. Vehicles deteriorate rapidly and have high maintenance requirements. The high freight rates reflect the condition and type of road, the topography, and the irregularity of loads, vehicle circulation, and backhauls. Transport presents a particular problem in the flow of agricultural products because the distribution of arable land is in relatively small valleys separated by rough gorges and ravines. A valley can therefore remain quite isolated, economically, even though it is quite near a road. The construction of access or penetration roads is extremely costly in the regions under consideration (above \$250,000 per km). Although distances are relatively short, the linking of all of the main valleys with penetration roads is therefore not justified until and unless a high level of development is reached.

Air transport with conventional aircraft would require a large number of airstrips to provide adequate access and it is doubtful if they could be constructed at a reasonable cost. Cost of transportation with alternative airborne modes have higher direct costs as well, for example, the 5 to 1 De Havilland twin otter, \$0.56 per ton km, the Helicopter Sikorski, \$1.49 per ton km, as compared to the 15-ton airship \$0.30 per ton km. Consequently, the VTOL air transport mode is envisioned to fulfill the communication needs.^{5/}

The transportation needs are for moving small cargoes for short distances to road, rail or river heads. The aspects favoring the dirigible, in addition to its relatively reasonable cost of operation, are its flexibility and very low infrastructure cost. It does not require landing strips. An open field in size a little over twice the length of the vehicle, with a simple mooring tower in its middle, around which the airship can weather-vane, will suffice. Thus in such region as described the airship could provide the link between the many isolated small communities and the few roads which provide general access to the region (see map, page 13).

The airship will be designed to operate out of a base located 700 m above sea level. Typical base points would be Atalaya at the confluence of the Ucayali and Tumbo rivers in central Peru; Tarapoto or Tingo Maria. Primitive airport facilities exist at these locations.

Transportation in the zone linked by the road Huanuco-Tingo Maria-Aguaytia - Presently the road is semi-completed. It is not paved and 30 km remain as a five-meter wide earth path. From Huanuco westward, the road links up to the coast highway. We are considering the airships as alternatives to road development east of Huanuco.

The cost of completing the construction and the improvement of the 219 km road from Huanuco to Aguaytia was estimated at \$57,597,000, \$263,000 per km. Depreciation over twenty years with maintenance cost of \$650 per km per year results in a total yearly cost of \$31,526 per km for this road. Costs that have already been incurred to date, for the original road, have not been included in this estimate.

In 1972, traffic over the 219 km road from Huanuco to Aguaytia varied from 350 vehicles per day between Huanuco and Tingo Maria to about 200-250 vehicles per day beyond Tingo Maria. At 300 vehicles per day the annual cost of the road would be \$0.282 per vehicle km or \$.115 per ton km at the average load of 2.5 tons. The operating cost of the medium trucks that ply this road has been estimated (in 1973) as \$.25 per ton km.^{6/}

TABLE III

SUMMARY OF TRANSPORTATION COST HUANUCO-AGUAYTIA

I. Road 219 km	
1. Capital Investment \$000's	\$57,597
2. Annual Capital Charge plus maintenance per km	\$31,500
3. Annual Capital Charge per ton/km \$/ton-km	.115
4. Total operating cost for truck \$/ton-km	.255
5. Total cost road transport \$/ton-km	.370

While the 2-ton airship at \$1.00 per ton km is not competitive on a commercial basis, the 15-ton airship (at \$0.296 per ton km) is highly competitive. In addition, it has inherent advantages over roads. It can stimulate agricultural development in a much broader zone, in regions far from this principal road where the developing stage would not justify the constructions of costly feeder roads for new agricultural development programs. The investment in an airship is minor, and its use is flexible, making it less risky than high, fixed road investment. The airship can aid the development of potentially rich agricultural zones such as those considered, almost immediately; it would be necessary to wait a long time before a road network is completed.

We conclude that in this case the airships are competitive with the construction and periodic reconstruction of the main road servicing the area. In addition, the airship can connect regions that are not effectively serviced by the road. Compared to feeder roads, which would also have very high costs but much lower traffic volumes, the airship is far less costly.

Transportation in an Isolated Region in the Peru Via Area - The Peru-Via area (see circle on map, page 13) is almost due east of Lima. An all weather road of about 180 km crosses the high Andes from Lima to San Ramon which is just on the western edge of this area.

Lack of transportation facilities represents the major obstacle to agricultural development in the Peru-Via area. Except for a few scattered landing strips for light planes, and small fringe areas where dirt roads penetrate, the region is almost inaccessible. It has been amply demonstrated through unsuccessful colonization experience east of the Andes, that transportation is indispensable to economic development. Without adequate transportation there is economic stagnation, a lack of progress, and large-scale farm abandonment. Colonization without proper transportation facilities would result in a waste of national resources.

Several zones in this area are under active consideration in the country's development plans for the settlement of 37,000 families in the Apurimac-Ene valleys and 20,000 in the Palcaza-Pichi region. The regions are apt for cattle, agricultural, and forest production. More generally within the radius of 150 km from Atalaya lie regions with an extremely rich potential. It can be expected that the presently existing population will multiply its output once a market for their products is established, and new production technologies can be introduced.

Atalaya is at a projected road distance of 365 km from the west-east road head near San Ramon which provides communication to the coast. The projected road implies 316 km of mountain road (average construction cost \$/km 250,000) and 49 km of level road (\$/km 150,000). To provide adequate communication, several hundred kilometers of feeder roads (estimated construction cost \$/km 30,000) would also be required.

The yearly capital charge for infrastructure of the principal linkage only, amortized over 20 years, is \$27,700 per km. The annual maintenance cost has been estimated at \$650 per km giving a total cost of \$28,350 per km.

With an average daily estimated traffic of 100 six-ton trucks and a return load factor of 30%, about 142,000 tons per year will be transported. Thus the cost for road usage would be average \$.199 per ton km. The truck operating cost per ton km on the new paved road is estimated at \$.32 based on the data provided by Sauti.

TABLE IV

SUMMARY OF TRANSPORTATION COSTS SAN RAMON-ATALAYA

I. Roads 365 km	
1. Capital Investment \$000's	\$86,350
2. Annual Capital Charge plus maintenance \$ per ton	\$28,350
3. Annual Capital and Maintenance Charge \$ per ton km	.30
4. Truck operation cost \$/ton-km	.32
5. Total cost per \$/ton-km	.52

This cost is less than the direct transportation cost on a 2-ton dirigible (\$/ton-km 1.00), but considerably more than on a 15-ton airship (\$/ton-km 0.296) as estimated under present conditions.

The present situation is that the produce of this zone does not leave the region due to lack of transport facility. The production remains limited as there are no accessible markets for trade. Thus we are faced with questions such as:

- (a) To develop or not to develop the zone.
- (b) To start the transport projects practically immediately, or in several years hence when the surface communication network can become operational.
- (c) To risk heavy investment capital to develop surface transport access at this time (before the development of the region is proven) or to postpone the projects until such time when the production of the zone is flourishing.

We would argue that in this case, where the road infrastructure is not yet in place, and the economic risk of road infrastructure is very large, that the investment in airships is far and away the most conservative approach to linking this isolated area to the market.

SCHEME OF ROAD SYSTEM AND CONNECTIONS TO ATLANTIC HIGHWAY -
PERU REFERENCE AREA

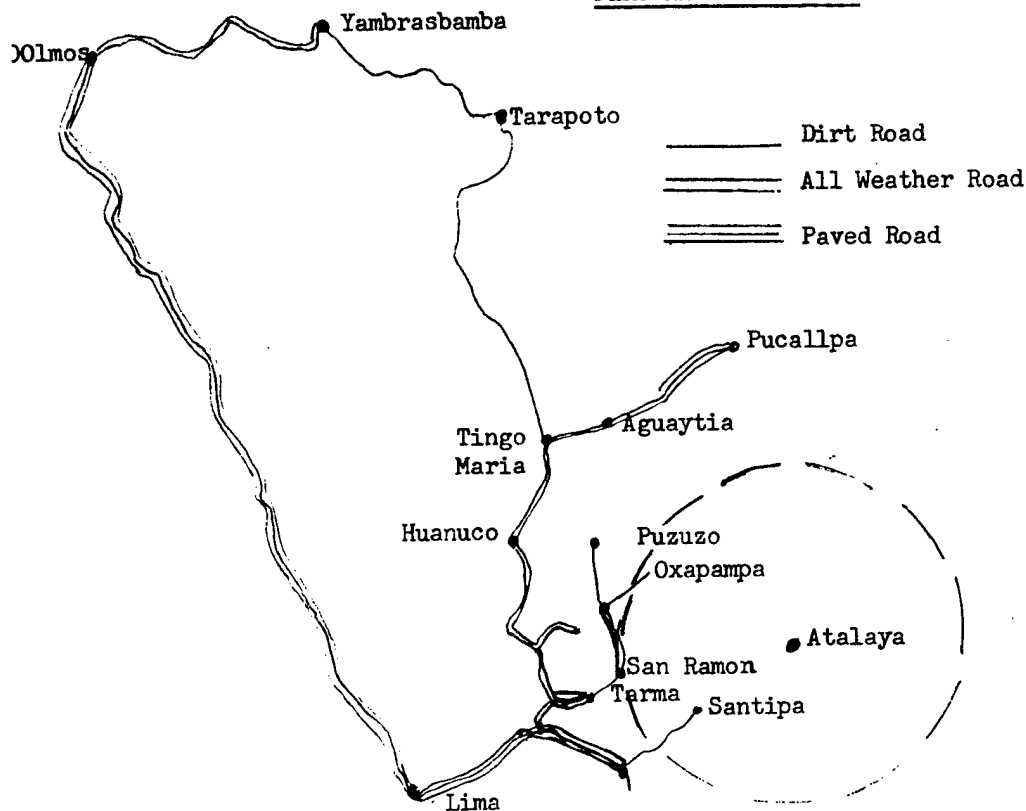

REFERENCES:

1. BCEOM, Etude de Transport de la Voie National (October 1971)
Volume I, p.25.
2. International Air Transport Association, Agreeing Rates and Fares
(January 1973) p.137 and supporting notes.
3. International* Air Transport Association, Aircraft Operations
Cost and Performance Report (July 1971) pp.26, 31.
4. Anon., Summary of Aircraft Operating Costs, Aviation Week
(July 31, 1972 and July 27, 1974).
5. C.A.B., Aircraft Operations and Maintenance Report.
6. SAUTI (Italian Consulting Firm), Consultants Report to Government
of Peru, ORETT (Peru's Transport Regulating Agency), produced
similar estimates.

THE APPLICATION OF THE AIRSHIP TO REGIONS
LACKING IN TRANSPORT INFRASTRUCTURE

Stephen Coughlin*

ABSTRACT: This paper considers the requirements for two areas of airship application. The first of these are those countries where there is a need to move consignments that are too large for the existing transport systems, and secondly those regions where ground characteristics have resulted in an area totally devoid of transport. The needs of the second group are considered in detail since they also require transport to provide social as well as economic growth. With this problem in mind, a philosophy is put forward for using airships in conjunction with LASH vessels. A specimen design is outlined and the initial costs estimated.

Introduction

In order to justify the future development of the airship, it is necessary to first identify those areas of application where it can provide transport facilities far superior to any other transport option. In an attempt to identify these areas, a number of operational situations have been considered. The most promising result of this study was the unique advantage displayed by the airship in its ability to provide transport facilities in those regions presently lacking in transport infrastructure, the results of which are summarised in this paper.

* Research Officer, Cranfield Institute of Technology, Cranfield, England

Identifying Areas of Need

In studying the present distribution of surface transport facilities it becomes apparent that although existing transport technology provides an effective coverage for most of the worlds land masses there are two major areas where present transport technology is seen to be inadequate:

- 1) those countries where increased industrial development is demanding the ability to transport units so large that existing transport infrastructure is unable to cope.
- and 2) certain discrete land areas almost totally devoid of any form of inland transport.

The first of these is a simple limitation of existing transport systems, and its implications are covered far more adequately by Stephen Keating in a later paper of this session. The second area of need is seen however as a complete inadequacy in our present technology, and it is with this area that this paper is primarily concerned, although in producing an airship design the needs of both markets will be considered.

The Implications of Inadequate Technology

The reason for the total lack of inland transport facilities in the regions outlined above is easily identified as the adverse terrain that exists within them. The legacy of this problem is a situation that has extensive ramifications upon the economic and social health of the regions involved. The lack of transport infrastructure makes it impossible for both the commercial agricultural and the industrial activity of the hinterland (mainly agrarian) to expand and develop. This prevents these regions improving their production from the land, and therefore constrains one of their major assets. Furthermore the lack of communication retards the growth of other industries into the hinterland, added to which the lack of transport infrastructure itself removes a major source of industry. For developing countries, that is, the provision of the facilities themselves.

This situation leaves those responsible for these regions in a frustrated position; the ability to transport goods is a primary requirement of any economy and many of the regions involved are rich in natural resources, presently in high demand in the world market an attribute they are eager to exploit.

The exploitation of these resources in the past has been hindered by the expense of actually providing the transport facilities necessary to extract them from within their adverse terrain. This situation is however changing rapidly; the increased demand for these resources has led to a major price escalation, which may justify the economic development of the hinterland. This has encouraged a radical reappraisal of available transport technologies, the results of which have included the use of helicopters for logging in Canada and proposals for many strange conventional aircraft for carrying oil out of Alaska. These extremes of technological application serve as perfect examples of the inadequacy of our existing transport technology, both conventional air and ground modes being unable to meet the full demands of the market.

Market Requirements

The transport needs of the regions discussed appear to be ideally met by the airship. It has been shown to provide a high capacity, low cost operation, totally independent of the surface conditions, although the topography of the region can give rise to economic constraints. Before it is proposed as the complete solution, however, the total implication of its application must be considered.

The Transport Needs of these Regions

The introduction of transport infrastructure is more than a simple ability to transfer goods. A developing country must not only consider the industry that is being served but also the industry generated by the operation and implementation of the system. With a ground based system there is probably as much economic advantage from the employment of those actually building the road or laying the track, as there is from the growth introduced by the ability of existing industries to transport their goods over a wider area.

With an airborne system this advantage is lost and it may be further aggravated where the country in question has to depend upon technical back-up from other countries due to the technological complexity of the vehicle. A situation like this could lead to a balance of payments situation that stifles rather than stimulates economic growth.

A developing country must therefore adopt a system that has a low foreign participation and foreign exchange component, thus dictating a system based upon conventional technology with very little need for specialist servicing or repair back-up. As it also has to operate in sparsely populated areas well away from centralised technical facilities, its construction should be such that it can sustain minor damage and still operate, or be easily repairable by the flight crew. What is in fact required is a standard "work horse" which can be simply flown and operated.

This is also likely to be the requirement for the first group outlined, (i.e. those requiring to transfer large unit loads), and the ideal "work horse" should cater for both of these markets.

For different reasons, both "user" groups outlined require a system that is based upon a minimum investment in ground facilities. This is consistent with a further requirement, that the system should be flexible in operation, and should not therefore depend upon specialised ground equipment, but use facilities readily available at present.

All of these points help to reduce the investment risk and make it possible to transfer the operation if it becomes justifiable to introduce alternative systems once the market is developed.

Design Philosophy

In terms of size, the requirements of the unit load sector of the market is an airship with a payload capacity at least in excess of several hundred tons. Those areas developing a transport infrastructure, however, will require a range of airship designs, with payloads from 20 tons upto several hundred tons.

Bearing the requirements of both groups in mind and attempting to produce a design that would interest both of the user groups, a large payload airship has been considered. The specimen design chosen has a useful lift capacity of 1000 tons. This provides a unit lift capacity for superior to any other option available for transport across difficult terrain whilst, for the general goods market for the areas discussed, it provides an acceptable commodity flow. The major attribute of this size of vehicle however is that, for the general commodity market, it is capable of carrying one of the large LASH barges. This allows the development of a total transport system with attributes well beyond any system yet available, a facility that will be discussed later.

Vehicle Design - The design of the hull is a key area in any airship project, but more so when considering operation in adverse terrain many miles from the nearest technical back-up. Past studies have normally proposed rigid shells which, if damaged, would require a highly competent technical back-up and extensive engineering facilities.

In an attempt to avoid this problem, Cranfield have been studying designs based on a fabric outer shell with a concentrated load bearing structure within it (ref 1). With this type of design, the shell is more easily replaced and repaired than with conventional rigid structures, and the central structure is far more substantial in proportion to its size and is therefore more easily constructed and handled. Both of these attributes provide a structure that can be easily handled by personnel with very little specialist training. A similar philosophy has been adopted in selecting the other systems (i.e. low technology engines and control systems).

Cargo Handling - Because of the difficult terrain in the regions being considered, the loading of the cargo must be undertaken as quickly as possible. For this reason it is far more efficient if the payload can be loaded as a single unit, with the airship hovering above the area. This does present design problems, but these can be easily catered for at the design stage, and would simplify all future operation.

Although it has been suggested that the loading of the airship is undertaken with a single unit, it is assumed that the container will be loaded with smaller units, the size of which will be matched to the market requirements. This provides a great deal of flexibility to the operation, as it means that the larger unit can be loaded with anything from trucks to plastic bags, a facility that should prove useful to this type of operation.

The development of the primary container could be undertaken very simply, if necessary. There is however, a standard container available that has a capacity of 850 tons. This has been developed by a shipping company as a barge for use on "lighter aboard ship" (LASH) operations. The further flexibility introduced by using a barge adds an extra dimension to the operation, by reducing the trip end facilities required. The reduced specialised equipment required for filling the container has already been mentioned, the container being able to accept any form of payload from the origin. At the outer end of the trip however, the barge can be placed in any piece of sheltered water and left for collection by tugs or a LASH vessel.

Terminal Facilities

Facilities at Origin - As the origins are expected to be located in rugged terrain, and the airship is at its highest risk when operating close to the ground, the loading manouvre must be undertaken as quickly as possible. For this reason the operation at the origin will be restricted to the loading of the payload and the discharge of any return load or ballast. The loading of fuel and replacement parts for the airship being undertaken at the outer end of the trip, where the terrain will be more amenable to long stays.

Because of its susceptibility to terrain it may be necessary to position the loading area away from the origin. It is estimated that the loading area should be chosen such that within the area of 2 miles by 1 mile a central area of a $\frac{1}{2}$ mile radius does not have any variations greater than 10' in the centre rising to 1,000' at the outer boundary, and for the area between the $\frac{1}{2}$ mile boundary and the outer limits the terrain should not vary much more than 2,000' in general, although odd peaks greater than this could be acceptable. The layout of the area will also depend upon the direction of the prevailing wind. An assessment of the total implications of this can only be undertaken in a complete feasibility analysis, but a preliminary study has shown that this is possible, although not always adjacent to the true origin of the goods.

The general philosophy will be to keep the equipment required at the inland end of the flight to a minimum, and hence reduce the "off vehicle" capital costs. This can only be introduced to a certain extent as the problems are difficult, and although the use of hovering and single load units will simplify this, special equipment will be necessary. The major problem is the quick loading of the containers and the removal of the returned unit. Fine manoeuvring of the airship to place and pick up a container from a specific point is very unlikely. This gives two options.

- a) Design the large container to be moved quickly to and from the airship
- b) Leave the container on the airship and unload and reload quickly

Both of these are technically feasible and would rely most probably on using an air cushion under either the whole container or cargo pallets. This keeps the equipment down to a minimum and will require very little specialised handling equipment, the facility requiring no more than standard agricultural vehicles. In addition to this a tank for holding standby ballast will also be required, with a capacity of approximately 250,000 gallons.

Facilities at Destination - The use of a barge as the container means that the airship can unload in sheltered water. This provides an ideal modal interchange; the payload either being taken ashore from the barge or being transferred directly to a ship for export. In addition to the interchange advantages the use of a sea-based terminal has many further advantages, i.e.

- i) Sea water ballast
- ii) Level terrain

- iii) Space to allow a certain amount of drift
- iv) Ample space for storage of barges close to shore, whilst waiting for shipping out
- v) No specialised equipment required
- vi) No investment for storage or terminal area.

The ballasting will be discussed later in the report but the ready available ability of water must not be ignored. By far the greatest attribute of the sea terminal is the unobstructed space and the flexibility of the location. The unobstructed space can allow more time to be spent at the terminal for repairs, refuelling and crew replacement, without a high risk. At the destination the only equipment needed will be a tug boat together with the exchange barge. This implies a very low capital investment, a facility that is only available with this type of system.

Ballasting System

For this type of operation the use of sea water ballast would seem logical. Fresh water may have advantages in certain areas but it does not provide the control advantage offered by a sea water system unless available in large quantities (i.e. lakes, etc). The ballasting system developed for this study plays a dual role of both stabilising the airship whilst moored and supplying the necessary ballast for flight.

The technique consists of suspending water carriers under the airship, which in a balanced situation would be half immersed in the sea. Any deviation from a balanced situation would either decrease the load on the airship by lowering the carrier into the water or vice versa. This means that the force which caused the airship to move is balanced by the automatic removal or addition of ballast, returning the airship to a balanced position. When ready for flight, ballast is discharged until the carriers leave the water and the airship is in equilibrium.

At the inland end of the trip a storage tank of standby ballast would be required to hold the airship during loading and unloading.

Discussion of Cargo Handling System

The cargo handling system that has been outlined is based on a low "off vehicle" capital investment and a high flexibility in types of application. This then makes it ideal for supplementing existing systems on an ad hoc basis, as special requirements occur; and also as an exploratory vehicle for serving new mines, oilfields etc until output justifies the investment in ground based systems. Apart from the specialised handling equipment no special equipment is required at the loading site, and the destination demands no more than standard port equipment. A further attribute is their implications on the project cash flow, as the whole system can be written off over a large network of operations. The characteristics of the cargo handling system also make it generally applicable to many types of market giving the airship resale and charter value, an attribute not available from many transport modes.

Implication of Cargo Handling System on Airship Design

The major penalty imposed by the cargo handling system outlined is the effect of the concentrated load applied to the structure. To cope with this, it would require extra structure within the hull to distribute the forces. The weight penalty would be small, but has been catered for in the design.

To prevent further weight penalties the ballasting system will be distributed in small units along the structure, and therefore reduce further load concentration problems.

Design of the Airship

To produce the design, a computer technique was adopted. This consisted of a parametric model, based on the latest design information, and a simple cash flow optimisation technique. The results of the study is given in Table 1.

LIFT AT 100% INFLATION	2,300 TONS
NORMAL LIFT	1,920 TONS
PAYLOAD	850 TONS + 150 TON CONTAINER
RANGE	1,000 MILES
FLIGHT ALTITUDE	6,000 FEET
VOLUME	83,000,000 FT ³
LENGTH	1,700 FEET
L/D	6
CRUISE SPEED	109 KNOTS
MAXIMUM SPEED	120 KNOTS
INSTALLED POWER	75,000 HP
PAYLOAD/NORMAL LIFT	46%

TABLE 1 TECHNICAL DETAILS

Cost Analysis

The estimated cost breakdown of the projects are given in Table 2. In producing these figures, the following assumptions were made:

Write off period	10 years
Interest on capital invested	20% per annum
Return load	75% possible payload

Maintenance	4% of first cost/annum
Insurance	1% of first cost/annum
Crew Costs	£140,000 per annum

The first cost can be further broken down into:

- 15% R & D wages and salaries
- 16% production wages and salaries
- 10% other wages and salaries
- 24% other overhead costs
- 35% purchased materials and components (inc. gas and engines)

These costs are structured to include a portion of an initial R & D investment of £100 million, assumed to be written off over forty large airships. This is assumed to be based on a consortium agreement and will be used for all initial R & D and the production of two test vehicles.

First Cost	£M 21
Annual Cost	£M 6.4
Fuel Cost/Year	£M 6.0
Total Cost/Year	£M 12.4
Cost/Ton.Mile Available	£ .038*
Break even Cost/Ton.Mile	£ .044**

TABLE 2 COST DETAILS

- * Assumes 100% return load
- ** Assumes 75% return load

These costs represent a 1000 mile range airship. An operating cost of £.042/TON MILE AVAILABLE is extremely competitive in a normal situation; in regions that are biased against ground modes it is likely to be far cheaper than any other option available. A more generalised cost curve showing the variation of operating cost with range is given in figure 1. It can be clearly seen that even on the short ranges the economics of the airship are attractive.

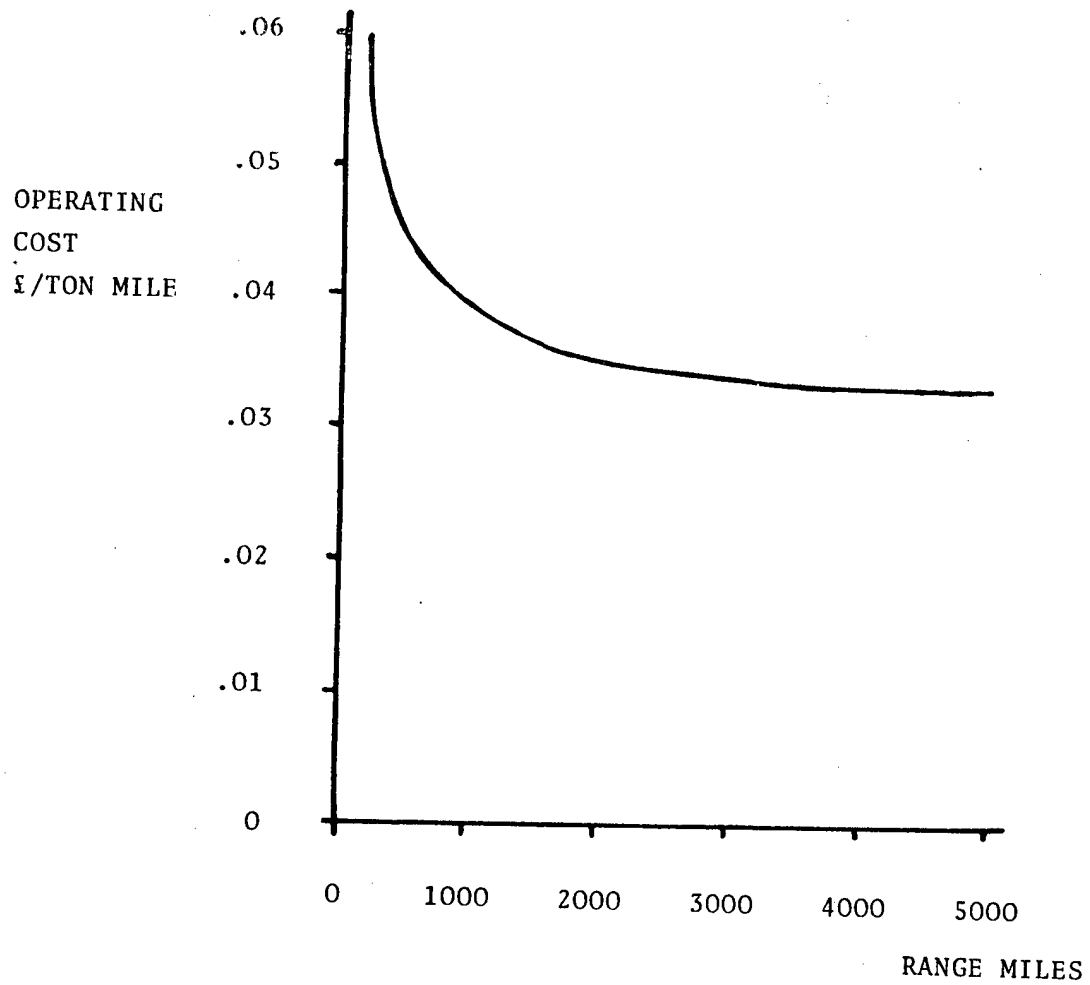

FIGURE 1 - VARIATION OF OPERATING COST WITH RANGE

REFERENCES:

1. Shelbourne E.H., Study of the Structural Design of Large Airships, Cranfield Institute of Technology, MSc Thesis, England, (1973).

A

MILITARY APPLICATIONS
OF RIGID AIRSHIPS

Ben B. Levitt*

ABSTRACT: The objective of this paper is to examine military roles and missions for which the rigid airship appears to be suited, and to suggest specific applications that the airship could potentially perform in an effective manner. Principal missions examined are the movement of military cargo and the surveillance aspects of the sea control mission.

MOVEMENT OF MILITARY CARGO

Probably the most general application of large rigid airships in military employment lies in its capabilities as a cargo carrier or troop transport. The unique capabilities of a rigid airship to haul commercial cargo and passengers is presented in some detail in other sessions. The use of an airship as a military transport requires only a few additional considerations. These include the ability to operate from relatively unprepared sites, the requirement for some structural alterations to the airship hull to permit hauling of military cargo, and provision for some degree of self-defense capability.

* Director, Tactical Systems Division, Operations Research, Inc., Silver Spring, Maryland

PRECEDING PAGE BLANK NOT FILMED

The ability to deliver large quantities of cargo and troops into remote areas with little or no ground support equipment is an extremely important military asset. Such a capability would permit a rapid response to emergency military needs of a brush-fire nature. It would also provide a new dimension in the flexibility with which military forces could be redeployed as the operational or political situation warranted. In areas in which no ground support equipment was available, advantage would be taken of the airship's capability to hover at low altitude, perhaps 100 to 300 feet. Cargo or troops would then be lowered to the ground on pallets or specially designed containers by winches contained in the airship's cargo holds. No runway or prepared area would be required for this operation.

If it appears likely that continued re-supply operations into the same area would be carried on, it might be desirable to erect an expeditionary mast to which the airship could be moored for loading and unloading and for servicing. Such a mooring mast could be carried aboard the airship itself and lowered to the ground as part of the initial cargo. It would be necessary that the site selected for the mast be cleared of obstructions in all directions to a distance at least equal to the length of the airship in order to permit the ship to weather-vane when moored to the mast. Thus, additional equipment might be required for site preparation and for mechanical handling of the airship. The U.S. Navy developed such an expeditionary mast for use with its blimp fleet. It was air transportable and could be erected for use within 8 hours.

Another means of accomplishing moored logistic operations in forward areas would be to use a ship equipped with a suitable mooring mast. The U.S. Navy successfully developed this technique for use with its large rigid airships. This type of operation would, of course, require an adequately protected anchorage area in the vicinity of the beach and lighterage or small craft to form the link between airship and beach.

Another mode in which the rigid airship could be used in military logistics would be to employ V/STOL aircraft capable of launching from and being recovered by the airship. This would permit the airship to maintain a stand-off distance from hotly contested battle areas. In this case site preparation would be a function of the landing and take-off characteristics of the V/STOL aircraft being employed as the cargo hauler.

VULNERABILITY CONSIDERATIONS

The use of rigid airships in the proximity of battle areas brings up the question of vulnerability of these large vehicles. This has always been a foremost argument against the military use of airships, both rigid and non-rigid. It should be remembered, however, that the military rigid airship evolved during World War I as a bombing platform designed to operate against formidable opposition—and at that time the lifting gas used was highly flammable hydrogen! The airship eventually lost the battle to become a first-line bomber or dreadnought of the skies, and has never since been considered seriously as a combat vehicle. Current technology has not reversed this decision but has contributed to the improvement in expected survivability when the airship is used in military support roles such as cargo transport or in other possible missions to be suggested.

From a technical aspect the large rigid airship could probably sustain hits from a number of air-to-air missiles or surface-to-air missiles without serious consequences. In this respect it is much more survivable than a C-5A, for example, where a single missile hit would normally be catastrophic. Damage control is feasible in a rigid airship since all of the structure and the gas cells are accessible to repair parties during flight. Even more important is the fact that the airship can be equipped with a very credible self-defense capability. This could consist of early warning and fire control radar, anti-air and anti-missile missiles, ESM equipment and a variety of electronic countermeasures suitable to the threat. In spite of this capability to sustain damage, to conduct in-flight repair and to provide for its own self-defense, prudent military operation would not permit the airship to be used in situations that were beyond its limited combat capabilities. In short, the answer to achieving acceptable levels of survivability lies in employing the airship in missions for which it is particularly suited, and in tactical environments for which it has been designed. In this regard the vulnerability aspects of a rigid airship are no different than a C-5A, a B-52 bomber, a CVA aircraft carrier or a large surface troop transport. Each of these vehicles must be operated in a tactical environment for which it has been designed if an acceptable level of survivability is to be attained.

NAVAL APPLICATIONS

Aside from its role as a cargo carrier and troop transport, the military applications of the large rigid airship seem most appropriate to the missions of the Navy. The over-water (and over-ice) environment has traditionally been most suitable for airship operations. It should also be noted that the airship is basically a low altitude vehicle. It can be operated most efficiently at altitudes below 10,000 feet. These inherent characteristics cause the military roles of the rigid airship to gravitate toward the recognized Navy missions. However, before examining potential specific military applications of the rigid airship, it is useful to note the change that is presently occurring in the major missions of the U.S. Navy.

Since World War II a primary mission of the Navy was perceived as the capability to project power ashore. To accomplish this mission required the ability to conduct a number of sub-missions: sortie and protect forces in transit to a forward objective area; establish air superiority and submarine defense in the forward area; provide air defense and strike support to amphibious forces as required; and conduct strikes against designated enemy sea and land targets. The essential combatant in this power projection mission was the large attack aircraft carrier.

In the last few years the Navy has gradually backed away from the power projection mission as its primary task. This has been evidenced by a significant reduction in its inventory of active aircraft carriers; development of the CV concept, a new operational technique that permits a single carrier to be equipped with a mixed complement of both attack and anti-submarine aircraft; and evolution of the sea control ship, a small ship that would initially be outfitted with ASW helicopters and V/STOL attack aircraft of the Harrier-type, but would eventually provide the optimum merger of high speed advanced ship concepts with high performance V/STOL ASW and attack aircraft. This evolving new mission has in fact been termed the sea control mission. It is perceived as the capability to gain control of the sea in any designated area of the world, including the surface, air and sub-surface domains, and to deny the use

of such an area to enemy forces. The sea control mission would be concerned primarily with protection of sea lines of communication but residual capability would exist to perform all of the traditional Navy missions including power projection ashore. The strategic missions of the Navy, involving employment of the Polaris/Poseidon fleet ballistic missile force (and the follow-on TRIDENT) would remain essentially unchanged.

The evolving emphasis on the mission of sea control requires, as a prime necessity, the capability to conduct surveillance of wide areas of the open ocean. This capability must include surveillance of the ocean surface, the air (and perhaps space), and the sub-surface if the entire threat spectrum is to be covered. It is in this role of ocean surveillance that the large rigid airship is best suited and in which its military effectiveness might be best applied. Let us look at the possible roles in which the rigid airship might be employed in each of the surveillance domains.

SURFACE SURVEILLANCE MISSION

Surface surveillance is a relatively straightforward task requiring that detection of all surface targets entering a specified ocean area. It has become increasingly important, however, as the size and military effectiveness of Soviet surface forces continues to grow at a geometric rate. The large rigid airship is ideally suited to conduct surface surveillance because of its size and shape. Using the immense sides of the airship, a phased array radar could be designed of unprecedented power and performance capability. This would permit the airship to maintain surface surveillance over extremely large ocean areas. The airship might also be used as a platform for surface surveillance sensors other than conventional radar as the tactical situation might warrant. Such sensors include IR, ESM, HF/DF and over-the-horizon radar.

The effectiveness of the airship's surface surveillance capability might be further enhanced if suitable classification or intelligence of detected targets is available. This would permit the airship to assume an offensive role by firing air-to-surface missiles at targets identified as unfriendly. Alternatively, the airship might launch its own aircraft to classify and attack detected targets. The use of aircraft might also be considered when the tactical situation indicates that the use of the airship's high powered surveillance radar would not be prudent due to the high threat level. In this case the airship would assume a condition of electromagnetic emission control (EMCON), and aircraft would be launched to conduct surveillance of the assigned area. In this situation the airship would still function as an airborne command and control post to receive and assess the surveillance information as it is transmitted from its aircraft. The parallel to surface aircraft carrier operations is obvious.

AIR SURVEILLANCE MISSION

The air surveillance task is similar in many respects to surface surveillance. Again it is the capability of the airship to act as a platform for very high performance radar (and other sensors) that makes it so well suited for the job. Against manned enemy aircraft the rigid airship might also be used as an offensive weapon system in addition to its surveillance role. Air-to-air missiles could be launched against detected targets at stand-off ranges approaching the detection range of the radar. Or interceptor aircraft might be launched and vectored to conduct the kill with their own air-to-air missiles.

If friendly surface forces are operating in the ocean area of interest, it is extremely important that the enemy be thwarted in any attempt to conduct air reconnaissance in the area. This denial of targeting intelligence can result in significant improvement in survival probability of the friendly surface forces. It stems from the fact that the effectiveness of stand-off surface-to-surface missiles is degraded when uncertainty exists about the location, composition and disposition of potential targets. This situation is emphasized also by the operational mode required of the Soviet cruise missile submarines of the JULIETTE and ECHO-II class. They would normally receive their targeting information from specially configured reconnaissance aircraft. If this information is denied, then they must close to acoustic detection range and their classification and targeting problem is much more difficult.

In this regard, the airship can provide a multiple capability against the cruise missile submarine threat. This threat is probably the most formidable one facing our surface naval forces (as well as our non-military convoys). The airship offers a capability to accomplish underwater detection of the submarine, and this is discussed further in regard to sub-surface surveillance. It also can contribute to the denial of targeting intelligence to enemy reconnaissance efforts. Additionally, the air surveillance capability of the rigid airship permits it to detect the cruise missile after it has been launched. This allows early warning of an attack to be given to the threatened forces and alerting of their area and point defense units. The airship might also take an active part in defense against the cruise missile by launching appropriate intercepting missiles, or vectoring CAP aircraft to an intercept position. Electronic warfare measures could also be directed against the cruise missile from the airship platform.

The air surveillance capabilities of the rigid airship could also play a vital strategic role. In this mission the airship would provide early warning of manned bomber attack in the same manner that Navy and Air Force radar pickets were used for many years. In fact, the last squadron of Navy non-rigid airships (ZPG-3W) were designed to perform this mission. The rigid airship would be vastly superior to both the blimps and the fixed wing aircraft due to its much longer endurance and improved radar performance.

The rigid airship would also provide a means for detection and early warning of ballistic missiles fired from submarines. This threat has become increasingly more important as the Soviets continue to construct and deploy their second-generation YANKEE class submarines. The YANKEE has 16 ballistic missiles with an estimated range of about 1500 nmi.¹ Employment of a depressed flight trajectory provides very little early warning time to CONUS defensive forces. The air surveillance capability of the rigid airship would provide for a significant improvement in available early warning time. Further, if the airship can also conduct suitable sub-surface surveillance, it provides a platform for launching counter-weapons against both the firing submarine and the missiles during their boost phase. The ballistic missile is most vulnerable to attack during the boost phase where its speed is low, exo-atmospheric conditions do not apply, and a large IR signature is available to an intercepting weapon.

It would also be feasible to design a rigid airship to detect submarine launched ballistic missiles in their mid-course trajectory, and to launch suitable interceptor missiles. This would be similar to the Navy's SABMIS ship concept, now dormant, but with significantly improved operational flexibility and survivability.

UNDERWATER SURVEILLANCE MISSION

Underwater surveillance is the third domain in which the rigid airship could contribute to accomplishment of the sea control mission. In this role the airship could be employed in several ways. It could be used to emplace and monitor large fields of moored sonar buoys in specific ocean areas where it is desired to establish a high level of underwater surveillance. Such sonar buoys would be similar to the Navy's Moored Surveillance System (MSS) currently in the developmental stage. The airship would monitor the buoy fields, classify and correlate detections and vector ASW forces to accomplish localization and attack against threat submarines. These ASW support forces might take the form of ASW aircraft operated from the airship itself. The airship would be capable of recovering and replacing surveillance buoys that fail, are damaged or drift from their desired position. Maintenance facilities could be carried aboard the airship. An entire surveillance buoy field might be recovered and redeployed as the situation warranted.

The rigid airship might be operated entirely as an ASW aircraft carrier (CVS) in order to accomplish the underwater surveillance role. In this mode the ASW aircraft would employ their own surveillance sensors in open ocean search. The airship would launch and recover the aircraft, provide facilities for maintenance and stores, and function as the command and control center for the search, localization and attack operations. As previously noted, the dedicated ASW aircraft carrier has been replaced in the Navy by the CV concept in which a mixed complement of ASW and attack aircraft must be carried. The rigid airship ASW aircraft carrier could provide a means of returning to a single mission ASW carrier, and without the need for accompanying destroyers or underway replenishment groups. It would again provide the Navy with a capability to conduct offensive ASW operations in the open ocean as opposed to the basically defensive posture associated with the CV concept. This hunter-killer type of operation proved to be very effective in the attrition of German submarines during World War II.

Another mode in which the rigid airship could be employed for underwater surveillance would be as a platform to tow horizontal linear passive sonar arrays. Such arrays could be designed with an extremely large aperture, essentially to the limits of the environment. Improved performance would result further from the fact that the interfering radiated noise of the towing ship would be eliminated. The resulting performance characteristics in terms of sweep rate should greatly exceed any other type of available platform-passive sonar system. The airship, once again, could carry its own ASW aircraft to localize and attack detections that are made, or it could vector other ASW forces to the scene.

The use of towed array systems with rigid airships seems especially suited to the task of maintaining surveillance on Soviet ballistic missile submarines. Coupling this capability with a boost phase intercept system, as indicated above in the discussion of air surveillance applications, would result in a particularly effective employment of the rigid airship's attributes.

COMMAND AND CONTROL MISSION

A final possible employment of rigid airships seems worthy of note. In all of the possible roles mentioned above to support the sea control mission, a single task always seems to emerge: the necessity for an adequate command and control system. The airship appears to be eminently suited to perform command and control tasks, either in conjunction with a specific surveillance role, or as an airborne mobile command and control post. In this latter task the airship would serve as the central command post and the operational control center for a designated sector of open ocean. The airship is large enough to house the most sophisticated communication equipment, computers and ancillary software, analysis and display equipment suitable for a major fleet command. The mobility of the airship would permit the area commander to remain literally "on top" of the situation in his assigned sector.

REFERENCES:

1. Blackman, R. V. B., Jane's Fighting Ships (1972-73).

POTENTIAL ASW MISSIONS
FOR LIGHTER THAN AIR SHIPS

Richard S. Stone*
Bernard O. Koopman*
Gordon Raisbeck*

ABSTRACT: This paper deals with the LTA as a potential counter to the ballistic and cruise missile launching submarine. The LTA ship can deploy a wide variety of submarine detection equipments effectively. Its long endurance, high speed, and large weapons inventory capability, coupled with the facts that it need not alert a potential submarine target as to its presence, and that it is essentially immune to attack by submarines indicate that it would prove to be a highly effective ASW unit.

A number of characteristics of the Lighter Than Air Ship indicate that it can be an ideal platform for mounting an effective counter to the threat posed by Ballistic Missile Launching and Attack Submarines. This paper investigates the requirements for such a counterforce and briefly illustrates why it is felt that the LTA ship can play a significant role.

Land-based ballistic missiles are presently being deployed on the basis of a counterforce strategy--that is missiles attacking missile bases rather than population centers, thereby providing additional scope for both negotiation and, if need arises, for controlled escalation. At this time, in the case of the Submarine Launched Ballistic Missile, there is no parallel to the land-based missile strategy. The SLBM represents a last option in a strategic missile war. At present, the SLBM remains as an uncountered threat.

*Arthur D. Little, Inc., Cambridge, Massachusetts

PRECEDING PAGE BLANK NOT FILMED

If it were possible to bring into being even a modestly effective counter to the SLBM, it would provide additional incentive for negotiation and, again if need be, additional options for escalation. However, at this time, it does not appear to be either technically or economically feasible to construct and deploy an effective counterforce to the SLBM.

In order to understand the nature of the problem, it is instructive to review the process by which the SLBM threat might be countered. The process consists of the following functional elements: (1) Initial detection, classification and localization of the submarine as it transits from its base to its patrol area; (2) Track and trail of the submarine on a "steady state" basis (a continuous stalking operation) to assure that the large majority of deployed submarines are continuously under surveillance and the threat of attack; (3) Attack, if and when necessary. The counterforce capability must be in position to deliver an attack with high lethality against the submarine under surveillance with minimal time delays.

INITIAL DETECTION

A number of technical alternatives have been employed to fulfill these functions in the past.

Initial detection, classification, and tracking is accomplished by means of wide area acoustic surveillance systems. However, if submarine radiated noise is reduced by quieting and the choice of operating areas is expanded by increasing the range of submarine launched missiles, the probability of detecting, localizing and tracking a large fraction of the deployed submarines will decrease. Present fixed passive acoustic area surveillance systems allow one to detect submarines transiting at higher speeds in selected areas. Since areas in which these systems are effective are limited by geo-oceanographic conditions, systems of this type will be of limited usefulness in the future. Initial detection, classification and localization can be provided by systems of this type, if augmented and deployed to cover the routes employed by submarines in transiting to their patrol areas. However, they may not provide a method of tracking and trailing these submarines on a continuous basis.

TRACK, TRAIL AND ATTACK

In the future, following detection in transit, it will be necessary to provide one or more platforms or vehicles to carry out the "steady state" tracking and trailing missions, as well as the attack mission, if and when required. The functional specifications for a platform that will fulfill these mission requirements is unique in the following respects: (1) The platform must have sufficient endurance and/or be supplied in sufficient number to provide long-term track and trail of all detected targets; (2) It must have sufficient speed capability to allow rapid deployment to a given holding position and vectoring on to a detected target. It must also have speed sufficient to allow it to out-maneuver a fast target attempting to escape continued tracking and attack; (3) It must be capable of utilizing a wide spectrum of sensors including sonobuoys, the more advanced towed acoustic arrays and active/passive reliable acoustic path sonars and MAD equipment; (4) It must be capable at all times of effective long-range communication and integration into a fast reaction command and control system; (5) It should not be subject to pre-emptive attack by the submarine

that is under surveillance. Preferably, the presence of the tracking and trailing platform should not alert the submarine; (6) The platform must be capable of carrying a sufficient weapons payload to provide a high probability of kill against the submarine if attack is ordered; (7) The costs associated with the construction, operation and maintenance of a fleet of these platforms to provide an effective counter to the limited number of submarines deployed must be such that the cost of mounting an effective submarine launched attack becomes prohibitively high, that is the platform must provide a low cost-to-benefit ratio.

A series of studies have been carried out to assess the potential of a number of different alternatives for satisfying these functional specifications including attack submarines, conventional displacement type ships; high speed ships such as the surface effects ship and hydrofoils; and aircraft including fixed wing, helicopters and VSTOL units. Each of these alternatives do, to a greater or lesser degree, fail to satisfy one or more of the specifications outlined above. A comparison of the alternatives, including LTA ships, for satisfying these requirements follows.

SUBMARINE DETECTION

In spite of the highly complicated and individual nature of any anti-submarine operation as it actually occurs, the effectiveness of the instrumentalities for detection can be characterized by a few simple parameters, that combine the effects of sensor and platform.

One of these is the search rate S: the number of square miles per hour that an idealized searcher would "sweep clean" (if it detects with certainty every target in the area it sweeps). For less idealized searches, S is defined statistically as the expected fraction of targets detected per hour out of a population of targets distributed uniformly and at random. Not only the sensor's detection range, but the relative speed of the platform, or the mean speed made good in a stop-and-start detection cycle, contribute vitally to the search rate S.

A second general parameter of search performance is the localization area A: to understand its importance we must realize that even after the detection of a target, only the probability distribution of its possible positions is known; this narrows down its probable positions, but in most cases leaves much uncertainty. Assuming that after detection the target's position is bivariate normal, the localization area A is defined as the area of the ellipse, centered at the center of the normal law, within which there is a probability $1-1/e$ of the target's being located. Obviously the smaller the A the better the information given by detection.

A third parameter of effectiveness measures the degree of confidence with which detection signals can be used to classify the target: "false alarm rate" is used for certain types of automatized detection devices; some equivalent quantity is needed in the present class of ASW systems; the subject will not be considered here in further detail.

In the light of these factors, the very special contribution of the Ligher Than Air ship can be explained as follows:

The possible methods of acoustic search include: (1) fixed listening arrays that provide bearing only data on noisy targets at long ranges; (2) ship or LTA towed listening arrays that provide data similar to fixed arrays at towing speeds at approximately 10 knots; (3) ship mounted echo ranging equipment which may provide bearing and range information to the order of 30 miles at ship speeds of 15 knots; (4) magnetic airborne detection to ranges of approximately 0.5 miles from aircraft making speeds of approximately 200 knots; and (5) reliable acoustic path sonars cable deployed from an LTA providing range and bearing data to ranges of 20-25 miles.

Both fixed and towed listening arrays provide bearings only data with uncertainty as to which of a number of narrow near surface zones the submarine may be in. These zones typically occur at 30-mile intervals. It is therefore necessary to follow up a detection made with a listening array by a second type of detector on a moving platform. Under these conditions, only the last three of the alternatives listed above are available. If we look in detail at these alternatives, one can consider the detection ranges and speeds listed in Table 1 for the three follow up alternatives.

DEPLOYMENT METHOD	DETECTION METHOD	DETECTION RANGE (MILES)	SPEED (KNOTS)	SEARCH RATE SQ. MI./HR.
Aircraft	MAD	0.5	200	200
Ship	Hull Mounted Sonar	30-35	15	900-1050
LTA	Reliable Acoustic Path Sonar (RAP)	20-25	100	1250-2000

Table 1
Relative Area Search Rates for
Alternative Submarine Detection Methods

The way that the search rate is developed in these three cases is illustrated in Figure 1. The aircraft sweeps out a long, narrow strip approximately one mile wide. Thus, it approximately is flying down a line in bearing, and there is a high probability that it can miss detecting target. The surface ship sweeps out a 60 mile wide swath at a speed of 15 knots. In doing so, it alerts the submarine as to its progress so that the submarine can maneuver to avoid detection.

The echo ranging equipment to be deployed from an LTA ship will most likely be a sonar that can be operated either passively or actively, cable deployed to deep depths to provide reliable acoustic path propagation conditions. In following up a prior "bearings only contact," the LTA ship can proceed down a line of bearing, deploy its sonar and listen. The submarine target at this time has no way of knowing that it is under surveillance. If no listening contact is made, the sonar can then be used in its active echo ranging mode to assure that the target is not attempting to hide by being quiet.

In order to illustrate the reasons for attempting to maximize search rate, it is illustrative to consider searching an area as large as the North Atlantic ($\sim 10^7$ square miles) and ask how long one might have to

search in order to attain a 50% probability of detection of these submarines under the assumption that the probability of finding a submarine at a particular location is uniform throughout the region. The results for fixed wing aircraft, conventional ships and for LTA ships under the above search rate assumptions is shown in Figure 2. The results indicate that ~35,000 fixed wing aircraft hours, ~8000 conventional ship hours and ~3500-6000 LTA ship hours would be required to obtain the indicated result. The first number for fixed wing aircraft even under the most optimistic assumption as to the number of aircraft that we could deploy is unreasonably high. The same is true of conventional ships; however, one could attain the indicated level of performance with 20 LTA ship units searching for a period of one to two weeks. Thus, it appears that, for the first time, one can attain reasonable wide area search capability with a limited number of searching units deployed.

SUBMARINE DETECTION EQUIPMENT OPTIONS

At this point, it is useful to consider the options for deploying the various types of submarine detection devices from alternative types of ships or aircraft. These possibilities are outlined in Table 2. Large listening arrays can either be fixed geographically or towed from any platform that is capable of making the slow speeds necessary for good listening. This rules out fixed wing aircraft, and it is perhaps not the most useful way of employing high speed ships such as hydrofoils or surface effect ships. Hull mounted echo ranging equipment may be deployed from any of the ship types and potentially it may be possible to design a towed body deployed from a LTA ship that could provide this type of performance. Deep cable deployed listening/echo ranging equipment can be usefully deployed from platforms that are capable of high speeds required for effective search rates. Thus, they may be used with high speed ships, helicopters or LTA ship platforms. Other means of detection include sonobuoys which can be deployed from any platform but which require reasonably high altitudes for effective monitoring. For this reason, only aircraft are considered as useful platforms in this case. Magnetic detection requires high speed to obtain useful search rates due to limited range. Therefore, only aircraft are considered as useful platforms for deploying this type of equipment. A review of the various equipments and deployment options show the LTA ship to be a generally useful deployment platform when compared with the other possible alternatives.

TARGET LOCALIZATION

In addition to the concern over search rate S, there is the additional concern over localization area A. In the three cases considered, this area is estimated to be of the order of 0.25 square miles. It is extremely important that this area be small as possible, since it directly affects the probability that one can place a weapon in the water within effective weapon range. The value quoted here is within acceptable limits. In the case of passive magnetic airborne detection, since the detection is made only after the aircraft is flown by the target, several aircraft passes are necessary to localize the target magnetically and in fact, final localization is usually made with the aid of air dropped sonobuoys. Magnetic airborne detection equipment and sonobuoys can be used as well by LTA ships as they can be from other types of aircraft.

TARGET CLASSIFICATION

If one considers the various data separately: (1) propeller noises on a given bearing; (2) an echo at a given range and bearing; and (3) a magnetic anomaly of the type generated by a submarine, one can possibly classify a distant ship, a whale or a natural magnetic phenomenon as a submarine. However, if these individual indicators coincide, then one can have high confidence in their correct classification of submarine and non-submarine targets.

ATTACK

All too often the analysis of ASW systems stop at detection, localization and classification of submarine targets. In addition to these functions, it is necessary to have the capability of launching an effective attack on detected targets. Largely because of weight limitations, air ASW weapons utilizing conventional explosives have a limited effectiveness against submarine targets. Even in the case of nuclear ASW weapons, there are severe limitations on the number of weapons that can be carried aboard a single aircraft or helicopter. As a result, first attack capability for air units is limited and, because of inventory limitations, multiple attack capability is almost non-existent. In general, it is necessary for air units to re-arm prior to mounting a second attack. Similar attack restrictions apply to our present smaller, conventional ship ASW units and smaller potential high speed ship ASW units.

An LTA ship, particularly larger air ships, should be capable of carrying a significant weapons payload coupled with the on-station endurance to provide a highly effective multiple attack capability. If this combination can be provided, one of the major limitations to the ASW effectiveness of single air or surface craft will have been overcome.

An additional concern in the attack situation is the vulnerability of the attacking platform to attack by the submarine. In the case of surface ships, this is extremely critical since it is almost impossible for our present or projected surface ASW units to close within weapons range of a submarine without alerting the submarine as to its presence and location. Thus, against surface ships, the submarine has the option of attacking as soon as it feels threatened. In the case of aircraft and LTA ship units, this first attack option is not available to the submarine. In fact, in the large majority of cases, the submarine will not know that it is under attack until after an ASW weapon has been launched.

CONCLUSIONS

In this paper, we have not analyzed the ASW capability of an LTA ship in detail. In terms of on-station endurance, search rate, target localization, and classification capability, ASW detection equipment deployment flexibility, attack capability in terms of on-board weapons inventory and nonvulnerability to direct attack by the submarine, it appears that a LTA ship would provide a unique and highly effective ASW unit. The ability to deploy a limited number of LTA ship units capable of long on-station endurance over wide ocean areas would provide the possibility of a highly effective counter to both Ballistic Missile Launching and Attack Submarines.

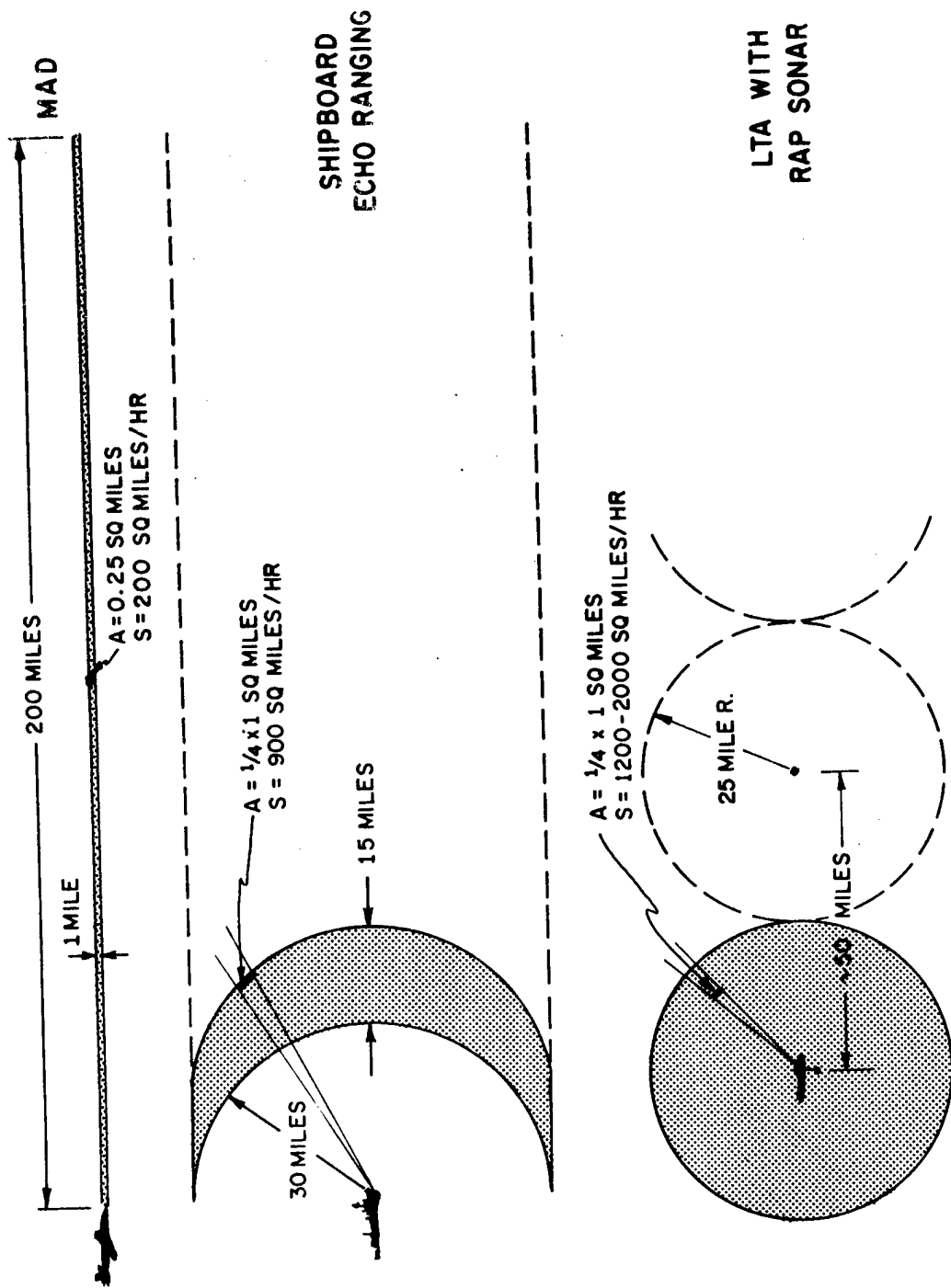

ALTERNATIVE SONAR SEARCH METHODS

Figure 1

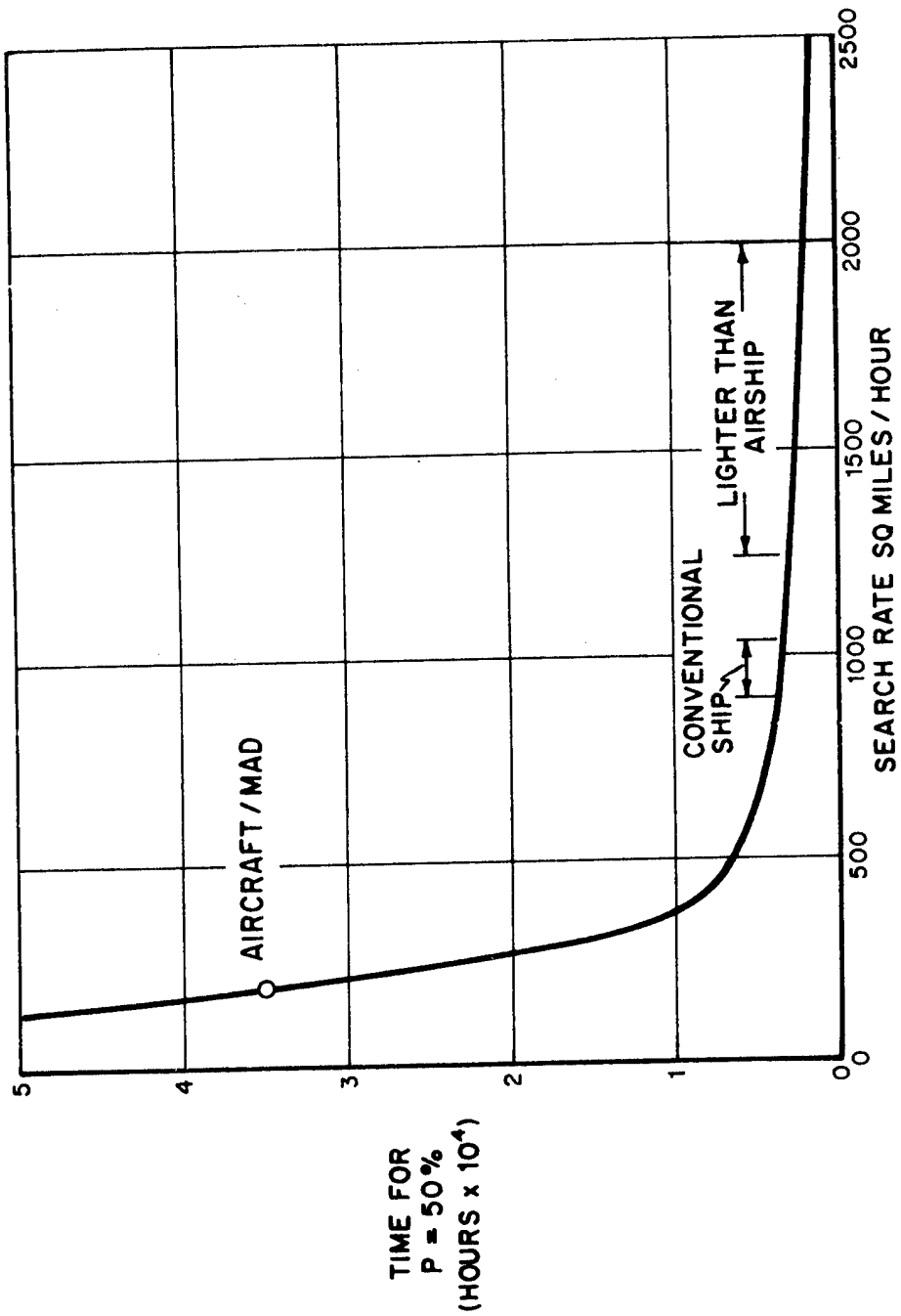

TIME REQUIRED TO OBTAIN A 50% PROBABILITY OF DETECTION IN 10⁷ SQ MILES VS SEARCH RATE

Figure 2

DEPLOYMENT METHOD

DETECTION EQUIPMENT	STATIONARY SURVEILLANCE	CONVENTIONAL SHIPS	HIGHSPEED SHIPS	FIXED WING AIRCRAFT	HELICOPTERS	LIGHTER THAN AIRSHIP
LARGE LISTENING ARRAYS	●	●	○		●	●
HULL MOUNTED LISTENING/ECHO RANGING		●	●			○
DEEP CABLE DEPLOYED LISTENING/ECHO RANGING			●		○	●
SONOBUOYS				●	●	●
MAGNETIC DETECTION				●	●	●

SUBMARINE DETECTION EQUIPMENT
DEPLOYMENT ALTERNATIVES

Table 2



ANTISUBMARINE WARFARE (ASW) -
A SPECIFIC NAVAL MISSION FOR THE AIRSHIP

Louis J. Free*
Cdr. Edwin E. Hanson*

ABSTRACT:** In discussions of conceptual platforms there is a general tendency to consider a platform with the potential to perform a wide range of tasks. This is done for the simple reason that the new platform advocate must convince a variety of sponsors that his nonexistent, or perhaps rudimentary, platform is worthy of further development. However, universal platforms usually perform no one task well enough to survive competition with other specialized platforms. Thus this paper will attempt to narrow the discussion of the airship platform to a reasonably specific issue - the potential usefulness of airships in performing the naval antisubmarine warfare (ASW) mission.

This discussion of the airship as an ASW platform is divided into four parts :

- I. A discussion of the kinds of tasks associated with the naval ASW mission,
- II. A definition of the platform characteristics which are critical to performing these tasks,
- III. A comparison of the airship to other competitive and complementary ASW platforms, and
- IV. A short discussion of the obvious research and development required to make the airship a successful ASW platform.

Part I discusses why the Navy discontinued its use of the airship as an ASW platform in the 1950's, the changes which have occurred since then to make it worth while reconsidering the airship as a naval platform, and finally, examines the ASW tasks it could best perform. Part II discusses the more apparent constraints that the ASW mission imposes on airship characteristics while Part III discusses how the potential capabilities of the airship compare with the capabilities of other ASW platforms. Finally in Part IV a cursory look is taken at what appears to be the most important R & D for both the sensors which could be borne by an ASW airship and the airship platform itself.

*Naval Underwater Systems Center, Newport, R. I.

**This paper was presented at a classified session sponsored by the United States Navy in conjunction with the Workshop. Interested parties should contact the authors directly for details.

PRECEDING PAGE BLANK NOT FILMED

This paper concludes that

- The ASW airship appears to be a potentially cost effective alternative to those systems which are being designed to replace present ASW platforms,
- The airship's greatest ASW potential lies in the convoy escort role, and
- The airship will appear in Navy inventory only if the other armed reserves, government agencies, and industry are willing to share the costs of development.

THE SURVEILLANCE AIRSHIP

L. E. Mellberg*
R.T. Kobayashi*

ABSTRACT:* Airships have a variety of attractive characteristics among which are their long endurance and ability to operate at low altitudes and low speeds. Because many of the evolving Naval surveillance systems require a platform with these characteristics, the airship warrants consideration for these military missions. In addition, these same characteristics make airships viable platforms for civilian uses such as search and rescue, coastal and open ocean monitoring for pollution control, natural resources surveying and other non-military surveillance missions.

The Navy employed airships in a valuable anti-submarine warfare (ASW) and airborne early warning role for many decades. Their usefulness in World War II as convoy escorts is unquestioned. Because airships could conduct close surface surveillance, they were a major ASW asset in the era when submarines were closely tied to the surface for charging batteries and gaining intelligence.

With the advent of nuclear and deep-diving submarines and the development of improved submarine sonars for search and fire control use, the submarines' tie to the surface diminished. Hence the value of close surface surveillance was downgraded, perhaps overly so. By the late 50's, the sonobuoys deployed in widely dispersed buoy fields became the primary airborne search sensor. The airship, due to its slow speed, was clearly unsuited for planting and monitoring such buoy fields and responding to surveillance contacts. These were among the reasons that LTA was no longer considered competitive with fixed wing or rotary wing aircraft for ASW missions.

However, subsequent sensor development may now be tilting the balance back towards the airship. Just as the sonobuoy systems clearly required platforms with the capabilities of fixed wing aircraft, the development of towed systems for search and surveillance clearly rules out

*Naval Underwater Systems Center, Newport, R. I.

**This paper was presented at a classified session sponsored by the United States Navy in conjunction with the Workshop. Interested parties should contact the authors directly for details.

fixed wing aircraft and makes the rotary wing aircraft a doubtful candidate because of its short endurance. Their use to monitor long endurance moored surveillance systems is also questionable. However, the special ability of the airship to operate for long periods and at low altitudes and low ground speeds makes it well suited as a towing or monitoring surveillance platform for surveillance systems.

The study presented in this paper investigated the endurance of a variety of airships to evaluate their use for surveillance. The airships considered were a three million cubic foot non-rigid, and three, four, and six million cubic foot rigids. Airships of these sizes would involve minimal technical risks for design, construction, equipping, and manning because of past experience and thus a realistic evaluation can be made of their mission capabilities.

Winds have considerable effect on an airship's endurance even at low speeds due to the airship's large surface area. The wind conditions considered were a) no winds, b) 100% head winds, c) 50% head winds - 50% no winds, and d) 50% head winds - 50% tail winds. In order to simplify these preliminary endurance calculations, it was assumed that when winds occurred, the airship was flying either directly into or with the winds and the wind conditions for each case prevailed for the full duration of the patrol and the transits to and from the patrol areas.

From a survey of the wind speeds existing in a plausible patrol area, wind speeds of 10, 20, 25, and 30 knots were used to cover the range of the more probable winds the airship would encounter. Gusts of higher speeds would be encountered, but were not considered because they would be of relatively short duration.

The results of the study indicate that non-rigid airships of three million cubic feet and larger, and rigid airships of four million cubic feet and larger will provide adequate on-station endurance for possible low speed, low altitude surveillance missions.

AIRSHIP LOGISTICS--
THE LTA VEHICLE A TOTAL CARGO SYSTEM

L. R. "Mike" Hackney, P. E. *

ABSTRACT: This paper deals with the design considerations for logistics, as they pertain to the large rigid LTA vehicle as either a commercial or military cargo carrier. Pertinent factors discussed are: (1) the basic mission; (2) types of payload; (3) the payload space in regards to configuration and sizing, its capacity, and its loadability. A logistic capability comparison of selected cargo airships versus jumbo jets is also made.

INTRODUCTION

As a member of the "fixed-wing" aircraft fraternity for many years, like all too many of us in aviation--the airship has been considered obsolete--a vehicle of the past. In brief, "elderly windbags" to quote from the title of a technical magazine article¹ which summarized the results of the AIAA meeting on LTA in Washington last winter, as "a heavy dose of cold water."

The mere thought that the airship might be modernized to perform certain of today's commercial and military logistic missions more efficiently than a modern jet, helicopter, or VTOL vehicle, seemed inconceivable. However, after being exposed to the in-depth work and logic of the LTA Technical Task Force of the Southern California Aviation Council, Inc. (SCACI) and then joining same--sufficient valid

*President, Hackney Associates, Sierra Madre, California, U.S.A. and Member LTA Technical Task Force of Southern California Aviation Council, Inc., Pasadena, California, U.S.A.

evidence has been seen, to become convinced that a "fresh and unbiased look" at airship transportation is warranted.

The purpose, therefore, during this workshop session is to discuss the LTA vehicle as a total cargo system. Using as the basis the family of seven rigid airship preliminary designs (ranging in size from 7.4 million cubic foot volume up to 55 million) developed by the LTA Technical Task Force of SCACI.² To describe for consideration, an airlift system which is unrestricted as to the size or weight of shipments or geographic destination.

While today's wide-body jet aircraft represents the sixth or seventh generation of progressive product improvement cycles, since the 1920-1930 time period--the same is far from the case for the lighter than air vehicle. These often maligned craft, for all ostensible purposes, are still in the state-of-the-art time-frames of the Fokker and Ford tri-motor transports.³ Granted there has been some LTA development in the ensuing period by Goodyear. Unfortunately, however, lack of funds and Government support for such vehicles precluded much in the way of modernization as compared to fixed wing aircraft.

DESIGN CONSIDERATIONS FOR LOGISTICS

Obviously in the time allocated, it is not possible to adequately cover the entire spectrum of LTA logistics. It was elected, therefore, to concentrate on the airship, as an airfreight carrier. A role for which it is uniquely suited--for airlifting both civil and military cargoes. This is not to say that there are not a number of other missions for which the LTA vehicle, when appropriately modified, is not equally well qualified to perform. Fortunately, these are being covered by others on this workshop agenda who are more intimately qualified to discuss same.

In the development of any future viable LTA configuration it is imperative that "design considerations for logistics" be taken into account concurrently along with all other major design factors. This allows for timely analysis to determine the most effective tradeoffs--before the fact rather than as a compromise after.

Basic Mission

As previously mentioned, for purposes of this discussion, the "basic mission" is examined only as: (1) a long range commercial cargo carrier, for either transcontinental operation; and/or (2) a very long range heavy lift logistic carrier for the Military Airlift Command (MAC), capable of operating non-stop from any U. S. aerial port of embarkation to any location overseas. For either type mission the basic configuration of the airship could well be much the same.

Types of Payload

As to types of payload, the large rigid LTA vehicle provides a true intermodal cargo system capability. It offers an airlift system which for all ostensible purposes is unrestricted as to a shipment's weight or size. As to the upper end of the spectrum, it is foreseeable that single shipments of over 300 tons or more will be moving by air.

This is evidenced by the presence of Combustion Engineering, Inc., transportation experts on the LTA Workshop program. C-E's Industrial Boiler Operations Division with its Schnabel car (maximum capacity 600,000 lbs.) developed for boiler transport has been moving its 220,000 lb. Type A units over the U.S. rail network for several years⁴. Manufacturers of large steam turbines and condensers, electric generators, forging presses, nuclear powerplant components, etc., have similar heavy lift transportation requirements.

A viable LTA vehicle offers the opportunity for greatly expanding the dimensional envelope restrictions now imposed by rail movement. No longer would it be necessary for builders of massive industrial equipment, as their respective product line grows in weight and size--to consider relocation of their expensive facilities adjacent to inland waterways or seacoasts. They can continue to factory assemble and pretest their huge units--thus avoiding the expensive process of assembly in the field. Further they can put their units into service more quickly after delivery to the site.

In addition to the massive or so-called extra heavy and outsize payloads just discussed, the large rigid airship should likewise be ideally suited for carrying all types and sizes of commercial and military vehicles. These can range up to the biggest truck mounted industrial crane, or to the Army's largest mobile combat equipment.

Regarding the more conventional types of commercial payloads presently moving by air on wide body cargo jets--the airship can readily accommodate these, including all types of ISO containers up to 40'. However, as to a very few types of commodities which might be carried therein (or separately)--there is question of the need for pressurization. For instance, certain pharmaceutical shipments may require a pressurized cargo compartment or its own pressurized container. Such specialized cargo traffic, however, is well below one percent of the total moving by air today.

As to air traffic of fresh fruits and vegetables as well as fresh flowers and nursery stock, both groups of which move in sizeable volume--it was at one time believed these were sensitive to altitude. Regarding fruits and vegetables, controlled laboratory tests have shown no adverse effects of altitude up to 30,000 feet and rates of climb or descent up to 3,000 feet per minute⁵, while altitudes as high as 20,000 feet had no effect on the flowers tested.

The Payload Space

During the recent resurgence of interest in LTA transportation systems, considerable material has been written and attention given to the airship as a whole--its hull design, powerplants, performance, economics, etc. Unfortunately however, little work or attention appears to have been given to the airship's payload space (or in the case of the military--useful load) requirements, and the design considerations relating thereto. It is trusted that the contents of other workshop papers will indicate this is no longer the case. In the event this is not so, it cannot be emphasized too strongly that this is an area which warrants much in-depth study by the LTA payloads design engineer.

Configuration and Sizing--First, a decision must be made as to the types and sizes of commercial and/or military cargoes, the payload compartment (or compartments) will be designed to accommodate. To mention a few, such questions which must be answered:

1. Will outsize and heavy shipments be airlifted, such as boilers, turbines, generators, etc? If so, will they be carried within the airship hull or suspended beneath? If carried internally, what are the cargo deck area requirements for spreading such concentrated bearing loads?
2. Assuming that ISO type intermode containers are carried, what will the cell arrangement be for storing same--single, double, or tiers? Will the containers be aligned fore and aft or thwartship in the payload compartment?
3. What are the number, size, and location of all cargo compartment access hatches (doors)? Will these be side entrance or bottom entrance hatches, or both?

Capacity--It is the practice of the U. S. Maritime Commission to use the 20' ISO container, as the common denominator, when rating the capacity of container ships⁷. As the LTA vehicle is for all purposes a ship, rather than an aircraft--it seems logical to follow suit--at least as one means of measuring cargo capacity.

Take for example the large rigid airship preliminary design MC-55 (55 million cu. ft. volume)--the largest of the seven classes developed as part of SCACI's Technical Task Force Report⁸. This LTA vehicle was estimated to have a cargo payload of some 1,026 tons at 6,000 statute miles. Based on past experience however, it has been observed that sufficient weight is seldom allocated for today's sophisticated onboard cargo handling and restraint systems and the supporting structure required for same. Therefore, an additional 26 tons (52,000 lbs.) is arbitrarily transferred, thus reducing the payload to 1,000 tons.

The common 20' ISO dry container's useful volume averages 1,100 cu. ft. per van. Thus:

20' Van Payload Cap. @ 15 lbs./cu/ft & 85% cube utilization =	14,025 lbs.
20' Van Tare Weight @	3,375 lbs.
	17,400 lbs. or 8.7 tons
Total	

$$\frac{1,000 \text{ tons}}{8.7 \text{ tons}} = 115 \text{ 20' Container Capacity for the MC-55}$$

As to the cargo space requirements to accommodate 115 20' containers. Allowing (8.5' x 20.5') 175.25 sq. ft. per unit, plus allocating some (174.25 sq. ft. x 5) 871.25 sq. ft. for cargo entrance hatches. The 115 units if stowed as a single tier--would require a cargo compartment of 51' in width by 410' in length. This is predicated on the containers being aligned fore and aft six abreast, with four rows of 20 each, one of 18 and one of 17 units.

Loadability--Obviously there are a number of container storage patterns which are feasible--two or three tiers high, etc.⁹ All of these justify a so-called "loadability study" using a systems engineering approach, before final selection. For loadability per se, involves the entire cargo loading and handling operations cycle--both into or out of the airship as well as the interfacing cargo procedures on the ground. One example of loadability would be--should a roll-on, roll-off capability be provided for the large LTA vehicle? Ro/Ro ships are growing in popularity in the maritime trade, as it permits all types of wheel vehicles to be readily driven on and off the vessel under their own power.

The On-Board Cargo Handling System

This is an area which is wide open to new ideas and innovations. It would be a most serious mistake for LTA payload designers to attempt to adopt or modify cargo jet aircraft loading systems for the airship without first taking into consideration all factors.

While these systems are satisfactory for aircraft--commerce of the type which the airship will be transporting, make it a somewhat different ball game. To name a few:

1. The aircraft cargo handling is aircraft movement oriented--not surface movement oriented. It is the outgrowth as well as the victim of the old 463 L Universal Cargo Pallet System which was initiated in the days of the Douglas C-124 transport. It started with the introduction of the 88"x 105" military cargo pallet--so sized that it could pass through this aircraft's bottom loading cargo hatch.
2. This system from its inception has espoused handling all aircraft type pallets, unit load devices, and containers--up to and including ISO size, from the bottom, on various types of roller conveyor systems. In consequence, most all intermodal ISO containers offered for air movement must first be placed on a special slave pallet before entering any wide body cargo jet.
3. On the other hand surface cargo, and ISO size containers in particular, are designed for hoisting from above, using the standardized corner fittings incorporated therein. As world commerce, with few exceptions, moves in these sea-land type containers rather than SAE AS 832 air-land demountable containers--any LTA logistics should take this fact into account.
4. The LTA cargo hoisting system will undoubtedly be patterned to a degree after the large quay side gantry crane systems used by containership terminals.

LOGISTIC CAPABILITY COMPARISON

If trade press coverage is any indication--it appears that 1974 will be known as "the year of the jumbo jet freighter." For this year is seeing a number of U.S. and foreign carriers following Lufthansa's footsteps, by introducing their own 747 F equipment--and thus offer van size container service.

Cargo Compartment Access

Recognition of shipper demand to extend the outsize cargo capability of the 747 F, is evidenced by the 10'x11' side cargo door being installed aft of the wing by a number of operators.¹¹ This feature overcomes the 8' height limit on containers loaded through the standard nose door. In fact, Boeing is considering elevating the 747 flight deck 38"--thus increasing the nose door from 8'2" to 11'4" in height and from 11'8" to 12'9" in width at the floor.¹² One objective being to increase the aircraft's ability to load and carry outsize military equipment.

The purpose of discussing the continuing efforts of the airframe constructor to provide improved access to the cargo compartment of its aircraft--is to draw a comparison with the ease of doing such work to a metal airship hull. Further, it is possible to incorporate much larger access provisions, as well as a greater number, for far less cost and weight. This is due to the relative simplicity of the LTA hull structure and its ability to accommodate sizeable cut-outs, with only minor beef-up to the surrounding structure.

Van Container Capacity

It was interesting to note that one jumbo jet operator has recently elected to describe its new 15 slot 20' container capacity cargo aircraft as "containerships."¹³ Yet this is a mere David in comparison with Sea-Land's new Goliath SL-7 supercontainerships. These 946', 51,000 ton vessels have a slot capacity for the equivalent of over 2,000 20' units.

To give a picture of 20' container capacities for the existing or proposed family of U.S. jumbo cargo jets--versus lighter than air containerships, the following figures are presented based on the listed assumptions.

Assumptions:

1. For jumbo jet freighters: 20' van capacity @ 1,100 cu. ft x 15 lbs. cu. ft. cargo density x 85(%) percent cube utilization = 14,025 lbs. plus van tare weight (for SAE AS 832 Air-Land demountable cargo container) of 2,200 lbs. A total weight of 16,225 lbs. or 8.1 tons per container.
2. For LTA freighters: tare weight of 20' container increased from 2,200 lbs. to 3,375 lbs. to allow for heavier surface type units. Thus, 14,025 lbs. + 3,375 lbs. = 17,400 lbs. or 8.7 tons per container.
3. Payload of all MC-series LTA freighters arbitrarily reduced 2.5 (%) percent to allow for onboard cargo loading and handling systems.

20' Intermode Container Capacity

Jumbo Jet Freighters¹⁴

LTA Freighters

<u>Manufacturer and Model</u>	<u>Container Capacity</u>	<u>SCACI Series (Model No.)</u>	<u>Container Capacity</u>
Douglas C-2	6	MC-7.4	10
Douglas DC-10	6	MC-15	26
Lockheed 1011	6	MC-22	41
Douglas C-4	12	MC-35	67
Lockheed L-500 (C-5A)	14	MC-42	84
Boeing 747F	15	MC-52	98
Douglas C-6	28	MC-55	115

REFERENCES:

1. Technology Review magazine, Dirigibles: Think of Elderly Windbags, (July/August, 1974).
2. Southern California Aviation Council, Inc. (SCACI), Committee on Lighter Than Air, Technical Task Force Report, (May 15, 1974).
3. The LTA Committee, SCACI, Lighter Than Air Transportation Feasibility Study - Proposal, (March, 1974) p.2.
4. Handling and Shipping magazine, The Midas Touch of a Physical Distribution Idea, (August, 1974) p.p. 54-57.
5. Hackney, L. R. and Rose, B. A., Altitude Tests on Fruits and Vegetables, Lockheed Air Cargo Progress Report, (February 15, 1949).
6. Della-Vedova, R. P. and Rose, B. A., Altitude Tests on Flowers, Lockheed Air Cargo Progress Report, (September, 1950).
7. Hackney, L. R., The Emerging Influence of the Intermodal Container, The Institute of Airline Marketing, (March 6-7, 1969) p.6.
8. Reference 2, p.63
9. Hackney, L. R., An Overhead Rail Automated Staging System for Containership Terminals, Stanray Corporation, (October, 1968), p.55.
10. Hackney, L. R., International Air Cargo--Its Future Ground Environment, International Air Cargo Forum--Air Age '70, (July, 1970), figure 2.
11. Commercial News (weekly), U. S. Trunk line to inaugurate 747 Freighter Service, (September 2, 1974) p.1.

12. Aviation Week, 747 Nose-Loading Door Growth Studied,
(September 2, 1974) p.25.
13. Commercial News, All-Cargo Airline Takes Delivery of Boeing 747F
Freighter, (August 12, 1974) p.11
14. Reference 10, figure 2.
15. Reference 2, pp. 57 through 63.

N76-15060

THE TRANSPORT OF
NUCLEAR POWER PLANT COMPONENTS

S. J. Keating, Jr.*

ABSTRACT: This paper deals with the problems of transporting nuclear power plant components to landlocked sites where the usual mode of transport by barge cannot be used. Existing methods of ground-based overland transport are discussed and their costs presented. Components are described and traffic density projections made to the year 2000.

Plots of units transported versus distance transported are provided for units booked in 1973 and booked and proposed in 1974. It is shown that, for these cases, overland transport requirements for the industry will be over 5,000,000 ton-miles/year while a projection based on increasing energy demands shows that this figure will increase significantly by the year 2000. The payload size, distances, and costs of existing overland modes are significant enough to consider development of a lighter than air (LTA) mode for transporting NSSS components.

INTRODUCTION

To meet the ever increasing demand for electric power as economically as possible, the size and number of nuclear fueled units have been increasing over the years. (At present, the AEC has set a maximum size limitation of approximately 1300 megawatts of electrical power per unit, though it is expected that the next step up to 1500 megawatts electric, which will correspond to a core thermal power of 5000 megawatts, will occur around 1979 with plants of this size going into service around 1987.) Many of the units being booked now will be located at landlocked power plant sites. The problems of overland shipment of the large components and subassemblies may place limits on the extent to which the economics of scale and the benefits of shop fabrication can be exploited in the future.

The concern with the future transportation requirements is not unique
*Project Engineer, Combustion Engineering, Inc. Windsor, Connecticut, U.S.A.

to Combustion Engineering, Inc.; it is shared by others in the industry. Though existing means can be used to deliver all units booked or proposed to date, a lighter than air (LTA) airborne mode may offer significant economic advantages for the future.

PAYLOAD

Specifically, the payload stimulating this consideration of a LTA mode of transport is the nuclear steam supply system (NSSS). NSSS provide energy input to turbines that drive electric power generators. This paper deals with NSSS using light water moderated reactor cores. According to a recent U.S. Atomic Energy Commission projection, light water reactors will continue to make up the bulk of NSSS sold in this country. There are two types of NSSS that fit this category: the pressurized water reactor (PWR) and the boiling water reactor (BWR). The PWR system uses a closed, reactor coolant loop containing water at a typical pressure and temperature of 2250 psia and 621 F to transfer core thermal power via large shell and tube type steam generators to a secondary water loop where boiling occurs at a typical pressure of 1000 psia. The steam generated goes to the turbine, is expanded, condensed, and then returned by the main feedwater pumps to the steam generator. In contrast to the PWR system, the BWR system permits the boiling to occur in the reactor core within the reactor vessel from which saturated steam at a typical pressure of 1000 psi is delivered to the turbine.

Because of the high temperatures and pressures within the vessels, the energy flow they handle, and the very high emphasis on safety and reliability, the vessels are large and heavy. PWR systems may have reactor vessels (Fig. 1) which weigh up to 540 tons, and are 22 feet in diameter and over 40 feet long. The vessel shown in the foreground of

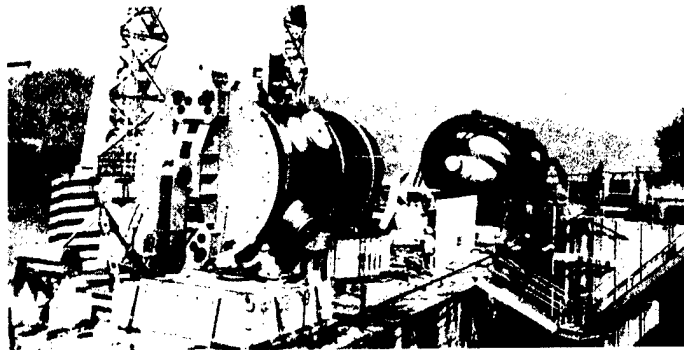

Figure 1: Pressurized water reactor vessel (foreground) and steam generator (background)

Fig. 1 has walls over 8 inches thick. The steam generators (Fig. 2) weigh up to 800 tons, and are up to 21 feet in diameter and up to 65 feet long. From two to four steam generators are used in each NSSS. BWR systems have reactor vessels (Fig. 3) that weigh up to 730 tons, and are up to 22 feet in diameter and up to 62 feet long. Typical weights and sizes for this equipment and the rest of the components for current NSSS and for the next generation NSSS are summarized in Table I.

Other utility equipment is in the same size and weight range. For instance, a typical 1300-Mw generator stator may weigh up to 500 tons and be up to 40 feet long. Heights and widths are presently in keep-

ing with the transport "window" imposed by present land-based modes though this situation may change as power level is increased.

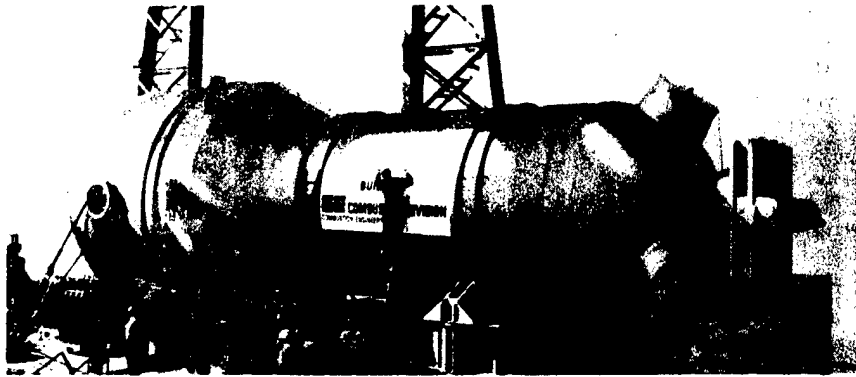

Figure 2: Steam generator for pressurized water reactor



Figure 3: Boiling water reactor vessel assembly

Another item of special interest is the moisture separator/reheater unit which processes steam going from the high pressure turbine to the low pressure turbines. These pressure vessels may weigh up to 150 tons, and are up to 100 feet long and 13 feet in diameter. Though the weight and diameter are within present ground-based transport mode capability, the length presents a serious problem when negotiating curves.

The fabrication of these components requires careful welding and heat treating. Following heat treating, the vessels are subjected to several independent nondestructive tests, including hydrostatic pressure, X-ray, ultrasonic, and magnetic particle tests. Recently, there have been attempts to field fabricate BWR vessels. Indications are, however, that it will be more economical to develop or adapt transportation modes so that full shop fabrication can be maintained rather than develop means for even partial field fabrication.

Until recently, nuclear fueled plants were usually sited near navigable water, so equipment was transported from the manufacturing

Table I

REACTOR COOLANT SYSTEM EQUIPMENT FOR LIGHT WATER MODERATED REACTOR
NUCLEAR STEAM SUPPLY SYSTEMS

PRESSURIZED WATER REACTOR				3800 MEGAWATT CORE THERMAL POWER				BOILING WATER REACTOR						
ITEM	QUANTITY	WEIGHT	DIAMETER	LENGTH	ITEM	QUANTITY	WEIGHT	DIAMETER	LENGTH	ITEM	QUANTITY	WEIGHT	DIAMETER	LENGTH
REACTOR VESSEL	1	540 TONS	22 1/2 FT	41 FT	REACTOR VESSEL	1	731 TONS	22 1/4 FT	62 FT	REACTOR VESSEL	1	731 TONS	22 1/4 FT	62 FT
REACTOR VESSEL HEAD	1	84	18	9	REACTOR VESSEL HEAD	1	99	22	10 1/2	REACTOR VESSEL HEAD	1	99	22	10 1/2
R.V. UPPER GUIDE STRUCTURE	1	50	15	11	R.V. CORE SHROUD	1	50	16 1/2	22	R.V. CORE SHROUD	1	50	16 1/2	22
R.V. CORE SUPPORT BARREL	1	100	15	32	CORE SHROUD HEAD	1	58	16 1/2	15	CORE SHROUD HEAD	1	58	16 1/2	15
CEDM COOLING SHROUD	1	18	14 3/4	7 3/4	STEAM DRYER ASSEMBLY	1	48	17	17 1/2	STEAM DRYER ASSEMBLY	1	48	17	17 1/2
STEAM GENERATOR - 2 LOOP	2	760 EACH	20 1/2	69 1/2										
OR														
STEAM GENERATOR - 4 LOOP	4	500	18 1/2	61 1/2										
5000 MEGAWATT CORE THERMAL POWER														
REACTOR VESSEL	1	800	24	51	REACTOR VESSEL	1	1000	25	70	REACTOR VESSEL	1	1000	25	70
REACTOR VESSEL HEAD	1	120	20 3/4	10	REACTOR VESSEL HEAD	1	130	24 1/2	11 3/4	REACTOR VESSEL HEAD	1	130	24 1/2	11 3/4
R.V. UPPER GUIDE STRUCTURE	1	70	16 1/4	16	R.V. CORE SHROUD	1	70	18 1/2	24	R.V. CORE SHROUD	1	70	18 1/2	24
R.V. CORE SUPPORT BARREL	1	140	16 1/4	41	CORE SHROUD HEAD	1	80	18 1/2	16 1/4	CORE SHROUD HEAD	1	80	18 1/2	16 1/4
CEDM COOLING SHROUD	1	23	17	8 1/2	STEAM DRYER ASSEMBLY	1	67	19	19	STEAM DRYER ASSEMBLY	1	67	19	19
STEAM GENERATOR - 4 LOOP	4	500	18 1/2	61 1/2										

site to the installation site by barge (Fig. 4). This is, by far, the most economical mode of shipment with costs of a few cents per ton-mile. Now, however, there is a trend in siting plants away from navigable water, as can be seen in Fig. 5, where the operating, under construction, and committed nuclear units are shown geographically along with the contiguous navigable waterways of the U.S. suitable for the passage of component barges. The components must be removed from the barge at the nearest practical landing and shipped overland to the power plant site by expensive, time-consuming methods that can require extensive enroute preparations to accommodate size and weight.

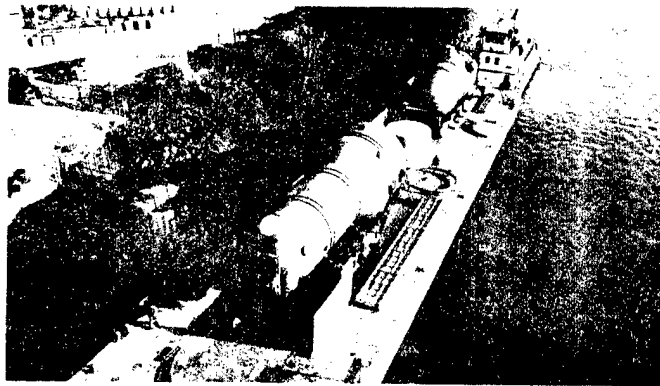

Figure 4: Barge shipment of nuclear components



Figure 5: Central station nuclear power plants and navigable waterways

Figure 6 illustrates one method of transporting these components either on highways or on suitably prepared surfaces. The average speed is about one mile per hour. Though varying widely depending on the specifics of the route, cost may range from around \$5 to well over \$20 per ton-mile. Since the height of the load vehicle combination approaches 30 feet, much of the cost of transport by this or other highway modes can be due to the necessity of either moving overhead obstacles or bypassing them. The width of these vehicles, which is about 20 to 24 ft, can also present problems.

Figure 7 shows a proposed rail-borne method for transporting nuclear

power unit components called a Schnabel car. Though potentially faster (operational speed may be as high as 15 miles per hour) and less expensive than highway modes, this mode of transportation has some limitations.

The Schnabel car makes use of the payload as the load carry-through structure and thus minimizes the overall height and center of gravity elevation by locating the base of the payload just above the rails. This reduces overhead clearance and lateral stability problems. This type of vehicle is in use here and abroad for transporting other, smaller, lighter objects. The Schnabel car shown in Fig. 8, which is a 12-axle car as contrasted with the 32-axle car shown in Fig. 7, is used to transport relatively small, fossil-fueled, fully

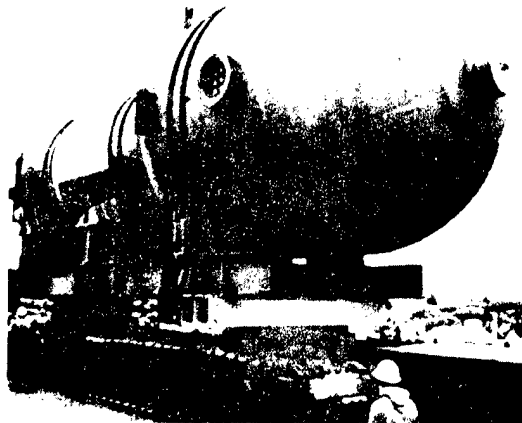

Figure 6: Steam generator on overland transporter

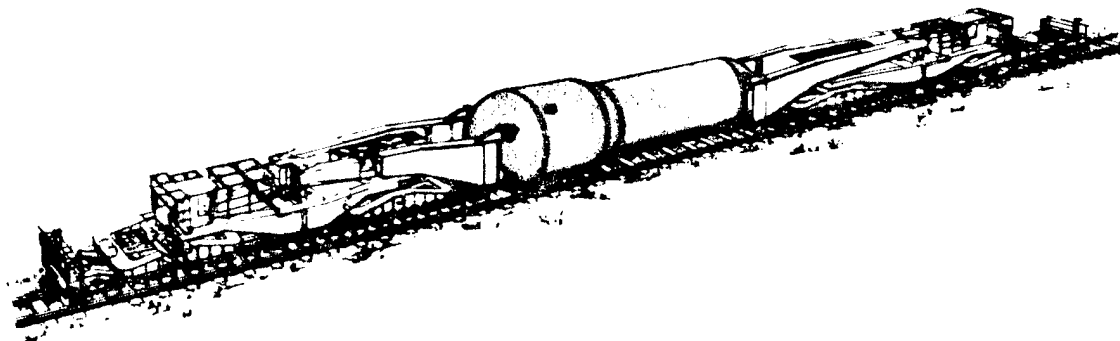

Figure 7: Nuclear component - Schnabel rail car of 800-ton capacity

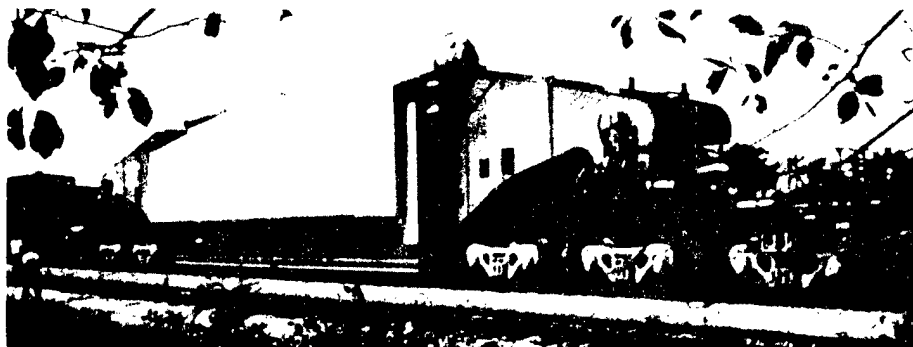

Figure 8: Schnabel car with shop-assembled fossil-fuel boiler shop-assembled boilers to power plant and industrial sites. The Type

A boiler shown in this figure typically weighs a quarter of a million pounds and is 54 feet long, 20 feet high, and 13 feet wide. It can generate up to 300,000 lbs of steam per hour as compared to the larger fossil-fueled boilers that can generate over 9 million lbs of steam per hour or compared to larger nuclear units that can deliver up to 16 million lbs of steam per hour.

The siting trend away from navigable water is due to several reasons, among which are the rapidly increasing cost of suitable water edge real estate, a number of safety regulations (such as exclusionary (low population) zone regulations), and environmentalist pressure to minimize plant thermal discharges to bodies of water previously considered suitable as cooling water sources. Those bodies of water used to provide cooling for the steam condensers are, in general, the locations where there might be large population centers. Exclusionary (low population) zone regulations, intended to limit the population density around nuclear power plants, are, in effect, forcing the plants away from the larger bodies of water suitable as waste heat sinks. Since, as Fig. 5 shows, many of these bodies of water are also the navigable waterways of the U.S., the net effect is to force power plants to be located where transport of components overland becomes mandatory if fabrication and quality assurance testing at the site is to be minimized.

One of the reasons siting away from large bodies of water is possible is the development of closed-cycle cooling techniques using cooling towers of various types, spray ponds, or cooling ponds. In general, the water needs of these types of cooling systems are relatively small compared to open cycle cooling and are limited to water lost by evaporation and windage. In effect, the heat sink becomes the atmosphere. This is done by transferring the waste heat from the steam condenser via a closed, water loop to the cooling tower or pond which, in turn, transfers it to the atmosphere. In doing so, however, thermal inefficiencies are introduced that reduce power output for a given physical size unit. In order to maintain a given unit power output, unit physical size has to be increased, thus increasing capital costs. These same added inefficiencies also increase the use of fuel, thus increasing operating costs.

Despite the increasing cost of nuclear power plants, which some have estimated will rise to over \$1000 per kwe by 1990, the economic advantage of nuclear power is even more pronounced today, due, in large part, to the ever increasing cost of fossil fuels.

Indications are that the trend to siting away from navigable water will continue. Of the 36 domestic nuclear units booked industry wide in 1973, 14 require overland transport of large, heavy components for distances ranging from 50 to 400 miles. Figure 9 indicates the distribution of units committed as a function of distance from nearest navigable water to plant site. Because of the frequent large disparity in distances for a given plant site depending on the transport mode involved, Fig. 9 is based on straight-line distances from barge landings to plant sites. If all light water reactor coolant system equipment that could benefit from a more economical overland transport mode is included, there will be a total transport requirement of nearly 5,100,000 ton-miles/year in the early 1980s. Not all units booked in 1973 are scheduled for start-up at the same time; at present, start-up ranges 8 to 10 years from the booking date. Thus, the heavy equipment, which is generally shipped about three years before the start-up

date will be arriving at the various sites over a spread of years. It is expected that in succeeding years the same sort of delivery time-spread will occur.

Though it is still too early to draw final conclusions from the nuclear sales record of 1974, data through the end of June indicates that the trend to remote siting is continuing and possibly increasing. Figure 10 gives the mileage distribution, not only for plants booked up to the end of June 1974, but also bids presently being evaluated and future unexercised options. Whereas in 1973, 36% of the units booked were for location at sites more than 20 miles from navigable water, it appears that in 1974 up to 40% will be remotely sited.

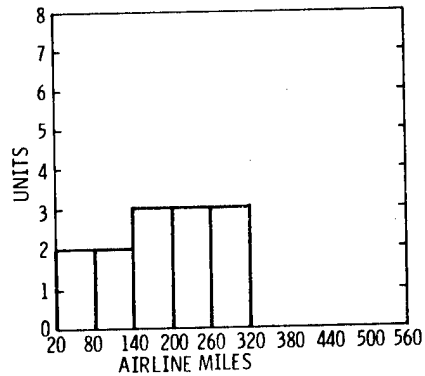

Represents Transport Requirements of 5, 104, 700 ton-miles

Figure 9: Distance of landlocked nuclear unit sites from navigable water for units booked in 1973

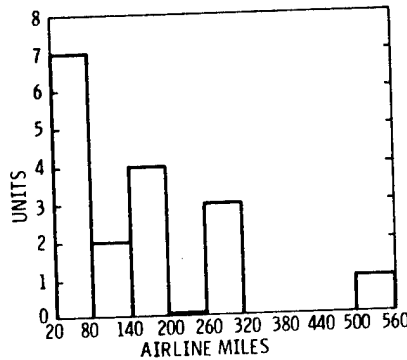

Represents Transport Requirements of 5, 400, 000 ton-miles

Figure 10: Distance of landlocked nuclear unit sites from navigable water for units booked, under construction, or on option in 1974

INDUSTRY GROWTH PROJECTIONS TO THE YEAR 2000

In order to justify the development, testing, and certification of a new transport mode, the size and growth of the nuclear power plant fabrication industry must be projected allowing also a reasonable amount of time to get some use from the new transport mode. For this purpose, the future of the industry to the year 2000 is estimated. This estimate relies very heavily on the studies of the U.S. Atomic

Energy Commission as discussed in the WASH-1139 Report, "Nuclear Power Growth, 1974-2000," dated February 1974. Based on the "Case D" projection in this AEC report and assuming an increase in average unit size, it is expected that over 700 nuclear units will be built in the period from 1981 to 2000, representing nearly 1,000,000 Mw of installed electrical power and an investment by the utilities of about \$700 billion. It is estimated that from 50 to 70% of these units will be located where the heavy components may have to be transported appreciable distances overland. As mentioned before, overland transport of these components by rail or highway will be difficult because of the size of the components. Rail and highway route clearances are sometimes not adequate to accommodate these large loads, so very expensive modifications to route-side and overhead structures and obstacles may have to be made, or else detours taken, in some cases, involving intermodal transfer. Figure 11 provides a graphic picture of the estimated number of LWR nuclear units that will be remotely sited versus year of shipment of heavy components for these units. Tables II and III provide a detailed breakdown of the number of components of each type estimated to be shipped per year to the year 2000.

Note that the data given in Fig. 11 and these tables do not include such reactor coolant system equipment as the pressurizer, reactor coolant circulating pumps and connecting pipe, all of which might also be shipped by air if the economics were favorable. Also, the information does not indicate the additional potential market for the transport of intermediate size components due to a potential shortage of ground-based transport equipment.

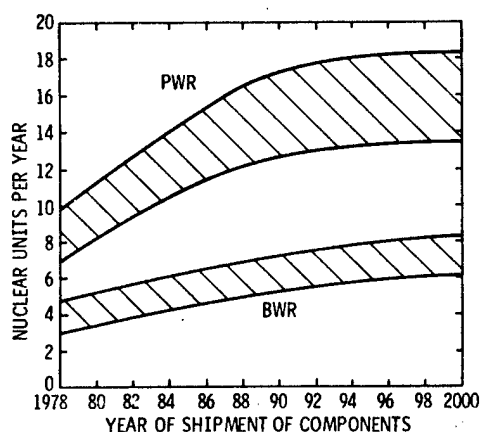

Figure 11: Nuclear units remote from navigable water

To provide some perspective on the dollars involved in transporting equipment by land-based means, cost data estimates from several sources have been plotted in Fig. 12. In evaluating the data, it must be recognized that each project is a special case. The problems and costs encountered in one case can be very different from those encountered in another. This accounts in part for the large scatter in the data.

SUMMARY

Of alternate modes investigated to obtain relief from the restrictions and costs of ground-based overland modes, the most likely to provide a good solution by relaxing load dimensional limitations may be an airborne mode based on the use of lighter than air technology. Part or all of the load could be carried externally, greatly relieving restrictions on load size and shape. (Vehicle speed could be kept low enough to preclude the necessity of streamlining.) This mode would not require extensive and expensive landing facilities in remote areas. Payload weight would still present a formidable problem and much work would have to be done to develop vehicles of adequate weight-lifting capability. The development of airborne means to deliver the heaviest

NSSS components could begin with considerably lighter, but still large industrial products.

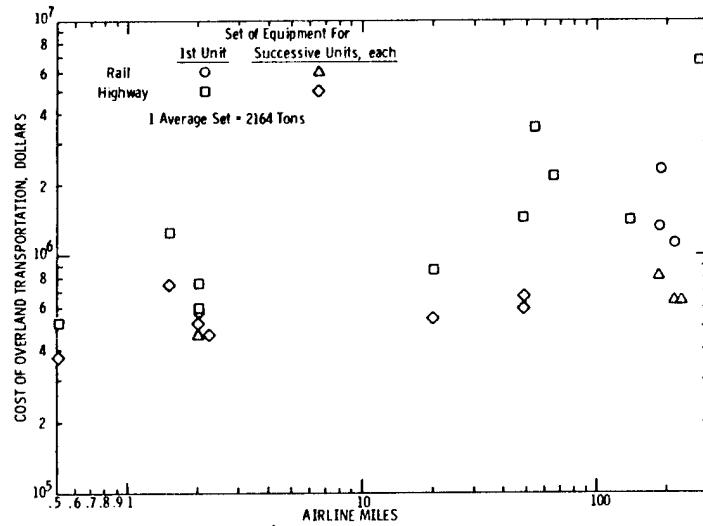

Figure 12: Cost of overland transportation of nuclear components

Table II

PRESSURIZED WATER REACTOR ITEMS SHIPPED OVERLAND/YEAR (4)

	RV	CSB	UGS	RVH	CEDM COOLING SHROUD	2 LOOP S.G.(3)	4 LOOP S.G.(2)	GEN. STATOR	TOTAL PWR ITEMS
1978	7-10	7-10	7-10	7-10	7-10	8-10	12-20	7-10	62-90 (1)
1979	8-11	8-11	8-11	8-11	8-11	8-12	16-20	8-11	72-98 (1)
1980	8-11	8-11	8-11	8-11	8-11	8-12	16-20	8-11	72-98 (1)
1981	8-12	8-12	8-12	8-12	8-12	8-12	16-24	8-12	72-108 (1)
1982	9-12	9-12	9-12	9-12	9-12	10-12	20-24	9-12	84-108 (1)
1983	10-14	10-14	10-14	10-14	10-14	10-14	20-28	10-14	90-126 (1)
1984	10-14	10-14	10-14	10-14	10-14	8-12	24-32	10-14	92-128 (1)
1985	11-15	11-15	11-15	11-15	11-15	6-10	20-40	11-15	92-140 (1)
1986	12-16	12-16	12-16	12-16	12-16	4-6	32-52	12-16	108-154
1987	12-16	12-16	12-16	12-16	12-16	4-6	32-52	12-16	108-154
1988	12-16	12-16	12-16	12-16	12-16	4-6	32-52	12-16	108-154
1989	12-17	12-17	12-17	12-17	12-17	4-6	32-56	12-17	108-164
1990	13-18	13-18	13-18	13-18	13-18	6-8	28-56	13-18	112-172
1991	13-18	13-18	13-18	13-18	13-18	6-8	28-56	13-18	112-172
1992	13-18	13-18	13-18	13-18	13-18	6-8	28-56	13-18	112-172
1993	13-18	13-18	13-18	13-18	13-18	6-8	28-56	13-18	112-172
1994	13-18	13-18	13-18	13-18	13-18	6-8	28-56	13-18	112-172
1995	13-18	13-18	13-18	13-18	13-18	6-8	28-56	13-18	122-172
1996	13-18	13-18	13-18	13-18	13-18	6-8	28-56	13-18	112-172
1997	13-18	13-18	13-18	13-18	13-18	6-8	28-56	13-18	112-172
1998	13-18	13-18	13-18	13-18	13-18	6-8	28-56	13-18	112-172
1999	13-18	13-18	13-18	13-18	13-18	6-8	28-56	13-18	112-172
2000	13-18	13-18	13-18	13-18	13-18	6-8	28-56	13-18	112-172

SIMPLIFYING ASSUMPTIONS:

- (1) ALL ITEMS SHIPPED THESE YEARS ARE FOR 3800 MWt SYSTEMS
- (2) 4 LOOP STEAM GENERATORS ARE SAME SIZE REGARDLESS OF POWER LEVEL
- (3) 2 LOOP SYSTEMS ARE ALWAYS 3800 MWt
- (4) BEYOND 1985, ALL 4 LOOP SYSTEMS ARE FOR 5000 MWt

Table III

BOILING WATER REACTOR ITEMS SHIPPED OVERLAND/YEAR

	RV	RV CORE SHROUD	RVH	GEN. STATOR	RV SHROUD HEAD	RV STEAM DRYER	TOTAL BWR ITEMS
1978	3-5	3-5	3-5	3-5	3-5	3-5	18-30
1979	3-5	3-5	3-5	3-5	3-5	3-5	18-30
1980	3-5	3-5	3-5	3-5	3-5	3-5	18-30
1981	4-6	4-6	4-6	4-6	4-6	4-6	24-36
1982	4-6	4-6	4-6	4-6	4-6	4-6	24-36
1983	4-6	4-6	4-6	4-6	4-6	4-6	24-36
1984	4-6	4-6	4-6	4-6	4-6	4-6	24-36
1985	5-6	5-6	5-6	5-6	5-6	5-6	30-36
1986	5-6	5-6	5-6	5-6	5-6	5-6	30-36
1987	5-7	5-7	5-7	5-7	5-7	5-7	30-42
1988	5-7	5-7	5-7	5-7	5-7	5-7	30-42
1989	5-7	5-7	5-7	5-7	5-7	5-7	30-42
1990	5-7	5-7	5-7	5-7	5-7	5-7	30-42
1991	5-7	5-7	5-7	5-7	5-7	5-7	30-42
1992	5-7	5-7	5-7	5-7	5-7	5-7	30-42
1993	5-8	5-8	5-8	5-8	5-8	5-8	30-48
1994	5-8	5-8	5-8	5-8	5-8	5-8	30-48
1995	5-8	5-8	5-8	5-8	5-8	5-8	30-48
1996	6-8	6-8	6-8	6-8	6-8	6-8	36-48
1997	6-8	6-8	6-8	6-8	6-8	6-8	36-48
1998	6-8	6-8	6-8	6-8	6-8	6-8	36-48
1999	6-8	6-8	6-8	6-8	6-8	6-8	36-48
2000	6-8	6-8	6-8	6-8	6-8	6-8	36-48

SIMPLIFYING ASSUMPTIONS :

- 1 ALL SYSTEMS DELIVERED TO 1985 ARE 3800 MWt
- 2 ALL SYSTEMS DELIVERED AFTER 1985 ARE 5000 MWt

AIRSHIPS FOR TRANSPORTING HIGHLY VOLATILE COMMODITIES

Miles Sonstegaard*

ABSTRACT: Large airships may prove feasible as carriers of commodities that move as gases or cryogenic liquids; buoyant gaseous cargo could be ballasted with liquid cargo. Airships are compact in shape, operate in a rarified medium, and hence can be fast and perhaps economic carriers of costly cryogenic tanks. The high-pressure gas pipeline has excessive surface area when carrying hydrogen and excessive fluid density when carrying natural gas, while the cryogenic ocean tanker runs in a dense medium and makes gravity waves. But the airship, despite its fluid dynamic advantages, faces problems of safety, weather, and altitude control.

A promising mission for airships is the long-distance, high-traffic-volume transportation of highly volatile commodities. Methane is presently the most important of the low-boiling-point commodities, but hydrogen, oxygen, and light hydrocarbons other than methane may achieve considerable volume in the future. (Consult [1] on thermochemical cycles for H_2-O_2 production, [2] on fusion energy and hydrogen, [3, 4] on handling of hydrogen, and [5] on cryogenic ocean transportation of methane.) It is conceivable that even nonfuel elements such as sulphur, phosphorus, and tin might be transported as gaseous hydrides blended with hydrogen to form slightly buoyant cargoes. In many cases the buoyancy of a gaseous cargo might conveniently be balanced by a quantity of the same commodity carried as a cryogenic liquid. Liquids having very low boiling points might be carried in spherical tanks, which are efficient for pressurization and in the utilization of

*Associate Professor of Economics, University of Arkansas, Fayetteville, Arkansas, U. S. A.

PRECEDING PAGE BLANK NOT FILMED

thermal insulation. Two or three such tanks might be suspended low in the nonrigid envelope of a very large airship, their content balancing the buoyancy of the gaseous cargo, above which would be positioned a body of permanent lifting gas capable of floating the unladen aircraft.

COMPETING MODES

Gas pipelines and cryogenic tankers appear to be the major competitors of high-volatile-cargo airships. Other possible competitors are cryogenic liquid pipelines, inland barges, and integral trains, but these latter modes are not likely candidates for long-distance, high-volume routes. Liquid pipelines suffer from extended surface and internal friction. Insulated area and influx of ambient heat are excessive if diameter is large, while heat from flow friction is excessive if diameter is small; hence much heat must be refrigerated out even when diameter is optimum. The low speeds, circuitous routes, and seasonality of inland barge service lead to poor utilization of costly cryogenic tanks and allow significant boiloff. And tanks tall enough to allow full-draft loading with liquid hydrogen would exceed many bridge clearances. Railroad tank cars suffer from restrictive horizontal and vertical clearances, which result in a somewhat extended surface and severely limit payload for the lighter cryogenic liquids.

AIRSHIPS VERSUS GAS PIPELINES

Because a pipeline is a container that extends from origin to destination, it need not shuttle back and forth. Yet for a given volume, great container length implies small diameter; hence this mode lacks the substantial scale economies associated with the batch handling of gas in vessels of compact shape. For example, a pipeline 1000 miles long and of uniform diameter has 59 times the surface area of a 1000-foot-diameter sphere of like volume. The relatively small surface of the batch vessel tends to give it a higher economic speed, which in turn implies a larger required volume for the pipeline. Of course the surface advantage of the batch process is partially offset by the need for container streamlining, multi-vehicle fleets, shuttling, and terminal transfer and storage. Yet on long hauls and assuming equal speed and throughput for the airship fleet and the pipeline, the surface area of a pipeline would still exceed that of an optimum airship fleet by an order of magnitude.

The gas pipeline suffers not only from an extended surface area resulting from its uncompact shape, but also from surface-protection problems. For practical purposes the line must be buried; hence it faces electro-chemical attack and concentrations of external pressure to a far greater extent than does the envelope of an airship. Therefore the optimized pipeline operates at many atmospheres of absolute pressure, but the resulting reduction in surface area is gained only by acceptance of severe requirements for propulsion power and tensile material.

The reason that required propulsion power increases with a scaling down of pipeline diameter and a corresponding increase in pressure is as follows. Surface area s in a pipeline of given length varies as the square root of volume V (i. e., $s \propto V^{1/2}$), while the specific gravity g of a given tonnage of contained gas varies inversely with volume (i. e., $g \propto V^{-1}$). Now, the force F required to move the gas through the pipeline at a given velocity is approximately proportional to gs , which is inversely proportional to the square root of volume (i. e., $F \propto gs = V^{-1/2}$).

Suppose, for example, that a perfect gas at one atmosphere absolute pressure in a pipeline eight yards in diameter were compressed to 64 atmospheres by reducing the pipeline diameter to one yard. Specific gravity \underline{g} would increase by a factor of 64, surface \underline{s} would decrease by a factor of 8, and \underline{gs} --and propulsion power-- would rise by a factor of eight. (Pipeline pressures of 64 atmospheres are roughly in line with natural gas pipeline practice.) Thus in terms of required propulsion power, the pipeline would appear to be worse off than the airship fleet--by two orders of magnitude. The assumption here is that average airship speed and average gas speed in the pipeline are equal and that at standard conditions the gas has the same density as air. In practice, gas would move faster via airship than via pipeline, so that the airship fleet would have a propulsion power advantage of one order of magnitude, along with a modest surface area advantage.

In the pipeline the absolute pressure of the gas is contained almost entirely by tensile material, while in the airship the absolute pressure of the gaseous cargo is contained almost entirely by the atmosphere. The quantity of tensile material required is proportional to the product of volume and gauge pressure, assuming a safety factor of unity. (Tensile material can be measured in pound-feet, the measure of a filament of such material being the product of its length and its maximum working strength. As shown in [6], three pound-feet are required to contain one cubic foot of gas at a gauge pressure of one pound per square foot.) The ratio R of required tensile material to a standard volume of contained gas is given by the equation:

$$R = 3 \left(1 - \frac{p_o}{p_i} \right), \quad (1)$$

where: p_o is the pressure of the atmosphere surrounding the container; p_i is the absolute pressure of the gas within the container; $p_i \geq p_o$; and the contained gas obeys Boyle's law. In an airship, p_i is only slightly greater than p_o . In a pipeline, p_i is ordinarily many times as large as p_o . Hence, R is much greater for the pipeline. Suppose, for example, that p_o is one atmosphere, p_i is 64 atmospheres for a pipeline, and an airship operates on a maximum gauge pressure of 20.4 inches water column, i.e., has a p_i of 1.05 atmospheres. The ratio of required tensile material is then 20.67 in favor of the airship, where airship and pipeline each contain the same mass of gaseous cargo.

Thus an airship fleet would require less container-surface area, less propulsion power, and less tensile material than a competing long-distance, high-pressure gas pipeline. And in the last two of these three basic indicators of cost, the airship fleet leads by an order of magnitude. (See [7] for quantitative airship-pipeline comparisons in the context of natural gas and under rather specific assumptions.) Other considerations in the comparison are: (1) the possibility of applying laminar boundary layer control to airships; (2) air/gas density ratio and the resulting ratio of liquid to gaseous cargo; (3) the compressibility coefficient of the gas; (4) propulsion efficiency; (5) air/gas viscosity ratio; (6) parasitic volume; (7) wind and weather; and (8) the geographic versatility of the airship fleet. Either of the last two considerations could turn out to be important, but the degree of importance would vary from one situation to another; hence in the present preliminary analysis these considerations are in the nature of imponderables. Of the six remaining factors, only the first two--they will be discussed in the succeeding paragraph--could affect the airship-pipeline comparison by a factor much exceeding 1.5. Compressibility coefficients (which measure deviations from Boyle's law) show a

volume reduction of some 15 percent for the high-pressure pipeline when methane is the cargo. Propulsion efficiency might be somewhat better for a centrifugal pipeline compressor than for airship propulsion, especially in view of the drag of airship control surfaces, but it is most unlikely that the propulsion power comparison would be affected by as much as a factor of 1.5. Hydrogen has an absolute viscosity about half that of air, but at best a doubling of the Reynolds number would cause a friction-factor reduction only of the order of 10 percent. Parasitic volume, which would be devoted largely to permanent lifting gas, inert shield gas, and cryogenic tanks, might run some 10 to 25 percent of total displacement, depending on aircraft type and size and on materials of construction.

The successful application of laminar boundary layer control to airships could be a highly significant advantage for this mode, the theoretical power saving at high Reynolds numbers ranging up to some 85 percent [8], which would be equivalent to reducing propulsion power by a factor of some $6 \frac{2}{3}$. The practical application of laminar boundary layer control to a pipeline would appear to be much more difficult if not entirely out of the question. Finally, a low gas/air density ratio could favor the pipeline in the propulsion power comparison, although it would simultaneously favor the airship in the surface area and tensile material comparisons. The difference in densities would be most pronounced if the highly volatile cargo were hydrogen, and the air would then be some $14 \frac{1}{2}$ times as dense as the gas. If the volume of the airship were reduced by a factor of $14 \frac{1}{2}$ (as compared with the original assumption that airship and pipeline volumes were equal), its surface area would fall by a factor of $(14 \frac{1}{2})^{2/3}$, that is by a factor of about 6. The specific gravity of the air would, however, be $14 \frac{1}{2}$ times that of the gas in the pipeline. The adjustment in the original airship-pipeline comparison would then call for a $14 \frac{1}{2}$ -fold increase of the airship's specific gravity g and a sixfold decrease in its surface area s , with the result that gs , and airship propulsion power, would rise by a factor of 2.4. The airship's relative economic gain by reason of the reduction of surface area would tend to be offset by the necessity of liquifying a large portion of the cargo.

The implicit assumption so far has been that airships operate at substantially the same altitude as pipelines. This may, at least for laden airships, be a reasonable working assumption in a comparison where concern is chiefly with order-of-magnitude differences. Yet an unladen airship might utilize the entire envelope volume--exclusive of that devoted to tanks and inert shield gas--to contain the permanent lifting gas at low absolute pressure and at a correspondingly high altitude. The empty return trip could then be made at higher speed--59 percent faster, on the assumptions that propulsion power is proportional to the cube of air-speed, normal power level is maintained at high altitude, and g is reduced by a factor of four.

AIRSHIPS VERSUS OCEAN TANKERS

The deep sea cryogenic tanker is a surface vessel, the airship a vessel submerged in a medium about $1/1000$ as dense as sea water, assuming a standard atmosphere at an altitude of about 7000 feet. The airship largely avoids wave drag and encounters a viscous drag smaller by an order of magnitude than that encountered by the ship. The lower viscous drag stems from the nonproportional behavior of specific gravity g and surface area s as a vessel of fixed shape and weight displacement is scaled up in volume while the density of the flotation medium is reduced

correspondingly. Although g falls in inverse proportion to volume displacement, s rises only as the two-thirds power of volume. Thus in the shift from sea water to air at 7000 feet, g falls by a factor of 1000 while s rises by a factor of 100, with a resulting 10-fold reduction in gs and almost that large a reduction in viscous drag.

Other factors in the airship-ocean tanker comparison include: (1) viscosity and fluid dynamic smoothness; (2) the volume-surface advantage of the surface vessel; (3) wave drag; (4) the possibility of high-altitude empty return flight for airships; (5) the portion of the cargo transported in gaseous form; and (6) wind and weather. Note that for airships and ocean vessels of like speed and tonnage displacement, Reynolds number does not differ greatly unless high altitudes or warm waters are involved; for 15° C and low airship altitudes the kinematic viscosity of air is some 12 to 15 times as great as that of water, but this difference is largely offset by the fact that the airship is about 10 times as long. Apparently the airship could be maintained in a relatively smoother condition, as it does not grow barnacles and has a thicker boundary layer within which to hide its roughness. A single-hull surface vessel has a volume-to-surface advantage over a submerged vessel, the reduction in wetted surface for a body symmetrical about a horizontal median plane which is also the water line being 20.63 percent, according to the "half-of-two-to-the-two-thirds law." Of course this saving may not be fully realized in practice, particularly if the surface vessel is to operate at sizable Froude numbers ($> \sim 0.20$) and will therefore need relatively small volumetric and prismatic coefficients in order to avoid excessive wave drag. Indeed, an ocean-going hydrogen tanker would have little if any volume-surface advantage by reason of operating at the interface; the low density of its cargo (1/15 that of sea water, 1/6 that of liquid methane) would dictate the use of a catamaran or of a rather broad, barge-like vessel.

Resistance arising from the generation of gravity waves would be experienced by ocean tankers but not ordinarily to any appreciable degree by airships, except perhaps while operating partly submerged in a stable layer of cold air. A cryogenic tanker, by reason of costly tanks, insulation, and boiloff, has a higher economic speed than does a conventional tanker of like displacement. A liquid hydrogen tanker, in particular, would be under economic pressure to move along; its cargo would be relatively valuable and its insulation task relatively difficult, the ratio of volume to heat of vaporization being some seven times as large for liquid hydrogen as for liquid methane. Wave drag, which rises roughly as the third power of speed in the 0.3-0.4 Froude-number range [9], would impose a stronger barrier to really high speeds than would viscous drag, which rises roughly as the second power of speed. If the cryogenic ocean tankers were extremely large, however, they might perhaps reach economic speed without encountering high Froude numbers and the associated high wave making resistance.

The possibility of making empty return voyages at high altitudes and relatively high speeds is a significant potential advantage of the airship, as is the ability to reduce liquifaction cost by transporting in gaseous form a portion of the cargo--3/5 for natural gas, 1/15 for hydrogen, 2/3 of the hydrogen for a stoichiometric oxygen-hydrogen carrier. Another advantage of the airship is freedom from the effects of waves, spray, and relative wind-water velocities; the airship, including its cryogenic tanks, can be more delicately constructed, since it is not subjected to high accelerations. But it does face the problems of operating in a relatively mobile

medium (winds being far more swift than ocean currents) and of maintaining a desired altitude.

THE VOLATILE-CARGO AIRSHIP

The airship designed for transporting highly volatile commodities on long hauls would be very large. A displacement of tens of thousands or even hundreds of thousands of tons would probably be typical, once the technique was developed. Great size would appear to call for a nonrigid airship with a framework of steel or fiberglass cables, fitted perhaps with a rigid, semibuoyant stern section that would provide propulsion and control. The nonrigid portion might be assembled out of doors, lifted by launch aerostats, and inflated in nonturbulent air at altitude. The rigid pusher section might be constructed indoors, lifted by an aerostat, and joined to the nonrigid section in midair.

In very large freight airships the forces of buoyancy and inertia would dominate. Wind gusts would be of little significance in ground handling. (Rosendahl [10] stated that even the 50-percent size increase from the Los Angeles to the Graf Zeppelin noticeably reduced the effect of gusts.) Propulsion power requirements would be low in relation to airspeed. And pitch might be controlled less by aerodynamic forces than by buoyant trim. Although positive and negative aerodynamic lift would provide valuable short-term altitude control, altitude would be controlled primarily via the control of buoyancy, probably by means of superpressure and/or superheating. A one-percent decrease in heaviness could be had by decreasing the gauge pressure by about four inches water column or by increasing the gas temperature about five degree Fahrenheit.

Conceptually, there are two distinct types of volatile-cargo airships, the light-gas tanker and the heavy-gas "bagger." The light-gas tanker transports commercial hydrogen as a buoyant cargo gas whose lift supports a volatile liquid cargo, refrigerated and/or pressurized. The heavy-gas bagger carries a gas of unitary specific gravity, e. g., a blend of methane and propane or of hydrogen and vinylidene chloride, and therefore needs no nongaseous ballast. In between these extremes are various gradations--airships transporting commercial gases denser than hydrogen but not as dense as air and carrying some liquid ballast.

The light-gas tanker tends to have high optimum speed, large fineness ratio, relatively small optimum size, and high construction cost per ton of capacity. The heavy-gas bagger tends to have lower optimum speed, smaller fineness ratio, relatively large optimum size, and low construction cost [11]. Although there are a number of commodities that could be blended with hydrogen or methane to form mixtures of unitary specific gravity [12], with most commodities it might be desirable to maintain some buoyancy in the cargo gas, either via composition or superheating, to reduce the probability of accidentally spilling dangerous gases on the ground.

Perhaps the most serious problem of the volatile-gas airship is that of safety. Flammable or noxious gases should perhaps be surrounded by a pressurized blanket of inert gas and the blanket sectionalized and metered. Routing, scheduling, and weather prediction should be precise or ample safety margins provided. The cargo airships might be remotely controlled and on-board repair men provided with escape devices. In an emergency, cryogenic tanks could be exploded and cargo and

lifting gas fired while a derelict airship was still in a relatively safe location. It is to be presumed that aerial cryogenic tankers would not be routed near cities, although heavy-gas baggers, slightly buoyant and ballasted with water, would be relatively safe. In any case, the pilot of a disabled volatile-cargo airship would have more time and a wider choice of ditching procedures than an airplane pilot has, and he would never have unprotected personnel aboard. Related problems are storm avoidance, wind regime utilization, and ground handling.

SUMMARY AND CONCLUSIONS

For operation at equal speeds, propulsion power is greater by two orders of magnitude for the high-pressure gas pipeline and by one order of magnitude for the cryogenic ocean tanker than it is for the airship. When speeds are optimized mode by mode, the airship is faster, and an airship fleet would use roughly the same power as a comparable ocean tanker fleet and about one-tenth as much as a pipeline of comparable throughput capacity. The airship fleet has almost as much surface area and about one-tenth the tensile material of the gas pipeline. Being faster and more adaptable to direct routing, an airship might make three or four times as many round trips per year as an ocean tanker, utilizing well the substantial investment in cryogenic tanks and reliquefaction equipment.

In the three-way comparison between airship, ocean tanker, and gas pipeline, the first two benefit from the compact shape of the batch container. In principle, the airship and the gas pipeline both enjoy the propulsion power advantage associated with a low density flow medium, but in the conventional, high-pressure version the pipeline sacrifices this advantage to gain a much needed reduction in surface area and volume. The airship and tanker can be deployed far from the construction site and redeployed as desired. Compared with the ocean tanker, the airship can travel more directly and reach more destinations, and it can take to high altitudes on empty return voyages. Nevertheless, the airship faces problems of safety, altitude control, storm avoidance, and wind regime utilization. Of the three modes, the airship is the only one that has never been tried out in practical, multikiloton sizes.

REFERENCES:

1. Marchetti, C., Hydrogen and Energy, 5 Chemical Economy and Engineering Review, Tokyo, Japan (January 1973).
2. Tanner, E. C. and Huse, R. A., A Hydrogen-Electric Utility System with Particular Reference to Fusion as an Energy Source, Proceedings, 7th Intersociety Energy Conversion Engineering Conference (1972).
3. Bartlit, J. R., Eduskuty, F. J. and Williamson, K. D., Jr., Experience in Handling, Transport, and Storage of Liquid Hydrogen--the Recyclable Fuel, Proceedings, 7th Intersociety Energy Conversion Engineering Conference (1972).
4. Gregory, D. P. and Wurm, J., Production and Distribution of Hydrogen as a Universal Fuel, Proceedings, 7th Intersociety Energy Conversion Engineering Conference (1972).

5. Wilson, J. J., An Introduction to the Marine Transportation of Bulk LNG and the Design of LNG Carriers, 14 Cryogenics, Guildford, England (March 1974).
6. Sonstegaard, M. H., Airships Versus Pipelines for Natural Gas Transportation, published by the author, Fayetteville, Arkansas (1970), p. 18.
7. Same, pp. 1-11.
8. Schlichting, H., Boundary-Layer Theory, Sixth Edition, McGraw-Hill Book Company, New York (1968), p. 487.
9. Hoerner, S. F., Fluid-Dynamic Drag, published by the author, Midland Park, N. Y. (1958) p. 11--15.
10. Rosendahl, C. E., What About the Airship, Charles Scribner's Sons, New York (1938) p. 195.
11. Sonstegaard, M. H., Airship Transportation of Commercial Gases: Preliminary Optimization and Cost Estimation, ASME Paper 72-Pet-41 (1972) pp. 3, 5.
12. Sonstegaard, M. H., Transporting Commercial Gases by Airship, published by the author, Fayetteville, Arkansas (1970) pp. 23-26.

USING LIGHTER THAN AIR VEHICLES
(DIRIGIBLES) IN HOUSING CONSTRUCTION

E. E. Shamis*
V. B. Moorychev**

ABSTRACT: This paper reports on the potential use of Lighter Than Air vehicles for the transport and erection of modular housing units. Comparisons are made between traditional methods of construction and the use of an airship. Data on LTA cost is based on an airship design study and the operation of a 12 meter model.

Lighter Than Air vehicles are capable of extended station-keeping with loads suspended from a cargo winch. This makes it possible to use dirigibles not only for the transport of housing modules but also for their erection at construction sites. This application has been investigated at the S. Lazo Politechnical Institute in Kishinev.

A transport-mounting dirigible, the TS.M-100, was designed by the K. E. Tsiolkovsky Dirigible Design Office in Leningrad for this purpose. The TS.M-100 is an unballasted dirigible 245 meters (789 ft.) long, with a fineness ratio of 6.67 (maximum diameter is 37 meters). Gross payload is 130 metric tons (143 short tons) and the useful load is 100 metric tons (110 short tons). The gondola is 60 x 5 x 5 meters (197 x 16.5 x 16.5 ft.). Cruising speed is 170 km/hr (106 mph). The vehicle is metal-clad and uses engine exhaust heat for aerostatic gas control. Tentative

* S. Lazo Politechnical Institute, Kishinev, U.S.S.R.

**Tsiolkovsky Public Dirigible Design Office, Leningrad, U.S.S.R.

cost per ton-kilometer is 2.2 kopecks (4.3¢ per short ton-mile), which is considerably below the cost of normal air transportation.

A twelve meter model was tested and has shown good maneuverability. It easily moved up, down and sideways, and turned around while holding position. The design study and test results allow the projection of performance for a full size Lighter Than Air vehicle of similar design.

The TS.M-100 would be used for both transportation and mounting of housing modules. Five or six standard three dimensional modules can be assembled in one to one-and-one-half hours using the TS.M-100 as a transport/crane. The TS.M-100 could also carry 30 to 50 wall panels but vehicle utilization would be low because it would take an eight hour shift to assemble the load.

Modular construction is the most progressive technology in housing today. A five story apartment house with 60 dwelling units uses 1,300 to 1,400 components if constructed from large wall panels that can be trucked to the site. A similar building can be made from 206 to 240 one room modules or 100 to 120 two room modules by a team of half a dozen workers in ten days.

Despite its potential, modular housing construction has been limited by two factors: (1) the difficulty of transporting and positioning large modules, and (2) the slow curing rate of normal concretes, leading to low output from the complex machines used to produce three dimensional structures. The latter problem has been solved at the Politechnical Institute in Kishinev by developing techniques that use quick setting concretes. Special equipment has been designed and tested that yields six to eight times the productivity of the older methods.

As a result the bottleneck is now transportation and installation of the modules. Modern construction management coordinates manufacture, transportation and installation into a single production cycle. The use of dirigibles to transport and position building modules could smooth production flow by eliminating delays caused by poor roads or great distances between the module factory and the construction site.

The cost of dirigibles and traditional methods of transport and construction were compared for three different building configurations. One story, 10.8 x 3.8 meter (35.4 x 12.5 ft.) modules were used in each building, loaded into the TS.M-100 gondola or suspended from its cargo winch at the factory. The building configurations studied are outlined in Table 1.

For each building configuration, three transportation/construction techniques were investigated. The first used tracked, caterpillar-type cranes for construction. The second used other types of cranes. The road transport equipment was the same in both cases. Table 2 lists the equipment used in these cases. The third technique used the TS.M-100 for transport and construction.

Type of Unit	Number of Apartments	Floor Space Meters ² (ft ²)	Modules per Unit	Total Weight Metric Tons (Short Tons)
2 Story	20	656 (7,050)	20	440 (485)
5 Story	50	3,280 (35,300)	100	2,200 (2,420)
9 Story	108	8,850 (95,200)	270	5,900 (6,500)

Table 1
Building Configuration Parameters

Type of Unit	Transportation		Construction	
	Truck Tractors	Truck Trailers	Case 1 Tracked Cranes	Case 2 Other Cranes
2 Story	1	2	1 (SKG-50)	1 Wheeled Crane
5 Story	2	4	1 (SKG-63)	1 Coach-Box Crane
9 Story	3	6	1 (SKG-100)	1 Tower Crane

Table 2
Conventional Transport and Construction
Equipment Requirements

Tables 3,4 and 5 present the results of the economic analysis for each building type and construction/transport method. Assembly and capital investment costs are included as are the labor costs for the transport, assembly and operation of the construction equipment. All cost data is per square meter of floor space. Consistent assumptions were used in all cases.

The data shows that the dirigible method of construction is most efficient economically over distances of 50 kilometers or more. It is less labor intensive at all distances. This would indicate that modular housing construction is a very promising potential market for Lighter Than Air.

Transport Distance km. (miles)	Case 1		Case 2		Case 3	
	Cost ¹	Labor ²	Cost ¹	Labor ²	Cost ¹	Labor ²
10 (6.2)	1.22 (0.15)	0.22	1.79 (0.22)	0.29	3.50 (0.44)	0.15
20 (12.4)	1.98 (0.25)	0.37	3.14 (0.39)	0.60	4.36 (0.54)	0.17
50 (31.1)	4.42 (0.55)	0.81	6.21 (0.78)	1.19	4.40 (0.55)	0.18
100 (62.1)	7.61 (0.95)	1.39	11.73 (1.47)	2.30	6.26 (0.78)	0.26

Table 3
Two Story Housing

Transport Distance km. (miles)	Case 1		Case 2		Case 3	
	Cost ¹	Labor ²	Cost ¹	Labor ²	Cost ¹	Labor ²
10 (6.2)	2.40 (0.30)	0.33	3.75 (0.47)	0.47	3.48 (0.44)	0.15
20 (12.4)	4.23 (0.53)	0.59	5.83 (0.73)	0.72	4.35 (0.54)	0.18
50 (31.1)	9.00 (1.13)	1.25	11.95 (1.49)	1.76	4.56 (0.57)	0.20
100 (62.1)	15.50 (1.94)	2.14	21.68 (2.71)	4.15	6.09 (0.76)	0.26

Table 4
Five Story Housing

Transport Distance km. (miles)	Case 1		Case 2		Case 3	
	Cost ¹	Labor ²	Cost ¹	Labor ²	Cost ¹	Labor ²
10 (6.2)	4.13 (0.51)	0.49	2.58 (0.32)	0.32	3.58 (0.44)	0.15
20 (12.4)	6.64 (0.83)	0.81	4.70 (0.59)	0.58	4.44 (0.55)	0.19
50 (31.1)	12.01 (1.50)	1.54	7.93 (0.99)	0.97	4.74 (0.59)	0.22
100 (62.1)	20.89 (2.62)	2.75	15.39 (1.93)	1.90	6.20 (0.78)	0.27

Table 5
Nine Story Housing

1. Rubles per square meter (Dollars per square foot based on a conversion rate of \$1.345 per ruble)
2. Man hours per square meter

N76-15062

ENVIRONIC IMPLICATIONS OF
LIGHTER THAN AIR TRANSPORTATION

Patrick Horsbrugh*

ABSTRACT: The advent of any new system of transportation must now be reviewed in the physical context and texture of the landscape. Henceforward, all transportation systems will be considered in respect of their effects upon the environment to ensure that they afford an environic asset as well as provide an economic benefit. This paper emphasizes the obligations which now confront the buoyancy engineers so that they may respond to these ethical and environic urgencies simultaneously with routine technical development.

The prospect of a system of global transportation by means of Lighter Than Air vehicles requires to be explored within the context of both the history of the economics of movement, and of the environic consequences arising from vehicular demands and impositions. There prevails a growing conviction that the right of movement supersedes any other social requisite, and the illusion is growing that transportation requirements cannot be resisted. Speed is the symbol of progress, and progress is of course irresistible. The capabilities of Lighter Than Air transportation are conditioned by particular factors which make the concept of such a system unique, while the seeming freedom from surface characteristics, which so inhibit all previous systems of incidental and scheduled mass-movement, hold vital environic promise for the improvement of the degraded human habitat. It is inevitable that inventive aeronautical genius will concentrate upon instruments that operate in the only element that is consistent in all regions of the earth,

*President, Environic Foundation International, Notre Dame, Indiana, U.S.A.

and redress the curious technical anomaly between the dramatic prowess achieved in aerodynamics and the tragedy strewn progress in aerostatics, by means of which the history of aviation began.

The potentialities of aerial lift of unprecedented size and weight permits the modified use of equipment of proven effectiveness tested in nuclear submarine, mammoth tanker and supersonic aircraft operations. Such exceptional advantages will ensure that the next generation of lighter than air vessels will develop comparatively rapidly. They will emerge in a sophisticated form for so wide a range of purposes that it is imperative that they should be assessed, for both their initial impact upon the environment and for the consequences of their presence.

It is now becoming mandatory planning policy to review existing, modified and proposed transport systems to determine their intended benefits and their inevitable obsolescence, under the competitive economic pressures of yet another system.

As the horse cart and the sailing ship have passed into the realms of kinetic romance, so will pass the wheel, and even the wing, but these present means of movement produce a legacy of environic degradation that no society can further afford.

It is essential, therefore, that any new or revised concept of transportation be fostered by those concerned with the quality of environic conditions, in their indivisible entirety.

For these pressing reasons that the Environic Foundation International sponsored the intended Symposium on Airship Development, in London, earlier this year,¹ it is believed that the prospects for Lighter Than Air transportation should be conveyed, cultivated and confirmed within the context of environmental seemliness as a social benefit. By such a strategy it is hoped that emotional antagonisms, economic frictions, legal conflicts and environmental affront can be avoided. Such sponsorship can encourage the realization that, for the first time since the invention of the sail, a system of movement can be achieved, on an unprecedented scale, without damage to the quality of life.

It is difficult to imagine any form of mechanized transportation without the vision of the scene despoiled. The railyards and stations, the docks and harbors, the roads and superhighways and even the newest airports, with their inseparable deserts of automobile parking, are all areas of spiritual and aesthetic desolation. Since the harnessing of steam, the wheel in its varying rotations, has become an environmental tyranny.

Lighter Than Air vehicles present, it would seem, a very different prospect. They may become an instrument of salvation, redeeming the effects of automotive despoilation, without imposing further demands upon the overstrained urban energies and spacial resources. It is now a planning imperative that this positive possibility be understood at this moment of the technical reassessment of a once discarded concept of transportation. It is axiomatic that those concerned with the physical conditions of good order become involved in the lighter than air research and investment from the beginning, in this exceptional instance, the re-beginning.

The justification for the inclusion of the subject of Environic Implications of Lighter Than Air Transportation in this, the first Workshop devoted to the technicalities of a revised concept of bulk transportation, lies in the urgency of obvious planning disarray, environmental degradation wrought by previous transport systems, and upon the potential reach (territorial and aquatic) which this system portends.

PROFESSIONAL COORDINATION, STRATEGIC AND TACTICAL

Recent social history has shown that the physical consequences of new systems of transportation have consistently increased environmental stress upon ecological and human well-being alike. No matter how convenient each new conveyance might have been, environic degradations increased as the demands of each particular system expanded.

Under the momentum of competition, new systems have momentarily superseded their predecessors in performance, but seldom have the new systems reoccupied areas or routes previously used. In consequence, the landscape, urban and rural alike, has become dominated by both the demands and the effects of successive systems of transportation.

For the first time, it is possible to consider a revised/new system of movement that is not hindered by the dispositions of land and water, or by the structural investment thereon. While this freedom of vehicular maneuver and of direct place to place contact may soon become fact; the stimulating effects of this facility upon land-use speculations require immediate acknowledgement. The aero-tatics of land and water planning must be propounded coincidentally with the designing and the testing of lighter-than-air craft, in all their likely hybridizations.

The planning professions, environologists, architects, engineers, urbanologists and landscape designers must appreciate the third dimension and the third, all-pervading element, air, as being their responsibility, indivisible from the surfaces of their design commissions.

The prospects of receipt and dispatch of materials and personnel from 'above', by suspension, in unprecedented quantity, without investment in costly intermediary equipment, structures, etc., are impelling and will exert an effect upon planning concepts that may be termed 'involutionary'. The consequent effects of such a transportation system on land values, will stimulate real-estate speculations, everywhere, and will impose new demands upon unencumbered territories that will range from industrial to recreational uses in locations that are presently inaccessible.

Such concepts of elemental planning coordination necessitate the creation of a particular transportation planning research office that is independent of government departments and of industrial/professional influences, so that the essential imagination required for the promotion of this unique vessel, the 'airship' is not hindered by conventional procedures and investments.

Reference to the post World War II position of maritime commerce is here relevant, in that the design of ships, ports and port facilities were less than co-incident and necessitated the founding of the International Cargo-Handling Coordination Association.² The extension of this organization to meet the same requirements to facilitate air to ground/water and air to other vehicle trans-handling would seem to be justified to ensure both equipment standardization and the effective re-use or 'supra-use' of those surfaces already in service.

It is essential, moreover, that the viability of such vessels are not exaggerated thereby causing operational disappointments, stimulate real-estate speculations, and premature investments combining to produce a loss of public confidence of the kind experienced by successive railway investment booms of the nineteenth century.

A comparative analysis of social amenity cost/benefit/degradation and of lasting convenience, based upon the environmental consequences of concurrent transportation systems, is fundamental in creating public and political confidence in the claims made in favor of any new system.

It would be a tactical and an economic misfortune if the advancement of lighter than air vessels were to be delayed by opposition from those who champion environmental causes, necessary and imagined. It would be unfortunate, indeed, if lighter than air transportation concepts were to be hindered by public hostility and political antagonism arising from misapprehensions about the environic consequences. It would be strategically disastrous if lighter than air pioneering were to be harassed by industrial or trades union interests, opposed to any challenge to their traditional means of livelihood.

ENVIRONIC FACT AND SPECULATION

The scale of transport planning is now so vast and so complicated that no new system can be added to the general operations without dire spacial, social, material and particular environic consequences. These vital issues are the concern of the environologists and their associated planning specialists and justify their practical participation in supporting the developments of lighter than air transportation at this moment of technological review and revival.

The laudible injunction requiring those invited to contribute Workshop Papers to concentrate upon the separation of fact from speculation is difficult to fulfill for the subject of environic condition includes the unknown. There is no formula for conditional measurement as applied to the material environment indivisible. While reports confirm that the condition of the inhabited landscape is deteriorating in ecological quality, and is increasing as an economic liability, the evidence is seldom accepted as fact, but rather as an opinion, and that mitigating circumstances can be pleaded.

Speculation, however, continues apace, and speculation is unavoidable so long as demands vary from place to place, and as the human purposes shifts from time to time. The whole kaleidoscope of economic operations is predecated upon speculation, and the reality of this fact must be recognized as the prime stimulant for invention. It is speculation, that has produced the crisis now reached in the demand for a more simplified, dependable and economic transportation system. This is a fundamental environic fact that is confirmed by environmental conditions.

EDUCATIONAL COMMITMENT

As the pressures of transportation inadequacy increase, the search for economic relief continues with intensified urgency. In consequence, this is a period of multiple specialization, and of inventive pioneering in diverging directions. There now prevails an educational commitment to specialization which will be disastrous, socially, economically and ecologically, unless it is tempered by a consistant attention to environic consequences of all that is undertaken in the re-redevelopment of transport operations. The emerging challenge of the lighter than air vessel, combining the most advanced mechanical and electronic technology with the most direct means of movement, offers the most positive prospects for environic quality redemption ever to arise.

I wish, therefore, to emphasize the opportunities for symbiosis between the lighter than air engineers and the territorial planners for the achievement of environic rejuvenation. The lighter than air transportation potentialities are of transcending importance, and constitute an unprecedented incident in the history of

invention, and in the economics of mechanical movement. Special educational programs are required to comprehend the rebirth of such vessels, since their emergence will impose significant intellectual challenges in social behavior and in geo-political relationships.

The subject of 'airships' is already familiar, and of proven validity in that craft using the 'first principal of flight' are, indeed, a practical proposition. After 40 years of oblivion, and of almost no advancement in popular uses (with the exception of the unique experiences of the Goodyear Aerospace Corporation), the coordination of several technological achievements will facilitate the production of a vessel of such varied use and potentiality that a particular educational program will be justified in advance of the event.

Transportation economics will undergo profound changes if any system can be devised which will reduce the necessity of vast structural investments, as exist in the form of harbors, railroad marshalling yards, airports and their supporting facilities. The economic appeal of any system which disposes with the construction and maintenance of previously indispensable interconnecting routes, and between remote terminals is not to be denied.

Vertical lift and float movement of loads of quantity, weight and bulk appear to offer such exceptional economic advantages that every aspect of territorial planning and disposition, urban, suburban, industrial, agricultural, recreational and constructional will be affected — immediately, as a matter of desperate real estate speculation. In consequence, the educational commitment to transport planning strategies, spacial reuses and territorial re-formations becomes a prime urgency and must be met simultaneously with the technological development of aerostatic vessels.

ENVIRONIC CONTEXT

For almost two centuries the landscape has suffered the surgery of successive systems of transportation. Nowhere is this more obvious than in the superbly varied landscapes of these United States, and nowhere has the price of social amenity been paid at such a high cost in the loss of personal and aesthetic amenities. Nowhere is there greater need for the redemption of these lost qualities of scene and serenity.

It is in this context of the wheel-riven landscape that I quote from Abraham Lincoln's healing address to the 62nd Congress, following the distractions of the Civil War, in which he expressed our present technical and professional planning perplexities so succinctly.

"The dogmas of the quite past are inadequate to the stormy present. The occasion is piled high with difficulty, and we must rise with the occasion. As our case is new so we must think anew and act anew. We must disenthrall ourselves, and then we shall save (the condition of) our country."

Nowhere are the difficulties piled higher than in the competitive patterns of successive systems of transportation. Nowhere is it more necessary to disenthrall ourselves than with the concepts of the conventional systems. Nowhere is the landscape so lacerated with the scars or so vibrant from the sounds of movement than in our country.

The transportation planners now have the exceptional advantage of reliable, consistent, repetitive, information upon the condition of the earth, in degrees of thermal and meteorological detail that confirm the primacy of environic discipline in all planning design and operation. This comprehension of context, continuity,

and consequence is now readable in the evidence from remote sensing satellites and must be reorganized as the critical factor in any systematic change in existing transportation by the addition of new systems. The consequences that follow from transport innovations are never anticipated, and the accumulative costs that society eventually has to bear are never estimated in advance, notwithstanding the lessons learned from railroad and shipping enterprises which are, even now, plaguing the aero-industries. Apart from the initial advantages, the effects of wheeled movement become a tyranny which society is swift to tolerate but slow to condemn.

Hitherto, concept has always preceded the technology. Now, in the instance of 'airship' revival, technology is in search of concept. The potential rapidity of development is phenomenal, the size of vessel unprecedented, the pay load and maneuverability unsurpassed, while the range and reach is almost without limit. In consequence appraisals made in the interests of the carriers and investors must be broadened to include the effects upon the environic context.

The re-emergence of the lighter than air vessel represents a momentary opportunity to reconcile the seemingly irreconcilable demands of improved mobility with improved environic conditions, provided that appropriate applications are foreseen and encouraged. Never again must the convenience of those in motion be gained at cost of the comfort of those in place.

APPROPRIATE APPLICATIONS

New technological developments are hindered, inevitably, in reaching full potential by their threat to existing investments, and it would seem prudent and politically dynamic to emphasize the advantages of using lighter than air vessels over those regions where existing services are few or non-existent. Northern Canada is the most obvious and challenging location for testing, where the development of the North depends upon the provision and maintenance of the most costly construction whether it be in the form of railways, highways, or runways.³

With the advent of the lighter than air vessel, to stimulate the competitive commercial economy, there is now no place that is remote -- and virtually no place that is inaccessible. Within the limits of operational height (pressure height), there is now no obstacle which cannot be avoided, no weather conditions and movements which cannot be observed in advance, computed, and position circumvented. In particular, the formidable dangers presented by weather conditions are much reduced as a result of consistent and continuous satellite recordings of the meteorological patterns. This reduction in risk, and resulting insurance economies, may compensate for the delays in rescheduling and rerouting necessitated by avoiding approaching storms by means of the vessels own speed of escape, whether the threat arises while the vessel is tethered or in passage.

Three questions may serve to identify the categories of task to which lighter than air vessels, and their specialized hybrids, can be applied: 1) What can be done better by lighter than air vessels than by any present system of transportation? 2) What can be done by lighter than air vessels that cannot be done by any present system of transportation? 3) What supporting services and facilities can lighter than air vessels dispense with, thereby providing maintenance and other economics which will ensure lower costs for routine operations, and reduce the varied impedimenta representing the conventional transport infrastructure that is so demanding of space, so imposing upon the scene?

The most significant influence of lighter than air vessels will be felt by those concerned with urban, wilderness and marine planning where the services of the 'aerocrane' hybridizations will permit the removal of site debris and the delivering of construction materials without imposition upon the conventional transport

services. The prospect of working platforms lowered from above are especially appealing to contractors whose operations are entirely dependent upon the nature of the routing to the site. The 'aerocrane' recalls the concept of Dr. Buckminster Fuller, first illustrated in 1927, where substantial building components are lowered complete at remote sites or within the crowded urban and industrial locations.

Such concepts, however, remain speculation since practical experience in aerocrane operations is limited, and largely concentrated in the pioneering constructional commissions undertaken by the Okanagan Helicopter Group.⁵ The most relevant evidence of economic/invention shifts may be found, also, in the profitable achievements of the containerization systems of cargo-handling pioneered by the British shipping company, Manchester Liners Limited, and in the simplification of trans-handling operations upon a world-round scale.⁶

Lighter than air vessel operations are of immediate relevance to geological and mineral exploration; forestry management and logging; agricultural services; crop fertilization spraying and even selective irrigation; stock supervision; pollution observation and assessment; mariculture and fisheries; off-shore oil-rig servicing; scheduled bulk transportation of routine cargos, of fragile perishables, and livestock; unscheduled, incidental deliveries and pipeline inspections. Hybrid 'aerocranes' are urgently required for the trans-shipment of cargos at transportation infrastructures and depositories, and may be especially effective for use in the routine collection, delivery and sorting of industrial/municipal 'waste' materials and garbage for recycling and return for further processing. Such vessels have obvious uses in the inventorying materials and conditions recorded by the Earth Resources Technology Satellite services and for harbor/canal/polder/causeway/island/dam constructions; dredging and excavation; mass-produced factory-assembled house moving and siting. Humanitarian uses of lighter than air vessels would include all forms of disaster; forest and oil refinery fire-fighting, oil-rig crew removal prior to tempest, aircraft and highway accidents, policing and general public safety. Special hospital facilities and operating equipment could be assembled aloft, as in any field hospital, and emergency food distribution, human and livestock, are obvious benefits, while educational travel and exploration, and tourism (for the revelation of territorial and natural wonders and wildlife sanctuaries to which public should not have access) are among the more pleasurable operations required of lighter than air vessels.

LEGAL ISSUES

The seeming economic and amenity advantages suggested by these likely activities for lighter than air vessels must be considered within the license of international law, for each operation is bound by legal obligations and hazards.

It is imperative, therefore, that an organization is created to arouse the interest of imaginative lawyers in this particular aspect of transportation, and to assess the few legal actions involving aerostatic craft that are on record. It is essential, also, to organize a body of informed opinion through whom to anticipate the various of legal issues that such flight is certain to create, ranging from injunctions based upon the charge of invasion of privacy, to implied danger to life and property, to insurance risks and policies. Even actions based upon the infringement of aesthetic and amenity rights caused by proximity and by shadows cast by such aerial leviathans must be expected.

PROFESSIONAL ASSOCIATION

The economic urgencies that now prevail justify the speedy formation of an independent organization devoted to the promotion of the lighter than air vessel, on

an international scale, and in a professional manner. The value of such associations for informing the public, for political lobbying, for strategies of policy, for encouraging concurrent educational programs, for fostering technical developments, and for stimulating the necessary investments are obvious. The effectiveness of forming subsections devoted to the promotion of particular uses and the development of the hybrid vessels required is also manifest.

The initiative shown by the convocation of this assembly should be commemorated by the inauguration of such an organization: THE INTERNATIONAL ASSOCIATION OF LIGHTER THAN AIR TRANSPORTATION, to ensure that governments, environic interests, industries, the press and the populace become acquainted with both the economic and environmental consequences of such a system of transport in the most effective way compatible with the emerging evidence. Such an association should draw members of all professional disciplines who share an enthusiasm for the purpose, and possess experience relevant to the promotion of this, the most promising transportation system yet devised.

PROMOTION

The advent of the lighter than air vessel represents a relatively new kinetic experience with aesthetic no less than commercial value. It is, essentially, a positive instrument of construction, offering advantages beyond the reach and realm of anything previously available. Recent centuries may be distinguished by particular transportational achievements, which have altered previous lifestyles and created the characteristic cultural momentum. The horsedrawn wagon had been the common carrier until the domination of the eighteenth century by the influence of the sailing ship; the nineteenth century was enthralled by the steam engine, while this twentieth century is atremble with the roar of the internal combustion engine in all its forms. The promise of aerial tranquility that is offered by the silence of the Lighter Than Air vessel confirms that this means of movement is, indeed, the most significant technological advancement, that will exert a greater influence over more varied territories with less imposition upon environic qualities than any instrument in the history of transportation.

Such a vessel deserves, I believe, a distinctive name and accompanying terminology wherewith to promote its re-emergence without the historic overtones associated with the appalation 'airship'.

REFERENCES:

1. Press Conference. London: Leo Burnett Ltd., February 15 (1974).
2. International Cargo Handling Co-ordination Association, London (1950).
3. Losee, F. MTPIC; AIP. Expand Canada. A National Policy Position Paper (1972).
4. Marks, R. The Dymaxion World of Buckminster Fuller. Reinhold, New York (1960).
5. Okanagan Helicopter Group. Vancouver International Airport, B. C.
6. Manchester Liners Limited, Manchester Liners House, Manchester, England.

UNMANNED AND TETHERED SYSTEMS AND APPLICATIONS

Aerocrane—A Hybrid LTA Aircraft for Aerial Crane Applications — Russel G. Perkins, Jr., Donald B. Doolittle

Unmanned Powered Balloons — Arthur O. Korn

Special Problems and Capabilities of High Altitude Lighter Than Air Vehicles — P. R. Wessel, F. J. Petrone

A Practical Concept for Powered or Tethered Weight-Lifting LTA Vehicles — M. Alain Balleyguier

A Revolutionary and Operational Tethered Aerostat System Illustrating New LTA Technology — James A. Menke

Technology Update—Tethered Aerostat Structural Design and Material Developments — Robert G. Witherow

Two Lighter Than Air Systems in Opposing Flight Regimes—An Unmanned Short Haul, Heavy Load Transport Balloon and a Manned, Light Payload Airship — R. A. Pohl

Balloon Logging with the Inverted Skyline — C. Frank Mosher

"LOTS" of LTA Applications — Jay S. Brown

Remotely Piloted LTA Vehicle for Surveillance — Gerald R. Seemann, Gordon L. Harris, Glen J. Brown

E H a

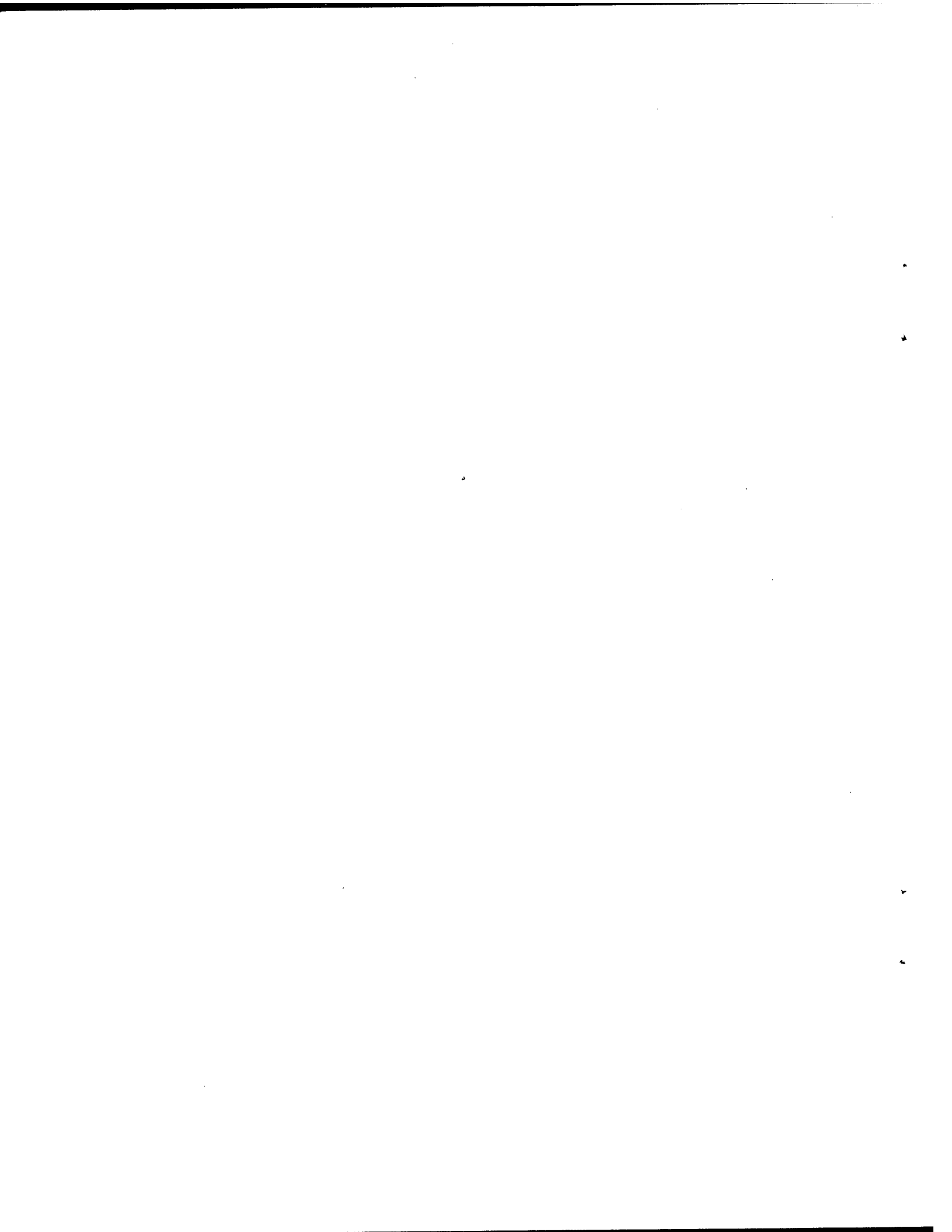

AEROCRANE

A HYBRID LTA AIRCRAFT FOR AERIAL CRANE APPLICATIONS

Russel G. Perkins, Jr.*

Donald B. Doolittle**

ABSTRACT: The Aerocrane, a hybrid aircraft, combines rotor lift with buoyant lift to offer VTOL load capability greatly in excess of helicopter technology while eliminating the airship problem of ballast transfer. In addition, the Aerocrane concept sharply reduces the mooring problem of airships and provides 360° vectorable thrust to supply a relatively large force component for control of gust loads. Designed for use in short range, ultra heavy lift missions, the Aerocrane operates in a performance envelope unsuitable for either helicopters or airships. This paper addresses basic design considerations and potential problem areas of the concept.

INTRODUCTION

The most serious deficiency in U.S. aircraft performance is the lack of a capability to pick-up, carry and implace large, bulky cargos. Present and projected VTOL aircraft offer very limited useful load capacities compared to fixed wing aircraft. Figure 1 illustrates this deficiency plotting aircraft useful load and speed envelope for conventional and VTOL aircraft. Conventional aircraft capabilities are bounded by C-5A performance - a useful load capacity of over 200 tons. Present VTOL capabilities are bounded by the CH-53E - a useful load capacity of only 18 tons. The Army's advanced Heavy Lift Helicopter (HLH) development program will double the present VTOL capability. This is a significant advance when compared to VTOL aircraft, but is insignificant when compared to present fixed wing aircraft.

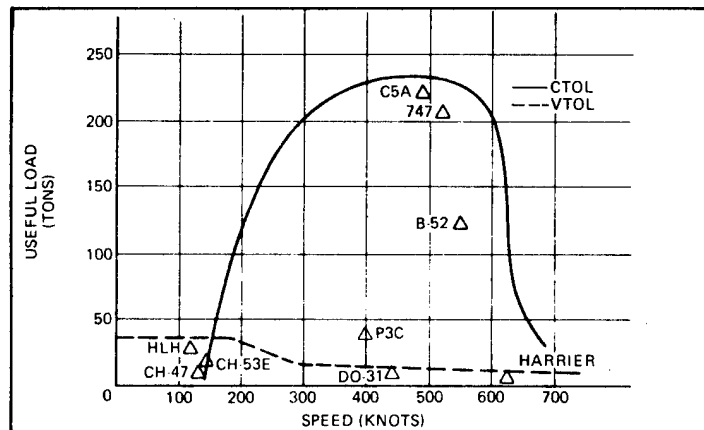

FIGURE 1. Aircraft Performance Spectrum

*Aircraft Concepts Manager, Naval Air Systems Command, Washington, D.C., U.S.A.

**Past President, All American Engineering Co., Wilmington, Delaware, U.S.A.

This performance gap arises from the impact of the "square-cube law" as aircraft size increases, and the relative inability of helicopter technology advances to compensate for its effects. The helicopter presents a more difficult, constrained, design problem than the fixed wing aircraft. The "square-cube law" states that the aerodynamic lift of an airfoil increases as the square of a basic dimension while its structural weight increases as the cube of that same dimension. Thus, the aircraft structural weight becomes an increasingly larger fraction of total aircraft weight. The application of improved materials, better design techniques, higher wing loadings and gas turbine engines to fixed wing aircraft has been very successful in compensating for the "square-cube law". The helicopter designer, while scaling up power requirements for larger rotors, finds that his transmission design torque loadings have increased at a faster rate because of the reduced rotor RPM. The rotor blade characteristics which are satisfactory for a smaller helicopter are not satisfactory for larger helicopters since the governing aerodynamic, centripetal and inertial forces do not scale similarly. Finally, there is no speed/productivity increase with larger helicopters as the maximum forward speed is limited by a fundamental aerodynamic problem, retreating blade stall.

In spite of these design trends and limitations, the helicopter is the only aircraft providing a military and commercial capability as an aerial crane. Its notable performance for these applications has not produced a widespread market because of its (1) low gross lifting capacity, (2) high acquisition and operating costs and (3) low operational reliability. It does not appear to be technically or financially feasible to achieve a VTOL lifting capability commensurate with conventional aircraft by building larger and larger helicopters. Present helicopters are inherently expensive and hard to maintain for aerial crane applications. Some departure from state-of-the-art design practice is necessary to alleviate this cost problem. Any aerial crane should have as a minimum design goal the operational reliability of commercial fixed wing aircraft. Achieving this goal for conventional helicopters does not appear to be technically feasible in the foreseeable future.

The Aerocrane is a hybrid Lighter Than Air (LTA) aircraft composed of balloon and helicopter elements which conceptually addresses each of the enumerated helicopter deficiencies. (As with any new idea or concept, its reduction to practice may produce other, more substantial deficiencies as yet undisclosed.). The basic concept is to integrate the controllable thrust vector of a rotary wing system with the brute lifting capability of a heavy lift balloon to transcend projected useful load limits of practical helicopters. Applied to the Aerocrane design, aerostatic lift supports two-thirds of the aircraft design takeoff weight, i.e., the full structural weight and up to 50% of the design sling load, while aerodynamic lift only supports the remaining 50% of the sling load.

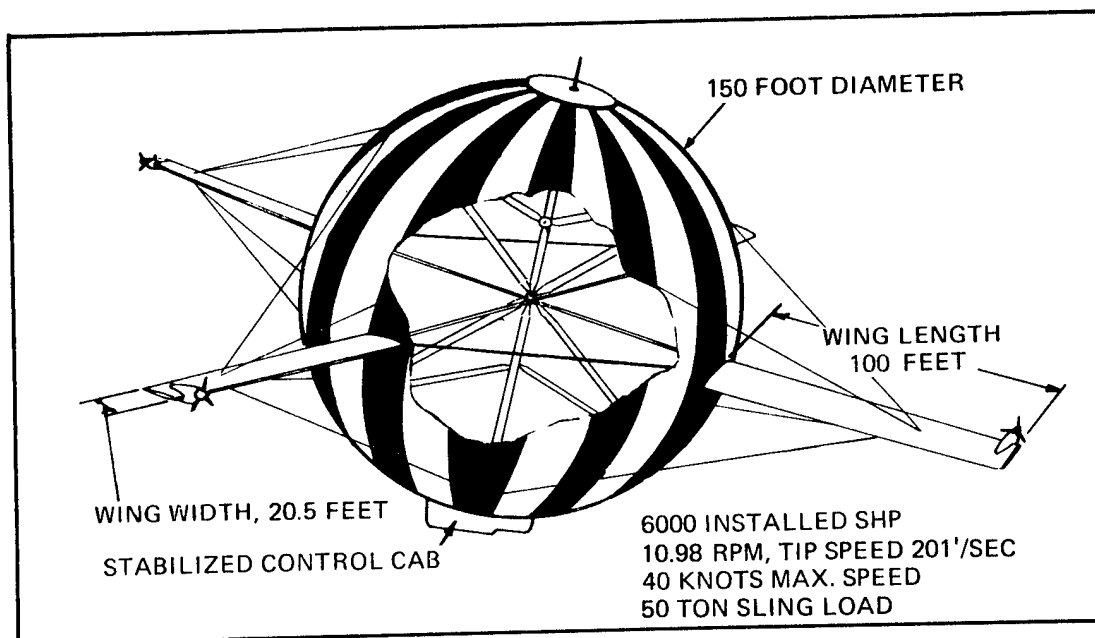

Figure 2. Aerocrane

AEROCRANE

The Aerocrane concept is characterized by wings attached to a large rotating central spheroid containing helium (Figure 2). Vectoring the aerodynamic thrust by collective and cyclic variation of wing angles of attack provides all propulsive and maneuvering forces in a manner directly analogous to a helicopter rotor system.

Since the Aerocrane wings are very lightly loaded (about 6.6 lbs/sq. ft. of wing area) and operate at low tip speeds (about 200 ft./sec.), centrifugal forces are not a significant factor in the structural support of the wings. These low forces allow tip propulsion eliminating the main transmission of a conventional helicopter. Because of the low tip speed, a braced wing structure may be used without a large power penalty, and the large centerbody provides space for a deep cabane section without an additional aerodynamic penalty. The internal cabane structure and wire bracing are arranged to support the wings in the vertical, axial and equatorial directions. This bracing system alleviates wing root in-plane and vertical bending moments. The central structure is principally composed of pin-ended compression and tension members. In addition to transferring loads between wings and sling load, the center structure provides focal points for transferring aerostatic lift.

Wing construction is anticipated to follow fixed wing rather than helicopter rotor design practice. Engines and propellers are mounted conventionally on the wing spar with additional structural support to resist centrifugal and gyroscopic forces. Fuel supply lines, hydraulic and electrical lines, control and instrumentation signals must pass from the wing into the center section thru a flexible joint.

The control cab and sling load are attached at the bottom of the centerbody and are isolated from rotation by low friction bearings and a retrograde drive system, either mechanical or aerodynamic.

Construction of the helium containing envelope follows the practice used by Goodyear for their blimps. A single gas containment envelope is used without partitions. A ballonnet system to provide internal pressure adjustments for ambient changes is located in the lower portion of the centerbody. An emergency helium valve is also provided to assure against critical over-pressure and allow free balloon control, if necessary.

The control system governs collective and cyclic wing angle of attack variation and is the most sophisticated component of the Aerocrane. Hydraulic actuation of wing root, pitch horns is contemplated for setting collective pitch. Cyclic pitch will be controlled by aerodynamic flap adjustments near the wing tip. This dual wing angle of attack control system also allows for a torsionally flexible wing (if feasible) introducing an ideal wing twist distribution. An electronic or electromechanical equivalent of a helicopter swash plate system will be located in the control cab feeding control signals to the hydraulic actuators. Some form of automatic gust sensing and load relief may be required. Standard aircraft practice for control reliability will be used in the control system design.

Lift Distribution

The required distribution between aerodynamic and aerostatic lift is governed by two design conditions resulting from the Aerocrane's concept of flight. During loaded flight the wings generate positive thrust to supplement the aerostatic lift thus supporting the total aircraft weight. In the unloaded condition the wings provide a downward aerodynamic thrust to compensate for an excess of aerostatic lift. Dual modes of flight are possible because of the geometric symmetry inherent in the Aerocrane design. Assuming equivalent aerodynamic thrust requirements for loaded and unloaded flight, the following relationships apply.

$$\text{Loaded Condition: } W_F + W_P + W_E = L_B + L_W \quad (1)$$

$$\text{Unloaded Conditions: } W_F + W_E = L_B - L_W \quad (2)$$

where

W_F = Fuel weight

W_E = Aircraft operating weight empty

W_P = Payload weight

L_B = Aerostatic Lift

L_W = Net aerodynamic lift

Solving these expressions, we find that:

$$L_W = W_p/2 \text{ and} \quad (3)$$

$$L_B = W_F + W_E + W_p/2 \quad (4)$$

The net aerodynamic lift equals 50% of the design sling load weight. In addition, aerodynamic thrust must be provided for translation and control power demands. The aerostatic lift supports the entire aircraft operating weight, fuel and 50% of the design sling load. Estimates of aircraft structural weight for hypothetical Aerocrane designs indicate operating aircraft empty weight fractions between .31 and .34. For these values the aerostatic lift supports approximately 67% of aircraft takeoff gross weight and aerodynamic lift 33%. It is worthwhile to note that this hybrid aircraft allows a modulation in total lifting capacity of around 66% of design takeoff gross weight. This very substantial capability is achieved without requiring a large installed power or ballast transfer.

Wing or Rotor Characteristics

The aerodynamic performance of the Aerocrane follows directly from the selection of rotor parameters. These characteristics are projected for a hypothetical 55-ton useful load Aerocrane (50-ton sling load and 5 tons of fuel).

Disk loading, $DL = .688$

Solidity, $\sigma = .149$

Maximum design tip speed, $VT = 200 \text{ ft./sec.}$

Blade loading, $BL = 6.59$

Balloon radius ratio, $\chi_1 = .43$

The first and most significant parameter is disk loading. By examining disk loading of any actuator disk such as a rotor, one can immediately determine its ideal lifting efficiency - i.e. pounds of thrust per unit of power required. From classical momentum theory, the following expression relates lift efficiency to disk loading for a free rotor.

$$\frac{T}{RHP} = \frac{550}{\sqrt{\frac{DL}{2\rho}}} \quad (5)$$

where

T = Rotor thrust

RHP = Rotor power required

ρ = Ambient air density

DL = Disk loading, thrust per unit disk area

Comparing an Aerocrane with a disk loading of .7 to a large helicopter with a disk loading of 10, we see that the Aerocrane can ideally produce 45.3 lbs. of thrust per rotor horsepower compared to 12 lbs./rhp for the helicopter. Large helicopter rotors are designed to less efficient, higher disk loadings because of several design considerations and constraints not applicable to Aerocranes. As helicopter disk loading decreases for a constant tip speed, transmission weight, rotor blade weight and rotor profile drag all increase substantially. Practical design considerations such as sufficient rotor kinetic energy for entry into autorotation, coning angle constraints and further transmission weight growth place a lower limit on helicopter tip speeds. The Aerocrane, on the other hand, with no main transmission and externally braced wings achieves good rotor performance at its low disk loadings only because of a concurrent reduction in rotor tip speeds. Thus, a high blade mean lift coefficient is maintained, and profile drag is only a small fraction of the induced drag.

The interplay among Aerocrane rotor design variables is best examined by developing an expression for the Aerocrane rotor figure of merit, M, analogous to a conventional rotor figure of merit. This is easily accomplished following the conventional rotor analysis contained in reference (1). Using conventional blade element theory and assuming an ideally twisted rotor, a uniform induced rotor velocity, v, hover flight, a constant blade profile drag coefficient and no blade taper; an expression for rotor blade element thrust may be derived. Integrating that expression over each blade from balloon surface to blade tip results in the following equation for rotor thrust.

$$T = \frac{1}{2} \rho \Omega^2 R^3 a \left[\theta_T - \frac{v}{\Omega R} \right] bc R (1 - \chi_1^2) \quad (6)$$

where

Ω = Rotor rotational velocity

R = Total rotor radius

a = Rotor blade lift curve slope

θ_T = Blade tip angle of attack

v = Induced inflow velocity across a blade element

b = Number of blades

c = Blade chord

χ_1 = Balloon radius r_B divided by R

ρ = Ambient air density

Defining the rotor thrust coefficient, C_T , in the conventional fashion based upon an annulus of a disk,

$$C_T = \frac{T}{\rho \pi R^2 (1 - \chi_1^2) \Omega^2 R^2} \quad (7)$$

and defining rotor solidity, σ , as the projected blade area (including balloon cutout) divided by the total disk area (including balloon cutout),

$$\sigma = \frac{bcR}{\pi R^2} \quad (8)$$

the classic expression for the thrust coefficient of a conventional rotor results.

$$C_T = \frac{\sigma}{4} a [\theta_T - \lambda] \quad (9)$$

where

$\lambda = \frac{v}{\Omega R}$ = rotor inflow ratio

others as defined previously

Similarly, an expression for rotor torque coefficient, C_Q , may be derived composed of induced power and profile power terms.

$$C_Q = \frac{Q}{\rho \pi R^2 (\Omega R)^2 R (1 - \chi_1^2)} \quad (10)$$

$$= \frac{\sigma}{8} C_{D_0} (1 + \chi_1^2) + \lambda C_T$$

where

C_{D_0} = Mean blade profile drag coefficient

others as defined previously

Now, assuming that momentum theory is valid for the Aerocrane rotor annulus,

$$T = 2\rho \pi R^2 (1 - \chi_1^2) v^2 \quad (11)$$

combining equations (7), (11) and the definition of rotor inflow ratio, λ leads to:

$$\lambda = \sqrt{\frac{C_T}{2}} \quad (12)$$

Thus,

$$C_Q = \frac{\sigma}{8} C_{D_0} (1 + \chi_1^2) + \frac{C_T^{3/2}}{\sqrt{2}} \quad (13)$$

To these conventional terms an allowance for the sphere's effects on rotor thrust and torque required must be added. The sphere may cause an increase in rotor power required to produce a given rotor thrust because of energy lost to frictional drag of the sphere acting on the airstream inflow velocity. On the other hand, the presence of the centerbody which eliminates conventional rotor recirculation at the center may exhibit a favorable pressure gradient across its surface adding to the rotor thrust. As the induced velocity is quite low for Aerocrane disk loadings and the centerbody radius unusually large compared to the rotor radius, it will be assumed that these two effects cancel. A second source of wasted power is the sphere frictional drag acting on the tangential velocity component at the sphere's surface in the plane of rotation. As the sphere skin speeds near its equator are considerably higher than the inflow velocities, this term may not be negligible. The torque required for this frictional drag may be derived by computing the elemental torque for an infinitesimal area on the surface of the sphere and integrating over the sphere's surface. This leads to:

$$Q = 1.178\rho(\Omega r_B)^2 \tau_s \pi r_B^3 \quad (14)$$

where

τ_s = local sphere skin friction drag coefficient

r_B = Centerbody radius

Combining equation (14) with the definition for Aerocrane torque coefficient leads to an expression for the torque coefficient due to sphere drag.

$$C_{Qsf} = 1.178 \frac{\chi_1^5}{(1 - \chi_1^2)} \tau_s \quad (15)$$

The Aerocrane's hover figure of merit, M , may be defined conventionally by dividing the induced rotor power required by the total power required, or in torque coefficient form,

$$M = \frac{\frac{C_T^{3/2}}{\sqrt{2}}}{\frac{C_T^{3/2}}{\sqrt{2}} + \frac{\sigma C_{DQ}}{8} (1 + \chi_1^2) + 1.178 \frac{\chi_1^5}{(1 - \chi_1^2)} \tau_s} \quad (16)$$

(Reference (2) presents an alternate development for the Aerocrane figure of merit based upon different assumptions about the centerbody's influence on the rotor.)

To examine the influence of tip speed selection, it is necessary to derive an expression for C_T in terms of σ and a blade mean lift coefficient, $\overline{C_L}$. By definition, $\overline{C_L}$ is defined from:

$$T = \overline{C_L} \int_{r_1}^R bc \frac{1}{2} \rho (\Omega r)^2 dr \quad (17)$$

Solving and substituting in equation (7) gives:

$$C_T = \frac{\overline{C_L}}{6} \sigma \frac{(1 + \chi_1 + \chi_1^2)}{(1 + \chi_1)} \quad (18)$$

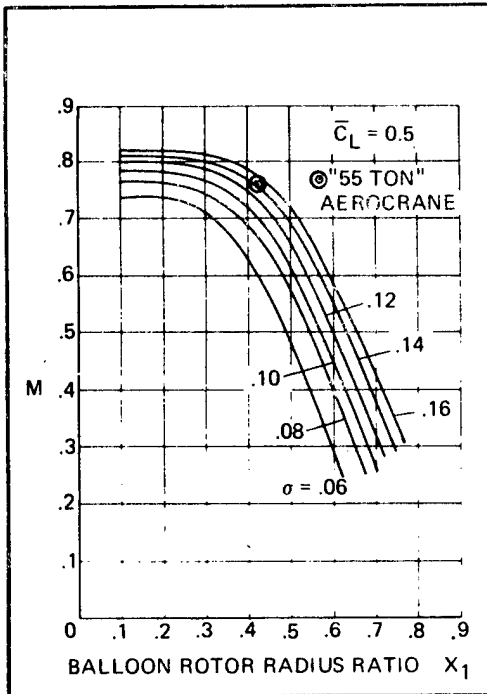

FIGURE 3.
M vs Balloon Rotor Radius Ratio

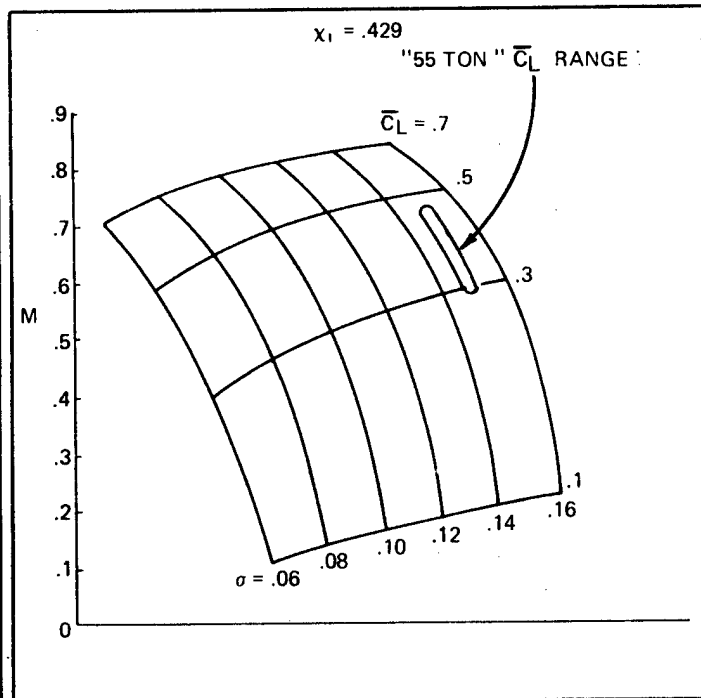

FIGURE 4. M vs Solidity and \bar{C}_L

Figure 3 plots M against balloon/rotor radius ratio for several values of rotor solidity for a constant \bar{C}_L . Rotor performance falls off drastically for values of χ_1 greater than .5.

Figure 4 is a carpet plot of M against rotor blade mean lift coefficient and solidity. Here we see the expected result that minimizing M profile drag maximizes rotor efficiency. For a constant thrust, χ_1 , and disk loading, higher lift coefficients combined with higher solidities produce higher figures of merit. This amounts to nothing more than maximizing rotor thrust coefficient by reducing tip speeds to maintain a constant thrust. Note that the Aerocrane may operate in hover over a substantial range of values for \bar{C}_L by reducing rotor tip speed below the forward flight condition.

On each figure, the design point for a 55-ton useful load Aerocrane is indicated. Initially, the selection of Aerocrane solidity may seem unduly high compared to a helicopter rotor. Modern helicopter rotors will have solidities between .06 and .09. If the Aerocrane solidity is corrected for the inclusion of the balloon cutout, then:

$$\sigma' = \frac{\sigma}{(1 + \chi_1)} \quad (19)$$

For a defined solidity of .149, an actual blade solidity (by conventional rotor definition) of .104 results. This value is still high for a rotor which operates at an advance ratio, μ , less than .35. A partial explanation is the impact of the relatively large balloon drag and substantial aerostatic lift on the relationship between forward thrust and vertical thrust requirements; and, thus, different solidity requirements for a given advance ratio.

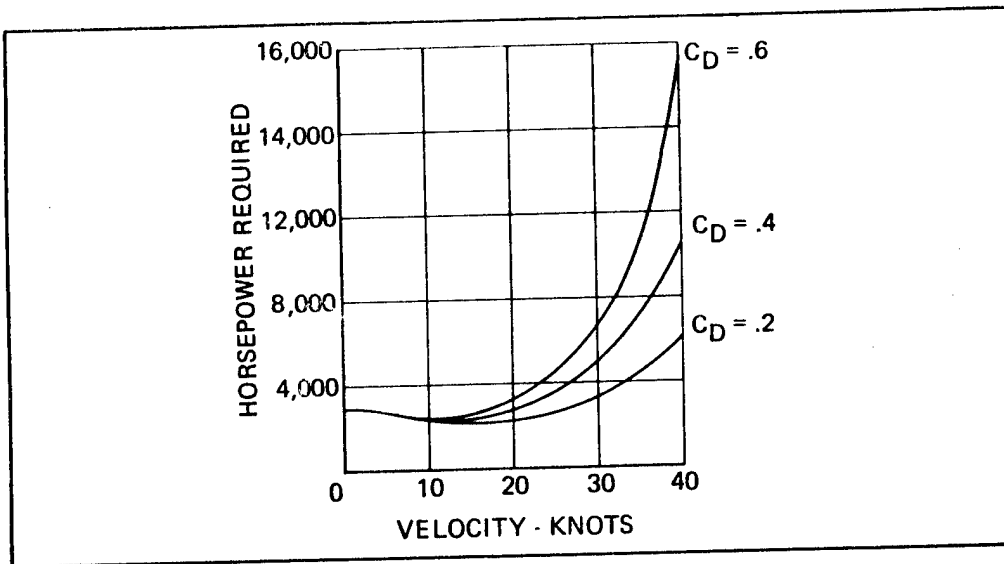

FIGURE 5. Installed Horsepower Required

Forward Flight Performance

The Aerocrane is, of course, an inherently low speed aircraft as its translational speed capabilities are constrained by the high drag of its balloon centerbody. Power requirements of a 55 ton useful load Aerocrane are shown in Figure 5 for hover and translational flight assuming several values for centerbody drag coefficient. Design conditions for this graph are discussed in a later section of this paper. It is clear from the graph that a substantial imbalance between hover power and translational power requirements exist for reasonable assumed values of sphere lift and drag at forward speeds greater than 35 knots. This power imbalance reduces as aircraft size increases because of "square-cube law" effects.

Aerocrane Blade Environment

Rotor blade design considerations and problems are substantially different from helicopter rotor design experience. Aerocrane wings (or blades) operate in a much more benign aerodynamic and centrifugal forces does not achieving a critical balance between rapidly varying, large aerodynamic and centrifugal forces does not dominate the design problem. A first major difference is in rates of cyclic pitch change accommodated by the control system. Figure 6 shows an order of magnitude difference between rates of rotor rotation and cyclic pitch variation for equal capacity aircraft. A disk loading of 10 and blade tip speed of 750 ft./sec. were assumed for the helicopter.

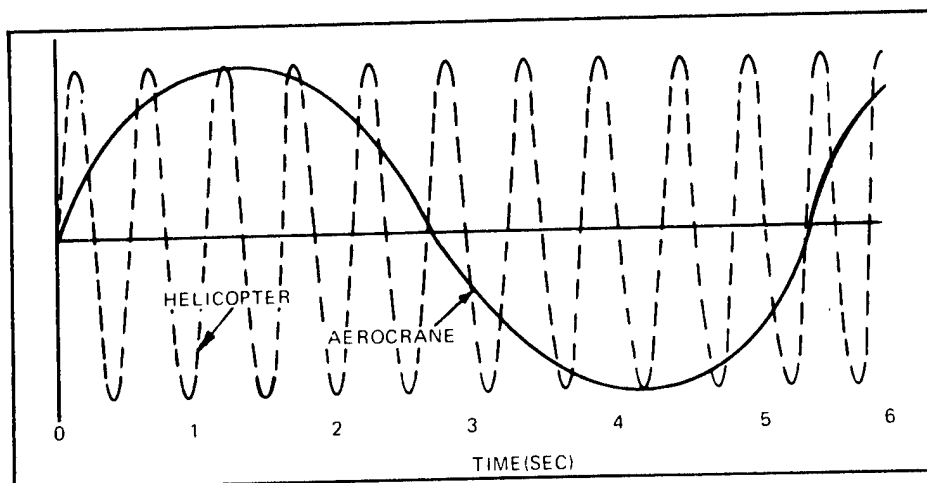

FIGURE 6. Cycles of Rotor Motion

A second major difference between helicopters and Aerocranes is in the magnitude and variation of the blade aerodynamic pressures seen by the respective blades. The tangential velocity component, V_T , seen by a blade section along the rotor is given by:

$$V_T = V_f \cos\alpha \sin\psi + \Omega r \quad (20)$$

where

- V_f = Forward flight speed
- α = Angle of rotor plane inclination with respect to free stream velocity
- ψ = Blade azimuth angle

Neglecting the effect of rotor tilt angle, the dynamic pressure, q , is given by:

$$q = \rho/2(V_f \sin\psi + \Omega r)^2 \quad (21)$$

and integrating over the appropriate rotor span and dividing by the blade length gives:

$$\text{Helicopter} \quad \bar{q} = \rho/2V_f^2 \sin^2 \psi + \rho/2V_f \sin\psi \Omega R + \rho/6(\Omega R)^2 \quad (22)$$

$$\text{Aerocrane} \quad \bar{q} = \rho/2V_f^2 \sin^2 \psi + \rho/2V_f \sin\psi \Omega R(1+\chi_1) + \rho/6(\Omega R)^2 (1+\chi_1 + \chi_1^2) \quad (23)$$

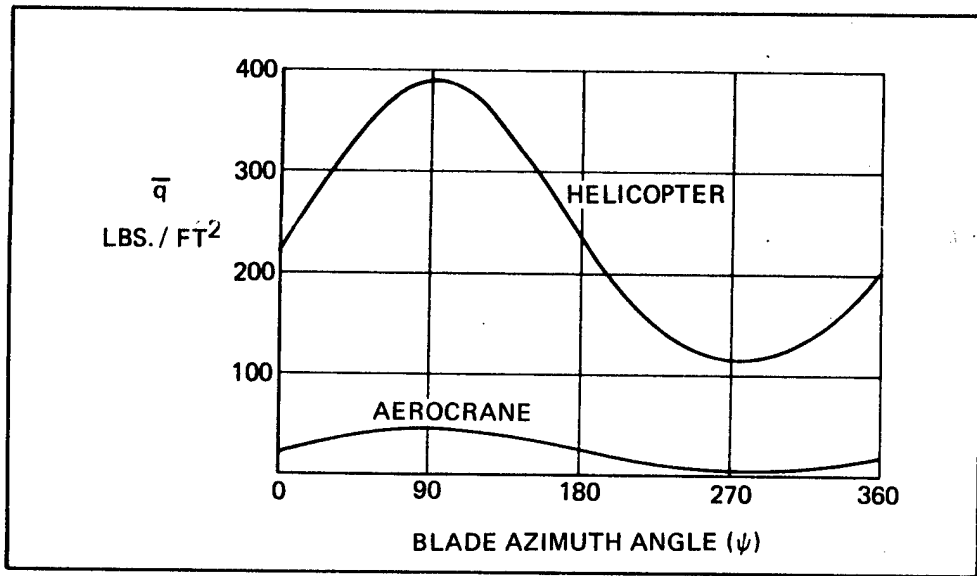

FIGURE 7. Blade Mean Dynamic Pressures

Figure 7 shows that a helicopter blade is exposed to dynamic pressures an order of magnitude greater than those experienced by an Aerocrane wing.

A third major difference between Aerocrane and helicopter blade environments is the magnitude of centripetal forces. The expression for this force, F_c , at a blade station r is:

$$F_c = mgr\Omega^2 \quad \text{or} \quad F_c/m = r\Omega^2 g \quad (24)$$

where

- g = Force of gravity
- m = Mass of rotor blade element

At the helicopter blade tip, an acceleration equal to 272 g's is experienced. At the blade tip of the Aerocrane, a force equal only to 7.1 g's is experienced.

Other differences which have a first order impact on the blade design problem are blade aspect ratio and blade root bending relief. In contrast with a helicopter rotor blade, an Aerocrane wing (or blade) has a much lower aspect ratio, and tends to exhibit greater torsional stability. Root bending moments are relieved by cable bracing. Column stability of the wing will be an important design consideration. In many respects the Aerocrane wing design problem is more comparable to standard, light aircraft fixed wing design than to helicopter blade design.

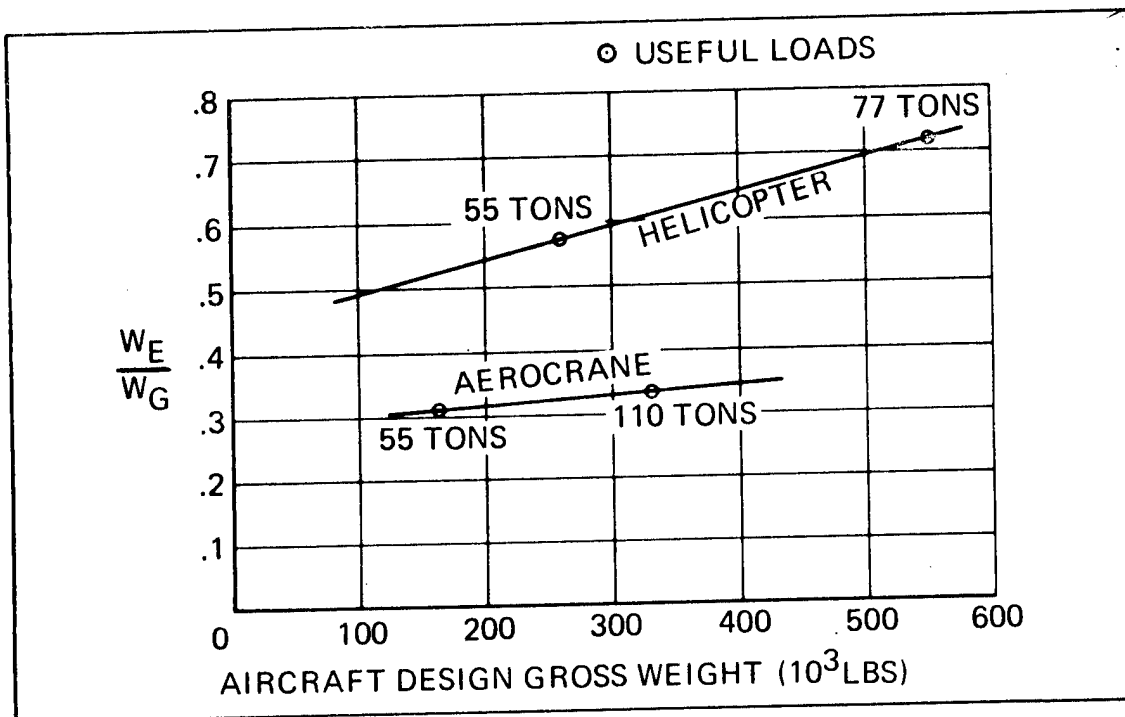

FIGURE 8. Aircraft Empty Weight Fraction

Size and Weight Comparisons Between Helicopters and Aerocranes

Although still in the first stages of preliminary design, it is worthwhile to attempt comparisons between projected Aerocranes and projections of helicopter technology. Figure 8 plots aircraft empty weight fraction as a function of design gross weight for very heavy lift helicopters and Aerocranes. It shows the Aerocrane to have a significant advantage compared to an equivalent capacity helicopter, and this advantage increases with aircraft size. The Aerocrane's very low projected empty weight fraction may seem more reasonable when one considers that 66% of the Aerocrane lift is produced by the balloon element, and existing heavy lift balloon designs exhibit empty weight fractions equal to .15 for this size. Figure 9 compares installed shaft horsepower of the point designs examined. The large installed shaft horsepower advantage shown by the Aerocrane is a direct result of its lower gross weight for a given payload, partial balloon lift and lower rotor disk loading. The Aerocrane is a substantially larger, more cumbersome aircraft than the helicopter, but as payload capability increases, the Aerocrane grows at a slower rate. The Aerocrane's centerbody is actually a dimensionally efficient lifting surface in large sizes. If its disk loading is defined as the buoyant lifting force divided by cross-sectional area, then the 55 ton useful load Aerocrane has a balloon disk loading of 5.94 lbs./sq. ft. This disk loading increases in proportion to centerbody radius.

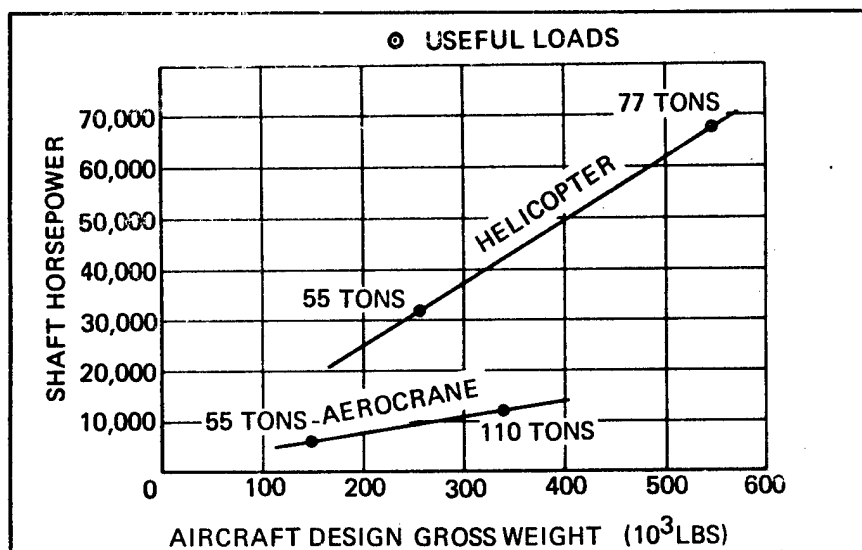

FIGURE 9. Aircraft Power Requirements

The Aerocrane weight trends were developed based upon preliminary design work completed to date. Estimates were made for a MIL STD 1371 weight breakdown format suitably modified to account for special features of Aerocranes. A design ultimate load factor of 5.25 was used. The Aerocrane's main structure is a truss with column and tension members. Column weights were estimated using the allowable compression stress for primary stability using 24 ST aluminum, and the tension members were assumed to be 1 x 19 steel aircraft cable. Weights of the wing fairing, controls and control cab were estimated by analyzing the design point Aerocrane in comparison to similar aircraft structure. Power plants and installation weights were estimated using engine manufacturer's data and fixed wing installation experience. Auxiliary equipment weights were derived from published heavy lift helicopter data. Parametric weight trends supplied by Raven Industries were used to estimate weights for the aerostatic envelope and gas management system. Installed shaft horsepower was calculated by determining rotor horsepower requirements for the forward flight design condition and assuming a propeller efficiency equal to .75.

Weight of the 110-ton useful load Aerocrane was established by applying growth factors to the 55-ton design point which was divided into three categories: (1) load bearing structure, (2) non-load bearing structure, and (3) special equipment. Load bearing structure was assumed to increase in proportion to the four-third power, non-load bearing structure increased directly and special equipment was held constant. The 110-ton projection produced an aircraft empty weight equal to 110,700 lbs. Adding 20,000 lbs. fuel, 600 lbs. crew, 120 lbs. of fluid residues and 200,000 lbs. of sling load, an aircraft gross weight equal to 231,420 lbs. and an empty weight/gross weight ratio equal to .334 results.

Helicopter empty weight trends were those discussed in reference (3). In that paper projections of future heavy lift helicopter empty weight fractions were developed based upon recent U.S. and Soviet helicopter design trends. A reasonably good check was applied to this trend by comparing the results of an advanced helicopter design study and data from the Army's HLH program. As might be anticipated, the hardware technology program came in high and the design study low. Using this trend hypothetical helicopter design points were selected. Installed shaft horsepower were calculated for the design points examined by assuming a design disk loading of 10 lbs./sq. ft., a tandem rotor configuration and a rotor figure of merit equal to .74. A transmission mechanical efficiency equal to .975 and a 4% hover download were used, and no losses were deducted for cooling and auxiliary power requirements.

Although it may be argued that the helicopter weight trend represents a far more established trend than the Aerocrane projections based upon the limited studies completed to date, it may also be argued that a more detailed understanding of the Aerocrane design will allow better definition of design loading conditions, more optimal selection of aircraft configuration parameters and a subsequent reduction in aircraft weight. In this paper, it is assumed that these considerations mutually cancel.

The significance of Figures 8 and 9 is that (1) the Aerocrane concept allows much larger capacity aircraft to be built than our present and foreseeable helicopter technology base, and (2) for equal capacity, the significantly lower structural weight fraction and installed shaft horsepower of the Aerocrane should imply a considerable savings in investment costs compared to an ultra heavy lift helicopter. These potential savings are discussed in reference (2).

NAVY AND MARINE CORPS APPLICATIONS

The Navy and Marine Corps anticipate growing future requirements for crane services (or vertical lift) in fleet support and amphibious assault operations. While many operational requirements for aerial lift have been established such as VERTREP and general amphibious assault support, many times the need exists to lift or transfer loads so far in excess of present aircraft capabilities that no real recognition of many situations as aerial problems has been made. If cost effective aerial cranes were available in the 100-ton range, military effectiveness would improve in many areas including transportation of special combat equipment, harbor preparation, construction of elevated causeways, combat road construction, ship repair and salvage, and submarine rescue operations. A principal application of the Aerocrane concept may be to support amphibious assaults and subsequent operations ashore. Aerocranes would be complementary to medium and heavy lift helicopter forces providing the very heavy lift capacity to complete a vertical envelopment in transporting heavy equipment critical during the different phases of operation.

In addition to the primary amphibious assault functions, the Aerocrane potentially offers effective operations in a wide variety of peacetime support missions. This includes recovery of damaged equipment, support of military construction projects, transportation of DSRV's for submarine rescue operations and mobile crane services for ship repairs.

REVIEW OF SELECTED PROBLEM AREAS

As with any new concept a particular advantage or new performance capability is easily projected. What is not as clear are the extent of technical unknowns and problems to resolve before a successful aircraft may be developed. The Aerocrane is not an exception. In this section, a number of potential problem areas are highlighted and peculiar design conditions discussed.

Presently, the most serious technical unknown is the increase in basic drag and lift of the Aerocrane centerbody due to Magnus forces. Magnus lift and drag are the result of the rotation of a body of revolution about its principal axis perpendicular to the free stream velocity. Its most serious effect on the Aerocrane concept is not the growth in thrust requirement as Magnus forces increase, but the increase in angular tilt of the Aerocrane required to produce compensating forces and the subsequent effects on rotor control moments, blade stall and other design considerations. The relationships for equilibrium flight are easily derived after construction of a free body diagram. Figure 10 is a free body diagram for an Aerocrane in equilibrium loaded flight. Summing the forces about each axis and algebraic manipulation leads to the following equations.

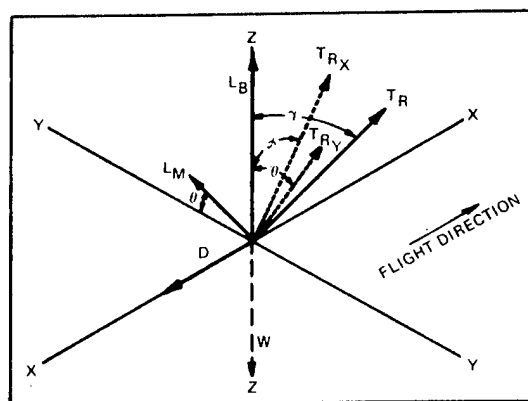

FIGURE 10. Free Body Diagram

$$\sin \gamma = \frac{\sqrt{D^2 (W \cdot L_B)^2 + L_M^2 (W \cdot L_B)^2 - L_M^4}}{\sqrt{(W \cdot L_B)^4 + (W \cdot L_B)^2 (D^2 - L_M^2)}} \quad (25)$$

where

γ = Angle of Aerocrane inclination required to compensate for Magnus lift and total Centerbody Drag

L_B = Aerostatic lift

L_M = Magnus lift

D = Total Centerbody Drag

W = Total aircraft weight

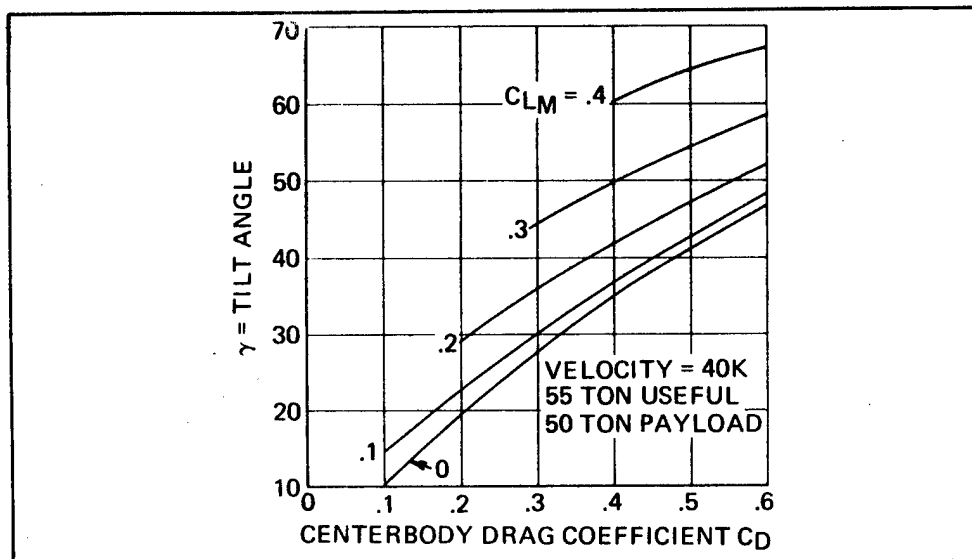

FIGURE 11. Aerocrane Skew Angle

Figure 11 plots total angular tilt as a function of assumed centerbody lift, C_{LM} , and drag coefficients for a 40 knot design cruise speed. Practical aircraft designs must demonstrate lift and drag coefficients permitting reasonable skew angles for the forward flight design conditions.

A literature survey has not produced experimental data appropriate to the Aerocrane problem. The closest experiments involved small, rotating spheres in a high speed flow. Here, sphere lift and drag coefficients as high as $C_{LM} = .4$ and $C_D = .6$ were measured for some values of sphere equatorial surface and free stream velocity ratios.

However, the applicability of this data to the Aerocrane problem is highly questionable for several reasons. First, the experiments were run at sub-critical Reynold's numbers, below that Reynold's number where a sharp drop in non-rotating sphere drag coefficient occurs. Second, the effects of inclination of the rotational axis into the free stream were not examined. All recorded data is for the perpendicular condition. Finally, the effect of the rotor on the airflow around the sphere is unknown.

A second technical unknown is the influence of the centerbody turbulent wake during forward flight on the rotating wings as they pass behind the sphere. This wake may represent only another structural loading to be considered in the design of the wing or it might produce a complex interaction effecting wing angle of attack variation, and hence, control system design and aircraft flying qualities.

A third area requiring extensive investigation to establish concept feasibility are the dynamics of aircraft motion. In the case where the control cab is attached to the centerbody surface, the rotor is separated a substantial distance from the control cab. Thus, unusual cab motions arising from rotor tilt to compensate for gusts or similar disturbances may confuse the pilot. In the unloaded condition rotor compensation for a gust disturbance causes the cab to translate against the direction of the disturbance - a stabilizing effect. However, in the loaded condition, tilting the rotor for gust compensation initially causes the cab to

translate in the direction of the disturbance - an undesirable, destabilizing effect. When maneuvering a load before release, the pilot will be queing on the motion of the load and an analysis of the total aircraft-payload system including the effects of payload pendular motion is necessary. If a significant problem exists, suspending the load and cab nearer to the sphere's center may be a viable alternative.

In addition to the previously mentioned major technical concerns, there are a number of peculiar design conditions not known to be previously encountered in aircraft design. Some of these are:

1. Exposure of the engines and propellers to continuous centripetal and gyroscopic forces.
2. The propellers located near the wing tips will have an unsteady flow field as a design condition.
3. A dual mode flight control system is required for loaded and unloaded flight.
4. Aerostatic forces must be integrated into a central rigid structure which supports aerodynamic and payload forces.

Operational Considerations

The Aerocrane exhibits to a lesser extent all of the size and inertia disadvantages of airships. Large aerodynamic forces will be generated by changes in ambient wind conditions. With an installed vectorable thrust at least equal to 34% of aircraft weight, substantial maneuvering forces in any direction may be generated to compensate for wind gusts and to accelerate and decelerate the Aerocrane. Accelerations will be faster than an airship, vectorable, but slower than a helicopter. Mooring may be accomplished anywhere a fixed attachment point to the ground is available. This simple mooring arrangement is in sharp contrast to the elaborate needs of the normal airship.

The Aerocrane's peculiar design will require many unusual maintenance features. Most important is access to the engine and wing flight controls. This will require special access routes within the wing and balloon structure. Electric winches must be integral to the wing design to allow an engine change without requiring a ground crane.

CONCLUSIONS

The Aerocrane concept offers a potential for order of magnitude improvements in maximum VTOL lift capacity and reduced acquisition costs compared to an equivalent lift helicopter. The mechanism which allows this is the partial substitution of low cost, heavy lift balloon technology for high cost, rotor technology. The penalties are the reduced forward speed envelope and the reduction of the excellent flying qualities of the helicopter. Operating weight empty fractions between .31 and .35 are estimated for Aerocranes compared to between .57 and .72 for very heavy lift helicopters. The Aerocrane's design simplicity, benign flight environment and potential for rugged construction because of a relaxed emphasis on minimizing structural weight fraction may result in a substantial improvement in aircraft operational availability. Principal areas of uncertainty to be addressed in a development program are aircraft stability and control characteristics, adequacy of forward speed capability and modes of operation considering its airship-size bulk and gust sensitivity.

These considerations clearly limit the normal missions of the Aerocrane to short range, high load/unload cycle requirements where loads are in excess of helicopter capabilities. In rare cases of heavy equipment transport, where high surface transportation costs are coupled with a need for controlled delivery to a construction site, the Aerocrane might find an area for service. Thus, the Aerocrane does not compete directly with either helicopters or future airships as the Aerocrane concept does not scale down to helicopter load size nor can the Aerocrane offer efficient long range service comparable to the airship. However, within the operational spectrum of the Aerocrane lies a significant area of use where lighter-than-air technology may be of service.

REFERENCES:

1. Gessow, A. and Myers, G.C., Aerodynamics of the Helicopter, Frederick Ungar Publishing Company, New York (1967).
2. Nichols, J.B. and Doolittle, D.B., Hybrid Aircraft For Heavy Lift, American Helicopter Society, New York (1974). Preprint No. 814, 30th Annual National Forum.
3. Carson, B.H., An Economic Comparison of Three Heavy Lift Airborne Systems, Proceedings of Lighter Than Air Workshop, Monterey, California (September 1974).

N76-15064

UNMANNED POWERED BALLOONS

Arthur O. Korn*

ABSTRACT: In the late 1960's several governmental agencies sponsored efforts to develop unmanned, powered balloon systems for scientific experimentation and military operations. Some of the programs resulted in hardware and limited flight tests; others, to date, have not progressed beyond the paper study stage. This paper briefly describes the balloon system designs, materials, propulsion units and capabilities, and points out critical problem areas that require further study in order to achieve operational powered balloon systems capable of long duration flight at high altitudes.

HISTORY

The early balloons would only go up and down or float in the direction of the prevailing winds. In order to make the balloon more useful it was soon concluded that it should be "dirigible" or directable. Throughout the nineteenth century ingenious men such as Meusnier, Giffard, Tissandier, Renard and Krebs worked on this problem. They built manned airships shaped as spindles, torpedos, cigars, stringbeans and even whales. Their biggest problem was the lack of a lightweight, efficient power plant. The steam engine, while dependable, was very heavy. In 1852, Giffard built a small engine using steam, but it weighed 100 lb per HP. (Today's automobile engines weigh as little as 2 lb per HP, and airplane engines, less than 1 lb per HP.) Those early inventors experimented with feather-bladed oars and screw propellers turned by hand using a crew of eight men! Engines were built

*Aerospace Engineer, AFCL, Hanscom AFB, Bedford, Massachusetts, USA

that used coal gas or hydrogen lifting gas from the airship. In 1884, Renard built an electric motor powered from a storage battery. Real progress in powered balloons had to wait for the invention of the internal combustion engine. In the 1890's the gasoline engine proved to be the long sought key to the (low altitude) propulsion problem. In 1901, Santos Dumont won the 100,000 franc prize for flying across Paris to circle the Eiffel Tower and return to his starting point. In the early 1900's Count Zeppelin started to develop big ships in Germany. The airship Clement Bayard II flew the English Channel in 1910 and made a 242-mile trip to London in 6 hours. Great progress continued throughout World War I into the 1930's. The blimp proved its usefulness during World Wars I and II. All of these airships flew at very low altitudes.

I will not dwell on blimps and zeppelins, since they are well recalled, but will now skip to the late 1960's when several U.S. Government agencies sponsored efforts with private industry to develop unmanned powered balloon systems for scientific experimentation and military operations. Some of the programs resulted in hardware and limited flight tests; others generated system designs and concepts that, to date, have not progressed beyond the paperwork stage. This paper gives an overview of these various programs.

BACKGROUND

For many years balloon flight managers have been minimizing the horizontal displacement of free balloons by preselecting the float altitude where the winds are known to be near minimum, monitoring the trajectory and correcting the drift by ballasting or valving to nearby altitudes where the wind will drive the balloon in the proper direction. This technique is based upon the seasonal atmospheric phenomenon illustrated in Figure 1. The westerly winds above easterly winds result in a transition level where the winds are essentially zero. Just above and below this level are bands of altitude where the winds are less than 10 knots. It was reasoned that if some small amount of propulsion could be added to a free balloon, the station-keeping capability and flight duration in the minimum wind fields could be greatly enhanced. With some margin in available thrust, such a powered balloon is not limited to stationkeeping, of course, but can travel in any direction.

HIGH ALTITUDE FLIGHTS

High Platform I (HPI) was one of the earliest attempts at powering a balloon at high altitude. It was developed and flown by Goodyear Aerospace Corp. and Winzen Research, Inc. In Figure 2 the system is shown being launched. The program objectives were (1) to demonstrate that it is feasible to maintain a free balloon on station at high altitude using an electrically driven propeller; (2) to examine the accuracy and output of a simple, single-axis-oriented silicon solar array for application as the eventual primary power source. The program was limited in scope in that off-the-shelf hardware was required for all systems. This requirement necessitated using a natural-shaped balloon, which has an undesirably high coefficient of drag. Because of the high drag force the flight test was planned during a period of minimum upper atmosphere winds. The design goals were: (1) float altitude, 70,000 ft; (2) maximum airspeed, 10 knots; (3) maximum deviation from station +50 miles. Flight duration was dependent on battery life. The balloon had a volume of 106,000 cu ft and was 63 ft in

diameter. A 2.75 HP motor drove a 14-ft diameter propeller with power from 112 lbs of silver zinc batteries. The goal was to control balloon orientation and heading at an airspeed of 10 knots by remote control of a styrofoam rudder in the propeller slipstream. The wooden propeller was designed to provide 25 lb thrust at 1000 RPM. Total system weight was 555 lb of which 106 lb was balloon. HPI was launched in the early morning and ascended at nearly 1000 ft/min. On its first power cycle the motor was run for 31 minutes. Directional response to rudder commands was good with no evidence of instability, but time delay between command and rudder actuation, the rate of rudder movement, and the time required to calculate and verify the actual heading resulted in a rather erratic flight path. During the second power cycle the rudder control was erratic. Rudder response then disappeared and recovery procedures were initiated. The direct current motor, when recovered, was severely charred and showed evidence of brush arcing. During the first 30 minute power cycle the system did demonstrate the capability to fly into the wind at an airspeed in excess of 10 knots, and to change the direction of the flight path. The sun sensor consistently tracked the sun accurately enough to estimate the maximum output of the solar array. The results show that an electrically driven propeller is a feasible method of station-keeping a high altitude balloon.

The High Platform II program (HPII) began in early 1969. This effort was conducted by Raven Industries. The statement of work called for the development of a unique airship having a capability of operating for very extended durations at an altitude of 70,000 ft. The flight system is shown in Figure 3. A completely sealed superpressure balloon was required to provide a duration capability of greater than 6 months. Desired speed capability was 20 knots. The motor-propeller assembly was powered by solar cells. A 3/1 fineness ratio, Class C hull configuration was used on HPII because of its greatly reduced coefficient of drag compared with HPI. The envelope was constructed of a bi-laminate of 1.0 mil and 0.35 mil Mylar S and was 81 ft in length. Control surfaces on the hull included one vertical, stationary fin, one rudder, two horizontal stabilizers and two elevators. Rudder and elevators were servo motor controlled. The lightened molded foam propeller, 10 ft in diameter, was designed to operate at 360 RPM with an efficiency of 78%. Propulsion motor characteristics were: 0.25 brake HP at 8200 RPM with an input of 24 VDC; predicted efficiency, 72%. A belt speed reducer dropped the motor speed to the desired 260 RPM of the propeller. The power supply was a 300 watt CdS solar array of 13 panels. CdS cells were chosen over silicon because of their greater flexibility and lighter weight. The gondola supported the mechanical components of the propulsion system and an anemometer was suspended beneath the gondola. The airship gross weight was 136 lb.

In May, 1970, the airship was test flown. The tow balloon launch technique was used to better control the very fragile system. When the motor was turned on, the airship immediately swung into the selected heading. The system rose in altitude, indicative of a positive angle of attack and forward speed which provided the airship with some aerodynamic lift. After 76 minutes the motor was turned off. Reflected light falling on the solar cell array prevented further acquisition of accurate heading data. The experimenters concluded that the airspeed was 10 knots rather than 17 knots, and that the reduction in speed was due to too low a design value for drag coefficient ($C_d = 0.11$ rather than the design value, $C_d = 0.045$, which was based upon wind tunnel data), and mismatch between the solar cell array and propulsion

system. They further concluded that a high altitude airship having a superpressure envelope to obtain extremely long duration flight, and thin film solar cells for power can be designed, constructed, successfully launched and remotely controlled.

POBAL (Powered Balloon) was an unclassified program started in 1969 by AFCRL with Goodyear Aerospace Corp. under contract to study feasibility of stationkeeping by remote control of a powered balloon at high altitudes. Both streamlined and natural shaped balloon configurations were considered, with reciprocating engines, turbines and electric motors as candidates for propulsion, and fuel cells, solar cells and batteries for electric power sources. As a result of this study an inexpensive system was designed for flight demonstration. The system built and flown by AFCRL, Figure 4, was larger, heavier and more powerful than High Platform I. For reasons of economy, the balloon, parachute system, rigging hardware and control system were off-the-shelf items currently used for conventional ballooning. A 711,000 cu ft, double wall polyethylene balloon was used on POBAL to carry nearly 4000 pounds to 60,000 ft altitude. An 8 HP DC electric motor drove a 35-ft diameter, FH-1100 helicopter rotor (through a gear reducer) at 200 RPM. Based on $C_d=0.19$, design speed capability was 15 knots, and duration, 8 hours - the life available from the residual, F-105 fighter starter batteries. (Nearly 2000 pounds of the payload were comprised of these batteries). Thrust direction was controlled by a rudder in the slip stream of the propeller. After the mission the balloon was expended and the gondola recovered by parachute.

The first flight was in September, 1972. All systems functioned for the first 43 minutes of power. The propulsion motor was then allowed to cool for 11 minutes and then another powered cycle was initiated. Various headings were commanded into the autopilot system during these powered cycles. The system also was flown via manual control of right and left rudder. After four power "on" cycles (3 hours of flight time) control of azimuth heading was no longer possible. It was then confirmed that the rudder had broken free of the payload. Subsequent examination of the failed rudder support tube indicated improper heat treatment after welding. The system did, however, attain air speeds in excess of 11 knots and demonstrated that the concept is feasible. It is felt that the design speed of 15 knots was not attained because of one or a combination of both of the following: (1) too low a design value for drag coefficient for the round balloon or (2) the propeller was not producing the calculated thrust.

LOW ALTITUDE FLIGHTS

Silent Joe I is shown in Figure 5. The balloon was a 5500 cu ft, Class C hull with a 3/1 fineness ratio developed by the Sheldahl Co. Design speed was 12 to 15 knots. The first version used two 3 HP McCulloch chain saw engines for propulsion. Steering was accomplished by varying the speed of either outboard-mounted engine. Problems were encountered in synchronization of the motor throttles and the gasoline engines were replaced with electric motors. This second version of Silent Joe I used two 2.5 HP electric motors powered by NiCd batteries for a planned flight duration of two hours. Silent Joe I was successfully flown on several occasions in Southeast Asia. It had well controlled performance at flight speeds of 10 to 12 knots.

Silent Joe II followed Joe I. Its configuration is shown in Figure 6. This program was conducted by Goodyear Aerospace Corp. and used the 150,000 cu ft Goodyear Mayflower blimp as the hull. The hull was

modified to add a propulsion unit in the stern. The propeller was driven by a hydraulic motor, pressure for which was generated from a unit in the forward end of the hull. The propulsion unit had a servo-controlled pitch and yaw gimbal system for vectoring the propeller thrust in order to achieve flight-path control. Nine flights of Silent Joe II were conducted in 1968 and 1969.

Micro Blimp was a low altitude airship program accomplished by Raven Industries. The hull was Class C shape with a 3/1 fineness ratio. The system is shown prior to launch in Figure 7. Hull volume was 2750 cu ft, and length, 37 ft. Propulsive power was provided by a stern-mounted, 4 HP Wankel engine driving an 8-ft diameter, molded polyurethane, three-bladed propeller. Directional control was obtained by gimbaling the engine-propeller assembly. Heading and pitch stability were maintained by an autopilot. Maximum cruise altitude was 5000 feet MSL and cruise speed, 30 knots. Maximum radio-controlled range was 5 miles with a control accuracy of 1500 ft. Endurance was 10 hours with a full load of fuel. Payload capacity was 20 to 50 pounds depending upon the amount of fuel carried. Many successful flights were made with the Micro Blimp. Its major problem was propeller breakage, but this was solved with propeller stiffeners.

STUDIES

Several programs generated system designs and concepts that, to date, have not progressed beyond the paperwork stage.

High Platform III, by Raven Industries, required the design of a solar-powered aerostat and the definition of a development program for a prototype system. The airship designed under the program has a volume of 600,000 cu ft. Envelope length is 309 feet and diameter, 62 feet. The airship is designed to be a constant altitude system and as such is superpressured. Nylon film is used for the hull. Fins are pressurized by a small air-compressor. Propulsion and control are accomplished by rear-mounted, gimballed propeller powered by an electric motor. The power supply is a solar array. The system is designed to be capable of maintaining airspeed of 15 knots continuously for 4 months. Flight altitude is 85,000 feet. Payload capacity is 10 pounds.

Several assumptions were made throughout the design study:

(a) A high strength nylon film will be sufficiently developed for superpressure balloons.

(b) The coefficient of drag of the airship is 0.048.

(c) Pulse charging techniques can be developed to increase the life of the battery.

(d) Cd S thin film solar cells of characteristics equal to or better than the cells used on High Platform II will be available.

If these assumptions cannot be met, changes in system size or capabilities will result. The proposed High Platform III airship is shown in Figure 8.

The HASKV (High Altitude Station Keeping Vehicle) program reviewed all past efforts in high altitude powered balloon stationkeeping. A comprehensive analysis of various system concepts was undertaken and a

preliminary design for a system was completed. Primary emphasis was placed on superpressure airships capable of flying for durations up to several months at altitudes ranging from 60,000 ft to 85,000 ft with speeds up to 30 knots. The major effort on HASKV was devoted to parametric analysis and trade-off studies of the many system components and concepts. Much valuable information was thus generated and reported upon in the HASKV Final Report. Using this information a system was designed that is similar to that proposed in the High Platform III Study. The major differences concern the construction of the balloon envelope and the use of the power cycle. The final HASKV design was for a vehicle capable of supporting a 200 lb payload at an altitude of 70,000 feet for a four-month duration. It is to be solar powered, to operate at 30-knot airspeed during the day and 10 knots during the night. This program was completed in 1973.

The AFCRL POBAL-S design effort with Raven Industries resulted in an airship very similar to the HASKV vehicle. The major difference lies in the system used to power the electric propulsion motor. You will recall that the HASKV airship is solar cell powered; POBAL-S obtains electric energy from a H_2-O_2 fuel cell. The fuel cell was selected so that more electric power, 500 watts, can be made available on a continuous basis to the user's payload. Duration is 7 days rather than 4 months for the solar-powered HASKV. Obviously, the two systems are designed for different operational missions. POBAL-S is shown in Figure 9. To summarize the capabilities of AFCRL's POBAL-S: it flies at a 70,000 ft altitude; has a payload capacity of 200 lb; continuous power of 500 watts for operation of the payload; speed capability of 16 knots continuously for a 7-day duration. The final report and drawings for the fabrication of a POBAL-S airship are due to be completed in the fall of 1974.

The U. S. Navy (NRL, NOL) HASPA (High Altitude Superpressure Powered Airship) is the largest active program in high altitude powered ballooning. HASPA is listed as a "study" only because the contract award for its development was still being negotiated at this writing. The goal is to carry a useful payload of 200 lb at 70,000 feet for durations exceeding one month. HASPA is to have a continuous speed capability of 15 knots, with maximum, shorter duration capability of 25 knots. Four flight tests are planned: (1) an unpowered flight to evaluate the launch technique and the integrity of the superpressured hull; (2) a battery powered flight to evaluate the propulsion system; (3) a fuel-cell evaluation flight; and (4) an all-up, long-duration, solar-cell powered flight. The program will take place over the next three years. The HASPA vehicle is shown in Figure 10.

SUMMARY

In the past six years much useful work has been accomplished without a great expenditure of funds. Several governmental agencies have been involved with all of the major balloon companies. The total result has not been outstanding, but, considering the very low funding and manning budget, and the magnitude of the problem, very good progress has been made toward achieving operational, long-duration, high-altitude powered balloons with usefully heavy payloads. The experimental systems that have been flown have clearly defined the remaining practical and theoretical problems to be solved. For example, future programs should spend more effort to obtain accurate drag coefficient measurements at the low Reynolds numbers encountered in the minimum wind fields. Another important area of uncertainty is the propeller

design. More basic work is required to predict accurately the propeller performance in the 60,000 to 85,000 ft altitude levels. Propellers have not normally been used at those altitudes; conventional procedures for scaling from ground level data are not adequate. We also must make use of the modern analytical tools for accurately determining the dynamic stresses in the structure and their distribution over the airship surface. If the pressurized hull volume to support a usefully heavy payload is to be kept within manageable limits without sacrificing structural reliability, then the allowable weight, strength and elastic properties of the materials are critical design parameters. It is hoped that future high altitude powered balloon programs will benefit from the experience reported herein.

REFERENCES:

1. Allen, H., (1943) The Story of the Airship (Non-Rigid), The Lakeside Press, Akron, Ohio.
 2. Goodyear Aerospace Corp., (1968) Report BB-2304, High Altitude Powered Balloon Test Program.
 3. Raven Industries, Inc., (1970), Report R-0870025, High Platform II.
 4. Raven Industries, Inc., (1971), Report 0871005, High Platform III, Design Study.
 5. Raven Industries, Inc., (1973), Report 0373003, Study of High Altitude Station Keeping Vehicles.
 6. Korn, A., Leclaire, R., 1st Lt, USAF, Rice, C., (1973), Report AFCRL-TR-73-0424, LDF Powered Balloon Program.
 7. Raven Industries, Inc., (1971), Report 1271010, Micro Blimp Final Report.
-

FIGURES:

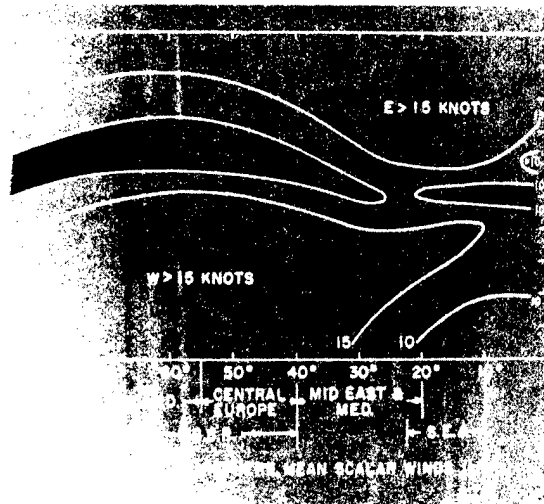
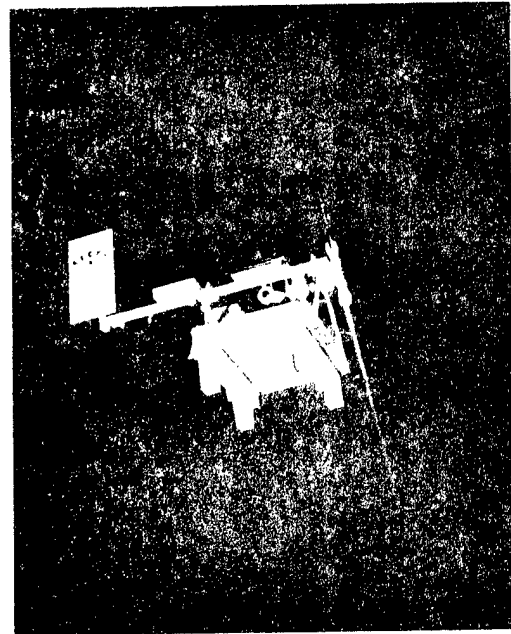
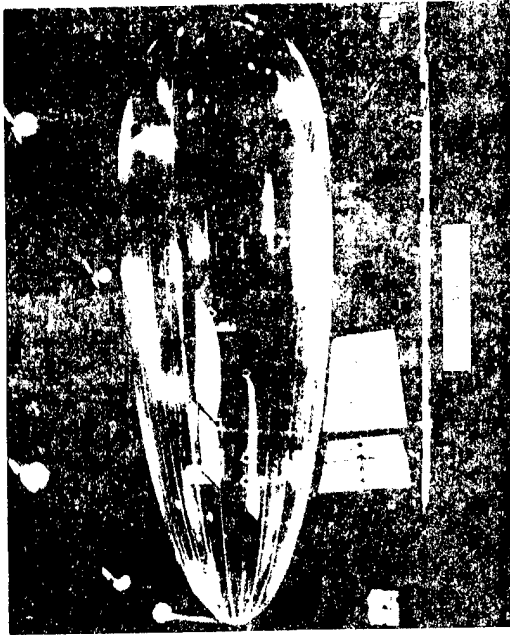

Figure 1 - Minimum Wind Field Phenomenon



HIGH PLATFORM: I

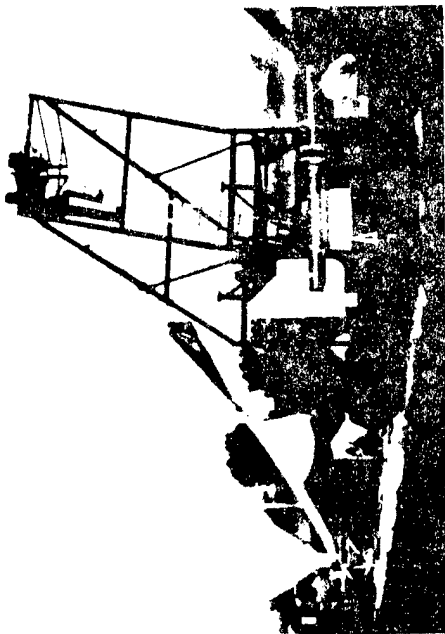

Figure 2 - High Platform I at Launch
(Above) .

Figure 3 - High Platform II During
Test (Above-right) .

Figure 4 - Pabal Undergoing Hangar
Tests (Right) .

... OF THE
ORIGINAL FACTS TO FOOT



17618

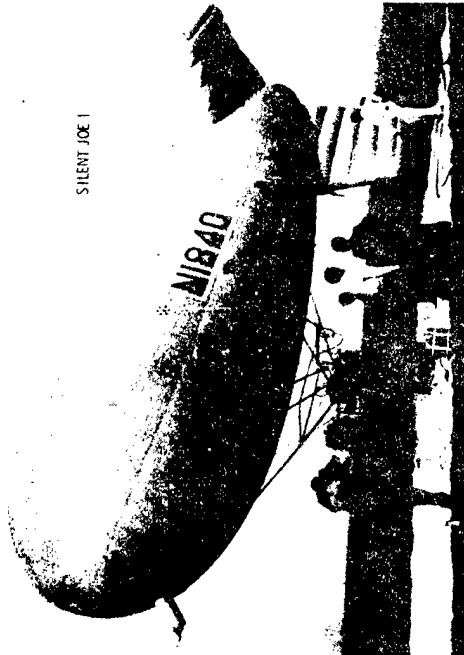

Figure 5 - Silent Joe I (Above).

Figure 6 - Silent Joe II in Flight
(Above-right).

Figure 7 - Micro Blimp at Launch
(Right).

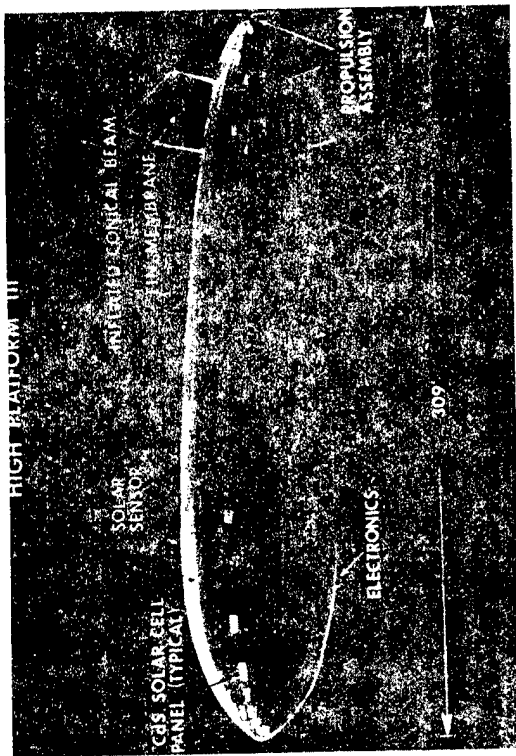
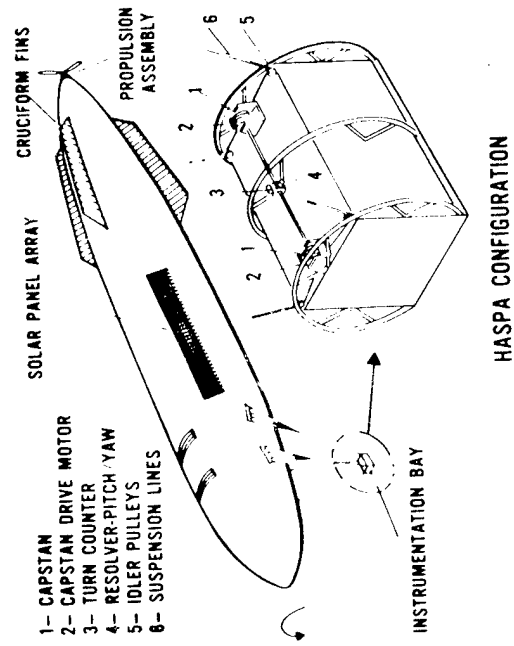
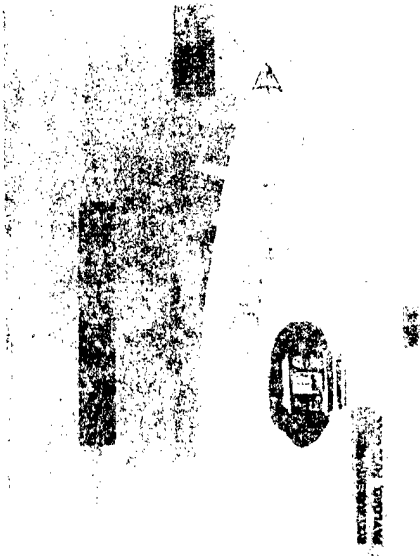

Figure 8 - High Platform III Arrangement (Above).

Figure 9 - Pobal - S Arrangement (Above-right).

Figure 10- HASPA Arrangement (Right).



SPECIAL PROBLEMS AND CAPABILITIES OF HIGH ALTITUDE LIGHTER THAN AIR VEHICLES[†]

P. R. Wessel*
F. J. Petrone**

ABSTRACT: Powered LTA vehicles have historically been limited to operations at low altitudes. Conditions exist which may enable a remotely piloted unit to be operated at an altitude near 70,000 feet. Such systems will be launched like high altitude balloons, operate like non-rigid airships, and have mission capabilities comparable to a low altitude stationary satellite. The limited lift available and the stratospheric environment impose special requirements on power systems, hull materials and payloads. Potential nonmilitary uses of the vehicle include communications relay, environmental monitoring and ship traffic control.

INTRODUCTION

The High Altitude Super pressured Powered Aerostat (HASPA) Program in which we are now engaged, will design, build, and test fly an LTA vehicle. While looking much like a conventional airship in shape and size this vehicle, designed for an operational altitude of 70,000 feet, must be unlike its low altitude counterpart in many ways. In this paper we are not as interested in describing the HASPA program as we are in initiating a discussion of the related technology with the LTA community. As a remotely piloted vehicle (RPV) embodying aspects of airships, balloons and space platforms, the HASPA development must ultimately include many diverse elements of technology.

[†]Work supported by the Naval Electronic Systems Command

*Research Physicist, Naval Ordnance Laboratory,
Silver Spring, Maryland

**Assistant Project Manager for HASPA, Naval Ordnance Laboratory,
Silver Spring, Maryland

OPERATING ALTITUDE

The operating altitude of 70,000 feet is not purely a matter of choice. One of the dominant features of the atmosphere is the existence of a minimum wind velocity near that altitude. A typical example of this minimum is shown in Figure 1.

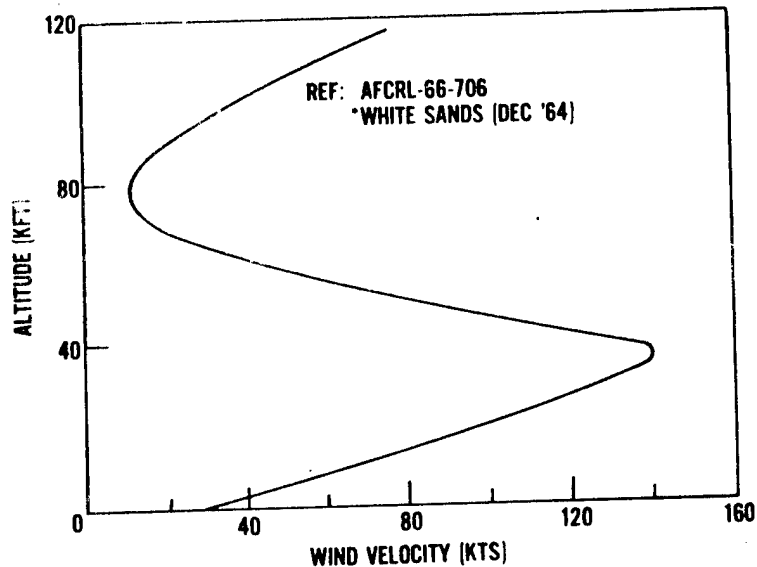

FIG. 1 TYPICAL WIND VELOCITY PROFILE

Clearly no other altitude offers a better design alternative. If, as a first approximation, drag (power consumption) and lift (power available) are both proportional to density while power consumption increases as the cube of velocity, then a minimum in the velocity/altitude curve represents an optimal point for operations. Thus we can say unequivocally that the next, and perhaps only, alternative to a conventional low altitude airship is one operating near 70,000 feet altitude. Future systems must carefully consider altitude controls to take advantage of favorable winds, even though this will exact a considerable penalty in weight and complexity.

It is purely fortuitous that the magnitude of the wind velocity remains low enough at most times so that it can be overcome by realistic system designs. Data on the distribution of wind velocities in the Northern Hemisphere at the 50 mb pressure level suggest that mean velocities in the midlatitude regions are typically 20 knots, with maximum velocities occasionally exceeding 30 knots. This condition generally persists from spring to autumn. Maximum velocities may exceed 40 knots at times for the more northerly latitudes in the winter and the equatorial regions in the summer.

Since the altitude of the minimum wind field varies as a function of latitude and season, the ability to control altitude or at least select the optimum point, would be highly desirable. The benefits to be obtained through altitude control can only be estimated from a reasonable knowledge of the temporal and spatial distribution of the high altitude wind field. Indeed, such information, which is presently very limited, is vital to the success of the entire concept.

By virtue of its influence on the operational altitude the wind pattern also affects other system characteristics, particularly volume and mode of operation. At 70,000 feet altitude the lift capability of either helium or hydrogen gas is approximately 4 lb/Mcf (pounds per thousand cubic feet). The weight of the power system needed to overcome the winds, plus the weight of controls and payload, and the vehicle weight itself combine to establish a minimum vehicle volume of approximately 1 MMcf (million cubic feet). Optimum system design requires hull materials with very high ratios of strength to specific gravity, power systems with high energy densities, and control systems and payloads using the lowest weight design approaches. It is evident that such systems must be unmanned, being unable to carry the weight of life support systems. Control systems may profitably make use of RPV technology as previously indicated.

HULL DESIGN

The hull shape will be much like that of conventional airships, enabling designers to take advantage of well established formulas for weight distribution, balance, pattern configurations, and so forth. The required hull strength and the selection of a hull fabric will be determined by many factors.

Fabric Selection

Fabric selection will be determined by environmental conditions as well as by weight, strength, and other basic parameters of the material. The usual LTA problems of fluctuations in gas temperature and deterioration of fabrics as a result of exposure to sunlight are magnified at high altitudes where thermal coupling to the atmosphere is reduced and ultraviolet radiation is increased. The hull must retain its shape and volume over appreciable changes in temperature and pressure to maintain its controllability and altitude, and of course it must not leak. Thus the ideal hull fabric should be very strong, extremely light, insensitive to extremes of temperature, impervious to ultraviolet radiation, ozone and bombardment with charged particles, have limited elasticity and no creep, and be impenetrable to helium or hydrogen. For ease of manufacture the material should be easy to cut, seam, and seal, and be readily available and cheap. In addition it should be insensitive to folding and creasing, and have a storage life of several years under the poorest of conditions. How much of each of these properties is absolutely necessary (or available) remains to be determined.

Material Strength

Fabric strength requirements are determined by two parameters, supertemperature and hull diameter. The first of these is a complex function of the absorptivity and emissivity of the hull surfaces and the radiations emanating from the earth and the sun. Rough estimates of the temperature variation experienced by the fill gas indicate that it may be of the order of 80°F, resulting in a pressure variation (P) that is 20% of ambient or approximately 0.15 psi. From this figure and the anticipated hull diameter (D) of 60 to 70 feet, the required strength (S) of the fabric is

$$S = PD/2 = 54 \text{ to } 63 \text{ lb/in} \quad (1)$$

Allowing for unequal stress loading, fabric imperfections and deterioration with time, and a reasonable safety factor increases the required strength to perhaps 150 lb/in. Analysis of other loads applied to the hull shows that they are far below this value. Effective control of the supertemperature, perhaps through application of thermal control techniques used in the space program, may allow appreciable reductions in hull strength and weight.

If we arbitrarily assume that 40% of the total system weight of 4000 pounds is hull material then the hull weight (W) alone will be 1600 pounds. Most of the fabrics considered as hull materials have densities (ρ) near 0.05 lb/in³ and the total hull area (A) will be approximately 70,000 feet². Using these numbers we can estimate the tensile strength (T) required of the hull fabric. This is obtained from:

$$T = SA\rho/W = 47,250 \text{ psi} \quad (2)$$

Fabrics of this strength, and greater, do exist. Whether or not they possess the other properties needed by the hull material is still under investigation. At the present time we are looking at the properties of many fabrics and materials. A Mylar/Kevlar combination appears particularly interesting.

Fabric Integrity and Durability

With mission durations expected to be of the order of months the hull fabric must retain its properties over a long period of time. Some stresses will be cyclic, but some will remain at all times. Hence the fabric must be able to withstand repeated stress loading and must have a high dead load strength. Resistance to creep must be unusually high. Inelastic elongation of even a few percent would cause the aerostat to become soft or limp at the low end of the temperature cycle. This would result in loss of shape and an inability to apply power or maneuver. Repeated exposure to solar radiation and extremes of temperature over the same extended time periods pose additional problems. This type of treatment is known to weaken and embrittle many materials.

The integrity required of the assembled hull is also very high. It must resist tearing or rupturing through the stresses and handling inherent in a high altitude balloon launch. Since the fabric will be much stronger than the usual balloon fabric this should be no problem. The permeability of materials like Mylar is more than adequate to limit gas losses by diffusion. Leakage is much more likely to be a problem. Relatively low leakage rates can become serious when extended over several months of time.

POWER REQUIREMENTS

Power requirements can be conveniently divided into three general categories, propulsion, payload operation, and control and telemetry. In general the greatest consumption will result from propulsion requirements. To estimate the power needed we will assume baseline system parameters as follows: Volume - 1 MMcf; Shape - Class "C" airship; Altitude - 70,000 feet; Speed 30 knots.

Propulsion Power

An appropriate expression for the drag, D, (of thrust, T) of a typical airship is,

$$T = D = \frac{1}{2} \rho C_D v^2 V^{2/3} \quad (3)$$

where ρ is the atmospheric density (slugs/ft³)
 C_D is the drag coefficient
 v is the flight velocity (ft/sec), and
 V is the volume of the vehicle (ft³).

Substituting the nominal system parameters Equation (3) leads to an estimated thrust requirement of

$$T = 0.1 v^2 \text{ lbs} \quad (4)$$

where v is expressed in knots, and a value of 0.05 is assigned to the drag coefficient. For a nominal speed of 30 knots the thrust requirement is only 90 pounds. This is an extremely small number when compared to the thrust requirements of the usual LTA vehicles. In the high altitude region thrust can be most efficiently provided by a larger low speed propeller, which may in turn be driven by an electric motor.

To produce this thrust level the power input to the propeller, P_i , reduced by the propeller efficiency ($E_\rho \cong 0.75$) must equal the product of thrust and forward velocity. Thus

$$P_i = \frac{0.167 v^3}{E_\rho} \frac{\text{lb.ft}}{\text{sec}} \quad (5)$$

Additional efficiency factors must be included for the mechanical drive system ($E_d \cong 0.9$) and for the electric motor conversion of electrical power to mechanical power ($E_c \cong 0.8$). Introducing these and converting P_i to watts leads to the final expression for propulsive power:

$$P_i = \frac{0.22 v^3}{E_\rho E_d E_c} \text{ watts.} \quad (6)$$

For the particular case under discussion this leads to a power requirement of 11 kW. The factor v^3 has been retained to emphasize its driving influence on the power requirement.

The primary uncertainties in the calculation of power requirements occur in the choice of the drag coefficient and the operating speed. A considerable body of data on drag was accumulated for airships at lower altitudes but the extrapolation to higher altitudes is uncertain because the Reynolds number moves into the transition region. Various estimates of the drag coefficient have ranged from 0.03 to 0.11. The uncertainty over the speed is due to the limited data on wind conditions.

Other Power Needs

Within the limits of the few hundreds of pounds of payload that the baseline system might carry, it is unlikely that payload power requirements will exceed the kilowatt level on a continuous basis. This would represent a small increase in the total power system capability required. Very efficient and sophisticated control and telemetry units have been developed and used for both high altitude balloon operations and for remotely piloted vehicles. The power consumption of such systems is typically a fraction of a kilowatt. This would also represent a small addition to the propulsion power requirements.

It is evident that power requirements will be largely determined by propulsion needs. Those needs will depend on unpredictable wind conditions and must therefore be considered as a continuous requirement for a long term system. By comparison to the 10 kW required for propulsion, the 1 kW required for payload and control functions is of lesser concern.

POWER SOURCES

Primary Power Sources

The term "primary" is used here to denote any system which uses a consumable fuel or non-renewable stored energy. Such systems will be limited by the small amount of fuel that can be carried aloft. We can readily make a rough estimate of what these limitations are. As a rough guideline we will assume average power requirements of 10 kW for electrical systems, to be provided out of a total weight of 1500 pounds, and 7.5 kW (10 shaft horsepower) for mechanical systems, to be provided out of a total fuel load of 1200 pounds.

Batteries - Some of the APOLLO space program primary batteries produced nearly 100 Wh/lb, which was the highest energy density available until very recently. At a power level of 10 kW, 1500 pounds of these batteries would last for 15 hours. Future battery developments promise as high as perhaps 300 Wh/lb which would provide power for 45 hours of flight. Thus even the most optimistic assumptions will result in inadequate mission durations to justify the system.

Fuel Consuming Engines - Liquid fueled, air-breathing engines may be difficult to operate efficiently at high altitudes, but we will ignore that point in our consideration. Whether one chooses a Wankel, a diesel or a turbine the basic fuel has an energy content of about 6000 Wh/lb. At an unrealistic 50 percent conversion efficiency this would be reduced to 3000 Wh/lb and the 1200 pounds of fuel would be exhausted in 20 days. For some applications this period may be adequate, if it can be provided.

Regenerative Power Sources

For this application we believe that it is possible to construct a regenerative system utilizing power from a solar array. An energy storage system, such as batteries would be used to provide power at night. An alternative approach, requiring substantially less weight, is a regenerative fuel cell.

The regenerative fuel cell system is composed of four basic components, as shown in Figure 2, and associated controls and plumbing. The system operates around a hydrogen/oxygen fuel cell which derives electrical energy from the conversion of those gaseous reactants into water. The water produced by the fuel cell reaction is pumped into an electrolysis chamber where the passage of an electrical current reconverts it to the gaseous state. Product gases are then held in high pressure storage until needed by the fuel cell. Electrical energy for operation of the electrolysis cell is obtained from a solar array distributed on the upper surface of the aerostat. Each of these major components has been developed and is available in some form today, though not optimized for the aerostat power application. We have attempted to determine the capabilities of existing hardware and project the results of anticipated modifications and improvements to estimate the performance of future systems.

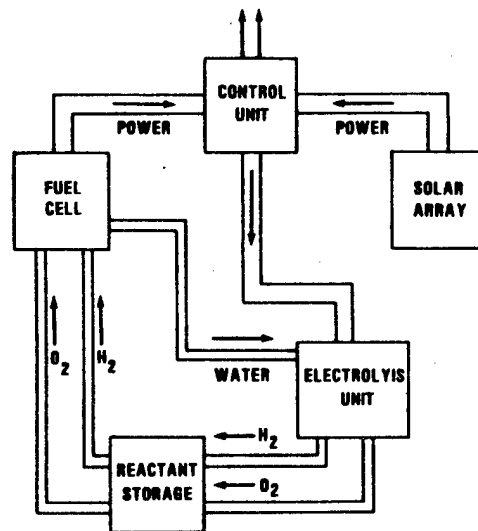

FIG. 2 REGENERATIVE FUEL CELL SYSTEM BLOCK DIAGRAM

Fuel Cell - The basic element of the power system is a hydrogen/oxygen fuel cell of the type used in space programs, which can meet very stringent requirements. The characteristics of a particular unit in which we are interested are as follows:

Average Power Output per Module	5 kW
Maximum Power Output per Module	10 kW
Specific Reactant Consumption	0.8 - 0.9 lb/kWh
Specific Weight at ave. output	25-30 lb/kW
Anticipated Cell Life	> 10,000 hrs.

Systems designed expressly for aerostat use should achieve a 10 kW output with a specific weight of about 15 lb/kW and a specific fuel consumption of 0.8 lb/kWh in the not too distant future. Significant advances beyond this point will be difficult since operating efficiency will be approaching realistic limits and weight reductions would result in more fragile and more costly components.

Solar Array - The FRUSA or Flexible Rolled-Up Solar Array² development indicated that it was possible to place solar cells on a flexible

plastic sheet with imbedded interconnections and achieve excellent reliability with very lightweight panels. It was capable of providing a power level of 52 W/lb, and advanced array systems utilizing lightweight cells were expected to produce 70 W/lb. Utilizing the FRUSA design without the protective glass cover slide, which may be unnecessary for terrestrial applications, would result in a power density of nearly 80 W/lb.

Recent announcements of advances in solar array performance, through increased light conversion efficiency, indicate that the present 10 to 11 percent efficiency may be raised to 14 to 16 percent levels. Indeed there are some suggestions that the influx of new efforts and support in energy research may raise the efficiency to 20 percent over the next few years. In any event it is not unreasonable to expect that the specific weights of 12 to 15 lb/kW available with existing technology will be reduced to 7 to 8 lb/kW in the future.

While the specific weight of the solar array may be low it must be remembered that it will be the ultimate source of all power. Since power can be generated only during the daylight hours the size of the array will have to be approximately doubled to account for the power needed during night hours. The exact factor will depend on geographic location and time of year. Since all parts of the array cannot be oriented directly toward the sun at all times another factor of two must be included to account for the average sun angle. A minimal roll control system on the aerostat would provide this level of capability in sun alignment. Finally, the fuel cell/electrolysis cycle, water/H₂-O₂/water, is no more than 60 percent efficient. Thus, an additional expansion of the solar array must be made to account for this power loss. To generate power adequate for a 10 kW continuous level of consumption will require a total generating capacity of 53.4 kW. This level can be reduced somewhat by improving the fuel cell efficiency.

Electrolysis Unit - An electrolysis unit, with an efficiency of better than 90 percent, has been developed for use in space. It is expected that the specific weight may be brought as low as 3 lb/kW. Operation is inherently stable, is unaffected by pressure, produces pure reactants, and requires only modest controls. Reliability and life expectancy are high.

Reactant Storage - To supply the fuel cell with reactant to produce 10 kW for 12 hours at a specific fuel consumption of 0.8 lb/kWh will require nearly 100 pounds of reactant, or roughly 11 pounds of H₂ and 88 pounds of O₂. At atmospheric pressure this would represent 2000 cubic feet of H₂ and 1000 cubic feet of O₂. The volume can be reduced by increasing the storage pressure. Some recent developments in the fabrication of filament wound pressure vessels have greatly reduced the weight required for gas storage. Test results indicate a storage specific weight requirement of about 0.025 lb/ft³ atmosphere, or a specific weight of 7.5 lbs/kW. Making full use of the available strength of these new materials would reduce the specific weight for reactant storage to about 5 lbs/kW.

System Summary - Combining the specific weights just discussed and including reasonable allowances for power conditioning, cabling, and other components, leads to an estimate of 88 lbs/kW for a complete regenerative power system. The life of each major component is of the order of 10,000 hours, offering the possibility for mission durations in excess of a year. Within the 1500 pounds of power system weight a capacity of 17 kW could be provided. This would increase the nominal speed capability to 35 knots, and enhance the utility of the vehicle.

APPLICATIONS

In addition to such obvious military applications as surveillance and communications relay, such a vehicle may find many uses in the commercial and governmental spheres. By being able to maintain an essentially fixed position for periods of the order of months it may usefully serve as a monitoring platform with line of sight coverage to more than 400,000 square miles of surface area. Thus it could provide environmental monitoring over entire drainage basins, serve as an educational TV outlet for large areas, as a system for monitoring or directing waterborne traffic in large harbor complexes, or provide continuous monitoring of offshore oil fields. In addition to these tasks the platform would be well suited for high altitude meteorological research. Its ability to carry out observations on a continuous basis at a fixed point would provide a dimension not readily available at the present time.

SUMMARY

This slightly unconventional airship is still a concept, as are many of the other ideas we have discussed. Translating those concepts into a high altitude instrument platform is the real challenge.

The ability of such a platform to perform useful missions, practically and economically, will depend on technological advances expected in the near future. These are primarily in the areas of solar array weights and costs, improvements in materials, and weight reductions in sensors and electronic assemblies. With such improvements the high altitude aerostat may become a valuable part of many programs in the 1980's.

REFERENCES:

1. General Electric, Fuel Cell Technology Program, GE SPR-044, Final Report, Contract NAS 9-11033, General Electric (1971).
2. Felkel, E. D., Wolff, G., et al., Flexible Rolled-Up Solar Array, AFAPL-TR-72-61, Contract F 33615-68-C-1676, Project B/682J, Hughes Aircraft Co. (1972).

N76-15066

A PRACTICAL CONCEPT FOR POWERED OR
TETHERED WEIGHT-LIFTING LTA VEHICLES

M. Alain Balleyguier*

ABSTRACT: This paper will deal with a concept for a multi-hull weight-lifting airship, based upon the author's experience in the design and handling of gas-filled balloons for commercial purposes. The concept was first tested in April, 1972. In the flight test, two barrage balloons were joined side-by-side, with an intermediate frame, and launched in captive flight. The success of this flight test led to plans for a development program calling for a powered, piloted prototype, a follow-on 40-ton model, and a 400-ton transport model. All of these airships utilize a tetrahedric three-line tethering method for loading and unloading phases of flight, which bypasses many of the difficulties inherent in the handling of a conventional airship near the ground. Both initial and operating costs per ton of lift capability are significantly less for the subject design than for either helicopters or airships of conventional mono-hull design.

The French company LA GRUE VOLANTE (hereinafter referred to as LGV) was founded to exploit the potential of a design configuration for a weight-lifting LTA vehicle offering greater economy and ease of handling than airships of the Zeppelin type.

PART I: PRESENTATION OF THE LGV CONCEPT RESEARCH PRINCIPLES

Because the static lift of a Lighter Than Air gas such as helium has a maximum figure of 1.1 ounces per cubic foot at sea level, and a portion of this lift must be converted into useful load, an airship has necessarily a very light structure. This fact limits its resistance to weather factors, particularly the force and turbulence of wind, and imposes limitations on the control surfaces, increasing the difficulty of piloting large volumes in buoyant equilibrium while accommodating different variables such as the pressure and temperature of both ambient air and internal gas (on which sunlight or the absence thereof, clouds, rain,

* President, La Grue Volante (The Flying Crane), 17, rue des Petits Bois,
92370 Chaville, France.

PRECEDING PAGE BLANK NOT FILMED

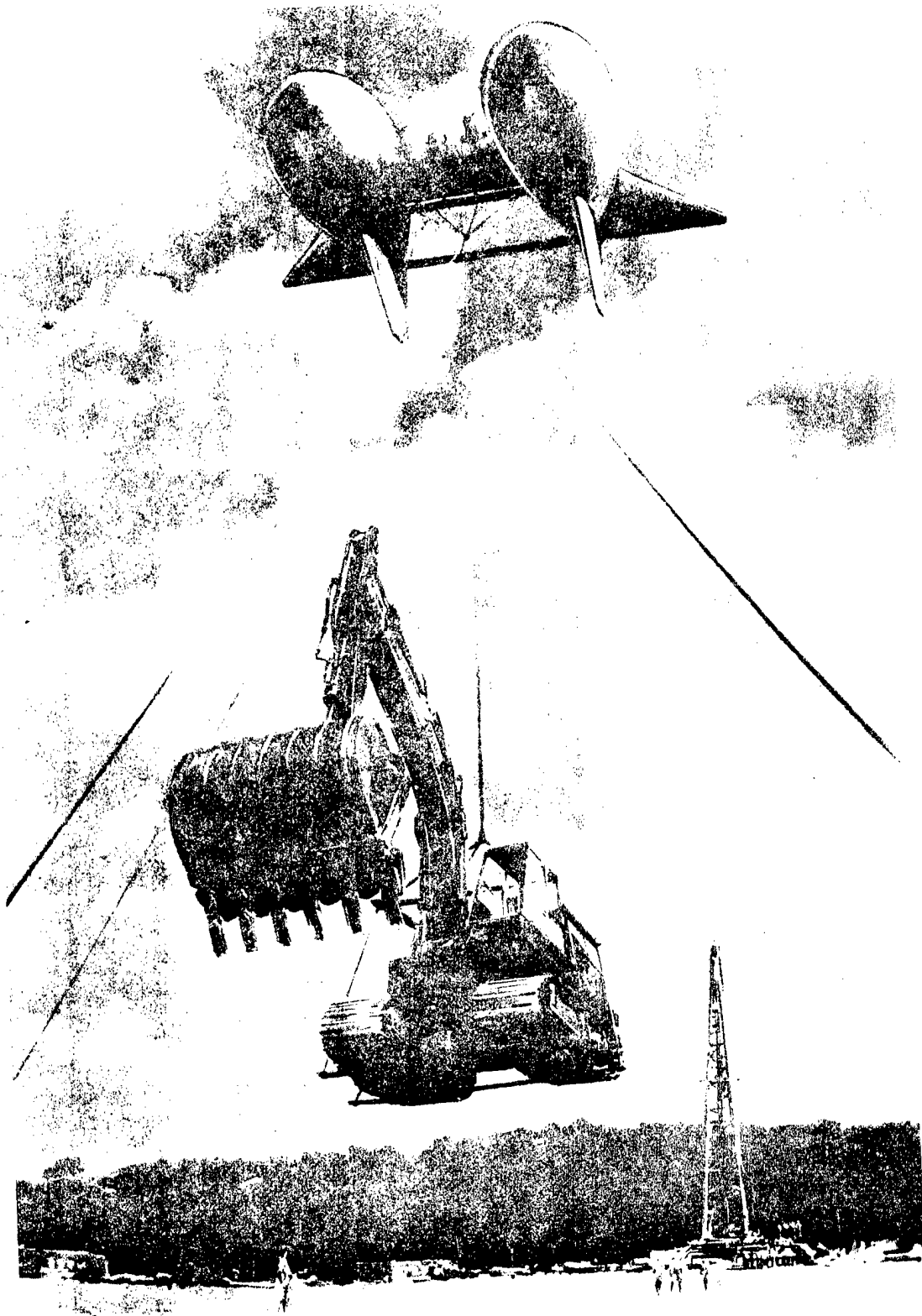

Artist's perspective of LGV weight-lifting LTA vehicle, illustrating tetrahedral tethering principle.

and snow can play a role) and the aerodynamic strength and shape of the balloon. All of these factors can vary simultaneously or at different times; some are very difficult to forecast accurately. The effect of slight differences on such a system is often magnified, and the net result is that the system is always in precarious equilibrium.

The pilotage of a conventional airship in approach and landing phases is difficult under any but the most ideal conditions. Conventional mooring at a mast does not facilitate loading and unloading, as the craft must be allowed to continuously weather-cock; and a relatively large surface area is required with the mast at center. Landing and mooring facilities must be duplicated at every location where it is desired to load or unload heavy undivisible industrial loads.

In the LGV concept, the airship is "moored" like a captive balloon, with three tether lines in a tetrahedric system. By utilizing this technique, the approach is simplified, requires less precision because it is farther away from the ground and other obstacles. As soon as the mooring system is attached, and tension is applied by a positive vertical lift, the summit of the tetrahedron is relatively fixed in space, and an undivisible load can be loaded or unloaded with nearly as much precision as with a crane. The LGV objective was to design such a vehicle with enough stability and resistance to weather variations to permit mooring in this manner -- without requiring hangar or landing facilities -- under all conditions of weather.

Above the summit of the tetrahedric mooring system, the vehicle can move freely in a horizontal plane, like a weather-cock. The three lines are continuously stretched if the system's L/D ratio is high enough to maintain the general resultant of forces within the volume of the tetrahedron. Observation and tests indicate that there are serious defects and limitations in the usual methods of obtaining an adequate L/D ratio for a captive balloon. Usually, in windy conditions, a streamlined balloon receives an aerodynamic lift dependent upon its general air foil shape, at a given incidence. For this reason, it is called a "kite balloon." But this kind of balloon presents two performance-limiting disadvantages. First, the aerodynamic lift of the balloon comes from the fact that its body is used as a wing, one with a very low span-to-chord ratio. The tip end vortex, or induced vortex, is relatively high, giving poor aerodynamic performance due to the low L/D ratio, resulting in significant instability. In a non-rigid balloon, the envelope material is required to provide large aerodynamic strengths. Also, the tail surfaces must themselves provide high aerodynamic strength to compensate for the above-noted instability and to compensate for the aerodynamic pitch couple due to the fact that aerodynamic lift is situated between 30% and 40% of the chord instead of at 40% to 50% for the static lift, requiring a positive incidence on the horizontal tail surfaces, and the resultant forces being transmitted by the envelope material.

In formulating the LGV concept, it was desired to avoid, as much as possible, any aerodynamic lift from the balloon when at zero incidence. But it was necessary to provide for aerodynamic lift in windy conditions. A solution was to provide the balloon with a wing offering a good L/D ratio, coming from a sizable span-to-chord ratio. This would be difficult for a single balloon; the heart of the LGV concept was to mount the wing between two balloons. The wing, with the balloons at either end, presents an increased L/D ratio, the balloons acting like huge wing-tip tanks. The tail surfaces are ideally placed outside the passage between the two hulls, and being only stabilators, are used at zero incidence, minimizing the aerodynamic forces to be transmitted by the fabric of the envelopes, as well as minimizing the requirement for aerodynamic strength of the balloons themselves. The patent for the concept is pending, covering captive balloons and airships moored like captive balloons.

Another improvement increasing the performance of such a balloon, in particular its resistance to wind and weather effects, is from the use of new cables and envelope materials, specifically two to three times better than conventional ones such as polyester or fiberglass. The new French products, named CEF (Chord Europe France), are made of duPont Kevlar 49 fibers, for the first time satisfactorily configured to produce a tensile strength in the range of 240,000 psi for a density of only 1.05, with a weak elongation of only 2%, good resilience, excellent resistance to UV rays, full compatibility with all usual resins or pigmentation treatments, and a cost (slightly below that of carbon fibers) actually between \$270 and \$360 a pound, depending upon the quality and performance required. The French company LA CELLOPHANE is already studying the use of the CEF products for new envelope fabrics and laminated materials, at the request of the Balloon Division of the CNES and also at the request of LGV. Such products will allow the manufacture of non-rigid balloons with higher pressures than usual, with lighter than usual envelopes and inflated tail surfaces -- and even in the LGV concept, the median wing. When the cost has been brought sufficiently low, non-rigid airships will probably be less expensive and provide better structural performance than rigid designs, even for the largest sizes.

The LGV concept encompasses two slightly different designs, depending upon the two main applications:

- a. Tethered or Captive Balloons. The balloons and tail surfaces have symmetrical profiles and zero angle of attack. The wing is fixed between the two hulls with a positive angle of attack, and its profile can be asymmetrical. There are no moving parts. The actual calculated L/D ratio of such captive balloons is about 6 to 1, higher than a conventional captive balloon, and LGV anticipates increasing the figure significantly after wind tunnel research. This is necessary to analyze aerodynamic interferences between different elements of the design, where calculations are insufficient for accurate prediction of performance, and to study different scales of wing span and thickness with relation to size of the hulls and to determine appropriate tail surface area required for a given stability.
- b. Powered Balloons or Airships. Here the design is dependent mainly upon the requirements of mooring and loading operations. During powered flight, the overall system is supposed to have zero aerodynamic lift. Thus the wing has no incidence, nor has the hull axis or the horizontal tail surfaces; a symmetrical profile is presented. To operate as a captive balloon, the pilot lowers wing flaps, with the help of conventional gear. During the transition from one type of flight to the other, the pilot must hover about the destination point, and has a relatively wide margin of space precision. To facilitate this, vertical axis power units are scheduled on all the powered craft designed; these help the pilot stretch the tether lines, once anchored to the ground, before actuating the wing flap, and help him to remove tension from and detach the tether lines prior to undertaking normal flight.

PART II: TETHERED BALLOONS

Subsequent to the wind tunnel research, the LGV program begins with flight tests for two different captive balloons, to study the structure in various weather conditions. These will have volume, respectively, of 1,400 and 10,000 cubic feet.

Subsequently, the company will make captive balloons of varying sizes for various applications. The high level of performance scheduled will open the market to new applications, in addition to the traditional scientific ones. For load-moving applications, LGV will develop a

system to vary the tether cable length to move the loading and unloading point within a given perimeter, and to make an on-board winch unnecessary. For conveyors, such balloons can be used like aerial poles. They can be used in off-shore operations, moored to anchored buoys. Such systems can obviate the need of a harbor for ship loading and unloading operations. In the same way, they can be used like "airborne buoys," to support the tether lines for a larger powered balloon of the same configuration, in locations where frequent loading and unloading operations can benefit from shortening the time interval required for mooring.

The efficiency of the tethered balloon concept is not affected by the size of the balloon. On the three types of forces applied (bursting, aerodynamic, and catenary), only the catenary forces increase more rapidly than the volume to limit the size of the balloon. The planned construction methods, which are proprietary, will void the need for hangars, permitting relatively low length to diameter ratios and permit large volumes with all-weather resistance and high useful load/total weight ratios. Unitary load capacities of up to 500 and even 1,000 tons are possible.

PART III: POWERED BALLOONS

Actually, the primary requirement for LTA devices in France is to lift and transport heavy, bulky undivisible loads, particularly such as nuclear vessels. At the same time, there is a potential world-wide demand for large airships to transport freight at speeds and rates less than those now required by commercial air transport. The load-carrying efficiency of an airship varies approximately linearly with her size, and therefore the larger the airship, the lower the ton/mile cost. But the risks involved in building airships of extreme size are such that no company (and for the moment, no government) would be well advised to start on too large a scale, even in spite of the numerous applicable improvements available since the time of the Zeppelins. Therefore, LGV recommends the development of new LTA systems systematically, with specific applications at each step, to attain the large sizes with optimum speed and safety.

After wind tunnel research and tests of the first two research captive balloons, the LGV program will divide into three main steps:

- a. A Powered, Piloted Model. This will be a four-seater configuration. The two balloons (hulls) will have a total volume of 81,000 cubic feet and a length of 115 feet. A special feature of this model will be that the complete gondola, weighing about 2,900 pounds, including engines, will be separable from the balloon section and can be lowered to the ground to simulate load transfer and facilitate engine maintenance. Therefore, it will be necessary to control the moving parts of the balloon with the system operable both from the air and from the ground. The wing flap and tail surface tabs will be operated by electric means; the pressure fans and control unit of the balloons will also be electrical and provided with a battery for redundancy.

To conserve time and money, the gondola will be the rebuilt fuselage of the prototype of an abandoned four-seat French push-pull aircraft, the "Jupiter" Matra-Moyonet, fitted with two 200 horsepower Lycoming engines. The rear propeller will incorporate reversible pitch. Two lateral pods will support the vertical axis power units, fitted with a pair of two-stroke Hirth engines of 55 or 70 horsepower, similar to that used on the BD 5 sport aircraft. The vertical thrust will be reversible, up or down. Calculated top speed will be 60 miles per hour, and cruise speed with 50% power, 50 miles per hour.

The first flight is scheduled one year subsequent to completion of the wind tunnel research. Special authorization of flight will be delivered, under appropriate restrictions, by French authorities; they are presently preparing new rules for future airship certification, and wish to be involved with the specific problems of such prototype models as our own.

As soon as test flights of this model produce satisfactory results, the limitations of use determined with good levels of safety and viability, the original gondola will be replaced by a more elaborate one, involving type certification and acceptability for on-line production.

LGV has already received requests from potential users for production models of this size, for schedule prices between \$400,000 and \$600,000, depending upon user specifications. Aerial surveying and advertising are among the more frequent requests. One request, from a utility company, is to use such airships both for advertising and to provide illumination for night public events (in captive configuration) in locations where the erection of poles is forbidden or too costly.

The cost for the first powered model is scheduled for \$300,000, including preliminary research; its development in the next configuration will cost about the same and require one more year.

- b. A 40-Ton Useful Load Model. This model was inspired by potential user requests from oil companies for drilling needs in difficult locations, some now served by helicopter. But such airships should be far less expensive to operate, with higher levels of safety and viability, because a load under sling disequilibrates a helicopter but not an LTA system. Heavier transported loads will also decrease drilling costs, by the use of standard systems, because the use of custom helicopters necessitates special and costly drilling systems, divisible in transportable elements of usually two and one half tons maximum. Mounting and dismounting of such elements would be reduced, and the transport logistics of a drilling operation would be greatly enhanced by the extension of the airborne phase, avoiding intermediate costs and delays such as river barge operations in some situations and the use of cargo planes in others.

Foresters also are interested in such weight-lifting airships for logging operations in difficult locations throughout the world. LGV is also in close contact with a world charity organization, the Order of Malta, to provide such airships for health and rescue. In the event of natural disasters, such as earthquakes, particularly where ground transport activities are disorganized or non-existent, these airships would be invaluable for such use as food transport and airborne hospitals.

Economic studies indicate that, after the first few units, serial production of such airships could be effected at costs low enough to make ton/mile costs competitive with surface transport in underdeveloped countries. At relatively low speeds, for example between 60 and 85 miles per hour, they are very economical of fuel, significantly more so than with conventional airships.

LGV is already in touch with an African government for the development of short-haul transports in their country, requiring initially ten 40-ton model units, only a part of the potential market envisioned.

Specifications of the 40-ton prototype include the following: Total volume of the two hulls will displace 3,150,000 cubic feet; length is 365 feet; maximum diameter 97 feet for each hull; overall width will be 550 feet; overall height 180 feet; installed power 2,300 horsepower, providing a top speed of 80 miles per hour and a cruise speed of 65 miles per hour at 50% power. Scheduled cost of the prototype, developed and built in France, is \$2,520,000 (at a rate of exchange of five French francs per U. S. dollar), and serial production models are scheduled to sell between \$1.6 million and \$1.8 million, or less, depending upon the number to be produced. For comparison purposes, the cost of a helicopter like the S-64 "Skycrane," able to lift and transport only 12 tons under sling, costs more than \$2 million, and involves higher operating costs.

LGV estimates that the first 40-ton production model could probably be operational and available three years after the start of the initial program.

One very interesting advantage of the concept will be that it requires only very short delays for mooring, unloading, reloading, and unmooring operations. The total sequence will take only two minutes during no-wind conditions, if mooring is not necessary, and five minutes if conventional mooring is necessary.

In mooring, the three tether cables are first properly anchored; and as with any airship, the mooring is never unfastened until the airship is reloaded with an equivalent weight of the one unloaded. The vertical axis power units are available to correct possible inaccuracies in the weight equilibrium, within a range of $\pm 5-10\%$ of the total weight. Thus for the hovering and transition flight sequences, the pilot can equilibrate within this margin during normal cruise flight, with the help of the tail surface control tabs.

The tether line anchorages are located at a distance from the center equivalent to about half of the mooring altitude, where loads have to be manipulated. As often as possible, the loads will be containerized or placed in nets, to shorten loading operation delays. When return freight is not available, even for a part of the total load, ballast is necessary, as often as possible with water in tanks or bags (or other ballast like sand, gravel, dust, suitably containerized by a ground crew), the total load for a powered flight always being the same, including fuel reserves.

- c. A 400-Ton Useful Load Model. Specifications -- Total volume of the two hulls: 23,000,000 cubic feet. Length: 750 feet. Maximum diameter of each hull: 200 feet. Overall width at horizontal fin tips: 1,000 feet. Overall height at vertical fin tips: 370 feet. Performance: top speed 80 miles per hour at full power (with 40,000 horsepower). Cruise speed: 65 miles per hour at 50% power. Normal range: 400 to 600 miles. Ceiling: 5,000 feet.

The range can be increased with a reduction of payload, at the rate of about five tons per 100 miles.

For special transport systems of industrial loads from and to industrial yards, such as nuclear power stations, a special system to accurately place the loads will be developed -- to stabilize the position of the load in space by an action at the summit of the tetrahedric tether, the ground terminus of the tether lines will be fitted with hydraulic jacks actuated by an automatic control system taking references from the space position of the load itself. In this way, all the possible (including cyclic) slight movements of the load due to the action of the wind on the balloon and tether lines can be compensated for. The natural precision of location is about 1% of the altitude of the balloon, and

with the control system could be reduced to 1/1000th and even to 1/10,000th with very accurate references.

For general freight use, the 400-ton model will present a ton/mile cost between 7.3¢ and 15¢ per mile, for 4,000 hours of flight per year and an average use of 80% of total capacity -- depending upon the cost of production of such models. It will provide excellent short and medium distance transport, for which the ease of mooring and loading operations offered by the LGV concept is more important than incremental ton/mile costs. However, it will not likely be as desirable for long distance transport, for which single hulled airships will present a lower drag and probably a lower ton/mile cost, even allowing for more difficult landing and loading operations requiring extensive ground facilities.

PART IV: FURTHER DEVELOPMENT OF THE CONCEPT

LGV has already studied such development in two directions: (1) Another configuration, covered by the same patents, providing possible improvements. (2) Development of fabrication technology, based primarily on an automatic machine for making the envelopes of the balloons, based on a completely new principle, more advanced than techniques already used in balloon manufacture (for example, the machines developed by the Balloon Division of the CNES in France and used by the Zodiac-Espace Company). The method of assembly of the different elements will also be completely new, and highly original. The main advantage will be to bypass the need of a costly hangar for the assemblage operation.

N76-15067

A REVOLUTIONARY AND OPERATIONAL TETHERED AEROSTAT
SYSTEM ILLUSTRATING NEW LTA TECHNOLOGY

James A. Menke*

ABSTRACT: A tethered aerostat system, which demonstrates utility of LTA systems, has been in operation for about one year. It was made possible by development of a reliable tethered aerostat that is used to support broadcast equipment at an altitude of 10,000 feet. Two elements of the TCOM system, the aerostat and mooring station, both designed and manufactured by Sheldahl, are particularly relevant to the LTA Workshop. They demonstrate the feasibility of using LTA vehicles in real, operational, all-weather applications and, in addition, illustrate an advance in the overall technology base of LTA. This paper presents a description of the aerostat and the mooring station including their technical design features and demonstrated performance characteristics.

INTRODUCTION

A revolutionary new telecommunications concept has been developed that utilizes a Lighter Than Air vehicle to elevate broadcasting equipment as shown in Figure 1. It is very likely the only operational LTA system in service anywhere in the world today.

Developmental work by Sheldahl over the past five years has produced certain technological breakthroughs which enable tethered buoyant vehicles or aerostats to be employed in practical around the clock operations. Heretofore, such vehicles have been limited to short duration scientific experimental use.

* Manager, Tethered Aerostat Systems, Sheldahl, Inc., Northfield, Minnesota, U.S.A.

The world need for a tethered aerostat which will float continuously over a fixed earth location with payload carrying capacity is quite extensive. For example, developing countries around the world cannot afford elaborate conventional communication networks such as are employed in the United States that use a combination of microwave broadcasting towers, telephone wiring networks and satellites.

The advent of a practical aerostat (balloon) system enables such a country to very economically acquire effectively a two-mile high broadcasting tower, or mini-satellite which can carry electronic broadcasting and relay equipment. Such electronic equipment suspended from a single aerostat flying nearly two miles (10,000 feet) overhead,

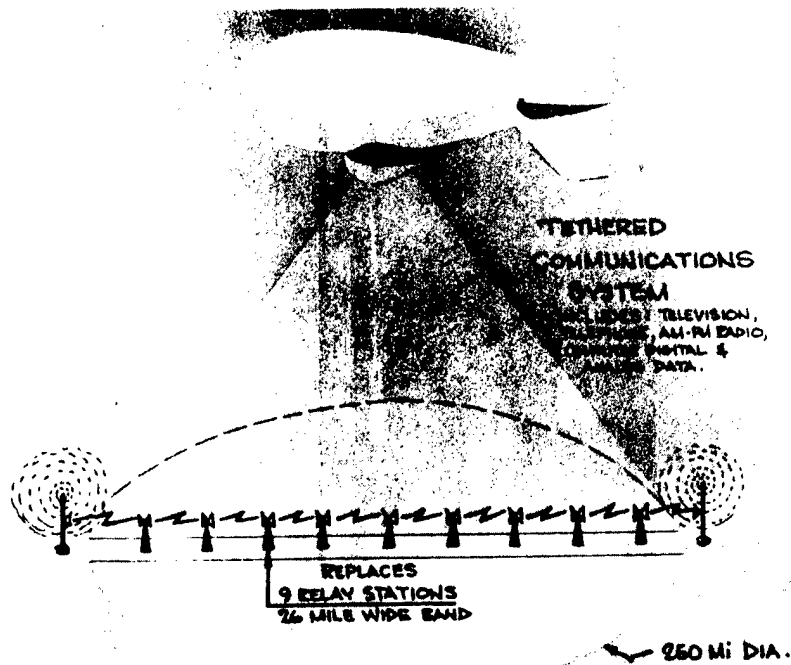

Figure 1
Tethered Communications System

can provide direct line of sight communications to an area covering 45,000 square miles. Multiple aerostat installations can extend this coverage indefinitely. Thus, a single aerostat installation can take the place of about 15 conventional microwave towers and yet offer much broader communications capability at 20 to 50 percent the cost of conventional equipment.

The TCOM Corporation, a subsidiary of the Westinghouse Electric Company, has been established to integrate and market this revolutionary telecommunications system, called the TCOM (for Tethered COMMunications) system, on a worldwide basis. At the present time, a complete demonstration system is in operation at TCOM's Grand Bahama Island facility and operational systems are being installed in the Republic of South Korea and Iran.

This paper will deal with the two major elements of the TCOM system that are particularly relevant to the LTA Workshop, that is, the aerostat and its mooring system. They demonstrate the feasibility of using LTA technology in real, operational, all-weather applications and, in addition, illustrate an advance in the overall technology base of LTA, particularly in the areas of structural design, flexible materials, and manufacturing operations.

DESCRIPTION

The aerostat and mooring station as shown in Figure 2 constitute a single system. During all phases of operation, including launch and retrieval, the aerostat and mooring station are joined and function as an inseparable system. The aerostat is flown directly from the mooring station. Both the aerostat and mooring station automatically rotate so that they are aligned with respect to the wind.

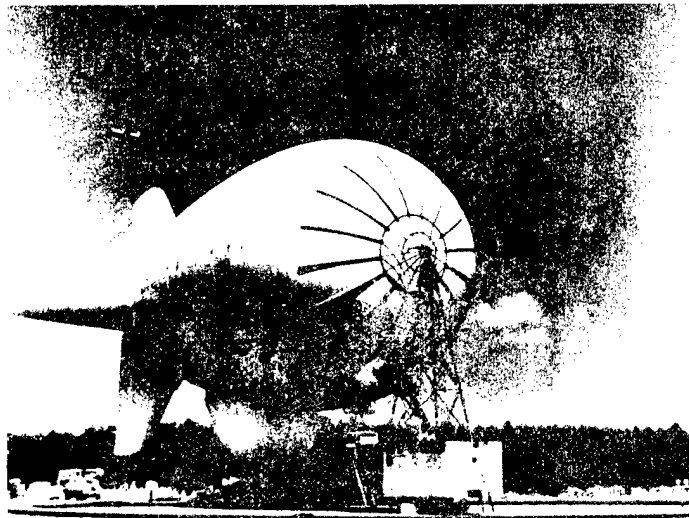

Figure 2
Moored Aerostat

Two features of the system that make the TCOM telecommunications concept economically feasible are the small crew size needed and its all-weather operating capability. Since this concept requires that the aerostat remain aloft for weeks or months at a time, a large full-time ground crew is cost prohibitive. The system, both mooring station and aerostat, also had to be designed to withstand worldwide environments, primarily winds and temperature, without hangar facilities.

Aerostat

The aerostat described herein and illustrated in Figure 3 is the Sheldahl Model CBV-250A. Specifications are presented in Figure 4. It is capable of supporting sizeable payloads at altitudes up to 15,000 feet above mean sea level. Nominal operating altitude is 10,000 feet.

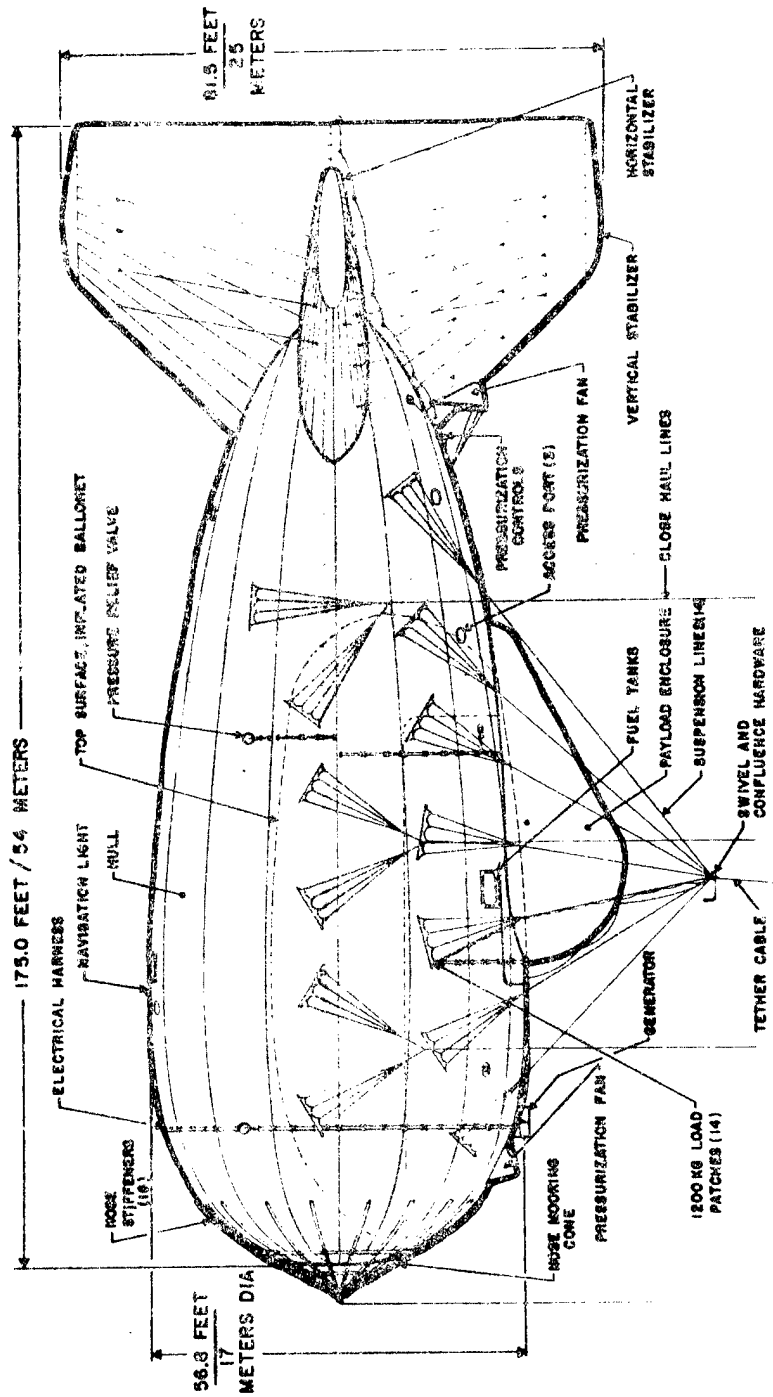

Figure 3
Sheldahl CBV-250A Aerostat

REPRODUCIBILITY OF THE ORIGINAL PAGE IS POOR

	<u>MODEL NUMBER</u>	
	<u>CBV-250A</u>	<u>CBV-350A</u>
<u>WEIGHT</u>	5,100 lbs	5,500 lbs
<u>DIMENSIONS</u>		
Hull Volume	267,000 cu ft	380,000 cu ft
Overall Length	175 ft	215 ft
Hull Length	148 ft	188 ft
Hull Diameter	56.8 ft	56.8 ft
Fin Span	81.5 ft	81.5 ft
Payload Enclosure Width	25 ft	25 ft
Payload Enclosure Height	15 ft	15 ft
<u>OPERATIONAL PERFORMANCE</u>		
Wind Speed @ MSL	90 knots	90 knots
Wind Speed @ 10,000 ft	100 knots	100 knots
Ceiling Altitude above MSL	15,000 ft	15,000 ft
<u>LOAD CAPACITY (PAYLOAD, POWER PLANT, FUEL)</u>		
@ 5,000 ft	7,000 lbs	12,000 lbs
@ 10,000 ft	4,000 lbs	8,000 lbs
@ 15,000 ft	1,000 lbs	4,000 lbs

Figure 4
Aerostat Specifications

The aerostat is controlled or "floated" from the ground control station. It is unmanned and can maintain its position in the immediate vicinity of the launch site for continuous flight durations approximating one week. Retrieval to ground level for refueling, helium replenishment and other maintenance can usually be accomplished within a few hours and the mission resumed. The aerostat is a highly reliable, rugged vehicle constructed to withstand very severe weather conditions. It is designed and constructed to operate safely in 85 knot winds and carry a 4,000 pound load at an altitude of 10,000 feet.

Hull pressure is maintained by a conventional ballonnet design. Fans and valves are automatically cycled to force air into or out of the ballonnet thereby controlling pressure to within prescribed limits.

The hull nose structure is made from a high strength aluminum alloy and is provided for docking the vehicle to the mooring station.

The main payload attachment point on the aerostat hull within the payload enclosure is capable of supporting a package weighing up to 1,500 pounds. The volume available for the payload inside the enclosure is that of a 25 foot diameter hemisphere. In addition to the main payload support structure, the underside of the aerostat has provisions for attaching other hardware such as the airborne power generator, fuel and fuel tanks. This load attachment provision extends 113 feet fore and aft on the underside of the aerostat.

Mooring Station

The mooring station is a permanent installation with primary functions to a) serve as the ground anchor for the aerostat when it is on station, and b) serve as a maintenance station for the aerostat between missions. The mooring system is shown in Figure 5.

A reasonably level area approximately 500 feet in diameter is needed to provide adequate ground clearance for the moored aerostat. A concrete pedestal is located at the center of this area to support the main winch and enclosure as well as the mast. Concrete footings are also provided for the monorail. These footings can either be a full circle of concrete or smaller footings at each rail anchor point. The mooring area need not be paved. However, gravel or some other stable surface is necessary to carry erection and maintenance equipment.

The mooring station consists of a central machinery enclosure and mast mounted on a large central bearing, a horizontal boom compression member and a circular monorail which supports the outboard boom end, flying sheave and close-haul winches that are mounted on rollers. A mechanical lock with a remote electrical release is provided at the top of the mast. Work surfaces are provided on the top deck of the machinery enclosure, on the boom and at the location of the aerostat payload when it is moored. A diesel powered main winch and an auxiliary power unit located within the machinery enclosure furnish the power required to launch and retrieve the aerostat and to moor it in the close-hauled mode. The main winch is used to control and store the tether cable during flight operations. Three smaller winches, one at the base of the mast and two on the circular rail, provide the restraints and control during early stages of launch and during

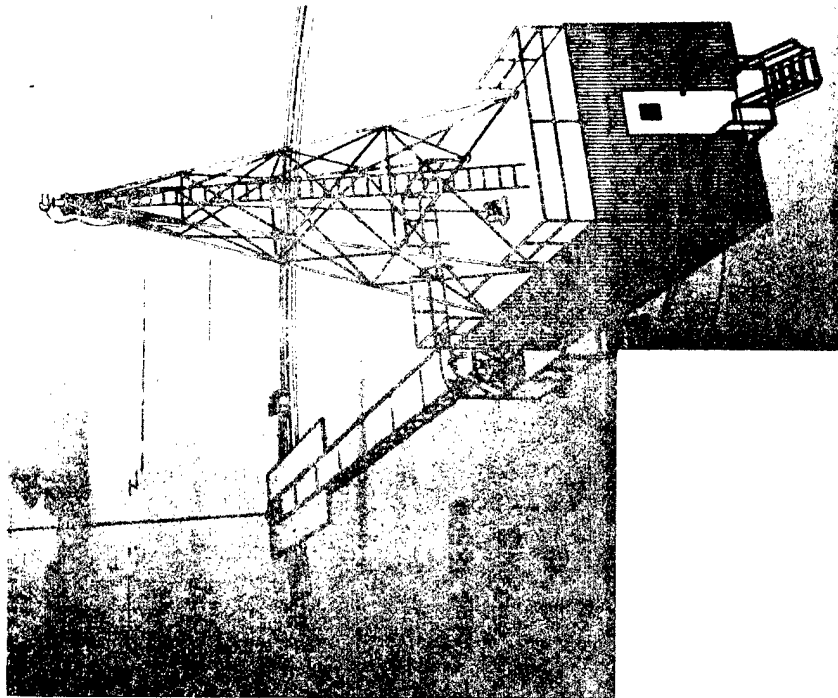

Figure 5
Mooring System

REPRODUCIBILITY OF THE
ORIGINAL PAGE IS POOR

Final recovery. A completely enclosed operator's cab is located on the forward side of the machinery enclosure, providing visibility to all operational areas. The specifications for this system are presented in Figure 6.

The principle feature of this design is its ability to be rotationally driven, either by the forces generated by the aerostat or externally, to align, in azimuth, with the aerostat or its tether cable. This allows a single operator to maintain the balloon in flight and only a four member crew to launch and recover the aerostat. During servicing and maintenance when moored, the crew rides with the system as it rotates into the wind thereby providing improved accessibility and greater safety and again reducing the crew size requirement.

SYSTEM PERFORMANCE

When moored the aerostat is mechanically locked to the mooring mast at the nose and secured by its suspension lines to the service platform under the aerostat payload. In this configuration, any changes in wind direction will cause a rotation of the complete system and maintain the balloon heading into the wind. It also allows the field crew to "ride" the mooring system and work without concern for shifting winds and gusts. In relatively calm weather (winds less than 15 knots), the brakes can be engaged so that heavy loads, such as the aerostat payload, can be transferred from truck to work platform.

The entire system is designed to sustain 90 knot wind loads with the aerostat in its moored mode. Thus a critical component design was that of the nose structure of the aerostat since it provides the mechanical attachment of the flexible aerostat to the rigid mooring tower. Maximum loads anticipated in 90 knot winds including dynamic loads are 26,000 pounds axial and 15,000 pound side load. The structure has been successfully tested to these values.

When the aerostat is moored, a 3 to 5 knot wind 10 degrees off the aerostat heading will cause the mooring station to realign itself into the new wind direction.

The maximum operating altitude for the aerostat is a function of aerodynamic forces on the aerostat and tether cable, helium volume at altitude, total weight aloft, and environmental factors, such as temperature and barometric pressure. The CBV-250A vehicle can attain an altitude of 15,000 feet; however, payload capability at this altitude is extremely limited. Typically, the CBV-250A is flown at 10,000 feet with a 4,000 pound load. Ascent and descent rates are approximately 200 feet per minute.

The aerostat is designed to operate in wind speeds up to 90 knots at sea level and higher speeds corresponding to a dynamic pressure of 27 pounds per square feet at higher altitudes.

Electrical power for vehicle and payload operation is supplied by either on-board rotary engines coupled to brushless generators or by using the tether cable as a conductor to transmit power from a ground source.

	<u>MODEL NUMBER</u>	
	<u>18500</u>	<u>18600</u>
APPLICATION	CBV-250A Aerostat	CBV-350A Aerostat
WEIGHT	95,600 lbs	99,600 lbs
DIMENSIONS		
Rail Diameter	173 ft	203 ft
Tower Height	47 ft	47 ft
Payload Service Platform	16 ft x 22 ft	16 ft x 22 ft
Machinery Enclosure	12' W x 9' H x 31' L	12' W x 9' H x 31' L
STRUCTURAL CAPABILITY		
Wind Speed (With Aerostat Moored)	90 knots	90 knots
Wind Speed (Without Aerostat)	120 knots	120 knots
Operating Temperature	-30 ^o F to +120 ^o F	-30 ^o F to +120 ^o F
Design Criteria	AISC Standards, 7th Edition	AISC Standards, 7th Edition
HYDRAULICS (Supplied by OECO)		
Main Winch		
Tether Cable Capacity	20,000 ft	20,000 ft
Maximum Pull	30,000 lbs	30,000 lbs
Maximum Line Speed	200 fpm	200 fpm
Close Haul Winches (3)		
Maximum Pull	12,000 lbs	12,000 lbs
Maximum Line Speed	140 fpm	140 fpm

Figure 6
Specification Summary, Sheldahl
Aerostat Mooring System

EXPERIENCE

A total of six aerostat systems have been built and three additional systems are presently under construction. One of these systems has been in operation on Grand Bahama Island for the past 14 months providing television coverage for the outer islands.

During this initial 14 month operating period many performance features of the system have been demonstrated. For example, the aerostat has flown in 85 knot winds, in electrical storms, and in heavy rain. The aerostat has remained on station aloft continuously for five days. Highest recorded superheat has been 25 degrees Fahrenheit. Supercooling at night has been as low as 10 degrees Fahrenheit. Tests of material samples removed from the hull after 12 months indicate no significant degradation. The aerostat has been launched in ground winds gusting to 35 knots. Ease of servicing both the aerostat and payload in variable direction ground winds has verified the functionalism of the automatically rotating mooring system. Launch and recovery operations have been conducted with only a four man crew.

FUTURE PLANS

At the present time a complete system is being installed in Korea. It will be fully operational this year. Shortly thereafter, a system will be installed in Iran.

A "stretched" version of the aerostat has been designed and is currently under construction. Its configuration will be identical to the CBV-250A except that a 40 foot cylindrical section will be added at the major diameter of the hull, thereby increasing hull volume by 100,000 cubic feet. Payload capacity will be increased to 8,000 pounds at 10,000 feet altitude. The mooring system design has also been modified to accept the larger vehicle. This larger vehicle designated CBV-350A will undergo flight qualification tests early in 1975.

SUMMARY

What is the significance of this new telecommunication system development as it relates to airships? Materials and technology, of course, are common to both. Further, based on experience with tethered aerostats, it is the opinion of this author that airships can be designed and constructed to operate as reliably as conventional aircraft. However, one of the more pertinent questions that must be answered is: "Will the airship solve a problem or provide a service more economically than other transportation systems?" There are, of course, many other issues and influences that must be considered, such as energy consumption, government subsidies, etc., but the key issue should be one of economics. The telecommunication system is viable mainly because the service it provides is done at a fraction of what it would cost if provided by other more conventional means. In like manner, if objective studies show that airships could solve a problem or provide a service at lower costs when compared to other solutions, then and only then would there be any merit in their development.

TECHNOLOGY UPDATE - TETHERED AEROSTAT STRUCTURAL DESIGN AND MATERIAL DEVELOPMENTS

Robert G. Witherow*

ABSTRACT: Requirements exist for an extremely stable, high performance, all-weather tethered aerostat system. This requirement has been satisfied by a 250,000 cubic foot captive buoyant vehicle as demonstrated by over a year of successful field operations. This achievement required significant advancements in several technology areas including composite materials design, aerostatics and aerodynamics, structural design, electro-mechanical design, vehicle fabrication and mooring operations. This paper specifically addresses the materials and structural design aspects of pressurized buoyant vehicles as related to the general class of Lighter Than Air vehicles--the subject of this Workshop.

INTRODUCTION

In the late 60's, Sheldahl, under sponsorship of ARPA (Advanced Research Projects Agency), undertook a project to design, develop and fabricate three 200,000 cubic foot tethered aerostats under the direction of the Air Force Range Measurement Laboratory (RML). Starting with the limited balloon and non-rigid airship technology that existed at the time, considerable effort was devoted to extend the applicable advanced design and analytical techniques already used by aerospace engineers to the design of aerodynamically shaped, buoyant, pressurized vehicles. Despite the fact that the 250,000 cubic foot Captive Buoyant Vehicle, which eventually evolved and is employed commercially today by TCOM (Tethered COMMunications, a division of Westinghouse Electric Company), is to some extent a marvel of art, it represents a significant technological improvement over previous LTA vehicles in terms of performance, reliability and ruggedness. The structures and materials technology advancements played a dominant role in the success of the aerostats being deployed worldwide today for communications, monitoring, and surveillance applications.

* Manager, Structures and Materials Engineering, Sheldahl, Inc.,
Northfield, Minnesota, U.S.A.

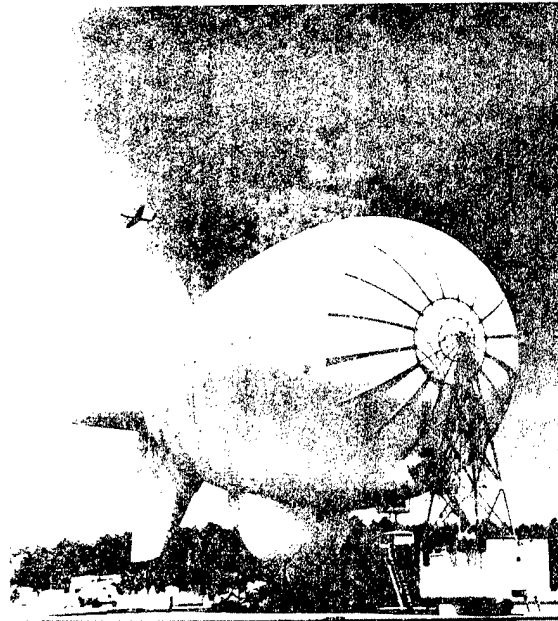

Figure A

250,000 CU. FT. AEROSTAT IN-FLIGHT/MOORED

OPERATIONAL/PERFORMANCE HISTORY

The CBV-250 is shown in flight and moored in Figure A. Each aerostat is completely rigged and checked out (including a proof pressure test) at a hangar facility in Elizabeth City, North Carolina, and then sent to its operational site. The first CBV-250 was operationally deployed in the Bahamas in the summer of 1973 and has provided valuable system design feedback since that time. The aerostat was flown in all types of weather typical of that climate including severe electrical storms and a hurricane. In October of 1973, during Hurricane Gilda, winds exceeding 82 knots were sustained by the aerostat flying at 3,000 feet with no apparent damage. Other experiences time and again demonstrated the structural ruggedness, stability, and operational advantages of this vehicle. The CBV-250 and the CBV-350 with payload capabilities of 4,000 pounds and 6,000 pounds respectively are compared in size in Figure B1.

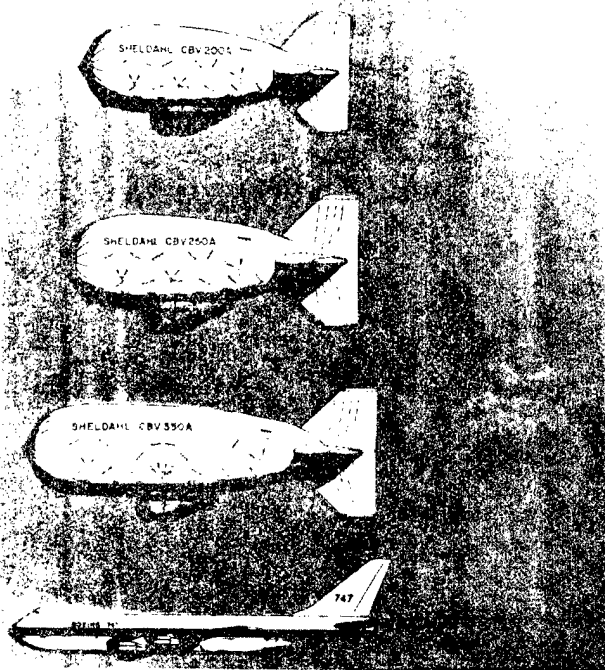

Figure B1
AEROSTAT SIZE COMPARISON

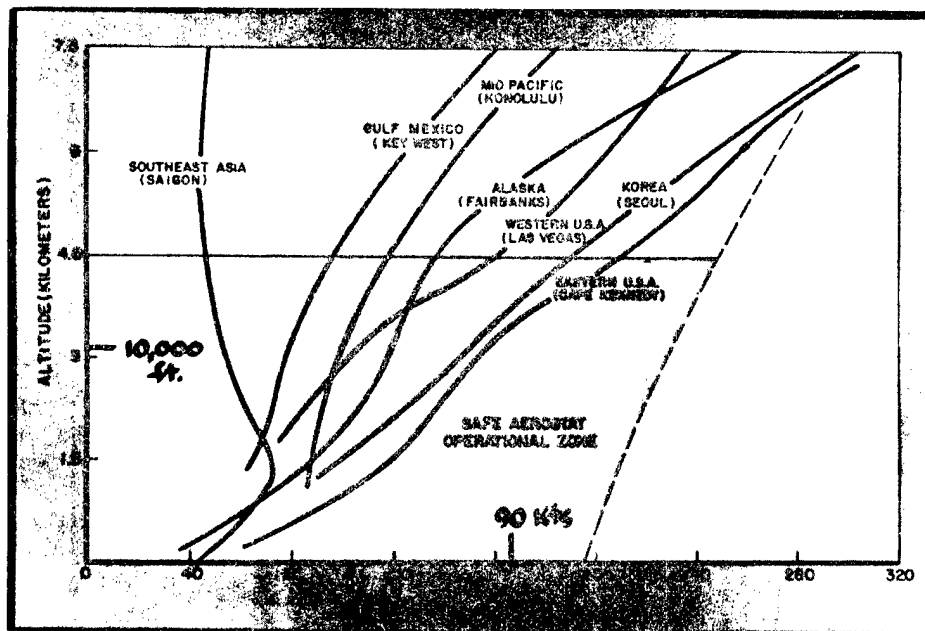

Figure B2
SAFE OPERATIONAL ZONE

REPRODUCIBILITY OF THE
ORIGINAL PAGE IS POOR

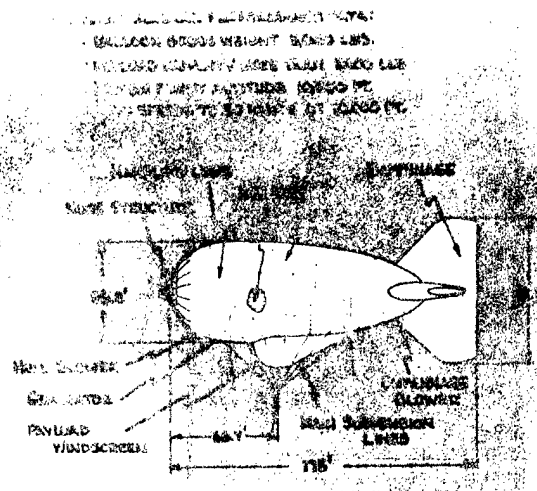

Figure C

MAJOR AEROSTAT SUBSYSTEMS

ENVIRONMENTAL REQUIREMENTS

The aerostats are being deployed in the Far East, the Mideast and other parts of the world--requiring design to climatic extremes. MIL-STD-210B has served as a valuable guide in establishing environmental requirements. The aerostats are designed to sustain winds of 85 knots at 10,000 feet with a minimum structural safety factor of 2. Winds aloft at various worldwide locations are also depicted in Figure B2 indicating the safe operational envelope of these vehicles. Temperature design criteria include the extremes from +120°F down to -40°F. A ten year life with minimal maintenance is required of the major structural envelopes, the hull and empennage. Other design criteria include requirements for blowing sand, hail and lightning to enable around-the-clock operational capability.

PRIMARY SUBSYSTEMS

The major subsystems of the CBV-250 aerostat are depicted in Figure C. Note the overall dimensions and general performance data. The payload is accessibly housed in the windscreen.

AEROSTAT MATERIALS

The fabrics of construction are pictorially described in Figure D. Most of the materials are composite adhesive bonded laminates of TEDLAR PVF film, for weathering and UV stability, MYLAR polyester film for helium impermeability and shear strength, and Dacron polyester plain weave cloth for the strength member. Urethane coatings are used where excessive material flexing occurs such as the windscreen and ballonet.

PRESSURE CONTROL SYSTEM

Pressure sensors, compartmental valves, and blowers comprise the pressure control system maintaining each main compartment at some level above freestream dynamic pressure, q , as shown in Figure E. The power is supplied by two on-board 18 hp Sachs-Wankel rotary combustion engines coupled to a static brushless generator with a static voltage regulator.

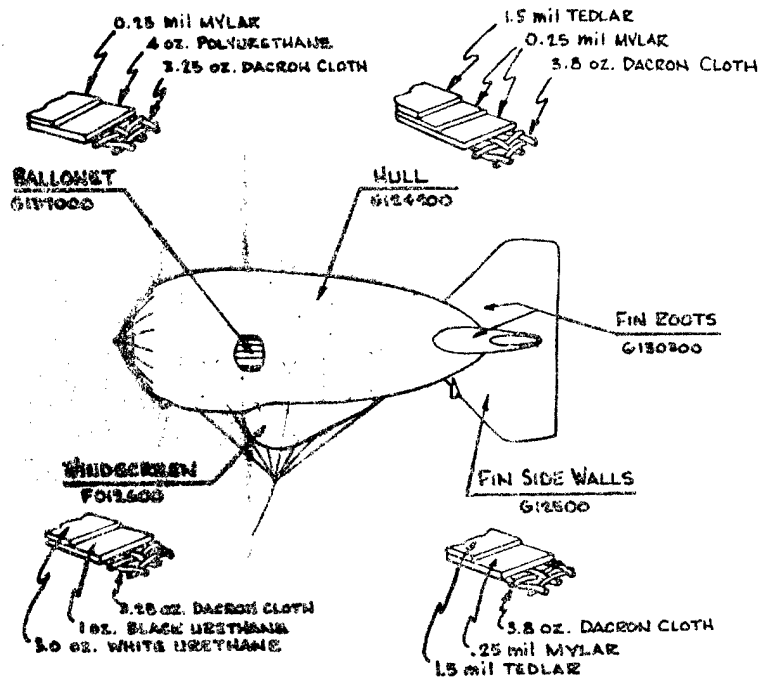
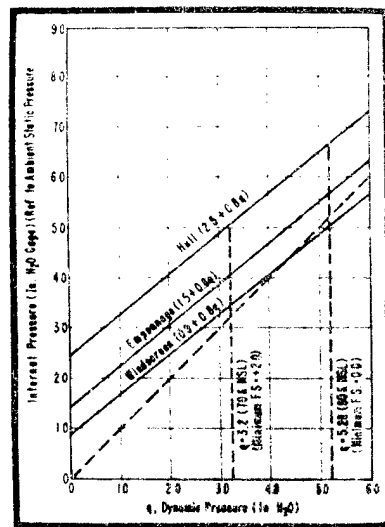
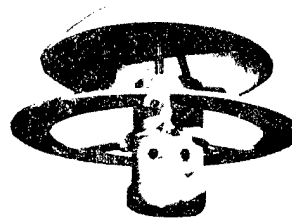

Figure D
AEROSTAT MATERIALS



AEROSTAT COMPARATIVE
PRESSURE REQUIREMENTS



TYPICAL AEROSTAT
PRESSURE RELIEF VALVE

Figure E
AEROSTAT PRESSURE REQUIREMENTS AND RELIEF VALVE

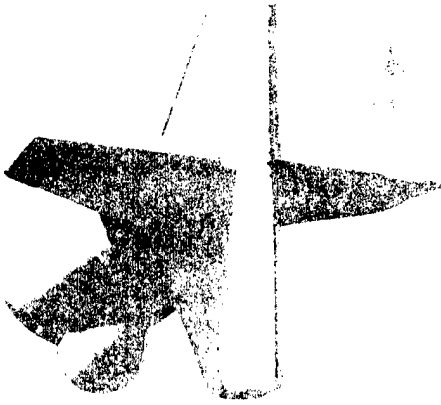

EXTERNAL VIEW

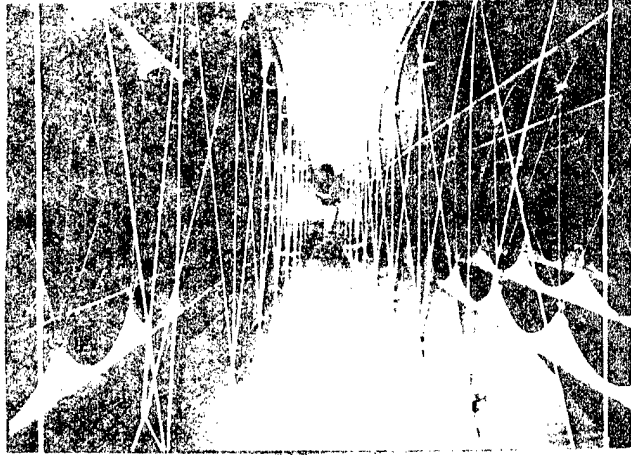

INTERNAL VIEW

Figure F
AEROSTAT EMPENNAGE

EMPENNAGE

The aerostat Empennage* as illustrated in Figure F is the product of a long-term development effort. The entire pressurized assembly is quite large and well aft on the hull--dictated by aerodynamic stability considerations. Fin ribs run spanwise for maximum flexural and shear stiffness and are quite unique--borrowing from the concept of a uniform load distributing parabolic shape, and are laced with Dacron cord. The aft hull is pressurized slightly above the empennage to allow for natural curvature. The fins are guyed one to another to prevent large rigid body rotations.

NOSE STRUCTURE

The nose structure illustrated in Figure G is the primary load transfer structure for the moored aerostat. A high strength, light weight tubular aluminum nose cone, and 16 aluminum nose beams, which are laced to the hull, react mooring loads equivalent to 90 knot surface winds based on a mooring dynamic analysis. The nose beams transfer the load into the hull fabric as a shear load.

PAYLOAD ATTACHMENT

The gimballed payload is suspended from a welded aluminum truss structure laced to the underside of the hull. The hull is at a higher pressure than the windscreen to prevent the interface from wrinkling and going flat.

SUSPENSION LOAD PATCH

The primary load carrying suspension patches also utilize the parabolic scallop design approach to uniformly distribute the 2,500 pound maximum suspension line load into the hull fabric. The suspension lines are sized based on stiffness in addition to strength to optimize distribution of the main tether load.

* Patent pending.

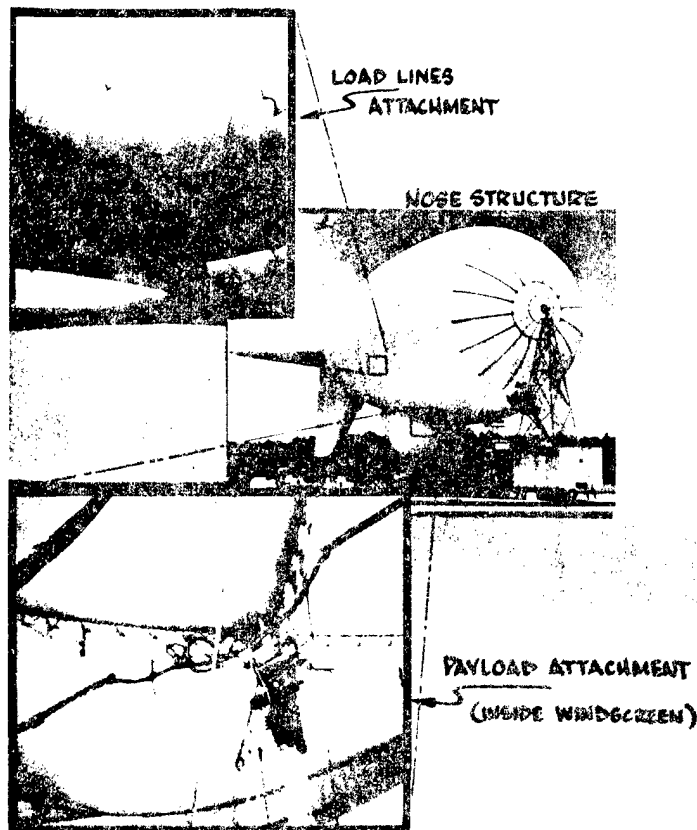

Figure G
LOAD ATTACHMENT HARDWARE

MATERIALS FABRICATION

The Dacron cloth is supplied by speciality weavers and is "set" by running the woven cloth through an adhesive bath. This permits the woven cloth rolls to be shipped to Sheldahl, wherein they are combined with the TEDLAR x MYLAR x MYLAR tri-laminate using special purpose polyester adhesives. All laminating variables are precisely controlled resulting in a consistent product. Figures H and I show a laminator, the flying thread loom (used to manufacture structural tape), and the weaving loom.

AEROSTAT FABRICATION

The flexible material sheet goods are then accurately cut into various shaped panels using full scale patterns. The panels are then bonded together using specially designed thermal impulse sealing equipment. The panel-to-panel bonds are constructed as butt joints using a two tape system--a structural tape on the inside and a weather protection TEDLAR cover tape on the outside.

08

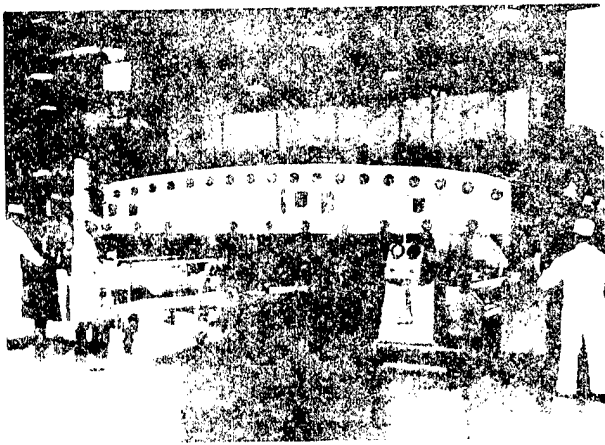

84" WIDE LAMINATOR



FLYING THREAD LOOM

Figure H
MATERIAL FABRICATION - SHELDAHL

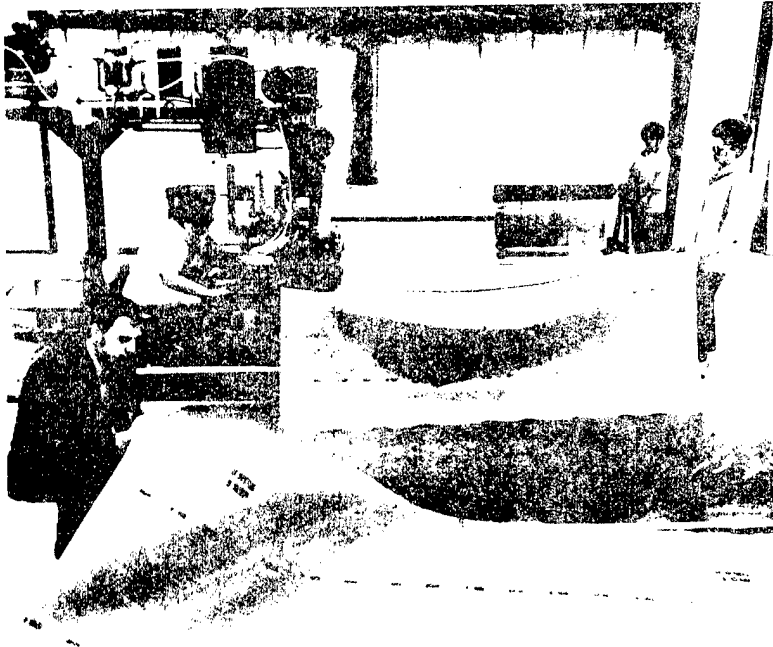

TRAVELING SEALER

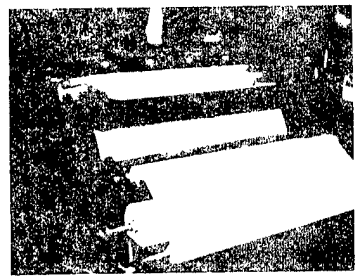

MATERIAL COATER

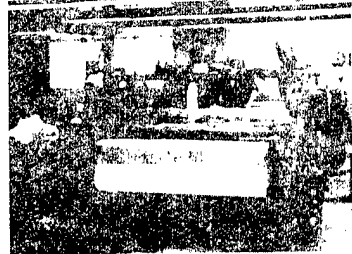

CLOTH LOOM

Figure I
AEROSTAT FABRICATION

REPRODUCIBILITY OF THE ORIGINAL PAGE IS POOR

STRUCTURAL DESIGN CRITERIA

The aerostat is designed to operate in winds to 70 knots MSL and at a constant q of 3.2 in. H_2O aloft. At 70 knots, there is a minimum factor of safety of two on fabric stresses (both direct and shear) and a factor of 1.5 on hull or fin buckling. Based on wind tunnel tests the angle of attack, α , was predicted to be ~ 6 degrees and this has been verified in flight tests. Additionally, the aerostat is designed to sustain 90 knot MSL winds with no structural safety factor; however, this requirement is less critical than the former. A dynamic mooring loads analysis established the nose structure load criteria of 25,000 pounds axial and 13,000 pounds side loads. A minimum factor of 1.5 is required on all metallic members. Tear propagation data for this particular material has been experimentally derived and is summarized in Figure J. During the checkout phase, each aerostat is thoroughly inspected for defects in the cloth such as burn marks; and, all such defects effecting more than 2-3 yarns are reinforced. Each aerostat is then proof pressure tested to equivalent 90 knot levels to insure that no design or fabrication defects remain. In-flight loads at 70 knots are predicted to be less critical than proof pressure loads-- hence a successful proof pressure test is evidence of a reliable vehicle.

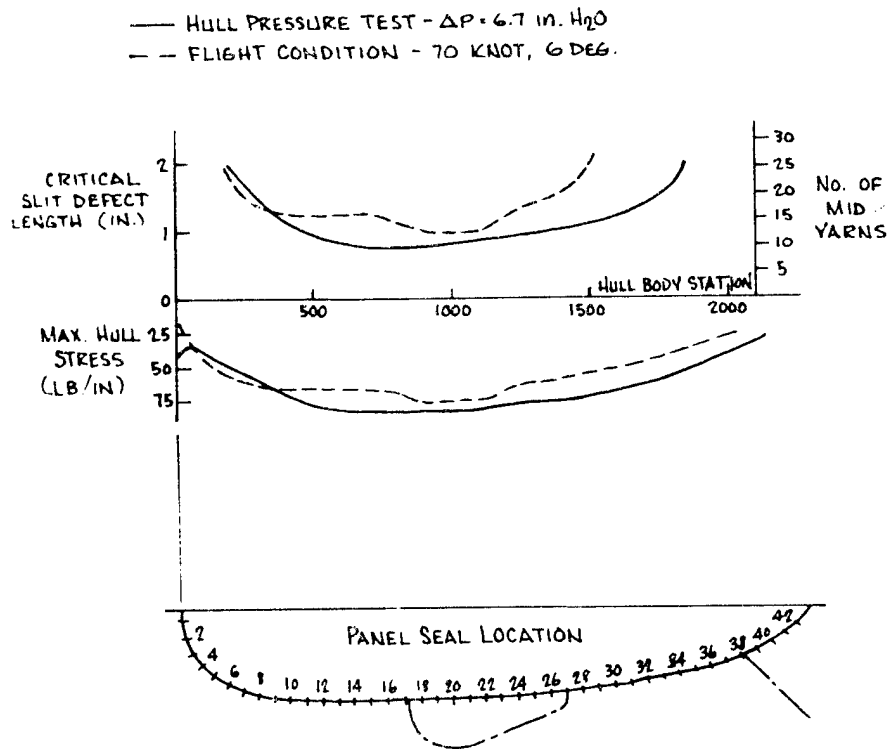

Figure J
 CRITICAL DEFECT LENGTH FOR TEAR PROPAGATION
 OF SHELDAHL CBV-350A AEROSTAT

STRUCTURAL ANALYSIS

The principal analytical tool used in the stress and deformation analysis of fabric portions of the aerostat was the large scale finite element computer program designated LD3DX, Large Deformation Analysis of Three-Dimensional Structures Extended. The program accommodates non-linear geometry behavior and orthotropic materials. Additionally, the program is designed such that external loads (buoyancy, aerodynamic pressure, skin friction drag, tether load, etc.) can be applied sequentially as they occur in service. Figure K illustrates the gross finite element computer plot of a horizontal fin and the aerodynamic pressure distribution on the fin as established by wind tunnel tests.

MATERIALS QUALIFICATION

Every material used in Sheldahl's CBV-250 aerostat, from the hull and ballonnet composites to the seal tapes and T-tapes, is tailored to its specific task. Despite the fact that each material is designed to different requirements, the design approach is the same: 1) define the requirements, and 2) perform qualification tests on the conditioned candidate materials. Figure L delineates the test equipment necessary to condition and qualify these materials and also illustrates the specially designed biaxial cylinder test machine which is used to determine the stress-strain characteristics of the composite laminate used as input to the structural analysis.

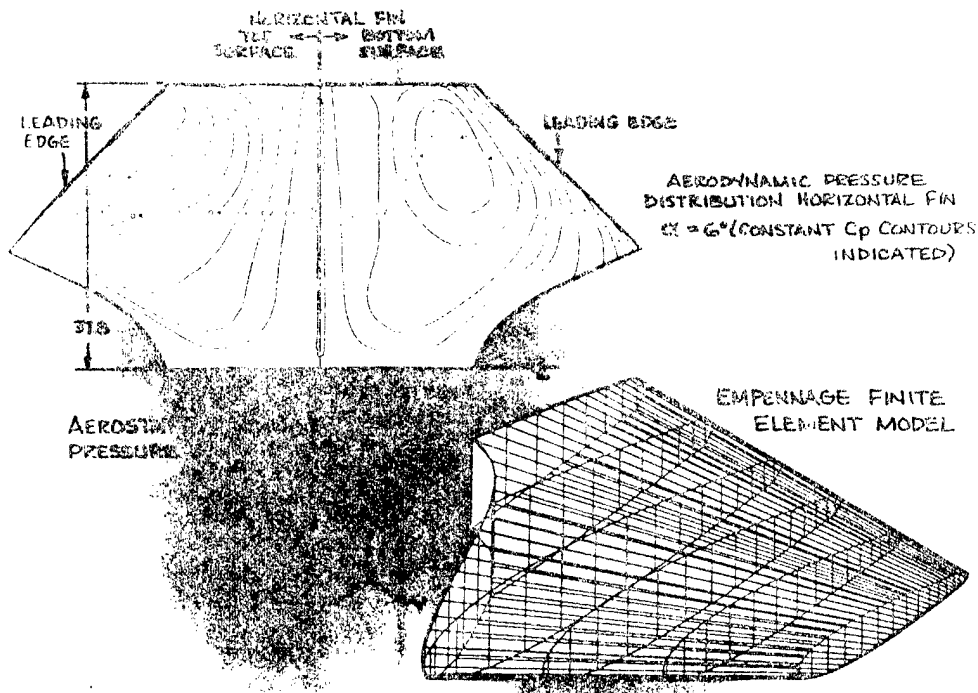

Figure K
AEROSTAT EMPENNAGE -
AERODYNAMIC LOADS AND STRUCTURAL MODEL

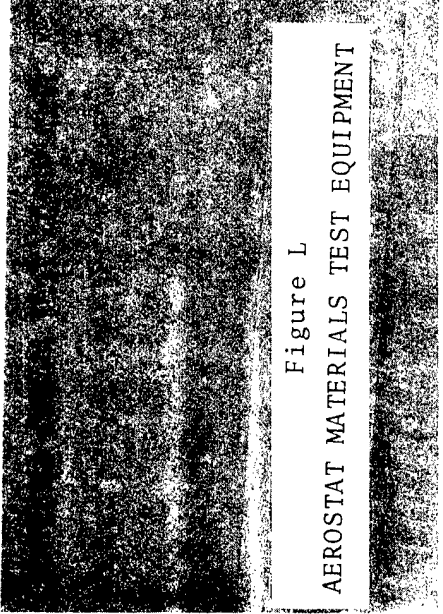
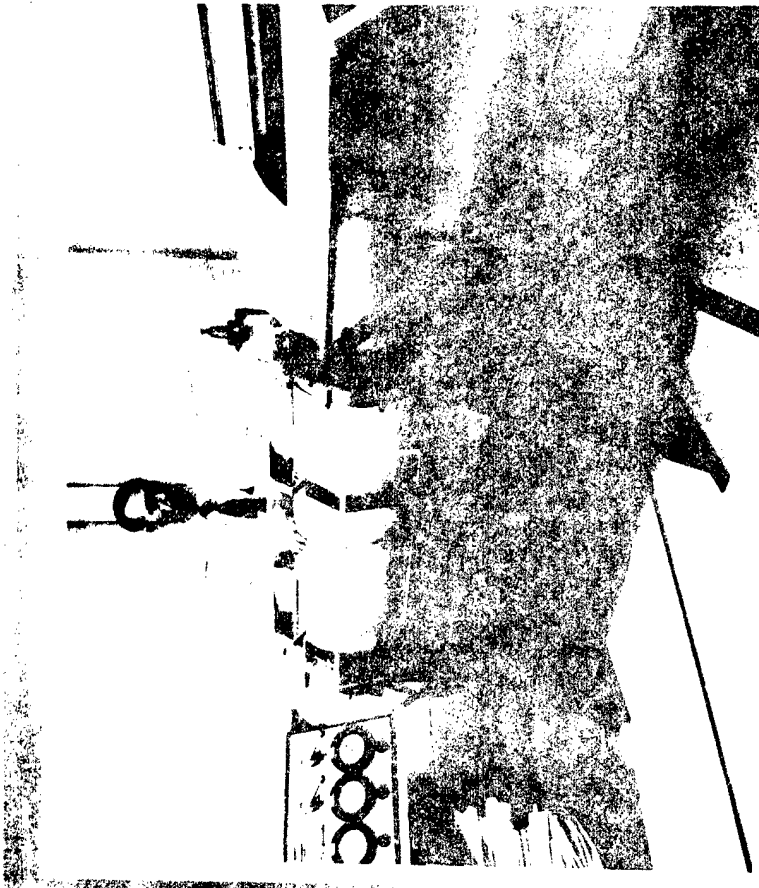
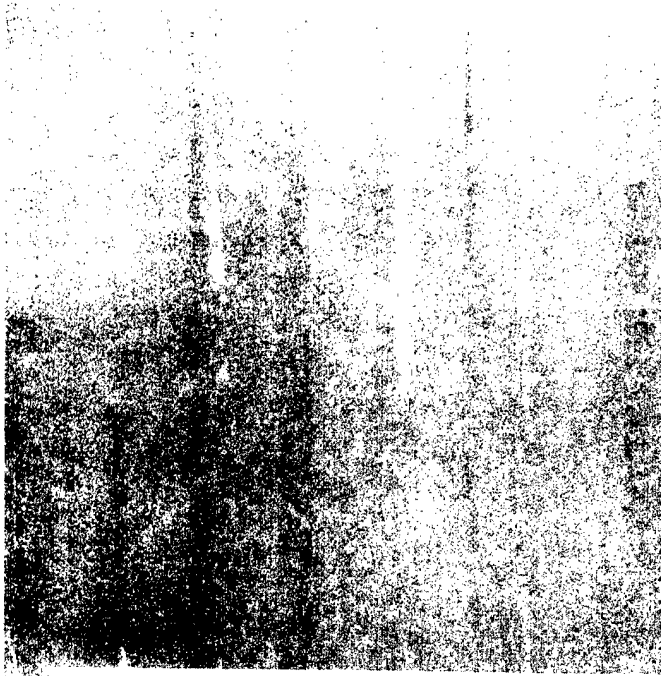

Figure L
AEROSTAT MATERIALS TEST EQUIPMENT

FLEXIBLE MATERIALS
CONDITIONING/QUALIFICATION TEST EQUIPMENT

PURPOSE	TEST ITEM	PURPOSE
BIAXIAL STRESS CYCLIC	9. CYLINDER TESTER	RELAXIAL AND SHEAR MODULI
HANDLING SIMULATION	10. SAND ABRASION	ABRASION RESISTANCE
PUNCTURE LOAD	11. RALLY-FLEX	CREASE LIFE
WEATHER AGING	12. COLD CHAMBER	LOW TEMPERATURE TESTING (-1000 F)
LONG TERM TESTING (1500 F MAXIMUM)	13. BAR COATER	ADHESIVE APPLICATION
HIGH TEMPERATURE (1500 F)	14. CYLINDER END CAPS	STATIC FATIGUE RESISTANCE
STATIC FATIGUE TEST	15. CARLE ABRASION	STATIC ABRASION
CRITICAL TENSILE STRENGTH		

REPRODUCIBILITY OF THE ORIGINAL PAGE IS POOR

TECHNOLOGY ADVANCEMENT

Figure M summarizes the more significant technological advances relating to the design and fabrication of pressurized buoyant vehicles as developed during this program.

Figure M

SUMMARY OF TECHNOLOGY ADVANCES IN STRUCTURES AND MATERIALS
FOR LTA (1960'S TO 1974)

	<u>IN 1960'S</u>	<u>IN 1974</u>	<u>IMPROVEMENT</u>
<u>BASIC MATERIALS</u>			
• WEATHERING LAYER	HYFALON	TEDEAR	MAINTENANCE FREE 20 YEAR LIFE AS OPPOSED TO ANNUAL MAINTENANCE
• GAS IMPERMEABLE LAYER	UNLUBRANE OR NEOPRENE COATING	MYLAR	FROM 1.0 TO 0.1 1/m ² /24 HR REDUCTION IN PERMEABILITY
• STRUCTURAL CLOTH	HIGH COUNT NYLON OR DACRON	LOW COUNT DACRON	GREATER TEAR STRENGTH, BETTER DIMENSIONAL STABILITY
• BIAS STRENGTH/ STIFFNESS LAYER	BIASED NYLON/ DACRON CLOTH	MYLAR	WEIGHT REDUCTION OF 1-3 OZ/YD ²
<u>MATERIAL COMPOSITE</u>			
• COMPOSITE WEIGHT	12.9 OZ/YD ²	7.8 OZ/YD ²	40% DECREASE
• COMPOSITE STRENGTH	195 LBS/IN	225 LBS/IN	30% INCREASE
• ADHESIVE IMPROVEMENTS	PRIMARILY COATINGS	FILM/FILM, CLOTH/FILM	GREATER PEEL, INTERPLY SHEAR STRENGTH
• STRESS-STRAIN CHARACTERIZATION	UNIAXIAL INSTRON	BIAXIAL CYLINDER	DETERMINE SIX CONSTITUTIVE COEFFICIENTS OF COMPOSITE
• MATERIALS CONDITIONING/ QUALIFICATION	BASICALLY ASTM TESTS	MANY SPECIAL PURPOSE TESTS	RELATIVE COMPARISON OF MATERIAL CHARACTERISTICS
<u>VEHICLE DESIGN</u>			
• VEHICLE ENVIRONMENTAL REQUIREMENTS	LIMITED STANDARDS	MIL-STD-210B NASA TMX-64589	ENVIRONMENTAL REQUIREMENTS FOR WORLDWIDE OPERATIONS THRU ALTITUDES OF INTEREST
• COMPUTERIZED FINITE ELEMENT STRUCTURAL ANALYSIS	NOT AVAILABLE	LD3DX COMPUTER PROGRAM	ALLOWS GROSS AND FINE ELEMENT MODELING USING ORTHOTROPIC MATERIALS AND ARBITRARY LOADS.
• LARGE, SHAPED, STRUCTURALLY SOUND EMPENNAGE	LIGHT & RIGID PANELS OR LIGHT WIND DEFLECTABLE DEVICES	AERODYNAMICALLY SHAPED FINS	INFLATED FIN SIMULATES A NACA FIN PROFILE WITH CHORDWISE AND SPANWISE TAPE
• VEHICLE DYNAMICS	LIMITED ANALYTICAL TECHNIQUES	COMPUTER PRO GRAMS PREDICT DYNAMIC RESPONSE	PREDICTIONS OF INFLIGHT STABILITY, AND INFLIGHT AND MOORED DYNAMIC LOADS
<u>VEHICLE FABRICATION</u>			
• SEALING METHODS	HAND SEALED	100% MACHINE CONTROLLED SEALING	IMPULSE, RF, AND TRAVELING WHEEL HEAT SEALERS
• QUALITY CONTROL	LIMITED CHECKS ON SEALS	100% Q.C. INSPECTION AND PRESSURE TEST	PROOF PRESSURE TESTS VERIFY RELIABILITY OF EVERY VEHICLE
• LOAD ATTACHMENTS	UNRELIABLE PERFORMANCE OF EXISTING ATTACHMENTS	ALL LOAD ATTACHMENTS REDESIGNED AND PROOF TESTED	VIRTUALLY ALL LOAD ATTACHMENT METHODS ARE DESIGNED TO SPREAD LOADS UNIFORMLY INTO HULL

Areas for Further Materials Research

In terms of improving the material composites for aerostats and for M2 vehicles in general, several areas require further research to improve performance and provide a more reliable product. Included are:

- Optimization of composite design in terms of strength and stiffness--tailored to a particular application at minimum weight.
- Evaluation of KEVLAR as a potential replacement for Dacron as the primary load carrying member.
- Develop fracture mechanics techniques applicable to pressurized fabric structures, and evaluate weight tradeoffs versus increased tear propagation strength.

Also, improvements in puncture resistance, sand abrasion, flexing, and thermal control would be beneficial for greater potential utility of these vehicles.

SUMMARY

While it is quite evident that much of the technology described herein is applicable to the design and development of airships, it is not quite so obvious as to what form the initial vehicle should take. If a minimum risk approach is contemplated, the following criteria are suggested:

- A semi-buoyant hybrid airship using helicopters for lift-off and in-flight control--interconnected by a rigid truss structure supported a non-rigid aerodynamically shaped pressurized hull.
- Attached to the hull for stability would be inflatable fins--designed to buckle under extreme gust loads prior to structural failure of the hull.
- Utilize the material composites and sealing techniques described herein. Employ tear stop features.
- Use a ballonnet/s--which has been proven, and results in minimum hull pressure stresses.
- Utilize a pressure control system to regulate compartmental pressures.
- Plan to proof pressure test every vehicle.
- Moor at bow--allowing the vehicle to weather vane.

TWO LIGHTER THAN AIR SYSTEMS IN OPPOSING FLIGHT REGIMES - AN
UNMANNED SHORT HAUL, HEAVY LOAD TRANSPORT BALLOON AND A
MANNED, LIGHT PAYLOAD AIRSHIP

R. A. Pohl*

ABSTRACT: Lighter Than Air Vehicles are generally defined or categorized by the shape of the balloon, payload capacity and operational flight regime. This paper describes two balloon systems that are classed as being in opposite categories. One is a cable guided, helium filled, short haul, heavy load transport Lighter Than Air system with a natural shaped envelope. The other is a manned, aerodynamic shaped airship which utilizes hot air as the buoyancy medium and is in the light payload class. While the airship is in the design/fabrication phase with flight tests scheduled for the latter part of 1974, the transport balloon system has been operational for some eight years.

INTRODUCTION

Balloon systems have been developed and are currently being used for short haul, heavy load transport operations. These balloons are designed to transport high tonnage log payloads over difficult or rough terrain. Such a transport technique has the obvious advantage of moving heavy loads in an airborne transfer mode without regard to terrain conditions. The balloon provides the lift or "skyhook" and a closed loop cable, powered by a double drum winch is the "power source" for lateral movement. Many years of full scale, commercial balloon logging have proven this Lighter Than Air method of short haul transport to be both reliable and economical.

Both government and commercial sources lead to the analysis of the logging balloon approach to ship-to-shore unloading and construction usage. Some preliminary field tests have demonstrated that a cable powered, natural shaped balloon can be used to unload cargo ships at beach

*Vice President, Raven Industries, Inc., Sioux Falls, South Dakota, USA

PRECEDING PAGE BLANK NOT FILMED

sites or unimproved harbors. Major construction companies are considering this method of materials movement for dam construction, pipeline installation, nuclear reactor locating and tower erection.

Opposed to this type of balloon and ground support system is the aerodynamic shaped airship with a light payload capacity and a buoyancy medium of hot air instead of helium. A hot air airship is being designed and constructed for manned free flight. Flight tests are scheduled for the fall of 1974. This vehicle has a 2.5:1 fineness ratio and is classed as a nonrigid airship. An aircooled power plant drives a propeller while a heat generator plus a powered fan is used to maintain the hull shape.

These two balloon systems, while being diametrically opposed in design and use functions, have one thing in common - they are both useful Lighter Than Air vehicles.

BACKGROUND

Natural shaped, spherical and aerodynamic configured balloons for scientific applications are usually thought of as being able to carry relatively light payloads to high altitudes. Such systems reflect various degrees of sophistication, including high altitude station keeping systems, long duration superpressure designs, and near-space environment thin film balloons with volumes in excess of 30 million cu. ft. Opposed to these high altitude systems are commercial heavy lift balloons which are utilized at very low altitudes. These systems are an outgrowth of the high altitude systems, since the basic technology of ballooning was developed from the high altitude, light payload balloons.

Low altitude, heavy lift balloons are characterized by payloads in the range of many tons, altitudes usually below 1000 ft., and nearly continuous operations. Such characteristics are the result of the need to provide for economic utilization of the system in commercial applications. This need for a high payload capacity for long time durations has led to the development of a class of natural shaped balloons which have nearly an all weather capability. Along with the basic balloon envelope, ground support equipment and operating techniques have been developed for this class of balloons.

Upon detailed analysis of the transport objectives, the natural shaped balloon design was selected. This shape was chosen since it has a high static lift efficiency, is not dependent upon aerodynamic lift, and can be fabricated with heavy coated fabrics which yield long life envelopes. Other parameters, such as the ability to withstand high shock loads entered into the balloon shape selection. Based on an excess of 150,000 hours of operations, the basic balloon design has proven to be correct.

On the other end of this flight spectrum is the aerodynamic shaped, manned, light payload airship which uses hot air as a lifting medium. Airships are usually thought of as being in two general classes - the rigid, classic Hindenberg types or the Goodyear advertising blimps. This paper describes a blimp type Lighter Than Air vehicle with a two man gondola and a nonrigid hull filled with heated ambient air for lift generation. The low drag hull shape, gondola, power plant and flight characteristic selection was based on costs, simplicity and ease of operation. It is intended only for relatively "fair weather" flight of hours' duration. With the nonrigid envelope, the vehicle is storable and transportable in a small truck and its base of operation can be mobile or fixed.

The following sections describe the heavy lift, unmanned natural shaped transport balloons and the manned light payload hot air airship - two vehicles with dissimilar shapes, characteristics and usage, yet both are in the class of Lighter Than Air flight vehicles.

NATURAL SHAPED, HEAVY LIFT, SHORT HAUL TRANSPORT BALLOONS

Balloon Design

The highest static lift efficiency of any balloon shape is a sphere, and the natural shaped balloon approximates that shape (Figure 1). The natural shape does not have any region of excess envelope material or extreme stress concentration. In this shape, the payload force is transmitted primarily into the balloon meridionally, and the circumferential stress is practically zero.

Shape - A natural shape is variable within bounds. A complex shape factor, called Σ , basically describes the relationship between the inflated height and diameter. The Σ value varies from 0 to 0.4, where at $\Sigma=0$, the balloon weight is small compared to the gross lift, and at $\Sigma=0.4$, the payload is light compared to the balloon weight. A high Σ value results in a fatter shape (i.e., diameter over height is larger). Heavy lift balloons are designed at low Σ values, since the balloon weight is relatively smaller than the gross lift.

An important feature of a natural shaped balloon is the ability of the design to carry heavy loads with relatively uniform load distribution into the envelope. This uniform distribution also enables the design to take shock loads with minimal introduction of stress concentrations and bending moments as is typical in our aerodynamic shape balloons. This basic balloon design property is of paramount importance to transport operations. A natural shaped balloon is also conducive to the addition of meridional direction, load carrying members to the gores, thereby permitting heavy payload designs.

Aerodynamic Considerations - The aerodynamic force coefficient properties of natural shapes are shown in Figure 2. Since a natural shaped balloon is a symmetrical body of revolution about the vertical axis, the force coefficients are independent of wind direction. This property is of prime importance in transport functions because the balloon must operate at or near full lift capacity regardless of wind direction. As shown in Figure 2, aerodynamic lift cannot be relied upon under normal wind conditions. In fact, the system will normally operate in the negative aerodynamic lift region. Since system design is predicated on static lift only, this coefficient is not considered in determining maximum usable lift. However, in designing a system for a specific payload, allowance is made, in the form of excess static lift, for predicted negative aerodynamic lift. This added lift is relatively small, since the negative lift coefficient is encountered only at lower wind speeds.

The drag coefficient for natural shapes generally falls between 0.2 and 0.3 for the Raynold's number range considered applicable in transport systems. While the drag coefficient range is considerably higher than that of aerodynamic shaped balloons, for the applications described herein, the advantages of volumetric efficiency, independence of aerodynamic force generation, (i.e., ability to operate at full lift capacity regardless of wind direction), high mass moment of inertia, gust stability, and uniform envelope loading far outweigh the advantage of a lower drag coefficient.

The natural shaped hull is very stable at low altitude operations due to its uniform cross section and the static lift. Gusty wind conditions effects on an inverted tear drop shape are minute in comparison to an aerodynamic shape, and oscillations are typically slow and quite limited in normal operating configurations.

Envelope stresses in a natural shape are due to the envelope internal pressure generated by the dynamic pressure and the distribution of the payload forces into the envelope. In a 530,000 cu. ft. balloon, the envelope stress, due to a 60 knot wind is 32.1 lb/in. (includes an over-pressurization factor). The maximum load input to a natural shape is at the skirt/balloon interface. Under a 60 knot flight condition, the load input at this interface is approximately 46,340 lbs. Assuming uniform loading, the skin stress is then 43.1 lb/in., and the gross load input in a 60 knot wind is 75.2 lb/in. The basic fabric strength is approximately 300 lb/in., thus the safety factor in the "material only" case is approximately 4. In the actual design, the applied loads are carried by the load webbings which are located on the balloon gores and the envelope material. A 530,000 cu. ft. balloon has 78 load webbings rated at 2,500 lbs. tensile. Considering the point of load input to the envelope, the safety factor relative to these applied loads will be in excess of 11.

Materials - The envelope material utilized in this class and shape of balloon is a 10.75 oz/yd² coated dacron fabric. This material has a tensile strength of approximately 300 lb/in., is UV resistant, and has a low permeability in the range of 0.3 liters/m²/24 hours. The elastomeric coatings are also highly resistant to abrasion and wear.

A continuous loop of steel cable is used as the top end fitting for the load webbing terminations. Steel cables form the interface couplings between the load webbings and the bottom end fitting. Lightning protection is provided by a top mounted tower and multiple braided cables extending down the load webbings to the bottom end fitting. This fitting incorporates a multiple swivel, and is coupled to double tether lines.

These balloons are normally inflated to 90% of their full volume to allow for temperature and pressure altitude changes. At this inflation level, the lower portion of the balloon is slack. An ambient wind pressurization skirt is used to protect the lower slack portion of the balloon. The skirt also serves as a load transfer coupling between the balloon and the bottom end fitting.

Advanced Developments - Based on some nine years of design, test, and operational usage, the envelope design and materials are presently being modified to increase the operational limits of these balloons. The new envelope material has been developed with better physical characteristics. The natural shape has been modified to a "round top" configuration and the skirt is being eliminated. A ballonet is being installed to enable higher operational conditions. These basic features are being incorporated into a logging balloon currently under construction.

Typical Balloon Sizes

Heavy lift balloon sizes that have been or are currently in operation have volumes of approximately 240,000, 530,000, 700,000 and 815,000 cu. ft. In volumetric comparison to high altitude balloons, these sizes

are small. However, since these units are used at very low altitudes, the payload capacities are large when compared to other types of balloons. The payload range for the above mentioned systems is 11,000 to 40,000 lbs.

The specifications for the balloon sizes that have been used operationally are shown below:

Balloon Specifications

<u>Models</u>	<u>250K</u>	<u>530K</u>	<u>700K*</u>	<u>815K</u>
Volume (cu. ft., max)	250,000	530,000	700,000	815,000
Diameter (ft.)	81	105	109	123
Height (ft.)	87	113	131	121
Approximate Balloon Weight (lbs.)	3,000	6,200	8,000	9,000
Net Usable Lift (lb.)				
Sea Level	11,000	25,000	33,000	40,500
5,000 Ft.	9,500	20,700	27,700	33,790
Approximate Wind Drag @ 45 mph, S.L.	2,400	4,100	3,100	5,600
Lift-to-Drag Ratio	4.6	6.1	11	7.0
Lean-Over Angle @ 25 mph	12°	9°	6°	8°
Estimated Lift Loss (lb./day)	25	40	45	50

*700K design based on advanced round top, no skirt configuration.

A 530,000 cu. ft. balloon, as shown in Figure 3, is normally flown in winds up to 40 mph. This 105 ft. diameter balloon is shown in the bedded down condition in Figure 4. In this condition, winds of approximately 100 mph have not had any detrimental effect on the balloon.

CABLE POWERED SHORT HAUL TRANSPORT

Natural shaped, heavy lift balloons were primarily developed for the logging industry. Large volumes of timber located in mountainous terrain cannot be harvested using ground skidding or cable systems due to their physical limitations, extensive road construction, and deleterious impact on the terrain. Other timber located in rough mountainous terrain is expensive to harvest with conventional equipment, and in many cases, cannot be transported from the cutting site to a road landing for hauling by truck to processing mills. Mountain road construction costs range from \$20,000 to \$75,000 per mile, and their usage is being restricted because of the damage to forest regions.

During the mid-1960's Raven Industries, Inc. and Bohemia Lumber Company initiated the development of an airborne log transport system using a natural shaped balloon. The balloon design was selected upon thorough analysis of the operating requirements and flight regime involved in carrying a payload of logs from the cutting site to the landing site (this phase of moving logs from the forest to a road site is called yarding).

Yarding logs with a balloon involves the use of the balloon to supply the lift and a winch powered cable arrangement for lateral direction movement. A typical layout is shown in Figure 5. The technique can be used practically anywhere a line can be strung - across steep slopes, valleys, swamps, high timber, rivers, and other obstructions. The winch or yarder (Figure 6), as it is commonly called, has two power driven

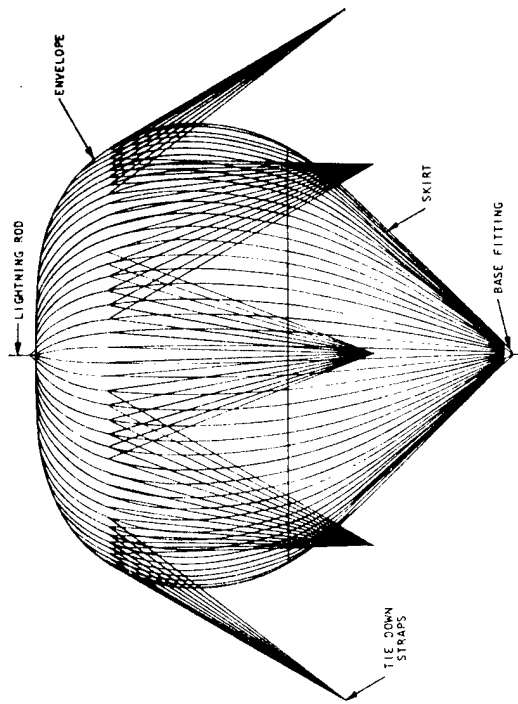

Figure 1. Natural Shaped Balloon Configuration

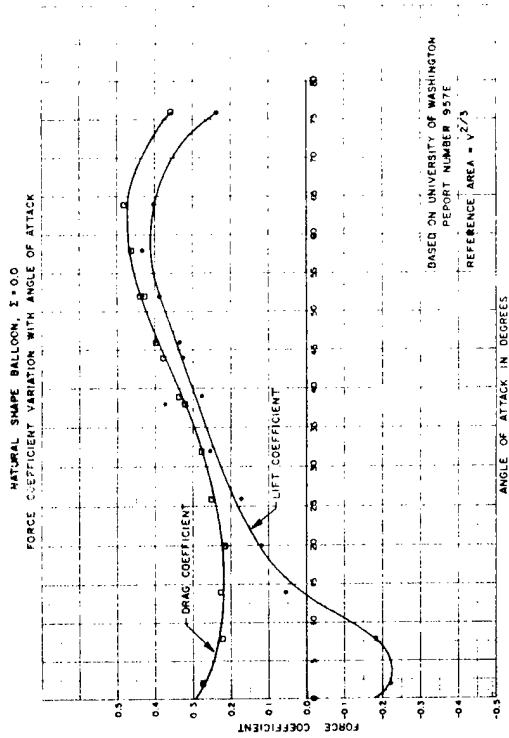

Figure 2. Force Coefficient Variation with Angle of Attack

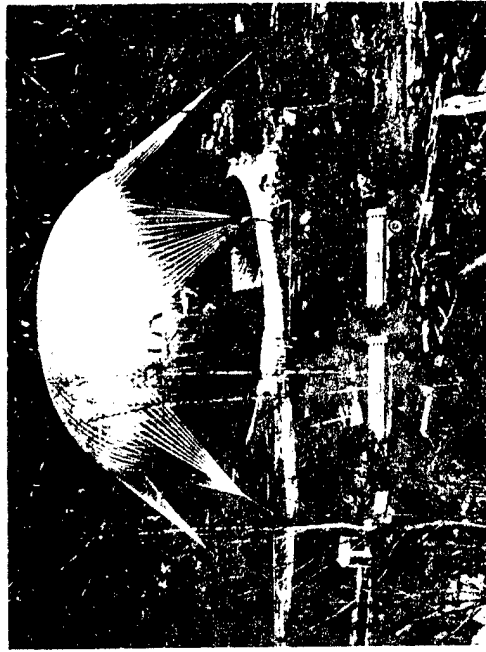

Figure 4. Natural Shaped Balloon in Bedded Down Condition

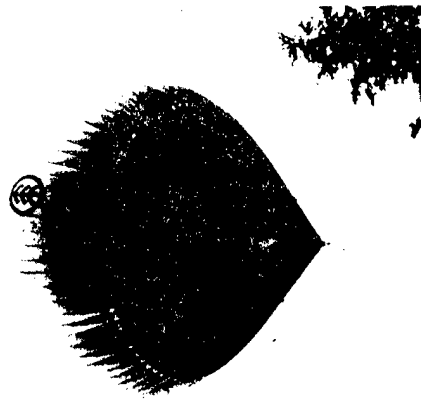

Figure 3. Natural Shaped Balloon in Flight

REPRODUCIBILITY OF THE ORIGINAL PAGE IS POOR

drums that can either be run in an interlock or independent manner. One drum contains the main line which extends to the balloon and powers the balloon on an inbound trajectory. The other drum is used to hold and power the haulback line for the outbound trajectory. With the mainline and haulback drums powered in interlock, both lines can be either taken in or let out, thus controlling the balloon altitude over a fixed point (i.e., the mainline and haulback act as a two-point tether line). The balloon is moved horizontally by letting out on either the haulback or mainline and pulling in the other line. Obviously, these two modes of coupling and uncoupling the haulback and mainline drums in either direction enable the balloon to be flown in a trajectory along the cable layout path. Maximum line speed is about 2,000 ft./minute.

Both lines from the drums go through fairleaders located on a tower on the front of the yarder. The haulback line is passed through a number of stump anchored tailblocks located on the upper end of the timber area being harvested. The free end is attached to the butt rigging, which is the main tether point of the balloon. The mainline extends from the yarder to the butt rigging, thereby forming a closed loop cable system.

The balloon is normally flown 250 to 300 ft. above the butt rigging, while the tag line, which extends down from the butt rigging, varies in length up to 500 ft. Chokers, which are short cables with quick couplers, are wrapped around the logs, and are connected to the tag line by a ring and toggle connection.

The "cable track" is initially set up with a lightweight straw line that enables the one in. steel cable to be strung through the tailblock layout under power from the yarder. Relocation of the cable layout in a given logging area is done by progressive movement of the tailblocks on the upper end of the area being harvested.

Yarding distances are presently limited to approximately 3600 ft. This distance is primarily determined by the mainline and the haulback drum size. Future systems, now in the planning stage, will extend this distance beyond a mile, and possibly, many miles.

A 530,000 cu. ft. balloon with 90% inflation level has a net lift of 25,000 lbs. at sea level. The nominal log payload range is 20,000 to 22,000 lbs., when allowances are made for the suspended cable and rigging.

The average transported load is lower than this, since the log selection process is done by gross scale estimates rather than a weigh-off. A turn of complete cycle time will vary from 5 to 8 minutes, depending on the yarding distance, log felling conditions, and timber density. In general, it can be said that the balloon logging system has a transport rate of 10 to 11 tons over distances up to 3500 ft. every 5 to 8 minutes. Actual tonnage rates vary from 50 to 100 tons per hour.

Balloon logging operations are conducted in winds up to 40 mph. Balloons have survived in partially sheltered bedding areas when winds in the vicinity have been recorded in excess of 100 mph. Two shift operations have been utilized with the use of portable illumination devices. During recent years some 150,000 hours of full inflation time have been recorded on natural shaped logging balloons. The only mishaps which occurred during this period were cases in which the balloon was flown in conditions outside the rated flight regime or because of malfunction

of the ground support equipment. The cases were (1) balloon on tether in winds of 100 mph, (2) icing conditions, (3) balloon struck by lightning prior to installation of a lightning protection device, and (4) breakage of pull down cable due to overtensioning by operator.

Relocation of balloon logging equipment is relatively simple. The yarder is track mounted and can be moved short distances under its own power. Larger hauls are made by loading the yarder on a low-boy trailer. The balloon is moved in a tethered state 200 to 300 ft. above a transfer vehicle, which is shown in Figure 7. Both rubber tired and crawler type transfer vehicles are used. The transfer vehicle is loaded on a lowboy trailer for long moves. The equipment and balloon have been moved over distances up to 80 miles in one night.

Other balloon transport applications being evaluated include ship-to-shore unloading, construction operations (i.e., a pipeline installation, swamp logging, and mining). A typical ship-to-shore setup is shown in Figure 8. Construction projects are close to being tried in a number of different areas.

These balloons have been used by major logging companies since May of 1967 when a Model 250K was made operational in timber country near Reedsport, Oregon. The first Model 530K was put into logging service in April of 1969. Today there are four Model 530K balloons at various locations in Oregon, Washington, and Alaska. These logging balloons have demonstrated that the transport of logs over rough terrain by a cable controlled balloon is both reliable and economical. In general, the costs of transporting timber from the cutting site to the landing site range from \$20 to \$25/1000 bd. ft. Doing this same transport function with a helicopter will cost in the neighborhood of \$100/1000 bd. ft. Direct comparison of these costs is not always justified since the total logging operation must be evaluated - both balloons and helicopters have their places in timber operations which require "free and clear of the ground" timber transport.

A turnkey balloon logging system which includes the balloon, yarder, running lines, cables, blocks, transport, helium, helium trailer, costs some \$500,000 to \$750,000 depending on the balloon size and ground support equipment. The continued use and expected expansion of this market proves that such capital equipment expenditures do yield a good return on investment. Both the federal and state governments are now specifying on numerous timber sales that logs must be yarded "clear and free of the ground" - in other words, they cannot use conventional logging systems for the most part on these particular logging sites.

The maintenance of a logging balloon is generally rather minimal. Upon initial inflation the balloon is thoroughly checked over the the lighting mast installed on top of the balloon. For the most part, the loss of helium through the heavy coated fabric envelope is minimal. A helium top-off (addition of helium after initial fill) is usually not required for the first 5 to 6 months. As the envelope material "wears in" top off operations are made on an as needed basis - usually 3 to 6 month intervals. Such helium additions are in the range of hundreds of pounds of lift.

Early in the program, the balloons were painted with elastomeric paints about every year. In recent years, new fabric coatings have minimized this - for example, the 530,000 cu. ft. balloon being used by Bohemia, Inc. has been in service two and one-half years and has not been painted

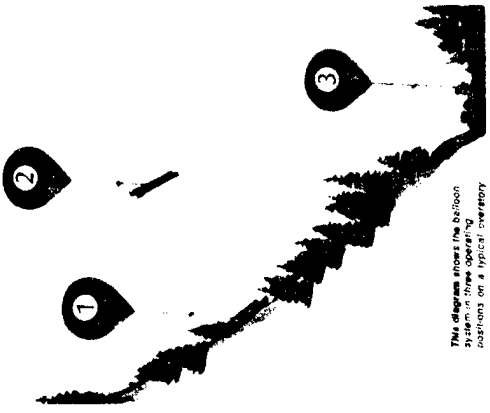

Figure 5. Typical Schematic of Logging Balloon Operation

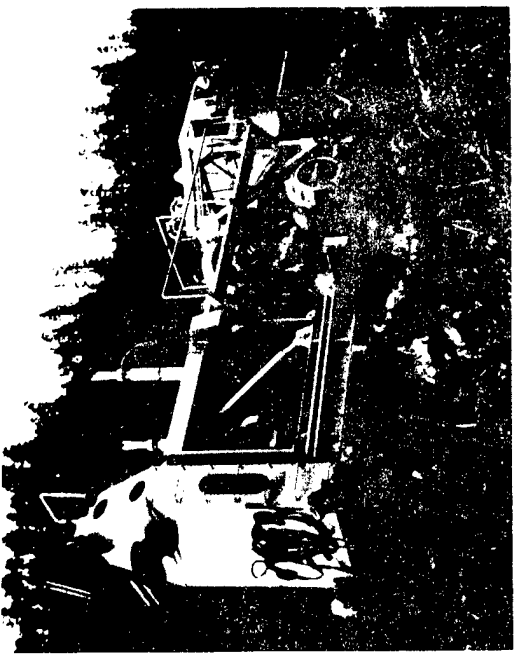

Figure 6. Balloon Yarder

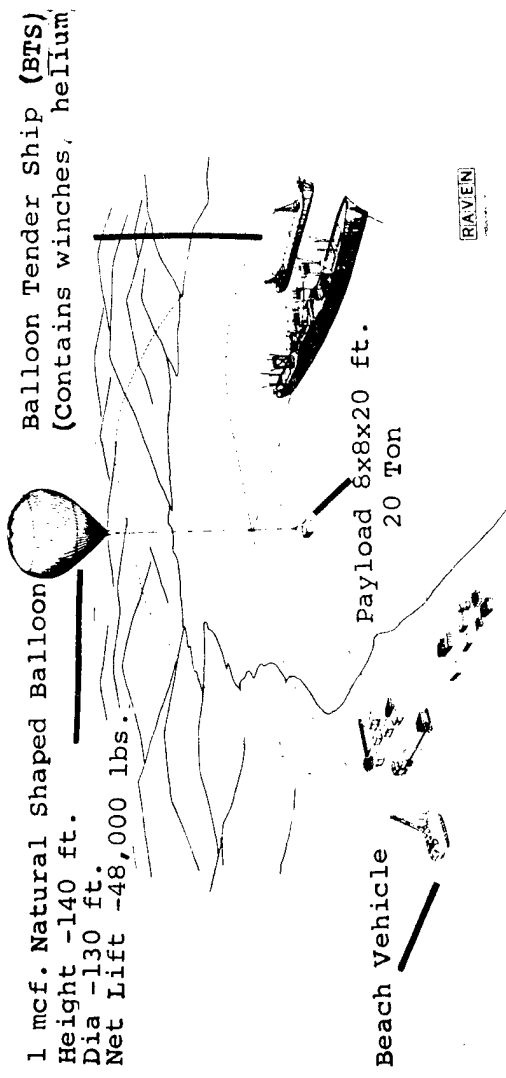

Figure 8. Typical Ship-to-Shore Balloon Transport Layout

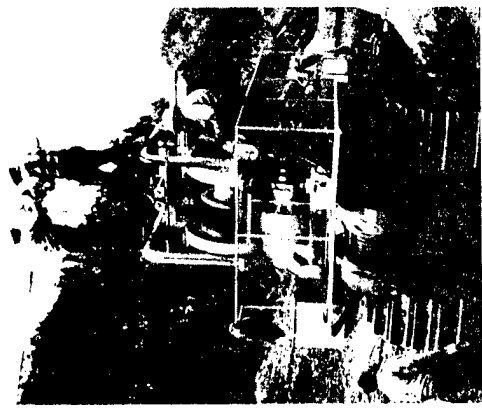

Figure 7. Balloon Transfer Vehicle

since being put into service. Upon recent inspection of this balloon it appears that the coated fabric is still in a near new condition after some 13,000 hours of being at full inflation.

Some small holes do occur during logging. These are due to the balloon being struck by a branch, or some wear. Such minor holes are repaired in the field with a cold patch being applied by a crew member being suspended on a rope ladder from the top molly or by literally walking around on the top of the balloon should a hole occur on the upper portion of the balloon. Maintenance problems for the most part are much more prevalent in the ground support equipment than in the balloons. New ground support currently being tested in the Pacific Northwest should reduce these maintenance costs to a minimum.

Natural shaped balloons with high payload capacities and long duration flight capabilities have been developed for use as transport vehicles. Current commercial operations in the forestry industry have demonstrated that this family of aerostats is both reliable and economical as a primary lift component in an airborne log transport system. Other current and future transport projects indicate a rather high degree of versatility for this area of Lighter Than Air technology which is based on natural shaped balloons that are cable guided. Some recent developments indicate great promise for hybrid systems that increase the payload capacities, extend the transport distance and overall system efficiency.

HOT AIR AIRSHIP

Introduction

Hot air sport balloons with a natural shaped configuration are a reliable and economical method of free ballooning at low altitudes. These balloons are primarily used as sport vehicles and in some cases, for advertising and promotion. With an onboard burner(s) and a hydrocarbon fuel source for maintenance and control of the buoyancy state, the balloons float with the wind and have practically no directional control other than the wind vector variations as a function of altitude. This flight regime is acceptable for the type of flying done by sport balloonists.

Hot air is an economical buoyancy medium for relatively short duration, low altitude flights with manned balloons. The obvious advantage of thermal buoyancy in a balloon is that it can be "generated" as needed or desired by the combustion of liquid fuels in relatively simple onboard burners. This basic fact has made hot air ballooning a popular sport that is quite commonplace throughout the United States.

The obvious next generation of hot air ballooning is a thermal airship with a low drag hull and an onboard power plant so the balloonist can control his direction. Such an airship is presently under construction this year. The general design and operating characteristics of this vehicle are described herein. This project and the vehicle are called STAR.

Hull Design

The hull of the STAR airship is based on a class C shape with a fineness ratio of 2.5:1 and a volume of 140,000 ft³. These parameters result in a hull length of 120 ft. and a diameter of 48 ft. (Figure 9). Four inflatable fins are located on the aft hull section for stability and directional control. The fins are inflated through gas transfer ports

located in the fin root/hull interface. Interweb sections maintain the fin thickness and determine taper angles. A movable rudder section is located on the upper vertical fin while both horizontal fins have elevator control surfaces.

The hull is constructed of a urethane coated polyester ripstop fabric (3 oz/yd²) with MD/TD strengths of 100 and 70 lb/in. Longitudinal gores constructed of panel sections are utilized to maximize the fabric properties. The hull is a single compartment cell with catenary suspensions located near the top of the hull as shown in Figure 10. These load suspensions are used to transfer the gondola loads into the hull at maximum lift locations and distribute the center of buoyancy/gravity intersection planes. Temperature distribution in the hull is anticipated to yield a somewhat uniform center of buoyancy area; however, one of the twin burners used to supply heat to the ship is gimballed to permit burner plane variations along the longitudinal axis.

Heat Generators and Hull Pressurization

Twin burners with a combined output of 4.5 million BTU/hr. are used to heat the air in the hull. The burners are located on the top of the gondola and within the hull and are combined with a pressurization fan to maintain the hull at 0.5 in. of H₂O. Liquid propane is used as a fuel and is contained in stainless steel tanks located in the gondola. Both the burners and pressurization fan are standard hot air sport balloon components. The pressure fan is powered by a small gasoline engine. A redundant feature of the fan power source is an engageable power takeoff from the main power plant.

Gondola and Power Plant

A fabric covered, aluminum frame gondola is located under the hull at a location which will yield a 6° negative angle of pitch with zero power application. This ten foot long gondola is configured for a side-by-side pilot/copilot in the forward section with the main power plant, fuel tanks, and blower/burner in the aft section (Figure 11). A pusher propeller located on the gondola aft section is driven by a 65 horsepower Revmaster Volkswagen aircraft engine with single ignition starter, and a 12 volt generator. Aviation 100 octane gasoline is the fuel source. An annular ring duct around the prop is used to maximize prop efficiency and thrust direction.

Controls and Instrumentation

Controls include rudder, elevators, propane flow to burners, main power plant throttle, burner override, propane pressure to burners, blower speed and aft burner gimbal. These basic controls are used for flight direction and internal hull temperature variations for gross lift modification. As is commonplace in manned hot air sport balloons, the large inertia mass of the ship will yield a somewhat slow response to the heat and/or rudder-elevator control inputs.

The panel in the forward section of the gondola will have the standard engine condition monitoring instrumentation. Also included on the panel are an airspeed indicator, altimeter, rate-of-climb, balloon internal temperature, hull pressure, fuel quantity and pressure gauges.

Operations

The STAR airship with its 65 horsepower engine is intended to have a

service ceiling of 4,000 ft. at a gross load of 2,030 lbs. which includes 78 gallons of propane and a 100 lb. payload. The anticipated flight duration is three hours. Under these conditions and at the maximum available thrust of approximately 350 lbs. STAR is predicted to have a top airspeed of 25-30 mph.

As has been noted, airship response to control surface deflection will not be rapid. For example, analysis indicated that at low airspeeds (up to 10 fps), large elevator deflections will have little impact on the pitch of the airship. This analysis predicts elevator deflections in excess of 40° (upwards) to achieve trim at airspeeds in this range. On the other hand, at maximum speed, response in pitch to elevator deflection is predicted to be quite sensitive, to the extent that pilot experience will be a major factor in achieving level flight. Nevertheless, since altitude control of STAR is for all practical purposes a function of thermal rather than aerodynamic considerations, these response characteristics will not affect system usability and the flying attitude accepted by the pilot will be largely a function of the flight conditions and his comfort.

Figure 12 indicates the elevator deflections required to achieve an angle of attack of 0° . The system weights for which this information has been derived are as follows:

- 2187 lb. - Full load, Pilot and Copilot, 100% fuel.
- 2007 lb. - Full load, Pilot only, 100% fuel.
- 1827 lb. - Full load, Pilot and copilot, 20% fuel.
- 1647 lb. - Full load, Pilot only, 20% fuel.

In this figure, the lack of low speed response is evident. Also it is here seen that the low speed "reversal" of control surface deflection at low speeds common in airships is predicted for STAR. However, since the medium static pitch angle is only approximately 6° at the maximum gross weight (approximately -1.5° at the minimum listed system weight), it will probably be found that no elevator deflections will be necessary at these speeds to give acceptable performance. This region of the flight envelope in which reversal occurs will be a factor only under higher gross weight conditions.

The size of all control surfaces was selected on the basis of those surfaces which have provided controllability in previous manned and unmanned airships. This predicted controllability in yaw has been verified by comparison to wind tunnel data available in general circulation for a specific airship model (not STAR). However, response to rudder deflection is expected to be quite slow, to the extent that it may be necessary under certain conditions to accelerate to the upper range of airspeed in order to achieve the required response characteristics. Control surface deflection will be achieved through a cable and hand crank system which will provide some mechanical advantage in deflecting the surfaces. Application of this force will be near the trailing edge of the control surfaces.

Normal flight operations are to be VFR in light to moderate wind conditions. Both takeoff and landings are the same as normal airship operations. VTOL operations will also be possible in light wind conditions. Since the hull is nonrigid and the buoyancy medium is generated onboard, the vehicle will be inflated at the takeoff site and deflated upon landing. The deflated hull, along with the gondola, can be transported with a medium sized truck.



Figure 9. STAR Thermal Airship



Figure 11. STAR Gondola Under Construction

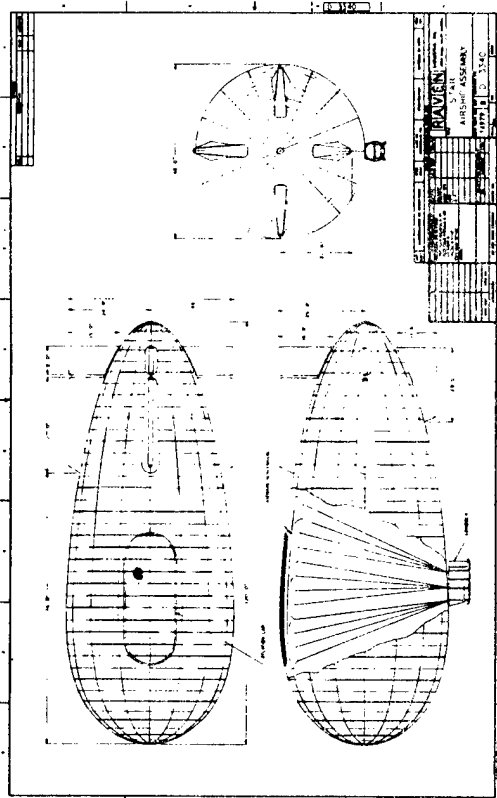

Figure 10. STAR Airship Assembly

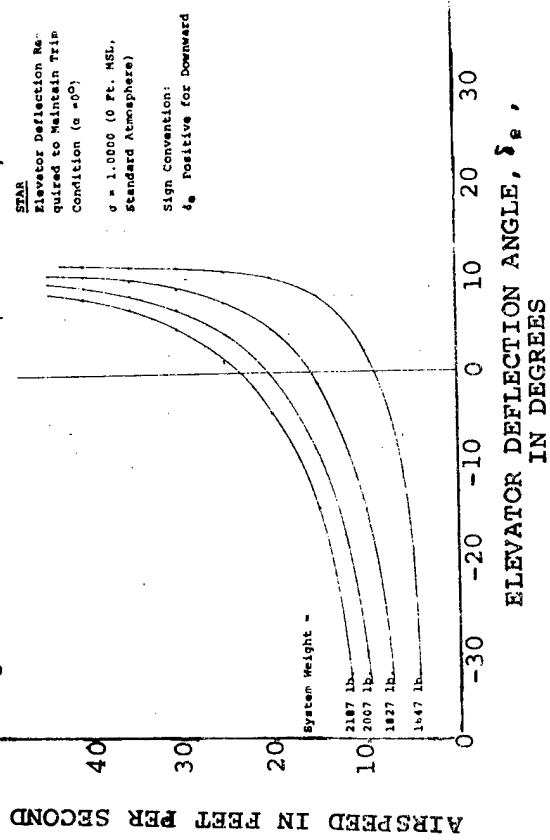

Figure 12. Elevator Deflection Required to Maintain Trim Condition

Handling lines are located around the hull to aid in operations. A deflation panel located on the hull topside will be pulled out by the pilot upon landing. The type of "pull out panel" is the same basic configuration as that used in hot air sport balloons. Once the hull is deflated, the panel is manually replaced.

The STAR vehicle is intended for the low and slow flight regime with directional control. It is designed for ease of maintenance, low operational costs and relatively simple logistics.

BALLOON LOGGING WITH
THE INVERTED SKYLINE

C. Frank Mosher*

ABSTRACT: There is a gap in aerial logging techniques that has to be filled. The need for a simple, safe, sizeable system has to be developed before aerial logging will become effective and accepted in the logging industry. This paper presents such a system designed expressly on the K.I.S.S. (Keep It Simple Stupid) principle, and with realistic cost and ecological benefits.

INTRODUCTION AND OBJECTIVE

Today, in my mind, we have the best potential mountain-logging system only with balloon transportation techniques. This is particularly true as we are having to face the most difficult and inaccessible areas in this coming generation of logging. With the constant increase in timber value, the requirement of recovering every last fiber of wood is becoming an absolute business and forestry necessity. Mountain-logging is creating serious problems at present, but surely we have the technology and brains to accomplish what has to be done for the future, within a reasonable cost, and within the constantly-increasing ecological requirements.

*President, Mosher Balloon Systems, Inc., Eugene, Oregon

I am pleased to have been involved in the old steam-donkey logging operations of the Pacific coast, as well as many other operations in the past 25 years, but to me, balloon logging has now evolved as an essential development for future logging operations. The necessary objective is brutally simple: to lift the full "tree package" off the stump, out of the woods, and down to the landing.

Thinking deeply of the future, it is not logically possible for us to continue to send high-priced cutters or fallers into the mountains to unavoidably shatter 10% to 20%, or more, of the total timber volume on rock bluffs, canyons, stumps and steep sidehills. It is also not possible that we can continue to yard, or drag, the remainder of that volume over similar bluffs, canyons, etc. for another 10% or 20% loss. This waste is far too valuable to be destroyed by slash fires or left to rot. Surely we can do better, and I believe the balloon system can provide us with the means.

Since 1960, when I first started thinking of balloon potential, I have been involved in most of the balloon logging developments, to try personally, as much as physically possible, to insure their relative success. As a result, I have probably accumulated more direct hours of daily balloon logging operation and supervision than anyone I know of. Balloon operations are now working in several areas of the Pacific Northwest, Alaska and Canada. The present system is driven by yarding machines which pull the balloons back and forth with lines known as the mainline and haulback. In rather short yarding distances, this system has worked, and along with the other two main aerial logging systems (skyline and helicopter), it is being utilized to the best of its capability.

Skylines and helicopters are excellent systems for logging in certain areas and under certain conditions, but they now have, and always will have, inherent problems that limit their usefulness. Balloon logging, however, is the only technologically-free system of transportation available to us to meet the necessary objective of "standing-tree logging." That is to say, properly developed, it has no inherent restrictions as to topography, deflection, lift, yarding distance, weather, future development, and most important, cost per thousand board feet (MBF).

The purpose of this report is to familiarize you with the systems-improvement proposal by my company to help make balloons and balloon transportation a hard reality in the hard world of competitive logging.

INHERENT PROBLEMS WITH PRESENT AERIAL SYSTEMS

Skyline System

Skyline logging is one of the oldest cable methods in the Pacific Northwest. For years we have utilized the system to log the concave or "good-deflection" valleys with ever-increasing efficiency. However, as a result, we have now reached a point where this process has caught up with us and we have fewer and fewer areas where adequate deflection

is satisfactory. This problem, combined with the requirements of longer yarding distances over rougher terrain, and the need for doing a better job of lifting, has caused the skyline system to become less useful over the years.

Helicopter System

Helicopter logging is the newest system in the West. In the past few years there has been much emphasis on the merits of this method because of its speed and versatility. However, the problems of its disaster-factor, limited lifting capacity, weather limitations and ever-increasing costs have dampened enthusiasm quite markedly. Yarding costs in the \$140-\$160/MBF range have been quoted, and with future Sikorsky Flying Cranes costing as much as 3.3 million dollars, who can predict where the costs will end? Certain areas of high value or scattered wood that cannot be logged by any other methods should be removed by helicopter. However, indiscriminate layouts for helicopters on normal timbered slopes, merely because it's easy, create a serious concern, as stumpage loss has to be accepted in order to keep these vehicles in business.

Present Balloon System

The present high-lead balloon system has developed gradually since 1964 into a workable method. Chronic yarder problems are being improved and with maximized daytime, good-weather production, annual yarding costs in the \$40-\$60/MBF range are possible.

However, in my mind, the critical problems with the system are snow on the natural-shaped balloon and a high drag co-efficient in relative wind conditions over 20 knots. The snow situation creates a disaster-factor that, similar to the helicopter operation, is far too high. During a heavy snowstorm, men have to climb on top of the balloon and remove the snow with brooms and shovels. Needless to say, this is an unnerving and hazardous job.

Similarly, wind problems, on many occasions, have given us serious periods of concern trying to get the balloons to safety before damage occurred.

What happens is that the front of the balloon flattens, as the wind builds up, and the co-efficient of drag jumps from approximately 0.5 to 1.1 or higher (similar to a circular disc). Then, suddenly, you have a serious increase in drag (approximately twice as much), which is difficult to handle for normal logging operations and hazardous for transportation to the bedding area.

As a result of the problems and limitations of the present balloon system, I believe it is essential to offer an improved balloon configuration and system that will lend itself to safe and easy handling in these critical situations and reduce the disaster factor to an absolute minimum.

IMPROVEMENTS POSSIBLE IN BALLOON SYSTEMS

Balloon Design

Several years ago I was gratified to discover the work being done in balloon design and development at the Range Measurements Laboratory, Patrick Air Force Base, Florida. Through their Family II Program and contractors, they were attempting to develop a balloon that would survive 90 knot winds. The significance of the effort impressed me a great deal. If these men could perfect that sort of vehicle, it had to be a breakthrough in balloon engineering and a significant breakthrough in potential industrial applications. (See attached drawing, Exhibit "A".)

Since then I have been steadily encouraged to find that they have persisted to the point where six or eight units have been built and flown, and 85 knot winds have been successfully survived. Not only that, but the configuration of the cigar-shape or blimp-shape with the round top and possible adaptation of an inverted "Y" empennage would provide us with an excellent start in our efforts to improve on the snow problems described above. Simple rolling of the vehicle, both in the air and on the ground, is a good initial action that we could readily adapt to our rigging techniques. Other actions also come to mind that could be easily and safely utilized with this vehicle to minimize the chronic snow problems.

Wind problems have already been significantly reduced when we consider that the balloon is safe aloft to at least 70 knots. Any winds exceeding that would be in the Columbus Day storm bracket that developed in the Pacific Northwest in 1962, and would be preceded by ample warning to move the balloon to a protected bedding area.

The key design factors that allow this balloon to meet these conditions are the pressurized blimp-shape and a very low co-efficient of drag (approximately 0.11 at 0° angle of attack). (See attached picture, Exhibit "B".)

The cost of the balloon, for the size needed to do the job, would be high - in the \$800,000 to \$1,000,000 bracket. However, for 50,000 pounds net lift to the turns, and the other advantages mentioned and to be described, it provides a much cheaper lifting vehicle than the S-64 Flying Crane at only 20,000 pounds approximate lift and a 3.3 million dollar price tag. If other balloon designs or improvements come along that will do the job better or cheaper, we will be looking at them immediately.

Equipment Design

The first major change planned in the logging equipment is to go to a powerful carriage mounted on an inverted skyline. The carriage will be operated by a person inside and will be held aloft by the balloon to travel back and forth on the inverted skyline by a traction drive.

system. The carriage will contain a power propeller, or "power-prop", to aid in sideways movement while hooking onto the turns. The skyline will be stored on a line horse at the landing end and will be attached to a ridge or sidehill at the other end by a "mountain-grabber" system of equally distributed load straps. There will be a powered winch in the carriage to reach directly down to the trees. (See attached drawing, Exhibit "C".)

The engineering and design of the carriage is progressing favorably. Every effort is being made to keep the design and construction as simple as possible. Weight, of course, is being watched closely, and readily accessible component parts will be used almost exclusively. Tentatively, the carriage will have approximately 1,500 h.p. and weigh in the neighborhood of 10,000 pounds. Serious consideration is being given to multiple engines of the rotary or "Wankel" design for simplicity, continuity of operation (if one should fail), ease of replacement, and satisfactory power-to-weight ratio. (See attached drawings, Exhibits "D" and "E".)

The traction system will be the multiple wheel and tire drive system with its own disc brakes. These will hold to the skyline while picking up a turn or in case of an emergency. This system, I feel, is a breakthrough for us because it allows the further use of already engineered components in a simple traction system. The skyline, which can be "regular lay" or "lang's lay", is rougher than a cob, so to speak, and can be utilized by standard tires for ready traction. We plan approximately 16 drive wheels squeezing on the skyline, which is twice as many as are used on the largest trucks for traction, and much more surface area than any locomotive ever had.

METHOD OF OPERATION

The secret of the whole operation lies in the large (1-3/4") inverted skyline which hangs up there doing most of the heavy work. If the mathematics of the operation are reviewed, it is readily apparent from the force diagrams, that the skyline is always keeping the complete system in stable equilibrium while supplying more than adequate safety factor.

In my mind, this big, strong, inert skyline replaces and does a better job than the complicated, mechanical, hydraulic, interlock, yarder systems that have yet been developed. It also reaches out any desired distance, with no running lines and no running blocks. The simplicity has to make sense, and it is simple.

Eventually, it may be possible to use a grapple to hook the trees and even uproot them, as indicated by Exhibit "C". However, for initial operation, plans are to climb the trees, choke them high, then snap the stump-cut as the balloon takes the load and creates a lead and leverage toward the landing. At the landing, the branches will be burned, dumped or utilized, depending on the situation, but the trees can be custom-bucked to quality grade for maximum utilization. The object of using chokers is to allow for more than one tree to be yarded at a

time, if so desired. Oversize trees will have to be felled and a portion bucked off before they can go to the landing.

Conservative production estimates are approximately 17.5/MBF (gross) per prime (or yarding) hour, with annual production of between 25MM and 100MM, depending on how the operation is run. Cost figures of approximately \$26/M have resulted from an eight hour day, 200 days a year and \$15/M from a 20 hour day, 350 days a year. The detailed cost analysis follows.

COST ANALYSIS

	Information	Cost
<u>Balloon</u>		
Balloon - 1.5 MM ft. ³ ; 65,000# net lift at hard point	1.5MM@\$.50/ft. ³ 20,000#	\$750,000
- Weight of balloon	70 knots	
- Survivability in air	90 knots plus	
- Survivability on ground	Excellent	
- Snow survivability (inverted "Y" tail)	1.4MM (05)	70,000
Helium - @ \$.05/ft. ³	Blocks, lines, etc.	<u>10,000</u>
Rigging - Balloon & bedding area		<u>\$830,000</u>
Subtotal Balloon		
<u>Carriage</u>		
Multiple engines (Wankle type) up to 2,000 h.p.		<u>\$200,000</u>
- Approximate weight	10,000#	
<u>Line-Horse</u>		
Line-horse - combination transfer vehicle		\$150,000
Line - 10,000 ft., 1-3/4" diam.; 300,000# b.s.; 5.5#/ft.	10,000 ft. @ \$4/ft.	40,000
Rigging - blocks, chokers, straps, etc.		<u>10,000</u>
Subtotal Line-Horse		
<u>Subtotal Package</u>		
<u>\$1,230,000</u>		
<u>Company Markup</u>		
Development, consulting, training, start-up, patent licensing	20%	<u>\$240,000</u>

Total Price of Package

Depreciation

Write-off in five years (average)

Information	Cost
	<u>\$1,470,000</u>
\$1,470,000/ 5 years	<u>\$294,000/yr</u>

Production Hours Available

Normal lost time - maintenance
& repair 5%
- weather 5%
- moving
& misc. 5%
- total 15%

∴ Availability is 85%

∴ Actual yarding or prime hours/
day is

∴ Actual prime hours/year is

8 hours/day 200 days/year	20 hours/day 350 days/year
------------------------------	-------------------------------

Production Per Prime Hour

Lift available = 65,000# less
10,000# (carriage) & 5,000# (line)
Average turn weight = 70% (50,000#)
Average turn size @ 10#/bd.ft. =
35,000/10 =
Average turns per prime hour (0 to
5000')

∴ Production/prime hour = 5 (3.5) =

∴ Production/day

∴ Production/year

.85(8)=6.8 hrs/day	.85(20)=17 hrs/day
6.8(200)= 1360 hrs/yr	17(350)= 5950 hrs/yr
50,000#	50,000#
35,000#	35,000#
3.5 M gross	3.5 M gross
5 turns/hour	5 turns/hour
17.5 M/hour	17.5 M/hour
17.5(6.8) = 120 M/day	17.5(17) = 300 M/day
17.5(1360) = 24 MM/ yr	17.5(5950) = 104 MM/year

	8 hours/day 200 days/year	20 hours/day 350 days/year
<u>Cost/M Gross</u>		
Depreciation	\$294,000/24 = \$12.30/M	\$294,000/104 = \$2.80/M
Operating labor - 10 men @ \$10/hr	100/17.5 = 5.50/M	5.50/M
Operating supplies - previous figures	4.00/M	3.00/M
Maintenance & repairs - previous figures	<u>4.00/M</u>	<u>3.00/M</u>
Total yarding/M gross	<u>\$25.80/M</u>	<u>\$14.30/M</u>

ADVANTAGES AND DISADVANTAGES

Advantages

I would like to list the obvious and not-so-obvious advantages I feel this system encompasses:

- Standing tree logging is possible for the first time in logging history, and is recommended. The necessary objective of maximum logging utilization is finally attainable.
- Safety in operation, wind, and snow is excellent. The disaster factor has quite factually been reduced to a minimum.
- Cost per/M is realistic.
- No expensive falling and bucking is required on the sidehills.
- The high capital cost and fire risk of felled and bucked inventories is eliminated.
- Maximum tree utilization is possible by bucking the trees to quality grades at the landing.
- Safety for the crew is improved with no dangerous felled and bucked logs hanging above them while they are logging.
- Night time logging is possible, and advisable, to take advantage of calmer weather usually prevailing.
- Maximum year-round logging is possible as standing trees are not buried by the snow; whereas, felled and bucked timber can be buried for many months.
- The production capability of the operation represents the equivalent of numerous normal high-lead sides if maximum annual hours are utilized.

- There are no running lines, running blocks and complicated layouts to be concerned with. Much rigging time and cost can be eliminated and the fire hazard can be reduced substantially.
- Yarding distances of up to 10,000 feet or more are possible if desired. Think what could be done with 10,000 foot corners instead of 1,000 foot corners in setting layout. Present road systems could probably be reactivated and road construction minimized or eliminated for many years, depending on planning flexibility within an operation.
- One combination landing and bedding area could replace many expensive landings on the sidehill or ridge tops.
- Future road construction could also be minimized. Two-thirds to three-quarters of the very expensive sidehill and ridge top roads could eventually be eliminated. Alternate drainage development could be followed.
- Savings in hauling costs can be realized due to less sidehill truck hauling.
- Uphill as well as downhill logging is possible, although downhill logging is recommended for reasons which will be discussed in the section, Future Potential.
- Minimum slash will be left on the sidehill.
- Slash burning will be minimized or eliminated, thereby reducing air pollution and the hazard of fire escapes.
- Valuable understory of saplings and seedlings will be preserved. Reforestation by fill-in with larger seedling stock could well be possible.
- Soil erosion is minimized.
- Clean creeks are a natural consequence of the system. Trees are not toppled and broken into the stream beds, causing muddy waters and fish-kill.

Disadvantages

- The main disadvantage of this system is the high capital cost. However, these are the prices that I have necessarily had to work with because of quotes from the various manufacturers. There may be savings in some areas and increases in others, but we're certainly in the ball park if we estimate logging costs at \$30/M gross, and lower, depending on how the operation is run. When the time comes for getting down to more detail in setting up this system, I will obtain more exact quotes from each of the balloon manufacturers and other manufacturers involved.

- The second disadvantage of the system, that bothers some people, is the man in the carriage. However, he is necessary to monitor all of the functions taking place up there and can do something if a tire blows, or engine quits, etc. The safety of this man is excellent because we have allowed high safety factors in all areas. The main concern would be the lines breaking between the carriage and balloon. This has never happened to us in ten years of balloon logging, using two lines in there at all times. This carriage is being designed for four 1-1/8" lines for the 250' between the balloon and carriage and each is strong enough to hold the balloon within the working stress of the individual lines.

If the inverted skyline itself should break, it will most likely happen in the back section (where most use and wear takes place), and in this event, the carriage will be clamped to the line and be brought in by the line horse or crawl down the line itself in low gear. If by the remotest possibility the balloon and carriage should get away from the skyline, they will at least go up instead of down and the operator can jump with a parachute. In ten years of balloon logging we have never had any of our balloons go up and get away from us. I would feel much safer and be much safer in that carriage than driving to the job each day and back. I will be the first operator on this rig, and train the other men as required. I have never asked any of my men to do anything I wouldn't do myself as long as I have been in the woods, and will continue to follow this practice in the development of this system.

FUTURE POTENTIAL

Energy on the Sidehills

For a number of years now, I have been concerned with how to ultimately utilize the natural energy clearly visible in the woods in the form of trees covering the mountains. Each of these trees is a certain weight and a certain distance above the landing. By taking these two basic facts, we can quite accurately calculate the natural energy per tree as so many foot-pounds energy (P.E.), available to us, if we can put it to work. A 3,300 board foot tree weighing 33,000 pounds (at 10 pounds per board foot) and standing 1000' vertically above the landing, has a P.E. of 33,000 (1000) or 33 million foot pounds. When we allow that tree to move through the 1000 feet, in one minute, we change the P.E. to kinetic energy (K.E.) and can actually calculate the work, in horsepower, that is available. In this example, 33,000,000 ft. lb. per min. divided by 33,000 ft. lb. per min. per h.p. equals 1,000 h.p. generated in a single minute. That's a lot of power, and we have to learn to use it.

Energy Utilization

With the inverted skyline, carriage, and a fast balloon (with very minimum drag), we can finally put this natural asset to work. As the empty balloon goes back with 50,000 pounds lift, "energy of retardation" has to be dissipated through engine retardation (like going downhill in

first gear), or through brake retardation (by brake application and heat loss). Now, rather than let this energy get away, there has recently been developed a super-flywheel, of very high performance, that could readily be adapted to the carriage for downhill logging. On the trip back to the woods, the flywheel could be "wound-up" by the retardation energy and have more than ample energy to bring in a normal turn. This is possible because the weight and movement of the turn downhill offsets most of the balloon lift and energy requirements, as previously described. In fact, my basic calculations indicate that under normal logging conditions, there is enough retardation energy on one run out to bring in two normal turns, or more, depending on the conditions. In other words, we have enough P.E. in those sidehill trees to run the entire operation continuously, and we've been looking at them and cursing them for years.

I would judge that within a very short period, after getting the first inverted skyline and carriage operational, we will have this flywheel carriage developed and available. It has to make sense, particularly with the growing need for energy conservation that we have been hearing about for some time now.

Future Potential Beyond the Flywheel

One of the continuing advantages of this balloon concept is that there is more that we can do in the future. Eventually, we will be looking at the retardation energy for electrical generation of hydrogen and oxygen through the electrolysis of water in the carriage. This will supply us with our operational fuels (hydrogen with oxygen in the air) and balloon lifting gas (hydrogen). There are a number of companies now developing hydrogen engines because of maximum efficiency, cleanliness, and a ready supply of fuel. Also, balloon lift by hydrogen is the maximum efficient gas, and free, by this system. However, there is a fear of its use to overcome and problems to work out. But the excess retardation energy and resultant excess gas can then be compressed and stored for some level or uphill logging operations and some extra balloon gas. This system could be very simple and very neat, if we don't run into unforeseen obstacles.

SUMMARY

Throughout this paper, I have talked in terms of mountain logging operations exclusively. However, it should be mentioned that the advantages for other aerial transportation requirements are directly applicable; e.g., swamp logging, ship-to-shore transportation, etc. The simplicity and safety possible, along with good potential production and reasonable cost per production unit, would indicate that the method is worth pursuing.

FAMILY II TETHERED BALLOON

201,000 CU. FT.

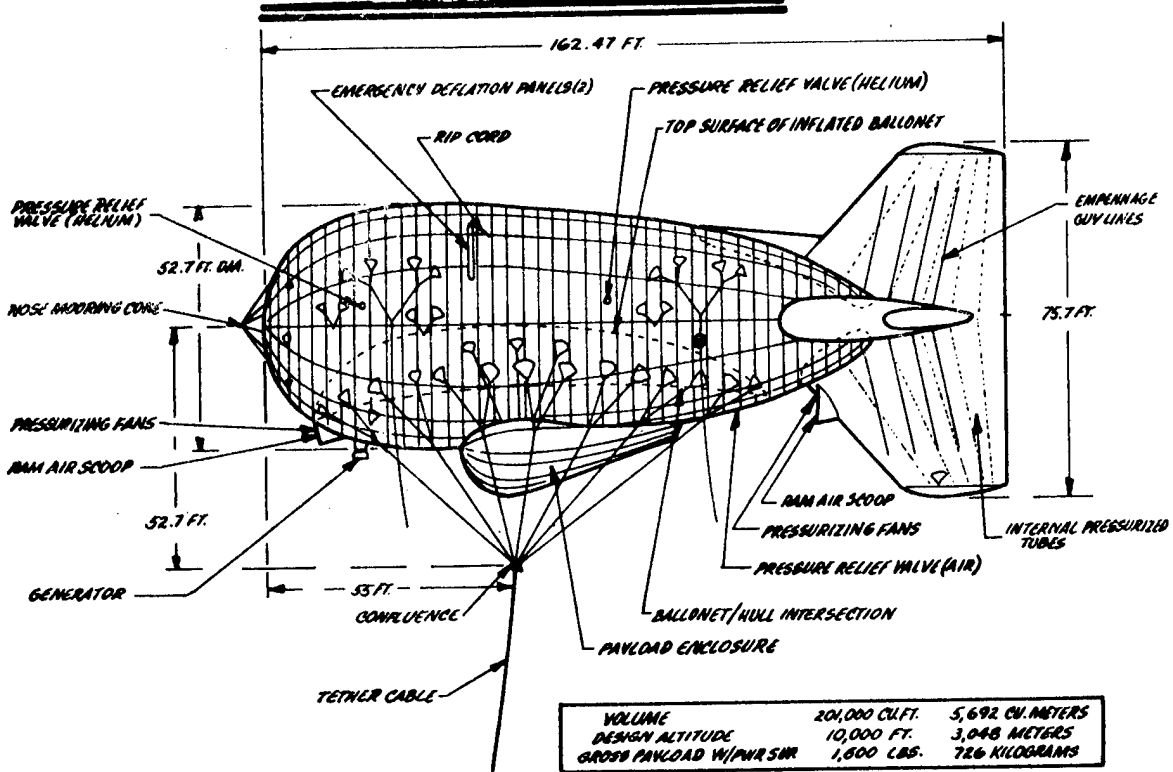
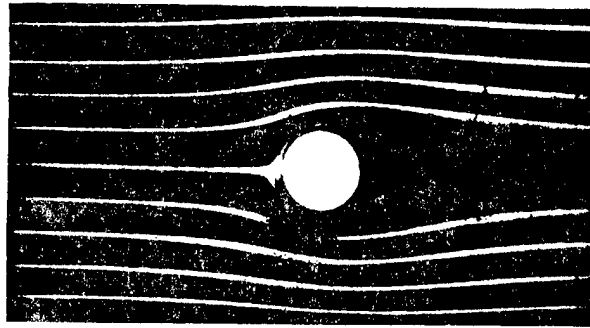
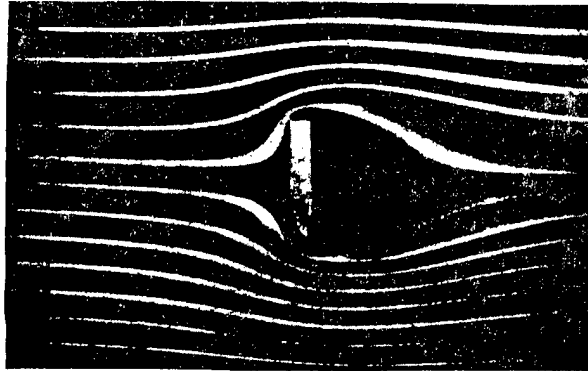

EXHIBIT "A"

(Small Family II balloon. Larger ones now being built.)



(a)



(b)

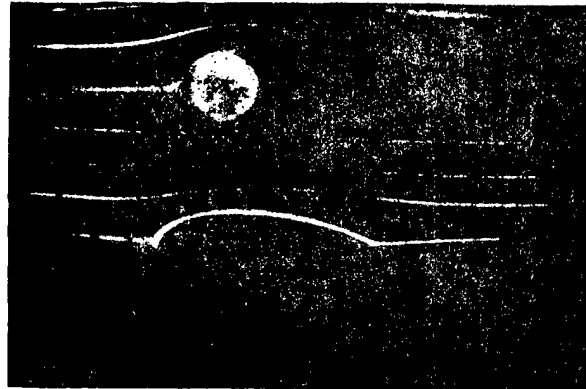

(c)

EXHIBIT "B"

"A picture is worth a thousand words." This picture is included just to give some idea of airflow (left to right), around (a) cylinder; (b) flat plate (similar to circular disc); (c) cylinder (similar to sphere) and streamlined body. This is from "Fluid Mechanics" by R. C. Binder, Ph.D. His comment was "the examples show that the phenomena giving rise to resistance are markedly affected by the rear of the body as well as by the front of the body."

Feb. 20, 1968

C. F. MOSHER

3,369,673

Tree Harvesting, Lifting and Transportation Apparatus

Filed Jan. 12, 1965

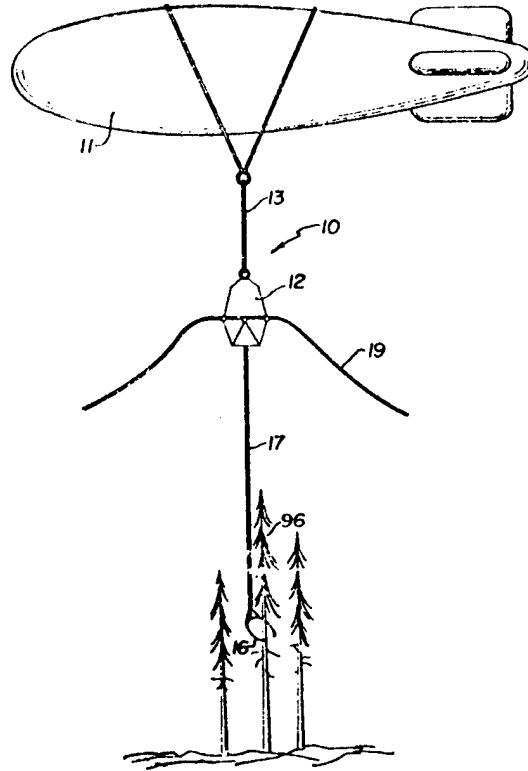
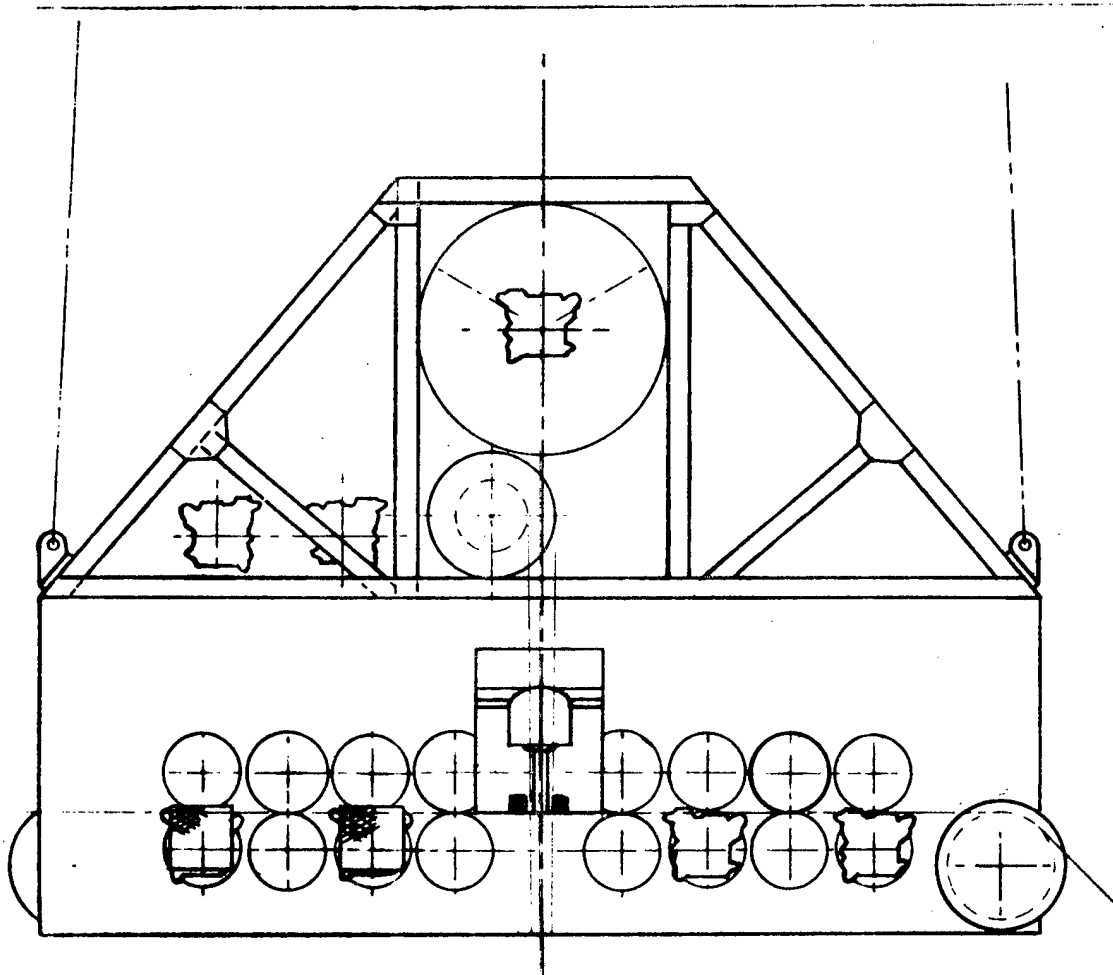

EXHIBIT "C"

INVENTOR
CLIFFORD F. MOSHER
BY
Hickston, Haugh & Co.
ATTORNEYS

BALLOON CARRIAGE FOR INVERTED SKYLINE
(side view)



SCALE $\frac{1}{4}'' = 1'$

9-5-74 SB

EXHIBIT "D"



"LOTS" OF LTA APPLICATIONS

Jay S. Brown*

ABSTRACT: This paper will briefly describe current problems facing the logistical planner in utilizing the new ships of the modern, intermodal sea transportation systems in a logistics-over-the-shore (undeveloped) environment. Then the employment of two potential LTA vehicle systems are described and discussed as significant parts of possible solutions to this range of logistical problems. Vulnerability aspects of these LTA vehicles are also briefly addressed because of their possible employment near combat areas.

INTRODUCTION

Definition of LOTS.

The acronym LOTS refers to "logistics-over-the-shore" operations, where armed forces operating in the field on a foreign shore are being resupplied over an undeveloped beach (i.e. no port facilities are available to assist in cargo discharge). Also implied in this definition is that no hostile activities are being conducted against the resupply operation.

Because of the non-hostile environment and the vast amount of supplies

*Director, Program Development Division; Plans, Programs, and Naval Control of Shipping Office; Military Sealift Command, Washington, D.C. 20390

being delivered to the shore in a LOTS operation, commercial cargo ships are normally used to carry the bulk of cargoes required. This was fine in the days of the boom-and-hatch, or breakbulk, freighter, because these ships could carry virtually any military cargo, go anywhere military forces could go, and unload themselves when they got there (self-sustaining cargo capability). Nowadays, new, commercial maritime innovations such as the container ships, barge carriers like LASH and Sea Barge, and Roll-on/Roll-off (RO/RO) ships are highly specialized vessels, operating as intermodal sea transportation systems, over particular route systems. These ships are not self-sustaining and cannot be unloaded except in sophisticated ports with certain facilities. Container ships are unloaded with specialized, shore-side cranes. Barge carriers can discharge barges, but cranes and other materials handling equipment (MHE) are required at the pier; additionally, barge marshalling and tug facilities are required. Some designs of RO/RO ships are self-sustaining with on-board ramps, but strong piers and adjacent parking and warehousing facilities are also useful. Other RO/RO's operate only in ports where ramps are available to them to allow for vehicular traffic on and off the ship. Some work has been done in resolving these problems, but usually the discharge methods are slow and heavy lift capacities are severely constrained. Thus, until now, logistical planners faced with handling cargoes from these ships in a LOTS environment had almost insurmountable problems in rapidly discharging sufficient quantities of military cargoes over a beach because the unit load weights are so large and MHE capabilities to work effectively at the surf zone are limited. Typical cargo discharge problems faced are: 8' x 8' x 20' container gross weight is 22 1/2 tons; LASH barges can gross to 450 long tons; Sea Barge barges to 1000 long tons; and 50 short tons is a typical weight for unit deliveries of tanks and other tracked vehicles. Therefore, while the new ship systems can transport a great deal, some imagination is needed in managing their discharge from ships in a LOTS operation.

LTA Role in LOTS.

What is it that LTA technology can offer to the LOTS operation? Relatively high speed transportation of heavy equipments or bulk supplies from ship to/over shore.

Originally under consideration was a family of applications which would have included blimps, the hybrid LTA vehicle, Aerocrane, and tethered balloon cargo lift systems. The inability to resolve the exchange of payload for ballast at the cargo destination forces elimination of consideration of the blimp as a cargo transport vehicle. The remaining two LTA vehicles offer complimentary capabilities for employment by the logistics planner.

LTA Vehicle Candidates for LOTS.

The Aerocrane Concept- The Aerocrane is a hybrid LTA vehicle using

aerostatic lift and aerodynamic lift and translation to perform its function. The helium contained in the aerostat supports the weight of the entire aircraft, its fuel, crew and 40% of its payload. The aerodynamic lift provides the balance of the payload lift and horizontal translation capability.

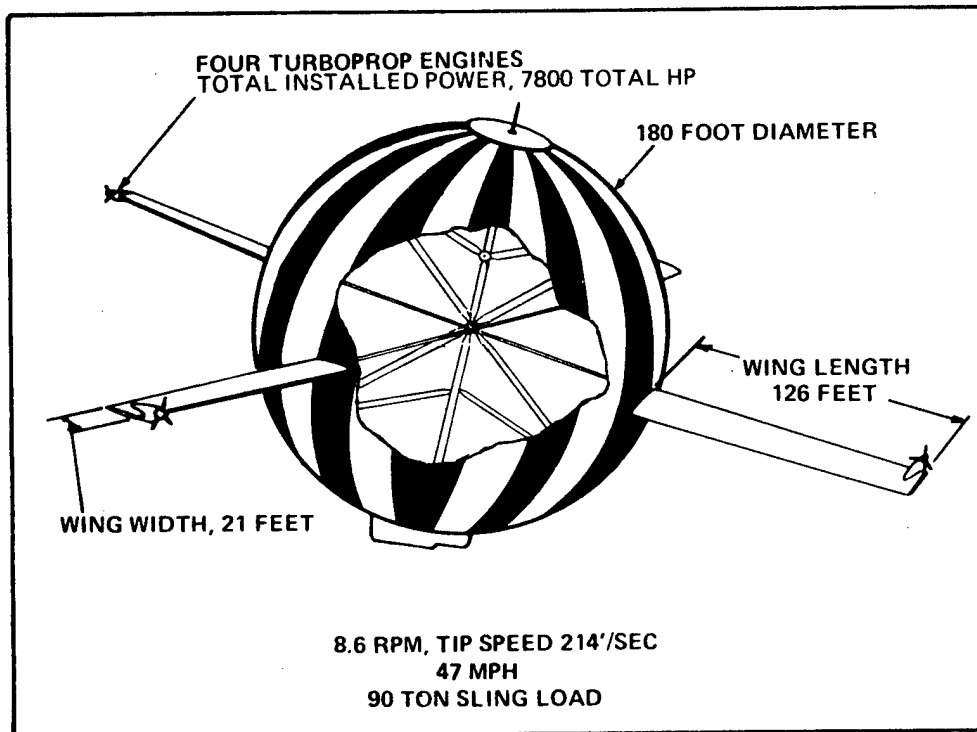

90 Ton Aerocrane

The 90 long ton sling load version would be powered by four, 2000 HP turboprop engines operating at one-fourth rated capacity (design payload ranges of from 50 to 500 long tons are considered feasible). Thus even with the failure of 3 engines the craft could perform to its rated capacity (eccentric power application by one engine would not be a problem because of the highly rigid connection of all the wings into the Aerocrane structure). The control cab would be powered and geared to rotate at the same speed, and in the opposite rotation to, the aircraft structure to maintain a "still" position relative to the aircraft. A 20° tilt of its axis would be necessary to obtain forward translation. When a load is delivered, the cyclic and collective controls determining the wings' angle of attack would be reversed and the rotating wings would then generate downward thrust to cancel the aerostatic lift. Fuller details on the aerocrane's design concepts, operational characteristics, and other factors are available in References 1 through 6.

Variation of Aerocrane- Another variant of the Aerocrane concept is shown below. The major differences include: the minor diameter equals the major radius; the vehicle would not be tilted to achieve a

translation vector; the engines on the wings would only rotate the aircraft to control the vertical motion vector; and cycloidal propulsion (similar in principle to the vertical screws employed by some tug boats) would provide the horizontal translation vector.

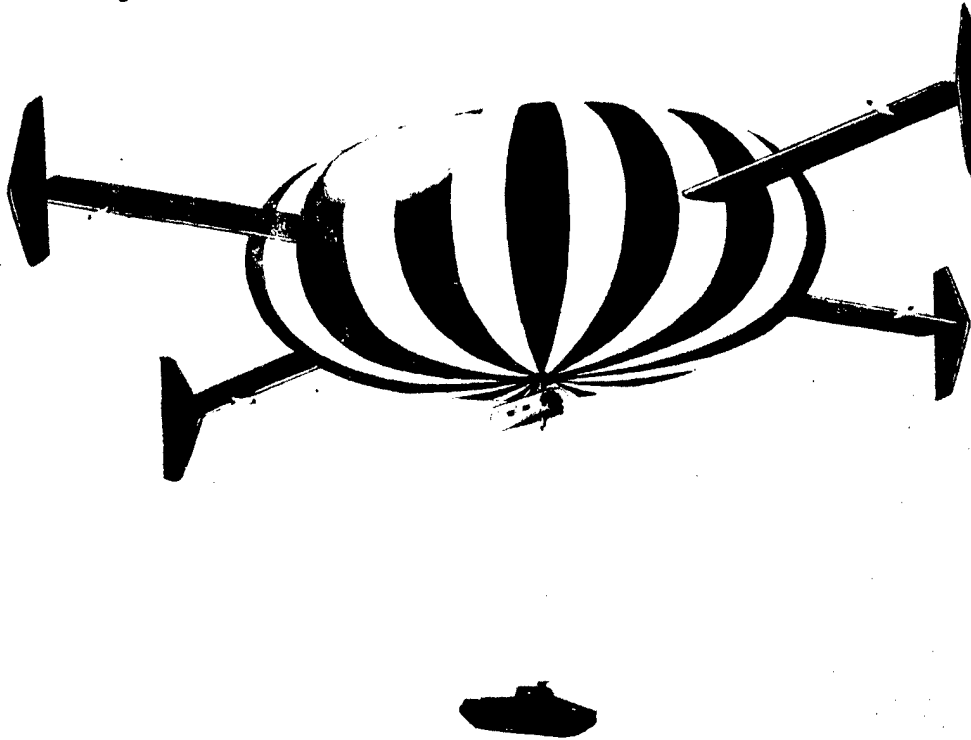

Aerocrane Variant

Parametric differences from the original concept are: for equivalent volume aerostats, the oblate spheroid only has 15% more surface area which requires an insignificant increase in volume to compensate for the very slight increase in aircraft weight and maintain a constant payload capacity; the theoretical drag coefficient is reduced by 50% from 0.2 to 0.1; and the speed is increased from 36 knots to 60-80 knots for the feasible payload ranges contemplated (horizontal translation speed increases with the size of the aircraft). This variation of the Aerocrane is much more complex in construction and control requirements and should only be considered if the higher speed capability is absolutely necessary. This concept variation is very recent and further information concerning it can be obtained from Reference 7 and Mr. Arthur Crimmins, All-American Engineering Co., Wilmington, Delaware.

Tethered Lighter Than Air Systems (TELTA)- A TELTA system could be one of several possible variants, but the idea stems from logging operations that have been conducted for the past ten years in Oregon. The concept was tested for possible military logistics applications at the Oregon logging sites in 1972 and 1973 by the Range Measurements

Laboratory (RML) Patrick AFB, Florida and the Naval Facilities Engineering Command (NAVFAC).

SHIP-TO-SHORE SITE LAYOUT

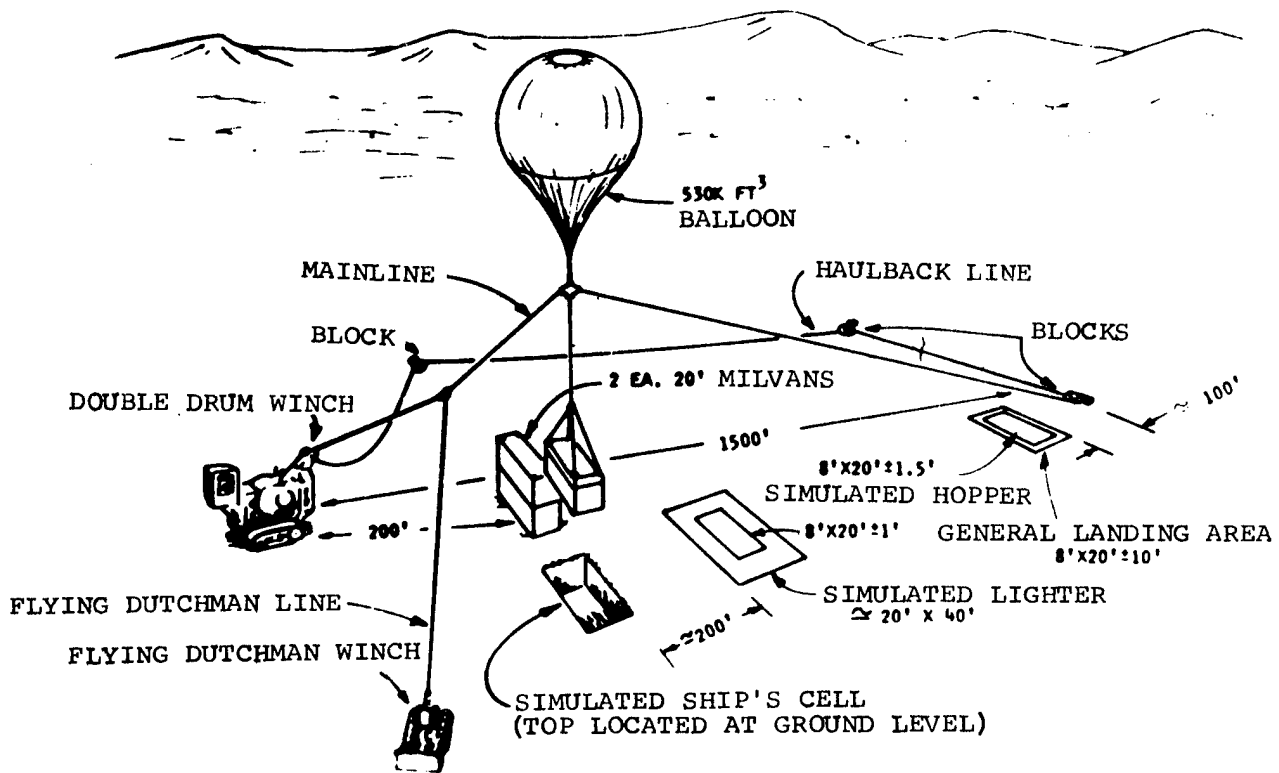

Oregon Test Array

References 8, 9, 10, and 11 provide complete reports on the test details, findings, and recommendations.

NAVFAC's concept of the system would be based on one or more aerodynamically shaped balloons similar to ILC's Family II design, but with total internal capacity sufficient to lift a 22 1/2 short tone payload.

Included in the system would be two yarders, one ashore and one to seaward aboard a ship, plus a flying dutchman for lateral positioning control perpendicular to the established line of travel.

This system would be employed to pick-up unit loads from shipboard for transfer ashore. Load sizes would range from multiple pallet sizes to 8' x 8' x 20' containers in transfers not to exceed a nautical mile in distance. Load cycle times would be approximately 6 minutes.

In other sessions of the workshop, more detailed information will also be presented on the characteristics of the Aerocrane and TELTA balloon systems.

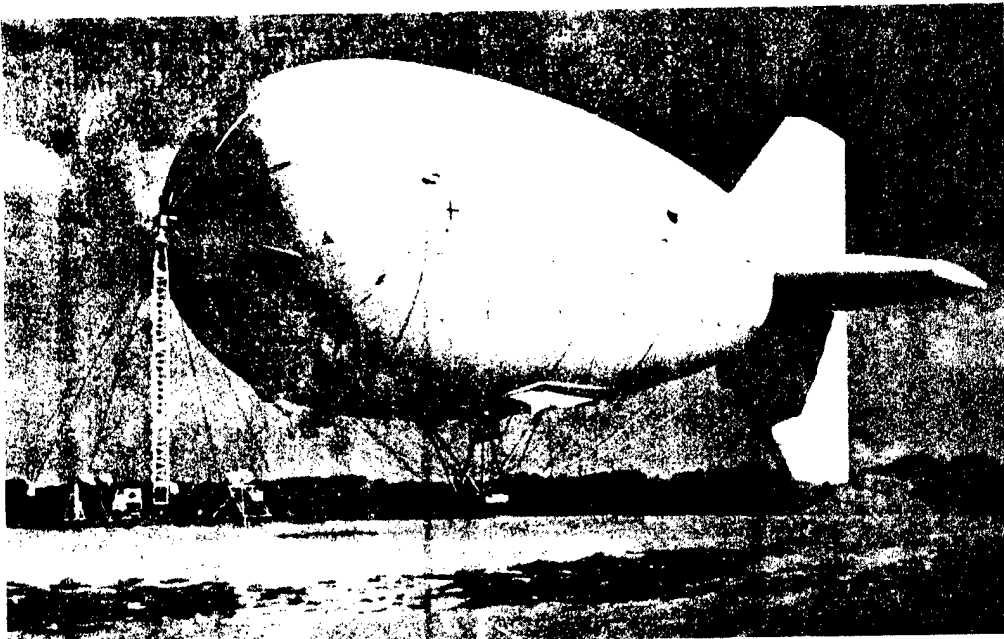

Family II Balloon

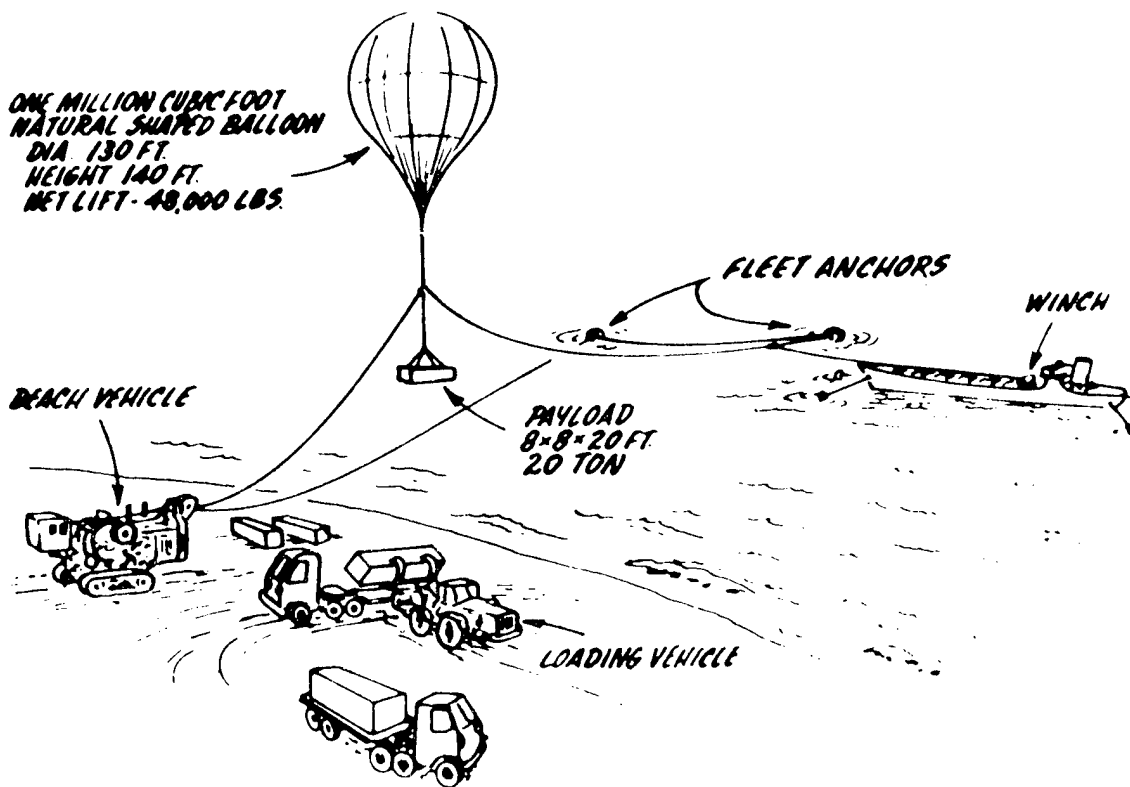

Ship-to-Shore TELTA Cargo Transfer System

LTA VEHICLE EMPLOYMENTS IN LOTS

Characteristics of Aerocrane Employment.

The basic characteristics of the mission profile of the Aerocrane in a LOTS operation would feature lifts of single-unit, heavy and/or high volume cargoes or bulk deliveries of other lesser commodities. Distances covered would be 15-75 nautical miles, enabling significant standoff distances to seaward and/or inland penetration. The time constraint of one hour and various speed capabilities (dependent upon size and model variant of Aerocrane) define the range limitations above. Generally, deliveries would be made directly to warehousing or distribution centers from shipboard, avoiding the congestion of deliveries over and through a narrow beach corridor. Such deliveries also avoid the surf zone which is always a critical and dangerous factor in any ship-to-shore movement evolution. Deployment of the Aerocrane can be accomplished by dedicating its payload capacity to a fuel load and let it fly to the desired transoceanic destination; or it could be towed by a ship as well.

Types of Aerocrane Operations.

Offshore Cargo-Handling Facilities for Ships- The Aerocrane and TELTA cargo delivery systems could not be expected to handle all the cargo deliveries of a LOTS operation. But the Aerocrane could assist in the positioning of equipment and hardware needed for typical dry cargo discharge operations. Placement of pontoon causeway sections for transshipment platforms and/or "roadways over water" (shorefast causeways) to the beach is possible. Delivery of crawler cranes, truck tractors and trailers, and other MHE to offshore transshipment points and beach sites could also be accomplished. This would give the on-site commander great flexibility in realigning his cargo discharge points based on the mobility and lifting capacity of the Aerocrane. Ramps to serve RO/RO ships could also be positioned at the transshipment points or at the seaward ends of shorefast causeways. Thus the Aerocrane would facilitate the installation of the hardware and MHE to discharge container, barge, and RO/RO ships which require certain sophisticated port capabilities, as well as directly off-loading priority cargo items from these ships onto beach sites.

The Aerocrane could also assist in the positioning of the heavy hardware items needed to establish the TELTA balloon cargo discharge system, such as the yarders, flying dutchman, mooring points, and cable runs. Additionally, Aerocrane could rapidly position floodable caissons for use as breakwaters in open roadsteads.

LSA Development Ashore- Logistics Support Areas (LSA's) could be built up ashore in similar fashion by first, putting in heavy ground clearing and road-building equipment; next pre-fabricated warehouses and

MHE would be introduced; and finally delivery of supplies and consumables to the new warehouse facilities would complete the operation with periodic resupply missions flown to keep stocks up to needed levels. The operation could be simplified to: providing tents and MHE, dumping supplies in a clearing, and providing tractors and trailers for deliveries. This would enable a rapid build-up of supplies in selected areas, well inland from the beach-oriented operations.

Forward Resupply- The Aerocrane could also provide inland resupply of critical items of major equipment, ammunition, food, and medical supplies at depots just to the rear of forward combat zones. This capability would drastically increase the effectiveness of the major LSA's and enable forward troops to be well supplied and mobile. Also, rapid removal of major equipments damaged in combat would facilitate their repair for reuse in the combat zone, decreasing the drain upon the stock levels of these items.

The Aerocrane's chief advantage in all these evolutions is its ability to pick up major, heavy equipments or bulk quantities of critical, consumable supplies (ammo, food, medical supplies, etc.) directly from shipboard or an LSA and deliver it directly to the "retail" depot without transshipment at a beachline or other point.

Characteristics of TELTA Balloon Employments.

The TELTA balloon cargo systems would be addressed to short-leg lifts of up to a mile and would lift cargoes over the surf zone and just beyond the beach area. Loads would be limited to the gross capacity of an 8' x 8' x 20' container, i.e., 22 1/2 short tons. Conceivably cycle times would be about 6 minutes per lift. The TELTA balloon cargo carrying system would become one of the several, near-shore, cargo discharge capabilities. The TELTA balloon(s) could be inflated prior to deployment and towed to a destination by a ship, or be inflated on-site.

Types of TELTA Balloon Operations.

The TELTA Balloon system as now envisioned by the Army and Navy, could become the primary means for discharge of non-selfsustaining containerships in the near-shore, sea area. Additionally, the system could be employed for deliveries of: unitized pallet loads of cargoes from breakbulk ships, or barges from LASH or Sea Barge ships, and off-loading small or light vehicles from RO/RO ships.

Hopefully, the TELTA balloon system's main feature will be a rapid cyclic rate over the designed one mile distance. This would be a significant improvement over current capabilities wherein 8-10 minutes cycles are required to off-load containers or other cargoes into light-erage for transfer to the shore; and then they must be further trans-

shipped at the beach to overland transportation for movement to a marshalling area. The TELTA balloon lifts the cargo from the ship, over the surf zone, and directly into the cargo marshalling area. Reference 5 provides more conceptual and detailed data concerning this and other military logistics applications of the TELTA balloon system.

LOTS SCENARIO

The offshore picture then becomes one where lighterage, barges, and ships are being discharged of cargo, containers, and cargo-laden vehicles at causeways, jacked-up piers, or floating platforms close-in to the shore. A little more seaward, TELTA balloon systems are off-loading container and/or RO/RO ships with loads up to 20 long tons directly to the shore. And further seaward, other ships are having bulk priority cargoes and heavy lift items being lifted directly ashore (beyond the beaches) by Aerocranes before the ships go alongside the TELTA or other cargo discharge stations. Additionally, some Aerocranes are helping to maintain or reposition some cargo discharge facilities or are retrograding damaged vehicles and equipment, such as tanks, other armor, trucks, helicopters, etc. Also included in the task force of ships would be a Liquified Natural Gas carrier filled with helium for support of the LTA systems employed in the LOTS operation.

VULNERABILITY CONSIDERATIONS

Common Problems with Both Systems.

The first consideration in any military operation is to be where the enemy isn't, or be there in strength against weakness. Proper placement of forces would then eliminate much of the threat against these deceptively tough vehicles. The point here is, that many people are unfamiliar with the low over-pressures characteristic of the proposed Aerocrane and TELTA balloon systems. They expect the helium envelope to "pop" when punctured and do not appreciate what the low escape velocity of helium means. For example, if the hybrid vehicle Aerocrane (in the 90 ton payload configuration) has a hole one square foot in area at the exact top of the lifting sphere, it would take eight hours for it to lose enough of its positive buoyancy to become neutrally buoyant. This gives plenty of time for the Aerocrane (and in like manner the TELTA balloon) to complete any current lift (or even a series of lifts missions) and be repaired at a convenient location and time. However, if either of these cargo systems are punctured, the resultant loss of pressure will eventually cause dimpling of the aerostat as it is moved through the air. This greatly increases the drag forces upon the vehicles and reduces their speed capability.

Anything that can either tear gigantic holes in the aerostat or cause severe over-pressures from within will disable these systems almost

instantaneously. But while such weapons systems can be derived from available technology, none now exist. Existing fusing techniques for explosive shells cannot be employed against the aerostats surfaces to cause delayed internal or exterior point detonation. And tactical laser weapons are not yet available. However, employment of LTA technology in or near combat zones will probably hasten developments of these potential anti-LTA weapons capabilities.

Considerations Peculiar to the Aerocrane.

Essentially the supporting structure of the Aerocrane can be hardened to a reasonable degree and the extra weight can be taken up with more helium in a larger aerostat. The supporting structure can be built of non-radar reflecting materials, giving the Aerocrane a very small reflecting picture to V.T. fuses or radar-guided missiles. The cross-sectional area of the aerostat's supporting structure represents only one or two percent of aerostat's total cross-sectional target area, yielding a low probability of a damaging, point-detonating explosion inside the helium envelope. With an armored control cab, the Aerocrane can be rendered relatively invulnerable to most of the normal types of ordnance that could be used against it. Finally, with turboprop engines, vulnerability to infra-red (I-R) guided missiles must be addressed. At long ranges the I-R weapon can track toward the Aerocrane. But as the missile gets closer (and with exhaust gases vented out the wing tips) eventually it will attempt to follow a wing tip and be turned away. Thus the Aerocrane is actually little more vulnerable to any form of existing weapons technology than an upowered, non-rigid aerostat.

CONCLUSION

It appears that with proper appreciation for the vulnerability considerations and unique lifting capabilities of the Aerocrane and TELTA balloon systems, that they have the potential to offer new and significant logistics support capabilities in the arenas adjacent to combat environments. These potential capabilities could also help solve some of the monumental problems now facing logistical planners in handling the ship-to-shore movement of cargoes from the new, highly specialized ships of the intermodal sea transportation systems becoming characteristic of current and future U.S. Flag merchant marine operations.

REFERENCES:

1. Nichols, J.B., and Doolittle, D.B., Hybrid Aircraft for Heavy Lift, American Helicopter Society, New York, New York (May, 1974).

2. All-American Engineering Co., Military Applications of the Aerocrane, Wilmington, Delaware.
3. ILC Dover, ILC Aerostats, Dover, Delaware, pp 14-19.
4. All-American Engineering Co., Sensitivity Analysis of Aerocrane Hybrid Vehicles Report No. ADTR 74-3, Wilmington, Delaware (July 15, 1974).
5. Range Measurements Laboratory (RML), Air Force Eastern Test Range (AFETR), A Presentation of Balloon RDT&E Activities, (January 30, 1974).
6. Nichols, J.B., Evaluation of the All-American Engineering Corporation "AEROCRANE" - A Hybrid Aircraft Heavy Lift System, ATR-74 (7291)-1, The Aerospace Corp., El Segundo, California, (October, 1973).
7. Reference 4, pp. 44-52.
8. RML, AFETR, A Proposal for Providing Logistics Support, Patrick AFB, Florida, (January, 1974).
9. RML, AFETR, (Sponsored by Advanced Research Projects Agency, ARPA Order No. 2176), Ship-to-Shore Oregon Test Series II - Preliminary Report, TELTA Report No. 73-026, Patrick AFB, Florida, (April 20, 1973).
10. RML, AFETR, Ship-to-Shore Oregon Test Series II Final Report, TELTA Report No. 73-030, Patrick AFB, Florida, (June 11, 1973).
11. Reference 5, pp. 3, 8, 9.

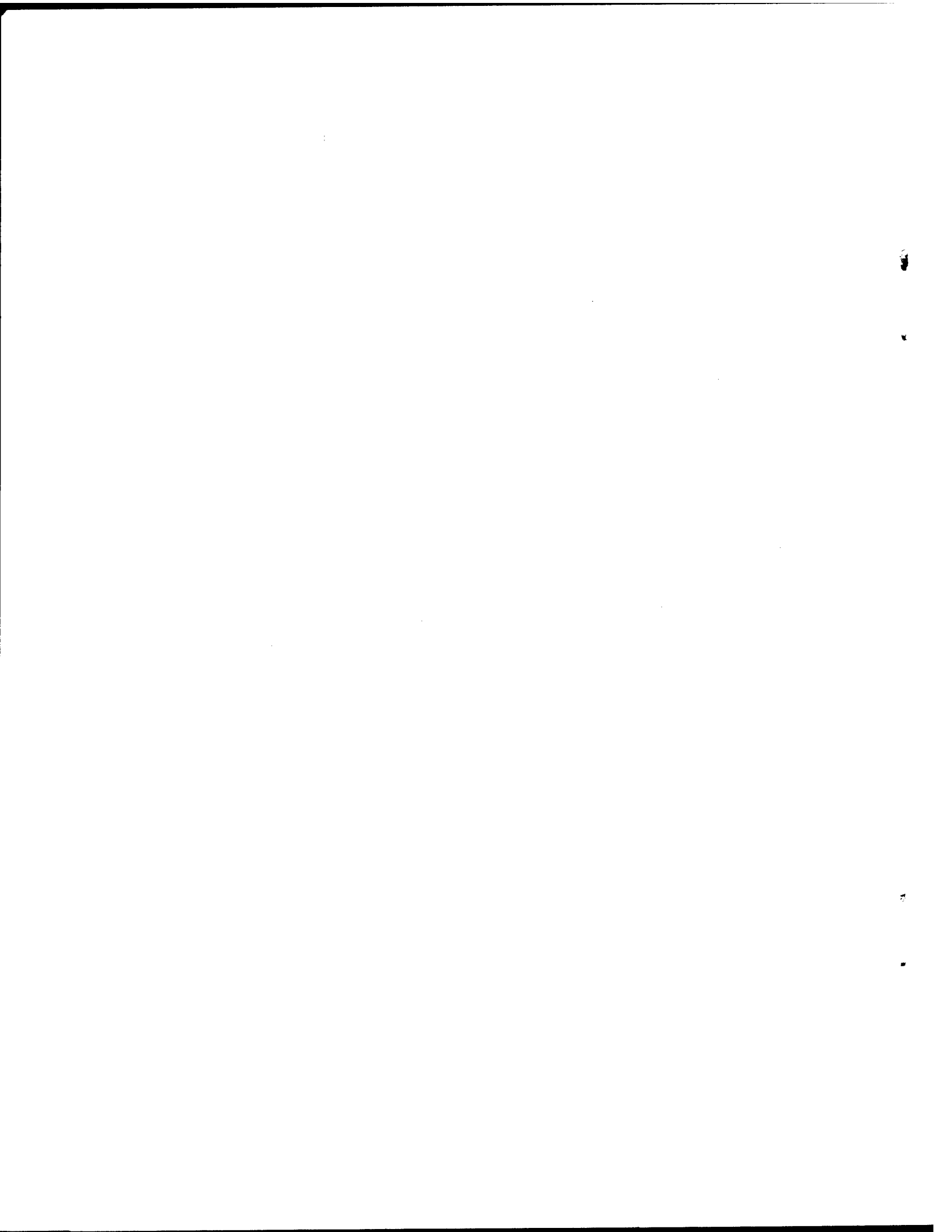

REMOTELY PILOTED
LTA VEHICLE FOR
SURVEILLANCE

Gerald R. Seemann*
Gordon L. Harris**
Glen J. Brown***

ABSTRACT: This paper deals with the various aspects of a remotely piloted mini-LTA vehicle for surveillance, monitoring and measurement for civilian and military applications. Applications, operations and economics are discussed.

INTRODUCTION

The remotely piloted mini-LTA vehicle offers a flexible, safe and economic airborne surveillance, measurement, and monitoring system. These systems have application in urban and rural environments as well as at military installations, harbors, and other key installations. Typical applications are cited below.

- . Traffic Monitoring (see Figure (1))
- . Urban Land Use Planning
- . Law Enforcement Surveillance
- . Search and Rescue
- . Emergency and Disaster
- . Harbor and Lake Monitoring
- . Industrial Security

*President, Developmental Sciences, Inc., City of Industry, California.

**Director of Research & Development, Developmental Sciences, Inc., City of Industry, Ca.

***Project Engineer, LTA Systems, Developmental Sciences, Inc., City of Industry, Ca.

- . Pollution Surveillance and Monitoring
- . Ice Formation in Seaways
- . Fish and Animal Migration Observation
- . Perimeter Surveillance
- . ASW
- . Command Post Data Link - Forward Theater TV-IR
- . ECM, Jammer

TECHNICAL DISCUSSION

Initial calculations and RPV experience have resulted in the selection of an RPLTA Vehicle size of about 5,000 ft³ being 55 ft long and 13 ft in diameter (see Figure (2)).

A typical blimp shape with fineness ratio of 4.1 has been selected. Conventional aerodynamic control systems are to be utilized. Internal and external catenary systems will be used to attach the payload. Propulsion system and associated equipment to the blimp envelope since this technique has been operational for some time. Typical construction methods of earlier Non-Rigid Airships will be utilized which have never had a failure in flight from structural or materials causes.

The catenary curtain distributes the loads in the suspension cables into the envelope material in a precise and uniform manner. The rudder/elevators are typical aircraft fabric covered metal frames for low weight. The central ballonnet permits control of envelope pressure during altitude and temperature variations. A continuously running fan will provide ballonnet air. Ballonnet pressure will be controlled by an automatic airship-type, low pressure-high volume, relief valve.

A film/fabric laminate material will be used for envelope construction consisting of mylar film and dacron cloth impregnated with an elastomer. A white hypalon surface coating will be applied externally to provide scuff resistance and desirable thermal properties. Lightweight stretched fabric will be used in the tail fin construction to conserve weight and enhance design simplicity.

The low internal helium pressure of about 2.5 inches of water and the rip-stop fabric make minor punctures or holes of little significance. Many airships have been operated for a full week with 1-inch holes in the fabric.

The RPV blimp inflated with helium is judged to give the proper buoyance with the following initial estimated weight distribution:

	<u>Weight, Lbs.</u>
Envelope, empennage, controls, ballonnet pressure system, suspension system	148
Car, propulsion, payload, associated equipment	160
Fuel	<u>32</u>
	340 lbs.

Using a lift factor of 0.063 lbs/ft^3 , a buoyancy of 300 pounds can be realized. For efficient performance it is anticipated that blimp takeoff under the heavy condition is realistic.

A nose down attitude is indicated during the landing condition to allow controlled landing under near-buoyant conditions. Use of landing skids rather than wheels is representative for RPV application. It is desirable for the airship to fly heavy even when the fuel load is expended to facilitate the landing. Permitting the maximum heaviness to go to 40 pounds allows the fuel-expended case to be 8 pounds heavy.

The blimp provides a stable platform for the miniaturized DSI equipment presently available. The distinct advantages of near-hoverability and long endurance particularly make the blimp attractive for surveillance RPV applications. The blimp is a rugged structure which can experience overload conditions due to winds and gusts and still retain structural integrity. This feature has been proven by Goodyear in operation and maintenance of the advertising blimps. RPV-Blimp size being smaller than these representative blimps will simplify launch and recovery operations. Use of small engines to propel the buoyant RPV will conserve energy and minimize pollution. Lower operator skill may be achieved for the blimp RPV compared to heavier-than-air RPVs primarily due to the slower speed of the blimp, buoyancy conditions and slower response time of the blimp controls.

Earlier airship envelopes were found to be radar transparent; therefore, it is expected that the RPV Blimp will have a low radar cross section. A noise level in the range of less than 85 db seems achievable. Flight endurances of up to 24 hours appear reasonable.

System payloads will be modular depending on the application. Black and white or color TV system can be used. The B&W can be fitted with light enhancement for night time operation and zoom lens (10:1) can be fitted on both B&W and color TV systems. Photographic equipment, IR and other payloads could also be used as the RPLTAV system will have a 400 watt alternator on board.

DSI in conjunction with Goodyear Corporation conducted some tests last spring - the L.A. basin. DSI hitched a ride on the Columbia airship and stowed in the car a colored TV system with a 10:1 zoom lense as well as a super 8 camera. For this flight an on-board video tape recorder was used to store the video output. The flight covered freeway, industrial, and harbor surveillance at a function of altitude and zoom setting. DSI also staged in concert with the Aerospace Corporation and the Gardena Police Department a mock robbery, chase, and apprehension of two suspects in their get-away car. This colored video tape is available for viewing by workshop participants and other interested parties.

A ducted fan propulsion system and associated fuel system is incorporated at the opposite end of the payload assembly. A 35 HP engine and pusher-type propeller arrangement is proposed.

An autopilot system will permit flying the LTA vehicle at a given altitude and also provide maneuver capability*.

*For other system details see Seemann, G.R. et al "A Technology Tool for Urban Applications the Remotely Piloted Blimp", AIAA Paper 73-981, September 26, 1973.

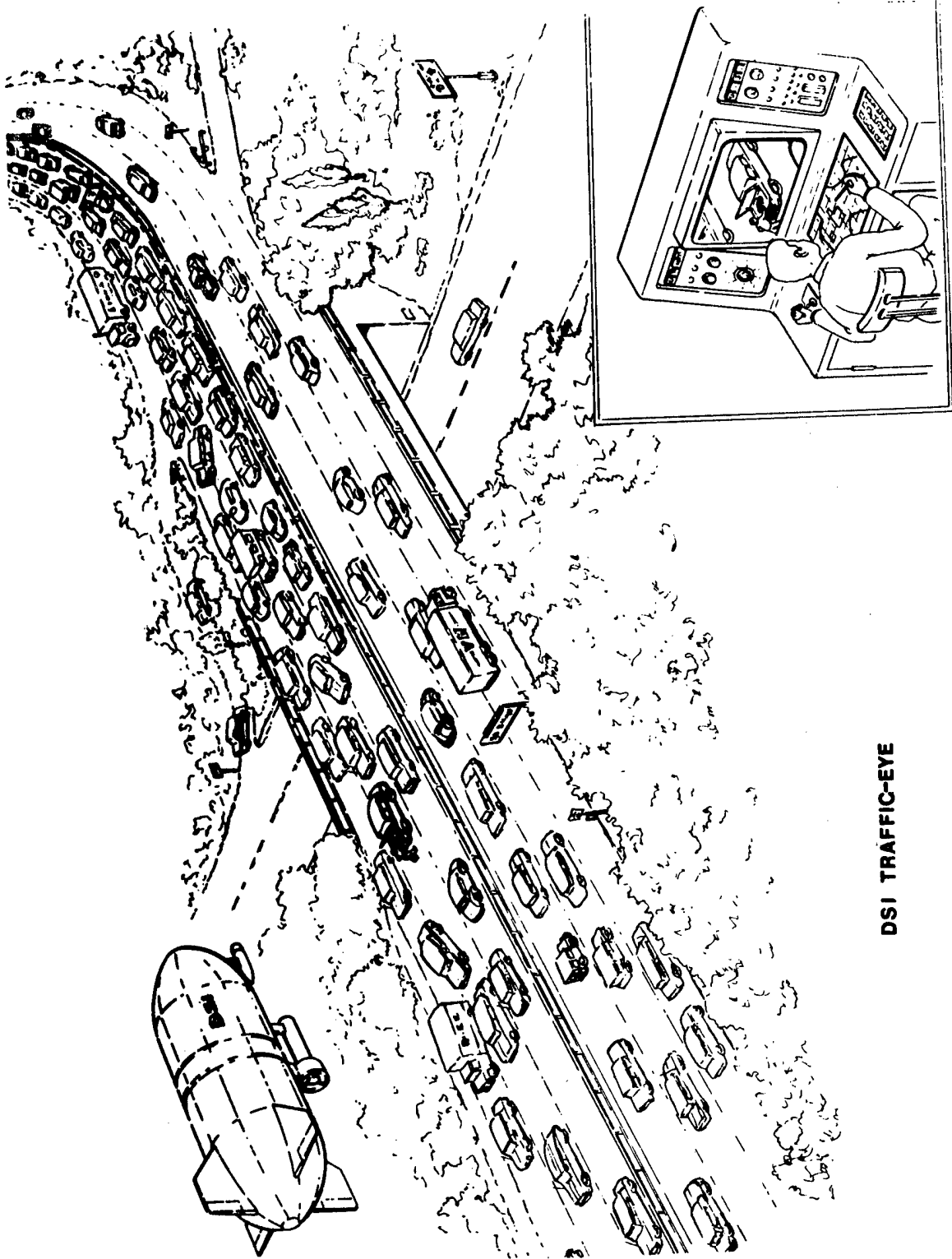

DSI TRAFFIC-EYE

FIGURE (1)

The proposed RPLTAV will have a top speed of about 60 mph.

The advantages and features of the remotely piloted mini-LTA vehicle are cited below:

- Excellent Endurance
- Good Top Speed
- Low Pollution
- No Minimum Speed
- Low Vibration Levels
- Low Maintenance
- Stable Platform
- Safety to Ground Personnel and Property
- Flexibility - Multi Use
- Economical - Capital and Operational
- Low Operator Skill Required
- Low Radar X-Section
- Ease of Launch and Recovery

Capital costs in production for a complete system will be considerably under \$100,000.00 including ground station. Operation and maintenance costs will be only a few dollars per hour.

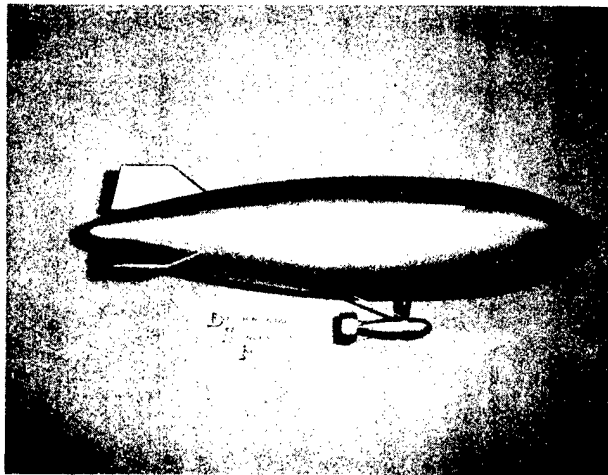

FIGURE (2)

APPENDICES

LTA Bibliography — Richard D. Neumann

Authors

11

LTA BIBLIOGRAPHY

Richard D. Neumann*

N76-15073

This bibliography of airship publications, dealing in engineering and design, stress calculation, history, pictorial, biographical and autobiographical remnants of the era when airships were a primary mode of long range, high speed transportation will well serve the serious student. Some of the publications mentioned herein are being sold at prices up to \$750.00 per volume and others for as little as \$2.50. Many of these airship publications have disappeared for somewhat unusual reasons, for example, the desires of collectors to use airship design forms as wall decorator items, and the somewhat primitive quality of prints produced during the first 40 years of the 20th century. Every book listed here exists and many are in the SCACI library. These publications have been used extensively as reference in the preparation of the SCACI papers.

SCACI will be happy to assist any serious researcher in obtaining copies or photocopies of any of these publications or at least help establish direct contact with the present owner of the publication.

Source Material

A Comparative Examination of the Airship and the Airplane, Carl B. Fritsche, Detroit, ASME, June 1927

The Metalclad Airship, Carl B. Fritsche, St. Louis, ASME, May 1929

Some Economic Aspects of the Rigid Airship, Carl B. Fritsche, Dayton, ASME, May 1930

The Metalclad Airship, Carl B. Fritsche, London, Royal Aeronautic Society, May 1931

Pressure Airships, Blakemore and Pagon, 1927

Pressure in Airships, W. A. Klinkoff, Detroit, ASME, May 1931

Pocket Book of Aeronautics, Moedebeck and Chanute, 1907

Free and Captive Balloons, Upson and Chandler, 1927

Balloon and Airship Gases, Chandler and Diehl, 1927

Dyke's Aircraft Engine Instructor, 1928

The Zeppelin in Combat, Robinson, 1973

Akron and Macon, Smith, 1965

The Zeppelin in the Atomic Age, Kirschner, 1957

The Age of the Airships, Horton, 1973

Goodyear Proposal—Job 2806-10/73

Goodyear Proposal—GAP 71-6370, Cargo Airships System

The Airship Case Study—Controversy in Soviet R & D, Rand Corporation, 1972

A General Review of Concepts for Reducing Skin Friction, Including Recommendations for Future Studies, Langley Research Center, 1974

A Proposal to Develop a Vehicle for Transporting Material at Low Cost Using Principles of Aerostatic Lift, E. W. Mason, 1972

SMD-100, All Metal Airship of 7.2 Million Cubic Feet Displacement, C. C. Slate, 1968

The LZ-129, W. E. Dorr, VDI, Berlin, March 1937

Development and Status of German Airships, The Automobile, Automotive Industries, May 1921

Request for Proposal for Metalclad Airships to Department of the Army and Department of the Navy, Aircraft Development Corporation (prepared by R. Upson, C. B. Fritsche, Charles F. Kettering), 1927

Man's Progress in Conquering the Air, July 1924; Seeing America from the Shenandoah, January 1925; Aboard a Blimp Hunting U-Boats, July 1943, National Geographic

Outline of Program for Airships, Vladimir Pavlecka, 1974

NACA Technical Memorandum No. 872

The Nonrigid Airship, No. 1170-250, January 1929; Balloons and Accessories, No. 1170-215, May 1929; The Airship Pilot (Training Reg.), No. 440-275, June 1929; Airship Dynamics, No. 1170-290, November 1929; Aerostatics, No. 1170-295, November 1929, U.S. Army Air Corps Technical Regulations

The Aeroplane, 1919

Flight of the R-34

Lighter-Than-Air Study, Southern California Aviation Council, Inc., 1974

Reports of the Acceptance Trials of the ZMC-2, 1929; Reports of the Navy Survey of ZMC-2, April 1941, United States Navy

U.S.S. Los Angeles (including report of Lakehurst NAS), 1927

The Dirigible and the Future

The Zeppelin Museum in Friedrichshafen, 1973

Ritter Der Luft, Marben, Hamburg, 1931

Zeppelin Adventures, Marben, London, 1934

*Chairman, Lighter Than Air Committee, Lighter Than Air Technical Task Force, Southern California Aviation Council, Inc., Pasadena, California, U.S.A.

- My Airship Flights (1915-1930)*, Mesger, London, 1970
- Kabinenjunge Werner Franz Von Luftschiff "Hindenburg"*, Medem, Berlin, 1942
- Airfare of Today & of the Future*, Middleton, London, 1917
- Way of the Air*, Middleton, London, 1917
- The First Century of Flight in America*, Millbank, New Jersey, 1943
- Military Ballooning, 1862*, London, 1967
- Book of Famous Flyers*, Mollison, London, 1934
- War on Great Cities*, Morison, London, 1937
- The German Air Raids on Great Britain*, Morris, London, 1969
- Aviation of Today*, Naylor & Owen, 1930
- The Zeppelin Story*, Nellson, London, 1955
- Die Internationalalen Luftschiff U Flugdrachen*, Neumann, Oldenburg, 1912
- Die Deutschen Luftstreitkräfte Im Weltkrieg*, Neumann, Berlin, 1921
- Graf Zeppelin Und Die Deutsch Luftfahrt*, Parsevel, Berlin, 1928
- Motorballon U Flugmaschine*, Parsevel, Wiesbaden, 1908
- L'Aviation Francaise*, Percheron, Paris, 1938
- Logbuch ZR 111*, Pochhammer, Freiburg, 1924
- ZR-111, Das Deutsch-Amerikanische Verkehrsluftschiff*, Pochhammer, Freiburg, 1924
- Luf Treisen*, Poeschel, Berlin, 1908
- Zeppelins Against London*, Poolman, New York, 1961
- Commercial Airships*, Pratt, London, 1920
- Die Fehler Des Starren Systems*, Prill, Hamburg, 1908
- Early British Balloon Posts*, Pringle, Manchester, 1927
- The Dirigible Book*, Proyor, New York, 1936
- Andress*, Putnam, New York, 1930
- What Constitutes Superiority In an Airship*, Renard, Washington, 1910
- Rigid Airship Manual*, Washington Navy Yard, Washington, 1927
- LZ-129*, Robinson, New York, 1965
- Experiences in an Airship of the French Army*, Rolls, London, 1908
- Up Ship*, Rosendahl, New York, 1931
- What About the Airship*, Rosendahl, New York, 1938
- Ferdinand Graf Von Zeppelin*, Rosenkranz, Berlin, 1931
- My Airships*, Santos-Dumont, London, 1904
- Aircraft and the Air*, Sargent, London, 1904
- Air Bombardment*, Saundby, New York, 1961
- Kapitaen V. Schiller's Zeppelinbuch*, Schiller, Leipzig, 1938
- Der Luftschiffbau*, Schutte, London, 1926
- Der Bau De Starrluftschiffe*, Schwengler, Berlin, 1925
- Handling and Mooring Airships*, Scott, London, 1929
- Helium, Child of the Sun*, Seibel, Kansas, 1968
- All About Airships*, Simmonds, London, 1911
- Target, Arctic*, Simons, Philadelphia, 1965
- Airships in Peace and War*, Sinclair, London, 1934
- Famous Airships of the World*, Sinclair, London, 1959
- Romance of Aircraft*, Smith, New York, 1919
- The Airship*, Sprigg, London, 1932
- Great Flights*, Sprigg, London, 1935
- 12000 Kilometer im Parseval*, Stelling, Berlin, 1911
- Aeroplanes and Dirigibles of War*, Talbot, Philadelphia, 1915
- Aloft in the Shenandoah*, Theis, New York, 1926
- Air Facts and Problems*, Thompson, New York, 1927
- Airship Attacks on England*, Truesch, London, 1919
- Collected Works of Tsiolkovsky Dirigibles*, Moscow, 1959
- Airplanes, Airships, Aircraft Engines*, Tucker, New York, 1921
- Aerial Navigation of Today*, Turner, London, 1910
- Fahrgastraume LZ-130*, Fredrickshafen, 1937
- Cruisers of the Air*, Hylander, New York, 1931
- The World's Aeroplanes and Airships*, Jackson, London, 1929
- Aerial California*, Johnson, California, 1961
- Horizons Unlimited*, Johnson, New York, 1941
- USS Shenandoah*, Keller, 1966
- De Zeppelfahrt*, Kieffel and Schultz, Berlin, 1938
- Achtung! Bomben Fallen*, Klein, Leipzig, 1934
- Die Arkisfahrt Des "Graf Zeppelin"*, Kohl-Larsen, Berlin, 1931
- Das Zeppelinluftschiff*, Kollman, Berlin, 1924
- In Die Luefte Empor*, Krogh, Charlotteburg, 1909
- L'Aeronautique*, Paris, 1922
- L'Aeronautique Des Origines*, LaVaulz, Tissandier, Dolfus, Paris, 1922
- Millionth Chance*, Leasor, London, 1957
- Auf Luftpatrouille Und Weltfahrt*, Lehman, Berlin, 1936
- My Zeppelins*, Lehman and Mingos, New York, 1927
- Avenir De L'Aerostation Dirigible En Russie*, Leloup, Paris, 1911
- Magg Brothers Catalog (1930-1945)*, London, 1946
- The Rigid Airship*, Lewitt, London, 1925

- George Washington and the First Balloon Flight*, Lindop, Chicago, 1959
- Why America Has No Airships*, Litchfield, Cleveland, 1945
- Aircraft of Bellgerents in the Year 1914*, Lucke, London, 1918
- The Strength of Transverse Frames of Rigid Airships*, Lyon, London, 1930
- Sefton Brancker*, Macmillan, London, 1946
- The Log of the HMA R-34*, Maitland, London, 1921
- Luftfahrt Voran*, Malina, Berlin, 1937
- De Tocht Van de "Graf Zeppelin"*, Eckener, Amsterdam, 1929
- Die Amerikafahrt Des 'Graf Zeppelin'*, Eckener, Berlin, 1928
- First Airship Flight Around the World*, Eckener, National Geographic, 1929
- Graf Zeppelin*, Eckener, Stuttgart, 1938
- Im Zeppelin Uber Lander Und Meere*, Eckener, Flensburg, 1949
- My Zeppelins*, Eckener, London, 1958
- Luftschiff Und Luftshiffahrt*, Engberding, Berlin, 1928
- Flying Around the World*, Falconer, Boston, 1937
- How It Flies*, Ferris, London, 1910
- Luftshiffahrt und Flugtechnik*, Frankenberg, Berlin, 1914
- Story of Aircraft*, Fraser, New York, 1935
- Many Fronts*, Freeman, London, 1918
- Mit Graf Zeppelin Um Die Welt*, Gelsenheyner, Frankfurt, 1929
- Autour De Monde En Zeppelin*, Gerville-Reache, Paris, 1929
- The World's Aeroplanes and Airships*, Gibbard-Jackson, London, 1930
- A Yankee Inventor's Flying Ship*, Gilman on Porter's Design, 1849
- Africa Zu Unsern Fussen*, Goebel, Berlin, 1925
- Voll Di Guerra*, Goebel, Milan, 1933
- 40,000 Kilometers Zepp-Kreigsfahrter*, Goebel-Foerster, Leipzig, 1933
- Count Zeppelin*, Goldsmith, New York, 1931
- Peterstrasser Der Fuhrer Der Luftshiff*, Goote, Frankfurt, 1938
- Les Ballons Dirigeables*, Gradis, Paris, 1923
- Graf Zeppelin* (Recording of Durr, Eckener, Lehman, Schiller and others)
- Safety in the Air*, Grantham, California, 1931
- Luftshiffhallenbau*, Haenig, Rostock, 1910
- Zeppelins and Super Zeppelins*, Hearne, London, 1916
- Das Zeppelin Buch*, Heiss, Berlin, 1936
- Historic Airships*, Hoeling, Boston, 1926
- Longitudinal Strength of Rigid Airships*, Hongaard, New York, 1922
- Les Aerostiers Militaires*, Bethuys, Paris, 1889
- Graf Zeppelin*, Biedenkapp, Braunschweig, 1917
- Navigation Aerienne et Dirigeable*, Boisset, Paris, 1902
- The Book About Aircraft*, London, 1934
- Lighter-Than-Air*, Boyd, New York, 1961
- Mit Luftshiff Hindenburg Ueber den Atlantic*, Brandt, Berlin, 1936
- Aeronautics 1815-1891*, Brewer and Alexander, Amsterdam, 1965
- Some Kite Balloon Experiments*, Brewer, London, 1940
- Wirluftshiffer*, Brockelman, Berlin, 1909
- Bibliography of Aeronautics*, Brockett, Detroit, 1910
- Histoire Aeronautique Par Les Monuments, Peints, Sculptes, Dessins et Grave Des Origines A 1830*, Bruel, Paris, 1909
- The World, The Air and The Future*, Burney, London, 1927
- Airship Attacks on Great Britain*, Buttlar, London, 1919
- Zepps Over England*, Buttlar, London, 1931
- Aerial Navigation*, Caulkins, Ohio, 1895
- The Machinery Installation of Airship R-101*, Cave, London, 1931
- Safety From Fire in Airships*, Cave, London, 1931
- Human Factors in the Design of Airships*, Cahnneil, Stamford, 1950
- A Contribution to the Analysis of Primary Stresses in the Hull of Rigid Airships*, Chitty and Southwell, London, 1931
- Mastery of the Air*, Claxton, London, 1915
- Luftshiff Voraus*, Colsmann, Stuttgart, 1932
- Aircraft, Airships and Aeroplanes*, Corbin, Virginia, 1914
- The External Forces of an Airship Structure*, Cox, London, 1929
- Z-101 Im Zepp Gegen Bukarest*, Dankwart, Berlin, 1916
- Le Triomphe De La Navigation Aerienne*, De La Vauz, Paris, 1911
- Mit Dem Zeppelin in Nach Amerika*, Dettman, Berlin, 1929
- Histoire Se L'Arme Aerienne Avant Le Moteur*, Duhem, Paris, 1964
- La Vie Heroique De Jean Du Plessis*, Du Plessis, Paris, 1925
- Aerostatics* (TM-1-305), U.S. Army Air Corps, 1940
- Life and Adventures of Col. Fred Burnby, 1824-1885*, Alexander
- House of Goodyear*, Allen, 1943
- Les Dirigeables*, Andre, Paris, 1902
- Moteurs D'Aviation et Des Dirigeables*, Andre, Paris, 1910
- Andre's Diaries*, Andre, London, 1931

- Andre's Story*, Andre, New York, 1930
- The Aeron or Flying Ship*, Andrews, New York, 1866
- Dirigible*, Andrews, New York, 1927
- Forces in a Cable Restricted Balloon System*, Angevine and Fulker, Boulder, 1970
- Voyages Scientifiques*, Arago, Paris, 1857
- Les Nouveaux Ballons*, Arsene-Oliver, Paris, 1876
- Beitraege Zur Erforschung Der Atmosphaere Mittels Des Luftballons*, Assman, Berlin, 1900
- Wissenschaftliche Luftfahrter* (3 vols), Assmann and Berson, Braunschweig, 1899
- Balloons, Airships and Flying Machines*, Bacon, London, 1904
- The Dominion of the Air*, Bacon, London 1924
- Memories of Land and Sky*, Bacon, London, 1924
- The Record of an Aeronaut*, Bacon, London, 1904
- Ballooning as a Sport*, Baden-Powell, London, 1907
- With Brass and Gas*, Baldwin, Boston, 1967
- Up in the Clouds*, Ballantyne, London, 1880
- The Balloon Section of the American Expeditionary Forces*, US, 1919
- L'Aeronautic*, Banet-Rivit, Paris, 1898
- Aeronautics in New York State*, Bassett, New York, 1962
- Ballons, Dirigeables and Aeroplanes*, Berget, Paris, 1908
- Conquest of the Air*, Berget, London, 1911
- U.S. Army Air Corps Stratosphere Flight Explorer 11*, Washington, 1936
- Graf Zeppelin*, Vaeth, New York, 1958
- Graf F. von Zeppelin*, Vomel, Berlin, 1908
- Der Fuhrer der Luftshilfe*, Peter Strasser, Frankfurt, 1938
- Daniel Guggenheim Airship Institute* (3 vols), New York, 1933
- Luftkreuzer Im Kampf*, von Koerber, Leipzig, 1916
- Graf Zeppelin*, von Rummel, Leipzig, 1910
- Die Amerikafahrt Des ZR-111*, von Witteman, Weisbaden, 1925
- Investigation of Powered LTA Vehicles*, Vorachek, Akron, 1968
- Wings of War*, Walbank, London, 1942
- Aerial Navigation*, Walker, New York, 1902
- Aerostatics*, Waner, New York, 1926
- Der Praktische Luftshiffer*, Wenger, Rostock, 1901
- The Aerial Age*, Wellman, New York, 1911
- The Zeppelin Fighters*, Whitehouse, New York, 1966
- Wonders of World Aviation* (2 vols), Winchester, London, 1937
- A System of Aeronautics*, Wise, London, 1850
- Through the Air*, Wise, London, 1873
- Zeppelin*, Berlin, 1964
- Die Eroberung Der Luft*, Zeppelin, Stuttgart, 1908
- Patent of the Navigable Balloon*, Zeppelin, Berlin, 1902
- Zeppelin Uber England*, Berlin, 1916
- Airships and Balloons*, Jackson, London, 1935
- Airship Aerodynamics* (TM-1-320), USAAC, Washington, 1941
- Goodyear Aircraft*, Allen, Akron, 1947
- The Strength of Rigid Airships*, Burgess
- Cross-Section Semi-Rigid Airships*, Evans, London, 1933
- The Rigid Airship In Relation to Full-Scale Experiment*, Frazier, London, 1925
- Zeppelin, Giganten Der Luft*, Grieder, Zurich, 1971
- The Skycraft Book*, Harney, Pennsylvania, 1932
- Aerodynamic Characteristics of the Airship as Deduced From Experiments on Models, with Application to Motion in a Horizontal Plane*, Jones, London, 1924
- Aerostation*, Pennington, New York, 1838
- Experimental Stress Analysis of Framework With Reference to Airship Design*, Pippard, London, 1924
- A Review On The Present Position In Regard To Airship Research and Experiment*, Richmond, London, 1926
- Giants in the Sky*, Robinson, London, 1973
- On the Calculations of Stresses In The Hulls Of Rigid Airships*, Southwell, London, 1926
- Type M Kite Balloon Handbook*, War Department, Washington, 1919
- Zeppelin*, Lehman, London, 1937
- The Age of the Airship*, Horton, London, 1973
- Bibliography of Aeronautics, Airships*, New York, 1938
- The Airship—A History*, Collier, London, 1974
- Airship Design*, Cox, London, 1951
- An Illustrated History of the Airship*, Deeson, London, 1973
- Balloons and Airships*, Ege, New York, 1974
- The Airfloat Project*, Fletcher, London, 1972
- Shenandoah Saga*, Hook, Maryland, 1973
- The Man Who Built The Zeppelin*, MacMeachen, London, 1915
- The Army Airship Roma*, Mitchell, Virginia, 1973
- Airship Pilot #28*, Williams, London, 1974
- Historic Airships*, Brooks, New York, 1973
- Upson Design 1,648,830, 1,706,830, 1,724,890, 1,750,141, 1,762,845, 1,763,835; Thaden Design 1,559,807, U.S. Patents

AUTHORS

Mark D. Ardema
Aerospace Engineer
NASA Ames Research Center
MS-202-7
Moffett Field, Ca. 94035
(415) 965-5887

Raymond A. Ausrotas
Associate Director, Flight Transportation Laboratory
Massachusetts Institute of Technology
Room 33-412
Cambridge, Ma. 02139
(617) 253-7574

M. Alain Balleyguier
President
La Grue Volante
17 rue des Petits Bois
92370 Chaville, France

George J. Beier
Economist, Transportation & Urban Projects Department
International Bank for Reconstruction and Development
1818 H St., N. W.
Washington, D. C. 20433
(202) 477-5334

Frederick Bloetscher
Systems Engineer
Goodyear Aerospace
Dept. 915G
1210 Massillon Rd.
Akron, Oh. 44315
(216) 794-7446

Glen J. Brown
Project Engineer, LTA Systems
Developmental Sciences, Inc.
15747 E. Valley Blvd.
City of Industry, Ca. 91744
(213) 330-6865

Jay S. Brown
Director, Program Development Division
Military Sealift Command
M-63
Dept. of the Navy
Washington, D. C. 20390
(202) 282-2824

Bernard H. Carson
Professor, Aerospace Engineering
U. S. Naval Academy
Annapolis, Md. 21402
(301) 267-3285

Stephen Coughlin
Research Officer, Centre for Transport Studies
Cranfield Institute of Technology
Cranfield, Bedford
England
Bedford 750111, ext. 525

Arthur C. Davenport
President
Dynapods, Inc.
P. O. Box 2568
New Orleans, La. 70176
(504) 899-8086

Donald B. Doolittle
Director, Aerocrane Program
All American Engineering Co.
801 S. Madison St.
P. O. Box 1247
Wilmington, De. 19899
(302) 654-6131

John L. Duncan
Professor, Mechanical Engineering
McMaster University
Hamilton, Ontario L8S 4L7
Canada
(416) 525-9140, ext. 4294

Louis J. Free
Special Assistant (Planning)
Naval Underwater Systems Center
New London Laboratory
New London, Ct. 06320
(203) 442-0771, ext. 2454

L. R. "Mike" Hackney
SCACI Technical Task Force on Lighter Than Air
Southern California Aviation Council, Inc.
c/o World Air Show
P. O. Box 1976
Pasadena, Ca. 91109
(213) 795-8150

Edwin E. Hanson
Cdr., USN
Office of the Chief of Naval Operations
OP-961C31
Dept. of the Navy
Washington, D. C. 20350
(202) 697-0059

Michael Harper
Aerospace Engineer
NASA Ames Research Center
MS-202-7
Moffett Field, Ca. 94035
(415) 965-5887

Gordon L. Harris
Director, Research & Development
Developmental Sciences, Inc.
15747 E. Valley Blvd.
City of Industry, Ca. 91744
(213) 330-6865

Robert Harthoorn
General Manager, Eq. Control A.C.L.
Holland America Line
Postbus 977
Rotterdam, The Netherlands
010-392370

C. Dewey Havill
NASA (Ret.)
22330 Holt Ave.
Los Altos, Ca. 94022
(415) 967-4858

Gerardo Cahn Hidalgo
Engineer and Economist, Transportation & Urban Projects
Department
International Bank for Reconstruction and Development
1818 H St., N. W.
Washington, D. C. 20433
(202) 477-5334

Patrick Horsbrugh
President
Environic Foundation
Notre Dame, In. 46556

Stephen J. Keating, Jr.
Program Manager, Airborne Heavy Lift Trans. Systems
Combustion Engineering, Inc.
C. E. Power Systems
1000 Prospect Hill Rd.
Windsor, Ct. 06095
(203) 688-1911, ext. 620

H. J. Kleiner
McMaster University
Hamilton, Ontario L8S 4L7
Canada
(416) 525-9140

R. T. Kobayashi
Naval Underwater Systems Center
PA-2
Newport, R. I. 02840
(401) 841-2660

Bernard O. Koopman
Sensor Research
Arthur D. Little, Inc.
15 Acorn Park
Cambridge, Ma. 02140
(617) 864-5770

Arthur O. Korn
Aerospace Engineer
Air Force Cambridge Research Laboratories
L. G. Hanscom Field
Bedford, Ma. 01730
(617) 861-3474

Ben B. Levitt
Director, Tactical Systems Division
Operations Research, Inc.
1400 Spring St.
Silver Spring, Md. 20910
(301) 588-6180

Paul-Armin Mackrodt
Flugwissenschaftliche Fachgruppe Gottingen e. V.
Bottingerstrasse 6-8
3400 Gottingen
West Germany

Robert T. Madden
Manager, Marketing
Goodyear Aerospace
Dept. 915G
1210 Massillon Rd.
Akron, Oh. 44315
(216) 794-7446

Walter P. Malersperger
Lt. Col., USAF (Ret.)
2 Forest Knoll Rd.
Monterey, Ca. 93940
(408) 625-2026

Fendall Marbury
Naval Architect
Ketron, Inc.
1400 Wilson Blvd.
Arlington, Va. 22209
(703) 527-4200

Henry S. Marcus
Asst. Professor, Marine Systems
Center for Transportation Studies
Massachusetts Institute of Technology
Room 5-207
Cambridge, Ma. 02139
(617) 253-5151

Alfred C. Masey
Aerospace Engineer
NASA Ames Research Center
MS-202-7
Moffett Field, Ca. 94035
(415) 965-5887

Norman J. Mayer
Program Manager, Advanced Concepts & Composite
Materials
NASA Headquarters
Code RWS
600 Independence Ave., S. W.
Washington, D. C. 20546
(202) 755-3280

Carmen J. Mazza
Head, Flight Dynamics Branch
Naval Air Development Center
Code 3015
Warminster, Pa. 18974
(215) 672-9000, ext. 2326

Leonard E. Mellberg
Research Physicist
Naval Underwater Systems Center
PA 2
Newport, R. I. 02840
(401) 841-2660

James Menke
Manager, Tethered Aerostat Systems
Sheldahl, Inc.
North Highway Three
Northfield, Mn. 55057
(507) 645-5633

William McE. Miller, Jr.
President
Aereon Corp.
1 Palmer Square
Princeton, N. J. 08540
(609) 921-2131

V. B. Moorychev
Director
Tsiolkovsky Public Dirigible Design Office
Leningrad, U.S.S.R.

C. Frank Mosher
President
Mosher Balloon Systems, Inc.
2026 Westwood Lane
Eugene, Or. 97401
(503) 343-9021

Edwin Mowforth
Design Director
Airfloat Transport Ltd.
Dept. of Mechanical Engineering
University of Surrey
Guildford, Surrey, U. K.
Guildford 71281, ext. 371

M. L. Mullins
Graduate Student, Mechanical Engineering
McMaster University
Hamilton, Ontario L8S 4L7
Canada
(416) 525-9140

Fred R. Nebiker
Manager, Aeromechanical Systems
Goodyear Aerospace
Dept. 915G
1210 Massillon Rd.
Akron, Oh. 44315
(216) 794-2994

Richard D. Neumann
Chairman, SCACI Technical Task Force on Lighter Than Air
Southern California Aviation Council, Inc.
c/o World Air Show
P. O. Box 1976
Pasadena, Ca. 91109
(213) 795-8150

John B. Nichols
President
United Technical Industries
142 3rd St
Manhattan Beach, Ca. 90286
(213) 372-0816

F. A. Pake
Flight Dynamics Section
Goodyear Aerospace
1210 Massillon Rd.
Akron, Oh. 44315
(216) 794-2994

Hermann Papst
President
Papst-Motoren K. G.
D-7742 St. Georgen im Schwarzwald
West Germany
07724-811

V. H. Pavlecka
SCACI Technical Task Force on Lighter Than Air
Southern California Aviation Council, Inc.
c/o World Air Show
P. O. Box 1976
Pasadena, Ca. 91109
(213) 795-8150

Russel G. Perkins, Jr.
Aircraft Concepts Manager
Naval Air Systems Command
AIR-03P32
Washington, D. C. 20361
(202) 692-7393

F. J. Petrone
Asst. Project Manager for HASPA
Naval Ordnance Laboratory
Code 244
White Oak
Silver Spring, Md. 20910
(202) 394-2274

Frank N. Piasecki
President
Piasecki Aircraft Corp.
Island Rd.
International Airport
Philadelphia, Pa. 19153
(215) 365-2222

S. Joseph Pipitone
Asst. to the Chief Engineer
Goodyear Aerospace
Dept. 915G
1210 Massillon Rd.
Akron, Oh. 44315
(216) 836-4450

Russell A. Pohl
Vice President
Raven Industries, Inc.
P. O. Box 1007
Sioux Falls, S. D. 57101
(605) 336-2750

Jean H. Pollock
Graduate Student, School of Business Administration
Babson College
Babson Park, Ma. 02157

Gordon Raisbeck
Sensor Research
Arthur D. Little, Inc.
15 Acorn Park
Cambridge, Ma. 02140
(617) 864-5770

Frank J. Regan
Supervisory Aerospace Engineer
U. S. Naval Ordnance Laboratory
Bldg. 402-201
Silver Spring, Md. 20910
(301) 394-2056

Ronald D. Resch
Assoc. Research Professor, Computer Science
University of Utah
Salt Lake City, Ut. 84112
(801) 581-8224

Paul O. Roberts
Director, Center for Transportation Studies
Massachusetts Institute of Technology
Room 5-204
Cambridge, Ma. 02139
(617) 253-7123

John Roda
SCACI Technical Task Force on Lighter Than Air
Southern California Aviation Council, Inc.
c/o World Air Show
P. O. Box 1976
Pasadena, Ca. 91109
(213) 795-8150

Charles E. Rosendahl
VAdm., U.S.N. (Ret.)
Flag Point
Toms River, N. J. 08753
(201) 244-1102

Ralph Schneider
President
Canadian Airship Developments
55 Glenconneron Road
No. 21 Thornhill
Ontario, G3T 1P2
Canada
(416) 881-0737

Gerald R. Seemann
President
Developmental Sciences, Inc.
15747 E. Valley Blvd.
City of Industry, Ca. 91744
(213) 330-6865

E. E. Shamis
Docent
S. Lazo Politechnical Institute
Kishinev, U.S.S.R.

William F. Shea
Chief, Division of Aeronautics
California Dept. of Transportation
Sacramento, Ca. 95800

Duncan Sheldon
President
Transportation Technology, Inc.
37 Pleasant St.
Marblehead, Ma. 01945
(617) 631-0793

Cynthia L. Smith
Aerospace Engineer
NASA Ames Research Center
MS-202-7
Moffett Field, Ca. 94035
(415) 965-5887

Miles Sonstegaard
Assoc. Professor, Economics
University of Arkansas
College of Business Administration
BA 235C
Fayetteville, Ak. 72701
(501) 575-2855

Richard S. Stone
Sensor Research
Arthur D. Little, Inc.
15 Acorn Park
Cambridge, Ma. 02140
(617) 864-5770, ext. 2956

D. L. G. Sturgeon
Research Supervisor, Textile Fibers Department
Bldg. 262
du Pont Experimental Station
Wilmington, De. 19898
(302) 772-3376

John C. Vaughan
Operations Research Analyst
AIR-03P3
Naval Air Systems Command
Washington, D. C. 20361
(202) 692-7392

T. K. Venkatachalam
Senior Research Chemist
E. I. du Pont de Nemours & Co.
Wilmington, De. 19898

Joseph F. Vittek, Jr.
Asst. Professor, Aeronautics & Astronautics
Flight Transportation Laboratory
Massachusetts Institute of Technology
Room 33-404
Cambridge, Ma. 02139
(617) 253-7572

Charles D. Walker
Manager
Aerling
2408 H St.
Bedford, In. 47421
(812) 279-5685

Hepburn Walker, Jr.
Rte. 2, Box 4-B
Vero Beach, Fl. 32960
(305) 567-6328

Donald F. Werb
Senior Aerospace Design Engineer, Air Vehicle Tech. Dept.
U. S. Naval Air Development Center
Code 305
Warminster, Pa. 18974
(215) 672-9000, ext. 2476

P. R. Wessel
Research Physicist
Naval Ordnance Laboratory
Code 244
White Oak
Silver Spring, Md. 20910
(202) 394-2259

R. G. Witherow
Manager, Structures and Materials Engineering Group
Sheldahl, Inc.
North Highway Three
Northfield, Mn. 55057
(507) 645-5633

John E. R. Wood
Aerospace Developments
19/21 Newbury St.
London, EC1, England
606-5981

Donald E. Woodward
922 S. Patrick St.
Alexandria, Va. 22314
(202) 325-9540