

REPORT DOCUMENTATION PAGE

*Form Approved
OMB No. 0704-0188*

The public reporting burden for this collection of information is estimated to average 1 hour per response, including the time for reviewing instructions, searching existing data sources, gathering and maintaining the data needed, and completing and reviewing the collection of information. Send comments regarding this burden estimate or any other aspect of this collection of information, including suggestions for reducing the burden, to Department of Defense, Washington Headquarters Services, Directorate for Information Operations and Reports (0704-0188), 1215 Jefferson Davis Highway, Suite 1204, Arlington, VA 22202-4302. Respondents should be aware that notwithstanding any other provision of law, no person shall be subject to any penalty for failing to comply with a collection of information if it does not display a currently valid OMB control number.

PLEASE DO NOT RETURN YOUR FORM TO THE ABOVE ADDRESS.

1. REPORT DATE (DD-MM-YYYY) 6/Sep/2001		2. REPORT TYPE THESIS		3. DATES COVERED (From - To)	
4. TITLE AND SUBTITLE VALUE STREAM ANALYSIS AND MAPPING FOR PRODUCT DEVELOPMENT				5a. CONTRACT NUMBER	
				5b. GRANT NUMBER	
				5c. PROGRAM ELEMENT NUMBER	
6. AUTHOR(S) 2D LT MILLARD RICHARD L				5d. PROJECT NUMBER	
				5e. TASK NUMBER	
				5f. WORK UNIT NUMBER	
7. PERFORMING ORGANIZATION NAME(S) AND ADDRESS(ES) MASSACHUSETTS INSTITUTE OF TECHNOLOGY				8. PERFORMING ORGANIZATION REPORT NUMBER CI01-216	
9. SPONSORING/MONITORING AGENCY NAME(S) AND ADDRESS(ES) THE DEPARTMENT OF THE AIR FORCE AFIT/CIA, BLDG 125 2950 P STREET WPAFB OH 45433				10. SPONSOR/MONITOR'S ACRONYM(S)	
				11. SPONSOR/MONITOR'S REPORT NUMBER(S)	
12. DISTRIBUTION/AVAILABILITY STATEMENT Unlimited distribution In Accordance With AFI 35-205/AFIT Sup 1					
13. SUPPLEMENTARY NOTES					
14. ABSTRACT					
<p>DISTRIBUTION STATEMENT A Approved for Public Release Distribution Unlimited</p> <p style="font-size: 2em; font-weight: bold;">20011017 006</p>					
15. SUBJECT TERMS					
16. SECURITY CLASSIFICATION OF:			17. LIMITATION OF ABSTRACT	18. NUMBER OF PAGES 137	19a. NAME OF RESPONSIBLE PERSON
a. REPORT	b. ABSTRACT	c. THIS PAGE			19b. TELEPHONE NUMBER (Include area code)

Value Stream Analysis and Mapping for Product Development

by

Richard L. Millard

Bachelor of Science, Aeronautical Engineering
U.S. Air Force Academy, 1999

**Submitted to the Department of Aeronautics and Astronautics
in Partial Fulfillment of the Requirements for the Degree of**

Master of Science in Aeronautics and Astronautics

at the
Massachusetts Institute of Technology
June 2001

© Massachusetts Institute of Technology
All rights reserved

Signature of Author _____
Department of Aeronautics and Astronautics
May 29, 2001

Certified by _____
Hugh L. McManus
Principal Research Engineer, Lean Aerospace Initiative
Thesis Supervisor

Accepted by _____
Wallace E. Vander Velde
Professor of Aeronautics and Astronautics
Chair, Committee on Graduate Students

This page left intentionally blank.

**THE VIEWS EXPRESSED IN THIS ARTICLE
ARE THOSE OF THE AUTHOR AND DO NOT
REFLECT THE OFFICIAL POLICY OR
POSITION OF THE UNITED STATES,
DEPARTMENT OF DEFENSE, OR THE U.S.
GOVERNMENT**

Value Stream Analysis and Mapping for Product Development

by

Richard L. Millard

Submitted to the Department of Aeronautics and Astronautics on May 29, 2001
in Partial Fulfillment of the Requirements for the Degree of
Master of Science in Aeronautics and Astronautics

ABSTRACT

This thesis explores of Value Stream Analysis and Mapping (VSA/M) as applied to Product Development (PD) efforts. It contains three parts: the background and history of PD VSA/M, a report of the current PD VSA/M practices within the U.S. aerospace industry, and the proposal of a general VSA/M method for Product Development activities.

Value Stream Analysis and Mapping is a method used for business process and product improvement, which originated with the development of the Lean business philosophy. The VSA/M background section includes a brief history of the method as described in foundational Lean literature. As with Lean practices in general, the application of VSA/M began in the manufacturing community, and has seen excellent results. However, the engineering and design efforts of Product Development provide a unique setting for the use of VSA/M.

The report of current PD VSA/M practices within the U.S. aerospace industry focuses on the research results taken from site visits to nine major Product Development sites. The VSA/M tools used at the sites are characterized and ranked in sophistication. The business context surrounding the use of the tools is also characterized and ranked. The reduction of the research data and this analysis shows the importance of both tool sophistication and the surrounding context in the success of a PD VSA/M exercise.

The proposal of a general VSA/M method for Product Development activities includes an outline for implementation. This outline is supported with a discussion of associated principles and the application of selected tools. The proposed method follows a pattern of analyzing and mapping the Current State of a process, and using heuristics to analyze and map an improved Future State. The tools used to accomplish this analysis and mapping include (1) a high-level Gantt chart or Ward/LEI map, (2) a detailed-level Process Flow map, and (3) a detailed-level Design Structure Matrix.

Contact Information: rmillard@alum.mit.edu

Thesis Supervisor: Dr. Hugh L. McManus
Principle Research Engineer
Lean Aerospace Initiative

Executive Summary

This thesis explores the concept of Value Stream Analysis and Mapping (VSA/M) as applied to Product Development (PD) efforts. Its three sections discuss: the background and history of PD VSA/M, a report of the current PD VSA/M practices within the U.S. aerospace industry, and the proposal of a general VSA/M method for Product Development activities.

Value Stream Analysis and Mapping is a method used for business process and product improvement, which originated with the development of the Lean business philosophy. In relation to this paper, Value Stream Analysis can be defined as *a method by which managers and engineers seek to increase the understanding of their company's development efforts for the sake of improving such efforts*. Value Stream Mapping can be defined as *the method by which the outcomes of Value Stream Analysis are depicted or illustrated*.

The VSA/M background section includes a brief history of the concept as described in foundational Lean literature. As with Lean practices in general, the application of VSA/M began in the manufacturing community, where it has seen dramatic results. The engineering and design efforts of Product Development provide a different setting for the use of VSA/M, but several Lean practices have shown initial applicability to PD efforts. The Product Development Team at MIT's Lean Aerospace Initiative have worked to translate the Lean principles of **value**, **value stream**, **flow**, **pull**, **perfection**, **waste**, and **people**, to the analysis of PD activities. Other documented sources also offer supporting literature and tools for the application of these principles to existing design processes.

Several applications of VSA/M to Product Development processes have been documented within industry, which have exhibited the remarkable potential of the method to enhance processes. Several key questions still existed, however, as to the distinguishing nature of VSA/M when used for PD. To address several of these questions, site visits were made to nine major U.S. aerospace industry Product Development organizations. Interviews, discussions, and participatory events were used to gather the research data. This data which focused on (1) the tools used in VSA/M efforts, (2) the business context surrounding the use of the tools, and (3) the motivation and success in completing the VSA/M efforts.

Acknowledgements

"Now I saw a new heaven and a new earth, for the first heaven and the first earth had passed away. Also there was no more sea. Then I, John, saw the holy city, New Jerusalem, coming down out of heaven from God, prepared as a bride adorned for her husband. And I heard a loud voice from heaven saying, "Behold, the tabernacle of God is with men, and He will dwell with them, and they shall be His people. God Himself will be with them and be their God. "And God will wipe away every tear from their eyes; there shall be no more death, nor sorrow, nor crying. There shall be no more pain, for the former things have passed away." Then He who sat on the throne said, "Behold, I make all things new." And He said to me, "Write, for these words are true and faithful." And He said to me, "It is done! I am the Alpha and the Omega, the Beginning and the End. I will give of the fountain of the water of life freely to him who thirsts. "He who overcomes shall inherit all things, and I will be his God and he shall be My son.

... The twelve gates were twelve pearls: each individual gate was of one pearl. And the street of the city was pure gold, like transparent glass. But I saw no temple in it, for the Lord God Almighty and the Lamb are its temple. The city had no need of the sun or of the moon to shine in it, for the glory of God illuminated it. The Lamb is its light. And the nations of those who are saved shall walk in its light, and the kings of the earth bring their glory and honor into it. Its gates shall not be shut at all by day (there shall be no night there). And they shall bring the glory and the honor of the nations into it. But there shall by no means enter it anything that defiles, or causes an abomination or a lie, but only those who are written in the Lamb's Book of Life.

... And he showed me a pure river of water of life, clear as crystal, proceeding from the throne of God and of the Lamb. In the middle of its street, and on either side of the river, was the tree of life, which bore twelve fruits, each tree yielding its fruit every month. The leaves of the tree were for the healing of the nations. And there shall be no more curse, but the throne of God and of the Lamb shall be in it, and His servants shall serve Him. They shall see His face, and His name shall be on their foreheads. There shall be no night there: they need no lamp nor light of the sun, for the Lord God gives them light. And they shall reign forever and ever. Then he said to me, "These words are faithful and true."

... "I, Jesus, have sent My angel to testify to you these things in the churches. I am the Root and the Offspring of David, the Bright and Morning Star." And the Spirit and the bride say, "Come!" And let him who hears say, "Come!" And let him who thirsts come. Whoever desires, let him take the water of life freely... He who testifies to these things says, "Surely I am coming quickly." Amen. Even so, come, Lord Jesus!"

Revelation 21:1-7,21-27 22:1-6,16-17,20-21

I would like to thank the many people around me who have contributed to this thesis and my life. To my family for filling my life with love and support. To my friends for the helping hand and much joy. To LAI for the opportunity to work in such an interesting field with such incredible people. To my advisor, Dr. Hugh McManus, for the coaching, and extra hours. To my coworkers who got me through the days with a smile. To the consortium members and research participants for showing an inexperienced graduate student the ropes. And above all, to God for your love, sacrifice, and promise. Keep a hold.

The second section, which reports on the current VSA/M practices within the U.S. aerospace industry, uses the research data to develop the relationships between tool sophistication, context, and success. The six different VSA/M tools used at the sites are characterized and ranked in sophistication. This ranking was based on the ability of the tool to support analysis of the process, rather than the ability to represent the process. The business context surrounding the use of the tools was also characterized and ranked. Three groupings of context emerged from this ranking: Group A includes those sites with a more traditional approach to Product Development; Group B, those in the midst of integrating the traditional methods with more Lean methods; and Group C includes those sites currently developing a comprehensive Lean PD environment.

The quantified tool sophistication and context values are used in support of the following observations:

1. VSA/M tool sophistication and use correlates with the success of the improvement effort, and
2. The context surrounding the tool use correlates with the selection and sophistication of tool use.

These observations suggest that the use of VSA/M tools is a useful and effective component of Lean PD efforts.

The third section includes the proposal of a general VSA/M method for Product Development activities. The method is presented in a step-by-step tutorial format, which includes an outline for implementation, a discussion of associated principles, and the application of selected tools. The method follows a pattern of analyzing and mapping the Current State of a process, and using heuristics to analyze and map an improved Future State. The tools used to accomplish this analysis and mapping include (1) a high-level Gantt chart or Ward/LEI map, (2) a detailed-level Process Flow map, and (3) a detailed-level Design Structure Matrix.

Contact Information: rmillard@alum.mit.edu

Thesis Supervisor: Dr. Hugh L. McManus
Principle Research Engineer
Lean Aerospace Initiative

Table of Contents

1.0 Introduction	13
2.0 Definitions and Problem Statement	15
2.1 Value Stream Analysis	15
2.2 Value Stream Mapping	16
2.3 Why VSA/M is Different	17
2.4 Problem Statement	18
3.0 Previous Work	19
3.1 VSA/M Progression Within the Lean Context	19
3.1.1 Manufacturing Application	20
3.1.2 Product Development Application	23
3.2 Available Tools for VSA/M in Product Development	27
3.2.1 Gantt Chart	27
3.2.2 Ward/LEI Map	27
3.2.3 Process Flow Map	29
3.2.4 Learning To See	29
3.2.5 System Dynamics	30
3.2.6 Design Structure Matrix	30
3.3 Documented Lean VSA/M Cases	31
3.3.1 F-16 Build-To-Package Support Center	31
3.3.2 F-22 Systems Program Office/F-119 Engine Development	33
3.3.3 Automotive Fuel System Development	35
3.4 Corollary Improvement Methods	37
4.0 Research Design	39
4.1 Key Issues	39
4.2 Research Scope	40
4.3 Research Methods	41
4.3.1 Data Collection	41
4.3.2 Data Reduction	42
5.0 Current Practices	45
5.1 Case Study Results	45
5.2 VSM Tool Characterization	45
5.2.1 Tool Descriptions and Capabilities	46
5.2.2 Tool Capability Quantification and Scaling	49
5.2.3 Applied Tool Characterization	51
5.3 VSA Surrounding Context	52
5.3.1 Group A: Traditional Business Methods	54
5.3.2 Group B: Fractional Lean Integration	54
5.3.3 Group C: Developing Comprehensive Lean Environment	55
5.4 Site VSA/M Success	56
5.5 Correlation	57

5.6 Summary	59
6.0 A General Method for Product Development VSA/M	61
6.1 VSA/M Method Introduction	61
6.1.1 VSA/M Method Description	62
6.1.2 VSA/M Step 1: Improvement Team Preparation	63
6.1.3 VSA/M Step 2: Value Stream Selection	64
6.2 Analysis and Mapping of the Value Stream	65
6.2.1 VSA/M Step 3: Value Stream Definition	65
6.2.2 VSA/M Step 4: Analyzing and Mapping the Current State	66
6.2.3 VSA/M Step 5a: Analyzing and Mapping the Future State	84
6.2.4 VSA/M Step 5b: Analyzing and Mapping the Ideal State	94
6.3 Analysis and Mapping Follow-up	97
6.3.1 VSA/M Step 6: Implement New Process	97
6.3.2 VSA/M Step 7: Continuous Improvement	99
7.0 Conclusions and Recommendations	101
7.1 VSA/M Background Summary	101
7.2 VSA/M Current Practices Results	102
7.3 Proposed VSA/M Method for Product Development	102
7.4 Recommendations for Further Study	103
Resource List	104
Appendix A: Corollary Process Improvement Methods	109
Appendix B: DSM Supplemental Information	115
Appendix C: Interview Guide	117
Appendix D: Case Study Results	121
Appendix E: Data Collection Form	135

List of Figures

Figure 1. Document Basis	15
Figure 2. Product Life Cycle Cost Committed and Management Leverage Expended	16
Figure 3. Sample Learning To See Value Stream Map	21
Figure 4. Product Development Boundaries	23
Figure 5. PD Value Context	24
Figure 6. PD Process Flow	25
Figure 7. PD Information Progression	26
Figure 8. Sample Gantt Chart	27
Figure 9. Sample Ward Value Stream Map	28
Figure 10. Process Mapping Symbology	29
Figure 11. Sample System Dynamics Map	30
Figure 12. Sample Design Structure Matrix	31
Figure 13. F-16 BTP Pre-improvement VSM	32
Figure 14. F-16 BTP Post-improvement VSM	32
Figure 15. F-22 SPO Enterprise FAST Map	34
Figure 16. Pratt & Whitney F-119 FAST Map	35
Figure 17. Fuel System Pre-improvement Process Map	36
Figure 18. Fuel System Post-improvement Process Map	37
Figure 19. VSM Tool Categorization	48
Figure 20. Gradient of Analytic Capability	51
Figure 21. Gradient of Applied Analytic Capability	52
Figure 22. VSA/M Success Plot	56
Figure 23. Success-Capability Correlation	58
Figure 24. Success-Context Correlation	58
Figure 25. Capability-Context Correlation	59
Figure 26. Process Decomposition	62
Figure 27. Opportunity Scatter Plot	64
Figure 28. Preliminary Design Framework As Used in Example	66
Figure 29. General Improvement Scheme	66
Figure 30. Example Gantt Chart	68
Figure 31. Example Ward/LEI Map	68
Figure 32. Level 1 Process Flow Map	75
Figure 33. Level 1 DSM	75
Figure 34. Level 2 Process Flow Map	79
Figure 35. Level 3 Process Flow Map	83

Figure 36. Improved Process Flow Map: Heuristics 1 and 2	87
Figure 37. Improved DSM: Heuristics 1 and 2	87
Figure 38. Improved Process Flow Map: Heuristics 1-3	89
Figure 39. Improved DSM: Heuristics 1-7	91
Figure 40. Improved Process Flow Map: Heuristics 1-7	93
Figure 41. Lean Product Development Framework	95
Figure 42. Concurrent Lean PD Framework	96
Figure 43. Example Ideal State Process Flow Map	96
Figure 44. Example Ideal State DSM- Expanded	97
Figure 45. Example Ideal State DSM- Condensed	97
Figure 46. Real Flow Illustration	100
Figure 47. Deming Cycle	110
Figure 48. Systems Engineering Framework	113
Figure 49. DSM Example—Development of a New Soda Bottle	115
Figure 50. Example of an Information Flow DSM, Partitioned to Show Reorganization	116
Figure 51. Learning To See Adaptation	123
Figure 52. Learning To See Adaptation	126
Figure 53. Sample Ward Map	128
Figure 54. Sample Interaction Matrix	129
Figure 55. Sample Process Flow Map	130

List of Tables

Table 1. Fundamental Lean Tenets	19
Table 2. Sample Manufacturing Metrics	21
Table 3. Sample Results of VSA/M for Manufacturing	22
Table 4. PD Information Wastes	26
Table 5. Ward Waste Categorization	28
Table 6. VSM Tool Characterization Matrix	46
Table 7. Tool Capability Quantification	50
Table 8. As-Applied Tool Capability Quantification	51
Table 9. VSA Context Quantification	54
Table 10. Quantified Value Summary	57
Table 11. VSA/M Improvement Scheme	62
Table 12. Level 1 Data Collection Guide and Legend	71
Table 13. Example Activity List	73
Table 14. Level 2 Data Collection Guide	77
Table 15. Level 3 Data Collection Guide	82
Table 16. Value Stream Improvement Heuristics	84

This page left intentionally blank.

1.0 Introduction

Do what is good. Business exists necessarily in partial fulfillment of human need, and the exercise of human labor.

Continuously improve. Business viability in a globally competitive and informed environment requires the continued ability to provide advantage over the competition.

If an organization already knows how to do accomplish these two maxims well enough, it can rest assured of future prosperity and integrity. The only problem is, that history has shown how difficult the realization of these two ideas can be. Many organizations find themselves today with much need for progress. The aim of this research is to offer assistance by presenting a method for improving an organization's Product Development (PD) processes. The method is called Value Stream Analysis and Mapping (VSA/M), and there has shown dramatic potential in its implementation. The problem addressed by this thesis, stated broadly, is the need to perform Product Development processes better and more efficiently. The thesis draws upon the principles and techniques of the Lean business philosophy to frame and address this need.

The Lean philosophy was initially developed in post-World War II Japan by the Toyota Motor Corporation. The introduction of Lean methods have revolutionized the way companies do business, and have seen dramatic results worldwide in its application to manufacturing operations. More recently, explicit Lean techniques have also made inroads to the engineering and design operations of Product Development. One of the foremost agencies in the application of Lean techniques to Product Development processes is the Lean Aerospace Initiative at MIT. Its PD Focus Team has translated basic Lean concepts for use in engineering and design activities, and its member companies have employed the Lean techniques to improve PD processes. One of the hallmark Lean techniques, Value Stream Analysis and Mapping, has been applied to PD processes in the past, but in an ad hoc manner, without a standardized method. Conversely, a number of Lean-based tools for PD process improvement have been developed, but often without a systematic Lean context surrounding their use.

This thesis directly addresses the problem of creating a systematic method for applying VSA/M to Product Development efforts. The thesis presents a brief description of Value Stream Analysis and Mapping and its Lean context, and a short history of how the method has developed within the manufacturing and engineering communities. A discussion of current Value Stream Analysis and Mapping practices follows, supported by a survey of the use of VSA/M techniques in aerospace PD process improvements. The strengths and weaknesses of various tools used for Product Development VSA/M are evaluated, and the success of the improvement exercise is correlated with the tool used. The thesis concludes by presenting a suggested method for Value Stream Analysis and Mapping as applied to Product Development activities, with examples for implementation.

2.0 Definitions and Problem Statement

In framing and discussing the outcomes of the research, this thesis will develop the basis outlined in Figure 1. Satisfaction of customer needs and enterprise learning can only occur with the intentional association of “top-down” principles with the “bottom-up” advancement of methods and processes. Related specifically to the issue of Value Stream Analysis and Mapping, successful improvement of business processes demands both the context of effective analysis and the application of capable tools.

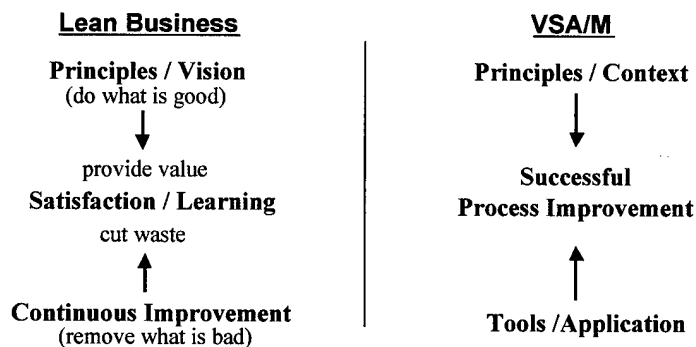

Figure 1. Document Basis

2.1 Value Stream Analysis

Value Stream Analysis is a method by which Lean principles are applied in the examination of business practices. In the context of this paper, Value Stream Analysis can be defined as *a method by which managers and engineers seek to increase the understanding of their company's development efforts for the sake of improving such efforts*. The analysis centers on the activities intended to add value to a final product, which aggregate to form a stream of value. VSA is performed with the combination of an overall systems perspective with the application of local process knowledge.

Many of the now inefficient processes within the aerospace industry were not intended or designed to run in a wasteful manner. An accumulation of special cases and quick fixes have been passed from one generation of employees to the next, resulting in the value-added time of many development efforts to become as low as 5% of the total cycle time [8]. However, early

implementation of VSA/M within Product Development efforts has shown to cut this wasted time (and cost) by upwards of 70-90% [57,60].

The potential reward for improving the Product Development process stems from the profound importance that PD plays in the overall business system addressed above. Figure 2 shows that approximately 75% of a program's resources are committed in the PD phase, and by the same notion, approximately 70% of a program's management leverage is expended [2]. The decisions made in this early phase go on to greatly affect the cost and performance of a product, which are manifested throughout the product's life.

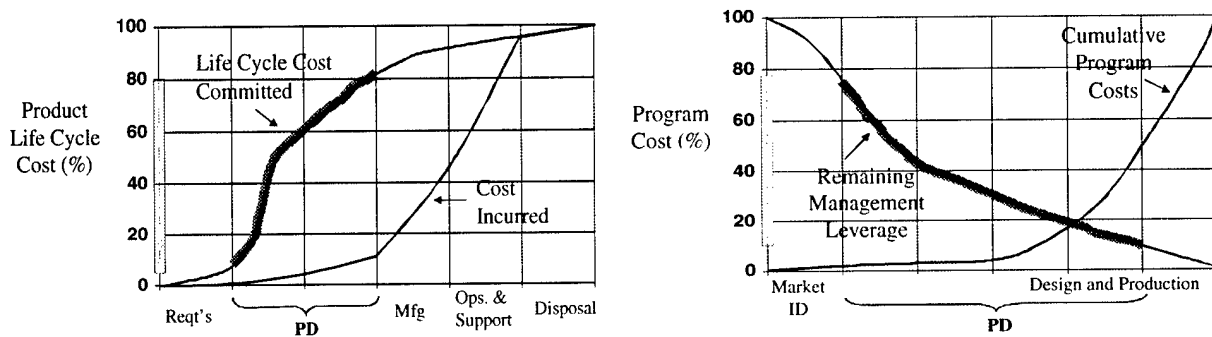

Figure 2. Product Life Cycle Cost Committed and Management Leverage Expended [2]

PD also provides the phase where design changes cost the least to execute. As a case in point, a software coding change implemented in the Initial Production phase can cost 1,000 times as much as the same change implemented earlier, in the Design phase [2]. A change made while in Final Production can cost 10,000 times as much as if it were implemented in the Design phase [2]. Neglecting the importance of an accurate and effective initial design can, and has, proven very costly in later stages of the business venture.

2.2 Value Stream Mapping

The Lean improvement philosophy makes use of Value Stream Mapping to support its associated analysis. Value Stream Mapping thus can be simply stated as *the method by which the outcomes of Value Stream Analysis are depicted or illustrated*. The VSM of a process serves to describe a highly complex real system in a less complex 2-D format. This simplification of the system

facilitates insight and understanding as only a static visual tool can, and provides a distinct means for the communication of that insight and understanding.

2.3 Why VSA/M is Different

Lean-based Value Stream Analysis and Mapping finds distinction from other process improvement approaches in the unique ability to support Lean ideology. The main themes by which this method strives to accomplish this goal are outlined below [41]:

- *Creating value for the customer*: providing for the customer with the right product, at the right time, with the right cost [54]. This research will use the definition of “customer” as the immediate recipient in the Value Stream. This recipient is an internal individual or group until the very last handoff. In applying this definition to the entire PD process, the “product” is the design package (or build-to-package), and the customer is the individual or organization responsible for receiving that design package.
- *Flows of information and material*: tailoring analysis to include the streams of actual design information (“product” information), command/control information, or physical material that may flow through the PD process. Depicting this flow is accomplished by mapping tasks, decisions, inputs/outputs, deliverables, organizations, or other product factors critical to a particular process. VSA/M may be performed upon any stage of the PD process, from market research to product completion and support, and can incorporate data or analysis provided by the other improvement methods.
- *Adaptability of processes to continually improve value and eliminate waste*: Lean is not simply about cutting out what is bad in a process, but also about using that waste removal as an intermediate step to doing what is good. As the process matures, more and more incremental improvements can be applied and further waste eliminated.
- *Time as an independent variable*: The schedule associated with a product holds great importance as to its success. Recognizing the opportunity in improving schedule and focus on time into its analysis is also what distinguishes the Lean approach from other improvement theories that focus only on maximizing the performance over cost.
- *Risk and variation in a creative and iterative design process*: acknowledging that unlike the management of many physical systems, design activities have no objective final answer, nor is

there an objectively correct path to get to an optimum design solution. This specific theme provides perhaps the defining issue in the discussion of how design activities differ from manufacturing activities, and why analysis of their respective processes may require such distinct approaches.

- *Foundation of an overall systems perspective, Value Stream Thinking*: looking at a process, not in isolation, but as part of a larger system; looking at everything that is done as part of a stream of dynamic and interdependent elements. This perspective requires an understanding of how decisions affect not only the immediate environment, but more importantly, how they will impact the larger overall system.

2.4 Problem Statement

The motivation for this research came from the desire held by industry consortium members of the Lean Aerospace Initiative (LAI) to better understand VSA/M for Product Development. Specifically, the members wanted to know if VSA/M is currently being applied effectively within PD efforts in the aerospace industry: If not, can it be effectively applied, and how? If so, how is it currently being applied, and are there general principles to be learned about its application? In response to this general question, this thesis will present:

1. A brief exploration of Value Stream Analysis and Mapping methods and their application to Product Development efforts, as found in supporting literature,
2. A characterization of the current Values Stream Analysis and Mapping practices within the Product Development efforts of the U.S. aerospace industry, and
3. A proposed Value Stream Analysis and Mapping method, with associated tools, to be used in the improvement of Product Development processes.

3.0 Previous Work

In attending to the resolution of the problem statement presented in Chapter 2, it is beneficial to first discuss the previous work performed in this area of process improvement. The following section describes the research and implementation efforts that provide foundation for this work, not only through direct Lean-based VSA/M development, but also through corollary process improvement methods.

3.1 VSA/M Progression Within the Lean Context

Previous work in the area of Value Stream Analysis and Mapping finds its roots in the development of the Lean business theory by the Toyota Motor Corporation, and the explication of that theory through publications that include *The Machine That Changed the World* and *Lean Thinking* [55,54,3]. These writings focus mainly on the manufacturing aspect of business rather than the engineering and design processes, but maintain that the same principles can be applied to both shopfloor and non-shopfloor activities.

Lean is a part of Enterprise Science, which attempts to capture all relevant aspects of business into a way of looking at things that allows forward-thinking decisions to be made [25]. As categorized by Womack and Jones, the main tenets of Lean theory are included below in Table 1 [54]. Since their initial publication, business and consulting organizations have also explicitly added Waste and People considerations to the list [53,34].

Table 1. Fundamental Lean Tenets [54]

1. Value: providing for the customer the right product for the right price, at the right time.
2. Value Stream: the set of actions that bring a product through the business phases of problem-solving, information management, and physical transformation.
3. Flow: seamless movement of only value-creating steps
4. Pull: allowing the customer to define and pull the product rather than forcing, or pushing, a product upon the marketplace.
5. Perfection: continuously and relentlessly improving the value, value stream, flow, and pull in business operations.

The Value Stream focus of Lean theory asserts that a set of activities that add value to a product link together in a stream of value. This Value Stream can be analyzed and mapped in order to reduce the waste in processes and continually improve products. The more value a company can generate within the Value Stream, the closer the business system can come to the ideal of Lean philosophy: providing value across the entire enterprise [54].

3.1.1 Manufacturing Application

The analysis and mapping of the physical material flowing through a manufacturing operation does not present the same level of difficulty as the creative and iterative nature of the engineering development operation. Consequently, many of the Lean principles and ideas have been taken to a much higher level of sophistication and application within the manufacturing community as opposed to the engineering community. In light of this, the next significant step for Value Stream Analysis and Mapping came with the introduction of the method developed in implementation-focused publications that include *Learning To See* [12,21]. These efforts provided general and robust methods for the practical implementation of Lean Value Stream concepts within manufacturing operations. A sample map generated by using the *Learning To See* method is shown in Figure 3.

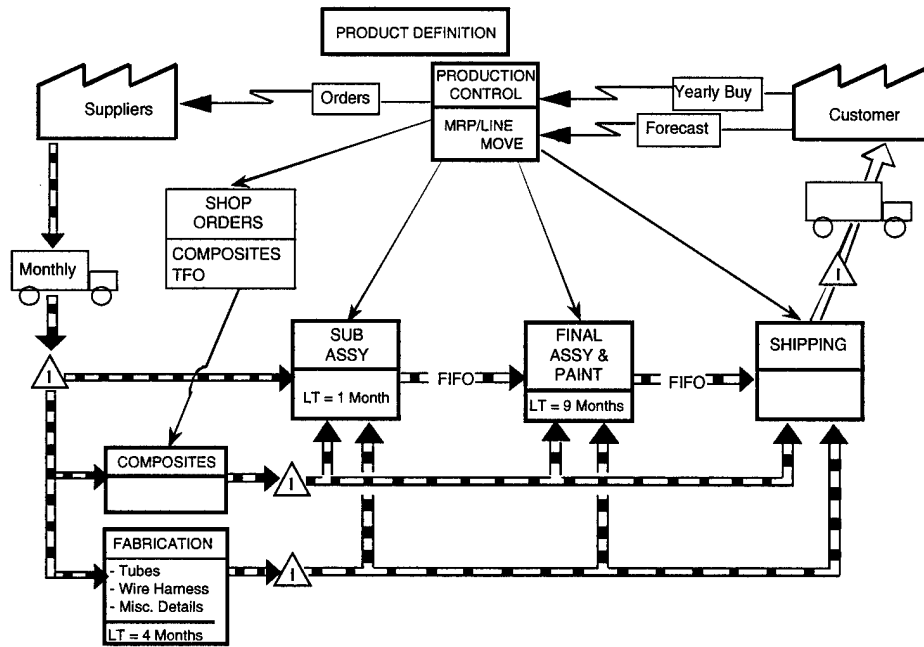

Figure 3. Sample Learning To See Value Stream Map [59]

The fundamental principle of the method includes the notion of mapping the Current State of a process and applying Lean-based techniques to create an improved Future State vision of the process. To develop this Future State, the improvement techniques are initially applied to eliminate activities within the process that are deemed Non-Value-Added. These are activities deemed to only support the true Value-Added tasks (Type I waste), or that are completely unnecessary in themselves (Type II waste) [54]. The improvement techniques are also used to introduce the correct cycle times driving the process. These cycle times include, among others, the customer requirement cycle, supplier cycle, actual process cycle time, and system lead time.

In order to generate and support process improvement decisions, metrics are used to characterize the process and reveal where the improvements should be made. Table 2 below includes a list of common metrics used within the manufacturing context and a short description of each.

Table 2. Sample Manufacturing Metrics [47]

Metric	Description
Cycle Time	time required to complete a process or sub-process
Changeover Time	time required to change from work on one product to another
On-Demand Uptime	time that machines and employees are performing work properly

Actual In-Process Time	time in which the product is being changed in order to add value
Production Batch Sizes	number of the same product produced at one time
Inventory	places where product accumulates within the process
Number of Operators	number of employees handling the product
Number of Product Variations	number of different ways in which the process must tailor a product
Pack Size	number of product within a shipping package
Working Time	available time for machines and employees to work
Scrap Rate	amount of scrap generated per completed process

Once the revised process has been drafted within the Future State map, an implementation plan is set into motion, and the changes are made. This Future State is then improved upon to generate a consecutive Future State, and the method of continuous improvement steadily increases the quality produced within the Value Stream of the product.

Standard symbology and terminology, along with clearly-communicated principles, allowed for the increased cross-communication about VSA/M and led to incredible manufacturing efficiency improvements across companies and entire industries. Toyota, Pratt & Whitney, Sikorsky, Delphi, Ford, and many other companies have reported savings amounting to billions of dollars due to the implementation of Lean principles within their manufacturing activities [48]. Improvements of 30-90% in factors such as floor space required, production operators, production lead time, and amount of work in progress are common results of Lean efforts enabled by VSA/M efforts. Table 3 shows actual results achieved by two companies: one in Oklahoma City, Oklahoma, and the other in Nogales, Mexico.

Table 3. Sample Results of VSA/M for Manufacturing [52]

Metric	Former Production	Leaned Production	Improvement
Floor Space	10,540 ft	5,670 ft	46%
Production/ Operators	7200/day 121 operators	7200/day 78 operators	36%
Lead Time	11.54 hr	6.16 hr	47%
Work In Progress	4618	2909	37%

Metric	Former Production	Leaned Production	Improvement
Floor Space	1,826 ft	422 ft	80%
Production/ Operators	1700/shift 11 operators	4518/shift 9 operators	76%
Lead Time	126 min	5 min	96%
Work In Progress	2067	53	97%

The successful implementation of Lean methods, to include VSA/M, within the manufacturing community spurred desire to achieve similar improvement effects within the design activities of Product Development.

3.1.2 Product Development Application

The Product Development Team at MIT's Lean Aerospace Initiative was launched in 1994 with co-funding from the U.S. Air Force and aerospace industry companies. The team, whose members represent military, industry, and academic interests, received the charter to apply and advance Lean ideas in relation to aerospace engineering and design efforts. In the seven years that have followed, and with the steady incorporation of the Lean philosophy into business practices, the vision of Lean PD has matured from rather obscure beginnings to having addressed several of the founding principles of Lean.

Framing the team's outcomes in terms of the five tenets of Lean as posited by Womack and Jones provides a post-facto description of the direction the team has taken. Attending to the context and meaning of **value** within the surrounding business system first prompted the definition of boundaries for PD activities and outputs. The phases of Product Development as shown in Figure 4 extend from the earliest requirements and system definition up to the actual production of the design.

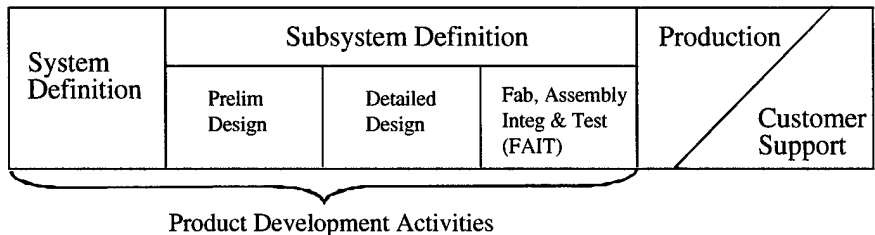

Figure 4. Product Development Boundaries [34]

The team went on to propose the value of the PD process as “a capability delivered at the right time, for the right price, as defined by the end user,” which culminated in the output of an effective and usable product design package [54]. This design package must come about by way of a **value stream**, in like manner to the manufacturing value stream, and must then fit in sequence with other activities in the business cycle, to create some overall value as shown below in Figure 5.

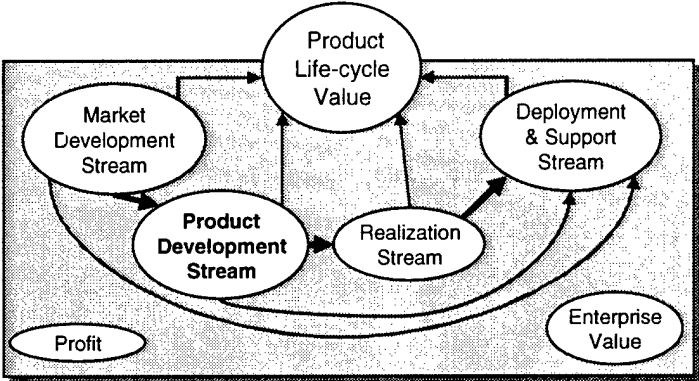

Figure 5. PD Value Context [41]

The figure shows that each phase of the business cycle contributes independently to the overall value of a product, as well as providing value for the subsequent phases (shown with the bold arrows). Also constituent to the system is the profit generated for the individual company and the value generated across the entire Lean enterprise.

To integrate the preceding ideas outlining PD boundaries, value, and value stream, the team developed the diagram depicted in Figure 6 below. The pyramid shape denotes increasing customer and company value as the value stream moves through the PD phases to production and support. Along with this increasing value also comes reduced risk perceived by the customer.

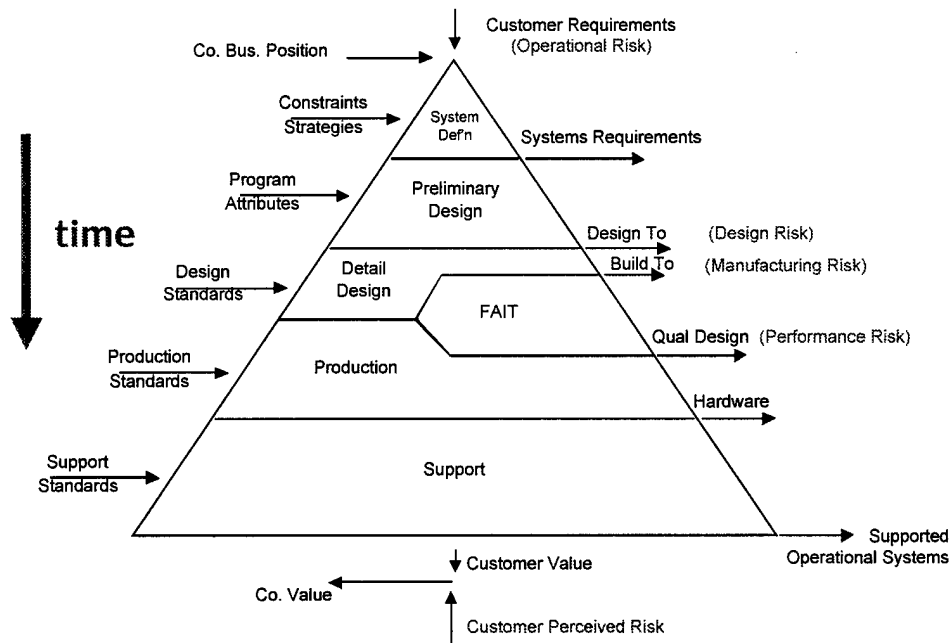

Figure 6. PD Process Flow [41]

Further analysis can be accomplished by breaking down each of the blocks into subprocesses and defining their inputs, outputs, constraints, and enablers. This exercise begins to address the **flow** through the PD process. The team took an important step with the consensus that it is information that flows through the PD process, as does physical material through the manufacturing process. The team characterized the quality of the information flow in terms of Form, Fit, Function, and Timeliness (FFFT), which are described below [41]. Value within PD develops not only as a function of the FFFT of the information included within the design package, but also as a function of how well that design package allows the final product to meet the FFFT desires of the customer.

- Form: information must be in concrete form, explicitly stored.
- Fit: information must be in a form that is useful to downstream processes and provided seamlessly.
- Function: information (in the form of a design) must satisfy end-user and downstream process needs, and communicate an acceptable amount of risk.
- Timeliness: the right information at the right time.

As the information flows and matures through this process, the tasks performed add value to the information, transforming it from its initial state of raw data, as shown in Figure 7.

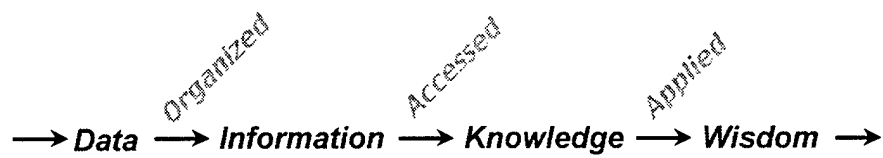

Figure 7. PD Information Progression [38]

However, not everything that begins as raw data results in applied wisdom, and the team recognized this through the application of the seven manufacturing waste categories to information. This application is listed in Table 4 below. This categorization of information waste does not imply that every design exploration or piece of data must end up in the final design for it to be considered valuable, but that there can be unnecessary or inefficient means of developing that information.

Table 4. PD Information Wastes [34,52,61]

	Waste	Description
1	Overproduction	too much detail, unnecessary information, redundant development, over-dissemination, pushing rather than pulling data
2	Transportation	information incompatibility, communication failure, multiple sources, security issues
3	Waiting	information created too early or unavailable, late delivery, suspect quality
4	Processing	unnecessary serial effort, too many iterations, unnecessary data conversions, excessive verification, unclear criteria
5	Inventory	too much information, poor configuration management, complicated retrieval
6	Unnecessary Movement	required manual intervention, lack of direct access, information pushed to wrong sources, reformatting
7	Defective Product	lacking quality, conversion errors, and incomplete, ambiguous, or inaccurate information, lacking required tests/verification

Though the definition and application of concepts about **value**, **value stream**, **flow**, and waste continue to evolve within the framework of Product Development, the team has also begun to set focus on the explication of **pull**, **perfection**, and people in the PD environment.

3.2 Available Tools for VSA/M in Product Development

Having defined the value in Product Development processes (as contribution to the Product Definition in terms of the form, fit, function, and timeliness of information), and having interpreted the PD Value Stream (in terms of its information), the mapping of the Value Stream may take place. A number of existing process analysis tools will be briefly reviewed here, some of which were not necessarily intended for use in the mapping of a Value Stream. This list is not intended to be exhaustive, but rather reflects the tools actually used in the U.S. aerospace industry case studies to follow in Chapter 5.

3.2.1 Gantt Chart

The Gantt Chart is a traditional method for displaying sequence, schedule, and dependency between tasks. It is widely used in the PD community for display of schedule and milestone information [42].

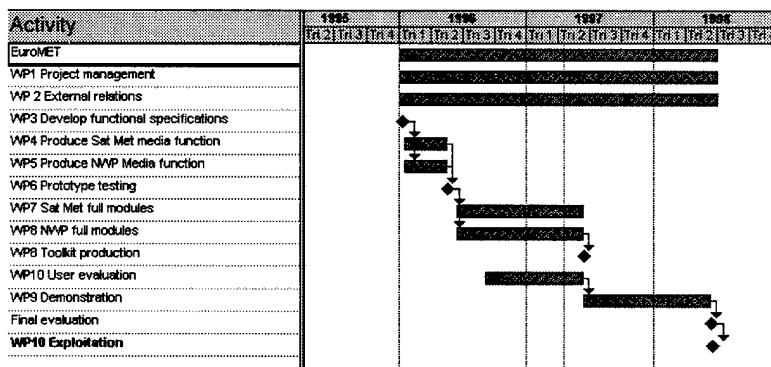

Figure 8. Sample Gantt Chart [6]

3.2.2 Ward/LEI Map

Ward Synthesis, Inc., in conjunction with the Lean Enterprise Institute, has advanced a framework that highlights the concurrent and cyclic nature of PD processes. Rather than using arrows in their maps to depict flow between process steps (which imply serial flow), overlapping curves are used to illustrate the time and resources required for each activity as shown in Figure 9.

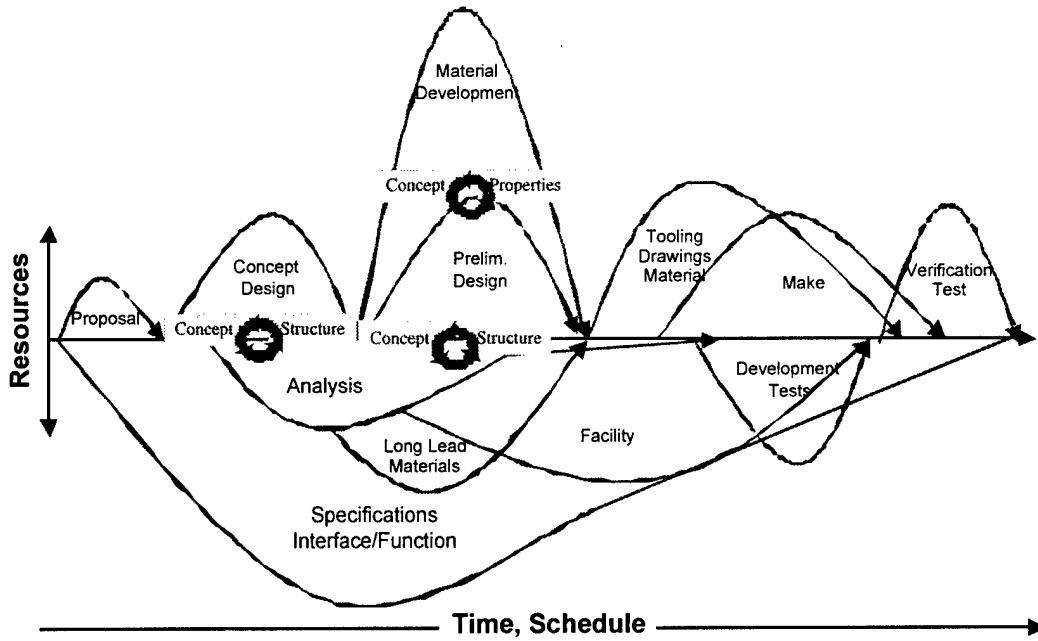

Figure 9. Sample Ward Value Stream Map [59]

The map shows time along the horizontal axis, and the magnitude of resources required to perform each task on the vertical axis (no positive or negative resources implied). The circle of arrows symbol denotes a task with a high degree of iteration. Once the process is mapped, waste can be identified and removed to improve the process. Table 5 below includes the most significant areas of waste and a short description of how each applies to PD activities.

Table 5. Ward Waste Categorization [53]

Waste	Description
Hand-offs	transfer of information: separates responsibility, knowledge, and action
Useless Information	unnecessary or redundant information
Discarded Knowledge	lessons or experience not transferred from preceding projects
Wishful Thinking	premature selection, inadequate experiment, and excessive agreement
Testing to Specification	not as valuable as testing to failure
Waiting	rarely does a PD process require sequential tasks
Ignored Expertise	wasted opportunity to increase quality through personnel
Scatter	reorganization, reprioritization, and disorganization
Wrong Tool	incorrect or inefficient resource

As with the iteration symbol shown in Figure 9, each of these wastes has an associated symbol that can be added to the map at the appropriate places. These symbols help to facilitate

discussion and communicate ideas about how to remove the waste. An additional strength of the Ward method lies with the associated discussion of business cycles. Matching the timing of product innovation or development cycles with customer cycles allows for a company to deliver new products when the customer wants them. This idea stems from the principle that the customer should be allowed to pull what they want from the marketplace, when they need it, rather than having the product forced upon them. The customer ends up with a highly satisfying product, and the company sees increasing profits with the continuous reduction of cycle times and the level-loading of resources across product cycles.

(Note: Lean Enterprise Institute products also include other mapping tools not mentioned here.)

3.2.3 Process Flow Map

The application of Lean ideas using traditional process mapping tools has also been developed through works such as Trischler's *Understanding and Applying Value-Added Assessment* [51]. These developments use process maps to highlight waste and areas for improvement. Standard symbols, such as shown in Figure 10, are connected by arrows to describe flow, and can utilize color-coding to denote value-added versus non-value-added assessment.



Figure 10. Process Mapping Symbology [51]

Once each of the activities in the process map has been placed and value-coded, the map can show where waste may exist in such activities as approvals, counting, sorting, moving, storing, and inspecting [51]. Discussions of how each of the categories of wastes apply to non-manufacturing operations serve to clarify if activities can be removed or accounted for in a more efficient manner.

3.2.4 Learning To See

The Learning To See method, based on factory floor mapping, can be adapted to PD processes once an understanding of how Lean concepts, like flow and waste, translate to PD activities. Learning To See provides the most proven tool for Lean-based VSA/M to date. A partial

description of the tool is found in the preceding Section 3.1, and the tool can be found described in its entirety in reference 47.

3.2.5 System Dynamics

Although not a Value Stream mapping method, per se, System Dynamics modeling can be accomplished in the context of a Lean improvement exercise. The System Dynamics method is described briefly in Appendix A.1, and is more fully described in reference 24. Figure 11 shows a sample System Dynamics map of the high level operational relationships within a large dairy company.

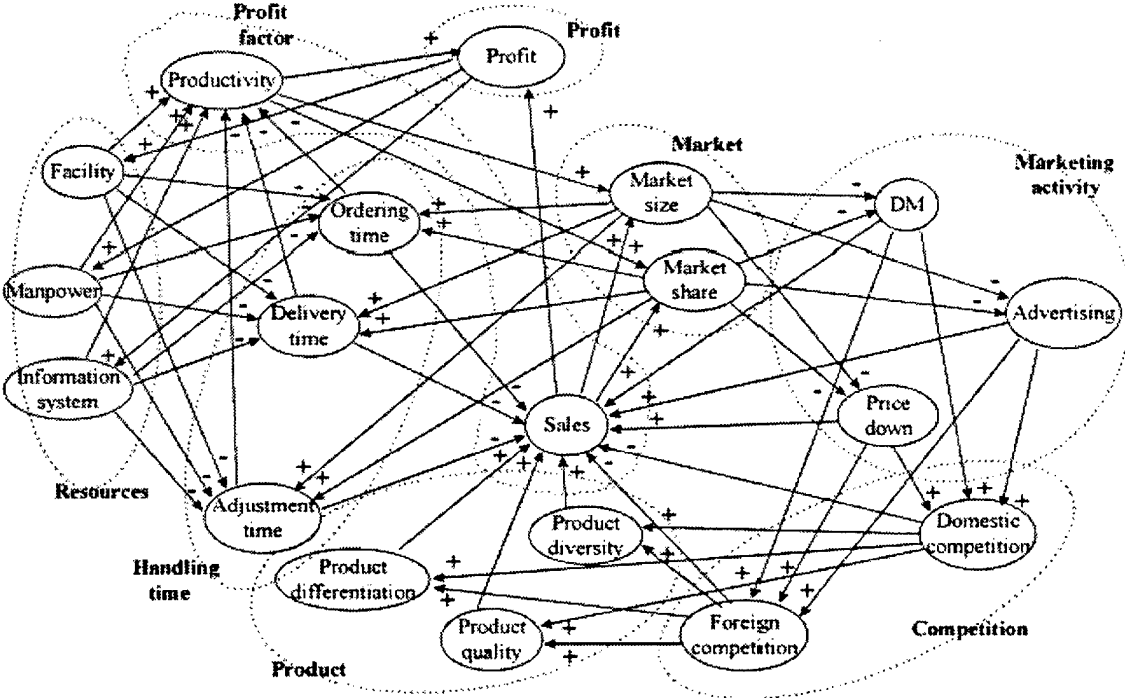

Figure 11. Sample System Dynamics Map [14]

3.2.6 Design Structure Matrix (DSM)

The Design Structure Matrix technique is not only a mapping tool, but rather, a well developed method for analyzing the sequences of, and information flows between, the tasks in a process. An “n-squared” matrix is used to depict the information flows from one task to another, such as in Figure 12 below. The matrix can be numerically optimized to minimize iterations and maximize the potential for concurrent work. A partial description of the method is included in

Appendix B, and shown implemented in Chapter 6 of this thesis. A complete description of the method, with tutorials for its use, can be found at the MIT-DSM website [16]. More sophisticated extension of this technique can also be found in the work by T. Browning in Reference 29.

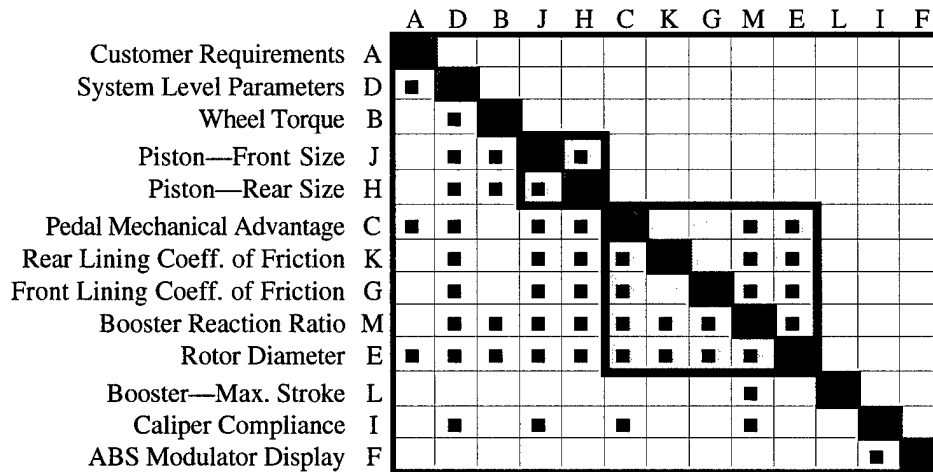

Figure 12. Sample Design Structure Matrix [29]

3.3 Documented Lean VSA/M Cases

Though explicit Lean-based Value Stream Analysis and Mapping is not currently considered a standard business practice in the Product Development community, the advancement of the ideas have led to several cases of significant implementation. Three of those example cases are described here.

3.3.1 F-16 Build-To-Package Support Center [43,57]

Lockheed Martin Tactical Aircraft Systems created the F-16 Build-To-Package (BTP) Support Center in mid-1999 to overcome schedule and cost overruns caused by late developments or changes in engineering deliverables. The center was created on the factory floor to best support co-location, concurrency of effort, single-piece flow, and communication. The higher-level Value Stream Maps completed in this improvement effort are shown in Figure 13 (pre-improvement) and Figure 14 (post-improvement).

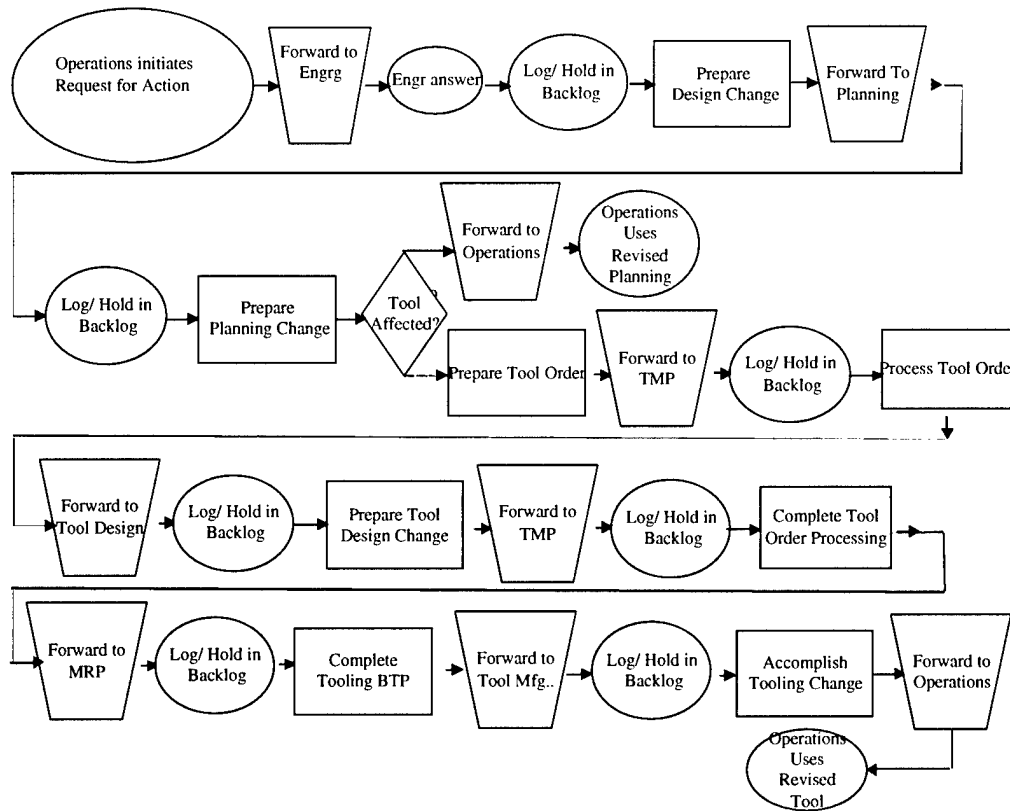

Figure 13. F-16 BTP Pre-improvement VSM [43]

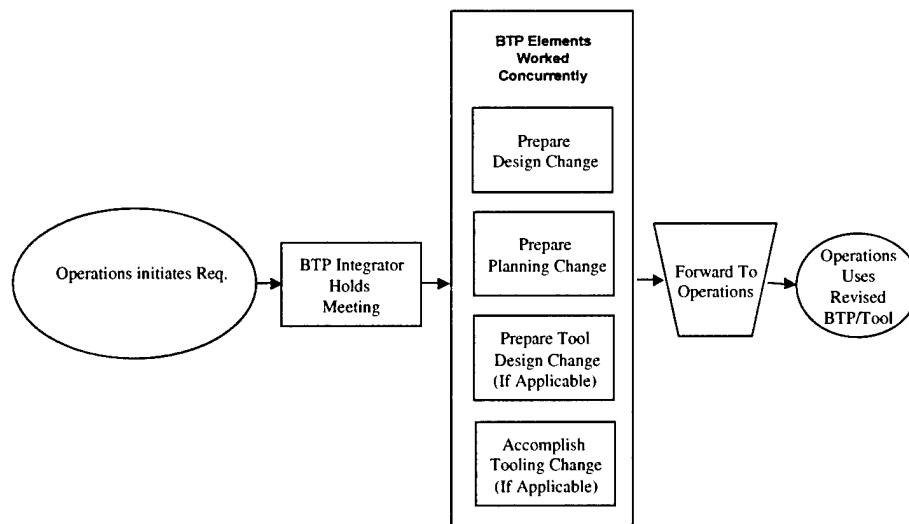

Figure 14. F-16 BTP Post-improvement VSM [43]

In the 849 Build-To-Packages created since the center’s introduction, the process has seen overall improvements of 75% reduction in cycle time, 40% reduction in process steps required, 75% reduction in number of handoffs, and 90% reduction in travel distance.

3.3.2 F-22 Systems Program Office/F-119 Engine Development [49,60]

The government Systems Program Office (SPO) for the F-22 program, and Pratt & Whitney, the contractor for the aircraft's F-119 engine, performed Value Stream Mapping in order to streamline and improve their respective development processes. The organizations used a mapping method called Function Analysis System Technique (FAST), which focuses on the functions required to complete a specific deliverable, rather than the activities chosen to embody those functions. This approach provides for generality in the description of the work required, which can allow greater creativity and optimization in designing the activities to fulfill that work. The FAST method also facilitates a common, natural language, based on the verb-noun convention it uses to describe tasks.

The Systems Program Office performed their process improvement exercise in order to clarify their roles, responsibilities, products, services, and customers. A sampling of the improvement outcomes, as applied to their standardized briefing process, saw 67% reduction in rework, 67% reduction in cycle time, and 75% reduction in labor resources required. Figure 15 includes a map of the overall enterprise Value Stream created in this effort.

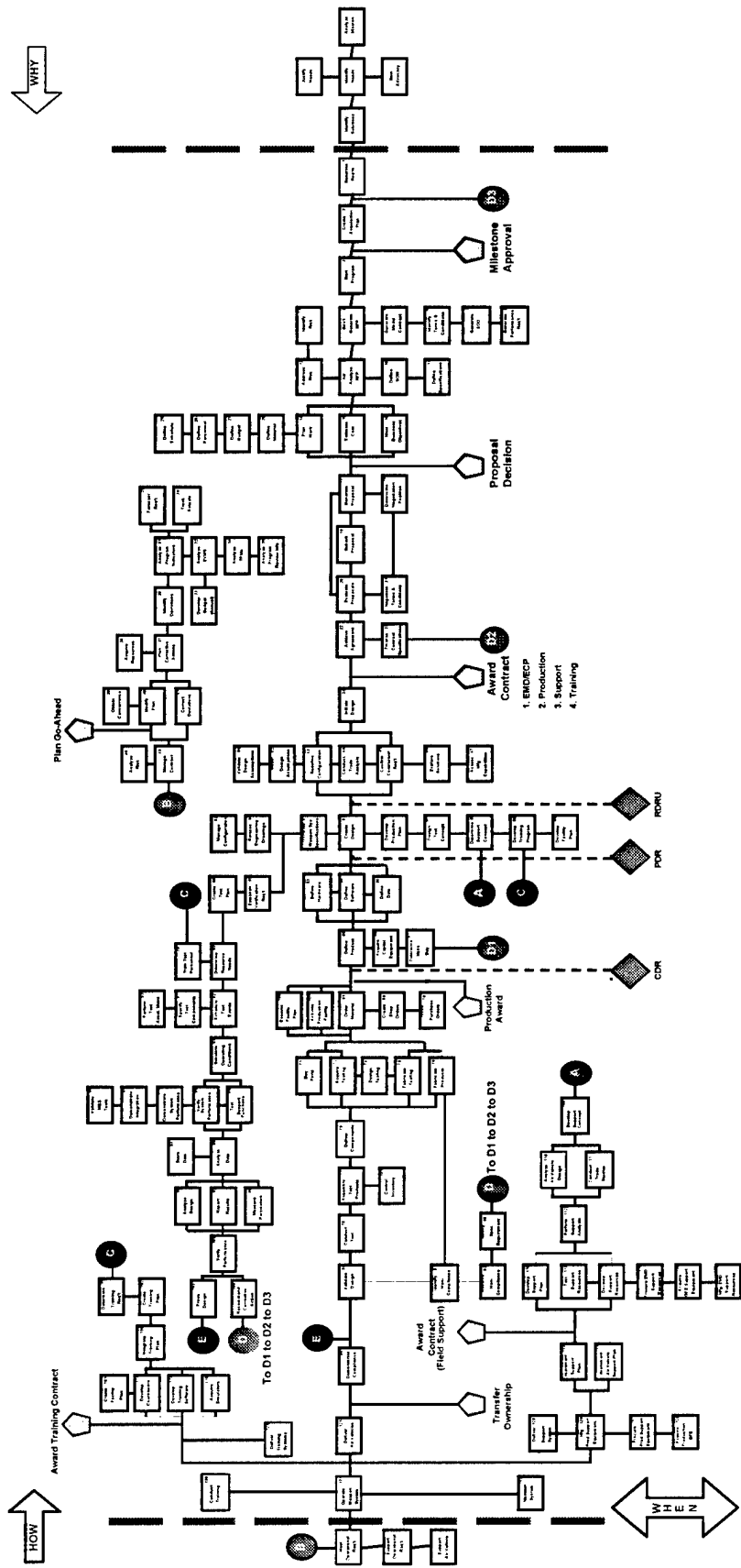

Figure 15. F-22 SPO Enterprise FAST Map [60]

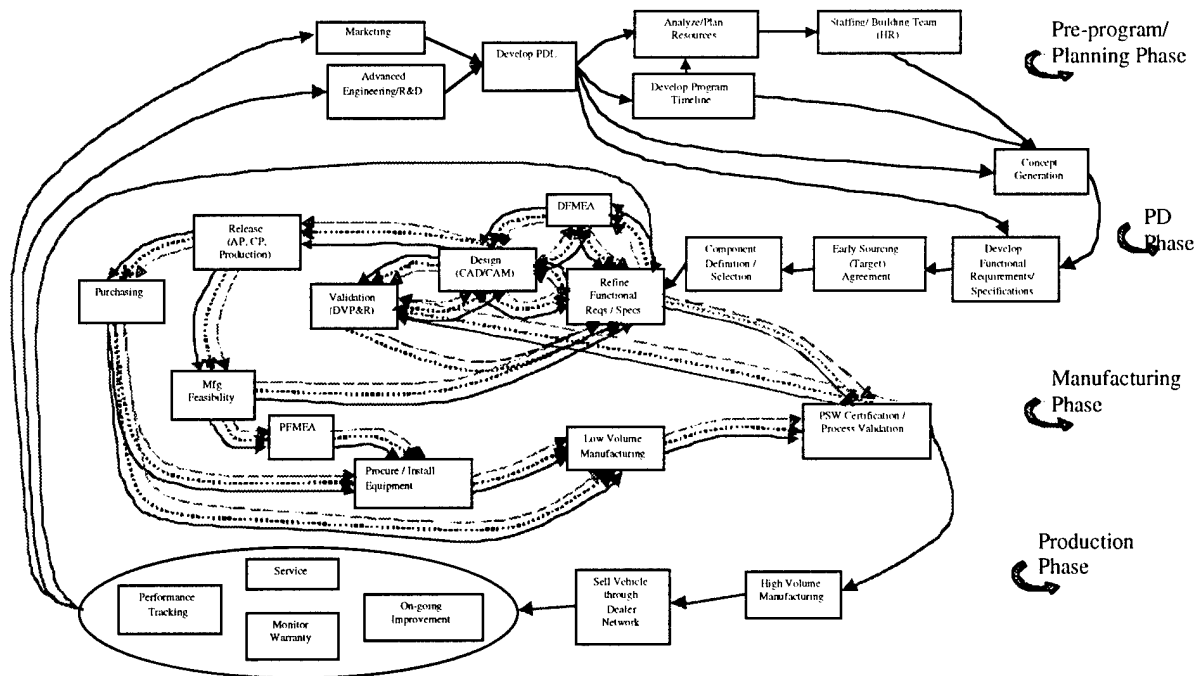

Figure 17. Fuel System Pre-improvement Process Map [48]

The company then employed Lean principles in determining their Future State map. All unnecessary iteration loops were removed, and emphasis was placed on correct first-processing of information and materials with the aid of self-checking systems. Seamless, real-time information was addressed for availability throughout the enterprise by means of improved communication paths. Metrics and incentives were employed to motivate learning and implementation of Lean practices. And finally, tighter integration of Product Development, supplier, and manufacturing teams reduced iterative loops and unnecessary handoffs. The Future State, post-improvement map, is shown in Figure 18.

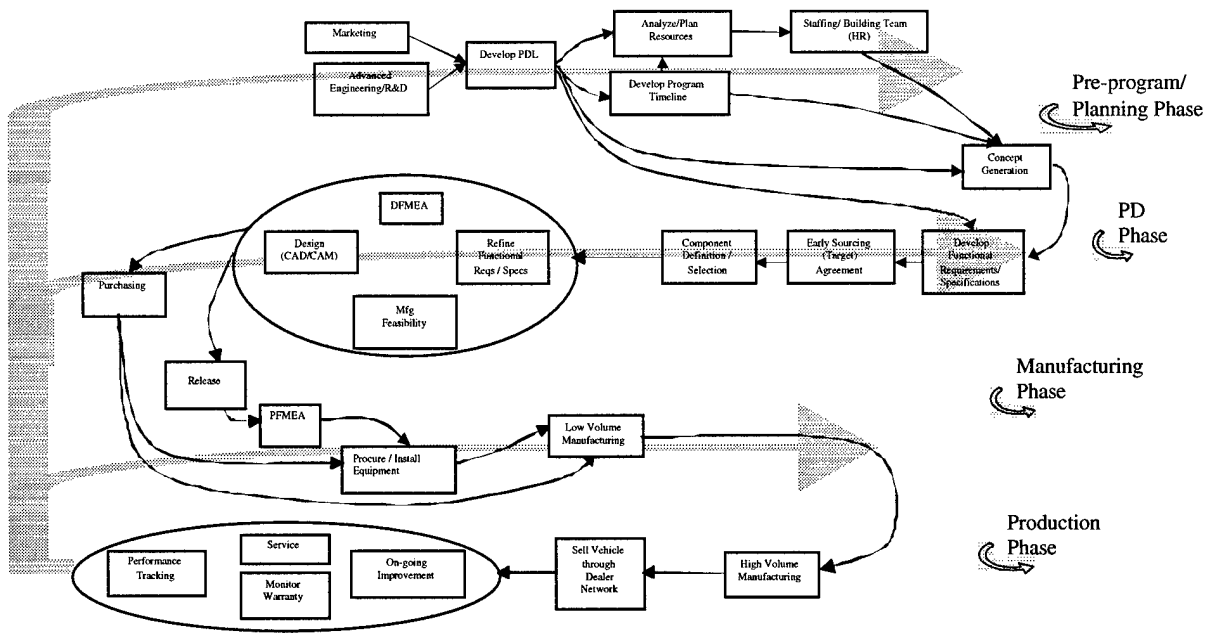

Figure 18. Fuel System Post-improvement Process Map [48]

3.4 Corollary Improvement Methods

The Lean business philosophy that has led to the development of Value Stream Analysis and Mapping however does not hold a monopoly on many of the underlying principles or application of those principles. One could say that the analysis of business practices has been around as long as business itself. In fact, employees at several aerospace companies have found that new movements aiming to comprehensively improve their organization's performance seem to enter the marketplace about every five to ten years. Each movement claims superior theory or application of existing theory, and usually captures certain areas of industry. But, in the end, companies typically find that the wholesale implementation of a particular method has not provide and equal benefit across all aspects of the organization. Rather, the greatest benefit is found in the directed and specific implementation of the method within a certain subset of their processes.

System Dynamics, Six Sigma, Total Quality Management, Process Re-engineering, and Systems Engineering all provide current perspectives on how organizations should improve their processes. Each method exhibits distinct strengths and weaknesses, but each has potential to make significant contribution to process improvement efforts. The interactions between these methods and Lean-based VSA/M efforts is explored briefly in Appendix A.

This page left intentionally blank.

4.0 Research Design

Prior to the outset of this research project, the Product Development team at LAI noted some key issues and unanswered questions concerning the application of Lean principles to PD. Several gaps existed in the collective knowledge about how Lean works in engineering activities as opposed to manufacturing. The desire to better address these gaps provided the motivation for this VSA/M research and several other projects. This section describes the research methodology developed to explore and address the key issues relevant to VSA/M.

4.1 Key Issues

With the assumption that the Lean philosophy and its principles apply, not only to shopfloor, but non-shopfloor activities, and several organizations set out with pilot programs to determine the effect of Lean on their PD efforts. The majority of these organizations represented companies that create complex products, such as in the aerospace, automotive, and electronics industries. Boeing, Northrop-Grumman, Lockheed-Martin, Ford, Hewlett Packard, Xerox, and Delphi are noted examples that have each brought individual motivations and approaches to the application of Lean to PD.

As with the application of Lean to manufacturing operations, the greatest verification of these Lean PD programs came in the realized improvement of the process and product [42]. The pilot programs showed the possibilities of Lean PD, but were noted within the LAI consortium as having encountered several unforeseen difficulties. The experience gained through the testing of these ideas helped to identify specific areas requiring further research. Value Stream Analysis and Mapping was identified as one of the areas where research could help to improve the effectiveness and robustness of the available methods and tools.

In the study of a still developing topic such as VSA/M, one approach to addressing the key research issues is found with the observation and categorization steps of the scientific method. A reasonable approach might include three fundamental steps: first, to gain a knowledge of current ideas and practices; second, to perform analysis of the collected data to find trends or patterns; and third, to use these in generating a framework to advance the understanding of the topic. In

these terms, applied specifically to Value Stream Analysis and Mapping for Product Development, the following key questions emerged:

- What methods and tools do organizations currently use to perform VSA/M within their Product Development processes?
- Do these current methods and tools contain common themes?
- Do these current methods and tools exhibit best practices?
- Could these common themes and best practices be characterized and advanced through established Lean principles?
- Could these themes and practices be unified to provide a general VSA/M framework for Product Development efforts?

4.2 Research Scope

This thesis focuses on the methods and tools used for VSA/M within PD efforts of commercial and military aerospace organizations. The paper does not, however, attempt to first prove the case that Lean principles apply unequivocally to PD efforts. Instead, it will rely on the anecdotal evidence established by previous study and experience. Lean methods and practices have shown powerful enough within manufacturing operations to warrant the initial application of Lean to PD efforts, and Lean pilot programs for PD have been established at each of the sites studied. These sites have then, in a sense, already made early investment that Lean principles do apply for Product Development.

Critical, yet somewhat implicit in the idea of PD Value Stream Thinking, is the discussion of value within non-shopfloor activities. Defining value, and continually increasing that value across the enterprise, is central to the idea of Lean business. This paper will not assume the task of the quantification and precise optimization of the value of each PD task, but will rather acknowledge the intuitive sense of value held by organizations and employees. Each business area or employee may perceive this value somewhat differently, but experience has shown that those who manage and perform the tasks associated within PD often have very ready convictions as to what tasks qualify as Value Added or Non-Value Added. This, of course, does represent an aspect of Lean PD that requires greater study. Several texts on the general analysis of value have

been written, in addition to a separate LAI thesis detailing the quantified value within Product Development [32].

4.3 Research Methods

As mentioned earlier in the Problem Statement, the emphasis of this paper will rest with:

1. The *exploration* of Value Stream Analysis and Mapping methods and their application to Product Development efforts,
2. The *characterization* of the current Values Stream Analysis and Mapping practices within the Product Development efforts of the U.S. aerospace industry, and
3. The *proposal* of a Value Stream Analysis and Mapping method, with associated tools, to be used in the improvement of Product Development processes.

Visits were made to nine major U.S. aerospace development sites to determine the current practices and maturity of VSA/M within the industry. These visits took place from January to August 2000. The research methodology involved collection of data by several means, including interviews, participatory research, workshops, presentations, and both formal and informal discussions concerning the topic. The data gathered through each of these research methods will be described in a general and non-attributable manner (except where noted) in order to protect the interests of the participants. The data collection focused on the three themes:

- The process mapping and VSA/M tools used at each of the sites,
- The business context surrounding their use, and
- The motivation and success of the respective process improvement efforts.

4.3.1 Data Collection

Twenty-seven interviews were performed with Lean Change Agents, executives, process owners, and engineers involved in Value Stream Analysis and Mapping at these sites. Four additional interviews were also completed by phone and mail. In total, the interviews included 48 contributors. These interviews were of a semi-structured nature, the guide for which can be found attached in Appendix C. The semi-structured nature allowed for the necessary flexibility in data collection often required in exploratory research efforts. The various interview participants often had very good knowledge of a particular section of the interview, and not so

for other sections. The semi-structured format allowed the participants to elaborate on the sections they were best able to answer. Also, by interviewing several employees at each site, the different areas of expertise and knowledge could be aggregated to provide a more complete set of information gathered from the individual perspectives.

The participatory research included a weeklong engagement in a Lean PD education and improvement event at one of the sites. This participation proved invaluable to understanding how this company views and employs VSA/M. It also clarified some of the common concerns and struggles that organizations have in improving their PD processes and products. This event spanned the execution of the Lean improvement method the company uses to enhance their processes, including the analysis and mapping of their Value Streams. Several phases of a single Value Stream were broken up into sub-processes and each assigned to a specific improvement team. These teams used the provided training and tools to gather background data, map the current process, improve upon the process to create a future state map, and then create an implementation plan.

4.3.2 Data Reduction

The raw data gathered from the different collection methods was reduced from handwritten notes to specific site reports. These reports categorized the data into the sections of *background*, *observed VSA/M practices*, and *critique* of those practices. The data transferred from the notes to the site reports was condensed by affinitizing the common experiences and observations. Adherence or exception to common themes was noted and entered into the reports. The themes that emerged from the data included:

- The state of health of the organization and their motivation for accomplishing VSA/M
- The associated evidence of Lean context surrounding the VSA/M effort
- The support, resources, and importance given to the VSA/M effort
- The prior work and level of sophistication of previous VSA/M methods and tools
- The background research performed for current VSA/M efforts
- The training provided for those accomplishing the VSA/M
- The utility of the current VSA/M tools
- The perceived success of the VSA/M efforts

- The direction of future process improvement efforts

More specific analysis of the data was completed in respect to (1) the capabilities of the specific Value Stream Mapping tools, (2) the context surrounding their associated Value Stream Analysis, and (3) the efficacy of the VSA/M exercise performed. The results of this analysis are found in Chapter 5, entitled Current Practices. First, the “theoretical” form of the six mapping tools seen used in VSA/M projects at the sites were examined in order to establish baseline performance. The capabilities of this form of the tools, as reported in the reference literature, were characterized and decomposed for analysis. Each of the tools was defined in its ability to address several common process attributes such as task duration, feedback, and concurrency.

Examination of the process attributes suggested a division into three distinct types, describing the time, work, or structure involved in the process. Each of the mapping techniques were then rated based on their ability to *represent* a process (based particularly on the capacity to account for the time attributes), and on their ability to *analyze* a process (based on the capacity to capture the work or structure attributes).

With the baseline performance and ranking established, the same analysis was then applied to the tools as used at the research sites. The “as-used” forms of the tools were characterized in terms of what process attributes they addressed, which was again quantified. The as-used tools were also ranked in their ability to support analysis, and then contrasted with their theoretical capabilities. This exercise created further distinction in the tool ranking, based on the level of tool sophistication as used.

Second, each of the sites were evaluated based on the Lean business context surrounding their Value Stream Analysis. Five general rating categories emerged from the data. The ratings involved the subjective assessment of five factors seen at each of the sites, taken from comments, observations, and documentation:

- Opportunity for Lean education and training
- General resource allocation for business improvement efforts
- Leadership involvement in business improvement efforts

- Organizational integration of Lean principles
- Lean vision or goal

The ratings of these factors were combined, and the sites were placed into one of three groups characterizing their surrounding context.

The final metric included an assessment of the success of the effort. “Success,” as used in the research discussion, describes the utility and efficacy of the VSA/M exercise performed, not the success of the product. This success measure represents the self-assessed comments and ratings of those most closely associated with each site’s process improvement efforts. The research will rely on this self-assessment rather than by a more quantified approach. The motivation for implementing VSA/M and the context surrounding their application varied widely, which left a concrete comparison of improvements less beneficial than simply the subjective judgement of the benefit seen (or foreseen) from the VSA/M effort.

Tool capability, surrounding context, and VSA/M success were correlated to quantify and graphically support their relationships. For each of the three correlations, the square of the Pearson’s coefficient (r^2) was found to quantify the relationships between the variables. This quantification was used only as support for the more qualitative proposition of relationships due to the data’s small sample size of 9.

The information gained from the data reduction was then used in the proposal of a general VSA/M method for Product Development, found in Chapter 6. The suggested method combines the research data reduction, information gathered from a review of background literature, and observations taken during the research site visits to offer a VSA/M tutorial.

5.0 Current Practices

The primary goal of this section is to report on the current Value Stream Analysis and Mapping practices used by several sites in the U.S. aerospace industry. The discussion will present the relationship between VSA/M tool sophistication, the context surrounding their use, and the success in completing the VSA/M efforts. An indirect goal of the discussion is also to allow for the determination of where an outside company's practices might stand within the industry.

The study of current aerospace industry VSA/M practices revealed no apparent standard method or set of tools used in PD process improvement efforts. Neither was a comprehensive best-practice yet established, though the maturity of the VSA/M efforts did exhibit a significant range across the sites. The push to transfer Lean principles from the manufacturing focus to design has garnered critical momentum only recently in the U.S., and many of these efforts still find themselves in the growing stages.

The results of this section will be presented as follows: in Section 5.1, the case studies are referred to; in Section 5.2, the tools used are discussed and rated, first in their "pure" form, and next as they were used at the case study site; in Section 5.3, the Lean context of the improvement efforts is characterized; in Section 5.4, the relative success of the VSA/M improvement efforts are presented; and in Section 5.5, the relationships are correlated.

5.1 Case Study Results

The case study results are summarized in Appendix D. The background and VSA/M practices used at each site are described, and the practices are critiqued and assessed for level of maturity. At the beginning of each subsection, a graphic shows the relative sophistication of the tools used for analysis at the site. This graphic is explained more fully in Section 5.2.3.

5.2 VSM Tool Characterization

Six different process mapping tools were seen used at the industry sites visited: Gantt charts, Learning To See maps, System Dynamics maps, Ward/LEI maps, Design Structure Matrices, and Process Flow maps. Each of the sites utilized one or more of these tools to varying degrees of

self-assessed effectiveness. As used at the sites, and as described in the reference literature, each of the mapping tools applied embody its own distinctions or advantages. A characterization of the tools was accomplished in the effort to determine how the use of specific tools may affect VSA/M success.

5.2.1 Tool Descriptions and Capabilities

The tools are described below, and characterized in Table 6 against a set of attributes commonly used in the analysis of business processes. A checkmarked box denotes the tool’s ability to account for that specific process attribute well in its fundamental structure. A checkmark in parentheses denotes those process attributes that can be added, or tagged onto, the fundamental map.

- Gantt charts: a scheduling tool highlighting precedence and concurrency.
- Process Flow charts: a process mapping tool highlighting flow and well suited for tagging on metrics and additional information.
- Design Structure Matrices: a product flow tool highlighting iteration, feedback, and precedence within the flow.
- Learning To See: a process mapping tool highlighting product flow and geography, which is well suited for the physical processes of manufacturing and assembly.
- System Dynamics: a system analysis tool highlighting inputs and outputs, and quantitative dependency equations.
- Ward/LEI: a mapping tool highlighting concurrency, milestones, and symbolic tags of process characteristics.

Table 6. VSM Tool Characterization Matrix

Process Attribute	Gantt	Process Flow	DSM	Learning To See	System Dynamics	Ward/LEI
concurrency	✓		✓		✓	✓
start/stop times	✓		(✓)			✓
task duration	✓					✓
decision branching		✓				
feedback			✓		✓	
flow:						
“product” info.		✓	✓			
command info.		✓		✓		

material		✓		✓		
inputs/outputs		✓		✓	✓	
iteration			✓		✓	✓
metrics		(✓)		(✓)		(✓)
task precedence	✓	✓	✓		✓	✓
resources:						
generalized						✓
specific	(✓)	(✓)	(✓)	(✓)	(✓)	
tasks	✓	✓	✓	✓		✓
value		(✓)		(✓)		(✓)
geography		(✓)		✓		
grouping/teaming			✓			
milestones	✓					✓
organizations			✓	(✓)		

The characterization matrix shows that some tools account for more process attributes than others, and some complement another's capabilities. But what does it mean to account for one group of attributes versus another? Does a tool that can account for more attributes necessarily better than a tool that accounts for fewer?

The process attributes from the matrix divided into three categories as to whether the attributes described the time, work, or structure involved in the process:

- Time: concurrency, task duration, and start/stop times
- Work: decision branching, feedback, flow, inputs/outputs, iteration, metrics, task precedence, resources, tasks, and value
- Structure: geography, grouping/teaming, milestones, and organizations

This breakdown of process attributes leads to the notion that the major distinction between tools lies how accurately a tool *represents* a process, versus how well the tool supports improvement *analysis* for the process. Critical to representing a process is the ability to capture the timing of the process: concurrency, start/stop times, and duration of the tasks in the map. Critical to supporting improvement analysis is the ability to capture the flow and value of the work required in a process. Both aspects will be shown to hold important roles in VSA/M efforts: the former aids more in the communication of a process to team members, whereas the latter aids more with the decisions team members make in creating a better process.

In order to provide for the *analysis* of a complex system, the tool must have the ability to break the system down into a format disposed for less complex analysis. That is to say, that one cannot simply show someone else a room full of engineers and give them the charge to comprehensively improve the processes used in the room based on first glance. To perform substantive analysis, they must first acquire and decompose more useful information. Of course, a good deal of the ideas for improving a process can indeed immediately spring from the current base of understanding and experience (which can account for the so-called “low-hanging fruit”). However, one can only generate the derived improvement ideas from what insights the process map can allow for [18].

Furthermore, among the tools that focus on support of improvement analysis, another distinction appeared in terms of whether the tool supported decisions concerning *what to do* or *how to do it* (this distinction will also become important as we look at the selection of tools for the VSA/M method proposed in Chapter 6). Due to the iterative nature of PD, these two ideas are very coupled in practice, but they can provide two very distinct viewpoints in analysis.

The tools that best aid in determining *what to do* focus on capturing the work attributes of a process. These tools seek to describe the value of an activity within the surrounding process. These tools address the question of functional analysis, or what is needed to fulfill the established requirements, as well as the reconciliation of these needs with the available solution options. The tools that best aid in determining *how do to* things, focus on capturing the structure attributes of a process. These tools address the optimization of activities within a process, based on relevant factors such as time, resources, and current capabilities. Figure 19 illustrates the categorization of tools below.

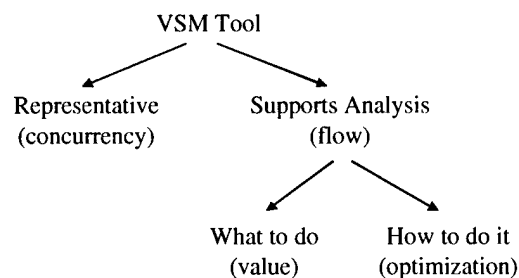

Figure 19. VSM Tool Categorization

The reason that “value” and “optimization” yet remain separate comes from the lack of an effective and robust method for quantifying the value of tasks within PD. Should any of the current research on quantifying this value succeed in the effort, the tools used in the analysis of these two aspects could reach a much higher level of integration. What has so far shown not to be extremely effective is the attempt to integrate the two aspects by forcing the qualitative assessment of value into numerical optimization tools. However, the robust quantification of value could make way for the development of new algorithms in the optimization of Product Development activities.

5.2.2 Tool Capability Quantification and Scaling

As the previous tool characterization matrix suggests, each of the VSM tools does not have to fit exclusively into one of the categories previously outlined in this section (*representative* versus *analytical*, and *what to do* versus *how to do it*). Rather, the tools often exhibit capabilities that allow them to be described by a combination of the categories, though the tools usually do focus on one category more than the others. Table 7 below includes a quantification of the tool characterization in an evaluation-matrix format. The same process attributes are listed along the left side, the tools across the top, and the ability of the tools to account for the attributes populates the matrix with a 0, 1, 3, 9 quantification scale. A zero denotes that the tool usually does not account for the attribute, a 1 indicates that the tool indirectly account for the attribute, a 3 indicates that the tool accounts for the attribute explicitly, and a 9 indicates that the tool accounts for the attributes very thoroughly.

Table 7. Tool Capability Quantification

Attribute	Gantt	Process Flow	DSM	Learning To See	System Dynamics	Ward/LEI	rep. weighting	analytic weighting
concurrency	9	1	3	1	3	9	5	2
start/stop times	9	1	1			9	4	1
task duration	9	1		3		9	5	2
decision branching		9					2	4
feedback		3	9	1	9	1	2	5
flow:								
"product" info.	1	9	9	3	3		2	5
command info.		9		3			1	4
material		3	3	9			1	4
inputs/outputs	1	3	1	9	9		2	4
iteration			9	1	3	3	2	5
metrics	3	9	1	9		1	1	5
task precedence	3	3	9	3	3	3	2	4
resources:								
generalized	1	3		1		9	1	1
specific	1	3	1	1	1		1	2
tasks	9	9	9	9	3	9	3	5
value	1	9	1	9		1	0	5
geography		1		9	1		2	1
grouping/teaming			9		3		1	2
milestones	9	3				9	5	1
organizations	3	1	9	1			1	1
Rep. Value	216	140	143	123	84	222		
Analytic Value	146	322	278	277	153	150		
Norm Rep. Value	0.97	0.63	0.64	0.55	0.38	1.00		
Norm Analytic Value	0.45	1.00	0.86	0.86	0.48	0.47		

The weighting numbers on the right-hand side provide subjective multiplication factors for how important a certain process attribute is to the representation or analysis of processes. The evaluation method of the matrix combines the 0, 1, 3, 9 characterization of the tools with these weightings to result in the tool values across the bottom of the matrix. Summing and normalizing the value of each tool shows that the Ward/LEI maps, with a normalized score of 1.00, and Gantt charts, with a score of 0.97 serve best to represent a process. Likewise, Process Flow maps, with a normalized score of 1.00, and DSMs, with a score of 0.86 best support analysis of a process.

Since the derivation of improvement measures stems mainly from the analysis-based aspects of the mapping tools, further discussion will focus on the analytic capabilities of the tools rather than their representative abilities. The normalized values for the analytic capabilities of the tools are presented graphically in Figure 20 to highlight where each tool stands in relation to the others.

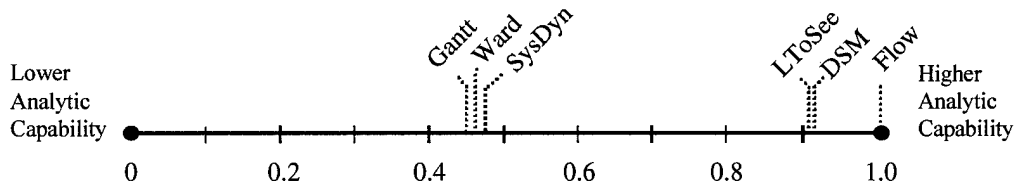

Figure 20. Gradient of Analytic Capability

5.2.3 Applied Tool Characterization

Again, the above scaling of the tools describes their capabilities as theorized in the reference literature. The actual application of the tools at the research sites deviated from this theory based on the motivation and sophistication in using the tool. Oftentimes, the tools were also used for means other than analysis, such as for communication, process control, and tracking. The tools were usually not used to their fullest potential in terms of mapping all possible process attributes, which is reflected by the change in the 0, 1, 3, 9 values from the “pure” form of the tools. The quantification of the tools as seen used at the research sites is included below in Table 8.

Table 8. As-Applied Tool Capability Quantification

Attribute	Site 1 Gantt	Site 2 LToSee	Site 3 Flow	Site 4 LToSee	Site 5 Ward/DSM	Site 6 Flow	Site 7 DSM	Site 8 Flow	Site 9 Flow/DSM	analytic weighting
concurrency	9	1	1	1	9	1	3	1	3	2
decision branching		1	3	1		9		9	1	4
task duration	9			3	9			1	1	2
feedback			3	1	3	3	9	3	9	5
flow:										
"product" info.	1	9	9	9	9	9	9	9	9	5
command info.		1	3	3				1	1	4
material			1	3		3	3	3	3	4
geography			1	3		1		1		1
grouping/teaming					3		1			2
inputs/outputs	1	3	3	3	1	3	1	3	3	4
iteration					3		9		9	5
metrics		9		3		1	1	3	1	5
milestones	3	1	3		9	3		1	3	1
organizations			1	1	9	1	3	1	3	1
task precedence	3	9	9	3	1	9	3	3	9	4
resources:										
generalized					9					1
specific		1					1		3	2
start/stop times	9				9		1		1	1
tasks	9	3	3	9	3	9	9	9	9	5
value			3					9	1	5
Analytic Value	114	166	173	174	176	213	227	248	279	
Norm Analytic Value	0.35	0.52	0.54	0.54	0.55	0.66	0.70	0.77	0.87	

Each site is listed across the top with an abbreviated description of the highest capability tool they used in their analysis. Six of the sites had used lower capability tools in conjunction or as predecessors to the use of more sophisticated tools. The entries include Gantt charts, *Learning*

To See (“LToSee”) method, a Ward map that fed into a DSM (“Ward/DSM”), Process Flow maps (“Flow”), DSM application, and a combination of Process Flow mapping and DSM tools. The analytic capabilities of the as-applied tools were then also normalized and placed below the previous scale, which included the theoretical capabilities of the tools. This scale is shown in Figure 21.

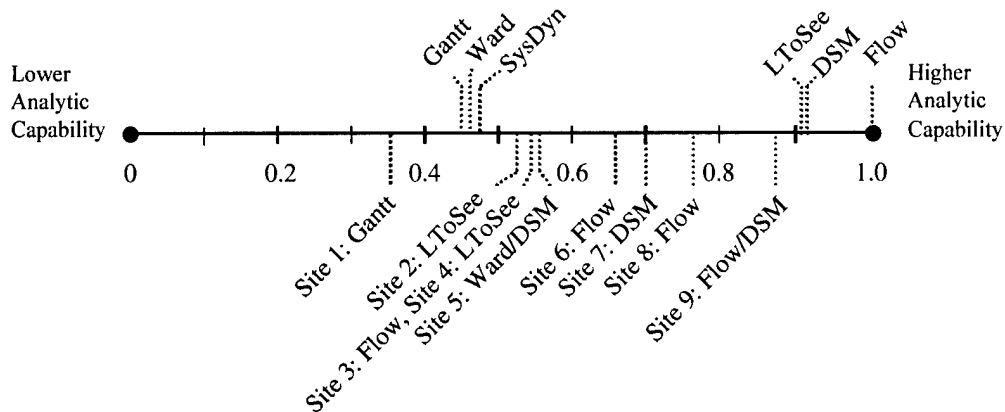

Figure 21. Gradient of Applied Analytic Capability

Each of the data points on the scale designates the relative capability of the VSA/M tools seen used at the research sites, labeled with the respective site reference number.

5.3 VSA Surrounding Context

The context surrounding the use of Value Stream Mapping tools also varied across the sites. The context varied widely in the terms that some sites encouraged and developed Lean ideas more than others, some put greater stake and investment into the idea of VSA/M, and all were in different stages of their experimentation with how to best apply VSA/M for their specific business area and products. Site visit data and observations suggested three levels of distinction concerning the context in which the sites employed VSA/M. The groupings includes those companies with a more traditional method at one end, those beginning a comprehensive implementation of Lean PD methods at the other end, and then those trying to employ a mixture of the two somewhere in the middle.

The ratings involved subjective assessment of five factors seen at each of the sites, taken from comments, observations, and documentation:

- *Opportunity for Lean education and training*: the sites ranged from providing no explicit Lean training... to providing training courses, information, and materials, as well as involvement in highly consequential process improvement exercises.
- *General resource allocation for business improvement efforts*: the sites ranged in situation from fulfilling the requirement to improve processes without significant changes in budget or resources... to the improvement of processes with the aid of a system of Lean offices, internal Lean experts, and financial support.
- *Leadership involvement in business improvement efforts*: leadership involvement ranged from the isolated high-level direction for improving product and process without direct involvement... to the direct involvement of leadership in improvement exercises, and salary incentives adjusted to that involvement.
- *Organizational integration of Lean principles*: the organizational structures ranged from taking little regard to integration of Lean principles away from traditional structures, or by name-only integration... to the direct configuration based on Lean principles, and the associated organizational committal.
- *Lean vision or goal*: the sites ranged in situation from wanting to do Lean, but without an established goal or plan to get there... to establishing an explicit definition of what the company should look like in the future, and how they will apply chosen principles to reach that goal.

These factors have been quantified in the evaluation matrix found below in Table 9. The assessment factors are listed on the left-hand side, the sites, across the top. As with the tool capability quantification, the matrix is populated with a 0, 1, 3, 9 scale, but in this case, all the assessment factors are weighted equally. The values for each site are summed, and normalized against the highest outcome.

Table 9. VSA Context Quantification

Attribute	Site 1	Site 2	Site 3	Site 4	Site 5	Site 6	Site 7	Site 8	Site 9	attribute weighting
education/training	1	3	1	9	3	1	3	9	3	1
resource allocation	1	3	3	3	3	3	9	3	3	1
leadership involvement	3	3	9	3	1	3	9	3	9	1
organizational integration	3	3	3	3	3	1	3	9	3	1
vision/goal	1	1	9	3	1	3	3	9	9	1
Value	9	13	25	21	11	11	27	33	27	
Normative Value	0.27	0.39	0.76	0.64	0.33	0.33	0.82	1.00	0.82	

Context Group A applies to those ratings between the normalized values of 0.0-0.3, which includes only Site 1. Group B applies to the ratings from 0.3-0.8, which includes sites 2 through 5. Group C applies to the ratings from 0.8-1.0, which includes sites 7 through 9.

5.3.1 Group A: Traditional Business Methods

The one company surveyed at the more traditional end of PD planning practices most often does not explicitly perform Value Stream Thinking using VSA/M or other Lean methods. However, projecting their practices onto the VSA/M framework can reveal comparable themes and areas for opportunity. The analysis of their Value Stream often rests with the program manager, who draws upon personal experience and organizational tradition to lay out PD steps. The processes developed and accepted along the history of the company are taken and applied to each new contract, without the focus of improving the processes themselves. For military contracts, the planning of the PD steps centers around the deliverables and gateway reviews required by the military acquisition process.

5.3.2 Group B: Fractional Lean Integration

The five companies in the middle of the spectrum account for the majority of the sites visited. Like the previous group, these companies rely on the traditional methods as their foundation of planning and performing Product Development, but they also attempt to incorporate several Lean ideas and practices within the existing framework. Due to the piecemeal implementation of Lean PD methods such as VSM, the results seen by these efforts varies from dramatic improvement to having little or no effect. The implementation of Lean tools does not have the support of a comprehensive Lean improvement environment, so their potency often remains unrealized outside of a Lean context. VSA within this group often still resides with the program manager by way of deliverables and gateway reviews. These companies are using many of the simple, yet

powerful, Lean tools and methods. However, they are often used in isolation, so that only one small piece of the system can be visualized.

The importance of such ideas as Integrated Product Teams (IPTs), concurrent engineering, and parallel processing is often well defined at these companies, however, all too often these initiatives are in name only. Members of IPTs and concurrent engineering teams sometimes do not exactly see how things have changed since before the new team inception. Managers sometimes charter IPTs with the unwritten hope that IPTs by themselves will drive process improvement. But implemented in isolation, these ideas cannot generate the same effect within the more tradition PD context as they do within a more Lean PD context, and so the teams often revert furtively back to traditional methods.

A new push within many of these companies, which holds a good deal of potential, is the development and implementation of electronic, internet-based, environments for the development and exchange of information. These systems do not necessarily imply a value stream in their operation, but have been shown to support the analysis of the PD value stream and provide a very effective method for enhancing pull and flow of information. Many of these tools include human resource, task, time, cost, and schedule information, and hold the potential to feed this information into a mapping of the value stream. Currently, the tools in this area have not yet been developed to this level, though there are plans to implement VSA/M based on these electronic environments.

5.3.3 Group C: Developing Comprehensive Lean Environment

The three companies at the most advanced level of VSA/M practices do not yet exhibit a comprehensive Lean PD environment, but have acknowledged the opportunity and importance of developing such an environment for their PD efforts. Though not yet at their end-goal of using systematic and robust VSA/M methods, they have taken large steps in moving toward and developing the idea within Lean PD. As part of this move toward systematic VSA/M, these companies are creating standard high-level VSM templates initializing the major steps required for every product or contract. Then based on the individual nature of the product, the template is tailored toward what areas require the most focus. These tailored processes are populated with

the correct support, resource, and instructional information from common databases, and what can result is an object-oriented process plan that integrates a great deal of data and information into one system. The processes are then broken down to the team or individual task level. While this system does not inherently focus on optimization of the Value Stream, one can see how when used within Value Stream Analysis, this approach could provide a clear and gainful map of the quality of a product.

5.4 Site VSA/M Success

Based on the comments and ratings gathered during the site visits, the plot found below in Figure 22 shows the self-assessed measure of success that each site attributed to their VSA/M efforts.

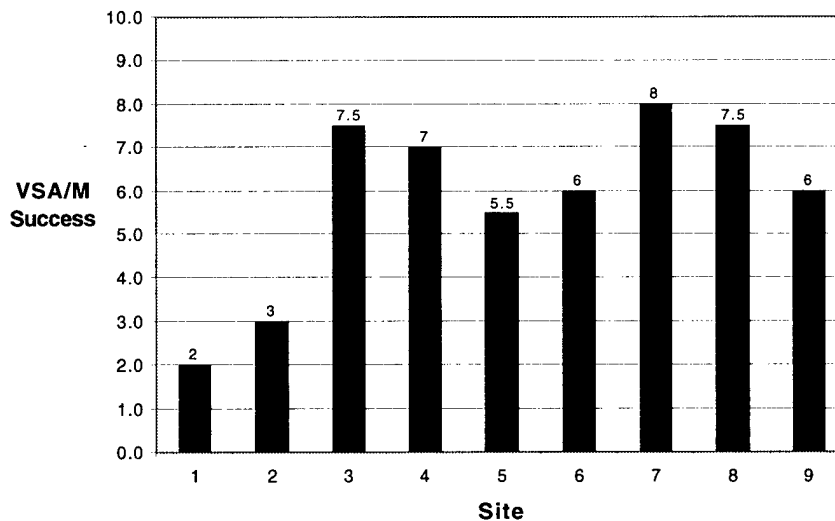

Figure 22. VSA/M Success Plot

The success was rated on a scale of 1 to 10, giving an average of 5.8 with a standard deviation of 2.1. As mentioned in the research design section, this range of self-assessed VSA/M success led to the development of two emergent themes. VSA/M tool sophistication, and the surrounding business context, were characterized and correlated to gain a better understanding of what factors drove the success of the various VSA/M efforts.

5.5 Correlation

A summary of the resulting values for VSA/M success, tool capability, and surrounding context at each of the research sites is included below in Table 10.

Table 10. Quantified Value Summary

	Site 1	Site 2	Site 3	Site 4	Site 5	Site 6	Site 7	Site 8	Site 9
VSA/M Success	2.0	3.0	7.5	7.0	5.5	6.0	8.0	7.5	6.0
Tool Capability	0.35	0.52	0.54	0.54	0.55	0.66	0.70	0.77	0.87
Context Quantification	0.27	0.39	0.76	0.64	0.33	0.33	0.82	1.00	0.82

Each of these metrics is plotted against the others, which allows for quantified correlations to be made.

An initial hypothesis at the outset of the research was that the sophistication of VSA/M tools was the critical driver for process improvement success. However, as Figure 23 below shows, the correlation between success of the VSA/M effort and tool capability does not, alone, provide a perfectly compelling relationship. The data exhibits an important trend, but statistically moderate correlation with an r^2 value of 0.383.

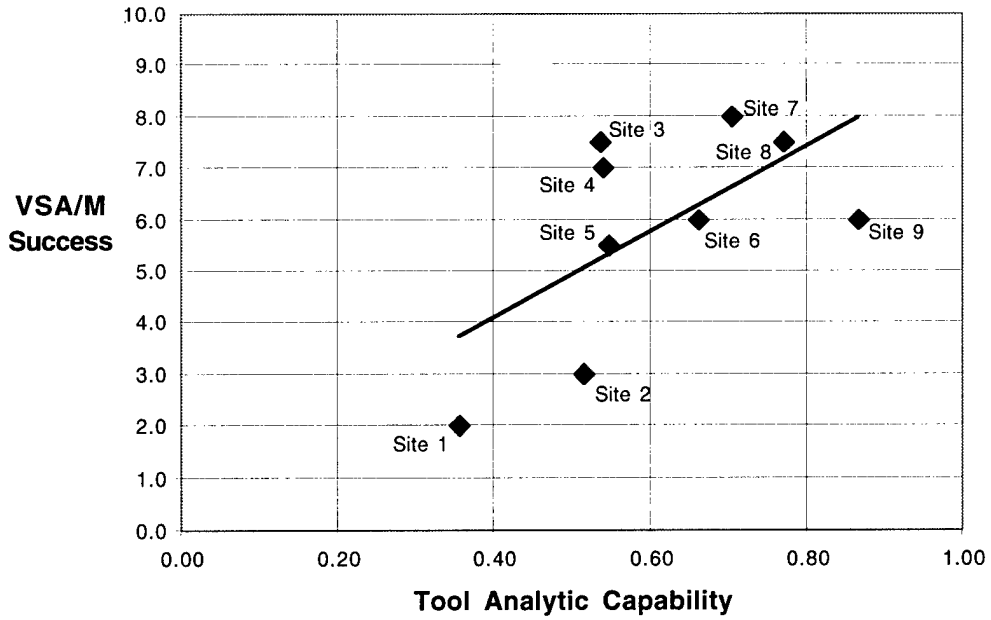

Figure 23. Success-Capability Correlation

The correlation of context to VSA/M success showed a stronger relationship. Figure 24 illustrates the relationship below, which exhibits an r^2 value of 0.572.

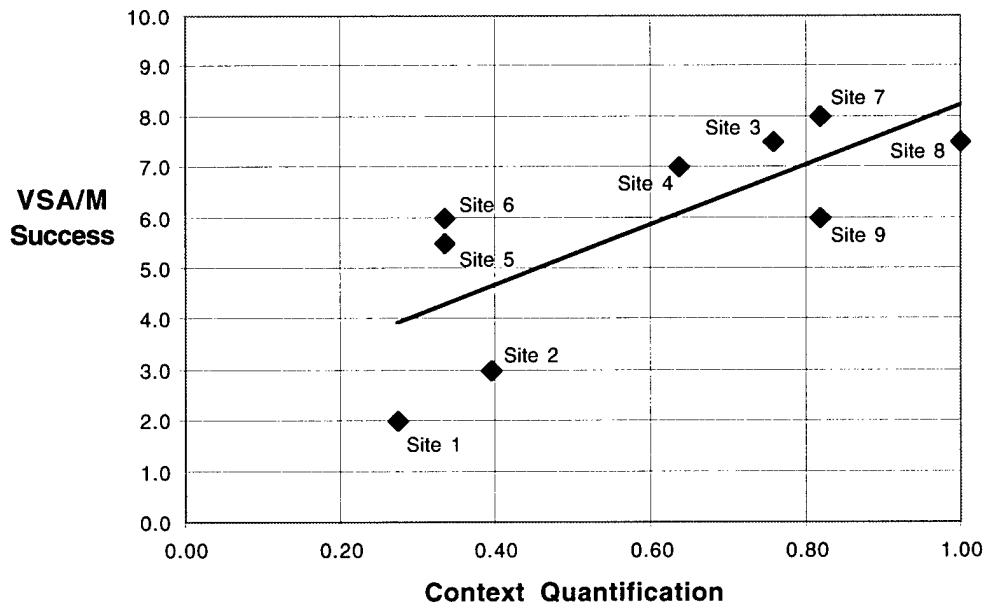

Figure 24. Success-Context Correlation

Figure 25 shows the relationship between context and tool capability. This relationship also shows a strong correlation with an r^2 value of 0.495.

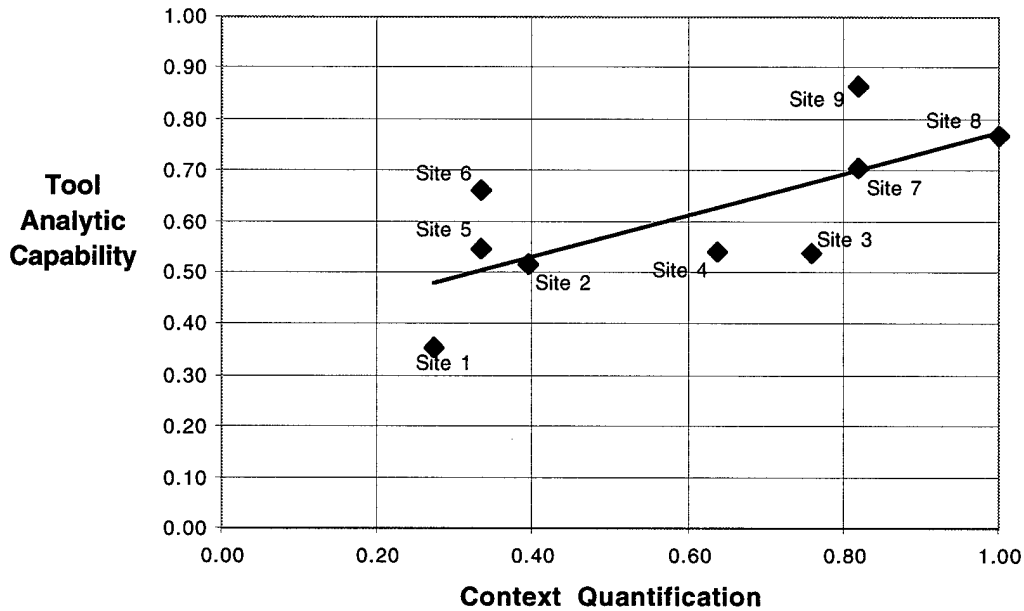

Figure 25. Capability-Context Correlation

5.6 Summary

It was found that VSA/M tools play an important role in all of the Lean PD efforts studied. A wide variety of tools are used, with various capabilities. A characterization of the mapping tools showed variation in whether a tool best *represents a process* or *supports improvement analysis* for the process, which shows that the various mapping tools have distinct capabilities. Using a tool outside of its capability, or using a low capability tool cannot support the same analysis as the correct application of a more sophisticated tool. A combination of the different mapping tools may best maximize their capabilities for use in a process improvement exercise. A Gantt chart or Ward/LEI map may be used to best describe and communicate a process, a Process Flow map may be used to best analyze the value of activities within a process (*what to do*), and a Design Structure Matrix may be used to best analyze the optimization and structure of a process (*how to do it*).

Although the capability of the VSA/M tool used correlated with success, it is also clear that the Lean context, in part, drives tool use. A company exhibiting a more mature Lean context for their improvement efforts will require different data and apply different constraints in the use of the tool than a company with a less mature context, which will affect their choice of tools and how they use the tool.

No standardized best practice was found within the practices of VSA/M, but observations and the above analysis of the tools and their use allows a suggested method to be developed. It is presented in the next section.

6.0 A General Method for Product Development VSA/M

The following method for Product Development Value Stream Analysis and Mapping provides a guide for process and product improvement. The outline for the method's implementation derives from site visit observations, research data reduction, and reference literature theory. The tools chosen to support the method were selected primarily as a result of the preceding research data reduction. The tools include the combination of a Gantt or Ward/LEI chart, a process flow map, and a Design Structure Matrix (DSM).

This method can offer no guarantee for success, however, used as part of an overall transition to Lean, it should provide a useful tool for understanding and improving Product Development processes. Keep in mind when using this method that there can be no cookbook method for process improvement which will replace thought and motivation, or the Lean context required for effective implementation. The improvement method is intended to serve only as a guide for better understanding Product Development practices and how they can be enhanced in the pursuit of a Lean vision.

This chapter contains three sections. In the first, 6.1, general guidance, based on the best observed practices, will be given for setting up an improvement effort, assembling an improvement team, and selecting processes for improvement efforts. In the second, 6.2, a detailed description of a method for the analysis, mapping, and improvement of a Value Stream will be given. This section is the heart of the chapter. A running example will illustrate the use of the method to improve the preliminary design of a hypothetical aero-structural part (such as a fairing or fin). The third section, 6.3, returns to a more general discussion of continuous improvement and the need to link individual process improvement to an overall enterprise vision.

6.1 VSA/M Method Introduction

The method will follow the definition of processes, activities, and tasks as shown below in Figure 26.

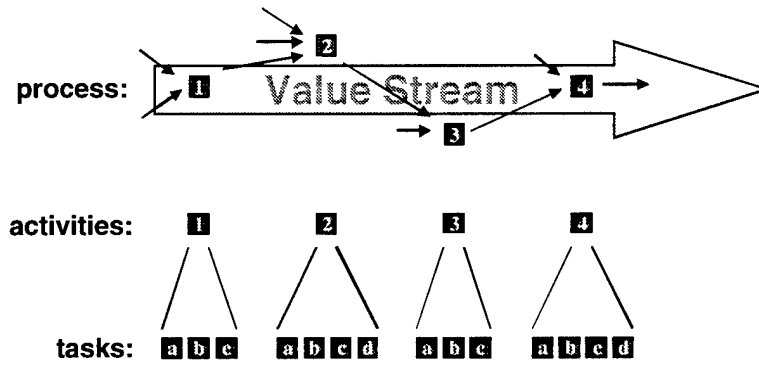

Figure 26. Process Decomposition [32]

The figure assumes value to be delivered to a customer, in the form of a product, by means of a Value Stream. To create the product, a process exists to develop the unfinished, raw inputs, into the finished product. This process consists of specific activities, which may or may not lie directly on the Value Stream, because they may or may not directly provide value. Activities further break down into tasks, which are the detailed efforts performed to complete the product.

The mapping of higher-level activities will, understandably, aid more in strategic analysis. Mapping the lower-level tasks will, in turn, aid with more tactical analysis. Previous VSA/M efforts have found that first mapping the higher levels can help to establish guidance and direction for the lower-level mapping. They have also found that mapping the activities or team-level tasks often provides the greatest insight for the effort required in collecting the necessary data.

6.1.1 VSA/M Method Description

The VSA/M method will follow the improvement scheme presented in Table 11 below, beginning with selection and training of the VSA/M team, and ending with implementation of the new process and continuous improvement.

Table 11. VSA/M Improvement Scheme

1. Assemble and train VSA/M team
2. Select Value Stream to improve
3. Define Value Stream elements

4. Analyze and map Current State
5. a) Analyze and map Future State
b) Analyze and map Ideal State
6. Implement new process
7. Continuous improvement

The first two steps of the method outline will be covered below. The next three will be covered in- depth in section 6.2, and the last two in 6.3.

6.1.2 VSA/M Step 1: Improvement Team Preparation

The improvement team should embody a balance of enterprise perspectives, whether they come from multi-skilled people, or multiple people. These perspectives should include:

- Lean Experts: for knowledge and experience in Lean theory, as well as the methods and tools used for the process improvement.
- Process Owners/Users: for knowledge and experience in the process to be improved, as well as the sources for further information about the process.
- System Thinkers: for enterprise consideration and continuity within the remainder of the business system.
- Customer/Supplier: for product value and external input consideration.

The team must have provided for them training on the Lean business philosophy and the methods and tools chosen for VSA/M. This training should provide a balance of systems and implementation instruction, and will play a critical role in the success of the VSA/M effort. Lean training is available from many sources, and this thesis will not attempt to provide or suggest specific training. Discretion is required, however, in the use of training materials aimed specifically at manufacturing (which most are). Product Development efforts require distinct training material to “translate” Lean concepts for engineering and design activities. Chapter 3 of this work provides the necessary fundamental concepts, and refers to supporting materials.

Also, external consultants may be called upon to fulfill one or more of the team roles. However, consultants do not share the same responsibility for an organization’s future, or hold the same

knowledge that an employee internal to the organization holds. They can provide excellent direction and objective additional views, but too often, consultants are hired to assume the burden of understanding an organization in a manner only sufficiently affected by someone within the company. A mutual disassociation of responsibility can occur when the consultant relies on company personnel to provide the critical information for his analysis, while the employees rely on the consultant’s understanding of the organization to tell them what that critical information is.

6.1.3 VSA/M Step 2: Value Stream Selection

The next step in preparing for the actual analysis and mapping of a PD Value Stream is to choose the Value Stream with which to begin your improvement efforts. To make this decision, a scatter plot of the relative risk and potential benefit of improving each set of processes has shown helpful. The plots, such as included in Figure 27 below, aid in determining the highest yield for the lowest risk in the VSA/M effort. This example shows Process B to provide the best candidate for an initial improvement endeavor.

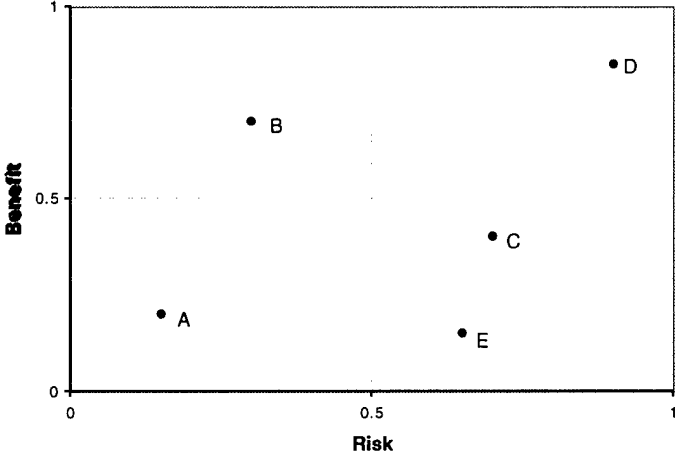

Figure 27. Opportunity Scatter Plot

As observed at the industry sites, the “benefit” of improving a certain process often associates with considerations of the relative cost of a process within a given program, the specific or high-leverage resources required for the process, the potential to create greater profit or business growth, and/or the potential for the process to serve as an improvement model for other processes. Selection may also be accomplished by finding bottleneck processes, determining

critical pacing processes through high-level analysis, or by experience with known deficient processes.

6.2 Analysis and Mapping of the Value Stream

This section describes the definition of Value Stream elements, the analysis and mapping of the Current State, and the analysis and mapping of the improved Future State.

6.2.1 VSA/M Step 3: Value Stream Definition

The improvement team must then define several critical elements of the Value Stream. The *bounds* of the stream include the beginning and ending point of the process, which will give scope to the analysis required. The *owner* will provide the point for direct responsibility for the stream, whether this be a group or an individual. The *product* provides reason for the stream to exist-- it is the packaged value generated by the given process. The *customer* then receives the product from the owner at the end of the Value Stream. This customer does not necessarily represent someone external to the organization, it may be an internal customer. The *inputs* provide the analogy of raw materials to be developed. The *constraints* provide a critical envelope for engineering capabilities and performance.

To demonstrate this step, and each of the VSA/M steps that follow, a running example will show the application of the relevant principles. The example includes a preliminary design process for a generic aero-structural part such as a fairing or fin. The motivation for the example's improvement will be to reduce cost and schedule, and address several known formatting and rework problems. The example will be mapped in a simple fashion to highlight the ideas and principles. It will not necessarily illustrate the full potential or complete application of the VSA/M tools. These tools work best when adapted and developed for the individual organizations and specific products.

For the given example, the Value Stream elements are included in the list below:

- Bounds: requirements definition to delivery of preliminary design report
- Owner: project managing engineer
- Product: design report and presentation
- Customer: detailed design group manager

Inputs: system requirements

Constraints: interface geometry, manufacturing standards and capabilities, company standards

These Value Stream elements are shown graphically in Figure 28 below, which represent a subsegment of the Product Development framework presented in Figure 6.

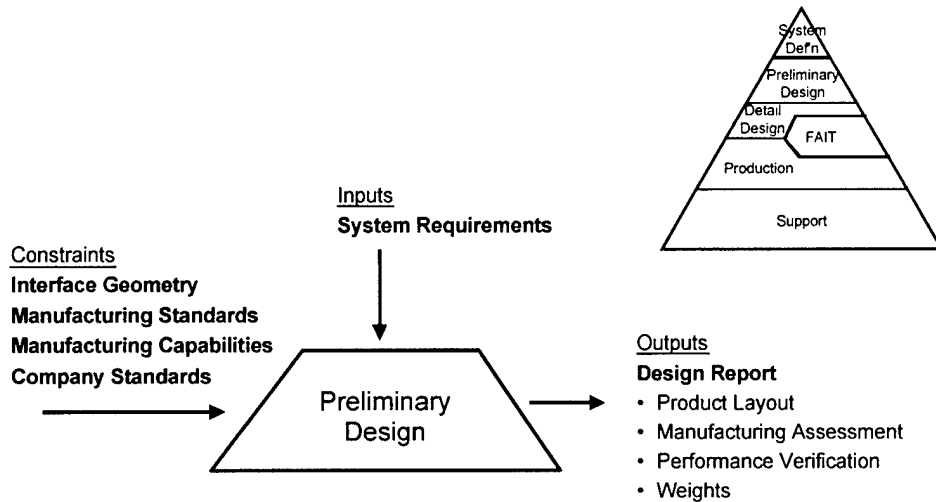

Figure 28. Preliminary Design Framework (from [41]) As Used in Example

6.2.2 VSA/M Step 4: Analyzing and Mapping the Current State

With the resources, background research, and team preparation now in place, the detailed analysis and mapping of the chosen Value Stream may begin. To first frame how the detailed analysis and mapping will be accomplished, Figure 29 below shows the general improvement scheme.

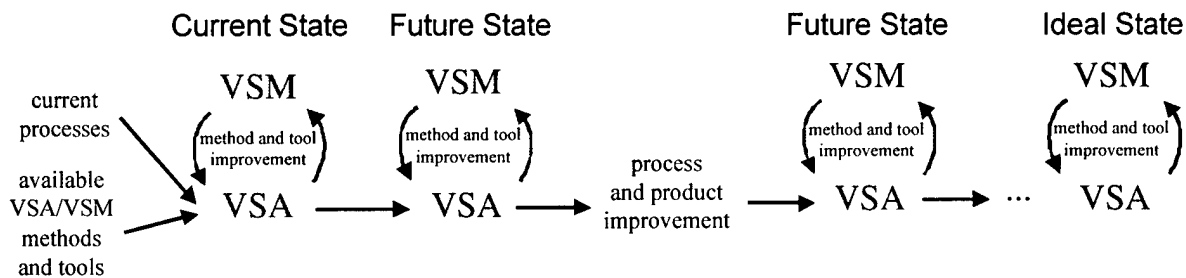

Figure 29. General Improvement Scheme

The above figure shows, as input to the system, the *current process* and the *available improvement methods and tools*. These inputs feed into the first cycle of Value Stream Analysis and Mapping of the Current State of the process. A draft of the Current State map then undergoes scrutiny to determine how accurately it represents the current process. This cycle of refinement continues until it produces a suitable Value Stream Map of the Current State.

The completion of the Current State map leads to the next phase of the improvement scheme, where Value Stream Analysis begins to look at the places to make the process better. A new map is developed, and the iteration continues until it produces a suitable Value Stream Map of the Future State. This map provides the blueprint for the implementation of process improvement measures. Then, as the figure shows, the successive Future States can continue for the life of the process, in pursuit of an Ideal State vision of the process. This iterative method is intended to generate an ever better product by means of an ever better process.

Each iteration of the VSA/M cycle may achieve a better process, not only because of the incremental improvement scheme, but also because learning curves found within each loop. The experience gained from each iteration allows the team to better understand the chosen improvement method and how to apply its tools to their process. The team may also even find ways to increase the sophistication and utility of the improvement tools in their own right.

VSA/M Tools

As determined in the previous section of current industry practices, the analysis of the Current State of the Value Stream will make use of a succession of three mapping tools:

1. A high-level representative tool to aid in defining the Value Stream and its context,
↓
2. A detail-level process flow map to aid in the determination of flow and value, and
↓
3. A Design Structure Matrix (DSM) to aid in the determination of process structure, groupings, and concurrency.

Representation of the high-level process with a Gantt chart or Ward-type map can help to provide a good initial “big picture” of the process, from which to base more detailed analysis. As the previous section noted, these maps have the ability to best represent the actual nature of a process, and do so very well in a high-level examination. This mapping may also help to better define the Value Stream elements established in the previous step. At this point in the mapping, the improvement team members should have a rough idea of what steps are included in the high-level process. The Gantt chart found in Figure 30 below, and the Ward/LEI map found in Figure 31, illustrate the high-level process of the Aerospace Piece-Part Example.

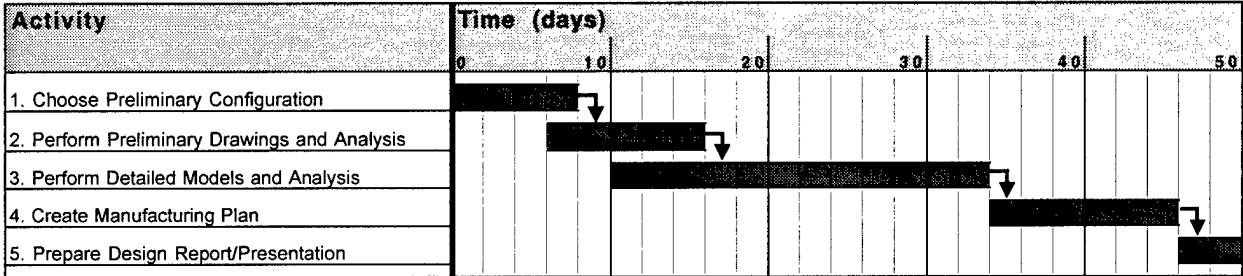

Figure 30. Example Gantt Chart

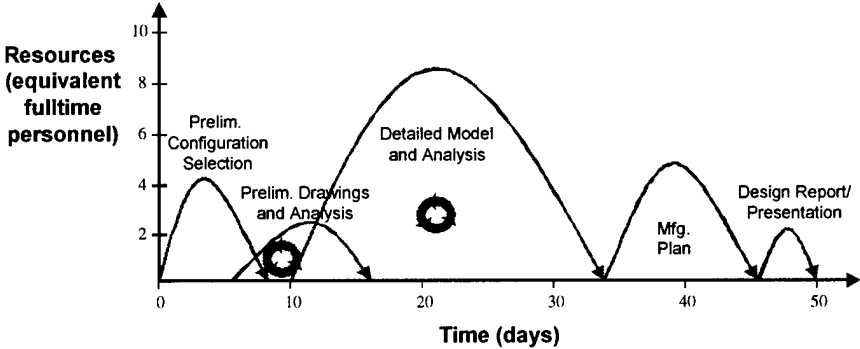

Figure 31. Example Ward/LEI Map

The completion of the high-level map should provide direction for now completing a Process Flow map of lower-level processes. Previous VSA/M efforts have found it most helpful to “drill-down” from the high-level process to focus on more detailed analysis, where inefficiencies become more apparent. As determined in the research data reduction, these Process Flow maps best allow for the analysis of flow and value. Initial maps should first include all of the steps in the process at a convenient, yet informative level.

Following the process flow map, a Design Structure Matrix will further aid in describing the flow of the Current Process. The research data reduction showed this tool to best support analysis for the structuring and concurrency aspects of a process. Detailed instruction for the use of the tool can be referenced at the MIT Design Structure Matrix website, and in Browning's discussion of the technique (a section of which is found in Appendix B) [16,29]. In the application specific to this method, the tool communicates very well the iteration and feedback loops required in processes.

Data Collection and Mapping

Application of the three Value Stream Mapping tools will include a progression of map sophistication. The progression of the Current State map should include the levels of maturity as (1) mapping activities and inputs/outputs, (2) mapping metrics and distinguishing process characteristics, and (3) consideration of activity value. The levels of mapping should not only incorporate more of the process attributes with each successive iteration, but also hopefully increase the understanding of the process as a result. The follow-on considerations of (4) time cycles, and (5) the "Real" flow of the process, will also be address in the concluding section.

A data collection sheet has been included in Appendix E to aid in the gathering of the necessary information for each of the mapping levels. For each of the mapping levels, an example of the data collection sheet will be shown, with the appropriate information highlighted. The method used for the data collection, whether it be interview, participation, or observation studies, may vary depending on the nature of the process to be improved. However, past VSA/M efforts have revealed the importance of taking the data from sources close to the process. This may include "walking" through the process with the team, or speaking to the actual personnel completing the process. It should most likely not rely solely on the given Work Breakdown Structure or collective team knowledge. Work Breakdown Structures, or similar process documentation, have been shown to conflict with what actually takes place in the process. Sometimes extra steps are required to complete a product, and sometimes "official" steps are unnecessary.

Mapping activities and inputs/outputs: this first level of mapping should best piece together the repeating question of, “what happens next?” in the process, and what information connects these steps. The first data collection sheet collects the general information about the process necessary to complete this level of mapping. This sheet is found below in Table 12. The appropriate boxes of the sheet are filled in with data from the example, the boxes not required at this level are shaded gray. An explanation of the terms and values is found in the sheet’s legend that follows.

Table 12. Level 1 Data Collection Guide and Legend [18,29,32,52,53]

General			Resources		
Activity Name	FEM Development		Elapsed Time		(days)
Location	Design Station #4		In-process Time		(hrs)
Pers./Org. Performing	Fernandez/Chase		Core Task Work Time		(hrs)
Completion Criteria	model finished		Activity Based Cost		
Success Criteria	analysis with no rework		Special Resources Req.		
Other:			Chance of Rework/Time	%	(hrs)
Input #1		Input #2		Input #3	
Name	Stability & Control		Name	Structural Rqmts.	
Sender	Kirtley		Sender	Uzair/Chambers	
Transfer	Documentation Report		Transfer	electronic file	
Quality	1 2 3 4 5 N/A	Quality	1 2 3 4 5 N/A	Quality	1 2 3 4 5 N/A
Utility	1 2 3 4 5 N/A	Utility	1 2 3 4 5 N/A	Utility	1 2 3 4 5 N/A
Format	1 2 3 4 5 N/A	Format	1 2 3 4 5 N/A	Format	1 2 3 4 5 N/A
Output #1		Output #2		Output #3	
Name	FEM model		Name		
Receiver	Walton		Receiver		
Transfer	electronic file		Transfer		
Purpose	Allow SS&L Analysis		Purpose		
Critical Drivers (metrics/attributes)					
Context (interaction with other VS)					
Value					
Non-Value-Added		Enabling		Value-Added	
1-----2-----		3-----4-----		5-----	
Functional Perform.	1 2 3 4 5 N/A	Enabling Activities	1 2 3 4 5 N/A		
Defn. of Processes	1 2 3 4 5 N/A	Cost/Schedule Savings	1 2 3 4 5 N/A		
Reduction of Risk	1 2 3 4 5 N/A	Other:	1 2 3 4 5 N/A		
Form of Output	1 2 3 4 5 N/A	Other:	1 2 3 4 5 N/A		
Waste Sources					
Waste of Resources					
Waste of Time					
Waste of Quality					
Waste of Opportunity					
Information Waste					
Other:					
Comments/Suggestions (improvement ideas, problems, stress points)					

Data Collection Sheet Legend	
<p>Elapsed Time: days from authorization to proceed, to the completion of the activity</p> <p>In-process Time: hours of active work, as measured, for example, by time charged</p> <p>Core Task Work Time: time when core task is being worked, excluding setup, data retrieval, etc.)</p>	<p>Special Resources Required: any personnel, tools, or information that may distinguish the activity or provide constraint</p> <p>Chance of Rework/Time: percent chance of rework being required for or because of the activity, and the time associated with that rework</p>
Input Criteria	
<p>Quality</p> <p>5 - Significantly more information than needed</p> <p>4 - More information than needed</p> <p>3 - Quality is just right</p> <p>2 - Information is missing</p> <p>1 - Info. is inaccurate and/or untrustworthy</p>	<p>Formatting</p> <p>5 - Ideal formatting for immediate use</p> <p>4 - Fairly good formatting</p> <p>3 - Acceptable formatting</p> <p>2 - Some reformatting necessary</p> <p>1 - Reformatting necessary</p>
<p>Utility</p> <p>5 - Direct and critical contribution</p> <p>4 - Important contribution</p> <p>3 - Beneficial contribution</p> <p>2 - Indirect contribution</p> <p>1 - No contribution</p>	<p>Transfer: the method of transfer by which the input arrives to the activity</p> <p>Output Purpose: the product that the output is contributing to, or the goal of the activity</p>
Critical Drivers: metrics that reveal the distinguishing nature and critical drivers of the process	
Context: interaction with other Value Streams (such as manufacturing and R&D), and any authority/review issues	
Value Criteria	
<p>Functional Performance (FP)</p> <p>Functional performance of the end product to be delivered to the customer</p> <p>5 - Direct specification of major FP parameters</p> <p>4 - Direct specification of FP parameters</p> <p>3 - Direct specification of minor FP parameters</p> <p>2 - Indirect specification of FP parameters</p> <p>1 - Possible specification of FP parameters</p>	<p>Form of Output</p> <p>The form of the output of this task (e.g. report, spreadsheet, build-to-package, etc.)</p> <p>5 - Flows easily into program milestone</p> <p>4 - Flows into milestone with some changes</p> <p>3 - Flows easily into downstream task</p> <p>2 - Flows into next task with some changes</p> <p>1 - Flows into next task with major changes</p>
<p>Definition of Processes</p> <p>Definition of processes necessary to deliver the end product to the customer</p> <p>5 - Direct spec. of major downstream processes</p> <p>4 - Direct spec. of downstream processes</p> <p>3 - Direct spec. of minor downstream processes</p> <p>2 - Indirect spec. of downstream processes</p> <p>1 - Possible spec. of downstream processes</p>	<p>Enabling Activities</p> <p>Enabling other tasks (e.g., the task is required for completion of program)</p> <p>5 - Major checkpoint preventing further work</p> <p>4 - Moderate checkpoint in program</p> <p>3 - Task necessary for continued work</p> <p>2 - Necessary, but not especially time-sensitive</p> <p>1 - Necessary, but not time sensitive</p>
<p>Reduction of Risk</p> <p>Reduction of risks and uncertainties associated with functional, process, or market areas</p> <p>5 - Major risks greatly reduced or eliminated</p> <p>4 - Significant reduction of risks</p> <p>3 - Minor reduction of risks</p> <p>2 - Indirect reduction of risks</p> <p>1 - Possible reduction of risks</p>	<p>Cost/Schedule Savings</p> <p>Cost and/or schedule savings resulting from task execution (i.e., a core competency)</p> <p>5 - Recognized as a core competency</p> <p>4 - Major improvement over hist. predecessor</p> <p>3 - Improvement over historical predecessor</p> <p>2 - Minor improvement over predecessor</p> <p>1 - Possible improvement over predecessor</p>
Waste Sources	
<p>Waste of Resources: possible misuse or non-optimization of resources</p> <p>Waste of Time: possible cause for delays, waiting, unplanned rework</p> <p>Waste of Quality: possible cause for lack of quality, errors, defects</p> <p>Waste of Opportunity: possible oversight of personnel, tool, or technology potential</p> <p>Info Waste: overproduction, inventory, transportation, unnecessary movement, overprocessing, transfers, scatter</p>	

Including the Level 1 information in a Process Flow map should help to reveal the nature of the process and how best to map its Current State. This map should illustrate what steps are required in the process, and how they fit together in terms of precedence. Include the process steps in as sequential a format as possible, which will help to describe the flow of the process, and do not force the map onto a small sheet of paper. Allowing the picture of the process to stretch from one end to another adds an implicit time dimension to the map, and supports further analysis of the set of activities. Enter the process steps in the form of “Verb” and “Noun” such as “Choose Configuration” to reveal the intended purpose of the activity and expose waste. Also, hand drawing the maps avoids lengthy conversion to electronic forms while maintaining effective communication.

After comparing the example’s official Work Breakdown Structure with the actual process, the list of activities in Table 13 below was developed.

Table 13. Example Activity List

1. Choose Preliminary Configuration
2. Create External and Mechanical Drawings
3. Perform Aerodynamic Analysis
4. Create Structural Configuration
5. Determine Structural Requirements
6. Perform Weight Analysis
7. Perform Stability and Control Analysis
8. Perform Loads Analysis
9. Develop Finite Element Model
10. Perform Strength/Stiffness/Life Analysis
11. Create Manufacturing Plan
12. Develop Design Report/Presentation

For each of these activities, inputs and outputs are collected on data forms such as included in Table 12. This information is sufficient to create the Level 1 Process Flow Map found in the following Figure 32, along with the associated DSM in Figure 33. The Process Flow Map includes the activities as well as several major reviews or formatting tasks. These tasks are denoted by a diamond symbol on the information flow path. More detailed analysis of tasks, which may include such things as formatting, review, software setup, analysis, cross-functional

communication, database search, integration, and documentation, may further reveal unnecessary steps and opportunities to improve time, cost, and quality.

Mapping the activities and inputs/outputs in a DSM will help to reveal where information is not currently flowing in the Current State. Activities will often indicate that they require input from a certain adjoining activity, which may not indicate that it provides this input. Conversely, an activity may indicate that it provides input to another activity, which may not indicate the need for the input. These disconnects may be actual problems the process, or they may represent errors in the data collection. Resolving the disconnects is the subsequent step in the VSA/M process.

Assuming these disconnects are resolved, activities and the flows of information between them can be mapped. The results for the given example are included in Figure 32 and Figure 33. Note that the Process Flow map in Figure 32 does not show feedback, but that it is, however, captured by the above-the-diagonal elements of the DSM in Figure 33.

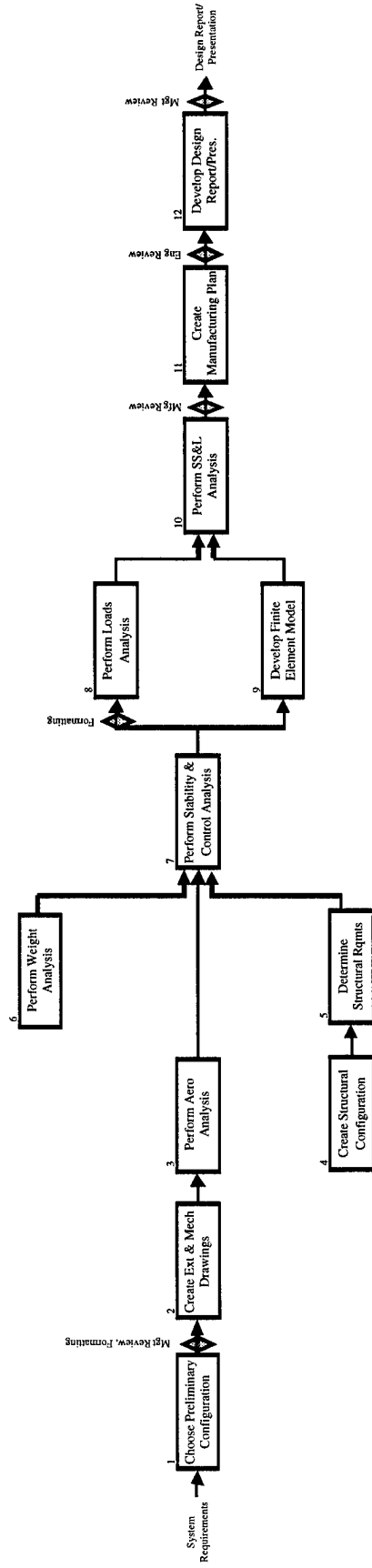

Figure 32. Level 1 Process Flow Map

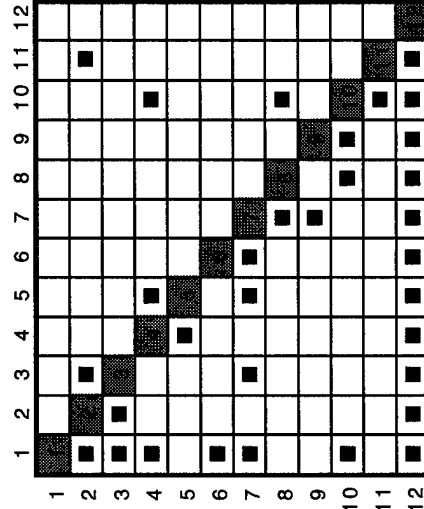

Figure 33. Level 1 DSM

- Choose Preliminary Configuration
- Create External and Mech. Drawings
- Perform Aerodynamic Analysis
- Create Structural Configuration
- Determine Structural Requirements
- Perform Weight Analysis
- Perform Stability and Control Analysis
- Perform Loads Analysis
- Develop Finite Element Model
- Perform Strength/Stiffness/Life Analysis
- Create Manufacturing Plan
- Develop Design Report/Presentation

Mapping metrics and distinguishing characteristics should start with first defining the successful outcome of the process at hand: “what is it that drives the critical quality of the product,” or “what would be the characteristics of the product were it made perfectly?” The answers to these questions will help to define the metrics needed for further analysis.

The chosen metrics should describe and allow insight into the features of the product or process that are perceived to be critical to delivering value to the customer [7]. These metrics should also further reveal the distinguishing nature and critical drivers of the process. No two processes will exhibit the same nature and set of drivers, so each mapping exercise will be different. However, there are several common metrics which can provide a starting point, such as found in the Level 2 data collection guide shown in Table 12 below. On this example sheet, the Elapsed Time (days from authorization to proceed, to the completion of the activity), the In-process Time (number of hours of active work on the activity, as measured, for example, by time charged), and Core Task Work Time (time when the core task is being worked, excluding setup, chasing necessary information, meetings, etc.) are collected. This section on the data collection sheet also includes the Activity Based cost (which may or may not be available at different sites), extra resources required, and percent chance (taken from historical experience) that the activity will require rework.

The final data collected are the Critical Drivers. In this example, the personnel performing the activity provide the characterization of these critical drivers, based on experience. However, techniques do exist for a more systematic approach to the issue, which may be more appropriate for other efforts. For more information on the driving characteristics of a product, refer to Lee and Thornton’s discussion of Key Characteristics and Six Sigma’s Critical-To-Quality (CTQ) characteristics [15,13].

Table 14. Level 2 Data Collection Guide [18,29,32,52,53]

General			Resources			
Activity Name	FEM Development		Elapsed Time	4 (days)		
Location	Design Station #4		In-process Time	21 (hrs)		
Pers./Org. Performing	Fernandez/Chase		Core Task Work Time	19 (hrs)		
Completion Criteria	model finished		Activity Based Cost	\$1,350		
Success Criteria	analysis with no rework		Special Resources Req.	design station/software		
Other:			Chance of Rework/Time	33 %	5 (hrs)	
Input #1		Input #2		Input #3		
Name	Stability & Control		Name	Structural Rqmts.		Name
Sender	Kirtley		Sender	Uzair/Chambers		Sender
Transfer	Documentation Report		Transfer	electronic file		Transfer
Quality	1 2 3 4 5 N/A		Quality	1 2 3 4 5 N/A		Quality
Utility	1 2 3 4 5 N/A		Utility	1 2 3 4 5 N/A		Utility
Format	1 2 3 4 5 N/A		Format	1 2 3 4 5 N/A		Format
Output #1		Output #2		Output #3		
Name	FEM model		Name			Name
Receiver	Walton		Receiver			Receiver
Transfer	electronic file		Transfer			Transfer
Purpose	Allow SS&L Analysis		Purpose			Purpose
Critical Drivers (metrics/attributes)			sensitivity of FEM software: varies based on type of model, and often causes rework			
Context (interaction with other VS)						
Value						
Non-Value-Added		Enabling		Value-Added		
1-----2-----		3-----4-----		5-----		
Functional Perform.	1 2 3 4 5 N/A		Enabling Activities		1 2 3 4 5 N/A	
Defn. of Processes	1 2 3 4 5 N/A		Cost/Schedule Savings		1 2 3 4 5 N/A	
Reduction of Risk	1 2 3 4 5 N/A		Other:		1 2 3 4 5 N/A	
Form of Output	1 2 3 4 5 N/A		Other:		1 2 3 4 5 N/A	
Waste Sources						
Waste of Resources						
Waste of Time						
Waste of Quality						
Waste of Opportunity						
Information Waste						
Other:						
Comments/Suggestions (improvement ideas, problems, stress points)						

Figure 34 below shows the incorporation of several metrics on the example Process Flow map. A summary and explanation of the metrics can be found in the previous Table 12. Activity elapsed time (“ET”), hours in-process (“HIP”), core task work time (“CT”), and activity-based cost (“C”) are calculated for each of the individual activities. Elapsed time and hours in-process are noted along with the total process elapsed time and total hours in-process (“*activity/total time*”). Each of the metrics in the Process Flow Map can also be electronically linked within a DSM, where a click of an activity intersection brings up the associated resources, schedule, and capabilities.

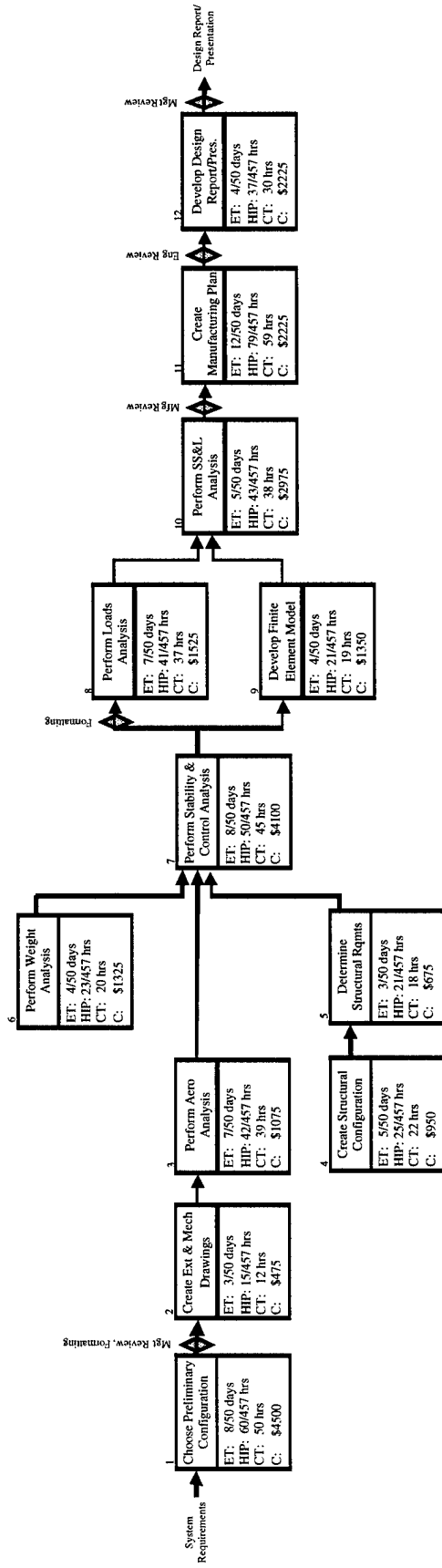

Figure 34. Level 2 Process Flow Map

Consideration of value incorporates analysis of the value of each activity onto the map. This value refers to the worth of the activity to the overall process and system as a whole. Until a robust method for quantification of this value becomes available, previous VSA/M efforts have used the basic distinction between Value-Added activities, Enabling activities, and Non-Value-Added activities. Though subjective, these ratings often find a high degree of agreement among the members of improvement teams.

Value-Added tasks are those practices that offer the real substance of the process. These tasks add quality to the product in reference to the overall Lean Product Development effort and ultimate Lean enterprise. Without these tasks, the process could not exist, and if there were some way to perform only these tasks, an ideal solution would not be far behind. Furthermore, the qualification of Value-Added tasks can break down further into how exactly Value-Added they are: from adding an extremely amount of value to the product to adding very little value to the product. These classifications will also point out opportunities for improvement.

The Non-Value-Added tasks often result from outdated or unnecessary bureaucracy, or reflect process steps that have not matured with changing capabilities and products. Take care not to cut steps out of the process haphazardly, because experience has shown that missed steps can cause dramatic and costly failures in the product. The Enabling tasks include such things as setup and supporting tasks, but the fact that they offer no direct value points immediately to opportunity for improvement. Care should be taken, however, in the presentation of work as Non-Value-Added to those whom perform the work. The case is not they their work or position has no value, but rather that the process may currently contain areas where their job could be made more efficient. Personnel do not often enjoy doing less meaningful work, and so they often find the pleasant surprise of a newly improved process by way of VSA/M, which had been relatively mundane or frustrating in the past.

A simple judgement of Value Added, Enabling, or Non-Value-Added may be sufficient in the characterization of activities. However, the data collection sheet also provides additional tools for making a more sophisticated judgement of value. The different types of value, as explained in the data collection sheet legend (Table 12), and in more detail by Chase [32], may be assessed.

Similar judgements may be applied to the quality of information provided to activities may be assessed. These are shown entered in the example data collection sheet in Table 15. The additional value assessments may be used in place of, or as enhancement to, the simple Value-Added, Enabling, or Non-Value-Added assessment (this is suggested for more sophisticated value determination).

Known sources of waste, as observed by those actually performing the process, should also be assessed at this time. The data collection sheet gives some examples of waste categories, but this is not meant to be an exhaustive list. Other sources of waste may well be found. Finding waste is the focus of much Lean training, and will not be explained in detail here. This exercise of discovering the waste is best accomplished by the personnel performing the activity. Creative thinking should be encouraged: *anything* that slows down or complicates the completion of the core task, even things that seem inevitable or unchangeable, should be addressed here.

The Level 3 data collection sheet, included in Table 15 below, collects information about value in the process necessary to complete this level of mapping. The following Figure 35 shows the assessed value that each activity provides to the end product onto the Level 3 Process Flow map. This value is entered as the simple aggregate score in this example. A more sophisticated analysis might include the various forms of value collected on the sheet, allowing for the tracing and assessment of several different types of value on the same sheet. Also, activities can be shaded to identify whether they are primarily Non-Value Added, Enabling, or Value-Added. The example is shown to highlight the four activities that are noticeably more Value-Added than the remaining.

Table 15. Level 3 Data Collection Guide [18,29,32,52,53]

General				Resources			
Activity Name	FEM Development			Elapsed Time	4 (days)		
Location	Design Station #4			In-process Time	21 (hrs)		
Pers./Org. Performing	Fernandez/Chase			Core Task Work Time	19 (hrs)		
Completion Criteria	model finished			Activity Based Cost	\$1,350		
Success Criteria	analysis with no rework			Special Resources Req.	design station/software		
Other:				Chance of Rework/Time	33 %	5 (hrs)	
Input #1		Input #2		Input #3			
Name	Stability & Control		Name	Structural Rqmts.		Name	
Sender	Kirtley		Sender	Uzair/Chambers		Sender	
Transfer	Documentation Report		Transfer	electronic file		Transfer	
Quality	1 2 3 4 (5) N/A		Quality	1 2 (3) 4 5 N/A	Quality	1 2 3 4 5 N/A	
Utility	1 (2) 3 4 5 N/A		Utility	1 2 3 (4) 5 N/A	Utility	1 2 3 4 5 N/A	
Format	(1) 2 3 4 5 N/A		Format	1 (2) 3 4 5 N/A	Format	1 2 3 4 5 N/A	
Output #1		Output #2		Output #3			
Name	FEM model		Name			Name	
Receiver	Walton		Receiver			Receiver	
Transfer	electronic file		Transfer			Transfer	
Purpose	Allow SS&L Analysis		Purpose			Purpose	
Critical Drivers (metrics/attributes)		sensitivity of FEM software: varies based on type of model, and often causes rework					
Context (interaction with other VS)		must schedule design station and personnel resources					
Value							
Non-Value-Added		Enabling		Value-Added			
1-----2-----3-X-----4-----5							
Functional Perform.	1 (2) 3 4 5 N/A	Enabling Activities	1 2 3 4 (5) N/A				
Defn. of Processes	(1) 2 3 4 5 N/A	Cost/Schedule Savings	1 2 3 (4) 5 N/A				
Reduction of Risk	1 2 (3) 4 5 N/A	Other: employee job sat.	1 2 3 (4) 5 N/A				
Form of Output	1 (2) 3 4 5 N/A	Other: customer	(1) 2 3 4 5 N/A				
Waste Sources							
Waste of Resources							
Waste of Time	waiting for material properties						
Waste of Quality	errors in meshing, connectivity						
Waste of Opportunity							
Information Waste							
Other:							
Comments/Suggestions (improvement ideas, problems, stress points)		over-multitasking of personnel at design station #4 often causes bottlenecks in the process and low flexibility with iteration.					

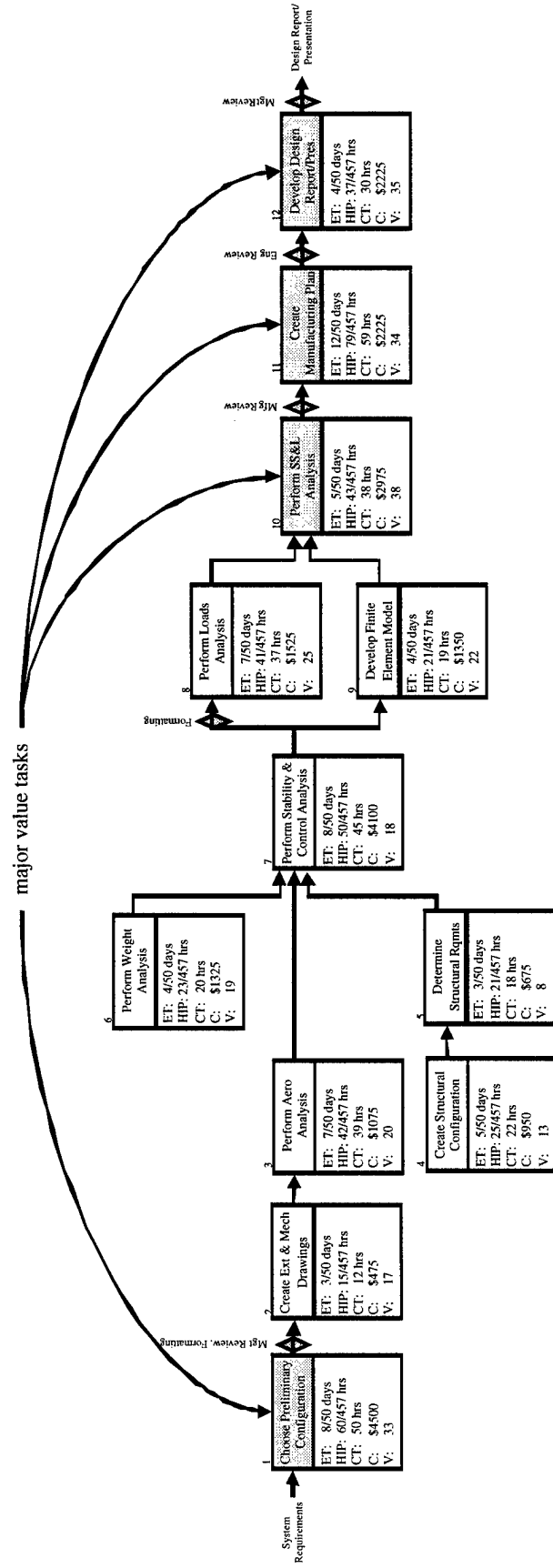

Figure 35. Level 3 Process Flow Map

6.2.3 VSA/M Step 5a: Analyzing and Mapping the Future State

An accurate and complete map of the Value Stream developed in the previous section allows for the effective improvement of the process in the next step. Step 5 of the VSA/M improvement scheme includes the concurrent development of the Future State Map (part a) in reference to the Ideal State vision (part b). The Future State map of the process will provide the picture of how the new version of the process will look, though it may differ from the ideal version of the process due to surrounding constraints.

The Future State map will lay the foundation and facilitate communication for the plan of proposed improvements upon the Current State. As with the Current State mapping, the Future State will follow iteration of analysis and mapping with levels of increasing sophistication. The key heuristics used to improve upon the Current State are included below in Table 16. A brief description of each idea follows in this section, and their application of each in the VSA/M example section. The description of each heuristic also includes its relationship to the Lean Enterprise Model (LEM) developed by the Lean Aerospace Initiative to frame the guiding attributes of a Lean enterprise [39]. Beneath each of the model's OverArching Practices (OAPs), is found a database of associated enablers, metrics, and best practices, which further expand the relevant principles.

Table 16. Value Stream Improvement Heuristics

1. Redundancy, Simplification, Standardization
2. Flow Continuity
3. Information Handoffs (Transfers)
4. Balanced Review and Responsibility
5. Communication Systems
6. Integrated Product and Process Development
7. Concurrent Processing

In any business improvement effort, there is a certain amount of artisanship required in translating the above heuristics into actual improvements. However, the goal in creating the Value Stream Map is to reveal suggestion for improvement measures and support for

improvement decisions. Based on the previous VSM tool characterization analysis, the process flow map developed for the Current State process should aid in the determination of the value of specific activities in the process, how well they flow together, the important decision branching, and for the display of metrics. The Design Structure Matrix should aid more in the determination of feedback loops, rework issues, process structure, concurrency, and grouping or teaming.

The earlier phases of Value Stream Analysis for the Future State will most likely focus on the so-called “low-hanging fruit.” The more obvious problems with clear solutions belong to this category, and they usually produce a great deal of benefit for the little analysis required. Oftentimes, the solution to obvious problems involves simply removing waste from the system. However, as the successive levels of heuristics will show, improvement of the process should include not only the removal of waste, but also increasing the worth of the product by means of a fundamentally better process.

Redundancy, Simplification, Standardization involves the self-explanatory confrontation of work that is completed more than once, more complicated than necessary, or fails to take advantage of potential standardization in the development, documentation, or presentation of information. As part of this category, automation of tasks where it is both viable and beneficial can provide for one method of simplifying and standardizing the overall process [28]. This heuristic relates to OAPs 9: “Maintain Challenge of Existing Processes,” and 11: “Ensure Process Capability and Maturation” of the Lean Enterprise Model.

Flow Continuity attends to the disconnects and misdirections in the flow of the current process. Effected continuity requires the availability of all input information and tools, and the correct direction of all outputs. This heuristic relates to OAPs 1: “Identify and Optimize Enterprise Flow,” and 2: “Assure Seamless Information Flow” of the Lean Enterprise Model.

The following figures incorporate these first two heuristics into the previously developed Process Flow Map (Figure 36) and DSM (Figure 37). The Flow map shows the removal of two major formatting steps by establishing a common format between adjoining activities, and the addition

of two major information links (shown by the dashed arrows). The DSM also shows the addition of these links (accented with a circle). The formatting problems were found by assessing the quality of information provided to the subsequent activities, and through observed formatting waste. The information links were added to establish explicit and controlled transfer of critical information, where it had been previously transferred by ungoverned and nonstandard means.

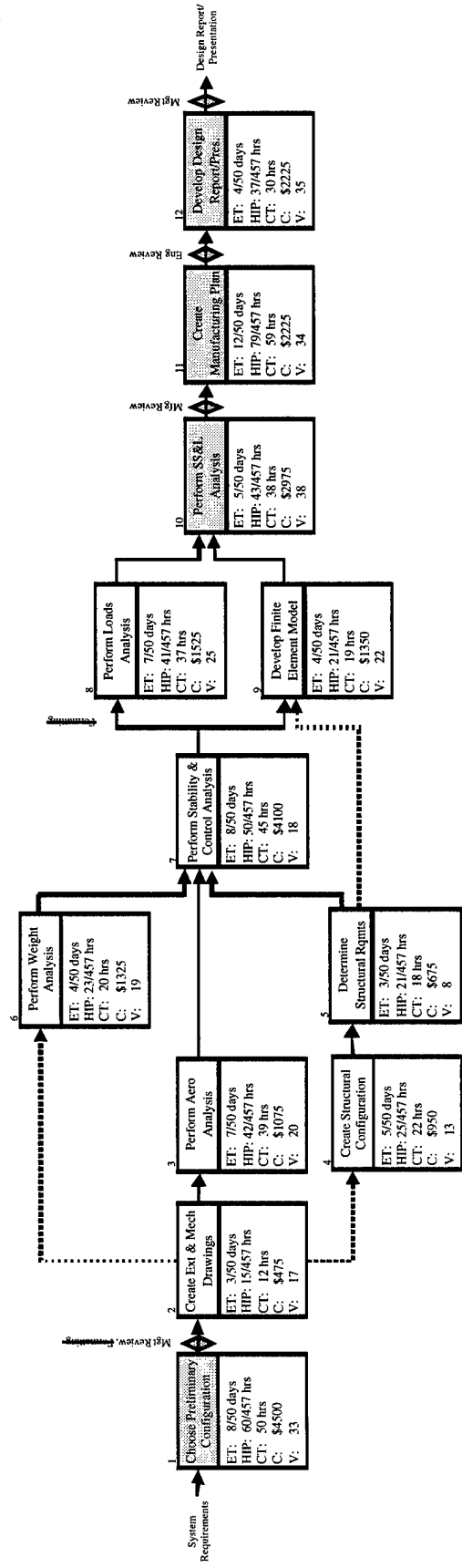
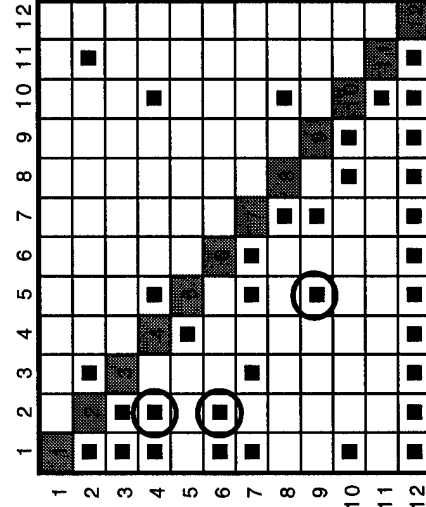

Figure 36. Improved Process Flow Map: Heuristics 1 and 2



- Choose Preliminary Configuration
- Create External and Mech. Drawings
- Perform Aerodynamic Analysis
- Create Structural Configuration
- Determine Structural Requirements
- Perform Weight Analysis
- Perform Stability and Control Analysis
- Perform Loads Analysis
- Develop Finite Element Model
- Perform Strength/Stiffness/Life Analysis
- Create Manufacturing Plan
- Develop Design Report/Presentation

Figure 37. Improved DSM: Heuristics 1 and 2

Information Handoffs (or Transfers) stems from the assertion that every time an idea or concept is passed from one party to another, it is impossible for the originator to fully convey to the receiver all the information required to comprehend the idea in the exact same manner. Not only does the amount and quality of the information suffer when transferred, but the context of the information can suffer based on the method of communication. Results from human communications studies state that less than half of the information transferred in a face-to-face conversation come from the actual words spoken [23].

In an ideal world, a single person, with all required knowledge, would complete the process from beginning to end and require no handoffs until product delivery to the customer. The problem comes in the amount of knowledge a single person can account for, and the time required to complete a large task. Thus emerges the need for a work breakdown structure, but while keeping the goal to create as few handoffs as feasible. This heuristic also relates to OAP 2: “Assure Seamless Information Flow” of the Lean Enterprise Model.

Figure 38 shows four areas where major handoffs occur, two with associated reviews. These handoffs will be accounted for with the following heuristics by both combining activities and integrating functions.

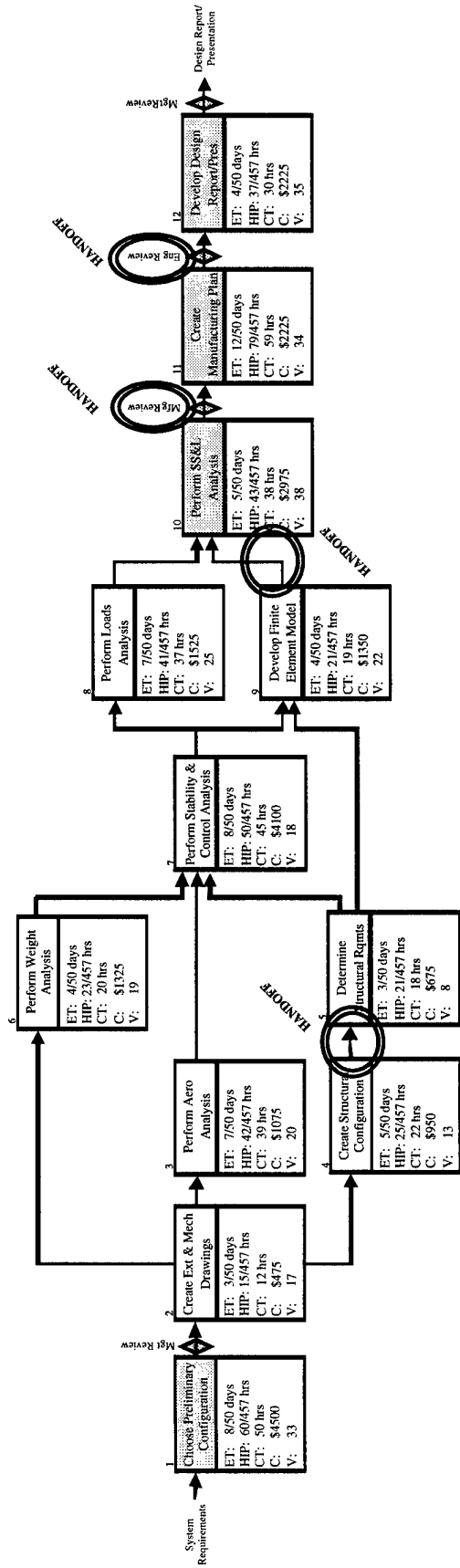

Figure 38. Improved Process Flow Map: Heuristics 1-3

Balanced Review and Responsibility focuses on requiring the correct amount of review to ensure the quality of a product without imparting the unnecessary bureaucracy of signatures and presentations that are not really needed. It is not uncommon for upwards of a third of all process steps to be reviews. Not only is time spent reviewing value rather than creating value, but reviews also require the time in preparing for presentations and reports that often find no direct audience. This heuristic relates to OAP 4: “Make Decisions at Lowest Possible Level” of the Lean Enterprise Model.

Communication Systems can aid in establishing pull systems for information and enable more efficient flow within the process. Web-based environments, common directories for information storage, and electronic transfer of data, can enable efficiencies not possible under many paper-based, push systems. This heuristic also relates to OAP 2: “Assure Seamless Information Flow” of the Lean Enterprise Model.

Integrated Product and Process Development addresses the opportunity for synergy in a multi-disciplinary team environment. This principle seeks to improve the decisions made about how to design and manufacturing a product through shared communication of available options and capabilities. This heuristic relates directly to OAP 5: “Implement Integrate Product and Process Development” of the Lean Enterprise Model.

Concurrent Processing involves collapsing the process into as high a level of concurrency as necessary when the more sequential process has been improved. This idea serves to reduce cycle time, when necessary, to match relevant business cycles and customer needs. This heuristic relates to the Enterprise Level Metric of “Flow Time” found in the Lean Enterprise Model.

The following figures incorporate these last four heuristics into the DSM (Figure 39) and Process Flow map (Figure 40). Analysis of the DSM using an expanded list of activities reveals the possibility for several process improvements. The increase in size of the DSM does not reflect the addition of tasks, but rather the breaking of several activities in to their initial and final segments. The grouping of initial and final analysis activities (highlighted in gray) allows for greater integration of employee skills by employing the IPT concept. Tightening the interaction

within groups such as these, which require high amounts of iteration and communication, can dramatically reduce errors, schedule, cost, and increase the overall product quality and job satisfaction. The grouping also allows for greater concurrency of activities, by running initial analyses and final analyses together, instead of requiring all final analysis to wait until the completion of the initial analysis. And finally, the groupings greatly reduce the threat of the feedback loop that occurs when finished design analysis is deemed unproducable in the manufacturing review, very late in the process. Instead, manufacturing problems can now be determined much earlier in the process, and new external and mechanical drawings can be created without the severity of time and cost repercussions.

The bottom row of inputs in the DSM, which showed the feed of every activity into to the design report development was removed to reflect the institution of single-piece flow. This single-piece flow of information is based on common and integrated documentation, which can be passed along the Value Stream in a uncorrupting manner, while at the same time, providing downstream activities complete access to all design information.

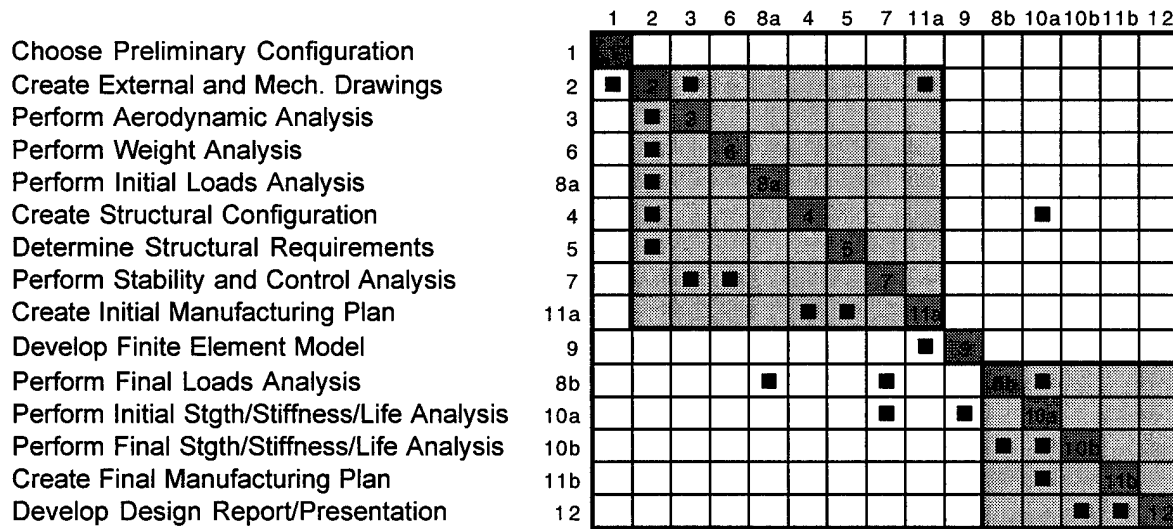

Figure 39. Improved DSM: Heuristics 1-7

Likewise, the Process Flow map shows the expansion of several activities into their initial and final analysis, and the establishment of concurrent processing where possible. The initial manufacturing analysis has been moved much farther forward in the process to avoid the costly

restart of the process when the product cannot be produced. The increased integration of manufacturing and design activities through establishing an Integrated Product Team (IPT), using Design For Manufacture and Assembly (DFMA) tools, has eliminated the need for their respective reviews, and they have been removed. Activities 4 and 5 have been integrated to eliminate an unnecessary handoff between personnel, and common formatting systems have removed the severity of the handoff between activities 9 and 10. Updating the metrics can reflect the improvements predicted in making these changes. In the example scenario, process *elapsed time* was reduced by 42%, *hours in-process* reduced by 33%, *non-core task work time* reduced by 71%, and *activity based cost* reduced by 40%. The process is not perfect yet, but it is much improved. With this Future State implemented, further enhancement can take place in the continuing pursuit of its ideal form.

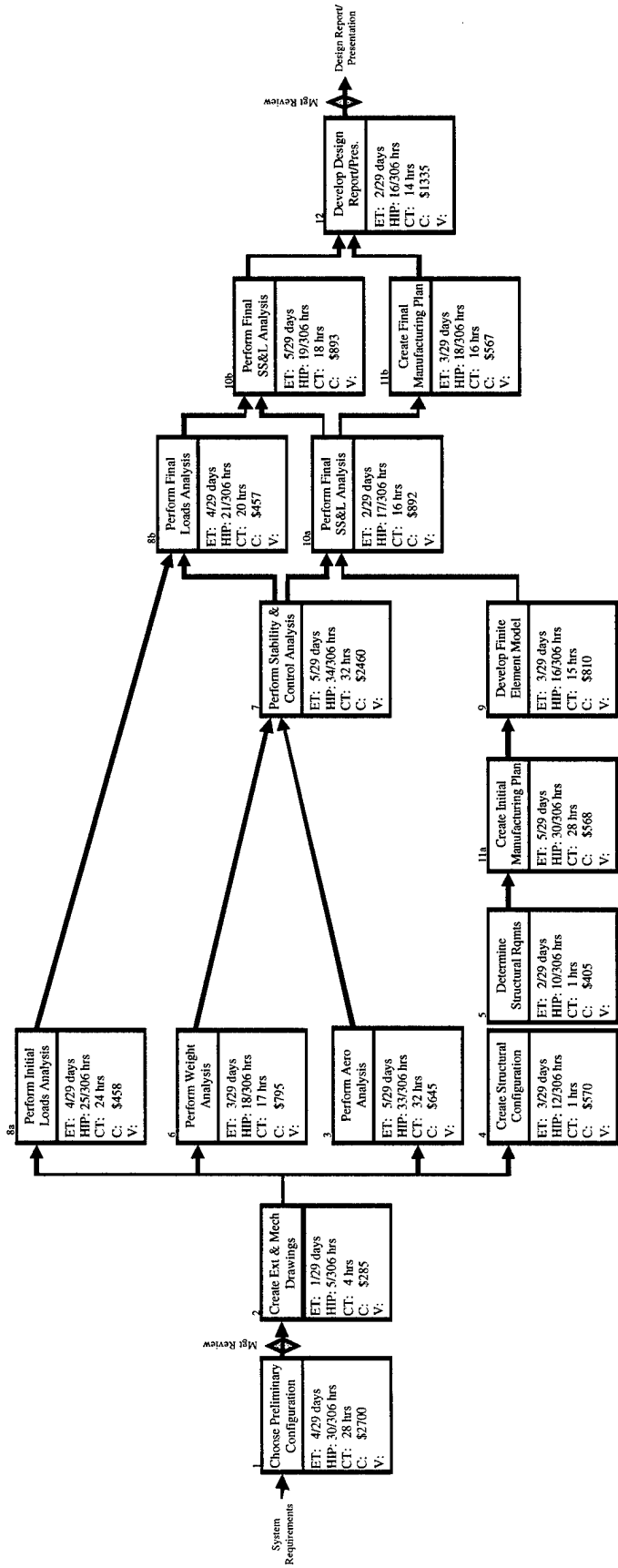

Figure 40. Improved Process Flow Map: Heuristics 1-7

6.2.4 VSA/M Step 5b: Analyzing and Mapping the Ideal State

In conjunction with mapping the Future State of a process, the next step of the VSA/M improvement scheme includes a mapping of the Ideal State. In order to make something better, one must first have a goal or vision which defines what is preferred, and the Ideal State map provides the reference, toward which, improvements are made. But the Ideal State map of an individual process can only be accomplished in further reference to an ideal state framework of the PD process as a whole. As Schmidt states, the biggest obstacle in extending the application of Lean principles beyond manufacturing currently appears to be that of a robust [ideal] state vision [48]. Oftentimes in process improvement exercises, changes are made without a clear sense of their intended direction.

Establishing this framework for Product Development weighs so heavily on the success of the improvement efforts because it provides the reference point by which improvement measures are evaluated. The framework will aid in the determination of whether a certain activity within the individual process is value-added, or whether it could be accomplished in a more effective manner. Questions can be posited concerning how well an activity contributes to the “what, how, and why” of the build-to-package, or how it could contribute more effectively.

When improving PD processes, hold them to the measure of how well they agree with, and accomplish, the Lean PD framework you develop. This test will facilitate creating the vision of the Ideal State of the specific process you wish to improve, in light of the Ideal State of the entire Lean PD process. This Ideal State map is the supposed perfect implementation of Lean business ideals and principles applied to your specific product and associated process, and this state of the process should be mapped within the projected context of a coherent and comprehensive Lean enterprise, no matter where your company may currently sit.

Figure 41 below provides a high-level picture for a possible Lean Product Development framework. Alternate process frameworks include the LAI PD Team pyramid representation, the Ulrich and Eppinger framework, and the MIT Product Development Design Decomposition (PD³), which provide similar and foundational perspectives of the PD process [41,26,1].

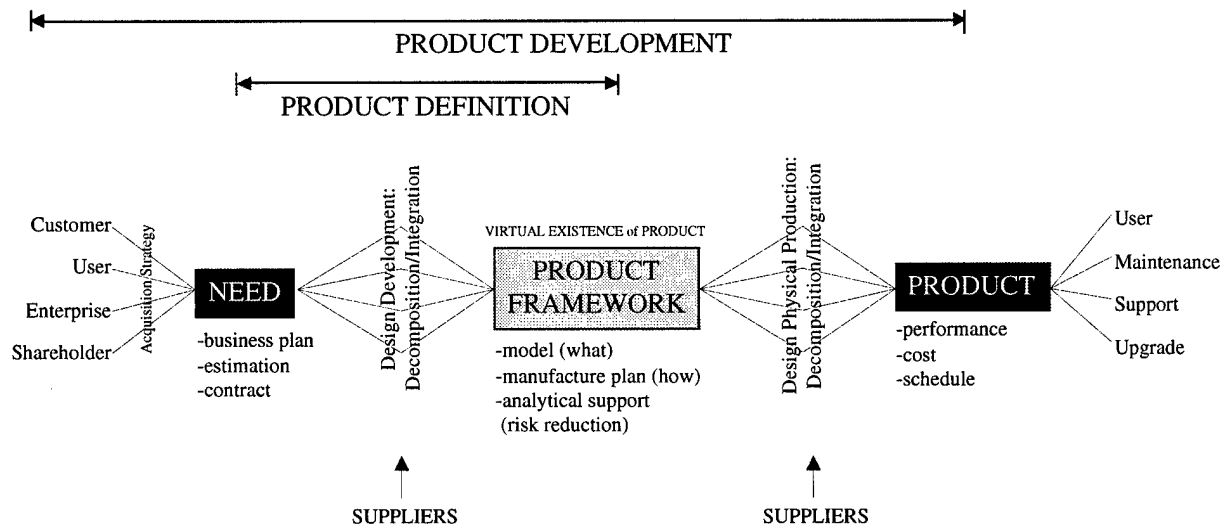

Figure 41. Lean Product Development Framework

The framework illustrated in the above figure shows the flow of business practices between the earliest of market and stakeholder identification through to the use and support of the product. The flow first shows various stakeholder inputs into an acquisition strategy. This acquisition strategy may then continue on to define an explicit definition of *need* within the marketplace, and a business strategy to fulfill that need. Upon initiation of the business plan, the design activities are decomposed to maximize resources use and minimize time required, and then integrated for design cohesion. Suppliers may provide a portion of this design work, and are thus shown to provide input to the system. The design efforts culminate in the delivery of the *product framework*, which is an existence of the product in a virtual form. This virtual product includes all necessary information for what to build, how to build it, as well as support for why to build it. As with the design activities, the physical manufacturing of the product then includes decomposition and integration of efforts, to include the input of suppliers. The manufacturing activities culminate with the delivery of a *product* with specific performance, cost, and schedule attributes which will or will not be accepted by those who must buy, use, support, or upgrade the product.

The framework defines Product Development as the set of activities between market and stakeholder identification through full-rate manufacture of the product. A subset of these activities is Product Definition, where much of the engineering and design takes place. This phase includes the activities from program initiation to delivery of the virtual product.

In the Lean PD framework presented, each phase of the process occurs sequentially, and customers require this in many cases. However, Lean principle suggests that concurrent completion of activities, where possible, can cut time and money required to complete a process by incredible margins. The activities may, in fact, exhibit greatest efficiency and quality when moving from the relatively sequential Lean PD framework presented above, toward a framework more like the one illustrated simply in Figure 42 below.

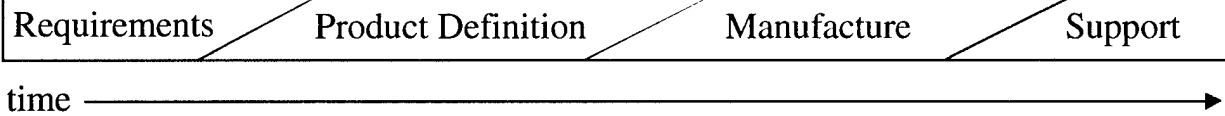

Figure 42. Concurrent Lean PD Framework

The more concurrent PD idea suggests that each successive phase of the PD process blends with the surrounding phases. For example, manufacture of some of the more stable parts of the design may begin before the completion of the entire design. Proper execution of these blended phases would rightly require a highly capable workforce within a highly dynamic task environment.

The Ideal State map of the example is shown below in Figure 43. Many of the process steps have been condensed into integrated analysis, made possible with integrated information and analysis systems. Internal computer iteration speeds up the process considerably, which allows for many more preliminary configurations to be explored. This requires an integration of databases and analysis systems that describe design capabilities, manufacturing capabilities, materials properties, and resource planning. Web-based environments and electronic information pull systems allow for efficiency and flexibility not possible with past PD systems. Several U.S. aerospace companies have begun development of this type of integrated data system, utilizing object oriented programming or networked real-time information systems.

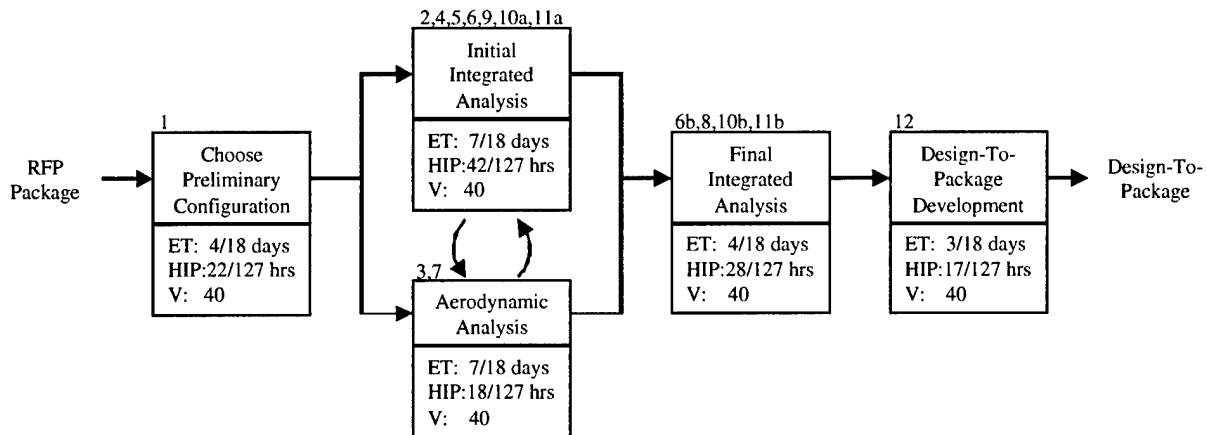

Figure 43. Example Ideal State Process Flow Map

The DSM of the example’s Ideal State, shown in Figure 44 below, depicts the integration of the steps with full communication within blocks of iteration.

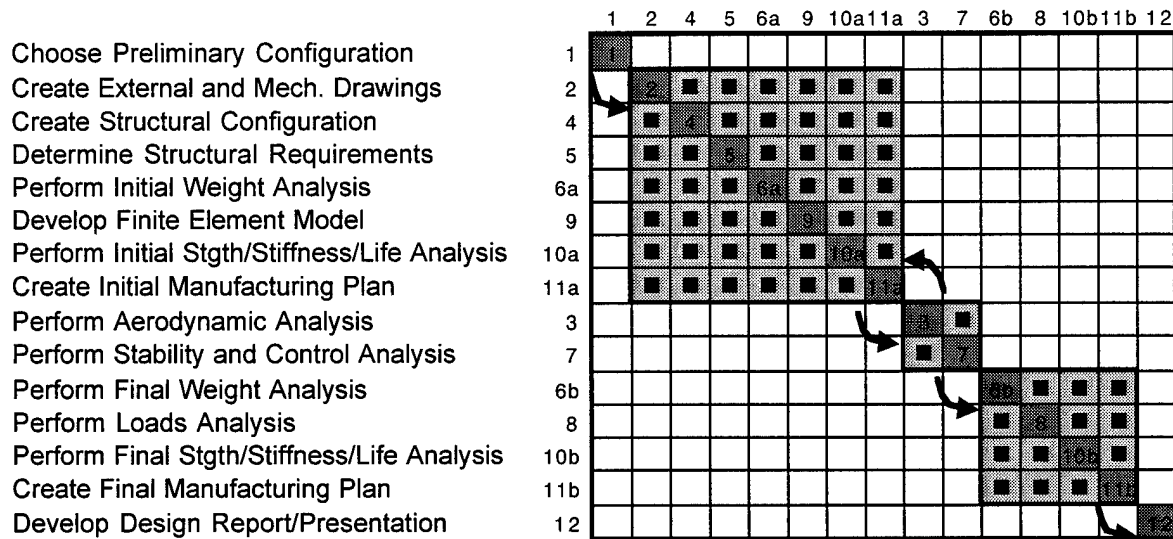

Figure 44. Example Ideal State DSM- Expanded

This expanded DSM is condensed in Figure 45 below.

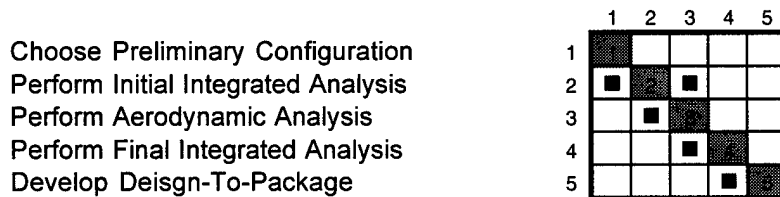

Figure 45. Example Ideal State DSM- Condensed

6.3 Analysis and Mapping Follow-up

The Future State Map can now serve to communicate the new process to others and provide the blueprint for its implementation. There exist several concerns and pitfalls, however, that must first be addressed in order to successfully implement the new process. These concerns and pitfalls have been commonly communicated in aerospace industry lessons learned. There are also considerations to be made for the continued sophistication of the VSA/M method used and continued improvement of the processes it is applied to.

6.3.1 VSA/M Step 6: Implement New Process

Perhaps the most significant concern is the implementation of an improvement plan that creates a locally optimized Future State process at the cost of global suboptimization. This phenomenon of improving the shortsighted view of things at the cost of the larger system is how a lot of the

inefficient processes developed in the first place. Another area for concern lies in the motivation behind the improvement effort. Organizations that enact Lean efforts simply to satisfy an invested party or short-term goal can leave everyone involved with a paralyzed impression of the entire philosophy. Lean for the sake of Lean, and not actual improvement, leads an army into battle without actually wanting to win the war.

Organizations using Lean to improve their processes have also encountered some pitfalls creating no small amount of difficulty in the improvement effort. Non-implementation of VSA/M results can occur when those potentially affected by the changes either do not trust the plan's benefit, or do not take the time to make the changes. Information wastes can create so much data and disjointed analysis that the meaningful ideas and opportunities get lost in the noise. Lack of coordination or communication surrounding Lean VSA/M efforts can leave the improvement effort without the required resources and authority, or isolate the various efforts beyond potential synergy and common direction. And the classic cultural barriers to Lean, some of which are listed below, may serve to inhibit the resolution of improvements necessary for the survival of the company [33]:

- Dismissal of Lean principles just another ineffectual management fad
- Fear of losing personal advantages gained through the old system
- Misconceptions that the objective of lean initiatives is to lay-off as many employees as possible
- General resistance to change due to lethargy or fear of the unknown
- Justified concern that participation in lean improvement activities may mean cutting out your own or your colleague's job
- Lack of education concerning the applicability of Lean across social and industrial cultures
- Organizational incompatibility to Lean principles
- Non-Lean customer requirements
- Lack of sustained support for improvement activities
- Unwillingness to meet risk of investing resources for long-term gain
- Management disassociation due to risk or lack of priority
- Lack of incentive for participation in improvement activities

- Haphazard implementation or “Hero Culture”

Other areas where previous Value Stream improvement efforts have noted lesson learned include the mistake of mapping the high-level process only, to where the analysis does not go deep enough to uncover the wasteful interactions or other opportunities for improvement. The entire high-level process is often seen as value-added, and to end the VSA/M exercise here usually does not prove as beneficial as expected. Also, analyzing a process without first defining the bounds or other important elements of its Value Stream can leave an improvement team in confusion as to what they are trying to improve. The process can become a “moving target” based on the conflicting opinions of team members, or at the least, a rather obscured target. Similarly, frustration arises when the improvement team does not have the benefit of working with a goal or vision for the Ideal State of the company’s overall PD system or specific process. When this is the case, the team does not know by what reference they should improve their process toward. As mentioned earlier, this may be one of the most significant hurdles PD improvement efforts currently face. Finally, the effective mapping of a Value Stream necessarily requires a certain level of understanding in order to know what best to enter on the map, and then to discern what the map shows. Mapping a Value Stream without the intention to gain an adequate understanding through supporting analysis can only reap proof of the map’s lack of human intelligence.

6.3.2 VSA/M Step 7: Continuous Improvement

As framed by the document basis presented earlier, this improvement method seeks to address both the top-down creation of value (doing what is good) and the bottom-up removal of waste (continuous improvement). In terms specific to the application of VSA/M, the method seeks to address both dramatic “clean-sheet” process redesign efforts, and “incremental” process improvements.

As shown in the previous VSA/M scheme diagram (Figure 29), the improvement of both the process and product can take place for the life of the Product Development organization. The increasing sophistication of Value Stream Maps through successive iterations of VSA and VSM can find analogy in the idea of general knowledge of a subject. A person first hears of a topic,

then learns a something about it, becomes more interested so that the learning continues, learns its technical usage, understands the topic well enough to teach it, and then understands the nature of the topic well enough to advance its meaning. The dramatic change in the analogy, and the crux of VSA/M, lies in the transition to understanding. In reaching this understanding, Levels 4 and 5 of the analysis and mapping sophistication should be accounted for.

Consideration of time includes analysis of the time required to complete a task in relation to the remainder of the process and system. This analysis also includes consideration of the Value Stream in relation to the customer, supplier, technology, business, and social cycles. The previously collected time metrics will aid in the analysis and further development of this level of mapping. See the discussion of time consideration and the associated cycles as mentioned by *Learning To See* and the Ward Value Stream Method [47, 53].

Observation and analysis of the “Real” flow cannot be accounted for on the Value Stream Map, but rather involves an intimate and applied understanding of the process. As the Figure 46 below depicts, despite the attempt of tools to generate any number of pictures of the process, the greatest potential in improving a process comes from real understanding of the flow through a process-- that which cannot be fully captured through documentation.

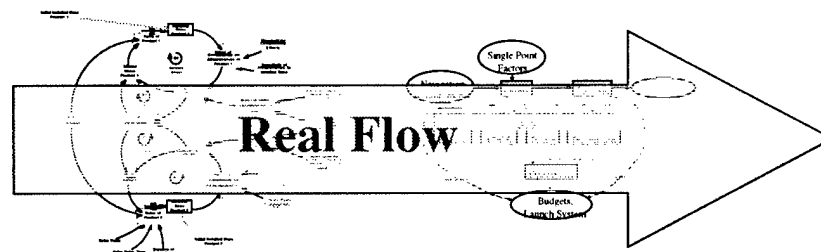

Figure 46. Real Flow Illustration

The concept of the “Real” flow finds its ties to the development of the ideal Product Development framework mentioned in the Ideal State discussion. The “Real” flow attempts to capture the significance and application of the idea that “the whole system is greater than the sum of its processes.”

7.0 Conclusions and Recommendations

This thesis explored the concept of Value Stream Analysis and Mapping (VSA/M) as applied to Product Development efforts. Its three sections discussed the background and exploration of VSA/M, a report of the current VSA/M practices within the U.S. aerospace industry, and the proposal of a general VSA/M method for Product Development activities.

Value Stream Analysis and Mapping is a method used for business process and product improvement, which originated with the development of the Lean business philosophy. In relation to this thesis, Value Stream Analysis can be defined as *a method by which managers and engineers seek to increase the understanding of their company's development efforts for the sake of improving such efforts*. Value Stream Mapping can be defined as *the method by which the outcomes of Value Stream Analysis are depicted or illustrated*.

7.1 VSA/M Background Summary

The VSA/M background section included a brief history of the concept as described in foundational Lean literature. As with Lean practices in general, the application of VSA/M began in the manufacturing community, where it has seen dramatic results. The engineering and design efforts of Product Development provide a different setting for the use of VSA/M, but several Lean practices have shown initial applicability to PD efforts. The Product Development Team at MIT's Lean Aerospace Initiative has worked to translate the Lean principles of **value**, **value stream**, **flow**, **pull**, **perfection**, **waste**, and **people**, to the analysis of PD activities. Other documented sources also offer supporting literature and tools for the application of these principles to existing design processes.

Several applications of VSA/M to Product Development processes have been documented within industry, which have exhibited the remarkable potential of the method to enhance processes. Several key questions still existed, however, as to the distinguishing nature of VSA/M when used for PD. To address several of these questions, site visits were made to nine major U.S. aerospace industry Product Development organizations. Interviews, discussions, and participatory events were used to gather the research data, which focused on (1) the tools used in VSA/M efforts, (2)

the business context surrounding the use of the tools, and (3) the motivation and success in completing the VSA/M efforts.

7.2 VSA/M Current Practices Results

The second section, which reports on the current VSA/M practices within the U.S. aerospace industry, used the research data to develop the relationships between VSA/M tool, context, and success. The themes and hypotheses that emerged from the data analysis were supported through quantification and variable correlations. The six different VSA/M tools used at the sites were characterized and ranked in sophistication. This ranking was based on the ability of the tool to support *analysis* of the process, rather than the ability to *represent* the process.

The business context surrounding the use of the tools was also characterized and ranked. Three groupings of context emerged from this ranking: Group A included those sites with a more traditional approach to Product Development; Group B, those in the midst of integrating the traditional methods with more Lean methods; and Group C included those sites currently developing a comprehensive Lean PD environment.

The quantified correlations of the VSA/M tool sophistication, surrounding business context, and VSA/M success support of the following observations:

1. VSA/M tool sophistication and use correlates with the success of the improvement effort, and
2. The context surrounding the tool use correlates with the selection and sophistication of tool use.

Although the small sample size does not allow statistical significance to be ascribed to these conclusions, they support the observations that both a good tool and a strong Lean context are necessary to generate success in Lean improvement efforts.

7.3 Proposed VSA/M Method for Product Development

The third section included the proposal of a general VSA/M method for Product Development activities. The method is presented in a step-by-step tutorial format, which included an outline for implementation, a discussion of associated principles, and the application of selected tools.

The method followed a pattern of analyzing and mapping the Current State of a process, and using heuristics to analyze and map an improved Future State. The tools used to accomplish this analysis and mapping included (1) a high-level Gantt chart or Ward/LEI map, (2) a detailed-level Process Flow map, and (3) a detailed-level Design Structure Matrix.

7.4 Recommendations for Further Study

This research project focused on the exploration of VSA/M at a broad base of observation, and in only one industry. Further analysis of this topic may find benefit in the more in-depth study of VSA/M examples, using this research as background. Also, verification studies of the proposed VSA/M method are necessary to determine the efficacy of the method, and how it may be advanced.

Resource List

Business and Process Analysis

1. Bocanegra, Cesar, and Dave Cochran, *Product Development Design Decomposition (PD³)*, Production Systems Design Laboratory (<http://lean2.mit.edu>), Massachusetts Institute of Technology, March 2001.
2. Boppe, Charles, *Aerospace Product Design*, 16.870 Course Material, Massachusetts Institute of Technology, Fall 1999.
3. Clark, Kim B, and Takahiro Fujimoto, Product Development Performance: Strategy, Organization, and Management in the World Auto Industry, Harvard Business School Press: Boston, MA, 1991.
4. Culotta, Ted, "The Promise of Value Chain Optimization," *Electron Economy*, culotta.ASCET.com.
5. Danilovic, Mike, *Loop: Leadership and Organization of Integration in Product Development*, Doctoral Thesis 40, Linköping University Institute of Technology, Sweden, 1999.
6. European Meteorological Education and Training, *EuroMET Gantt Chart 1998*, <http://euromet.meteo.fr/external/info/gantt.htm>, February 2001.
7. Fine, Charles H., Clock Speed: Winning Industry Control in the Age of Temporary Advantage, Perseus Books: Reading, Massachusetts, 1998.
8. Garvin, David A., "The Processes of Organization and Management," *Sloan Management Review*, Summer 1998.
9. Gustafsson, Anders, "Conjoint Analysis: A Useful Tool in the Design Process," *Total Quality Management*, May 1999.
10. Guthenke, G. and M. Leiters, "Fast Elimination of Product Faults in Current Series," *Total Quality Management*, July 1999.
11. Hammer, Michael, and James Champy, Reengineering the Corporation: A Manifesto for Business Revolution, HarperBusiness: New York, 1993.
12. Hammer, Michael, and James Champy, The Reengineering Revolution, HarperBusiness: New York, 1995.
13. Harry, Mikel, and Richard Schroeder, Six Sigma, Currency: New York, 2000.
14. Kwahk, KY and YG Kim, "Supporting Business Process Redesign Using Cognitive Maps," *Decision Support Systems* 25, 1999.
15. Lee, Don J, and Anna C Thornton, *The Identification and Use of Key Characteristics in the Product Development Process*, ASME Design Theory and Methodology Conference, Irvine, CA, August 1996 (<http://web.mit.edu/afs/athena.mit.edu/org/c/consortia/keychar>).
16. The MIT Design Structure Matrix - DSM - Home Page, Massachusetts Institute of Technology, web.mit.edu/dsm, 2000.
17. *NASA Systems Engineering Handbook*, SP-6105, PPMI, June 1995.

18. Ould, Martyn A., Business Processes: Modelling and Analysis for Re-engineering and Improvement, John Wiley & Sons: Chichester, England, 1995.
19. *The Quality Approach*, Air Force Handbook 90-502, Online, 1 August 1996.
20. Scholtes, Peter R., The Team Handbook, Joiner Associates Inc, Madison, WI, 1991.
21. Sekine, Kenichi and Keisuke Arai, Design Team Revolution, Productivity Press: Portland, OR, 1994.
22. "Six Sigma Secrets," *Industry Week*, 2 November 1998.
23. Smith, Preston G. and Donald G. Reinertsen, Developing Products in Half the Time: New Rules, New Tools, Second Edition, John Wiley & Sons, Inc: New York, 1998.
24. Sterman, John D., Business Dynamics: Systems Thinking and Modeling for a Complex World, Irwin/McGraw-Hill, Draft, Winter 2000.
25. Tschirky, Hugo P., *Bringing Technology Into Management: The Call From Reality*, Swiss Federal Institute of Technology (ETH), www.tim.ethz.ch, MIT Management of Technology Seminar, Cambridge, MA, April 2000.
26. Ulrich, Karl T, and Steven D. Eppinger, Product Design and Development, Second Edition, Irwin McGraw-Hill: Boston, 2000.
27. Wertz, James R. and Wiley J. Larson, Space Mission Analysis and Design, Third Edition, Microcosm Press: Torrance, CA, 1999.

Lean Principles and Application

28. Bicheno, John, "Automotive Value Stream Mapping," Lean Enterprise Research Centre, Cardiff Business School, 1998.
29. Browning, Tyson R., *Modeling and Analyzing Cost, Schedule, and Performance in Complex System Product Development*, Doctoral Thesis, Massachusetts Institute of Technology, December 1998.
30. Browning, Tyson R., *Systematic IPT Integration in Lean Development Programs*, Masters Thesis, Massachusetts Institute of Technology, June 1996.
31. Browning, Tyson R., Deyst, Eppinger, and Whitney, *Complex System Product Development: Adding Value by Creating Information and Reducing Risk*, LAI White Paper 99-03, December 1999.
32. Chase, James P., *Measuring Value in Product Development*, Lean Aerospace Initiative Working Paper WP00-05 (and pending thesis), Massachusetts Institute of Technology, 2001.
33. *Cultural Barriers to Lean*, MIT Lean Aerospace Initiative Product Development Focus Team, Summer Workshop, July 1999.
34. Harmon, Ed, *Ideas On Identifying the Product Development Value Stream*, Northrop Grumman, February 1998.
35. Higginson, Jonathan E, *Mapping Value Creation in Research and Development*, Masters Thesis, Massachusetts Institute of Technology, June 1997.
36. Hines, Peter, et al, "Value Stream Management," *International Journal of Logistics Management*, Ponte Vedra Beach, 1998.

37. LAI Product Development Value Stream Workshop, *PD Flow*, July 1999.
38. LAI Product Development Value Stream Workshop, *Summary Presentation*, August 1998.
39. *The Lean Enterprise Model: Summary Chart With Enabling Practices*, Lean Aerospace Initiative, lean.mit.edu, July 1998.
40. Masotto, Tom K, *Managing New Product Development to Create Sustained Business Value*, Masters Thesis, Massachusetts Institute of Technology, May 1992.
41. McManus, Hugh, *A Framework for Lean Engineering*, MIT Lean Aerospace Initiative Product Development Focus Team, March 1999.
42. McManus, Hugh, *Outputs of the Winter 2000 Workshop on Mapping the Product Development Value Stream*, MIT Lean Aerospace Initiative Working Paper, WP00-02, January 2000.
43. McManus, Hugh, *Seeing and Improving the Product Development Value Stream*, Lean Aerospace Initiative Executive Board Roundtable Briefing and associated discussion, June 2000.
44. MIT Lean Aerospace Initiative Product Development Focus Team, *Identifying the Value Stream in Product Development*, MIT LAI White Paper 41, July 1998.
45. Pepin, Michael P., *An Investigation of the Enablers and Inhibitors to Achieving a Shorter cycle Product Development System*, Masters Thesis, Massachusetts Institute of Technology, December 1999.
46. Perschbacher, Philip J, *Value Stream Analysis of IPT's and the Test/Certification Phase of Product Development*, Masters Thesis, Massachusetts Institute of Technology, February 2000.
47. Rother, Mike and John Shook, *Learning To See: Value Stream Mapping to Add Value and Eliminate Muda*, Lean Enterprise Institute: Brookline, MA, 1999.
48. Schmidt, Marc Anthony, *Application of Lean Principles to an Enterprise Value Stream: A Lean Analysis of an Automotive Fuel System Development Process*, Masters Thesis, Massachusetts Institute of Technology, January 2000.
49. Slack, Robert A., *The Application of Lean Principles to the Military Aerospace Product Development Process*, Masters Thesis, Massachusetts Institute of Technology, December 1998.
50. Spear, Steven and H. Kent Brown, "Decoding the DNA of the Toyota Production System," *Harvard Business Review*, September-October 1999.
51. Trischler, William E., Understanding and Applying Value-Added Assessment: Eliminating Business Process Waste, ASQC Quality Press: Milwaukee, Wisconsin, 1996.
52. Walton, Myles A., *Strategies for Lean Product Development*, MIT Lean Aerospace Initiative Working Paper 99-01, January 1999.
53. Ward, Allen C., *Value Stream Mapping for Product and Process Development*, Ward Synthesis, Inc., Ypsilanti, MI, 2000.
54. Womack, James P and Daniel T. Jones, Lean Thinking, Simon & Schuster: New York, NY, 1996.
55. Womack, James P, Daniel T. Jones, and Daniel Roos, The Machine That Changed the World, Harper Perennial: New York, NY, 1992.

Industry VSA/M Implementation

56. Continental Design & Engineering, *Lean Manufacturing Results*, www.continental-design.com, February 2001.
57. Goodman, Gary, *F-16 Lean Build-To-Package Support Center Process*, Lockheed Martin, LAI Product Development Team Winter Workshop, January 2000.
58. Miller, Craig, *Value Stream Mapping*, Northrop-Grumman, Lean Aerospace Initiative Meeting, September 1999.
59. Miller, Jeanine, *Value Stream Analysis Applied to the Product Development Process*, Aerojet, LAI Product Development Team Winter Workshop, January 2000.
60. Pitstick, James O., *F-22 SPO: On the Road to Lean*, F-22 Systems Program Office, Lean Aerospace Initiative Executive Board Roundtable Briefing, June 2000.
61. McManus, Hugh, *Identifying the Product Development Value Stream*, Lean Aerospace Initiative Plenary Workshop, October 1998.

This page left intentionally blank.

Appendix A: Corollary Process Improvement Methods

A.1 System Dynamics

The emphasis of systems thinking within VSA/M draws heavily on the ideas of System Dynamics, where displacement of even the smallest factor within a system can be shown to dramatically impact the overall system outcome. Before any of these factors are altered, the effect on the system as a whole should be taken into account. System Dynamics uses modeling of critical factors through stocks and flows, to set up analysis far too computationally intricate for a person to accurately perform in real time [24]. Choosing the right critical factors to model requires a good deal of initial understanding, however, and the method lives or dies by how well these factors and their interactions are chosen. When mapped out, the stocks and flows of a system form a cognitive map where the nature and strength of relationships between factors are described. The strength of System Dynamics modeling has traditionally rested with its ability to aid with strategic decision making, though, and not the improvement of business processes [14].

A.2 Six Sigma

This method provides a way to monitor and recreate processes with the aim of reducing defects to a “six sigma” level, or 3.4 defects per million opportunities [13]. The methodology includes phases that identify, characterize, optimize, and institutionalize processes. By applying these steps, Six Sigma attempts to allow process improvement decisions based on objective data rather than subjective sense or feel [13]. The data collection requires monitoring and quantification of practices through the use of metrics, and it uses these metrics to prevent the processes from generating defects in the first place. The method does not suggest a particular method to map a process for improvement analysis, but acknowledges the utility of many of the common analysis and mapping tools.

Six Sigma has traditionally found its success within manufacturing operations improvements, but several companies have pushed to incorporate more and more of the method’s philosophy into their PD efforts. Strict application of ideas such as maintaining a certain number of defects does not apply as well to engineering, but other facets of the philosophy have received acceptance, such as applying statistical methods to define and control design tasks. The more traditional

sense of Six Sigma does not always apply because design efforts often require variation as part of the output, do not follow repeatable paths, and do not always consider non-selected design concepts as failures or defects. However, the improvement philosophy also includes principles on more commonly applicable concepts, such as concurrent engineering, multifunctional teaming, program management, active inclusion of the customer, design to cut cycle time, design for quality, and creating value for the customer [22]. Because many of these ideas do share common roots with the Lean philosophy, several companies have begun the integration of Six Sigma tools and quantification ideas into their Lean business transition.

A.3 Total Quality Management

The focus within Lean VSA/M to improve the quality produced by a process also provides foundation for efforts within the quality movement, and Total Quality Management (TQM) in particular. TQM does not necessarily endorse the use of a specific mapping tool in process improvement activities, but rather places greater emphasis on statistical and control point analysis. These tools are implemented in the effort to gain process control and incrementally increase the quality produced by a process [8]. The TQM improvement scheme naturally develops the Deming Cycle depicted in Figure 47.

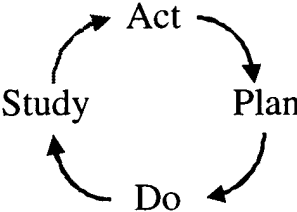

Figure 47. Deming Cycle [19]

Managers first determine how a process can be measured, assure its stability, and then follow up by monitoring the process once improvements are implemented. Lessons learned from monitoring the new process are applied in the next cycle, and hopefully the quality produced by the process will continually increase throughout the life of the process. Deming also proposed that a process flow map can aid these improvement efforts by exposing areas of low quality: duplication, unnecessary tasks, illogical or insufficient sequencing, complexity, unclear lines of responsibility, opportunities for error, impact of supplier inputs, inconsistencies, and disconnects [18].

As with the application of Six Sigma to Product Development practices, TQM requires finding the balance between the application of process control and allowing creativity and ingenuity in engineering tasks. The Act-Plan-Do-Study loop may not provide as much benefit in the unique and non-repeatable aspects of design, but adding visualization and rigor to the more baseline tasks can result in more professional and effective design operations. Using value quantification like Quality Function Deployment (QFD) and other conjoint analysis techniques, in association with the correct databases, can aid managers in overseeing and improving engineering processes [9, 10]

A.4 Process Re-engineering

Lean-based VSA/M and Business Process Re-engineering share many ideas about the need for change in business practices, but diverge in some of the fundamental ideas about how to change those practices. Both VSA/M and Re-engineering look to process-based analysis to improve business practices and product quality. Processes provide an effective, intermediate level of analysis between the “forest” of strategic analysis the “trees” of detailed tasks [8]. Both methods also assert that redesign of processes holds dramatic potential to generate improvements, and that these gains may require radical change from the current processes [11, 12]. Both also share many of the heuristics used to base improvement ideas upon, such as simplification, concurrency, and efficient communication. However, VSA/M utilizes Lean-based principles to realize these improvements, whereas Process Re-engineering relies heavily on the implementation of information technology methods and tools [8].

Where VSA/M first looks to analyze the current state of the process to enable the improvement of that process, Re-engineering does not suggest the same level of benefit in examining the current process. Rather, it suggests “radical and rulebreaking revolution” in the way businesses operate, and not merely improvement upon current processes [11]. Finding an end-state vision in the Re-engineering literature, or point of reference by which to improve these processes is difficult though, which has led to some frustration with the implementation of the method. Re-engineering also notes the importance of conveying understanding of the improvements to

everyone in the organization, but does not direct a visual technique by which to depict the new process.

A.5 Systems Engineering

Systems Engineering provides the set of ideas perhaps most closely tied to Lean-based VSA/M of all the corollary improvement methods. Engineers have traditionally used these ideas in the design of physical architectures, but with the introduction of advanced electronics have also extrapolated them to the development of informational systems. The tools used in the method have thus been created with the design of a product in mind, rather than the improvement of a business process, but many of these tools have been tailored for the latter purpose. Analysis and mapping tools to include Quality Function Deployment, context maps, inputs/output maps, Axiomatic Design Analysis, system architecture maps, and Design Structure Matrices (or N^2 Diagrams) all allow a system designer greater insight into the design of a product or process [2,17,19,27].

Analysis at the so-called “fuzzy front end” of Systems Engineering involves translating customer desires into the product’s technical requirements through such tools as QFD [2]. These tools along with context or input/output maps help to define what functions the product should perform. Methods such as Axiomatic Design then aid in the translation of product functions to specific design choices. System architecture maps help to define the interaction between the physical design choices and their overall outcome. DSMs or N^2 diagrams can then help to clarify and optimize the system [16,29,31]. A sample map of this process is included below in Figure 48, which has been adapted from a MIL-STD-499B draft [2]. The figure summarizes the phases of (1) defining the system context, (2) defining system behavior, and (3) designing the structure/architecture.

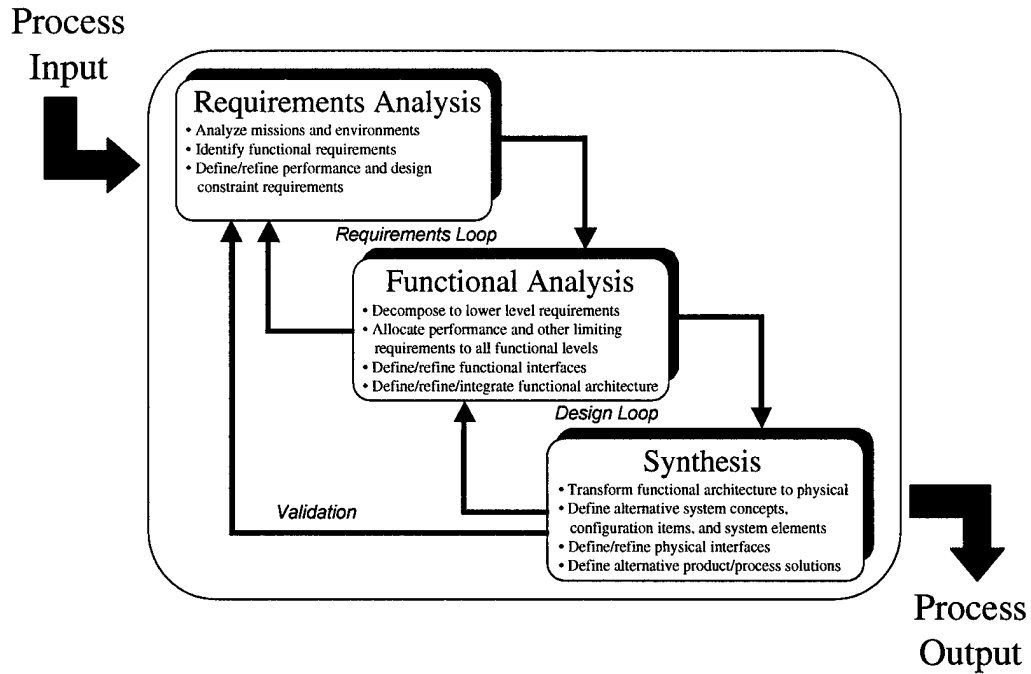

Figure 48. Systems Engineering Framework [2]

This page left intentionally blank.

Appendix B: DSM Supplemental Information

Taken from *Systematic IPT Integration in Lean Development Programs* by T. Browning, 1996 [30].

A Design Structure Matrix (DSM) consists of a matrix in which system elements, tasks, or teams are listed down the left side (one per row) with an associated letter or number. See Figure 49 below for an example DSM for the development of a new soda bottle, where here the key tasks in such a program are listed. An “X” in the matrix signifies an interaction—here, an information flow between two tasks. Marks below the diagonal imply a “feed-forward” flow of information (e.g., task A must provide information to tasks B, C, D, E, and I); marks above the diagonal note feedback information (e.g., completion of task B requires [or depends on] information from tasks C, D, F, H, and I). Hence, interactions in a sequential task DSM proceed in a counter-clockwise direction. Reading across a row reveals the sources of inputs to a task; reading down a column indicates where the outputs of a task must go (the “sinks”).

	A	B	C	D	E	F	G	H	I
Perform Market Research	A								
Select Bottle Material	x	B	x	x		x		x	x
Design Bottle Shape	x	x	C		x	x		x	x
Select Cap Material	x	x		D	x		x	x	x
Detail Cap Geometry	x		x	x	E		x	x	x
Develop Bottle Mold		x	x			F			
Design Cap Mfg. Process				x	x		G		
Layout Assembly Process		x	x	x	x			H	
Test Cap Sealing	x		x		x				I

Figure 49. DSM Example—Development of a New Soda Bottle

Figure 50 below shows a simple example of a DSM used to reorganize teams. Here teams one through four are reorganized based on the information that flows between them, symbolized by an “X” in the matrix. Reading across a row of the DSM indicates which other teams the team in that row *depends* on for information; reading down a column shows which other teams the team in that column *provides* information to. Rearranging the DSM as in the right side of Figure 50

shows that teams one and four are best grouped together (perhaps as a system team), as are teams two and three.

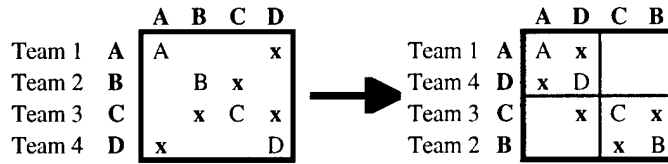

Figure 50. Example of an Information Flow DSM, Partitioned to Show Reorganization

The DSM has several close relatives in the systems engineering world. In some ways, it is similar to the “roof” of the House of Quality (in QFD) or an N^2 diagram. The DSM approach can be utilized on several levels, including the component level (where it resembles some of the latter levels of a QFD approach), the system level, and the task level; it can also model communication, scheduling, and risk.

Appendix C: Interview Guide

Rich Millard

LEAN AEROSPACE INITIATIVE

JUNE 14, 2000

“Value Stream Mapping Methods and Tools for Product Development” Site Visit Objectives & Interview Guide

This interview is designed specifically to characterize the use of Value Stream Mapping through both methods and their associated tools. This study is part of an on-going research project by a consortium involving the U.S. Air Force, a number of firms in the defense aerospace sector, and the Massachusetts Institute of Technology. The research projects focus on the investigation of the application of "Lean" practices in the defense aerospace industry. Your cooperation is vital to the success of this study. Please answer the questions as they apply to you. Answering of the questions is voluntary. You are not obligated to answer any question. If you are uncomfortable with any question, or feel in any way coerced or pressured into participating in the survey or any part of it, you may decline to answer any or all questions. Your decision to decline to answer a question will be treated with the same confidentiality as positive answers. The interview should take no more than 50 to 60 minutes to complete.

Please be candid and honest in your responses. We understand that you may have concerns about confidentiality. The interview is intended to be anonymous and several measures will be taken to ensure that your responses will remain confidential. Only the researchers named below will have access to the information requested in this interview. All analyses and reviews of the data will be presented in the form of aggregated statistics. No individuals or individual programs will be identified in the analysis, reviews, or reporting of the responses. We understand that the success of any research depends upon the quality of the information on which it is based, and we take seriously our responsibility to ensure that any information you entrust to us will be protected.

Research Team: Dr. Hugh McManus (MIT), Rich Millard (MIT), LAI Product Development Team (MIT).

Introduction

1. Confirm reception of background information, give a brief description of research, and note disclosure policy.

Background

2. Could you briefly describe your company's position (health, service) in the aerospace industry? How has the introduction of Lean affected your company?
3. Could you briefly describe your role/contribution in the product development process? What organization or product are you attached to? Who do you report to?

Value Stream Analysis (VSA) Description

4. Does your organization plan or analyze the steps taken in the PD process? What do you call it? How often is this performed?
5. What does your analysis focus on (i.e. tasks, information, processes, data, product/material)?

6. Does your analysis include considerations for **a)** schedule **b)** cost **c)** risk **d)** quality (review)? How? What is their prioritization within the analysis?
7. What are the boundaries of your analysis? What do you start with? Who is your customer? What do you give them? Is your PD value stream tied into other streams (enterprise, manufacturing, customer/supplier)?

VSA Execution

8. At what level is VSA done—is it lead by function/programs? Who performs the analysis? Does anyone on the VSA team have an overall systems perspective?
9. Are the **a)** suppliers **b)** customer(s) involved in the VSA? How?
10. Do you use an explicit definition of how to best improve the product (value definition)? Is it tracked along the product development process?

VSA Outcomes

11. Why are you interested in VSA? What is your motivation-- what do you hope to achieve through VSA (qualitatively/quantitatively)?
12. Have you found VSA/M to be useful/effective? Why? Is there any cost-benefit analysis tied to your VSA/M efforts (or example of direct comparison between programs with and without VSA)?

Tools

13. What tools do you use in your VSA efforts? What data do they collect? How do these tools help in the VSA efforts?
14. How do the current tools/methods compare to any previous VSA efforts?
15. How do the current tools/methods compare to any future VSA plans? Are there plans to standardize the analysis across programs/functions?
16. What are the shortcomings of current VSA tools/methods? Where are the greatest opportunities for improvement (what would best help plan out or analyze the PD process in your organization)?

Documents

17. What are your company's sources (consultation, literature, conferences) for your VSA/M methods/tools?

18. Would it be possible to view/obtain any documents/mappings/tools related to the above questions?

Wrap-up

19. Do you have any questions regarding this research? Are there any suggestions you would like to make?

20. Would you like to be updated on this research project?

21. Contact Information

Name: _____

Organization: _____

Phone: _____

Email: _____

Thank you for your participation.

This page left intentionally blank.

Appendix D: Case Study Results

D.1 Site 1

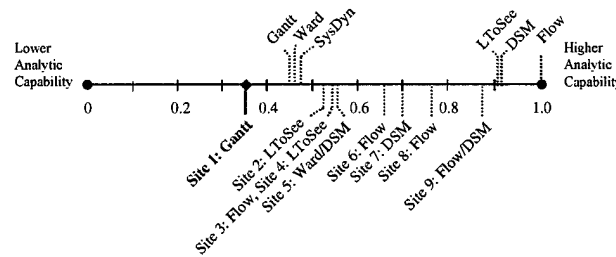

Background: A new push beyond a previous initiative that suffered some disappointments and failures focuses on developing new products in a more integrated manner, using shared tools. The previous initiative, in effect, kept the same organizational structure and processes, but required the processes to be accomplished in less time and with less money. Some functions in the PD process were discarded, which led to several serious problems. The new initiative aims to fit the current projects into the surrounding socio-political environment of reduced budget, increased competition for funding, openness of information, and consideration of value for the paying customer.

VSA/M Practices: The site relies heavily on systems engineering. Process improvements do occur, but not based on explicit Lean principle. In fact, much of the changes are performed in an ad-hoc manner. Process planning centers on the project manager, who leads by deliverables and gateway review deadlines. Scheduling tools, such as the Gantt chart shown previously in Figure 8, are often used to communicate and track the program tasks and milestones. This type of mapping focuses mainly on *representing* the process as is, but can also offer assistance with analysis of *how to do* things with respect to time. The chart provides a good representation of processes by including task durations, start/stop times, and milestones, but lacks the ability to breakdown the flow of a process. For this reason, the tool as used here was placed low on the plot of analytic maturity.

The new initiative aiming to improve process planning seeks to aid projects in 1) requirements development, 2) project plans, 3) risk assessment, and 4) cost analysis. Top management launched the new initiative in the attempt to improve sharing of resources and knowledge, and to increase standardization of the planning process. The initiative focuses on human resources, processes, and quite heavily on tools in order to help make a project better, faster, and cheaper, if possible. Some current sentiment arises that maybe to make a project better, faster, and cheaper is not possible however, and that projects should strive for any two of the three.

Critique of Practices (Scale: Introductory-Intermediate-Advanced)

Fidelity to Lean Principles: Introductory. Much of the systems engineering work is very advanced, but not all of it is codified or standardized. Much of the work done is compartmentalized and often unnecessarily repeated. Systems engineering often creates a great deal of data and information about a product or process, but does not give necessary theory as to what it means or how to improve the product or process. As one engineer stated, the humans are still the “weak link” in these efforts. The current systems engineering framework creates a project plan which includes a “hodge-podge” of processes, standards, and other project

requirements. Decisions are still made largely through experiential knowledge and mentorship, without standardized planning or analysis.

Level of VSA/M Maturity: Introductory. Much of the project planning still resides with the project manager who leads from the required receivables/deliverables and required government reviews. However, in a push consistent with Lean principles, the site is trying to include more of their cooperation and supplier base into their planning. The new initiative to improve the Product Development process places heavy emphasis on the tools that are used within the Value Stream. Much of this effort involves deciding the value of each tool, updating tools, and coordinating resources. There exists some sentiment at the site that they should wait until the better-faster-cheaper motivation stabilizes and matures before they can implement planning and tracking of their projects in a methodical manner.

Noteworthy Practices: The site exhibited an acclaimed human resources network that, in part, supports the Product Development process.

D.2 Site 2

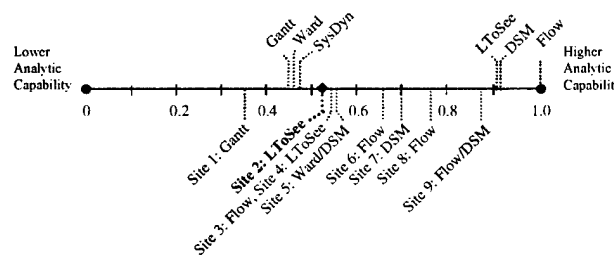

Background: This site’s PD efforts encompass several types of military products, and contribute to the development, production, and support of the various platforms. Most VSA/M and Lean efforts have focused on manufacturing, which have helped to escalate these operations to a reportedly high level of sophistication. The improvement emphasis has been placed largely on one product platform in particular, which provides their most recent large contract. They have found it much easier to incorporate Lean processes into the newer programs, which provide more of a “clean slate” to work with. Lean improvements have been used to reduce cycle time, reduce scrap and rework, and reduce sensitivity to production rate. Kaizen events are used to develop and implement these Lean improvements. However, many of those interviewed from the engineering department, like many across the industry, still find themselves unsure as to how VSM could work for PD.

VSA/M Practices: The planning for products occurs at a program level, as does the planning for many of the operations at the site. The current VSA tools include master plans that track milestones, reviews, and deliverables, and master schedules that track processes and deliverables. These tools also use Gantt charts to communicate and track the program tasks and milestones. The involvement from leadership in overseeing and tracking a project includes weekly meetings and Project Manager meetings to track metrics. These metrics are displayed with plots and spotlight charts with the motivation to increase visibility into program health and to catch problems while still correctable. These meetings then flow down to departmental/functional daily meetings where more specific metrics are tracked.

An independent attempt at VSM for PD also took place at the site, with the objective of reducing defects in computer code for aircraft avionics. This effort focused on mapping cost and quality to reduce defects, labor hours, and rework. The team relied heavily on the direct application of the *Learning To See* method. Headcount, manhours, cycle time, and documented errors were found for each step in the process, from requirements development through to software release. The team identified four main opportunities for improvement through the exercise: better program planning metrics, reduction in the multitasking of programmers, reduction in wait time between groups, and improvement of their corrective action process during testing. The team mapped only the highest-level process, and did not explicitly consider value in their analysis. Their rendering of the *Learning to See* method, as shown below in Figure 51, falls under the title “LToSee 1” on the plot of analytic maturity.

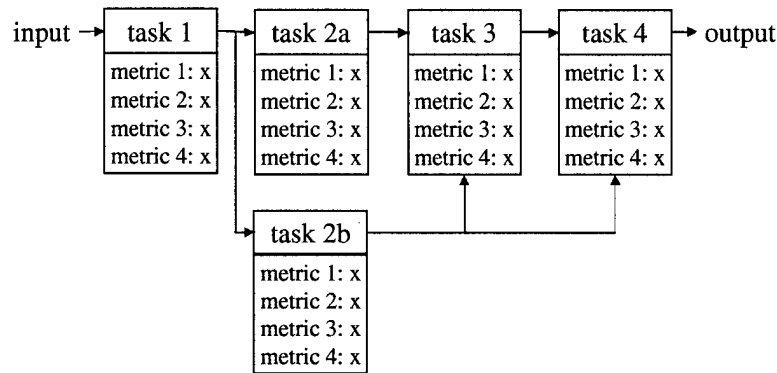

Figure 51. Learning To See Adaptation

This method of mapping does break down the flow for *analysis* and makes use of metrics to characterize each process step, but attempts to directly apply a tool tailored for analysis of manufacturing operations. As shown in the above figure, the ties to geography, so important to the analysis of physical manufacturing systems, are dropped, because they do not serve the same purpose in an electronic design environment. The product of engineering efforts, which is most often design information, can be processed simultaneously, transferred without limitation to physical movement, and most often provides a solution where there is no predetermined outcome.

Critique of Practices (Scale: Introductory-Intermediate-Advanced)

Fidelity to Lean Principles: Intermediate. Overall, Lean is seen favorably but not well understood for PD, as with many other sites. IPTs are used heavily in the newer programs, and their integration into the entire Value Stream is improving. The use of metrics is effective in tracking a program’s progress, but they can become cumbersome, especially if new metrics are added as the project develops. Also, metrics are sometimes not well understood as for causality, and thus can drive incorrect behavior. Management by metric generally does not seek to improve the process, but rather to maintain control of the process as is.

Level of VSA/M Maturity: Introductory. The master plan/schedule method is relegated to program managers to use as they see fit. There existed some sentiment that this tool does not work for management of “production programs” because the projects are now based on serial events rather than deadlines, so efficiency, cost, and schedule can suffer when managed like a

developing program. Overall, the site's projects do not currently focus on using VSA/M in as an integral and comprehensive aspect of their project management. Much of the learning at the site is passed down through "tribal knowledge," and some of the new ideas like concurrent engineering and IPTs are trying to mesh with a system that does not systematically improve processes. Rather, the system relies on the experience of the leadership and gateway reviews. The new ideas are also trying to be integrated while using legacy tools, where common and smooth information tools may prove more effective.

The independent attempt at VSM for PD provided a good initial start and foundation for further improvement efforts. The exercise did not prove as effective as hoped, but may lend greater success when more specific value analysis is included, and to a deeper level in the process. Future improvement efforts will also need to overcome the difficulties seen in bounding the analysis and generating metrics to reveal critical defect drivers. As with many of the sites, they expressed the need for further study and tool development within the application of VSA/M to Product Development efforts.

Noteworthy Practices: This site made extensive use of metrics, which can allow for useful insight into a process.

D.3 Site 3

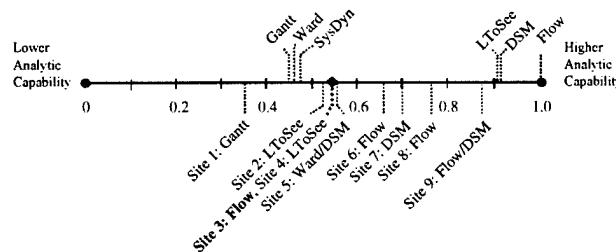

Background: This site runs a very successful weapons program according to DoD reports. This program includes somewhat of a pilot effort concerning new acquisition and planning strategies. There exists a high level focus on value and tracking the definition of value through the program, which accounts for the fact that the preceding program of a similar nature was cancelled due to overruns. The comment was made that PD is not as important with programs such as this, where around 85% of the program cost is in manufacturing as opposed to many aircraft programs where much more of the lifecycle cost includes support and maintenance.

VSA/M Practices: Much of the planning effort focused on requirements definition and choosing business partners/suppliers. Later efforts centered on creating an effective working environment with the partners. A definition of value was directed from the program manager level, which focused on cost and schedule. The program office held its customer fiscally responsible for cost of performance of the product and requirements changes. In this cost analysis, three requirements, or key performance parameters, were deemed critical while the rest were considered tradable against cost. Also, no gateway reviews were used: the program office wanted "insight" not "oversight" into the program, and used some of their own employees in the IPT system of the business partners to gain that insight. Much of the program planning came from the program manager's experiential knowledge. This program has cut headcount required by 88% compared to the preceding program, and cut cost of product by around 75%.

Some explicit mapping of the site's Value Stream did take place, but they used it mainly to *representing* the PD process for the sake of communication. The site used an adaptation of a process flow map to describe their process, and though not expressed in connection to the map, they have thoroughly applied their concept of value to each of the tasks they perform. This entry also falls under the title "Flow 1" on the scale of analytic maturity.

Critique of Practices (Scale: Introductory-Intermediate-Advanced)

Fidelity to Lean Principles: Advanced. Much of the planning was done implicitly by experience, but holds true to many Lean principles: a single fiscally responsible customer, teamwork environment across organizations, uniform visibility and trust, emphasis on front-end program planning, creating value for the customer, reducing requirements creep, focus on affordability, timeliness, and meeting or exceeding the customer's needs, explicit definition of value, tracking that definition throughout the program, using flexible supplier chains, maintaining much of the program responsibility at the contractor level, willingness to take risk, and setting high goals.

Level of VSA/M Maturity: Introductory. There was little explicit VSM was done. More emphasis was placed on getting the right people with the right experience and motivation to run the program. Much of the planning rested with the formation of IPTs, and not necessarily how all the teams fit together. However, processes were analyzed and fixed when problems arose, rather than applying a "bandaid" workaround that creates a more bureaucratic and wasteful operation.

Noteworthy Practices: This site reported high customer satisfaction with their acquisition strategy, customer/partner environment, and an innovative product warranty.

D.4 Site 4

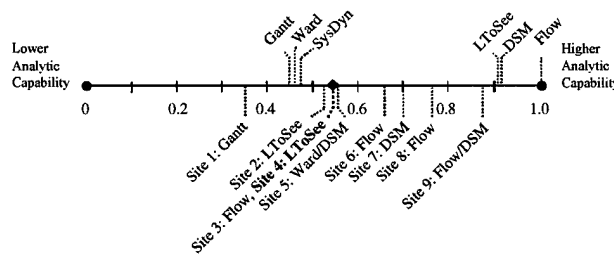

Background: This site as a whole has initiated a transition to Lean, and has reportedly taken large steps in the area of manufacturing. The company has also implemented a system of kaizen events to promote Lean education, many of which are focused on PD. The company has attempted to use these events to implement Lean changes piecemeal, in the hopes that the participants continue the transition to Lean in their own areas of responsibility.

VSA/M Practices: Many of the more traditional projects at this site still do not include explicit VSA/M in their planning, and focus instead on mistake-proofing and proper utilization of resources. The transition to Lean PD must still overcome several strong cultural barriers, and crisis usually brings fallback to the old and trusted way of doing things. Again due to military requirements, much of program planning ties tasks to required deliverables. An information development and sharing environment has been chartered to allow virtual co-location of

company and supplier engineers. Included in the new initiative is the attempt to link all aspects of the PD cycle and its deliverables into an integrated management framework: requirements, RFP, proposal, Statement of Work, Work Breakdown Structure, master plan, risk reduction plan, master schedule, and cost.

Work with several different VSM tools has been attempted. An Information Technology tool tried at the site did not gain acceptance because it could not effectively capture the iterative and complex PD processes. Powerpoint is now used to depict some rather intricate *Learning To See* maps of the Value Stream, as shown in Figure 52 below, which include some PD tasks. Again, in this direct application of the *Learning To See* method, the tool provided more for the *representation* of the PD process than *analytic* support, but does allow for some determination of *what to do* with respect to the value of tasks. The type of map shown below, which is labeled “LToSee 2” on the scale of analytic maturity, differs from the “LToSee 1” entries in the amount of information and level of detail included in the map. Also, those creating these maps feel that the ability to follow a product through its lifecycle helps to clarify the Value Stream, but they have found that this takes a great deal of collaborative research because “no one really knows the whole process.”

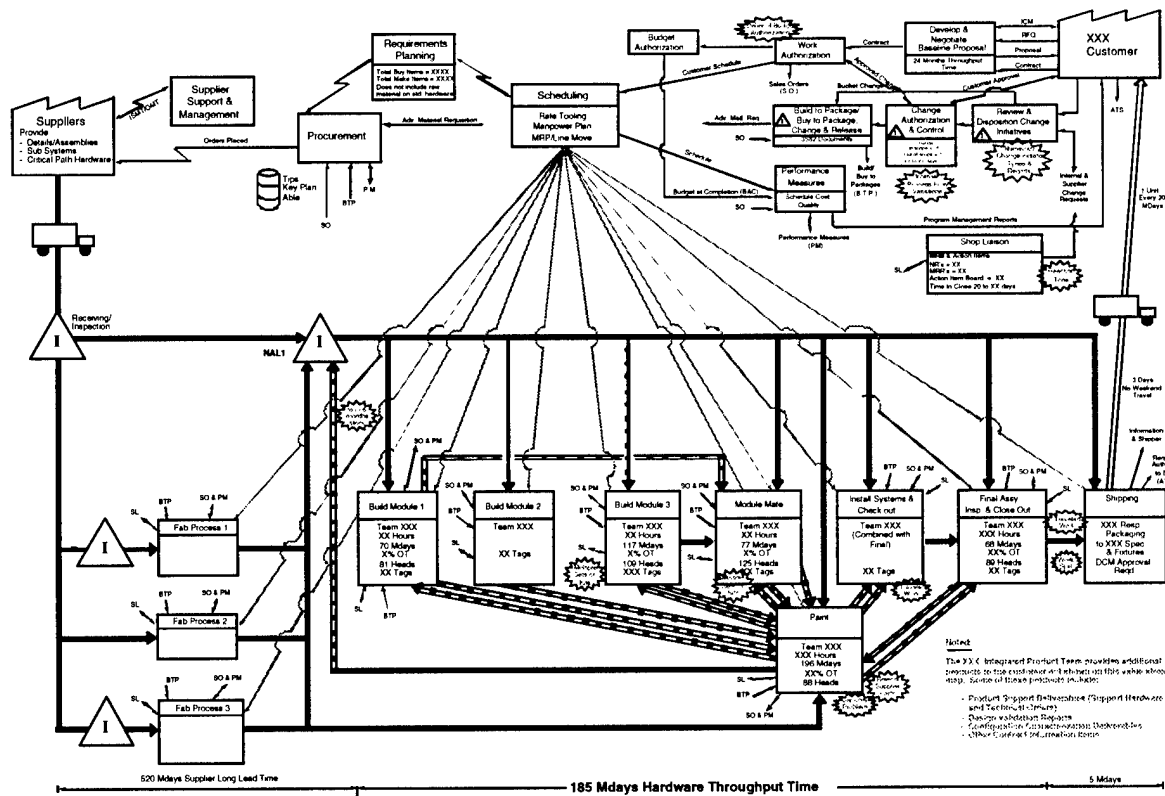

Figure 52. Learning To See Adaptation

Some other, more localized, VSM efforts focus on mapping the deliverables, organizations, customers, and interfaces. These localized efforts face three main constraints on their effectiveness: (1) authorization, (2) low prioritization for resources, and (3) difficulty in defining

problems with very long throughput times. There is also an attempt to smooth the transition of the Build-to-Package from engineering to manufacturing. This effort includes creating a consistent set of engineering drawings/models with a comprehensive set of information: drawings, specs, process work instructions, and the planning document. The Build-To-Package standardization also includes increased emphasis on DFMA analysis through co-located engineers from the aero, industrial, and manufacturing houses. Concurrently, a system dynamics model of the PD process is being developed, as well as a more effective method for defining metrics.

Critique of Practices (Scale: Introductory-Intermediate-Advanced)

Fidelity to Lean Principles: Intermediate to Advanced. Value of a product and value to the customer are ideas commonly referred to at the site, however, value is still not well understood at the program level. Also, the idea of taking a systems view of operations is gaining more acceptance at the site. Much of the improvement expertise is still localized, however, and the quick push to Lean can leave opportunity to create Lean advisors without a great deal of foundational Lean understanding.

Level of VSA/M Maturity: Intermediate. VSM is used well in the goal of creating visibility into a process, however, little in the way of optimization seems to take place. The site efforts often concentrate much on cutting out the waste in small process segments rather than using VSM to directly improve the way the process is done.

Noteworthy Practices: The site exhibited a high commitment to Lean transition and education, as well as the development of Lean ideas.

D.5 Site 5

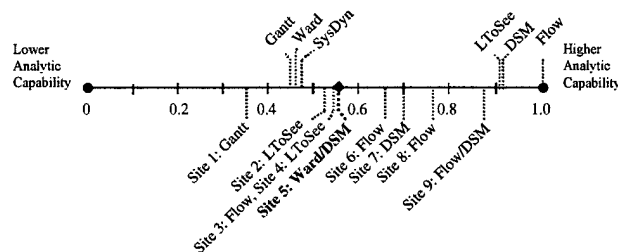

Background: As with several companies in the aerospace industry, recent reductions in personnel left this site sensitive to find new and better ways to operate. Their main VSM efforts are funded through an external research organization. A VSM team has been formed, which has called upon independent consultation to help define and map their product’s Value Stream.

VSA/M Practices: The improvement team’s efforts concentrate on two areas: the first is a set of graphics that outline and describe flow of information through departments (handshake diagrams, organizational tie diagrams, processes flow diagrams), and the other is a computer tool intended to provide an information pull/kanban system. The company has established a Lean office to execute the implementation of Lean ideas, and a major pilot program has been established in one of their more successful projects.

This site utilizes the Ward method for VSM, as well as the DSM tool for their interaction analysis. As used, the Ward map seeks to best *represent* a process, but also offers assistance with analysis of *how to do* things with respect to time. The map also does some to provide analysis of *what to do* by the consideration of waste in PD. The map emphasizes the concurrency of tasks, as well as their durations and start/stop times, but does not allow for the breakdown of the flow of a process as well as other tools, and was placed lower on the plot of analytic maturity.

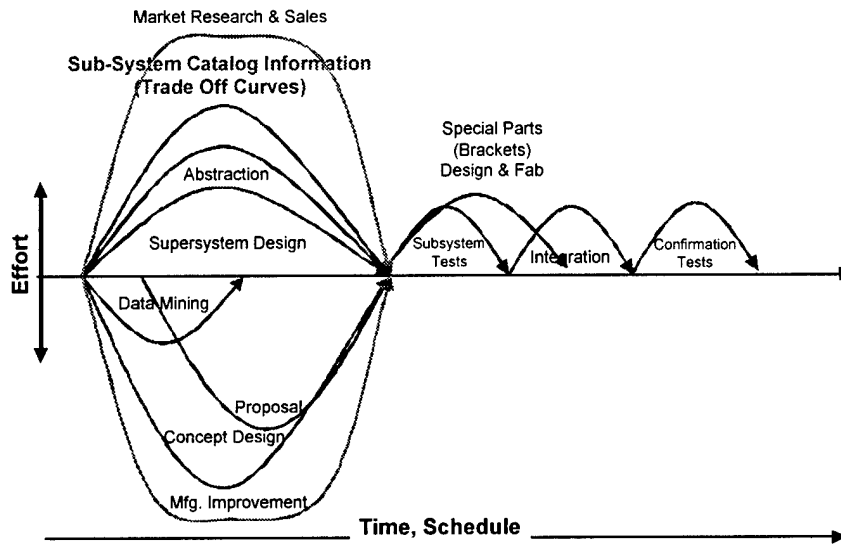

Figure 53. Sample Ward Map

The site found use of a DSM-type tool in the analysis of flow through the various information transfers between design groups. Figure 54 below shows whether a group knew from where they received information and to whom they sent it. As used here, the tool aids in *analysis* of information flow through the PD process, to remove interruptions or deadends. It was not used for optimization of the process, and does not suit well to the *representation* of the process. On the plot of analytic maturity, this example falls under the title “DSM 1.” Color coding designates four possibilities: no interaction, a transfer where only one party is aware of the interaction, a transfer where both parties are aware, or a transfer where neither party is aware.

From To	Anal.	Modeler	Process Eng.	Oper/ Tech	Design	PM/PT Lead	Buyer	Test	Tooling	S	S	CMC	Quality
Anal.	■												
Modeler		■											
Process Engineer			■										
Operator/ Technician				■									
Design					■								
PM/PT Lead						■							
Buyer							■						
Test								■					
Tooling									■				
S										■			
S											■		
CMC												■	
Quality													■

Figure 54. Sample Interaction Matrix

Critique of Practices (Scale: Introductory-Intermediate-Advanced)

Fidelity to Lean Principles: Intermediate. The consultation given to the company does provide them with good Lean foundation and motivation for introducing Lean, however, this again tends to shift the responsibility of really understanding the Lean principles to the consultant, who cannot fully comprehend the company's process the way its employees do. Much of the Learning effort focuses on establishing flow of existing processes and performing tasks concurrently where possible. The Lean office is currently attempting to integrate more quantification of value into their analysis, which would allow for more optimization work.

Level of VSA/M Maturity: Intermediate. Much of their work is centers on establishing and depicting flow, but does not necessarily then follow up with any optimization of the flow. There also existed a sentiment that they had taken their VSM to as a high a level of sophistication as they wanted, and that they can move on to more of the analysis. Within this statement does exist a somewhat hazy interpretation of how their info-pull tool contributes to VSM for PD. The tool does attempt to follow the VSA methods available for manufacturing and establish an implicit Value Stream; however, it currently seems to leave the real understanding and improvement of the Value Stream also as implicit.

Noteworthy Practices: This site generated several forms of information flow analysis, which gave them an understanding of their flow from several perspectives.

D.6 Site 6

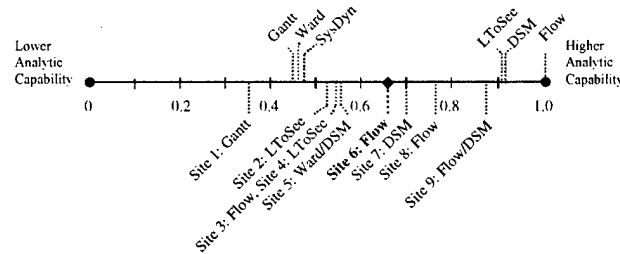

Background: This site possesses a self-proclaimed niche of producing unique, high performance aerospace products. However, the company as a whole seems to want to “first make the shift to Lean and then to improve quality,” which offers a bit of contradiction in terms. The specific VSA/M case studied at the site involves an attempt to verify and validate products more efficiently by testing at better places in the Value Stream, and identifying more defects in a less costly manner. The current testing practices catch defects too late. An external consulting firm was hired to provide assistance with process mapping tools and methodology.

VSA/M Practices: The VSM tool used at the site includes a map with inputs/outputs, process steps, and decision branches in a chronological manner. The map also includes a large system of rework loops, which accounts for much of the current effort at the site. A large group, including process owners and other informed engineers, performed the Current State mapping in a very short period. One of the problems they attempted to resolve was the practice of having each individual design group diverging from nominal testing procedure to meet their needs. Due to a lack of up-front planning, this unnecessary tailoring of the process has created a good deal of extra cost and inefficiency.

The group used a process flow map tool with standard symbology, such as in Figure 55 below, to lay out and analyze their process. This application of the tool does serve to *represent* the process by showing task precedence and decision points, but its strength comes in allowing *analysis* of the flow of value through the process. This tool works best in the determination of *what to do*, and the team did use it to some extent to know what testing to perform. However, the team wanted to use the tool to optimize their testing tasks, and the tool’s current level of sophistication provided some frustration in determining how best to perform the testing. On the plot of analytic maturity, this example falls under the title “Flow 1.”

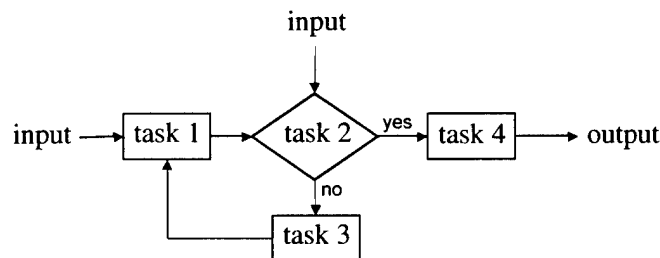

Figure 55. Sample Process Flow Map

Critique of Practices (Scale: Introductory-Intermediate-Advanced)

Fidelity to Lean Principles: Intermediate. The site relayed a positive view of the potential of Lean in their area, but expressed common limitations to the application of Lean to PD. The specific case did consider the importance of understanding the process, flow, and planning. However, the team focused on adding and changing testing practices to catch more failures, and gave little attention to the improvement of the overall process to prevent failures. A large portion of all activities included testing, and a large portion of all parts required rework.

Level of VSA/M Maturity: Intermediate. An interesting environment of mutual disassociation of responsibility and understanding occurred at the site: the consultants focused on the tool and not necessarily the understanding or improvement of the Value Stream, and the company team relied on the consultants for the application of the VSM tool to their Value Stream. When taken to the extreme, this leaves no one to really shoulder the burden of understanding how things should best be improved in the process.

Noteworthy Practices: This site had a specific goal and motivation in performing their VSA/M.

D.7 Site 7

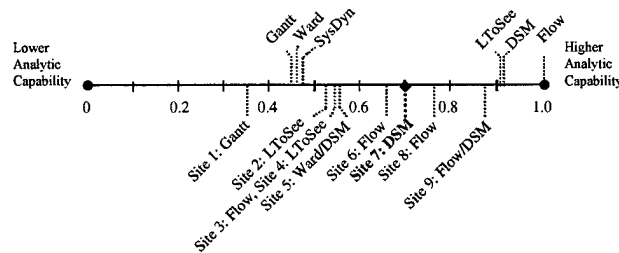

Background: Several years ago, this site foresaw their operations as too expensive to ever develop a completely new system. To counter this trend, they chartered a team to cut cost and schedule in the creation process.

VSA/M Practices: This site relies heavily on the new team for implementation of VSA/M, given the motivation to provide a faster and cheaper PD process. Their analysis shows that saving money in PD equals saving money in entire production cost due to time-value aspect of money. Thus, the team has focused on cutting cost in PD much more than schedule. They studied the incorporation of Lean in the auto industry to learn about standardization, reuse, and technology roadmaps. Microsoft Project was used to breakdown and describe processes. The analysis also uses the “Quality x Acceptance = Effectiveness” model heavily, with each value equal to a subjective approximation from zero to one. They apply several lenses to gain different perspectives on the value of a process to include cost, schedule, risk, and improvement opportunity. The efforts have been applied to a few smaller projects/tasks, each with improvements, but it is not yet standard throughout the group.

Currently, project teams define their own processes, and different design domains remain separate within the business groups. A new computing infrastructure has been chartered to provide sharing and common environments for all of the PD work within the company. This environment emphasizes the interaction between people, data, and tools. The environment has been piloted, which resulted in the reduction of the time it took for a certain study to be completed from 6 weeks to around 2-4 days.

Large-scale DSM projects have also begun work on establishing continuous flow and reducing rework throughout major process families. No specific optimization work such as grouping or tiering has been introduced yet, but could easily follow using the existing DSM structure. The current structure, which focuses more on the *analysis* of *what to do* in their PD process, falls under “DSM 2” on the analytic maturity plot.

Critique of Practices (Scale: Introductory-Intermediate-Advanced)

Fidelity to Lean Principles: Intermediate. Many of their improvement efforts were done in tandem with the development of Lean ideas—some of the ideas are similar, like cutting cost and schedule, but PD efforts don’t necessarily originate from Lean principles. More and more Lean principles are being directly incorporated into PD, but this is currently done in a piecemeal fashion, without a comprehensive push for change.

Level of VSA/M Maturity: Intermediate. Company wide, VSA/M is either not utilized or not standardized, and improvement efforts are often localized and hit-and-miss in nature. The site’s efforts of clarifying and describing the current processes have been very effective, and have set the foundation for further, more sophisticated VSM work. Their analysis tools are also following this trend of advancement. Commercial products like Visio, Powerpoint, and DSM tools are used and being advanced to object-oriented, and more powerful products.

Noteworthy Practices: This site exhibited the most widespread incorporation and use of DSM tools.

D.8 Site 8

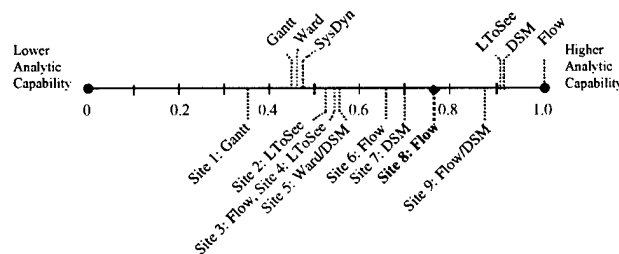

Background: Much of the introduction of Lean at this site has come from the highest levels of leadership with the critical motivation for survival. The company uses kaizen events to introduce and educate about Lean methodology and practices, and supports an internal system of Lean offices with advisors and coordinators. The site deals mainly with the PD side, where Lean is now being applied explicitly and purposefully. The company in general has implemented Lean throughout their manufacturing operations.

VSA/M Practices: One typical kaizen event included around six months of background work to develop tools and map out the current state of several Value Streams. This event focused on improving the engineering change process and first mapped the high level process and then “drilled down” in several places. Several improvement teams were given one week to first understand and map their piece of the Value Stream, make Lean improvements, and then create an implementation strategy. Internal Lean consultants and Lean advisors aided with the Lean

theory and improvements. Each Value Stream was mapped in a future state, and outbriefed to management.

The site uses process flow maps in their VSA/M efforts, which focus on the *analysis* of flow and value within their PD process. Because of this focus, the tool aided in determining *what to do* much more than *how to do* things. The maps include tasks that are determined to be Value Added, Non-Value Added, or Non-Value Added But Necessary. Also, the maps do not normally include metrics attached for each individual task, but do so for the larger processes. This entry is titled “Flow 2” on the plot of analytic maturity.

Critique of Practices (Scale: Introductory-Intermediate-Advanced)

Fidelity to Lean Principles: Intermediate. Significant emphasis was placed on Lean theory as fundamental to the process improvements as well as the communication between management and the working groups. More preparatory Lean training could have helped the team members better understand and execute their improvement efforts.

Level of VSA/M Maturity: Intermediate. No explicit definition of value was established for which to determine the value of each activity in the process. There existed a clear initiative and motivation for actual implementation of changes, and the leadership team took their involvement very seriously. The improvement teams had a wide range of participants, from academia, supplier, customer, process owners, and leadership interests.

Noteworthy Practices: This site took very seriously the involvement of leadership in the improvement process, and has tied compensation to participation.

D.9 Site 9

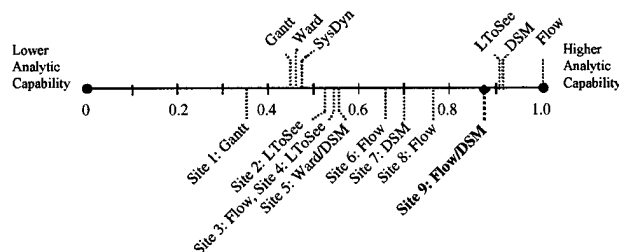

Background: This group was chartered within the overall company to 1) look for new technological opportunities, and 2) to support military contracts. The rest of the company often looks to this group for the cutting-edge application of product and process analysis.

VSA/M Practices: This group relies heavily on a new initiative to integrate more data into their process analysis. This project is still in the experimental phase, and not yet fully implemented. Much of the process planning is still driven by deliverables required by the military customer, and based on a master plan (including tasks) and master schedule (including resources). The new process initiative attempts to provide a standard process for Product Development, from which different aspects can be compressed or expanded depending on the type of program. A process flow tool is used in the mapping of the standard and tailored processes. Much of the analysis relies on experience to know which aspects to cut out of the standard process for a certain product. This analysis has been applied to a few pilot programs, where benefits have

been seen in each, however, much is still being learned about its implementation. Some significant cultural barriers have presented themselves in the area of process adoption and acceptance.

The initiative uses also DSM as a flow *analysis* tool, but does not yet continue that analysis to the focus of *optimizing* their processes. The tool is used mainly to depict the connection of tasks within a larger process and identify/reduce feedback loops. The DSM models include several process attributes: input, output, interaction with other processes, completion criteria, metrics criteria, communication between, navigation between, and others. For each step in the process flow map, one of these DSMs is generated to describe its interaction with the surrounding process steps. An electronic integration environment then allows for information from several databases to be accessed from the VSM tool, to include things like work instructions, resource allocation, and schedules. This combination of tools falls under the title “Flow/DSM combination” on the plot of analytic maturity.

Critique of Practices (Scale: Introductory-Intermediate-Advanced)

Fidelity to Lean Principles: Intermediate. Many of the improvement efforts were done in tandem with the development of Lean ideas. Some of the ideas are common, like cutting cost and schedule, but PD improvement efforts do not necessarily originate from Lean principles. More Lean principles are being directly incorporated into PD, but this is currently done in a piecemeal fashion.

Level of VSA/M Maturity: Intermediate. Company wide, VSA/M is either not utilized or not standardized. Much of their analysis is done in an ad-hoc manner. DSM and process flow analysis showed that many of their processes were not well understood and/or did not flow. The new data/process initiative allows them to gain insight into their processes, but they have not yet determined how to effectively optimize them. The site has begun work on standardizing the PD processes they use, however, it is still in the preliminary stages, and they are not sure yet how to make it robust and widespread.

Noteworthy Practices: This site exhibited the highest level of process analysis sophistication.

Appendix E: Data Collection Form

Adapted from *Measuring Value in Product Development* by J. Chase, 2001 [32].

This page left intentionally blank.

Value Stream Analysis and Mapping Data Collection Sheet													
General					Resources								
Activity Name					Elapsed Time		(days)						
Location					In-process Time		(hrs)						
Pers./Org. Performing					Core Task Work Time		(hrs)						
Completion Criteria					Activity Based Cost								
Success Criteria					Special Resources Req.								
Other:					Chance of Rework/Time		%	(hrs)					
Input #1			Input #2			Input #3							
Name			Name			Name							
Sender			Sender			Sender							
Transfer			Transfer			Transfer							
Quality	1	2	3	4	5	N/A	Quality	1	2	3	4	5	N/A
Utility	1	2	3	4	5	N/A	Utility	1	2	3	4	5	N/A
Format	1	2	3	4	5	N/A	Format	1	2	3	4	5	N/A
Output #1			Output #2			Output #3							
Name			Name			Name							
Receiver			Receiver			Receiver							
Transfer			Transfer			Transfer							
Purpose			Purpose			Purpose							
Critical Drivers (metrics/attributes)													
Context (interaction with other VS)													
Value													
Non-Value-Added			Enabling			Value-Added							
1-----2-----3-----4-----5													
Functional Perform.	1	2	3	4	5	N/A	Enabling Activities	1	2	3	4	5	N/A
Defn. of Processes	1	2	3	4	5	N/A	Cost/Schedule Savings	1	2	3	4	5	N/A
Reduction of Risk	1	2	3	4	5	N/A	Other:	1	2	3	4	5	N/A
Form of Output	1	2	3	4	5	N/A	Other:	1	2	3	4	5	N/A
Waste Sources													
Waste of Resources													
Waste of Time													
Waste of Quality													
Waste of Opportunity													
Information Waste													
Other:													
Comments/Suggestions (improvement ideas, problems, stress points)													

Data Collection Sheet Legend	
<p>Elapsed Time: days from authorization to proceed, to the completion of the activity</p> <p>In-process Time: hours of active work, as measured, for example, by time charged</p> <p>Core Task Work Time: time when core task is being worked, excluding setup, data retrieval, etc.)</p>	<p>Special Resources Required: any personnel, tools, or information that may distinguish the activity or provide constraint</p> <p>Chance of Rework/Time: percent chance of rework being required for (or because of) the activity, and the time associated with that rework</p>
Input Criteria	
<p>Quality</p> <p>5 - Significantly more information than needed</p> <p>4 - More information than needed</p> <p>3 - Quality is just right</p> <p>2 - Information is missing</p> <p>1 - Information is inaccurate and/or untrustworthy</p>	<p>Formatting</p> <p>5 - Ideal formatting for immediate use</p> <p>4 - Fairly good formatting</p> <p>3 - Acceptable formatting</p> <p>2 - Some reformatting necessary</p> <p>1 - Reformatting necessary</p>
<p>Utility</p> <p>5 - Direct and critical contribution</p> <p>4 - Important contribution</p> <p>3 - Beneficial contribution</p> <p>2 - Indirect contribution</p> <p>1 - No contribution</p>	<p>Transfer: the method of transfer by which the input arrives to the activity</p> <p>Output Purpose: the product that the output is contributing to, or the goal of the activity</p>
Critical Drivers: metrics that reveal the distinguishing nature and critical drivers of the process	
Context: interaction with other Value Streams (such as manufacturing and R&D), and any authority/review issues	
Value Criteria	
<p>Functional Performance (FP)</p> <p>Functional performance of the end product to be delivered to the customer</p> <p>5 - Direct specification of major FP parameters</p> <p>4 - Direct specification of FP parameters</p> <p>3 - Direct specification of minor FP parameters</p> <p>2 - Indirect specification of FP parameters</p> <p>1 - Possible specification of FP parameters</p>	<p>Form of Output</p> <p>The form of the output of this task (e.g. report, spreadsheet, build-to-package, etc.)</p> <p>5 - Flows easily into program milestone</p> <p>4 - Flows into milestone with some changes</p> <p>3 - Flows easily into downstream task</p> <p>2 - Flows into next task with some changes</p> <p>1 - Flows into next task with major changes</p>
<p>Definition of Processes</p> <p>Definition of processes necessary to deliver the end product to the customer</p> <p>5 - Direct specification of major downstream processes</p> <p>4 - Direct specification of downstream processes</p> <p>3 - Direct specification of minor downstream processes</p> <p>2 - Indirect specification of downstream processes</p> <p>1 - Possible specification of downstream processes</p>	<p>Enabling Activities</p> <p>Enabling other activities to occur (e.g., the other activity is required for completion of program)</p> <p>5 - Major checkpoint preventing further work</p> <p>4 - Moderate checkpoint in program</p> <p>3 - Task necessary for continued work</p> <p>2 - Necessary, but not especially time-sensitive</p> <p>1 - Necessary, but not time sensitive</p>
<p>Reduction of Risk</p> <p>Reduction of risks and uncertainties associated with functional, process, or market areas</p> <p>5 - Major risks greatly reduced or eliminated</p> <p>4 - Significant reduction of risks</p> <p>3 - Minor reduction of risks</p> <p>2 - Indirect reduction of risks</p> <p>1 - Possible reduction of risks</p>	<p>Cost/Schedule Savings</p> <p>Cost and/or schedule savings resulting from task execution (i.e., a core competency)</p> <p>5 - Recognized as a core competency</p> <p>4 - Major improvement over hist. predecessor</p> <p>3 - Improvement over historical predecessor</p> <p>2 - Minor improvement over predecessor</p> <p>1 - Possible improvement over predecessor</p>
Waste Sources	
<p>Waste of Resources: possible misuse or non-optimization of resources</p> <p>Waste of Time: possible cause for delays, waiting, unplanned rework</p> <p>Waste of Quality: possible cause for lack of quality, errors, defects</p> <p>Waste of Opportunity: possible oversight of personnel, tool, or technology potential</p> <p>Info Waste: overproduction, inventory, transportation, unnecessary movement, overprocessing, transfers, scatter</p>	