



# **M1A2 SEP Tank Embedded Training Technology**

**Carl Hobson  
*President & CEO***

**Oasis Advanced Engineering**

**Email: [hobson@OasisAdvancedEngineering.com](mailto:hobson@OasisAdvancedEngineering.com)**

**Phone: (248) 373 – 9800 • Fax: (248) 373 – 9898**

## Report Documentation Page

<b>Report Date</b> 29May2001	<b>Report Type</b> N/A	<b>Dates Covered (from... to)</b> -
<b>Title and Subtitle</b> M1A2 SEP Tank Embedded Training Technology	<b>Contract Number</b>	
	<b>Grant Number</b>	
	<b>Program Element Number</b>	
<b>Author(s)</b> Hobson, Carl	<b>Project Number</b>	
	<b>Task Number</b>	
	<b>Work Unit Number</b>	
<b>Performing Organization Name(s) and Address(es)</b> Oasis Advanced Engineering	<b>Performing Organization Report Number</b>	
<b>Sponsoring/Monitoring Agency Name(s) and Address(es)</b> NDIA (National Defense Industrial Association) 211 Wilson Blvd., Ste. 400 Arlington, VA 22201-3061	<b>Sponsor/Monitor's Acronym(s)</b>	
	<b>Sponsor/Monitor's Report Number(s)</b>	
<b>Distribution/Availability Statement</b> Approved for public release, distribution unlimited		
<b>Supplementary Notes</b> Proceedings from 2001 Vehicle Technologies Symposium - Intelligent Systems for the Objective Force 29-31 May 2001 Sponsored by NDIA		
<b>Abstract</b>		
<b>Subject Terms</b>		
<b>Report Classification</b> unclassified	<b>Classification of this page</b> unclassified	
<b>Classification of Abstract</b> unclassified	<b>Limitation of Abstract</b> UU	
<b>Number of Pages</b> 24		

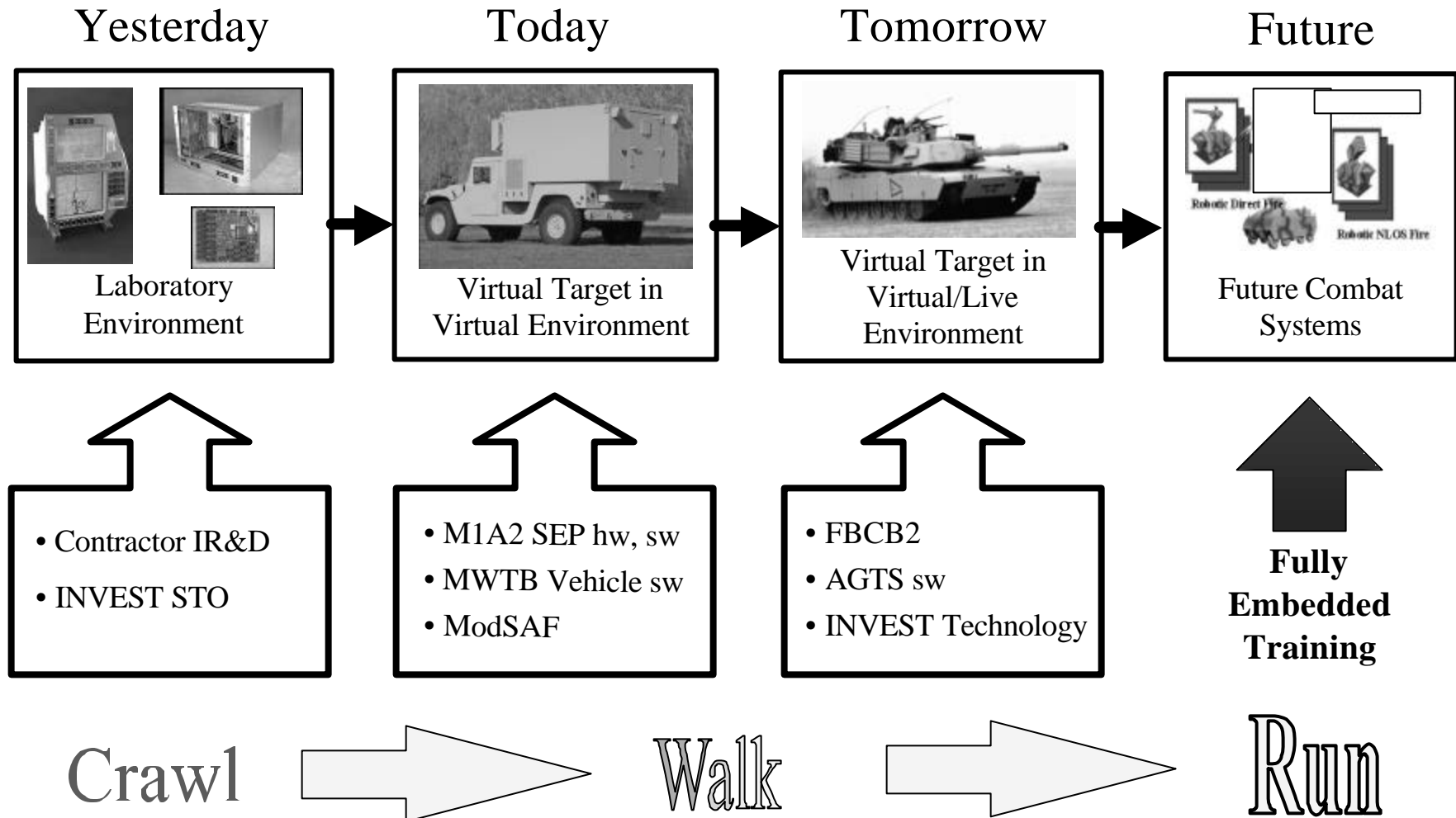

# Laboratory Based Research & Development



**Yesterday**

# Reconfigurable Test Platform



## Mobile Laboratory

- **Utilized for Vehicle-on-the-Move Testing**
- **AM General M1097A2 HMMWV with a Military Shelter**
  - 15KW Generator
  - 24,000 BTU ECU





# Mobile Crew Station Simulation Laboratory (MCSSL)



Facilitates M1A2 SEP Tank Embedded Training Technology Implementation

- Incorporates M1A2 SEP Tank LRUs or Commercial Equivalents
- Utilizes M1A2 SEP Tank Software
- Pre-platform Integration Risk Reduction

**Today**



Cost Effective • Reconfigurable • Mobile

# MCSSL Top Level Functional Diagram

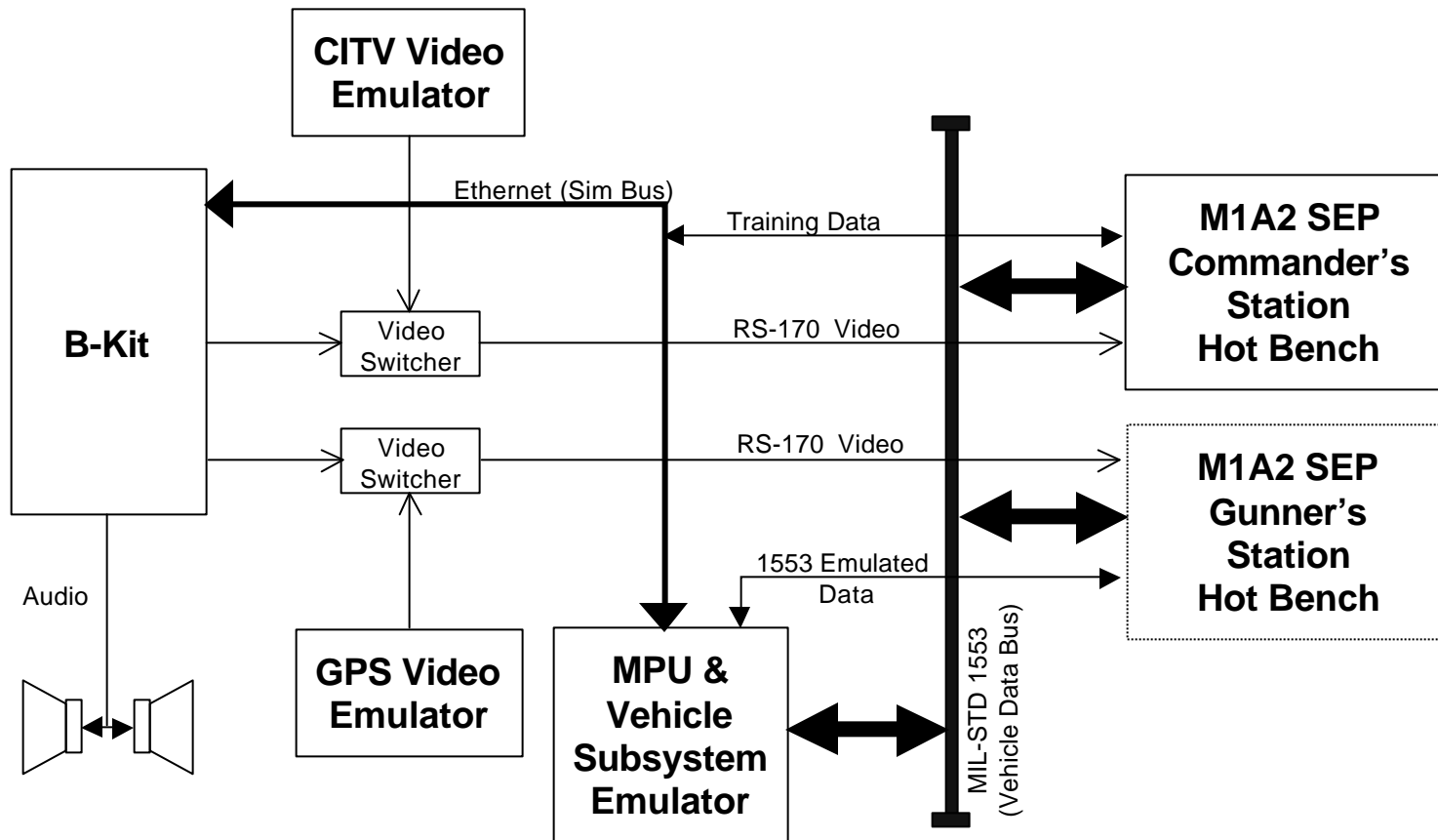

# MCSSL Detail Architecture Diagram

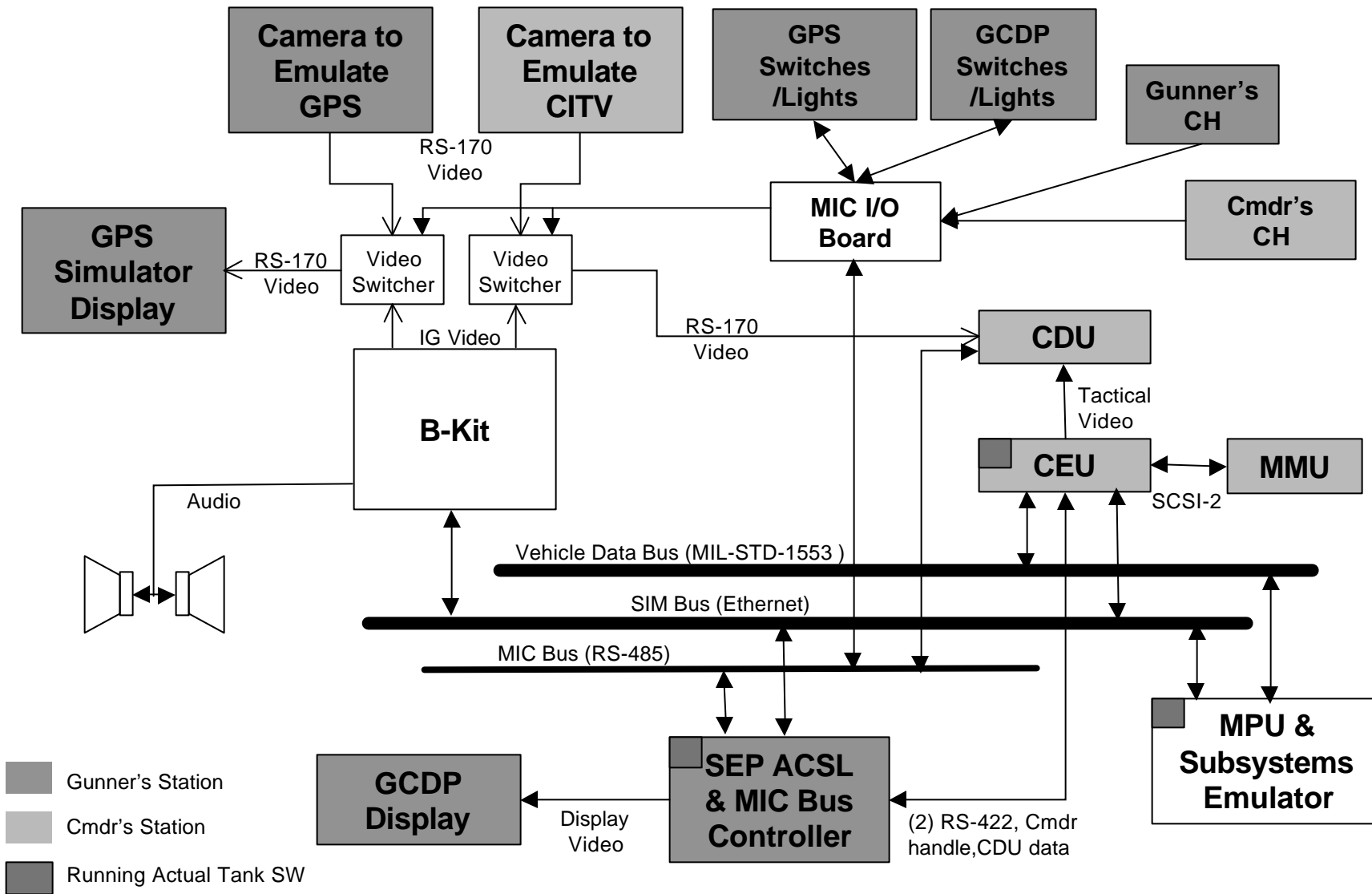



# B-Kit Architecture Diagram

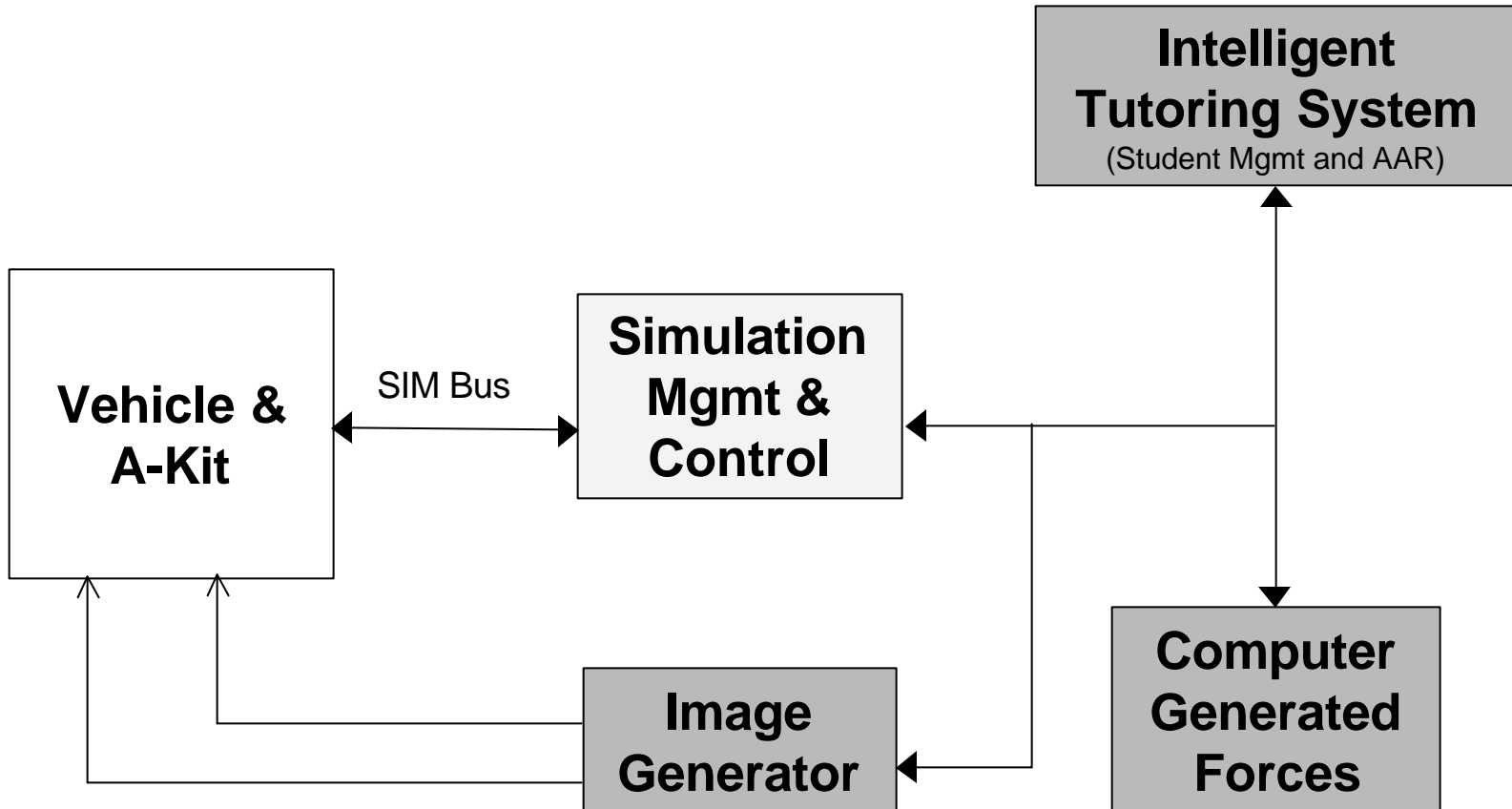



# M1A2 SEP Tank





# M1A2 SEP Tank - Embedded Training Demonstrations



General Capabilities	Objective Demo	Initial Demo AUSA
Full Virtual Environment	X	X
After Action Review	X	No
AGTS Software Integration	X	No
Distributed Interactive Simulation (DIS)	X	Limited
<b>Gunner Station Capabilities</b>		
Gunner's Primary Sight (GPS)	X	Limited
Gunner's Control Display Panel (GCDP)	X	X
Gunner's Control Handle	X	X
<b>Commander Station Capabilities</b>		
Commander's Independent Thermal Viewer (CITV) Sight	X	X
Command & Control (including FBCB2)	X	No
Integrated Training Menus on CDU	X	X
Commander's Control Handle	X	X
<b>Hardware Features</b>		
Ruggedized Embedded Training LRUs	X	X
A-Kit for M1A2 SEP Tank	X	Limited

# M1A2 SEP Tank Embedded Training System Architecture

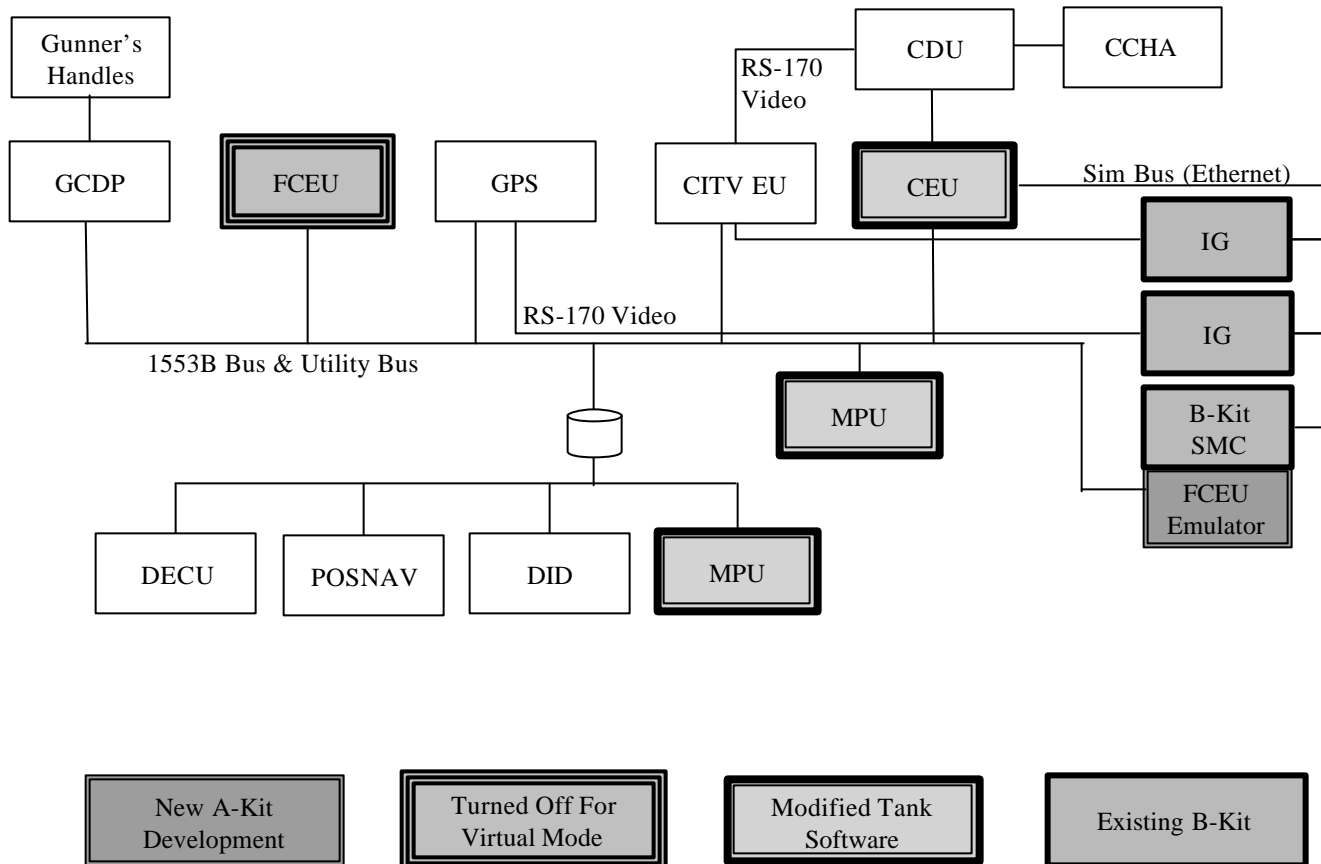

# B-Kit Architecture

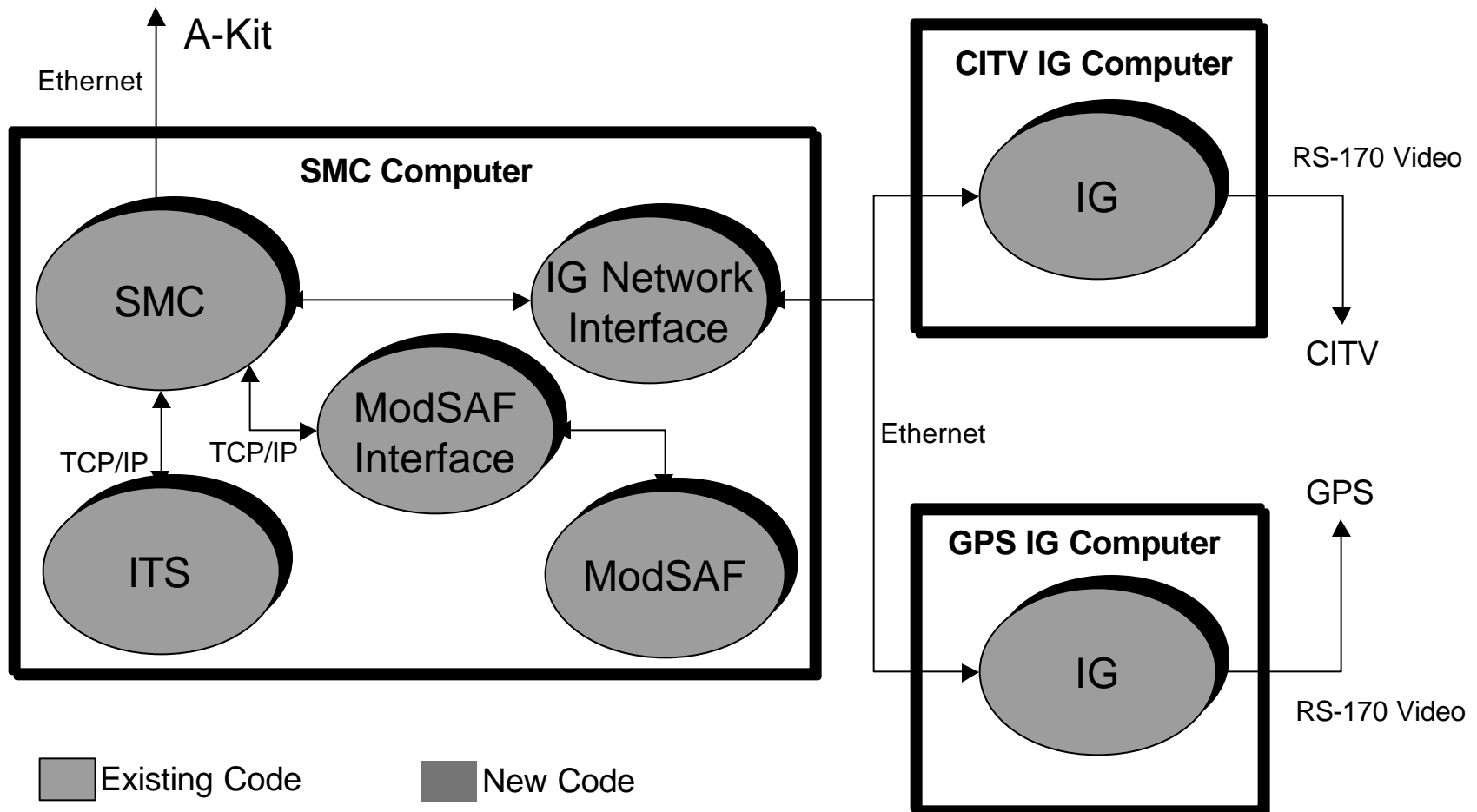

# Commander's Electronic Unit (CEU) Architecture

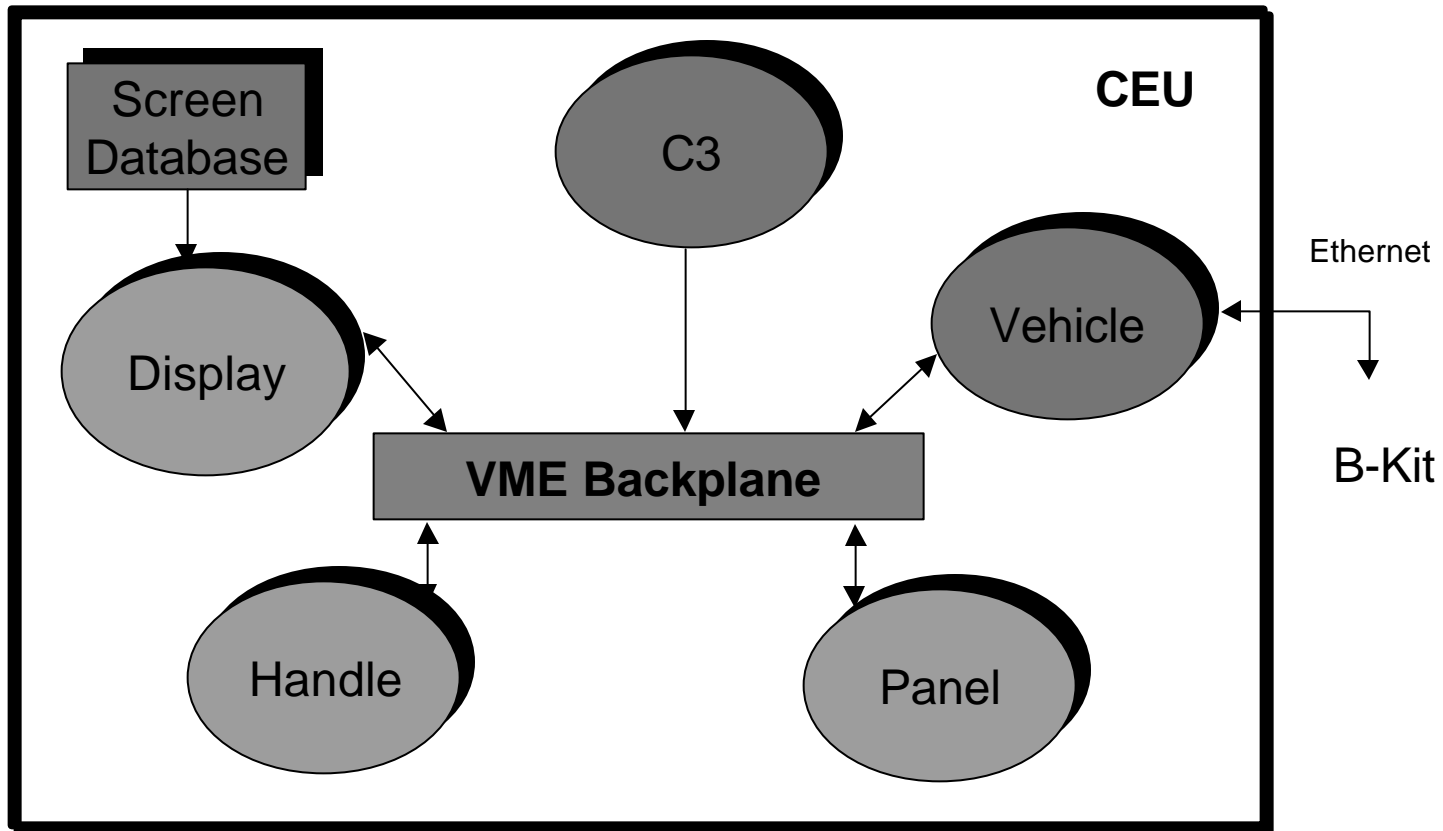

Unmodified
  Modified

# FCEU Emulator Architecture

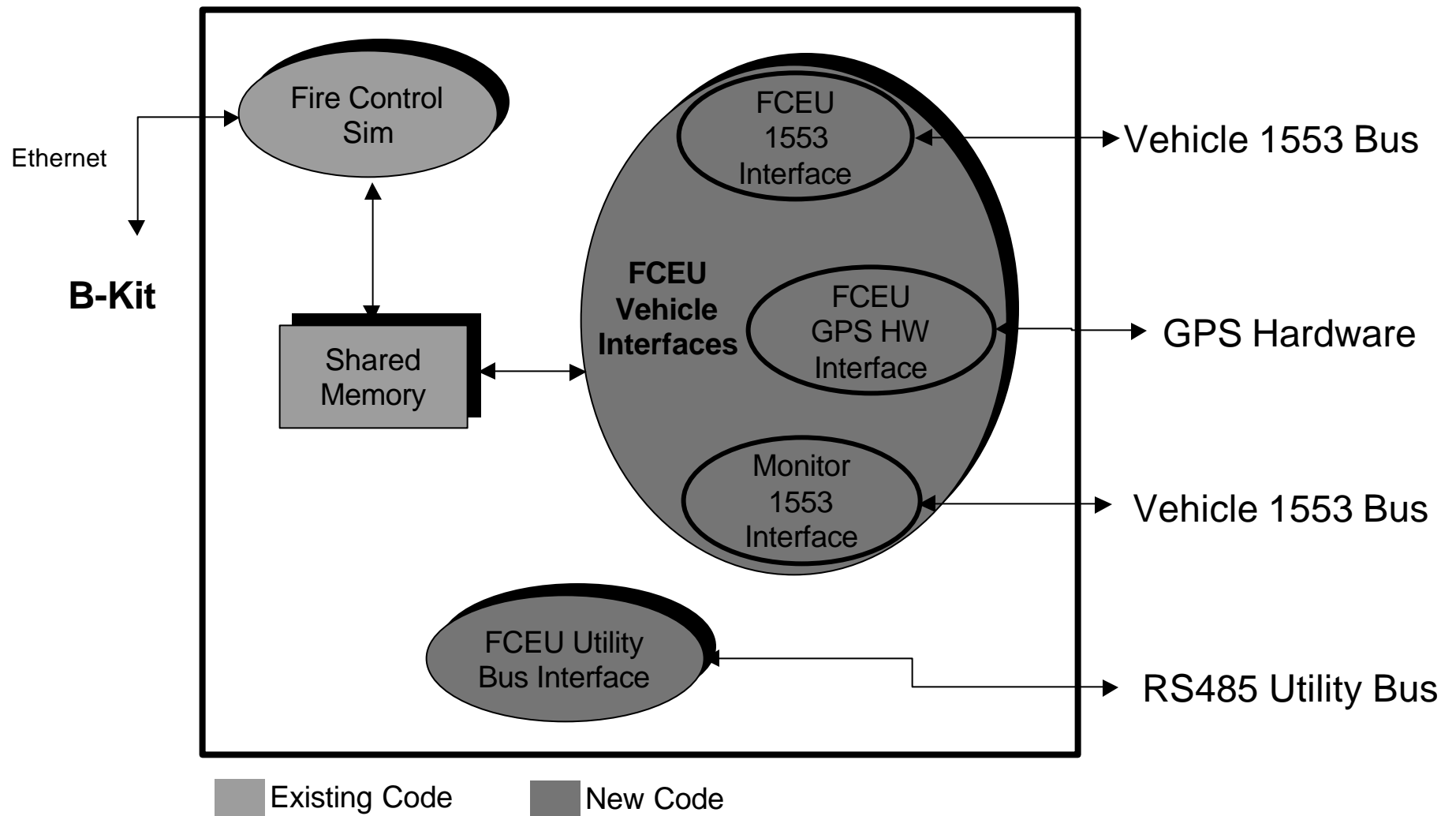

# Technical Approach - Building Block Solution

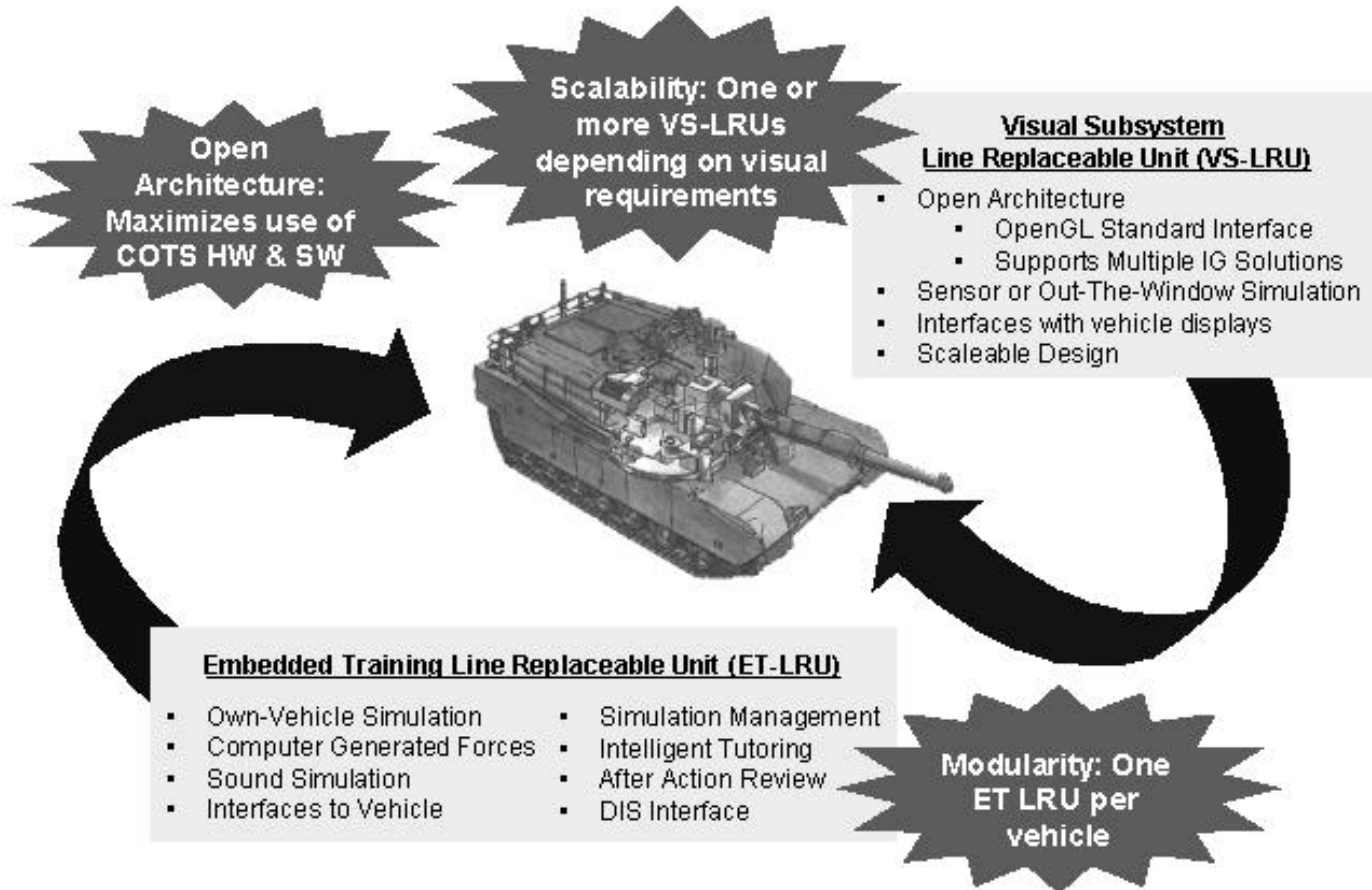

**A building block approach using an ET-LRU and multiple VS-LRUs allows for maximum flexibility and cost effectiveness**





# Building Block Approach Advantages



<b>Attribute</b>	<b>Advantages</b>
<b>Placement</b>	<b>Placement of multiple small boxes will be easier to achieve within the tight confines of the legacy ground combat vehicle.</b>
<b>Environmental</b>	<b>Distribution of the heat loads assists in heat load management.</b>
<b>Power Management</b>	<b>Distribution of the power loads assists in power management.</b>
<b>Scalability</b>	<b>Additional capabilities (e.g., adding the driver) can be achieved by adding a VS-LRU in the driver's area.</b>
<b>Modularity</b>	<b>System modularity is achieved by logical distribution of software and hardware functions allowing changes in subsystem configuration without impacting the entire architecture.</b>
<b>Graceful Degradation</b>	<b>Failure of a single VS-LRU does not imply total system failure.</b>

# ET & VS LRUs – Maximum Use of Common COTS SRUs

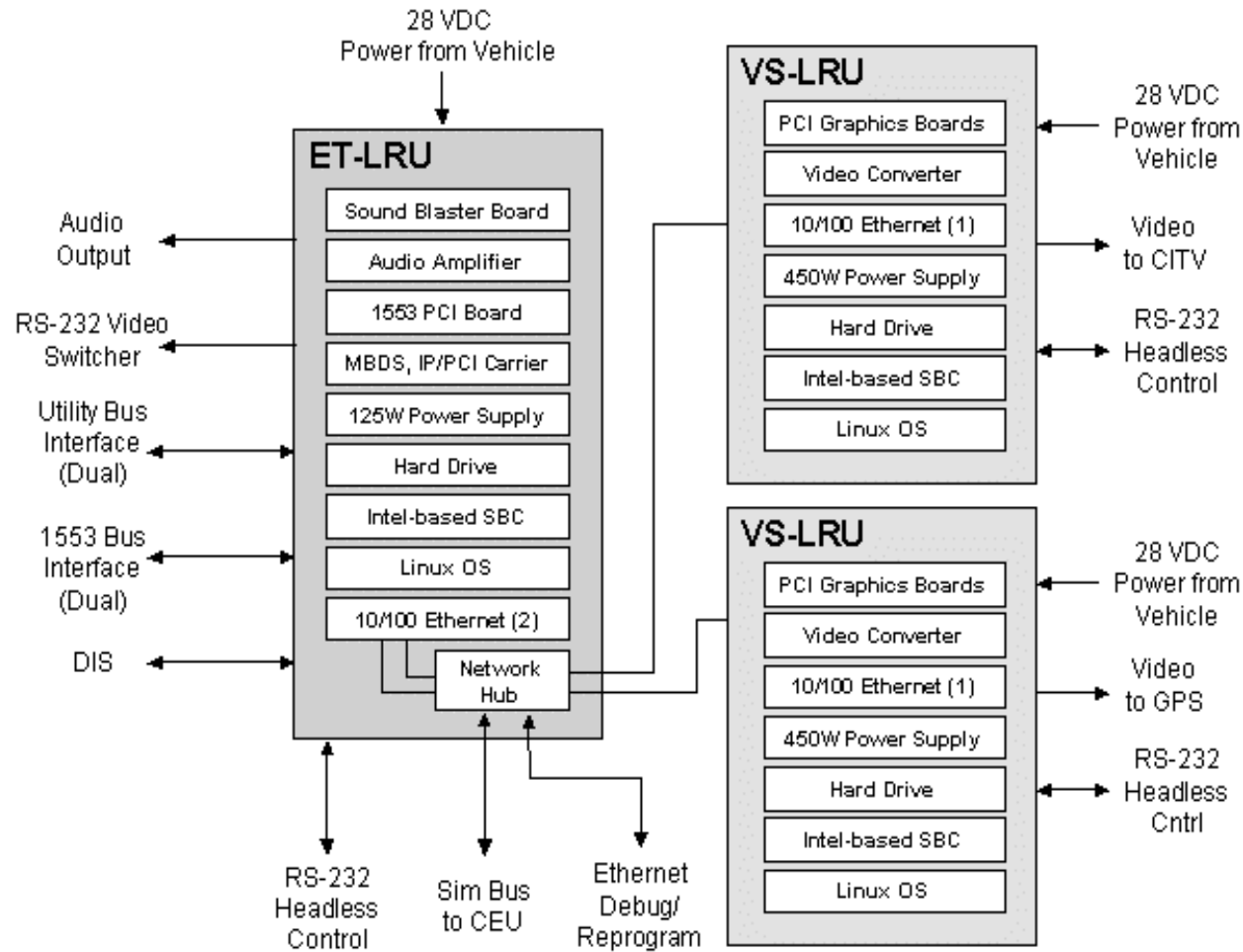

# AUSA Demo Hardware Architecture

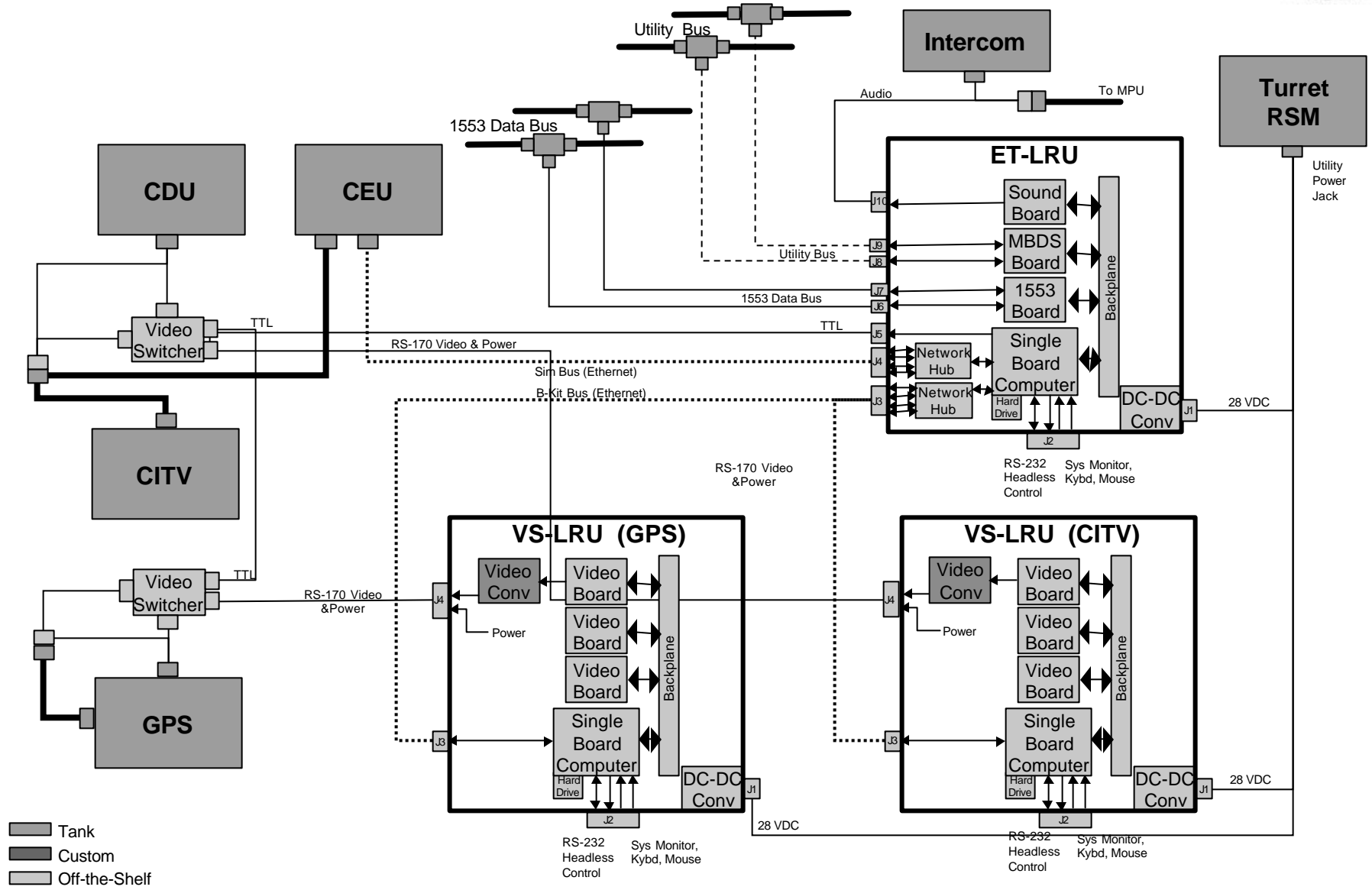



# AUSA Demo Prototype LRUs

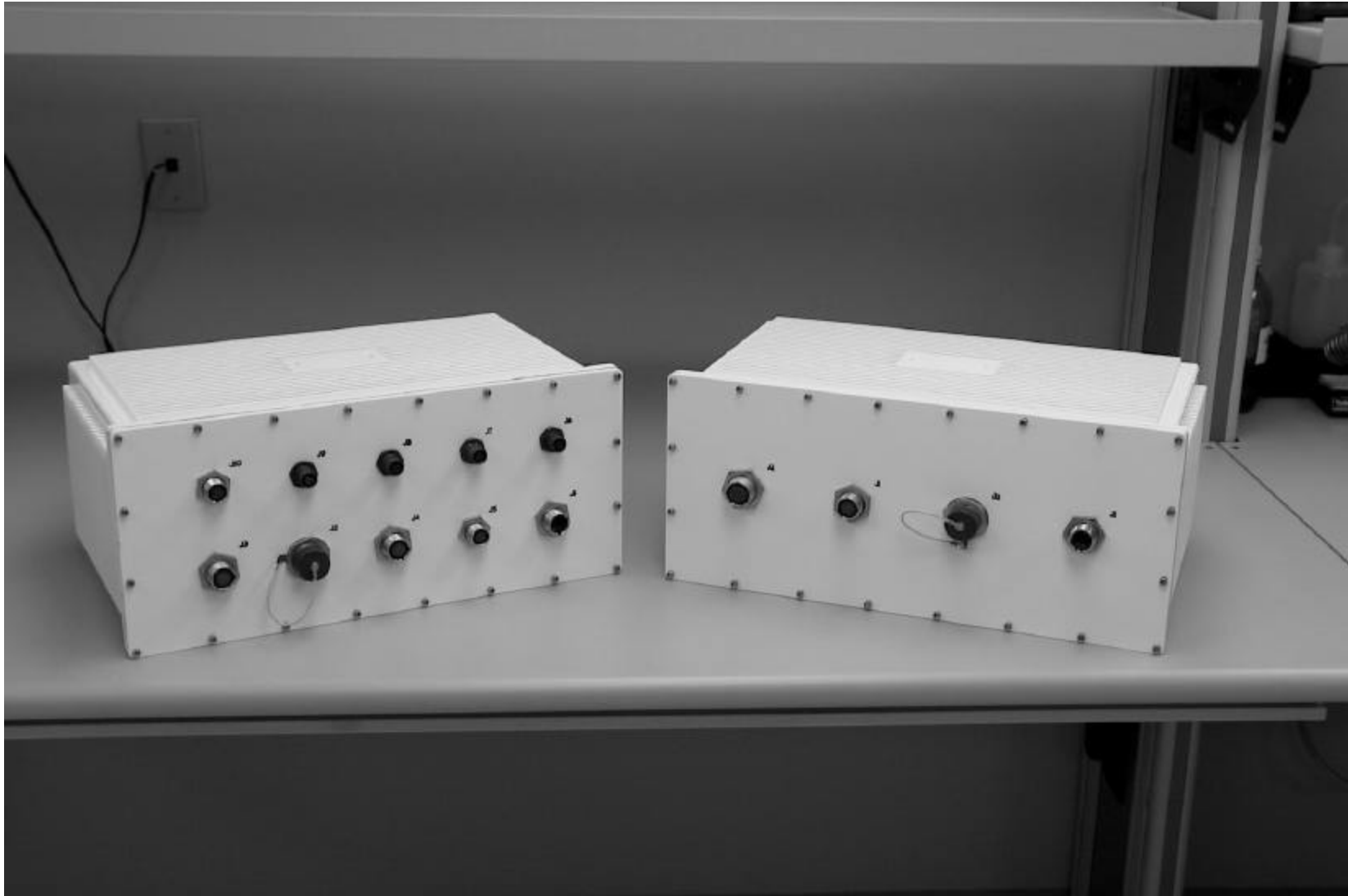



# Visual Subsystem (VS) Prototype LRU

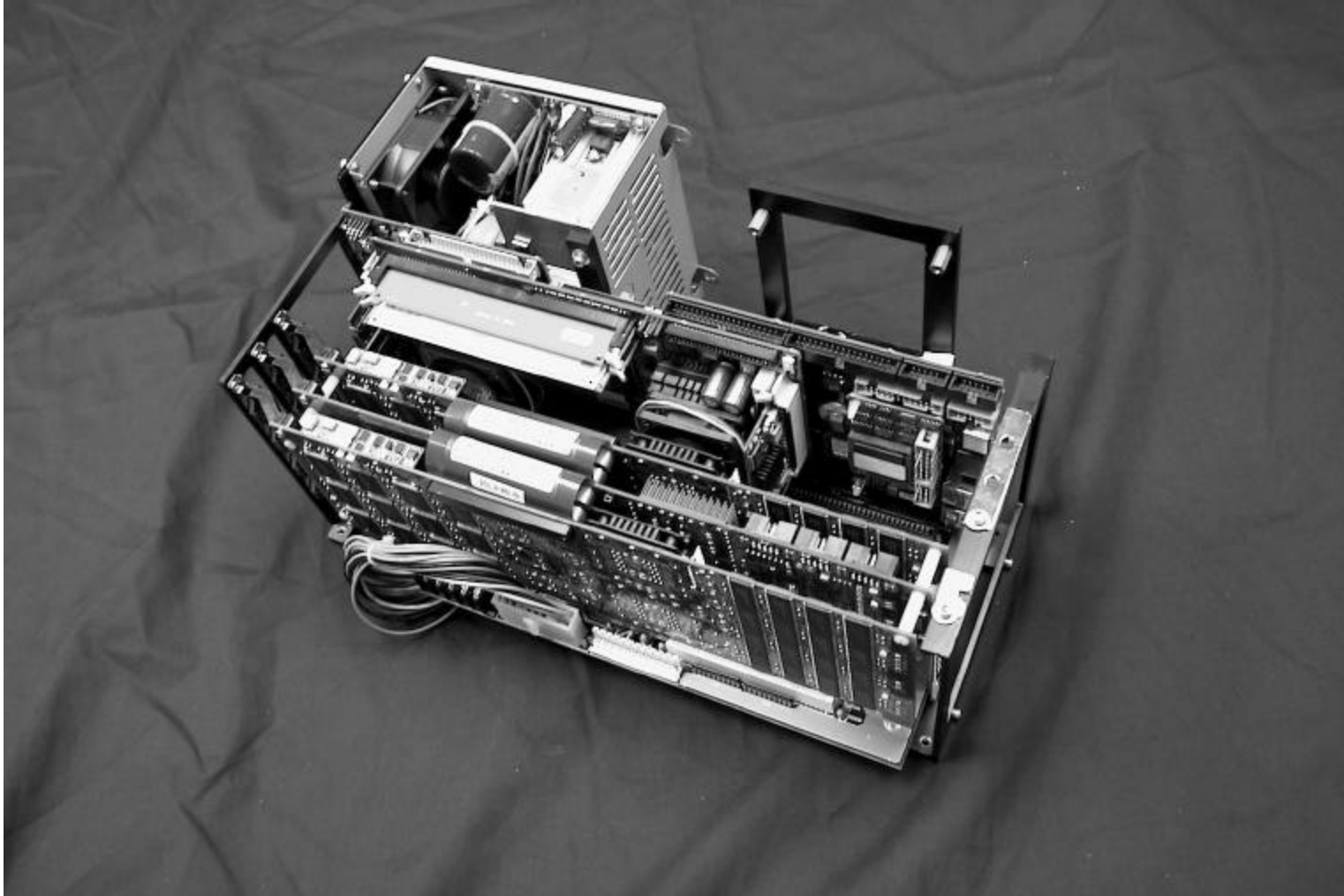

# Embedded Training (ET) Prototype LRU

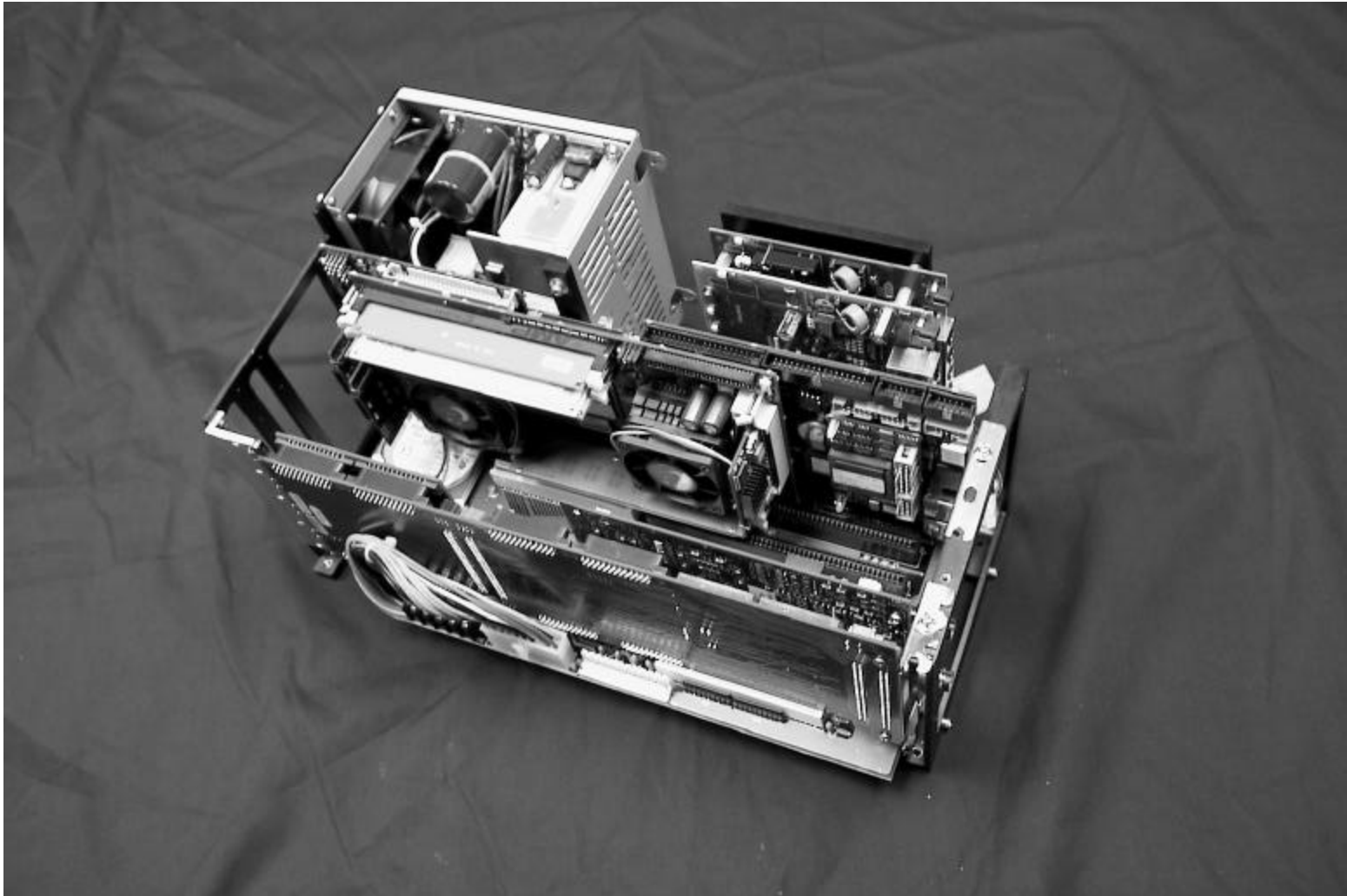

# M1A2 SEP Tank Embedded Training Technology



M1A2 SEP Tank Block Upgrade  
FY 03/04



Requirements

Technology Transfer



MCSSL (ET R&D)

- Design & Documentation
- A/B-Kit Development

- Precision Gunnery
- Full Crew Training
- Mission Planning/Rehearsal
  - Mobility Training
- Section/Platoon Gunnery
- Combined Arms Training



# Embedded Training Technology Challenges

- **Medium Risk Technology Challenges**
  - Hardware Miniaturization, Ruggedization, Heat Management
  - Secure High Bandwidth Inter-vehicular Communication
  - Real-time Database Development & Deployment
- **High Risk Technology Challenges**
  - Virtual Image Insertion into Live Imagery
  - Synchronized Semi-Auto Forces



# Future Combat Systems

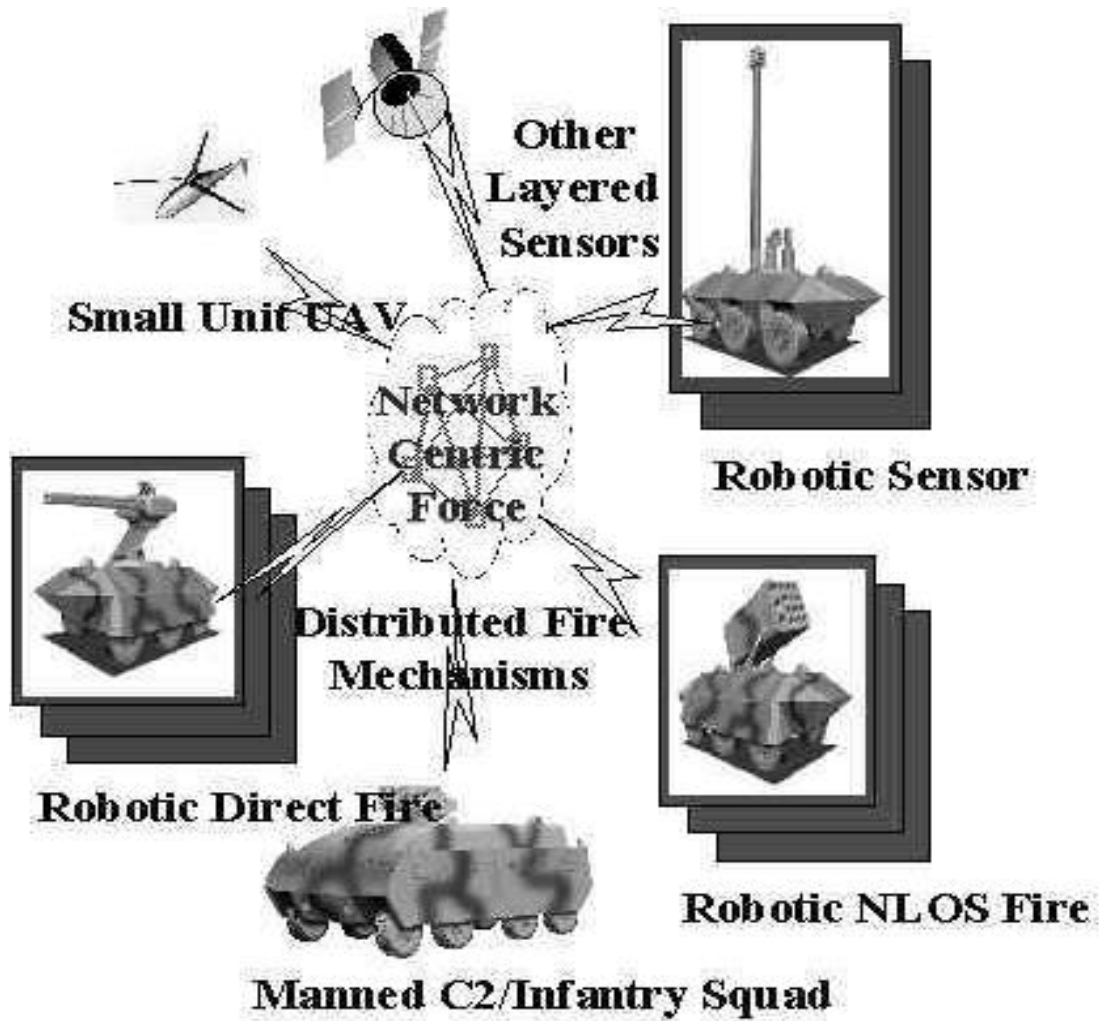

**Future**

**Embedded Training**