



OFFICE OF THE DEPUTY UNDER SECRETARY OF DEFENSE (ENVIRONMENTAL SECURITY)

Unexploded Ordnance (UXO)

The Department of Defense (DoD) defines military munitions/explosive ordnance as any munition, weapon delivery system, or ordnance item that contains explosives, propellants, or chemical agents. UXO is military munitions/explosive ordnance that has been primed, fused, armed, or otherwise prepared for action, and that has been fired, dropped, launched, projected, or placed in such a manner as to constitute a hazard to operations, installations, personnel, or material, and remains unexploded either by malfunction, design, or for any other cause.

UXO vs HTRW

With respect to its threat to human health and the environment, UXO differs from other hazards in several ways that can be inferred from the quick comparison chart below. Hazardous, toxic, and radiological wastes (HTRW) generally present a threat to human health and the environment through repeated and accumulated exposures to certain contaminants above acceptable exposure limits. UXO presents an immediate risk of acute physical injury from fire or explosion resulting from accidental or unintentional detonation.

General Characteristics	
UXO	HTRW
Not very mobile	Very mobile
Not chemical specific	Chemical specific
Not concentration dependent	Concentration dependent
Single exposure	Multiple exposure
Narrow target population	Broad target population
Immediate acute physical injury	Long-term health effects

Box 1

UXO Risk Assessments

Risk models use site-specific data on the distribution and density of UXO to estimate the threat to human health and the environment according to current and reasonably anticipated future land use. The models are used to determine risk on the basis of the characteristics of the UXO present (amount, depth, size, and type), the characteristics of the site (topography, vegetation, soil type, and climate), and the range of potential exposure (current and future land use, and population size and proximity to site).

UXO Safety and Reporting

It is important to understand how to react responsibly in the presence of UXO.

If you encounter UXO:

- STOP! Do not move closer.
- DO NOT touch, move, or disturb UXO.
- Do not transmit radio frequencies (walkie-talkies, citizens band radio, cellular telephones, etc.).
- Do not attempt to remove anything near UXO.
- Clearly mark the UXO area.
- Complete Reporting Memorandum listing:
 - Time of encounter (date, time)
 - Location (coordinates, street/grid names)
 - Individuals present (names, organizations)
 - Ordnance condition (buried, partially buried, exposed)
 - Type of ordnance (rocket, grenade, projectile)
 - Estimated size of ordnance (length, width, height)
 - Distinctive features of ordnance (shape, color, markings)
 - Nearby structures (landmarks, names, types, distance from ordnance).
- Forward the completed memorandum to the nearest EOD personnel (if available) or public safety office.

*In case of emergency, call
(404) 362-3333
(52nd Ordnance Group)*

UXO Response Process

DoD Components conduct UXO response actions to address explosives safety hazards posed to public health, welfare, or the environment. Depending on the amount of time available for responding to the threat, response actions may take place within a few hours or may last several years. Where UXO presents an imminent, immediate threat to human health or the environment, the DoD Component may initiate an *Emergency Response* to address the immediate, unacceptable hazards (e.g., possibility of acute

Form SF298 Citation Data

Report Date ("DD MON YYYY") 00 Mar 1999	Report Type N/A	Dates Covered (from... to) ("DD MON YYYY")
Title and Subtitle Unexploded Ordnance (UXO)	Contract or Grant Number	
	Program Element Number	
Authors	Project Number	
	Task Number	
	Work Unit Number	
Performing Organization Name(s) and Address(es) Office of the Under Secretary of Defense Acquisition and Technology 3000 Defense Pentagon Washington, DC 20301-2000	Performing Organization Number(s)	
Sponsoring/Monitoring Agency Name(s) and Address(es)	Monitoring Agency Acronym	
	Monitoring Agency Report Number(s)	
Distribution/Availability Statement Approved for public release, distribution unlimited		
Supplementary Notes Document has color		
Abstract The Department of Defense (DoD) defines military munitions/explosive ordnance as any munition, weapon delivery system, or ordnance item that contains explosives, propellants, or chemical agents. UXO is military munitions/explosive ordnance that has been primed, fused, armed, or otherwise prepared for action, and that has been fired, dropped, launched, projected, or placed in such a manner as to constitute a hazard to operations, installations, personnel, or material, and remains unexploded either by malfunction, design, or for any other cause.		
Subject Terms		
Document Classification unclassified	Classification of SF298 unclassified	
Classification of Abstract unclassified	Limitation of Abstract unlimited	
Number of Pages 4		

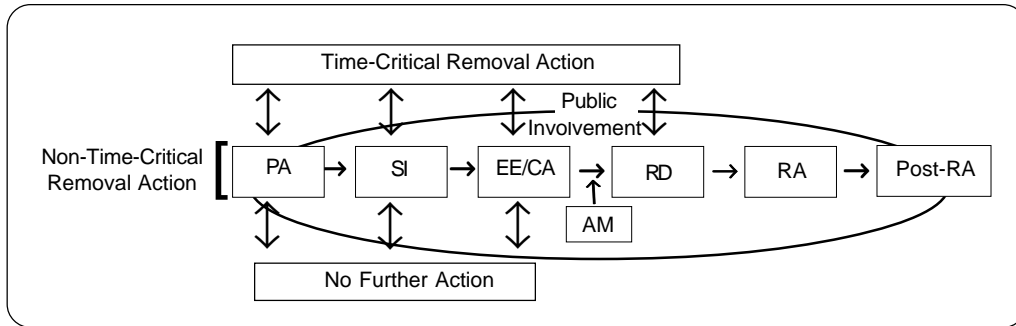

Figure 1. UXO Assessment and Removal Process

physical injury, death, destruction of property). Under circumstances that only allow a response within a few months, the Component may initiate a *Time-Critical Removal Action (TCRA)*, which may involve surface clearance, fencing or other measures to deny access, restrictive signs to warn of the hazards, or a combination of the foregoing. However, Components typically conduct UXO response activities as *Non-Time-Critical Removal Actions (NTCRA)*, following a longer process that involves the public and regulatory communities early and continually throughout the process, as depicted in Figure 1. Even during the NTCRA process, circumstances may give rise to the need to conduct a more expedited response, such as an Emergency Response or a TCRA. The standard phases of the NTCRA are explained below:

Removal Preliminary Assessment (PA) This phase involves recognizing the existence of the site in question, determining whether a UXO hazard is present, and identifying whether further action is needed.

Removal Site Investigation (SI) During this phase, an Archives Search Report (ASR) is begun. Information from the ASR is combined with results from a preliminary risk assessment to verify the extent of the suspected UXO hazard. Components of the ASR include a historical records search, interviews with knowledgeable personnel, and interpretation of aerial photos and old maps to gain a better understanding of the types and amounts of UXO hazards potentially present.

Engineering Evaluation/Cost Analysis (EE/CA) A geophysical survey is performed in suspected UXO areas. A geostatistically based sampling program can be used to develop a sampling strategy to characterize areas suspected of containing UXO.

In this phase, a range of site-specific response actions, consistent with future land use, are evaluated according to criteria in the National Contingency Plan. This evaluation compares and contrasts the alternatives with respect to their

overall protectiveness, implementability, and cost. The evaluation results provide the basis for selection of the action to be taken. The EE/CA is made available for public comment to solicit input on the potential response and reasonably anticipated future land uses. After the installation has responded to the public comments, the response action is finalized in an Action Memorandum (AM).

Removal Design (RD) During the design phase, an RD plan is prepared that will achieve the UXO response objectives outlined in the Action Memorandum. The plan defines the contract specifications, response plans, safety and personnel qualifications, and anticipated depth of clearance. During this phase, an explosives safety submission must be prepared for the DoD Explosives Safety Board (DDESB) to review and approve prior to start of the Removal Action.

Removal Action (RA) During this phase, the selected solution is implemented according to the specifications defined in the RD plan. The removal action may consist of detonating UXO in place or at off-site demolition grounds, provided that DDESB approves the explosive safety submission.

Post-Removal Action (Post-RA) This phase may be required in the Action Memorandum and can include public education, periodic UXO sweeps, long-term monitoring, land use restrictions, and additional UXO actions if land use changes.

Public Involvement

Public involvement is a key component in the entire removal process. Each UXO project phase has a specific requirement to keep the public informed and to seek public support. Communication with the public and regulators is critical to successful and timely project completion. This can be accomplished through the use of Restoration Advisory Boards, which consist of volunteer public and government stakeholders for a specific site.

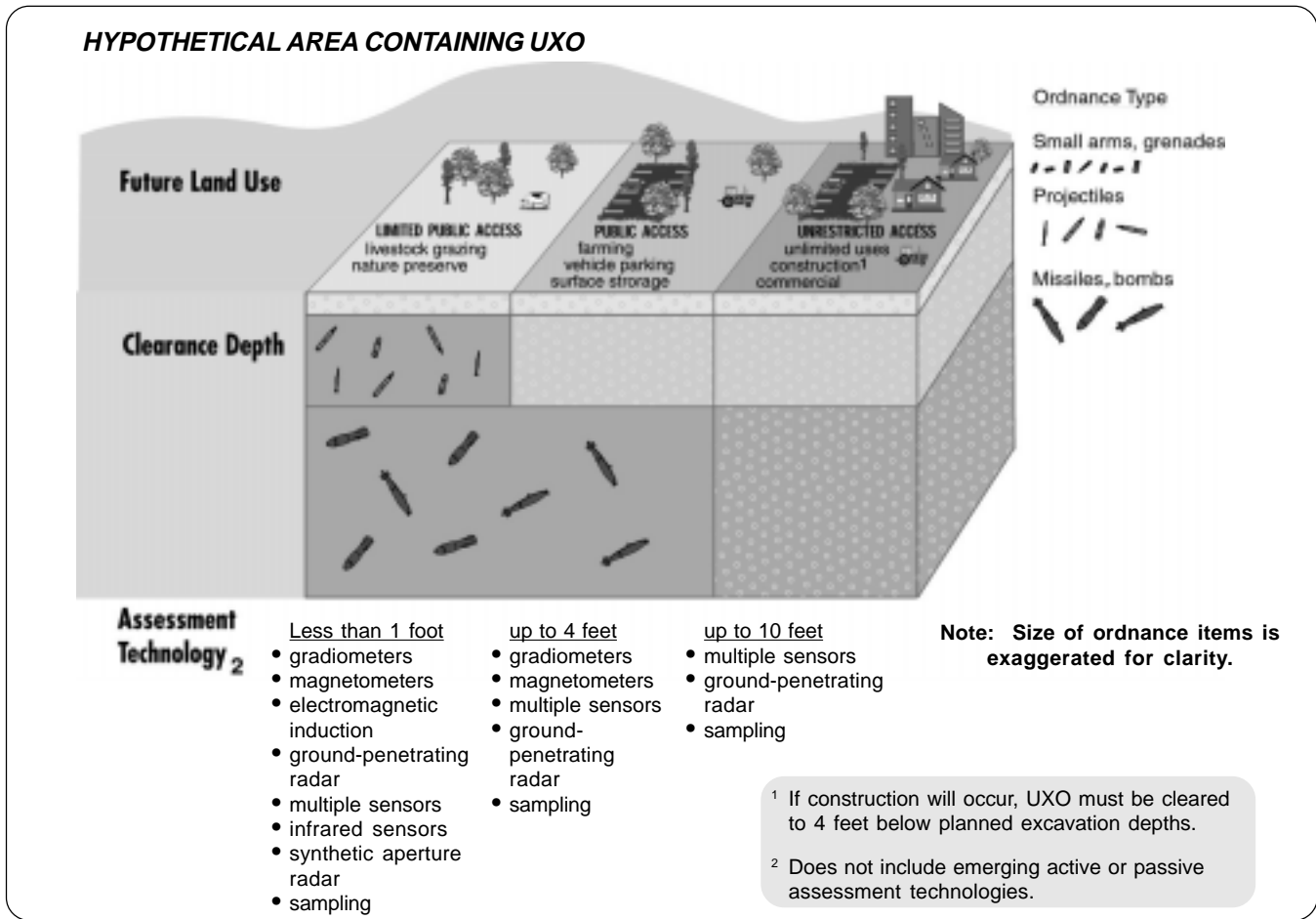

Figure 2. Determining Clearance Depths Based on Future Land Use

UXO Clearance Standards

Figure 2 shows a hypothetical area with UXO. If a response involves clearance, the preferred method of determining clearance depth is to use site-specific information, including site conditions and planned land use. This figure illustrates the generic clearance depths recommended by DDESB, when site-specific planning is not possible, to support different future land uses. The figure also shows the current assessment technologies available for identifying and characterizing the presence of UXO at the stated depths.

Recent Developments

The following DoD and Federal regulations also influence the UXO response process.

- DoD 6055.9-STD *DoD Ammunition and Explosives Safety Standards*, effective August 1997, establishes uniform safety standards applicable to ammunition and explosives and to both associated and unassociated personnel and property. This standard supersedes DoD 6055.9-STD *Ammunition and Explosives Safety Standards*, October 1992. This information is available on the DDESB web page.

- EPA's Military Munitions Rule, finalized August 12, 1997, identifies the point at which conventional and chemical military munitions become a solid waste under the Resource Conservation and Recovery Act (RCRA) and provides for the safe storage and transportation of such waste.
- The DoD Range Rule, proposed September 26, 1997, includes Comprehensive Environmental Response, Compensation, and Liability Act (CERCLA)-like methodology and focuses on the specific needs of range evaluation and response. The Range Rule is being developed by DoD, in consultation with EPA, other Federal agencies, states, and Native American tribes to identify appropriate response actions on military ranges that (1) have been taken out of service and put to a new use, (2) are formerly used defense sites, and/or (3) are slated for transfer out of military control. The Range Rule public comment period ended in December 1997. *When it is finalized, the Range Rule is expected to become the assessment and response standard for these ranges.* A new, comprehensive UXO risk model is being developed in conjunction with the Range Rule. Box 2 outlines the five phases of the proposed Range Rule.



Proposed Range Rule Process

Table with 2 columns: Assessment Stages, Definition. Rows include Range Identification, Range Assessment & Accelerated Response, Range Evaluation & Site-specific Response, Recurring Review, and Administrative Closeout.

Box 2

Where to Learn More

Federal Regulations and Guidance

- Military Munitions Rule: Hazardous Waste Identification and Management; Explosives Emergencies; Manifest Exemptions for Transport of Hazardous Waste on Right-of-Ways on Contiguous Properties. 62 FR 6621 (Feb 12, 1997), 40 CFR Part 266, Subpart M, and EPA/530/F-97/004, February 1997.
Closed, Transferred, and Transferring Ranges Containing Military Munitions, Proposed Rule. Federal Register, Volume 62, Number 187, Pages 50795-50843.
CERCLA/Superfund Orientation Manual. EPA/542/R-92/005, October 1992.
Guidance on Conducting Non-Time-Critical Removal Actions Under CERCLA. EPA/540/R-93/057, August 1993.
DoD Instruction 6055.14, "Unexploded Ordnance (UXO) Safety on Ranges," January 23, 1998.
DoD 6055.9 - STD, "DoD Ammunition and Explosives Safety Standards," August 1997.

Other Information

- Unexploded Ordnance (UXO): An Overview. Naval Explosive Ordnance Disposal Technology Division. October 1996.
BRAC Environmental Fact Sheet: Expediting BRAC Cleanups Using CERCLA Removal Authority, Spring 1997.
Report of the Defense Science Board Task Force on Unexploded Ordnance (UXO) Clearance, Active Range UXO Clearance, and Explosive Ordnance Disposal (EOD) Programs. Office of the Under Secretary of Defense for Acquisition and Technology. April 1998.
DDESB Web Page: http://www.acq.osd.mil/ens/esb/esbhombp.html
U.S. Army Environmental Center Web Page: http://aec-www.apgea.army.mil:8080/

Points of Contact

- Navy Ordnance Environmental Support Office: (301) 744-4450/4534
U.S. Army Engineering and Support Center Huntsville: (205) 895-1545

This and other documents on the BRAC Environmental Program are available at: http://www.dtic.mil/envirodod/brac/

We welcome and invite your comments on this fact sheet, as we seek ways to improve the information provided. Please send comments to the following address:

OADUSD (Environmental Cleanup)
Attn: Fast-Track Cleanup
3400 Defense Pentagon
Washington, DC 20301-3400