

FINAL REPORT
APRIL 1997

REPORT NO. 97-13

MK84, 2,000-POUND BOMBS
LOADED ON
M871 AND M872 SEMITRAILERS
TRANSPORTABILITY TESTS

DISTRIBUTION STATEMENT A
Approved for Public Release
Distribution Unlimited

Distribution Unlimited

Prepared for:
U.S. Army Defense Ammunition Center
ATTN: SIOAC-DET
Savanna, IL 61074-9639

20010227 058

VALIDATION ENGINEERING DIVISION
SAVANNA, ILLINOIS 61074-9639



AVAILABILITY NOTICE

A copy of this report will be furnished each attendee on automatic distribution. Additional copies or authority for reprinting may be obtained by written request from Director, U.S. Army Defense Ammunition Center, ATTN: SIOAC-DEV, Savanna, IL 61074-9639.

DISTRIBUTION INSTRUCTIONS

Destroy this report when no longer needed. Do not return.

Citation of trade names in this report does not constitute an official endorsement.

The information contained herein will not be used for advertising purposes.

REPORT DOCUMENTATION PAGE				Form Approved OMB No. 0704-0188		
1a. REPORT SECURITY CLASSIFICATION UNCLASSIFIED			1b. RESTRICTIVE MARKINGS			
2a. SECURITY CLASSIFICATION AUTHORITY		3. DISTRIBUTION / AVAILABILITY OF REPORT UNLIMITED				
2b. DECLASSIFICATION / DOWNGRADING SCHEDULE						
4. PERFORMING ORGANIZATION REPORT NUMBER(S) 97-13			5. MONITORING ORGANIZATION REPORT NUMBER(S)			
6a. NAME OF PERFORMING ORGANIZATION U.S. Army Defense Ammunition Center		6b. OFFICE SYMBOL (if applicable) SIOAC-DEV	7a. NAME OF MONITORING ORGANIZATION			
6c. ADDRESS (City, State, and ZIP Code) ATTN: SIOAC-DEV Savanna, IL 61074-9639			7b. ADDRESS (City, State, and ZIP Code)			
8a. NAME OF FUNDING / SPONSORING ORGANIZATION U.S. Army Defense Ammunition Center		8b. OFFICE SYMBOL (if applicable) SIOAC-DET	9. PROCUREMENT INSTRUMENT IDENTIFICATION NUMBER			
8c. ADDRESS (City, State, and ZIP Code) ATTN: SIOAC-DET Savanna, IL 61074-9639			10. SOURCE OF FUNDING NUMBERS			
			PROGRAM ELEMENT NO.	PROJECT NO.	TASK NO.	WORK UNIT ACCESSION NO.
11. TITLE (Include Security Classification) MK84, 2,000-Pound Bombs Loaded on M871 and M872 Semitrailers Transportability Tests						
12. PERSONAL AUTHOR(S) Ejike J. Ajalla						
13a. TYPE OF REPORT Final		13b. TIME COVERED FROM _____ TO _____		14. DATE OF REPORT (Year, Month, Day) 1997 April	15. PAGE COUNT	
16. SUPPLEMENTARY NOTATION						
17. COSATI CODES			18. SUBJECT TERMS (Continue on reverse if necessary and identify by block number)			
FIELD	GROUP	SUB-GROUP				
19. ABSTRACT (Continue on reverse if necessary and identify by block number) The U.S. Army Defense Ammunition Center (DAC), Validation Engineering Division (SIOAC-DEV), was tasked by DAC, Transportation Engineering Division (SIOAC-DET), to verify the procedure, loading and bracing with wooden dunnage of palletized MK84, 2,000-pound bombs loaded on M871 and M872 semitrailers, would meet the transportability requirements of hazard, road trip and washboard simulation tests. The loading and bracing procedures successfully passed all tests and were approved.						
20. DISTRIBUTION / AVAILABILITY OF ABSTRACT <input checked="" type="checkbox"/> UNCLASSIFIED/UNLIMITED <input type="checkbox"/> SAME AS RPT. <input type="checkbox"/> DTIC USERS			21. ABSTRACT SECURITY CLASSIFICATION UNCLASSIFIED			
22a. NAME OF RESPONSIBLE INDIVIDUAL JEROME H. KROHN			22b. TELEPHONE (Include Area Code) 815-273-8929		22c. OFFICE SYMBOL SIOAC-DEV	

U.S. ARMY DEFENSE AMMUNITION CENTER
VALIDATION ENGINEERING DIVISION
SAVANNA, IL 61074-9639

REPORT NO. 97-13

MK84, 2,000-POUND BOMBS LOADED ON M871 AND M872 SEMITRAILERS
TRANSPORTABILITY TESTS

TABLE OF CONTENTS

PART	PAGE NO.
1. INTRODUCTION.....	1-1
A. BACKGROUND.....	1-1
B. AUTHORITY.....	1-1
C. OBJECTIVE.....	1-1
D. CONCLUSION.....	1-1
2. ATTENDEES.....	2-1
3. TEST PROCEDURES.....	3-1
4. TEST EQUIPMENT.....	4-1
5. TEST RESULTS.....	5-1
6. PHOTOGRAPHS.....	6-1
7. DRAWING.....	7-1

PART 1

INTRODUCTION

A. BACKGROUND. The U.S. Army Defense Ammunition Center (DAC), Validation Engineering Division (SIOAC-DEV), was tasked by DAC, Transportation Engineering Division (SIOAC-DET), to perform transportability tests on palletized MK84, 2,000-pound bombs loaded on M871 and M872 semitrailers.

B. AUTHORITY. This test was conducted IAW mission responsibilities delegated by the U.S. Army Armament, Munitions and Chemical Command (AMCCOM), Rock Island, Illinois.

C. OBJECTIVE. The objective of these tests was to assess the ability of M871 and M872 semitrailers to safely transport palletized MK84, 2,000-pound bombs. These procedures will be used to support planned FY 97 shipments during Operation Golden Cargo.

D. CONCLUSION. A validated restraint method for on/off-highway transport of pallets of MK84, 2,000-pound bombs on M871 and M872 semitrailers has been developed.

PART 2

29 March - 11 April 1997

ATTENDEES

Ejike J. Ajalla
Mechanical Engineer
DSN 585-8434
815-273-8434

Director
U.S. Army Defense Ammunition Center
ATTN: SIOAC-DEV
3700 Army Depot Road
Savanna, IL 61074-9639

John D. Simons
Industrial Engineer
DSN 585 - 8074
815 - 273 - 8074

Director
U.S. Army Defense Ammunition Center
ATTN: SIOAC-DET
3700 Army Depot Road
Savanna, IL 61074-9639

Jerome H. Krohn
Supervisory General Engineer
DSN 585-8908
815-273-8908

Director
U.S. Army Defense Ammunition Center
ATTN: SIOAC-DEV
3700 Army Depot Road
Savanna, IL 61074-9639

William R. Frerichs
Supervisory General Engineer
DSN 585-8071
815-273-8071

Director
U.S. Army Defense Ammunition Center
ATTN: SIOAC-DET
3700 Army Depot Road
Savanna, IL 61074-9639

PART 3

TEST PROCEDURES

TRANSPORTABILITY TESTS: The test procedures outlined in this section were extracted from TP-94-01. This standard identifies six steps that a load must undergo if it is considered to be acceptable. The four tests that were conducted on the test specimen are synopsized below.

A. ROAD HAZARD COURSE. The test load was subjected to the road hazard course. Using a suitable tractor/trailer, the test load was driven over the hazard course two times prior to the road trip and two times following the road trip. The specimen load was driven at a speed approximately 5 mph. The speed may be increased or decreased, as deemed appropriate, to produce the most violent load response (see Figure 1).

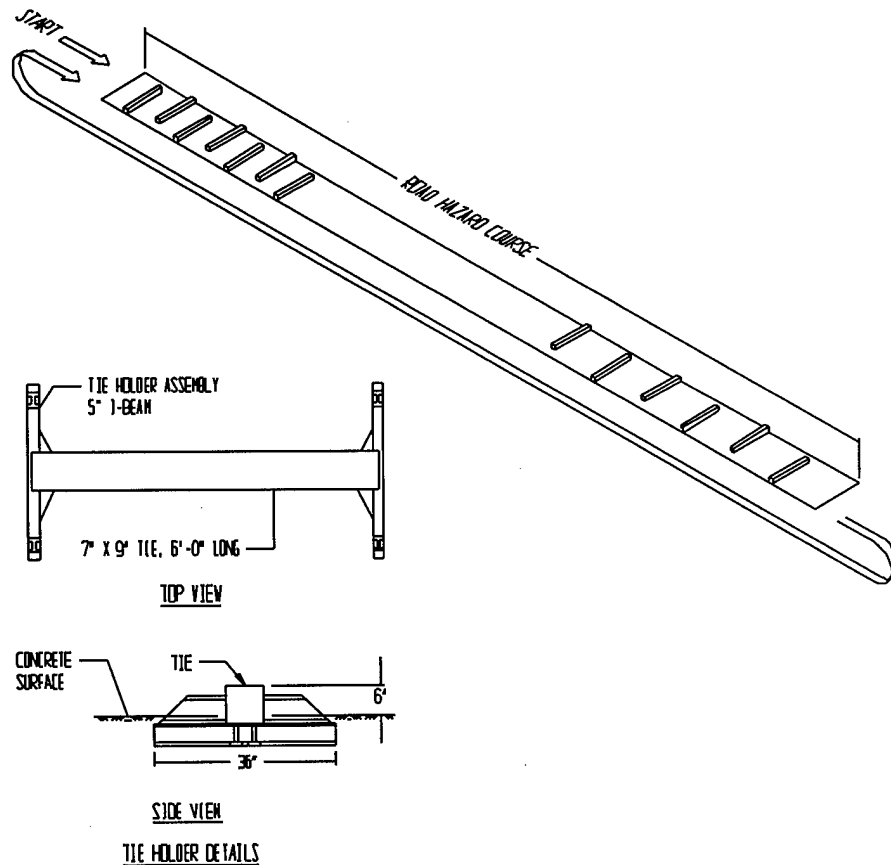

FIGURE 1

B. ROAD TRIP. Using a suitable tractor/trailer, the specimen load was driven for a total distance of at least 30 miles over a combination of roads surfaced with gravel, concrete, and asphalt. The test route included curves, corners, railroad crossings, cattle guards, stops, and starts. The test vehicle traveled at the maximum speed suitable for the particular road being traversed, except as limited by legal restrictions.

C. PANIC STOPS. This step provides for the specimen load to be subjected to three full air brake stops while travelling in the forward direction and one in the reverse direction. The first three stops were at 5, 10, and 15 mph, while the stop in the reverse direction was at approximately 5 mph.

D. WASHBOARD COURSE. Using a tractor/trailer, the specimen load was driven over the washboard course at a speed which produced the most violent response in the test load (see Figure 2).

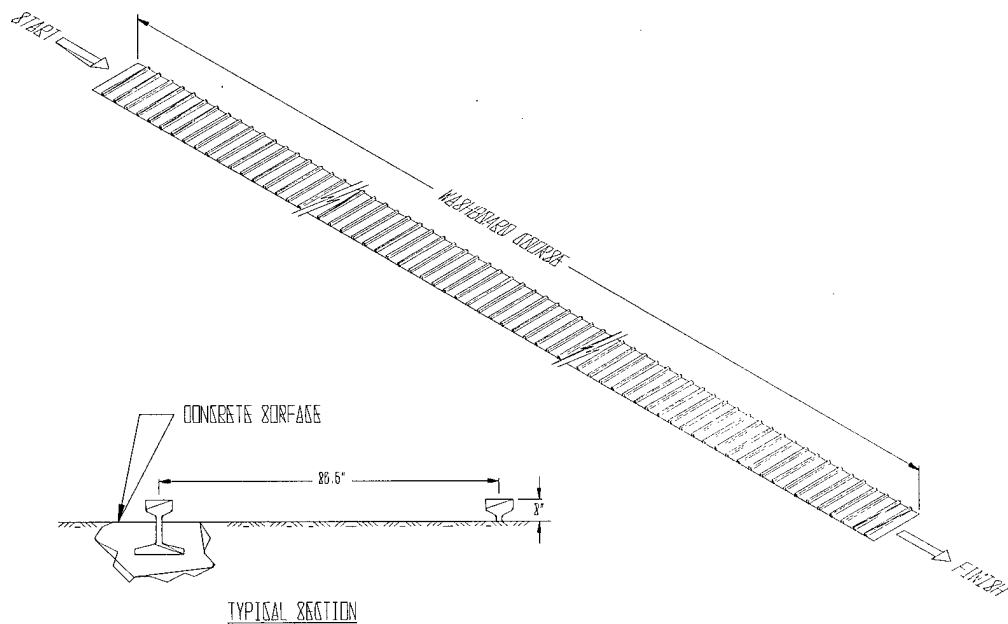

FIGURE 2

E. INSPECTIONS AND DATA COLLECTIONS. At selected intervals during testing, thorough inspections of the specimen loads were made by technically proficient personnel to collect data on the specimen load and equipment resulting from above load test steps. This data is recorded in Part 5.

PART 4

TEST EQUIPMENT

A. MK84, 2,000-POUND BOMB PALLET.

1. Quantity:	8 pallets - one-layer load 12 pallets - two-layer load
2. Bombs Per Pallet:	2
3. Pallet Weight:	4,133 pounds
4. Width:	38 inches
5. Length:	99 inches
6. Height:	24-1/4 inches
7. Cube:	52.8 cubic feet

B. M872 SEMITRAILER.

1. Capacity:	34 tons
2. Length:	489-1/2 inches
3. Width:	96 inches

C. M871 SEMITRAILER.

1. Capacity:	22-1/2 tons
2. Length:	358 inches
3. Width:	96 inches

PART 5

TEST RESULTS

TRANSPORTABILITY TESTS:

A. Two Layers:

(1) An M871 semitrailer was loaded with 8 pallets of MK84, 2,000-pound bombs (2 rows of 2 pallets wide and 2 layers high). Between the 2 rows of bombs were 4 pallets of 105mm boxes to simulate a stack of 4 pallets each containing 2 MK84, 2,000-pound bombs. A separator gate was placed between the rows of pallets. Side blocking was nailed to the floor of the trailer along the base of the pallets. Each row of the pallets had two web straps extended over the top attached to removable tiedown anchors to secure them in place. The bombs were also secured longitudinally by a retainer gate at the aft end, with two web straps attached to removable tiedown anchors holding the load in place (see photo on page 6-3).

(2) The loaded trailer, towed by a semitractor, completed the hazard course; the 30-mile road course; the 5, 10, and 15 mph panic stops, and reverse 5 mph panic stops; and the washboard course as shown below. No physical damage was noticed on the loads. This load passed the transportability test parameters.

<u>COURSE</u>	<u>TIME</u> <u>(min:sec)</u>	<u>SPEED</u> <u>(mph)</u>
HAZARD COURSE NO. 1	00:27.0	4.4
HAZARD COURSE NO. 2	00:21.6	5.5
30-MILE ROAD TRIP	54:00.0	33.3
PANIC STOPS		5, 10, 15 and reverse 5
HAZARD COURSE NO. 3	00:26.4	4.3

<u>COURSE</u>	<u>TIME</u> <u>(min:sec)</u>	<u>SPEED</u> <u>(mph)</u>
HAZARD COURSE NO. 4	00:26.4	4.3
WASHBOARD COURSE	00:51.0	4.0

B. One Layer:

(1) An M872 semitrailer was loaded with 8 pallets of 2,000-pound bombs (4 rows of 2 pallets wide). The bombs were loaded in two columns, with the nose end butted against the nose end and the base end of the initial row against the forward bulkhead of the trailer. The bombs were secured by separator gates that were placed between the rows of the pallets. Side blocking was nailed to the floor of the trailer along the base of the pallet. Each row of the pallets had two web straps extended over the top attached to removable tiedown anchors on each side of the load to secure them in place. The bombs were also secured longitudinally by a retainer gate at the aft end, with two web straps attached to removable tiedown anchors holding the load in place (see photo on page 6-2 and the load shown on page 7-8).

(2) The loaded trailer, towed by a semitractor, completed the hazard course; the 30-mile road course; the 5, 10, and 15 mph panic stops, and reverse 5 mph panic stop; and the washboard course as shown below. No physical damage was noticed on the loads at the end of the test. This load passed the transportability test parameters.

<u>COURSE</u>	<u>TIME</u> <u>(min:sec)</u>	<u>SPEED</u> <u>(mph)</u>
HAZARD COURSE NO. 1	00:26.4	4.5
HAZARD COURSE NO. 2	00:27.0	4.4
30-MILE ROAD TRIP	53:00.0	34.0
PANIC STOPS		5, 10, 15 and reverse 5
HAZARD COURSE NO. 3	00:25.2	4.7
HAZARD COURSE NO. 4	00:23.4	5.1
WASHBOARD COURSE	00:48.0	4.3

PART 6

PHOTOGRAPHS

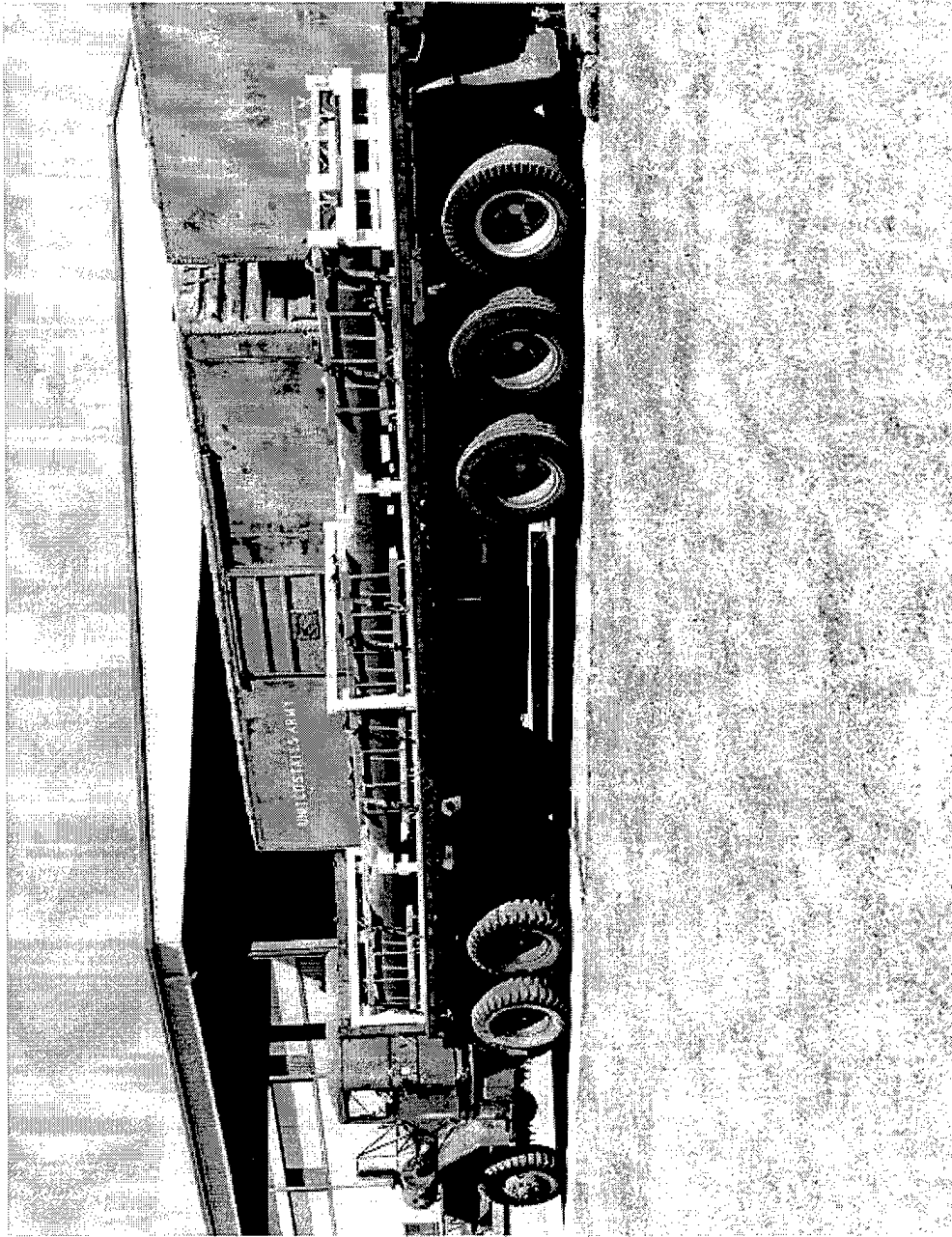

U.S. ARMY DEFENSE AMMUNITION CENTER -
SAVANNA, IL

AO317-SCN97-1531. This photo shows 8 pallets of 2,000-pound bombs loaded on the M872 semitrailer.

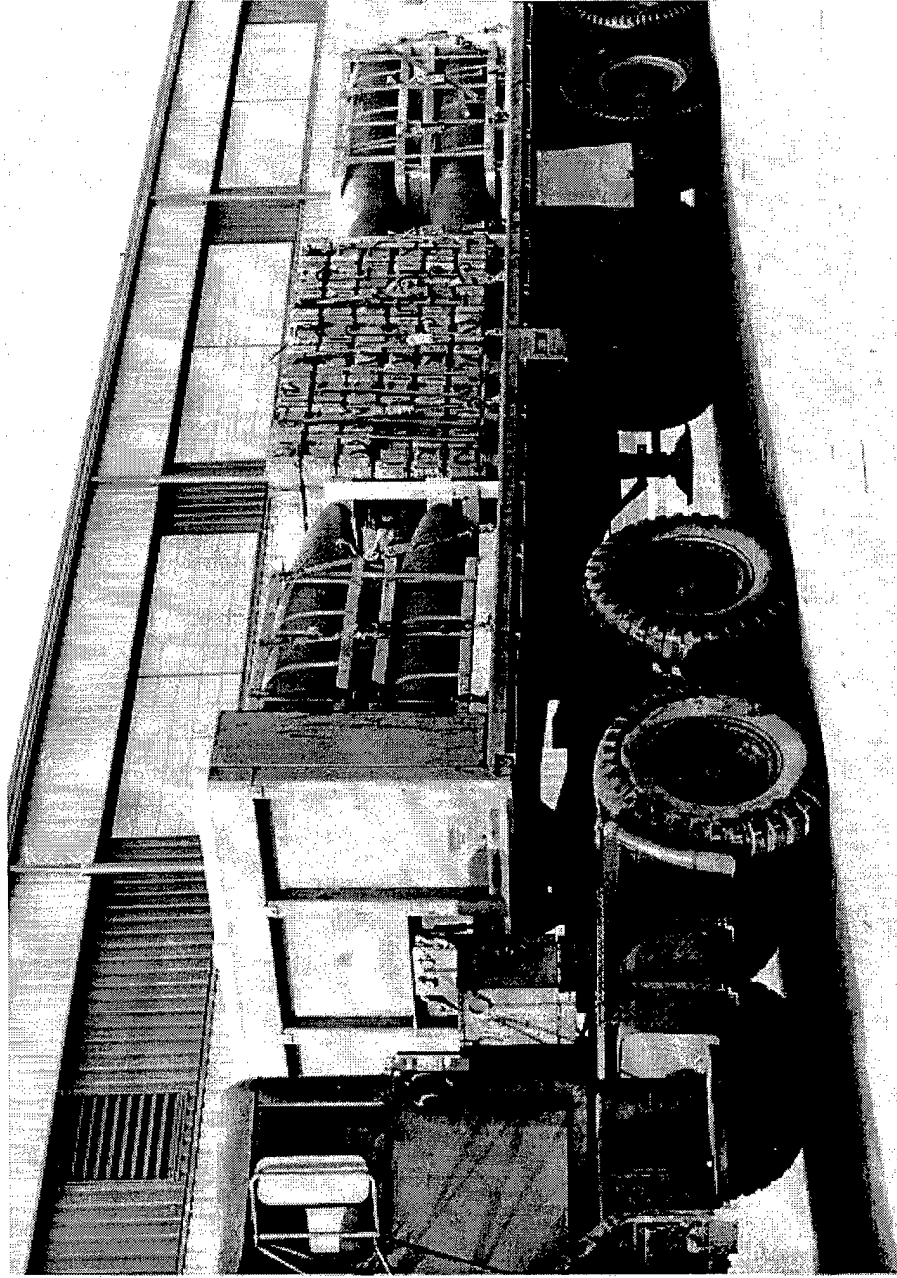

U.S. ARMY DEFENSE AMMUNITION CENTER -
SAVANNA, IL

AO317-SCN97-1528. This photo shows a mixed load, two layers high, of 8 pallets of 2,000-pound bombs and boxes of 105mm boxed ammunition loaded on the M871 semitrailer.

PART 7

DRAWING

OPERATION GOLDEN CARGO

LOADING AND TIEDOWN PROCEDURES FOR THE M117 750 LB BOMB AND THE MK84 2,000 LB BOMB LOADED ON THE 34-TON M872 SEMITRAILER

INDEX

<u>ITEM</u>	<u>PAGE(S)</u>
GENERAL NOTES AND MATERIAL SPECIFICATIONS - - - - -	2
LOADING, TIEDOWN, AND UNLOADING PROCEDURES AND PALLET UNIT DETAILS - - -	3
ONE PALLET HIGH LOAD OF 750 LB BOMBS - - - - -	4,5
TWO PALLET HIGH LOAD OF 750 LB BOMBS - - - - -	6,7
ONE PALLET HIGH LOAD OF 2,000 LB BOMBS - - - - -	8,9
TWO PALLET HIGH LOAD OF 2,000 LB BOMBS - - - - -	10,11
DUNNAGE DETAILS - - - - -	12-14
TIEDOWN ANCHOR DETAILS - - - - -	15
RATCHET/RATCHETING DETAILS - - - - -	16,17

● THE PROCEDURES DEPICTED WITHIN THIS DRAWING
ARE FOR ON/OFF HIGHWAY USE ONLY.

Prepared during April 1997 by:
U.S. Army Defense Ammunition Center
ATTN: SIDAC-DET
Savanna, IL 61074-9639
POC: Mr. John Sinons
DSN 585-8072/8927
Com (815) 273-8072/8927
Fax 585-8811
E-mail: siaocdet@savanna-enh1.army.mil

William R. Frerichs
Chief, Transportation Engineering Division

GENERAL NOTES

- A. THIS DOCUMENT HAS BEEN PREPARED AND ISSUED IN ACCORDANCE WITH AR 740-1.
- B. THIS DRAWING COVERS PROCEDURES APPLICABLE TO THE TRANSPORT OF THE M117 750 LB BOMB AND MK84 2,000 LB BOMB, LOADED ON THE 34-TON M872 SEMITRAILER EQUIPPED WITH THE 10,000 POUND TYPE I (MICKEY MOUSE) TIEDOWN ANCHORS AND HAVING AN EMPTY WEIGHT OF 16,800 LBS (APPROX). THE MAXIMUM LOAD WEIGHT ON THE KINGPIN IS 27,600 LBS AND THE MAXIMUM LOAD WEIGHT ON THE THREE REAR AXLES IS 56,400 LBS. NOTE: THE LOADS SHOWN DO NOT EXCEED THE AVERAGE HIGHWAY WEIGHT LIMIT OF 42,000 POUNDS ON THE THREE M872 TRAILER AXLES.
- C. FOR DETAIL OF THE M117 750 LB BOMB PALLET UNIT, AND THE MK84 2,000 LB BOMB PALLET UNIT, SEE PAGE 3 OF THIS DRAWING.
- D. ALL LOADS SHOWN HEREIN ARE TYPICAL AND ARE BASED ON TESTED PROCEDURES FOR ON AND/OR OFF HIGHWAY TRANSPORT OF FULL AND/OR LESS THAN FULL PALLET UNITS. COMBINATIONS OF PROCEDURES MAY BE USED. HOWEVER, THE APPROVED METHODS SPECIFIED HEREIN MUST BE FOLLOWED AS CLOSELY AS POSSIBLE.
- E. WEB STRAP TIEDOWN ASSEMBLIES MUST BE SECURELY HOOKED INTO ANCHORING DEVICES ON THE TRANSPORTING VEHICLE AND FIRMLY TENSIONED. FIRMLY TENSIONED MEANS, WHEN THE OPERATOR PULLS ON THE RATCHET HANDLE BY HAND, THE RATCHET WILL NOT ADVANCE ANOTHER NOTCH. NO TYPE OF MECHANICAL EXTENSION OR LEVER WILL BE USED. EXERCISE CARE DURING STRAP APPLICATION. AVOID TWISTS IN THE STRAP TO THE EXTENT POSSIBLE (IF TIME PERMITS) BUT ENSURE THERE ARE NO KNOTS IN THE STRAP. ON THE TAKE-UP SPOOL OF THE RATCHET, ENSURE STRAIGHT LAY OF THE STRAP WHEN TENSIONING. AFTER INITIAL WEBBING-TO-WEBBING CONTACT HAS BEEN MADE, BY ROTATING THE TAKE-UP SPOOL UNTIL NO METAL ON THE SPOOL IS SHOWING AND THE STRAP HAS MADE CONTACT WITH ITSELF. THE TENSIONED STRAP MUST FORM AT LEAST 1/2 BUT NOT MORE THAN 1-1/2 WRAPS OF STRAP ON THE TAKE-UP SPOOL OF THE TENSIONING RATCHET. AFTER TENSIONING IS COMPLETED, ENSURE THAT THE SPOOL LOCKING LATCH IS FULLY SEATED AT BOTH ENDS OF THE SPOOL IN MATCHING LOCKING NOTCHES. TIE BACK THE LOOSE END OF THE STRAP AFTER TENSIONING IS COMPLETED (LOOSE ENDS MAY BE FOLDED AND TAPEO OR TIED TO THE TENSIONING STRAP IF TIME PERMITS). FOR ADDITIONAL GUIDANCE, SEE "RATCHET/RATCHETING DETAILS" ON PAGES 16 AND 17.
- F. ADJUSTABLE SCUFF SLEEVES PROVIDED ON WEB STRAP TIEDOWN ASSEMBLIES WILL BE LOCATED TO PROVIDE A PAD WHERE STRAPS PASS OVER SHARP EDGES, OR RATCHETS AND HOOKS ON PREVIOUSLY INSTALLED WEB STRAP TIEDOWN ASSEMBLIES.
- G. IF THE SIDE RACKS FOR A SEMITRAILER ARE TO TRANSPORTED ON THE LOADED TRAILER, THEY WILL BE STACKED ON THE TRAILER AND SECURED WITH A SUFFICIENT QUANTITY OF WEB STRAP TIEDOWN ASSEMBLIES TO PREVENT LOSS DURING TRANSPORT. NOTE: IF DESIRED, THE SIDE RACKS FOR THE M871 AND M872 SEMITRAILERS MAY BE POSITIONED IN PLACE AFTER THE LOAD HAS BEEN SECURED. AFTER ALL SIDE PANELS AND REAR PANELS ARE IN POSITION, THE STAKES MUST BE SECURELY "PINNED" OR "WIRE-TIED" TO THE STAKE POCKETS TO PREVENT VERTICAL DISPLACEMENT DURING TRANSPORT. ALSO, THE SIDE PANELS MUST BE SECURED AT THE TOP WITH THE CROSS-CHAINS WHICH ARE PROVIDED WITH THE VEHICLE.

(CONTINUED AT RIGHT)

MATERIAL SPECIFICATIONS

- LUMBER - - - - - : SEE TM 743-200-1 (DUNNAGE LUMBER) AND FED SPEC MM-L-751.
- NAILS - - - - - : FED SPEC FF-N-105; COMMON.
- STRAP - - - - - : WEBBING, UNIVERSAL TIEDOWN, NSN 5340-01-204-3009, PN9392419, OR NSN 5340-01-089-4997, PN11669588, OR NSN 1670-00-725-1437, PN1376-013, OR NSN 5340-00-980-9277, PN10900880.
- STRAPPING, STEEL - - : ASTM D3953; FLAT STRAPPING, TYPE I, HEAVY DUTY, FINISH A, B (GRADE 2), OR C.
- SEAL, STRAP - - - - : ASTM D3953; CLASS H, FINISH A, B (GRADE 2), OR C, DOUBLE NOTCH TYPE, STYLE I, II, OR IV.

(GENERAL NOTES CONTINUED)

- H. PROCEDURES DEPICTED HEREIN ARE TYPICAL IN NATURE RELATIVE TO ITEM LOCATION IN/ON THE VEHICLE AND THE QUANTITIES SHOWN. ITEM LOCATION AND QUANTITIES OF THE DESIGNATED ITEM MAY BE VARIED TO SATISFY OPERATIONAL REQUIREMENTS, PROVIDING LOADING AND TIEDOWN PRINCIPLES SPECIFIED HEREIN ARE RETAINED.
- J. WHEN ONE WEB TIEDOWN STRAP ASSEMBLY IS NOT LONG ENOUGH TO SPAN THE DISTANCE DEPICTED, TWO ASSEMBLIES MAY BE HOOKED TOGETHER TO GAIN THE NECESSARY LENGTH.
- K. CONVERSION TO METRIC EQUIVALENTS: DIMENSIONS WITHIN THIS DOCUMENT ARE EXPRESSED IN INCHES, AND WEIGHTS ARE EXPRESSED IN POUNDS. WHEN NECESSARY, THE METRIC EQUIVALENTS MAY BE COMPUTED ON THE BASIS OF ONE INCH EQUALS 25.4MM AND ONE POUND EQUALS 0.454 KG.
- L. SOME TIEDOWN METHODS WITHIN THIS DRAWING SHOW TWO HOOKS TO BE CONNECTED TO ONE TIEDOWN EYE. THIS IS AUTHORIZED AS SPECIFIED HEREIN.
- M. DURING LONG HAULS, WHEN POSSIBLE, STRAPS SHOULD BE CHECKED DURING VEHICLE STOPS AND TIGHTENED, IF NECESSARY.
- N. ONLY THE CARGO BODIES OR BEDS OF THE TACTICAL VEHICLES HAVE BEEN SHOWN HEREIN TO PREVENT DISTRACTION FROM THE DELINEATED LOADING AND TIEDOWN PROCEDURES, AND ARE SHOWN IN OUTLINE FORM WITH THE STRUCTURAL PORTIONS OMITTED AS NECESSARY TO IMPROVE THE CLARITY OF THE DEPICTED PROCEDURES.
- O. DUE TO VARIOUS REASONS, SUCH AS ROUGH TERRAIN DURING OFF HIGHWAY TRANSPORT, PANIC STOPS, METAL FLOORS ON VEHICLES AND NORMAL STRETCH OF WEB STRAPS, LOADED ITEMS MAY SLIDE SLIGHTLY Laterally AND/OR LONGITUDINALLY DURING TRANSPORT. THIS IS AN ACCEPTABLE CHARACTERISTIC AND IS NOT DETRIMENTAL TO LOAD SECUREMENT.
- P. IF THE TIEDOWN ANCHORS ON THE SIDE OF THE VEHICLE ARE TOO CLOSE TOGETHER, TOO FAR APART, OR ARE NOT IN A LOCATION THAT WILL ALLOW ADEQUATE HOLD DOWN OF LOAD WHEN WEB STRAPS ARE POSITIONED STRAIGHT OVER TOP, THE LOAD HOLD DOWN STRAPS MAY BE CROSSED OVER THE TOP OF THE LOAD AS SHOWN IN THE LOAD ON PAGE 4.
- Q. FOR ADDITIONAL GUIDANCE SEE THE "LOADING, TIEDOWN, AND UNLOADING PROCEDURES" ON PAGES 3, AND THE "SPECIAL NOTES" ON EACH LOAD PAGE.

LOADING, TIEDOWN, AND UNLOADING PROCEDURES:

1. PRIOR TO LOADING AND/OR UNLOADING, SET BRAKES ON TACTICAL VEHICLE AND REMOVE SIDE RACKS AND/OR TARPS, IF INSTALLED. ASSURE THAT THE TRAILER FLOOR IS FREE OF EXCESSIVE AMOUNTS OF DIRT, SAND AND GRAVEL.
2. PRIOR TO LOADING THE TRAILER, DETERMINE THE QUANTITY OF PALLETS TO BE LOADED AND SELECT THE BEST METHOD TO SECURE THE ITEMS FROM THE METHODS SHOWN WITHIN THIS DRAWING. NOTE: A COMBINATION OF THE METHODS SHOWN WITHIN THIS DRAWING MAY BE USED IN/ON THE SAME TRAILER.
3. ALL PALLETS OF BOMBS MUST BE BLOCKED AT EACH END TO KEEP THE BOMBS FROM "INCHING" OUT OF POSITION DURING TRANSPORT. DO NOT POSITION PALLET UNITS OF 750 LB BOMBS WITH THE NOSE END POINTING TOWARD THE SIDE OF THE TRAILER.
4. ASSURE THAT ALL STEEL STRAPPING ON EACH PALLET IS IN POSITION AND IS TIGHT. MISSING AND/OR LOOSE STEEL STRAPPING SHOULD BE REPLACED.
5. NOTE THAT AFTER THE SIDE BLOCKING HAS BEEN NAILED IN PLACE ON EACH SIDE OF THE LOAD, THE PALLET UNITS CAN BE REMOVED AND/OR LOADED WITHOUT REMOVING THE SIDE BLOCKING.
6. ASSURE THAT ALL PALLET UNITS ARE POSITIONED TIGHTLY AGAINST EACH OTHER Laterally AND LONGITUDINALLY AS LOADING PROGRESSES. THIS WILL REDUCE LOAD MOVEMENT AND THE QUANTITY OF WEB STRAPS REQUIRED TO SECURE THE LOAD. VOID SPACES BETWEEN PALLET UNITS WILL FILL IN DURING TRANSPORT CAUSING WEB STRAPPING TO BECOME LOOSE.
7. AFTER ALL LOADING PROCEDURES ARE COMPLETE, CHECK ALL WEB STRAP TIEDOWN ASSEMBLIES FOR MAXIMUM TIGHTNESS AND RATCHET TIGHTER, IF REQUIRED, PRIOR TO FOLDING UP AND SECURING THE LOOSE ENDS OF STRAP. SEE GENERAL NOTE "E" ON PAGE 2.
8. THE M872 SEMITRAILER IS EQUIPPED WITH TWO DIFFERENT TYPES OF TIEDOWN ANCHORS AS INDICATED IN THE LOAD ON PAGE 4. TYPE I IS A REMOVABLE TIEDOWN ANCHOR THAT HAS ONE RING AND IS POSITIONED BY REACHING UNDER THE FLOOR OF THE TRAILER, INSERTING IT UP THROUGH THE HOLE AND ROTATING IT INTO POSITION. THERE ARE 28 LOCATIONS FOR THESE TIEDOWN ANCHORS ON EACH SIDE OF THE M872 SEMITRAILERS. THE QUANTITY AND LOCATION MAY VARY ON SOME M872 SEMITRAILERS. THE SECOND TYPE OF TIEDOWN ANCHOR IS THE "TEE-HOOK". THIS IS A REMOVABLE TIEDOWN ANCHOR EQUIPPED WITH ONE ELONGATED RING AND IS POSITIONED BY INSERTING IT INTO ONE OF THE ELONGATED SLOTTED HOLES WHICH ARE AT A 45° ANGLE TO THE SIDE OF THE TRAILER. THERE ARE FIVE LOCATIONS FOR THESE TIEDOWN ANCHORS ON EACH SIDE OF THE M872 SEMITRAILERS. THE QUANTITY AND LOCATION MAY VARY ON SOME M872 SEMITRAILERS. ASSURE THAT THE TIEDOWN ANCHOR IS FIRMLY SEATED AND ROTATED APPROXIMATELY 45° TO ENGAGED POSITION BEFORE ATTACHING THE WEB STRAP TIEDOWN ASSEMBLY. THE LOADS WITHIN THIS DRAWING REQUIRE THE USE OF TYPE I TIEDOWN ANCHORS AND TEE-HOOK TIEDOWN ANCHORS. SEE "TIEDOWN ANCHOR DETAILS" ON PAGE 15.

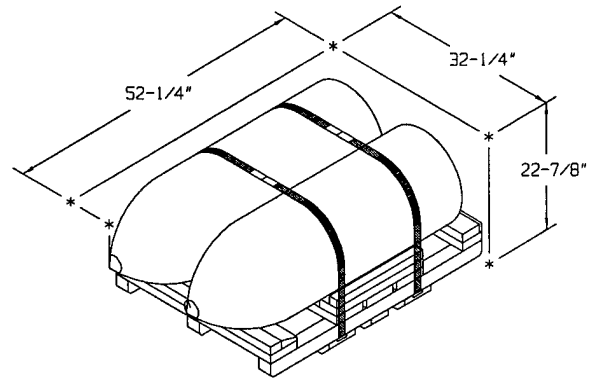

M117 750 LB BOMB PALLET UNIT

GROSS WEIGHT - - - 1,575 LBS (APPROX)
 CUBE - - - - - 22.3 CUBIC FEET

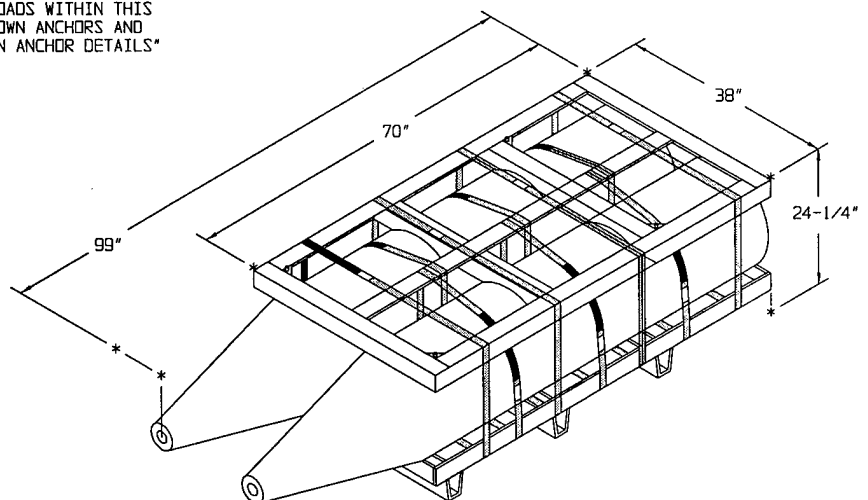

MK84 2,000 LB BOMB PALLET UNIT

GROSS WEIGHT - - - 4,133 LBS (APPROX)
 CUBE - - - - - 52.8 CUBIC FEET

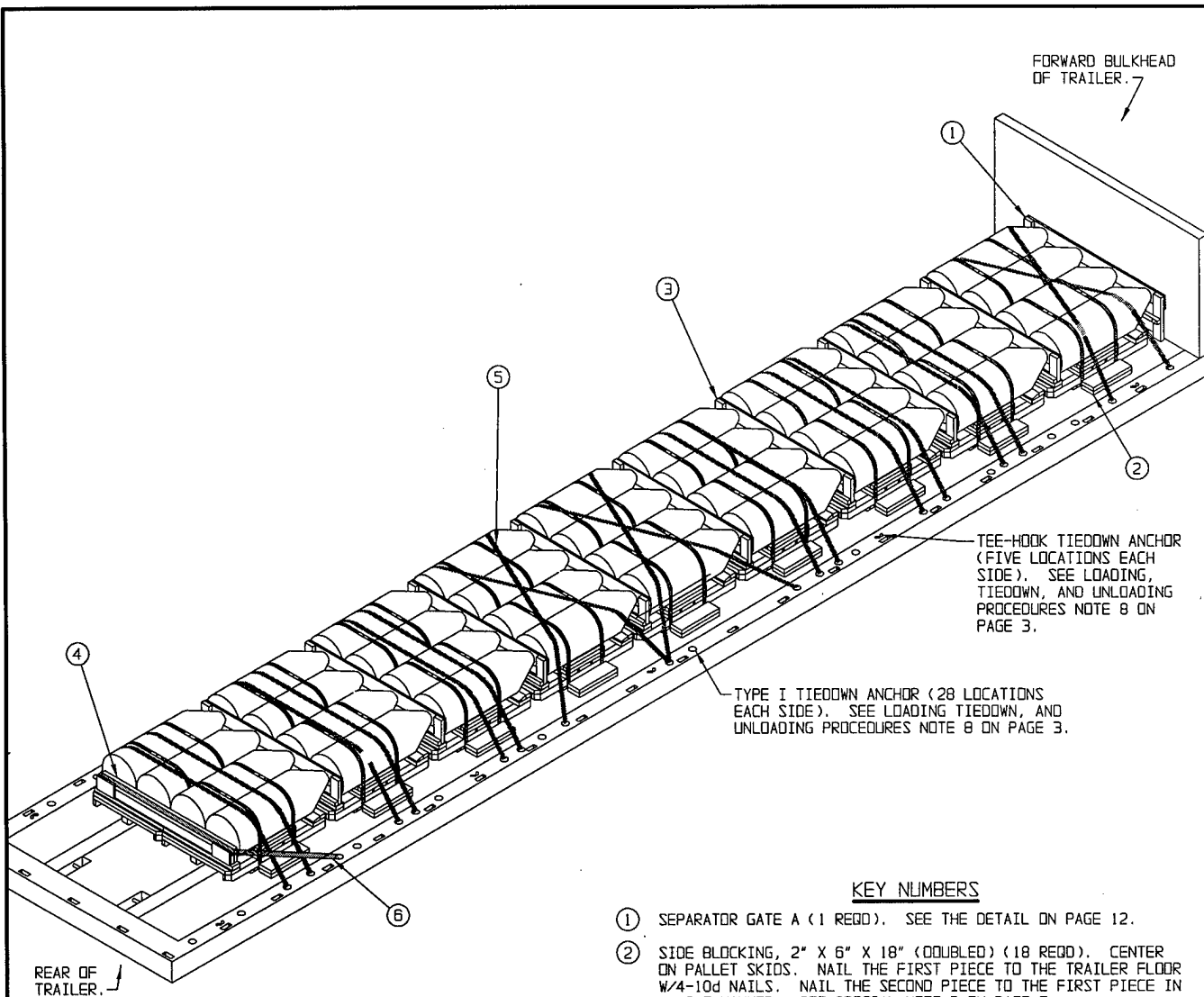

ISOMETRIC VIEW

KEY NUMBERS

- ① SEPARATOR GATE A (1 REQD). SEE THE DETAIL ON PAGE 12.
- ② SIDE BLOCKING, 2" X 6" X 18" (DOUBLED) (18 REQD). CENTER ON PALLET SKIDS. NAIL THE FIRST PIECE TO THE TRAILER FLOOR W/4-10d NAILS. NAIL THE SECOND PIECE TO THE FIRST PIECE IN A LIKE MANNER. SEE SPECIAL NOTE 3 ON PAGE 5.
- ③ SEPARATOR GATE B (8 REQD). SEE THE DETAIL ON PAGE 12.
- ④ RESTRAINT ASSEMBLY A (1 REQD). SEE THE DETAIL ON PAGE 13.
- ⑤ WEB STRAP TIEDOWN ASSEMBLY (18 REQD). INSTALL EACH STRAP TO EXTEND FROM A TIEDOWN ANCHOR ON SIDE OF TRAILER, OVER TOP OF PALLET UNITS, TO A TIEDOWN ANCHOR ON OPPOSITE SIDE OF TRAILER. POSITION STRAP SCUFF SLEEVES AT SIDE OF BOMBS. TAKE UP EXCESS SLACK IN STRAP AND THEN RATCHET TIGHT. SEE SPECIAL NOTE 4 ON PAGE 5 AND GENERAL NOTES "E" AND "F" ON PAGE 2.
- ⑥ WEB STRAP TIEDOWN ASSEMBLY (1 REQD). INSTALL STRAP TO EXTEND FROM A TIEDOWN ANCHOR ON SIDE OF TRAILER, AROUND RESTRAINT ASSEMBLY A, TO A TIEDOWN ANCHOR ON OPPOSITE SIDE OF TRAILER. POSITION STRAP SCUFF SLEEVES AT SHARP EDGES. TAKE UP EXCESS SLACK IN STRAP AND THEN RATCHET TIGHT. SEE GENERAL NOTES "E" AND "F" ON PAGE 2.

SPECIAL NOTES:

1. A TYPICAL LOAD OF 18 PALLETS OF M117 750 LB BOMBS IS SHOWN ON THE 34-TON M872 SEMITRAILER HAVING DIMENSIONS OF 489-1/2" LONG BY 96" WIDE.
2. POSITION THE LOAD AGAINST THE FORWARD BULKHEAD OF THE TRAILER. ALL PALLETS MUST BE POSITIONED TIGHTLY AGAINST EACH OTHER Laterally AND LONGITUDINALLY TO REDUCE LOAD MOVEMENT. VOID SPACES BETWEEN PALLETS WILL FILL IN DURING TRANSPORT CAUSING WEB STRAPPING TO BECOME LOOSE. IF LOADING LESS THAN 18 PALLETS, OMIT PALLETS FROM THE AFT END OF THE LOAD.
3. POSITION THE SIDE BLOCKING PIECES APPROXIMATELY 1/4" AWAY FROM THE SKIDS SO THE PALLETS CAN BE REMOVED AND/OR LOADED WITHOUT REMOVING THE SIDE BLOCKING.
4. EACH LATERAL LOAD UNIT OF TWO PALLETS MUST BE SECURED WITH TWO WEB STRAPS OVER THE TOP AS SHOWN. THESE TWO STRAPS MAY BE CROSSED AND/OR POSITIONED STRAIGHT ACROSS THE TOP, DEPENDING ON THE LOCATION OF THE TIEDOWN ANCHORS. AVOID POSITIONING THE STRAPS OVER THE OGIVE AT THE NOSE END OF THE BOMB. HOWEVER, IF IT IS NECESSARY FOR A STRAP TO BE POSITIONED OVER THE OGIVE, THE STRAPS MUST BE CROSSED.
5. A TOTAL OF 19 WEB STRAP TIEDOWN ASSEMBLIES ARE REQUIRED FOR THE LOAD SHOWN.

BILL OF MATERIAL		
LUMBER	LINEAR FEET	BOARD FEET
1" X 6"	50	25
2" X 2"	48	16
2" X 4"	21	14
2" X 6"	60	60
NAILS	NO. REQD	POUNDS
6d (2")	98	3/4
10d (3")	189	3
WEB STRAP	19 REQD	95 LBS

LOAD AS SHOWN (SEE NOTE BELOW)

ITEM	QUANTITY	WEIGHT (APPROX)
PALLET UNIT	18	28,350 LBS
QUINNAGE		329 LBS
TOTAL WEIGHT		28,679 LBS

NOTE: THE LOAD WEIGHT ON THE KINGPIN, INCLUDING THE TRAILER WEIGHT, IS 10,535 LBS (APPROX), AND THE LOAD WEIGHT ON THE THREE REAR AXLES, INCLUDING THE TRAILER WEIGHT, IS 18,144 LBS (APPROX). SEE GENERAL NOTE "B" ON PAGE 2.

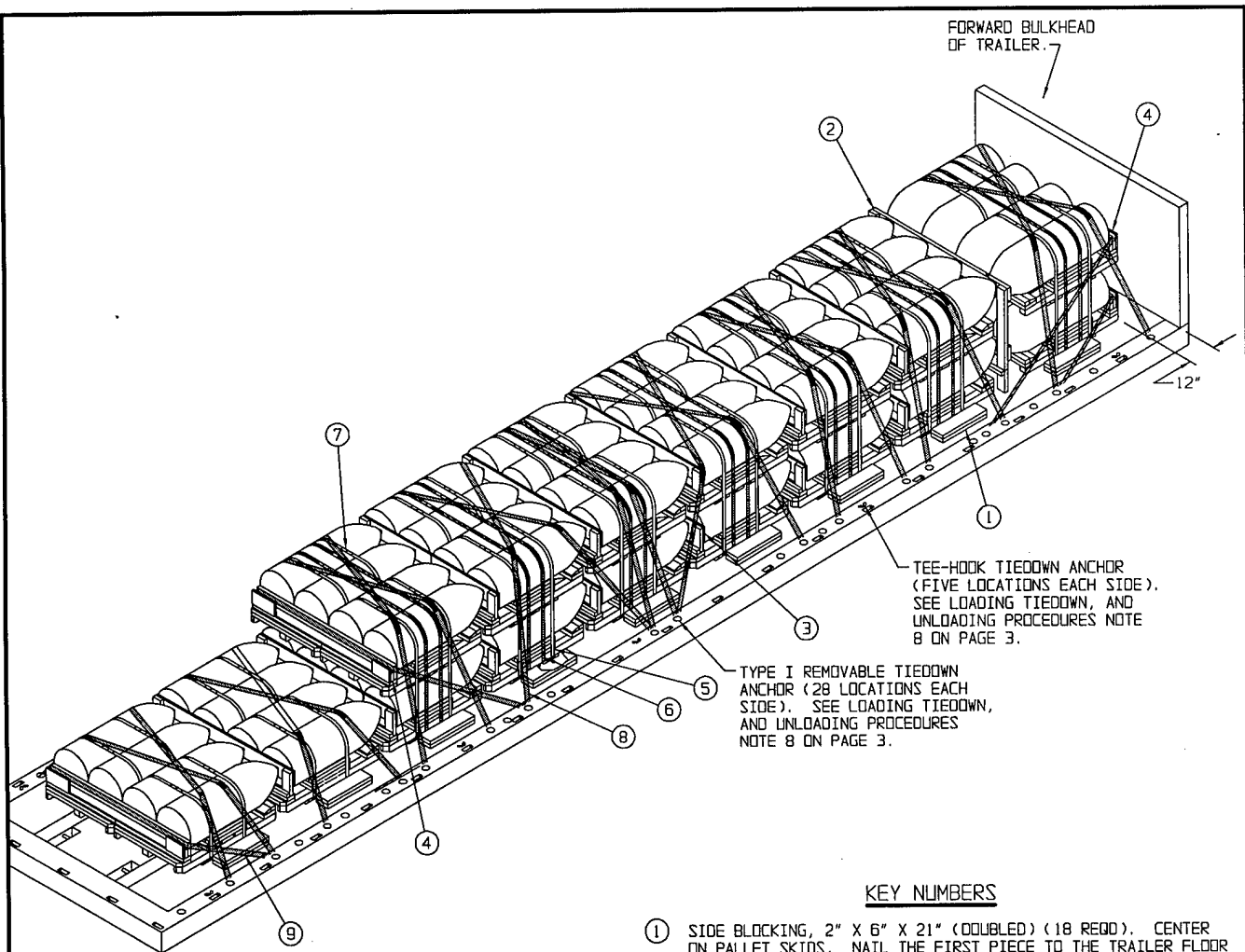

REAR OF TRAILER.

ISOMETRIC VIEW

FORWARD BULKHEAD OF TRAILER.

TEE-HOOK TIEDOWN ANCHOR (FIVE LOCATIONS EACH SIDE). SEE LOADING TIEDOWN, AND UNLOADING PROCEDURES NOTE 8 ON PAGE 3.

TYPE I REMOVABLE TIEDOWN ANCHOR (28 LOCATIONS EACH SIDE). SEE LOADING TIEDOWN, AND UNLOADING PROCEDURES NOTE 8 ON PAGE 3.

KEY NUMBERS

- ① SIDE BLOCKING, 2" X 6" X 21" (DOUBLED) (18 REQD). CENTER ON PALLET SKIDS. NAIL THE FIRST PIECE TO THE TRAILER FLOOR W/6-10d NAILS. NAIL THE SECOND PIECE TO THE FIRST PIECE IN A LIKE MANNER. SEE SPECIAL NOTE 4 ON PAGE 7.
- ② SEPARATOR GATE C (1 REQD). SEE THE DETAIL ON PAGE 12.
- ③ SEPARATOR GATE B (12 REQD). SEE THE DETAIL ON PAGE 12.
- ④ RESTRAINT ASSEMBLY A (4 REQD). SEE THE DETAIL ON PAGE 13.
- ⑤ UNITIZING STRAP, 1-1/4" X .035" OR .031" BY 14'-0" LONG STEEL STRAPPING (28 REQD, 2 PER VERTICAL STACK OF BOMB PALLETS). THREAD STRAPPING THROUGH STRAP SLOTS ON BOTTOM PALLET. BRING ENDS OF STRAP UP OVER TOP OF BOMBS ON THE TOP PALLET AND SEAL WITH ONE SEAL MARKED ⑦. SEE SPECIAL NOTE 5 ON PAGE 7.
- ⑥ BUNDLING STRAP, 1-1/4" X .035" OR .031" BY 19'-0" LONG STEEL STRAPPING (14 REQD, 2 PER LOAD UNIT OF FOUR BOMB PALLETS). THREAD STRAPPING THROUGH THE OPENING ON EACH SIDE OF THE CENTER SKID, ON THE BOTTOM PALLETS. ENCIRCLE ALL FOUR PALLETS IN THE STACK AND SEAL WITH ONE SEAL MARKED ⑦. SEE SPECIAL NOTE 5 ON PAGE 7.
- ⑦ SEAL FOR 1-1/4" STEEL STRAPPING (ONE PER STRAP IF DOUBLE NOTCHED AND TWO PER STRAP IF DOUBLE CRIMPED).
- ⑧ WEB STRAP TIEDOWN ASSEMBLY (18 REQD). INSTALL EACH STRAP TO EXTEND FROM A TIEDOWN ANCHOR ON SIDE OF TRAILER, OVER TOP OF PALLET UNITS, TO A TIEDOWN ANCHOR ON OPPOSITE SIDE OF TRAILER. POSITION STRAP SCUFF SLEEVES AT SIDE OF BOMBS. TAKE UP EXCESS SLACK IN STRAP AND THEN RATCHET TIGHT. SEE SPECIAL NOTE 6 ON PAGE 7 AND GENERAL NOTES "E" AND "F" ON PAGE 2.
- ⑨ WEB STRAP TIEDOWN ASSEMBLY (4 REQD). INSTALL EACH STRAP TO EXTEND FROM A TIEDOWN ANCHOR ON SIDE OF TRAILER, AROUND THE RESTRAINT ASSEMBLY A, TO A TIEDOWN ANCHOR ON OPPOSITE SIDE OF TRAILER. POSITION STRAP SCUFF SLEEVES AT SHARP EDGES. TAKE UP EXCESS SLACK IN STRAP AND THEN RATCHET TIGHT. GENERAL NOTES "E" AND "F" ON PAGE 2.

SPECIAL NOTES:

1. A TYPICAL LOAD OF 32 PALLETS OF M117 750 LB BOMBS IS SHOWN ON THE 34-TON M872 SEMITRAILER HAVING DIMENSIONS OF 489-1/2" LONG BY 96" WIDE.
2. POSITION THE FIRST ROW OF FOUR PALLETS 12" FROM THE FORWARD BULKHEAD AND CENTERED ACROSS THE TRAILER WIDTH. THIS SPACE IS REQUIRED TO AVOID EXCEEDING THE MAXIMUM WEIGHT ALLOWED ON THE KINGPIN. SEE GENERAL NOTE "B" ON PAGE 2.
3. ALL PALLETS MUST BE POSITIONED TIGHTLY AGAINST EACH OTHER Laterally and longitudinally to reduce the load movement. VOID SPACES BETWEEN PALLETS WILL FILL IN DURING TRANSPORT CAUSING WEB STRAPPING TO BECOME LOOSE.
4. POSITION THE SIDE BLOCKING PIECES APPROXIMATELY 1/4" AWAY FROM THE PALLET SKIDS SO THE PALLETS CAN BE REMOVED AND/OR LOADED WITHOUT REMOVING THE SIDE BLOCKING.
5. EACH STACK OF TWO HIGH PALLET UNITS MUST BE UNITIZED WITH TWO UNITIZING STRAPS MARKED ⑤, AND EACH LATERAL LOAD UNIT OF FOUR PALLET UNITS MUST BE BUNDLED WITH TWO BUNDLING STRAPS MARKED ⑥.
6. EACH LATERAL LOAD UNIT OF ONE HIGH AND/OR TWO HIGH PALLET UNITS MUST BE SECURED WITH TWO WEB STRAPS OVER THE TOP AS SHOWN. THESE TWO STRAPS MAY BE CROSSED AND/OR POSITIONED STRAIGHT ACROSS THE TOP, DEPENDING ON THE LOCATION OF THE TIEDOWN ANCHORS. AVOID POSITIONING THE STRAPS OVER THE OGIVE AT THE NOSE END OF THE BOMB. HOWEVER, IF IT IS NECESSARY FOR A STRAP TO BE POSITIONED OVER THE OGIVE, THE STRAPS MUST BE CROSSED.
7. IF LOADING A LESSER QUANTITY THAN SHOWN OMIT PALLET UNITS FORM THE AFT END OF THE TOP LAYER. HOWEVER, OMIT TWO PALLETS UNITS AT A TIME.
8. A TOTAL OF 22 WEB STRAP TIEDOWN ASSEMBLIES ARE REQUIRED FOR THE LOAD SHOWN.

BILL OF MATERIAL		
LUMBER	LINEAR FEET	BOARD FEET
1" X 6"	70	35
2" X 2"	70	24
2" X 4"	47	32
2" X 6"	95	95
NAILS	NO. REQD	POUNDS
6d (2")	152	1
10d (3")	316	5
STEEL STRAPPING, 1-1/4"	658' REQD	94 LBS
SEAL FOR 1-1/4" STRAPPING	42 REQD	2 LBS
WEB STRAP	22 REQD	110 LBS

LOAD AS SHOWN

ITEM	QUANTITY	WEIGHT (APPROX)
PALLET UNIT	32	50,400 LBS
DUNNAGE		584 LBS
TOTAL WEIGHT		50,984 LBS (APPROX)

NOTE: THE LOAD WEIGHT ON THE KINGPIN, INCLUDING THE TRAILER WEIGHT, IS 26,908 LBS (APPROX), AND THE LOAD WEIGHT ON THE THREE REAR AXLES, INCLUDING THE TRAILER WEIGHT, IS 40,876 LBS (APPROX). SEE GENERAL NOTE "B" ON PAGE 2.

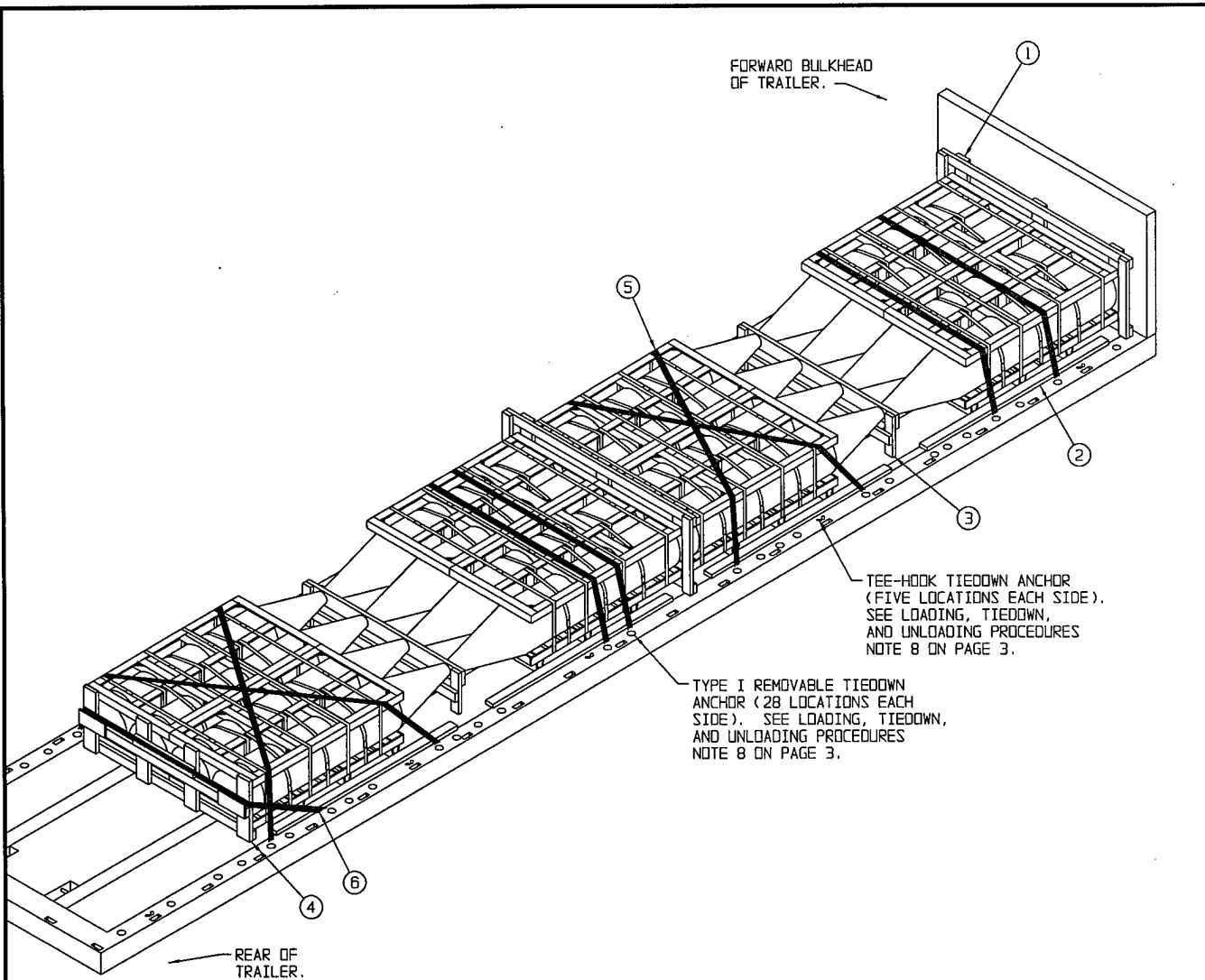

ISOMETRIC VIEW

KEY NUMBERS

- ① SEPARATOR GATE E (2 REQD). SEE THE DETAIL ON PAGE 13.
- ② SIDE BLOCKING, 2" X 4" X 7'-0" (8 REQD). CENTER ON THE BOMB LENGTH. POSITION 1/4" AWAY FROM THE PALLET SKIDS AND NAIL TO THE TRAILER FLOOR W/11-10d NAILS. SEE SPECIAL NOTE 4 ON PAGE 7.
- ③ SEPARATOR GATE D (2 REQD). SEE THE DETAIL ON PAGE 13.
- ④ RESTRAINT ASSEMBLY B (1 REQD). SEE THE DETAIL ON PAGE 14.
- ⑤ WEB STRAP TIEDOWN ASSEMBLY (8 REQD). INSTALL EACH STRAP TO EXTEND FROM A TIEDOWN ANCHOR ON SIDE OF TRAILER, OVER TOP OF PALLET UNITS, TO A TIEDOWN ANCHOR ON OPPOSITE SIDE OF TRAILER. POSITION STRAP SCUFF SLEEVES AT SIDE OF BOMBS. TAKE UP EXCESS SLACK IN STRAP AND THEN RATCHET TIGHT. SEE SPECIAL NOTE 5 ON PAGE 7 AND GENERAL NOTES "E" AND "F" ON PAGE 2.
- ⑥ WEB STRAP TIEDOWN ASSEMBLY (1 REQD). INSTALL STRAP TO EXTEND FROM A TIEDOWN ANCHOR ON SIDE OF TRAILER, AROUND THE RESTRAINT ASSEMBLY B, TO A TIEDOWN ANCHOR ON OPPOSITE SIDE OF TRAILER. POSITION STRAP SCUFF SLEEVES AT SHARP EDGES. TAKE UP EXCESS SLACK IN STRAP AND THEN RATCHET TIGHT. GENERAL NOTES "E" AND "F" ON PAGE 2.

SPECIAL NOTES:

1. A TYPICAL LOAD OF 8 PALLETS OF MK84 2,000 LB BOMBS IS SHOWN ON THE 34-TON M872 SEMITRAILER HAVING DIMENSIONS OF 489-1/2" LONG BY 96" WIDE.
2. POSITION THE FIRST ROW OF TWO PALLETS AGAINST THE FORWARD BULKHEAD AND CENTER ACROSS THE TRAILER WIDTH.
3. ALL PALLETS MUST BE POSITIONED TIGHTLY AGAINST EACH OTHER Laterally and Longitudinally to reduce the load movement. VOID SPACES BETWEEN PALLETS WILL FILL IN DURING TRANSPORT CAUSING WEB STRAPPING TO BECOME LOOSE.
4. POSITION THE SIDE BLOCKING PIECES APPROXIMATELY 1/4" AWAY FROM THE PALLET SKIDS SO THE PALLETS CAN BE REMOVED AND/OR LOADED WITHOUT REMOVING THE SIDE BLOCKING. NOTE THAT THE SIDE BLOCKING WILL EXTEND PARTIALLY ONTO THE STEEL SIDE RAIL ON THE TRAILER.
5. EACH LATERAL LOAD UNIT OF TWO PALLETS MUST BE SECURED WITH TWO WEB STRAPS OVER THE TOP AS SHOWN. THESE TWO STRAPS MAY BE CROSSED AND/OR POSITIONED STRAIGHT ACROSS THE TOP, DEPENDING ON THE LOCATION OF THE TIEDOWN ANCHORS. ALL WEB STRAPS MARKED (C) MUST BE POSITIONED OVER THE PALLET FRAME MEMBERS.
6. IF LOADING A LESSER QUANTITY THAN SHOWN OMIT PALLET UNITS FROM THE AFT END OF THE LOAD. HOWEVER, OMIT TWO PALLET UNITS AT A TIME.
7. A TOTAL OF 9 WEB STRAP TIEDOWN ASSEMBLIES ARE REQUIRED FOR THE LOAD SHOWN.

BILL OF MATERIAL

LUMBER	LINEAR FEET	BOARD FEET
1" X 6"	2	1
2" X 4"	128	86
2" X 6"	35	35
NAILS	NO. REQD	POUNDS
6d (2")	8	1/4
10d (3")	202	3-1/4
WEB STRAP	9 REQD	45 LBS

LOAD AS SHOWN

<u>ITEM</u>	<u>QUANTITY</u>	<u>WEIGHT (APPROX)</u>
PALLET UNIT	8	33,064 LBS
DUNNAGE		293 LBS
TOTAL WEIGHT		33,357 LBS (APPROX)

NOTE: THE LOAD WEIGHT ON THE KINGPIN, INCLUDING THE TRAILER WEIGHT, IS 20,034 LBS (APPROX), AND THE LOAD WEIGHT ON THE THREE REAR AXLES, INCLUDING THE TRAILER WEIGHT, IS 30,123 LBS (APPROX). SEE GENERAL NOTE "B" ON PAGE 2.

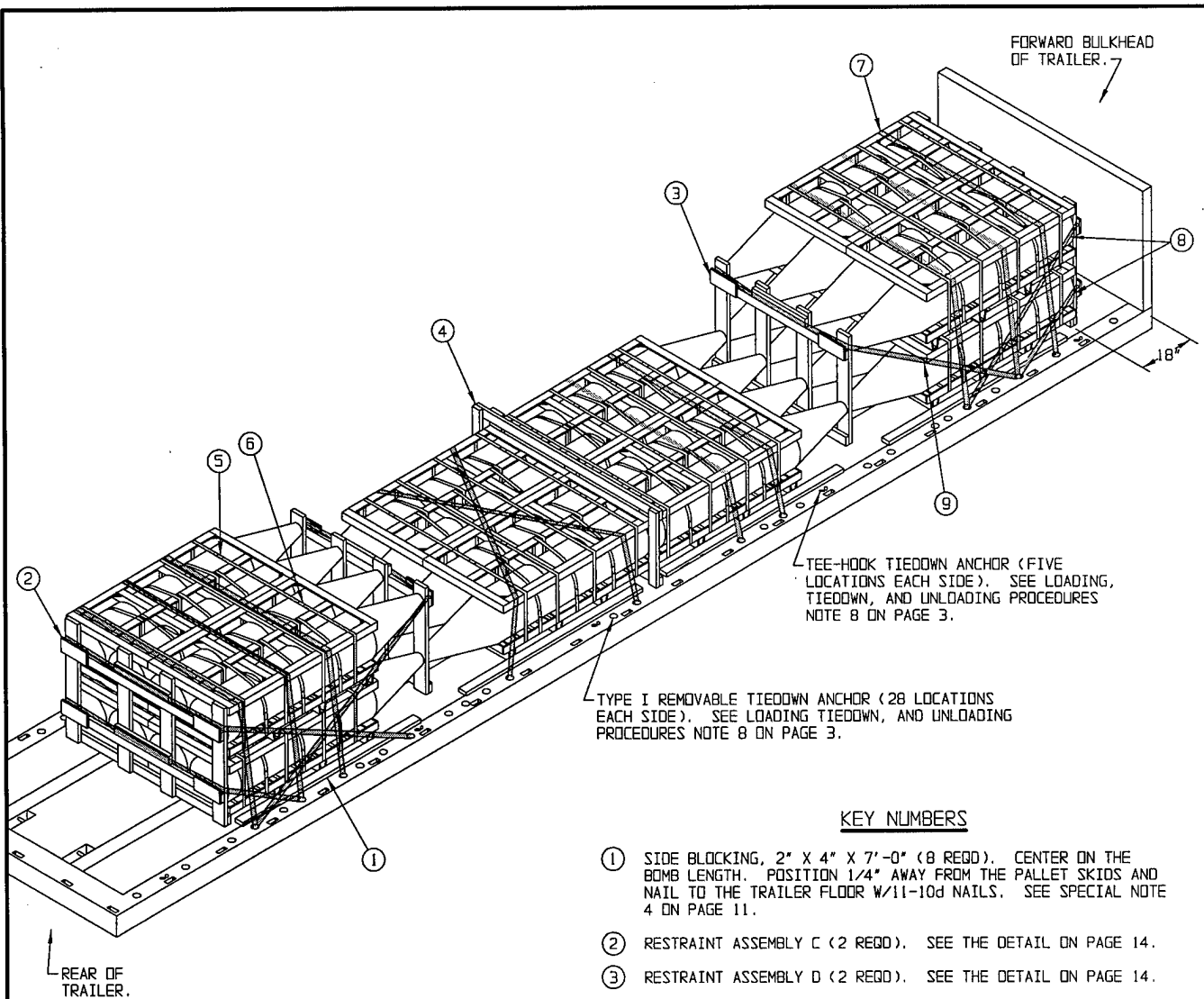

ISOMETRIC VIEW

KEY NUMBERS

- ① SIDE BLOCKING, 2" X 4" X 7'-0" (8 REQD). CENTER ON THE BOMB LENGTH. POSITION 1/4" AWAY FROM THE PALLET SKIDS AND NAIL TO THE TRAILER FLOOR W/11-10d NAILS. SEE SPECIAL NOTE 4 ON PAGE 11.
- ② RESTRAINT ASSEMBLY C (2 REQD). SEE THE DETAIL ON PAGE 14.
- ③ RESTRAINT ASSEMBLY D (2 REQD). SEE THE DETAIL ON PAGE 14.
- ④ SEPARATOR GATE E (1 REQD). SEE THE DETAIL ON PAGE 13.
- ⑤ BUNDLING STRAP, 1-1/4" X .035" OR .031" BY 21'-0" LONG STEEL STRAPPING (4 REQD, 2 PER LOAD UNIT OF FOUR BOMB PALLETS). POSITION A STRAP APPROXIMATELY 8" FROM EACH END OF THE PALLET FRAME AND ENCIRCLE ALL FOUR PALLETS IN THE TWO HIGH LOAD UNIT. SEAL EACH STRAP WITH ONE SEAL MARKED ⑥. SEE SPECIAL NOTE 5 ON PAGE 11.
- ⑥ SEAL FOR 1-1/4" STEEL STRAPPING (ONE PER STRAP IF DOUBLE NOTCHED AND TWO PER STRAP IF DOUBLE CRIMPED).
- ⑦ WEB STRAP TIEDOWN ASSEMBLY (10 REQD). INSTALL EACH STRAP TO EXTEND FROM A TIEDOWN ANCHOR ON SIDE OF TRAILER, OVER TOP OF PALLET UNITS, TO A TIEDOWN ANCHOR ON OPPOSITE SIDE OF TRAILER. POSITION STRAP SCUFF SLEEVES AT SHARP EDGES. TAKE UP EXCESS SLACK IN STRAP AND THEN RATCHET TIGHT. SEE SPECIAL NOTE 6 ON PAGE 11 AND GENERAL NOTES "E" AND "F" ON PAGE 2.
- ⑧ WEB STRAP TIEDOWN ASSEMBLY (4 REQD). INSTALL EACH STRAP TO EXTEND FROM A TIEDOWN ANCHOR ON SIDE OF TRAILER, AROUND RESTRAINT ASSEMBLY C, TO A TIEDOWN ANCHOR ON OPPOSITE SIDE OF TRAILER. POSITION STRAP SCUFF SLEEVES AT SHARP EDGES. TAKE UP EXCESS SLACK IN STRAP AND THEN RATCHET TIGHT. SEE GENERAL NOTES "E" AND "F" ON PAGE 2.
- ⑨ WEB STRAP TIEDOWN ASSEMBLY (2 REQD). INSTALL EACH STRAP TO EXTEND FROM A TIEDOWN ANCHOR ON SIDE OF TRAILER, AROUND TOP OF RESTRAINT ASSEMBLY D, TO A TIEDOWN ANCHOR ON OPPOSITE SIDE OF TRAILER. POSITION STRAP SCUFF SLEEVES AT SHARP EDGES. TAKE UP EXCESS SLACK IN STRAP AND THEN RATCHET TIGHT. SEE GENERAL NOTES "E" AND "F" ON PAGE 2.

SPECIAL NOTES:

1. A TYPICAL LOAD OF 12 PALLETS OF MK84 2,000 LB BOMBS IS SHOWN ON THE M872 SEMITRAILER HAVING DIMENSIONS OF 489-1/2" LONG BY 96" WIDE.
2. POSITION THE FIRST STACK OF FOUR PALLETS 18" FROM THE FORWARD BULKHEAD AND CENTERED ACROSS THE TRAILER WIDTH. THIS SPACE IS REQUIRED TO AVOID EXCEEDING THE MAXIMUM WEIGHT ALLOWED ON THE KINGPIN. SEE GENERAL NOTE "B" ON PAGE 2.
3. ALL PALLET UNITS MUST BE POSITIONED AGAINST EACH OTHER Laterally and longitudinally to reduce the load movement. VOID SPACES BETWEEN PALLETS WILL FILL IN DURING TRANSPORT CAUSING WEB STRAPPING TO BECOME LOOSE.
4. POSITION THE SIDE BLOCKING PIECES APPROXIMATELY 1/4" AWAY FROM THE SKIDS SO THE PALLETS CAN BE REMOVED AND/OR LOADED WITHOUT REMOVING THE SIDE BLOCKING. NOTE THAT THE SIDE BLOCKING WILL EXTEND PARTIALLY ON TO THE STEEL SIDE RAIL ON THE TRAILER.
5. EACH STACK (LATERAL LOAD UNIT) OF FOUR PALLETS MUST BE BUNDLED WITH TWO BUNDLING STRAPS MARKED (5).
6. EACH LATERAL LOAD UNIT OF TWO PALLETS MUST BE SECURED WITH TWO WEB STRAPS OVER THE TOP, AND EACH LOAD UNIT OF FOUR PALLET UNITS MUST BE SECURED WITH THREE WEB STRAPS OVER THE TOP AS SHOWN. THESE STRAPS MAY BE CROSSED AND/OR POSITIONED STRAIGHT ACROSS THE TOP, DEPENDING ON THE LOCATION OF THE TIEDOWN ANCHORS. ALL WEB STRAPS MUST BE POSITIONED OVER THE PALLET FRAME MEMBERS.
7. IF LOADING A LESSER QUANTITY THAN SHOWN OMIT TWO PALLETS AT A TIME FROM THE TOP LAYER AND SECURE AS SHOWN IN THE ONE HIGH LOAD ON PAGES 8 AND 9.
8. A TOTAL OF 16 WEB STRAP TIEDOWN ASSEMBLIES ARE REQUIRED FOR THE LOAD SHOWN.

BILL OF MATERIAL		
LUMBER	LINEAR FEET	BOARD FEET
1" X 6"	12	6
2" X 4"	147	98
2" X 6"	65	65
NAILS	NO. REQD	POUNDS
6d (2")	48	1/2
10d (3")	274	4-1/4
STEEL STRAPPING, 1-1/4" --- 84' REQD --- 12 LBS		
SEAL FOR 1-1/4" STRAPPING --- 4 REQD --- NIL		
WEB STRAP --- --- 16 REQD --- 80 LBS		

LOAD AS SHOWN

ITEM	QUANTITY	WEIGHT (APPROX)
PALLET UNIT	12	49,596 LBS
DUNNAGE		435 LBS
TOTAL WEIGHT		50,031 LBS (APPROX)

NOTE: THE LOAD WEIGHT ON THE KINGPIN, INCLUDING THE TRAILER WEIGHT, IS 25,407 LBS (APPROX), AND THE LOAD WEIGHT ON THE THREE REAR AXLES, INCLUDING THE TRAILER WEIGHT, IS 41,424 LBS (APPROX). SEE GENERAL NOTE "B" ON PAGE 2.

SUPPORT PIECE
2" X 4" X 17-1/2"
(2 REGD).

POSITION THIS SIDE AGAINST
FORWARD BULKHEAD ON TRAILER.

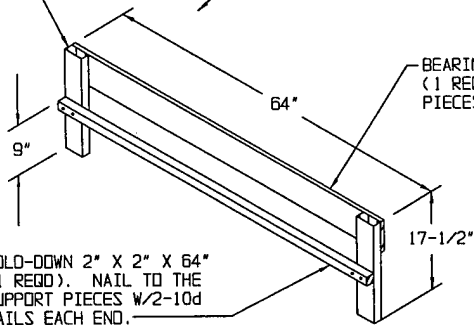

HOLD-DOWN 2" X 2" X 64"
(1 REGD). NAIL TO THE
SUPPORT PIECES W/2-10d
NAILS EACH END.

SEPARATOR GATE A

POSITION BETWEEN NOSE END OF 750 LB
BOMBS AND FORWARD BULKHEAD ON TRAILER.

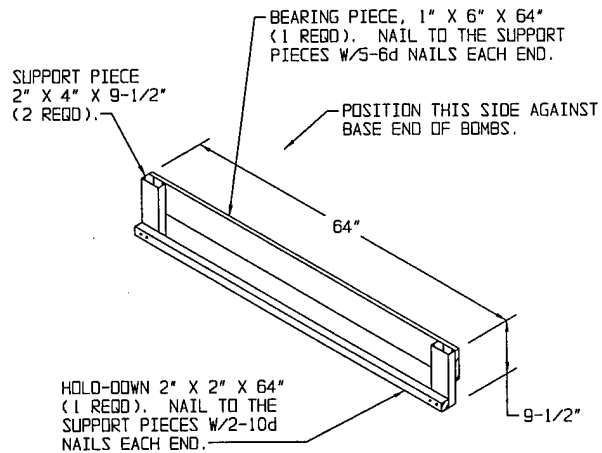

SUPPORT PIECE
2" X 4" X 9-1/2"
(2 REGD).

BEARING PIECE, 1" X 6" X 64"
(1 REGD). NAIL TO THE SUPPORT
PIECES W/5-6d NAILS EACH END.

POSITION THIS SIDE AGAINST
BASE END OF BOMBS.

HOLD-DOWN 2" X 2" X 64"
(1 REGD). NAIL TO THE
SUPPORT PIECES W/2-10d
NAILS EACH END.

SEPARATOR GATE B

POSITION ON TOP OF THE BASE END STOP
PIECES ON THE 750 LB BOMB PALLETS.

SUPPORT PIECE
2" X 4" X 39"
(2 REGD). NAIL
TO THE BEARING
PIECES W/3-10d
NAILS AT EACH
JOINT.

POSITION THIS SIDE AGAINST
FORWARD BULKHEAD ON TRAILER.

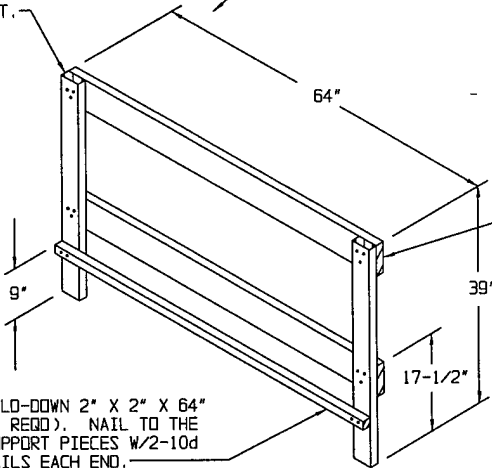

BEARING PIECE,
2" X 6" X 64"
(2 REGD).

HOLD-DOWN 2" X 2" X 64"
(1 REGD). NAIL TO THE
SUPPORT PIECES W/2-10d
NAILS EACH END.

SEPARATOR GATE C

POSITION BETWEEN NOSE ENDS OF 750 LB BOMBS
AND/OR BETWEEN NOSE END OF 750 LB BOMBS
AND THE FORWARD BULKHEAD ON TRAILER.

SIDE RETAINER PIECE,
2" X 4" X 16" (2 REQD).
NAIL TO THE BEARING
PIECE W/3-10d NAILS.

BEARING PIECE, 2" X 6"
X 72" (1 REQD).

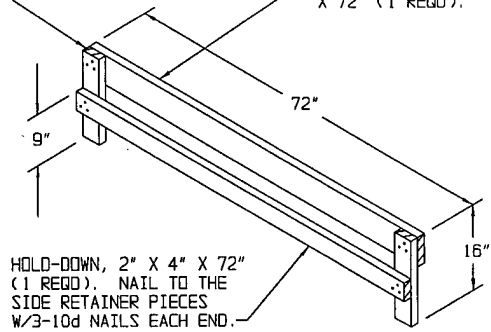

HOLD-DOWN, 2" X 4" X 72"
(1 REQD). NAIL TO THE
SIDE RETAINER PIECES
W/3-10d NAILS EACH END.

SEPARATOR GATE D

POSITION BETWEEN NOSE END OF 2,000 LB BOMBS.

BEARING PIECE, 2" X 6"
X 30" (3 REQD).

SIDE BLOCKING PIECE,
2" X 4" X 30" (2 REQD).
NAIL TO THE TIE PIECES
W/3-10d NAILS EACH END.

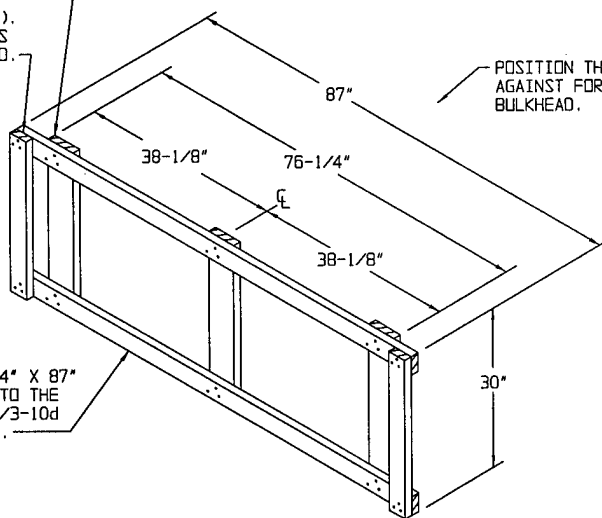

POSITION THIS SIDE
AGAINST FORWARD
BULKHEAD.

TIE PIECE, 2" X 4" X 87"
(2 REQD). NAIL TO THE
BEARING PIECES W/3-10d
NAILS EACH JOINT.

SEPARATOR GATE E

POSITION BETWEEN BASE END OF 2,000 LB BOMBS
AND/OR BETWEEN BASE END OF 2,000 LB BOMBS
AND THE FORWARD BULKHEAD ON TRAILER.

POSITION THIS SIDE
AGAINST BASE END
OF BOMBS.

STRAP SUPPORT PIECE,
2" X 4" X 62" (1 REQD).
NAIL TO THE BEARING
PIECE W/9-10d NAILS.

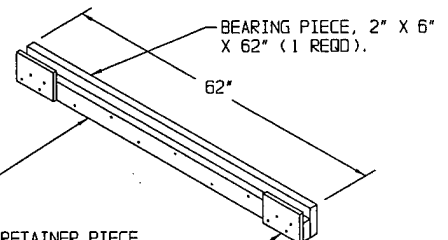

STRAP RETAINER PIECE,
1" X 6" X 8" (2 REQD).
NAIL TO THE STRAP SUPPORT
PIECE W/4-6d NAILS.

RESTRAINT ASSEMBLY A

POSITION ON TOP OF THE BASE END STOP
PIECES ON THE 750 LB BOMB PALLET.

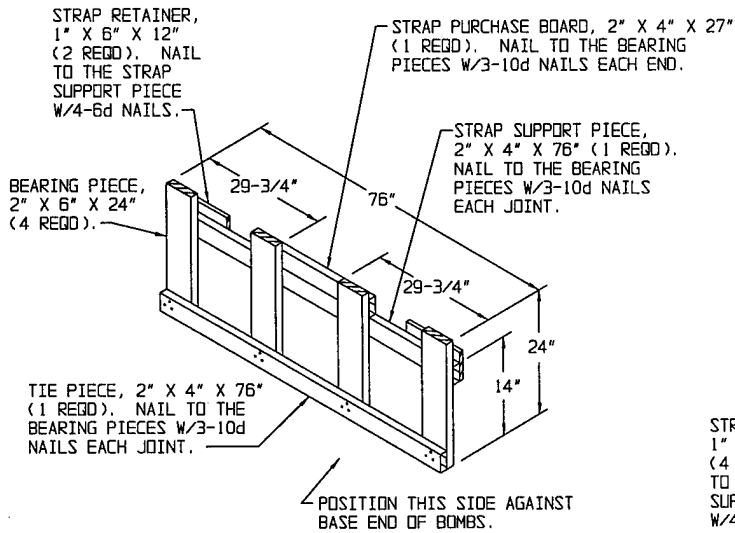

RESTRAINT ASSEMBLY B

POSITION AT AFT END OF THE 2,000 LB BOMB LOAD.

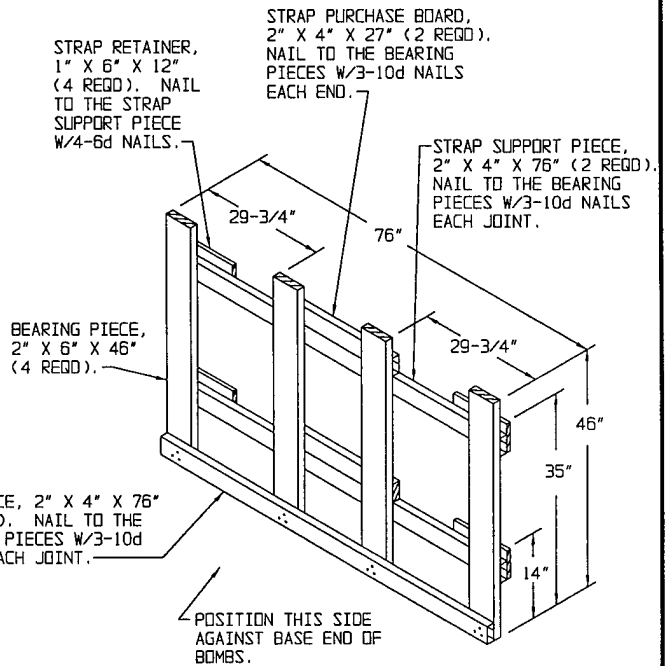

RESTRAINT ASSEMBLY C

POSITION AT AFT END OF THE 2,000 LB BOMB LOAD.

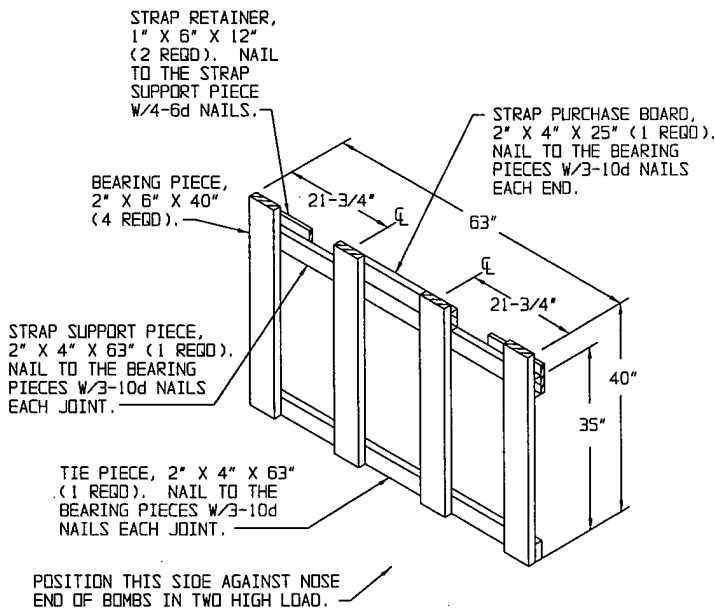

RESTRAINT ASSEMBLY D

POSITION BETWEEN NOSE END OF 2,000 LB BOMBS.

TIEDOWN RING.

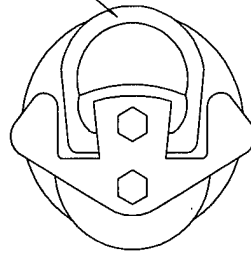

REMOVABLE TIEDOWN ANCHOR (TOP VIEW)

THIS TIEDOWN ANCHOR IS RATED AT 10,000 POUNDS AND IS INSTALLED ON THE M872 SEMITRAILERS. IT IS COMMONLY REFERRED TO AS THE "MICKEY MOUSE" TIEDOWN ANCHOR. THERE ARE APPROXIMATELY TWENTY-EIGHT LOCATIONS IN EACH SIDE RAIL OF THE M872 SEMITRAILER. FOR INSTALLATION OF THIS TIEDOWN ANCHOR, IT IS POSITIONED BY REACHING UNDER THE FLOOR OF THE SEMITRAILER, INSERTING IT UP THROUGH THE HOLE AND ROTATING IT COUNTERCLOCKWISE UNTIL THE CENTER OF THE TIEDOWN RING POINTS DIRECTLY ACROSS THE TRAILER WIDTH. THIS TIEDOWN ANCHOR IS FURTHER IDENTIFIED AS NSN 2540-01-112-1732. SEE LOADING, TIEDOWN, AND UNLOADING PROCEDURES NOTE 8 ON PAGE 3.

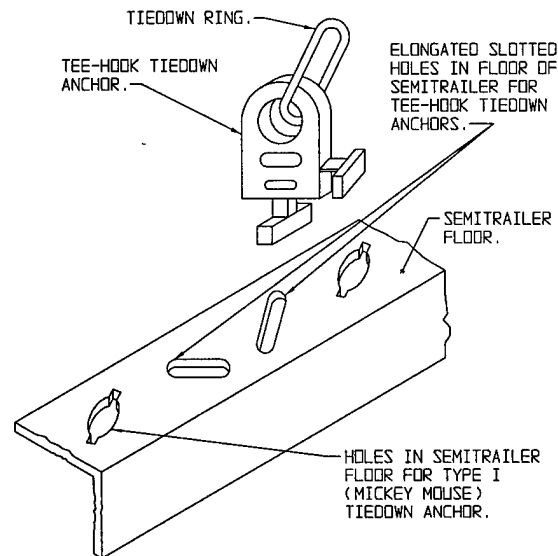

TEE-HOOK TIEDOWN ANCHOR (ISOMETRIC VIEW)

THIS TIEDOWN ANCHOR IS RATED AT 5,000 POUNDS AND IS INSTALLED ON THE M872 SEMITRAILERS. IT IS COMMONLY REFERRED TO AS THE "TEE-HOOK" TIEDOWN ANCHOR. THERE ARE FIVE TIEDOWN ANCHOR LOCATIONS IN EACH SIDE RAIL OF THE M872 SEMITRAILER. FOR INSTALLATION OF THIS TIEDOWN ANCHOR, IT IS POSITIONED BY INSERTING IT FROM THE TOP INTO ONE OF THE ELONGATED SLOTTED HOLES LOCATED IN THE SIDERAIL. ASSURE THAT THE TIEDOWN ANCHOR IS FIRMLY SEATED AND ROTATED APPROXIMATELY 45° TO ENGAGED POSITION BEFORE ATTACHING THE WEB STRAP TIEDOWN ASSEMBLY. THIS TIEDOWN ANCHOR IS FURTHER IDENTIFIED AS NSN 2540-01-113-9285. SEE LOADING, TIEDOWN, AND UNLOADING PROCEDURES NOTE 8 ON PAGE 3.

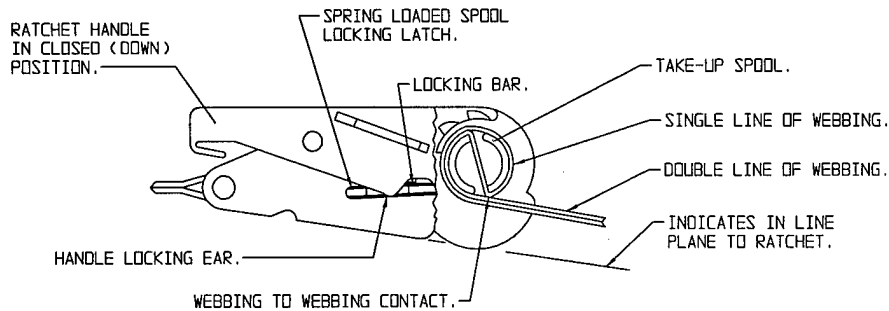

STEP 1

IN THIS VIEW PART OF THE RATCHET HOUSING IS SHOWN BROKEN AWAY TO DEPICT WEBBING-TO-WEBBING CONTACT ON THE TAKE-UP SPOOL OF THE RATCHET. WEBBING-TO-WEBBING CONTACT IS ACHIEVED WHEN THE OPERATOR HOLDS THE DOUBLE LINE OF WEBBING IN AN "IN LINE PLANE TO THE RATCHET" AND IT MAKES CONTACT WITH THE SINGLE LINE OF WEBBING.

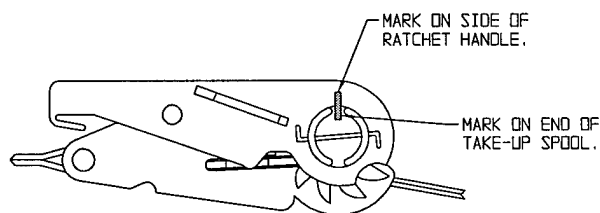

STEP 2

THIS VIEW DEPICTS THE LOCATION OF THE FIXED MARK ON THE RATCHETING HANDLE, WITH ANOTHER MATCHING MARK ON THE TAKE-UP SPOOL, AFTER WEBBING-TO-WEBBING CONTACT HAS BEEN MADE.

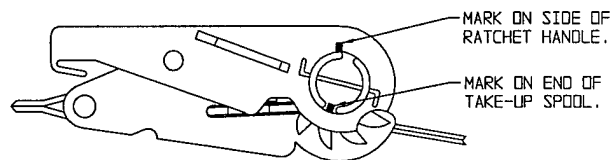

STEP 3

THIS VIEW DEPICTS THE LOCATION OF THE MARK ON THE END OF THE TAKE-UP SPOOL AFTER THE SPOOL HAS BEEN ROTATED ONE-HALF TURN, AFTER WEBBING-TO-WEBBING CONTACT HAS BEEN MADE.

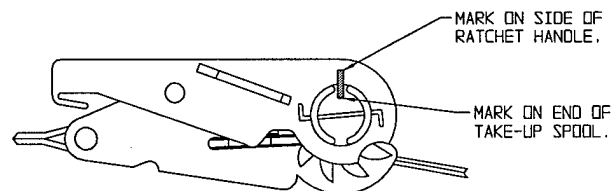

STEP 4

THIS VIEW DEPICTS THE LOCATION OF THE MARK ON THE END OF THE TAKE-UP SPOOL AFTER THE SPOOL HAS BEEN ROTATED ONE FULL TURN, AFTER WEBBING-TO-WEBBING CONTACT HAS BEEN MADE.

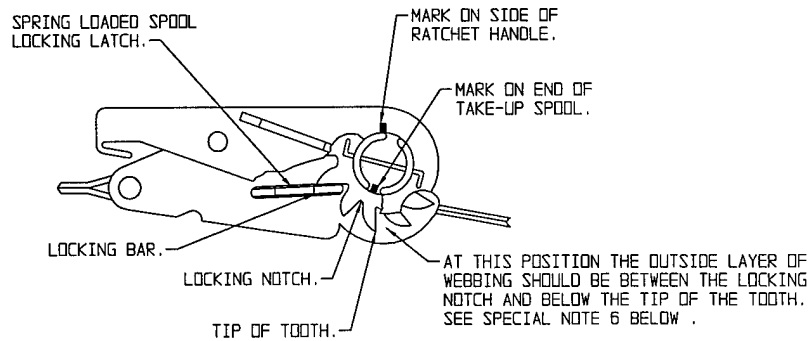

STEP 5

THIS VIEW DEPICTS THE LOCATION OF THE MARK ON THE END OF THE TAKE-UP SPOOL AFTER THE SPOOL HAS BEEN ROTATED ONE AND ONE-HALF TURNS, AFTER WEBBING-TO-WEBBING CONTACT HAS BEEN MADE. ALSO IN THIS VIEW, PART OF THE RATCHET HANDLE IS BROKEN AWAY TO SHOW THE LOCKING BAR FULLY SEATED IN THE MATCHING LOCKING NOTCH (SPROCKET GEAR TEETH).

SPECIAL NOTES:

1. THE PURPOSE OF THE RATCHET DETAILS ON PAGE 16 AND THE DETAIL AND NOTES ON THIS PAGE ARE TO AUGMENT THE GUIDANCE SET FORTH WITHIN GENERAL NOTE "G" ON PAGE 2.
2. THE REQUIREMENTS FOR 1/2 BUT NOT MORE THAN 1-1/2 WRAPS OF STRAP ON THE TAKE-UP SPOOL OF THE TENSIONING RATCHET, AS SPECIFIED WITHIN GENERAL NOTE "M" ON PAGE 2, ACTUALLY MEANS 1/2 TO 1-1/2 WRAPS OF DOUBLE WEBBING, THE 1/2 TO 1-1/2" TURNS. ALSO, THE 1/2 TO 1-1/2 WRAPS (TURNS) ARE TO BE ACCOMPLISHED ONLY AFTER ENOUGH WEBBING HAS BEEN WOUND ONTO THE SPOOL TO ACHIEVE A WEBBING-TO-WEBBING CONFIGURATION, AS SHOWN IN THE "STEP 1" DETAIL ON PAGE 16.
3. ONE METHOD THAT CAN BE USED TO ENSURE THAT THE 1/2 TO 1-1/2 WRAPS ARE WOUND ONTO THE TAKE-UP SPOOL, AFTER WEBBING-TO-WEBBING CONTACT HAS BEEN MADE, IS TO PLACE A FIXED MARK (PAINT OR SIMILAR MATERIAL) ON THE SIDE OF THE RATCHETING HANDLE, WITH THE HANDLE IN ITS CLOSED (DOWN) POSITION, AND ANOTHER SHORT MATCHING MARK ON THE END OF THE SPOOL, AS SHOWN IN THE "STEP 2" DETAIL ON PAGE 16. AS THE SPOOL IS ROTATED TO TENSION A TIEDOWN STRAP ASSEMBLY, THE NUMBER OF WRAPS (TURNS) CAN BE DETERMINED VISUALLY BY COMPARING THE "MARK" LOCATION ON THE SPOOL TO THE "MARK" LOCATION ON THE RATCHETING HANDLE WITH THE HANDLE IN CLOSED POSITION. SEE THE "STEP 3" AND "STEP 4" DETAILS ON PAGE 16, AND "STEP 5" ABOVE.
4. ANOTHER METHOD THAT CAN BE USED TO ENSURE THAT THE 1/2 TO 1-1/2 WRAPS ARE ACHIEVED, AFTER WEBBING-TO-WEBBING CONTACT HAS BEEN MADE, IS TO COUNT THE AUDIBLE CLICKS MADE BY THE RATCHET ASSEMBLY AS A WEB STRAP ASSEMBLY IS BEING TENSIONED. THE RATCHET ASSEMBLY ON MOST WEB STRAP ASSEMBLIES HAVE 11 TEETH ON THE GEARLIKE DEVICE ON EACH END OF THE TAKE-UP SPOOL; SOME OTHER STRAP ASSEMBLIES HAVE ONLY 9 TEETH. THEREFORE, AFTER INITIAL WEBBING-TO-WEBBING CONTACT HAS BEEN MADE, ROTATE (TURN) THE SPOOL THROUGH A MINIMUM OF 6 TO A MAXIMUM OF 17 CLICKS (1/2 TO 1-1/2 WRAPS) WHEN THE GEAR HAS 11 TEETH, AND ROTATE (TURN) THE SPOOL THROUGH A MINIMUM OF 5 TO A MAXIMUM OF 14 CLICKS (1/2 TO 1-1/2 WRAPS) IF THE GEAR HAS 9 TEETH.

(SPECIAL NOTES CONTINUED)

5. AFTER A STRAP ASSEMBLY HAS BEEN PROPERLY TENSIONED, CARE MUST BE EXERCISED TO ASSURE THAT THE TAKE-UP SPOOL LOCKING LATCH (SPRING LOADED DEVICE WITH A LOCKING BAR ON EACH SIDE OF THE RATCHET ASSEMBLY) IS FULLY SEATED ON BOTH SIDES IN MATCHING LOCKING NOTCHES, WHICH ARE SIMILAR TO SPROCKET GEAR TEETH, THAT ARE LOCATED ON EACH END OF THE TAKE-UP SPOOL. SEE "STEP 5" DETAIL ABOVE. THE LOCKING LATCH IS "FULLY SEATED" WHEN THE HANDLE WILL CLOSE AND THE LOCKING EAR, OR SIMILAR DEVICE ON THE HANDLE, PREVENTS THE ACCIDENTAL WITHDRAWAL OF THE LOCKING LATCH. SEE "STEP 1" DETAIL ON PAGE 16. IF THE FULLY SEATED CONDITION CANNOT BE ACHIEVED, THE STRAP MUST BE RELEASED AND HAND RETENSIONED AS TIGHT AS POSSIBLE TO ACHIEVE THE FULLY SEATED CONDITION.
6. ANOTHER VISUAL METHOD OF DETERMINING WHEN THERE IS 1/2 TO 1-1/2 WRAPS OF WEBBING ON THE TAKE-UP SPOOL, AFTER INITIAL WEBBING-TO-WEBBING CONTACT HAS BEEN MADE, IS TO LOOK AT THE SPOOL. WHEN A TIEDOWN IS COMPLETE, THE STRAP WEBBING ON THE SPOOL OF THE RATCHET SHOULD BE ABOVE THE LOWER CURVE OF THE LOCKING NOTCH, AND SHOULD BE BELOW THE TIPS OF THE TEETH OF THE RATCHET AS IDENTIFIED IN "STEP 5" ABOVE. IT SHOULD BE NOTED THAT ANY PROCEDURES THAT ENSURE PROPER TENSIONING ARE ACCEPTABLE AND METHODS ON THE DRAWING ONLY PROVIDE SOME METHODS.

