

~~SECRET~~

UNCLASSIFIED

~~CONFIDENTIAL~~

THE VIET CONG SOLDIER:
HIS STRENGTHS, WEAKNESSES AND VULNERABILITIES

An abstract for a thesis presented to the Faculty of
the U. S. Army Command and General Staff College in
partial fulfillment of the requirements of the
degree

MASTER OF MILITARY ART AND SCIENCE

UNCLASSIFIED

REGRADED.....

BY AUTHORITY OF **DOD, DIR 5200.10**

BY **WNS**.....

ON **26 Jun 80**.....

by
ANDREW L. COOLEY, Major, USA

CLASSIFIED BY: _____

DECLASSIFY ON: _____

Fort Leavenworth, Kansas
1966

UNCLASSIFIED

~~CONFIDENTIAL~~

19990806 041

~~SECRET~~

DOWNGRADED AT 3 YEAR INTERVALS;
DECLASSIFIED AFTER 12 YEARS
DOD DIR 5200.10

REPORT DOCUMENTATION PAGE

Form Approved
OMB No. 074-0188

Public reporting burden for this collection of information is estimated to average 1 hour per response, including the time for reviewing instructions, searching existing data sources, gathering and maintaining the data needed, and completing and reviewing this collection of information. Send comments regarding this burden estimate or any other aspect of this collection of information, including suggestions for reducing this burden to Washington Headquarters Services, Directorate for Information Operations and Reports, 1215 Jefferson Davis Highway, Suite 1204, Arlington, VA 22202-4302, and to the Office of Management and Budget, Paperwork Reduction Project (0704-0188), Washington, DC 20503

1. AGENCY USE ONLY (Leave blank)		2. REPORT DATE 25 May 1966	3. REPORT TYPE AND DATES COVERED Master's Thesis August 1965 - May 1966	
4. TITLE AND SUBTITLE THE VIET CONG SOLDIER: HIS STRENGTHS, WEAKNESSES AND VULNERABILITIES			5. FUNDING NUMBERS	
6. AUTHOR(S) Cooley, Andrew L., Major, U.S. Army				
7. PERFORMING ORGANIZATION NAME(S) AND ADDRESS(ES) U.S. Army Command and General Staff College 1 Reynolds Ave. Fort Leavenworth, KS 66027			8. PERFORMING ORGANIZATION REPORT NUMBER	
9. SPONSORING / MONITORING AGENCY NAME(S) AND ADDRESS(ES)			10. SPONSORING / MONITORING AGENCY REPORT NUMBER	
11. SUPPLEMENTARY NOTES				
12a. DISTRIBUTION / AVAILABILITY STATEMENT Approved for public release; distribution is unlimited.			12b. DISTRIBUTION CODE A	
13. ABSTRACT (Maximum 200 Words) The purpose of this thesis is to examine the regular force Viet Cong soldier and the effects of his organization, training, and leadership on his combat capability. As a part of this examination the relationship between the Viet Cong and the North Vietnamese Army will also be studied. From this examination strengths and exploitable weaknesses will be evaluated. No attempt is made to compare Viet Cong methods with those of the South Vietnamese army. The primary sources for this thesis are Viet Cong documents and prisoner of war interrogation reports. The Viet cong soldier is a strong, resourceful fox. His strength is derived from an effective organization, strict discipline, and the ability of his organization to effectively integrate a wide variety of activities, and focus them upon clearly defined goals. However, they have weaknesses which can be exploited if the military planner realizes that the Viet Cong soldier is not the result of an ideological myth but merely the product of good, sound, tactical planning which emphasizes leadership by example, training, and command supervision.				
14. SUBJECT TERMS Vietnamese Conflict; Viet Cong; Counterinsurgency; World War I; World War II			15. NUMBER OF PAGES 209	
			16. PRICE CODE	
17. SECURITY CLASSIFICATION OF REPORT U	18. SECURITY CLASSIFICATION OF THIS PAGE U	19. SECURITY CLASSIFICATION OF ABSTRACT U	20. LIMITATION OF ABSTRACT U	



U. S. ARMY COMMAND AND GENERAL STAFF COLLEGE

(Abstract Approval Page)

Name of Candidate ANDREW L. COOLEY, Major, USA

Title of Thesis THE VIET CONG SOLDIER: HIS STRENGTHS, WEAKNESSES
AND VULNERABILITIES

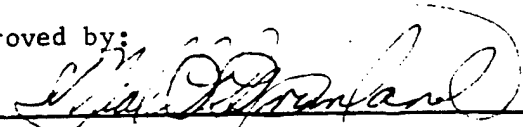
Approved by:

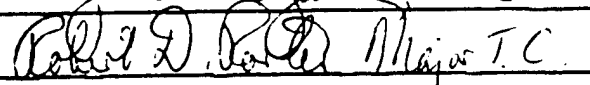
, Research and Thesis Monitor
 LTCR INF, Member, Graduate Faculty
 Major T.C., Member, Graduate Faculty

Date 25 May 1965

The opinions and conclusions expressed herein are those of the individual student author and do not necessarily represent the views of either the U. S. Army Command and General Staff College or any other governmental agency. (References to this study should include the foregoing statement.)

TABLE OF CONTENTS

	Page
PREFACE.	iii
LIST OF ILLUSTRATIONS.	viii
Chapter	
I. INTRODUCTION.	1
II. THE INFLUENCE OF NORTH VIETNAM.	6
III. THE INFLUENCE OF THE COMMUNIST PARTY.	15
IV. MANPOWER, ORGANIZATION AND LOGISTICS OF THE VIET CONG.	37
V. LEADERSHIP.	78
VI. VIET CONG TRAINING.	120
VII. TACTICAL APPLICATION OF VIET CONG DOCTRINE.	150
VIII. CONCLUSIONS.	177
BIBLIOGRAPHY.	186

~~SECRET~~

ABSTRACT

(U) The purpose of this thesis is to examine the regular force Viet Cong soldier and the effects of his organization, training and leadership on his combat capability. As a part of this examination the relationship between the Viet Cong and the North Vietnamese Army will also be studied. From this examination strengths and exploitable weaknesses will be evaluated. No attempt is made to compare Viet Cong methods with those of the South Vietnamese Army.

(U) It is assumed that both the Viet Cong and the South Vietnamese Army recruit soldiers from the same population base so neither side gains any significant advantage from the type of people recruited. Thus any strengths and weaknesses discovered result from organization, training and leadership.

(U) The primary sources for this thesis are Viet Cong documents and prisoner of war interrogation reports which were translated from Vietnamese into English by personnel of the U. S. Military Assistance Command, Vietnam, and distributed as Department of Defense Intelligence Information Reports. Other principle sources of material were Rand Corporation Reports, and a study by the John F. Kennedy Center For Special Warfare, which contained additional documents. All references are available at the Fort Leavenworth, Kansas Library.

(U) Initial research for this thesis indicated that the soldier is influenced by the Communist party (Party) and the National Front For The Liberation Of South Vietnam (Front). Since both of these

~~SECRET~~

UNCLASSIFIED

UNCLASSIFIED

~~SECRET~~

~~CONFIDENTIAL~~

organizations were created by North Vietnam, it was necessary to examine in detail both the role of North Vietnam and that of the Party to determine how it was related to organization, training and leadership.

From an analysis of the available information, certain Viet Cong strengths were identified. One strength is the physical and moral support provided by North Vietnam. Not only does North Vietnam support the insurgency, but it is responsible for the existence of the entire Viet Cong apparatus. The extent of North Vietnam's influence is not readily apparent to the soldier since it disguises its actual role and operates through two subsidiary organizations; the People's Revolutionary Party and the Front. The dominance of the Party over organization, promotions, training and leadership doctrine is a further source of strength. The Viet Cong military organization is effective and efficient when considered in conjunction with Party controls and the leadership concept. In this regard the cell organization is particularly influential since it develops group identification, and facilitates the practice of military, political and economic democracy by allowing the cell members to express themselves, and participate in discussions. Another strength is leadership doctrine. It is strengthened by the kiem thao sessions conducted daily at cell level where the soldier can relieve his frustrations by criticizing, within limits, the conduct of the war. Viet Cong training is well-planned and supervised. It emphasizes the use of lesson plans, rehearsals, and demonstrations in order to take maximum advantage of the available training time. It stresses practical application and student participation.

Major weaknesses have been identified in training, logistics, and motivation. The Viet Cong depend upon North Vietnam and their own

~~SECRET~~

~~CONFIDENTIAL~~
UNCLASSIFIED

base areas for logistics and training. If these base areas are denied, it reduces the soldier's combat capability. The logistics system also depends upon the soldier to both produce and procure a high percentage of his food. This dependence restricts the mobility of units and requires that soldiers devote valuable training time to production and procurement. Another weakness is a lack of experience found in main force regiments in coordinating and controlling regimental sized operations. Motivational problems exist that result in defection and security violations by Viet Cong soldiers when captured. Defection usually results from hardship and excessive family separations and is further aggravated by the existence of nationalistic elements within Viet Cong units. From these problems it appears that political and ideological indoctrination does not completely motivate the soldier to withstand privation, hardship and capture.

The Viet Cong are vulnerable to measures that disrupt their campsites and force them to move into new areas. Combinations of ground, artillery and air attacks increase hardships on the soldier, adversely affect his morale, and create doubts as to the effectiveness of his leaders. The Viet Cong soldier's willingness to talk when captured can be exploited by the proper treatment of prisoners and by acting rapidly on the information received.

(U) The Viet Cong soldier is a strong, resourceful foe. His strength is derived from an effective organization, strict discipline, and the ability of his organization to effectively integrate a wide variety of activities, and focus them upon the attainment of clearly defined goals. However, they have weaknesses which can be exploited if the military planner realizes that the Viet Cong soldier is not the



UNCLASSIFIED

result of an ideological myth but merely the product of good, sound, tactical planning, which emphasizes leadership by example, training and command supervision.



~~SECRET~~

UNCLASSIFIED
~~CONFIDENTIAL~~

THE VIET CONG SOLDIER:
HIS STRENGTHS, WEAKNESSES AND VULNERABILITIES

A thesis presented to the Faculty of the U. S. Army
Command and General Staff College in partial
fulfillment of the requirements of the
degree

MASTER OF MILITARY ART AND SCIENCE

by
ANDREW L. COOLEY, Major, USA

Fort Leavenworth, Kansas
1966

~~CONFIDENTIAL~~

~~SECRET~~

DOWNGRADED AT 3 YEAR INTERVALS;
DECLASSIFIED AFTER 12 YEARS
DOD DIR 5200.10

UNCLASSIFIED

U. S. ARMY COMMAND AND GENERAL STAFF COLLEGE

(Thesis Approval Page)

Name of Candidate ANDREW L. COOLEY, Major, USA

Title of Thesis THE VIET CONG SOLDIER: HIS STRENGTHS, WEAKNESSES
AND VULNERABILITIES

Approved by:

Michael J. ..., Research and Thesis Monitor

Frederic ... LTCR. IWC, Member, Graduate Faculty

Robert D. Porter Major TC, Member, Graduate Faculty

Date 25 May 1966

The opinions and conclusions expressed herein are those of the individual student author and do not necessarily represent the views of either the U. S. Army Command and General Staff College or any other governmental agency. (References to this study should include the foregoing statement.)

PREFACE

(U) I have undertaken this examination of the Viet Cong soldier in order to provide some detailed information on a facet of the war in Vietnam that I feel is often neglected in favor of its more academic aspects. Military students who are interested in studying the Vietnamese war will find a wealth of material dealing with its causes and many diverse opinions expressed by prominent writers on its political aspects. For the most part, though, these writings have avoided an important factor in this war: the Viet Cong soldier.

(U) I feel that this lack of emphasis on the Viet Cong soldier is responsible for misconceptions and generalizations about his effectiveness and the type of operations that will exploit his weaknesses. The popular conception that the Viet Cong soldier fights because there is a "gun at his back" or that he places no value on life or living conditions, because of a fanatical devotion to communism, is not substantiated by research. Rather research indicates that the Viet Cong soldier fights not as a devoted communist but as a result of sound training, organization, and leadership. Further, such frequently criticized operations as the destruction of base areas, large unit sweeps through Viet Cong controlled areas, and the use of unobserved artillery and air strikes are effective causes of defection even when no Viet Cong are killed.

(U) In preparing this thesis I have also included some personal observations made while serving as an advisor to a South Vietnamese infantry battalion in 1964-65. My tour of duty at battalion level enabled

me to observe first hand both regular and irregular Viet Cong soldiers implement their tactical doctrine as well as some of their training camps located in War Zones C and D. I was present during many interrogations of Viet Cong prisoners and observed their willingness to cooperate with their captors.

(U) This thesis is limited by both my inability to read Vietnamese, and the factor of time. Since it was prepared during the Regular Course at the U. S. Army Command and General Staff College, my research has been limited to those translated documents and reports available at the Command and General Staff College Library. While these documents deal only with the insurgency prior to the increased buildup of United States troops in July 1965, I do not feel that this has invalidated any of the conclusions since these documents are representative of Viet Cong operations that were successful enough to require the United States buildup.

(U) I hope that this thesis will provide a clear picture of the Viet Cong soldier to interested military students who desire a better understanding of a revolutionary soldier. I also hope that this thesis will provide a point of departure for those military students desiring to explore further the complex and interesting aspects of the Viet Cong soldier.

(U) The preparation of this thesis could not have been successfully completed without the assistance of my research and thesis monitors, Colonel Neal G. Grimland, Lieutenant Colonel E. M. Lynch, and Major Robert D. Porter. I am particularly indebted to Colonel Grimland who took a considerable amount of time from a busy schedule to render me invaluable assistance in the preparation and organization of my material. Further assistance was also provided by the staff of the Command and General Staff College Library of whom Mr. Byron Taylor, and First Lieutenant C. E. Beard

were particularly helpful. To my typist, Mrs. Irene King, goes my deepest appreciation for her ability to interpret my notes, and her assistance in the preparation of the final copy of this thesis.

(U) Lastly, but by no means least, I must recognize the support and encouragement furnished by my wife, Joan, who did not begrudge me the many nights and weekends that had to be devoted to the preparation of this — thesis. Without her encouragement and support, this paper would not have been possible.

TABLE OF CONTENTS

	Page
- PREFACE.	iii
LIST OF ILLUSTRATIONS.	viii
Chapter	
I. INTRODUCTION.	1
II. THE INFLUENCE OF NORTH VIETNAM.	6
III. THE INFLUENCE OF THE COMMUNIST PARTY.	15
IV. MANPOWER, ORGANIZATION AND LOGISTICS OF THE VIET CONG.	37
V. LEADERSHIP.	78
VI. VIET CONG TRAINING.	120
VII. TACTICAL APPLICATION OF VIET CONG DOCTRINE.	150
VIII. CONCLUSIONS.	177
BIBLIOGRAPHY.	186

LIST OF ILLUSTRATIONS

Figure	Page
1. Organization of the Viet Cong Apparatus	9
_ 2. Front-Communist Party Relationships	18
3. Viet Cong Organization	45
4. Political/Military Organization	46
5. The Central Office For South Vietnam	47
6. Viet Cong Military Regions and War Zones	49
7. Province Military Affairs Committee	52
8. Type Viet Cong Regiment	56
9. Type Viet Cong Battalion	57
10. Type Viet Cong Company	57
11. U Minh Battalion Provincial Mobile Force	62
12. Can Tho Battalion, Provincial Mobile Force	62
13. Ap Bac Battalion	64
14. 502d Battalion	64
15. Cuu Long Battalion	64
16. Viet Cong Military Units Available to a Province	75
17. Viet Cong Military Units Available to a Province	76

~~SECRET~~

UNCLASSIFIED

~~CONFIDENTIAL~~

CHAPTER I

INTRODUCTION

Foreword

(U) Communism triumphed again in Asia when the Geneva Agreement of 1965 divided Vietnam at the seventeenth parallel. The creation of the Democratic Republic of Vietnam (North Vietnam), allied militarily and politically to the Soviet Union and Communist China, provided another base for the exportation of communism into Southeast Asia. At the present time the Republic of Vietnam (South Vietnam) is experiencing an insurgency planned and supported from this base.

(U) This new insurgency is a continuation of the French-Indochina War when an unsophisticated "people's army" known as the Viet Minh defeated a highly sophisticated, well-equipped modern army in a "protracted war." Superior French fire-power was not decisive against the Viet Minh who practiced a flexible doctrine that stated, "Is the enemy strong? One avoids him. Is he weak? One attacks him."¹ To offset their lack of modern equipment the Viet Minh relied upon a politically motivated soldier who thrived in a war where there was "no fixed line of demarcation, the front being where the enemy is found."² Currently South Vietnam and her allies³ are fighting a similar war against the same enemy, but his name has been changed to Viet Cong.

¹General Vo Nguyen Giap, People's War People's Army (Washington: U. S. Government Printing Office, 1962), p. 48.

²Ibid.

³These allies include the United States, South Korea, Australia, New Zealand, and the Philippines, who provide either combat troops or technical advisors.

UNCLASSIFIED

~~CONFIDENTIAL~~

~~SECRET~~

UNCLASSIFIED

~~SECRET~~

~~CONFIDENTIAL~~

(U) By employing the same concepts as did their Viet Minh forebearers, the Viet Cong have achieved sufficient successes against conventional South Vietnamese units to require an increase in United States military forces in order to stabilize the military situation.

(S) The Viet Cong's military capabilities are significant to future military planners in at least two cases. First, North Vietnam has publicized the fact that their type of revolutionary warfare can be a "blueprint" for other underdeveloped nations to follow in order to defeat the forces of a more technically developed country.⁴ Secondly, since the war in Vietnam pits Vietnamese against Vietnamese, the ability of North Vietnam and the Viet Cong to train and motivate their soldiers can be readily contrasted with the ability of the United States and South Vietnam to train and motivate the same type individual. In a comparison between the North and South Vietnamese armies, the Defense Intelligence Agency noted that North Vietnam had "dedicated and capable leadership; combat-trained personnel inured to physical hardship; cohesive and disciplined organization assuring loyalty through tight party control;..."⁵ They described the South Vietnamese as having "insufficient qualified and aggressive leadership; insufficient but improving counterinsurgency training;..."⁶ Thus there may be much to gain from a study of North Vietnam's and the Viet Cong's concepts of organization, training and leadership for both the present Vietnam situation and "liberation wars" in other areas.

⁴Giap, p. 8.

⁵U. S. Defense Intelligence Agency, Army Intelligence Digest (AID)-VIETNAM (NORTH) (COMMUNIST), 15 Feb 1964, p. 3. (SECRET-NOFORN).

⁶Ibid. VIETNAM (SOUTH), p. 3.

UNCLASSIFIED

~~SECRET~~

~~CONFIDENTIAL~~

~~CONFIDENTIAL~~
UNCLASSIFIED

(U) The purpose of this thesis is to examine the regular force Viet Cong soldier and the effects of his organization, training and leadership on his combat capability. As a part of this examination, the relationship between the Viet Cong and the North Vietnamese Army will also be studied. From this examination strengths and exploitable weaknesses can be properly evaluated.

Assumptions

(U) This thesis is based on the following assumptions:

(1) No significant advantage accrues to either the South Vietnamese or the Viet Cong, as to the type of personnel recruited or drafted for military service.

(2) Therefore, the strengths and weaknesses revealed in this thesis result from organization, training, leadership, and motivation.

Definitions⁷

In order to clarify communication between the writer and the reader, an understanding of the following terms and their definitions is necessary.

Army of the Republic of Vietnam (ARVN)--Refers to the South Vietnamese army, trained and supported by the United States.

District Forces--This is the lowest echelon of Viet Cong military units. They are subordinate to the district and normally operate within its geographical limits.

Democratic Republic of Vietnam (DRVN)--(North Vietnam)--The communist country north of the seventeenth parallel.

⁷These definitions are found in U. S. Headquarters, U. S. Military Assistance Command, Vietnam, ORDER OF BATTLE VIET CONG FORCES REPUBLIC OF VIETNAM (U), Vol. I, 1 Jul 1964, pp. 1-5, (CONFIDENTIAL).

~~CONFIDENTIAL~~
SECRET

UNCLASSIFIED

~~CONFIDENTIAL~~

UNCLASSIFIED

CHAPTER II

THE INFLUENCE OF NORTH VIETNAM

The Viet Minh Legacy

(U) The purpose of this chapter is to examine the influence of the Viet Minh and North Vietnam upon the concepts of organization, training, and leadership within the Viet Cong. This examination will reveal significant similarities between the Viet Cong and the North Vietnamese Army. It will establish a basis for concluding that documents pertaining to the North Vietnamese Army may be examined with reference to the Viet Cong.

Upon the conclusion of hostilities in 1954, the Viet Minh military forces responded to the Geneva Agreement by ordering one segment of their regular forces and their dependents to regroup North, while a second group remained in the South.¹ In addition to these military units, there were about two million South Vietnamese civilians who had worked closely with the Viet Minh for about nine years and were sympathetic to their goals.² There was also a third group of elite forces who never came out in the open. They "quietly buried their well-greased

¹John C. Donnell, Guy J. Parker and Joseph J. Zasloff, Viet Cong Motivation and Morale: A Preliminary Report (U) (Santa Monica: March 1965) p. 12. A report to the Office of the Assistant Secretary of Defense/International Security Affairs, prepared by the Rand Corporation. (CONFIDENTIAL).

²B.S.N. Murti, Vietnam Divided: The Unfinished Struggle (New York: Asia Publishing House, 1964), p. 197.

~~CONFIDENTIAL~~

UNCLASSIFIED

~~CONFIDENTIAL~~
UNCLASSIFIED

weapons, hid their personal belongings, and simply returned for the time being to the humdrum tasks of sowing and harvesting rice."³

(U) When the elections, for the purpose of unifying the country, failed to materialize in 1956 the communists in North Vietnam began to reactivate and strengthen their already operational underground apparatus in the South. They alerted the stay-behind military units, and began infiltrating agents across the seventeenth parallel in accordance with a plan designed to detach the rural population from the government of the south.⁴

One example of the Viet Minh underground was Tran Thai Hoa. Hoa had been a youth group cadre for the Viet Minh. In 1954 he was ordered to "stay behind to conduct the political struggle and continue firmly to control the Youth Group."⁵ In 1956, Hoa was contacted by a Viet Cong underground cadre and ordered to reconstitute his group and to continue the political struggle for peace and the re-unification of South and North Vietnam.⁶ This reactivation of old cadre marked the transition from Viet Minh to Viet Cong.⁷

³Bernard B. Fall, The Two Vietnams, Revised Edition (New York: Frederick A. Praeger, 1964), p. 129.

⁴Robert Scigliano, South Vietnam: Nation Under Stress (Boston: Houghton Mifflin Co., 1963), p. 137.

⁵U. S. Department of Defense Intelligence Information Report, Stay-Behind Operation-Organization of Militia and Communist Party Cells (U), Report Number 6075035865, 17 June 1965, (File Number C-18745.99, Fort Leavenworth, Kansas Library). A translation of a captured Viet Cong prisoner of war report. (CONFIDENTIAL). Additional descriptions of stay-behind operations can be found in these interrogation reports from April to August 1965 under the same file number.

⁶Ibid.

⁷U. S. Army John F. Kennedy Center For Special Warfare (Abn), The Viet Cong, (2d ed. rev., Fort Bragg, N. C.: John F. Kennedy Center For Special Warfare (Abn), November 1965), p. 1-50. (SECRET).

~~CONFIDENTIAL~~
SECRET

UNCLASSIFIED

~~SECRET~~

(U) Limitations of the Study

This thesis will only examine the regular force Viet Cong soldier and the political, military organizations and doctrines that affect him. Any comparisons between the Viet Cong soldier and other military forces will be left to the reader.

This study will rely upon reports by prisoners-of-war, observers, and captured documents as primary sources. Most of these reports were translated from Vietnamese into English by the U. S. Military Assistance Command, Vietnam. These documents are available at the U. S. Army Command and General Staff College Library.

Finally, the conclusions reached in this thesis must not be viewed in a vacuum. The Viet Cong operate as an instrument of the Communist party to wage revolutionary war. Viet Cong doctrine has been tested only in Vietnam. The Viet Cong have been organized and trained to fight a particular kind of a war in their homeland, and it is in this light that the conclusions should be studied.

Since the Viet Cong are a part of Hanoi's overall scheme to subvert South Vietnam, it will be necessary to devote some detail to the influence that North Vietnam has upon the Viet Cong organization, training and leadership. This effect will be discussed in Chapter Two.

~~SECRET~~

~~SECRET~~
~~CONFIDENTIAL~~

UNCLASSIFIED

Guerrilla.--The armed element of Viet Cong militia which usually conducts most of the small scale activities occurring in the Republic of Vietnam.

Hamlet.--A settlement or group of dwellings which would be called a village in the United States. There are more than 15,000 hamlets in the Republic of Vietnam.

Lao Dong Party.--The Vietnamese Communist party whose central committee is located in North Vietnam.

Main Forces.--Viet Cong military forces directly subordinate to a military region.

Local Forces.--Viet Cong military forces subordinate to a provincial or district headquarters.

People's Army of Vietnam (PAVN).--The North Vietnamese regular army. Also the current designation of the old Viet Minh army.

Provincial Forces.--Local Viet Cong military units subordinate to a provincial headquarters. They normally operate within the terrain confines of the province.

Regular Forces.--Military forces which comprise the People's Army of Vietnam.

Viet Cong (VC).--A contraction of the Vietnamese VIETNAM CONG SAN meaning Vietnamese Communist. It includes both North and South Vietnamese but in common usage refers to Vietnamese Communist forces in South Vietnam.

Viet Minh.--A contraction of VIETNAM DOC LAP DONG MINH HOI meaning the "League for the Independence of Vietnam." A military-political entity which existed from 1944 to 1954.

Village.--The principal administrative and political subdivision of a district, closely resembling a United States township.

~~SECRET~~
~~CONFIDENTIAL~~

UNCLASSIFIED

~~CONFIDENTIAL~~

CONFIDENTIAL

(U) Organization. In reality Viet Cong are not independent insurgents but an extension of the government of North Vietnam, organized and controlled by them as a means for waging war in the South. Captured Viet Cong documents show how the Viet Cong are dependent upon the North in areas of organization and training. In May of 1963, Nguyen Chi Thanh, a member of the Lao Dong Central Committee, clarified the relationship between North Vietnam and the Viet Cong when he stated that "Our party set forth two strategic tasks to be carried out at the same time: to transform and build socialism in the North and to struggle to unify the country. Our army is an instrument of the class struggle in carrying out these two strategic tasks."⁸ North Vietnam's Defense Minister, General Giap, put it more bluntly when he stated, "The North has become a large rear echelon of our army...The North is the revolutionary base for the whole country."⁹

The military affairs of the Viet Cong are the responsibility of the High Command of the People's Army of North Vietnam under the close supervision of the Lao Dong Party. The extent that the Lao Dong Party is responsible for direction can be seen from Figure 1. The leaders in Hanoi supervise the activities of Viet Cong military units through the Central Office for South Vietnam which is located in Tay Ninh Province in the South.¹⁰ This supervision includes preparing operational plans,

⁸U. S. Department of State, Aggression From the North: The Record of North Viet-Nam's Campaign to Conquer South Viet-Nam, Department of State Publication 7839 (Washington: U. S. Government Printing Office, February 1965), p. 21, quoting Nguyen Chi Thanh in a Hanoi newspaper in May 1963.

⁹Ibid., quoting General Giap in the Communist Party Journal Hoc Tap.

¹⁰Ibid., p. 23.

~~CONFIDENTIAL~~

~~SECRET~~

UNCLASSIFIED

~~CONFIDENTIAL~~

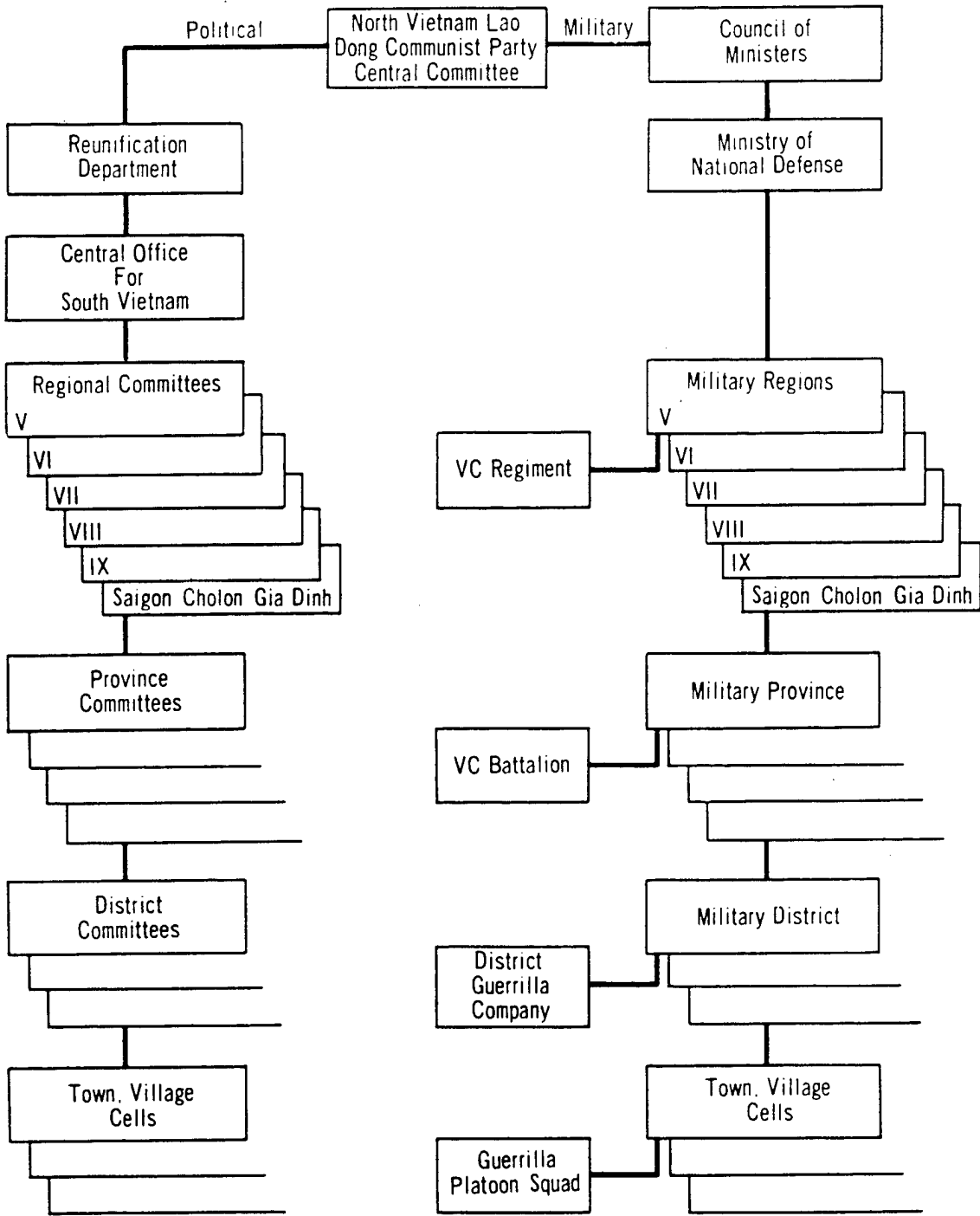

FIGURE 1
Organization of the Viet Cong Apparatus

~~CONFIDENTIAL~~

assignment of individuals and regular units, training programs, distribution of military personnel and supplies, communications and tactical intelligence.¹¹

The Central Office for South Vietnam translates the policies of the Lao Dong Party into operational directives and orders for implementation by the lower echelon Viet Cong units. Communication with Hanoi is maintained by radio, courier and agents.¹²

(U) Thus the organization shown in Figure 1 was not created by the insurgent Viet Cong, but was planned by North Vietnam as a means of controlling the insurgency. Further control is maintained through a parallel military-political chain of command at the regional level which is carried down throughout the chain of command. Each of the organizations shown in Figure 1 has a political and military element consisting of either an individual or a small staff.¹³ This blending of political and military activity was designed to insure complete cooperation in support of the total communist mission. Political control is maintained over the military and Hanoi has direct contact with its principle military units through the Central Office for South Vietnam.

The Leaders

North Vietnam influences the leadership within the Viet Cong by providing a sense of continuity since many of the Viet Minh leaders, well-known in the South, occupy key positions in the Northern government. The major leader is still Ho Chi Minh, regarded by many Vietnamese as the

¹¹Ibid.

¹²John F. Kennedy Center For Special Warfare (Abn), p. II-4.

¹³Department of State, Aggression From the North, p. 23.

UNCLASSIFIED

~~SECRET~~

11

"father of his country." In his capacity as the leader of the Viet Minh against the French and now as the President of the Democratic Republic of Vietnam, it is probable that "Uncle Ho" is still regarded as a national hero and great patriot by most Vietnamese, including those in the South. It is significant to note that the South Vietnamese government rarely mentions Ho Chi Minh, possibly because of his continuous popularity and the probable boomerang effect on them of acknowledging his influence as a communist leader.¹⁴

(U) Other prominent leaders in North Vietnam who influence the Viet Cong are General Vo Nguyen Giap, the Minister of Defense; Le Duan, the Secretary General of the Lao Dong (Communist) Party; Truong Chinh, the Vice Premier; and Pham Van Dong, The Premier and Minister of Foreign Affairs. These leaders have a historical advantage since they were successful against the French. Those Viet Cong who believe that the current war in the South is a continuation of the war with France are serving the same leaders. Both Giap and Chinh have written military documents on organization, training and leadership, of which Giap's book People's War People's Army is the most famous. In his book, Giap outlined the relations between officers and men, the role of the Party, and defined discipline, law and order for use in a guerrilla army.¹⁵

Another contribution from North Vietnam is the cadre. These cadre provide the Viet Cong with most of their leaders from squad to regimental level. These cadre come from two sources. One group is from

¹⁴Joseph J. Zasloff, The Role of North Vietnam In The Southern Insurgency (U) (Santa Monica: July 1964), p. 54. A report for United States Air Force Project Rand, prepared by the Rand Corporation. (SECRET).

¹⁵General Vo Nguyen Giap, People's War People's Army (Washington: U. S. Government Printing Office, 1962), pp. 41A-64.

~~SECRET~~

UNCLASSIFIED

UNCLASSIFIED

~~SECRET~~
12

the approximately 87,000 Viet Minh troops who went North in 1954, and another is from the 43,000 civilians who accompanied them.¹⁶ Recently North Vietnam has also utilized ethnic North Vietnamese, who have been drafted into the People's Army Vietnam, as replacements for both Viet Cong leaders and individual soldiers.¹⁷

4) In order to facilitate a future infiltration policy, most of the Southern Viet Minh troops were formed into Nam-bo (Southern) units and integrated into the North Vietnamese Regular Army. These units were designated as 325th, 305th, 324th, 308th divisions and the 120th Regiment. The regrouped Can-bo (civilian cadre) were absorbed by the North Vietnamese government.¹⁸ These personnel furnished North Vietnam with a valuable pool for future leaders to organize and train the Viet Cong. These cadre or leaders were sent South starting in 1956 to help expand the Viet Cong organization. Additional training cadre were sent South, prior to 1960, to prepare Viet Cong training programs.¹⁹

~~(S)~~ Training

Currently the most important influence that North Vietnam has upon the Viet Cong is in pre-infiltration training. This training is given

¹⁶Donnell, Parker and Zasloff, p. 12.

¹⁷U. S. Department of Defense Intelligence Information Report, Training, Infiltration, Organization of VC Districts, Report Number 607-50387, 24 June 1965, (File Number C-18745.99, Fort Leavenworth, Kansas Library). A translation of a captured Viet Cong prisoner of war report. (CONFIDENTIAL). Additional indications of draftees from the North fighting in Viet Cong units can be found in these interrogation reports from June to August 1965 under the same file number.

¹⁸Zasloff, p. 33.

¹⁹Ibid., citing U. S. Military Assistance Command, Vietnam (MACV), "Viet Cong Infiltration Into South Vietnam," July 1, 1962, p. 2. (SECRET-NOFORN).

UNCLASSIFIED

~~SECRET~~

~~SECRET~~

~~SECRET~~

13

to both potential cadre and draftee soldiers. North Vietnamese schools are equipped to give technical training from relatively secure and permanent facilities. The largest infiltration school is located at Xuan Mai and processes at least three thousand men every three months.²⁰ Since most of the trainees sent to Xuan Mai are members of the North Vietnamese Regular Army, this provides another method for influencing the Viet Cong.²¹ In reality, personnel from the North are now and always have been the backbone of the entire Viet Cong operation.²² Through this training program and infiltration, North Vietnam supplies the Viet Cong with both hard-core unit officers and noncommissioned officers.²³

Evaluation

(U) This chapter has outlined the influence of the Viet Minh and the Democratic Republic of Vietnam upon the organization, leadership, and training of the Viet Cong. From the Viet Minh the Viet Cong inherited a military organization that was simple, effective, and tailored to function in a "People's War." They also fell heir to a doctrine of leadership that stressed political and military integration.

(U) North Vietnam influenced the Viet Cong by supplying the key leaders necessary to organize and train insurgent forces. These leaders are using concepts practiced in the North Vietnamese Army and based upon victory.

²⁰Ibid., p. 40.

²¹Ibid.

²²U. S. Department of State, Aggression From The North, The Record of North Viet-Nam's Campaign To Conquer South Viet-Nam, Department of State Publication 7839 (Washington: U. S. Government Printing Office, February 1965), p. 3.

²³Ibid., p. 5.

UNCLASSIFIED

~~SECRET~~

~~CONFIDENTIAL~~
14

UNCLASSIFIED

(U) Through extensive pre-infiltration training, the use of regular army troops, and the chain of command, the North Vietnamese Army has exerted its influence over the training of the Viet Cong and is responsible for its doctrine. The evidence clearly points to the conclusion that: "the hard-core of the Communist forces attacking South Vietnam were trained in the North and ordered into the South by Hanoi."²⁴

(U) Documents captured from Viet Cong soldiers confirm the similarity between their training and that received by the North Vietnamese Army. The fact that this training is conducted by North Vietnamese indicates that the Viet Cong may not be a separate entity but merely an extension of the North Vietnamese Army. North Vietnamese documents do apply to the Viet Cong, and in the remainder of this thesis the methods used within the North Vietnamese Army will be considered as applicable to the Viet Cong from the standpoint of organization, training and leadership.

²⁴Ibid., p. 1

~~CONFIDENTIAL~~

UNCLASSIFIED

~~SECRET~~

UNCLASSIFIED

CHAPTER III

THE INFLUENCE OF THE COMMUNIST PARTY

(U) North Vietnam's Defense Minister Vo Nguyen Giap stated in his book People's War People's Army that the Viet Minh were successful because they were "organized and led by the Party of the working class"¹ He further stated that "the Viet Nam People's Army has been created by the Party, which ceaselessly trains and educates it. It has always been and will always be under the leadership of the Party...."²

(U) The Viet Cong adhere to a similar concept of Party supremacy by stating "our Army, the revolutionary armed forces, under the leadership of the Party, is entrusted with carrying on the revolutionary war until the nation's liberation."³ The role of the Party is a significant factor in a study of the Viet Cong soldier. Most democratic countries go to extremes to keep the soldier out of politics, but the Viet Cong leaders have recognized the advantage of a politically motivated soldier in a revolutionary war.

(U) The purpose of this chapter is to examine the effect of the Communist Party upon the Viet Cong soldier, and to provide background for a later examination of organization, training and leadership. This

¹ General Vo Nguyen Giap, People's War People's Army (Washington: U. S. Government Printing Office, 1962), p. 35.

²Ibid., p. 54

³U. S. Department of Defense Intelligence Information Report, Viet Cong Counterintelligence Activities, Report Number 6075039765, 28 June 1965, p. 1, (File Number N16961.40, Fort Leavenworth, Kansas Library). A translation of a captured Viet Cong Document.

~~SECRET~~

UNCLASSIFIED

examination will further attempt to clarify the complex political environment of the Viet Cong soldier and determine the extent that Party loyalty and political controls affect his efficiency.

(U) An examination of the Communist party influence within the Viet Cong is complicated to some extent since the Communist party has changed its name in the South in an apparent effort to mislead the South Vietnamese government and their allies. This change also enabled North Vietnam to give the impression that many spontaneous independent parties operate in the South and are nationalistic rather than communistic in nature. This enables the Viet Cong to broaden their appeal to include nationalistic groups. For this reason it is expedient to examine in turn the Communist party and the front organization, the political organization of the Viet Cong, the ideology, and the requirements for Communist party membership.

The Communist Party and the Front

(U) The Lao Dong Party. The Lao Dong or workers party of North Vietnam is the Vietnamese Communist party. It is the directing force behind the Viet Cong and provides trained agents for use in indoctrination, recruiting, political training, propaganda and other political activities.⁴ In North Vietnam, as in every other communist state, the party is an integral part of the regime. Through its central committee, the Lao Dong Party passes to either the Central Office for South Vietnam or the Defense Ministry instructions for the eventual execution by the Viet Cong soldier.

⁴U. S. Department of State, Aggression From The North, The Record of North Viet-Nam's Campaign To Conquer South Viet-Nam, Department of State Publication 7839 (Washington: U. S. Government Printing Office, February 1965), p. 1.

SECRET

UNCLASSIFIED

~~CONFIDENTIAL~~

(U) Prior to 1961 the Lao Dong Party made little effort to conceal its existence in the South. Party members, who were the cadre for the Viet Cong units, carried membership cards stamped by the Lao Dong Party.⁵ Documents captured during this period stressed the ultimate leadership of the Lao Dong Party in the insurgency, and cautioned cadre to always bear in mind the Lao Dong Party's role as the leader of the revolution.⁶

(U) In late 1961, Hanoi gave the appearance the Vietnamese Communist Party had split when it created a strictly South Vietnamese Communist Party, the People's Revolutionary Party, in order to minimize the role of the North in the Southern insurgency. This approximated the formation of the National Front for the Liberation of South Vietnam.

(U) The People's Revolutionary Party. In 1961 Hanoi created the People's Revolutionary Party in order to explain the presence of a communist organization within the National Front for the Liberation of South Vietnam.⁷ This presence, as well as relationships to other organizations, is shown in Figure 2. At this announcement the Lao Dong Party cadre operating with the Viet Cong merely changed their membership to the People's Revolutionary Party. At the present time membership in this party is easily converted from the Lao Dong Party in order to accommodate

⁵U. S. Department of State, A Threat to Peace Part II, Far Eastern Series 110 (Washington: U. S. Government Printing Office, December 1961), pp. 80-101. These translated documents indicate the influence of the Lao Dong Party. Note that the Vietnamese words Dang Lao Dong (Lao Dong Party) are either a part of the heading or mentioned in the text.

⁶Department of State, Aggression From The North, p. 22.

⁷Ibid., p. 23.

~~CONFIDENTIAL~~

UNCLASSIFIED

Theoretical Relationship Between The Communist Party and The Front

UNCLASSIFIED

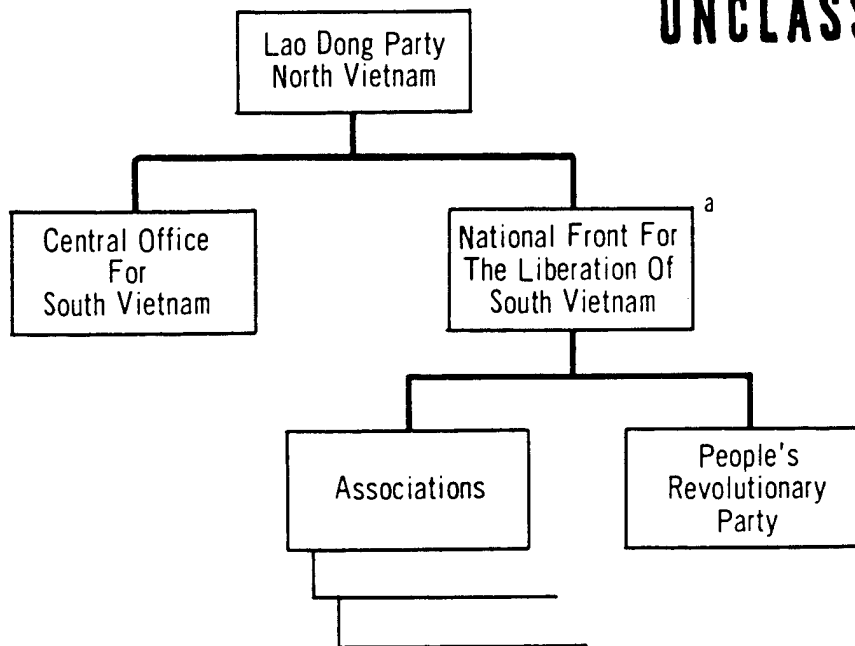

Operational Relationship Between The Communist Party and The Front

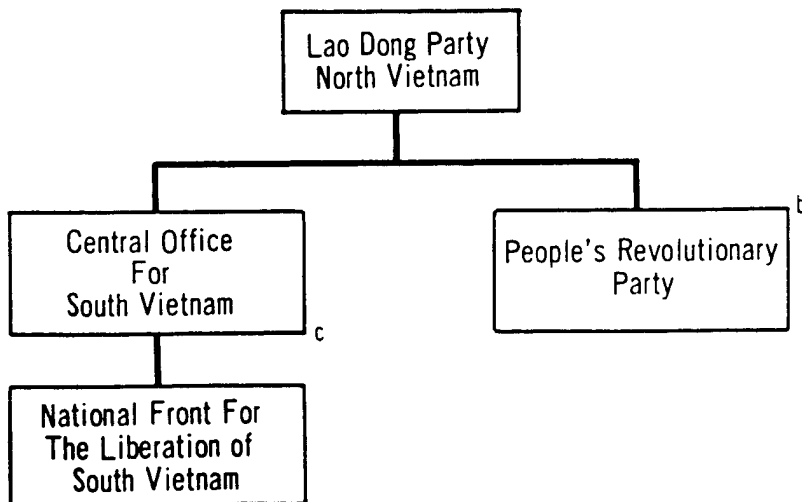

a. The Lao Dong Party would like the Front to appear on an equal level with it, and in this regard the Front sends ambassadors to other countries, but they carry North Vietnamese passports.

b. There is no real division between the People's Revolutionary Party and the Central Office. Party members are key personnel in the Central Office.

c. The Front also has offices in every succeeding echelon of Viet Cong organizations. They are subordinate to Province, District and Village.

FIGURE 2
Front-Communist Party Relationships

UNCLASSIFIED

~~CONFIDENTIAL~~

CONFIDENTIAL

infiltrators from the North. Time spent in either party now counts toward total party service.⁸

(U) Party leaders explain the existence of the two communist parties to the rank and file Viet Cong party members by maintaining that the Lao Dong Party in the North is oriented toward the buildings of socialism, whereas the People's Revolutionary Party is aimed at the liberation of South Vietnam.⁹ In line with this explanation there are indications that party membership in the South is less restrictive since it has a short range mission and the Party is more apt to go along with marginal members as long as their skills are needed in the war effort.¹⁰

(U) While there has not been a major effort to explain the existence of the two parties to the people of the South, the communists have made sure that key party members understand the true nature of both parties. Party members were told at the time of the creation of the new Southern party that "...our party is nothing but the Lao Dong Party of Viet-Nam (Viet-Minh Communist Party), unified from North to South...the chief of which is President Ho..."¹¹ Party members were told to "...realize that our country is one country that the Vietnamese People's Revolutionary Party and the Viet-Nam Lao Dong Party are one party..."¹²

⁸John C. Donnell, Guy J. Parker and Joseph J. Zasloff, Viet Cong Motivation and Morale: A Preliminary Report (U) (Santa Monica: March 1965), p. 32. A Report to the Office of the Assistant Secretary of Defense/International Security Affairs, prepared by the Rand Corporation. (CONFIDENTIAL).

⁹Ibid.

¹⁰Ibid.

¹¹Department of State, Aggression From the North, p. 57. Quoting a translated Viet Cong document dated December 7, 1961 from the Ba Xuyen Province Communist Party Committee addressed to the District Committees.

¹²Ibid. Quoting a translated Viet Cong document captured in Chuong Thien Province in November 1964.

~~CONFIDENTIAL~~
~~SECRET~~ UNCLASSIFIED

UNCLASSIFIED

~~SECRET~~

20

~~CONFIDENTIAL~~

(U) Thus it appears that the effect of the two parties is the same. Regardless of the names, the Communist party is still a leader in the revolution and as far as the individual Viet Cong is concerned, it makes no real difference to him whether he is a member of the Northern or Southern party. It is apparent, though, that new party members recruited in the South join the People's Revolutionary Party. Hereafter in this thesis the word Party will refer to both the Lao Dong Party and the People's Revolutionary Party and mean the Communist party.

~~SECRET~~ The National Front for the Liberation of South Vietnam (Front).

The Front is not designed as a communist party, but was created by the Third Lao Dong Party Congress in 1960 to "work in a very flexible manner in order to rally all forces that can be rallied...(and) draw the broad masses into the general struggle."¹³ The Front is staffed primarily with members of the People's Revolutionary Party¹⁴ and is a major influence in the life of the Viet Cong soldier. By using the Front as a screen, North Vietnam tries to create the impression that the Viet Cong campaign is indigenous to the South, and tries to unite all Vietnamese regardless of backgrounds in opposition to the government by nationalistic appeals. The Front includes member associations which consist of student, labor, peasant and youth groups.¹⁵ Through the associations, the Front hopes to win

¹³Department of State, A Threat To Peace Part II, p. 2.

¹⁴U. S. Department of Defense Intelligence Information Report, Report Number 6075052465, 30 July 1965, (File Number N-16961.40, Fort Leavenworth, Kansas Library). A translation of a captured Viet Cong Document citing Front propoganda which urges members to welcome the People's Revolutionary Party as a strong element of the Front.

¹⁵A complete listing of member associations in the Front can be found in Joseph J. Zasloff, The Role of North Vietnam In The Southern Insurgency (U) (Santa Monica: July 1964), p. 11. (SECRET). A Report for United States Air Force Project Rand, prepared by the Rand Corporation.

UNCLASSIFIED

~~SECRET~~

~~CONFIDENTIAL~~

UNCLASSIFIED

~~SECRET~~
21

~~CONFIDENTIAL~~

popular support, minimize the communist aspect of the insurgency and recruit a nationalistic element in the Viet Cong.

(U) The message of the Front is disseminated to the Viet Cong soldiers through newspapers, radio, and party members during political training periods. The following excerpts are examples of the Front appeals to both soldiers and civilians.

The herio (sic) people of SVN (South Vietnam) is determined to fight and chase the American imperialists to liberate SVN, to build an indepent (sic) democratic, peaceful and neutral SVN and pave the way to the re-unification of the country.

.....
The heroic SVN people and Liberation Army are determined to accomplish their holy mission of fighting and chasing the American imperialists to liberate SVN and to protect NVN (North Vietnam).

.....
The entire people stands together, the entire people equips itself and valiantly continues to fight, defeat the American aggressors and the Vietnamese traitors.¹⁶

The Front frequently refers to the Viet Cong military forces as the "Liberation Army" and there is reason to conclude that many Viet Cong soldiers join believing they are fighting for independence rather than a communist doctrine. The Front reinforces this concept by calling for "the entire people, cadre, and soldiers...(to) follow the liberation flag, be determined to rise up, fight and drive the American aggressors and their henchmen away in order to save our country, our homes."¹⁷ The Viet Cong soldier is told the fight may "take 10, 20 years or longer...until the last American aggressor leaves our Fatherland's soil..."¹⁸ This appeal by the

¹⁶U. S. Department of Defense Intelligence Information Report, VC Document-Unconventional Forces, Report Number 6075024765, 25 May 1965, (File Number N-16961.40, Fort Leavenworth, Kansas Library), A translation of a captured Viet Cong Document.

¹⁷Ibid.

¹⁸Ibid.

UNCLASSIFIED

~~CONFIDENTIAL~~

~~SECRET~~

Front orient's the Viet Cong from a battle between ideologies and makes him seem a saviour of his country. Finally, the Front gives the Viet Cong soldier three simple reasons for fighting: to "liberate SVN (South Vietnam), protect NVN (North Vietnam), and reunify the country."¹⁹

① A Rand study concluded that the Front has had some success in convincing Viet Cong soldiers that the revolution is independent from the North. When prisoners were asked if Hanoi could order a cease fire, practically all the Southern prisoners and even some of the Northern returnees answered firmly, "No, that is a decision the Liberation Front would have to make."²⁰ Some prisoners did believe that Hanoi might be consulted.²¹

② Through the Front, the Viet Cong soldier is able to identify himself with a popular movement. As a member of the "Liberation Army" he can feel he is a part of a coordinated military and civilian effort to free his country. If he is commended, his commendation will bear a heading from the "Liberation Army of the Front."²² His political officer will be a member of the Military Affairs Committee of the Front, and also a

¹⁹Ibid.

²⁰Donnell, Parker, Zasloff, Viet Cong Motivation and Morale, p. 49. 145 prisoners-of-war were interviewed. They were divided as follows: 36% Southern prisoners, 29% regrouped from the North, 21% defectors, 11% suspects and 3% North Vietnamese infiltrators.

²¹Ibid.

²²U. S. Department of Defense Intelligence Information Report, Unconventional Forces-Viet Cong, Report Number 6075022165, 19 May 1965, Inclosure 10, (File Number N-16961.40, Fort Leavenworth, Kansas Library). A translation of a captured Viet Cong document.

UNCLASSIFIED

~~CONFIDENTIAL~~

Communist party member.²³ By using the Front, the Viet Cong attempt to insure a politically motivated soldier who will work as a part of a united bloc of workers, peasants, and soldiers to insure success based upon the worker-peasant alliance.²⁴ This means that the Party actually controls the soldier regardless of whether the soldier believes he is fighting for communism or nationalism.

Parallel Party Organization Within Viet Cong Military Units

(U) General. The Party organization in the military forces is not always clearly defined. In main force units the party members are assigned to specific positions on a full time basis. These political cadre are usually full time party cadre oriented toward the political well-being of their troops, but with a considerable amount of military experience. At the provincial and local force levels the political officers often serve on various provincial district, or village committees as well as perform their military duties. Nevertheless, the political cadre are responsible for the political climate of their troops and are expected to be the vanguard for the revolutionary movement.

(U) Organization In Main Force Regiments. In the main force regiments, which are usually found organic to military regions, the Party places its members in every key position from regiment to cell. Full time political officers are found at the regiment, battalion, company and platoon; while within the squads, the squad leaders and assistant

23U. S. Department of Defense Intelligence Information Report, Organization of the Communist Party in the Saigon/Dia Binh Special Zone (U), Report Number 6075021965, 17 May 1965, (File Number R-16961.40, Fort Leavenworth, Kansas Library). A translation of a captured Viet Cong Document.

24U. S. Department of State, A Threat to Peace Part 11, p. 2.

~~CONFIDENTIAL~~

UNCLASSIFIED

~~CONFIDENTIAL~~

UNCLASSIFIED

squad leaders are required to be party members and double both as military and political leaders.

(C) The Party uses three methods to classify soldiers politically in main force units. The first method divides the soldiers into four groups. Those that are party members, probationary party members, Labor Youth Group (feeder organization for the Party) members, and non-party members.²⁵ The second method divides cadre and soldiers into classes. The first class is called the basic class. These are the hard-core element of the command. They are party members that, due to their background, are the most trusted by the Viet Cong. Generally they are the soldiers and cadre from a labor, tenant farmer or destitute farmer background. The second class consists of individuals with middle class farmer or a poor background. In some cases, they may include minor bourgeoisie, or petty land-lords and civil servants; however, these individuals are not trusted by the Viet Cong and are treated with caution. This could be a possible weakness since many of these class two personnel are in command positions.²⁶ The final or upperclass individuals have a bourgeois background and are not trusted. They are constantly watched and their positions of responsibility vary accordingly.²⁷

²⁵J. S. Department of Defense Intelligence Information Report, Political Statistics of the 1st Regiment (U), Report Number 6075024365, 25 Mar 1965, p. 2. (File Number G-18745.99, Fort Leavenworth, Kansas Library). A translation of a Viet Cong Prisoner of War Report. (CONFIDENTIAL).

²⁶Ibid., p. 3. It should also be noted that this second method has no relationship to the first method. This second method can include members from all four groups in method one.

²⁷Ibid.

~~CONFIDENTIAL~~

UNCLASSIFIED

UNCLASSIFIED

~~SECRET~~ CONFIDENTIAL

4) A third control measure used by the Party is to classify members of units according to their individual character and political background. Category A members are those with unquestionable loyalty to the Party. They are trusted completely by the Viet Cong and selection into this group goes to those soldiers who have shown absolute subservience and confidence in the Party, fought bravely for the cause, and never complained about hardships. This last qualification about complaining seems to be a fetter with the Viet Cong and much of the self-criticism of members deals with complaints concerning hardship. Category B personnel are composed of members who have an unsteady attitude and do not fully comply with the Party's regulations. Category C personnel generally have no fighting spirit and are chronic complainers. They generally oppose Party policy during open debates or question periods. It is interesting to note that personnel in all of the above categories can be party members which leads to the conclusion that the references to the easing of restrictions to membership in the People's Revolutionary Party mentioned earlier in this chapter may be valid.²⁸

5) Through a parallel political organization in military units the Party can work within the established military chain of command and still maintain a political awareness of the members of the regiment. By the system of categories the Communist party can ascertain the quality, quantity, and morale of the soldiers and judge the ideological attitude of each subordinate military unit. Thus, the Party can adjust or replace the forces of the Party within the military units or accelerate the development of forces in order to maintain control. The Party can promote indoctrination movements within units actually lacking party members or

²⁸Ibid., p. 5.

~~CONFIDENTIAL~~
~~SECRET~~

UNCLASSIFIED

that are not under the firm control of the Party. This system also allows the Party to make organizational changes based upon tactical requirements or battle casualties. Party reports based upon classification and division are consolidated at company, battalion and regimental level and are eventually reported to the military region where the unit is assigned.²⁹

The following figures are an example of typical party membership in a main force regiment. Out of a total figure of 2173 officers and men, 917 are party members, 86 probationary members, 742 members of the Labor Youth Group and 428 non-party members. Out of the total party membership of 917 there were 700 listed in Category A (those with unquestioned loyalty) which indicates that there were at least 217 party members whose loyalty is questioned. 1100 members were listed in Category B (unsteady attitude), and 373 place in Category C (unreliable).³⁰

(U) As a means of comparing Party control in main force units with that of District Companies, which are also regular military units, the following figures indicate the number of cadre assigned and the total number of party members within the unit. These figures indicate that individual soldiers are party members, thereby increasing party control. These seven companies were selected as a partial representation.³¹

²⁹U. S. Department of Defense Intelligence Information Report, Political Statistics of the 1st Regiment (U), p. 5.

³⁰Ibid., Inclosure.

³¹U. S. Department of Defense Intelligence Information Report, Unconventional Forces, Report Number 6075033265, 11 June 1965, p. 17, (File Number N-16961.40, Fort Leavenworth, Kansas Library). A translation of a captured Viet Cong Document.

<u>Company</u>	<u>Strength</u>	<u>Cadre</u> ³²	<u>Party Members</u>
401	123	48	60
403	129	42	47
405	102	23	26
407	72	29	30
409	61	29	34

(U) Other Party Military Organizations. Since the Party organizes its military units beginning at the lowest level, an examination of the village military organization will shed light on Party controls as they affect the soldier. The first unit organized is a squad usually recruited from a hamlet. The goal of the Party is to have from two to three party members within the squad in addition to the squad leader and assistant squad leader. Leaders are advised by the Party to start a party chapter within their units as soon as possible in order to insure the leadership of the Party. At the village level a platoon is organized that has its own organic squads independent of those at the hamlet level.³³ The platoon leader should be a party member, but at this level there is a full time platoon political officer and two assistant platoon leaders. The political officer is usually selected from the District Party committee and should have military experience. This political officer is the unit political commander. He is responsible for the development of the unit's political activities, and qualitative and quantitative

³²Cadre includes all personnel who occupy leadership positions.

³³The Viet Cong military organization will be discussed in Chapter IV. The village level platoon has squads organic to it. The squads at the hamlet level are independent squads, however, these independent squads may be upgraded and formed into provisional platoons for certain missions.

administration of the Party and Labor Youth Group revolutionary activities such as political indoctrination, emulation and awards.³⁴

(U) The squads and the platoons of the district companies are organized politically in the same manner.

(U) For planning purposes and to coordinate and act on party matters, a Platoon Command Committee consisting of the platoon leaders, the political officer and the two assistant platoon leaders exists.³⁵ This command committee is Party oriented and is responsible to the District Command Committee which is similarly organized with a military commander and his political advisor.

(U) It must be mentioned that a further organization exists in addition to the political control side if there are a significant number of party members in an organization. If a unit has three party members, then one secretary is appointed. An assistant secretary is added if the membership increases to four or five. If there are from seven to nine party members, a Chapter Committee is formed which includes all party members in addition to the secretary and the assistant.³⁶ When this organization is formed, the secretary becomes responsible for the political organization, training, and propaganda of the party members; and the assistant is responsible for security.³⁷

(U) The Party organization for the control of the military can be summarized by stating that the Party tries to achieve the maximum

³⁴U. S. Department of Defense Intelligence Information Report, Organization of Guerrilla Forces, Report Number 6075031665, 8 June 1965, p. 1, (File Number N-16961.40, Fort Leavenworth, Kansas Library). A translation of a captured Viet Cong Document.

³⁵Ibid.

³⁶Ibid., p. 3.

³⁷Ibid., p. 4.

~~CONFIDENTIAL~~

UNCLASSIFIED

number of party members in each squad. The squad leaders and assistants are party members and report political activities to the Platoon Command Committee, which in turn reports to a Company Command Committee and a Battalion Command Committee if one exists at province level. Main force units follow the same reporting procedure except there is a regimental and military regional headquarters added. Thus party control is insured through a third chain of command in addition to the military and political one.

Party Responsibilities

(U) Ideology. The ideology that affects the Viet Cong soldier is expounded by his political cadre in terms of a "Combat Ideology of the People's Army."³⁸ This calls for the soldier to make positive attacks against any reactionary force. The revolutionary character of the army is emphasized and the soldier is told that the battle is waged under Party leadership for social class interests. The theme of independence, peace and democracy, and re-unification of the country is emphasized over and over again.

(U) Most of the Viet Cong soldiers receive this indoctrination in regimental activities. These activities are generally spelled out in Party directives and are another check the Party has on the political progress of units. The most effective regimental activities are conducted at the squad and platoon level. The self-criticism sessions which will be covered in Chapter V are a basic part of these activities. Party Chapters meet at least once a month at the platoon level, and subordinate party units at least four times monthly to discuss Party documents and

³⁸U. S. Department of Defense Intelligence Information Report, Viet Cong Military and Political Doctrine, Report Number 6075046065, 11 July 1965, p. 1 (File Number N-16961.40, Fort Leavenworth, Kansas Library). A translation of a captured Viet Cong Document.

~~CONFIDENTIAL~~

UNCLASSIFIED

to report on achievements.³⁹ During these meetings reports are received on the military and political activities and the participants may contribute opinions or review either the strong or weak points of past activities.

(U) This ideology is a reiteration of Giap's views on a politically motivated army. Giap noted that political work in the ranks was the "soul of the army,"⁴⁰ and it would seem that the Viet Cong are continuing to practice this concept. It falls to the Party to "...strengthen leadership, train (the men) in ideology, discipline, tactics...(and) provide guidance and leadership..."⁴¹ It is the duty of the Party to solidify the relations between the officers and men, and establish rapport between them.⁴² In short, the party cadre preach that the revolution will succeed because of the Viet Cong's political superiority in a fight for a "just cause."⁴³ Party cadre emphasize the importance of training in order to provide a guerrilla unit responsive to the Party and determined to fight and win.⁴⁴

³⁹U. S. Department of Defense Intelligence Information Report, Organization of Guerrilla Forces, pp. 2-5.

⁴⁰Giap, p. 55.

⁴¹U. S. Department of Defense Intelligence Information Report, Viet Cong Counterintelligence Activities, p. 1.

⁴²Giap, p. 59.

⁴³U. S. Department of Defense Intelligence Information Report, Viet Cong Military and Political Doctrine, p. 1.

⁴⁴U. S. Department of Defense Intelligence Information Report, VC Resolution on Military Mission in 1965, Report Number 6075047365, 12 July 1965, p. 8, (File Number N-16961.40, Fort Leavenworth, Kansas Library). A translation of a captured Viet Cong document.

~~SECRET~~

31

UNCLASSIFIED

(U) Promotions. The promotion of Viet Cong soldiers is the responsibility of the Party. It establishes the criteria for promotion which is usually described as talent and virtue. Virtue is defined as the basic reflection of unlimited loyalty to the Party and the revolution. Candidates for future leadership positions are evaluated by the political side of the chain of command and are first recommended by the local Party Chapter Committee. As was noted earlier, this committee, at the platoon level, is normally composed of the military commanders plus the political officer. Applicants must submit a detailed personal history which is carefully studied and reviewed by all Party committees.⁴⁵

(U) It can be concluded that the Party affects the Viet Cong soldier through organization, political training, and promotions. At the squad and platoon levels those Party functions are usually simplified since the military leaders and the party cadre are the same, but at the higher levels of command the division of labor becomes more apparent and the possibilities for friction between professional military and political advisors can become acute.

Party Membership

(U) Procedures. Applicants for party membership must follow a rigid procedure. These applicants are first screened by the squad level Party committee and then two party members are assigned to help indoctrinate the applicant on Communism after the initial investigation is completed. This investigation into the applicant's background is then sent forward to the next higher Party Chapter for approval, after being certified correct by the two sponsors. When the next higher level notes

⁴⁵U. S. Department of Defense Intelligence Information Report, Viet Cong Policy on the Promotion of Squad Cadre, Report Number 6075033765, 12 June 1965, pp. 1-2, (File Number N-16961.40, Fort Leavenworth, Kansas Library). A translation of a captured Viet Cong Document.

~~SECRET~~

UNCLASSIFIED

its approval the applicant is free to begin to study Party regulations and formally execute a volunteer statement. The volunteer statement for party membership must be hand written by the prospective member in order to test his understanding and literacy. The applications are then sent up the Party chain of command for final consideration at the Military Region.⁴⁶

(U) Examples of Applications. The following excerpts indicate the type of information required in the personal history questionnaire. In addition to the normal biographical data, applicants must describe their history and activities from their earliest recollection.

When the Resistance broke out, I still worked as a hired laborer and lived with my family. Little by little I saw the social injustice and I joined the Revolution in 1950 as a village guerrilla. After the cease fire and restoration of peace, I got married and lived with my mother and my youngest brother. I owned only one hectare (sic) of land issued by the Revolution during the 9-year (Resistance), and could only make enough money to support my mother.⁴⁷

(U) In addition to the background data the applicant must also include information as to his family's economic status, a list of his relatives working for both the Viet Cong or the government of South Vietnam, and a summary of his strong and weak points in his own words.⁴⁸

(U) In his handwritten application for party membership, the applicant acknowledges that "the Party combat policy is consistent with

⁴⁶U. S. Department of Defense Intelligence Information Report, Organization of Guerrilla Forces, p. 5. The Military Region seems to be the level for administrative decisions. Examples of promotion orders and letters or commendation originate at this level and it is reasonable to conclude that when the Viet Cong refer to "the highest level for decision" they mean the Military Region.

⁴⁷U. S. Department of Defense Intelligence Information Report, Viet Cong-Unconventional Forces, Report Number 6075025265, 25 May 1965, Inclosure 3, (File Number N-16961.40, Fort Leavenworth, Kansas Library). A translation of a captured Viet Cong Document.

⁴⁸Ibid.

Marxism and Leninism..."⁴⁹ The applicant's sponsors provide comments on the application such as, "Comrade Truc always felt assured and performed his mission in an enthusiastic manner. Specifically he had voiced no complaint when he was assigned to do farm work for a long period of time"⁵⁰ or "Comrade Truc always proved to be enthusiastic in his mission."⁵¹ The sponsors may also mention weak points observed such as comments to the effect that "when he served in the production he failed to protect public properties and lost a number of items."⁵²

(U) The applicant's self critique that accompanies the application reflects the emphasis the Viet Cong place on complete "soul searching." Strong points are described in this manner.

(I) have strictly complied with all the instructions and resolutions from higher echelons.

have always had a peaceful mind when accomplishing official mission, and unflinching energy when facing with (sic) hardships.

have well succeeded in the masses' indoctrination, did my best to help the masses, and stayed close to the latter in an effort to help them.

have fought bravely and never wavered in difficult circumstances.

have regularly attended classes and studied by myself to improve my own political and cultural knowledge.⁵³

⁴⁹Ibid., Inclosure 4.

⁵⁰Ibid., Inclosure 6.

⁵¹Ibid.

⁵²Ibid.

⁵³U. S. Department of Defense Intelligence Information Report, Unconventional Forces-Viet Cong, Report Number 6075022165, 19 May 1965, Inclosure 6, (File Number N-16961.40, Fort Leavenworth, Kansas Library). A translation of a captured Viet Cong Document.

~~SECRET~~
~~CONFIDENTIAL~~

UNCLASSIFIED

If the applicant has any weak points, he might describe himself as "a hot tempered man, I sometimes quarrelled with my comrades in arms. Lacked consistency in helping my comrades-in-arms. Lacked ideological determination so later, under enemy firepower, I felt discouraged."⁵⁴

Evaluation

(U) Based upon this examination of Viet Cong-Party relationships it seems that the Viet Cong have encountered no major problems with the two operating Communist parties in Vietnam. It is doubtful if the Viet Cong soldier is aware of the similarities between the Lao Dong and People's Revolutionary Party unless he is a party member and if this similarity was revealed it would probably have no adverse effect upon his overall fighting capability.

(U) The Front has given the Viet Cong a significant motivational weapon. In this organization the soldier can lose himself in patriotism and feel united with a civilian popular movement. It is doubtful if any significant advantage would occur to the South by exposing the Front as a subordinate creation of the North. The fact that the Front advocates re-unification of the country might explain to the soldier's satisfaction its close relationship with Hanoi.

(U) Possibly, the biggest weakness in Party relationships is the admission that motivational problems exist among party members. Those soldiers who find the rigors of guerrilla warfare distasteful and those who are subjected to discrimination because of family background, constitute serious weaknesses. These factors may be exploitable since the Viet Cong have admitted a preference for soldiers with poor peasant backgrounds,

⁵⁴Ibid.

~~CONFIDENTIAL~~

~~SECRET~~

UNCLASSIFIED

but this weakness should ~~CONFIDENTIAL~~ in light of the effective Party system created to identify these problem areas.

(U) Party members within Viet Cong units have demonstrated their ability to centralize command in accordance with their stated goals. The reference to early organization of Party chapters within units indicates that without this additional means of control the purely military structure might be ineffective. Once Party controls are implemented, the Viet Cong soldier is quickly absorbed into the system and given systematic indoctrination oriented toward making the system work. In this regard the Party organization is an effective means for insuring solidarity and provides the soldier with strong motivationalities.

(U) It is possible that friction could develop between military commanders and political cadre, but regimental activities tend to solve these problems through self-criticism. The total supremacy of the Party in controlling promotions could be a cause for friction, but again, if the soldier is conditioned to this system and knows of no other selection criteria, he could adjust to it.

(U) There is an advantage in requiring Party applicants to "bare their souls" in Party applications. This method of self-criticism can have two effects. It can cause applicants to lie about their backgrounds and emphasize the poorer aspects of their lives, but it can also assist the Party by making the applicant intentionally de-emphasize the pleasanter aspects of his life, thereby placing the Party above himself, since he knows this is what the Party wants to read. Self analysis forces the applicant to examine himself, and "clear his conscience" of any anxieties that might cause him future trouble if left concealed. This makes him

~~CONFIDENTIAL~~
~~SECRET~~

UNCLASSIFIED

~~SECRET~~
UNCLASSIFIED

more dependent on the Party since these evaluations, once in the record, are not erased.

(U) In the next chapter the Viet Cong military organization will be examined and the overall effect of the Party will become more apparent when viewed along side the military structure.

UNCLASSIFIED

~~SECRET~~

~~SECRET~~
~~CONFIDENTIAL~~

UNCLASSIFIED

CHAPTER IV

MANPOWER, ORGANIZATION AND LOGISTICS OF THE VIET CONG

(U) The purpose of this chapter is to examine the military organization of the Viet Cong in order to determine its effect upon the soldier. In Chapter Three, the Viet Cong political apparatus was shown to be an integral part of any organization and will parallel the military organizations described in this chapter. At the higher levels this parallel organization consists of a political committee. At regiment and below there is a political officer who, in most cases, has the same authority as the unit commander. As mentioned in Chapter Three, the squad leader performs both the military and political functions. This chapter will first examine manpower sources and recruiting techniques; then examine control headquarters and the tactical units; followed by a brief description of logistics as it affects the soldier.

Manpower Sources and Recruiting

The Viet Cong recruit soldiers from both North and South Vietnam. Viet Cong recruited in the North are trained there and then infiltrated south to join their units. This infiltration is not limited to Northerners, however, since some Southern recruits are also sent north for training and return south through infiltration. In most cases, though, the bulk of the Viet Cong soldiers are recruited and trained in the South.¹

¹Jeanne S. Mintz, Herbert M. Silverberg, James E. Trinnaman, A Short Guide to Psychological Operation In The Republic of Vietnam 1965 (U), prepared by the Special Operations Research Office, The American University (Washington, D. C., June 1965), p. 75. (CONFIDENTIAL).

~~SECRET~~

~~CONFIDENTIAL~~

UNCLASSIFIED

~~CONFIDENTIAL~~
~~SECRET~~
UNCLASSIFIED

The initial Viet Cong recruiting drive coincided with their buildup of military forces in 1960 and was based upon careful family studies conducted by Viet Cong cadres in their respective areas. These studies were designed to reveal vulnerabilities in the population that the Viet Cong could exploit with their propaganda, and usually centered around local grievances against the government.²

Viet Cong recruiters were prepared to exploit any form of discontent. They appealed to religious sects,³ persecuted under the Diem regime, and to the social rebels and adventurers that always seem to live on the "fringes of society."⁴ Another source of recruits during this period were inhabitants living in areas controlled by the Viet Minh. These areas had been under communist influence since 1946 and were inherited by the Viet Cong.⁵

In-Country Recruiting

(U) In South Vietnam, Viet Cong regard military proselyting, or recruiting, as a major activity and they constantly appeal to the "... masses to join the Revolution..."⁶ Proselyting, according to one Viet

²John C. Donnell, Guy J. Parker and Joseph J. Zasloff, Viet Cong Motivation and Morale: A Preliminary Report (U), (Santa Monica: March 1965), p. 19. A Report to the Office of the Assistant Secretary of Defense/International Security Affairs, prepared by the Rand Corporation. (CONFIDENTIAL).

³Joseph J. Zasloff, The Role of North Vietnam In The Southern Insurgency (U), (Santa Monica: July 1964), p. 35. A report for United States Air Force Project Rand, prepared by the Rand Corporation. (SECRET).

⁴Ibid., p. 57.

⁵Ibid., p. 35.

⁶U. S. Department of Defense Intelligence Information Report, Proselyting Task To Be Conducted By The Viet Cong, Report Number 6075048365, 14 July 1965, p. 2, (File Number N-16961.40, Fort Leavenworth, Kansas Library). A translation of a captured Viet Cong Document.

UNCLASSIFIED

UNCLASSIFIED

~~SECRET~~

Cong source, "plays a strategic role as regards the mission of Viet-Nam's Revolution as a whole, and South Vietnam's Revolution in particular."⁷ Higher echelons of the Party demand that recruiting cadre devote most of their time and attention to this field and quote impressive figures to attest to their success. One document told cadre that "since the uprising we (Viet Cong) have made 60,000 (South Vietnamese Government) soldiers desert enemy ranks throughout Vietnam."⁸ They claimed that one area had produced 18,393 deserters and 723 weapons since 1960, and another area 13,374 deserters and 347 weapons.⁹

Much of the Viet Cong recruiting effort is directed toward the more populated areas such as the Mekong Delta. Emphasis is placed on recruiting youths between seventeen and thirty-five years of age. Special targets are those men subject to conscription in the South Vietnamese Army,¹⁰ since the Viet Cong would rather get their soldiers before they are drafted rather than try to get them to desert afterwards.¹¹ However, a large amount of effort is still placed on getting South Vietnamese regulars and para-military troops to desert.¹²

⁷Ibid.

⁸Ibid. It must be remembered these figures are unconfirmed and are probably exaggerated by the Viet Cong to further motivate their cadre.

⁹Ibid.

¹⁰Zasloff, p. 35.

¹¹U. S. Department of Defense Intelligence Information Report, Viet Cong Recruitment Activities, Report Number 6075039365, 24 June 1965, p. 1, (File Number N-16961.40, Fort Leavenworth, Kansas Library). A translation of a captured Viet Cong Document.

¹²Zasloff, p. 36.

UNCLASSIFIED

~~SECRET~~

~~SECRET~~

~~TOP SECRET~~

~~CONFIDENTIAL~~

Appeals

1) A Rand study concluded that purely political appeals were relatively ineffective in influencing village youths to enlist. According to the Rand study, youths joined the Viet Cong to avoid the South Vietnamese draft or because they had been harshly treated by South Vietnamese soldiers. A few harbored resentment against corrupt local officials and others joined purely for adventure.¹³ One captured Viet Cong recruiting document tends to validate these Rand conclusions since it directed its cadre to seek volunteers from families with a revolutionary background, (previous service against the French), or from those who had either real or fancied grievances against the government.¹⁴ It further instructed cadre to appeal to ambitious youths who want technical training that is not available to them in their village.¹⁵

2) Appeals are different in the Viet Cong controlled areas. Here they tend to call for recruits to defend the legitimate (Viet Cong) government against the imperialists and help establish a climate favorable for social justice. This type of appeal emphasizes the nationalistic character of the Front¹⁶ and is sometimes tied in with appeals to the effect that Vietnamese are being killed by Americans and the South Vietnamese Government and that this killing of Vietnamese by Vietnamese must stop.¹⁷

¹³Donnell, Parker, Zasloff, p. 17.

¹⁴Mintz, Silverberg, Trinnaman, p. 76.

¹⁵Ibid.

¹⁶Ibid.

¹⁷Department of Defense Intelligence Information Report, Viet Cong Recruitment Activities, p. 2.

~~SECRET~~

~~SECRET~~

UNCLASSIFIED

~~SECRET~~ 41 ~~CONFIDENTIAL~~

7) The Viet Cong are not above using coercion and armed propaganda on doubtful recruits. One method is to convince reluctant youths to help them in some minor task, but one punishable by the South Vietnamese Government. Then youths are blackmailed into enlisting.¹⁸ Sometimes government deserters are used to tell of the hardships and low morale in the Southern Army. Thus it is evident that much of the Viet Cong effort is directed toward proselyting,¹⁹ and much of its success is due to the extensive and well organized propaganda system that supports it.²⁰

(U) If the cadre are successful in recruiting an individual, the recruit is required to execute this enlistment application, which is addressed to the Front. It reads:

I, the undersigned, realizing that the U. S. imperialists have openly invaded South Vietnam and that it is the duty of a citizen to stand up and liberate himself, am hereby determined to enlist in the army to kill the enemy, until the day the imperialists withdraw from the country.²¹

Infiltration From The North

7) Infiltration provides another source of manpower to the Viet Cong. Initial infiltrators were from the Southerners that regrouped to North Vietnam under the Geneva Agreement, and were the main source for Viet Cong cadre.²² In addition to these southerners the North Vietnamese

¹⁸Mintz, Silverberg, Trinnaman, p. 76.

¹⁹U. S. Department of Defense Intelligence Information Report, Formation of VC Cadre Affairs Sections in I and III Saigon Districts, Report Number 6075027165, 1 June 1965, (File Number C-18745.99, Fort Leavenworth, Kansas Library). A translation of a captured Viet Cong Document. (CONFIDENTIAL).

²⁰Zasloff, p. 36. Contrary to popular belief, there was little evidence to substantiate that the Viet Cong recruit soldiers at gun-point.

²¹U. S. Department of Defense Intelligence Information Report, Viet Cong Unconventional Forces, Report Number 6075025265, 25 May 1965, Inclosure 7, (File Number N-16961.40, Fort Leavenworth, Kansas Library). A translation of a captured Viet Cong Document.

²²Zasloff, p. 32.

UNCLASSIFIED

~~SECRET~~

~~CONFIDENTIAL~~

UNCLASSIFIED

government has sent North Vietnamese Regular Army officers and noncommissioned officers into the South as cadre for Viet Cong units and then used local recruits to fill up the ranks.²³ United States sources in Vietnam placed this infiltration at 39,000 from 1959 to 1964.²⁴

Recently North Vietnam has been sending draftees to Viet Cong units. One North Vietnamese prisoner stated he had been drafted and trained for duty with the North Vietnamese 325th division which he indicated had infiltrated South. He further stated that North Vietnamese youths between eighteen and twenty-five were being drafted for Southern service.²⁵ This North Vietnamese infiltration of regular units was also noted in the July USARPAC Intelligence Bulletin which placed the 101st regiment of the 325th division in the South.²⁶ This same bulletin places Viet Cong strength in the South at 66,150 as of 1 July 1965, an increase of 31,250 over the 31 January 1965 figure. According to USARPAC sources this was mainly due to in-country recruiting.

²³Ibid., p. 37.

²⁴U. S. Army John F. Kennedy Center for Special Warfare (Abn), The Viet Cong (2d ed rev; Fort Bragg, N. C.: John F. Kennedy Center For Special Warfare (Abn), November 1965), p. II-39. (SECRET).

²⁵U. S. Department of Defense Intelligence Information Report, Recruit Battalion and Recruit Training, Report Number 6075051865, 28 July 1965, p. 2, (File Number C-18745.99, Fort Leavenworth, Kansas Library). A translation of a captured Viet Cong prisoner of war report. (CONFIDENTIAL). The John F. Kennedy Center For Special Warfare (Abn), has also recognized this infiltration. On page II-43 they conclude that the 18th, 101st and 95th regiments of the North Vietnamese 325th Division have infiltrated into South Vietnam and are fighting with the Viet Cong.

²⁶U. S. Headquarters, U. S. Army Pacific, USARPAC Intelligence Bulletin (U), prepared by the Assistant Chief of Staff G2, February 1966, p. 65. (SECRET).

UNCLASSIFIED

~~SECRET~~

~~CONFIDENTIAL~~

Organization

(U) In describing the Viet Minh organization against the French, Giap wrote that "from the first days there appeared three types of armed forces: para-military organizations or guerrilla units, regional troops and regular units."²⁷ He further stated that the regular forces "had the task of waging mobile warfare on a large battlefield aimed at annihilating the enemy forces."²⁸ The regional forces "had the task of fighting locally and combining its action with the regular army or with guerrilla units,"²⁹ and the guerrilla units "had the task of defending the villages, participating in production, and combining with local forces and regular army in the preparation of the battlefield as well as in the attack."³⁰ This entire organization was aimed at "the policy of arming the whole people, and it was the form of organization of the armed force of the people's war and revolutionary war."³¹

(U) Bernard Fall noted that the Viet Cong have retained the basic organization of the Viet-Minh. In his description of current Viet Cong organization he noted that "at the bottom, there are du-kich (militia) units raised in each village; above the du-kich, there are dia-phuong-quan (regional troops); and at the top of the ladder are the chu-luc (main force) regulars."³² The remainder of this section will examine

²⁷General Vo Nguyen Giap, People's War People's Army (U. S. Government Printing Office, 1962), p. 51.

²⁸Ibid., p. 141.

²⁹Ibid.

³⁰Ibid.

³¹Ibid.

³²Bernard B. Fall, The Two Vietnams, Revised Edition, (New York: Frederick A. Praeger, 1964), p. 35).

~~CONFIDENTIAL~~

control headquarters and these organizations. The complete Viet Cong organization is shown in Figure 3.

Control Headquarters

Central Office For South Vietnam

The highest Viet Cong executive organ in the South is the Central Office For South Vietnam. This organization receives its instructions from the Central Committee of the Communist Party (Lao Dong) in Hanoi and translates these instructions into policies, orders and instructions for all Viet Cong units in the South.³³ As was noted in Chapter Three, the military structure of the Viet Cong is completely integrated with the political structure. In the Central Office there is a military and a political headquarters, each with a military section and a political section. At subordinate unit levels each political headquarters has a military element and each military headquarters a political element.³⁴ In theory both the military and political elements share equal status but in reality the political headquarters is in control. Usually this control is exercised through an executive committee. A type military-political relationship is shown in Figure 4. The Central Office has direct command of two regiments, one guard battalion and three security companies as shown in Figure 5. Subordinate to the Central Office are the six military regions numbered five through nine, plus the Saigon/Cholon/Gia Dinh special zone.³⁵

³³U. S. Headquarters U. S. Military Assistance Command, Vietnam, Order of Battle Volume I Viet Cong Forces Republic of Vietnam (U), prepared by the Office of The Assistant Chief of Staff, G2, APO 143, 1 July 1964, with changes to 1 January 1965, p. 9. (CONFIDENTIAL).

³⁴U. S. Army John F. Kennedy Center For Special Warfare (JCSA), p. II-25.

³⁵Ibid., p. II-29.

CONFIDENTIAL

~~CONFIDENTIAL~~

CONFIDENTIAL

~~UNCLASSIFIED~~

~~SECRET~~
45

~~CONFIDENTIAL~~

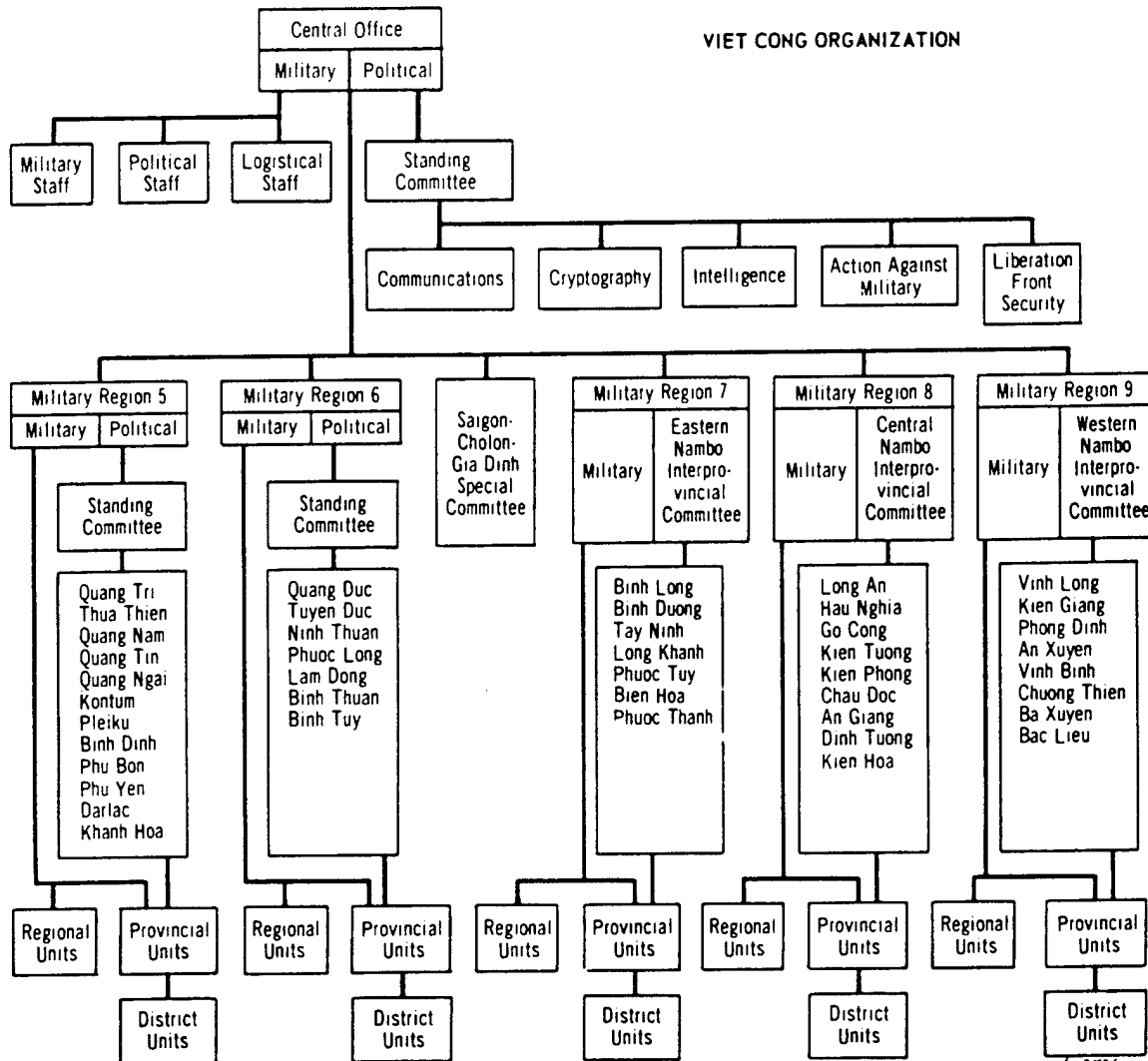
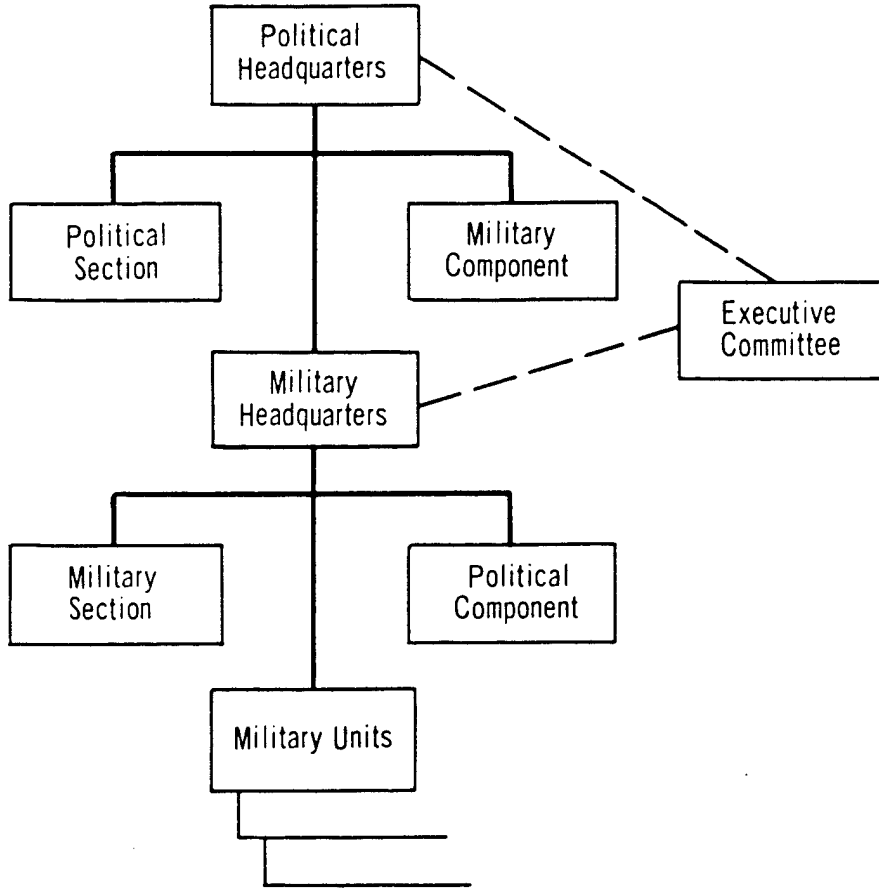

FIGURE 3
Viet Cong Organization
Source: USARPAC Intelligence Bulletin, December 1965, p. 48.

~~SECRET~~

~~UNCLASSIFIED~~
~~CONFIDENTIAL~~

Viet Cong Political/Military Organization



Integrated Structure of the Viet Cong Political/Military Organization

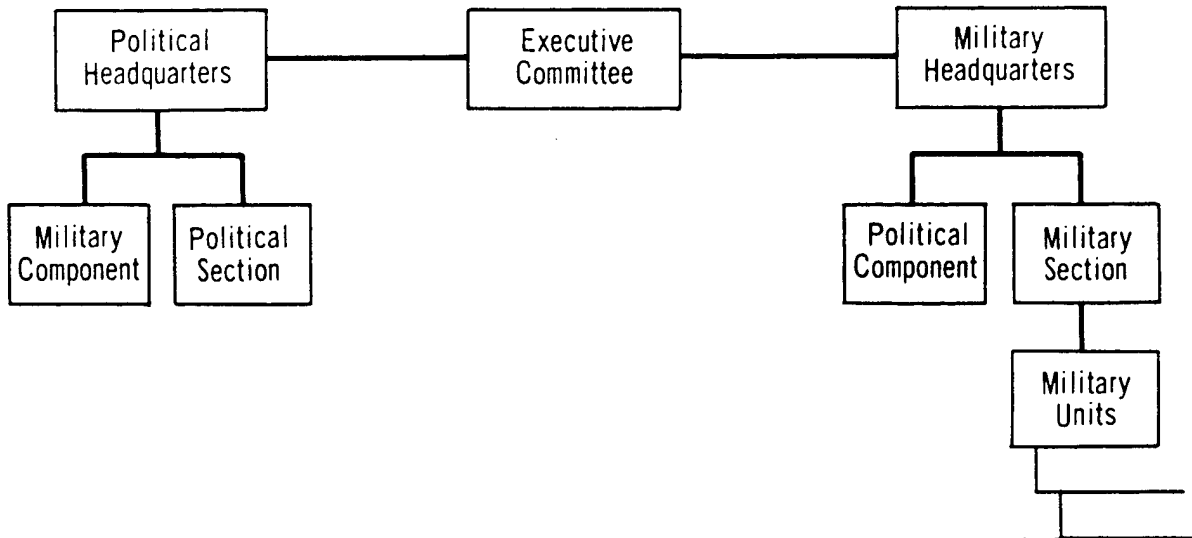

FIGURE 4

UNCLASSIFIED

Source: U. S. Army John F. Kennedy Center For Special Warfare (Abn), pp. 11-26-27.

UNCLASSIFIED

~~SECRET~~
47

~~CONFIDENTIAL~~

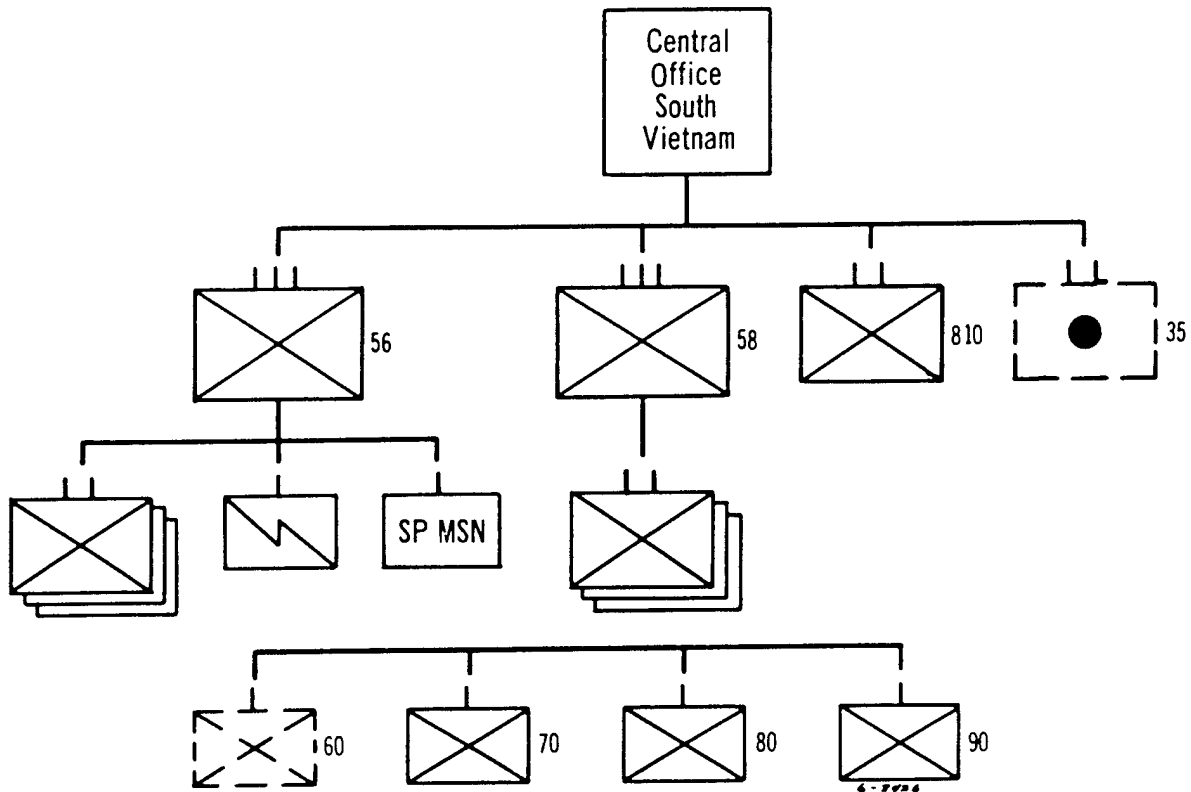

FIGURE 5

The Central Office For South Vietnam

Source: U. S. Military Assistance Command, Order of Battle, p. 35.

UNCLASSIFIED

~~CONFIDENTIAL~~

~~SECRET~~

~~SECRET~~

48

Military Regions

Military regions are primarily responsible for conducting large scale operations against the regular South Vietnamese Army units,³⁶ and operate according to policies laid down by the Central Office. The military regions control all military and political activities within their area of influence.³⁷ These areas are shown in Figure 6. A military region has a political headquarters, a military headquarters, region headquarters units, and subordinate regiments and or battalions with which to accomplish their mission.³⁸ The one exception is Military Region Seven. Here operational responsibility is shared with the Central Office, and the main force units of region seven are often augmented by the units assigned directly to the Central Office.³⁹

In addition to military forces each military region has a base area that was established during the French war and is used for securing the headquarters and training activities. Some of the war zones that have been identified are shown in Figure 6. These War Zones are the U Minh War Zone, located on the west coast of Bac Lieu Province in Region nine, Dong Thap Huoi War Zone located west of Saigon in the "Plain of Reeds" area for Region Eight, Dong Minh Chau (War Zone C) located in Tay Ninh Province on the Cambodian border in Region Seven, War Zone "D" located north of Saigon between the Dong Nai and Song Be rivers also in Region Seven and Do Xa War Zone in Quang Ngai Province in Military Region

³⁶U. S. Military Assistance Command, Order of Battle, p. 10.

³⁷U. S. Army John F. Kennedy Center For Special Warfare (Abn), p. II-29.

³⁸U. S. Military Assistance Command, Order of Battle, p. 10.

³⁹Ibid.

~~SECRET~~

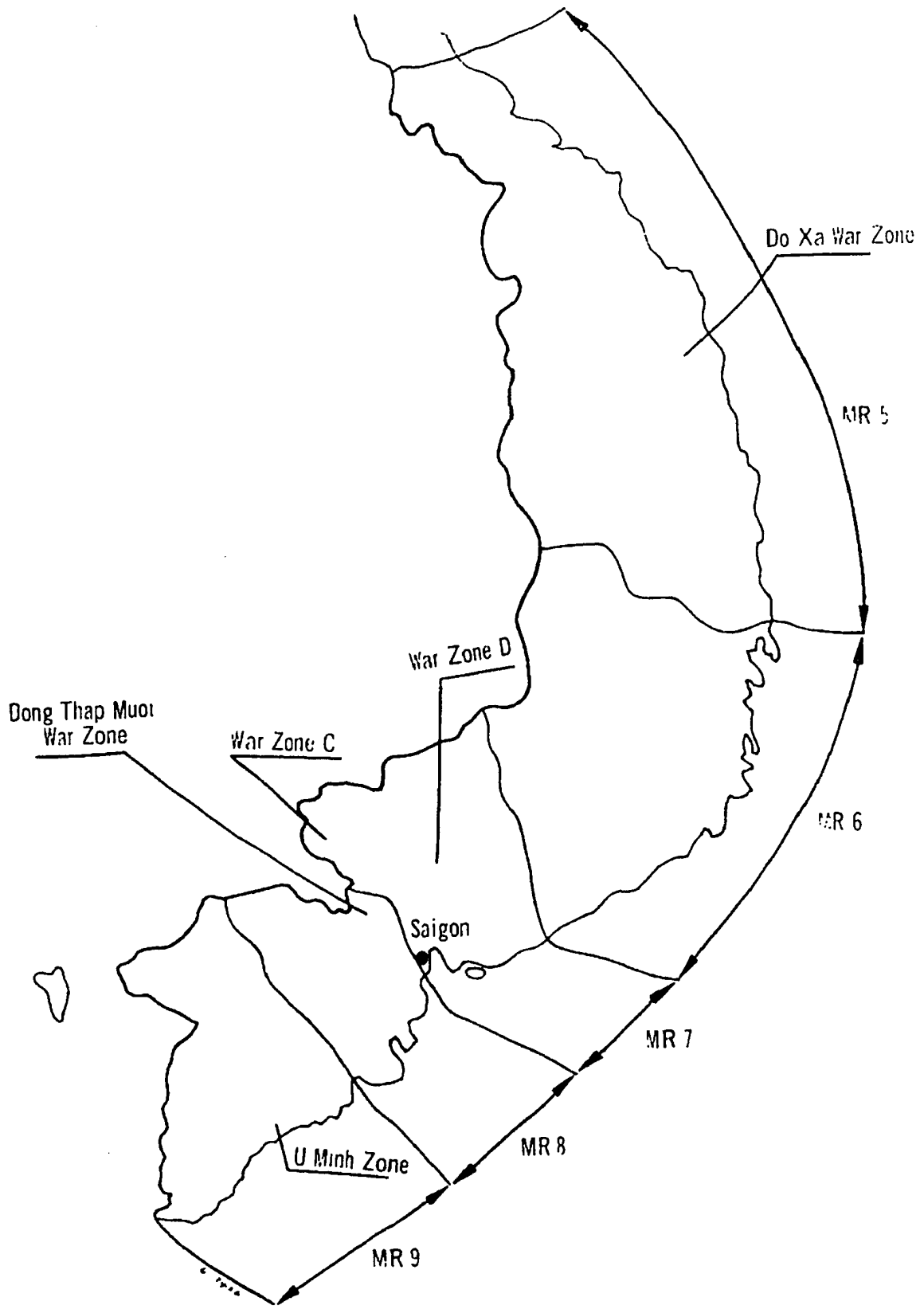

FIGURE 6
Viet Cong Military Regions and War Zones

UNCLASSIFIED

50

~~CONFIDENTIAL~~

Five.⁴⁰ It is in these zones or "safe areas" the Viet Cong soldier or recruit gets his initial training, and returns for advanced military schooling.

The political headquarters of the military region establishes policy and is responsible for liaison with the Front. It also plans and conducts all political activities within the region to include education, propaganda, proselyting, finance and entertainment.⁴¹

The military headquarters is divided into a political staff, military staff and a logistical staff. The political staff is the watchdog on all directives issued by the political headquarters in addition to responsibility for security, propaganda, recruiting and continuous loyalty checks on cadre.⁴² The military staff plans and supervises the regular military operations, special missions, military training and intelligence collection.⁴³ The logistics staff is responsible for all procurement which includes arms, equipment, medical supplies, facilities and the funds for their use.⁴⁴

At regional level there are organic regular military units. In addition to these units the region can count on certain specialized units for reconnaissance, guard and a special mission unit that is used

⁴⁰U. S. Army John F. Kennedy Center For Special Warfare (Abn), p. II-39. Exceptions to this exist in military region 6 and the Saigon/Cholon/Gia Dinh areas where the evidence available does not list any war zones. The Do Xa War Zone is not mentioned in this publication. Reference to it is in the January 1966 USARPAC Intelligence Bulletin, p. 19.

⁴¹Ibid., p. II-29.

⁴²Ibid. These loyalty checks on the cadre at military region level use the report cited in Chapter III.

⁴³Ibid., p. II-34.

⁴⁴Ibid.

UNCLASSIFIED

UNCLASSIFIED

~~SECRET~~
51

for unconventional missions like sabotage, assassinations, kidnapping and armed propaganda.⁴⁵ Other specialized units found at the region level are anti-aircraft, signal and liaison company, engineer company, workshops and a training center.⁴⁶

Province Headquarters

(C) The Province headquarters is organic to the military region and contains an operational staff of about three hundred persons. The province headquarters is in radio and courier contact with its higher and subordinate headquarters.

(C) The chief planning body at province level for military matters is the Province (Party) Committee Agency. This consists of an executive committee, a current affairs committee and a military affairs committee.⁴⁷ The military affairs committee is shown in Figure 7. It is in radio and courier contact with all province military forces.⁴⁸ Its executive or standing committee usually consists of a secretary, an assistant secretary, (who may be concurrently the political officer of the provincial military unit, and a propaganda and training section. This last section is divided into an organization subsection for research and administration, and a printing subsection.⁴⁹ This province committee

⁴⁵Ibid.

⁴⁶Ibid.

⁴⁷U. S. Department of Defense Intelligence Information Report, Stay-Behind Operation-Organization of Militia and Communist Party Cells (U), Report Number 6075035665, 17 June 1965, p. 3, (File Number C-18745.99, Fort Leavenworth, Kansas Library). A translation of a captured Viet Cong Document. (CONFIDENTIAL).

⁴⁸U. S. John F. Kennedy Center For Special Warfare (Abn). p. 11-34.

⁴⁹U. S. Department of Defense Intelligence Information Report Organization of the VC Quang Ngai Provincial Committee, Report Number not indicated, undated, p. 2. (File Number C-18745.99, Fort Leavenworth, Kansas Library). A translation of a captured Viet Cong Document. (CONFIDENTIAL).

UNCLASSIFIED

~~SECRET~~

~~CONFIDENTIAL~~

UNCLASSIFIED

52

~~CONFIDENTIAL~~

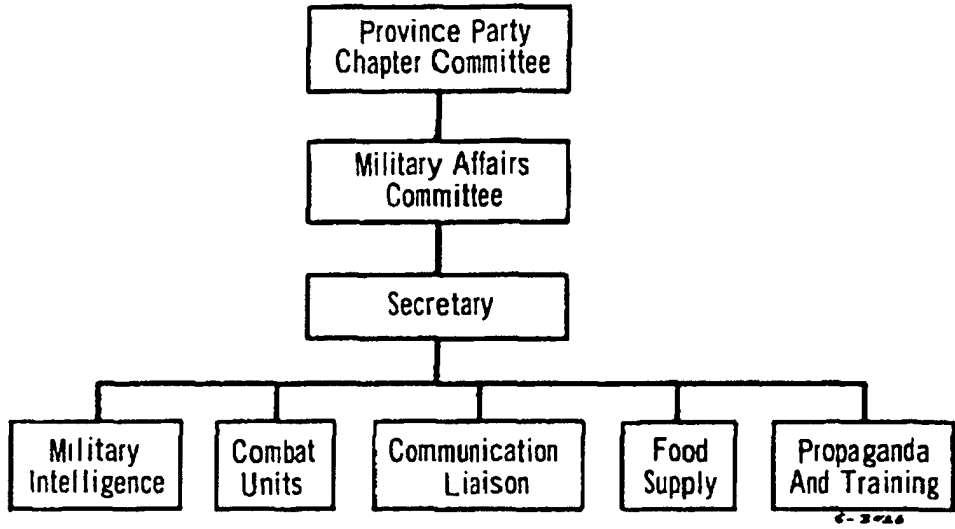

FIGURE 7

Province Military Affairs Committee

Source: U. S. Department of Defense Intelligence Information Report, Sapper Training and Infiltration, Report Number 6075051665, 28 July 1965 (File Number C-18745.99, Fort Leavenworth, Kansas Library). ~~(CONFIDENTIAL)~~

UNCLASSIFIED

~~CONFIDENTIAL~~

~~CONFIDENTIAL~~

assumes all the political and military leadership of the province. The cadre of this standing committee are mainly interested in the political atmosphere and the provincial unit with military affairs. If the province has a main force unit(s) attached to it this unit is directly subordinate to the Province Committee.⁵⁰

District Headquarters

To many Viet Cong the district level is the key to the organization. Here quotas for military service are established, military training of irregular forces is conducted, and "agitprops," agitators and propagandists, are organized.⁵¹ Basically, the districts are organized similar to the provinces but on a smaller scale.⁵² District committees control operations similar to the province setup through a leading (executive) committee. Subordinate elements include a propaganda and training committee, economics committee, a security guard, civilian proselyting section, Front section and the district military unit(s).⁵³ Below the district are the villages and hamlets. At this level there is a committee as in all the higher levels and they function to control the irregular forces, which are part-time soldiers and will not be examined in this thesis.⁵⁴

⁵⁰Ibid., p. 5

⁵¹U. S. John F. Kennedy Center For Special Warfare (Abn), p. II-35.

⁵²Ibid.

⁵³Department of Defense Intelligence Information Report, Organization of the VC Quang Ngai Provincial Committee, pp. 3-4. In this case out of eleven districts in Quang Ngai Province, eight of the District Chiefs were members of the Provincial Committee, so control and planning were very centralized.

⁵⁴U. S. John F. Kennedy Center For Special Warfare (Abn), p. II-35.

UNCLASSIFIED

54

Regular Forces

(S) Viet Cong military units are classified either as regular or irregular forces. The regular forces comprise the best trained and best equipped units, led by cadre trained in North Vietnam.⁵⁵ The chu-luc or regular soldier, according to Bernard Fall,

...is part of an educational, political, and military elite. He can always read and write and often has completed six or eight years of school, often was trained in North Viet-Nam, is a Communist Party member or aspires to become one...and above all, is proud of doing the job he is doing...⁵⁶

G. K. Tanham described them as operationally "kept free to engage in the war of movement and to select both the field and the time for battle... (they) rarely engage in combat when the issue was in doubt."⁵⁷ Regular forces are further divided into main forces and local forces.

Main Forces

Main forces in the Viet Cong organization are directly subordinate to the Central Office or a military region.⁵⁸ They are well-trained highly disciplined guerrilla fighters who follow a rigid training schedule that is roughly two-thirds military and one-third political in content.⁵⁹ Main force units are organized into regiments and separate battalions. Information currently available does not indicate the existence of main force divisions although the possibility does exist at

⁵⁵Ibid., p. II-28.

⁵⁶Fall, p. 351.

⁵⁷George S. Patton, Portrait of An Insurgent: A Study of the Motivation of the Main Force Vietnamese Communist Fighting Man (U), (U. S. Army War College, Carlisle Barracks, Pennsylvania, 3 May 1965), p. 41. Quoting G. K. Tanham.

⁵⁸U. S. John F. Kennedy Center For Special Warfare (Abn), p. II-28.

⁵⁹U. S. Department of State, Aggression From The North, p. 23.

UNCLASSIFIED

military region level to employ two or more regiments in coordinated operations.⁶⁰ A type Viet Cong main force regiment is shown in Figure 8. As noted on the figure, there does not seem to be any exact information as to the number of crew-served weapons or radios in these main force units. Most weapons and radios vary with each regiment and seem to be based upon availability.⁶¹

The preferred regimental organization from the information available depicts a triangular organization of three rifle battalions, a weapons battalion, air defense company, signal company, engineer company, reconnaissance company and medical company. This organization corresponds essentially to the Viet Minh organization used against the French in the early stages.⁶²

Subordinate to the regimental headquarters are three rifle battalions each consisting of three rifle companies, an artillery company and a sapper company, as shown in Figure 9. The rifle companies are divided into three platoons of three squads each.⁶³ (Figure 10)

⁶⁰The Military Assistance Command, Vietnam, has referred to reports of Viet Cong division sized units, but as yet these reports are unconfirmed. The largest tactical unit remains at regimental level.

⁶¹An idea of the types of crew-served weapons can be noted in the figures showing the unit organizations.

⁶²U. S. French Indo China: Information concerning Viet Minh (1946-1950), Report Number 777494, 30 March 1951, p. 39, (File Number S-17313.1, Fort Leavenworth, Kansas Library). Prepared by the Assistant Chief of Staff, G2, Far East based upon interrogations of Viet Minh defectors. (SECRET).

⁶³U. S. Army, Headquarters Military Assistance Command, Vietnam, J2 Section, Translation Branch, Rallier Interrogation Report. (Non-Infiltrator) (Control Number 0633). (File Number C-18745.99, Fort Leavenworth, Kansas Library). (CONFIDENTIAL).

~~SECRET~~
56

UNCLASSIFIED

~~CONFIDENTIAL~~

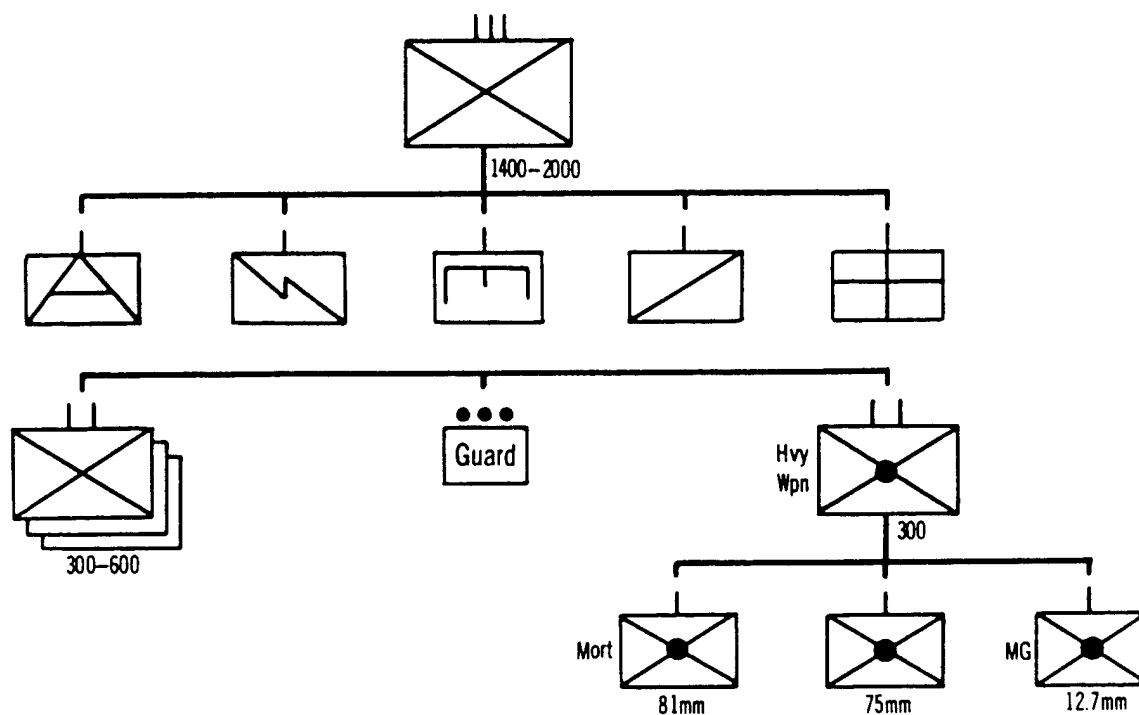

FIGURE 8

Type Viet Cong Regiment

Source: U. S. Military Assistance Command, Order of Battle, p. 27.

UNCLASSIFIED

~~SECRET~~

~~CONFIDENTIAL~~

~~SECRET~~
57

UNCLASSIFIED

~~CONFIDENTIAL~~

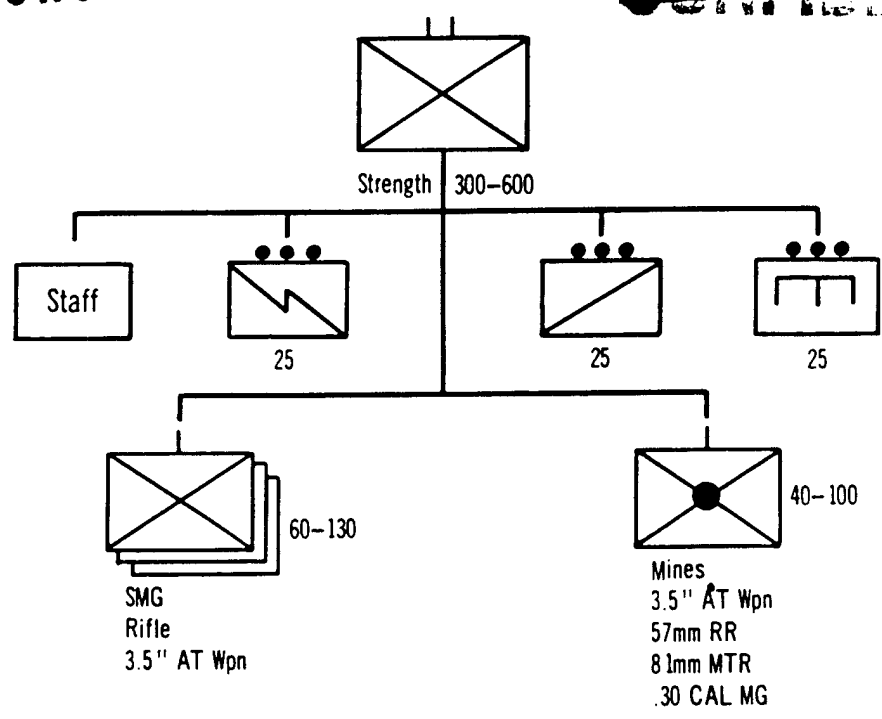

FIGURE 9

Type Viet Cong Battalion

Source: U. S. Military Assistance Command, Order of Battle, p. 28.

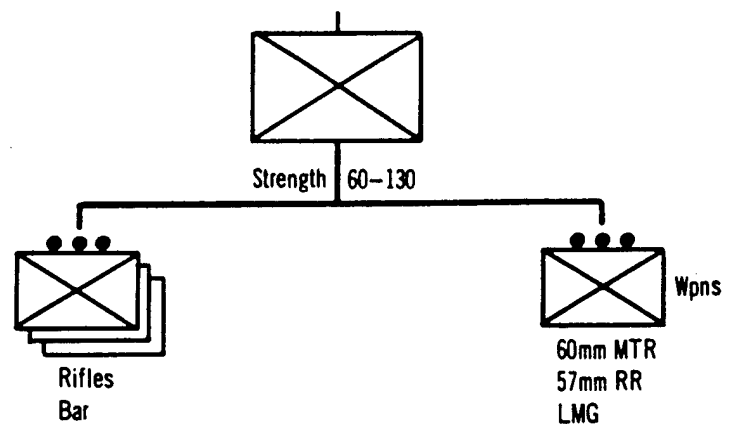

FIGURE 10

Type Viet Cong Company

Source: U. S. Military Assistance Command, Order of Battle, p. 29.

UNCLASSIFIED

~~SECRET~~

~~CONFIDENTIAL~~

UNCLASSIFIED

~~SECRET~~
58

~~CONFIDENTIAL~~

(C) Key regimental officers are the regimental commander, the executive officer and the political officer. The mission of the main force units is to counter the government sweep operations and ambush government forces.⁶⁴

(D) The July 1965 USARPAC Intelligence Bulletin lists ten operational Viet Cong regiments including the 101st regular North Vietnamese regiment.⁶⁵ Additional insight into main force operations can be gained from an examination of five of the older regiments. These are the 56th and 58th regiments organic to the Central Office and the 1st, 2d, and 3d regiments organic to Military Region Five.

(E) All of the above main force regiments were organized with cadre trained and infiltrated from North Vietnam.⁶⁶ Four out of the five main force regiments were activated in 1962. The exception was the 56th which was organized in 1961.⁶⁷ Regiments were built around a nucleus of a headquarters and one or two rifle battalions and were usually complete with all three battalions by 1963. According to information in the "Viet Cong Order of Battle" prepared by the United States Military Assistance Command, Vietnam, the 56th was still short an anti-aircraft company, engineer and medical companies in June 1965.⁶⁸ The other regiment organic to the Central Office, the 58th, has all its elements. The 1st Regiment is complete and has added a recoilless rifle company.⁶⁹

⁶⁴Ibid.

⁶⁵USARPAC Intelligence Bulletin, September 1965, p. 59.

⁶⁶U. S. Military Assistance Command, Order of Battle, pp. 39, 52, 79, 96, 125.

⁶⁷Ibid., p. 39.

⁶⁸Ibid.

⁶⁹Ibid., p. 79.

UNCLASSIFIED

~~SECRET~~

~~CONFIDENTIAL~~

~~SECRET~~
59

The 2d Regiment is the largest currently with four rifle battalions, two special mission companies and a transportation company.⁷⁰ The 3d Regiment is now complete and has added a guard and special mission company.⁷¹

~~Information~~ Information as to regimental operations is extremely limited. As of January 1965, the indications were that none of the five regiments currently listed had fought as a regiment with the exception of the 56th and 1st Regiments, who had each coordinated a two battalion operation.⁷² Another possible indication as to the lack of regimental operation was that prisoners from the 1st and 2d Regiments identified themselves not with their regiments but with battalions and sometimes companies.⁷³ Indications were higher in 1965, starting in May, when four battalions attacked Song Be and in June, three battalions operated in Kontum Province. USARPAC Intelligence Bulletins listed a total of five regimental operations in 1965 which seems to point to the fact that these units are used sparingly.⁷⁴ Evidence seems to indicate that regiments spend most of their time training. Some regiments have pre-requisites for admittance. In the 56th Regiment, personnel must have two months of prior military and political training with emphasis on the military, but this might be due to their sensitive mission with the Central Office.⁷⁵ This use of regiments tends to confirm earlier ideas that the main force units are not committed unless the issue is clear cut.

⁷⁰Ibid., p. 96.

⁷¹Ibid., p. 125.

⁷²Ibid., pp. 39, 79.

⁷³Ibid., p. 79.

⁷⁴USARPAC Intelligence Bulletin, February 1966, p. 47.

⁷⁵U. S. Military Assistance Command, Order of Battle, p. 39.

UNCLASSIFIED

~~SECRET~~

~~CONFIDENTIAL~~

(1) Main force battalions organic to regiments generally conform to Figure 9. Battalion strengths average 500 men. The cadre were initially infiltrated from North Vietnam and the remainder of the soldiers recruited locally. One exception to this is the 60th battalion of the 1st Regiment. This entire battalion was trained in North Vietnam and infiltrated to the South.⁷⁶ Another case is the 32d Battalion of the 3d Regiment which was formed from 500 North Vietnamese volunteers.⁷⁷

(2) Individual battalions are usually more active than the regiments, but still not used indiscriminately. For example, the 3d battalion of the 56th Regiment had no combat operations credited as of January 1965 whereas the 104th Battalion of the 58th Regiment had five.⁷⁸ Main force prisoners indicate that main force units frequently operate in company or smaller when not training but these operations are against carefully selected targets.⁷⁹

(3) Even the separate main force battalions organic to military regions seem to prefer small unit actions.⁸⁰ The USARPAC Intelligence Bulletins recorded only 82 battalion operations from 68 separate battalions

⁷⁶Ibid., p. 83

⁷⁷Ibid., p. 132. A prisoner from this unit stated these men volunteered to come south only because their families lived there.

⁷⁸Ibid., pp. 49, 55.

⁷⁹U. S. Department of Defense Intelligence Information Report, Organization of 3d Company, 490th Main Force Battalion, Report Number 607-5040865, 30 June 1965, (File Number C-18745.99, Fort Leavenworth, Kansas Library). A prisoner of war interrogation. (CONFIDENTIAL). This was also established by another prisoner in Department of Defense Intelligence Information Report, Organization and Operations of Viet Cong 44th Hoa Da District Company, Report Number 6075036265, 18 June 1965, under the same file number.

⁸⁰Ibid.

in 1965.⁸¹ The 800th Battalion in Military Region Seven had only five operations from its founding in 1960 to January 1965 and the 261st in Military Region Eight conducted eight.⁸² One of the most active and the oldest of the separate battalions is the 306th or "Phu Loi I" Battalion in Military Region Nine which dates back to 1956.⁸³

Local Forces

Regular forces also include local forces which operate in a province or district. These forces are also full time soldiers and are no less combat effective than the regiments and separate battalions, and in many ways are more active. Local forces can consist of battalions or separate companies. If they are responsive to the Province Party Committee they are designated Provincial Mobile Units. These mobile units are available for employment anywhere in the province or in conjunction with main force units.⁸⁴ District Concentrated Units are company sized local forces operating under the District Party Committee.⁸⁵ All of these forces can be massed by the Province Party Committee in any combination for specific operations. A study of organization charts has revealed no significant differences in organization between local force battalions and companies and those of main force units.

One example of a provincial force mobile unit is the U-Minh Battalion shown in Figure 11. This unit was organized in 1959 from a

⁸¹USARPAC Intelligence Bulletin, February 1966, p. 47, and September 1965, p. 59. These two sources show the number of battalion operations, and the number of listed battalions. This divides out into one plus operation per battalion per year which is not very active.

⁸²U. S. Military Assistance Command, Order of Battle, pp. 169, 182.

⁸³Ibid., p. 199.

⁸⁴U. S. John F. Kennedy Center For Special Warfare (Abn), p. II-28.

⁸⁵Ibid.

DECLASSIFIED

UNCLASSIFIED

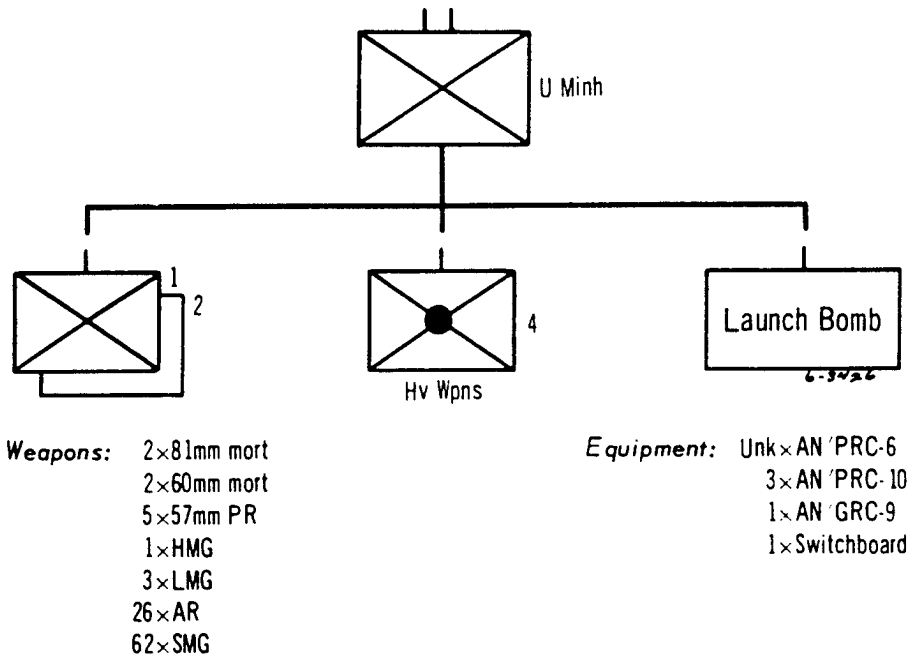

FIGURE 11

U Minh Battalion, Provincial Mobile Force

Source: U. S. Military Assistance Command, Order of Battle, p. 221.

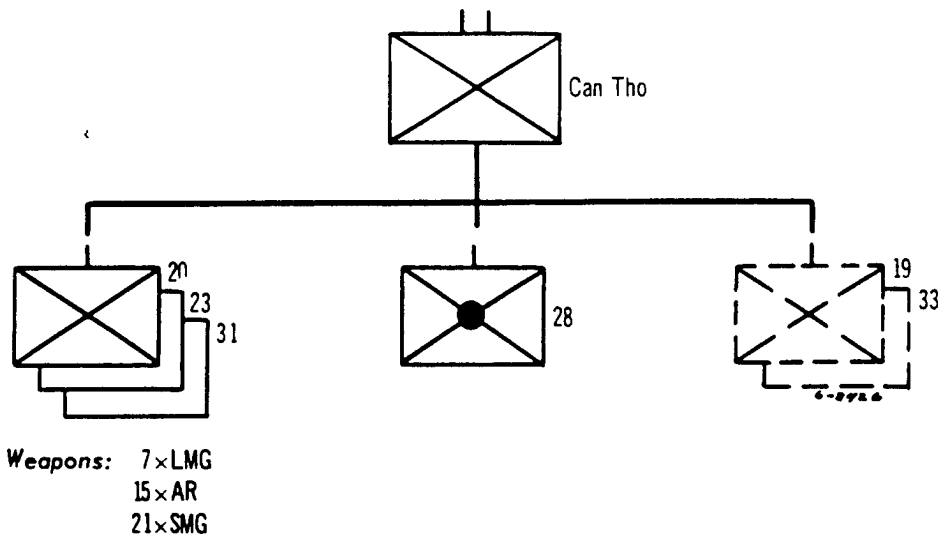

FIGURE 12

Can Tho Battalion, Provincial Mobile Force

Source: U. S. Military Assistance Command, Order of Battle, p. 271.

~~SECRET~~
UNCLASSIFIED

North Vietnamese cadre platoon.⁸⁶ By 1962 it had increased to 400 soldiers in five companies. It is now re-organized into four companies composed mostly of youths and has conducted eight battalion operations since 1959.⁸⁷ Figure 12 is another example, the Can Tho Battalion organized in 1963.⁸⁸

(S) The Viet Cong consider the 514th (Ap Bac) Battalion, shown in Figure 13, their most famous provincial battalion. This unit was named for participation in the Ap Bac battle and is frequently mentioned in Viet Cong propaganda as a unit to be imitated. It has conducted ten battalion operations.⁸⁹ Other examples of provincial battalions are the 502d Battalion in Figure 14, and the Cuu Long Battalion in Figure 15.

Irregular Forces

(S) Below province level are the militia or irregular forces. These units are subordinate to villages or hamlets.⁹⁰ These are the part-time soldiers, the "eyes and ears" of regional and provincial units but by the unit upgrading system are also a potential source of manpower for regular units.⁹¹ Irregular forces are divided into guerrilla forces and People's Self Defense Forces.

Guerrilla Forces

(S) These can be full-time squads or platoons⁹² but their main functions are to collect taxes, distribute propaganda, provide security for

⁸⁶U. S. Military Assistance Command, Order of Battle, p. 219.

⁸⁷Ibid.

⁸⁸Ibid., p. 270.

⁸⁹Ibid., pp. 277,278.

⁹⁰U. S. John F. Kennedy Center For Special Warfare (Abn), p. IT-28.

⁹¹Ibid.

⁹²Ibid.

~~SECRET~~
SECRET

UNCLASSIFIED

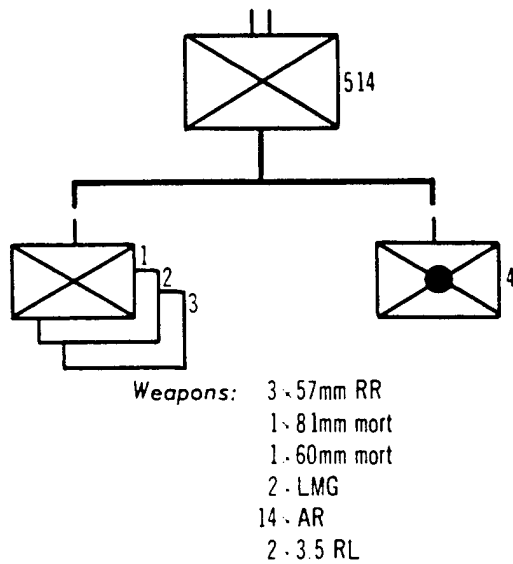

FIGURE 13

AP BAC Battalion

Source: U. S. Military Assistance Command, Order of Battle, p. 279.

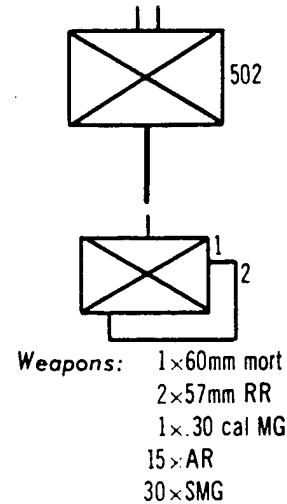

FIGURE 14

Source: U. S. Military Assistance Command, Order of Battle, p. 302.

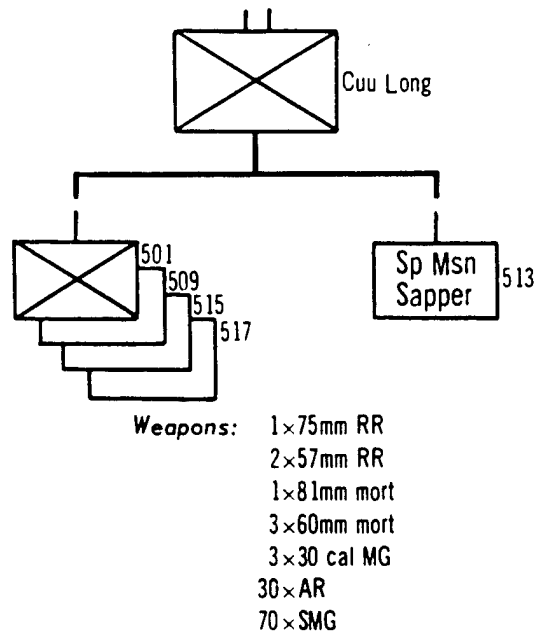

FIGURE 15

Cuu Long Battalion

Source: U. S. Military Assistance Command, Order of Battle, p. 437.

party members, and conduct some sabotage and terrorism.⁹³

People's Self Defense Forces

(S) These are a para-military organization for local defense of Viet Cong hamlets or villages. They operate locally in such tasks as digging fortifications and as lookouts and sentries in and around the hamlets.⁹⁴ The irregular organization at squad and platoon level is similar to that of regular units and will be discussed next.

Platoon, Squad and Cell Organization in Either Regular or Irregular Units

(U) The organizations of the platoon and squad are important because at this level the Viet Cong soldier receives most of his military and political training. In most cases these squads and platoons are recruited from the same hamlet or village so this places the soldier in a familiar environment for most of his service. The platoons and squads seem to have a similar organization regardless of their level and vary only as to the number and type of weapons.

Platoon Organization

(U) A Viet Cong rifle platoon consists of from twenty to thirty men as shown in Figure 10. Platoons normally have a platoon headquarters called a Platoon Command Committee which consists of a platoon leader, two assistant platoon leaders and a political officer. These are also called platoon cadre.⁹⁵ The platoon command committee is responsible to higher headquarters for the execution of all orders, the organization and training of the platoon and the conduct of all combat operations. The assistant

⁹³Ibid.

⁹⁴Ibid.

⁹⁵ U. S. Department of Defense Intelligence Information Report, Organization of Guerrilla Forces, Report Number 6075031665, 8 June 1965, p. 1, (File Number 16961.40, Fort Leavenworth, Kansas Library). A translated captured Viet Cong Document.

UNCLASSIFIED

66

platoon leaders replace the platoon leader if he is absent and are also responsible for equipment, weapons and ammunition of the platoon. The political officer is responsible for the unit's political training, indoctrination, promotion, emulation and award system.⁹⁶

Squad Organization

Viet Cong squads are organized around ten soldiers.⁹⁷ Some squads such as those with heavy weapons, may have extra soldiers to carry ammunition but these personnel are not permanent members of the squad. At the squad level the soldier is subjected to the strict discipline of Party and individual control. Squads are commanded by a squad leader, who is selected for his maturity and political reliability. Great care is taken in his selection, because he is in daily contact with the soldier. One example of squad leadership requires the squad leader to inspect his own weapon in front of the squad before he inspects any other weapons.⁹⁸ The squad leader must train and command the squad.⁹⁹ He has an assistant squad leader who is responsible for squad logistics and administration.¹⁰⁰ This ten man squad is further divided into three, three man cells.

⁹⁶Ibid.

⁹⁷U. S. Headquarters United States Military Assistance Command, Vietnam, Office of the Assistant Chief of Staff J2, Viet Cong Squads, Platoons, and Companies, 12 September 1963, p. 1, (File Number C-18745.29-G, Fort Leavenworth, Kansas Library). A translation of a captured Viet Cong Document. (CONFIDENTIAL)

⁹⁸Ibid., p. 15.

⁹⁹Department of Defense Intelligence Information Report, Organization of Guerrilla Forces, p. 1.

¹⁰⁰Ibid.

CONFIDENTIAL

CONFIDENTIAL

UNCLASSIFIED

Cell Organization

The cell is the basic combat and political unit of the Viet Cong military organization. The three cells include an automatic rifle cell, a rifle cell, and a close-combat cell.¹⁰¹ The automatic rifle cell furnishes fire support for the other two cells in combat. The mission of any cell is to fight in the assault. Cell leaders are responsible for the political security and propaganda of the members and in this regard the leaders must always set an example. This cell organization complies with guerrilla characteristics by being light, simple and neat. It favors sniper tactics.

The cell is designed to emphasize team work and respect, so that cell members will take responsibility for one another, confide in one another and never leave a member under any circumstances.¹⁰² Interrogated prisoners frequently coin a motto for cell members, "three for one and one for three, inseparable in work, combat and death."¹⁰³ Thus the men come to think of each other as brothers. This may help explain the infrequent loss of weapons by Viet Cong and the fact that few bodies are recovered by South Vietnamese government forces.

(U) At cell level the "self-criticism" sessions which will be explained in Chapter 5, are held daily. Cell leaders meet each evening with the squad leader after these sessions to discuss the results.

Logistics

(U) The Viet Cong soldier is vitally affected by his logistics system since his survival is dependent upon a source of food, weapons,

¹⁰¹Viet Cong Squads, Platoons, and Companies, p. 16.

¹⁰²ibid.

¹⁰³ibid.

~~CONFIDENTIAL~~

UNCLASSIFIED

~~SECRET~~
68

UNCLASSIFIED

clothing and shelter. As long as the Viet Cong depended solely on small, locally organized guerrilla units, supply was not a serious problem, but the growth of regional and regular forces, plus the addition of an administrative structure required an extensive logistical system.¹⁰⁴ Nonetheless, this system does require the soldier to attempt self-sufficiency and endure hardship. It requires the soldier to "live off the land," which to him is the local population, the Armed Forces of South Vietnam or his own resourcefulness.¹⁰⁵

(U) Viet Cong logistics seems to be dependent on a base area where the system is controlled and coordinated.¹⁰⁶ These base areas are needed in order to provide secure locations for headquarters, billets, administrative units and production activities.¹⁰⁷

The System

(U) The Viet Cong soldier is a key part of the logistics system since he is often the procurer. It is the soldier that works in the fields to grow food, and it is the soldier that captures the weapons and equipment that gives him the means to fight. The personnel that handle the soldier's logistics are the assistant squad leaders, assistant platoon leaders¹⁰⁸ and the adjutants at company, battalion and regimental level.

¹⁰⁴Robert Scigliano, South Vietnam: Nation Under Stress, (Boston: Houghton-Mifflin Company, 1963), p. 139.

¹⁰⁵Joseph B. Mayo, Logistics of the Viet Cong (U), (U. S. Army War College, Carlisle Barracks, Pennsylvania, 6 March 1964), p. iv. (SECRET).

¹⁰⁶Ibid.

¹⁰⁷Ibid.

¹⁰⁸Department of Defense Intelligence Information Report, Organization of Guerrilla Forces, p. 1.

~~SECRET~~

UNCLASSIFIED

(U) The adjutant is the full time supply officer for Viet Cong units. At company level, according to one captured document, he checks on waste and corruption, provides food, is responsible for the company production plan, and receives and issues money to the platoons and squads.¹⁰⁹ These duties are the same at battalion level with the additional responsibilities of supervising the sewing cell which make clothing, establishing monthly operational budgets and supervising the equipment requirements of the battalion.¹¹⁰

Supplies

(U) The main stay of the Viet Cong soldier's diet is rice, flavored with "nuoc mam," a locally procured fish sauce. Soldiers are issued rice in a monthly ration that has been purchased by the adjutant. If the unit is in a good location this rice ration may be supplemented by some meat or fish, and vegetables. In some main force regiments the combat troops are issued more rations than the support troops,¹¹¹ and if the soldier is a member of a heavy weapons squad his ration may be increased. Rations are issued to the soldier through his squad and cell chain of command. Soldiers cook their own rice on squad or cell fires.

(U) Excess food is sometimes stored with the units, but it is not uncommon for selected farmers to cache food for Viet Cong units.¹¹³ This is particularly true for units that will be operating away from their normal base areas.

¹⁰⁹U. S. Department of Defense Intelligence Information Report, Duties of Adjutants, Report Number 6075028765, 3 June 1965, p. 1, (File Number 16961.40, Fort Leavenworth, Kansas Library). A translated captured Viet Cong Document.

¹¹⁰Ibid.

¹¹¹U. S. Military Assistance Command, Order of Battle, p. 39.

¹¹²U. S. John F. Kennedy Center For Special Warfare (Abn), p. VII-6.

¹¹³Mayo, p. 27.

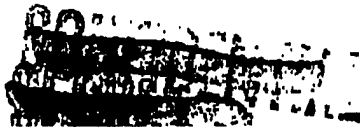

UNCLASSIFIED

~~SECRET~~
70

~~CONFIDENTIAL~~

(U) The Viet Cong soldier is issued clothing and equipment of local manufacture. This normally includes at least¹¹⁴

- Two suits of local peasant garb.
- One colored armband or scarf.
- Headgear.
- One pair of tennis shoes.
- One waterproof ground sheet.
- One mosquito net.
- One canteen.
- One mess kit.

These items may be replaced when worn out, but the soldier must be sure this replacement was due to "fair-wear-and-tear" since wastage is an important discussion topic at the nightly "self-criticism" sessions. The Class III needs of the soldier are minimal since he needs only a small amount of kerosene for cooking.

(U) The Viet Cong soldier will fight with a weapon either locally made, captured from the South Vietnamese army or infiltrated from North Vietnam. There is evidence to indicate Viet Cong units have the capability to make various types of weapons. One prisoner stated that he worked in a machine shop that produced small arms ammunition, mines, and repaired individual and some crew served weapons.¹¹⁵

~~SECRET~~ Ammunition is critical to the Viet Cong, and it is not uncommon in some units for the soldier to turn in empty cases before drawing new rounds.¹¹⁶ An example of a basic load of ammunition for one combat operation was mentioned in a captured document as 600 rounds for each machine gun,

¹¹⁴Mayo, p. 17.

¹¹⁵U. S. Department of Defense Intelligence Information Report, Viet Cong Interrogation Report, Report Number 6075025765, 26 May 1965, (File Number 16961.40, Fort Leavenworth, Kansas Library). A translation of a prisoner interrogation.

¹¹⁶U. S. John F. Kennedy Center For Special Warfare (Abn), p. VII-55.

UNCLASSIFIED

~~SECRET~~

~~CONFIDENTIAL~~

300-400 rounds for each automatic rifle, 150-200 rounds for each sub-machine gun and 80-100 rounds for each rifle.¹¹⁷

~~(S)~~ Weapons captured by the Viet Cong soldier are required to be turned in through channels to his regiment or battalion, if a separate unit. They reissue the weapons to other Viet Cong units based upon their needs.¹¹⁸

~~(S)~~ Indications that logistics is a limiting factor in Viet Cong operations is evidenced by the number of maneuver units often required to produce food. According to the "Viet Cong Order of Battle," one battalion of the 58th regiment is always engaged in food production. In the 1st regiment, one rifle and one reconnaissance company are needed to grow food.¹¹⁹

Medical System

~~(S)~~ Each level of command within the military structure contains a medical element. There is a dispensary at each military region staffed by two medical officers, including a surgeon,¹²⁰ which can handle from twenty to thirty patients. At regimental level there is a medical team that can provide emergency surgery and treats battle casualties. This team consists of four medical officers, including a surgeon and two aidmen.¹²¹

¹¹⁷U. S. Department of Defense Intelligence Information Report, Viet Cong Interrogation Report, Report Number 6075021765, 17 May 1965, p. 48, (File Number C-18745.99, Fort Leavenworth, Kansas Library). A translation of a prisoner interrogation. (CONFIDENTIAL).

¹¹⁸U. S. Military Assistance Command, Order of Battle, p. 179.

¹¹⁹Ibid., pp. 61,86.

¹²⁰Letter, Headquarters, United States Military Assistance Command, Vietnam, 15 September 1964, subject: "Viet Cong Medical System" (U), (File Number C-18745.81, Fort Leavenworth, Kansas Library). (CONFIDENTIAL). There is a political officer assigned to this dispensary.

¹²¹Ibid. Of the three medical officers reported captured in this letter only one had any extensive medical training.

UNCLASSIFIED

72

The battalions each have a first aid cell with one surgeon, a doctor, a surgical assistant and two aidmen.¹²² At company level there is one aidman capable of administering first aid.¹²³ All units submit requests for medical supplies through military channels to the province military region.¹²⁴

() For the evacuation of battle casualties the Viet Cong are dependent upon civilian porters. These are usually recruited on the basis of four porters for each litter casualty.¹²⁵

() The logistics section of the military region provides general supervision over the entire medical system of the military region.¹²⁶

() The Viet Cong have a well organized system to support their tactical operations even though the level of professionalism in their doctors appears to be below western standards and they are usually short of equipment and medicine.¹²⁷ The system does seem capable of rendering minimal care to its military personnel, and the fact that this system exists is no doubt an effective morale factor for the soldier.

() By western standards the Viet Cong logistical system is primitive, but it does not seem to hamper their current operations. The biggest weakness is its failure to support sustained operations due to its

122 Ibid.

123 Ibid.

124 U. S. Department of Defense Intelligence Information Report, Viet Cong Medical and Rear Service Support Activities, Report Number 6075034965, 14 June 1965, p. 8, (File Number N-16961.40, Fort Leavenworth, Kansas Library). A translation of a captured Viet Cong document.

125 Viet Cong Medical System, p. 2. One prisoner stated that in his area twenty percent of the wounded died.

126 Ibid.

127 Ibid.

UNCLASSIFIED

UNCLASSIFIED

73

reliance on local production, but to the Viet Cong it is a simple, effective and combat tested system. Its lack of mechanization compliments the terrain, the tactics, and the mobility employed by the Viet Cong in a revolutionary war.

Evaluation

The Viet Cong have been able to maintain and increase their strength by making attractive appeals to the population of South Vietnam. So long as the South Vietnamese government is unable to effectively control the population, and the Viet Cong offer the only outlet for redressing grievances, this will be one of their major strengths. The validity of their propaganda does not pose a significant problem to them, since once a soldier is committed the organizational system absorbs him. In this way soldiers are isolated from contact with the Southern government and subjected to intense propaganda by cadre in order to reinforce Viet Cong ideals. If the Viet Cong are forced to depend upon infiltration as a source of trained cadre, this could pose some problems in rapidly filling unit vacancies. This might happen if the Viet Cong could be denied their traditional base and training centers in the South, and make them dependent on training areas outside South Vietnam. Current available evidence, though, does indicate that the Viet Cong can successfully recruit in the South.

Draftees from North Vietnam could cause problems in motivation and training. These soldiers may not be as strongly motivated as native Southerners and may not be used to the rigors of guerrilla warfare.

(U) The Viet Cong have not deviated significantly from Giap's concept of organization. The three types of units allow the Viet Cong to "arm the people" with a minimum amount of overhead. It also allows

UNCLASSIFIED

~~UNCLASSIFIED~~

74

~~CONFIDENTIAL~~

units to have a military status while executing para-military missions such as a village guerrilla unit escorting Viet Cong officials.

(C) The military organization facilitates mobility and small unit employment, and still retains relatively strong organization for employment against important targets. A major deficiency, though, is the lack of heavy weapons throughout the organizations which requires more effort on the part of the soldier to accomplish his mission.

(C) Control headquarters facilitate the conduct of a guerrilla war. Military regions are used to control different types of forces which are massed for specific operations. As long as the Viet Cong can select a target and rehearse their plans, this method is effective; however, this does not train these units in rapid reaction to changing situations. This employment may be hampered by a lack of permanent working arrangements between units. The advantage of massing selected units for a single operation may be lessened by increased coordination problems, and a lack of practical experience on the part of regimental and battalion staffs in planning and conducting large unit operations. Figures 16 and 17 are examples of military units operating in a province. These units could be used by a province control headquarters for an operation if military region approved.

(C) The organization of small units is a definite advantage. It provides for a close relationship between soldiers in a cell and forces the soldiers to depend upon one another. It facilitates motivation and control by the Party, and is ideally suited to the needs of the soldier in a guerrilla war that emphasizes small unit employment.

(C) The Viet Cong lack a logistics capability for sustained effort. The fact that food must be produced at the unit level makes these

~~UNCLASSIFIED~~

~~CONFIDENTIAL~~

PAGES 75 & 76
ARE
MISSING
IN
ORIGINAL
DOCUMENT

UNCLASSIFIED

~~SECRET~~
~~CONFIDENTIAL~~

units dependent upon some base area where their food is grown and thereby decreases unit mobility. It also forces tactical units, many of which are highly trained, to divert some of their combat capability toward production. This logistics system requires close supervision by leaders to avoid waste and thereby inflicts some hardships upon the soldier.

~~SECRET~~ The medical system seems to provide adequate care for the wounded in light of his background. A weakness in medical supply is sometimes overcome by local purchase and if these local sources were removed, this could pose a significant problem.

(U) The organizational aspects of the Viet Cong does not pose significant weaknesses if they are able to conduct a war on their own terms. The organization is designed to function in an insurgency where the people constitute the main objective and in this light the organization is extremely effective. There are, however, weaknesses that, if exploited, could have an adverse affect on the Viet Cong, but these weaknesses will not be detrimental as long as the war is fought within the limits set by the Viet Cong.

(U) The next chapter will consider the leadership and motivational aspects of the Viet Cong in order to determine their effect on the soldier and compliment the organizational structure.

~~CONFIDENTIAL~~
~~SECRET~~

UNCLASSIFIED



UNCLASSIFIED

CHAPTER V

LEADERSHIP

(U) The purpose of this chapter is to examine the leadership doctrine of the Viet Cong in order to determine its effect in motivating soldiers. This examination will also isolate some critical leadership problems and explain some of the methods the Viet Cong use to solve them.

(U) The parallel Party organization materially influences leadership by placing personnel in responsible positions, and by providing an ideology that can be used as an aid to motivation. Therefore, the role of the Party, as explained in Chapter Three, provided some background for this chapter by explaining the role of the Party as it affected the soldier. It will become apparent here that no discussion of leadership is complete unless the Party influence is considered.

(U) It will also be helpful to bear in mind the cellular organization of the Viet Cong mentioned in Chapter Four. This small unit plays an important part in providing leadership supports which influence both the leadership situation, the leaders, and the led. In this regard, Giap's views on leadership are important since, in the position of Defense Minister of North Vietnam, his influence is felt as far down the chain of command as the cellular organization.

Giap's Influence On Leadership

The Situation

(U) Giap developed his leadership concepts for use in a revolutionary war. In such an environment, it was obvious to him that operating forces must be capable of efficient operation under adverse



UNCLASSIFIED

~~TOP SECRET~~
79

UNCLASSIFIED

conditions; be capable of operating with little materiel support, and would initially be manned and staffed by personnel generally unfamiliar with military methods. This situation also assumed a mobilization of the entire population.

(U) The Party.--In order to live in this situation Giap wrote that a revolutionary army must be built upon democratic principles and under the leadership of the Party. Thus he wrote that

in leading the building of the army, our Party has firmly stuck to the principle of democratic centralism... (which)... is the organizational principle of our Party;... it has taken care to build the army with a genuine inner democracy and also a very strict conscious discipline.¹

He also observed that "to practice democracy is also to apply the mass line of the Party in leading the army,"² thereby formally establishing the relationship of the Party to democracy and discipline.

(U) Democracy.--Giap felt a revolutionary army must be based on political, military and economic democracy. To him political democracy meant open meetings where the officers and men could state their views on such tasks as fighting, work, study and questions of living conditions.³ He set the stage for the now familiar self-criticism sessions when he wrote that in our army "not only have the officers the right to criticize the soldiers but the latter also have the right to criticize the former."⁴

¹General Vo Nguyen Giap, People's War People's Army (U. S. Government Printing Office, 1962), p. 128.

²Ibid.

³Ibid.

⁴Ibid.

~~TOP SECRET~~

UNCLASSIFIED

UNCLASSIFIED

~~SECRET~~
80

~~CONFIDENTIAL~~

(U) This political democracy was somewhat similar to military democracy since Giap referred to both as democratic meetings, called whenever circumstances permitted. In these meetings plans were discussed and both officers and men attempted to overcome their difficulties together. However, lest an observer get the idea that there was a pure democracy operating in the military, he also added that the soldier must obey his officers without question.⁵

(U) Economic democracy was a form of public accountability where all ranks had the right to take part in the management of resources. He stated that by making finance public "...we succeeded in promoting the activity and creativeness of the masses of officers and men, and...(concentrated) their wisdom to solve the most difficult and complicated problems..."⁶ Thus it appears that even the lowest ranking soldier would have the right to question the use of resources and taxes. This could possibly be an advantage in a guerrilla unit which lacked experienced personnel in financial matters, since a member of the unit might, based upon civilian experience, be able to contribute possible solutions to financial problems overlooked by his equally inexperienced comrades.

~~(S)~~ Discipline.--Giap felt that the peculiar nature of a "people's war" called for a conscious discipline, that required a political awareness of both officers and men, and that was maintained through education and training rather than punishment. In this situation the military, of their own accord, would respect and maintain discipline by reminding each other of their responsibilities.⁷ The existence of this

⁵Ibid., p. 58.

⁶Ibid., p. 129.

⁷Ibid.

UNCLASSIFIED

~~SECRET~~

~~CONFIDENTIAL~~

UNCLASSIFIED

~~SECRET~~
81

~~CONFIDENTIAL~~

type of discipline was confirmed by five Japanese, who deserted the Viet Minh in 1950 and were interrogated by U. S. personnel in Japan. These prisoners noted that criticism and education were used extensively as punishment. In some cases, punishment for minor offenses was often decided at company level, by a majority vote.⁸ Lest this benevolent concept be misleading, however, these prisoners also noted the existence of a comprehensive punishment system throughout the military organization which even allowed regimental commanders to inflict the death penalty.⁹ So while Giap wrote that a democratic army "submits to a rigorous discipline, but one freely consented to,"¹⁰ there were more conventional safeguards to this system than mere verbal rebukes.

(U) The sum total of these concepts enabled Giap to conceive a situation of a politically oriented army based on revolutionary concepts of "internal democracy and iron discipline."¹¹ The iron discipline meant that "everyone in the army, regardless of rank or office, must observe (it)...and no infringements are (were) allowed."¹²

Giap Views The Leaders

(U) Even in a revolutionary army, there is a requirement for leaders. Giap explained this need when he wrote "owing to the demand of the revolutionary work, there are in our army differences in ranks and

⁸U. S. French Indo China: Information concerning Viet Minh (1946-1950), Report Number 777494, 30 March 1951, p. 10, (File Number S-17313.1, Fort Leavenworth, Kansas Library). Prepared by the Assistant Chief of Staff, G2, Far East based upon interrogations of Viet Minh defectors.(SECRET)

⁹Ibid.

¹⁰Giap, p. 53.

¹¹Ibid., p. 131.

¹²Ibid., p. 128.

UNCLASSIFIED

~~CONFIDENTIAL~~

~~SECRET~~

offices," but he also preserved the revolutionary and democratic flavor of the army when he added, "...they have not and cannot influence the relations of political equality in the army."¹³ This meant that while the soldiers may have different ranks and military duties, they are equal in the eyes of the Party.

(U) Giap wanted officers with the "common touch." In his situation both officers and men would cooperate together and recognize that even though each had particular responsibilities toward the cause, their relationship would still be one of comradeship based on political equality. The officer would like his men, guide them in their work and take an interest in their lives. An officer, he wrote, must set a good example, be resolute and brave in order to insure discipline, internal democracy and achieve unity among his men. He must behave like a chief and a leader but at the same time cultivate a mutual affection of brothers-in-arms tested and forged in battle.¹⁴

Giap Views The Led

(U) Giap's writings also outlined the responsibilities of the soldier in this revolutionary army. These responsibilities are summarized in the ten points of the "Oath of Honour," the code of the Viet Minh soldier, and which are, according to George K. Tanham, currently followed by the North Vietnamese soldier. In this oath the soldier swears to:¹⁵

¹³Ibid.

¹⁴Ibid., p. 57.

¹⁵George S. Patton, Portrait of An Insurgent: A Study of The Motivation of the Main Force Vietnamese Communist Fighting Man (U), (U. S. Army War College, Carlisle Barracks, Pennsylvania, 3 May 1965), p. 59 (SECRET), quoting G. K. Tanham.

~~SECRET~~

UNCLASSIFIED

Sacrifice everything for the good of the cause.
Obey his officers.
Fight resolutely and without complaint.
Train diligently.
Keep secrets.
Bear torture if captured.
Never to reveal information.
Take care of his equipment.
Respect and help the civilian population.
Maintain high morale.

(U) In his book, Giap describes the first point of the oath in more detail. He stated the soldier promised:¹⁶

To sacrifice himself unreservedly for the Fatherland, fight for the cause of national independence, democracy, and socialism, under the leadership of the Viet Nam Worker's Party (Lao Dong) and of the Government of the Democratic Republic, to build a peaceful, reunified, independent, democratic and prosperous Viet Nam and contribute to the strengthening of peace in Southeast Asia and the world.

Thus, Giap looked for the soldier to give himself completely to the cause, but under the leadership of the Party. This meant that from the outset the soldier would understand he was part of a political movement aimed at the ultimate reunification of the country.¹⁷

(U) He amplified points two and three of the oath by emphasizing the fighter's responsibility to vigorously carry out the orders of his superiors and "throw himself body and soul into the immediate and strict fulfillment of the tasks entrusted to him."¹⁸ This should help emphasize the idea that self-conscious discipline could not be allowed to subvert the primary mission of devotion to duty.

¹⁶Giap, p. 54.

¹⁷These goals in the soldier's oath closely parallel the aims of the Front noted in Chapter Four, and used in recruiting for the Liberation Army.

¹⁸Giap, p. 58.

~~SECRET~~

UNCLASSIFIED

UNCLASSIFIED

(U) Finally, Giap emphasized the importance of the people in a revolutionary war. In Point nine of the oath, he cautioned the soldier to follow three rules in contact with the people. He must respect, help, and defend them, in order to win their confidence and affection and solidify the union between the people and the army.¹⁹

Giap's Legacy

(U) The affect of Giap's leadership concepts on the Viet Cong will be apparent in the succeeding pages of this chapter. It should be remembered that when the Viet Cong speak of leadership, they are not preaching a new doctrine that has risen overnight. Theirs is a product that has been conceived for a specific purpose, to fit a particular army, and it has been battle tested.

(U) Giap has given the Viet Cong a viable concept of leadership that advocates internal democracy "hand in hand" with self-conscious discipline. This concept was designed to emphasize the democratic character of the army and the political equality of officers and men. It is based on an assumption that officers and men are dedicated to a single goal, victory for the Party, and will cast aside personal differences in order to fulfill the stated goals of the revolution.

(U) Giap's leader will lead by example and guide his men through persuasion and education rather than by punishment.

(U) For the soldier, Giap has given strict guidelines in the "ten point oath." The soldier knows he is expected to sacrifice himself for the cause, devote all his energies toward fulfillment of the mission, obey his officers, keep secrets and respect the people. At the same time the soldier also has a responsibility to make policy work, and has an

¹⁹Ibid., p. 56.

~~SECRET~~

UNCLASSIFIED

opportunity through democratic means to criticize his leaders if he feels these policies are not in the best interest of the cause.

The Viet Cong Leadership Situation

Environmental Influences

(U) The leadership situation that confronts the Viet Cong is in many ways similar and fraught with the same hardships as those experienced by Giap and his Viet Minh soldiers. Even though the Viet Cong, as did the Viet Minh, live in close proximity to the people they are still subjected to a poor diet, lack of adequate shelter and the prospect of a long protracted struggle. While they feel this struggle will eventually insure victory, it is still a basic cause of their miserable existence. When the South Vietnamese forces maintain pressure on the Viet Cong, he is forced to constantly change locations and faces the prospect of losing even such basic luxuries as hot food. His tactical doctrine of the ambush requires patience and long periods of waiting, often in uncomfortable positions, in addition to maintaining strict light, noise and camouflage discipline. Added to this are the lonely nights without his family.

One example of this lonely existence is the strict, almost puritanical sexual code imposed on the Viet Cong.²⁰ This was noted in a Rand report that indicated Viet Cong soldiers are not allowed any romantic contacts with women unless it leads to marriage and family, and that soldiers are, in fact, encouraged to delay marriage until after the revolution. On the positive side, the report noted that in some cases the Viet Cong do help members find wives, if they are thought to be ready for the

²⁰John C. Donnell, Guy J. Parker and Joseph J. Zasloff, Viet Cong Motivation and Morale: A preliminary Report (U), A report to the Office of the Assistant Secretary of Defense/International Security Affairs, prepared by the Rand Corporation (Santa Monica: March 1965), p. 12. (CONFIDENTIAL).

~~SECRET~~

86

~~CONFIDENTIAL~~

responsibility, but even marriage does not change the rule forbidding families to accompany soldiers.²¹

Democracy In The Viet Cong

UNCLASSIFIED

(U) The evidence available points to the fact that the Viet Cong have endeavored to create a leadership situation similar to that used by the Viet Minh. In order to maintain the same type of leadership situation referred to in Giap's writings, the Viet Cong have imitated the concept of democracy and discipline.

(U) One form of political democracy used by the Viet Cong is the criticism sessions and regimental activities at unit level where the soldiers have the opportunity to speak their views and criticize one another. This continued use of criticism is apparent from Viet Cong documents, one of which called for cadres to "boldly promote criticism and self-criticism"²² in order to solidify the Party base. Another example of its use came from Y Lon, a defector, who stated that after each day "we indulge in sessions of stocktaking and criticism."²³

(U) Military democracy to the Viet Cong refers to "battle analysis." Leaders are continually reminded to institute it prior to and after each engagement.²⁴ This concept of military democracy is primarily a training and briefing vehicle to insure that all members know their duties, but it has been used even in periods where rapid decisions were necessary. This was noted in the case of Nguyen-Bat who was in charge of

²¹Ibid.

²²U. S. Department of Defense Intelligence Information Report, Viet Cong Letter Box Numbers, Report Number 6075036965, 21 June 1965, Attachment 2, (File Number N-16961.40, Fort Leavenworth, Kansas Library). A translation of a captured Viet Cong Document.

²³U. S. Department of State, A Threat to Peace Part II, Far Eastern Series 110 (Washington: U. S. Government Printing Office, December 1961), p. 32.

²⁴Ibid., p. 102

~~SECRET~~

~~CONFIDENTIAL~~

UNCLASSIFIED

a boat carrying contraband into the South. When his mission had aborted due to bad weather and there was a crucial choice to be made as to whether to save the boat or the cargo, Bat stated that "after everyone expressed his ideas, I had all the supplies and weapons thrown overboard."²⁵ This democracy, though, is not meant to be used in the heat of battle. While the Viet Cong allow this discussion before or after a battle, during the fight, orders must be obeyed without question by all soldiers.

Discipline In The Viet Cong

(U) The Viet Cong rely on discipline to maximize the efficiency of their operations and minimize the hardships they must endure. They also, as was noted in Chapter Three, submit to the absolute discipline of the Party and the sacrifices that it requires. To this end, cadre are constantly reminding the soldiers of the necessity to sacrifice themselves for the people and the Fatherland.²⁶

☛ In line with Giap's concept of a freely consented to discipline, Viet Cong documents indicate a similar concept for maintaining this discipline. Breaches of discipline within the Viet Cong are punished not by corporal punishment, but by prolonged self criticism.²⁷ While no documentation exists to confirm the Viet Cong use of confinement or the death penalty, the fact that it existed in the Viet Minh makes it reasonable to assume that it is also used to some extent within the Viet Cong.

☛ One example of the strict discipline required of Viet Cong units is found in a document describing the infiltration of these units into South Vietnam. Here emphasis is on squad leaders who must insure

²⁵Ibid., p. 102.

²⁶Ibid., p. 32.

²⁷Donnell, Parker and Zasloff, p. viii.

UNCLASSIFIED

SECRET

~~CONFIDENTIAL~~

that during the move no leaves are picked, bushes cut down, or dry wood cut. Noise discipline is strictly enforced and all personnel are restricted to the route of march and campsite areas during halts. No cooking is allowed after 1900 hours and weapons are always hung in readiness near the soldiers. Plastic sheets, ponchos and tents are forbidden even in the rain.²⁸ When a campsite is closed, it is policed by the soldiers and all traces of habitation are removed, all leaves dispersed and bushes untied.²⁹

(U) A final part of the leadership situation that influences all aspects of the Viet Cong military situation is the use of a historical base for military existence. According to Bernard Fall, the "Vietnamese Communist forces...have seen to it that all their military exploits became part of their own military tradition, which thus stretches back to the first Communist guerrilla groups in Tonking in 1944,...they connected their own military operations to Viet-Nam's earlier military past by giving their offensives the names of heroes of Vietnamese history."³⁰

(U) Thus, the Viet Cong have a situation that is ideally suited for the leadership techniques they have instituted. This situation reflects an environment in which the leaders and the led can effectively function within the framework of their experience, abilities and devotion to the cause.

²⁸U. S. Department of Defense Intelligence Information Report, Security Measures of the 53d Gp In Effect On Their Infiltration Trip, Report Number 6075027265, 1 June 1965, p. 3, (File Number C-18745.99, Fort Leavenworth, Kansas Library). A translation of a captured Viet Cong Document. (CONFIDENTIAL).

²⁹Ibid.

³⁰Bernard B. Fall, The Two Viet-Nam's, Revised Edition (New York Frederick A. Praeger, 1964), p. 106. By comparison the South Vietnamese trace their exploits only to 1955.

UNCLASSIFIED

~~SECRET~~

UNCLASSIFIED

~~SECRET~~
CONFIDENTIAL

The Viet Cong Leader

Cadre

(U) Just as Giap referred to the need for a system of ranks to denote leaders in the Viet Minh, so have the Viet Cong recognized a similar need. In the Viet Cong, the leaders are the cadre. These cadre are anyone with command or administrative responsibilities. In the military, cadre are usually those ranks from squad leader to regimental commander.³¹

(U) The cadre are usually Party members or at least members of the Liberation Youth. Cadre are usually pictured as dedicated personnel, ever willing to endure hardship in return for a chance to serve the revolution. From the sources available it appears cadre do not get any type of preferential treatment, and in fact a Rand study noted that the only advantage officers seemed to have was they were exempt from guard duty; a fact that impressed Viet Cong recruits. This study further concluded that the cadre presented a heroic image because of the qualities of leadership and self-sacrifice they maintained.³²

(U) Another author described the cadre as "the enemy's raw material: tough indoctrinated men, willing to die; men of great physical endurance who had known few softening distractions in a lifetime of hardships."³³

(U) In keeping with this image cadre are supposed to volunteer for combat and hazardous duty. By setting the example they provide ideological guidance to the soldiers and enhance the internal solidarity of

³¹The Viet Cong do not refer to cell leaders as cadre, even though they serve a very important leadership function. In some cases an assistant squad leader might be included in a cadre meeting, but generally the lowest level for cadre is squad leader.

³²Donnell, Parker and Zasloff, p. 33.

³³David Halbertstam, The Making of a Quagmire, (New York: Random House, 1964), p. 115.

UNCLASSIFIED

~~SECRET~~ CONFIDENTIAL

UNCLASSIFIED

~~CONFIDENTIAL~~

units. They study extensively and are supposed to be the experts on concepts of revolutionary war.³⁴ The Viet Cong seem to feel that cadre, motivated through intensive study of revolutionary documents, will not panic in the face of the enemy.³⁵ This tendency to rely on political instruction as a leadership support seems to be a common practice, at least in Viet Cong writings.

Responsibilities

B) The responsibilities of the cadre are to supervise the execution of orders, as well as maintain the fighting spirit and sense of organization and discipline within units.³⁶ They are urged to accomplish this through patience and sound judgment. Prior to combat operations the cadre will "fire up" the troops against the South Vietnamese government and attempt to reduce their fear of combat.³⁷ After the battle the cadre will conduct critiques and try to raise the morale of soldiers, particularly those who have lost comrades, and encourage the troops to fight again.³⁸

C) Cadre, particularly those belonging to the command echelons of units, are told to always be in the vanguard, but they are cautioned to

³⁴Department of Defense Intelligence Information Report, Viet Cong Letter Box Numbers, Attachment 2.

³⁵Department of State, A Threat to Peace Part II, p. 99.

³⁶Letter, Headquarters, U. S. Military Assistance Command, Vietnam, Subject: "Viet Cong Training (U), 28 April 1965, p. 3. (File Number C-18745.124, Fort Leavenworth, Kansas Library). (CONFIDENTIAL).

³⁷U. S. Department of Defense Intelligence Information Report, Viet Cong Interrogation Report (U), Report Number 6075024465, 25 May 1965, p. 33, (File Number C-18745.99, Fort Leavenworth, Kansas Library). A translation of a Viet Cong prisoner interrogation. (CONFIDENTIAL).

³⁸Ibid., p. 35.

UNCLASSIFIED

~~CONFIDENTIAL~~

UNCLASSIFIED

~~CONFIDENTIAL~~

be modest and not bragg since they are servants of the Party and the Party is in command of the Army.³⁹ One case of leadership by example, as previously pointed out, is where small unit cadre, those below company level, are required to inspect their own weapons in front of their soldiers before inspecting any others, and even the officers are required to do this.⁴⁰

The cadre must always thoroughly brief and explain the mission to their soldiers. They are also responsible for the condition of the health, welfare and equipment of their men.⁴¹ The Viet Cong require these leaders to understand the psychology of their men and treat leadership problems on an individual basis.⁴² They emphasize that leadership must be closely tied to the fighting man, and that he must be given the best of care.⁴³

Political Leadership

In accordance with Giap's concept of Party control, the Viet Cong have set up a parallel system of command utilizing political commissars on the same level with unit commanders.⁴⁴ The specific duties of

³⁹U. S. Department of Defense Intelligence Information Report, Unconventional Forces, Report Number 6075024765, 25 May 1965, p. 3, (File Number N-16961.40, Fort Leavenworth, Kansas Library). A translation of a captured Viet Cong Document.

⁴⁰U. S. Headquarters United States Military Assistance Command, Vietnam, Office of the Assistant Chief of Staff, J-2, Viet Cong Squads, Platoons, and Companies, 12 September 1963, p. 15, (File Number C-18745.29-G, Fort Leavenworth, Kansas Library). A translation of a captured Viet Cong Document. (CONFIDENTIAL).

⁴¹Ibid., p. 18

⁴²Ibid., p. 26.

⁴³Ibid., p. 30.

⁴⁴Giap, p. 134.

CONFIDENTIAL

UNCLASSIFIED

political officers were mentioned in Chapter Three and these duties are closely allied to a leadership function which is the political well-being of soldiers. They also become actively involved in the political preparation of soldiers before combat where they supplement lower ranking cadre by giving ideological indoctrination which emotionally conditions the soldier to combat and ties in the tactical action with the political goals.⁴⁵

One author commented that the political officer is really the equivalent of a chaplain, special services officer and Troop Information and Education Officer for the Viet Cong soldier. In this regard one of his political functions, as well as that of morale officer, requires him to establish and supervise within each unit an entertainment and poster cell, a sports cell, sanitation cell and cultural-educational cell. This same author described the political officer as the "mother image" and the military commander the "father image."⁴⁶ The exact degree of control of a political officer will depend on the unit and the personality of the military commander, but his influence cannot be underrated. There is a frequent impression, indicated by the following observation, that the Viet Cong's military commanders were completely under the control of the political officers since every decision was based first on political needs, and secondarily on military ones,⁴⁷ but this general statement cannot be substantiated.

Effect Upon The Soldier

6) The actual effects of the cadre upon the soldier are uncertain. While the Viet Cong would like to believe that their cadre fulfill

⁴⁵U. S. Army John F. Kennedy Center for Special Warfare (Abn), The Viet Cong, (2d ed rev, Fort Bragg, N. C.: John F. Kennedy Center For Special Warfare (Abn), November 1965), p. IV-7. (SECRET).

⁴⁶Donnell, Parker and Zasloff, p. 39.

⁴⁷Halberstam, p. 117.

UNCLASSIFIED

~~SECRET~~

their requirements for a perfect leader, there are, nevertheless, problems which occur that frequently hamper their effectiveness. One problem is to find and train qualified personnel to fill the cadre positions. One captured Viet Cong company commander was extremely bitter about the type of personnel selected for cadre training. He felt that most of the platoon leader trainees he commanded in an officers' school were unenthusiastic and unimaginative. He regarded only one-third of the trainees as having some capability for leadership, one-third marginal and one-third were totally inadequate, yet they were graduated as platoon leaders.⁴⁸ Another prisoner stated that the cadre within his unit were willing to fight, but became easily discouraged because of hardships and the duration of the war. These cadre felt that the current conflict was more difficult than the war with the French. They missed their families and were constantly denied permission to visit them. These problems lowered their morale considerably and were reflected in the attitudes of the troops.⁴⁹

On the other hand, a Rand study, wherein Viet Cong prisoners were questioned in some detail on the effect of cadre, concluded that those prisoners who were not cadre felt they could never qualify for leadership positions. In general, they regarded their own cultural level as too low, or that the responsibilities were too great a challenge, and they did not have the capability to cope with them.⁵⁰ Other Viet Cong prisoners seemed

⁴⁸Department of Defense Intelligence Information Report, Viet Cong Interrogation Report (U), p. 24.

⁴⁹U. S. Department of Defense Intelligence Information Report, VCC Interrogation Report (U), Report Number 6075021765, 17 May 1965, p. 32, (File Number N-16961.40, Fort Leavenworth, Kansas Library). A translation of a prisoner interrogation. This possible lack of motivation among cadre was noted in Chapter Three and evidenced by the division of cadre into categories of reliability.

⁵⁰Donnell, Parker and Zaslowski.

~~SECRET~~ CONFIDENTIAL UNCLASSIFIED

to be extremely impressed with the cadre, especially the fact that the cadre cared so much about what they personally thought. They liked the way the cadre looked after their personal needs, thoroughly briefed them on all aspects of tactical situations and kept them informed on the progress of the war. These prisoners also reinforced the favorable effect of the lack of corporal punishment. They stated that cadre relied on persuasion to accomplish both political and tactical missions.⁵¹

Leadership Traits

(U) A captured Party directive concerning May Day activities indicated the type of leadership traits the Party desire when it ordered that "especially in liberated areas, in agencies, units and worksites, indoctrination will be conducted to make every citizen, Party member, cadre, personnel, soldier be imbued with the morality of President Ho (zeal, thrift, uprightness, resolution, justice, impartiality) who devotes and sacrifices his entire life to the liberation of classes and people."⁵²

The Led

General Contributions

(U) Most of the specific leadership contributions by the soldiers to the overall leadership effort are noted in Ciap's "ten point Oath." This oath may be reasonably assumed to be applicable to the soldier since, as was noted in Chapter Four, North Vietnamese Regular Army units are operating in the South as a part of the Viet Cong organization. Since most of

⁵¹Ibid., p. 62.

⁵²U. S. Department of Defense Intelligence Information Report, Directive (On the Celebration of May Day), Report Number 6075053665, 9 August 1965, p. 2, (File Number N-16961.40, Fort Leavenworth, Kansas Library). A translation of a captured Viet Cong document.

UNCLASSIFIED

the cadre for the main force Viet Cong units were trained in North Vietnam, it is probable that this concept of the soldier's responsibility in a revolutionary war has been integrated into the Viet Cong soldier's training.

(U) A diary that was found on the body of a Viet Cong officer did mention some other responsibilities for the soldier that may be applicable to the leadership situation. These rules for the soldier required him to pay attention to the following points:

1. Do not disclose army secrets. Do not be curious about your own responsibilities and duties.
2. Do not discuss the duties you must carry out.
3. You must respect absolutely the regulations which protect documents during your activities. Do not carry with you those things that regulations prohibit you from carrying. If you are captured by the enemy, be determined not to give in. Slogan: "Absolute loyalty to the revolution. Death is preferable to slavery."
4. Keep secret our method of hiding weapons.
5. Do not take the liberty of listening to enemy broadcasts or of reading their newspapers or documents. Do not spread false rumors.
6. Do not have any relations with any organization with evil segments of the population which are harmful to the revolution.
7. Do not take your family or relatives or friends to military camp sites.
8. Keep order and security among the population as well as among yourselves.
9. Do not cease to carry out self-criticism or being vigilant, and continue your training.
10. Implement seriously these ten rules, mentally as well as in deeds.⁵³

(U) If these rules quoted in the diary can be taken at face value, they would seem to contradict some of Giap's concepts on democracy since the soldier is forbidden to be curious about his duties and responsibilities. Since most of the primary sources for this thesis come from information either received from prisoner interrogations, or captured documents and diaries, it would appear that the leaders are not very effective in making the soldiers security conscious.

⁵³Department of State, A Threat to the Peace Part II, p. 68.

UNCLASSIFIED

(U) There is evidence to indicate that the soldier is expected to adhere to the leadership concept of setting the example for the population. In this regard one diary noted that the leaders must "see to it that our troops use only our own dry food supply and do not touch the property of the population,"⁵⁴ and this important relationship with the people will be apparent in the section of this chapter on awards.

Contributions In Combat

In battle the Viet Cong soldier must not leave his place of duty on his own accord. He is told to exhibit initiative so that if orders are not received, or if he loses contact with his cell leader he will continue to fight and accomplish his mission. In any case, he must maintain an "iron will" and not speak or make any gestures which could adversely influence his comrades during the battle. If the man next to him is killed, his first duty is to collect the weapon, ammunition, equipment and report immediately to the cell leader.⁵⁵

Motivation

(U) Another important leadership consideration pertaining to the soldier, is how he regards himself and his participation in the insurgency. In this case some feeling for the patriotic motives can be determined from one volunteer who felt his mission was sacred. He wrote that

I answered the call of the Party when I was very young, and what did I do for the people of my village? I devoted myself to the people, I took part in propaganda and aroused the people to carry out the policy of the Party and the Government and helped organize village defense and fighting forces.⁵⁶

⁵⁴Ibid., p. 42.

⁵⁵Viet Cong Squads, Platoons and Companies, p. 18.

⁵⁶Department of State, A Threat to the Peace Part II, p. 66.

UNCLASSIFIED

Another source, a North Vietnamese infiltrator, wrote that he had temporarily left the North to return to his nation in the South in order "to liberate my compatriots from the yoke of misery imposed by Mi Diem (American-Diem). This has been my ideal for a long time."⁵⁷ The families of soldiers also reflect a patriotic note as was indicated in one letter in which the family encouraged a soldier "...to strive in your revolutionary mission...(wish you) continuous strength for your mission and that you show initiative..."⁵⁸ In another instance a soldier wrote, "What shall I do now to be a worthy son of Interzone 5?"⁵⁹

(U) A Viet Cong medical officer reflected an idealistic approach when he observed that:

The most precious thing for a man is his life, because one has only one life. One must, then, live in such a way that one does not have to regret the wasted years and months, that one does not have to be ashamed of a pitiful past, that one is able to say before passing away; my whole strength have been devoted to the most elevated and the most beautiful cause--the struggle for the liberation of mankind...⁶⁰

(U) Both hard-core cadre and soldiers from the North appear to regard themselves as saviours who fight for the defense of the North and the continuation of the war in the South. One such soldier wrote that "I joined the ranks of the liberation army in answer to the call of the front for the liberation of the South."⁶¹ Another soldier wrote his wife

⁵⁷Ibid., p. 65.

⁵⁸Department of Defense Intelligence Information Report, Viet Cong Letter Box Numbers, Attachment 6.

⁵⁹Department of State, A Threat to the Peace Part II, p. 65. The term "Interzone" may refer to the old Viet Minh term for a military region. This term is not normally used by the Viet Cong.

⁶⁰Ibid., p. 74.

⁶¹Ibid., p. 67.

UNCLASSIFIED

that "...I am striving to carry out every mission in order to soon destroy the enemy and to liberate South Vietnam so that you and I can be reunited."⁶² These hard-core soldiers frequently coin phrases such as "...our patriotism and our determination to liberate the native land will help us overcome all the difficulties and accomplish our mission,"⁶³ particularly when discussing hardships and low morale.

These statements by Viet Cong members tend to confirm the Rand conclusions that many Viet Cong see themselves as patriots sent to liberate their homeland.⁶⁴ These Viet Cong believe they are fighting to expel the American imperialist because they fear that American influence in South Vietnam may cause the South to become purely a source of raw materials and a market for American products. These Viet Cong believe they are fighting to end poverty, redistribute the land, and end unemployment. They do not regard the war as a class war between North and South Vietnam.⁶⁵

Traits

(U) From this examination of Viet Cong, some characteristics or desirable traits appear that seem to lend themselves to the leadership system. First of all the Viet Cong seem to want a soldier willing to dedicate himself to the cause, and sacrifice himself if necessary. They want a soldier who, while feeling he is a part of a revolutionary movement, and has some say in the way things are run, nevertheless is not overly curious about the

⁶²U. S. Department of Defense Intelligence Information Report, Unconventional Forces-Viet Cong, Report Number 6075022165, 19 May 1965, (File Number N-16961.40, Fort Leavenworth, Kansas Library). A translation of a captured Viet Cong Document.

⁶³Department of State, A Threat to the Peace Part II, p. 75.

⁶⁴Donnell, Parker and Zasloff, p. 11.

⁶⁵Ibid.

~~CONFIDENTIAL~~

~~SECRET~~

~~CONFIDENTIAL~~

UNCLASSIFIED

"big picture" to the extent that he tries to learn more than his leaders feel he needs to know. He should be sufficiently self-disciplined to refrain from reading enemy propaganda, and not attempt to visit his family without permission. He should keep faith with the cause by resisting interrogation if captured. Above all, he must be a resolute fighter and a self-sacrificing patriot, especially toward the civilian population. He must be willing to participate in continual self analysis, recognize and cleanse himself of any ideas or thoughts harmful to the cause. Lastly, in battle he should display courage and initiative.

Leadership Stresses

(U) An examination of the evidence available seems to indicate that the most pressing leadership problem to the Viet Cong is defection. This section will outline some of the more serious problems of leadership that, according to Viet Cong writings and interrogation reports, lead to defection, and discuss in the following section the supports they have established to counteract and reduce the impact of these problems.

Defection

A major problem of the Viet Cong is defection, which in most cases is caused by prolonged family separation, or an inability of the soldier to adapt to the rigors of revolutionary life. According to Rand, statistics based upon reports of 1,360 defectors from January to March 1965, the biggest reason given for defection was the harshness of material life. None of the defectors mentioned ideology.⁶⁶

Defection Due to Family Stress--This conclusion was reinforced by one defector who stated he became more and more indifferent toward the Viet Cong because they would never give him permission to visit his family. He

⁶⁶Ibid., p. 41

UNCLASSIFIED

claimed this had an adverse effect on morale because the parents never knew where their children were. Another soldier was similarly disenchanting and lost all hope due to the prolonged family separation.⁶⁷ This problem has not escaped the notice of Viet Cong cadre. Documents are frequently interspersed with observations such as "we must organize a system for relations with families,"⁶⁸ or favorable comments on operations noting that "good secrecy was observed. No man left to visit his family."⁶⁹

Defections due to Harsh Life.--Another major cause of defection is the harshness of guerrilla life. One defector reported that he deserted the Viet Cong because the living conditions were miserable and his family was still required to support him.⁷⁰ Another Viet Cong noted in his diary that "life in this base is really difficult"...but this individual in the same sentence indulged in self-analysis and continued "but I shall overcome all these difficulties in order to fulfill my duty in the revolution in the south."⁷¹ This same diary noted additional hardships by adding "after three months and nine days, after having crossed many a border...after having gone through all this hardship and danger, I think I have accomplished at this point a part of my duty."⁷² In another document a shortage of food

⁶⁷Ibid., this is also noted in Department of State, A Threat to the Peace Part II, p. 32.

⁶⁸Department of State, A Threat to the Peace Part II, p. 42.

⁶⁹Ibid., p. 44.

⁷⁰U. S. Department of Defense Intelligence Information Report, 512th Mobile Battalion Organic to AN GIANG Province, and AN GIANG Provincial Organization, Report Number 6075052565, 30 July 1965, p. 3, (File Number C-18745.99, Fort Leavenworth, Kansas Library). A translation of a Viet Cong defector interrogation. (CONFIDENTIAL).

⁷¹Department of State, A Threat to the Peace Part II, p. 75

⁷²Ibid.

UNCLASSIFIED

~~SECRET~~

101

was apparent when a cadre wrote "we must be careful with the rice; we may run short of it..." and "the working conditions are difficult."⁷³

(U) Still another guerrilla combined the stress of guerrilla life with self analysis when he wrote,

A few lines to remind me of this remote place! Not enough rice; meals tasteless because there is not enough salt; clothing is not warm enough for this very high peak. Nevertheless, in his determined heart, the fighter for the liberation of the South remains faithful to the Party, to the people of the South, and he remains faithful to his only love."⁷⁴

For two days we have been short of food and had only glutinous rice. This portion of our route is really hard. The sun is burning hot. We do not have enough drinking water. Now my life is full of hardship -- not enough rice to eat nor enough salt to give a taste to my tongue, not enough clothing to keep myself warm! But in my heart I keep loyal to the Party and to the people. I am proud and happy."⁷⁵

Defeatism

~~SECRET~~ Another major leadership problem, and cause of defection, is a general defeatism stemming from a fear of superior weapons available to the South Vietnamese which is usually followed by a general disillusionment with the cause. The often repeated slogan "the Viet Cong live splendidly and die gloriously"⁷⁶ did not impress one defector who lost heart after his unit suffered a defeat in February 1965, which resulted in 37 killed and 64 wounded.⁷⁷ Another Viet Cong gave up because he became

⁷³Ibid., p. 42

⁷⁴Ibid., p. 65.

⁷⁵Ibid., pp 65-67.

⁷⁶Donnell, Parker and Zasloff, p. vii.

⁷⁷Department of Defense Intelligence Information Report, 312th Mobile Battalion Organic to AN GIANG Province, and AN GIANG Provincial Organization, p. 3.

UNCLASSIFIED

~~SECRET~~

UNCLASSIFIED

~~CONFIDENTIAL~~

102

dissatisfied and disillusioned with Communist political policy. This was based on a combination of events including too much forced labor, and his disgust at seeing inexperienced youths killed leading attacks.⁷⁸

(U) Allied with this problem of defeatism was one of military initiative. One prisoner stated that if the South seized the initiative it adversely affected morale because the Viet Cong were used to timing their own operations and desired to act rather than react.⁷⁹

(U) Air power has also contributed to this defeatist attitude by rendering Viet Cong "safe areas" untenable. In addition it has hampered the timing of operations, the delivery of food and the training of replacements. Aircraft flares frequently cause some attacks to be aborted, and some Viet Cong regard this as a defeat.⁸⁰

(U) The use of air has severely jarred the complacent attitude of both the cadre and soldiers that prevailed in the early stages of the war.⁸¹ One captive went so far as to state that members of his unit felt that death was certain when they attacked a South Vietnamese post because of the availability of air power. Some cadre even felt the war was lost because of this.⁸²

⁷⁸U. S. Department of Defense Intelligence Information Report, Preliminary Interrogation Report, Report Number 6075040465, 29 June 1965, p. 3, (File Number C018745.99, Fort Leavenworth, Kansas Library). A translation of an interrogation of a Viet Cong defector. (CONFIDENTIAL).

⁷⁹Leon Goure, Some Impressions of the Effects of Military Operations on Viet Cong Behavior (U), (Santa Monica: March 1965), p. 3. A report to the Office of the Assistant Secretary of Defense/International Security Affairs, prepared by the Rand Corporation. (CONFIDENTIAL).

⁸⁰Department of Defense Intelligence Information Report, VCC Interrogation Report (U), p. 32.

⁸¹Goure, p. 3.

⁸²Department of Defense Intelligence Information Report, VCC Interrogation Report (U), p. 43.

~~CONFIDENTIAL~~

~~SECRET~~

UNCLASSIFIED

UNCLASSIFIED

103

~~CONFIDENTIAL~~

The Rand study summed up the leadership problems by noting the adverse effects of air upon the morale of the Viet Cong since it frequently disrupted their moves and operations. If this use of air was in conjunction with a surprise ground attack it reduced the soldier's confidence in the ability of his leaders to anticipate Southern operations.⁸³ The harassment of Viet Cong camp sites caused unplanned moves which increased hardships and disrupted logistical support. The disruption of an already limited food supply, plus family separations and general war-weariness were major motivating factors for defection and these factors pose some very real leadership problems for the Viet Cong cadre.

Leadership Supports

(F) The Viet Cong are not blind to their leadership problems. In order to maintain their effectiveness as a fighting force, they have taken some positive measures to strengthen the morale and motivation of their soldiers. To this end, and due to their limited resources, in addition to the nature of their concept of warfare, they rely chiefly upon propaganda and indoctrination which is often included in letters of commendation and slogans. The system of unit upgrading facilitates indoctrination since it keeps the soldier in the system longer. The Viet Cong also promote and punish. However, the basic leadership support is the self-criticism session. All of these supports will be outlined in the succeeding pages of this chapter.

Awards

Letters of Commendation.--The most frequent type of award for bravery or exemplary performance of duty is the letter of commendation.⁸⁴ This letter

⁸³Goure, p. 3.

⁸⁴Viet Cong awards for exemplary performance are usually letters of commendation. Research disclosed only one medal, the 2d class Combat Medal but the research did not reveal any more information.

UNCLASSIFIED

~~CONFIDENTIAL~~

UNCLASSIFIED

is usually given by the Military Region and is under the heading of the Liberation Army or the Front. Some insight can be gained from the type of service rewarded by examining the wording of these letters. As in any army, the usual courageous acts are recognized as warranting recognition but in some cases political acts or character traits are coupled with acts of courage indicating the reliance the Viet Cong place on this type of act.

(U) One such letter recognized the successful accomplishment of the mission but in addition commented on such things as solidarity, hardship and privation. This can be seen from an examination of the following letters of commendation.

LIBERATION ARMY
WESTERN NAMBO REGION

NATIONAL FRONT FOR LIBERATION
OF SOUTH VIETNAM

LETTER OF COMMENDATION

Comrade: VO VAN BE

Rank: Squad Leader-Position-Squad Leader

Unit: 3rd Platoon, 104th Company, 96th Battalion

Place of Birth: Thoi Lai Village, O Mon District, Can Tho Province

Achievements: In operations conducted on 20 July 1964, Subject showed a high spirit of solidarity, overcame all hardships and privations always confidently performed his duties and gloriously accomplished his mission.⁸⁵

For the Battalion Command Committee
s/Dung Tien

LETTER OF COMMENDATION

Comrade: Vo Van Be

Rank: Squad Leader, Position: Squad Leader

Unit: 104th of the 96th Battalion

Native Village: Thoi Lai Village, O Mon District, Can Tho

Province has scored the following achievement: during the 2 September 1964 emulation phase, subject always carried out his missions properly and understood clearly his duties, showed a high spirit of solidarity, positively executed directives and satisfactorily accomplished the mission assigned.⁸⁶

⁸⁵Department of Defense Intelligence Information Report, Unconventional Forces, Viet Cong, Inclosure 3.

⁸⁶Ibid., Inclosure 4.

UNCLASSIFIED

~~SECRET~~
105

UNCLASSIFIED

(U) Other excerpts from letters of commendation reflect achievements of skills or physical courage. One states

This is to commend comrade Nguyen Van Lam Member of 3d Platoon, 104th Company, 96th Battalion, native Vinh Vien Village, Lon My District, Can Tho Province for achievement gained in the battle against paratroopers in Canals 11, 13, 14, from 12 April to 15 April, 1964. He has displayed high fighting spirit, stubbornly attacked the enemy, overcome every difficulty to accomplish his mission in a glorious manner.⁸⁷

Another letter for a combat action noted

Has scored the following achievement: as a new AR gunner, he was calm in combat, delivered timely fire to neutralize, inflict casualties on the enemy and to protect the evacuation of the wounded.⁸⁸

(U) From an examination of these letters which are representative of Viet Cong awards, it is apparent that such attitude traits as "solidarity," comprehension of duties and the ability to overcome hardship and privation are on an equal plain with courage and bravery. This seems to indicate that the Viet Cong recognize these factors as stresses on the soldier and feel that recognition of the soldier's ability to successfully deal with them constitutes a definite leadership support.

(U) Individual or Unit Awards.--Another example of Viet Cong awards appears in Military Region Eight and Nine where there is a year-end award for both individual soldiers and units. This award consists of allowing the best mobile force company and village local platoon to have the motto THI DUA AP BAC embroidered on their flag. The outstanding individual soldier

⁸⁷U. S. Department of Defense Intelligence Information Report, Viet Cong Unconventional Forces, Report Number 6075025265, 25 May 1965, Inclosure 1, (File Number N-16961.40, Fort Leavenworth, Kansas Library). A translation of a captured Viet Cong Document.

⁸⁸Department of Defense Intelligence Information Report, Unconventional Forces-Viet Cong, Inclosure 9.

~~SECRET~~
UNCLASSIFIED

UNCLASSIFIED

UNCLASSIFIED

wears this motto on his shoulder. This award is an emulation award and is based upon the criteria of combat, enemy or civilian proselyting and training.⁸⁹

(U) To qualify for the AP BAC award the soldier must have demonstrated the qualities of bravery, industry, and diligence in at least three combat situations. In addition, he must have successfully attempted at least three times to save a comrade's life by a physical act of heroism or by rendering him first aid.⁹⁰

(U) In the field of enemy or civilian proselyting the candidate must have followed all regulations regarding the civilian population and not violated either the people's property rights or endangered their lives. In addition, he must have treated prisoners properly. This attitude toward the people may be accomplished by either the acts of bravery on their behalf or material assistance. In combat the candidate must have endangered himself while calling upon at least one enemy soldier to surrender.⁹¹

(U) In the field of training a prospective candidate must have had a perfect attendance record at all military and political training classes.⁹²

(U) The Viet Cong appear to realize the difficulties inherent in finding personnel who can fulfill all the requirements for the AP BAC award so they have allowed soldiers to be eligible if they only meet the requirements of combat and proselyting.⁹³

⁸⁹Department of Defense, Intelligence Information Report, Policy On Awards, Report Number 6075028565, 3 June 1965, p. 1, (File Number N-16961.40, Fort Leavenworth, Kansas Library). A translation of a captured Viet Cong Document.

⁹⁰Ibid.

⁹¹Ibid.

⁹²Ibid.

⁹³Ibid.

UNCLASSIFIED

~~SECRET~~
107

UNCLASSIFIED

(U) To qualify for the unit award, the unit must have "paralyzed" the strategic hamlet program and conducted at least two-thirds of the required number of attacks. This seems to be a contradiction in determining superior performance but possibly the Viet Cong realize they ask their units for standards too high to meet and, in turn, reward the best all around performance. In their operations the unit should have destroyed one enemy unit and captured important (automatic) weapons. An alternative would be to build a strong combat hamlet which has successfully countered a South Vietnamese Army sweep operation with few friendly casualties. In addition to these criteria the unit must have had 100 per cent attendance at all important meetings. Further, no Party member or Labor Youth Group member can have deserted, and the desertion rate of non-Party or Group members must have been less than one per cent of the unit strength. Lastly, if the organization is a local or provincial mobile force unit, it must have met its production standards and insured self-support as outlined in the Party Chapter directives.⁹⁴

(U) Individual candidates are required to prepare a report based upon his daily activities and a self-critique which is first approved by his squad, then the Platoon Party Chapter and finally the company. Winning candidates at company level are honored with a ceremony. These winners, at company level, are then presented to either the battalion or district committees where these recommendations are again consolidated and forwarded to regiment, or region, in the case of personnel from separate companies or battalions, where the final selection is made.⁹⁵

⁹⁴Ibid., p. 2.

⁹⁵Ibid., p. 4.

~~SECRET~~

UNCLASSIFIED

(U) Promotions.--As was noted in Chapter Three, promotions are usually controlled and supervised by the Party. Viet Cong commanders are encouraged to recommend qualified cadre for promotion whenever possible and not allow authorized spaces to remain vacant. Commanders are told that the proper management of cadre, particularly squad cadre, will insure a pool of qualified individuals that can later fill vacancies for platoon cadre and higher.⁹⁶

(U) For squad leaders, the rank is given to personnel in command of from 10-15 men. Individuals may be promoted regardless of their previous command experience as long as they meet the requirements of talent and virtue described in Chapter Three. There is a further notation that the requirements for squad cadre are higher than those for platoon level, presumably due to the close contact maintained at squad level. Promotions are held twice a year and based upon the recommendations of the Party Chapter Committees.⁹⁷

(U) The promotion system is regarded as extremely important by Viet Cong leaders and cadre are told to carefully screen all applicants and give these individual promotion applicants their fullest attention to insure quality. They are reminded that if these procedures are followed closely, the soldiers will be more enthusiastic and efficient.⁹⁸

(U) Attention must be paid to political background because the squad is the key to development into platoon and company cadre. Likely

⁹⁶U. S. Department of Defense Intelligence Information Report, Viet Cong Policy on the Promotion of Squad Cadre, Report Number 6075033765, 12 June 1965, p. 1, (File Number N-16961.40, Fort Leavenworth, Kansas Library). A translation of a captured Viet Cong Document.

⁹⁷Ibid., p. 2.

⁹⁸Ibid., p. 3.

~~UNCLASSIFIED~~

109

~~CONFIDENTIAL~~

enlistees may be trained for squad leadership by schools or by on-the-job training.⁹⁹

(U) When a promotion of a soldier is approved it is published in the following example of a promotion order, under the heading of the Liberation Army.

Western (Nam Bo) Liberation Army
V. 25

Date: 24 February 1964

- Considering the behaviour and capabilities of the cadre concerned.
- Considering the requirements of the Revolutionary mission.
- Considering the recommendation of the Commander of Unit 38.

D E C I S I O N

I. Comrade Vo Van Be, Assistant Squad Leader, acting Squad Leader, is promoted to Squad Leader of Unit 38.

II. This decision is effective as of the date it is signed.

III. The Chief of Staff, V. 25 Political Section the Commander of Unit 38 and Comrade Be, are charged, each within his sphere of responsibility with the execution of this order.

For V.25 Commander
s/ Thanh.100

Kiem-Thao (Self-Criticism)

 Kiem-Thao, which means literally verification and discussion, is the common Vietnamese term for the self-criticism sessions which are held within the Viet Cong organizations from cell to battalion level. Though this term is commonly applied to self-criticism, it also implies a freedom for members to openly criticize anyone within the organization.¹⁰¹ These sessions are held daily at cell and weekly at squad level. The Viet Cong soldier will normally participate in two platoon sessions and one

⁹⁹Ibid.

¹⁰⁰Department of Defense Intelligence Information Report, Unconventional Forces-Viet Cong, Inclosure 5.

¹⁰¹Donnell, Parker, and Zasloff, p. 35. These sessions are also noted in U. S. Department of Defense Intelligence Information Report, Organization of Guerrilla Forces, Report Number 6075031665, 8 June 1965, p. 2, (File Number N-16961.40, Fort Leavenworth, Kansas Library). A translation of a captured Viet Cong Document.

UNCLASSIFIED

~~CONFIDENTIAL~~

UNCLASSIFIED

~~CONFIDENTIAL~~

company session a month. These meetings are usually divided into two types, the criticism session in which routine daily activities are discussed and the "battle analysis" which occurs either before or immediately after a combat operation.¹⁰²

Cell Criticism.--The daily meeting at cell level is held just before the evening meal and usually lasts between thirty and forty-five minutes. Here, among his cell members, the Viet Cong soldier will "search out his heart to see that all sentiments of homesickness have been rooted out,"¹⁰³ and discuss ideological problems, review the day's activities and discuss such important personal characteristics as frugality, job performance and politics.

Depending upon the situation there may be time given to a discussion of soldier-civilian relations if problems have existed in this area. These sessions will be characterized by the use of slogans such as "eat with the people, work with the people, sleep with the people," and "do not waste what the people have given us."¹⁰⁴

(U) The cell meetings are held informally. The cell leaders realize that theirs is not an administrative unit designed to solve administrative problems, so they are oriented toward solving leadership

¹⁰²Ibid., p. 35.

¹⁰³U. S. Department of Defense Intelligence Information Report, Organization of Guerrilla Forces, Report Number 6075031665, 8 June 1965, p. 2, (File Number NI6961.40, Fort Leavenworth, Kansas Library). A translation of a captured Viet Cong Document.

¹⁰⁴Donnell, Parker and Zasloff, p. 35.

~~CONFIDENTIAL~~

~~CONFIDENTIAL~~

UNCLASSIFIED

~~SECRET~~

111

UNCLASSIFIED

problems concerning political motivation, in order to instill confidence in the members.¹⁰⁵

(U) In support of these sessions the cell leaders are encouraged to give additional assistance and counseling to the soldiers outside the atmosphere of the cell meetings in order to help them overcome their problems. Difficult problems can, of course, be reported to the squad leader for additional help.¹⁰⁶

(U) After each evening cell meeting, the cell leaders report the results of the session to the squad leaders. Then after this squad cadre meeting, the squad leader, in turn, goes to a platoon cadre meeting where he receives orders from the platoon command committee. At the conclusion of this meeting the squad leaders return and hold another meeting with their cell leaders.¹⁰⁷

(U) Squad Criticism.--At the weekly squad meeting the regulations pertaining to the squad are reviewed and new plans are outlined to the squad members. At this meeting each of the squad must again submit all of his activities during the past week for evaluation by the squad members. Then each member is criticized and if he feels he was in error, he follows with a self-criticism of himself, and a promise to improve. All members are encouraged to contribute any ideas on leadership.¹⁰⁸

(U) Platoon Criticism.--At the bimonthly platoon activity, the general order of business is discussion of the combat and training situation of the platoon and an orientation of all platoon members. After

¹⁰⁵Department of Defense Intelligence Information Report, Organization of Guerrilla Forces, p. 2.

¹⁰⁶Ibid., p. 3.

¹⁰⁷Ibid.

¹⁰⁸Ibid., p. 2.

~~SECRET~~

UNCLASSIFIED

UNCLASSIFIED

this, the policies of higher headquarters are reviewed and new policies read to the troops. Then plans are proposed to execute new directives. At this meeting any leadership problems that affect the platoon are discussed and again each individual is allowed to criticize the Platoon Command Committee or indulge in self-criticism.¹⁰⁹ This latter self-criticism could also be done by the platoon leader, if he was found to be in error.

Kiem Thao and Awards.--In some Viet Cong platoons the self-criticism sessions are held in conjunction with an award program to select the best soldier, cell and squad of the month. If this is done, the cell members will select their best candidate at a nightly meeting at least one week before the squad meeting.¹¹⁰ This selection will be based upon the data each cell member recorded in his notebook and all candidates will be examined to determine the most outstanding one.

(U) At the weekly squad meeting then these reports from the cell are read aloud and examined by all the squad members. The members then select the best individual of the three cells and may also select an outstanding cell to represent them at the platoon competition. This same procedure is followed at the platoon meeting where the one outstanding soldier and cell for the platoon is selected. At this level, however, the final selection is by the platoon command committee. Based upon these selections the outstanding soldier and the cell of the month is announced, and the winners are honored at a company formation.¹¹¹

¹⁰⁹Ibid.

¹¹⁰Ibid., p. 3. This is somewhat similar to the AP BAC emulation.

¹¹¹Ibid.

SECRET**UNCLASSIFIED**

~~SECRET~~

113

UNCLASSIFIED

Battle Analysis

~~CONFIDENTIAL~~

One of the most effective training vehicles utilized by the Viet Cong is the critique following each combat action. This self-critique is normally made as soon after the event as possible, once the Viet Cong unit is back in a safe area. This critique enables members to profit from the successes and failures of each other, especially if the meeting is immediate. During these critiques the comments are very pointed and designed to fully examine both the favorable and unfavorable parts of the action including an analysis of the performance of each cell, squad, platoon or company involved.¹¹² The findings of these unit critiques may be published in after action reports and distributed to other units depending upon the significance of the final results.

(U) As a part of this type of criticism and as a leadership technique to immediately recognize the reward outstanding performance of duty, an outstanding soldier or cell may be singled out for a single engagement and honored similarly as was the soldier or cell of the month. In this critique, just like all others, the candidates must describe out loud to all members just what they accomplished in the battle, and based upon a vote by the cell, squad and platoon the best members are selected and rewarded.

(C) The indication of the scale the Viet Cong may go in self-criticism and battle analysis, is reflected in a Viet Cong leaflet which was distributed to the inhabitants of Quang Ngai, Quang Nam, and Binh Dinh Provinces in which they admitted a military failure. The leaflet said

¹¹²Letter, Headquarters, United States Military Assistance Command, Vietnam, 18 March 1965, Subject: "Viet Cong Tactics-Withdrawal," (File Number Roll 67 MACV microfilms, Fort Leavenworth, Kansas Library),

(CONFIDENTIAL)

~~CONFIDENTIAL~~

~~SECRET~~

UNCLASSIFIED

During the attack...on 25 November 1962, two Liberation Army Battalions failed to achieve their objective due to errors in planning and the subjective attitude of command echelons in Underestimating the enemy...

.....
In a revolutionary war the revolutionary forces are not always victorious. There are times when they win and times when they lose and it is in the midst of defeat that the struggle must be more vigorously pressed forward until the day of final victory.¹¹³
.....

Viet Cong Evaluation of Self-Criticism

There are varied reactions to the self-criticism sessions by participants but the continued references to them by prisoners and in documents attests to a continued reliance by the Viet Cong on this technique. A Rand study which interviewed Viet Cong prisoners about self-criticism noted that most, at first, experienced embarrassment at expressing their innermost thoughts. However, as time wore on they found it less difficult to express themselves and later reactions were, "I felt glorious, I believed I could solve all my own problems and help others to solve theirs too."¹¹⁴

(C) A company commander stated he used the self-criticism sessions to help overcome the fear his cadre had of U. S. Armored Personnel carriers and helicopters,¹¹⁵ he felt that after his cadre had overcome their fear, they could then give the proper ideology to the soldiers.

(C) It appears that in the final analysis the self-criticism serves four practical functions. First it enables the members of a unit to profit from each other's experiences. When this is done as a part of "battle analysis" it not only serves a leadership function but a training

¹¹³Letter, Headquarters, United States Military Assistance Command, Vietnam, 9 January 1963, Subject: "Viet Cong Propaganda Leaflet," (File Number C-18745.31, Fort Leavenworth, Kansas Library). (CONFIDENTIAL).

¹¹⁴Donnell, Parker and Zasloff, p. 37.

¹¹⁵U. S. Department of Defense Intelligence Information Report, Viet Cong Interrogation Report, Report Number 6075025765, 26 May 1965, (File Number 16961.40, Fort Leavenworth, Kansas Library). A translation of a prisoner interrogation.

vehicle as well. Secondly, this process enables the cadre to detect and cope with politically unreliable thoughts and attitudes in the group. Since the cell leaders almost immediately go from the cell sessions to the squad meetings, critical morale problems can be quickly identified. Third, it gets all the members involved and participating in the critique. None are allowed to listen passively, so some therapeutic value may be gained from the mass participation. Everyone must make some individual effort to comprehend and evaluate the subject under discussion and at the very least must express the group line in his own words and relate it to his own problems.¹¹⁶

c) Finally, it appears to be an effective means of reducing all kinds of psychological tensions arising in this style of life, so fraught with physical deprivations and focused so intensely on subordination of the individual to the group. Prisoners stated that it was difficult to bear a grudge against any comrade after these sessions because open discussion of dissatisfactions and anxieties tended greatly to "clear the air."¹¹⁷

d) Unit Upgrading.--There are two other leadership supports used by the Viet Cong that are unit oriented. One is the process of unit upgrading. This allows meritorious service at a lower level to be rewarded by moving a soldier higher in the system from, as an example, irregular force to local force and finally main force.¹¹⁸ This has a strong advantage in that it keeps experienced soldiers in the system and thus insures a reliable soldier. By the time a soldier has worked his way up

¹¹⁶Donnell, Parker and Zasloff, pp. 36-37.

¹¹⁷Ibid., p. 37.

¹¹⁸Ibid., p. 24.

the ladder he would have been in contact with the Viet Cong ideology a sufficiently long time to make him fairly reliable. This type of upgrading can also be made without promotion so this can be done without regard to rank limitations.

Retraining.--Another method is a periodic retraining cycle. If a unit is selected for this process, it will, according to one document, be retrained but emphasis will be on political reorientation and self-criticism. This retraining is usually conducted in a "safe area" and may be done by the unit cadre, or a selected professional committee from the military region. This document also noted that if this training was required to be reduced in scope, the military portion would be abbreviated but not the political reorientation.¹¹⁹

Evaluation

(U) The Viet Cong have conceived a concept of leadership that can effectively operate within the situation for which it was designed, and attempts, wherever possible, to satisfy the needs of the individual. This concept of leadership further recognizes the necessity for dependence on the Party which has the resources in personnel and expertise to make the doctrine work.

(U) The blending of leadership and organization should now be apparent, particularly in the cell organization. As was noted in Chapter Four, this concept of "three for one and one for three" is an excellent method for motivating soldiers to "pull together" toward a common goal. This cell is also a very fine tool for leadership since the inter-reactions of the cell members upon each other is inescapable. It would appear that the Viet Cong have set up in their cell, and developed through

¹¹⁹Department of Defense Intelligence Information Report, Viet Cong Interrogation Report (U), p. 55.

~~SECRET~~
117

UNCLASSIFIED

their Kiem-Thao sessions, a strong group integrity much like the one described by Shils and Janowitz as existing in certain German units at the close of World War II.¹²⁰ Thus, the Viet Cong have recognized that an important motivational aid for the fighting man is to gain and maintain the respect of his comrades.

(U) Basically a study of the Viet Cong concept of the leader and the led reveals no new ideas. The traits desired by the Viet Cong in both their officers and men, such as leadership by example, dedication, courage and loyalty are similar to those desired by most armies. What is significant is the method used to achieve these traits, and motivate this army.

(U) The Viet Cong have been extremely successful in motivating their officers and men and creating the type of leadership required for an insurgency. They have taken maximum advantage of all aspects of the situation to insure conservation of their manpower by carefully choosing their targets for operations and have motivated their soldiers by making them feel a part of the cause, not only in words but by deeds.

(U) By using their self-criticism sessions, they insure that the daily frustrations of the soldier are recognized and made the concern of the group. These sessions also provide an excellent method for briefing the soldier and testing his reaction to policy. This system of sessions at cell and squad level also enables the soldier to be rewarded or punished by the group, and it is at this level, with his comrades, that the rewards and punishments are most effective. In short, this system makes the soldier feel that someone cares about him.

¹²⁰Edward S. Shils and Morris Janowitz, Cohesion and Disintegration In The Wehrmacht in World War II, Public Opinion Quarterly, Volume 12, Summer, 1948 (Princeton University: 1948). This study gives an excellent account of the relationships formed in small military units and their effect on leadership and efficiency.

~~SECRET~~

UNCLASSIFIED

~~SECRET~~

118

UNCLASSIFIED

(U) One weakness in this system is its apparent inability to impress upon the soldier his duty toward interrogation when captured. It appears that soldiers of all ranks freely disclose any and all information to their interrogators once they are captured.

(U) Another weakness is the inability to solve the problem of defection. In spite of the criticism sessions, and the emphasis on devotion to duty, the Party and its leaders have not been able to stem a rising tide of soldiers surrendering. The apparent inability of leaders to solve defection due to defeatism and hardship was noted by Keyes Beech of the Chicago Daily News Syndicate, when he wrote recently that Viet Cong defections were on the increase since allied forces regained the offensive in the South. He noted one case where 500 Viet Cong had defected simply due to fear of allied air and artillery, and noted that twenty-seven per cent of these defectors indicated their comrades were also willing to surrender.¹²¹ This seems to indicate that the Viet Cong concept of using ideology to build courage is in error. It would appear that their soldiers need more tangible supports than words when confronted with hardships and sophisticated fire power.

(U) It must be remembered, though, that this defection in number is a recent trend. For over five years the Viet Cong system was strong and functioned effectively. It took a massive increase in United States support in order to place significant stresses upon it.

(U) In the final analysis the Viet Cong leadership system is strong and works. The weaknesses that occur do not stem from a faulty system but rather from the hardships posed by this type of a war. As

¹²¹Kansas City Star, March 24, 1966, p. 2.

~~SECRET~~

UNCLASSIFIED

~~SECRET~~

119

UNCLASSIFIED

was noted by Rand, in an earlier part of this chapter, most Viet Cong that deserted did so for physical rather than ideological reasons.

(U) The leadership of the Viet Cong is strengthened by its good organization and discipline, and its ability to integrate effectively the Party and a variety of other activities, and focus them toward the accomplishment of clearly defined goals.

UNCLASSIFIED

~~SECRET~~

~~SECRET~~
~~CONFIDENTIAL~~
UNCLASSIFIED

CHAPTER VI

VIET CONG TRAINING

(U) The purpose of this chapter is to examine Viet Cong training doctrine and methods. This chapter should provide additional insight into the strengths and weaknesses of the Viet Cong soldier and at the same time re-emphasize the inter-relationships of North Vietnam, the Party, organization and leadership in molding the soldier into an efficient fighting man.

Factors Influencing Training

Purpose of Training

~~SECRET~~ The purpose of Viet Cong training is to build and maintain a strong, disciplined army.¹ This army must be built, from inexperienced peasants, into a guerrilla army capable of fighting a "people's war." Furthermore, as the protracted war escalates into advanced stages, the army must be prepared to make a transition to conventional forms of warfare.²

(U) The Viet Cong fully realize the close relationship between training and combat. They feel that the battlefield and the training area are the same, consequently they place identical emphasis on leadership in training as well as in combat.³ Party committees are told to closely

¹U. S. Army John F. Kennedy Center For Special Warfare (Abn), The Viet Cong (2d ed rev; Fort Bragg, N. C.: John F. Kennedy Center For Special Warfare (Abn), November 1965) quoting a Viet Cong training document captured in Vinh Long, South Vietnam, p. III-34. (SECRET).

²Ibid., pp. III-3, 34.

³U. S. Department of Defense Intelligence Information Report, Training Goals for 1965, Report Number 6075040165, 29 June 1965, p. 4, (File Number N-16961.40, Fort Leavenworth, Kansas Library). A translation of a Viet Cong Document.

~~SECRET~~
~~CONFIDENTIAL~~
~~SECRET~~

UNCLASSIFIED

supervise their training responsibilities. Cadre are advised to make on-the-spot corrections of training deficiencies to quickly reward exemplary performance and to discipline offenders. Cadre must remember, however, that training is primarily educational, and even though disciplinary measures may have to be applied to insure realism, training should never be used as punishment.⁴ Whenever possible, live ammunition is used in training.

Time

~~(S)~~ Time is usually a limiting factor on Viet Cong training, so cadre are told to conduct training, whenever possible, concurrent with combat operations.⁵ The factor of time also requires Viet Cong training to be functional, practical and adaptable to local situations. For this reason non-essential subjects are omitted from schedules and only the practical aspects of the subjects are stressed. Thus training is short and intensive. Military and political training is integrated whenever possible.⁶

The Soldier

(U) Due to the inexperience and relatively low skill levels of the soldier, the Viet Cong require his complete involvement in all types of training. Student participation is accented in all subjects, and theory is immediately followed by practical work.

⁴U. S. Army John F. Kennedy Center For Special Warfare (Abn), p. III-34.

⁵Department of Defense Intelligence Information Report, Training Goals for 1965, p. 4.

⁶U. S. Army John F. Kennedy Center For Special Warfare (Abn), pp. III-4, 34. This does not mean that political training is de-emphasized. The Viet Cong feel that this type of training is necessary in order to increase the will of the soldier to resist.

~~CONFIDENTIAL~~

~~SECRET~~

UNCLASSIFIED

UNCLASSIFIED

Offensive Doctrine

(U) General.--The training of the Viet Cong soldier stresses the offensive nature of his role in the revolution and is based on the concept of "One Slow Action, Four Fast Ones" which are:

SLOW and meticulous attack preparations and rehearsals;
FAST closing in with the enemy and attack;
FAST and determined destruction of enemy resistance;
FAST mopping-up of the battle area (arms, prisoners, own casualties);
FAST withdrawal to base areas.⁷

This concept of the offense is re-emphasized in his later training by such slogans as: always move forward, never withdraw, penetrate deep and encircle the enemy. To increase offensive spirit the Viet Cong train the soldier for hand-to-hand combat.⁸

(U) Offensive doctrine requires the soldier to seek opportunities to attack enemy weakness. If the enemy defends, the soldier must respond by harassment in order to force him to disperse. If the enemy lays an ambush, it must be countered, and if he is strong in one place, he must be struck in another place.⁹ This continued emphasis on the offense is of paramount tactical importance in guerrilla warfare since it builds a feeling of superiority and confidence the Viet Cong want instilled in their soldiers. Thus the recruit comes to believe that the Viet Cong always choose the time and place of a battle and fight only when victory is certain.

⁷Bernard B. Fall, The Two Viet-Nam's Revised Edition (New York Frederick A. Praeger, 1964), p. 367.

⁸U. S. Department of Defense Intelligence Information Report, Viet Cong Military and Political Doctrine, Report Number 6075046065, 11 July 1965, p. 2, (File Number N-16961.40, Fort Leavenworth, Kansas Library). A translation of a Viet Cong Document.

⁹Ibid., p. 4.

UNCLASSIFIED

(U) Aggressiveness.--Offensive doctrine requires an aggressive, motivated soldier, who is willing to attack an enemy force armed with superior weapons. For this reason the soldier is told that his enemy has weak morale, and relies upon weapons rather than courage. If the enemy's weapons and equipment are captured, his will to resist will collapse.¹⁰

(U) The Attack.--The attack is the essential and fundamental form of combat for the Viet Cong soldier. He is told that he can exterminate the enemy only by this offensive tactic. Training must also emphasize night attacks, since the soldier knows this is a Viet Cong tradition.¹¹

~~(U)~~ Ambush.--The ambush is a primary tactic because it can harass or exterminate an enemy plus serve as a source for resupply and prisoners. The ambush accents a Viet Cong strength; intelligence from the people.¹²

(U) The Raid.--Raids are classified as surprise; executed by small units on limited objectives, or superior force, up to battalion size against well defended positions. Raids utilize commando tactics, fire support, and engineers.¹³ The soldier is told that raids are not

¹⁰ibid., p. 3.

¹¹U. S. Department of Defense Intelligence Information Report, Viet Cong Small Unit Tactics, Report Number 6075015365, 2 May 1965, pp. 1-3, (File Number N-16961.40, Fort Leavenworth, Kansas Library). A translation of a captured Viet Cong Document.

¹²Jeanne S. Mintz, Herbert M. Silverberg, James E. Trinnaman, A Short Guide To Psychological Operations In The Republic Of Vietnam 1965 (U), A report prepared for the Special Research Office, American University (Washington, D. C.: June 1965), pp. 79-80. (CONFIDENTIAL).

¹³Department of Defense Intelligence Information Report, Viet Cong Small Unit Tactics, p. 6.

~~CONFIDENTIAL~~~~SECRET~~

UNCLASSIFIED

UNCLASSIFIED

124

~~CONFIDENTIAL~~

conducted unless success seems likely. Raids are aimed at enemy rear areas or anywhere he feels secure.¹⁴

Security

(U) The emphasis placed on security by the Viet Cong in combat operations has been evidenced in part by the number of successful ambushes conducted against the South Vietnamese Army, and the relative freedom of movement they enjoyed, prior to the introduction of sophisticated aerial surveillance devices. This reliance on security requires continued emphasis in training.

(U) This emphasis on security requires that the Viet Cong soldier understand the use of reconnaissance elements, in conjunction with liaison parties, before leaving a safe area. To insure compliance, this doctrine must be stressed at cell and squad level. The soldier must be taught to move at night, preferably between 2000 and 0400 hours, and observe strict light and noise discipline.

~~(S)~~ When the soldier moves as a part of his unit, he knows that reconnaissance cadre precede the move by six hours to coordinate with village guerrillas. These reconnaissance agents later become guides for the unit.¹⁵

~~(S)~~ When the soldier's battalion is on the march other reconnaissance parties precede the column as a point, followed by an infantry company, the headquarters and weapons company, and the remaining rifle units.¹⁶

¹⁴Department of Defense Intelligence Information Report, Training Goals for 1965, p. 3.

¹⁵U. S. Department of Defense Intelligence Information Report, VCC Interrogation Report, Report Number 6075021765, 17 May 1965, p. 44, (File Number C18745.99, Fort Leavenworth, Kansas Library). A translation of a Viet Cong prisoner interrogation. (~~CONFIDENTIAL~~).

¹⁶Ibid.

~~CONFIDENTIAL~~

~~SECRET~~

UNCLASSIFIED

UNCLASSIFIED

~~CONFIDENTIAL~~
125

The Viet Cong soldier must be trained to march with a four to five meter interval between men.

(U) An example of the detail required to train the soldier in road crossing techniques can be seen from a main force prisoner's description of the operation.

Upon arrival at 150 meters from the road, the unit halted and established defense as it (did) (when it) crossed a river, and the unit assigned two additional elements of the point platoon to both ends of the road section where the company planned to cross to secure those areas. These elements were located from 50 to 100 meters apart. One squad was then ordered to cross the road and make reconnaissance on the other side of the road. After the 1st platoon already crossed the road, both flank security elements would follow it and the other two would replace them to secure for another platoon to cross. Then the same would be repeated until the whole company was through.

If the reconnaissance agents were posted at both ends of the road section, these security elements would only accompany their platoon until the whole unit was through. The whole unit would not resume its movement until the Company Executive Officer, who was the last to come finished reporting.¹⁷

Defensive Doctrine

(U) The regular Viet Cong soldier relies on the offense. He assumes the defense only when trapped or surprised. His doctrine does not stress the conduct of the defense other than to tell him to be resolute and brave. For the most part, the Viet Cong soldier delays rather than defends, usually as part of a security force for a raid or an ambush. This concept enables an integration of offensive and defensive training, which saves training time, and retains offensive spirit. The soldier is taught that the ultimate result of delaying or defensive tactics

¹⁷U. S. Department of Defense Intelligence Information Report, Viet Cong Interrogation, Report Number 6075024465, 24 May 1965, p. 57, (File Number NI6961.40, Fort Leavenworth, Kansas Library). A translation of a Viet Cong prisoner interrogation.

~~CONFIDENTIAL~~

~~SECRET~~

UNCLASSIFIED

is not feasible, another common tactic is to attack the strongest point of the encircling force using automatic weapons. This initial fierce probe is immediately repeated in other areas in order to make the encircling force think the Viet Cong are strong, and hopefully prevent the circle from being closed. Once this is accomplished and the encircling force is stopped, the Viet Cong soldier waits for nightfall and exfiltrates out of the circle.²¹

Summary

(U) The factors discussed in the previous pages influence the training of the Viet Cong soldier. The emphasis on offensive doctrine means that more training time is devoted to it at the expense of other forms of combat as long as the spirit of the offense is maintained. The limitation of time and the requirement for an aggressive soldier require emphasis on the offense.

(U) The remainder of this chapter will be devoted to the methods used by the Viet Cong to teach these influencing factors to their soldiers.

Pre-Infiltration Training

(U) The pre-infiltration training conducted in North Vietnam by the North Vietnamese Army is designed to strengthen the combat potential of the Viet Cong forces in the South. This training assists in maintaining the strength of Viet Cong units since safe areas are provided where new units or individual replacements can be organized and equipped.

Most of the infiltration training is conducted at Xuan Mai and Son Tay, which are permanent North Vietnamese Army facilities.²²

²¹Ibid., p. 65.

²²John F. Kennedy Center For Special Warfare (Abn), p. III-19.

UNCLASSIFIED

128

Xuan Mai appears to be the largest facility, accomodating 3,000 men in cycles of from 300 to 500 trainees.²³ Courses vary from ten days to six months, the average training period being three months.²⁴

Military Courses

The courses at these centers are usually taught by committees but some infiltration units may be trained by their own cadre. The courses review military and political subjects and emphasize the employment of forces in the South. Most of the trainees are members of the North Vietnamese Army and have completed basic and advanced training. Individual and squad tactics, bayonet training, attack and defense tactics and physical training are emphasized. Obstacle courses and forced marches carrying heavy loads of bricks, help prepare the trainee for the rigors of guerrilla life.²⁵

Trainees receive refresher training on the more common Viet Cong weapons, including the SK rifle, the AK assault rifle, and 60 and 81 millimeter mortars.²⁶

Political Courses

Political training for the infiltrators appears to be based on their projected employment in the South, and their previous service in

²³Joseph J. Zasloff, The Role Of North Vietnam In The Southern Insurgency (U) (Santa Monica: July 1964) p. 40. A report to the Office of the Assistant Secretary of Defense/International Security Affairs, prepared by the Rand Corporation. (SECRET).

²⁴John F. Kennedy Center For Special Warfare (Abn), pp. III-5-6. This is also noted in Department of Defense Intelligence Information Report Number 6075038765, 24 June 1965.

²⁵Ibid., Additional information can be found in Department of Defense Intelligence Information Reports Number 6075021765 and 6075038765.

²⁶Ibid.

UNCLASSIFIED

~~CONFIDENTIAL~~

UNCLASSIFIED

~~SECRET~~ CONFIDENTIAL
129

the North Vietnamese Army. Soldiers designated as political cadre receive a concentrated training program of seven and one-half hours a day for one month, and are required to watch political films at night. This training is entirely political and is taught by members of the Central Re-unification Committee of the Lao Dong Party.²⁷ For the average infiltrator who will perform purely a military function, the formal political training lasts less than one month and is primarily designed to deepen the soldier's moral resolution to free the South.²⁸ This latter type of political training dwells on the political situation in South Vietnam, and the mission of the insurgency. Courses are also included on how to treat the people in the South.

(U) It must be remembered, however, that additional political training is always integrated in the evening self-criticism sessions, and study periods which are not shown on training schedules.

☉ Lately, the trend has been toward shorter infiltration courses, and in some cases political training has been omitted if the subject has had extensive regular military service and appears to be properly motivated.²⁹

☉ There is evidence to show that some infiltrators receive additional technical schooling prior to their infiltration. Selected students receive this instruction from North Vietnamese Army schools in such fields as signal, artillery or anti-aircraft techniques.³⁰

²⁷U. S. Department of Defense Intelligence Information Report, Organization, Training and Infiltration Route of K.16 Group, Report Number 6075051565, 28 July 1965, p. 2, (File Number C-18745.99, Fort Leavenworth, Kansas Library). A translation of a Viet Cong prisoner interrogation, (CONFIDENTIAL).

²⁸John F. Kennedy Center For Special Warfare (Abn), p. III-7: . . .

²⁹Ibid., p. 6.

³⁰Ibid.

UNCLASSIFIED

~~SECRET~~ CONFIDENTIAL

UNCLASSIFIED

~~CONFIDENTIAL~~

(U) Infiltrators selected for leadership training as future Viet Cong cadre attend North Vietnamese Army schools which vary in length according to the rank of the individual and the position for which he is being trained. Some examples of the duration of leadership and training courses for various ranks are:

Private to Private First-Class	Three months
Private First-Class to Corporal	Six months
Corporal to Sergeant	Six months
Sergeant to Senior Sergeant	Six months
Senior Sergeant to Aspirant	One year ³¹

Daily Routine

(U) Reports from prisoners give some insight as to the daily routine and the amount of training conducted at Xuan Mai. Two such schedules are shown below.

0500 Reveille and Physical Training	0530-0600 Reveille and Physical training
0530 Breakfast	0600-0630 Breakfast
0600 Personal Hygiene and area police	0630-0700 Preparation for training
0630 Training	0700-1130 Training
1030 Break	1130-1200 Lunch
1100 Lunch and rest	1200-1330 Rest
1315 Reveille	1330-1630 Training
1330 Training	1630-1730 Sports
1730 Break and Weight Carrying (30 kilos of bricks)	1730-1800 Dinner
1800 Dinner	1800-1900 Rest
2130 Bed and lights out. ³²	1900-2100 Newspaper Reading
	2100 Bed. ³³

³¹U. S. Department of Defense Intelligence Information Report, Western Highlands Autonomous Regiment 120, Report Number 6075051955, 28 July 1965, (File Number C-18745.99, Fort Leavenworth, Kansas Library). A translation of a Viet Cong prisoner interrogation. (CONFIDENTIAL).

³²Department of Defense Intelligence Information Report, VCC Interrogation Report, p. 13.

³³U. S. Department of Defense Intelligence Information Report, Training, Infiltration, Organization of Viet Cong Districts, Report Number 6075038765, 24 June 1965, p. 9, (File Number N.16961.40, Fort Leavenworth, Kansas Library). A translation of a Viet Cong prisoner interrogation.

~~CONFIDENTIAL~~

~~CONFIDENTIAL~~

UNCLASSIFIED

~~SECRET~~

131

UNCLASSIFIED

(U) From these schedules it appears that formal training lasts about seven and one-half hours, but the length of the training day does provide for the inclusion of political subjects during the rest periods and the periods after dinner. Prisoners indicated that physical training and load carrying was done daily. During the small unit tactical phase the trainees were moved to the field and required to function under adverse conditions.³⁴

Effect on The South

(U) Infiltration training provides the Viet Cong with crucial skills, experience and leadership qualities that support those of the southern trained soldier. Without this support the Viet Cong would have to select and train local personnel for the jobs now being filled by the infiltrators. This could possibly cause personnel problems in recruiting and selecting politically loyal and technically competent soldiers. It appears that so far at least, the North Vietnamese Army has a sufficient reserve of infiltrators to continue to assist the Viet Cong.

(U) An additional advantage of having the assistance of the North comes from the fact that the South could not match the training facilities of North Vietnam or the variety and degree of specialization in North Vietnamese Army programs. Not only would these elaborate training sites be vulnerable to attack by the South Vietnamese but their staffing would require more manpower, weapons and ammunition be withdrawn from a combat commitment.

(U) Prisoners, trained in the North, have indicated that there are pressing equipment problems at these training sites. One such prisoner stated that in his course, composed of draftees, they were forced by a lack of equipment to make their own rifles out of wood. In addition,

³⁴ Ibid., p. 8.

~~SECRET~~

UNCLASSIFIED

each trainee had to make one dummy grenade, one silhouette target, a circle target and a mockup of a mortar with one dummy round. He was allowed to fire only three live, rifle, rounds for familiarization.³⁵

Individual In-Country Training

General

(U) The in-country training conducted by the Viet Cong is characterized by a formal, controlled and closely supervised program of instruction for skill levels necessary to supplement the infiltration from the North. Recently, due to the increased air activity in the South, the in-country training has become less formalized, but prior to this the Viet Cong were able to conduct intensive, almost uninterrupted training at facilities located in their safe areas.

~~(S)~~ The in-country training program makes maximum use of "on-the-job" training as well as a formalized system of schools, mobile training teams, recruit and unit training. In main force units, this training is thorough, well disciplined and marked by close political control.³⁶

Responsibilities

~~(S)~~ In South Vietnam, the responsibility for conducting schools differs according to the level of the control headquarters.³⁷ The Central Office for South Vietnam is responsible for providing formal advanced schooling for battalion and company commanders, and technical training in intelligence, signal, artillery and recruiting techniques. On the

³⁵Ibid. Additional information was found in Defense Intelligence Report Number 6075051865, 25 July 1965, p. 2.

³⁶John F. Kennedy Center For Special Warfare (Abn), p. III-7.

³⁷These control headquarters were described in Chapter Four, and include the Central Office for South Vietnam, the Military Region, Province and District.

political side, the Central Office trains all company and battalion political officers.³⁸

(c) The military region has the responsibility for training recruits, platoon and company officers, special mission personnel and engineers. In addition they train the platoon political officers, district committeemen and provide technical training on weapons manufacture and administration.³⁹

(d) The province is the lowest level able to conduct recruit training. It is also responsible for training assistant squad and platoon leaders, as well as some special mission and intelligence personnel. The district provides training for guerrillas and militia.⁴⁰

Platoon Leader Training

The military region conducts a six month course for Viet Cong officer candidates which stresses the political and military responsibilities of officers. One prisoner, who was a candidate at one of the schools, said the political training consisted of courses in combat leadership based upon Viet Cong ideology. In line with this ideology, and its political characteristics, candidates were told to look and dress like the people. Emphasis was placed on their responsibilities for supply economy. All candidates were impressed with their reliance upon the Party for organization, training and leadership.⁴¹

The military training of officer candidates emphasized their responsibilities to train soldiers in political subjects, improve the

³⁸Ibid., p. III-8.

³⁹Ibid.

⁴⁰Ibid.

⁴¹U. S. Department of Defense Intelligence Information Report, Viet Cong Interrogation Report (U), Report Number 6075024465, 25 May 1965, p. 18, (File Number C-18745.99, Fort Leavenworth, Kansas Library). A translation of a Viet Cong prisoner interrogation. (CONFIDENTIAL).

educational level of their units and train them in tactics. The tactics dealt mainly with small units up to company level. All candidates were trained on those weapons commonly found within the Viet Cong rifle company.⁴²

Specialist Training

(U) Each level of command has responsibility for training certain specialists that are normally employed in their area of influence. It would appear that this might cause an overlap in training, since for example, sapper and reconnaissance are usually organic to each level of command, but nevertheless the districts, provinces and regions all train those personnel under their command.

Reconnaissance and Sapper Training.--These personnel, which are a part of all regular force organizations are trained at the district, province or military region. Reconnaissance training emphasizes attacks on fortified positions, but also includes guiding and marking of routes as well as normal reconnaissance missions. The sapper training stresses minefield clearance, demolitions and breaching of obstacles.⁴³ This training is strict and closely monitored since these soldiers are the "eyes and ears" of the commander.⁴⁴

Anti-Aircraft Training.--This type of training appears to be the most complex of any Viet Cong combat training. This training utilizes formal lesson plans, blackboards, and detailed topics are taught in three

⁴²Ibid., pp. 21-22. These weapons include the MAS 36 rifle, the Thompson sub-machinegun, automatic rifle, caliber 30 machinegun, 60 millimeter and 81 millimeter mortar.

⁴³John F. Kennedy Center For Special Warfare (Abn), p. III-16.

⁴⁴U. S. Department of Defense Intelligence Information Report, Viet Cong Document-Unconventional Forces, Report Number 6075024765, 25 May 1965, Inclosure 7, p. 7, (File Number N-16961.40, Fort Leavenworth, Kansas Library). A translation of a captured Viet Cong Document.

UNCLASSIFIED

~~SECRET~~
135
~~CONFIDENTIAL~~

hour blocks. Each anti-aircraft specialist learns in detail the capabilities of the 12.8 machine gun and the detailed preparation of emplacements, the methods of engaging aircraft, fire commands, and crew drill. The firing drills are detailed and require a great deal of discipline and proficiency. Examples of this detail are shown by some guidelines to crews. When a helicopter is landing, aim at the bottom of the fuselage; when it is taking off, aim above the fuselage. When it flies straight and level, lead it by two lengths. Shoot at the nose of a fighter when it dives and at the tail as it climbs away. Lead fighters by three lengths in level flight and at less than 1,000 meters of altitude.⁴⁵

◆ Signal.--Evidence points to the existence of communications schools but there is very little information on them. A captive described one school as very well equipped with professional instructors. An interesting note was that the criteria for admission required the student receive some training from the South Vietnamese government. Students went to school ten days a month and took correspondence courses for twenty days a month. All students were given proficiency tests at the conclusion of the course.⁴⁶

● Artillery.--As in the case of signal, there is not much information on artillery training. The U. S. Army Special Warfare Center alludes to the fact that training is conducted on the 75 millimeter pack howitzer, mortars and recoilless rifles, but no lesson plans or programs

⁴⁵U. S. Defense Intelligence Agency, Defense Intelligence Digest, Volume 3, Number 2, February 1965, p. 17. (SECRET-NOFORM).

⁴⁶U. S. Department of Defense Intelligence Information Report, HA DONG Province Basic/Intermediate Communications Correspondence School, Report Number 6075040665, 29 June 1965, p. 1, (File Number C-18745.99, Fort Leavenworth, Kansas Library). A translation of a captured Viet Cong Document. (CONFIDENTIAL).

UNCLASSIFIED
~~SECRET~~

~~CONFIDENTIAL~~

of instruction are available. It is frequently mentioned in documents that these artillery units emphasize its employment at night.⁴⁷

In-Country Recruit Training In Training Centers

(D) Viet Cong recruit training is conducted either by the military region, or decentralized to province and sometimes to main force units when distance and communications makes the centralized training infeasible.

- Training for the irregular forces is usually conducted at the province or district level and varies from a few days to three months depending upon local requirements.⁴⁸

(E) Recruit training is not uniform throughout South Vietnam since the Viet Cong try to base their training on the local conditions. There appear to be two methods of recruit training. One method trains the recruits in one place, and the other method requires units to move from location to location with the training getting progressively more advanced with each move.⁴⁹

Single Camp Method

(F) The single camp method is normally conducted by the military region using training facilities located in war zones. This type of training is taught by the committee system and lasts from one to three months depending upon the requirements for replacements. Training begins with a one to two week ideological orientation based on the educational level of the trainees. In this initial orientation the recruit is told the goals of the Front, the aims of the Party, the political situation and generally why he is in the Army and must fight. After this orientation the soldier

⁴⁷John F. Kennedy Center For Special Warfare (Abn), p. III-17.

⁴⁸Ibid., pp. III-8-19.

⁴⁹Ibid., pp. III-14.

receives basic military subjects of drill, cell and squad training and weapons. The recruits are moved only if the South Vietnamese forces threaten to attack or operate in the war zone.⁵⁰

County Fair Method

(U) The second method of training is similar to the "county fair" system with training conducted at successive stations. Normally the first station is an ideological orientation lasting from ten to forty-five days. The next station is weapons instruction which lasts from fifteen days to one month and the final station is live firing.⁵¹ One advantage of this method is that recruits get additional training in tactics, bivouac, and security while moving from station to station. If contact is made with the South Vietnamese army enroute, combat experience is gained. This type of training is usually found at the province level where the military situation may not be conducive to assembling a number of recruits in one place for extended periods.

Assignment

(U) After training, most of the recruits are assigned to specific cells of local or main force units. Outstanding recruits may be selected for further technical training or squad leader preparatory schools.⁵²

Military Training

(U) The average recruit, based on the documents examined, receives 206 hours of military training. Of this total, forty-nine hours is devoted

⁵⁰Ibid.

⁵¹Ibid., p. III-15.

⁵²Ibid., This specialist training would include intelligence, demolitions, medical, signal, artillery, engineers, propaganda or saboteur and assassination training.

to tactics, twelve hours at night. Training emphasizes the use of terrain, march security and tactics. The goal is to enable the trainee to apply this training as a member of a squad under normal combat conditions.⁵³

(U) Weapons training is ninety-four hours and stresses those weapons common to the unit. Classes are given on functioning, sighting and aiming, positions, care and cleaning, and firing. The goal is simple. The recruit must be able to engage targets accurately, correct stoppages, clean and maintain his weapon. Part of this ninety-four hours is devoted to range estimation, thirty-five hours to live firing. Throughout his training the use of the demonstration is emphasized.⁵⁴

(U) In addition to the above training, the recruit receives fourteen hours of bayonet training, fourteen hours on grenades, fourteen hours on camouflage and fortifications, and twenty-one hours of drill and command.⁵⁵

Political Training

(U) Political training totals twenty days. Normally seven days are devoted to the code of the Liberation Army, three days on the mission of the Viet Cong, eight days on the policies toward prisoners-of-war, and two days on military security. Two hours each day is devoted to daily news. This political training is designed to make the trainee understand why he fights, and condition him to accept orders.⁵⁶

⁵³Ibid., p. III-55.

⁵⁴Ibid., pp. III-56-61. There was no indication from the documents pertaining to training in South Vietnam of an ammunition shortage as was noted by North Vietnamese infiltrators.

⁵⁵Ibid.

⁵⁶Ibid., pp. 54-55.

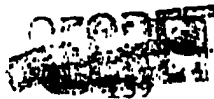

UNCLASSIFIED

In-Country Recruit Training In Units

(U) Recruit training in the main force units does not differ materially from the training conducted in the training centers. An example of the similarity was noted in a prisoner report on recruit training in the 512th Main Force Battalion located in An Giang Province. This battalion ran its own training center for recruits which was staffed by three permanent instructors and eight cooks. The center could accommodate from twenty to fifty trainees who attended a three month course consisting of both military and political subjects. These subjects were identical to those taught in the training center except for the addition of a history of the 512th battalion.⁵⁷

(U) The trainees in the 512th followed a schedule that began at:

0430-0500 Reveille and Physical Training
0500-0530 Area Police
0530-0600 Breakfast
0600-0730 Rest
0730-1130 Training
1130-1330 Break
1330-1400 Lunch
1400-1630 Training
1630-1700 Supper
1730-1800 Regimental Activities
1800-2100 Rest
2100 Bed⁵⁸

In-Country Unit Training

Responsibilities

(U) As a general rule, the training of Viet Cong regular forces is left to the discretion of the unit commanders. These commanders are free

⁵⁷U. S. Department of Defense Intelligence Information Report, 512th Mobile Battalion Organic to AN GIANG Province, and AN GIANG Provincial Organization, Report Number 6075052565, 30 July 1965, p. 27, (File Number N-16961.40, Fort Leavenworth, Kansas Library). A translation of a Viet Cong prisoner interrogation.

⁵⁸ibid.

UNCLASSIFIED



UNCLASSIFIED

to prepare their own training programs, but it is not uncommon for a high headquarters such as the military region or a province party committee to establish limits or minimum essential goals.

(U) This guidance can be in the form of a directive or a training program and may simply state the minimum number of hours the unit will devote to training. One such directive simply required units to train three hours during combat days, and seven hours a day on non-combat days. Another directive specified in more detail that units would devote twenty days (140 hours) to political training and thirty days (227 hours) to military training a year.⁵⁹

Training Programs

(U) The Viet Cong use training programs to outline specific requirements, usually on a yearly basis. One such program ordered units organic to the province to spend ten days training for the attack of enemy units outside fortifications, eight days on ambushes, three and one-half days on weapons training and one and one-half days on classes devoted to guard duty, maintenance and cleaning of weapons and regulations concerning combat readiness. All training was to be conducted with live ammunition, and would terminate with company and battalion tests.⁶⁰

Centralized Training

(U) It is not uncommon for a higher headquarters to centralize certain training. For example, a Province (Party) Committee may give

⁵⁹John F. Kennedy Center For Special Warfare (Abn), p. III-54.

⁶⁰Department of Defense Intelligence Information Report, Training Goals for 1965, pp. 5-6.



UNCLASSIFIED

~~SECRET~~
141

UNCLASSIFIED

tactical and technical training to all company cadre. They may also centralize the training of squad and platoon cadre at the battalion level.⁶¹

(U) A higher headquarters, such as province, may also set certain standards for staff members. One document required all province staffs be able to prepare overlays, fireplans and thoroughly understand the methods for the conduct of an attack of a post.⁶² When this is prescribed it is normal for the headquarters prescribing it to teach it.

(U) District staff members are usually required to know the operating procedures for local forces and battalion tactics. In almost every case, the Viet Cong require their personnel to know the duties of the next higher echelon.⁶³

Examples of Training in Main Force Units

(U) Some insight into main force unit training was gained by an examination of a document from the 512th Battalion. When not in combat this battalion required its cadre to solve basic combat problems, which were portrayed on a sand table. This training was conducted four nights a week from 1930 to 2130 hours. After this sand table training, units would be sent to areas that approximated those shown on the sand table for practical work. This practical work was usually conducted at night.⁶⁴

(U) Individual weapon firing exercises were conducted at night at ranges from 50 to 100 meters. This battalion emphasized training in

⁶¹Ibid., pp. 7-8.

⁶²Ibid.

⁶³Ibid.

⁶⁴Department of Defense Intelligence Information Report, 512th Mobile Battalion Organic to AN GIANG Province, and AN GIANG Provincial Organization, pp. 16-17.

~~SECRET~~

UNCLASSIFIED

UNCLASSIFIED

~~SECRET CONFIDENTIAL~~

fire and movement, platoon level ambushes and mobile warfare. The daily routine of this battalion when no night training was scheduled is shown below.

0430 Cooking and Reveille
0500 Pack equipment
0515 Physical training
0540 Breakfast
0600 Rest
0700 Training
0900 Care and cleaning
1400 Study period
1630 Dinner
1700 Critique period
2100 Bed⁶⁵

(U) All training was conducted at platoon and company level under the close supervision of the cadre. Subjects given to squad and lower were taught by demonstration teams from the company cadre to insure uniformity. At the conclusion of each training period company cadre conducted critiques. Cadre emphasized that "hard field training saved blood in combat." This unit had blackboards for training aids and used typed lesson plans. The training was meant to be seven and one-half hours a day or night, but it depended completely on the tactical situation and the vulnerability of the battalion in its base area.⁶⁶

(U) Another example of unit training was found in a diary, which appeared to belong to a company officer. The notes in this diary indicated that his unit's goal for the year was twenty days of military training divided as follows: ten days on tactics, eight days on weapons and two days devoted to review. Emphasis was on small unit training. The diary

⁶⁵Ibid. This schedule does not reflect the night training.

⁶⁶Department of Defense Intelligence Information Report, Viet Cong Interrogation Report, p. 23.

UNCLASSIFIED

~~SECRET CONFIDENTIAL~~

~~SECRET~~

UNCLASSIFIED

noted that this unit had accomplished one hundred twenty-eight hours of training in two weeks, which meant it had been training at least nine hours a day.⁶⁷ Weapons firing was also conducted at night and was taught by the assistant company commander and assistant platoon leaders. Weekly critiques were given based upon the results of training by squad and platoon leaders.⁶⁸

Critiques and Training Inspections

(U) Critiques and training inspections are conducted by all command echelons and play an important role in the soldier's training. Records of these inspections indicate the Viet Cong are deeply concerned at not only the quality of the instruction but the administrative preparations as well. Viet Cong inspectors comment on both favorable and unfavorable aspects of training and their comments are quite candid. Examples of favorable comments reflect such things as

the company deployed rapidly...unit cadre and soldiers were fully aware of the purpose and the significance of training...the cadre knew their jobs...instructors reviewed old lessons prior to teaching new material and this resulted in a better understanding on the part of the soldiers...⁶⁹

(U) Unfavorable comments reflect such things as lack of instructor or student enthusiasm, poor lesson plans, poor supervision, and confused practical exercises. Usually when these statements are made they are followed with a comment that the unit's ideology is poor.⁷⁰

⁶⁷U. S. Department of Defense Intelligence Information Report, Viet Cong Tactics and Signal Codes, Report Number 6075039065, 23 June 1965, p. 4, (File Number N-16961.40, Fort Leavenworth, Kansas Library). A translation of a captured Viet Cong Document.

⁶⁸Ibid., pp. 10-13.

⁶⁹Ibid., p. 22.

⁷⁰Ibid., p. 23.

~~SECRET~~

UNCLASSIFIED

~~SECRET~~
UNCLASSIFIED

Reorientation Training

(U) Reorientation of the Viet Cong military units was mentioned in Chapter Five as a leadership support. An example of this type of training was described in a document captured from the 503d company. This unit was required to undergo retraining every year around February. The training and reorientation period lasted about one month. Three province cadre taught the reorientation and three district cadre taught the training.⁷¹

(U) The reorientation portion was the most important part of the training and consisted of classes on the characteristics of the Viet Cong and their traditions, the policy of protracted war, and the requirement for soldiers to endure hardships and difficulties. Self-criticism was conducted by all members to cleanse them of faulty ideology. It is significant to note that if time was short, the training could be suspended, but not the reorientation.⁷²

Training For Irregular Units

(U) Irregular forces receive their training at the village level. Normally these courses are less than two months long and are conducted whenever time permits. These courses provide the necessary political and military training but emphasize the cell and tactics, loading and unloading the MAS 36 or other common type weapons. This training is not detailed since the degree of proficiency is not expected to be that of the main force units.⁷³

⁷¹Department of Defense Intelligence Information Report, 512th Mobile Battalion Organic to AN GIANG Province, and AN GIANG Provincial Organization, p. 1.

⁷²Ibid., p. 4.

⁷³Ibid., p. 40.

~~SECRET~~
UNCLASSIFIED

Techniques Of Instruction

Planning Instruction

(U) The Viet Cong emphasize the planning phase of instruction by outlining some definite procedures instructors must follow in the preparing of a lesson. These procedures are an estimate of what is to be taught and a review of previous material so that the instructor will have a firm background in the subject. Instructors should approach the subject by starting with the easiest and progressing to the more difficult. Instruction should emphasize student participation and be based on the premise of "talk little and work much."⁷⁴

(U) The instructor is cautioned to check his training areas in advance, estimate the feasibility of training aids, and rehearse his assistant instructors. If he is teaching marksmanship, life-sized targets should be used.⁷⁵

The Lesson Plan

(U) The Viet Cong stress the need for a lesson plan because training time is limited and must not be wasted. Instructors are told that in order to properly prepare a lesson plan, he must first understand the Party's absolute leadership in the training field. Once this is firmly in mind, he may commence a careful study of the subject in order to best decide how to present it to the students.⁷⁶

⁷⁴Department of Defense Intelligence Information Report, Training Goals for 1965, p. 5.

⁷⁵John F. Kennedy Center For Special Warfare (Abn), p. III-58.

⁷⁶U. S. Department of Defense Intelligence Information Report, Method of Preparing A Lesson Plan, Report Number 607503365, 11 June 1965, p. 1, (File Number N-16961.40, Fort Leavenworth, Kansas Library). A translation of a captured Viet Cong Document.

(U) The lesson plan must be based on the training directives and plans issued by the higher headquarters. It must show the purpose of the lesson, the requirements for the students, and the methods for presenting it if prescribed in Party directives. The lesson plan must also include considerations of time, weather, site selection and training aids. Lesson plans are approved by the Party Chapter Committee or the Command Committee responsible for the conduct of the training.⁷⁷

(U) There are at least two acceptable forms for the lesson plan that are mentioned in Viet Cong documents. The most common form is shown below, and should give some insight on the aspects of training the Viet Cong emphasize. These lesson plans are typed, whenever possible.

LESSON PLAN

- I. PROCEDURES:
 - Troop assembly, weapons and equipment inspection.
 - Expression of wishes for good health.
 - Submission of report to higher echelon (if available).
- II. DECLARATION OF THE START OF CLASS:
 - Objective: To make known the requirements of the training subject, action, ideology and attitudes of the students.
- III. TRAINING CONTENTS:

Include various training subjects, (in order), total time, the account of time used for the movement, for breaks and training.

 - The training method used.
 - The training site, direction of land marks, and reporting of training aids available.
 - Review of a number of points relating to the next training subject if available.
- IV. CONDUCT OF TRAINING:
 - Quick conference on notions (of the training subject).
 - Quick demonstration and explanation (demonstrate and explain at the same time).
 - Repetition by the entire class.

⁷⁷Ibid., p. 2.

V. ASSIGNMENT OF TRAINING MISSIONS:

Distribute lesson plans to units, indicate training methods and assign cadre to make corrections.

VI. OBSERVATIONS ON THE TRAINING:

Results, morale, attitude, strong and weak points etc, names of those needing more training.⁷⁸

Conduct of Instruction

(U) In the conduct of instruction, the Viet Cong use the conference lecture and demonstration with practical work. Student participation is stressed and instructors are advised to select the brighter students and give them responsibilities in the lessons. Normally the instructor first explains the lesson in a conference, always starting first with the simple points and working up to the more difficult. If possible, a review is conducted of previous training in order to get all the students properly motivated and in the correct frame of mind.⁷⁹

(U) If the training is on weapons, the instructor must have a blackboard and a pointer. If possible, assistant instructors should be present to assist the students. All training is geared at a slow pace, and the most emphasis is placed on the practical exercise.

(U) If practical exercises involve field training, instructors are told to maintain unit integrity and use the existing cadre of the unit as assistants. These assistant cadre are also responsible to make evaluations on the progress of the students, and make on-the-spot corrections of any deficiencies noted.

Evaluation

It appears that the Viet Cong recognize the relationship of training to combat as evidenced by their emphasis on the commander's role

⁷⁸Ibid., p. 3.

⁷⁹Department of Defense Intelligence Information Report, Method of Preparing A Lesson Plan, p. 5.

UNCLASSIFIED

~~CONFIDENTIAL~~ CONFIDENTIAL

148

in training and their well organized system of control, designed to make training realistic. The emphasis on the functional aspects of training, basing it on local conditions, enables commanders to make maximum use of their training time. Further emphasis on functional training is noted by the offensive doctrine and the lack of emphasis on defense, which the Viet Cong have chosen to disregard in the current stage of the protracted war. Instead the Viet Cong concentrate on offensive actions, such as the ambush, that will give them the best results for the effort.

(U) There is no doubt that the availability of training facilities in North Vietnam constitute an advantage for the Viet Cong in fulfilling their needs for specialist training, and replacement cadre, but the overall value of this base does not seem to produce better qualified personnel except in the technical fields. As long as the in-country training facilities are subjected to interdiction though, the Viet Cong will continue to be dependent on the North for support.

(U) The strongest aspect of Viet Cong training is their ability to produce a system of inspections and critiques that make the system work. Training is accomplished because the high command is willing to see that it is done, and make corrections where necessary. By providing guidance, and supervising the training programs of units, the Viet Cong have succeeded in motivating their leaders to make their system of training work.

(U) The apparent lack of defensive doctrine could be considered a weakness, if and when the Viet Cong decide to escalate the nature of the insurgency, but at the present time, as long as they are able to fight their war of movement, the amount of training they give their soldiers in this field seems to be adequate.

UNCLASSIFIED

(U) The lack of uniformity in recruit training, or unit training for that matter, does not allow the Viet Cong to readily transfer units of

~~CONFIDENTIAL~~ CONFIDENTIAL

UNCLASSIFIED

~~SECRET~~ ~~CONFIDENTIAL~~

149

individuals throughout the country, but it appears that due to the present level of the conflict, the leaders are willing to live with this limitation.

7) In the final analysis, the Viet Cong training system is effective. It has been able to handle the amount of recruits necessary to maintain unit strengths and has provided trained motivated soldiers that have thus far been able to secure objectives desired by the Party. As one source noted, the key to curtailing Viet Cong training is the denial of training sites. The problem is not to speculate on how well trained the Viet Cong are, or look for holes in their methods, but to keep them from getting better.⁸⁰

⁸⁰John F. Kennedy Center For Special Warfare (Abn), p. III-19.

~~CONFIDENTIAL~~
~~CONFIDENTIAL~~

~~SECRET~~

UNCLASSIFIED

~~SECRET~~

UNCLASSIFIED

CHAPTER VII

TACTICAL APPLICATION OF VIET CONG DOCTRINE

(U) The purpose of this chapter is to analyze Viet Cong operations to determine the extent to which they conform to the doctrine expressed in the previous chapters. Three examples have been selected from the information available as being representative of normal Viet Cong operations.

(U) A raid is the first example selected. This was selected since it emphasizes Viet Cong attack doctrine as well as intelligence and coordination. It also is a common tactic, used by the Viet Cong, to counter the "Strategic Hamlet" Program. The objective is the destruction of supervisory personnel for a hamlet usually located in an area where they feel secure. This feeling of security makes them vulnerable to raid, by Viet Cong standards. This raid keynotes the use of small units, one of the Viet Cong strengths.

(U) The ambush of a 3/4 ton truck was selected for the same reason. It characterizes small unit employment against relatively weak targets as a means of arms resupply.

(U) The last example, the battle of Ap Bac, embodies both the principles of attack and defense and at the same time accents the courage of the Viet Cong soldier in a pitched battle against superior forces. It further confirms the conclusion noted in Chapter Six that the Viet Cong rely on audacity and offensive spirit to equalize their lack of firepower.

~~SECRET~~

UNCLASSIFIED

(U) Lastly, Ap Bac is a key battle in Viet Cong history. This battle showed that the Viet Cong could successfully defeat government sweep operations, and fight a limited set piece battle. Ap Bac illustrates those principles of organization, training and leadership necessary to complete the picture of the Viet Cong soldier in combat.

The Raid¹

At 2300 hours on 21 September 1962, the Viet Cong raided supervisors responsible for the construction of a strategic hamlet in An Binh Tay village. The mission of the raid was to destroy the supervisory unit, seize their weapons and delay the construction of the strategic hamlet program by killing the leaders.

The Setting

The supervisory team, for the construction of hamlets located in An Binh Tay village, was composed of approximately thirty military personnel plus some civic action, Republican Youth, and Para-military women. The team was commanded by a second lieutenant and a police cadreman. They lived in the old village house compound located in the center of the village about 300 meters from a main road. They were armed with two Thompson sub-machineguns, seven carbines, two pistols and about nineteen MAS 36 rifles. This unit was secured by its own patrols and by its close proximity to South Vietnamese regular and civil guard troops. A short distance east of the village was one regular rifle company of the South Vietnamese Army.²

¹Letter, Headquarters, United States Military Assistance Command, Vietnam, 29 January 1963, Subject: "Letter of Transmittal" pp. 1-11, (File Number C-18745.29D, Fort Leavenworth, Kansas Library). (CONFIDENTIAL). This is an after action report made by the Viet Cong concerning a raid on An Binh Tay Village, 21 September 1962, and furnished the material used in this chapter.

²The exact distance was not noted in the report, but this unit was close enough to cause the Viet Cong to place one group to block their approach, as will be noted later.

Two Civil Guard Companies were 1000 meters west of the village, and another company was located to the south.

Viet Cong intelligence reported that the personnel in the village house felt secure due to the proximity of military forces, consequently they were lax in their security at night and employed only the minimum number of guards.

Preparations For The Raid

Based on this lack of security, the Viet Cong targeted this area as a possible objective for a raid. They felt that if a secure area was successfully attacked and destroyed, the confidence in the South Vietnamese government would be shaken. Late in the summer of 1962, one intelligence unit of the 580th district company reinforced with additional province intelligence units received the mission of analyzing this target area for a raid. Based upon the reports of these intelligence units, the following data was assembled and studied by the Province Military Affairs Committee.

Intelligence Data.--The objective was a village house located in the center of a compound approximately thirty meters square. Within the compound was the three-room village house and five meters behind it an eight-room reception house. There were three entrances into the village house; front, back, and east. The wall around the house was 1.8 meters high and 20 centimeters thick. On the west side of the house there were plants .8 meters high in rows 50 meters long. On the north, twenty meters from the house was the strategic hamlet wall, 2 meters thick at the base, and 1.5 meters high. Potatoes and weeds covered the area from the wall to the house on the north.

One squad of men was billeted in the reception house. Only the front gate and a balcony, where sentries sometimes shone flashlights into

UNCLASSIFIED

the yard, were guarded. At night one squad was assigned to two static guard posts in front and behind the village house. Two kerosene lamps were hung at night on opposite corners of the house. No patrols of any kind were conducted outside the compound. The sentries were lax in their duties. The terrain facilitates a raid in conjunction with surprise, if the assault forces crawl into the objective area.

Plan of Attack

Based upon this intelligence, the Province Committee decided upon a night attack utilizing combined infantry forces of two reinforced squads from the provincial local company for the assault and blocking with all available local guerrillas.

The assault forces were divided into six groups. The first group consisted of three to four men, armed with one automatic rifle, two carbines and three grenades. They set up an ambush on the east side of the compound, blocking the major avenue of approach from the east, where the regular rifle company was located, and provided close covering fire for the eastern assault groups. The second group, three men armed with Thompson sub-machineguns, would assault the front door and clean out the porch. The third group armed also with three Thompson sub-machineguns would assault the west side of the house. The fourth group, armed with machetes, followed the third group on the west, prepared to engage in hand-to-hand combat. The fifth group, with two sub-machineguns, two carbines, one automatic rifle, and three concussion grenades, supported the assault by fire and pinned down any enemy at the three entrances to the house. On order they seized and secured the front yard and provided security for the other assault elements as they mopped up the compound. The sixth group, composed of guerrillas, was held outside the compound

UNCLASSIFIED

~~CONFIDENTIAL~~

154

UNCLASSIFIED

in reserve. Their primary mission was to evacuate wounded and captured material. An element of the Province Party Committee controlled the operation from a position located about 1500 meters from the objective.

Irregular forces, divided into seven groups, were disposed along the approaches into the village and covered the east, west and south routes. They had homemade mines, mortars and some rifles with which to delay reinforcements.

The committee stated that if the force was observed by the South Vietnamese prior to reaching the front gate of the compound, the attack would abort.

Based upon this plan, the Military Affairs Committee ordered that all participating personnel would rehearse the operation twice a day on a sand table model, under the supervision of the Command Committee. Prior to departure, the province political cadre held a departure ceremony and all troops executed an oath before the Party Chapter promising to give their utmost in the operation.

The time of departure from the base area, fifteen kilometers from the objective, was set for 1500 hours 21 September so that the units would arrive at their assault positions by 2300 hours.

Conduct of the Raid

At 1500 hours the force departed the base area as scheduled and moved on multiple routes. Rain provided additional security for the move. After encountering some problems with the sampan transportation, the force arrived at the prescribed location, 1500 meters from the objective where it was met by local guerrillas and given a final intelligence briefing. The units conducted final checks and moved to their assault positions. At 2300 the first three assault groups began crawling

~~CONFIDENTIAL~~

UNCLASSIFIED

UNCLASSIFIED

toward the compound. Five meters from the compound guard post at the front gate, a guard flashed a light in their direction and all units opened fire and began the assault.

Since the gate was closed, the assault groups could not enter, so they began firing from the walls. Three unsuccessful attempts were made to climb them. The fire by the defenders was intense and two men were wounded. On the fourth attempt, the assault group cleared the walls, using grenades and automatic weapons fire and entered the compound. Seven minutes had elapsed and the assault was going badly. The commander, realizing time was important, ordered the fifth group to cease its support role and join in the assault. This added force was enough, and the house was rapidly seized and secured. The commander allowed eight minutes for the area to be policed of all material, and the force withdrew as scheduled, without incident.

The results of the raid were fifteen South Vietnamese soldiers killed, including the commander, nine soldiers wounded and five personnel captured, including the wife of the commander.³ The prisoners were indoctrinated on the spot and released. Captured equipment included one carbine, seven MAS 36 rifles, one grenade, 360 rounds of ammunition, one explosive detonator, two radio receivers, one electrical equipment tester and many documents.

Viet Cong casualties were two men wounded, 1,320 rounds of ammunition and eight grenades expended.

³These personnel captured included one male civilian cadre and three female para-military women in addition to the wife of the commander.

UNCLASSIFIED

(S) Evaluation of the Raid

An analysis of this raid points out that its success was due primarily to the inability of the South Vietnamese to react rapidly to the attack, rather than the validity of the plan. This fact was recognized by the Viet Cong, in their critique conducted immediately after the battle. This raid does, however, point out some of the doctrine that was mentioned previously in this thesis.

Organization.--The composition of the forces for this raid required an integration of both regular forces and irregular forces. This seemed to pose no real problems, and illustrated the ability of a province and district to efficiently control and organize this type of an operation.

Intelligence units from the province were able to provide sound intelligence on the objective, and correctly analyzed the South Vietnamese troop dispositions and reactions. The one major error in intelligence was noted by the Viet Cong in their critique. The intelligence underestimated the ability of the South Vietnamese to defend, and did not correctly analyze the problem of getting the force through the gate.

The Party.--This raid emphasized strict Party control. From the outset in the planning phase, Party resources from the Military Affairs Committee of the Province were utilized. The Party required a departure ceremony and oath taking in order to inspire the soldiers to accomplish their mission.

Training.--It appears that the Viet Cong followed their criteria for a raid to the letter. As was noted in Chapter Six, raids are aimed at enemy rear areas, where he feels secure and, based on the South

~~CONFIDENTIAL~~

157

UNCLASSIFIED

Vietnamese troop dispositions, this area appeared to be secure. This was facilitated by the laxness of the South Vietnamese supervisors in the compound.

The Viet Cong adhered to a pattern of thorough briefing, the use of a sand table mock-up and rehearsals in order to thoroughly familiarize personnel with their duties. This technique was noted in Chapter Six as frequently used in main force units. Even with this rehearsal, though, problems developed in the plan. As the Viet Cong noted themselves, this operation almost failed due to the defense by the South Vietnamese and the fact they could not penetrate the gate. They noted that they had erred in not taking this into consideration and providing mines or demolitions for the attacking force so the gate could be blasted open once it was shut. They recognized the disadvantage of assaulting over the wall.

On the plus side of the training, the commander was able to rapidly change the mission of the fifth group from support to assault which was a key in taking the objective. While there is no evidence to substantiate that this change of mission was recognized in the rehearsal, it is reasonable to assume that some thought was given to this contingency, since the unit rapidly assumed a different role.

Leadership.--The attacking unit appears to have been well led. As the Viet Cong favorably noted in their critique, the cadre and soldiers were aggressive. The commander on the ground was able to make sound decisions and rapidly transmit them to the soldiers. True to their leadership doctrine, a critique was held immediately after the raid, and the battle analyzed. Based on this analysis, Groups two, three and four were selected as the outstanding elements of the attack, and were mentioned in

~~CONFIDENTIAL~~

UNCLASSIFIED

the written critique, emphasizing the use of battle analysis and the selection of outstanding members immediately after a battle as a leadership support.

The Ambush⁴

(S) In 1961, in support of the Strategic Hamlet program, two South Vietnamese Army posts were established west of Ben Cat, in Binh Duong province, along provincial road 14 which is on the fringe of a Viet Cong controlled area known as the "iron triangle." One post was established at Rach Bap and contained one Cao Dai intelligence platoon, and the other post was built at Ban Xinh four kilometers down the road. The post at Ban Xinh contained one engineer platoon and two ranger platoons. In order to resupply the post of Ban Xinh, one squad of soldiers rode to the market at Ben Cat every Sunday. These posts interfered with the lines of communication between Viet Cong units, so the decision was made to commence a program to eliminate them.

In line with this objective, the Ben Cat District Committee announced that an ambush would be conducted against the market truck, with the mission of destroying the squad accompanying it, seizing their weapons and demonstrating by this act the inability of the South Vietnamese government to protect the people.

(S) Intelligence Requirements

Based on the mission, the Viet Cong began their intelligence collection. This intelligence was very important, since the only unit

⁴U. S. Department of the Army Intelligence Report, Republic of Vietnam Armed Forces Article on Viet Cong Ambush Tactics (U), A translation of Republic of Vietnam Armed Forces publication "Know Your Enemy," Number 11, Report Number 2197833, 28 March 1962, pp. 13, 38, (File Number C-18745.17-B, Fort Leavenworth, Kansas Library). (CONFIDENTIAL). This document contains the Viet Cong after action report of the ambush and some comments by the South Vietnamese Army.

~~CONFIDENTIAL~~ UNCLASSIFIED

available for the attack was C61, the district local company, and it had been defeated three times recently in engagements with South Vietnamese forces. This company suffered from low morale, and the people were beginning to doubt its ability to function.

One intelligence and liaison cell from C61 was ordered to study the enemy for fifteen days, beginning in January, 1961. Based upon this study, the following points were observed by the district committee.

The Cao Dai intelligence unit at Rach Bap was armed with one automatic rifle, one sub-machine gun and rifles. The unit at Ban Xinh had six automatic rifles, two mortars and rifles and carbines.

The best ambush site would be on highway 14, nine kilometers from Ben Cat, and between the Ban Xinh and Rach Bap post, since the truck would be slowed down due to the bad road. At this point the jungle was 500 meters deep and close to both sides of the road. This would facilitate immediate withdrawal. It would take the government unit at Ben Cat thirty minutes to reinforce this ambush. Rach Bap or Ban Xinh could reinforce in five minutes. The biggest problem noted by the intelligence unit was that the soldiers in the truck, frequently fired on both sides of the road as the truck moved, so there was a danger the ambush might be discovered prematurely. This would have to be considered by the committee. The soldiers were evaluated as afraid of the Viet Cong, and committed to their posts. All patrolling was conducted close to the posts, and was ineffective. Generally the troops in the truck were passive and believed the area secure.⁵

⁵While the troops did fire at the sides of the road when they moved, this fire was noted by the Viet Cong as dangerous only to the extent that Viet Cong soldiers might fire back and prematurely trigger the ambush. It did not mean that the soldiers were alert.

~~CONFIDENTIAL~~

UNCLASSIFIED

~~CONFIDENTIAL~~

160

UNCLASSIFIED

~~(C)~~ Plan of the Ambush

Based on the intelligence information, the District Command Committee made their plans. The ambush would abort only if the truck was escorted by foot elements, or if more than one truck went to market. The Command Committee allocated a reinforced platoon from C61 consisting of five squads armed with twelve automatic rifles, three carbines, three machine guns, and some rifles, swords, and axes.

These units were divided into a main body and a flank security force. The main body was further sub-divided into a firepower (support) squad of thirteen men, a strike force of sixteen men, and a ten man assault squad. One cell of the assault squad would detonate a six kilo mine under the truck.

A flank security force consisting of one nine-man squad would block forces from the Ban Xinh post and one section of six men block the Rach Bap post. These forces had to hold South Vietnamese reinforcements for fifteen minutes.

The command group for the ambush consisted of the platoon political officer and one assistant platoon leader.⁶ The assault squad leader would give the signal for the mine to detonate and to insure compliance, he delegated three men for this mission.

The concept for the ambush was that as the mine exploded, the firepower squad would open fire. Then the strike squad would move up to the area and in conjunction with the assault squad, overrun the truck, with the strike squad destroying the personnel attempting to flee the ambush,

⁶No mention is made of the platoon leader in this critique. It is possible that he had been either wounded or relieved, based on the previous battle failures. In any case, this ambush was commanded by Party personnel.

~~CONFIDENTIAL~~

UNCLASSIFIED

and the assault squad destroying the truck and capturing weapons. The units would withdraw on order, using two routes. A first aid cell would accompany each squad.

Based upon this plan, refresher training was held for the unit. Ten days was devoted to squad training, after which the entire reinforced platoon practiced the ambush for an additional ten days. In addition to this tactical training, intensive political training was given the unit.

Conduct of the Ambush

The first attempt at the ambush aborted when the mine failed to detonate. The troops returned to their base area, and a new date of 5 February was decided upon.⁷

By 0500 hours on 5 February, the Viet Cong ambush was ready. This time the ambush was almost aborted again, when a civilian bus had a flat tire forty meters from the mine, but the platoon political officer ordered no change in the schedule.

At 0645 hours the truck containing one squad of government troops reached the mine, which was detonated. The detonation was not strong enough to overturn the truck and it skidded to the left of the road toward the assault group. Eight or nine government soldiers were thrown into the assault group and quickly killed. The entire ambush was over in eight minutes.

When it heard the shooting, one section of government troops moved from Ban Xinh to reinforce the ambushed force but it was stopped by three rifle grenades fired by the Viet Cong flank security element. No

⁷Sometime after this first attempt, there was a security leak. One of the Viet Cong soldiers told the wife of the Ban Xinh post commander of the first attempt. There seems to be no explanation why the ambush was re-scheduled as planned unless the Viet Cong found out about this leak from one of the prisoners. This will be discussed during the portion on evaluation.

~~CONFIDENTIAL~~

162

UNCLASSIFIED

reinforcement came from the Rach Bap post. All elements withdrew as scheduled.

The results of this ambush were, according to government sources, eleven killed, eight captured and five missing. The Viet Cong only claimed that eighteen soldiers were in the truck.⁸ The Viet Cong captured five carbines, six automatic rifles, 347 rounds of carbine ammunition, 472 rounds of automatic rifle ammunition, eleven smoke pots, 1 dagger, ten hats, three watches, one fountain pen and 1,446 piastres in addition to uniforms. The money was distributed to each of the Viet Cong villages. Viet Cong casualties were one man slightly wounded by the mine shrapnel. They expended 269 rounds of small arms ammunition, three rifle grenades and one mine. Leaflets and letters were left at the ambush and flank security site, pointing out to the other government troops that this was only a sample of what was to come if they did not leave the area.

Evaluation

A critique immediately followed this operation. A written copy of this critique was captured by South Vietnamese forces who noted in their analysis of this operation, that the Viet Cong did not provide sufficient security forces, and if the South Vietnamese had reinforced in strength, the ambush would have been destroyed. This fact points out the Viet Cong's complete understanding of reaction force procedures. They knew the typical reaction of the South Vietnamese and took a calculated risk that their security forces would be adequate. This idea of the calculated risk will be noted throughout their operations when their intelligence on enemy possible reactions is firm.

⁸A question arises as to the exact number in the truck. Both the Viet Cong and the South Vietnamese differ as to the exact amount. According to the report only one squad was supposed to go. The author has personally observed the Vietnamese fill these trucks over their capacity many times, with soldiers going on pass. This may have been the case here.

~~CONFIDENTIAL~~

UNCLASSIFIED

~~CONFIDENTIAL~~

163

UNCLASSIFIED

Organization.--This ambush, again, illustrates the ability of the Viet Cong to take a small unit from their existing organization, reinforce it and control it at district level. A deviation from their normal operating procedure placed a platoon political officer in command. No mention was made in the report of the platoon leader. Since the Party played an important role in this operation and it is possible that the political side overruled the military since success was important.

The Party.--It appears that from the significant role of the Party in this operation, its influence was used to insure the success in order to help restore the confidence of the people in the cause of the Viet Cong. Thus the Party was ordered to build up the morale of C61 by a political movement, based on the slogan "be determined to fight and be determined to win."

This movement was conducted by Party civilian cadre from six local hamlets, in order to make the soldiers aware of civilian support. Before the unit deployed, a two day training course was given to the commune Party cadre by province. This course stressed the proper attitude for a victorious soldier, the motto for annihilation of the enemy, why they fight, esprit-de-corps in combat, and the glory of the revolutionary soldier.

After this initial training period, the Party conducted the military training on the methods and purposes of the attack, and the policy toward prisoners-of-war.

The significance here is that the Party took complete charge of the operation in order to insure its success. In this respect the control of the Party was evidenced by its teaching of military training and the fact that a political officer was placed in command of the operation. Thus the firm Party control discussed in Chapter Three was evident.

~~CONFIDENTIAL~~

UNCLASSIFIED

~~CONFIDENTIAL~~

UNCLASSIFIED

164

Training.--Just as in the instance of the raid, the Viet Cong were able to devote specific training for this operation since they determined the time and place for the battle. The objective of the ambush followed their doctrine as mentioned in Chapter Six, to destroy an enemy, and provide resupply for their units. This ambush emphasized their reliance on small unit tactics.

The ambush was laid according to plan, and executed in eight minutes. This indicated that the training of the soldiers was effective. Based on the critique by the Viet Cong after the operation, the major training errors noted were a lack of accurate fire, and the fact that silence was not observed during withdrawal. If this latter was true, it was probably due to the exuberance of the soldiers at having achieved their first victory in quite some time. The Viet Cong did note that one of their strengths was the accurate use of terrain and the emplacement of weapons. They also discussed that in future ambushes, if a truck is to be overturned, a larger mine is needed.

Leadership.--In this case, as was noted in the raid, an immediate battle analysis was conducted after the operation. Based upon this analysis three cell leaders, one intelligence squad leader and one of his soldiers were selected as the outstanding participants of the ambush. Their reward was immediate Party membership. This leadership support, also noted in the raid, is one frequently used by the Viet Cong. From it they gain a strong leadership advantage by immediately recognizing outstanding service. This type of recognition may tend to inspire the other soldiers. Since this recognition is usually made by the cell, and then confirmed by the squad and platoon, it helps foster the group integrity needed in order to have the guerrilla unit survive in times of hardship.

UNCLASSIFIED

~~CONFIDENTIAL~~

Additional insight into leadership techniques was noted from the actions taken after the first ambush aborted. The soldiers were all told by the cadre why they did not attack. This helped reinforce the idea that the Viet Cong conserve their manpower by attacking only when the situation is right, an obvious leadership support for the men.

The recurring problem of security still plagued this unit. After this initial abort, one of the soldiers leaked this information to the wife of the post commander at Ban Xinh, evidently telling her how lucky she was to still have her husband. As was noted in Chapter Five, this problem of security is a real one to the Viet Cong, and no matter how they try to solve it, the problem does not seem to disappear. One of their major leadership weaknesses is their inability to impress upon their soldiers the need for security.

The Battle At Ap Bac⁹

Situation

The village of Ap Bac is situated in western Dinh Tuong Province about fifteen miles from the province capital of My Tho on the edge of the "Plain of Reeds." Ap Bac is a strong guerrilla village surrounded by rice fields interlaced with small man-made canals, which restrict the movement of vehicles and boats. Most of these rice fields are muddy and flooded during the year. Swamp areas are located north and east of the village. At one time, the villagers had constructed spike traps and fences on the approaches into the village, but these had been rendered

⁹Letter, Headquarters, United States Military Assistance Command, Vietnam, 20 April 1963, Subject "Letter of Transmittal," pp. 1-37, (File Number C-18745.29-E, Fort Leavenworth, Kansas Library). (CONFIDENTIAL). An english translation of a captured Viet Cong after action report on the battle at Ap Bac. This is the primary source for this section and all material found here is from this document except where indicated by additional footnotes.

~~CONFIDENTIAL~~

106

ineffective due to the rainy season. David Halberstam quoted one U. S. advisor as saying, "you can get into a fight any time you want to up there." The villages in this area had prepared foxholes and most houses had bomb shelters.¹⁰

Late in December 1962, intelligence sources reported that a Viet Cong company had moved into this area. On 28 December, these same sources placed an enemy battalion, the 514, in the village of Ap Bac.¹¹

Based upon this intelligence, the South Vietnamese scheduled an operation for the 2nd of January 1963. This operation would involve a large number of forces to encircle the Viet Cong in three directions, resembling an open claw, with other forces available to attack and destroy the enemy once the encirclement was in place. The details of the plan were for a battalion of the 11th Regiment of the South Vietnamese 7th Division to land by helicopter on the north of the village, while two battalion task forces of Civil Guard troops blocked from the South. One company of M113's would block on the west, and a reserve force was provided to land anywhere in the battle area. The east was deliberately left open in the hopes that the Viet Cong would attempt to withdraw through this area, in which case artillery, air and the reserve force could be employed to destroy them.¹²

The exact reason for the Viet Cong force being in Ap Bac is not clear. From their captured after action report, it has been confirmed

¹⁰David Halberstam, The Making of a Quagmire (New York: Random House, 1965), p. 146.

¹¹Ibid.

¹²Ibid., p. 148.

~~CONFIDENTIAL~~

UNCLASSIFIED

that only 1st Company of the 514th Battalion and 1st Company of the 261st Battalion were there in addition to the:

- 13th Support Unit (one machinegun and one 60mm mortar).
- 2 Squads of 5th Company, 261st Battalion.
- 1 Platoon, Chau Than District.
- 30 Hamlet guerrillas from Ap Bac area.
- 1 Platoon Province Base Security.
- 2 Cells Base Guerrillas for operations on the river.

This force was commanded by a provisional battalion commander, named Duyen, who stated that he had received information that the attack was coming at 1900 hours the day before. According to his report, a decision was made to stand and fight, at least initially, in order to attempt to counter this type of government sweep operation. Halberstam gives another concept, in that he portrays the Viet Cong as initially attempting to get away, based on the fact that attacking units encountered fierce fire fights in their initial movement to contact. He felt the Viet Cong only took up their positions in the tree line when they found escape impossible.¹³

At first glance, it would seem that Halberstam's analysis is correct, since this is the most common Viet Cong tactic; however, according to the Viet Cong critique, they deployed local intelligence units forward beginning at 0200 hours the morning of January 2nd to give the forces in Ap Bac early warning. These intelligence forces had the mission of delaying the South Vietnamese forces in order to allow the Viet Cong regular forces to occupy their positions. Since these intelligence units were used, and did observe that the eastern end was left open, long before the encircling forces were in position, it would appear that the

¹³Ibid., p. 149.

UNCLASSIFIED

Viet Cong were planning to stay and fight. It is possible that those fierce encounters reported by Halberstam were these intelligence forces executing the delay.

In the event of an attack, Duyen, the provisional Viet Cong battalion commander ordered his troops disposed as follows: They would defend a tree line east of the hamlet, with the positions facing west. The 1st Company, 261 Battalion (261st) would be on the left, the 1st Company 514th (514th) on the right, and the south flank of the 261st would be protected by the regional platoon of Chau Thanh District. These positions had inter-connecting trenches and were well camouflaged. Excellent and devastating grazing fire could be brought to bear on all approaches into Ap Bac.

Intelligence units were attached to the companies. Both the 261st and the 514th controlled three intelligence cells. These cells were outposted at the farthese limits of the hamlet and had long range observation over all approaches. As it turned out, many of these cells occupied the line of departure of the South Vietnamese troops.

Four attack plans had been prepared, and according to Duyen, rehearsed for this operation.¹⁴ It would appear from the success of these plans when later employed, that this was true. The plan for countering heliborne operations was for each company to have anti-aircraft cells in position to cover the likely landing zones. These companies would be responsible for attacking heliborne forces on their own

¹⁴These attack plans appear to be more like counter-attack plans. It appears the Viet Cong actually planned to attack the flank of the South Vietnamese as soon as contact was made and the situation developed. Chapter Six noted the emphasis placed on the offense by the Viet Cong. Even though this situation appears to be a defense, the Viet Cong viewed it as an offense.

UNCLASSIFIED

~~CONFIDENTIAL~~

169

UNCLASSIFIED

initiative. Anti-aircraft positions had been previously dug, at the same time the fortifications had been prepared, probably by the local villagers. According to Duyen, all positions had been reconnoitered by 2200 hours the night of 1 January, and all units were prepared to occupy them.

(C) Conduct of the Battle

The South Vietnamese plan began as scheduled. By 0600 hours, 2 January the encircling forces were in position. At 0400 the battle started for the Viet Cong when their intelligence units reported the South Vietnamese troop movements. The alert was sounded, and all positions were occupied by 0500 hours. At 0600 hours, an intensive artillery preparation began.

The first attack by the South Vietnamese followed this preparation and an estimated two Civil Guard companies attacked into the sector of the 3rd platoon, 261st. The Viet Cong held their fire until the enemy was within thirty meters and then fired from concealed positions. This first fifteen minute fight broke up the attack with forty South Vietnamese casualties. This engagement was followed by an immediate counter-attack by the Viet Cong regional platoon, which broke up the remainder of the South Vietnamese attacking units.¹⁵

Probes by the South Vietnamese into the 261st positions continued until 0900 hours. All were repulsed. During this period, 261st company executed two successful attacks on the South Vietnamese flank. These attacks were led by the assistant company political officer.

¹⁵Wilfred G. Burchett, VIETNAM: Inside Story of the Guerrilla War (New York: International Publishers Company, Inc., 1965), p. 86. Also noted in Letter, Military Assistance Command, 20 April 1963, p. 11.

~~CONFIDENTIAL~~

UNCLASSIFIED

~~CONFIDENTIAL~~
1/6

UNCLASSIFIED

Around 0900 hours, the South Vietnamese committed a reserve force by helicopter to land in the rear of the 261st. Fifteen helicopters flew over the Viet Cong positions and the first three landed safely due to confusion on the part of the Viet Cong as to when to open fire. The last three were hit, and downed. The rest of the helicopters aborted. The heliborne troops were immediately pinned down by the Viet Cong fire. This caused a temporary lull in the battle, and the battalion ordered the news of the damaged helicopters relayed to all soldiers, and for officers to visit the wounded. By this time there were four wounded.

After the failure of the heliborne operation, the South Vietnamese attacked with four infantry companies in an attempt to hit the 261st from the rear and envelope them from the north. This attack came into the area of the 514th which as yet was undiscovered and unengaged. As the attack materialized the 514th was ordered to deploy reconnaissance personnel on the north flank and be prepared to shift and meet the attack. The 514th deployed four cells to cover its rear and pulled one squad from its 2nd platoon as a reserve. The attack advanced and the Viet Cong held their fire until the South Vietnamese were within twenty meters of the position. The initial burst of fire broke up the attack. Then the Viet Cong commander of the 514th ordered one cell (approximately four men) to hold the forward position where as yet no contact had been made, and counterattacked the retreating South Vietnamese with the rest of the company. Casualties were estimated at one South Vietnamese platoon destroyed, and all their weapons were captured.

These failures, plus the requirement for securing the downed helicopters led to the commitment of the M113's. At this time, the situation in the 261 area had become critical due to the heavy fighting and

~~CONFIDENTIAL~~

UNCLASSIFIED

UNCLASSIFIED

171

they had been ordered to tighten up and consolidate their position. The attack by the M113's was launched at 1200 hours in the area of the 261st. This company deployed one squad armed with grenades, to destroy the carriers, and two were damaged. Repeated attacks were broken up as the M113's were caught in machinegun cross fire, which supported the assaults of Viet Cong grenadiers, and resulted in six vehicles damaged and their personnel killed.

The final phase of the battle was the commitment of an airborne battalion by parachute. This assault came at about 1600 hours. The troopers landed in the middle of the 514th who fired on them as they were in the air and landing, causing heavy casualties. According to Duyen, the battle was over at 1700 hours.

76. The Withdrawal

After the airborne attack was defeated, Duyen made a new estimate. In spite of the successes, he felt the situation for the next day was too vague. He had no way of knowing what additional reinforcements would come or what their employment might be. His troops had fought well, but they were tired, low on ammunition and supplies. Based on these factors, he ordered a withdrawal to commence at 2200 hours.

The withdrawal order was simple. One reconnaissance cell of the 514th scouted the South Vietnamese positions and found an open route. Boats were secretly brought up the canals into the position left open by the South Vietnamese. The 514th left one platoon in contact, as did the 261st, and the withdrawal began on schedule. It was completed without problems, and all units were in their base camps by 0700 the next morning.

UNCLASSIFIED

UNCLASSIFIED

Results of the Battle

The results of the battle are still not confirmed. Based on the captured Viet Cong afteraction report, and figures supplied by the South Vietnamese, the U. S. Military Assistance Command recorded the following figures:

Viet Cong Figures		South Vietnamese Figures
Enemy KIA	370	101
Enemy WIA		Unknown
Friendly KIA	18	68
Friendly WIA	39	100
U. S. KIA	10	3
U. S. WIA	9	10
Prisoners	0	36

Evaluation

The significant features of this battle are the employment of the Viet Cong units, based on the factors of organization, Party control, training and leadership.

Organization.--The Viet Cong, in their critique held on the 3rd of January, recognized the significance of this battle on their organization. They noted that they were able to command effectively three types of forces, regular, regional, local guerrilla, and integrate them into an effective command structure. The provisional battalion commander, operating under Party control, was able to mold these units into effective, cohesive teams to accomplish the overall mission.

The critique also noted that the Province Military Section could control operations over a wide area. When this section learned from radio reports that the battle had started, it ordered the 2nd Company, 514th to disperse into squads and platoons and attack South Vietnamese installations, hamlets and boats moving on the major canals.

UNCLASSIFIED

UNCLASSIFIED

The Party.--The influence of the Party is not readily apparent from the conduct of the battle, but there are significant notations in the critique to surmise that the Party played a critical role during the preparation phase.

According to this critique, 1st Company, 261st Battalion had suffered some serious morale problems prior to the action as a result of two previous battles. Their soldiers lacked confidence in their cadre and were afraid of the South Vietnamese, as well as helicopters and the M113's. Some of the personnel of this company had requested discharge, and many cadre were noted to be lax in their leadership responsibilities.

Necessary corrective action was immediately initiated by the Central Military Section and the Party Committee of the 261st Battalion. They used organic unit chapters to consolidate the unit and solve the political dissention between the cadre and soldiers. By these actions leadership was strengthened. This seems to be confirmed by the fact that it was squads from this company that assaulted and destroyed six M113's during the battle.

Training.--The conduct of the battle seems to confirm the reliance the Viet Cong place on offensive action. This battle was not a defense in the classical sense, but was a series of holding actions by some troops, while the Viet Cong used other forces in attacks. The success of these attacks is a matter of record. During the operation, the Viet Cong were able to maintain this spirit of the offense.

From the outset of the battle, Viet Cong commanders were alert to the situation. They were constantly informed by their reconnaissance units of the disposition of the South Vietnamese, and were thus able to

UNCLASSIFIED

conserve manpower in certain, inactive areas, and mass power at decisive points of the battlefield. The camouflage and battle discipline of the troops, indicated it had received emphasis during their training, since they were able to conceal their positions and hold their fire until attacking troops closed to decisive range. Another tribute to their camouflage was the fact that the 514th could remain unobserved for over half the battle.

Further evidence of the offensive spirit was the determined attacks against heliborne forces, the airborne unit, and attacking M113's. The marksmanship of the soldier when firing against helicopters accounted for five damaged.

This battle seemed to indicate that the training of these two main force companies had been thorough, and in accordance with the methods outlined in Chapter Six.

In their critique of the battle the Viet Cong noted favorably the fact that their training had proved their units could counter sweep operations even when deficient in fire power. According to their figures, over 2000 artillery rounds had hit their positions, yet the soldiers remained steady. They noted with pride that their soldiers had been inventive and showed initiative in dealing with the M113's. They further noted that now their soldiers clearly understood the superiority of men over weapons, reemphasizing their point that they have courage, while the South Vietnamese have weapons.

Unfavorable comments noted were that the company commanders still did not react fast enough to South Vietnamese weakness. Particularly noted was the failure of the 514th to send more than four cells to protect its rear in the latter part of the battle. Since the front was

inactive, the commander should have taken a calculated risk and moved his entire unit to attack the force in his rear. This would have caused more South Vietnamese casualties. This same lack of reaction was mentioned in regard to the airborne attack. Evidently the Viet Cong felt they had sufficient firepower to have completely annihilated this force.

A final note on training was their emphasis on the fact that a unit must have counter-sweep plans made for each move. Each time a new area is reached, positions must be dug, and plans made. Coordination must be made with local forces to facilitate the conduct of the operation.

Leadership.--The leadership tactics and techniques in this battle were emphasized by the Viet Cong. Throughout the conduct of the fight the battalion commander made sure that the news of successes on other parts of the battlefield were made known to all troops. In short, all fighting personnel were made aware of the progress of the battle so they could understand the part they were playing.

During lulls in the battle, the battalion commander ordered his officers to visit the wounded, and explain to them the progress of the battle. Some cadre, when wounded, even refused evacuation.

As evidenced by this report on 3 January, the day after the battle, a battle analysis was conducted. Two units, the 4th Platoon of the 261st battalion and the 1st Company of the 514th were selected as the outstanding units. From this selection of 1st Company, 514th, came the Ap Bac award, mentioned in Chapter Five.

Evaluation

This chapter concludes a formal evaluation of the Viet Cong's organization, training, leadership and Party control as it effects the

soldier. In this chapter, some tactical applications of their principles were analyzed and certain strengths and weaknesses noted. These will be discussed in detail, in the next chapter. The significance of this Chapter, however, lies in the similarity of doctrine, not only in its theoretical but practical application as well.

In all three of the tactical instances, the Viet Cong showed their organizational concepts to be viable and capable of controlling both regular and irregular units. The Party was used in its primary role as an organizer, and in at least two instances was used to improve the training and morale of units prior to a combat.

In the field of training, the Viet Cong soldier demonstrated his ability to absorb and apply his doctrine in both the raid, ambush and a limited offense, and in the case of the latter, was able to counter effectively three different types of sophisticated forces, heliborne, mechanized and airborne. In this last feat alone, he proved his worth as a soldier, and demonstrated the fact that his functional training, emphasizing the offensive spirit, was compatible with his ability to execute it. In all cases, his training was able to provide him with the patience to maintain his camouflage, and battle discipline to the point that it gave him a significant tactical advantage.

In all three cases, leadership was personal. After each battle the critique was held and in all cases, outstanding performance was immediately recognized. During battle, the cadre set the example for the soldier. In the latter case, of the Ap Bac Battle, the soldiers that participated, helped create a new award system that is used throughout Viet Cong military forces.

~~SECRET~~

UNCLASSIFIED

CHAPTER VIII

CONCLUSIONS

Major Conclusions Of This Study

(U) This thesis examined the organization, training and leadership of the Viet Cong soldier in order to identify strengths, weaknesses and vulnerabilities. The vulnerabilities that are mentioned are based upon weaknesses capable of exploitation in the military sense. It is recognized that civic action and various types of popular reforms in the South will greatly assist in reducing the recruiting appeals of the Viet Cong. However, there are certain vulnerabilities that are peculiar to the Viet Cong soldier and are capable of immediate military exploitation, irrespective of civic action programs.

Strengths

(U) Since it is the prime force behind the Southern insurgency, North Vietnam has a decided influence upon the Viet Cong soldier. It is responsible for the existence of the entire Viet Cong apparatus. The Lao Dong Party furnishes guidance for the doctrine, organization, training and leadership currently practiced by the Viet Cong. Since North Vietnam prefers to operate through its subsidiary organizations in the South, the People's Revolutionary Party and the Front, the exact extent of their involvement is not readily apparent to the soldier.

(U) From the evidence available, it is reasonable to conclude that the soldier realizes that North Vietnam provides training facilities, infiltrators, and some logistical support. The evidence also points to the conclusion that the Viet Cong soldier sees himself as a member of the

~~SECRET~~

UNCLASSIFIED

UNCLASSIFIED

~~SECRET~~ CONFIDENTIAL

Front, independent of the North, and dedicated to the liberation of the South. This conclusion was reinforced by Viet Cong prisoners who firmly believed that the Front could end the war on their own accord without consulting the North. The fact that North Vietnam physically controls and supports the Viet Cong, and furnishes moral support stemming from their successful war of independence, constitutes a major source of strength to both the Viet Cong movement and the soldier.

(U) The Viet Cong soldier is completely dominated by the Party. This domination is not readily apparent to the soldier unless he is a Party member. While the Party is regarded as a major force behind the insurgency, and Viet Cong documents acknowledge its influence in organization, training and leadership, the Party prefers to function through the Front. Even though the Party monitors and controls the military-political organization, promotion system, and self-criticism sessions, the soldier sees only the prominence of the Front, who appears to reward and promote him. A definite source of strength to the Viet Cong is the Party's ability to produce a motivated soldier by controlling his organization, subjecting him to Party leadership, controlling his promotions and inducing him to conduct self-analysis.

(S) The Viet Cong military organization is effective and efficient since it provides the forces necessary for military operations at the various echelons from district to military region. These control headquarters are capable of integrating main force, local force and irregular units for combined operations of short duration. However, the military organization of the Viet Cong does not by itself constitute a strength since it is basically a simple, triangular, structure organized on a rather austere basis. Its significance to the soldier is important only when it is considered along with the role of the Party, and integrated into the leadership concept.

UNCLASSIFIED

~~SECRET~~ CONFIDENTIAL

UNCLASSIFIED

~~SECRET~~
179

~~CONFIDENTIAL~~

This importance is particularly apparent at the squad level where the squad leader is charged with both military and political responsibility, and may even be the Party Chapter representative. By wearing these three hats, it is relatively easy for the squad leader to preach Party doctrine as a function of his military command.

(S) The cell organization is a significant strength because of its military and political uses. It is ideally suited to develop the interdependence and inter-relationship among members necessary to insure both military success and Party control. The conduct of political indoctrination and criticism sessions at cell level forces the soldier to identify with this group. At the cell level the Viet Cong practice their military, political and economic democracy by allowing the cell members to express themselves and participate in discussions. It is within the framework of the cell that members are rewarded and punished. By this close association of cell members, stronger motivational ties are developed.

(S) The Viet Cong have an effective concept of leadership which, in conjunction with Party controls, is capable of effectively motivating the soldier. The concept emphasizes leadership by example and immediate reward and punishment. Leadership in the Viet Cong is strengthened through the kiem thao sessions which are conducted daily at cell level. These sessions allow the soldier to relieve his frustrations and criticize, within limits, the conduct of the war. Its use at cell level stresses participation by all members. It subordinates the soldier to the group and at the same time causes the soldier to depend more and more on the cell since they share his inner-most secrets. Since kiem thao is closely monitored by military and political leaders, it not only enhances Party control over the soldier but strengthens the military organization as well. Viet Cong leadership

UNCLASSIFIED

~~SECRET~~

~~CONFIDENTIAL~~

UNCLASSIFIED

~~SECRET~~
~~CONFIDENTIAL~~

motivates the soldier to work toward clearly defined goals, and identifies the soldier with the cause.

Ⓢ Viet Cong training is designed to produce an efficient, well-disciplined soldier capable of functioning in a guerrilla war. The effectiveness of this training depends on the availability of base areas and strong command emphasis. It is well-planned and supervised. It is effective because it is functional and adaptable to local conditions. Training emphasizes the use of lesson plans, rehearsals and demonstrations in order to take maximum advantage of the training time available. It stresses practical application and student participation.

Weaknesses

Ⓢ In an attempt to develop a broad political base for their revolution, the Viet Cong, under the name of the Front, have recruited members from all backgrounds. Many of these members are nationalists who believe they are fighting for a better way of life, and are not interested in the Party movement. The Party is forced to accept these individuals into the movement in order to maintain manpower levels. The motivational problems, admitted to exist in the Viet Cong, which required classification of cadre and soldiers based on their family background and loyalty may be a result of this mass recruiting. These people threaten absolute Party control and constitute a potential source of defectors and dissenters, if the actual extent of Party control were known. Evidence of their existence indicates that the system of political indoctrination is not capable of motivating all members of the movement.

Ⓢ A major weakness in Viet Cong training is its dependence upon infiltration from North Vietnam for both technically trained specialists and other replacements. This could be a definite shortcoming if the war escalates concurrently with the denial of the North's facilities. Tied in

UNCLASSIFIED

~~SECRET~~
~~CONFIDENTIAL~~

UNCLASSIFIED

181

~~CONFIDENTIAL~~

with this weakness is the dependence of the Viet Cong on their own base areas for training. The well-coordinated and planned training programs demand facilities and time to train. If these are denied, the training effort suffers. By the same token, the reliance on purely offensive doctrine at the expense of other forms of combat constitutes a definite weakness in the event the war escalates and the Viet Cong are faced with the problem of holding ground.

Another weakness that could affect the soldier is the apparent lack of experience that main force regiments have in coordinating and controlling regimental sized operations. If the war escalates, this inexperience could cause severe coordination problems and the inefficient employment of units. While the Ap Bac battle did indicate that a provisional control headquarters could effectively manage a battle on short notice, newspaper accounts of current battles indicate that large Viet Cong units are still faced with this problem.

The Viet Cong logistical system, which is dependent upon base areas, the soldier, and local purchase for its efficiency, constitutes a weakness. It decreases the mobility of the units, and requires that soldiers devote valuable training time to production and procurement. It will not support sustained operations. This logistical problem is a prime cause of defection.

Defection is a definite weakness. Its primary cause is hardship, and excessive family separations. It indicates a weakness in political and ideological indoctrination which is supposed to sufficiently motivate the soldier to withstand privation. In reality, it does not appear that political indoctrination can take the place of material comfort or substitute for family companionship.

UNCLASSIFIED

~~CONFIDENTIAL~~

(B) The Viet Cong have not been able to solve the problem of security violations when they are captured. Viet Cong prisoners talk freely and willingly to all interrogators. With all the emphasis they place on security, the fact remains that the soldier, when captured, constitutes a serious weakness to the Viet Cong system.

(C) Lastly, the protracted war may well be a weakness for the Viet Cong. They have time and again emphasized the advantage of a prolonged war since they felt they had time and motivation on their side. The evidence, however, points to the fact that the Viet Cong soldier is easily discouraged, particularly when subjected to repeated air and artillery attacks. When these attacks are coupled with the hardships and family separations, it definitely weakens his will to resist. In both the examples of the ambush and the Ap Bac battle, extensive indoctrination was necessary prior to the operations in order to restore the soldier's confidence in the cause. It appears that as the war continues, the problem of defection will continue to plague the Viet Cong.

(C) Vulnerabilities

The Viet Cong are vulnerable to measures taken that disrupt their campsites and force them to move into new areas. These measures require the soldier to endure new hardships since it disrupts their logistical support, and requires continuous reconnaissance for new areas. These moves deny the soldier permanent base areas for training. Combinations of hardship and a lack of training facilities adversely affects their morale and reinforces the idea of defection.

The Viet Cong are also vulnerable to surprise air, artillery or ground attacks. As a result of these attacks, the soldier begins to doubt the ability of his leaders to anticipate friendly operations. These attacks sometimes cause severe casualties, but most frequently require a

UNCLASSIFIED

UNCLASSIFIED

~~CONFIDENTIAL~~

change in location. Combinations of these actions foster a defeatist attitude in some elements within the Viet Cong. These members, when dissatisfied, voice criticism of their leaders. This action weakens the chain of command and provides additional reasons for defection.

A further vulnerability of the Viet Cong is the willingness of the soldier to talk when captured. This vulnerability can be exploited by the proper treatment of prisoners, and by acting rapidly on the information received. When these vulnerabilities are exploited to create additional hardships and a general war-weariness they add to the Viet Cong defection rate and thereby reduce their capability to function efficiently.

(U) Implications Of These Conclusions

The Viet Cong soldier is a strong, resourceful foe. His strength is derived from an effective organization, strict discipline, and the ability of his organization to effectively integrate a wide variety of activities and focus them upon the attainment of clearly defined goals. The impact of weapons and new ideas will be effective only in relation to the scale and intensity with which they are brought to bear. In order to fully exploit their effects upon the soldier, weapons and ideas must be integrated and supported by political and psychological means. It is recognized that while these measures will not necessarily strike the sources of the insurgency, they will reduce the intensity of Viet Cong attacks, and provide impetus for defection.

For these reasons it is apparent that even unobserved artillery fire, and air strikes conducted against known or suspected Viet Cong base areas is effective in forcing him to continually change his locations. By the same token, ground operations into his base areas may be effective even if no contact is made.

UNCLASSIFIED

~~CONFIDENTIAL~~

It has been popular in the past to characterize the Viet Cong soldier as fighting because there is a "gun at his back." It should be apparent from this thesis that this concept is false. The Viet Cong soldier fights well, because he is motivated, well trained and well led. This is not accomplished by merely arming idealistic volunteers, but is due to a well conceived and well executed plan that recognizes the need for a well defined set of values, training standards, organizational concepts, and leadership supports.

The Party uses its resources to provide this type of soldier. By speaking through the chain of command, it insures that the soldier is provided with a set of believable ideals which are within his ability to achieve. Whether this doctrine is misleading or not is immaterial. It is constantly repeated, and emphasized by leaders, until the soldier believes them and is willing to die for them.

The Party realizes its inferiority in weapons and the fact that their greatest weapon is the soldier. Therefore, leaders closely scrutinize his training, and all aspects of his daily life in order to insure this resource is properly educated and motivated to function as an instrument of the Party. This determined effort by the Party, when coupled with the proper small unit integrity and group identification, is capable of providing a reliable, combat effective soldier; a soldier who is willing to follow orders and fight as a member of the Liberation Army of the Front.

The weaknesses and vulnerabilities identified in this thesis may be exploited if the military planner realizes that soldiers in this type of revolutionary war are not products of any ideological myth. They are merely a product of good, sound, tactical planning, which emphasizes

UNCLASSIFIED

training, command supervision, and leadership by example. Once this is realized, an efficient plan for the training of counter-insurgent forces can be made which will effectively reduce the capabilities of insurgent forces.

UNCLASSIFIED

BIBLIOGRAPHY

Public Documents

- U. S. Army. USARPAC Intelligence Bulletin, September 1965.
- _____. USARPAC Intelligence Bulletin, February 1966.
- U. S. Defense Intelligence Agency. Army Intelligence Digest. VIETNAM (NORTH) (COMMUNIST). 15 February 1964.
- _____. Defense Intelligence Digest. Vol 3, No 2, February 1965.
- U. S. Department of State. Aggression From The North, The Record of North Viet-Nam's Campaign To Conquer South Viet-Nam. Department of State Publication 7839, February 1965.
- _____. A Threat to Peace, Part II. Far Eastern Series 110, December 1961.

Books

- Burchett, Wilfred G. VIETNAM: Inside Story of the Guerrilla War. New York: International Publishers Co., Inc., 1965.
- Fall, Bernard B. The Two Viet-Nams. Revised Edition. New York: Frederick A. Praeger, 1964.
- Giap, Vo Nguyen. People's War People's Army. Washington D. C.: U. S. Government Printing Office, 1962.
- Halberstam, David. The Making of a Quagmire. New York: Random House, 1965.
- Murti, B. S. N. Vietnam Divided: The Unfinished Struggle. New York: Asia Publishing House, 1964.
- Scigliano, Robert. South Vietnam: Nation Under Stress. Boston: Houghton-Mifflin Co., 1963.

Articles and Periodicals

- Beech, Keyes. Kansas City Star, March 24, 1966.
- Shils, Edward A., and Janowitz, Morris. "Cohesion and Disintegration in The Wehrmacht in World War II," Public Opinion Quarterly, Vol 12, Summer, 1948.

Reports

- Donnell, John C., Parker, Guy J., Zasloff, Joseph J. Viet Cong Motivation and Morale: A Preliminary Report (U). Santa Monica: The Rand Corporation, March 1965.
- Goure, Leon. Some Impressions of the Effects of Military Operations on Viet Cong Behavior (U). Santa Monica: The Rand Corporation, March 1965.
- Mintz, Jeanne S., Silverberg, Herbert M., Trinnaman, James E. A Short Guide To Psychological Operations In The Republic of Vietnam, 1965 (U). Washington D.C.: Special Research Office, American University, June 1965.
- Zasloff, Joseph J. The Role of North Vietnam in the Southern Insurgency (U). Santa Monica: The Rand Corporation, July 1964.

Unpublished Materials

- Far East Command. French Indo China: Information Concerning Viet Minh (1946-1950). A report of interrogations of Japanese nationals serving with the Viet Minh. Prepared by the Assistant Chief of Staff, G2, Far East. Translated from Japanese into English. Report Number 777494, 30 March 1951. (File Number S-17313.1-7, Fort Leavenworth, Kansas Library). (SECRET).
- Mayo, Joseph B. Logistics of the Viet Cong. U. S. Army War College, Carlisle Barracks, Pennsylvania, 6 March 1964.
- Patton, George S. Portrait of an Insurgent: A Study of the Motivation of the Main Force Vietnamese Communist Fighting Man (U), U. S. Army War College, Carlisle Barracks, Pennsylvania, 3 May 1965.
- U. S. Army. Department of the Army Intelligence Report. "Republic of Vietnam Armed Forces Article on Viet Cong Ambush Tactics (U)." Translated from Vietnamese into English from the Vietnam Armed Forces publication Know Your Enemy, No. 11. (File Number C-18745.17-B, Fort Leavenworth, Kansas Library). (CONFIDENTIAL).
- _____. John F. Kennedy Center For Special Warfare (Abn). The Viet Cong (U). John F. Kennedy Center For Special Warfare (Abn), November 1965.
- U. S. Department of Defense. Intelligence Information Reports. Captured Viet Cong documents and interrogations of prisoners and defectors, translated from Vietnamese into English. Reports Number 6075021765 to 6075052565, 17 May through 30 July 1965. (File Number C-18745.99, Fort Leavenworth, Kansas Library). (CONFIDENTIAL).

- _____ . Intelligence Information Reports. Captured Viet Cong documents and interrogations of prisoners and defectors, translated from Vietnamese into English. Reports Number 6075015365 through 607-5053665, 2 May through 9 August 1965. (File Number N-16961.40, Fort Leavenworth, Kansas Library).
- U. S. Military Assistance Command, Vietnam. Letter, 15 September 1964, Subject: "Viet Cong Medical System (U)". (File Number C-18745.81, Fort Leavenworth, Kansas Library). (CONFIDENTIAL).
- _____ . Letter, 9 January 1963, Subject: "Viet Cong Propaganda Leaflet," a copy of a Viet Cong leaflet translated from Vietnamese into English. (File Number C18745.31, Fort Leavenworth, Kansas Library). (CONFIDENTIAL).
- _____ . Letter, 28 April 1965, Subject: "Viet Cong Training (U)," (File Number C-18745.124, Fort Leavenworth, Kansas Library). (CONFIDENTIAL).
- _____ . Letter, 29 January 1963, Subject: "Letter of Transmittal," a copy of a Viet Cong after action report translated from Vietnamese into English. (File Number C-18745.29-D, Fort Leavenworth, Kansas Library). (CONFIDENTIAL).
- _____ . Letter, 20 April 1963, Subject: "Letter of Transmittal," a copy of a Viet Cong after action report translated from Vietnamese into English. (File Number C-18745.29-E, Fort Leavenworth, Kansas Library). (CONFIDENTIAL).
- _____ . Order of Battle Viet Cong Forces Republic of Vietnam (U). 1 July 1964, with change 1, 1 January 1965. (CONFIDENTIAL).
- _____ . Rallier Interrogation Report (Non-Infiltrator), a copy of a Viet Cong prisoner interrogation translated from Vietnamese into English. (File Number C-18745.99, Fort Leavenworth, Kansas Library). (CONFIDENTIAL).
- _____ . Viet Cong Squads, Platoons, and Companies, a copy of a Viet Cong document translated from Vietnamese into English. (File Number C-18745.29-G, Fort Leavenworth, Kansas Library). (CONFIDENTIAL).