

**U.S. Coast Guard Research and Development Center**  
1082 Shennecossett Road, Groton, CT 06340-6096

---

**Report No. CG-D-08-99**

**Review of Leeway:  
Field Experiments and Implementation**



**FINAL REPORT  
APRIL 1999**



This document is available to the U.S. public through the  
National Technical Information Service, Springfield, VA 22161

Prepared for:

U.S. Department of Transportation  
United States Coast Guard  
Operations (G-O)  
Washington, DC 20593-0001

DTIC QUALITY INSPECTED 2

19990802 157

# NOTICE

This document is disseminated under the sponsorship of the Department of Transportation in the interest of information exchange. The United States Government assumes no liability for its contents or use thereof.

The United States Government does not endorse products or manufacturers. Trade or manufacturers' names appear herein solely because they are considered essential to the object of this report.

This report does not constitute a standard, specification, or regulation.



Marc B. Mandler, Ph.D.  
Technical Director  
United States Coast Guard  
Research & Development Center  
1082 Shennecossett Road  
Groton, CT 06340-6096

Technical Report Documentation Page

1. Report No. <b>CG-D-08-99</b>		2. Government Accession Number		3. Recipient's Catalog No.	
4. Title and Subtitle  <b>Review of Leeway: Field Experiments and Implementation</b>				5. Report Date <b>April 1999</b>	
				6. Performing Organization Code <b>Project No. 1012.3.16 / UDI 27</b>	
7. Author(s) <b>Arthur A. Allen and Jeffery V. Plourde</b>				8. Performing Organization Report No.  <b>R&amp;DC 08/98</b>	
U.S. Coast Guard Research and Development Center 1082 Shennecossett Road Groton, CT 06340-6096		Analysis and Technology Route 2, P.O. Box 220 North Stonington, CT 06369		10. Work Unit No. (TR AIS)	
				11. Contract or Grant No.	
12. Sponsoring Organization Name and Address  U.S. Department of Transportation United States Coast Guard Operations (G-O) Washington, DC 20593-0001				13. Type of Report & Period Covered <b>Final Report</b>	
				14. Sponsoring Agency Code <b>Commandant (G-OPR) U.S. Guard Headquarters Washington, DC 20593-0001</b>	
15. Supplementary Notes  This report is the twenty-first in a series that documents the Improvement of Search and Rescue Capabilities (ISARC) Project at the USCG R&D Center. The R&D Center's technical point of contact is Arthur A. Allen, 860-441-2747.					
16. Abstract (MAXIMUM 200 WORDS)  Fundamental shortfalls in our understanding of leeway drift behavior have hampered the search and rescue (SAR) planning community's ability to predict search object drift with high confidence. This report organizes the existing body of knowledge on leeway to address many of the shortcomings in the present use of leeway.  Ninety-five leeway target types reported on by twenty-five field studies are presented. The test objects and methods used to measure leeway in these studies are reviewed. The leeway guidance of the present U.S. Coast Guard search planning tools is also reviewed. A comparison between an older leeway data set and a recent leeway data set is used to illustrate recent gains in our understanding of leeway behavior.  A new model is presented for the prediction of leeway drift that takes full advantage of the higher data quality. With search object classes for which high-quality leeway data have been measured, this new model provides substantial reductions in search area size when the new model is compared to leeway predictions made by existing U.S. Coast Guard search planning methods.  A systematic categorization of the possible targets of interest to the Coast Guard is presented as a leeway taxonomy. The leeway taxonomy is based upon rules that describe the target and help quickly guide the search planner through the seven possible levels of the taxonomy.  Sixty-three search object leeway classes and their leeway speed coefficients and divergence angles are recommended for manual search planning tools.					
17. Key Words search and rescue leeway taxonomy drift modeling			18. Distribution Statement This document is available to the U.S. public through the National Technical Information Service, Springfield, VA 22161		
19. Security Class (This Report) <b>UNCLASSIFIED</b>		20. Security Class (This Page) <b>UNCLASSIFIED</b>		21. No of Pages	22. Price

Form DOT F 1700.7 (8/72) Reproduction of form and completed page is authorized.

## ACKNOWLEDGMENTS

The comments of Quincy Robe, Anthony Patterson, Myles Ross, Jean Maillette, Louis Nash, Vonnie Summers, Penny Herring and Renee Mercaldo-Allen are appreciated and helped to improve this report. Kay Howard-Strobel provided graphics support. Elizabeth Anderson provided extensive support in clarifying Appendix B.

Questions from Gary Hover, Don Cundy, LT Robert Patton, Joe Discenza, LCDR Phil Muir, and LT Gregory Purvis provided the necessary and appreciated motivation for this report.

The translation and interpretations of the Japanese papers by Takako Shigehisa, Haruo Sato and Sin Young Kang was very much appreciated.

Johnny Rice of Custom Surfboards, Santa Cruz, CA provided his historical knowledge of surfboards used to estimate the size of surfboards typical to the late 1950's to the present.

## DEDICATION

This report is dedicated to CAPT William. E. Chapline, Jr., USCG, (Ret.), who published in 1960 a two and one-half page report "Estimating the Drift of Distressed Small Craft." in the Coast Guard Alumni Association Bulletin. His work forms the basis of much of our present day guidance for leeway drift. Many of his observations and recommendations ring true today.

I only hope that this report is up to the highest standards that were set by W. E. Chapline in 1960. His report is included as Appendix D in this report.



## EXECUTIVE SUMMARY

### INTRODUCTION

Leeway is the motion of an object on the surface relative to the local background surface currents. Having an understanding of the leeway of survivors and survivor craft is necessary for prediction of the total drift of those survivors during search and rescue (SAR) cases. In addition to traditional civilian SAR, leeway is critical in combat SAR cases and for the prediction of surface drift objects in Law Enforcement (LE) and Marine Environmental Protection (MEP) missions.

Leeway has been studied since World War II; however, recent studies conducted by the R&D Center and others have provided a number of new and improved leeway data sets and drift models for a variety of SAR craft. Numerous questions regarding this diverse body of leeway data and drift models have been asked within the search planning community. Most of these questions focused on the desire to extract maximum information from available data while providing a cohesive means of presenting the data and modeling leeway drift. This report addresses nine leeway-related questions that: 1.) Organize the existing body of leeway knowledge. 2.) Present a cohesive set of leeway models that make maximum use of available data. 3.) Quantify the impact of leeway model accuracy on the overall SAR mission planning process, particularly with respect to search area size.

### QUESTIONS and FINDINGS

#### *1) Which leeway targets have been studied? (For what targets do we have data?)*

During 25 field studies 95 leeway target types, including 38 life rafts, 14 small craft (mostly outboards), and 10 fishing vessels, were studied. Other leeway target types studied included surfboards, sailboats, life capsule, Cuban refugee raft, fishing vessel boating debris, and Persons-in-the-Water (PIWs). There have been two significant changes regarding leeway targets since World War II when leeway studies began. First, target descriptions have greatly improved from merely providing the model type of the target to providing line drawings with dimensions. Hopefully, this trend will continue to improve until full 3-D digital images of the targets are available. The second is that SAR targets have themselves been evolving over the years. For example, life rafts have been improved by the addition of full canopies and extensive ballast systems so that they are quite different from the old World War II rubber raft.

#### *2) What methods were used in each leeway field study? (How good is that data?)*

Two basic methods of measuring leeway have been used: indirect and direct. The indirect method was used by seventeen studies to generate most of the original guidance for search planning. This method consists of setting out leeway targets near a surface current drifter and measuring the on-scene winds. Then the drift of the surface current drifter is subtracted from the total displacement of the leeway target to estimate the leeway portion of the motion. The accuracy and precision of this method is dependent on the quality of the surface current drifters and the navigation used to position the surface current drifters and leeway targets. The indirect method requires constant maintenance of the leeway targets and drifters as they tend to separate. Thus, this method generally

produced data only in light to moderate winds. The indirect method produced reasonable estimates of the leeway rates of many common SAR targets. However, the results of the indirect method often contained too much noise in the directions of wind and leeway to provide useful guidance on the leeway angle or divergence from the downwind direction.

In the 1990's, the direct method of measuring leeway using internally recording current meters attached to the drifting craft was introduced and calibrated against the indirect method. The new current meters combined with wind monitoring systems, data loggers for GPS positions, and satellite beacons allowed the deployment of leeway targets before a storm and their recovery after the storm, with leeway data recorded throughout. The results were long, continuous records of leeway through the high wind conditions that are of most interest to SAR planning. There have been eight studies performed using the direct method.

*3) What is the present level of understanding of leeway behavior?*

The following survivor craft leeway behavior has been observed in recent leeway data sets: divergence of the craft from the downwind direction, changes in relative wind direction that lead to changes in sign of the divergence (jibbing), capsizing, and swamping. With larger leeway data sets on a single target type, the difference between positive and negative crosswind components as functions of wind speed is apparent. The downwind component of leeway is higher during rising winds than falling winds for a given wind speed. Observing and quantifying these characteristics of the leeway drift of survivors and survivor craft provides new and clearer understanding of the mechanism of leeway.

*4) How can we model the present level of understanding of leeway behavior?*

A new model of leeway behavior is introduced that uses linear regression equations and variance of both the downwind and crosswind components of leeway to predict the drift of the targets. This third generation model of leeway drift area is called AP98. AP98 incorporated many features of leeway behavior that have recently been observed, the most significant of which is the inclusion of crosswind components of leeway to express the divergence of the target from the downwind direction.

*5) What is present leeway guidance for search planning?*

The leeway guidance provided by the National SAR Manual, and the U.S. and Canadian Coast Guard's search planning tools are reviewed in Chapter 5. The guidance provided by these search planning tools is restricted to leeway rate for a limited number of target classes based primarily upon the Chapline (1960) study. Additional guidance for life rafts was added by several studies in the 1970s and 1980s. The very limited guidance on leeway angle or divergence is based upon Hufford and Broida's (1974) report on four small craft (12-21 foot outboards).

*6) How does the present leeway guidance compare to the new models of leeway behavior?*

A sensitivity study of predicted leeway drift areas showed significant reductions in search area size were achieved by the AP98 leeway model when compared to the first and second generation leeway search area models presently used.

7) *What classes of leeway targets should be included in our search planning tools?*

A systematic categorization of the possible targets of interest to the Coast Guard is presented as a leeway taxonomy in Chapter 6. The leeway taxonomy is based upon rules that describe the target and help guide the search planner quickly through the seven possible levels of the taxonomy. The taxonomy uses published annual boating guides and references as much as possible to provide the search planner with cross-reference ability. The taxonomy was designed to be easily implemented in numerical search planning tools.

8) *Are there new, broader categories of search objects within the leeway taxonomy for which leeway equations can be generated from the available data?*

Leeway data from multiple sources were combined together from lower levels in the leeway taxonomy to generate predictions for generalized classes of PIWs, Maritime Life Rafts, Commercial Fishing Vessels, and Medical Waste objects. This analysis is presented in Chapter 7. The combination of deep-ballasted canopied life rafts revealed the importance of the presence or absence of a drogue to the leeway drift of life rafts, and how little effect loading of the raft had on the raft's leeway drift rate. Data combined systematically up the leeway taxonomy table provide leeway drift equations to the search planner as he descends through the leeway taxonomy table from the general to the specific. Thus the SAR planner has leeway guidance for larger, more inclusive categories at the beginning of a SAR case when information about the target type is often incomplete. When further information about the target types has been obtained, more specific leeway guidance will allow for a finer definition of the search area by the SAR planner.

9) *What are the recommendations for modeling leeway in search planning tools?*

Sixty-three new leeway classes and their values are recommended for inclusion in the next version of the National SAR Manual. These leeway classes are characterized by the leeway taxonomy introduced in Chapter 6 and outlined in Appendix A. The values for the leeway equations are presented in Appendix B. This provides the SAR planner with 63 systematically ordered and fully described leeway categories instead of the present seven poorly defined categories.

10) *What is the present level of modeling efforts?*

A separate report titled "Modeling of Leeway Drift" by Anderson et al. (1998) addresses this tenth question.

## CONCLUSION

This report and Anderson et al. (1998) reflect the status of the field of leeway study and its operational guidance in 1998. There have been significant gains in the understanding of leeway behavior since the field studies of the 1960's and 70's. A newer, more sophisticated model of leeway behavior was therefore developed to accurately reflect the recent advancements achieved in determining the leeway of common SAR targets. It is anticipated that the findings and recommendations of this report will lead to operational guidance that will result in smaller and more accurately defined search areas.

## TABLE OF CONTENTS

	<u>Page</u>
EXECUTIVE SUMMARY .....	v
LIST OF ACRONYMS AND ABBREVIATIONS .....	xxvii
1. INTRODUCTION .....	1-1
1.1 MOTIVATION.....	1-1
1.2 SCOPE.....	1-1
1.3 LEEWAY IN SEARCH AND RESCUE .....	1-2
1.4 DEFINITIONS OF PARAMETERS.....	1-3
2. REVIEW OF PREVIOUS LEEWAY FIELD EXPERIMENTS .....	2-1
2.1 LEEWAY FIELD EXPERIMENTS: METHODS.....	2-1
2.1.1 Indirect Method .....	2-1
2.1.2 Direct Method.....	2-4
2.2 LEEWAY FIELD EXPERIMENTS: OBJECTS .....	2-7
3. COMPARISON OF THE LEEWAY OF TWO LIFE RAFTS.....	3-1
3.1 INTRODUCTION.....	3-1
3.2 THE LEEWAY OF A 12-FT RUBBER RAFT AND A TULMAR 4-PERSON LIFE RAFT.....	3-1
3.2.1 Leeway Speed and Angle.....	3-2
3.2.2 Downwind and Crosswind Components of Leeway .....	3-8
3.3 EFFECTS OF UNCERTAINTY ON LEEWAY MODELING .....	3-16
4. MODELS OF LEEWAY DRIFT AREAS.....	4-1
4.1 INTRODUCTION.....	4-1
4.2 GDOC AMM LEEWAY DRIFT AREA.....	4-2

TABLE OF CONTENTS (continued)

	<u>Page</u>
4.3 CASP LEEWAY DRIFT AREA .....	4-3
4.4 A NEW MODEL OF LEEWAY DRIFT AREA (AP98) .....	4-7
4.5 MODIFICATION OF GDOC AMM LEEWAY DRIFT AREA .....	4-8
4.6 COMPARISON OF LEEWAY DRIFT AREA MODELS .....	4-8
5. IMPLEMENTATION OF LEEWAY INTO SEARCH PLANNING TOOLS .....	5-1
5.1 INTRODUCTION .....	5-1
5.2 NATIONAL SEARCH AND RESCUE MANUAL .....	5-1
5.2.1 Leeway Speed in the National SAR Manual .....	5-1
5.2.2 Leeway Angle in the National SAR Manual .....	5-5
5.3 AUTOMATED MANUAL METHOD In GDOC.....	5-5
5.3.1 Leeway Classes .....	5-5
5.4 CASP Version 1.1X.....	5-7
5.4.1 Leeway Classes .....	5-7
5.4.1.1 CASP User Defined Leeway Input.....	5-8
5.5 CANADIAN SEARCH-PLANNING TOOLS .....	5-9
5.6 CASP Version 2.0 .....	5-14
5.7 COMPARISONS OF PRESENTLY AVAILABLE LEEWAY VALUES VERSUS IMPLEMENTED LEEWAY VALUES.....	5-15
5.7.1 Leeway Category I, "Light Displacement Cabin Cruisers, Outboards, Rubber Rafts, etc. (Without Drogue)" .....	5-16
5.7.2 Leeway Category II, "Large Cabin Cruisers" .....	5-21
5.7.3 Leeway Category III, "Light Displacement Cabin Cruisers, Outboards, Rubber Rafts, etc. (With Drogue)" .....	5-21

TABLE OF CONTENTS (continued)

	<u>Page</u>
5.7.4 Leeway Category IV, “Medium displacement sailboats, fishing vessels such as trawlers, trollers, tuna boats, etc.” .....	5-21
5.7.5 Leeway Category V, “Heavy Displacement Deep Draft Sailing Vessels” .....	5-28
5.7.6 Leeway Category VI, “Surfboards” .....	5-28
5.7.7 Leeway Category VII, “Person-in-the-Water (PIW)” .....	5-29
5.7.8 Leeway Speed Guidance Provided by National SAR Manual .....	5-30
5.7.9 Leeway Angle Guidance Provided by National SAR Manual .....	5-39
6. TAXONOMY OF LEEWAY DRIFT TARGETS.....	6-1
6.1 INTRODUCTION .....	6-1
6.2 ESTABLISHING THE LEEWAY TAXONOMY.....	6-2
6.3 LIMITATIONS OF THE LEEWAY TAXONOMY .....	6-6
6.4 EXAMPLES OF USING THE LEEWAY TAXONOMY.....	6-7
7. LEEWAY OF COMBINED CLASSES OF TARGETS.....	7-1
7.1 INTRODUCTION .....	7-1
7.2 METHODS OF ANALYSIS.....	7-1
7.3 LEEWAY OF COMBINED CLASSES .....	7-2
7.3.1 PIWs.....	7-2
7.3.2 Maritime Life Rafts .....	7-2
7.3.2.1 Maritime Life Rafts with No Ballast Systems .....	7-2
7.3.2.2 Maritime Life Rafts with Shallow Ballast Systems and Canopy .....	7-3

TABLE OF CONTENTS (continued)

	<u>Page</u>
7.3.2.3 Maritime Life Rafts with Deep Ballast Systems.....	7-3
7.3.2.3.1 Maritime Life Raft (deep ballast, canopy, without drogue, 4-6 person, light loading) .....	7-3
7.3.2.3.2 Maritime Life Raft (deep ballast, canopy, with drogue, 4-6 person, light loading).....	7-9
7.3.2.3.3 Maritime Life Raft (deep ballast, canopy, without drogue, 4-6 person, heavy loading).....	7-14
7.3.2.3.4 Maritime Life Raft (deep ballast, canopy, with drogue, 4-6 person, heavy loading) .....	7-19
7.3.2.3.5 Maritime Life Raft (deep ballast, canopy, 4-6 person, without drogue).....	7-23
7.3.2.3.6 Maritime Life Raft (deep ballast, canopy, 4-6 person, with drogue) .....	7-23
7.3.2.3.7 Maritime Life Raft (deep ballast, canopy, 4-6 person).....	7-24
7.3.2.3.8 Maritime Life Raft (deep ballast, canopy, 15-25 person).....	7-32
7.3.2.3.9 Maritime Life Raft (deep ballast, canopy).....	7-37
7.3.3 Commercial Fishing Vessels.....	7-42
7.3.4 Medical Waste .....	7-42
7.4 LIMITATIONS OF THE ANALYSES OF COMBINED CLASSES .....	7-43
8. SUMMARY AND RECOMMENDATIONS .....	8-1
8.1 INTRODUCTION.....	8-1
8.2 SUMMARY .....	8-1
8.3 RECOMMENDATIONS FOR LEEWAY GUIDANCE FOR THE MANUAL METHOD .....	8-4

TABLE OF CONTENTS (continued)

	<u>Page</u>
8.4 FUTURE WORK.....	8-14
REFERENCES.....	R-1
APPENDIX A    LEEWAY TAXONOMY TABLES .....	A-1
APPENDIX B    CLASS DESCRIPTIONS OF LEEWAY DRIFT OBJECTS.....	B1-1
APPENDIX C    ANNOTATED BIBLIOGRAPHY FOR LEEWAY TAXONOMY.....	C-1
APPENDIX D    CHAPLINE (1960) "ESTIMATING THE DRIFT OF DISTRESSED SMALL CRAFT" .....	D-1



## LIST OF ILLUSTRATIONS

<u>Figure</u>	<u>Page</u>
1-1 Relationship between Relative Wind Direction (RWD) and Leeway Angle .....	1-4
1-2 Relationship between the Leeway Speed and Angle and the Downwind and Crosswind Components of Leeway .....	1-5
2-1 Mark 7 life raft .....	2-13
2-2 16-foot Outboard Motor Boat .....	2-13
2-3 18-foot Outboard Motor Boat .....	2-13
2-4 30-foot Utility Boat .....	2-13
2-5 Japanese 8-person and 13-person life rafts .....	2-13
2-6 RFD 6-person MK3A Life Raft .....	2-13
2-7 Switlik 4-person Life Raft .....	2-14
2-8 Givens Buoy 6-person Life Raft .....	2-14
2-9 Avon 4-person Life Raft .....	2-14
2-10 Winslow 4-person Life Raft .....	2-14
2-11 20-foot Cabin Cruiser .....	2-14
2-12 Beaufort 5-sided 4-person Life Raft .....	2-14
2-13 Beaufort 6-sided 4-person Life Raft .....	2-15
2-14 Beaufort circular 20-person Life Raft .....	2-15
2-15 5.6-m open wooden-planked boat .....	2-15
2-16 SOLAS approved 22-person Life Capsule .....	2-15
2-17 L1011 Aircraft Evacuation / Slide 46-person Life Raft .....	2-15
2-18 USCG Sea Rescue Kit .....	2-15

LIST OF ILLUSTRATIONS (continued)

<u>Figure</u>	<u>Page</u>
2-19 Tulmar 4-person Life Raft .....	2-16
2-20 Switlik 6-person Life Raft with four small ballast bags .....	2-16
2-21 12.5-m Korean Fishing Vessel.....	2-16
2-22 Cuban Refugee Raft with Sail.....	2-16
2-23 Cuban Refugee Raft without Sail .....	2-16
2-24 15-m Fishing Vessel with rear -reel for net fishing .....	2-16
2-25 Switlik 6-person Life Raft with full toroidal ballast bag .....	2-17
2-26 PIW, with Type I PFD .....	2-17
2-27 PIW in Survival Suit.....	2-17
2-28 Sea Kayak .....	2-17
2-29 Wind-surf Board .....	2-17
2-30 Wharf Box (cubic meter bait box) .....	2-17
2-31 36-foot Senator (Sport Cruisers, Motor Yacht, Modified V-hull, Covered aft deck, with bridge canopy).....	2-18
2-32 PIW, with Type II PFD.....	2-18
2-33 13.8-m Fishing Vessel with rear-reel for net fishing .....	2-18
2-34 65-foot Sailboat (Mono-hull, full keel, deep draft, with masts) .....	2-18
3-1 The Unconstrained Linear Regression and 95% Prediction Limits of Leeway Speed for Hufford and Broida's (1974) 12-foot Rubber Raft without sea anchor versus Wind Speed (unadjusted) and a Tulmar 4-person Life Raft (1-person loading, no drogue) versus $W_{10m}$ .....	3-3

LIST OF ILLUSTRATIONS (continued)

<u>Figure</u>	<u>Page</u>
3-2	(A) The 10-m Wind Speed from 1800 (UTC) on Yearday 338 to 0700 on Yearday 339, 1992, at the Tulmar life raft. (B) Leeway Speed versus 10-m Wind Speed during the above period Separated by Rising and Falling Winds..... 3-5
3-3	The Progressive Vector Diagram of the Leeway Displacement Vectors for the Nine Drift Runs of the Tulmar 4-person Life Raft (1-person loading, no drogue) ..... 3-7
3-4	The Unconstrained Linear Regression and 95% Prediction Limits of the Downwind Component of Leeway for Hufford and Broida's (1974) 12-foot Rubber Raft without sea anchor versus Wind Speed (unadjusted) and a Tulmar 4-person Life Raft (1-person loading, no drogue) versus $W_{10m}$ ..... 3-9
3-5	The Unconstrained Linear Regression and 95% Prediction Limits of the Positive and Negative Absolute Values of Crosswind Components of Leeway of Hufford and Broida's (1974) 12-foot Rubber Raft without sea anchor versus unadjusted Wind Speed..... 3-11
3-6	The Piece-Wise Unconstrained Linear Regression and 95% Prediction Limits of the Crosswind Component of Leeway of a Tulmar 4-person life raft (1-person loading, no drogue) versus $W_{10m}$ ..... 3-12
3-7	Illustration of Leeway Threshold Behavior as a Function of wind speed ..... 3-15
4-1	The leeway drift area of GDOC AMM for (A) a divergence less than 38 degrees and for (B) a divergence greater than 38 degrees ..... 4-3
4-2	The leeway drift area of CASP for a divergence angle of [A] 35 degrees and for (B) 60 degrees..... 4-5
4-3	The leeway drift area of CASP and GDOC AMM for Category I leeway targets for after 6 and 24 hours of a steady 20 knot wind..... 4-6
4-4	The leeway drift area of leeway distribution model AP98 for Hufford and Broida's (1974) 12-foot Rubber Raft without a sea anchor, along with the CASP and GDOC AMM for category I leeway targets after 6 and 24 hours of a steady 20 knot wind ..... 4-9

LIST OF ILLUSTRATIONS (continued)

<u>Figure</u>	<u>Page</u>
4-5	The Leeway Drift Area of Leeway Distribution Model AP98 for Hufford and Broida's (1974) 12-foot Rubber Raft without a sea anchor, along with the GDOC AMM original, GDOC AMM modified and CASP Leeway Drift Areas for Category I Leeway Targets after 96 hours of a Steady 5 knot Wind. The standard errors used in the AP98 model are: [A] 1 cm/s; [B] 3 cm/s; [C] 5 cm/s; [D] 7 cm/s; [E] 9 cm/s; and [F] 11 cm/s.....4-13
4-6	The Leeway Drift Area of Leeway Distribution Model AP98 for Hufford and Broida's (1974) 12-foot Rubber Raft without a sea anchor, along with the GDOC AMM original, GDOC AMM modified and CASP Leeway Drift Areas for Category I Leeway Targets after 48 hours of a Steady 10 knot Wind. ....4-14
4-7	The Leeway Drift Area of Leeway Distribution Model AP98 for Hufford and Broida's (1974) 12-foot Rubber Raft without a sea anchor, along with the GDOC AMM original, GDOC AMM modified and CASP Leeway Drift Areas for Category I Leeway Targets after 32 hours of a Steady 15 knot Wind. ....4-15
4-8	The Leeway Drift Area of Leeway Distribution Model AP98 for Hufford and Broida's (1974) 12-foot Rubber Raft without a sea anchor, along with the GDOC AMM original, GDOC AMM modified and CASP Leeway Drift Areas for Category I Leeway Targets after 24 hours of a Steady 20 knot Wind. ....4-16
4-9	The Leeway Drift Area of Leeway Distribution Model AP98 for Hufford and Broida's (1974) 12-foot Rubber Raft without a sea anchor, along with the GDOC AMM original, GDOC AMM modified and CASP Leeway Drift Areas for Category I Leeway Targets after 12 hours of a Steady 40 knot Wind. ....4-17
5-1	The Leeway Drift Area of the AP98 Leeway Distribution Model for 5.5 meter open Boat, along with the CASP and GDOC AMM areas for Category I Leeway Targets after 6 and 24 hours of a Steady 20-knot Wind..... 5-18
5-2	The Leeway Drift Area of the Leeway Distribution Model AP98 for 5.5-m open Boat for Steady Winds of 5 knots for 96 hours, 10 knots for 48 hours, 20 knots for 24 hours and 40 knots for 12 hours ..... 5-20
5-3	The CASP and GDOC AMM Leeway Distribution Areas for a Fishing Vessel with a leeway of 4% of 20 knot wind after 6 and 24 hours. Divergence angle is 35 degrees..... 5-24

## LIST OF ILLUSTRATIONS (continued)

<u>Figure</u>	<u>Page</u>
5-4	The CASP and GDOC AMM Leeway Distribution Areas for a Fishing Vessel with leeway of 4% of 20 knot wind after 6 and 24 hours. Divergence angle is 60 degrees.....
	5-25
5-5	The Leeway Drift Distributions from CASP, GDOC AMM, and AP98 for a Fishing Vessel with a leeway of 4% of 20 knot wind after 6 and 24 hours. Divergence angle used in CASP and GDOC AMM was 35 degrees.....
	5-26
5-6	The Leeway Drift Distributions from CASP, GDOC AMM, and AP98 for a Fishing Vessel with a leeway of 4% of 20 knot wind after 6 and 24 hours. Divergence angle used in CASP and GDOC AMM was 60 degrees.....
	5-27
5-7	The Leeway Drift Distribution from AP98 for a Tulmar 4-person Life Raft with 1-person loading without a drogue. Winds used were Steady at 20 knots for 6 and 24 hours.....
	5-36
5-8	The Leeway Drift Distribution from AP98 for a Tulmar 4-person Life Raft with 1-person loading without a drogue. Winds used were Steady at: 5 knots for 96 hours, 10 knots for 48 hours, 20 knots for 24 hours, and 40 knots for 12 hours.....
	5-37
5-9	The Leeway Drift Distribution from AP98 for a Tulmar 4-person Life Raft with 1-person loading without a drogue. Winds used were Steady at 5, 10, 20, and 40 knots for 12 hours. Also shown is the outline of CASP leeway drift distribution for a Category I leeway target for a Steady Wind of 20 knots for 12 hours. ....
	5-38
6-1	Top-Level View of Leeway Taxonomy.....
	6-3
7-1	The Unconstrained Linear Regression and 95% Prediction Limits of the Leeway Speed versus Wind Speed at 10m, Maritime Life Rafts, deep ballast systems, canopy, without drogue, 4-6 person capacity, light loading. ....
	7-5
7-2	The Unconstrained Linear Regression and 95% Prediction Limits of the Downwind Component of Leeway versus Wind Speed at 10m, Maritime Life Rafts, deep ballast systems, canopy, without drogue, 4-6 person capacity, light loading. ....
	7-6

## LIST OF ILLUSTRATIONS (continued)

<u>Figure</u>	<u>Page</u>
7-3	Crosswind Component of Leeway versus Wind Speed at 10m, Maritime Life Rafts, deep ballast systems, canopy, without drogue, 4-6 person capacity, light loading. .... 7-7
7-4	The Unconstrained Linear Regression and 95% Prediction Limits of the Crosswind Component of Leeway versus Wind Speed at 10m, Maritime Life Rafts, deep ballast systems, canopy, without drogue, 4-6 person capacity, light loading. .... 7-8
7-5	The Unconstrained Linear Regression and 95% Prediction Limits of the Leeway Speed versus Wind Speed at 10m, Maritime Life Rafts, deep ballast systems, canopy, with drogue, 4-6 person capacity, light loading. .... 7-10
7-6	The Unconstrained Linear Regression and 95% Prediction Limits of the Downwind Component of Leeway versus Wind Speed at 10m, Maritime Life Rafts, deep ballast systems, canopy, with drogue, 4-6 person capacity, light loading. .... 7-11
7-7	Crosswind Component of Leeway versus Wind Speed at 10m, Maritime Life Rafts, deep ballast systems, canopy, with drogue, 4-6 person capacity, light loading. .... 7-12
7-8	The Unconstrained Linear Regression and 95% Prediction Limits of the Absolute values of the Crosswind Component of Leeway versus Wind Speed at 10m, Maritime Life Rafts, deep ballast systems, canopy, with drogue, 4-6 person capacity, light loading. .... 7-13
7-9	The Unconstrained Linear Regression and 95% Prediction Limits of the Leeway Speed versus Wind Speed at 10m, Maritime Life Rafts, deep ballast systems, canopy, without drogue, 4-6 person capacity, heavy loading. .... 7-15
7-10	The Unconstrained Linear Regression and 95% Prediction Limits of the Downwind Component of Leeway versus Wind Speed at 10m, Maritime Life Rafts, deep ballast systems, canopy, without drogue, 4-6 person capacity, heavy loading. .... 7-16
7-11	Crosswind Component of Leeway versus Wind Speed at 10m, Maritime Life Rafts, deep ballast systems, canopy, without drogue, 4-6 person capacity, heavy loading. .... 7-17

LIST OF ILLUSTRATIONS (continued)

<u>Figure</u>	<u>Page</u>
7-12	The Unconstrained Linear Regression and 95% Prediction Limits of the Crosswind Components of Leeway versus Wind Speed at 10m, Maritime Life Rafts, deep ballast systems, canopy, without drogue, 4-6 person capacity, heavy loading. .... 7-18
7-13	The Unconstrained Linear Regression and 95% Prediction Limits of the Leeway Speed versus Wind Speed at 10m, Maritime Life Rafts, deep ballast systems, canopy, with drogue, 4-6 person capacity, heavy loading. .... 7-20
7-14	The Unconstrained Linear Regression and 95% Prediction Limits of the Downwind Component of Leeway versus Wind Speed at 10m, Maritime Life Rafts, deep ballast systems, canopy, with drogue, 4-6 person capacity, heavy loading. .... 7-21
7-15	The Unconstrained Linear Regression and 95% Prediction Limits of the Crosswind Component of Leeway versus Wind Speed at 10m, Maritime Life Rafts, deep ballast systems, canopy, with drogue, 4-6 person capacity, heavy loading..... 7-22
7-16	The Unconstrained Linear Regression and 95% Prediction Limits of the Leeway Speed versus Wind Speed at 10 m, Maritime Life Rafts, deep ballast systems, canopy, 4-6 person capacity ..... 7-26
7-17	The Unconstrained Linear Regression and 95% Prediction Limits of the Downwind Component of Leeway versus Wind Speed at 10 m, Maritime Life Rafts, deep ballast systems, canopy, 4-6 person capacity ..... 7-27
7-18	The Crosswind Component of Leeway versus Wind Speed at 10 m, Maritime Life Rafts, deep ballast systems, canopy, 4-6 person capacity, with drogue with light and heavy loading, and without drogue with light and heavy loading. .... 7-28
7-19	The Unconstrained Linear Regression and 95% Prediction Limits of the Positive and Negative Crosswind Component of Leeway versus Wind Speed at 10m, Maritime Life Rafts, deep ballast systems, canopy, without drogue, 4-6 person capacity. .... 7-29

## LIST OF ILLUSTRATIONS (continued)

<u>Figure</u>	<u>Page</u>
7-20	The Unconstrained Linear Regression and 95% Prediction Limits of the Leeway Speed versus Wind Speed at 10m, Maritime Life Rafts, deep ballast systems, canopy, 4-6 person capacity. .... 7-30
7-21	The Unconstrained Linear Regressions and 95% Prediction Limits of the Downwind Component of Leeway versus Wind Speed at 10m, Maritime Life Rafts, deep ballast systems, canopy, 4-6 person capacity ..... 7-31
7-22	The Unconstrained Linear Regression and 95% Prediction Limits of the Leeway Speed versus Wind Speed at 10m, Maritime Life Rafts, deep ballast systems, canopy, 15-25 person capacity. .... 7-33
7-23	The Unconstrained Linear Regression and 95% Prediction Limits of the Downwind Component of Leeway versus Wind Speed at 10m, Maritime Life Rafts, deep ballast systems, canopy, 15-25 person capacity ..... 7-34
7-24	The Crosswind Component of Leeway versus Wind Speed at 10m, Maritime Life Rafts, deep ballast systems, 15-25 person capacity. .... 7-35
7-25	The Unconstrained Linear Regression and 95% Prediction Limits of the Positive and Negative Crosswind Component of Leeway versus Wind Speed at 10m, Maritime Life Rafts, deep ballast systems, canopy, 15-25 person capacity. .... 7-36
7-26	The Unconstrained Linear Regression and 95% Prediction Limits of the Leeway Speed versus Wind Speed at 10m, Maritime Life Rafts, deep ballast systems and canopy..... 7-38
7-27	The Unconstrained Linear Regression and 95% Prediction Limits of the Downwind Component of Leeway versus Wind Speed at 10m, Maritime Life Rafts, deep ballast systems and canopy..... 7-39
7-28	The Crosswind Component of Leeway versus Wind Speed at 10m, Maritime Life Rafts, deep ballast systems and canopy. .... 7-40
7-29	The Unconstrained Linear Regression and 95% Prediction Limits of the Positive and Negative Crosswind Components of Leeway versus Wind Speed at 10m, Maritime Life Rafts, deep ballast systems and canopy.... 7-41



## LIST OF ILLUSTRATIONS (continued)

<u>ILLUSTRATIONS IN APPENDIX B</u>	<u>Page</u>
Examples of Boating PIW and their PFDs .....	B1-3
Examples of Maritime Survival Craft.....	B2-1
Examples of Person-Powered Craft .....	B3-1
Examples of Full Keel One-Design Sailboats .....	B4.1-1
Examples of Fin Keel One Design Sailboats.....	B4.2-1
Examples of Dagger/Centerboard One Design Sailboats .....	B4.3-1
Examples of Bare Bottom One Design Sailboats .....	B4.4-1
Example of a Sport Catamaran .....	B4.5-1
Example of a Sport Trimaran.....	B4.6-1
Examples of Full Keel Cruising Sailboats .....	B4.7-1
Examples of Fin Keel Cruising Sailboats.....	B4.8-1
Example of a Water Ballast Trailer Sailboat .....	B4.9-1
Examples of Cruising Catamarans.....	B4.10-1
Examples of Cruising Trimarans .....	B4.11-1
Example of a Hovercraft.....	B5.1-1
Examples of Inflatable Boats .....	B5.2-1
Examples of Skiffs.....	B5.3-1
Example of a Personal Water Craft .....	B5.4-1
Examples of Sport Boats .....	B5.5-1
Examples of Sport Fishers.....	B5.6-1
Examples of Sport Cruisers.....	B5.7-1

LIST OF ILLUSTRATIONS (continued)

<u>ILLUSTRATIONS IN APPENDIX B (continued)</u>	<u>Page</u>
Examples of Commercial Fishers .....	B5.8-1
Examples of Coastal Freighters .....	B5.9-1
Examples of Aviation PIW's PFDs.....	B7-1
Examples of Aviation Survival Craft .....	B8-1
Examples of Combat SAR Aviation PIW's PFDs .....	B10-1
Example of a Combat SAR Aviation Survival Craft.....	B11-1
Examples of Combat SAR Maritime PIW's PFDs.....	B13-1
Example of a Combat SAR Maritime Survival Craft.....	B14-1

## LIST OF TABLES

<u>Table</u>	<u>Page</u>
1-1	Conversion Factors for Units..... 1-6
2-1	Leeway Studies Using the Indirect Method of Measuring Sea Currents and Wind to Determine Leeway ..... 2-2
2-2	Leeway Studies Using the Direct Method of Measuring Leeway ..... 2-6
2-3	Objects that have been field tested for leeway values.....2-8
3-1	Unconstrained Linear Regression of Leeway Speed of Hufford and Broida 's (1974) 12-foot Rubber Raft without sea anchor on Wind Speed and of Tulmar 4-person Life Raft (1-person loading, no drogue) on 10-meter wind ..... 3-2
3-2	The Coefficients of the Polynomials Describing 95% Prediction Limits of the Unconstrained Linear Regression of Leeway Speed on Wind Speed for Hufford and Broida (1974) 12-foot rubber raft without sea anchor, and on 10-meter Wind Speed for Tulmar 4-person Life Raft (1-person loading, no drogue) ..... 3-4
3-3	Summary of Leeway Drift Runs Tulmar 4-person Life Raft (1-person loading, no drogue)..... 3-6
3-4	Leeway Angle: Hufford and Broida's (1974) 12-foot Rubber Raft without sea anchor and Tulmar 4-person Life Raft (1-person loading, no drogue)..... 3-8
3-5	Hierarchy of Methods for Leeway Data Analysis.....3-10
3-6	Unconstrained Linear Regression of Leeway Components on Wind Speed for Hufford and Broida 's (1974) 12-foot Rubber Raft without sea anchor and on 10-meter wind for Tulmar 4-person Life Raft (1-person loading, no drogue) ..... 3-13
3-7	The Coefficients of the Polynomials Describing 95% Prediction Limits of the Unconstrained Linear Regression of Leeway Components on Wind Speed for Hufford and Broida (1974) 12-foot rubber raft without sea anchor, and on 10-meter Wind Speed for Tulmar 4-person Life Raft (1-person loading, no drogue) ..... 3-14

LIST OF TABLES (continued)

<u>Table</u>	<u>Page</u>
4-1 Drift Error Factors For Modified GDOC AMM.....	4-8
4-2 Comparison of AP98 Leeway Drift Area Model with Varying Values for the Standard Deviation of the Normal Distribution for 12-foot Rubber Raft without sea anchor for a Steady Wind of 5 knots for 96 hours.....	4-10
4-3 Comparison of AP98 Leeway Drift Area Model with Varying Values for the Standard Deviation of the Normal Distribution for 12-foot Rubber Raft without sea anchor for a Steady Wind of 10 knots for 48 hours.....	4-11
4-4 Comparison of AP98 Leeway Drift Area Model with Varying Values for the Standard Deviation of the Normal Distribution for 12-foot Rubber Raft without sea anchor for a Steady Wind of 15 knots for 32 hours.....	4-11
4-5 Comparison of AP98 Leeway Drift Area Model with Varying Values for the Standard Deviation of the Normal Distribution for 12-foot Rubber Raft without sea anchor for a Steady Wind of 20 knots for 24 hours.....	4-12
4-6 Comparison of AP98 Leeway Drift Area Model with Varying Values for the Standard Deviation of the Normal Distribution for 12-foot Rubber Raft without sea anchor for a Steady Wind of 40 knots for 12 hours.....	4-12
5-1 National SAR Manual's Leeway Target Classes, Values and References .....	5-2
5-2 USCG GDOC AMM Leeway Target Classes and Values.....	5-6
5-3 USCG CASP 1.1X Leeway Target Classes and Values .....	5-7
5-4 Canadian CG Search-Planning Tools Leeway Target Classes, Leeway Speed and References .....	5-9
5-5 Canadian CG Leeway Target Classes, Leeway Divergences, Angles and References.....	5-13
5-6 Leeway Classes Proposed for CASP 2.0 .....	5-14
5-7 Comparison of Leeway Drift Area Models for a Steady Wind of 20 knots for 6 and 24 hours (No Sea Surface or Wind Currents, LKP is a point) .....	5-17

LIST OF TABLES (continued)

<u>Table</u>	<u>Page</u>
5-8	Comparison of Leeway Drift Area Models for a Steady Wind of 10 knots for 48 hours, 20 knots for 24 hours, and 40 knots for 12 hours (No Sea Surface or Wind Currents, LKP is a point) ..... 5-19
5-9	Comparison of Leeway Drift Area Models for a steady wind of 20 knots for 6 and 24 hours (No Sea Surface or Wind Currents, LKP is a point) ..... 5-23
5-10	Downwind Displacement for Raft with Canopies, With Ballast Systems, without Drogues (10 meter Winds for 24 hours at 10, 20, 30 and 40 knots)..... 5-31
5-11	Downwind Displacement for Raft with Canopies, Without Ballast Systems, without Drogues (10 meter Winds for 24 hours at 10, 20, 30 and 40 knots)..... 5-32
5-12	Total Displacement for Life Rafts with Canopies and Deep Ballast Systems, with and without Drogues (10 meter Winds for 24 hours at 10, 20, 30 and 40 knots ..... 5-34
5-13	Comparison of Leeway Drift Area Models Life Raft with Canopy and Ballast System, No Drogue for a steady wind of 5, 10, 20 and 40 knots for 12 hours (No Sea Surface or Wind Currents, LKP is a point)..... 5-35
6-1	Leeway Drift Taxonomy Classification Rules..... 6-2
8-1	Recommended Leeway Speed and Direction Values for Search Planning Tools ..... 8-5
A-1	Leeway Taxonomy Tables: Cross-Reference Matrix ..... A-1
A-2	Boating PIW..... A-2
A-3	Maritime Survival Craft..... A-3
A-4	Person-Powered Craft ..... A-9
A-5	Sailing Vessels..... A-10
A-6	Power Vessels ..... A-18
A-7	Boating Debris ..... A-23

LIST OF TABLES (continued)

<u>Table</u>	<u>Page</u>
A-8 Aviation PIW .....	A-23
A-9 Aviation Survival Craft.....	A-24
A-10 Aviation Debris .....	A-30
A-11 Combat SAR Aviation PIW.....	A-31
A-12 Combat SAR Aviation Survival Craft .....	A-31
A-13 Combat SAR Aviation Debris .....	A-34
A-14 Combat SAR Maritime PIW .....	A-34
A-15 Combat SAR Maritime Survival Craft .....	A-35
A-16 Combat SAR Power Vessels (TBD).....	A-40
A-17 Combat SAR Maritime Debris.....	A-41
A-18 Law Enforcement Drift Objects .....	A-41
A-19 Maritime Safety Drift Objects .....	A-41
A-20 Military Drift Objects .....	A-42
B-1 Cross-Reference of Leeway Drift Objects .....	B1-1
C-1 USCG-Approved Life Raft Service Centers.....	C-6

## LIST OF ACRONYMS AND ABBREVIATIONS

AMM	Automated Manual Method or also known as the Automated Manual Solution
AP98	Allen and Plourde (1998) model of leeway drift area
CANSARP	CANadian Search And Rescue Prediction program
CAPT	Captain
CASP	Computer Assisted Search Planning program
CFR	Code of Federal Regulations
CG	Coast Guard
cm	Centimeters
cm/s	Centimeters per second
C-MAN	Coastal Marine Automated Network
COMDTINST	U.S. Coast Guard, Commandant Instruction
CTTO	Central Tactics and Trial Organization
CWL <sup>[1]</sup>	CrossWind component of Leeway
DCS	Doppler Current Sensor
Displ.	Displacement
DIW	Dead-In-the-Water
DWL	DownWind component of Leeway
EMCM	Electromagnetic Current Meter
F/V	Fishing Vessel
FAU	Florida Atlantic University
ft	Feet
GDOC	Geographic Display Operations Computer
GPS	(NavStar) Global Positioning System
HazMat	Hazard Materials
I.D.	Inside Diameter
ISARC	Improvement in Search And Rescue Capabilities project
km	Kilometers
kts	Knots (international)
L	Leeway speed
L $\alpha$	Leeway Angle
LCDR	Lieutenant Commander
LE	Law Enforcement
LKP	Last Known Position
LOST'98	Leeway OPS Search and rescue Test 1998
LT	Lieutenant
m	Meters
m/s	Meters per second
max	Maximum
min	Minimum
MEP	Marine Environmental Protection
min	Minute

## LIST OF ACRONYMS AND ABBREVIATIONS (continued)

MRS	(Motorola) Mini-Ranger microwave positioning System
MTS	Microwave Tracking System
N/A	Not Applicable
nm	Nautical Mile
OPS	Ocean Prediction System
PFD	Personnel Floatation Device
PIW	Person-In-the-Water
POC	Probability of Containment
POD	Probability of Detection
POS	Probability of Success
PWC	Personnel Water Craft
R&DC	Research and Development Center
RWL	Relative Wind Direction
s	Seconds
SS	Survival Suit
Std. Dev.	Standard Deviation
SAR	Search and Rescue
SLDMB	Self-Locating Datum Marker Buoy
SOLAS	Safety Of Life At Sea
Sq.	Square
$S_{y/x}$	Standard Error of the Estimate
U	Wind Speed
USCG	United States Coast Guard
USCGC	United States Coast Guard Cutter
USCGR	United States Coast Guard, Retired
w	With
w/o	Without
<b>W</b> <sub>10m</sub>	Wind Speed vector adjusted to 10 meter height

[1] Vectors quantities are in bold type.



# CHAPTER 1

## INTRODUCTION

### 1.1 MOTIVATION

This review of leeway was motivated by several questions about the status of leeway. Those questions were:

- 1) *Which leeway targets have been studied? (For what targets do we have data?)*
- 2) *What methods were used in each leeway field study? (How good is that data?)*
- 3) *What is the present level of understanding of leeway behavior?*
- 4) *How can we model the present level of understanding of leeway behavior?*
- 5) *What is present leeway guidance for search planning?*
- 6) *How does the present leeway guidance compare to the new models of leeway behavior?*
- 7) *What classes of leeway targets should be included in our search planning tools?*
- 8) *Are there new broader categories of search objects within the leeway taxonomy for which leeway equations can be generated from the available data?*
- 9) *What are the recommendations for leeway guidance for search planning tools?*
- 10) *What is the present level of modeling efforts?*

Questions of this nature have been raised recently and repeatedly within the Coast Guard and search planning communities. This report is an attempt to address the first nine questions. A companion report by Anderson et al. (1998) addresses the tenth question.

### 1.2 SCOPE

Leeway has been studied since World War II when Pingree (1944) reported on the leeway of Navy rafts. Since that time, twenty-five studies have reported on the leeway of common search and rescue (SAR) targets. This review updates the sources of original leeway studies used in the present versions of the United States and Canadian search planning tools. These tools include the National SAR Manual; Geographic Display Operations Computer (GDOC) Automated Manual Method (AMM); Computer Assisted Search Planning (CASP) program; and CANadian Search and Rescue Prediction (CANSARP) program. A brief review of the definition of leeway is presented in sections 1.2 and 1.3. The experimental methods and the craft used in each study are presented in Chapter 2, thus addressing questions (1) and (2) from section 1.1. Chapter 3 presents two well-documented life rafts from an old and a recent leeway study and the lessons learned from the two data sets, thereby addressing question (3). Chapter 4 is a review of the leeway drift portion of the CASP and GDOC AMM search engines. A new generation search area propagation engine, which uses mean and variance of the leeway components equation regressed against wind speed along with mean and variance of wind and sea surface currents, is introduced. A modification to GDOC AMM is proposed. A sensitivity analysis comparing these four models for generating leeway drift areas is presented. This attempts to address question (4). The leeway coefficients and sources of each

leeway class for the National SAR Manual, CASP 1.1.X and 2.0, and CANSARP are presented in Chapter 5 in answer to question (5). Chapter 5 also contains comparisons between the leeway distribution areas of GDOC, CASP and the new model introduced in Chapter 4 which addresses question (6). Chapter 6 includes the recommendation of establishing a taxonomy of leeway targets (the answer to question (7)) to provide accurate target descriptions for both the search planner and the researchers. Chapter 7 presents the results of analyses for leeway data sets combined using the leeway taxonomy outlined in Chapter 6, thus providing the answer to question 8. Chapter 8 provides recommendations for leeway guidance in the National SAR Manual and GDOC AMM (modified) and answers question 9.

Anderson et al. (1998) presents a companion review to this report on the status of modeling leeway dynamics, which addresses question 10. They reviewed four reports and provided their own presentation of leeway dynamics modeling. The four reports are Hodgins and Mak (1995), Richardson (1997), Su (1986) and Su, Robe and Finlayson (1997). A fifth report on leeway modeling efforts Central Tactics and Trial Organization (CTTO), (1974) was reviewed by Nash and Willcox (1991), but the CTTO report was not located after an extensive library search. Hoggins and Hoggins (1998) have recently released a report on modeling the leeway dynamics of a 20-person life raft and a 5.6-meter open boat.

### 1.3 LEEWAY IN SEARCH AND RESCUE

A key element of a successful search is the accurate prediction of the total displacement of a SAR target from its estimated Last Known Position (LKP). For a search object located on the surface of the water, the total displacement is the vector addition of the sea surface currents and leeway.

Leeway as defined by the National SAR Manual is "that movement of a craft through the water, caused by the wind acting on the exposed surface of the craft." This definition of leeway is physically correct, but it has two major operational shortcomings. The SAR planner does not have access to estimates of the wind profile integrated over the height of leeway object nor estimates of a vertical profile of the sea current. Objects on the surface of the ocean are at the interface of two boundary layers where there is high vertical shear in the velocity profiles of wind and sea currents. Fitzgerald et al. (1993) proposed a revised leeway definition:

"Leeway is the velocity vector of the SAR object relative to the downwind direction at the search object as it moves relative to the surface current as measured between 0.3m and 1.0m depth caused by winds (adjusted to a reference height of 10m) and waves."

This definition standardizes the reference levels for the measurement of the leeway of SAR objects. Estimates of the velocity fields at both of these levels are readily available to the operational SAR planner. Most "sea level" wind products are adjusted to the 10 meter height. The new Self-Locating Datum Marker Buoys (SLDMBs) are designed with drag elements between 0.3 m and 1.0 m depth – matching exactly the depth range of the new revised definition of leeway.

The revised definition of leeway is an operational definition and not a purely correct physical definition. Therefore, there are certain limitations to this definition. At very low wind speed there are limitations in the adjustment algorithms of the wind profile during very stable conditions. See Smith (1988) for a discussion of the limitation for his algorithm. Deep draft leeway targets (such as ships, swamped barges, capsized sailboats) greatly extended beyond the depth range of the surface current as defined by the 0.3 to 1.0m layer. For these target types the effect of the deeper currents may be significantly greater and different from the effect of the surface currents between 0.3 and 1.0m depth. With deep draft vessels at low wind speed, the vessel could be moving more in response to the deeper current than to the upper currents. The vertical shear between the lower current and upper current could produce an apparent leeway. SAR objects such as sea kayaks and surf/sail boards, that have little freeboard and draft limited to less than 30 centimeters will have a leeway due primarily to wind driven drift of the top 30 cm of the ocean and not necessarily due to direct wind forcing.

#### 1.4 DEFINITIONS OF PARAMETERS

**Leeway Angle** ( $L\alpha$ ) is defined as leeway drift direction minus the direction towards which the wind is blowing with a deflection to the right of downwind being positive and to the left being negative, as shown in Figures 1-1 and 1-2. This is the same convention as relative wind direction. A leeway angle of 0 degrees indicates that the craft drifts directly downwind.

**Leeway speed** ( $|L|$ ) is the magnitude of the leeway velocity, as shown in Figure 1-2. Leeway speed is always positive. Leeway speed and angle are the polar coordinates for the leeway velocity vector.

**Downwind and Crosswind components of Leeway** are the components of the leeway velocity vector expressed in rectangular coordinates relative to the wind velocity vector (i.e.  $W_{10m}$ ), as shown in Figure 1-2. The two components of leeway can be positive or negative. However, as a practical matter, the downwind component of leeway is almost always positive. The crosswind component is the divergence of the SAR craft from the downwind direction. Positive crosswind components are divergence to the right of the wind and negative crosswind components are divergence to the left of the wind. A clear advantage of using crosswind components of leeway rather than leeway angle to express the divergence of SAR craft from the downwind direction comes at low wind speeds. Since crosswind components of leeway are multiplied by wind speed, the scatter in the crosswind component is reduced compared to the scatter of leeway angles at low wind speeds. The net result is that statistical regressions of the components of leeway can be directly implemented in numerical search planning tools.

**Leeway rate** is defined as the leeway speed ( $|L|$ ) divided by the wind speed adjusted to the 10-meter reference level ( $W_{10m}$ ). Taking into account that the units of  $|L|$  are cm/s and the units of  $W_{10m}$  are m/s, the result has units of percentage of the wind speed.

**Relative Wind Direction** is the direction from which the wind blows, measured in degrees about a chosen axis and reference point of the test craft, as shown in Figure 1-1.

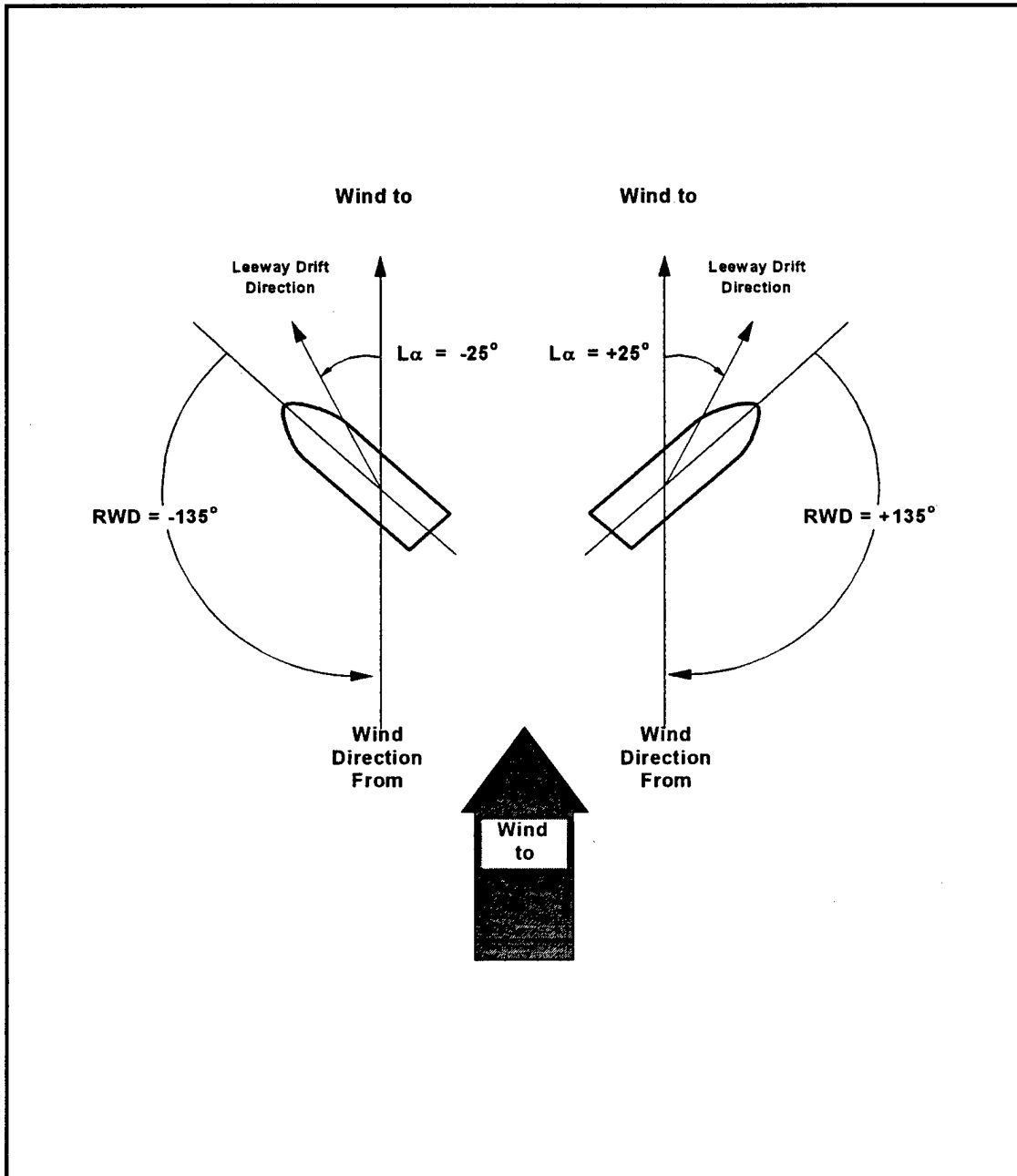
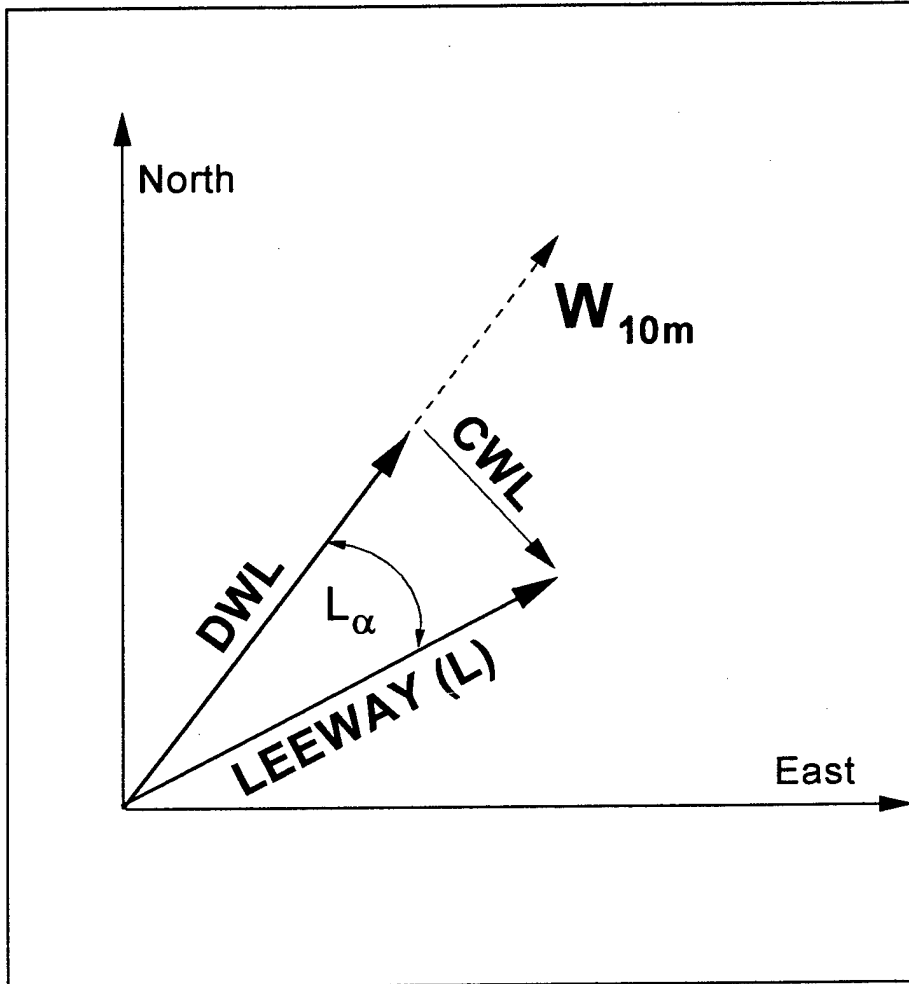

Figure 1-1. Relationship between Relative Wind Direction (RWD) and Leeway Angle ( $L\alpha$ ).



$W_{10m}$  = Wind velocity vector adjusted to 10m height,  
 $L$  = Leeway vector,  
 $L\alpha$  = Leeway angle,

$$\frac{|L|}{|W_{10m}|} = \text{Leeway rate,}$$

$$DWL = |L| \sin(90^\circ - L\alpha) = \text{Downwind Leeway component,}$$

$$CWL = |L| \cos(90^\circ - L\alpha) = \text{Crosswind Leeway component.}$$

Figure 1-2. Relationship between the Leeway Speed and Angle and the Downwind and Crosswind Components of Leeway

Historically, the objects of the search are referred to as leeway objects or leeway targets. The term leeway target is usually used when referring to SAR survivors or survivor craft. The term leeway object is usually used when referring to a broader range of drifting objects that include non-SAR objects as well as SAR targets. The terms leeway class and leeway category refer to objects or targets belonging to the same descriptive grouping. Leeway classes and leeway categories will be used interchangeably in this report.

Both English and metric units have been used in leeway reports. Leeway speed has been reported in units of knots (kts) and in centimeters per second (cm/s). The units for wind speed have been either knots or meters per second (m/s). Degrees are used for angular measurements – leeway angle, relative wind direction, and wind direction. Degrees Celsius are used for air and water temperatures. Wave heights are expressed as significant wave height in units of meters.

Table 1-1 provides conversion factors for metric to and from English units.

Table 1-1  
Conversion Factors for Units

To Convert from	To	Multiply by
meters	feet	3.2808399
kilometers	nautical miles	0.53995680
nautical miles	kilometers	1.852
nautical miles	meters	1852.
(nautical mile) <sup>2</sup>	(kilometer) <sup>2</sup>	3.429904
(kilometer) <sup>2</sup>	(nautical mile) <sup>2</sup>	0.291553346
m/s	knots	1.9438462
cm/s	knots	0.0194385
knots	m/s	0.514444
knots	cm/s	51.4444

## CHAPTER 2

### REVIEW OF PREVIOUS LEEWAY FIELD EXPERIMENTS

- 1) *Which leeway targets have been studied?*
- 2) *What methods were used in each leeway field study?*

#### 2.1 LEEWAY FIELD EXPERIMENTS: METHODS

There are two basic methods of measuring leeway: direct and indirect. The direct method uses a current meter attached directly to the leeway drift target to measure relative motion of the target through the water. The indirect method estimates leeway by subtracting a sea current vector from the total displacement vector to estimate the leeway vector. Both methods have their relative strengths and weaknesses.

##### 2.1.1 Indirect Method

The leeway table in the National SAR Manual is based upon the leeway field studies previous to joint US/Canadian field experiments that started in the early 1990's. With the exception of two studies, leeway studies prior to Fitzgerald et al. (1993) used the indirect method. Nash and Willcox (1991) first summarized the indirect investigations used by the National SAR Manual. Table 2-1 summarizes the methods of measuring sea currents, winds, and positions of the leeway targets for the sixteen studies that used the indirect method to investigate leeway.

The leeway studies that indirectly measured leeway had several shortcomings in the data collection itself. The buoys or drifters used to measure ocean currents contained systematic slippage errors. For the dye patch method, there was uncertainty in the depth of dye patch as measured by aerial photography. Navigational errors in determining the location of drifters and leeway targets caused errors of the leeway estimates. Drifters used to measure surface currents were not co-located with the leeway target. Thus, the leeway vector contained a combination of errors of surface current vector and the total displacement vector. Winds were determined by reading the ship anemometer or by measurements made at the leeway target. Ships' winds tended to overestimate the wind speed compared to the wind speed at the standard 10-meter reference level. Ships' anemometers which contain flow distortion biases were often not adjusted downward to the 10-meter level. Wind data from anemometers at 2-meter height aboard leeway targets required adjustment for motion of target and then further adjustment to the 10-meter height using a boundary layer model for winds.

The error of the leeway estimates for a SAR object included all the errors in the associated sea current measurements and wind measurements, plus the navigational errors used for determining the velocity of SAR objects. The surface currents at the time and position of the SAR object were interpolated or extrapolated from the sea current measurements. Maintaining an array of sea surface current measuring instruments relative to drifting leeway target was a

major logistical problem. This led to short and discontinuous data sets, especially when the sea conditions got rough which are exactly the conditions of most interest to the Coast Guard. Measurement of leeway angle was particularly difficult with the indirect method as the navigational errors tended to generate errors that masked the directional estimates of leeway. Spot measurements of winds that were not co-located with the leeway target also contaminated the results and generated noisy estimates of leeway directions.

Table 2-1

Leeway Studies Using the Indirect  
Method of Measuring Sea Currents and Wind  
To Determine Leeway

STUDY	SEA CURRENTS	WINDS	NAVIGATION
Pingree (1944)	upper 15 ft	at 10 ft	not reported
Chapline (1960)	15x300 ft drift net	Buoy Tender	Radar & visual Bearing & ranges
Hiraiwa, Fujii, and Saito (1967)	Gill Net several miles long	ship's anemograph	range and bearings
Hufford and Broida (1974)	Dye Patch aerial Photographed every 5 min.	Cup-anemometer at 2 m, reading at 5 min intervals	Scaling of aerial photographs by landmarks and altitude
Morgan, Brown, and Murrell (1977); Morgan (1978)	28 ft. dia. parachute drogue, tracked by ship, 20 min sampling	USCGC(s) EVERGREEN COURAGEOUS LAUREL ROCKAWAY	Range (radar) Bearing (visual or radar)
Scobie and Thompson (1979)	15 ft buoy w/ 10x10 ft window shade drogue tracked by ship	USCGC EVERGREEN hourly readings	Visual & radar bearing and ranges from ship
Osmer, Edwards, and Breitler (1982)	Buoy w/ window shade drogue tracked by ship, Expendable surface current probes	USCGC EVERGREEN 15 min readings	MRS for range visual bearing using ship's pelorouses, ship position Loran-A or C



Table 2-1 (Continued)

Leeway Studies Using the Indirect  
Method of Measuring Sea Currents and Wind  
To Determine Leeway

STUDY	SEA CURRENTS	WINDS	NAVIGATION
Igeta, Suzuki, & Sato (1982)	2 meter current measuring pipe	15 min. reading at 3 m, adjusted by 1.22 to $W_{10m}$	DECCA
Suzuki, Sato, Okuda, and Igeta (1984)	current measuring pipe	15 min. reading at 3 m, adjusted by 1.22 to $W_{10m}$	DECCA
Suzuki, Sato & Igeta, (1985)	current measuring pipe	15 min. reading at 3 m, adjusted by 1.22 to $W_{10m}$	DECCA
Nash and Willcox (1985)	Surface Drifters tracked by MTS at 2 min intervals	R.M. Young anemometer 6 ft, 3 sec averages every 30 or 40 seconds	Microwave Tracking System (MTS)
Nash and Willcox (1991)			
Fitzgerald, Russell, and Bryant (1990)	Loran-C Surface Drifters 5 min intervals	R.M Young anemometer 1.6 m, 10 sec ave every 2 min	Loran-C 5 min intervals
Valle-Levinson and Swanson (1991)	Rhodamine dye at 15 cm depth & drift cards	Anemometer at 1 m, reading every 5 min.	X-Y grid of 2.1m on edge of swimming pool
Su, Robe and Finlayson (1997)	Surface drifters of FAU design	C-MAN station anemometer 20 ft, hourly Adjusted ( $z/10$ ) to $1/7$ power	Triangulation from shore using transits
Kang (1999)	colored vinyl bag	OHOTO Anemometer, 5 or 10 min. Adjusted ( $z/10$ ) to $1/7$ power	Triangulation from shore using transits

### 2.1.2 Direct Method

The direct method, as the name implies, measures leeway directly with instruments attached to the leeway craft. Besides a current meter, instruments attached to the leeway craft include a wind monitoring system aboard the SAR object as well as a positioning system and locating beacons.

The earliest direct method study of leeway was by Suzuki and Sato (1977). They used a 3.9 meter bamboo pole which was allowed to drift from the ship until the pole came to the end of a string. Measurements of the drift direction and time of pay-out of the pole were regressed against the ship's wind speed. During the early 1990s, the availability of internal-recording, high-speed, non-mechanical current meters made it possible to outfit a wide variety of leeway targets for autonomous operations. The targets typically included attached current meters, on-board wind monitoring systems, some type of positioning system, and radio beacons for relocation of the target. Table 2-2 summarizes the methods used by the eight leeway studies which so far have used the direct method of leeway measurement.

The first trials using autonomous outfitted leeway targets were conducted by Fitzgerald et al. (1993). They conducted an experiment off Newfoundland during the summer of 1992 to compare the indirect method with the direct method of determining leeway.

The direct method eliminates many of the errors associated with the indirect method by directly measuring the leeway of the SAR object using an attached current meter. A wind monitoring system was placed aboard the SAR object along with a positioning system and a locating beacon. This method resulted in long, continuous records of leeway even in high wind conditions and when the craft swamped or capsized. The errors of measuring, interpolating or extrapolating sea currents to the location of a drifting leeway target were eliminated. Remaining errors were random instrument errors and systematic errors associated with interactions between the measuring instruments and the SAR object. With the direct method, the SAR object was modified by the addition of a wind monitor and a tethered current meter. The wind monitor had a minimal effect on the drift of medium size SAR targets. The SAR object possibly distorts or deflects the wind field locally causing a systematic error in both speed and direction at the location of the anemometer. The tethered current meter acted as a drogue and may have affected the crosswind component of leeway by reducing jibing.

Six of the eight leeway studies using the direct method have used an S4 electromagnetic current meter (EMCM) produced by InterOceans System, Inc. The procedure for using an S4 EMCM is as follows: The S4 EMCM was suspended with an aluminum frame at 0.75 meters depth. The frame was attached to a float sized to match the drift of the leeway craft. A 15-meter line attached the frame with S4 EMCM to the pivot point of the leeway craft. S4 EMCMs sampled at 2 Hz and were vector averaged over 10-minute periods. An internal flux-gate compass converted the two orthogonal components of velocity to magnetic north and east coordinates. The raw directions of currents from the S4 EMCM were adjusted for the magnetic variation and then rotated 180 degrees. The 180-degree rotation converts from the motion of water relative to the current meter reference frame to the reference frame of the motion of target craft relative to water. Two tilt sensors in the

S4 EMCM were used to apply, at 2 Hz, the cosine correction for the tilt angle to the current speed. Temperature at 0.75-meter depth was also sampled every 10 minutes. The S4 EMCMs were calibrated yearly by InterOceans.

The newly produced Aanderaa current meter (DCS 3500) uses acoustic Doppler techniques to remotely sense the currents at a distance of 0.5 to 2.0 meters from the sensor head. The sensor head is a disc 11.3 cm across by 4.5 cm high and contains compass and tilt sensors. A cable between the sensor and a separate data logger and battery unit delivers data and power. The Aanderaa DCS 3500 was calibrated in a series of tests including a comparison test with an S4 EMCM during a leeway experiment with a 36 foot Senator (sport cruisers, motor yacht, modified-V hull, covered aft deck, with bridge canopy). The results of the calibration are presented in O'Donnell and Oates (1999).

During fall of 1997 off Fort Pierce, Florida, the Aanderaa DCS 3500 was used to obtain leeway measurements on three variations of PIWs. A mannequin PIW was outfitted with the data logger in the chest cavity and the sensor head located below the PIW at 70-centimeter depth. The PIW with a type I PFD or type II PFD or a survival suit was deployed within the immediate region of a MiniMet buoy which provided the on-scene wind and weather conditions.

The Coast Guard R&D Center recently purchased a new acoustic current meter produced by Sontek Corporation. The Sontek Argonaut XR current meter measures two-horizontal components of current and the vertical component in a bin that is vertically separated from the current meter head. For the Argonaut XR current meter with a sampling frequency of 1.5Mhz the sampling bin is located between 0.5 and 15 meters from the sensor head with a minimum size of 1.0 meters. During leeway field tests conducted off the Delaware coast during January 1998, the Argonaut XR 1.5 MHz current meter was used in a windsurfer board with the bin's depth range set 0.5 to 1.5 meters. Another Argonaut XR with a sampling frequency of 3 MHz current will shorten the bin range to 0.25 meters to 7.5 meters with a minimum size of 0.5 meters. This will allow sampling the depth range from 0.25 to 0.75 meters.

Wind measurements were made using the R. M. Young propeller/vane Model 05103 anemometer for eight leeway studies. The anemometers were sampled at 1 Hz and vector averaged over 10-minute periods. The winds were first adjusted for the motion of the craft using the Argos, Loran-C or GPS positions to determine speed over the ground. Then the winds were adjusted to the 10-meter height based upon the stability of the air and wind speed using Smith (1981) and (1988). The compasses and vanes for each wind monitoring system were calibrated before each leeway study. Where possible, the winds from the leeway targets were checked against the winds from a MiniMet buoy moored in the center of the study area, since the MiniMet had nil wind flow distortion associated with it.

Table 2-2  
Leeway Studies Using the Direct  
Method of Measuring Leeway

Study	Measurement of Leeway	Measurement of Winds	Navigation of targets
Suzuki and Sato (1977)	3.9 m bamboo pole tethered to ship	Ship's winds	None required
Fitzgerald, Finlayson, Cross, and Allen (1993)	S4 EMCMS at 0.7 m depth, 10 min. averages	R.M. Young anemometer 2m or 3m, 10 minute averages, adjusted to 10m using Smith (1988)	Argos positions
Fitzgerald, Finlayson, and Allen (1994)	S4 EMCMS at 0.7 m depth, 10 min. averages	R.M. Young anemometer 2m or 3m, 10 minute averages, adjusted to 10m using Smith (1988)	GPS positions every 5 min. stored on data logger
Kang (1995)	Marsh-McBirney EMCM at 1 m depth	Japanese anemometer at 5 m, adjusted to 10m using 1/7 power law	Loran-C and GPS
Fitzgerald (1995)	S4EMCMS at 0.7 m depth, 10 min. averages	R.M. Young anemometer 2m, 10 minute averages, adjusted to 10m using Smith (1988)	GPS positions every 5 min. stored on data logger
Allen (1996)	S4EMCMS at 0.7 m depth, 10 min. averages	R.M. Young anemometer 2m or 6.5m, 10 minute averages, adjusted to 10m using Smith (1988)	GPS positions every 5 min. stored on data logger
Allen and Fitzgerald (1997)	S4EMCMS at 0.7 m depth, 10 min. averages	R.M. Young anemometer 2m, 10 minute averages, adjusted to 10m using Smith (1988)	GPS positions stored every 5 min and Argos positions.
Allen, Robe and Morton (1999)	S4 EMCM, Aanderaa DCS, and Sontek Argonaut XR at 0.7m, 10 min. averages	R.M Young anemometer, 10 min ave. adjusted to 10m using Smith (1988).	GPS positions stored every 10 minutes

## 2.2 LEEWAY FIELD EXPERIMENTS: OBJECTS

Ninety-five leeway target types have been studied during twenty-five field studies. Forty life rafts, fourteen small craft (mostly outboards) and ten fishing vessels have been studied. Other leeway target types studied include PIWs, surfboards, sailboats, life capsules, Cuban refugee rafts, fishing vessel boating debris, and medical / sewage waste. Table 2-3 lists target craft or objects and their descriptions as provided by these twenty-five field studies.

Column one (Target Description) of Table 2-3 contains exact descriptions of leeway target types as presented in the reports. Some reports provided illustrations of the leeway targets. Those illustrations are reproduced here as Figures 2-1 through 2-34 and are referenced in column one of Table 2-3. Pingree (1944); Chapline (1960); Hufford and Broida (1974); and Suzuki, Sato, and Igeta (1985) do not provide full descriptions of the leeway objects that they used in their studies. The Japanese leeway studies of vessels [Hiraiwa, Fujii, and Saito (1967), Suzuki and Sato (1977), and Igeta, Suzuki, and Sato (1982)] include tables for each vessel's gross tonnage, length, beam, freeboard, draft, and ratio of longitudinal projected area above and below the water line. Morgan et al. (1977) included line illustrations of 4 of their 5 craft. The 20-person life raft was not illustrated nor were any results reported. Scobie and Thompson (1979) provided brief descriptions of the three rafts from which they obtained leeway data. Osmer et al. (1982) and Suzuki, Sato, Okuda and Igeta (1984) provided a reproduction of photos of some craft and a table with the length, height, and width measurements. Nash and Willcox (1991); Fitzgerald et al. (1990), (1993) and (1994); Fitzgerald (1995); Kang (1995); Allen (1996) and Allen and Fitzgerald (1997) provide line illustrations with dimensions for all leeway craft. Blanks in Table 3 indicate that the relevant report did not indicate the loading of the craft or whether the craft was drogued or un-drogued.

Chapline (1960) summarized his results of five groups into a single table that has become the standard leeway values for craft other than life rafts. In Chapline's Alumni Association Bulletin article, the word "Surfboards" appears only once and is part of Group I in his table. Group II is "heavy displacement, deep draft sailing vessels." Chapline's (1960) Group III is described as "Moderate displacement, moderate draft sailing vessels and fishing vessels such as trawlers, trollers, sampans, draggers, seiners, tuna boats, halibut boats, etc." However, it is unclear whether Chapline had any data on fishing vessels other than the fishing sampans common to the 14<sup>th</sup> District (Hawaii). Group IV is "moderate displacement cruisers" and Group V is "light displacement cruisers, outboards, planing hull types, skiffs, etc." In Chapline's discussion of leeway rate and angle he described some of his vessels as the "Very light, high-speed types, so popular among the yachting fraternity, such as Cris Craft, Owens, Trojan, etc." Since Chapline did not provide a complete description of the vessels used in his field work and both he and his co-worker, LCDR James McGary, USCGR ('43) are deceased it is unlikely that a complete description of the actual vessels used in "Operation Spindrift" can be obtained.

Table 2-3.

Objects that have been field tested for leeway values.

TARGET DESCRIPTION	LOADING	DROGUE		STUDY
		WITH	WITHOUT	
Mark I life raft	1 person	Yes	Yes	Pingree (1944)
Mark II life raft	2 person	Yes	Yes	
Mark IV life raft	3 person	Yes	Yes	
Mark VII life raft	5 person	Yes	Yes	
Army E I life raft	5 person	Yes	Yes	
Army A3 life raft	3 person	No	Yes	
Surfboards				Chapline (1960)
Heavy Displ. deep draft sailing vessels				
Moderate Displ. moderate draft sailing vessels and fishing vessels (trawlers, trollers, sampans, draggers seiners, tuna boats, halibut boats)				
Moderate Displ. cruisers				
Light Displ. cruisers, outboards, paning [planing] hull types skiffs				
60.5 m Fishery Training Vessel				Hiraiwa, Fujii, & Saito (1967)
33.0 m Fishery Training Vessel				
21 ft MARINER		Yes	Yes	Hufford and Broida (1974)
15.2 ft GLASTRON		Yes	Yes	
15 ft BARGE		Yes	Yes	
12 ft SILVER SKIF		Yes	Yes	
12 ft Rubber raft		Yes	Yes	
61.8 m fishing vessel, (1104 gross tons)			Yes	Suzuki and Sato (1977)
45.0 m research vessel, (702 gross tons)			Yes	
Mark 7 7-person life raft, w/o canopies or ballast system [Fig. 2-1]	nil	Yes	No	Morgan (1978)
20-person life raft		Yes	No	Morgan, Brown, and Murrell (1977)
16 ft Outboard motor boat [Fig. 2-2]	nil	No	Yes	
18 ft Outboard motor boat [Fig. 2-3]	nil	No	Yes	
30 ft Utility boat [Fig. 2-4]	nil	No	Yes	

Table 2-3 (Continued)  
 Objects that have been field tested for leeway values.

TARGET DESCRIPTION	LOADING	DROGUE		STUDY
		WITH	W/O	
Switlik Oblong 6-person life raft	3 person		Yes	Scobie and Thompson (1979)
Given 25-person life raft	12 person		Yes	
Goodrich circular 20-person life raft	10 person		Yes	
Avon circular 6-person Canopy life raft		Yes	Yes	Osmer, Edwards, & Breitler (1982)
Switlik Oblong 6-person Canopy life raft		Yes	Yes	
Switlik Circular 4-person Canopy life raft		Yes	Yes	
USCG Mark 7, 7-person Non- Canopy life raft		Yes	Yes	
16.7 m fishing vessel – longliner	Empty, half and full		Yes	Igeta, Suzuki, and Sata (1982)
17.5 m fishing vessel – longliner			Yes	
PFD				
Life Ring (42.5 cm I.D, 76 cm O.D)				
Glass fishing float balls (30.25cm dia.)				
Fish box lid (121 x 61 x 10cm)				
Wooden board (152 x 9.5 x 2.3cm)				
Small outboard boat w/o any superstructures (247 x 110 x 43 cm)				
PIW (65 kg)				
Japanese 8-person life raft, MTB-8 [Fig. 2-5]	Empty, half, and full	Yes	No	Suzuki, Sato, Okuda, & Igeta (1984)
Japanese 13-person life raft, TRB-13B		Yes	No	
Japanese 25-person life raft, MTB-25		Yes	No	
PIW, (vertical with PFD)				
Japanese life raft (MTB-8 ) w & w/o canopy	Empty, half	Yes	No	Suzuki, Sato and Igeta (1985)
Japanese life raft (TRB-13B) w & w/o canopy	Empty, half	Yes	No	
Japanese 25-person life raft "F"	Empty, half	Yes	No	
Japanese 25-person life raft "S"	Empty, half	Yes	No	
PIW, (vertical, sitting, horizontal positions)				
RFD 6-person MK3A life raft [Fig. 2-6]	80-100 lb.	No	Yes	Nash and Willcox (1985)
Switlik 4-person life raft [Fig. 2-7]	80-100 lb.	No	Yes	
Givens Buoy 6-person life raft [Fig. 2-8]	80-100 lb.	No	Yes	

Table 2-3 (Continued)  
Objects that have been field tested for leeway values.

TARGET DESCRIPTION	LOADING	DROGUE		STUDY
		WITH	W/O	
Switlik 4-person life raft	720 lb.	Yes	Yes	Nash and Willcox (1991)
Givens Buoy 6-person life raft	1040 lb.	Yes	Yes	
Avon 4-person life raft [Fig. 2-9]	720 lb.	No	Yes	
Winslow 4-person life raft [Fig. 2-10]	720 lb.	No	Yes	
14 ft Outboard (Boston Whaler-type)	100 lb.	No	Yes	
19 ft Outboard (Center-console sport fisherman w/ outboard)	200-300 lb.	No	Yes	
20 ft Cabin Cruiser [Fig. 2-11]	80 lb.	No	Yes	
Medical & sewage waste: (vials, syringes tampon applicators, I.V. bags, surgical masks, gloves, glass bottles)	N/A	No	No	Valle-Levisnson & Swanson (1991)
Beaufort 5-sided 4-person life raft	2 and 4 person	Yes	Yes	Fitzgerald et al. (1990)
Beaufort 5-sided 4-person life raft [Fig. 2-12]	1 person	No	Yes	Fitzgerald et al. (1993) and (1994)
Beaufort 5-sided 4-person life raft	4 person	Yes	Yes	
Beaufort 6-sided 4-person life raft [Fig. 2-13]	1 person	No	Yes	
Beaufort circular 20-person life raft [Fig. 2-14]	4 person	No	Yes	
Beaufort circular 20-person life raft	20 person	Yes	No	
5.6 m Open plank boat [Fig. 2-15]	2-3 person	No	Yes	
SOLAS approved 22-person life Capsule [Fig. 2-16]	12 person	No	Yes	
L1011 aircraft evacuation slide/ 46-person raft [Fig. 2-17]	20 person	No	Yes	
USCG Sea Rescue Kit [Fig. 2-18]	0 person	Yes	No	
Tulmar 4-person life raft [Fig. 2-19]	4 person	Yes	Yes	
Tulmar 4-person life raft	1 person	Yes	Yes	
Switlik 6-person Life Raft w/4 small ballast bags [Fig. 2-20]	1 person	Yes	Yes	Fitzgerald (1995)
12.5 m Korean Fishing Vessel [Fig. 2-21]	3-5 person	No	Yes	Kang (1995)
Cuban Refugee raft w/sail [Fig. 2-22]	1 person	No	Yes	Allen (1996)
Cuban Refugee raft w/o sail [Fig. 2-23]	1 person	No	Yes	
15 m Fishing Vessel w/ rear-reel for net fishing [Fig. 2-24]	4 person	No	Yes	



Table 2-3 (Continued)  
Objects that have been field tested for leeway values.

TARGET DESCRIPTION	LOADING	DROGUE		STUDY
		WITH	W/O	
5.5 m Wooden-planked Open Boat: (Upright and Empty) and (Swamped)	2-3 person	No	Yes	Allen and Fitzgerald (1997)
Switlik 6-person Life Raft w/Full Toroidal Ballast bag: (Upright and Empty) [Fig. 2-25] and (Swamped)	1 person	Yes	No	
Switlik 6-person Life Raft w/4 small ballast bags: (Upright and Empty) and (Capsized)	1 person	Yes	No	
Beaufort 5-sided 4-person life raft: (Upright and Empty) and (Capsized)	4 person	Yes	No	
PIW	N/A	No	Yes	Su, Robe, Finlayson (1997)
PIW in survivor suit	N/A	No	Yes	
PIW, Type I PFD [Fig. 2-26]	N/A	No	Yes	Allen, Morton and Robe (1999)
PIW, Survival Suit [Fig. 2-27]	N/A	No	Yes	
Sea Kayak [Fig. 2-28]	0 & 1 – person	No	Yes	
Wind-surfer board [Fig. 2-29]	1-person	Yes	Yes	
Wharf box, (cubic meter bait box) [Fig. 2-30]	1 & 4 person	No	Yes	
PIW – wetsuit, floating vertically	N/A	No	Yes	Kang (1999)
PIW – Scuba gear, floating horizontally	N/A	No	Yes	
36 ft Senator (Sport Cruisers, Motor Yacht, Modified-V Hull, Covered aft deck, w/ Bridge Canopy) [Fig. 2-31]	3 person	No	Yes	No results available (see note 1 below)
PIW, Type II PFD [Fig. 2-32]	N/A	No	Yes	
13.8 m Fishing Vessel w/ rear-reel for net fishing [Fig. 2-33]	4 person	No	Yes	
65 ft Sailboat (Mono-hull, full keel, deep- draft, w/masts) [Fig. 2-34]	5-6 person	No	Yes	

Note 1 for Table 2-3.

Leeway data has been collected on these four targets, but results are not available at this time. O'Donnell, Oates and Reas (1999) used the 36-foot Senator as a test platform for an inter-comparison test of S4 EMCM and Aanderaa DCS 3500 acoustic current meter. Further analysis of the leeway data set revealed that there was insufficient data to present even preliminary results for this target, (Herring, personal communication). Allen et al. (1999) investigated the leeway data collected on the PIW with a Type II PFD during the Fort Pierce 1997 leeway field test and determined that it too contained insufficient data for the presentation of

preliminary results. Both the 13.8-m fishing vessel and the 65-foot sailboat data sets are awaiting analysis. As time permits, analysis of these two data sets will be conducted. The 13.8-meter fishing vessel is similar in design to the 15-m fishing vessel studied by Allen (1996). The 65-foot sailboat's leeway data set will be studied in conjunction with data set yet to be collected on 30-foot sailboat that has been outfitted for heavy weather leeway studies.

Designs of leeway craft, especially life rafts, have significantly changed since the earliest studies. Over the past fifty years, the design of life rafts has evolved from a single rubber tube with a floor to fully canopied life rafts with multiple air chambers and large ballast bags. Not only have the leeway objects themselves evolved, but also the descriptions of the study targets have improved along with improvements in the methods used to collect leeway data. Therefore, care must be exercised when applying leeway values from early studies to modern SAR cases, since there have been considerable design changes that will dramatically affect the leeway of the SAR target in question.

Figures 2-1 through 2-34 are reproductions of the available figures of leeway objects that have been field-tested.

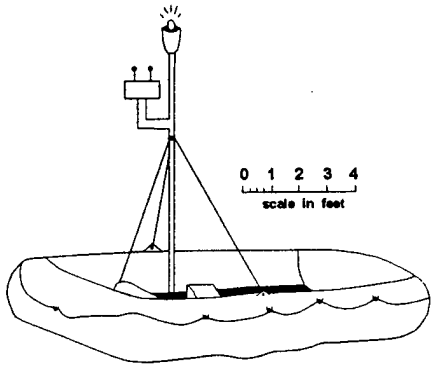

Figure 2-1. Mark 7 life raft

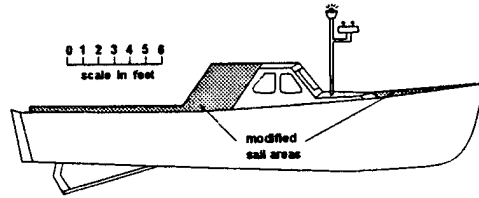

Figure 2-4. 30-foot Utility Boat

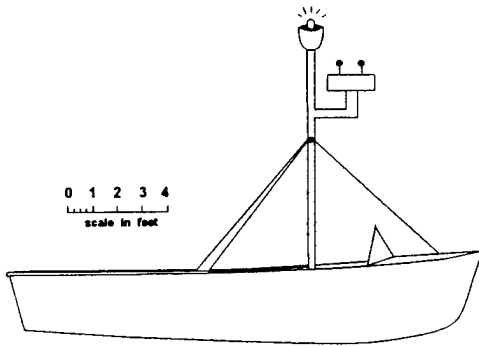

Figure 2-2. 16-foot Outboard Motor Boat

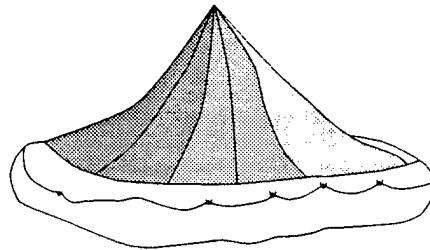

Figure 2-5. Japanese 8-person and 13-person life rafts

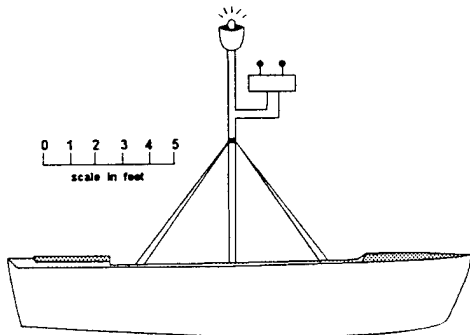

Figure 2-3. 18-foot Outboard Motor Boat

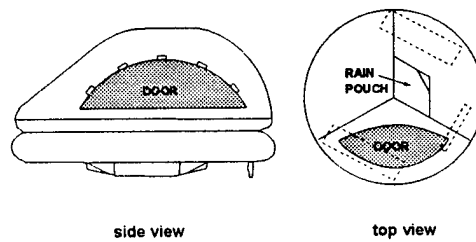

Figure 2-6. RFD 6-person MK3A life raft

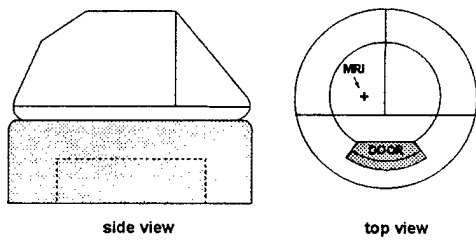

Figure 2-7. Switlik 4-person life raft

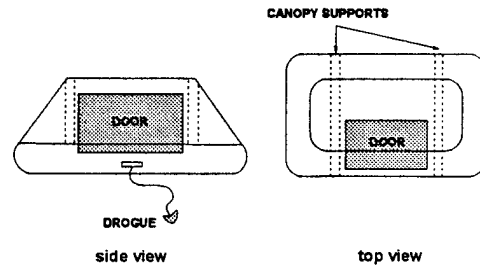

Figure 2-10. Winslow 4-person life raft

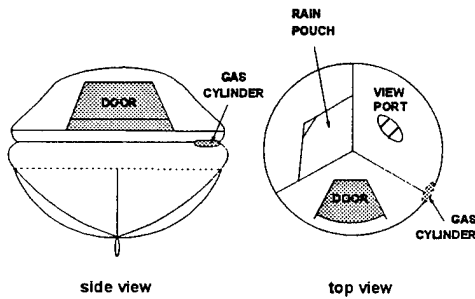

Figure 2-8. Givens Buoy 6-person life raft

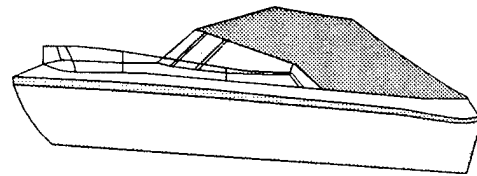

Figure 2-11. 20-foot Cabin Cruiser

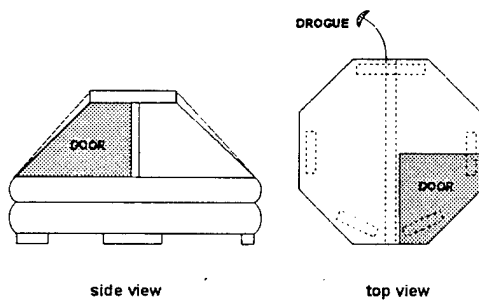

Figure 2-9. Avon 4-person life raft

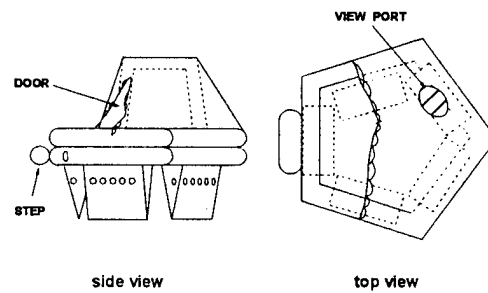

Figure 2-12. Beaufort 5-sided 4-person life raft

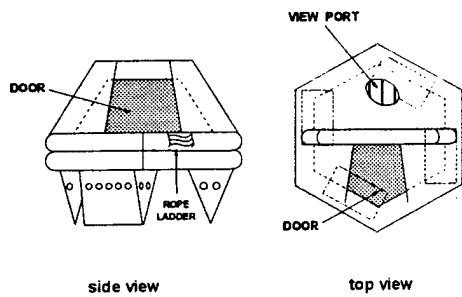

Figure 2-13. Beaufort 6-sided 4-person life raft

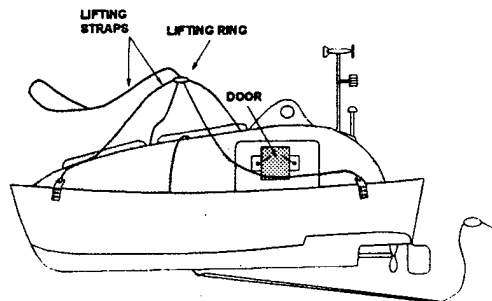

Figure 2-16. SOLAS approved 22-person Life Capsule

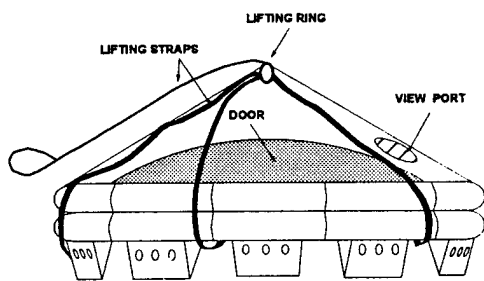

Figure 2-14. Beaufort circular 20-person life raft

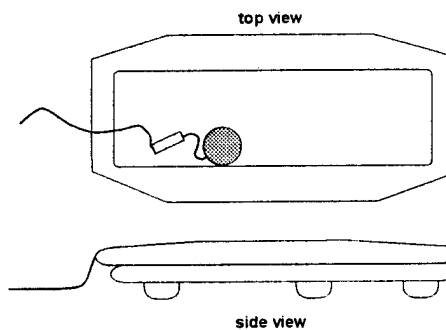

Figure 2-17. L1011 aircraft evacuation slide 46-person life raft

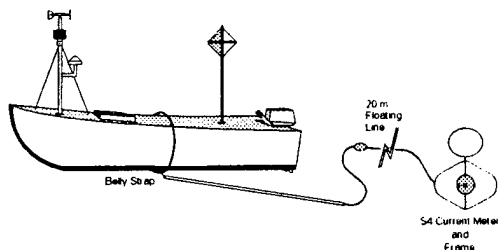

Figure 2-15. 5.6-m open wooden-planked boat

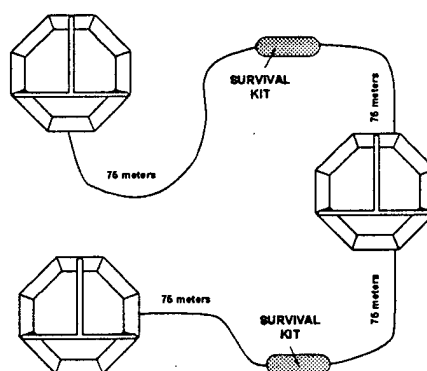

Figure 2-18. USCG Sea Rescue Kit

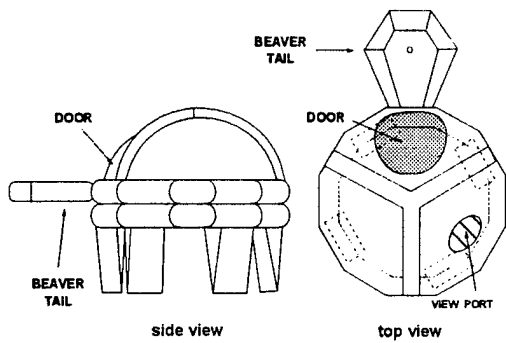

Figure 2-19. Tulmar 4-person life raft

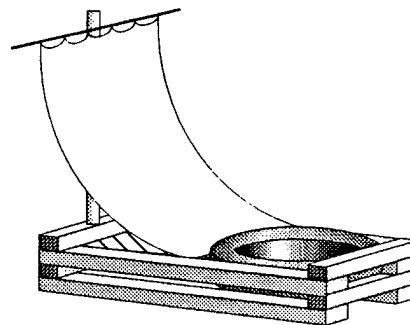

Figure 2-22. Cuban Refugee Raft with sail

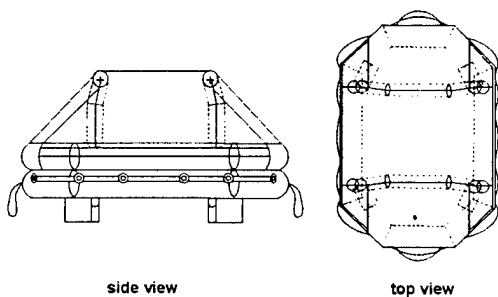

Figure 2-20. Switlik 6-person life raft with four small ballast bags

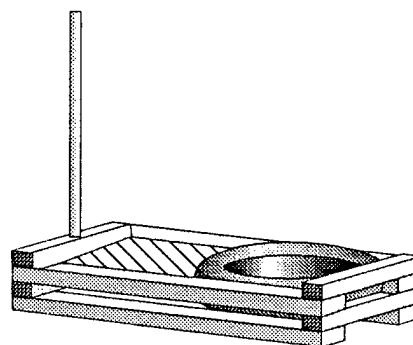

Figure 2-23. Cuban Refugee Raft without sail

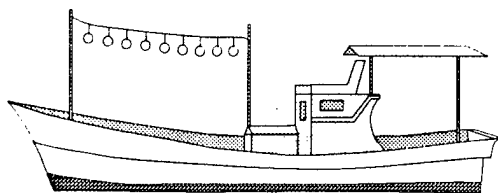

Figure 2-21. 12.5-m Korean Fishing Vessel

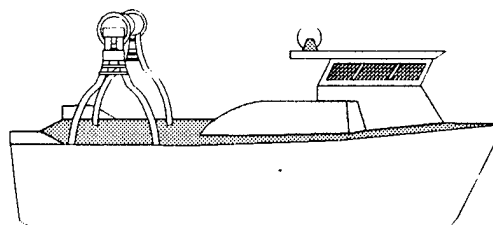

Figure 2-24. 15-m Fishing Vessel with rear-reel for net fishing

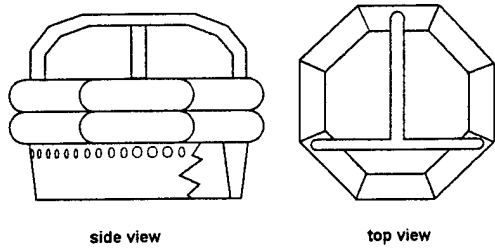

Figure 2-25. Switlik 6-person Life Raft with full Toroidal Ballast bag

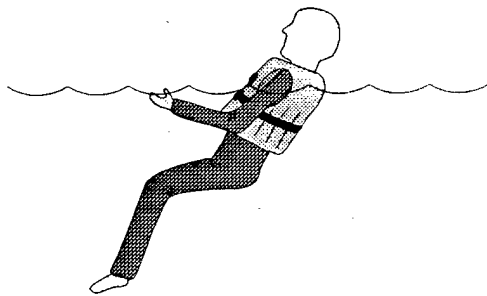

Figure 2-26. PIW, with Type I PFD

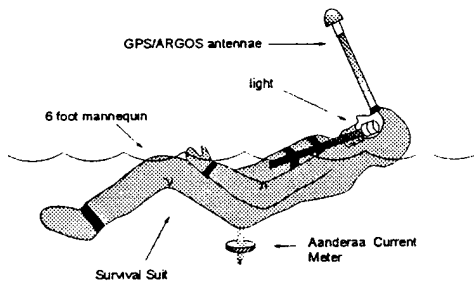

Figure 2-27. PIW in survival suit

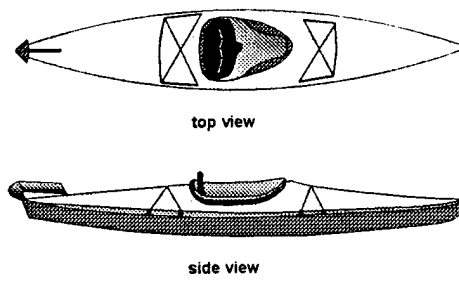

Figure 2-28. Sea Kayak

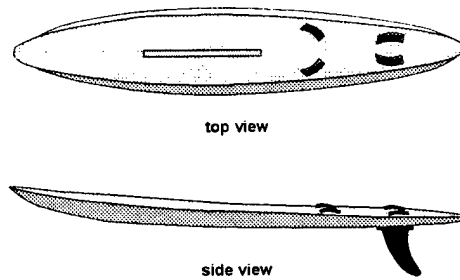

Figure 2-29. Wind-surf board

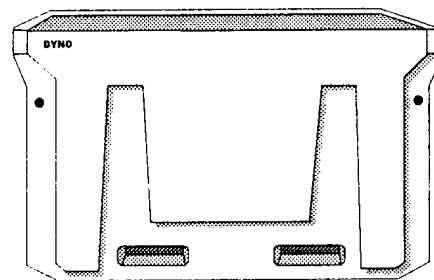

Figure 2-30. Wharf box, (cubic meter bait box)

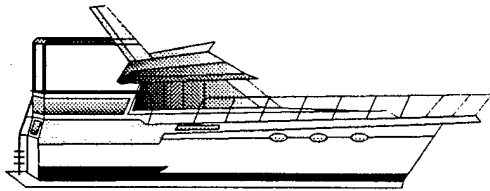

Figure 2-31. 36-foot Senator (Sport Cruisers, Motor Yacht, Modified-V hull, Covered aft deck with bridge canopy)

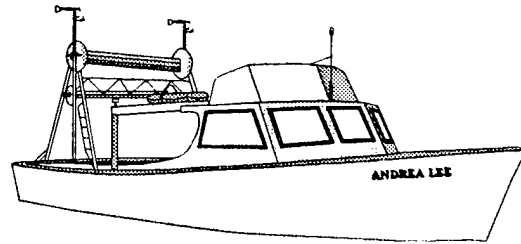

Figure 2-33. 13.8 m Fishing vessel with rear-reel for net fishing

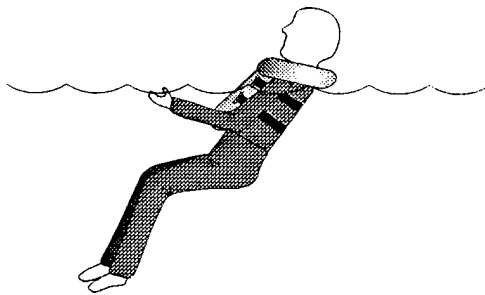

Figure 2-32. PIW, with Type II PFD

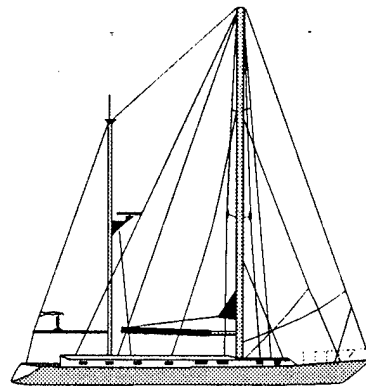

Figure 2-34. 65-foot Sailboat (Monohull, full keel, deep draft, with masts)



## CHAPTER 3

### COMPARISON OF THE LEEWAY OF TWO LIFE RAFTS

- 3) *What is the present level of understanding of leeway behavior?*

#### 3.1 INTRODUCTION

A review of the leeway behavior a single target type is presented here to illustrate the present level of understanding of leeway behavior. The data set collected by the direct method on a Tulmar 4-person life raft with 1-person loading without a drogue is presented in this section. A comparison between the Tulmar data set and a data set collected by Hufford and Broida (1974) using the indirect method on a 12-foot rubber raft is also presented to show the advancements that have been achieved by using the direct method compared to the indirect method.

A new model of leeway that generates a leeway distribution area is also introduced in this chapter. This model incorporates the level of understanding presently available in the analysis of data sets such as those for a Tulmar life raft as illustrated in this chapter. This model is used in Chapter 4 in a comparison with the presently implemented models of leeway distribution areas.

#### 3.2 THE LEEWAY OF A 12-FT RUBBER RAFT AND A TULMAR 4-PERSON LIFE RAFT

Hufford and Broida (1974) using the indirect method studied the leeway of a 12-foot rubber raft. The 12-ft. raft had 13.9 inches of freeboard, and 0.1 inches of draft and a weight of 50 pounds and was similar to the life raft illustrated in Figure 2-1. This 12-ft raft was studied with and without a sea anchor. Hufford and Broida provide a listing of data, which included both wind speed and direction and leeway speed and direction. Therefore the leeway data set from the 12-ft.raft without a sea anchor is used here as an example of an early leeway data set collected by the indirect method. The maximum wind speed for their data set was 8.2 m/s. This is an important and relevant data set since the results of Hufford and Broida (1974) provides much of the present guidance used by search planning tools.

Fitzgerald et al. (1993) using the direct method studied a Tulmar 4-person life raft (with 1-person loading, without a drogue) as shown in Figure 2-19. During the 1992 US/Canadian Field Experiment the Tulmar life raft was deployed on nine drift runs for a total of 1,166 10-minute averages or about 8 days of data. The wind speed ranged from 1 to 16 m/s for this data set. This data set represents one of the more complete sets collected by using the direct method on a specific configuration of a life raft.

The leeway speed and angle from these two data sets are compared in the section 3.2.1. In the section 3.2.2, a comparison of the downwind and crosswind components of leeway is presented.

### 3.2.1 Leeway Speed and Angle

The unconstrained linear regression of the leeway speed versus wind speed for the two data sets (12-foot raft, Tulmar life raft) are shown in Figure 3-1. There are two major points illustrated in this figure. (1) The two rafts had different mean regression slopes. The 12-foot rubber raft with neither ballast system nor canopy drifted at about 5.7 percent of the wind speed. The Tulmar life raft, which had a deep ballast system and a canopy, drifted slower at about 3.3 percent of the 10-meter wind. Since the two rafts were actually quite different in design it is not unexpected that the mean leeway rates would also be different. (2) Clearly the new data collected by the direct method provided higher quality data over much greater range of conditions with a smaller variance about the mean regression than the older data set collected by the indirect method.

The coefficients of the unconstrained linear regressions for the two data sets are presented in Table 3-1 and the coefficients for the 95% prediction limits equations are presented in Table 3-2. The standard error of the regression for the Tulmar life raft was 18% that of the standard error of the 12-foot raft.

Table 3-1

Unconstrained Linear Regression of Leeway Speed (cm/s)  
of  
Hufford and Broida (1974) 12-foot Rubber Raft without sea anchor  
on Wind Speed (m/s)  
and of  
Tulmar 4-person Life Raft (1-person loading, no drogue)  
on 10-meter Wind Speed (m/s)

Leeway speed (cm/s)	Leeway Study	# samples	Slope (% wind)	y- intercept (cm/s)	r <sup>2</sup>	S <sub>y/x</sub>	Wind Speed (m/s)
12-ft rubber raft	Hufford & Broida (1974)	21	5.74	10.87	0.59	10.37	1.1 to 8.2
Tulmar life raft	This report	1166	3.34	1.44	0.98	1.90	0.8 to 16.7

Hufford and Brodia (1974) 12 ft Rubber Raft with sea anchor  
 This report, Tulmar 4-person life raft, 1-person loading, no drogue

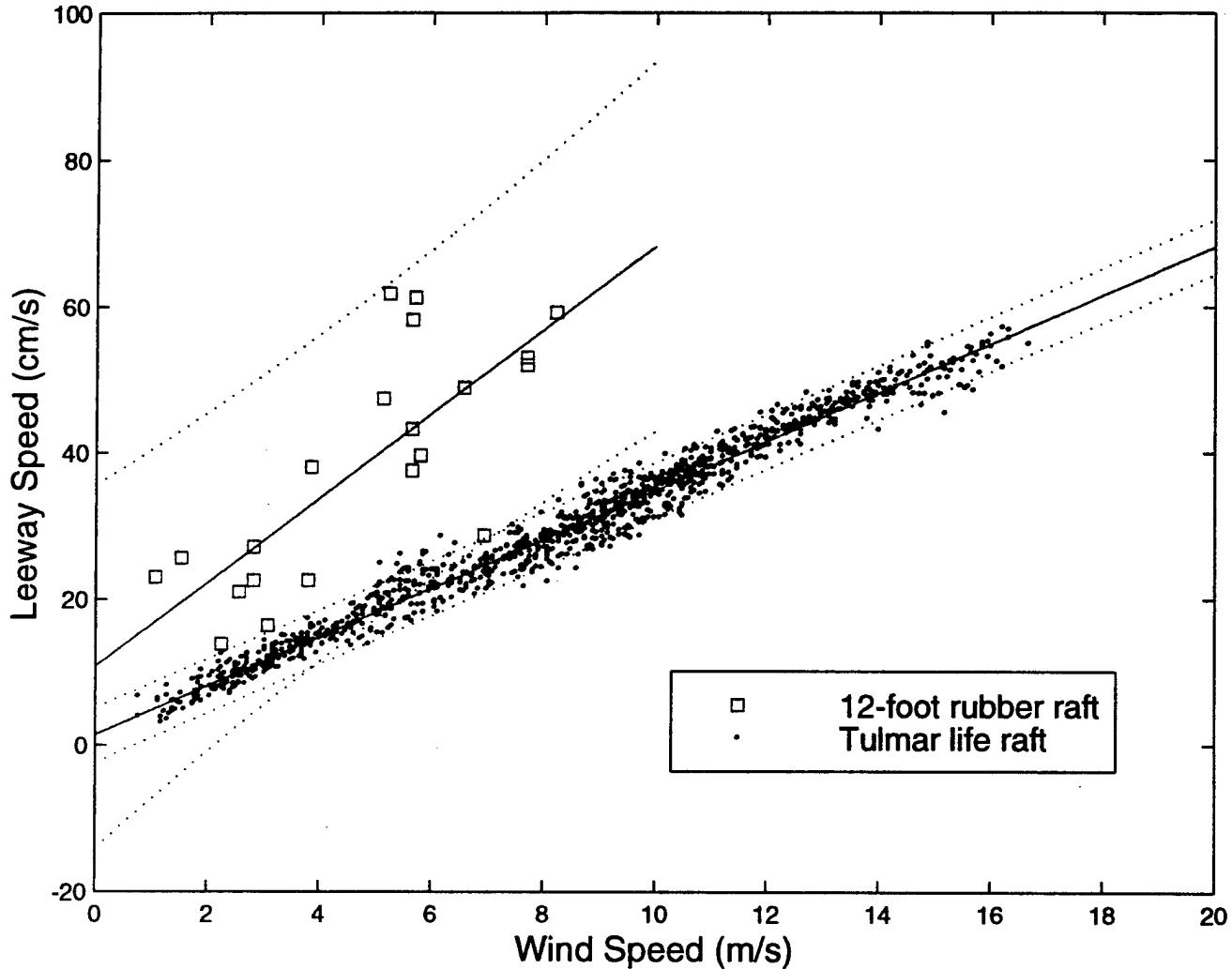

Figure 3-1. The Unconstrained Linear Regression and 95% Prediction Limits of Leeway Speed for Hufford and Brodia's (1974) 12-foot Rubber Raft without sea anchor versus Wind Speed (unadjusted) and a Tulmar 4-person Life Raft (1-person loading, no drogue) versus  $W_{10m}$ .

Table 3-2

The Coefficients of the Polynomials Describing  
 95% Prediction Limits of the  
 Unconstrained Linear Regression of Leeway Speed (cm/s)  
 (95% prediction limits =  $c_1(W_{10m})^2 + c_2(W_{10m}) + c_3$ )  
 of  
 Hufford and Broida (1974) 12-foot Rubber Raft without sea  
 on Wind Speed (m/s)  
 and of  
 Tulmar 4-person Life Raft (1-person loading, no drogue)  
 on 10-meter Wind Speed (m/s)

Leeway Speed	Upper limits			Lower Limits		
	$c_1(W_{10m})^2$	$c_2(W_{10m})$	$c_3$	$c_1(W_{10m})^2$	$c_2(W_{10m})$	$c_3$
12-ft rubber raft	0.1122	4.67	35.7	-0.1122	6.80	-14.0
Tulmar life raft	0.0001	3.34	5.19	-0.0001	3.34	-2.30

Recent high-quality leeway data sets have revealed some of the more subtle leeway behaviors. Leeway speeds during rising winds are higher than the leeway speeds occurring during decreasing winds. An example of this behavior is illustrated in Figure 3-2. In the top panel of Figure 3-2, the 10-m wind speeds from a portion of the drift run are shown to first increase from 8 m/s to a peak of 16 m/s in 6 hours and then over the next 7 hours decrease to 10m/s. When the leeway speed of the Tulmar life raft is plotted versus wind speed (Figure 3-2, (B)) separated into two sections (rising and falling wind), the leeway speed during the rising wind is clearly higher than the leeway during the falling wind. This behavior may be associated with the more effective transfer of energy from the atmosphere to the oceans during rising wind conditions than during decreasing wind conditions. When waves are growing, the atmosphere is transferring energy into the sea surface; when waves are decreasing, the waves are transferring energy back to the atmosphere.

Tulmar 4-person life raft, 1-person loading, no drogue

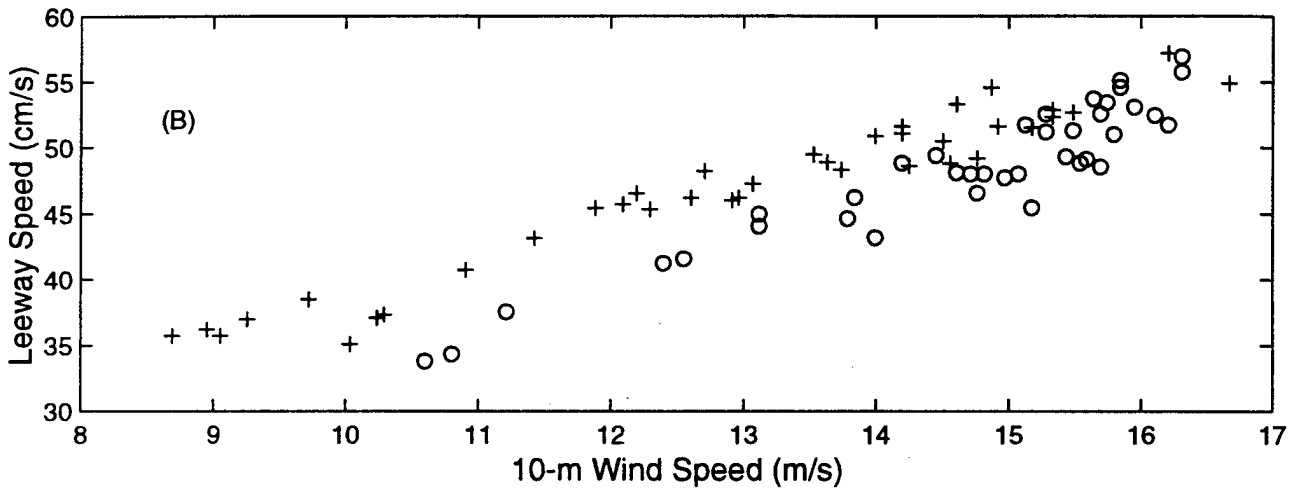
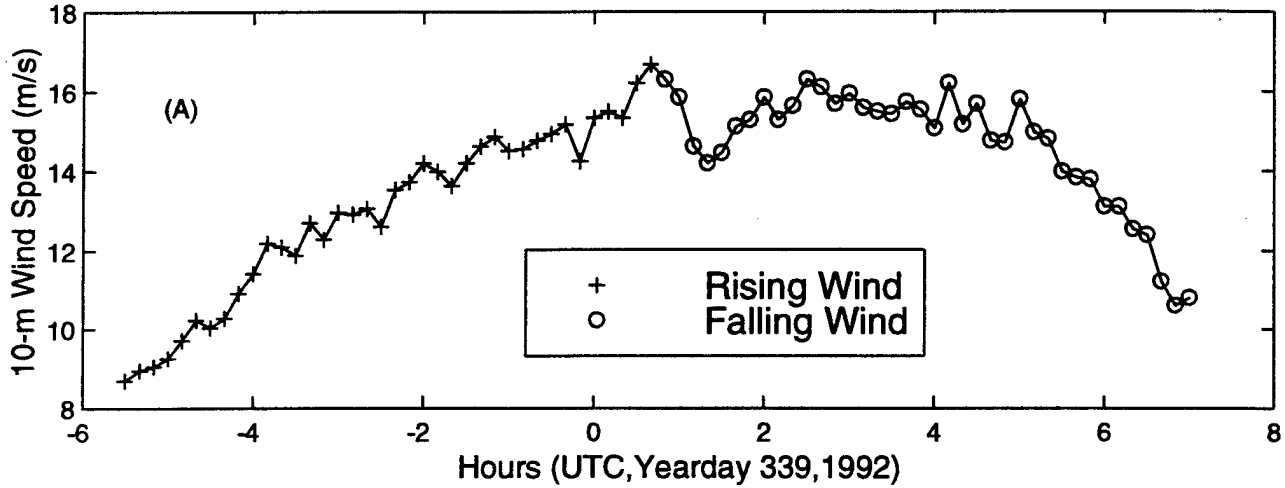

Figure 3-2. (A) The 10-m Wind Speed from 18:00 (UTC) on Yearday 338 to 07:00 on Yearday 339, 1992, at the Tulmar Life Raft. (B) Leeway Speed versus 10-m Wind Speed during the above period Separated by Rising and Falling Winds.

The divergence of a drift object from the downwind direction can be illustrated by progressive vector diagram of the displacement vectors rotated relative to the downwind direction. The mean angles off the downwind direction are readily apparent in a plot of the progressive vector diagrams. To make a progressive vector diagram the duration of each leeway speed and direction data pair must be known. Unfortunately, Hufford and Broida did not provide information on the duration of their samples. Thus we can only present progressive vector diagrams for each of the nine Tulmar life raft drift runs.

Figure 3-3 illustrates the cumulative spread or divergence of the leeway vectors for the Tulmar life raft about the downwind direction. The nine drift runs had vectors that were between -25 and +15 degrees of the downwind direction. By way of comparison, the present guidance for life raft divergence of plus and minus 35 degrees about the downwind direction is also plotted on Figure 3-3. Summary of drift runs and the total length for nine leeway displacement vectors are presented in Table 3-3. The lengths of displacement vectors were measured from start to end in a straight line (end point) and along the curved length of the vector (cumulative).

Table 3-3  
Summary of Leeway Drift Runs  
Tulmar 4-person Life Raft (1-person loading, no drogue)

Leeway Run	# samples	Duration (hours)	Leeway Displacement (km)		$W_{10m}$ (m/s)
			End Point	Cumulative	
2	15	2.5	3.1	3.1	8.8 - 11.6
3	16	2.7	2.2	2.2	5.1 - 6.3
4	42	7.0	6.8	6.8	6.5 - 10.5
16	163	27.2	29.5	29.6	6.0 - 11.7
17	115	19.2	20.9	21.0	2.3 - 11.2
18	244	40.7	58.1	58.3	6.5 - 15.6
19	285	47.5	30.2	30.4	0.8 - 12.0
20	141	23.5	14.0	14.2	0.8 - 12.6
23	145	24.2	38.2	38.2	7.8 - 16.7

Tulmar 4-Person Life Raft, (1man loading, No Drogue) RUNS 2-4,16-20,23

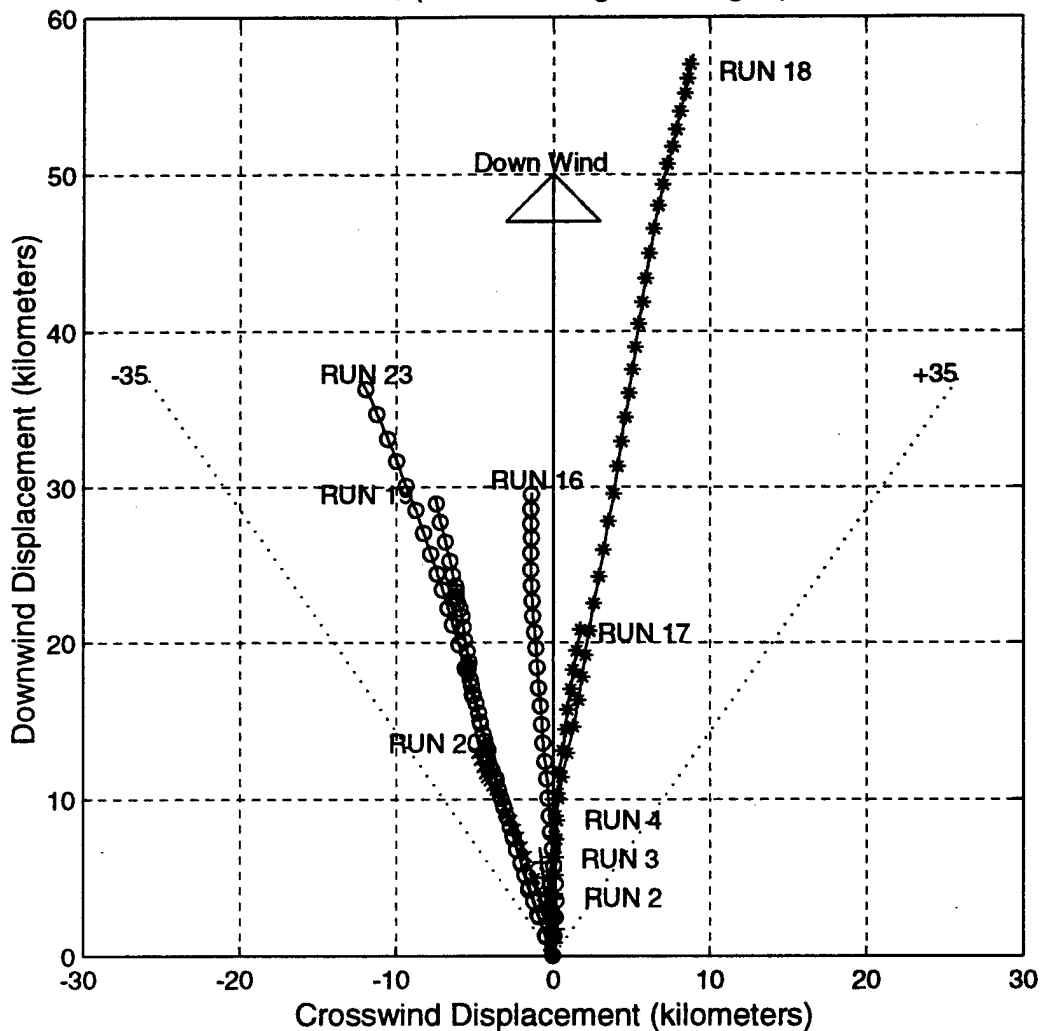

Figure 3-3. The Progressive Vector Diagram of the Leeway Displacement Vectors for the Nine Drift Runs of the Tulmar 4-person Life Raft (1-person loading, no drogue).

Since most of the present guidance for leeway divergence comes from the Hufford and Broida (1974) report, a comparison of leeway angle data is presented in Table 3-4. Leeway angle measurements suffer greatly at low wind speed since light airs have highly variable direction, thus the leeway angle data sets were divided by low (0 to 5 m/s) and high (greater than 5 m/s) wind speeds. The standard deviation of the leeway angles for wind speeds greater than 5 m/s for the Tulmar life raft was 61 % that of 12-foot raft.

Table 3-4  
Leeway Angle (degrees)  
Hufford and Broida's (1974) 12-foot Rubber Raft without sea anchor  
and  
Tulmar 4-person Life Raft (1-person loading, no drogue)

Leeway Study	# samples	W <sub>10m</sub> (m/s)	Leeway Angle				Abs. Angle	
			mean	s.dev.	min	max	mean	s.dev.
12-ft. raft	9	0 – 5	9.2	21.8	-25	52	17.7	14.8
	12	5 – 8.2	-12.6	19.1	-35	25	19.1	11.8
	21	0 – 8.2	-3.2	22.6	-35	52	18.5	12.8
Tulmar Life Raft	261	0 – 5	-17.1	13.4	-79	30	18.5	11.3
	905	5 – 16.2	-3.8	11.6	-28	18	10.3	6.5
	761	0 – 10	-9.2	12.7	-79	30	12.4	9.6
	405	10 – 16.2	-2.2	12.9	-28	16	11.6	6.0
	1166	0 – 16.2	-6.8	13.2	-79	30	12.2	8.5

### 3.2.2 Downwind and Crosswind Components of Leeway

Since both data sets contain leeway speed and angle, we were able to resolve the leeway vector into the down and crosswind components of leeway. Hufford and Broida did not adjust their wind speed to 10-meter height. The wind speeds for the Tulmar life raft were adjusted to 10-meter height using the Smith (1988) algorithm.

The unconstrained linear regression of the downwind component of leeway on wind speed and the 95% prediction limits are plotted along with the data pairs for both data sets in Figure 3-4. The points illustrated by Figure 3-1 of leeway speed are recapitulated in Figure 3-6 for the downwind components. The downwind component of leeway is clearly linearly dependent on the wind speed up to 16.7 m/s for the Tulmar 4-person life raft. The variance of the regression of the downwind component of leeway of the 12-foot raft is much greater than for the Tulmar life raft. The downwind speed of the 12-ft raft was approximately 5.3 percent of the wind compared to 3.3 percent of the wind for the Tulmar life raft. The slopes of the downwind components, as expected, are slightly lower than the slopes for leeway speeds.



The coefficients of the unconstrained linear regressions for the two data sets are presented in Tables 3-5 and the coefficients for the 95% prediction limits equations are presented in Table 3-6. The standard error of the regression for the Tulmar life raft was 22% that of the standard error of the 12-foot raft.

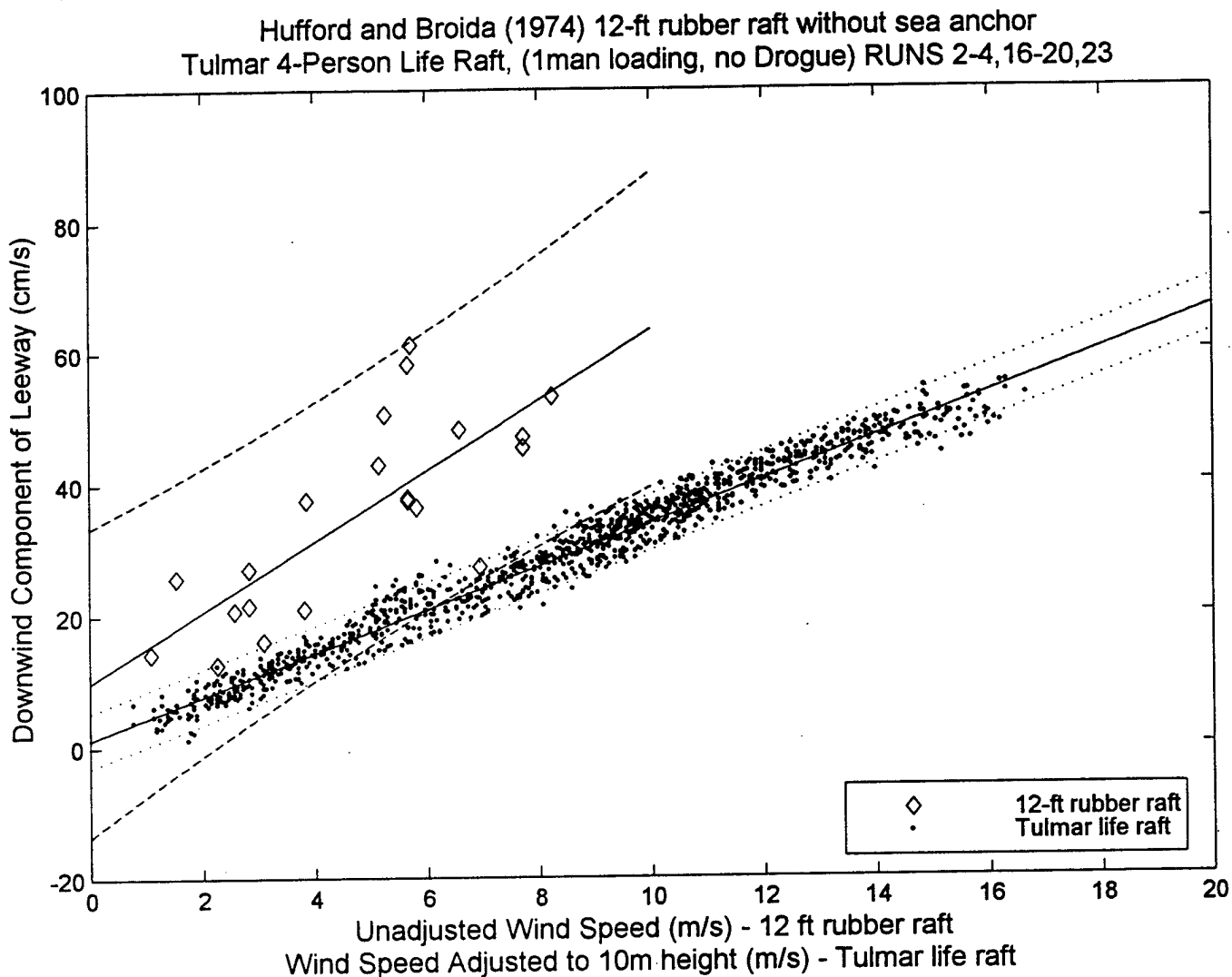

Figure 3-4. The Unconstrained Linear Regression and 95% Prediction Limits of the Downwind Component of Leeway for Hufford and Broida's (1974) 12-foot Rubber Raft without sea anchor versus Wind Speed (unadjusted) and a Tulmar 4-person Life Raft (1-person loading, no drogue) versus  $W_{10m}$ .

The crosswind component of leeway (CWL) for the two craft provides further information. Since freely drifting craft can set up on either a port or starboard tack, the data sets of crosswind components versus wind speed tend to be bi-modal. Allen and Fitzgerald (1997) present a set of hierarchical guidelines for the analysis of leeway data sets. Their Table 3.1 is reproduced here as Table 3-5. When there is a limited number of crosswind component data pairs, symmetry about the downwind direction is assumed for that craft. The regression is then conducted on the absolute values of the crosswind components versus wind speed and presented as a mirror pair of regression equations.

Table 3-5  
Hierarchy of Methods for Leeway Data Analysis

Analysis that can be performed	Available Leeway and Wind Data				
	Limited # of Data, at limited Wind Speed	Limited Range of Wind Speeds	Range of Wind Speeds	Wind Direction and Range of Wind Speeds	Multi-Drift Runs over a Range of Wind Speed with Wind Direction
Leeway Rate	YES (mean)	YES (mean)	YES (time series)	YES (time series)	YES (time series)
Leeway Speed vs. $W_{10m}$ (Constrained)	NO	YES (preliminary)	YES	YES	YES
Leeway Speed vs. $W_{10m}$ (Unconstrained)	NO	NO	YES	YES	YES
Leeway Angle	NO	NO	NO	YES	YES
DWL vs. $W_{10m}$	NO	NO	NO	YES	YES
CWL vs. $W_{10m}$	NO	NO	NO	YES (assume symmetry about the downwind direction)	YES (determine symmetry / non-symmetry)

When there are sufficient crosswind data pairs, symmetry does not have to be assumed, and therefore a piece-wise regression scheme can than be applied to the data set. Allen and Fitzgerald (1997) also present guidelines for conducting piece-wise regressions of leeway components versus wind speed. Following Allen and Fitzgerald, the guidelines for piece-wise regressions are:

- 1) All legitimate data pairs shall be used. (Use all data that is valid).
- 2) Use the data pairs only once. (All good data pairs have weighting of one.)
- 3) Make breaks along natural boundaries (Divisions should not be random.)
- 4) Recombine regressions to provide a model that includes most of the original data pairs and excludes regions without data pairs. (Predictions limits should encompass the data and avoid large regions where no observations occurred.)

- 5) The combined regressions are to be mathematically implemented. (Avoid discontinuities and ambiguities in the model, while providing for smooth transitions with minimum decision rules.)

When the crosswind components of the 12-foot raft are plotted versus wind speed, no clear pattern emerges. A hint of a bifurcation above 6 m/s could be suggested. When the absolute values of the crosswind components are plotted against wind speed, as shown in Figure 3-5, a linear regression can be applied with some success. For this raft, it is assumed that the drift was symmetrical about the downwind direction. Therefore both positive and negative absolute values are used to generate a mirror pair of regression equations.

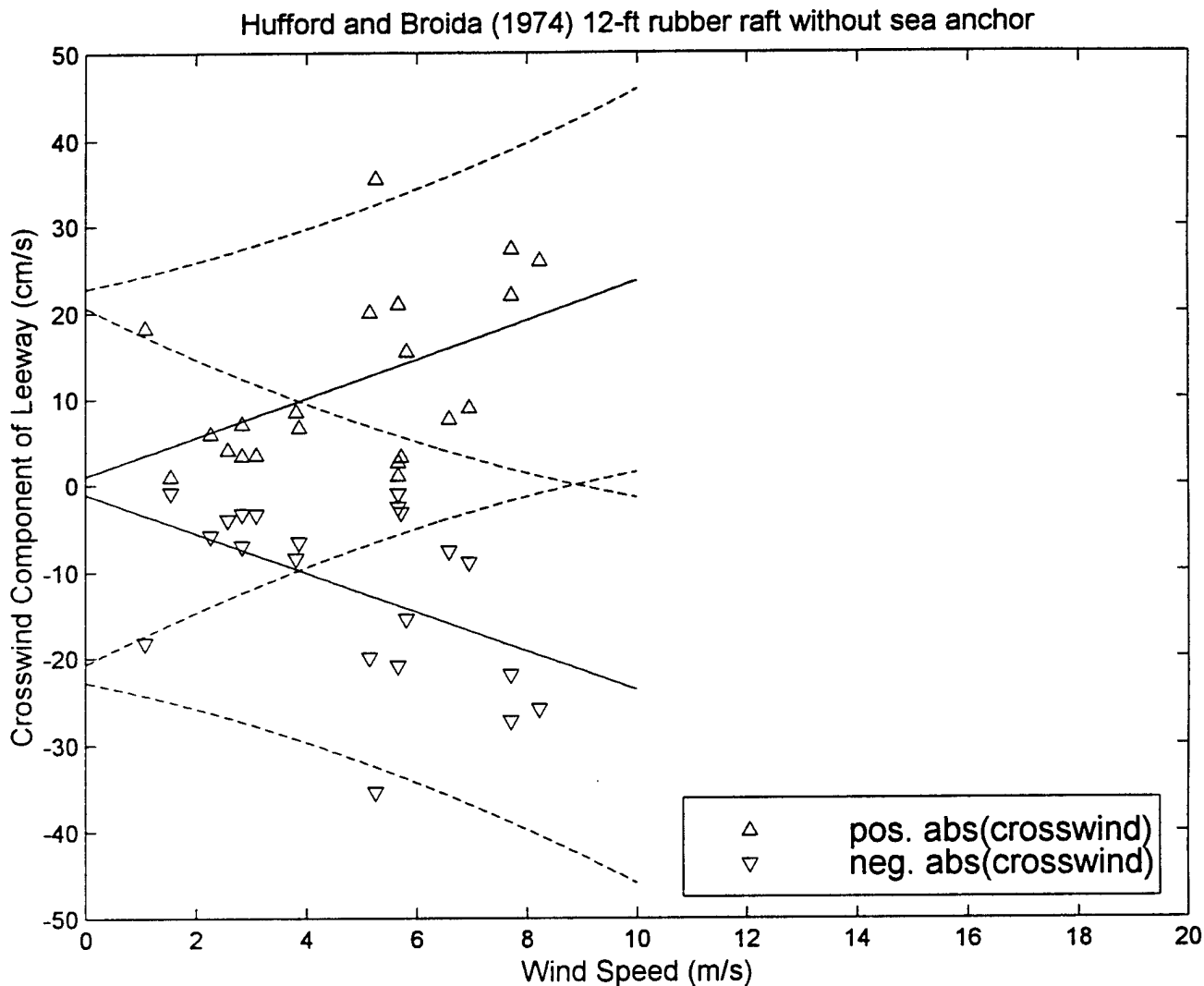

Figure 3-5. The Unconstrained Linear Regression and 95% Prediction Limits of the Positive ( $\Delta$ ) and Negative ( $\nabla$ ) Absolute Values of Crosswind Components of Leeway of Hufford and Broida's (1974) 12-foot Rubber Raft without sea anchor versus unadjusted Wind Speed.

The crosswind data set for the Tulmar life raft is complete enough that symmetry can be tested, and not assumed. The piece-wise regression crosswind component of leeway versus 10-meter wind followed the rules outlined above. All of the data pairs were used and used just once. The division of the data set was along drift runs, thus the raft's initial setup determined if it was to drift left or right of the downwind direction. Once the Tulmar life raft was on a tack, it remained on that tack for the rest of the drift run. The piece-wise regression for the Tulmar life raft is shown in Figure 3-6. The intersection of the two regression equations occurs at  $W_{10m} = 3.81$  m/s. For winds speeds below the intersection only the negative crosswind regression equation is used. When winds are greater than 3.81 m/s, then either one or the other equation should be used for a specific replication.

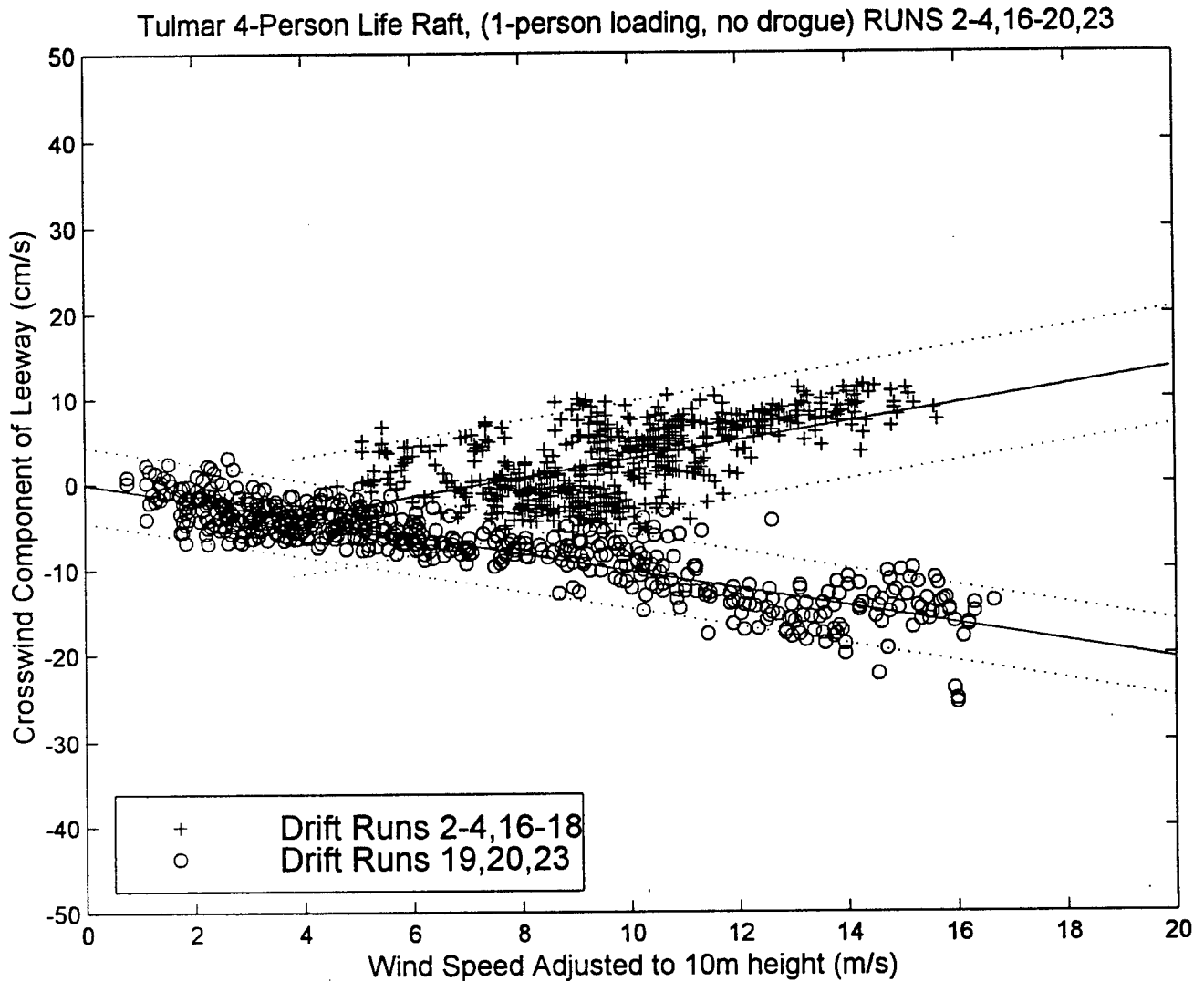

Figure 3-6. The Piece-Wise Unconstrained Linear Regression and 95% Prediction Limits of the Crosswind Component of Leeway of a Tulmar 4-person life raft (1-person loading, no drogue) versus  $W_{10m}$ .

The coefficients of the unconstrained linear regressions for the two data sets are presented in Table 3-6 and the coefficients for the 95% prediction limits equations are presented in Table 3-7. The slopes of the regression equations for **CWL** of the Tulmar life raft are approximately half the slope of the 12-ft. raft. The standard error of the regression for the Tulmar life raft was 25 – 38 % of the standard error of the 12-foot raft. The positive and negative regressions of **CWL** for the Tulmar life raft have essentially the same slope. However, the positive regression of **CWL** for the Tulmar life raft has larger standard error and much larger intercept than the negative regression of **CWL**.

Table 3-6

Unconstrained Linear Regression of Leeway Components (cm/s)  
on Wind Speed (m/s)  
Hufford and Broida's (1974) 12-foot Rubber Raft without sea anchor  
and  
on 10-meter Wind Speed (m/s)  
Tulmar 4-person Life Raft (1-person loading, no drogue)

Leeway Craft	Dependent Variable	Leeway Run	# samples	Y-intercept (cm/s)	slope (% wind)	r <sup>2</sup>	S <sub>y/x</sub>	W <sub>10m</sub> (m/s)
12-ft Rubber raft	<b>DWL</b>	N/A	21	9.91	5.34	0.582	9.82	1.0 – 8.2
	<b>+CWL</b>	N/A	21	1.04	2.26	0.226	9.08	1.0 – 8.2
	<b>-CWL</b>	N/A	21	-1.04	-2.26	0.226	9.08	1.0 – 8.2
Tulmar Life raft	<b>DWL</b>	all 9 runs	1166	1.20	3.28	0.970	2.14	6.7 – 20.4
	<b>+CWL</b>	2-4, 16-18	595	-8.09	1.09	0.364	3.46	0.2 – 14.4
	<b>-CWL</b>	19,20,23	571	-0.03	-1.02	0.791	2.24	0.8 – 16.7

Table 3-7

The Coefficients of the Polynomials Describing  
 95% Prediction Limits of the  
 Unconstrained Linear Regression of Leeway Components (cm/s)  
 on Wind Speed (m/s)  
 Hufford and Broida's (1974) 12-foot Rubber Raft without sea anchor  
 and  
 on 10m Wind Speed (m/s)  
 Tulmar 4-person Life Raft (1-person loading, no drogue)

Leeway Craft	Dependent Variable	Upper limits			Lower Limits		
		$c_1(W_{10m})^2$	$c_2(W_{10m})$	$c_3$	$c_1(W_{10m})^2$	$c_2(W_{10m})$	$c_3$
12-ft Rubber raft	DWL	0.1062	4.33	33.4	-0.1062	6.35	-13.6
	+CWL	0.0982	1.33	22.8	-0.0982	3.20	-20.7
	-CWL	0.0982	-3.20	20.7	-0.0982	-1.33	-22.8
Tulmar Life raft	DWL	0.0001	3.28	5.41	-0.0001	3.28	-3.00
	+CWL	0.0010	1.07	-1.21	-0.0010	1.11	-15.0
	-CWL	0.0002	-1.03	4.39	-0.0002	-1.02	-4.45

The crosswind component of leeway for the Tulmar life raft as a function of wind speed (Figure 3-6) provides an illustration of typical leeway divergence for life rafts. This same pattern has been observed in several other leeway craft. The basic pattern of leeway is shown in Figure 3-7 is as follows:

At very low wind speeds, the leeway craft is free to rotate relative to the downwind direction. When the wind speed exceeds a certain threshold for the particular leeway craft, the craft locks onto a specific tack (relative wind direction orientation) and remains on that tack. This "tack-locking" wind speed threshold ( $T_1$  in Figure 3-7) is specific to individual craft. Nash and Willcox's (1991) Figure 19 is a clear illustration of the "tack-locking" behavior for a deep-ballast Givens 6-person life raft. In that study, when the wind speeds were between 2 and 6 knots (1.0 and 3.1 m/s), the life raft rotated freely between 240 and 20 degrees relative to the wind direction. As soon as the wind speed increased above 6 knots (3.1 m/s) the relative wind direction locked at 250 to 260 degrees and stayed there for the rest of the sampling period. Thus the "tack-locking" wind speed threshold for the Given life raft is 6 knots (3.1 m/s). This threshold,  $T_1$ , may be at very low wind speeds.

The second threshold ( $T_2$  in Figure 3-7) is the wind speed at which the leeway craft begins to diverge from the downwind direction. Between zero wind speed and  $T_2$ , the craft exhibits little or no divergence from the downwind direction. For the Tulmar 4-person life

raft,  $T_2$  is approximately 8 m/s. This threshold,  $T_2$ , may be at a speed greater than or equal to that the "tack-locking" threshold,  $T_1$ .

Between the second threshold and a third one,  $T_3$ , the divergence from the downwind direction appears to linearly increase with wind speed with the craft maintaining the tack it had initially. Depending on its tack, the craft goes either to the right or the left of downwind. In this range the craft does not jibe, which would change the sign of the leeway divergence. However, as wind speed and wave energy increase, the third threshold is reached ( $T_3$  in Figure 3-7). At and above this threshold, breaking waves are large enough to directly affect the behavior of the craft by causing jibes, swamping, or capsizing. All of these drastically affect leeway drift and can cause the craft to change speed and direction. The third threshold for the Tulmar 4-person life raft is above 16.7 m/s, which was the maximum wind speed observed during the Tulmar drift runs. Leeway behavior at and above the third threshold was observed during the 1995 leeway experiment with open boats and several configurations of life rafts (Allen and Fitzgerald, 1997).

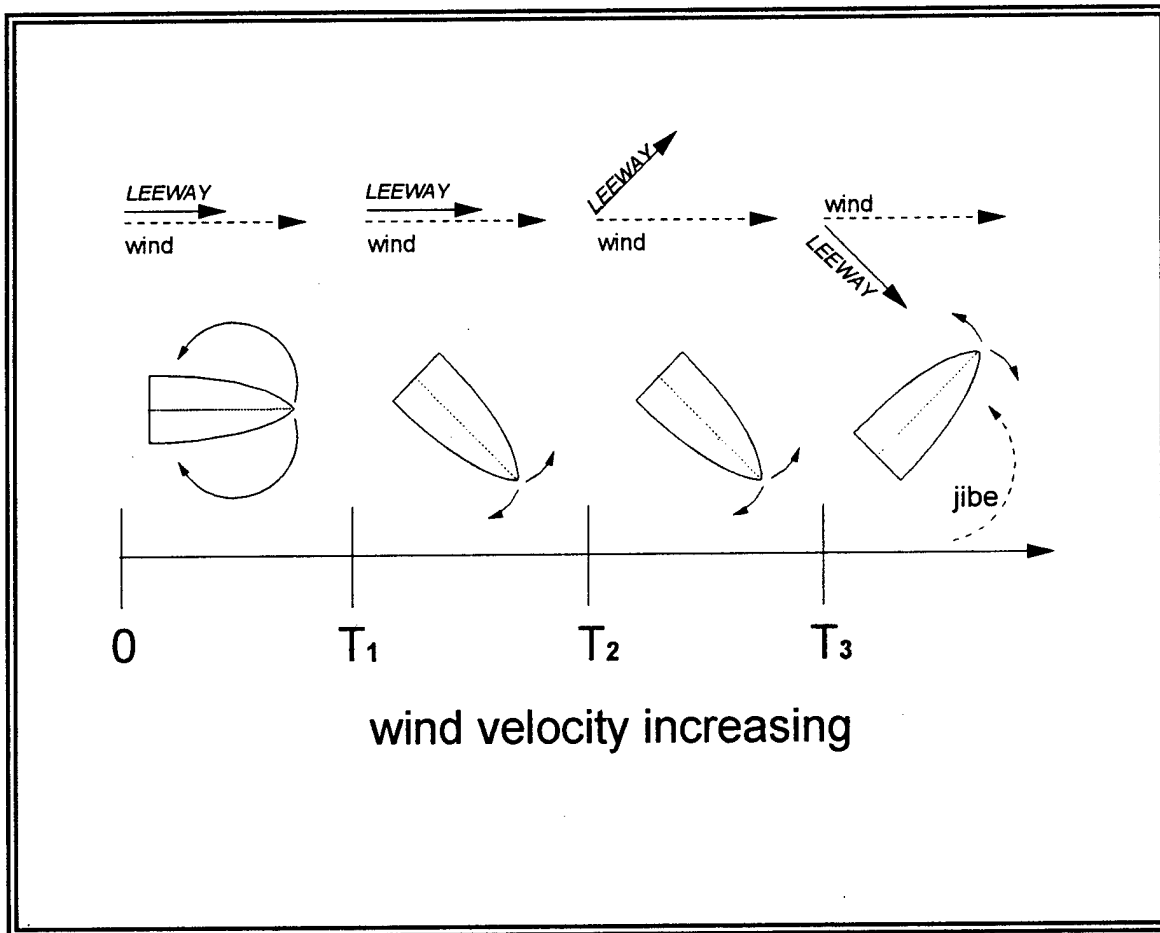

Figure 3-7. Illustration of Leeway Threshold Behavior as function of wind speed.

### 3.3 EFFECTS OF UNCERTAINTY ON LEEWAY MODELING

The limits of a search area are affected by the limits of the possible surface currents, surface winds and leeway. These limits or uncertainty can be expressed statistically as the variance of the variables and by covariance of their interrelationships. Allen (1996) introduced a technique that uses the variance of the leeway components to provide an estimate of the spreading of the search area due to the uncertainty in the original leeway data and their regression equations. The following chapter presents a new model that takes advantage of the lessons learned from the new leeway data sets and provides improved estimates of leeway drift predictions. The new model is based upon an extension of Allen's (1996) technique to a Monte Carlo scheme for the generation of leeway drift distributions using the standard error of the downwind and crosswind regression equations.



## CHAPTER 4

### MODELS OF LEEWAY DRIFT AREAS

4) *How can we model the present level of understanding of leeway behavior?*

#### 4.1 INTRODUCTION

Search-planning tools contain search area propagation models. Search area propagation models start with estimates of the initial distribution of survival craft, applies estimates of the displacement due to winds and sea surface currents, and generates a search area. Search planners use the search area to plan their searches and allocate available SAR resources. A well-designed search-planning tool minimizes the search area while containing the search object and estimates the spatial probability distribution of the search object. In a properly generated search plan, the probability of containment (POC) should approach 100%. Having the search units focus their search efforts in the regions with highest POC can thereby maximize the probability of success (POS). The ultimate goal of search planning is the maximization of the probability of success. For a complete discussion of search planning theory see Frost (1997).

Search planning tools model the movement of search objects from the initial distribution through to the final distribution. The movement and spreading of the final distribution from the initial distribution is dependent upon the effect of wind on the object and the displacement due to sea surface currents. The effect of wind on a drift object is its leeway. The final distribution of the end points of the leeway displacement vectors or the area generated by the model's rules and leeway equations is the leeway drift area.

The leeway drift areas are due solely to leeway equations, leeway variance and leeway rules of a particular model. Excluded from the final distribution are any influences due to initial target distribution, wind variance, and sea currents. Thus, the initial distribution (LKP or Last Known Position) is assumed to be a point in space and time, the wind speed and direction are assumed constant and without any variance; and there are no surface current effects. With these simplifying assumptions in place, the search area is due solely to how leeway is applied for that model. Therefore using this method, differences between leeway drift models can be quantified in terms of search area spreading.

Four models for generating leeway drift areas are presented in this chapter. The first model is from GDOC AMM, which uses rules and leeway equations to generate an area that encompasses a leeway drift area. The second model is from CASP and it uses uniform distributions about the mean leeway drift to generate distributions of end points. Two new models for generating leeway drift areas are also introduced in this chapter. The third model is a completely new model called AP98. It uses the downwind and crosswind components of leeway equations and normal distributions based upon the leeway components' variances to

generate leeway drift areas. The fourth model is a variation on the manual method of GDOC where rules for accounting for the range of leeway variance are included.

The incorporation of the variance of the leeway data into the new models is the fundamental difference between new models and currently used models (GDOC AMM and CASP). A sensitivity study of the effects of wind speed and variance of the leeway equations for the four models is presented in Section 4.6.

#### 4.2 GDOC AMM LEEWAY DRIFT AREA

GDOC automated manual method is a first generation leeway drift model. GDOC generates a leeway drift area by using the leeway speed equation at the two maximum leeway divergence angles ( $d_{max}$  and  $d_{min}$ ). The mid-point of a straight line connecting the two ends of the maximum divergence angles is the center point of the leeway drift area. A drift error factor of 0.3 is applied to generate two circles with a radius of 0.3 times the Leeway\_Drift displacement vectors at the ends of each Leeway\_Drift vector. For the first search a 1.1 confidence factor is then applied to the leeway radius. The GDOC AMM leeway drift area is a square boxing the resulting circle as shown in Figure 4-1. When these guidelines are used with simplified SAR cases where winds are held steady, and LKP is a point and there are no sea currents, the following equations apply.

$$\begin{aligned} & \text{GDOC leeway\_radius} = \\ & [(\text{Leeway\_Drift} \times \sin(\text{Divergence angle})) + (0.3 \times \text{Leeway\_Drift})] \times 1.1 \end{aligned} \quad (4.1)$$

The GDOC AMM leeway\_drift\_area is a square with each side twice the search area's radius and centered on the same center point. Thus,

$$\text{GDOC leeway drift\_area} = (2 \times \text{GDOC leeway\_radius})^2. \quad (4.2)$$

By this method if the target had a leeway drift of 10 nautical miles the search area would be 369 square nautical miles when the divergence angle was thirty-five degrees. If the divergence angle was forty-five or sixty degrees the leeway search area increases to 490 or 658 square nautical miles. An interesting artifact of this method is that, when the divergence angle is greater than 38 degrees, the leeway search area includes area upwind of the initial position. In Section 4.7 several comparisons (using the above simplifying assumptions) of GDOC AMM leeway drift areas will be made with the leeway drift areas of the new model AP98.

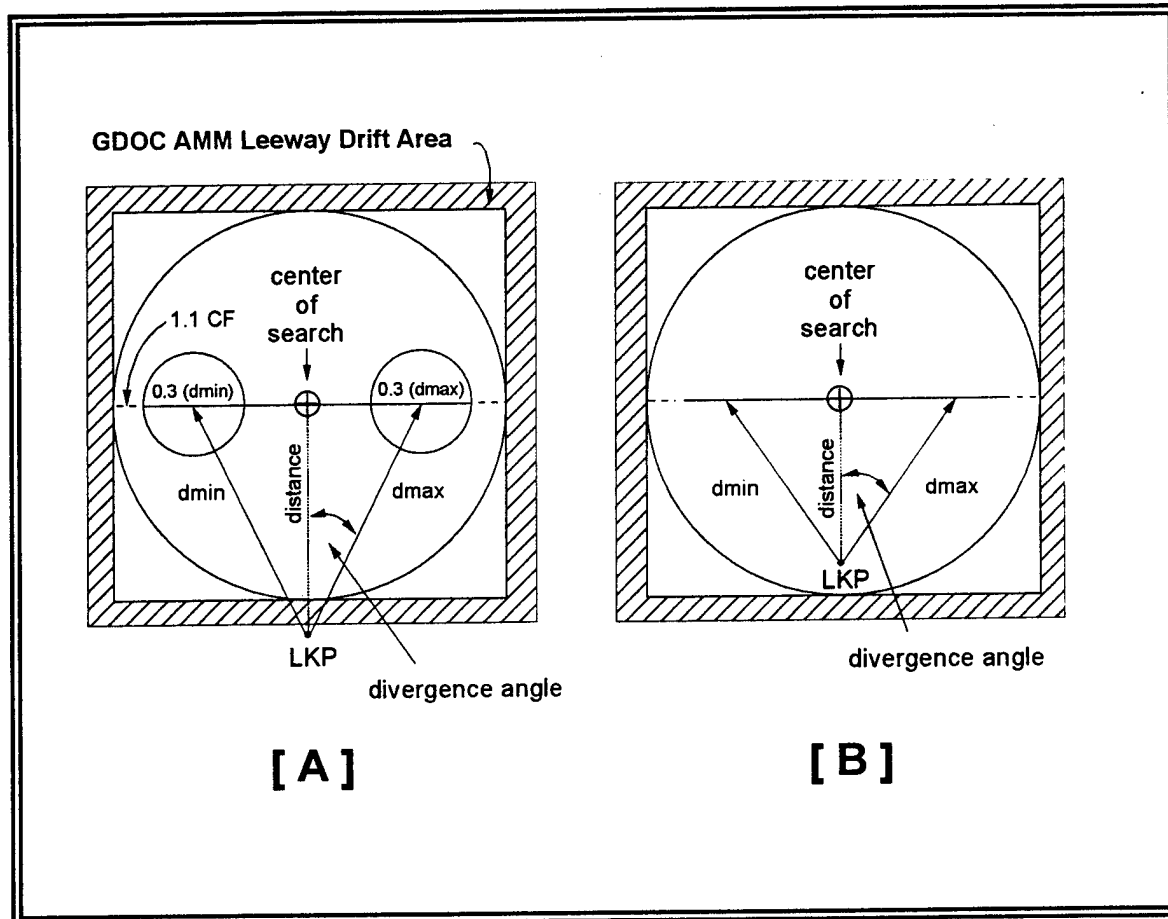

Figure 4-1. The leeway drift areas of GDOC AMM for (A) a divergence less than 38 degrees and for (B) a divergence greater than 38 degrees.

#### 4.3 CASP LEEWAY DRIFT AREA

CASP's module for leeway drift is a second-generation leeway drift model. The uncertainty in the predicted displacement of a survivor craft by CASP (versions 1.0 and 1.1X) is handled by using the Monte Carlo technique. The Monte Carlo technique uses many replications (1000s) and builds a probability distribution from the results. Raunig, Robe, and Perkins (1995) describe how CASP handles the spreading of the drift search area from the initial probability distribution. There are several estimates of errors or uncertainty distributions used in CASP to generate the final drift area distribution. In order to investigate the effect of leeway on the final drift area distribution, all non-leeway errors and uncertainties were set to zero. Thus the initial distribution at the LKP was a point, there were zero surface currents, and there were no errors or uncertainty in the wind measurements. This third condition, zero uncertainty in the wind vector, eliminates the drawing of a sample wind vector from a circular normal distribution with a standard deviation of 5 knots about the wind vector's head. This is present method used by

CASP to include wind uncertainty into the search area distribution. The resulting final distribution is only a function of the CASP leeway model, and is termed leeway drift area.

The leeway drift areas for a leeway target are generated in CASP from distributions of the leeway angle and speed. The leeway angle for each replication is randomly selected from a uniform distribution between the maximum left and right leeway angles for that target. Each replication maintains its own leeway angle throughout the entire drift run. A leeway speed multiplier for each replication is randomly selected from a uniform distribution. The leeway speed is a uniform distribution between the leeway multiplier plus a third of the leeway multiplier and the leeway multiplier minus a third of the leeway multiplier. The leeway speed multiplier for each replication is maintained throughout the entire drift run.

The leeway drift area of CASP can be determined by equation 4.5.

$$\text{Leeway\_drift\_area} = (\text{leeway\_divergence\_angle} \times \pi/180) \times [(\text{upper\_displacement})^2 - (\text{lower\_displacement})^2] \quad (4.5)$$

where:

leeway\_divergence\_angle is in degrees,

$$\text{upper\_displacement} = [\text{leeway\_multiplier} + (\text{leeway\_multiplier} \times 0.3333)] \times \text{wind\_speed\_ (knots)} \times \text{time\_ (hours)}$$

and

$$\text{lower\_displacement} = [\text{leeway\_multiplier} - (\text{leeway\_multiplier} \times 0.3333)] \times \text{wind\_speed\_ (knots)} \times \text{time\_ (hours)}$$

The distribution of replications (the leeway drift area distribution) is contained within an arc bounded by maximum left and right divergence angle and by the upper and lower displacement, as shown in Figure 4-2. The distribution of the replications within the arc is uniform as shown in Figure 4-3, for a CASP category I target (see section 5.7.1, for discussion of CASP's leeway category I). Thus, the guidance provided by CASP is limited to uniformly searching within the arc and no searching outside of the arc.

Also clearly evident in Figure 4-3 is the difference between the leeway drift areas generated by CASP and by GDOC AMM for identical inputs and conditions. Two new leeway drift models are introduced in sections 4.4 and 4.5. The leeway drift areas generated by CASP, GDOC AMM and the two new leeway drift models are compared in section 4.6.

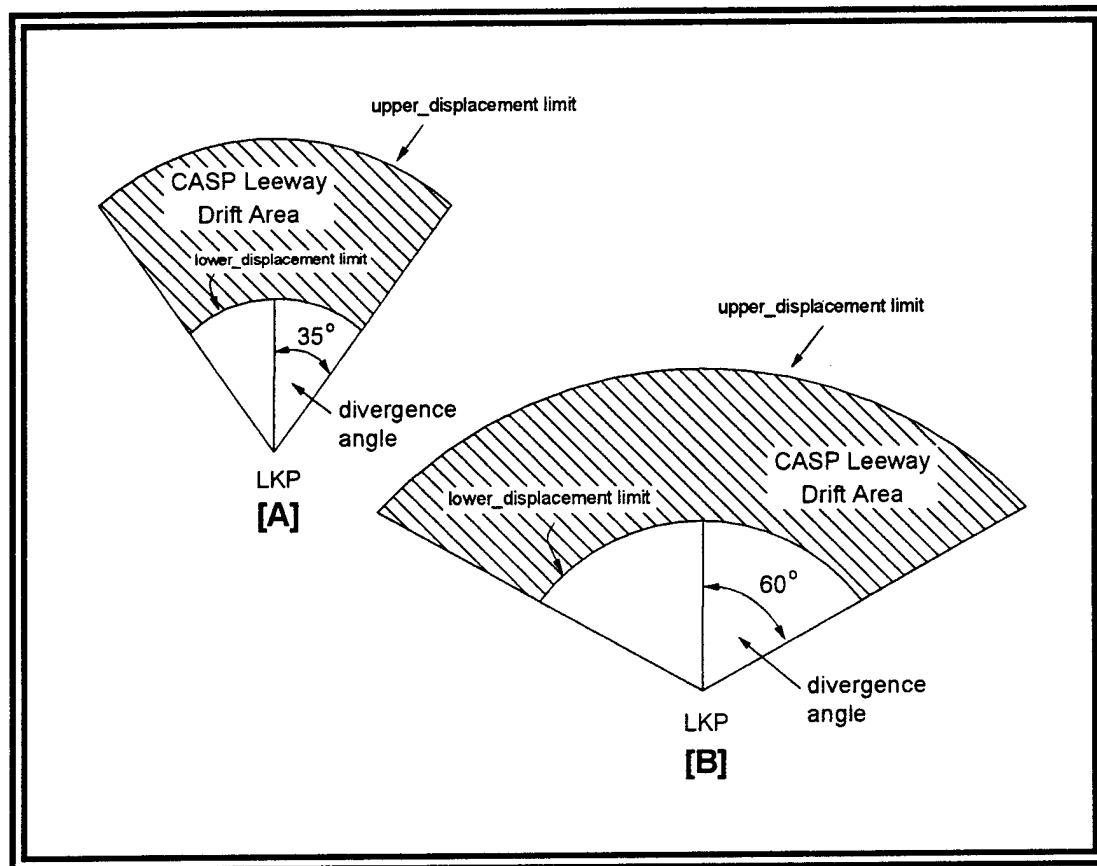

Figure 4-2. The leeway drift area of CASP for a divergence angle of [A] 35 degrees and for [B] 60 degrees.

In section 5.7, the CASP's leeway drift area defined here will be compared to the leeway drift areas of GDOC AMM and the new model AP98.

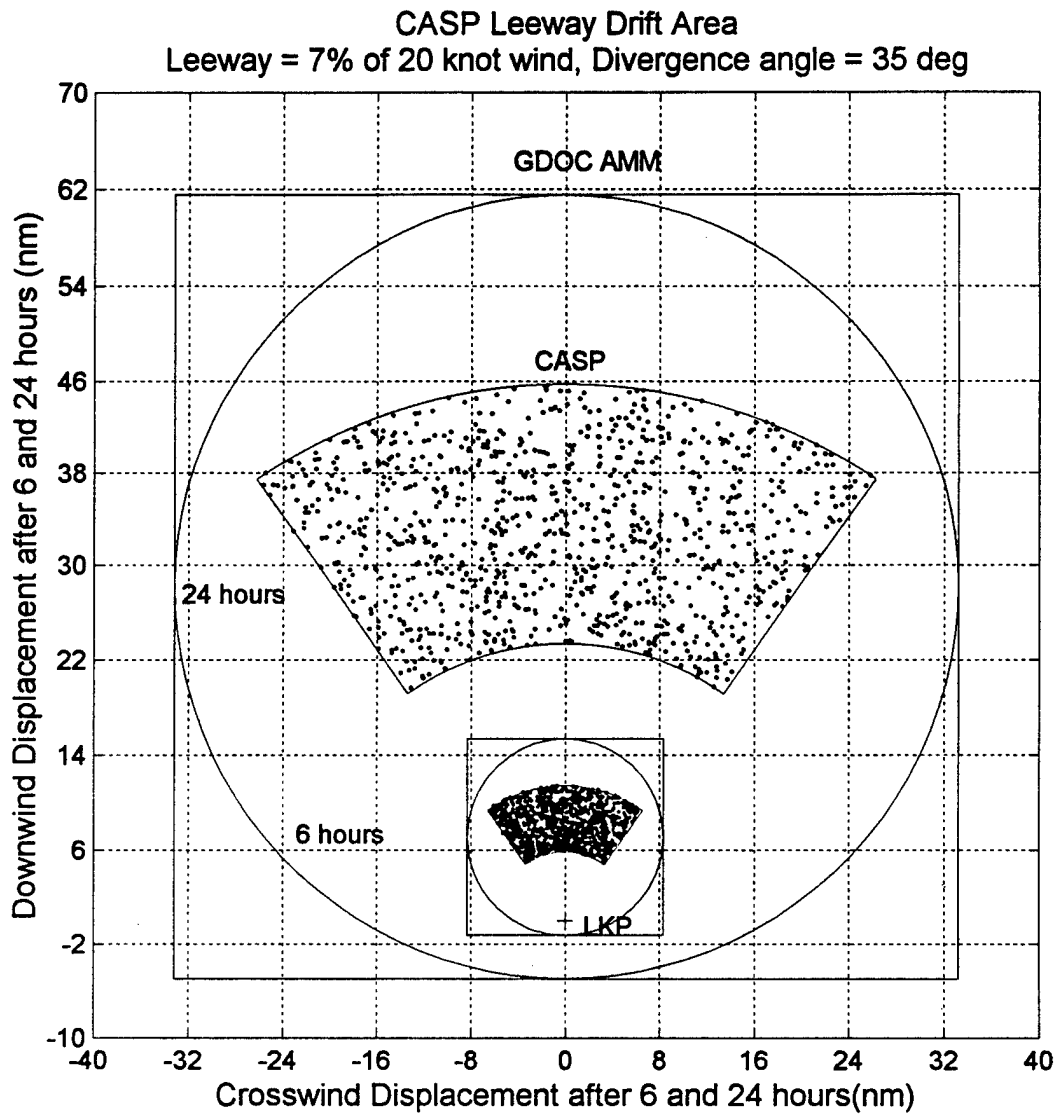

Figure 4-3. The leeway drift area of CASP and GDOC AMM for Category I leeway targets after 6 and 24 hours of a steady 20 knot wind.

#### 4.4 A NEW MODEL OF LEEWAY DRIFT AREA (AP98)

“AP98” is a third generation leeway distribution model based upon using the unconstrained linear regressions of downwind, positive crosswind and negative crosswind components of leeway versus the wind speed adjusted to 10-meter height ( $W_{10m}$ ). The premise of AP98 is that the actual drift object may drift faster or slower than the test object(s) used to determine the leeway values for that category. Therefore, offsets from the three regressions are used to predict possible combinations of targets with faster or slower downwind, positive crosswind and negative crosswind components of leeway. The AP98 offsets from the regression equations are for the y-intercept only. Each replication has two new y-intercepts chosen randomly from normal distributions with standard deviations equal to the standard error of the regression estimate ( $S_{y/x}$ ) for the downwind component of leeway and one of the crosswind leeway components. The y-intercepts are chosen at the start of the drift and are maintained throughout the remainder of the drift run for each replication. Thus if 1000 replication are used to generate a search area, then 1000 downwind equations are generated that are parallel and normally distributed about the mean downwind regression equation and 500 equations are normally distributed about each of the two crosswind regression equations. A thousand pairs of equations are then used to generate 1000 tracks which form a distribution of drift end points for a particular target class and a given wind speed and direction time series. This model was written in MATLAB® 5.2 on a PC computer.

For a specific leeway target class, nine coefficients and one intersection point are the inputs into the AP98 model. Each of the three leeway components (downwind, positive crosswind and negative crosswind) has slopes of the regression versus 10m wind, the y-intercepts of the regression, and the standard errors of the regression. These are the nine coefficients input to the above model. The tenth input is the wind speed at which the mean regressions of the crosswind components of leeway intersect. In the piece-wise models, wind speeds below the intersection point are limited to only one of the crosswind regressions; above the intersection point, both positive and negative components of leeway are used to describe the distribution (see Figure 3-6). Examples of the AP98 leeway drift predictions will be shown later in this chapter.

The AP98 model of leeway area distributions in its present form has several limitations. The model is presently hardwired to have an equal distribution of both the positive and negative components of leeway. The assumption is that it is equally likely that the target was on a port or starboard tack. With the addition of a variable, the user could weigh one tack over the other. The second limitation of this model in the current form is that it does not allow for jibbing or tacking of the target. Also, this model is strictly a function of the 10-meter wind speed. No other environmental factors such as air-sea temperature difference, wave steepness, waves – wind direction, and wind speed history are included. The model at the present time does not have provisions for the target to change phase. Thus there are no sub-models for swamping, capsizing, or deploying or losing a drogue. Despite these limitations, which could be addressed with further work, this new model of leeway drift is used and compared to the currently available and implemented models of leeway drift in the following sections of this report.

#### 4.5 MODIFICATION OF GDOC AMM LEEWAY DRIFT AREA

The leeway drift area model of GDOC AMM was presented in section 4.2. A drift error factor of 0.3 is multiplied by  $d_{min}$  and  $d_{max}$  to generate two error circles about the end points of the leeway drift vectors at the maximum divergence angles, as shown in Figure 4-1 and equation 4.1. The modification made to GDOC AMM was to vary the drift error factor from 0.0 to 0.4 based upon the sensitivity analysis conducted in section 4.6. Changing the drift error factor changes the size of the GDOC AMM leeway drift area. Within the limits of GDOC AMM calculation, this brings GDOC AMM predictions closer in line with the improved predictions of the AP98 model.

The guidelines for selecting the drift error factor were based upon providing a reasonable match between the leeway drift areas of AP98 and the modified GDOC AMM leeway drift areas (as will be shown in section 4.6). The drift error factor in this modified GDOC AMM is a function of: 1.) the variance of the leeway data set used to produce the drift model and 2.) wind speed. Appendix B lists the standard error (in cm/s) for the reported leeway equations, where possible. Most of the older leeway reports did not list standard errors for their leeway equations. However, we re-analyzed Hufford and Broida's (1974) data sets and found that their standard error was around 10 cm/s. Recent leeway studies have typically had standard errors of 1 to 3 cm/s. Therefore, there appears to be a natural break at about 6 cm/s between the higher quality recent leeway data sets and the older, higher variance leeway data sets. At wind speeds less than 10 knots (5.1 m/s) considerably more scatter is apparent in the AP98 leeway drift areas, therefore a break was also included at 10 knots of wind for drift error factor. The results of comparing AP98 to GDOC AMM are four different drift error factors, as shown in Table 4-1.

Table 4-1.  
Drift Error Factors  
For Modified GDOC AMM

	Wind speed ≤ 10 knots	Wind speed > 10 knots
$Sy/x \geq 6$ cm/s	0.4	0.3
$Sy/x < 6$ cm/s	0.1	0.0

#### 4.6 COMPARISON OF LEEWAY DRIFT AREA MODELS

The comparisons between models were conducted using Leeway Category I ("Light Displacement Cabin Cruisers, Outboards, Rubber Rafts etc. (without Drogue)" for GDOC AMM (original and modified) and CASP, and using Hufford and Broida's (1974) 12-foot rubber raft without sea anchor for the AP98 model. Hufford and Broida's 12-ft rubber raft was part of their data set that was used to generate the leeway equation for Category I. Therefore, we can expect that the AP98 leeway drift area for a 12-ft rubber raft to closely match GDOC AMM and CASP Category I leeway drift area predictions. See section 5.71 for further discussions of Leeway Category I.



The AP98 leeway drift area for the 12-ft rubber raft shown in Figure 4-4 used the downwind and crosswind component of leeway equations and their respective standard errors (from Table 3-6). The AP98 model uses the standard error of the estimate for each leeway component to set the standard deviation of the normal distribution about the mean regression line for that component, (see section 4.4 for more details). The standard error for the downwind component of leeway for the 12-ft raft is 9.8 cm/s and the crosswind component of leeway standard error is 9.1 cm/s. When the leeway equations and standard errors for the 12-foot raft are used in the AP98 model, the resulting leeway drift area closely matches the leeway drift area of CASP as shown in Figure 4-4.

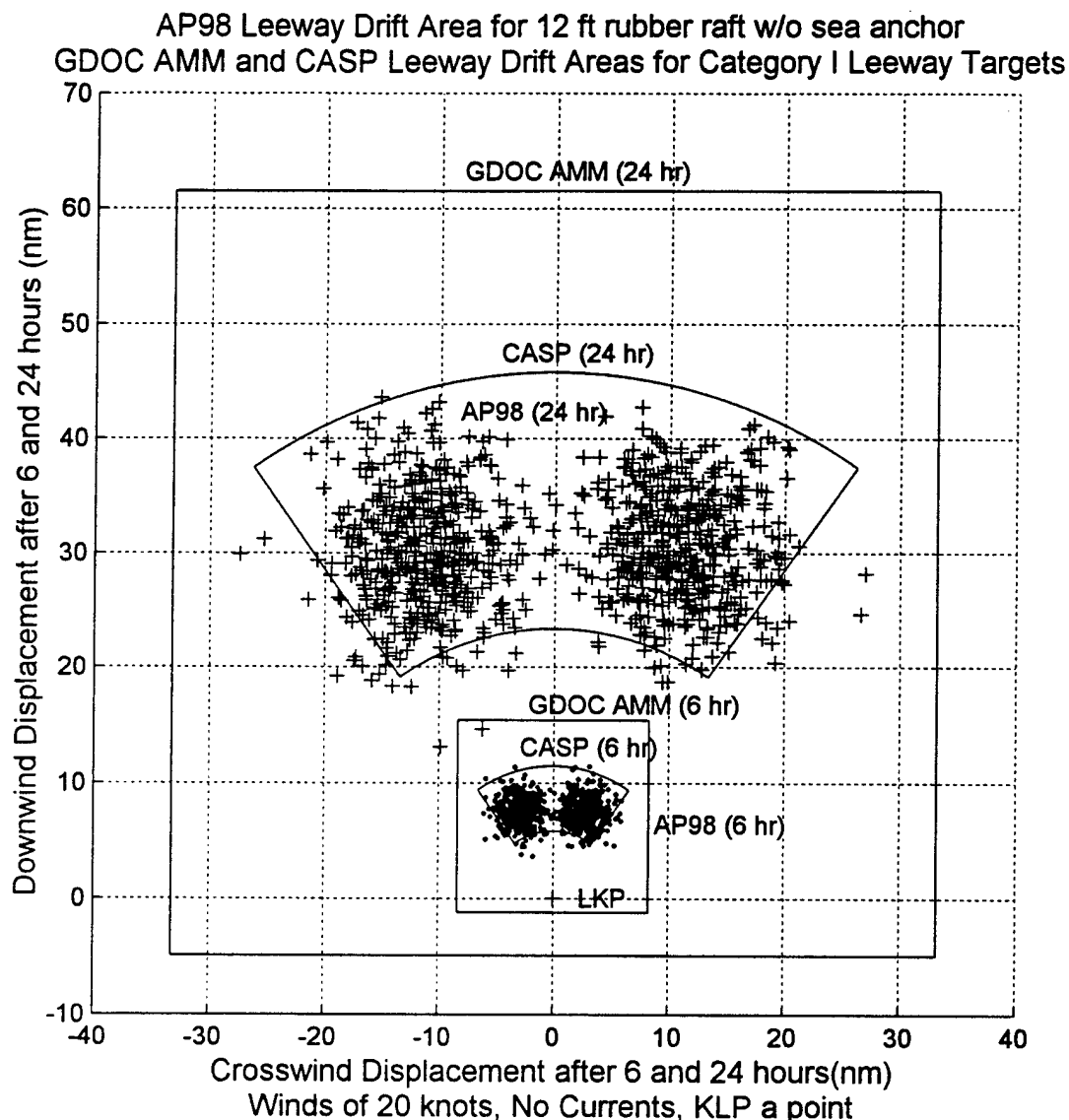

Figure 4-4. The leeway drift area of leeway distribution model AP98 for Hufford and Broida's (1974) 12-foot rubber raft without a sea anchor, along with the CASP and GDOC AMM areas for Category I leeway targets after 6 and 24 hours of a steady 20 knot wind.

To test the sensitivity of this model, the AP98 model was then run using the same downwind and crosswind leeway equations as before for 12-ft raft, but the standard error was allowed to vary between 1 and 11 cm/s. The leeway drift areas from the AP98 model were then superimposed over leeway drift areas of GDOC AMM (original and modified) and CASP. Runs were conducted over the range 5 to 40 knots of wind. Duration (hours) of the runs were adjusted inversely to the wind speed to maintain a constant wind displacement vector (e.g. 20 knots x 24 hrs = 480 nm and 10 knots for 48 hrs = 480 nm) which maintains nearly constant leeway displacement vectors among the runs.

The sensitivity of the AP98 leeway drift area to the standard error is illustrated in Figures 4-5 through 4-9. Also shown in the five figures are the corresponding outlines of the GDOC AMM original (the square with solid lines), GDOC AMM modified (the square with dashed lines) and CASP (the annulus with solid lines) leeway drift areas. Note that when the GDOC AMM original and GDOC AMM modified produce the same leeway drift area, only one square with solid lines is evident in the five figures. The areas of the distributions for the four models are summarized in Tables 4-2 through 4-6, corresponding to Figures 4-5 through 4-9. The AP98 areas contain 99.9% of the Monte Carlo replications. Also presented are the ratios of the leeway drift area from four models to leeway drift area of CASP. This ratio is termed CASP ratio in the following tables.

$$\text{CASP ratio} = \left[ \frac{\text{Model\_leeway\_drift\_area}}{\text{CASP\_leeway\_drift\_area}} \right] \times 100\%$$

Table 4-2  
 Comparison of AP98 Leeway Drift Area Model  
 with Varying Values for the Standard Deviation of the Normal Distribution  
 for 12-foot Rubber Raft without a sea anchor  
 for a Steady Wind of 5 knots for 96 hours  
 (No Sea Surface or Wind Currents, LKP is a point)

Leeway Drift Model	Craft Type	Steady Winds of 5 knots, 96 hours			
		S <sub>y/x</sub> (cm/s)	mean (sq. nm.)	std. dev. (sq. nm.)	CASP ratio (%)
AP98	12-ft rubber raft without sea anchor	1	229	8.9	22%
		3	1,471	35	144%
		5	3,289	92	320%
		7	6,495	227	634%
		9	8,700	346	849%
	11	11,220	320	1090%	
GDOC AMM original	Category I	1 - 11	5,178	0	505%
GDOC AMM modified	Category I	1, 3, 5	3,078	0	300%
	Category I	7, 9, 11	6,431	0	627%
CASP	Category I	1 - 11	1,025	0	100%

Table 4-3  
 Comparison of AP98 Leeway Drift Area Model  
 with Varying Values for the Standard Deviation of the Normal Distribution  
 for 12-foot Rubber Raft without a sea anchor  
 for a Steady Wind of 10 knots for 48 hours  
 (No Sea Surface or Wind Currents, LKP is a point)

Leeway Drift Model	Craft Type	Steady Winds of 10 knots, 48 hours			
		$S_{y/x}$ (cm/s)	mean (sq. nm.)	std. dev. (sq. nm.)	CASP ratio (%)
AP98	12-ft rubber raft without sea anchor	1	98	5.8	10%
		3	639	21	65%
		5	1,329	41	137%
		7	1,950	78	201%
		9	3,856	105	397%
	11	4,751	194	488%	
GDOC AMM original	Category I	1 - 11	4,660	0	479%
GDOC AMM modified	Category I	1, 3, 5	2,770	0	285%
	Category I	7, 9, 11	5,788	0	595%
CASP	Category I	1 - 11	972	0	100%

Table 4-4  
 Comparison of AP98 Leeway Drift Area Model  
 with Varying Values for the Standard Deviation of the Normal Distribution  
 for 12-foot Rubber raft without a sea anchor  
 for a Steady Wind of 15 knots for 32 hours  
 (No Sea Surface or Wind Currents, LKP is a point)

Leeway Drift Model	Craft Type	Steady Winds of 15 knots, 32 hours			
		$S_{y/x}$ (cm/s)	mean (sq. nm.)	std. dev. (sq. nm.)	CASP ratio (%)
AP98	12-ft rubber raft without sea anchor	1	63	3.2	7%
		3	224	15	23%
		5	720	29	75%
		7	1,254	33	131%
		9	1,635	26	171%
	11	3,067	77	321%	
GDOC AMM original	Category I	1 - 11	4,494	0	471%
GDOC AMM modified	Category I	1, 3, 5	1,937	0	203%
	Category I	7, 9, 11	4,494	0	471%
CASP	Category I	1 - 11	954	0	100%

Table 4-5  
 Comparison of AP98 Leeway Drift Area Model  
 with Varying Values for the Standard Deviation of the Normal Distribution  
 for 12-foot Rubber Raft without a sea anchor  
 for a Steady Wind of 20 knots for 24 hours  
 (No Sea Surface or Wind Currents, LKP is a point)

Leeway Drift Model	Craft Type	Steady Winds of 20 knots, 24 hours			
		$S_{yx}$ (cm/s)	mean (sq. nm.)	std. dev. (sq. nm.)	CASP ratio (%)
AP98	12-ft rubber raft without sea anchor	1	25.0	1.1	3%
		3	157	5.1	17%
		5	305	13.5	32%
		7	637	14.2	67%
		9	890	30.5	94%
		11	1,296	55	137%
GDOC AMM original	Category I	1 - 11	4,412	0	466%
GDOC AMM modified	Category I	1, 3, 5	1,902	0	201%
	Category I	7, 9, 11	4,412	0	466%
CASP	Category I	1 - 11	946	0	100%

Table 4-6  
 Comparison of AP98 Leeway Drift Area Model  
 with Varying Values for the Standard Deviation of the Normal Distribution  
 for 12-foot Rubber Raft without a sea anchor  
 for a Steady Wind of 40 knots for 12 hours  
 (No Sea Surface or Wind Currents, LKP is a point)

Leeway Drift Model	Craft Type	Steady Winds of 20 knots, 24 hours			
		$S_{yx}$ (cm/s)	mean (sq. nm.)	std. dev. (sq. nm.)	CASP ratio (%)
AP98	12-ft rubber raft without sea anchor	1	13.8	0.005	1.5%
		3	40	1.0	4%
		5	128	4.9	14%
		7	264	9.1	28%
		9	471	9.2	51%
		11	590	17	63%
GDOC AMM original	Category I	1 - 11	4,290	0	460%
GDOC AMM modified	Category I	1, 3, 5	1,849	0	198%
	Category I	7, 9, 11	4,290	0	460%
CASP	Category I	1 - 11	933	0	100%

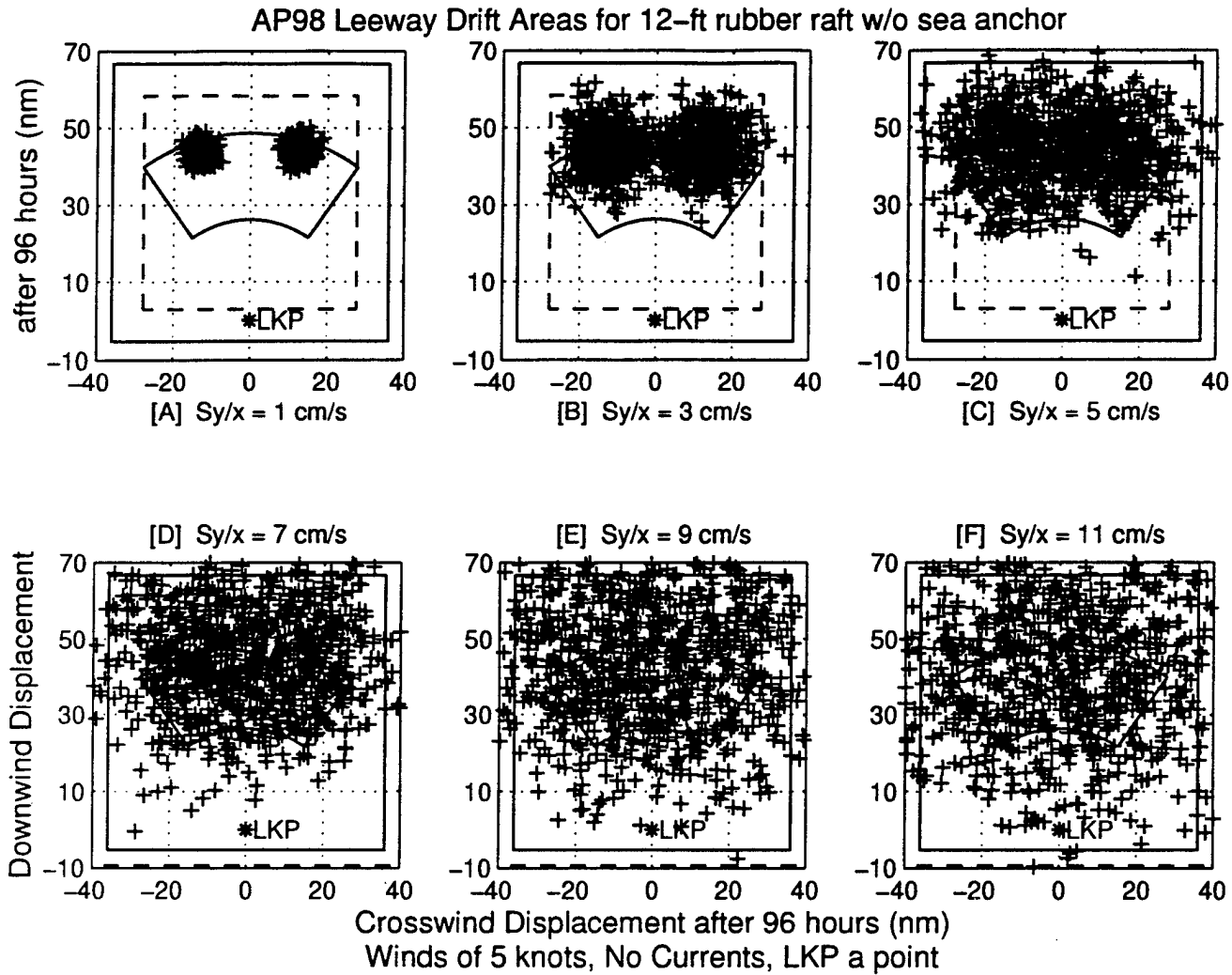

Figure 4-5. The Leeway Drift Area of Leeway Distribution Model AP98 for Hufford and Broida's (1974) 12-foot Rubber Raft without a sea anchor, along with the GDOC AMM original (square with solid lines), GDOC AMM modified (square with dashed lines) and CASP (annulus with solid lines) Leeway Drift Areas for Category I Leeway Targets after 96 hours of a Steady 5 knot Wind. The standard errors used in the AP98 model are: [A] 1 cm/s; [B] 3 cm/s; [C] 5 cm/s; [D] 7 cm/s; [E] 9 cm/s; and [F] 11 cm/s.

AP98 Leeway Drift Areas for 12-ft rubber raft w/o sea anchor

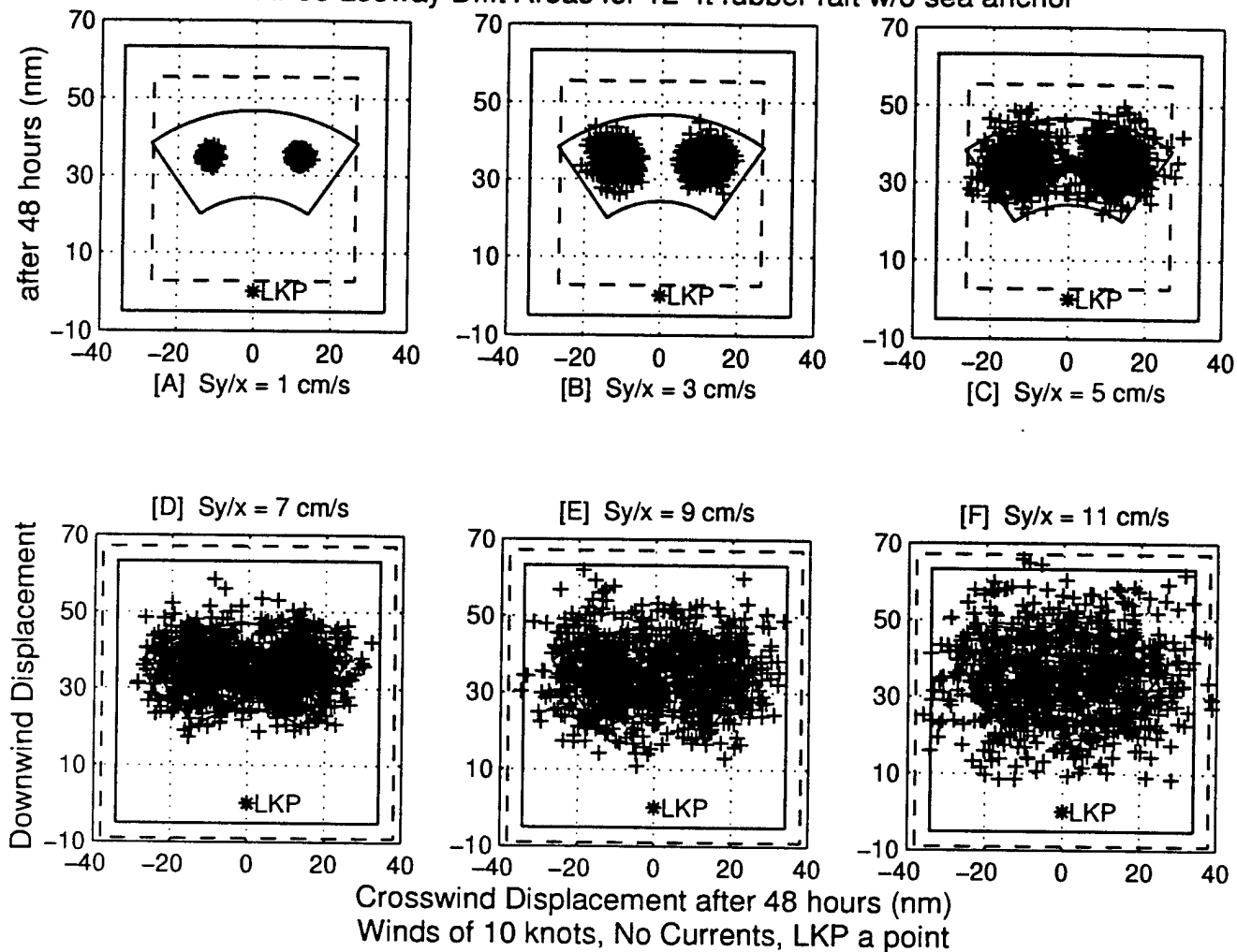
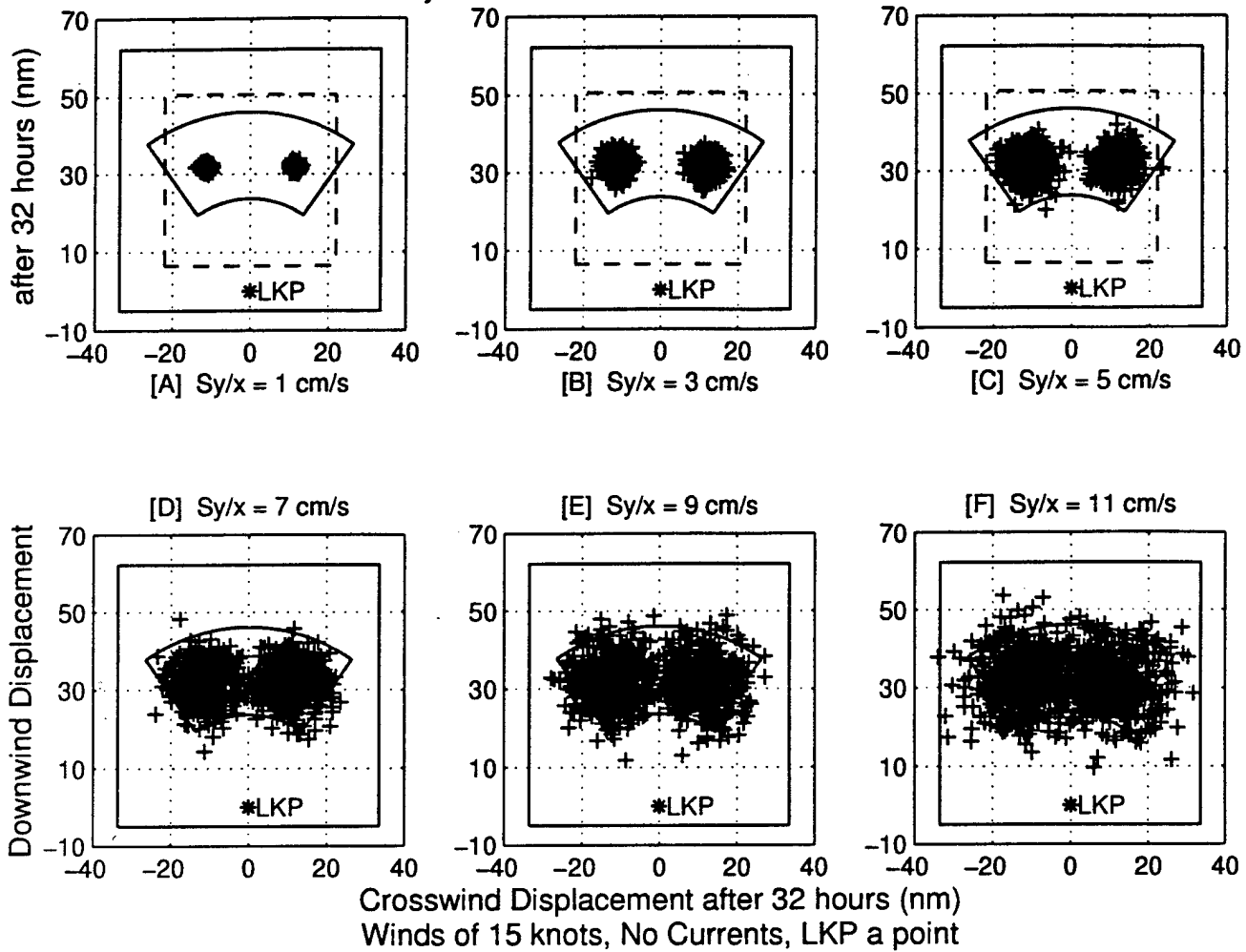

Figure 4-6. The Leeway Drift Area of Leeway Distribution Model AP98 for Hufford and Broida's (1974) 12-foot Rubber Raft without a sea anchor, along with the GDOC AMM original (square with solid lines), GDOC AMM modified (square with dashed lines) and CASP (annulus with solid lines) Leeway Drift Areas for Category I Leeway Targets after 48 hours of a Steady 10 knot Wind. The standard errors used in the AP98 model are: [A] 1 cm/s; [B] 3 cm/s; [C] 5 cm/s; [D] 7 cm/s; [E] 9 cm/s; and [F] 11 cm/s.

AP98 Leeway Drift Areas for 12-ft rubber raft w/o sea anchor



Winds of 15 knots, No Currents, LKP a point

Figure 4-7. The Leeway Drift Area of Leeway Distribution Model AP98 for Hufford and Broida's (1974) 12-foot Rubber Raft without a sea anchor, along with the GDOC AMM original (square with solid lines), GDOC AMM modified (square with dashed lines) and CASP (annulus with solid lines) Leeway Drift Areas for Category I Leeway Targets after 32 hours of a Steady 15 knot Wind. The standard errors used in the AP98 model are: [A] 1 cm/s; [B] 3 cm/s; [C] 5 cm/s; [D] 7 cm/s; [E] 9 cm/s; and [F] 11 cm/s.

AP98 Leeway Drift Areas for 12-ft rubber raft w/o sea anchor

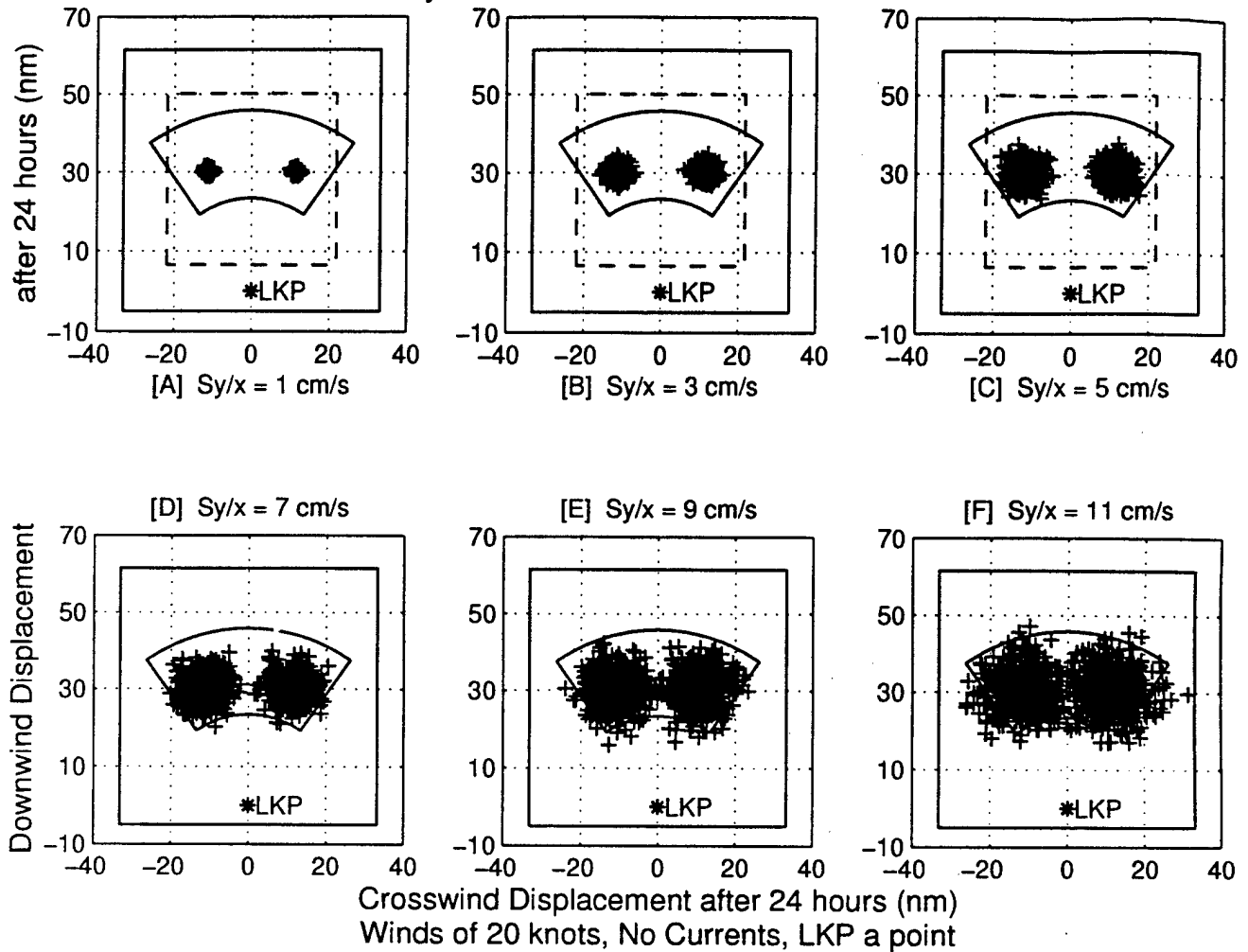

Figure 4-8. The Leeway Drift Area of Leeway Distribution Model AP98 for Hufford and Broida's (1974) 12-foot Rubber Raft without a sea anchor, along with the GDOC AMM original (square with solid lines), GDOC AMM modified (square with dashed lines) and CASP (annulus with solid lines) Leeway Drift Areas for Category I Leeway Targets after 24 hours of a Steady 20 knot Wind. The standard errors used in the AP98 model are: [A] 1 cm/s; [B] 3 cm/s; [C] 5 cm/s; [D] 7 cm/s; [E] 9 cm/s; and [F] 11 cm/s.



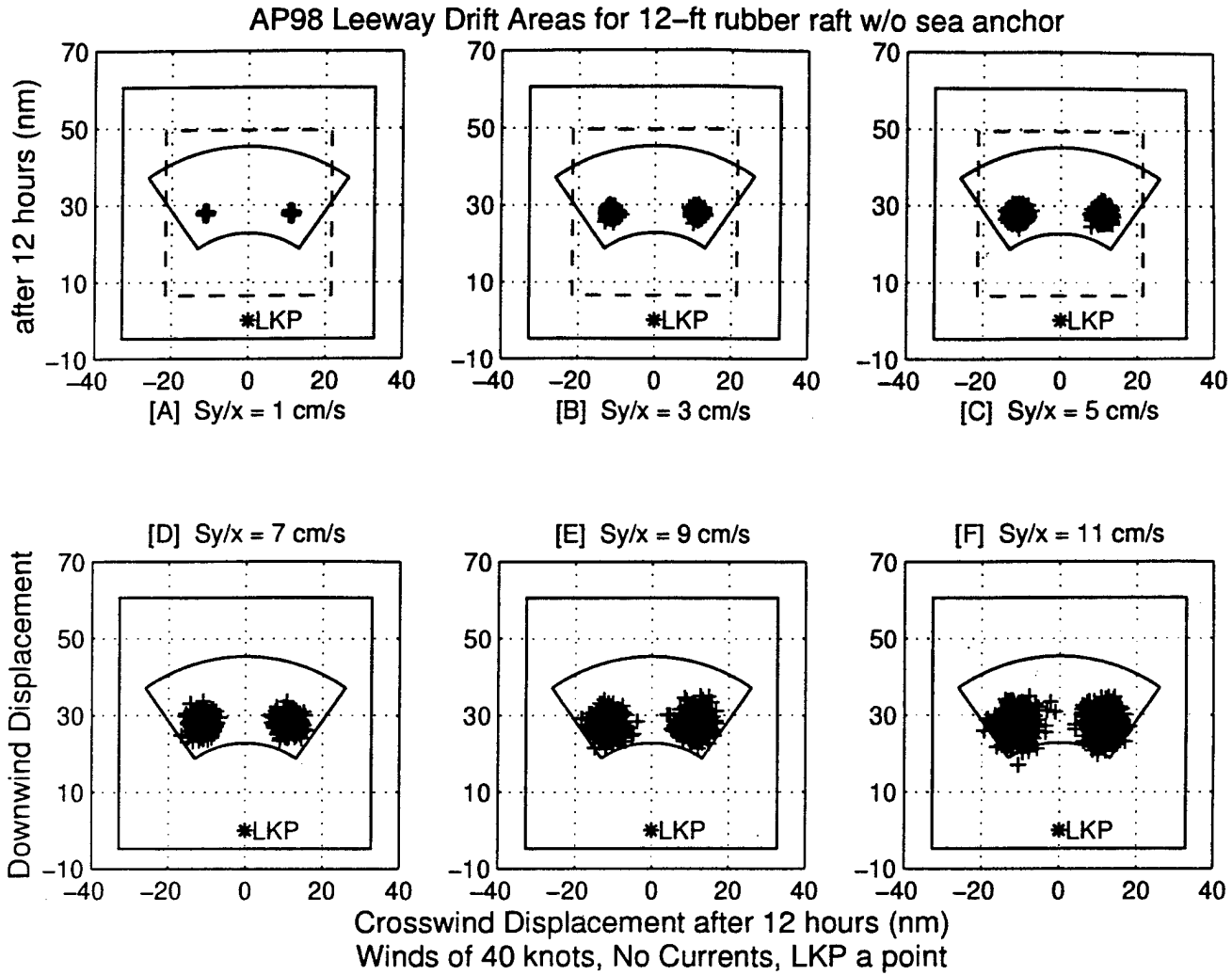

Figure 4-9. The Leeway Drift Area of Leeway Distribution Model AP98 for Hufford and Broida's (1974) 12-foot Rubber Raft without a sea anchor, along with the GDOC AMM original (square with solid lines), GDOC AMM modified (square with dashed lines) and CASP (annulus with solid lines) Leeway Drift Areas for Category I Leeway Targets after 12 hours of a Steady 40 knot Wind. The standard errors used in the AP98 model are: [A] 1 cm/s; [B] 3 cm/s; [C] 5 cm/s; [D] 7 cm/s; [E] 9 cm/s; and [F] 11 cm/s.

The following observations can be made from the preceding five figures and tables. The first three observations are about the leeway distributions of the AP98 model. The next four observations concern the leeway drift areas of CASP and GDOC AMM (original and modified).

Clearly, as the standard error term ( $S_{y/x}$ ) increases in value from 1 to 11 cm/s the leeway drift area of AP98 increases for a given wind speed. The leeway drift areas typical of recent leeway studies with low  $S_{y/x}$  (1 to 5 cm/s) are 3 to 30 percent that of leeway drift areas from older studies that normally have  $S_{y/x}$  of 7 to 11 cm/s. In other words when the standard error term used in AP98 increased from 1 to 7 cm/s (or 3 to 9, or 5 to 11 cm/s) the size of the leeway drift areas increased by 3 to 30 times. Thus a considerable penalty occurs when using the AP98 model for leeway equations with high variance.

Recall that the AP98 model uses the standard error from each leeway component equation to set the standard deviation parameter of the normal distributions and that the spread of a normal distribution is determined by its standard deviation parameter. Random offsets are drawn from those normal distributions about the y-intercept for each leeway component equation. A series of linear and parallel equations that are normally distributed about the mean unconstrained linear regression equations of both downwind and crosswind components of leeway as functions of wind speed are generated. Therefore the effect of  $S_{y/x}$  on AP98 leeway drift area can be explained. As  $S_{y/x}$  increases the spread of the normal distribution about the mean y-intercept of the leeway equations increases, resulting in a wider range of leeway equations. Hence there is greater spreading about the mean leeway equation and therefore larger leeway drift areas as  $S_{y/x}$  increases.

The second readily apparent observation is that as the wind speed decreases from 40 to 5 knots there is an increase in the leeway drift areas of AP98 for equal displacement vectors. That is to say, the leeway drift areas predicted from the AP98 model increase by 10 to 20 times when the winds decrease from 40 to 5-10 knots. The effect of wind speed on leeway drift areas has to do with the decreasing importance of the slope term (leeway rate x wind speed) at low wind compared to the y-intercept term. The y-intercept term, which has units of leeway speed, is multiplied by duration of the drift (here in hours) to generate a displacement offset. Those offsets are proportionally larger for light winds and longer durations. Therefore leeway drift area of AP98 increases at low winds and long durations.

A less apparent effect of the y-intercept is on the center of the leeway drift area. When the mean y-intercept is positive, the displacement offset is also positive or in the downwind direction. The 12-foot rubber raft used for these examples had a positive y-intercept for the regression of the DWL [9.91 cm/s (0.19 knots) as shown in Table 3-6]. The center of leeway drift area after 96 hours at 5 knots (see Figure 4-2 [A]) was 44 nm downwind. The center of the leeway drift area after 12 hours at 40 knots (see Figure 4-9 [A]) was only 28 nm downwind. This 16 nm difference between these two mean downwind displacements is equal to mean y-intercept (0.19 knots) times the difference (96 - 12

hours) in duration between these two drift runs. If the y-intercept had been negative, then the displacement offset would also have been negative or in the upwind direction.

CASP and GDOC AMM (original) generate leeway drift areas that are not functions of the variance of the leeway equations. The CASP and GDOC AMM areas did increase slightly with the longer displacements that were associated with lower winds. Again this was because the y-intercept term was positive for these examples and adding to the overall leeway displacement. If the y-intercept term had been negative, there would have been a corresponding decrease in the leeway displacements and therefore slightly smaller areas with lower winds instead. The leeway drift area of GDOC AMM was 4.6 to 5.1 times that of CASP.

The leeway drift areas of CASP (CASP ratios from Tables 4-2 – 4-6 of 50 to 150%) match reasonably well with the distributions from AP98 for 10 of the 30 test cases (as shown in Figure 4-5 [B], Figure 4-6 [B and C], Figure 4-7 [C and D], Figure 4-8 [D, E and F], and Figure 4-9 [E and F]). The leeway drift area of CASP was significant larger than the distribution from AP98 (CASP ratio < 50%) for 11 of the 30 test cases and significant smaller (CASP ratio > 150%) for 9 of the 30 cases. At lower values of  $S_{y/x}$  and higher winds CASP generates leeway drift areas larger than those of AP98 by factors up to 68 times. For high values of  $S_{y/x}$  and lower winds, CASP underestimates the leeway drift area compared to AP98 by as much as a factor of 10.

The leeway drift areas of GDOC AMM (original) ( $\pm 50\%$  of AP98's areas from Tables 4-2 to 4-6) match reasonably well with only 5 of the 30 test cases of the distributions from AP98 (as shown in Figure 4-5 [D and E], Figure 4-6 [E and F] and Figure 4-7 [F]). These five cases are lower wind speeds and higher values of  $S_{y/x}$ . For the rest of the drift runs GDOC AMM (original) generates leeway drift areas larger than those of AP98 by factors up to 300 times. The leeway drift areas of GDOC AMM also tend to be centered upwind of leeway drift areas of AP98 and CASP. This is due to GDOC AMM connecting the end points of  $d_{max}$  and  $d_{min}$  by a straight line and not with an arc.

Except for high variance ( $S_{y/x}$  greater than 5 cm/s) and low winds (less than 15 knots), modified GDOC AMM overestimates the leeway drift area compare to area generated by AP98. At winds 20 knots and higher the modified GDOC AMM overestimates by 3 to 130 times the leeway drift area of AP98. The leeway drift areas of modified GDOC AMM also contain a downwind bias of leeway drift areas compared to the areas of AP98 and CASP. This is the result of the same procedural mechanism of connecting the two end points by a straight line as in the original GDOC AMM.

While AP98 and modified GDOC AMM represent significant improvements over CASP and GDOC AMM (original), they require further development to include the effects of wind and current variance on the final distributions before they will be ready for implementation.

[BLANK]

## CHAPTER 5

### IMPLEMENTATION OF LEEWAY INTO SEARCH PLANNING TOOLS

- 5) *What is present leeway guidance for search planning?*
- 6) *How does the present leeway guidance compare to the new models of leeway behavior?*

#### 5.1 INTRODUCTION

In this chapter, values for leeway presently in use by the U.S. and Canadian Coast Guards in their search planning tools are reviewed. The sources of those leeway values are documented. This chapter concludes by comparing leeway values and the distributions generated by the search planning tools to values and distributions from more recent leeway studies.

Currently four operational search planning tools plus one under development use leeway to predict the drift of SAR objects. The basic search-planning tool is the National SAR Manual, the official SAR guidance for the U.S. Coast Guard. The other operational search-planning tools follow and reflect the guidance outlined in the National SAR Manual. The present version of CASP (version 1.1X) and GDOC automated manual method are the computer search tools used by the USCG. The USCG has a new CASP (version 2.0) partially developed but has not yet implemented it. The Canadian Coast Guard uses its own computer search tool, CANSARP. Tables 5-1 through 5-3 present the leeway target classes, their leeway equations, and the equations' sources for the target classes in the National SAR Manual, CASP, and GDOC AMM. Comments on the classes, references, and the leeway values used by the various search-planning tools follow the tables.

#### 5.2 NATIONAL SEARCH AND RESCUE MANUAL

##### 5.2.1 Leeway Speed in the National SAR Manual

The National SAR Manual presents leeway speed both graphically and as formulas in a table. The leeway classes and the equation for leeway speed from the National SAR Manual are shown in Table 5-1. Although the National SAR Manual does not list references for the leeway equations, the references listed in Table 5-1 are believed to be their sources upon a careful examination of the documents. Table 5-1 is derived in part from Nash and Willcox's 1991 Table 2-2. Column one of Table 5-1 presents the leeway classes directly from the National SAR Manual. Note that these descriptions of the leeway classes in National SAR Manual (Table 5-1, Column 1, this report) closely match the descriptions provided by the leeway reports (as shown Table 2-3, Column 1, this report).

Table 5-1.  
National SAR Manual's Leeway Target Classes, Values and References

TYPE of Craft	National SAR Manual Leeway Speed (knots) [U is wind speed in knots]	Reference
Light Displ. cruisers, Outboards, rubber rafts w/o drogue	$0.07U + 0.04$	Hufford and Broida (1974)
Large Cabin Cruisers	$0.05U$	Chapline (1960)
Light Displ. cruisers, Outboards, rubber rafts w/ drogue	$0.05U - 0.12$	Hufford and Broida (1974); also, Scobie and Thompson (1979)
Medium Displ. sailboats, fishing vessels	$0.04U$	Chapline (1960)
Heavy Displ. deep draft sailing vessels	$0.03U$	Chapline (1960)
Surfboards	$0.02U$	Chapline (1960)

In addition to formulas and graphics, the National SAR Manual provides additional leeway guidance based upon Scobie and Thompson (1979) and Nash and Willcox (1991). The National SAR Manual also contains comments (presented below in bold) that provide modifications of the overall guidance for several categories of life rafts and the only guidance on leeway angles.

Rafts as described by the National SAR Manual have neither canopies nor ballast systems. Pingree (1944), Hufford and Broida (1974), Morgan et al. (1977) and Osmer et al. (1982) studied these types of rafts. The values for rafts in the National SAR Manual are from Hufford and Broida (1974) who lumped four 12 to 21 foot outboard/light displacement cruisers with a rubber raft and studied the five craft with and without drogues. The description and leeway values of the remaining four categories of Table 5-1 are directly from Chapline (1960).

The National SAR Manual was amended in September 1983 by the addition of further guidance for life rafts with canopies and ballast pockets. No algorithms are provided for the guidance quoted below. Items (a), (b) and (c) are basically unchanged from the original amendment (No. 5), while item (d) has undergone further revision. The comments in bold below are from the National SAR Manual (1991 version).

a) **“Rafts with canopies and ballast pockets have leeway speeds approximately the same as rafts without this equipment.”** (National SAR Manual, 1991)

Since the basic description of rubber rafts in the National SAR Manual is that the rafts have neither canopy nor ballast systems, this statement implies that drogued life rafts with canopies and ballast systems will have the same leeway values as rubber rafts that have neither canopies nor ballast systems but that are drogued. Likewise, life rafts with canopies and ballast systems which are not drogued will have the same leeway values as rubber rafts that have neither canopies nor ballast systems and are also undrogued.

The apparent source for this guidance is from a recommendation by Scobie and Thompson (1978), their page 27, "Until more data can be collected, leeway drift for improved ballast life rafts should be calculated by continuing to use the equation in the National Search and Rescue Manual for rubber rafts with drogue." Scobie and Thompson studied three life rafts with canopies and ballast bags, with and without drogues. It appears that the guidance in the National SAR Manual erroneously applied Scobie and Thompson's recommendation by suggesting that life rafts with canopies and ballast systems without drogues will have leeway drift equivalent to rubber rafts (without canopies and ballast systems) that are undrogued.

Accurate engineering drawings of the life rafts studied were not provided in reports prior to Nash and Willcox (1985). Nash and Willcox (1985) and (1991) provide figures of two life rafts that have a canopy and a ballast system, which is not a deep-ballast system. The total volumes of these non-deep ballast systems were approximately 0.02 and 0.04 cubic meters.

**b) "Rafts with canopies have leeway speeds approximately 20 percent faster than rafts without." (National SAR Manual, 1991)**

Life rafts with canopies but no ballast system will drift 20 percent faster than rafts that have neither a canopy or ballast system.

**c) "Rafts with ballast pockets have leeway speed approximately 20 percent slower than rafts without." (National SAR Manual, 1991)**

Life rafts with a ballast system but no canopies will drift 20 percent slower than rafts that have neither a canopy or ballast system.

The source of guidance items (b) and (c) is unknown. None of Scobie and Thompson (1978) leeway equations are either approximately 20 percent faster or slower than the leeway equations used in the National SAR Manual as provided by Hufford and Broida (1974) for rubber rafts. Guidance items (a), (b), and (c) in the present form, and the original form of (d), pre-date Nash and Willcox (1985) report on the their 1983 summer leeway experiment.

d.) **“Rafts with canopies *and* a deep ballast system have uncertain leeway speed. Speeds approximately the same as for rafts with drogue may be assumed.”**

Therefore:

For rafts with canopies and deep ballast systems  
leeway speed =  $0.05U - 0.12$

Continuing: **“The minimum leeway speed is zero for winds of 5 knots or less, and 0.1 knot for winds greater than 5 knots.”**

Therefore:

Rafts with canopies and deep ballast systems have leeway speed above the following minimums.

leeway speed => 0.0            for wind of less than 5 knots, and  
leeway speed => 0.1 knot      for wind greater than 5 knots.

Further continuing: **“For a deep ballast raft where the canopy does not deploy, the leeway speed falls to between 3 percent of wind speed and zero.”** (National SAR Manual, 1991)

Therefore:

Rafts with deflated canopies and deep ballast systems have leeway speed in the following range.

leeway speed =  $0.0U$  to  $0.03U$

The original version of item (d) as it appeared in Amendment 5 to National SAR Manual 1973 version is as follows:

d. (Original version) *“Rafts with canopies and new deep draft ballast systems: Leeway speed is approximately the same as that given for rafts with drogue. If the canopy does not employ, the leeway speed will be approximately 2.3% of the wind speed.”* (National SAR Manual, 1973, Amendment 5)

Therefore the original guidance was to use the following equations:

Rafts with canopies and deep ballast systems  
leeway speed =  $0.05U - 0.12$

and

Rafts with deep ballast systems and a canopy that did not deploy.  
Leeway speed =  $0.023 U$

The source for the original version of item (d) is from Scobie and Thompson (1978). Their leeway equation for a Givens life raft with a deep ballast system with its canopy deployed is:

Leeway speed =  $0.054 U - 0.177$

and when the canopy failed to deployed the leeway equation is:



$$\text{Leeway speed} = 0.023 U + 0.091$$

Item (d) was then modified to its present form based upon recommendations of Nash and Willcox (1985).

The volume of the deep ballast system of a Switlik 4-person life raft with a toroidal ballast system studied by Nash and Willcox (1991) was 2.6 cubic meters and the volume of the ballast system of a Givens life raft was 1.4 cubic meters. This is 70 times greater than the 0.02 and 0.04 cubic meters for the non-deep ballasted life rafts.

These algorithms represent the authors' interpretation of the leeway guidance presented National SAR Manual. These interpretations along with GDOC AMM interpretations of the National SAR Manual (presented in section 5.3) are compared in section 5.7 to the new leeway models introduced in sections 4.4 and 4.5 using values from recent leeway studies.

### 5.2.2. Leeway Angle in the National SAR Manual

The National SAR Manual guidance for leeway maximum angle off the downwind direction is:

<b>"Craft with shallow draft</b>	<b>± 60 degrees.</b>
<b>Craft with moderate to deep draft</b>	<b>± 45 degrees.</b>
<b>Rubber rafts</b>	<b>± 35 degrees.</b>
<b>Circular rafts with symmetrical ballast systems</b>	<b>± 15 degrees."</b>

Chapline (1960) provided the first guidance on leeway angle. However, the apparent reference for the first three leeway angle categories listed above is Hufford and Brodia (1974), page 21. Hufford and Brodia's (1974) results were based on a limited data set of four small craft collected during winds of less than 20 knots. Nash and Willcox's (1985) recommendations (page 58) provide the basis for the National SAR Manual guidance on circular rafts with symmetrical ballast systems.

## 5.3 AUTOMATED MANUAL METHOD In GDOC

### 5.3.1 Leeway Classes

Table 5-2 summarizes the leeway classes and values in the GDOC Automated Manual Method. The GDOC method uses six classes from the National SAR Manual plus two additional categories (PIWs and Attached to Land). Included in the GDOC AMM leeway page are two toggle buttons for increasing or decreasing the leeway speed by the addition of a canopy or ballast buckets to the craft.

Table 5-2  
USCG GDOC AMM Leeway Target Classes and Values

TYPE of Craft	GDOC Automatic Manual Method	
	Divergence Angle (Degrees) [1]	Leeway Speed (knots) [U = Wind Speed in knots]
Attached to Land	0	0.0
PIW	0	0.0
Light Displ. cruisers, Outboards, rubber rafts w/o drogue	$\pm 35$	$0.07U + 0.04$
Large Cabin Cruisers	$\pm 60$	$0.05U$
Light Displ. cruisers, Outboards, rubber rafts w/ drogue	$\pm 35$	$0.05U - 0.12$
Medium Displ. sailboats, fishing vessels	$\pm 60$	$0.04U$
Heavy Displ. deep draft sailing vessels	$\pm 45$	$0.03U$
Surfboards	$\pm 35$	$0.02U$
Above classes with Canopy [2]		$1.2 \times (\text{leeway})$
Above classes with Ballast Buckets [3]		$0.8 \times (\text{leeway})$

Notes:

[1] The source of the divergence angles used by the GDOC automated manual method are variations on the National SAR Manual guidance for leeway angles which came from Hufford and Broida. Since Hufford and Broida (1974) studied only four small craft and a rubber raft, the extrapolation of their results to the other leeway categories is questionable. Chapline (1960) observed that light displacement craft with greater amounts of freeboard and sail area had smaller leeway angles and that fishing sampans had leeway angles of two points (22.5 degrees) off the wind. Chapline (1960) did not provide any observations on the leeway angle for surfboards.

[2] GDOC automated manual method has two toggle buttons for modifying the above leeway equations. The first toggle is to add a canopy to the above classes, which multiplies the leeway equation by a factor of 1.2. This was meant for use with the rubber raft classes, with and without drogues, but can be applied to all the classes.

[3] This is the second GDOC automated manual method toggle button for modifying the leeway equation by multiplying the equation by 0.8. This was meant for the addition of ballast buckets to rubber rafts. If both toggle buttons are on, then they nearly cancel each other out, leaving the original leeway equation essentially unmodified.

## 5.4 CASP Version 1.1X

### 5.4.1. Leeway Classes

The present version of CASP (Computer Assisted Search Planning) program has eight predefined categories of leeway targets to choose from plus a "User Defined Leeway", as shown in Table 5-3. User Defined Leeway allows the search planner to input values other than those provided in the eight predefined categories. Six of eight categories follow the guidance provided in the leeway table of the National SAR Manual. As with GDOC, the two additional classes are "PIWs" and "Anchored to Land."

Table 5-3.  
USCG CASP 1.1X Leeway Target Classes and Values

TYPE of Craft	CASP 1.1X	
	Divergence Angle (Degrees)	Leeway Speed (knots) [U = Wind Speed (knots)]
Anchored/Land	0	0.0
PIW	0	0.0
Light Displ. cruisers, Outboards, rubber rafts w/o drogue	±35	0.07U (0.047U to 0.097U) [1]
Large Cabin Cruisers	+60	0.05U (0.034U to 0.067U)
Light Displ. cruisers, Outboards, rubber rafts w/ drogue	±35	0.05U (0.034U to 0.067U)
Medium Displ. sailboats, fishing vessels	±60	0.04U (0.027U to 0.053U)
Heavy Displ. deep draft sailing vessels	+45	0.03U (0.020U to 0.040U)
Surfboards	+35	0.02U (0.013U to 0.027U)
User Defined Leeway	[2]	[2]

Notes:

[1] The CASP 1.1X leeway equation is a linear regression constrained through the origin with a 33.33% uncertainty in the rate. The minimum and maximum uncertainties in the leeway rate are the bracketed values in Column 3, Table 5-3.

[2] To use "User Defined Leeway" the search planner must provide three values: Multiplier, Uncertainty and Divergence. The Multiplier is the factor by which the wind speed is multiplied to reduce the wind speed to leeway speed.

$$\text{Leeway Speed} = \text{Multiplier} \times \text{Wind Speed} \quad (5.1)$$

Therefore the Multiplier is the slope the linear regressions constrained through the origin of leeway speed versus wind speed.

The Uncertainty is the factor by which a range of Multipliers is generated. The Uncertainty therefore generates the maximum and minimum slope of the constrained regression of leeway speed versus wind speed.

$$\text{Slope Uncertainty Range} = \text{Multiplier} \pm (\text{Multiplier times Uncertainty}) \quad (5.2)$$

Divergence is the divergence angle of the target.

#### 5.4.1.1 CASP User Defined Leeway Input

CASP's User Defined Leeway inputs require the user to provide Multiplier, Uncertainty and Divergence values. These terms are defined in Note 2, Table 5-3. Using these input values and the calculated Slope Uncertainty Range, CASP generates several thousand replications of leeway speed coefficient and leeway angle for a series of time steps.

For each replication CASP selects a leeway speed coefficient from a uniform distribution within Slope Uncertainty Range. At each time step, each replication is multiplied by a wind speed vector that is selected from a circular normal distribution about the end point of the mean wind vector for that time step. The circular normal wind-vector distribution has a standard deviation of 5 knots. The leeway speed coefficient is then applied to this wind vector. For example, if the search planner inputs a Multiplier of 0.05 and an Uncertainty factor of 0.1, this corresponds to an object drifting at 5 percent of the wind speed with 10 percent error. That makes the Slope Uncertainty Range 0.045 to 0.055. Thus for each replication CASP randomly selects a value between 0.045 and 0.055 to multiply times the wind speed to determine the speed of the object through the water for that time step and replication.

CASP randomly chooses a leeway angle for each replication from a uniform distribution between the positive and negative maximum leeway angle. The Divergence is the maximum leeway angle from the downwind direction and is in degrees. For each time step the circular normal distribution of the wind vector also creates a variance in the wind direction about the mean downwind direction relative to the mean downwind direction.

For each individual time step, CASP calculates the drift object location based on the calculated leeway speed and the selected leeway angle. That location is then used as the initial starting point for the next time step when CASP determines a new leeway speed based on the previously selected leeway speed coefficient and the new wind speed vector, while maintaining the same leeway angle. Thus in an iterative manner, CASP calculates the drift of thousands of replications of an object through time.

For a complete discussion of "User Defined Leeway" in CASP, see Allen and Staubs (1997) which is reproduced in Appendix A of Allen and Fitzgerald (1997). In the present version of CASP, User Defined Leeway mean leeway angle is fixed at zero degrees or directly downwind. There is no provision to input a mean leeway angle.

## 5.5 CANADIAN SEARCH-PLANNING TOOLS

The Canadian Coast Guard has its own National SAR Manual and numerical search-planning program (CANSARP). In these search-planning tools there are 27 leeway classes to choose from. The Canadian leeway classes and the leeway equations for the drogued and non-drogued targets have been recently updated based upon the recommendations of Robe (1998) and are shown in Table 5-4.

Table 5-4  
Canadian CG search-planning tools Leeway Target Classes, Leeway Speed & References<sup>[1]</sup>

Type of Craft	With Drogue	Reference	No Drogue	Reference
PIW	0.0 U	[2]	0.0 U	
Surfboard	2.0% U		2.0% U	Chapline (1960)
Raft (any size) capsized or swamped	1.3% U - 0.120	Allen & Fitzgerald (1997) [3] [4]	1.3% U - 0.120	Allen & Fitzgerald (1997) [3] [4]
1 Person Raft	2.8% U-0.12		3.7% U +0.04	
4 Person Raft	2.8% U-0.12	Fitzgerald et al. (1993) p66 [5]	3.7% U +0.04	Fitzgerald et al. (1994) p49 [6]
6 Person Raft	2.8% U-0.12		3.7% U +0.04	
8 Person Raft	2.8% U-0.12		3.7% U +0.04	
10 Person Raft	2.8% U-0.12		3.7% U +0.04	
15 Person Raft	3.1% U-0.12		3.7% U +0.04	
20 Person Raft	3.1% U-0.12	Fitzgerald et al. (1994) p68 [7]	3.7% U +0.04	[8]
25 Person Raft	3.1% U - 0.12		3.7% U +0.04	
Power Boat <15ft	5.0% U -0.12	Hufford and Broida (1974)	7.0% U +0.04	Hufford and Broida (1974) [9]
Power Boat 15-25ft	5.0% U -0.12		7.0% U +0.04	
Power Boat 25-40ft	5.0% U	Chapline (1960)	5.0% U	Chapline (1960)
Power Boat 40-65ft	5.0% U		5.0% U	
Power Boat 65-90ft	4.0% U	Chapline(1960)	4.0% U	Chapline(1960)[10]
Sailboat 15 ft	5.0% U-0.12	Hufford &Broida (1974) [11]	7.0% U+0.04	Hufford &Broida (1974) [11]
Sailboat 20 ft	5.0% U-0.12		7.0% U+0.04	
Sailboat 25 ft	4.0% U		4.0% U	
Sailboat 30 ft	4.0% U	Chapline (1960)	4.0% U	Chapline (1960)
Sailboat 40 ft	4.0% U		4.0% U	
Sailboat 50 ft	3.0% U		3.0% U	
Sailboat 65-75 ft	3.0% U	Chapline (1960)	3.0 %U	Chapline (1960)
Sailboat 75-90 ft	3.0% U		3.0% U	
Ship 90-150 ft	3.0% U	[12]	3.0% U	
Ship 150-300 ft	3.0% U	[12]	3.0% U	
Ship > 300 ft	3.0% U		3.0% U	

Notes for Table 5-4:

[1] In Table 5-4 U is the wind speed in knots as used in the referenced study, the coefficient is percent, and intercept is also in knots. In the Canadian National SAR Manual the intercept of the leeway speed versus  $W_{10m}$  regression is called the "correction," while the slope is termed the "coefficient."

[2] Both the U.S. and Canadian Coast Guards use 0.0% of Wind speed as the leeway for PIWs.  
Recent studies, however, suggest this is unrealistically low and the leeway speed of PIW is between 0.5% and 1.5% of  $W_{10m}$ , dependent upon the configuration of the PIW.

Suzuki, Sato, and Igeta, (1985) studied PIWs in the vertical, sitting, and horizontal positions and found values of:

Leeway speed of horizontal PIW (knots) = 1.5% U + 0.077 knots

Leeway speed of vertical PIW w/PFD (knots) = 0.5% U + 0.074 knots

Leeway speed of sitting PIW greater than vertical PIW and less than horizontal PIW

Su, Robe, and Finlayson (1998) using laboratory measurements suggests that leeway of a PIW, without survival suit, floating upright is

Leeway speed of PIW = 0.6% ( $U_{air} - U_{water}$ )

and a PIW in a survival suit is

Leeway speed of PIW/SS = 3.23% ( $U_{air} - U_{water}$ ).

The results of Su, Robe, and Finlayson (1998) field trial for winds between 5 and 12 knots for a PIW in a survival suit is

Leeway speed of PIW/SS (knots) = 2.7%  $W_{10m}$   
with a standard error of 0.133 knots, or 6.8 cm/s.

Allen, Robe and Morton (1999) used the direct method to study a PIW with an offshore-lifejacket Type I PFD in the sitting position and a PIW in the horizontal position in a survival suit. Their results are:

Leeway speed of PIW in Type I PFD (cm/s) = 1.17%  $W_{10m}$  + 0.2 cm/s

Leeway speed of PIW in Survival Suit (cm/s) = 1.44%  $W_{10m}$  + 5.25 cm/s

Kang (1999) used the indirect method to study real subjects in scuba gear and wet suits. The subjects in the scuba gear floated on their backs in a horizontal position. The subjects in wet suits floated vertically. Winds were adjusted to the 10-meter height.

PIW scuba gear = 0.7 %,  $W_{10m}$  + 4.3 cm/s                      5.92 cm/s  $S_{y/x}$

PIW wet suit (vertical) = 0.05 %,  $W_{10m}$  + 2.5 cm/s                      2.07 cm/s  $S_{y/x}$

[3] Robe (1998) generalized the results of Allen and Fitzgerald (1997) into a single class of swamped or capsized rafts based upon taking 42% of rate (3.1% U) for the twenty-person life raft with drogue resulting in the 1.3% coefficient.

[4] The correction terms (-0.12 and +0.04) used by the CCG search-planning tools are from Hufford and Broida's (1974) equations for small craft with drogues and without drogues, respectively.

[5] Fitzgerald et al. (1993), page 66, presented the results for a Beaufort life raft, 4-person loading, drogued, as  $2.8\% U - 0.07$  knots where  $U$  is the wind speed at 2-meter height. Fitzgerald et al. (1994), page 68, presents results for a Tulmar and Beaufort 4-person life rafts with drogues.

$$\text{Tulmar leeway speed (knots)} = 1.9\% W_{10m} + 0.14 \text{ knots}$$

$$\text{Beaufort leeway speed (knots)} = 2.1\% W_{10m} - 0.11 \text{ knots}$$

Since Fitzgerald et al. (1994) includes data from Fitzgerald et al. (1993), either of these two equations would be preferable to the equation used by the CCG search planning tools as shown in Table 5-4. If the Fitzgerald et al. (1993) equation is to be used, then the correct correction term (- 0.07 knots) should be used, not the incorrect term that is presently in place (- 0.12 knots).

[6] Fitzgerald et al. (1994), page 49, presented results combined from symmetrical 4-person Tulmar and Beaufort life rafts and also combined from three 4-person and one 20-person life rafts. Both categories are for lightly loaded, with deep ballast systems, canopies, and without drogues. Robe (1998) recommended the use of the equation (a) below for the combined 4 and 20 person life rafts for all life rafts categories without drogue. However, the CCG search planning guidance contains an incorrect correction term (+ 0.040 knots); the correct correction term is - 0.035 knots which may be rounded to (- 0.04 knots). Perhaps two equations are more appropriate for life rafts without drogues. Equation (b) is based upon combined data from two symmetrical 4-person life rafts and could be used for 1 to 10-person life rafts categories, while the equation in Note [8] maybe more appropriate for 15-25 person life rafts, without drogues.

(a) Combined 4 and 20 person life rafts leeway speed =  $3.7\% W_{10m} - 0.035$  knots

(b) Symmetrical 4-person life raft leeway speed =  $3.3\% W_{10m} + 0.005$  knots

[7] Fitzgerald et al. (1994) (pages 68, 110) suggest a linear equation for a fully-loaded Beaufort 20 person life raft with drogue of:

$$\text{Leeway speed (knots)} = 3.1\% W_{10m} - 0.070 \text{ knots.}$$

The CGC search planning guidance contains a wrong correction term (- 0.12 knots), instead of the correct correction term of - 0.070 knots.

[8] The present value in CANSARP is for combined 4-person and 20-person life rafts without drogues from Fitzgerald et al. (1994) (see note 6). Perhaps a more appropriate equation would be Fitzgerald's et al. (1994) (pages 47, 109) equation for a lightly loaded Beaufort 20-person life raft without drogue of:

$$\text{Leeway speed (knots)} = 0.039 W_{10m} - 0.059 \text{ knots}$$

where  $W_{10m}$  is the Wind speed in knots adjusted to the 10-meter reference level.

- [9] CCG search-planning tools currently use Hufford and Broida's (1974) equation of 7.0% of the wind speed + 0.04 knots for leeway of <15 ft and 15-25 ft power boats. Perhaps Fitzgerald et al's (1994) equation which is based upon 173 hours of leeway data from a 5.6 m (18.4 ft) open plank boat without a drogue would be more appropriate:

$$\text{Leeway speed (knots)} = 0.029 W_{10m} + 0.077 \text{ knots.}$$

- [10] Chapline's (1960) Group III has 4% of wind speed for leeway but does not contain any powerboats. It does include moderate displacement sailing vessels and fishing vessels.
- [11] These equations are from Hufford and Broida (1974), but Hufford and Broida did not study sailboats, only outboards and a rubber raft.
- [12] The values used by CANSARP are extrapolations from Chapline (1960) values for deep draft sailing vessels. There are three Japanese studies of larger vessels which suggest leeway rates for larger vessels are between 3% and 6% of the wind speed. Hiraiwa, Fujii, and Saito (1967) studied two fishery-training ships of 33 m (108 ft) and 60.5 m (195 ft) length and found leeway values of 6.3% and 6.8% of wind speed, respectively. Suzuki and Sato (1977) studied a 62 m (203 ft) fishing vessel and 45 m (147 ft) research vessel and found leeway speed of 4.2% and 2.8% of the wind speed. Igeta, Suzuki and Sato (1982) studied two 17 m (56 ft) Japanese-fishing vessels with various loadings. They found leeway rates between 5.4% and 6.5% for 5 m/s wind and a decrease to 3.3% to 4.0% for winds of 10 m/s.

The leeway divergence values used in CANSARP are shown in Table 5-5. Chapline (1960) provided the first guidance on leeway angle. However, the apparent reference for the first three leeway angle categories listed above is Hufford and Broida (1974), page 21. Hufford and Broida's (1974) results were based on a limited data set of four small craft collected during winds of less than 20 knots.

CANSARP uses the leeway divergence angle to establish the maximum angle off the downwind direction. The range from maximum left to maximum right angle is divided into eleven equal angles. Eleven separate estimates of leeway drift are then made by CANSARP. Because the limits for leeway angles are large compared to the limits of the leeway speed, CANSARP tends to produce an arc distribution pattern centered on the downwind direction. CANSARP has no provision to input a mean leeway angle.

Allen and Staubs (1997) recommended divergence angles for CASP's User Defined Leeway as being equal to two standard deviations of the leeway angle data collected for wind speeds 10 knots and higher. Plus and minus two standard deviations include 95.4 percent of a normal distribution. Leeway angle was limited to winds above 10 knots because there is excessive noise in the leeway angle data at low wind speeds. Recommendations for leeway divergence values for specific CCG target classes are presented in the notes for Table 5-5. The recommended divergence values are based upon using twice the standard deviation of the leeway angle for winds above 10 knots or 5 m/s where possible.



Table 5-5  
Canadian CG Leeway Target Classes, Leeway Divergence, Angles and References

Type of Craft	Leeway Divergence (Degrees)	Reference
PIW	00	None
Surfboard	00	None
Raft (any size) capsized or swamped	00	None [1]
1 Person Raft	35	Hufford and Broida (1974)
4 Person Raft	35 [2]	
6 Person Raft	35	
8 Person Raft	35	
10 Person Raft	35	
15 Person Raft	35	
20 Person Raft	35 [3]	
25 Person Raft	35	
Power Boat <15ft	35	
Power Boat 15-25ft	35 [4]	
Power Boat 25-40ft	45	Hufford and Broida (1974)
Power Boat 40-55ft	45	
Power Boat 65-90ft	45	
Sailboat 15 ft	45	
Sailboat 20 ft	45	
Sailboat 25 ft	45	
Sailboat 30 ft	45	
Sailboat 40 ft	45	
Sailboat 50 ft	45	
Sailboat 65-75 ft	45	
Sailboat 75-90 ft	45	
Ship 90-150 ft	45	
Ship 150-300 ft	45	
Ship > 300 ft	45	

Notes for Table 5-5:

- [1] Allen and Fitzgerald (1997), p 5-8, suggest divergence angles of 11 to 16 degrees for swamped or capsized life rafts, although they did not directly measure leeway angles for swamped or capsized life rafts.

- [2] Fitzgerald et al. (1994), pp 108-110, list the standard deviation of leeway angle (for all wind speeds) for the 4-person life rafts as 3 to 10 degrees. In Table 3-4 of this report, the standard deviation for the Tulmar 4-person life raft for winds greater than 5m/3 is 11.6 degrees. Perhaps the divergence for 4-person life rafts should be 25 degrees (twice 11.6 degrees rounded up).
- [3] Fitzgerald et al. (1994), pp 109-110, list the standard deviation of leeway angle (for all wind speeds) for the 20-person Beaufort life rafts as 6 degrees. Perhaps the divergence for 20-person life rafts should be 15 degrees (twice 6 degrees rounded up).
- [4] Allen and Fitzgerald (1997), p4-7, report a standard deviation of 10.1 degrees for leeway angle for winds greater than 5 m/s for a wooden-planked open boat. Perhaps the divergence for 15-25 foot powerboats should be 20 degrees (twice 10.1 degrees).

## 5.6 CASP Version 2.0

Recently, Wagner Associates worked on a replacement for CASP 1.1X called CASP 2.0. Table 5-6 presents the leeway classes and the leeway values associated with CASP 2.0. As of 2 Aug. 1996 CASP 2.0 had zero leeway speed set in the default values (Discenza, personal communication).

Table 5-6.  
Leeway Classes and Values Proposed For CASP 2.0

Class	Leeway Rate	Leeway Angle	Lower Leeway Tacking Threshold	Upper Leeway Tacking Threshold
Anchored on Land	Default to zero	0.0	0.0	999
Empty PFD	Default to zero	0.0	0.0	999
Flotsam	Default to zero	0.0	0.0	999
Surfboard	Default to zero	5.0	10.0	40.0
Oil Slick	Default to zero	0.0	0.0	999
PIW w/PFD	Default to zero	0.0	0.0	999
PIW w/o PFD	Default to zero	0.0	0.0	999
Raft w/ Canopy	Default to zero	5.0	10.0	40.0
Raft w/o Canopy	Default to zero	5.0	10.0	40.0
Power Boat	Default to zero	10.0	10.0	40.0
Sail Boat	Default to zero	15.0	10.0	40.0
Fishing Vessel	Default to zero	15.0	10.0	40.0
Cabin Cruiser	Default to zero	15.0	10.0	40.0
Ship	Default to zero	20.0	10.0	40.0
User Defined	Default to zero	0.0	0.0	999

CASP 2.0 includes for each target type a "Leeway Angle" (in degrees, column 3), "Lower Leeway Tacking Threshold" (in knots, column 4) and a "Upper Leeway Tacking Threshold" (in knots, column 5). When the wind speed is between the two thresholds, the target remains on the last tack until the wind speed either decreases below the first or increases above the second threshold. The angle of the tack of the downwind direction is equal to the "Leeway Angle". If the replication does not have a tack one is chosen randomly equally between left and right tacks. When the wind speed is either below the first "Leeway Tacking Threshold" or above the second "Leeway Tacking Threshold" the target goes straight downwind. There is a 10 percent factor about each threshold to prevent rapid changes due to small wind changes near the threshold wind speeds. Targets that have Leeway Tacking Thresholds of 0.0, 999 go directly downwind, (Discenza, personal communication).

### 5.7 COMPARISONS OF PRESENTLY AVAILABLE LEEWAY VALUES VERSUS IMPLEMENTED LEEWAY VALUES

The search planning tools have categories of target types for which leeway speed equations are combined with leeway angles to produce leeway drift areas. There are three factors that contribute to the leeway area distribution: (1) the leeway targets that comprise the category, (2) the leeway equations for that category, and (3) the method of implementation of the leeway equations. In this section we will look at the six categories of leeway craft common to first generation search planning tools (the National SAR Manual, and its automated solution, GDOC AMM) and the second generation search planning tool (CASP). The six categories of leeway craft were listed in Tables 5-1, 5-2 and 5-3. A seventh category, Person-in-the-Water (PIW), present in GDOC AMM and CASP, is similarly reviewed. Also discussed are the National SAR Manual comments that provide additional guidance for several categories of life rafts and the only guidance on leeway angles. When possible, the comparisons between the present guidance and implementation models and more recent studies and implementation models (AP98) will be made for similar target types. All leeway drift areas will be based upon the drift of targets with steady winds of 20 knots blowing for six and twenty-four hours or steady winds of 10 knots for 48 hours or 40 knots for 12 hours. Other simplifying conditions include use of an initial distribution (LKP) from a point, no sea or wind currents, and no variance applied to the winds. Winds of twenty knots (10.3 m/s) were chosen as a standard because they are likely to be encountered during a typical SAR case and because 20 knots is within the range of most leeway data sets. Examples at 10 and 40 knots were also included to investigate changes in leeway drift areas as a function of wind speed.

### 5.7.1 Leeway Category I, "Light Displacement Cabin Cruisers, Outboards, Rubber Rafts, etc. (Without Drogue)"

The first category common to CASP and GDOC is "Light displacement cabin cruisers, outboards, rubber rafts, etc. (without drogue)" with a leeway rate of (7% of wind + 0.04 knots) and a divergence of 35 degrees. Since Hufford and Broida (1974) provided the leeway speed value for this category, several studies have included targets that were examples of this category. Nash and Willcox (1991) studied two outboards and one light displacement cabin cruiser, all without drogues, and found leeway rates slower than the recommended rate for this category. Nash and Willcox (1991) proposed that the leeway rate equation be changed to 6.2 percent of the wind speed, with an uncertainty of 0.50. Nash and Willcox's leeway angles were within the 35 degree limits for this category, so they recommended no changes be made to the divergence term.

An undrogued 5.5-meter wooden-planked open boat with an outboard motor was studied by Fitzgerald et al. (1993) and (1994) and summarized by Allen and Fitzgerald (1997). This craft was an example of a vessel that would fit in the first leeway category. The 5.5 m open boat had a leeway speed of 3.37 percent of the 10 m-wind speed with a standard error of 4.4 cm/s for 1370 ten-minute samples. Allen and Fitzgerald (1997) presented a piece-wise regression model of the leeway components versus wind speed adjusted to 10-meter height. The model was based upon separating the data set by the relative wind direction.

The GDOC AMM and CASP leeway drift areas for a Category I craft after 6 and 24 hours of 20-knot wind are shown in Figure 4-3. The CASP area was 59 square nautical miles after 6 hours and 946 square nautical miles after 24 hours. The GDOC AMM area was 276 square nautical miles after 6 hours and 4,412 square nautical miles after 24 hours. The GDOC AMM leeway drift area was 4.7 times larger than the CASP leeway drift area.

Using the AP98 model of leeway introduced in section 4.4, the leeway end point distributions in the down and crosswind component system for the 5.5 m wooden planked open boat with an outboard motor and no drogue are shown in Figure 5-1 for the same winds conditions as Figure 4-3. The area within the 99.9% contour level was 27.7 (104) square nautical miles with a standard deviation of 0.6 (3.6) square nautical miles for 11 runs of 1000 replications after 6 (24) hours. The areas of the distributions are summarized in Table 5-7. Also presented are the ratios of the leeway drift area from the new model (AP98) to leeway drift area of the existing Leeway Drift Models. This ratio is termed the AP98 ratio in the following tables.

$$\text{AP98 ratio} = \left[ \frac{\text{AP98 leeway drift area}}{\text{Model leeway drift area}} \right] \times 100\%$$

The 12-ft rubber raft without sea anchor studied in Chapter 3 was part of Hufford and Broida's (1974) small craft data set used to establish the leeway rates for Category I. The 99.9% contour based upon a 2 (4)-km grid spacing contained an area of 115 (1160) square nautical miles with a standard deviation of 4 (40) sq. nm. for 11 runs of 1000 replications after 6 (24) hours.

Table 5-7  
 Comparison of Leeway Drift Area Models  
 for a Steady Wind of 20 knots for 6 and 24 hours  
 (No Sea Surface or Wind Currents, LKP is a point)

Leeway Drift Model	Craft Type	Steady Winds of 20 knots, No Currents,			
		6 hours		24 hours	
		sq. nm.	AP98 ratio	sq. nm.	AP98 ratio
AP98	5.5m open boat	27.7	100%	103.9	100%
AP98	12ft raft	115	24% [1]	1160	9% [1]
CASP	Category I	59	47%	946	11%
GDOC AMM	Category I	276	10%	4412	2%

Note: [1] The AP98 ratio for this row is: AP98 area for 5.5 m open boat / 12 ft raft's AP98 area.

Thus, the CASP leeway drift area was 2.1 times the size of the leeway drift area generated by AP98 after 6 hours of drift and 9.1 times the area after 24 hours for the 5.5 open boat. The GDOC AMM leeway drift area after 6 hours was 10 times the leeway drift area of AP98 and after 24 hours was 42 times larger than AP98's leeway drift area for the open boat. However, the CASP leeway drift area for Category I was 82% that of leeway drift area generated by AP98 when it uses an early data set (Hufford and Broida's (1974) 12-foot raft).

AP98 Leeway Drift Area for 5.5m wooden open Boat  
 GDOC AMM and CASP Leeway Drift Areas for Category I Leeway Targets

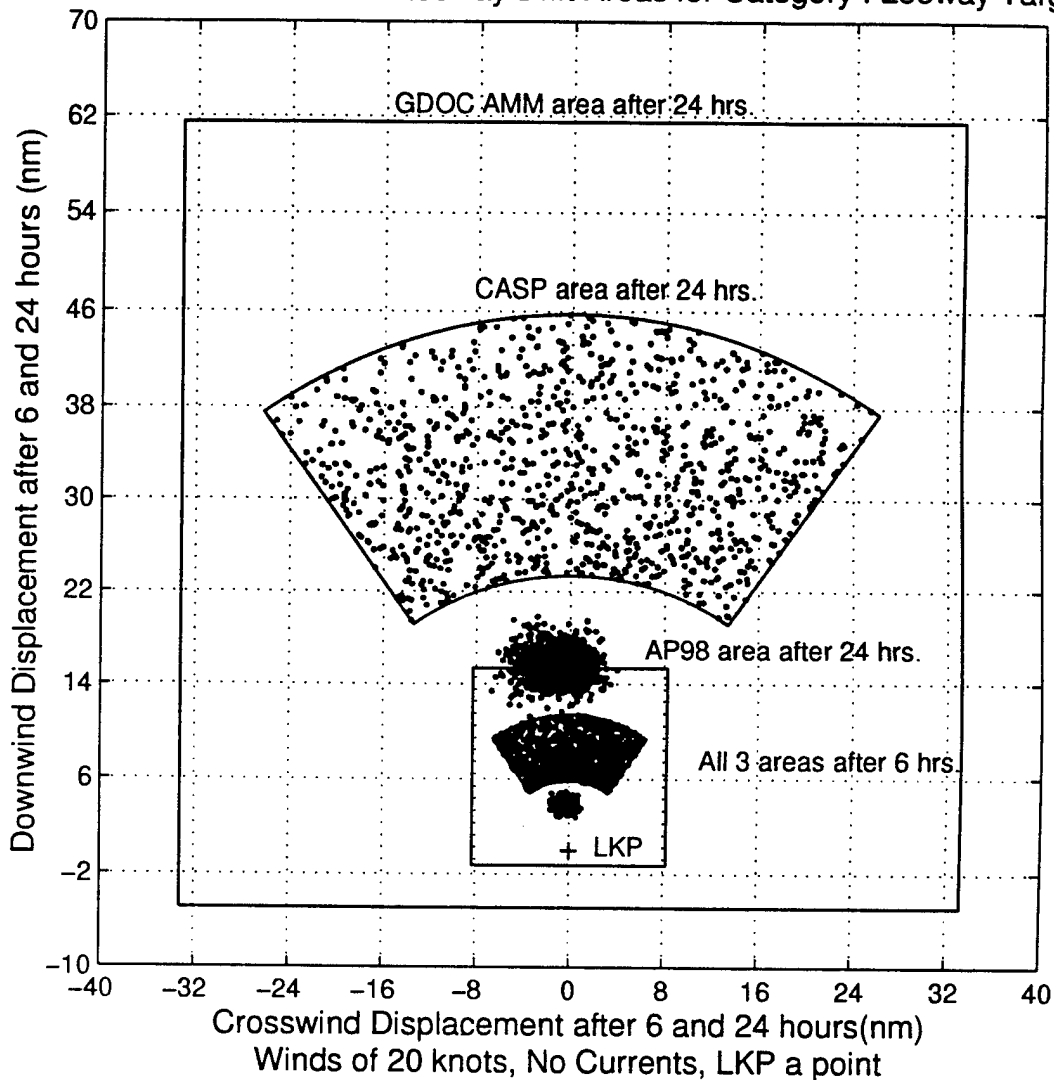

Figure 5-1. The Leeway Drift Area of Leeway Distribution Model AP98 for 5.5 meter open Boat along with the CASP and GDOC AMM areas for Category I Leeway Targets after 6 and 24 hours of a Steady 20-knot Wind.

The leeway drift areas of CASP and GDOC AMM do not differentiate between strong winds for a short time and lighter winds of longer duration. The leeway drift areas remain essentially the same, i.e., CASP and GDOC AMM leeway drift areas for 20 knots wind over 24 hours are only slightly different from the leeway drift areas determined by either a 10 knot wind over 48 hours or a 40 knot wind for 12 hours. The leeway drift areas from AP98 model, however, are quite different. The differences in distribution for distinct wind conditions for all models are shown in Table 5-8. Figure 5-2 shows the different distributions produced by AP98 model of leeway drift for a 5.5 m open outboard boat for different wind speeds. At low wind speeds, the distribution is larger than at higher wind speeds. When the winds are above 20 knots, the distribution shows a bifurcation into two distinct peaks.

Table 5-8  
Comparison of Leeway Drift Area Models  
for a steady wind of 10 knots for 48 hours, 20 knots for 24 hours, and 40 knots for 12 hours  
(No Sea Surface or Wind Currents, LKP is a point)

Leeway Drift Model	Craft Type	Steady Winds of 10, 20 , and 40 knots, No Currents, LKP is a point					
		10 kts for 48 hrs.		20 kts for 24 hrs.		40 kts for 12 hrs.	
		Sq nm.	AP98 ratio	Sq nm.	AP98 ratio	Sq nm.	AP98 ratio
AP98	5.5 m open boat	218 6.5 std.dev	100%	103.9	100%	68 0.9 std dev	100%
CASP	Category I	972	22%	946	11%	933	7%
GDOC AMM	Category I	4660	5%	4412	2%	4290	1.6%

AP98 Leeway Drift Area for 5.5m wooden open Boat  
(No Currents, LKP a point)

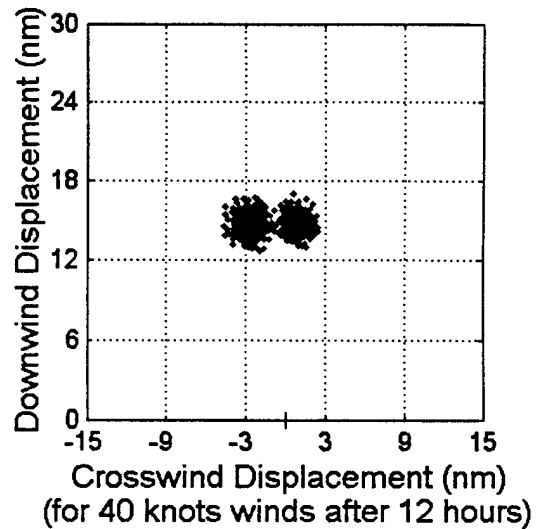
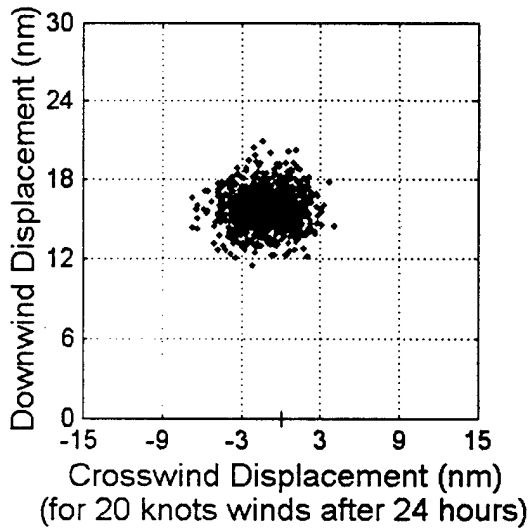
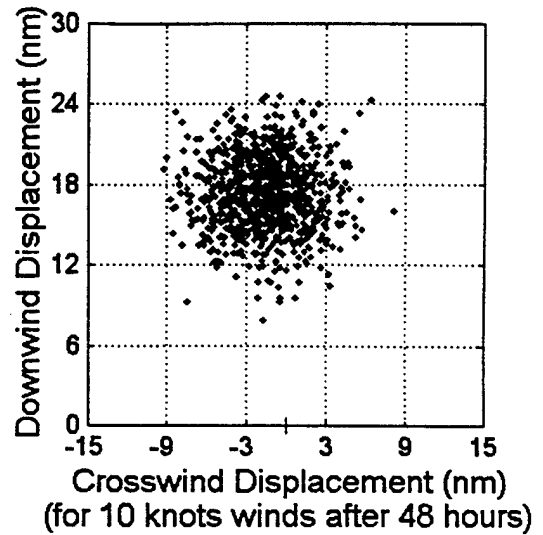
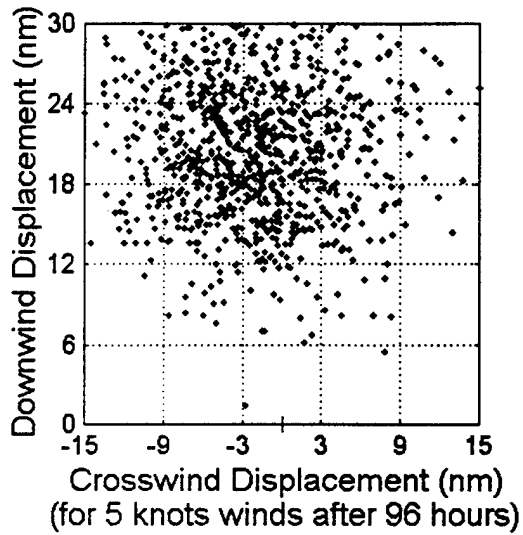

Figure 5-2. The Leeway Drift Area of the AP98 Leeway Distribution Model for 5.5 meter open Boat for Steady Winds of 5 knots for 96 hours, 10 knots for 48 hours, 20 knots for 24 hours and 40 knots for 12 hours.



### 5.7.2 Leeway Category II, "Large Cabin Cruisers"

The second category common to CASP and GDOC is "Large cabin cruisers" with a leeway rate of 5% of wind. For Category II, GDOC AMM default value for divergence is 60 degrees. The leeway rate for this category is from Chapline's (1960) group of vessels he called "Group IV, Moderate displacement cruisers." Chapline (1960) provided some initial observations on leeway angle. Hufford and Broida (1974) later provided the guidance for the leeway divergence angles presently used for this category despite the fact that they did not directly study a large cabin cruiser.

Morgan, Brown, and Murrell (1977) studied a thirty-foot utility boat that was modified with plywood to increase its cross-sectional sail area. The leeway rate of the utility boat was 6.5% of 20 knots of wind.

O'Donnell and Oates (1999) conducted a comparison test of the Aanderaa DCS 3500 current meter against the InterOcean S4 EMCM using a cabin cruiser (36-foot Senator (Sport Cruisers, Motor Yacht, Modified-V Hull, Covered aft deck, w/ Bridge Canopy). Both current meters simultaneously measured a total of six hours of leeway drift.

### 5.7.3 Leeway Category III, "Light Displacement Cabin Cruisers, Outboards, Rubber Rafts, etc. (With Drogue)"

The third category common to CASP and GDOC is "Light displacement cabin cruisers, outboards, rubber rafts, etc. (with drogue)" with a leeway rate of (5% of wind - 0.12 knots). For Category III, GDOC AMM default value for divergence is 35 degrees. Hufford and Broida (1974) provided the leeway rate and guidance for divergence angle for this category.

Morgan, Brown, and Murrell (1977) studied a rubber raft with a drogue and obtained results similar to Hufford and Broida (1974) for a rubber raft without a drogue. Morgan, Brown, and Murrell (1977) found leeway rates from 6.5 to 8.3 percent of the wind speed. Osmer, Edwards, and Breitler (1982) attempted to study the leeway of a rubber raft with a drogue but failed to obtain any useful data on leeway rates because of losses due to heavy weather. No studies since Hufford and Broida (1974) have studied either light displacement cabin cruisers with drogues or outboards with drogues.

### 5.7.4 Leeway Category IV, "Medium displacement sailboats, fishing vessels such as trawlers, trollers, tuna boats, etc."

The fourth category common to CASP and GDOC is "Medium displacement sailboats, fishing vessels such as trawlers, trollers, tuna boats, etc." with a leeway rate of 4% of wind. For Category IV, GDOC AMM default value for divergence is 60 degrees. The leeway rate for this category is from Chapline's (1960) group "Group III, Moderate displacement, moderate draft sailing vessels and fishing vessels such as trawlers, trollers, sampans, draggers, seiners, tuna boats, halibut boats, etc." Chapline provided some initial observations on leeway angle. Hufford and Broida (1974) again provided the guidance for the leeway divergence angles that are used for this category,

again despite the fact they did not study sailboats or fishing vessels. There have been no studies since Chapline (1960) on medium displacement sailboats.

There are seven studies that have included fishing vessels, including three by Japanese researchers. Hiraiwa, Fujii and Saito (1967) found leeway rates of 6.3% and 6.8% for a 33-meter and 60.5 meter fishery training vessels.

Suzuki, and Sato (1977) found leeway rates of 2.8% and 4.2% for 61.8 and 45.0 meter vessels respectively. Suzuki and Sato presented a table that lists the gross tonnage, length, beam, depth, mean draft, cross-sectional areas above and below the water line and the ratio of the cross-sectional areas for the two vessels.

Igeta, Suzuki and Sata (1982) found leeway rates for two Japanese fishing vessels decreased from 5.4 – 6.5% at wind speed of 5 m/s to 3.3 – 4.0% at winds of 10 m/s. They varied the loading of the two vessels from empty to half loaded to full loading, thereby changing the freeboard to draft ratio. The lower leeway rates were associated with full loadings. These two fishing vessels were 16.7 and 17.5 meter long and had 3.8 meter freeboard, and 1.5 meter draft, and were 19.3 and 19.8 tons.

Kang (1995) determined the leeway of a 12.5 m Korean fishing boat as 2.66% of 10m wind + 0.049 m/s. Allen (1996) studied a 15 meter commercial fishing vessel with a rear-reel for net fishing and determined its leeway to be (3.98% of 10m wind + 0.31 cm/s). A second 13.5-meter commercial fishing vessel with a rear-reel for net fishing was studied during Leeway97 field test off Ft. Pierce FL, but the leeway data were insufficient for analysis.

CASP's leeway drift area for a constant wind of twenty knots for six and twenty-four hours is shown in Figure 5-3. The target used in this example is a fishing vessel with a leeway multiplier of 4% of the wind speed, and a divergence angle of 35 degrees.

The CASP areas of the distributions shown in Figure 5-3 are 18.8 square nautical miles after 6 hours and 300. square nautical miles after 24 hours for a divergence angle of 35 degrees. The GDOC AMM areas are 85 and 1,362 square nautical miles after 6 and 24 hours for a divergence angle of 35 degrees. When the divergence angle is 60 degrees, the default value in GDOC AMM, all areas increase. The CASP area is 31.2 (514) square nautical miles after 6 (24) hours and the GDOC AMM area is 152 (2,426) square nautical miles after 6 (24) hours as shown in Figure 5-4.

The leeway drift areas for the AP98 model for the 15 m commercial fishing vessel studied by Allen (1996) are shown in Figure 5-5 for the same winds conditions as Figure 5-3. The area within the 99.9% contour level was 20.5 (190) square nautical miles with a standard deviation of 0.5 (8) square nautical miles for 11 runs of 1000 replications after 6 (24) hours. The contours were based upon a grid spacing of 1 kilometer for the six-hour drift runs and 2 kilometers for the 24-hour drift runs. The leeway drift areas are summarized in Table 5.9.

Also presented in the table are the ratios of the leeway drift area from new model AP98 to leeway drift areas of CASP and GDOC AMM. Thus, the CASP leeway drift area, when divergence angle was 35 degrees, was about the size of leeway drift area generated by AP98 after 6 hours of drift but was 4.2 times the area after 24 hours. The GDOC AMM leeway drift area, when divergence angle was 35 degrees, after 6 hours was 1.6 times the leeway drift area of AP98 and after 24 hours was 7.2 times larger than AP98's leeway drift area.

When the divergence angle in CASP and GDOC AMM are set to 60 degrees, the leeway drift areas increased, as shown in Table 5-9. The CASP leeway drift area increased by a factor of 1.7 compared to its leeway drift area with a divergence angle of 35 degrees. The GDOC AMM leeway drift area with a divergence angle of 60 degrees was 1.8 times larger than GDOC AMM leeway drift area with divergence angle of 35 degrees. A comparison of these leeway drift areas and those of AP98 is presented in Figure 5-6. Again note the uniform distribution of end points for CASP and clumped distribution the end points from the AP98 model.

Table 5-9  
 Comparison of Leeway Drift Area Models  
 for a Steady Wind of 20 knots for 6 and 24 hours  
 (No Sea Surface or Wind Currents, LKP is a point)

Leeway Drift Model	Craft Type	Divergence Angle (degrees)	Steady Winds of 20 knots, No Currents			
			6 hours		24 hours	
			sq. nm.	AP98 ratio	sq. nm.	AP98 ratio
AP98	15m F/V		20.5	100%	190	100%
CASP	Category IV	35	18.8	109%	300	63%
		60	31.2	66%	514	37%
GDOC AMM	Category IV	35	85	24%	1,362	14%
		60	152	13%	2,426	8%

### GDOC AMM and CASP Leeway Drift Areas for Category IV Leeway Targets

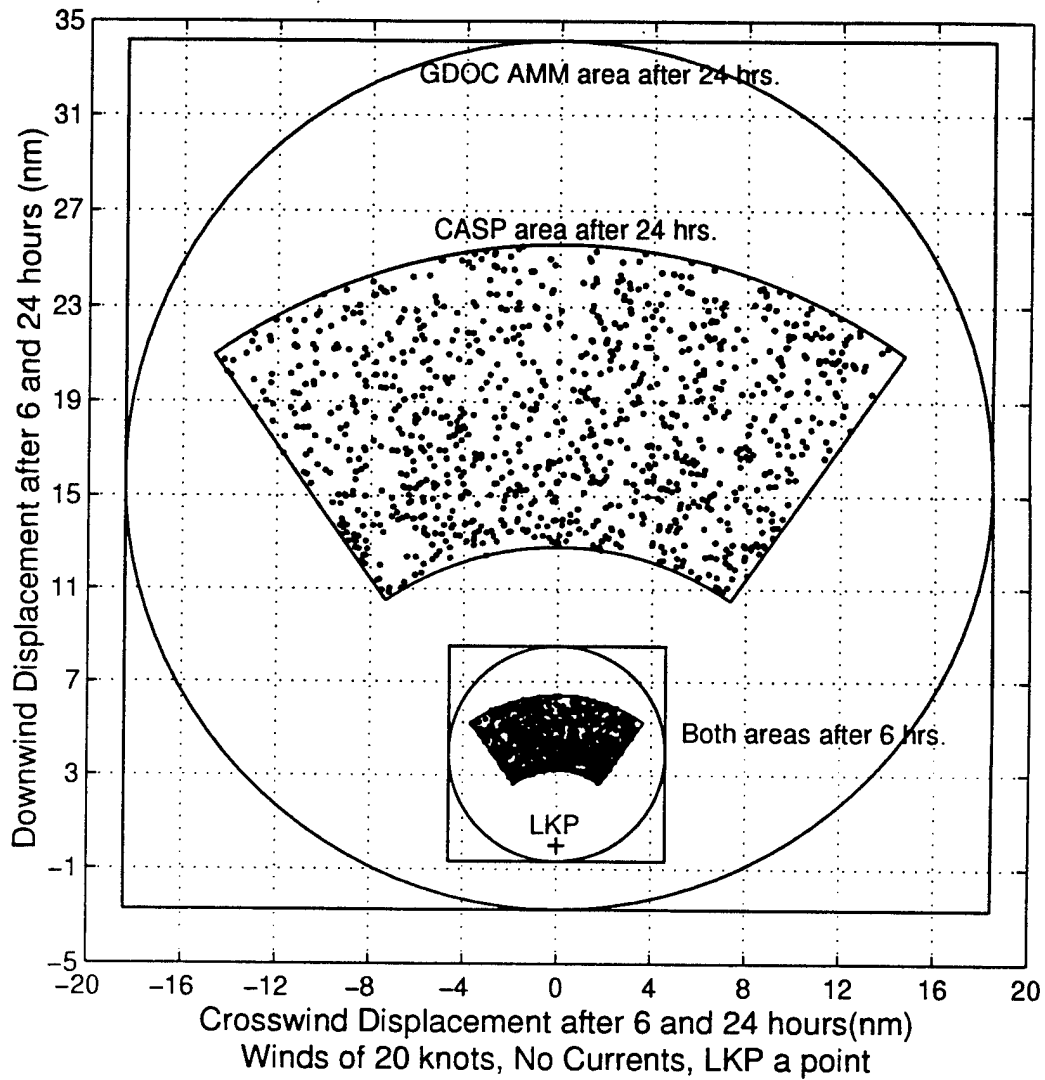

Figure 5-3. The CASP and GDOC AMM Leeway Distribution Areas for a Fishing Vessel with leeway of 4% of 20 knot wind after 6 and 24 hours. Divergence angle is 35 degrees.

GDOC AMM and CASP Leeway Drift Areas for Category IV Leeway Targets

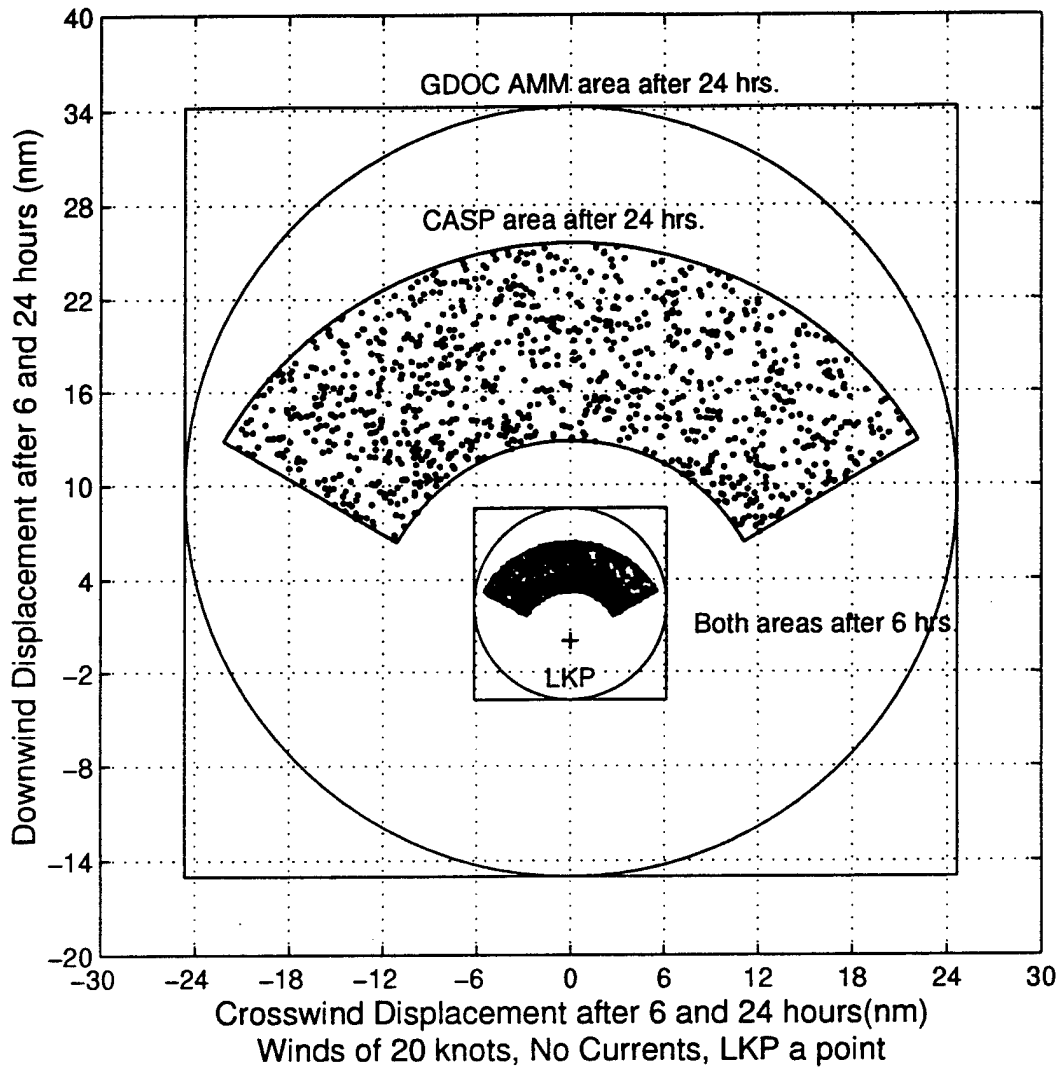

Figure 5-4. The CASP and GDOC AMM Leeway Distribution Areas for a Fishing Vessel with leeway of 4% of 20 knot wind after 6 and 24 hours. Divergence angle is 60 degrees.

**AP98 Leeway Drift Area for a Fishing Vessel**  
**GDOC AMM and CASP Leeway Drift Areas for Category IV Leeway Targets**

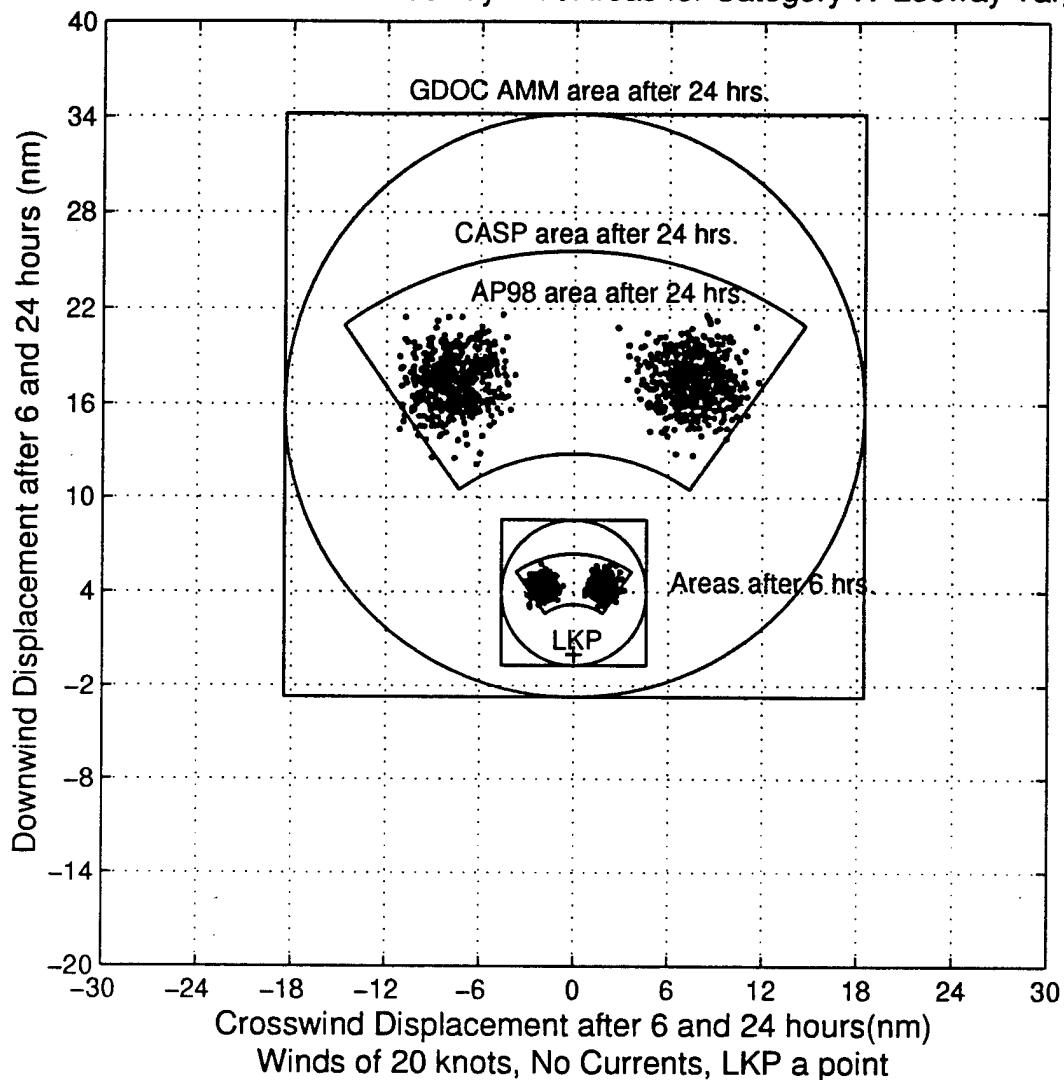

Figure 5-5. The Leeway Drift Distributions from CASP, GDOC AMM, and AP98 for a Fishing Vessel with a leeway of 4% of 20 knot wind after 6 and 24 hours. Divergence angle used in CASP and GDOC AMM was 35 degrees.

**AP98 Leeway Drift Area for a Fishing Vessel**  
**GDOC AMM and CASP Leeway Drift Areas for Category IV Leeway Targets**

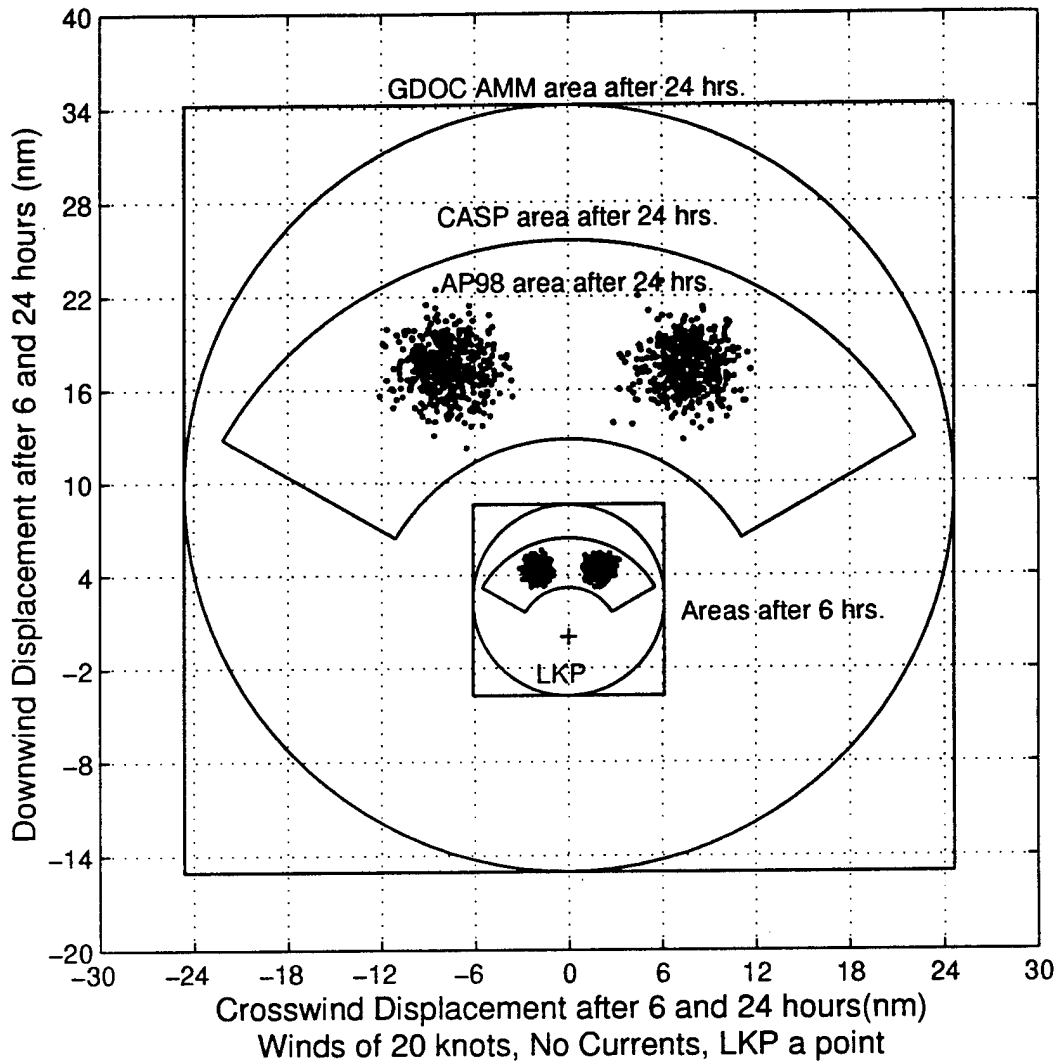

Figure 5-6. The Leeway Drift Distributions from CASP, GDOC AMM, and AP98 for a Fishing Vessel with a leeway of 4% of 20 knot wind after 6 and 24 hours. Divergence angle used in CASP and GDOC AMM was 60 degrees.

### 5.7.5 Leeway Category V, "Heavy Displacement Deep Draft Sailing Vessels"

The fifth category common to CASP and GDOC is "Heavy displacement deep draft sailing vessels" with a leeway rate of 3% of wind. For category V, the GDOC AMM default value for divergence is 45 degrees. The leeway rate for this category is from Chapline's (1960) group of vessels he called "Group II, Heavy displacement, deep draft sailing vessels." Chapline (1960) provided some initial observations on leeway angle. Hufford and Broida (1974) later provided the guidance for the leeway divergence angles used for this category, even though they did not directly study any sailboats.

A 65-foot mono-hull, full keel, deep draft, sailboat with two masts was studied using the direct method during Leeway97 field test off Fort Pierce, FL. The data are awaiting analysis. A second mono-hull, 30-foot sailing vessel with a shoal keel with centerboard, is being readied for leeway field-testing. This vessel will be studied in different configurations: centerboard down and up; mast up and de-masted; rudder in the mid-position, hard to windward, and without a rudder; with and without a sea anchor. The information from these experiments will be used to update the leeway rate and leeway angle for Category V sailing vessels.

### 5.7.6 Leeway Category VI, "Surfboards"

The sixth category common to CASP and GDOC is "Surfboards" with a leeway rate of 2% of wind. For category VI, the GDOC AMM default value for divergence is 35 degrees. The leeway rate for this category is from Chapline's (1960) "Group I, Surfboards." Chapline (1960) provided some initial observations on leeway angle. Hufford and Broida (1974) later provided the guidance for the leeway divergence angles. Again they did not study surfboards directly. No other leeway drift studies of surfboards are found in the literature.

Allen, Robe and Morton (1999) studied a wind-surfer board with a person on the deck, without the sail dragging in the water. Their results for a wind-surfer board is:

$$\text{Leeway speed of Windsurfer (cm/s)} = 2.30\% W_{10m} + 5.2 \text{ cm/s}$$

The mean leeway angle for  $W_{10m} > 5$  m/s is  $-8$  degrees with a standard deviation of 8 degrees.

Allen et al. (1999) recommended value for divergence angle is 16 degrees, which is considerably less than the presently recommended value of 35 degrees for a surfboard.

The 12.2-foot wind-surfer board of the 1990's studied by Allen et al (1999) had a volume of approximately 200 liters. Long (9-10 foot) surfboards that were commonly available during the 1950's in Hawaii when Chapline conducted his study and that are still used today have volumes of approximately 70-80 liters. However, today's long surfboards are considerably lighter (11 lbs.) than the 1950's surfboards (35-40 lbs.) Since the late 1960's, surfers have used short surfboards (6-7 feet) which weigh 6-8 pounds and have an approximate volume of 35-40 liters (Rice, personal communication).



### 5.7.7 Leeway Category VII, "Person-in-the-Water (PIW)"

A seventh category in GDOC AMM and CASP but not in National SAR Manual is "PIW" with a leeway rate of zero and a divergence of zero. There is no leeway study upon which these values are based. The likely source is the apparent similarity in drift between PIWs and radio-direction-finder style DMBs used in real SAR cases.

Suzuki, Sato, and Igeta, (1985) studied PIWs in the vertical, sitting, and horizontal positions and found values of:

Leeway speed of horizontal PIW (knots) = 1.5% Wind + 4cm/s.

Leeway speed of vertical PIW w/PFD (knots) = 0.5% Wind + 4cm/s.

Leeway speed of sitting PIW greater than vertical PIW and less than horizontal PIW

Su, Robe, and Finlayson (1998) using laboratory measurements suggest that leeway of a PIW, without survival suit, floating upright is:

Leeway speed of PIW = 0.6% ( $U_{\text{air}} - U_{\text{water}}$ )

and a PIW in a survival suit is:

Leeway speed of PIW/SS = 3.23% ( $U_{\text{air}} - U_{\text{water}}$ ).

The result of Su, Robe, and Finlayson (1998) field trial for winds between 5 and 12 knots for a PIW in a survival suit is:

Leeway speed of PIW/SS (knots) = 2.7%  $W_{10m}$   
with a standard error of 0.133 knots or 8.6 cm/s.

Su, Robe and Finlayson (1998) used the indirect method during the field studies.

Allen, Robe and Morton (1999) used the direct method to study a PIW with an offshore-lifejacket Type I PFD in the sitting position and a PIW in the horizontal position in a survival suit. Their results are:

Leeway speed of PIW in Type I PFD (cm/s) = 1.17%  $W_{10m}$  + 0.2 cm/s

The mean leeway angle for  $W_{10m}$  > than 5 m/s is 4 degrees with a standard deviation of 12 degrees.

Leeway speed of PIW in Survival Suit (cm/s) = 1.44%  $W_{10m}$  + 5.25 cm/s

The mean leeway angle for  $W_{10m}$  > than 5 m/s is 18 degrees with a standard deviation of 20 degrees.

Kang (1999) used the indirect method to study real subjects in scuba gear and wet suits. The subjects in the scuba gear floated on their backs in a horizontal position. The scuba gear included fins, facemask, snorkel, tanks, weights, and an inflated buoyancy compositor. The subjects in wet suits floated vertically while wearing facemask and snorkel and a weight belt. They did not wear fins. Winds were adjusted to the 10-meter height.

$$\begin{array}{ll} \text{PIW scuba gear} = 0.7 \% , W_{10m} + 4.3 \text{ cm/s} & 5.92 \text{ cm/s } S_{y/x} \\ \text{PIW wet suit (vertical)} = 0.05 \% , W_{10m} + 2.5 \text{ cm/s} & 2.07 \text{ cm/s } S_{y/x} \end{array}$$

These four studies of PIWs in various configurations suggest that PIWs have leeway values between 0.5 and 1.5 % of  $W_{10m}$ . The lower values of leeway are associated with PIW in the vertical or sitting configuration and the higher values with PIWs in the horizontal position.

#### 5.7.8. Leeway Speed Guidance Provided by National SAR Manual

The National SAR Manual also contains further guidance for life rafts that have canopies and ballast pockets. The quotes in bold below are from the National SAR Manual (1991 version).

- a) **“Rafts with canopies and ballast have leeway speeds approximately the same as rafts without this equipment.”**

GDOC AMM interpretations of this statement are the following (where U is wind speed; leeway speed, wind speed and y-intercept are all in knots):

Rafts with canopies and ballast without drogue:

$$\text{leeway speed} = 0.07U + 0.04$$

Rafts with canopies and ballast with drogue:

$$\text{leeway speed} = 0.05U - 0.12$$

These are the correct mathematical interpretations.

Nash and Willcox (1985) studied a RFD 6-person MK3A life raft that had a canopy and a shallow ballast system without a drogue. The total volume of the ballast system was approximately 0.04 cubic meters. They proposed the following equation for a raft with canopy and no drogue:

Rafts with canopies without drogue:

$$\text{leeway speed} = 0.0568U + 0.145$$

Table 5-10 compares the equation proposed by Nash and Willcox (1985) and the values used in GDOC AMM for downwind displacement at four wind speeds. Nash and Willcox's (1985) values were 85 to 96% of the values used by GDOC AMM.

Table 5-10  
Downwind Displacement for Raft with Canopies,  
With Ballast Systems, without Drogues  
(10 meter Winds for 24 hours at 10, 20, 30 and 40 knots)

LEEWAY CRAFT	LEEWAY Equations	Displacement (nm) after 24 hours for $W_{10m}$ of			
		10 knots	20 knots	30 knots	40 knots
Rafts w/canopy & shallow ballast w/o drogue	AMM GDOC	17.8	34.6	51.4	68.2
	Nash & Willcox (1985)	17.1	30.7	44.4	58.0

- b) **“Rafts with canopies have leeway speeds approximately 20 percent faster than rafts without.”**

The interpretations of this statement in the automated manual method used by GDOC are the following:

Rafts with canopies and ballast without drogue:

$$\text{leeway speed} = 1.2 (0.07U + 0.04)$$

Rafts with canopies and ballast with drogue:

$$\text{leeway speed} = 1.2 (0.05U - 0.12)$$

However, the correct mathematical interpretations are:

Rafts with canopies without drogue:

$$\text{leeway speed} = (0.07U + 0.04) + 0.2 \text{ abs}(0.07U + 0.04)$$

Rafts with canopies with drogue:

$$\text{leeway speed} = (0.05U - 0.12) + 0.2 \text{ abs}(0.05U - 0.12)$$

Nash and Willcox (1991) studied a Winslow 4-person life raft that had a canopy but no ballast system of any kind. The configuration of the Winslow life raft during the study was without a drogue. Nash and Willcox (1991) proposed a leeway equation for the Winslow life raft, 4-person loading, without drogue of:

$$\text{leeway speed} = (0.0371U + 0.1123)$$

Table 5-11 compares the equation proposed by Nash and Willcox (1991) and the values used in GDOC AMM for four wind speeds. Nash and Willcox's (1991) values were 47 to 54% of the values used by GDOC AMM.

Guidance (b) can not be validated, and the coding of guidance (b) in GDOC was apparently never verified.

Table 5-11  
Downwind Displacement for Raft with Canopies,  
Without Ballast Systems, without Drogues  
(10 meter Winds for 24 hours at 10, 20, 30 and 40 knots)

LEEWAY CRAFT	LEEWAY Equations	Displacement (nm) after 24 hours for $W_{10m}$ of			
		10 knots	20 knots	30 knots	40 knots
Rafts w/canopy w/o ballast w/o drogue	AMM GDOC	21.3	41.4	61.6	81.8
	Nash & Willcox (1991)	11.6	20.5	29.4	38.3

c.) **“Rafts with ballast pockets have leeway speeds approximately 20 percent slower than rafts without.”**

GDOC AMM interpretations of this statement are:

Rafts with canopies and ballast without drogue:

$$\text{leeway speed} = 0.8 (0.07U + 0.04)$$

Rafts with canopies and ballast with drogue:

$$\text{leeway speed} = 0.8 (0.05U - 0.12)$$

However, the correct mathematical interpretations are:

Rafts with ballast pockets without drogue:

$$\text{leeway speed} = (0.07U + 0.04) - 0.2 \text{ abs}(0.07U + 0.04)$$

Rafts with ballast pockets with drogue:

$$\text{leeway speed} = (0.05U - 0.12) - 0.2 \text{ abs}(0.05U - 0.12)$$

There have not been any studies conducted on life rafts without a canopy but with a shallow ballast system. Guidance (c) can not be validated, and the coding of guidance (c) in GDOC was apparently never verified.

d.) **“Rafts with canopies and a deep ballast system have uncertain leeway speed. Speeds approximately the same as for rafts with drogue may be assumed.”**

Therefore

Rafts with canopies and deep ballast systems:

$$\text{leeway speed} = 0.05U - 0.12$$

Continuing: **“The minimum leeway speed is zero for winds of 5 knots or less, and 0.1 knot for winds greater than 5 knots.”**

Therefore, rafts with canopies and deep ballast systems have leeway speeds above the following minimums.

leeway speed  $\Rightarrow$  0.0            for wind of less than 5 knots, and  
leeway speed  $\Rightarrow$  0.1 knot      for wind greater than 5 knots.

Further continuing: **"For a deep ballast raft where the canopy does not deploy, the leeway speed falls to between 3 percent of wind speed and zero."**

Therefore

Rafts with deflated canopies and deep ballast systems have leeway speeds in the following range.

leeway speed =  $0.0U$  to  $0.03U$

Neither CASP nor GDOC AMM provides algorithms for guidance (d). However, this class of life rafts with canopies and deep ballast systems has been studied using the direct method by Nash and Willcox (1991); Fitzgerald et al. (1993) and (1994); Allen and Fitzgerald (1997); and this report (see Chapter 3). The life rafts were a Tulmar 4-person life raft with deep Icelandic ballast pockets; two variations of Dunlop-Beaufort 4-person life rafts with deep Icelandic ballast pockets; and a Switlik 4-person and a Switlik6-person life rafts both with full toroidal ballast bag.

The un-drogued life rafts with canopies and deep ballast systems had leeway speeds (knots) of:

Switlik 4-person life raft

leeway speed =  $0.0183 U - 0.0393$  knots

Givens 6-person life raft

leeway speed =  $0.0101 U - 0.0023$  knots

(Nash and Willcox (1991), pages 48 and 56, where  $U$  is the wind speed in knots at approximately 2 meter height)

Tulmar 4-person life raft

leeway speed =  $0.032 W_{10m} + 0.035$  knots

Beaufort 4-person, 5-sided life raft

leeway speed =  $0.0172 W_{10m}$                       ( $W_{10m} < 5$  knots)

leeway speed =  $0.049 W_{10m} - 0.159$  knots    ( $W_{10m} > 5$  knots)

Beaufort 4-person, 6-sided life raft

leeway speed =  $0.034 W_{10m} - 0.028$  knots

(Fitzgerald et al (1994), page 108-109, where  $W_{10m}$  is 10-m wind speed in knots.)

The drogued life rafts with canopies and deep ballast systems had leeway speeds (knots) of:

Tulmar 4-person life raft

leeway speed =  $0.019 W_{10m} + 0.014$  knots

Beaufort 4-person, 5-sided life raft

leeway speed =  $0.021 W_{10m} - 0.011$  knots  
(Fitzgerald et al (1994), page109-110)

Switlik 6-person life raft in the standard configuration

leeway speed =  $0.016 W_{10m} + 0.057$  knots

Switlik 6-person life raft swamped

leeway speed =  $0.0101 W_{10m} - 0.042$  knots

(Allen and Fitzgerald (1997), page 4-48)

The displacements of a life raft with canopy and ballast with and without drogues after 24 hours of steady wind at four wind speeds are shown in Table 5-12. The life raft displacements are based upon the methods used in the automated manual method (AMM) of GDOC or recommended by Fitzgerald et al. (1994) and Allen and Fitzgerald (1997).

Table 5-12  
Total Displacement for Life Rafts with Canopies and Deep Ballast Systems,  
with and without Drogues  
(10 meter Winds for 24 hours at 10, 20, 30 and 40 knots)

LEEWAY CRAFT	LEEWAY Equations	Displacement (nm) after 24 hours for $W_{10m}$ of			
		10 knots	20 knots	30 knots	40 knots
Rafts w/canopies & deep ballast without drogue	GDOC AMM	17.76	34.56	51.36	68.16
	Tulmar	8.52	16.20	23.88	31.56
	Beaufort 5 sided	7.94	19.70	31.46	43.22
	Beaufort 6-sided	7.49	15.65	23.81	31.97
Life Rafts w/canopies & deep ballast with drogue	GDOC AMM	9.12	21.12	33.12	45.12
	Tulmar	4.90	9.46	14.02	18.58
	Beaufort 5 sided	4.78	9.82	14.86	19.90
	Switlik Std. Conf.	5.21	9.05	12.89	16.73
	Switlik Swamped	1.42	3.84	6.26	8.69

The values reported by Fitzgerald et al. (1994) and Allen and Fitzgerald (1997) are considerably lower than those used in the National SAR Manual.

The downwind and crosswind components of leeway for a Tulmar 4-person life raft with 1-person loading without a drogue were presented in Chapter 3 of this report. The CASP and GDOC AMM predicted leeway area for this type of life raft is shown in Figure 4-3. The leeway drift distribution from the AP98 leeway model for a Tulmar 4-person life raft without drogue is shown in Figure 5-7.

The AP98 leeway distributions for the Tulmar life raft when the total wind displacement vector is held constant are shown in Figure 5-8. In this figure we can see that as the wind speed increases, the leeway distribution area decreases and bifurcates. Since AP98 uses a normal distribution about the y-intercept of constant slopes, at low wind speeds the y-intercept

dominates the equation. At high wind speed, the (slope x wind speed) term dominates the equation. The four distributions show the bias in the data-driven equation to the left of the downwind direction.

The series of distributions in Figure 5-8 sheds light on the early leeway distribution models. Most of the early studies were conducted in light to moderate wind conditions, which means wind speeds of less than 15 to 20 knots. The wide scatter seen in the early leeway studies can thus be attributed to the effects of light winds as well as to the measurement errors inherent in the indirect method. The early leeway distribution models were appropriate for the quality of the leeway data available at that time.

The AP98 distributions shown in Figure 5-9 are for steady winds of 5, 10, 20, and 40 knots blowing over the Tulmar life raft for 12 continuous hours. In addition, the outline of the CASP distribution is shown for the 20-knot case. Clearly the CASP distribution for a life raft with canopy and a ballast system similar to the Tulmar's overestimates by a factor of two the downwind drift. The areas for each distribution are presented in Table 5-13; the ratio of area of distribution of the AP98 to that of each model is also provided.

Table 5-13

Comparison of Leeway Drift Area Models  
Life Raft with Canopy and Ballast System, No Drogue  
For a Steady Wind of 5, 10, 20 and 40 Knots for 12 Hours  
(No Sea Surface or Wind Currents, LKP is a point)

Leeway Drift Model	Craft Type	Steady Winds for 12 hours, No Currents, LKP is a point							
		5 knots		10 knots.		20 knots		40 knots	
		Sq nm.	AP98 ratio	Sq nm.	AP98 ratio	Sq nm.	AP98 ratio	Sq nm.	AP98 ratio
AP98	Tulmar 4-person life raft, no drogue	14	100%	39	100%	51	100%	70	100%
CASP	Life raft, canopy, ballast system	16	88%	61	64%	236	22%	933	8%
GDOC AMM	Life raft, canopy, ballast system	81	17%	291	13%	1,103	5%	4,290	2%

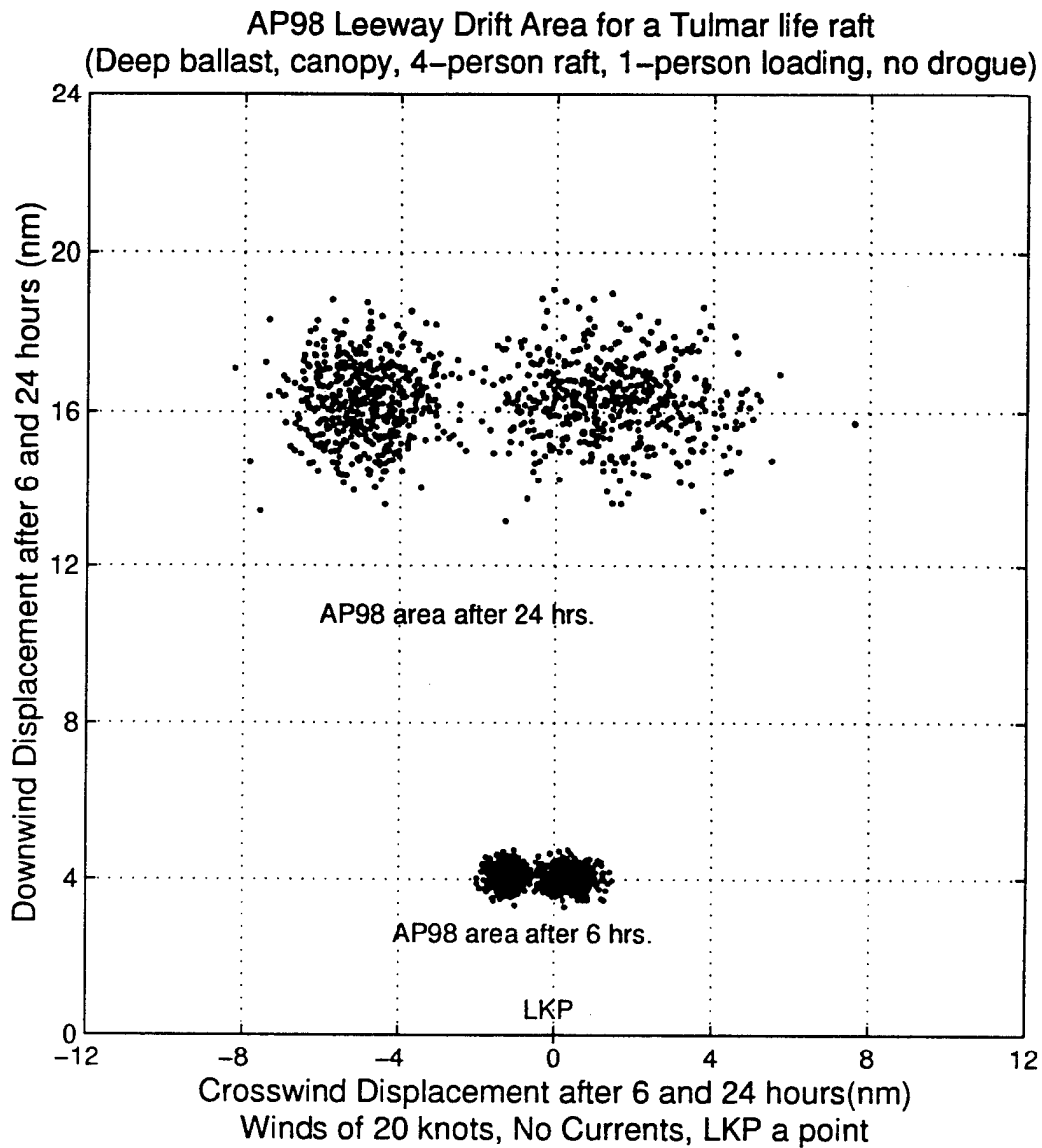

Figure 5-7. The Leeway Drift Distribution from AP98 for a Tulmar 4-person Life Raft with 1-person loading without a drogue. Winds used were Steady at 20 knots for 6 and 24 hours.



AP98 Leeway Drift Area  
Tulmar 4-person life raft, 1-person loading, no drogue

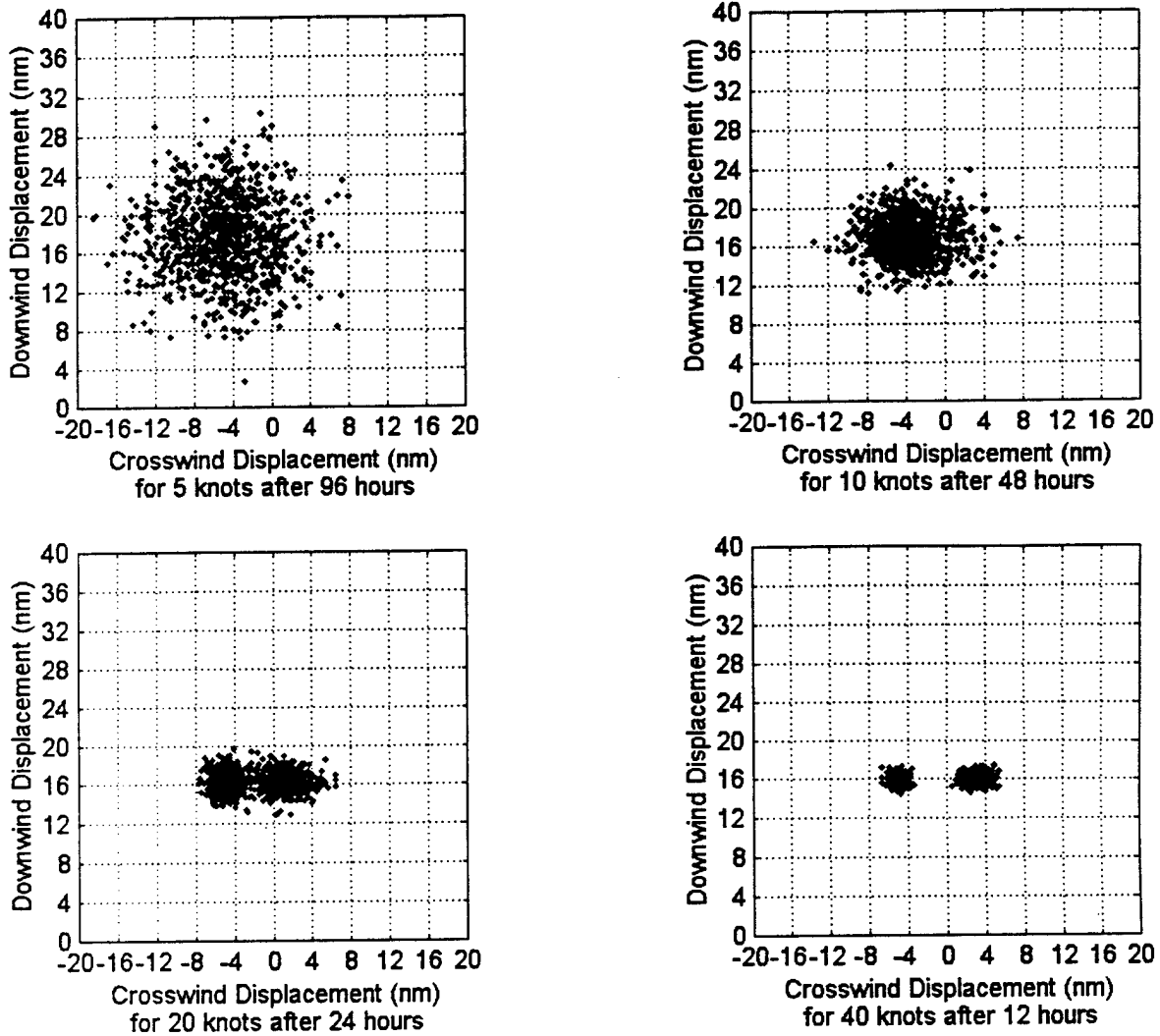

Figure 5-8. The Leeway Drift Distribution from AP98 for a Tulmar 4-person Life Raft with 1-person loading without a drogue. Winds used were Steady at: 5 knots for 96 hours, 10 knots for 48 hours, 20 knots for 24 hours, and 40 knots for 12 hours.

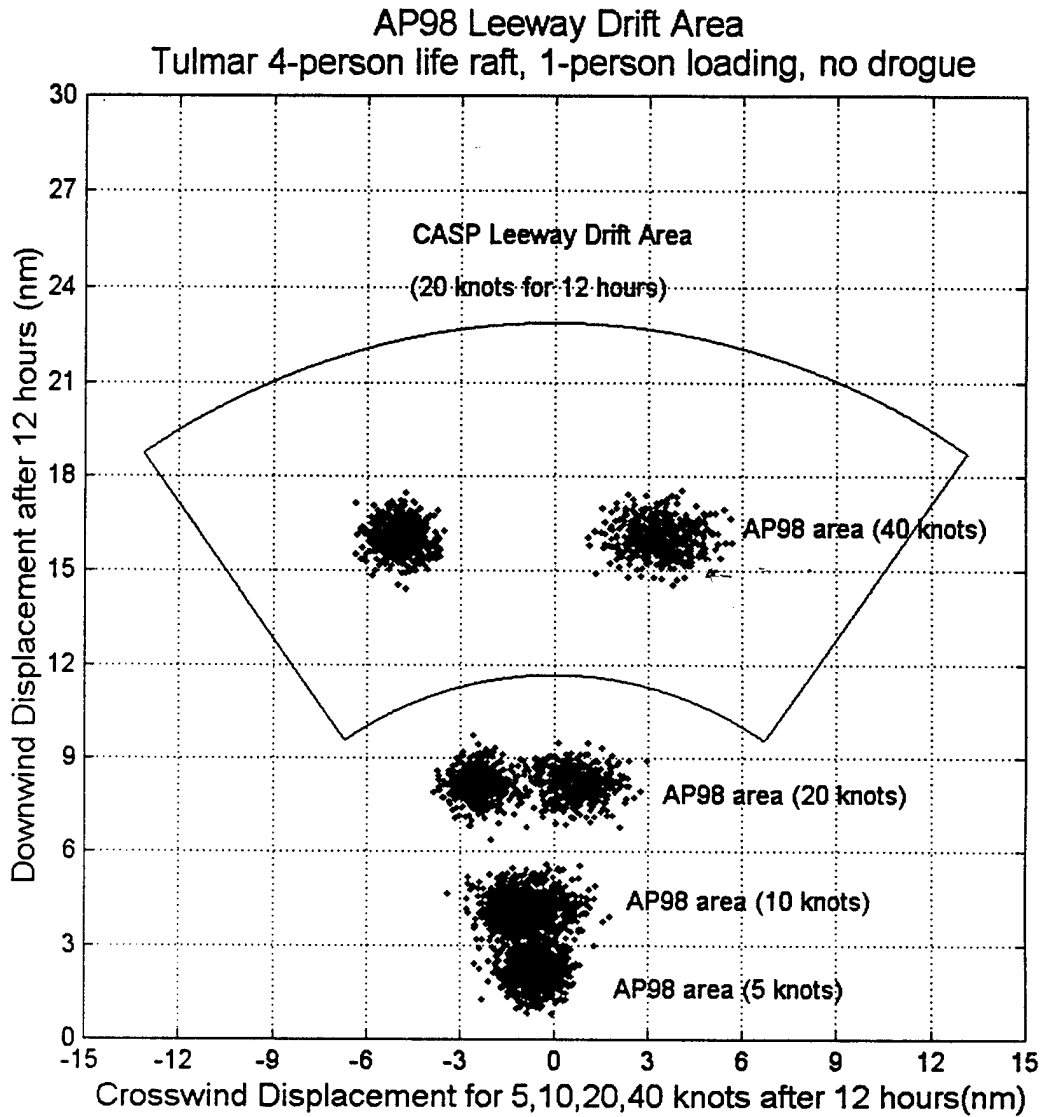

Figure 5-9. The Leeway Drift Distribution from AP98 for a Tulmar 4-person Life Raft with 1-person loading without a drogue. Winds used were steady at 5, 10, 20, and 40 knots for 12 hours. Also shown is the outline of CASP Leeway Drift Distribution for a Category I Leeway Target for a Steady Wind of 20 knots for 12 hours.

### 5.7.9. Leeway Angle Guidance Provided by National SAR Manual

The National SAR Manual guidance for leeway maximum angle off the downwind direction is as follows:

<b>"Craft with shallow draft</b>	<b><math>\pm 60</math> degrees.</b>
<b>Craft with moderate to deep draft</b>	<b><math>\pm 45</math> degrees.</b>
<b>Rubber rafts</b>	<b><math>\pm 35</math> degrees.</b>
<b>Circular rafts with symmetrical ballast systems</b>	<b><math>\pm 15</math> degrees."</b>

The apparent references for leeway angle are from Hufford and Broida (1974) and Nash and Willcox (1985). Since those two reports were written, considerable data has been collected and analyzed on the leeway angle of SAR targets.

Nash and Willcox (1991) present leeway angles versus wind speed for three craft with shallow draft that are much less than the  $\pm 60$  degrees used in the National SAR Manual. Nash and Willcox (1991) studied a 14-ft Boston Whaler outboard with 6 inches of draft, a 19-ft center console sport fisherman outboard, and a 20-ft Cabin Cruiser (Beachcomber by Cruisers) with 2 to 2.5 ft draft. The 19-ft sport fisherman exhibited maximum leeway angles of  $39^\circ$  to the left and  $32^\circ$  to the right for wind speed less than 12 knots. The Boston Whaler and the Cabin Cruiser maximum leeway angles were less than  $35^\circ$ . The Boston Whaler leeway angle was bifurcated into two groups with no directly downwind values for winds between 7 and 12 knots. The Boston Whaler either drifted to the right of the wind with a mean leeway angle of  $+14^\circ$  or to the left of the wind with a mean angle of  $-24^\circ$ .

Allen and Fitzgerald (1997) also studied a craft with shallow draft: a 5.5 m wooden-planked open boat with a draft of 30.5 cm. Leeway angle data for the 5.5 m open boat consisted of 1,163 10-minute samples collected during eight separate drift runs with wind speeds up to 20.4 m/s. The maximum leeway angle observed was  $50^\circ$  to the left of the wind and  $46^\circ$  to the right of the wind. Most of the high leeway angles (greater than  $\pm 30^\circ$ ) were associated with wind speed less than 5 m/s or with the 1995 leeway drift when wind direction measurement was not directly co-located with the craft. The mean leeway angle for winds  $>5$  m/s was  $5.1^\circ$  to the left of wind with a standard deviation of  $\pm 11^\circ$ . This is considerably less than  $\pm 60$  degrees used in the National SAR Manual.

Allen (1996) studied a craft with moderate to deep draft, a 15 m commercial fishing vessel with a draft of 1.5 meters. The mean absolute value for leeway angle was  $29.0^\circ \pm 13.4^\circ$  standard deviation, based upon 177 10-minute samples collected on 13 drift runs. Assuming that the fishing vessel drifted symmetrically, then the leeway angles would be between  $16^\circ$  and  $42^\circ$  left or right of the wind. This agrees with the values suggested in the National SAR Manual for maximum leeway angles of  $\pm 45$  degrees.

Nash and Willcox (1985), Fitzgerald et al. (1993) and (1994), Fitzgerald (1995), and Allen and Fitzgerald (1997) studied modern life rafts with ballast systems and canopies. Fitzgerald et al. (1994, pages 57 and 70), summarize leeway angle statistics for lightly-

loaded life rafts without drogues and fully-loaded with drogues. With 3438 10-minute samples of leeway angle, the mean for lightly-load life rafts was  $-2$  degrees with a standard deviation of 12 degrees. Leeway angle is a function of wind direction, and as a practical matter, fails when the wind speed approaches zero. Therefore, the errors in leeway angle increased as the wind speed decreased below 10 knots. When only those samples with wind speed over 10 knots were considered (2802 10-minute averages) the standard deviation dropped to 8 degrees. Since three standard deviations would include 99% of samples, this implies that lightly-loaded life rafts without drogues have leeway angles of  $-2 \pm 24$  degrees for winds above 10 knots and  $-2 \pm 36$  degrees for all winds. For fully- loaded life rafts with drogues the leeway angles were  $+4 \pm 24$  degrees for winds above 10 knots and  $+2 \pm 51$  degrees for all winds. For wind speed greater than 10 knots the National SAR Manual value of  $\pm 35$  degrees is larger than the  $\pm 24$  degrees that Fitzgerald et al. (1994) found.

Allen and Fitzgerald (1997) studied a circular raft with a symmetrical ballast system, a Switlik 6-person life raft with canopy and full toroidal ballast bag. The mean leeway angle of 128 10-minute samples was  $+7.8$  degrees with a standard deviation of 5.3 degrees. The minimum angle was  $-14$  degrees and the maximum leeway angle was  $+21$  degrees. All samples were associated with wind speeds of 5 to 21 m/s. Using three standard deviations, the expected leeway angle should be between  $-8$  and  $+24$  degrees. The National SAR Manual uses  $\pm 15$  degrees which is in agreement with this preliminary data set on circular rafts with symmetrical ballast system.

## CHAPTER 6

### TAXONOMY OF LEEWAY DRIFT TARGETS

- 7) *What classes of leeway targets should be included in our search planning tools?*

#### 6.1 INTRODUCTION

This section presents a discussion of taxonomy of craft and targets based upon their shared characteristics that affect their leeway drift. The taxonomy of leeway drift targets is a classification system that establishes the relationships between different types of leeway drift objects. The leeway taxonomy is based on a set of drift object classification rules that create a system where all elements of the taxonomy are uniquely identifiable. Since the rules and the leeway drift objects are predominantly man-made, this taxonomy becomes a "living" document that should be updated to reflect new classes of craft and targets or it will become outdated and cease to serve its purpose.

The primary purpose of this taxonomy is to provide, within the numerical search planning tools, a classification system that allows the search planner to identify an appropriate class for the distress craft, survivor craft, or drifting target of interest. A secondary purpose of this taxonomy, when combined with Table 2-3, is that it provides the framework for determining what craft and target types still need to be studied. This will help in establishing the priorities for future leeway studies.

The leeway taxonomy is proposed as a replacement to the current concept of leeway target classification. As has been described earlier, leeway drift objects are categorized into broad, non-descriptive target categories. These categories are based on the early leeway studies, predominately the study of Chapline (1960). As additional studies have been conducted, the tendency has been to add another category reflecting the objects of the new study. This has resulted in an ever-increasing list of leeway categories without any relational order among the categories. Therefore, an attempt has been made to develop a compressive categorization of all the possible targets of interest to the Coast Guard by their leeway drift characteristics. Thus, this "Leeway Taxonomy" is independent of leeway studies.

The following guidance was used to establish the taxonomy of leeway targets.

- 1) Rules would be established and used to rank categories
- 2) Targets would be described by their leeway characteristics.
- 3) Taxonomy should be easily incorporated into a numerical search-planning tool.
- 4) Where possible, categories would be referenced to boating guides.

## 6.2 ESTABLISHING THE LEEWAY TAXONOMY

Given the enormous diversity of objects for which the Coast Guard could possibly be expected to predict drift, a hierarchy was defined for leeway taxonomy. Table 6-1 presents the leeway drift classification rules used in the leeway drift taxonomy. The left-hand column provides a reference number for the seven taxonomy levels. The center column provides a short title for each rule. The right hand column provides a brief explanation of the key discriminating factors within each rule.

Table 6-1  
Leeway Drift Taxonomy Classification Rules

<b>Taxonomy Level</b>	<b>Level Description</b>	<b>Level Explanation</b>
Level 1	Governmental Response Mechanism / Organizations	<ul style="list-style-type: none"> <li>• Reflects governmental response mechanisms that are triggered</li> <li>• Reflects behavioral differences in response units</li> <li>• Identifies expected behavioral characteristics of the drift target</li> <li>• Reflects an expectation of the amount and types of datum information that may be available</li> </ul>
Level 2	Primary Source of the Leeway Target	<ul style="list-style-type: none"> <li>• Identifies the primary source of the drift object</li> <li>• SAR targets originate from marine or aviation sources</li> <li>• Non-SAR targets originate from non-SAR sources</li> </ul>
Level 3	Major Target Categories	<ul style="list-style-type: none"> <li>• First level using specific drift object characteristics</li> <li>• Identifies broad categories of intended object use</li> <li>• Highest level that could possibly have leeway information</li> </ul>
Level 4	Target Sub-Categories	<ul style="list-style-type: none"> <li>• Identifies major divisions within drift object categories</li> <li>• First level for which the size or shape of the drift object determines its placement in the taxonomy</li> <li>• First level that considers the ratio of drift object surface area above and below the waterline</li> <li>• The majority of current target leeway drift information will be found at this level</li> </ul>
Level 5	Primary Target Leeway Descriptor	<ul style="list-style-type: none"> <li>• Identifies the drift object feature that exerts the greatest influence on the drift object leeway ratio (typically above or below the waterline)</li> <li>• Swamping or capsizing are dominant leeway characteristics</li> </ul>
Level 6	Secondary Target Leeway Descriptor	<ul style="list-style-type: none"> <li>• Identifies the drift object feature that exerts the second strongest influence on the drift object leeway ratio (typically the above or below the waterline features opposite the primary feature)</li> </ul>
Level 7	External Modifiers	<ul style="list-style-type: none"> <li>• Identifies those items that can affect an object's leeway drift that have not been addressed in earlier levels</li> <li>• These items are usually controlled by the occupants onboard leeway targets</li> <li>• These items effectively modify the primary and secondary influences identified in Levels 5 and 6.</li> </ul>

Figure 6-1 depicts the first three levels of the proposed taxonomy. It is obvious from the figure that the full seven layers of taxonomy will result in an enormous table. Appendix A presents the remaining four levels of the taxonomy in table form with one table for each Level 3 Search and Rescue (SAR) and Combat SAR category and one table for each Level 2 non-SAR category. Appendix B supports this taxonomy information by providing detailed descriptions of each drift object class and its typical features. Where available, the description will also include references that can be consulted to gain further information concerning specific leeway objects. These descriptions and reference materials can supply the user with information that may not otherwise be available and that can be useful when classifying a target that does not easily fit the classification categories by name. Appendix B also contains a summary of the reported leeway equations for the objects within each Level 3 class. Where possible the standard errors of the estimates for the leeway equations are also listed. Appendix C provides a bibliographical listing of each of the references used in Appendix B and contains a list of life raft manufacturers and repair facilities. Repair facilities can often provide information about the size, type, and features of a raft carried onboard a particular vessel by simply referencing their database by the name of the vessel.

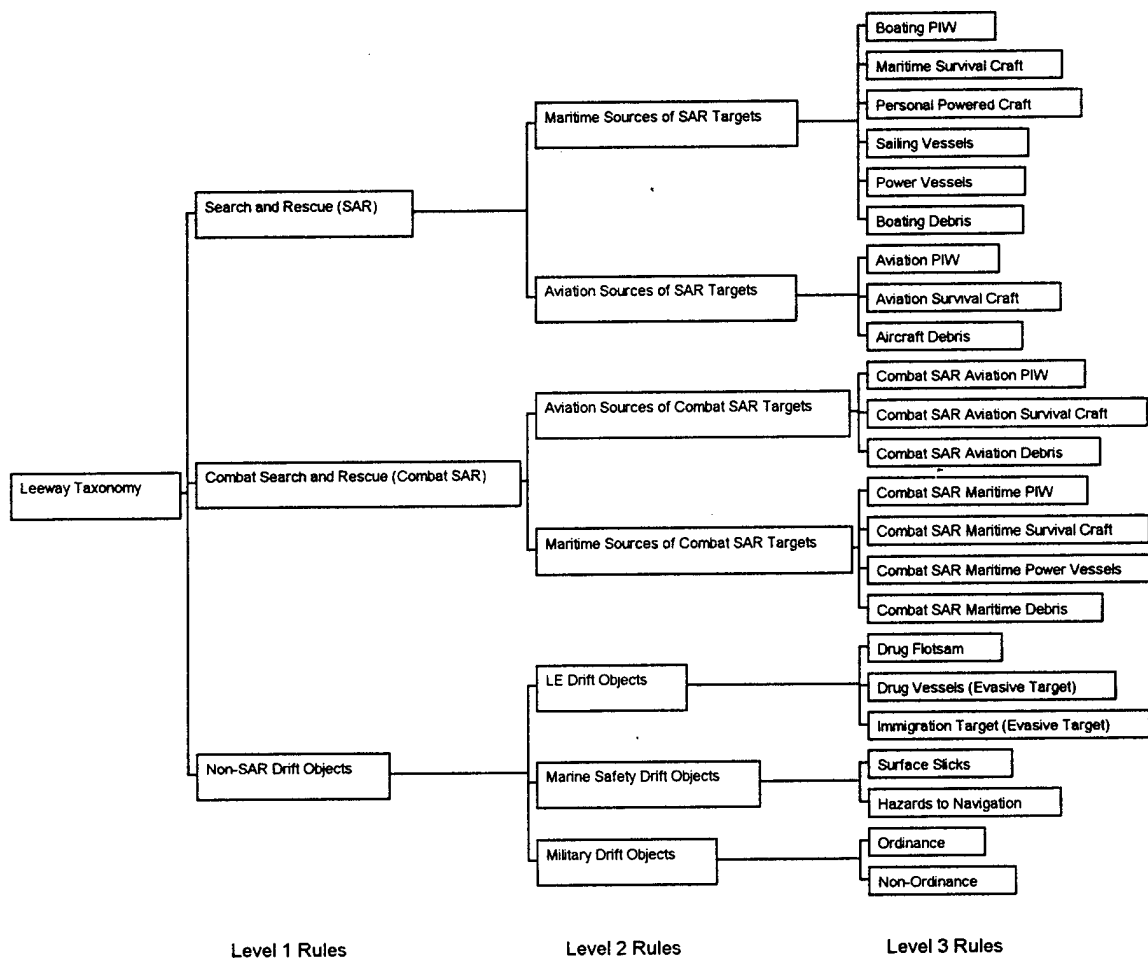

Figure 6-1: Top-Level View of Leeway Taxonomy

Tables A-1 through A-23 of Appendix A propose a specific system of identifying leeway drift targets based on the rules described in Table 6-1 above. For the SAR categories, the tables in Appendix A represent the drift objects that occur within the major target categories established by the rules of Level 3 as depicted in the far right portion of Figure 6-1. For non-SAR categories, the tables represent Level 2 drift object categories. Tables such as these should be available to SAR planners and other CG resources to accurately predict the behavior of drift objects. The SAR planner can use these tables and their supporting information to gain knowledge about a particular leeway target and to locate the most applicable leeway drift data.

### **Level 1 [Governmental Response Mechanism / Organizations]**

Level 1 of the taxonomy reflects the principal organizational unit that is responsible for responding to the incident. In short, who was called. The nature of response is fundamentally different across the Level 1 categories: SAR oriented, combat SAR oriented, and non-SAR oriented. The SAR category of the taxonomy contains the majority of all leeway targets of interest to the CG. It consists of the targets historically included in the SAR planning tools. This is the category that is normally associated with the search and rescue operations of the Coast Guard. The combat SAR category includes the military sources of leeway drift targets. Drift targets from military sources are expected to yield more complete information about the rescue equipment carried and a better definition of datum. They may involve additional search resources to supplement those available to the CG. This is the category normally associated with the combat search and rescue operations of the Armed Forces. The non-SAR leeway category contains the drifting objects of interest to the Law Enforcement (LE) and Marine Environmental Protection (MEP) branches of the Coast Guard. Leeway objects in this category will often have a known location and the CG has a requirement to determine their drift to estimate which coastal areas potentially impacted. The prediction of the drift of these targets would be used for recovery of LE contraband, deployment of MEP resources, and providing notice of hazards of navigation to mariners.

### **Level 2 [Primary Source of the Leeway Target]**

Level 2 of the taxonomy reflects the source of the leeway targets. For SAR incidents the question is whether the leeway target is from a maritime or aviation accident. If the incident is non-SAR the question is whether the drifting object is from a MEP, LE or the military source. For example, a 4-person aviation life raft with deep ballast and a canopy is generally made of lighter materials than its maritime counterpart. Personnel onboard will usually be less familiar with waterborne activity than those on a similar marine life raft. On the other hand, the same life raft under the combat SAR branch will typically provide good datum and carry personnel who are better trained in survival techniques and more familiar with the rescue gear onboard. In addition, the military is capable of providing additional search resources, if required. Each category in Level 2 represents unique sources of leeway drift objects.



### **Level 3 [Major Target Categories]**

Level 3 of the taxonomy contains the first major categories of the leeway targets. These are broad categories where the targets within the category share common descriptive and leeway drift characteristics. At Level 3, a correlation begins between the categories and the boating guides and references. While this is the highest level that could possibly have leeway information associated with it, the categories are still rather broad at this stage. The categories in Level 3 are typically various craft, PIWs and floating debris from the Level 2 sources.

### **Level 4 [Target Sub-Categories]**

Level 4 of the taxonomy identifies the sub-classes of drift objects as described by their size, shape and normal function. This is the highest level for which size and shape of the drift object determine its placement in the taxonomy. Level 4 will generally be the highest level for which leeway drift information can be summarized from the lower levels. Reference guides may have either a one-to-one correspondence with a Level 4 category or several Level 4 categories. The reference guides become very useful at Level 4 for providing description and guidance for a particular craft to place it in the correct Level 4 category and providing similar guidance for the next one to four levels.

The first four levels have been used to provide a categorization of drifting objects of interest to the Coast Guard. These top four levels are common to taxonomies based upon leeway drift and the Probability of Detection of the object. In the next levels, the leeway taxonomy consists of categories characterized by factors that directly affect the leeway drift of the object.

### **Level 5 [Primary Target Leeway Descriptor]**

Level 5 of the taxonomy sub-divides the Level 4 categories by the characteristic that has the greatest influence on the leeway drift behavior for drift objects of Level 4 category. The cross-sectional area of the above or below waterline that contains the most variation is generally used in Level 5. At Level 5 swamping and capsizing of small craft is introduced as a possible configuration that should be considered for SAR planning purposes. Level 5 is the final level for many of the non-SAR objects. At Level 5, the reference guides will be very helpful in providing information for determining the appropriate classification of a particular target. Since Level 5 is based upon the feature that most influences leeway of those Level 4 objects, it behooves the SAR planner to make every effort to gather sufficient information about the target to be able to place it in the proper Level 5 category.

### **Level 6 [Secondary Target Leeway Descriptor]**

Level 6 of the taxonomy sub-divides the Level 5 categories by the characteristic that has a secondary influence on the leeway drift behavior for drift objects of Level 4. Typically, the opposite cross-sectional area of the above or below waterline from that used in Level 5 is used in Level 6. If the reference guides provided information on Level 5 features, then generally there should be information on Level 6 as well since the two levels are often

paired together. For sailing vessels, the concept of being de-masted is introduced at this level.

### **Level 7 [External Modifiers]**

Level 7 of the taxonomy are the external modifiers that have or may have some influence of the leeway drift of the objects. Modifiers of leeway include the following: presence or absence of drag devices such as drogues or sea anchors; capacity and loading of craft; and rudder or engine status – windward, mid-ships, or missing. Usually, the SAR planner will not have sufficient information about the drift object in question to choose among the external modifiers to produce a single and final leeway description of the drift object. Therefore, computing several drift scenarios using different external modifiers may provide an estimate of the possible range of drift area solutions. Also, external modifiers play an important role with the field experiments of leeway objects. The leeway experiments are conducted on specific leeway objects. For a given leeway object, the field experiments are designed to test the relative influence of external modifiers with the intent of eliminating or combining as many of them as possible.

### **6.3. LIMITATIONS OF THE LEEWAY TAXONOMY**

It must be noted that personnel onboard leeway targets in either SAR branch of the taxonomy may be able to change the target's leeway drift in ways that are not possible to predict. Examples of this behavior include: PIW targets that may attempt to swim toward nearest shore or a passing vessel; a skiff or small boat with an oar that may be paddled by persons onboard; and even the person in a life raft who opens half of the canopy, deflates the ballast system and uses the drogue as a steering device to try to sail the life raft (this was advertised as a possibility by several manufacturers). None of these possibilities are within the scope of leeway drift. The leeway object is assumed to be passive. That is, the only forces affecting the drift object's motion are those associated with its leeway drift.

The reader must be cautioned that the description of leeway objects found or used in the marine environment does not currently rely on one universally accepted set of classification rules. The rules proposed here are the result of market surveys and the authors' knowledge. It is acknowledged that there may be areas where a drift target may fit more than one category, but an attempt has been made to include all possible targets of interest. The few exceptions to this inclusive design are vessels that generally are not operated in areas where they might become open-ocean drift targets or are sufficient large that they are sources of survivor craft. The first case involves boats found in rivers and lakes and includes competition water ski boats, paddle boats, personal hovercraft, and airboats. The second case involves "mega-" yachts, large commercial fishers and freighters, and military vessels where it is assumed that, if they are in sufficient trouble to warrant drift computation and an active search, the people onboard have left the vessel and are in their rescue equipment.

A quick comparison of the leeway drift data presented earlier in this paper with the categories of targets in Appendix A indicates that very few of the targets in Appendix A

currently have leeway drift data associated with them. Upon further study, it is apparent that some of these target types may have similar leeway drift characteristics and could possibly be combined into one target type. This honing of the taxonomy is the next logical step; however, caution must be observed. There is currently insufficient field data or verified model data to reliably reduce the taxonomy without risking the same oversimplification inherent in the current models. A review of CG priorities is in order and targets can be selected for in-depth field analysis from that review. If performed in conjunction with leeway drift modeling techniques, such field tests may also yield leeway drift models that would greatly reduce the cost of quantifying leeway drift of other targets within the taxonomy. The recommendations section of this report will prioritize target types based on the amount of information available about them. It will address the commonality of the need for leeway drift information concerning the target and the relative capability to conduct appropriate field studies for these targets. These recommendations should be reviewed by the operational community and prioritized for funding purposes.

#### 6.4. EXAMPLES OF USING THE LEEWAY TAXONOMY

The intent of these tables is that leeway drift information will exist for each target class and each of its descriptors and modifiers. The search planner would use the table representing the particular type of leeway target and then be required to identify the pertinent information for the target of interest. The information in Appendix B could be used to clarify the particular features of interest and also provide leads on where to find amplifying information about the particular leeway drift target. Three examples of the possible use of the appendices follow:

##### **Example 1: Sport Fisher**

The SAR planner receives information that the 32-foot sport fisher "Reel Time" is broken down on Georges Bank and that weather is closing in. The skipper reports that Blackfin builds the boat and that it has an enclosed helm.

Entering Table A-6 for Power vessels, the SAR planner is able to follow the table to sport fishers. The SAR planner does not know whether the boat is a center console, walk around cuddy, or convertible nor the form of the hull. The skipper only reports that it is a planing hull. The description for sport fisher in Appendix B provides a resource reference. The McKnew/Parker Consumers Guide to Sport Fishing Boats, 28 - 82 foot is organized alphabetically and the controller finds the 32-foot Blackfin. The picture confirms that it is a convertible and the written description indicates that it is a deep-V hull.

Now the SAR planner is able to follow table A-6 from sport fisher to convertible with bridge enclosure and must decide or question whether a drogue might be deployed.

### **Example 2: Monohull Sailboat**

The SAR planner receives information that the 53-foot Sailboat “Puffin” is taking on water off the Faralon Islands during a storm. She is reported to be a 6-foot draft monohull built by Beneteau.

After reading the sailboat description in section B.4, the search planner looks into the Sailboat Buyers Guide and searches alphabetically for Beneteau. The 53-ft is in the list of boats Beneteau manufactures. By using the information in the buyers guide, the SAR planner knows that it is probably a fin keel with wing ballast and does not have an inboard engine. The only remaining question is whether or not the vessel operator is using a drag device to slow the drift and provide a more stable platform.

Note: Knowing the draft of a sailing vessel helps determine the keel shape.

### **Example 3: Catamaran**

The 39-foot “Kitty Cat” is reported taking on water with failing pumps in calm seas outside the Santa Cruz Islands. The skipper reports that the boat is an Escale catamaran, built by Prout Catamarans and carries a 6-foot sailing dinghy as a harbor shuttle/life boat.

The SAR planner looks in the taxonomy, finds cruising catamarans, and must reference the description in section B4.10. Using that description, the SAR planner consults the Sailor’s Multihull Guide, uses the index to find either Escale or Prout, and locates the boat on Page 290. The SAR planner now knows what the boat looks like and that it has low-aspect integral keels, and he knows that an inboard engine is standard, although twin outboards may also be used.

The SAR planner may now go to table A-5 for cruising catamarans with low-aspect integral keels and an inboard engine, and assign a lower probability that twin outboards may be used. The controller may also consider using table A-5 for a centerboard dinghy with a mast if the skipper and crew abandoned the catamaran.

## CHAPTER 7

### LEEWAY OF COMBINED CLASSES OF TARGETS

8) *Are there new categories of leeway targets based upon the leeway taxonomy that can be combined from available leeway data to generate leeway equations?*

#### 7.1 INTRODUCTION

The leeway taxonomy introduced in Chapter 6 provides a new way of categorizing leeway targets into groups with similar leeway characteristics. Almost all analysis of leeway data has been done on a specific configuration of a single target. Fitzgerald et al. (1994) started to combine several life rafts into more general groups before performing linear regression analysis on the data sets. In this chapter, we use the categories suggested by the leeway taxonomy to determine appropriate groupings and then determine leeway characteristics for combined classes of leeway targets. Categories of combined classes include: Person-in-the-Water; Maritime Life Rafts; Commercial Fishing Vessels; and Medical Waste. The results are then incorporated into the new leeway classes and values recommended in Chapter 8.

#### 7.2 METHODS OF ANALYSIS

Three methods of analysis were used to determine leeway equations for generalized leeway classes. The first method was applied at the lower specific levels, where more than one data set was available from different target types within that level. Raw leeway data were combined and linear regressions calculated following the procedures outlined in Chapter 3. All available data were used without any weighting among or between target types. The amount of data in these combined leeway classes varied from as little as 128 data points up to 2712 points. The second method used when combining lower classes up one level was to algebraically combine the individual linear regression lines rather than using the raw data itself. Thus the weighting between classes was considered to be equal. The third method was applied only to those lower specific classes for which there were no available leeway studies. Using values and relationships of other similar leeway classes, estimates were made by interpolation or extrapolation, and values were assigned for the leeway speed's slope versus wind speed and divergence angle (intercept was assigned 0.0; standard error was assigned  $> 15$  cm/s). The third method was used sparingly.

For each leeway class Appendix B lists the leeway references and their leeway equations; these are not repeated in Section 7.3 below. When the original study did not report a standard error for the leeway equation of leeway speed versus wind speed, a standard error of  $> 10$  cm/s was assigned for that equation. When combining classes one level up (method 2) or interpolating a leeway equation (method 3) a standard error term of  $> 15$  cm/s was assigned for that equation.

### 7.3 LEEWAY OF COMBINED CLASSES

#### 7.3.1 PIWs

The leeway category Person-in-the-Water (PIWs) is divided into five sub-categories: vertical position, sitting position, and horizontal position which is further divided into either in a category for a survivor in a survival suit, in a scuba suit or category for a deceased person. There are equations for leeway speed versus wind speed for these five PIW categories. The equations were algebraically combined by summing and then dividing by five.

Vertical PIW =	0.5 % $W_{10m}$ + 3.8 cm/s	> 10 cm/s $S_{y/x}$
Sitting PIW =	1.17 % $W_{10m}$ + 0.2 cm/s	1.38 cm/s $S_{y/x}$
PIW Survival Suit =	1.44 % $W_{10m}$ + 5.25 cm/s	1.85 cm/s $S_{y/x}$
PIW Scuba Suit =	0.7 % $W_{10m}$ + 4.3 cm/s	5.92 cm/s $S_{y/x}$
<u>PIW deceased =</u>	<u>1.5 % <math>W_{10m}</math> + 4.0 cm/s</u>	<u>&gt; 10 cm/s <math>S_{y/x}</math></u>
PIW combined =	1.1 % $W_{10m}$ + 3.5 cm/s	> 15 cm/s $S_{y/x}$

#### 7.3.2 Maritime Life Rafts

Maritime Life Rafts are divided by the ballast systems, the presence or absence of canopies, use of drogues, then capacity, size and finally loading. The choices of ballast system are no ballast, shallow ballast or deep ballast systems.

##### 7.3.2.1 Maritime Life Rafts with No Ballast Systems

Three of four categories for life rafts without ballast systems have references. A fourth category, with canopy and with a deployed drogue, has not been studied. Therefore the third method of extrapolation was used to estimate a value for this category based on the other three categories.

Maritime Life raft without Ballast Systems:

Without Canopy, Without Drogue	5.74 % $W_{10m}$ + 10.9 cm/s	10.4 cm/s $S_{y/x}$
Without Canopy, With Drogue	4.44 % $W_{10m}$ - 10.3 cm/s	4.8 cm/s $S_{y/x}$
<u>With Canopy, Without Drogue</u>	<u>3.71 % <math>W_{10m}</math> + 5.7 cm/s</u>	<u>2.1 cm/s <math>S_{y/x}</math></u>
With Canopy, With Drogue	$\approx (4.44 \% / 5.74 \%) \times 3.71 \%$	
	$\approx 3.0\% W_{10m} + 0.0 \text{ cm/s}$	> 15 cm/s $S_{y/x}$

The value can now be computed for the entire class by the algebraic method.

Maritime Life Rafts without Ballast Systems:

$$4.2 \% W_{10m} + 1.6 \text{ cm/s} \quad > 15 \text{ cm/s } S_{y/x}$$

### 7.3.2.2 Maritime Life Rafts with Shallow Ballast Systems and Canopy

Three of three categories for life rafts with shallow ballast systems and canopies have references. The value can now be computed for the standard configuration for the entire class by the algebraic method using just the first two categories of the life rafts in the standard configurations (with and without drogues). The third category was for capsized maritime life rafts with shallow ballast systems and canopies.

Maritime Life raft with Shallow Ballast Systems and Canopies:

With Canopy, Without Drogue	3.2 % $W_{10m} - 1.0$ cm/s	0.9 cm/s $S_{y/x}$
With Canopy, With Drogue	2.53 % $W_{10m} + 0.68$ cm/s	4.24 cm/s $S_{y/x}$

Maritime Life Rafts with Shallow Ballast Systems and Canopies:

$$2.9 \% W_{10m} - 0.2 \text{ cm/s} \qquad > 15 \text{ cm/s } S_{y/x}$$

### 7.3.2.3 Maritime Life Rafts with Deep Ballast Systems

Eight configurations of deep draft life rafts were studied at Level 6 of the leeway taxonomy. Four, 4- to 6- person deep draft life rafts and one twenty-person life raft have been studied and are available to be combined for categories of life rafts with deep ballast systems. These life rafts were then drifted with and without a drogue, and in their light and heavy loading configurations. The seventh and eighth configurations were deep draft life rafts that either capsized or swamped.

The four 4- to 6- person life rafts with deep ballast systems were a Tulmar life raft, a Beaufort 5-sided life raft, a Beaufort 6-sided life raft and Switlik 8-sided life raft. The twenty-person life raft with a deep ballast system was a Dunlop-Beaufort nearly circular life raft. Figures of these life rafts can be found in Fitzgerald et al. (1994) and Allen and Fitzgerald (1997).

Either Fitzgerald et al. (1994) or Allen and Fitzgerald (1997) reported on four of the eight configurations for the deep draft life raft at Level 6 of the leeway taxonomy. The four report categories include: 15-25 person life raft without drogue and lightly-loaded; 15-25 person life raft with drogue and heavily-loaded; capsized deep draft life rafts and swamped deep draft life rafts. The remaining four configurations were combined here and analyzed by linear regression of the appropriate original data sets. The results for remaining four categories are presented below.

#### 7.3.2.3.1 Maritime Life Raft (deep ballast, canopy, without drogue, 4-6 person, light loading)

For this category leeway data from the Tulmar life raft were combined with data from the Beaufort 5 and 6 sided life rafts. The leeway runs of the Tulmar were; 2, 3, 4, 16, 17, 19, 20

and 23 which included 1,166 ten-minute samples. The leeway runs of the Beaufort (5-sided) were 30, 32, 34, 35, 36, 38, 45 and 54 which included 747 ten-minute samples. The Beaufort (6-sided) runs were 44, 49 and 55, which provided 799 ten-minute samples for a total of 2,712 ten-minute samples or 18.8 days of leeway data. The results for all the data points combined equally are presented below. In Figures 7-1 and 7-2 the unconstrained linear regression of the leeway speed and downwind component of leeway versus  $W_{10m}$  are presented, along with the 95% prediction limits. In these two figures, the data are separated by life raft type. The asymmetric 5-sided Beaufort drifts the fastest at 4.9% of  $W_{10m}$ , while the symmetric Tulmar and symmetric 6-sided Beaufort drifted at 3.2% and 3.4% of  $W_{10m}$ , respectively. These two figures provide the only leeway data set extensive enough to validate the premise of AP98 model that the differences between life rafts can be modeled by changing the intercept and not the slope of regression equation.

The crosswind components (separated by life raft type) versus  $W_{10m}$  are presented in Figure 7-3. Following the same procedure as in Chapter 3 for the Tulmar life raft, the crosswind components were separated by drift runs into positive and negative components. However, during drift run 38, the life raft started with a negative component of crosswind leeway and after 26.2 hours, within a single 10-minute sample period, switched to positive crosswind leeway for the remainder of the drift run. Therefore run 38 was divided into two sections before being used in the crosswind regression. The unconstrained linear regressions of positive and negative crosswind components of leeway versus  $W_{10m}$  along with the 95% prediction limits are shown in Figure 7-4.

Statistics on the leeway angle for this category were computed using all wind speeds and a second time using only winds above 5.0 m/s.

Maritime Life Raft (deep ballast, canopy, w/o drogue, 4-6 person, light loading)

$$\begin{aligned} \text{Leeway speed} &= 3.79 \% W_{10m} - 2.11 \text{ cm/s} & S_{y/x} &= 4.50 \text{ cm/s} \\ \text{Leeway angle } (W_{10m} > 0 \text{ m/s}) &: \text{ mean} = -2.7^\circ, \text{ std. dev.} = 13.2^\circ, \\ \text{Leeway angle } (W_{10m} > 5 \text{ m/s}) &: \text{ mean} = -2.3^\circ, \text{ std. dev.} = 9.7, \text{ min.} = -28^\circ, \text{ max} = 34^\circ \\ \text{DWL} &= 3.75 \% W_{10m} - 2.32 \text{ cm/s} & S_{y/x} &= 4.51 \text{ cm/s} \\ \text{+CWL} &= 1.00 \% W_{10m} - 5.31 \text{ cm/s} & S_{y/x} &= 3.91 \text{ cm/s} \\ \text{-CWL} &= -0.47 \% W_{10m} - 0.14 \text{ cm/s} & S_{y/x} &= 3.91 \text{ cm/s} \end{aligned}$$



Maritime Life Rafts with Deep Ballast System and Canopy  
(without drogue, light loading)

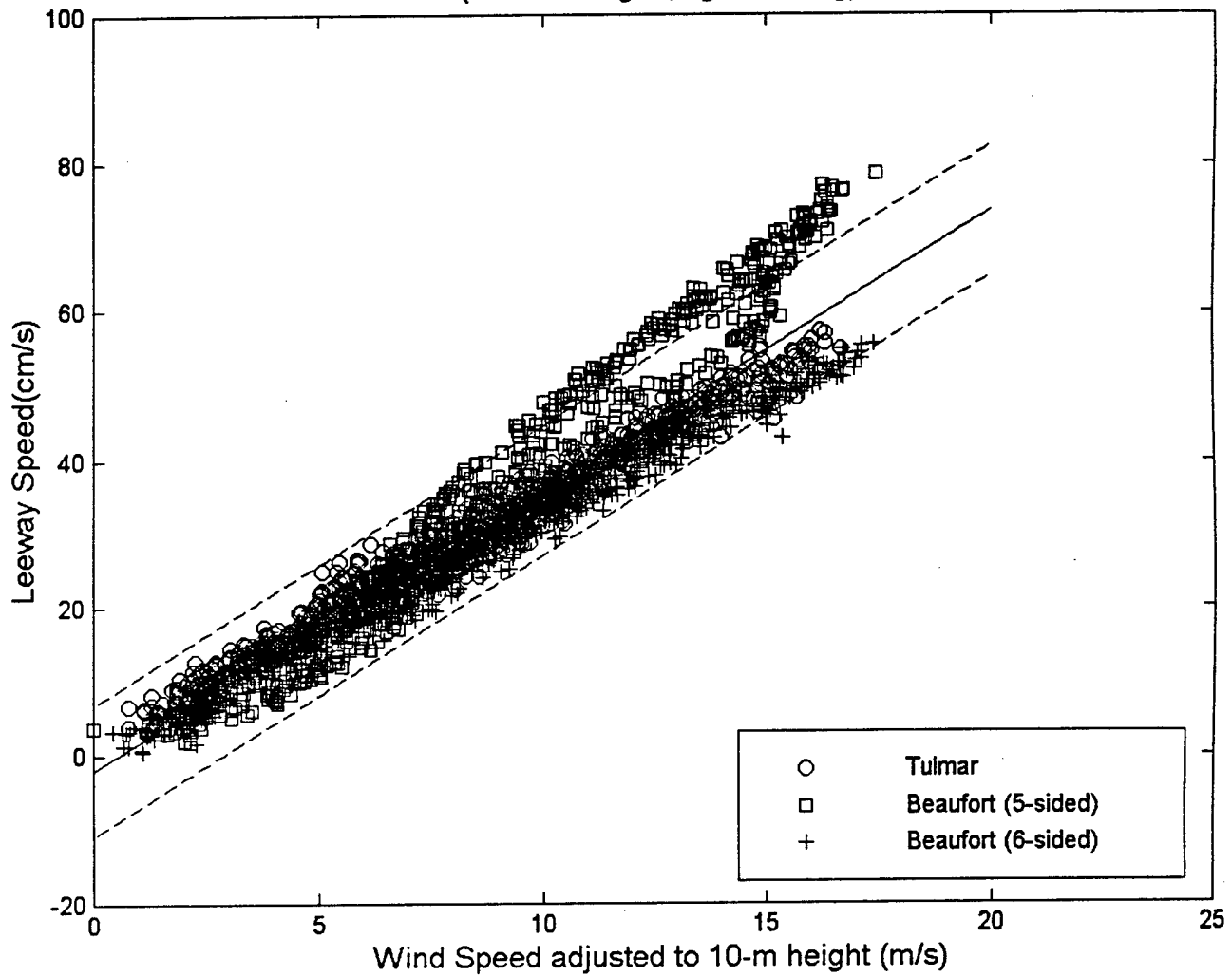

Figure 7-1. The Unconstrained Linear Regression and 95% Prediction Limits of the Leeway Speed versus Wind Speed at 10 m, Maritime Life Rafts, deep ballast systems, canopy, without drogue, 4-6 person capacity, light loading.

Maritime Life Rafts with Deep Ballast System and Canopy  
(without drogue, light loading)

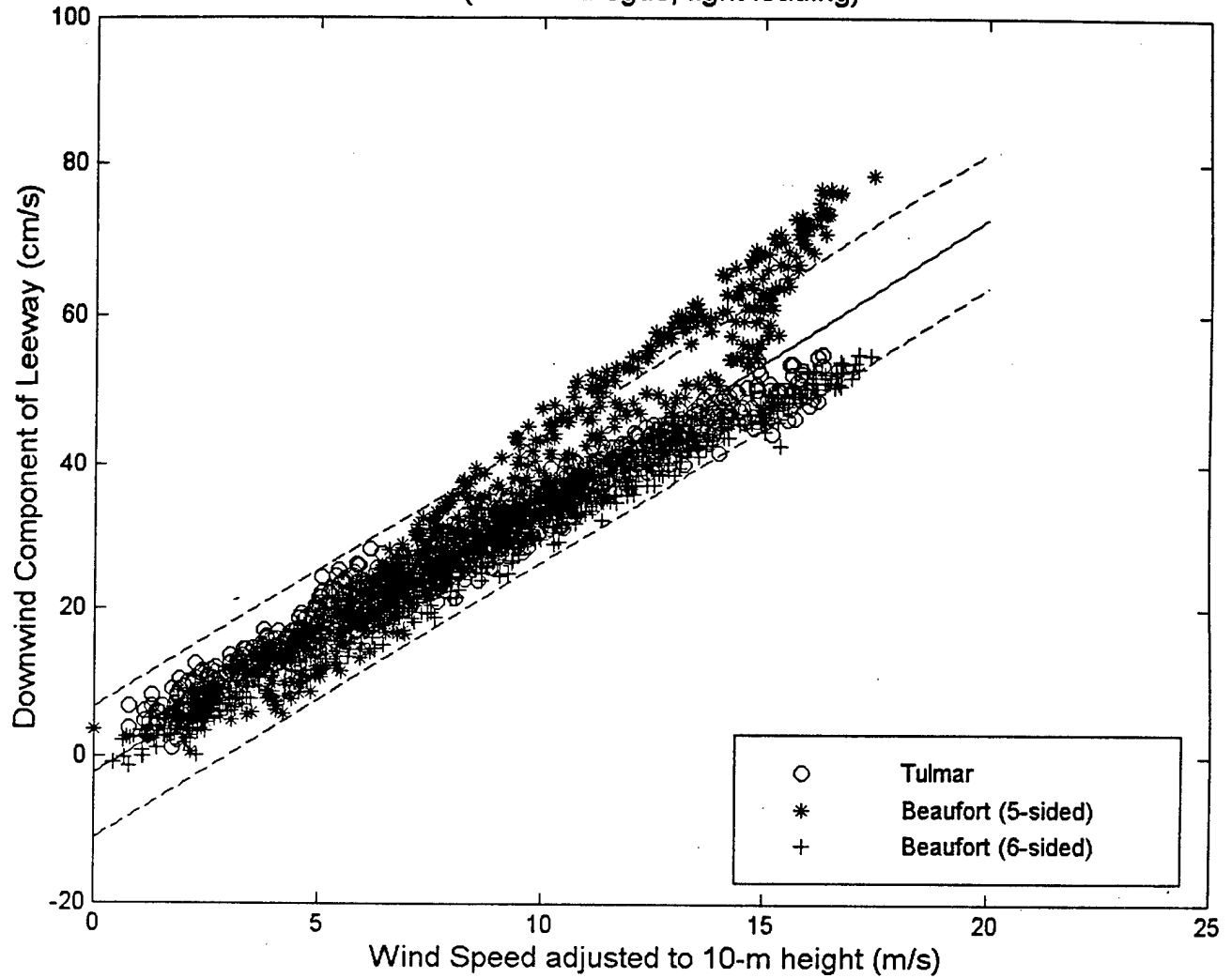

Figure 7-2. The Unconstrained Linear Regression and 95% Prediction Limits of the Downwind Component of Leeway versus Wind Speed at 10 m, Maritime Life Rafts, deep ballast systems, canopy, without drogue, 4-6 person capacity, light loading.

Maritime Life Rafts with Deep Ballast System and Canopy  
(without drogue, light loading)

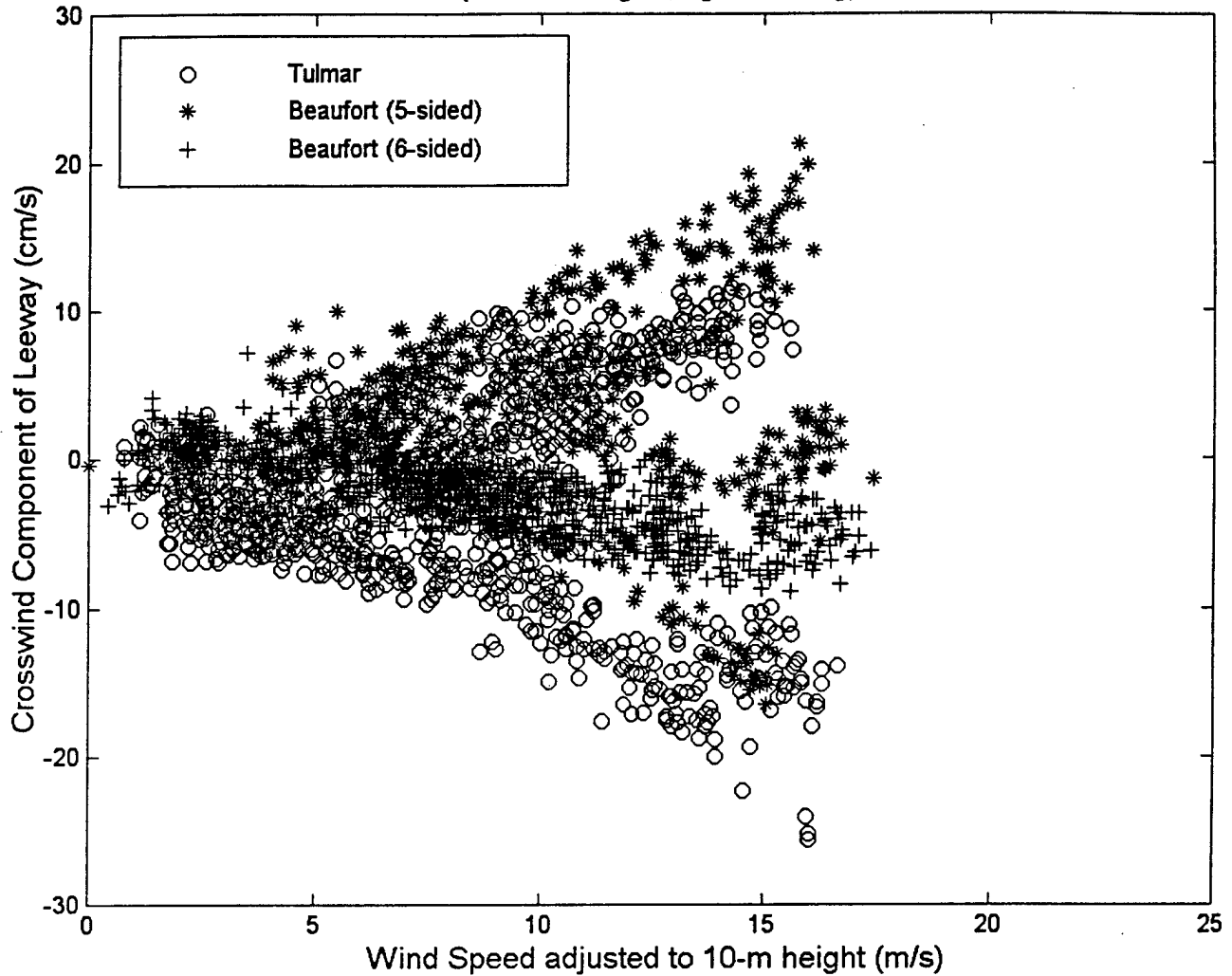

Figure 7-3. The Crosswind Component of Leeway versus Wind Speed at 10 m, Maritime Life Rafts, deep ballast systems, canopy, without drogue, 4-6 person capacity, light loading.

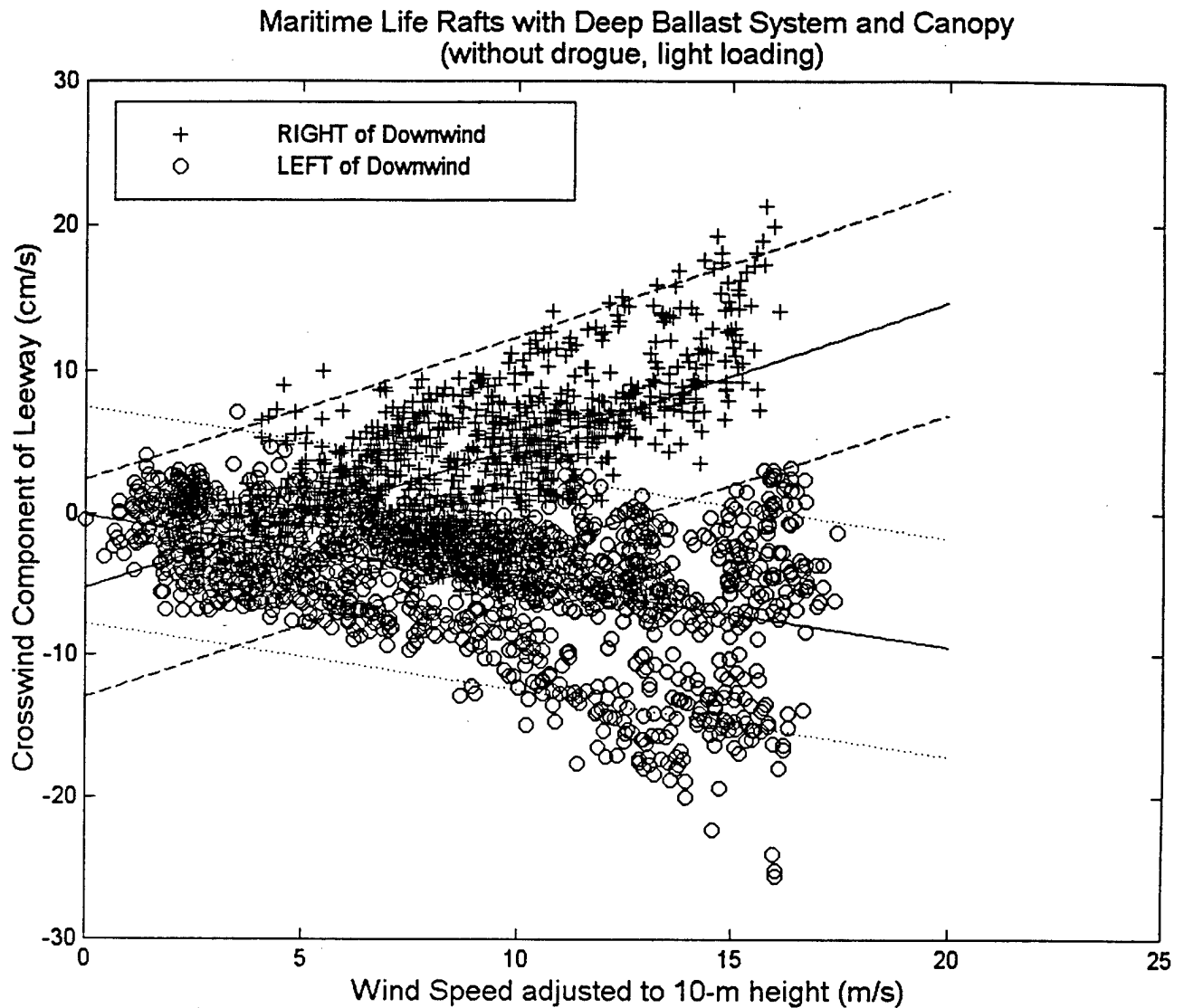

Figure 7-4. The Unconstrained Linear Regression and 95% Prediction Limits of the Positive and Negative Crosswind Components of Leeway versus Wind Speed at 10 m, Maritime Life Rafts, deep ballast systems, canopy, without drogue, 4-6 person capacity, light loading.

### 7.3.2.3.2 Maritime Life Raft (deep ballast, canopy, w/ drogue, 4-6 person, light loading)

The data set as analyzed by Allen and Fitzgerald (1997) for the Switlik life raft "J" with a deep toroidal ballast bag was combined with run 5 of the Tulmar life raft from Fitzgerald et al. (1993). Three hundred thirty-three (333) points from run 63 of the Switlik were used for leeway speed and 127 for leeway angle and the leeway components. From run 5 of the Tulmar, only the last 15 points were used. There were a number of points for which Smith's (1988) algorithm fails to provide a wind adjustment factor under low wind and stable conditions and therefore were not available for this analysis. The results for all data points combined equally are presented below. In Figures 7-5 and 7-6 the unconstrained linear regression of the leeway speed and downwind component of leeway versus  $W_{10m}$  are presented, along with the 95% prediction limits. In these two figures, the data are separated by life raft type.

The positive and negative crosswind components of leeway were based upon using the unconstrained linear regression of the absolute values of the crosswind components of leeway versus  $W_{10m}$ . The crosswind components (separated by life raft type) versus  $W_{10m}$  are presented in Figure 7-7, while Figure 7-8 shows the unconstrained linear regression of the absolute values of the crosswind component of leeway versus  $W_{10m}$ .

#### Maritime Life Raft (deep ballast, canopy, w/ drogue, 4-6 person, light loading)

$$\begin{aligned} \text{Leeway speed} &= 1.61 \% W_{10m} + 2.67 \text{ cm/s} & S_{y/x} &= 2.98 \text{ cm/s} \\ \text{Leeway angle: mean} &= +3.2^\circ \text{ std. dev.} = 16.3^\circ, W_{10m} > 0 \text{ m/s} \\ \text{DWL} &= 1.95 \% W_{10m} - 0.53 \text{ cm/s} & S_{y/x} &= 3.59 \text{ cm/s} \\ \text{+CWL} &= 0.21 \% W_{10m} + 1.29 \text{ cm/s} & S_{y/x} &= 2.15 \text{ cm/s} \\ \text{-CWL} &= -0.21 \% W_{10m} - 1.29 \text{ cm/s} & S_{y/x} &= 2.15 \text{ cm/s} \end{aligned}$$

Maritime Life Rafts with Deep Ballast System and Canopy  
(with drogue, light loading)

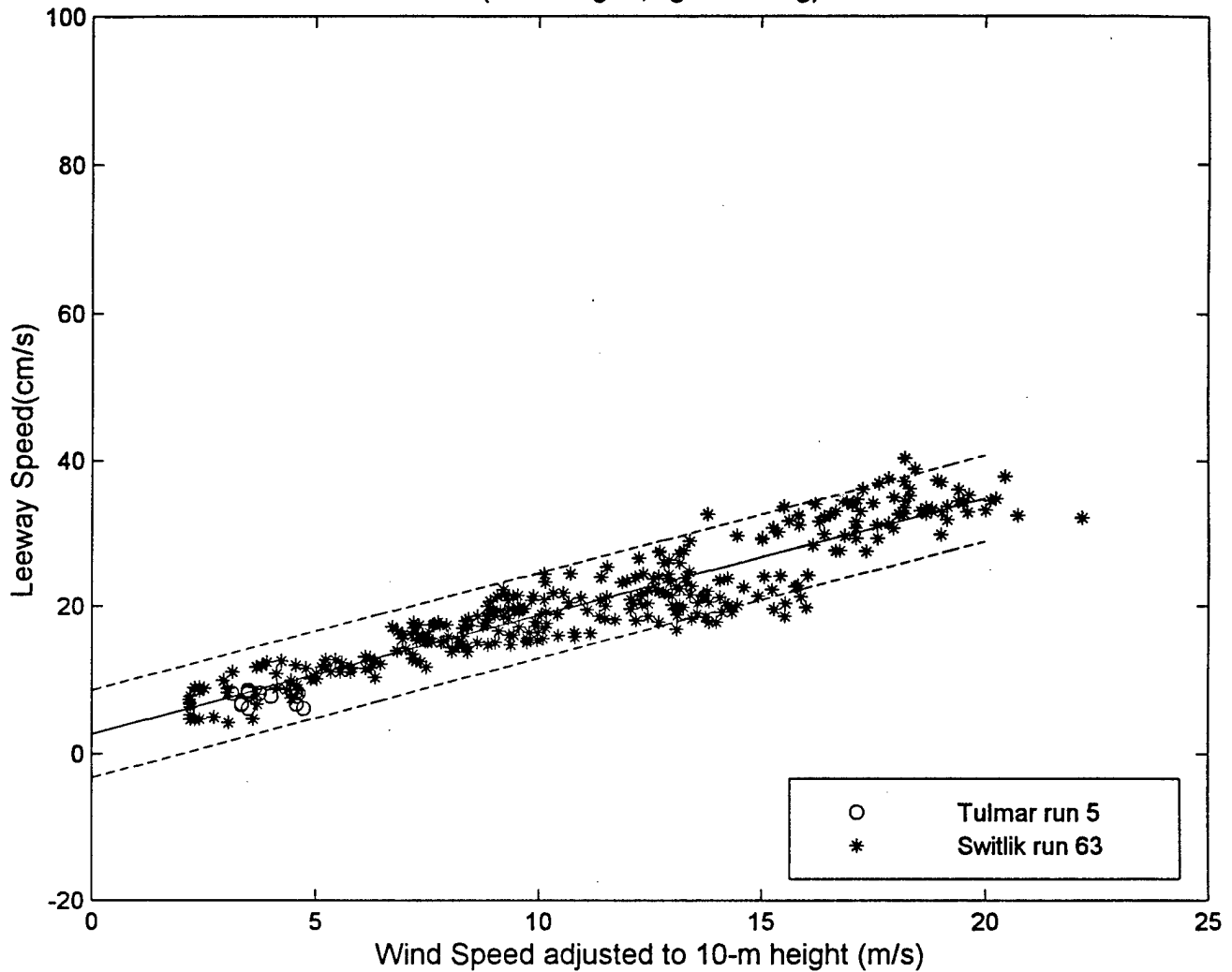

Figure 7-5. The Unconstrained Linear Regression and 95% Prediction Limits of the Leeway Speed versus Wind Speed at 10 m, Maritime Life Rafts, deep ballast systems, canopy, with drogue, 4-6 person capacity, light loading.

Maritime Life Rafts with Deep Ballast System and Canopy  
(with drogue, light loading)

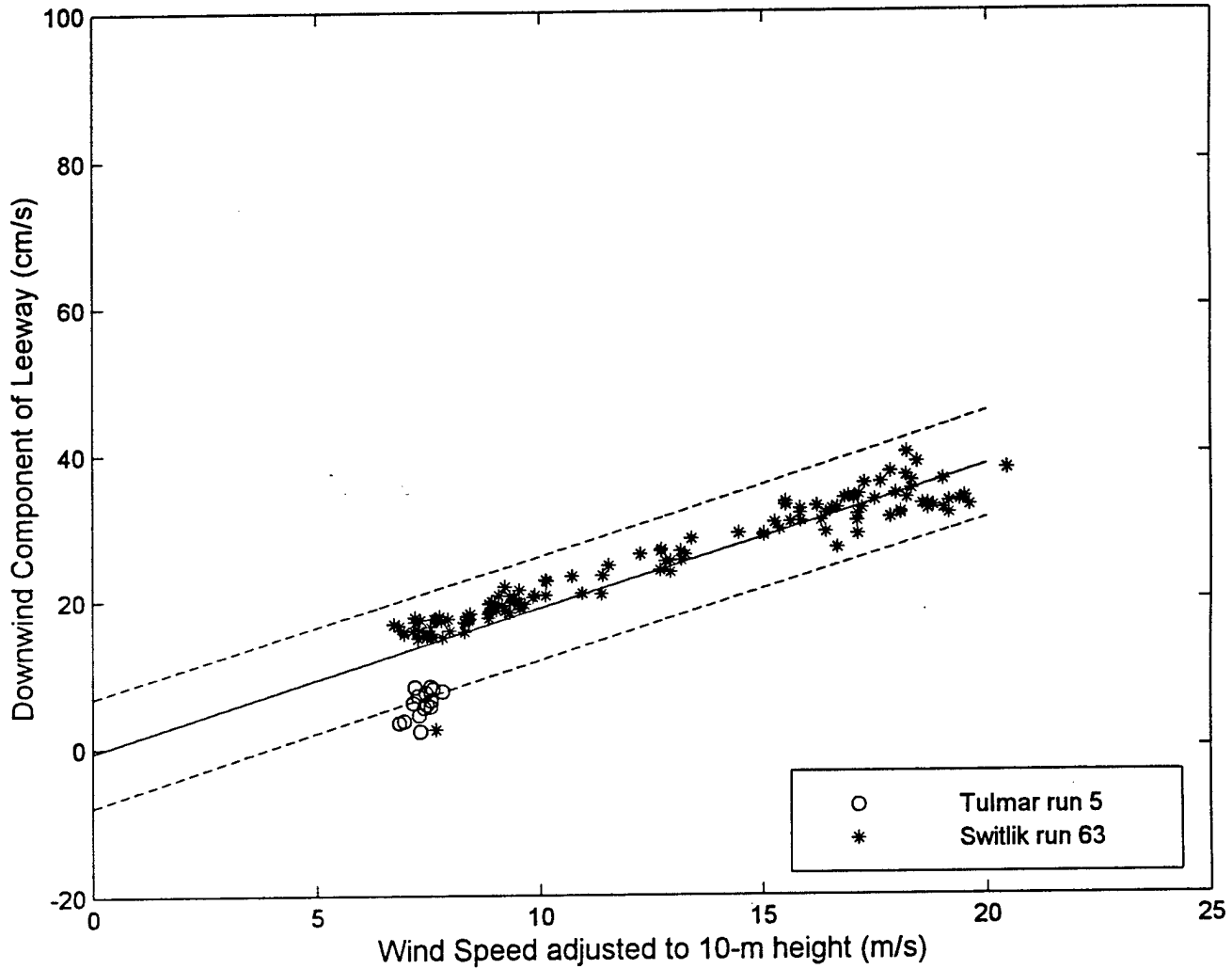

Figure 7-6. The Unconstrained Linear Regression and 95% Prediction Limits of the Downwind Component of Leeway versus Wind Speed at 10 m, Maritime Life Rafts, deep ballast systems, canopy, with drogue, 4-6 person capacity, light loading.

Maritime Life Rafts with Deep Ballast System and Canopy  
(with drogue, light loading)

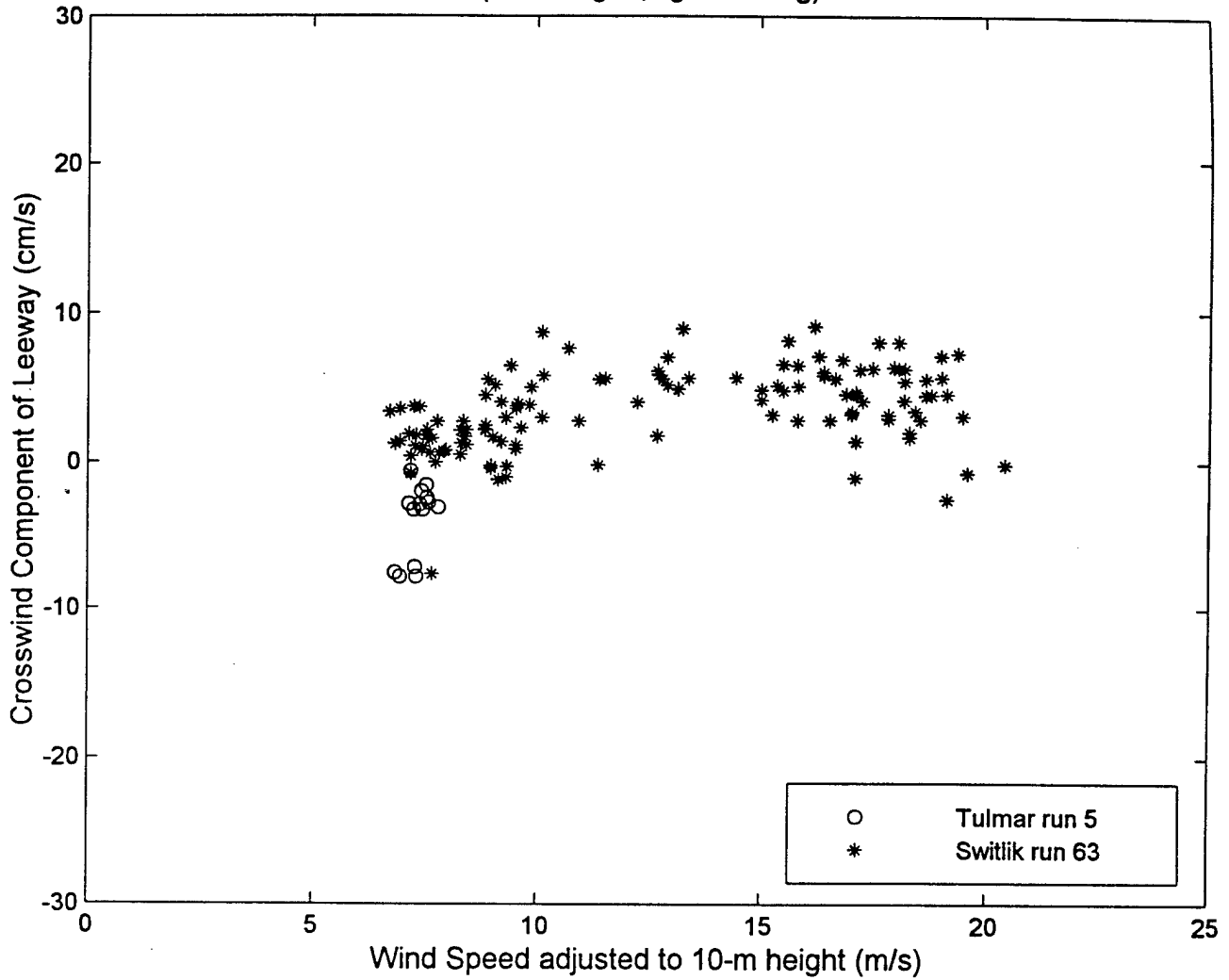

Figure 7-7. The Crosswind Component of Leeway versus Wind Speed at 10 m, Maritime Life Rafts, deep ballast systems, canopy, with drogue, 4-6 person capacity, light loading.



Maritime Life Rafts with Deep Ballast System and Canopy  
(with drogue, light loading)

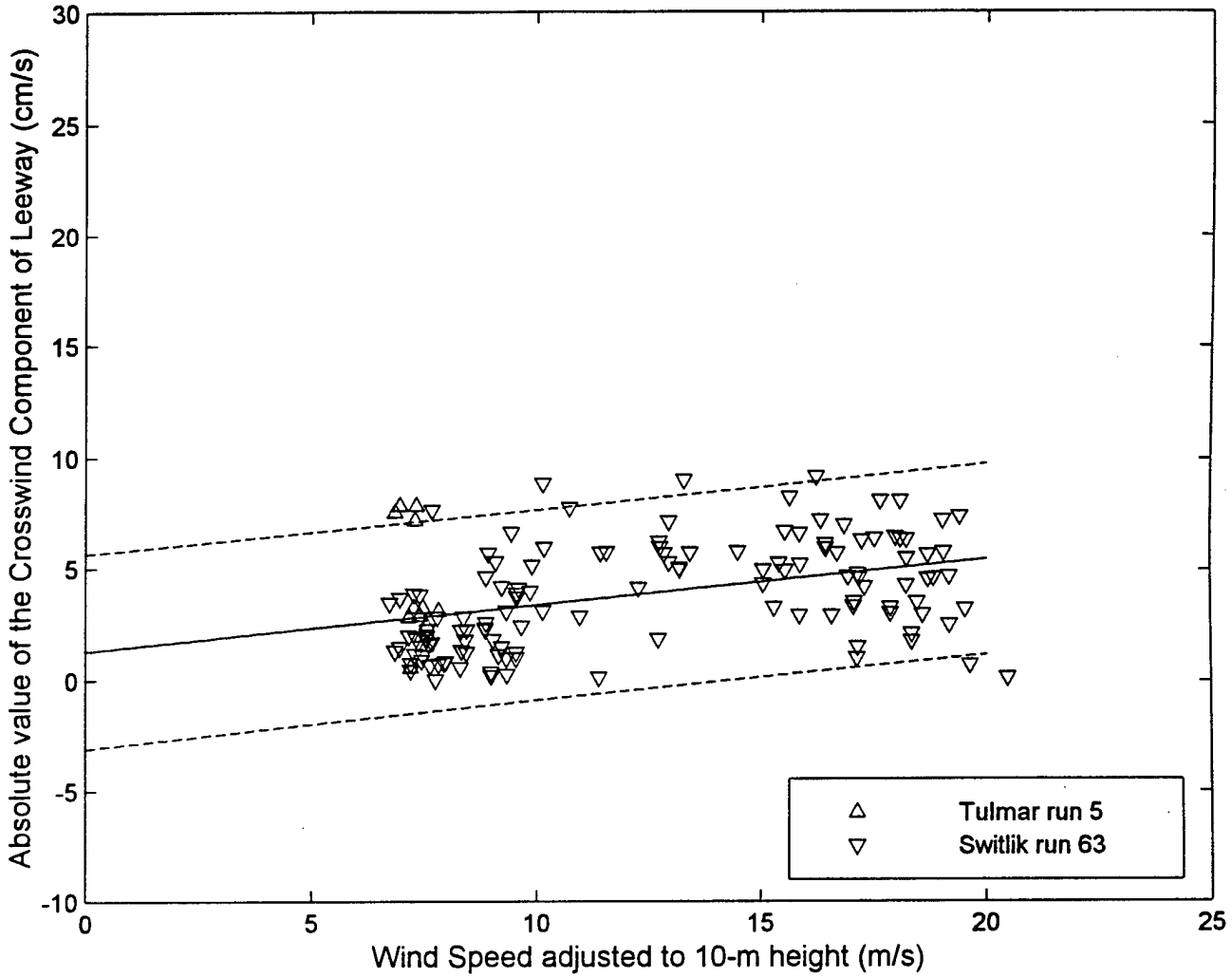

Figure 7-8. The Unconstrained Linear Regression and 95% Prediction Limits of the Absolute values of the Crosswind Components of Leeway versus Wind Speed at 10 m, Maritime Life Rafts, deep ballast systems, canopy, with drogue, 4-6 person capacity, light loading.

7.3.2.3.3 Maritime Life Raft (deep ballast, canopy, without drogue, 4-6 person, heavy loading)

Leeway data from Tulmar runs 6, 7, and 8 were combined with Beaufort (5-sided) runs of 9 and 10 after runs 9 and 10 were edited to remove winds that could not be converted to  $W_{10m}$  by Smith (1988). The Tulmar runs contained 104 ten-minute samples and 14 ten-minute samples were used from the Beaufort life raft for a total of 128 ten-minute samples or 21.3 hours of data. The results for all the data points combined equally are presented below. In Figures 7-9 and 7-10 the unconstrained linear regression of the leeway speed and downwind component of leeway versus  $W_{10m}$  are presented, along with the 95% prediction limits. In these two figures, the data are separated by life raft type.

Since only positive values of crosswind component of leeway were available, the unconstrained linear regression was conducted on only the positive values of the crosswind components of leeway versus  $W_{10m}$ . Symmetry about the downwind direction was assumed to provide the coefficients for the negative crosswind component of leeway. The crosswind components (separated by life raft type) versus  $W_{10m}$  are presented in Figure 7-11, while Figure 7-12 shows the unconstrained linear regression of the crosswind component of leeway versus  $W_{10m}$ . Since the unconstrained linear regression had a positive slope with a near zero intercept this regression was used for the +CWL, and its reciprocal was used for the -CWL equation.

Maritime Life Raft (deep ballast canopy, w/o drogue, 4-6 person, heavy loading)

$$\begin{aligned} \text{Leeway speed} &= 3.59 \% W_{10m} - 1.54 \text{ cm/s} & S_{y/x} &= 2.51 \text{ cm/s} \\ \text{Leeway angle: mean} &= +7.3^\circ \text{ std. dev.} = 10.2, W_{10m} > 0 \text{ m/s} \\ \text{DWL} &= 3.59 \% W_{10m} - 1.92 \text{ cm/s} & S_{y/x} &= 2.56 \text{ cm/s} \\ \text{+CWL} &= 0.48 \% W_{10m} - 0.16 \text{ cm/s} & S_{y/x} &= 2.17 \text{ cm/s} \\ \text{-CWL} &= -0.48 \% W_{10m} + 0.16 \text{ cm/s} & S_{y/x} &= 2.17 \text{ cm/s} \end{aligned}$$

Maritime Life Rafts with Deep Ballast System and Canopy  
(without drogue, heavy loading)

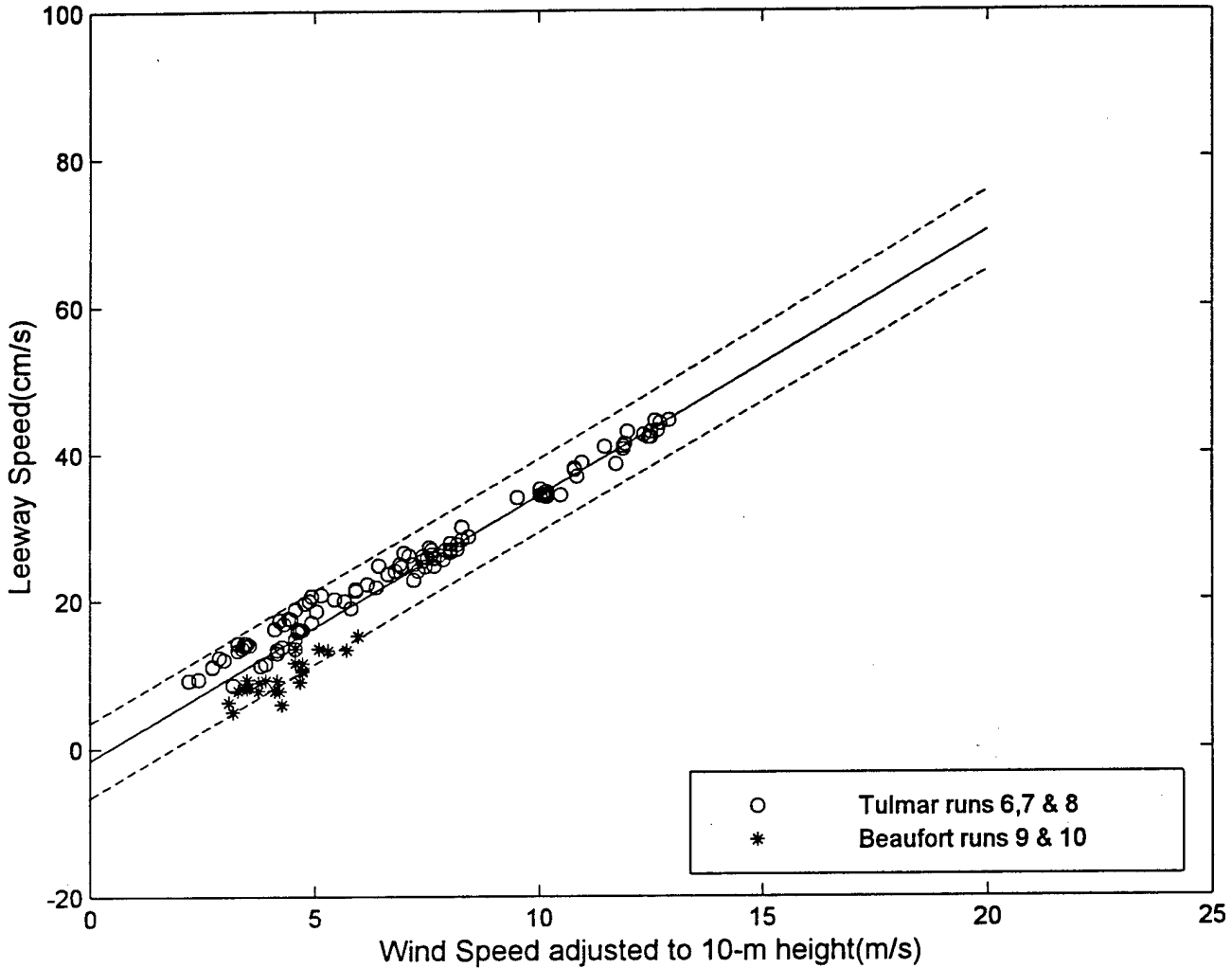

Figure 7-9. The Unconstrained Linear Regression and 95% Prediction Limits of the Leeway Speed versus Wind Speed at 10 m, Maritime Life Rafts, deep ballast systems, canopy, without drogue, 4-6 person capacity, heavy loading.

Maritime Life Rafts with Deep Ballast System and Canopy  
(without drogue, heavy loading)

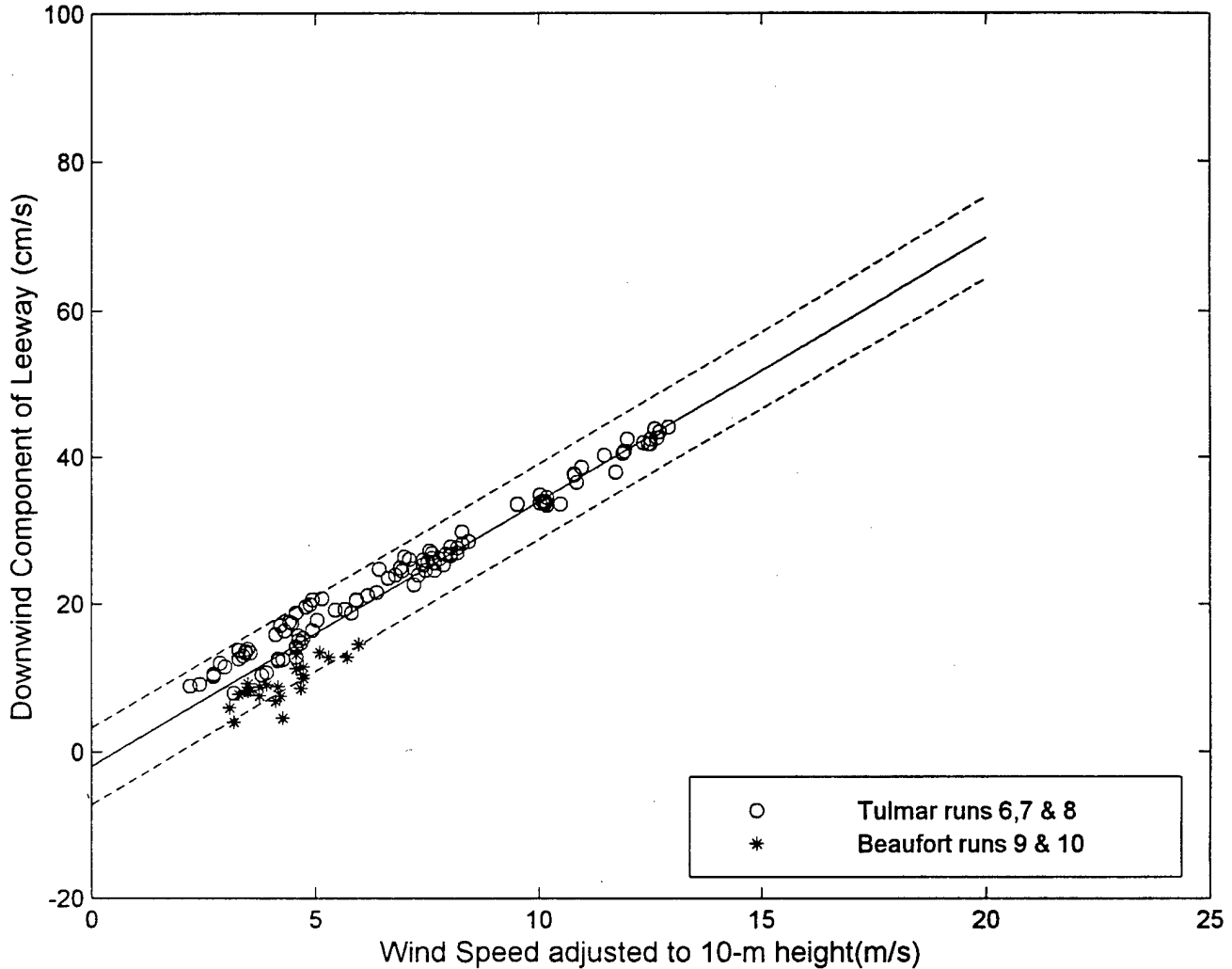

Figure 7-10. The Unconstrained Linear Regression and 95% Prediction Limits of the Downwind Component of Leeway versus Wind Speed at 10 m, Maritime Life Rafts, deep ballast systems, canopy, without drogue, 4-6 person capacity, heavy loading.

Maritime Life Rafts with Deep Ballast System and Canopy  
(without drogue, heavy loading)

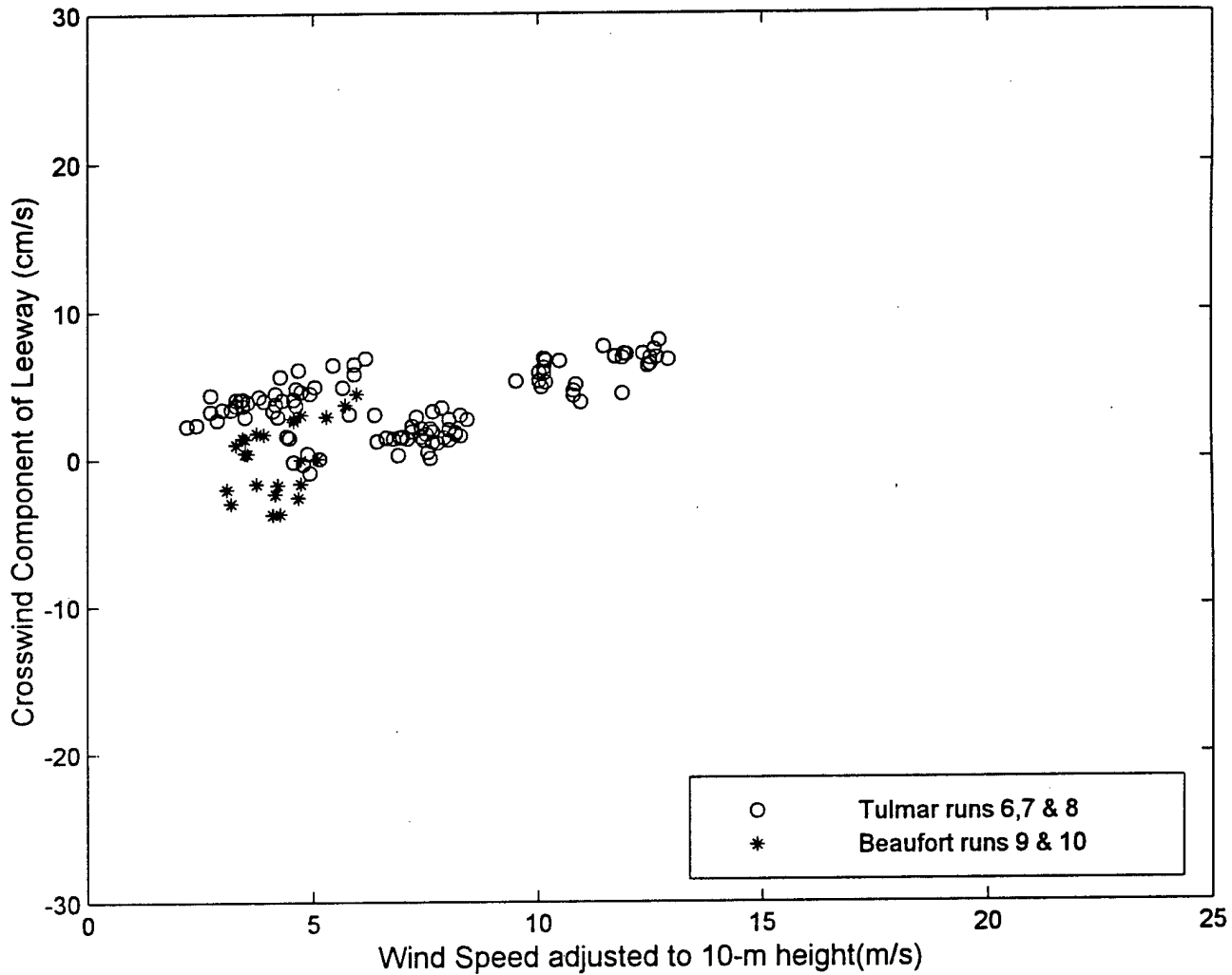

Figure 7-11. The Crosswind Component of Leeway versus Wind Speed at 10 m, Maritime Life Rafts, deep ballast systems, canopy, without drogue, 4-6 person capacity, heavy loading.

Maritime Life Rafts with Deep Ballast System and Canopy  
(without drogue, heavy loading)

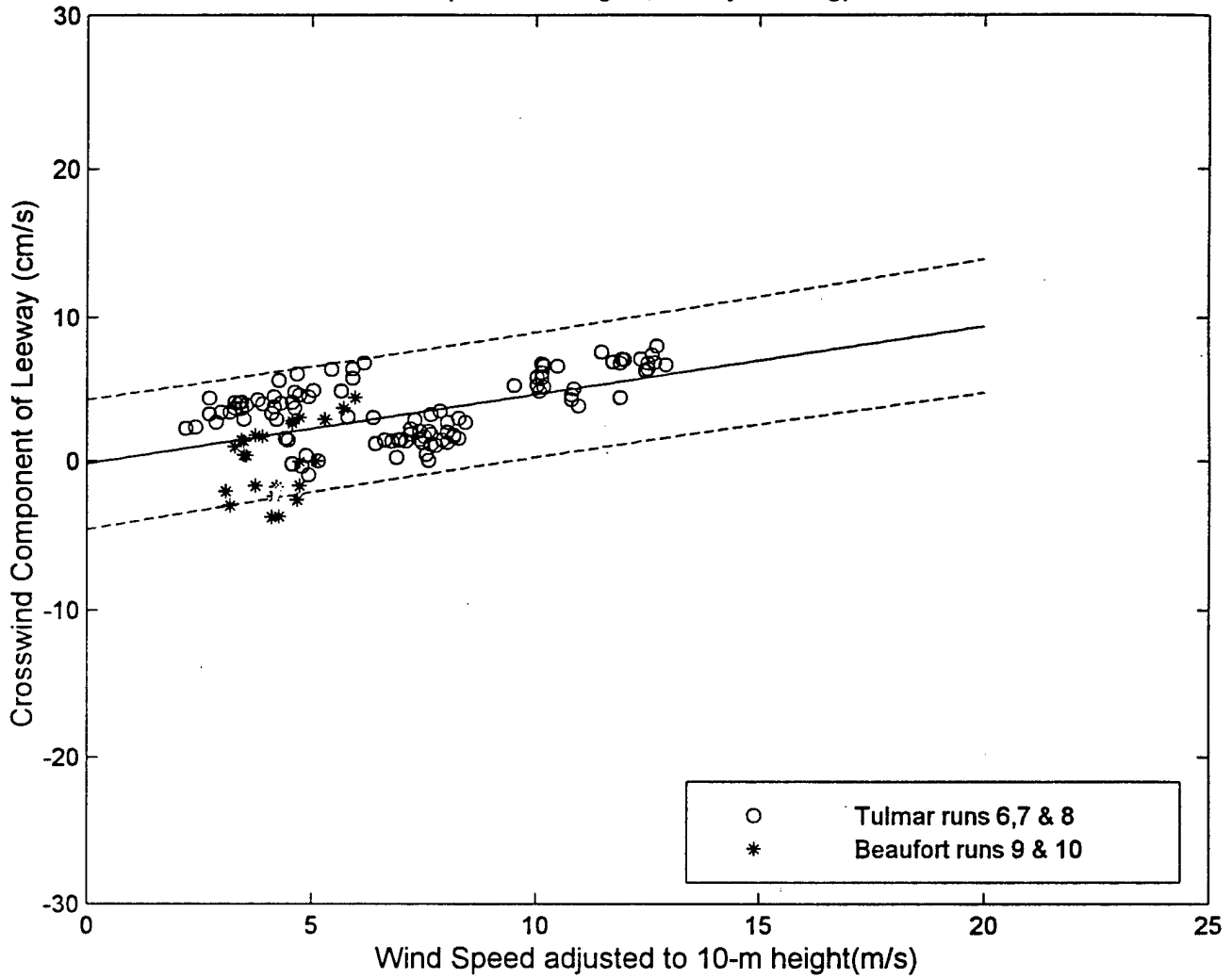

Figure 7-12. The Unconstrained Linear Regression and 95% Prediction Limits of the Crosswind Components of Leeway versus Wind Speed at 10 m, Maritime Life Rafts, deep ballast systems, canopy, without drogue, 4-6 person capacity, heavy loading.

#### 7.3.2.3.4 Maritime Life Raft (deep ballast, canopy, w/ drogue, 4-6 person, heavy loading)

For this category leeway runs 15 (138 ten-minute samples) and 22 (296 ten-minute samples) of the Beaufort (5-sided) were combined with run 24 (146 ten-minute samples) of the Tulmar life raft. Thus leeway speed is based upon 580 ten-minute samples or about 4.0 days. Run 22 was not used for leeway angle, **DWL** and **CWL** therefore these values are based upon 284 ten-minute sample or about 47.3 hours of data. The results for all the data points combined equally are presented below. In Figures 7-13 and 7-14 the unconstrained linear regression of the leeway speed and downwind component of leeway versus  $W_{10m}$  are presented, along with the 95% prediction limits. In these two figures, the data are separated by life raft type.

The positive and negative crosswind components of leeway were based upon using the unconstrained linear regression of the positive components of the crosswind components of leeway versus  $W_{10m}$ . The unconstrained linear regression of the crosswind component of leeway versus  $W_{10m}$  is shown in Figure 7-15. Since the unconstrained linear regression had a positive slope, this regression was used for the **+CWL**, and its reciprocal was used for the **-CWL** equation.

#### Maritime Life Raft (deep ballast, canopy, w/ drogue, 4-6 person, heavy loading)

$$\begin{aligned} \text{Leeway speed} &= 2.05 \% W_{10m} - 0.05 \text{ cm/s} & S_{y/x} &= 2.70 \text{ cm/s} \\ \text{Leeway angle: mean} &= +1.3^\circ \text{ std. dev.} = 13.5^\circ, W_{10m} > 0 \text{ m/s} \\ \text{DWL} &= 2.19 \% W_{10m} - 0.96 \text{ cm/s} & S_{y/x} &= 1.01 \text{ cm/s} \\ \text{+CWL} &= 1.39 \% W_{10m} - 7.9 \text{ cm/s} & S_{y/x} &= 1.46 \text{ cm/s} \\ \text{-CWL} &= -1.39 \% W_{10m} + 7.9 \text{ cm/s} & S_{y/x} &= 1.46 \text{ cm/s} \end{aligned}$$

Maritime Life Rafts with Deep Ballast System and Canopy  
(with drogue, heavy loading)

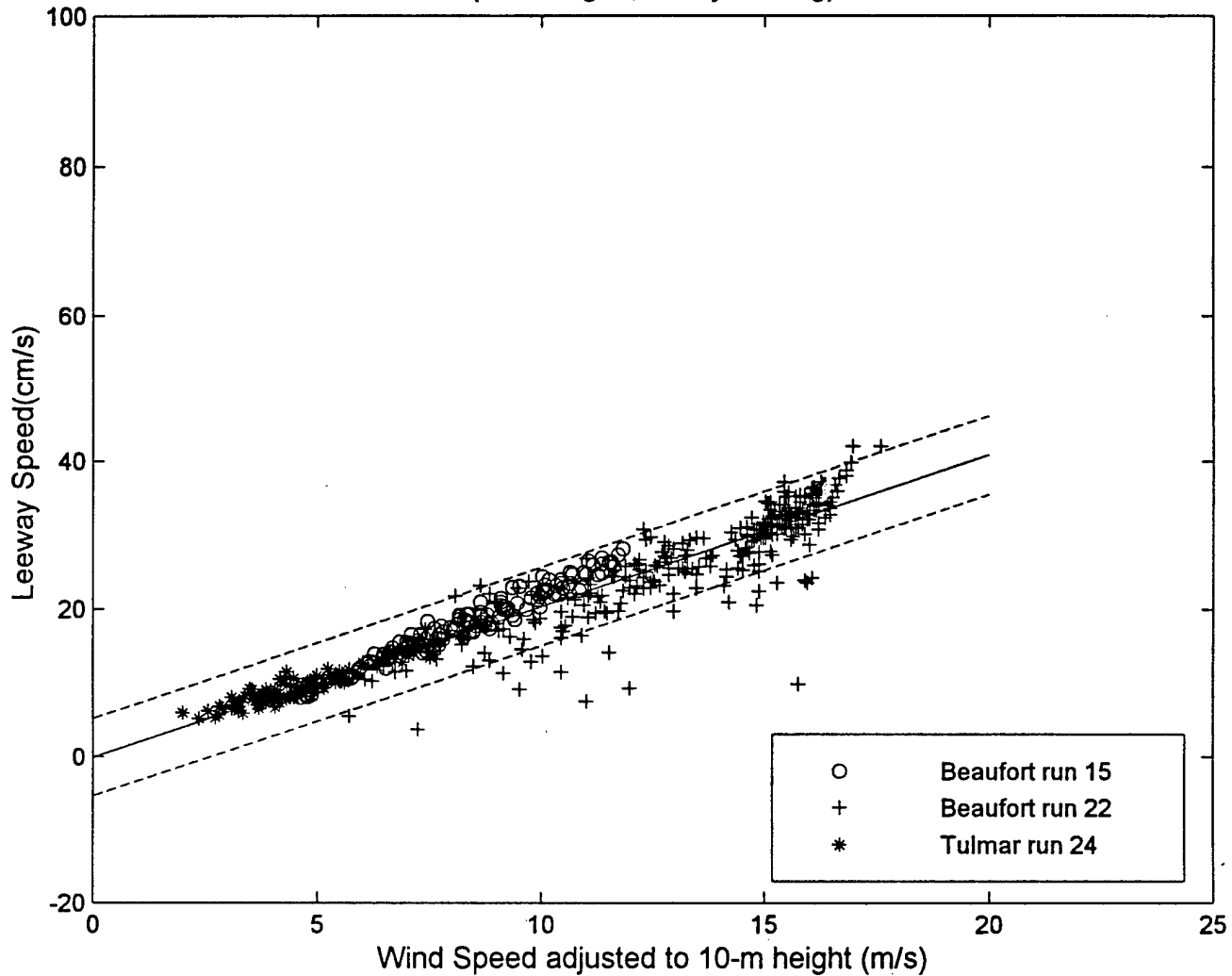

Figure 7-13. The Unconstrained Linear Regression and 95% Prediction Limits of the Leeway Speed versus Wind Speed at 10m, Maritime Life Rafts, deep ballast systems, canopy, with drogue, 4-6 person capacity, heavy loading.



Maritime Life Rafts with Deep Ballast System and Canopy  
(with drogue, heavy loading)

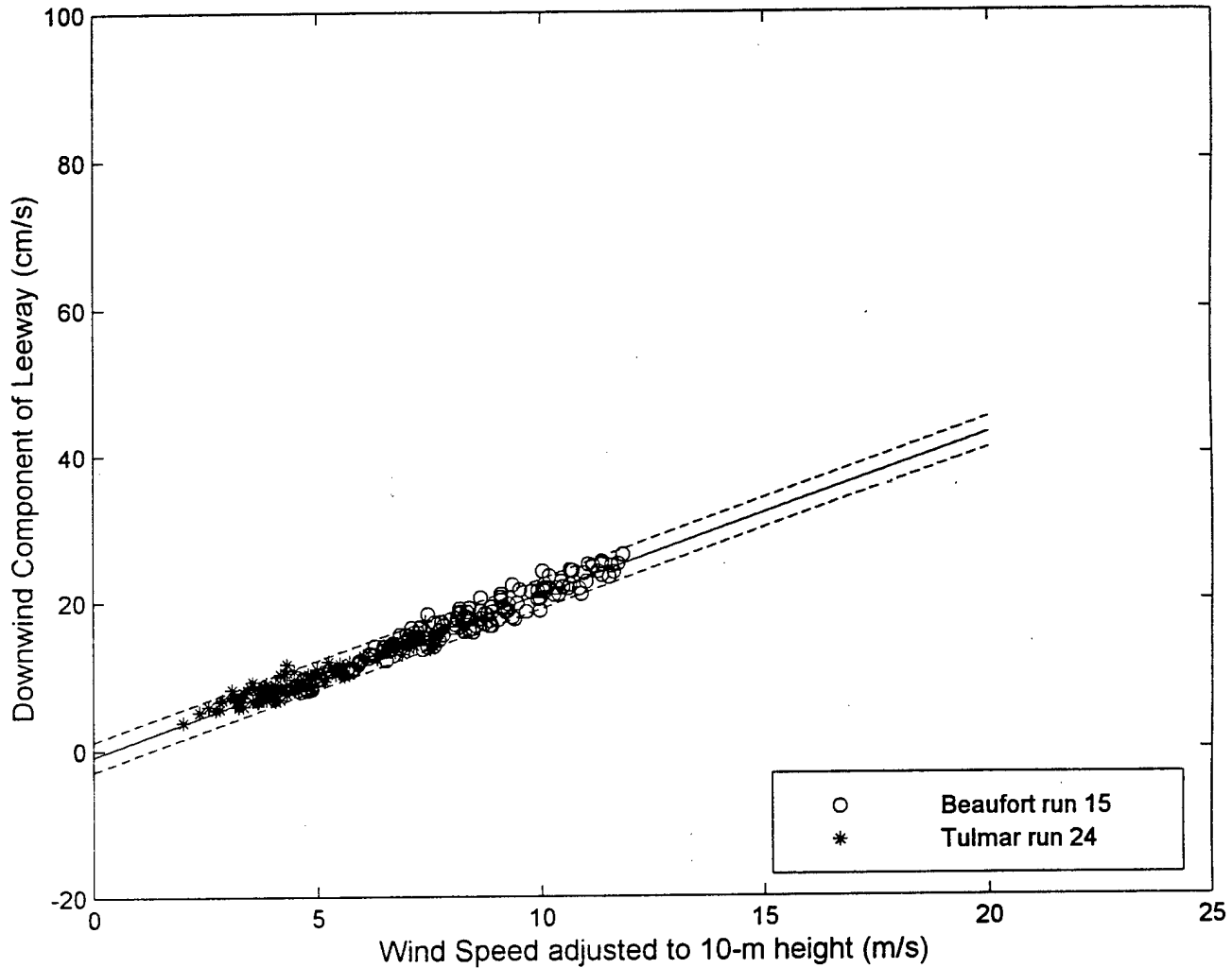

Figure 7-14. The Unconstrained Linear Regression and 95% Prediction Limits of the Downwind Component of Leeway versus Wind Speed at 10m, Maritime Life Rafts, deep ballast systems, canopy, with drogue, 4-6 person capacity, heavy loading.

Maritime Life Rafts with Deep Ballast System and Canopy  
(with drogue, heavy loading)

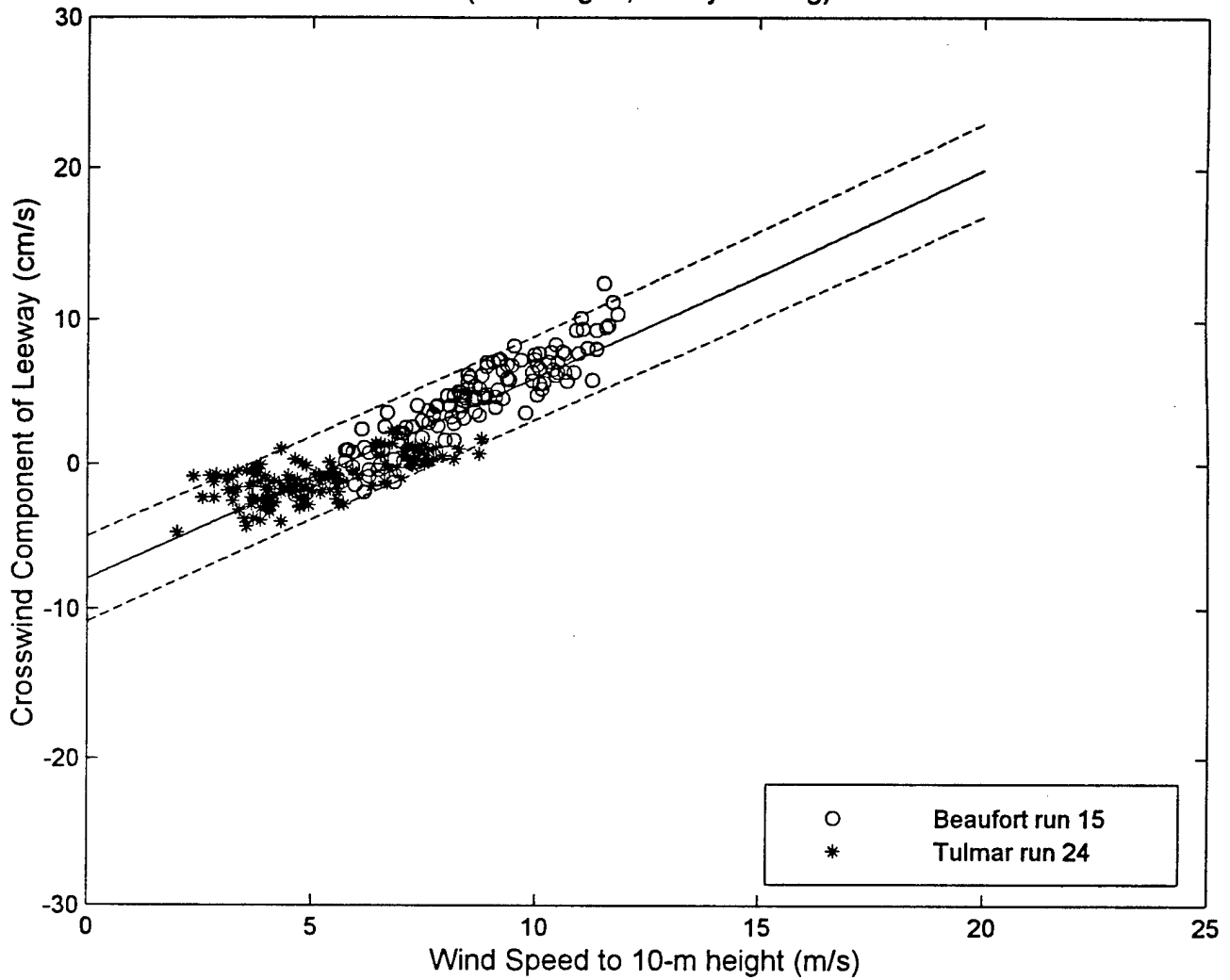

Figure 7-15. The Unconstrained Linear Regression and 95% Prediction Limits of the Crosswind Component of Leeway versus Wind Speed at 10m, Maritime Life Rafts, deep ballast systems, canopy, with drogue, 4-6 person capacity, heavy loading.

### 7.3.2.3.5 Maritime Life Raft (deep ballast, canopy, 4-6 person, without drogue)

For this category the data sets of the 4-6 person deep draft life rafts without drogues that were lightly and heavily loaded were combined together. There was a considerable difference between the number of data points of the lightly loaded (2712) life rafts as compared to number of data points with heavily loaded (128) life rafts. With such a large difference between the two data sets, leeway equations were first algebraically combined. However it was found that unconstrained linear regressions on the combined data produced the same mean and had the added benefit of providing direct estimates of standard error,  $S_{y/x}$ . The results of the regressions are presented below.

The unconstrained linear regression of leeway speed versus 10-m wind speed along with the 95% prediction limits is shown in Figure 7-16. The unconstrained linear regression of downwind component of leeway versus 10-m wind speed along with the 95% prediction limits are shown in Figure 7-17.

The positive and negative crosswind components of leeway were based upon using the unconstrained linear regression of the combined data set for all 4-6 person deep-draft life rafts. All of the crosswind components separated by life raft sub-category versus 10-m wind speed are shown in Figure 7-18. The unconstrained linear regression of the positive and negative crosswind component of leeway versus  $W_{10m}$  are shown in Figure 7-19.

Statistics on the leeway angle for this category were computed using all wind speeds and a second time using only winds above 5.0 m/s.

#### Maritime Life Raft (deep ballast, canopy, 4-6 person, without drogue)

$$\begin{aligned} \text{Leeway speed} &= 3.79 \% W_{10m} - 2.1 \text{ cm/s} & S_{y/x} &= 4.4 \text{ cm/s} \\ \text{Leeway angle } (W_{10m} > 0 \text{ m/s}) &: \text{mean} = -2.2^\circ \text{ std. dev.} = 13^\circ \\ \text{Leeway angle } (W_{10m} > 5 \text{ m/s}) &: \text{mean} = -1.9^\circ \text{ std. dev.} = 10^\circ, \text{min.} = -28^\circ, \text{max} = 34^\circ \\ \text{DWL} &= 3.75 \% W_{10m} - 2.3 \text{ cm/s} & S_{y/x} &= 4.4 \text{ cm/s} \\ \text{+CWL} &= 0.78 \% W_{10m} - 3.6 \text{ cm/s} & S_{y/x} &= 3.6 \text{ cm/s} \\ \text{-CWL} &= -0.47 \% W_{10m} - 0.1 \text{ cm/s} & S_{y/x} &= 3.9 \text{ cm/s} \end{aligned}$$

### 7.3.2.3.6 Maritime Life Raft (deep ballast, canopy, 4-6 person, with drogue)

Within the combined data set of lightly and heavy loaded 4-6 person deep draft life rafts with drogues, there was sufficient parity of data point that statistics would not be affected by the combination. The number of data points of the lightly loaded (349 for leeway speed, 143 for leeway angle, **DWL** and **CWL**) life rafts compared well to number with heavily-loaded (580 and 284 respectively) life rafts. Unconstrained linear regression of leeway speed and the leeway components versus 10-m wind speed were performed on the combined data set.

In Figures 7-16 through 7-19 the unconstrained linear regression of the leeway speed and the components of leeway versus  $W_{10m}$  are presented for the 4-6 person life rafts with and without drogues.

The positive and negative crosswind components of leeway were based upon using the unconstrained linear regression of data set for all 4-6 person deep-draft life rafts. The unconstrained linear regression of the positive and negative crosswind component of leeway versus  $W_{10m}$  are shown in Figure 7-19 for drogued and undrogued life rafts.

Statistics on the leeway angle for this category were computed using all wind speeds and a second time using only winds above 5.0 m/s.

Maritime Life Raft (deep ballast, canopy, 4-6 person, with drogue)

$$\begin{aligned} \text{Leeway speed} &= 1.84 \% W_{10m} + 1.4 \text{ cm/s} & S_{y/x} &> 3.1 \text{ cm/s} \\ \text{Leeway angle } (W_{10m} > 0 \text{ m/s}) &: \text{mean} = + 1.9^\circ \text{ std. dev.} = 15^\circ \\ \text{Leeway angle } (W_{10m} > 5 \text{ m/s}) &: \text{mean} = + 8.0^\circ \text{ std. dev.} = 8^\circ, \text{ min.} = -15^\circ, \text{ max} = 28^\circ \\ \text{DWL} &= 1.91 \% W_{10m} + 0.9 \text{ cm/s} & S_{y/x} &= 1.6 \text{ cm/s} \\ \text{+CWL} &= 0.78 \% W_{10m} - 3.6 \text{ cm/s} & S_{y/x} &= 3.6 \text{ cm/s} \\ \text{-CWL} &= -0.47 \% W_{10m} - 0.1 \text{ cm/s} & S_{y/x} &= 3.9 \text{ cm/s} \end{aligned}$$

7.3.2.3.7 Maritime Life Raft (deep ballast, canopy, 4-6 person)

For this category the data sets of the four sub-categories, 4-6 person deep draft life rafts with and without drogues that were lightly and heavily loaded were combined together. This produced a data set that contained 3,769 ten-minute samples of leeway speed and 3,267 samples of leeway angle, downwind and crosswind components of leeway. This represents more than 26.2 and 22.7 days of leeway samples, respectively.

The unconstrained linear regression of leeway speed versus 10-m wind speed along with the 95% prediction limits are shown in Figure 7-20. The unconstrained linear regression of downwind component of leeway versus 10-m wind speed along with the 95% prediction limits are shown in Figure 7-21.

Crosswind components were separated by drift runs into positive and negative crosswind components. Unconstrained linear regression of the positive and negative crosswind components versus 10-m wind speed along with the 95% prediction limits are shown in Figure 7-19.

Statistics on the leeway angle for this category were computed using all wind speeds and a second time using only winds above 5.0 m/s.

Maritime Life Raft (deep ballast, canopy, 4-6 person)

Leeway speed =  $2.87 \% W_{10m} + 2.0$  cm/s       $Sy/x = 8.6$  cm/s

Leeway angle ( $W_{10m} > 0$  m/s): mean =  $-1.7^\circ$  std. dev. =  $14^\circ$

Leeway angle ( $W_{10m} > 5$  m/s): mean =  $-0.7^\circ$  std. dev. =  $10^\circ$ , min. =  $-28^\circ$ , max =  $34^\circ$

**DWL** =  $3.50 \% W_{10m} - 1.8$  cm/s       $Sy/x = 6.4$  cm/s

**+CWL** =  $0.78 \% W_{10m} - 3.6$  cm/s       $Sy/x = 3.6$  cm/s

**-CWL** =  $-0.47 \% W_{10m} - 0.1$  cm/s       $Sy/x = 3.9$  cm/s

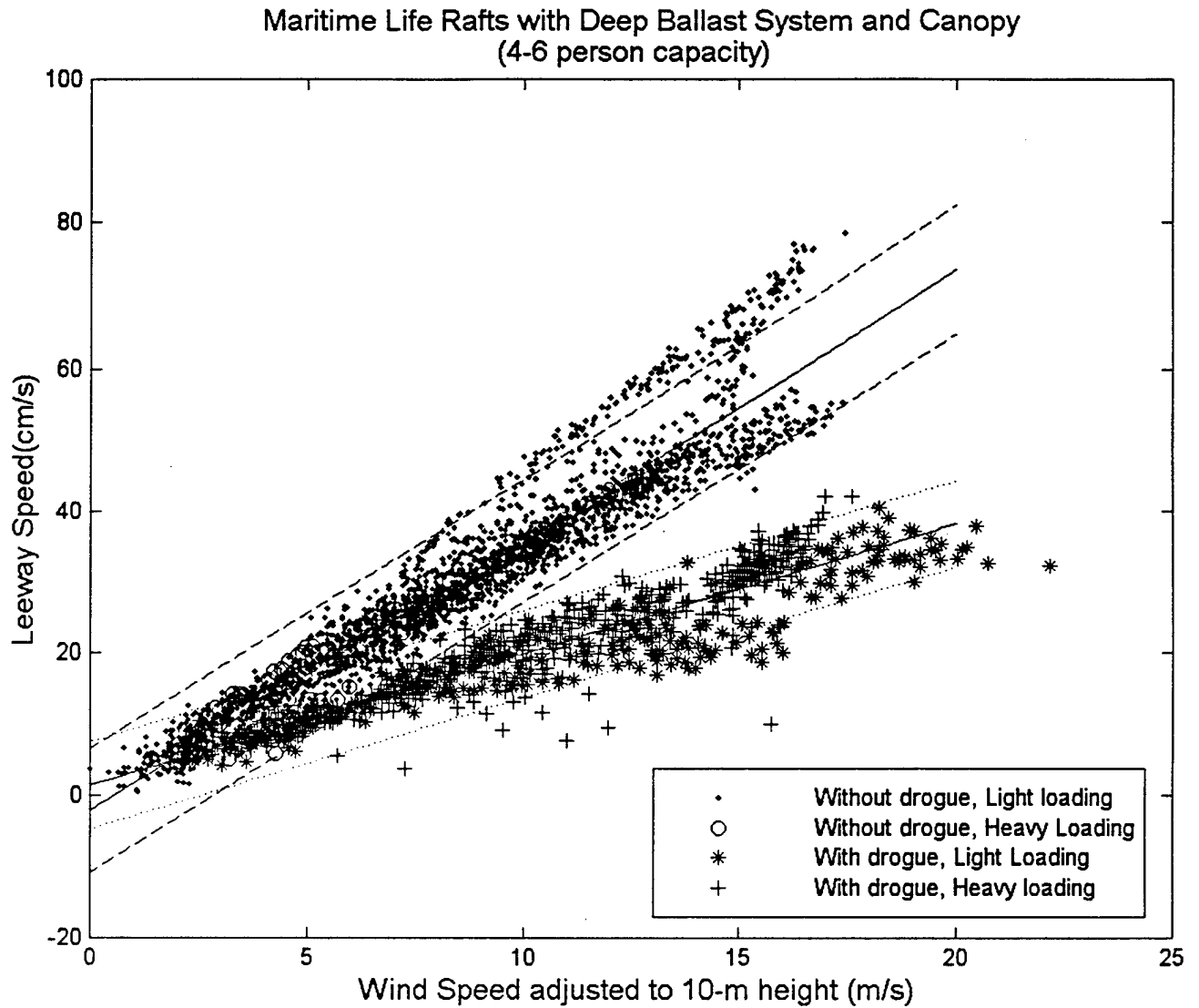

Figure 7-16. The Unconstrained Linear Regressions and 95% Prediction Limits of the Leeway Speed versus Wind Speed at 10 m, Maritime Life Rafts, deep ballast systems, canopy, 4-6 person capacity. Upper regression line is for life rafts without drogues both light and heavy loading combined. Lower regression line is for life rafts with drogue both light and heavy loading combined.

Maritime Life Rafts with Deep Ballast System and Canopy  
(Light loading)

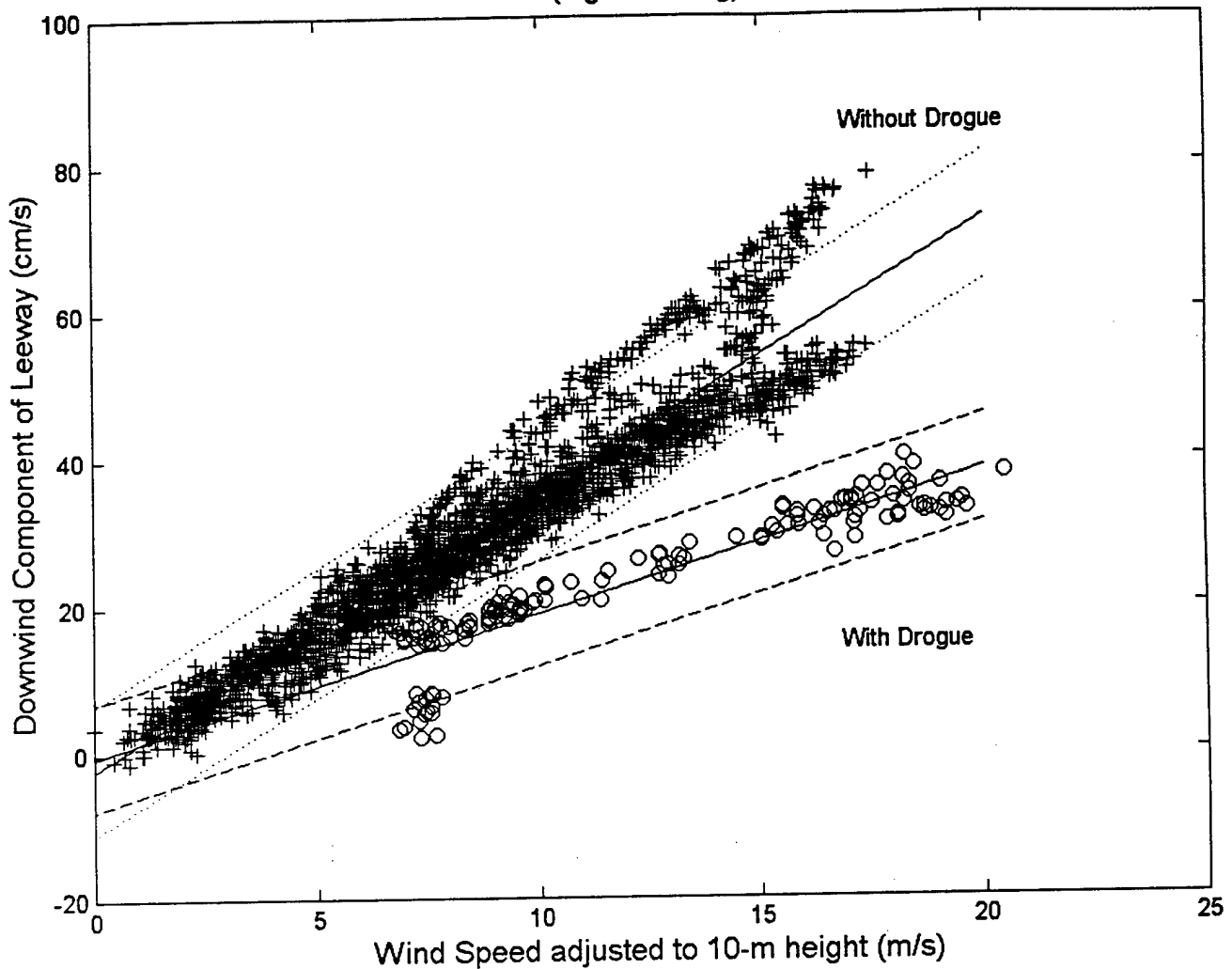

Figure 7-17. The Unconstrained Linear Regressions and 95% Prediction Limits of the Downwind Component of Leeway versus Wind Speed at 10 m, Maritime Life Rafts, deep ballast systems, canopy, 4-6 person capacity. Upper regression line is for life rafts without drogues both light and heavy loading combined. Lower regression line is for life rafts with drogue both light and heavy loading combined.

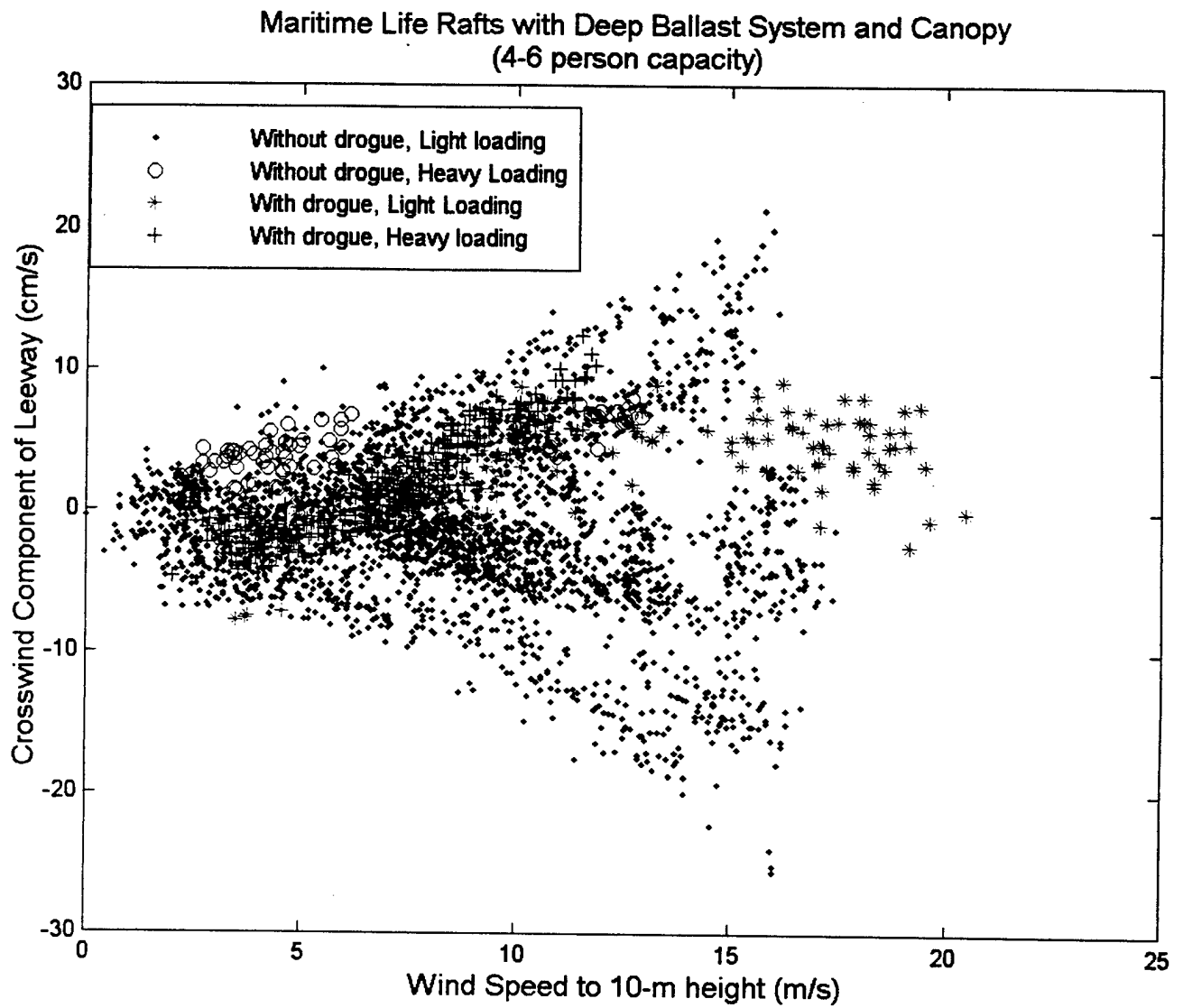

Figure 7-18. The Crosswind Component of Leeway versus Wind Speed at 10 m, Maritime Life Rafts, deep ballast systems, canopy, 4-6 person capacity; with drogue with light and heavy loading, and without drogue with light and heavy loading.



Maritime Life Rafts with Deep Ballast System and Canopy  
(4-6 person capacity)

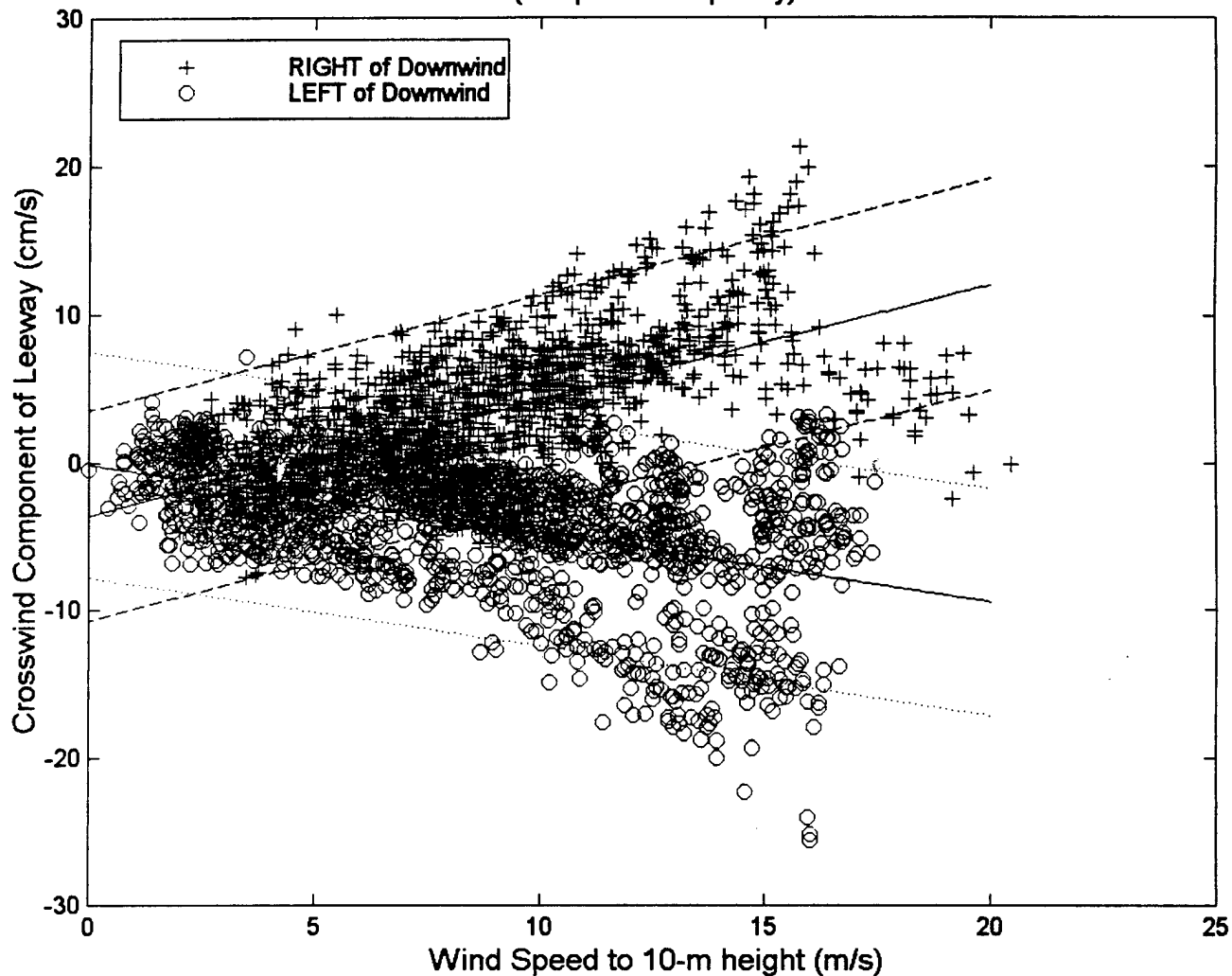

Figure 7-19. The Unconstrained Linear Regression and 95% Prediction Limits of the Positive and Negative Crosswind Component of Leeway versus Wind Speed at 10 m, Maritime Life Rafts, deep ballast systems, canopy, 4-6 person capacity.

Maritime Life Rafts with Deep Ballast System and Canopy  
(4-6 person capacity)

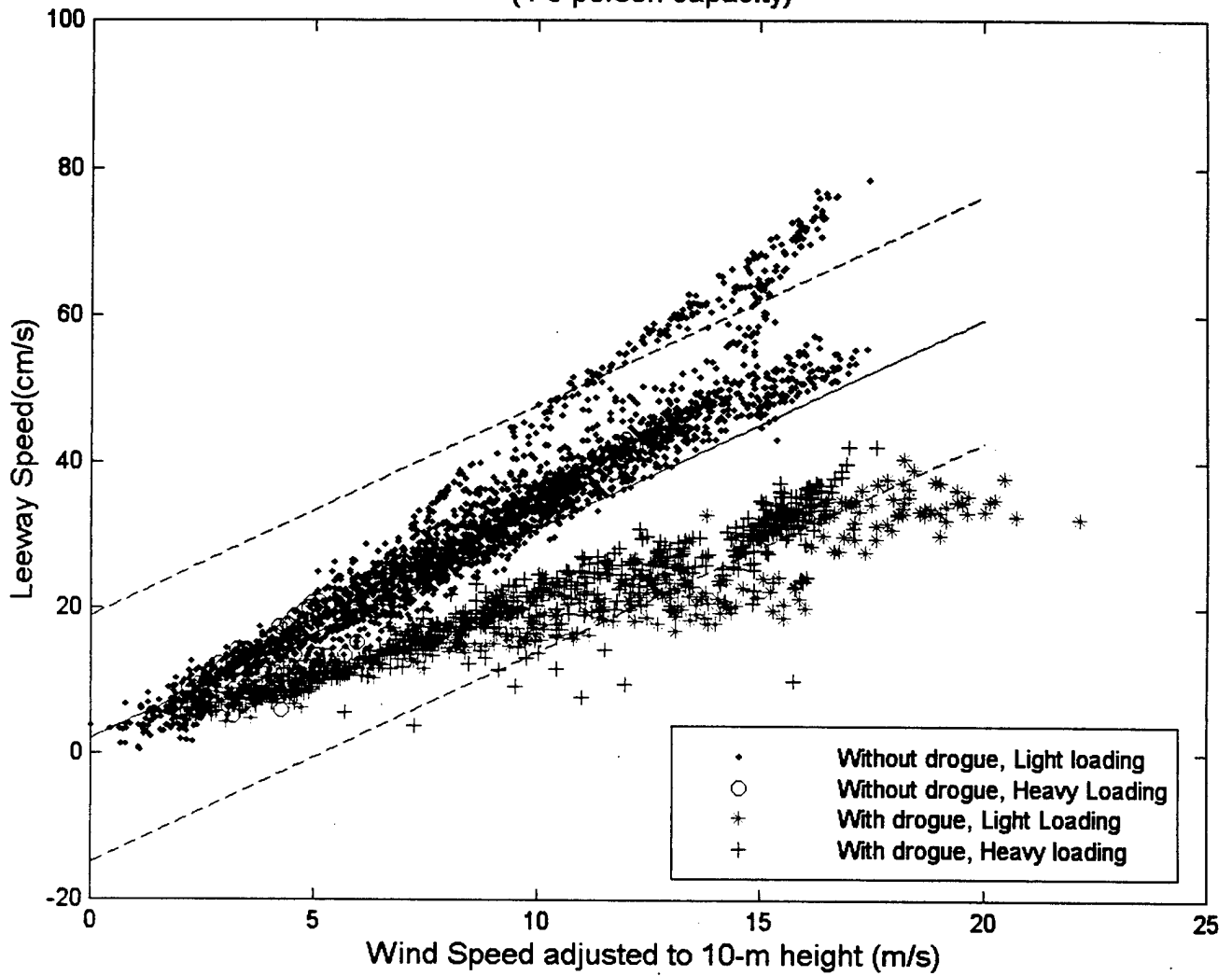

Figure 7-20. The Unconstrained Linear Regression and 95% Prediction Limits of the Leeway Speed versus Wind Speed at 10 m, Maritime Life Rafts, deep ballast systems, canopy, 4-6 person capacity.

Maritime Life Rafts with Deep Ballast System and Canopy  
(4-6 person capacity)

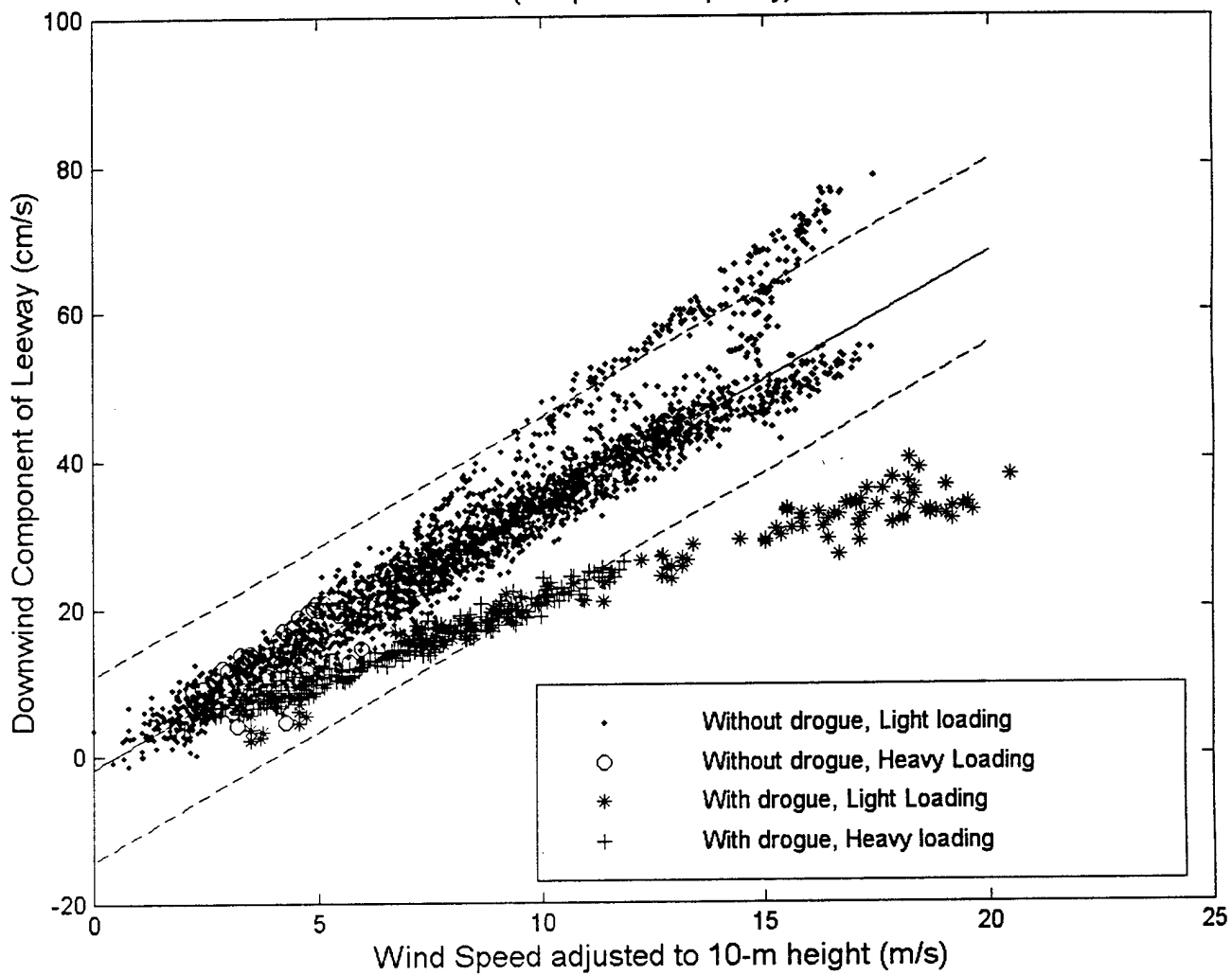

Figure 7-21. The Unconstrained Linear Regressions and 95% Prediction Limits of the Downwind Component of Leeway versus Wind Speed at 10 m, Maritime Life Rafts, deep ballast systems, canopy, 4-6 person capacity.

### 7.3.2.3.8 Maritime Life Raft (deep ballast, canopy, 15-25 person)

A Beaufort 20-person circular life raft was drifted six times, three times with light loading and no drogue (runs 37, 43, and 48) and three with heavy loading with a drogue deployed (runs 40, 42, and 47). For this category leeway there is sufficient parity between the number of data points lightly-loaded and without drogue (816) compared to number with heavily-loaded and with drogue (794) that the two data sets were combined for a total of 1610 ten-minute samples, or about 11.2 days of data. In Figures 7-22 and 7-23, the unconstrained linear regression of the leeway speed and the downwind component of leeway versus  $W_{10m}$  are presented for the 15-25 person life rafts.

The crosswind components (separated by life raft loading) versus  $W_{10m}$  are presented in Figure 7-24. Following the same procedure as in Chapter 3 for the Tulmar life raft, the crosswind components were separated by drift runs into positive and negative components. However, during drift run 47, the life raft started with a negative component of crosswind and after 32.0 hours, within a single 10-minute sample period, switched to positive crosswind components for the remainder of the drift run. Therefore run 47 was divided into two sections before being used in the crosswind regression. The unconstrained linear regressions of positive and negative crosswind components of leeway versus  $W_{10m}$  along with the 95% prediction limits are shown in Figure 7-25.

Statistics on the leeway angle for this category were computed using all wind speeds and a second time using only winds above 5.0 m/s.

#### Maritime Life Raft (deep ballast, canopy, 15-25 person)

$$\text{Leeway speed} = 3.64 \% W_{10m} - 4.37 \text{ cm/s} \quad S_{y/x} = 5.37 \text{ cm/s}$$

$$\text{Leeway angle}(W_{10m} > 0 \text{ m/s}): \text{mean} = -1.1^\circ \text{ std. dev.} = 14.1^\circ$$

$$\text{Leeway angle}(W_{10m} > 5 \text{ m/s}): \text{mean} = -1.3^\circ, \text{std. dev.} = 7.1^\circ, \text{min} = -21^\circ, \text{max} = 30^\circ$$

$$\text{DWL} = 3.68 \% W_{10m} - 4.96 \text{ cm/s} \quad S_{y/x} = 5.37 \text{ cm/s}$$

$$+\text{CWL} = 0.34 \% W_{10m} - 1.85 \text{ cm/s} \quad S_{y/x} > 2.50 \text{ cm/s}$$

$$-\text{CWL} = -0.49 \% W_{10m} + 1.58 \text{ cm/s} \quad S_{y/x} > 2.63 \text{ cm/s}$$

Maritime Life Rafts with Deep Ballast System and Canopy  
(15-25 person)

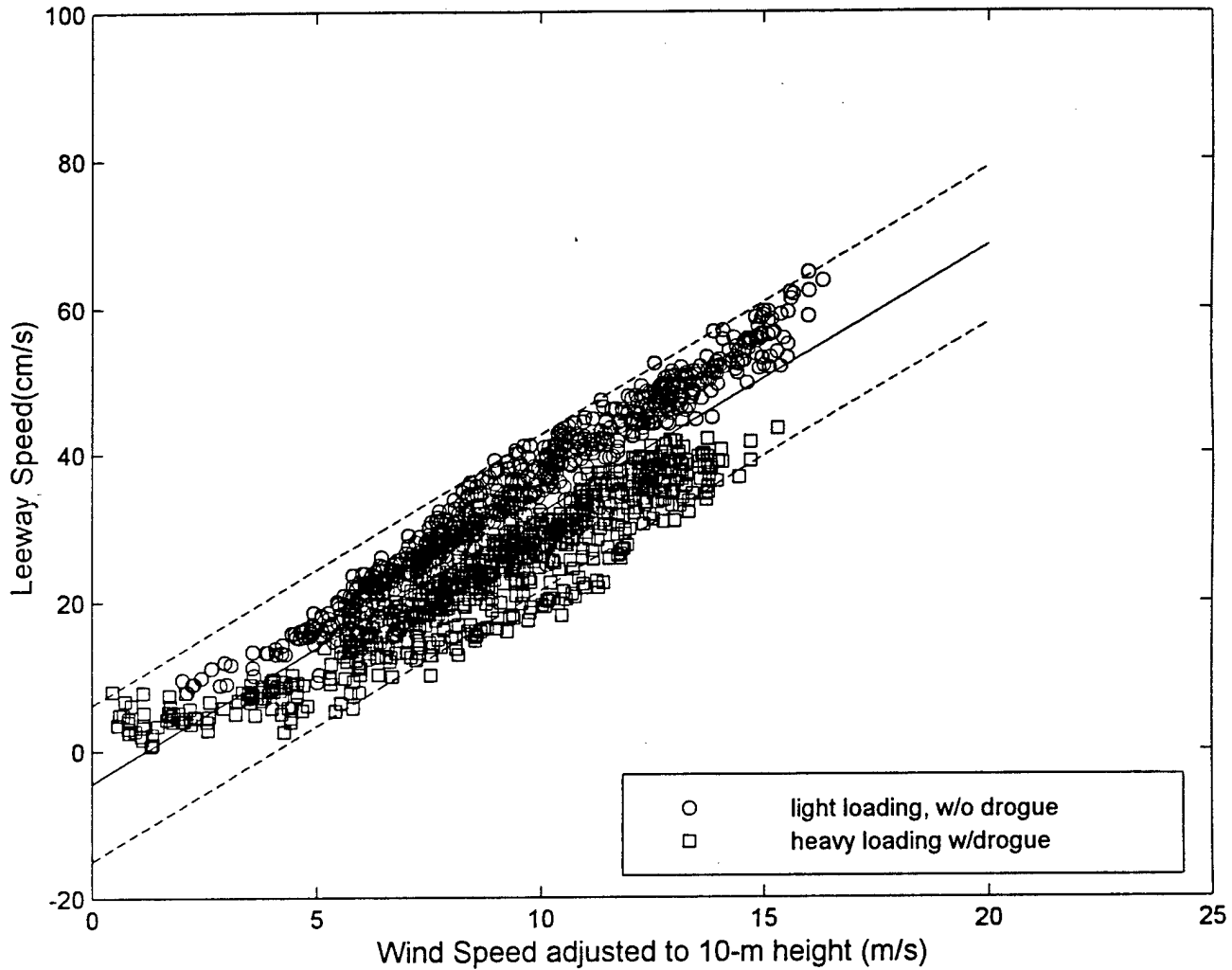

Figure 7-22. The Unconstrained Linear Regression and 95% Prediction Limits of the Leeway Speed versus Wind Speed at 10 m, Maritime Life Rafts, deep ballast systems, canopy, 15-25 person capacity.

Maritime Life Rafts with Deep Ballast System and Canopy  
(15-25 person)

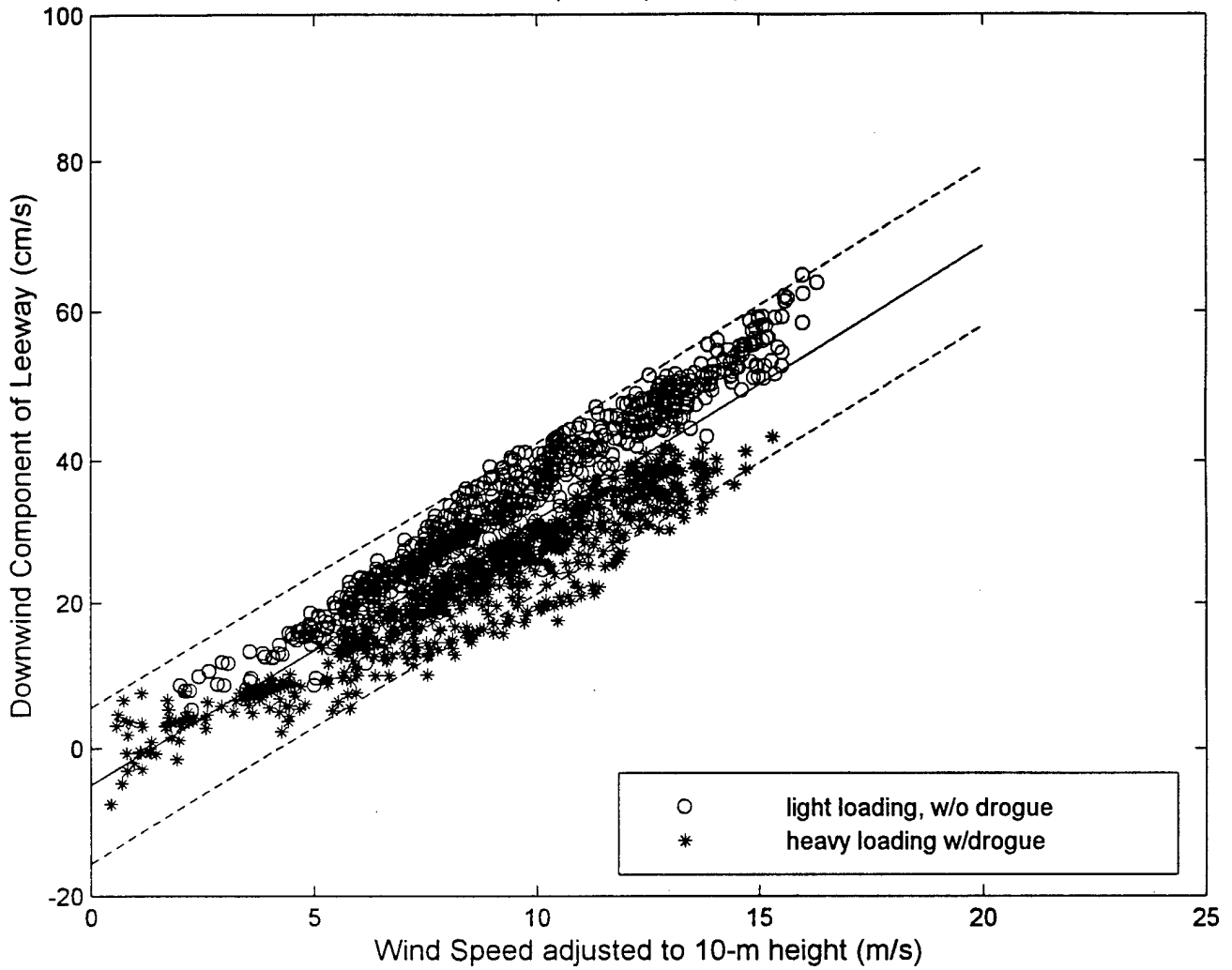

Figure 7-23. The Unconstrained Linear Regression and 95% Prediction Limits of the Downwind Component of Leeway versus Wind Speed at 10 m, Maritime Life Rafts, deep ballast systems, canopy, 15-25 person capacity.

Maritime Life Rafts with Deep Ballast System and Canopy  
(15-25 person)

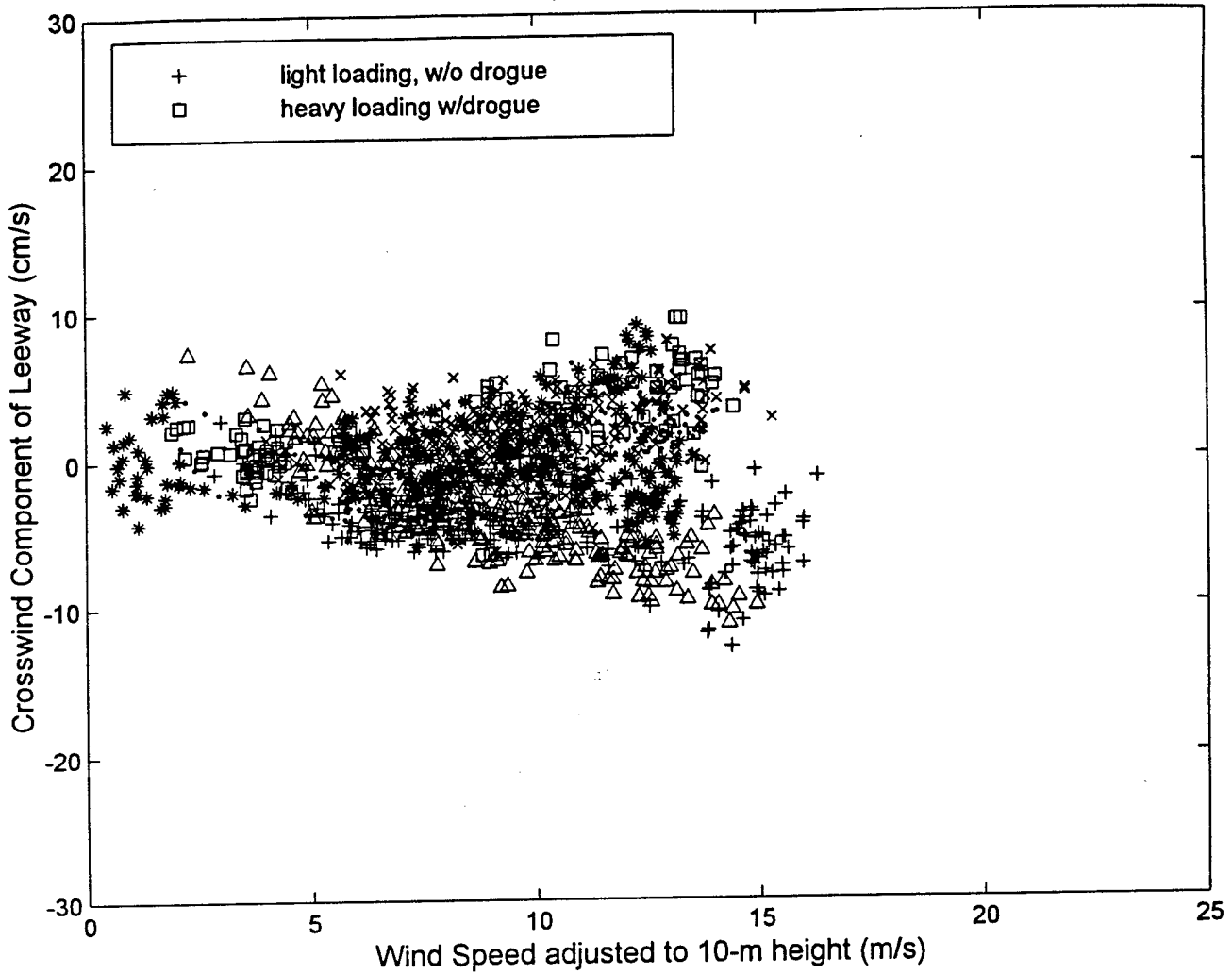

Figure 7-24. The Crosswind Component of Leeway versus Wind Speed at 10 m, Maritime Life Rafts, deep ballast systems, 15-25 person capacity.

Maritime Life Rafts with Deep Ballast System and Canopy  
(15-25 person)

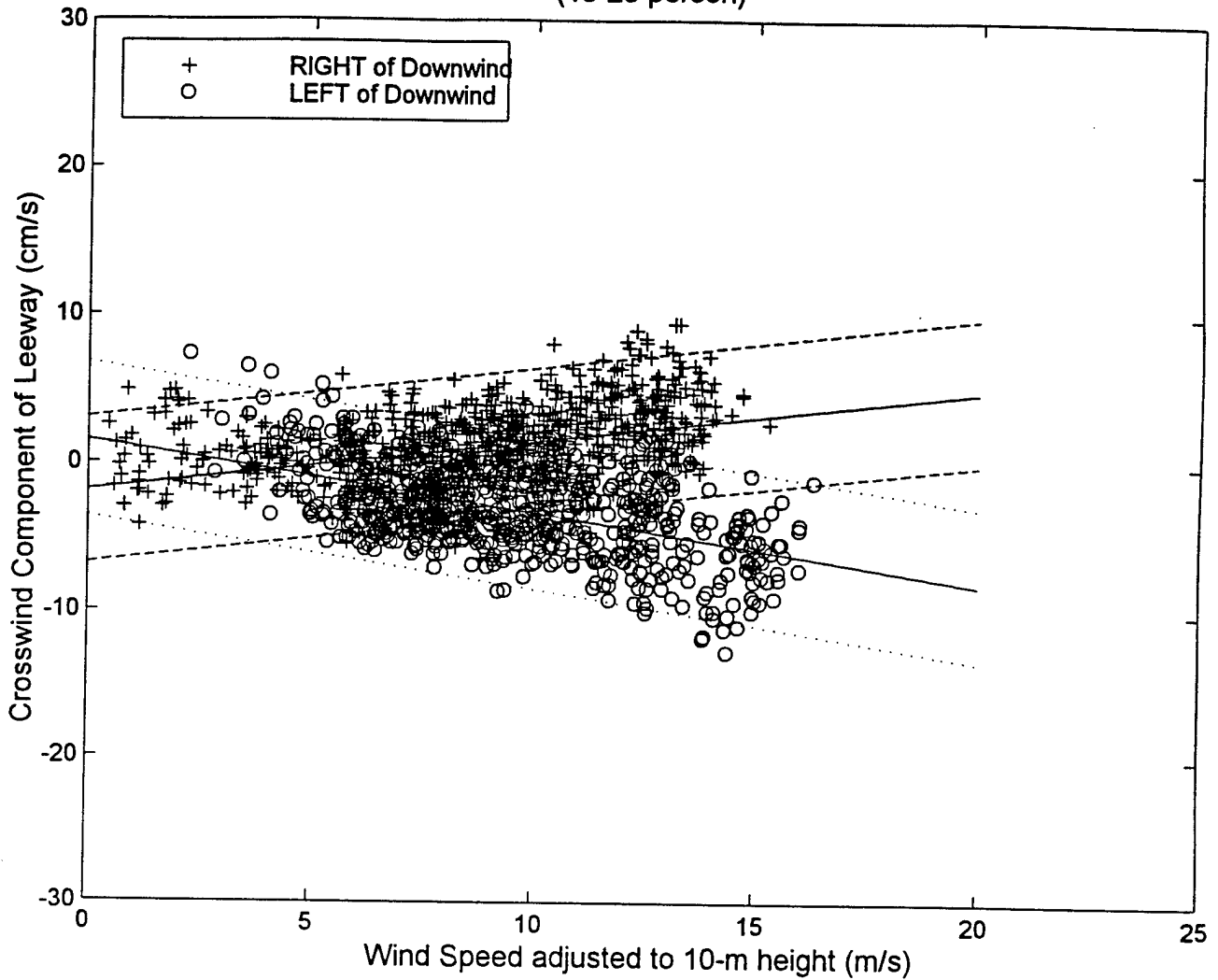

Figure 7-25. The Unconstrained Linear Regression and 95% Prediction Limits of the Positive and Negative Crosswind Components of Leeway versus Wind Speed at 10 m, Maritime Life Rafts, deep ballast systems, canopy, 15-25 person capacity.



### 7.3.2.3.9 Maritime Life Raft (deep ballast, canopy)

For this category the data sets of the six sub-categories were combined together. Four were 4-6 person deep draft life rafts with and without drogues that were lightly and heavily loaded and two were 15-25 person life rafts heavy loaded with drogue and lightly loaded without drogue. This produced a data set containing 5,379 ten-minute leeway speed data points and 4,877 samples of leeway angle, downwind and crosswind components of leeway. This represents more than 37.4 and 33.9 days of leeway samples, respectively.

The unconstrained linear regression of leeway speed versus 10-m wind speed along with the 95% prediction limits are shown in Figure 7-26. The unconstrained linear regression of downwind component of leeway versus 10-m wind speed along with the 95% prediction limits are shown in Figure 7-27.

The crosswind components of leeway separated by life raft capacity are shown in Figure 7-28. Crosswind components were then separated by drift runs into positive and negative crosswind components. Unconstrained linear regression of the positive and negative crosswind components versus 10-m wind speed along with the 95% prediction limits are shown in Figure 7-29.

Statistics on the leeway angle for this category were computed using all wind speeds and a second time using only winds above 5.0 m/s.

#### Maritime Life Raft (deep ballast, canopy)

$$\text{Leeway speed} = 3.02 \% W_{10m} + 0.8 \text{ cm/s} \quad S_{y/x} = 7.9 \text{ cm/s}$$

$$\text{Leeway angle}(W_{10m} > 0 \text{ m/s}): \text{mean} = -1.5^\circ \text{ std. dev.} = 14^\circ$$

$$\text{Leeway angle}(W_{10m} > 5 \text{ m/s}): \text{mean} = -1.0^\circ \text{ std. dev.} = 9^\circ, \text{min.} = -28^\circ, \text{max} = 34^\circ$$

$$\text{DWL} = 3.52 \% W_{10m} - 2.5 \text{ cm/s} \quad S_{y/x} = 6.1 \text{ cm/s}$$

$$+\text{CWL} = 0.62 \% W_{10m} - 3.0 \text{ cm/s} \quad S_{y/x} = 3.5 \text{ cm/s}$$

$$-\text{CWL} = -0.45 \% W_{10m} - 0.2 \text{ cm/s} \quad S_{y/x} = 3.6 \text{ cm/s}$$

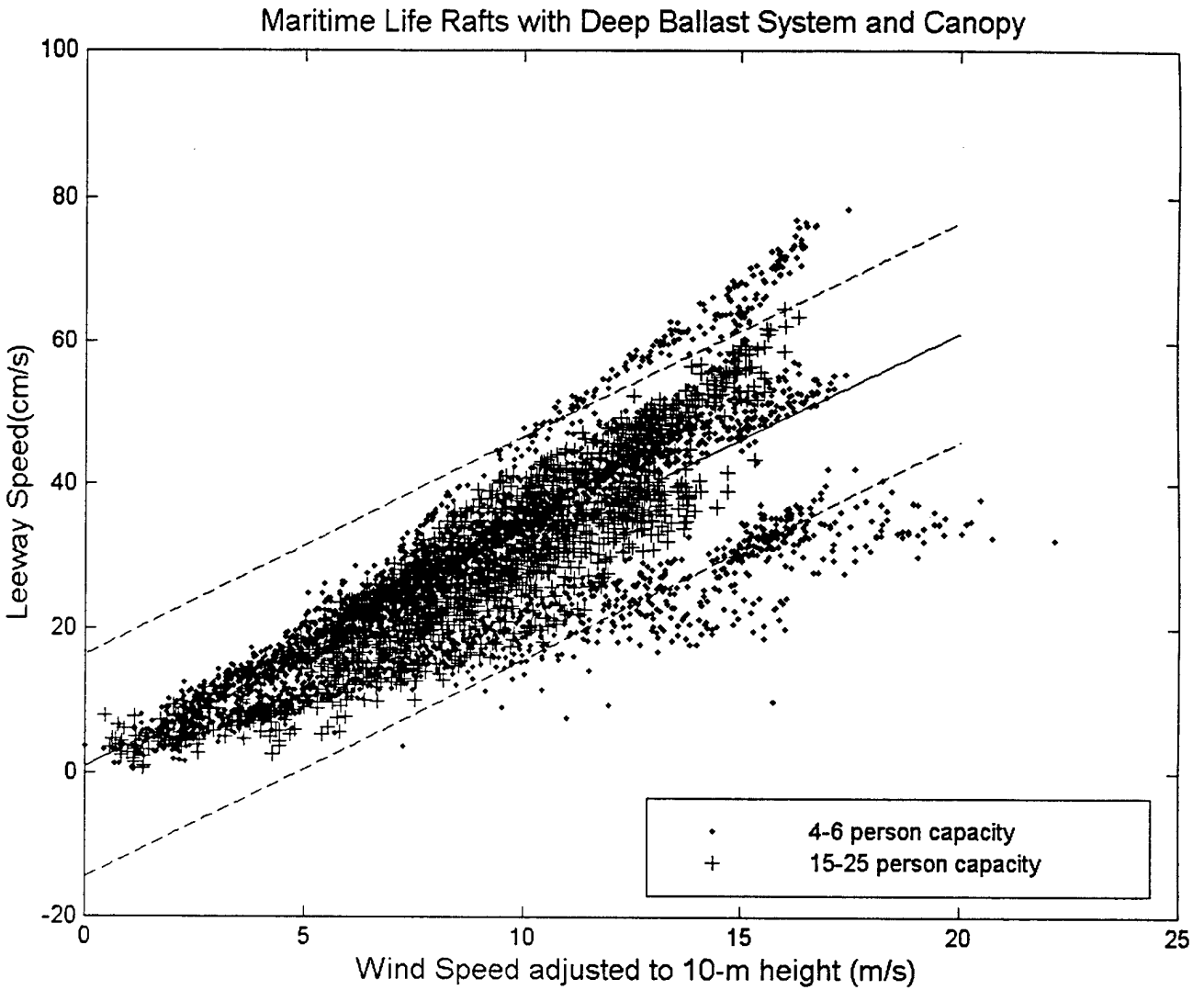

Figure 7-26. The Unconstrained Linear Regression and 95% Prediction Limits of the Leeway Speed versus Wind Speed at 10 m, Maritime Life Rafts, deep ballast systems and canopy.

### Maritime Life Rafts with Deep Ballast System and Canopy

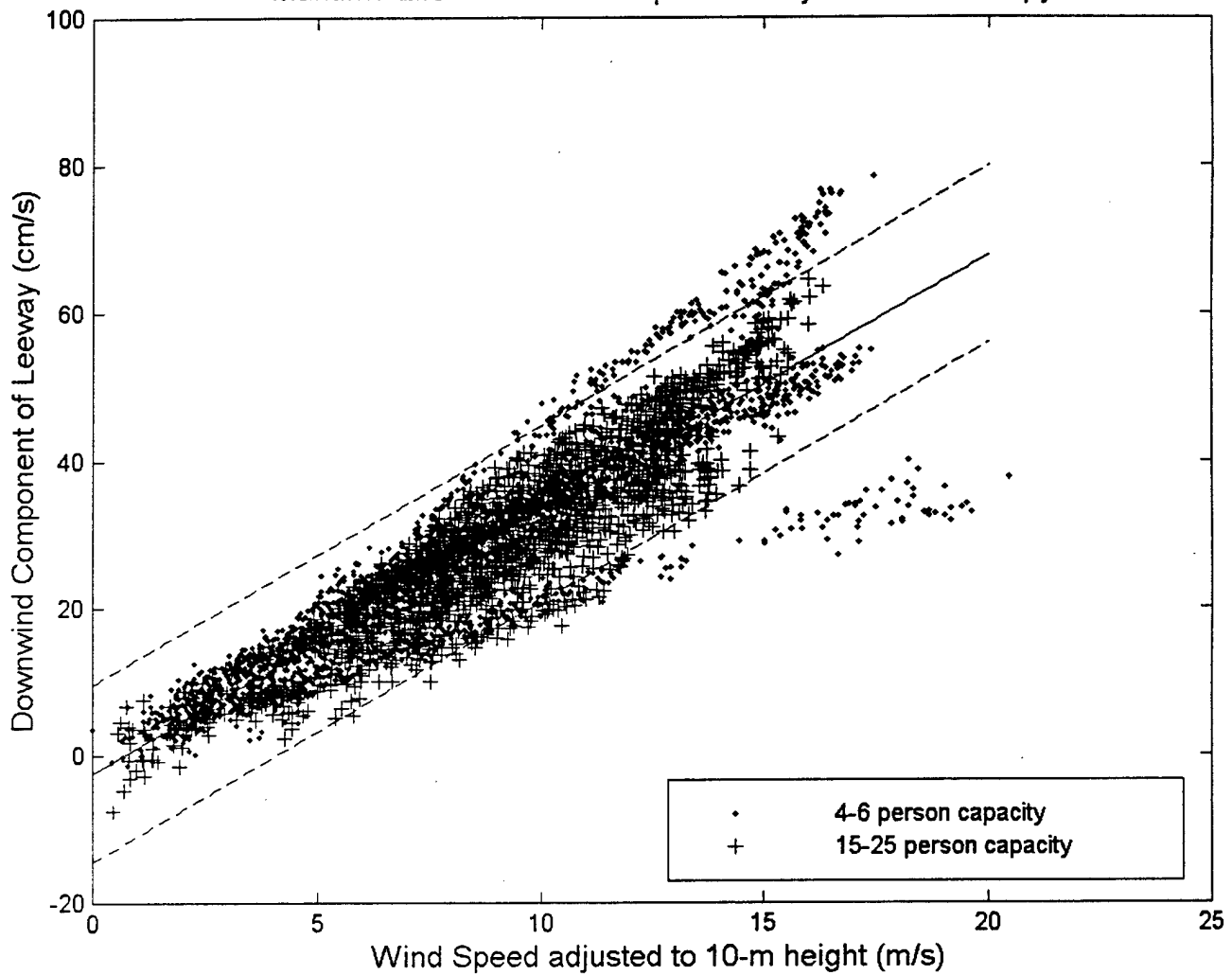

Figure 7-27. The Unconstrained Linear Regression and 95% Prediction Limits of the Downwind Component of Leeway versus Wind Speed at 10 m, Maritime Life Rafts, deep ballast systems and canopy.

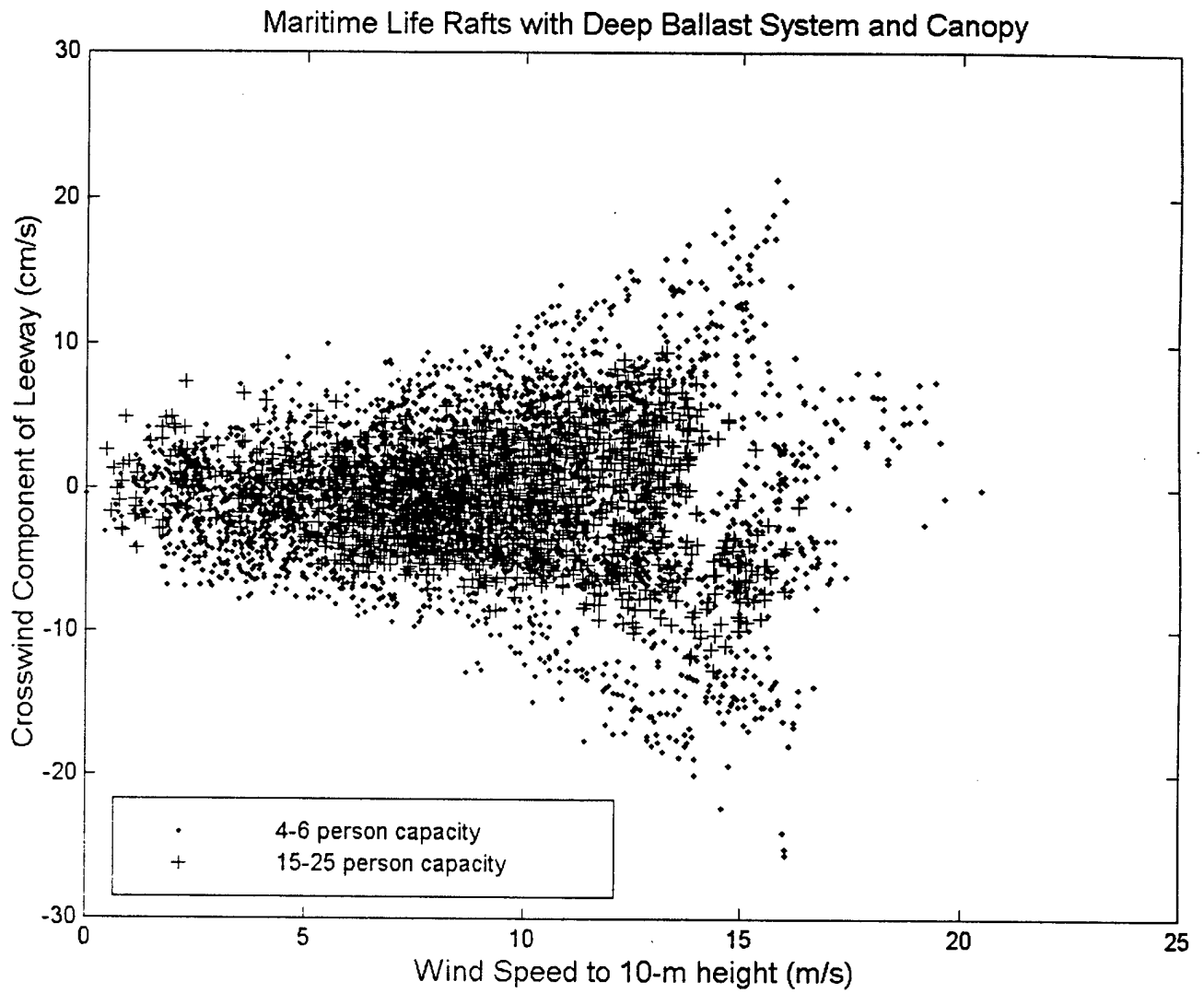

Figure 7-28. The Crosswind Component of Leeway versus Wind Speed at 10 m, Maritime Life Rafts, deep ballast systems and canopy.

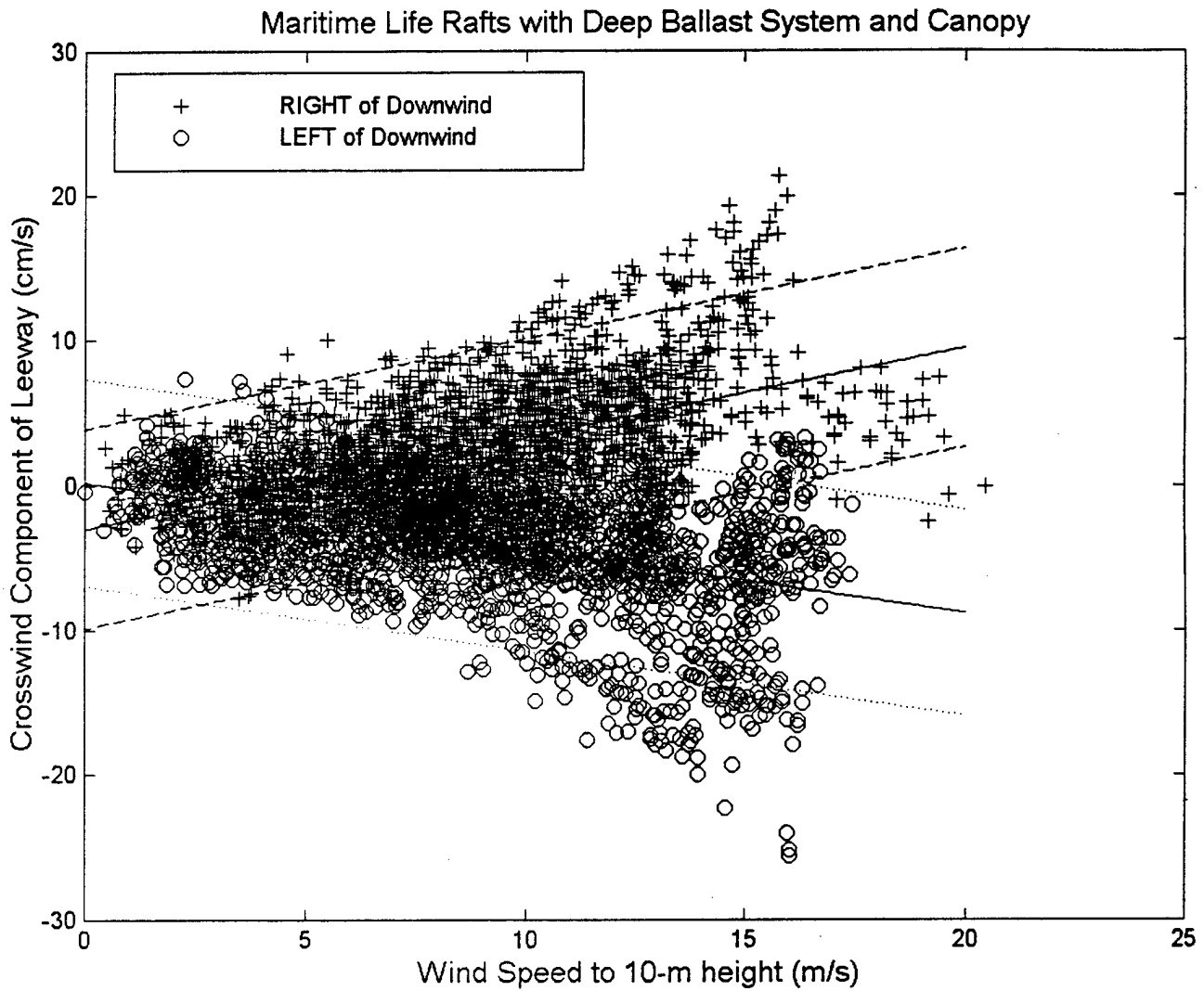

Figure 7-29. The Unconstrained Linear Regression and 95% Prediction Limits of the Positive and Negative Crosswind Components of Leeway versus Wind Speed at 10 m, Maritime Life Rafts, deep ballast systems and canopy.

### 7.3.3 Commercial Fishing Vessels

The leeway category Commercial Fishing Vessel has five different studies of five different kinds of commercial fishing vessels. There are equations for leeway speed versus wind speed for these five vessels. These five equations algebraically combined as follows: The five equations were summed and divided by five. Standard errors were assigned values according to the rules outlined in section 7.2.

Sampans	=	4.0 %	$W_{10m} + 0.0 \text{ cm/s}$	> 10 cm/s	$S_{y/x}$
Side-stern troller	=	4.2 %	$W_{10m} + 0.0 \text{ cm/s}$	> 10 cm/s	$S_{y/x}$
Longliner	=	3.7 %	$W_{10m} + 0.0 \text{ cm/s}$	> 10 cm/s	$S_{y/x}$
Korean F/V	=	2.66 %	$W_{10m} + 4.9 \text{ cm/s}$	3.9 cm/s	$S_{y/x}$
<u>Gill-netter</u>	=	<u>3.98 %</u>	<u><math>W_{10m} + 0.31 \text{ cm/s}</math></u>	<u>3.0 cm/s</u>	<u><math>S_{y/x}</math></u>
F/V combined	=	3.7 %	$W_{10m} + 1.0 \text{ cm/s}$	> 15 cm/s	$S_{y/x}$

### 7.3.4 Medical Waste

The leeway category Medical Waste has two sub-categories; Vials and Syringes, which are further divided by size, large and small. There are equations for leeway speed versus wind speed for these four leeway objects. These four equations algebraically combined as follows: The two equations for Vials were averaged and the two equations for Syringes were averaged, then these two sub-categories were combined for the Medical Waste category. Standard errors were assigned values according to the rules outlined in section 7.2.

Large Vials	=	4.4 %	$W_{10m} + 0.0 \text{ cm/s}$	> 10 cm/s	$S_{y/x}$
<u>Small Vials</u>	=	<u>3.0 %</u>	<u><math>W_{10m} + 0.0 \text{ cm/s}</math></u>	<u>&gt; 10 cm/s</u>	<u><math>S_{y/x}</math></u>
Vials	=	3.7 %	$W_{10m} + 0.0 \text{ cm/s}$	> 15 cm/s	$S_{y/x}$

Large Syringes	=	1.8 %	$W_{10m} + 0.0 \text{ cm/s}$	> 10 cm/s	$S_{y/x}$
<u>Small Syringes</u>	=	<u>1.8 %</u>	<u><math>W_{10m} + 0.0 \text{ cm/s}</math></u>	<u>&gt; 10 cm/s</u>	<u><math>S_{y/x}</math></u>
Syringes	=	1.8 %	$W_{10m} + 0.0 \text{ cm/s}$	> 15 cm/s	$S_{y/x}$

Vials	=	3.7 %	$W_{10m} + 0.0 \text{ cm/s}$	> 10 cm/s	$S_{y/x}$
<u>Syringes</u>	=	<u>1.8 %</u>	<u><math>W_{10m} + 0.0 \text{ cm/s}</math></u>	<u>&gt; 10 cm/s</u>	<u><math>S_{y/x}</math></u>
Medical Waste	=	2.8 %	$W_{10m} + 0.0 \text{ cm/s}$	> 15 cm/s	$S_{y/x}$

#### 7.4 LIMITATIONS OF THE ANALYSES OF COMBINED CLASSES

There are two major limitations to the analyses conducted in section 7.3. The weighting was done by available data, not by relative occurrence of life raft types in the general population. As yet, we have not conducted a census of the population of life rafts by leeway characteristics; however after such a census is conducted, it might be possible to provide appropriate weighting factors when combining life raft classes. This is the primary reason why values were not combined across all life raft classes.

The linear regression statistical methods used do not adequately account for the different slopes of the leeway values versus wind speed when multiple craft are included into a single leeway category. The 95% prediction limits about the mean regression lines (see Figures 7-1, 7-2, 7-4, 7-16, 7-17, 7-19, 7-20, 7-21, 7-26, 7-27, and 7-29) tend to overestimate the observed variance at low winds speeds ( $< 5$  m/s) and underestimate the variance at higher wind speeds ( $>15$  m/s). Thus the modeling of leeway variance by a simple offset (as the model AP98 does) does not include the all of the variance for a combined leeway category.

Both of these limitations are presently being addressed. A census of life rafts manufactured in the US will be conducted to provide some estimates of the relative frequency of life rafts as described by the leeway taxonomy. This census will provide the relative occurrence of life rafts by make and manufacturer, thus allowing us to make reasonable weighting estimates across life raft leeway categories. The life raft census should tell us which are the most common of the life rafts. When that information is compared to what life rafts have been studied, it should be clear which life rafts still need to be studied.

AP98 was developed to capture the variance of a single-craft leeway data set. It is clear from the many examples presented in section 7-3 that AP98 needs further modification to adequately model the variance of a multi-craft leeway data set. The successor to AP98 will include slope, as well as y-intercept, offset terms to reflect the spreading of data points about the mean regression line at higher wind speeds. This model is presently in development and will be presented in a future report.

[BLANK]



## CHAPTER 8

### SUMMARY AND RECOMMENDATIONS

#### 8.1 INTRODUCTION

Leeway has been studied since World War II; however, recent studies conducted in the 1990's have provided a number of new and improved leeway data sets on a variety of SAR craft. In the spirit of cost/benefit analysis, questions about leeway were addressed to USCG Research and Development Center's Improvement in Search and Rescue Capabilities program on leeway. This report was motivated by these questions.

- 1) *Which leeway targets have been studied? (For what targets do we have data?)*
- 2) *What methods were used in each leeway field study? (How good is that data?)*
- 3) *What is the present level of understanding of leeway behavior?*
- 4) *How can we model the present level of understanding of leeway behavior?*
- 5) *What is present leeway guidance for search planning?*
- 6) *How does the present leeway guidance compare to the new models of leeway behavior?*
- 7) *What classes of leeway targets should be included in our search planning tools?*
- 8) *Are there new broader categories of search objects within the leeway taxonomy for which leeway equations can be generated from the available data?*
- 9) *What are the recommendations for leeway guidance for search planning tools?*

This report addresses these nine questions. The answers given in this report reflect the status of the field of leeway in 1998. The answers to the above questions will continue to change as further knowledge is gained in this field. This report will need to be periodically updated.

#### 8.2 SUMMARY

- 1) *Which leeway targets have been studied? (For what targets do we have data?)*

Ninety-five leeway target types have been studied during twenty-five field studies. Thirty-eight life rafts, fourteen small craft (mostly outboards), and ten fishing vessels have been studied. Other leeway target types studied include surfboards, sailboats, life capsule, Cuban refugee raft, fishing vessel boating debris, and PIWs. Table 2-3 lists leeway studies and the provided descriptions of target craft used. Illustrations are available for thirty-four of the research leeway targets and they are shown in Figures 2-1 through 2-34. There are two trends occurring in regards to leeway targets since World War II. First, the completeness of the descriptions of the targets has greatly improved from merely providing the model type of the target to providing line drawings with dimensions. Hopefully, this trend will continue to improve until full 3-D numerical models of the targets are available. The second trend is SAR targets have themselves been evolving over the years. For example, life rafts have been improved by the

addition of full canopies and extensive ballast systems so that they are quite different from the old World War II rubber raft.

2) *What methods were used in each leeway field study? (How good is that data?)*

Two basic methods of measuring leeway have been used: indirect and direct. The indirect method was used by seventeen studies to generate most of the original guidance for search planning. This method consists of setting out leeway targets near a current drifter or drifters and measuring the on-scene winds. Then the drift of the current drifter(s) is subtracted from the total displacement of the leeway target to estimate the leeway portion of the motion. The accuracy and precision of this method is dependent on the quality of the surface drifter and the navigation used to position the surface drifter and leeway targets. The indirect method requires constant maintenance of the leeway targets and drifters, as they tend to separate. Thus, this method generally produced data only for light to moderate winds. The indirect method produced reasonable estimates of the leeway rates of many common SAR targets. However, the results of the indirect method often contained too much noise in the directions of wind and leeway to provide useful guidance on the leeway angle or divergence from the downwind direction.

In the 1990's, the direct method of measuring leeway using internally recording current meters directly attached to the SAR craft was introduced and calibrated against the indirect method. The new current meters combined with wind monitoring systems that vector average over 10-minute samples, data loggers for GPS positions, and satellite beacons allowed the deployment of leeway targets before a storm and their recovery after the storm, with leeway data recorded throughout the storm. The results were long, continuous records of leeway up and through the high wind conditions that are of most interest to SAR planning. There have been eight studies using the direct method with internally recording current meters.

3) *What is the present level of understanding of leeway behavior?*

The following survivor craft leeway behavior has been observed in recent leeway data sets: the divergence of the craft from the downwind direction, the relative wind direction and changes in relative wind direction which lead to changes in sign of the divergence (jibbing), capsizing, and swamping of the target. With larger leeway data sets on a single target type, the difference between positive and negative crosswind components as functions of wind speed are apparent. The downwind component of leeway is higher during rising winds than falling winds at a given wind speed.

4) *How can we model the present level of understanding of leeway behavior?*

A new model of leeway behavior is introduced in Chapter 4. It uses the linear regression equations and variance of both the downwind and crosswind components of leeway to model the leeway of the targets. This third generation model of leeway drift area is called AP98. A modification to the Geographic Display Operations Computer (GDOC) Automated Manual Method (AMM) that varies the drift error factor as a simple function of wind speed and

quality of the leeway equations for that target type is also proposed . A sensitivity study of leeway drift areas of AP98, Computer Assisted Search Planning (CASP) present version (1.1X), and GDOC AMM (original and modified) is presented as justification for the modification proposed to GDOC AMM.

5) *What is present leeway guidance for search planning?*

The leeway guidance provided by the National SAR Manual, GDOC AMM, CASP present version (1.1X) and proposed upgrade (2.0), and the Canadian Coast Guard's search planning tool (CANSARP), is reviewed in Chapter 4. The guidance provided by these search planning tools is restricted to leeway rate for a limited number of target classes, based primarily upon Chapline's (1960) study. Additional guidance for life rafts was added by several studies in the 1970s and 1980s. The very limited guidance on leeway angle or divergence is based upon Hufford and Broida's (1974) report on four small craft (12-21 foot outboards).

6) *How does the present leeway guidance compare to the new models of leeway behavior?*

Significant reductions in search area size were achieved by the third generation leeway search area model AP98 as compared to the first generation leeway search area model of GDOC and the second generation model of CASP 1.1X.

7) *What classes of leeway targets should be included in our search planning tools?*

A systematic categorization of the possible targets of interest to the Coast Guard is presented as a leeway taxonomy in Chapter 6. The leeway taxonomy is based upon rules that describe the target and help guide the search planner quickly through the seven possible levels of the taxonomy. The taxonomy uses published annual boating guides and references as much as possible to provide the search planner with cross-reference capability. The taxonomy was designed to be easily implemented in numerical search planning tools.

8) *Are there new broader categories of search objects within the leeway taxonomy for which leeway equations can be generated from the available data?*

Leeway data from multi-sources were combined together from lower levels in the leeway taxonomy to higher levels for PIWs, Maritime Life Rafts, Commercial Fishing Vessels, and Medical Waste objects. The combination of deep-ballasted canopied life rafts revealed the importance of the presence or absence of a drogue to the leeway drift of life rafts, and how little affect loading of the raft had on the raft's leeway drift rate. By combining data up the leeway taxonomy table systematically, leeway drift equations are provided to the search planner as he descends through the leeway taxonomy table from the general to the specific. The combined leeway classes also provide our best and most complete leeway data sets to test our leeway drift area models.

### 8.3 RECOMMENDATIONS FOR LEEWAY GUIDANCE FOR THE MANUAL METHOD

Table 8-1 is the new recommended leeway classes and values for the National SAR Manual, GDOC AMM, and CASP. The chart below provides the organizational structure of the first two levels of the leeway classes recommended in Table 8-1.

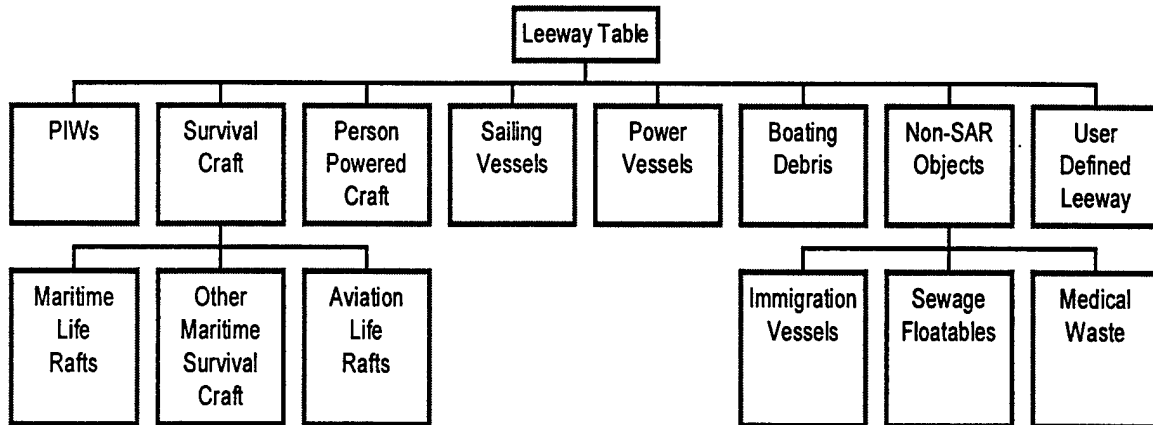

The first four columns of Table 8-1 are Levels 1 through 4 of the leeway taxonomy presented in Chapter 6 and Appendix A, with only those classes for which leeway values are available or will soon be available included. Sub-table 8-1A provides levels 3 through 6 for Maritime Life Rafts with deep ballast systems and canopies. The bold horizontal lines separate Level 1 categories.

The fifth and sixth columns of Table 8-1 are the coefficients to the leeway speed versus wind speed equation shown below.

$$\text{Leeway speed (cm/s)} = [\text{Slope (\%)} * \text{Wind Speed (m/s)}] + \text{Y-intercept (cm/s)} \quad (8.1)$$

An example of using this equation for PIW for winds of 10 m/s is shown below:

$$\text{Leeway speed (cm/s)} = 1.1 \text{ (cm/s)/(m/s)} * 10 \text{ m/s} + 3.5 \text{ cm/s} = 14.5 \text{ cm/s}$$

To convert Leeway speed in cm/s to knots multiply by 0.0194385.

The seventh column in Table 8-1 is the divergence angle in degrees. The eighth column is the standard error of the estimate ( $S_{y/x}$ ) for the leeway speed versus wind speed equation. The standard error is not used in the present search planning tools, but it is anticipated that it will be used in future versions of search planning tools. Included in column nine are reference notes as to the sources of the leeway coefficients.

Table 8-1  
Recommended Leeway Speed and Direction Values for Search Planning Tools

Leeway		Target	Class	Leeway Speed (cm/s)		Divergence	S <sub>y/x</sub>	Reference	
Level 1	Level 2	Level 3	Level 4	Slope (%) W <sub>10m</sub>	Y-intercept (cm/s)	Angle (deg)	cm/s	Notes	
PIW	Vertical			1.1	3.5	40	> 15	[1]	
	Sitting			0.5	3.8	24	> 10	[2]	
				1.2	0.2	24	1.38	[3]	
		Survival Suit	face up		1.4	5.3	40	1.85	[4]
	Horizontal	Scuba Suit	face up		0.7	4.3	40	5.92	[5]
		Deceased	face down		1.5	4.0	40	> 10	[6]
Survival Craft		No		4.2	1.6	38	> 15	[7]	
	Maritime	Ballast	no canopy, no drogue	5.7	10.9	32	10.4	[8]	
		Systems	no canopy, w/ drogue		4.4	- 10.3	38	4.1	[9]
			canopy, no drogue		3.7	5.7	32	2.1	[10]
			canopy, w/ drogue		3.0	0.0	38	> 15	[11]
	Life Rafts	Shallow Ballast Systems and Canopy			2.9	- 0.2	30	> 15	[12]
			no drogue		3.2	- 1.0	30	0.9	[13]
			with drogue		2.5	0.7	30	4.2	[14]
			Capsized		1.7	- 5.2	11	2.1	[15]
		Deep Ballast Systems & Canopies	(See Table 8-1A for Levels 4-6)		3.0	0.8	18	7.9	[16]
Other Maritime Survival Craft	USCG Sea Rescue Kit								
Aviation Life Rafts	no ballast, w/canopy	4-6 person, w/o drogue		3.8	- 4.1	30	1.4	[29]	
	Evac/ Slide	46-person		2.5	- 2.1	10	4.0	[30]	
				3.7	5.7	32	2.1	[31]	
				2.8	- 0.6	20	4.0	[32]	

Table 8-1 (Continued)  
 Recommended Leeway Speed and Direction Values for Search Planning Tools

Sub -Table 8-1A  
 (Sub-table for Maritime Life Rafts with Deep Ballast Systems and Canopies)

Level 3	Leeway		Target	Class	Leeway Speed (cm/s)		Divergence Angle (deg)	S <sub>y/x</sub> cm/s	Reference
	Level 4	Level 5			Level 6	Slope (%) W <sub>10m</sub>			
Maritime Life Rafts with Deep Ballast Systems and Canopies	4-6 person capacity	without drogue	Level 6	Level 6	2.9	2.0	20	8.6	[17]
					3.8	-2.1	20	4.4	[18]
		with drogue	Level 6	Level 6	3.8	-2.1	20	4.5	[19]
					3.6	-1.5	20	2.5	[20]
		with drogue	Level 6	Level 6	1.8	1.4	16	3.1	[21]
					1.6	2.7	32	3.0	[22]
		with drogue	Level 6	Level 6	2.1	0.0	27	2.7	[23]
					3.6	-4.4	14	5.4	[24]
	15-25 person capacity	w/o drogue	Level 6	Level 6	3.9	-3.1	12	2.9	[25]
					3.1	-3.6	12	3.3	[26]
Capsized				0.9	0.0	16	2.2	[27]	
Swamped				1.0	-2.2	11	2.0	[28]	

Table 8-1 (Continued)  
Recommended Leeway Speed and Direction Values for Search Planning

Level 1	Leeway		Target	Class	Leeway Speed (cm/s)		Divergence Angle (deg)	S <sub>y/x</sub> cm/s	Reference Notes
	Level 2	Level 3			Level 4	Slope (%) W <sub>10m</sub>			
Person-Powered Craft	Sea Kayak	W/ Person on	aft deck		1.1	12.5	20	3.52	[33]
	Surf board	w/ person			2.0	0.0	20	>10	[34]
	Windsurfer	w/ person and mast	& sail in water		2.3	5.2	16	2.32	[35]
Sailing Vessels	Mono-hull	Full Keel	Deep Draft		3.0	0.0	65	>10	[36]
		Fin Keel	Shoal Draft		4.0	0.0	65	>10	[37]
Power	Skiffs	Flat Bottom	Boston whaler		3.4	2.1	30	1.8	[38]
		V-hull	Std. Conf.		3.0	3.9	20	4.1	[39]
	Sport Boats	Cuddy Cabin	Modified V-hull		1.7	0.0	20	3.0	[40]
			Center Console	Open cockpit		6.9	- 4.1	25	2.9
Sport Fisher				6.0	- 4.6	30	3.3	[42]	
Vessels	Commercial	Sampans	Hawaiian		3.7	1.0	65	> 15	[43]
					4.0	0.0	65	>10	[44]
					4.2	0.0	65	>10	[45]
	Fishing	Longliners	Japanese		3.7	0.0	65	>10	[46]
					2.7	4.9	65	3.9	[47]
Coastal Freighter	Gill-netter	w/rear reel		4.0	0.3	45	3.0	[48]	
				2.8	0.0	65	> 10	[49]	

Table 8-1 (Continued)  
Recommended Leeway Speed and Direction Values for Search Planning Tools

Level 1	Leeway		Target		Class	Leeway Speed (cm/s)		Divergence Angle (deg)	S <sub>y/x</sub> cm/s	Reference
	Level 2	Level 3	Level 4	Slope (%) W <sub>10m</sub>		Y-intercept (cm/s)				
Boating Debris	F/V debris			2.0		0.0	14	>10	[50]	
	Bait/wharf box			1.3		13.8	42	4.50	[51]	
	holds a cubic meter of ice	lightly loaded		2.6		9.2	20	2.96	[52]	
Non-SAR		full loaded		1.6		8.0	44	2.70	[53]	
	Immigration Vessel	Cuban refugee raft	w/o sail	1.5		8.7	23	1.5	[54]	
	Sewage Floatables	Tampon Applicators	w/ sail	7.9		-8.9	45	5.4	[55]	
Objects				1.8		0.0	7	3	[56]	
				2.8		0.0	14	>15	[57]	
				3.7		0.0	14	>15	[58]	
	Medical	Vials	Large		4.4		0.0	13	3	[59]
			Small		3.0		0.0	14	6	[60]
	Waste	Syringes	Large		1.8		0.0	7	>15	[61]
Small				1.8		0.0	7	3	[62]	
				1.8		0.0	7	2	[63]	
User Defined Leeway				[64]		[65]	[66]	[67]		



Notes for Table 8-1.

- [1] Leeway speed is from this report, Chapter 7. Leeway divergence angle was extrapolated from the value for PIW- survival suit from Allen et al. (1999). Algebraically combined values of  $S_{y/x}$  were assigned a value of  $> 15$  cm/s.
- [2] Leeway speed is from Suzuki, Sato, and Igeta, (1985). Leeway divergence angle was extrapolated from the value for PIW –sitting from Allen et al. (1999). Unknown values of  $S_{y/x}$  were assigned a value of  $> 10$  cm/s.
- [3] Leeway speed, angle and  $S_{y/x}$  are from Allen et al. (1999). The value for leeway divergence angle is twice the standard deviation of leeway angle for winds greater than 5 m/s.
- [4] Leeway speed, angle and  $S_{y/x}$  are from Allen et al. (1999). The value for leeway divergence angle is the mean plus the standard deviation of leeway angle for winds greater than 5 m/s.
- [5] Leeway speed and  $S_{y/x}$  are from Kang (1999). Leeway divergence angle was extrapolated from the value for PIW- survival suit from Allen et al. (1999).
- [6] Leeway speed is from Suzuki, Sato, and Igeta, (1985). Leeway divergence angle was extrapolated from the value for PIW- survival suit from Allen et al. (1999). Unknown values of  $S_{y/x}$  were assigned a value of  $> 10$  cm/s.
- [7] Leeway speed is from this report, Chapter 7. Leeway divergence angle was extrapolated from the value for life raft without canopy or ballast system, with drogue. Algebraically combined values of  $S_{y/x}$  are assigned a value of  $> 15$  cm/s.
- [8] Leeway speed, angle and  $S_{y/x}$  are from the re-analysis of Hufford and Broida's (1974) data in this report, Chapter 3. The value for leeway divergence angle is absolute value of the mean plus one standard deviation of leeway angle for winds greater than 5 m/s.
- [9] Leeway speed, angle and  $S_{y/x}$  are from the re-analysis of Hufford and Broida's (1974) data in this report, Appendix B. The value for leeway divergence angle is absolute value of the mean plus one standard deviation of leeway angle.
- [10] Leeway speed and  $S_{y/x}$  are from Nash and Willcox (1991). Leeway divergence angle was extrapolated from the value for life raft without canopy or ballast system, without drogue.
- [11] Leeway speed and angle are from this report, Chapter 7. Leeway divergence angle was extrapolated from the value for life raft without canopy or ballast system, with drogue. Extrapolated values of  $S_{y/x}$  are assigned a value of  $> 15$  cm/s.

- [12] Leeway speed is from this report, Chapter 7. Leeway divergence angle was extrapolated from the value for life raft with shallow ballast systems and canopy (Fitzgerald (1995)). Algebraically combined values of  $S_{y/x}$  are assigned a value of  $> 15$  cm/s.
- [13] Leeway speed, angles and  $S_{y/x}$  are from Fitzgerald (1995). The value for leeway divergence angle is the mean plus twice the standard deviation of leeway angle.
- [14] Leeway speed and  $S_{y/x}$  are from Allen and Fitzgerald (1997). Leeway angle is from Fitzgerald (1995), where the leeway divergence angle is the mean plus one standard deviation of leeway angle.
- [15] Leeway speed and  $S_{y/x}$  are from Allen and Fitzgerald (1997). Leeway divergence angle was extrapolated from the divergence angle recommended for the standard configuration of the same life raft (Allen and Fitzgerald (1997), their Table 5-4).
- [16] Leeway speed, angle, and  $S_{y/x}$  are from this report, Chapter 7. Leeway divergence angle is twice the standard deviation of the leeway angle.
- [17] Leeway speed, angle, and  $S_{y/x}$  are from this report, Chapter 7. Leeway divergence angle is twice the standard deviation of the leeway angle for winds greater than 5 m/s.
- [18] Leeway speed, angle, and  $S_{y/x}$  are from this report, Chapter 7. Leeway divergence angle is twice the standard deviation of the leeway angle for winds greater than 5 m/s.
- [19] Leeway speed, angle, and  $S_{y/x}$  are from this report, Chapter 7. Leeway divergence angle is twice the standard deviation of the leeway angle for winds greater than 5 m/s.
- [20] Leeway speed, angle, and  $S_{y/x}$  are from this report, Chapter 7. Leeway divergence angle is twice the standard deviation of the leeway angle for all winds.
- [21] Leeway speed, angle, and  $S_{y/x}$  are from this report, Chapter 7. Leeway divergence angle is twice the standard deviation of the leeway angle for winds greater than 5 m/s.
- [22] Leeway speed, angle, and  $S_{y/x}$  are from this report, Chapter 7. Leeway divergence angle is twice the standard deviation of the leeway angle for all winds.
- [23] Leeway speed, angle, and  $S_{y/x}$  are from this report, Chapter 7. Leeway divergence angle is twice the standard deviation of the leeway angle for all winds.
- [24] Leeway speed, angle, and  $S_{y/x}$  are from this report, Chapter 7. Leeway divergence angle is twice the standard deviation of the leeway angle for winds greater than 5m/s.
- [25] Leeway speed, angle, and  $S_{y/x}$  are from Fitzgerald et al. (1994). Leeway divergence angle is twice the standard deviation of the leeway angle for winds greater than 10 knots.

- [26] Leeway speed, angle, and  $S_{y/x}$  are from Fitzgerald et al. (1994). Leeway divergence angle is twice the standard deviation of the leeway angle for winds greater than 10 knots.
- [27] Leeway speed and  $S_{y/x}$  are from Allen and Fitzgerald (1997). Leeway divergence angle was extrapolated from the divergence angle recommended for the standard configuration of the same life raft (Allen and Fitzgerald (1997), their Table 5-4).
- [28] Leeway speed and  $S_{y/x}$  are from Allen and Fitzgerald (1997). Leeway divergence angle was extrapolated from the divergence angle recommended for the standard configuration of the same life raft (Allen and Fitzgerald (1997), their Table 5-4).
- [29] Leeway speed, angle, and  $S_{y/x}$  are from Fitzgerald et al. (1994). Leeway divergence angle is twice the standard deviation of the leeway angle for winds greater than 5 knots.
- [30] Leeway speed, angle, and  $S_{y/x}$  are from Fitzgerald et al. (1994). Leeway divergence angle is twice the standard deviation of the leeway angle for winds greater than 5.7 knots.
- [31] Leeway speed and  $S_{y/x}$  are from Nash and Willcox (1991). Leeway divergence angle was extrapolated from the value for life raft without canopy or ballast system, without drogue.
- [32] Leeway speed, angle, and  $S_{y/x}$  are from Fitzgerald et al. (1994). Leeway divergence angle is twice the standard deviation of the leeway angle for winds greater than 15 knots.
- [33] Leeway speed, angle and  $S_{y/x}$  are from Allen et al. (1999). Leeway divergence angle is twice the standard deviation of the leeway angle for winds greater than 5 m/s.
- [34] Leeway speed is from Chapline (1960). Leeway divergence angle was extrapolated from the value for sea kayaker. Unknown values of  $S_{y/x}$  are assigned a value of  $> 10$  cm/s.
- [35] Leeway speed, angle and  $S_{y/x}$  are from Allen et al. (1999). Leeway divergence angle is twice the standard deviation of the leeway angle for winds greater than 5 m/s.
- [36] Leeway speed is from Chapline (1960). Leeway divergence angle was extrapolated from the divergence angle recommended for Korean fishing vessel studied by Kang (1995). Unknown values of  $S_{y/x}$  are assigned a value of  $> 10$  cm/s.
- [37] Leeway speed is from Chapline (1960). Leeway divergence angle was extrapolated from the divergence angle recommended for Korean fishing vessel studied by Kang (1995). Unknown values of  $S_{y/x}$  are assigned a value of  $> 10$  cm/s.
- [38] Leeway speed, angle, and  $S_{y/x}$  are from Nash and Willcox (1991). Divergence angle was interpolated from Nash and Willcox's Figure 26.
- [39] Leeway speed and  $S_{y/x}$  are from Allen and Fitzgerald (1997). Leeway divergence angle is twice the standard deviation of the leeway angle for winds greater than 5m/s.

- [40] Leeway speed and  $S_{y/x}$  are from Allen and Fitzgerald (1997). Leeway divergence angle was extrapolated from the divergence angle recommended for the standard configuration of the same vessel (Allen and Fitzgerald (1997), their Table 5-4).
- [41] Leeway speed, angle, and  $S_{y/x}$  are from Nash and Willcox (1991). Divergence angle was interpolated from Nash and Willcox's Figure 28.
- [42] Leeway speed, angle, and  $S_{y/x}$  are from Nash and Willcox (1991). Divergence angle was interpolated from Nash and Willcox's Figure 30.
- [43] Leeway speed and  $S_{y/x}$  are from this report, Chapter 7. Leeway divergence angle was extrapolated from the divergence angle recommended for Korean fishing vessel studied by Kang (1995).
- [44] Leeway speed is from Chapline (1960). Unknown values of  $S_{y/x}$  are assigned a value of  $> 10$  cm/s. Leeway divergence angle was extrapolated from the divergence angle recommended for Korean fishing vessel studied by Kang (1995).
- [45] Leeway speed is from Suzuki and Sato (1977). Unknown values of  $S_{y/x}$  are assigned a value of  $> 10$  cm/s. Leeway divergence angle was extrapolated from the divergence angle recommended for Korean fishing vessel studied by Kang (1995).
- [46] Leeway speed is from Igeta, Suzuki and Sato (1982). Unknown values of  $S_{y/x}$  are assigned a value of  $> 10$  cm/s. Leeway divergence angle was extrapolated from the divergence angle recommended for Korean fishing vessel studied by Kang (1995).
- [47] Leeway speed, angle, and  $S_{y/x}$  are from Kang (1995). The leeway divergence angle is the mean plus one standard deviation for winds greater than 5 m/s.
- [48] Leeway speed, angle, and  $S_{y/x}$  are from Allen (1996). The leeway divergence angle is the mean plus one standard deviation for all winds.
- [49] Leeway speed is from Suzuki and Sato (1977). Unknown values of  $S_{y/x}$  are assigned a value of  $> 10$  cm/s. Leeway divergence angle was extrapolated from the divergence angle recommended for Korean fishing vessel studied by Kang (1995).
- [50] Leeway speed is from Igeta et al. (1982). Leeway divergence angle was extrapolated from the value for medical waste (Valle-Levinson and Swanson (1991)). Unknown values of  $S_{y/x}$  are assigned a value of  $> 10$  cm/s.
- [51] Leeway speed, angle and  $S_{y/x}$  are from Allen et al. (1999). The leeway divergence angle is the mean plus one standard deviation for winds greater than 5 m/s.

- [52] Leeway speed, angle and  $S_{y/x}$  are from Allen et al. (1999). The leeway divergence angle is the mean plus one standard deviation for winds greater than 5 m/s.
- [53] Leeway speed, angle and  $S_{y/x}$  are from Allen et al. (1999). The leeway divergence angle is the mean plus one standard deviation for winds greater than 5 m/s.
- [54] Leeway speed, angle and  $S_{y/x}$  are from Allen (1996). The leeway divergence angle is the mean plus twice standard deviation for all winds.
- [55] Leeway speed, angle and  $S_{y/x}$  are from Allen (1996). The leeway divergence angle is the mean plus twice standard deviation for all winds.
- [56] Leeway speed, angle, and  $S_{y/x}$  are from Valle-Levinson and Swanson (1991). The leeway divergence angle is the mean plus twice standard deviation for all winds.
- [57] Leeway speed, angle, and  $S_{y/x}$  are from this report, Chapter 7. Leeway divergence angle was extrapolated from the value for the medical waste object with the highest divergence angle, (Valle-Levinson and Swanson (1991)). Algebraically combined values of  $S_{y/x}$  are assigned a value of > 15 cm/s.
- [58] Leeway speed, angle, and  $S_{y/x}$  are from this report, Chapter 7. Leeway divergence angle was extrapolated from the value for the medical waste object with the highest divergence angle, (Valle-Levinson and Swanson (1991)). Algebraically combined values of  $S_{y/x}$  are assigned a value of > 15 cm/s.
- [59] Leeway speed, angle, and  $S_{y/x}$  are from Valle-Levinson and Swanson (1991). The leeway divergence angle is the mean plus twice standard deviation.
- [60] Leeway speed, angle, and  $S_{y/x}$  are from Valle-Levinson and Swanson (1991). The leeway divergence angle is the mean plus twice standard deviation.
- [61] Leeway speed, angle, and  $S_{y/x}$  are from this report, Chapter 7. Leeway divergence angle was extrapolated from the value for the medical waste object with the highest divergence angle, (Valle-Levinson and Swanson (1991)). Algebraically combined values of  $S_{y/x}$  are assigned a value of > 15 cm/s.
- [62] Leeway speed, angle, and  $S_{y/x}$  are from Valle-Levinson and Swanson (1991). The leeway divergence angle is the mean plus twice standard deviation.
- [63] Leeway speed, angle, and  $S_{y/x}$  are from Valle-Levinson and Swanson (1991). The leeway divergence angle is the mean plus twice standard deviation.
- [64] User defined leeway speed as a percentage of wind speed adjusted to the 10-meter reference level.

- [65] User defined y-intercept coefficient (cm/s) for the regression of leeway speed versus  $W_{10m}$ .
- [66] User defined maximum divergence angle (degrees). Usually expressed as twice the standard deviation of the leeway angle for winds above 5 m/s.
- [67] User defined standard error of the estimate (cm/s) of the regression of leeway speed versus  $W_{10m}$ .

#### 8.4 FUTURE WORK

The Coast Guard should continue to conduct leeway field experiments on selected drift objects. The taxonomy of leeway drift objects proposed in Chapter 6 when combined with Tables 2-3 and 8-1 provide a starting point for selecting the appropriate objects within categories to be studied. The leeway taxonomy shows that there are far too many possible leeway targets to be studied directly, therefore, field studies will need to be combined with modeling studies to interpolate leeway behavior within categories of objects.

In order to combine leeway data up levels in the leeway taxonomy, values from several lower categories should be weighted by individual targets' percentage of the population of the higher category. This will require further studies along the lines of market surveys to determine the total populations of life rafts and other craft. This information will also be useful in determining specifically which targets are most representative of a class and therefore which ones should be directly studied.

The leeway taxonomy presented is a beginning and should continue to be modified as appropriate to include or delete those objects that are new, obscure, inadvertently left out, or of a more international interest. Modifying factors of leeway categories that prove to have inconsequential effects on leeway behavior should be eliminated or combined into other factors to reduce the scope of the taxonomy as much as possible.

The numerical leeway distribution model (AP98) in its present form is not recommended for inclusion into CASP. In its present form AP98 is essentially a demonstration tool and not an operational model. There is considerable effort required to take AP98 from a demonstration tool to an operational model where each replication is individually tracked across a time varying topographic 2-D grid. Further modifications to AP98 will include the variances of wind speed, wind direction, current speed and direction. Also to be added to AP98 is the ability to input initial positions from a distribution, not just a single point. Further refinements of AP98 are needed to include the variance of leeway categories based upon multi-targets.

Table 8-1 provides leeway guidance for search planning tools that use leeway speed and divergence angle as inputs. Leeway distribution models such as AP98 and its successors require leeway coefficients and standard error estimates ( $S_{yx}$ ) for the downwind and crosswind components of leeway versus wind speed equations. This will require companion table to Table 8-1 that contains the inputs required by these third generation search engines.

With the completion of the companion table to 8-1 and the modification to AP98, then sensitivity studies can be conducted. The relative effect of four environmental variances (wind speed, wind direction, sea current speed, and sea current direction), the two leeway variances (DWL and CWL), and initial position variance on the size of the search area can be estimated and compared to each other. This should provide insight as to which of the seven factors influence the size of maritime search areas the least and which the most. A sensitivity study of this nature should provide input for the guidance as to where the Coast Guard can make the most gains by investing in research and modeling / planning tools development to reduce the areal extent of its search areas while maintaining high Probability of Containment.

A sensitivity study may also provide guidance as to how the Manual Method can be changed to accurately reflect the search distribution areas generated by the third generation search planning engines.

**This review of leeway reflects the present status of leeway in the year 1998. The status of leeway will need to be checked and updated periodically.**

[BLANK]



## REFERENCES

Allen, A. A., 1996. "The Leeway of Cuban Refugee Rafts and a Commercial Fishing Vessel," U.S. Coast Guard Report No. CG-D-21-96.

Allen, A. A., and R.B. Fitzgerald. 1997. "The Leeway of an Open Boat and Three Life Rafts in Heavy Weather," U.S. Coast Guard Report No. CG-D-03-98.

Allen, A.A., R.Q. Robe, and E.T. Morton, 1999. "The Leeway of Person-In-Water and Three Small Craft," U.S. Coast Guard R&D Center Report No. R&DC 24/98.

Allen, A. A. and P. Staubs, 1997. "CASP User Defined Leeway Input for Maritime Life Rafts," Letter report, included as Appendix A of Allen and Fitzgerald (1997).

Anderson, E., A. Odulo, and M. Spaulding, 1998. "Modeling of Leeway Drift," U.S. Coast Guard Report No. CG-D-06-99.

Baca V. M., 1995. "Evolution of the 'life jacket'," Proceeding of the Marine Safety Council, Vol. 54., No.4, pp. 30-34.

Central Tactics and Trial Organization (CTTO), 1974. "Life Raft Drift Rates." CTTO/10756/44/LRMO, Canada.

Chapline, W. E., 1960. "Estimating the Drift of Distressed Small Craft." Coast Guard Alumni Association Bulletin, U.S. Coast Guard Academy, New London, CT, Vol. 22, No. 2, March-April 1960, pp 39-42.

Fitzgerald, R. B., 1995. "Target Detection Experiment Phase I - Experiment Planning," Contract report prepared for Transportation Development Centre, Transport Canada, Montreal, TP# 12441E.

Fitzgerald, R.B., J. Russell, and D. Bryant, 1990. "Search and Rescue Experiment to Derive Leeway and Drift Rates for Common Search and Rescue Objects, Notre Dame Bay, Newfoundland, Summer 1989." Contract report prepared for Transportation Development Centre, Transport Canada, Montreal, TP#10221E.

Fitzgerald, R. B., D. J. Finlayson, and A. Allen, 1994. "Drift of Common Search and Rescue Objects - Phase III." Contract report prepared for Canadian Coast Guard, Research and Development, Ottawa, TP# 12179.

Fitzgerald, R. B., D. J. Finlayson, J. F. Cross, and A. Allen, 1993. "Drift of Common Search and Rescue Objects - Phase II." Contract report prepared for Transportation Development Centre, Transport Canada, Montreal, TP# 11673E.

Frost, J. R., 1997. "The Theory of Search: A Simplified Explanation." Contract report prepared for U.S. Coast Guard.

Grupa M. D., 1995. "PFDs They come in many types and sizes," Proceeding of the Marine Safety Council, Vol. 54. No.4, pp11-15.

Hart, C. T., 1988. "A Study of the Factors Influencing the Rough Water Effectiveness of Personal Flotation Devices," David Taylor Research Center Report No. DTRC-88/026.

Hiraiwa, T., T. Fujii, and S. Saito, 1967. "An Experimental Study of Drift and Leeway," Journal of the Institute of Navigation, London: Vol. 20., No. 2., pp. 131-145.

Hodgins, D. O. and S. L. M. Hodgins, 1998. "Phase II Leeway Dynamics Study Program Development and Verification of a Mathematical Drift Model for Liferrafts and Small Boats." Prepared for Canadian Coast Guard College, Dept. Fisheries and Oceans.

Hodgins, D.O. and R.Y. Mak, 1995. "Leeway Dynamic Study Phase I Development and Verification of a Mathematical Drift Model for Four-person Liferrafts." Prepared for Transportation Development Centre, Transport Canada Report # TP 12309E.

Hufford, G.L., and S. Broida, 1974. "Determination of Small Craft Leeway." U.S. Coast Guard Research and Development Center Report No. 39/74, December 1974.

Igeta, Yuzo, Tsuneo Suzuki and Haruo Sato, 1982. "Experiment on the Sea Regarding Distress and Search of Small Fishing Boat - I," The Journal of Japan Institute of Navigation. No. 68, pp. 103 - 112.

Kang, S.Y., 1995. "Drift Experiment for the Determination of Small Boat Leeway", Journal of the Society of Marine Safety, Vol.1, No.1., pp. 8 (Abstract in English, text in Korean).

Kang, S.Y., 1999. "A Field Experiment for the Determination of Drift Characteristics of Person-in-Water", Journal of the Society of Marine Safety, Vol. 5, No. 1, pp. 29-36 (Abstract in English, text in Korean).

Large, W. G. , J. Morzel and G. B. Crawford, 1995. "Accounting for Surface Wave Distortion of the Marine Wind Profile in Low-Level Ocean Storm Wind Measurements," J. of Physical Oceanography, Vol. 25. pp.2959 - 2971.

Marko, J.R., D.B. Fissel and J.D. Miller, 1988. "Iceberg Movement Prediction Off the Canadian East Coast," in *Natural and Man-Made Hazards*, M.I.El-sabh and T.S. Murty (eds.), D. Reidel Publishing Co., pp. 435-462.

Morgan, C.W., 1978. "Seven Man Life Raft Leeway Study," U.S. Coast Guard Oceanographic Unit Technical Report 78-1, Washington, D.C.

Morgan, C.W., S.E. Brown, and R.C. Murrell, 1977. "Experiments in Small Craft Leeway," U.S. Coast Guard Oceanographic Unit Technical Report 77-2, Washington, D.C.

Nash, L., and J. Willcox, 1985. "Summer 1983 Leeway Drift Experiment," U.S. Coast Guard Report CG-D-35-85.

Nash, L., and J. Willcox, 1991. "Spring 1985 Leeway Experiment," U.S. Coast Guard Report CG-D-12-92.

O'Donnell J., C. Oates and G. Reas, 1999. "Aanderaa DCS3500 Current Meter Test and Evaluation Report."

Osmer, S.R., N.C. Edwards, Jr., and A.L. Breitler, 1982. "An Evaluation of Life Raft Leeway, February 1982." U.S. Coast Guard Report No. CG-D-10-82.

Pingree, F. deW., 1944. "Forethoughts on Rubber Rafts." Woods Hole Oceanographic Institution, 26 pp.

Raunig, D.L., R.Q. Robe, and B.D. Perkins, 1995 "Computer Aided Search Planning (CASP) Version 1.0 Validation Interim Report." U.S. Coast Guard Informal Report, 44pp.

Report of the Workshop, 1995. "Oil Spill Modeling: Status and Prospectus," University of Massachusetts, Dartmouth MA.

Robe, R.Q, 1998. "A Requirement to Update NSM Leeway Drift Factors for Search and Rescue Planning." Canadian Coast Guard informal report, 4pp.

Richardson, P. L., 1997. "Drifting in the wind: leeway error in shipdrift data," Deep Sea Res. I, Vol. 44. No.11, pp1877-1903.

Scobie, R.W., and D.L. Thompson, 1979. "Life Raft Study, February 1978." U.S. Coast Guard Oceanographic Unit Technical Report 79-1, Washington, D.C.

Smith, S.D., 1981. "Factors for adjustment of wind speed over water to a 10m height." Rep BI-R-821-3, Bedford Institute of Oceanography, Dartmouth, N.S.

Smith, S.D., 1988. "Coefficients for Sea Surface Wind Stress, Heat Flux, and Wind Profiles as a Function of Wind Speed and Temperature," J. Geophysical Res. Vol. 93, No. C12, pp. 15,467-15,472, 5 December 1988.

Su, Tsung-chow, 1986. "On Predicting the Boat's Drift for Search and Rescue," U.S. Dept. of Transportation Report DOT/OST/P-34/87/059, Aug. 1986, pp.159.

Su, Tsung-chow, R. Q. Robe, and D. J. Finlayson, 1997. "On Predicting the Leeway and Drift of a Survival Suit Clad Person-In-Water." U.S. Coast Guard Report No. CG-D-14-98.

Sutton, O.G., 1953. *Micrometeorology. A Study of Physical Processes the Lowest Layers of the Earth's Atmosphere.* McGraw-Hill Book Co. New York, NY USA. 333p.

Suzuki, Tsuneo, and Harou Sato, 1977. "Measurement of the Drifting of a Fishing Boat or Research Vessel Due to Wind and Wave," The Journal of Japan Institute of Navigation. No. 57, pp. 71 -76.

Suzuki, Tsuneo, Harou Sato, Ikuto Okuda and Yuzo Igeta, 1984. "Experiment on the Sea Regarding Distress and Search of Small Fishing Boat – II – Drift Characteristics of Inflatable Life-Raft (home made the second type) and Floating Life-Sized Doll." The Journal of Japan Institute of Navigation, No. 71, pp. 1-9.

Suzuki, Tsuneo, Harou Sato, and Yuzo Igeta, 1985. "Experiment on the Sea Regarding Distress and Search of Small Fishing Boat - III. A Determination of Search Area When Wind Direction Changes," The Journal of Japan Institute of Navigation. No. 73, pp. 95 - 101.

U.S. Coast Guard, Commandant Instruction M13520.1A, "Aviation Life Support Systems Manual," Washington D.C. 1 June 1994.

U.S. Coast Guard, Commandant Instruction M3710.1D, "Air Operation Manual," Washington D.C. 7 May 1997.

U.S. Coast Guard, Commandant Instruction M10470.10C, "Coast Guard Rescue and Survival Systems Manual," Washington D.C, 16 July 1992.

U.S. Coast Guard, Commandant Instruction M16120.2, "National Search and Rescue Manual," Washington D.C. 1 July 1973.

U.S. Coast Guard, Commandant Instruction M16120.5A, "National Search and Rescue Manual," Washington D.C. 1 February 1991.

Valle-Levinson, A. and R.L. Swanson, 1991. "Wind-Induced Scattering of Medically-Related and Sewage-Related Floatables," Marine Technology Society Journal, Vol. 25, No., Summer 1991, pp. 49-56.

## Appendix A

### LEEWAY TAXONOMY TABLES

This appendix presents a set of tables that describe the taxonomy of leeway drift objects. These tables were generated from the rules described in Section VII. Each table lists the drift objects that occur within the major target categories established by the rules of Level 3 (Level 2 for non-SAR drift objects) and depicted in the right-hand portion of Figure 3 in Section VII. Table A-1 provides a quick reference to assist the reader with finding the major target category. The information in Tables A-2 through A-20 should be available to SAR planners and other Coast Guard resources to accurately predict the behavior of drift objects. The SAR planner should be provided with information about a specific leeway target and use these tables to locate the most applicable leeway drift data.

An effort has been made to include all targets with the potential to become open-ocean leeway targets of interest to the Coast Guard. Boats such as competition water ski, house boats, and vessels (over 100 feet) are not included. The former are not expected to be used in the waters of interest and the latter are expected to be self sufficient in all but the most extreme conditions, in which case it may be assumed that the survival gear rather than the vessel itself has become the leeway target.

**Table A-1.  
Leeway Taxonomy Tables: Cross Reference Matrix**

Leeway Target Category	Table Number	Page Number	Appendix B Reference
Boating PIW	A-2	A-2	B-1
Maritime Survival Craft	A-3	A-3	B-2
Person-Powered Craft	A-4	A-9	B-3
Sailing Vessels	A-5	A-10	B-4
Power Vessels	A-6	A-18	B-5
Boating Debris	A-7	A-23	B-6
Aviation PIW	A-8	A-23	B-7
Aviation Survival Craft	A-9	A-24	B-8
Aviation Debris	A-10	A-30	B-9
Combat SAR Aviation PIW	A-11	A-31	B-10
Combat SAR Aviation Survival Craft	A-12	A-32	B-11
Combat SAR Aviation Debris	A-13	A-34	B-12
Combat SAR Maritime PIW	A-14	A-34	B-13
Combat SAR Maritime Survival Craft	A-15	A-35	B-14
Combat SAR Maritime Power Vessels	A-16	A-40	B-15
Combat SAR Maritime Debris	A-17	A-41	B-16
Law Enforcement Drift Objects	A-18	A-41	B-17
Marine Safety Drift Objects	A-19	A-41	B-18
Military Drift Objects	A-20	A-42	B-19

**Table A-2.  
Boating PIW**

<b>Category</b>	<b>Primary Drift Variable</b>	<b>State of PIW</b>	<b>PFD Style</b>
<b>Persons in the Water (PIW) from Maritime Sources</b>	<b>PIW in the Vertical position</b>	<b>Conscious</b>	<b>No Flotation</b>
			<b>Sport and Work vest</b>
			<b>Anti-Exposure suit</b>
			<b>Float Coat</b>
	<b>PIW in the Sitting Position</b>	<b>Conscious</b>	<b>Offshore lifejacket</b>
			<b>Horse-collar</b>
			<b>Inflatable Vests</b>
		<b>Unconscious</b>	<b>Throwable devices</b>
			<b>Offshore lifejacket</b>
			<b>Horse-collar</b>
	<b>PIW in the Horizontal Position</b>	<b>Conscious</b>	<b>Inflatable Vests</b>
			<b>Survival Suit</b>
		<b>Unconscious</b>	<b>Survival Suit</b>
			<b>No Flotation</b>
		<b>Victims</b>	<b>Sport and Work vest</b>
<b>Anti-Exposure suit</b>			
<b>Float Coat</b>			

**Table A-3.  
Maritime Survival Craft**

Category	Primary Drift Var.	Secondary Drift Var.	Drogue Modifier	Capacity Modifier	Loading Modifier
Marine Life Rafts	No Ballast System	With Canopy	With Drogue	1-2 Person	
				4-6 Person	Light Loading
					Heavy Loading
				8-10 Person	Light Loading
					Heavy Loading
				10-15 Person	Light Loading
				Heavy Loading	
			15-25 Person	Light Loading	
				Heavy Loading	
			25-50 Person	Light Loading	
				Heavy Loading	
			50-100 Person	Light Loading	
			Heavy Loading		
		Without Canopy	With Drogue	1-2 Person	
				4-6 Person	Light Loading
					Heavy Loading
				8-10 Person	Light Loading
					Heavy Loading
				10-15 Person	Light Loading
				Heavy Loading	
			15-25 Person	Light Loading	
				Heavy Loading	
			25-50 Person	Light Loading	
				Heavy Loading	
50-100 Person	Light Loading				
	Heavy Loading				
Without Canopy	Without Drogue	1-2 Person			
		4-6 Person	Light Loading		
			Heavy Loading		
		8-10 Person	Light Loading		
			Heavy Loading		
		10-15 Person	Light Loading		
		Heavy Loading			
	15-25 Person	Light Loading			
		Heavy Loading			
	25-50 Person	Light Loading			
		Heavy Loading			
	50-100 Person	Light Loading			
	Heavy Loading				

**Table A-3.  
Maritime Survival Craft (Continued)**

Category	Primary Drift Var.	Secondary Drift Var.	Drogue Modifier	Capacity Modifier	Loading Modifier
Marine Life Rafts (Continued)	With Shallow Pocket Ballast System	With Canopy	With Drogue	1-2 Person	
				4-6 Person	Light Loading Heavy Loading
				8-10 Person	Light Loading Heavy Loading
				10-15 Person	Light Loading Heavy Loading
				15-25 Person	Light Loading Heavy Loading
				25-50 Person	Light Loading Heavy Loading
				50-100 Person	Light Loading Heavy Loading
			Without Drogue	1-2 Person	
				4-6 Person	Light Loading Heavy Loading
				8-10 Person	Light Loading Heavy Loading
				10-15 Person	Light Loading Heavy Loading
				15-25 Person	Light Loading Heavy Loading
				25-50 Person	Light Loading Heavy Loading
				50-100 Person	Light Loading Heavy Loading
		Without Canopy	With Drogue	1-2 Person	
				4-6 Person	Light Loading Heavy Loading
				8-10 Person	Light Loading Heavy Loading
				10-15 Person	Light Loading Heavy Loading
				15-25 Person	Light Loading Heavy Loading
				25-50 Person	Light Loading Heavy Loading
				50-100 Person	Light Loading Heavy Loading
			Without Drogue	1-2 Person	
				4-6 Person	Light Loading Heavy Loading
				8-10 Person	Light Loading Heavy Loading
				10-15 Person	Light Loading Heavy Loading
				15-25 Person	Light Loading Heavy Loading
				25-50 Person	Light Loading Heavy Loading
				50-100 Person	Light Loading Heavy Loading



**Table A-3.  
Maritime Survival Craft (Continued)**

Category	Primary Drift Var.	Secondary Drift Var.	Drogue Modifier	Capacity Modifier	Loading Modifier
Marine Life Rafts (Continued)	With Deep Ballast	With Canopy	With Drogue	1-2 Person	
				4-6 Person	Light Loading
					Heavy Loading
				8-10 Person	Light Loading
					Heavy Loading
				10-15 Person	Light Loading
				Heavy Loading	
			15-25 Person	Light Loading	
				Heavy Loading	
			25-50 Person	Light Loading	
				Heavy Loading	
			50-100 Person	Light Loading	
			Heavy Loading		
		Without Drogue	1-2 Person		
			4-6 Person	Light Loading	
				Heavy Loading	
			8-10 Person	Light Loading	
				Heavy Loading	
			10-15 Person	Light Loading	
			Heavy Loading		
		15-25 Person	Light Loading		
			Heavy Loading		
		25-50 Person	Light Loading		
			Heavy Loading		
50-100 Person	Light Loading				
	Heavy Loading				
Without Canopy	With Drogue	1-2 Person			
		4-6 Person	Light Loading		
			Heavy Loading		
		8-10 Person	Light Loading		
			Heavy Loading		
		10-15 Person	Light Loading		
		Heavy Loading			
	15-25 Person	Light Loading			
		Heavy Loading			
	25-50 Person	Light Loading			
		Heavy Loading			
	50-100 Person	Light Loading			
	Heavy Loading				
Without Drogue	1-2 Person				
	4-6 Person	Light Loading			
		Heavy Loading			
	8-10 Person	Light Loading			
		Heavy Loading			
	10-15 Person	Light Loading			
	Heavy Loading				
15-25 Person	Light Loading				
	Heavy Loading				
25-50 Person	Light Loading				
	Heavy Loading				
50-100 Person	Light Loading				
	Heavy Loading				

**Table A-3.  
Maritime Survival Craft (Continued)**

Category	Primary Drift Var.	Secondary Drift Var.	Drogue Modifier	Capacity Modifier	Loading Modifier
Marine Life Rafts (Continued)	Swamped	With Canopy	With Drogue	1-2 Person	
				4-6 Person	Light Loading Heavy Loading
				8-10 Person	Light Loading Heavy Loading
				10-15 Person	Light Loading Heavy Loading
				15-25 Person	Light Loading Heavy Loading
				25-50 Person	Light Loading Heavy Loading
				50-100 Person	Light Loading Heavy Loading
			Without Drogue	1-2 Person	
				4-6 Person	Light Loading Heavy Loading
				8-10 Person	Light Loading Heavy Loading
				10-15 Person	Light Loading Heavy Loading
				15-25 Person	Light Loading Heavy Loading
				25-50 Person	Light Loading Heavy Loading
				50-100 Person	Light Loading Heavy Loading
		Without Canopy	With Drogue	1-2 Person	
				4-6 Person	Light Loading Heavy Loading
				8-10 Person	Light Loading Heavy Loading
				10-15 Person	Light Loading Heavy Loading
				15-25 Person	Light Loading Heavy Loading
				25-50 Person	Light Loading Heavy Loading
				50-100 Person	Light Loading Heavy Loading
			Without Drogue	1-2 Person	
				4-6 Person	Light Loading Heavy Loading
				8-10 Person	Light Loading Heavy Loading
				10-15 Person	Light Loading Heavy Loading
				15-25 Person	Light Loading Heavy Loading
				25-50 Person	Light Loading Heavy Loading
				50-100 Person	Light Loading Heavy Loading

**Table A-3.  
Maritime Survival Craft (Continued)**

Category	Primary Drift Var.	Secondary Drift Var.	Drogue Modifier	Capacity Modifier	Loading Modifier	
Marine Life Rafts (Continued)	Capsized	With Canopy	With Drogue	1-2 Person		
				4-6 Person	Light Loading	
					Heavy Loading	
				8-10 Person	Light Loading	
					Heavy Loading	
				10-15 Person	Light Loading	
					Heavy Loading	
				15-25 Person	Light Loading	
				Heavy Loading		
			25-50 Person	Light Loading		
				Heavy Loading		
			50-100 Person	Light Loading		
				Heavy Loading		
			Without Drogue	1-2 Person		
				4-6 Person	Light Loading	
					Heavy Loading	
		8-10 Person		Light Loading		
				Heavy Loading		
		10-15 Person		Light Loading		
				Heavy Loading		
		15-25 Person		Light Loading		
			Heavy Loading			
		25-50 Person	Light Loading			
			Heavy Loading			
		50-100 Person	Light Loading			
			Heavy Loading			
		Without Canopy	With Drogue	With Drogue	1-2 Person	
					4-6 Person	Light Loading
						Heavy Loading
					8-10 Person	Light Loading
						Heavy Loading
					10-15 Person	Light Loading
	Heavy Loading					
15-25 Person	Light Loading					
	Heavy Loading					
25-50 Person	Light Loading					
	Heavy Loading					
50-100 Person	Light Loading					
	Heavy Loading					
Without Drogue	Without Drogue		Without Drogue	1-2 Person		
				4-6 Person	Light Loading	
					Heavy Loading	
		8-10 Person		Light Loading		
				Heavy Loading		
		10-15 Person		Light Loading		
				Heavy Loading		
		15-25 Person		Light Loading		
	Heavy Loading					
25-50 Person	Light Loading					
	Heavy Loading					
50-100 Person	Light Loading					
	Heavy Loading					

**Table A-3.  
Maritime Survival Craft (Continued)**

<b>Category</b>	<b>Primary Drift Var.</b>	<b>Secondary Drift Var.</b>	<b>Drogue Modifier</b>	<b>Capacity Modifier</b>	<b>Loading Modifier</b>	
Open Life Boat	With Engine	With Helm Control	With Drogue		Lightly Loaded	
					Heavily Loaded	
		Without Drogue			Lightly Loaded	
					Heavily Loaded	
		With Tiller Control	With Drogue		Lightly Loaded	
					Heavily Loaded	
	Without Drogue			Lightly Loaded		
				Heavily Loaded		
	Without Engine	With Drogue			Lightly Loaded	
					Heavily Loaded	
		Without Drogue			Lightly Loaded	
					Heavily Loaded	
	Swamped	With Drogue			Lightly Loaded	
					Heavily Loaded	
Without Drogue				Lightly Loaded		
				Heavily Loaded		
Capsized	With Drogue			Lightly Loaded		
				Heavily Loaded		
	Without Drogue			Lightly Loaded		
				Heavily Loaded		
Life Capsule	Standard Configuration	With Drogue			Lightly Loaded	
					Heavily Loaded	
		Without Drogue			Lightly Loaded	
					Heavily Loaded	
	Swamped					
Capsized						
USCG Sea Rescue Kit			With Drogue		Empty	
					Lightly Loaded	
					Heavily Loaded	
				Without Drogue		Empty
						Lightly Loaded
					Heavily Loaded	

**Table A-4.  
Person-Powered Craft**

<b>Category</b>	<b>Primary Drift Var.</b>	<b>Secondary Drift Var.</b>
Row Boats	Rowing Dinghy	Standard Configuration
		Swamped
		Capsized
	Open Row Boat	Standard Configuration
		Swamped
		Capsized
	Inflatable Boat	Standard Configuration
		Swamped
		Capsized
	Double Ended Row Boat	Standard Configuration
		Swamped
		Capsized
Crew Shell	Standard Configuration	
	Swamped	
	Capsized	
Sea Kayaks/Canoes	Open Canoe	With Drogue
		Without Drogue
	Covered Canoe	With Drogue
		Without Drogue
	Canoe With Outrigger	With Drogue
		Without Drogue
	Sea Kayak	With Person on aft deck
		Without kayaker
	Swamped Canoe/Kayak	With Drogue
	Capsized Canoe	With Drogue
Without Drogue		
Capsized Kayak	With Drogue	
	Without Drogue	
Surf Boards	Surf board w/person	
	Windsurfer board w/ person lying on board	Mast & sail in water
		w/o mast & sail
Aquacycle		

**Table A-5.  
Sailing Vessels**

Category	Primary Drift Var.	Secondary Drift Var.	Drag Device Modifier
Full Keel One Design Sailboat	Open Cockpit	With Mast	Not common on small sailboats
		Demasted	
	Cabin Sailboat	With Mast	
		Demasted	
	Swamped	With Mast	
		Demasted	
	Capsized	With Mast	
		Demasted	
Fin Keel One Design Sailboat	Open Cockpit	With Mast	
		Demasted	
	Cabin Sailboat	With Mast	
		Demasted	
	Swamped	With Mast	
		Demasted	
	Capsized	With Mast	
		Demasted	
Dagger/Centerboard One Design Sailboat	Scow/Board Boat	Trap Boat	
		Side Trawler	
		Stern Trawler	
	Dinghy	Bottom Dragger	
	Open Cockpit	With Mast	
		Demasted	
	Cabin Sailboat	With Mast	
		Demasted	
	Swamped	With Mast	
Demasted			
Capsized	With Mast		
	Demasted		
Bare Bottom One Design Sailboat	Open Cockpit	With Mast	
		Demasted	
	Cabin Sailboat	With Mast	
		Demasted	
	Swamped	With Mast	
		Demasted	
	Capsized	With Mast	
		Demasted	
Sport Catamaran	Standard Configuration	With Mast	
		Demasted	
	Capsized	With Mast	
		Demasted	
Sport Trimaran	Standard Configuration	With Mast	
		Demasted	
	Capsized	With Mast	
		Demasted	

**Table A-5.  
Sailing Vessels (Continued)**

Category	Primary Drift Var.	Secondary Drift Var.	Power Modifier	Drag Device Modifier
Full Keel Sailboat	Deep Draft	With Mast	Inboard Engine	With Drogue
				With Sea Anchor
				Without Drag Device
			Outboard Engine	With Drogue
				With Sea Anchor
				Without Drag Device
		Without Engine	With Drogue	
			With Sea Anchor	
			Without Drag Device	
		Demasted	Inboard Engine	With Drogue
				With Sea Anchor
				Without Drag Device
	Outboard Engine		With Drogue	
			With Sea Anchor	
			Without Drag Device	
	Without Engine	With Drogue		
		With Sea Anchor		
		Without Drag Device		
	Shoal Draft	With Mast	Inboard Engine	With Drogue
				With Sea Anchor
				Without Drag Device
			Outboard Engine	With Drogue
				With Sea Anchor
				Without Drag Device
		Without Engine	With Drogue	
			With Sea Anchor	
			Without Drag Device	
		Demasted	Inboard Engine	With Drogue
				With Sea Anchor
				Without Drag Device
	Outboard Engine		With Drogue	
			With Sea Anchor	
			Without Drag Device	
	Without Engine	With Drogue		
		With Sea Anchor		
		Without Drag Device		
Swamped	With Mast	Inboard Engine	With Drogue	
			With Sea Anchor	
			Without Drag Device	
		Outboard Engine	With Drogue	
			With Sea Anchor	
			Without Drag Device	
	Without Engine	With Drogue		
		With Sea Anchor		
		Without Drag Device		
	Demasted	Inboard Engine	With Drogue	
			With Sea Anchor	
			Without Drag Device	
Outboard Engine		With Drogue		
		With Sea Anchor		
		Without Drag Device		
Without Engine	With Drogue			
	With Sea Anchor			
	Without Drag Device			
Capsized	With Mast	With Drogue		
		With Sea Anchor		
		Without Drag Device		
	Demasted	With Drogue		
		With Sea Anchor		
		Without Drag Device		

**Table A-5.  
Sailing Vessels (Continued)**

<b>Category</b>	<b>Primary Drift Var.</b>	<b>Secondary Drift Var.</b>	<b>Power Modifier</b>	<b>Drag Device Modifier</b>
Fin Keel Sailboat	Deep Draft Fin Keel Sail	With Mast	Inboard Engine	With Drogue
				With Sea Anchor
				Without Drag Device
		Outboard Engine	With Drogue	
			With Sea Anchor	
			Without Drag Device	
	Without Engine	With Drogue		
		With Sea Anchor		
		Without Drag Device		
	Demasted	Inboard Engine	With Drogue	
			With Sea Anchor	
			Without Drag Device	
		Outboard Engine	With Drogue	
			With Sea Anchor	
			Without Drag Device	
	Without Engine	With Drogue		
		With Sea Anchor		
		Without Drag Device		
	Shoal Draft Fin Keel Sail	With Mast	Inboard Engine	With Drogue
				With Sea Anchor
				Without Drag Device
			Outboard Engine	With Drogue
				With Sea Anchor
				Without Drag Device
Without Engine		With Drogue		
		With Sea Anchor		
		Without Drag Device		
Demasted		Inboard Engine	With Drogue	
			With Sea Anchor	
			Without Drag Device	
	Outboard Engine	With Drogue		
		With Sea Anchor		
		Without Drag Device		
Without Engine	With Drogue			
	With Sea Anchor			
	Without Drag Device			
Shoal Draft Bulb Keel Sail	With Mast	Inboard Engine	With Drogue	
			With Sea Anchor	
			Without Drag Device	
		Outboard Engine	With Drogue	
			With Sea Anchor	
			Without Drag Device	
	Without Engine	With Drogue		
		With Sea Anchor		
		Without Drag Device		
	Demasted	Inboard Engine	With Drogue	
			With Sea Anchor	
			Without Drag Device	
Outboard Engine		With Drogue		
		With Sea Anchor		
		Without Drag Device		
Without Engine	With Drogue			
	With Sea Anchor			
	Without Drag Device			



**Table A-5.  
Sailing Vessels (Continued)**

Category	Primary Drift Var.	Secondary Drift Var.	Power Modifier	Drag Device Modifier
Fin Keel Sailboat	Shoal Draft Wing Keel Sail	With Mast	Inboard Engine	With Drogue
				With Sea Anchor
				Without Drag Device
			Outboard Engine	With Drogue
				With Sea Anchor
				Without Drag Device
		Without Engine	With Drogue	
			With Sea Anchor	
			Without Drag Device	
		Demasted	Inboard Engine	With Drogue
				With Sea Anchor
				Without Drag Device
	Outboard Engine		With Drogue	
			With Sea Anchor	
			Without Drag Device	
	Without Engine	With Drogue		
		With Sea Anchor		
		Without Drag Device		
	Shoal Draft Low Aspect Ratio Keel Sail	With Mast	Inboard Engine	With Drogue
				With Sea Anchor
				Without Drag Device
			Outboard Engine	With Drogue
				With Sea Anchor
				Without Drag Device
		Without Engine	With Drogue	
			With Sea Anchor	
			Without Drag Device	
		Demasted	Inboard Engine	With Drogue
				With Sea Anchor
				Without Drag Device
	Outboard Engine		With Drogue	
			With Sea Anchor	
			Without Drag Device	
	Without Engine	With Drogue		
		With Sea Anchor		
		Without Drag Device		
Swamped	With Mast	Inboard Engine	With Drogue	
			With Sea Anchor	
			Without Drag Device	
		Outboard Engine	With Drogue	
			With Sea Anchor	
			Without Drag Device	
	Without Engine	With Drogue		
		With Sea Anchor		
		Without Drag Device		
	Demasted	Inboard Engine	With Drogue	
			With Sea Anchor	
			Without Drag Device	
Outboard Engine		With Drogue		
		With Sea Anchor		
		Without Drag Device		
Without Engine	With Drogue			
	With Sea Anchor			
	Without Drag Device			
Capsized	With Mast	With Drogue		
		With Sea Anchor		
		Without Drag Device		
	Demasted	With Drogue		
		With Sea Anchor		
		Without Drag Device		

**Table A-5.  
Sailing Vessels (Continued)**

Category	Primary Drift Var.	Secondary Drift Var.	Power Modifier	Drag Device Modifier
Water Ballast Trailer Sailboat	Centerboard Down	With Mast	Inboard Engine	With Drogue
				With Sea Anchor
				Without Drag Device
			Outboard Engine	With Drogue
				With Sea Anchor
				Without Drag Device
		Without Engine	With Drogue	
			With Sea Anchor	
			Without Drag Device	
		Demasted	Inboard Engine	With Drogue
				With Sea Anchor
				Without Drag Device
	Outboard Engine		With Drogue	
			With Sea Anchor	
			Without Drag Device	
	Without Engine	With Drogue		
		With Sea Anchor		
		Without Drag Device		
	Centerboard Raised	With Mast	Inboard Engine	With Drogue
				With Sea Anchor
				Without Drag Device
			Outboard Engine	With Drogue
				With Sea Anchor
				Without Drag Device
		Without Engine	With Drogue	
			With Sea Anchor	
			Without Drag Device	
		Demasted	Inboard Engine	With Drogue
				With Sea Anchor
				Without Drag Device
	Outboard Engine		With Drogue	
			With Sea Anchor	
			Without Drag Device	
	Without Engine	With Drogue		
		With Sea Anchor		
		Without Drag Device		
Wing Keel	With Mast	Inboard Engine	With Drogue	
			With Sea Anchor	
			Without Drag Device	
		Outboard Engine	With Drogue	
			With Sea Anchor	
			Without Drag Device	
	Without Engine	With Drogue		
		With Sea Anchor		
		Without Drag Device		
	Demasted	Inboard Engine	With Drogue	
			With Sea Anchor	
			Without Drag Device	
Outboard Engine		With Drogue		
		With Sea Anchor		
		Without Drag Device		
Without Engine	With Drogue			
	With Sea Anchor			
	Without Drag Device			

**Table A-5.  
Sailing Vessels (Continued)**

Category	Primary Drift Var.	Secondary Drift Var.	Power Modifier	Drag Device Modifier
Water Ballast Trailer Sailboat	Swamped	With Mast	Inboard Engine	With Drogue
				With Sea Anchor
				Without Drag Device
		Outboard Engine	With Drogue	
			With Sea Anchor	
			Without Drag Device	
		Without Engine	With Drogue	
			With Sea Anchor	
			Without Drag Device	
	Demasted	Inboard Engine	With Drogue	
			With Sea Anchor	
			Without Drag Device	
		Outboard Engine	With Drogue	
			With Sea Anchor	
			Without Drag Device	
Without Engine	With Drogue			
	With Sea Anchor			
	Without Drag Device			
Capsized	With Mast	With Drogue		
		With Sea Anchor		
		Without Drag Device		
	Demasted	With Drogue		
		With Sea Anchor		
		Without Drag Device		
Cruising Catamaran	Racing Hull	With Mast	Inboard Engine	With Drogue
				With Sea Anchor
				Without Drag Device
		Outboard Engine	With Drogue	
			With Sea Anchor	
			Without Drag Device	
		Without Engine	With Drogue	
			With Sea Anchor	
			Without Drag Device	
	Demasted	Inboard Engine	With Drogue	
			With Sea Anchor	
			Without Drag Device	
		Outboard Engine	With Drogue	
			With Sea Anchor	
			Without Drag Device	
	Without Engine	With Drogue		
		With Sea Anchor		
		Without Drag Device		
Canoe Hull Low Aspect Ratio Keel	With Mast	Inboard Engine	With Drogue	
			With Sea Anchor	
			Without Drag Device	
	Outboard Engine	With Drogue		
		With Sea Anchor		
		Without Drag Device		
	Without Engine	With Drogue		
		With Sea Anchor		
		Without Drag Device		
Demasted	Inboard Engine	With Drogue		
		With Sea Anchor		
		Without Drag Device		
	Outboard Engine	With Drogue		
		With Sea Anchor		
		Without Drag Device		
Without Engine	With Drogue			
	With Sea Anchor			
	Without Drag Device			

**Table A-5.  
Sailing Vessels (Continued)**

Category	Primary Drift Var.	Secondary Drift Var.	Power Modifier	Drag Device Modifier
Cruising Catamaran (Continued)	Dagger/Centerboard	With Mast	Inboard Engine	With Drogue
				With Sea Anchor
				Without Drag Device
			Outboard Engine	With Drogue
				With Sea Anchor
				Without Drag Device
		Without Engine	With Drogue	
			With Sea Anchor	
			Without Drag Device	
		Demasted	Inboard Engine	With Drogue
				With Sea Anchor
				Without Drag Device
	Outboard Engine		With Drogue	
			With Sea Anchor	
			Without Drag Device	
	Without Engine	With Drogue		
		With Sea Anchor		
		Without Drag Device		
	Swamped	With Mast	Inboard Engine	With Drogue
				With Sea Anchor
				Without Drag Device
			Outboard Engine	With Drogue
				With Sea Anchor
				Without Drag Device
Without Engine		With Drogue		
		With Sea Anchor		
		Without Drag Device		
Demasted		Inboard Engine	With Drogue	
			With Sea Anchor	
			Without Drag Device	
	Outboard Engine	With Drogue		
		With Sea Anchor		
		Without Drag Device		
Without Engine	With Drogue			
	With Sea Anchor			
	Without Drag Device			
Capsized	With Mast	With Drogue		
		With Sea Anchor		
		Without Drag Device		
	Demasted	With Drogue		
		With Sea Anchor		
		Without Drag Device		
Cruising Trimaran	Racing Hull	With Mast	Inboard Engine	With Drogue
				With Sea Anchor
				Without Drag Device
		Outboard Engine	With Drogue	
			With Sea Anchor	
			Without Drag Device	
	Without Engine	With Drogue		
		With Sea Anchor		
		Without Drag Device		
	Demasted	Inboard Engine	With Drogue	
			With Sea Anchor	
			Without Drag Device	
Outboard Engine		With Drogue		
		With Sea Anchor		
		Without Drag Device		
Without Engine	With Drogue			
	With Sea Anchor			
	Without Drag Device			

**Table A-5.  
Sailing Vessels (Continued)**

Category	Primary Drift Var.	Secondary Drift Var.	Power Modifier	Drag Device Modifier
Cruising Trimaran (Continued)	Bare Hull/Skeg Fin	With Mast	Inboard Engine	With Drogue
				With Sea Anchor
				Without Drag Device
			Outboard Engine	With Drogue
				With Sea Anchor
				Without Drag Device
		Without Engine	With Drogue	
			With Sea Anchor	
			Without Drag Device	
		Demasted	Inboard Engine	With Drogue
				With Sea Anchor
				Without Drag Device
	Outboard Engine		With Drogue	
			With Sea Anchor	
			Without Drag Device	
	Without Engine	With Drogue		
		With Sea Anchor		
		Without Drag Device		
	Dagger/Centerboard	With Mast	Inboard Engine	With Drogue
				With Sea Anchor
				Without Drag Device
			Outboard Engine	With Drogue
				With Sea Anchor
				Without Drag Device
		Without Engine	With Drogue	
			With Sea Anchor	
			Without Drag Device	
		Demasted	Inboard Engine	With Drogue
				With Sea Anchor
				Without Drag Device
	Outboard Engine		With Drogue	
			With Sea Anchor	
			Without Drag Device	
	Without Engine	With Drogue		
		With Sea Anchor		
		Without Drag Device		
Swamped	With Mast	Inboard Engine	With Drogue	
			With Sea Anchor	
			Without Drag Device	
		Outboard Engine	With Drogue	
			With Sea Anchor	
			Without Drag Device	
	Without Engine	With Drogue		
		With Sea Anchor		
		Without Drag Device		
	Demasted	Inboard Engine	With Drogue	
			With Sea Anchor	
			Without Drag Device	
Outboard Engine		With Drogue		
		With Sea Anchor		
		Without Drag Device		
Without Engine	With Drogue			
	With Sea Anchor			
	Without Drag Device			
Capsized	With Mast	With Drogue		
		With Sea Anchor		
		Without Drag Device		
	Demasted	With Drogue		
		With Sea Anchor		
		Without Drag Device		

**Table A-6.  
Power Vessels**

Category	Primary Drift Var.	Secondary Drift Var.	Leeway Modifier
Hover Craft	Personal Size		
	Commercial Size		
	Swamped		
	Capsized		
Inflatable Boats	Rigid Hull	Engine Tiller Control	
		Helm Control	
	Inflatable Keel	Standard Configuration	
	Flat Bottom	Standard Configuration	
	Swamped		
	Capsized		
Skiffs	Flat Bottom	Without canvas	
		With raised canvas	
	V-Hull	Without canvas	
		With raised canvas	
	Double Ended Keel-Hull	Without canvas	
		With raised canvas	
	Swamped	Without canvas	
		With raised canvas	
	Capsized	Without canvas	
		With canvas	
Personal Water Craft	Sitting Style	1-2 Person	
		3 Or More Persons	
	Standing Style		
Sport Boats	Bow Rider	Deep-V Hull	With Canvas Canopy
			Without Canvas Canopy
		Modified-V Hull	With Canvas Canopy
			Without Canvas Canopy
		Multi-Hull	With Canvas Canopy
			Without Canvas Canopy
	Closed Bow	Deep-V Hull	With Canvas Canopy
			Without Canvas Canopy
		Modified-V Hull	With Canvas Canopy
			Without Canvas Canopy
		Multi-Hull	With Canvas Canopy
			Without Canvas Canopy
	Cuddy Cabin	Deep-V Hull	With Canvas Canopy
			Without Canvas Canopy
		Modified-V Hull	With Canvas Canopy
			Without Canvas Canopy
		Multi-Hull	With Canvas Canopy
			Without Canvas Canopy
	High Performance	Deep-V Hull	
		Modified-V Hull	
		Multi-Hull	
	Swamped	Bow Rider	With Canvas Canopy
			Without Canvas Canopy
		Closed Bow	With Canvas Canopy
		Without Canvas Canopy	
Cuddy Cabin		With Canvas Canopy	
		Without Canvas Canopy	
Capsized	High Performance		
	Open Bow	With Canvas Canopy	
		Without Canvas Canopy	
	Closed Bow	With Canvas Canopy	
		Without Canvas Canopy	
	Cuddy Cabin	With Canvas Canopy	
	Without Canvas Canopy		

**Table A-6.  
Power Vessels (Continued)**

Category	Primary Drift Var.	Secondary Drift Var.	Leeway Modifier	
Sport Fishers	Center Consol	Deep-V Hull	With Helm Canopy	
			With Helm Enclosure	
			Open Cockpit	
		Modified-V Hull	With Helm Canopy	
			With Helm Enclosure	
			Open Cockpit	
		Multi-Hull	With Helm Cover	
			With Helm Enclosure	
			Open Cockpit	
	Walk Around Cuddy	Deep-V Hull	With Helm Cover	
			With Helm Enclosure	
			Open Cockpit	
		Modified-V Hull	With Helm Canopy	
			With Helm Enclosure	
			Open Cockpit	
		Multi-Hull	With Helm Canopy	
			With Helm Enclosure	
			Open Cockpit	
	Semi-Displacement Hull	With Helm Canopy		
		With Helm Enclosure		
		Open Cockpit		
	Convertible	Deep-V Hull	Bridge Canopy	Without Drogue
				With Drogue
			Bridge Enclosure	Without Drogue
				With Drogue
			Open Bridge	Without Drogue
				With Drogue
		Modified-V Hull	Bridge Canopy	Without Drogue
				With Drogue
			Bridge Enclosure	Without Drogue
				With Drogue
			Open Bridge	Without Drogue
				With Drogue
		Semi-Displacement Hull	Bridge Canopy	Without Drogue
				With Drogue
			Bridge Enclosure	Without Drogue
	With Drogue			
	Open Bridge		Without Drogue	
			With Drogue	
	Swamped	Center Consol	With Helm Canopy	
			With Helm Enclosure	
			Open Cockpit	
Walk Around Cuddy		With Helm Canopy		
		With Helm Enclosure		
		Open Cockpit		
Convertible		Bridge Canopy		
		Bridge Enclosure		
		Open Bridge		
Capsized	Center Consol	With Helm Canopy		
		With Helm Enclosure		
		Open Cockpit		
	Walk Around Cuddy	With Helm Canopy		
		With Helm Enclosure		
		Open Cockpit		
	Convertible	Bridge Canopy		
		Bridge Enclosure		
		Open Bridge		
	Convertible With Spotting Tower	Bridge Canopy		
		Bridge Enclosure		
		Open Bridge		

**Table A-6.  
Power Vessels (Continued)**

Category	Primary Drift Var.	Secondary Drift Var.	Leeway Modifier	
Sport Cruisers	Express Cruiser	Deep-V Hull	With Canvas Canopy	
			With Canvas Enclosure	
			Without Canvas	
		Modified-V Hull	With Canvas Canopy	
			With Canvas Enclosure	
			Without Canvas	
		Multi-Hull	With Canvas Canopy	
			With Canvas Enclosure	
			Without Canvas	
	Family Cruiser	Deep-V Hull	With Canvas Canopy	
			With Canvas Enclosure	
			Without Canvas	
		Modified-V Hull	With Canvas Canopy	
			With Canvas Enclosure	
			Without Canvas	
		Semi-Displacement Hull	With Canvas Canopy	
			With Canvas Enclosure	
			Without Canvas	
	Dory Cruiser	Displacement Hull	With Canvas Canopy	
			With Canvas Enclosure	
			Without Canvas	
		Semi-Displacement Hull	With Canvas Canopy	
			With Canvas Enclosure	
			Without Canvas	
	Motor Yacht	Displacement Hull	Full Deck House	Bridge Canopy
				Bridge Enclosure
				Open Bridge
			Covered Aft Deck	Bridge Canopy
				Bridge Enclosure
				Open Bridge
Open Aft Deck			Bridge Canopy	
			Bridge Enclosure	
			Open Bridge	
Semi-Displacement Hull		Full Deck House	Bridge Canopy	
			Bridge Enclosure	
			Open Bridge	
		Covered Aft Deck	Bridge Canopy	
			Bridge Enclosure	
			Open Bridge	
		Open Aft Deck	Bridge Canopy	
			Bridge Enclosure	
			Open Bridge	
Modified-V Hull		Full Deck House	Bridge Canopy	
			Bridge Enclosure	
			Open Bridge	
	Covered Aft Deck	Bridge Canopy		
		Bridge Enclosure		
		Open Bridge		
	Open Aft Deck	Bridge Canopy		
		Bridge Enclosure		
		Open Bridge		
High Performance	Deep-V Hull	Open Cockpit		
		Covered Cockpit		
	Multi-Hull	Open Cockpit		
		Covered Cockpit		



**Table A-6.  
Power Vessels (Continued)**

Category	Primary Drift Var.	Secondary Drift Var.	Leeway Modifier	
Sport Cruisers (Continued)	Swamped or Sinking	Express Cruiser	With Canvas Canopy	
			With Canvas Enclosure	
			Without Canvas	
		Family Cruiser	With Canvas Canopy	
			With Canvas Enclosure	
			Without Canvas	
		Dory Cruiser	With Canvas Canopy	
			With Canvas Enclosure	
			Without Canvas	
		Motor Yacht	Full Deck House	Bridge Canopy
				Bridge Enclosure
				Open Bridge
	Covered Aft Deck		Bridge Canopy	
			Bridge Enclosure	
			Open Bridge	
	Open Aft Deck	Bridge Canopy		
		Bridge Enclosure		
		Open Bridge		
	High Performance	Open Cockpit		
		Covered Cockpit		
	Capsized	Express Cruiser	With Canvas Canopy	
			With Canvas Enclosure	
			Without Canvas	
		Family Cruiser	With Canvas Canopy	
With Canvas Enclosure				
Without Canvas				
Dory Cruiser		With Canvas Canopy		
		With Canvas Enclosure		
		Without Canvas		
Motor Yacht		Full Deck House	Bridge Canopy	
			Bridge Enclosure	
			Open Bridge	
	Covered Aft Deck	Bridge Canopy		
		Bridge Enclosure		
		Open Bridge		
Open Aft Deck	Bridge Canopy			
	Bridge Enclosure			
	Open Bridge			
High Performance	Open Cockpit			
	Covered Cockpit			

**Table A-6.  
Power Vessels (Continued)**

Category	Primary Drift Var.	Secondary Drift Var.	Leeway Modifier	
Commercial Fishers	Side Trawler	Standard Configuration		
	Stern Trawler/Troller	A-Frame Rig		
		Boom Rig		
		Outrigger Rigged		
	Gillnetter	Stern Picker		
		Bow Picker		
	Long Liner	Standard Configuration		
	Purse Seiner	Standard Configuration		
	Trap Boat	Standard Configuration		
	Sampan	Standard Configuration		
	Lobster Boat	Standard Configuration		
	Swamped		Side Trawler	
			Stern Trawler/Troller	
			Bottom Dragger	
			Long Liner	
			Purse Seiner	
			Trap Boat	
			Sampan	
	Capsized		Lobster Boat	
			Side Trawler	
		Stern Trawler/Troller		
		Bottom Dragger		
		Long Liner		
		Purse Seiner		
		Trap Boat		
Coastal Freighter	Forward Deckhouse	Light Loading		
		Heavy Loading		
	Midship Deckhouse	Light Loading		
		Heavy Loading		
	Aft Deckhouse	Light Loading		
		Heavy Loading		
	Swamped	Forward Deckhouse		
		Midship Deckhouse		
		Aft Deckhouse		
	Capsized	Forward Deckhouse		
Midship Deckhouse				
Aft Deckhouse				

**Table A-7.  
Boating Debris**

Category	Primary Drift Var.	Secondary Drift Var.
Boating Wreckage	Hull Portion	
	Transom Portion	
	Fender	
	Fragmented Debris	
	Canvas	
Boat Cushions	Seat Cushion	
	Bench Cushion	
	Bunk Cushion	
Ice Chests	Six Pack Cooler	Empty
		Loaded
	Soft Sided Cooler	Empty
		Loaded
	Less than 70 Quart Ice Chest	Empty
		Loaded
	More than 70 Quart Ice Chest	Empty
		Loaded
	1-cubic meter Commercial Bait / Wharf Box	lightly loaded
		Heavy loaded
Build-in Ice / Bait Box	lightly loaded	
	Heavy loaded	
Distress Beacons	Life Ring	With Light Float
		Without Light Float
	EPIRB	Full Size
		Mini-Beacon
	Light Float	

**Table A-8.  
Aviation PIW**

Category	Primary Drift Variable	State of PIW	PFD Style
Persons in the Water (PIW) from Aviation Sources	Vertical Position	Conscious	No Flotation
			Anti-Exposure suit
	Sitting Position	Conscious	Inflatable Vests
			Seat Cushions
	Horizontal Position	Unconscious	Inflatable Vests
			No Flotation
	Victims	Anti-Exposure suit	

**Table A-9.  
Aviation Survival Craft**

Category	Primary Drift Var.	Secondary Drift Var.	Drogue Modifier	Capacity Modifier	Loading Modifier
Aviation Life Rafts	No Ballast System	With Canopy	With Drogue	1-2 Person	
				4-6 Person	Light Loading
					Heavy Loading
				8-10 Person	Light Loading
					Heavy Loading
				10-15 Person	Light Loading
				Heavy Loading	
			15-25 Person	Light Loading	
				Heavy Loading	
			25-50 Person	Light Loading	
				Heavy Loading	
			Without Drogue	1-2 Person	
		4-6 Person		Light Loading	
				Heavy Loading	
		8-10 Person		Light Loading	
				Heavy Loading	
		10-15 Person		Light Loading	
			Heavy Loading		
		15-25 Person	Light Loading		
			Heavy Loading		
		25-50 Person	Light Loading		
			Heavy Loading		
		Without Canopy	With Drogue	1-2 Person	
				4-6 Person	Light Loading
	Heavy Loading				
8-10 Person	Light Loading				
	Heavy Loading				
10-15 Person	Light Loading				
	Heavy Loading				
15-25 Person	Light Loading				
	Heavy Loading				
25-50 Person	Light Loading				
	Heavy Loading				
Without Drogue	1-2 Person				
	4-6 Person	Light Loading			
		Heavy Loading			
	8-10 Person	Light Loading			
		Heavy Loading			
	10-15 Person	Light Loading			
	Heavy Loading				
15-25 Person	Light Loading				
	Heavy Loading				
25-50 Person	Light Loading				
	Heavy Loading				

**Table A-9.  
Aviation Survival Craft (Continued)**

Category	Primary Drift Var.	Secondary Drift Var.	Drogue Modifier	Capacity Modifier	Loading Modifier
Aviation Life Rafts (Continued)	With Shallow Pocket Ballast System	With Canopy	With Drogue	1-2 Person	
				4-6 Person	Light Loading
					Heavy Loading
				8-10 Person	Light Loading
					Heavy Loading
				10-15 Person	Light Loading
				Heavy Loading	
			15-25 Person	Light Loading	
				Heavy Loading	
			25-50 Person	Light Loading	
				Heavy Loading	
			Without Drogue	1-2 Person	
		4-6 Person		Light Loading	
				Heavy Loading	
		8-10 Person		Light Loading	
				Heavy Loading	
		10-15 Person		Light Loading	
			Heavy Loading		
		15-25 Person	Light Loading		
			Heavy Loading		
		25-50 Person	Light Loading		
			Heavy Loading		
		Without Canopy	With Drogue	1-2 Person	
				4-6 Person	Light Loading
	Heavy Loading				
8-10 Person	Light Loading				
	Heavy Loading				
10-15 Person	Light Loading				
	Heavy Loading				
15-25 Person	Light Loading				
	Heavy Loading				
25-50 Person	Light Loading				
	Heavy Loading				
Without Drogue	1-2 Person				
	4-6 Person	Light Loading			
		Heavy Loading			
	8-10 Person	Light Loading			
		Heavy Loading			
	10-15 Person	Light Loading			
	Heavy Loading				
15-25 Person	Light Loading				
	Heavy Loading				
25-50 Person	Light Loading				
	Heavy Loading				

**Table A-9.  
Aviation Survival Craft (Continued)**

Category	Primary Drift Var.	Secondary Drift Var.	Drogue Modifier	Capacity Modifier	Loading Modifier
Aviation Life Rafts (Continued)	With Deep Ballast	With Canopy	With Drogue	1-2 Person	
				4-6 Person	Light Loading Heavy Loading
				8-10 Person	Light Loading Heavy Loading
				10-15 Person	Light Loading Heavy Loading
				15-25 Person	Light Loading Heavy Loading
				25-50 Person	Light Loading Heavy Loading
			Without Drogue	1-2 Person	
				4-6 Person	Light Loading Heavy Loading
				8-10 Person	Light Loading Heavy Loading
				10-15 Person	Light Loading Heavy Loading
				15-25 Person	Light Loading Heavy Loading
				25-50 Person	Light Loading Heavy Loading
		Without Canopy	With Drogue	1-2 Person	
				4-6 Person	Light Loading Heavy Loading
				8-10 Person	Light Loading Heavy Loading
				10-15 Person	Light Loading Heavy Loading
				15-25 Person	Light Loading Heavy Loading
				25-50 Person	Light Loading Heavy Loading
			Without Drogue	1-2 Person	
				4-6 Person	Light Loading Heavy Loading
				8-10 Person	Light Loading Heavy Loading
				10-15 Person	Light Loading Heavy Loading
				15-25 Person	Light Loading Heavy Loading
				25-50 Person	Light Loading Heavy Loading

**Table A-9.  
Aviation Survival Craft (Continued)**

Category	Primary Drift Var.	Secondary Drift Var.	Drogue Modifier	Capacity Modifier	Loading Modifier
Aviation Life Rafts (Continued)	Swamped	With Canopy	With Drogue	1-2 Person	
				4-6 Person	Light Loading
					Heavy Loading
				8-10 Person	Light Loading
					Heavy Loading
				10-15 Person	Light Loading
				Heavy Loading	
			15-25 Person	Light Loading	
				Heavy Loading	
			25-50 Person	Light Loading	
				Heavy Loading	
			Without Drogue	1-2 Person	
		4-6 Person		Light Loading	
				Heavy Loading	
		8-10 Person		Light Loading	
				Heavy Loading	
		10-15 Person		Light Loading	
			Heavy Loading		
		15-25 Person	Light Loading		
			Heavy Loading		
		25-50 Person	Light Loading		
			Heavy Loading		
		Without Canopy	With Drogue	1-2 Person	
				4-6 Person	Light Loading
	Heavy Loading				
8-10 Person	Light Loading				
	Heavy Loading				
10-15 Person	Light Loading				
	Heavy Loading				
15-25 Person	Light Loading				
	Heavy Loading				
25-50 Person	Light Loading				
	Heavy Loading				
Without Drogue	1-2 Person				
	4-6 Person	Light Loading			
		Heavy Loading			
	8-10 Person	Light Loading			
		Heavy Loading			
	10-15 Person	Light Loading			
	Heavy Loading				
15-25 Person	Light Loading				
	Heavy Loading				
25-50 Person	Light Loading				
	Heavy Loading				

**Table A-9  
Aviation Survival Craft (Continued)**

Category	Primary Drift Var.	Secondary Drift Var.	Drogue Modifier	Capacity Modifier	Loading Modifier
Aviation Life Rafts (Continued)	Capsized	With Canopy	With Drogue	1-2 Person	
				4-6 Person	Light Loading
					Heavy Loading
				8-10 Person	Light Loading
					Heavy Loading
				10-15 Person	Light Loading
				Heavy Loading	
			15-25 Person	Light Loading	
				Heavy Loading	
			25-50 Person	Light Loading	
				Heavy Loading	
			Without Drogue	1-2 Person	
		4-6 Person		Light Loading	
				Heavy Loading	
		8-10 Person		Light Loading	
				Heavy Loading	
		10-15 Person		Light Loading	
			Heavy Loading		
		15-25 Person	Light Loading		
			Heavy Loading		
		25-50 Person	Light Loading		
			Heavy Loading		
		Without Canopy	With Drogue	1-2 Person	
				4-6 Person	Light Loading
	Heavy Loading				
8-10 Person	Light Loading				
	Heavy Loading				
10-15 Person	Light Loading				
	Heavy Loading				
15-25 Person	Light Loading				
	Heavy Loading				
25-50 Person	Light Loading				
	Heavy Loading				
Without Drogue	1-2 Person				
	4-6 Person	Light Loading			
		Heavy Loading			
	8-10 Person	Light Loading			
		Heavy Loading			
	10-15 Person	Light Loading			
	Heavy Loading				
15-25 Person	Light Loading				
	Heavy Loading				
25-50 Person	Light Loading				
	Heavy Loading				



**Table A-9.  
Aviation Survival Craft (Continued)**

Category	Primary Drift Var.	Secondary Drift Var.	Drogue Modifier	Capacity Modifier	Loading Modifier		
Aviation Slide Rafts	Without Ballast	With Canopy	With Drogue	25-40 Person	Light Loading		
				45-80 Person	Heavy Loading		
			Without Drogue	25-40 Person	Light Loading		
				45-80 Person	Heavy Loading		
			Without Canopy	With Drogue	25-40 Person	Light Loading	
					45-80 Person	Heavy Loading	
		Without Drogue		25-40 Person	Light Loading		
				45-80 Person	Heavy Loading		
		With Pocket Ballast		With Canopy	With Drogue	25-40 Person	Light Loading
						45-80 Person	Heavy Loading
			Without Drogue		25-40 Person	Light Loading	
					45-80 Person	Heavy Loading	
	Without Canopy		With Drogue		25-40 Person	Light Loading	
					45-80 Person	Heavy Loading	
			Without Drogue	25-40 Person	Light Loading		
				45-80 Person	Heavy Loading		

**Table A-10.  
Aviation Debris**

<b>Category</b>	<b>Primary Drift Var.</b>	<b>Secondary Drift Var.</b>
Aircraft Wreckage	Insulation	
	Airframe Portion	
	Fragmented Debris	
	Door Panel	
Aircraft Seat	Full Seat	
	Seat Cushion	
	Seat Back	
Luggage	Backpack	
	Strap Bag	
	Roller Bag	
	Hanging Bag	
	Suit Case	
	Animal Cage	
	Copier Box	
	Travel Chest	
Distress Beacons	ELT	Full Size
		Mini-Beacon
	EPIRB	Full Size
		Mini-Beacon
	Light Float	

**Table A-11  
Combat SAR Aviation PIW**

Category	Primary Drift Variable	State of PIW	PFD Style
Persons in the Water (PIW) from Military Aviation Sources	Vertical Position	Conscious	No Flotation
			Anti-Exposure suit
	Sitting Position	Conscious	Inflatable Vests
		Unconscious	Inflatable Vests
	Horizontal Position	Conscious	Survival Suit
		Unconscious	Survival Suit
		Victims	No Flotation
			Anti-Exposure suit

**Table A-12.  
Combat SAR Aviation Survival Craft**

Category	Primary Drift Var.	Secondary Drift Var.	Drogue Modifier	Capacity Modifier	Loading Modifier
Combat SAR Aviation Life Rafts	No Ballast System	With Canopy	With Drogue	1-2 Person	
				4-6 Person	Light Loading
					Heavy Loading
				8-10 Person	Light Loading
					Heavy Loading
			10-15 Person	Light Loading	
				Heavy Loading	
			Without Drogue	1-2 Person	
				4-6 Person	Light Loading
					Heavy Loading
		8-10 Person		Light Loading	
				Heavy Loading	
		10-15 Person	Light Loading		
			Heavy Loading		
		Without Canopy	With Drogue	1-2 Person	
				4-6 Person	Light Loading
					Heavy Loading
				8-10 Person	Light Loading
					Heavy Loading
			10-15 Person	Light Loading	
	Heavy Loading				
Without Drogue	1-2 Person				
	4-6 Person		Light Loading		
			Heavy Loading		
	8-10 Person	Light Loading			
		Heavy Loading			
10-15 Person	Light Loading				
	Heavy Loading				

**Table A-12.  
Combat SAR Aviation Survival Craft (Continued)**

Category	Primary Drift Var.	Secondary Drift Var.	Drogue Modifier	Capacity Modifier	Loading Modifier
Combat SAR Aviation Life Rafts (Continued)	With Shallow Pocket Ballast System	With Canopy	With Drogue	1-2 Person	
				4-6 Person	Light Loading
					Heavy Loading
				8-10 Person	Light Loading
				Heavy Loading	
			10-15 Person	Light Loading	
				Heavy Loading	
			Without Drogue	1-2 Person	
		4-6 Person		Light Loading	
				Heavy Loading	
		8-10 Person		Light Loading	
				Heavy Loading	
		10-15 Person		Light Loading	
				Heavy Loading	
		Without Canopy		With Drogue	1-2 Person
			4-6 Person		Light Loading
			Heavy Loading		
	8-10 Person		Light Loading		
			Heavy Loading		
	10-15 Person		Light Loading		
			Heavy Loading		
	Without Drogue		1-2 Person		
		4-6 Person	Light Loading		
			Heavy Loading		
		8-10 Person	Light Loading		
		Heavy Loading			
	10-15 Person	Light Loading			
		Heavy Loading			
	With Deep Ballast	With Canopy	With Drogue	1-2 Person	
				4-6 Person	Light Loading
					Heavy Loading
				8-10 Person	Light Loading
			Heavy Loading		
10-15 Person			Light Loading		
			Heavy Loading		
Without Drogue			1-2 Person		
		4-6 Person	Light Loading		
			Heavy Loading		
		8-10 Person	Light Loading		
			Heavy Loading		
		10-15 Person	Light Loading		
			Heavy Loading		
		Without Canopy	With Drogue	1-2 Person	
4-6 Person				Light Loading	
	Heavy Loading				
8-10 Person	Light Loading				
	Heavy Loading				
10-15 Person	Light Loading				
	Heavy Loading				
Without Drogue	1-2 Person				
	4-6 Person	Light Loading			
		Heavy Loading			
	8-10 Person	Light Loading			
	Heavy Loading				
10-15 Person	Light Loading				
	Heavy Loading				

**Table A-12.  
Combat SAR Aviation Survival Craft (Continued)**

Category	Primary Drift Var.	Secondary Drift Var.	Drogue Modifier	Capacity Modifier	Loading Modifier
Combat SAR Aviation Life Rafts (Continued)	Swamped	With Canopy	With Drogue	1-2 Person	
				4-6 Person	Light Loading
					Heavy Loading
				8-10 Person	Light Loading
				Heavy Loading	
			10-15 Person	Light Loading	
				Heavy Loading	
			Without Drogue	1-2 Person	
		4-6 Person		Light Loading	
				Heavy Loading	
		8-10 Person		Light Loading	
				Heavy Loading	
		10-15 Person		Light Loading	
				Heavy Loading	
				Heavy Loading	
		Without Canopy	With Drogue	With Drogue	1-2 Person
	4-6 Person				Light Loading
					Heavy Loading
	8-10 Person				Light Loading
				Heavy Loading	
	10-15 Person			Light Loading	
				Heavy Loading	
	Without Drogue			1-2 Person	
			4-6 Person	Light Loading	
				Heavy Loading	
			8-10 Person	Light Loading	
				Heavy Loading	
			10-15 Person	Light Loading	
				Heavy Loading	
				Heavy Loading	
	Capsized		With Canopy	With Drogue	1-2 Person
		4-6 Person			Light Loading
		Heavy Loading			
8-10 Person		Light Loading			
		Heavy Loading			
10-15 Person		Light Loading			
		Heavy Loading			
Without Drogue		1-2 Person			
		4-6 Person	Light Loading		
			Heavy Loading		
		8-10 Person	Light Loading		
			Heavy Loading		
		10-15 Person	Light Loading		
			Heavy Loading		
			Heavy Loading		
Without Canopy		With Drogue	With Drogue	1-2 Person	
	4-6 Person			Light Loading	
				Heavy Loading	
	8-10 Person			Light Loading	
			Heavy Loading		
	10-15 Person		Light Loading		
			Heavy Loading		
	Without Drogue		1-2 Person		
		4-6 Person	Light Loading		
			Heavy Loading		
		8-10 Person	Light Loading		
			Heavy Loading		
		10-15 Person	Light Loading		
			Heavy Loading		
			Heavy Loading		

**Table A-13.  
Combat SAR Aviation Debris**

Category	Primary Drift Var.	Secondary Drift Var.
Aircraft Wreckage	Insulation	
	Airframe Portion	
	Fragmented Debris	
	Door Panel	
Aircraft Seat	Full Seat	
	Seat Cushion	
	Seat Back	
	Ejection Seat	
Distress Beacons	ELT	Full Size
		Mini-Beacon
	EPIRB	Full Size
		Mini-Beacon
	Light Float	

**Table A-14.  
Combat SAR Maritime PIW**

Category	Primary Drift Variable	State of PIW	PFD Style
Persons in the Water (PIW) from Military Maritime Sources	PIW in the Vertical position	Conscious	No Flotation
			Using Uniform for Flotation
			Work vest
			Anti-Exposure coveralls
			Float Coat
	PIW in the Sitting Position	Conscious	Offshore lifejacket
			Inflatable Vests
		Unconscious	Throwable devices
			Offshore lifejacket
	PIW in the Horizontal Position	Conscious	Inflatable Vests
			Survival Suit
		Unconscious	Survival Suit
			No Flotation
		Victims	Work vest
			Anti-Exposure coveralls
Float Coat			

**Table A-15.  
Combat SAR Maritime Survival Craft**

Category	Primary Drift Var.	Secondary Drift Var.	Drogue Modifier	Capacity Modifier	Loading Modifier	
Combat SAR Marine Life Rafts	No Ballast System	With Canopy	With Drogue	4-6 Person	Light Loading	
					Heavy Loading	
				8-10 Person	Light Loading	
					Heavy Loading	
				10-15 Person	Light Loading	
					Heavy Loading	
			15-25 Person	Light Loading		
				Heavy Loading		
			25-50 Person	Light Loading		
				Heavy Loading		
			50-100 Person	Light Loading		
				Heavy Loading		
		Without Canopy	With Drogue	Without Drogue	4-6 Person	Light Loading
						Heavy Loading
					8-10 Person	Light Loading
						Heavy Loading
					10-15 Person	Light Loading
						Heavy Loading
			15-25 Person	Light Loading		
				Heavy Loading		
			25-50 Person	Light Loading		
				Heavy Loading		
			50-100 Person	Light Loading		
				Heavy Loading		
Without Canopy	With Drogue	Without Drogue	4-6 Person	Light Loading		
				Heavy Loading		
			8-10 Person	Light Loading		
				Heavy Loading		
			10-15 Person	Light Loading		
				Heavy Loading		
	15-25 Person	Light Loading				
		Heavy Loading				
	25-50 Person	Light Loading				
		Heavy Loading				
	50-100 Person	Light Loading				
		Heavy Loading				

**Table A-15.  
Combat SAR Maritime Survival Craft (Continued)**

Category	Primary Drift Var.	Secondary Drift Var.	Drogue Modifier	Capacity Modifier	Loading Modifier
Combat SAR Marine Life Rafts (Continued)	With Shallow Pocket Ballast System	With Canopy	With Drogue	4-6 Person	Light Loading
					Heavy Loading
				8-10 Person	Light Loading
					Heavy Loading
				10-15 Person	Light Loading
					Heavy Loading
			15-25 Person	Light Loading	
				Heavy Loading	
			25-50 Person	Light Loading	
				Heavy Loading	
			50-100 Person	Light Loading	
				Heavy Loading	
		Without Drogue	4-6 Person	Light Loading	
				Heavy Loading	
			8-10 Person	Light Loading	
				Heavy Loading	
			10-15 Person	Light Loading	
				Heavy Loading	
		15-25 Person	Light Loading		
			Heavy Loading		
		25-50 Person	Light Loading		
			Heavy Loading		
		50-100 Person	Light Loading		
			Heavy Loading		
Without Canopy	With Drogue	4-6 Person	Light Loading		
			Heavy Loading		
		8-10 Person	Light Loading		
			Heavy Loading		
		10-15 Person	Light Loading		
			Heavy Loading		
	15-25 Person	Light Loading			
		Heavy Loading			
	25-50 Person	Light Loading			
		Heavy Loading			
	50-100 Person	Light Loading			
		Heavy Loading			
Without Drogue	4-6 Person	Light Loading			
		Heavy Loading			
	8-10 Person	Light Loading			
		Heavy Loading			
	10-15 Person	Light Loading			
		Heavy Loading			
15-25 Person	Light Loading				
	Heavy Loading				
25-50 Person	Light Loading				
	Heavy Loading				
50-100 Person	Light Loading				
	Heavy Loading				



**Table A-15.  
Combat SAR Maritime Survival Craft (Continued)**

Category	Primary Drift Var.	Secondary Drift Var.	Drogue Modifier	Capacity Modifier	Loading Modifier
Combat SAR Marine Life Rafts (Continued)	With Deep Ballast	With Canopy	With Drogue	4-6 Person	Light Loading
					Heavy Loading
				8-10 Person	Light Loading
					Heavy Loading
				10-15 Person	Light Loading
					Heavy Loading
			15-25 Person	Light Loading	
				Heavy Loading	
			25-50 Person	Light Loading	
				Heavy Loading	
			50-100 Person	Light Loading	
				Heavy Loading	
		Without Drogue	4-6 Person	Light Loading	
				Heavy Loading	
			8-10 Person	Light Loading	
				Heavy Loading	
			10-15 Person	Light Loading	
				Heavy Loading	
		15-25 Person	Light Loading		
			Heavy Loading		
		25-50 Person	Light Loading		
			Heavy Loading		
		50-100 Person	Light Loading		
			Heavy Loading		
Without Canopy	With Drogue	4-6 Person	Light Loading		
			Heavy Loading		
		8-10 Person	Light Loading		
			Heavy Loading		
		10-15 Person	Light Loading		
			Heavy Loading		
	15-25 Person	Light Loading			
		Heavy Loading			
	25-50 Person	Light Loading			
		Heavy Loading			
	50-100 Person	Light Loading			
		Heavy Loading			
Without Drogue	4-6 Person	Light Loading			
		Heavy Loading			
	8-10 Person	Light Loading			
		Heavy Loading			
	10-15 Person	Light Loading			
		Heavy Loading			
15-25 Person	Light Loading				
	Heavy Loading				
25-50 Person	Light Loading				
	Heavy Loading				
50-100 Person	Light Loading				
	Heavy Loading				

**Table A-15.  
Combat SAR Maritime Survival Craft (Continued)**

Category	Primary Drift Var.	Secondary Drift Var.	Drogue Modifier	Capacity Modifier	Loading Modifier
Combat SAR Marine Life Rafts (Continued)	Swamped	With Canopy	With Drogue	4-6 Person	Light Loading
					Heavy Loading
				8-10 Person	Light Loading
					Heavy Loading
				10-15 Person	Light Loading
					Heavy Loading
			15-25 Person	Light Loading	
				Heavy Loading	
			25-50 Person	Light Loading	
				Heavy Loading	
			50-100 Person	Light Loading	
				Heavy Loading	
		Without Drogue	4-6 Person	Light Loading	
				Heavy Loading	
			8-10 Person	Light Loading	
				Heavy Loading	
			10-15 Person	Light Loading	
				Heavy Loading	
		15-25 Person	Light Loading		
			Heavy Loading		
		25-50 Person	Light Loading		
			Heavy Loading		
		50-100 Person	Light Loading		
			Heavy Loading		
Without Canopy	With Drogue	4-6 Person	Light Loading		
			Heavy Loading		
		8-10 Person	Light Loading		
			Heavy Loading		
		10-15 Person	Light Loading		
			Heavy Loading		
	15-25 Person	Light Loading			
		Heavy Loading			
	25-50 Person	Light Loading			
		Heavy Loading			
	50-100 Person	Light Loading			
		Heavy Loading			
Without Drogue	4-6 Person	Light Loading			
		Heavy Loading			
	8-10 Person	Light Loading			
		Heavy Loading			
	10-15 Person	Light Loading			
		Heavy Loading			
15-25 Person	Light Loading				
	Heavy Loading				
25-50 Person	Light Loading				
	Heavy Loading				
50-100 Person	Light Loading				
	Heavy Loading				

**Table A-15.  
Combat SAR Maritime Survival Craft (Continued)**

Category	Primary Drift Var.	Secondary Drift Var.	Drogue Modifier	Capacity Modifier	Loading Modifier	
Combat SAR Marine Life Rafts (Continued)	Capsized	With Canopy	With Drogue	4-6 Person	Light Loading	
					Heavy Loading	
				8-10 Person	Light Loading	
					Heavy Loading	
				10-15 Person	Light Loading	
					Heavy Loading	
			15-25 Person	Light Loading		
				Heavy Loading		
			25-50 Person	Light Loading		
				Heavy Loading		
			50-100 Person	Light Loading		
				Heavy Loading		
		Without Canopy	With Drogue	Without Drogue	4-6 Person	Light Loading
						Heavy Loading
					8-10 Person	Light Loading
						Heavy Loading
					10-15 Person	Light Loading
						Heavy Loading
			15-25 Person	Light Loading		
				Heavy Loading		
			25-50 Person	Light Loading		
				Heavy Loading		
			50-100 Person	Light Loading		
				Heavy Loading		
Without Canopy	With Drogue	Without Drogue	4-6 Person	Light Loading		
				Heavy Loading		
			8-10 Person	Light Loading		
				Heavy Loading		
			10-15 Person	Light Loading		
				Heavy Loading		
	15-25 Person	Light Loading				
		Heavy Loading				
	25-50 Person	Light Loading				
		Heavy Loading				
	50-100 Person	Light Loading				
		Heavy Loading				

**Table A-15.  
Combat SAR Maritime Survival Craft (Continued)**

Category	Primary Drift Var.	Secondary Drift Var.	Drogue Modifier	Capacity Modifier	Loading Modifier
Open Life Boat	With Engine	With Helm Control	With Drogue		Lightly Loaded
			Without Drogue		Heavily Loaded
		With Tiller Control	With Drogue		Lightly Loaded
			Without Drogue		Heavily Loaded
		Without Engine	With Drogue		Lightly Loaded
			Without Drogue		Heavily Loaded
	Swamped	With Drogue	Lightly Loaded		
			Heavily Loaded		
		Without Drogue	Lightly Loaded		
			Heavily Loaded		
	Capsized	With Drogue		Lightly Loaded	
		Without Drogue		Heavily Loaded	
	Life Capsule	Standard Configuration	With Drogue		Lightly Loaded
			Without Drogue		Heavily Loaded
Swamped		With Drogue		Lightly Loaded	
		Without Drogue		Heavily Loaded	
Capsized		With Drogue		Lightly Loaded	
		Without Drogue		Heavily Loaded	

**Table A-16.  
Combat SAR Power Vessels**

**TBD**

**Table A-17.  
Combat SAR Maritime Debris**

Category	Primary Drift Var.	Secondary Drift Var.
Boating Wreckage	Hull Portion	
	Ball Fender	
	Tube Fender	
	Fragmented Debris	
	Bedding	
Distress Beacons	Life Ring	With Light Float Without Light Float
	EPIRB	Full Size Mini-Beacon
	Light Float	

**Table A-18.  
Law Enforcement Drift Objects**

Source	Category
Drug Flotsam	Drug Brick in Plastic Bag
	Bale
	Powdered Drug in Cylinder
Drug Vessels (Evasive)	Sailboat
	Sport Cruiser
	High Performance Cruiser
	Convertible Sport Fisher
	Commercial Fisher
	Coastal Freighter
Immigration Vessel	Cuban Life Raft
	Paddled Raft
	Yola
	Haitian Sailboat
	Coastal Freighter

**Table A-19.  
Marine Safety Drift Objects**

Source	Category
Surface Slick	Light Oil
	Heavy Oil
	Sewage
	Medical Waste
Hazards to Navigation	Large Iceberg
	Small Iceberg
	Ice Growler Pack
	Flotsam / Trash
	55-gallon drums
	Cargo Container
	Disabled Oil Barge
	Disabled Coastal Freighter
	Disabled Tanker
	Dead Whale
Tree Trunk	

**Table A-20.**  
**Military Drift Objects**

<b>Source</b>	<b>Category</b>
Ordinance	Mine
	Torpedo
Non-Ordinance	Target Balloon
	Target Craft

## Appendix B

### CLASS DESCRIPTIONS OF LEEWAY DRIFT OBJECTS

Appendix B provides descriptive information for each of the classes of leeway drift objects included in Appendix A. Table B-1 provides a cross-reference between the Appendix A taxonomy tables and the Appendix B descriptions for each class of leeway drift objects.

For most of the classes, the descriptive information includes:

- Representative illustrations
- A description of the class including class characteristics and the specific values that define the class characteristics--Descriptive material in this section is generally from the resource references included in Appendix C, although some of the material is from the leeway drift study references.
- Rescue equipment that may become leeway drift targets
- References for class descriptions
- Leeway drift study references and notes

**Table B - 1. Cross-Reference of Leeway Drift Objects**

Taxonomy Table	Class Of Leeway Drift Objects	Appendix B Subsection
A-2	Boating PIW	B1
A-3	Maritime Survival Craft	B2
A-4	Person-Powered Craft	B3
A-5	Sailing Vessels	B4
	Full Keel One-design Sailboat	B4.1
	Fin Keel One-design Sailboat	B4.2
	Dagger/Centerboard One-design Sailboat	B4.3
	Bare Bottom One-design Sailboat	B4.4
	Sport Catamaran	B4.5
	Sport Trimaran	B4.6
	Full Keel Cruising Sailboat	B4.7
	Fin Keel Cruising Sailboat	B4.8
	Water Ballast Trailer Sailboat	B4.9
	Cruising Catamaran	B4.10
	Cruising Trimaran	B4.11
A-6	Power Vessels	B5
	Hovercraft	B5.1
	Inflatable Boats	B5.2
	Skiffs	B5.3
	Personal Water Craft	B5.4
	Sport Boats	B5.5
	Sport Fishers	B5.6
	Sport Cruisers	B5.7
	Commercial Fishers	B5.8
	Coastal Freighters	B5.9

<b>Taxonomy Table</b>	<b>Class Of Leeway Drift Objects</b>	<b>Appendix B Subsection</b>
A-7	Boating Debris	B6
A-8	Aviation PIW	B7
A-9	Aviation Survival Craft	B8
A-10	Aviation Debris	B9
A-11	Combat SAR Aviation PIW	B10
A-12	Combat SAR Aviation Survival Craft	B11
A-13	Combat SAR Aviation Debris	B12
A-14	Combat SAR Maritime PIW	B13
A-15	Combat SAR Maritime Survival Craft	B14
A-16	Combat SAR Maritime Power Vessels	B15
A-17	Combat SAR Maritime Debris	B16
A-18	Law Enforcement Drift Objects	B17
	Drug Flotsam	B17.1
	Drug Vessels	B17.2
	Immigration Vessels	B17.3
A-19	Marine Safety Drift Objects	B18
	Surface Slicks	B18.1
	Hazards to Navigation	B18.2
A-20	Military Drift Objects	B19



## B1 BOATING PIW



**Type I Reversible  
Horse-Collar PFD**

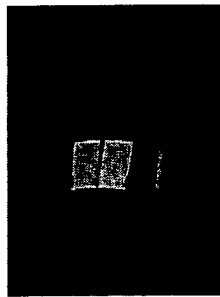

**Type I Non-reversible  
Off-shore Lifejacket**



**Type II Reversible  
Horse-collar PFDs**

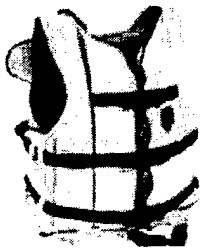

**Type III Sport  
Vest**

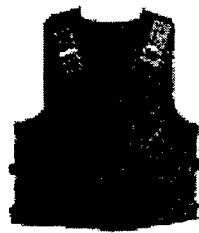

**Type III Float  
Coat**



**Type IV Life-Ring**

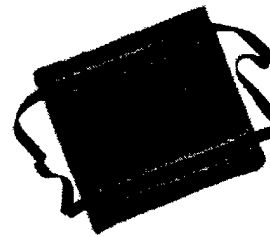

**Type IV Seat  
Cushion**



**Type V Anti-exposure Suit**

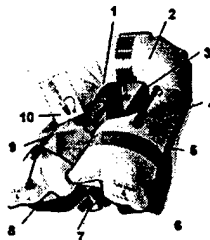

**Type V Inflatable Vest**



**Immersion Suit**

### Description

Boating PIW are persons in the water from a maritime source. The class of Boating PIW includes:

- a) persons without any floatation,
- b) persons with a throwable cushion,
- c) persons with a PFD,
- d) persons in an anti-exposure suit,
- e) persons in a survival/immersion suit and
- f) persons in Scuba gear.

## **Position**

The primary drift class characteristic is position. Position may be:

- vertical,
- sitting, or
- horizontal.

The vertical position generally requires dynamic maintenance by a conscious and active PIW. The PIW will either be slightly inclined backwards or forwards. A forward inclined PIW is actively swimming towards a goal. A backward inclined PIW is maintaining orientation to the waves.

The sitting position is the classic fetal position with legs drawn up and arms huddled across the PFD. This is the preferred position a person assumes in cold water. The natural orientation of a sitting PIW is to face away from the oncoming waves.

The horizontal position requires floatation around the legs for a survivor. Victims floating face down will be in a nearly horizontal position with arms and legs dangling from the PFD.

## **State of PIW**

PIW may be in any of three states:

- a) conscious,
- b) unconscious, or
- c) victims.

Conscious PIW's play an active role in maintaining their position relative to the water surface and wave/wind direction.

Unconscious PIW's are passive, usually from hypothermia, and "frozen" into a position. They cannot hang onto a throwable device.

Victims are deceased PIW's.

## **PFD Style**

Federal performance requirements specify six PFD types (see table B-2). Nine basic styles or designs of PFD's have been developed in response to these requirements:

- 1) Type I reversible horse-collar PFD
- 2) Type I non-reversible offshore lifejacket
- 3) Type II reversible horse-collar PFD
- 4) Type III sport vest

- 5) Type III float coat
- 6) Type IV throwable life-rings and seat cushions
- 7) Type V work vests and anti-exposure coveralls, including wet suits and dry suits
- 8) Type V inflatable vests and suspender style PFD's.
- 9) Survival/immersion suits. (Note: A conscious or unconscious PIW in a survival suit will float horizontally on his back with his head into the waves.)

**Table B -2. Personal Floatation Device Type Requirements**

Type	Buoyancy			Use
	Adult	Child	Infant	
I	22 lbs.	11 lbs.	N/A	Offshore
II	15.5 lbs.	11 lbs.	7 lbs.	Near Shore/Inland
III	15.5 lbs.	11 lbs.	7 lbs.	Sport Vests, Float Coats
IV				Throwable device
V	Only to be used according to instructions on the label			Work Vest, Deck Suits
Hybrid V	Required to provide equivalent buoyancy to the PFD it replaces			Inflatable PFD

#### References for Class Descriptions

1. Grupa M. D., 1995. "PFDs They come in many types and sizes," Proceeding of the Marine Safety Council, Vol.54. No.4, pp11-15.
2. Baca V. M., 1995. "Evolution of the 'life jacket'," Proceeding of the Marine Safety Council, Vol.54, No.4, pp. 30-34.
3. Hart, C. T., 1988. "A Study of the Factors Influencing the Rough Water Effectiveness of Personal Flotation Devices," David Taylor Research Center Report No. DTRC-88/026.
4. 44 CFR 33.35, 160.001, 160.002, 160.005, 160.006 and 160.055

#### Leeway Drift Study References and Notes

Suzuki, Tsuneo, Harou Sato, Ikuto Okuda and Yuzo Igeta, (1984). "Experiment on the Sea Regarding Distress and Search of Small Fishing Boat - II - Drift Characteristics of Inflatable Life-Raft (home made the second type) and Floating Life-Sized Doll" The Journal of Japan Institute of Navigation. No. 71, pp. 1 - 9.

Suzuki, Sato, Okuda, and Igeta, studied a PIW with a life-jacket that was floating vertically. The mannequin was 160 cm tall.

$$\text{Leeway speed of vertical PIW w/PFD (knots)} = 0.5\% U + 0.061 \text{ knots}$$

Suzuki, Tsuneo, Harou Sato, and Yuzo Igeta, (1985). "Experiment on the Sea Regarding Distress and Search of Small Fishing Boat - III. A Determination of Search Area When Wind Direction Changes," The Journal of Japan Institute of Navigation. No. 73, pp. 95 - 101.

Suzuki, Sato, and Igeta, studied PIWs in the vertical, sitting, and horizontal positions and found values of:

- a) Leeway speed of horizontal PIW (knots) =  $1.5\% U + 0.077$  knots (4.0 cm/s)
- b) Leeway speed of vertical PIW w/PFD (knots) =  $0.5\%U+0.074$  knots (3.8cm/s)
- c) Leeway speed of sitting PIW w/PFD greater than vertical PIW and less than horizontal PIW

Su, Tsung-chow, R. Q. Robe, and D. J. Finlayson. (1997). "On Predicting the Leeway and Drift of a Survival Suit Clad Person-in-Water," U.S. Coast Guard Report No. CG-D-14-98.

Su, Robe, and Finlayson used laboratory measurements for a vertical PIW and a horizontal PIW in survival suit and field trials for winds between 5 and 12 knots for a PIW in a survival suit. Su et al. (1998) used the indirect method of measuring leeway and adjusted winds to 10-m height.

- a) Leeway speed of vertical PIW =  $0.6\% (U_{air} - U_{water})$
- b) Leeway speed of horizontal PIW/SS =  $3.23\% (U_{air} - U_{water})$ .
- c) Leeway speed of PIW/SS =  $2.7\% W_{10m}$ ,  $S_{s/x} = 0.133$  knots, or 6.8 cm/s  
Divergence angle of 38 degrees is recommended.

Allen A., Q. Robe, and E. Morton (1999). "The Leeway of Person-in-Water and Three Small Craft," USCG Research and Development Center Report No. R&DC 24/98.

The direct method was used to study PIW with type I, II PFD, and survival suits. Mannequins were outfitted with either and offshore-lifejacket Type I PFD or a horseshoe collar Type II PFD or in a survival suit. Aanderaa Doppler current sensors were used to directly measure leeway. Winds from an adjacent leeway target were adjusted to 10-meters. Results were presented for Type I PFD and the survival suit.

PIW (sitting position, offshore-lifejacket Type I PFD)

$$\begin{aligned} \text{Leeway speed} &= 1.2 \% W_{10m} + 0.2 \text{ cm/s; } S_{y/x} = 1.38 \text{ cm/s} \\ \text{Leeway angle for } W_{10m} > 5\text{m/s} & \text{ (mean } 4^\circ; \text{ std. dev. } 12^\circ; \text{ min. } -24^\circ; \text{ max } +22^\circ) \\ \text{DWL} &= 1.60 \% W_{10m} - 3.98 \text{ cm/s, } S_{y/x} = 2.42 \text{ cm/s} \\ \text{CWL} &= 0.13 \% W_{10m} + 0.33 \text{ cm/s, } S_{y/x} = 2.11 \text{ cm/s} \end{aligned}$$

PIW (horizontal position, survival suit)

$$\begin{aligned} \text{Leeway speed} &= 1.4 \% W_{10m} + 5.3 \text{ cm/s}, S_{y/x} = 1.85 \text{ cm/s} \\ \text{Leeway angle for } W_{10m} > 5\text{m/s} & \text{ (mean } 18^\circ; \text{ std. dev. } 20^\circ; \text{ min. } -24^\circ; \text{ max } +42^\circ) \\ \text{DWL} &= 1.71 \% W_{10m} + 1.12 \text{ cm/s}, S_{y/x} = 3.93 \text{ cm/s} \\ \text{+CWL} &= 1.36 \% W_{10m} - 3.30 \text{ cm/s}, S_{y/x} = 1.71 \text{ cm/s} \\ \text{-CWL} &= -0.13 \% W_{10m} - 2.65 \text{ cm/s}, S_{y/x} = 1.62 \text{ cm/s} \end{aligned}$$

Allen, A. and J. Plourde, "Review of Leeway: Field Experiments and Implementation," USCG Research and Development Center and Analysis & Technology, Inc., 1999.

Allen and Plourde (Chapter 7) combined leeway equations from the above studies.

$$\text{PIW combined} = 1.1 \% W_{10m} + 3.5 \text{ cm/s} > 15 \text{ cm/s } S_{y/x}$$

Kang, S.Y. (1999), "A Field Experiment for the Determination of Drift Characteristics of Person-in-Water," 1999.

Kang, S.Y. (1999) used the indirect method to study real subjects in scuba gear and wet suits. The subjects in the scuba gear floated on their backs in a horizontal position. The scuba gear included fins, facemask, snorkel, tanks, weights, and an inflated buoyancy compositor. The subjects in wet suits floated vertically while wearing facemask and snorkel and a weight belt. They did not wear fins. Winds were adjusted to the 10-meter height.

$$\begin{aligned} \text{PIW scuba gear} &= 0.7 \% W_{10m} + 4.3 \text{ cm/s} && 5.92 \text{ cm/s } S_{y/x} \\ \text{PIW wet suit (vertical)} &= 0.05 \% W_{10m} + 2.5 \text{ cm/s} && 2.07 \text{ cm/s } S_{y/x} \end{aligned}$$

## B2 MARITIME SURVIVAL CRAFT

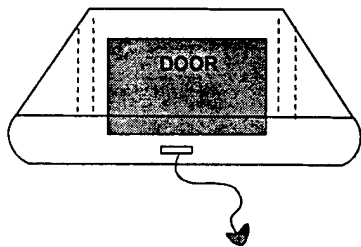

**No Ballast Life Raft**

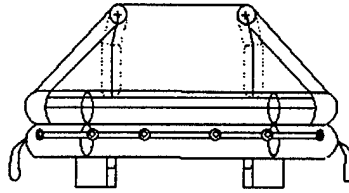

**Shallow Pocket Ballast**

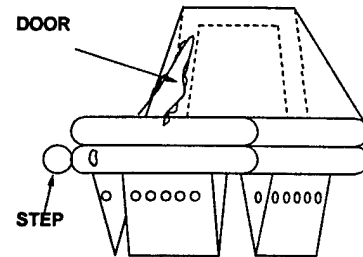

**Deep Pocket Ballast**

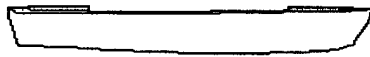

**Life Boat**

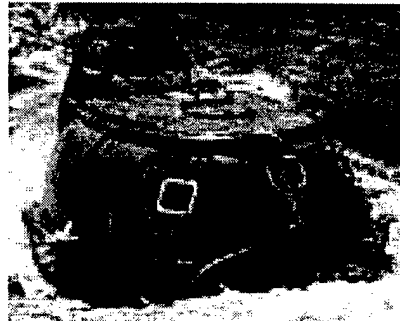

**Life Capsule**

### Description

The Class of Maritime Survival Craft includes:

- 1) life rafts,
- 2) life boats, and
- 3) life capsules.

Dinghies and inflatable boats are not included in this class (see section B3).

Life rafts on commercial vessels in US waters must be USCG approved. Most commercial European and open ocean sailing competitions require compliance with SOLAS regulation. Questions about the features of the maritime survival craft carried on a vessel may sometimes be answered by calling a life raft repair and repackaging facility close to the homeport of the distressed vessel.

## **Ballast**

The primary drift class characteristic is ballast. Ballast may be:

- no ballast,
- shallow pocket ballast,
- deep ballast,
- swamped, or
- capsized.

Shallow pocket ballast systems consist of a series of fabric pockets generally 4 inches in diameter and less than 6 inches in depth. Deep pocket systems consist of large fabric bags, from 3 to 7 on the raft, that are 1+ feet wide-by 2+ feet long-by 2+ feet deep. Torroidal ballast systems consist of a ring of deep pockets, sometimes connected to form a doughnut around the outside of the raft. The Givens pocket is a single deep pocket that is larger than the raft itself.

## **Presence/Absence of a Canopy**

The secondary drift class characteristic is the presence or absence of a canopy.

## **Drogue Modifiers**

Most manufacturers supply automatically deploying drogues, also called sea anchors, with new life raft purchases.

Lifeboats are open boats from 15 to 25 feet in length, with or without an engine. (Note: Because this class of drift objects is often able to move some distance before it runs out of gas or its occupants become tired of rowing or give up trying to sail the boat, caution should be used when applying leeway drift equations.)

Life capsules are fully enclosed craft commonly used on large merchant and military vessels.

## **References for Class Descriptions**

1. USCG-Approved Life Raft Service Centers, See Appendix C
2. 44 CFR 33.05, 33.07, and 33.15

## Leeway Drift Study References and Notes

Pingree, F. deW., 1944. "Forethoughts on Rubber Rafts." Woods Hole Oceanographic Institution, 26 pp.

Pingree presented two graphs of leeway drift rates for 6 types of military life rafts with and without drogues. The rafts are World War II vintage rubber rafts, which are assumed not to have canopies or ballast systems. The values below are the portions of the graphs between 10 and 18 knots of wind.

- a) Life rafts (no ballast system, no canopy, w/ drogue)  
Leeway Speed = 2.8 to 3.4% Wind (10-18kts).
- b) Life raft (no ballast system, no canopy, w/o drogue)  
Leeway Speed = 5.0 to 8.5% Wind (10-18kts).

Hufford, G.L., and S. Broida. 1974. "Determination of Small Craft Leeway." U.S. Coast Guard Research and Development Center Report No. 39/74, December 1974.

Hufford and Broida studied a 12-foot rubber raft with and without a drogue. The rubber raft had a sail area of 13.9 square feet and keel area of 0.1 square feet. Thus this raft was assumed to have neither canopy nor ballast system and a 1.2 ft wide single tube.

- a) Life raft (no ballast system, no canopy, w/ drogue)  
Leeway Speed = 4% Wind - 0.20 knots. (- 10.3 cm/s)
- b) Life raft (no ballast system, no canopy, w/o drogue)  
Leeway Speed = 6% Wind + 0.17 knots. (+8.7 cm/s)

Morgan, C.W., S.E. Brown, and R.C. Murrell. 1977. "Experiments in Small Craft Leeway," U.S. Coast Guard Oceanographic Unit Technical Report 77-2, Washington, D.C.

Morgan, Brown and Murrell (1977) studied a Standard USCG 7-person MARK-7 one-tube life raft without canopy or ballast system. Morgan, Brown and Murrell provided a scaled line drawing of the raft and motor launch. A graph of their results is presented. The leeway speed is approximately given by:

Life raft (no ballast system, no canopy, 7-person, w/ drogue)  
Leeway Speed = 7% Wind.

Morgan, C.W., 1978. "Seven Man Life Raft Leeway Study," U.S. Coast Guard Oceanographic Unit Technical Report 78-1, Washington, D.C.

Morgan combined all the data on the same MARK-7 life raft studied by Morgan et al. (1977) and presented results for leeway rate and angle for wind speed above 5 knots.

Life raft (no ballast system, no canopy, 7-person, w/ drogue)  
Leeway Speed =  $4 \pm 3\%$  Wind.

Leeway Angle (> 5 kts) =  $0^\circ \pm 13^\circ$  downwind direction for a given wind speed.  
Leeway Angle (> 10 kts) =  $0^\circ \pm 20^\circ$  (range) of the downwind direction, from their Figure 1.



Scobie, R.W., and D.L. Thompson. 1979. "Life Raft Study, February 1978." U.S. Coast Guard Oceanographic Unit Technical Report 79-1, Washington, D.C.

Scobie and Thompson studied three life rafts, all without drogues. They reported linear regressions and 95% confidence limits of leeway speed versus wind speed. The 6-person Switlik was an oblong raft "modified with an improved stability system," and had a canopy. The 25-person Givens raft was tested with canopy deployed and with the canopy down. The Givens raft had "improved stability system." The third raft was a B. F. Goodrich 20-person raft also with canopy and an "improved stability system." Scobie and Thompson also presented the linear regression for the combination of the three life rafts with their canopies deployed.

- a) Switlik (ballast system, canopy, w/o drogue, 6-person) Marine Life Raft  
Leeway Speed = 3.4% Wind + 0.09 knots.
- b) Givens (ballast system, canopy, w/o drogue, 25-person) Marine Life Raft  
Leeway Speed = 5.4% Wind - 0.18 knots.
- c) Goodrich (ballast system, canopy, w/o drogue, 20-person,) Marine Life Raft  
Leeway Speed = 4.9% Wind + 0.02 knots.
- d) Combined (ballast system, canopy, w/o drogue) Marine Life Rafts  
Leeway Speed = 4.2% Wind + 0.06 knots.  
Givens (ballast system, canopy down, w/o drogue, 25-person) Marine Life Raft  
Leeway Speed = 2.3% Wind + 0.09 knots.

Osmer, S.R., N.C. Edwards, Jr., and A.L. Breitler. 1982. "An Evaluation of Life Raft Leeway, February 1982." U.S. Coast Guard Report No. CG-D-10-82.

Osmer, Edwards and Breitler studied four life rafts and were unable to present any leeway rate results. Osmer et al. give the dimensions for a Mark-7 life raft as 12 ft long, by 5.5 ft wide by 2 ft high and provide a low quality photographic reproduction of a Mark-7 life raft with two tubes.

Suzuki, Tsuneo, Harou Sato, Ikuto Okuda and Yuzo Igeta, (1984). "Experiment on the Sea Regarding Distress and Search of Small Fishing Boat – II – Drift Characteristics of Inflatable Life-Raft (home made the second type) and Floating Life-Sized Doll," The Journal of Japan Institute of Navigation, No. 71, pp. 1 - 9.

Suzuki, Sato, Okuda, and Igeta studied three Japanese life rafts. All three rafts had shallow ballast bags and canopies. Loading for the three rafts varied from empty to half to full. Results were presented for the empty rafts and for half and full loading combined for each raft. The life rafts were an 8-person MTB-8, a 13-person TRB-13B and a 25-person MTB-25. Freeboard to draft ratios were: 7.51 for the MTB-8, 16.45 for the TRB-13B and 12.83 for the MTB-25.

Maritime Life raft (shallow ballast systems, w/o canopy, w/o sea anchor, empty)

a) Three rafts combined leeway speed = 5.8% U

Maritime Life raft (shallow ballast systems, w/ canopy, w/sea anchor, empty)

b) 8-person MTB-8 life raft leeway speed = 3.3 % U

c) 13-person TRB-13B life raft leeway speed = 4.6 % U

d) 25-person MTB-25 life raft leeway speed = 3.0 % U

Maritime Life raft (shallow ballast systems, w/ canopy, w/sea anchor, heavy loading)

e) Three rafts combined leeway speed = 4.3% U

Suzuki, Tsuneo, Harou Sato, and Yuzo Igeta, (1985). "Experiment on the Sea Regarding Distress and Search of Small Fishing Boat - III. A Determination of Search Area When Wind Direction Changes," The Journal of Japan Institute of Navigation. No. 73, pp. 95 - 101.

Suzuki, Sato and Igeta studied four Japanese life rafts: one from "F" manufacturer and one from "S" manufacturer, and the same two MTB-8 and TRB-13B life rafts used by Suzuki et al. (1984). The rafts were studied with and without canopies, empty and half-loaded, with a sea anchor. Ballast systems for MTB-8 and TRB-13B life rafts were small and shallow, but the ballast systems for "F" and "S" life rafts are unknown, (Sato, personal communication).

a) Maritime 8, 13-person life raft (shallow ballast system, w/o canopy, w/sea anchor, empty)

3.4% Wind < MTB-8 & TRB-13B leeway speed < 3.7% Wind

b) Maritime 8, 13-person life rafts (shallow ballast system, w/o canopy, w/sea anchor, ½ loading)

4.1% Wind < MTB-8 & TRB-13B leeway speed < 4.4% Wind

c) Maritime 8, 13-person life rafts (shallow ballast system, w/ canopy, w/sea anchor, empty to half loading)

2.8% Wind < MTB-8 & TRB-13B leeway speed < 4.3% Wind

d) Maritime 8, 13-person life rafts (shallow ballast system, w/o canopy, w/sea anchor, empty to half loading)

3.4% Wind < MTB-8 & TRB-13B leeway speed < 4.4% Wind

Suzuki, Tsuneo, Harou Sato, and Yuzo Igeta, (1985). "Experiment on the Sea Regarding Distress and Search of Small Fishing Boat - III. A Determination of Search Area When Wind Direction Changes," The Journal of Japan Institute of Navigation. No. 73, pp. 95 - 101. (Continued)

- e) Maritime 25-person life rafts (unknown ballast system, w/o canopy, w/sea anchor, empty)  
4.1% Wind < F and S life rafts leeway speed < 5.5% Wind
- f) Maritime 25-person life rafts (unknown ballast system, w/o canopy, w/sea anchor, ½ loading)  
4.9% Wind < F and S life rafts leeway speed < 6.5% Wind
- g) Maritime 25-person life rafts (unknown ballast system, w/ canopy, w/sea anchor, empty to half loading)  
4.0% Wind < F and S life rafts leeway speed < 5.2% Wind
- h) Maritime 25-person Life raft (unknown ballast system, w/o canopy, w/sea anchor, empty to half loading)  
4.1% Wind < F and S life rafts leeway speed < 6.5% Wind

Nash, L., and J. Willcox. 1985. "Summer 1983 Leeway Drift Experiment," U.S. Coast Guard Report CG-D-35-85.

Nash and Willcox studied three life rafts with canopies, without drogue and with 1-person loading: an RFD 6-person with a shallow pocket ballast system; 4-person Switlik and 6-person Givens life rafts with deep ballast systems. Nash and Willcox presented 90% confidence limits, correlation coefficients,  $S_{y/x}$ , and other statistical parameters. Wind speed ranged from 2 to 11 knots at approximately 2-meter height.

- a) RFD (shallow ballast, canopy, w/o drogue, 6-person, light loading)  
Marine Life Raft  
Leeway speed = 5.68% Wind + 0.145 knots  
 $S_{y/x}$  = 0.118 knots or 6.1 cm/s
- b) Switlik (deep ballast, canopy, w/o drogue, 4-person, light loading)  
Marine Life Raft  
Leeway speed = 0.83% Wind + 0.100 knots  
 $S_{y/x}$  = 0.040 knots or 2.1 cm/s
- c) Givens (deep ballast, canopy, w/o drogue, 6-person, light loading)  
Marine Life Raft  
Leeway speed = 0.64% Wind + 0.100 knots  
 $S_{y/x}$  = 0.044 knots or 2.3 cm/s

Nash, L., and J. Willcox. 1991. "Spring 1985 Leeway Experiment," U.S. Coast Guard Report CG-D-12-92.

Nash and Willcox studied three marine life rafts and one marine/aviation life raft in winds of 2 to 14 knots. A Switlik 4-person marine life raft with deep ballast system, canopy, with and without drogue, heavy loaded was studied. A Givens 6-person marine life raft with deep ballast system, canopy, with and without drogue, heavy loaded was also studied. An Avon 4-person marine life raft with shallow ballast system, canopy, without drogue, heavy loaded was studied. The fourth life raft, a 4-person Winslow life raft, lacked a ballast system but had a canopy, and was deployed with a drogue and heavy loading. The Winslow life raft was typical of rafts carried by recreational and non-regulated boater and small aircraft during the 1980's. Nash and Willcox (1991) report that leeway angles were nil for all their life rafts.

- a) Switlik (deep ballast, canopy, w/o drogue, 4-person, heavy loading)  
Marine Life Raft  
 $DWL = 1.83 \% \text{ Wind} - 0.04 \text{ knots}$   
 $S_{y/x} = 0.03466 \text{ knots or } 1.8 \text{ cm/s}$
- b) Givens (deep ballast, canopy, w/o drogue, 6-person, heavy loading)  
Marine Life Raft  
 $DWL = 1.02 \% \text{ Wind} - 0.002 \text{ knots}$   
 $S_{y/x} = 0.02338 \text{ knots or } 1.2 \text{ cm/s}$
- c) Switlik (deep ballast, canopy, w/ drogue, 4-person, heavy loading)  
Marine Life Raft  
Leeway speed = approximately zero
- d) Givens (deep ballast, canopy, w/ drogue, 6-person, heavy loading)  
Marine Life Raft  
Leeway speed = approximately zero
- e) Avon (shallow ballast, canopy, w/o drogue, 4-person, heavy loading)  
Marine Life Raft  
 $DWL = 2.12 \% \text{ Wind} - 0.14 \text{ knots}$   
 $S_{y/x} = 0.05704 \text{ knots or } 2.9 \text{ cm/s}$
- f) Winslow (no ballast, canopy, w/o drogue, 4-person, heavy loading)  
Marine / Aviation Life Raft  
 $DWL = 3.71 \% \text{ Wind} + 0.11 \text{ knots (+ } 5.7 \text{ cm/s)}$   
 $S_{y/x} = 0.04102 \text{ knots or } 2.1 \text{ cm/s}$

Fitzgerald, R.B., J. Russell, and D. Bryant, 1990. "Search and Rescue Experiment to Derive Leeway and Drift Rates for Common Search and Rescue Objects, Notre Dame Bay, Newfoundland, Summer 1989." Contract report prepared for Transportation Development Centre, Transport Canada, Montreal, TP#10221E.

Fitzgerald, Russell and Bryant (1990) studied a 4-person Beaufort life raft in wind up to 17 knots. The Beaufort raft was a marine life raft with deep ballast pockets, canopy, with and without drogue, 2 and 4 man loading. For wind speed at 1.6-meter height and above 5 knots the following results were reported:

- a) Beaufort (deep ballast, canopy, w/o drogue, 4-person, heavy loading)  
Marine Life Raft

$$\text{Leeway speed} = 4.71 \% \text{ Wind} - 0.14 \text{ knots}$$

$$\text{Leeway angle} = +25 \pm 25 \text{ degrees for winds} > 15 \text{ knots.}$$

- b) Beaufort (deep ballast, canopy, w/ drogue, 4-person, heavy loading)  
Marine Life Raft

$$\text{Leeway speed} = 3.38 \% \text{ Wind} - 0.10 \text{ knots}$$

$$\text{Leeway angle} = +25 \pm 25 \text{ degrees for winds} > 15 \text{ knots.}$$

Fitzgerald, R.B., D.J. Finlayson, J.F. Cross, and A. Allen. 1993. "Drift of Common Search and Rescue Objects - Phase II." Contract report prepared for Transportation Development Centre, Transport Canada, Montreal, TP# 11673E.

Fitzgerald, Finlayson, Cross and Allen used the same Beaufort life raft studied by Fitzgerald, Russell and Bryant (1990), along with a Tulmar 4-person life raft with deep ballast pockets and a canopy. Fitzgerald et al. (1993) used the direct method of measuring leeway and adjusted wind to the 10-meter height. Winds speeds ranged up to 38 knots.

- a) Beaufort (deep ballast, canopy, w/ drogue, 4-person, heavy loading)  
Marine Life Raft

$$\text{Leeway speed} = 2.2 \% W_{10m} - 0.32 \text{ knots; } S_{y/x} = 0.058 \text{ knots (3.0 cm/s)}$$

$$\text{Leeway speed} = 1.56 \% W_{10m}; 0 \leq W_{10m} < 5 \text{ knots}$$

$$\text{Leeway angle (mean } 10^\circ; \text{ std. dev. } 9^\circ; \text{ min. } -16^\circ; \text{ max } +27^\circ)$$

$$\text{DWL} = 2.2 \% W_{10m} - 0.39 \text{ knots, } S_{y/x} = 0.023 \text{ knots (1.2 cm/s)}$$

$$\text{CWL} = 1.6 \% W_{10m} - 0.19 \text{ knots, } S_{y/x} = 0.023 \text{ knots (1.2 cm/s)}$$

- b) Beaufort (deep ballast, canopy, w/o drogue, 4-person, light loading)  
Marine Life Raft

$$\text{Leeway speed} = 4.7 \% W_{10m} - 0.06 \text{ knots; } S_{y/x} = 0.065 \text{ knots (3.3 cm/s)}$$

- c) Tulmar (deep ballast, canopy, w/ drogue, 4-person, heavy loading)  
Marine Life Raft

$$\text{Leeway speed} = 1.9 \% W_{10m} + 0.01 \text{ knots; } S_{y/x} = 0.016 \text{ knots (0.8 cm/s)}$$

$$\text{Leeway angle (mean } -9^\circ; \text{ std. dev. } 11^\circ; \text{ min. } -59^\circ; \text{ max } +9^\circ)$$

$$\text{DWL} = 2.0 \% W_{10m}, S_{y/x} = 0.016 \text{ knots (0.8 cm/s)}$$

$$\text{CWL} = 0.7 \% W_{10m} - 0.09 \text{ knots, } S_{y/x} = 0.021 \text{ knots (1.1 cm/s)}$$

- d) Tulmar (deep ballast, canopy, w/o drogue, 4-person, heavy loading)  
Marine Life Raft

$$\text{Leeway speed} = 3.4 \% W_{10m} + 0.02 \text{ knots; } S_{y/x} = 0.028 \text{ knots (1.4 cm/s)}$$

Fitzgerald, R.B., D.J. Finlayson, J.F. Cross, and A. Allen. 1993. "Drift of Common Search and Rescue Objects - Phase II." Contract report prepared for Transportation Development Centre, Transport Canada, Montreal, TP# 11673E. (Continued)

- e) Tulmar (deep ballast, canopy, w/o drogue, 4-person, light loading)  
Marine Life Raft

Leeway speed =  $3.2 \% W_{10m} + 0.04$  knots;  $S_{y/x} = 0.051$  knots (2.6 cm/s)

Leeway angle (mean  $-5^\circ$ ; std. dev.  $13^\circ$ ; min.  $-79^\circ$ ; max  $+30^\circ$ )

DWL =  $3.4 \% W_{10m} + 0.01$  knots,  $S_{y/x} = 0.039$  knots (2.0 cm/s)

CWL =  $0.9 \% W_{10m} - 0.14$  knots,  $S_{y/x} = 0.084$  knots (4.3 cm/s)

Fitzgerald, R.B., D.J. Finlayson, and A. Allen. 1994. "Drift of Common Search and Rescue Objects - Phase III." Contract report prepared for Canadian Coast Guard, Research and Development, Ottawa, TP# 12179.

Fitzgerald, Finlayson and Allen used the same Beaufort and Tulmar life rafts studied by Fitzgerald et al. (1993), along with second Beaufort 4-person and a Beaufort 20-person marine life rafts. Fitzgerald et al. (1994) combined the data from Fitzgerald et al. (1993) were possible when presenting their results. These life rafts were studied in two configurations, lightly loaded without drogue and heavy-loaded with drogue, which are the fastest and slowest configurations. A SOLAS approved 22-person life capsule and an 18-person USCG sea rescue kit were also studied. Fitzgerald et al. (1994) used the direct method of measuring leeway and adjusted wind to the 10-meter height. Winds speeds ranged up to 38 knots.

Lightly loaded marine life rafts without drogue

- a) Tulmar symmetric (deep ballast, canopy, w/o drogue, 4-person, light loading)  
Marine Life Raft

Leeway speed =  $3.2 \% W_{10m} + 0.04$  knots;  $S_{y/x} = 0.051$  knots (2.6 cm/s)

Leeway angle for  $W_{10m} > 10$  kts. (mean  $-1^\circ$ ; std dev  $10^\circ$ ; min.  $-27^\circ$ ; max  $+18^\circ$ )

DWL =  $3.4 \% W_{10m} + 0.01$  knots,  $S_{y/x} = 0.039$  knots (2.0 cm/s)

- b) Beaufort asymmetric 5-sided (deep ballast, canopy, w/o drogue, 4-person, light loading) Marine Life Raft

Leeway speed =  $4.9 \% W_{10m} - 0.15$  knots;  $S_{y/x} = 0.068$  knots (3.5 cm/s)

Leeway angle for  $W_{10m} > 10$  kts. (mean  $+4^\circ$ ; std. dev.  $9^\circ$ ; min.  $-19^\circ$ ; max  $+36^\circ$ )

DWL =  $4.8 \% W_{10m} - 0.15$  knots,  $S_{y/x} = 0.069$  knots (3.5 cm/s)

- c) Beaufort symmetric 6-sided (deep ballast, canopy, w/o drogue, 4-person, light loading) Marine Life Raft

Leeway speed =  $3.4 \% W_{10m} - 0.03$  knots;  $S_{y/x} = 0.035$  knots (1.8 cm/s)

Leeway angle for  $W_{10m} > 10$  kts. (mean  $-6^\circ$ ; std. dev.  $3^\circ$ ; min.  $-15^\circ$ ; max  $+11^\circ$ )

DWL =  $3.4 \% W_{10m} - 0.03$  knots,  $S_{y/x} = 0.036$  knots (1.9 cm/s)

- d) Beaufort symmetric (deep ballast, canopy, w/o drogue, 20-person, light loading) Marine Life Raft

Leeway speed =  $3.9 \% W_{10m} - 0.06$  knots;  $S_{y/x} = 0.056$  knots (2.9 cm/s)

Leeway angle for  $W_{10m} > 10$  kts. (mean  $-5^\circ$ ; std. dev.  $6^\circ$ ; min.  $-21^\circ$ ; max  $+19^\circ$ )

DWL =  $3.9 \% W_{10m} - 0.06$  knots,  $S_{y/x} = 0.058$  knots (3.0 cm/s)

Fitzgerald, R.B., D.J. Finlayson, and A. Allen. 1994. "Drift of Common Search and Rescue Objects - Phase III." Contract report prepared for Canadian Coast Guard, Research and Development, Ottawa, TP# 12179. (Continued)

Lightly loaded marine life rafts without drogue (Continued)

- e) Symmetric (deep ballast, canopy, w/o drogue, 4-person, light loading) Marine Life Rafts. (Tulmar and Beaufort 6-sided life rafts combined and weighted equally.)

Leeway speed =  $3.3 \% W_{10m} + 0.01$  knots;  $S_{y/x} = 0.050$  knots (2.6 cm/s)

Leeway angle for  $W_{10m} > 10$  kts. (mean  $-3^\circ$ ; std. dev.  $8^\circ$ ; min.  $-27^\circ$ ; max  $+18^\circ$ )

Lightly loaded marine life rafts without drogue (Continued)

- f) Symmetric (deep ballast, canopy, w/o drogue, 4 & 20-person, light loading) Marine Life Rafts. (Tulmar, Beaufort 6-sided, Beaufort 20-person life rafts combined and weighted equally.)

Leeway speed =  $3.4 \% W_{10m}$ ;  $S_{y/x} = 0.061$  knots (3.1 cm/s)

Leeway angle for  $W_{10m} > 10$  kts. (mean  $-4^\circ$ ; std. Dev.  $8^\circ$ ; min.  $-27^\circ$ ; max  $+19^\circ$ )

- g) All (deep ballast, canopy, w/o drogue, 4 & 20-person, light loading) Marine Life Rafts. (Tulmar, Beaufort 5-sided Beaufort 6-sided, Beaufort 20-person life rafts combined and weighted equally.)

Leeway speed =  $3.7 \% W_{10m} - 0.04$ knots;  $S_{y/x} = 0.090$  knots (4.6 cm/s)

Leeway angle for  $W_{10m} > 10$  kts. (mean  $-2^\circ$ ; std. Dev.  $8^\circ$ ; min.  $-27^\circ$ ; max  $+36^\circ$ )

Fully loaded marine life rafts with drogue

- h) Tulmar symmetric (deep ballast, canopy, w/ drogue, 4-person, heavy loading) Marine Life Raft

Leeway speed =  $1.9 \% W_{10m} + 0.01$  knots;  $S_{y/x} = 0.016$  knots (0.8 cm/s)

Leeway angle for  $W_{10m} > 10$  kts. (mean  $-1^\circ$ ; std dev.  $6^\circ$ ; min.  $-15^\circ$ ; max  $+9^\circ$ )

DWL =  $2.0 \% W_{10m}$ ,  $S_{y/x} = 0.016$  knots (0.8 cm/s)

- i) Beaufort asymmetric 5-sided (deep ballast, canopy, w/ drogue, 4-person, heavy loading) Marine Life Raft

Leeway speed =  $2.1 \% W_{10m} - 0.01$  knots;  $S_{y/x} = 0.060$  knots (3.1 cm/s)

Leeway angle for  $W_{10m} > 10$  kts. (mean  $12^\circ$ ; std. Dev.  $8^\circ$ ; min.  $-9^\circ$ ; max  $+28^\circ$ )

DWL =  $2.3 \% W_{10m} - 0.03$  knots,  $S_{y/x} = 0.022$  knots (1.1 cm/s)

- j) Beaufort symmetric (deep ballast, canopy, w/ drogue, 20-person, heavy loading) Marine Life Raft

Leeway speed =  $3.1 \% W_{10m} - 0.07$  knots;  $S_{y/x} = 0.065$  knots (3.3 cm/s)

Leeway angle for  $W_{10m} > 10$  kts. (mean  $2^\circ$ ; std. Dev.  $6^\circ$ ; min.  $-18^\circ$ ; max  $+30^\circ$ )

DWL =  $3.2 \% W_{10m} - 0.09$  knots,  $S_{y/x} = 0.065$  knots (3.3 cm/s)

Fully loaded marine life rafts without drogue

- k) Beaufort asymmetric 5-sided (deep ballast, canopy, w/o drogue, 4-person, heavy loading) Marine Life Raft

Leeway speed =  $2.9 \% W_{10m} - 0.05$  knots;  $S_{y/x} = 0.028$  knots (1.4 cm/s)

Leeway angle for all  $W_{10m}$ . (mean  $-2^\circ$ ; std. Dev.  $17^\circ$ ; min.  $-39^\circ$ ; max  $+17^\circ$ )

Fitzgerald, R.B., D.J. Finlayson, and A. Allen. 1994. "Drift of Common Search and Rescue Objects – Phase III." Contract report prepared for Canadian Coast Guard, Research and Development, Ottawa, TP# 12179. (Continued)

Fully loaded marine life rafts without drogue (Continued)

l) Tulmar symmetric (deep ballast, canopy, w/o drogue, 4-person, heavy loading) Marine Life Raft

Leeway speed =  $3.3 \% W_{10m} + 0.03$  knots,  $S_{y/x} = 0.026$  knots (1.3 cm/s)

Leeway angle for  $W_{10m} > 10$  kts. (mean  $7^\circ$ ; std. Dev.  $4^\circ$ ; min.  $0^\circ$ ; max  $+18^\circ$ )

Other Maritime Survival Craft

m) SOLAS approved life capsule (22-person capacity, 12-person loading)

Leeway speed =  $3.8 \% W_{10m} - 0.08$  knots;  $S_{y/x} = 0.027$  knots (1.4 cm/s)

Leeway angle for  $W_{10m} > 5$  kts. (mean  $-1^\circ$ ; std. Dev.  $15^\circ$ ; min.  $-27^\circ$ ; max  $+37^\circ$ )

n) USCG Sea Rescue Kit (consists of three 6-person Switlik life rafts and two survival kits deployed along 300m of line, with small self-deploying drogues)

Leeway speed =  $2.5 \% W_{10m} - 0.04$  knots;  $S_{y/x} = 0.077$  knots (4.0 cm/s)

Leeway angle for  $W_{10m} > 5$  kts. (mean  $-5^\circ$ ; std. dev.  $5^\circ$ ; min.  $-12^\circ$ ; max  $+9^\circ$ )

Fitzgerald, R.B. 1995. "Target Detection Experiment Phase I - Experiment Planning." Contract report prepared for Transportation Development Centre, Transport Canada, Montreal, TP# 12441E.

Fitzgerald presented results for a 6-person Switlik life raft with four small ballast pockets and a canopy. The raft was lightly loaded with and without drogue attached. Fitzgerald used the direct method of measuring leeway and adjusted wind to the 10-meter height. Winds speeds ranged up to 26 knots.

a) Switlik (shallow ballast, canopy, w/o drogue, 6-person, light loading) Marine Life Raft

Leeway speed =  $3.2 \% W_{10m} - 0.02$  knots;  $S_{y/x} = 0.017$  knots (0.9 cm/s)

Leeway angle for  $W_{10m} > 5$  kts. (mean  $24^\circ$ ; std. dev.  $3^\circ$ ; min.  $+19^\circ$ ; max  $+30^\circ$ )

b) Switlik (shallow ballast, canopy, w/ drogue, 6-person, light loading) Marine Life Raft

Leeway speed =  $1.9 \% W_{10m} - 0.04$  knots;  $S_{y/x} = 0.029$  knots (1.5 cm/s)

Leeway angle for  $W_{10m} > 10$  kts. (mean  $23^\circ$ ; std. dev.  $5^\circ$ ; min  $+11^\circ$ ; max  $+39^\circ$ )

Allen, A. A., and R.B. Fitzgerald. 1997. "The Leeway of an Open Boat and Three Life Rafts in Heavy Weather," U.S. Coast Guard Report No. CG-D-03-98.

Allen and Fitzgerald (1997) studied three life rafts in their standard configuration and in the swamped or capsized configuration. The Beaufort 5-sided life raft was the same raft used by Fitzgerald et al. (1994). A Switlik 6-person life raft with a deep toroidal ballast bag was from the Sea Rescue Kit used by Fitzgerald et al. (1994). The Switlik 6-person life raft with four small ballast pockets was same raft studied by Fitzgerald (1995). Allen and Fitzgerald (1997) used the direct method of measuring leeway and adjusted wind to the 10-meter height. Winds speeds ranged up to 22 m/s (42 knots).



Allen, A. A., and R.B. Fitzgerald. 1997. "The Leeway of an Open Boat and Three Life Rafts in Heavy Weather," U.S. Coast Guard Report No. CG-D-03-98. (Continued)

a) Switlik (deep ballast, canopy, w/ drogue, 6-person, light loading) Marine Life Raft

Leeway speed =  $1.59 \% W_{10m} + 2.96 \text{ cm/s}$ ;  $W_{10m} \leq 22 \text{ m/s}$ ,  $S_{y/x} = 3.02 \text{ cm/s}$

Leeway angle (mean  $8^\circ$ ; std. dev.  $5^\circ$ ; min.  $-4^\circ$ ; max  $+21^\circ$ )

DWL =  $1.66 \% W_{10m} + 4.2 \text{ cm/s}$   $S_{y/x} = 1.73 \text{ cm/s}$

+CWL =  $0.25 \% W_{10m} + 0.5 \text{ cm/s}$   $S_{y/x} = 2.04 \text{ cm/s}$

-CWL =  $-0.25 \% W_{10m} - 0.5 \text{ cm/s}$   $S_{y/x} = 2.04 \text{ cm/s}$

b) Switlik (shallow ballast, canopy, w/ drogue, 6-person, light loading) Marine Life Raft

Leeway speed =  $2.53 \% W_{10m} + 0.68 \text{ cm/s}$ ;  $W_{10m} \leq 19 \text{ m/s}$ ,  $S_{y/x} = 4.24 \text{ cm/s}$

c) Beaufort asymmetric 5-sided (deep ballast, canopy, w/ drogue, 4-person, heavy loading) Marine Life Raft

Leeway speed =  $2.21 \% W_{10m} - 2.92 \text{ cm/s}$ ;  $W_{10m} \leq 20 \text{ m/s}$ ,  $S_{y/x} = 4.24 \text{ cm/s}$

d) Switlik (swamped, canopy, w/ drogue, 6-person, light loading) Marine Life Raft

Leeway speed =  $1.01 \% W_{10m} - 2.17 \text{ cm/s}$ ;  $W_{10m} \leq 17 \text{ m/s}$ ,  $S_{y/x} = 1.99 \text{ cm/s}$

e) Switlik (capsized, canopy, w/ drogue, 6-person, light loading) Marine Life Raft

Leeway speed =  $1.66 \% W_{10m} - 5.18 \text{ cm/s}$ ;  $W_{10m} \leq 17 \text{ m/s}$ ,  $S_{y/x} = 2.09 \text{ cm/s}$

f) Beaufort asymmetric 5-sided (capsized, canopy, w/ drogue, 4-person, heavy loading) Marine Life Raft

Leeway speed =  $0.885 \% W_{10m}$ ;  $W_{10m} \leq 19 \text{ m/s}$ ,  $S_{y/x} = 2.19 \text{ cm/s}$

Allen, A. and J. Plourde, "Review of Leeway: Field Experiments and Implementation," USCG Research and Development Center and Analysis & Technology, Inc., 1999.

Allen and Plourde (1999), Section 3.2 this report, present results for the same Tulmar life raft used by Fitzgerald et al. (1994) and the 12-foot rubber raft without sea anchor used by Hufford and Broida (1974). Allen and Plourde conducted re-analysis of 12-ft raft with sea anchor from Hufford and Broida (1974) and the four life rafts studied by Scobie and Thompson (1979). Allen and Plourde (1999), Chapter 7, also conducted analysis of combined life raft categories from Fitzgerald et al. (1993) and (1994), and Allen and Fitzgerald (1997). The results of Allen and Plourde analysis are presented below.

(This report)

Tulmar symmetric (deep ballast, canopy, w/o drogue, 4-person, light loading) Marine Life Raft

Leeway speed =  $3.34 \% W_{10m} + 1.44 \text{ cm/s}$   $S_{y/x} = 1.90 \text{ cm/s}$

Leeway angle: mean =  $-3.8^\circ$  std. dev. =  $11.6^\circ$ ,  $W_{10m} > 5 \text{ m/s}$

DWL =  $3.28 \% W_{10m} + 1.20 \text{ cm/s}$   $S_{y/x} = 2.14 \text{ cm/s}$

+CWL =  $1.09 \% W_{10m} - 8.09 \text{ cm/s}$   $S_{y/x} = 3.46 \text{ cm/s}$

-CWL =  $-1.02 \% W_{10m} - 0.03 \text{ cm/s}$   $S_{y/x} = 2.24 \text{ cm/s}$

Allen, A. and J. Plourde, "Review of Leeway: Field Experiments and Implementation,"  
 USCG Research and Development Center and Analysis & Technology, Inc., 1999.  
 (Continued)

Hufford and Broida (1974)

12-foot rubber raft (no ballast system, no canopy, no drogue, light loading)

Marine Life Raft

$$\text{Leeway speed} = 5.74\% U + 10.87 \text{ cm/s} \quad S_{y/x} = 10.37 \text{ cm/s}$$

$$\text{Leeway angle: mean} = -12.6^\circ \text{ std. dev.} = 19.1^\circ, W_{10m} > 5 \text{ m/s}$$

$$\text{DWL} = 5.34\% U + 9.91 \text{ cm/s} \quad S_{y/x} = 9.82 \text{ cm/s}$$

$$+\text{CWL} = 2.26\% U + 1.04 \text{ cm/s} \quad S_{y/x} = 9.08 \text{ cm/s}$$

$$-\text{CWL} = -2.26\% U - 1.04 \text{ cm/s} \quad S_{y/x} = 9.08 \text{ cm/s}$$

12-foot rubber raft (no ballast system, no canopy, with drogue, light loading)

Marine Life Raft

$$\text{Leeway speed} = 4.44\% U - 10.28 \text{ cm/s} \quad S_{y/x} = 4.08 \text{ cm/s}$$

$$\text{Leeway angle: mean} = -11.4^\circ \text{ std. dev.} = 26.7^\circ,$$

$$\text{DWL} = 3.15\% U - 4.47 \text{ cm/s} \quad S_{y/x} = 3.96 \text{ cm/s}$$

$$+\text{CWL} = 1.51\% U \quad S_{y/x} = 5.02 \text{ cm/s}$$

$$-\text{CWL} = -1.51\% U \quad S_{y/x} = 5.02 \text{ cm/s}$$

Scobie and Thompson (1979)

Switlik (ballast system, canopy, w/o drogue, 6-person) Marine Life Raft

$$\text{Leeway Speed} = 3.41\% \text{ Wind} + 4.66 \text{ cm/s.}$$

$$S_{y/x} = 14.94 \text{ cm/s}$$

Givens (ballast system, canopy, w/o drogue, 25-person) Marine Life Raft

$$\text{Leeway Speed} = 5.36\% \text{ Wind} - 8.9 \text{ cm/s.}, S_{y/x} = 8.84 \text{ cm/s}$$

Goodrich (ballast system, canopy, w/o drogue, 20-person,) Marine Life Raft

$$\text{Leeway Speed} = 3.59\% \text{ Wind} + 12.9 \text{ cm/s}, S_{y/x} = 16.72 \text{ cm/s}$$

Combined (ballast system, canopy, w/o drogue) Marine Life Rafts

$$\text{Leeway Speed} = 3.61\% \text{ Wind} + 8.36 \text{ cm/s}, S_{y/x} = 14.5 \text{ cm/s}$$

Givens (ballast system, canopy down, w/o drogue, 25-person) Marine Life Raft

$$\text{Leeway Speed} = 2.26\% \text{ Wind} + 5.34 \text{ cm/s.}, S_{y/x} = 4.27 \text{ cm/s}$$

(This report, Chapter 7)

Maritime Life raft without Ballast Systems

(With Canopy, With Drogue)

$$\approx 3.0\% W_{10m} + 0.0 \text{ cm/s} \quad > 15 \text{ cm/s } S_{y/x}$$

Maritime Life Rafts without Ballast Systems

$$4.2\% W_{10m} + 1.6 \text{ cm/s} \quad > 15 \text{ cm/s } S_{y/x}$$

Maritime Life Rafts with Shallow Ballast Systems

$$2.9\% W_{10m} - 0.2 \text{ cm/s} \quad > 15 \text{ cm/s } S_{y/x}$$

Allen, A. and J. Plourde, "Review of Leeway: Field Experiments and Implementation,"  
USCG Research and Development Center and Analysis & Technology, Inc., 1999.

(Continued)

(This report, Chapter 7, Continued)

Maritime Life Raft (deep ballast, canopy, w/o drogue, 4-6 person, light loading)

Leeway speed =  $3.79 \% W_{10m} - 2.11 \text{ cm/s}$   $Sy/x = 4.50 \text{ cm/s}$

Leeway angle: mean =  $-2.7^\circ$  std. dev. =  $13.2^\circ$ ,  $W_{10m} > 0 \text{ m/s}$

Leeway angle: mean =  $-2.3^\circ$  std. dev. =  $9.7$ , min. =  $-28^\circ$ , max =  $34^\circ$ ,  
 $W_{10m} > 5 \text{ m/s}$

DWL =  $3.75 \% W_{10m} - 2.32 \text{ cm/s}$   $Sy/x = 4.51 \text{ cm/s}$

+CWL =  $1.00 \% W_{10m} - 5.31 \text{ cm/s}$   $Sy/x = 3.91 \text{ cm/s}$

-CWL =  $-0.47 \% W_{10m} - 0.14 \text{ cm/s}$   $Sy/x = 3.91 \text{ cm/s}$

Maritime Life Raft (deep ballast, canopy, w/ drogue, 4-6 person, light loading)

Leeway speed =  $1.61 \% W_{10m} + 2.67 \text{ cm/s}$   $Sy/x = 2.98 \text{ cm/s}$

Leeway angle: mean =  $+3.2^\circ$  std. dev. =  $16.3^\circ$ ,  $W_{10m} > 0 \text{ m/s}$

DWL =  $1.95 \% W_{10m} - 0.53 \text{ cm/s}$   $Sy/x = 3.59 \text{ cm/s}$

+CWL =  $0.21 \% W_{10m} + 1.29 \text{ cm/s}$   $Sy/x = 2.15 \text{ cm/s}$

-CWL =  $-0.21 \% W_{10m} - 1.29 \text{ cm/s}$   $Sy/x = 2.15 \text{ cm/s}$

Maritime Life Raft (deep ballast, canopy, w/o drogue, 4-6 person, heavy loading)

Leeway speed =  $3.59 \% W_{10m} - 1.54 \text{ cm/s}$   $Sy/x = 2.51 \text{ cm/s}$

Leeway angle: mean =  $+7.3^\circ$  std. dev. =  $10.2$ ,  $W_{10m} > 0 \text{ m/s}$

DWL =  $3.59 \% W_{10m} - 1.92 \text{ cm/s}$   $Sy/x = 2.56 \text{ cm/s}$

+CWL =  $0.48 \% W_{10m} - 0.16 \text{ cm/s}$   $Sy/x = 2.17 \text{ cm/s}$

-CWL =  $-0.48 \% W_{10m} + 0.16 \text{ cm/s}$   $Sy/x = 2.17 \text{ cm/s}$

Maritime Life Raft (deep ballast, canopy, w/ drogue, 4-6 person, heavy loading)

Leeway speed =  $2.05 \% W_{10m} - 0.05 \text{ cm/s}$   $Sy/x = 2.70 \text{ cm/s}$

Leeway angle: mean =  $+1.3^\circ$  std. dev. =  $13.5^\circ$ ,  $W_{10m} > 0 \text{ m/s}$

DWL =  $2.19 \% W_{10m} - 0.96 \text{ cm/s}$   $Sy/x = 1.01 \text{ cm/s}$

+CWL =  $1.39 \% W_{10m} - 7.9 \text{ cm/s}$   $Sy/x = 1.46 \text{ cm/s}$

-CWL =  $-1.39 \% W_{10m} + 7.9 \text{ cm/s}$   $Sy/x = 1.46 \text{ cm/s}$

Maritime Life Raft (deep ballast, canopy, 4-6 person, without drogue)

Leeway speed =  $3.79 \% W_{10m} - 2.1 \text{ cm/s}$   $Sy/x = 4.4 \text{ cm/s}$

Leeway angle: mean =  $-2.2^\circ$  std. dev. =  $13^\circ$ ,  $W_{10m} > 0 \text{ m/s}$

Leeway angle: mean =  $-1.9^\circ$  std. dev. =  $10^\circ$ , min. =  $-28^\circ$ , max =  $34^\circ$ ,

$W_{10m} > 5 \text{ m/s}$

DWL =  $3.75 \% W_{10m} - 2.3 \text{ cm/s}$   $Sy/x = 4.4 \text{ cm/s}$

+CWL =  $0.78 \% W_{10m} - 3.6 \text{ cm/s}$   $Sy/x = 3.6 \text{ cm/s}$

-CWL =  $-0.47 \% W_{10m} - 0.1 \text{ cm/s}$   $Sy/x = 3.9 \text{ cm/s}$

Allen, A. and J. Plourde, "Review of Leeway: Field Experiments and Implementation,"  
USCG Research and Development Center and Analysis & Technology, Inc., 1999.

(Continued)

Maritime Life Raft (deep ballast, canopy, 4-6 person, with drogue)

$$\text{Leeway speed} = 1.84 \% W_{10m} + 1.4 \text{ cm/s} \quad S_{y/x} > 3.1 \text{ cm/s}$$

$$\text{Leeway angle: mean} = +1.9^\circ \text{ std. dev.} = 15^\circ, W_{10m} > 0 \text{ m/s}$$

$$\text{Leeway angle: mean} = +8.0^\circ \text{ std. dev.} = 8^\circ, \text{ min.} = -15^\circ, \text{ max} = 28^\circ, \\ W_{10m} > 5 \text{ m/s}$$

$$\text{DWL} = 1.91 \% W_{10m} + 0.9 \text{ cm/s} \quad S_{y/x} = 1.6 \text{ cm/s}$$

$$+\text{CWL} = 0.78 \% W_{10m} - 3.6 \text{ cm/s} \quad S_{y/x} = 3.6 \text{ cm/s}$$

$$-\text{CWL} = -0.47 \% W_{10m} - 0.1 \text{ cm/s} \quad S_{y/x} = 3.9 \text{ cm/s}$$

Maritime Life Raft (deep ballast, canopy, 4-6 person)

$$\text{Leeway speed} = 2.87 \% W_{10m} + 2.0 \text{ cm/s} \quad S_{y/x} = 8.6 \text{ cm/s}$$

$$\text{Leeway angle: mean} = -1.7^\circ \text{ std. dev.} = 14^\circ, W_{10m} > 0 \text{ m/s}$$

$$\text{Leeway angle: mean} = -0.7^\circ \text{ std. dev.} = 10^\circ, \text{ min.} = -28^\circ, \text{ max} = 34^\circ, \\ W_{10m} > 5 \text{ m/s}$$

$$\text{DWL} = 3.50 \% W_{10m} - 1.8 \text{ cm/s} \quad S_{y/x} = 6.4 \text{ cm/s}$$

$$+\text{CWL} = 0.78 \% W_{10m} - 3.6 \text{ cm/s} \quad S_{y/x} = 3.6 \text{ cm/s}$$

$$-\text{CWL} = -0.47 \% W_{10m} - 0.1 \text{ cm/s} \quad S_{y/x} = 3.9 \text{ cm/s}$$

Maritime Life Raft (deep ballast, canopy, 15-25 person)

$$\text{Leeway speed} = 3.64 \% W_{10m} - 4.37 \text{ cm/s} \quad S_{y/x} = 5.37 \text{ cm/s}$$

$$\text{Leeway angle: mean} = -1.1^\circ \text{ std. dev.} = 14.1^\circ, W_{10m} > 0 \text{ m/s}$$

$$\text{Leeway angle: mean} = -1.3^\circ, \text{ std. dev.} = 7.1^\circ, \text{ min} = -21^\circ, \text{ max} = 30^\circ, \\ W_{10m} > 5 \text{ m/s}$$

$$\text{DWL} = 3.68 \% W_{10m} - 4.96 \text{ cm/s} \quad S_{y/x} = 5.37 \text{ cm/s}$$

$$+\text{CWL} = 0.34 \% W_{10m} - 1.85 \text{ cm/s} \quad S_{y/x} > 2.50 \text{ cm/s}$$

$$-\text{CWL} = -0.49 \% W_{10m} + 1.58 \text{ cm/s} \quad S_{y/x} > 2.63 \text{ cm/s}$$

Maritime Life Raft (deep ballast, canopy)

$$\text{Leeway speed} = 3.02 \% W_{10m} + 0.8 \text{ cm/s} \quad S_{y/x} = 7.9 \text{ cm/s}$$

$$\text{Leeway angle: mean} = -1.5^\circ \text{ std. dev.} = 14^\circ, W_{10m} > 0 \text{ m/s}$$

$$\text{Leeway angle: mean} = -1.0^\circ \text{ std. dev.} = 9^\circ, \text{ min.} = -28^\circ, \text{ max} = 34^\circ, \\ W_{10m} > 5 \text{ m/s}$$

$$\text{DWL} = 3.52 \% W_{10m} - 2.5 \text{ cm/s} \quad S_{y/x} = 6.1 \text{ cm/s}$$

$$+\text{CWL} = 0.62 \% W_{10m} - 3.0 \text{ cm/s} \quad S_{y/x} = 3.5 \text{ cm/s}$$

$$-\text{CWL} = -0.45 \% W_{10m} - 0.2 \text{ cm/s} \quad S_{y/x} = 3.6 \text{ cm/s}$$

## B3 PERSON-POWERED CRAFT



Row Boat



Sea Kayak

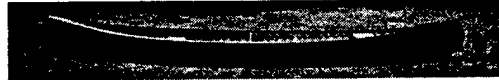

Canoe



Surf Board

### Description

The class of personal powered boats includes all forms of rowed and paddled boats, such as rowboats, inflatable boats without motors, canoes, kayaks, surfboards, and windsurfers. Because there are many variations of shape, material, draft, etc. within this class and because pertinent leeway drift data are sparse, generalizations about this class have been made.

### Above-Water Shape

The primary drift characteristic of this class is the above-water shape of the vessel. These vessels all have a relatively shallow draft and the above-water shape dominates the leeway drift ratio.

### Ballast

The secondary drift characteristic of this class is ballast. It is not uncommon for a sea kayak or a canoe to have a sea anchor on-board to permit the crew to rest. Likewise, it is not uncommon for vessel flotation to be lost, causing the vessel to flood and float partially submerged.

### Rescue Equipment That May Become Drift Targets

Rescue equipment typically includes PFD's and throwable flotation devices in U.S. waters. This equipment may not be carried, especially in overseas locations.

## Reference for Class Descriptions

1. Canoe and Kayak magazine, November issue, 'Yearly Buyer's Guide'.

## Leeway Drift Study References and Notes

Chapline, W.E. 1960. "Estimating the Drift of Distressed Small Craft." Coast Guard Alumni Association Bulletin, U.S. Coast Guard Academy, New London, CT, Vol. 22, No. 2, March-April 1960, pp 39-42.

Chapline studied surfboards. Surfboards of the 1950's were about the size of windsurfer boards of the 1990's.

Surfboard

Leeway speed = 2% wind

Allen A., Q. Robe, and E. Morton (1999). "The Leeway of Person-in-Water and Three Small Craft," USCG Research and Development Center Report No. R&DC 24/98.

Leeway data have been collected on two configurations of a sea kayak. The two configurations represent two possible search scenarios: 1) a survivor draped across the back deck of a sea kayak and 2) an empty sea kayak – for back-drifting for its PIW. Results were presented for only the first configuration.

Leeway data have been collected on two configurations of a windsurfer. The two configurations were without a mast and with the mast dragging in the water. Results were presented for only the first configuration.

Sea Kayak (with person on aft deck)

Leeway speed =  $1.1 \% W_{10m} + 12.5 \text{ cm/s}$ ;  $S_{y/x} = 3.52 \text{ cm/s}$

Leeway angle for  $W_{10m} > 5 \text{ m/s}$  (mean  $7^\circ$ ; std. dev.  $10^\circ$ ; min.  $-17^\circ$ ; max  $+43^\circ$ )

DWL =  $1.16 \% W_{10m} + 11.12 \text{ cm/s}$ ,  $S_{y/x} = 4.12 \text{ cm/s}$

CWL =  $0.41 \% W_{10m} + 0.00 \text{ cm/s}$ ,  $S_{y/x} = 4.39 \text{ cm/s}$

Windsurfer (with person on aft deck, mast and sail in water)

Leeway speed =  $2.3 \% W_{10m} + 5.2 \text{ cm/s}$ ;  $S_{y/x} = 2.32 \text{ cm/s}$

Leeway angle for  $W_{10m} > 5 \text{ m/s}$  (mean  $-8^\circ$ ; std. dev.  $8^\circ$ ; min.  $-34^\circ$ ; max  $+7^\circ$ )

DWL =  $2.25 \% W_{10m} + 5.03 \text{ cm/s}$ ,  $S_{y/x} = 2.50 \text{ cm/s}$

CWL =  $0.69 \% W_{10m} - 1.30 \text{ cm/s}$ ,  $S_{y/x} = 2.96 \text{ cm/s}$

## **B4 SAILING VESSELS**

Sections B4.1 through B4.11 describe sailing vessels. These are all craft that generally employ sails as the primary form of propulsion. Motor sailers are included in this section. (Note: Vessels over 100 feet in length are not included in these subsections because they may have significantly different drift ratios and are assumed to have sufficient resources on-board to radio for help in all but the most extreme conditions. When these vessels are unable to handle the conditions, their rescue gear becomes the leeway drift targets. Windsurfers are also not included (see section B3).

Two main groupings of sailboats exist:

- One-design sailboats are typically small to medium mono-hull and multi-hull sailboats that are used for day sailing, protected water racing, and occasional overnighing. These boats are generally less than 20 feet long and have no inboard engine.
- Coastal/ocean sailboats are medium to large mono-hull and multi-hull sailboats that are used for cruising and open water racing. These 19 to 45 feet long sailboats usually have a cabin.

Both groups contain boats with differing hull shapes, the primary drift characteristic. (Note: Any classification system will overlap between the classes. Under these conditions, a decision must be made about the most probable class to use. For example, a 24-foot full keel cruising sailboat with light loading may drift similar to a one-design sailboat with a full keel and a cabin.)

When drifting, it is assumed that the sails are down or missing, and the crew is unable to maneuver the vessel.

Many sailboats used for coastal or offshore sailing carry either drogues or sea anchors.

## **B4.1 FULL KEEL ONE-DESIGN SAILBOAT**

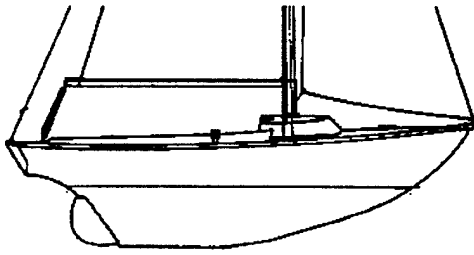

**Open Cockpit**

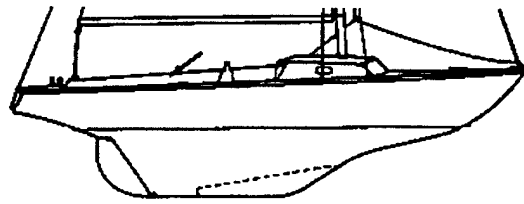

**Cabin**

### **Description**

Full keel one-design sailboats are small to medium size sailing vessels. They are typically designed for a single purpose such as racing or day sailing, but they may be used for different purposes than those for which they were designed. Although they can employ an outboard engine when day sailing, they almost never have inboard engines.

Full keel one-design sailboats have a keel that runs the full length or nearly the full length of the hull. While the forward portion of the keel may be modified or eliminated on some full keel sailboats, the keel always extends aft to the rudder. Full keel is an older hull design. Although it provides good interior volume, this design produces slower sailing speed than other designs, and is not commonly used in new hull construction. Deep and shoal keel versions are uncommon.

Full keel one-design sailboats are typically small enough to be trailer sailers and have a sufficiently small draft that a smaller tender is not needed.

### **Open Cockpit or Cabin**

The primary variable force on leeway drift is the above-water structural windage. The freeboard style and the presence/absence of a cabin structure describes the above-water structural portion. Few of these vessels have canvas shelters or drogue devices onboard.

### **Above-water Mast**

The secondary variable force on leeway drift is the above-water mast portion. The presence/absence of the vessel's mast is the major modifier in windage.

### **Rescue Equipment That May Become Drift Targets**

Rescue equipment found onboard is usually limited to PFD's and throwable flotation devices.



**Reference for Class Descriptions**

1. Sherwood, R.M., A Field Guide to Sailboats, Second Edition, Houghton Mifflin Company, Boston, 1994.

**Leeway Drift Study References and Notes**

None

## **B4.2 FIN KEEL ONE-DESIGN SAILBOAT**

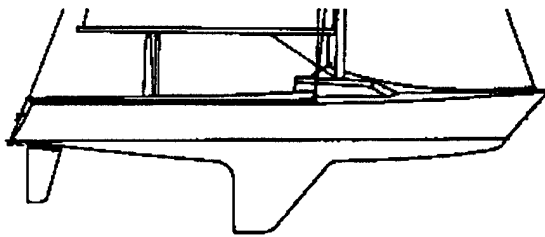

**Open Cockpit**

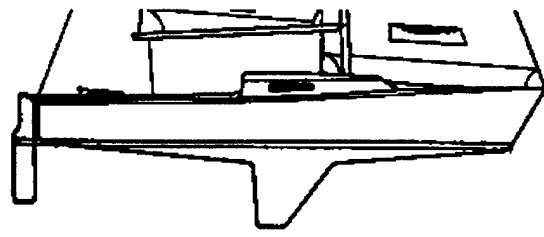

**Cabin**

### **Description**

Fin keel one-design sailboats are small to medium size sailing vessels. They are typically designed for a single purpose such as racing or day sailing, but they may be used for different purposes than those for which they were designed. Although they can employ an outboard engine when day sailing, they almost never have inboard engines.

Fin keel one-design sailboats have permanent keel skegs that do not extend aft to the rudder. Although different boats will have differently shaped skegs, the drift difference between low aspect and full spade skegs is believed to be minimal, permitting all permanent keel skeg boats to be classified together.

### **Open Cockpit or Cabin**

The primary variable force on leeway drift is the above-water structural windage. The freeboard style and the presence/absence of a cabin structure describes the above-water structural portion. Few of these vessels have canvas shelters or drogue devices onboard.

### **Above-water Mast**

The secondary variable force on leeway drift is the above-water mast portion. The presence/absence of the vessel's mast is the major modifier in windage.

### **Rescue Equipment That May Become Drift Targets**

Rescue equipment found onboard is usually limited to PFD's and throwable flotation devices.

### **Reference for Class Descriptions**

1. Sherwood, R.M., A Field Guide to Sailboats, Second Edition, Houghton Mifflin Company, Boston, 1994.

### **Leeway Drift Study References and Notes**

None

### B4.3 DAGGER/CENTERBOARD ONE-DESIGN SAILBOAT

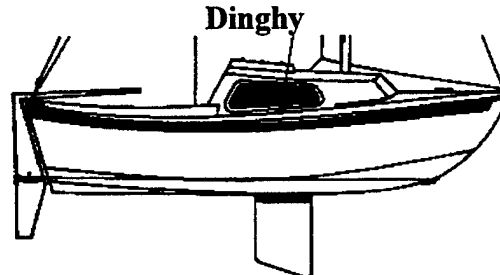
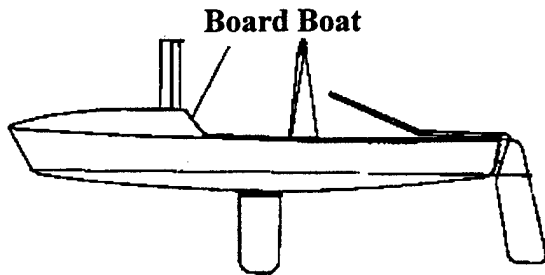
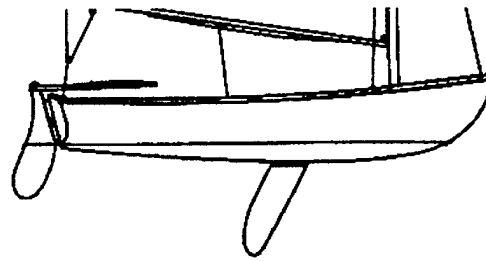
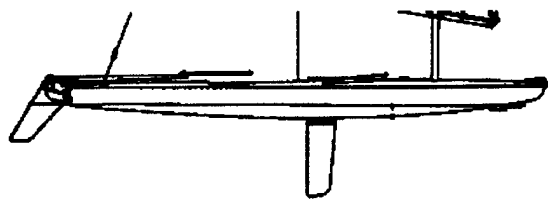

**Board Boat**

**Dinghy**

**Open Cockpit**

**Cabin Sailboat**

#### Description

Dagger/centerboard one-design sailboats form a class of small to medium size sailing vessels. They are typically designed for a single purpose such as racing or day sailing, but they may be used for different purposes than those for which they were designed. Although they can employ an outboard engine when day sailing, they almost never have inboard engines.

Dagger/centerboard one-design sailboats have a retractable dagger or a centerboard to reduce windward leeway. Although different boats will have differently shaped boards, the drift differences are believed to be minimal, permitting all dagger/centerboard boats to be classified together. It is possible that the board may be stuck in a 'up' position, causing the boat to drift as a bare bottom drift object (see section 4.4).

Since the draft of these vessels is sufficiently shallow, deep and shoal keel versions are uncommon.

#### Above-water Structure

The primary variable force on leeway drift is the above-water structural windage. The freeboard style and the presence/absence of a cabin structure describes the above-water structural portion. Few of these vessels have canvas shelters or drogue devices onboard. (Note: Because some of these boats are self-bailing, swamped or capsized drift will be less likely. If the occupants tire or cannot right the boat, capsized drift will occur.)

### **Above-water Mast**

The secondary variable force on leeway drift is the above-water mast portion. The presence/absence of the vessel's mast is the major modifier in windage.

### **Rescue Equipment That May Become Drift Targets**

Rescue equipment found onboard is usually limited to PFD's and throwable flotation devices.

### **Reference for Class Descriptions**

1. Sherwood, R.M., A Field Guide to Sailboats, Second Edition, Houghton Mifflin Company, Boston, 1994.

### **Leeway Drift Study References and Notes**

None

## B4.4 BARE BOTTOM ONE-DESIGN SAILBOAT

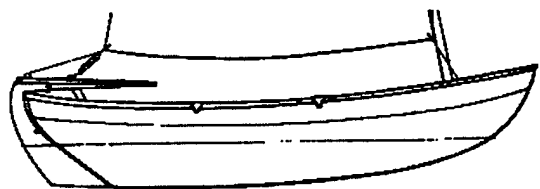

**Open Cockpit**

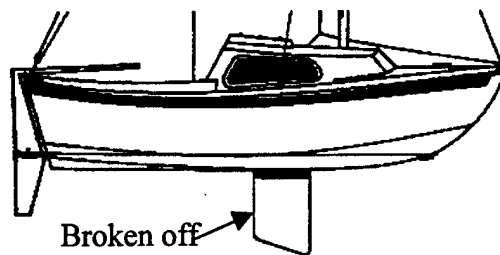

**Cabin**

### Description

Bare Bottom one-design sailboats form a class of small to medium size sailing vessels. They are typically designed for a single purpose such as racing or day sailing, but they may be used for different purposes than those for which they were designed. Although they can employ an outboard engine when day sailing, they almost never have inboard engines.

Bare bottom one-design sailboats do not have appendages to the hull that improve windward sailing by reducing leeway. The majority of boats in this class are dinghies and small board boats. Although different boats will have differently shaped hulls, the drift differences are believed to be minimal, permitting all bare bottom boats to be classified together. A dagger/centerboard sailboat that has its board stuck in a 'up' position is considered a bare bottom drift object.

### Above-water Structure

The primary variable force on leeway drift is the above-water structural windage. The freeboard style (board or dinghy) and the presence/absence of a cabin structure describes the above-water structural portion. Few of these vessels have canvas shelters or drogue devices onboard. (Note: Some boats are self-bailing, making swamped or capsized drift less likely. In situations where the boats do capsize, because of their small size, they may usually be righted and may simply remain swamped. Tired or inexperienced occupants may not be able to right a capsized boat and capsized drift will occur.)

### Above-water Mast

The secondary variable force on leeway drift is the above-water mast portion. The presence/absence of the vessel's mast is the major modifier in windage.

### Rescue Equipment That May Become Drift Targets

Rescue equipment found onboard is usually limited to PFD's and throwable flotation devices.

### **Reference for Class Descriptions**

1. Sherwood, R.M., A Field Guide to Sailboats, Second Edition, Houghton Mifflin Company, Boston, 1994.

### **Leeway Drift Study References and Notes**

None

## **B4.5 SPORT CATAMARAN**

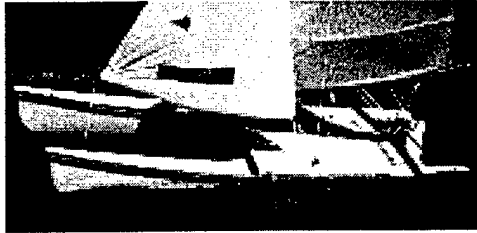

**Sport Catamaran**

### **Description**

Sport catamarans are generally less than 25 feet long and do not have any cabin feature. They consist of two hull sections joined above the water by a cockpit or bridge section. Most sport catamarans have trampoline netting that permits the crew to maneuver between hull sections. Most of these boats have canoe hulls, that is, they have neither dagger/centerboard nor keel skeg features.

Because sport catamarans have closed hulls without cabin or hull openings, they cannot be swamped. They can, however, be easily capsized, and pitchpoling is considered a hazard. Although hull shapes vary from manufacturer to manufacturer, the differences are not sufficient to substantially change the drift rate.

### **Upright or Capsized**

The primary force on leeway drift is whether the boat is upright or capsized.

### **Above-water Windage Portion**

The secondary force on leeway drift is the above-water windage portion that is dominated by freeboard. The presence/absence of the vessel's mast will modify windage.

### **Rescue Equipment That May Become Drift Targets**

Rescue equipment found onboard is usually limited to PFD's and throwable flotation devices.

### **References for Class Descriptions**

1. Wales, Patience, et al., 1997 Sailboat Buyers Guide, K-III Magazine Corp., New York, NY, 1996.
2. Sherwood, R.M., A Field Guide to Sailboats, Second Edition, Houghton Mifflin Company, Boston, 1994.

### **Leeway Drift Study References and Notes**

None

## **B4.6 SPORT TRIMARAN**

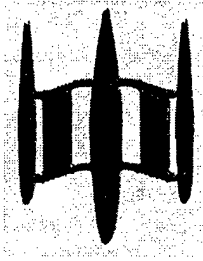

**Sport Trimaran**

### **Description**

Sport trimarans are generally less than 27 feet long and do not have any cabin feature. They consist of a main hull section in the center and smaller hull sections on the sides. Rigid arms commonly join these three hull sections fore and aft with trampoline netting that permits the crew to maneuver between hull sections. Most of these boats have canoe hulls, that is, they have neither dagger/centerboard nor keel skeg features.

Because sport catamarans have closed boats without cabin or hull openings, they cannot be swamped. They can, however, be easily capsized, and pitchpoling is considered a hazard. Although hull shapes vary from manufacturer to manufacturer, the differences are not sufficient to substantially change the drift rate.

### **Upright or Capsized**

The primary force on leeway drift is whether the boat is upright or capsized.

### **Above-water Windage Portion**

The secondary force on leeway drift is the above-water windage portion that is dominated by freeboard. The presence/absence of the vessel's mast will modify windage.

### **Rescue Equipment That May Become Drift Targets**

Rescue equipment found onboard is usually limited to PFD's and throwable flotation devices.

### **References for Class Descriptions**

1. Wales, Patience, et al., 1997 Sailboat Buyers Guide, K-III Magazine Corp., New York, NY, 1996.
2. Sherwood, R.M., A Field Guide to Sailboats, Second Edition, Houghton Mifflin Company, Boston, 1994.

### **Leeway Drift Study References and Notes**

None



## **B4.7 FULL KEEL CRUISING SAILBOAT**

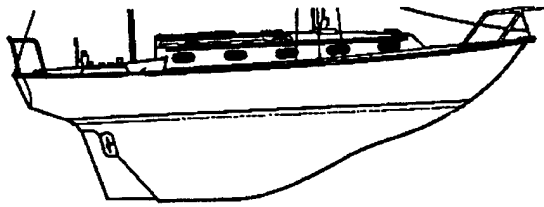

**Deep Draft**

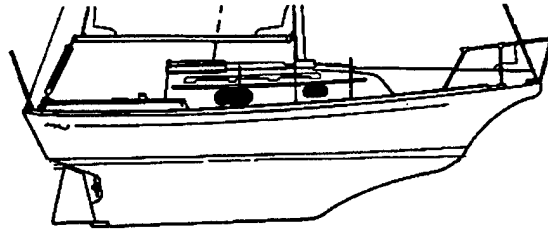

**Shoal Draft**

### **Description**

Full keel cruising sailboats are medium to large size (greater than 19 feet in length) cabin sailboats. They may have a canvas surround for cockpit protection. The keel runs the full length or nearly the full length of the hull. Some full keel boats have the forward portion of the keel modified or eliminated, but the keel on all of them extends aft to the rudder. The differences between deep draft and shoal draft full keels are primarily due to the shape of the hull section. Rounder bottoms with lighter displacement produce shallower drafts, while sharper hull entries with heavier displacement produce deeper drafts. Full keel is an older hull design. Although it provides good interior volume, this design produces slower sailing speed than other designs, and is not commonly used in new hull construction. Because little underwater leeway drag is added when full keel cruising sailboats are outfitted with an engine, full keel motor sailers are not classified separately in the taxonomy tables.

### **Underwater Drag**

The primary force on leeway drift is the underwater drag portion.

### **Above-water Windage Portion**

The secondary force on leeway drift is the above-water windage portion. The freeboard style and the presence of a cabin structure dominate the above-water windage portion. The presence/absence of the vessel's mast is the primary modifier of windage. The addition of canvas cockpit covers and the deployment of a drogue/sea anchor also modify windage.

### **Rescue Equipment That May Become Drift Targets**

Rescue equipment found onboard is usually limited to PFD's and throwable flotation devices. Full keel cruising sailboats generally have some form of tender that can be used for transport ashore while anchored. While many of these tenders are small rowboats or sailboats, inflatable boats are also common. The tender may be used as a life boat in an emergency.

## References for Class Descriptions

1. Averitt, Max, Boatwatch, Master Guide to Sailboats of the World, Library of Congress Number 92-093088, ISBN: 0-9627152-1-2, M.W. Averitt/Boatwatch, San Jose, CA, 1992.
2. Wales, Patience, et al., 1997 Sailboat Buyers Guide, K-III Magazine Corp., New York, NY, 1996.
3. Sherwood, R.M., A Field Guide to Sailboats, Second Edition, Houghton Mifflin Company, Boston, 1994.

## Leeway Drift Study References and Notes

Chapline, W.E. 1960. "Estimating the Drift of Distressed Small Craft." Coast Guard Alumni Association Bulletin, U.S. Coast Guard Academy, New London, CT, Vol. 22, No. 2, March-April 1960, pp 39-42.

Chapline included result for "Heavy displacement, deep draft sailing vessels."

Mono-hull sailboat with full keel, deep draft, with mast.

Leeway speed = 3 % wind.

Allen A., Q. Robe, and E. Morton (1999). "The Leeway of Person-in-Water and Three Small Craft," USCG Research and Development Center Report No. R&DC 24/98.

Leeway data were collected on a 65-foot mono-hull sailboat, full keel, deep-draft, with mast, inboard engine, without drag device during testing. The leeway data were collected using the direct method. Winds speed were light.

## B4.8 FIN KEEL CRUISING SAILBOAT

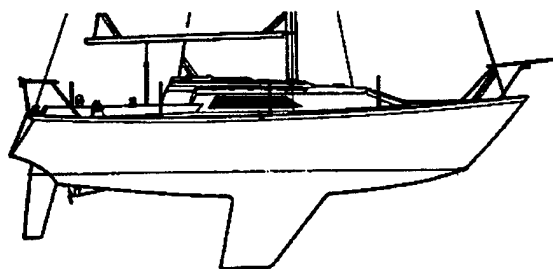

**Deep Draft Fin Keel**

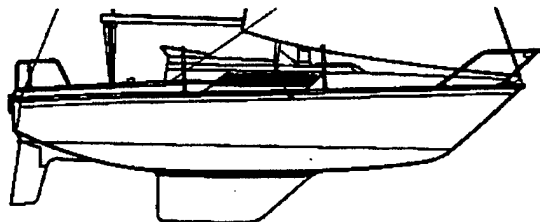

**Shoal Draft Fin Keel**

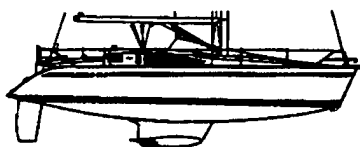

**Shoal Draft Bulb Keel**

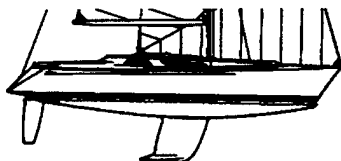

**Shoal Draft Wing Keel**

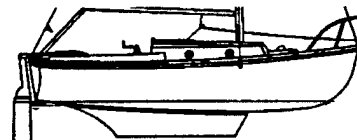

**Shoal Draft  
Low Aspect Ratio Keel**

### Description

Fin keel cruising sailboats are medium to large size (greater than 19 feet in length). Racing hulls are narrow, but the majority is a compromise between narrow racing fin hulls and wide full keel internal volume. They almost always have some low cabin superstructure amidships and a helm cockpit aft.

Deep fin keel sailboats are often associated with racing. They have narrow hull cross sections and long deep straight narrow fin keel skegs. Shoal keel sailboats compromise some of the windward sailing advantage of the deep fin keel for a shallower draft and therefore have the ability to sail in more places. The shoal draft keel skeg is modified to increase the weight at the tip. These modifications can be winglets, bulbs, or a longer, low aspect keel shape. All are designed to provide a righting moment equivalent to that of a deep fin keel.

Racing sailers are not outfitted with engines, but racer-cruiser sailboats may have an outboard or inboard engine in the after portion of the hull. When an inboard engine is employed, a skeg fin is added to the underside of the hull to protect the propeller.

### Underwater Drag

The primary force on leeway drift is the underwater drag portion.

## **Above-water Windage Portion**

The secondary force on leeway drift is the above-water windage portion. The freeboard style and the presence of a cabin structure dominate the above-water windage portion. The presence/absence of the vessel's mast is the primary modifier of windage. The presence/absence of engines and the deployment of a drogue/sea anchor also modifies windage.

## **Rescue Equipment That May Become Drift Targets**

Rescue equipment found onboard is usually limited to PFD's and throwable flotation devices. Fin keel cruising sailboats generally have some form of tender that can be used for transport ashore while anchored.

## **References for Class Descriptions**

1. Averitt, Max, Boatwatch, Master Guide to Sailboats of the World, Library of Congress Number 92-093088, ISBN: 0-9627152-1-2, M.W. Averitt/Boatwatch, San Jose, CA, 1992.
2. Wales, Patience, et al., 1997 Sailboat Buyers Guide, K-III Magazine Corp., New York, NY, 1996.
3. Sherwood, R.M., A Field Guide to Sailboats, Second Edition, Houghton Mifflin Company, Boston, 1994.

## **Leeway Drift Study References and Notes**

Chapline, W.E. 1960. "Estimating the Drift of Distressed Small Craft." Coast Guard Alumni Association Bulletin, U.S. Coast Guard Academy, New London, CT, Vol. 22, No. 2, March-April 1960, pp 39-42.

Chapline included result for "Moderate displacement, moderate draft sailing vessels."

Mono-hull sailboat with fin keel, shoal draft, with mast.

Leeway speed = 4 % wind.

## **B4.9 WATER BALLAST TRAILER SAILBOAT**

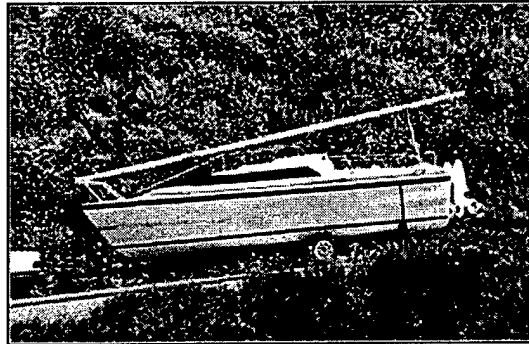

**Water Ballast Trailer Sailboat**

### **Description**

Water Ballast Trailer Sailboats are sailboats that are small and light enough to be moved by a boat trailer behind a car. A water ballast system is used so that the sailboat's weight can be reduced for trailering while maintaining the heavy stability necessary for safe sailing. After launching, the transom valve is opened and a tank in the bottom of the hull is gravity filled with sea water. The valve is then closed, trapping the water. The ballast makes the boat stable and self righting.

### **Centerboard/Keel**

The primary force on leeway drift is the position (up/down) of the centerboard or the presence of a winged keel.

### **Mast**

The secondary force on leeway drift is whether or not the sailboat has been demasted.

### **Rescue Equipment That May Become Drift Targets**

Rescue equipment found onboard is usually limited to PFD's and throwable flotation devices.

### **Leeway Drift Study Notes**

None.

## B4.10 CRUISING CATAMARAN

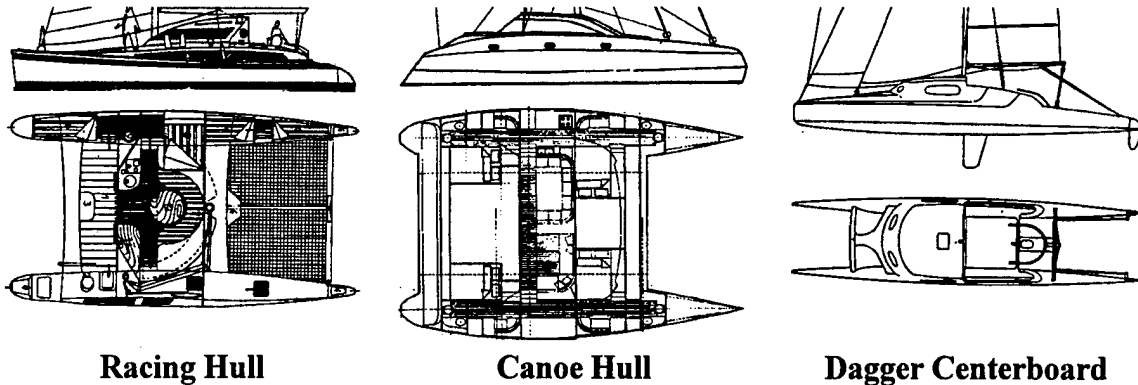

### Description

Cruising catamarans are greater than 24 feet long and have some form of berthing or living accommodations. A bridge deck that often provides additional cabin space joins the two hull sections. The widths and full forms vary widely in this class and there are many manufacturers/builders. Because of their size and the possibility of powered propulsion, the hull shape significantly changes the leeway drift. Racing catamarans use narrow hull forms with sharp entry into the water, but cruising catamarans typically compromise speed for wider hull designs and some form of motorized propulsion. The basic hull shapes are canoe hulls without keel skegs, a low-aspect integral skeg keel, and a dagger/centerboard configuration.

### Underwater Drag

The primary force on leeway drift is the underwater drag portion.

### Above-water Windage Portion

The secondary force on leeway drift is the above-water windage portion. Freeboard and the cabin structure, assumed to be present on these vessels, dominate the above-water windage portion. The presence/absence of the vessel's mast is the primary modifier of windage. The presence/absence of engines and the deployment of a drogue/sea anchor also modify windage.

### Rescue Equipment That May Become Drift Targets

Rescue equipment found onboard includes PFD's and throwable flotation devices. Cruising catamarans generally have some form of tender that can be used for transport ashore while anchored.

### **References for Class Descriptions**

1. Jeffrey, Kevin and Kanter, Charles, Sailors Multihull Guide, Avalon House Publishing/Sailco Press, Ashland, MA, 1994.
2. Wales, Patience, et al., 1997 Sailboat Buyers Guide, K-III Magazine Corp., New York, NY, 1996.
3. Sherwood, R.M., A Field Guide to Sailboats, Second Edition, Houghton Mifflin Company, Boston, 1994.

### **Leeway Drift Study References and Notes**

None

## B4.11 CRUISING TRIMARAN

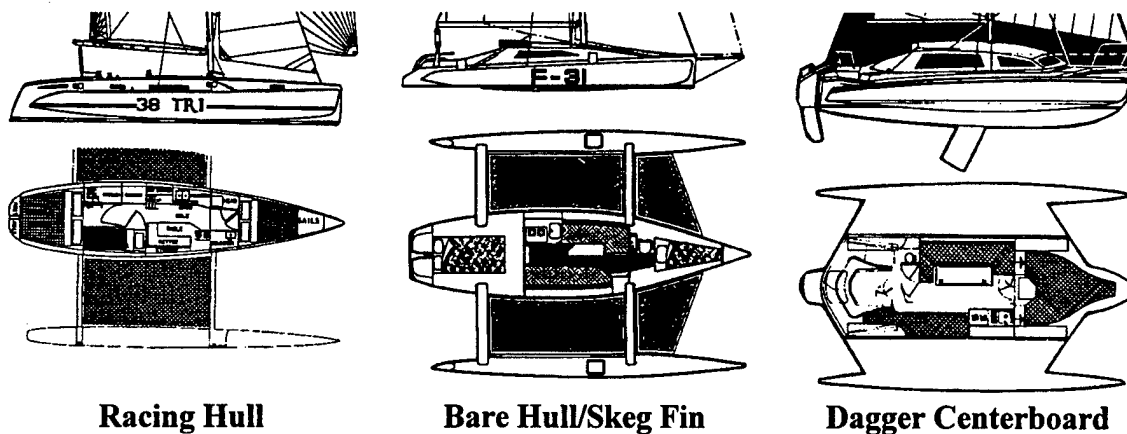

**Racing Hull**

**Bare Hull/Skeg Fin**

**Dagger Centerboard**

### Description

Cruising trimarans are greater than 24 feet long and have some form of berthing or living accommodations. Three hull sections, joined by connecting arms that often support trampoline nets to facilitate crew movement onboard, form the cruising trimarans. Although the widths and hull forms vary widely in this class and there are many manufacturers/builders, the general form is a larger hull section in the middle with matching smaller hull sections abeam. Because of their size and the possibility of powered propulsion, the hull shape significantly changes the leeway drift. Racing trimarans use narrow hull forms with sharp entry into the water, but cruising trimarans typically compromise speed for wider hull designs and some form of motorized propulsion. The basic hull shapes are a low aspect keel skeg and a dagger/centerboard configuration.

### Underwater Drag

The primary force on leeway drift is the underwater drag portion.

### Above-water Windage Portion

The secondary force on leeway drift is the above-water windage portion. Freeboard and the cabin structure, assumed to be present on these vessels, dominate the above-water windage portion. The presence/absence of the vessel's mast is the primary modifier of windage. The presence/absence of engines and the deployment of a drogue/sea anchor also modify windage.

### Rescue Equipment That May Become Drift Targets

Rescue equipment found onboard includes PFD's and throwable flotation devices. Cruising trimarans generally have some form of tender that can be used for transport ashore while anchored.



### **References for Class Descriptions**

1. Jeffrey, Kevin and Kanter, Charles, Sailors Multihull Guide, Avalon House Publishing/Sailco Press, Ashland, MA, 1994.
2. Wales, Patience, et al., 1997 Sailboat Buyers Guide, K-III Magazine Corp., New York, NY, 1996.
3. Sherwood, R.M., A Field Guide to Sailboats, Second Edition, Houghton Mifflin Company, Boston, 1994.

### **Leeway Drift Study References and Notes**

None

## **B5 POWER VESSELS**

Sections B5.1 through B5.9 deal with power vessels. Power vessels include all craft that generally use engines as their primary form of propulsion. These vessels include, but are not limited to, 'mega' yachts, large commercial fishers, most merchant vessels, and cruise ships. (Note: Vessels over 100 feet in length are not included in these subsections because they may have significantly different drift ratios and are assumed to be a source of marine survival craft and not a leeway target themselves. Pontoon boats, house boats, and competition water ski boats are also not included because they are primarily fresh water craft .)

(Note: Any classification system will overlap between the classes. Under these conditions, a decision must be made about the most probable class to use. For example, a 34 convertible could be classified as either a family cruiser or a sport fisher depending on the operator's intended purpose.)

It is assumed that all powered vessels are adrift. Therefore, either the vessel is without fuel or the engine/propeller systems are inoperable and the crew is unable to maneuver the vessel. Most powerboats do not carry drogues or sea anchors; however, these devices cannot be discounted when dealing with larger cruisers or commercial fishing vessels since they are sometimes employed for extended offshore operations.

## **B5.1 HOVERCRAFT**

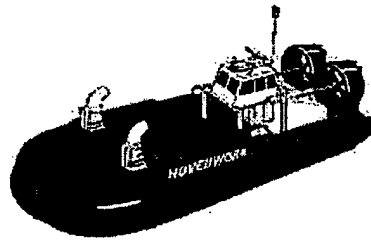

**Hovercraft**

### **Description**

Military forces or commercial ferry services use the majority of Hovercraft. Hovercrafts used for personal enjoyment are rare, but as the technology becomes more readily available, these craft may enjoy more popularity. Hovercrafts operate on a cushion of air enclosed in a rubber/fabric skirt. Air pumps or large fans provide the lift and directional control.

### **Above-water Portion**

When not active, these craft, regardless of function, rest on the flattened skirt and the above-water portion of the craft is the primary variable force on leeway drift. For craft in distress in the marine environment, the lack of ballast may result in an unstable condition leading to swamping or capsizing. As Hovercraft become more popular, a finer definition of drift variation will be warranted.

### **Rescue Equipment That May Become Drift Targets**

Rescue equipment found onboard is typically limited to personal flotation devices and throwable flotation devices. Commercial transport vessels also carry life rafts.

### **References for Class Descriptions**

None

### **Leeway Drift Study References and Notes**

None

## **B5.2 INFLATABLE BOATS**

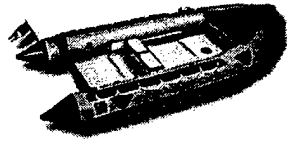

**V-Hull**

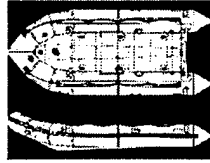

**Inflatable Keel**

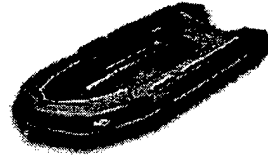

**Flat Bottom**

### **Description**

Powered inflatable boats do not include inflatable boats that are incapable of supporting an engine. These are found under the category 'Person-Powered Craft' (see section B3).

All inflatable boats have inflatable tubes that form the sides of the boat. The tubes meet at the bow, but most do not meet at the stern. The transom is typically a wooden or fiberglass panel capable of supporting an outboard engine. Hulls can be either rigid (typically fiberglass) or flexible (rubber or fabric). Many flexible hulls have plank decking that provides an operator with firm footing and increases the structural strength of the boat. The underwater portion of fabric hulls can either be flat or have an inflatable keel. For most inflatable boats the flat fabric bottom is 2-3 inches higher than the bottom of the tubes. Although this provides a better planing ride, the differences for leeway drift are negligible.

### **Hull Shape**

The primary variable force on leeway drift is the hull shape or style. The hull styles are V-hull, inflatable keel, and flat bottoms.

### **Engine Position**

For rigid hull inflatable boats, weight distribution differences between inboard and outboard engines significantly effect the leeway drift.

### **Rescue Equipment That May Become Drift Targets**

Rescue equipment found onboard is typically limited to personal flotation devices and throwable flotation devices.

### **Reference for Class Descriptions**

1. Wales, Patience, et al., 1997 Sailboat Buyers Guide, K-III Magazine Corp., New York, NY, 1996.

### **Leeway Drift Study References and Notes**

None

## **B5.3 SKIFFS**

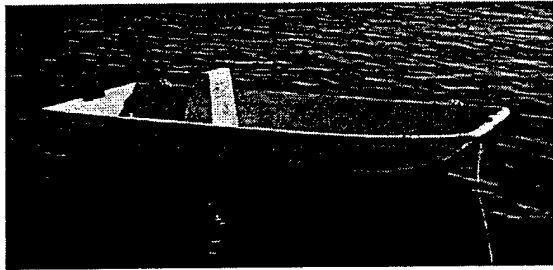

**Flat Bottom Skiff**

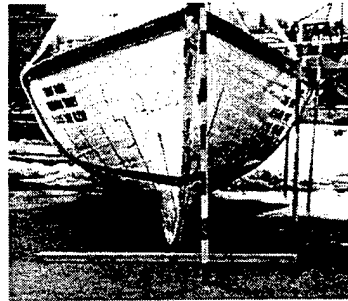

**V-Hull Skiff**

### **Description**

Skiffs are open boats less than 20 feet long that use an outboard motor as the primary source of propulsion. Some have characteristics identical to rowed boats with the exception that an outboard motor has been attached to the stern. This group includes but is not limited to, tenders for larger vessels, bass boats, hunting boats, Jon boats, and a large category of utility boats. Skiffs are usually found in lakes and rivers, but are also common in the calm waters of many bays and rivers that provide access to larger bays and eventually, open ocean.

Some skiffs are self-bailing and therefore, a swamped condition may be unlikely. Many skiffs are used for fishing, and an experienced boater may use a bait bucket or tackle box as a form of drogue to stabilize the ride and slow the drift rate when in trouble.

### **Below-water Hull Portion**

The primary variable force on leeway drift is the below-water hull portion. The hull styles are V-hull and flat bottoms.

### **Above-water Portion**

The secondary forces on leeway drift are the above-water hull and canvas structures. The hull styles are V-hull and flat bottoms. Because skiffs are low boats, the above-water modifier is the presence or absence of canvas tops or shelters.

### **Rescue Equipment That May Become Drift Targets**

Rescue equipment found onboard is typically limited to personal flotation devices and throwable flotation devices.

### **References for Class Descriptions**

1. Bass & Walleye Boats, Nov./Dec. Issue.
2. Trailer Boats, Nov./Dec. Issue.

### Leeway Drift Study References and Notes

Chapline, W.E. 1960. "Estimating the Drift of Distressed Small Craft." Coast Guard Alumni Association Bulletin, U.S. Coast Guard Academy, New London, CT, Vol. 22, No. 2, March-April 1960, pp 39-42.

Chapline presented result for a class of targets that included "outboards, paning [(sic), planing] hull type skiffs"

Outboards and Skiffs (flat bottom)

Leeway speed = 6% Wind

Hufford, G.L., and S. Broida. 1974. "Determination of Small Craft Leeway." U.S. Coast Guard Research and Development Center Report No. 39/74, December 1974.

Hufford and Broida studied a 12-foot "Silver Skiff" that weighted 115 pounds and had an average freeboard of 1.4 feet and a draft of 3 inches. They studied with and without a drogue.

a) Skiff (12-foot, flat bottom, without canvas, w/o drogue)

Leeway speed = 7% Wind + 0.11 knots

b) Skiff (12-foot, flat bottom, without canvas, w/ drogue)

Leeway speed = 4% Wind - 0.07 knots

Nash, L., and J. Willcox. 1991. "Spring 1985 Leeway Experiment," U.S. Coast Guard Report CG-D-12-92.

Nash and Willcox studied a 14-foot Boston Whaler-type outboard with less than 6 inches of draft. The boat was lightly loaded. An outboard motor was kept in the down position. The boat drifted beam to the wind in either of two configurations. Leeway angle was therefore divided into two groups.

Boston Whaler Skiff (14-foot, flat bottom, without canvas, w/o drogue)

Leeway speed = 3.44% Wind + 0.04 knots

Leeway angle = mean +14° and mean -24°,  $S_{y/x} = 0.03537$  knots or 1.8 cm/s

Fitzgerald, R.B., D.J. Finlayson, J.F. Cross, and A. Allen. 1993. "Drift of Common Search and Rescue Objects - Phase II." Contract report prepared for Transportation Development Centre, Transport Canada, Montreal, TP# 11673E.

Fitzgerald et al. studied a 5.53-meter wooden-planked open boat with an outboard motor common to the Newfoundland region. Fitzgerald et al. (1993) used the direct method of measuring leeway and adjusted wind to the 10-meter height. Winds speeds ranged up to 18 knots.

5.5- open skiff (V-hull, without canvas, with outboard motor, no drogue)

Leeway speed = 3.0 %  $W_{10m}$  + 0.11 knots;  $S_{y/x} = 0.032$  knots or 1.6 cm/s

Leeway angle (mean -9°; std. dev. 16°; min. -77°; max +45°)

DWL = 3.0 %  $W_{10m}$  + 0.09 knots       $S_{y/x} = 0.037$  knots (1.9cm/s)

CWL = 0.3 %  $W_{10m}$  - 0.05 knots       $S_{y/x} = 0.069$  knots (3.5 cm/s)

Fitzgerald, R.B., D.J. Finlayson, and A. Allen. 1994. "Drift of Common Search and Rescue Objects - Phase III." Contract report prepared for Canadian Coast Guard, Research and Development, Ottawa, TP# 12179.

Fitzgerald et al. studied the same 5.53-meter wooden-planked open boat used by Fitzgerald et al. (1993) and obtained considerably more data. Fitzgerald et al. (1994) used the direct method of measuring leeway and adjusted wind to the 10-meter height. Winds speeds ranged up to 28 knots. The two data sets were combined to provide the following.

5.5-m open skiff (V-hull, without canvas, with outboard motor, no drogue)  
Leeway speed =  $2.9 \% W_{10m} + 0.08$  knots;  $W_{10m} \leq 28$  knots,  $S_{y/x} = 0.058$   
knots or 3.0 cm/s  
Leeway angle for  $W_{10m} > 10$  knots (mean  $-3^\circ$ ; std. dev.  $7^\circ$ ; min.  $-29^\circ$ ; max  $+19^\circ$ )

Allen, A. A., and R.B. Fitzgerald. 1997. "The Leeway of an Open Boat and Three Life Rafts in Heavy Weather," U.S. Coast Guard Report No. CG-D-03-98.

Allen and Fitzgerald (1997) studied the same 5.53-meter wooden-planked open boat used by Fitzgerald et al. (1993) and (1994) and added analysis of the downwind and crosswind components of the boat in its standard configuration and as well as when it was swamped. The crosswind component of leeway for the boat in the standard configuration was conducted with a piece-wise regression separated by relative wind direction (RWD) of the boat. Allen and Fitzgerald (1997) used the direct method of measuring leeway and adjusted wind to the 10-meter height. Winds speeds ranged up to 22 m/s and wave heights to 9.3 meters.

a) 5.5- open skiff (V-hull, without canvas, with outboard motor, no drogue) standard configuration

Leeway speed =  $3.0 \% W_{10m} + 3.9$  cm/s  $W_{10m} \leq 22$  m/s,  $S_{y/x} = 4.14$  cm/s  
Leeway angle  $W_{10m} > 5$  m/s (mean  $-4^\circ$ ; std. dev.  $10^\circ$ ; min.  $-39^\circ$ ; max  $+44^\circ$ )  
 $DWL = 2.87 \% W_{10m} + 3.98$  cm/s  $S_{y/x} = 3.3$  cm/s  
 $+CWL = 0.32 \% W_{10m} - 2.93$  cm/s  $S_{y/x} = 2.52$  mc/s (-RWD)  
 $-CWL = -0.62 \% W_{10m} + 1.03$  cm/s  $S_{y/x} = 3.05$  mc/s (+RWD)

b) 5.5- open skiff (V-hull, without canvas, with outboard motor, no drogue) Swamped

Leeway speed =  $1.73 \% W_{10m}$ ;  $W_{10m} \leq 22$  m/s,  $S_{y/x} = 3$  cm/s

Allen, A. and J. Plourde, "Review of Leeway: Field Experiments and Implementation,"  
USCG Research and Development Center and Analysis & Technology, Inc., 1999.

Allen and Plourde also conducted re-analysis of skiff data from Hufford and  
Broida (1974) following the procedures used in section 3.2. The results of Allen  
and Plourde re-analysis are presented below.

Skiff (12-foot, flat bottom, without canvas, w/o drogue)

Leeway speed =  $6.84 \% W_{10m} + 5.5 \text{ cm/s}$   $W_{10m} \leq 8 \text{ m/s}$ ,  $S_{y/x} = 9.99 \text{ cm/s}$

Leeway angle for all wind (mean  $+5^\circ$ ; std. dev.  $38^\circ$ ; min.  $-60^\circ$ ; max  $+73^\circ$ )

DWL =  $6.87 \% W_{10m} - 2.39 \text{ cm/s}$   $S_{y/x} = 11.7 \text{ cm/s}$

+CWL =  $1.31 \% W_{10m} + 12.3 \text{ cm/s}$   $S_{y/x} = 13.7 \text{ cm/s}$

-CWL =  $-1.31 \% W_{10m} - 12.3 \text{ cm/s}$   $S_{y/x} = 13.7 \text{ cm/s}$

Skiff (12-foot, flat bottom, without canvas, with drogue)

Leeway speed =  $3.99 \% W_{10m} - 3.7 \text{ cm/s}$   $W_{10m} \leq 10 \text{ m/s}$ ,  $S_{y/x} = 5.68 \text{ cm/s}$

Leeway angle for all wind (mean  $+6^\circ$ ; std. dev.  $24^\circ$ ; min.  $-30^\circ$ ; max  $+55^\circ$ )

DWL =  $2.97 \% W_{10m} + 0.55 \text{ cm/s}$   $S_{y/x} = 4.29 \text{ cm/s}$

+CWL =  $1.28 \% W_{10m}$   $S_{y/x} = 8.7 \text{ cm/s}$

-CWL =  $-1.28 \% W_{10m}$   $S_{y/x} = 8.7 \text{ cm/s}$



## **B5.4 PERSONAL WATER CRAFT**

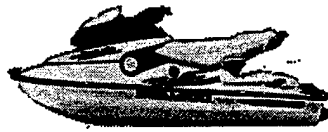

**Jet Ski**

### **Description**

Personal Water Craft (PWC), originally known as jet skis, are one-to-four person water craft in which the operator is seated, as on a motorcycle, or stands. PWC are controlled by motorcycle-style handgrips. The PWC offer positive buoyancy when not in operation and tend to float in an upright position in moderate-to-calm water. Hull designs include race, concave, multi-chine, and full or modified V. Draft is minimal and the above-waterline section varies by model type.

The authors could not locate any references that would indicate that the leeway drift of these craft has been studied. The minor differences in hull shape are insufficient to result in discernible drift rates.

### **Seated or Standing Style**

Style (seated or standing) has the primary effect on drift rate.

### **Deadweight**

The deadweight (roughly associated with person capacity) has the secondary effect on drift rate.

### **Rescue Equipment That May Become Drift Targets**

Rescue equipment is typically limited to personal flotation devices, which are generally worn. Since PWC operate with safety keys, it is unlikely that the PWC would run away from a spilled operator. It is likely that an operator could remain with his PWC until fatigue overcame him.

### **Reference for Class Descriptions**

1. Water Craft Magazine, April 1997, "1997 Watercraft Buyers Guide".

### **Leeway Drift Study References and Notes**

None

## **B5.5 SPORT BOATS**

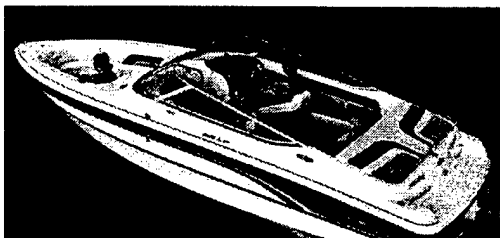

**Bow Rider**

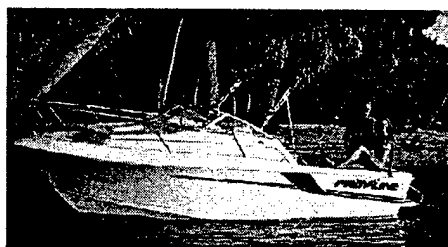

**Closed Bow**

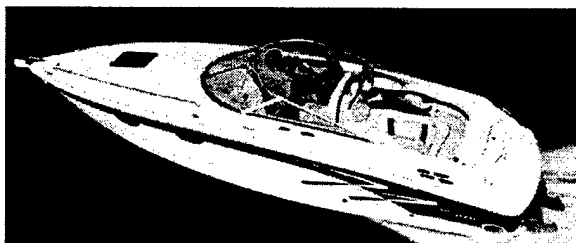

**Cuddy Cabin**

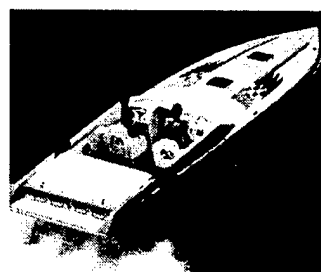

**High Performance**

### **Description**

The large category of sport boats includes pleasure craft from 15 to 28 feet long with beam widths from roughly 6 to 9 feet. It includes metal, fiberglass, and wood vessels with V, modified-V, or deep-V hull forms. Sport boats can be outfitted with inboard, outboard, or I/O propulsion. This category includes side console (closed bow and bow riders) and cuddy cabin boats. Sport boats may be used for short live aboard excursions but are not outfitted for extended cruising.

### **Above-water Windage Portion**

The primary force on leeway drift is the above-water windage portion. Typical modifiers are canvas bow and cockpit covers. Few sport boats will have drogue devices onboard.

### **Underwater Drag Portion**

The secondary force on leeway drift is the underwater drag portion. The typical modifier for outboard models is whether or not the engine is left in the water or raised out of the water.

### **Rescue Equipment That May Become Drift Targets**

Rescue equipment found onboard is usually limited to personal flotation devices and throwable flotation devices. General practice does not include wearing the PFD during normal operations and the accessibility of PFDs cannot be guaranteed.

## Reference for Class Descriptions

1. Trailer Boats Magazine, Nov./Dec. Issue.

## Leeway Drift Study References and Notes

Hufford, G.L., and S. Broida. 1974. "Determination of Small Craft Leeway." U.S. Coast Guard Research and Development Center Report No. 39/74, December 1974.

Hufford and Broida studied a 21-foot "MARINER" and a 15.2-foot "GLASTRON." The MARINER was 1191 pounds with a sail and keel areas of 48.0 and 8.1 square feet, respectively. The GLASTRON was 1069 pounds with a sail and keel areas of 24.3 and 17.1 square feet, respectively. Both craft were studied with and without a drogue.

MARINER w/o drogue

$$\text{Leeway speed} = 6\% \text{ Wind} + 0.01 \text{ knots}$$

GLASTRON w/o drogue

$$\text{Leeway speed} = 6\% \text{ Wind} - 0.02 \text{ knots}$$

MARINER w/ drogue

$$\text{Leeway speed} = 6\% \text{ Wind} - 0.12 \text{ knots}$$

GLASTRON w/ drogue

$$\text{Leeway speed} = 5\% \text{ Wind} - 0.09 \text{ knots}$$

Morgan, C.W., S.E. Brown, and R.C. Murrell. 1977. "Experiments in Small Craft Leeway," U.S. Coast Guard Oceanographic Unit Technical Report 77-2, Washington, D.C.

Morgan, Brown and Murrell studied a 16-foot outboard and an 18-foot motor launch but presented their results as two graphs both labeled "16-ft boat".

Nash, L., and J. Willcox. 1991. "Spring 1985 Leeway Experiment," U.S. Coast Guard Report CG-D-12-92.

Nash and Willcox studied a Beachcomber 20-foot cabin cruiser with cubbyhole cabin manufactured by Cruisers.

Beachcomber by Cruisers (Sport Boat, Cuddy Cabin, modified-V hull, with canvas top, 20-foot, inboard/outboard motor)

$$\text{DWL} = 6.9\% \text{ Wind} - 0.08 \text{ knots}, S_{y/x} = 0.05631 \text{ knots or } 2.9 \text{ cm/s}$$

$$\text{Leeway angle mean} = \text{nil}, \text{min} = -26^{\circ} \text{ and max.} = 27^{\circ}.$$

Allen, A. and J. Plourde, "Review of Leeway: Field Experiments and Implementation,"  
USCG Research and Development Center and Analysis & Technology, Inc., 1999.

Allen and Plourde also conducted re-analysis the MARINER and GLASTRON  
from Hufford and Broida (1974) following the procedures used in section 3.2.  
The results of Allen and Plourde re-analysis are presented below.

MARINER (21-foot, without canvas, without drogue)

Leeway speed =  $6.21 \% W_{10m} + 1.64 \text{ cm/s}$   $W_{10m} \leq 8 \text{ m/s}$ ,  $S_{y/x} = 7.29 \text{ cm/s}$

Leeway angle for all wind (mean  $+2^\circ$ ; std. dev.  $27^\circ$ ; min.  $-46^\circ$ ; max  $+56^\circ$ )

DWL =  $5.40 \% W_{10m} + 2.32 \text{ cm/s}$   $S_{y/x} = 6.98 \text{ cm/s}$

+CWL =  $2.54 \% W_{10m} - 0.1 \text{ cm/s}$   $S_{y/x} = 8.8 \text{ cm/s}$

-CWL =  $-2.54 \% W_{10m} + 0.1 \text{ cm/s}$   $S_{y/x} = 8.8 \text{ cm/s}$

GLASTRON (15-foot, without canvas, without drogue)

Leeway speed =  $6.44 \% W_{10m} - 1.1 \text{ cm/s}$   $W_{10m} \leq 8 \text{ m/s}$ ,  $S_{y/x} = 6.68 \text{ cm/s}$

Leeway angle for all wind (mean  $0^\circ$ ; std. dev.  $28^\circ$ ; min.  $-105^\circ$ ; max  $+49^\circ$ )

DWL =  $6.23 \% W_{10m} - 3.06 \text{ cm/s}$   $S_{y/x} = 7.98 \text{ cm/s}$

+CWL =  $1.81 \% W_{10m} + 0.3 \text{ cm/s}$   $S_{y/x} = 8.8 \text{ cm/s}$

-CWL =  $-1.81 \% W_{10m} - 0.3 \text{ cm/s}$   $S_{y/x} = 8.8 \text{ cm/s}$

MARINER (21-foot, without canvas, with drogue)

Leeway speed =  $5.80 \% W_{10m} - 5.85 \text{ cm/s}$   $W_{10m} \leq 9 \text{ m/s}$ ,  $S_{y/x} = 3.69 \text{ cm/s}$

Leeway angle for all wind (mean  $+9^\circ$ ; std. dev.  $21^\circ$ ; min.  $-38^\circ$ ; max  $+43^\circ$ )

DWL =  $4.62 \% W_{10m} - 1.19 \text{ cm/s}$   $S_{y/x} = 4.97 \text{ cm/s}$

+CWL =  $1.77 \% W_{10m}$   $S_{y/x} = 8.60 \text{ cm/s}$

-CWL =  $-1.77 \% W_{10m}$   $S_{y/x} = 8.60 \text{ cm/s}$

GLASTRON (15-foot, without canvas, with drogue)

Leeway speed =  $5.08 \% W_{10m} - 4.78 \text{ cm/s}$   $W_{10m} \leq 9 \text{ m/s}$ ,  $S_{y/x} = 5.19 \text{ cm/s}$

Leeway angle for all wind (mean  $13^\circ$ ; std. dev.  $19^\circ$ ; min.  $-12^\circ$ ; max  $+42^\circ$ )

DWL =  $3.68 \% W_{10m} + 1.60 \text{ cm/s}$   $S_{y/x} = 4.9 \text{ cm/s}$

+CWL =  $1.60 \% W_{10m}$   $S_{y/x} = 7.4 \text{ cm/s}$

-CWL =  $-1.60 \% W_{10m}$   $S_{y/x} = 7.4 \text{ cm/s}$

## B5.6 SPORT FISHERS

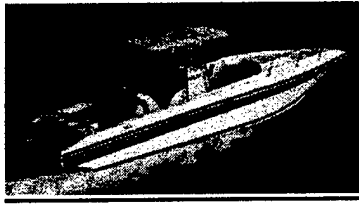

**Center Console**

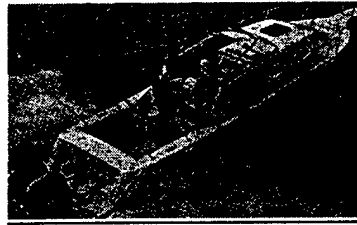

**Walk Around Cuddy**

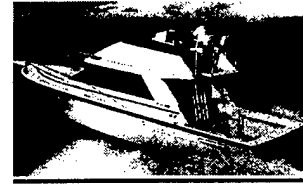

**Convertible**

### **Description**

Sport fishers include pleasure and commercial craft from 17 to approximately 100 feet long with beam widths up to 24 feet. The majority are between 30 to 50 feet long with beam widths between 10 and 15 feet. Vessels over 100 feet long are not included in this class. Instead, they are considered sources of leeway targets. This class includes both semi-displacement and planing hull forms that can be outfitted with inboard, outboard, or I/O propulsion. This category includes boats with a simple center console or walk-round cabin. Convertibles are sport fishers with a walk around cabin and a flying bridge. Convertibles designed for offshore fishing may also have a spotting tower. Many convertibles provide extended cruising capabilities similar to sport cruisers, but their after deck design provides a larger open area to work fishing gear. Some of these vessels can also be found in the family cruiser or motor yacht categories.

### **Above-water Windage Portion**

The primary force on leeway drift is the above-water windage portion. Typical modifiers are canvas cockpit covers. Few sport cruisers have drogue devices onboard.

### **Underwater Drag Portion**

The secondary force on leeway drift is the underwater drag portion. The typical modifier for outboard models is whether the engine is left in the water or raised out of the water.

### **Rescue Equipment That May Become Drift Targets**

Rescue equipment found onboard is usually limited to personal flotation devices and one throwable flotation device. General practice, however, does not include wearing the PFD during normal operations and the accessibility of PFDs cannot be guaranteed. Some sport cruisers are outfitted with a life raft, inflatable, skiff, or a PWC.

## References for Class Descriptions

1. McKnew, Ed and Parker, Mark, The McKnew/Parker Consumer's Guide to Sport Fishing Boats, 17' - 27' 1975-Present, International Marine, Camden, ME, 1996.
2. McKnew, Ed and Parker, Mark, The McKnew/Parker Consumer's Guide to Sport Fishing Boats, 28' - 82' 1975-Present, International Marine, Camden, ME, 1996.

## Leeway Drift Study References and Notes

Chapline, W.E. 1960. "Estimating the Drift of Distressed Small Craft." Coast Guard Alumni Association Bulletin, U.S. Coast Guard Academy, New London, CT, Vol. 22, No. 2, March-April 1960, pp 39-42.

Chapline presented result for a class of targets that included "light displacement cruisers."

Light Displacement Cruisers

Leeway speed = 6% Wind

Nash, L., and J. Willcox. 1991. "Spring 1985 Leeway Experiment," U.S. Coast Guard Report CG-D-12-92.

Nash and Willcox studied a 19-foot center-console sport fisherman with an outboard motor.

(Sport Fisher, Center Consul, Open Cockpit)

$DWL = 6.0\% \text{ Wind} - 0.9 \text{ knots}$ ,  $S_{y/x} = 0.06448 \text{ knots or } 3.3 \text{ cm/s}$

Leeway Angle min =  $-39^{\circ}$  max =  $+32^{\circ}$ .

## B5.7 SPORT CRUISERS

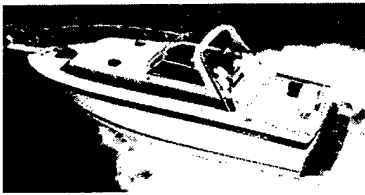

**Express Cruiser**

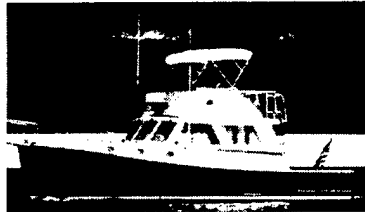

**Family Cruiser**



**Dory Cruiser**



**Motor Yacht**



**High Performance**

### Description

Sport cruisers include pleasure and commercial craft from 24 to approximately 100 feet long with beam widths up to 18 feet. Vessels over 100 feet long are not included in this class. Instead, they are considered sources of leeway targets. The majority of sport cruisers are constructed of fiberglass and wood; however, some metal cruisers are available. This class includes both displacement and planing hull forms that can be outfitted with inboard, outboard, or I/O propulsion. This category includes boats with and without an extended superstructure. Sport cruisers can support extended live-aboard excursions.

Express cruisers are an open-style design without a fly bridge or a hardtop, while family cruisers have a flybridge or hardtop.

### Above-water Windage Portion

The primary force on leeway drift is the above-water windage portion. Typical modifiers are canvas cockpit covers. Few sport cruisers have drogue devices onboard.

### Underwater Drag Portion

The secondary force on leeway drift is the underwater drag portion. The typical modifier in outboard models is whether the engine is left in the water or raised out of the water.

## **Rescue Equipment That May Become Drift Targets**

Rescue equipment found onboard is usually limited to personal flotation devices and one throwable flotation device. General practice, however, does not include wearing the PFD during normal operations and the accessibility of PFDs cannot be guaranteed. Some sport cruisers are outfitted with a life raft, inflatable, skiff, or a PWC.

## **References for Class Descriptions**

1. McKnew, Ed and Parker, Mark, The McKnew/Parker Consumer's Guide to Family and Express Cruisers 1975-Present, International Marine, Camden, ME, 1996.
2. McKnew, Ed and Parker, Mark, The McKnew/Parker Consumer's Guide to Motor Yachts and Trawlers 1975-Present, International Marine, Camden, ME, 1996.
3. "One More Look, Details on 41 Hot '97s," Hot Boat Magazine, April 1997.
4. Offshore Racing Magazine.

## **Leeway Drift Study References and Notes**

Chapline, W.E. 1960. "Estimating the Drift of Distressed Small Craft." Coast Guard Alumni Association Bulletin, U.S. Coast Guard Academy, New London, CT, Vol. 22, No. 2, March-April 1960, pp 39-42.

Chapline (1960) presented result for a class of targets "Moderate displacement cruisers."

Moderate Displacement Cruisers  
Leeway speed = 5% Wind



## B5.8 COMMERCIAL FISHERS

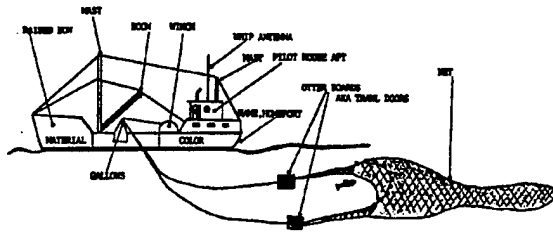

Side Trawler

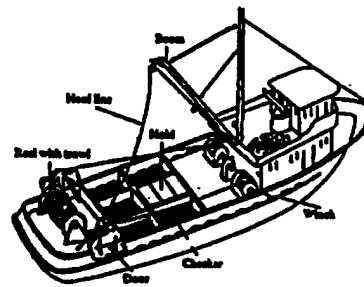

Stern Trawler

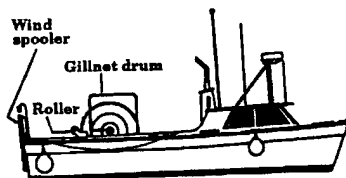

Gillnetter

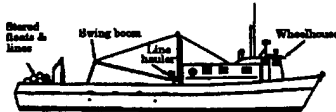

Longliner

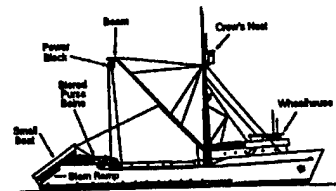

Purse Seiner

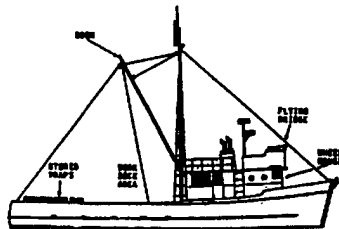

Trap Boat

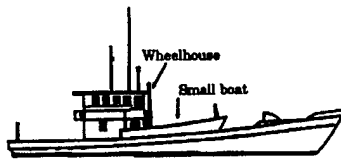

Sampan

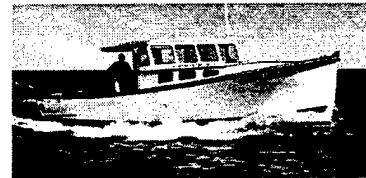

Lobster Boat

### Description

Commercial fishing vessels include vessels from 45 to 100 feet long designed for fishing or shell fishing in coastal and ocean waters. Vessels over 100 feet long are not included in this class. Instead, they are considered sources of leeway targets. Commercial fishers include side and stern trawling rigs, long liners, bottom dragging rigs, and purse seiners. Pole fishers are simply a modified use of sport fishers or sport cruisers, and leeway information is found in those categories. Commercial fishers can be working alone, as paired vessels, or as the mother ship to a group of smaller fishing skiffs. These vessels have different design features based on their purpose, but all have some form of deck house and an open area from which nets and lines are worked. A deck winch and boom system is commonly used to handle nets or lines.

Many of these vessels, particularly those of U.S. Asian and European registry, have substantial electronics capabilities that may include radar, LORAN/GPS, and radios. While these capabilities do not affect leeway drift, they can be used to provide position information in an emergency.

These are displacement vessels whose hulls are designed for carrying their target fishing species and little variation occurs within a category.

### **Above-water Structural Design**

The primary variable on the leeway drift ratio is described by the design of the above-water structural design. Many mid-size commercial fishers will have drogue devices onboard.

### **Rigging**

The secondary force on leeway drift is the above-water structural rig placement that varies with this class.

### **Rescue Equipment That May Become Drift Targets**

Rescue equipment found onboard will include personal flotation devices and throwable flotation devices. The general practice does not include wearing the PFD during normal operations and the accessibility of PFDs cannot be guaranteed. Many commercial fishers carry 4-6-person life raft(s). Many also carry a sea anchor to permit them to remain on the fishing grounds and to rest during heavy weather.

### **References for Class Descriptions**

1. Lloyds Register of Shipping, 1990, LR Printing Services, Ltd., West Sussex, United Kingdom, 1990.
2. Pacific Area Training Team, Pacific Regional Fisheries Training Group Fishing Vessel & Gear Identification Job Aid, Afloat Version, 1996.

### **Leeway Drift Study References and Notes**

Chapline, W.E. 1960. "Estimating the Drift of Distressed Small Craft." Coast Guard Alumni Association Bulletin, U.S. Coast Guard Academy, New London, CT, Vol. 22, No. 2, March-April 1960, pp 39-42.

Chapline presented result for a class of targets that included "fishing vessels such as trawlers, trollers, sampans, draggers, seiners, tuna boats, halibut boats, etc." Chapline may have only studied sampans and applied results to other classes of fishing vessels.

Fishing Vessels  
Leeway speed = 4% Wind

Hiraiwa, T., T. Fujii, and S. Saito (1967). "An Experimental Study of Drift and Leeway," Journal of the Institute of Navigation, London: Vol. 20., No. 2., pp. 131-145.

Hiraiwa, Fujii, and Saito studied a 60.5-meter and a 33.0-meter fishery training vessels. Although the 60.5-meter fishery training vessel exceeds the 100 foot size, it was actually studied as a leeway target.

a) 60.5-m fishery training vessel

Leeway speed = 6.8% Wind

b) 33.0-m fishery training vessel

Leeway speed = 6.3% Wind

Suzuki, Tsuneo, and Harou Sato, (1977). "Measurement of the Drifting of a Fishing Boat or Research Vessel due to Wind and Wave," The Journal of Japan Institute of Navigation. No. 57, pp. 71 -76.

Suzuki and Sato studied a 62-m fishing vessel. This vessel was characterized as a side-stern troller. Although the 62-meter fishing vessel exceeds the 100 foot size, it was actually studied as a leeway target.

62-m fishery training vessel

Leeway speed = 4.2% Wind

Igeta, Yuzo, Tsuneo Suzuki and Haruo Sato, 1982. "Experiment on the Sea Regarding Distress and Search of Small Fishing Boat - I," The Journal of Japan Institute of Navigation. No. 68, pp. 103 - 112.

Igeta, Suzuki and Sato studied two 17-m Japanese-longliners fishing vessels with various loading.

Two 17-m Japanese longliners

Leeway speed = 5.4 to 6.5% Wind for winds at 5m/s

Leeway speed = 3.3 to 4.0% Wind for winds at 10m/s

Kang, S.Y. 1995. "Drift Experiment for the Determination of Small Boat Leeway," Journal of the Society of Marine Safety, Vol.1, No.1., pp. 8 (Abstract in English, text in Korean).

Kang studied a 12.5-meter Korean fishing vessel (shown in Figure 2-21) that was 3.5-meters wide. Kang used the direct method and adjusted winds to 10m height using  $1/7^{\text{th}}$  power law.

Korean fishing vessel

Leeway speed =  $2.66 \% W_{10m} + 4.9 \text{ cm/s}$       $S_{y/x} = 3.9 \text{ cm/s}$

Leeway angle (mean = -46.78; std. dev. = 18.32 for  $W_{10m} > 5 \text{ m/s}$ ).

Allen, A. A., 1996. "The Leeway of Cuban Refugee Rafts and a Commercial Fishing Vessel," U.S. Coast Guard Report No. CG-D-21-96.

Allen using the direct method studied a 15-meter commercial fishing vessel with a rear-reel for net fishing common to Florida waters. Wind speeds were adjusted to 10-meter height.

Commercial Fishing Vessel (Gillnetter, rear-reel for net fishing)

Leeway speed =  $3.98 \% W_{10m} + 0.31 \text{ cm/s}$ ;  $W_{10m} \leq 10 \text{ m/s}$ ,  $Sy/x = 3.00 \text{ cm/s}$

Leeway angle (mean  $-22^\circ$ ; std. dev.  $23^\circ$ ; min.  $-64^\circ$ ; max  $+118^\circ$ )

Leeway angle ( $> 5 \text{ m/s}$ ), mean of abs. values  $27.2^\circ$ ; std. dev. of abs. values  $10.8^\circ$ )

**DWL** =  $3.72 \% W_{10m} - 0.87 \text{ cm/s}$   $Sy/x = 3.33 \text{ cm/s}$

**+CWL** =  $1.41 \% W_{10m} + 2.0 \text{ cm/s}$   $Sy/x = 3.36 \text{ cm/s}$

**-CWL** =  $-1.41 \% W_{10m} - 2.0 \text{ cm/s}$   $Sy/x = 3.36 \text{ cm/s}$

Allen, A. and J. Plourde, "Review of Leeway: Field Experiments and Implementation," USCG Research and Development Center and Analysis & Technology, Inc., 1999.

Allen and Plourde—Chapter 7 combined leeway equations from the above studies.

Commercial Fishing Vessels combined

$3.7 \% W_{10m} + 1.0 \text{ cm/s}$   $> 15 \text{ cm/s } Sy/x$

## B5.9 COASTAL FREIGHTERS

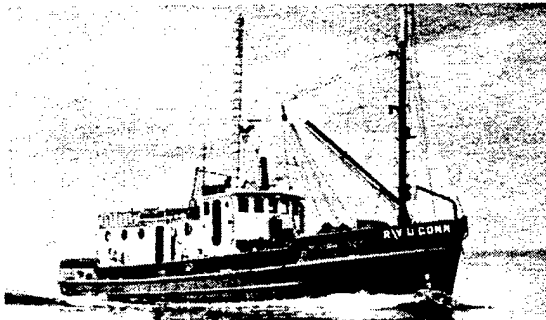

**Coastal Freighter with Mid Deckhouse**

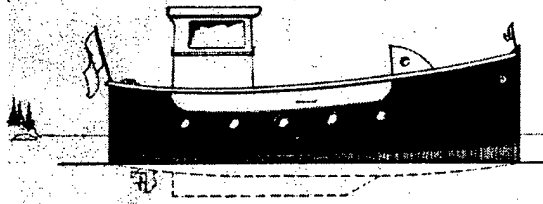

**Coastal Freighter with Aft Deckhouse**

### **Description**

Coastal Freighters include a wide range of commercial shipping platforms up to 100 feet in length. Vessels over 100 feet long are not included in this class. Instead, they are considered sources of leeway targets. Coastal Freighters transfer cargo from one port to another. Shipping agents can provide estimated voyage schedules. Coastal freighters include vessels with a deckhouse on the forecastle (as with Great Lakes vessels), amidships, and most commonly, aft.

### **Deckhouse Location**

The primary force on leeway drift is the location of the deckhouse.

### **Relative Cargo Loading**

The secondary force on leeway drift is the relative loading with cargo.

### **Rescue Equipment That May Become Drift Targets**

For vessels involved in onboard will include personal flotation devices, throwable flotation devices, and depending on length, 4-6 or 8-10-person life raft(s). General practice does not include wearing PFDs during normal operations and the accessibility of PFDs cannot be guaranteed.

### **Reference for Class Descriptions**

1. Lloyds Register of Shipping, 1990, LR Printing Services, Ltd., West Sussex, United Kingdom, 1990.

### **Leeway Drift Study References and Notes**

Suzuki, Tsuneo, and Harou Sato, (1977). "Measurement of the Drifting of a Fishing Boat or Research Vessel due to Wind and Wave," The Journal of Japan Institute of Navigation. No. 57, pp. 71 -76.

Suzuki and Sato (1977) studied a 45m-research vessel.

Leeway speed = 2.8% Wind

## B6 BOATING DEBRIS

### Description

Boating debris is any debris that can be expected from a boat that is sinking and/or breaking up. It may include paper, plastic containers, bedding, clothing, and a variety of fragmented boat sections.

Survivors of a sinking or breaking up boat can be expected to attempt to remain with floating debris or to use it for flotation. One or more survivors can use large floating objects such as bait or wharf boxes as "survival craft."

### References for Class Descriptions

None

### Leeway Drift Study References and Notes

Igeta, Yuzo, Tsuneo Suzuki and Haruo Sato, 1982. "Experiment on the Sea Regarding Distress and Search of Small Fishing Boat - I," The Journal of Japan Institute of Navigation. No. 68, pp. 103 - 112.

Igeta et al. studied debris typical to a Japanese fishing vessel. The floating debris included a lifejacket, life ring, glass fishing float balls, a fishing box lid and a wooden board.

Leeway speed = 3.3 to 5.0% Wind for winds at 3m/s

Leeway speed = 2.0 to 3.6% Wind for winds at 7m/s

Leeway speed = 1.4 to 2.4% Wind for winds at 11m/s

Allen A., Q. Robe, and E. Morton (1999). "The Leeway of Person-in-Water and Three Small Craft," USCG Research and Development Center Report No. R&DC 24/98.

A commercial 1-cubic meter bait / wharf box, lightly and fully loaded, was studied using the direct method. The direct method of measuring leeway was used and winds were adjusted to the 10-meter height. Winds speeds ranged up to 12 m/s.

#### Wharf Box

Leeway speed =  $1.3 \% W_{10m} + 13.8 \text{ cm/s}$ ;  $S_{y/x} = 4.50 \text{ cm/s}$

Leeway angle for  $W_{10m} > 5\text{m/s}$  (mean  $28^\circ$ ; std. dev.  $14^\circ$ ; min.  $-2^\circ$ ; max  $+54^\circ$ )

DWL =  $0.72\% W_{10m} + 15.8 \text{ cm/s}$ ,  $S_{y/x} = 5.59 \text{ cm/s}$

CWL =  $1.86\% W_{10m} - 5.26 \text{ cm/s}$ ,  $S_{y/x} = 4.20 \text{ cm/s}$

#### Wharf Box (with 1-person loading)

Leeway speed =  $2.6 \% W_{10m} + 9.2 \text{ cm/s}$ ;  $S_{y/x} = 2.96 \text{ cm/s}$

Leeway angle for  $W_{10m} > 5\text{m/s}$  (mean  $11^\circ$ ; std. dev.  $9^\circ$ ; min.  $-2^\circ$ ; max  $+37^\circ$ )

DWL =  $2.53\% W_{10m} + 9.01 \text{ cm/s}$ ,  $S_{y/x} = 3.05 \text{ cm/s}$

$$\text{CWL} = 1.09 \% W_{10m} - 2.76 \text{ cm/s}, S_{y/x} = 4.14 \text{ cm/s}$$

Wharf Box (with 4-person loading)

$$\text{Leeway speed} = 1.6 \% W_{10m} + 8.0 \text{ cm/s}, S_{y/x} = 2.70 \text{ cm/s}$$

Leeway angle for  $W_{10m} > 5\text{m/s}$  (mean  $35^\circ$ ; std. dev.  $9^\circ$ ; min.  $-2^\circ$ ; max  $+54^\circ$ )

$$\text{DWL} = 1.15\% W_{10m} + 7.94 \text{ cm/s}, S_{y/x} = 3.17 \text{ cm/s}$$

$$\text{CWL} = 1.48 \% W_{10m} - 0.32 \text{ cm/s}, S_{y/x} = 2.99 \text{ cm/s}$$



## B7 AVIATION PIW



**Type V Anti-exposure Suit**

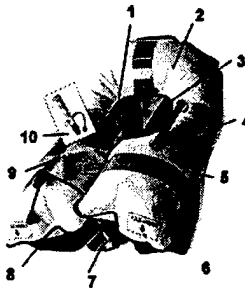

**Type V Inflatable Vest**

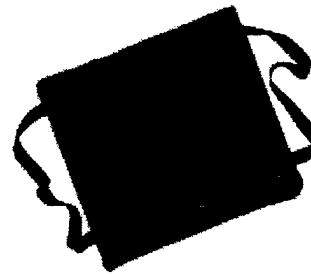

**Type IV Seat Cushion**

### Description

Aviation PIW involves person in the water targets generated from any aviation source. It includes persons without any flotation, with a seat cushion, and with a PFD. Due to space and weight requirements, most of the personnel flotation devices are inflatable suspenders, hybrid type V PFDs with flotation equivalent to a Type I (offshore) PFD (see Table B-2). In the event that a passenger airliner evacuates in the water, most passengers will be limited to seat cushion flotation. Conscious PIWs with a seat cushion float in the seated position similar to PIW with a Type II PFD. These taxonomy categories reflect the orientation of the PIW, and therefore the surface area affected by wind and water

### Position

The primary drift class characteristic is position. Position may be:

- vertical,
- sitting, or
- horizontal.

The vertical position generally requires dynamic maintenance by a conscious and active PIW. The PIW will either be slightly inclined backwards or forwards. A forward inclined PIW is actively swimming towards a goal. A backward inclined PIW is maintaining orientation to the waves.

The sitting position is the classic fetal position with legs drawn up and arms huddled across the PFD. This is the preferred position a person assumes in cold water. The natural orientation of a sitting PIW is to face away from the oncoming waves.

The horizontal position requires flotation around the legs for a survivor. Victims floating face down will be in a nearly horizontal position with arms and legs dangling from the PFD.

## **State of PIW**

PIW may be in any of three states:

- g) conscious,
- h) unconscious, or
- i) victims.

Conscious PIW's play an active role in maintaining their position relative to the water surface and wave/wind direction.

Unconscious PIW's are passive, usually from hypothermia, and "frozen" into a position. They cannot hang onto a throwable device.

Victims are deceased PIW's.

## **PFD Style**

There are three basic styles or designs of PFDs in use for civilian aircraft:

- 1) Seat cushions are used as PFD for aircraft passengers.
- 2) Aviation passenger life vest are similar to Type hybrid V PFDs which include the inflatable vests and suspenders style of PFDs.
- 3) Some pilots may wear anti-exposure suits .

## **References for Class Descriptions**

- 1. FAR 125.209 Emergency Equipment: Extended Overwater Operations.
- 2. Airline Emergency Equipment Personnel

## **Leeway Drift Study References and Notes**

There are no specific leeway studies of Aviation PIW, however, for general PIW leeway studies see Maritime PIW, section B1.

## B8 AVIATION SURVIVAL CRAFT

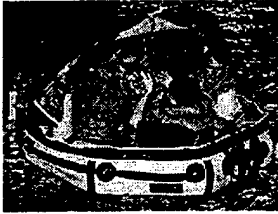

**Aviation Life Raft**

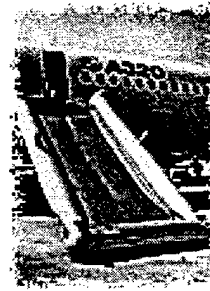

**Aviation Slide Raft**

### **Description**

Aviation survival craft are limited to life rafts. Aviation life rafts fall into two groups, life rafts and slide rafts. Aviation life rafts are similar to marine life rafts, but are usually made from lighter materials. In some cases, manufacturers use the same rafts and only package them differently. Slide rafts are specifically designed devices intended to ease evacuation from an aircraft. They mount to door frames or near wing emergency exits and are cut loose from the airframe once fully loaded. On commercial flights, life rafts and slide rafts must meet TSO requirements.

### **Ballast**

The primary drift class characteristic is ballast. Ballast may be:

- no ballast,
- shallow pocket ballast,
- deep ballast,
- swamped, or
- capsized.

Shallow pocket ballast systems consist of a series of fabric pockets generally 4 inches in diameter and less than 6 inches in depth. Deep pocket systems consist of large fabric bags, from 3 to 7 on the raft, that are 1+ feet wide by 2+ feet long by 2+ feet deep. Torroidal systems consist of a ring of deep pockets, sometimes connected to form a doughnut around the outside of the raft.

### **Drogue Modifiers**

Most manufacturers supply automatically deploying drogues, also called sea anchors, with new life raft purchases.

## Reference for Class Descriptions

1. FAR 125.209 Emergency Equipment: Extended Overwater Operations.

## Leeway Drift Study References and Notes

Nash, L., and J. Willcox. 1991. "Spring 1985 Leeway Experiment," U.S. Coast Guard Report CG-D-12-92.

Nash and Willcox studied a marine / aviation life raft in winds of 2 to 14 knots. The life raft was a 4-person Winslow life raft, lacked a ballast system, but had a canopy, and was deployed with a drogue and heavy loading. The Winslow life raft was typical of rafts carried by recreational and non-regulated boaters and small aircraft during the 1980's.

Winslow (no ballast, canopy, w/o drogue, 4-person, heavy loading)  
Marine / Aviation Life Raft

$$DWL = 3.71 \% \text{ Wind} + 0.11 \text{ knots (+ 5.7 cm/s)}$$

$$S_{y/x} = 0.04102 \text{ knots or 2.1 cm/s}$$

Fitzgerald, R.B., D.J. Finlayson, and A. Allen. 1994. "Drift of Common Search and Rescue Objects - Phase III." Contract report prepared for Canadian Coast Guard, Research and Development, Ottawa, TP# 12179.

Fitzgerald et al studied a L1011 aircraft evacuation slide 46-person life raft. The slide/life raft was equipped with 6 small ballast bags, configured with a loading of 20-persons with no canopy and no drogue. Fitzgerald et al. (1994) used the direct method of measuring leeway and adjusted wind to the 10-meter height. Winds speeds ranged up to 26 knots.

Evacuation/slide (shallow ballast, no canopy, w/o drogue, 46-person, heavy loading) Aviation Life Raft

$$\text{Leeway speed} = 2.8 \% W_{10m} - 0.01 \text{ knots (-0.6 cm/s); } W_{10m} \leq 26 \text{ knots}$$

$$S_{y/x} = 0.077 \text{ knots or 4.0 cm/s}$$

$$\text{Leeway angle (mean } -3^\circ; \text{ std dev } 10^\circ; \text{ min. } -35^\circ; \text{ max } +17^\circ)$$

## **B9 AVIATION DEBRIS**

### **Description**

Aviation debris is any debris from an aircraft making water landing, whether it breaks up on impact or sinks after the water landing. It includes paper articles, textiles and insulation, seats, luggage, life vests, slide ramps or slide rafts, and fragmented plane sections. Many sections of an aircraft are made with a honeycomb core structure because it provides strength at a lower weight than solid construction. The fragmented plane sections are those made of this honeycomb construction which includes cabin paneling, doors, galley stowage, access panels and wing leading edge, flaps, and ailerons.

### **References for Class Descriptions**

None

### **Leeway Drift Study References and Notes**

Igeta, Yuzo, Tsuneo Suzuki and Haruo Sato, 1982. "Experiment on the Sea Regarding Distress and Search of Small Fishing Boat - I," The Journal of Japan Institute of Navigation. No. 68, pp. 103 - 112.

Igeta et al. (1982) studied debris typical to a Japanese fishing vessel. The floating debris included a lifejacket and a life ring, which are similar to some aircraft debris.

#### **Life Ring**

Leeway speed = 5.0% Wind for winds at 3m/s

Leeway speed = 2.9% Wind for winds at 7m/s

Leeway speed = 2.0% Wind for winds at 11m/s

## B10 COMBAT SAR AVIATION PIW

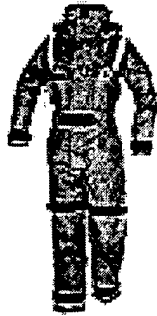

Type V Anti-exposure Suit

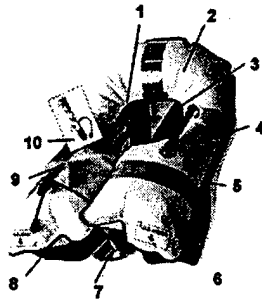

Type V Inflatable Vest



Survival suit

### Description

Although safety standards may vary slightly from service to service, it is reasonable to assume that aircraft personnel will be wearing a hybrid Type V PFD onboard helicopters and small airplanes. These PFDs can be a flight vest or working harness, but the flotation device is worn. Flotation devices are readily available onboard larger aircraft, but are not donned until needed.

All aviation PFDs rely on inflatable air bladders for buoyancy. In the event that the bladders rupture, service training includes the practice of using the uniform for additional flotation.

### Position

The primary drift class characteristic is position. Position may be:

- vertical,
- sitting, or
- horizontal.

The vertical position generally requires dynamic maintenance by a conscious and active PIW. The PIW will either be slightly inclined backwards or forwards. A forward inclined PIW is actively swimming towards a goal. A backward inclined PIW is maintaining orientation to the waves.

The sitting position is the classic fetal position with legs drawn up and arms huddled across the PFD. This is the preferred position a person assumes in cold water. The natural orientation of a sitting PIW is to face away from the oncoming waves.

The horizontal position requires floatation around the legs for a survivor. Victims floating face down will be in a nearly horizontal position with arms and legs dangling from the PFD.

## **State of PIW**

PIW may be in any of three states:

- j) conscious,
- k) unconscious, or
- l) victims.

Conscious PIW's play an active role in maintaining their position relative to the water surface and wave/wind direction.

Unconscious PIW's are passive, usually from hypothermia, and "frozen" into a position. They cannot hang onto a throwable device.

Victims are deceased PIW's.

## **PFD Style**

There are three basic styles or designs of PFDs carried onboard military aircraft. Brief descriptions and examples of the three styles are listed below.

- 1) Anti-exposure suits are worn by military aircrews and rescue swimmers. Anti-exposure suits include wet suits and dry suits. Rescue swimmers will also be equipped with a one-person life raft.
- 2) Military aircrew PFD are high floatation variations of the Type hybrid V PFDs which include the inflatable vests and suspenders style of PFDs.
- 3) Survival suits, also called immersions suits, are carried on board some military aircraft. Conscious and unconscious PIW in survival suits float horizontally on their backs with their heads into the waves.

## **References for Class Descriptions**

- 1. FAR 125.209 Emergency Equipment: Extended Overwater Operations.
- 2. U.S. Coast Guard, Commandant Instruction M13520.1A, "Aviation Life Support Systems Manual," Washington D.C. 1 June 1994.
- 3. U.S. Coast Guard, Commandant Instruction M3710.1D, "Air Operation Manual," Washington D.C. 7 May 1997.

## **Leeway Drift Study References and Notes**

There are no specific leeway studies of Combat SAR Aviation PIW, however, for general PIW leeway studies see Maritime PIW, section B1.

## **B11 COMBAT SAR AVIATION SURVIVAL CRAFT**

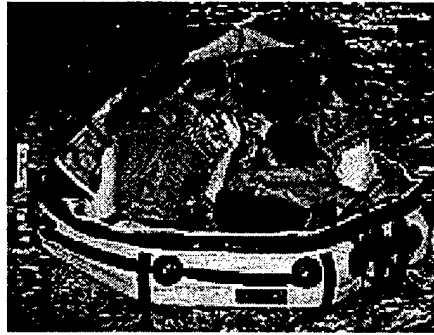

**Aviation Life Raft**

### **Description**

Combat SAR Aviation survival craft are limited to life rafts. The majority of combat SAR aviation life rafts are similar to those found in general aviation. The major differences are in the gear carried aboard the raft. The gear onboard will be specific to each service's requirements and function.

### **Ballast**

The primary drift class characteristic is ballast. Ballast may be:

- no ballast,
- shallow pocket ballast,
- deep ballast,
- swamped, or
- capsized.

Shallow pocket ballast systems consist of a series of fabric pockets generally 4 inches in diameter and less than 6 inches in depth. Deep pocket systems consist of large fabric bags, from 3 to 7 on the raft, that are 1+ feet wide by 2+ feet long by 2+ feet deep. Torroidal systems consist of a ring of deep pockets, sometimes connected to form a doughnut around the outside of the raft.

### **Drogue Modifiers**

Most manufacturers supply automatically deploying drogues, also called sea anchors, with new life raft purchases.



### **References for Class Descriptions**

1. FAR 125.209 Emergency Equipment: Extended Overwater Operations.
2. U.S. Coast Guard, Commandant Instruction M13520.1A, "Aviation Life Support Systems Manual," Washington D.C. 1 June 1994.

### **Leeway Drift Study References and Notes**

There are no specific leeway studies of Combat SAR Aviation survival craft, however, for general life leeway studies see Aviation survival craft, section B8.

## **B12 COMBAT SAR AVIATION DEBRIS**

### **Description**

Aviation debris is any debris from an aircraft making water landing, whether it breaks up on impact or sinks after the water landing. It includes paper articles, textiles and insulation, seats, luggage, life vests, slide ramps or slide rafts, and fragmented plane sections. Many sections of an aircraft are made with a honeycomb core structure because it provides strength at a lower weight than solid construction. The fragmented plane sections are those made of this honeycomb construction and include cabin paneling, doors, galley stowage, access panels and wing leading edge, flaps, and ailerons. The amount and probability of finding aviation debris in a combat aircraft water landing is lower than that expected from a logistics flight because of the size and different materials used for harsher flight conditions expected of combat missions.

### **References for Class Descriptions**

None

### **Leeway Drift Study References and Notes**

There are no specific leeway studies of Combat SAR Aviation Debris, however, for general aviation debris leeway studies see Aviation Debris, section B9.

## B13 COMBAT SAR MARITIME PIW



**Type V Anti-exposure Suit**



**Work Vest**



**Type III Float Coat**

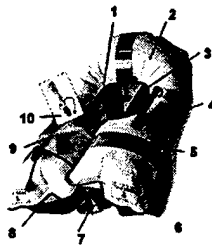

**Type V Inflatable Vest**



**Survival Suit**

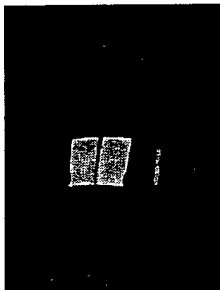

**Type I Non-reversible  
Offshore Vest**

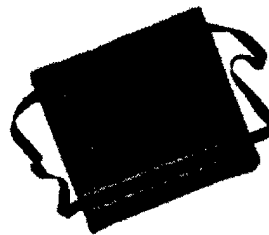

**Type IV Seat Cushion**



**Type IV Life Ring**

### Description

Crews can be expected to wear personal flotation devices onboard many of the smaller military vessels (up to 80 feet long). These PFDs are usually working vests. Working vests are used for work details onboard larger vessels, but will be replaced by Type I (offshore) flotation devices in the event of a sinking or scheduled special operations such as general quarters, underway replenishment, flight operations and practice drills.

### Position

The primary drift class characteristic is position. Position may be:

- vertical,
- sitting, or
- horizontal.

The vertical position generally requires dynamic maintenance by a conscious and active PIW. The PIW will either be slightly inclined backwards or forwards. A forward inclined PIW is actively swimming towards a goal. A backward inclined PIW is maintaining orientation to the waves.

The sitting position is the classic fetal position with legs drawn up and arms huddled across the PFD. This is the preferred position a person assumes in cold water. The natural orientation of a sitting PIW is to face away from the oncoming waves.

The horizontal position requires floatation around the legs for a survivor. Victims floating face down will be in a nearly horizontal position with arms and legs dangling from the PFD.

### **State of PIW**

PIW may be in any of three states:

- a) conscious,
- b) unconscious, or
- c) victims.

Conscious PIW's play an active role in maintaining their position relative to the water surface and wave/wind direction.

Unconscious PIW's are passive, usually from hypothermia, and "frozen" into a position. They cannot hang onto a throwable device.

Victims are deceased PIW's.

### **PFD Style**

There are eight basic styles or designs of PFDs carried onboard military vessels

- 1) Anti-exposure suits may be worn by military vessel crews. Anti-exposure suits also include wet suits and dry suits.
- 2) Work vests,
- 3) And float coats may also be worn.
- 4) Where solid filled PFDs would be too restrictive to personnel aboard military surface vessels during operations, high floatation variations of the Type hybrid V PFDs which include the inflatable vests style PFDs may be used.
- 5) Survival suits, also called immersions suits, are carried on board some military vessels. Conscious and unconscious PIW in survival suits float horizontally on their backs with their heads into the waves.
- 6) The military has a specific version of the offshore lifejacket for its use.
- 7) Type IV PFDs are throwable devices that include life-rings and seat cushions.

- 8) Military personnel are trained to use their pants as auxiliary floatation by knotting the ends of the pant legs and swinging the pants overhead capturing air inside the pants. The use of the uniform as floatation places the PIW in the vertical position.

#### **Reference for Class Descriptions**

1. U.S. Coast Guard, Commandant Instruction M10470.10C, "Coast Guard Rescue and Survival Systems Manual," Washington D.C 16 July 1992.

#### **Leeway Drift Study References and Notes**

There are no specific leeway studies of Combat SAR Maritime PIW, however, for general PIW leeway studies see Maritime PIW, section B1.

## B14 COMBAT SAR MARITIME SURVIVAL CRAFT

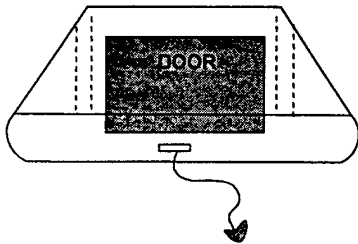

**No Ballast Life Raft**

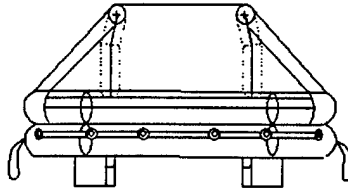

**Shallow Pocket Ballast**

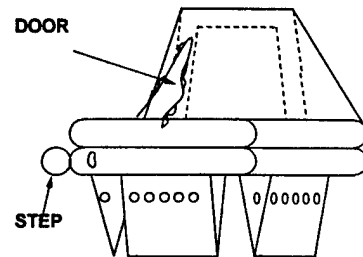

**Deep Pocket Ballast**



**Life Boat**

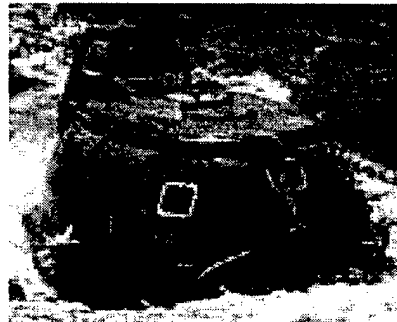

**Life Capsule**

### Description

Combat SAR maritime survival craft are similar to those found in general marine use. The major differences are in the gear carried aboard the survival craft. The gear onboard will be specific to each service's requirements and function.

Life capsules are fully enclosed craft commonly used on large vessels. Motor lifeboats are open boats from 15 to 25 feet in length with an inboard engine. Many military vessels will carry one motor lifeboat and one rigid hull inflatable. Caution must be used applying leeway drift equations for these targets since they are often able to move some distance before running out of gas or before people become tired from paddling the boat.

### Ballast

The primary drift class characteristic is ballast. Ballast may be:

- no ballast,
- shallow pocket ballast,
- deep ballast,
- swamped, or
- capsized.

Shallow pocket ballast systems consist of a series of fabric pockets generally 4 inches in diameter and less than 6 inches in depth. Deep pocket systems consist of large fabric bags, from 3 to 7 on the raft, that are 1+ feet wide by 2+ feet long by 2+ feet deep. Torroidal systems consist of a ring of deep pockets, sometimes connected to form a doughnut around the outside of the raft. The Givens pocket is a single deep pocket that is larger than the raft itself.

### **Drogue Modifiers**

Most manufacturers supply automatically deploying drogues, also called sea anchors, with new life raft purchases.

### **References for Class Descriptions**

None

### **Leeway Drift Study References and Notes**

There are no specific leeway studies of Combat SAR Maritime Survival Craft, however, for general Survival Craft leeway studies see Maritime Survival Craft, section B2.

## **B15 COMBAT SAR MARITIME POWER VESSELS**

### **Description**

This category is left undefined. The author believes the military services should be allowed to determine which of their small vessels or boats do not fit a commercial category and should be included as an entry in this section. This may include small boats, amphibious vehicles, and submersibles.

### **Rescue Equipment That May Become Drift Targets**

None

### **References for Class Descriptions**

None

### **Leeway Drift Study References and Notes**

None



## **B16 COMBAT SAR MARITIME DEBRIS**

### **Description**

Boating debris is any debris that can be expected from a boat sinking and/or breaking up. It can include paper, plastic containers, bedding, clothing, and a variety of fragmented boat hull sections. Survivors of a sinking or breaking up boat can be expected to attempt to remain with floating debris or to use it for flotation.

### **References for Class Descriptions**

None

### **Leeway Drift Study References and Notes**

There are no specific leeway studies of Combat SAR Aviation Debris, however, for general aviation debris leeway studies see Maritime Debris, section B6 or Aviation Debris, section B9.

## **B17 LAW ENFORCEMENT DRIFT OBJECTS**

Law Enforcement Drift Objects are described in three subsections:

1. Drug Flotsam
2. Drug Vessels
3. Immigration Vessels

## B17.1 DRUG FLOTSAM

### Description

Drug flotsam refers to miscellaneous drug related items the Coast Guard has found drifting at sea. The interest in leeway drift of these objects relates to possible attempts to identify where they may have come from. These targets include bales of contraband, plastic bags filled or protecting contents, and other small containers often found.

### References for Class Descriptions

None

### Leeway Drift Study References and Notes

Valle-Levinson, A. and R.L. Swanson. 1991. "Wind-Induced Scattering of Medically-Related and Sewage-Related Floatables," Marine Technology Society Journal, Vol. 25, No., Summer 1991, pp. 49-56.

Valle-Levinson and Swanson studied the following medical and sewage waste items: large and small vials, large and small I.V. bags, surgical masks, tubing, gloves, glass bottles, large and small syringes, and tampon applicators. They studied these items in pool that was adjacent to the ocean. Winds were measured at 1-meter height and adjusted to 10m by the Sutton (1953) method.  $S_{y/s}$  are based upon the plus and minus error limits of leeway speed versus  $W_{10M}$  at a wind speed of 10 m/s.

Large vials

Leeway speed =  $5.5 \pm 0.4$  % wind, wind at 1m

Leeway speed =  $4.4 \pm 0.3$  %  $W_{10M}$

$S_{y/s}$  = approximately 3 cm/s

Leeway angle =  $-9^\circ \pm 2^\circ$

Small vials

Leeway speed =  $3.8 \pm 0.7$  % wind, wind at 1m

Leeway speed =  $3.0 \pm 0.6$  %  $W_{10M}$

$S_{y/s}$  = approximately 6 cm/s

Leeway angle =  $-6^\circ \pm 4^\circ$

Valle-Levinson, A. and R.L. Swanson. 1991. "Wind-Induced Scattering of Medically-Related and Sewage-Related Floatables," Marine Technology Society Journal, Vol. 25, No., Summer 1991, pp. 49-56. (Continued)

Small syringes

Leeway speed =  $2.3 \pm 0.2$  % wind, wind at 1m

Leeway speed =  $1.8 \pm 0.2$  %  $W_{10M}$

$S_{y/s}$  = approximately 2 cm/s

Leeway angle =  $-3^\circ \pm 2^\circ$

Tampon applicators

Leeway speed =  $2.2 \pm 0.4$  % wind, wind at 1m

Leeway speed =  $1.8 \pm 0.3$  %  $W_{10M}$

$S_{y/s}$  = approximately 3 cm/s

Leeway angle =  $-3^\circ \pm 2^\circ$

Large syringes

Leeway speed =  $2.2 \pm 0.2$  % wind, wind at 1m

Leeway speed =  $1.8 \pm 0.3$  %  $W_{10M}$

$S_{y/s}$  = approximately 3 cm/s

Leeway angle =  $-3^\circ \pm 2^\circ$

Allen, A. and J. Plourde, "Review of Leeway: Field Experiments and Implementation," USCG Research and Development Center and Analysis & Technology, Inc., 1999.

Allen and Plourde--Chapter 8 combined leeway equations from the above study.

Vials

$3.7$  %  $W_{10m}$  + 0.0 cm/s > 15 cm/s  $S_{y/x}$

Syringes

$1.8$  %  $W_{10m}$  + 0.0 cm/s > 15 cm/s  $S_{y/x}$

Medical Waste

$2.8$  %  $W_{10m}$  + 0.0 cm/s > 15 cm/s  $S_{y/x}$

## **B17.2 DRUG VESSELS**

### **Description**

Drug vessels refers to particular types of vessels typically employed in the business of transporting illegal substances to U.S. ports. The districts along the southern U.S. coast and Caribbean territories are most likely to encounter these leeway targets. Operations centers in these areas are best suited to identifying particular types of these leeway targets. Determining leeway drift for these may be coupled with similar efforts for other leeway target types and may result in similar if not the same leeway information.

### **References for Class Descriptions**

None

### **Leeway Drift Study References and Notes**

None

## B17.3 IMMIGRATION VESSELS

### Description

Immigration vessels refer to particular types of vessels typically employed in the business of illegally transporting alien persons to U.S. ports. They range from small coastal vessels to sailing vessels, homemade rafts, and inner tubes. The districts along the southern U.S. coast and Caribbean territories are most likely to encounter these leeway targets. Operations centers in these areas are best suited to identifying particular types of these leeway targets. Determining leeway drift for these may be coupled with similar efforts for other leeway target types and may result in similar if not the same leeway information.

### References for Class Descriptions

None

### Leeway Drift Study References and Notes

Allen, A. A., 1996. "The Leeway of Cuban Refugee Rafts and a Commercial Fishing Vessel," U.S. Coast Guard Report No. CG-D-21-96.

Allen using the direct method studied a Cuban refugee raft with and without a sail. Wind speeds were adjusted to 10-meter height.

Cuban Refugee Raft (w/o sail)

Leeway speed =  $1.55 \% W_{10m} + 8.7 \text{ cm/s}$ ;  $W_{10m} \leq 10 \text{ m/s}$ ,  $Sy/x = 1.52 \text{ cm/s}$

Leeway angle (mean  $-11^\circ$ ; std. dev.  $6^\circ$ ; min.  $-28^\circ$ ; max  $+5^\circ$ )

DWL =  $1.56 \% W_{10m} + 8.30 \text{ cm/s}$   $Sy/x = 1.53 \text{ cm/s}$

+CWL =  $0.78 \% W_{10m} + 2.7 \text{ cm/s}$   $Sy/x = 1.52 \text{ cm/s}$

-CWL =  $-0.78 \% W_{10m} - 2.7 \text{ cm/s}$   $Sy/x = 1.52 \text{ cm/s}$

Cuban Refugee Raft (w/ sail)

Leeway speed =  $7.93 \% W_{10m} - 8.9 \text{ cm/s}$ ;  $W_{10m} \leq 10 \text{ m/s}$ ,  $Sy/x = 5.38 \text{ cm/s}$

Leeway angle (mean  $-7^\circ$ ; std. dev.  $19^\circ$ ; min.  $-43^\circ$ ; max  $+27^\circ$ )

DWL =  $6.43 \% W_{10m} - 3.47 \text{ cm/s}$   $Sy/x = 3.63 \text{ cm/s}$

+CWL =  $5.19 \% W_{10m} - 16.2 \text{ cm/s}$   $Sy/x = 6.50 \text{ cm/s}$

-CWL =  $-5.19 \% W_{10m} + 16.2 \text{ cm/s}$   $Sy/x = 6.50 \text{ cm/s}$

## **B18 MARINE SAFETY DRIFT OBJECTS**

Marine Safety Drift Objects are described in two subsections:

1. Surface Slicks
2. Hazards to Navigation

## **B18.1 SURFACE SLICKS**

### **Description**

Surface slicks include man-made as well as naturally occurring slicks that may pose danger to the marine environment. Slicks include oil spills and discharges, sewage slicks and waste, and medical waste. The drift of some surface slicks has already been studied and the Coast Guard may identify the resulting models and choose those that best apply and are available for use. Report of the Workshop (1995) provides an overview of the present state of modeling oil spills.

### **Reference for Class Descriptions**

1. Report of the Workshop, 1995. "Oil Spill Modeling: Status and Prospectus," University of Massachusetts, Dartmouth MA.

### **Leeway Drift Study References and Notes**

None



## **B18.2 HAZARDS TO NAVIGATION**

### **Description**

Hazards to navigation include man made as well as naturally occurring objects that may pose danger to the marine environment or boats and vessels at sea. These include icebergs, ice growlers, dead whales, trees or logs, a lost cargo container, and so forth. Marko, Fissel and Miller (1988) present a summary of iceberg models used in applications off the eastern coast of Canada. Their report includes an extensive list of references.

### **Reference for Class Descriptions**

1. Marko, J.R., D.B. Fissel and J.D. Miller. 1988. "Iceberg Movement Prediction Off the Canadian East Coast," in *Natural and Man-Made Hazards*, M.I.El-sabh and T.S. Murty (eds.), D. Reidel Publishing Co., pp. 435-462.

### **Leeway Drift Study References and Notes**

None

## **B22 MILITARY DRIFT OBJECTS**

### **Description**

Military drift objects refers to non-SAR objects that may be lost as part of military exercises. They fall into two major groups of (ordnance or non-ordnance) based the expected importance of recovering. Ordnance may include mines that have broken free of their tethers or post exercise torpedoes or missiles. Non-SAR may include target balloons and other non-ordnance items. These classes should be developed based on the needs of the services that operate over the water.

### **References for Class Descriptions**

None

### **Leeway Drift Study References and Notes**

None

## **Appendix C**

### **ANNOTATED BIBLIOGRAPHY FOR LEEWAY TAXONOMY**

Appendix A presented the proposed tables developed to complete the taxonomy of leeway drift objects. Appendix B provided descriptions of the leeway drift object classes in the tables. Where available, each description listed resource references that could provide additional information about a specific drift object class. This appendix provides the full bibliographic listing for those resources references and provides a brief summary of the information available in the resource.

Appendix C has five sections. The first lists book references, the second lists magazine references, the third lists government standards/codes, the fourth provides a list of USCG-approved life raft service centers and the last is list of Internet world wide web sites.

## BOOKS

Averitt, Max, Boatwatch, Master Guide to Sailboats of the World, Library of Congress Number 92-093088, ISBN: 0-9627152-1-2, M.W. Averitt/Boatwatch, San Jose, CA, 1992.

A compendium of information about more than 16,000 sailboats and motor sailers from over 20 feet long to more than 80 feet long. The sailboats are arranged alphabetically and include line drawings of the side (often including underwater portion) and top views. A symbol-oriented description is given for each sailboat.

Jeffrey, Kevin and Kanter, Charles, Sailors Multihull Guide, Avalon House Publishing/Sailco Press, Ashland, MA, 1994

This book is organized into four categories of cruising-multihull sailboats. Each is organized alphabetically by the manufacturer. Each boat is given a full-page description that discusses the hull and sail plan layout and propulsion systems, and a full page of line drawings (typically side and top views) and dimensions. The book begins with a good discussion of the many facets of multihull design and tradeoffs.

Lloyds Register of Shipping, 1990, LR Printing Services, Ltd., West Sussex, United Kingdom, 1990.

Loyds is a well-known and comprehensive register of shipping encompassing vessels from 40-feet long and longer throughout the world. It includes fishing vessels, tugs, freight carriers, tankers, etc. The information that is provided in this resource includes basic design characteristics.

McKnew, Ed and Parker, Mark, The McKnew/Parker Consumer's Guide to Family and Express Cruisers 1975-Present, International Marine, Camden, ME, 1996.

McKnew, Ed and Parker, Mark, The McKnew/Parker Consumer's Guide to Motor Yachts and Trawlers 1975-Present, International Marine, Camden, ME, 1996.

McKnew, Ed and Parker, Mark, The McKnew/Parker Consumer's Guide to Sport Fishing Boats, 17' - 27' 1975-Present, International Marine, Camden, ME, 1996.

McKnew, Ed and Parker, Mark, The McKnew/Parker Consumer's Guide to Sport Fishing Boats, 28' - 82' 1975-Present, International Marine, Camden, ME, 1996.

A series of four books derived from the Powerboat Guide by the same authors. Each book of the series takes a look at a particular boat class established by the authors. Boats are listed alphabetically by manufacturer and by length for each a manufacturer. One or

two boats are represented on each page. For each boat there is a black and white picture of the boat underway, a pair of line drawings (both side and top view or two top views, if produced in different layouts), and a brief description. Included in the description is a reference to the deadrise, the secondary leeway drift factor for power vessels as described by the taxonomy in this report. There are plans to release this series on a CD-ROM.

Pacific Area Training Team, Pacific Regional Fisheries Training Group Fishing Vessel & Gear Identification Job Aid, Afloat Version, 1996.

Discusses and illustrates the features of pacific region fisheries vessels.

Sherwood, Richard, A Field Guide to Sailboats, Houghton Mifflin Co., New York, NY, 1994.

This book discusses two major classes of sailboats, one design (small sailboats without engines) and cruisers/auxiliaries. Although the guide does not include as many of the larger vessels as other references, it is the only one that provides a comprehensive discussion of one-design sailboats. The book starts with a discussion of hull forms and mast rigging options. The book contains a listing of one-design class associations. These associations could provide the interested reader with valuable information concerning vessels in their particular class.

Wales, Patience, et al., 1997 Sailboat Buyers Guide, K-III Magazine Corp., New York, NY, 1996.

The book provides information about many currently manufactured sailboats from 15 to 50 feet long. The bulk of the material is organized alphabetically by the boat building company name. The buyers' guide includes brief descriptions and line drawings of the side of the boat, including underwater portion, a list of boats by length, and a rather informative discussion of inflatable boats. The back of the book contains a sailing industry directory. This publication is also available in CD ROM format and on the Internet.

## MAGAZINES

### Bass & Walleye Boats

A sister publication of Trailer Boats. This magazine is published every two months and looks at fishing-type trailer boats rather than purely recreational boats. Although they have not published a comprehensive review of available boats, they do perform boat reviews that provide information concerning boat types. According to their circulation department, the Nov/Dec.1998 issue will begin a yearly review of fishing-type trailer boats.

Canoe and Kayak magazine has an annual buyer guide released during November that listed by manufacturer canoes, river and sea kayaks, inflatable canoes / kayaks, river rafts and PFDs.

“Catapulting To The Future,” Cruising World, April 1997.

Provides a discussion of the design considerations of catamarans.

“One More Look, Details on 41 Hot ‘97s,” Hot Boat Magazine, April 1997.

The April and October issues of Hot Boat Magazine provide a review of current-model boats tested by magazine personnel. This magazine does monthly in-depth reviews of particular high-performance boats and these reviews can provide a good basis of information concerning high-performance boats in general.

### Offshore Racing Magazine

Although not specifically useful for boat design issues, this magazine provides insight into the offshore use of high performance boats. Review of this magazine and contact with offshore racing personnel resulted in the elimination of purely racing high performance vessels from the taxonomy since these races are typically well monitored and many race teams supply their own helicopter observation teams.

“1997 Watercraft Buyers Guide,” Watercraft Power, April 1997.

The April issue provides a comprehensive review of the different personal watercraft models available in the current year group.

### Trailer Boats

Trailer Boats is a sister publication of Bass & Walleye Boats. This magazine is published every two months and looks at recreational-type trailer boats rather than fishing boats. Various trailer boating issues are discussed. According to their circulation department, the Nov/Dec. 1998 issue will begin a yearly review of recreation-type trailer boats.

## GOVERNMENT STANDARDS/CODES

### FAR 125.209 Emergency Equipment: Extended Overwater Operations

This section of the Federal Aviation Requirements discusses aircraft carriage requirements for aviation life rafts and life preservers. The Transportation Safety Organization evaluates life rafts against requirements and issues approvals for those that meet the requirements. These approvals are only required onboard commercial aircraft.

44 CFR 33.05, 33.07, and 33.15

These sections of the Code of Federal Regulations discuss the requirements for vessels underway to carry life boats and/or maritime life rafts. The U.S. Coast Guard evaluates life rafts against requirements, and issues approvals for those that meet the requirements. These approvals are only required onboard commercial vessels.

44 CFR 33.35, 160.001, 160.002, 160.005, 160.006 and 160.055

These sections of the Code of Federal Regulations discuss the requirements for vessels underway to carry life preservers and present minimum required flotation.

**USCG-APPROVED LIFE RAFT SERVICE CENTERS**

Table C-1  
USCG-Approved Life Raft Service Centers

Region	Service Centers	Phone/Fax	
6-CARIB	CARIBBEAN INFLATABLE SERVICES East End Road Park 56 Frydenhoj St. Thomas, USVI 00802	Phone: Fax:	(340) 775-6159 (340) 775-2014
6-CARIB	LIFERAFTS, INC. 621 Avenida Fernandos Juncos Box 2081 San Juan, PR 00903	Phone; Fax:	(809) 723-3237 (809) 723-3237
1-N.E.	LANDRIGAN CORPORATION 2-12 Jeffries Street Box 444 East Boston, MA 02128	Phone: Fax:	(617) 567-2182 (617) 569-6627
1-N.E.	I.M.P. FISHING GEAR, LTD. 44 South Street New Bedford, MA 02740	Phone: Fax:	(508) 993-0010 (508) 993-9005
1-N.E.	MAINE LIFERAFT & INF. SERVICE CO. 36 Union Wharf Portland, ME 04101	Phone: Fax:	(207) 772-8095 (207) 772-8471
1-N.E.	OFFSHORE REPACK & REPAIR 1285 Boston Post Road Box 878 Westbrook, CT 06498	Phone: Fax:	(860) 399-7004 (860) 399-4735
1-N.E.	REVERE SUPPLY COMPANY, INC. 3 Fairfield Crescent West Caldwell, NJ 07006	Phone: Fax:	(973) 575-8811 (973) 575-1788
1-N.E.	VANE BROTHERS MARINE SAFETY & SCVS. 4209 Newgate Avenue Baltimore, MD 21224	Phone: Phone: Fax:	(410) 631-5167 (410) 631-5118 (410) 631-7781
1-N.E.	USA SERVICES, INC. 1818 Margaret Avenue Annapolis, MD 21401	Phone: Fax:	(410) 626-1122 (410) 626-1144
2-S.E.	USA SERVICES, INC. 1111 Ingleside Road Box 12103 Norfolk, VA 23502	Phone: Fax:	(757) 855-2233 (757) 855-7533



Table C-1.  
USCG-Approved Life Raft Service Stations (Cont'd)

Region	Service Centers	Phone/Fax	
2-S.E.	VANE BROTHERS MARINE SAFETY & SVCS. 4565 Progress Road, Suite 2B Norfolk, VA 23502	Phone: Fax:	(757) 858-2501 (757) 858-2504
2-S.E.	RIVER SERVICES, INC. 2827 River Drive Thunderbolt, GA 31404	Phone: Fax:	(912) 354-7777 (912) 354-3326
2-S.E.	DATREX, INC. 618 Talleyrand Avenue Jacksonville, FL 32202	Phone: Fax:	(904) 355-1401 (904) 353-8269
2-S.E.	DATREX, INC. 3795 N.W. 25th Street Miami, FL 33142	Phone: Fax:	(305) 638-8220 (305) 634-4552
2-S.E.	INFLATABLE SERVICES, INC. 990 West State Road 84 Fort Lauderdale, FL 33315	Phone: Fax:	(954) 779-7000 (954) 779-7603
3-GULF	BONANNI SHIP SUPPLY, INC. 107 North 11th Street Drawer 3208 Tampa, FL 33601	Phone: Fax:	(813) 229-6411 (813) 222-0617
3-GULF	SEA SAFE SERVICES, INC. 1221 East Madison Street Tampa, FL 33602	Phone: Fax:	(813) 221-5112 (813) 221-5679
3-GULF	STANDARD EQUIPMENT COMPANY 75 Beauregard Street Drawer G Mobile, AL 36601	Phone: Fax:	(205) 432-1705 (205) 438-3642
3-GULF	MARINE & IND. SUPPLY CO., INC. 150 Virginia Street Mobile, AL 36603	Phone: Fax:	(334) 438-4617 (334) 438-4623
5-LAKES	SAMSEL SUPPLY COMPANY 1285 Old River Road Cleveland, OH 44133	Phone: Fax:	(216) 241-6318 (216) 241-3426

Table C-1.  
USCG-Approved Life Raft Service Stations (Cont'd)

Region	Service Centers	Phone/Fax	
5-LAKES	AMERICAN MARINE 4031 East 1st Street Superior, WI 54880-4256	Phone: Fax:	(715) 398-7500 (715) 398-7580
3-GULF	SEVIN, INC. 7830 Townsend Place New Orleans, LA 70126	Phone: Fax:	(504) 246-9900 (504) 246-9910
3-GULF	FIRE PROTECTION SERVICE, INC. 8050 Harrisburg Houston, TX 77012	Phone: Fax:	(713) 924-9600 (713) 923-6272
4-WEST	MARINE HARDWARE COMPANY 345 Beacon Street San Pedro, CA 90731	Phone: Fax:	(310) 831-9261 (310) 831-4442
4-WEST	AVALON RAFTS 218 North Marine Avenue Wilmington, CA 90744	Phone: Fax:	(310) 549-9665 (310) 549-4824
4-WEST	OCEANS WEST MARINE & IND. SUPPLY CO. 2886 Main Street San Diego, CA 92113	Phone: Fax:	(619) 544-1900 (619) 696-0646
4-WEST	HEWETT MARINE COMPANY 555 Selby Street San Francisco, CA 94124	Phone: Fax:	(415) 826-4433 (415) 826-1122
4-WEST	COAST MARINE & IND. SUPPLY INC. 398 Jefferson Street San Francisco, CA 94133	Phone: Fax:	(415) 673-1923 (415) 673-1927
7-OTHER	LIFE SUPPORT SYSTEMS HAWAII 134 Nakolo Place Honolulu, HI 96819	Phone: Fax:	(808) 836-3669 (808) 839-1666
4-WEST	ENGLUND MARINE SUPPLY 101 15 <sup>th</sup> Street Box 296 Astoria, OR 97103	Phone: Fax:	(503) 325-4341 (503) 325-6421

Table C-1.  
USCG-Approved Life Raft Service Stations (Cont'd)

Region	Service Centers	Phone/Fax	
4-WEST	PACIFIC MARINE DISTRIBUTORS 2320 N.W. 21st Street Portland, OR 97209	Phone: Fax:	(503) 243-2258 (503) 224-4958
4-WEST	LFS, INC. 851 Coho Way Bellingham, WA 98225	Phone: Fax:	(360) 734-3336 (360) 734-4058
4-WEST	OCEAN SAFETY SERVICE DIVISION OF NET SYSTEMS 2355 Kachemak Drive Suite 102 Homer, AK 99603	Phone: Fax:	(907) 235-7908 (907) 236-7918
4-WEST	NETS-PACIFIC 325 Shelikof Street Kodiak, AK 99615	Phone: Fax:	(907) 486-5350 (907) 486-2655
4-WEST	OCEAN SAFETY SERVICES, INC. 2663 Airport Beach Road Box 920127 Dutch Harbor, AK 99692	Phone: Fax:	(907) 581-2677 (907) 581-2850
4-WEST	SOUTHEAST OCEAN SUPPLY 1900 Tongass Avenue Box 9131 Ketchikan, AK 99901	Phone: Fax:	(907) 225-8985 (907) 225-8986

## INTERNET

### World Wide Web Sites:

#### **Aircraft Evacuation Systems**

3414 S. 5th St.

Phoenix, AZ 85040

602-243-2200

FAX: 602-243-2300

#### **Aviation life raft review**

<http://www.equipped.com/avraft.htm>

Reviews of aviation life rafts for private and small airplanes. This site has links to:

[BFGoodrich Aerospace - Aircraft Evacuation Systems \(BFG\) \(formerly Pico\)](#)

[Eastern Aero Marine \(EAM\)](#)

[Hoover Industries \(Hoover\)](#)

[Revere Aerospace Products \(RFD\)](#)

[Survival Products, Inc. \(SPI\)](#)

[Winslow LifeRaft Co. \(Winslow\)](#)

#### **Avon Inflatables Ltd.**

<http://www.avon-inflatable.com/>

Avon Inflatables manufactures two types of marine life rafts, and a full line of inflatables for civilian and governmental use. Web site includes figures, dimensions, listing of options and features of life rafts along with worldwide dealer listing.

**Tel. 01554-741155 - Fax 01554-741500 - E-mail [avon@celtic.co.uk](mailto:avon@celtic.co.uk)**

Dafen, Llandelli, Dyfed SA14 8NA

South Wales

United Kingdom

**BFGoodrich Aerospace**

<http://www.bfgaerospace.com/>

The information on BFGoodrich evacuation systems from their web site is shown below.

---

**Evacuation Systems**

Designs, develops and manufactures, and provides overhaul and repair, of evacuation slides, slide rafts, liferafts and associated control systems, for commercial and business aircraft.

**Headquarters:** 3414 S, 5th Street, Phoenix, AZ 85040 / Phone (602) 232-4000 / FAX (602) 232-4100

**Other Manufacturing:** 190 Industrial Park Road, Spencer, WV 25276 / Phone (304) 927-5106 / FAX (304) 927-1699

**Other Sales & Engineering:** 11400 SE 8th Street, Suite 110, Bellevue, WA 98004 / Phone (206) 454-3348 / FAX (206) 455-4285

**Evacuation System Service Centers:**

**Seattle:** Suite B3, 2031 196th St. SW, Lynnwood, WA 98036  
Phone (425) 775-2114 / FAX (206) 776-2122

**Miami:** 7805 NW 67th St., Miami FL 33166  
Phone (305) 591-8350 / FAX (305) 591-7668

**Los Angeles:** 1610 E, Philadelphia Ave., Ontario, CA 91761  
Phone (909) 923-8600 / FAX (909) 923-9677

**Singapore:** 36 Loyang Dr., Singapore 1750  
Phone 65-545-2765 / FAX 65-545-2769

**Paris:** 9, Rue de la Grande Borne, 77990 Le Mesnil Amelot, France  
Phone 33-1-64-02-67-67 / FAX 33-1-64-02-60-61

**Bangalore:** Number 117, Industrial Suburb, Yeshwanthpur  
Bangalore-560022, Karnataka, India  
Tel : 91-80-3344011 / FAX 91-80-3344011

**Eastern Aero Marine**

<http://www.theraft.com/>

Eastern Aero Marine web site provides only a listing of products, with any illustrations. They make aviation and marine life rafts, along with EBIRBs and emergency kits.

3850 N.W. 25th St.

Miami, FL 33142

800-843-7238

305-871-4050

FAX: 305-871-7873

**Hoover Industries**

No web site at this time.

7260 N.W. 68th St.

Miami, FL 33166

305-888-9791

FAX: 305-883-1925

**Revere Aerospace Products**

<http://www.reveresupply.com/>

Revere Survival Products

A Division of Revere Supply Company, Inc.

3 Fairfield Crescent

West Caldwell, NJ 07006-6204

Voice (201) 575 8811 Fax (201) 575 1788

E-Mail [hwk@webspan.net](mailto:hwk@webspan.net)

Revere Survival Products web site includes figures of life rafts and listing of FAA requirements and regulations regarding ditching equipment.

Revere Survival Products include aviation and marine life rafts.

3 Fairfield Crescent

West Caldwell, NJ 07066

201-575-8811

FAX: 201-575-1788

**Survival Products, Inc. (SPI)**

<http://www.mypid.com/survival/>

5614 S.W. 25th St.

Hollywood, FL 33023

954-966-7329

FAX: 954-966-3584

Manufactures a 4-person life raft. A figure and description are provided in the web site.

**Switlik life rafts**

<http://www.switlik.com>

Switlik web site includes a complete catalog with figures and list of Switlik authorized life raft service stations.

Switlik Parachute Company

1325 East State Street  
Trenton, N.J. 08609  
Phone 609-587-330  
Fax 609-586-6647  
Email: [info@switlik.com](mailto:info@switlik.com)

### **Viking Life-Saving Equipment**

<http://www.viking-life.fi/>

P.O. Box 3060  
6710 Esbjerg

Denmark  
(45 87) – 15 06 44

### **Winslow LifeRaft Company**

<http://www.winslowliferaft.com/>

The Winslow LifeRaft Company makes both aviation and marine life rafts. Web site includes complete illustrations of all life raft types with complete descriptions of on-board equipment and features.

928 S. Tamiami Trail  
P.O. Box 888  
Osprey, FL 34229  
800-838-3012  
941-966-9791  
FAX: 941-966-9235  
24 Hour Emergency: 941-966-3771 or 941-966-4250  
E-mail: [rafts@winslowliferaft.com](mailto:rafts@winslowliferaft.com)

### **Zodiac Group (Zodiac, Bombard, Air Cruisers,**

<http://www.zodiac.fr/eng.htm>

Zodiac Group is a manufacturer of life rafts, inflatables and rigid hull inflatables, aircraft evacuation slide/ life rafts, aircraft seats, and inflatable canoes, kayaks, and rafts for river running.

The Zodiac Group includes Zodiac, Bombard, and Air Cruisers. Jumbo is the line of inflatable canoes, kayaks, and rafts for river running.

The web site includes figures for all products.

[BLANK]



## APPENDIX D

The following is Chapline's 1960 article in the Coast Guard Alumni Bulletin on results of Operation Spindrift. *Italics* are CDR Chapline emphases, while **Bold** are my emphases based on a 1998 viewpoint. Original spellings and misspelling are faithfully reproduced, while (*Sic*) is used to indicate typographic errors. Corrections are suggested within the parentheses.

### ESTIMATING THE DRIFT OF DISTRESSED SMALL CRAFT

By Commander W.E. Chapline, USCG

One of the most complex (*sic*) and important factors to be considered in the planning of a search for a distressed small craft offshore is the estimate of drift. Although there is a table in Chapter 6 of the National Search and Rescue Manual giving data on life raft leeway as an aid to drift computation, there is nothing similar available for small craft. The writer has upon numerous occasions been required to make such an estimate, and in doing, has consulted (*sic*) other experienced officers, when available, in order to obtain their opinions. The wide latitude of these "guesstimates" has always been cause for considerable chagrin; consequently, recent tests were conducted in the 14th Coast Guard District, with the cooperation of the Coast Guard Auxiliary, local commercial fishermen, and other small boat owners, in an effort to shed some light on the subject.

LCDR James W. McGary, USCGR ('43), now employed as an oceanographer with the U.S. Fish and Wildlife Service in Honolulu, generously gave his advice and assistance to these experiments, aptly dubbed "Operation Spindrift." The principal objective was to obtain data on the leeway rates for various types of drifting small craft in order that this might later be used for similar craft under similar conditions in computing drift rates. (Leeway as used herein is defined as the movement of a boat through the water caused solely by the wind and sea. Drift is defined as the total movement of the boat over the bottom and include the effect of leeway, (*sic*) current, etc. Both are expressed terms of direction and velocity.)

Briefly, these tests were conducted as follows: A drift net as used by the Fish and Wildlife Service to determine surface currents was employed. This constituted a fine mesh net about 300 feet long and 15 feet wide. It was equipped with floats on one side and small weights on the other. A small flag on a separate float is attached to one end of the net. This net has such small air/underwater drag ratio that for all practical purposes makes no leeway and thus moves with the current. Any fish net of about this size should serve the purpose equally well. This net was placed offshore in deep exposed water by a buoy tender. As the participating small craft appeared on the scene they stop their engines and commence to drift about 2 to 3 miles upwind of the tender which had remained in the vicinity of the net. About every half hour the tender maneuvered so as to be close aboard the net and simultaneous radar ranges and visual bearing were taken on each small boat. These were plotted on a large maneuvering board sheet, H.O. No 2665. Inasmuch as the

ranges and bearing were plotted from the net each time, and the net was moving with the current, the current could be eliminated from the problem and the resultant relative motion of the target was pure leeway (*sic*). Good data could be obtained for each boat in from six to eight hours. The wind and sea conditions during the period were carefully observed and recorded.

**Strangely enough, many of the boats did not make their leeway directly down wind.** This was particularly true of the sail types, the tendency to move off the wind line being more pronounced with increased draft for a given displacement; i.e., have a large underwater lateral plane. Almost all the craft of this type lay to with the bow about nine to thirteen points off the wind. The sailing vessels had their helm hard over to windward or their tillers lashed to leeward in the standard "hove to" position. It was found that the **position of the rudder on the sailing craft affect the leeway rate considerably**, whereas for the lighter displacement craft such as the motor cruisers, the effect was negligible. It was further found that th elighter (*sic [the lighter]*) the displacement of a vessel in proportion to amount of freeboard and topside hamper the more nearly she made her leeway directly down wind. Very light, high-speed types, so popular today among the yachting fraternity, such as Cris Craft, Owens, Trojan, etc., were found to move directly down wind. Fishing sampans were inclined to lay with bow about ten points off the wind but made their leeway directly off their beam!

In general, **leeway rates** are indicated to be **directly proportional to the wind velocities, at least for moderate to fresh winds**. This lead to the below listed general data on leeway rates as expressed in terms of percent of the wind velocity V:

Group I.	Surfboards	2% V
Group II.	Heavy displacement, deep draft sailing vessels	3% V
Group III.	Moderate displacement, moderate draft sailing vessels and fishing vessels such as trawlers, trollers, sampans, draggers, seiners, tuna boats, halibut boats, etc.	4% V
Group IV.	Moderate displacement cruisers	5% V
Group V.	Light displacement cruisers, outboards paning ( <i>sic [planing]</i> ) hull types, etc.	6% V

So often our extensive search are poorly planned and executed do to the absence of valid leeway data. Quite often, too, there seems to be a tendency to concentrate the search in an area where the vessel was once known to have been rather that where is *probably is now*. There can be no question but that such traditional thinking leads to more lengthy, expensive and fruitless searches, *Thorough* and *comprehensive planning* is the prerequisite to any expeditiously successful search.

Of course, once the leeway is determined, the method outlined in Chapter 6, National Search and Rescue Manual is utilized to arrive at the final vector solution for total drift employing the average and local wind current, sea current, leeway, etc. **It is recommended that in using the above data, a maximum and minimum leeway figure be assumed, commensurate with the type and size small craft being sought, and that therefrom, a limiting area of detection probability be established wherein the search is to be concentrated.**

Although sufficient data was obtained to permit formation these preliminary conclusions, it is **strongly recommended that other districts conduct similar test** with small craft typical of those in use locally. Such data can be obtained with a relatively small expenditure of effort on our part. While it is believed that **14th District sampans will exhibit leeway similar** to draggers and shrimpers of the East Coast and about the same as trollers and seiners of the West Coast, **this is by no means an established fact.** However, it is believed that the above information will serve as a **useful guide until something better is forthcoming.**

It was difficult at time to obtain sufficient volunteers from among the local small boat owners due mainly to the discomfort involved while drifting, the relatively small size of the local Coast Guard Auxiliary, and generally small number of boat available in Hawaii. It is believed that other districts would not encounter these difficulties, and where the Auxiliary is large and active, based upon past experience, the membership would undoubtedly be enthusiastic in their support of such an operation.

Chapline, W.E. 1960. "Estimating the Drift of Distressed Small Craft." Coast Guard Alumni Association Bulletin, U.S. Coast Guard Academy, New London, CT Vol., No. 2. March-April, 1960, PP 39-42.