



**FOREIGN
BROADCAST
INFORMATION
SERVICE**

JPRS Report

Science & Technology

Europe

19990211 066

DISTRIBUTION STATEMENT A

**Approved for public release;
Distribution Unlimited.**

Science & Technology Europe

JPRS-EST-89-010

CONTENTS

3 MARCH 1989

WEST EUROPE

ADVANCED MATERIALS

- BMFT Reports Progress of Material Research Project
[Duesseldorf *HANDELSBLATT*, 19 Dec 88] 1

AEROSPACE, CIVIL AVIATION

- FRG: Aerospace Agency to Begin Operation
[Bonn *TECHNOLOGIE NACHRICHTEN-MANAGEMENT INFORMATIONEN*, 25 Oct 88] 1
- Goals of New FRG Aerospace Agency DARA Described
[Holm Kilbert; Stuttgart *VDI NACHRICHTEN MAGAZIN*, Dec 88] 1
- FRG Microgravity Research Facility to Open Mid-1989
[Bonn *TECHNOLOGIE NACHRICHTEN-MANAGEMENT INFORMATIONEN*, 25 Oct 88] 2
- Wind Tunnel Testing of FRG's CRISP Propfan Engine
[Wolfgang Fischer; Munich *SUEDDEUTSCHE ZEITUNG*, 15 Dec 88] 2
- Significance of MBB Takeover for Daimler-Benz Discussed 3
- Government-Industry Relations Discussed
[Karl-Heinz Bueschemann, Klaus-Peter Schmid; Hamburg *DIE ZEIT*, 11 Nov 88] 3
- AEG Chief Interviewed [Heinz Duerr interview; Hamburg *DIE ZEIT*, 11 Nov 88] 7
- Industry Failure To Apply Aerospace Technology Criticized
[Frankfurt/Main *FRANKFURTER ALLGEMEINE ZEITUNG*, 19 Dec 88] 10
- French Firm Dassault Announces Increased Space Activity
[Pascale Nivellet; Paris *LIBERATION*, 18 Dec 88] 10
- French Cooperation on AI Systems for Satellites
[Paris *LA LETTRE HEBDOMADAIRE DU GIFAS*, 17 Nov 88] 11
- Crouzet Developing Nadir MK-10 Navigation System
[Paris *LA LETTRE HEBDOMADAIRE DU GIFAS*, 17 Nov 88] 11
- Thomson-Aerospatiale Accord Focuses on Electronic Flight Equipment
[Claire Blandin; Paris *LE MONDE*, 1 Dec 88] 12
- French Firms Developing AI Projects for Space
[Paris *FRENCH TECHNOLOGY SURVEY*, Nov 88] 13
- Italian-British Infrared Laser Accord [Rome *FINMECCANICA NOTIZIE*, 30 Nov 88] 13
- Alfa Romeo Avio, Rolls Royce Sign Agreement For 'Tay' Engine [Rome *AIR PRESS*, 14 Dec 88] 13
- Italy: Space Research Program Described 14
- Chamber of Deputies Approves Program [Rome *AIR PRESS*, 30 Dec 88] 14
- ASI Director On Future Plans
[Luciano Guerrero interview; Turin *MEDIA DUEMILA*, Dec 88] 14
- First Space Robot Project [Enrica Battifoglia; Turin *MEDIA DUEMILA*, Jan 89] 15
- Italian-French Space Cooperation Encouraged [Rome *AIR PRESS*, 30 Dec 88] 16
- Italy: Future Strategies of FIAT Aviazione Described [Rome *AIR PRESS*, 7 Dec 88] 16
- Fiat Aviazione to Develop Cryogenic Engine for ARIANE 5
[Marco Tavasani; Milan *ITALIA OGGI*, 6 Dec 88] 18

BIOTECHNOLOGY

- EUREKA Biotech, Biomedical Projects Overviewed
[Sylvia Vaisman, Claude Vincent; Paris *BIOFUTUR*, Sep 88] 19
- Microgravity Purifying Project Gains EUREKA Status
[Toulouse *LA LETTRE DU CNES*, 8 Aug 88] 24
- FRG: Research on New Computer-Aided Molecular Modeling Technology
[Bonn *TECHNOLOGIE NACHRICHTEN-MANAGEMENT INFORMATIONEN*, 29 Aug 88] 24
- Round-Up of Research by Belgian Biotech Firm [Christian Vincent; Paris *BIOFUTUR*, Sep 88] 25

COMPUTERS

| | |
|---|----|
| British Supercomputer Exported to Japan [Beijing JISUANJI SHIJIE [CHINA COMPUTERWORLD], 21 Dec 88] | 26 |
| Bavarian Artificial Intelligence Research Center Established [Carsten Schroeder; Stuttgart VDI NACHRICHTEN, 16 Dec 88] | 27 |
| French Firm Produces Image Analysis System [Paris FRENCH TECHNOLOGY SURVEY, Dec 88] | 27 |
| Belgian Government Funds Supercomputer Network Development [Guy Duplat; Brussels LE SOIR, 24-25 Dec 88] | 28 |
| Austrian Researchers Debate Supercomputer Acquisition [Johannes Steinbach; Vienna DIE PRESSE 9 Dec 88] | 29 |

EAST EUROPE

COMPUTERS

| | |
|---|----|
| GDR's ROBOTRON A5015 Computer Described [Gert Keller, Gunter Kleinmichel; East Berlin MIKROPROZESSORTECHNIK No 10, 1988] | 31 |
| GDR's KC 85/4 Small Computer Enters Serial Production [East Berlin RECHENTECHNIK-DATENVERARBEITUNG, No 1, 1989] | 34 |
| Romanian Computer Technology, Competitiveness Noted [Bucharest AGERPRES, 10 Feb 89] | 34 |
| Hungary: VIDEOTON's New VT 32 Microcomputer Introduced [East Berlin MIKROPROZESSORTECHNIK, No 11, 1988] | 34 |

FACTORY AUTOMATION, ROBOTICS

| | |
|--|----|
| Development of CEMA Machine Tool Industry Reviewed [R. Wengermeier; FERTIGUNGSTECHNIK UND BETRIEB, No 10, 1988] | 36 |
| Flexible Manufacturing Systems in GDR | 40 |
| Precision Machining, Machining Cells [J. Krausz, G. Fleischer; East Berlin FERTIGUNGSTECHNIK UND BETRIEB, No 9, 1988] | 40 |
| FMS for Machining Prismatic Components [W. Guenther, U. Kind; East Berlin FERTIGUNGSTECHNIK UND BETRIEB No 9, 1988] . | 43 |
| GDR Uses CAE for Simulating Industrial Robots [East Berlin RECHENTECHNIK-DATENVERARBEITUNG, No 1, 1989] | 47 |
| Czechoslovak Robotization of Engineering Processes Reviewed [Pavel Filipovsky, Milos Ecer; Brno STROJIRENSKA VYROBA, No 11, 1988] | 48 |
| Overview of Electrically-Driven Robots in CSSR [Vladimir Racek; East Berlin ELEKTRIE No 10, 1988] | 57 |
| Czechoslovak-Soviet Collaboration in Robotics Discussed [Pavel Sutak; Prague CESKOSLOVENSKA STANDARDIZACE, No 11, 1988] | 61 |

MICROELECTRONICS

| | |
|---|----|
| Microelectronics Production at Leading GDR Combine Examined [Warsaw PRZEGLAD TECHNICZNY, No 41, 1988] | 63 |
| Products | 63 |
| IC Production | 64 |
| IC Bonding Equipment | 66 |
| New Products of Czechoslovak Electronics Research Reviewed [Prague VYBER INFORMACI Z ORGANIZACNI A VYPOCETNI TECHNIKY, Sep-Oct 88] | 67 |

NUCLEAR ENGINEERING

| | |
|--|----|
| First 1,000-Megawatt Nuclear Reactor Tested [Prague RUDE PRAVO, 20 Feb 89] | 71 |
|--|----|

SCIENCE & TECHNOLOGY POLICY

| | |
|---|----|
| CSSR's Jakes on EUREKA Program [Milos Jakes interview; Prague RUDE PRAVO, 25 Feb 88] | 72 |
| Bulgaria-Yugoslavia Chemical Agreement Signed [Sofia BTA, 9 Feb 89] | 72 |

TELECOMMUNICATIONS R&D

| | |
|---|----|
| ISDN Components for GDR's Digital Switching System Detailed [J. Lolischkies, R. Siemon; East Berlin NACHRICHTENTECHNIK-ELEKTRONIK, No 9, 1988] | 73 |
| Development of Czechoslovak Digital Switching System Surveyed [Emanuel Prager; Prague TELEKOMUNIKACE, No 11, 1988] | 78 |
| Czechoslovak Approaches to Modern Telecommunications Reviewed [Slavomir Cerny; Prague TELEKOMUNIKACE, No 11, 1988] | 83 |
| CSSR: Satellite Television To Come On-Line in 1990 [East Berlin RADIO FERNSEHEN ELEKTRONIK] | 86 |
| Second INTERSPUTNIK Ground Station Built in CSSR [Vaclav Zvonar; Prague PTT REVUE, Nov-Dec 88] | 86 |

ADVANCED MATERIALS

BMFT Reports Progress of Material Research Project

36980108c *Duesseldorf HANDELSBLATT in German*
19 Dec 88 p 8

[Text] Bonn, 17/18 Dec—In the estimate of experts in the research ministry, the Europeans need to exert themselves substantially more if they do not want to fall further behind the United States and above all Japan in the field of the development of new materials.

It follows from an initial stocktaking produced by the BMFT [Ministry of Research and Technology] with respect to its assistance program for materials research that the Japanese are clearly ahead, especially with the use of new ceramics materials in industry. A new study by the U.S. Office for Technology Assessment (OTA) is cited, in which the fear was expressed that "in the future, irreversible leads by the Japanese with respect to electronic components could appear in the sector of structural materials as well." As the experts in the research ministry explained, Japanese ceramics makers and automobile manufacturers are working closely together, with these groups even absorbing the initial financial losses before achieving a profitable unit-quantity level. On the other hand the United States is still the trailblazer in the application of modern fiber composite materials—that is, above all in the aerospace industry.

Nevertheless Research Minister Heinz Riesenhuber was satisfied with the results achieved so far in the assistance program, which has a term of 10 years and a fund of DM1.1 billion. He said that the FRG has once again entered the ranks of the leading materials-research nations. As examples he mentioned the development of high-strength aluminum alloys and of high-performance composite materials. So far, 140 separate projects, including 120 cooperative projects, have been assisted by funds amounting to about DM940 million, with the Federal Government having assumed a good half of this assistance.

AEROSPACE, CIVIL AVIATION

FRG: Aerospace Agency to Begin Operation

3698M069 *Bonn TECHNOLOGIE*
NACHRICHTEN-MANAGEMENT
INFORMATIONEN in German 25 Oct 88, pp 5-6

[Text] The FRG Space Agency (DARA) is scheduled to begin operations on 1 January 1989. Representatives of the FRG government have informed the Bundestag Research Committee that there is already agreement at the state secretary level on the DARA project and that a cabinet decision on the subject may be expected in due time. It is preferred that DARA should take the form of a limited liability company, since this would provide sufficient flexibility to manage the entire range of aerospace activities in the FRG. As in the case of the

Technical Control Association (TUEV), government commissions will be assigned to DARA by virtue of its legal status as a public company, authorized by law to act on behalf of an estate. With the exception of the Ministry of Finance, which would prefer to finance DARA through institutional funding as in the case of major research facilities, the other ministries concerned favor contract financing.

It is further reported that the new agency will be located "in the vicinity of government headquarters." About 300 people are expected to be employed, and some of these jobs will be offered to staff members of the German Aerospace Research and Experimental Institute (DFVLR). Management will be assigned to a director general who will represent the FRG on committees of the European Space Agency (ESA) unless government interests are expressly affected.

As for the agency's connection with the DFVLR and industry, it was stated that DARA should merely stimulate and coordinate activities. It will not be commissioned to undertake research of its own. As demanded by the SPD [FRG Socialist Party] during a meeting, there will be adequate parliamentary control. The ministries involved will therefore establish a "Cabinet Committee on Aerospace" to coordinate space activities at the political level. A state secretary committee, whose meetings will also be attended by the DARA director general, will report to this committee. The CDU/CSU [Christian Democrat Party/Christian Socialist Party] committee members urged that all ministries transfer their space activities to the new agency, including the PTT and transport ministries.

Goals of New FRG Aerospace Agency DARA Described

36980109b *Stuttgart VDI NACHRICHTEN MAGAZIN*
in German Dec 88 p 12

[Article by Holm Kilbert: "The German Space Agency (DARA)"]

[Text] Involvement in the development of Ariane, the Hermes space shuttle and the international manned space station are the cornerstones of a long-term space policy to which the FRG government has largely committed itself. Now, the necessary organizational structure must be created in order to manage these projects effectively and optimally.

As early as in 1986, the federal minister for Research & Technology commissioned the Ottobrunn industrial systems company to prepare a report on decision-making structures and processes in the area of space for the FRG; based on this study, he recommended an improvement in organizational structures in the space sector. Improvements were suggested in coordination and consultation within the federal government, as well as in the management of space programs and projects.

The creation of a German Space Agency (DARA) is intended to achieve the following goals:

DARA is to work on space planning, the implementation of space programs (in particular the awarding of grants and orders, project management), while looking after German space interests on the international level, particularly in ESA.

These tasks should be delegated by federal government departments to DARA as much as possible; the federal departments have control over tasks involved with space policy, and delegation of them will mean independent responsibility for DARA. In the area of technology, the main goal is to give a long-term and adequate national structure to preliminary research. Ideas for subsequent generations of systems can be analyzed early on.

In practice, this means that the federal minister for Research & Technology wants to transfer to DARA the management responsibilities for furthering research and technology in the space sector; insofar as it is reconcilable with the policy areas of other departments, DARA should also assume management responsibilities for space operations. In the industrial sector, DARA should be used to achieve the needed improvement in coordinating activities. The goal is a better balance in systems and components, as well as in system management and in hardware supplies.

There is no precedent in the FRG for an agency with this range of tasks. For this reason, numerous questions are being raised concerning its organizational structure and legal status, questions that demand a fundamental response. It is primarily a matter of harmonizing elements of public-legal responsibility with the flexibility needed to handle management tasks.

FRG Microgravity Research Facility to Open Mid-1989

3698M072 Bonn *TECHNOLOGIE NACHRICHTEN-MANAGEMENT INFORMATIONEN* in German 25 Oct 88 pp 10-11

[Text] In mid-1989 the Bremen gravity tower will close an existing gap in the FRG facilities for microgravity experiments. Various universities, the space industry, other industrial sectors, and the European Space Agency have already shown considerable interest in using the gravity tower. Additional agreements on the use of the gravity tower for microgravity tests have already been concluded with Japanese universities and companies.

The experiments are carried out in a gravity capsule which drops 110 meters (equal to 4.74 seconds) in an evacuated steel tube. The capsule is decelerated in a container filled with plastic granules. The steel tube stands free inside the tower itself, and data from the experiment can be recorded telemetrically during free descent (1 Mbit/sec).

The Bremen gravity tower is being built by the University of Bremen under the leadership of the Center for Applied Space Technology and Microgravity. The Ministry of Research and Technology (BMFT) has provided a subsidy of approximately DM7 million for the development and construction of the Bremen gravity tower, which will cost a total of DM18.2 million including actual construction. The BMFT subsidy covers technical equipment costs, while the City of Bremen and the Ministry of Education and Science each share 50 percent of the costs for the construction work within the framework of the subsidy program for the construction of university buildings. Three Bremen companies, OHB-System, Krupp Atlas-Elektronik, and MBB/ERNO are also participating in this project.

The Bremen gravity tower will initially be able to accommodate all microgravity experiments that can be carried out within 4.7 seconds, (though this limit will subsequently be extended to 9.5 seconds). The particular strength of the gravity tower is that it allows systematic experiments (several flights a day) combined with relatively short downtimes for personnel, as well as extremely low "mission costs" compared to conventional space experiments.

Wind Tunnel Testing of FRG's CRISP Propfan Engine

36980109a Munich *SUEDDEUTSCHE ZEITUNG* in German 15 Dec 88 p 50

[Article by Wolfgang Fischer: "Economical Propfan: New Engine Design on the Test Bench"]

[Text] Since 1985, German firms (MTU, Munich, the German Aerospace Research and Testing Institute [DFVLR]) have been conducting research and development work in the area of propfan engines for commercial aircraft within the framework of a national propfan program supported by the Federal Ministry for Research & Technology. Within the DFVLR, participants in the research work are, besides the Wind Tunnel Division, the Institutes for Engine Technology, for Design Aerodynamics, for Aeroelastics and for Experimental Fluid Mechanics.

In the joint "CRISP" project, the DFVLR wind tunnels in Goettingen are being used to demonstrate the power of a new design of engine (in the form of a model at a scale of 1 to 6.25) that promises fuel savings of nearly 20 percent compared to modern bypass engines.

Engine Structure

The CRISP engine is designed with two contrarotating propellers, each with 8 to 10 blades, positioned in series. The wind tunnel model has two propellers, each with 10 blades. Contrarotation is achieved by a gear positioned

between the propfan and the generator. The casing decreases near-field noise diffusion and makes possible a small engine diameter, so that existing aircraft can be converted to this engine.

In the model, power is generated through an air turbine, which is connected with the rotors via a reverse gear and two coaxial wavelength prolongations. The mounting of the model on an adjustment mechanism for setting various angles of incidence is achieved through a strut mount that is adapted to flow conditions and in which all measuring lines, as well as supply and waste disposal lines for compressed air (turbine propulsion), safety air (sealing of the oil system) and freon (cooling of the slip ring transformer) are housed.

Extensive Measurement Technology

The model head is equipped with extensive measurement technology. For example, there is a rotating thrust and torque balance in the hub of each rotor. The measured data are transferred from the rotating systems via a loop transformer for rotor 1 and a telemetric system for rotor 2. Recording, processing and evaluating the data gathered here is very costly in terms of personnel and special equipment.

The first phase of measurements begins in the low-velocity wind tunnel (NWG) in Goettingen, with the following objectives:

1. Functional test of the CRISP model fully equipped with instrumentation;
2. Determination of the performance characteristics for various rotor blade angles;
3. Study of the takeoff and landing phase at various angles of incidence and velocities in a blower stream;
4. Preliminary experiments on acoustic behavior;
5. Determination of behavior during reverse thrust.

This program segment alone requires an unprecedented amount of wind tunnel occupancy time for assembly, measurement and conversion: 150 days for one measurement run. The functional test began in early August, and was concluded after only a week, to the satisfaction of all interested parties. The performance characteristic tests in the NWG, which were done without wind tunnel flow, have already yielded good results. For these measurements, the model is additionally equipped with an intake and in the prolongation of the jet outlet with a variable diffuser. The tests under real flow conditions corresponding to those in flight will begin in the transonic wind tunnel (TWG) in 1989. During this important test, it must be proven that the CRISP design still provides the anticipated thrust at passenger aircraft velocities of 0.78 Mach. This part of the experiments is especially difficult, since the complicated structure must be housed in the narrow measurement range of 1m x 1m.

Significance of MBB Takeover for Daimler-Benz Discussed

Government-Industry Relations Discussed
36980096 Hamburg DIE ZEIT in German
11 Nov 88 pp 25, 27

[Article by Karl-Heinz Bueschemann and Klaus-Peter Schmid: "The Stars Look Bad—Bonn in the Hands of Arms Giant Daimler"]

[Text] When the basics are at stake, Count Otto Lambsdorff is never at a loss in coming up with some strong remarks. For example, in May 1987, he came out with this comment on the slogan "Active Industrial Policy": "Intervention in market-economy structural change takes place not only for the purpose of preserving yesterday. The market is damaged just as much by the kind of intervention that is intended to shape our tomorrow by means of government guidance."

What was decided by the cabinet in Bonn last Monday evening with Lambsdorff's express approval is at the same time a case of government interventionism aimed simultaneously at yesterday and at tomorrow. The federal government wants to subsidize Airbus production until the year 2000. This clears the way—at least as far as the federal government is concerned—for the participation of Daimler-Benz AG [Inc.] in MBB (Messerschmitt-Boelkow-Blohm). Just last weekend, Lambsdorff registered his objection: "There are objections of a system-policy kind which simply consist of the fact that what we have here is the formation of a syndicate which in some sectors does bring with itself certain shares of the market—which translates into power on the market—that are opposed by cartel-law and competition-policy objections."

FDP [Free Democratic Party] boss Lambsdorff charged far ahead of the column—too far, as even his friends in the party are criticizing him for now. SPD [Social Democratic Party of Germany] economic spokesman Wolfgang Roth mocked with relish: "After all the theatrical thunder, which he staged in recent days, the marquis wound up with egg on his face." Even a prominent FDP member commented: "That will teach Lambsdorff a lesson."

What the Liberals retouched on the very last handout covering the administration concept is nothing more than cosmetics. Economy Minister Martin Bangemann ("after all, I just took this whole mess over") might protest seriously that he fully met the "information needs" of his friends in the party and that he pushed substantial improvements through—but all of this is nothing but window dressing that not even the FDP is taking seriously.

The count could have figured out his critical remarks earlier because the merger talks with Daimler-Benz have been going on for more than 2 years and the early history

of this disputed entry is long. Back in 1985, when the Daimler-Benz auto syndicate accomplished a majority gobble-up of aircraft builder Dornier as well as MTU [Motor and Turbine Union], Franz Josef Strauss, the late minister-president of Bavaria, in his capacity as member of the board of MBB and as strong man in the Munich aviation and space enterprise went off in search for somebody who might be suitable to take MBB over. Strauss was afraid that, backed by the financial strength of the Daimler syndicate, Dornier, the little MBB competitor, would turn into a growing threat to the folks in Munich. An inquiry by the minister-president at the neighboring Siemens Concern was turned away politely but definitely. "We are only concerned with things of which we understand something," was the message that Siemens boss Karlheinz Kaske had passed on to the minister-president. But Strauss got a rebuff, which presumably is much closer to the truth, from Eberhard von Kuenheim, the chairman of the board of BMW [Bavarian Motor Works, Inc.] because Strauss had also turned to BMW, looking for help: "MBB cannot be managed as an enterprise, in entrepreneurial terms," announced von Kuenheim after a detailed analysis of the aircraft builder who was offered up for sale.

Now, von Kuenheim believes that strictly company-management criteria cannot be applied to this enterprise with its 38,500 employees because MBB is, of all things, a special case in the German business world. First of all, the syndicate, whose headquarters is located in Ottobrunn near Munich, represents high technology from satellite construction all the way to medical equipment. On the other hand, however, MBB so far has been an enterprise that has been managed according to political viewpoints because it is the decisive German supplier of the Bundeswehr [West German Armed Forces]. Fighter aircraft, military helicopters, or rocket weapons and other war materiel account for around 50 percent of MBB sales which during the current year will come to about DM7 billion. MBB can be described as just about dependent on the government because the syndicate also participates to the extent of 40 percent in the European civilian aircraft, the Airbus, which at the same time is also being built by British Aerospace, by Aerospatiale of France, and by CASA [Aeronautical Construction, Inc.], a Spanish aircraft construction company. But the Airbus, which is considered to be a political symbol for European cooperation, cannot be sustained without financial aid from the government exchequer because it can be sold only at a loss against the overwhelming American transport aircraft competition.

Industrial partners, such as Bosch, Siemens, or Aerospatiale and some banks as well as insurance companies only play a subordinate role. The federal states of Bavaria, Hamburg, and Bremen so far have been holding 52 percent of the company capital and—headed for a long time by Strauss—always construed their participation as a tried and tested means for providing job security. The kind of management that one finds in a normal industrial enterprise was just about undesirable under the supreme authority of Franz Josef Strauss.

There are good reasons for the fact that Daimler boss Edzard Reuter now dares approach MBB. In spite of the objections from Lambsdorff, he was able to negotiate conditions for entering this line of business which can only yield advantages for Daimler-Benz, whereas the government continues to be stuck with the disadvantages and risks. The federal states, for example, whose power was still able to frighten BMW boss von Kuenheim away, are ready in the case of Daimler-Benz to reduce their share to about 36 percent in favor of the people in Stuttgart. But the federal government is also rolling out the red carpet for the high-class syndicate in Stuttgart: Reuter can now take over the technologically and economically interesting divisions of MBB and can put them together with Dornier, a Daimler affiliate. The Airbus, on the other hand, will not be a burden to the Daimler empire. "We are not assuming any Airbus risk," was Reuter's discussion base from the very beginning. The government accepted that and declared that it was ready to strike old debts and new losses of Airbus with a rather expensive stroke of the pen that cost around DM10 billion. What aroused attention was above all the readiness of the federal government to relieve the German Airbus Company in the future even of the currency risk which again and again mars the aircraft deals that are figured in United States currency. Because the Airbuses have a calculation base of DM2 per Dollar, the federal government will assume currency-caused losses out of the government budget until the year 2000. If the Dollar—as has now been happening again for the past 2 years—is below the DM2 quotation, then the government will make an adjustment payment. If it tops that figure, the government will skim the foreign currency profits off at MBB. Only if the Dollar should fall below the DM1.60 mark does the enterprise have to make good for the loss all by itself according to the latest decisions made in Bonn. Long before this agreement had been worked out, the board of experts that normally is expected to put its stamp of approval on the development of the economy as a whole castigated such promises, which depend on the exchange rate, as being an "incalculable budget risk." But Finance Minister Gerhard Stoltenberg planned a total of DM4.3 billion for that purpose. By the end of this millennium, the European aircraft could cost the German taxpayer about DM15 billion.

In the opinion of Daimler boss Edzard Reuter, the Airbus is "a bottomless pit." This is precisely why a clause newly formulated last Monday is of the utmost importance for the finance minister: the profits, which MBB, the Daimler affiliate, earns from military business, would have to be balanced off against Airbus losses. But as we hear from Daimler headquarters, Reuter does not want to go along with this demand by Lambsdorff.

Before he takes over the first 30 percent from MBB with DM800 million, the Airbus Works of MBB, located in North Germany, will be taken out of the MBB Group as an independent stock company. To be sure, MBB will

retain a majority of 80 percent in this aircraft construction affiliate which is called MBB-Commercial. But to stress the government's responsibility for the Airbus, which was wanted on political grounds, Reuter in addition insisted on a 20-percent share of the federal government in this company. It has of course been decided that Daimler-Benz must take this share of the government over at the latest on 21 December 1999. This correction by Lambsdorff also looks nice but is rather more in the nature of wishful thinking. One can hear the following comment even in FDP circles: "If push comes to shove, the pressure potential would be so great that the political establishment could not get out of this." The same would apply if the Dollar should fall below the DM1.60 mark; in that case, Lambsdorff's remarks on Monday would have to apply quite logically: "We simply cannot jump off a running train." Besides, research and development costs could be charged to the government even after the turn of the millennium.

The federal government always did everything to please Daimler-Benz. We can say this because, during the early stage of the takeover talks already, the Stuttgart auto managers made it perfectly clear that they would embark on the MBB adventure only if big blocks of orders amounting to something like DM70 billion for MBB were actually to be decided upon by the federal government. Reuter got everything he was after. The federal government approved the PAH-2 AT helicopter, German participation in the Columbus space station, the Hermes space shuttle, as well as the Ariane-5 European rocket and, last but not least, the disputed Model 90 Fighter so that orders and jobs for MBB will to a good extent be secured into the 1990's.

With this 30-percent entry into MBB, which contains an option for a majority, the Stuttgart managers moved ahead quite considerably on the road of diversification of what once upon a time was a pure-bred car maker group. A few years ago they picked up the Dornier family business, MTU, as well as the AEG [General Electric Company] electrical syndicate which was still quite shaky after insolvency proceedings, as part of a series of takeovers that was unique in German industrial history; and they maintained that they were on the road toward technological and economic domination on land, on the sea, and in the air. But the ambitious Daimler managers Edzard Reuter and Werner Niefer were to find out very soon that getting into the comparatively small aircraft and space company of Dornier was by no means enough to tackle competitors worldwide, that is, competitors who are more than ten times the size of that affiliate which has a business volume of just about only DM2 billion and which employs 9,600 workers.

It is quite understandable that Reuter showed interest the moment MBB was offered up to him. With comments such as: "We are not talking here about the little federal republic; instead we must be looking at Europe," Reuter straightened out those critics who suspected that the merger of the two aircraft and space companies

would turn out to be a mistake in terms of regulatory policy and would amount to government promotion of a monopoly. The markets, it was argued, had long ago shifted to the international level and anybody who now thinks only within national boundaries is simply frittering his future away.

No Child's Play

But Edzard Reuter cannot simply disregard this criticism. This is because, as a result of this step, Daimler-Benz will not only become by far the biggest German enterprise with a business volume of DM73 billion and 360,000 employees or the third-largest European aircraft and space company which could very well measure itself against mighty foreign competitors. Daimler-Benz thus becomes a factor which the federal government simply cannot ignore any longer. Regardless of whether the Bundeswehr needs a modern aircraft or whether the post office minister wants a new telecommunications satellite. Because the federal government is by no means doing its buying internationally, but rather does its procurement mostly at home out of consideration for domestic enterprises and jobs, we can say that Daimler-Benz gets a key position in relation to aircraft and space projects. Out of the around DM20 billion, which the Bundeswehr spends annually for the procurement of products ranging from AT helicopters all the way to sugar cubes, 80 percent regularly remain in the country because the German Army feels that only a domestic armament industry could meet its requirements—and that as a rule is Daimler-Benz. After the confession by Federal Defense Minister Rupert Scholz, 70 percent of all development projects of the Bundeswehr would shortly be handled via Daimler companies or firms that are intertwined with that group—a special position which, according to estimates of arms managers, practically puts him in a position where he can prescribe expensive arms projects and the pertinent prices to the Bundeswehr.

The argument which is used again and again here—to the effect that big armament projects, such as the Model 90 Fighter, cannot be handled by domestic companies and can be carried out only if they were to be built through cooperation with competitors abroad—that argument is no help either here. This objection boils down to nothing because Europe's aircraft and space syndicates are by no means involved in stiff competition. Regardless of whether several countries build a combat aircraft for their armed forces or a research satellite for ESA, the European Space Agency. The construction shares of the individual countries, which are always guided by their financing shares, are always predetermined precisely and are then awarded to domestic firms; in Germany, they will always go to Daimler/MBB because there is no domestic competition.

Wolfgang Kartte, the president of the Federal Cartel Bureau, which can forbid this merger, but which would have to go along with the anticipated special permit from

the federal economy minister, only hopes "that we will be spared having to tackle that case." It is however also conceivable that the Cartel Bureau might tack some special requirements on such a permit. This is where FDP Deputy Hermann Otto Solms sees a chance for some followup improvement: "This flank is still open; we simply cannot have a situation where the economy minister simply disregards such requirements."

Ulrich Immenga, a professor at Goettingen [University] and chairman of the Monopoly Commission, complains that what the government is doing here "has nothing to do with regulatory policy" and threatened to resign. His predecessor in the Monopoly Commission, Hamburg Professor Erhard Kantzenbach even noted: "A big concern can become something like a state within a state. I am very worried if we get to a point where there is only one German armament group."

A Daimler Group, which would try to push Bonn for military orders so as to make full use of its capacities at AEG, Dornier, MBB, or MTU, would have to throw more into the political scales than any German enterprise ever before. It could proliferate with a hefty establishment of almost 400,000 German jobs. The City State of Bremen, which has a high unemployment rate, for example, would be careful not to overlook the interests of the men in Stuttgart. Because Daimler is already building cars in the Hanseatic City, around 20,000 or 6.4 percent of all employees of the city would be working for Daimler firms after the Stuttgart people get into MBB. The actual power of the House of Daimler was noticeable in Bonn already in recent days. Because the Mercedes Group had its board of directors meeting on 9 November—with MBB participation on the agenda—the administration in Bonn felt obligated to approve the conditions for this in advance and rather hastily during a special cabinet meeting.

But a concentration of power, which causes uneasiness, can also be recognized from another angle. Deutsche Bank plays an essential role in Daimler-Benz. It is the decisive Daimler stockholder and no central group decision ever gets past it. Deutsche Bank boss Alfred Herrhausen, the gray eminence of the German economy, however is not only the chairman of the board of Daimler-Benz who himself actively collaborated in the merger undertaking. Herrhausen is also the economic-policy advisor of Federal Chancellor Helmut Kohl.

Perhaps it so happened that the federal government was completely swept off its feet by the fascination of the Daimler star. The federal government went so far that it obviously lost every reasonable measure for the concessions and allowed itself to be talked into conditions—with an eye to self-assured super-manager Edzard Reuter—of which BMW boss von Kuenheim could only dream once upon a time. Bangemann even promised things which he was not allowed to promise: in his paper submitted to the special cabinet meeting last Monday, we can read words to the effect that the new, separated

Airbus Company of MBB would be getting additional jobs and positive coverage contributions "from military production." That could only mean the Model 90 Fighter, an aircraft project that runs into the billions and for which the Lower House so far has approved only the development phase but not actual production.

What Daimler was able to get for itself in the form of MBB however will not be child's play from the viewpoint of the Stuttgart group managers. This is because MBB is an enterprise which, over the past 20 years, resulted from numerous mergers, which today produces at 21 different locations scattered all over the republic, and which again and again faced problems especially in years past. During the past fiscal year, the technology group—which believes that it is the one and only national think tank—earned a profit of just about DM5 million from a sales volume of DM6 billion. The year before, it even had a loss of DM100 million.

The personnel force of more than 38,000 employees is rather abundant for that enterprise. To be sure, comparisons between enterprises are always difficult but the French government-owned Aerospatiale establishment is doing more business than MBB with less personnel. And so it is perhaps no accident that the BMW experts, who once upon a time took a real close look at MBB, arrived at the result that the MBB personnel force would either have to be cut by around 10,000 persons or it would have to achieve a business volume of DM10 billion. And so we cannot be surprised by the fact that the MBB personnel force now fears the iron rule of the men from Stuttgart, especially since there is a worldwide surplus capacity in the aviation and space industry.

The Stuttgart Daimler managers must still struggle to get a free hand for themselves at MBB. With their share of more than one-third, the federal states initially retain a strong position among the group of partners because MBB holds the blocking minority at a capital share of 15 percent. "The federal states will naturally stake their claims," said an official of the Bavarian state government quite unmistakably. Even under a Daimler monopoly management, the people in Munich start with the assumption that MBB is not an enterprise just like any other. Said the official: "After all, they do not produce just condensed milk." Bremen—which today still holds a share of more than 10 percent in MBB—is firmly concentrating on the company's jobs in this City State: "We got that participation for ourselves with the only goal of saving jobs here," said a confidant of Mayor Klaus Wedemeier and, according to the comments of the official, the folks in the Hanseatic City obviously rely on the fact that they will be able to continue to prevent a rationalization shock in their regions because of their MBB board of directors seats.

Many Question Marks

But this kind of thinking bodes ill for the five locations of MBB in Lower Saxony and the three plants in Baden-Wuerttemberg, but above all for the about 800 employees in the Speyer helicopter plant which is located in

Rhineland-Palatinate and about whose closing there has been open speculation for a long time. The approximately 9,000 MBB employees outside the partner states do not have a lobby in the board of directors.

When the time comes, the name of the boss in the economy ministry will, according to all expectations, be Helmut Haussmann who until a short time ago was secretary-general under FDP Chairman Bangemann. So far, Haussmann has refused to make a binding statement as to what he would do when push comes to shove. He hinted, of course, that there is something that would not be quite right if he would reject what Bangemann submitted and what Lambsdorff has given his blessings to.

But does Haussmann want to reconcile his blessing for the biggest industrial concentration in the history of the federal republic with the assurance to the effect that, in his capacity as economy minister, he would be concerned primarily with "the competitive capacity of the small and medium enterprises?" What does Lambsdorff want to do in order to get everybody to forget the tactical failure of recent weeks which once again earned him the sobriquet "Lying-down Lambsdorff?" And for how long will the federal government consider it quite normal that MBB should have a full-fledged lobbyist in its ranks in the person of CSU [Christian Social Union] State Secretary Erich Riedl?

Lambsdorff was still seeing "many question marks" over the weekend and complained about the "highly worrisome project." But suddenly there is no talk of that any more. Even State Secretary Otto Schlecht, tried and tested in many a tempest, appointed guardian of the market economy by quite a few people, consoled himself in a resigned fashion by quoting Ludwig Erhard: "In politics, you can sin from time to time; but you have to know that it is a sin."

AEG Chief Interviewed

36980096 Hamburg DIE ZEIT in German
11 Nov 88 pp 27-28

[Interview with AEG Boss and Daimler-Benz Board of Directors Member Heinz Duerr by Wolfgang Hoffmann and Nikolaus Piper: "We Must Find a National Consensus"]

[Text] DIE ZEIT: The participation of Daimler-Benz in MBB marks the biggest merger in West German history. Does it matter to you that, with your AEG, you are now only a little wheel in the Daimler-Benz Group?

Heinz Duerr: If things were the way you put them, it would certainly matter to me. But that is not the way it is. First of all, MBB will be less than half as big with its business volume of DM6.27 billion as against DM13 billion for AEG and with 38,500 employees as against 89,000. Second—and this is the decisive factor—no enterprises are being "swallowed up here" and none are robbed of their identity. Instead, all of us are working

together under the roof of Daimler-Benz AG, specifically, as integrated technology concern. In competition with other offerors, AEG naturally will continue to supply Mercedes-Benz also in the future. By the way, we will continue to offer top-of-the-line products in many other fields that are not directly connected with the "Auto System."

DIE ZEIT: Can this merger be justified in terms of the economy as a whole? Is not Daimler-Benz increasingly becoming a state within a state?

Heinz Duerr: First of all, let me say this: nobody in the House of Daimler-Benz would arrogate unto himself the kind of role that seems to shine through in the second part of your question. We figure that the democratic rules of the game must remain untouchable and that responsibilities must remain regulated in an absolutely crystal-clear fashion. As for the benefit to society as a whole, we must realize that aviation and space technology today are the point of intersection and the focal point of all high-tech developments. That is when we, as the federal republic, must decide whether we want to be in on that. I can only urgently advise that we get into this.

By the way, I am falling back here on the 1987-1988 annual report from the board of experts which writes the following about the consequences of Germany getting out of the Airbus: "Accumulated technical knowledge would be devalued. European cooperation would also suffer because the Airbus Program is designed as a community undertaking. The only thing to do now is to make it possible for the State gradually to withdraw from the Airbus Program. Efforts by the federal government to get industry to participate more in the Airbus are aimed in the right direction." Daimler-Benz in other words will in the last analysis have to bear its share of an industry policy decision.

DIE ZEIT: Mr Duerr, earlier you pleaded in favor of making the federal republic "weather-proof" for international competition. But, after all, the economy is running outstandingly well at this time. What makes you so pessimistic?

Heinz Duerr: The current situation of the economy is actually very good. But what does worry me is the entire environment in which we are moving in terms of the international economy, the procedure used by our competitors in technologies that determine the future. Their procedure is different from ours.

Looking at the technologies of the future, it is very difficult to be successful as an individual enterprise. Here the first thing we are concerned with consists of high capital investments and, second, long periods of time. This is why other nations, above all Japan, long ago found a consensus between government, industry, and employees concerning the goals of technology policy and how these goals are to be attained. The situation is similar in France and in the United States there are also

beginnings that no longer leave the development of technology simply up to the market. Now, it is not at all true that, in Germany, the State does not also cooperate in the economy. Overall, DM140 billion per year go to the economy in the form of subsidies or subsidy-resembling expenditures.

DIE ZEIT: And you want to increase this sum?

Heinz Duerr: No, if anything, I want to reduce it. But it has to be used in a specifically goal-oriented fashion. Today, money is spent by the most varied agencies for the most varied purposes in the most varied places and to some extent even with the most varied objectives.

DIE ZEIT: In other words, you want investment management. Have you become a leftist?

Heinz Duerr: Whether left or right, I want to make sure that the money is used in a specifically goal-oriented fashion—and to that extent you can also speak of investment guidance. The question only is this: who is at the wheel? I should think that this must not be the State. We must find a national consensus between those who are in positions of responsibility, the politicians, the entrepreneurs, and the labor unions. Perhaps we

should also include the churches. That is how the goals have to be worked out.

DIE ZEIT: Are you thinking of the "shaped society," such as Ludwig Erhard was thinking about it?

Heinz Duerr: The concept certainly was not a particularly happy choice by Ludwig Erhard. But, in terms of the approach, he recognized correctly even then that one cannot leave everything to the invisible hand of the market because, after all, that hand can also pull the wrong lever.

A first step in order to arrive at such a consensus would perhaps be a technology-policy board of experts, such as it was proposed by Rudolf Scheid (the chief business manager of ZVEI, the Central Association of Electro-technology and of the Electronics Industry). Such a body would first of all of course have to spell out the following in a generally understandable and generally binding fashion over a period of years: what is happening specifically in this or that sector, where are the trends, and what should we concern ourselves with? As a second step, the federal government would have to launch an initiative and the groups, which I mentioned, would have to get together around the same table. That is where a dialogue would have to begin about what we want to turn into the most important future-oriented fields in our society. The branches which we do not consider to be future-oriented fields—such as agriculture—would also have to be included. Or the shipyard industry which I personally consider to be a future-oriented industry...

DIE ZEIT: ...that is surprising...

Heinz Duerr: ...because a large part of the goods will continue to be transported over the world's oceans also in the future. We must not only think of the steel which the shipyard industry is processing. In the meantime, more than 50 percent of a ship in many cases consist of electronics. What we are concerned with here is "the ship as a system." And the federal republic must be in on that.

DIE ZEIT: Even if it should cost billions?

Heinz Duerr: That would not at all be necessary under certain circumstances. Right now, we are spending more than DM1 billion for the shipyard industry; but this amount is distributed uniformly over all shipyards—a typical example of the way we are scattering our forces. Why could not this shipyard aid be provided with a requirement to the effect that the industry has to get its act together and determine which shipyard will in the future make what? Everybody knows that shipyard capacities are too big and that there is too much duplication of effort.

DIE ZEIT: Why should one not leave the reorganization of the shipyard industry to the market?

Heinz Duerr: The market economy has one big disadvantage: only short-term thinking gets anywhere in it. The processes which are involved here, that is to say, the development of new technologies and the restructuring of industries, are of a long-term nature. The market does not like that. The market says: buy your ships in Korea because they are cheaper there. And in the end we will have no shipyard industry at all any more.

DIE ZEIT: Do you believe that a commission made up of government directors, labor union secretaries, association officials, and clergymen knows better what the future will bring?

Heinz Duerr: Certainly not. I am thinking here of those in positions of responsibility.

DIE ZEIT: Specifically?

Heinz Duerr: Experts thinking along entrepreneur lines would have to be called in to tackle certain questions. There are enough people in Germany who know something about these things. A minister or even the federal chancellor might seize the initiative and, according to a certain system, might say: we are well off but, just take a look at what is going on all around us. For example, is it correct that 60 percent of the microelectronic building blocks that are vital for our industry come from Japan or the United States?

DIE ZEIT: Do you want a new industry ministry, like Lothar Spaeth?

Heinz Duerr: No, we have enough ministries. All we have to do is to organize the distribution of jobs better, the way we have to do it in a corporation anyway. When you

get a new assignment, then somebody who sits on the board of directors must be told: take charge of this and do something about this topic. I believe that this is how Mr Spaeth meant it.

DIE ZEIT: Listening to you, one thinks often that one is listening to Lothar Spaeth. Do you often swap with him?

Heinz Duerr: We have known each other for a long time. But it is not true that these ideas sprang up only in recent months. As far as I am concerned, by the way, the relatively good economic position in Baden-Wuerttemberg is due to the fact that the question of a consensus has advanced relatively far here. Mr Spaeth has time for entrepreneurs. Not just for big industry but also for medium-sized industry. And the labor unions are also in on this. They do not always shout "hurrah!" from the very beginning—but so what.

DIE ZEIT: Perhaps things would run in Bonn the way they are running in Stuttgart if there were a new chancellor in Bonn.

Heinz Duerr: Bonn is not Stuttgart.

DIE ZEIT: Just the same, Spaeth in Bonn would have to look attractive to you. Do say yes to that!

Heinz Duerr: I, too, only have one vote under our democratic system, thank God.

DIE ZEIT: In Japan, there is an institution, the MITI [Ministry of International Trade and Industry], which coordinates industry policy in a very detailed fashion. Is that a model for you?

Heinz Duerr: Japanese culture is quite different than ours. I do not believe that a simple transposition of a policy from the Japanese MITI to our conditions is possible. But the basic idea is correct. The only thing is, we must first of all to begin with find an approach to the consensus and we must say: we cannot go on like this. For example, there is all this hullabaloo about the Airbus: the Airbus is currently the world's best aircraft. The American aircraft are merely derivations of existing series. The Airbus however is really something new. Now there is some people who say that the Airbus should be discontinued while others want to push it forcefully. And there are still others who think that the Airbus is a combat aircraft. The decisive thing is first of all to arrive at an objective discussion here.

DIE ZEIT: Here is what the problem is: the Airbus is too expensive.

Heinz Duerr: The Airbus is no more expensive than other aircraft. You have to realize that the American companies profit to a very great extent from defense contracts. That is something that has to be considered when you figure the price.

DIE ZEIT: You mentioned defense. Does the federal government now still want to spend billions on the Model 90 Fighter. Can that be justified?

Heinz Duerr: The Model 90 Fighter is a European project and the federal republic must participate in it. That is not a question of keeping our factories busy; instead, it is a question of technology. The important thing here is whether or not we will still have our own independent aviation and space industry during the next millennium. This industry happens to be the point of intersection of all technological developments.

The lead which the Americans obtained during the 1960's sprang from space technology. A part of micro-electronics today became possible through space travel to begin with. Here is what that means: if we want to keep up technologically, then we must not only copy the aircraft of the Americans; we must push our own developments.

The Japanese have now drawn up a national plan for the development of their aircraft and space industry. By the year 2010, they want to achieve a market share of 20 percent. That is a national objective: but here, in Germany, that is subjected to doubt.

DIE ZEIT: Do we absolutely have to have a military project for that?

Heinz Duerr: The question as to whether we can develop new technologies in the civilian sector instead of in the military sector must naturally be answered in the affirmative, theoretically speaking. The only thing is that the real world in which we live is not like that.

DIE ZEIT: You advocate many expensive projects. Do you also have proposals for savings?

Heinz Duerr: Well, I would take a look at agriculture which costs us DM40 billion per year. Of course, the farmers are going to say: he should talk, with the salary he makes as chairman of the board! I grant you that, but the question must be cleared up just the same: do we really want to subsidize agricultural products which we afterward only store or should we not do something more sensible with the money? To make myself perfectly clear: we do need the farmers because who else is going to take care of our agriculture!

As for other projects, which are technologically interesting, I would only say this: this is where we have to muster more community of interest. For example, we come to the question as to whether, in space travel, we really have to build test facilities for satellites in two or even three places.

DIE ZEIT: The watchword now is: industry must be based in the federal republic. In your opinion, should we accept the fact that more and more wage-intensive production activities are being transferred abroad or should we try to keep them at home?

Heinz Duerr: First of all, let me say this: we must have factories in the federal republic that turn out products. The idea of the federal republic being a blue-print republic is basically wrong. You can develop products only if you also know how they are being produced.

Now, there are people who say: if wages were lower, then everything would be much simpler. That is easy to say and, objectively speaking, it is not wrong; the only thing is, this is not reality. Our prosperity after all depends on the fact that we have high wages and salaries. We must raise our productivity and it depends not only on wage costs but also on capital costs. Here is one solution for our country: better utilization of plants and thus also higher productivity. This means uncoupling machine running time and personal working time.

DIE ZEIT: Can you visualize a situation where the federal republic, in the context of the social consensus designed by you, will decide to do entirely without technology because it is too risky?

Heinz Duerr: Yes.

DIE ZEIT: Might you have a specific proposal?

Heinz Duerr: Not here.

DIE ZEIT: Well, you might be able to say "nuclear energy."

Heinz Duerr: No, that would be wrong. We have to make a choice between an energy supply that can be kept under control according to human standards, that is, nuclear energy, and an energy supply, through fossil fuels, which can no longer be controlled because it threatens the entire climate on a global scale. The choice, in other words, is between a residual risk and a 100-percent risk.

As a human being, who would still plant a tree today, I would pick the residual risk.

Industry Failure To Apply Aerospace Technology Criticized

36980105a Frankfurt/Main FRANKFURTER ALLGEMEINE ZEITUNG in German 19 Dec 88 p 6

[Text] Bonn, 18 December. German industry is not getting enough benefit from aviation and space travel. Innovations and new technologies, which are being developed for the construction of aircraft, rockets, and satellites, so far have done little good for other industries. This situation was deplored in a study by the DIW (German Institute for Economic Research) which has now been presented to the public in Bonn.

According to this study, the big aviation and space companies do not have the experience and organization needed for spreading the innovations to companies outside their branches. This technology transfer works only where subcontracting firms are involved in the solution of complex and demanding technical problems. The study by the DIW does credit German aircraft and satellite builders with a good overall position; today they employ a total of 87,000 workers. Although the branch is rather small in terms of the number of its enterprises, it nevertheless did expand much more since 1970 than any other German industry branch. Its labor productivity has likewise risen extraordinarily. On the other hand, one must not overlook shortcomings such as in the case of the Airbus program, project director Hornschild stated during the presentation of the study in Bonn. Work projects are being divided up among the individual nations and companies. For example, if one of the participants were to rationalize heavily, that could under certain circumstances merely mean that he would get less money during the next distribution round. In other words, there is no competition and rationalization pressure, something that does not adversely affect the financial requirements of the Airbus makers. There is presumably a rather confused blend of industry and politics which has to be cleared up.

The situation is said to be similar in space which depends extensively on government contracts. There is no clear position on the part of the government which would have to determine what policy it should be pursuing in aviation and space travel in long-range terms. It is necessary to gain a clear understanding as to how aviation and space travel could be used in an optimum fashion to benefit industry as a whole and what measures would have to be taken to implement such a policy.

The merger of Daimler-Benz and MBB (Messerschmitt-Boelkow-Blohm), which has been much discussed in recent days, was no longer a subject of the study that has now been presented in Bonn. But project director Hornschild left no doubt that the merger was the right way to go considering the domestic market that was anticipated for the year 1992. Hornschild said that an even bigger corporation, which could be joined by other big firms, such as Siemens, would offer even more opportunities. Then the innovations from aviation and space technology could be quickly transferred to other sectors of the economy and industry. Hornschild did not rule out the possibility that, worldwide, there might soon only be two big, supranational aviation and space concerns, a European one and an American one.

French Firm Dassault Announces Increased Space Activity

36980101a Paris LIBERATION in French 18 Dec 88 p 29

[Article by Pascale Nivelles: "Dassault, One Foot in Space"]

[Text] Eventually, Dassault wants the space sector to account for 10 percent of its sales. First step: Star-H, a launcher for the Hermes shuttle.

Always more space. That seems to be the goal of the Marcel Dassault Aircraft-Breguet Aviation company [AMD-BA]. In Bordeaux, it just announced that, in 10 years from now, 5 percent of its sales would come from the space sector. That would be the first stage of the new Dassault strategy, as the company hopes to raise that percentage from the current 2 percent to 10 percent in a more distant future.

Since October 1985, the CNES [National Center for Space Studies] has entrusted Dassault with all the aerodynamics-related work on the European Hermes spacecraft: aerodynamics, aerothermics, study of flight characteristics and steering during the atmospheric phase, including the overall structural design. "We designed the current shape of Hermes," Jean-Maurice Roubertie explained. The stocky dolphin-shaped profile of the spacecraft was designed at Dassault over 25 years ago.

Already during the 1960's, the Tas-1, a two-stage military transport spacecraft, showed an older variant of Hermes nestled against the belly of a huge recoverable spacecraft vaguely resembling the Concorde. At Dassault, nothing is ever wasted; this rough draft, the dream of science-fiction fans 25 years ago, is now used for non-military purposes. It has become the Star-H, an acronym for "Aerobic Transport System Recoverable During Takeoff and Landing."

This huge aircraft with a rectilinear profile takes off horizontally, carrying tiny-looking Hermes on its back; it is powered by 5 gas turbine engines providing each 40 tons of thrust. In altitude, the Ariane-5 rocket engine attached to the tail of the spacecraft takes over and boosts Hermes into orbit while the Star-H returns to base on a traditional runway. The assembly is said to be over 80 m long, with a takeoff weight in excess of 400 tons. Such a recoverable transport aircraft would throw back traditional launchers in the mists of time; British Aerospace is also working on a project of this type, the single-stage Hotol, and so do the Americans and the Germans.

People at Dassault stress the futuristic aspect of the Star-H: the mammoth projected on screen in three dimensions was not designed solely to propel Hermes to the outer limits of the atmosphere. For the time being, it serves essentially as support for a "technological database" which the CNES asked Dassault to provide in 1987. In a way, it sums up and illustrates all the aeronautical and space research carried out at AMD-BA and all that French engineers know about foreign projects.

"We never throw anything away," Jean-Maurice Roubertie explained. "Inventions made 15 years ago on a Mirage may be found again on the Star-H." The database also makes possible a rapid evaluation of what an older project will look like when parameters are modified. "If

one day the CNES asks us to make a spacecraft for 10 passengers and a 1-ton payload," he added, "we shall be in a position to do it before the others."

French Cooperation on AI Systems for Satellites
3698A041 Paris LA LETTRE HEBDOMADAIRE DU GIFAS in English 17 Nov 88 p 1

[Unattributed article: "Artificial Intelligence for Satellites: French Cooperation"]

[Text] Aerospatiale, ESD (Electronique Serge Dassault), and Framentec have decided to cooperate in artificial intelligence systems for the orbital life of geostationary satellites. With the storage possibility of all technical data concerning a satellite and with the experience of design engineers, it is now possible to make a complete, rational, and easily accessible transfer of data to all persons in charge of operations. This system, known as "Systeme Expert," facilitates the work of operators while improving response time, especially during delicate situations or when rapid decisions must be made. The agreement concerns an initial study phase, followed by the development and construction of a prototype. This phase will be followed by the marketing and maintenance of the expert systems. Two basic types are being planned: first, ground-based systems, and second, airborne systems capable of dialogue with the former. The artificial intelligence will be provided by an expert system generator made by ESD and known as the EMICAT and by other tools developed within the ESPRIT project in which Aerospatiale has participated, together with Framentec's Department of Research and Development. This program has the full support of the French Ministry of Industry and benefits by the cooperation of CNES [National Center for Aerospace Studies].

Crouzet Developing Nadir MK-10 Navigation System
3698A042 Paris LA LETTRE HEBDOMADAIRE DU GIFAS 17 Nov 88 p 2

[Unattributed article: "The New Crouzet Navigation System: Nadir MK-10"]

[Text] Crouzet is launching a new mission navigation and management product which answers many needs of military and civilian operators: the Nadir MK-10. Lead-off prototypes will be ready by the end of 1989 for application in 1990. This integrated navigation and management computer has been developed for use by light helicopters and provides them with either ground mission aid (air mobility, tactical transportation, air/ground missions, etc...) or naval aids (offshore, rescue at sea, surveillance and maritime patrol). The aircraft version, "Gemini," is designed for military carriers. The Nadir MK-10 completes the Crouzet line of airborne computers Nadir MK-1, MK-2. According to which MK-10 version is chosen, its functions, which are less sophisticated than with the MK-2, will be multi-sensor navigation (Doppler, radio navigation), management of

flight plan, navigation and mission monitoring, system liaisons. A derivative for civil applications, the R-NAV, is also planned. The Nadir MK-10 is a one-piece box weighing 3 kg in the basic version, including two main modules: a front face module and a processing-supply module. The front face module constitutes the main element in the man-machine interface conception of the system. Owing to the modular conception of the Nadir MK-10, the right architecture can be combined for any given need. Using various functional modules juxtaposed, a custom-made system can be created at optimum cost with built-in development possibility.

Thomson-Aerospatiale Accord Focuses on Electronic Flight Equipment

36980072b Paris LE MONDE in French
1 Dec 88 pp 1, 36

[Article by Claire Blandin: "Restructuring for European Leadership: Thomson-Aerospatiale Agreement on Avionics"; first four paragraphs are LE MONDE introduction]

[Text]

On Wednesday 30 November, the French groups Thomson and Aerospatiale announced that they had started negotiations to regroup their civil and military airborne electronic equipment productions. The new entity would rank first in Europe. It is an answer to the restructuring which is now taking place in the world aeronautical industry. The Ministries of Defense and Industry are pleased with the project.

The talks between Thomson and Aerospatiale involve avionics. Avionics are manufactured by Thomson's Avionics Division, where they account for Fr1.57 billion in sales, and by Aerospatiale's SFENA [French Company for Air Navigation Equipment], Crouzet and EAS [Aerospace Electronics] subsidiaries, totaling sales of about Fr2 billion.

The partnership should be concluded at par (50-50), as both groups consider the sector as of strategic importance for their future. With sales of Fr3.6 billion, The entity created will rank 4th worldwide, behind 3 U.S. companies, and 1st in Europe.

This operation starts the restructuring of the French civil and military aeronautical equipment sector, a sector still excessively scattered among manufacturers that are too small to remain in the technological race at a time when their competitors are closing ranks worldwide.

Start of a Large-Scale Restructuring: Thomson and Aerospatiale Will Regroup their Avionics Divisions

On Wednesday 30 November, Thomson-CSF and Aerospatiale announced the start of negotiations to regroup their avionics divisions. These negotiations, which should take about 3 months, would lead to the creation

of a European avionics leader, ranking 4th worldwide, with sales of Fr3.6 billion. The group, at first controlled 50-50 by the two partners, may subsequently consider regrouping with other companies, in France as well as in Europe.

The regrouping considered would include the civil and military "visionics" systems (on-board computer, instruments, displays, etc.) of Thomson-CSF Avionics Division, representing Fr1.57 billion in sales and 1,880 people, and the activities of three Aerospatiale subsidiaries: SFENA (automatic flight control, navigation unit, displays, etc.), with Fr1.34 billion in sales and 2,280 people; Aerospace Electronics (radio communications, radio navigation, etc.), with Fr170 billion in sales and 240 people; and finally the aeronautical department of Crouzet (navigation computers, instrument panel components, etc.), with Fr680 in sales (out of a total of Fr2.24 billion, for 3,600 people).

Eyed by Foreign Companies

With sales of Fr3.6 billion, the new entity will rank 4th worldwide and 1st in Europe; it will be controlled jointly "in a manner that should reflect in the best possible way the positions of the two groups." Bear in mind that both groups see this as a strategic sector.

With the official announcement of these negotiations, which have the blessing of the authorities, of both the Ministry of Defense and that of Industry, the electronics group Thomson and the aircraft manufacturer Aerospatiale start the restructuring of the French aeronautical equipment industry. Abroad, it started already 2 years ago.

France could not remain on the sidelines. The French aeronautical equipment sector is still very much dispersed; many companies are too small to compete on international markets. The government was aware of the problem, all the more so as some recent alerts had shown that the sector was eyed by foreign companies—witness the succession problems at Turbomeca and Fiat's acquisition of an interest in Labinal.

But operators willing to unite the sector had to be found. Aware of what was brewing abroad, Thomson, world leader in defense electronics, and Aerospatiale, leading European aircraft manufacturer, were getting concerned and decided to implement a restructuring of the aeronautical equipment industry, as it is of vital importance to their operations. They have not yet agreed on the legal framework within which their cooperation will take place, but it should start on a 50-50 basis.

However, 50-50 partnerships seldom last forever; the problem of leadership is bound to arise some day and it is unlikely that Thomson will not assume a dominant position in this case. Especially as this regrouping is just a first step. The two partners will invite other companies to join them, "whenever it will appear beneficial for both

sides." And the sector will also have to give some thought to its global position. Can France support two radar manufacturers (Thomson and Serge Dassault aircrafts)? What will become of Dassault Aircraft now that the company has become isolated in Europe? What orientation should be given to the united European arms industry? Finally, what military repercussions will industrial operations such as this one have within NATO?

World Avionics Leaders (1988 Sales)

| | |
|----------------------------------|---------------|
| 1. Honeywell-Sperry (U.S.) | Fr9 billion |
| 2. Litton (U.S.) | Fr5.1 billion |
| 3. Allied (U.S.) | Fr4.8 billion |
| 4. Thomson-Aerospatiale (France) | Fr3.6 billion |
| 5. Smiths (Great-Britain) | Fr3.4 billion |
| 6. Rockwell (U.S.) | Fr3.3 billion |

Source: Thomson-Aerospatiale

The regrouping of Thomson's Avionics Division (Fr1.57 billion in sales) with SFENA (Fr1.34 billion), Crouzet Aeronautics (Fr680 million) and Aerospace Electronics (Fr170 million) will create the 4th largest avionics manufacturer worldwide, and the 1st in Europe.

French Firms Developing AI Projects for Space *AN890065 Paris FRENCH TECHNOLOGY SURVEY in English Nov 88 p 16*

[Unattributed article: "Artificial Intelligence for Satellites"]

[Text] Aerospatiale, ESD (Electronique Serge Dassault) and Framentec have decided to pool their efforts in the field of artificial intelligence for operating geostationary satellites while in space.

By entering all the technical data of a satellite in a memory and with the experience of the engineers that designed it, it is possible to transfer fully, rationally and in a completely accessible manner all the know-how to the persons responsible for these operations.

This system, designated by the term "expert system," lightens the task of operators and improves their response time notably in difficult situations where a rapid decision must be made.

The agreement covers the study, development and production of a prototype and, at a later stage, the marketing and maintenance of expert systems.

Two main types are planned: ground-based systems, initially followed by on-board systems conversing with the first type at a later stage.

The artificial intelligence equipment comes from two different sources: ESD expert system generator EMI-CAT, and tools developed under the ESPRIT program in which Aerospatiale and Framentec's R&D Department participated.

Italian-British Infrared Laser Accord *MI890102 Rome FINMECCANICA NOTIZIE in Italian 30 Nov 88 pp 11-12*

[Text] A cooperation agreement for the development of infrared technology has been reached between an Italian consortium, led by Aeritalia with the participation of Breda Meccanica Bresciana and Officine Galileo, and a British consortium headed by Ferranti International Signal with the participation of British Aerospace and GEC Avionics. The agreement covers the development of infrared technology and is currently focused on the TIALD [Thermal Imaging Airborne Laser Designator] program.

Simply put, infrared technology in this specific case can be defined as a technique for night vision; infrared sensors actually make it possible to see as clearly at night as during the day, to see through clouds, to see beyond the limits of human sight, and to see without being seen.

The combination of infrared and laser technology enables the TIALD, housed in a specially designed container, attached below the wing or fuselage of military aircraft, to display a detailed vision of the ground on the pilot's instrument panel under any night visibility conditions. The technology also offers the possibility of identifying specific targets.

In June, Aeritalia and Ferranti International Signal reached a draft cooperation agreement on exploiting the considerable opportunities offered by the joint use of proprietary electronics technology.

Alfa Romeo Avio, Rolls Royce Sign Agreement For 'Tay' Engine *MI890110 Rome AIR PRESS in Italian 14 Dec 88 p 2359*

[Text] (AIR PRESS)—Alfa Romeo Avio and Rolls Royce have signed a draft cooperation agreement for the design, development, and production of the new 670 version of the 'Tay' turbofan for commercial air liners. This was announced—AIR PRESS reports—in a press release by the Italian company dated 13 December, stating that it will focus on the design and construction of components for the hot part of the engine—its area of specialization—and that its activities are expected to generate some 500 billion lire in total sales over the next few years.

The Tay 670, a high-technology engine developed in accordance with new regulations to reduce air and noise pollution that will be in effect by the early 1990's, is designed to supply additional power for new 100-120

seat aircraft as well as to replace the motors of existing aircraft such as the DC-9, B-727, and B-737-200, which do not meet the new standards. In fact, the engine has been developed quite recently for use on new aircraft such as the elongated version of the Fokker F-100, and as part of a far-reaching motor replacement program for existing aircraft. This program is at the center of the cooperation agreement involving Aeritalia (the corporation controlling Alfa Romeo Avio), Rolls Royce, and the U.S. holding company Anacorp; the agreement has also been signed by Gulfstream Aerospace, the manufacturer of one of the two aircraft (Gulfstream IV; the other is the Fokker F-100) using current versions of the Tay. Aeritalia is participating in the project through its U.S. subsidiary, the Dee Howard Co., which performed the first conversion of an existing aircraft (a BAC-111) with Tay engines, with the addition of thrust reversers based on an in-house design. Part of the job assigned to the Texas company within this trilateral agreement will be carried out at Aeritalia's Pomigliano d'Arco plant; the recent agreement between Alfa Avio and Rolls Royce stipulates that the Pomigliano plant will also be involved in operations directly related to the development of the Tay engines.

Italy: Space Research Program Described

Chamber of Deputies Approves Program

MI890105 Rome AIR PRESS in Italian
30 Dec 88 p 2423

[Text] (AIR PRESS)—The bill governing the implementation and development of the National Aerospace Research Program (PRORA), which had been debated by the cabinet on 11 March 1988, was officially approved by the Committee for Productive Activities of the Chamber of Deputies, chaired by Mr Viscardi (DC) [Christian Democrat Party] during the meeting held on 21 December. As AIR PRESS reports, the program, whose origins date back to 1969 (Caron Committee), has taken on a more concrete form over time through successive CIPE resolutions (1979, 1981, 1985-1986). The bill defines the legal instruments and procedures necessary to finance the program designed for "research, experimentation, exchange of information, and personnel training in the aerospace sector," in compliance with the objectives of the Space Agency. The program involves an overall expenditure of 600 billion lire over the 5-year period 1988-1992. As Minister Antonio Ruberti and Undersecretary Learco Saporito declared, "the program carries significant weight not only because it aims at strengthening infrastructures and national laboratories in the aerospace sector, but also because it will be implemented in southern Italy and will thus contribute to the policy of equilibrium that we are pursuing. We hope the Senate will examine it soon so final approval and concrete development may be rapidly achieved." The program will establish an Aerospace Research Center at a 160-hectare site in Santa Maria Capua Vetere. CIRA S.p.A. has been entrusted with the design of the center.

ASI Director On Future Plans

MI890108 Turin MEDIA DUEMILA in Italian
Dec 88 p 73

[Interview with Luciano Guerriero, president of the Italian Space Agency (ASI), entitled "Perhaps a Mission to Mars;" date and place not given]

[Text] "The Italian Space Agency's primary concern during the last few months of 1988 was the preparation of the legal and administrative procedures required to begin operations. I hope the agency is fully operational by 1989-90, first of all through adequate staffing, expected by the first months of 1989." This statement was made by the president of ASI, Prof Luciano Guerriero, in an interview with MEDIA DUEMILA.

"This is a particularly important time for the space industry world-wide. Recent events, such as the launching of the Soviet shuttle Buran, testify to a stability in development after a period of considerable trouble, such as the Challenger disaster, which had undermined our confidence in the soundness of certain choices over others. Traditional launchers have been rehabilitated, and another notable step was NASA's decision to switch to 'mixed fleet' carrier rockets, a combination based on the identification of the launcher best suited for any given mission. The Soviets, on the other hand, have concentrated their efforts on projects such as marketing the Proton and launching the Buran. On the whole, both parties have chosen the same combination ('expendable' rockets and shuttle)."

"A definite frame of reference for future development has been established with the signing of the troubled agreement for the space station by the ESA, the United States, Canada, and Japan. The agreement is important both for its implications and its institutionalization of the instruments required to work in space."

"These are major steps toward defining the framework in which ASI will carry out its activities—and both time and place are right. The agency's main objective is to provide unity and consistency for national programs, for ESA programs—in which Italy is playing a leading role—and for other bilateral programs which hopefully will soon be extended to the Soviet Union, one of the signatories of the latest international agreement. This should put an end to the dichotomies of the past, and also act as a link to the San Marco program. The University of Rome has developed an important program; the Malindi base itself is a major achievement: Italy is one of the few countries that can rely on its own launch site, and, what's more, one located in the equatorial zone. The new policy on launchers emphasizes once again the role of small scientific satellites; this, together with the fact that Prof Luigi Broglio is an active member of the agency's board of directors, will offer us a host of new opportunities."

"There are good prospects for expanding the base and increasing the capability of the Scout carrier rocket so it can launch satellites weighing 500-600 kg. NASA has taken an active interest in the San Marco program; there is much that we can do for scientific satellites and microgravity. The industrial initiative for the Topas program may be superseded by events, but we have not lost all hope."

"We must quickly submit our proposals for updating the National Space Plan for the next 5-year term," Prof Guerriero added. "For the Plan itself will differ considerably from the preceding one, as a result of the development that has taken place during the intervening period. Our main task is to carry out the programs we have undertaken, according to which the first Italsat will be launched in 1990, the Tethered satellite will be launched one year later, and so on. Our next step is to encourage new projects to strengthen Europe's position; these should be consistent with our participation in the ESA's space station program (for which we are supplying the Columbus module). Consistency must also be sought in bilateral initiatives with other countries such as France, the Soviet Union, and possibly Japan. New missions are being developed internationally: there is a great amount of activity for the exploration of Mars—with fascinating prospects. We will also have to find ways to participate in the experiments, which necessarily implies an increase in quality in many areas of space technology."

"We should also encourage applications of the Tethered satellite system—a purely Italian concept—which lends itself to many missions, including the space station project. One might even consider carrying out a mission to Mars, for example introducing a probe into the atmosphere and then retrieving it. The prospects are extremely stimulating, and we shall have to carry out our projects in cooperation with industry and science."

"I believe that the position taken by the government prior to the introduction of the bill allocating 400 billion lire per year to the national programs and 400 billion lire to the international ones (based on 1985 prices), establishes a useful point of reference when discussing the financial requirements of space activities. Should we be confronted with particularly important problems involving heavier investments," Guerriero concluded, "we shall present the government with our demands and support our arguments with suitable evidence."

First Space Robot Project

*MI890123 Turin MEDIA DUEMILA in Italian
Jan 89 pp 78-79*

[Article by Enrica Battifoglia: "Spider, the First Italian Space Robot"]

[Text] A cylinder on a polygonal base, one and a half meters long, and weighing about 400 kilograms: this is the first Italian space robot. It will be called Spider

[Space Inspection Device for Extravehicular Repairs] and was designed for the inspection of space structures—to which it will be attached by an arm—using instruments and techniques of artificial intelligence to control its operations. For example, it could work around the international space station the United States will put into orbit in the mid-1990s. Finally, there will be no lack of technological impact on "earth" industries.

Designed last January at the Italian Space Agency by a work group primarily composed of experts in artificial intelligence, the Spider program will keep Italian research busy in space robotics for the next twelve years. It is divided into three phases; only in the final phase will the arms used by the robot to attach itself to a space structure and those used for micromanipulation appear.

Spider should be completely financed within Italy, but there is no overall cost estimate as yet. "Spider's first phase will run approximately 400 to 500 billion lire," says Simonetta Di Pippo, coordinator of robot automation activities for the National Space Plan.

The Italian space robot will be 90 cm in diameter and will have a volume of one cubic meter; two-thirds of its surface will be covered with solar cells, and it will also contain a set of batteries that can be recharged in orbit. "Apart from its small dimensions, Spider is also characterized by retrievability," Simonetta Di Pippo explains, "and a modular structure, which will permit 'biological' development with the possibility of adding new structures to existing ones."

The robotics will occupy the anterior of the structure—a module weighing approximately 170 kilograms that will include a telecamera and lasers for measuring distance. Two modules installed in the robot's body will check information on the internal status of the space vehicle as well as that of the external space, such as position and speed of the space vehicle or the characteristics of the objectives.

Spider will shortly begin operations in the first of its three phases, and the robot will be ready in about six years. Its first mission will essentially be a test flight to see if Spider can measure distances exactly and if it therefore is not dangerous. In other words, the objective will be to check the robot's capacity to work without damaging vehicles or the structures it approaches when working. "We are only thinking about how important this safety would be if Spider should have to make repairs outside an inhabited space station," Simonetta Di Pippo says.

Spider's capacity to visually inspect and locate any damage to space structures will be tested in this first mission. Spider 1 will be strictly remote-controlled; in other words, it will be controlled by humans even for the most simple operations and will be able to "passively"

attach itself to other space structures using parts that have the same shapes and the same standard dimensions of analogous parts installed on space vehicles.

How Can Spider's Capabilities Be Tested?

"There are two hypotheses at the moment," Simonetta Di Pippo responds. "The first is to launch Spider 1 with the Shuttle and make it work on a damaged satellite or around an object that is not dangerous. The second hypothesis is to have Spider 1 work around the international space station, but in this case, serious security problems must be faced."

As soon as the funds are available, the Italian Space Agency will assign the study of the robot system to TecnoSpazio; the studies of systems for the detailed analysis of possible missions will be assigned to Aeritalia.

Only general outlines exist for Spider's future missions. Spider 2 should start in about nine years. Given its modular structure, it will have the same characteristics as Spider 1 but with greater autonomy; in other words, it will require less human control—man will be limited to the role of supervisor.

The manipulating arms will appear on Spider 3: two arms one meter long and a third, shorter arm will allow the robot to latch onto non-standardized objects. Spider 3 will also be able to make precision repairs using micromanipulation techniques. The most difficult problem for the moment is the robot's slow movement around a complex structure.

Spider is the first major program for space robotics in Italy and there are no reports of similar programs in the rest of Europe, although their existence cannot be discounted. "Besides the European Space Agency," Simonetta Di Pippo continues, "France and the FRG are working on space studies: for example, France is working on the arm of the European spaceship Hermes. If there are European projects on the level of Spider, they have never been made public."

Short-term areas of research for Italian programs in the nineties primarily involve the study of robot arms, sensors, and the man-machine interface. The new thing about these fields is that by definition, they are projected into the future. The first studies of the short-term program on space robotics have already been commissioned.

The TecnoSpazio and Tecnomare companies will work on manipulation systems, with special attention paid to micromanipulation techniques and arms of limited dimension (maximum length one meter). The study of sensors and their integration has been assigned to Officine Galileo, Cise, Tecnomare, and Italspazio. TecnoSpazio, Laben, and Csata are studying the man-machine interface, with the goal of designing instruments capable

of guaranteeing greater speed and safety. Among other Italian firms working on space robotics, there are some that were established for robotics in general and which later dedicated a division to space. "Space robotics cannot stem from the automatic transfer of robotics knowledge to space problems," says Cesare Albanesi, director of the studies and planning division of the National Space Plan. "What is needed is an industry founded on specialization in space robotics that considers all knowledge and problems relative to space when designing a project."

Italian-French Space Cooperation Encouraged

M1890106 Rome AIR PRESS in Italian 30 Dec 88
p 2446

[Text] Italian-French cooperation in scientific space activities and telesurveying operations, AIR PRESS reports, are the areas singled out for cooperation at a summit meeting held in Paris by the two countries' space agencies, ASI and CNES, respectively. The Italian delegation was headed by ASI's chairman, Prof Luciano Guerriero, and by its chief executive, Carlo Buongiorno; the French delegation was headed by their counterparts, Lyons and D'Allest. "The Paris meeting," Guerriero noted, "was the first of a series of contacts which Italy's recently-established space agency will have with the space agencies of other countries." The delegates decided to establish mixed working groups to organize the details of their joint programs. The French delegation emphasized its interest in the SPOT family and in the scientific satellite VESTA. The programs developed by ESA [European Space Agency] were also discussed at the meeting, as both Italy and France play major roles in these programs. Among other things, the participants recalled that Selenia Spazio is to be prime contractor for the DRS satellite, the fourth element of the Columbus system.

Italy: Future Strategies of FIAT Aviazione Described

3698M107 Rome AIR PRESS in Italian
7 Dec 88 pp 2313-2316

[Text] Brindisi (AIR PRESS)—In his first press conference since being appointed managing director of FIAT Aviazione, Paolo Torricelli said that European skills in the field of commercial aircraft engines must be joined in a cooperative effort similar to the one for military engines or, better still, the one for airframes with consortia such as Airbus Industrie. Otherwise, Torricelli stated, "we risk dispersing our technological wealth and the enormous resources that have been invested and we will end up fighting each other while General Electric and Pratt & Whitney alone take up over 80 percent of the world market." In reply to a question posed by AIR PRESS, Torricelli added that Italy must confront this European consolidation by streamlining its domestic aircraft engine activity which currently involves too many entities (FIAT Aviazione, Alfa Romeo Avio, and

the engine division of IAM Rinaldo Piaggio). In this way, Italy can take part in international negotiations with the necessary qualifications and industrial strength.

The press conference was called to demonstrate FIAT Aviazone's liquid oxygen turbopump before its formal presentation at Technospace'88, the space exhibition which opened in Bordeaux on 6 December. The turbopump was developed by FIAT Aviazone for the European space launcher Ariane 5's HM60 Vulcain cryogenic engine. The press conference was held on 2 December in Brindisi, the location of a FIAT Aviazone plant which was visited by journalists at the conclusion to a general overview of the company's activities and future strategies in the various sectors of air and spacecraft propulsion. Also participating in the press conference were Bruno Cussigh, in charge of the helicopter and space division, Davide Maccagnani, design manager, Marzella, and Rowinski.

The turbopump is a masterpiece of mechanical engineering and advanced technologies: weighing only 130 kg and with limited dimensions (about 1 meter long and 60 cm in diameter), it generates a power of 3,200 kW to supply the HM60 engine (with 100 tons of thrust) at a flow rate of 200 kg of liquid oxygen per second. Bruno Cussigh, who is also program manager for the turbopump, said that the first model was completed in April, and by October had successfully gone through the first test cycle at the laboratories of the FRG firm MBB in Ottobrunn near Munich. The agreement signed by FIAT Aviazone and the French company SEP (prime contractor for the HM60 engine—which also involves the Swedish company Volvo for the turbine, and MBB [Messerschmitt-Boelkow-Blohm] for the testing facilities) stipulates that the Italian company will construct 28 turbopumps at a cost of 143.6 billion lire for the development stage, which will last until the launch of the Ariane 5 (in 1995). After that, plans call for 8 to 10 turbopumps per year to be built for the operation of the launcher, at a cost of approximately 800 million lire each.

As the Brindisi meeting underlined, FIAT Aviazone's commitment to the space sector is not restricted to this achievement. Indeed, activities are foreseen in all fields in which the company's experience in turboengines may be applied—accordingly, in all propulsion systems using liquid propellants (thus integrating the activities of SNIA-BPD, another member of the FIAT Group, in solid and plasma propellant systems). This course of action is also followed in view of possible aircraft propulsion spinoffs for the engine of the future. This will be possible by integrating technology and skills acquired in the space sector with FIAT's lengthy experience in building conventional aircraft engines for turboengines and helicopter transmissions for the development of advanced reduction gears to be used in propfan propulsion systems. Future strategies described in Brindisi point to across-the-board integration. In fact, Cussigh stated that "participation in the Ariane 5 engine is part of a space program that is being developed on different

fronts, one of which concerns the replacement of current solid rockets with others that use liquid propellants such as methane and oxygen. We are also collaborating with MBB and SEP for the development of a liquid hydrogen and oxygen rocket ranging from 20 to 60-100 KN. This rocket will be used in the orbital transfer vehicles that will become necessary once the space station is operational. The third major area of research involves a study carried out with the FRG firms MBB and MTU [Motors and Turbines Union] on propulsion systems for the future hypersonic aircraft, which is expected to reach a speed of 6,000-7,000 km per hour." Torricelli then pointed out that this involves the lower stage of the Saenger system, the spaceplane being studied in the FRG under an existing agreement with MBB and MTU. However this agreement does not exclude other collaborators, including U.S. companies.

An agreement with the U.S. firm Marquardt already exists, involving small engines for attitude regulation in orbit. New plants, "not necessarily located in Italy," will be built for this activity, with a total investment of about 8 billion lire excluding infrastructure. It is a highly promising field: for example, the possibility is being considered of constructing engines in Italy for the European Hermes spacecraft.

Torricelli pointed out that prospects for expanding FIAT Aviazone's space activities—currently about 40 billion lire, accounting for 6 percent of total sales (estimated at 722 billion lire for 1988, a 15 percent increase over 1987)—are related to the existence of ASI, the Italian Space Agency. Through ASI, Italy will be able to play a much more authoritative international role. Among other things, Italy will therefore be in a position to question some of the division of labor within the European Space Agency, with the ultimate possibility of proposing FIAT Aviazone for the development of the second Ariane 5 turbopump, the one used for liquid hydrogen. AIR PRESS reports that Torricelli highly commended the commitment of ASI President Professor Guerriero, and ASI General Manager Buongiorno to the promotion of an increasingly qualified Italian presence in European programs.

The Brindisi plant is now considerably larger and better equipped than it was at a previous visit by AIR PRESS. It now includes a second test cell which is totally automated and has double power (up to 100,000 pound-/thrust), as well as updated equipment in its laboratories, component production departments, and quality control divisions (with robots for measuring dimensions). All overhauling operations of the J79 turbojets for the Italian Air Force's F104's are being transferred to Brindisi from Turin; this process will be concluded next February. Indeed, by that time everything, including reassembly, will be carried out in Brindisi. Production mainly involves components of the AMX Spey engine and the V2500 civilian engine, which has reached the 100th group [as published]. On behalf of General Electric, development activities are underway in the large

test cell for a CF6-80C2 equipped with FADEC [Full Authority Digital Electronic Control], a system planned for certification within 2 years. The Brindisi plant covers an area of about 125,000 square meters (of which 35,000 are indoors) and employs slightly fewer than 900 people out of FIAT Aviazione's total workforce of 4,779.

Fiat Aviazione to Develop Cryogenic Engine for ARIANE 5

*3698M084 Milan ITALIA OGGI in Italian
6 Dec 88 p 20*

[Article by Marco Tavasani: "Fiat Aviazione Takes Off: Destination Space"]

[Text] Brindisi—Fiat Aviazione will have an increasingly large commitment in the space sector, which is expected to grow rapidly over the next few years, particularly in the area of the European space programs that are now approaching maturity. This briefly summarizes the message transmitted by the Fiat Aviazione management in Brindisi, where the Turin colossus has a modern factory for the manufacture of engine components, research, and revision on the eve of Tecnospace, the specialized exhibition of space activity that starts today in Bordeaux.

Engineer Bruno Cussigh, head of the Helicopter and Space Division, gave a presentation on the most important space program in which Fiat Aviazione is involved—the development of the liquid oxygen pump for the HM60 large cryogenic engine for the Ariane 5 vector, whose first demonstration launch has been scheduled for 1995. "The first of 28 turbopumps," stated Cussigh, "was finished in April and has already successfully completed the test cycle at MBB in Ottobrunn. In financial terms, Fiat's participation amounts to 144 billion lire, equal to 15 percent of the entire Ariane 5 engine."

It need hardly be stated that this fundamental engine component is of great importance for the outcome of the missions that will employ the Ariane 5 vector, intended for the launch of the European manned space shuttle Hermes. In Fiat Aviazione's industrial program for this space activity, the prime contractor is the French firm SEP, responsible for the Vulcain HM60 cryogenic main engine with its 100 tons of thrust, in collaboration with Volvo (for the turbine) and the FRG firm MBB (for the test systems).

After 1996, when the first Ariane 5 launches have completed the demonstration phase, Fiat Aviazione must be able to deliver between 8 to 10 turbopumps per year (in addition to the 28 to be supplied between now and 1995), which are estimated to cost approximately 800 million lire each.

"While this is our most important commitment," stated Engineer Cussigh, "our future programs are also concerned with other systems such as upgrading the vectors

through improved cryogenic engine performance, the creation of space propulsion systems for transferring large loads from low orbit to the space station's orbit, and the development of mixed propulsion engines capable of using the oxygen in the atmosphere for combustion combined with liquid hydrogen as fuel. We are currently defining the terms of a bilateral collaboration with MBB and MTU for this program, for which there will be applications in systems such as the FRG's Saenger and the U.S. transatmospheric aircraft (capable of conventional takeoff and landing).

Fiat Aviazione sales should close the year at approximately 722 billion lire (a 15 percent increase over 1987). Space activity accounts for 40 billion lire, representing a decrease of 6 percent over the previous year, but as Engineer Paolo Torricelli, the new managing director of this division stated, this share is destined to increase substantially over the next few years.

The 4,779 employees of Fiat Aviazione work at the three factories in Turin and Brindisi, and are primarily involved in the overhaul of engines for the Italian Air Force, the construction (under license from Rolls Royce) of the "Spey" KK807 engine for the new AMX fighter aircraft and the Ct7-6 for the Anglo-Italian EH-101 helicopter, as well as [the construction] of the Lm2500 and Lm500 gas turbines based on aircraft engines, but which will now be used to equip ships.

In the military sector, the most important commitment of the Turin company is currently the 4-nation program (together with Spain, the UK, and the FRG) for the new EJ200 engine that will be used to equip the EFA [European Fighter Aircraft]. The first propulsion system has already been tested in Munich, fully meeting timing and program deadlines.

Fiat Aviazione is also active in some of the most important programs in the civilian sector: it has a 4 percent participation in the PW2037 (the Pratt & Whitney engine for the Boeing B757 twin-engined aircraft), 3 percent in the PW4000 (another Pratt & Whitney propulsion system for the B747 Jumbo), 6 percent in the V2500 (the Airbus A320 engine) as part of the International Aero Engines consortium, and 7 percent in the Cf6-80C2, the most powerful turbofan ever developed which delivers 61,000 pounds of thrust.

Fiat Aviazione has invested over 12 billion lire in this engine, which was developed by General Electric, and has constructed an advanced, fully computerized test room capable of supporting up to 100,000 pounds of thrust at its factory in Brindisi. In collaboration with the U.S. company, testing is currently underway at this facility that within 2 years will lead to certification of the FADEC [Full Authority Digital Electronic Control] system, which is in effect a computer that optimizes engine performance.

Engineer Torricelli believes that it is necessary for manufacturers of civilian engines to reach an accord similar to the one reached in the military engines sector: "The only way that European engine manufacturers can hope to effectively stand up against the dominant position of the two U.S. giants is by agreeing among themselves. Failure to do so could lead to a dispersion of our technological know-how and the enormous financial resources that have been invested, as we fight one another while General Electric and Pratt & Whitney together have over 80 percent of the world market."

BIOTECHNOLOGY

EUREKA Biotech, Biomedical Projects Overviewed

AN890001 Paris BIOFUTUR in French
Sep 88 pp 18-21

[Article by Sylvia Vaisman and Claude Vincent:
"EUREKA for Biotechnology!"]

[Text] After 3 years of operation, it is time now for EUREKA's first evaluations and major refocusing. The life sciences, which had formerly been neglected, enjoyed great success at the 1988 Copenhagen ministerial conference. In the age of major international projects (Human Frontier, Human Genome, Star Wars...), is EUREKA the technology program that Europe needs?

No one today can deny its success. Launched barely 3 years ago by France, after the sixth ministerial conference in Copenhagen, it includes 213 projects involving almost 800 firms and research centers from 19 European countries and totaling more than Fr33 billion in investments. Fifty-four new projects, 21 of which involve French participation, were approved during the most recent meeting on 15 and 16 June 1988. Although it is still too early to judge whether EUREKA has met its objectives, it is obvious that the French challenge—which initially raised more skepticism than enthusiasm—has today reached its cruising speed, if not its asymptote. Upon analysis, the budget allotment of the Stockholm conference is found to have been halved to Fr2.7 million, compared to the Fr5.2-million budget granted in Madrid last year for roughly the same number of projects (56). Major projects exceeding Fr100 million [figures as published] have received proportionately less, allowing many smaller new projects to be funded. Approximately 20 projects involve sums of less than Fr30 million. This parameter reflects, in fact, the definitive arrival of small- and medium-sized companies and industries. After some initial caution, these have now committed themselves more resolutely. However, the most remarkable characteristic is the distinct shift of projects involving French participation toward the "biotechnological and medical" sector: 9 projects out of 21.

Refocus on Biotechnology

This change in emphasis has been welcomed with relief. Until now French R&D participated in only one quarter of all the projects in this sector—the lowest rate of the 12 sectors (see Table 1)—and gave the disturbing impression of lacking initiative in fields widely recognized as having priority. However, the swing of the pendulum is so marked this time that one may wonder whether it is simply the effect of the dynamism peculiar to EUREKA. According to Minister of Research and Technology Hubert Curien, who is anxious to reaffirm the necessary spontaneity of the European program, there is no need to search for an underlying political motivation: The present biotechnology thrust, "delayed" with regard to other sectors, reflects the sector-specific difficulty of identifying and launching projects within the EUREKA rationale framework—products, equipment, and services aimed at short- and medium-term markets. It is also the result of the growing involvement of small- and medium-sized firms¹.

However, one can observe that the relative weakness in biotechnology was above all a French trait, possibly reflecting a certain inadequacy on the part of French industry in the face of new biotechnology markets. Yet the political will is truly present, even if it is more a matter of promoting awareness than making decisions: "It is unfortunate to leave too much room for robotics and electronics," insists Hubert Curien, who emphasizes the limited presence of certain traditional sectors such as agro-food. The minister was no sooner appointed than he initiated interministerial discussions on this subject. He has taken up certain points emphasized by Rene Sautier in his recent report to the prime minister. The outgoing president of Sanofi deplored gaps in French agro-food R&D and recalled the necessity to "desequestrate" biotechnology as regards both multidisciplinary technologies and its structures for research and industrial implementation.

Table 1. Distribution by Sector of the 213 EUREKA Projects Adopted by 1 July 1988

| Sector | Total Projects | Projects With French Participation |
|-----------------------------------|----------------|------------------------------------|
| Information technology | 35 | 15 |
| Factory automation, robotics | 46 | 26 |
| Materials | 21 | 10 |
| Transportation | 11 | 5 |
| Ocean, environment, town planning | 12 | 4 |
| Biotechnology and medical sector | 40 | 16 |
| Lasers | 13 | 7 |
| Energy | 10 | 6 |
| Communications | 11 | 5 |
| Microelectronics | 14 | 8 |
| Total | 213 | 102 |

Major Programs and Polemics

There are now 40 biotech projects out of 213, with or without French participation, including the 16 newly adopted projects in Copenhagen (see Table 2). This recent breakthrough of biotechnology within EUREKA should be seen in the broader context of international R&D policy. Projects such as the American SDI², the "Human Frontier Science Program" proposed by Japan to the West for cooperation in life sciences research, and the two U.S. human genome sequencing programs (of NIH and the Department of Energy) all tend to elevate biological disciplines to the rank of true sciences. While the latter two are concerned with long-term and basic research, EUREKA involves short-term projects pursuing specific industrial applications.

This principle was clearly reaffirmed in response to the criticisms expressed by Glyn Ford, the author of a report on EUREKA for the European Parliament's Committee for Energy, Research, and Technology. Ford asserts in his concluding pages that "EUREKA does not constitute an appropriate response to the U.S. technological drive, which is mainly based on SDI. EUREKA cannot even be regarded as a partial strategic approach... nor is it a response to the Japanese Human Frontier Science Program. The EUREKA initiative is not and will never be the ambitious European program that Europe needs."

This assertion was challenged by Michel Auber, deputy coordinator of the French EUREKA Secretariat: "EUREKA's aim is to spark off dynamic communications and information exchanges among European competitors. The initiative was taken by manufacturers, hence the willingness to maintain a noncentralized and noninterventionist attitude, which Glyn Ford seems to

regret when he refers to the EC's system of framework programs while judging EUREKA. These programs cannot be compared, one being as it were the negative of the other."

It is true that the EC has always taken a dim view of the French initiative that threatens to encroach upon its prerogatives. Thus, EUREKA functioned as a goad, spurring the Community to action and prompting it to rethink and reorient its efforts toward basic research along research-industry axis. Likewise, the Human Frontier initiative prompted the EC to strengthen its efforts in basic biological research. The new emphasis on biological sciences in the Framework Program is focused on three disciplines for which new funds have been allocated³: the science of the brain, plant sciences, and the sequencing of small model genomes *Bacillus subtilis*, *Sacharomyces*, and *Arabidopsis*.

This development is not without interest to Europe, because an association of EC programs and EUREKA projects—if real synergy and dialogue became firmly established—could constitute an excellent tool for rapid access to basic results obtained within the framework of major international projects. The extension of EC projects, which already involve manufacturers, toward the development of products or services, notably through EUREKA, would then assume its full force and significance. This has been well understood by some companies, such as Bertin, the prime contractor of Labimap 2001 (see box). This project is aimed at the rapid development of automated equipment that can handle all operations of molecular biology, a subject which is also being covered in EC programs. The strategy is clear: basic or applied research cannot be done without instruments. This is a case of virtually immediate and essential spin-off that should not be overlooked, a lesson which the Japanese learned a long time ago.

Table 2. Biotech and Medical Projects Adopted in Copenhagen

| Project | Leading Partners | Duration (months) | Cost (million ECU) |
|--|---|-------------------|--------------------|
| EU 123: Industrial culture medium for mammal cells | IBF Biotechnics (F), Diosynth (NI), LBE (E), APP (UK) | 48 | 3.7 |
| EU 225: Development of quantitative latex-immunoassay methods with photometric readings | IFCI spa (I), Codiapharm (CH) | 24 | 3.8 |
| EU 237: Synthesis of sulfated oligosaccharides, especially for prevention of venous thrombosis | Institut Choay (F), Organon International (NI) | 36 | 6 |
| EU 242: Space Bio Separation (purification of biotech products under microgravity) | Biospace Technology (B), Esclat (E), Matra (F) | 72 | 25.1 |
| EU 246: Blood donor screening (diagnosis of hepatitis and lymphocytic infections caused by a retrovirus, notably HIV and HTLV 1) | Cremascoli (I), Biokit (E) | 42 | 11.25 |
| EU 247: Varietal creation and organoleptic qualities of fruit | Biosem (F), Vioryl (G) | 48 | 1.4 |
| EU 255: Serological determination of syphilis (development of reagents, diagnosis and automation) | Diesse (I), Serolab (E) | 30 | 2.1 |

Table 2. Biotech and Medical Projects Adopted in Copenhagen

| Project | Leading Partners | Duration (months) | Cost (million ECU) |
|---|---|-------------------|--------------------|
| EU 260: Labimap 2001 (development and marketing of an automated and programmable laboratory for molecular biology) | Bertin (F), Amersham International (UK) | 24 | 7.4 |
| EU 267: Effervescent and foaming drinks | Moet Hennessy (F), Heineken (NI) | 72 | 3.3 |
| EU 270: The industrial application of Novel plant materials (varietal improvement of barley) | Heineken (NI), Carlsberg (DK) | 60 | 17.2 |
| EU 278: CALIES | Bertin (F), BHP Laboratories (Irl), BTS (I) | 48 | 12.67 |
| EU 280: Paciflor | Metall und Farben (A), Guyomarc'h (F), Kunath Futter (CH) | 36 | 0.9 |
| EU 286: Autoantigens for autoimmune diseases | Nova Industri (DK), Middlesex Hospital (UK) | 60 | 7.3 |
| EU 290: RFLP's corn | Biosem (F), Ami (I), KWS (D), Van Der Have (NI) | 60 | 12.1 |
| EU 292: Processing of bitter lupines into high-protein feed components (evaluation of commercial enzymatic preparations for processing lupine grains) | Europroteina (P), Mittex Anlagenbau (D) | 18 | 0.75 |
| EU 294: Medical materials (interactive biocompatible composite materials) | Rwth Aachen (D), Industria Ceramica (I), University of Patras (G) | 60 | 0.45 |

A=Austria
B=Belgium
CH=Switzerland
D=FRG
DK=Denmark
E=Spain
UK=United Kingdom

F=France
G=Greece
I=Italy
Irl=Ireland
NI=Netherlands
P=Portugal

[Box, pp 20-21]

Description of Biotech (and Related) EUREKA Projects Involving French Participants Approved at the Copenhagen Ministerial Conference

1. Industrial Culture Medium for Mammal Cells (EU 123)

Coordinated by Advanced Protein Product Ltd (APP, UK), this project is intended to identify and test the performance of the appropriate culture medium for each strain of mammal cells. Alternatives to the traditional fetal calf serum will be envisaged, in particular immunoglobulin-free bovine serums complemented by growth factors for myeloma and hybridoma cells in culture, but also so-called semisynthetic mediums. Development of specific carriers (hollow fibers and fibronectine substrates) will also be studied. Although the market in culture mediums for eukaryotic cells is still limited today (approximately \$1 billion), its long-term prospects are promising with an expected 23-percent annual growth rate in the 1990's. With an annual growth rate of nearly 30 percent, serums retain the largest volume share in this market.

The various participants in project EU 123, besides APP, are:

- IBF Biotechnics (a Rhone-Poulenc subsidiary),
- INSERM U284 [French National Institute for Health and Medical Research],
- Laboratorios Bioquimicos Espanoles S.A. (LBE, Spain),
- Laboratorios Sobrine S.A. (Spain),
- Diosynth B.V. (Netherlands),
- Centraal Diergeneeskundig Instituut (CDI [Central Veterinary Institute], Netherlands), and
- finally the French Bertin & Cie, which will supply the bioreactor. Remember that this company also participates in project EU 104, which was accepted under the EUREKA label on 30 June 1986 (development of an automatic bioreactor for continuous animal cell cultures, ECU 25.5 million) and whose state of progress was presented at the Copenhagen meeting. APP will provide the biggest financial contribution: ECU 1.867 million spread over the project's 4-year duration.

IBF will contribute a total of ECU 0.94 million and will assign one researcher to the program for the first 3 years, as will Bertin and CDI, whose contributions will be ECU 226 million and 160 million, respectively.

The Netherlands company Diosynth will participate only in the 2d and 3d year and contribute an overall ECU 135 million.

Each partner will be entitled to commercially utilize the achieved technological results thanks to his contribution. INSERM will do this through Bio-France Reactifs.

2. Space Bio Separation: SBS (EU 242)

This program consists of setting up a complete and fully automated line for the purification of biological molecules under microgravity. The first stage involves experiments with zone electrophoresis, which, depending on the results obtained, will be coupled to other commercial operations such as purification by isoelectric focusing or prepurification by chromatography, for example. Preliminary ground-based studies will be conducted to optimize and automate all the technological steps and to develop and arrange the specific sensors required.

Several equipment rating flights are already scheduled during the 6 years of the project:

- Preliminary tests will take place in Soviet capsules in 1989;
- the first instrument flight, aboard the U.S. space shuttle in 1991; and
- the second and third instrument flights beginning in 1993 will be European.

Economic spin-offs from EU 242 are expected in the field of instrumentation and parapharmacy. Within 2 to 3 years, research and analysis laboratories will be shown liquid electrophoresis cells with a higher resolution factor than that of HPLC [high performance liquid chromatography] equipment, which is routinely used in industry (European market potentially in excess of Fr60 million).

EU 242 is also expected to produce optical-fiber UV detection systems coupled to purification equipment but also usable for fermentation control in bioreactors (European market of approximately Fr20 million) and laboratory robots developed for purification line automation (existing market of about Fr10 million). In the more remote future, scientists anticipate the development of a complete purification line associating techniques such as ultracentrifugation, chromatography, electrophoresis, etc (potential market estimated at more than Fr100 million).

The cost of the program amounts to Fr185 million (Fr110 million for feasibility studies alone), of which Fr70 million will be defrayed by French participants, flight costs excluded. The various partners are:

Matra (17 percent),
CNES [National Center for Space Studies] (7 to 9 percent),

CRISA (electronics and data processing part, 12 percent),
Esclat (development of instrumentation, 12 percent),
Roussel-Uclaf (selection and production of biological molecules, 7 to 9 percent), and
Biospace Technology.

3. Varietal Creation and Organoleptic Qualities (EU 247)

Whereas selectors today base their qualitative appraisal of agricultural products essentially on the findings of sampling panels, this project seeks to develop objective criteria to determine organoleptic qualities, particularly in the fruit sector.

Two sample plants will be used: the melon and the strawberry. Other plants could be included in the program later on. The first phase will involve the identification of the principal compounds contributing to taste and aroma followed by a study of their genetic variability. The second phase will be a search for the enzymes involved in the synthesis of these compounds, with the aim of understanding the effects of accidents due to the many soil characteristics and to prevent them. Vioryl (Greece) will conduct the physicochemical studies of the molecular compounds determining flavor in the species concerned (existing or required genetic variability), while Biosem (Limagrain Group) will be responsible for sensory analyses, selection, and varietal creation. Greek and French public laboratories may provide limited assistance. The project will cost Fr9.8 million, including 3.8 million contributed by the French.

4. Labimap 2001 (EU 260)

"A superb project," says Hubert Curien. Starting with an 18-month definition phase, Labimap 2001 seeks to market, within 4 years, an automated line performing the principal operations of molecular biology: nucleic acid extraction, strain preparation, hybridization, cloning, mapping of cloned fragments, sequencing, and data base production. The various modules will operate autonomously, but they will be mutually compatible. They will cost Fr200,000 on average.

According to Bertin, there will be a market for approximately 275,000 modules in the next 10 years. As prime contractor, Bertin is associated with Amersham International PLC (applications and reagents, UK), CEPH (Center for Human Polymorphism Studies, run by Prof Jean Dausset) and with the ICRF (Imperial Cancer Research Fund). The budget as announced totals Fr52 million for the first 18-month phase, half of which is reportedly funded by Bertin (about Fr15 million) and CEPH (about Fr12 million). The creation of a specific structure aimed at involving new partners for technology development or finance sharing in the manufacturing phase has already been planned. It will associate French, German, Swiss, and Italian manufacturers, each of

which will develop several pieces of automatic equipment (three or four for France). Marketing will be handled by a European company.

5. Paciflor (EU 280)

Initiated by Guyomarc'h, notably through its work on understanding the activity of "growth factor" probiotics (living microorganisms capable, after ingestion, of improving intestinal bacteria), this 3-year project is devoted to the development of the Paciflor probiotic (registered under the code name IP-5832) for animal feed. Long since used in human applications, it remains stable at rising temperatures. It is in fact believed to be an intermediary microorganism between *Bacillus subtilis* and *Bacillus cereus*, covered by a Guyomarc'h patent. It seems, therefore, to be extremely well suited to granular feed for livestock other than calves, and could thus represent an excellent alternative to antibiotics. The total budget (Fr6.4 billion) is divided among the various partners concerned as follows: Guyomarc'h (46.5 percent), Metall und Farben (23.3 percent, Austria), and Kunath (30.2 percent, Switzerland).

6. RFLP Corn (EU 290)

This project focuses on the genetic improvement of corn by RFLP [restriction fragment length polymorphism] for the selection of qualitative (resistance to disease) and quantitative (yield, precocity) characteristics. It associates four partners of different nationalities: Klainwanzeleber Saatzucht AG (KWS, FRG), Van Der Have Seeds (Netherlands), Agricola Mais Ibridi (AMI, Italy), and Biosem, a subsidiary of the Limagrain group. Each partner will work on 50 initial lines.

The project can be divided into two distinct phases:

- The first, lasting 2 years, will consist of preparing plant material and gaining a better command of the technologies of molecular biology and the necessary statistics.
- The second phase (3 years) will be devoted to obtaining and analyzing the results.

The analyses of the varieties retained, crossbreedings to be carried out, field tests, and statistical analysis programs will be conducted in close cooperation with the University of Hohenheim, The Max Planck Institute of Cologne, and the CNRS [National Center for Scientific Research] GPDP [Genetic and Physiological Plant Development] laboratory at Gif-sur-Yvette (Jean Pernes). Although the four partners have fairly shared out the work to be done among themselves, the French participation is less than 7 percent of the program's total budget (Fr84.7 million).

7. Effervescent and Foaming Drinks (EU 267)

This project, involving Moët & Chandon (subsidiary of the LVMH [not further identified] group) and Heineken (Netherlands), will run from 1988 to 1993 and seeks to deepen knowledge of the physical nature of foam, of the physicochemical links enabling it to remain stable (analysis and influence of the presence of proteins, polysaccharides, and lipids), and of the sources of bubble nucleation.

It should result not only in better control of the quality of carbonated and effervescent products, but also in development of new foaming drinks. The French company's contribution will be limited to 30 percent of the total budget, or Fr6.5 million of the Fr23 million required.

8. CALIES (EU 278)

The stimulation of muscles by electrical impulses in order to restore mobility to the handicapped is one of the objectives pursued by many researchers. The CALIES (Computer-Aided Locomotion by Implanted Electro-Stimulation) project is aimed at coordinating and streamlining this work, while improving technological support and preparing an appropriate medical infrastructure.

Under the leadership of Bertin & Cie, CALIES unites several participants whose skills cover all aspects of the program:

- INSERM (Montpellier), the Souriau company, and the Marseilles Institute of Neurophysiology (CNRS) for France;
- West Germany's Biocybernetic Institute and Neuro-surgical Clinic;
- BHP Laboratories Ltd, the University of Dublin, and the University College of Dublin for Ireland;
- the Robert and Agnes Hunt Orthopedic Hospital, the Liverpool University's Medicine Departments, the MRC [Medical Research Council] Neurological Prosthesis Unit, and the University of Strathclyde for the UK;
- Bioengineering Technology & Systems, the Bioengineering Center and the Brescia surgical clinic for Italy; and finally
- the University of Technology at Twente for the Netherlands.

This is an impressive number of partners for project EU 278, which will be spread over 4 years and will require Fr88.7 million (French participation: Fr43.5 million).

9. Synthesis of Complex Sulfated Oligosaccharides (Research Phase) (EU 237)

This project appeared in concrete form following work done by Institut Choay (Sanofi) that was awarded the 1986 Galien award for demonstrating that a short heparinized sequence (only five saccharide units) produces

the anticoagulant activity of heparin, without, however, causing the undesirable side effects. The concrete objective of the 3-year cooperation with Organon GmbH is to control the industrial process for the organic synthesis of new antithrombotic oligosaccharides and to prove their therapeutic significance. French participation amounts to Fr21 million of the 42 million expected.

Footnotes

1. In 1989, an insurance policy will go into effect which will cover half of the financial risks taken by small companies in case of "failure" (dead-end technologies, technological blockage, a partner's default, or a missed deadline). The French groups Axa and AGF [General Insurance Company of France] are working on this matter. A premium rebate of 25 to 30 percent during a limited period (5 years, for example) could help to launch the system. This initiative has been warmly welcomed by manufacturers and should prompt small- and medium-sized firms (which abound in the biotechnology sector) to increasingly take part in EUREKA projects.

2. Strategic Defense Initiative

3. As of next autumn, there will be Fr24 million for sequencing *Saccharomyces* genomes and Fr200 million for the *Bacillus* and the model plant. The sequencing of the human genome will be budgeted under the preventive medicine program.

Microgravity Purifying Project Gains EUREKA Status

3698A008 Toulouse LA LETTRE DU CNES in French
8 Aug 88 p 11

[Unattributed article: "European EUREKA Project: Purification in Microgravity (SBS)"]

[Text] In connection with the EUREKA program, CNES, Matra, and Roussel Uclaf have been awarded the contract for the European "Purification in Microgravity" project. This first biotechnology contract in the field of microgravity awarded to industrial firms in Europe will involve France, Belgium, and Spain.

The 6-year Fr185 million contract calls for the development of a Space Bio Separation (SBS) laboratory for the purification of biological products. The development will be conducted in collaboration with scientists involved in relevant research, at CNRS [National Center for Scientific Research] and the Paul Sabatier University in Toulouse.

Obtaining products of extreme purity is an increasingly critical problem, especially for therapeutic applications. The purity facilitates a better understanding of the molecule—both its active principle and its three-dimensional structure—after crystallization, for example.

The program will consist in developing a fully automated, complete purification chain, operating in microgravity.

During the initial stage, a zone electrophoresis experiment will be carried out. The aim of SBS is to develop new separation procedures in order to isolate and purify biological products with a high specific value.

The studies will attempt to develop expertise in heat exchange and transfer phenomena in microgravity, separation methods, and measurement techniques.

FRG: Research on New Computer-Aided Molecular Modeling Technology
3698M021 Bonn TECHNOLOGIE NACHRICHTEN-MANAGEMENT INFORMATIONEN in German
No 486, 29 Aug 88 p 11

[Excerpts] Molecular modeling is suitable for analyzing large biomolecules and for planning the synthesis of new composites. Using this technique a chemical engineer working on a chemical synthesis, for example, can interactively test his project with the computer, allowing him to assess the possibility of success or failure. Using computer modeling and color computer graphics, the scientist can gradually design an architecture for the desired molecule and can immediately investigate his design with an indepth structure-effect analysis—a fast combination of computer construction and computer testing. It is also a helpful development for processing complex problems in molecular biology.

The BMFT is subsidizing projects aimed at improving and expanding these methods for use in biotechnology. Modeling physical and chemical parameters for atoms and molecules, especially large biomolecules, is not a finalized process, but rather one that is only beginning to be developed. It is therefore always important to improve the flexibility of the subprograms as well as their connection to the overall program.

This new method offers molecular biologists the interesting possibility of making specific alterations to protein molecules through genetic engineering. In this way the stability of known enzymes can be increased by exchanging certain amino acids or altering the specific nature of their reactions so they can be applied in technical fields (such as the foodstuffs industry or waste recycling).

A small group of scientists met at two workshops held in June 1987 and May 1988 at the Darmstadt Technical University to discuss problems arising from the subsidized projects and to introduce the new methodology to young scientists. New price reductions in the computer market give rise to hope that computer-aided molecular modeling will quickly become established in many biotechnology laboratories. The BMFT welcomes this development and will support it further in the coming years by providing subsidies for specific projects.

Round-Up of Research by Belgian Biotech Firm
AN890002 Paris BIOFUTUR in French
Sep 88 pp 48, 51-52

[Article by Christian Vincent: "Field Testing: Plant Genetic Systems Intensifies Its Programs"]

[Excerpts] [passage omitted] Plant Genetic Systems (PGS) is incontestably the leading genetic engineering company in Europe. In addition, it was the first company to genetically modify plants to increase their resistance to insects by introducing the gene coding for the *B. thuringensis* toxin (1985). The company plans to carry out 12 field tests in five European countries and in the United States (see table). The tests involve various crops, such as colza, potatoes, alfalfa, tobacco, tomatoes, and poplar trees.

These transgenic, genetically engineered plants have been made resistant either to insects (by introducing the gene coding for the *B. thuringensis* toxin) or to a broad-spectrum herbicide such as phosphinotricine, which is the active principle of a herbicide marketed by Hoechst under the registered trademark BASTA. Phosphinotricine epitomizes the new generation of herbicides characterized by excellent biodegradability, nontoxicity to man and animals, and a remarkable power to kill weeds...and most cultivated plants. Therefore, such herbicides cannot be used on extensive crops, unless the plants are made resistant. For certain extensive crops such as sugar beets, for example, selective herbicides cost two to three times more than the seeds. Companies working on this problem estimate that if such plants could be made resistant to broad-spectrum herbicides such as phosphinotricine, the farmers' weeding programs would be easier and less expensive. PGS researchers

have therefore developed a technique making it possible to introduce a *Streptomyces hygrosopicus* gene coding for phosphinotricine acetyltransferase into the plants. This enzyme modifies phosphinotricine in such a way that the derivative becomes nontoxic to the transgenic plant.

Between the laboratory and the consumer, it is essential that the transgenic plant be tested in the field to evaluate the environment's impact on the introduced gene's expression and to test its economic value. Field tests also play two other major roles: First, they provide experience in a relatively unknown area and are helpful in working out regulations; second, they inform the public. All PGS' field tests are thus conducted in cooperation with independent research institutes having agronomic expertise in the plant being studied. In France, such institutes are INRA [National Institute for Agronomic Research] and SEITA [National Society for Industrial Exploitation of Tobacco and Matches] for tobacco. Through the Tobacco Institute of Bergerac SEITA contributes its knowledge, from the seed to the tobacco, and its know-how in plant improvement (see box).

The first field tests of transgenic tobacco seedlings resistant to phosphinotricine were conducted at the Tobacco Institute of Bergerac in 1987, with the consent of the Biomolecular Engineering Commission and in accordance with a strict protocol designed to prevent transmission of the resistant gene to other tobaccos by pollination. Following satisfactory tests on commercial tobacco varieties and no longer on sample tobacco plants, an evaluation will be made of the principal physicochemical characteristics of the raw material, residues of the herbicide and its metabolites, and of biological tests of smoke. According to Plant Genetic Systems, the first transgenic plants could be marketed in 1991...provided that regulations keep pace.

PGS Field Testing Program

| Country | Transgenic Plant Tested | Transgenic Activity Studied | Remarks |
|---------|-------------------------------|---|--|
| Belgium | -Potato -Alfalfa | Resistance to phosphinotricine | -Authorization granted in May -Authorization granted in June |
| France | -Potato -Tobacco -Colza | Resistance to phosphinotricine Enrichment of storage proteins with essential amino acids | -Tests in progress -Authorization requested from the Biomolecular Engineering Commission |
| UK | -Potato | Resistance to phosphinotricine | -Authorization granted during first quarter of 1988. However, because of UK requirements regarding importation of tubers, field tests will not take place until 1989. Transgenic greenhouse seedlings will be quarantined in a laboratory in Scotland. |

PGS Field Testing Program

| Country | Transgenic Plant Tested | Transgenic Activity Studied | Remarks |
|-----------------|---------------------------------|---|--|
| Spain | -Potato -Tomato | Resistance to insects Resistance to phosphinotricine | -Authorization granted in June. |
| The Netherlands | -Potato | Resistance to phosphinotricine | Authorization requested |
| United States | -Tobacco (commercial varieties) | Resistance to insects | -Agreements with Rohm and Hass Inc. Tests will be made at the Northrup King Inc. experimental farm located in Laurinburg, North Carolina |

[Box, p 51]

Research at SEITA

The Directorate for Research, Development, and quality Control has a staff of almost 400 people, based mainly in two research centers, besides the Paris headquarters:

—The Center for Tests and Technological Research on Tobacco at Aubrais (CERTTA). Created in 1954, the center is devoted to technological research in the broad sense: basic knowledge of the raw material and of its influence on the composition of smoke; product design; study of manufacturing components; equipment testing; specific metrology for the tobacco industry; and quality control.

—The Tobacco Institute of Bergerac (ITB). Created in 1927, the institute is focusing on agronomic research relating to tobacco.

SEITA's ITB institute is one of the very first tobacco research centers in the world. The institute's mission is to study all factors in the production of tobacco as a raw material and to sustain and monitor the development of tobacco cultivation in France, with a view to improving quality and finding adapted processing techniques. ITB has a staff of 80, approximately half of which is directly involved in research. The institute has 1,500 square meters of laboratories, an estate of 57 hectares of cultivable land for rotating experimental crops, one of the richest gene banks in the world (close to 1,000 different species and varieties), and an annual budget of Fr22 million.

Its activities are divided among three departments: Biology, Agrochemistry, and Experimentation and Tobacco as a Raw Material.

The Biology Department is the oldest. Pathology and genetics have always been associated, because in parasitic control priority is given to the creation of resistant varieties. In cooperation with other companies, the institute tests varieties produced by genetic engineering. Species cultivated in the botanical garden make it possible to create new varieties by hybridization, mutation, or androgenesis.

The Agrochemical Department studies the influence of environmental factors on tobacco crop yields and the physicochemical characteristics of tobacco as a raw material. A laboratory analyzes soil samples and plants and determines the concentration of pesticide residues. The institute also studies tobacco processing techniques after the harvest, and the biochemical and physical phenomena accompanying this transformation.

The Experimentation Department for Tobacco as a Raw Material is tasked with conducting all tests proposed by the other departments. In addition, it does its own testing relative to cultivation techniques and to plant and crop protection. This department also evaluates the tobacco as raw material based on agronomic trials.

As the internationally recognized French tobacco specialist, the institute cooperates:

- In France, with INRA (with the creation of a Scientific Interest Group, GIS in 1987), with universities (Bordeaux, Toulouse, and Paris), and manufacturers;
- Abroad, with approximately 50 tobacco research institutes or universities, particularly in Europe, Japan, and all other major tobacco-producing countries.

In addition, the institute provides scientific support to countries cultivating renowned tobaccos, such as Cuba and Bulgaria, particularly in the development of new varieties.

COMPUTERS

British Supercomputer Exported to Japan
36980124 Beijing JISUANJI SHIJIE [CHINA COMPUTERWORLD] in Chinese 21 Dec 88 p 8

[Text] According to a British newspaper report, the first British supercomputer ever sold to Japan will soon be operational. This 2.5-BIPS [billion instructions per second] computer, built by the English firm (Meike), has a memory of 1000 megabytes, which is equivalent to the storage capacity of 2500 IBM PCs. The computer is inexpensive, selling for only \$2 million, about one-tenth the usual price for a supercomputer. For example, the world's currently most powerful supercomputer, the

Cray YMP, is a 1-BIPS model, but its selling price is close to \$20 million. The British supercomputer is based on the Transputer computer chips produced by the Inmos Company. Computing power can be greatly increased by inserting additional circuit boards (each board having four Transputer chips and associated memory devices).

Bavarian Artificial Intelligence Research Center Established

*36980111a Stuttgart VDI NACHRICHTEN in German
16 Dec 88 p 2*

[Article by Carsten Schroeder: "Intensified Research on Knowledge-Based Systems in Erlangen: Threesome for Artificial Intelligence: Bavaria Expresses Reservations About Riesenhuber's Centralization Plan"]

[Text] Erlangen, 16 Dec 88—It is the third research center for artificial intelligence to be dedicated this year: The Bavarian Research Center for Knowledge-Based Systems in Erlangen. Only 2 months after work began, it was committed to its task last Thursday by the brand-new minister president, Max Streibl, with typical Bavarian informality.

The Federal Ministry for Research and Technology (BMFT) and the Baden-Wuerttemberg Land government had moved a little faster. Their institutes, the German Research Center for Artificial Intelligence (DFKI) in Kaiserslautern and the Research Institute for Application-Oriented Knowledge Processing in Ulm, are a couple of months older.

Nevertheless, it is not that easy to say whether all good things come in threes, or whether West German research on artificial intelligence, which enjoys a very good reputation, will gain further stimulus from the institutes. In theory, it still sounds very simple: Kaiserslautern is oriented towards fundamental research, Ulm towards applications and Erlangen towards technology transfer. The computer industry is substantially involved in all three institutes. It almost sounds as if this threesome is the result of a well thought-out plan.

However, if one examines the political developments that preceded the establishment of the institutes, which are thus far unique in the FRG, the role played by the rivalry between the three sites becomes clear. After Federal Minister for Research and Technology Heinz Riesenhuber announced the establishment of the DFKI, Bavaria and Baden-Wuerttemberg followed suit. Lothar Spaeth was afraid that his high tech-oriented Land might lose its prominent position, and the Bavarians were unable to comprehend why a German AI center should be located outside the semiconductor stronghold around Munich.

With the DFKI, Riesenhuber wants to concentrate the rarely seen AI researchers in one center. However, he is drawing scientists from the technical colleges, where they are being missed for their role in the critically necessary training of the next generation.

"In the FRG, we have a very spoiled research landscape," complains Prof Nikolaus Fiebiger, president of the University of Erlangen. "There is a danger that research will leave the universities." Because the federal government will not allow the Laender joint say in educational policy, he says, it is obvious "that the federal government will establish its own institutes."

Bavarian Minister for Research Wolfgang Wild is convinced that the Erlangen setup is the best one: "The three centers for excellence in the area of computer science in Erlangen, Munich and Passau together constitute a trans-university focus for research." Wild believes that an additional institute does not represent an effort to thwart the policy of the federal minister for Research and Technology, who wants to centralize AI strength. However, "no one could really expect us Bavarians, who have the best computer science know-how, to sit idly by while people are wandering off to Ulm or Kaiserslautern."

The organizational problems arising from splitting up the center among three universities will not be small ones. Some research projects are supposed to be conducted in parallel at all three sites. At present, the computer specialists are dreaming of exchanging their data through the Bundespost network at 140 MBit/sec. However, it will probably be some time before this is possible.

For the first two years, the Land government has earmarked a budget of DM7 million for the center. Because the institute is supposed to support technology transfer to industry in particular, the private sector is willing to provide an equivalent amount. However, not much more than DM1 million has been raised thus far. Thus, it remains unclear how the stock of 40 scientists who are to conduct research at the center in less than 3 years is to be built up. Thus far, 10 employees have been hired. According to Minister for Research Wild, the addition of more jobs is still a point of discussion.

French Firm Produces Image Analysis System *AN890071 Paris FRENCH TECHNOLOGY SURVEY in English Dec 88 p 8*

[Unattributed article: "New System for Artificial Vision"]

[Text] The Infographics-Archiving Division of TITN has produced an image analysis system called Fabvision 2005 operating on a PC AT type microcomputer. It is used to recognise forms, true colors and code colors,

measure dimensions, shapes, check the appearance, presence, and position of parts. It has been designed to fit easily into an industrial or laboratory environment. It provides the following:

- Two hardware versions: a standard version for laboratory applications and a more robust version for industrial applications. Both have cabled processors for processing color images and a series line for connection to the existing industrial computer installation;
- A standard and user-friendly software that simplifies all human intervention (menus, mouse and windows),
- An automatic application program generator enabling nonspecialists to produce their own applications.

Fabvision 2005 can "see" in 3-D: luminance (the only datum perceptible by a black and white system), hue, and saturation. Irrespective of lighting faults, it can recognise true colors that it can identify, measure, and compare (it can even recognise a color code on a moving product).

This system comprises a color matrix CDD camera, a PC AT type computer with a mouse, image processing cards, and a color graphic display screen. The software architecture has four hierarchical layers: MS-DOS by Microsoft, Windows, 2005 base software, and specific application software.

This tool will provide mechanical, automotive, pharmaceutical, and other industries using color codes with an effective automatic identification system.

Belgian Government Funds Supercomputer Network Development

*36980101b Brussels LE SOIR in French
24-25 Dec 88 pp 1, 3*

[Article by Guy Duplat: "Supercomputers: Belgium Wants To Catch Up"]

[Excerpt] [Passage omitted] All major countries are getting a few supercomputers. And high-thruput digital data transmission networks are beginning to connect these mainframes. Belgium, unfortunately, lags far behind.

True, we are about to acquire three supercomputers, but the government and the Telegraph and Telephone Administration [RTT] have done nothing to speed up things and, above all, to implement the indispensable network that will connect all universities to these powerful computing tools. Last Friday, the Council of Ministers approved a large incentive program in this respect, with a budget of 900 million francs over 4 years.

We may regret that this program shows a lack of determination in the sector where it is most needed: the implementation of a high-throughput network connecting universities.

Scientific research is no longer conceivable without computers. But traditional (i.e. "scalar") computers are far too slow to digest the new scientists' programs. Recent years have witnessed a rush of researchers and engineers toward more efficient computers.

In astrophysics, cosmology, molecular dynamics and microelectronics, supercomputers have even become indispensable. With them, it is possible to make dynamic simulations of mechanical structures instead of developing costly prototypes. Already in 1984, the National Council on Scientific Policy, including both unions and management as well as university presidents, pointed out that our country was lagging behind in this respect.

The other two scientific authorities, the FNRS (National Fund for Scientific Research) and the SPPS (Scientific Policy Programming Departments), chimed in with a request for the government to set up an incentive program for supercomputers.

Today, Belgium possesses only three supercomputers (vectorial computers). At the KUL, an IBM 3090-300/400; at the ULB-VUB [Free University of Brussels], a Cray X-MP-14-SE (to become operational next February); and at the Management Unit for the North Sea Mathematical Model, a CDC-Cyber ETA-10-P. the universities of Liege, Antwerp and Namur also possess so-called "powerful" computers.

The problem, however, lies not so much in how many of these supercomputers there are, as in training researchers to use them and providing communication links so that remote users may get "on line."

Already in 1984, IBM launched an inter-university network, the EARN [European Academic and Research Network] which connects European research centers to one another. The Belgian node of this network is the KUL computer. IBM is now proposing the EASI (European Academic Supercomputer Initiative) project to connect the few European and American supercomputing centers.

In Belgium, however, the project is stalled by difficulties in getting the RTT to install high-thruput communication links between users and the mainframes.

The program submitted to the government on Friday provides for the implementation of such a network. But it will take some time before it is actually started. In fact, a working group consisting of experts must submit a report in 6 months, and completion of the links between universities and supercomputers is expected to require 4 years and 200 million francs.

Meanwhile, the government would grant an immediate allocation of 50 million francs so that the 3 centers which already have these machines could invite users from other universities. It will cost an estimated 70 million francs to train and recycle the scientific personnel that will use these mainframes.

In addition, the government will provide 250 million francs to finance research programs using these supercomputers, and another 300 million francs for advanced computing research projects.

"Social" Programs

This program for aids to supercomputers is due to the government's desire to bring Belgium's scientific policy in line with that of other countries. And yesterday the Council of Ministers approved another scientific project: a social research program on aids to political decision-making: 21 projects involving all Belgian universities and covering themes dear to the current majority. A total of 82 million francs will be provided in the 1989 budget.

This research includes, in the health sector: development of medical imagery, medical consumption of senior citizens, institutional care of the elderly.

To support the policy of the future royal commissioner to immigration, research is carried out on the Belgians' opinions on immigrants and on the immigrants' opinions and expectations. As far as social security is concerned, the universities will study the "dynamics of social rehabilitation" and flexibility at the end of a professional career.

Willy Claes, minister of economic affairs, who wants to reorganize the National Institute for Statistics on sounder bases, will be able to rely on research carried out by three universities on the reform of economic, financial and social statistics.

Other studies will consider preventive detention, the evaluation of aiding research, and "affirmative action" in favor of women.

In short, as the year ends, all ministers will find in their Christmas stockings one present from the Santa-Claus ministers of scientific policies, Hugo Schiltz and Marcel Colla.

Austrian Researchers Debate Supercomputer Acquisition

36980094b Vienna DIE PRESSE in German
9 Dec 1988 Supplement p 4

[Article by Johannes Steinbach, Graz: "Who'll Get the Supercomputer? Researchers in Vienna and Laender in Tug-of-War Over Site"]

[Text] "If everyone continues to 'do his own thing,' we won't be able to make any progress at all," lamented Hans Tuppy, Minister for Science and Research,

recently following a day's worth of lectures and discussions at a conference in Graz on the subject of "Supercomputing in Austria," during which two groups of thought clearly evolved: The "Vienna Group" was opposed by specialists for the various Laender. One group wants a "central supercomputer" costing 200 million shillings (such as a Cray, for example) which would be accessible to users throughout Austria, while members of the other group have called for a decentralized arrangement comprising "several small supercomputers."

The "Viennese group"—universities together with the inter-university EDP Center (IEZ) of the Technical University of Vienna, the Academy of Sciences or the Fund for the Promotion of Scientific Research—have presented persuasive arguments in support of their point of view: Certain calculations such as the simulation of natural processes (fluid flow, vibration and chemical processes) would only be possible in Austria if a supercomputer were purchased.

The Graz and Salzburg groups remained unconvinced, because they had an even better card up their sleeve: While those in the capital city continue to long for a vector computer of this type, three mini-supercomputers were set up secretly in Western Austria within the last six months, thereby providing solutions to precisely the same problems with which researchers in Vienna had run up against a brick wall in trying to solve with existing computers: fluid flow simulations and calculations, solutions in the fields of statics and dynamics using the finite-element method, and structural analyses, to mention only a few.

"We are approaching the Cray by a factor of three," crowed Helmut List, for example, head of AVL-List, a research company in Graz and the first private company in Austria to acquire such a mini-supercomputer (a Convex C 2).

The attempt is thus being made to show that comparative numbers of megaflops (million floating-point operations per second), are misleading because the maximum capacity of the Convex C 2 with four processors is given as 200 megaflops, which would represent only one sixth of the capacity of "the smallest Cray," the Cray XMP-4 with a capacity of 1200 megaflops. "But these numbers represent only the maximum speed on the clock," counter the supporters of "smaller supercomputers."

"Economy Model" in Salzburg

These smaller computers, however, are much less expensive: Mr List, the private entrepreneur, maintains a polite silence concerning the sum invested, but Alfred Urban, the head of the Salzburg Technology Center freely quotes the cost of acquiring one: "Salzburger Hochgeschwindigkeitsrechner GmbH" [High Speed Computer Company of Salzburg], a wholly-owned subsidiary of Salzburg Technology Village forked out 17

million shillings for the computer (including peripheral equipment), so that the same computer as the one in the Graz Research Center AVL can now be installed here.

Surprisingly, the first Austrian "number cruncher" was located at a university site: A "Convex C 1" (with one tenth the computing capacity of a Cray) is being rented for four years by the Technical University of Graz at a yearly rate of two million shillings. "That is the same amount we were paying every year in maintenance costs for a 1978 Univac," explained Johann Theurl, who is the official head of the Data Processing Center at the Technical University of Graz, and acknowledged by the university as the "father of Austrian supercomputing."

What is incredible about the acquisition at the university on the Mur River is the fact that a year ago the Ministry for Science and Research was completely against it, because a concept for such vector computers had not yet been presented. The government in Vienna did not give the go-ahead to the university until the university stopped talking about a supercomputer, and began referring steadfastly to a "vector computer for training purposes."

"Our researchers must first learn about supercomputing," said Salzburg's Mr Urban, thereby lending support to his colleague Theurl in Graz. And seven companies as well as three university institutes in Upper Austria, Salzburg and Tyrol have thus banded together in support of the computer in the city of Mozart's birth. "At present, the AVL Company alone is able to take full advantage of such a computer," Urban says, paying his Styrian friends an excellent compliment.

The research think tank in Graz, AVL (with 800 employees), wants to live up to this compliment by forming a computer network comprising the Technical University of Graz and the regional Styrian research association Joanneum. After development by the association's engineers of a software package which has enjoyed immense success on the world market—"FIRE" [Flows in Reciprocating Engines] which is primarily intended to simulate flow characteristics in engines—List has now presented a list of nine further research projects totaling more than 30 man-years: In cooperation with institutes at the Technical University, simulation models are to be designed for secondary flow characteristics, knocking

behavior, soot formation, component strength, as well as for dynamic imaging processes such as retarded ignition and cylinder-wall turbulence.

For these projects, List would make available roughly half of the needed research capacity, and—for the first time in Europe—would establish a computer network between his computer center and the facilities of the University. In accordance with FDDI Standards, the fiber-optic cables would be designed from the very start to handle the extremely high data transmission rate of 100 megabits per second. Although such cables cost a good hundred shillings per meter, it would be substantially less expensive than a link to a supercomputer in Vienna; according to most recent calculations by the federal post office, the yearly rent for a two-megabit point-to-point line from Graz or Salzburg to Vienna would be 2-2.5 million shillings. And this type of line cannot be used for graphics transmissions.

This amount corresponds not only to the rental cost paid by the Technical University of Graz for its Convex, but also to the value of the "Titan" mini-supercomputer in the four-processor version currently being marketed by Convex-competitor Ardent. EDP Center head Theurl sees the most important difference between this and other computers in the fact that the Ardent Titan is also graphics-capable, but operates otherwise at the same speed. This fact is also supposed to have impressed Science and Research Minister Tuppy as he observed a flow simulation program in Graz: A majestic flag fluttered on-screen according to the input wind direction until torn from its staff by a (programmed) storm.

A working group formed at the conclusion of the conference is to develop a concept for the participation of Austria in supercomputing. Tuppy explained to journalists that a special supercomputing budget could be set up in Austria which, in monetary terms, could rival the Swiss example of approximately 1.5 billion shillings (within five years). However, skeptics in the west are fearful that, as prices rapidly drop, the money could be wasted on an expensive "Austrian super solution" which they could not use. The acquisition of an IBM 3090/400—with a list price of more than 100 million shillings—which is expected to take place this year at the University of Vienna, is not even being included in the discussion, as it is not considered a vector computer.

COMPUTERS

GDR's ROBOTRON A5015 Computer Described *23020034 East Berlin MIKROPROZESSORTECHNIK in German No 10, 1988 pp 292-293*

[Article by Drs Gert Keller and Gunter Kleinmichel from Otto Schoen Robotron Electronics Testing VEB, Dresden: "Robotron A5105 Teaching Computer"]

[Text] At the Otto Schoen Robotron Electronics Testing VEB in Dresden, the development of the new Robotron A 5105 teaching computer has been concluded. The first model of this powerful tool is now being made available to the educational system for tryout.

The development of the teaching computer (BIC) became necessary, since the small computers of the KC 85 and KC 87 series available until now (also see inner cover page 4) only partially meet the demands for adequate and modern education. These computers were originally conceived for other main application areas.

In the BIC, the foundation will be created for a uniform teaching base in the field of information, both in the general education schools, the expanded secondary schools and in the special schools, as well as in the various educational facilities for vocational training.

Pedagogical-Technical Demands on the BIC

Based on the central education goals of

- Formation of an understanding in principle of how a computer operates
- Imparting the basic knowledge of programming
- Learning safe handling of standard user software

The pedagogical-technical requirements of the teaching computer were worked out with the Ministry for Public Education, the State Secretariat for Vocational Training, the Otto Schoen Robotron Electronics Testing VEB, Dresden, and the following points of emphasis:

Construction

- The construction should be robust but well-designed and meet the valid ergonomic demands (keyboard height, viewing distance).
- Due to the limited space for storage, a 31-cm picture tube (black-white or color) is necessary.
- A modern computer keyboard should be used.

Software

- Make available a modern version of BASIC that corresponds with international trends for the basic training and support of user-friendly graphics by means of this BASIC
- The opportunity to process SCP standard software for

the PC 1715, meaning compatibility relative to system interfaces and the diskette format of this computer.

Hardware

- Support the ability to run the software necessary for the required ROM and RAM memory areas
- Support a powerful video version for text and graphics corresponding with common standards (in color as well), among others the important 25 line x 80 line format for SCP software
- Integration of a 5.25-inch diskette drive
- Offer numerous interfaces to assure varied and flexible training; connection possibilities (for printer, plotter, students' experimental equipment, additional color television unit, magnetic cassette tape, joy stick and various modules
- Interlinking capability for computer cabinets.

Detail Data

- Umlauts in the standard character set and on the keyboard
- Programmable character set, also for quasi-graphics
- Programmable function keys
- Acceptance of proven operating instructions from the HC-BASIC of the KC 85/1 into the BASIC of the BIC, such as WINDOW and PAUSE
- Connection possibility for television units, which already exist in the schools.

In accordance with the established upper price limit, it was agreed to build the teaching computer on the basis of the 8-bit integrated circuit family of the U 880.

Brief Description of Development Results for the Teaching Computer

Hardware and Construction

The BIC consists of the three equipment components: Basic computer unit (CGG), Diskette drive unit (DSE), Monitor (MON)

which have a mechanically fixed connection with another. The CGG contains, under a standard computer keyboard, a printed circuit board with the component groups processor, main, video and program memories, BUS and memory control, video output and cassette interface. In addition to a bus interface there is a special module slot and connections for two joysticks and a magnetic tape unit; two plug-in connectors are included for coupling the CGG to the DSE.

The DSE contains the power supply component group for the BIC, a 1.6 diskette drive and numerous interface selection slots, for example serial and parallel data exits for the connection of printer, plotter and students' experimental equipment, local power connections and connections for a variety of video output equipment.

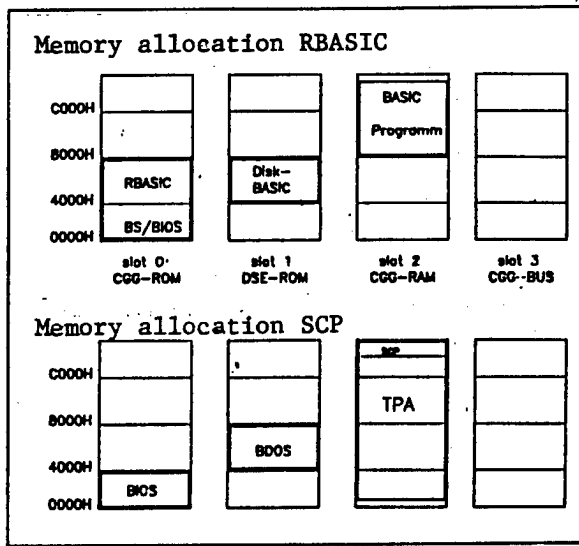

Figure 1. Memory allocations for the A 5105 for RBASIC and SCP.

The monitor includes a monochrome 12-inch picture tube and is mounted on the DSE so that it can be turned and swivelled. The basis of the processor unit is the 8-bit CPU printed circuit U 880 of the 4-MHz product line. The internal equipment bus is, as for the small robotron computers, electrically, and in design, largely compatible with the K-1520 bus and designed both for the module slot of the CGG and for a bus coaxial connector (on the back side of the DSE). The bus is completely operated and short circuit-proof.

The memory configuration consists of a 64-Kbyte main memory, 64 K x 16 bit video memory and at least 48 Kbytes of program memory. The addressable memory space can be expanded by means of a four-time SLOT case shift to 256 Kbytes. The arrangement within these 4 areas, to 64 Kbytes each, is shown in Figure 1. The memory control as well as an audio generator, keyboard control and address decoding for the E/A ports are realized in an application-specific integrated circuit (ASIC).

For the video output unit, the U 82720 graphics display controller and an additional application-specific integrated circuit are employed. With that, it is possible to get high-capacity graphics representation with up to 16 colors per pixel. This color representation is, of course, only usable with alternative or additional connection of a color monitor or a color television unit with RGB signal entry. The required signal exits are present on the DSE.

The controlling assembly for a maximum of 3 drive assemblies is set up with the U 8272 floppy disk controller, whereby the DSE has a connection for two additional external drive assemblies. The power supply unit is

designed as a component of the switching network and delivers, in addition to the necessary supply voltages of +5 V, +12 V and -12 V, a reserve for the user of about 1 A with +5 V.

Software

In accordance with the very different input requirements, two operating systems are being readied for the teaching computer, both of which work with the diskette and data formats normal for the SCP.

RBASIC Operating System

The RBASIC operating system is contained in 48 Kbytes ROM of the computer and, in addition to numerous driver programs usable in the SCP as well (for keyboard, video output, interfaces), offers a high-capacity BASIC interpreter.

In RBASIC about 150 BASIC commands, statements and functions are available, which are compatible in syntax and mode of operation with those of the BASIC for the robotron EC 1834 personal computer.

Some of the characteristics of the RBASIC:

- SCREEN editor
- WINDOW statement for text and graphics
- 3 number formats (maximum 12 positions of accuracy)
- Support of various video formats

Text: 25 x 40 and 25 x 80 characters (each character 16 colors).

Graphics: 320 x 200 and 640 x 200 points (each point 4 out of 16 colors) 320 x 200 points (each point 16 colors)

The architecture of the video memory can be found in Figure 2.

- Work with up to 16 text and 6 graphics images
- Work with sequential data sets (diskette and cassette)
- Work with access files (diskette)
- Commands for file management on diskette
- Hard copy program for text and graphics integrated.

SCPX 5105 Operating System

The SCPX 5105 operating system works in the 64-Kbyte RAM area of the computer. It is totally compatible with the SCPC 1715 of the Robotron 1715 personal computer widely used in the GDR, so that all user programs which contain the operating system interfaces of the Robotron 1715 can also run on the Robotron A 5015 teaching computer.

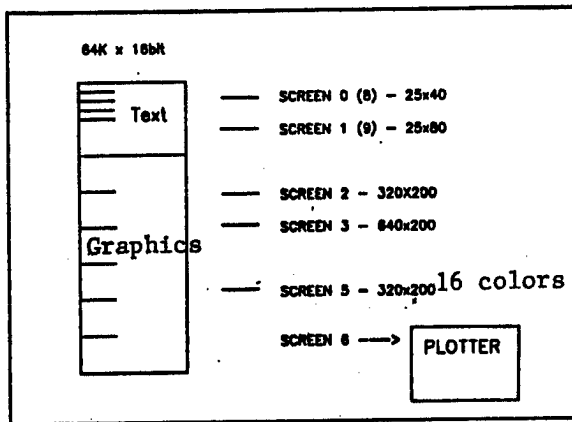

Figure 2. Video memory and SCREENS.

Special characteristics of the SCPX 5105 are:

- TPA [transient program area] greater than 48 Kbytes
- Preferably supported by the 25 x 80 character video format
- Special utility program for rational copying of files with only one diskette drive
- Possibility of using BIOS calls from RBASIC (for instance for graphics routines in PASCAL).

Particular Development Features

The goal in developing the order from the educational authorities was to achieve the clearly demanded high performance parameters while staying within the given economic conditions. In so doing, fulfillment of the requirement program could only be assured by using the most modern components available and implementing the most rational manufacturing technologies, even though it was often necessary to enter new technological territory, and above-average costs were necessary in the manufacturing preparations. Because of the parallel process of equipment development and development of application-specific integrated circuits, the work was combined with a high degree of risk.

With the placement technology for add-on components, the digital in-circuit test as the principal testing method and the use of all-plastic housing, the foundation is laid for a rational production in large quantities.

In designing the software, the education authorities' basic demand had to be taken into account, that in software design and operating philosophy the BIC should demonstrate a high degree of compatibility with the computers, which the student will encounter in his practical professional life.

Important Technical Data

| | |
|---|--|
| Processor: | UA 880 D |
| Video controller: | U 82720 |
| Floppy Disk Controller: | U 8272 |
| Clock frequency: | 3.75 MHz |
| Memory capacity: | 48 (or 64) Kbytes ROM with BASIC operating system, floppy disk drive and systems programs 64 Kbytes RAM main user memory 64 K x 16 bit RAM video memory |
| Mass storage: | 5 ¼ inch diskette Magnetic cassette tape (with motor current switch) |
| Keyboard: | Flat computer keyboard (8-bit character set) |
| Video output: | 12-inch monitor, monochrome or black-white television via high-frequency modulator or color monitor and color television via RGB output |
| Image structure: | <i>Alphanumeric output with</i> 25 lines x 40 lines 25 lines x 80 lines 16 basic foreground, 8 basic background colors <i>Graphics output with</i> 320 x 200 image dots in 4 out of 16 colors 640 x 200 image dots in 4 out of 16 colors 320 x 200 image dots with 16 colors per dot 3 channels, 8 octaves through audio output |
| Audio output | |
| Additional external connections: | -Module plug-in -Bus connection -V.24 printer interface (nondirectional) -V.24 plotter interface (bidirectional) -2 x 8-bit parallel interface (for connecting students' experimental equipment and programmable as Centronics interface) -Power connection for hooking up computer networks (ROLANET compatible) -2 joystick connections -Connection for auxiliary diskette equipment (maximum 2 drives) |

Important Technical Data

| | |
|---------------------------------|---|
| Software: | RBASIC in ROM (48 Kbyte) -SCREEN editor -14-place calculating accuracy -User-friendly graphics instructions -Sequential and direct access files on diskette SCPX5105 as RAM operating System -Fully compatible with the SCP of the PC 1715 robotron -Systems diskette with important service programs -Diskette and file formats identical for both systems |
| Measurements: (WxDxH) | Basic computer equipment: 390mm x 220mm x 50mm Disk drive unit: 390mm x 400mm x 135mm Monitor: 340mm x 325mm x 260mm |
| Weight: | Total of 23 kg |

GDR's KC 85/4 Small Computer Enters Serial Production

23020042 East Berlin RECHENTECHNIK-DATENVERARBEITUNG in German No 1, 1989 p 2

[Article: "GDR's KC 85/4 Small Computer Enters Serial Production"]

[Text] East Germany's upgraded KC 85/4 small computer has gone into serial production at the VEB Microelectronics "Wilhelm Pieck" in Muehlhausen. The new computer has nearly four times the memory capacity of its predecessor. Other advantages for the user include an expanded refresh memory as well as improved graphics capabilities. The applications spectrum of the small computer, designed for the efficient execution of engineering and managerial tasks as well as for training and further education, will thus be correspondingly expanded.

Romanian Computer Technology, Competitiveness Noted

AU1002102889 Bucharest AGERPRES in English 0954 GMT 10 Feb 89

[Text] Bucharest AGERPRES 10/2/1989—Large-memory computers Felix 5000 have been developed by Bucharest's computer enterprise for use in great economic units where big databases are required to meet the growing demand for information in the Romanian economy and on world markets. Also of Romanian design are the high-speed and easy-of-access memory Coral and Independent computer families. Coral 4021 and Coral 8730, and Independent f/4m and Independent 106 are modern compact modular equipment that can give simultaneous access to up to 16 independent users. And so are the high-performance microcomputers m 118, cd 80, cub 7z, hc 85, cce, the spot 83 industrial process computer and the IBM compatible Felix pc personal computer, complete with alpha-numeric and graphic

videoterminals vdt 52 sa, vdt 52 sb, vdt 232, vdt 125, etc. Miniaturization and lower costs per microprocessor and their circuitry have ended up in thousands of microprocessors incorporated in one computer and in the steady diversification of their applications. So, for instance, computer assisted design, computer assisted manufacture and computer assisted engineering systems are used in research and design activities.

That production renewal has been in the focus of the Bucharest enterprise shows in its over 80 percent new product index in 1988. ICE [Electronic Computer Enterprise] Bucharest has improved also its exporter status, with foreign deliveries rising 32.2 percent in 1988 from 1987.

Hungary: VIDEOTON's New VT 32 Microcomputer Introduced

23020037 East Berlin MIKROPROZESSORTECHNIK in German No 11, 1988 p 354

[Text] The VT 32 is a 16-bit microcomputer of modern architecture manufactured by the Hungarian VIDEOTON Enterprise. The VT 32 is equipped with a 32-bit system bus. The computer system is specifically characterized by:

- Modular construction permitting the interconnection of different mutually compatible computers. That is, separate computers with one or several workplaces, work stations forming part of a computer system, or server station can be built up.
- An expandability permitting adaptation to the existing range of tasks.

Technical Structure

Three different modules can be distinguished: the processor module, the memory module and the interface modules. The modules are as independent of one another as possible. Most of them can carry out several

functions simultaneously. They communicate with one another via the system bus, in accordance with the subordination principle (asynchronously). The powerful VME bus was chosen as the system bus.

Four priority levels make possible concurrent use of the bus by the modules. Buffered peripheral devices or devices with variable speeds are linked together by low-priority interfaces. Data with bit lengths of 8, 16 or 32 bits can be transmitted via the system bus so that the data width can change dynamically, in keeping with the bus cycle. The address space of the bus is 16 Mbytes.

The processor module has a branch bus, the so-called local bus, with 16 data and 24 address channels. Data traffic can flow through this bus in a manner parallel to the data traffic of the system bus. The local bus and the processor interface also make possible the interconnection of a cache memory unit.

Processor Module

The processor module has the following functional units:

- A central processing unit: 16-bit external interface, 32-bit internal organization, 16 Mbyte directly accessible address space, 14 address types, 56 types of commands with numerous variants, 5 data types (bit, byte, word, double, word, BCD) as well as a memory-mapped I/O;
- Memory organization unit: enables the processor to transform addresses, allows protection of the memory segments and the separation of the command and data fields. The parameters of 32 memory segments are thereby supported. The size of a segment may vary between 256 bytes and 16Mbytes;
- Internal memory (EPROM/RAM) for the load, test, system initiation and diagnostic programs;
- A 24-bit programmable counter/clock;
- Two sequential interfaces (CCITT V.24) for terminal connection, for the connection of printers with sequential interfaces or for the connection of a host [computer]. The transfer rate is programmable in the range from 50-19,200 bits/sec;
- Programmable parallel interface. In the basic configuration, there is a CENTRONICS interface to the printer;
- System bus interface and control for ensuring a standard VME bus;
- Internal local bus interface and control.

Memory Module

The system contains a dynamic memory module equipped with priority protect. The capacity of a module is 512 Kbytes. The address space of the system is 16 Mbytes. However, the present configuration (the number of plug-in circuit card slots, current supply capacity) reduces the physical memory capacity to 2 Mbytes, that is, four modules.

The memory module has 32-bit internal file organization such that 8-, 16- or 32-bit files can be transmitted via the system bus. That means that interfaces with faster direct memory access can use the 32 bits of the bus, thereby substantially reducing the bus load. The read time of the memory is 400 ns; the write time is 370 ns. The circuits of the memory module can also be powered by a storage battery.

External Memory Interface Card

This unit makes possible the interconnection of two diskette units (SA460/SA850) and four fixed disks (ST506/ST412), via the standard peripheral interface.

Communications Module

The communications module supports four independent channels. They can be used alternatively by making use of asynchronous, byte-synchronous (BSC) or bit-synchronous (SLDC/HDLS) protocols. The transfer rate is programmable by individual channel.

Graphics Subsystem

The graphics subsystem is provided by a pair of modules (control module and memory module) connected to the VME bus. The primary task of this subsystem is quick execution of two-dimensional graphical operations and the support of peripheral devices.

For the graphics subsystem, a 19" color monitor with a resolution of 1024 x 768 pixels is used. The number of colors that can be represented depends upon the number of graphics modules.

| | |
|----------------|--------------------|
| 1 memory unit | 16 of 4096 colors |
| 2 memory units | 256 of 4096 colors |
| 3 memory units | 4096 colors |

Some of this subsystem's typical performance characteristics are:

| | |
|---|---------------------|
| Drawing rate of vectors | Mpixel/sec |
| Filling in of areas and logical raster operations | 256Mbit/sec |
| Rate at which characters are drawn | 3000 characters/sec |

Device Interface

The device interface contains the necessary technical means for controlling the parallel IEEE-488 (GBIP) bus.

Local Network Interface

This unit permits the interconnection of several VT 32s over relatively short ranges (around 1 km) in the local network. The physical connection and data exchange are effected in accordance with ETHERNET specifications.

Further Development of Modules

The system's selection of modules is being continually developed. Of the modules currently under development, the control unit which is connectable to the system bus (graphics processor and bit-map memory) is worthy of note. It is suitable for controlling black and white and color monitors with different resolutions and graphic input devices.

Peripheral Devices

The standard VT 32 configuration includes:

- 2 to 6 alphanumeric or graphic terminals with average resolution;
- A 720 Kbyte minidiskette unit (5.25") and a 20-40 Kbyte 5.25" fixed disk unit (in the basic configuration, a maximum of 2 diskettes and two fixed disk units can be accommodated);
- Matrix printer (120 characters/sec) or chain printer (300, 600 or 900 lines/min).

Software

Operating System

The VT 32 computer operates with the DMOS multiuser operating system which is UNIX-compatible.

Languages

The majority of the system programs as well as the operating system are written in C. Apart from C, compilers for ASSEMBLER, FORTRAN 77, COBOL Level II and PASCAL (ISO) are also available.

Communications Software

The available communications software can accommodate the following:

- Asynchronous connections with:
 - uucp (UNIX to UNIX copy) between two VT 32s;
 - KERMIT: between a VT 32 and an R 11; between a VT 32 and a PC
- Synchronous connections to:
 - An IBM 2780 (BSC) emulator
 - An IBM 3274 (BSC, SDLC) emulator
- Local network configurations:
 - EXLOC 4.1 (VT 32 - VT 32)
 - EXLOC 4.2 (VT 32 - VT 11)

CRT-oriented Editor

Initially, the editor represents a means for program modification; however, it is also suitable for the simpler text preparation tasks, making use of CRT operational capabilities.

Pixel Manager - Pixman

Pixman (Pixel Manager) is a program package stored in the EPROM of the graphics subsystem. Higher level interfaces (i.e., CGI, GKS) expand upon the services offered by the Pixman. The program contains over 200 functions.

FACTORY AUTOMATION, ROBOTICS

Development of CEMA Machine Tool Industry Reviewed

23020022 East Berlin FERTIGUNGSTECHNIK UND BETRIEB in German No 10, 1988 pp 582-584

[Article by Dr R. Wengermeier, Academy of Social Sciences of the Central Committee of the SED, Berlin: "Development of the Machine Tool Industry in CEMA Countries"]

[Text]

Introduction

At the Leipzig spring fair 1988, one of the product lines extensively offered by all European CEMA member countries was flexible machine tool manufacturing technology.

The success in this key machine construction industry is evidenced by the fact that the machine tool factory Auerbach, for instance, was honored with a gold medal for the manufacturing cell FC 400 K/2.6, the Moscow machine tool enterprise "Red Proletarian" for a CNC lathe equipped with diamond tools or the CSSR enterprise TOS Trencin for a universally usable CNC lathe. The orientation of countries towards rapid increase in the efficiency of the machine tool industry has good reasons:

First, machine tool construction acts as a catalyst for the broad application of key technologies (such as flexible automation, new machining methods) in overall machine construction.

Second, modern machine tools have a considerable effect on the transition to an intensively expanded reproduction in the machine tool industry. The technical and economic levels of the machine tools largely affect the manufacturing time, material and energy required, as well as the quality and the technical level of the machine construction products.

Third, the machine tool industry plays an important role for increasing the export ability of the European CEMA member countries (as a separate export branch as well as an influencing factor for the ability of machine construction products to compete on the world market).

The role of the machine tool industry confirms a statement by Marx which goes back over a hundred years that machines are the most powerful means for increasing labor productivity.

New Quality Requirements

The necessary transition to an intensive expansion of reproduction and its long-term implementation, the new phase of the scientific-technical revolution and the escalating competition with imperialism in the technological area result in new and complicated quality requirements for the machine tool industry of the European CEMA countries.

These are related primarily to mastering complex renovation processes for products and technologies in machine construction. The radical change occurring in the technological level of machinery production is directed in the long run towards shaping a new type of technology—the automated, programmable, and flexibly usable work means—and the development of a new social mode of operation—the complex, automated production. This results in a new potential for making technology more efficient.

QD-The combination of process technology and modern information technology based on microelectronics and other technical innovations which is characteristic of the new type of technology allows time savings in all economic processes of machinery production, and an acceleration of the economic cycle from order receipt to product delivery. Implementing this potential for efficiency involves new requirements regarding the development of the material-technical basis and organizing the division of labor process in the machine tool industry.

These new requirements involve first of all an increase in production and broad application of automated, programmable and flexibly usable manufacturing technology such as NC-machines, machining centers, flexible manufacturing cells, sections and systems, industrial robots as well as software. For the next 10 to 15 years, the European CEMA countries will focus on the close integration of conventional process technology and modern information technology in the product and of conventional and modern manufacturing technology in a uniform technological process.

A second requirement is the qualitative change of the division of labor process for developing, producing and effectively using modern manufacturing technology with the following priorities:

- increasingly complex product and performance structure of the machine tool manufacturers while consistently integrating electronic (including microelectronic) and software development and production into the performance profile;

- more effective organization of technological cycles which are relatively closed and oriented towards the final product including important suppliers, manufacturers and users of manufacturing technology; and
- closer linkage between the elements of the renewal cycle consisting of science - technology - production - sale.

A third requirement is the perfection of the planned management of all complex interrelationships associated with developing the performance of the machine tool industry in the reproduction process of the national economy. Such interrelationships which have to be planned and directed include, for instance, the proportional development of production of supplies, the expansion of projection, construction and technology capacities in various branches to master CIM-related high technologies, perfection of the production technology used by new equipment and modernization, adjustment of broad social areas (such as education, communication, transport) to the requirements regarding the production of modern technology, etc.

Performance Status of the Machine Tool Industry

The extent to which the present performance of the machine tool industry in the European CEMA member countries meets the new requirements varies greatly. An international comparison between the production and export structures of the machine tool industry shows both positive results of the countries as well as a number of problems which still need to be solved.

In the seventies, all seven European CEMA countries started the development and production of NC machine tools, NC and CNC controls for machine tools and industrial robots, machining centers, etc. and have expanded them considerably since then. The first samples of flexible manufacturing systems including the related system components were developed and tested. In this context, the top performances of a number of automation solutions in the GDR are particularly noteworthy. This involves among others the automated finishing of side walls for printers in the VEP Printer Plant Planeta Radebeul, the Automated Flexible Manufacturing System MS 2000 which requires very few operators and is used for machining prismatic large machine tool parts in the VEB Machine Factory Meuselwitz or the automated manufacturing plant for producing sewing machine stepper motors in the VEB Elmo Dessau. The USSR already produces certain flexible manufacturing systems in series (e.g. in 1986, the machine tool production association Iwanowo produced 20 units of the FMS "Talka 500"). The CSSR and the People's Republic of Bulgaria are also able to manufacture and deliver flexible manufacturing systems. Of the more than 1,000 FMSs used worldwide in 1986, the socialist countries accounted for about half of them (of those 400 are used in the USSR alone).

For performance characteristics such as the production of NC cutting machine tools per 100,000 inhabitants and the use of industrial robots per 100,000 inhabitants a few socialist countries have reached a level which is comparable to that of such developed capitalistic countries as the U.S., Great Britain, France, or Italy. (See tables 1 and 2).

Table 1. Production of NC Cutting Machine Tools Per 100,000 Inhabitants - number of units -

| Country | 1970 | 1980 | 1985 |
|-------------------------------|------|------|------------|
| People's Republic of Bulgaria | | 3.4 | 5.8 |
| Hungarian People's Republic | 3.2 | 5.3 | |
| GDR | 2.0 | 5.1 | 7.7 |
| Polish People's Republic | 0.04 | .9 | .9 |
| USSR | .7 | 3.3 | 6.4 |
| CSSR | .2 | 4.2 | 5.2 |
| FRG | 1.3 | 7.9 | 16.8(1984) |
| Japan | 1.4 | 18.9 | 37.2 |
| USA | .9 | 3.9 | 2.2 |
| France | .3 | 2.0 | 2.5 |
| Great Britain | .6 | 1.5 | 2.9 |

Calculations based on:

-The National Economy of the CEMA Member Countries in 1986, Moscow 1987 (Russian).

-Economic Handbook of the Machine Tool Industry 1986..87, National Association of Machine Tool Manufacturers of the U.S., West Park Drive, Mc Lean, 1986 (English).

-The Economy of Capitalistic Countries in Figures, IPW-Research Center 1/1987, Berlin 1987.

Table 2. Industrial Robots (1) in the National Economy - in units per 100,000 inhabitants.

| Country | 1985 | 1986 |
|-------------------------------|------|------|
| People's Republic of Bulgaria | 8 | 12 |
| Hungarian People's Republic | 4 | 4 |
| Polish People's Republic | 3 | |
| USSR | 12 | 16 |
| CSSR | 4 | 4 |
| FRG | 15 | 21 |
| Japan | 54 | 74 |
| USA | 8.5 | 11 |
| Italy | 5 | 6 |

1) Excluding fixed-programmed manipulators some of the data for the individual countries are estimates based on production and usage figures for the respective years.

However, in the majority of the European CEMA countries the results achieved so far are only a starting point for the required increase in the quality level of machine tool construction performance. The USSR, the People's Republic of Bulgaria, CSSR, the People's Republic of Poland and the Socialist Republic Rumania have not yet been able to reach beyond "insular solutions" for mastering the modern methods and technology for a broader machine tool application. The quality of NC control

systems, the production of industrial robots of higher generations, the complexity and the automation level of existing FMSs, the production of finishing modules and peripheral devices for automation solutions still lag considerably behind the international top level. This means relatively low kilogram yields of these socialist countries in the export of machine tools to the capitalistic industrial countries and considerable productivity disadvantages of the machine tool industry compared with developed capitalistic countries. In the CEMA countries mentioned, these problems are primarily due to the orientation of the machine tool industry towards the requirements of an extensively expanded reproduction which prevailed until the late eighties, i.e. an orientation towards predominantly quantitative goals in the production of conventional technology.

Efforts Primarily Directed Towards Closer Ties Between Science and Production

In their long-term economic strategy, the sister parties of the European CEMA countries intend to achieve a qualitative reorganization of the product and performance structure as well as production technologies in the machine tool and machine industries. Here, the basic problem of the machine tool industry is the need to meet new quality requirements in the gradual shaping of computer-integrated manufacture (CIM) on the one hand, and on the other hand to solve current problems related to removing existing deficiencies and the causes of the relatively low productivity. In addition to the GDR the USSR, CSSR and the People's Republic of Bulgaria and the Hungarian People's Republic have developed concepts for implementing CIM solutions. In the CSSR, a sample of a CIM solution was established for testing purposes at the research institute for the management of the scientific-technical development in general machine construction (VUSTE). In 1985, the test operation of a complex automated facility with small series production was started (TOS Hostivar Prag, manufacture of grinding machines).

Countries such as the USSR and the People's Republic of Bulgaria on the other hand did not start the organization of a quality control program (official government product acceptance) and an effective customer service in the machine construction industry until 1986/87.

In the European CEMA countries, this two-fold basic problem can best be solved by developing a new quality in the division of labor as it relates to the development and production of modern manufacturing technology and the utilization of its efficiency potential by using it throughout the national economy or for profitable exports. To this end, first of all measures for the organic coordination of science and production are taken, particularly by organizing relatively closed reproduction processes in the economic units of the machine tool industry. The intent is to shorten the research, development and transition time considerably and to produce a much larger portion of world-class products.

In these countries, science, technology, production and sales are integrated in different ways depending on their specific situation. In the USSR, for instance, scientific-technical complexes are formed between individual branches in important areas of technical progress (so far a total of more than 20). Of these, "Increased Machine Reliability", "Robot", "Rotor", "Technological Laser", as well as "Powder Metallurgy", "Electronic Welding", and "Fiber Optics Technology" directly affect machine tool construction. The complex "Robot" illustrates how they work. In this case, the Ministry for Machine Tool Construction and the Machine Tool Industry with the Research Institute for Cutting Machine Tools ENIMS is the controlling body and has the main responsibility. Members of this complex are the Ukrainian Research Institute for Machine Tools and Tools, machine tool factories in Moscow, Muskatshevo and Sterlimatek, the Institute of the Academy of Sciences of the USSR as well as institutions of the ministries for device construction, automation means, open- and closed-loop control technology, electronic industry, heavy and transport machine construction, automobile industry and universities. "Robot" is responsible for doing research, designing and testing as well as producing robot technology prototypes, for small-series production and testing including preparation of user requirements.

In the People's Republic of Bulgaria "prioritized structural complexes" were established which are intended to solve focused technological tasks comprising several branches. The first of these structural complexes contains electric engineering/electronics, robotics and the production of metal finishing machines. The association "Electronics" established in January 1987 comprises all crucial projection, design, technology, and production capacities of the national economy, which are to ensure the long-term switch to electronics and the complex automation of production and control. This association is a self-governing economic group of economic associations and scientific institutions and has the task of implementing a uniform technology, investment and market policy in this area.

In the CSSR, machine tool construction is largely represented by the concern TST Prague whose product line is an approximate combination of the products of the combines FHK, SOB and WKS. In 1986, this concern (with almost 50,000 workers) included 19 production facilities, 2 research institutes (VUOSO) for cutting tools and VUNAR for tools, a projecting operation (INPRO) as well as a marketing organization (OSAN). Each facility has its own research and development capacities in addition to the research institutes.

In the European CEMA countries, the measures for a closer integration of science and production are accompanied by multiple efforts towards a centralized production of modules and components with similar design and technology, towards establishing a system of contractors and subcontractors for setting up and starting complex machinery systems, to increase the quality level of the

production technology used and above all for increasing the abilities, skills and qualification levels of the machine tool builders and creating better conditions for their creative work.

For the majority of the European CEMA countries, ensuring a performance development in machine tool construction which will make it more intensive is a complex and long-term process which these countries have just started.

New Level of International Socialist Cooperation

In all CEMA countries, an essential source of growth in machine tool construction is the more efficient organization of the international socialist division of labor. Based on common goals and a common concept for mastering key technologies—as it is laid down particularly in the complex program of the scientific-technical progress of the CEMA member countries until the year 2000 of December 1985—all CEMA countries strive towards achieving top performances in the main areas of the scientific-technical progress. This is also the purpose of common measures, coordinated within CEMA, such as implementation of the "General Agreement on Multilateral Cooperation in the Development and Organization of the Specialized and Cooperating Production of Flexible Manufacturing Systems for Machine Construction and their Broad-Based Introduction into the National Economy" of 27 Jun 1985. On the basis of the general agreement, more than 400 ministries, enterprises and organizations from 8 CEMA countries and the Socialist Federative Republic of Yugoslavia work together to jointly ensure the development and production of standardized components of FMSs as well as complete FMS's and their mutual delivery. The major portion of these systems and components developed as part of this cooperation will go into production in the nineties. However, in the period 1986 to 1990, first results have been and are being obtained in the implementation of the general agreement. Based on 15 branch programs for scientific-technical cooperation, approximately 450 different types of FMSs, manufacturing modules and finishing products are to be developed, and production of about 350 types is to be started. The present plan is to mutually deliver a total of 240 systems, 520 modules and 10,000 units by 1990.

At the same time, important work was carried out in the past three years, in particular within the framework of the coordinating council for the general agreement regarding FMSs and industrial robots, to develop a theoretical and conceptual agreement on methods of computer-integrated manufacturing among the CEMA countries. These efforts are intended to standardize the technical development of FMSs and CIM solutions in the countries. During future implementation of the General Agreement on FMSs and Industrial Robots additional efficiency reserves will be opened up even more for the specific organization of the international socialist division of labor in CEMA. These include among others

better coordination of work on FMSs and industrial robots with the efforts regarding computer technology and CAD/CAM systems, increased concentration of joint efforts on the development and production of software, accelerating the preparation and conclusion of mutual economic agreements through direct cooperation of economic units of the countries as well as continued concentration of efforts on key areas.

Conclusion

The European CEMA member countries make great efforts to dynamically increase the efficiency of the machine tool industry as a crucial producer of means for increasing machine construction efficiency as a whole. It is measured against the requirements related to the transition to an intensively expanded reproduction and its permanent organization and against the international advance of technical progress. To be able to better meet the resulting new quality requirements the socialist countries concentrate on more effectively organizing the mutual division of labor for developing, producing and efficiently using flexible manufacturing technology both within their own economies and among them within CEMA and on perfecting the production technology used in machine tool construction itself.

Flexible Manufacturing Systems in GDR

Precision Machining, Machining Cells

23020014 East Berlin FERTIGUNGSTECHNIK UND BETRIEB in German No 9, 1988, pp 521-524

[Article by Engineer J. Krausz, Chamber of Technology member, with the Karl-Marx-Stadt Research Center for Industrial Machinery Construction in the "Fritz Heckert" Industrial Machinery Combine VEB, and Engineer G. Fleischer, Chamber of Technology member, with the Dresden Niles Servo Drives VEB, in the Berlin "7 October" Industrial Machinery Combine VEB: "Precision Turning in Flexible Manufacturing Systems and Machining Cells"]

[Text]

0. Introduction

An important basis for automated manufacturing in Flexible Manufacturing Systems (FMS) is a highly efficient, quality-oriented, and operationally reliable technological process. In such a process, the cutting tools used take on an even greater significance in terms of their design, cutting material, cutting-edge construction, and tool preparation. In order to economically utilize cost-intensive FMS's the tools must achieve the shortest possible output times with high operational reliability and with finished workpieces of the requisite quality.

The tools should be rapidly changeable and available to an adequate extent. To avoid downtimes, these must be replaced in a timely way—that is, before the end of the tool life.

To that end, workpiece-related outputs per sharpening should be determined; these become a component of the NC turning programs. Moreover, parameters should be stipulated for cutting-edge wear, and also for built-up edges in the case of aluminum precision machining.

In the FMS F/W 250—manufactured by the Berlin "7 October" Industrial Machinery Combine—machining cells FC DFS 2 and FC DFS 2/2 are used for the manufacturing of engine parts from aluminum GD- AlSi10Mg , G- AlSiCu1 , and gray cast iron GGL 15. These cells are manufactured by the Karl-Marx-Stadt "8 May" Heavy-duty Lathe Construction VEB in the Berlin "7 October" Industrial Machinery Combine VEB.

The parts to be machined are primarily flange-shaped, with the range of diameters being 60 to 250 mm and with lengths from 10 to 290 mm. Generally 200 to 300 workpieces are machined in each production run.

1. Cutting-edge Geometries, Constructions, and Cutting Materials

In the above-mentioned FMS a complete adaptation of the tools to the job task is necessary. Peak values with respect to productivity, quality, and operational reliability were achieved through tool studies whose results determined the cutting-edge geometries, the cutting-edge constructions, and the selection of cutting materials. Because of the requisite precision machining (workpiece tolerance IT 7 and surface roughness $R_z = 6.3$ and 10 μm) the points of main concern in the studies were the turning of aluminum and gray cast iron.

1.1. Turning of Aluminum

In the turn-machining of aluminum the design and construction of the tools used are not always in line with the international state of the art. Often tools are used that do not allow for the specific cutting conditions of the machined materials and lead to an unsatisfactory constancy of fit and surface quality.

As a result of the tool studies, this FMS uses carbide-alloy cutting-edge constructions, press-worked and rounded for rough-machining and finely ground or lapped for finish-turning. In order to diminish the formation of built-up edges in finish machining the primary cutting edges must be very cleanly made (with surface roughness $R_z = 1.2 \mu\text{m}$ and average edge notchiness = 3.2 μm). These values can be achieved only by using an absolutely working-sharp diamond abrasive wheel.

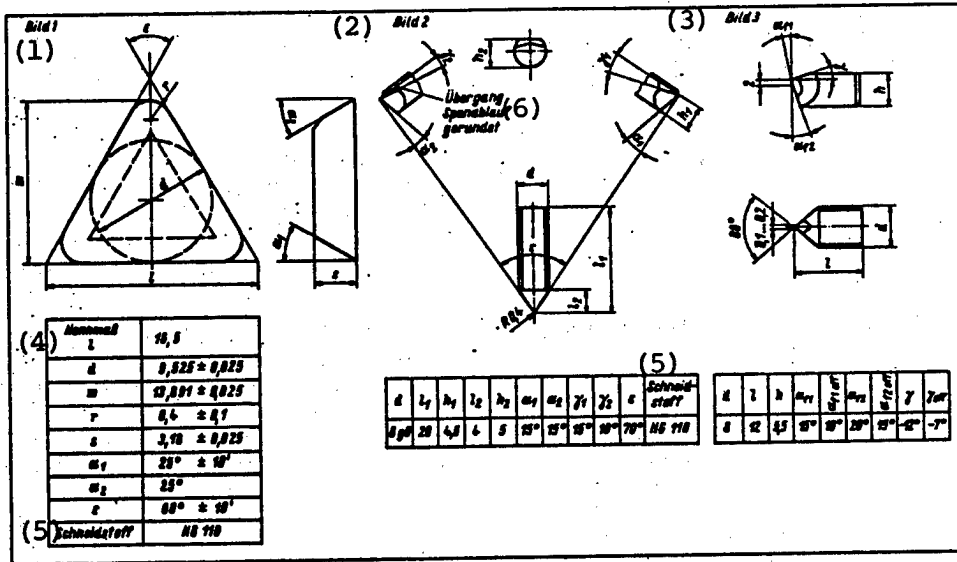

Figures 1-3. Figure 1: Cutting-edge Geometry of the Reversible Carbide Tip for the Turning of Aluminum ("a" less than 2 mm); Figure 2: Cutting Edge Geometry of Carbide-alloy Boring-bar Inserts for the Turning of Aluminum ("a" less than 1.5 mm); Figure 3: Cutting-edge Geometry of the Carbonado Insert PB 0501 for the Inside Turning of Aluminum

Key:—1. Figure 1.—2. Figure 2.—3. Figure 3.—4. Nominal dimension—5. Cutting material—6. Rounded change-over of cutting process

In finish machining a characteristic feature is the radially and axially inclined rake angle, for the purpose of having favorable cutting conditions for the longitudinal and face turning.

Attempts to conduct precision machining with the carbide alloy HG 110 gave negative results. The range of fluctuation of the outputs per sharpening was too high, and departures from fit occurred too often.

With the use of the polycrystalline cutting material carbonado in connection with precision machining, considerably better results were achieved in both outside and inside work compared to carbide alloy (on the average, two to three dimensional corrections per shift and a surface roughness R_z less than $6.3 \mu\text{m}$). The results obtained with carbonado in the testing period were confirmed in routine production work and so they have led to a reliable technological process.

Cutting-edge geometries, constructions, and cutting materials as used in the FMS F/W 250 are listed in Table 1 and are illustrated by Figures 1, 2, 3, and 4. The tool holders for the tips shown in Figures 1 to 4 can be seen in Figures 5 to 8 [not reproduced in translation].

1.2. Turning of Gray Cast Iron

In precision machining with carbide alloy, hardness differences in the material being machined lead to irregular wear and to problems of fit, so that this cutting material fails to qualify for an automated manufacturing process. An analysis of the internationally available assortment of cutting materials led to the choice of

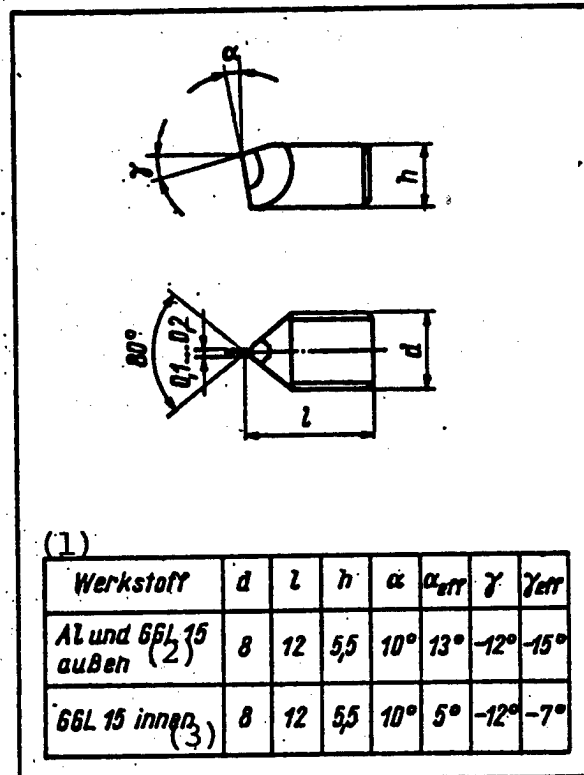

Figure 4. Cutting-edge Geometry of the Carbonado and Composite Insert
Key:—1. Machined material—2. Al and GGL 15 outside—3. GGL 15 inside

Composite 01, a cutting material based on cubic boron nitride. Materials that are difficult to cut can be machined with this. Tests on using this cutting material on GGL 15 had successful results. Compared to carbide

alloy substantial improvements in tool life and also in surface quality were achieved. However, a condition for using this is an almost constant finished dimension ($a = 0.2 + 0.1$ mm), see Table 1.

Table 1. Cutting-edge Geometries, Constructions, and Cutting Materials in Face and Longitudinal Turning for Reversible Carbide Tips, Carbonado, and Composite

| Material | Workpiece surface roughness R_z μ | Cutting depth mm | Cutting edge geometry | | | | SA | Cutting material |
|-------------|---|---------------------|-----------------------|------------------|------------------|-------------|----|------------------|
| | | | ϵ Deg. | γ Deg. | α Deg. | r/f mm | | |
| GD-AlSi10Mg | 40 | ...2 | 60 | 0 | 25 | 0.4 | 2 | HG 110 |
| TGL 6556 | 10 inside | 0.1 | 80 | -7 | 10 | 0.2 | 1 | carbonado |
| | 10 outside | 0.1 | 80 | -15 | 13 | 0.2 | 1 | carbonado |
| G-AlSi7Cu1 | 160 | ...3 | 90 | +15 | 0 | 1.2 | 3 | HG 412 |
| TGL 6556 | 160 | ...3 | 80 | +15 | 0 | 1.2 | 3 | HG 412 |
| | 40 | ...2 | 60 | 0 | 25 | 0.4 | 2 | HG 110 |
| | 10 inside | 0.1 | 80 | -7 | 10 | 0.2 | 1 | carbonado |
| | 10 outside | 0.1 | 80 | -15 | 13 | 0.2 | 1 | carbonado |
| GGL 15 | 160 | ...3 | 90 | 0 | 0 | 1.2 | 3 | HG 412 |
| | 160 | ...3 | 80 | 0 | 0 | 1.2 | 3 | HG 412 |
| | 40 | ...1 | 80 | +15 | 0 | 0.4 | 3 | HG 412 |
| | 6.3 inside | 0.2 | 80 | -7 | 5 | 0.2 | 1 | composite 01 |
| | 6.3 outside | 0.2 | 80 | -15 | 13 | 0.2 | 1 | composite 01 |

Cutting-edge construction (SA)

1 lapped

Cutting-edge construction

2 ground without rounding of cutting edges ($R_z = 3.2 \mu\text{m}$)

Cutting-edge construction

3 press-worked and rounded

2. Cutting Values and Parameters for Wear and Built-up Cutting Edges

In the FMS F/W 250, for the above-mentioned working materials usually thin-walled and buckle-prone parts are machined. For the purpose of having an increased ability to machine here as well, studies related to specific parts were done whose results have been introduced into the NC turning program. It is not possible to give a complete account of these results within the confines of this report,

but Table 2 gives pointers for the selection of cutting speeds and power feeds for typical machining cases. Moreover Table 2 also contains parameters for wear and built-up edge height. The permissible height of the built-up cutting edge in finish-turning with an "aluminum indexable insert" was determined for the purpose of preventing cutting-edge chipping. Figures 9 to 12 [not reproduced in translation] show built-up cutting edges when using carbide alloy and cutting-edge wear for carbonado and Composite 01 for an average period of contact of $t_c = 60$ minutes.

Table 2. Cutting Values and Parameters for Wear and Height of Built-up Cutting Edges

| Material | Workpiece surface roughness, R_{perm} μm | Cutting depth mm | v m/min | s mm/U | VB_{perm} mm | ASH_{perm} mm | Cutting material |
|------------|--|---------------------|--------------|-------------|-------------------|--------------------|------------------|
| | | | | | | | |
| TGL 6556 | 10 inside | 0.1 | 250 | 0.06 | 0.05 | — | carbonado |
| | 10 outside | 0.1 | 250 | 0.06 | 0.05 | — | carbonado |
| G-AlSi7Cu1 | 160 | ...3 | 100 | 0.3 | 0.5 | — | HG 412 |
| TGL 6556 | 20 | ...2 | 150 | 0.2 | — | 0.5 | HG 110 |
| | 10 inside | 0.1 | 250 | 0.06 | 0.05 | — | carbonado |
| | 10 outside | 0.1 | 250 | 0.06 | 0.05 | — | carbonado |

Table 2. Cutting Values and Parameters for Wear and Height of Built-up Cutting Edges

| Material | Workpiece surface roughness, R_{perm} | Cutting depth | v | s | VB_{perm} | ASH_{perm} | Cutting material |
|----------|---|---------------|-----|------|-------------|--------------|------------------|
| GGL 15 | 160 | ...3 | 80 | 0.3 | 1.2 | — | HG 412 |
| | 20 | ...1 | 120 | 0.2 | 0.5 | — | HG 412 |
| | 6.3 inside | 0.2 | 150 | 0.06 | 0.2 | — | composite 01 |
| | 6.3 outside | 0.2 | 150 | 0.06 | 0.2 | — | composite 01 |

VB_{perm} : Permissible cutting-edge wear on the flank
 ASH_{perm} : Permissible height of built-up cutting edge

Outputs Per Sharpening

For the reliable organization of tool use and an adequate supply of tools, a knowledge of workpiece-related outputs per sharpening is required. These were determined from wear studies in routine production and are available for most parts that call for turning work.

Table 3 contains an example:

The outputs per sharpening have been incorporated in the NC turning program; they provide a way of avoiding tool breakage and overly-extensive cutting-edge wear through a timely replacement of the tools.

Table 3. Outputs of a Workpiece Per Sharpening

| Field Magnet RSM 10 00750-100 | | Single clamping | |
|-------------------------------|------------|---|-----|
| AS | WN | WB | SM |
| T01 | 1308 11 02 | Recessing tool li TGL 0-4981 2016, b = 5.0 mm, HG 110 | 200 |
| T04 | 1405 10 01 | Recessing tool li 1010 (special design) in clamp-type toolholder, HSS, b = 5.0 mm | 100 |
| T 07 | 1309 11 02 | Recessing tool li TGL 0-4981 2016, b = 5.0 mm, HG 110 | 250 |
| T 10 | 1406 10 01 | Hook recessing tool 2025 b = 4.0 mm, HG 110 | 250 |

AS: Stage of operation;
 WN: Tool number;
 WB: Tool characterization;
 SM: Output per sharpening

FMS for Machining Prismatic Components
 23020014 East Berlin FERTIGUNGSTECHNIK UND
 BETRIEB in German No 9, 1988, pp 528-530

[Text]

Introduction

Tool use in flexible manufacturing systems (FMS) is essentially characterized by

[Article by Dr of Engineering W. Guenther, Chamber of Technology member, and Graduate Engineer U. Kind, Chamber of Technology member, with the Karl-Marx-Stadt Research Center for Industrial Machinery Construction in the Karl-Marx-Stadt "Fritz Heckert" Industrial Machinery Combine VEB: "Technical and Organizational Aspects of Tool Use in Flexible Manufacturing Systems for the Machining of Prismatic Workpieces in Industrial Machinery Construction"]

- Type and number of tools needed for the manufacturing or mechanical working of the formal elements occurring in an assortment of parts;
- The strategy for effecting the availability of the tools at the machining centers (C), which in turn is a function of the mutually dependent tool variety and variety of formal elements, of storage-unit capacities, and of the temporal rhythm of the flowthrough of the parts;

The contact time of the tools per manufacturing unit (number of workpieces that are on a machine pallet), which depending on the designed machining sequence is to be considered as per workpiece, per flowthrough, or per clamping configuration [1]. The above characterizations result in requirements for supplying the system's machinery with tools in a timely fashion and with the appropriate types and qualities. Included here is also the organizational-technological meshing of the readying sequences, for example the tool replacement and the tool feeding and return, which are to be adapted to the level of automation of the FMS.

Last but not least, the problems involved in designing an optimal storage organization and tool stockage also are of great importance for an FMS characterized by high reliability and availability.

1. Ensuring Operationally Usable Tool Sets in the Machining Centers

The availability of the various tool/tool-holder combinations is of great importance in ensuring a continuous system operation. Availability is achieved when the technologically predetermined loading of the storage-unit of a machining center has been done and all the tools in it are in an operationally serviceable condition. Thus availability and serviceability are in a proportional relationship. Availability decreases to the same extent that the tools' serviceability is exhausted through tool wear.

There are numerous causes for the emergence of wear on the tool cutting edges, but although these causes can be pinpointed for the most part they cannot be exactly described in terms of their time behavior, let alone be predetermined. Therefore in the flexibly automated manufacturing of parts it is customary to generate information on the condition of the tools with the aid of process monitoring, in order to be knowledgeable at all times on availability.

To that end, the following automated solutions [2] [3] are available for machining centers from the GDR's sector of industrial machinery construction.

- Counting of the operation times;
- Tool breakage determination via sensors;
- Vibration behavior via sensors;
- Measuring the quality of the tool surface;
- Monitoring the current consumption.

The first and second solutions allow a direct determination of the wear condition, whereas with the third, fourth, and fifth the measurement of wear is of an indirect nature, because it is done via intermediate stages (Figure 1). These automated solutions for determining wear condition require a high technical input and for the most part can be used only to a limited extent. In the FMS's of the GDR's industrial machinery construction sector, tool-life monitoring is carried out by means

of operation-time meters in both DNC and CNC enterprises. This monitoring constitutes a comparison between the computationally determined life of a tool and the using up of this time. But with this counting of tool operation times the influences acting on the tool cutting edges during the machining of the parts cannot be taken into account. Therefore it is necessary to check out the progress of wear on the tool cutting edge at regular time intervals, which are determined by tool type and period of contact.

Empirical values show that under the existing technological-organizational conditions of parts manufacturing in industrial-machinery construction it is reasonable and justifiable with respect to the effort involved to make a thorough inspection of the tools each shift. In this way the condition of the cutting edges of all tools that were in use since the previous inspection is checked out. Other inspections in the nature of a quick survey between close inspections are also advisable. They help in the early recognition of and initiation of measures against any departures from the computationally determined tool wear (for example cutting-edge chipping).

As a result of the inspections and depending on the tool life to be expected in accordance with the planned machining sequence, decisions are to be made on:

- What tools are to be included in the next scheduled exchange;
- Whether an early tool exchange by the operator is necessary for one or more tool/tool-holder combinations (TTC's);
- For what tools can one extend the tool lives that have been set in the machine control unit and are still available?

Criteria for the assessment of cutting-edge quality (for milling tools) are for:

Rough-milling B_v , approximately equal to 1.2 mm,
Finishing B_v , approximately equal to 0.3 to 0.5 mm.

The inspections are carried out by the system operator. He himself organizes his work depending on the sequence of operations on the relevant machining center. In this way it is possible to avoid unnecessary stoppages of the machining center during a machining sequence.

The working steps for close inspections can be seen in Figure 2. The time expended for close inspections, which are to be done each shift, is made up of the following components:

- 8 s for moving the TTC to the observing position;
- 11 s for checking out the cutting-edge condition and recording the result;
- 10 s for operating the chain magazine and for the trip from the control panel to the observation point and back.

The time values are based on determinations made in the FMS's [4] [5].

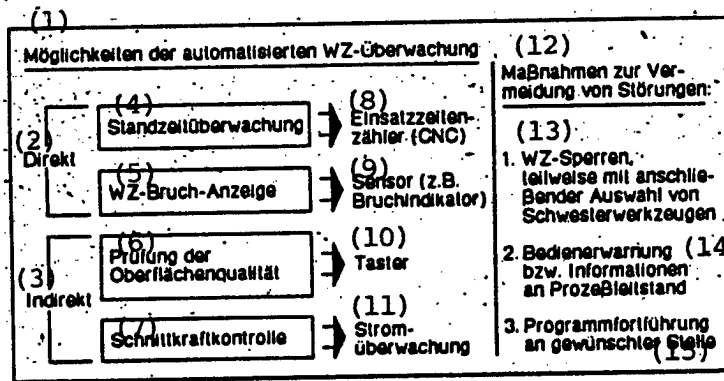

Figure 1. Technical Solutions for the Automated Monitoring of the Serviceability of TTC's.

Key:—1.Ways of automated tool monitoring—2.Directly—3.Indirectly—4.Tool life monitoring—5.Tool breakage indication—6.Checking the surface quality—7.Cutting-force monitoring—8.Operation-time meter (CNC)—9.Sensor (for example, breakage indicator)—10.Probe—11.Current monitoring—12.Measures to avoid malfunctions—13. 1) Tool lockout, in some cases with subsequent selection of equivalent tools—14. 2) Operator alarm or information at the process control station—15. 3) Program continuation at a desired point

For each inspection the time consumed is about 30 s. The downtime of the machining center for a close inspection is reached through multiplication by a number depending on the tools affected per inspection.

These inspections prepare the way for the actual exchanging of the tools, which ensures an availability of

tools sharp enough to do the work. It is not practical to change the tools individually and at differing points in time. For this reason, for each FMS a tool exchanging strategy has been developed with which a methodicalness is to be achieved with respect to parts to be exchanged and time intervals.

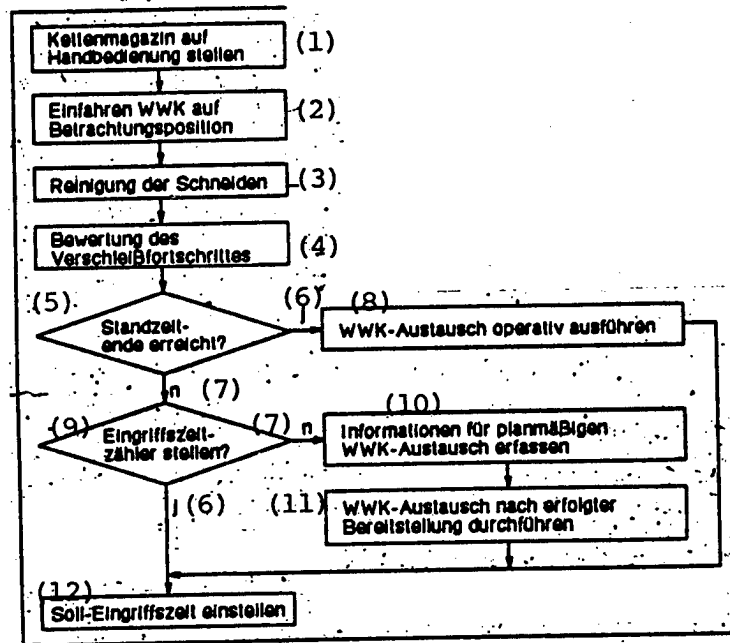

Figure 2. Flow Chart for the Inspection Process

Key:—1.Set chain magazine to hand operation—2.Move in TTC to observation position—3.Cleaning of the cutting edges—4.Assessment of extent of wear—5.End of tool life reached?—6.Yes—7.No—8.Operatively execute TTC exchange—9.Contact-time meter set?—10.Determine information for scheduled TTC exchange—11.Carry out TTC exchange after completed readying—12.Set desired contact time

Depending on the technological-organizational conditions of an FMS, the tools can be exchanged either at the same time as

- a change in the production batch,
- a change of workpiece

or else during the current production batch at an empirically determined point in time synchronized with the manufacturing control unit (for example, at a change of shift).

Criteria for the determination of the proper intervals for tool replacement are

- Material and geometry of the workpieces,
- Material, frequency of use, and contact time of the tools;
- the wear to be expected under well-defined technological conditions.

In case of tool breakage or premature end of tool life, the tool replacement is to be done by the operator. In such cases a downtime for the machining center can be expected amounting to about 10 min per tool to be exchanged.

This time specification takes into account the fact that each TTC part, in the way that it is in use at the current point of time in the system, is available in the tool store as a spare part with an immediate data access capability. In a manner similar to the inspection the routine exchanging of tools also requires a stoppage of the relevant machining center. On an average, the following times are needed:

- 8 s for positioning the storage unit;
- 25 s per tool for the tool exchange by hand (10 s for operating the chain with the trip there and back by the operator plus 15 s for receiving the tool and exchanging at the magazine station);
- 15 s for data input to the machine control unit (storage unit number, T-address, specimen number).

It takes a total of 48 s to exchange a TTC.

As a rule, tool inspection and tool replacement are separate activities. The downtimes that result from this for a machining center should be added by taking into account the number of tools to be inspected and replaced, if one wants to determine the total value for a certain time interval (for example, 1 day).

2. Organization of Tool Exchanging

For the routine exchanging of tools during system operation, tool requests are delivered by the manufacturing control unit at prearranged time intervals to the tool presetting unit or the tool store. The specific particulars

on the parts to be exchanged are provided by the preceding inspection each time. Almost without exception there are computer-aided solutions for the transmission of the tool requests.

The tool presetting unit or tool store make a check on and implement the availabilities of the tools. The tools that have been prepared for the point in time of the exchange are made available in the form of sets. As a rule this is done in relation to the particular machining center. Even with machining centers of the same type an exchange between machines is not permissible.

For each TTC, after its setting in the tool presetting unit there is an input of the following data at the terminal:

- T-address (4 places);
- Specimen number (2 places);
- Correction values in the series:
 - Length correction (L_E)
 - Radius correction (R_K)
 - Auxiliary correction 1 (for example DK)
 - Auxiliary correction 2 (for example WK).

It is useful to generate a punched-tape record for each tool set to be exchanged; this tape is brought along to the machining center and is entered as input after a completed tool exchange. This ensures that the status of all tool data for the machining of the workpieces is current.

Depending on the existing degree of automation of an FMS, the tool sets are brought to the machining centers at the predetermined times either by the system operator or by way of mechanical or automated transport solutions.

In an operator's tool exchange, the tools are taken from the reserves on hand for this purpose, which are either in a room near the machinery or in the tool store. These TTC's are provided with a label band on which the indicated data are recorded.

If for certain parts equivalent tools are also supplied that are not inserted immediately into the chain magazine, they are to be identified by label bands in a similar way. After the TTC exchange has been completed and a ready signal has been given to the CNC, the dispatcher of the system is to signal the operational readiness of the machining center.

In every case a tool exchange conforming to what was requested is ensured by way of a tool store assigned to the FMS. This takes on the functions of stockage, tool-use preparation, allocating, and recovery of the TTC's to be used in the system. Organizationally speaking, the tool store is a connecting link between the cutting cycle (tool presetting, tool use, tool recovery) and procurement cycle (needs determination, ordering, and central stockage) (Figure 3).

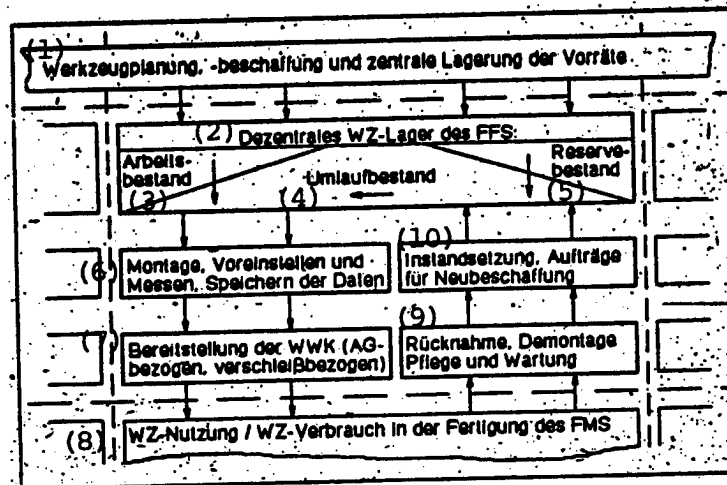

Figure 3. Store and Operational Areas of TTC Ready for FMS's.

Key:—1.Tool planning, procurement, and central storage of the tool supplies—2.Decentralized tool store of the FMS—3.Working stock—4.Circulating stock—5.Reserve stock—6.Mounting, presetting and measuring, storage of the data—7.Readying the TTC's (AG-related, wear-related)—8.Tool use/tool depletion in the FMS production work—9.Returning, disassembly, servicing, and maintenance—10.Repairing, orders for fresh procurements

The central tool store of the enterprise is responsible for tool procurement.

Maintenance of stocks in the tool store of the FMS is governed by the tool depletion values determined in the technological preparations for production. The maximum inventory should not exceed the quantity of tools used up within 2 years.

3. Summary

By way of an already implemented FMS it could be shown how the technological conditions for tool use, such as tool diversity, TTC data file, allowance for correction values, and filling of the storage unit, form the basis for an optimal tool-exchanging strategy and organizing tool-stock maintenance, in connection with which the data flows were also adapted to these requirements.

Literature

[1] Guenther, W.; Kind, U.: "Technical-technological Aspects of Tool Use in an FMS for the Machining of Prismatic Workpieces in Industrial-machinery Construction," FERTIGUNGSTECHNIK UND BETRIEB, Berlin 38 (1988) 8, pp 457-459.

[2] Pamphlet: "Process Monitoring in the "Fritz Heckert" Machine Tool Combine—parent enterprise—Karl-Marx-Stadt," 1986.

[3] Popke, H.; Scharfenort, U.: "Sensor Engineering on Lathes for Low-personnel Operation," Scientific-technical Communications of the Magdeburg FER [Research, Development, and Rationalization] VEB, 1984, 4.2., pp 79-86.

[4] Guenther, W. et al.: "Organization of Tool Flow in the FMS 1000," FZW Karl-Marx-Stadt, 1981, R&E Report.

[5] Authors' collective: "Flexible Automatic Manufacturing System FMS 2000—Detailed Technological-organizational Concept," FZW Karl-Marx-Stadt, 1987, R&E Report.

GDR Uses CAE for Simulating Industrial Robots
23020044 East Berlin RECHENTECHNIK-DATENVERARBEITUNG in German No 1, 1989 p 38

Employees of the Institute for Automation of the GDR Academy of Sciences, in collaboration with the ZIM [Central Industrial Plant Construction Facility for Metallurgy] Combine, developed the program KINSIM for kinematic simulation of industrial robots (IRs). The program can be run on EC 1834-compatible equipment (DOS operating system; FORTRAN). The kinematic equations are automatically formulated so that, in the dialogue, the user need only formulate his particular task. First of all, the structure of the robot must be determined, that is, an input must be made as to whether the robot has swivel joints or sliding joints, how these are oriented with respect to one another and how great the distance is between the joints. These topological data as well as the permissible range of values for the joint axes are stored in the computer as an internal model. Then, for the simulation of motion, the gripper path in space or the position of the joint axes of the robot are given.

KINSIM offers the following application possibilities for new designs and the preparation of IRs for use:

- optimization of work space or the setup of the IR within a production cell;
- simulation of the sequences of motions and cycle times;
- visualization of the motion of the robot in its environment (collision studies);
- determination of positioning accuracy.

The resulting data are stored on a floppy disk or hard disk and can be called up from there with evaluation programs, as tables, curve diagrams and graphic representations of movement in space (in the form of single images or sequences of images). Variant calculations can thus be carried out and an optimal geometry and kinematic structure for a robot can be determined.

The 3D-graphics software, specifically developed for KINSIM, permits:

- the perspective graphical representation of the robot in its environment, with free choice of the observation point;
- alternative elimination of hidden edges and coloration of surfaces;
- enlargement of graphic sections in freely selectable areas.

The resolution of the graphics screen is 320 x 200 pixels; for the printer, it is alternatively 274 x 230, 480 x 400 or 720 x 600 pixels. The features of the graphics package are of immense importance, particularly for the control of positioning accuracy in the layout arrangement of production cells and in collision studies.

HANSI (handling simulation in manufacturing cells), KINSIM's successor, is currently under development. With it, it will be possible to simulate the interaction of several robots and technological units.

Czechoslovak Robotization of Engineering Processes Reviewed

24020013 Brno STROJIRENSKA VYROBA in Czech No 11, 1988 pp 804-814, 823

[Article by Eng Pavel Filipovsky and Eng Milos Ecer, State Commission for Scientific-Technical and Investment Development: "Robotization of Technological Processes"]

[Text] During the course of the 7th Five-Year Plan, the Government of Czechoslovakia adopted a number of significant measures to assure the automation of production processes with the aid of industrial robots, provisions which became the fundamental point of departure for the development of this discipline in Czechoslovakia. Specific tasks in the development of production and in the utilization of industrial robots and robotized work stations, as well as in other areas connected with the development of robotization, were worked up into the appropriate SCP's (state goal-oriented program) as follows:

- SCP-07—"Industrial Robots and Manipulators," realized during the years of the 7th Five-Year Plan and

- SCP-05—"Robotization of Technological Processes," realized in the years of the 8th Five-Year Plan.

According to the unified methodological directives, the SCP's are an inseparable part of the 8th Five-Year Plan and of the implementation plans for the individual years of the 5-year plan and, thus, form a fundamental basis for the preparation of these plans.

Results Achieved During the 7th Five-Year Plan

For purposes of the expansion of robotization during the years of 1981-1985 in Czechoslovakia, the resolution of the Czechoslovak Government approving SCP-07—"Industrial Robots and Manipulators," was key. According to this program, a total production of 3,500 PRaM's (industrial robot and manipulator) was anticipated during the years of the 7th Five-Year Plan in the knowledge that their utilization will make it possible to establish 1,500 ATP's (computerized technological work station).

In actual fact, 4,650 PRaM's were produced in the following compositions:

- 815 standard model PRaM's were produced and introduced into production area No 479,
- 835 special-purpose manipulators were produced, and
- 3,000 manual manipulators were fabricated.

During the period 1981-1985, almost 2,000 ATP's were realized with the aid of PRaM's.

Despite the fact that the goal-oriented program SCP-07 was fulfilled in its totality during the 7th Five-Year Plan, some problems did arise. Primarily, these involved the shift in the assortment toward greater production of simpler special-purpose and manual manipulators at the expense of standardized PRaM's. One of the decisive factors which exerted an unfavorable influence upon the structure of PRaM production in the 7th Five-Year Plan was the delay in developing a production base involving specialized producers of robots. The application of PRaM's was connected primarily with a number of minor rationalization actions in existing capacities. It was not possible to successfully prosecute this technology on a larger scale in important investment projects which were being realized.

At the same time, during this period, 12 basic types of PRaM's were developed; primarily with the framework of the tasks outlined in the state plan of technical development entitled "Adaptive Industrial Robots and Unified Manipulators" (A-07-124-102). The basic parameters of Czechoslovak industrial robots which have been developed thus far and which have been repeatedly manufactured are listed in Table 1. Additionally, a number of special-purpose and manual simple manipulators were developed within the framework of various economic plans which are produced by appropriate enterprises virtually on an exclusive basis for their own use.

Table I. Basic Technical Data of Czechoslovak Industrial Robots and Manipulators

| Model | Load Capacity (kg) | Coordinate System | Number of Motions | Type of Drive | Type of Control | Range of Motion (mm) | Maximum Speed (m/s) | Accuracy of Positioning | Control System Model | Producer | Applications |
|----------------|--------------------|--------------------------|-------------------|----------------------|--------------------------|---------------------------|---------------------|-------------------------|----------------------|--------------------------|--------------------------------------|
| 1 | 2 | 3 | 4 | 5 | 6 | 7 | 8 | 9 | 10 | 11 | 12 |
| AM-1-T | 1.25 | Rectangular | 2 | Electric | Dual-phase PTP stop type | 1,000 H, 50 V | 30 cycles/min | +/-0.2 | Special | ZPA Presov | Manipulation in flat forming |
| AM-5 | 3x5 | Cylindrical | 4 | Pneumatic | Dual-phase PTP stop type | 630 H, 100 V | 1 | +/-0.2 | RS-1-A | ZPA Presov | Manipulation in flat forming |
| M-40 | 40 | Rectangular | 2 | Pneumatic | Dual-phase PTP stop type | 1,150 H, 60 V | 15 cycles/min | +/-0.5 | Special | BAZ Bratislava | Manipulation |
| M-63 | 63 | Rectangular | 2-5 | Hydraulic | PTP | According to modification | 0.6 | +/-0.5 | RS-1C | ZTS Bardejov | Manipulation |
| MTL-10 | 10 | Spherical | 5 | Hydraulic | Dual-phase PTP stop type | 700 H, 700 V | 0.8 | +/-0.3 | RS-1C | VIHOR-LAT Snina | Manipulation in pressure casting |
| AM-80 | 80-160 | Rectangular, cylindrical | 1-6 | Hydraulic | PTP | 1,400 H, 1,400 V | 1 | +/-1 | RS-3 | VUKOV Presov | Manipulation in spot welding |
| AM-20 (AME-20) | 2x20 | Rectangular | 3 | Hydraulic (electric) | PTP | 6,000 H, 870 V | 1 | +/-0.5 | NS-880 | TOS Trencin | Manipulation |
| PR-16-P | 16 | Cylindrical | 5 | Pneumatic | PTP stop type | 1,000 H, 500 V | 1 | +/-0.3 | RS-1C | ZPA Presov | Manipulation |
| PR-32-E | 32 | Multian-gular | 5 | Electric | PTP | 1,150 H, 2,000 V | 1 | +/-0.5 | RS-3 | ZEZ Prague, VUKOV Presov | Welding manipulation |
| APR-2.5 | 2.5-5 | Rectangular, cylindrical | 2-5 | Electric, pneumatic | PTP | 300 H, 300 V | 1 | +/-0.05 | RS-3 | VUKOV Presov | Assembly work |
| APR-20 | 10 | Cylindrical | 6 | Electric | PTP/CP | 1,100 H, 1,100 V | 1 | +/-0.5 | RS-4A | VUKOV Presov | Arc welding |
| APR-40 | 60-80 | Multian-gular | 6 | Electric | PTP/CP | 960 H, 1,200 V | 1.2 | +/-1 | RS-3, RS-4A | ZEZ Prague | Spot welding |
| SPR-10 | 10 | Multian-gular | 6 | Hydraulic | CP | 1,000 H, 2,000 V | 1.5 | +/-5 | Special | SAM Myjava | Surface treatment |
| OJ-10-RS | 10 | Multian-gular | 5 | Electric | CP | 3,400 H, 2,658 V | 1.3 | +/-0.3 | RSP-01 | ZTS Detva | Arc welding |
| PR-300 | 20 | Cylindrical (SCARA) | 3 | Electric | CP | 3,340 H, 1,200 V | 1 | +/-0.1 | RSP-02 | ZTS Martin | Assembly work |
| PROB-10 (20) | 10 (20) | Cylindrical | 6 | Hydraulic | PTP | 1,020 H, 500 V | 0.5 | +/-0.3 | RSB-01 | CZM Strakonice | Manipulation |
| PROB-5 | 5 | Cylindrical (SCARA) | 6 | Electric | PTP/CP | 1,250 H, 500 V | 0.3 | +/-0.2 | NU-RIS-730-R | CZM Strakonice | Assembly work, manipulation, welding |
| IPR-8 | 2x8 | Cylindrical | 5 | Hydraulic | PTP | 600 H | 0.5 | +/-0.5 | NS-880 | TOS Rakovnik | Manipulation |

Program for the Development of Robotization During the Years of the 8th Five-Year Plan

The main quantitative change in the substantive content of this program, realized during the 8th Five-Year Plan, can be briefly characterized as the effort to make a transition from the production of independent individual robots and manipulators, with the aid of which developers configured ATP's, for the most part, with their own forces, toward a broader application of robots in more complicated production groupings, supported by higher deliveries of complete work stations.

With the goal in mind of maintaining the appropriate technical level of the program, its effectivity was outlined more clearly and manual manipulators and balancers were deleted from further monitoring. Moreover, there was an effort to unify and simplify the variety of concepts used hitherto in this area. For purposes of the SCP-05 program, the concepts which were used were based on the standards prepared by CEMA member countries. The following concepts are involved:

Industrial Robot (PR)—an automatic machine containing the manipulators of an industrial robot with two or more movable axes and a programmable control system to accomplish motion and control functions in a production process which supplant analog functions executed by man in moving production items or technological accessories.

Robotized Work Station (RTP)—purposefully grouped production facilities and industrial robots which execute manipulations or technological operations involved in a given production process, or its parts in an autonomous mode and using automatic work cycles.

Robotized Production Cell (RTK)—a set of two or more robotized work stations and automated intraoperational manipulation devices which realize sequential technological and manipulation operations in automatic work cycles.

The basic goal of the program is to increase the technical-economic level of production processes, the raising of productivity while lowering costs, and a saving in manpower—something which was attained through the application of robotized work stations and robotized production cells. Within the framework of the program, it is anticipated that a minimum of 3,950 robotized work stations will be developed with the maximum use of these stations in integrated production cells and that, thus, will lead to savings of roughly 12,000 workers. For purposes of the user sphere in domestic terms and for export, it is planned to produce several thousand industrial robots in the years 1986-1990.

Within the framework of the SCP-05 program, there is an effort to apply robots in more complex production groupings, supported by higher deliveries of robotized

work stations. In support of this concept, the task entitled "Robotized Technological Complexes" was included in the state plan of technical development. The responsibility of individual enterprises for accomplishing higher deliveries, assembly, and service functions pertaining to robotized work stations was outlined using the following method.

The TST Engineering Technology Plants act as the coordinating organization for deliveries of the following:

- RTP's for metal cutting and metal forming,
- RTP's for surface treatment.

The ZTS Heavy Machine Tool Enterprises act as the coordinating organization for deliveries of the following:

- RTP's for arc welding,
- RTP's for forming operations on the basis of LEK presses.

VUKOV Presov is responsible for deliveries of RTP's for assembly work involving groups of engineering products as well as complete engineering products.

The ZSE High-Voltage Electric Engineering Plants in Prague are responsible for deliveries of RTP's for electric welding processes, including the basic technical equipment.

The VUMA Enterprise in Nove Mesto nad Vahom is responsible for deliveries of RTP's for microelectronics.

The CHEPOS Enterprise in Brno is the coordinating organization for deliveries for RTP's for pressure casting.

The Vitkovice Plant in Ostrava is the coordinating organization for deliveries of RTP's for free forging.

Current Status of Plan Fulfillment

Based on the evaluation of the SCP-05 program for the years 1986-1987, it is evident that the established goals are being successfully fulfilled, for the most part. For this period, it was planned to activate 1,260 RTP's utilizing 2,300 industrial robots; in actual fact, by the end of 1987, some 1,530 RTP's were activated, utilizing 2,240 industrial robots (statistical data obtained from SCP-A-05/SK-VTRI/I-02).

Let us attempt to at least accomplish an orientational comparison of goals and results attained in fulfilling the program with anticipated trends in the other countries. The determination of these factors is not simple because published data in the area of robotization are not always based on the same fundamental nomenclature and not even the concept of industrial robots is specifically expressed in a unified manner internationally. A comparison of industrial robots actually utilized through 1985 and the anticipated trend through 1990 in Czechoslovakia and in some European countries is presented

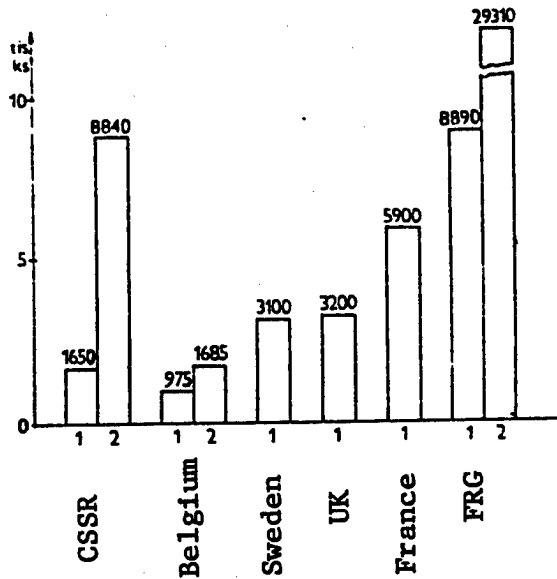

Figure 1. Application of industrial robots throughout the world:—1. Actual status in 1985.—2. Anticipated status in 1990.

in Figure 1. In view of the deviation in the definition of the concept of an industrial robot, it is necessary to consider the listed data merely as being informative.

Figure 2 is a percentile comparison of the existing status and the anticipated use of industrial robots in individual technologies in Czechoslovakia (statistics derived from SCP-A-05/SK-VTRI/I-02) and the FRG (INDUSTRIAL ROBOT, December 1987). From the graph it is evident that in Czechoslovakia, during the years 1985-1987, the use of simpler special-purpose industrial robots for the servicing of production machines prevailed, primarily involving metal-cutting and metal-forming machines. Expressly, we show a lower percentage of industrial robot application than does the FRG in the execution of technological operations involving arc welding, surface treatments, and assembly work. A steep rise in the application of industrial robots in spot welding in 1987 in Czechoslovakia is caused by the establishment of the chassis welding shop for the production of the SKODA-FAVORIT automobile, for which purpose 103 industrial robots from the KUKA firm in the FRG were imported. For lack of adequately suitable additional applications in the area of spot welding, we can anticipate a decline in this value. The most marked difference between Czechoslovakia and the FRG exists in the application of industrial robots in internal assembly work (the assembly of components and products). Whereas, in Czechoslovakia, the percent use of industrial robots is low and continues to decline since 1985, in the FRG, on the other hand, the percentage has been rising steeply since 1985. It is expected that the FRG will be using approximately 35 percent of all industrial robots for internal assembly operations in 1990. This primarily involves the broad

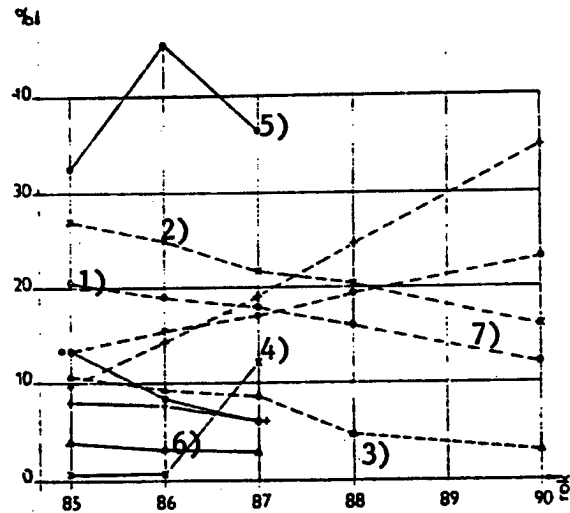

Figure 2. Application of industrial robots in individual technologies.

Key:—1. Arc welding—2. Resistance welding—3. Surface treatment—4. Assembly—5. Machine operations—6. CSSR—Solid line—7. FRG—Dotted line

application of SCARA-type robots in the electrotechnical industry in assembling circuit boards. In Czechoslovakia, the greatest problem involves support of the tasks stipulated by the SCP-05 program specifically in the area of the electrotechnical industry.

The application of industrial robots and individual technologies is, of course, connected with the development of the production of suitable models of Czechoslovak industrial robots. The ranking of individual models of industrial robots in Czechoslovakia by actual production numbers in 1986-1987 and in terms of the production planned for 1988 is listed in Table II. Despite the fact that the most prevalent model is the OJ-10 industrial robot for arc welding (produced by the ZTS Enterprise at Detva), production of more simple industrial robots intended for manipulation involved in the manufacture of production machinery continues to prevail. Of these industrial robots, the largest number produced were PROB-10's (produced by CZM Strakonice). Production of additional models of industrial robots intended for technological operations, as, for example, the APR-20, APR-40, APR-2.5, and the SPR-10, has continued not to be mastered in a satisfactory manner.

Table II. Ranking of Individual Types of Czechoslovak Industrial Robots According to Production in the Period 1986-1988

| Ranking | Industrial Robot Model | Number Produced |
|---------|------------------------|-----------------|
| 1 | OJ-10-RS | 120 |
| 2 | PROB-10 | 109 |
| 3 | PR-16-P | 98 |
| 4 | M-63 | 69 |

Table II. Ranking of Individual Types of Czechoslovak Industrial Robots According to Production in the Period 1986-1988

| Ranking | Industrial Robot Model | Number Produced |
|---------|------------------------|-----------------|
| 5 | PR-32-E | 62 |
| 6 | M-40 | 61 |
| 7 | AM-20 | 59 |
| 8 | IPR-8 | 58 |
| 9 | SPR-10 | 52 |
| 10 | AM-80 | 51 |
| 11 | AM-5 | 48 |
| 12 | APR-20 | 46 |
| 13 | AM-1-T | 44 |
| 14 | APR-40 | 20 |

Examples of Standardized Robotized Work Stations (RTP) and Robotized Production Cells (RTK)

Virtually all decisive ministries are participating in realizing the SCP-05—"Robotization of Technological Processes," for the years 1986-1990. Naturally, this leads to the establishment of many different RTP's and RTK's with differing concepts of their fabrication which utilize universal industrial robots on the one hand or special-purpose industrial robots (manipulators) produced by specialized producers or directly by users themselves for their own needs. The subsequent portion of this report provides information on existing findings relating to realized RTP's and RTK's and lists their specific characteristics which are based, on the one hand, on the possibilities of available domestic equipment as well as specific conditions which exist in the Czechoslovak engineering production base.

Machining

The application of industrial robots in machining is directed primarily to the area of operational or intraoperational manipulation involving workpieces. The technological utilization of industrial robots for actual machining is virtually unknown. According to the shape of the workpiece it is possible to break down the technology of machining as follows:

- the machining of nonrotating components (housings, boxes);
- the machining of rotating shaft-type and flange-type components;
- the machining of components of a general shape.

In machining box-type components, automation of manipulative operations is generally solved by having a transport system, involving the moving of technological pallets to which the workpieces are fastened. The industrial robot then handles only loading and unloading operations at the beginning and at the end of the transport system. For Czechoslovak conditions, it is characteristic to use robots in machining of rotating components whose weight is then limited by the capacity of the

utilized industrial robot. In the machining of rotating components, there are roughly four types of RTP's or RTK's, based on CNC machine tools serviced by the following:

- a portal Model M-63, AM-20, or AM-80 industrial robot;
- a Model AM-80 bridge-type industrial robot;
- free-standing industrial robots like the Model PROB-10 (PROB-20), PR-16-P, or PR-32-E;
- a Model IPR-8 integrated industrial robot.

In an RTK with portal industrial robots (manipulators), machine tools are arranged in parallel series, one behind the other, at right angles to the intraoperational transporter, which is the backbone of the entire system. Manipulators, located above the machine perpendicular to the transporter, take care of operational manipulation between the machine and the transporter. Loading at the beginning of the system and unloading at the end of the system is accomplished either by the crew or by an industrial robot. RTK's of this arrangement have been realized, for example, at the following facilities:

- at the ZSE-MEZ in Frenstat p. Radhostem, in the production of electric motor rotors. Here, there are 2 RTK's of which the first is comprised of 12 manipulators of the PIRIN type from Bulgaria. The second RTK is broken down into two parts, the first of which contains six Model M-63-27 manipulators and machines shafts and the second part contains six Model M-300 manipulators and machines the complete rotors weighing up to 284 kg;
- at the Jihostroj Enterprise at Velesin, for working on gear wheels for hydraulic gear pumps. The RTK here is made up of nine machine tools and nine Model M-63-33 and M-63-52 manipulators;
- at the Bardejov plant of the ZTS Enterprise of Kosice, for grinding crankshaft journals. The RTK is made up of seven machine tools and seven Model M-63-31 manipulators.

In utilizing a bridge-type industrial robot (manipulator), intraoperational manipulation within the RTK is handled by a rack-type storage facility with a loader. The machine tools are arranged in parallel, one behind the other, at right angles to the storage facility for systems pallets. Manipulators are positioned above the machines so that each virtually services several machines. Only one RTK of this configuration has thus far been activated, at the ZSE-MEZ Brno, the Nedvedice plant, where flange-type shaft components for Mezomatic electric motors are fabricated and where the diameter of the flange is a maximum of 300 mm and the diameter of the shafts a maximum of 80 mm. The RTK is broken down into three work stations, each with two lathes which are serviced by a Model AM-80 manipulator. Pallets are pushed into the work station area of the AM-80 manipulator by a special-purpose manipulator. Each of the lathes operates independently of the other.

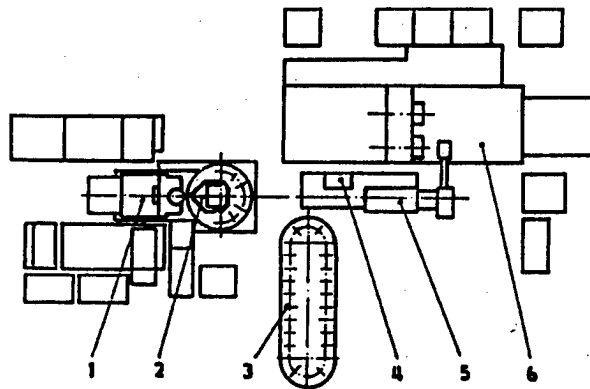

Figure 3. RTK for the production of gear wheels—Model AUCOR-16:

Key:—1. Model OHA-32-CNC hobbing shaper—
2. Device for the automatic exchange of workpieces and tools—3. Storage bin—4. Raising platform—5. Model IPR-8 industrial robot, including travel device—
6. Model SPS-2/25-NC lathe.

Machine tools utilizing a free-standing industrial robot are usually grouped into so-called nests or production cells, generally made up of two to five machines, involve operational and intraoperational manipulation which is handled by one or more industrial robots. Semifinished products are placed into intraoperational containers or directly onto conveyor belts. An RTP of this configuration, for example, is operational at the Vodnany plant of the MOTOR Enterprise, where two types of regulator bodies are machined. The RTP is made up of two semiautomatic lathes and a Model PROB-10 industrial robot which manipulates workpieces located in a carousel-type storage bin.

The Model IPR-8 integrated robot is positioned on the frame of a machine tool and forms a whole with it. The industrial robot generally takes semifinished products from a walking storage bin and positions them on the machine. After machining, the industrial robot changes the workpiece for a new semifinished product and places the finished product back into the storage bin or onto a conveyor belt or, possibly, into the area of another machine. An interesting RTK of this configuration, named AUCOR-16 (Figure 3), is intended for the production of gear wheels weighing up to 8 kg and having a diameter of 160 mm.

Forming

In Czechoslovak forges and press shops, there occur three categories of products:

- heavy forgings of up to several tons in weight which are processed as free forgings;
- medium-size forgings weighing several tens through hundreds of kilograms which, with a few exceptions (for example, railroad wheels and wheels for cargo trucks), are produced in small or medium-size series;

- lightweight forgings and pressings weighing up to 10 kg, produced in series or even mass produced.

Depending on the weight and size of series, appropriate manipulation devices are used. In the case of large and heavy forgings, primarily heavy rail-bound manipulators are used such as, for example, the Model SKODA rail manipulator with a capacity of up to 8 tons or the Model QKK rail manipulator (produced by the VITKOVICE Concern Enterprise at Zdas) which is produced in four sizes and in capacities ranging from 3 to 8, 12, and 20 tons. In the case of medium-size forgings, free-standing manipulators (teleoperators) are usually used and they are usually the Model ANDROMAT. The majority of these manipulators are controlled by an operator or are handled by remote control. For forming small and lightweight components, Czechoslovakia uses primarily production lines composed of forming presses and:

- Model AM-1T or AM-5 manipulators having the capacity to handle castings up to 1.25 kg or 5 kg in weight;
- Model PR-16-P industrial robots with a capacity of up to 16 kg;
- Model M-40 manipulators to manipulate sheet metal plates weighing up to 40 kg.

In utilizing the Model AM-1T manipulator which is designed to accomplish simple manipulation involving two products at eccentric presses, the forming machinery is positioned in-line, one behind the other. The manipulator takes care of all manipulation operations before and after technological operations, that is to say, it removes components with one arm from the press and, at the same time, passes them on to another press from the intermediate space. RTK's of this configuration have been activated, for example:

- at the SANDRIK Enterprise at Hodrusa-Hamre, where the production line is made up of six eccentric presses and six manipulators and fabricates three types of blanks for steel canisters. Semifinished products enter the line via a high-capacity storage bin for precut parts;
- at the Elektro-Praga Enterprise at Hlinsko and at the Elektro-Praga Plant at Jablunkov, where the production lines, in both cases, are comprised of four eccentric presses and four manipulators and make use of sheet metal coils to press bracing or housing for electric irons.

The Model AM-5 pneumatically controlled manipulator with two or three arms is utilized primarily in the manipulation required by Model LEK eccentric presses or for manipulations required by mandrel-type and hydraulic presses. As a rule, the forming machines are located in a line next to each other or, as appropriate, at right angles to each other. The manipulator uses one arm to remove the pressing from the press and, after turning 90 degrees, positions it either directly on another press or

unloads it to the interim space, from whence another manipulator takes it and positions it in another press. RTK's of this configuration were activated, among others, at the following facilities:

- at the PAL Enterprise in Kromeriz for pressing the flanges, drive gears, and housings for automobile switches. The RTK is composed of two Model PYE-40 and 160 hydraulic presses, one Model LEN-63-C eccentric press and three AM-5 manipulators;
- at the Eska Enterprise in Cheb for stamping converters for bicycles. The RTK is composed of two Model F-1730-A mandrel-type presses, two Model LEK-160 eccentric presses, and three AM-5 manipulators.

In forming large-dimension stampings having a maximum dimension of 1,000 x 2,000 mm, manipulation of the sheet metal is accomplished by a simple pneumatic Model M-40 manipulator. The backbone of such an RTK is, as a rule, a roller-type conveyor belt from which the manipulator positions sheets of metal in the press and, after the technological operation has been concluded, returns them to the conveyor belt or, possibly, following the final operation of a finished stamping, stacks the work on a pallet. The grasping arm of the manipulator is, most frequently, equipped with suction ports. RTK's of this configuration were realized, for example, at the following facilities:

- at the NORMA Enterprise in Frydlant, where two types of doors and plates for turntables for metal kitchen appliances are pressed. The RTK is composed of a Model LKT-200 crank-handle drawing press, a single-purpose forming machine, and three Model M-40 manipulators;
- at the TATRAMAT Enterprise at Poprad, where lids and bottoms for electric water-heater housings are stamped, the RTK is composed of two hydraulic Model PYE-250 presses, a semiautomatic flanging machine, and three Model M-40 manipulators.

As far as utilization of the PR-16-P robot is concerned in metal forming, a number of work stations have been realized. As a typical example, it is possible to cite the RTK for forging the bodies of gear pumps and the RTK for forging drive wheels and driven wheels for gear pumps at the Jihostroj Enterprise at Velesin.

Welding

Robotization of welding operations is among the most widely used technological applications of industrial robots in Czechoslovakia and it can be anticipated that, by the end of the current 5-year plan, it will undergo further express growth. The utilization of industrial robots in the production of weldments is aimed at three types of operations under conditions prevailing in Czechoslovakia:

- the industrial robot handles manipulation tasks in charging semifinished products into the welding jig

- and in moving finished weldments;
- the industrial robot carries the welding torch or the electrode holder for spot welding, with the weldment held in the jig on a firm table or in rotator;
- during the course of welding, the industrial robot manipulates the grasped weldment against a stable welding torch.

For arc welding in Czechoslovakia, thus far Model PR-32-E, Model OJ-10-RS, and Model APR-20 robots are in use. Apart from using the above types of welding robots and control systems, these work stations are made up of the following:

- firm tables or single-table or possibly dual-table rotators with welding jigs;
- a source of welding current;
- devices for manipulating weldments (generally a manual manipulator);
- a safety and protective system;
- a ventilation device.

With respect to Model OJ-10-RS and Model APR-20 robots, it is also possible to utilize their adaptive characteristics, that is to say, to correct the trajectory of the welding torch in accordance with geometric deviations found in imprecisely produced semifinished products. The work station must, therefore, be further equipped with a sensor system, attached to the robot control system.

Welding RTP's using Model PR-32-E welders and dual-table Model DOM-200 rotators or firm worktables operate in a number of Czechoslovak enterprises. For example, three RTP's are used to weld parts of the AVIA cargo truck chassis at the CKD Enterprise at Kutna Hora; a number of work stations incorporating numerous modifications were activated at the TATRA Plant at Novy Jicin to weld parts of cargo trucks (bumper, undercarriage, vacuum piping, etc.). At the Prakovce plant of the ZTS Enterprise of Kosice, an RTK has been activated where eight Model PR-32-E robots manipulate components against firmly held welding torches and another two Model PR-32-E robots take care of intraoperational manipulation functions. An interesting application for the Model PR-32-E robot are the work stations in the foundries at the CKD Enterprise at Kutna Hora and at the Skoda plant at Ceske Budejovice for burning off risers in castings with the use of oxyacetylene flames. The robot is equipped with a contact sensor which assures the correct positioning of the welding torch.

The Model OJ-10 RTP is intended for use in welding in a protective atmosphere or for the plasma thermal-mechanical cutting of conductive metals (the plasma medium is air). Its basis is formed by the OJ-10-RS robot in conjunction with two single-table programmable rotators with a capacity of 250 kg. Such RTP's are operational, for example, at the Krupina plant of the ZTS

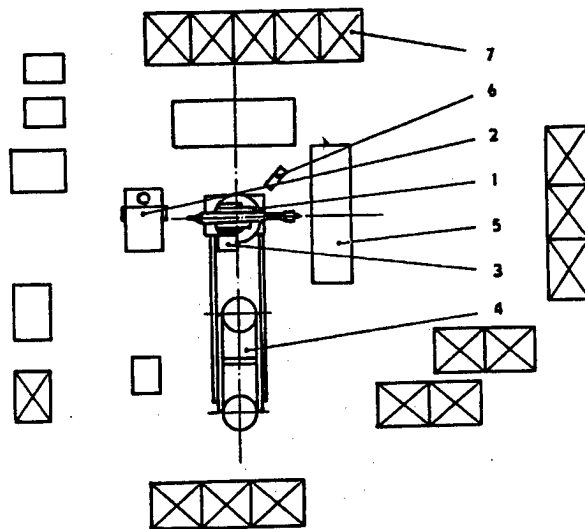

Figure 4. RTP for arc welding at the BSS National Enterprise at Brandys nad Labem:

Key:—1. Model APR-20 industrial robot —2. Semiautomatic welder —3. Feed mechanism —4. Model MZ-250 weldment manipulator —5. Stationary table with fume suction —6. Cleaning device —7. Pallet.

Enterprise at Detva and are used for welding small parts, or at the ZVU Plant at Hradec Kralove, where they are used for welding on of crane wheels.

RTP's on the basis of the adaptive Model APR-20 robot and dual-table Model MZ-250 and Model MZ-500 rotators, or possibly single-table Model RP-250 rotators, have thus far been realized, for example, at the BSS Plant at Brandys nad Labem for welding subassemblies of AVIA cargo trucks (Figure 4) and are being realized at the Vagonka Rolling Stock Enterprise at Poprad for the welding of cross girders for railroad rolling stock trucks.

In the area of spot welding, little has thus far been accomplished at the AZNP Plant at Mlada Boleslav apart from the welding of the chassis for the new SKODA automobile. An RTP for spot welding, including a Model APR-40 robot, is actually operating at the KAROSA Enterprise at Vysoke Myto, where it is spot welding entrance doors and trunk lid doors for buses. At the TATRA Enterprise of Koprivnice, a Model AM-80 manipulation system is in use for spot welding parts of cargo truck driver compartments. Two RTP's are making use of a free-standing configuration and a third is using a portal configuration of the AM-80 system.

Surface Treatment

RTP's or RTK's for the application of coatings or powdered plastics are composed of an industrial spray robot or a manipulator and appropriate technological equipment. The basic technological components for establishing an RTP for surface treatment are the following:

- a product conveyor;
- a storage bin and distributor of coating materials;
- an automatic spray gun;
- identification elements;
- a safety system;
- power distribution.

In Czechoslovak enterprises, two types of RTP's are currently being used as follows:

- those with a Model SM spray manipulator, designed for flat and simple product surfaces;
- those equipped with an industrial Model SPR-10 robot intended for the spraying of products having complicated surfaces.

The Model SM-1000, -1500, and -3000 spray manipulators execute one basic movement of the spray gun, mostly along a vertical axis, a telescopic movement along a horizontal axis, and can tilt the spray gun. Products are mounted on a suspension-type conveyor having a continuous motion. In making up the RTP or the RTK, use is made of one or two manipulators positioned on either side of the conveyor. The RTK can operate either in a continuous (firm) operations regime or it can function as a flexible system when spraying the surface of various products. The correct functioning of the RTK in this event is assured by identification elements (sensors) which identify the presence or perhaps the position of products in the spray zone, indicate the type of product and the speed of motion. In this configuration, RTK's for spraying have been realized, for example, at the following enterprises:

- Brandys nad Orlice Plant of KAROSA, with two spray manipulators and a constant operational regime for electrostatic spraying of powdered plastics onto metal products;
- KAROSA at Vysoke Myto (Figure 5) with two manipulators to accomplish base coat spraying using high-pressure airless spraying in an electric field for randomly changing components of bus chassis and involving changing velocities of the suspension-type conveyor.

In utilizing the Model SPR-10 industrial robot, the products are suspended on a conveyor or positioned on technological carriers of a floor-type conveyor having continuous velocity of movement or a step-type regime of conveying. The RTK having a Model SPR-10 robot is intended primarily for products whose shape and size permit them to be rotated in the spray booth or for products whose shape and size require direct passage through the work station and spraying from both sides. In these configurations, RTP's have been realized, for example, at the following facilities:

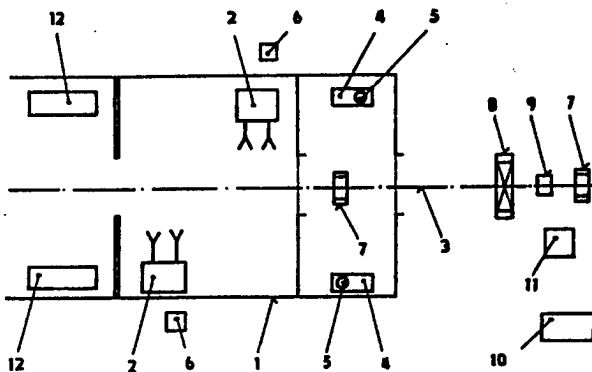

Figure 5. RTP for high-pressure spraying at the KAROSA National Enterprise at Vysoke Myto:

Key:—1. Spray booth —2. Manipulator —3. Conveyor —4. Reservoir for coating —5. Pump —6. Source of vn —7. Presence identifier —8. Type identifier —9. Velocity sensor —10. RTP control —11. Manipulator control —12. Manual work station.

- at the ceramics plant at Znojmo, for air spraying of an enamel suspension onto sanitary ceramic products;
- at the AZNP at Mlada Boleslav for spraying on a protective coating of plastizol to the bottom of automobile chassis.

Assembly Work

Internal assembly work, that is to say, the assembly of modules and products, occupies an extraordinary position in production processes in comparison with other technologies. This kind of assembly does not have at its disposal the classical assembly machines having a wide utility, the integration of which with universal industrial robots could lead to the formation of comprehensive assembly systems with a higher degree of automation, as, for example, can be seen in metal-cutting or metal-forming machines. Solution of the problem of internal assembly work has, in the past, been concentrated primarily on the areas of large-series or mass production. Gradually, the focal point of automating assembly work began to be moved even to lower types of production processes. The development of assembly devices, which can basically be broken down into two fundamental categories, corresponded to this process. The two categories are as follows:

- automated assembly machines and lines intended to perform assembly work involving one type of product;
- flexible assembly systems (PMS) making it possible to use a single device in the assembly of several technologically related products.

To the extent to which man also engages in assembly work, we are dealing with a PMS with an operator; where man does not directly engage in assembly work, this is a

PMS without an operator. In the past time frame, Czechoslovakia developed automatic synchronous assembly machines of a rotating type and of a step type for the assembly of the more simple products of smaller dimensions, asynchronous assembly lines for more complex products, having a free movement of intraoperational conveyors, as well as flexible assembly systems employing an operator for the assembly of products having smaller dimensions. In flexible assembly systems without an operator, the fundamental component is an assembly-type industrial robot, an intraoperational conveyor system, and a system for controlling the assembly lines, including a set of sensors. However, these basic units have not been hitherto adequately mastered from the development or production standpoint in Czechoslovakia to permit the realization of a robotized assembly work station and to permit the compilation of completely robotized assembly lines. Currently, only some partial units are available for practical purposes. These are primarily the following:

- the Model APR-2.5 modular industrial robot with a capacity of 3.5 kg which makes it possible to realize special-purpose assembly sets using the Cartesian or cylindrical coordinate system (developed by VUKOV in Presov);
- the Model PROB-5 industrial robot with a capacity of 5 kg, having a SCARA-type coordinate system (developed by the CZM Enterprise at Strakonice).

Thus far, the only purposefully developed system is a modular set of robotized assembly cells, the basis for which is the Model PR-300 adaptive assembly robot having a capacity of 20 kg and a SCARA coordinate system, equipped with a set of sensors including a visual system and a system for the automatic exchange of working units. The above-named technical devices for assembly, however, have thus far not been verified under demanding operational conditions because their application is still in the preparatory stage with respect to their first-time users.

Conclusion

The Proclamation of Comprehensive Automation as the second priority direction in the Comprehensive Program of Scientific and Technical Progress Among CEMA Nations Through the Year 2000 has brought about a period which demands that a transition be made from partial applications of automated facilities to the comprehensive application of automation technology. The results attained within the framework of the SCP-05—"Robotization of Technological Processes" program thus actually become one of the fundamental points of departure for the realization of a substantially more complicated task, the task of comprehensive automation in selected areas of the Czechoslovak national economy.

Bibliography

1. Filipovsky, P., Miklos, V., et al., "Plan of the State-Goal Oriented Program No 05—Robotization of Technological Processes," SK VTRI, VUKOV, 1985.

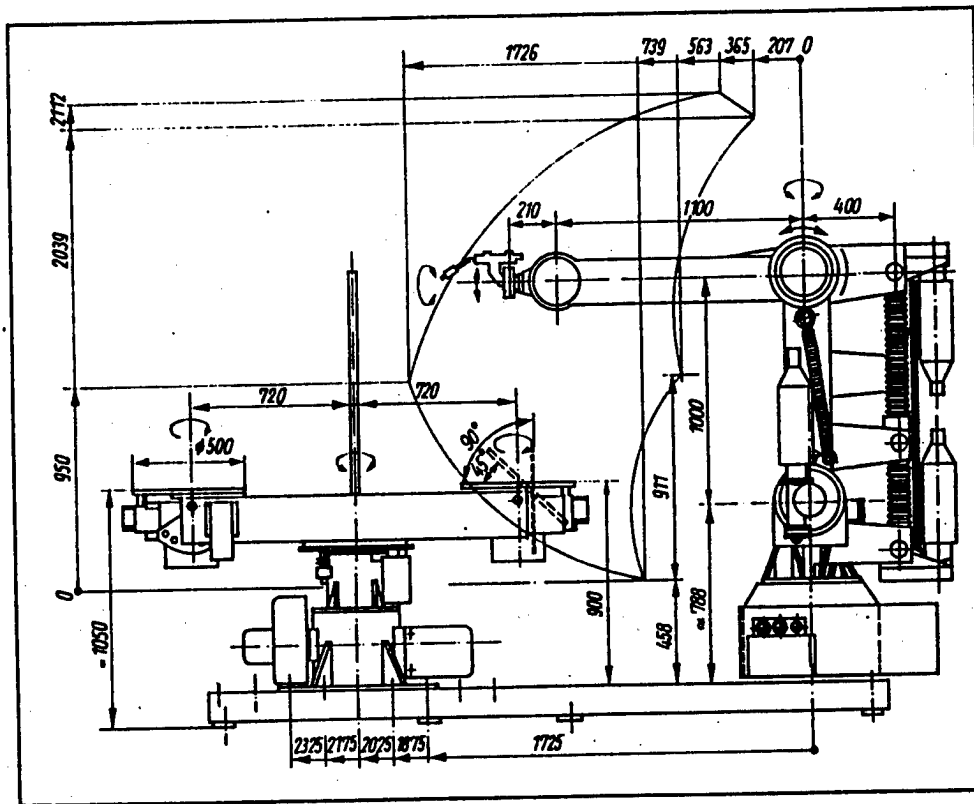

Figure 1. Welding workstation with PR 32 E robot

2. "How, When, Where, and Why To Robotize," Parts I and II, TECHNICKA PRACE, 1985.

3. The journal INDUSTRIAL ROBOT, December 1987.

4. Plasek, M., "Skupinove nasazovani PRaM—vybrane realizacni vystupy" [Group Application of PRaM's—Selected Realizational Outputs], Presov, November 1987.

5. Prusek, J., and Krejcek, V., "Robotizace lakoven" [The Robotization of Paint Shops], Prague, January 1987.

Overview of Electrically-Driven Robots in CSSR

23020029 East Berlin ELEKTRIE in German No 10, 1988 pp 377-380

[Article by Prof Vladimir Racek, head of the professorship for electrical motors, Bratislava Technical University: "Electrically Driven Industrial Robots"]

[Text] Until now, industrial robots have mostly been used for welding jobs. These are not only determined by monotonously repetitive work operations, but must

above all be regarded from the aspect of liberating the human being (welder) from working in an unhealthy working environment. Another field is now opening up for the robots—assembly.

The drive units for robots intended for welding and assembly work must be very dynamic. In addition, the motors must have high engine torque with extremely low rpm (on the order of 0.1 r/s), a low moment of inertia and small mass.

The electrical drive system selected affects the entire design of the robot. This will be demonstrated for various types of robots with electrical motors.

1. Robots With Direct-Current, High-Torque Motors

One of the first Czech electrically driven industrial robots is the PR32E robot. Its kinematic structure is expressed in spherical coordinates. The manipulation range is shown in Figure 1. The robot has five degrees of freedom with point (PTP) and continuous-path control (CP). The repeatable positioning accuracy is +/- 0.5 mm.

Motors with controlled rectifiers and direct-current, high-torque motors are being used. These motors basically have a classical design with drum armature. They were originally developed for feed motors in machine

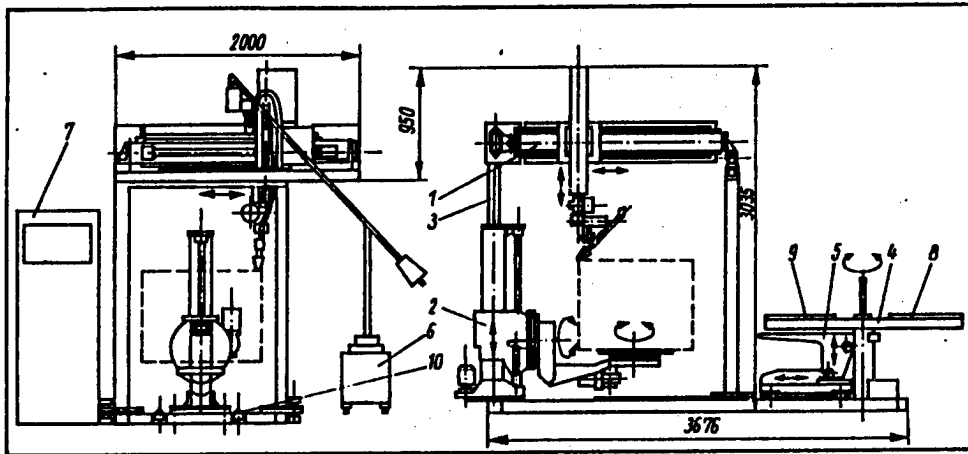

Figure 3. 7RL2 automated welding workstation

tools. The design of the robots is shown in Figure 2 [not reproduced]. It should be noted that the construction of the robot is very robust, that it carries its deck motor with it and has to manipulate with its relatively considerable mass. The total mass of the robot alone amounts to 1,350 kg, with the control system 1,900 kg. It works with a welding manipulator. The manipulator has a carrying capacity of 200 kg and two degrees of freedom; positioning accuracy is ± 0.2 mm. This welding station is intended for arc welding in a protective atmosphere (CO_2). It is used for welding medium-sized objects with a mass of up to 200 kg.

2. Robots With Stepping Motors

Robots with stepping motors are another development phase. The use of these motors would be very advantageous if pulse loss could be excluded, since the motors then work without a speed indicator and without a position indicator; both magnitudes are derived from the motor stepping digit. The initial aversion toward stepping motors as robot motors is due to the fact that resonance effects can occur. This problem can be solved by successfully modulating the current of the motor.

An example of a welding robot with stepping motor is the automated welding station 7 RL-2, which was developed in cooperation with ZTS Detva and ZTSEVU Nova Dubnica (Figure 3). The system contains five degrees of freedom. Its kinematic structure is expressed in cartesian coordinates (axes X, Y, Z, Figure 4). At the end of the Z-axis are two additional motors, for rotating the welding torch (ϵ) as well as for adjusting the rotation radius (r).

The welding object is fastened on the operation manipulator, which, by means of its two degrees of freedom (α, γ), can adjust the object to the best position for the welding.

Figure 5 [not reproduced] shows the work station with yet another auxiliary manipulator and two tables. This station serves to exchange the welding objects for the operation manipulator, as well as to prepare the next object.

The drive units are designed with stepping motors. The linear kinematic units (axes X, Y, Z) have a ball spindle drive. The stepping motors are operated in an open loop and are fed from a transistor power source in a bridge circuit method. The stepping motors are controlled with sinusoidal currents. By so doing, it is possible to avoid oscillations in motors in resonance zones and in case synchronization fails. Also, in the dynamic moment a large reserve serves to prevent stepping loss. If, in exceptional cases, stepping losses were to occur, the robot would return to the starting point after the end of each work cycle, and a correction would eventually be made.

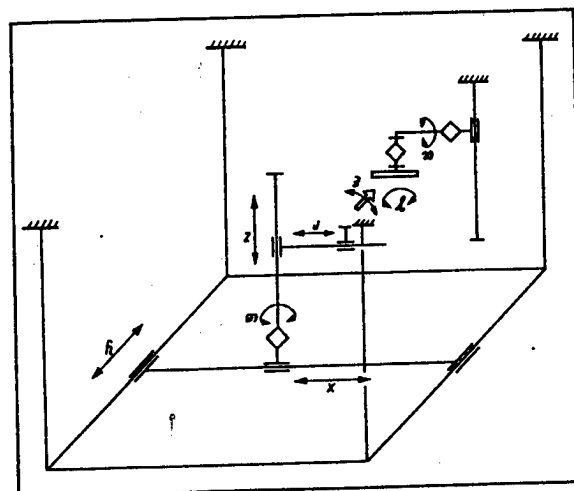

Figure 4. Kinematic view of the 7RL2 robot workstation

The core of the control system is the JPR 13 processor with an operational memory of 4 k x 16 bit. The system can carry out the following movements: straight in the plane, straight in space, circle in the plane, circle in space and spiral in the plane. Programming is undertaken through teach-in. The work station is intended for welding jobs in a protective gas atmosphere (CO₂). The maximum dimensions of the parts to be welded are: 1,000 mm x 1,000 mm x 800 mm; their maximum mass is 250 kg.

The application area corresponds to that of the PR 32 E robot. In comparing design, it must be recognized that the maximum of the mass is located in the immovable supporting structure, while the movable robot parts form the considerably smaller part of the mass. The total mass of the work station including the manipulators and the control system amounts to 3,000 kg. The mass of the robot, meaning that of the movable parts, is only 400 kg.

Robots With Direct-Current Disk-Armature Motors

The best results so far have been achieved with robots which have a direct-current disk-armature motor and are fed by a transistor frequency converter. In the CSSR, disk-armature motors from the production of the Romanian Socialist Republic are used. Their technical parameters are compiled in Table 1.

Table 1. Technical Parameters for the Disk-Armature Motors

| Motor type | P W | M Ncm | n min ⁻¹ | M _{max} Ncm | J kgcm ² | U V | I A | I _{max} A | m kg |
|------------|--------|----------|------------------------|-------------------------|------------------------|--------|--------|-----------------------|---------|
| SRD 80 | 100 | 31.8 | 3000 | 152 | 3.5 | 15.5 | 13.6 | 65 | 3.2 |
| SMU 180 | 180 | 57.5 | 3000 | 340 | 3.5 | 24 | 11 | 65 | 7.5 |
| SRD 350 | 350 | 112 | 3000 | 1220 | 3.2 | 62 | 17.4 | 65 | 8.0 |
| SRID 2 | 750 | 238 | 3000 | 1425 | 15* | 64 | 16 | 95 | 25* |
| SRD 1000 | 1000 | 320 | 3000 | 2440 | 12 | 82 | 15 | 100 | 14.5 |

*)Including brakes

It can be seen from the technical parameters that the motors have a high torque overload (4 to 7.5 times) and a very low moment of inertia, which results in the low mechanical time constant. The low mass of the motor is also very favorable. A disadvantage is the rated speed of 3,000 rpm. This problem is resolved by using an arbor drive with a ratio of i = 100 to 200.

This motor was developed and produced in the CSSR by the ZTS Research and Development Institute in Zvolen. Its technical parameters are given in Table 2.

Table 2. Parameters of the ZTS-VVU Zvolen Arbor Drive

| Type | HP60 | HP80 | HP100 | HP120 | HP160 | | |
|------|------|------|-------|-------|-------|-----|------|
| i | 124 | 104 | 207 | 104 | 207 | | |
| M | Nm | 71 | 153 | 320 | 565 | 600 | 1120 |

| | | | | | | | |
|------------------|--------------------|------|------|------|------|------|------|
| n _{max} | min ⁻¹ | 7500 | 7000 | 5600 | 4500 | 4500 | 3500 |
| J | kg/cm ² | 0.5 | 2.0 | 6.0 | 15 | 15 | 65 |
| m | kg | 0.6 | 1.25 | 2.3 | 4.55 | 4.55 | 9.35 |

i = Conversion ratio
M = Torque of the slow-moving wave,
n_{max} = Maximum entry speed,
J = Moment of inertia related to entry wave,
m = Mass of the motor components.

The disk-armature motors in connection with arbor drives achieve the required low operating speed. For the nominal motor speed of 3,000 rpm, the output speeds are 0.48 s⁻¹ (with i = 104) to 0.24 s⁻¹ (with i = 207). It is important that the drives have a low moment of inertia and a small mass.

A successfully implemented example of robots with this motor system is the OJ-10 robotized modular operational work station. This system was developed in cooperation with ZTS-EVU Nova Dubnia, ZTS-VVU Zvolen and the Institute for Technical Cybernetics of the Slovak Academy of Sciences (UTK-SAV), Bratislava. A schematic drawing of the work station is shown in Figure 6, and its kinematic structure in Figure 7 [not reproduced]. The work station consists of the OJ-10 RS industrial robot with five degrees of freedom, two OJ-10P position manipulators with a carrying capacity of 250 kg and two controllable axes, the adaptive control system for 10 continuously variable axes and an image recognition system. It is intended for arc welding in protective gas atmospheres in small and medium-sized series production. The modular conception makes it possible to use the industrial robot for assembly work as well. In that case the robot is equipped with an additional (sixth) degree of freedom.

The overall design of the robot is shown in Figure 8. The motor units are constructed with direct-current disk-armature motors (Table 1) (Type SRD 350 with 350 W power and SRD 80 with 100 W power). The position manipulators are equipped with motors of type SRID2 (750 W) in both axes. All axes have arbor drives (ZTS VVU Zvolen; Table 2).

The gear motors are fed by four-quadrant transistor impulse converters. The converters have a clock frequency of 3 kHz. In order to achieve the maximum possible dynamic including reverse operation, the motor is fed by symmetrical (positive and negative) voltage pulses. The result of this is that in the vicinity of zero the average voltage value is zero. The converters are designed for a nominal voltage of 70 V and a nominal current of 25 A, as well as a maximum current of 50 A.

The suspension design of the OJ-10 RZ robot is shown in Figure 9 [not reproduced]. The two robots can work together. In this configuration the suspended robot brings the welding parts to a manipulator. After finishing the operation, the robots work on the opposite manipulator.

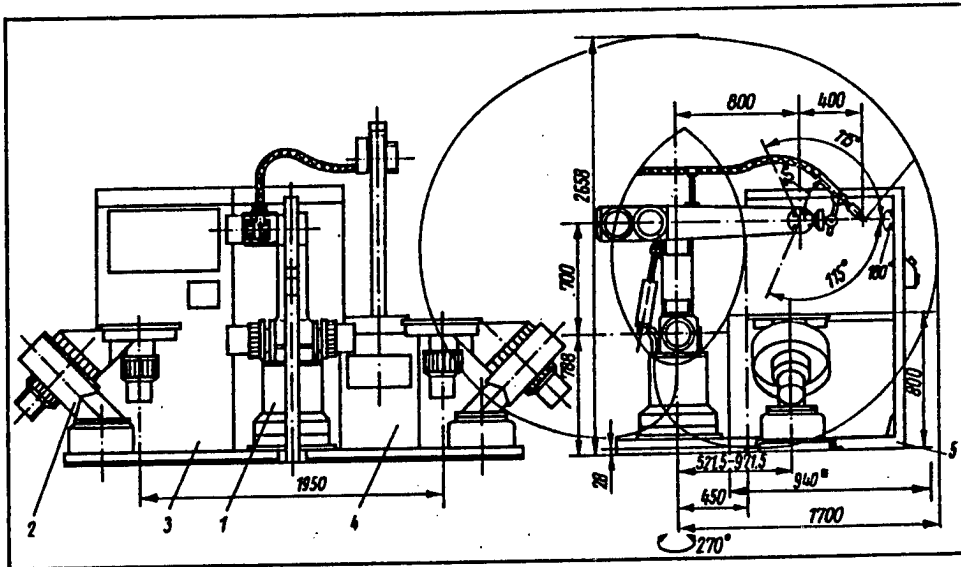

Figure 6. 0J-10 modular robot workstation. (* table surface)

The control system carries out the following basic functions:

a) Automatic operation

- Movement of the articulated ends of the robots according to a prescribed course with linear or circular interpolation (CP control) at constant speed; the speed of the end can be selected in 8 steps
- Movement from point to point (PTP control)
- Independent movement of the manipulators in two axes

b) Manual operation

- Movement of the individual motors of the robots and the manipulators with 8-step variable speed

c) Control of the technical welding installation

- Welding current power in five steps
- Welding wire feed in five steps

d) Enables control of an additional 16 application-specific functions through customer inputs and outputs.

A modular adaptive control system, MARS-1, forms the central part of the control system. It involves a modified microcomputer system based on the SM 50/50, which was developed at the UTK-SAV. The basic design of the microcomputer contains a 16-bit processor and a 28 k x 16-bit operational memory.

The SM 54/30 image recognition system was developed in order to be able to use the robot for assembly work. The image resolution contains 256 x 256 pixels. The speed of the image processing is characterized by:

- reading, coding and storing the image: 20 ms
- analyzing interrelationships by calculating moments of the first and second degree: 300 ms.

The 0J-10 robot is produced in lightweight construction. Its mass is 300 kg, that of the control system 500 kg.

4. Summary

Electrically driven industrial robots with disk-armature motors and arbor drives combined with transistor impulse converters form the drive units which meet the highest demands for dynamics, positioning accuracy, wide operating range and low mass. Industrial robots with these drives achieve good technical parameters. Automated production systems can be equipped by connecting up additional machines and installations, particularly by using the mobile robot system (MRS),

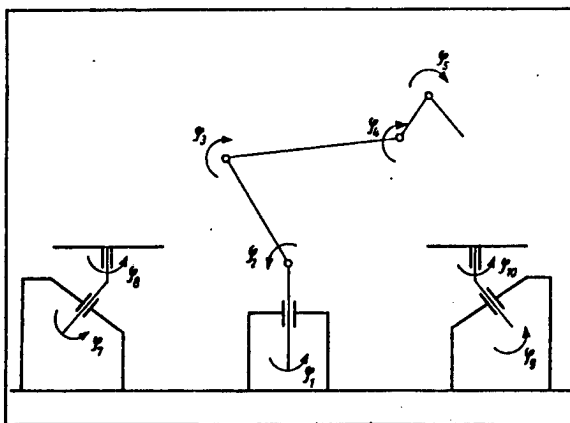

Figure 8. 0J-10 industrial robot

which can be interlinked. An example of a similar system from the ZTS production was demonstrated on the occasion of the international trade fair "ROBOT'86" in Brno.

Bibliography

1. Racek, V; Docar, M.: "Control System and Regulating Drives of an OJ-10 Automated Robot Modular Workstation," 5th Power Electronic Conference, Budapest 1985, Conference Proceedings, Hungarian Elektrotechnical Association.
2. Racek, V.: "Elektrische Antriebe fuer Industrieroboter" [Electrical Drives for Industrial Robots], International Scientific Conference: "Der Beitrag der Wissenschaften zur automatisierten bedienarmen Production" [The Contribution of the Sciences to Automated Low-Labor Production], Karl-Marx-Stadt Technical University, 1986.
3. Docar, M; Buday, J.: "Riadiaci system a pohony robotizovaneho pracoviska OJ-10"[Guiding Systems and Driving Mechanisms for an Automated Workshop OJ-10], VYKONOVA ELEKTRONIKA 7 (1983) p 3.
4. Palacka, V; Galik, L; Biernacki, E.; Magyar, F.: "Operacny system riadiaceho systemu automatickeho zvaracieho zariadenia"[Operating System for a Guiding System in an Automated Welding Facility], VYKONOVA ELEKTRIKA 7 (1983) p 3.

Czechoslovak-Soviet Collaboration in Robotics Discussed

24020015 Prague CESKOSLOVENSKA
STANDARDIZACE in Slovak No 11, 1988 pp 445-447

[Article by Eng Pavel Sutak, VUKOV State Enterprise, Presov: "Inclusion of the VUKOV Enterprise in International Scientific-Technical Collaboration With Organizations in the USSR"]

[Text] From the beginning of its activities in the 1970's, the VUKOV State Enterprise in Presov, at that time still functioning as the Research Institute for the Metals Industry—took an active part in the international division of labor. The goal of this activity was to utilize the possibilities presented by the socialist division of labor and to use direct cooperation in the acceleration and improvement of the quality of research and developmental activities in the creation of complex engineering and electrotechnical facilities, which also include robotization and automation devices and complexes falling into the research and development and production program of the VUKOV Enterprise in Presov.

The most important partner within the framework of including the VUKOV Enterprise in the international scientific-technical collaboration among socialist countries is the Soviet Union. An important share in the active inclusion and intensification of cooperation

involving organizations in the USSR was played by the adoption of the Comprehensive Program for Scientific and Technical Cooperation Between Czechoslovakia and the USSR in the area of robotics which, at the time of its adoption in 1982, included 13 topics, the majority of which were aimed at the joint development of industrial robots, manipulators, and RTK's (robotized production cells) intended for technologies handling machining, metal forming, pressure casting, arc welding, and surface treatments, with 5 topics being cross-sectional in character. These topics were aimed at the development of microcomputer control systems for PR's (industrial robots) and RTK's, elements and components for the production of PR's, research in the long-term directions of robotic development and standards and standardized regulations covering the given area.

In the period 1981-1985, the most important outputs stemming from scientific-technical cooperation with organizations in the USSR included the completed work involving the joint development of the following types of industrial robots:

- UM-160—for the creation of RTK's for the machining of heavy crankshafts, which was developed in cooperation with ENIMS in Moscow;
- AM-5—for the creation of RTK's for flat metal forming, developed in cooperation with ENIKMAS in Voronezh;
- MTL-10—for the creation of RTK's for pressure casting, developed together with the NIISL in Odessa.

Joint development was able to shorten the research—development—production—use cycle by 2 years. Simultaneously, utility parameters were increased, the degree of unification of developed PR's through the use of elements produced in Czechoslovakia, the USSR, and the other CEMA member countries resulted in considerable savings pertaining to research-developmental capacities.

The above-listed industrial robots and manipulators were included in the production program of the ZPA Industrial Automation Plants at Presov, at the Snina Plant at Vihorlat, and were also produced by selected Soviet organizations.

Extremely good results were achieved in the period under consideration involving IES Patona in Kiev where, within the framework of jointly solving the problem of sensors for guiding welding torches, a joint invention (VUKOV—IES) was registered and a technical report led to the mutual exchange of materials for developing an RTK for arc welding, something which contributed to the higher technical level of solving tasks in both cooperating organizations.

The culmination of cooperation with Soviet organizations during this period involved the establishment of a joint design and technological office—the PKTK "Robot" at Presov—which was established in 1983 for purposes of jointly designing RTK's and technological

production lines in accordance with specific user requirements in Czechoslovakia and in the USSR. Within the framework of the activities conducted by the PKTK "Robot" office, designs and documentary material were worked out for preparing contracts for the delivery of a flexible production system for machining crankshaft components with a mass of up to 160 kg and a flexible production system for a production line for flat forming, involving stampings weighing up to 1 kg.

The contract for delivery of the flexible production system for machining crankshafts was concluded and delivery of the system was made to the Velikiye Luki Locomotive Repair Works (USSR).

Currently, with the participation of appropriate foreign trade enterprises, preparations are under way for concluding a contract for the delivery of a production line for flat forming.

Scientific-technical cooperation which is gradually transformed to a contractual basis is a characteristic manifestation of the realization of joint intentions of the organizations involved in the given period.

The participation of the VUKOV Enterprise in Presov in the technical-economic preparation and startup of activities of the MVVZ ROBOT (Czechoslovak-Soviet International Scientific-Production Association for Robotics), which has its seat at Presov, must be viewed as being of no less significance than the participation of the PKTK "Robot" office in establishing and fulfilling its tasks.

The establishment of the MVVZ ROBOT in 1985 gave rise to the creation of suitable conditions for the work of a joint collective of specialists from both countries, the goal of which is the efficient utilization of existing developmental and production capacities for the accelerated application of robotics and automation technology in Czechoslovakia, in the USSR, and in the other CEMA member countries. The work program is gradually taking on solutions of demanding tasks which we are encountering in the area of comprehensively automated plants and involving the comprehensive automation of the national economy.

A new era of cooperation involving the VUKOV State Enterprise in the area of automation and robotization with organizations of the USSR began at the end of 1985 and at the beginning of 1986. The approval and signing of the Comprehensive Program of Scientific Progress for CEMA Member Countries Through the Year 2000 (KP VTP) established an entire series of demanding tasks which can only be solved through active participation in the process of international socialist division of labor. The second priority direction of the KP VTP—"Comprehensive Automation"—follows, among others, the problem of developing and introducing into practice flexible automated production processes, industrial robots (accompanied by lowering their production costs

and their design costs by one-third); support for broad mutual interchangeability of aggregates, modules, and components selected by CEMA member countries while lowering the labor intensity of producing these facilities by one-half; the objective is to achieve a two- to fivefold increase in labor productivity by introducing flexible production systems. These are extremely important tasks which, in the framework of bilateral cooperation between Czechoslovakia and the USSR, were specified in the adopted Comprehensive Program of Scientific-Technical Cooperation (VTS) in the area of development and production of robotic equipment, robotized complexes, flexible production systems and their components for various branches of the national economy and for various organizations and for their coproduction involving Czechoslovakia and the USSR for the period 1986-1990.

Currently, the Comprehensive Program of VTS includes the following:

- 13 topics of a basic scientific research and standardization nature in the area of robotics equipment;
- 11 topics of a design character.

In addition, cooperation is ongoing in the area of developing and delivering RTK's and flexible production systems on the basis of orders placed by organizations in the USSR and in Czechoslovakia.

With the goal of assuring the tasks stipulated in the Comprehensive Program of VTS, the VUKOV Enterprise is participating in the fulfillment of 17 work plans concluded prior to 1986 or during 1986. Among the most important outputs involving the tasks being solved during the period from the beginning of 1986, it is possible to list the following:

- conclusion of acceptance tests including the Model APR-2.5 industrial robots for assembly work and for the Model GNOM-51 industrial robot for flat forming of workpieces weighing 1 kg;
- completion of the work involved in the development of a Model APR-20 industrial robot for arc welding. Development of a mechanical part of the industrial robot was taken care of by the Czechoslovak side; the Soviet partner provided the asynchronous drive (both of the above topics were realized on the basis of contracts);
- technical orders for the production of industrial robots for robotized complexes for the production of batteries (OVNIIETO Kharkov) and for the hot working of camshafts for tractors (VNIITVC Leningrad) were serviced;
- technical orders for the development of an RTK using four various types of coating applications were serviced together with the SVUOM Enterprise of Prague and involved the NPO Lakokraspokrytiye and the NPO Astrakhanmasokraska Plant in Astrakhan.

At this point, it is necessary to recall the long-term contract which the VUKOV organization has with Gosstandart of Moscow, on the basis of which cooperation in the area of standards and standardization is developing.

Currently, this cooperation is aimed at working out seven unified standards in the area of robotics. The working out of the documentation for individual standards is broken down according to specialty between both participating organizations and both VUKOV and also Gosstandart are having the material worked out by professional organizations. In the process of working out the standards, they are commented on and coordinated on a bilateral basis.

Cooperation between VUKOV and Gosstandart in Moscow is turning out to be advantageous during the time of preparation and realization of the multilateral negotiations of the CEMA member countries regarding this problem area.

The VUKOV Enterprise in Presov is also actively participating in the multilateral cooperation among CEMA member countries in the area of standardization pertaining to components of industrial robots.

Overall, the VUKOV Enterprise is participating in the solution of 15 CEMA standards in the area of industrial robots. Five of these standards (VUKOV is the author and coordinator of one of them) were the subject of negotiations by the Temporary Working Group of Specialists, which took place in March (1988) in Presov. The negotiations resulted in a number of positive results and two CEMA standards (Industrial Robots, General Technical Requirements, and Modular Industrial Robots—Modules, Classification) were approved; with respect to another two standards, in view of the necessity for accepting the principles of the standards issued by the International Standardization Organization, it was agreed to complete the work with changed deadlines.

The results of the negotiations of the Temporary Working Group of Specialists in Presov were fully approved at the Sixth Session of the Branch Bureau No 2 in June of this year in Yugoslavia.

A broad area in the realization of cooperation involving organizations in the USSR was created after the signing of the Agreement on the Establishment of the INTER-ROBOT International Scientific-Production Association (18 December 1985). Cooperation between partner organizations is realized on the basis of agreements which are prepared in conjunction with overall rules for the establishment of direct relationships.

In the previous period, VUKOV Presov concluded agreements with the MNTK ROBOT organization in Moscow, the subject of which is the development of a number of portal robots with a capacity of 80 and 160 kg, the development of assembly devices, and the development of test stands for testing industrial robots. An

agreement was concluded with the NIIRavtoprom in Kiev calling for the erection of automated suspension conveyors for the automobile industry.

In order to solve a number of problems involving portal robots and with the goal of supporting the individual concepts of unification, specialization, and coproduction, a joint collective consisting of specialists from VUKOV Presov, from MNTK ROBOT in Moscow, from UKRNIISIP in Odessa, and from MVVZ ROBOT Presov was established in Moscow and began to function in May 1987. Realization of the prepared concept anticipates the participation of additional organizations (S.M. in Kirov, in Mukachevo, and the Sterlitamak VTS Enterprise) which will lead to the efficient utilization of existing production capacities and to the creation of conditions for the development of the production potential existing in Czechoslovakia and in the USSR which is capable of supporting the needs of both nations.

Realization of the intentions at VUKOV Presov within the framework of scientific-technical cooperation and involving organizations in the USSR in the area of robotics has led to the creation of conditions for the comprehensive solving of tasks stipulated in the second priority direction of the KP VTP—"Comprehensive Automation." Experiences hitherto clearly confirm that the quantity of problems which must be solved on an accelerated basis in the given area can be mastered within the framework of the international socialist division of labor and as a result of mutually advantageous cooperation between CEMA member countries, an example of which is the cooperation between the VUKOV Enterprise of Presov and organizations in the USSR.

MICROELECTRONICS

Microelectronics Production at Leading GDR Combine Examined

Products

Warsaw PRZEGLAD TECHNICZNY in Polish
No 41, 1988, p 5

[Article by KD: "Automatic Multipoint Probe—Ion Etching"]

[Text] This article discusses the equipment used to manufacture very large scale integrated circuits. (This issue contains additional details on the accomplishments of the Carl Zeiss Jena integrated enterprise (combine) in the GDR.)

Automatic Multipoint Probe

The Elektromat plant in Dresden (part of the Carl Zeiss Jena integrated enterprise) manufactures AVT 120 automatic equipment for measuring punctate integrated circuits prior to cutting of the base, to eliminate defective circuits from subsequent technological operations, that

is, assembly and sealing. Measurement is carried out by bringing the contact halves of each integrated circuit into contact on the circuit board through the tips of the measuring needles, inputting certain electric signals, and measuring the voltage at specific points of the circuit. The circuit is rated as good or bad on the basis of the measurement results. Bad circuits are marked and their location on the board is stored in the memory of the control computer. The AVT 120 can be used to measure the values of integrated circuits on boards up to 150 millimeters in diameter with a maximum of 60, 80, or 90 contact fields (leads) having minimum dimensions of the order of 100 x 100 millimeters. The measuring table can be displaced 400 millimeters and 170 millimeters respectively along the x and y axes. The bases are introduced into an input magazine, automatically removed, and transferred by compressed air to a testing stage, where, after the characteristic points have been found and set by the operator (under the microscope), measurements are made automatically for all the circuits on the board in accordance with a program, the bad circuits are marked, and the board is transferred to an output magazine.

Ion Etching

The ISA 150 made by the Carl Zeiss Jena integrated enterprise is designed for ion etching of layers of semiconductors, insulating materials, and metals in production of large-scale and very large-scale integrated circuits, on boards up to 125 millimeters in diameter. Regulated amounts of 4 different gases may be used for the etching; the ones most commonly used are argon and gases containing oxygen and fluorine. The type of gas employed depends on the assumed nature of the process. When inert gases are used, the process is physical in nature, while chemical reaction begins to predominate when the number of ions of active gases such as fluorine, chlorine, and oxygen increases. The ions of gases in the plasma state are accelerated to energies of 200 to 2,000 electron-volts and are focussed in an electron optical system. The equipment is controlled by computer, with data stored on floppy disks.

Layer Production

The majority of modern semiconductor elements are made in layers. The process by which they are produced begins with creation on a semiconductor circuit board of a uniform layer possessing the desired type of conduction and concentration of dopants. The technology most commonly employed for producing such layers is chemical application from the gaseous phase (CVD, chemical vapor deposition). The VEB Elektromat plant in Dresden makes a number of HCVD series devices for creation of thin semiconductor layers by this method. The HCVD 43 machine (with which the boards are loaded before the process begins) and the HCVD 63 (a continuous-flow unit) are used at normal pressure and at temperatures up to 773 degrees Kelvin (500 degrees centigrade). They are used to produce doped and undoped layers of silicon and silicon dioxide in an

atmosphere of oxygen and silicon compounds (SiH_4), phosphorus (PH_3), and boron (B_2H_6). The more recent HCVD 52, 53, 54, and 55 units operate under a reduced pressure of 10 to 1,000 Pascal, also at temperatures of 773 to 1,223 degrees Kelvin (500 to 950 degrees centigrade). The HCVD 53-55 models are thermal units, and the HCVD 53 may be used to generate layers by thermal methods or by use of high-purity plasma. In addition to generation of doped and undoped silicon and silicon dioxide layers, these units create doped and undoped layers of polysilicon and silicon nitride (especially HCVD 52). In addition to the compounds named earlier, they use silicon hydrochloride (the HCVD 55 SiH_2Cl_2 only), ammonia, nitrogen, and nitric oxide. The stabilized-temperature operating area of the equipment is 800 millimeters long. A total of 50 to 100 silicon circuit boards 76 to 125 millimeters in diameter are processed in a single operation.

IC Production

Warsaw *PRZEGLAD TECHNICZNY* in Polish
No 41, 1988, pp 24-25

[Article by KD: "Microelectronics Across the Oder"]

[Text] The greatest achievements in microelectronics in the CEMA countries have been made by the German Democratic Republic, along with the Soviet Union. This is due among other things to the action taken consistently to integrate scientific and industrial potential. The Carl Zeiss Jena integrated enterprise can today market a virtually complete production line for manufacturing very large-scale integration integrated circuits with traces 1 micron wide. Few countries have reached a technological level such as this in this area.

This article presents the accomplishments of this integrated enterprise in building technological equipment for microelectronics. Some of the items are discussed in greater detail in "Sygnaly o Technice" [Engineering Notes] (p 5).

The development of electronics occupied a prominent place in the economic plan of the GDR for the current 5-year period, which called among other things for a 24 to 26-percent increase in national income, 22 to 24-percent growth of industrial output, and a rise of at least 22 percent in real wages. These figures approximate the targets reached during the last 5-year plan period and on the basis of accomplishments observed thus far should be reached or exceeded. Consecutive decisions have led to significant increase in the tasks assigned to the electronics industry. A total of 90,000 computer systems are to be produced rather than the 28,000 originally scheduled. There are to be 65,000 robots and manipulators in operation in industry by 1990, that is, their number is to be double the initial figure. The value of the annual output of microelectronic products is to rise by about 40 percent, while prices for such products are to drop sharply. Similar growth is projected in other areas of electronics. Particular emphasis has been placed on

development of communications equipment; plans call for creation of an integrated digital communications network utilizing fiber optic connections.

Production of modern high-output technological equipment for the semiconductor industry occupies an important place in these plans. Some types of this equipment have been made in the past by the Carl Zeiss Jena combine, which has also been selected as the primary manufacturer of such equipment. Development work started at the beginning of the 1970s on many items of "microlithographic" equipment (to use the German terminology), and later production of such equipment began. It is used to create patterns (topology) of integrated circuits on photomasks and semiconductor substrates, along with measuring equipment to monitor these processes. The firm has exploited its experience in the areas of optics and electron optics.

A decisive factor in initiating the very costly work was cooperation with the USSR and the prospect of large Soviet orders running to hundreds of units for such equipment (ZBA, ARM, AUR) each costing several hundred thousand and totalling more than a million rubles. A new plant was built in Jena during the 1970s specifically for the manufacture of production equipment. The decision to concentrate manufacture of production equipment at the Carl Zeiss Jena combine was incorporation of the Elektromat plant, the Hochvakuum plant, and the Microelectronic Research Center, all located in Dresden, in this combine as of 1 January 1988.

For many years the Elektromat plant has made monitoring equipment for the semiconductor industry. Somewhat later it began to make equipment for creation of thin films on the surface of semiconductors by diffusion, vapor deposition, and cathode sputtering, along with other equipment for treatment of semiconductor chips. The Hochvakuum plant makes vacuum equipment, while the Microelectronic Research Center concerns itself with applications of the equipment manufactured, programming the development of this equipment, and production of certain types of integrated circuits.

The most recent Leipzig Spring Fair afforded an excellent overview of the state of the art and the production of the combine. The exhibit placed on display in the combine's own pavilion (built by Polish enterprises) confirms that the combine has consistently switched over to microelectronics production (without, however, neglecting manufacture of glass, optical instruments, photographic apparatus, etc). Virtually the entire range of equipment was on display at the fair, including units requiring extremely clean air conditioned rooms not open to the general public. Several new items have made their appearance to supplement the previous product mix. The result is that the combine can now market an almost complete set of equipment required for manufacturing very large scale integrated (VLSI) circuits with traces of the order of 1 micron or narrower.

The set of equipment includes the following:

Equipment for Creation of Patterns on Photomasks and Semiconductor Chips.

- The ZBZ 20 and ZBA 21 systems for creation of submicron patterns on glass chips (photomasks) with dimensions ranging from 4 x 4 inches to 17 x 7 inches and on semiconductor substrates with a diameter of 2.5 to 6 inches by electron beam exposure.
- AER optical equipment for transfer and reproduction (1:10 reduction) of patterns onto photomasks measuring 4 x 4 inches to 7 x 7 inches.
- AUR optical equipment for transfer and reproduction (1:5 reduction) of patterns onto semiconductor substrates with diameters of 4 to 6 inches by using ultraviolet radiation.
- The JuB 2111 automatic exposure unit for direct transfer of submicron patterns to submicron substrates measuring 3 inches to 4 inches.
- The Jub 2104 exposure unit for direct transfer of patterns to semiconductor chips with diameters from 1.5 to 3 inches, or to photomasks measuring 50 x 50 millimeters to 101 x 101 millimeters.

Control and Measuring Equipment

- The ZRM 20 electron microscope with a maximum resolution of 10 nanometers and magnification ranging from 180 x to 300,000 x for monitoring photomasks and semiconductor masks with the dimensions indicated above.
- The DKG11 for monitoring photomasks (automatic flaw seeking starting at the micron level) measuring 3 x 3 inches to 7 x 7 inches.
- Equipment for comparison of SVG 20 photomasks with the foregoing dimensions with submicron accuracy.
- The Jenatech microscope with magnification of 25 x to 1600 x.
- SKP 01 and SKP 02 stands for visual inspection of masks and substrate plates.
- The AVT 120 stand for point measurements of circuits on semiconductor boards before they are cut*.

Equipment for Machining Semiconductor Boards

- This category includes a number of systems for creating thin films on the surface of a semiconductor by vacuum deposition from the gaseous phase by a thermal method: the HCVD 43, HCVD 63, HCVD 53, HCVD 54, and HCVD 55, and the HCVD 52 plasma unit. The systems are used to create thin films of silicon oxide, silicon nitride, and polycrystalline silicon with the possibility of doping*.
- The HZSU 03 for plasma spraying of chiefly metal film on the surfaces of semiconductor and ceramic chips and the HZSK 04 for application to capacitor ceramics (both sides).

- The BET 150 system for washing, application, and generating photoresistance on the surface of semiconductor chips with diameters of 2 inches to 5 inches (a system for 6 inches is in preparation)*.
- The ISA 150 for ion etching of semiconductor chips with a diameter of 5 inches.

Bonding and Sealing Equipment

- The VACB 01 equipment for eutectic bonding, cementing, and soldering of semiconductor structures with an assembly length of 0.3 to 6/10 millimeters on open-work or dielectric bases*.
- The VADB 20 for automatic bonding with ultrathermocompression gold wire or VADB 60 for ultrasonic bonding with aluminum wire of 60 connections of the fields of semiconductor contact structures or contact fields on a ceramic chip (hybrid version of the VADB 60)*.
- The MDG 10/11 for manual ultrasonic assembly with aluminum wire and MD 20/21 for contact field connection of semiconductor structures with contact terminals or fields in hybrid systems.
- The MIII assembly line made up of the following equipment: the MCK for assembly of structures on ceramic bases, MKK taping unit, MVK system for enclosing in flat-pack 14-pin or 16-pin ceramic housings, and the TVK furnace for heat-sealing housings.

Only a few countries manufacture such a complete set of equipment for microelectronics. Among the socialist countries, only the USSR makes such a wide range of equipment. In Poland no attempt has ever been made to develop the majority of these types of equipment. The technical characteristics of the equipment correspond to the world average. The majority of the systems, aside from the simplest units, are computer-controlled. Laser interferometers are generally used to position chips and adjust sharpness in the microlithographic systems. The majority of the integrated circuits and other subassemblies used are made in the GDR (mention should be made of integrated diode scales made up of 1,024 diodes and used in the DKG instruments).

Very large scale integration circuits were also on display at the Leipzig Fair: static RAM of up to 64 kilobytes, dynamic RAM of up to 256 kilobytes, single-circuit 4-bit microprocessors, gating matrices, and standard cells. The Microelectronics Research Center has used its own equipment to manufacture these circuits. The U2164 64-kilobyte dynamic RAM chip containing 140,000 transistors has been in production since the end of 1985, 400,000 units being made by the end of 1988. Production has also begun of the U61256DC 256-kilobyte dynamic memory chip and the U6264DG 64-kilobyte static RAM chip, each cell of which contains 6 transistors. These circuits are made by CMOS technology, with a trace width of 1.5 micron. One cell of dynamic (single-transistor) memory occupies an area of 50 square microns, and one cell of static memory 286 square microns. The gating matrix and standard cell circuits and microprocessor circuits with RAM expansion units

on a common board, also made by using CMOS technology, are circuits with which a customer can design his own connection layout to create a system tailored to meet his own specific requirements.

Despite the demand for production equipment made in the GDR, only individual copies of older microetching equipment, manually operated assembly equipment, exposure devices, and rather simple measuring instruments have been in service in Poland. This situation is due to unfamiliarity with the production programs of neighboring countries, coupled with the passive approach adopted by the Unitra Foreign Trade Enterprise (which until recently had responsibility for this product range), possibly resulting from very poor staffing of the department servicing the GDR market, and trade balance restrictions in the annual Polish-GDR trade plans. It has been difficult to obtain German supply offers because of the heavy domestic demand and the GDR's long-term export commitments. The situation is better today to the extent that the services of other more efficient agencies are available. Moreover, aside from the equipment difficult to obtain, there are many products which may be purchased immediately. If some of the available items are bought, it is easier to start discussions about purchase of other equipment. Representatives of the Carl Zeiss Jena combine state expressly that they are very interested in exporting the combine's products to Poland, among other things because many of them are in operation in other socialist countries and Poland represents almost the only blank spot on the GDR export map. The activities of the combine's technical bureau at the GDR Skilled Craft Industries and Trade Office in Warsaw, which have been vigorously pursued for some time now, and the series of seminars organized in 1989 at the GDR Culture and Information Center show that these statements are true.

IC Bonding Equipment

*Warsaw PRZEGLAD TECHNICZNY in Polish
No 41, 1988, p 25*

[Article by KD: "Assembly Equipment"]

[Text] The latest equipment made by the Elektromat plant in Dresden (part of the Carl Zeiss Jena combine) is the VACB 01 automatic bonder for fastening structures, integrated circuits (chips), on openwork boards, and the VADB 60 for bonding wire connections. The VACB 01 bonder consists of 2 work stations. At the first station the quality of structures cemented on a foil strip is checked and the structures are taken from the strip and positioned on openwork boards. Eutectic bonding of the structures and boards is carried out at the other station. Soft soldering, glass bonding, and cementing may also be carried out at this station. The equipment is outfitted with an image recognition television system operating in conjunction with a computer controlling the operation of the entire system for the purpose of quality control and structure positioning. The structure strip and the openwork board strip are fed automatically. The process of

separating the structures from the strip and their transfer and positioning is also carried out automatically. The output of the system is as high as 3,600 connections per hour.

The VADB 60 system for ultrasonic bonding of aluminum wire 25 to 50 microns in diameter is made in two versions, one for hybrid assembly and one for mounting on openwork boards. The versions differ from each other in the size of the operating field and the possibility of displacing the base relative to the tool along all three axes (hybrid version) and the pertinent equipment required. The system is controlled by a computer operating in conjunction with a display system for monitoring the positioning and the connections bonded. The connection bonding time, the ultrasonic energy intensity, and the tool pressure are automatically program-adjusted. The Elektromat plant also makes the VADB 20 ultrathermo-compression system for bonding integrated circuit structures on openwork boards with gold wire 17.5 to 50 microns in diameter. The system is similar to the VADB 60, except that the connections are bonded by thermo-compression, with the option of auxiliary use of the energy of ultrasonic vibrations.

New Products of Czechoslovak Electronics Research Reviewed

24020010 Prague VYBER INFORMACI Z ORGANIZACNI A VYPOCETNI TECHNIKY in Czech Sep-Oct 88 pp 683-690

[Article by MSG: "Novelties in Czechoslovak Electronics Research"]

[Text] The development and production of electronic novelties was presented in a graphic manner at the traditional exposition entitled "Days of New Equipment Stemming From Electrotechnical Research" which was organized this year in May in Prague and Bratislava by the A.S. Popov Tesla Research Institute for Communications Technology and saw the participation of 50 developmental and production organizations which showed a total of 180 exhibits. These included numerous components for optical communication, new types of lasers, a microprocessor control center for the production of optic fibers, units for the satellite reception of television and radio programs, hi-fi masts and color television sets controlled by a microcomputer. The majority of the exhibits were functioning samples which will not be ready for series production until the beginning of 1990-1991 for the most part. Unfortunately, there continue to exist a number of already developed facilities which would also contribute to the electronization of our national economy, but, for the time being, producers are showing no interest in them. From the standpoint of technical solutions, our research and development teams have demonstrated the capability of putting together truly key facilities; however, from the standpoint of design technology, our electronics production continues to lag behind world developments, as was

stated by Eng Rudolf Sorm, candidate of sciences, director of the A.S. Popov Tesla Research Institute, at a press conference on the occasion of the opening of the "Days of New Equipment" exposition. This is primarily a matter of applying the technology of surface assembly—a progressive process which has a decisive influence upon reliability and the functional parameters of components and final products. The following review lists those of the products which were exhibited which have a bearing on computer and information technology.

New Products Developed by the Czechoslovak Academy of Sciences and by the Advanced Schools

TC-85 System Intelligent Terminal for Computers of the Unified System of Electronic Computers (JSEP)

(Eng J. Poupe, candidate of sciences, and a collective, Computer Center of the Czechoslovak Academy of Sciences (CSAV); production assured as of 1988 by the Science Production Association of the Computer Center of the CSAV-Tesla—ZPA Equipment and Automation Plants at Cakovice; anticipated price of the program for the system—Kcs 200,000)

The TC-85 system is conceived in such a manner that it would satisfy the broadest scale of JSEP computer user requirements. The system is open and permits the attachment of specialized peripheral equipment, technological processes, and facilitates the solution of tasks in the most varied regions of the national economy, both in the routine data processing mode and also data processing used in the science and research area.

Set of Peripheral Microcomputer Plates

(Eng P. Kreipl, candidate of sciences, and J. Pribil, Institute of Radio Technology and Electronics of the CSAV, Prague; production initiated in 1988; anticipated price according to type of plate, up to Kcs 5,000)

The set includes plates for various peripheral equipment for SAPI-1 microcomputers. They are designed in such a way as to facilitate their easy adaptation for use on other types of microcomputers or collectors. Thus, for example, the plate for the EPROM disk permits the storage of programs of up to 32-Kbyte length; the plate for the A/D converter permits the conversion of 8-10-12-15 bits; the plate for the semigraphic color screen has 2,048 characters and 256 colors.

Microcomputer Modules

(M. Bursa and Eng A. Sokolik, Eng F. Kostka, candidate of sciences, and Eng V. Novak, Institute of Radio Technology and Electronics of the CSAV, Prague; production initiated in 1988)

The modules are controlled either by a single-plate microcomputer with a Model 8086/8087/8089 microprocessor or with an 8044/8051 microprocessor. Apart

from controlling an AMS or SMP collector, the microcomputer facilitates a connection to the bitbus collector and, thus, the interconnection of several microcomputer systems. The modules contain units which are completely universal, as well as units, the development of which was compelled by MCVD technology. In view of the fact that the AMS and SMP converters were recommended for the Czechoslovak electrotechnical industry, it can be anticipated that it will be gradually possible to augment these modules by the addition of units from other Czechoslovak producers.

Hodaton

(Eng P. Sindler, Eng J. Kos, and J. Loeffelmann, Institute of Radio Technology and Electronics of the CSAV, Prague; production initiated in 1988; anticipated price—Kcs 15,000)

This is a clock which is synchronized by a time code and controlled by a single-pin microcomputer. It represents a simple time standard for the industrial and the consumer sphere. The output is an LED display which shows the time, the date, and the day of the week, there are four outlets for controlling external devices in selected time regimes, there is an audio signal with a possibility for controlling up to four time registers. Accuracy in the autonomic mode is $\pm 1.10^{-5}$ and the controlled mode has a time error rate of ± 10 msec.

Insulating 16-Bit Digital/Analog Converter

(Eng L. Jansak, candidate of sciences, and Eng M. Gabor, Electrotechnical Institute of the CEFV of the Slovak Academy of Sciences, Bratislava; prototype samples; anticipated price—Kcs 5,000)

This device has a galvanically separated digital input and an analog output and operates with the assistance of an optical digital line. Its use is intended in automated production systems, in robotics, and in remote control operations and it has a high capability to provide insulation.

FPS Functional Programming System

(Dr R. Fiby, Dr S. Molnar, and I. Weigl, Institute of Technical Cybernetics of the Slovak Academy of Sciences, Bratislava; production to be initiated in 1990; price by agreement)

This is a language device of the developed program environment which will make possible the effective creation of knowledge systems. Its use is intended for the processing of symbolic information, for applications requiring the simulation of intelligence, for the creation of related data bases, and for other areas of artificial intelligence.

PRES-80/87 Diagnostic Device for Microcomputers

(Eng E. Chan and collective, College of Machine and Electrical Engineering, Plzen; anticipated price—Kcs 9,000; assurance of production is being negotiated)

This is a piece of servicing apparatus for rapid and effective diagnostics involving microcomputer systems which have Model 8080 processors. It is capable of testing a processor with memories, to verify the correct functions of computer inputs and outputs and of peripheral equipment attached to it. It is located in a portable suitcase weighing 4.9 kg; in the servicing industry, it will result in substantially faster repairs and lower service costs.

Illuminated Information Panel

(Eng M. Stork, candidate of sciences, and P. Hrdlicka, College of Machine and Electrical Engineering, Plzen; functioning sample)

This panel is composed of floppy circuits and illuminated diodes. In conjunction with a microcomputer, it makes it possible to depict alphanumeric data. It is intended as a piece of peripheral equipment, which can be attached in the same manner as a printer. Alphanumeric data are depicted so as to be visible even from a greater distance.

ZAVT [Automation and Data Processing Technology] Concern

MXP-16 Multiprocessor Computer System

(Eng B. Kisa of the Research Institute for Computer Technology, Zilina; production has already been initiated; anticipated price—Kcs 400,000)

The system is made up of 1 controlling and 16 subordinate microcomputers, which are locally interconnected in a polygon structure through the function of segments of the operational memory. It can facilitate an operating speed of 160,000 to 4 million operations per second, depending on the regime of activity, which is provided by the operating system. In the graphics mode, it is possible to digitalize an analog signal to 10 MHz, it is further possible to generate signals for a color television monitor, including synchronization on a screen having 512 x 512 points. The operating memory of subordinate processors can be used as a RAM disk with a total capacity of 1 Mbyte. The system is intended for a broad set of applications in the area of creating and processing programs having a general nature in the multiprogram and multiuser mode; it can also be used in the area of automatic digitalization and processing of pictorial information, as well as in the area of data transmission in telecommunications networks and for data collection.

Model XSH-572 Analog/Digital Converter

(Eng J. Dostal, candidate of sciences, Research Institute for Mathematical Machines, Prague; production to be initiated in 1988; anticipated price—Kcs 1,500-2,000)

This is a 12-bit approximating analog/digital converter with a unipolar or bipolar input and a parallel or in-series output. It is intended for multiplex-type analog input units of computers and for general apparatus applications.

Multiwire Processor Plate

(A collective of solvers from the Research Institute of Mathematical Machines and from the Aritma-Praha Concern Enterprise; production as of 1988; anticipated price varies by plate dimension and density of connections and will be set individually)

This is a plate for flat hard-wire contacts for Model ADT-type computers, for testing technology, for computer systems, and for electronic control systems for technological installations. Flat hard-wire contacts make it possible to increase the density of connections by placing insulated conductors of design class V and VI in a transverse manner, that is to say, as many as three conductors in a raster measuring 2.5 mm.

Models KS-X and KS-A Personal Computers

(Assembled by the Office Machines Enterprise from imported components as of this year; price—Kcs 85,000)

The Model KS-X computer has a fundamental unit based on the Model Intel 8088 microprocessor, an operating memory of 640 Kbytes, a 360-Kbyte floppy disk unit, a 20-Mbyte hard disk unit, a keyboard, a dot-matrix printer with 80 or 136 columns, a 36-cm color monitor with a CGA or EGA control unit and other auxiliary devices according to user needs. The Model KS-A has a fundamental unit on the basis of the Intel 80286 microprocessor, a 1-Mbyte operating memory, a 1.2-Mbyte floppy disk unit, a 40-MByte hard disk unit, a keyboard, a dot-matrix printer with 80 or 136 columns, and a 36-cm color monitor.

Pulse-Regulated Source in Plate Configuration

(Eng J. Hrach, Eng Z. Petak, and Eng P. Parkan, Research Institute for Mathematical Machines, Prague; production assured by the ZPA Enterprise in Decin as of 1989; anticipated price—Kcs 2,500)

This is a network power supply source, whose input levels are sources of safe low voltage with a high degree of effectiveness. To be used in microprocessor equipment, in auxiliary devices, in measuring technology, and in automation.

Unix Unified Basic Programming

(Dr J. Pelouch and a collective, Research Institute of Mathematical Machines, Research Institute of Computer Technology Research, the Office Machines Enterprise, and the Data System Enterprise; producer as of 1989 will be the Office Machines Enterprise in Prague and the Data System Enterprise in Bratislava)

This program makes possible the efficient development of applications which are transferable among various computer systems. This is a result of the solution of a state task. The program is intended for use with the JSEP, the SMEP, the PC/XT, and the AT systems; programming languages are Fortran, Pascal, C and ADA.

Microprocessor Regulator for the Heating Industry

(Eng F. Stary and Eng L. Sapara, Automation Research Institute, Prague; producer is the ZPA Trutnov in its Usti nad Labem plant as of 1990; price of the basic system—Kcs 20,000)

This is a set of technical and program devices for the establishment of regulatory and control circuits at relay stations located in networks of the central distribution of heat, with superimposed control exerted from a higher control center. The basis for the system is a single-pin Model MHB-8031 microcomputer.

Concerns and Organizations of the Tesla Group

Model HV-03 Voice Output Device

(A collective from the A.S. Popov Tesla Research Institute, Prague)

This is an autonomous peripheral unit for the conversion of character text in the Czech or Slovak languages (alternatively also in the Russian language) to a spoken synthetic signal. Text is entered in accordance with current orthography and the phonetic transcription is accomplished automatically. The device is intended to be used as an audio output for computers, in automatic technology, in control centers, in testers, for remote guidance to be given to repair crews, as a device for the blind, or an output for information systems. It weighs 2 kg.

Apparatus for the Transmission of Information via Optic Fibers

(Eng M. Syrovatko and a collective, A.S. Popov Tesla Research Institute, Prague; to be produced as of 1989 at the plant in Kosice; anticipated price—about Kcs 75,000)

The apparatus is intended for the transmission of a color television signal on a wavelength of 0.85 micrometer for monitoring purposes and for the transmission of data in computer technology and in controls. The maximum distance of transmission is 2 km and the transmission band width is 6 MHz.

System for Collecting Data From Mobile Devices

(Eng P. Landkammer and a collective, A.S. Popov Tesla Research Institute, Prague; production to be initiated in 1990; price depends on the extent of the system)

The system is intended to be used in directing and controlling the activities of mobile facilities, including data collection in the area of agricultural enterprises. It is designed to cooperate with Models VR-20 and VR-21 vehicular radio stations and with a Model ZR-21 base station. It uses two standard radio telephone channels in the 25-kHz range (a data channel and a voice channel) which are controlled by a base station equipped with a Model SAPI-1 microcomputer within a star-shaped network. The control device has a Model RS-232-C interface to facilitate connection to a superior computer.

Dispatcher Facility for 30 to 60 Subscribers

(Eng P. Rajnak and a collective, A.S. Popov Tesla Research Institute and the Tesla Plant at Stropkov, which will take care of production as of 1989; anticipated price—Kcs 150,000 to 190,000)

This device is intended for use wherever a dispatcher-type control of operations is required. It is an autonomous communications device for the transmission of spoken information between subscribers of the dispatcher network. It is characterized by centrally programmed microcomputer control, by electronic subscriber sets, by an electronic spatial communications field, by modular design, and has its own diagnostics. It can accommodate a maximum of 3.2 km of subscriber lines.

"Minifon" Autonomous Telephone Instrument

(Eng P. Hruscak and a collective, Tesla Plant at Stropkov; production initiated in 1990; anticipated price—Kcs 400)

The handset has push-button dialing, presents the possibility of redialing the last number dialed, is put together on the basis of modern electronic components, and is intended for use in a mixed digital and analog network. This handset is a fundamental representer of a new series of wall telephones.

Model M3T-324 Interface Converter

(Eng M. Vojta and Eng J. Musil, Metra Plant at Blansko; production has already been started; price—Kcs 2,000)

The converter assures the conversion of the interface to the power supply loop, which leads to lengthening the range of communications devices to a distance of several hundred meters. It can operate in a broad range of transmission speeds up to 9,000 bits/sec⁻¹. It facilitates the connection of intelligent terminals with the computer center. It also handles the mutual connection of personal computers, the attachment of distant peripheral equipment to cooperating computers, connects distant measuring centers and the controlling computer, as well as making it possible for the CNC system to be connected to a superior computer.

Push-Button Set for the Model TNS Microcomputer

(L. Brazda, Tesla Plant at Jihlava; production has already been initiated; price is being determined)

This device is intended for use on microcomputers produced by the Agrokombinat Unified Agricultural Cooperative at Slusovice and can be used to supply input data for various electronic instruments. The switching part with its housing is mounted on a metal panel which is then installed, for example, in the control housing of the computer or into another superimposed system.

Model GRM-4423 Graphic Raster Monitor

(Eng M. Bajdich and Eng S. Taraj, Tesla Plant at Orava; production initiated in 1988; anticipated price—Kcs 8,000)

This device makes it possible to depict alphanumeric or graphic information, or possibly special symbols, in color. It is suitable for attachment to series PP personal computers and to similar devices which have the required output port. The image has 320 x 200 points and the monitor weighs 19 kg.

Model Tesla Color 428 Lux Television Set With Microcomputer Controls

(Eng M. Malik and a collective, Tesla Plant at Orava; production initiated in 1990; price has not yet been determined, but will be at the level of current products)

Microcomputer control results in expressly higher utility characteristics: full electronic control of the receiver with 30 possibilities for preselection, with automatic selection of programs and their storage in memory, including individually set optimal analog values, digital depiction of set brightness levels, contrast levels, color levels, sound levels, balancing of channels, depth correction, and height correction; a system of multifunctional remote control with 79 commands which can operate in three different modes: television set control, teletext control, and magnetoscope which even provides the possibility to install a CD preheater and provides the opportunity for receiving information in the Czechoslovak alphabet as well as in the alphabet of neighboring countries. Among other advantages are included the reception and reproduction of stereophonic sounds or

two sound channels, stereo operation, quasi-stereo operation, the electronic expansion of the stereo base, and regulated auxiliary listening through earphones. The monitor has 16 push-button local controls for controlling basic functions, power requirements, including all functions, are only 90 watts. In comparison with previous types, the number of components used has been reduced by 200 (among others, there are 27 fewer transistors, 124 fewer resistors, 39 fewer diodes, etc.), the labor intensity of this monitor is also lower by 35 percent and the reliability has been increased by a factor of 2.5.

Tesla Rotes 2-01 Assembly Robot

(Eng J. Hecko and a collective, Tesla Research and Production Institute for High-Voltage Electrical Engineering, Bratislava; production initiated in 1990 by Tesla Bratislava; price—Kcs 400,000)

This is a progressive design involving SCARA cinematics for the automation and robotization of the Tesla Consumer Electronics Concern. It is equipped with a system for exchanging gripper arms so that it can accomplish a larger number of technological operations. The nominal capacity is 2 kg, the control system is modular, employs multiple 16-bit processors.

Voice Output for Computers

(Eng T. Ciller and Eng P. Foksa, Basic Svazarm Organization of the Hifiklub, Zilina)

This is a piece of peripheral equipment for attachment to microcomputers which have a possibility for providing for the phonetic output of data. It is capable of processing text from a superior system which is written in phonetic form. The balancing memory contains 79 characters; the device can transmit continuously and, simultaneously, receive additional text. It facilitates operation in two modes—Slovak and Czech. It can be used everywhere where audio control is required.

Silicon Photodiode for Optical Communication

(Eng B. Tryzna and a collective, A.S. Popov Tesla Research Institute; production initiated in 1989; anticipated price—Kcs 6,000)

This is a semiconductor version of a photomultiplier and is intended for the detection of radiation having a wavelength of 550 through 1,100 nm, is characterized by its considerable speed and by its low noise level. The pin is produced by planar diffuse technology and is located within a case having a glass window.

Optical Channels Made of Fibers

(Eng K. Kovats, candidate of sciences, West Slovak Electric Power Plant Research Institute for Cables and Insulators, Bratislava; production as of 1989 at the ZSE Kablo Concern Plant at Decin; single-fiber channel, Kcs 25/meter, and eight-fiber channel, Kcs 180/meter)

The cables are intended for optical electronic telecommunications transmissions at a wavelength of 850 nm over a distance of several kilometers.

New Model KNK-30-S Digital Transmission System

(Collective of workers from the Tesla Research Institute of Telecommunications, Prague, from Tesla Stranice, Tesla Karlin, and Tesla Stropkov; gradual initiation of production of individual devices as of 1988)

This is a 30-channel transmission system for the transmission of voice, data, and radio signals. Its modular design facilitates the assembly of variable systems. Compared to older systems, which are in use in our telecommunications network, it is characterized by its modern components base, primarily by the presence of integrated ALS or CMOS circuits, which make it possible to reduce the power inputs for the entire system by 75 percent and make it possible to decrease its dimensions, its weight, and to increase its reliability. Currently, these same organizations are developing a digital communications system to modernize the Czechoslovak communications network, which is part of the development of a unified communications system within the framework of CEMA (JSPST-N), being solved on the basis of the Comprehensive Program of Scientific-Technical Progress [Among CEMA Member Countries] Through the Year 2000.

NUCLEAR ENGINEERING

First 1,000-Megawatt Nuclear Reactor Tested *26020019 RUDE PRAVO in Czech 20 Feb 1989 p 2*

[Text]Plzen—The workers' and technicians' collective of the reactor manufacturing plant at the Plzen Skoda factory has successfully completed a pressure test on the vessel and lid of the first Czechoslovak nuclear reactor of the VVER-1000 type. Control measurements on the steel colossus confirmed that these parts of the first 1,000-megawatt reactor were qualitatively manufactured.

On Friday [17 February] the working crew raised the unique weldment, with a diameter of 5.3 meters, a length of 13 meters and a mass of 350 tons, from the testing shaft, and on Saturday further control and measuring operations continued.

Also, ultrasonic and capillary methods will be utilized in turn to check whether there are cracks or other defects in the welded anticorrosion layer or in the basic material.

Work on the first vessel of the VVER-1000 light-water reactor has thereby reached the final phase. Toward the end of March the shipment of the finished piece to the Belene nuclear power station in Bulgaria will begin.

SCIENCE & TECHNOLOGY POLICY

CSSR's Jakes on EUREKA Program

AU2802110389 Prague RUDE PRAVO in Czech 25 Feb 89 pp 1, 2

[Interview with General Secretary Milos Jakes by RUDE PRAVO chief Zdenek Horeni: "Comrade Milos Jakes Answers RUDE PRAVO's Questions; Our Initiative Provides New Stimuli"]

[Excerpts] On Friday [24 February] Comrade Milos Jakes, general secretary of the CPCZ Central Committee, answered questions posed by RUDE PRAVO chief editor Zdenek Horeni, in connection with the 1st anniversary of the proclamation of the well-known Czechoslovak foreign policy initiative pertaining to the establishment of a zone of trust, cooperation, and good neighborly relations along the line of contact between the Warsaw Pact and NATO states. [Passages omitted]

RUDE PRAVO: During his visit to the CSSR, French President Francois Mitterrand mentioned, among other things, the possibility of the central and Eastern European countries participating in the West European technological and audiovisual program EUREKA. Do we have in our country an idea of how to join some of the EUREKA programs? Have we taken any steps already?

Milos Jakes: We have been interested in the EUREKA technological program for some years now. EUREKA is an important instrument of West European integration, the objective of which is to enhance the technical and technological standards of the participating countries—today it already includes 18 West European states. In harmony with the main directions of scientific-technical development, our scientific-research institutes have selected some advanced civilian projects of the EUREKA program. We are interested, for example, in taking part in the Eurotrac project (tracing the pollution of the atmosphere), the Eurobot (the development, production, and use of industrial robots), the Euomat (new materials), the Eurotrans (transportation), the Eurolas (the development, production, and use of industrial and medical lasers), and the Eurocom (communications) projects.

It is clear, however, that the involvement of the socialist states, including Czechoslovakia, requires the elimination of some obstacles. They concern the contractual-legal and financial nature of cooperation on the level of enterprises, because individual projects are being realized on the basis of contracts between individual companies. Here also are in effect the continuing restrictions of NATO's coordination committee for the control of exports of advanced technology to the socialist countries (Cocom). This is literally an anachronism in our times and a great hindrance to mutually advantageous trade.

We have already taken certain steps to assess the possibility of Czechoslovak participation in the projects of the EUREKA program. For example, during talks with Mr Mitterrand and other French representatives we arrived at the identical view that the EUREKA program should be open to all European states that want to take part in this top-of-the-line technical program and have the prerequisites. France, the FRG, but also other Western partners realize the fact that there exist technologies in which Czechoslovakia is really advanced and that it thus could make an active contribution to that program.

We also discussed the possibility of our participation in a new project—in the audiovisual EUREKA. What is involved is the exchange of audiovisual productions and the effective utilization of telecommunication systems; the solution of issues in the entire sphere of culture including such as how to counter the danger of the Americanization of European culture; information; teaching of languages; and such like. It is obvious that the participation of the socialist states, including Czechoslovakia, in this future-oriented project would provide new dimensions to the European countries' scientific-technical and cultural cooperation. [Passages omitted]

Bulgaria-Yugoslavia Chemical Agreement Signed

AU0902200989 Sofia BTA in English
1838 GMT 9 Feb 89

["Bulgaria-Yugoslavia: Cooperation in the Chemical Industry"]

[Text] Sofia, February 9 (BTA)—Bulgaria and Yugoslavia will deepen and improve with new varieties of cooperation in the chemical industry. The agreement signed today on product and technological cooperation between the Devnya Economic Association and Chimimport on the Bulgarian side and the largest Yugoslav production organization in the field of the chemical industry "Ina", Zagreb will contribute to this end. Cooperation and exchange of chemical products to the amount of 150 million dollars is planned.

The Yugoslav delegation was received by Mr Petko Danchev, chairman of the association "Biotechnological and Chemical Industry", alternate member of the Politburo of the CC of the BCP. Satisfaction was expressed with the positive development of cooperation between Bulgaria and Yugoslavia in the sphere of chemistry and the possibilities considered for the use of the new types of long-term industrial and market cooperation for the setting up of joint enterprises and joint participation on third markets.

TELECOMMUNICATIONS R&D

ISDN Components for GDR's Digital Switching System Detailed
23020003 East Berlin NACHRICHTENTECHNIK-ELEKTRONIK in German No 9, 1988 pp 329-332

[Article by Dr of Engineering Juergen Lolischkies and Graduate Engineer Rolf Siemon, Berlin Center for Communications Electronics Research and Technology, research center of the Communications Electronics Combine VEB, Edisonstr. 63, Berlin, 1160, both members of the GDR Chamber of Technology: "ISDN Components for the Digital Switching System DVZ 2000"]

[Text]

1. Occasion and Objective

At present the focal points of the GDR's development work in digital switching technology are the digital switching system DVZ 2000 [1] and the NZ 400. On the basis of the actual needs of the GDR, the completely analog network environment for new network introductions, and the possibilities for realizations, a modular system concept has been developed that in the long run also ensures ISDN compatibility [7]. But the first development stage does not carry the burden of involving preliminary work for ISDN. Figure 1 shows the basic structure of the system DVZ 2000, and Figure 2 shows the network environment existing at the time of its introduction in the GDR.

Currently it can be noted as a fact that on the basis of the stage of development of individual countries it is predominantly in highly developed industrial states that different communications networks have arisen for voice and data communication. Therefore given the objective of developing an ISDN it becomes necessary to ensure the interworking of these networks over a relatively long period, until an ultimate integration in an ISDN is done on the basis of the telephone network. The recommendations X.30 and X.31 or the equivalent I-recommendations I.461, I.462 show the possibilities for interworking between an ISDN subscriber's access via circuit-switched B-channels and data networks (circuit-switched and packet-switched). The above-named recommendations were adopted at the end of 1984 by the CCITT in Rotbuch and thus for the GDR also they are an obligatory basis for any prospective network planning on the initial integration of new forms of communication for voice and data communication. The fundamental ISDN strategy, where ISDN is developed from the circuit-switching digital telephone network on the basis of a transparent 64-kbit/s channel and an efficient signaling procedure, remains unaffected by this [2] [3] [4] [7].

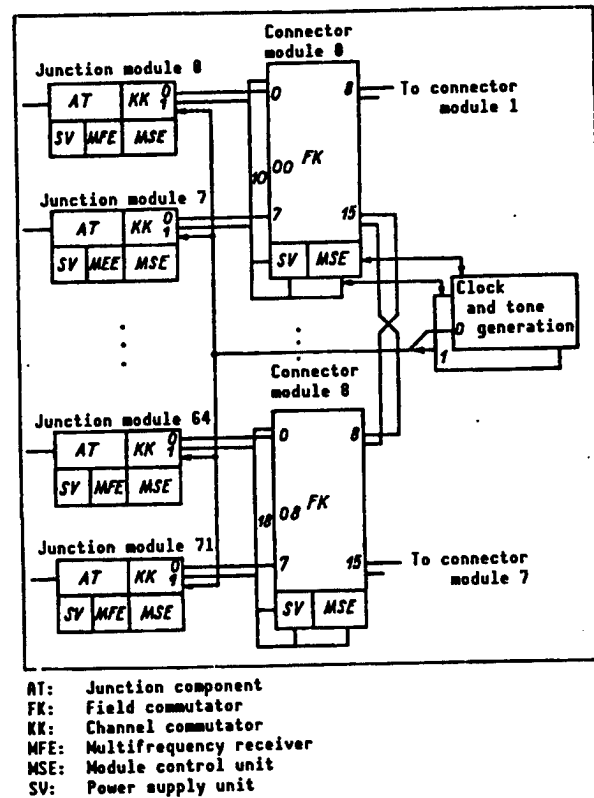

Figure 1. Basic Structure of a Central Exchange for the DVZ 2000 System

2. DVZ 2000 Network Incorporation

In the introduction phase provisions are made to use the digital switching exchanges DVZ 2000 as local exchanges (dependent or terminal exchanges). Here the digital switching system DVZ 2000 is to be used within the network of the German Postal and Telecommunications Service primarily in typically analog (rural) hook-up areas, with analog subscriber's lines and analog or digital trunk lines. It is required here that the basic service capacities of the exchange with respect to its telephone service not be technically and economically impaired by new capacities. For the network of the German Postal Service this results in a digitization strategy from bottom to top—that is, the beginning of digitization lies in the municipal or rural peripheral network sections. The introduction of ISDN performance characteristics into the digital private branch exchanges NZ 400 is to begin in parallel with this.

Fundamental work on the digitization strategy of the German Postal Service was done in 1983/84 in connection with a study on this. Information on the digitization strategy as well as on the development of data services can be found in [5] [6] [7]. In this connection it is assumed in [6] that because of increasing qualitative and quantitative user requirements as well as the economic

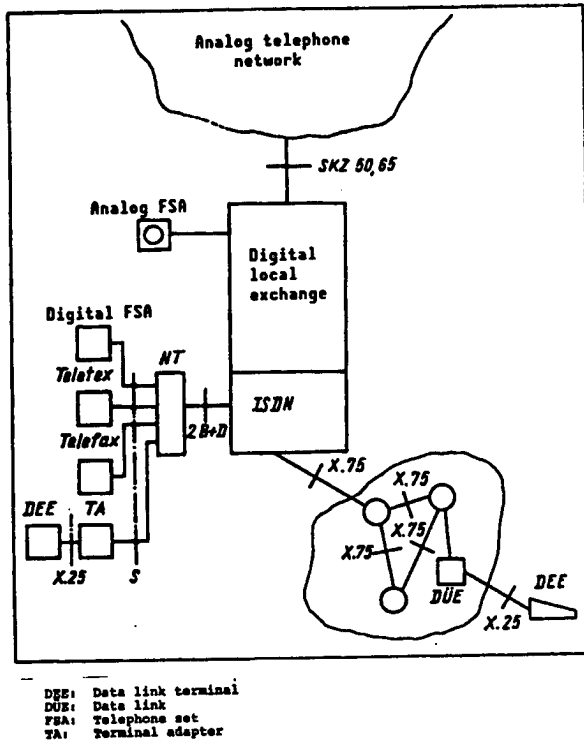

Figure 2. Digital Local Exchanges in the GDR Network

effects to be expected, a uniform digital secondary network must be established for teleprinter and data services. This network can only be an overlay network.

It was decided by the German Postal Service that in the GDR a packet-switching public data network (PVDN) will be developed in the period up to 1995.

Now a digitization of the peripheral network sections offers the possibility of achieving, via digital circuit-switched local or private branch exchanges, a low-cost entry into the PVDN and thus of utilizing the PVDN over a wide area as a digital overlay network for data services.

In the study period from 1980 to 1984, extensive work was done within the CCITT on making recommendations for the development of an ISDN. Of particular interest here are the recommendations X.30 and X.31 or I.461 and I.462 for the interworking of a circuit-switching ISDN with circuit-switching (X.30) or packet-switching (X.31) data networks [3] [4].

What is important in both recommendations is the statement that for the integration of data services into a circuit-switched ISDN either a minimal or a maximal integration is possible. According to X.30, the minimal integration is characterized by the fact that terminal devices based on X.21 or X.21-bis are connected physically via transparent 64-kbit/s channels to an ISDN

central exchange, but logically they are connected via a circuit-switched data network. In a maximal integration in line with X.30, the X.21 and X.21-bis terminal devices are both physically and logically switched via the ISDN central exchanges to which they are connected.

The recommendation X.31 describes similar configurations for terminal devices based on X.25. Here, in X.31, Point 1.2 a minimal integration is shown in which the ISDN central exchange assigns to an X.25 terminal a switched or dedicated B-channel. The switching function takes place in the packet switching exchange.

Point 1.1.2 describes the maximal integration of terminal devices based on X.25. Here a packet switching and concentrator function is integrated into the ISDN central exchange. Thus there exists an internal packet switching within the ISDN central exchange itself (packet-handler function). The transition to the PVDN takes place via the standardized interface X.75 [3].

Figures 3 and 4 show the basic possibilities of minimal or maximal integration for data link terminals based on X.25.

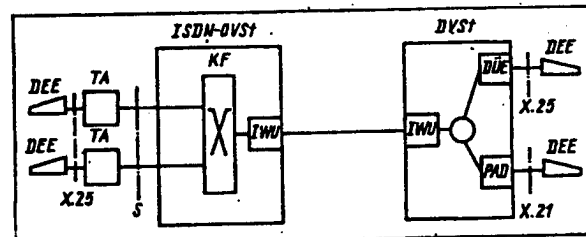
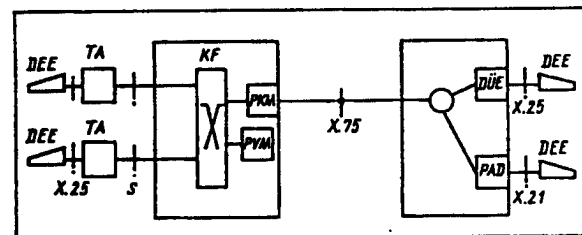

Figure 3. Minimal Integration of Data services in ISDN Local Exchanges Based on CCITT X.31



DEE: Data link terminals
DVST: Data switching terminals
KF: Switching matrix
OVSt: Local exchange
PAD: Packet assembler deassembler
PVM: Packet switching module
PKM: Packet concentrator module

Figure 4. Maximal Integration of Data Services in ISDN Local Exchanges based on CCITT X.31

3. ISDN Configuration DVZ 2000

3.1. ISDN Junction Module

Figure 5 shows a possible maximal integration of data services in accordance with CCITT X.31 for terminal devices based on X.25. For terminal devices based on

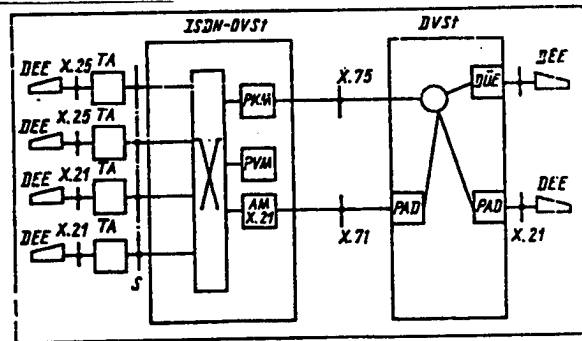

Figure 5. Integration Possibilities for Data Link Terminals Based on X.21 and X.25 in ISDN Local Exchanges

X.21 this variant represents the minimal integration. Here, means for internal packet switching and packet concentration are integrated into the prospective ISDN-compatible digital local exchange. Thus this exchange satisfies recommendation X.31 for maximal integration. The transition to the PVDN is done via the interface X.75 standardized within the CCITT.

Terminal devices based on X.25 above all are to be connected up to this local exchange. For terminal devices based on X.21, means of minimal integration are provided—that is, transparent-connected 64-kbit/s channels to the PVDN, in which the PAD [Packet Assembler Deassembler] function is realized centrally or decentrally.

Thus, beginning with the basic structure of the system DVZ 2000 shown in Figure 1, for the ISDN configuration the structure shown in Figure 6 arises.

In order to realize initial ISDN performance characteristics on the basis of the PVDN of the GDR, the following new junction modules are needed in the system DVZ 2000:

- | | |
|----------------------------------|------|
| 1. ISDN subscriber module | ITM |
| 2. Packet switching module | PVM |
| 3. Packet concentrator module | PKM |
| 4. Central signaling module No 7 | ZZM. |

Table 1 shows the following operational possibilities as a function of carrying out the mentioned installations.

The development series ITM, PKM, PVM, and ZZM was derived by considering the actual network configuration of the GDR. Here, the communication possibilities provided in Table 1 presuppose a point-by-point use of ISDN-capable DVZ 2000 central exchanges and are based in principle on external communication-traffic conditions.

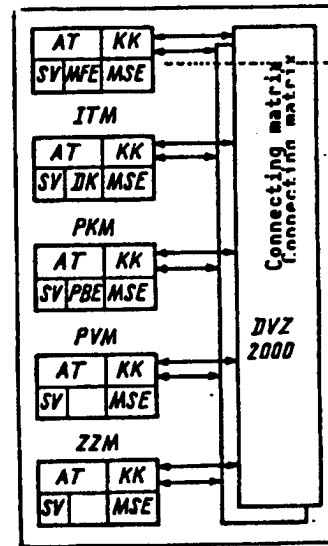

- AT: Junction component
- DK: D-channel concentrator
- ITM: ISDN subscriber module
- KK: Channel commutator
- MFE: Multifrequency receiver
- SV: Power supply
- PKM: Packet switching module
- ZZM: Central signaling module

Figure 6. Basic Structure for an ISDN Exchange DVZ 2000.

Table 1. ISDN Operational Possibilities DVZ 2000

| Modules | Performance Characteristics |
|-----------------|---|
| ITM PVM PKM ZZM | |
| x | Telephoning without accompanying user information |
| x x | Telephoning with accompanying user information |
| x x | Packet data communication, switched in the PVDN |
| x x x | Packet data communication, locally switched in and between DVZ 2000 |
| x | Switching of a transparent 64-kbit/s channel |
| x x | Circuit-switched data communication with outslot signaling |

3.2. Basic Structure of the ITM

The ISDN subscriber module for the DVZ 2000 has the same basic structure and the same primary interfaces as each junction module of this system. Thus the requirement as to modularity is ensured.

In its internal structure (Figure 7) there are two important differences because of the comprehensive requirements for the realization of the basic subscriber access.

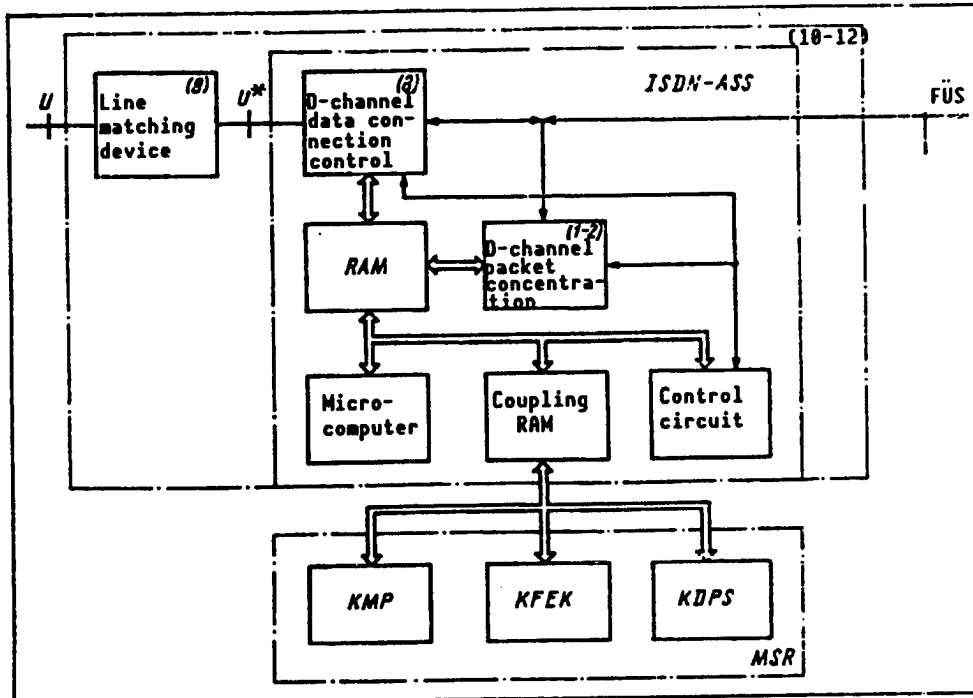

ASS: Connection control circuit
 KMP: Module processor
 FEK: Error correction unit
 KDPS: Dynamic program memory
 MSR: DVZ 2000 module control computer
 FUS: DVZ 2000 field transmission interface

Figure 7. Basic Structure of an ISDN Subscriber Module.

The first concerns the considerable expense involved for the transmission of 144-kbit/s useful information via the conventional two-wire subscriber hook-up line inclusive of remote power-supply capability, while the second difference results from extensive additional hardware and software for handling the transport levels of the protocol for the subscriber signaling channel (D-channel).

The two requirements can be fulfilled economically only through the use of highly complex applications-specific circuits.

Furthermore the handling of level 2 in the ITM requires a considerably larger preprocessing capacity on the part of the connection control device ASS. Depending on the extent of the hardware support through applications-specific circuits, with a connection control device only 4 to 8 ISDN basic accesses can be operated (compared to 200 analog subscriber hook-up lines).

Assuming a hook-up capacity between 80 and 100 ISDN subscriber lines for an ITM (feasible because of the higher traffic capacity of such a line) the necessity arises for 10 to 20 times the previous preprocessing output.

3.2.1. Applications-specific Circuits for ISDN Subscriber Access

Figure 8 shows the basic ISDN subscriber access—in a greatly simplified block form—that can be realized by

applications-specific circuits. Not shown are the devices required for local or remote power supply and for line testing at the exchange, network termination unit, and terminal unit. These devices are less complex, but they are subject to the same requirements as the analog SLIC

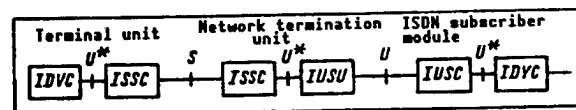

Figure 8. Applications-specific Integrated Circuits for ISDN Subscriber Access

with respect to the voltages to be handled.

The three applications-specific circuits shown must execute the following chief tasks:

ISSC, Integrated S-interface controller

- Capability of being used in the network termination and terminal units;
- Realization of all parameters stipulated in CCITT recommendation I.430 for the ISDN S-interface (activation, deactivation, frame structure, D-channel access, status transitions, synchronization, levels and impedances);
- Realization of a nationally standardized interface between the circuits to be used for the descending and ascending transmission of useful and control information (interface U*).

IDVC, Integrated data connection controller

- Possibility for use in the terminal device and in the central exchange
- Handling of bit-oriented functions of level 2 of the D-channel protocol (flag recognition, null fade-in/fade-out, termination recognition, security code calculation/analysis;
- Relieving the burden on the controlling microcomputer through internal organization of the storage access (for example DMA or an internal intermediate store for block transfer);
- A processor-independent interface for the controlling microcomputer;
- Realization of the interface U*.

IUSC, Integrated U-interface controller

- Possibility for use in the network termination device and in the central exchange;
- Transmission of the 144-kbit/s useful information as well as synchronization and servicing information, full-duplex, via a conventional two-wire subscriber hook-up line with a range up to 8 km;
- Realization of the interface U*.

For all three circuits only CMOS techniques can be used because of the requirement as to remote-power feedability. The most exacting requirements with respect to packing density are set by the IUSC. The internationally increasingly more popular transmission method for the subscriber connection line, time and frequency co-channel transmission with digital echo compensation, requires 100,000 transistor functions—that is, a chip area of 120 square millimeters with structure widths of 2 micrometers [8] [9].

3.3. Packet Concentrator Module PKM

In line with the basic configuration shown in Figure 5, for the packet concentrator module the main task that arises is the matching of ISDN-compatible central exchanges to the PVDN and the associated realization of the interface procedures X.75.

To that end, in the PKM the following subtasks are to be handled:

- Physical matching to the digital 64-kbit/s trunk lines (level 1) provided for X.75;
- Realization of the packet concentration function for the packet data information arriving from the DVZ 2000 and vice-versa (levels 2 and 3);
- Conversion of the DVZ-internal messages into standardized messages based on X.75 and vice-versa (levels 2 and 3);
- Realization of the requirements going beyond recommendation X.75 with respect to putting into operation, maintenance, upkeep, and toll-charge determination for packet data lines.

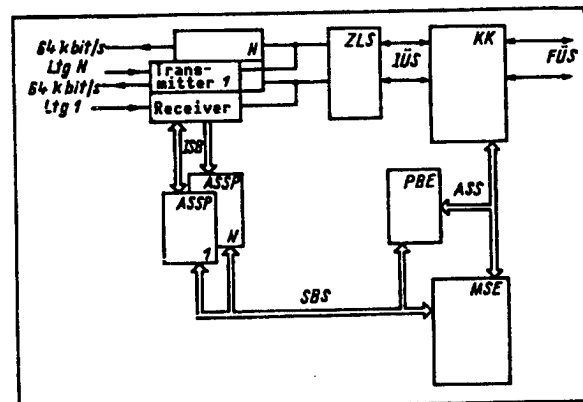

ASSP: Connection control for packet handling
 KK: Channel commutator
 MSE: Module control device
 PBE: Packet handling device
 ZLS: Time co-channel circuit

Figure 9. Basic Structure of the Packet Concentrator Module.

Figure 9 shows the basic structure of this conception for a packet concentrator module.

4. Possibilities for New Forms of Communication

With reference to the development of terminal devices based on X.21 and prospectively on X.25 and the planned establishment of the PVDN, Figure 10 shows a future digital island structure of the exchanges DVZ 2000, OZ 100, and NZ 400. A network-engineering prerequisite for these configurations is a linking of the OZ 100 and NZ 400 via digital 64-kbit/s channels to corresponding access modules of the DVZ 2000. For the exchange of identification, in addition to the 64-kbit/s channels a GZK [common signal channel] is anticipated for signaling purposes. On the basis of theoretical estimates of future traffic volume and prerequisites of network engineering, the orientation is toward the use of PCM 30 systems. At the same time the hooking up of digital private branch exchanges to digital local exchanges is anticipated. What seems reasonable here is the direction recommended by the CCITT of interfacing via the structure 30 B + D, since this structure could be realized relatively simply as a software modification of the PCM module of the DVZ 2000.

In this configuration the following voice and data communications possibilities arise:

- Voice communication in line with the requirements of the telephone network;
- Data communication using modems in line with the requirements of the telephone network;
- Data communication DEE X.21 with DEE X.21 in the island region;
- Data communication DEE X.25 with DEE X.25 in the DVZ 2000 via PVM, external traffic via PKM;

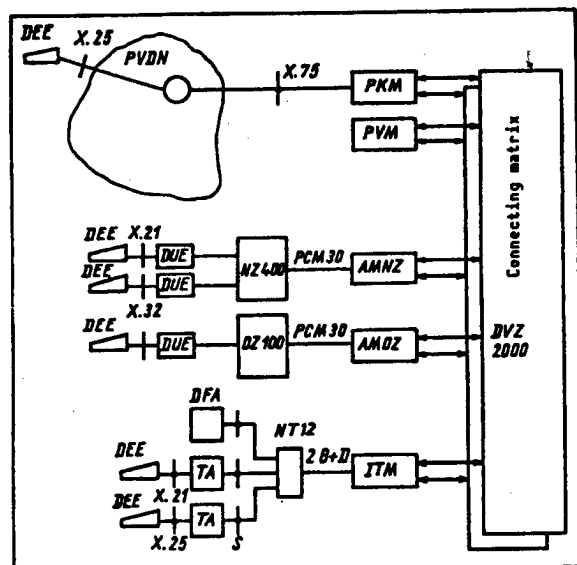

AMNZ: Junction module for extensions
 AMDZ: Junction module for local exchanges
 PKM: Packet concentrator module
 PVM: Packet switching module
 ITM: ISDN subscriber module

Figure 10. Possibilities for Data Communication in Digital Islands DVZ 2000, OZ 100, NZ 400.

- Data communication DEE X.25 not possible with DEE X.21.

Agreements on these conceptual ideas are currently being vigorously worked out between the GDR's communications industry and the German Postal Service, and they form the basis for more far-reaching development work.

5. Abbreviations AM: Junction module CCITT: Comité Consultatif International Téléphonique et Télégraphique [International Telephone and Telegraph Consultative Committee] DEE: Data link terminal DVSt: Data switching exchange DP: German Postal and Telecommunications Service EVSt: Terminal exchange GZK: Common signal channel ISDN: Integrated Service Digital Network ITM: ISDN subscriber module OVSt: Local exchange PAD: Packet Assembler Deassembler PVDN: Packet switching data network PKM: Packet concentrator module TVSt: Dependent exchange X...: CCITT recommendation of the X-series ZZM: Central signaling module

Literature

- [1] "Principles and Performance Characteristics of the Digital Switching System DVZ 2000," INT Berlin 1984.
- [2] CCITT recommendation X.30, I.461; support of X.21 and X.21-bis based DTE's by an ISDN (status 1984).
- [3] CCITT recommendation X.21, I.462; support of packet mode terminal equipment by an ISDN (status 1984).

[4] Frantzen, V.: "Packet switched Data Communication Services in the ISDN," ICC 82, Proc. 1982, pp 25-30.

[5] Bartsch, G.; Mehlhorn, N.: "On Some Questions of Digitization of the German Postal Service Networks," Communications from IPF 27 (1983) 2, pp 4-7.

[6] Herrmann, L.; Mehlhorn, N.: "On Planning for Traffic and Subscriber Growth in the Teleprinter and Data Services of the German Postal Service," Communications from IPF 25 (1981) 4, pp 12-21.

[7] Koehler, D.; Schuenemann, G.: "Organization and Planning of a Service-integrated Digital Communications Network," NACHRICHTENTECHNIK-ELEKTRONIK 36 (1986) 3, pp 107 to 109.

[8] Dierckx, R.; Guebels, R.; Six, P.: "ISDN Line Terminal in Large-scale Integration," ELEKTRISCHES NACHRICHTENWESEN 59 (1984) 4, pp 411-417

[9] Schott, H.: "The S-module in the ISDN Network Termination NT," in NTG-Fachberichte ["NTG Technical Reports"], Vol 88, Berlin, Offenbach: VDE-Verlag GmbH 1985.

Development of Czechoslovak Digital Switching System Surveyed 24020011 Prague TELEKOMUNIKACE in Czech No 11, 1988 pp 163-165

[Article by Eng Emanuel Prager, candidate of sciences, TESLA Research Institute for Telecommunications, Prague: "Development of the JSPST-N Digital Communications System"]

[Text] The No 3 issue of this journal in 1986 presented the overall direction of work being conducted in Czechoslovakia with respect to the development of digital communications systems and, primarily, regarding the development of the JSPST-N system as the national variant of a unified JSPST system developed within the framework of international collaboration among CEMA countries. That article also listed the basic principles used in solving the system as a whole and for some of its more significant modules. This system, which is intended to modernize the Czechoslovak communications net through the use of local centrals having medium capacities of up to 8,000 subscriber circuits (possibly even having capacities in excess of 10,000 subscriber circuits) utilizing digital switching equipment was gradually being further developed in the TESLA enterprises and, in 1987, two prototypes of a public and private branch exchange having a capacity of 500 circuits were developed and are being systematically verified at the TESLA Karlin and TESLA Liptovsky Hradok enterprises and will subsequently be subjected to prototype testing within the communications network.

The present article deals primarily with the evaluation of the current status of development and outlines future prospects for production as well as additional innovative steps.

Fundamental Characteristics of the JSPST-N System

Development of the JSPST-N system has undergone a number of developmental phases with its basic concept and structure, which were adopted at the beginning of development and were discussed in the above-mentioned article, having virtually remained without change except that some portions of the system experienced partial changes caused by solutions, by rendering requirements more precisely, and as a result of technological reasons. Similarly, the results of tests in the individual developmental phases brought about some partial changes.

The basic characteristics of the system involve a modular structure utilizing microprocessor control and digital switching. The modular structure makes it possible to consider the system to be open from the standpoint of its further expansion as to capacity and function. The modular structure of the system makes it possible for it to be adapted, in the future, for use in the ISDN network in conjunction with the international recommendations of the CCITT and in accordance with worldwide trends.

If we speak of a modular structure, this means that the individual modules are connected to the common communications field of the central via their unified interfaces, which in turn switches the signals at a transmission speed of kbit/sec without regard to whether these signals carry voice or data information. Thus, the communications field is transparent from the standpoint of transmitting various types of information. The individual modules connected with this communications field have standard output ports despite the fact that they take care of various functions in the communications network and can operate both in the

voice mode and also in the data transmission mode. This basic structure is actually a logical consequence of the development of various principles of controlling the communications system and of the development of microelectronics. The modular structure not only presents the possibilities for a simple expansion of the system, but is also advantageous from the standpoint of programming, which can be proposed and changed independently for the individual modules. Actual cooperation between the modules is accomplished asynchronously through the system of information passed between the modules.

In utilizing this modular structure, the individual modules are so designed as to be uniform from the standpoint of equipment as well as programming and suitable for various types of systems use (public or private centrals and for various sizes of centrals), as well as for various network applications. For the sake of completeness, let us list the present set of individual modules which form the basis of the system and which can be utilized in various combinations for various centrals (Table 1). Several of the listed modules may even have several built-in variants, for example, the module for analog circuits can be fabricated in a number of variants to handle various types of signals in analog channels; the module for analog subscriber circuits can have several versions for various operational loads and, thus, even a varying number of attached circuits at its standard interface with the communications field, that is to say, a multiplex bundle of 32/30 PCM channels. Similarly, for the private branch exchange version of the system, several typical modules can be augmented; for example, the module at the work site of the communicator. The possibility of a variable solution also holds true for some systems modules, for example, the module for servicing and oversight can be simpler or more complicated depending on whether it is intended to handle simple functions in an unmanned small secondary central or functions of a centralized maintenance center in a key central.

Table 1. Listing of Basic Modules for the JSPST-N System

| Module | Purpose | Size or Characteristics |
|--------|--|---|
| AUS | For attaching subscriber circuits | For attaching 128 circuits at an operational load of 0.15 Erl/pp |
| ASV | For attaching analog communications circuits | For attaching 30 nf channels carrying various types of signals |
| DSV | For attaching a digital cable | for 30 digital PCM channels |
| CSP | Communications field (duplicated) | To accommodate 1,024 x 1,024 channels with the possibility for building in 512 or 2,048 and 4,096 channels |
| CI-DT | Central source of pulses and digital tones (duplicated) | With the possibility of external synchronization |
| KPV | Code transmitter and receiver (duplicated) | For R2 codes (or even R1 codes) |
| RVI | For control of information exchange (duplicated) | Interconnects 16 channels among modules |
| PAPI | Memories of operational information (duplicated) | To register selected numbers, categories, etc. |
| KN | For conference purposes and connection purposes | For connections between switching facilities or to facilitate conferences between several circuits |
| OD | For servicing and oversight (duplicated) | For communication between maintenance personnel and equipment, for evaluation of diagnostics, billing, etc. |
| PST | For operational testing and for testing of attached circuits | Makes it possible to test the system while in operation or as ordered by Module OD |

Note: Module OD has several items of peripheral equipment attached to it, such as a keyboard, a printer, a display monitor, etc.

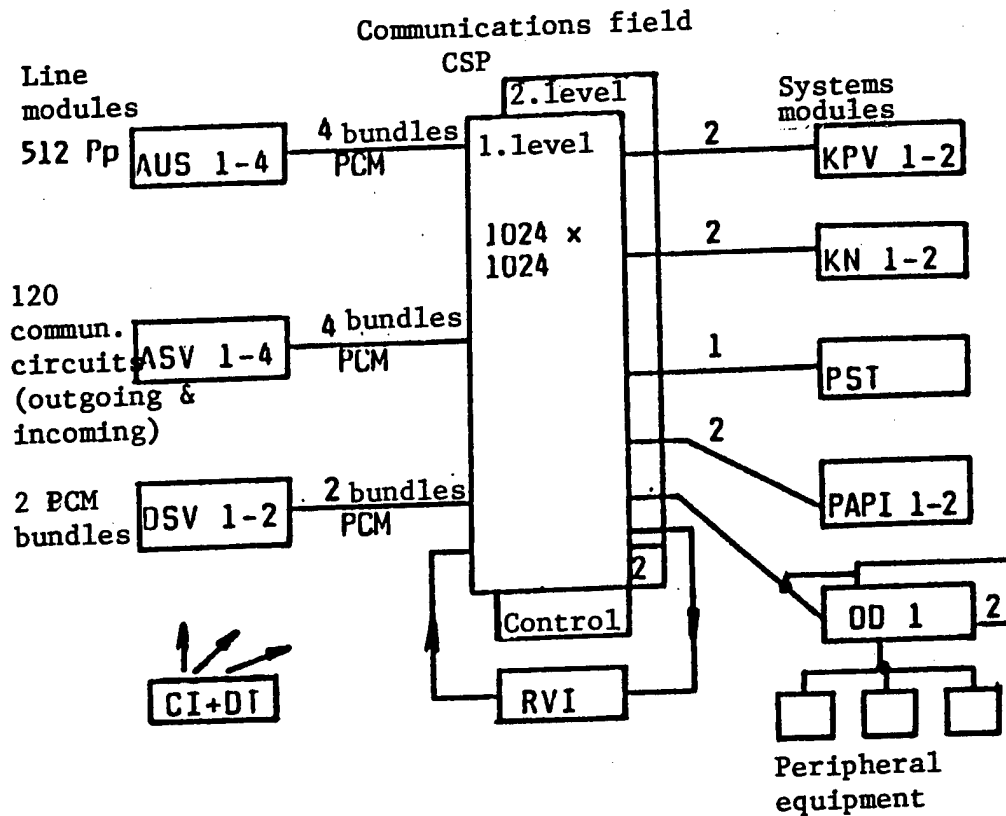

Figure 1. Block diagram of the prototype substation of the JSPST-N system.

Individual modules appear in the central more frequently according to size and operational loading to which the central is subjected. This is true not only of line modules, whose number is directly dependent upon the magnitude of the central, but also of common modules, for example, the memory module for operational information, whose numbers depend not only on the magnitude of the central, but also on the network connection and the functional parameters of the central.

Current Status of Development Pertaining to the JSPST-N System

In 1987, two prototypes, a subcentral and a private branch central, were produced and can handle 500 circuits each; they were gradually activated and subjected to the necessary tests and measurements, at first on the premises of the producing enterprise, TESLA Karlin (public central) and TESLA Liptovsky Hradok (private branch exchange), and later will be patched into the communications network for purposes of test operations.

As an example, Figure 1 provides the block diagram of the prototype of the substation (secondary central) for 512 circuits, 120 analog channels, and 2 PCM bundles (that is to say, 60 digital channels). Figure 2 indicates the positioning of modules on the substation rack. It should

be added that this positioning is not typical and that there are some modules here which will be used only in larger centrals; some racks are not fully occupied or the number of modules does not correspond to the actual size of the central. The total number of racks for a central having 512 circuits will actually be smaller.

During the course of the prototype tests conducted hitherto in the laboratories, the individual required functions were tested and various statistical tests and measurements of electrical and nonelectric parameters were conducted. During the course of statistical testing, which was intended to verify the failure rate of the centrals, the number of calls, generated both from automatic sources and also as the result of supplemental operation by telephone instruments, gradually increased. The statistical tests also led to the uncovering of some defects which were gradually removed. Gradually, an overall failure rate of less than 1 percent was achieved.

The prototype was subjected also to tests of its cooperation with the public network by connecting it with prototypes of the PK202 and P51 systems. Verification of cooperation involving various types of signals through ASV and DSV modules with the attachment of PCM bundles was also conducted.

Part of the tests of the prototypes involved various measurements. One of the basic measurements was the

| | | | | | | |
|------------------------------|---------|-----------------------|---------------------|---------|---------|------------------------------|
| Deflection level for cooling | DSV 1,2 | CSP - 0 | ASV - 1 | AUS - 1 | | Principal distribution board |
| | | CSP - 1 | Common to ASV 1 & 2 | | KN | |
| | KPV 2 | | ASV - 2 | AUS - 2 | KPV 1 | |
| | | | | | | |
| | OD 1 | | ASV - 3 | AUS - 3 | PST | |
| | OD 2 | RCSP 0 RCSP 1-PAPI | Common to ASV 3 & 4 | AUS - P | | |
| | | RVI | ASV - 4 | AUS - 4 | CI - DT | |

Figure 2. Positioning of equipment on the racks of the prototype of the JSPST-N system.

measurement of interference. Modern electronic communications systems are not only a source of interference, but are also sensitive to interference arising within the system, as well as to interference from outside sources. It is, therefore, necessary to make the required provisions for minimizing all types of interference by suppressing their sources, possibly by adding filtration at various locations within the system. This is aided also by thorough grounding and shielding of parts which cause interference. Measurements conducted on the prototypes showed a relatively high level of interference in the early period and it was, therefore, necessary to take a series of measures designed to suppress this interference. In this regard, a great role was played by power sources and by common power feeds.

Another type of measurement involving the prototype was thermal measurement which was intended to indicate thermally stressed locations in the central, as well as the distribution of temperatures in the equipment racks and on circuit boards having flat circuits. It is well-known, and foreign experiences also speak of this, that by increasing the concentration of electronic components in an equipment rack and on circuit boards, the temperature within the rack rises and leads to the undesirable warming of components and, thus, to deterioration in their reliability. The measurements showed that, in the majority of cases, results were satisfactory. In some cases, circuit boards were redesigned with the objective of reducing the amount of heat stress to which they are subjected.

Diagnostics Pertaining to the JSPST-N System and the Reliability Results Attained

The diagnostic system for determining defects is assured primarily through programming. The technical equipment only has sensing elements to detect erroneous

functions within the modules and means for closing down control loops. Intramodular diagnostics are basically divided into several tasks, facilitating both the preventive testing of modules, for example, an automatic test of the control unit, and also the generation of defect reports and supplemental localization of the defect in the event the actual preventive testing is inadequate.

The assurance of all diagnostic tasks in the individual modules is, for the time being, uneven in the prototype. In some modules, it is already 80-percent complete; in others, it is, for the time being, substantially below that level. The diagnostic programs will be gradually augmented within the course of prototype tests because they are, to a substantial extent, dependent on the types and distribution of defects which can show up during testing.

The principal function of systems diagnostics is handled within the system by the service and oversight module in cooperation with the operational testing module. To make the evaluation of defect reports arriving at the service and oversight module easier, a defect glossary has been worked out which contains approximately 160 types of defect reports during the prototype activation phase (this number will be increased). To evaluate these reports, a program was worked out to receive such reports in the OD module, and a program was worked out for questioning the module status. Constantly greater attention is devoted to systems diagnostics during development in view of the fact that the maintainability of the system will depend on this function to a great extent.

Computations of reliability, based on the failure rate of individual components, indicate that the average time between defects is approximately 270 hours for the

substation prototype with a capacity of 500 circuits. From this, the calculated time required for maintenance, computed for one circuit and 1 year, is approximately 0.2 hour per circuit per year.

The average time between defects of individual modules varies between 2,800 hours (AUS module) and 14,000 hours (KN module). On average, this value is around 4,000 hours for individual modules. With regard to the AUS module, this failure rate is shared primarily by subscriber sets (their number within the module is 128), whose failure rate does lead to the necessity to exchange circuit boards or to repair them, but does not lead to a breakdown in the system.

The overall computed probability of a breakdown as a result of the failure of central organs (the duplicated communications field or the common modules for control) is 1.05×10^{-8} with the average time required for defect repair being 0.5 hour. The calculated number of defects for a central with 6,000 to 8,000 circuits is 3.5 defects per 100 circuits per year.

From the above computations, which will necessarily have to be verified by longer tests in the operation of communications, it is evident that the failure rate of the JSPST-N system, in terms of its individual indicators, is only a little worse than the values noted for foreign products. With the passage of time, it is expected that electronic components will improve and their quality will rise, resulting in a lowering of the failure rate which must necessarily be reflected in lowering the fundamental indicator, that is to say, the number of defects per 100 circuits per year.

Future Prospects of Development Pertaining to the JSPST-N System

Tests of the prototype substation and private branch exchange central are to be concluded in 1988 in the enterprise test series and in 1989 it is planned to initiate test operation within the communications network.

Parallel with this work, there will be development of a main central, including the junction component and development of the VAUS module (subscriber concentrator) so as to accomplish an integrated system for junction-type networks to be used in rural as well as urban service.

During the subsequent course of development, the inclusion of CENTREX-type services will be monitored which should facilitate a fundamental change and the overall conception of private branch exchange service equipment and its inclusion into the public network.

Another important question is that of the possibility of increasing the maximum capacity of centrals. The JSPST-N system, as currently configured, is capable, on the basis of the capacity of its central, of handling up to 10,000 circuits in the public network (perhaps even more

with lower operational loading), or it can do the work of junction centrals of equivalent size or the work of combined centrals. Increasing the capacity of the central above these limitations with regard to the structure and configuration of the digital communications field will depend, on the one hand, on the availability of special microelectronic circuits for the communications field or upon the development of a JSPST system developed in international cooperation.

Given the overall development thus far and further innovations of the system, the possibilities of developments in microelectronics will, understandably, also be monitored. This development can be manifested both in the introduction of 16-bit control units and also in the configuration of some typical components of the system (for example, the introduction of circuits having a higher degree of integration by combining the filter and coding circuits into one, etc.) in subscriber sets. Similarly, it is expected in the future that the communications field will utilize special integrated circuits which should make it possible to find more economic solutions and to expand the capacity of centrals. In the current components base, further development will adapt to and result in the gradual introduction of the production of new types of microelectronic circuits, for instance, the high-speed CMOS series which will lead to an overall reduction in the consumption of power, fabrication of gate field circuits resulting in the obtaining of special circuits for the overall purpose of simplifying the circuitry of individual components of the central, etc.

For the future integrated ISDN network, development of supplements to the JSPST-N system so as to serve the ISDN network will also begin within the framework of follow-on work. The concept of an integrated ISDN network is understood today to be the entire complex of equipment, centrals, transmitters, centralized facilities, and a number of terminals, making it possible, on the basis of the present telephone network (which is the most widespread), to assure participants in the network both a telephone connection and also various types of data transmission and, in the future, even video transmission for purposes of accomplishing mutual connections and for distribution, for example, of television programs, etc. It is anticipated that ISDN networks will gradually provide an ever growing number of subscribers with the possibility of attaching various terminals in government offices, in homes, etc., and providing them with the possibility of being connected with various centralized services.

From the standpoint of new services and the possibilities of their gradual realization in communications systems and in networks, ISDN services are today divided into narrow-band services, based on the transmission possibilities of a single PCM channel, that is to say, they have a transmission velocity of 64 kbit/sec, and wide-band services for the transmission of pictures with a transmission velocity which is one or more degrees of magnitude greater.

A digital communications system for future utilization within the narrow-band integrated networks must, therefore, have the following minimum augmentations:

- It must be expanded by modules permitting the attachment of various terminals, but primarily of data terminals.
- It must have adequately accurate synchronization to facilitate operation of digital centrals in major networks.
- It must have a suitable signaling system between centrals (No 7 of the CCITT recommendations).
- It must create transition facilities for existing data networks so that it would be possible to utilize them after the transition period and within the expanding ISDN network.

From the structure of the JSPST-N system and from the analysis of future ISDN services and methods for their possible integration into digital communications systems it is evident that the JSPST-N system in today's configuration with its open structure will facilitate the future integration of additional function modules to make it possible to utilize ISDN services. The integration of these new modules will be based on the requirements of communications for the gradual expansion of these services and will stem from the possibilities of assuring the necessary microelectronic components base. The integration of services within narrow-band networks will result in some other views of the question regarding the operational loading of the system and of the network, it will result in other views regarding the question of tariffs, etc. The solution of these questions will be particularly important during the initial phases of ISDN service realization, which will, most likely, first be accomplished in private branch networks, in which the limitation of operations and tariff questions do not play such an important role.

The article describes the status of development of the digital communications system designated as the JSPST-N during 1988 and outlines existing results and prospects of further development. Even though the developmental stages accomplished thus far have shown up several problems, it is clear that the direction of the work has been correct and that it is possible to anticipate that, following the conclusion of development and the introduction of production, this system will represent a contribution to the modernization of the Czechoslovak telecommunications network. The achieved parameters are primarily dependent upon the level of domestic microelectronic circuits which form the principal share in the entire component base of the developed JSPST-N system.

Czechoslovak Approaches to Modern Telecommunications Reviewed

24020012 Prague TELEKOMUNIKACE in Czech No 11, 1988 pp 171-172

[Article by Eng Slavomir Cerny, candidate of sciences, Federal Ministry of Transportation and Communications: "New Approach to Modern Communications Systems"; first paragraph is TELEKOMUNIKACE introduction]

[Text] The following information is intended to serve as

an introduction to a series of articles which will provide more detailed evaluations of the influence of the characteristics of new types of technological devices for the Unified Telecommunications Network upon the entire complex of their utilization, starting from the instant of specification of the required functional characteristics by a future user and ranging through the ongoing status of operation and adaptation to the changing environment of the telecommunications network. Particular attention will be devoted to communications equipment net, particularly that portion which predominantly determines functional characteristics—the software. The word "modern" used in the title should be replaced by the term "contemporary" to the extent to which any information involves a comparison with world practices. In view of the composition and age of the equipment in the Unified Telecommunications Network, however, the term "modern" comports with the views of the Czechoslovak communications public.

The introduction of new communications equipment into the telecommunications network brings with it fundamental changes in the working processes of communications organizations which are building and operating these systems. The reason is a totally different conception in comparison with the previous electromechanical systems. The change in the structure of the actual organization of maintenance and in the working processes and methods exerts a palpable impact primarily on the human factor and its relationship toward modern technology in the possession of SPC centrals. An essential characteristic of these systems is their "computer" character, when operational processes occurring in these centrals are controlled by inserted and changeable programs, according to the requirements of network integration and the required functional characteristics.

Added to this is the necessity to apply unified program modification procedures in the future involving all SPC systems operating within the Unified Telecommunications Network. In this regard, a unity must be seen not only between processes involved in the introduction of modification changes, but also with regard to their content. It is necessary to keep in mind the vulnerability of these entities, where relatively simple individual changes, for example, in the data programming, could, in practice, result in undesirable differences at various work sites. An essential requirement of functional compatibility, of a unified approach to specifications, of uniform model configurations, of unified communications servicing and diagnostics, which in contemporary systems is reflected primarily in the design of the makeup and positioning of equipment in racks of the appropriate central, reaches primarily into the programming area when it comes to SPC systems.

A significant step which was forced by the introduction of this progressive technology was the establishment of the TELESOFT unit (TELEcommunications SOFTware)

in the MTTU (the long-distance telephone and telegraph) central in Prague as a ministrywide communications center for specifications, development, and maintenance of SPC system programming. In this regard, it is necessary to keep in mind all three fundamental directions of orientation of the TELESOFT unit activity which involve SPC systems, diagnostic devices, and cooperation in creating special-purpose databases.

The introduction of a centralized work site for the maintenance of programming into the organizational structure of the ministry has meant the creation of an independent technical-economic organ with responsibility primarily for the operation of future communications equipment. A prerequisite for the execution of all tasks is close cooperation with the user, the producer, and with other components sharing in establishing the program-controlled systems, that is to say, with designing facilities, with the research base, and with assembly components. In this area, the Czech Administration for Communications has embarked on a direction which is taken by all communications directorates throughout the world, because only a centralized coordinating organ can assure the required areawide unity which, in view of the character of the servicing process, dictates the conditions for the very function of the Unified Telecommunications Network.

In the area of SPC technology, it is fundamentally possible to break down the activities of the central facility into three main groups as follows:

- A. Systems support for SPC communications systems already in operation.
- B. Systems support within the framework of further development of SPC systems diagnostics and other network facilities as required by operational conditions.
- C. Systems support of special-purpose databases, including recordkeeping and actualization of specifications for new modifications undertaken by producers.

For Group A, the main criteria of activity are the following:

- observing the system and recognizing errors or shortcomings;
- eliminating systems errors in generating new program changes;
- consulting functions pertaining to actual operations.

For Group B:

- timely verification and assurance of compatibility with the system;
- preparation of new or supplemental conditions for the producer;
- verification and evaluation of services being offered;
- acceptance test, involving evaluation of individual functions and systems compatibility;

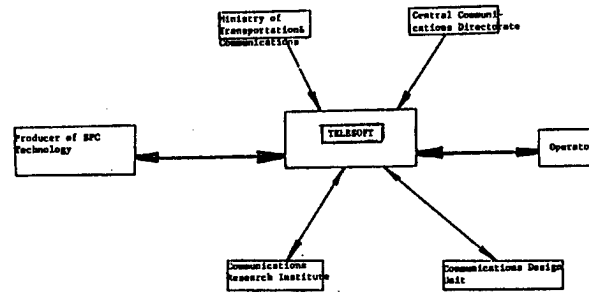

Figure 1. Basic organizational ties involving the TELESOFT unit of the MTTU in Prague.

- generation of changes and introduction of modifications into actual operational systems.

For Group C:

- testing for the purpose of coordinating existing technical conditions among producers;
- testing of individual functions;
- testing for systems compatibility;
- generating changes and introduction of modifications.

Figure 1 depicts the organizational schematic for including an independent TELESOFT component, complete with its organizational ties to actual operations and to the producer.

From the standpoint of ties to the operational systems, the following main activities are characterized:

- the TELESOFT unit assures equal development of programming for the given SPC system in all locations where the system is being introduced into operation or where it already exists and consistently maintains the identity of programming;
- the unit cooperates with maintenance or the responsible oversight center for the SPC system with the objective of catching concealed errors or shortcomings in programming and eliminating the defect through appropriate incursion;
- the unit specifies parameters which are tied to the system and defines some operational procedures. In case of need, it provides support for introduction of systems;
- the unit coordinates the utilization of systems with a view to changes in technology or for reasons involving the introduction of new functions.

In making the decisions regarding the composition of a TELESOFT unit, use was made of experiences collected during the long-term operation of the international AKE13 central in Prague, where the purposefulness and advantage of permanently including maintenance technicians for the system in developmental and design work was confirmed. By expanding their activities which go

beyond the confines of current maintenance, it was possible to more rapidly and more efficiently approach the expansion of communications technology. This was the principal reason behind utilizing this cadre of workers for conceptual solutions of this problem in the entire complex of preparation and realization.

Experiences from maintenance practices involved in the SPC AKE13 system demonstrated that a small but well-harmonized team is capable of providing the necessary support for a communications system. Team members have deep knowledge regarding the system, each has certain specializations, so that the entire collective covers the problem in a comprehensive manner. Development of centralized programming activities in the areas of SPC systems application was practically verified at the time the international AKE13 central was being expanded, when employees were able, thanks to their knowledge regarding the creation of programming, to independently and creatively cooperate directly with the foreign producer in working up the design. This resulted in expressly lowering the foreign exchange costs and in speeding up and improving the quality of the design work undertaken.

The deep knowledge on the part of the user of the internal data structures provided inspiration for the idea to realize the expanded system in the form of extensive conversion of the types of line signals at attached points, requiring a minimum of subsequent incursions into the programming. Requirements of this type are solved by the producing firm generally by another method which involves a number of independent modifications, both as to programs as well as with regard to technical equipment. In its results, this means higher financial costs. The character and extent of the conversions worked out by the Czechoslovak side in the design phase were unique and, in essence, eliminated the effects of the limitation of the COCOM embargo. Inquiry involving expansion by 9,600 attachment points, with the anticipated installation of 5 processors, anticipated a further expansion in 1995. The above-mentioned conversion design, which meant a completely new solution for the producer, provided the possibility of covering the requirement by 1992-1993 and involved the current configuration of four processor units. Production of the necessary programming was realized by way of close cooperation between maintenance technicians and the producer and, thus, achieved a shortening of the developmental cycle while maintaining high quality.

This approach, which is new for our ministry, and which is based on the existence of the above-mentioned collective, in which the user participates in production, was not only advantageous from the standpoint of shortening deadlines for completion. For the Communications Directorate, the primary criterion is the reliability of telecommunications facilities. In the case of SPC technology, this normally means a relatively long period of tuning new programs during actual operations before the recommended limit of failure rate is achieved.

In the case of the expansion of the international AKE center in Prague, this time was expressly curtailed. As early as the time of acceptance in 1987, the qualitative indicators and stability of the system were at a very good level, which had been attained by the original programming from 1979 after 4 years.

The most important aspect for the producer and the Communications Directorate is the fact that the TELESOFT unit will be taking over responsibility for direct cooperation in the following areas:

- creation of error reporting which will be verified; a record of errors is maintained;
- improving the weaker sides of systems which were found during testing or during trial operations, involving representatives of producer firms;
- coordination of devices for overall error recordkeeping;
- coordination of temporary programming solutions;
- coordination of program outputs of systems changes in cooperation with the work site dealing with specifications for systems changes within the framework of the Unified Telecommunications Network;
- creation of the conceptual digitalization of the Czechoslovak Unified Telecommunications Network;
- cooperation with producers of digital communications systems with respect to specifications and development of programming.

With regard to the last point, it is necessary to state that programming represents a considerable portion of the capital expenditures for SPC systems (roughly 80 percent of the entire cost of acquisition). Generally, programming capacities are in very short supply and, therefore, sought after; the nondependence of domestic programming capacities upon foreign suppliers is undoubtedly an advantage for the operator from the standpoint of comprehensive support for the Unified Telecommunications Network.

The realization of the program to digitalize the Czechoslovak Unified Telecommunications Network requires extremely close contacts with suppliers of the necessary technical devices to a greater extent than ever before. An important step in this is to write suitable specifications for a reference configuration of the network in the form of "pilot designs" to assure the full compactibility of new and existing technical facilities within the Unified Telecommunications Network.

As a result of not quite a full year of existence of the TELESOFT unit, the first good experiences involving the new concept of organization pertaining to centralized support for programming of SPC systems and the Czechoslovak Unified Telecommunications Network are available.

In addition to the already worked out and formalized procedures for recordkeeping and achieving changes in the area of the data component of programming for the E10 system, future effort will be aimed at achieving a higher degree of independence in the programming component. Moreover, in conjunction with the realization of restructuring in the Ministry of Transportation and Communications, it has proven to be useful to carefully evaluate the question of orientation of bilateral advantageous international cooperation with developed world producers. One of the ways can be the establishment of contacts with foreign producers through the appropriate Czechoslovak representational offices with the goal of gradually realizing cooperation in the area of solving programming for SPC systems, which can also be utilized by designers and by service personnel.

CSSR: Satellite Television To Come On-Line in 1990

23020025 East Berlin RADIO FERNSEHEN ELEKTRONIK in German No 11, Nov 88 p 683

[Text] In the 1990s, pursuant to an agreement with the International Telecommunications Union (ITU), the CSSR plans to begin transmitting television programs via satellite. In this way, it will participate in the elaboration of the fundamental system approaches and technical principles for satellite transmission systems, within the framework of the complex program for the scientific and technical progress of the CEMA member countries through the year 2000. The Soviet Union will provide most of the equipment for geostationary satellites.

The CSSR is conducting research in wave propagation for satellite television transmission. It is also working on the development of different types of ground stations for satellite television and is testing two cable network configurations in residential areas. By the early 1990s, there should be 80 ground stations to receive the signals from space and relay them in the conventional manner.

The next stage in the development of satellite television is to begin around the year 2000, with the transmission of television programs over four or five channels. At present, the CSSR has two television channels. One channel can be picked up in about 95 percent of the country, where more than 98 percent of the CSSR's inhabitants reside; the other channel is picked up by 75 percent of the CSSR's inhabitants.

Second INTERSPUTNIK Ground Station Built in CSSR

24020018 Prague PTT REVUE in Czech Nov-Dec 88 pp 166-168

[Article by Eng Vaclav Zvonar: "Second Ground Station of the INTERSPUTNIK System in Czechoslovakia"; first paragraph is PTT REVUE introduction]

[Text] Toward the end of August of this year, the second Czechoslovak ground station of the INTERSPUTNIK system of cosmic telecommunications was activated. Its

development is proceeding in two stages. During the first stage, the problem is to assure the temporary reception of television signals from channel 10 of the Stacionar 13 satellite with equipment located in a container. This stage was concluded on 18 August 1988 when comprehensive verification tests were carried out and when the installation was placed into operation on the basis of the temporary approval of the management of INTERSPUTNIK. It is anticipated that, in conjunction with the agreement, final approval will be issued at the session of the Intersputnik Council in October of this year. During the second stage, it is expected that the installation will be augmented so as to assure duplex television and telephone operations by the end of 1989.

Before discussing the more detailed data pertaining to the station, let us return to history.

Cooperation with the Soviet Union in the area of cosmic communications dates back to the year 1966 when, on the basis of an offer by the USSR, a program for scientific cooperation involving the socialist countries in the area of space research and space applications, designated INTERKOSMOS, was accepted and which also encompassed the problem of space telecommunications. A number of research projects from the area of space communications, which were carried out within the framework of the INTERKOSMOS program, have found application in practice. The most express example of this experience is the international system of space telecommunications, referred to as INTERSPUTNIK.

The international Intersputnik organization was established in 1971 as an open international organization, open to membership by any nation, provided it pledged to abide by the provisions of the Agreement To Create Intersputnik, dated 1971. The goal of the organization is to secure for member nations and other nations telecommunications with the aid of space technology and to thus afford them the opportunity for an operational, reliable, and highly economical method for transmitting information over great distances.

In 1971, nine socialist countries were the founding members of Intersputnik. They were Bulgaria, the GDR, Cuba, the Mongolian People's Republic, Hungary, Poland, Romania, Czechoslovakia, and the USSR. Currently, the organization has 15 members; in addition to those already named, they are Afghanistan, the People's Democratic Republic of Yemen, the Korean People's Democratic Republic, Laos, Nicaragua, and Vietnam. Upon completion of formalities, Syria will also become a member. However, the technical means of the INTERSPUTNIK operational system are utilized actively not only by its members or the owners of ground stations such as Algeria, Iraq, Kampuchea, Japan, and the United States, but by many other countries (France, Italy, Spain, etc.) through the use of transit channels.

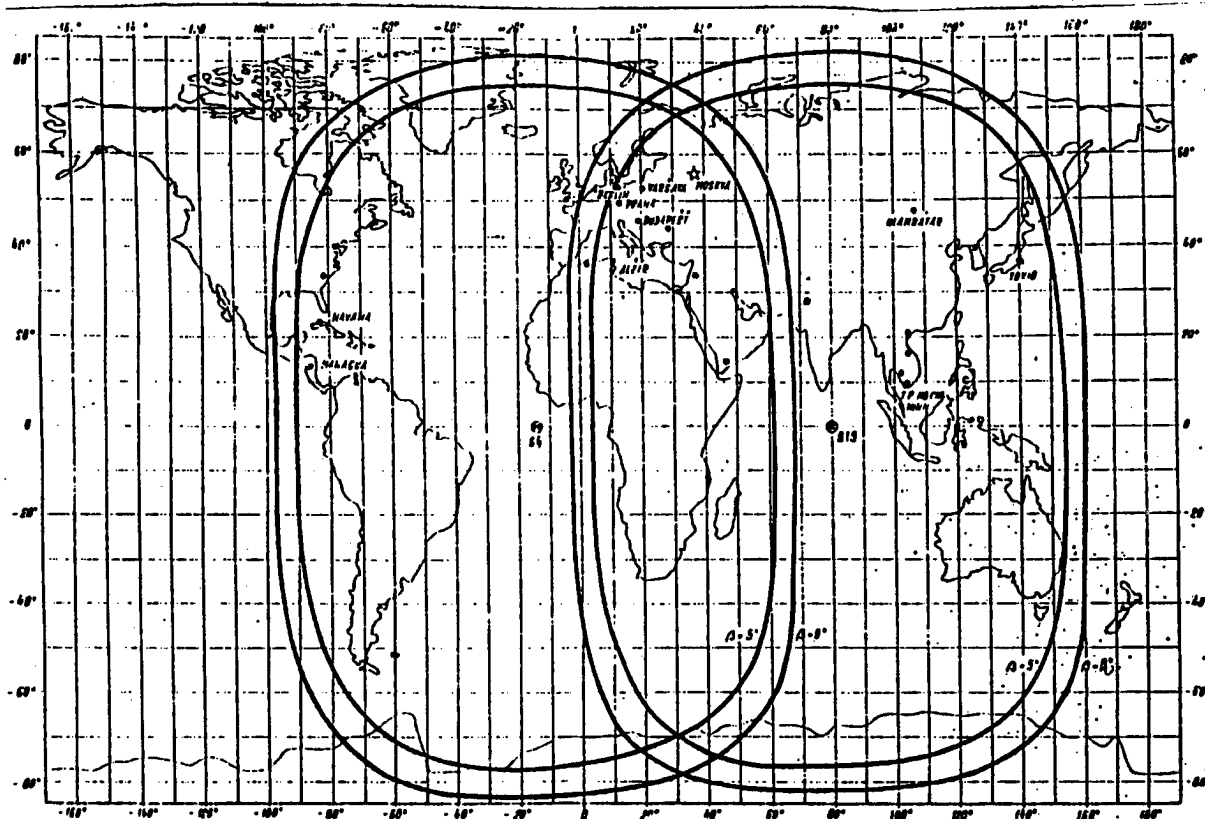

Figure 1. Earth coverage from Stacionar 4 and Stacionar 13 satellites.

Currently, a total of 23 ground stations are functional in the system and 2 others are being planned, in Libya and in Angola. The ground stations use two satellites located in geostationary orbits. One covers the region of the Atlantic Ocean and is located at 14° West longitude (Stacionar 4), the second, located at 80° East longitude (Stacionar 13), covers the region of the Indian Ocean (see Figure 1). Aboard each satellite, INTERSPUTNIK has rented broad-band channels for the transmission of television, radio, and telephone circuits. Stacionar 4, with which 13 stations operate, utilizes 2 channels for the transmission of television signals and 2 for the transmission of telephone circuits. Stacionar 13, in whose area 10 stations operate, utilizes a single television and a single telephone channel.

In the beginning, Intersputnik was a budgetary organization. Annual contributions during the early years were the same for all countries; later, they were differentiated in conjunction with the volume of operations undertaken by each country. Beginning in 1983, Intersputnik became a commercial organization based on the principle of cost accounting (khozraschet). Revenues for utilizing the system cover operational expenses for the system and other expenditures of the organization; the

final balance of the organization is a profit balance ranging between 20 and 30 percent. Part of the profits is distributed among member countries based on the extent of operational utilization of the system by these countries. The current financial situation of the Intersputnik organization can be designated as being fully stabilized and, given the gradual increase in the membership base, it is possible to anticipate a greater increase in the volume of operations. The participation of Czechoslovakia in the Intersputnik organization is profitable; the overall revenue Czechoslovakia derives from the organization has already balanced both the volume of Czechoslovakia's contribution during the initial phase, as well as the one-time contribution to the statutory fund, made in 1982.

Czechoslovakia participated in the work involved in the creation and expansion of INTERSPUTNIK from the very beginning. Not long after signing the Agreement To Create Intersputnik in 1971, a contract was signed for the delivery of technological equipment by the USSR for a Czechoslovak ground station which, after completion, became the first ground station for INTERSPUTNIK in central Europe and was the third in line in the system, following the USSR and Cuba.

Thanks to assistance received from the USSR, television reception was initiated as early as 1 May 1974 and telephone operations began 1 February 1976.

In the beginning stage, the system operated with the assistance of a MOLNIYA-type satellite and had an elongated elliptical orbit. The ground stations were equipped with Soviet-made equipment, derived from the equipment used on the ORBITA satellite for a single television and a single telephone channel. The gradual expansion of operations of the system led to additional technical development of the system and, toward the end of 1979, the transition was made toward operating from a geostationary satellite of the Stacionar type. Between 1983 and 1984, the majority of ground stations operating in the zone of Stacionar 4 were expanded and modernized.

Modernization of the Czechoslovak station was undertaken by the Czechoslovak Directorate of Communications in two stages. In the first stage, the parametric amplifiers, the guidance system, and the antenna reflector feed were exchanged. In the second stage, the waveguide tract was expanded to operate four channels, and assembly of Grunt and Gelikon transmitters was accomplished. At the same time, MDVU-40 terminal equipment was installed for the transmission of telephone channels utilizing the time ceiling aboard the satellite (as opposed to the existing Gradient-N equipment which is based on frequency division). Furthermore, the television transmitter was retuned from channel 10 to channel 9 and channel 7 was equipped with receiver equipment. The results of the modernization were a substantial increase in the quality of operations and in increased efficiency of utilization pertaining to the leased channels involved in telephone operations.

From the first television transmissions and from the organization of the initial telephone international circuits, operations taken care of by the Czechoslovak ground station have substantially increased, particularly with regard to the number and length of television transmissions. This is particularly due to the fact that the technical means of INTERSPUTNIK currently account for more than 60 percent of television transmissions between member organizations of the OIRT. For Czechoslovakia, there is great significance in the fact that it is the host country for these international television and radio organizations, including their technical and program coordination centers. Thanks to this, the utilization of the technical means at the disposal of the Czechoslovak Directorate of Communications and, thus, also the profits based on their operations, are growing. On the other hand, however, there is the obligation to create, for members of the OIRT, suitable conditions, for example, to facilitate simpler, more reliable, and more operational coordination involved in the exchange of television topics between countries of the western, central, and eastern regions of the Intersputnik organization.

Apart from the above-listed considerations, the decision to build a second Czechoslovak ground station for the INTERSPUTNIK system was motivated by the following experiences:

- Currently, transit transmissions between the Atlantic and Indian Ocean regions of INTERSPUTNIK are handled only by two ground stations located on USSR territory. However, the distance between the two stations is several hundred kilometers;
- In view of the favorable geographic position occupied by Czechoslovakia, the Czechoslovak station will make it possible to handle transit transmissions from the area of the Indian Ocean to the countries of western and central Europe;
- Transit transmissions involving both zones of the INTERSPUTNIK system are accomplished from a single location, without utilizing any additional territorial communications means;
- Czechoslovak interest in expanding space telecommunications, motivated by the effort to improve the quality and expand the Czechoslovak international telecommunications system.

Preparations for the expansion were initiated in 1986. During 1987, the design proposals for the structural expansion of the Czechoslovak ground station were completed, as were the proposals for its technical equipment.

The structural expansion of the Czechoslovak ground station to handle communications with the eastern region of the INTERSPUTNIK system, which will be realized during the second stage of expansion, is based on the existing technological area and the social hinterland which exists at the Sedlec radio communications station. As a result, it was possible to hold requirements for construction work and for a growth in manpower to a minimum and to take care of the obligations of the Czechoslovak Directorate of Communications at the lowest possible cost in capital expenditures. The solution is based on the installation of a new independent east wing, tied directly to the circuit portion of the existing station facilities. The latter create a natural functional center for the new project, as can be seen from Figure 2. As a result of this solution, an overall balance and symmetry of the composition was achieved in contrast to the existing status when an asymmetric west wing was added to the circular central building. The existing operations of the station will not be disrupted by the construction of the new portion, since all construction activity will be carried on outside of the existing facility and the only connection between the two buildings will be an opening in the existing structure.

The 12-meter-diameter antenna is located in a separate block in such a manner that the elevational axis of the antenna is approximately 7.2 meters above the surrounding terrain. Because the working operational angle of the antenna is approximately 8°, the lower edge of the

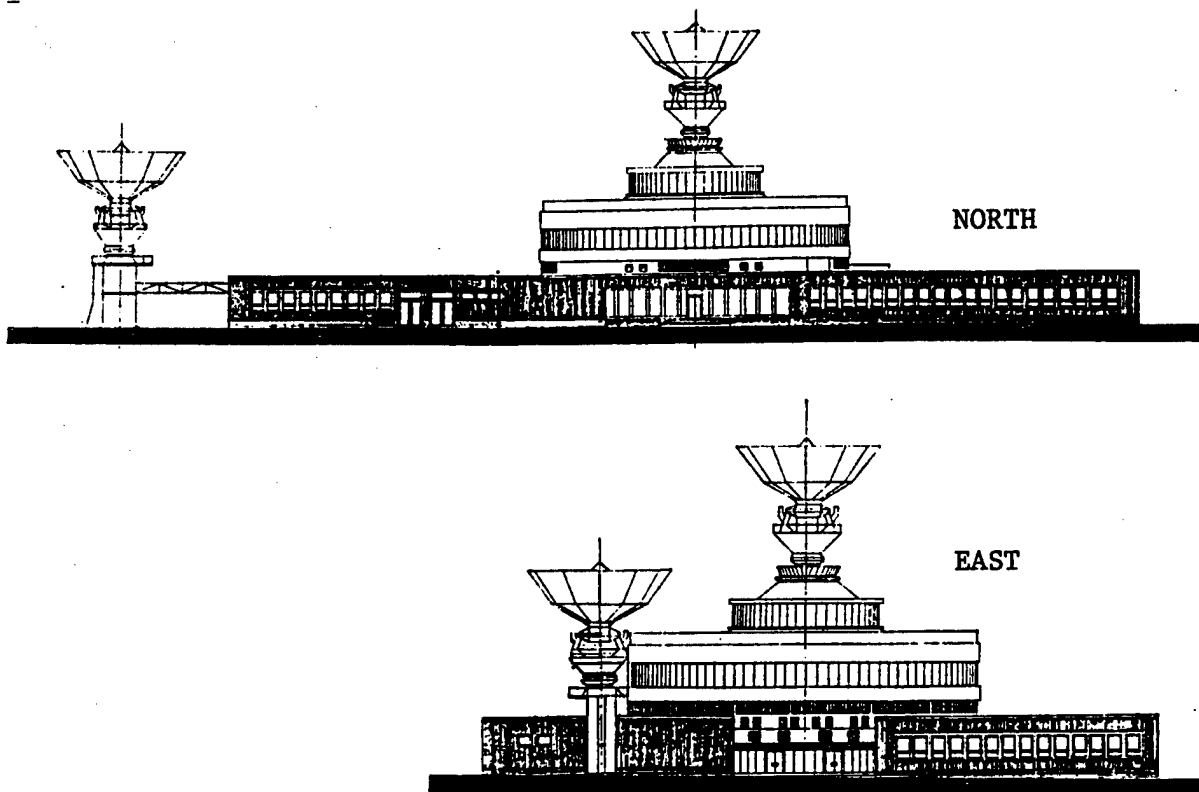

Figure 2. Ground station after completion of second stage of expansion—view from the north and the east.

antenna will be only about 1.5 meters aboveground. But even under these conditions, all parameters of communications will be in line with the technical standards of Intersputnik regulations.

In 1987, a contract was concluded with the USSR for the delivery of technological equipment for the station to facilitate the reception and transmission of television signals and duplex telephone operations, excluding terminal telephone equipment. Here, it is anticipated that, in conjunction with developmental materials developed by the Intersputnik organization, use will be made of Hungarian INTERCHAT equipment. The apparatus works on the principle of "a single channel for carrier frequencies," utilizes PCM and ADPCM modulation, and facilitates cooperation with SCPC equipment which is utilized in the INTELSAT system. The equipment makes it possible to advantageously create telephone circuits in specific directions having a small number of channels, as is anticipated in accordance with existing operational requirements. More detailed technical data on the establishment of the second Czechoslovak ground station will be found by interested readers in the October 1988 issue of the journal *TELEKOMUNIKACE*, in the article written by Frantisek Sebek and entitled "Permanent Satellite Service in the INTERSPUTNIK System."

For the Czechoslovak Directorate of Communications, a second ground station not only signifies an increase in operations involving the exchange of television topics with countries of the eastern zone, but also the creation of additional transmission pathways between Moscow and Prague. Apart from terminal operations, the Czechoslovak ground station will, once it is completed, be able to assure transit duplex television transmissions and telephone circuits. Even if, during the current period, stations in the Afghan Democratic Republic, in the Korean People's Republic, in Laos, in Mongolia, in Vietnam, in Kampuchea, in Japan, and the USSR are operating in the zone of the Indian Ocean, it is possible to anticipate, on the basis of preliminary information, that additional stations will be built in China, India, and elsewhere. According to the OIRT, the exchange of television programs involving the Asian-Pacific Broadcast Association (APB) should be possible through the actions of one of the Asian countries. It is further anticipated that television transmissions will be exchanged with Japanese broadcasters and television organizations (ASAHI and NHK), which have become associate members of the OIRT.

All of this creates the prerequisites for letting the Czechoslovak Center for Satellite Telecommunications become an important international telecommunications center for the Atlantic and Indian Ocean regions.

10

22161

31

NTIS

ATTN: PROCESS 103

5285 PORT ROYAL RD

SPRINGFIELD, VA

22161

This is a U.S. Government publication. It contains the policies, views, or attitudes of the U.S. Government. Users of this publication may cite FBIS or JPRS provided they do so in a manner clearly identifying them as the secondary source.

Foreign Broadcast Information Service (FBIS) and Joint Publications Research Service (JPRS) publications contain political, economic, military, and sociological news, commentary, and other information, as well as scientific and technical data and reports. All information has been obtained from foreign radio and television broadcasts, news agency transmissions, newspapers, books, and periodicals. Items generally are processed from the first or best available source; it should not be inferred that they have been disseminated only in the medium, in the language, or to the area indicated. Items from foreign language sources are translated; those from English-language sources are transcribed, with personal and place names rendered in accordance with FBIS transliteration style.

Headlines, editorial reports, and material enclosed in brackets [] are supplied by FBIS/JPRS. Processing indicators such as [Text] or [Excerpts] in the first line of each item indicate how the information was processed from the original. Unfamiliar names rendered phonetically are enclosed in parentheses. Words or names preceded by a question mark and enclosed in parentheses were not clear from the original source but have been supplied as appropriate to the context. Other unattributed parenthetical notes within the body of an item originate with the source. Times within items are as given by the source. Passages in boldface or italics are as published.

SUBSCRIPTION/PROCUREMENT INFORMATION

The FBIS DAILY REPORT contains current news and information and is published Monday through Friday in eight volumes: China, East Europe, Soviet Union, East Asia, Near East & South Asia, Sub-Saharan Africa, Latin America, and West Europe. Supplements to the DAILY REPORTs may also be available periodically and will be distributed to regular DAILY REPORT subscribers. JPRS publications, which include approximately 50 regional, worldwide, and topical reports, generally contain less time-sensitive information and are published periodically.

Current DAILY REPORTs and JPRS publications are listed in *Government Reports Announcements* issued semimonthly by the National Technical Information Service (NTIS), 5285 Port Royal Road, Springfield, Virginia 22161 and the *Monthly Catalog of U.S. Government Publications* issued by the Superintendent of Documents, U.S. Government Printing Office, Washington, D.C. 20402.

The public may subscribe to either hardcover or microfiche versions of the DAILY REPORTs and JPRS publications through NTIS at the above address or by calling (703) 487-4630. Subscription rates will be

provided by NTIS upon request. Subscriptions are available outside the United States from NTIS or appointed foreign dealers. New subscribers should expect a 30-day delay in receipt of the first issue.

U.S. Government offices may obtain subscriptions to the DAILY REPORTs or JPRS publications (hardcover or microfiche) at no charge through their sponsoring organizations. For additional information or assistance, call FBIS, (202) 338-6735, or write to P.O. Box 2604, Washington, D.C. 20013. Department of Defense consumers are required to submit requests through appropriate command validation channels to DIA, RTS-2C, Washington, D.C. 20301. (Telephone: (202) 373-3771, Autovon: 243-3771.)

Back issues or single copies of the DAILY REPORTs and JPRS publications are not available. Both the DAILY REPORTs and the JPRS publications are on file for public reference at the Library of Congress and at many Federal Depository Libraries. Reference copies may also be seen at many public and university libraries throughout the United States.