

*te technical note techn*

**Airport Surveillance Radar  
Model 11 (ASR-11)  
FAA Test and Evaluation  
Master Plan (TEMP)**

Ronald Weber  
Joseph Schanne

February 1998

DOT/FAA/CT-TN97/27

Document is on file at the William J. Hughes Technical Center  
Library, Atlantic City International Airport, NJ 08405



U.S. Department of Transportation  
**Federal Aviation Administration**  
William J. Hughes Technical Center  
Atlantic City International Airport, NJ 08405

19990202 072

#### **NOTICE**

This document is disseminated under the sponsorship of the U.S. Department of Transportation in the interest of information exchange. The United States Government assumes no liability for the contents or use thereof.

The United States Government does not endorse products or manufacturers. Trade or manufacturers' names appear herein solely because they are considered essential to the objective of this report.

1. Report Number DOT/FAA/CT-TN97/27		2. Government Accession Number		3. Recipient's Catalog Number	
4. Title and Subtitle Airport Surveillance Radar Model 11 (ASR-11) FAA Test and Evaluation Master Plan (TEMP)				5. Report Date February 1998	
				6. Performing Organization Code	
7. Author(s) Ronald Weber, Joseph Schanne (Section 6)				8. Performing Organization Report Number DOT/FAA/CT-TN97/27	
9. Performing Organization Name and Address U.S. Department of Transportation Federal Aviation Administration William J. Hughes Technical Center Atlantic City International Airport, NJ 08405				10. Work Unit Number (TRAVIS)	
				11. Contract or Grant Number	
12. Sponsoring Agency Name and Address U.S. Department of Transportation Federal Aviation Administration Enroute Surveillance Products, AND-440 Washington, DC 20591				13. Type of Report and Period Covered Technical Note	
				14. Sponsoring Agency Code	
15. Supplementary Notes					
16. Abstract  <p>The Airport Surveillance Radar, Model 11 (ASR-11) is a joint Federal Aviation Administration (FAA)/Department of Defense (DOD) procurement program with the United States Air Force (USAF) assuming overall lead responsibility. The DOD has designated their program as the Digital Airport Surveillance Radar (DASR). A joint FAA/DOD Test and Evaluation (T&amp;E) program will be conducted in order to support a joint production decision. A Memorandum of Agreement (MOA) between the two agencies defines overall roles and responsibilities for each agency in accomplishing this effort.</p> <p>This ASR-11 Test and Evaluation Master Plan (TEMP) provides an overview of the joint FAA/DOD test program. It outlines the approach and philosophy to be implemented by the FAA to ensure that all FAA test requirements are met. It assigns responsibilities for each T&amp;E phase, defines requirements for test readiness and acceptance, and identifies how each critical issue and major systems requirement will be tested. The FAA test program outlined in this TEMP will be accomplished in accordance with the Acquisition Management System (AMS) T&amp;E Process Guidelines.</p>					
17. Key Words Airport Surveillance Radar Model 11 (ASR-11) Digital Airport Surveillance Radar (DASR) Primary Surveillance Radar (PSR) Monopulse Secondary Surveillance Radar (MSSR) Test and Evaluation Master Plan (TEMP)			18. Distribution Statement Document is on file at the William J. Hughes Technical Center Library, Atlantic City International Airport, NJ 08405		
19. Security Classification (of this report) Unclassified		20. Security Classification (of this page) Unclassified		21. Number of Pages 97	22. Price

## TABLE OF CONTENTS

	Page
EXECUTIVE SUMMARY	vii
1. INTRODUCTION	1
1.1 Background	1
1.2 Purpose	2
1.3 Scope	3
2. REFERENCE DOCUMENTS	6
3. NAS SUBSYSTEM DESCRIPTION	8
3.1 NAS Subsystem Implementation	8
3.2 NAS Subsystem	9
3.3 Interfaces	10
3.4 Critical System Characteristics (CSC) and Critical Performance Parameters (CPP)	16
3.5 Critical Operational Issues (COI)	18
3.6 Minimum Operational Performance	22
4. T&E PROGRAM MANAGEMENT	29
4.1 Management	29
4.2 Integrated Schedule	30
4.3 Test and Evaluation Funding	34
4.4 Test Plans	35
4.5 Test Program Resources	39
4.6 Test Configuration Management	43
5. T&E PROGRAM DESCRIPTION	44
5.1 Completed DT&E/PAT&E	44
5.2 Completed NAS OT&E Integration Testing	44
5.3 Completed NAS OT&E Operational Testing	44
5.4 DT&E Testing	45
5.5 PAT&E Testing	47
5.6 NAS OT&E Integration/Operational Testing	47
5.7 Delta System Testing	49
5.8 OT&E Test Limitations	49
6. INDEPENDENT OPERATIONAL TEST AND EVALUATION (IOT&E)	51
6.1 Independent OT&E Purpose/Scope	51
6.2 IOT&E Strategy	51
6.3 IOT&E Resource Requirements	56
6.4 IOT&E Documentation	58
7. ACRONYMS AND GLOSSARY	60

## APPENDIX

## LIST OF ILLUSTRATIONS

Figure	Page
1.3-1 DOD Testing Versus FAA Testing	4
3.3-1 ASR-11 to ARTS IIA Interface (Operational Configuration)	11
3.3-2 ASR-11 to ARTS IIA Interface (Alternate Configuration)	12
3.3-3 ASR-11 to ARTS IIE Interface	12
3.3-4 ASR-11 to ARTS IIIA Interface	13
3.3-5 ASR-11 to ARTS IIIE Interface	14
3.3-6 ASR-11 to STARS Interface	14
3.3-7 ASR-11 to $\mu$ EARTS Interface	15
3.3-8 ASR-11 to NIMS Interface	16
4.2-1 Integrated Schedule	32

## LIST OF TABLES

Table	Page
3.4-1 Critical System Characteristics and Critical Performance Parameters	16
3.5-1 ASR-11 Critical Operational Issues Resolution Matrix	19
3.6-1 ASR-11 Minimum Acceptable Operational Performance	22
4.1-1 Organizational Responsibilities	29
4.3-1 T&E Funding Profile	34
4.5.1-1 Manpower Requirements	40
6.3.1-1 IOT&E Roles	56
6.3.2-1 Staffing Estimates for IOT&E in Man-Years	57
6.3.7-1 IOT&E Funding Requirements.	58



## EXECUTIVE SUMMARY

The Airport Surveillance Radar, Model 11 (ASR-11) is a joint Federal Aviation Administration (FAA)/Department of Defense (DOD) procurement program with the United States Air Force (USAF) assuming overall lead responsibility. The DOD has designated their program as the Digital Airport Surveillance Radar (DASR). A joint FAA/DOD Test and Evaluation (T&E) program will be conducted in order to support a joint production decision. A Memorandum of Agreement (MOA) between the two agencies defines overall roles and responsibilities for each agency in accomplishing this effort.

This ASR-11 Test and Evaluation Master Plan (TEMP) provides an overview of the joint FAA/DOD test program. It outlines the approach and philosophy to be implemented by the FAA to ensure that all FAA test requirements are met. It assigns responsibilities for each T&E phase, defines requirements for test readiness and acceptance, and identifies how each critical issue and major systems requirement will be tested. The FAA test program outlined in this TEMP will be accomplished in accordance with the Acquisition Management System (AMS) T&E Process Guidelines.

The ASR-11 program will be subjected to Independent Operational Test and Evaluation (IOT&E). Section 6 of this TEMP provides an overview of the efforts to be accomplished during the IOT&E phase of this test program.



## 1. INTRODUCTION.

### 1.1 BACKGROUND.

This is the first revision of the Test and Evaluation Master Plan (TEMP) for the Airport Surveillance Radar Model 11 (ASR-11). The ASR-11 acquisition program has progressed through several major transformations since release of the initial TEMP. Many of these changes present a direct impact on the Test and Evaluation (T&E) program. This revision of the TEMP is submitted to reflect the current direction of the test program by addressing the significance of the following program modifications:

- a. The ASR-11, originally defined as a Primary Surveillance Radar (PSR), now includes an integrated Air Traffic Control Radar Beacon System (ATCRBS) Monopulse Secondary Surveillance Radar (MSSR).
- b. The Federal Aviation Administration (FAA) has relinquished the role of Lead Procurement Agency; the Department of Defense (DOD) has assumed this responsibility. The DOD has designated their program as the Digital Airport Surveillance Radar (DASR).
- c. In order to arrive at a joint Production Decision, the FAA and DOD have agreed to conduct a joint T&E effort.
- d. The FAA will conduct Independent Operational Test and Evaluation (IOT&E) on the ASR-11 program in accordance with a Memorandum Of Agreement (MOA), dated 1/11/96, between the Associate Administrator for Research and Acquisitions (ARA-1) and the Associate Administrator for Air Traffic Services (ATS-1).
- e. The FAA Acquisition Management System (AMS), which became effective April 1, 1996, has modified the T&E process. Testing is now organized into three test types: System Test, IOT&E, and Field Familiarization.
- f. The requirement for an external interface to the Maintenance Processor Subsystem (MPS) of the Remote Maintenance Monitoring System (RMMS) has been deleted. Remote monitoring of the ASR-11 will be accomplished through an interface to the National Airspace System (NAS) Infrastructure Management System (NIMS).

Under the new AMS, System Test is defined as encompassing what had previously been referred to in FAA Order 1810.4B as Development Test and Evaluation (DT&E), Operational Test and Evaluation (OT&E) Integration, Operational, and Shakedown, and Production Acceptance Test and Evaluation (PAT&E). It includes all NAS subsystem testing other than IOT&E and Field Familiarization. System test is the responsibility of the Integrated Product Team (IPT) with test leadership provided by the FAA William J. Hughes Technical Center. Responsibility for what was previously defined as OT&E

Shakedown has been transferred from AOS to ARA and will be completed as part of System Test. IOT&E will be conducted by the ATS test team and will follow System Testing. Field Familiarization, formerly referred to as Field Shakedown, will be conducted by Airway Facilities (AF) and Air Traffic (AT) field personnel. Further definition of the new FAA T&E process is provided in the Acquisition Reform Interim Guidance (ARIG) 96-1 document, dated July 10, 1996.

The ASR-11 program was granted approval for Key Decision Point (KDP) 3 in September 1995, and is now in the full-scale development phase. The DASR Request For Proposals (RFP) was released October 19, 1995. Proposals were received December 18, 1995, and a contract for the DASR/ASR-11 was awarded to the Raytheon Corporation on August 9, 1996. A formal protest against the contract award forced a stop work order that remained in place until the protest was resolved on November 27, 1996.

The system is being procured as a Non-Development Item (NDI). The government expects to purchase a "mature" system that is currently operational and in production. It will require only minimal modifications which will be considered development tasks. Among these tasks will be the design of FAA and DOD specific external interfaces.

The ASR-11 has been identified by ATS-1 as a program that will be subjected to the conduct of IOT&E. IOT&E will be conducted by the ATS Test Team which includes members from the FAA Office of IOT&E (ATQ), AF, and AT. Dedicated IOT&E testing will be accomplished at the conclusion of System Testing. A complete description of the IOT&E activities planned for this program is included in section 6 of this document.

## 1.2 PURPOSE.

This document provides an overview of the T&E program for the ASR-11 radar and facilities subsystems. It introduces the concept and framework of an integrated FAA/DOD test effort and furnishes direction for the development and implementation of lower level test plans and procedures. It assigns responsibilities for each test and evaluation phase, outlines requirements for test readiness and acceptance, and identifies how each critical issue and major systems requirement will be tested.

System requirements for the ASR-11 are contained in the Final Requirements Document (FRD). This document, which is currently available in draft form, incorporates the requirements for an integrated MSSR that were not included in the existing, signed Operational Requirements Document (ORD). The FRD will supercede the ORD upon joint approval from the ATS and ARS organizations. As of this TEMP's publication, a NAS Change Proposal (NCP) to revise the NAS-SS-1000 to include the FRD requirements has not been submitted. Specific references to the NAS-SS-1000 system specification and any changes to the FRD will be included in subsequent revisions.

### 1.3 SCOPE.

This revision of the TEMP focuses on the overall philosophy that will be utilized by the FAA in the joint FAA/DOD T&E effort. In order to streamline the acquisition process, the DOD and FAA have agreed to conduct a joint T&E program. Overall conduct of the test program is outlined in the DASR/ASR-11 Interagency Agreement Between DOD and USDOT/FAA, Sub-Agreement 3, Subsection 1 - Test and Evaluation, dated August 30, 1995; this document is commonly referred to as the MOA. The MOA specifies that both agencies will be involved in all phases of testing and will work together as a fully integrated team. The underlying philosophy of this approach is to avoid redundancy in the test program and allow for a joint Production Decision upon the completion of testing. The MOA further requires that both agencies agree on system acceptability before this program can enter the Production and Deployment phase.

The FAA and DOD have developed two Joint Master Test Plans (JMTPs) which define the two major phases of this joint test program. The DOD was lead agency in the development of these documents. As a result, DOD processes, terminology, and semantics were utilized to describe the test program. Individual JMTPs define the specific roles and responsibilities of each organization involved in the two phases of DOD testing: DT&E and Initial OT&E (also referred to as IOT&E but is greater in scope than FAA IOT&E).

DOD DT&E is conducted to verify that system function and performance complies with the specification. Testing must demonstrate that the system design and development is complete, that design risks have been minimized, and that the system will perform as required in its intended environment. Formal tests may be conducted by either the contractor or the government, however, government-led testing is generally limited to verification of requirements that were not completely satisfied by contractor testing. Successful completion of DT&E leads to system certification of readiness for dedicated DOD Initial OT&E. The 46<sup>th</sup> Test Squadron (46TS) from Eglin Air Force Base (AFB), Florida, is the lead organization for DT&E in the DASR program. The Technical Center's Communication/Navigation/Surveillance Engineering and Test Division, Surveillance Branch, ACT-310, will work jointly with the 46TS throughout DT&E testing in order to ensure that FAA DT&E requirements are met.

DOD Initial OT&E is conducted to evaluate a system's operational effectiveness, maintainability, and supportability with respect to predefined Critical Operational Issues (COIs), Measures of Effectiveness (MOEs) and Measures of Performance (MOPs). Initial OT&E testing is performed by an independent team with participation from the user organizations. Testing is conducted under conditions that are as operationally realistic as possible and practical. Specific tests are performed to identify any operational or logistics support deficiencies and to define the need for modifications to resolve them. Initial OT&E testing must be completed before the production decision. The Air Force Operational Test and Evaluation Command (AFOTEC) will be the lead organization for Initial OT&E. AFOTEC's mission spans what the FAA refers to as the OT&E component of System Testing and IOT&E. ACT-310 will work jointly with AFOTEC

until FAA System Testing is complete. The FAA system will be certified and utilized to control "live" air traffic during the final stages of System Testing. At the conclusion of FAA System Testing, ACT-310 will provide input to the IPT on the program's ability to support an FAA Independent OT&E Readiness Declaration (IOTRD). Issuance of the IOTRD will signify the beginning of dedicated FAA IOT&E testing. The ATS Test Team will work jointly with AFOTEC during FAA IOT&E.

Figure 1.3-1 illustrates a basic comparison of DOD and FAA test phases; correlations are based on the objectives of each phase.

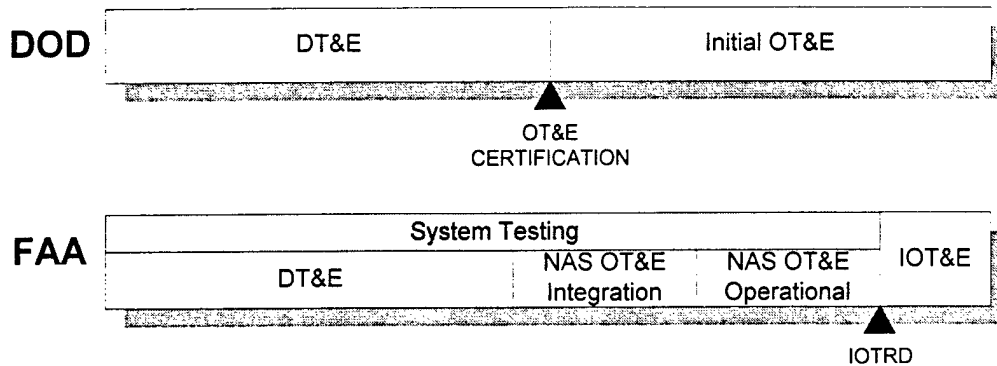

FIGURE 1.3-1. DOD TESTING VERSUS FAA TESTING

As part of proposal evaluation, each prospective contractor conducted an Operational Capabilities Demonstration (OCD) for their product. The OCD was used to corroborate portions of each offeror's technical proposal and to review existing test data. The sole purpose of the OCD was to help determine the "maturity" of the systems offered. No specific tests were conducted at the government's direction.

At contract award, the FAA and DOD purchased one preproduction system for each agency. During factory DT&E, ASR-11 surveillance data will be remoted to the Technical Center where automation system interfaces will be tested. Upon completion of factory DT&E, the systems will be installed at government key sites located in Stockton, California (FAA) and Eglin AFB, Florida (DOD). Raytheon will conduct on-site DT&E at both key sites to verify any system requirements which could not be adequately tested in the factory. Government-led testing will be conducted at these key sites and will begin immediately after completion of any contractor on-site DT&E testing. Each agency will be responsible for the conduct of government testing that occurs at the key site they fund. As a joint team, however, both agencies will retain the ability to conduct testing at the location which is best suited for accomplishment of any particular test, regardless of who funds the site.

The objective of key site selection was to identify two sites that would provide a wide range of traffic and clutter characteristics. The FAA key site at Stockton controls a

moderate traffic load, reporting 123,612 instrument operations in 1993. Most of this traffic is comprised of commercial aircraft flying into and out of San Francisco and Oakland area airports along airways that traverse Stockton's assigned airspace. Takeoff and approach traffic at the Stockton airport is light, allowing the site to operate on a 16-hour day by handing off control of its airspace to Oakland Center during the early morning hours. This down time will provide greater opportunities for dedicated ASR-11 testing than could be realized at a site that operates on a 24-hour day. The site is affected by several clutter conditions including urban, mountain, woods, ground traffic, angel (birds) and second time around clutter types as well as Anomalous Propagation (AP). In order to minimize impact on operations, an additional Automated Radar Terminal System (ARTS) IIE, along with associated peripherals and a video mapper, will be installed at Stockton to support the test program. The DOD key site at Eglin AFB is a joint use site with all air traffic control (ATC) operations under military control. The traffic load is light and includes both military and commercial aircraft. The site typically operates on less than a 24-hour day which will allow time for dedicated testing. Clutter conditions affecting this site include sea, weather, urban, woods, and angel clutter types as well as AP.

## 2. REFERENCE DOCUMENTS.

The following documents were referenced in the development of this TEMP and may be useful in gaining a better understanding of the ASR-11 program.

### FAA Documents:

- NAS-SS-1000      NAS System Specification
- NAS-MD-110      Test and Evaluation (T&E) Terms and Definitions for the NAS, dated March 27, 1987
- NAS-IR-34120002      Surveillance Systems to Terminal User Systems ASTERIX Interface for Surveillance and Weather, Draft, dated October 19, 1996
- NAS-IR-34032105      Interface Requirements Document for the Terminal Surveillance Radar/Terminal Air Traffic Control System (DRAFT), dated August 1, 1995
- FAA-G-2100F      Electronic Equipment, General Requirements
- FAA-STD-024B      Content and Format Requirements for the Preparation of Test and Evaluation Documentation, dated August 22, 1994
- FAA Order 1810.4B      FAA NAS Test and Evaluation Policy, dated October 22, 1992
- FAA Order 6050.32      Spectrum Management Regulations and Procedures Manual, dated September 8, 1987
- ICD SE007-3E      ASR-9 External Interface Control Document for ASR-9 to SCIP, dated April 29, 1988
- ICD SE007-4E      ASR-9 External Interface Control Document for ASR-9 SCIP to Terminal Computer, dated June 8, 1989
- FAA National Airspace System Test and Evaluation Policy and Guidance, (DRAFT) Version 3, dated July 12, 1996
- ARIG: 96-1      Acquisition Reform Interim Guidance: FAA NAS Testing and Evaluation Process, dated July 10, 1996
- FAA Operational Requirements Document for the Airport Surveillance Radar Model 11 (ASR-11), dated October 4, 1993

Final Requirements Document: Airport Surveillance Radar, Model 11 (DRAFT), Version 2

Acquisition Plan for the Airport Surveillance Radar Model 11 (ASR-11)

Acquisition Management System Test and Evaluation Process Guidelines, dated July 22, 1997

DOD Documents:

F19628-95-R-0007 DASR Request For Proposals (RFP)

F19628-96-D-0038 DASR Contract

Other Documents:

DASR/ASR-11 Interagency Agreement Between DOD and USDOT/FAA, Sub-Agreement 3, Subsection 1 - Test and Evaluation, dated August 30, 1995

ATS-1/ARA-1 Memorandum Of Agreement: Implementation of Independent OT&E, dated January 11, 1996

Data Authentication Group (DAG) Charter, dated January 13, 1997

DOD/FAA Joint Reliability and Maintainability Evaluation Team (JRMET) Charter for the Digital Airport Surveillance Radar (DASR/ASR-11)

ICAO Annex 10 Volume 1 to the Convention on International Civil Aviation, dated April 1985, and Amendment 69, International Standards, Recommended Practices and Procedures for Air Navigation Services, dated November 11, 1993

### 3. NAS SUBSYSTEM DESCRIPTION.

ASR-11 Prime Mission Equipment (PME) consists of the following items:

- a. PSR Subsystem
- b. ATCRBS MSSR Subsystem
- c. Antenna(s)
- d. Tower
- e. Radome (when necessary)
- f. Local and remote control panels
- g. Maintenance surveillance display
- h. Field level spares
- i. Support equipment and technical manuals
- j. Electronics equipment shelter(s)
- k. Environmental controls
- l. Power Conditioning System (PCS)
- m. Backup power equipment
- n. Moving Target Indicator (MTI) reflectors
- o. MSSR Remote System Monitor (MRSM, beacon parrot)
- p. External transmission modem system
- q. External interfaces, including the Surveillance Data Translator (SDT) (at all ARTS II/III, Radar Air Traffic Control Facility (RATCF), and Direct Altitude and Identity Readout (DAIR) sites), Site Interface Unit (SIU), and all interconnecting cabling.

The DASR contract identifies five basic configurations that will be utilized to purchase production systems; two purchase options tailored for the DOD and three for the FAA. Each configuration includes a unique combination of PME and permits variations as required to accommodate each individual installation site. All FAA purchase options include an external interface to the NIMS. The major difference between the three FAA configurations involves equipment shelters; options include new construction or utilization of existing shelters, pre-engineered shelters, and a mobile platform for all PME. One DOD configuration represents the Navy purchase option of a PSR only system with an external interface to a government furnished Secondary Surveillance Radar (SSR). This configuration does not include contractor installation which will be accomplished by government personnel. The other DOD option utilizes prefabricated equipment shelters to house the system PME. The FAA may also exercise this option for purchase of production systems.

#### 3.1 NAS SUBSYSTEM IMPLEMENTATION.

The ASR-11 is a turnkey program to replace aging ASR-7s, ASR-8s, and Air Traffic Control Beacon Interrogator (ATCBI) Models 4 and 5. It will also be used to satisfy new radar siting requirements for terminal surveillance service, including FAA takeover of



military facilities. The program will be implemented as NDI with the exception of specifically designed NAS interfaces. Design of these interfaces will be designated as a development task. Included in interface development is the design of an SDT and an SIU. The SDT will convert ASR-11 digital surveillance output messages to the analog and digital formats required by existing automation systems including the ARTS II and ARTS III. Interfaces to future automation systems such as the Standard Terminal Automation Replacement System (STARS) will be accomplished through a direct digital link from the SIU. The SIU will provide a minimum of four digital data ports capable of independent simultaneous output in any combination of the following formats: Modified Common Digitizer (CD-2) as defined in NAS-IR-34032105 and ASTERIX in accordance with an IRD that has not yet been defined. Expansion of the SIU to up to 16 output data ports will be available.

### 3.2 NAS SUBSYSTEM.

The ASR-11 system features a PSR fully integrated with an ATCRBS MSSR. The system employs new technologies that provide improved detection performance and system reliability while reducing operating costs. It will interface with present and future automation systems to provide air traffic controllers with state-of-the-art aircraft and weather detection in the terminal environment. Some of the major capabilities that the ASR-11 will provide include:

- a. Fully digital radar data output to automation systems, interoperable with FAA and DOD formats;
- b. Reliable radar detection of aircraft in the presence of all anticipated types of clutter and/or beacon False Replies Unsynchronized In Time (FRUIT) over the entire coverage volume;
- c. Reduced false target detections in the presence of all anticipated types of clutter and FRUIT;
- d. Internal processing and merging of beacon and radar reports;
- e. Monopulse processing of beacon targets for improved target positional accuracy;
- f. Extensive integral built-in-test and fault-isolation capabilities with access available through the NIMS;
- g. Reports weather data in accordance with the National Weather Service (NWS) six-level precipitation density format;
- h. Simultaneous output of surveillance and weather data in several formats.

### 3.3 INTERFACES.

The ASR-11 will interface with both FAA and DOD systems. Each agency will be responsible for testing their own planned interfaces. Testing responsibilities for common interfaces will be shared by both agencies. This TEMP, as an FAA document, discusses only those interfaces that the FAA intends to utilize. The ASR-11 will provide the capability to interface with the NAS and/or DOD systems listed below. The applicable agency for each interface is also identified:

- a. ARTS IIA [FAA]
- b. ARTS IIE [FAA]
- c. ARTS IIIA [FAA]
- d. ARTS IIIE [FAA]
- e. NIMS [FAA]
- f. STARS [FAA/DOD]
- g. Digital Bright Radar Indicator Tower Equipment (DBRITE) [FAA]
- h. Micro-Enroute Automated Radar Tracking System ( $\mu$ EARTS) [FAA]
- i. Programmable Indicator Display Processor (PIDP) [DOD]
- j. Radar Air Traffic Control Facility Direct Altitude and Identity Readout (RATCF DAIR) [DOD]
- k. TPX-42 with UPX-27 Interrogator/Receiver [DOD]

When interfaced with ARTS automation systems (IIA, IIE, IIIA, IIIE), the ASR-11 will digitally output surveillance, weather, azimuth, and status data to a dual redundant ethernet Local Area Network (LAN) located at the radar site. This data will be output in the ASTERIX format utilized by Raytheon's original NDI design. In a typical installation, dual fiberoptic links will be used to remote the radar site LAN to the indicator site; modems and conventional telephone lines or microwave links will be utilized at any locations where the use of fiberoptics is not practical. The SDT will receive radar data over the LAN and output it in the specific digital format required by each automation system. Redundant ethernet hubs will distribute digital radar data from the SDT to Digital Video Generators (DVGs) located at each Planned Position Indicator (PPI) display. The DVGs will provide reconstituted video to individually drive each display. Contract requirements include the capability to drive up to 12 PPI displays. During site transition/switchover, the DVGs will be used to switch between ASR-11 and existing radar videos through commands issued at the SDT.

Figure 3.3-1 shows a simplified block diagram of the intended operational configuration for the ASR-11 to ARTS IIA interface. This configuration does not utilize the digital output capabilities of the SDT. Instead, a DVG will provide beacon mode pairs, raw beacon code, trigger, and azimuth videos to the ARTS to support beacon tracking and alphanumeric (A/N) and slash generation. Each PPI display and the DBRITE will receive radar, raw beacon, trigger, weather, and azimuth videos from a separate, co-located DVG. Azimuth and trigger videos to drive the video mapper will be daisy-chained from the DVG that feeds either the DBRITE or ARTS.

An alternate interface to the ARTS IIA can be accomplished through utilization of the Mode S/ASR-9 Line Adapter (MALA). Figure 3.3-2 illustrates this interface. In this configuration, the SDT will output digital beacon, search, and status messages in Modified Common Digitizer (CD) format over two isolated and identical interfaces. Each interface is conducted over three RS-449/RS-422 serial communication links operating at 9600 bits per second (bps). This digital interface conforms with the requirements of ICD SE007-4. ASR-11 digital data enters the ARTS IIA through the MALA boards. When two MALA boards are present in the ARTS, the data from each SDT interface is fed to both boards as shown in figure 3.3-2. In a single MALA board configuration, both SDT interfaces provide data through direct connections. DVGs provide radar, beacon, triggers, weather, and azimuth videos to the DBRITE, video mapper, and each PPI display, as well as beacon (mode pairs and raw beacon code), trigger, and azimuth videos to the ARTS for beacon slash generation. In the event that the digital interface fails, the ARTS will utilize this beacon video for tracking and A/N generation.

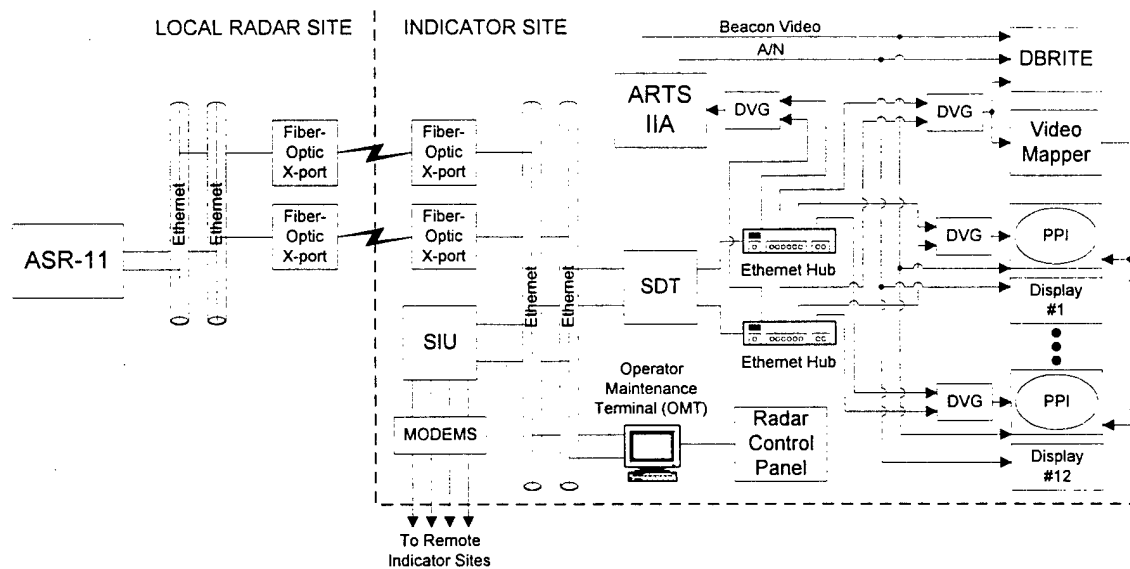

FIGURE 3.3-1. ASR-11 TO ARTS IIA INTERFACE (OPERATIONAL CONFIGURATION)

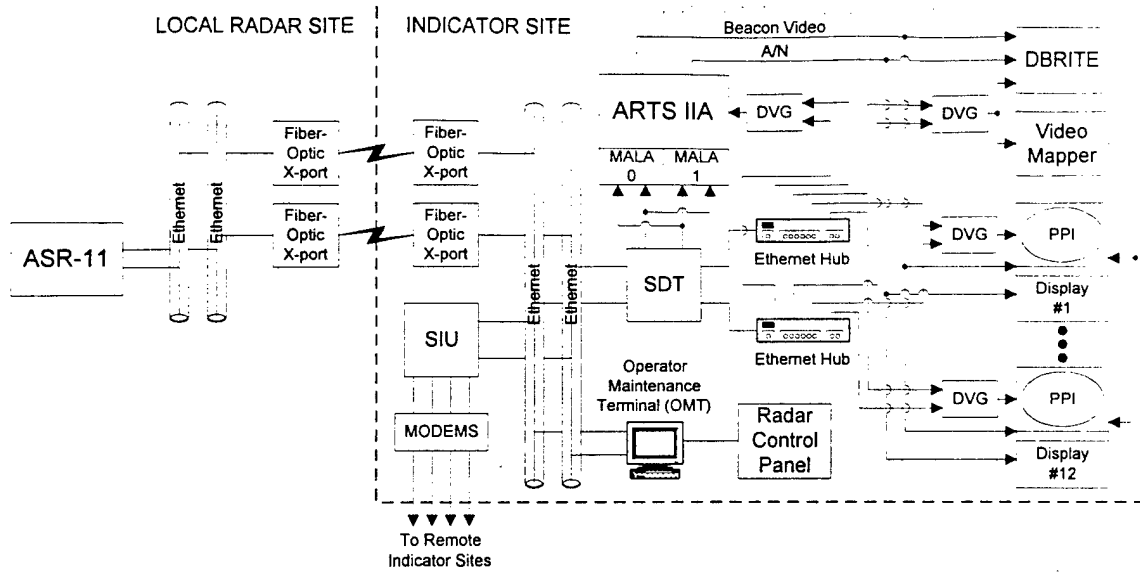

FIGURE 3.3-2. ASR-11 TO ARTS IIA INTERFACE (ALTERNATE CONFIGURATION)

The ARTS IIE is an upgrade to the ARTS IIA that includes an integrated digital interface for surveillance data inputs. The ASR-11 to ARTS IIE interface functions exactly the same as the alternate ARTS IIA interface described above, with the exception that MALA boards are not used in the ARTS IIE. Figure 3.3-3 shows the ASR-11 to ARTS IIE interface.

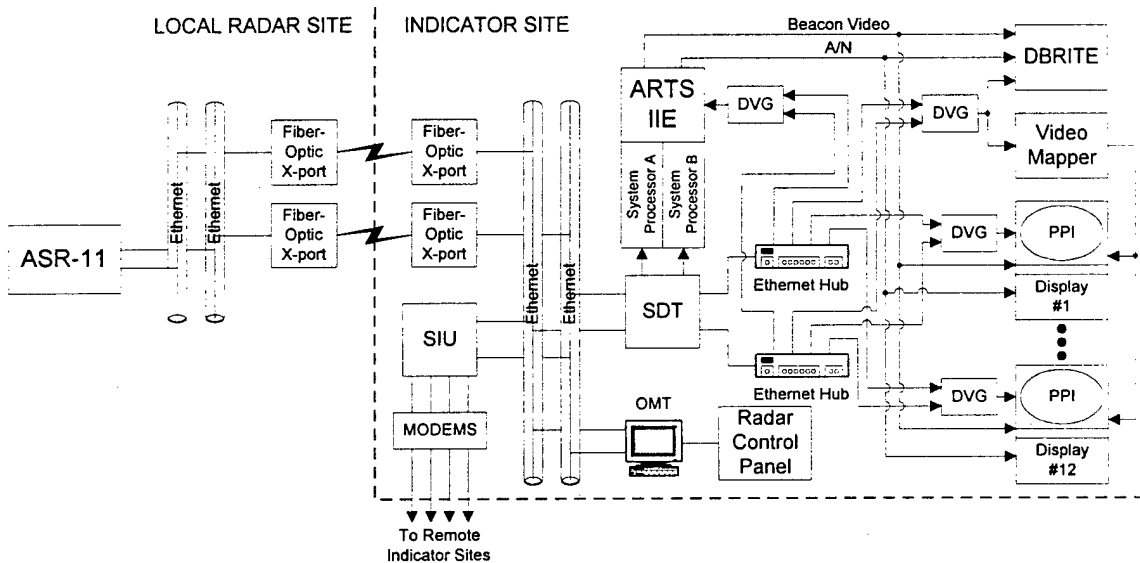

FIGURE 3.3-3. ASR-11 TO ARTS IIE INTERFACE

When the ASR-11 is interfaced with an ARTS IIIA, the SDT provides digital beacon, search, and status messages to the ARTS in Sensor Receiver And Processor (SRAP) format as defined in ICD SE007-4. This interface is conducted over two isolated parallel (30 data bits, 2 control bits) data links operating at 10,000 32-bit word transfers per second. DVGs will provide reconstituted videos to the DBRITE, Solid State Radar Beacon Decoder (SSRBD), video mapper, and each PPI display. Figure 3.3-4 illustrates the ASR-11 to ARTS IIIA interface.

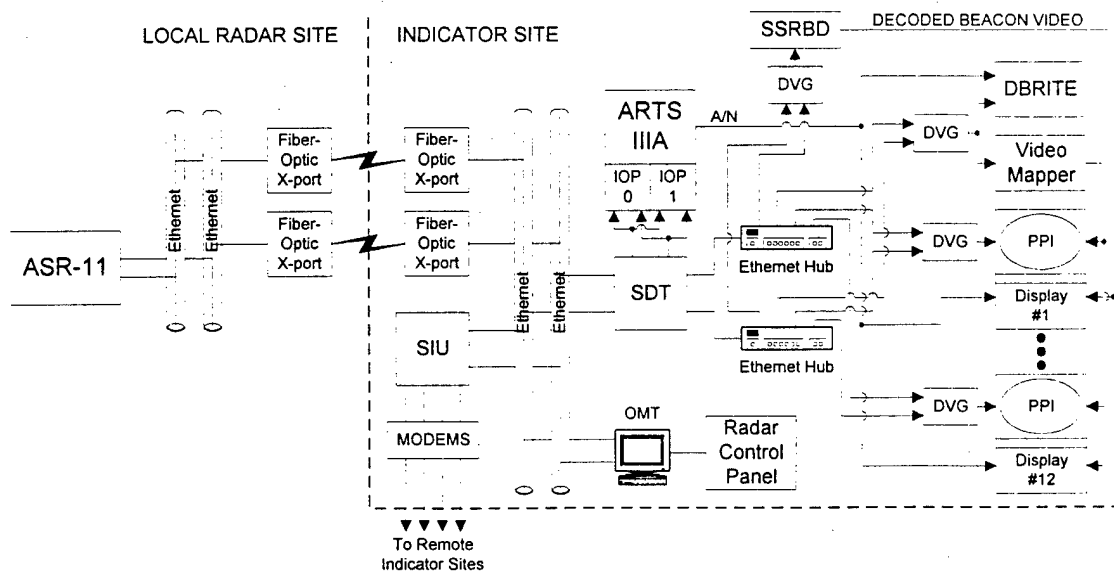

FIGURE 3.3-4. ASR-11 TO ARTS IIIA INTERFACE

The ASR-11 to ARTS IIIIE interface is functionally equivalent to the ARTS IIIA interface. Digital inputs to the ARTS IIIIE are accomplished through Sensor Gateways versus the Input/Output Processors (IOP) used in the ARTS IIIA. Figure 3.3-5 illustrates this interface.

The ASR-11 to STARS interface will be entirely digital. The radar system will transmit all surveillance, weather, azimuth, and status data to the LAN utilizing the system's NDI ASTERIX format. The SIU will receive this data over the LAN and convert it to the Modified CD format utilized in the ARTS IIA/IIIIE interface and/or ASTERIX, in accordance with an IRD that has not yet been defined. STARS currently supports only the CD interface. Future support for the ASTERIX interface is a STARS program Pre-Planned Product Improvement (P<sup>3</sup>I). One of the SIU's output ports will be used to drive the local STARS system while the others will remain available to support remote indicator sites. If the SIU is located at the indicator site, it will have a direct link to the STARS system. If the SIU is located at the radar site, modems will be used to transmit the ASR-11 output data to the local indicator site and STARS. Figure 3.3-6 illustrates the ASR-11 to STARS interface.

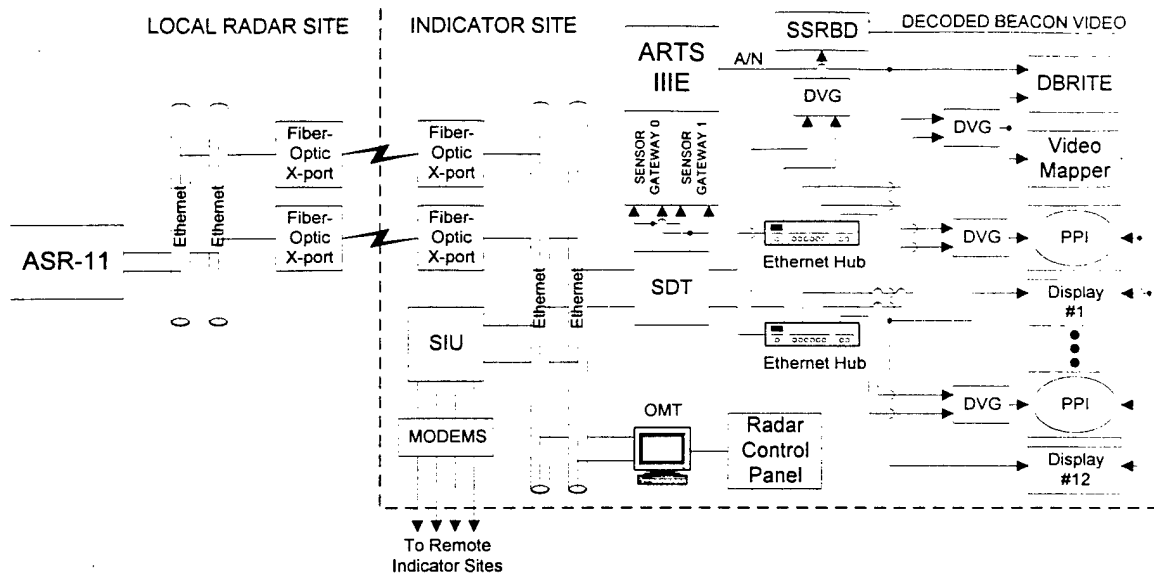

FIGURE 3.3-5. ASR-11 TO ARTS IIIIE INTERFACE

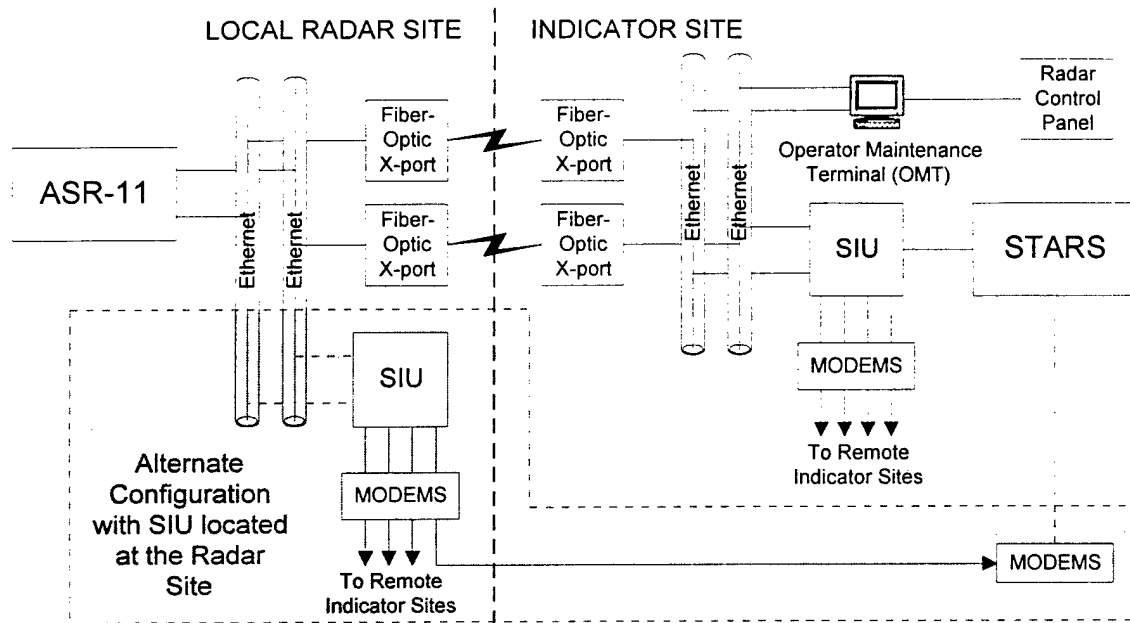

FIGURE 3.3-6. ASR-11 TO STARS INTERFACE

The ASR-11 to  $\mu$ EARTS interface is functionally the same as the STARS CD interface. Radar data is output through the SIU in Modified CD format and transmitted to the remote  $\mu$ EARTS facility via modems and a commercial telephone network. ASR-11

output data enters the  $\mu$ EARTS through MX-6A interface cards installed in each Radar Interface Processor. Figure 3.3-7 shows this interface.

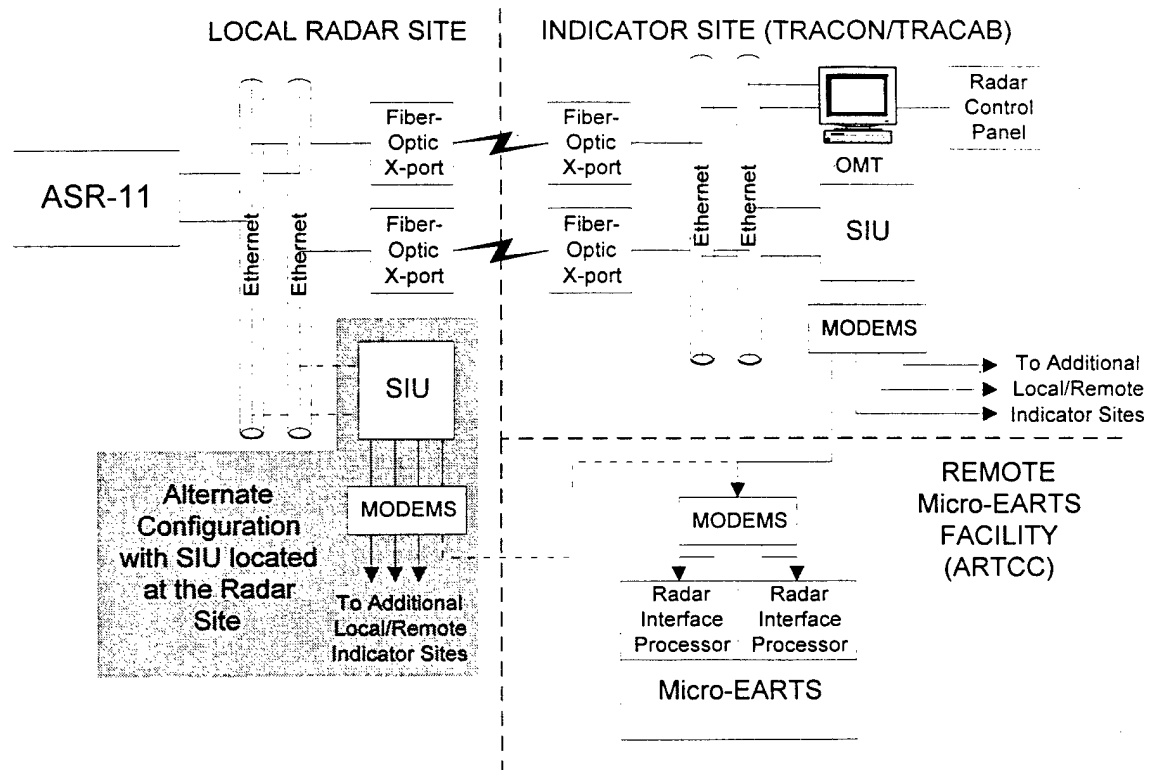

FIGURE 3.3-7. ASR-11 TO  $\mu$ EARTS INTERFACE

The ASR-11 includes an RMS which collects and processes system status and performance data. The RMS will interface with NIMS to provide remote system monitoring and control at centralized NAS monitoring facilities. This interface will be conducted over a commercial telephone network through a gateway attached to the ASR-11's dual ethernet LAN at either the radar site or the indicator site. Message contents and format will be defined by Raytheon in an ICD and will be the same as those sent to any remote OMT connected to the ASR-11. A proxy agent, which can be located at either end of the telephone network, will reformat the messages and output them in a format suitable for the NIMS. This format is unknown since NIMS is not completely defined. The NIMS program will be responsible for design and implementation of the proxy agent. An OMT will be furnished at the remote monitoring facility until NIMS and the proxy agent are fielded. This interim configuration will not require use of the proxy agent. Figure 3.3-8 shows a block diagram of this interface.

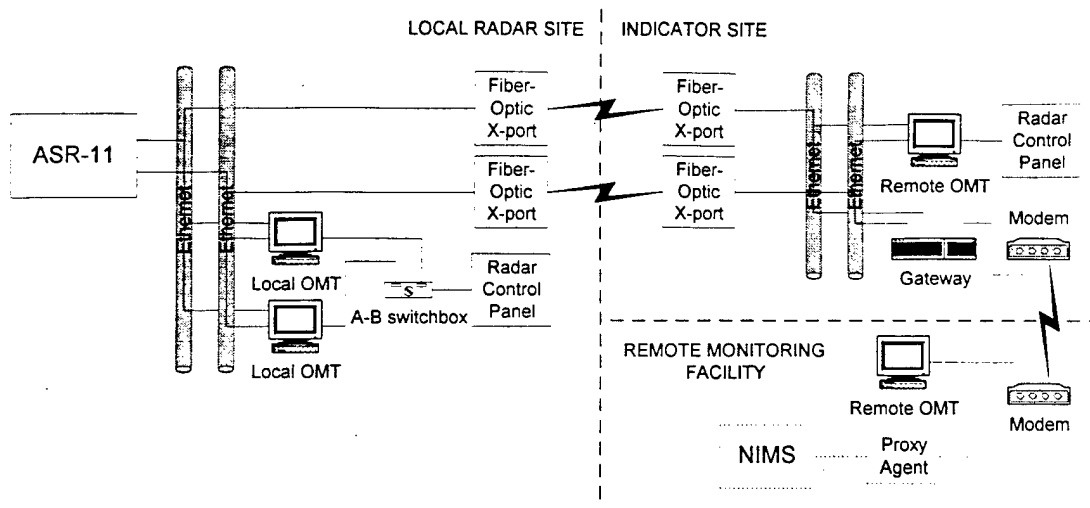

FIGURE 3.3-8. ASR-11 TO NIMS INTERFACE

3.4 CRITICAL SYSTEM CHARACTERISTICS (CSC) AND CRITICAL PERFORMANCE PARAMETERS (CPP).

Table 3.4-1 lists the ASR-11 CSCs and CPPs.

TABLE 3.4-1. CRITICAL SYSTEM CHARACTERISTICS AND CRITICAL PERFORMANCE PARAMETERS

Critical System Characteristic	Critical Performance Parameters
1. PSR Detection Volume	<u>Slant Range:</u> 0.5 to 55 nautical miles (nmi); <u>Azimuth:</u> 360 degrees (°); <u>Altitude:</u> 0 to 24,000 feet Above Ground Level (AGL); <u>Elevation:</u> 0 to 30° with respect to the horizontal plane tangent to the earth at the radar antenna.
2. PSR Probability of Detection ( $P_d$ )	The PSR shall be capable of detecting a 1.0 m <sup>2</sup> Radar Cross Section (RCS), Swerling 1 target to a range of 55 nmi in the clear and at the nose of the beam with a single scan $P_d$ of 0.8 and a Probability of False Alarm ( $P_{FA}$ ) of 10 <sup>-6</sup> .
3. Operational Subclutter Visibility (SCV)	Operational SCV shall be 42 dB minimum at all ranges for nonfluctuating targets.



TABLE 3.4-1. CRITICAL SYSTEM CHARACTERISTICS AND CRITICAL PERFORMANCE PARAMETERS (continued)

Critical System Characteristic	Critical Performance Parameters
4. MSSR Detection Volume	<p><u>Slant Range:</u> 0.5 to 60 nmi.</p> <p><u>Azimuth:</u> 360°.</p> <p><u>Altitude:</u> 0 to 25,000 feet AGL as limited by elevation coverage requirement below.</p> <p><u>Elevation:</u> from 0.25° above local radar horizon as determined by earth curvature, atmospheric refraction, and as further limited by terrain screening to 30° with respect to the horizontal plane at the radar antenna.</p>
5. MSSR P <sub>d</sub>	<p>The MSSR P<sub>d</sub> shall be 0.995 minimum for targets with a round reliability of 0.75 and three-fourths of the modes responding, in a steady state condition of 10,000 ATCRBS and 200 Mode S FRUIT per second, of which 30 percent are in the main beam.</p>
6. Data Timeliness	<p>The ASR-11 shall support the NAS requirement for data timeliness, from radar boresight to display, of 2.2 seconds or less.</p>
7. Target Capacity	<p>The ASR-11 shall be capable of processing search or beacon targets as follows:</p> <ul style="list-style-type: none"> <li>a. 700 real aircraft, in any mix of radar only, radar/beacon merge, or beacon only, in the presence of 300 false search targets uniformly, or nonuniformly, distributed in azimuth for a 360° scan, and in the presence of 100 false beacon targets uniformly, or nonuniformly, distributed in azimuth for a 360° scan;</li> <li>b. 250 total targets uniformly distributed in a contiguous 90° sector;</li> <li>c. 100 total targets uniformly distributed across two contiguous 11.25° sectors;</li> <li>d. 16 total targets per 1.3° wedge for two contiguous wedges.</li> </ul>

TABLE 3.4-1. CRITICAL SYSTEM CHARACTERISTICS AND CRITICAL PERFORMANCE PARAMETERS (continued)

Critical System Characteristic	Critical Performance Parameters
8. Weather Detection and Reporting	<p>The ASR-11 shall:</p> <ul style="list-style-type: none"> <li>a. categorize weather data intensity to the six standard NWS levels when operating in either linear or circular antenna polarization modes;</li> <li>b. report weather data for the complete detection volume with a resolution of 0.5 nmi in range and 1.4° in azimuth;</li> <li>c. reduce the occurrence of false weather reports due to A/P;</li> <li>d. complete the collection and processing of all weather data every 6 scans or less, and transmit to the automation system within three scans or less of completion of collection and processing of the weather data.</li> </ul>
9. Automation Interfaces	<p>The ASR-11 shall interface with the following analog and digital interfaces: ARTS IIA, IIE, IIIA, IIIE, DBRITE, STARS, and <math>\mu</math>EARTS.</p>
10. Reliability, Maintainability, and Availability (RMA)	<p><u>System Inherent Availability (<math>A_s</math>):</u> <math>\geq 0.999</math> (including weather channel and Remote Maintenance Monitoring (RMM)).</p> <p><u>Mean Time Between Preventative Maintenance Action (MTBPMA):</u> <math>\geq 2190</math> hours.</p> <p><u>Mean Time Between Critical Failure (MTBCF):</u> Equivalent to a dual channel system having a single channel Mean Time Between Failure (MTBF) of 750 hours and an antenna MTBF of 10,000 hours including RMM.</p> <p><u>Mean Time To Repair (MTTR):</u> <math>\leq 0.5</math> hours.</p> <p><u>Mean Time to Restore (MTR):</u> <math>\leq 1.0</math> hours.</p>

### 3.5 CRITICAL OPERATIONAL ISSUES (COI).

COIs for the ASR-11 program are identified in table 3.5-1. These COIs were approved as an amendment to the ASR-11 ORD by ATR-100 in a memo dated August 18, 1995. Resolution of the COIs will be accomplished through evaluations of the MOEs or Measures of Suitability (MOSs) related to each. Section 7.2.2 of the AMS T&E Process Guidelines, dated July 22, 1997, provides the following definitions for operational effectiveness and suitability:

a. Operational Effectiveness: The degree to which a product accomplishes its mission when used by representative personnel in the expected operational environment.

b. Operational Suitability: The degree to which a product intended for field use satisfies its availability, compatibility, transportability, interoperability, reliability, maintainability, safety, human factors, logistics supportability documentation, personnel, and training requirements.

The VRTM in appendix A of this document includes a column which provides traceability between each requirement and the COI(s) to which it pertains.

TABLE 3.5-1. ASR-11 CRITICAL OPERATIONAL ISSUES RESOLUTION MATRIX

Critical Operational Issue	Measures of Effectiveness	Measures of Suitability
1. <u>Coverage</u> : Does the performance and coverage volume of the ASR-11 support air traffic control operations?	a. PSR Coverage Volume	
	b. MSSR Coverage Volume	
	c. PSR Target Detection	
	d. MSSR Target Detection	
	e. Target Tracking	
	f. Target Capacity	
2. <u>False Alarm Rate</u> : Does the number and distribution of false target reports from the ASR-11 allow reliable aircraft detection, identification, and tracking consistent with the ATC mission and airspace requirements?	a. PSR False Alarm Rate	
	b. MSSR False Alarm Rate	
	c. PSR Target Split Rate	
	d. MSSR Target Split Rate	
	e. Scan-to-Scan Correlation	
3. <u>Aircraft Separation</u> : Does the ASR-11 resolve closely spaced aircraft with sufficient reliability to allow the controller to maintain separation standards?	a. PSR Accuracy	
	b. MSSR Accuracy	
	c. PSR Resolution	
	d. MSSR Resolution	

TABLE 3.5-1. ASR-11 CRITICAL OPERATIONAL ISSUES RESOLUTION MATRIX  
(continued)

Critical Operational Issue	Measures of Effectiveness	Measures of Suitability
<p>4. <u>Reliability, Maintainability, and Availability (RMA)</u>: Is the RMA of the ASR-11 suitable for incorporation into the NAS when used in an operational environment with the available resources, logistics plan, maintenance procedures, and personnel?</p>		a. Reliability
		b. Preventative Maintenance
		c. Corrective Maintenance
		d. Availability
		e. Fault Detection and Isolation
		f. Fault Tolerance
		g. Maintenance Equipment
		h. Logistics Support
		i. Certification
		j. Software Maintenance
		k. Technical Manuals
<p>5. <u>Site Adaptation and Optimization</u>: Does the ASR-11 system design and procedures allow the radar system to be optimized, adapted to site conditions, and certified in a reasonable time by available maintenance personnel?</p>		l. Performance Verification Targets
		a. Site Adaptability
		b. Optimization Procedures
		c. Reoptimization Requirements and Periodicity

TABLE 3.5-1. ASR-11 CRITICAL OPERATIONAL ISSUES RESOLUTION MATRIX  
(continued)

Critical Operational Issue	Measures of Effectiveness	Measures of Suitability
6. <u>NAS Interoperability:</u> Is the ASR-11 capable of interfacing and operating effectively with other NAS systems?	a. Data Timeliness	
	b. ARTS IIA/IIIE External Interface (Includes SDT)	
	c. ARTS IIIA/IIIE External Interface (Includes SDT)	
	d. STARS External Interface	
	e. DBRITE External Interface	
	f. $\mu$ EARTS External Interface	
	e. NIMS External Interface	
	f. Video Display Control	
	g. System Monitoring and Control	
	h. Data Security	
	i. Data Storage and Retrieval	
	j. RMS Functional Performance	
	k. Electromagnetic Interference/Compatibility	
	l. Spare Memory	
m. Facilities Subsystems		
7. <u>Safety:</u> Are the operation, maintenance, and facilities of the ASR-11 system safe?		a. Operational Safety
		b. Facility Safety
		c. Noise Levels
		d. Radiation Hazards
		e. Facility Security

TABLE 3.5-1. ASR-11 CRITICAL OPERATIONAL ISSUES RESOLUTION MATRIX  
(continued)

Critical Operational Issue	Measures of Effectiveness	Measures of Suitability
8. <u>Human Factors</u> : Does the ASR-11 provide user friendly interfaces that support operations and maintenance and minimizes personnel skill requirements and training time?		a. Controller Interface (DVG/VDCU, RCP)
		b. Controller Presentation
		c. ATC Training
		d. AF/Maintenance Training
		e. Local Maintenance Interface (OMT)
		f. Remote Maintenance Interface (OMT, NIMS)
9. <u>Weather Detection and Display</u> : Does the ASR-11 provide accurate and reliable weather data suitable for safe aircraft routing by air traffic control?	a. Weather Intensity Reporting	
	b. Weather Mapping Accuracy	
	c. Weather Mapping Resolution	
	d. Weather Data Latency	

### 3.6 MINIMUM OPERATIONAL PERFORMANCE.

Minimum acceptable operational requirements, as defined by the ASR-11 FRD, are contained in table 3.6-1.

TABLE 3.6-1. ASR-11 MINIMUM ACCEPTABLE OPERATIONAL PERFORMANCE

Performance Parameter	Minimum Acceptable Operational Requirement
PSR Detection Volume	<u>Slant Range</u> : 0.5 to 55 nmi. <u>Azimuth</u> : 360°. <u>Altitude</u> : 0 - 24,000 feet AGL. <u>Elevation</u> : 0 to 30° with respect to horizontal plane tangent to the earth at the radar antenna.
PSR Target Definition	A target is considered to be any aircraft within the ASR-11 detection volume which has the following characteristics: <u>Velocity</u> : 25 to 700 knots.

TABLE 3.6-1. ASR-11 MINIMUM ACCEPTABLE OPERATIONAL PERFORMANCE (continued)

Performance Parameter	Minimum Acceptable Operational Requirement
PSR Probability of Detection ( $P_d$ ):	The PSR shall detect a 1.0 m <sup>2</sup> RCS, Swerling 1 target to a range of 55 nmi in the clear and at the nose of the beam with a single scan $P_d$ of 0.8 at a $P_{FA}$ of 10 <sup>-6</sup> .
PSR Range Accuracy	The range error shall not exceed 275 feet root mean square (rms), including bias.
PSR Azimuth Accuracy	For a target with a Signal-to-Noise Ratio (SNR) greater than 30 dB and at an elevation angle of 1° to 20° with the antenna horizontal plane, the system shall achieve an azimuth accuracy of 0.16° rms, including bias.
PSR Range Resolution	When returns are detected from two Swerling 1 targets, separated in range by at least 0.125 nmi, on the same azimuth, with the same or different radial velocities, and located at any point in the coverage volume, the PSR shall resolve the two targets and generate two unique target reports 80 percent of the time for any combination of RCS from 1 to 20 m <sup>2</sup> provided that the larger target's RCS is not more than 8 dB greater than the smaller target's RCS.
PSR Azimuth Resolution	When returns are detected from two Swerling 1 targets, separated in azimuth by 2.6°, at the same range, with the same or different radial velocities and located at any point in the coverage volume, the PSR shall resolve the two targets and generate two unique target reports 80 percent of the time for any combination of RCS from 1 to 20 m <sup>2</sup> provided that the larger target's RCS is not more than 8 dB greater than the smaller target's RCS.
Target Splits	The single scan probability of a split report shall be less than 1 percent for targets having an SNR greater than or equal to 20 dB.
System Stability	The total system stability prior to coherent filtering shall be 55 dB minimum at all ranges.
Operational SubClutter Visibility (SCV)	The operational SCV shall be 42 dB minimum at all ranges for nonfluctuating targets.
PSR Operating Frequency	The system shall be limited to operation in no more than two frequencies in the range of 2700 to 2900 MHz.

TABLE 3.6-1. ASR-11 MINIMUM ACCEPTABLE OPERATIONAL PERFORMANCE (continued)

Performance Parameter	Minimum Acceptable Operational Requirement
PSR Antenna Polarization	The radar shall operate in either linear or circular antenna polarization modes.
Report Update	All search aircraft target reports within the detection volume shall be updated, in a clockwise direction, once every 4.8, plus 0.53 or minus 0.44, seconds.
MSSR Detection Volume	<u>Slant Range:</u> 0.5 - 60 nmi. <u>Azimuth:</u> 360°. <u>Altitude:</u> 0 - 25,000 feet AGL as limited by the elevation coverage requirement below. <u>Elevation:</u> From 0.25° above local radar horizon as determined by earth curvature, atmospheric refraction and as further limited by terrain screening to 30° with respect to horizontal plane at the radar antenna.
MSSR $P_d$	The MSSR $P_d$ shall be 0.995 minimum for targets with a round reliability of 0.75 and three-fourths of the modes responding, in a steady state condition of 10,000 ATCRBS and 200 Mode S FRUIT replies/second, of which 30 percent are in the main beam.
MSSR Range Accuracy	The standard deviation of the range errors shall not exceed 0.03125 nmi.
MSSR Azimuth Accuracy	With MSSR round reliability of 0.75, and all modes responding, the azimuth error shall be no greater than 0.08° rms, including bias.
MSSR Range Resolution	At least 95 percent of the time, the ASR-11 beacon shall resolve two detected, stationary and identical, noninterfering targets with the same center azimuth if they are separated (in slant range) by 0.05 to 0.5 nmi inclusive. The targets shall be resolved at least 99.9 percent of the time when they are separated by more than 0.5 nmi.



TABLE 3.6-1. ASR-11 MINIMUM ACCEPTABLE OPERATIONAL PERFORMANCE (continued)

Performance Parameter	Minimum Acceptable Operational Requirement
MSSR Azimuth Resolution	Assuming identical transponder delays, the MSSR shall resolve two detected, identical targets that are within 0.05 nmi of each other in slant range and which are separated by 2.1° at least 95 percent of the time, and resolve two targets that are within 0.05 nmi of each other in slant range and have at least one distinguishing characteristic (different Mode 3/A code or a Mode C code representing an altitude separation of more than 500 feet) and are separated by 1.5° at least 99 percent of the time.
Beacon Code Validation	The MSSR code validations: <ul style="list-style-type: none"> <li>a. shall be validated 95 percent of the time when four or more replies are received per mode;</li> <li>b. shall be correct at least 99 percent of the time in the presence of FRUIT;</li> <li>c. shall have validation of incorrect codes due to FRUIT or other causes less than 1.0 percent of the time.</li> </ul>
Target Capacity	The ASR-11 shall be capable of processing search or beacon targets as follows: <ul style="list-style-type: none"> <li>a. 700 real aircraft, in any mix of radar only, radar/beacon merge, or beacon only, in the presence of 300 false search targets uniformly, or nonuniformly, distributed in azimuth for a 360° scan, and in the presence of 100 false beacon targets uniformly, or nonuniformly, distributed in azimuth for a 360° scan;</li> <li>b. 250 total targets uniformly distributed in a contiguous 90° sector;</li> <li>c. 100 total targets uniformly distributed across two contiguous 11.25° sectors;</li> <li>d. 16 total targets per 1.3° wedge for two contiguous wedges.</li> </ul>
Scan-to-Scan Correlation	Scan-to-scan correlation shall be used to reduce false alarms and assure a high confidence in reported aircraft targets with velocities of 25 to 700 knots and maneuvering up to 1g.

TABLE 3.6-1. ASR-11 MINIMUM ACCEPTABLE OPERATIONAL PERFORMANCE (continued)

Performance Parameter	Minimum Acceptable Operational Requirement
False Target Processing	<p>The ASR-11 shall provide false aircraft target processing to:</p> <ul style="list-style-type: none"> <li>a. report no more than one false scan-to-scan correlated search report per scan averaged over fifteen minutes under normal clutter conditions;</li> <li>b. report no more than 10 false scan-to-scan correlated search reports per scan averaged over 10 scans when the clutter environment exceeds normal conditions;</li> <li>c. report no more than one false target report per scan when averaged over 15 minutes in the steady-state FRUIT condition of 10,000 ATCRBS and 200 Mode-S FRUIT replies/second of which 30 percent are in the mainbeam.</li> </ul>
Search/Beacon Merge	<p>The ASR-11 shall provide search/beacon merge processing to merge search and beacon target reports from the same aircraft into a single target report.</p>
Data Timeliness	<p>The ASR-11 shall support the NAS requirement for data timeliness, from radar boresight to display, of 2.2 seconds or less.</p>
Target Overload Processing	<p>The ASR-11 shall provide graceful degradation in target capacity by processor range reduction in order to extract preferred data during data overload conditions which may cause loss of data while maintaining the performance requirements for the remaining target reports.</p>

TABLE 3.6-1. ASR-11 MINIMUM ACCEPTABLE OPERATIONAL PERFORMANCE (continued)

Performance Parameter	Minimum Acceptable Operational Requirement
Weather Detection and Reporting	<p>The ASR-11 shall:</p> <ul style="list-style-type: none"> <li>a. categorize weather data intensity to the six standard NWS levels when operating in either linear or circular antenna polarization modes;</li> <li>b. report weather data for the complete detection volume with a resolution of 0.5 nmi in range and 1.4° in azimuth;</li> <li>c. reduce the occurrence of false weather reports due to A/P;</li> <li>d. complete the collection and processing of all weather data every 6 scans or less, and transmit to the automation system within three scans or less of completion of collection and processing of the weather data.</li> </ul>
System Monitoring and Control	<p>The ASR-11 shall provide or be expandable to provide for both local and remote maintenance as follows:</p> <ul style="list-style-type: none"> <li>a. on-line performance monitoring to isolate problems to three line replacement units (LRUs);</li> <li>b. interface compatibility with NIMS to allow remote operational control and monitoring;</li> <li>c. local operational control and monitoring shall be provided through on-line performance monitoring diagnostics and off-line fault isolation diagnostics;</li> <li>d. provide identical control panels and associated software at all ATC sites (radar site, TRACON, and ATC tower).</li> </ul>
Automation Interfaces	<p>The ASR-11 shall interface with the following analog and digital interfaces: ARTS IIA, IIE, IIIA, IIIE, DBRITE, STARS, and <math>\mu</math>EARTS.</p>
System Recovery	<p>The system shall recover from cold start within 7 minutes</p>

TABLE 3.6-1. ASR-11 MINIMUM ACCEPTABLE OPERATIONAL PERFORMANCE (continued)

Performance Parameter	Minimum Acceptable Operational Requirement
RMA	<p><math>A_p \geq 0.999</math> (including weather channel and RMM).</p> <p><u>MTBPMA</u>: <math>\geq 2190</math> hours.</p> <p><u>MTBCF</u>: Equivalent to a dual channel system having a single channel MTBF of 750 hours and an antenna MTBF of 10,000 hours including RMM.</p> <p><u>MTTR</u>: <math>\leq 0.5</math> hours.</p> <p><u>MTR</u>: <math>\leq 1.0</math> hours.</p>
Enhanceability	<p>All Random Access Memory (RAM) and non-volatile memory capacity and processor throughput shall be capable of being upgraded by at least 50 percent with only minor hardware modifications and software changes. The upgrade can be accomplished by, for example, adding memory, adding chips, installing new processors, and/or adding boards to existing back planes.</p>
Human-Product Interface	<p>The ASR-11 shall provide human-product interfaces that support operations and maintenance.</p>
Employee Safety and Health	<p>The ASR-11 system/facility shall be designed in compliance with OSHA and FAA Order 3900.</p>
Maintenance Staffing Requirements	<p>To Be Determined (TBD).</p>

#### 4. T&E PROGRAM MANAGEMENT.

##### 4.1 MANAGEMENT.

The ASR-11/DASR program is a joint FAA/DOD acquisition with the DOD assuming the role of lead procurement agency. The United States Air Force (USAF) Electronics Systems Command (ESC) Communications and Airspace Management Systems Program Office has overall responsibility for this acquisition with FAA support from the Enroute Surveillance Products Program Office, AND-440. Within the FAA, the Enroute Surveillance Products IPT has been designated as the lead for the ASR-11 acquisition.

The T&E program will be an entirely integrated effort between the two agencies. Testing will be conducted by a team comprised of representatives from the FAA and the USAF. The roles and responsibilities of all organizations forming this team are summarized in table 4.1-1.

TABLE 4.1-1. ORGANIZATIONAL RESPONSIBILITIES

ORG.	NAME	RESPONSIBILITY
ACT-310	FAA Technical Center Surveillance Branch	IPT Test Lead: System Test, Supply Test Tools, Technical Support
AND-440	FAA Enroute Surveillance Products Program Office	FAA Program Management, IPT Engineering Lead, Technical Support, DT&E monitoring
ACT-330	FAA Technical Center Communication/Infrastructure Branch	NIMS, RMS, System Test Support
AOS-230	FAA Surveillance Systems Engineering Branch	FAA System Test Support
ATQ-1	FAA Office of IOT&E	FAA Independent OT&E
AFR-304	FAA Surveillance Life-Cycle Division	IPT Logistics Lead: Logistics Support
ANS-210	FAA Implementation Management Division	IPT NAS Implementation Lead
ARN-100	FAA Air Traffic Plans and Requirements System Plans and Programs Terminal Branch	Air Traffic Controllers (System Test Support), Operational Requirements
AAF-1	FAA Airway Facilities Service	Maintenance Technicians (System Test Support)
ASU-230	FAA Office of Acquisitions Quality Assurance Branch	IPT Quality Lead, QRO
ESC	USAF Electronics Systems Command	Overall Program Management, Technical Support

TABLE 4.1-1. ORGANIZATIONAL RESPONSIBILITIES (continued)

ORG.	NAME	RESPONSIBILITY
46TS	USAF 46 <sup>th</sup> Test Squadron, Eglin AFB, FL	DOD DT&E, Technical Support
AFOTEC	USAF Operational Test and Evaluation Center	DOD Initial OT&E
NAVAIR PMA-213	Naval Air Command	U.S. Navy Program Management
NISE EAST 315	Naval Command, Control and Ocean Surveillance Center In-Service Engineering East Coast Division	U.S. Navy Testing, Site Installation, Integration, System Engineering

A Test Planning Working Group (TPWG) has been formed with membership from the following organizations: ACT-310, ATQ, AOS-230, AND-440, AT, AF, 46 TS, AFOTEC, and ESC. This group will be co-chaired by one designated test lead from each agency. The TPWG will develop and implement a management process for the entire T&E program in accordance with the MOA. It will be responsible for the development, approval, and maintenance of all test reports, plans, and procedures, as well as coordinating and scheduling all testing resources. Working level disagreements between the two agencies will be addressed by the TPWG with each agency maintaining equal voting rights within this group. Issues which cannot be resolved at this level will be elevated to the DOD and FAA DASR/ASR-11 program offices. Each agency will retain the right to offer a dissenting opinion on any final agreements and to document the reasons for dissension in their technical report.

At the DOD's request, a Joint Reliability and Maintainability Evaluation Team/Test Data Scoring Board (JRMET/TDSB) was formed to assist in the collection, evaluation, and classification of RMA data collected during testing. Members of the JRMET/TDSB were drawn from both agencies with each agency having equal voting rights and dissension privileges on data classification issues. The responsibilities of each organization with membership in this group are outlined in the DOD/FAA Joint Reliability and Maintainability Evaluation Team Charter for the Digital Airport Surveillance Radar (DASR/ASR-11). This document was developed by ESC, AFOTEC, and 46TS. It is currently available in draft form and requires approval from both agencies. Raytheon will provide technical expertise as a member of the JRMET, but, will have no voting rights and will not be a member of the TDSB.

#### 4.2 INTEGRATED SCHEDULE.

The schedule in figure 4.2-1 illustrates relative durations for T&E events as well as major milestones for the ASR-11 test program. This schedule was derived from the latest available Master Integrated Program Schedule (MIPS), as well as information provided by Raytheon at Technical Interchange Meetings (TIMs) and Program Management

Reviews (PMRs) conducted since contract award. Updates to the MIPS should be referenced for the most current schedule information.







#### 4.3 TEST AND EVALUATION FUNDING.

Funding requirements for the ASR-11 T&E program are summarized in table 4.3-1.

TABLE 4.3-1. T&E FUNDING PROFILE

Required Resource	Cost (x \$1,000)		
	FY 98	FY 99	FY 00
<b>DT&amp;E:</b>			
ACT-310 Contractor Support	110	75	0
ACT-310 Travel	272	20	0
Data Link to WJHTC	20	0	0
AOS-230 Contractor Support	95	20	0
AOS-230 Travel	60	10	0
AFR-304 Travel	10	5	0
<b>DT&amp;E TOTALS</b>	<b>567</b>	<b>130</b>	<b>0</b>
<b>NAS Integration/Operational Testing:</b>			
Air Traffic Support	10	50	35
Airway Facilities Support	10	30	20
ACT-310 Contractor Support	165	375	218
ACT-310 Travel	20	230	75
Data Link to WJHTC	0	20	20
ARIES Maintenance	25	25	25
Test Aircraft	0	300	0
Test Tools/Instrumentation	170	100	50
GPS Ground Station Geodetic Survey	0	15	0
AOS-230 Contractor Support	20	95	0
AOS-230 Travel	20	35	0
AFR-304 Travel	10	5	0
<b>NAS Integration/Operational TOTALS</b>	<b>450</b>	<b>1280</b>	<b>443</b>
<b>PAT&amp;E</b>			
ACT-310 Contractor Support	0	0	32
ACT-310 Travel	0	0	25
AOS-230 Contractor Support	0	50	55
AOS-230 Travel	0	12	12
<b>PAT&amp;E TOTALS</b>	<b>0</b>	<b>62</b>	<b>124</b>
<b>TEST PROGRAM TOTALS</b>	<b>1017</b>	<b>1472</b>	<b>567</b>

#### 4.4 TEST PLANS.

The following test plans will be developed for the DASR/ASR-11 program:

##### 4.4.1 Contractor's Test Plans.

Due to the NDI nature of this acquisition, the government expects that a reasonable amount of prior test data will be available from Raytheon. With prior government approval, some of this data may be utilized to verify system requirements in lieu of further testing. Raytheon's test plans, which must be approved by the government, will identify each requirement to be verified by this method.

Raytheon is responsible for developing the following test plans for the ASR-11 program:

##### 4.4.1.1 Contractor's Master Test Plan (CMTP).

The CMTP outlines all T&E activities to be accomplished by Raytheon in association with the DASR/ASR-11 program. It provides the approach, requirements verification methods, and responsibilities to be implemented in the management, control and execution of the contractor's test program. It also identifies any subordinate test documents and provides direction for their development. The CMTP includes a Verification Requirements Traceability Matrix (VRTM) which defines the method of test (Test, Demonstration, Analysis, or Inspection) to be utilized in verifying each individual system requirement. It will also identify those requirements that will be validated through the use of prior test data.

An initial draft of this document was submitted as part of Raytheon's technical proposal. A number of subsequent revisions have been submitted and reviewed by the government to date. A final version, which incorporates the results of an Engineering Change Proposal (ECP) to the system specification, is expected within the next 60 days.

##### 4.4.1.2 Developmental Test and Evaluation (DT&E) Test Plans.

The government has accepted a proposal from Raytheon to implement an incremental approach for the accomplishment of DT&E on the ASR-11. Under this approach, DT&E testing is performed over several discrete test events. Test events are sequenced in a manner which allows incremental integration of subsystems into a full ASR-11 system. As each subsystem becomes available, incorporating any modifications to the NDI product necessary to meet the system specification, it is integrated into the system and a separate test event is performed to verify related specification requirements. Individual test events are governed by a separate test plan. Each test plan defines:

- a. Test objectives;
- b. Test approach;

- c. Requirements to be fully verified by this test;
- d. Requirements to be partially verified by this test;
- e. Requirements to be verified through use of previous test data (previous test data must be attached for review and approval);
- f. Equipment configuration;
- g. Equipment under test;
- h. Standard test equipment required to support this test;
- i. Specialized test equipment required to support this test (including detailed descriptions of hardware, software, and capabilities);
- j. Data reduction and analysis techniques used to interpret recorded data;
- k. Validation procedure;
- l. Location of test (Raytheon facility, subcontractor facility, or government test site);
- m. Test event schedule;
- n. Test duration.

Tests identified in each plan must adhere to the verification methods defined in the VRTM of the CMTP. DT&E testing will utilize both government test assets, as well as an additional system provided by Raytheon with all systems under strict configuration management. There is no set schedule for submission of test plans, however, they must be approved by the government prior to actual execution of the related test.

#### 4.4.1.3 Production Acceptance Test Plan.

The Production Acceptance Test (PAT) Plan defines those tests which will be performed by Raytheon on each production unit prior to shipment to government designated field sites to ensure that it conforms to the design qualified in DT&E. PAT will be accomplished by performing subsets of the test ran during DT&E. Initial submission of this document is not expected until all DT&E plans have been approved..

#### 4.4.1.4 Site Acceptance Test Plan.

The Site Acceptance Test (SAT) Plan identifies all testing that will be conducted by Raytheon on each production unit to verify system operation upon installation at a

designated field site. SAT will include a subset of those tests performed as part of DT&E. Satisfactory completion of these tests will lead to government acceptance of the system at each deployment site. Initial submission of this document is expected until all DT&E plans have been approved.

#### 4.4.2 Government Test Plans.

The following test plans will be developed by the government in support of the DASR/ASR-11 program:

##### 4.4.2.1 DT&E Joint Master Test Plan (JMTP).

The DT&E JMTP focuses on the assignment of testing responsibilities to each agency in the area of testing referred to as DT&E by the DOD. This plan covers the DT&E portion of FAA System Test. This document includes a project VRTM which identifies each subsystem requirement as well as the test method by which it will be verified. It also addresses any government testing that is planned during this phase of testing. The lead for development of the DT&E JMTP is the 46TS with support from ACT-310. A final revision of this plan has been released and is currently advancing through the approval process.

##### 4.4.2.2 IOT&E Joint Master Test Plan.

The IOT&E JMTP defines the approach to be incorporated by the joint test team in accomplishing what the DOD refers to as Initial OT&E. The FAA will complete the OT&E portions of System Test, as well as IOT&E during this phase of testing. This document provides guidance to ensure that independent DOD and FAA test plans are coordinated in a manner which minimizes test duplication and maximizes the sharing and use of pertinent test results. The JMTP also identifies areas of mutual interest and describes the process for jointly reporting Initial OT&E test results. AFOTEC is responsible for the development of this plan with FAA support from ACT-310 and the ATS Test Team. This document has been released for approval and is currently available as a final revision.

##### 4.4.2.3 FAA System Test Plan.

The FAA System Test Plan identifies and describes the government test activities associated with FAA DT&E, NAS OT&E Integration and Operational, and PAT&E. The plan outlines test activities to be performed by the FAA in accordance with the new FAA AMS and the JMTPs. It also identifies any FAA concerns relating to joint interest requirements that will be tested by the DOD and witnessed by the FAA. ACT-310 is responsible for the development of this document with DOD approval required for those sections pertaining to FAA verification of joint interest requirements. Where a particular FAA test does not fully verify a DOD test requirement, the DOD will request modification to the FAA test or perform a separate test to ensure that DOD requirements are fully verified.

NAS OT&E Integration testing is performed to ensure that the system will interface with existing and future NAS equipment without causing degradation to overall NAS performance. Specific issues which are addressed by this testing include:

- a. System optimization;
- b. Digital target reporting;
- c. System control functions;
- d. Radar and beacon coverage, detection, and resolution;
- e. False Alarm Rate (FAR);
- f. Aircraft separation standards and procedures;
- g. Timeliness of data output;
- h. Target capacity loading;
- i. Weather processing and reporting;
- j. Remote fault isolation and certification;
- k. RMS functionality;
- l. Facilities subsystems.

NAS OT&E Operational testing is performed to ensure that the system is operationally suitable and effective. Tests focus on actual operation of the radar and specifically address the following issues:

- a. Reliability, Maintainability, and Availability (RMA);
- b. Degraded Operations and operational utilization scenarios;
- c. NAS loading, capacity, and delay evaluation;
- d. Site Adaptation and Optimization;
- e. Human Factors;
- f. Safety;
- g. Security;
- h. Transition and Switchover;
- i. Integrated Logistics Support.

OT&E is accomplished to evaluate the system's performance when installed and functioning as an integral part of the NAS. If any of the issues listed above are sufficiently addressed by Raytheon's On-site DT&E, testing will not be repeated during OT&E. The System Test plan is expected to be complete no later than 90 days prior to the beginning of FAA NAS OT&E testing.

#### 4.4.2.4 DOD DASR DT&E Method of Test.

The DASR DT&E Method of Test defines the objectives of the DOD DT&E test program and describes how the DOD will address verification of requirements that are not sufficiently demonstrated by Raytheon. The 46TS is responsible for development of this document. ACT-310 will provide support to ensure that FAA requirements are fully

verified. This test plan is expected to be complete no later than 180 days after contract award.

#### 4.4.2.5 DOD Initial OT&E Test Plan.

The Initial OT&E Test Plan describes the test activities to be performed by the DOD during the Initial OT&E phase of testing. It will identify the approach and method that the DOD will utilize to verify any joint requirements for which the FAA has agreed to accept DOD test results. FAA approval will be required for these sections. Where a particular DOD test does not fully verify an FAA test requirement, the FAA will request modification to the DOD test or perform a separate test to ensure that FAA requirements are fully verified. This plan will be developed by AFOTEC with FAA support from ACT-310 and the ATS Test Team. It is expected to be complete no later than 90 days prior to the beginning of DOD Initial OT&E.

#### 4.4.2.6 FAA IOT&E Test Plan.

The IOT&E Test Plan describes the test activities to be performed by the FAA during the IOT&E phase of testing. It will be developed by the ATS Test Team in accordance with the IOT&E JMTP. The initial IOT&E Test Plan is expected to be complete no later than 1 year prior to the beginning of FAA IOT&E testing.

### 4.5 TEST PROGRAM RESOURCES.

ACT-310, as the lead organization for FAA System Testing, will rely on support from various FAA organizations to successfully complete the ASR-11 test program. The following organizations will provide personnel with the specialized knowledge required to accomplish the specific tasks described:

- a. AT - Provide ATC specialists to aid in evaluations of the ASR-11's operational effectiveness and suitability from an air traffic standpoint;
- b. AF - Provide NAS maintenance technicians to aid in evaluations of the ASR-11's operational effectiveness and suitability from a maintenance standpoint;
- c. AOS-230 - Support those portions of System Test that were formerly defined as OT&E Shakedown;
- d. ACT-330 - Conduct NIMS interface testing;
- e. AFR-304 - Evaluate logistics support capabilities;
- f. AND-440 - Support for facilities subsystems and power testing;
- g. ANS-500 - Support for facilities safety and security testing.

Resources required for ASR-11 IOT&E testing are included in section 6 of this document.

4.5.1 Manpower and Training.

Raytheon will provide training specific to the radar and facilities subsystems required for the conduct of government testing. The courses will provide all knowledge necessary to allow government personnel to operate, maintain, and support the system during government-led testing. A minimum of four employees from ACT-310 will require this training. Manpower requirements for the DASR/ASR-11 test program are outlined in table 4.5.1-1.

TABLE 4.5.1-1. MANPOWER REQUIREMENTS

Organization	Manpower (Years)		
	FY 98	FY 99	FY 00
<b>DT&amp;E:</b>			
ACT-310	4	1	0
AOS-230	1	0.2	0
Support Contractors	2.8	0.7	0
<b>DT&amp;E TOTALS</b>	<b>7.8</b>	<b>1.9</b>	<b>0</b>
<b>NAS Integration and Operational:</b>			
ACT-310	1	4	2
ACT-330	1	2	1
AOS-230	1	2	0.5
AFR-304	1@50%=0.5	1@50%=0.5	0
AT	1@10%=0.1	10@5%=0.5	7@5%=3.5
AF	2@10%=0.2	2@15%=0.3	2@10%=0.2
Support Contractors	1.7	3.3	1.75
<b>NAS Integration and Operational TOTALS</b>	<b>5.5</b>	<b>12.6</b>	<b>8.95</b>
<b>PAT&amp;E:</b>			
ACT-310	0	0	1
AOS-230	0	0.5	1
Support Contractors	0	0.5	0.75
<b>PAT&amp;E TOTALS</b>	<b>0</b>	<b>1</b>	<b>2.75</b>
<b>PROGRAM TOTALS</b>	<b>13.3</b>	<b>15.5</b>	<b>11.7</b>



#### 4.5.2 Test Articles and Test Sites.

The government exercised options for two preproduction test systems at contract award, one system per agency. Contractor-led DT&E testing will be conducted primarily at the contractor's facility and will utilize both systems. The DOD system will be designated as the primary test article. During interface design qualification testing, radar data will be remoted to the Technical Center where the interfaces to existing automation systems and the SDT will be tested. This will require installation of an SDT in the Technical Center's terminal automation system laboratory. The SIU and interface to STARS will also be tested if a STARS system is available at the Technical Center during this time frame. Upon completion of in-plant DT&E, both systems will undergo PAT before being shipped to the government key sites at Stockton, California, and Eglin AFB, Florida. Raytheon will be responsible for installation and checkout of the systems, as well as performing SAT before government testing will begin. The Eglin site will be used for any on-site Delta DT&E required by Raytheon to complete specification compliance verification. If further Delta DT&E is required, Raytheon may conduct these tests at the Stockton site. Government testing will occur simultaneously at both key sites with each agency leading the test efforts at the key site they fund. Portions of FAA System Testing may include remoting of ASR-11 data from either test site to the Technical Center's automation system laboratory. In order to reduce impact on ATC operations, an additional ARTS IIE system, with associated peripherals, and video mapper will be installed at Stockton to support the test program. The ASR-11 will be interfaced with the operational ARTS prior to system certification during the final stages of System Test. FAA IOT&E testing will be conducted with the system in this configuration and will not require use of the additional ARTS.

The FAA test article will consist of the following configuration, installed at the Stockton key site: PSR with antenna; MSSR with antenna; antenna tower; MRSM system with antenna and prefabricated housing; two MTI reflectors; one SDT; one SIU with one Modified CD-2 interface; one local and two remote radar control panel positions; surveillance display; local and remote Operator Maintenance Terminals (OMTs); built-on-site electronics equipment shelter; NIMS interface; Engine-Generator (E-G) set with prefabricated housing; Uninterruptable Power Supply (UPS); external transmission modem systems; Grounding, Bonding, and Lightning (GB&L) protection for all elements; associated field level spares, support equipment and technical manuals. In addition, the following equipment will be installed at the Technical Center and is considered part of the FAA's test article: one SDT; one remote radar control panel position; one OMT; associated spares; complete set of technical manuals.

Configuration of the DOD's test article will include the following equipment to be installed at Eglin AFB: PSR with antenna; MSSR with antenna; antenna tower; MRSM system with antenna and prefabricated housing; three MTI reflectors; one SDT; one SIU with one Modified CD-2 interface; local and remote radar control panel positions; surveillance display; local and remote OMTs; prefabricated electronics equipment shelter; E-G set with prefabricated housing; external transmission modem systems;

UPS; GB&L protection for all elements; associated field level spares, support equipment and technical manuals.

#### 4.5.3 Test Support Equipment.

The following test equipment will be required to support the ASR-11 test program:

- a. ARTS IIE system and peripherals installed at the Stockton key site and dedicated to the test program;
- b. Video mapper installed and integrated with the ARTS IIE system provided for testing;
- c. One small RCS aircraft equipped with ATCRBS and/or Mode S transponder and Global Positioning System (GPS) receiver for  $P_d$  and accuracy testing;
- d. Two unequal RCS aircraft, the larger of which has an RCS no more than 8 dB greater than the smaller, equipped with ATCRBS and/or Mode S transponders and GPS receivers for accuracy and resolution testing;
- e. Two portable Personal Computers (PCs) for GPS data recording;
- f. One GPS ground station for accuracy and resolution testing;
- g. Technical Center ARTS automation system laboratory for interface testing;
- h. Aircraft Reply and Interference Environment Simulator (ARIES) for beacon target load, throughput, and FRUIT environment testing;
- i. Integrated Radar Evaluation System (IRES) for data reduction and analysis;
- j. Radar Beacon Analysis Tool (RBAT) for data reduction and analysis;
- k. Real-Time Aircraft Display System (RTADS) for remote surveillance display;
- l. Four Pentium PCs for radar data recording and analysis;
- m. BEXR Beacon Target Extractor Tool for beacon reply video analysis;
- n. VideoBITS for beacon test target injection;
- o. Network Analyzer for cable loss and phase measurements;
- p. Peak Power Meter for radar output power measurements;

- q. Digital Oscilloscope for signal measurements;
- r. Spectrum Analyzer for radar and ARIES signal measurements;
- s. Multimeter for signal measurements;
- t. Pulse Generator;
- u. Power Quality Monitor for power quality analysis;
- v. Ground Resistance Measuring Equipment for GB&L system analysis;
- w. Low Resistance Ohmmeter for GB&L system analysis;
- x. Temperature Monitors for Heating, Ventilation, and Air Conditioning (HVAC) analysis.

#### 4.6 TEST CONFIGURATION MANAGEMENT.

Raytheon will maintain a Configuration Management (CM) program to manage the form, fit, and functional configuration of the system. This program shall address configuration tracking and status to support program testing, logistics tasks, functional and physical audits, and program life-cycle documentation. Under DOD acquisition guidelines, Raytheon will retain ownership of all test articles and equipment provided under this contract until government acceptance upon completion of the test program. Any configuration changes proposed by the contractor shall be subject to government approval.

## 5. T&E PROGRAM DESCRIPTION.

The ASR-11 test program shall be governed by the new AMS which has redefined the FAA T&E process. Testing is now organized into three test types: System Test, IOT&E, and Field Familiarization. System Test is the responsibility of the IPT with test leadership provided by ACT-310. IOT&E will follow System Test and is the responsibility of the ATS Test Team. AF and AT field personnel will conduct Field Familiarization following site acceptance testing at each field site. This testing was formerly referred to as Field Shakedown. This TEMP covers System Test and IOT&E (section 6) for the ASR-11 test program.

The objectives of System Test were formerly met by conducting DT&E, OT&E (Integration, Operational, and Shakedown), and PAT&E. In accordance with the existing guidelines, ASR-11 System Test will be performed in four parts: DT&E, PAT&E, NAS OT&E Integration, and NAS OT&E Operational.

### 5.1 COMPLETED DT&E/PAT&E.

OCDs were conducted by each bidder during the proposal evaluation process. They were designed to provide the government with some indication of the maturity of the systems being offered. A cursory review of prior test data was accomplished, however, no specific tests were conducted to validate system requirements. During DT&E, the government may accept data from prior tests run by the contractor in lieu of further testing. The extent of this utilization cannot be determined until all pertinent test data has been reviewed and accepted/rejected by the government.

DT&E test event 2A was completed on October 22, 1997. This test event focused mainly on verification of functional requirements pertaining to the PSR. Sixty-seven of the 68 subtests defined by this test were satisfactorily completed. One subtest was deferred to a later DT&E test event due to differing interpretations of a specification requirement between Raytheon and the government.

### 5.2 COMPLETED NAS OT&E INTEGRATION TESTING.

No NAS OT&E Integration testing has been completed to this date.

### 5.3 COMPLETED NAS OT&E OPERATIONAL TESTING.

No NAS OT&E Operational testing has been completed to this date.

#### 5.4 DT&E TESTING.

DT&E testing will be performed by Raytheon to verify that the DASR/ASR-11 system design conforms to all specification parameters. Design qualification may be obtained through any one of four verification methods including inspection, analysis, demonstration, and test. Since the DASR/ASR-11 is an NDI system, the government expects that Raytheon has accumulated extensive prior test data. With advance government approval, pertinent portions of this data may be utilized to verify system performance in lieu of further testing. A Data Authentication Group (DAG) has been established to facilitate government review and acceptance of data supplied by Raytheon. The DAG includes members from both the FAA and DOD. The process for acceptance of prior test data is outlined in the DAG Charter, dated January 13, 1997. The following general criteria will be used as a guide to determine the acceptability of prior test data on a case-by-case basis:

- a. Test performed on a baselined and configuration controlled system that is substantially the same as the DASR/ASR-11. Modifications to the test item that would affect prior test results will eliminate those results from consideration. This criteria might limit much of the system level test results, but not lower level test data.
- b. Test witnessed by independent internal or external Quality Assurance (QA) or the customer. For system level testing, the witness should be a customer representative and this should be documented.
- c. Test data, procedures, and reports must be made available for review. The government will review this material to verify that the test method was technically sound and that the test was conducted using documented procedures. Test data sheets must be certified by the customer and/or independent QA. Method of data reduction and analysis will be reviewed. Raw data should be available upon government request.
- d. Standard test equipment used for the test was in calibration with verification included with contractor test data.
- e. Simulators and special test tools utilized in the test were independently certified. Independent certification may be accomplished by an independent QA organization within the contractor corporation, a nonaffiliated company, or a government organization.

Accepted prior test data will be treated as a substitute for the design qualification verification methods listed above.

Raytheon is responsible for generating all test plans, procedures and reports associated with contractor-led DT&E testing. The government will review and approve this documentation. The CMTP will include a project VRTM which clearly defines the method and specific test in which each specification parameter will be verified. It is

Raytheon's responsibility to perform all verifications to the satisfaction of the government. Parameters that cannot be adequately verified at Raytheon's facility will be verified during Delta DT&E at one of the government test sites. Delta DT&E activities at the FAA test site will be limited to verification of those requirements which cannot be accomplished at the factory or DOD test site. Formal tests will be witnessed by representatives from the FAA and/or DOD.

As part of DT&E, Raytheon may conduct testing that utilizes the ARIES which will be supplied as Government Furnished Equipment (GFE) by the Technical Center. The ARIES will be used to inject beacon replies and interference at the RF level in accordance with specially designed test scenarios. The digital search target report output capabilities of the ARIES may also be utilized if the radar is capable of supporting such an interface. Since there are no live world environments available to stress the system at maximum load, the ARIES will be an essential tool in the test program.

Raytheon shall be provided with access to Government Furnished Property (GFP) for qualification testing of external system interfaces. GFP for the ASR-11 program consists of the following equipment: ARTS IIA/IIE, ARTS IIIA, and DBRITE. Testing of the automation system interfaces, including the SDT, will be accomplished, in part, by remoting the radar's digital surveillance output data to the Technical Center. This will be achieved by installing an SDT at the Technical Center with the radar operating at the Raytheon test facility. During the final stages of DT&E interface testing at the Technical Center, ATC specialists will be utilized as observers to aid in evaluation of the radar's performance and identify any deficiencies. The goal of this testing is to ensure proper operation of all external interfaces before the test assets leave the Raytheon facility.

#### 5.4.1 DT&E Exit Criteria.

The following criteria must be met in order for DT&E testing to be considered complete:

- a. Testing has verified that all specification requirements have been met;
- b. A stable hardware and software baseline has been established and fully documented;
- c. Installation of all radar and facility components at the key site has been completed;
- d. Interface testing utilizing the Technical Center automation systems has been successfully completed;
- e. The On-site System Readiness Demonstration (OSRD) at the key site has been successfully completed.

## 5.5 PAT&E TESTING.

A complete series of production tests will be performed by Raytheon on each production unit to ensure compliance with the accepted design and operation of the first articles. PAT&E tests will be comprised of a subset of the tests performed in DT&E. The following tests will be conducted to satisfy the requirements of PAT&E:

### 5.5.1 Production Acceptance Test (PAT).

PAT will include full testing of each system, including facility components and spares, at the factory. ACT-310 will participate in validation of the plans and procedures at Raytheon's production facility upon conclusion of OT&E. Raytheon shall provide test results to the government Quality Reliability Officer (QRO).

### 5.5.2 Site Acceptance Test (SAT).

SAT includes installation and checkout of all radar and facilities subsystems at the designated field sites. Validation of the plans and procedures for this testing will occur at both key sites upon completion of government testing. Upon successful completion of SAT, the system is fully accepted by the government.

## 5.6 NAS OT&E INTEGRATION/OPERATIONAL TESTING.

NAS OT&E Integration/Operational testing will be conducted by the FAA to determine the operational effectiveness and suitability of the ASR-11 under realistic operating conditions. Tests are directed towards resolution of the COIs as well as verifying that all operational requirements are met. This phase of testing will involve participation of air traffic controllers and maintenance personnel. These specialists will operate, maintain, and observe the system to identify deficiencies and needed improvements with respect to the COIs. All system problems and deficiencies discovered during testing will be noted in trouble reports. Regression testing may be performed as a result of modifications to the system configuration that are required to correct deficiencies identified during testing. Prior to beginning OT&E testing, all test personnel will receive training from Raytheon on how to operate and maintain the system.

Results of this testing will be used by the IPT to derive an IOTRD issued by ARA-1. An IOTRD signifies the end of System Test and establishes system qualification for entry to IOT&E. There may be requirements, however, which cannot be sufficiently tested at either key site during NAS OT&E Integration/Operational testing that do not provide sufficient impact on the program to delay an IOTRD or the production decision. These requirements will cause System Test to extend beyond the IOTRD and into another phase of testing known as Delta System Testing. This testing will be conducted at operational sites on the ASR-11 delivery schedule determined to exhibit the environment required to successfully complete testing.

### 5.6.1 NAS OT&E Integration.

NAS OT&E Integration testing will be conducted by ACT-310 at the FAA key site. If necessary or beneficial, however, the DOD key site may also be used for some testing. Interface testing will include remoting of ASR-11 surveillance data to the Technical Center where an SDT can be interfaced to each automation and display subsystem with which the ASR-11 is intended to operate.

Extensive testing of the ARTS IIE interface will be conducted on a dedicated ARTS system installed at Stockton for the purposes of testing. Live and simulated target reports will be observed at each display or recorded at the automation system and compared to known inputs to verify proper interfacing, throughput, capacity, and delay. FAA maintenance technicians and air traffic controllers will be available to support this testing. Technicians will operate and maintain the system as well as execute specific test scenarios. Data will be collected during as wide a variety of environmental conditions as possible. ACT-330 will provide support for testing of the RMS to NIMS interface. Support for facilities subsystem testing will be provided by AOS-230 and AND-440. Results of DT&E testing which satisfactorily demonstrate compliance with requirements for this phase of testing may be accepted as a means of reducing overall redundancy in the test program.

#### 5.6.1.1 NAS OT&E Integration Exit Criteria.

The FAA NAS OT&E Integration test effort will be considered complete when a determination has been made in regards to the system's ability to resolve COIs 1, 2, 3, 6, and 9, table 3.5-1 of this document. Any critical system deficiencies which pertain to the MOEs for these COIs must be resolved and the corresponding MOE(s) must be successfully reevaluated.

### 5.6.2 NAS OT&E Operational.

NAS OT&E Operational testing will be conducted at the FAA key site. Subject air traffic controllers will be made available during flight testing of coverage, accuracy, and resolution as well as live environment operational testing. They will simulate or perform their normal duties to determine if the ASR-11 performance and established ATC procedures are acceptable. Trained AF technicians will participate in operational testing through performance of maintenance actions in accordance with baselined ASR-11 procedures. Testing that requires a system configuration which is not available at the key site will be conducted at a follow-on field site during Delta System Test. AOS-230 will provide support for test issues involving optimization, safety, security, human factors, training, and system documentation during this phase of testing. ANS-500 will also provide support for safety and security issues. Testing which involves logistics support issues will be supported by AFR-304.



#### 5.6.2.1 NAS OT&E Operational Exit Criteria.

The FAA OT&E NAS Operational test effort will be considered complete when a determination has been made in regards to the system's ability to resolve COIs 4, 5, 7, and 8, table 3.5-1 of this document. Any critical system deficiencies which pertain to the MOSs and MOEs for these COIs must be resolved and the corresponding MOSs and MOEs must be successfully reevaluated.

#### 5.7 DELTA SYSTEM TESTING.

Delta System testing will be performed to evaluate any requirements which could not be verified during NAS OT&E Integration/Operational testing due to limitations of the key site or test article configuration. This testing will be accomplished at suitable field sites on the ASR-11 delivery schedule. Verification of requirements pertaining to radomes, pre-engineered electronics equipment shelters, and the mobile radar facility are known candidates for this testing. Any requirements identified for interfacing the ASR-11 to Air Route Traffic Control Centers (ARTCCs) will also be tested during this phase.

#### 5.8 OT&E TEST LIMITATIONS.

OT&E will be performed on the ASR-11 under as operationally realistic conditions as possible. Integration testing conducted at the Stockton key site will utilize a dedicated ARTS IIE system installed for the sole purpose of supporting the test program. Configuration of this automation system will be modeled after the operational ARTS systems in use at the key site. The ASR-11 will be integrated into the operational environment prior to completion of OT&E Operational testing and the system certification flight check.

The scope of OT&E testing may be limited by certain known, unknown, and uncontrollable circumstances. These limitations include:

a. There are no "live" environments which are capable of stressing the system at the specified maximum target load. To partially mitigate this problem, the ARIES will be utilized during testing to inject a simulated beacon full target load, with FRUIT, on the ASR-11 MSSR. The test program does not, however, have access to a simulator capable of stressing the system at a full search only or search/beacon target load. Without this capability, overall performance characteristics of the system under full load cannot be absolutely verified;

b. Clutter conditions at Stockton and Eglin may not be sufficient to properly test all clutter rejection performance parameters. Delta System Testing may be required to adequately assess the system's performance capabilities in clutter conditions not available at the key sites;

c. Due to varying weather conditions, full testing of the PSR's weather detection and reporting capabilities may not be achievable during the designated OT&E test period. Verification of these parameters may be accomplished during Delta System Test, if necessary;

d. Performance characteristics of the antenna radome cannot be verified during OT&E since neither the FAA nor DOD test asset will be procured with one. Delta System Test at the first operational site to employ a radome will be necessary;

e. Evaluations of the ASR-11 to STARS interface may not be accomplished during the designated OT&E test period if the automation system is not available at this time. Delta System Testing may be required;

f. Evaluations of the ASR-11 to ARTS IIA, ARTS IIIA and ARTS IIIE interfaces will not be accomplished in an operational environment during the designated OT&E test period. Limited testing is to be performed on these systems at the Technical Center. Delta System Testing will be required to evaluate these interfaces in an operational environment.

g. The Mode S upgradeability option for the MSSR will be assessed by analysis only. To fully evaluate the feasibility and performance of this option would require procurement of an upgrade kit, which is not planned. Delta System Test will be required if and when this upgrade is exercised;

h. Verification of some requirements contained in the Facilities Requirements Document (FaRD) (e.g., pre-engineered shelter) will not be accomplished during OT&E due to options not included with the test asset configurations. Delta System Testing will be required to verify these requirements.

## 6. INDEPENDENT OPERATIONAL TEST AND EVALUATION (IOT&E).

### 6.1 INDEPENDENT OT&E PURPOSE/SCOPE.

ATS-1 has designated the ASR-11 for IOT&E. IOT&E is a full system-level evaluation conducted in a realistic operational environment by an ATS Test Team. ASR-11 IOT&E will be conducted following ARA-1's IOTRD which declares the system's readiness for IOT&E and addresses the availability of resources required to conduct IOT&E.

IOT&E confirms the operational readiness of a system to be part of the NAS. Through the resolution of COIs, the ATS Test Team, led by a specialist from ATQ with members from AT, AF, and ARS, assesses and reports on the operational effectiveness and operational suitability of a system. This assessment of the ASR-11 will be reported to ATS-1 and utilized in support of an acquisition decision in 1999.

### 6.2 IOT&E STRATEGY.

IOT&E will be conducted on the ASR-11 in its intended operational environment by a test team composed of personnel from the ATS organization (e.g., ATQ, ARS, AT and AF headquarters and field). The ATS Test Team will provide an independent assessment to ATS-1 on the operational effectiveness and suitability of the ASR-11. IOT&E activities will occur in two phases: monitoring and test conduct.

a. Monitoring: The ATS Test Team will be formed to monitor IPT System Testing to document any potential ASR-11 risk areas that may need to be further addressed during IOT&E. This team will also determine what USAF test data from Eglin, AFB can be used to supplement the data collected during the actual IOT&E conduct on the ASR-11.

b. Test Conduct: The test conduct phase of IOT&E will be conducted at Stockton, CA, and will commence after the completion of IPT test activities and the IOTRD by ARA-1. The ATS Test Team will observe and interact with system operations and maintenance. Quantitative and qualitative data (questionnaires, recordings, and observations) will be collected while the system personnel conduct their normal duties. Testing will be based on normal traffic and unplanned maintenance events. AT and AF personnel will be requested to respond to the appropriate questionnaires related to the effectiveness and suitability of the ASR-11. FAA IOT&E may use the AFOTEC OT&E test data to supplement and/or resolve each COI.

#### 6.2.1 IOT&E Prerequisites.

The conduct of IOT&E is dependent on the following conditions:

- a. IOTRD;
- b. Release and installation of the ASR-11 hardware/software baseline which is intended for operational use and has been configuration controlled;
- c. Site Acceptance by the FAA at the key site (Stockton, CA) is complete;
- d. IOT&E participants representative training is complete;
- e. Draft user and maintenance manuals are complete;
- f. All outstanding issues for entry into IOT&E have been fully described and resolved.

#### 6.2.2 Limitations to Scope of IOT&E.

IOT&E will be conducted on the ASR-11 in its normal operational mode. However, certain pre-existing conditions and circumstances may limit the scope of IOT&E. These limitations include:

- a. Occurrence of varying weather conditions;
- b. Availability of future NAS automation interfaces (STARS);
- c. No dedicated flight tests will be used to evaluate radar/beacon performance.

#### 6.2.3 Strategy for Resolution of COIs.

IOT&E will focus on the resolution of COIs in order to determine the operational readiness of the ASR-11. All measures of effectiveness or suitability and data collected will be traceable to the resolution of the following approved COIs.

COI 1.0: Does the DASR/ASR-11 performance and coverage volume support air traffic control operations?

*This COI will be resolved by the collection and analysis of qualitative data (AT questionnaires, etc.) and quantitative data (digital recorded surveillance data). Quantitative data will be analyzed by AF personnel using radar analysis tools such as TRACS-9, RBAT, and RTADS. Results from FAA System Test, and USAF DT&E and OT&E may be used to supplement IOT&E data.*

COI 2.0: Does the number and distribution of false target reports from the DASR/ASR-11 allow reliable aircraft detection, identification, and tracking consistent with the air traffic control mission and airspace requirements?

*This COI will be resolved by the collection and analysis of qualitative data (AT questionnaires, etc.) and quantitative data (digital recorded surveillance data).*

*Quantitative data will be analyzed by AF personnel using radar analysis tools such as TRACS-9, RBAT, and RTADS. Results from FAA System Test, and USAF DT&E and OT&E may be used to supplement IOT&E data.*

COI 3.0: Does the DASR/ASR-11 detect closely spaced aircraft with sufficient reliability to allow the controller to maintain separation standards?

*This COI will be resolved by the collection and analysis of qualitative data (AT questionnaires, etc.) and quantitative data (digital recorded surveillance data). Quantitative data will be analyzed by AF personnel using radar analysis tools such as TRACS-9, RBAT, and RTADS. Results from FAA System Test, and USAF DT&E and OT&E may be used to supplement IOT&E data.*

COI 4.0: Is the reliability, maintainability, and availability of the DASR/ASR-11 suitable for incorporation into the NAS when used in an operational environment with the available resources, logistics plan, maintenance procedures, and personnel?

*This COI will be resolved by the collection and analysis of qualitative data (AF questionnaires) and quantitative data (MPS data supplemented by JRMET process, unplanned maintenance actions, etc.). Results from FAA System Test, and USAF DT&E and OT&E will be used to supplement IOT&E data.*

COI 5.0: Does the DASR/ASR-11 system design and procedures allow the radar system to be optimized, adapted to site conditions, and certified in a reasonable time by available maintenance personnel?

*This COI will be resolved by analysis of site optimization results, interviews from the site optimization team, and AF ability to certify the system via the maintenance handbook. Results from FAA System Test, and USAF DT&E and OT&E will be used to supplement IOT&E data.*

COI 6.0: Is the DASR/ASR-11 operating effectively and capable of interfacing with other NAS systems?

*This COI will be resolved by the collection and analysis of qualitative data (AT and AF questionnaires) and quantitative data (radar data, NIMS logs, etc.) on the ability of the ASR-11 to interface with NIMS, ARTS IIA/IIIE, etc. at Stockton. The data collected during FAA System Test, and USAF DT&E and OT&E will be used to supplement FAA's IOT&E on other possible automation systems (ARTS-III,  $\mu$ EARTS, STARS, etc.).*

COI 7.0: Is the DASR/ASR-11 system safe to operate and maintain?

*This COI will be resolved by ATS Test Team inspections, analysis of regional safety audits, and collection and analysis of AF questionnaires.*

COI 8.0: Does the DASR/ASR-11 provide user friendly interfaces that support operations and maintenance and minimizes personnel skill requirements and training time?

*This COI will be resolved by the collection and analysis of qualitative data (AT and AF questionnaires).*

COI 9.0: Does the DASR/ASR-11 provide accurate and reliable weather data suitable for safe aircraft routing by air traffic control?

*This COI will be resolved by the collection and analysis of qualitative data (AT questionnaires) and quantitative data (observations, data recordings, etc.). When weather events are reported within the radar coverage, data may be qualitatively and possibly quantitatively compared to other weather data that is available (i.e., NEXRAD, ARSR-4, etc.). Results from FAA System Test, and USAF DT&E and OT&E will be used to supplement IOT&E data.*

#### 6.2.4 COI Resolution and System Assessment Process.

The ATS Test Team follows a structured approach when resolving COIs and assessing systems. For each COI, a determination is first made on the sufficiency of test data. If there is sufficient data, an assessment of the COI is made which in turn allows for the assessment of the system's operational effectiveness and operational suitability. COI resolution is a measure of the sufficiency of data collected to support assessing a COI. COIs are resolved as follows:

- a. Resolved - The COI was evaluated and the data collected was sufficient to make an assessment.
- b. Partially Resolved - The COI was evaluated, but due to limitations of scope or extenuating circumstances, further testing is required for final resolution. The assessment in this case is based on the partial resolution.
- c. Not Resolved - The COI was not evaluated during the IOT&E Phase.

If the users believe that a significant risk exists due to any unresolved COIs, ATS-1 will request that either the ATS Test Team or the IPT further evaluate the system. The ATS Test Team addresses the assessment of the resolved COIs by the degree that the data and analysis satisfy the questions posed by the COIs. There is a data trail, in the IOT&E Test Plan, from each COI question to its corresponding MOEs/MOSs and their corresponding test data elements. The assessment of each COI is directly related to the IOT&E results, and, if applicable, data collected during earlier test phases. COIs are assessed based on

the experience of the operational members of the ATS Test Team and supported by data collected during the evaluations. The COIs may be assessed as:

- a. Satisfactory (SAT),
- b. Potentially Satisfactory/Unsatisfactory, or
- c. Unsatisfactory (UNSAT)

The ATS Test Team will make a determination of the system's Operational Effectiveness and Operational Suitability based on the resolution/assessment of COIs. Each resolved COI will be assessed as Satisfactory or Unsatisfactory, based on their MOEs and MOSs.

The system will be assessed for Operational Suitability and Operational Effectiveness based on the resolution/assessment of the individual COIs. The definitions of Operational Effectiveness and Operational Suitability are as follows:

Operational Effectiveness: The degree to which a product accomplishes its mission when used by representative personnel in the expected operational environment.

Operational Suitability: The degree to which a product intended for field use satisfies its availability, compatibility, transportability, interoperability, reliability, maintainability, safety, human factors, logistics supportability, documentation, personnel, and training requirements.

Systems may be assessed as:

Fully Operationally Effective/Suitable: The COIs were satisfactorily resolved, and the system meets/exceeds the operational requirement defined by the COIs.

Partially Operationally Effective/Suitable: Most of the COIs were satisfactorily resolved, and the COIs that are potentially UNSAT or UNSAT are assessed not to be critical enough to rate the system as Not Operationally Effective/Suitable.

Not Operationally Effective/Suitable: A majority of the COIs were not satisfactorily resolved, and the system meets none or very few of the operational requirement expressed in the COIs or at least one of the COIs have operational shortcomings which are considered critical enough to rate the system as Not Operationally Effective/Suitable.

If as a result of IOT&E the ATS Test Team determines the system is not operationally ready, the Team will recommend to ATS-1 that the system be returned to ARA for further development and/or corrective action. During the conduct of IOT&E, ARA/IPT may decide to withdraw the system if they determine that further development and/or corrective action is required before IOT&E proceeds.

### 6.3 IOT&E RESOURCE REQUIREMENTS.

IOT&E will be conducted by the ATS Test Team. The ATS Test Team's responsibilities include preparing test plans and procedures, monitoring OT&E, coordinating with facilities, obtaining resources, collecting data, assessing results, and reporting the assessment. In the execution of these responsibilities, the ATS Test Team will require resources from ATQ, the IPT, and ATS.

#### 6.3.1 Roles and Responsibilities.

IOT&E will be planned and conducted by the ASR-11 ATS Test Team. The following provides definitions for the prime IOT&E roles and the responsibilities:

The ATS Test Team Lead will manage the IOT&E; coordinate with ARA and ATS for required support during IOT&E; facilitate the reporting of the results and recommendations to ATS-1; and coordinate the development of the IOT&E Plan, Procedures, Quick Look, and Final reports.

The ATS Test Team Members will be involved in developing the IOT&E Plan, Procedures, Quick Look, and Final reports. As ATS Test Team members, AT and AF will be responsible for identifying their respective ATS Test Team members and coordinating as necessary with the appropriate labor organizations. Field ATS Test Team members will assist in coordinating the IOT&E conduct at their facilities. All ATS Test Team members will participate in the system assessment.

The IOT&E participants: conduct normal AT & AF operations during IOT&E; participate in interviews and provide input to questionnaires; and coordinate with appropriate ATS Test Team members.

Table 6.3.1-1 identifies the roles of all organizations involved with the IOT&E effort.

TABLE 6.3.1-1. IOT&E ROLES

ORGANIZATION	ROLES
ATQ	ATS Test Team Lead
AT	Test Team member
AT Field	Test Team member; IOT&E participant
AF	Test Team member
AF Field	Test Team member; IOT&E participant
AOS	Test Team member



TABLE 6.3.1-1. IOT&E ROLES (continued)

ORGANIZATION	ROLES
AND-400 Surveillance IPT	Coordinate with ATQ and provide resources required to support IOT&E as described in section 6.3. The IPT may observe IOT&E.
ACT	Provide access to System Test data, results, and reports as required to support assessment of COI's.

6.3.2 Personnel.

The ATS Test Team will be led by an assigned ATQ specialist and will include members from ARS and AT and AF field and headquarters representatives. The Headquarters AT/AF ATS Test Team members will coordinate with their respective organizations to obtain field representatives to act as ATS Test Team members and IOT&E participants. Table 6.3.2-1 contains staffing estimates for IOT&E in man-years.

TABLE 6.3.2-1. STAFFING ESTIMATES FOR IOT&E IN MAN-YEARS

Personnel	FY 98	FY 99
ATQ and ATS Headquarters	1.2	1.8
ATS Field Personnel (AT and AF)	0.2	0.6

6.3.3 IOT&E Training.

The IPT has reserved two training slots for ATQ to participate in the ASR-11 training courses. The two courses offered, at the contractor's facility, are Operations and Maintenance (7 weeks) and IOT&E (2 weeks).

6.3.4 Travel.

With the exception of the Stockton ATS Test Team personnel, other ATS Test Team members will be required to travel to the test site (Stockton, CA) to conduct IOT&E. All ATS Test Team members will be required to travel to a site to be determined to participate in writing the IOT&E Quick Look Report. Travel funding for the ATS Test Team will be provided by ATS through National/Regional Block Funding.

6.3.5 Backfill Overtime (BFOT).

Backfill Overtime is for the field personnel who will not be able to perform their operational duties because of participation in IOT&E plan and procedure preparation, conduct, or report writing. BFOT will be paid for by ATS.

### 6.3.6 Facilities.

No special test facilities will be required to conduct IOT&E.

### 6.3.7 Funding.

The funding indicated in table 6.3.7-1 will be required to accomplish IOT&E. Travel and BFOT, for ATS Test Team members (which does not include ATQ and ATQ's support contractors), will be paid for by ATS.

TABLE 6.3.7-1. IOT&E FUNDING REQUIREMENTS.

IOT&E Funding (Dollars in thousands)			
Funding Type	98	99	Total
Travel	4.5	12.0	16.5
Back-Fill Overtime	0.0	16.8	16.8

### 6.3.8 Schedule.

IOT&E will start at the direction of ATS-1 after the IOTRD. An Integrated Schedule listing the IOT&E activities is contained in figure 4.2-1 of this TEMP.

## 6.4 IOT&E DOCUMENTATION.

The ATS Test Team will be responsible for preparing IOT&E documentation. For IOT&E conduct of ASR-11, documentation will include plans, procedures, and reports.

### 6.4.1 IOT&E Plan.

The ASR-11 IOT&E Plan will form the basis for the conduct of ASR-11 IOT&E. The plan will provide more detail on the approach to addressing the COIs, to executing the procedures, and to analyzing and reporting the results. The plan will also provide more detail on the system and personnel resources required to prepare for and conduct IOT&E.

### 6.4.2 IOT&E Procedures.

The ATS Test Team will develop procedures to ensure resolution of COIs in an operational environment. Procedures for IOT&E at Stockton may include observation forms, questionnaires, test logs, and discrepancy reports. These procedures will provide the guidance necessary to allow ATS Test Team members to record relevant data in an operational environment. Configuration management of IOT&E data will be under the control of the ATS Test Team Lead.

#### 6.4.3 IOT&E Reports.

The ATS Test Team will prepare Reports (Quick Look and Final) and will submit them to ATS-1. Due to different timeframes associated with AFOTEC and ATQ test efforts, AFOTEC will prepare an interim summary report which will be included as an attachment to the ATS Test Team's Quick Look Report. This interim summary report will provide a status of AFOTEC testing to date so that the FAA acquisition decision makers will have an understanding of AFOTEC test efforts and test results. A joint IOT&E Final Report will be developed by AFOTEC and the ATS Test Team after completion of DOD testing.

## 7. ACRONYMS AND GLOSSARY.

A <sub>i</sub>	Inherent Availability
AAF-1	FAA Airway Facilities Service
ACP	Azimuth Change Pulse
ACT-310	FAA Technical Center Surveillance Branch
ACT-330	FAA Technical Center Communication/Infrastructure Branch
AF	Airways Facilities
AFB	Air Force Base
AFOTEC	United States Air Force Operational Test and Evaluation Command
AFR-304	FAA Surveillance Life-Cycle Division
AGL	Above Ground Level
AMS	Acquisition Management System
A/N	Alphanumerics
AND-410	FAA Surface Products Program Office
ANS-210	FAA NAS Implementation Management Division
ANS-500	FAA NAS Transition and Implementation, Environmental Energy and Safety Division
AOS	FAA Operational Support
AOS-230	FAA NAS Surveillance Systems Engineering Branch
AP	Anomalous Propagation
ARA-1	FAA Associate Administrator for Research and Acquisitions
ARIES	Aircraft Reply and Interference Environment Simulator
ARIG	Acquisition Reform Interim Guidance
ARP	Azimuth Reference Pulse
ARS	FAA Air Traffic Requirements Service
ARTCC	Air Route Traffic Control Center
ARTS	Automated Radar Terminal System
ASR-8	Airport Surveillance Radar Model 8
ASR-11	Airport Surveillance Radar Model 11
ASU-230	FAA Office of Acquisitions Quality Assurance Branch
AT	Air Traffic
ATC	Air Traffic Control
ATCBI	Air Traffic Control Beacon Interrogator
ATCRBS	Air Traffic Control Radar Beacon System
ATQ	FAA Office of Independent Operational Test and Evaluation
ARN-100	FAA Air Traffic System Requirements Service Communications/Navigation/Surveillance Branch
ATS-1	FAA Associate Administrator for Air Traffic Services
BIT	Built-In-Test
bps	bits per second
BRTQC	Beacon Real-Time Quality Control

CD	Common Digitizer
CFR	Code of Federal Regulations
CLIN	Contract Line Item Number
CM	Configuration Management
CMTPL	Contractor's Master Test Plan
COI	Critical Operational Issue
CPP	Critical Performance Parameter
CSC	Critical System Characteristic
DAIR	Direct Altitude and Identity Readout
DASR	Digital Airport Surveillance Radar
dB	decibels
dBz	Weather Reflectivity Level in decibels
DBRITE	Digital Bright Radar Indicator Tower Equipment
DDAS	Decoding Data Acquisition System
DOD	Department of Defense
DT&E	Developmental Test and Evaluation
DVG	Digital Video Generator
E-G	Engine-Generator
EIA	Electronics Industries Association
EMI	Electromagnetic Interference
ESC	United States Air Force Electronic Systems Command
FAA	Federal Aviation Administration
FAR	False Alarm Rate
FI	Fault Isolation
FaRD	Facilities Requirements Document
FRD	Final Requirements Document
FRUIT	False Replies Unsynchronized In Time
FY	Fiscal Year
GB&L	Grounding, Bonding, and Lightning
GFE	Government Furnished Equipment
GFP	Government Furnished Property
GHz	gigahertz
GPS	Global Positioning System
HVAC	Heating, Ventilation, and Air Conditioning
ICAO	International Civil Aviation Organization
ICD	Interface Control Document
IOT&E	Independent Operational Test and Evaluation

IOTRD	Independent OT&E Readiness Declaration
IP	In-Plant
IPT	Integrated Product Team
IRD	Interface Requirements Document
IRES	Integrated Radar Evaluation System
JMTP	Joint Master Test Plan
JRMET	Joint Reliability Maintainability Evaluation Team
KDP	Key Decision Point
LAN	Local Area Network
LRU	Line Replacement Unit
MALA	Mode S/ASR-9 Line Adapter
MIPS	Master Integrated Program Schedule
μEARTS	Micro-Enroute Automated Radar Tracking System
MOA	Memorandum Of Agreement
Mode S	Mode Select Beacon System
MOE	Measure Of Effectiveness
MOP	Measure Of Performance
MOS	Measure Of Suitability
MPS	Maintenance Processor Subsystem
MRSM	MSSR Remote System Monitor
MSSR	Monopulse Secondary Surveillance Radar
MTBCF	Mean Time Between Critical Failure
MTBF	Mean Time Between Failure
MTBPMA	Mean Time Between Preventative Maintenance Action
MTI	Moving Target Indicator
MTP	Master Test Plan
MTR	Mean Time to Restore
MTTR	Mean Time To Repair
NAS	National Airspace System
NCP	NAS Change Proposal
NDI	Non-Developmental Item
NIMS	NAS Infrastructure Management System
nmi	nautical mile
NTIA	National Telecommunications and Information Administration
NWS	National Weather Service
OCD	Operational Capabilities Demonstration
OMT	Operator Maintenance Terminal
ORD	Operational Requirements Document

OS	On-Site
OSHA	United States Occupational Safety and Health Administration
OSRD	On-site System Readiness Demonstration
OT&E	Operational Test and Evaluation
$P_d$	Probability of Detection
$P_{FA}$	Probability of False Alarm
PAT	Production Acceptance Test
PAT&E	Production Acceptance Test and Evaluation
PC	Personal Computer
PCS	Power Conditioning System
PIDP	Programmable Indicator Display Processor
PME	Prime Mission Equipment
PMR	Program Management Review
PPI	Planned Position Indicator
$P^3I$	Pre-Planned Product Improvement
PRF	Pulse Repetition Frequency
PSR	Primary Surveillance Radar
QA	Quality Assurance
QRO	Quality Reliability Officer
RAM	Random Access Memory
RATCF	Radar Air Traffic Control Facility
RBAT	Radar Beacon Analysis Tool
RCP	Radar Control Panel
RCS	Radar Cross Section
RF	Radio Frequency
RFP	Request For Proposals
RMA	Reliability, Maintainability and Availability
RMMS	Remote Maintenance Monitoring System
RMS	Remote Monitoring Subsystem
rms	root mean square
RMSDT	Remote Monitoring Subsystem Design Tool
RTADS	Real-Time Aircraft Display System (Test Tool)
RTQC	Real-Time Quality Control
SAT	Site Acceptance Test
SCV	Subclutter Visibility
SDT	Surveillance Data Translator
SIU	Site Interface Unit
SNR	Signal-to-Noise Ratio
SRAP	Sensor Receiver And Processor
SRD	System Requirements Document
SRTQC	Search Real-Time Quality Control

SS	System Specification
SSR	Secondary Surveillance Radar
STARS	Standard Terminal Automation Replacement System
T&E	Test and Evaluation
TBD	To Be Determined
TDSB	Test Data Scoring Board
TEMP	Test and Evaluation Master Plan
THD	Total Harmonic Distortion
TIM	Technical Interchange Meeting
TPRC	Test Policy Review Committee
TPWG	Test Planning Working Group
TRACON	Terminal Radar Approach Control
UPS	Uninterruptable Power Supply
USAF	United States Air Force
VDCU	Video Display Control Unit
VRTM	Verification Requirements Traceability Matrix
46TS	United States Air Force 46th Test Squadron



APPENDIX A

VERIFICATION REQUIREMENTS TRACEABILITY MATRIX (VRTM)

VERIFICATION REQUIREMENTS TRACEABILITY MATRIX.

Verification of Final Requirements Document (FRD) requirements and the System Requirements Document (SRD) "shall" statements will be accomplished in accordance with the VRTM, table 2. A more detailed VRTM that includes all system and facilities requirements to be verified by this test program will be included in the System Test Plan. Table 1, below, gives a description of the contents of each column in the VRTM.

Table 1. VRTM Column Definitions

Column	Heading	Content Description
1	TEST ID #	Provides a unique number for each requirement to facilitate tracking. ID numbers in the correlate directly to Raytheon's "shall" notations in the SS.
2	REQUIREMENTS paragraph ref	Identifies the paragraph number, if any, in which the requirement appears in pertinent program documents. The following abbreviations were used to indicate which document the associated paragraph number refers to: FRD Final Requirements Document SS System Specification SRD System Requirements Document I NAS-SS-1000 Volume I II NAS-SS-1000 Volume II III NAS-SS-1000 Volume III
3	DESCRIPTION	Provides a descriptive title for the requirement
4	DT&E - IP	Identifies the requirement verification method(s) to be employed during the In-Plant (IP) portion of DT&E.
5	DT&E - OS	Identifies the requirement verification method(s) to be employed during the On-Site (OS) portion of DT&E.
6	PAT&E - PAT	Identifies the requirement verification method(s) to be employed during the Production Acceptance Test (PAT).
7	PAT&E - SAT	Identifies the requirement verification method(s) to be employed during the Site Acceptance Test (SAT).
8	OT&E - I	Identifies the requirement verification method(s) to be employed during the Integration portion of OT&E testing.
9	OT&E - O	Identifies the requirement verification method(s) to be employed during the Operational portion of OT&E testing.

TABLE 1. VRTM COLUMN DEFINITIONS (continued)

Column	Heading	Content Description
10	THRESHOLD MAJOR	States the most stringent requirement from the document(s) referenced in column 2 of this table. Any differences between referenced documents are noted in column 12 of this table.
11	COI #	Correlates each requirement to the COI(s) under which it will be evaluated. COI numbers are derived from Table 3.5-1 of this document.
12	REMARKS	Provides a space for comments or remarks on each requirement.

Verification methods indicated in columns four through nine are defined as follows:

T = Test: Measures equipment's performance under specified configurations, load conditions and after the controlled application of known stimuli. Quantitative values are measured, compared against previously predicted success criteria and then evaluated to determine the degree of compliance.

(T) = Indicates that results from DT&E testing may be accepted in lieu of performing an additional OT&E test. DT&E test results will only be accepted if the following criteria are satisfied:

- a. An actual test was performed by Raytheon during DT&E;
- b. The test satisfied all of the requirements of an OT&E test;
- c. The test was performed on-site;
- d. The system configuration was substantially the same as that under OT&E testing.

If the DT&E test performed by Raytheon does not completely satisfy these requirements, the government will perform a separate test as part of OT&E.

A = Analysis: Consists of comparing hardware or software design with known scientific and technical principles, technical data, or procedures and practices to validate the design will meet the requirement.

D = Demonstration: Where qualitative versus quantitative validation of a requirement is made during a dynamic test of equipment. In general, software functional requirements are validated by this method.

I = Inspection: Consists primarily of visual observations, or mechanical measurements of equipment, locations or technical examination of engineering support documentation.

Table 2. ASR-11 Verification Requirements Traceability Matrix

TEST ID #	REQUIREMENTS paragraph ref.	DESCRIPTION	SYSTEM TEST										THRESHOLD MAJOR	COI #	REMARKS
			DT&E		PAT&E			OT&E							
			IP	OS	PAT	SAT	I	O							
0313.0	3.0 (SS)	General Surveillance Requirement	N	D	N	D	T	T	T	O		The ASR-11 shall provide terminal surveillance of aircraft in support of FAA and DOD ATC requirements at current and planned ATC facilities	1 2 3 4 5 6 7 8 9		
	3.0 (SRD)														
0314.0	2.1 (FRD)	General Detection Requirement	N	D	N	D	T	T	T			The system shall provide detection of air carrier, military, air taxi, and general aviation aircraft in ground, weather, and anomalous propagation clutter and output accurate reliable surveillance (range and azimuth) data to ATC facilities, and provide six-level weather detection	1 2 3 4 5 6 8 9		
	3.0 (SS)														
0315.0	3.0 (SRD)	General NAS Requirements Compliance	AD	A	N	N	T	T	T			The system shall be capable of unmanned operation with an inherent system availability compatible with NAS requirements for critical systems	4 6		
	2.1 (FRD)														
0316.0	3.1.1 (SS)	PSR Detection Volume	TA	D	N	T	(T)	T	T			Slant Range: 0.5 - 60 nmi Azimuth: 360° Altitude: 0 - 24,000 feet AGL as limited by the elevation coverage requirement stated below Elevation: from local radar horizon as determined by earth curvature, atmospheric refraction, and as further limited by terrain screening to 30° with respect to the horizontal plane at the radar antenna Antenna Scan Rate: 4.8 +0.53 or 0.44 seconds/revolution	1 8	Slant Range: 0.5 - 55 nmi (SRD, FRD) Altitude: 0 - 20,000 feet AGL (III)	
	3.1.1 (SRD)														
	3.1.1.1 (FRD)														
	3.1.1.1.13 (FRD)														
	3.2.1.2.7.5 (I)														
	3.2.1.1.4.2.1 (III)														
0317.0	3.1.2 (SS)	PSR Target Definition	TA	D	N	N	(T)	T	T			The PSR shall detect all aircraft within the detection volume with the following characteristics: Ground Speed: 25 - 700 knots RCS: 1 - 10,000 m <sup>2</sup> (SS, SRD)	1 8	1) RCS requirement not included in FRD. 2) Full range of RCS will not be tested during OI&I.	
	3.1.2 (SRD)														
	3.1.1.2 (FRD)														

TEST ID #	REQUIREMENTS paragraph ref.	DESCRIPTION	SYSTEM TEST										THRESHOLD MAJOR	COI #	REMARKS
			DT&E		PAT&E			OT&E							
			IP	OS	PAT	SAT	I	O							
0318.0	3.1.3.1 (SS) 3.1.3.1 (SRD) 3.1.1.8 (FRD) 3.2.1.2.7.2 (I) 3.2.1.1.4.2.2 (III)	PSR Detection Performance in the Clear	TA	D	N	T	T	(T)	T			In the clear, the PSR shall detect a 1 m <sup>2</sup> Swerling 1 target anywhere within the detection volume with a single scan $P_d \geq 0.8$ at a $P_{FA}$ of $10^{-6}$ over 92% of the radial velocities between -700 and +700 knots	1 2 8		
0330.0	3.1.4 (SS) 3.1.4 (SRD) 3.1.1.3 (FRD) 3.2.1.1.4.2.5 (III)	PSR Range Accuracy	A	T	N	T	T	(T)	N			For an aircraft target with SNR $\geq 30$ dB, including processing gain, the range error shall not exceed 275 feet RMS, including bias	1 3		
0331.0	3.1.5 (SS) 3.1.5 (SRD) 3.1.1.4 (FRD) 3.2.1.1.4.2.6 (III)	PSR Azimuth Accuracy	A	T	N	T	T	(T)	N			For an aircraft target with SNR $\geq 30$ dB including processing gain and at elevation angles 1° to 20° with respect to the horizontal plane at the radar site, the azimuth error shall not exceed 0.16° RMS, including bias	1 3		
0332.0	3.1.6 (SS) 3.1.6 (SRD) 3.1.1.5 (FRD) 3.2.1.1.4.2.3 (III)	PSR Range Resolution	A	T	N	T	T	(T)	N			When returns are detected from two Swerling 1 targets, separated in range by at least 0.125 nmi, on the same azimuth, with the same or different radial velocities, and located at any point in the coverage volume, the PSR shall resolve the two targets and generate two unique target reports 80% of the time for any combination of RCS from 1 to 20 m <sup>2</sup> provided that the larger target's RCS is not more than 8 dB greater than the smaller target's RCS	1 3		

TEST ID #	REQUIREMENTS paragraph ref:	DESCRIPTION	SYSTEM TEST							THRESHOLD MAJOR	COI #	REMARKS
			DT&E		PAT&E		OT&E					
			IP	OS	PAT	SAT	I	O				
0333.0	3.1.7 (SS) 3.1.7 (SRD) 3.1.1.6 (FRD) 3.2.1.1.4.2.4 (III)	PSR Azimuth Resolution	A	T	N	T	(T)	N	When returns are detected from two Swerling 1 targets, separated in azimuth by 2.8°, at the same range, with the same or different radial velocities and located at any point in the coverage volume, the PSR shall resolve the two targets and generate two unique target reports 80% of the time for any combination of RCS from 1 to 20 m² provided that the larger target's RCS is not more than 8 dB greater than the smaller target's RCS	1 3		
0334.0	3.1.8 (SS) 3.1.1.7 (FRD)	Target Splits	A	T	N	T	(T)	N	The single scan probability of a split report shall be less than 0.75% for targets having an SNR ≥ 20 dB	1 2	Less than 1% (FRD)	
0335.0	3.1.9 (SS) 3.1.1.9 (FRD)	System Stability	T	N	T	N	(T)	N	Total system stability for both surveillance and weather functions, exclusive of scan modulation, shall be -55 dB (relative to carrier) or better at all ranges	1 9		
0336.1	3.1.10 (SS) 3.1.10 (SRD) 3.1.1.10 (FRD)	Subclutter Visibility (SCV)	N	T	N	T	(T)	T	The average SCV of a non-fluctuating target shall be ≥ 42 dB under the following conditions: <u>P<sub>d</sub></u> : 0.5 <u>P<sub>FA</sub></u> : 10 <sup>-6</sup> <u>Radial Velocities</u> : 20 to 700 knots and -20 to -700 knots <u>Range</u> : 0.5 to 55 nmi <u>Antenna Rotation</u> : Nominally 4.8 seconds/revolution <u>Clutter Type</u> : Point clutter and distributed clutter	1 2 8		

TEST ID #	REQUIREMENTS paragraph ref:	DESCRIPTION	SYSTEM TEST							THRESHOLD MAJOR	COI #	REMARKS
			DT&E		PAT&E		OT&E					
			IP	OS	PAT	SAT	I	O				
0339.0	3.1.13 (SS) 3.1.13 (SRD) 3.1.1.11 (FRD)	PSR Operating Frequency	D	N	D	N	N	(T)	N	The PSR shall transmit in the frequency range of 2700 to 2900 MHz requiring no more than two frequency assignments within National Telecommunications and Information Administration (NTIA) guidelines for radar emission bandwidth	5 6	
0341.0	3.1.15 (SS) 3.1.15 (SRD)	PSR Spectrum Engineering Criteria	T	N	N	N	(T)	N	The PSR shall meet the requirements stated in 5.3.3, "Radar Spectrum Engineering Criteria," NTIA Manual of Regulations and Procedures for Federal Radio Frequency Management," (Title 47, Part 300 of CFR)	5 6		
0365.0	3.1.17.1.8 (SS) 3.1.17.a (SRD) 3.1.1.12 (FRD)	PSR Antenna Polarization	D	N	N	D	(T)	T	The PSR antenna shall be operator-selectable for either linear or circular polarization	1 5 6 8 9		
0454.0	3.2.1 (SS) 3.2.1 (SRD)	System Configurations	D	D	N	N	(T)	N	The DASR/ASR-11 shall support both of the configurations below: 1. Integrated MSSR 2. GFE BTE-2000 sliding window reply processor, GFE TPX-42 interrogator/receiver and GFE FAA-E-2660 LVA antenna	1 2 3 6	FAA will only test integrated MSSR configuration.	
0455.0	3.2.2 (SS) 3.2.2.a (SRD)	MSSR ATCRBS Ground Equipment Compliance	T	N	N	D	T	T	The SSR shall comply with ATCRBS ground equipment requirements of FAA Order 1010.51A (for Modes 2, 3/A, and C) and ICAO Annex 10 and be fully compatible with the other ATCRBS elements described in these documents	1 5 6 8		
0456.0	3.2.2 (SS) 3.2.2.b (SRD)	MSSR Transponder Compatibility	T	N	N	N	(T)	T	The SSR shall achieve MSSR requirements for probability of detection, accuracy, and resolution for aircraft equipped with ATCRBS or Mode S transponders operating over the full range of acceptable limits specified in FAA Order 1010.51A	1 3 6 8		



TEST ID #	REQUIREMENTS paragraph ref.	DESCRIPTION	SYSTEM TEST							THRESHOLD MAJOR	COI #	REMARKS
			DT&E		PAT&E			OT&E				
			IP	OS	PAT	SAT	I	O				
0457.0	3.2.2 (SS) 3.2.2.c (SRD)	MSSR Site Selectable Pulse Repetition Frequency (PRF)	T	N	N	N	N	(T)	N	The SSR shall meet all requirements for a broad selection of PRFs to allow government allocation of PRFs at all sites according to the requirements of FAA Order 6050.32 Paragraph 1302	1 2 3 6	
0463.0	3.2.2.3 (SS) 3.2.2.3 (SRD) 3.1.2.1 (FRD)	MSSR Detection Volume	N	T	N	T	(T)	T	Slant Range: 0.5 to 60 nmi Azimuth: 360° Altitude: 0 to 60,000 feet AGL as limited by the elevation coverage requirement Elevation: From 0.25° above local radar horizon as determined by earth curvature, atmospheric refraction and as further limited by terrain screening to 40° with respect to the horizontal plane at the radar antenna	1 8	Altitude: 0 - 20,000 feet AGL (FRD) Elevation: 0.25° - 30° (FRD)	
0464.0	3.2.2.4 (SS) 3.2.2.4 (SRD) 3.1.2.2 (FRD)	MSSR Probability of Detection (P <sub>d</sub> )	TA	D	N	D	(T)	T	The MSSR P <sub>d</sub> shall be 0.995 minimum for targets with a round reliability of 0.75 with three-fourths of the modes responding, in a steady state condition of 10,000 ATRBS and 200 Mode S FRUIT per second, of which 30% are in the main beam	1 2 8		
0465.0	3.2.2.5 (SS) 3.2.2.5 (SRD) 3.1.2.3 (FRD)	MSSR Range Accuracy	A	T	N	T	(T)	N	The MSSR range error shall be ≤190 feet RMS with transponder error (includes bias) at any point in the detection volume	1 3		
0466.0	3.2.2.6 (SS) 3.2.2.6 (SRD) 3.1.2.4 (FRD)	MSSR Azimuth Accuracy	A	T	N	T	(T)	N	With MSSR round reliability of 0.75, and all modes responding, the azimuth error shall be no greater than 0.08° RMS, including bias	1 3		

TEST ID #	REQUIREMENTS paragraph ref.	DESCRIPTION	SYSTEM TEST							THRESHOLD MAJOR	COI #	REMARKS
			DT&E		PAT&E		OT&E					
			IP	OS	PAT	SAT	I	O				
0487.0	3.2.2.7 (SS) 3.2.2.7 (SRD) 3.1.2.5 (FRD)	MSSR Range Resolution: 0.05 to 0.5 nmi Separation	TA	T	N	D	(T)	N	At least 95% of the time, the MSSR shall resolve two detected, stationary and identical, non-interfering targets with the same center azimuth if they are separated in slant range by 0.05 to 0.5 nmi inclusive (assuming identical transponder delays) when the ranges of both targets are between the minimum and maximum range limits	1 3		
0489.0	3.2.2.7 (SS) 3.2.2.7 (SRD) 3.1.2.5 (FRD)	MSSR Range Resolution: > 0.5 nmi Separation	TA	T	N	D	(T)	N	At least 99.9% of the time, the MSSR shall resolve two detected, stationary and identical, non-interfering targets with the same center azimuth if they are separated in slant range by more than 0.5 nmi inclusive (assuming identical transponder delays) when the ranges of both targets are between the minimum and maximum range limits	1 3		
0490.0	3.2.2.8 (SS) 3.2.2.8 (SRD) 3.1.2.6 (FRD)	MSSR Azimuth Resolution	TA	T	N	D	(T)	N	Assuming identical transponder delays, the MSSR shall resolve two detected identical targets that are within 0.05 nmi of each other in slant range and which are separated by 2.1° at least 95% of the time and resolve two targets that are within 0.05 nmi of each other in slant range and have at least one distinguishing characteristic and are separated by 1.5° at least 99% of the time	1 3		
0502.0	3.2.2.11 (SS) 3.2.2.11 (SRD) 3.1.2.7.1 (FRD)	MSSR Code Validation and Accuracy: Validation Rate	TA	T	N	T	(T)	N	MSSR codes shall be validated 95% of the time when four or more replies are received per mode	1 2		
0503.0	3.2.2.11 (SS) 3.2.2.11 (SRD) 3.1.2.7.2 (FRD)	MSSR Code Validation and Accuracy: Accuracy Rate	TA	T	N	T	(T)	N	MSSR code validations shall be correct at least 99% of the time in the presence of FRUIT as specified in SS paragraph 3.2.2.4	1 2		
0505.0	3.2.2.11 (SS) 3.2.2.11 (SRD) 3.1.2.7.3 (FRD)	MSSR Code Validation and Accuracy: Incorrect Validation	TA	T	N	T	(T)	N	The MSSR shall have validation of incorrect codes due to FRUIT or other causes less than 1% of the time	1 2		

TEST ID #	REQUIREMENTS paragraph ref.	DESCRIPTION	SYSTEM TEST										THRESHOLD MAJOR	COI #	REMARKS
			DT&E		PAT&E			OT&E							
			IP	OS	PAT	SAT	I	O							
0516.0	3.3 (SS) 3.3 (SRD) 3.1.3.1 (FRD) 3.2.1.1.4.2.7 (III) 3.2.1.1.4.2.11 (III)	Weather Detection and Reporting: NWS Precipitation Density Reporting	AT	D	N	N	D	(T)	(T)	N		The PSR shall detect, categorize, and report precipitation within the six reflectivity-intensity range levels (18 to 57 dBz) defined by the NWS	19		
0520.0	3.3.3 (SS) 3.3.3 (SRD) 3.1.3.4 (FRD) 3.2.1.1.4.2.12 (III)	Weather Detection and Reporting: Data Latency	T	N	N	N	D	(T)	(T)	T		The PSR shall collect reflectivity data, within a maximum period of six scans, output data within one scan following collection, and update the weather map once every six scans	1689	The ASR-11 shall complete collection and processing of all weather data every 6 scans or less, and transmit to the automations system within 3 scans or less of completion of collection and processing of the weather data (FRD)	
0521.0	3.3.4 (SS) 3.3.4 (SRD) 3.1.3.2 (FRD) 3.2.1.1.4.2.13 (III)	Weather Detection and Reporting: Data Resolution	T	N	N	N	N	(T)	(T)	T		The PSR shall report weather data for the complete volume with a data granularity of 0.5 nmi in range and 1.4°	189		
0526.0	3.3.8 (SS) 3.1.3.3 (FRD)	Weather Detection and Reporting: Performance in AP	TA	D	N	N	D	(T)	(T)	T		In the clear, the false weather report rate due to 1 <sup>st</sup> time AP shall be less than 10% at all ranges where the AP system SNR exceeds 15 dB	189	The ASR-11 shall reduce the occurrence of false weather reports due to AP (FRD)	

TEST ID #	REQUIREMENTS paragraph ref:	DESCRIPTION	SYSTEM TEST							THRESHOLD MAJOR	COI #	REMARKS
			DT&E		PAT&E		OT&E					
			IP	OS	PAT	SAT	I	O				
0527.0	3.4.1 (SS) 3.4.1 (SRD) 3.1.4.1 (FRD) 3.2.1.1.4.2.14 (III)	Target Capacity	T	T	N	N	N	(T)	N	The system shall provide target processing capacity as defined below: a. 700 real aircraft targets in any mix of PSR only, PSR/SSR merge, or SSR only targets, in the presence of an additional 300 false PSR reports and 100 false SSR reports, uniformly or non-uniformly distributed in azimuth for a 360° scan, and not be impacted by weather channel processing b. A peak of 250 targets uniformly distributed in a 90° sector c. A peak of 100 targets uniformly distributed across two contiguous 11.25° sectors d. A peak of 16 targets per a 1.3° wedge lasting for not more than two contiguous wedges	1 2 3 6	
0528.0	3.4.2.1 (SS) 3.4.2.1 (SRD) 3.1.4.3 (FRD) 3.1.4.4.1 (FRD) 3.1.4.4.2 (FRD)	Scan-to-Scan Correlated Target Reports	AT	T	N	T	T	(T)	T	Scan-to-scan correlation shall be used to reduce false alarms and assure a high confidence in reported aircraft targets with velocities of 25 to 700 knots and maneuvering up to 1g of centripetal or linear acceleration as follows: a. Report no more than 1 false scan-to-scan correlated search report per scan averaged over 15 minutes under normal clutter conditions b. Report no more than 10 false scan-to-scan correlated search reports per scan averaged over 10 scans when the clutter environment exceeds normal conditions	1 2 8	

TEST ID #	REQUIREMENTS paragraph ref:	DESCRIPTION	SYSTEM TEST							THRESHOLD MAJOR	COI #	REMARKS
			DT&E		PAT&E		OT&E					
			IP	OS	PAT	SAT	I	O				
0530.0	3.4.2.1.1.1 (SS) 3.1.4.6 (FRD)	PSR Track Processing: Overload Conditions	D	N	N	N	N	(T)	N	When overload conditions prevail, priority shall be given to targets closest in range	16	
0531.0	3.4.2.1.1.1 (SS) 3.1.4.6 (FRD)	PSR Track Processing: Target Drops in Overload Condition	D	N	N	N	N	(T)	N	When overload conditions prevail, the targets farthest in range shall be dropped first	16	
0596.0	3.4.2.4 (SS) 3.4.2.4 (SRD) 3.a.4.d.3 (ORD)	MSSR False Target Reporting: False Target Rate	AT	T	N	T	T	(T)	N	The MSSR shall report no more than one false target report per scan when averaged over 15 minutes in the steady-state FRUIT condition of 10,000 ATCRBS and 200 Mode S FRUIT per second of which 30% are in the main beam	2	
0597.0	3.4.2.4 (SS) 3.4.2.4 (SRD) 3.1.4.4.3 (FRD)	MSSR False Target Reporting: Beacon Split Rate	AT	T	N	T	T	(T)	T	The MSSR shall generate no more than one split target per scan when averaged over 15 minutes, this includes single aircraft beacon's discrete Mode 2 and Mode 3 replies and non-discrete replies	28	
0610.0	3.4.3 (SS) 3.4.3 (SRD) 3.1.4.2 (FRD)	Search/Beacon Merge Function: Target Merging	D	N	N	D	D	T	T	The ASR-11 shall merge SSR and PSR target reports when the same aircraft target is detected by both radars	168	

TEST ID #	REQUIREMENTS paragraph ref:	DESCRIPTION	SYSTEM TEST							THRESHOLD MAJOR	COI #	REMARKS
			DT&E		PAT&E		OT&E					
			IP	OS	PAT	SAT	I	O				
0640.0	3.4.4 (SS) 3.4.4 (SRD) 3.1.4.5 (FRD)	Data Timeliness	TA	T	N	N	N	(T)	N	Under peak capacity conditions, the ASR-11 delay shall be no greater than: a. 1.3 seconds for correlated digital PSR reports, exclusive of communication equipment delay b. 0.8 seconds for uncorrelated digital PSR only reports, exclusive of communication equipment delay c. 0.8 seconds for SSR only reports and SSR/PSR merged reports, exclusive of communication equipment delay d. 1.3 seconds for correlated digital PSR/SSR merged reports, exclusive of communication equipment delay e. 1.7 seconds for reconstituted video, exclusive of communication equipment delay f. No greater than 0.3 seconds for the communications equipment	6	The ASR-11 shall support the NAS requirement for data timeliness, from radar boresight to display, of 2.2 seconds or less (FRD)
0641.0	3.4.5 (SS) 3.4.5 (SRD) 3.1.4.6 (FRD)	Target Overload Processing: Automatic Report Decrease	D	N	N	N	(T)	N	When target load exceeds the capacity defined in 3.4.1, the ASR-11 shall have internal processing capable of automatically decreasing the number of reports	1 6		
0644.0	3.5 (SS) 3.5 (SRD) 3.1.6.3 (FRD)	System Monitoring and Control	N	D	N	D	(T)	T	The ASR-11 shall be capable of: a. Local and remote monitoring PSR and SSR parameters required for certification, including receiver sensitivity, transmitted power, and reflected power b. Local and remote control, monitoring, and troubleshooting from Operator Maintenance Terminals (OMTs)	4 5 6 8		

TEST ID #	REQUIREMENTS paragraph ref:	DESCRIPTION	SYSTEM TEST								THRESHOLD MAJOR	COI #	REMARKS
			DT&E		PAT&E		OT&E						
			IP	OS	PAT	SAT	I	O					
0815.1	A.1.1.2 (SS) 3.1.6.2 (FRD)	RMS Operational Concept	N	D	N	D	N	D	T	T	The RMS shall allow the same control and monitoring capability of the ASR-11 system from any OMT or NIMS proxy agent	4 5 6 8	
0645.0	3.5.1 (SS) 3.5.1 (SRD) 3.1.6.4 (FRD)	Control Panels: Identical Hardware and Software Provided	N	I	N	I	N	I	I	I	The ASR-11 shall provide identical control panels and associated software at all ATC sites (TRACON and ATC towers)	8	
0696.1	3.5.3 (SS) 3.5.3 (SRD)	Point of Control: Status Information Display with Control Panel in Control	N	D	N	D	N	D	(T)	N	If an ASR-11 control panel is in control, system status shall be provided to the OMTs and and future NIMS proxy	4 6	
0697.0	3.5.4 (SS) 3.5.4 (SRD)	Surveillance Display: Physical Location	D	D	N	N	N	N	I	I	A surveillance display shall be provided at the radar site to display selected PSR and SSR target reports and weather	4 5 8	

TEST ID #	REQUIREMENTS paragraph ref.	DESCRIPTION	SYSTEM TEST								THRESHOLD MAJOR	COI #	REMARKS
			DT&E		PAT&E			OT&E					
			IP	OS	PAT	SAT	I	O					
0732.0	3.5.5 (SS) 3.5.5 (SRD)	Performance Verification Targets	T	N	N	D	(T)	T			4 5 6 8	The ASR-11 shall provide the following performance monitoring capabilities: a. The following search and beacon RTQC targets are required in accordance with ICD SE007-3: 1. Search Real-Time Quality Control (SRTQC) uncorrelated test target 2. SRTQC correlated test target 3. Beacon Real-Time Quality Control (BRTQC) Test Target b. Provide up to 25 individual MTI reflectors c. Provide a MRSM consisting of redundant ground-based transponders and antennas included as an integral part of the beacon monitoring function at each site, capable of replying to Modes 3/A and C as specified in FAA Order 1010.51A, and permit the introduction of a calibrated variable range delay	
0732.1	3.5.5.a.1 (SS) 3.5.5.a (SRD)	SRTQC Uncorrelated Test Target: Message Generation	T	N	N	D	(T)	T			4 5 6 8	The PSR shall output an internally generated SRTQC uncorrelated once per scan	
0732.2	3.5.5.a.1 (SS) 3.5.5.a (SRD)	SRTQC Uncorrelated Test Target: Message Content	T	N	N	D	(T)	N			4 6	The formatted message shall include position, characteristic and unique (SRTQC) ID information	
0732.3	3.5.5.a.1 (SS) 3.5.5.a (SRD)	SRTQC Uncorrelated Test Target: Positioning	T	N	N	D	(T)	N			4 5 6	The SRTQC range and azimuth position shall be programmable anywhere within the instrumented volume	



TEST ID #	REQUIREMENTS paragraph ref:	DESCRIPTION	SYSTEM TEST								THRESHOLD MAJOR	COI #	REMARKS				
			DT&E		PAT&E		OT&E		IP	OS				PAT	SAT	I	O
			IP	OS	PAT	SAT	PAT	SAT									
0732.4	3.5.5.a.2 (SS) 3.5.5.a (SRD)	SRTQC Correlated Test Target: Message Generation	T	N	N	D	D	(I)	N					The PSR shall pass the uncorrelated RTQC test target through the track process and output a formatted correlated search RTQC message once per scan at the same location but with a unique ID	4 5 6		
0732.5	3.5.5.a.3 (SS) 3.5.5.a (SRD)	BRTQC Test Target: Message Generation	T	N	N	D	D	(I)	T					The MSSR shall output an internally generated BRTQC message once per scan	4 5 6 8		
0732.6	3.5.5.a.3 (SS) 3.5.5.a (SRD)	BRTQC Test Target: Message Content	T	N	D	D	D	(T)	N					The message shall be formatted the same as a beacon report message but with a unique (BRTQC) ID	4 6		
0736.1	3.5.6 (SS) 3.2.2 (FRD)	System Startup/Recovery	AT	N	N	D	D	T	N					The equipments shall assume an operational role within seven minutes of application of power for external temperatures from -5°C to +70° C	6		
0739.0	3.6 (SS) 3.6 (SRD) 3.1.5 (FRD) 3.1.6.2 (FRD)	External Interfaces	N	T	N	T	T	T	N					The ASR-11 shall interface with the following analog and digital interfaces: ARTS IIA, IIE, IIIA, IIIE, DBRUTE, STARS and μEARTS	6	The ASR-11 system shall be designed to provide external interfaces to the following subsystems in accordance with IRDs and ICDs: ARTS IIA, ARTS IIIA, PIDP, STARS, NIMS (SS, SRD - Contract Mod in progress)	

TEST ID #	REQUIREMENTS paragraph ref:	DESCRIPTION	SYSTEM TEST										THRESHOLD MAJOR	COI #	REMARKS		
			DT&E		PAT&E		OT&E		IP	OS	PAT	SAT				I	O
			IP	OS	PAT	SAT	I	O									
0740.0	3.6.1 (SS) 3.6.1 (SRD)	Automation Interface: Output Ports Provided	T	D	N	N	D	T	N						6	The ASR-11 shall provide four digital data ports to provide independent outputs simultaneously in any combination of the formats listed below: a. Modified Common Digitizer (CD-2) as defined in IRD NAS-IR-34120001 (STARS and existing automation systems) b. Digital Surveillance Format as defined in IRD "B" (from SDT) c. ASTERIX as defined in NAS-IRD-34002105 (STARS)	
0741.0	3.6.1 (SS)	Automation Interface: Output Port Expandability	D	N	N	N	(T)	N							6	The ASR-11 shall be capable of being expanded up to 16 digital data ports	
0742.0	3.7.2 (SS) 3.7.2 (SRD) 3.2.3.1 (FRD)	System Inherent Availability (A <sub>i</sub> )	A	N	N	N	T,A	T,A	T,A						4 6	The ASR-11 system shall have an A <sub>i</sub> of 0.99999	0.999 (FRD)
0742.1	3.2.3.3 (FRD)	Mean Time Between Critical Failure (MTBCF)	N	N	N	N	T,A	T,A							4 6	The MTBCF shall be equivalent to a dual channel system having a single channel Mean Time Between Failure (MTBF) of 750 hours and an antenna MTBF of 10,000 hours including Remote Maintenance Monitoring	Not a specification requirement
0748.0	3.7.3 (SS) 3.7.3 (SRD)	Redundancy: Antenna Drive Motors	D	N	N	N	T	N							4 6	Antenna drive motors shall be redundant	
0749.0	3.7.4 (SS) 3.7.4 (SRD) 3.2.3.2 (FRD)	Preventive Maintenance: Mean Time Between Preventative Maintenance Action (MTBPMA)	A	A	N	N	T,A	T,A							4 6	Preventive maintenance shall be required no more than four times each year (equates to an MTBPMA of 2190 hours)	
0751.0	3.7.4 (SS) 3.7.4 (SRD)	Preventive Maintenance: Effect on System Operation	A	D	N	N	(T)	T							4 6	Preventive maintenance shall be done with the ASR-11 in the operational state and without degrading system performance	
0752.0	3.7.5 (SS) 3.7.5 (SRD)	Built-In Test/Fault Isolation (BIT/FI): Implementation	D	N	N	N	T	T							4 6	The ASR-11 shall implement fault detection and isolation functions	

TEST ID #	REQUIREMENTS paragraph ref:	DESCRIPTION	SYSTEM TEST								THRESHOLD MAJOR	COI #	REMARKS
			DT&E		PAT&E		OT&E						
			IP	OS	PAT	SAT	I	O					
0754.0	3.7.5.a (SS) 3.1.6.1 (FRD)	BIT/FI: Performance	T	N	N	N	N	(T)	T	BIT/FI detection rates shall be 90% or greater to an ambiguity group of three LRUs or less using automatic mode	4 6	The ASR-11 shall provide on-line performance monitoring to isolate problems to three LRUs (FRD)	
0761.0	3.7.7 (SS) 3.7.7 (SRD) 3.2.3.4 (FRD)	Mean Time To Repair (MTTR)	T	A	N	N	N	T	T	The system MTTR shall be ≤ 0.5 hours, as tested in accordance with MIL-STD-470B	4 6		
0761.1	3.2.3.5 (FRD)	Mean Time to Restore (MTR)	N	N	N	N	N	T	T	The system MTR shall be ≤ 1 hour	4 6		
0767.0	3.8.4 (SS) 3.8.4 (SRD) 3.3.2 (FRD)	Noise Levels: OSHA Compliance	D	T	N	N	N	(T)	T	Noise levels generated by the system shall be maintained at a level consistent with current OSHA regulations, as specified in CFR Title 29, Part 1910	7		
0771.0	3.8.5 (SS) 3.8.5 (SRD)	Radiation Hazards	T	N	N	N	T	(T)	N	The system shall meet the following radiation requirements: a. X-ray radiation less than 2 milliroentgen per hour at all times in any areas where normal maintenance is performed both inside and outside cabinets b. Electromagnetic radiation will not exceed the permissible exposure limits specified in FAA Order 3910.3A, Paragraph 33	7		
0772.0	3.9 (SS) 3.2.4 (FRD)	Computer Resource Reserve Capacity	A	N	N	N	N	(T)	N	All RAM and nonvolatile memory capacity and processor throughput shall be capable of being upgraded by at least 50% with only minor hardware modifications and software changes	6		
0773.0	3.10 (SS) 3.10 (SRD)	External Transmission Modem Systems: Automation Systems Interfaces	N	D	N	N	D	T	N	For existing automation systems and STARS, the ASR-11 shall provide modem systems to interface with the TRACON, ATC tower, and in some cases ARTCCs	6		

TEST ID #	REQUIREMENTS paragraph ref.	DESCRIPTION	SYSTEM TEST										THRESHOLD MAJOR	COI #	REMARKS
			DT&E		PAT&E			OT&E		I	O				
			IP	OS	PAT	SAT	PAT	SAT							
0774.0	3.10 (SS) 3.10 (SRD)	External Transmission Modem Systems: NIMS Interface	N	T	N	T	N	T	N	T	N	External transmission modem systems for the NIMS interface shall be provided as defined in NIMS-IR-G709906	6		
0775.0	3.12 (SS) 3.12 (SRD)	Site Transition/Switchover: Design and Installation	N	D	N	N	N	T	T	T	T	The ASR-11 system design and installation shall allow for a transition period between the existing system and the new ASR-11 system	4 5 6		
0776.0	3.12 (SS) 3.12 (SRD)	Site Transition/Switchover: Switchover Time	N	T	N	T	(T)	(T)	(T)	(T)	(T)	Transition switchover shall include all required functions necessary to return the site to a fully operational status, and take no longer than 5 minutes to complete	4 5 6		
0905.0	3.3.1 (FRD)	Human-Product Interface	N	N	N	N	N	N	N	N	T	The ASR-11 shall provide human-product interfaces that support operations and maintenance	8		
0906.0	3.3.2 (FRD)	Employee Safety	N	N	N	N	N	N	N	N	T	The ASR-11 system/facility shall be designed in compliance with OSHA and FAA Order 3900	7		