

JPRS-EST-89-029
29 SEPTEMBER 1989

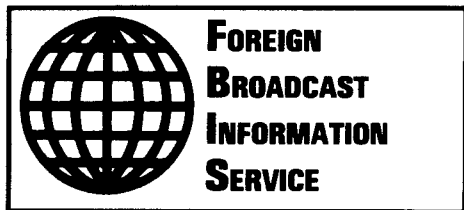

JPRS Report

Science & Technology

Europe

REPRODUCED BY
U.S. DEPARTMENT OF COMMERCE
NATIONAL TECHNICAL INFORMATION SERVICE
SPRINGFIELD, VA. 22161

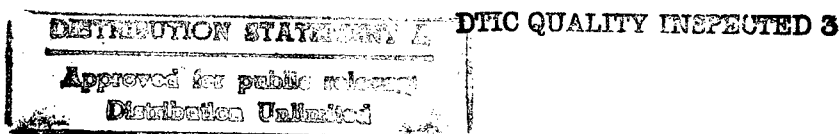

19990106 074

Science & Technology Europe

JPRS-EST-89-029

CONTENTS

29 SEPTEMBER 1989

WEST EUROPE

AEROSPACE, CIVIL AVIATION

Dassault. Aerospatiale Automate Composites Production	1
Design	
[Michel Defaux et al.; Paris L'USINE NOUVELLE (TECHNOLOGIES supplement), May 89]	1
Manufacturing	
[Michel Defaux et al.; Paris L'USINE NOUVELLE (TECHNOLOGIES supplement), May 89]	2
Quality Control [Michel Defaux et al., Paris L'USINE NOUVELLE, May 89]	4
Ariane 5 Vulcain Engine Development Projects	
[Helga L. Hillebrand; Stuttgart FLUG REVUE, Jun 89]	5
Superalloys Developed for Rafale M88 Engine	
[Thierry Lucas; Paris L'USINE NOUVELLE, May 89]	6

DEFENSE INDUSTRIES

France's RIAS Air-Defense Radar System	
[Marc Chabreuil; Paris L'USINE NOUVELLE, May 89]	9

ENERGY

EC Forms Thermie Energy Technology Program [Duesseldorf VDI-NACHRICHTEN, 2 Jun 89]	10
--	----

FACTORY AUTOMATION, ROBOTICS

FRG: CIM Activities Discussed	11
Growth of Specialized Institutions [Duesseldorf VDI-NACHRICHTEN, 9 Jun 89]	11
Technical Training Needs	
[Manfred Ronzheimer; Duesseldorf VDI-NACHRICHTEN, 2 Jun 89]	13

LASERS, SENSORS, OPTICS

FRG Laser Industry Analyzed [Coburg OPTO ELEKTRONIK, May 89]	15
--	----

MICROELECTRONICS

Siemens. Matsushita Found Components Subsidiary	
[Munich SUEDEDEUTSCHE ZEITUNG, 16 Jun 89]	15
Fraunhofer IC Institute Funded [Munich SUEDEDEUTSCHE ZEITUNG, 15 Jun 89]	16

SCIENCE & TECHNOLOGY POLICY

BMFT Reports on University Research Funding	17
University-Institute Cooperation	
[Bonn BUNDESMINISTERIUM FUER FORSCHUNG UND TECHNOLOGIE PRESSEREFERAT, 6 Mar 89]	17
Industry-Science Community Operation	
[Bonn BUNDESMINISTERIUM FUER FORSCHUNG UND TECHNOLOGIE PRESSEREFERAT, 6 Mar 89]	19
USSR-UK Joint Venture To Produce Computer Equipment, Software	
[Ya. Lomko; Moscow SOTSIALISTICHESKAYA INDUSTRIYA, 7 Apr 89]	19

TECHNOLOGY TRANSFER

Italy, USSR Form Computer Automation Joint Ventures	20
Computer Science [Turin MEDIA DUEMILA, Jul-Aug 89]	20
Railroad System Automation [Turin MEDIA DUEMILA, Jul-Aug 89 p 41]	21

EAST EUROPE

BIOTECHNOLOGY

Hungarian Enterprises Formed To Exploit Biomass [Budapest DELTA-IMPULZUS, 17 Jun 89]	22
---	----

COMPUTERS

Robotron Exhibit at Budapest International Fair [Budapest COMPUTERWORLD/SZAMITASTECHNIKA, 17 Jun 89]	23
Hungarian Expert System For Concurrent-Parallel Processes [Katalin Szenes and Peter Forro; Budapest MAGYAR ELEKTRONIKA, No 7, 1989]	23
Foreign Interest in Hungarian Quality Control Program [Andor Dobo Interview; COMPUTERWORLD/SZAMITASTECHNIKA, 29 Jul 89]	25
Hungarian 3D Graphics System Described [Edit Kadar and Janos Balazs; COMPUTERWORLD/SZAMITASTECHNIKA, 5 Aug 89]	27
Computer Exhibits at Budapest International Fair Described [Huba Bruckner et al; COMPUTERWORLD/SZAMITASTECHNIKA, 10 Jun 89]	27

FACTORY AUTOMATION, ROBOTICS

GDR's Programming Package for Robotized Assembly Described [J. Lotzsch, J. von Pistor; East Berlin FERTIGUNGSTECHNIK UND BETRIEB, No 7, 89 pp 395-397]	31
Applications of FMSs Discussed	34
Prismatic Components [M. Boehme, et al.; East Berlin FERTIGUNGSTECHNIK UND BETRIEB, No 6, 1989]	34
Rotationally-Symmetric Workpieces [W. Simon, K. Nothnagel; East Berlin FERTIGUNGSTECHNIK UND BETRIEB, No 6, 1989]	39

TELECOMMUNICATIONS

Hungarian Analog Subscriber Carrier Frequency Telephone Equipment [Peter Galambos; MAGYAR ELEKTRONIKA, No 6, 1989]	43
---	----

AEROSPACE, CIVIL AVIATION

Dassault, Aerospatiale Automate Composites Production

Design

36980263 Paris L'USINE NOUVELLE
(TECHNOLOGIES supplement) in French
May 89 pg 52-55

[Article by Michel Defaux, Thierry Lucas and Michel Vilnat: "Optimizing Design"; first two paragraphs are editorial introduction]

[Text] Following a manual-production phase, the manufacture and quality control of composites is being automated. Design and industrial engineering departments are combining their efforts to devise easy-to-manufacture pieces. Cost reduction and improved quality are the rewards of this investment.

Well-designed and easier-to-manufacture pieces: improved productivity begins in the engineering and design department.

The value of composites in the aeronautics industry needs no further demonstration. Elements made of composites result in a 20 percent gain in mass compared to conventional solutions using light alloys. On a civilian craft like the ATR 42 regional-transport plane, mass is reduced by 100 kg, which translates into a 100-km increase in flying range—a very high number for a craft designed to go short distances.

Making planes lighter is not the only advantage of composites. "A composite helicopter blade is practically impervious to fatigue and corrosion, while the lifespan of an aluminum blade barely exceeds 2,500 to 3,000 hours," points out Jacques Hetzel, head of manufacturing at the helicopters division of Aerospatiale in La Courneuve. Moreover, composites allow the manufacture of complex sections (corkscrew-shapes and pieces of varying thicknesses) practically impossible to make for a reasonable price with metal.

The cost of materials still needs to be lowered: a kilo of aluminum alloy sells for 50 French francs per kilo, a kilo of carbon/epoxy composites 800 francs, and a kilo of carbon/carbons or SiC-SiC's (silicon carbide/silicon carbide) still more. With the proportion of composites used in airplanes on the increase, the problem is a timely one. In civil aeronautics, the blade now accounts for 20 percent of total mass, and is said to represent 24 percent on Dassault's Rafale. On a helicopter like Aerospatiale's Dauphin, it even exceeds 25 percent. For the American Advanced Tactical Fighter it will come to about 45 percent, not to mention the B2 Stealth bomber, for which a figure of 90 percent is advanced! Moreover, production rates are rising continuously and are drawing nearer to mass-production rates. For the first 9 months of 1988, over 12,000 carbon/carbon brake disks rolled off the lines of SEP (European Propellant Company)

workshops in Bordeaux. Aerospatiale celebrated its 100,000th helicopter blade last November, of which 30,000 were made of composites. Likewise, the airplanes division of Aerospatiale in Nantes plans to use 42 metric tons of carbon prepregs and 68 tons of aramids, glass and hybrids in 1990, or an increase of 150 percent over 1988.

Airplane manufacturers, who met this month at the Bourget Show, are all pursuing the same goal: industrializing the use of composites to cut costs and bring production up to assembly-line speed. Several examples in various areas (carbon/carbon brakes, helicopter blades, ATR 72 wing unit) illustrate this course. Christian Beugnet, director of Aerospatiale's Nantes factory, the group's pilot plant for composites, explains: "The present cost of labor for the ATR 72 outer wing unit made entirely of composites is the same as for wing tips of light alloy. But the price gap between composite materials and classical metals still needs to be closed. We should reach that goal by somewhere around the 100th ATR." At La Courneuve, thanks to an automated workshop, the sale price of composite blades is already slightly lower than the sale price of metal blades.

70 Pieces for the Ecureuil Rotor Instead of 377

Optimization of design is fundamental: better design of pieces, and integration of several functions to reduce the number of components, assemblies, and seams. For instance, the ATR longeron is now made of a single piece instead of three light-alloy pieces. More spectacular still is the gain realized on the Ecureuil rotor, an Aerospatiale light helicopter: 377 pieces in the old version have been replaced by only 70 pieces for a 100-percent composite rotor.

To optimize development of composite pieces for the Rafale, Dassault is forming integrated teams which combine personnel of the Saint-Cloud engineering and design department with those in charge of manufacturing methods and production. The pieces are being adapted for industrial manufacture in the Biarritz factory, where components of the Atlantic 2, Falcon 900, Mirage F1 and Mirage 2000 are also manufactured. Gathered around the "drawing board", the design and manufacturing engineers take into account production constraints and necessary investments from the very first design stage. This collaboration makes it possible to cut the aggregate cost of a piece and save time. Likewise, when an airplane project is initiated at Aerospatiale, specialists in the different technologies meet in the Toulouse design and engineering department to design the pieces together. Next, "prototype" groups in the factories work on developing them. These groups, however, stay in touch with the design and engineering department. "It is the only realistic way to proceed," stresses Didier de Wismes, head of industrial engineering at the Nantes plant. "Otherwise, in most cases we would have to reverse course after choices had been made, drawings done, and mass balances calculated . . .

agonizing revisions for a design and engineering department to make! Real-time collaboration allows us to reorient choices as the work progresses."

An example: for draping of composite pieces made from unidirectional sheets (aligned, parallel carbon fibers), a designer may be tempted to ask that the fibers be oriented in exactly the same way the stresses in the piece are distributed. This request would result in a need to deposit fibers in a multitude of different directions, and in a manufacturing process so complex it would be a minor feat to perform. "We agreed with the engineering and design department to lay out the material in only four directions (0 degrees, 90 degrees, and plus or minus 45 degrees), because industrially we can only handle four axes." These steps to optimize the design and development of a simple manufacturing schedule are the product of the V-10 F (carbon-fiber Falcon-10 wing units designed by Aerospatiale and Dassault) and CSPC (composite primary-structure caisson) programs. They produced a wholly composite external wing unit on the ATR 72—a world premiere for that type of craft.

Manufacturing

36980263 Paris *L'USINE NOUVELLE*
(*TECHNOLOGIES* supplement) in French
May 89 pp 56-59

[Article by Michel Defaux, Thierry Lucas and Michel Vilnat: "Facilitating Industrial Manufacture"; first paragraph is editorial introduction]

[Text] Automation boosts productivity, but also quality. Next step: the flexible workshop.

A key point in cutting costs is still the manufacturing process itself. It is a process that must be integrated into the entire chain of CAD programs and best-adapted production equipment. In the Biarritz Dassault factory, the entire production line is connected to the DNC (Direct Numerical Control) network which runs through the shops. The manufacturing-methods department receives from the Saint-Cloud design and engineering department the layer-by-layer specifications of the composite pieces, designed using a specialized module of the Catia CAD software program. The geometry and fiber-orientation of each prepreg layer is described. The work of the industrial engineers then consists of decomposing these layers into widths, verifying that the specifications of the piece are compatible with the capabilities of the draping machine, and optimizing waste losses and manufacturing time. After possible modifications approved by the design and engineering department, the command program can be sent to the machine, via the DNC. This same program authorizes loading of the programs for machining the tools, on which the prepreg sheets will be deposited and stacked.

At Aerospatiale, the Nantes plant has access to the Toulouse design and engineering department's CAD design of pieces. The Paomad (computer-assisted program for draping machine) software program allows the

production and set-up divisions to directly call up the specifications of pieces in the Toulouse computer. This enables them to choose which manufacturing method they will use and to define the tooling equipment and programs for cutting and draping of components. They can thus directly generate the numerical-command orders of the different cutting and draping machines. All that remained to be done was develop the machines. Draping, touchier than cutting, required the design of totally new equipment. This month a numerically-commanded draping machine (an investment of 18 million French francs) will arrive in Nantes. Built by Brisard Machines-Outils (BMO), it was developed as part of the "pilot composites workshop", a program jointly funded by government departments, Dassault, and Aerospatiale. The interest of such a workshop lies mainly in its simplicity. "In cooperation with the manufacturer, we did not try to develop a universal draping machine that would accept complex, undevelopable, deeply embossed forms. We more realistically designed a reliable and competitive machine, limiting its range of use." The pieces to be draped are therefore simple in form.

The engineers began with the idea of separating cutting and draping. This separation results in greater reliability (an out-of-order component does not block the machine) and better performances (mask time cutting, for instance, whereas other machines cut a fold and lay down the layers). These features required the writing of a more complex software program than those used in "classic" draping machines, since coherence between the two tooling outfits' coordinate systems must be ensured. The cutting machine—which works with three carbon-fiber ribbons of different sizes (one way of limiting waste loss)—uses mechanical knives for now. Integration of the water jet is currently being researched, but for now is running up against delicate problems of crowding and miniaturization of components, given that the piping supports a pressure of 3,000 bars. The cut pieces are recovered and stored in a case, which is picked up and then mounted on the head of the draping machine. The exact productivity gains remain confidential. There is talk of a factor of 3 to 5 compared to manual deposit. During trials at Suresnes, in the pilot composite workshop, spectacular results were cited; with prepreps of epoxy carbon/resin fibers on an ATR 42 end wing-unit casing (12 to 72 layers), the waste loss rate was 11 percent, with cutting capacity of 1.4 kg/hr and a deposit capacity of 1.17 kg/hr. For prepreps of the same size, automation of cutting reduced the waste-loss rate by 30 to 40 percent.

The machine has since been improved further: a "Z" compliance system, new carbide knives, and a post-processor integrated with the Paomad. Performance is certainly superior, not to mention the effects on quality. Later, the equipment will control pressures and will deposit in a reproducible way. The effects will be cumulative: the time needed for each phase will be cut while repetitiveness is increased at the same time.

Dassault also considers improvement in quality to be the major advantage of automating draping. "During manual draping, controlling the correct stacking of layers takes up to 20 percent of manufacturing time," comments Claude Picard, head of the new technologies department at the general technical directorate. Moreover, the maximum size of hand-manufactured pieces is one meter. With a draping machine, it is possible to fabricate units several meters in size. "By way of comparison, a Rafale wing-unit panel, which contains a maximum of 173 layers of prepreg, takes 3 weeks of hand-work. Using automated draping, Dassault specialists think they can fabricate a panel in 4 to 5 days. To develop mass production of composite pieces, the Biarritz shop has purchased an Ingersoll machine, which cuts and lays down prepreg for units whose maximum dimensions are 7 by 4 meters.

The machine drapes at a peak speed of 30 m/min. To date, 150 carbon casings for Mirage 2000 elevons have been automatically manufactured. As for the Rafale wing-unit panel, its many local reinforcing pieces (50 percent of the sheets) are hand-deposited and the remainder (85 percent of total weight) placed by the machine. "In an automated process, the initial state of the basic material is of prime importance," stresses Claude Picard. "We are working with suppliers to precisely define the optimal 'pegosity' (more or less adhesive character) of the prepreg, which is linked to the degree of ageing of the resin at the time it is used." In the long run, mass manufacture (notably of the Rafale) will employ several draping machines, which have not yet been selected. For reasons of reliability as much as productivity, each of these machines will be dedicated to a certain type of piece.

To Complete the Automation Process, a Reorganization of Stations and Conveyance

At the Courneuve Aerospatiale site, the constraints are different. Here, instead of large surfaces to drape, there are many elements to assemble: carbon ribbons, nomex, titanium leading edge, glass-fiber reinforcing piece, metal counterbalance weight, and so on. Since the goal was to eliminate buffer stocks and reduce handling, the automated shop was built. All movements are orchestrated by a Solar computer. As a result, the technician is automatically forwarded, without leaving his work station, various blade components via overhead conveyors. Ovens have been eliminated and replaced at each station by self-heating molds, run by microprocessors. Indeed, polymerization is not a simple operation and temperature and pressure levels must be respected to avoid defects, or even outright breakage. The longeron, manufactured simultaneously, is "dressed" in these molds in a carbon fabric which will be the blade's aerodynamic profile. After 8 hours of polymerization, the blades are shipped to quality control, still via overhead conveyors. "Our way of doing things has not changed, but the new way in which stations are organized and their automation has made it possible to cut cycle time by two thirds," Jacques Hetzel says.

Fabrication Time of Brake Disks Cut by Nine-Tenths

The same concern for rationalizing production motivates SEP engineers. At the Bordeaux factory, where carbon/carbon brake disks are produced, new techniques were developed.

Pieces were originally made from carbon fabric impregnated with phenolic resin. Many steps were required: molding of a preform through polymerization, successive carbonizations and impregnations, etc.

It was a long and delicate process which required the material to be handled frequently. Moreover, the risk of flaws was far from negligible. To remedy these problems, the engineers developed a totally new process dubbed Noveltex. Carbon fibers are woven in three dimensions, producing an easy-to-handle stiff preform. The carbon matrix is produced in a single chemical-deposition operation. Methane is injected into a vacuum oven heated to around 1,000 degrees. At this temperature, the gas is pyrolysed and the carbon deposited on the fibers, while the hydrogen is burned outside. The operation is relatively long, but since the ovens are automatically piloted, staff is small. New equipment operates at night under the sole surveillance of the crew of another shop that runs three shifts. Fabrication time was thus cut by 30 percent and the reject rate divided by 5 or 6. But gains are most spectacular in the machining of brake disks. A machining assembly line piloted by numerical control was set up. Instead of changing machines to perform the different machining tasks, all operations are done at the same work station. Moreover, control is integrated into the production line. The disks are weighed after machining, then routed to a painting cabin, also automated. The result: production time has been divided by a factor of 10. SEP has even created a subsidiary (Carbone Industrie) to develop this kind of production. It is a promising market, for Airbuses, Falcon 900's, and even Rafales use these brake disks, not to mention the Formula 1, which consumes more than 2,000 a season.

Nantes engineers consider autoclave time to be one of the remaining bottlenecks. But there is little to be gained here in terms of reducing cycles, unless new resins are found. One exception is the placement of pieces on the autoclave carts, which is still done manually. With automated loading, the number of cycles could drop to three per day.

Other studies deal with data-processing models and expert systems, principally within the framework of Europari (Eureka program). The goal is to simulate the real behavior of the whole piece (number of layers, geometry) and of the tooling equipment (constructed of light alloy 8.50 meters long) in the autoclave. In the long term, this information could be taken into account from the very first stage of CFAO [computer-assisted manufacturing design] design of tooling equipment.

Optimization of Curing Begins with Loading of Autoclave

At Biarritz, four computer-piloted autoclaves are used to manufacture and develop composites used by Dassault. The polymerization cycles are thus precisely controlled and the data recorded to verify that the process conforms to manufacturing norms. One of the autoclaves is dedicated to thermoplastic-matrix composites, which are expected to show better shock resistance.

Optimization of the curing phase of production begins with loading. The large Biarritz autoclave (4 meters in diameter and 8 meters deep) can hold all the composite pieces of a Mirage 2000, or four wing-unit panels of a Rafale, simultaneously. Determination of the curing cycle is based on knowledge of the basic materials and the quantities in question, but also on simulations carried out at the Saint-Cloud Technical Center for New Manufacturing Technologies. These results are rounded out by experimental data on tool-caused heat inertia, which can be massive, and more generally on heat transmission in the autoclave.

Besides automating the different manufacturing stations, optimization depends on studying the environment, that is, piece fluxes, manufacturing steps, automatic handling . . . in short, a flexible workshop. That is the purpose of Aerospatiale's Safir (Computerized and Rationalized Advanced Manufacturing System) project, which should begin production in Nantes in 1991. The operation will be based on a local management system which will optimize use of each of the stations, autoclaves (automatic loading and unloading), and control devices (automatic feeding of pieces). The flexible composite workshop will be organized around a transfer/storage warehouse which will house 450 to 500 empty tooling outfits, or later, outfits with pieces. It will be linked to the different work stations, from which operators will request a tool, material, or machine program depending on the command to be processed. The tools, transported by wire-guided carts with 4 guide wheels, will feed the draping machines (two machines in 3 or 4 years) and the automatically loaded autoclaves (one 2.60 by 13 meters long, one 2 by 3 meters long, and a large one, 13 by 4.60 meters, in 1990). "We are going to copy the world of the tool-machine, that is, use piece-loaded pallets and group them by family." After manufacture, distribution of voluminous pieces like wing-unit caissons (68 kg and 8 meters long) will be handled by air-transport systems for shipment to quality-control stations (four Siam systems are planned.) One of the acknowledged ambitions is to optimize the floor space of the air-conditioned shops: with prepregs, it is vital to work at constant temperature and hygrometry (20 degrees C and 50-percent, plus or minus 5 percent, humidity) to fully control quality and reproducibility. This regulated atmosphere (regulating humidity is not simple) necessary for the raw material costs a great deal. From the total investment of 68 million French francs, management expects a 15 to 20 percent gain in production costs.

■Box p 59■ Composites Are Easily Repaired

Contrary to certain popular misconceptions, composites can be repaired, and often much more easily than metal pieces. Though wing-unit components are almost totally resistant to fatigue, they do sometimes suffer shocks, usually on the ground but also in flight (impact of birds or various projectiles in the case of military planes). To solve these problems, Aerospatiale in La Courneuve has built a repair shop, while its Nantes factory developed a composites training center for its customers (ATR and Airbus) in 1987.

For helicopter blades, the first step consists of removing the paint. This is done by an automatic sanding machine that uses plastic microbearings. Two cameras inspect the piece. They stop the "blasting" when the coat of paint is gone (the laminate must remain intact). After localizing the flaws, the deteriorated fabric is hand-removed, layer by layer, taking care to form a staircase that will be used to affix the replacement layers (a numerically-commanded miller is being tested to do this). Once the internal structure (Nomex, polyurethane foam, etc.) is replaced, the skin is reconstituted using carbon, Kevlar or glass fiber before placing the blade in a self-heating mold whose pressure and temperature are monitored by a microprocessor. After sanding, the blade is inspected using holography. Complete repair, including testing, takes 4 months. The technology used is identical for work on commercial planes, the only difference being that the planes must be repaired wherever they are. To do this, Aerospatiale has put together portable repair kits (machining, polymerization and inspection). After 40 hours of training (including 12 of theory), trainees are capable of doing different kinds of repairs (glass, Kevlar and carbon).

Quality Control

36980263 Paris L'USINE NOUVELLE in French
May 89 pp 61-62

[Article by Michel Defaux, Thierry Lucas and Michel Vilnat: "Automating Quality Control"; first sentence is editorial introduction]

[Text] Holography and ultrasound are speeding up this operation, with excellent reliability.

Quality control that is 100-percent effective is the golden rule for guaranteeing the safety of structural pieces. Naturally, composites are no exception. Their specific nature, however, raises a certain number of problems, as Serge Hollinger, in charge of quality assurance at SEP (European Propulsion Co.) explains: "Composite materials by nature are heterogeneous and always show discontinuities. Those that are anomalies must therefore be pinpointed." It is useless, for instance, to place a test piece in an oven; it only tells you about that particular piece!

In the inspection of composite materials, the most sophisticated methods are often still used side by side

with manual techniques. Just like the trainmen of bygone days who "sounded" the wheels of cars before departure, inspectors lightly tap structures with metal objects. If impregnation is not good, the piece rings "hollow." This method is still used for certain helicopter blades that are complex in structure or in which metal is combined with various composites. Such practices do not favor industrial manufacture. More generally, quality control is often considered a bottleneck by specialists. To remedy the situation, engineers have developed original methods, as in the Aerospatiale factory at La Courneuve.

A cabin placed at the end of a production line is equipped with a laser interferometer that works in green light. The set-up makes a hologram of the blade to be inspected, then another of the same piece in which a depression was made (10 millibars is enough). Structural heterogeneities are shown through the creation of interference fringes that locate the flaws. This method is rapid and reliable (a total of 30 minutes). However, it requires the presence of an inspector to interpret the hologram. According to quality-control managers, fewer than 1 percent of the blades show anomalies.

Researchers at Nantes sought to reduce this inspection time. Aerospatiale specialists combined seven ultrasound sensors on a structure that scanned the entire surface of an ATR 72 panel in one sweep. Whereas it took almost a week to manually verify a unit of this kind, the time is cut to one-fourth using the sensor grid. Measurements are interpreted by Siam (Microprocessor-assisted Ultrasound Inspection System), which integrates the data of the design and engineering department with the mapping of the pieces. We now have standard deviations in real time.

An Expert System Analyzes Results in Four Minutes

The same course is being followed by the manufacturer of the Rafale, who is implementing two automated ultrasound-inspection methods. The first begins by submerging the piece in a basin. The transmitter and receiver simultaneously scan the component to be inspected, and the signal is captured after double transmission by a reflector placed at the bottom of the tank. The entire surface of a planar piece, an elevon for instance, can be inspected in this way at the rate of one point every 3 mm.

For pieces whose geometry is more complex, a water jet is used for couplage with the transmitter. The ultrasound signal is then analyzed on the other side of the material, following simple transmission. These methods make it possible to detect porosity and delamination flaws and to evaluate their size by interpreting the attenuation of the ultrasound wave. A complementary manual system, operating this time by reflection, allows the position of a flaw to be located precisely in the [material's] thickness, by analyzing the propagation time of the echo. To facilitate the engineers' work, a computerized image-processing system establishes, based on measurement

results, a map of the piece, whose coloring varies with the degree of attenuation. The operator must then compare these data with the tolerance curves which he has, an operation that can be relatively time-consuming. That is why inspection specialists have developed, in collaboration with the Grenoble company Itmi, an expert system for analyzing results. The system identifies the dubious areas of an elevon in 4 minutes, instead of 20 "by hand." It detects the parts that fall outside tolerance limits and interprets results using the know-how supplied by the specialists. With a knowledge bank and rules bank for each type of piece, expert systems will be important elements in mass-production lines.

Ultrasound inspection techniques currently present a problem. It is essential that there be liquid between the piece and the ultrasound transmitter. Tomorrow, however, this will probably no longer be the case. A small American company has developed an ultrasound inspection system which functions in air. The Bordeaux SEP is interested in this technique. It is certainly not alone.

Ariane 5 Vulcain Engine Development Projects

*36980259b Stuttgart FLUG REVUE in German
Jun 89 p 27*

[Article by Helga L. Hillebrand: "New Materials for Ariane 5 Engine"]

[Text] Although Messerschmitt-Boelkow-Blohm (MBB) has been working on the Vulcain engine for the Ariane 5 since early 1988, only now has an official agreement been signed between the French prime contractor, SEP (Societe europeenne de propulsion), and MBB's communications systems and engines division. This agreement regulates their development and production cooperation for the period between 1 January 1988 and 31 December 1994. MBB will act as subcontractor in this project with responsibility for the Vulcain thrust chamber; this will be worth DM 245.8 million. Besides development and production, this also includes the tests for the Ariane 5 engine, which is to fly in 1995.

Work on Ceramic Thrust Nozzles

MBB is far from the only German contractor in this program. Some 30 medium-sized firms have obtained slices from this large pie. MBB itself has awarded subcontracts to MAN in Munich and Volvo in Sweden.

Prime contractor SEP in Vernon, a subsidiary of France's SNECMA, is working at top speed. At the SEP plant, not far from the PF52 test stand, which was built to test the Ariane 5 engine's turbopumps, another unit is currently under construction for tests of the entire Vulcain engine. Two further facilities for component tests have long been in use. The new final test facility must be ready by spring 1990 because tests of the entire engine start then.

SEP says that in principle its European partners already possess the technological know-how to build the Vulcain

engine. However, there are certainly a few areas where further research could lead to further improvements. SEP hopes to achieve much from the use of better, state-of-the-art materials. Scientists intend to focus their attention on this in particular.

This contrasts with the Japanese thinking about the engine for their H-II rocket. They hope to produce systemic improvements, i.e. in basic design, in construction. Although they appear to have some interesting ideas, SEP's designers feel that they can achieve equally good weight savings through the use of new materials but at considerably less risk—and they will also save some time, which could in turn lead to cost savings.

One example is the thrust nozzle. It may be possible to produce a ceramic nozzle. This would eliminate complicated cooling mechanisms and the countless very fine cooling pipes in the walls. There would no longer be any need for active cooling; the liquid hydrogen used for that in the past could be used much more productively as fuel. The entire element would be lighter. In addition a ceramic nozzle could stand higher temperatures and thus produce greater combustion and general efficiency.

The SEP also has high hopes for new developments in composites. Just through 1990 the firm will obtain 100 million French francs from the European Space Agency, ESA, for research into new rocket engines. With respect to fiber laminate research, for instance, a superb new exit cone for the HM7 engine (stage 3 of the Ariane 4) is now being developed from laminates for test purposes. This alone could save 70 kilograms, increasing payload by that amount.

First Component Tests Successful

The partners in the Vulcain program are now conducting tests of components. In Ottobrunn, for instance, the Ariane 5 turbopump is being tested. Early this year, on 28 February, SEP finally defined the general long-term direction of its cooperation with MBB in a general agreement. This officially ratified the earlier contracts. SEP has also signed similar agreements with other firms from Germany (such as MTU) and Europe. After all, some 50 percent of the SEP's space contracts go to European partners.

Superalloys Developed for Rafale M88 Engine

36980260b Paris L'USINE NOUVELLE
(TECHNOLOGIES supplement) in French
May 89 pp 68-72

[Article by Thierry Lucas: "School of Mines: The Crucible of Superalloys"]

[Text] **High-temperature resistance, durability: aircraft engines must be able to withstand shocks. The Materials Center of the School of Mines has developed superalloys (N18 and AM1) for the turbine blade and disks of the**

M88, the latest of SNECMA's ■National Company for Aircraft Engine Study and Manufacturing■ turbojet engines.

After one year on the test bench, the M88, SNECMA's new engine designed for the future Rafale combat aircraft will undergo its first flight tests early in 1990. Inside the turbine, the gas intake temperature (the decisive parameter as far as engine performance is concerned) will reach 1600°C. This will be tough on the materials used for critical parts, turbine disks and blades, which must also withstand high mechanical stresses. To achieve this leap (several tens of degrees) in the operating temperature, while ensuring adequate strength and durability, new high-performance alloys had to be devised. That long and difficult task was entrusted some 10 years ago to the Materials Center of the School of Mines working in collaboration with ONERA and Imphy.

Housed for over 20 years at the SNECMA laboratory in Evry, the Materials Center has not forgotten its initial purpose: training. In fact, 25 "regular" researchers are training and supervising some 50 "thesis-writing" graduate students, and a large proportion of the scientific staff of the center is involved in teaching. Research is financed 50 percent through industrial contracts; not surprisingly, half of these are related to the aeronautics and space sectors. The total 1988 budget amounted to Fr40 million.

Strongly geared to structural materials, the School of Mines Center obviously includes teams specialized in high-performance composites and ceramics. As for the development of new aeronautical superalloys, "it involves all the usual stages in the design of a new material," Jean-Pierre Trottier, director of the Evry Center, pointed out. Preparation of the alloys, observation of their microstructure, mechanical tests, numeric simulations of their behavior: all these complementary approaches have required several teams of researchers to work on the engine of the 1990's.

Two Ni-base superalloy grades have now been selected. The AM1 for turbine blades, and the N18 for turbine disks. The industrialization of these two new materials has now reached its final stage, under the responsibility of Imphy (N18) and SNECMA (AM1). But to reach this stage extensive basic research was required.

The general specifications set by SNECMA mentioned, of course, the performance characteristics that had to be achieved; but they also included preliminary choices. For instance, the alloy destined for turbine disks had to be suitable for operation at 650°C, and it had to be obtained by powder metallurgy, a process which limits the extent of segregation in alloys having a complex composition. The other half of the specifications dealt with turbine blades: obtained by monocrystalline solidification, they had to withstand the highest temperatures in the engine. Actually, monocrystals have a much better creep strength, as they contain no grain boundaries. SNECMA owed it to itself to demonstrate its expertise in

these two manufacturing techniques, both of which were initially introduced by the engine manufacturer Pratt & Whitney.

A Decisive Criterion for Turbine Disks: Damage Tolerance

The criteria used in selecting alloy compositions are directly related to the risks of damage to the parts. "The major damage that can occur inside a turbine is the splitting of the disk," Luc Remy, head of the microstructure and mechanical-properties research team at the Materials Center, explained. Indeed, in flight, the disk is subject to a centrifugal stress and to temperatures ranging from 400 to 650°C. In addition, the repetition of start-and-stop cycles causes fatigue in the material and microcrack propagation. The formation of microcracks is triggered by porosities or debris of a size similar to that of the powder grains used (50 to 80 microns). To counteract this major risk, tolerance to damage became the decisive criterion in selecting the N18 alloy. In practice, this means that crack propagation must be slow enough to guarantee the disk integrity between scheduled overhauls.

The second risk of engine damage is the rupture of turbine blades: several such ruptures can occur in succession. The blades are attached to the disk circumference and the centrifugal force they must withstand can be as high as 50,000 times their own weight! For high-temperature operation, therefore, a turbine blade must have a high creep strength. In addition, as the engine speed varies, large temperature differentials may occur between different points of the part. "These thermal fatigue phenomena are emphasized by the presence of internal cooling channels and become the limiting factor in the blade service life," Luc Remy indicated.

To develop these two new materials, researchers at the Center obviously started with the best commercially available grades. These are Ni-base superalloys consisting of about 10 elements. These alloys contain heat-resistant metals (tungsten, molybdenum, tantalum, etc.) and are hardened by precipitation of a set Ni₃(Al/Ti)-type gamma phase in the solid-solution gamma matrix.

The N18 alloy designed to make disks started with Astroloy. Astroloy provided a good trade-off between tensile strength and resistance to damage, which requires more ductility. The alloy composition was thus modified to improve both characteristics. Using mechanical tests involving parameters such as the time to creep rupture and the number of cycles required for crack propagation at a given temperature and stress level, it was possible to optimize the proportions of the various elements. The effect of molybdenum, cobalt and chromium on the strengthening of the gamma matrix was studied systematically.

Minor elements (under 1 percent) such as carbon, boron, zirconium and hafnium, which alter properties at grain boundaries, were added in proportions suitable to

improve creep strength. The relations between the alloy microstructure and its mechanical characteristics were also researched. For instance, the amount of gamma prime precipitates (Ni₃(Al/Ti)), which are used to prevent the movement of dislocations within the crystal lattice, was set at 55 percent instead of 47 percent in Astroloy. That proportion will increase the strength of the material while retaining adequate ductility for defect tolerance. Finally, the fabrication process adopted—hot extrusion of the compacted powder and isothermal forging (at 1100°C)—made it possible to control the alloy grain size (a fine-grain structure, in particular, makes ultrasonic testing of the parts easier).

Parameter Optimization Through Computer Simulation

Finally, the N18 alloy has the advantage of a high yield point at up to 700°C, and a crack propagation velocity two to three times smaller than with Astroloy. To research the forgeability of the new alloy, computer simulation was used to optimize the implementation parameters (temperature, deformation rate, intermediate stages, etc.) so as to obtain the desired characteristics under conditions suitable for industrial application. Using the Forge-2 software developed by the Materials Shaping Center (CEMEF)—another site of the School of Mines, located in Sophia-Antipolis—simulation studies were made, first with Astroloy, then directly with the N18 alloy. Based on experimental results (deformation rate, temperature map) obtained from simple test specimens, and on rheological parameters, Forge-2 computes the variations of the part's shape, the temperature of all points, the stresses placed on the tools, and even the microstructure of the forged alloy.

The development of the AM1 alloy, designed to make monocrystalline turbine blades, also benefited from numeric simulation. In this case, the part dimensions were determined by the computer, in order to minimize the need for time-consuming and costly manufacturing tests.

The computing inputs were the rotational speed and temperature range, i.e. the actual operating conditions of turbine blades in an engine. The outputs were the stresses and deformations in all points of the part; together with a rupture model, these should make it possible to compute the part service life.

"The original feature of these computations," Georges Cailletaud, head of the numeric-simulation team, indicated, "is that they take into account the micromechanical characteristics of the material. The monocrystal is anisotropic, and therefore quite sensitive to stress orientation, so that we must modelize the various sliding planes of the alloy."

Computer-controlled anisothermal fatigue tests, producing simultaneous stress and temperature cycles, were also used to test and validate these models. As with the N18 alloy, the initial research consisted in defining a composition that would achieve the goals set in the specifications. "There were two difficulties," Jean-Louis

Strudel, head of the high-temperature deformation and creep team, explained. "Starting with commercial alloys, we had to optimize creep strength while providing good monocrystalline solidification characteristics."

The key factor in the composition arrived at is the addition of tantalum (8 percent) which has a dual effect in hardening the alloy. In fact, this heat-resistant metal will harden both the solid gamma solution and the gamma prime precipitates scattered within the matrix. The optimum proportion of gamma prime phase was set at 65 percent by volume: the alloy proper accounts therefore for less than half of the material... As there are no grain boundaries, minor elements such as carbon and boron were kept at levels below 100 ppm.

The Range of Application of These Alloys Will Certainly Increase

Using samples only one tenth of a micron thick, but representative in the case of a monocrystal, Jean-Louis Strudel's team studied the correlations between the metallurgical structures observed under the electronic microscope (precipitates, dislocations, etc.) and the results obtained during creep tests. One of the predominant factors thus discovered was that, during creep, precipitates will gather to form small plates perpendicular to the direction of stress. This phenomenon effectively hinders the movement of dislocations inside the crystal.

"Defined for 20 years," SNECMA's two new alloys will certainly be improved over the years. Also, their application range will increase: initially developed for military applications directly related to the M88 project, a material like the N18 alloy could readily be used in a civil engine; for instance it could appreciably increase its service life.

As for possible (composite or ceramic) substitution materials, engine requirements are so numerous that it will still be a long time before these materials are used for critical parts. "But much remains to be done with the new alloys," Jean-Pierre Trottier pointed out. "Significant progress should be expected mostly from a more thorough understanding of anisotropy and thermal-fatigue behavior."

■Box, p 72■

From the Laboratory to Series Production

New materials will require new industrial processes. Whether in fabricating turbine disks by powder metallurgy or turbine blades by monocrystalline solidification, there was no lack of difficulties. The production of an N18-alloy turbine disk starts with the preparation of the powder, which is Imphy's responsibility. The cast alloy is sprayed into droplets by an inert gas. The powder is compacted by extrusion. Then, the alloy is shaped by forging at about 1100°C. The development of each

process stage was helped by a complete pilot unit installed at SNECMA's Gennevilliers plant. The process was first optimized for Astroloy, serving as a reference material, and later refined for the N18 alloy as soon as its composition had been set. Vital problems that had to be solved included cleanliness. A traditional problem in powder metallurgy, the presence of inclusions is a disaster in this case, as it is directly related to the disk strength. That is why powders are manufactured in clean rooms, and the permissible proportion of inclusions is less than 0.1 ppm. For the time being, as Europe lacks the required equipment, full-scale manufacturing of the disks is subcontracted in the United States, under Imphy's responsibility. A "European" solution is being considered, but the press it requires represents an investment of over Fr100 million. On the other hand, the thermal-gradient oven required to manufacture monocrystalline turbine blades costs only about Fr10 million. A pilot and production ovens are installed at Gennevilliers, where very sophisticated casting techniques are used. The key problem is to control the advance of the solidification front and to prevent any deviation from the monocrystalline state. The complex shape of turbine blades makes this still more difficult. And the axis of the part must be aligned with a preferred crystallographic orientation... Finally, as monocrystalline solidification requires slow casting, problems related to the strength of the mold and its reacting with the alloy required the development of special tools. Several thousands of experimental blades were manufactured, and the AM1 alloy is already used on the M88 engines currently being developed.

A Subtle Balance

Composition of the Superalloys Used in the M88 Engine (Percent)

	AM1 (1)	N18 (2)
Nickel	app. 59.3	app. 57
Cobalt	6.5	15.7
Chromium	7.5	11.5
Molybdenum	2	6.5
Tungsten	5.5	-
Tantalum	8	-
Aluminum	-	4.35
Titanium	1.2	4.35
Hafnium	-	0.5
Zirconium	-	0.03
Carbon	< 100 ppm	0.015
Boron	< 100 ppm	0.015

(1) Monocrystalline turbine blades.

(2) Turbine disks obtained by powder metallurgy.

DEFENSE INDUSTRIES

France's RIAS Air-Defense Radar System

36980260a Paris L'USINE NOUVELLE
(TECHNOLOGIES supplement) in French
May 89 pp 64-68

[Article by Marc Chabreuil: "A Radar to Detect 'Invisible' Aircraft"]

[Text] The secrets of the RIAS ■ Synthetic Pulse and Antenna Radar ■ designed by ONERA ■ National Office for Aerospace Studies and Research ■ in collaboration with Thomson-CSF have less to do with its technology than with its computing power. Using HV and VHF waves and tens of fixed antennas, it processes several billion operations per second with two processors. Exploratory development is about to begin.

The technological race between aircraft and radar designers has been escalating for years. Stealth has become their obsession. In other words, the famous "invisible" aircraft. A few months ago, with quite Hollywood-like staging, the Pentagon unveiled its future "discreet" B-2 bomber. Practically at the same time, in secret, Thomson-CSF and ONERA technicians were completing their tests on a RIAS mock-up, in the garage of Ile du Levant, at the Mediterranean Testing Center [CEM]. This revolutionary system could well nullify the efforts of aircraft designers with respect to radar stealth. After considering the results obtained, the Technical Department for Telecommunications and Aeronautical Equipment (STTE) expressed its intention to go on to a more industrial stage. By the end of the year, it should have ordered the construction of an operational demonstration unit that would better reflect the potential of the RIAS. This exploratory development, scheduled to last 4 years and to cost a little over Fr100 million, will probably be entrusted to Thomson-CSF.

Mistakenly called invisible, these new-generation aircraft are undeniably far more discreet than their predecessors: they emit much less radioelectric and infrared waves and they absorb part of the radar radiation or reflect it in another direction.... Still, whatever information on these aircraft filters through is, to say the least, biased. When the U.S. Department of Defense states that its F-117 fighter and its B-2 bomber are no more visible to a radar operator than a raven or a sparrow, when it maintains that they have "radar cross-sections" of 0.01 and 0.001 m²... it is probably right. But only for a given attitude and especially a given radar transmission frequency. That is because the radar cross-section (a mathematical quantity used to determine the power received by a radar illuminating a target) is a function of the wavelength. "Now, we know how to decrease the radar cross-section, and therefore the visibility, of an aircraft or a missile illuminated by a 'traditional' radar transmitting between 8 and 18 GHz; but the problem is much more complex at 'low' frequencies. That's the weak spot!

Currently, there is no way to confer stealth to an aircraft caught in the beam of an HF (40 MHz) or VHF (40-300 MHz) radar, i.e. operating in the metric-wave range. At these wavelengths, which are in resonance with the dimensions of the airframe, aircraft designers are still helpless," we were told by Gerard Garnier, assistant director of general studies at ONERA. This ONERA division has been working on aircraft stealth since 1975. And more recently on the Rafale stealth, as the aircraft was deemed somewhat too "visible."

Emphasis on Signal Processing

For at least a few more years, we seem to have the answer to stealth aircraft. Future radars, at least some of them, will transmit in the HF/VHF range. The RIAS will, and it increases appreciably the radar cross-section of an aircraft. By how much, we do not know. The results are classified. But to achieve this, an entirely new concept had to be developed. Mathematically, the decrease in frequency, resulting in a deterioration of angular resolution, must be offset by an increase in the antenna diameter, i.e. an increase in the number of antenna elements. However, instead of emphasizing the mechanical and radioelectric "perfection" of a single aerial, ONERA researchers relied on radar signal processing; and they placed minimum demands on the hardware. The result is surprising, to say the least. The RIAS set up at the CEM consists of 50 aerials which look like telegraph poles and are distributed along the circumference of a circle 400 m in diameter (such a network is characterized by the perimeter of its "pupil"). Of these poles, 25 are receivers. The remainder are illuminate the sky uniformly, they operate permanently on different frequencies (the spectrum transmitted is scattered among all transmitters). All these elements use a most traditional technology: HF tubes. Actually, most of the RIAS performance characteristics are due to its focusing (using the method called "computed beam generation") and to the processing of the signals backscattered by the target.

Considerable computing power and precision are required: each zone in the area observed must be separated and subject to specific processing; this involves distance, bearing, elevation, radial-velocity and target-acceleration measurements. "We must take into account all the signals received by all the receivers, which are all located at different distances from the target," Michel Carpentier, scientific and technical director at Thomson-CSF, indicated. For many years, the lack of electronic components powerful enough was a stumbling block for this technology, which was devised in 1976 by Jacques Dorey, now director of general studies. What was needed was a dedicated non-programmable system, faster and more powerful than present supercomputers. At first, an analog optical processor was developed. But it allowed only for off-line processing. Then, with the progress of electronics, two parallel-architecture digital pipeline processors were developed (it is this architecture that provides for high-speed computing, as the internal clock

operates at "only" 8 MHz). With these processors, real-time computing becomes possible. The first one, designed for surveillance missions, was developed at Thomson-CSF by a five-engineer team headed by Gerard Auvray. Using VLSI technologies and tested in 1988, it can compute at the rate of 1.2 billion floating-point operations per second (1.2 Gflops). The second one, designed for tracking, was developed at ONERA; tested last January, it is simpler and more powerful (equivalent to 3.2 Gflops) but does not lend itself as well to extrapolations. "The processor selected for the demonstration unit will certainly be a synthesis of the two. But, as the facility is more complex and performance characteristics have been improved (surveillance of the whole angular sector), its computing power will have to be multiplied at least by 20," Gerard Garnier disclosed.

The demonstration unit, the development of which will require Thomson-CSF to set up a team of about 50, will probably be installed at an air base. It will include at least 25 receivers and probably more transmitters, with power ratings in the 10-100 kW range. It will foreshadow the operational RIAS which would consist of about 100 aerials distributed along a circle 1 km in diameter (providing coverage of about 450 km). Other architectures, however, could be devised, as this radar provides a coding of space: it sends a different message in every direction. The target then retransmits the (coded) message corresponding to the zone in which it finds itself. Any receiver, no matter where it is located, can localize it. "Actually, to get maximum benefit from the RIAS, it should be installed over a still larger area. Ideally, we should install one transmitter and one receiver at each triangulation point in France, on the roof of each town hall, each church, etc. This would require inconceivable computing power, inconceivable at least for the next 50 years." Michel Carpentier predicted.

Costing no more than traditional systems, RIAS-type radars could deal the death blow to the ruinous stealth aircraft. The B-2 project, which is now said to have been delayed by 2 years, is estimated to cost Fr360 billion. And an F-117 fighter would cost six times as much as an F-15! But some have hinted that the objective of "stealth" aircraft is essentially to force the "enemy" to spend billions to alter its surveillance radar network. At any rate, the RIAS—which for the time being seems to be without equivalent (the Americans are said to work on a similar project, but no results have been published)—will lead to other types of equipment. Already, the Nostradamus, the "trans-horizon radar" developed by ONERA with the cooperation of LETI [Laboratory for Electronics and Data Processing Technologies], is the result of a similar approach. Made up of 200 elements (an 800-m span network) and operating in the decametric-wave range, it aims at detection ranges of over 1,000 km. In the next few months, it, too, could lead to the launching of an exploratory development program. And ONERA, which (like Thomson-CSF) will continue to use the Ile-du-Levant mockup and to develop an optical processor, is already devising other applications... but they are still top secret.

■Box, p 65■ Seven Additional Assets

In addition to increasing the radar cross-section of aircraft and missiles, which will thus become far less discreet, the RIAS radar also offers the following advantages: —Increased reliability, as there are no moving mechanical parts; —Easier maintenance: transmitters and receivers are all identical and based on traditional technologies; —Low vulnerability: the widely scattered aerials are redundant; the signal processors can be moved elsewhere or buried; —Inoperative countermeasures: on-board HF jammers cannot be very powerful, as they would jam the avionics; —Easier interception: the target does not know whether the RIAS is in the surveillance or in the tracking mode (it is "on" at all times) and cannot tell whether it has been spotted or not; in addition, the interceptor equipped with a receiver does not have to turn on its tracking radar; —Low-altitude visibility: VHF waves propagate better above ground than higher frequencies; —Possibility of tracking several targets simultaneously.

■Box, p 67■ Proof Through Experiment

Theoretical computations (finite-element method, geometric theory of diffusion, optics, physics, etc.) offer only a limited potential when it comes to stealth. According to ONERA experts, experimenting is the only efficient way to compute and reduce the radar cross-section of an aircraft or missile. To do this, ONERA has acquired impressive measurement facilities. For instance, at Chalais-Meudon, a wind-tunnel big enough to accommodate a full-scale Mirage III was fitted into a "holographic base." The rotating aircraft (1 rpm) is illuminated by a radar beam at frequencies of 2-18 GHz, 35 GHz and 94 GHz. The echoes are measured frequency by frequency, yielding a two-dimensional map of the "shiny points" (reflective areas) of the target. Resolutions as high as 7.5 cm have been achieved, and the sensitivity of the radar cross-section measurement is 0.005 m². Identical measurements can be made on aircraft in flight, using the Brahms mobile station (lengthwise tomography with a 15-cm resolution, or real-time computation of the aircraft radar cross-section). The Brahms station was sent to Istres for a diagnostic of the Rafale.

ENERGY

EC Forms Thermie Energy Technology Program

36980258a Duesseldorf VDI NACHRICHTEN
in German 2 Jun 89 p 25

[Article by M.P.: "'Thermie' Aims To Close Gap Between Demonstration and Market. New EC Support Program for Energy Technology"]

[Text] Energy policy and technology are as much a part of the European internal market as is the elimination of customs barriers. Of course, removing border signs will be an easy task in comparison with creating an EC energy

market. The EC Commission has therefore worked out a new program named Thermie to promote energy technologies.

The EC's demonstration and hydrocarbon programs expire at the end of this year and are to be replaced by Thermie. The main reason the EC feels the need to act is that the energy situation is still ticklish. Almost half of EC energy needs are met by imports, with the EC depending on supplies from third countries for 70 percent of its petroleum needs. Environmental requirements limit the use of coal. Growing public opposition creates a sense of uncertainty about the use of nuclear energy.

Autarky and diversification of energy sources are the most important goals of the new program. The EC Commission intends to support technologies to improve energy efficiency because energy savings also reduce dependence on imports.

The Thermie program will include efficient use, new energy sources, the clean use of coal, and the exploration and opening up of oil and gas reserves. The commission will focus on two points. It intends to support innovative projects that show what new technologies can be used on a large scale, while transfer and dissemination projects are to help new processes once they have been proven.

This marks the difference between the old and new energy programs. The commission wants "to overcome the current inhibition threshold between the successful demonstration and market application of new technologies." These new technologies must go beyond demonstration to produce "a tangible effect on the community's energy situation." "Thus demonstration alone may well not be sufficient to secure an adequate and effective market response," says an expert's report cited by the commission.

In order to achieve its goal, the commission will have to reach deeper into its pocket. For the 5 years 1990-94 it plans to allocate ECU 700 million (ECU 1 is about DM 2.10). Current programs will cost Brussels ECU 125 million between 1986 and the end of this year.

The commission wants to give priority to small and medium-sized firms in its project grants. It says the projects with the best chance will be those where at least two independent firms from two EC states cooperate. The final version of Thermie is to be decided on in the fall.

FACTORY AUTOMATION, ROBOTICS

FRG: CIM Activities Discussed

Growth of Specialized Institutions

36980259a Duesseldorf VDI-NACHRICHTEN
in German 9 Jun 89 p 30

[Article by Dr Eng Hubert Schmid: "CIM Center Multiplies Benefits of Practical Experience. Computer Integrated Manufacturing Does Not Happen by Itself"; first paragraph is VDI-NACHRICHTEN introduction]

[Text] CIM, CIM, CIM... centers of competence set up by large computer manufacturers, technology transfer centers at universities, advisory centers and factories—hardly a week goes by when we do not receive new information about a new organization. How do they differ? Who is behind them? What do they have to offer? Dr Eng Hubert Schmid, head of CIM-Center Nordrhein-Westfalen GmbH, reports below, based on his experience.

Not so long ago at well-attended lectures and industrial fairs one encountered scenarios about what the factory of the future would look like once the technical groundwork for computer-integrated production had been laid.

However, it was soon discovered that a great deal still was not feasible. As a communications standard, MAP was and still is wishful thinking for the future. Interfaces between systems have to be worked out one by one in tedious, detail.

The necessary infrastructure investments far exceeded what industry was accustomed to. The training of personnel at all levels was inadequate for the ambitious plans.

In addition, there is an urgent need for vital specialists as well as for engineers with experience in "thinking in systems."

Now it is no longer just a few large firms that are having to deal with this. Virtually every medium-sized business finds itself compelled to think about integrating computer applications. Medium-sized firms in particular often lack the necessary prerequisites for this.

During this phase, which has already lowered expectations in many firms, there have been various reports about the possibility of public subsidies for CIM projects.

In order to strengthen the competitiveness of industry in Europe and in the Federal Republic of Germany, authorities have developed plans to support CIM activities. At the European level, for instance, we should mention the CIM projects included in the Esprit Program. The FRG government has undertaken various initiatives with its "Production Technology Program."

These include aid to CIM users in the form of indirect-specific subsidies. DM 300 million is being allocated for this; given the maximum subsidy of 40 percent, this means that projects worth at least DM 750 million are being started up.

Since this program was announced, very many firms have requested subsidies, but for the most part they have lacked the necessary personnel resources to carry out the substantive work proposed in the subsidized projects.

In another area, the Federal Minister for Research and Technology is supporting measures to standardize CIM

interfaces as development proceeds, as well as technology transfer from universities to industry by setting up CIM Technology Transfer Centers (CIM-TTZ's) at 16 universities.

The purpose of these technology transfer centers is as follows:

- provide information about the state of the art in CIM;
- give orientation advice;
- hold seminars on selected topics from various areas of CIM;
- demonstrate model CIM solutions that already exist in university laboratories or are now being built for that purpose.

CIM Grows

What the CIM technology transfer centers have to offer depends on the research specialization of the specific institutes. Depending on its own special interests, each center has defined broad topics to focus on.

The CIM-TTZ's have already given birth to some new organizations that will do more extensive work in the private sector. As examples, we might mention here the Beratungszentrum CIM-Technologie in Dortmund or the CIM-Fabrik Hannover, a nonprofit corporation.

People in North Rhine-Westphalia, and in Aachen in particular, have taken another route. In 1987, as a result of their awareness of the problems in implementing CIM projects and at the suggestion of the Laboratory for Machine Tools and Factory Studies (WZL) at the Aachen Rhein-Westphalian Technical University, some firms joined together to form the CIM-Verein Nordrhein-Westfalen.

Its program includes basic seminars, workshops on current problems, company-specific special seminars right in the company, and working circles where a group of experts work on selected problems at a series of meetings.

Comparing its services with those of other organizations, we see that the CIM-Center Nordrhein-Westfalen is not intended to compete with existing CIM technology transfer centers at universities or the centers of competence set up by computer manufacturers; rather it views itself as a hands-on supplement, although the various sectors of CIM certainly are interrelated.

In the short period they have been operating, the various CIM centers have found that many of the firms they exist to serve are not even aware of the massive need for trained personnel as they introduce the new production technology.

Training Personnel at All Levels

Although many businessmen are already thinking very intensively about future requirements for trained personnel and often talk about the urgent need to invest in human capital, there are still great discrepancies between theory and practice.

What is urgently needed is thorough training of personnel at all levels in firms' CIM organization. However, the workers involved often do not even have the time to keep up with developments that could serve as a model for their own CIM activities.

Thus there is still a need for a lot of consciousness raising before even getting down to the transfer of technical details. It is also urgently necessary to reconsider and reformulate the priorities between day-to-day work and long-term action.

■Box, p 30■

CIM Innovation and Advisory Centers

Aachen

CIM-Center NW GmbH fuer Technologietransfer

(Advice, project leader, training, development, testing, demonstration)

Aachen CIM-TTZ, Chair for Machine Tools, WZL, Rhein-Westphalian Technical University, Aachen

(Focuses on simulation in CIM)

Berlin

Berlin CIM-TTZ, Institute for Machine Tools and Production Technology, Berlin Technical University

(Focuses on data banks for CIM)

Innovations-Zentrum Management GmbH, Berlin

(Organized on purely private sector basis)

Bochum

Ruhr CIM-TTZ, Bochum, Institute for Automation Technology, Chair for Production Systems, Ruhr University, Bochum

(Focuses on CIM production islands)

Braunschweig

Braunschweig CIM-TTZ, Institute for Machine Tools and Production Technology, Braunschweig Technical University

(Focuses on CAQ centered linkage of CIM modules)

Bremen

Bremen CIM-TTZ, Production Systems Section, Chair for Production Technology, Bremen University

Darmstadt

Darmstadt CIM-TTZ, Section for Shaping Technology and Machine Tools, Darmstadt Technical University

(Focuses on the process of CIM planning and introduction)

Dortmund

Dortmund CIM-TTZ, Institute for Shaping Production,
Dortmund University

(Focuses on CIM definition and CIM basic modules)

Beratungszentrum CIM-Technologie GmbH (BCT),
Dortmund

(Organized on purely private sector basis)

Erlangen

Erlangen CIM-TTZ, Chair for Production Automation
and Production Systems, Erlangen-Nuremberg University

(Focuses on assembly planning in CIM)

Frankfurt

German Mechanical Engineering Institute, Frankfurt

(Advice, training)

Hamburg

Hamburg CIM-TTZ, Production Technology Section I,
Hamburg-Harburg Technical University

(Focuses on PPS oriented linkage of CIM modules)

Hanover

Hanover CIM-TTZ, Institute for Production Technology
and Shaping Machine Tools, Hanover Technical Univer-
sity

(Focuses on factory analysis and restructuring)

CIM-Fabrik Hannover, gemeinnuetzige Gesellschaft
mbH Hannover (like Hanover CIM-TTZ)

CIM-Center, IBM

(IBM-specific advice to clients)

Kaiserslautern

Kaiserslautern CIM-TTZ, Institute for Machine Tools
and Factory Organization

Karlsruhe

Karlsruhe CIM-TTZ, Institute for Machine Tools and
Factory Technology, Karlsruhe University

(Focuses on seams)

Kiel

Kiel CIM-TTZ, Institute for CAD/CAM Applications,
Kiel Technical University

Mainz

CIM-Center, IBM

(IBM-specific advice to clients)

Munich

Munich CIM-TTZ, Chair for Machine Tools and Fac-
tory Sciences, Munich Technical University

(Focuses on CAD/CAM centered linkage of CIM modules)

CIM-Center, IBM

(IBM-specific advice to clients)

Saarbruecken

Saarbruecken CIM-TTZ, Institute for Business Data
Processing, University of Saarland

(Focuses on CIM strategy as part of firm strategy)

Gesellschaft fuer integrierte Datenverarbeitungssysteme
mbH (IDS), Saarbruecken

(Seminars, conferences, training)

Sindelfingen

CIM-Center, IBM

(IBM-specific advice to clients)

Stuttgart

Stuttgart CIM-TTZ, Institute for Industrial Production
and Factory Operation, Stuttgart University

(Focuses on Personnel development and training)

Source: CIM-Center NW

Technical Training Needs

36980259a Duesseldorf VDI-NACHRICHTEN in
German 2 Jun 89 p 37

[Article by Manfred Ronzheimer: "Departmental
Thinking Hinders the Factory of the Future. Gaps Still
Remain in University CIM Training. Modern Enter-
prises Are Also Social Systems"]

[Text] Berlin, 2 Jun 89 (VDI-N)—In addition to aca-
demic research into the factory of the future, universities
will also have to pay greater attention to CIM in their
teaching. Fundamental issues in education for CIM were
discussed at the IBM University Congress in Berlin at
the end of April.

Modernizing the curriculum for computer integrated
manufacturing—or "production data processing" as a
new buzz word has it—must be mainly an interactive
process between business and universities, stressed Com-
mercial Eng Willi Poths from the German Mechanical and
Facilities Engineering Union (VDMA) at the 3-day confer-
ence, which was attended by some 1,000 university
teachers from all over the Federal Republic. Besides the
new topic of CIM training, the conference focused on
possibilities for applications of computers in the humani-
ties.

Poths argued that in view of the changing demands being
made on university graduates in the production sector, it

must be the universities' task to teach the "basics and philosophy of CIM" as part of the engineering curriculum and in other disciplines such as computer science and business administration as appropriate. They really ought to be providing such education about the individual components of CIM already.

At any rate, Poths said, in view of the complexity of CIM, it would be desirable if all universities where CIM is an important subject "had appropriate laboratories where it would be possible at least to simulate examples of CIM, and perhaps carry out some simpler types of it." At the congress examples of this were cited from Hanover and Berlin.

The role of industry in CIM training, according to the VDMA representative, is to supplement the basic principles taught at the university with "practical know-how." In this regard, in larger firms in particular a certain specialization in one of the "CIM paths" will develop, e.g. CAD, CAP, and CAM. This presents the next challenge for CIM training. Increased work in these individual paths will produce extraordinarily detailed knowledge about the various subnetworks in company operations. Poths said.

"Then we no longer need just the CAD specialist or the CAM specialist: we need an 'integrator.'" But to avoid the "danger of compartmentalization between the various CIM sectors" industry must train experts capable of "linking the various CIM subnetworks together into a total network."

The experts' discussion in Berlin showed that progress in CIM at universities is likely to run up against structural difficulties just like those in industry. Just as the practical implementation of CIM—the totally integrated concept for the factory of the future—meets one of its greatest obstacles in the "departmental thinking" of the factory of today, so too one of the universities' main problems will be to overcome the "barriers between the disciplines."

Prof Guenther Seliger of Berlin's Fraunhofer Institute for Production Facilities and Construction Technology (IPK) pointed out that the Production Technology Center, which is operated jointly with the Berlin Technical University, has already been able to integrate the work of mechanical, electrical, and commercial engineers and computer scientists in production technology research. Now some initial projects are also trying to include psychologists, pedagogues, and other social scientists.

According to Seliger, this represents an effort "to take into account in analysis and practice the hitherto neglected aspect of the factory as a social system." The goal is to design socio-technical production systems not only from a production technology point of view but also taking into account the factors of work psychology, training or acquisition of knowledge, and artificial intelligence.

Interdisciplinary Courses a Recent Phenomenon

On the other hand it is only recently and at a few universities that there have been interdisciplinary courses such as "production and commercial data processing." The Berlin IPK scientist said this lack should be eliminated quickly. After all, Seliger said, university graduates should "possess knowledge that goes beyond the limits of a specific engineering field."

Eng Martin Schaele from CIM-Fabrik Hannover gemeinnuetzige GmbH—a CIM technology transfer center set up by Hanover university institutes last year—spoke more frankly about the universities' shortcomings. A fundamental obstacle to the introduction of CIM is the often inadequate training of staff, according to Schaele.

This means that universities first of all must provide future engineers with necessary CIM knowledge. Schaele: "They must formulate new teaching goals that no longer focus only on individual products or individual elements of production technologies, but on the interaction of product development, product function, and production processes, as well as the rules and methods by which these are can be viewed as a system."

Schaele named as the four most important teaching goals:

- familiarization with CAE systems as elements of modern production;
- recognizing linkage problems that arise with integration;
- viewing production as a total system; and
- assessing effects on productivity, flexibility, and quality.

To meet these goals at Hanover University, four mechanical engineering institutes have joined together, according to Schaele, to "teach jointly in the production data processing field." This is done through lectures on principles and applications, in theoretical courses and seminars, and in the Integrated Information Systems/Production (IIP) Laboratory.

The IIP, which is also to be used for continuing education for engineers in a CAD/CAM-CIM system, was developed through a research project carried out in cooperation with IBM. Schaele explained that the IIP Laboratory has several CAD work stations, a network (Token Ring), and extensive software that permit "students to do all the activities that you meet with in practice, from product design to calculation to the production of drawings and NC programming."

Schaele was not the only one to emphasize that today CIM training and CIM technology transfer are a task that "demands intensive interdisciplinary cooperation across the boundaries of the classic university institutes." Schaele said that in Hanover they have found a new organizational form for this interdisciplinary cooperation in the nonprofit corporation CIM-Fabrik Hannover.

LASERS, SENSORS, OPTICS

FRG Laser Industry Analyzed

89MI0395 Coburg OPTO ELEKTRONIK in German
Vol 5 No 3, May 89 p 223

[Excerpt] The German laser industry is gaining world market leadership in laser and laser systems for materials processing. This emerges from statistics compiled for the first time by the VDMA [Association of German Mechanical Engineering Companies] working group on lasers for materials processing. The group, founded in March 1988, brings together practically all German manufacturers of industrial lasers and laser systems. According to the statistics, 420 CO₂ lasers worth DM109 million and 220 Nd-YAG lasers worth DM29 million were produced in Germany in 1988.

With an estimated world production of 1,400 CO₂ lasers worth DM300 million and 825 Nd-YAG lasers worth DM110 million, this means that the FRG holds world market shares of 36 percent for CO₂ lasers and 26 percent for Nd-YAG lasers. Even considering that about 40 percent of the CO₂ lasers are exported and a certain proportion are imported, we must assume that approximately 25 percent of the materials processing lasers produced worldwide are used in Germany.

Dr Peter Wirth of Rofin Sinar, chairman of the VDMA laser group, said that it was possible to achieve this position only through extremely high R&D investment by the companies and with the help of BMFT [Federal Ministry for Research and Technology] subsidies.

About 40 percent of the lasers produced in Germany are installed in German laser cutting and welding systems. In this area the German world market share amounts to about 17 percent. Dr Wollermann-Windgasse, deputy chairman of the laser group and managing director of Trumpf Laser Technology, explained that cutting with laser systems represents the primary market. This will also hold true for the foreseeable future. But the use of lasers for welding is constantly expanding, as is their use in surface treatment processes.

The further development of laser fiber optic cables for high performance transmission will provide additional impetus for the Nd-YAG laser systems. Flexible beam control with high performance beam waveguide cables shows promise, especially for welding applications.

In view of the wide, still untapped applications potential for lasers in manufacturing, the industry is optimistic about the future and considers growth rates of over 10 percent possible.

The VDMA working group on lasers for materials processing was founded on 1 March 1988 to bring together laser and laser system manufacturers in the FRG to form a business association to represent their interests. The VDMA was the natural host organization, since industrial lasers are predominantly used in manufacturing and

thus to a particularly high degree in mechanical engineering as well. The initiative for founding the group thus came from among the VDMA's members. The group, which in organizational terms is attached to the specialized Machine Tools and Production Systems Association, currently has 23 member companies, covering almost the entire German market for lasers and laser systems.

The members are: Alltec GmbH & Co KG, Luebeck C. Bassel Laser Technology GmbH, Starnberg C. Behrens AG, Alfeld/L. Coherent General, Laser Optronic GmbH, Karlsfeld Doerries Scharmann GmbH, Mechernich Esab-Held GmbH, Heusenstamm Haas Laser GmbH, Schramberg KUKA Welding Equipment + Robot GmbH, Augsburg Lambda Physics, Goettingen LKS Integrated Laser Systems GmbH, Weilheim/Teck Photon Sources GmbH, Munich MAN Technology GmbH, Munich Mauser Works Oberndorf GmbH, Oberndorf/N. MBB Industrial products, Munich Messer-Griesheim GmbH, Puchheim near Munich MSL Munc Laser Systems GmbH, Munich Nothelfer GmbH Ravensburg, Ravensburg Rofin Sinar Laser GmbH, Hamburg Schott Glassworks GB Optics, Mainz Siemens AG - KWU, Offenbach Trumpf Laser Technology GmbH + Co, Ditzingen Waldrich Siegen GmbH, Burbach Carl Zeiss, Oberkochen.

Dr Peter Wirth, managing director of Rofin Sinar GmbH, is chairman, and Dr Reinhold Wollermann-Windgasse, manager of the Trumpf Laser Technology GmbH, deputy chairman of the group. With a turnover of approximately DM350 million and about 2,200 employees engaged in the production of lasers and laser systems for materials processing, this represents but a small share of the whole mechanical engineering sector. However, laser technology is playing an increasingly important role in manufacturing engineering as a whole. [passage omitted]

MICROELECTRONICS

Siemens, Matsushita Found Components Subsidiary

36980257 Munich SUEDEDEUTSCHE ZEITUNG
in German 16 Jun 89 p 35

[Article: "Siemens and Matsushita Join Forces: Electronics Firms Found Joint Subsidiary for Passive Components"; first paragraph is SUEDEDEUTSCHE ZEITUNG introduction]

[Text] Two competing giants are joining hands. Europe's largest electronics firm, Siemens AG of Berlin/Munich, and Japan's leading electronics manufacturer, Matsushita Electric Industrial Co (MEI) of Osaka, have just agreed to cooperate in the area of passive components. To that end, Siemens-Matsushita Components GmbH & Co. KG of Munich is to be established with the German company putting its activities in this area into the firm.

However, in contrast, no Siemens participation in corresponding production at MEI is planned. Talking to the press in Munich, neither Siemens CEO Karlheinz Kaske nor MEI president Akio Tanii ruled out expansion of the cooperation to other areas.

The agreement in principle just signed provides for the joint subsidiary to begin operation on 1 October. At the beginning, Siemens participation in the DM100 to DM150 million capital will be 74.9 percent and Matsushita's will be 25.1 percent. In the following 2 years, the Japanese share will increase to 50 percent. However, even after 1 October 1991, the majority voice will remain with Siemens. The German firm will furthermore retain the right to appoint the manager. Matsushita will be allowed to name the assistant manager.

Five Siemens Plants

Siemens will bring the assets of its existing passive components division with a book value of DM160 to DM200 million into the joint venture. The amount the Japanese are having to pay for their participation has not been disclosed. Siemens-Matsushita-Components (SMC) will take over the existing Siemens plants in Heidenheim, Munich, Deutschlandsberg (Austria), Bordeaux (France), and Malaga (Spain). According to Kaske, there will be no changes in the sites or personnel (a total of 5,000). SMC will start out with annual sales of DM700 to DM800 million, which should expand to approximately DM1 billion in the next few years. Admittedly, the joint venture will depend primarily on the existing Siemens product line.

SMC will be responsible for development, production, and marketing. Sales will, however, fall to the two parent companies. Gradual enlargement of the SMC product spectrum is provided for with products from Matsushita Electronic Components Co. Ltd (Maco), where MEI has concentrated its passive components activity. In this Siemens plans first to merely sell appropriate Maco products, adding production later.

Siemens CEO Kaske justifies the cooperation by stating that only those manufacturers who are able to hold their own in global competition will survive over the long term. For this it is necessary to remain technologically in the lead and to be able to sell cost-effectively throughout the world. New markets and customers are also needed. Siemens obviously did not consider its current passive components and tubing division—which showed a loss last year, but which, according to Kaske, will be back in the black at the end of the current period (30 September)—capable of doing this by itself.

The focus of Siemens activities in passive components lies geographically in Europe and technologically in industrial electronics. Its major application area throughout the sector is, however, entertainment electronics where, according to Kaske, approximately 40 percent of the world market volume of DM27 billion (1988) in passive components lies. This is followed by

communications with about 20 percent, industrial electronics and data technology with 15 percent each, and automotive, leisure, and household electronics with a combined total of 10 percent. Geographically speaking, in 1988, Japan accounted for approximately DM11.5 billion (roughly 40 percent) and the United States and Europe (including DM2 billion for the FRG) each accounted for a good DM5 billion.

Whereas Siemens achieved approximately 80 percent of its DM700-million sales in this sector in 1987-88 in Europe, Maco realized approximately 90 percent of its income of a good DM6 billion in Asia. According to reports, only about half of Maco deliveries go to the parent company, the largest Japanese producer of entertainment electronics. Siemens is also pinning its hopes for the cooperation on Matsushita the "customer." SMC will reportedly penetrate more heavily into entertainment electronics and will make deliveries to the company's European plants from Osaka. It is anticipated that in from 2 to 3 years, sales of DM60 to DM90 million will open up. Additionally, a clear increase in exports to Japan (currently DM5 to DM10 million per year) is expected.

Further Cooperation?

Kaske sees other advantages of the cooperation in larger production lots and the sharing of costs in R&D as well as in investments. Finally, the Japanese, who are the leaders in highly automated mass production as well as in basic components developments, should also prove to be technologically helpful.

Tanii explained that Maco could expand its product line through cooperation with Siemens. Access to the EC market, which might be made more difficult by the [EC] internal market, also played a role. The joint venture will not affect the cooperation in semiconductors and tubing with Philips of the Netherlands. Like Kaske, Tanii did not rule out more extensive Siemens-Matsushita cooperation.

Fraunhofer IC Institute Funded

36980258b Munich SUEDEDEUTSCHE ZEITUNG
in German 15 Jun 89 p 36

[Article: "50 Million for Fraunhofer Institute—Lang Praises Erlangen Research Work—Connection With JESSI [Joint European Submicron Silicon Initiative]?"]

[Text] Erlangen is acquiring a Fraunhofer institute. In 1988 the decision was made to convert the Working Group for Integrated Circuits into a permanent institute in stages but now the financial resources for that conversion are being provided. In Nuremberg August R. Lang, Bavarian Minister for Economics and Transport, provided a written undertaking that Bavaria will allocate DM 50 million.

DM 30 million of this will go to acquire land and construct and equip the new institute, while 20 million is

to continue the working group's activity, since it will not become part of the Fraunhofer Institute until 1993.

Spent According to Need

The Bavarian ministry will thus have spent a total of DM 100 million to support extra-university microelectronics research in Erlangen. It has already promised and spent according to need DM 50 million to build up and operate the working group in 1984-90. Economics Minister Lang: "The private sector's great interest in the research work being done in Erlangen proves that this money has been well invested."

The Land government further contributes to the development of northern Bavaria with its financial support for Bavaria's Land Trade Agency (LGA). It has promised financial aid worth DM 150 million for the LGA's new building in Nuremberg and the new building for its branch in Wuerzburg. Lang: "The LGA plays an important role in the Land-wide technology transfer system, in close cooperation with the chambers of commerce and the universities. Today over half of all contact and advisory units for new technologies are in northern Bavaria." Northern Bavaria also has a lead among technology and start-up centers, the minister stressed. "About 3/4 of all subsidies allocated for that by Bavaria have gone not to Munich but to the two technology centers of Wuerzburg and Erlangen."

JESSI, the planned European microelectronics project shows that these research institutions enjoy international respect, Lang said. With estimated total spending of at least DM 8 billion, Europe will attempt to avert the danger of strategic dependence on Japanese and American chip producers. Lang: "Erlangen has a very good chance of playing a major role in this important project."

Proposals Approved

The Bavarian Council of Ministers and the Baden-Wuerttemberg government have both approved proposals for cooperation between the two Laender under an Erlangen scientist. "We are confident that this will provide optimal coverage of the JESSI subsector for semiconductor production equipment and materials." Bavaria will certainly be ready to lay the necessary groundwork to bring that about, Lang said.

SCIENCE & TECHNOLOGY POLICY

BMFT Reports on University Research Funding

University-Institute Cooperation

36980247 Bonn BUNDESMINISTERIUM FUER
FORSCHUNG UND TECHNOLOGIE
PRESSEREFERAT in German 6 Mar 89 pp 5-11a

[Text]

Bonn, 1 March 1989. College Cooperation on Larger GFE Instruments

Alfred Wegener Institute for Polar and Ocean Research (AWI), Bremerhaven,

"Polarstern" Research Vessel (investment costs around DM250 million, operating costs around DM20 million per year); college research share about 1/3;

Georg von Neumeyer Station in the Antarctic (investment costs around DM15 million, operating costs around DM3 million per year); college research share about 1/3.

German Electron Synchrotron Foundation (DESY), Hamburg

DORIS, with HASYLAB synchrotron radiation laboratory and ARGUS detector (investment costs around DM115 million, operating costs around DM47 million per year);

college research share ARGUS around 35 percent (in the context of international cooperation); HASYLAB around 70 percent;

HERA storage ring, currently under construction, commissioning in 1990 (investment costs DM1.360 million);

HERA will be used in international cooperation undertakings in which about 30 percent German college scientists participate.

German Aviation and Space Research Institute, Registered Association (DLR), Cologne

share of college research cannot be expressed in quantitative terms in view of the individual instruments involved.

German Cancer Research Center (DKFZ), Heidelberg,

Cyclotron (investment costs around DM4.5 million, operating costs around DM0.75 per year); college research share around 55 percent; TRIGA Heidelberg II research reactor (investment costs around DM8 million, operating costs around DM0.45 million per year); college research share around 40 percent; nuclear spintomograph (investment costs around DM6.75 million, operating costs around DM0.65 million per year); college research share around 60 percent; Positron Emission Tomograph (PET) (investment costs around DM6 million, operating costs around DM0.35 million per year); college research share around 60 percent; Computer-Tomograph (investment costs around DM3.3 million, operating costs around DM0.45 million per year); college research share around 70 percent; Gamma Cameras (investment costs around DM1.8 million, operating costs around DM0.3 million per year); college research share around 60 percent. MEVATRON 77 Linear Accelerator (investment costs around DM1.85 million, operating costs around DM0.3 million per year); college research share around 60 percent; KARIN Neutron

Therapy System (investment costs around DM2.5 million, operating costs around DM1.2 million per year); college research share around 50 percent.

Company for Biotechnological Research, Limited Liability (GBF), Brunswick Bioengineering Practical Experimentation Facility for fermentation and subsequent product processing (investment costs about DM8 million, operating costs around DM2 million per year); college research share about 20 percent; besides, around 25 percent college research share for the various large-scale measurement instruments: mass spectroscopy (MS), gas chromatography/mass spectroscopy (GC/MS), nuclear magnetic resonance spectroscopy (NMR), and x-ray structure analysis (RSA).

GKSS Research Center Geesthacht, Inc., Geesthacht, GUSI Diving Simulation Facility (investment costs around DM40 million, operating costs around DM10 million per year); college research share around 6 percent; FRG I and II and Cold Source research reactors (investment costs around DM20 million, operating costs around DM5 million per year); college research share around 50 percent.

Society for Radiation and Environmental Research, Limited Liability (GSF), Neuherberg, Exposure chambers for environmental research (investment costs around DM12 million, operating costs around DM2.5 million per year); college research share around 70 percent; Central Laser Laboratory (investment costs around DM3.0 million, operating costs around DM1.00 million per year); college research share around 75 percent.

Society for Heavy Ion Research, Limited Liability (GSI), Darmstadt, UNILAC heavy ion accelerator (investment costs around DM155 million, operating costs around DM36.5 million per year); college research share around 75 percent; SIS heavy ion synchrotron and ESR storage ring, currently under construction, commissioning in 1989 (investment costs around DM275 million); college research share around 80 percent.

Hahn-Meitner Institute, Berlin, Inc. (HMI), Berlin, VICKSI heavy ion accelerator (investment costs around DM73 million, operating costs around DM9.5 million per year); college research share around 40 percent; BER II research reactor, currently being remodelled, resumption of operations in 1990 (investment costs around DM121 million, operating costs around DM12.5 million per year); college research share around 50 percent.

Max Planck Institute for Plasma Physics (IPP), Garching, Experiments in the Field of Nuclear Fusion; — ASDEX (investment costs around DM80 million, operating costs around DM30 million per year); college research share around 10 percent; — Wendelstein VII AS (investment costs around DM45 million, operating costs around DM23 million per year); college research share 20 percent.

Juelich Nuclear Research Facility, Inc. (KFA), Juelich, FRJ-2 (DIDO) research reactor (investment costs

around DM13.8 million, operating costs around DM21.7 million per year); college research share around 30 percent; ELIAS electron accelerator (investment costs around DM1.3 million, operating costs around DM1.2 million); college research share around 50 percent; Juelich Isochromcyclotron including BIG KARL magneto spectrograph (investment costs around DM34.6 million, operating costs around DM9.8 million per year); college research share around 30 percent, currently less because of remodelling; COSY Juelich Cooler Synchrotron, under construction, commissioning in 1992 (investment costs around DM94 million); mostly used by colleges.

TEXTOR Exploration of Plasma-Wall Interaction in Fusion Plasmas (investment costs around DM43.9 million, operating costs around 11.1 percent [as published]); college research share around 10 percent; HLRZ high-performance computer center (operating costs around DM12.5 million, including computer system rental costs); college research share around 60 percent.

Karlsruhe Nuclear Research Center, Inc. (KfK), Karlsruhe, Van-de-Graaff accelerator for analysis of thin films (investment costs around DM1 million, operating costs around DM0.27 million per year); college research share around 10 percent; EELS spectrometer for the determination of the electron structure of solids (investment costs around DM2 million, operating costs around DM0.15 million per year); college research share around 30 percent; KIZ cyclotron for making radioisotopes (investment costs around DM25 million, operating costs around DM5-6 million per year); college research share around 50 percent; KAZ cyclotron for making radioisotopes (investment costs around DM15 million, operating costs around DM2 million per year); college research share around 15 percent; Gyrotron for Plasma Heating (fusion) (investment costs around DM8 million, operating costs around DM4.5 million per year); college research share around 20 percent; measurement mast for data on meteorological parameters (investment costs around DM1.5 million, operating costs around DM0.3 million per year); college research share around 50 percent; mass spectrometer for analysis, specific surfaces, electrochemistry, fusion chemistry, and hydraulic technology (investment costs around DM8 million, operating costs around DM1 million per year); college research share around 30 percent; KARMEN neutrino-detector (investment costs around DM10 million, operating costs around DM0.2 million per year); college research share around 50 percent; KALIF light ion instrument for investigations on highly-compacted substances with ion rays (investment costs around DM7 million, operating costs around DM0.5 million per year); college research share around 20 percent; Pollux Pulse generator for the development of plasma diagnosis (investment costs around DM0.5 million, operating costs around DM0.1 million per year); college research share around 10 percent; Pollux Pulse generator for investigations on gas discharges in compact plasmas-electron x-ray source [as published] (investment costs

around DM0.3 million, operating costs around DM0.1 million per year); college research share around 100 percent.

College-used Large Instruments of Basic Research outside of the German Large-scale Research Institutions Maximum-flow reactor (ILL Grenoble) (investment costs DM210, operating costs DM88 million, BMFT [Federal Ministry of Research and Technology] share 33 percent); college research utilization share about 30 percent.

European Synchrotron Radiation Source (ESRF, Grenoble) (investment costs DM800 million, operating costs DM100 million, BMFT share 25 percent); college research utilization share about 25 percent.

Berlin Electron Storage Ring (BESSY) (investment costs DM75 million, operating costs DM14 million, BMFT share 38 percent); college research utilization share about 50 percent.

Paul Scherrer Institute (PSI), Villingen (operating costs DM65 million, BMFT share 10 percent); college research utilization share about 20 percent.

European Organization for Nuclear Research (CERN), Geneva (investment costs DM945 million, BMFT share 25 percent); college research utilization share about 25 percent.

Continental Deep-drilling Program (KTB) (investment costs DM449.5 million); college research utilization share about 90 percent.

ROSAT x-ray satellite (investment costs DM4800.7 million, German-United States Program, BMFT share DM238.1 million); college research utilization share about 40 percent;

European Space Observatory ESO (investment costs DM382 million, BMFT share DM102.2 million); college research share about 25 percent;

Space Telescope (investment costs DM425 million, US/ESA program, BMFT share DM124.5 million); college research utilization share not precisely quantifiable;

METEOR Research Vessel (investment costs DM99 million); college research utilization share about 90 percent.

Industry-Science Community Operation

36980247 Bonn BUNDESMINISTERIUM FUER FORSCHUNG UND TECHNOLOGIE PRESSEREFERAT in German 6 Mar 89 p 13

[Excerpts] "Research Cooperation Between Industry and Science" Promotional Measure—Status as of 1 January 1989

Objectives: — Promotion of knowledge transfer of (publicly institutionally promoted) R&D installations to industry; — promotion of science trainees in key technology fields

Activity: — Promotion of assignment of science trainees by industrial enterprises to research installations up to a maximum of 3 years; — The activity of the science trainees is to be concentrated in the area of key technologies, such as, for example, electronics, communications engineering and data processing, robotics, sensor engineering, physical technologies, biotechnology, novel energy techniques, environmental and recycling technologies; — The group of research installations includes federal research institutes, large-scale research installations, the facilities of the joint research promotion program by the federal government and the states (Blue List), Max Planck institutes, institutes of the Fraunhofer Society, as well as institutes of colleges and institutes of member associations of the Working Community of Industrial Research Associations (AIF).

Scope of Promotion Effort:

The promotional effort shall amount to DM33.750 [million] during the 1st year, DM30.000 [million] during the 2nd year, and DM26.250 [million] during the 3rd year of [trainee] assignment to a research installation.

Enterprises Entitled to Apply:

Legally independent enterprises; the promotional effort however is confined to a maximum of 6 cooperation undertakings per enterprise.

Application Filing and Processing:

Working Community of Industrial Research Associations, Registered Association (AIF), Bayenthalguertel 23, 5000 Koeln 51.—This activity has a deadline of 31 December 1991.

Statistics

Number of promotional activity cases (1985—31 December 1988) = 931;

including cooperation activities with colleges = 706;

allocation amount = around DM85 million;

1989 budget estimate = DM21 million.

USSR-UK Joint Venture To Produce Computer Equipment, Software

36980168 Moscow SOTSIALISTICHESKAYA INDUSTRIYA in Russian 7 Apr 89 p 3

[Article by Ya. Lomko. First paragraph is source introduction]

[Text] It was in the spacious conference hall of the Center for Foreign Tourism in southwest Moscow that business people from Great Britain and the Soviet Union, along with journalists and guests, marked the birth of yet another joint Soviet-British venture, which goes by the intriguing name 'Trio.'

"Why a 'Trio' and not a Soviet-British 'Duet,' and what kind of a program is 'Trio'?" These were the first questions asked of the General Director of 'Trio,' Valentin Petrovich Nachayev.

"There are three partners in this joint venture: Quest Automation Ltd. (Great Britain) and two Soviet organizations, the USSR Industrial Construction Bank and the scientific-industrial union, 'Khimmashtekhnologiya' of the USSR Ministry of Chemical Machine Building."

They joined forces to produce computer equipment which is badly needed by Soviet organizations and enterprises. 'Trio' will produce computer systems based on personal computers with peripherals, and basic and applications software.

The first computers will go on sale in June of this year. In the first year of its existence the joint venture will produce 1,600 computers systems designed for various purposes.

In addition to its own products, 'Trio' will place on the Soviet market peripherals, software, and other products of Quest Automation. Branches of 'Trio' are planned for Leningrad, Taganrog, Tashkent, and Alma-Ata. Their job (and their number will gradually increase) is to provide high-quality servicing of equipment purchased by Soviet consumers.

"And what prompted the choice of a relatively small English company as a partner?"

"We chose Quest Automation, and they us, after we got well acquainted with each other. Quest Automation has today's technology to produce computers. Their computers meet all the requirements of the world market. And it is very important that they approached this matter very solidly."

"And what does Quest Automation gain from a collaboration with Soviet partners," we asked Aurel Paskar, head representative of the firm in Moscow.

"Our firm has done business in the USSR for 17 years, supplying our customers with advanced technology. The creation of a joint venture makes it possible to increase the level of our business in the USSR. We can move our products into areas and regions where we had no business contacts before, or which were closed to us."

But this was not all that was discussed by those attending the conference from Great Britain, the director and manager, E. D. Ibel, and the chairman and executive director of the Erskin company, Brian MacGillivrey, for whom Quest Automation is a 'daughter' company.

The creation of the 'Trio' venture makes it possible to jointly produce high-quality products which are fully competitive in today's world market, both in technical level and in price.

Are there difficulties on the path of business links with the USSR? Many technical difficulties are encountered.

They often occur when British and Soviet approaches to specific problems are different. One approach must be chosen. But this is a surmountable problem, as the experience of collaboration has shown. And British businessmen look to the future with optimism. This optimism is encouraged by the fact that their Soviet partners are people who are highly educated in technical fields, and this insures the necessary level of technical expertise for production. But this is not the only basis for optimism.

As B. MacGillivrey emphasized, both he and his business colleagues are thinking about expanding contacts with business circles in the USSR.

"We all benefit from mutual collaboration," he said. "I don't know what specific results will come of the meeting of Gorbachev and Thatcher. But this meeting makes it possible to renew the good personal relations existing between them. This in turn creates a favorable atmosphere for the development of links between the peoples of our two countries in a wide variety of fields, including business collaborations."

'Trio' is beginning its game at a good time.

TECHNOLOGY TRANSFER

Italy, USSR Form Computer Automation Joint Ventures

Computer Science

*89MI0386 Turin MEDIA DUEMILA in Italian
Jul-Aug 89 p 40*

[Text] Olivetti has entered into the first Italian-Soviet joint venture in the sector of data processing services. The main goal of this cooperation agreement, signed by the Soviet Ministry of Automation's VNIPI [Specialized Automatic Control Systems] Institute and Olivetti Information Services, is to develop data processing systems for equipment supplied to the USSR by European companies. This collaboration will be concentrated in a new company, International Information Services. The company will have a capital of 1 million rubles (approximately 2.2 billion lire) divided equally between the two partners.

"This joint venture is an extremely important event," explained Franco De Benedetti, president and managing director of Olivetti Information Services, "because the cooperation agreement involves the supply of services rather than the production of goods. The new company will be a great benefit to European exporters of complex systems. Furthermore, the agreement with the Ministry of Automation could create great opportunities in the course of introducing data processing systems in the USSR. I am especially proud that Olivetti Information Services is the first company to set up an Italian-Soviet joint venture in the software sector."

The Director General of the USSR's VNIPI Institute, Valentin Solomatin, is equally satisfied: "The launching of the joint venture will permit an effective exchange of technology between the two countries. Above all, it will represent another step toward increasing the participation of Soviet scientists and specialists in the world data processing market."

Olivetti is placing special emphasis on the importance of data processing systems that will be developed by the new company for European equipment in the USSR. This will permit a rapid integration of the industrial culture of the country of origin and the country of the end user.

Railroad System Automation

*89MI0386 Turin MEDIA DUEMILA in Italian
Jul-Aug 89 p 41*

[Text] Ansaldo and Fata will be involved in automating the Soviet railroad system. The two Italian companies have signed a memorandum of understanding with the Soviet Railroad Authority to set up a joint company, with headquarters in Moscow, for the production of signaling, automation, remote control, and telecommunications equipment. The Italians will hold 49 percent of the capital, and the USSR will hold 51 percent. The agreement was signed before the president of IRI [Institute for the Reconstruction of Industry], Romano Prodi, and Finmeccanica's managing director, Fabio Fabiani.

For Ansaldo and Fata, this major agreement with the USSR falls within the field of "railroad signaling systems." However, it will involve railroad engineering in the true sense of the word. The goal will be to use automation to regulate traffic, starting with visual signal systems and progressing to integrated automated systems for large networks covering enormous distances.

In terms of products, the task of the joint venture is to manufacture signaling equipment, automatic blocking systems, and automated stations in the USSR and in other countries. In addition, the joint company will be required to modernize, reorganize, and restructure the Soviet companies currently operating in the field of railroad signaling. The goal is to make the equipment manufactured by the Italians and Soviets as uniform as possible.

The joint venture for signaling equipment, signed in one of the halls of Moscow's Pavelezki Vokzal station, becomes effective on 1 November. The agreement is based on the Soviet program for the development of railroads, with a total investment of 300 trillion lire. This program is intended to control expenditures and reduce the number of accidents. In the course of studies carried out during the 7-month negotiation period, Italian engineers and managers came to the conclusion that the Soviet railroad network—10 times the size of Italy's, and with a passenger capacity more than 10 times that of Italy—is essentially "equivalent" to the U.S. network in terms of traffic density and the geographic characteristics of the territory it covers. Therefore, there is a good possibility of integration with U.S. automation technologies, an area in which Ansaldo is a leading company.

BIOTECHNOLOGY

Hungarian Enterprises Formed To Exploit Biomass

25020256 Budapest DELTA-IMPULZUS in Hungarian
17 Jun 89 p 22

[Article: "A Less Harmful Lifestyle."]

[Text] In the new ecological equilibrium, which may bring a solution to global problems, a great importance will be assigned to the algae and the various trees and grasses, the reproducing elements of the biosphere, or the so-called primary biomasses. A new, complex processing of the biomass may become the primary activity for the chemical, pharmaceutical and food-processing industries of the 21st century. Cyclo-dextrines can be manufactured from macro-molecules, molecular fragments which, like capsules, can incorporate other molecules, and thus make new, less hazardous applications possible.

Xylitol production, which utilizes waste material of cellulose content, is only one small element and example of how we in this country look to the future, said assistant professor Gyula Marton in his presentation at the Academy during the scientific session titled "The Situation, Problems and Perspectives of Carbohydrate Intake in Hungary." He then went on to say that the volume of biomass produced on Earth through photosynthesis is 2.10 (11) tons of dry matter annually, which is more than twenty times as much as the total volume of coal, oil and gas exploited. Hungary's bio-product amount to about 50 million tons a year. Of this volume, we fail to utilize or under-utilize 15-20 million tons. A decisive majority of this unprocessed volume is made up of plants containing cellulose, or waste material having plant origins. A shared characteristic of these plants is that they are made up primarily of three chemical components: cellulose, hemicellulose and lignine (lignose) macromolecules. The structure of substances called hemicellulose are varied to the greatest degree, because in annuals their main component is xilane made up of pentose, and in perennials glycomannan is the characteristic contributor to the formation of polymer. Xylitol, a product new to our country, is a sugar alcohol with five carbon atoms. It can be produced by hydrogenating the D-xylose that is derived from breaking down xylane. Hydrogenation can be accomplished by using nickel catalysts at high temperatures and under 100-200 bars of pressure, or through bio-catalysis. Xylitol is a natural substance which appears in several fruits and green plants. For example, a kilogram of ripe strawberries contains almost four grams of xylitol. When it comes to its utilization, it is very important to take several factors into consideration. Its sweetening effect and energy value is nearly identical with, and its taste is nearly indistinguishable from that of sucrose (saccharose.) Its processing in the human digestive system takes place in part independently of insulin, so that (under medical supervision) it can be administered as diabetes medicine. In the mouth xylitol significantly inhibits the formation of bacteria that causes

cavities, thus it can be used in the manufacturing of anti-cavity sweeteners, candies, pastries, chewing gum, fruit juices or even toothpaste. Due to its greater ability to resist bacterial infection, xylitol a more effective conserving agent than sucrose (saccharose.)

The chemical process department of the Veszprem University of Chemical Industries, the Pet Nitrogen Works and the Bio-Energy Innovation Management Consortium have for several years owned a xylitol production technology that has been tested at the manufacturing-laboratory level and has been in part developed by themselves. Production level experiments are likely to begin this year.

University Professor Jozsef Szejtli gave a presentation titled "The Cyclo-Dextrines as Bearing Substances and their Utilization." Following successful basic research performed at the chemical research laboratories of the Chinoin enterprise, an independent research organization, the CYCLOLAB Cyclo-Dextrine Research Division, came into existence. (We have reported on previous developments in No. 5, 1987 of this publication.) Cyclo-dextrines can be produced out of starch with the use of enzymes that breaks the micro-molecules into dextrines made up of six, seven or eight glucose units. Connecting the ends of molecule-fragments thus created, it forms closed rings. Cyclo-dextrines are, in fact, molecule-sized empty rolls, whose outer surfaces are hydrophillic, while their insides are apolar and of such size that, under suitable conditions, the molecules of certain aromatic, pharmaceutical, plant-protective or explosive substances may be locked inside them. A cyclo-dextrine molecule is similar to an empty capsule of molecular size. When filled with the molecules of other substances, it is referred to as a "closed complex." These complexes are units made up two or more molecules, with the "host" molecule partly or completely incorporating (through the use of physical force, that is, without covalent ties) "guest" molecules. Guest molecules may form complexes of entirely different stability in association with different cyclo-dextrines. Even though the physical and chemical characteristics of enclosed molecules are greatly altered inside the containment, under certain physiological circumstances these complexes easily spread, and thus the guest molecule can exert its desired effect.

Thus, cyclo-dextrines can be used in numerous areas of industry. In the manufacture of pharmaceuticals to be taken orally, liquid substances can be transformed into crystalline ones, which then can be pressed into tablets. By forming complexes described above, we can significantly reduce unpleasant aromas and odors. When it comes to low-dosage tablets, the unitary nature of volume can be realized by forming tablets of micro-crystalline complexes. In manufacturing liquid medications, such as those to be injected or those to be dropped into the eye, non-water-soluble pharmaceuticals can be transformed into stable watery solutions without the use of organic solvents, and side effects can be reduced.

In creating food-aromas and perfume products, cyclodextrine can be used, among other things, to achieve stabilization, for example, to prevent losses due to oxidation, reactions brought on by light, decay caused by heat, spontaneous decay, evaporation and sublimation. Unpleasant tastes and odors can also be reduced.

COMPUTERS

Robotron Exhibit at Budapest International Fair

25020254b Budapest *COMPUTERWORLD*/
SZAMITASTECHNIKA in Hungarian
17 Jun 89 pp 1, 4

[Article: "Roboton Revue in Kobanya"]

[Text] The 1834 computer, with 50 megabytes storage capacity, and its peripherals dominated nearly a third of the substantial exhibit area of Robotron [at the Budapest International Fair]. The basic machine was developed jointly with the CGK firm in the FRG but in regard to its peripherals Hungary is one of the most significant developmental partners of Robotron. The network interface was prepared jointly with Budasoft and Datacoop made possible its use as a cashier's machine suitable for reading bar code. We could see the Liesegang equipment, which can be connected to a personal computer, with which the contents of the screen can be projected. They also exhibited their disk copier, which did not seem really productive with a speed of one copy per minute. The product family also includes a nine pin printer with a speed of 200 signals per second.

Image Processing

The image processing system of Robotron is worthy of note: with the aid of a video camera connected to an electromicroscope it can read in, digitize, store and modify images and display them on a monitor with a resolution of 512 x 512 pixels. The system can distinguish 356 shades of color and it is also possible to recolor the images.

The entire configuration includes the K 6405 digitizing tablet and the K 6314 printer. Four digitized images can be stored on the 20 megabyte hard disk.

The system can be used successfully in industrial quality control and medical science; by reading in space photographs it can be used in environmental protection, forestry, water management and geology. One of its most interesting use areas is chromosome studies. With its aid we can not only display an enlarged image of the chromosome studied we can also identify it by comparing it with samples in the chromosome memory.

The image processing system is used in the GDR in colleges and research institutes and in the army. In Hungary it used at the Oncological Institute.

The New 32 Bit Computer

They are already manufacturing their new 32 bit machine, the RVS-K 1840. Sixteen disk units can be connected to the machine, which has virtual memory management. The fixed disks have a capacity of 160 megabytes and the changeable disks have a capacity of 200 megabytes. Depending on load the central unit can handle a maximum of 90 terminals; in the case of graphic work stations—which really tie up a computer—four or five work stations can be connected to it. There is Hungarian cooperation in this case also—Videoton provides the printers.

Hungarian Expert System For Concurrent-Parallel Processes

25020266 Budapest *MAGYAR ELEKTRONIKA*
in Hungarian No 7, 1989 pp 21-24

[Article by Katalin Szenes, of the LSI Applications Consulting Service, and Peter Forro, of the Mikroteszt Small Cooperative: "An Expert System to Calculate the Operation of Process Systems"]

[Excerpts] The system was prepared to design and model systems consisting of parallel and/or concurrent processes, to test the plans thus obtained through simulation and to actually execute the accepted plans. It received its name from the initial letters of a more modest undertaking—Planning Parallel Processes—and thus became P³ or PCUBE.

The user provides the structure of his processes, the possibilities for their cooperation and the goals to be achieved by the cooperation of these processes: on this basis PCUBE "calculates" a process cooperation plan satisfying one or more task specifications and this plan will actually be a model of the original sketch plan of the user. While preparing this model PCUBE also tests to see if this model is correct, so this model preparation also includes a simulation phase for the model.

Special properties of the system make it possible for the user to put together from the models passing such a test a system which can be run. With this system he can control with his computer the control task to be solved by his processes, doing so directly without using the model building capabilities of PCUBE.

One of the chief goals of the development was for the services of the system to be at the artificial intelligence (AI) level, retaining, however, the many valuable traditional possibilities for process management and simulation. [passage omitted]

For computer implementation it was desirable to use a list management language. Since a personal computer was available to prepare the system the choice fell on the FORTH programming language, because of the speed and small space requirement of programs prepared in it.

So a hierarchical system, consisting of levels, was developed. It is already suitable for solving simple manufacturing scheduling tasks, similar at the task description level to those run in the PROLOG based T-PROLOG, which aroused some interest at the time in production control circles. [passage omitted]

Input for PCUBE—The Model of the User System

We chose the task specific style of languages based on first-order predicate calculus. That is, the user task description consists of the following chief elements:

- a description of the environment of the task to be solved: this is essentially a part of the program's "database;" and
- the goals to be achieved in the condition system defined by this environment description. [passage omitted]

We say that a process system consists of parallel processes if we permit interaction effects between the processes and we say that it is parallel in time if the occurrence of some of the steps of the processes can be tied to some point in the absolute time valid for all the processes making up the system [system time].

A parallel process system is concurrent if it has at least two processes which have steps which can take place at once but which need the same resource. [passage omitted]

So the user system consists of so-called clauses, similar to the input for languages based on first-order predicate calculus. Some of these, the so-called database, provide the conditions for the running of the several processes; the others, the so-called goal description part, provide the goals posed for the process system. Speaking informally the clause is a statement which asserts the truth of some fact, either with or without conditions. If we want to describe the running of the processes with conditions, for example, then these facts can take the following form:

I-TAKE-THE-PENCIL (if) THERE-IS-A-PENCIL (and) I-WANT-TO, and I-WANT-TO (if) IT-IS-NOT-RAINING. These conditional statements are so-called reductor type clauses. IT-IS-NOT-RAINING is an unconditional statement, a so-called fact statement type clause.

This example also corresponds to a program in the PROLOG language. A problem of this type is solved by both PROLOG and PCUBE with the same result and with the same logical method, but the logical method is realized differently.

The method for describing the interactions of the processes, that is, giving the conditions connected with time and with management of resources, will be given in the part formulating the FORTH implementation. As we will see, a large part of the possibilities resemble those of T-PROLOG, from the user's viewpoint, but the method

of realizing them is different and the new types of supports derive from this. [passage omitted]

These possibilities, differing from languages based on PROLOG, could be provided precisely because PCUBE does not solve the task—in principle—in one pass with the aid of a compiler or interpreter but rather in a number of steps corresponding to its levels. [passage omitted]

Structure of PCUBE, the Hierarchy of the System

The system has a highest level serving specification of the problem. The data types of the lower realization levels are also accessible at this level. Under this is a level for list handling which is also a complete language suitable for list handling; here are prepared the solution algorithms corresponding to the chosen model of the process system. Under this is the implementation level which serves "only" efficiency; it is prepared in the FORTH programming system and it realizes the data types and operations of the list handling level. FORTH is a system and program language widely used for programming microcomputers. According to its believers it competes with assemblers in speed, it is weaker by only a factor of ten, but the space it occupies is more favorable.

The transparency relationships between levels also differ from the customary. The fact that the system is transparent from below upwards affects primarily designing and affects the user only if he wants to work not primarily in the language of the first level—as in PROLOG—but rather, for example, wants to work in the list handling language. This is sensible only if he does not want to use the system for process handling or if he wants to rewrite previously provided services, for example the scheduling of processes. We also allow for reverse transparency, from above downwards, so the possibilities of the lower levels—primarily those realized in the interest of implementation—are accessible at the top level too. And there is a very important practical example of this, the possibility of actually controlling the processes. This can be achieved by building the FORTH language part into the user program.

Managing Parallel or Concurrent Process Systems and Time With the PCUBE System; The FORTH Implementation Level

The behavior in time of the processes, as we said when defining them, can be described with a common time valid for every individual process. This is the so-called system time for PCUBE. When starting the processing of the process system its value is zero and if any process changes this value while running (we permit only whole numbers) then all the others naturally take note of it. The scheduler takes care of this as one of its chief tasks—after interpreting the instructions.

With the aid of the BEFORE, AFTER or AT instructions we can tie any step of the processes or the starting of them to a given point in time. The parameter for all three is the desired point in time and their effect—as for the

other reserved word instructions—is precisely what is expressed by the English words.

We can delay processes for a given duration with the HOLD instruction. The system interprets the whole number given as a parameter as a time interval which starts from the current value of system time and lasts for a given time.

The HOLD instruction is indispensable for management of resources too, to give the time resources are tied up. Resources are taken with the TAKE instruction and released with the RELEASE instruction. Both have one parameter, the name of the resource, which, naturally, is given by the user, as he desires. But how many of a given name are available to a process system must be declared with the RESOURCE instruction. One of the parameters of this is the name of the resource and the other gives the number of units of the given name which can be used.

With the SEND instruction the processes can send messages to each other and with the WAIT instruction they can wait for messages from one another. These instructions are dedicated, so they can also apply to a given process, which is indicated by one of the parameters of the instruction if necessary. If we do not use this then both the sending of the message and the waiting for it apply to "everyone." The message itself is an obligatory parameter of the instructions and it can be any character series.

The current value of system time can be queried by the TIME instruction.

With the keyword ACTIVATE we indicate that we want to write an instruction to be actually executed. This is followed by a FORTH program segment—a "definition word" in FORTH terminology. This can be used when we are already satisfied with our process models and want to actually execute a series of steps which can be "calculated" with it, for example if we want to control a work operation directly from the computer.

We have not had an opportunity to test this last possibility but the T-PROLOG examples which were prepared at one time to illustrate the language or solve a production control task (manufacturing scheduling) also run under PCUBE. [passage omitted]

Foreign Interest in Hungarian Quality Control Program

25020267 Budapest *COMPUTERWORLD*/
SZAMITASTECHNIKA in Hungarian
29 Jul 89 pp 12-13

[Interview with Andor Dobo by Endre Megyeri: "Here's the Joker. Where's the Joker?"]

[Excerpts] **Megyeri:** You are a mathematician. How did you get involved with a problem which is more economic than scientific, the problem of quality, or rather how to measure it?

Dobo: The question of reliability in the mathematical sense received a central role around the world in the 1960's. [passage omitted]

The KGM [Ministry of Metallurgy and the Machine Industry] ISZSZI [Institute of Industrial Management, Organization and Computer Technology] wanted to acquire a computer at the beginning of the 1960's and had to decide on the model to get. In connection with this decision I discovered a primitive version of the similarity function, not even suspecting what an important role it would play later. This similarity function measures the similarity or difference of two objects on the basis of their properties.

I again met the problem of product evaluation in 1975. The question was formulated more generally: Is it possible to use the known tools of mathematics to handle comparison problems with opposing expectations? This gave birth to the general form of the similarity function. Despite the fact that the Ministry of Metallurgy and the Machine Industry asked us for a bid—which we prepared—there was no commission for a concrete task.

Megyeri: Why not?

Dobo: Partly because it was felt that quality could not be measured with mathematical tools. [passage omitted]

It is my experience that those working at supervisory organs, the authorities, are often men with weak abilities who cannot differentiate between science and pseudo-science, and often prefer the latter. Not even to speak of the intrigues and comradely contacts, which play a very great role. With one or two exceptions I have never received ministerial support for my work. [passage omitted]

But in the meantime our research matured and we found an enterprise, Kontakta, which was willing to finance the preparation of computerized systems for models. So between 1983 and 1986 we prepared, at Comporgan, the RANG-64 and REND-64 programs for a Commodore 64, for the simple reason that Kontakta had only these computers. [passage omitted]

Practical experience convinced us that there was "more" in this software, so we adapted it for the IBM PC, and this became the Joker.

Megyeri: I think you had to find new support for this.

Dobo: Yes. In the middle of 1987, out of several possible partners, experts from the CompuDrug Small Cooperative—Mrs Laszlo Csirmaz and Ivan Erdos—undertook the adaptation work at their own risk. This was not at all easy, considering that the documentation filled 25 notebooks. Later the staff of experts working on this left CompuDrug and founded a new small cooperative under the name InfoKer, so the work was completed here in March of this year.

At the same time they began using RANG-64, running on a Commodore 64, for product evaluation at Prodinform. This was financed by the Ministry of Industry. They formed an Industrial Quality Council. The Ministry of Industry also provided money to begin a methodical study of the quality of industrial products using computerized and other methods which could be found in Hungary. They examined three product evaluation methods—ELECTRE, from France, REM, the work of a Hungarian developmental group, and RANG-64. They brought in about 500 experts for the experimental application of these, and the sum provided by the ministry for the first year was spent on this work. (passage omitted)

In November 1987 the Ministry of Industry invited experts from the American Westinghouse firm to give advice on improving the quality of Hungarian products. They were shown RANG-64 too. Within two days they recommended to Laszlo Kapolyi, then Minister of Industry, the creation in Hungary of a Westinghouse-Prodinform Quality Center. The American firm undertook to perform quality studies for a year and half, using their own methods, at designated Hungarian enterprises. We would install the Joker in a quality affairs databank at the center, to be known as SZATIR (Szamitogepes Termekminositó Információs Rendszer, Computerized Product Evaluation Information System). There was also talk of introducing on American markets the Hungarian products found by them to be qualitatively acceptable and if new technology was needed for this they would bring it to Hungary. Finally nothing came of the whole thing and SZATIR got stuck at the level of developing the conception.

Megyeri: What do you think was the reason?

Dobo: Decision-making uncertainties, in addition to the permanent shortage of money and the eternal reorganizations. In addition, parallel with Westinghouse, the ministry asked the Japanese Professor Shiba to make the quality improving methods developed by him available in Hungary. This would have required 38 million forints per year. Originally this would have been available in addition to the sum intended for SZATIR. But because of the financial restriction there was an agreement between Prodinform and the ministry to give to Shiba the larger part of the sum approved earlier. I got a total of 1.7 million forints, 15 percent of the sum due for the year, to prepare the SZATIR conception. [passage omitted]

On the basis of a short study it has been established that in the United States the costs connected with quality make up 30-35 percent of the production of products while in Hungary this same ratio is around three percent!

Megyeri: What did the Americans like about Joker?

Dobo: Among other things the fact that Joker determines where one must intervene in the production process for a given product so that by changing a few parameters we get a product better than the competing product. So one

does not have to do an expensive and time-consuming analysis of the entire technological process.

Megyeri: I have heard that there has been interest in Joker from socialist countries, primarily the Soviet Union. How did they even know the software existed?

Dobo: In the spring of this year a committee from the Soviet Union visited the OMIKK [National Technical Information Center and Library], among other places, and they were asked to show the Soviets the system. After seeing Joker they went to the embassy to ask for help in using the system in the Soviet Union. Then Joker was shown to the experts from the embassy and they said that they would like to use it to evaluate the quality of Hungarian products exported to the Soviet Union, among other things. And they presumed that we would similarly evaluate Soviet products. Somewhat later we were invited to give a professional demonstration in the Soviet Union. We also showed the system in Sofia where representatives of the Informa firm said that they would like to sell Joker. We also received an invitation to Varna to the May meeting of an inter-government committee dealing with international scientific information systems. Here we were approached by the Vietnamese delegation, who would buy it for dollars at the expense of aid received from the UNIDO. They would like us to train their experts and when we were convinced of their applications abilities we would be invited to Vietnam in January of next year. The Fortschritt Kombinat in the GDR is interested in buying it; they bought the RANG-64 and REND-64 programs earlier.

There may be very serious commercial problems in regard to domestic applications. According to a preliminary estimate done at the Ministry of Industry the system is so strict that if it were used to evaluate the quality of commercial trade in the socialist relationship then the Hungarian economy would suffer a loss of about 45 billion forints per year. At present there is verbal evaluation for commodity shipment agreements, instead of evaluating the natural indicators—anything can be explained. So the Hungarians have no interest in using the system. [passage omitted]

It is not in the interest of the enterprises to know the quality of their products, to know their weaknesses. Their monopoly situation and the lack of market competition do not force them to transform their product structure. The Ministry of Industry is tied down by its own internal problems and does not deal enough with the questions of the quality development of products.

Megyeri: If some enterprise did buy the system, how much would it cost?

Dobo: The price of the 2.0 version, prepared in March, is 300,000 forints, and is sold by InfoKer and Prodinform. A newer version will probably come out in September; it will make the work of the user much easier. [passage omitted]

Hungarian 3D Graphics System Described

25020268 Budapest *COMPUTERWORLD*/
SZAMITASTECHNIKA in Hungarian
5 Aug 89 pp 24-25

[Article by Edit Kadar and Janos Balazs: "Exhibit of Computerized Technology at Stuttgart"]

[Excerpts] It was the goal of Mesago GmbH, the creator of the CAT (Computer-Aided Technology) exhibit, to present the largest CAD/CAM exhibit in West Germany and thus the most significant such exhibit in Central Europe: they succeeded in finding the ideal partners for this. Because of the developed industry and large number of users in the South German region, the Messe Stuttgart organization is in a very favorable geographical location and it provides the perfect infrastructure. The other partner, the World Computer Graphics Association, guarantees the high level of the exhibit and the associated congress. [passage omitted]

The Trias 3D graphics system developed by the Hungarian Trias 3D CAD Studio was present at the Stuttgart exhibit for the first time. At the exhibit of the firm which ordered the program and sells it in West Germany there was significant interest in the program, which is fundamentally different from previous systems. Visitors were especially impressed by the fact that one can solve with it tasks for which one has to build in separate applications modules when using other programs.

This difference derives from the fact that instead of binary storage of data the system uses a text database, so it satisfies the most modern needs and trends. Those interested were attracted by the user defined hierarchical database, the full scale associative dimensioning, the parameterized conversational language and the simple network connection. [passage omitted]

The Trias 3D Graphics System

Three Functions in One Program

- Three-dimensional modelling with traditional CAD operations, production, modification and archiving of drafts and technical drawings and development of plan libraries.
- A new type of tool—a text editor for building and modifying the graphics database and a graphics editor which transfers to the database, as text, the graphic modifications made on the screen. The result of changes made with the text or graphics editor can be seen immediately.
- A developmental program package for experts preparing CAD applications, with the support of a concise, efficient, conversational mode graphics language.

The Most Important Services

The user-defined ASCII format graphics database structure provides a link with traditional database management systems and networks; it makes possible the combined handling or linking of graphic and technical data.

Graphic elements are described in a conversational graphics data description language with full scale parameterization.

One can create from the graphics elements an element library and an application specific hierarchical database suiting user needs.

The database can be displayed in two ways simultaneously, graphically (in different windows from several views at once or in different magnifications) and with text lines describing the graphics database.

The full scale associative dimensioning makes it possible for the technical drawing and its dimensioning to constitute a unified whole. Graphic modification of the drawing produces automatic change of the dimensioning and vice versa.

The created bodies are displayed in the hidden line and surface painted mode.

Cross section preparation, with crosshatching of the cross section.

The user can select among several spatial mappings.

With the aid of the quasi-animation module the three-dimensional model prepared with Trias 3D can travel along a path provided by the user.

Handling the system is extraordinarily simple; in the multi-screen structure the user can freely define, independent of the hardware, the number, size and location of the various communication windows. The pictogram menu appears in a previously designated graphics window; it can be modified and redesigned freely. The hardware requirement is a 386 AT compatible computer with co-processor, with two monitors and a DATA-GRAF auxiliary.

It is sold by the Trias 3D Studio.

Computer Exhibits at Budapest International Fair Described

25020254a Budapest *COMPUTERWORLD*/
SZAMITASTECHNIKA in Hungarian 10 Jun 89 pp 1-5

[Articles by Huba Bruckner, Endre Megyeri, Zoltan Mikolas, Szilard Szabo and Marton Vargha (the individual items are not individually attributed): "BNV (Budapest International Fair): The Prize Winning Assembly Line and the Others"]

[Excerpts]

The MEV ■Microelectronics Enterprise■

The surface mounting technology is regarded today as the most modern in the manufacture of circuit cards. A few years ago we were still struck with wonder at devices made with SMD elements and then we celebrated together the placing into operation at Videoton of the Japanese automatic mounting devices. And we are similarly happy that at the 89th Budapest International Fair we could see at the Microelectronics Enterprise a circuit card manufacturing line with the aid of which the most modern electronic elements can be used.

The MEV received the fair prize for the surface mounting line consisting of an MS-400 screen printer, a Robomat 2000 surface mounting automat, an MK 3508 wave soldering unit, an MV 01 visual inspection station and the manual parts mounting station needed to repair assembled circuit cards, the MM 01. The order in which the units are listed indicates the steps in the technology. In the case of circuit cards made with surface mountable elements also the first step is to form the soldering points. The screen printer of the MEV does this semi-automatically. If required, the machine, with a printing speed of 50-150 mm/s, can transfer the desired mask to both sides of a circuit card simultaneously. The size of the printed circuit sheet cannot exceed 300 x 400 millimeters.

The most striking and most intelligent device of the technology is the Robomat 2000, manufactured on the basis of a license purchased from the French firm Eurosoft Robotique. When developing it the designers took into consideration every essential requirement for the manufacture of printed circuit cards and hybrid technology carrier elements. After positioning the base sheet the parts are mounted automatically. The largest size of the card can be 490 x 300 millimeters, the mounting precision is plus or minus 0.1 millimeters, or plus or minus one degree. The device can handle the most varied components, thus circuit chips, melf, minimelf, SOT and SO elements, among others, can be built onto the base sheet. These are sucked out by vacuum from ribbon, tube and wafer stores or bulk bins. When the part reaches the desired position on the card it is positioned automatically and the required contact on the sheet is checked. The sequence of work phases for the equipment, with a capacity for 2,000 parts per hour, is optimized by computer, and with a supplementary unit it is also possible to check bipolar components before mounting.

The next step in the technology is soldering and the modern tool for this is the MK 3508 wave soldering machine. Then the finished card can be checked under a microscope; if necessary faulty parts can be removed and new components built in. In the case of surface mounting technology these operations can be done only with tools with laboratory precision, with soldering irons at a very precisely maintained temperature.

According to the exhibitors the Robomat 2000 is a unique product not only in our country but in the offerings of the socialist countries. The first is already in use at the Ajka factory of Videoton. The MEV experts assert that this device counts as modern even on Western markets; the French firm selling the license is living well on it.

Now it is up to the parts manufacturing industry, because for the time being the Hungarian machines can be fed mostly only with foreign parts.

The AMFK Company

The leading product of the Creative Technical Development and Commercial Joint Stock Company [AMFK Rt.], formed from the Creative Youth Association, continues to be the Navel-Cord data transmission system (described in detail in our issue No 23, 1988); they exhibited the further developed 2.0 version of this. Data transmission is now possible not only PC to PC but also between PC, MicroVAX, TPA and ESZR [Uniform Computer Technology System] computers. The built-in VT100 and VT52 terminal emulation makes it possible to access about 80 percent of the open foreign databases. They have also prepared a defense against virus infection; an environment test is done every time it is started up. The KERMIT protocol used and the multilevel error check ensure the reliability of long-distance data transmission. In 6 months they sold more than 200 systems and orders for another 60 copies are expected, proving that the constant development of the program was not unprofitable. The price of the Navel-Cord with increased services is still 49,900 forints.

The ASK Limited Liability Company

The Spring BNV, as we know, is specialized for investment goods. So the process controllers certainly better suit the exhibit than the game programs seen here and there and studied with great delight. They are spectacular and a viewer might think of them as games too.

The ASK Kft. exhibited the DIAGEM program package, which so far has two users. It is used in Szazhalombatta at the Danubian Thermal Power Plant and in Budapest to monitor the 10 kilovolt line system of the MAV [Hungarian State Railways]. The software is general and can be tailored to order. The purchaser himself can draw the symbols and icons to build the images used to track the processes. The image elements can be easily assigned to the given input and output channels with simple parameterization and can be arranged on the screen in accordance with the technology of the process being monitored.

The ASK experts did not try to get the DIAGEM installed on an IBM AT to do everything. Guidance tasks and intervention were left to the PLC's closer to the process.

The BHG ■Beloianisz Communications Engineering Factory■

It is well known that today domestic telephone exchange equipment already resembles a computer more than it does its electro-mechanical predecessors. The eyes of a fair visitor might have lit up at the stand of the BHG Communications Engineering Enterprise if he had noticed, among a number of other, smaller telephone exchanges, the ER 256 stored program controlled electronic terminal exchange. Indeed, he could have immediately tried it out, although in this case Budapest numbers could be reached only as long-distance calls after dialing 06-1. (The exchange was made for a provincial area.)

The prescriptions of the Hungarian Post Office were taken into consideration in a far-reaching way in this system, developed at the Developmental Institute of the BHG with OMF [National Technical Development Committee] support. The exchange is recommended for a capacity of 200-1,000 subscribers, thus it is intended primarily to provide modern telephone service for smaller settlements. But there is no obstacle to expanding it. In regard to its structure its control system can be compared to a computer network formed with single card controls operated by 8085 microprocessors. Its switching field has a three stage, back-looped structure; it can transmit only analog speech signals. The ER 256 is not a digit exchange, but it is substantially more modern than its ARK predecessors, so it is intended to replace them—together with network expansion and elimination of the manual exchanges.

It would take a long time to list its services. We should mention a few of the new features—automatic local calls without involving higher level exchanges (in its predecessors even local calls went through a higher level exchange, which superfluously loaded the network); domestic and international long-distance calls with two dial tones; call transfer to other subscribers within the exchange; handling special calls; sending digitally recorded messages (burned into an EPROM), for example a "speech" busy signal; operating remote subscriber counters; and use of public telephones which can use several types of coins. In addition to the subscriber services mentioned the ER 256 offers a number of new possibilities for the operators of the system.

The BHG was thinking not only of the Hungarian Post Office as an operator, for they hope that in accordance with the new postal law various companies and other undertakings will also need exchanges which are modern in terms of domestic telephone technology. The new exchange is being tested in practice in Tarjan, near Tatabanya. If it passes and if there is a customer with enough capital the BHG can begin larger series manufacture, because there is no denying that there is a need for them. [passage omitted]

Dataplan

They exhibited three new products in addition to their already traditional TIS and PC compatible computers.

The dp-PCVAV computer protection system has the task of preventing unauthorized use or theft of computers. It consists of two main parts, an adapter card built into the computer to be protected and a protective system which can be hidden, to which the computers are connected. In a network it can also be used on the computers functioning as servers. The task of the adapter is to ensure that after the computer is turned on the operating system will be loaded only after giving a certain password. A program records the password and the time of entry and exit, so it is possible to check the last 250 events or users. After authorization of the start-up of the system the protective card does not interfere with the operation of the computer or the running of user programs. In the event of unsuccessful start-up attempts (faulty password) or damage to the machine (dismounting the hard disk, opening the box) or cutting the wires the system sounds an alarm. The alarm can be an independent unit or the system can be connected to existing central equipment.

The password system has two levels; the secondary passwords can be changed only by someone who knows the primary password. The latter can be changed only by opening the computer and disconnecting the alarm system.

Use of the protective system is expected in areas where the protection of data poses a greater need than usual—for example in state administration and in banking and financial applications.

The second new item, the DPTX automatic telephone calling and telex equipment, is basically a supplementary service of the TIS system but it can make any model computer suitable for operation as a telex station in a switched telex network. [passage omitted]

Dataplan has also entered the laptop market. It exhibited the SuperSport 286 type AT compatible model of the famous Zenith firm. [passage omitted]

The Mikromed Limited Liability Company

Mikromed is a Soviet-Hungarian mixed enterprise, with headquarters in Esztergom, specialized for medical electronics. Today it sells 80 percent of its products on the Soviet market but it would like to open to the West in the near future. In this spirit it exhibited at the BNV a number of devices with nice design and, in more than one case, at the world level.

The simplest device, made in two versions, is an ultrasonic instrument with which, depending on the model, one can check the state of sinuses or the thickness of fat on hogs (the first version is called SINUS-CHECK and the other is called FAT-CHECK).

Many Hungarian hospitals will be happy with the modern 16 channel EEG equipment connected to a PC.

The real novelty is that the computer processes the signals and depicts various "brain maps" on the screen. In this way interpretation of the signals becomes so simple that even a suitably trained nurse can handle the task.

Probably one of the quiet political sensations of the BNV was that a product of an Israeli firm, ELSCINT, could be seen at the stand of a Soviet-Hungarian mixed enterprise. The ESI 2000 ultrasonic device is a world level product suitable for abdominal cavity, gynaecological and cardiological examinations, among other things. On one of its two 9 inch screens one can see a high resolution echo image and on the other one can follow the results of a real-time interpretation. For the time being Mikromed is selling the ESI 2000 (for about 3.5 million forints) but later it will manufacture it as well; the first will be put into operation in our country in the Esztergom hospital.

The MIKI

The Instrument Industry Research Institute (MIKI) had a rich offering at the fair; the Measurement Technology Software Development Subsidiary exhibited at the same stand. They exhibited an integrated circuit testing automat with transmitter, a process control device based on an IBM XT/AT, a laser movement meter, a force and mass sensor, an inductive transmitter and a high frequency sampling voltmeter. We could see the Dentolux fiber optic dentistry device, a banknote counting device and a linear and rotating signal code transmitter. All the equipment can communicate with a computer—via a special connector.

The MIKI deals primarily with the solution of ad hoc technical problems in the area of mechanics, instrument technology, hardware and software. The products exhibited were intended to demonstrate primarily the abilities of the developers of the research institute. They will also undertake to make individual products; in the event of large series manufacture they seek a cooperating partner. In addition to the products exhibited they deal with installation protection, digital speech processing and aircraft and drive diagnostics.

The Measurement Technology Development Subsidiary was formed 6 years ago. Its activities are concentrated on four chief themes. An important area is development of software for circuit testing equipment for the foodstuffs and canning industry and for chemical industry process control equipment. They deal with development of applications systems for active memory cards, thus with records on the histories of medical patients, with credit card functions in the banking area and with inventory systems. Their fourth main area is image processing. They have achieved significant results in the processing of X-ray pictures and maps using the scanning technique. [passage omitted]

Vilati

It is well known that a major reconstruction has begun at Vilati with the support of the OMFB and the World

Bank. The goal is manufacture of the VME bus system circuit cards used throughout the world in process control. Last year they bought from Philips a license for the entire module set and now they are discussing whether the Dutch firm will buy back a part of their production. Samples of a number of cards were exhibited at the fair.

They plan to set up a mixed enterprise with another Western firm, the Finnish Fiskars. Unfortunately preparations have been dragging on for a year already. In any case a number of uninterrupted power sources, made by Fiskars, figured in the fair offerings.

Finally we heard about one other cooperation, with the Swiss Indigel AG. They already manufacture a miniature network power unit called DATAPAC which contains a transformer and which can be mounted on a printed circuit; and they have received from their partner an order for them worth 20,000 Swiss francs. For the time being they are offered in Hungary for 80-100 SF but according to the plans they will be obtainable for forints as well. With a similar deal they are making and selling the TP-2000 training-development system which is also suitable for plugging together microprocessor test connections.

5G

"Three is the right number, the fourth is added on." I used to say when I was a child. Presumably the 5G Small Cooperative also lived in the spell of number mystique when it tried to win the interest of the visitors with three things, and finally a fourth grew out of it. The first was the very attractive Gertrud Stefanek handing out autographs (and smiles) at the 5G stand. The second was the Master educational program designing system, with which lecturers with no programming experience can simply compile lesson material.

Their third noteworthy achievement was the ARCAD architectural designing system. This already won the grand prize at the CAD exhibit in Miskolc; in the meantime it has been significantly further developed and is now suitable for pillaring and floor shifting tasks and designing sheathing and footings. I was happy to see that they intend not only to sell ARCAD; the 5G itself will undertake designing the reconstruction of family houses—more quickly and more cheaply than "registered" designers, according to their announcement.

So what was added on? It is true it was rather hidden away but they did show their newest development, the CGS-N-1 color graphic terminal with a resolution of 2048 x 2048 pixels; it has a serial line connection and can be connected to any computer. It can display 16 colors and has a drawing speed of 1.6 microseconds. There is an independently configured version and a version on a normal card which can be built into a PC.

FACTORY AUTOMATION, ROBOTICS

GDR's Programming Package for Robotized Assembly Described

23020081 East Berlin FERTIGUNGSTECHNIK UND BETRIEB in German No 7, 89 pp 395-397

[Article by Prof. Dr. sc. nat. J. Lotzsch, and J. von Pistor: "Automatic Task-Oriented Programming of Industrial Robots for Assembly"]

[Text]

Introduction

There is wide agreement internationally when it comes to the evaluation of programming methods for industrial robots^{1, 4, 8, 9, 13, 14, 15, 16, 17.}

Differing programming methods (playback, teach-in, manipulation-command-level, manipulation-high-level, task-level), etc.) are still justified in terms of their existence on the basis of various practical employment requirements.

The off-line share at the programmer position keeps growing because of the switch to through-going CAD/CAM systems.

Explicit movement intentions partly recede into the background and must be supplemented out of the context.

It has been found that higher robot programming languages did indeed bring about tremendous progress in robot programming but that there is still a discrepancy with respect to the work techniques of the technologist. The latter has developed its own specific language tools in order to model the assembly tasks as descriptively as possible. Using such problem-oriented language resources, the technologist can attain a high-productivity level in his assembly-preparation work. This is why the goal must be to explore this technical language of the technologist as comprehensively as possible for man-computer communication.

1. The Special Assembly Tasks Experimental System

On the basis of a newly-developed method, the Dresden experimental system called SMA (Special Assembly Tasks) serves for the automatic programming of industrial robots^{2, 6, 12.} The main point here is represented by the use of a controllable class called "Special Assembly Tasks" (SMA) in flexible automatic assembly cells. The specifics of this novel method therefore consists in the fact that—for the immediate communication of the machine-building technologist with the computer—a technical language of descriptive character has been implemented with the help of the DEPOT2a Metasystem^{3, 11.} This eliminates one additional programmer for the adaptation and translation of the specialized technical problems. This SMA specialized technical language does

not constitute just another copy of a traditional industrial robot programming language but rather a language:

For modeling the product to be assembled,

For describing the assembly system (assembly cell),

For the illustration of the relationships between both (relations).

The means for expressing the SMA language were taken directly from the customary language usage of the technologists. There is practically no additional effort when it comes to learning this specialized technical language.

One quality characteristic which must be specially underscored furthermore has to do with the fact that the assembly tasks are illustrated non-algorithmic and that the process of generating the assembly or handling algorithms (and, finally, those programs) is completely assigned to the computer. But that requires us to record the knowledge and experiences of technologists to systematize them, to process them, and to transfer them to the industrial-robot program generator.

Presently, the SMA system can be used for the automatic programming of flexible assembly cells, consisting of the following components:

Assembly stations (assembly press, screw device, etc.) including pertinent tools;

A central industrial robot (ZIM60, IR10E, IR60E, and the like) with gripping devices;

Storage units for structural components (pallets, shaft magazines, stacking magazines, slides, storage for deposit places);

Tools guided by robot.

2. SMA and Technical Language

A complete specification of an assembly task has the following structure:

ASSEMBLY TASK "Task Name":

"structural components specification,"

"cell specification,"

"relations specification."

It is worked out in SMA practical application step 1 (Figure 1) in a computer-assisted manner. In this connection one can also make reference to already existing libraries of specification parts (for example, for layouts, flexible components, collision freedom, etc.).

In the 2nd SMA practical application step, we can now check the developed assembly task specification statistically for errors with the help of special service software (syntactical mistakes, neglected context dependencies, static semantics). The type and place of the error are communicated to the technologist who can then perform

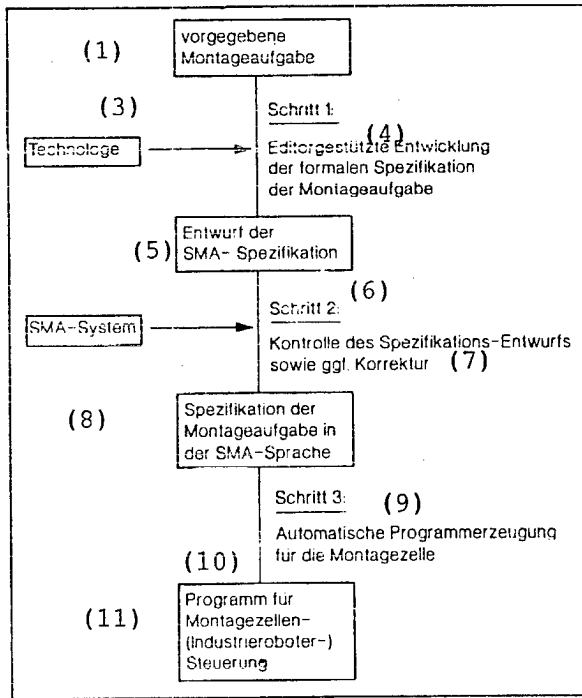

Figure 1. Application of SMA system 395

Key: 1—Predetermined assembly task; 2—1st step; 3—technologist; 4—editor-assisted development of formal specification of assembly task; 5—draft of SMA specification; 6—2nd step; 7—checking on specification draft and, possibly, correction; 8—specification of assembly task in SMA language; 9—3rd step; 10—automatic program generation for assembly cell; 11—program for assembly cell (industrial robot) control.

a (renewed) edit of the SMA specification. A pretty-printer, which at the same time processes the permitted abbreviations and standard determinations, is available. A graphic simulation system for checking on the dynamic semantics is presently not yet connected in.

Finally, in the 3rd SMA practical application step, the assembly task specification is converted into assembly algorithms. The program which can be executed for the control of the assembly cell is now generated.

2.1 On the Modeling of the Product To Be Assembled

Before a special assembly task can be specified with the help of SMA language, an exact structural or resolution survey (TGL [GDR norms] 13 393) must be prepared for the subsystem to be assembled. It forms the foundation for the structural component as well as relation specifications.

2.2. Description of the Assembly Cell

The flexibility of an assembly cell is determined by the fact that various assembly and handling operations can be carried out and that they can be combined into any

desired sequences. Increasingly, however, the cell elements themselves are also equipped in a flexible manner (assembly stations, storage units, robots, etc.). In technical terms, this is solved in that function-determining parts (tools, pallets, etc.) can be exchanged.

In order to be able to derive the handling operations of the central robot automatically in a simple manner, the following are introduced into the cell specification:

An indication of a collision-free area, as well as a safety distance SD for the peripheral cell elements.

A cell specification thus has the following basic structure:

ASSEMBLY STATIONS:

:

ROBOTS:

:

STORAGE:/*FOR STRUCTURAL COMPONENTS*/

:

COLLISION FREEDOM:

:

Table 1 and Figure 3 [not reproduced] illustrate such specifications:

Table 1. Example of cell specification:

Robot, press, pallet

Robot:

Type IR60E,
base at (0 0 -940);
2 grasping devices,
2 power stages,
grasping device out of magazine
at (-1500 -1500 240),
raster 2* vertical (D=120),
depth = 10, SD = 200;
Press: 3 tools,
2 power stages,
structural components at (1000 1000 0),
depth = 50, SD = 250,
tools at (1000 1000 200),
from magazine at (500 1400 20),
raster 3* tangential (D = 100),
depth = 50, SD = 180;
Pallet 2:
20 degree inclination,
structural components at (0 1400 -200),
raster 2* tangential (D = 200),
4* radial (D = 100),
depth = 120, SD = 150;

2.3. Collision Freedom

An area is specified in the cell in which the robot can most extensively move in a collision-free manner. The basic shape of this area is given by two concentric

cylinders. The upper cylinder can furthermore be subdivided into sectors for which in each case a collision-free radius is given.

2.4. Relations

The relation relations specifications contain the data—necessary for each transport operation—for picking up, grasping, transporting, and depositing the structural component or tools. (for example, grasping force, grip width, grip type). Table 2 contains an example.

Table 2. Example of relations specification: Bearing, shaft subassembly.

Bearing 1:

With Grasping Device 1 (width = 50, force = 1);

On Stack Magazine 1

grip at (0 0 0),

grasping device retention

(horizontal, rotation = 0),

without load, horizontal;

On Press.

same as on stack magazine 1;

Shaft Subassembly:

With grasping device 2 (width = 40, force = 2);

On Press:

Grip at (0 0 70),

grasping device retention

(horizontal, rotation = 0),

without load, horizontal;

On Pallet 2.

grip at (0 70 20),

grasping device retention

(normal, rotation = 0),

without load, normal; On Screwing Unit,

same as On Press;

3. Assembly Laboratory

The following equipment was available for the assembly and computer experiments.

Assembly Cell

An automatic assembly cell was placed in operation early during the 1980's at the Dresden Technical University, initially with one and later on with two robots⁵. Fundamental research work for the automation of assembly in machine-building was done with this cell but several industrial objects were also worked on, for example, the assembly of cooling agent pumps, the assembly of axle subassemblies for agricultural machinery, and the assembly of more than 10 variator types. To some extent, complex systems were thus developed with industrial robots, assembly machines, manual work stations, and automatic storage units.

The assembly cell is in each case adapted to the current research and development tasks. The basic structure remains essentially unchanged: Assembly stations and storage units are arranged around the ZIM [Central Institute of Metallurgy] 60 industrial robot (articulated

robot, five axes, 60 kg manual handling mass, manufacturer: ZIM Combine, Berlin) which is centrally arranged in the cell. The following functions can be performed in the cell: Elementary joining, longitudinal pressing, lateral pressing, and application. The structural components can be stored in pallets, in slideway magazines and in shaft magazines. For special tasks, the robot carries tools in the grasping unit (assembly of thin sheet metal rings, sensor-controlled assembly of shrunk-on rings). The storage units can accept various parts of structural components. The stations are able to accomplish various tasks by exchanging tools. The assembly process can be interrupted as desired by means of intermediate storage facilities and can thus be varied.

All actions of the components of the assembly cell are currently triggered or monitored by means of robot control. The control unit is designed for teach-in programming. For this purpose, the robot makers applies the teach-in Programming System TIPS⁷. TIPS processes a command-oriented language at the assembler level.

Computer Equipment

Computers of the PDP11 type were initially used for the off-line programming of the industrial robots. In the meantime, the SMA system is also running on all MSDOS-compatible computers.

As part of a central laboratory for production automation at the Dresden Technical University, a flexible automatic assembly system is provided which contains three different types of robots and which is to be built in several stages. CAP and CAM techniques can be implemented by means of tie-into work piece and tool flow systems as well as into a central computer network.

4. Conclusions

The completion of this research work marks a local, independent contribution was made to the fundamentals and applications of a — technological-technical-language-oriented, — technologist's knowledge and experience integrating, — thoroughly computer-assisted — technological preparation of the use of industrial robots.

This work is aimed at: — Transferring demanding intellectual activities by the technologist to the computer. — formally making available knowledge and experience (intelligence), — and installing efficient work force-computer systems, — which will lead to a definite increase in the productivity of the production-preparing and production sectors.

The experiments with the SMA system showed that such a method is feasible not only basically but that it has in the meantime matured to the point where it can be prepared for use in actual practice (Table 3). The SMA experimental system is designed as a building block in the context of a through-going, computer-assisted technological preparation process¹⁰. An IRDATA interface

is being prepared.

Table 3. Test objects—technologist's time expenditure

Test Object	Evaluation Criteria		
	Structural Components	Specification	
Time expenditure	Units	A4 Pages	Min
Cooling agent pump	6	3	60
Coupling subassembly	5	2	60
Valve subassembly	3	2	45
Cube symbol	6	1.5	45
Cube tower	5	1.5	10

Bibliography

- Blume, C., Jakob, W., "Programmiersprachen fuer Industrieroboter" [Programming Languages for Industrial Robots], Wuerzburg, Vogel Book Publishers, 1983.
- Bauche, V., Loetzsch, J., Nauroschat, D., von Pistor, J., "On Automated Software Supply for Flexible Assembly Cells." Dresden Technical University, Informationen [Information Bulletin], 07-16-85, 1985.
- Grossman, R., Hutschenreiter, J., Lampe, J., Loetzsch, J., Mager, K., "DEPOT2a Metasystem for the analysis and Processing of Interconnected Technical Languages." "DEPOT2a Anwenderhandbuch" [DEPOT2a User Handbook], WBZ MKR/IV, Publication Series (1987) 85, Dresden Technical University.
- Heidenbluth, H., "Programming Languages for Industrial Robots at the Manipulator Level," Dresden Technical University, Informationen, 15-05-88, 1988.
- Hoerow, G., Modler, K.-H., von Pistor, J., Schmidt, H., Zachau, "Automation of Assembly of Subassemblies in Machine-Building in the Area of Small to Medium Unit Numbers." FERTIGUNGSTECHNIK UND BETRIEB [production technology and plant] Berlin, 32, 1982, 8 pp 477 ff.
- Hutschenreiter, U., Kecke, S., "Anwenderhandbuch SMA." Research Report, Dresden Technical University, Mathematics Section, 1988.
- : Technical Documentation on the Industrial Robot Metallurgy SIM 60, amendment to technical documentation for ZIM60-1/ZIM10, VEB [State Enterprise] Central Engineering Enterprise for Metallurgy, Berlin, 1982.
- Latombe, J.C., A survey of advanced software for robot manipulators. Rapp. d. Recherche, [Research Report] IMAG no 330, Novembre 1982, Grenoble.
- Latombe, J.C., Advanced Information Processing in Robotics. Proceed. Conf. on "AI - Information Processing at the threshold of practical application," North-Holl, 1985.
- Liebschner, B., "Assembly Preparation System," System and Documentation, Dresden Technical University, Mathematics Section, 1988.
- Loetzsch, J., Specialized language centered communication and its automatic implementation. Proceed. JFIP - Work. Conf. on "Off-line programming of industrial robots," North-Holl, 1987.
- Loetzsch, J., v. Pistor, J., A dedicated language for off-line programming of an assembly cell. Proceed. IFIP-Work. Conf. on "Off-line programming of industrial robots," pp 71-82, 1986.
- Lozano-Perez, T., Robot Programming, M.I.T., A.I. Memo No. 598/598a, Dec. 1982/April 1983.
- Niehaus, T., "Computer Assisted Application Program Development for Industrial Robots and Flexible Automation Equipment." "Fortschrittsberichte VDI" [Progress Reports of the Association of German Engineers], Series 2: Production Technology, No. 138; VID Publishing House, Duesseldorf, 1987.
- Praeger, K.P., "Kopplung externer und interner Programmiersysteme fuer Industrieroboter" [Coupling of External and Internal Programming Systems for Industrial Robots], Munich, Vienna, Carl Hanser Publishing House, 1983.
- Sata, T., Kimura, F., Hiraoko, H., et al., Comprehensive Modelling of a Machine Assembly for Off-line Programming of Industrial Robots. Proceed. JFIP Work. Cof. on "Off-line programming of industrial robots," pp 19-33, North-Holland 1987.
- Wecks, J.K., "Task-oriented Robot Programming for Flexible Automatic Assembly," INDUSTRIE-ANZEIGER [Industrial Advertiser], Essen, 13, 1988, pp 32 ff.

Applications of FMSs Discussed

Prismatic Components

23020066 GDR East Berlin FERTIGUNGSTECHNIK UND BETRIEB in German No 6, 1989 pp 350-354

[Article by Dr. M. Boehme, Machine Tool Manufacture Research Center Karl-Marx-Stadt, F. Doehler, J. Weichselbaum, VEB Machine Tool Factory "Vogtland" Plauen: "Flexible Automation in Industrial and Large Scale Manufacture of Prismatic Workpieces"]

[Text]

0. Introduction

Industrial and large scale workpiece manufacture must meet demands for high productivity, quality, and reliability with minimal productions costs on the one hand, while being forced to make increasing modifications in response to demands for flexibility on the other. Micro-electronic controls and new methods of automation

technology both for handling workpieces and tools and for transporting workpieces have led to a new generation of flexible special purpose machines and conveyor belts.

1. The Need for Flexible Automation in Industrial and Large-Scale Manufacture

The need for flexible automation in industrial and large scale manufacture of prismatic workpieces arises primarily from the following factors:

- the rate of innovation continues to climb steadily, and the life-span of a conventional special purpose machine or transfer line and the product that is manufactured on it are no longer at odds;
- new products should be manufactured with maximum productivity from the outset in order to avoid transitional technology;
- product variants are being manufactured;
- the production of families of workpieces is desired or required on demand.

Concerning this last factor, workpieces processed on a flexible special purpose machine or production line usually belong to an open or closed workpiece family.

Typical examples of workpiece families are: the housings and end plates of electric motors and dynamos; the cylinder heads and crankcases of internal combustion engines; the housings and caps of transmissions; industrial fixtures; and many other products that are economical to manufacture only in very large piece numbers and to meet a specific demand.

As the trend toward smaller job lots has caused the number of product variants to increase, production lines and special purpose machines, which operate at maximum productivity in accordance with the flow principle, must switch rapidly between different workpiece variants. The highest degree of required flexibility is thereby characterized by job lot and by the random insertion of workpieces into the production line. In the wake of this development, flexible production lines and special purpose machines were created that are still highly productive, but which also have parts flexibility and can process different workpieces without lengthy changeover times. The operative range of flexible production lines is from around 3,000 to 150,000 part numbers per year, whereas on the production line 2 to 15 different workpieces can be processed. In contrast to flexible manufacturing systems, flexible assembly lines have a unidirectional workpiece flow, which means that simple controls requiring minimal programming can be used.

2. Configuration and Components of Flexible Production Lines and Special Purpose Machines

Flexible production lines and special purpose machines consist of three parts: the processing system, the material handling system, and the information handling system. Suitable building blocks and modules appropriate to the manufacturing task at hand must be selected for these

subsystems (figure 1) and combined into a single economical and technically effective system.

2.1 Processing Units

The processing system accounts for some two thirds of the overall system and serves the most important function. The flexibility of The processing system is directly related to the technological flexibility of the processing units, which is achieved by using NC (numerical control) or CNC (computerized numerical control) as well as SPS (stored-programmable control) functions and by including tool change in the overall function of the processing units. 3-D processing units (three orthogonal linear feed axes on the tool surface) are particularly suitable for flexible production lines because of this simple configuration of the workpiece flow through one- and two-sided connections between the 3-D units and the central supports of the workpiece handling system. When the building block principal is used in combination with the additive principle in planning and manufacturing the processing units, the units can be used in various ways, such as: simple NC axis as feed unit (1-D); 2-D operation; 3-D operation; 3-D + tool changer; and 3-D + tool changer + tool storage. The requirements of the manufacturing task will dictate which of these will be selected for use in the flexible production line.

The following processing units are now being produced in the VEB Machine Tool Collective Combine "Fritz Heckert":

The EFS and EFW CNC3-D Milling Units

These processing units can be used with the standardized structural components of conveyor belts and special purpose machines. Depending on the task at hand, the milling units are equipped with either one or two horizontal or vertical milling spindles, with various milling spindle bearing applications for rough or smooth milling. Figure 2 shows an EFW milling unit and figure 3 an EFS milling unit with a fine milling spindle. [Figures 2 and 3 not reproduced]

The EW 40/3 CNC and EW 50/3 CNC3-D Boring Units

These units also produce the x, y, and z axes on the tool surface and can be used with the structural components of special purpose machines and conveyor belts. They are suitable for the single-spindle processing used in boring, counterboring, reaming, threading, milling/groove milling/cylindrical milling, chamfering, and fine boring. Special tools, NC- and surface-boring heads, small multiple-spindle drill heads, and angle drill or milling heads also can be installed. Figure 4 [not reproduced] shows the EW 40/3 CNC modification with ISO steep-angle taper 40 and a maximum of 6,000 spindle revolutions/min with tool changer and tool storage, as well as the associated workpiece surface. Derived from the 3-D units, 1- and 2-D boring and milling units are available for appropriate processing jobs.

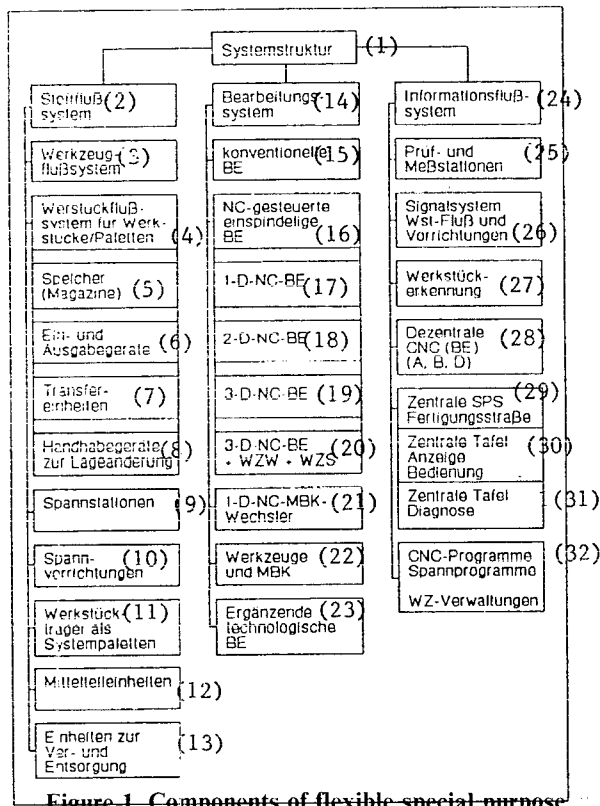

Figure 1. Components of flexible special purpose machines and production lines. BE ■ processing unit; WZW ■ tool change; WZS ■ tool storage; MKB ■ multiple-spindle drill-head; A ■ display; B ■ operation; D ■ diagnosis.

Key:—1. System configuration—2. material handling system—3. tool handling system—4. workpiece handling system for workpieces/palettes—5. storage (magazine)—6. input and output devices—7. transfer units—8. positioning handling devices—9. gripper stations—10. clamping device—11. workpiece shuttles as system palettes—12. core units—13. feed and storage units—14. processing system—15. conventional BE—16. NC single spindle BE—17. 1-D-NC-BE—18. 2-D-NC-BE—19. 3-D-NC-BE—20. 3-D-NC-BE + WZW + WZS—21. 1-D-NC-MBK-changer—22. tools and MBK—23. auxiliary technological BE—24. information handling system—25. inspection and measurement stations—26. signal system, workpiece flow and devices—27. workpiece identification—28. decentral CNC (BE) (A,B,D)—29. Central SPS production line—30. central table, display, operation—31. Central table diagnosis 32. CNC program, gripper program, WZ administration

BWMRS 4 x 630 x 630 Horizontal Multiple-Spindle Drilling Machine

This unit, which is for a configuration with a maximum of four multiple-spindle drill heads of 630 mm by 630 mm, is intended for boring, counterboring, reaming, and tapping. Four control probes can be operated after each

operation. Figure 5 [not reproduced] provides a view of this machine. Multiple-spindle drill-head changer machines are highly productive as a result of an overlapping start-up time for boring, counterboring, and tapping. The automatic change of drill heads provides for a limited adaptation to several workpieces.

2.2 Material handling system

The material handling system (Figure 1) consists of the workpiece handling system, the tool handling system, and subsystems for retrieval and storage. In flexible production lines, the tool handling system is directly connected with the processing units. Accordingly, only the workpiece handling system and a few of the more recent developments in palette transport and workpiece gripping devices will be addressed here. The configuration of the workpiece handling system determines the basic configuration of the flexible production line. Workpieces can be transported by using system palettes as workpiece shuttles or, in direct workpiece transfers, by using units of the transport system. The use of system palettes as workpiece shuttles requires a self-contained workpiece handling system, as the system palettes must be retrieved from the workpiece output location independently. Therefore, contrary to the FMS, one is always dealing with a directed workpiece flow.

In contrast to inflexible transfers, palette transport systems with independent longitudinal and cross units, rotary changers, and rotary stations, as well as gripping and storage areas, can flexibly interlink various processing units with flexible special purpose machines, including palette retrieval. Combining asynchronous transportation with temporary storage also provides greater availability.

The following units can be used for a palette transportation system based on the standardized TGL/DIN palette:—linear transportation with conveyors, rotary units, rotary changers;—cross and retrieval transportation, also as storage; and—input and output conveyors, stacking and gripping areas.

Figure 6 shows the use of these units in conjunction with a special purpose machine.

For two- or four-sided processing and for angled processing in the 360 x 1 range, this machine can also be equipped with 3-D boring units and multiple-spindle drill-head changer. The setup varies and corresponds with the end use of the machine. Workpieces can be lined up for processing consecutively by using palettes, and removal is possible with palette storage areas.

The workpiece shuttles and gripping devices are important parts of the workpiece handling system and are closely connected to it. The workpiece gripping devices and associated workpiece handling equipment account for the largest portion of the financial investment at approximately one quarter of the overall cost. The modular units used in automatic gripping techniques are increasingly being used for workpiece gripping devices.

These units are also installed in devices on system palettes if conditions require hydraulic gripping devices. Standard elements have been built and are mounted on the system palettes as needed. Pneumoelectric signaling is used for signaling the status and condition of devices and the suitable signal transmitters, pneumatic couplers, and pneumoelectric transformers are available for this purpose. The element of the automatic gripping technique are listed in the Machine Tool Manufacture Research Center's device construction catalog.

2.3. Information System for Control and Monitoring

Figure 1 shows the most important workpieces of the information handling system of flexible production lines.

The random processing of various workpieces on flexible production lines requires workpiece identification at every work station. This is achieved by coding the workpiece or palette and installing the corresponding identification sensors. After workpiece identification, the central SPS calls up the NC workpiece program, the SPS gripping program for positioning and gripping the devices, and the functions of the workpiece transportation system for moving workpieces from one work station to another. The complex operation and monitoring of the flexible production line conducted via a central operating stand for manual, tool, and automatic operation with displays to indicate working order, as well as via operation and display facilities near the machine, such as work station control diagnostics. The SPS portions of the processing unit controls can, if necessary, control not only the machine function, but also the associated automatic device functions. Control of the material handling system units is executed from the central SPS. The main control tasks are linking and reporting signals, which are also used for diagnosis. Directed workpiece flow creates clear functions for the workpiece flow, so that comparing the status reported by the signals with the optimum status provides a simple and rapid diagnosis. At the same time, central control of the flexible production line provides data to an overriding operational data acquisition and organization computer, which ensures inclusion in the general system of planning, executing, and controlling the operation.

3. Operational Examples

3.1. Flexible production lines

The penetration of flexible manufacturing into the field of industrial scale manufacture began on the international scale at the beginning of the 1980's and has been accelerating since 1985. The VEB Machine Tool Collective Combine "Fritz Heckert" responded to this development with a program of modular units for flexible production lines that is gradually being implemented. The type and sequence of the workpieces for flexible

production lines developed in recent years were determined by contracts for 1) a flexible production line for milling crankcases, and 2) a flexible production line for gear-box processing.

Seven 3-D milling units are used in the assembly line for milling crankcases, of which five have vertical spindles (EFS) and two have horizontal spindles (EFW). The crankcases for 4, 5, 6, VD 13.5 motors are milled on this assembly line, in addition to the crankcase for the standard 4 VD 14.5 motor. As a result of the differing outer contours of the 4 VD 14.5 and the 4, 5, 6 VD 13.5, the overall parts assortment represents an open parts family.

Premilling and final milling of the cylinder heads, oil pan, and surfaces occurs on the production line. The storage passage is also premilled. Fine milling of the cylinder heads and oil pan replaced surface grinding, and roughness values of $R_z = 12.5$ and evenness of 0.02 mm are being sought.

The crankcase, with a mass of 120 to 180 kg, is transferred openly, without workpiece shuttles. Moving the workpieces into the milling line can be completely random. Job lot 1 is implemented without changeover time.

All flexible gripping devices are controlled through the SPS of the associated milling stations. Each milling station identifies one particular workpiece. All devices are equipped with a pneumoelectric signal system for control via the SPS of the CNC-H 646. Control of the entire assembly line occurs through two stored-programmable PC-603's, whereby the workpiece programs in the CNC-H 646 connected to the station are also called up. A central operations and control panel with operational status displays makes it possible to operate automatically, manually, and with tools. The milling line has been used in three-shift operations since November 1986. A maximum output per shift of 125 milled crankcases and a maximum daily output of 336 milled workpieces was achieved with a clock-time of 3.4 minutes and preservation of the required quality. This results in standard quantities of several hundred crankcases from the rough milling stations and 2,000 to 4,000 workpieces from the fine milling stations. While the milling line for crankcases uses free workpiece transportation, palette-related transportation with workpiece shuttles equipped for particular workpieces are used for gear boxes. On the production line, crankcases must be processed as open parts families of eight different workpieces, and for each workpiece 24,000 to 36,000 part numbers must be assembled per year. The required processing units are 2-D milling units as stripped down versions of the 3-D milling units, 3-D boring units (EW 40), and multiple-spindle drill head changers. Workpiece transportation takes place via workpiece shuttles, which are equipped for two-sided workpiece gripping. The technological sequence of operations is accomplished by passing the workpieces along the conveyor belt twice, whereby separate and connecting surfaces of the driving

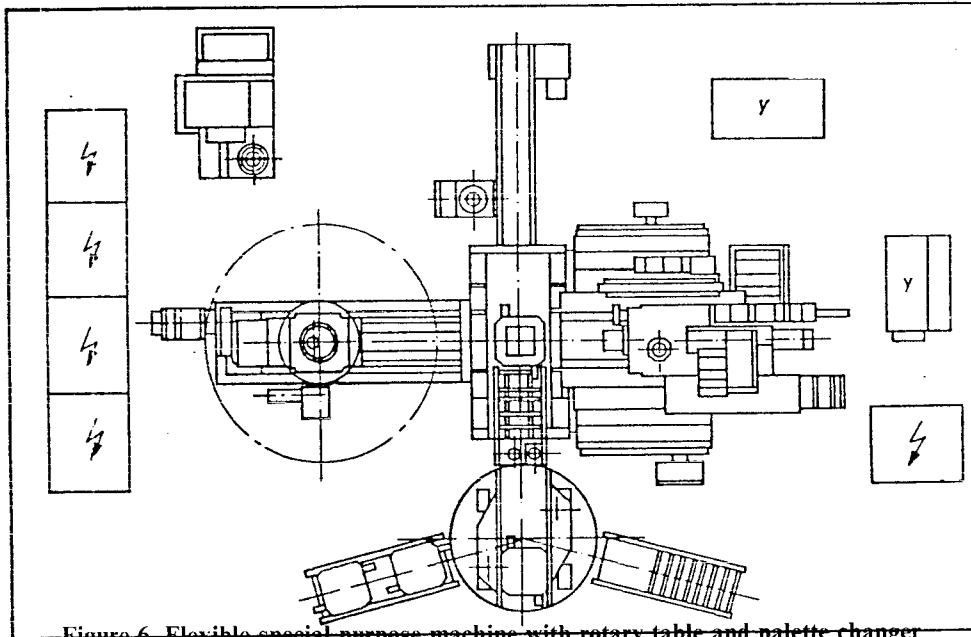

Figure 6. Flexible special purpose machine with rotary table and palette changer

gears are processed one after the other in two gripping positions (left and right side of the same device). An important element of the conveyor belt is the robot gripping area, where the cast parts are fed to the device from the workpiece storage area, transferred from the first to the second gripping position, and returned to the workpiece storage area from the second gripping position after the second pass-through of the workpiece shuttle (Figure 7) [not reproduced]. The IR2P-S2 portal robot with associated IRS 713 control is used as loading robot. The portal robot automatically executes the gripper change required for handling the various workpieces. The workpiece-shuttle gripping devices, which are equipped for specific workpieces, adjust the workpieces (Figure 8) [not reproduced].

The connecting rod or drawbar of a hydraulic cycle aggregate with a stroke of 2,250 mm on slide rails (Figure 9) [not reproduced] is used to transport the workpiece shuttles and fixture them to the stations. The return trip is made using transverse and return rails similar to conventional conveyor belts. An STR 2000 rail transport robot is used to automatically transfer whatever devices are needed into and out of the production line. Workpiece identification occurs at each station by scanning the palette coding. The material handling system of the flexible production line is controlled with a PC 603. The optimum clock time is 2.4 minutes. The initial operation of the flexible production line was concluded by December 1988.

Flexible Special Purpose Machines

Flexible special purpose machines for workpiece families are primarily produced as rotary indexing table machines. The processing units used are the same as

those used in flexible production lines, except that in this case a rotary indexing table is used for the internal interlinking.

Figure 10 shows a flexible special purpose machine with rotary table and four secondary rotary tables.

This kind of highly productive, flexible special purpose machine can also be equipped with 3-D boring units or multiple-spindle drill head changers depending on the needs of the job. The large rotary table is used as a means of linking the peripheral processing units. The attached secondary rotary tables have independent changers, so that multi-sided processing can take place at each work station and the gripping station can be easily accessed from all sides.

The secondary rotary table permits 5-sided processing by adding a small angle device to the spindle of the 4-D boring unit. The high productivity and accuracy of the special purpose machine are combined with flexibility. The workpiece assortment most effectively processed on the flexible special purpose machine are housing parts requiring multi-sided processing. One example of large scale manufacture is sleeve drum machines, which are used for multi-sided processing (usually three sides) of mountings, but also for similarly formed parts in other branches of industry, e.g. brake cylinders. During simultaneous 3-sided processing, up to 15 sleeves, 2 x 5 axes, and 5 radials are installed. As for technological procedures, boring, counterboring, reaming, and threading can be accomplished, as well as fine boring. To a large extent, required power, work spindle revolutions/minute, and rate of speed can be adapted to the type of

Figure 10. Flexible special purpose machine with secondary rotary table

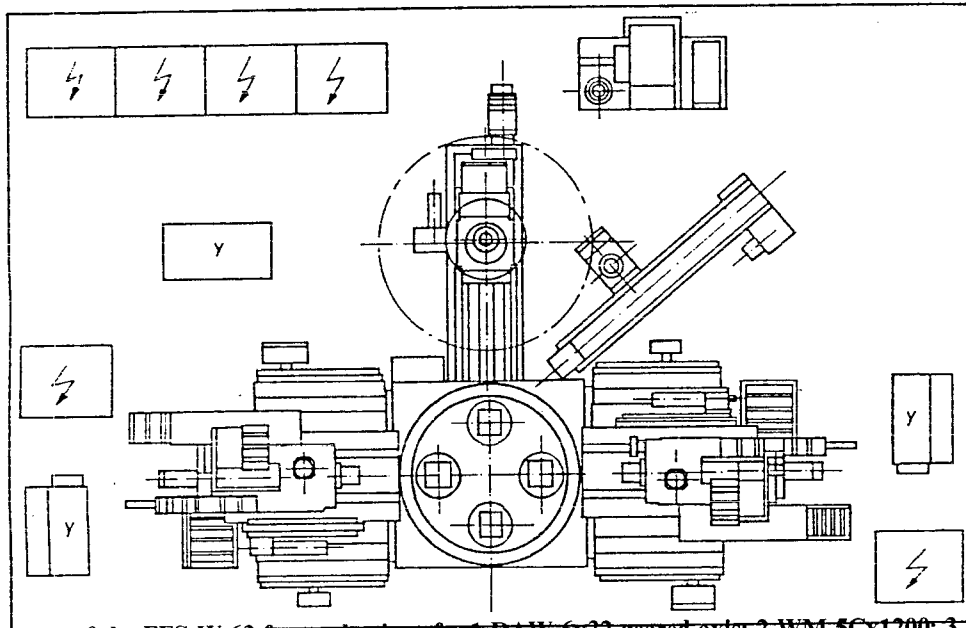

Figure 2. Layout of the FFS W 63 for production of a 1 DAW 6x32 geared axis; 2 WM 5Cx1200; 3 SASL 3 AE; 4 Unitherma 350; 5 cross storage

workpiece and material. Maximum productivity is ensured with a 10 second clock time and a 3 second drum clock time.

4. Conclusion

Flexible manufacturing is becoming increasingly important in industrial and large scale manufacture. With the resources available today, flexibility and high productivity are no longer mutually exclusive. A case in point is the processing of workpiece families, i.e. geometrically and technologically similar workpieces. 1-D, 2-D, and 3-D NC processing units are installed with optional tool changer and multiple-spindle drill head stations combined with CNC processing units. The workpiece handling system is characterized by directed workpiece flow and is carried out according to the criteria of the manufacturing task either as free transfer or as transportation with workpiece shuttles.

The information handling system consists of a central SPS as well as decentralized controls on the processing units. Selected combinations of CNC and SPS controls make possible the necessary control functions for processing units, transport systems, workpiece gripping devices, and workpiece handling devices. Flexible production lines and special purpose machines have defined interfaces in the material and information handling, which at any time allow them to be coordinated with a CIM concept of operations.

Rotationally-Symmetric Workpieces

[23020066 GDR East Berlin FERTIGUNGSTECHNIK UND BETRIEB in German no 6, 1989 pp 355-358

[Article by Dr. W. Simon, K. Nothnagel, VEB Machine Tool Collective Combine "7 October" Berlin: "Flexible Production Lines for Processing Rotationally-Symmetric Workpieces for Industrial and Large Scale Manufacture"]

0. Introduction

[Excerpts] Production lines for industrial and large scale manufacture have long occupied an important position in the product line of the VEB Machine Tool Collective Combine "7 October" in Berlin.

The Combine decided to devote the 5-year period between 1986 and 1989 to developing and producing higher quality complex technological solutions to large scale and industrial manufacture. This decision was supported by the existing results and experiences of traditional production line producers, such as the VEB Mikrosa Leipzig, the VEB Machine Tool Factory Berlin, and the VEB Machine Tool Factory "Hermann Matern" Magdeburg, whose products were primarily delivered to roller bearing and electric motor industries in the Soviet Union, and were required by the long-term trade agreement between the German Democratic Republic and the Soviet Union. This process, which is currently underway, is characterized by:

—improving the traditional production lines for the roller bearing and electric motor industry;

- developing and delivering flexible production lines for the automobile industry, primarily in the Soviet Union; and
- increasing the degree of technological consistency, and thereby the production scope, that can be achieved through the combine's general contractors by exporting the parent plant's assets.

Achieving adaptability to microelectronic machines and system controls, a condition of the flexibility needed in large scale and industrial manufacture, is given particular emphasis in the development process.

This challenging program can only come to fruition if all the combine's resources are used effectively. It will also serve to interweave the development and production potential of the enterprise and its subcontractors more tightly. The general contractor of the combine assumes a central responsibility in this program by coordinating and directing the technical, organizational, and commercial activities of the enterprise, both internally and externally.

1. Production line production concept

—Technological sphere The production concept contains production lines for 1) roller bearing ring and roller body processing, with turning, grinding, and superfinishing procedures, 2) shaft parts processing (including pinion shafts), with turning, grinding, and gear-forming, and 3) chuck processing (including toothed gears), with turning, grinding, and gear-forming.—Auxiliary procedures for increasing the degree of technological consistency are realized through subcontracts from the GDR and abroad.—Basic technical concept The basic technical concept includes the functionally complex processing system (use of manufacturing cells and auxiliary processing devices), the workpiece handling system (transportation and storage), the control system (linking the technologically independent parts system with the production line), and the quality control system (measuring and inspection).

A production line's degree of flexibility depends on 1) the adaptability of the processing and workpiece handling system with the varying workpiece geometries and dimensions, 2) the retooling requirements with minimized lot piece numbers, and 3) the requirements for using freely programmable computer controls.

One must also bear in mind that production lines generally have limited flexibility because of their technological specialization as equipment for small-lot production. This affects variant flexibility, whereas production lines require a higher level of process flexibility with regard to productivity and minimizing downtime.

—Basic subsystem features Processing systems based on machine developments contained in the turning, grinding, and gear-forming production concepts, with

an increasing proportion of CNC machines and production cells adapted to the conditions of industrial scale manufacture.

Workpiece flow system:

internal: priority given to CNC portal robots, but also additional robots and workpiece-specific manipulators; external: chain (plastic or metal) conveyors, roller conveyors, walking beam conveyors, and possibly palletes.

Control systems for workpiece flow, process status acquisition, and process inspection tasks based on SPS technology (PC 603, PC 610, EFE 700).

Quality control systems based on the use of external measuring stations with electronic or pneumatic transmitters for monitoring size. [passage omitted]

2. Examples from the Production Program 2.1. Productions lines for FFS RWR roller bearing processing

The technological activity of these production lines includes hardening the internal and external rings through slide grinding, bore grinding, slide finishing, and washing, among other integrated processes, for the following types of roller bearings: radial deep-groove ball bearing, angular ball bearing, cylindrical roller bearing, and tapered roller bearing in the P6/P5 quality.

The processed workpiece, which can be transported and stored in the flexible workpiece handling system "BWF - VARIOTRANS," falls within the following measurements:—workpiece diameter: 25 to 100 mm;—workpiece width: 12 to 32 mm; and—workpiece mass: 1,000 g.

In the FFS RWR 63, the following automatic machines are used among others:—SIE 3, SIW 4 internal automatic grinders with preliminary and final measuring stations as well as URSA-LOG 5022 microprocessing control with CAC functions;—SAW 4, SWaeAGL 50, SWaeAGL 125 external cylindrical automatic grinders with final measuring stations and PC 610 microprocessing control;—SZW 4 automatic superfinisher; and—automatic washers.

Control of the workpiece handling system uses an S 2000 memory programmable control from VEB EAW Berlin. An example of an FFS RWR 63 from the VEB Berlin Machine Tool Factory is shown in Figure 1 [not reproduced].

2.2. Shaft Processing

2.2.1. Production lines for threaded parts with centerless grinding and auxiliary procedures - FFS W 63

The technological activity of these flexible production lines includes the centerless grinding of threaded parts with auxiliary procedures. Typical workpieces are:—generator and rotor shafts;—piston and shock absorber rods;—sliding selector shafts; and—bolts and cylinders.

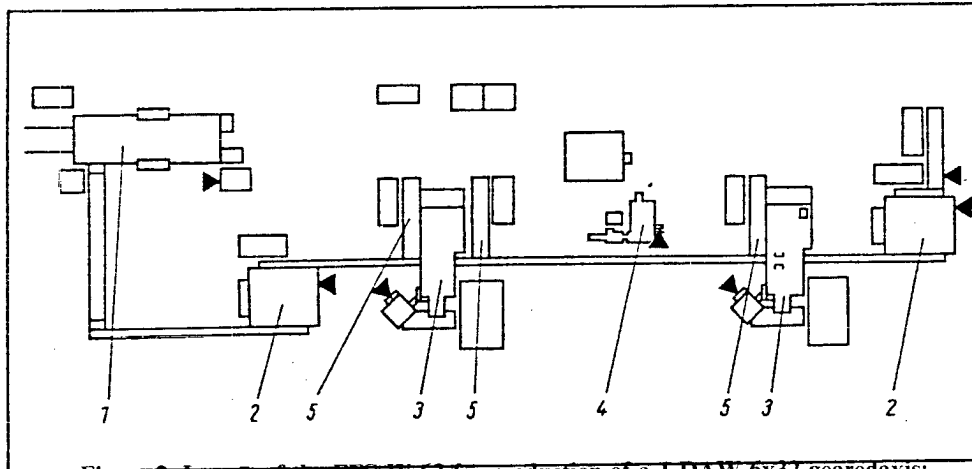

Figure 2. Layout of the FFS W 63 for production of a 1 DAW 6x32 geared axis; 2 WM 5Cx1200; 3 SASL 3 AE; 4 Unitherma 350; 5 cross storage

The FFS W 63 can be set up for one workpiece as well as for a group of workpieces, such as piston rods. The processed workpiece ranges from 6 to 63 mm in diameter and from 40 to 450 mm in length in plunge-cut grinding and from 100 to 1,200 mm in throughfeed grinding.

The production line module of the VEB Mikrosa Leipzig provides for use of the following fixtures:—centerless automatic grinders from the SASL product line;—multiple-spindle automatic lathe from the DAM/DAMF product line;—WM 50 x 1220 washing machines;—high frequency hardeners;—roll-forming machine from the UPW product line;—FX 1 groove-milling machine;—FZWD 160 two-sided shaft-milling and centering machine

—BRD 60 two-surface grinding machine; and—special boring and milling machines.

The workpiece handling system consists of various sizes and shapes of the following basic fixtures:—longitudinal conveyors;—cross conveyors, cross storage;—shaft retrieval and storage devices;—double portal clamps; and—vertical lot manipulator.

The central control, which consists of one or more PC 603's, controls the entire signal exchange of the workpiece handling system and, if necessary, of individual special purpose machines. Figure 2 depicts the layout of an FFS W 63 for production of a geared axis in a Soviet automobile factory. est0964;171;2w

2.2.2. Production lines for shaft and rotor processing of electric motors—FFS W 630 E

FFS W 630 E's are used for turning and grinding (and necessary auxiliary procedures) electric motor shafts and completed rotors for a motor shaft center height of 71 to 112 mm or 112 to 132 mm. The workpieces to be processed fall within the following dimensions: shaft

diameter: 20 to 60 mm; shaft mass: 1 to 25 kg; rotor diameter: 60 to 160 mm; rotor mass: 2 to 30 kg; and length: 150 to 630 mm.

The nominal man-hour output of the FFS W 630 depends on the workpiece and ranges from 20 to 40 pieces/hour. The utilization coefficient is 75 percent and is related to the production volume guaranteed for a given time period.

The FFS W 630 E consists of two independent production line sections. In the shaft processing section, the following machines are used:—special-purpose cutting, centering, and boring machine;—DFS1 CNC 700 high-performance lathe;—FNW 32x800 groove-milling machine; and—SA 6 A cylindrical surface grinder.

In the rotor processing section of the production line, the SA 6 AS cylindrical surface grinder and the DXRO 2 CNC rotor lathe are used.

The workpiece handling system contains KR 20 friction roller conveyors, PR 01 portal manipulators, diameter inspection stations, lubricating stations, and locating stations.

The FFS W 630 E is controlled with the KR 20 friction roller conveyor's memory programmable PROKON control. The PR 01 portal manipulators are equipped with the PC 610. Use of a DFS 1 CNC 700 high-performance lathe in a production line for a shaft center height of 71 to 112 is shown in Figure 3 [not reproduced].

2.2.3. Production lines for shaft processing with FFS W/WZ 630

The FFS W/WZ 630 for turning and gear-forming, or for grinding and microfinishing, including the necessary auxiliary processes, is set up for the following workpiece configuration:—workpiece diameter range: 20 to 250 mm;—length: max. 630 (800) mm; and—mass: max. 30 kg.

The setup of the production line for shaft processing depends on the specifics of the technological task at hand. Shafts without gears are processed on an FFS W 630. The FFS W/WZ 630 is planned and built for complete processing as well as for independent sections, for example after heat treatment. The following machines can be used in the production line depending on the task at hand:—FZWD 160 x 1000 shaft milling and centering machine;—DFS 2/2-4A CNC 700 K high performance lathe;—SA 6 A/AS external cylindrical grinding machine;—FNW 32 x 500 groove-milling machine;—ZFZ 03 CNC gear-tooth generating machine;—OHA 16 B gear-tooth forming machine; and—UPWS 25 roll-forming machine. In addition, it is presumed that fixtures provided by the clients will be integrated. This involves the processes of washing, gear edge processing, trimming, cold rolling, and honing.

The flexible workpiece handling system consists of a KR 20 friction roller conveyor, green and finished parts storage, portal robots and manipulators. Locating stations, lubricating stations, workpiece counting devices, workpiece turning devices, and workpiece transfer devices are integrated. The workpiece handling system is controlled by the KR 20 friction roller conveyor's memory programmable PROKON control. The EFE 700 control is used for the measuring and auxiliary devices. Figure 4 [not reproduced] depicts the use of a SA 6 A external cylindrical grinding machine in an FFS W 630 for the manufacture of a secondary shaft in a Soviet automobile factory.

2.3. Chucking 2.3.1. Production lines for FFS F 250 chuck lathe The FFS F 250 is used for turning chucks, particularly in the automobile and roller bearing industries. Typical workpieces for these technological tasks are flanges, caps, hubs, roller bearing rings, and gears, with the following workpiece measurements:—outside diameter, max.: 250 mm;—workpiece length, max.: 125 mm; and—workpiece mass, max.: 5 kg. Depending on the concrete technological task, two to six two-spindle DFF 2/124-CNC 700 chucking lathes are interlinked with a FFS F 250.

The flexible workpiece handling system considerably minimizes retooling time. Individual palettes, supported on a curved, horizontal, oval, revolving plastic chain, store and transport the workpieces. The workpiece handling system consists of several individual feeders, in which plastic chains revolve continuously. The machine is fed by a portal loader, on whose portal wagon two vertical processing units have been fixtured. Lifting and locating stations can be added to the plastic chain feeder if needed.

Control and turning stations are fed by the portal loader. The workpiece handling system is characterized by the following parameters:—plastic chain width: 55 mm;—length of modular units for oval revolving plastic chain: up to 2 m;—load, max.: 25 kg/m; and—speed: 6 m/min. PC 601's are used for controlling the workpiece handling system. Control of the portal loader is coupled

with the CNC 700 control of the FD DFF 2/124-CNC 700. Figure 5 shows the configuration of an FFS F 250 that is being used in a Soviet automobile factory.

2.3.2. Production lines for turning and gear-forming with auxiliary processes—FFS FZ 250 The FFS FZ 250 for turning and gear-forming spur-toothed wheels, including the necessary auxiliary processes, is set up for the following workpiece category:—workpiece outside diameter: 60 to 200 mm;—face width: 8 to 35 mm;—size of bore: 35 to 100 mm; and—workpiece mass: 0.4 to 5 kg. The following machines are used in the FFS FZ 250:—DAMF 6 x 160 or DAMF 6 x 200 multiple-spindle automatic lathe;—DFS 1 CNC 700 high performance lathe;—ZFZ 03 CNC gear-tooth generating machine;—SI 4 A internal cylindrical grinding machine; and—OHA 16 B gear-tooth forming machine. The workpiece handling system consists of modular longitudinal conveyors and transport sections, which operate according to the walking beam principle. The longitudinal conveyors are used for moving workpieces into and out of storage as well as for linking the individual fixtures. The transfer of the workpiece from the longitudinal conveyor into the machine occurs via the lifting station of the longitudinal conveyor by means of portal robots or transfer manipulators, whereby the individual machines are partially given an interim storage. PC 603 type memory programmable controls are used as the central control in the FFS FZ 250. The FFS FZ 250 consists of a production line section for turning and a production line section for gear-forming.

The workpiece is a gearwheel with an outside diameter of 82 mm, a width of 37 mm, and a mass of 1.2 kg. The nominal man-hour output is 40 pieces/hour. The utilization coefficient for the time-guaranteed production volume is 75 percent.

Conclusion and Prospects

The production program of production lines in the VEB Machine Tool Collective Combine "7. Oktober" Berlin represents one of the main directions in which flexible automation in workpiece manufacture is moving, particularly for the roller bearing, electric motor, and automobile industries. It is being expanded and optimized by meeting the following goals:—reduction of retooling time;—increase in utilization opportunities; and—increase in quality control through diagnostics and measurement systems.

The technical realization of these requirements is being accomplished largely through opportunities in computer technology in general and through CNC technology for machine tools and robots in particular. In the process, more and more CNC solutions are being found that suit the specific conditions of industrial and large scale manufacture, for flexibility of production lines is different from flexibility as it is required and understood in small-lot production.

One further goal is to increase the degree of technological consistency in production lines as it concerns complete

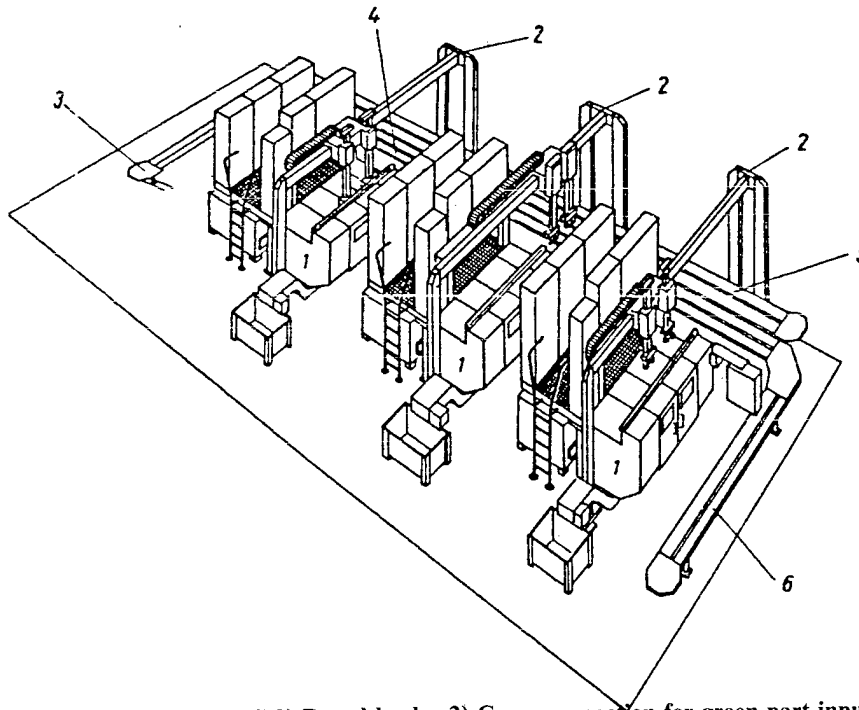

Figure 5. FFS F 250. 1) DFF 2/124-CNC 2) Portal loader 3) Conveyor section for green part input 4) Conveyor section for green part feeding 5) Conveyor section for finished part removal 6) Conveyor section for finished part output

processing. This is being achieved by steadily increasing international cooperation with the COMECON countries.

TELECOMMUNICATIONS

Hungarian Analog Subscriber Carrier Frequency Telephone Equipment

25020255 Budapest *MAGYAR ELEKTRONIKA* in Hungarian No 6, 1989 pp 26-28

[Article by Peter Galambos, Triton Small Cooperative: "LEGAFON, 1+1 Channel Analog Subscriber Carrier Frequency Telephone Equipment"]

[Excerpts] For economic reasons the cable system of telephone networks has only limited reserves. [passage omitted] Subscriber networks are often supplemented by single channel analog carrier frequency equipment. [passage omitted]

We developed, on the basis of the Post Office prescriptions, 1+1 channel analog equipment which received a Hungarian patent in 1986. The Triton Computer Technology and Telecommunications Small Cooperative obtained the manufacturing rights and began series manufacture of the 1+1 channel analog subscriber carrier frequency telephone equipment under the name LEGAFON. The equipment satisfies the recommendations of the CCITT and the prescriptions figuring in the

transmission plan of the Hungarian Post Office. It satisfies the MEEI [Hungarian Electrotechnical Control Institute] requirements and standards MSZ 10190 and MSZ 172.

By using carrier frequencies on any cable pair of the telephone network the LEGAFON equipment creates an independent transmission channel above the baseband voice frequency range. The baseband range is 0 to 12 kHz, the receiving carrier frequency range is 36.6 to 43.4 kHz, and the transmitting carrier frequency range is 60.6 to 67.4 kHz.

The equipment consists of three subunits: an exchange-side unit, a subscriber unit, and a baseband low-pass filter.

When the LEGAFON equipment is used the baseband circuit is connected on the exchange side and on the subscriber side through a low-pass filter, which ensures transmission of the baseband telephone channel in the 0-12 kHz frequency band and prevents the baseband and carrier frequency channels from having an effect on one another. It also separates the carrier frequency signals from the telephone exchange and from the baseband subscriber set.

The exchange-side units of the LEGAFON equipment are used in telephone exchanges in larger numbers so the circuits are placed in a rack system. Printed circuits for 14 exchange-side units can be placed in one box; these

include the baseband low-pass filters. They receive power from the DC voltage of the telephone exchange.

There are two versions of the subscriber unit depending on use:

—A single box version is made to set up one telephone station. It gets power from the AC grid or can be operated by a storage battery. The battery can be charged from the AC grid or by an automatic line charging stage.

—To establish a number of carrier frequency channels in one place (e.g. at a sub-exchange) the LEGAFON subscriber units can be placed in a rack system—similar to the exchange-side units. The group subscriber rack unit can contain four circuits. The AC grid or the local DC voltage supplies the power. A built-in storage battery cannot be used with this version.

The LEGAFON equipment has automatic carrier level regulating circuits. Companding circuits reduce the effect of cable crosstalk from other carrier frequency equipment and other electric interference. Transmission of the 12 kHz fee pulses and of polarity changes takes place in the physical baseband. There is polarity independence for line switching. There are no moving electromechanical parts.

The equipment conserves power. It is not necessary to test or set the carrier frequency when it is installed. LED indicators show operational status. Maintenance is not required.

In order to use the LEGAFON equipment one can use any telecommunications cable pair on which 0-12 kHz frequency range signals are transmitted. The equipment cannot be used in a subscriber net which contains

uninsulated overhead wire sections. The maximal attenuation of the line at the higher frequency is 43 dB/150 ohm/64 kHz. In the case of line storage battery charging the maximum permitted resistance of the line loops is 2,000 ohm. [passage omitted]

The LEGAFON 1+1 channel analog subscriber carrier frequency telephone equipment can be used advantageously whenever a new station must be set up but there is no free cable pair. [passage omitted]

A telephone connection and a telex or data transmission channel can be established simultaneously on one cable pair. It can be used for switched data transmission in the 0.3-3.4 kHz frequency band.

Using the LEGAFON equipment together with Telexfon B telex transmission equipment one can use a single cable pair three times. With the aid of a so-called "jump through" filter the LEGAFON equipment makes it possible to realize a continuous carrier frequency connection on several independent trunk circuit sections while using the basic circuits for other purposes.

A four-wire version of the LEGAFON equipment can be used advantageously to set up four-wire data transmission equipment networks so that by using carrier frequencies on the existing telephone or telex cable pairs one can create independent channels in the transmitting and receiving direction, thus creating a real four-wire connection.

The four-wire version can be used for—among other things—establishing two two-wire baseband transmission, releasing the leased four-wire connection, so that one can form two four-wire carrier frequency channels above the baseband transmission. This also makes it possible to have multiple use of the more expensive, limited capacity trunk networks (with one baseband two-wire connection and one carrier frequency four-wire connection on one trunk cable pair).