

AD \_\_\_\_\_

AWARD NUMBER DAMD17-96-C-6069

TITLE: Breast Cancer Center Support Grant

PRINCIPAL INVESTIGATOR: Marc E. Lippman, M.D.

CONTRACTING ORGANIZATION: Georgetown University  
Washington, DC 20057

REPORT DATE: September 1998

TYPE OF REPORT: Annual

PREPARED FOR: Commanding General  
U.S. Army Medical Research and Materiel Command  
Fort Detrick, Maryland 21702-5012

DISTRIBUTION STATEMENT: Approved for Public Release;  
Distribution Unlimited

The views, opinions and/or findings contained in this report are those of the author(s) and should not be construed as an official Department of the Army position, policy or decision unless so designated by other documentation.

Reproduced From  
Best Available Copy

DTIC QUALITY INSPECTED 3

# REPORT DOCUMENTATION PAGE

*Form Approved*  
*OMB No. 0704-0188*

Public reporting burden for this collection of information is estimated to average 1 hour per response, including the time for reviewing instructions, searching existing data sources, gathering and maintaining the data needed, and completing and reviewing the collection of information. Send comments regarding this burden estimate or any other aspect of this collection of information, including suggestions for reducing this burden, to Washington Headquarters Services, Directorate for Information Operations and Reports, 1215 Jefferson Davis Highway, Suite 1204, Arlington, VA 22202-4302, and to the Office of Management and Budget, Paperwork Reduction Project (0704-0188), Washington, DC 20503.

1. AGENCY USE ONLY <i>(Leave blank)</i>	2. REPORT DATE <b>September 1998</b>	3. REPORT TYPE AND DATES COVERED <b>Annual (1 Sep 97 - 31 Aug 98)</b>	
4. TITLE AND SUBTITLE <b>Breast Cancer Center Support Grant</b>		5. FUNDING NUMBERS <b>DAMD17-96-C-6069</b>	
6. AUTHOR(S) <b>Marc E. Lippman, M.D.</b>		8. PERFORMING ORGANIZATION REPORT NUMBER	
7. PERFORMING ORGANIZATION NAME(S) AND ADDRESS(ES) <b>Georgetown University Washington, DC 20057</b>			
9. SPONSORING / MONITORING AGENCY NAME(S) AND ADDRESS(ES) <b>U.S. Army Medical Research and Materiel Command Fort Detrick, Maryland 21702-5012</b>		10. SPONSORING / MONITORING AGENCY REPORT NUMBER	
11. SUPPLEMENTARY NOTES		19981229 100	
12a. DISTRIBUTION / AVAILABILITY STATEMENT <b>Approved for Public Release; Distribution Unlimited</b>		12b. DISTRIBUTION CODE	
13. ABSTRACT <i>(Maximum 200 words)</i>  <p>This document represents the annual report for our Breast Cancer Center Support Grant. Our grant consists of five areas, three projects and two cores. Projects include: Project 1 - Impact of Genetic Testing for Breast Cancer Susceptibility; Project 2 - A Coordinated Approach to Breast Cancer Diagnosis; and Project 3 - Development of Novel Antiangiogenic Therapies in Metastatic Breast Cancer. These projects are supported by Core 1 - Patient Accession Core, and Core 2 - Cancer Clinical and Economic Outcomes Evaluations Core. During the project period, each of the cores have been fully functional, and each of the projects continues to meet its objectives. Detailed summaries of the work in progress is provided in each of the project areas. Taken together, we believe that these projects, supported by their appropriate cores, have been successful in meeting their statements of work, and in fulfilling their scientific objectives during the granting period.</p>			
14. SUBJECT TERMS <b>Breast Cancer</b>		15. NUMBER OF PAGES <b>304</b>	
17. SECURITY CLASSIFICATION OF REPORT <b>Unclassified</b>		16. PRICE CODE	
		20. LIMITATION OF ABSTRACT <b>Unlimited</b>	
18. SECURITY CLASSIFICATION OF THIS PAGE <b>Unclassified</b>		19. SECURITY CLASSIFICATION OF ABSTRACT <b>Unclassified</b>	

FOREWORD

Opinions, interpretations, conclusions and recommendations are those of the author and are not necessarily endorsed by the U.S. Army.

\_\_\_ Where copyrighted material is quoted, permission has been obtained to use such material.

\_\_\_ Where material from documents designated for limited distribution is quoted, permission has been obtained to use the material.

✓ Citations of commercial organizations and trade names in this report do not constitute an official Department of Army endorsement or approval of the products or services of these organizations.

\_\_\_ In conducting research using animals, the investigator(s) adhered to the "Guide for the Care and Use of Laboratory Animals," prepared by the Committee on Care and use of Laboratory Animals of the Institute of Laboratory Resources, national Research Council (NIH Publication No. 86-23, Revised 1985).

✓ For the protection of human subjects, the investigator(s) adhered to policies of applicable Federal Law 45 CFR 46.

\_\_\_ In conducting research utilizing recombinant DNA technology, the investigator(s) adhered to current guidelines promulgated by the National Institutes of Health.

\_\_\_ In the conduct of research utilizing recombinant DNA, the investigator(s) adhered to the NIH Guidelines for Research Involving Recombinant DNA Molecules.

\_\_\_ In the conduct of research involving hazardous organisms, the investigator(s) adhered to the CDC-NIH Guide for Biosafety in Microbiological and Biomedical Laboratories.

Manu Lippman MD  
PI - Signature Date

**TABLE OF CONTENTS**

**Front Cover** ..... 1

**Standard Form 298** ..... 2

**Foreword** ..... 3

**Table of Contents** ..... 4

**Principal Investigator's Introduction** ..... 5

**Project 1** ..... 6  
*Impact of Genetic Testing for  
Breast Cancer Susceptibility*

**Project 2** ..... 12  
*A Coordinated Approach to  
Breast Cancer Diagnosis*

**Project 3** ..... 19  
*Development of Novel  
Antiangiogenic Therapies  
in Metastatic Breast Cancer*

**Core 1** ..... 33  
*Patient Accession Core*

**Core 2** ..... 46  
*Cancer Clinical and Economic  
Outcomes Evaluations Core*

**Appendix Packet**



## PRINCIPAL INVESTIGATOR'S INTRODUCTION

Since the inception of our Breast Cancer Center Grant, the participants have worked closely with one another to achieve the goals of the grant. While each of the projects had significant problems to overcome during Year 1, substantial success has been achieved. For example, within **Project 1 (Impact of Genetic Testing For Breast Cancer Susceptibility)**, 365 individuals have undergone testing for BRCA1/2 mutations. Follow-up surveys and cost-effectiveness modeling continue to be documented according to the project specific aims. **Project 2 (A Coordinated Approach to Breast Cancer Diagnosis)** is actively accruing patients, and is gathering data on patients with both benign and malignant disease. Finally, within **Project 3 (Development of Novel Antiangiogenic Therapies in Metastatic Breast Cancer)** the Thalidomide trial has been completed, and another series of clinical trials are underway. Detailed information about each of the projects and the two cores which support them (**Patient Accession Core and Cancer Clinical and Economic Outcomes Evaluation Core**) will be found on the following pages.

## PROJECT 1: IMPACT OF GENETIC TESTING FOR BREAST CANCER SUSCEPTIBILITY

**I. INTRODUCTION:** Up to 10% of breast/ovarian cases are due to an alteration in the BRCA1 or BRCA2 genes. Women who inherit an alteration in either of these genes have an estimated 55-85% risk of developing breast cancer and a 15-60% chance of getting ovarian cancer. The reasons for the variability of cancer risks are not well characterized; however, it is likely that modifier genes and environmental factors play an important role.

The impact of screening and prevention options in women with a BRCA1/2 alteration, including preventive mastectomies or removal of the ovaries, remains largely unknown. Similarly, there are little data available about the role of reproductive factors and hormone use in mutation carriers. Nevertheless, guidelines for increased surveillance and possible preventive options are discussed with all carriers. In addition, it is important to gather both short- and long-term data on the psychological well-being of clinic based high-risk individuals such as those represented in this study. Thus, the specific aims of this study are:

- 1) to identify determinants of who decides to undergo BRCA1/2 testing;
- 2) to evaluate the short- and long-term impact of BRCA1/2 testing on quality of life;
- 3) to evaluate the impact of genetic testing on prevention and surveillance practices;
- 4) to identify early predictors of psychological morbidity and nonadherence among participants in genetic testing programs; and
- 5) to develop a preliminary model to estimate the costs of BRCA1/2 testing per quality-adjusted life years ahead.

## II. EXPERIMENTAL METHODS

**A. ELIGIBILITY CRITERIA:** The probability of obtaining an informative test result is maximized by first testing an individual with breast or ovarian cancer at a young age. Usually, these women also have one or more first-degree relatives who have also had breast and/or ovarian cancer. For this study, consistent with recommendations from the American Society of Clinical Oncology, individuals who have at least a 10% chance of carrying a BRCA1/2 mutation are eligible for participation. These criteria remain unchanged from the first annual report, submitted September 1997.

**B. ACCRUAL PROCEDURES:** Family history forms and brochures are distributed at various clinics at Georgetown University Medical Center, including medical oncology, surgery, the comprehensive breast center, and obstetrics/gynecology. (Brochures refer to the study as the CARE, Cancer Assessment and Risk Evaluation, Program.) In addition, patients complete family history forms in selected off-site surgeons' offices. Patients are also directly referred by their physician, and numerous in-services have been provided to keep staff current about study eligibility and pertinent clinical issues. Lists of patients with breast or ovarian cancer are reviewed periodically, and with permission of the physician, patients are mailed a brochure about the program and a letter inviting them to call for more information about their eligibility. We have also placed advertisements in local publications. A major source of accrual is from relatives of individuals who test positive. To facilitate this process, we have developed a brochure for positive patients to distribute to their relatives. This material is designed for both educational purposes, and to provide information about participation in the program (see Appendix 1). We have been working closely with the Patient Accession Core to evaluate methods for improving enrollment of minorities into the study.

**C. STUDY PROCESS:** Patient flow through the study is generally unchanged since the last annual report. As information about cancer risks and risk modifiers has been obtained, patient education material has been modified (see Appendix 2).

**D. COST-EFFECTIVENESS MODEL OF BRCA1/2 TESTING:** Currently, we are working with the Cancer Clinical and Economic Outcomes Core (Core 2) on the cost-effectiveness analysis of testing high-risk women for BRCA1/2 susceptibility mutations. We are in the process of programming the decision model which will form the basis of the cost-effectiveness analysis. We have programmed the basic Markov model templates, which will be used to model the natural history of breast cancer, ovarian cancer, and competing mortality. Literature data has been abstracted for model parameters. In Year 3, we plan to finish model programming and to perform meta-analyses to obtain point estimates and probability distributions for model parameters.

**E. UTILITY PRIMARY DATA COLLECTION:** In Year 1 we developed data collection instruments to determine participant preferences for outcomes that could occur distal to testing and counseling (e.g., development of cancer, choosing prophylactic surgery). The preference data will be used to adjust outcomes for health-related quality of life in the cost-effectiveness analysis. To date, these measures of preference for outcomes (also known as health utilities) have been administered in 75 baseline, 109 6-month, and 139 12-month surveys. Utility data collected include time trade-off and linear rating scale assessments for the following health states: mastectomy for early breast cancer, breast conserving surgery and radiation therapy for early breast cancer, prophylactic bilateral mastectomy for early breast cancer, prophylactic bilateral oophorectomy, breast cancer recurrence, metastatic breast cancer, advanced ovarian cancer, and the participants' current health. Core 2 provides a detailed description of the utility data collected to date. In Year 3, we will continue with utility data collection. We are also currently performing face-to-face validity interviews for twenty participants, which will be finished in the upcoming year.

### III. RESULTS AND DISCUSSION

**A. STUDY ACCRUAL:** The following table summarizes the number of patients referred by different sources. Note that some subjects may not have completed a baseline, and some may not have been eligible for participation.

Table 1: Primary Sources of Referral to the CARE Program

Referral Source	# of Subjects Referred
Georgetown Providers	269
Relative with Positive Result	190
External Providers	71
Advertisements	42

To date, 623 individuals have completed the initial baseline phone interview. Approximately 90% of the individuals who completed baselines are Caucasian and 10% are minorities. Of note, 446 individuals have completed a pre-test genetic counseling session: 68% were probands and 32% were relatives of a positive individual. Although almost all the probands

were females with breast or ovarian cancer, two probands were men with a history of breast cancer. Of the relatives who completed a pre-test session, 75% were female and 25% were male.

There were 365 individuals who have undergone testing for BRCA1/2 mutations thus far and 323 patients have received their results, which are summarized in Table 2, below:

**Table 2: Results of BRCA1/2 Testing**

Test Outcome	# of Subjects
BRCA1/2 Positive	103
BRCA1/2 Mutation Negative (Uninformative)	136
BRCA1/2 Result of Unknown Significance	24
True Negative (i.e., relatives negative for the mutation found in their family)	60

With respect to completion of follow-up surveys (conducted after an individual received test results or declined testing), 390 individuals have completed their 1-month follow-up, 315 have done the 6-month, and 218 have finished the final 12-month survey.

## B. ABSTRACTS OF STUDIES USING DATA FROM THIS PROJECT

1) A detection panel of prevalent mutations in BRCA1/2 genes is sensitive and cost effective in an initial screen of high risk patients. **Peshkin BN, Lerman C, Isaacs C, Brown KM, de Leon A, Abbaszadegan MR.** Proceedings of the American Association for Cancer Research 1998; 39: 3232. (Poster Presentation, March 1998.)

Over 300 risk-conferring mutations have been identified in BRCA1 and BRCA2. While many of these mutations are family-specific, several occur with increased frequency, especially 3 that account for the majority of BRCA1/2 mutations in Ashkenazi Jews (185delAG, 5382insC in BRCA1 and 6174delT in BRCA2). The present study examined the sensitivity of a panel of 12 mutations in BRCA1/2 in an allelic discrimination assay in a high-risk group of women. This mutation panel included the 3 above and 6 others in BRCA1 (C61G, 1294del40, 4184del4, C4446T, 1136insA, T>Gins59bp) and 3 in BRCA2 (3134del4, 6503delTT, 982del4). These mutations were selected for inclusion because they are among the most common reported in the BIC database. 144 women with breast and/or ovarian cancer were tested. 33% (n=47) tested positive for a BRCA1/2 mutation; of these, 68% (n=32) had a mutation on the panel and 32% (n=15) had a mutation that was detected on full gene screening by CSGE analysis or sequencing. There was a significant association between those of Jewish descent and the likelihood of a positive result from the panel (FET 2 tail 0.0039). 88% of Jewish women (n=22) had one of the 3 common mutations (on panel) whereas only 45% (n=10) of non-Jewish women tested positive for a panel mutation. 12% (n=3) of Jewish women had a non-panel mutation. In non-Jewish women, 55% (n=12) had a non-panel mutation. These results suggest that a panel of common BRCA1/2 mutations, while most sensitive for high-risk individuals of Jewish descent, is useful for an initial screening of all high-risk patients and can provide significant cost savings.

2) Racial differences in the use of BRCA1/BRCA2 genetic testing in high risk breast cancer probands. **Schwartz MD, Hughes C, Roth J, Main D, Peshkin B, Isaacs C, Kavanagh C, Lerman C.** Journal of the National Cancer Institute, submitted. (See Appendix 3.)

The goals of this study were to evaluate BRCA1/2 test utilization among women who had self-referred to genetic counseling in a clinical research setting and to examine sociodemographic factors which influence test use. Of the 207 probands studied, 79% chose to receive their test results. Of the 21% who chose not to receive test results, 73% did not participate in the initial education session, 16% participated in pre-test education but did not give a blood sample, and the remaining 11% gave a blood sample but chose not to learn their results. Caucasians were nearly four times more likely than African Americans to receive genetic testing results (OR = 3.8, 95% CI = 1.2, 12.3) and participants who reported very strong spiritual faith were less than half as likely to receive test results compared to participants who reported moderate or less spiritual faith (OR = 0.42, 95% CI = 0.21, 0.83). The lower test uptake rate of African American compared to Caucasian women may be attributable, in part, to concerns about exploitation and genetic discrimination. Alternatively, they may perceive themselves to be at lower risk of breast cancer than comparable risk Caucasian women. Lower BRCA1/2 test uptake rates in women with strong spiritual faith may result from the belief that One's life course is determined by a higher power rather than by genetic factors. Further research is needed to elucidate the specific determinants of BRCA1/2 testing decisions in Caucasian and African American women in order to develop culturally-specific genetic counseling programs.

3) Family disclosure in genetic testing for cancer susceptibility: determinants and consequences. **Lerman C, Peshkin BN, Hughes C, Isaacs C.** Journal of Health Care Law and Policy 1: 201-220, in press. (See Appendix 3.)

The identification of BRCA1/2 carriers raises numerous psychological and social challenges for those being tested and their family members. One of the most pressing and least studied issues involves the process and outcomes of disclosure of genetic information within families. This article reviews the clinical aspects of family disclosure, empirical literature on this topic, and preliminary data on the determinants and outcomes of disclosure of test results within hereditary breast cancer families. The latter is summarized as follows: About 81% of carriers and noncarriers of BRCA1/2 mutations disclosed their test results to sisters and 45% disclosed to brothers. Of interest, 40% of noncarriers disclosed their test results to a child age 14-18 as compared to 14% of carriers. Further, 21% of noncarriers disclosed to a child under age 13 as compared to 9% of carriers. This suggests that some genetic testing participants may be motivated to disclose negative results for the purpose of reassuring their children. With regard to the psychological impact of disclosure on the proband, the outcome appears to depend on the object of the disclosure. For example, BRCA1/2 carriers (mostly females in this study) who disclosed their result to their sister exhibited a small decrease in psychological distress, while those who elected not to tell exhibited a small increase. This difference in trend was both statistically and clinically significant. Thus, this finding suggests that sharing a positive test result with a sister may initially have a positive effect on quality of life. This may be attributable to the proband fulfilling a perceived responsibility to share information that could be medically significant to a close relative, and the fact that the proband may obtain emotional support from the relative. By contrast, the reverse pattern was observed in the context of disclosure of positive test results to young children. In this case, probands who did not disclose their positive test results experienced reductions in distress, while those who did disclose experienced significant increases. Although preliminary, it is tempting to speculate that disclosure to young children

may generate, rather than alleviate, psychological distress in carriers. Guilt about transmitting risk to one's offspring may be exacerbated by such discussions. Given the complexities of the medical decision-making and psychological adjustment associated with genetic testing, it is hoped that an understanding of the unique determinants and consequences of disclosure to family members can help clinicians provide better counseling to these individuals and will encourage legislators to enact and enforce protections for patient autonomy and confidentiality. This strategy will help ensure that individuals who decide to pursue genetic testing, even in the context of its uncertainties, can obtain maximum benefit while the potential for harm is minimized.

#### IV. RECOMMENDATIONS

- Continue current recruitment of study subjects referred from Georgetown providers and private practice surgeons, as well as family members of known mutation carriers. Recruitment is currently on target.
- Continue to work closely with the Patient Accession Core to increase recruitment of minority subjects.
- Continue cost-effectiveness modeling and utilities analysis.
- Perform data analysis on baseline and follow-up data regarding uptake, psychological impact, and medical implications of BRCA1/2 testing.

**V. CONCLUSIONS:** Genetic testing in high-risk families can have significant implications both medically and psychologically. Therefore, it is critical that such testing occur in the setting of comprehensive genetic counseling, both before and after testing. Identifying eligible patients for this study has been most successful by facilitating recruitment from internal providers and relatives of those who tested positive for a BRCA1/2 alteration. The substantial numbers of patients opting to get tested, and to provide detailed medical and family history information, has contributed to a better understanding of the sensitivity of BRCA1/2 testing and the cancer risks associated with alterations in these genes. We have also noted that African-American women are less likely to desire genetic counseling and testing than Caucasian women, suggesting that we need to investigate and overcome potential barriers in reaching this population. Within families, the dissemination of information is highly variable. As we learn more about the determinants of this communication, we may be able to tailor genetic counseling programs to help individual share information with relatives.

In the coming year, we will be analyzing the data to gain more specific information about who opts for testing (building on Isaacs et al., 1996) and what the impact of testing is on medical decision making (see Isaacs et al., 1997) and emotional well being. In addition, we will be examining the cost-effectiveness of genetic counseling and testing, and the health state preferences in this unique high-risk population. We will also continue to modify our educational materials and content of counseling, as new information becomes available.

## VI. REFERENCES

Frank TS, Manley SA, Olopade OI, ... **Isaacs C, Peshkin B**, et al. Sequence analysis of BRCA1 and BRCA2: correlation of mutations with family history and ovarian cancer risk. *J Clin Oncol* 1998; 16: 2417-2425.

**Isaacs C, Peshkin B, Benkendorf J, Hughes C, Lerman C**. Interest in testing for BRCA1: correlation between patient risk and desire for testing. *Proc Am Soc Clin Oncol* 1996; 15: 329.

**Isaacs C, Peshkin B, Reutenauer J, Reed M, Main D, Lerman C**. Cancer screening practices in women from high risk breast cancer families. *Proc Am Soc Clin Oncol* 1997; 17: 1916.

**Lerman C, Peshkin BN, Hughes C, Isaacs C**. Family disclosure in genetic testing for cancer susceptibility: determinants and consequences. *Journal of Health Care Law and Policy* 1: 201-220, in press.

**Peshkin BN, Lerman C, Isaacs C, Brown KM, de Leon A, Abbaszadegan MR**. A detection panel of prevalent mutations in BRCA1/2 genes is sensitive and cost effective in an initial screen of high risk patients. *Proc Am Assoc Cancer Res* 1998; 39: 3232.

**Schwartz MD, Hughes C, Roth J, Main D, Peshkin B, Isaacs C, Kavanagh C, Lerman C**. Racial differences in the use of BRCA1/BRCA2 genetic testing in high risk breast cancer probands. *Journal of the National Cancer Institute* (submitted).

Shattuck-Eidens D, Oliphant A, McClure M, ... **Isaacs C, Peshkin B, Lippman ME**, et al. BRCA1 sequence analysis in women at high risk for susceptibility mutations: risk factor analysis and implications for genetic testing. *JAMA* 1997; 278: 1242-1250.

## VII. APPENDICES (included in full packet following annual report text)

Appendix 1: Educational material for relatives of positive patients

Appendix 2: General educational material distributed at visit one (pre-test)

Appendix 3: Article reprints

## PROJECT 2: A COORDINATED APPROACH TO BREAST CANCER DIAGNOSIS

**I. INTRODUCTION:** This project focuses on developing improved paradigms for breast cancer diagnosis using new methods of imaging and molecular markers of neoplasia measured in nipple aspirate fluid. The ultimate objective of such research is to reduce the number of unnecessary biopsies by improving the specificity and positive predictive value of diagnostic methods.

Currently, there are two parts of the imaging evaluation of women with possible breast cancer. These are called screening and diagnosis. In the first, the patient has a mammogram with two views of each breast obtained and may also have clinical breast examination. If any suspect region is found on the screening mammogram, then the patient proceeds to the second part. In the second part, a radiologist uses those imaging methods that are available to determine whether or not this suspect lesion is real, and whether the positive predictive value is great enough that biopsy is indicated.

Currently, approximately 10% (range 4-14 %) of women having a screening mammogram are called back for diagnostic mammography. In the diagnostic work up, special mammographic views such as compression spot views, magnification views or special mammographic projection views may be obtained. The patient may also have sonography and/or breast magnetic resonance imaging with gadolinium. In some centers imaging with  $^{99m}\text{Tc}$  Sestamibi may be used. This radiotracer labeled agent, which was recently approved by the FDA, localizes in breast cancer.

After a full diagnostic work up, many patients are excluded from needing biopsy, but approximately 1/3 to 1/4 still needs a biopsy. Of those who have a biopsy, 17-32% will have cancer based on the characteristics of the initial suspect region (some findings are more suspicious than others). With some patterns, the likelihood of cancer is close to 100%. But this still means that at least 2/3 of those having biopsy will not have cancer. This project, A Coordinated Approach to Breast Cancer Diagnosis (CABCAD), is designed to establish statistically supported criteria so that some of those women who now have biopsy, and who are then found to have only benign disease, could be safely followed without biopsy.

**II. BODY:** In the CABCAD protocol, women with a suspect lesion identified by screening mammography and/or clinical breast examination and who have had a current standard diagnostic work up with the recommendation of biopsy are recruited into the study. Each woman who agrees is then studied with both advanced imaging methods and with experimental methods. The standard methods are breast MRI with gadolinium enhancement and nuclear scanning with  $^{99m}\text{Tc}$ Sestamibi. At the time the study was initiated, Sestamibi was still an experimental agent for breast cancer evaluation. It is now FDA approved. Some of the women had had sonography as part of their standard breast imaging evaluation. The experimental procedures incorporated into the original protocol were digital mammography, and sonoelastography, breast MRI with gadolinium,  $^{99m}\text{Tc}$  Sestamibi and (in premenopausal women) nipple fluid was aspirated for cytogenetic analysis. In the original protocol, the Sestamibi imaging was performed with both a standard gamma camera and with a prototype high sensitivity high resolution dedicated breast gamma camera.

Each of these tests was selected because it looks at a different biological spectrum of disease. The digital mammogram looks at anatomy, the sonography looks at tissue texture, the elastography evaluates hardness, the MRI evaluates microvascularity, the Sestamibi evaluates an unknown factor that is related to p-glycoprotein and mitochondrial localization probably based on molecular charge of the Sestamibi, the nipple aspirate fluid looks at cytogenetic lesions indicating biological change in the epithelium. Of



the available imaging studies likely to be useful in this differentiation, only positron emission tomography is not included because of its great expense.

**A. PROGRESS:** In the first year of this project, there was a long delay caused by disagreements between the consent forms as approved by the Georgetown University Institutional Review Board and the US Army Human Subjects requirements. Multiple versions were submitted until we arrived at one form acceptable to both. Therefore, Project 2 was officially started June 30, 1997. Since that time, we have initiated the protocol and have recruited 143 women into it. In the initial start up phase, scheduling problems were encountered so that not all patients could have all studies. The situation has improved with regard to digital mammography and Sestamibi imaging, but there continue to be scheduling problems with MRI. We are now recruiting two patients a week into the study which is the number limited by availability of the MRI machine. Starting in November, 1998, we will have additional time slots available for MRI with the capability of accessioning up to four patients per week. At this rate, we will be able to meet the required recruitment needs within the available time for the study. We are working to increase the recruitment rate slightly so that we are left with six months at the end of the four-year project to allow for data analysis.

Currently, 143 patients have been recruited into the study. Of these, biopsy results are currently available for 93. Most of those without biopsy results had their surgery at an outlying institution. While we have received informal reports as to the findings of many of these, the office pathology reports have not yet been received. Our research coordinator will be visiting these sites to make copies of the missing pathology reports. Of our patient volunteers, 109 had digital mammography, 94 had MRI and 126 had Sestamibi studies. Eight-two had both MRI and Sestamibi.

The tables for MRI, Sestamibi and a combined chart for MRI and Sestamibi are presented below. We have not included equivocal results from the imaging studies.

### MRI results

	<u>MRI positive</u>	<u>MRI negative</u>	<u>Sums</u>
Invasive CA + DCIS	12	3	15
Benign	8	45	53
Sums	20	48	68

Sensitivity 0.8      Specificity 0.85      NPV 0.94

The NPV is calculated for the incidence of disease characteristics of this experimental group.

### Sestamibi Results

	<u>Sestamibi positive</u>	<u>Sestamibi negative</u>	<u>Sums</u>
Invasive CA + DCIS	12	7	19
Benign	11	37	48
Sums	23	44	67

Sensitivity 0.63      Specificity 0.77      NPV 0.84

The NPV is calculated for the incidence of disease characteristics of this experimental group.

**Combined MRI and Sestamibi**

	<u>MRI +/Ses +</u>	<u>MRI +/Ses -</u>	<u>MRI -/Ses +</u>	<u>MRI-/Ses-</u>	<u>Sums</u>
Invasive CA + DCIS	8	3	2	2	15
Benign	1	4	6	27	38
Sums	9	7	8	29	53

**For both tests together:** Sensitivity 0.53      Specificity 0.97      NPV 0.84  
The NPV is calculated for the incidence of disease characteristics of this experimental group.

**For either test:**      Sensitivity 0.87      Specificity 0.71      NPV 0.93  
The NPV is calculated for the incidence of disease characteristics of this experimental group.

These findings indicate that each of these tests separately and the two tests combined are not likely to have sufficient negative predictive value to allow one to avoid biopsy. The NPV for MRI is, however, getting close to the desired number. When one uses the American College of Radiology Breast Imaging Reporting and Data System (BI-RADS) system, category three lesions are those that are probably benign and are suitable for short term follow-up. This is usually interpreted as meaning that the risk of this lesion being cancer is less than 2-3%. It is possible that by further sub-categorizing lesions according to their mammographic or physical examination features, that the NPV of MRI could be increased to this level. Furthermore, as our sample size increases, the underlying prevalence of breast cancer may change, which will also affect the negative predictive value of the tests. Further analysis of the data is now proceeding. We will be comparing the mammographic abnormality that resulted in the recommendation for biopsy using the BIRADS criteria and also the physical examination findings for those cases in which the index lesion was found by physical examination. The goal is to find those features at the time of presentation that would best indicate the likely value of MRI or Sestamibi imaging for excluding the presence of cancer for a patient presenting with those findings in the index lesion.

During the start-up phase, many patients were unable to be scheduled for all studies. The situation has improved after discussions with each of the imaging areas. We have encountered sufficient problems with the breast dedicated gamma camera, that we have stopped using it. The updated model that was going to be used to replace it, still has major limitations and we are not using this method until we have more evidence that it will work. The elastography measurements were stopped when the physician developer of this system left Georgetown and took his system with him. Up until the time that he left, he was unable to provide us with interpreted data on the hardness of lesions. We are currently working with a small company (Genex Technologies, Kensington, MD), that is developing tactile measurement devices for the breast under an SBIR. There is currently insufficient data to decide whether or not to add that measure of hardness into this protocol.

Some patients are refusing to undergo certain procedures in the protocol. There has been moderate patient resistance to both the MRI and the Sestamibi imaging. The causes of refusal are being noted as we believe that issues influencing patient unwillingness to have the study will be an important factor if these methods are determined to be important in the benign/malignant decision. This data is being recorded along with other indices of patient satisfaction with the study, to be used in cost-effectiveness and quality of life analyses conducted in conjunction with the Cancer Clinical and Economic Outcomes Evaluation Core (Core 2).

The low rate of uptake in the nipple aspirate studies reflects the fact that only 22 patients were premenopausal, the group most likely to yield breast fluid. The initial difficulties in scheduling influenced the lower than expected yield (6/22 = 27%). In the initial phases of the study, it was

necessary to reserve specific time slots ahead of time for each modality to balance machine usage between clinical and research activities. Because the time allotted to each imaging modality was often exceeded in the initial period of the study, the Project Coordinator (who accompanied patients through all studies and also collected the nipple aspirate samples) was often rushed during the nipple aspiration procedure. This limited the time for the Project Coordinator to explain the nipple aspiration procedure, for the patient to milk her breast (which usually requires several minutes), and for the Project Coordinator to repeat the aspiration attempt several times if the first was unsuccessful. Successful completion of the nipple aspiration technique requires adequate time repeated aspiration attempts, and for the woman to massage the breast toward the nipple (moving fluid toward the duct openings). These scheduling problems have been corrected and yield is now improving. We have also obtained warming pads that safely and comfortably allow us to warm the breast prior to the aspiration procedure. In other studies we have shown that this increases the yield. In addition, we are beginning to attempt nipple aspiration of post-menopausal women as well as pre-menopausal, since the former may be expected to yield fluid in 25-50% of women below the age of 70.

### 1. New Research Information that is relevant to this study

a. **Comparative evaluation of conventional vs. digital mammography:** We have completed additional prospective evaluation of the digital mammography system that we are using in this protocol. We evaluated this system in a series of 134 cases which included 23 cancer cases. Six radiologists with no prior experience with digital mammography were, on average, better at distinguishing benign and malignant lesions on the digital images than on conventional high quality original mammograms. This result did not achieve statistical significance with this sample size, but the trend is clearly shown in Table 4. The initial data has been presented in the SPIE Medical Imaging Conference in February, 1997 and published in their proceedings. An updated analysis was presented at the Third International Conference on Digital Mammography, Nijmegen, Netherlands, June, 1998. This article has been submitted for peer publication now that we have a two year follow-up of the benign lesion cases so that we know that no cancers were missed.

**Table 4**

Reader	#1	#2	#3	#4	#5	#6	Average
Digital	0.600	0.656	0.735	0.697	0.462	0.643	0.633
Screen-film	0.609	0.616	0.556	0.575	0.495	0.644	0.583
p-value	0.923	0.637	0.085	0.069	0.741	0.992	

Table 4 shows the individual ROC areas under the ROC curves for each of the six readers as well as the average of these six values. The digital system is on average, better, but these results do not reach statistical significance with this relatively small sample size.

There have been additional publications on digital mammography performed elsewhere. These articles have all been based on variations of the Storage Phosphor technique that we have been using or an alternate method we demonstrated and reported on in 1993. Findings by Hundertmark, Cowen, Funke, and Perlet agree with our basic findings that this method of digital mammography is equivalent to conventional mammography. An article by Kheddache indicates that the system is not as good as screen film conventional mammography. We have been unable to find any publications of clinical series done with other methods for digital mammography. Non-published information suggests that the three

competing systems under test have not shown clinical advantages compared to screen film conventional mammography, but may be equivalent.

**b. FDA approval for Sestamibi:** At the time of the original grant submission,  $^{99m}\text{Tc}$  Sestamibi had not completed evaluation by the FDA for use as a breast cancer imaging agent. This evaluation has now been completed and Sestamibi has received FDA approval for this purpose.

There have been additional studies published comparing the accuracy of breast MRI and Sestamibi. In order for any test or group of tests to meet the requirements for avoiding breast biopsy, very high negative predictive values are necessary. Results reported by Palmedo show a NPV for Sestamibi of 83% and for MRI of 75%. Fenlon reports NPV for Sestamibi of 95% and for MRI of 91%. Helbich reports NPV of 81% for Sestamibi and 98% for MRI. Helbich's results are unusually good for NPV of MRI and less than usually reported for Sestamibi, for uncertain reasons. It is likely that the variability of results reflect different characteristics of the suspect breast lesions included in each study. Because of this, we are recording in our data base detailed information about the clinical and mammographic findings in each case. The mammographic descriptions are those of the Breast Imaging Reporting and Data System (BI-RADS). We expect that this analysis will improve the negative predictive value of these tests

If this effort is successful, we would then be able to provide a flow chart indicating that for a lesion having certain BIRADs defined characteristics, MRI and/or Sestamibi would likely provide the best information to help avoid a biopsy. Alternatively, for a lesion with other characteristics, MRI or Sestamibi imaging would not add information sufficient to avoid biopsy. Similar results would also be provided for palpable lesions based on their characteristics.

**2. Changes in Protocol:** We have eliminated the experimental test of sono-elastography. In the first year of the protocol, the investigator of this technique was unable to provide us with an interpretation of his data. He has left the institution so that the machine for elastography is no longer available.

We have suspended the use of the breast sized dedicated gamma camera because of technical problems in its operation. The inventor of this system had indicated that a new system was being built and would become available. He has now indicated that the newer system will not perform to meet our requirements. We are joining in a grant proposal with another investigator regarding a differently designed high resolution gamma camera. Should that project be funded, the new experimental camera might become available in the last year of this project.

We have modified our approach to cytogenetic analysis of nipple aspirate fluid (NAF) in a very novel way. The major problem to conducting cytogenetic analyses on mammary epithelial cells derived NAF is that a sample may contain as few as 10 epithelial cells, which is too few for immunohistochemical methods. We have been able to successfully culture the cells obtained from NAF to increase the number of cells to the point where we can conduct cytogenetic analyses on them. No one has ever accomplished this before. We reported this at the American Association for Cancer Research this year (Haddad 1998) (manuscript in preparation). In addition to the analyses of p53 and erbB-2 originally proposed, we recently began applying a state-of-the-art molecular cytogenetic method, comparative genomic hybridization (CGH) (Kallioniemi 1992) to NAF-derived mammary epithelial cells to identify chromosomal gains and losses associated with early breast cancer. CGH permits the rapid screening of chromosomal imbalances over the entire genome. Although the results are based on only three samples, we have shown that cells from two women with normal histology had no CGH abnormalities, while cells

from one woman with a breast tumor showed chromosomal gains in both 19q and 20q. Again, no one else has ever reported being able to do CGH on cells derived from NAF. We will continue to apply this approach to patients in the study.

**Other technologies under investigation:** We are in discussions with the Biofield (Atlanta, Ga) and the TransScan Medical (Ramsey, NJ) companies. Each has developed methods to record electrical activity from the breast and from breast cancer. Data from TransScan suggest that it may have a sufficiently high NPV (100% in a small series) to be of use as an adjunctive test. Dr Freedman is working with Genex Technologies, Kensington, MD, as a consultant to their SBIR in the development of a method for recording tactile information from the breast. The system is currently capable of detecting the inclusions in breast palpation training phantoms, but it is unclear at this time how much characterization of the lumps will be possible.

Recently reported work in Breast MRI has shown the feasibility of MRI spectroscopy of the breast (Roebuck, 1998) and other work has shown the possible value of MRI perfusion imaging (Kuhl, 1997). We are currently evaluating whether or not additional sequences should be added to our MRI imaging sequences to incorporate this work. Recent work with Sestamibi (Vecchio, 1997) has shown that in certain types of breast cancer, there is rapid washout of sestamibi associated with the presence of p-glycoprotein expression. We are also evaluating whether this analysis can be added to our assessment in patients with positive sestamibi scans.

3. **Clinical and Economic Outcomes:** We are collecting information on patient satisfaction, test acceptability, and costs using materials developed by Core 2.

4. **Data acquisition and analysis:** We are recording data as acquired. We perform routine demographic analysis of the study. Because of the small number of cases to date, we have not yet performed a statistical analysis of the imaging features being found.

**III. CONCLUSIONS:** Project 2, A Coordinated Approach to Breast Cancer Diagnosis is actively recruiting patients and is gathering data on patients with both benign and malignant disease. Initial scheduling problems have been addressed and recruitment is almost at the desired level. We have changed several aspects of the protocol based on the new knowledge. We have eliminated elastography as this was not producing adequate results. Trials of the breast dedicated gamma camera have shown that because of technical problems the camera is not currently ready for use in a clinical trial. It is clear that imaging analysis applied to all patients will not provide sufficient information to eliminate the need for biopsy. As we analyze the combination of imaging results with the mammographic and/or physical examination findings of the index lesion, we are hopeful that we will be able to provide guidelines for the choice of MRI vs Sestamibi vs biopsy without the use of additional imaging. We have also incorporated state of the art approaches to cytogenetic analyses, and are the first to show that epithelial cells from NAF can be grown in culture and analyzed with CGH.

#### IV. REFERENCES

American College of Radiology Breast Imaging Reporting and Data System (BIRADS). American College of Radiology, Reston VA 1993

Cowen AR, Launderers JH, Jadav M, et al. Visibility of microcalcifications in computed and screen-film mammography *Phys Med Biol* 1997. 42: 1533-1548 (only abstract reviewed)

Fenlon HM, Phelan NC, O'Sullivan P, et al. Benign versus malignant breast disease: comparison of contrast enhanced MR imaging and Tc-99m tetrofosm scintimammography. *Radiology* 1997; 205:214-220

Freedman M, Steller Artz D, Hogge J, Zuurbier RA, Jafroudi H, Lo S-CB, Mun SK. An ROC Study of Screen Film Mammography and Storage Phosphor Digital Mammography: Analysis of Non-Concordant Classifications. Implications for the approval of digital mammography systems. *Proc. SPIE Medical Imaging 1997*. Harold Kundel Editor. 3606:281-291

Funke M, Breiter N, Hermann KP, et al. Storage phosphor direct magnification mammography in comparison with conventional screen-film mammography—a phantom study. *Br. J. Radiol* 1998; 71: 528-534. (only abstract reviewed).

Haddad B, McCormack S, Young H, Trock B, et al. Molecular cytogenetic screening of epithelial breast cells in nipple aspirate fluid by comparative genomic hybridization. *Proc Amer Assoc Cancer Res* 1998; 39:334-335.

Helbich TH, Becherer A, Trattng S, et al. Differentiation of benign and malignant breast lesions: MR imaging versus Tc-99m sestamibi scintimammography. *Radiology* 1997; 202:421-429.

Hundertmark C, Breiter N, Hermann KP, et al. Digital magnification mammography in computed radiography. Initial clinical results. *Radiologe* 1997; 37:597-603. (Only English language abstract reviewed)

Kallioniemi OP, Kallioniemi A, Sudar D, et al. Comparative genomic hybridization for molecular cytogenetic analysis of solid tumors. *Science* 1992; 258:818-821.

Kheddache S, Kvist H, Digital mammography using storage phosphor plate technique—optimizing image processing parameters for the visibility of lesions and anatomy. *Eur J Radiology* 1997. 24:237, 244. (only abstract available)

Kuhl CK, Bieling H, Gieseke J et al. Breast neoplasms: T2\* Susceptibility-contrast first pass perfusion MR imaging. *Radiology* 1997; 202:87-95

Palmedo H, Grunwald F, Bender H, et al. Scintimammography with technetium-99m methoxyisobutylisonitrile: comparison with mammography and magnetic resonance imaging. *Eur J Nucl Med* 1996, 23: 940-946

Perlet C, Becker C, Sittek H et al. A comparison of digital luminescence mammography and conventional film-screen system: preliminary results of clinical evaluation. *Eur J Med Res* 1998 3:165-171. (only abstract available)

Roebuck JR, Cecil KM, Schnall MD et al. Human breast lesions: Characterization with Proton MR Spectroscopy. *Radiology* 1998; 209: 269-275

Vecchio SD, Ciarmiello A, Pace L, et al. Fractional retention of technetium-99m-sestamibi as an index of p-glycoprotein expression in untreated breast cancer patients. *J Nuclear Medicine* 1997. 38:1348-1351

## **PROJECT 3: DEVELOPMENT OF NOVEL ANTIANGIOGENIC THERAPIES IN METASTATIC BREAST CANCER**

**I. INTRODUCTION:** The overall purpose of this proposal is to evaluate the clinical benefits of inhibitors of angiogenesis in regards to improving the care of patients with breast cancer. We are complementing these clinical trials with studies of the quality of life of participating patients, as well as with studies of the cost effectiveness of application of these agents in comparison to standard care.

As described in our original proposal, several possible angiogenic inhibitors are available for study. We selected two of these agents for our studies: the fumagillin derivative, TNP-470; and the sedative, thalidomide. Both had been shown to have anti-neovascular and anti-neoplastic properties in preclinical studies, and phase I studies of these drugs were either completed or underway at the time of our original proposal.

Clinical trials are now underway that will lead to accomplishment of our goals and aims. We have completed a Phase II study of thalidomide, and a Phase I pilot study of TNP-470 in combination with paclitaxel is actively accruing. We anticipate submitting a phase III trial in which paclitaxel plus TNP470 will be compared to paclitaxel alone. The following sections will describe our progress to date, as well as problems we have encountered and the actions we have taken to resolve them.

### **II. BODY**

**A. HYPOTHESIS/PURPOSE:** We hypothesize that incorporation of well-tolerated antiangiogenic agents into standard treatment regimens for breast cancer will increase progression free survival, improve quality of life and, due to fewer treatment related side effects, decrease health care costs. Because these agents are unlikely to result in objective, measurable tumor regressions, we feel it is necessary to develop innovative trial designs to document their efficacy.

#### **B. TECHNICAL OBJECTIVES:**

1. To evaluate the antitumor activity of novel, non-cytotoxic antiangiogenic agents for the treatment of metastatic breast cancer in Phase II and Phase III trials. These studies will increase the availability of investigational agents to minority and underserved patient populations with metastatic breast cancer.
2. To evaluate the impact on quality of life of non-cytotoxic antiangiogenic agents in a diverse spectrum of patients with metastatic breast cancer.
3. To evaluate the cost-effectiveness of non-cytotoxic antiangiogenic agents in patients with metastatic breast cancer.

**C. OVERVIEW OF CLINICAL TRIALS OF ANTI-ANGIOGENESIS:** In our initial proposal, we planned two separate clinical trials of anti-angiogenic agents. In the first, we proposed to test the activity of the angiogenic inhibitor, TNP-470, using a novel trial design. In a second study, we proposed to test the efficacy of oral thalidomide, in a randomized phase II clinical trial. After some initial adjustments in trial design, we have now completed the thalidomide trial, and we are actively accruing to a Phase I study of the combination of weekly paclitaxel plus TNP470. The pre-clinical data and rationale for these studies was fully presented in our update last year. The following sections review our progress in these two studies, to date.

1.) **Studies of TNP470 and paclitaxel:** In our last report, we provided evidence that the combination of TNP470 and paclitaxel is of interest. Prior Phase I studies with TNP470 alone demonstrated that the plasma half life of TNP470 is very short. Preclinical evidence suggests that paclitaxel might prolong the half-life of TNP470, presumably by reducing hepatic clearance. Moreover, paclitaxel alone has demonstrated anti-angiogenic activity. Finally, recent studies from other sites have demonstrated that paclitaxel can be administered weekly with an excellent safety profile.

**Revised Research Plans.** Taken together, these results suggest that the combination of paclitaxel and TNP-470 might result in both direct tumor cell cytotoxicity due to the paclitaxel and, more germane to this proposal, to additive and perhaps synergistic suppression of angiogenesis due to both drugs. However, the precise dose, schedule and toxicities of combining these two agents have not been determined.

**We therefore proposed to delay initiation of our randomized trial while we performed a pilot phase I clinical study to determine whether weekly administration of paclitaxel, coupled with simultaneous TNP-470, is safe, and to determine the MTD of TNP470 when delivered in combination with paclitaxel. The endpoints we will use to make this decision include pharmacokinetics (TNP-470 levels), toxicities, convenience of drug delivery, and overall cost of administration.**

We plan to perform a randomized trial in patients with metastatic breast cancer after we have determined the optimal dose of weekly paclitaxel and TNP-470. As proposed in our last update, the pilot trial of weekly paclitaxel and TNP470 is being performed in patients with any metastatic malignancy that is refractory to standard therapy or for whom paclitaxel would be considered appropriate therapy. However, we are preferentially placing any patient with breast cancer for whom taxol is a reasonable treatment option on these trials. We have chosen this strategy for the following reasons: 1) there is no reason to believe that the toxicities and pharmacokinetics observed in patients with other solid tumors would not be applicable to patients with breast cancer; 2) paclitaxel is active in many malignancies, and the schedule to be tested is novel and may have even greater activity than that used in the standard clinical setting; and 3) wider eligibility will hasten our ability to complete this pilot and move on with the breast cancer-specific randomized trial.

Following completion of this study, which we anticipate will take approximately six months to complete, we will proceed with a randomized trial comparing paclitaxel vs. paclitaxel plus TNP-470 in patients with metastatic breast cancer, using the paclitaxel and TNP470 dose and schedule selected from the pilot.

We are requesting the same support as previously awarded to conduct the pilot paclitaxel/TNP-470 trial. The trial is partially supported by TAP Pharmaceuticals. However, the research nurse supported by the DOD is actively participating in regards to the quality of life and cost effectiveness analyses, which are not funded by TAP. Therefore, data management and other responsibilities of the research nurse, including QOL and CEA will be entirely supported by DOD funds.



**Figure 2** illustrates our current clinical trial plan:

Year/Month	1998 10	11	12	1999 1	2	3	4	5	6	7	8	9	10	11	12	2000 1..
Thalidomide	Submit data for presentation at National Meeting						Submit Data for Publication									
TNP/Taxol Pilot																
Randomized Trial	Plan and Write			Submit to IRB for Review			Begin Accrual									

**TNP-470 PILOT TRIAL 2: Pilot Trial of Paclitaxel and TNP-470 II. Weekly 1 hr Infusion Paclitaxel plus TNP-470**

In anticipation of initiating a prospective randomized trial of paclitaxel with or without TNP-470, we wish to determine whether the optimal dose of this combination of drugs, using a relatively novel schedule.

We are currently performing a pilot trial that takes advantage of the recently reported results of administration of paclitaxel at relatively high doses (80-100mg/m<sup>2</sup>) on a weekly schedule with acceptable toxicities. We will gather QOL and pharmacokinetic data from patients in this pilot study, in order to model these parameters for the prospective randomized trial.

## 1. OBJECTIVES

**1.1 To determine the dose limiting toxicities (DLTs), maximum tolerated dose (MTD) and pharmacokinetics of TNP-470 and paclitaxel when administered together by intravenous (IV) infusion of paclitaxel over 1 hour followed by TNP-470 over 4 hours, once every week in patients with advanced, incurable malignancies.**

**1.2 To document any objective antitumor responses that occur in patients treated on this protocol.**

**1.3 To obtain a metabolic profile on each patient with respect to P4502D6, P4503A4, P4502C18 and N-acetyltransferase and to evaluate the data obtained from this trial with respect to these parameters.**

**1.4 To describe quality of life (QOL) and cost of treatment for patients on this protocol.**

## 2. PATIENT ELIGIBILITY:

### 2.1 Patient must meet all of the following criteria:

**2.1.1 Patients must have a histologically confirmed, incurable malignancy with locally unresectable disease or distant metastasis. Patients must have malignancies considered to be unresponsive or poorly responsive to the best cancer treatments currently available. Specifically, there must be no other mode of therapy which would have a greater chance of producing cure or significant palliation.**

**2.1.2 Patients must be 18 years of age or older.**

- 2.1.3 Patients must have an anticipated survival of at least 8 weeks.
- 2.1.4 Patients must be fully informed about their illness and the investigational nature of the study protocol (including foreseeable risks and possible side effects), and must sign an informed consent.
- 2.1.5 Patients must be ambulatory, with an ECOG performance status of 0, 1 or 2 and must be maintaining a reasonable state of nutrition, consistent with weight maintenance.
- 2.1.6 Patients must have adequate organ function:
  - 2.1.6.1 Hematologic: WBC 3,000/mm<sup>3</sup>, granulocytes 1,500/mm<sup>3</sup> and platelet count 100,000/mm<sup>3</sup>);
  - 2.1.6.2 Coagulation: PT and PTT within the normal range unless on anti-coagulants;
  - 2.1.6.3 Hepatic: bilirubin  $\leq$  1.2; SGOT, SGPT  $\leq$  2 x ULN; and
  - 2.1.6.4 Renal: serum creatinine  $\leq$  1.5 (or creatinine clearance 60 ml/min).
- 2.1.7 Patients must be on stable doses of any drugs which may affect hepatic drug metabolism or renal drug excretion (e.g.--non-steroidal anti-inflammatory drugs, corticosteroids, diphenylhydantoin, barbiturates, narcotic analgesics, probenecid). Such drugs should not be initiated while the patient is participating in this study unless required to ameliorate toxicity.
- 2.1.8 Patients must have recovered from the reversible side effects of prior therapy

## 2.2 Contraindications to Enrollment

- 2.2.1 Recent major surgery (within 21 days).
- 2.2.2 History of a bleeding diathesis
- 2.2.3 Recent ( $\leq$  6 weeks) history of seizures.
- 2.2.4 History of peripheral neuropathy Grade 2.
- 2.2.5 Frequent vomiting or severe anorexia.
- 2.2.6 History of weight loss  $>$  10% of current body weight within the last 4 weeks.
- 2.2.7 Pregnant (obtain pregnancy test in women with child bearing potential) or lactating women. (NOTE: women and men enrolled in the study are to practice an effective method of birth control while on the study and for at least six months after their last treatment on protocol).
- 2.2.8 Serious intercurrent medical illnesses which would interfere with the ability of the patient to carry out the treatment program.
- 2.2.9 The following therapies are prohibited and may not be administered to patients being treated on this protocol: chemotherapy other than that specified in this protocol, and immunotherapy. Limited field radiation is permitted for painful bony lesions or other palliation.
- 2.2.10. Patients who have been treated with a hormonal therapy for 6 months and who have evidence of progressive disease may be entered on this protocol and continued on their current hormonal therapy if the patient and their physician feel it is in the patient's best interest.

- 3. **TREATMENT PLAN: Summary.** Eligible patients who have signed the consent form will have their metabolic profile determined. TNP-470 alone will be administered as a 4-hour infusion on day 1. Taxol will be administered starting on day 8 as a 1-hour infusion, followed by TNP-470 as a 4-hour infusion.

The second and subsequent cycles will be administered at 1 week intervals from the first day of Taxol infusion. For each cycle, Taxol will be administered as a 1 hour infusion with TNP-470 given as a 4-hour infusion on the same day as Taxol treatment. All treatment will be done on an outpatient basis.

	D1	D8	D15	D22	D29
TNP-470	X	X	X	X	X
Paclitaxel		X	X	X	X

In the absence of progressive disease, patients may be continued on treatment. Patients who experience dose limiting toxicities may resume treatment at a lower dose if the side effects resolve within 3 weeks.

**3.1. Patient dose escalation.** In the absence of TNP-470, the MTD for paclitaxel alone given on a weekly schedule is reported to be 80-100 mg/m<sup>2</sup>. Therefore we will not strive to exceed 100mg/m<sup>2</sup> weekly, and we will stop the study if toxicity is satisfactory at dose level 6. If patient has not had  $\geq$  grade 1 toxicity during previous four weeks and at least one patient is at a higher dose level for  $>3$  weeks without DLT, then the former patient may be treated for his/her next cycle at the higher dose level. These patients will not be counted towards defining the DLT.

### 3.2 Dose levels.

Level	TNP-470 (mg/m <sup>2</sup> )	Taxol (mg/m <sup>2</sup> )
1	88.5	70
2	88.5	80
3	133	80
4	133	90
5	177	90
6	177	100

The first 3 patients will begin on dose level 1. If no patients develop dose limiting toxicity during the first 4 weeks, then the next 3 patients will be started at dose level 2. If 1 of 3 patients experience dose limiting toxicity during the first 4 weeks of TNP-470, then an additional 3 patients will be started at that dose level. If less than 2 of 6 patients treated at any dose level experience dose limiting toxicity, the next patients will be started at the next dose level. As soon as two patients at a given dose level experience dose limiting toxicity, no additional patients will be started at that dose level. If at least six patients have been studied on the previous dose level then that dose level will then be considered the MTD.

**3.3 Definition of the Maximum Tolerated Dose (MTD) and the Recommended Phase 2 Dose (RP2D), which is the dose we will use in the prospective randomized trial of paclitaxel vs. paclitaxel + TNP-470.** The MTD is defined as the highest dose level which results in Dose Limiting Toxicity (DLT, defined by the shaded boxes in the NCI Common Toxicity Criteria) in fewer than 2/6 patients. When  $\geq 2$  patients experience DLT at a given dose level, the MTD will have been exceeded and the previous dose level will be declared the MTD provided 6 patients were treated at that level.

Often the RP2D will be the same as the MTD. However, if the toxicities observed at the dose level above the MTD or in 1 of 6 patients at the MTD were particularly severe, irreversible or fatal, and clearly related to drug administration, the next lower dose level would be declared the RP2D provided the side effects observed in all 6 patients treated at this dose level were acceptable. As explained above, tolerance to the RP2D will then be confirmed by the study of 6 additional patients.

**3.4. Accrual of women and minorities.** Characterization of drug metabolism, pharmacokinetics and pharmacodynamics in anticipation of a prospective randomized trial in women with metastatic breast cancer is a major objective of this pilot trial. However, as noted, although we will preferentially treat women with breast cancer on this study, it will not be limited to patients with breast cancer. If fewer than 50% of the patients treated at the RP2D are women, additional women may be accrued at the RP2D to evaluate any possible differences in drug processing. Since, by definition, minority patients (Black, Hispanic, Oriental, and Native American) are less likely to be studied in any clinical trial, additional minority patients may be entered at the RP2D to obtain data relevant to these populations. Indeed, as described in the Patient Access Core section of this report, we are making a special effort to enroll minorities in these studies.

#### **4. PHARMACOKINETICS**

**4.1 Collection of blood samples.** Blood samples (9 ml) will be collected in heparinized (nonseparator) tubes. At each sampling time 1 ml of whole blood will be withdrawn and discarded to remove blood diluted with the heparin used to maintain catheter patency. Vacutainer collection tubes are to be immediately placed on ice and centrifuged at 4°C for 5 - 10 min. To 1 ml of plasma, add 100 :l of 2% (wt.%) H<sub>2</sub>SO<sub>4</sub> (Mallinckrodt, Paris, KY, USA). The addition of sulfuric acid to the samples has the effect of acidifying the plasma to a pH of 4 to 5, a pH range in which TNP-470 is most stable. Acidification of the plasma also serves to partially denature plasma proteins. Plasma is divided into 2 aliquots in screw top polyethylene tubes and then labeled and stored at -70oC or lower. Samples will be assayed by the Abbott Laboratories.

**4.2 Time points for sampling.** TNP-470 pharmacokinetics. Complete pharmacokinetics are mandatory after the day 1 and 8 injections. Pharmacokinetics may be repeated in patients who continue to receive paclitaxel/TNP-470 past day 29. A blood sample should be obtained just prior to the injection and then and 4 hours during the infusion and 5, 15, 30, 60, and 120 minutes after the end of the infusion and 24 and 48 hours after the beginning of the infusion. The exact date and time that the infusion was started and completed, and each blood sample was obtained must be recorded.

**4.2.1 Taxol Pharmacokinetics and other fluids and tissues.** These specimens will be collected, processed, and handled as described above for Pilot Trial I.

#### **5. TREATMENT MODIFICATIONS AND MANAGEMENT OF TOXICITY**

**5.1 Dose modification for toxicity.** Dose limiting toxicities (DLTs) are identified in the NCI Common Toxicity Criteria appended to the protocol. Specifically, hematologic DLT will be defined as granulocyte nadir <500 /:µL for >7 days, platelet count <50,000/:µL or febrile neutropenia (temperature >38°C with AGC <1,000/µL). When DLT occurs, treatment with TNP-470 and taxol will be interrupted until the toxicity decreased by 2 grades or returns to baseline.

In case of hematologic DLT, the patient may be retreated at the same dose level with appropriate medical management of toxicity as described below. If, however, the hematologic DLT recurs despite appropriate medical management, the patient should be treated at the next lower dose level on subsequent cycles. In case of a non-hematologic DLT, the patient should be treated at the next lower dose level on subsequent cycles. Patients who experience a non-hematologic DLT on the first dose level should be restarted at 50% of the dose for both, TNP-470 and taxol. Hematologic DLTs should receive appropriate medical management without dose reduction. If the hematologic DLT recurs despite appropriate medical management, the patient should be retreated at 50% of the doses for both, TNP-470 and taxol.

Patients who experience toxicities 1 Grade or more above DLT will be considered to have had potentially life threatening toxicity from TNP-470. In general these patients should not be restarted on TNP-470 once toxicity resolves unless there is some indication of patient benefit. In these cases the reason(s) for reinstating TNP-470 must be clearly indicated in the case report form.

## **5.2 Management of anticipated toxicities.**

5.2.1 TNP-470. Toxicities observed in phase-I trials of TNP-470 included mild fatigue, nausea and central nervous system (CNS) toxicities. CNS toxicities included ataxia, gait disturbance, dizziness, light-headedness, nystagmus, increased anxiety and emotional lability. These were dose limiting and resolved within 4 weeks of stopping the treatment. During the study, physical and neurologic exams and laboratory parameters (platelet counts and coagulation studies) will be closely monitored. TNP-470 will be discontinued at the first clinical evidence of bleeding (e.g.--cutaneous or retinal petechiae, guaiac positive stools), thrombocytopenia, coagulation abnormalities, seizures, or ataxia (see dose limiting toxicities that have been shaded in NCI Common Toxicity Criteria).

5.2.2 Paclitaxel. Blood counts will be closely monitored for myelosuppression, by far the commonest toxicity. For patients experiencing only dose limiting myelosuppression in the absence of other non-hematologic DLT, granulocyte-colony stimulating factor ([G-CSF] filgrastim; Amgen, Thousand Oaks, CA) 5:g/kg/day will be administered subcutaneously on days 5 through 12 beginning 24 hours after the completion of the taxol infusion. G-CSF will be continued, if necessary, till the AGC is >2,000/L for 3 consecutive days. Nausea and vomiting will be treated as per the anti-emetic guidelines at the Lombardi Cancer Center; diarrhea may be managed with anti-motility agents like loperamide; mucositis may be managed with mouth washes; arthralgias/ myalgias may be treated with analgesics e.g. tylenol with codeine. Peripheral neuropathies are generally transient and require no specific treatment. Febrile neutropenia will be treated as per current guidelines at Lombardi Cancer Center. Hypersensitivity reactions to taxol are rare; however as a prophylaxis, decadron 20 mg p.o. will be given 12 hrs and 6 hrs prior to taxol administration, followed by decadron 20 mg i.v., diphenhydramine 50 mg i.v. and famotidine 20 mg i.v. 60 minutes prior to taxol administration. Treatment for toxicities in individual patients will be determined by the principal investigator. Treatment will be held at the first evidence of non-hematologic DLT as defined by the shaded boxes in the NCI Common Toxicity Criteria.

**5.3 Removal from study for prolonged toxicity.** Patients who do not experience DLTs may continue to receive treatment. If DLT occurs, treatment must be interrupted and the patient assessed at weekly intervals. Treatment may be resumed according to the guidelines mentioned above. If it is not possible to resume therapy after a 4 week delay due to persistent treatment related toxicities, the patient should be taken off study.

**5.4 Continued treatment of patients who are experiencing significant clinical benefit.** It may be in the patient's best interest to continue on treatment despite the occurrence of prolonged or otherwise unacceptable toxicity. Patients who are experiencing a significant clinical response from treatment and in whom continued therapy is indicated may be continued at a reduced dose of TNP-470 as determined by the Principal Investigator.

**5.5 Unavoidable treatment delays for non-medical reasons.** Treatment interruptions for non-medical reasons (for any reason, at the discretion of the patient and physician) are at times unavoidable and are permissible under this protocol. However, every attempt should be made to avoid any non-medical treatment delays, especially during the first 4 weeks of treatment. Patients who require frequent or prolonged treatment interruptions should be taken off study. Patients who have their treatment interrupted for reasons not related to side effects during the first 14 days of treatment will not be included in the determination that it is safe to enter subsequent patients at the next higher dose level and an additional (replacement) patient will be started at this dose level.

## **6. TOXICITY MONITORING AND ADVERSE EXPERIENCE REPORTING**

### **6.1 At each weekly visit during the first 4 weeks and every 2 weeks thereafter:**

6.1.1 an interim history will be obtained and a directed physical examination (to include at a minimum ECOG performance status, weight, fundoscopic exam, examination of skin and mucosal surfaces for petechiae) will be performed;

6.1.2 obtain a CBC, differential, platelet count, coagulation studies;

6.1.3 obtain a chemistry survey (to include BUN, creatinine, LDH, SGOT/AST, alkaline phosphatase, total bilirubin, calcium, glucose, and uric acid), electrolytes and SGPT.

6.1.4 Obtain a urinalysis and stool guiac.

**6.2 Laboratory studies will be repeated more frequently if clinically indicated, and any abnormalities potentially related to treatment will be followed until they have resolved, or have been determined to not be treatment-related.**

## **7. CRITERIA FOR TERMINATING TREATMENT**

**7.1 Patients who experience substantial benefit attributed to treatment should continue to receive protocol therapy until progressive disease is discovered.** Reasons for continued treatment are to be documented in the case records.

**7.2 Rapid disease progression in the first month of treatment ( 50% enlargement of measurable disease) is grounds for termination of treatment.** Patients with less rapid disease progression may remain on-study, at the discretion of the investigator after discussion with the patient.

**7.3 Any disease progression ( 25%, or new metastases) occurring after the first month on study, requires treatment termination.**

**7.4 DLT that does not resolve within 3 weeks of stopping TNP-470.**

**7.5 Intercurrent illness which prevents further therapy.**

**7.6 General or specific changes in the patient's condition which render the patient unacceptable for further treatment in the judgment of the investigator.**

**7.7 The patient or patient's physician is free to discontinue treatment and take the patient off study at any time, if this is believed to be in the patient's best interest.**

**8. STATISTICAL CONSIDERATIONS:** This study will determine the Dose Limiting Toxicities (DLTs) and Maximum Tolerated Dose (MTD) for TNP-470 and Taxol administered by IV injection on a weekly schedule. The MTD is defined as the highest dose level which results in DLT during the first 4 weeks of treatment in fewer than 2/6 patients, unless Dose Level 6 is reached without DLT. In that case, Dose Level 6 will be used for subsequent studies. When 2 patients experience DLT at a given dose level, the MTD will have been exceeded and the previous dose level will be declared the MTD.

**8.1 PK and Correlative Science Studies.** TNP-470 will be assayed in plasma and urine for each patient treated on this study by Abbott Laboratories. Plasma samples will be collected for assays of circulating angiogenic factors, including VEGF and bFGF, as well as for assays of global angiogenic potential, as measured by growth stimulation or inhibition of human umbilical vein endothelial cells in culture. These studies will be performed in the laboratories of Dr. Anton Wellstein and Dr. Daniel F. Hayes.

**8.1.1 Quality of Life (QOL) and Cost Effectiveness Analysis (CEA).** Each patient will be assessed for QOL parameters prior to and during therapy. These will be described in great detail in the Cancer Clinical and Economic Outcomes Evaluations Core. Of note, particular care will be made to assess patient choice regarding the effects of having weekly infusions, including the inconvenience and cost of the having to visit the outpatient infusion room at the Lombardi Clinic, and the 5-6 hours necessary for infusion each week.

**Summary of TNP-470 Pilot Studies.** In summary, preclinical and clinical data suggest that the combination of paclitaxel and TNP-470 may be additive if not synergistic as a result of prolonged half-life of TNP-470 and additive anti-angiogenic activities. Therefore, we plan to conduct a prospective randomized trial comparing paclitaxel and TNP-470 to paclitaxel alone in women with metastatic breast cancer. This pilot study will provide data that permit us to select a schedule and dose for this combination, based on pharmacokinetics, quality of life, and cost of the two regimens.

**Progress to Date:** As of September 15, 1998, seven patients have entered into this Phase I trial. One patient has discontinued therapy and the others remain on therapy with no dose limiting toxicities thus far. The following table summarizes the patient characteristics of these subjects:

Dose Level	Disease	Gender
I	Cervical Cancer	F
	Anal Cancer	
	Cancer of Unknown Origin	
II	Ovarian Cancer	F
	Breast Cancer	F
III	Breast Cancer	F
	Lung Cancer	

In addition, there are three more patients waiting to begin therapy. One of these will be at dose level III, and the next two will be at dose level IV. According to protocol guidelines, we are placing three patients on study per month. We anticipate enrolling patients up to and including dose level VI unless we observe DLTs prior to that level. **We will then place three more (total of six) patients onto the MTD. At the current accrual, we anticipate completing this Phase I trial in March or April, 1999.**

**We have now begun writing the prospective randomized trial. We will select the dose of paclitaxel/TNP470 as indicated from the results of the Phase I trial. We anticipate opening the prospective randomized trial in mid-late spring 1999.**

2.) **Clinical Trial of Thalidomide Overview.** As described in our initial proposal, the sedative thalidomide has been shown to have potent anti-angiogenic activity in preclinical models. Indeed, it has recently been approved for clinical use in this country for non-neoplastic diseases, with the caveats necessary to avoid exposure to pregnant women.

We therefore chose to pursue a randomized Phase II study of thalidomide in patients with breast cancer. We have now fully completed accrual and followup of patients on this trial. The following is a progress report of the clinical aspects of this study. The correlative science, QOL, and cost studies are not yet sufficiently mature to report.

Pharmacokinetics will be performed at Georgetown in the laboratory of Dr. Robert Flockhart. Circulating bFGF, VEGF, and TNF levels will be performed at Georgetown in the laboratory of Dr. Anton Wellstein.

### **Phase II Evaluation of Thalidomide in Patients with Metastatic Breast Cancer**

**Patients accrued to Thalidomide:** Twenty eight patients have been accrued at the four centers by 6/9/1998 as seen in the accompanying table. Fourteen patients were accrued on each of the two dose levels.

Dose	Georgetown	Dana Farber	Chicago	Duke	Total
200mg	6	4	3	1	14
800mg	9	3	2	0	14
Total	15	7	5	1	28



All patients have been removed from the study due to progressive disease except two patients. The first was removed due to grade 3 peripheral neuropathy and the second refused to continue treatment on study due to mild side effects ( refused dose reduction).

### Patient Characteristics

Characteristic	200mg	800mg
<b>Age</b>		
30-40	1	3
41-50	7	2
51-60	5	4
61-70	0	4
71-85	1	1
<b>Prior Chemotherapy regimens</b>		
0-1	2	2
2-3	12	12
ABMT	3	2
<b>Number of Hormonal Therapy</b>		
0-1	7	5
2-4	7	9
<b>Site of Disease</b>		
Bone Only	1	0
LN only	3	1
Liver Only	1	1
Chest Wall	1	0
2-4	8	12

### Dose modifications:

One patient at the 200mg dose required dose reduction due to grade 3 neuropathy. At the 800mg dose, four patients had to reduce dose to 600mg and two patients to 400mg, all due to neurotoxicity (somnia). Three patients continued at the 800mg dose with no changes.

### Duration of treatment:

At the 200mg level, one patient was taken off study at 2 weeks and a second patient at 4 weeks from starting treatment due to progressive disease. Ten patients were taken off at 8 weeks due to progressive disease at the time of staging. Two patients went beyond the first 8 weeks staging, one was removed from study at 11 weeks due to G3 neuropathy and the second at 16 weeks due to progressive disease at the time of staging.

At the 800mg level, two patients were removed from study at 4 weeks, one due to progressive disease and the second refused to continue treatment due to side effects ( also, refused dose reduction). For patients were taken off study at six weeks due to progressive disease and eight patients were taken off at 8 weeks due to progressive disease. None of the patients at the 800mg continued beyond the first eight weeks of treatment.

### Adverse Events:

Only one patient was removed from the study due to grade 3 neurotoxicity (peripheral neuropathy). This patient was on the 200mg dose and was removed at week 11. The main dose limiting toxicity was somnolence (grade 2) requiring dose reduction at the 800mg dose level. The dose was reduced from 800 mg to 600mg for four patients, and from 800 mg to 400mg dose for two patients. The other adverse events did not require dose reduction or removal from the study.

Adverse Event	Number of Patients Treated at:		Total
	200mg	800mg	
Constipation	3	10	13
Somnolence	4	8	12
Fatigue	6	6	12
Peripheral neuropathy	5	4	9
Dizziness and Instability	2	4	6
Dry Mouth	2	6	8
Skin rash	1	2	3
Nausea	0	2	2
Anorexia	1	1	2
Arrhythmia	1	0	1
Neutropenia	1	1	2
Headaches	1	0	1

### **Efficacy/Response to Treatment:**

**Response:** No patient achieved partial or complete response.

**Time to Treatment Failure/Progression.** In addition to determining response, we also prospectively assessed evidence of failure to progress at eight weeks, with the assumption that to do so in a group of patients with previously progressive disease would indicate activity of the drug. Two patients at the 200mg dose had stable disease at the 8 weeks staging. The first patient had reduction in the hilar and mediastinal lymphadenopathy (only site of disease) by 47% at the 8 weeks staging. However, at the 16 weeks staging, she had progressive disease at that site and was removed from the study. The second patient had chest wall disease that was slowly progressing on no treatment over the last twenty months before starting thalidomide. At the 8 weeks staging she had stable disease, she was removed from the study at week 11 due to grade 3 peripheral neuropathy.

Thirteen patients at the 800mg dose had progressive disease at 8 weeks or before, and none went beyond the first 8 weeks. One patient refused to continue treatment beyond week 4 due to side effects and refused dose reduction

### **Current plans:**

We conclude that thalidomide at 800 mg/day had no detectable activity in this setting. Furthermore, it was only moderately tolerable, mostly due to somnolence and other neurotoxicities. According to our prospectively written criteria, at least one patient, and perhaps two, failed to progress at 8 weeks on the lower dose. Therefore, thalidomide may have some activity in patients with metastatic breast cancer, but it must be considered minimal, at best.

No more patients will be added to the 800mg arm and this arm is closed.

Further discussions with CTEP-NCI are to be held in the near future regarding adding further patients to 200mg dose arm according to the current results with the first fourteen patients.

Pharmacokinetics, angiogenic growth factor and angiogenesis assays, as well as the pilot QOL and cost analyses will be performed in the near future. We anticipate submission of an abstract reviewing our experience to the American Society of Clinical Oncology in December, 1998, for presentation at the May, 1999 meeting. We anticipate preparation of a manuscript by early spring, 1999.

**III. OVERALL SUMMARY:** As stated, the overall goals of this project are to evaluate the effects of angiogenic inhibitors in prospective clinical trials in patients with breast cancer. We have now successfully completed a randomized phase I/II study of thalidomide, which have provided insights into the relative lack of activity high dose (800-1200 mg) and standard dose (200 mg) thalidomide. Companion studies regarding pharmacokinetics, circulating angiogenic activity, and QOL and Cost analysis are underway.

Furthermore, we have begun a pilot trial that will lead to our proposed randomized trial regarding whether TNP-470 contributes added benefit, in regards to efficacy, QOL, or cost/benefit, to the chemotherapeutic agent, paclitaxel. We anticipate finishing this pilot study during the six months, and initiating the randomized trial for patients with breast cancer within the next calendar year. Taken together, these studies should permit us to determine if inhibitors of angiogenesis have clinical value in metastatic breast cancer, and whether they should be studied in the adjuvant setting.

#### IV. REFERENCES

1. Bhargava P, Marshall J, rizvi N, Dahut W, Yoe J, Figueira M, et al. A study of TNP-470 in patients with advanced cancer. *Proc Am Acad Cancer Res* 1007;38:221a.
2. Sledge G, Neuberg D, Ingle J, Martino S, Wood W. Phase III trial of doxorubicin vs. paclitaxel vs doxorubicin + paclitaxel as first line therapy for metastatic breast cancer: An Intergroup trial. *Proc Am Soc Clin Oncol* 1997;16:1a.
3. Seidman A. The emerging role of paclitaxel in breast cancer therapy. *Clin Cancer Res* 1995;1:247-256.
4. Wilson W, Berg S, Bryant G, Wittes R, Bates S, Fojo A, et al. Paclitaxel in doxorubicin-refractory or mitoxantrone-refractory breast cancer: A phase I/II trial of 96-hour infusion. *J Clin Oncol* 1994;12:1621-1629.
5. Seidman A, Murphy B, Hudis C. Activity of Taxol by weekly 1h infusion in patients with metastatic breast cancer. *Proc Am Soc Clin Oncol* 1997;16:148a.
6. Breier S, Lebedinsky C, Pelayes L. Phase I/II weekly paclitaxel at 80 mg/m<sup>2</sup> i pretreated patients with breast and ovarian cancer. *Proc Am Soc Clin Oncol* 1997;16:163a.
7. Belotti D, Nicoletti I, Vergani V. Paclitaxel, a microtubule affecting drug, inhibits tumor induced angiogenesis. *Proc AACR* 1996;37:57a.
8. Oktaba A, Hunter W, Arsenault A. Taxol: A potent inhibitor of normal and tumor-induced angiogenesis. *Proc AACR* 1995;36:454a.
9. Klauber N, Parangi S, Flynn E, Hamel E, D'Amato RJ. Inhibition of angiogenesis and breast cancer in mice by the microtubule inhibitors 2-methoxyestradiol and taxol. *Cancer Res* 1997;57:81-86.
10. Winternitz C, Jackson J, Oktaba A, Burt H. Development of a polymeric surgical paste formulation for Taxol. *Pharm Res* 1996;13:368-75.

11. Placidi L, Cretton-Scott E, Sommadossi J. Potential metabolic drug interactions between the angiogenesis inhibitor TNP-470 and anticancer agents. Proc AACR 1997;38:51a.

12. Oliver S, Banguerigo M, Brahn E. Suppression of collagen-induced arthritis using an angiogenesis inhibitor, AGM-1470, and a microtubule stabilizer, Taxol. Cell Immunol 1994;157:291-9.

## CORE 1: PATIENT ACCESSION CORE

**I. INTRODUCTION:** The overall goal of the Patient Accession Core (PAC) is to promote and facilitate increased participation, in current and proposed Lombardi Cancer Center Breast Center research protocols, by patients and high-risk women who have historically had difficulty accessing and benefiting from cancer prevention, diagnostic and treatment trials. Two particular groups of patients and high-risk women are the focus of these outreach efforts: 1) medically underserved populations, particularly African-American and elderly patients and 2) high-risk individuals who are members of health maintenance organizations (HMOs).

The following is an account of the Year 2 efforts directed toward meeting the objectives specified for the Patient Accession Core of the Department of Defense-funded Breast Cancer Research Center of the Lombardi Cancer Center. In some cases, the PAC has been engaged in activities different from those specified in the original proposal. As such, these are described within the discussion of original objectives or in the conclusion of this section.

The specific aims of the proposed PAC remain as follows:

1. **Expand Lombardi's established links with the community-based Washington D.C. clinics already serving the primary care needs of the area's medically underserved.** This was done by forming a Community Advisory Board to the Lombardi Breast Cancer Research Center in order to review community-based education, protocol promotion, clinical referral, and patient transportation mechanisms. This is to ensure that, while efforts are made to increase medically underserved patient participation in Lombardi clinical trials, continuity of primary care is maintained for illnesses and health problems unrelated to breast cancer.
2. **Expand Lombardi's links with local and national Health Maintenance Organizations (HMO) serving the greater Washington D.C. area.** This was done by forming an HMO advisory board to the Lombardi Breast Cancer Center to review HMO member education, protocol promotion and clinical referral mechanisms and to participate in evaluating cost-effectiveness data from HMO members participating in breast cancer diagnosis and treatment trials at the Lombardi Center.
3. **Expand Lombardi's existing breast cancer education materials and health promotion programs** by making them available through the information superhighway (e.g. the Internet) for HMO members and by basing these materials and programs in medically underserved community settings. All messages materials and programs will be made culturally and educationally appropriate for different racial/ethnic, age and socioeconomic breast cancer patient and high-risk groups.
4. **Provide cultural awareness and sensitivity training to Lombardi Breast Cancer Center clinicians** involved with prevention, diagnostic and treatment research protocols to ensure supportive patient care for all patients on clinical trials.
5. **Provide free transportation**, with the Lombardi Cancer Center van, for medically underserved patients for whom transportation to, and/or parking in, Georgetown may represent a barrier.

## II. PROGRESS REPORT 1997-1998

### A. Community Outreach Initiatives

**Community Advisory Board (CAB):** During Year II the Community Advisory Board met twice, once on August 27, 1997 and again on February 10, 1998. The August meeting focused on the CARE (genetic counseling and testing) program. A flow chart depicting how women are processed through the CARE program was reviewed in detail with the CAB. Following the "walk through" it was suggested that members of the CAB that were eligible for the CARE program consider enrolling. The PAC believed that their experiences would be beneficial in two ways; 1) they could better articulate the process to interested constituents, and 2) they could inform PAC of specific matters or experiences that they felt might inhibit participation in that particular study. Along with the flow chart, PAC staff presented a table that compared participation in a commercial genetic testing firm's program with participation in the CARE program. Some of the benefits of CARE were no cost, confidentiality and the ability to undergo individualized genetic consultation with a masters trained genetic counselor.

During this meeting the CAB was asked to evaluate the video, "Genetic Testing for Breast Cancer Risk: It's Your Choice," and consider its use with their constituents. The CAB members spoke favorably about the video. PAC staff offered to secure copies of the video for those organizations that were interested in obtain their own copy.

In the February 1998 meeting of the CAB, members received honoraria for their contributions during Year 1 of the grant. Dr. Kerner presented an overview of the three Breast Cancer Center studies for the benefit of the new CAB members. He took the opportunity to present data reflecting the accrual rates for the studies by ethnicity and contrasted these figures with the metropolitan area demographics. This highlighted the need for greater participation in clinical trial by ethnic minorities especially African Americans.

Anna Robertson presented an account of the recruitment strategies that were suggested by the CAB and were either being implemented or under development by members of the PAC. These strategies included information about understanding clinical trials, fact sheets on the specific studies of the Breast Cancer Center, business card style recruitment tools, PAC staff's participation in CAB organizations' staff meetings, and CARE posters for specific sites.

CAB members were alerted that the PAC would be contracting with an independent company to support the patient recruitment efforts for clinical research. Lenora Johnson solicited potential candidates for the contract at that time. CAB members were also informed of the PAC plans to offer training workshops in cultural awareness and sensitivity to LCC staff members working with patients in clinical trials. An overview of the training workshop was shared with members of the CAB.

The accounting of the efforts to meet with the Community Advisory Board members one-on-one can be reviewed in the grid on the following page.

Community Advisory Member	Meeting Date	Results and Action Points
<p><b>L. Sue Andersen, Esq.</b> Project Director Health Insurance Counseling Project 2136 Pennsylvania Avenue, NW Washington, DC 20052 (202) 676-3900 (202) 293-4043 fax</p>	Met on 12/16/97	<ul style="list-style-type: none"> <li>• Offered legal expertise to the CAB member constituents who may be having difficulty getting medical coverage</li> <li>• Will continue to "promote" CARE to in coming clients when appropriate</li> </ul>
<p><b>Deborah J. Barnes, BSW</b> Education Outreach Coordinator Cancer Services Greater Southeast Community Hospital 1310 Southern Ave, SE Washington, DC 20032 (202) 574-5444</p>	1/22/98	<ul style="list-style-type: none"> <li>• Met with Ms. Barnes and Ms. Crestwell and decided best approach is to attend one of the Caring and Sharing Support Groups to talk about clinical trial participation</li> </ul>
<p><b>Vivian Crestwell</b> Sharing and Caring Support Group Greater Southeast Community Hospital 2100 Brooks Drive Apt. 418 Forestville, MD 20747 (301) 420-6868</p>	7/6/98	<ul style="list-style-type: none"> <li>• After a number of cancellations during Spring 98, provided educational sessions on genetics and breast cancer to members of the support group that meet at GSECH in Southeast:</li> <li>• Included what is a clinical trial, the rights of someone entering a trial and why it is important to get under represented groups to participate.</li> </ul>
<p><b>U. Michael Currie, MPH</b> Executive Director Maryland State Council on Cancer Control 201 West Preston Street Suite 546 Baltimore, MD 21201 (410) 767-4055</p>	February 1998	<ul style="list-style-type: none"> <li>• Not interested in meeting one-on-one</li> <li>• Will continue to support PAC and attend CAB meetings</li> </ul>
<p><b>M. Linden Griffith</b> Washington Seniors Wellness Center 3001 Alabama Ave, SE Washington, DC 20020 (202) 581-WELL (202) 581-0657 fax</p>	Met with Ms. Griffith on 12/10/97 @ the Sr. Wellness Center... <i>A Health Emphasis Place for Older Adults</i>	<ul style="list-style-type: none"> <li>• Suggested we work with Ms. Delores Botts, who heads up the comprehensive health promotion program for older adults. The programs that would make the most sense for PAC include:</li> <li>• <b>Core Curriculum</b> - 12 week cycle of classes that provide educational and applied learning in nutrition, exercise and <b>health dialogues</b>.</li> <li>• <b>Seminar Series</b> - topical areas, usually 90-120 minutes from 4-8 sessions held once a week.</li> <li>• <b>Support Groups</b> - designed to provide support, information and education, and a feeling of belonging.</li> <li>• Upon talking with Ms. Botts, we were informed that Howard University provides them with all the Health Education support they would need, so LCC services were not desired.</li> </ul>

Community Advisory Member	Meeting Date	Results and Action Points
<p><b>Tylene Harrell</b>            Program Associate            National Black Women's Health Project            1211 Connecticut Avenue, NW            Suite 310            Washington, DC 20036            (202) 835-0117 (202) 833-8790 fax</p>	<p>Lenora and Anna met with Ms. Harrell on 12/3/97</p>	<ul style="list-style-type: none"> <li>• Suggested we think about writing article for <i>Vital signs</i> "a news magazine communicating health issues affecting women of African decent, their families and communities." Next due date is January 15<sup>th</sup>, 2 page, double spaced, provide on desk on either WordPerfect 6.0 or Word 6.0. Include information about Lombardi, PAC and genetic testing for breast cancer.</li> <li>• Fact sheets to be designed for women</li> <li>• Attend their breast cancer evening seminar and show video on breast cancer and genetic testing. Include a dialog about what is a clinical trial, the rights of someone entering a trial and why it is important to get under represented groups to participate.</li> </ul>
<p><b>Linda Jackson</b>            The National Caucus and Center on Black Aged, Inc.            Director – Wellness Promotion/Disease Prevention Program            1424 K Street, NW - Suite 500            Washington, DC 20005            (202) 637-8400 (202) 347-0895</p>	<p>New member to CAB</p>	<ul style="list-style-type: none"> <li>• Desired assistance in funding events that pull together their breast health advocates (i.e. luncheons, etc.). If LCC could fund such they would provide a forum for educating about clinical trials.</li> </ul>
<p><b>Ginger Jevne</b>            Links, Inc.            Health &amp; Wellness Coordinator            1200 Massachusetts Avenue, NW            Washington, DC 20005            (202) 842-8686</p>	<p>Has not been an active member of the CAB, was not given an honorarium. Unclear of involvement, doesn't return calls or written correspondence and never provided us with a replacement representative</p>	
<p><b>Juanita E. Lyle</b>            Metro Coalition Leader            National Black Leadership Initiative on Cancer            Washington Metro Area            1101 3<sup>rd</sup> Street, SW - #513            Washington, DC 20024            (202) 994-1364</p>	<p>Ms. Lyle requested we meet after the Holiday season</p>	<ul style="list-style-type: none"> <li>• Extremely supportive of clinical trial participation. Not quite sure that she can push genetic testing in that it is an uncomfortable decision for herself - supported focus groups to discern what some barriers might be</li> </ul>
<p><b>Teresa McLaughlin</b>            Providence Hospital            Oncology Nursing Educator            Infusion Center/4 East            1150 Varnum Street, NE            Washington, DC 20017            (202) 269-7497</p>	<p>Became a member in 1998</p>	<ul style="list-style-type: none"> <li>• No longer at Providence Hospital</li> </ul>



Community Advisory Member	Meeting Date	Results and Action Points
<b>Cathy Miedel</b> Providence Hospital Wellness Center 1150 Varnum Street, NE Washington, DC 20017	Ms. Miedel continues to ignore any correspondence	<ul style="list-style-type: none"> <li>• May want to consider removing from CAB</li> </ul>
<b>Valerie Rochester</b> Bethune Program Center National Council of Negro Women, Inc. 633 Pennsylvania Avenue, NW Washington, DC 20004 (202) 383-9141 (202) 383-9144 fax	Met with in March 1998	<ul style="list-style-type: none"> <li>• Met with staff to discuss issues related to recruitment. Was not sure the Black Family Reunion was the most effective vehicle for recruitment of minorities to clinical trials. Would discuss at next meeting.</li> <li>• Organization in transition</li> </ul>
<b>Lenora J. Sherrard, MPH</b> Senior Health Educator Department of Health and Human Services Health Promotion and Prevention 8630 Fenton Street, 10 <sup>th</sup> Floor Silver Spring, MD 20010 (301) 217-1708	Met with MS. Sherrard on 12/10/97. Heads up the Health Promotion Division - involves community planning, coalition building and education to address unhealthy lifestyle behaviors. Also provided consultation and health information to the community.  2/13/98 - Met with Betty Raekimper and Janice Malley - Women's Cancer Control Program	<ul style="list-style-type: none"> <li>• Suggested contact: Betty Raekimper, Manager for the Women's Cancer Control Program - provides fee mammogram, breast exam, Pap test to screen low-income women (50 years and over) for breast and cervical cancer. They already have a "base" of women and train outreach workers to interface with clients. (301) 217-1605</li> <li>• Suggested contact: Judy Kovich, Manager for the School of Health Services. Attend staff meetings and talk about PAC (301) 217-1626.</li> <li>• Suggested contact: Women's Health &amp; Tobacco - targeting minority underserved women. Planning committee meetings take place in January to include county outreach and housing workers.</li> <li>• Provided <i>A Guide for the Community</i> listing of community services in the areas of: Adult Mental Health and Substance Abuse; Aging and Disability; Children, Youth and Family; Crisis, Income and Victimization, Public Health Services.</li> <li>• Agreed to refer women from their program to CARE. Summer 98 received first referral.</li> </ul>
<b>Michael D. Thompson</b> Director of Marketing, Planning, & Community Outreach Providence Hospital 1150 Varnum Street, NE Washington, DC 20017 (202) 269-7026 (202) 269-7160 fax	Lenora and Jon have continued to connect with Mr. Thompson.	<ul style="list-style-type: none"> <li>• Still working closely with Providence to establish a collaborative partnership that is mutually beneficial. Currently, awaiting meeting with hospital CEO.</li> </ul>
<b>Brenda Turner</b> Director Aging Services Division Greater Washington Urban League, Inc. 2900 Newton Street, NE Washington, DC 20018 (202) 529-8701 (202) 832-3127 fax		<ul style="list-style-type: none"> <li>• Active when does attend CAB meetings, but continue to have difficulty contacting to meet one-on-one.</li> </ul>

Community Advisory Member	Meeting Date	Results and Action Points
<b>Edna Kane-Williams</b> Manager Health and Long Term Care Issues Staff American Association of Retired Persons 601 East Street, NW Washington, DC 20049 (202) 434-2277 (202) 434-6474 fax	Not a participating CAB member	
<b>Kimberley D. Willis, MSW, ACSW</b> Director of Public Sector Marketing Green Spring Health Services 5565 Sterrette Place, Suite 500 Columbia, MD 21044-2644 (410) 964-8476 temp (410) 740-8573 fax		<ul style="list-style-type: none"> <li>Met with Ms. Willis in Fall 97, moved on to new job Spring 98. Since she changing jobs Ms. Willis continues to be supportive.</li> </ul>

**Primary Care Clinic Advisory Board:** Just as with the CAB, the Primary Care Clinic Advisory Board met twice during Year II on the same days as the CAB. For the most part the matters covered were identical with the exception of recruitment strategies. For clinics there were two paramount challenges to recruitment. The first was our ability to provide services to Spanish speaking populations (two of the clinics on the board provide health services to Hispanic communities) and developing efficient referral methods for clinic clinicians. In response to the concern for meeting the needs of Hispanics, PAC worked with Dr. Caryn Lerman on a proposal to broaden the range of the CARE program by procuring a bilingual genetic counselor and the capacity to provide CARE services off site in community settings. All of the clinics belonging to the PAC advisory board submitted letters of support for that proposal.

PAC staff continues to work with CARE staff to develop time efficient ways for clinicians to make referrals. Clinicians prefer to call the study referral line for the patient. Given this, PAC and CARE staff are working together to determine whether there are sufficient resources to staff a referral line. The current line(s) are answered with a machine and prospective participants are asked to leave name, number and a convenient time they can be reached. Member of the clinic advisory board feel that this might deter referrals from their clinicians because a great deal of their clinicians are volunteers and would not be able to leave a number.

While identifying a bilingual genetic counselor might be difficult, clinic board members felt it was necessary that women whose native language is Spanish should be counseled in the Spanish language. The Cancer Genetics Network proposal should support this.

The account of the one-on-one clinic visits conducted in Year II can be found in the grid on the following page.

Report of one-on-one Meetings with Clinic Advisory Board Members				
Members of the Clinic Advisory Board	Met with or Will meet with	Telephones	Date	Comments
Washington Free Clinic P.O. Box 43202 Washington, DC 20010 16 <sup>th</sup> and Newton St. Stephen's Church	Nina Paterno	202 667-1106	12/1	Would like in-service on the studies for volunteers (non-professionals) on a Saturday morning
Spanish Catholic Center 3055 Mt. Pleasant St NW Washington DC 20009	Sister Kay Koppes OSF,RN,RNP	202 332-6664 fax 234-7349	12/3	In-service on the studies for staff would be useful  Is interested in finding ways to employ unlicensed physician and nurses to serve a population badly in need of care
Zacchaeus Free Clinic 1525 7 <sup>th</sup> Street NW Washington, DC 20001	Randi Abramson	202 265-2400 fax 745-1081	12/2	Recommends an in-service for professional volunteers as well. They use the genetic counseling study folder just to circle number and tell patient to call the number. Recommends business cards for distributing with name of study and number to call
La Clinica del Pueblo 1470 Irving Street NW Washington, DC 20010	Juan Romagoza	202 462-4788 fax 667-3706	12/15	Thinks an in-service would be good for the couple of staff he has who deal with following the mammogram results. Suggests that it be done before April because once spring happens they are out running around with health fairs, etc.  Dr. Romagoza suggested that we might be able to consider employing foreign physicians or nurses who are not yet licensed to practice here but who are bilingual and could translate for genetic counseling. He suggests that we could set up the counseling once a week or so in one of the three clinics serving Latinos (since they are all within a five block radius).
Washington Free Clinic P.O. Box 43202 Washington, DC 20010 16 <sup>th</sup> and Newton St Stephen's Church	Lois Wessel	202 667-1106		Not yet set up
Spanish Catholic Center 3055 Mt. Pleasant St NW Washington DC 20009	Sister Kay Koppes OSF,RN,RNP	202 332-6664 fax 234-7349	8/28	Interested in exploring being a SHARE host site. Work with Catholic Charities to resolve follow-up of abnormalities when necessary Sees lack of follow-up and free care as an obstacle Looking forward to accessing Spanish genetic counseling for her clients.

Report of one-on-one Meetings with Clinic Advisory Board Members				
Members of the Clinic Advisory Board	Met with or Will meet with	Telephones	Date	Comments
Zacchaeus Free Clinic 1525 7 <sup>th</sup> Street NW Washington, DC 20001	Randi Abramson	202 265-2400 fax 745-1081	8/31	Also interest in exploring host site possibilities at Zacchaeus. Also have need for free follow-up We again explored with them the possibility of a referral form that they would fax to us but we would not use to contact patients. Considered the possibility of offering free biopsy as part of CABCAD
La Clínica del Pueblo 1470 Irving Street NW Washington, DC 20010	Juan Romagoza	202 462-4788 fax 667-3706	8/21	Overwhelming issue is GUMC presence in community. Partner with other hospitals for services (Providence, Howard maybe DC General) but nothing with GUMC. No place to send abnormalities, extensive staff hours spent locating free services for patients in need of them
Woodridge	Cheryl Williams	202 408-3373		

**B. HMO Advisory Board:** Working in collaboration with other entities at the Georgetown University Medical Center responsible for HMO outreach, PAC staff members have redirected their approach to reaching managed care organizations. During Year II PAC staff met with Linda Meili, RN, MS, ONC, Coordinator for Managed Care Programs, Lombardi Cancer Center and Patricia Robinson, Senior Account Manager, Managed Care Department - GUMC. It is believed that a cooperative strategy for reaching managed care organizations may prove more successful. Also, given the legislative attention relating to broadening opportunities for managed care membership participation in clinical research trials, it is believed that the provision of an informational session (seminar, presentation, symposium) for leaders of area managed care organizations may be of interest. PAC staff will continue to work with LCC and GUMC staff to develop and implement effective ways of reaching out to the dynamic managed care system.

**C. Breast Cancer Education Plan:** Materials developed during Year 2 served to either support recruitment efforts or increase awareness (clinic posters) of the clinical trials in research settings. PAC staff is still faced with the challenge of developing the most effective material for the clinics. The operations of the primary care centers are somewhat less structured than other facilities. Many of the providers are volunteers and actually practice elsewhere in the city. PAC continues to work with clinic representatives to determine the most appropriate tools that can be readily accessible and strategically placed in the clinic for ease of use and quick recognition. Suggestions explored include a referral pad (similar to a prescription pad) that physicians could carry in their pockets and family history forms that are revised to be more suitable for these settings.

PAC staff are finding that materials that are distributed are often difficult to locate upon site visits. Similarly, the managed care organizations will duplicate the materials many times as opposed to calling PAC for replacements. PAC staff will work to develop a materials distribution system that assures the materials are being used in the manner in which they were intended. Copies of materials produced can be found appended.

It was originally intended that the Breast Cancer Resource Committee (BCRC) would develop and promote a campaign around the topic of clinical trials participation for African American women. Half way through the 02 year, BCRC decided that it would not be in their best interest to enter into a contractual agreement with LCC. As such, PAC released a Request for Proposals to identify another provider for this service. Proposals were narrowed to three strong candidates. After review of the proposals by PAC staff and Breast Cancer Center investigators the decision was made to award the subcontract to Matthews Media Group, Inc. (MMG) located in Rockville, Maryland.

MMG has a track record in recruiting patients to clinical research trials. They have worked with the National Cancer Institute in developing materials and systems to aid the recruitment process. In addition, MMG has established a network throughout the metropolitan area consisting of clinics and providers that are supportive of clinical research trials and willing to work collaboratively to set up referral processes for desired study populations.

The sites where they have gained trust, and through which they have been able to accrue, include:

- Area C Chest Clinic
- Arlington County Chest Clinic
- Community for Creative Non-Violence Clinic
- D.C. General Hospital
- *La Clinica del Pueblo*
- *Spanish Catholic Center*
- Upper Cardozo Community Clinic
- *Woodridge Neighborhood Clinic*
- *Zacchaeus & Bread for the World*

The italicized clinics are those already represented on the PAC Clinic Advisory Board and the underlined is one site that PAC has identified for research partnership for Year 3. However, given that MMG has the capacity for on-site study promotion and accrual, we believe that a potentially better use of DOD funds for patient accrual would be to broaden MMG's contractual role in patient recruitment for the Breast Cancer Research Center trials.

At the time of this report, PAC is still awaiting approval of DOD to revise the contract to replace BCRC with MMG. That request also included the merging of Year 2 and Year 3 funds to accommodate the delay in making the award. We are now proposing to expand this contract further by re-budgeting the Year 3 and 4 year funds for the salary plus fringe benefits of the 50% health educator and using these funds to expand the patient accrual contract with Matthews Media Group. A formal request will be submitted under separate cover.

**D. Cultural Awareness Training:** The successful recruitment and retention of culturally diverse communities and individuals can be challenging for even the most experienced clinical investigators. The overall goal of the Patient Accession Core is to promote and facilitate increased participation, in current and proposed Lombardi Cancer Center Breast Center research protocols, by patients and high-risk women who have historically had difficulty accessing and benefiting from cancer prevention, diagnostic and treatment trials. Education For Quality Living (EQL), an agency based here in Washington DC, conducted a focus group and a series of in-depth interviews in Year 2 to obtain data which would enable them to tailor an existing workshop to the specific needs of

LCC staff members. That data was compiled and reported on (poster presentation) at the Cancer and Literacy conference offered by the Moffitt Cancer Center in Florida on April 30th. The results can be found appended to this report.

The *Culture & Health* workshop was offered as a pilot to 12 staff members in June 1998. PAC staff worked with EQL to revise the workshop based upon feedback of this workshop in preparation for a September 1998 (rescheduled from July 1998) workshop. The major changes included a focus on research staff members and greater input from participants with respect to their personal experiences with cancer rather than depend on EQL for that input.

**E. Patient Transportation Support:** The degree to which lack of transportation may present a barrier for potential participants in the breast cancer clinical trials has been discussed in detail during meetings with local hospital personnel, the CAB-OG and the CAB-CPC. Originally, the plan was to utilize the Lombardi Cancer Center van to pick up a group of patients at their referring hospital or clinic site. The logistics of such an endeavor are complicated in that the CARE and CAB/CAD studies require two to four hours of time for each individual to complete their sessions, and only one woman may attend a counseling session or receive diagnostic testing at one time. Therefore, asking a group of women to come to Lombardi to participate on the same day would require extra time to wait for each person to complete their appointment. As most of the women served by the primary care clinics are working or in school, lack of time during weekdays is a great barrier to participation in research studies.

To address transportation barriers, alternate mechanisms are in place for provision of parking and taxi vouchers. It is expected that many of the women referred from the primary care clinics to the CARE and CAB/CAD studies will need to take taxis to get to Georgetown. A system is already in place, for the CAB/CAD study, where women who need to take a taxi are identified during the intake session over the telephone and asked to call a taxi service under contract with Georgetown University Medical Center. When the patient arrives at Lombardi Cancer Center, the project coordinator for the study meets her taxi and provides the driver with a voucher. Likewise, when the patient leaves to go home, a taxi is called and a voucher is provided.

#### **F. Additional Patient Accrual Efforts**

**Extramural Research Committee (ERC):** During the first year of the PAC, additional recruitment efforts were developed at the recommendation of the senior investigators and the Cancer Center's administration. The most intense effort has been the coordination between the PAC and the LCC Extramural Research Committee. This committee consists of two representatives from PAC, Dr. Jon Kerner (Associate Director for Prevention and Control) and Lenora Johnson (Senior Health Educator), Dr. John Marshall (Associate Director for Extramural Research, Clinical Research Management Office and Associate Professor of Medicine), Caryn Steakley (Clinical Research Coordinator), and Jan Hewitt (Research Nurse). This group meets monthly to coordinate those efforts underway to increase research referrals from external sources; namely physicians' practices. To date, the activities of this group have been to:

- secured funding from the Lombardi Cancer Center to provide additional support for extramural research activities from the Director's shared resources allocations

- conducted focus groups amongst local community and private practice oncologists and surgeons to identify barriers to partnering for the purpose of clinical trial recruitment

PAC will continue to work with the Committee to alleviate any confusion associated with several entities of the same institution making agreements relating to patient accession to different clinical trials.

**Community Hospital Partnerships:** PAC staff has been communicating with the Cancer Committee of Providence Hospital (NE Washington, DC) for more than 12 months for the purpose of working through a process for collaboration in clinical research studies. These communications have been limiting, in that the hospital CEO has not been involved. In that she is the ultimate decision maker, her involvement is important. Currently, Providence and PAC staff members are working to coordinate a meeting with the Cancer Committee, Lombardi Extramural Clinical Research directors, and the CEO of Providence Hospital.

The PAC obtained a listing from the Maryland Tumor Registry of the ten Maryland hospitals that served the largest number of African American breast cancer patients in the state. Of the hospitals treating the 110 breast cancer cases in Montgomery and Prince George's counties in 1995, Prince George's Medical Center and Doctor's Hospital in Prince George's County treated the most patients. In Year III, these two hospitals will be targeted for collaboration.

**Physician Practices:** PAC has developed a database of all oncologists and oncology surgeons in the Washington Metropolitan Area. The list is approximately 250 members in size, which includes multiple offices of a single practice. A letter was mailed to these practices that addresses referrals to clinical trials. A brochure that briefly explains clinical trials accompanied the letter along with the materials already developed and produced for each of the three Breast Cancer Research Center protocols. Twelve physicians responded with an interest in collaborating with GUMC for the purpose of collaborating in cancer treatment trials.

**III. SUMMARY:** Despite considerable effort by the PAC staff to implement the minority patient recruitment plan, through extensive meetings and collaboration with the Community Advisory and Clinic Advisory Boards, the level of minority patient accrual, to date, has been less than anticipated.

The tables on the following page represent accrual figures for Years 1 and 2 for the prevention and diagnostic studies.

**Accrual Data for CARE Study**

Racial/Ethnic Group	Year One		Year Two	
	Completed Baseline Only	Completed Baseline & Education Session	Completed Baseline Only	Completed Baseline & Education Session
African American	12	7	7	3
Caribbean or West Indian	0	0	1	0
White/non-Hispanic	218	161	162	114
Hispanic	1	1	2	2
Asian or Pacific Islander	1	1	1	1
Native American	0	0	1	1
Other	1	1	4	2
Unknown	1	0	0	0
<b>Total</b>	<b>234</b>	<b>171</b>	<b>178</b>	<b>123</b>
<b>Total Minority Accrual</b>	<b>15 (6.4%)</b>	<b>9 (5.3%)</b>	<b>16 (9.0%)</b>	<b>9 (6.9%)</b>

**Accrual Data for CABCAD Study**

Racial/Ethnic Group	Year One	Year Two
White/non-Hispanic	46	80
African American	4	6
Hispanic	0	1
Asian or Pacific Islander	2	2
Other	1	1
<b>Total</b>	<b>53</b>	<b>90</b>
<b>Total Minority Accrual</b>	<b>7 (13.3%)</b>	<b>10 (11.1%)</b>

Based on an analysis of this experience, and a review of other successful and unsuccessful efforts at minority clinical trials accrual, the PAC is proposing to contract with Matthews Media Group (MMG) to assist the PAC with the accrual of minority study participants. Matthews Media Group, Inc. creates communications solutions for leading private sector and government organizations. An important part of MMG's health communications practice is the recruitment of patients to clinical trials and treatment studies. As noted previously, MMG has developed a strong network that allows for their physical presence in primary care clinics through the District of Columbia. This will greatly enhance our ability to recruit minorities by including LCC's Breast Cancer Research Center clinical trials in the sites where MMG staff are already accruing for non-cancer related studies.

Given this more direct outsourcing strategy for minority patient recruitment, through established clinical channels, the LCC PAC requests the authority to re-budget it's DOD approved Year 3 and Year 4 funding for the 50% health educator and materials development (including carry over funds from Years 1 and 2) to expand these outsourcing efforts with Matthews Media Group. Formal request will be submitted under separate cover.



**IV. REFERENCES**

None

**V. APPENDICES (included in full packet following annual report)**

Appendix 1: Breast Cancer Educational Materials

Appendix 2: Poster Presentation, Cancer Literacy Conference

## CORE 2: CANCER CLINICAL AND ECONOMIC OUTCOMES EVALUATION CORE

**I. INTRODUCTION:** This Cancer Clinical and Economic Outcomes Evaluation Core has constituted a multi-disciplinary research team (including oncology, nursing, primary care, economics, health services research, psychology, and biostatistics) with broad methodological expertise to conduct evaluations of the costs and outcomes of the new translational technologies evaluated in the three projects included in this Breast Cancer Center grant. Following a review of the general scope of work originally outlined for the Cancer Clinical and Economic Outcomes Evaluation Core (hereinafter referred to as the "Outcomes Core"), we present the progress made in completing our Year 2 objectives for each project, and outline our plans for Year 3.

**Scope of the Outcomes Core Research:** The overarching mission of this Outcomes Core has been twofold: 1) to expand the technical capacity for outcomes evaluations for current and future research at the Lombardi Cancer Center; and 2) to provide expertise and support to the research projects included in the Breast Cancer Center. A summary of the Core technical aims is listed below:

1. To conduct cost-effectiveness analyses (CEAs) of each of the projects.
2. To evaluate the impact of tests or treatments on quality of life (QOL).
3. To evaluate the impact of the other Center Core, the Patient Accession Core (PAC).
4. To develop a centralized library of data for use in cancer outcomes research, and provide consultation to investigators on the incorporation of outcomes assessment into new research initiatives.

**II. BODY:** Although the Outcomes Core evaluations will be done in a coordinated manner across all projects, for sake of clarity of presentation, the progress and methods applicable to each project are presented separately. Table 1 presents an overview of the original Outcomes Core approach for each project. The narrative that follows highlights any additions/changes in approach, and preliminary results. Finally, this section concludes with a presentation of general Outcomes Core activities and progress that are cross-cutting in this Breast Cancer Center Project (ie, Technical Aims #3 and 4).

**Table 1: Overview of Planned Outcome Evaluations**

	<b>Project 1: Prevention: Genetic Testing</b>	<b>Project 2: Diagnosis: New Technologies</b>	<b>Project 3: Treatment: Novel Palliative Rx</b>
<b>Design</b>	Observational Cohort	Case Series	Phase I, II studies and a Phase III RCT
<b>Outcomes</b>	QOL Utility QALYs	Cancers Detected, Delayed, and Missed	QOL Utility Progression Time; QALYs
<b>Costs</b>	Direct; Time Costs	Direct and Time Costs	Direct and Time and Care-giver
<b>Economic Analysis</b>	CEA Model	Cost per Case Diagnosed; Decision Analysis Model	CEA

**A. Project 1: BRCA1/2 Genetic Testing: Develop an Exploratory Cost-Effectiveness Analysis (CEA), Combining Primary and Secondary Data, to Identify the Key Parameters Which Drive the Costs and Effectiveness of Genetic Testing and Counseling as a Strategy to Prevent Breast Cancer and Decrease Cancer Mortality among High-Risk Women:** The specific objectives of Year 2 were to: 1)

continue to collect primary data on patient-related costs of genetic testing, adherence to surveillance guidelines, and preferences for potential outcomes of genetic testing; 2) begin the review of secondary literature to define parameters in the natural history model; and 3) start programming of the three-dimensional markov simulation model (to model the simultaneous risk of breast and ovarian cancers, and death from other causes) that will be used to evaluate the cost-effectiveness of genetic testing and counseling. This section summarizes our Year 2 progress in completing these interim objectives.

**Primary Data Collection:** In Year 1 we developed integrated data collection instruments to be administered during the intervention to evaluate project-related costs of counseling and testing as well as patient costs associated with participation (e.g., time spent traveling and receiving the testing), preferences for outcomes that could occur distal to the intervention (e.g., development of cancer, choosing prophylactic surgery), and probabilities of adherence to post-intervention surveillance (e.g., regular mammography). The preference data will be used to generate quality-adjusted life years (QALYs) as the final health effects.

We use two assessments to measure health state utilities, the time trade-off (TTO) assessment (Torrance, 1987) and the linear rating scale (LRS) assessment (Froberg and Kane, 1989). The TTO assesses what percentage of life-expectancy they think a woman would be willing to forgo to improve their health state from the state being assessed (e.g. having a mastectomy for early breast cancer) to excellent health. The LRS asks a woman to assign a number between 0 (representing death) and 100 (representing the best state of health the woman can imagine) to the state of health. Utilities for hypothetical health states were assessed by telephone interview using a third-person format of the health state descriptions, as the distribution of results using this format was less skewed than first-person format in pilot testing. Table 2 shows preliminary results for the hypothetical states of health assessed. Results are presented as 0 (death) to 1 (excellent health) for the TTO, and 0 (death) to 100 (excellent health) for the LRS. To decrease respondent burden, participants randomly receive 2 TTO and LRS assessments for treatment of localized breast cancer (the first 3 scenarios in Table 2), and 1 from the remaining scenarios. Briefly, these preliminary results show that participants tend to have higher utilities measured with the TTO compared to the LRS; this is consistent with other investigators' work (O'Leary, et al, 1995). The utilities for early breast cancer were quite high, especially with the TTO assessment, and the measures were not responsive to changes across the three modes of treatment. The LRS showed a decrease in-breast recurrence although the TTO did not. Both assessments showed a large decrease in utilities for metastatic breast cancer and for advanced ovarian cancer. Overall, correlation between the TTO and LRS was 0.42.

We are concerned by the high utilities, particularly the TTO assessments, assessed in this study population. We are currently in the process of validating the phone assessments with face-to-face utility interviews using visual aids to increase comprehension. We use for this analysis a subset of women who come to Georgetown for genetic counseling. Women are interviewed face-to-face prior to counseling an average of approximately 4 weeks after their baseline interview (range 7-65 days). To date, eight women out of 20 planned have undergone both a phone and a face-to-face interview; in the face-to-face interview women receive the same three scenarios in the same order as assessed via the baseline phone interview. Correlation between the phone and face-to-face TTO assessments overall is 0.48 (Spearman rank correlation, used for skewed data); correlations for the LRS assessments was 0.93. Dr. Lawrence has attended 4 of the 8 face-to-face interviews. In open ended questioning, participants are able to relate an understanding of the hypothetical health states.

**Table 2. Preliminary Utility Data [Mean (s.d.)]**

Scenario	N	TTO	LRS
Modified Radical Mastectomy*	128	0.91 (.15)	80.1 (15.2)
BCS/Radiation Therapy*	128	0.91 (.15)	81.2 (17.6)
Prophylactic Bilateral Mastectomy*	140	0.90 (.15)	79.3 (15.4)
Prophylactic Bilateral Oophorectomy*	47	0.90 (.11)	76.7 (15.3)
Breast Cancer Recurrence	46	0.89 (.15)	73.5 (20.5)
Metastatic Breast Cancer	47	0.55 (.34)	43.5 (20.7)
Ovarian Cancer	12	0.64 (.33)	40.8 (20.1)
Current Health	44	0.88 (.23)	82.2 (15.3)

\*With early stage breast cancer.

We also assessed participants' current health using a utility index, or a survey that provides a societal utility for a participant's state of health. We use a modification of the Health Utilities Index (HUI) (Feeny, et al., 1996), abbreviated by removing low-variation response items as determined by the breast cancer Patient Outcome Research Team results. The average HUI score for 221 participants was 0.82 (s.d. 0.10), on a scale ranging from 0 (death) to 1 (excellent health). The HUI showed a significant decrease with age, with participants under age 40 averaging 0.90 and participants age 60 and older averaging 0.80. The HUI score for the participant's current health did not correlate with most of the hypothetical health state utilities, although as expected the HUI did correlate moderately well with the TTO ( $r=.40$ ) and the LRS ( $r=.37$ ) for the participants' current health.

The next portion of work has included assessing the costs of counseling and testing. An important component of the overall cost of a BRCA1/2 testing program is the cost incurred in genetic counseling. We are currently in the process of analyzing the costs associated with genetic counseling in Project #1, both for people who undergo genetic testing, and for those who undergo counseling without testing. Table 3 shows preliminary data on the resource utilization necessary to provide counseling. Counselor time costs were estimated based upon 4 weeks of monitoring two genetic counselors; future work will include retrospective chart reviews to delineate time for those testing positive for a BRCA1/2 mutation, those testing negative, and those who decline to receive testing results. Costs for counselor time were calculated using national average salary plus fringe (total \$52,330/year) (Doyle, 1996), and estimating an average hourly cost to the institution based upon 2000 hours of work per year.

**Table 3. Costs of Genetic Counseling**

Parameter	Time	Cost
<i>Counselor Time Costs</i>		
New Participant Counseling Time	114 min	\$49.7
Disclosure	42 min	\$18.3
Phone Follow-up	13 min	\$5.7
Preparation/documentation/letter dictation	45 min	\$19.6
Clerical time (estimated)	30 min	\$7.7
Phlebotomist time (estimated)	30 min	\$7.7
Office/lab space (pro-rated for time)		\$7.0
Cost of test (retail, full gene sequencing)		\$2400
<i>Patient costs</i>		
Travel		
Counseling		
Caregiver costs		

In the next project year we will continue to collect and analyze these primary data. Also, in Year 3 we will estimate age- and stage-specific treatment costs for breast and ovarian cancer using existing data; race-specific data will be used to the extent available. All data will then be incorporated into the model in Year 4.

**Analysis of Data to Develop Model Parameters:** In Year 2 we have also begun the review of the literature to estimate the effects of all possible events that flow from the initial testing choices, the probability of each event, and the probability of transition from one state to the next. Using standardized data abstraction tools developed in Year 2 (Appendix 1), data are being abstracted from the best designed and least biased studies available (e.g., well designed randomized clinical trials and observational studies, and administrative databases, such as SEER). In Year 3, meta-analytic techniques will be used to derive effect size estimates (e.g., the expected cancer risk reduction associated with bilateral mastectomies). A preliminary list of parameters reviewed to date is included in Table 4. In Year 3 of the grant we will conduct formal meta-analyses on these data, to obtain point estimates and probability distributions for use in the cost-effectiveness model Monte Carlo simulation. As can be seen the table, the prevalence of BRCA1 is very dependent on the population examined, ranging from under 1% in the general population to almost 70% in some hereditary breast-ovarian cancer families. BRCA1/2 prevalence for the baseline cost-effectiveness analysis will be based upon data from Project #1; prevalence data in the table will be used for determining parameter distributions and for sensitivity analysis.

Table 4. Model Parameter Estimates

Parameter	Estimate (Range)	Sources
<b>Initial Tree</b>		
Prevalence of BRCA genes		
General population BRCA1	0.0045 (0.00 ~ 0.026)	Claus, 1991; Ford, 1995; Oddoux, 1996; Roa, 1996; Whittemore, 1997; Malone, 1998; Newman, 1998
High-risk population BRCA1	0.155 (0.0029 ~ 0.6875)	Offit, 1996; Hakansson, 1997; Shattuck-Eidens, 1997; Couch, 1996; Malone, 1998; Schubert, 1997; Whittemore, 1997; Ford, 1995; Struewing, 1997; Rebbeck, 1996; Langston, 1996; Zelada-Hedman, 1997; Newman, 1998; Roa, 1996
BRCA2	0.067 (0.00 ~ 0.273)	Neuhausen, 1996; Hakansson, 1997; Schubert, 1997; Lancaster, 1996; Struewing, 1997; Rebbeck, 1996; Oddeux, 1996; Roa, 1996
Sensitivity of full gene sequencing	98% (85 ~ 100%)	Myriad Genetic Laboratories, 1998
Specificity of full gene sequencing	99% (98 ~ 100%)	Myriad Genetic Laboratories, 1998
Probability of prophylactic bilateral mastectomy	0.17	Lerman, 1996; Data to be provided by Project I
Probability of prophylactic oophorectomy, BRCA1 (+)	0.33	Lerman, 1996; Data to be provided by Project I
BRCA2 (+)		Data to be provided by Project I
Probability of intense breast cancer screening, BRCA1/2 (+)		Data to be provided by Project I
BRCA1/2 (-)		Data to be provided by Project I
Probability of usual breast cancer screening with no genetic tests in high risk population		Data to be provided by Project I
Probability of intense breast cancer screening with no genetic test in high risk population		Data to be provided by Project I
<b>Disease Initiation Model</b>		
Population all-cause mortality	(0.001 ~ 0.059) <sup>§</sup>	Statistics Abstract of the United States, 1995
Breast cancer incidence		
Cumulative probability of BRCA1 (+)		
By 50 years old	0.50 (0.33 ~ 0.73)	Easton, 1995; Ford, 1994; Narod, 1995; Struewing, 1997; Whittemore, 1997
By 70 years old	0.74 (0.56 ~ 0.87)	
Cumulative probability of BRCA2 (+)		
By 50 years old	0.30 (0.28 ~ 0.32)	Schubert, 1997; Ford, 1998
By 70 years old	0.76 (0.67 ~ 0.84)	
BRCA1/2 (-)	(0.00001 ~ 0.00304)*	SEER, 1991-1995
After prophylactic bilateral mastectomy (will request data to compute relative risk)	0.0054	Hartmann, 1997
Ovarian cancer incidence		
Cumulative probability of BRCA1 (+)		
By 50 years old	0.20 (0.07 ~ 0.29)	Easton, 1995; Ford, 1994; Narod, 1995; Struewing, 1997
By 70 years old	0.44 (0.16 ~ 0.63)	
Cumulative probability of BRCA2 (+)		
By 50 years old	0.004	Ford, 1998
By 70 years old	0.27	
BRCA1/2 (-)	(0.00003 ~ 0.00063)*	SEER, 1991-1995
<b>Surveillance<sup>†</sup></b>		
Breast cancer		
Mammography / CBE		
Sensitivity	82.8 % (74 ~ 88%)	Shapiro, 1988; Chamberlain, 1991; Miller, 1992; Fletcher, 1993

Parameter	Estimate (Range)	Sources
Specificity	98.7% (97.7 ~ 99.8%)	Shapiro, 1988; Chamberlain, 1991; Miller, 1992; Fletcher, 1993
<b>Ovarian cancer</b>		
Conventional transvaginal ultrasound		
Sensitivity	81.6% (0 ~ 100%)	Grover, 1995; DePriest, 1997; Bourne, 1993; van Nagell Jr., 1991; Franchi, 1995; Hata, 1992; Zantta, 1994; Weiner, 1992; DePriest, 1994;
Specificity	81.4 % (65.4 ~ 98.7%)	
Doppler transvaginal ultrasound		
Sensitivity	89.9% (75.7 ~ 100%)	Franchi, 1995; Hata, 1992; Kawai, 1992; Zanetta, 1994; Weiner, 1992; Caruso, 1996; Vuento, 1995; Kurjak, 1992; Tepper, 1995; Bourne, 1993
Specificity	86.9 % (52.8 ~ 99.2%)	
CA-125		
Sensitivity	79.7% (44.4 ~ 100%)	Franchi, 1995; Maggino, 1994; Jacobs, 1994; Helixsouer, 1993; Soper, 1990; Hata, 1992; Kawai, 1992; Zanetta, 1994; Peters, 1995; Gadducci, 1996; Weiner, 1992; Jacobs, 1992; Zurawski, 1990; Grover, 1995
Specificity	77.7 % (40.0 ~ 100.0%)	
<b>Breast cancer treatment</b> (Probability of getting certain types of treatment)		
Local/regional breast cancer		
Mastectomy	64.3% (37.4 ~ 85%)	Satariano, 1994; Young, 1996; Nattinger, 1996
Breast conserving surgery with radiation therapy	31.8% (15 ~ 51.1%)	Young, 1996; Satariano, 1994; Nattinger, 1996
Tamoxifen	13.4% (2 ~ 29%)	Kurtz, 1989; Quiet, 1995; Smith, 1994; Zissiadis, 1997; Kini, 1998; Haffty, 1991; Matthews, 1988; Hacene, 1990; Fourquet, 1989
Chemotherapy	14.1% (5 ~ 34%)	Recht, 1996; Kurtz, 1989; Quiet, 1995; Smith, 1994; Zissiadis, 1997; Kini, 1998; Haffty, 1991; Hacene, 1990; Fourquet, 1989
<b>Breast cancer natural history</b>		
Probability of local/regional recurrence after treatment of local or regional breast cancer	12.7% (3.3 ~ 35.9%)	Rutgvist, 1993; Kurtz, 1989; Jacobson, 1995; Quiet, 1995; Ferguson, 1982; Demicheli, 1996; Huseby, 1988; Fletcher, 1989; Ragaz, 1997; Arriagada, 1996; Kini, 1998; Haffty, 1991; Matthews, 1988; Fourquet, 1989; van Dongen, 1992; Lee, 1984; Orel, 1993
Probability of local recurrence given recurrence	28.4% (0 ~ 87.5%)	Fisher, 1993; Zyl, 1995; Fisher, 1996; Fisher, 1989; Smith, 1994; Pierce, 1992; Zissiadis, 1997; Horiguchi, 1997; Powles, 1995; Fowble, 1997
Probability of regional recurrence given recurrence	14.8% (0 ~ 50%)	
Probability of distant recurrence given recurrence	56.8% (6.3 ~ 90.8%)	
Median survival, distant stage of breast cancer (months)	20.2 (9.5 ~ 28)	Patanaphan, 1988; Koenders, 1992; Kimmick, 1991; Brincker, 1988; SEER, 1989-1994 <sup>‡</sup>

§ Expected deaths over alive at specified age between 20 and 80 years old.

\* Incidences of invasive breast or ovarian cancer in every 5 years from 20 to 85+ years old.

† Data summarize the accuracy of screening for breast cancer and screening or diagnosis for ovarian cancer.

‡ Derived from the 5-year survival rate of distant breast cancer.

**Stochastic Simulation Model of Simultaneous Breast, Ovarian, and Other Cause Mortality:** The model evaluates three strategies: genetic testing for BRCA1 mutations and counseling, counseling alone, and routine medical practice/surveillance. In terms of mapping primary data to the model, these three groups correspond

respectively to the following groups in Project #1: women agreeing to testing and counseling, women counseled who decline testing, and women who decline testing and counseling. Figure 1 summarizes our basic modeling approach. The first decision point is whether or not a woman decides to having BRCA1/2 testing and/or counseling. If she accepts, she has a certain pre-test probability of testing positive for the mutation. Each pathway is also associated with certain probabilities of morbidity and mortality. For instance, there may be decrements in quality of life associated with knowledge of mutation positivity, or anxiety associated with evaluation of positive (and false-positive) early detection tests, or morbidity or mortality associated with undergoing prophylactic surgery. Ultimately, these paths would lead to death from breast or ovarian cancer or non-cancer related causes.

There are several unique aspects of this analysis that have guided our approach, including the facts that 1) the impact of genetic testing on survival (and costs) occurs distal to the intervention in Project #1, and 2) much of the data on the effectiveness of prevention and early detection strategies for mutation positive women are still uncertain. Thus, a preliminary mathematical stochastic simulation model is being employed to extend the analysis time horizon; the best quality recent literature being reviewed; and sensitivity analyses will address the impact of uncertain parameters on cost-effectiveness results. Based on recent data, the model has also been updated to include a choice of tamoxifen use for prevention of cancer.

Beginning this past year, we starting programming the decision model. We are using SAS IML programming language for its rich complement of matrix-handling capabilities. We have programmed the basic Markov model templates, which will be used to model the natural history of breast cancer, ovarian cancer, and competing mortality. Currently we are in the process of programming procedures to allow limited memories in the models (semi-Markov models), so that we may revise transition probabilities for cancer progression based upon past events (e.g. to allow higher progression rates if a patient has had a breast cancer recurrence). We plan on finishing the programming and program debugging in Year 3; analyses will be completed in Year 4.

**B. Project 2: Coordinated Approach to Breast Cancer Diagnosis: Technical Aim: Conduct an economic evaluation, develop a decision analysis model comparing the costs per cancer detected for new breast cancer diagnostic evaluation strategies, and assess test-related patient Satisfaction:** Project #2 is prospectively enrolling a cohort of approximately 400 white and African-American women, from several DC-

Flow Diagram of BRCA 1/2 Natural History Model

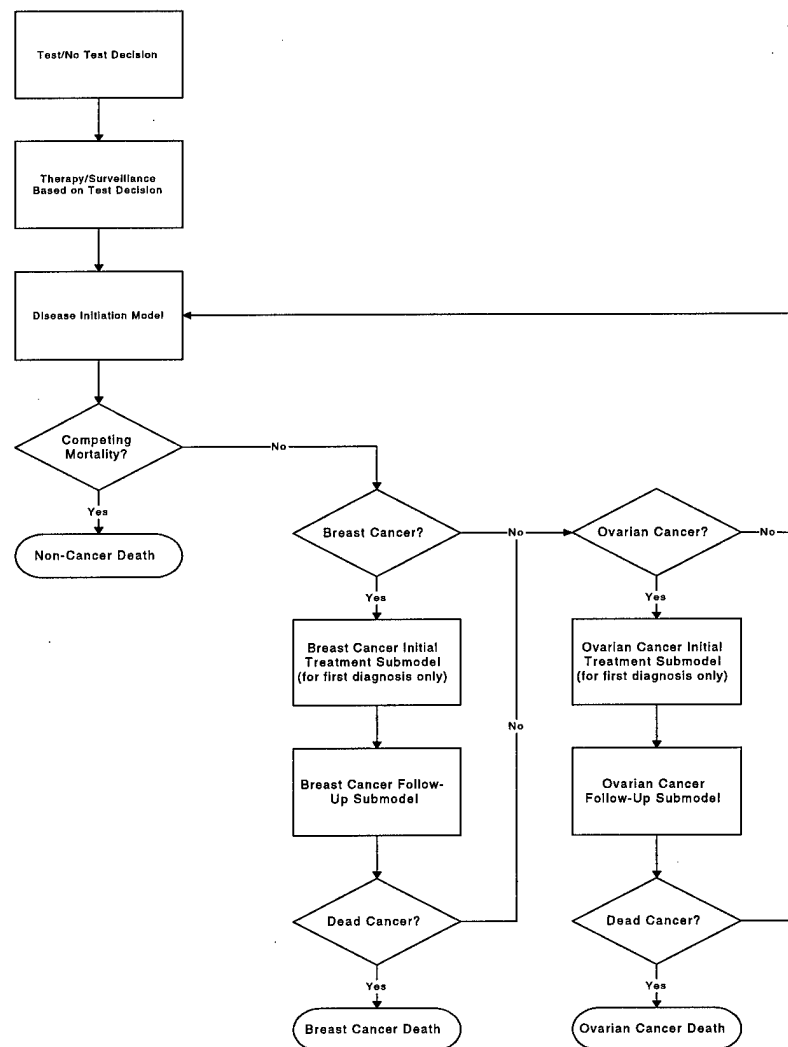



metropolitan area clinics, hospitals, and HMOs, who have abnormal breast physical examination, mammography, and/or standard sonography results and have been recommended to have a breast biopsy. The goals of the project include evaluating the accuracy of several simultaneously administered new technologies, including digital mammography, magnetic resonance imaging (Gd-DTPA enhanced MRI), nuclear medicine evaluation (Tc-99m-sestamibi scanning), special ultrasound evaluation (radio frequency elastography imaging), and nipple aspirate fluid (NAF) cytology via correlation with pathological results of surgical excisional biopsy. Women with negative biopsies will receive 12-month follow-up mammography and CBE.

The Outcomes Core objectives for this project are to: 1) conduct an economic evaluation to compare the costs per cancer detected for each for each of the innovative diagnostic technologies; 2) using the general methods of decision analysis and modeling described above for the genetic testing project, use the primary data on test sensitivity, specificity, and costs, combined with natural history data (e.g., molecular markers in NAF), to develop a decision analysis model for hypothetical cohorts of women comparing the costs per intermediate outcome (correct early diagnosis, delayed diagnosis, and missed diagnosis) for alternative diagnostic tests (or combination of tests) and surgical excisional biopsy; and 3) to evaluate the acceptability of, and satisfaction with, the tests.

**Satisfaction and Acceptability of Tests:** In Year 2, we continued to collect primary data from women on their satisfaction with the tests. A short self-administered questionnaire was given to women by the project coordinator after completion of all tests (see Appendix 2 for the protocol for survey administration). We measure two components of satisfaction with the diagnostic tests in Project 2, discomfort and embarrassment. To provide a relative standard, we asked the participants to rate discomfort of the tests compared to having a routine mammogram. To date, we have 64 survey respondents; no women have refused. Of these respondents, the majority (67%) reported a routine mammogram to be "extremely uncomfortable", and 84% considered mammograms to be "not embarrassing at all". Of those receiving the test, 100% of those receiving ultrasonography, 84% of those receiving MRI, 17% of those receiving digital mammography, 94% of those receiving sestamibi imaging, and 100% of those receiving a nipple aspirate found the procedure more comfortable than a mammogram. The procedure was less comfortable than mammography for 9% of those receiving MRI, and 3% of those receiving sestamibi imaging.

We also asked participants to rate their overall satisfaction with participating in the study. We used a modification of the Medical Outcomes Study Visit Rating Questionnaire (Rubin, et al., 1993), measuring satisfaction with the receiving the tests overall, with the technical skills of the staff, the personal manner of the staff, the convenience of getting the tests, the length of time spent waiting for the tests, and the explanation of what was done for the participants. On a scale from 0 to 100, where 100 represents the highest possible satisfaction score, the mean score was 98 (s.d. 5.2).

We have also used willingness to pay assessment as a measure of "process utility", or a measure of preference for procedures a woman must undergo to achieve a health outcome. Our measures ask the participant how they think a woman would be willing to pay out of pocket to have one of the tests they experienced in Project 2 *instead of* a biopsy procedure. We asked this under two conditions: first, if the test was as accurate at diagnosing cancer as a biopsy; and second, if the test was almost (95%) as accurate as a biopsy. We asked participants to imagine the test was whichever test they would most prefer having, to avoid the respondent burden of asking about each test separately. Thus, the assessment provides the maximum the respondent would be willing to pay for any of the tests. Under conditions of equal accuracy to a biopsy, the 56 women who provided a response were willing to pay an average of \$235 to have a test instead of a biopsy (range \$0-\$1000), with 27% of women not willing to pay any money out of pocket. The willingness to pay decreased to an average of \$147 in the case of 95% accuracy (range \$0-\$750), with 39% of women not willing to pay any money. Based on this interim data, we conclude that women find the test preferable to biopsy, although a significant minority of participants would either be indifferent or prefer biopsy if the test were less accurate than biopsy for diagnosing cancer.

**Decision Analysis:** In Years 1 and 2, the decision analysis model structure was developed. This model will calculate the incremental cost per cancer diagnosed (intermediate outcome) and years of life saved (final outcome) for the use of single and paired combinations of diagnostic tests for follow-up of an abnormal mammogram and/or clinical breast examination, compared to a surgical excisional biopsy. The strategies to be compared include digital mammography, sestamibi scan, breast ultrasound, and breast MRI, singly and

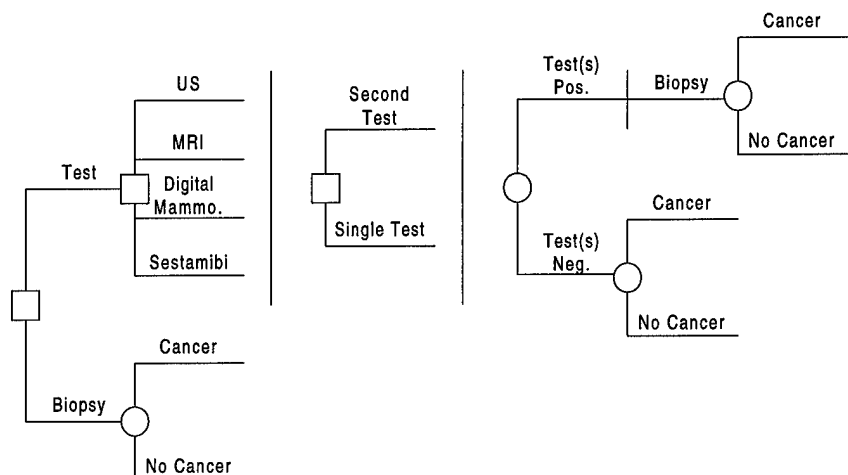

in paired combination, compared to surgical excisional biopsy for follow-up of suspicious breast abnormalities (on mammogram [films interpreted as suspicious or positive for cancer] or clinical breast exam). We will examine two time frames: one short-term frame (through the completion of the diagnostic evaluation of the breast abnormality), and one long-term (from point of diagnostic evaluation through death). For the short-term time horizon of analysis, we will not discount results to present value; the long-term analysis will discount future costs and health effects at a rate of 3%.

The model will be also used to estimate the number of true positive and false negative diagnoses, based upon the prevalence of disease in the population. Figure 2, above, includes a preliminary decision tree for this model. Data for parameters in the model will be derived from Project 2, the published literature, other Outcomes Core related projects, and Dr. Hillner's (Advisor) prior research. An important goal of Project 2 (and the decision/CEA analysis) is to identify the optimal diagnostic algorithm for follow-up diagnostic testing for women with suspicious mammographic abnormalities or clinical breast examinations. This goal guided the development the decision model. All testing algorithms are compared to the gold standard diagnostic work-up of surgical excisional biopsy. We consider the four potential diagnostic tests in comparison to biopsy. For each test, the choice could be made to use the test alone, or add a second diagnostic test (of the remaining 3 tests). We have chosen to simplify the analysis by restricting consideration to single diagnostic tests or to paired combinations; in sensitivity analysis, we will examine more than two tests in combination.

In the decision tree, women with screen-detected abnormalities may have palpable or non-palpable masses; diagnostic tests (or pairs of tests) may be interpreted as positive, negative, or indeterminate for a cancer; negative women will return to routine screening; women with falsely negative results will have delayed diagnosis; women with indeterminate results can either have other tests performed immediately or under-go interval re-screening (ie, 3-4 months later); women who are positive may have cancer or not; etc. In this manner we will calculate the number of women correctly diagnosed with cancer, and the impact of test results on life expectancy.

We will also address two important issues in these analyses. First, the results of combinations of tests can be interpreted either in series or in parallel. If tests are performed in series, the first test is performed, and if positive, the second test is performed. If tests are performed in parallel, then both tests are performed, and if either test is positive then the woman is considered to have a positive diagnostic work-up, and a biopsy would be recommended. For our base analyses, we will assume parallel use of paired tests, as this strategy most closely

matches the experimental conditions of Project 2 and maximizes the overall sensitivity of the combination of test pairs (ie, minimizes the number of false negative diagnoses).

The second issue that must be addressed is that of conditional dependence of diagnostic accuracy between the tests. Typically in decision analyses, if two diagnostic tests are to be used, analysts assume conditional independence of test results (i.e. the results of the second test are independent of the findings of the first test). This approach is usually necessary because there are no data on test dependencies. In the case of Project 2, all four diagnostic tests are being performed for all women, we can examine conditional dependence of test results. For instance, we can calculate the probability that an ultrasound will provide a true positive result given that a sestamibi scan was negative. We can then incorporate these conditional diagnostic accuracies into the model when we are examining paired combinations of tests, allowing for more clinically valid model results.

The costs for this decision model/CEA will include test costs and patient-related costs as measured in Project 2, and all downstream costs (from secondary sources). The general approach to estimating down-stream costs will be similar to that described for the CEA of BRCA1/2 genetic testing, above. Work completing the model will be done in Year 3; analyses will be done in Year 4 with primary project data.

**Economic Evaluation:** Data for the economic evaluation of the diagnostic tests will be collected in Year 3; analyses will be completed in Year 4. We will use actual costs of the tests, including equipment and staff time; patient costs will be imputed from travel and test time (collected in the satisfaction survey, above).

**C. Project 3: RCTs of Novel Palliative Treatments for Metastatic Breast Cancer:** Project 3 is enrolling white and African-American women from several DC-metropolitan area settings (including cancer centers, community practices, and managed care organizations) who have advanced metastatic breast cancer (clinical stage 4) and who have no tumor progression after  $\geq 6$  cycles of induction chemotherapy. After phase one and two evaluations are completed, women will be enrolled in phase three randomized treatment interventions of anti-angiogenic agents alone and in combination with standard chemotherapy, with or without a no therapy observation. In all trial phases, the Outcomes Core will provide descriptions of the QOL of life of participants and the quality-adjusted costs and costs-per unit of clinical outcome.

**Quality of Life:** In Year 2, during the phase II trial of thalidomide was conducted. We collected several measures of quality of life in the Thalidomide trial. Unfortunately, due to delays in obtaining IRB approval, we were only able to obtain survey data on 5 participants in this trial prior to closure. We present data for the FACT-B (Cella, et al, 1993), a breast cancer-specific health profile survey, the HUI (Feeny, 1996), a health utilities index providing societal preference for health, and the LRS assessment, a holistic assessment of a participant's preference for her state of health. The FACT-B measures health on 6 domains: physical well-being (PWB), social well-being (SWB), relationship with doctor (RWD), emotional well-being (EWB), functional well-being (FWB), additional breast cancer-specific concerns (BCS). We also present the results of the Rotterdam Symptom Checklist (de Haes, et al., 1990), which provides a listing of possible symptoms.

The HUI scores averaged 0.81 across all observations. There was no significant change in the HUI scores across the maximum of 8 weeks that the respondents were enrolled in the study. The LRS scores averaged 0.71 (s.d. 0.15) across all observations. While the score decreased from baseline to week 8 from 0.79 to 0.58, the majority of the change is due to dropout of women with higher LRS scores at baseline. The average FACT-B score for the entire study was 124 (s.d. 14.7), on a scale scored from 0 (worst functioning) to 148 (best functioning). There was a trend towards higher scores with study progression, with means ranging from 121 at baseline to 128 at week 6.

The overall symptom score showed that participants had few symptoms. We summed the individual responses for all 30 symptoms, the mean score was 40.7, where 30 would represent no symptoms at all, and 120 would represent severe symptoms for each question. There was little change in the amount of symptoms over the 8 weeks. The largest change in individual symptoms was an increase in dry mouth.

We assessed satisfaction with the study at all follow-up visits. The satisfaction survey was a modification of the Medical Outcomes Study Visit Rating Questionnaire (Rubin, et al., 1993), and assessed satisfaction with the visits to the study site overall, the technical skills of the staff, the personal manner of the staff, the convenience of participating, the time spent waiting for study visits, and the explanation of what was done for the participant. The overall average of responses was 73.4 (s.d. 17.3) on a scale ranging from 0 (least satisfaction) to 100 (most satisfaction). The primary source of dissatisfaction was in the convenience of participating in the study.

Cost data calculation is currently awaiting completion of study data entry for determination of exact resource utilization. Direct medical care costs from the study will be calculated by determining the number of procedures (See Figure 3 below for an example) multiplied by the cost of the procedures to GUMC.

Participation also has a cost to the patients, in terms of time and travel expense. Of the 5 participants, 3 were employed and needed to take time from work - all received compensation for this time from work. While most traveled by car, two required air travel to get to the study site. All participants had health insurance. None required arranging for child or adult care while participating. Costs for time and for travel will be included in the analysis.

---



---

Level 3 office visit (4)

---



---

Laboratory:

CBC, Differential, Platelets (4)  
 MMP, TNF, VEGF, bFGF (4)  
 CEA (3)  
 Thyroid Function, Urinalysis, HIV (1)  
 Serum Thalidomide Levels (40) (for  
 pharmacokinetics)

Radiology/Nuclear Medicine

Chest X-ray (1)  
 Abdominal CT (1)  
 Bone Scan (1)

EKG (1)

Thalidomide (low or high dose) - 56 doses

---

**D. Develop a Centralized Library of Data for use in Cancer Research on QOL, Utility, and Cost Measurement Tools and Approaches, and Provide Consultation to Investigators on the Incorporation of Such Tools into New Research Initiatives:** The development of this comprehensive cancer outcomes library is occurring over the entire four years of the project, with most activity targeted for Year 3. We had initially planned to build library materials in Year 2, but management of primary data collection and abstraction of data for Project 1 took slightly more time than anticipated. Therefore, we have revised our time line to complete the basic library in Years 3 and 4. Finally, we are still considering a private-public partnership to apply for an SBIR grant to make such a library available on the worldwide web and/or CD rom.

**E. Consultations:** In Year 2 we continued providing consultations to Lombardi investigators on the use of outcomes measures in cancer research. One example of a successful consultation included the funding of a three-year project on intermediate-term issues for breast cancer survivors. The Outcomes Core will be responsible for conducting an analysis of the costs of interventions to improve the transition from treatment to cured patient in this multi-site project. The aims of the project are included in Appendix 3. Funding from this project, which began 8/1/98, will allow use to hire additional personnel to conduct this research and contribute to overall Outcomes Core activities. Other consultation activities are summarized in Appendix 4.

**F. Outcomes Core Meetings:** The Core has met regularly during Year 2 to discuss current activities and potential new directions. Minutes of these meetings are included in Appendix 5. In Year 3, the format of these meetings will be expanded to include educational seminars for all Lombardi staff. An tentative outline of seminar series is included in Table 5.

**Table 5. CCEOC Seminar Series**

Topic	Presenter
Pushing the age envelope: Should we screen all older women for cancer ? A use of decision analysis	Jeanne Mandelblatt
Cost-effectiveness analysis in cancer prevention	William Lawrence
Health-related quality of life and quality of life assessment measures: Their use in cancer survivor samples	Julia Rowland
Beyond survival: Soft outcomes--Scale reliability and validity	Karen Gold
Framing the message: Does it influence clinical outcomes such as mammography adherence?	Caroline Burnett
The impact of physician-patient communication on treatment choices for breast cancer	Wenchi Liang

**G. Grant Submissions:** In Year 2 Outcomes Core members have contributed to, or have been the lead investigators for 6 newly funded peer-reviewed grants that highlight cancer clinical and/or economic outcomes evaluations. Moreover, 4 new grant applications were submitted. These grants are summarized in Table 6 and Appendix 6.

**Table 6. New Active and Pending Grants**

<b>Principal Investigator</b>	<b>Core Members</b>	<b>Title</b>
<i>Active</i>		
Fahs/Mandelblatt	Mandelblatt Lawrence Burnett	CEA of Breast Cancer Control for African Americans National Cancer Institute
Ganz	Rowland Mandelblatt Lawrence	Breast Cancer Preparing for Survivorship National Cancer Institute
Lerman	Mandelblatt Lawrence	Comparing Models of Counseling for BRCA1/2 Testing National Cancer Institute
Schulman	Rowland	Economic and Quality of Life Evaluation of Protocol 039: Zoledronate Trial Novartis
Taylor	Taylor	Informed Decision Making in Prostate Cancer Screening National Cancer Institute
Taylor	Taylor	Prostate Cancer Screening in the PLCO Trial: Quality of Life and Adherence (Ancillary study to the PLCO Cancer Screening Trial) National Cancer Institute
<i>Pending</i>		
Lawrence	Lawrence Mandelblatt	BRCA Genetic Testing: A Primary Care Perspective National Cancer Institute
Lawrence	Lawrence Mandelblatt Gold	Breast Cancer Genetic Susceptibility Testing: A Primary Care Perspective Department of the Army
Meropol	Rowland Burnett	Patient Decision Making in Phase I Cancer Trials NINR/NCI
Taylor	Taylor	Improving Black Men's Knowledge of the Prostate Cancer Screening Dilemma Centers for Disease Control

**H. Publications:** In Year 2, ten papers were accepted for publication and 5 were submitted for peer review (Abstracts and Title pages are included in Appendix 7).

**I. Assess the Impact of the Patient Accession Core:** In Year 2, we worked with the Patient Accession Core to evaluate the costs of outreach and accrual of non-Lombardi Cancer Center patients/individuals to the three projects. Evaluation of the on-going costs of the PAC continues using structure monthly data collection forms. We have tracked the costs of the Patient Accession Core (Core 1) to examine the costs involved in enhancing participant recruitment and participant retention in diverse populations. Preliminary data includes costs from September, 1996 to August, 1998. Table 7 lists the costs by category. We will continue to collect costs data in Year 3. PAC representatives will also continue to attend our regular Core meetings and seminars.

We have tracked the costs of the Patient Accession Core (Core 1) to examine the costs involved in enhancing participant recruitment and participant retention in diverse populations. Preliminary data includes costs from September, 1996 to August, 1998. Table 4 lists the costs by category.

**Table 7. Patient Accession Core Costs**

<b>Parameter</b>	<b>Cost</b>
External development of project-specific recruitment material	\$2841
General participant educational and recruitment material	\$653
Technology for outreach	\$1895
Training workshop on Cultural Sensitivity	\$9816
Advisory Board	
Honoraria	\$4750
Meeting materials and costs	\$1797
Staff educational material	\$229
Participant transportation and parking	\$1205
Travel	\$765
Focus group transcription	\$81
Photocopying (general and recruitment material)	\$2934
Telephone	\$1226
Postage/UPS/Courier	\$196
Computer LAN fees	\$550
Office supplies	\$2048
Personnel time	
Health Educators	\$48521
Administrative assistants	\$10748
Fringe	\$14225

**III. CONCLUSIONS:** The science of conducting outcomes research, including economic evaluations in oncology practice, is a relatively new discipline and one which is rapidly evolving. This Outcomes Core is extending the state-of-the-art by consisting a unique cross-disciplinary research team with the methodological expertise to evaluate the costs and benefits of new and existing cancer services. Incorporating clinical and economic outcomes into center-wide research focused on translating new advances from the laboratory to individuals, and from a cancer center to community-based hospitals, managed care organizations, and community groups is allowing Lombardi Cancer Center to expand its leadership position to informing on-going clinical, policy and resource allocation debates. We continue to balance efforts to contain costs, while providing care that maximizes health and quality of life, cost-effectiveness and other outcomes analyses, such as those outlined in this Core. These efforts will be critical to understanding which treatments work best, under which circumstances, for which populations, and at what cost.

#### IV. REFERENCES

Cella DF, Tulsky DS, Gray G, et al: The functional assessment of cancer therapy (FACT) scale. development and validation of the general measure. *Journal of Clinical Oncology* 11;570-579, 1993.

DeHaes JCJM, van Knippenberg FCE, Neijt JP. Measuring psychological and physical distress in cancer patients: Structure and application of Rotterdam Symptom Checklist. *Brit J of Cancer* 1990; 62: 1034-1038.

Doyle DL. The 1996 Professional Status Survey. *Perspectives in Genetic Counseling*. 1996;18 (3 Suppl):1-8.

Feeny DH, Torrance GW, Furlong WJ. Health Utilities Index. In: Spilker B, ed. *Quality of life and pharmacoeconomics in clinical trials*, 2<sup>nd</sup> ed. Lippincott-Raven, Philadelphia, 1996.

Froberg DG, Kane RL (1989). Methodology for measuring health-state preferences. II: Scaling methods. *Journal of Clinical Epidemiology*, 42, 459-71.

O'Leary JF, Fairclough DL, Jankowski MK, et al. (1995). Comparison of time-tradeoff utilities and rating scale values of cancer patients and their relatives: Evidence for a possible plateau relationship. *Medical Decision Making*, 15, 132-37.

Rubin HR, Gandek B, Rogers WH, Kosinski M, McHorney CA, Ware JE. Patients' ratings of outpatient visits in different practice settings. *JAMA*. 1993; 270:835-840.

Torrance GW. Utility approach to measuring health-related quality of life. *J Chronic Dis* 40;593-600, 1987.

#### V. APPENDICES

Appendix 1: Data Abstraction Tools for BRCA1/2 Natural History Model

Appendix 2: Protocol for Administration of CABCAD Participant Satisfaction Survey

Appendix 3: Survivorship Grant

Appendix 4: Core Meeting Minutes

Appendix 5: Core Consultations

Appendix 6: Funded Grants Including Core Members

Appendix 7: Publications Submitted by Core Members



# **APPENDIX MATERIALS FOR ALL PROJECTS AND CORES**

## **Project 1: Impact of Genetic Testing for Breast Cancer Susceptibility**

Appendix 1: Educational material for relatives of positive patients

Appendix 2: General educational material distributed at visit one (pre-test)

Appendix 3: Article reprints

## **Project 2: A Coordinated Approach to Breast Cancer Diagnosis**

None

## **Project 3: Development of Novel Antiangiogenic Therapies in Metastatic Breast Cancer**

None

## **Core 1: Patient Accession Core**

Appendix 1: Breast Cancer Educational Materials

Appendix 2: Poster Presentation, Cancer Literacy Conference

## **Core 2: Cancer Clinical and Economic Outcomes Evaluations Core**

Appendix 1: Data Abstraction Tools for BRCA1/2 Natural History Model

Appendix 2: Protocol for Administration of CABCAD Participant Satisfaction Survey

Appendix 3: Survivorship Grant

Appendix 4: Core Meeting Minutes

Appendix 5: Core Consultations

Appendix 6: Funded Grants Including Core Members

Appendix 7: Publications Submitted by Core Members

## **Project 1: Impact of Genetic Testing for Breast Cancer Susceptibility**

Appendix 1: Educational material for relatives  
of positive patients

Appendix 2: General educational material  
distributed at visit one (pre-test)

Appendix 3: Article reprints

# Appendix 1: Educational Material for Relatives

## **Appendix 2: General Pre-Test Educational Material**

# CARE

Cancer Assessment  
and Risk Evaluation

Lombardi  
Cancer  
Center

*Research*  
*Education*  
*Treatment*

GEORGETOWN  
UNIVERSITY  
MEDICAL CENTER



**T**his material will introduce you to a free genetic counseling and testing program. There is now a genetic test that can help you learn more about cancer risks for you and your family. If you want to learn more about genetic testing, please take a few moments to read through this information.

### ***What is the CARE program?***

The CARE (Cancer Assessment and Risk Evaluation) program is a free genetic counseling and testing program offered by the Lombardi Cancer Center at Georgetown University Medical Center. This program is supported by research grants from the National Institutes of Health, the Department of Defense, and the Susan G. Komen Foundation.

### **Participation in CARE**

Through the CARE program, each participant meets with a genetic counselor to discuss:

- *a detailed family history and risk factor assessment*
- *the genetics and inheritance of breast and ovarian cancer*
- *personalized guidelines for cancer prevention and screening*
- *the options available for genetic testing for cancer susceptibility, including the pros and cons of testing (genetic testing is offered to all eligible individuals)*

CARE is a clinical research program. Therefore, all participants are asked to complete telephone and in-person interviews and questionnaires before and after participation. These assessments allow us to evaluate the benefits of the program and learn more about how people make decisions about genetic testing. We also hope to learn how these decisions affect their lives. Even if you decide that you are not interested in testing, we would like to interview you briefly on the telephone. This is a critical part of our research.

## *How is genetic testing performed?*

As an alteration in BRCA1 or BRCA2 has already been identified in your family, it is a simple process to test you. A small blood sample is drawn. From it, genetic material (DNA) is obtained and analyzed for the specific alteration previously identified in your relative. This testing can be completed in a relatively short period of time. It is very accurate and provides results that are clearly positive or negative for a particular alteration.

## *What are the pros and cons of testing?*

There are potential benefits to being genetically tested. There also are potential risks and limits to the information that can be obtained. Each individual needs to consider whether the potential benefits outweigh the risks in order to decide whether or not to be tested. All individuals who decide to provide a blood sample for genetic testing must sign a consent form. The form contains additional information about the benefits, limitations, and risks of genetic testing.

### **Increased knowledge:**

Genetic tests may provide you with more information about your risk of getting cancer. It may also provide insight as to why cancer developed in your family.

### **Health care decisions:**

Information about cancer risk can facilitate decisions about whether certain screening tests should be considered. It may help women decide about risk-reducing surgery.

### **Emotional implications:**

Learning the test results may produce a sense of relief. It may reduce uncertainty about cancer risk. People whose test results are negative may feel a sense of reassurance. However, those who learn their test results are positive may feel sad, angry, or anxious. Given its impact on relatives or children, this information may strain relationships. Individuals may feel guilty regarding the outcome or possible outcome of testing. Each person responds differently to information about risk. Sometimes, psychological counseling and support may be helpful.

### **Possible discrimination:**

Genetic testing may place individuals at risk for discrimination by health, life, and disability insurers, as well as employers. Knowledge that you have a genetic predisposition to cancer may compromise your ability to obtain or maintain insurance coverage. Today, fewer than half the states restrict the extent to which health insurers may use genetic information. Almost all states allow life and disability insurers to ask questions about genetic predisposition to cancer, and then use the answers in their underwriting decisions. Recently enacted federal legislation may help protect those individuals who decide to undergo genetic testing. In August 1996, President Clinton signed The Health Insurance Portability and Accountability Act of 1996. It recognizes "genetic information" as protected medical information. It forbids those who provide health care coverage from using such information to deny access to individuals who must change health plans when they change jobs.

The act also states that, based on genetic information, a group medical plan cannot require an individual to pay a premium or contribution (to join the plan or stay in it) that is greater than that for a "similarly situated" enrollee. The term "similarly situated" means that a plan or coverage could vary benefits available to different groups of employees, such as full-time versus part-time, or employees in different geographic locations. A limitation of the act is that it does not restrict the premiums charged for individual health insurance. Such premiums need only comply with state law. These insurance reform provisions went into effect on July 1, 1997.

The Health Insurance Portability and Accountability Act of 1996 is a major step toward protecting individuals who undergo genetic tests; however, it does not address the issue of confidentiality, nor does it require an individual's permission to release genetic information. There has been no federal legislation passed regarding medical record privacy, employment, and other forms of insurance, such as life and disability. The Senate and the House are reviewing bills that would offer additional federal protection from genetic discrimination.

The staff of the CARE program will do everything possible to maintain the privacy of genetic test results. Each participant is identified by a unique number, and no information about him or her is released to third parties without that participant's consent. Our research program received a Certificate of Confidentiality from the Department of Health and Human Services. This allows CARE to withhold information about participants from any outside sources, unless an individual has given written consent.



The clinical staff of CARE includes two master's-level genetic counselors and a medical director—a physician trained in medical oncology. The program's principal investigator is a behavioral scientist and clinical psychologist. These individuals work closely with other oncologists, surgeons, nurses, and psychologists at Georgetown University Medical Center to provide services and information to CARE participants.

For more information about CARE, or to find out how to enroll, please call (202) 687-1750.

### *What is the significance of breast cancer susceptibility genes?*

It is estimated that hereditary breast cancer accounts for approximately 5 percent to 10 percent of all breast cancer cases. Breast Cancer 1 (BRCA1) and Breast Cancer 2 (BRCA2) are the two major breast cancer susceptibility genes that have been identified to date. Alterations in these genes are thought to account for the majority of inherited breast and ovarian cancers. The frequency of these altered genes in the general population is not known. One estimate suggests that BRCA1 alterations occur in about 1 of every 800 individuals.

The BRCA1 and BRCA2 genes are thought to act as "tumor suppressor" genes when they function properly. Tumor suppressor genes prevent cells in our body from growing out of control; however, alterations of these genes can change their usual function. This change can increase the chance of developing breast, ovarian, and other cancers.

Because the BRCA1 and BRCA2 genes are very large, there are many places within each gene where an alteration (mutation) can occur. Thus far, more than 100 alterations have been detected in these genes and some mutations occur much more frequently than others. A few mutations have been found with increased frequency in specific populations.

A specific alteration in one of these genes has been identified in your family. Research is under way to learn more about this and other mutations in BRCA1 and BRCA2. This research will improve our understanding of the cancer risks associated with these alterations and will provide more information about the function of these genes. Ultimately, these discoveries may lead to improved prevention, early detection, and treatment of cancer.

## *What are the risks associated with BRCA1 and BRCA2 alterations?*

Cancer risks associated with BRCA1 and BRCA2 alterations must be evaluated in the context of your medical and family history. In general, a woman with an alteration in the BRCA1 gene has a 55 percent to 85 percent chance of developing breast cancer, and a 15 percent to 60 percent chance of developing ovarian cancer. There may also be an increased risk of prostate cancer for men, as well as an increased risk of colon cancer for men and women.

Identification of the BRCA2 gene took place more recently. We know less about the cancer risks associated with alterations in this gene. When a BRCA2 alteration is present, the risk of breast cancer is estimated to be from 55 percent to 80 percent. The risk of ovarian cancer is thought to be between 15 percent and 20 percent. BRCA2 alterations also are associated with other cancers, such as breast and prostate cancer in men, pancreatic cancer, and possibly other cancers.

Research is in progress to better define these risks. As more information becomes available, these estimates may change. It is important to remember that risk varies from individual to individual and from family to family. We cannot predict with certainty the type of cancer to which an individual is most susceptible, or the age at which cancer may develop.

## *What is my chance of having the BRCA1 or BRCA2 alteration which is present in my family?*

The genetic counselor can discuss your individual risk based upon your position in your family tree. An individual with a BRCA1 or BRCA2 alteration has a 50 percent chance of passing it down to his or her children. This happens because eggs and sperm each carry only one copy of each gene pair. Each child of a parent with an altered gene and each full brother or sister of an individual with an altered gene has a 50 percent chance of inheriting it. Individuals also have a 50 percent chance of inheriting the functioning gene. The risk is not affected by the sex of the child or the affected parent, or by the child's birth order. It cannot be predicted based on how much a child resembles either parent.

### *How do I get more information?*

If you are interested in participating in CARE, you are eligible to come to Georgetown University Medical Center and receive free genetic counseling and testing. Even if you are not interested in genetic counseling or testing, we would appreciate your participation in a few brief telephone interviews. If you are interested in genetic testing, but cannot travel to Georgetown, one of our research assistants can provide information about referrals in your local area. Many of these referral programs charge a fee for genetic counseling and testing.

Please feel free to contact us at (202) 687-1750 for more information.

lombardi

**care**

*Cancer Assessment and Risk Evaluation*

**information packet**

LOMBARDI  
CANCER  
CENTER

RESEARCH •  
EDUCATION •  
TREATMENT •

GEORGETOWN  
UNIVERSITY  
MEDICAL CENTER



## CARE Program Overview

The CARE (Cancer Assessment and Risk Evaluation) Program is a genetic counseling and testing program offered by the Lombardi Cancer Center at Georgetown University Medical Center. This is a free program that is supported by research grants from the National Institutes of Health, the Department of Defense, and the Susan G. Komen Foundation.

### Participation in CARE

Through the CARE Program, each participant meets with a genetic counselor or nurse educator to discuss:

- *a detailed family history and risk factor assessment*
- *the genetics and inheritance of breast and ovarian cancer*
- *personalized guidelines for cancer prevention and screening*
- *the options available for genetic testing for cancer susceptibility, including the pros and cons of testing (genetic testing is offered to all eligible individuals)*

The CARE program is a clinical research program. Therefore, all participants are asked to complete telephone and in-person interviews and questionnaires both before and after participation. These assessments are important to evaluate the benefits of the program, and will help us learn more about how people make decisions about genetic testing and about the impact of these decisions on their lives.

### CARE Staff

The clinical staff of the CARE program includes two master's level genetic counselors, a master's level nurse educator and a medical director—a physician trained in medical oncology. The principal investigator of the CARE program is a behavioral scientist and clinical psychologist. These individuals work closely with other oncologists, surgeons, nurses, and psychologists at Georgetown University Medical Center to provide services and information to CARE participants.

# Major Risk Factors for Breast and Ovarian Cancer

All women have a risk of developing breast and ovarian cancer over their lifetimes. Breast cancer is a common disease, with over 180,000 women diagnosed every year in the United States. Ovarian cancer is a much rarer disease, which is newly diagnosed in about 24,000 women annually.

The cause of these diseases cannot be pinpointed to a single factor. Breast and ovarian cancers result from a combination of genetic (inherited) and environmental (non-inherited) factors. Key risk factors for breast and ovarian cancer are summarized below:

**Age:** A woman's age is the most significant risk factor for getting breast or ovarian cancer. The older a woman is, the higher her risk of developing breast or ovarian cancer. At least three-fourths of breast and ovarian cancers are diagnosed in women over the age of 50. However, women with an inherited predisposition to breast and ovarian cancer face an increased risk of developing these cancers at younger ages, such as in their 30s and 40s.

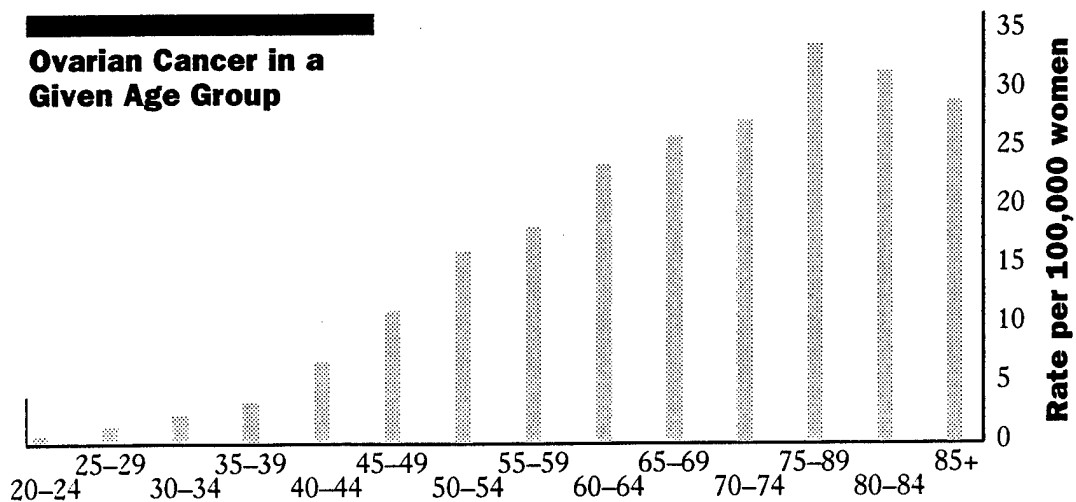
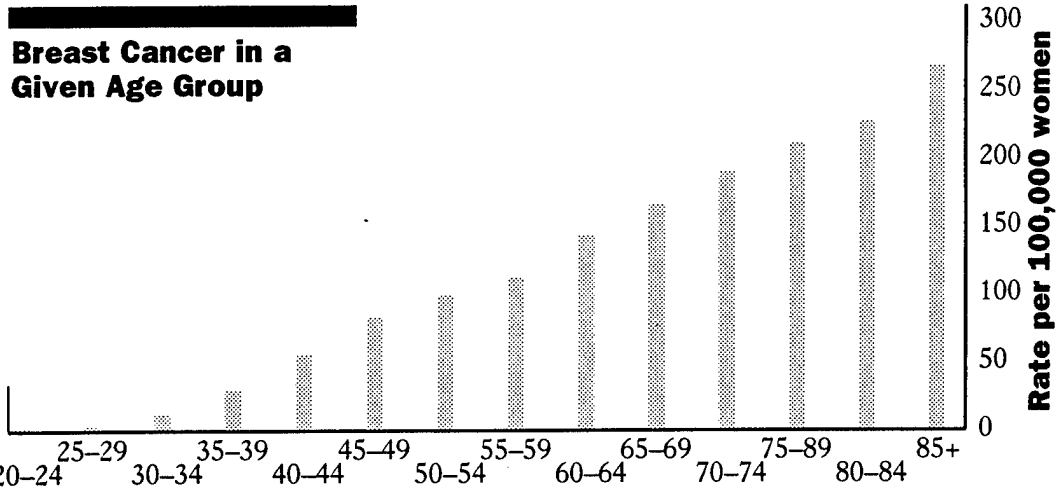

**Family history:** The risk of developing breast or ovarian cancer is higher among women who have one or more close relatives with these cancers. The risk may be further increased if the cancers were diagnosed at a young age, especially before menopause, or if breast cancer occurred in both breasts. Although many women with breast cancer have a close relative with this disease, only about 5–10% of women are thought to have inherited a cancer susceptibility gene, such as the BRCA1 or BRCA2 gene. Because ovarian cancer is much rarer, familial clusters are less common. A family tree constructed by the genetic counselor is a useful tool to help determine whether an individual's family history is suggestive of an inherited pattern of cancer predisposition.

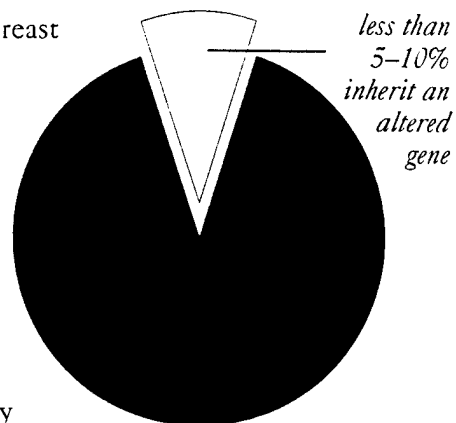

**Biopsy history:** Most breast lumps, often called “fibrocystic disease,” are benign (not cancerous). However, a breast biopsy that shows the growth of altered cells (known as atypical hyperplasia) is associated with an increased risk of developing breast cancer. This risk is further increased if a woman has a close relative with breast cancer.

**Prior cancer history:** Any woman who has a prior history of breast cancer has an increased risk of developing a second breast cancer (for example, in her opposite breast after a mastectomy). Women with a prior history of breast cancer also have a slight increased risk for ovarian cancer. These risks are significantly higher if a woman is found to have an alteration in a gene such as BRCA1.

## **Other Risk Factors for Breast and Ovarian Cancer**



In addition to a woman's age, history of breast biopsies or cancer, and family history, other factors may contribute to a woman's risk for developing breast or ovarian cancer. It is important to understand that for women with an inherited predisposition to breast or ovarian cancer, it is not known to what extent the risk factors listed below may affect risk. Studies are underway to address these issues.

### **Reproductive factors:**

Hormonal changes related to menstruation and pregnancy may increase a woman's risk for breast cancer. These include having menstrual periods before age 12, menopause after age 55, never having children, or giving birth to a first child after age 30. A woman who has never given birth also has a somewhat increased risk for ovarian cancer.

### **Oral contraceptives:**

The use of oral contraceptives (OCs) is not associated with a significantly elevated risk of breast cancer, although long-term use of OCs in women under age 25 may be associated with a slight increase in the risk of developing breast cancer at a young age. However, even short-term (i.e., 6 month) use of OCs may reduce the risk of ovarian cancer.

### **Hormone replacement therapy:**

Some studies have demonstrated that long-term hormone replacement therapy (HRT), with estrogen alone or estrogen and progesterone, slightly increases breast cancer risk. It is important to remember, however, that estrogen replacement therapy may also provide other health benefits such as relief of menopausal symptoms, and protection from cardiac and bone disease (i.e., osteoporosis).

### **Other factors:**

Based on current information, it is not clear whether high amounts of fat in the diet increase the chance of developing breast cancer; however, reducing fat in the diet can reduce the risk of other diseases and cancers. Alcohol consumption is also associated with a slight increase in breast cancer risk, and appears to be related to the amount consumed over a period of years.



# Inheritance of Cancer Susceptibility



In order to better understand how an individual may inherit a susceptibility to cancer, it is helpful to know some basic concepts in genetics.

## Chromosomes:

Chromosomes are found in the nucleus or control center of a human cell and are the structures on which genes are located. There are 46 individual chromosomes, or 23 different pairs, in each cell. The chromosomes are passed down, or inherited, randomly from parent to child; 23 chromosomes are passed down from the mother and 23 chromosomes are passed down from the father. Since our chromosomes are found in pairs, the genes they contain are also found in pairs.

## Genes:

There are approximately 50,000 to 100,000 genes in a human cell. Genes are the blueprints or instructions that control the growth, development, and normal function of the body. Only a small proportion of our genes is associated with cancer susceptibility. When genes are working properly, our bodies are able to develop and function smoothly. However, when a gene is altered (e.g., by the addition, deletion, or rearrangement of genetic material), a normal cell function, such as cell growth, may be impaired or changed. Thus, in some instances, altered genes may result in a deformity or the development of disease. An altered gene may also result in very subtle effects. In fact, it is estimated that each individual has between 4 to 8 altered genes that have no harmful effects.

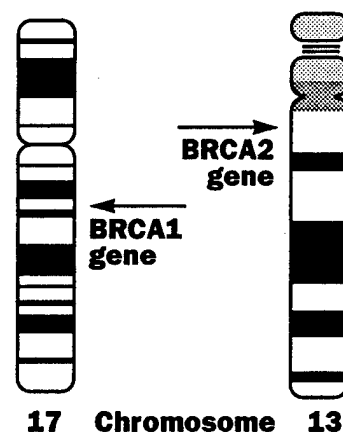

## Dominant Inheritance:

The way that cancer susceptibility may be passed down in families is by dominant inheritance. People have two copies of every gene (one copy from each parent). Both copies of a gene pair control the same function but may vary in form from each other, since each copy is received from a different parent. An alteration or change in one copy of a gene pair can affect how the body functions even though the other copy of that gene may not be altered. In this situation, the altered gene has a dominant effect on a specific body function. Alterations in BRCA1 and BRCA2 are inherited in a dominant fashion.

In large families, this inheritance pattern may be observed clearly because there are multiple individuals in several generations affected with breast and/or ovarian cancer, often at young ages. The family tree on the following page depicts dominant inheritance of a cancer susceptibility gene, showing individuals who have inherited the altered gene, and whether they have developed cancer.

**Pedigree of Hereditary Breast or Ovarian Cancer Family**

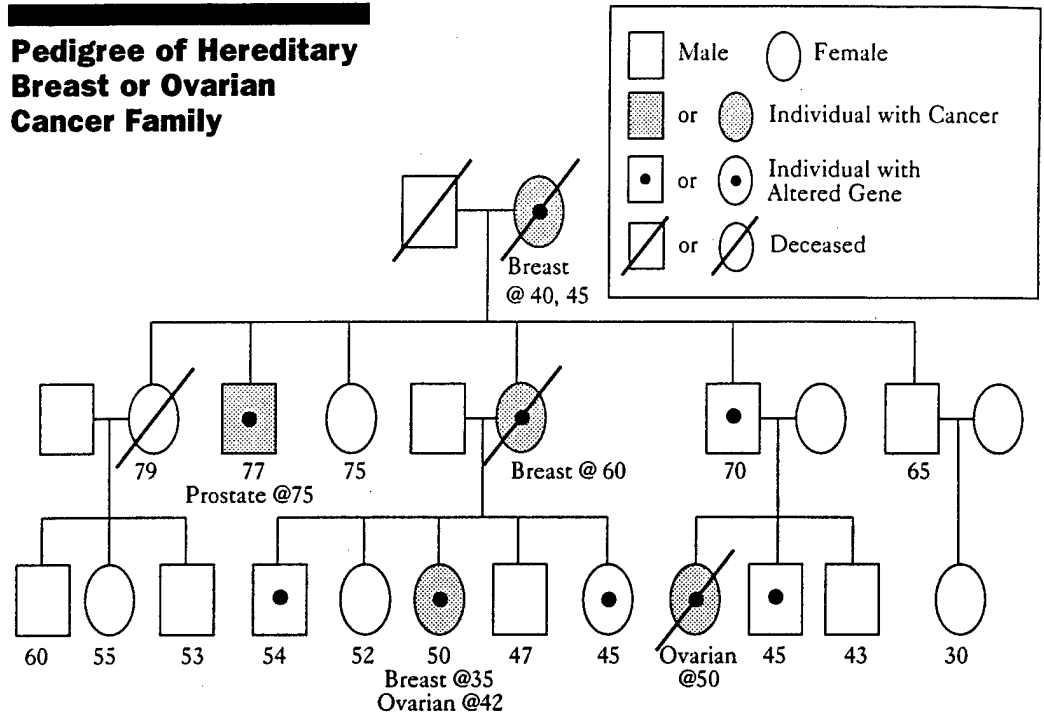

An individual with a BRCA1 or BRCA2 alteration has a 50% chance of passing down that alteration to his or her children. This happens because eggs and sperm each carry only one copy of each gene pair. Thus, each child of a parent with an altered gene has a 50% chance of inheriting the altered gene and a 50% chance of inheriting the functioning gene (see below). The risk is not affected by the sex of the child or the affected parent, or by the child's birth order, and cannot be predicted based on how much a child may resemble one or the other parent.

**Inheritance of a Dominant Breast Cancer Susceptibility Gene**

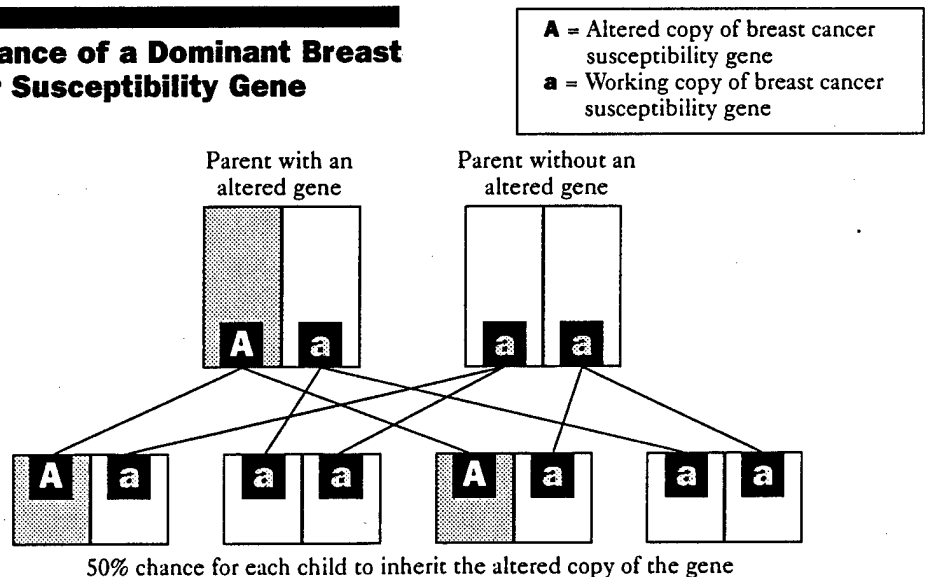

## Breast Cancer Susceptibility Genes

**B**reast CAncer-1 (BRCA1) and BREast CAncer-2 (BRCA2) are the two major breast cancer susceptibility genes that have been identified to date. Alterations in these genes are thought to account for the majority of inherited breast and ovarian cancers. The frequency of these altered genes in the general population is not known, but one estimate suggests that BRCA1 alterations occur in up to 1 of every 800 individuals in the general population and BRCA2 alterations appear to be even more rare.

The BRCA1 and BRCA2 genes are thought to act as “tumor suppressor” genes when they are functioning properly. Tumor suppressor genes prevent cells in our body from growing out of control. However, alterations of these genes can change their usual function. This change in function can increase a person’s chance of developing breast, ovarian, and some other cancers.

Hundreds of alterations have been detected in these genes. The BRCA1 and BRCA2 genes are very large. Therefore, there are many places within each gene where an alteration (mutation) can occur. However, some mutations occur much more frequently than others.

A few mutations have been found with increased frequency in specific populations. For example, a study of over 5000 Ashkenazi (Central or Eastern European) Jewish individuals in the Washington DC area revealed that about 1 in 44, or 2.3%, of the participants carried one of three alterations in the BRCA1 or BRCA2 genes. Specifically, the alterations are referred to as 185delAG and 5382insC in the BRCA1 gene and 6174delT in the BRCA2 gene. The notation refers to the place in the gene where some material was *deleted* or *inserted*. Studies also suggest that the 185delAG alteration may account for a significant proportion of breast and ovarian cancer in young Jewish women, especially breast cancer in women diagnosed at or before age 40, and ovarian cancer in women diagnosed less than age 50. Many of these women may not have a strong family history of breast/ovarian cancer. While these mutations occur mostly in Jewish families, they have also been observed in families with no known Jewish ancestry.

Research is underway to identify and characterize mutations in BRCA1 and BRCA2. This research will lead to more rapid and efficient means of genetic testing, an improved understanding of the cancer risks associated with these alterations, and more information about the function of these genes. Ultimately, these discoveries may lead to improved prevention, early detection, and treatment of cancer.

## **Estimated Cancer Risks Associated with BRCA1 and BRCA2 Alterations**

The risks for cancer associated with BRCA1 or BRCA2 alterations, summarized below, are based on several disease-conferring mutations. As the BRCA2 gene was identified more recently than the BRCA1 gene, there is less information about the cancer risks associated with BRCA2 alterations.

The available risks are cumulative (lifetime) and are only estimates, derived in part from studies of large families in which multiple women developed breast and ovarian cancer. However, some of the risks are derived from studies in which individuals who were tested were not selected because of a strong family history of breast or ovarian cancer. It is therefore important to note that as additional families are studied, these risks may be modified. However, it is unclear by how much these cancer risks may change.

The table on the next page summarizes estimated lifetime risks for different cancers for individuals with a BRCA1 or BRCA2 alteration as compared to the general population.

As more information becomes available, these estimates may be modified and better defined. It is also important to remember that risk varies from individual to individual and from family to family, so it is not possible to predict with certainty the type of cancer to which an individual is most susceptible or the age at which cancer may develop.

**Estimated Cancer Risks Associated with BRCA1 and BRCA2 Alterations**

*Updated September 1998*

Type of Cancer	Estimated lifetime risk in BRCA1 mutation carriers	Estimated lifetime risk in BRCA2 mutation carriers	Lifetime risk in general population
Breast cancer (female) <sup>1</sup>	55%-85%	55%-85%	13%
2nd breast cancer (contralateral) <sup>1</sup>	Up to 65%	Possibly similar to BRCA1 risks	Up to 1% a year (leveling off at up to 25%)
Ovarian cancer <sup>1</sup>	15%-60%	15%-27%	1.4%
Ovarian cancer after breast cancer <sup>1</sup>	Up to 30%-55%	Significantly elevated	2-3% (about twice the average risk)
Colon cancer <sup>2</sup>	Possible 4-fold increased risk	Possible increased risk	About 6%
Prostate cancer <sup>3</sup>	Increased risk, possibly up to 3-fold	Probable increased risk	At least 10% (risk is difficult to quantify due in part to clinically undetectable cancers)
Breast cancer (male)	A few reported cases	Approximately 6%	Extremely rare
Pancreatic cancer <sup>4</sup>	Not increased	Associations noted	Rare

<sup>1</sup> Early ages of onset for breast and ovarian cancer have been reported to occur frequently in women with BRCA1 or BRCA2 alterations. Whereas women in the general population often develop breast or ovarian cancer after age 50, women with BRCA1 or BRCA2 alterations have an increased risk of developing breast cancer before age 50 and throughout their lifetimes.

<sup>2</sup> When colon cancer has been reported in individuals with a BRCA1 or BRCA2 alteration, the ages of onset do not appear to be significantly younger than those found in the general population. The peak incidence of colon cancer occurs in men and women over age 60.

<sup>3</sup> Although early ages of onset for prostate cancer has been reported occasionally, in general, the ages at diagnosis do not appear to differ significantly from those noted in the general population. Prostate cancer occurs most often in men over age 60.

<sup>4</sup> Early ages of onset have been reported in association with pancreatic cancer; however, additional research is needed to confirm these findings. The median age of diagnosis for pancreatic cancer is age 70.

## Cancer Screening

At present, there are no long term studies that have demonstrated the best methods to screen for or prevent cancer in an individual with an alteration in the BRCA1 or BRCA2 gene. Participants in the CARE program receive individualized guidelines for cancer risk management that should be discussed with personal physicians. The following summarizes the general approaches that are now suggested.

### **Breast Cancer Screening:**

Monitoring for breast cancer includes:

- *monthly breast self-examination*
- *frequent clinician breast exams*
- *mammography*

Women at increased risk for breast cancer may choose to undergo exams at a younger age and more frequently than women in the general population.

### **Ovarian Cancer Screening:**

Women in the general population do not undergo routine screening to detect ovarian cancer. An annual gynecological exam, which should be a part of every woman's care, includes a Pap smear, a test used to detect cancer of the cervix, and a pelvic exam. A pelvic exam is important for detecting some problems, but it is not a sensitive method to detect ovarian cancer. Therefore, for women at increased risk of ovarian cancer, screening involves two tests in addition to pelvic exams: a CA-125 blood test and a pelvic ultrasound with color Doppler enhancement. Although these additional screening tests are available, they have not been proven to detect ovarian cancer in its early stages, when treatment is most effective. In other words, these tests can be abnormal even when no cancer is present, or can be normal when cancer is present.

### **Colon Screening:**

All individuals (men and women) are encouraged to undergo routine screening for colon cancer beginning at age 50. Such exams include digital rectal exams and fecal (stool) blood test annually, in addition to sigmoidoscopy (an exam of the lower colon) every 3-5 years. If you have other medical conditions which might increase your risk for colon cancer, a family history of colon cancer, or an alteration in the BRCA1 or BRCA2 gene (which may also increase the risk of colon cancer), then a colonoscopy could be considered. A colonoscopy is a more extensive exam of the whole colon and enables the physician to remove polyps (growths) at the time of the exam. Your physician can help determine which procedure(s) is right for you.

### **Prostate Screening:**

Men should have regular screening for prostate cancer, beginning at age 50, or earlier if certain risk factors exist, such as a family history of prostate cancer. Screening tests for prostate cancer include a PSA (prostate specific antigen) blood test and a digital rectal exam.

# Prevention for Breast and Ovarian Cancer

## **Prophylactic Surgery:**

Some women at increased risk for breast cancer may consider having their breast(s) removed preventively, a procedure known as prophylactic mastectomy. This procedure involves the removal of the entire breast, including the skin overlying the breast and the nipple. However, because some breast tissue remains after this surgery, there is still a small chance for a woman to develop breast cancer after having prophylactic mastectomy.

Due to the limitations of ovarian screening, women at high risk for ovarian cancer may consider having their ovaries removed, especially after childbearing is completed. This procedure is known as prophylactic oophorectomy. While this surgery significantly reduces the risk of ovarian cancer, there is still a small chance of developing an ovarian-like cancer after the ovaries are removed. Women who have had this surgery generally do not undergo screening tests for ovarian cancer, but are closely followed by their physicians.

It is important to remember that there is no right or wrong decision about getting prophylactic surgery. We know that women who undergo preventive surgery still have residual risks for cancer, and it is possible that women with an inherited susceptibility to breast or ovarian cancer may face a higher remaining risk than women without a genetic predisposition to cancer. There are many other factors to be considered before undergoing surgery, such as the effectiveness of currently available screening procedures, the type and extent of surgery that would be performed, the emotional impact of surgery, other medical implications, and financial costs. Before deciding whether to have surgery, all of these issues should be discussed in more detail with your physicians.

## **Other Methods of Prevention:**

### **Tamoxifen:**

A recent study showed that Tamoxifen ( a hormonal medication) reduced the risk of breast cancer in healthy high-risk women. However, it is not yet known if these results will apply to women with a BRCA1 or a BRCA2 alteration. It is expected that this information will become available in the future. Some studies have not shown that Tamoxifen decreases breast cancer risk in women at high-risk. In addition, the long-term effects for healthy women taking Tamoxifen are not clear. In women who have gone through menopause, there may be other health benefits from Tamoxifen as well as risks. Clinical trials looking at the effectiveness of Tamoxifen and other medications to reduce breast cancer risk are being planned. At present, another possible option for healthy high-risk women age 35 or older is participation in a trial at the National Institutes of Health (NIH) looking at the role of Tamoxifen and a vitamin A derivative. This study is not randomized; thus all participants are guaranteed to receive the medications. Additional information about this study may be obtained through the CARE program.

### Oral Contraceptive Use:

A recent study showed that women with an alteration in BRCA1 or BRCA2 who used oral contraceptives (OCs) for six or more years reduced their risk of ovarian cancer by 60%. Use of the pill for three years was associated with a 20% reduction in ovarian cancer risk. This was the first study to show a significant decrease in ovarian cancer risk for mutation carriers who used oral contraceptives. Further studies are needed to confirm these findings. Previous studies of women in the general population and in those with a family history of ovarian cancer have also shown that OCs reduced the risk of ovarian cancer. However, the potential risks associated with OCs should also be considered. For example, it is not known whether the pill increases breast cancer risk for women with an inherited tendency for developing this cancer. A very small study of women with a BRCA1 or BRCA2 alteration suggested that the pill may be associated with increased risks for breast cancer, but larger studies need to confirm these findings.



## **Other Screening and Prevention Issues**

### **Hormone Use:**

As with every important medical decision, the relative pros and cons of using oral contraceptives (OCs) or hormone replacement therapy (HRT) must be weighed very carefully. We are just beginning to learn what the effects of these medications may be in women with a BRCA1 or BRCA2 alteration. It is therefore a good idea to consider a range of options with your physician that may provide benefits similar to those provided by taking OCs or HRT. For example, it is important to consider what other forms of birth control may be acceptable; what non-hormonal methods are available to reduce the symptoms of menopause; what other medications or interventions may provide similar health benefits to HRT in reducing risk of heart disease and osteoporosis. Each woman must make an informed decision with which she is comfortable.

### **Risk Avoidance:**

All individuals are encouraged to minimize their intake of alcohol and dietary fat, refrain from tobacco smoking, and minimize sun exposure. While these measures may not reduce the risk of breast or ovarian cancer, they do have proven benefits in maintaining general good health and in reducing the risk of other cancers.

## The Process of Genetic Testing

The process of genetic testing is different from most other medical tests. A genetic test for cancer susceptibility is not diagnostic; that is, it does not reveal the presence or absence of cancer, but whether an individual has an inherited tendency or predisposition to cancer. Also, the methods used in performing genetic analysis are very complex and time consuming. Unlike most routine lab work, results from genetic testing may take several weeks or months to obtain and sometimes results may be difficult to interpret. Another difference is that most of the risks associated with genetic testing are not physical risks, but involve risks associated with how one may feel or how others, including family members, may react after learning about a genetic test result. For this reason, education and counseling before and after testing are offered as part of the CARE program.

A small blood sample is needed in order to perform genetic testing. Genetic material (DNA) is then obtained from your blood and analyzed for alterations (mutations). For a family in which a mutation has not been previously found, it is helpful to first test a blood sample from a woman with breast and/or ovarian cancer who was diagnosed at a young age. Scientists have a number of ways of looking for genetic mutations. In some instances, testing is performed in steps, whereby common mutations in a gene are looked for first. If these are ruled out, then more complete analysis of the gene may be undertaken. The most complex type of genetic analysis is called sequencing, which means that the "chemical alphabet" of an individual's DNA is obtained and compared to DNA that is known to be "normal." The process of sequencing is comparable to looking for a single spelling mistake in a several thousand page book—a very difficult and time consuming process. Alterations include those in which some genetic material is missing, substituted, or inserted. In very rare instances, an alteration may be identified that is of questionable clinical significance (in other words, the alteration may represent a normal variation in DNA as opposed to an alteration known to be associated with increased cancer risks). Interpretation of such results is handled on a case by case basis.

Once a clinically significant alteration in the BRCA1 or BRCA2 gene has been identified in a close relative, it is easier to test other individuals in the family. Because the specific alteration in the gene is known, other individuals in the family are usually tested only for the presence or absence of that mutation. This testing can be completed in a relatively short period of time and is very accurate, providing results that are clearly positive or negative for a particular alteration.

If an alteration is not identified in a family member who has had cancer, relatives are usually not tested. This is because testing would not be expected to provide further information about their cancer risks. For example, it may be determined that the first woman to be tested within a family who has a prior history of breast cancer does not have a BRCA1 or BRCA2 alteration. This test result may be due to one of the following possibilities:

- Current methods may not be sensitive enough to detect a mutation in the BRCA1 or BRCA2 gene (e.g., the mutation may be in a part of the gene that is difficult to analyze).
- A mutation is present in a different cancer susceptibility gene for which testing was not performed.
- The individual(s) tested does not have an inherited susceptibility to cancer due to an alteration in a single gene such as BRCA1 or BRCA2.

## Genetic Testing: Pro and Cons

There are potential benefits to having genetic testing, as well as potential risks of testing and limitations to the information that is obtained. Each individual needs to consider whether the potential benefits outweigh the potential risks in order to make his or her own decision about whether or not to be tested. All individuals who decide to provide a blood sample for genetic testing must sign a consent form which contains additional information about the benefits, limitations, and risks of genetic testing. Some of the major points are highlighted below.

### **PROS:**

There are potential benefits of testing which may lead some individuals to decide to have testing for alterations in cancer susceptibility genes.

**Increased knowledge:** Genetic testing may provide individuals with more information about their risk for getting cancer and provide insight as to why cancer developed in themselves or their family.

**Health care decisions:** Information about cancer risk can facilitate decisions about whether certain screening tests should be considered and may help women decide about prophylactic surgery.

**Information for other relatives:** Testing may provide information about cancer risk for children, siblings, and other family members.

**Emotional benefits:** Learning the results of testing may produce a sense of psychological relief because uncertainty about cancer risk may be reduced.

**Contribution to research:** Participation in genetic counseling and testing programs will help further understanding about inherited cancer. In addition, we have also established a family registry to learn more about hereditary breast/ovarian cancer, including the risks associated with BRCA1 and BRCA2 alterations, the possible discovery of new genes, and the best way to prevent and treat hereditary cancer. You and your relatives may be invited to participate in this program. Through the registry you and your family members would be asked some medical questions and would be offered the opportunity to contribute a blood sample for future research.

### **CONS:**

There are limitations and potential risks of testing which may lead some individuals to decide they do not wish to have testing.

**Difficulties in test result interpretation:** Because genetic testing for BRCA1 and BRCA2 alterations is investigational, it is possible that test results will be uninformative or difficult to interpret. Genetic testing does not provide a definitive answer about an individual's risk for getting cancer.

**Length of time to receive results:** There is a possibility that test results will take a long time to acquire. Such a delay may make it more difficult to make decisions about cancer prevention and screening.

**Discrimination:** Genetic testing may place individuals at risk for discrimination by health, life, and disability insurers, as well as employers. Knowledge that you have a genetic predisposition to cancer may compromise your ability to obtain or maintain insurance coverage. At the present time, fewer than half of the states have laws restricting the extent to which genetic information may be used by health insurers. Almost all states allow life and disability insurers to ask questions about genetic predisposition to cancer and use the answers in their underwriting decisions. However, recently enacted federal legislation may help to protect those individuals who decide to undergo genetic testing. In August 1996, President Clinton signed The Health Insurance Portability and Accountability Act of 1996, which recognizes "genetic information" as protected medical information, and forbids those who provide health care coverage from using such information to deny access to individuals who must change health plans when they change jobs.

The Act also states that, based on genetic information, a group medical plan cannot require an individual to pay a premium or contribution (to get into the plan or to stay in the plan) that is greater than that for a "similarly situated" individual enrolled in that plan. The term "similarly situated" means that a plan or coverage would be permitted to vary benefits available to different groups of employees, such as full-time vs part-time or employees in different geographic locations. A limitation of the Act is that the premiums charged for individual health insurance are not restricted by the Act, and need only comply with state law. These insurance reform provisions of the Act went into effect on July 1, 1997.

The Health Insurance Portability and Accountability Act of 1996 is a major step toward gaining protection for individuals who undergo genetic testing. However, it does not address the issue of confidentiality and does not require the individual's permission to release genetic information. Although there has been no federal legislation passed regarding the areas of medical record privacy, employment, and other forms of insurance, such as life and disability, both the Senate and the House are reviewing bills that would offer additional federal protection from genetic discrimination.

The staff of the CARE program will do everything possible to protect the privacy of genetic testing results for participants in the CARE program. Each individual is identified by a unique ID number and no information about a participant of the program is released to third parties without the consent of that individual. Likewise, our research program has been issued a Certificate of Confidentiality from the Department of Health and Human Services, which allows the CARE program to withhold information about CARE participants from any outside sources, unless that individual has given written consent.

**Emotional implications:** Individuals who learn their test results may feel sad, angry, or anxious. Particularly when the impact on relatives or children is considered, relationships may become strained and individuals may feel guilty regarding the outcome or possible outcome of testing. Each person responds differently to information about risk and in some circumstances, psychological counseling and support may be helpful.

**Family information:** The correct interpretation of the test results is based on the family history provided by each participant. In gathering this information and pursuing genetic testing, it is possible that you may learn unanticipated information, such as information regarding adoption or non-paternity (i.e., that someone is not the biological father of a child).

## Resources

*M*any resources for information and support are available at Georgetown University Medical Center and in the surrounding community, as listed below:

### **Physicians/Professional Services at GUMC:**

#### **Betty Lou Ourisman Center (202) 687-2122**

Offers women the keystones of breast health: instruction in monthly breast self-examination, breast examinations by a health care professional, and regular mammograms.

#### **Lombardi CancerLine (202) 784-4000**

##### *Cancer Information and Referral*

A toll-free hotline with a registered nurse, who is certified in oncology, and will answer questions about cancer screening, diagnosis, and treatment.

*Other referrals to specific physicians, nutritionists, or psychologists are provided upon request.*

### **Other Organizations:**

#### **American Cancer Society 1-800-ACS-2345**

Web page: <http://www.cancer.org>

A nationwide community-based voluntary health organization dedicated to eliminating cancer as a major health problem by preventing cancer, saving lives from cancer, and diminishing suffering from cancer through research, education, and service.

#### **National Alliance of Breast Cancer Organizations (212) 719-0154**

Web page: <http://www.nabco.org>

A network of breast cancer organizations that provides information, assistance, and referrals to anyone with questions about breast cancer, and acts as a voice for the interests and concerns of breast cancer survivors and women at risk.

#### **National Breast Cancer Coalition (202) 296-7477**

Web page: <http://www.natlbcc.org>

A national advocacy group concerned with furthering research about breast cancer. The group is also involved in lobbying efforts for issues such as legislation to protect against genetic discrimination.

**National Ovarian Cancer Coalition (NOCC) (954) 351-9555**

Web page: <http://www.ovarian.org>

The NOCC was founded by ovarian cancer survivors whose mission it is to save women's lives by raising awareness about ovarian cancer. Their goal is to increase research opportunities and to improve treatment methods for ovarian cancer.

**National Cancer Institute's Cancer Information Service 1-800-4CANCER**

Web page: <http://www.nci.nih.gov>

A nationwide telephone service for cancer patients and their families, the public, and health care professionals providing up-to-date and understandable information about cancer screening, diagnosis, and treatment. Many publications are available free of charge.

**Gilda's Club (212) 647-9700**

Web page: <http://www.jocularity.com/gilda1.html>

Education and support for people with cancer and their families.

**SHARE (212) 719-0364**

24 hr. Hotline in English and in Spanish

Breast Cancer Hotline (212) 382-2111

Ovarian Cancer Hotline (212) 719-1204

Web page: <http://www.sharecancersupport.org>

Share is a self-help organization that provides information to women and their family members who have been affected and/or impacted by a diagnosis of breast and/or ovarian cancer.

**Y-ME National Breast Cancer Organization 1-800-221-2141**

Web page: <http://www.yme.org>

National support hotline for breast cancer survivors. A large, comprehensive breast cancer support program founded in 1978 by two breast cancer patients.

## Books/Publications:

Baker, N.C. **Relative Risk: Living With a Family History of Breast Cancer.** New York: Penguin. 1992. A guide for women at risk for developing breast cancer. This book provides coping mechanisms for dealing with feelings of vulnerability and susceptibility, and offers practical advice on protecting one's health.

Berger, K., and Bostwich, J. **A Woman's Decision. Breast Care, Treatment, and Reconstruction.** St Louis: Quality Medical Publishing, Inc. 1994. An authoritative text designed to help women assess their options, familiarize themselves with breast cancer treatment, and prepare themselves for what to expect medically and emotionally from reconstructive surgery.

Harpham, W.S. **When a Parent has Cancer: A Guide to Caring for Your Children.** New York: Harper Collins. 1997. Written by an internist who herself has battled cancer, this informative text explains how to prevent and respond to common problems experienced by children whose parent has been diagnosed with cancer.

Krause, C. **How Healthy is Your Family Tree? A Complete Guide to Tracing Your Family's Medical and Behavioral History.** New York: Simon and Schuster. 1995. A helpful guide to gaining vital information about your family history.

Latour, K. **The Breast Cancer Companion.** New York: William Morrow & Co. 1993. Written in lay terms by a breast cancer survivor, this practical guide discusses everything a breast cancer patient needs to know from diagnosis through recovery. The text is also liberally illustrated with personal patient accounts of their experience.

**What You Need to Know Series: Breast, Ovarian, Colon, and Prostate Cancer.** Free publications from the National Cancer Institute's Cancer Information Service explaining the symptoms, diagnosis, and treatment of these cancers.

**Understanding Genetic Testing.** Free booklet by the National Cancer Institute providing information about gene testing. This booklet also provides answers to frequently asked questions about the potential risks and benefits of genetic testing.



## Web Sites:

### **Breast Cancer Information Clearinghouse**

<http://nysernet.org/bcic>

The purpose of this webserver is to provide information for breast cancer patients and their families. It is maintained as a partnership of organizations which provides information about cancer to the public.

### **Breast Cancer. Net**

<http://www.breastcancer.net>

Internet news items related to breast cancer are published daily and provided free of charge as part of this service. Over 2,200 breast cancer survivors, health professionals, and legislators subscribe.

### **The Breast Gene and BRCA123 Information Directory**

[http://www.ncgr.org/gpi/bc\\_pg\\_front.html](http://www.ncgr.org/gpi/bc_pg_front.html)

The National Center for Genome Resources' Genetic and Public Issues Program has compiled this page to help people understand recent developments in genetic testing related to breast cancer.

### **Cancer Net**

<http://cancernet.nci.nih.gov>

A service of the National Cancer Institute's International Cancer Information Center which provides current information on cancer.

### **Oncolink**

<http://www.oncolink.upenn.edu>

A multimedia cancer information resource developed and maintained by the University of Pennsylvania Cancer Center.

### **The Gene Letter**

<http://www.geneletter.org>

The U.S. Department of Energy has awarded the Shriver Center a 2 year grant to develop and generate an electronic newsletter about genetics and public policy. The major purpose of the Gene Letter is to inform consumers and professionals about advances in genetics and to encourage discourse about emerging policy dilemmas.

### **Legislative information on the Internet**

A service of the Congress through its library

<http://www.thomas.loc.gov>

<http://college.georgetown.edu/research/ihcrp/hipaa>

**GEORGETOWN**   
*The Art of Medicine*



A Comprehensive Cancer  
Center Designated by the  
National Cancer Institute

## Appendix 3: Article Reprints

DRAFT

**Brief Communication**

Racial Differences in the Use of BRCA1/BRCA2 Genetic  
Testing in High Risk Breast Cancer Probands

Marc D. Schwartz, Chanita Hughes, Joan Roth, David Main,  
Beth Peshkin, Claudine Isaacs, Carol Kavanagh, Caryn Lerman

Affiliation of Authors: Lombardi Cancer Center/Georgetown University Medical Center

Correspondance to: Marc Schwartz, Lombardi Cancer Center, Cancer Genetics, 2233  
Wisconsin Avenue, Suite 317, Washington DC 20007. Telephone (202) 687-0185; Fax  
(202) 687-8444. E-Mail: Schwartm@gunet.georgetown.edu.

Key Words: BRCA1 testing, BRCA2 testing, Race, Spirituality

RUNNING HEAD: Racial Differences in Test Uptake

## Racial Differences in the Use of BRCA1/2 Genetic Testing in Breast Cancer Probands

The BRCA1 and BRCA2 genes are believed to account for most hereditary breast cancer (HBC) cases (1). Preliminary reports suggest that 40%-80% of HBC family members elect to learn their genetic status for BRCA1/2 (2,3). However, these reports were based upon large Caucasian HBC families, most of whom participated in prior linkage research. Thus, these participants may not be representative of individuals from clinical populations (4) and the rate of BRCA1/2 test utilization may not generalize to individuals who are newly identified as being at high risk (2).

The goals of the present study were to: (1) evaluate BRCA1/2 test utilization among women who had self-referred to genetic counseling in a clinical research setting and (2) to examine sociodemographic factors which influence test use. Of particular interest was the association between race and BRCA1/2 test utilization. Research conducted prior to the availability of BRCA1/2 testing showed that, compared to Caucasians, African Americans expressed less interest in genetic testing (5). However, the present study is the first to examine whether African Americans and Caucasians actually have different rates of BRCA1/2 test use.

Participants were women who self-referred to the Cancer Assessment and Risk Evaluation (CARE) program at the Lombardi Cancer Center at Georgetown University Medical Center. Adult females affected with breast or ovarian cancer (probands) with a minimum 20% prior probability of having a BRCA1/2 mutation (6) were eligible for participation. If a risk-conferring mutation was identified, then enrollment in the CARE program was extended to other family members. However, the present report is limited

to the first 207 probands to enter CARE.

Probands who contacted the CARE program were screened by telephone to determine eligibility. Eligible probands completed a telephone interview which included sociodemographics, family history of cancer, knowledge of HBC and BRCA1/2 testing, and spiritual faith (a single Likert-style item adopted by the NIH Cancer Genetic Studies Consortium assessing strength of spiritual faith: not strong, moderately strong, or very strong). Following the baseline interview, participants were invited to a pre-test education session with a genetic counselor. Those who completed the education session could provide a blood sample for BRCA1/2 mutation testing after providing written consent. When a participant's test result became available, the participant was invited to an individual disclosure/counseling session. Participants could decline to continue at any point in the process.

Characteristics of the study sample are displayed in Table 1.

-----  
Insert Table 1 about here  
-----

Of the 207 probands, 79% (n = 163) received their test results and 21% (n = 44) chose not to receive test results. Of those who chose not to receive test results, 73% (n = 32) declined to participate in the initial education session, 16% (n = 7) participated in the education session, but declined to provide blood for testing, and 11% (n = 5) provided blood, but declined subsequently to learn their test result. Among those who chose not to receive test results, none of the predictor variables were significantly associated with the stage at which this decision was made (i.e., prior to the education session vs following the

education sessions vs following blood provision).

The bivariate associations between the predictor variables and BRCA1/2 test utilization are shown in Table 2.

-----

Insert Table 2 about here

-----

To identify independent predictors of BRCA1/2 test uptake, we conducted a backward stepwise logistic regression. Variables with significant bivariate associations with test use were included in the initial model (age, race, and spiritual faith) along with the race by spiritual faith interaction term. Age and the race by spiritual faith interaction were eliminated on the first two steps of the stepwise procedure (P-values >.10). Race and spirituality both remained in the model due to their significant (P < .05) independent associations with uptake. Caucasians were nearly four times more likely than African Americans to receive their test results (OR = 3.8, 95% CI = 1.2, 12.3) and participants who reported very strong spiritual faith were less than half as likely to receive test results compared to participants who reported moderate or less (OR = 0.42, 95% CI = 0.21, 0.83).

Although test utilization has been evaluated among research participants in linkage analysis studies (2), our study is the first to examine BRCA1/2 test usage among newly ascertained and racially diverse HBC probands. The uptake rate of 79%, although higher than previously reported (2,3), may be more reflective of actual test usage among women who self-refer to genetic counseling programs. As BRCA1/2 testing moves into clinical settings, it is likely that participants will be self-referred and therefore more

highly motivated to receive test results.

The lower test uptake rate of African American compared to Caucasian participants is consistent with previous reports demonstrating that African American women had weaker intentions to participate in BRCA1/2 testing despite their high expectations about the medical benefits of testing (7,8). This may be attributable, in part, to concerns about exploitation and genetic discrimination in medical research conducted in the African American population (9). Alternatively, African American women may perceive themselves to be at lower risk of breast cancer than comparable risk Caucasian women (10).

Although African Americans report greater religious commitment than Caucasians (11,12), level of spiritual faith was independently associated with BRCA1/2 test utilization. Lower BRCA1/2 test uptake rates in women with strong spiritual faith may result from the belief that one's life course is determined by a higher power rather than by genetic factors. Further research is needed to elucidate the specific determinants of BRCA1/2 testing decisions in Caucasian and African American in order to develop culturally-specific genetic counseling programs.



## References

1. Ford D, Easton DF, Stratton M, Narod S, Goldgar D, Devilee P, et al. Genetic heterogeneity and penetrance analysis of the BRCA1 and BRCA2 genes in breast cancer families. *American Journal of Human Genetics* 1998;62:676-689.
2. Lerman C, Narod S, Schulman, K, Hughes C, Gomez-Caminero A, Bonney G, et al. BRCA1 testing in families with hereditary breast-ovarian cancer. *Journal of the American Medical Association* 1996;275:1885-1892.
3. Patenaude AF, Schneider KA, Kieffer SA, Calzone KA, Stopfer JE, Basili LA, et al. Acceptance of invitations for p53 and BRCA1 predisposition testing: Factors influencing potential utilization of cancer genetic testing. *Psycho-Oncology* 1996;5:241-250.
4. Lerman,C, Schwartz MD, Lin TH, Hughes C, Narod S, Lynch HT. The influence of psychological distress on use of genetic testing for cancer risk. *Journal of Consulting and Clinical Psychology* 1997;65:414-20.
5. Lerman C, Biesecker B, Benkendorf J, Kerner J, Gomez-Caminero A, Hughes C, et al. Controlled trial of pretest education approaches to enhance informed decision-making for BRCA1 gene testing. *Journal of the National Cancer Institute* 1997;89:148-157.
6. Couch FJ, DeShano ML, Blackwood MA, Calzone K, Stopfer J, Campeau L, et al. BRCA1 mutations in women attending clinics that evaluate the risk of breast cancer. *New England Journal of Medicine* 1997;336:1409-1415.
7. Lerman C, Hughes C, Benkendorf JL, Biesecker B, Kerner J, Willison J, et al. Racial differences in testing motivation and psychological distress following pre-

test education for BRCA1 gene testing. *Cancer Epidemiology Biomarkers and Prevention*; in press.

8. Hughes C, Gomez-Caminero A, Benkendorf J, Kerner J, Isaacs C, Barter J, et al. Ethnic differences in knowledge and attitudes about BRCA1 testing in women at increased risk. *Patient Education and Counseling* 1997; 32:51-62.
9. Gamble VN. A legacy of distrust: African Americans and medical research. *American Journal of Preventive Medicine* 1993;9:35-38.
10. Hughes C, Lerman C, Lustbader E. Ethnic differences in risk perception among women at increased risk for breast cancer. *Breast Cancer Research and Treatment* 1996;40:25-35.
11. Greely HT. Genetic testing for cancer susceptibility: Challenges for creators of practice guidelines. *Oncology* 1997;11:171-176.
12. Telfair J, Nash KB. African American Culture. In NL Fisher (Ed.), *Cultural and Ethnic Diversity: A Guide for Genetics Professionals* (pp36-59). Baltimore MD: The Johns Hopkins University Press, 1996.

## Notes

Supported by grant DAMB 17-96-C-6069 (Lerman) from the Department of Defense, RO1 CA/HG74861 (Lerman) from the National Cancer Institute and Institute for Human Genome Research, and KO7 CA65597 (Schwartz) from the National Cancer Institute.

We thank our patient counselors, Tiffani DeMarco and Barbara Brogan, our data managers, Kristen Willard and Rachel Manasan, and our telephone interviewers, Jerrianna Stead, Annalisa Dialino, and Lisa Smith.

Table 1. Sample Characteristics

Variable	Levels	N
Age	< 45	77 (37%)
	≥ 45	130 (63%)
Marital Status	Married	158 (76%)
	Unmarried	49 (24%)
Race	Caucasian	194 (94%)
	African American	13 (6%)
Education	< College Grad	51 (25%)
	≥ College Grad	156 (75%)
Religion	Catholic	46 (22%)
	Jewish	71 (34%)
	Protestant	72 (35%)
	Other	18 (9%)
Spiritual Faith	Not strong/moderately strong	120 (58%)
	Very strong	87 (42%)
Relatives affected with breast and/or ovarian CA	0-2	169 (82%)
	3+	38 (18%)

Table 2. Bivariate Associations of Sociodemographic Variables With BRCA1/BRCA2 Test Use

Variable	Levels	% Receiving Test Results	X <sup>2</sup>
Age	< 45	71	3.92*
	≥ 45	83	
Marital Status	Married	78	0.03
	Unmarried	80	
Race	Caucasian	81	8.80**
	African American	46	
Education	< College Grad	73	1.55
	≥ College Grad	81	
Religion	Catholic	74	2.54
	Jewish	84	
	Protestant	78	
	Other	72	
Spiritual Faith	Not strong/moderately strong	86	8.57**
	Very strong	69	
Affected Relatives	0-2	79	0.00
	3+	79	

Note. \* p < .05, \*\* p < .01

\$19DKA400:(DATA\M.L.H.1-3)\ML.HR02.TXT:1 HUGHESD Seq: 1 15-JUL-98 9:54

**FAMILY DISCLOSURE IN GENETIC TESTING FOR  
CANCER SUSCEPTIBILITY:  
DETERMINANTS AND CONSEQUENCES†**

**CARYN LERMAN PH.D.,\***  
**BETH N. PESHKIN M.S.,\*\***  
**CHANITA HUGHES PH.D.,\*\*\* AND**  
**CLAUDINE ISAACS M.D.\*\*\*\***  
**LOMBARDI CANCER CENTER, GEORGETOWN UNIVERSITY  
MEDICAL CENTER**

† We would like to thank our study collaborators, including Drs. Henry Lynch, Stephen Lemon, Steven Narod, and Marc Schwartz. Other members of the research team contributing to family ascertainment, counseling, and evaluation include Jeri Reutenauer, M.S., Tiffani DeMarco, M.S., David Main M.A., M.S., Carol Anne Kavanagh, B.A., Margaret Reed, B.A., Kristen Willard, B.A., Rachel Manasan, B.A., Theresa Brownson, B.A., and Susan Marx, B.S. Last, but not least, we are grateful to all of the men and women who participated in this clinical research program.

MA  
MED

\* Associate Professor in the Departments of Medicine and Psychiatry and Director of Cancer Genetics at the Lombardi Cancer Center, Georgetown University Medical Center. Dr. Lerman has participated as a member and chair of the National Human Genome Research Institute's ad hoc study section: Ethical, Legal, and Social Implications of Human Genetics Research and is a member of the National Cancer Institute's Board of Scientific Advisors. She has conducted extensive research on the psychosocial implications of genetic testing. For this work she has received an award from the American Psychological Association for Outstanding Contributions to Health Psychology.

\*\* Certified Genetic Counselor and Research Instructor at Georgetown University. Ms. Peshkin is the Senior Genetic Counselor and Project Director for a Department of Defense funded grant at Georgetown, "Impact of Genetic Testing for Breast Cancer Susceptibility." She is also a co-investigator on other funded grants related to genetic testing. With over four years experience in cancer genetic counseling, she has counseled several hundred individuals about issues related to genetic testing. She has also contributed to the development of educational programs and materials for professionals and patients.

\*\*\* Project Director for two multi-institutional grants related to genetic testing in hereditary breast and colon cancer families at the Lombardi Cancer Center, Georgetown University Medical Center. Dr. Hughes is currently conducting research on the role of family communication in the genetic counseling process, ethnic differences in responses to genetic testing for cancer susceptibility, and the development and evaluation of culturally-sensitive genetic counseling protocols.

\*\*\*\* Assistant Professor of Medicine at the Georgetown University Medical Center and board certified medical oncologist with expertise in breast cancer. Dr. Isaacs is the Medical Director of the Cancer Assessment and Risk Evaluation Program. She is the co-principal investigator of a National Cancer Institute ("NCI") funded study to determine the impact of genetic counseling and testing in women who are newly diagnosed with breast cancer and is the principal investigator of an NCI funded study on educating physicians about hereditary breast cancer. She is also a co-investigator on several other NCI and Department of Defense funded breast cancer treatment or chemoprevention studies.

## I. INTRODUCTION AND OVERVIEW

The isolation of the BRCA1 and BRCA2 genes has made it possible to identify women at increased risk for breast and ovarian cancer, thereby facilitating informed decisions about surveillance and cancer prevention options.<sup>1</sup> Despite these potential medical benefits, the identification of carriers of deleterious mutations raises numerous psychological and social challenges for those being tested and for their family members.<sup>2</sup> One of the more pressing and least studied issues involves the process and outcomes of disclosure of genetic information within families. The present article addresses family disclosure of information about genetic testing for cancer susceptibility. Following an overview of the clinical aspects of family disclosure and the empirical literature on this topic, we present our preliminary data on the determinants and outcomes of disclosure of BRCA1 and BRCA2 ("BRCA1/2") genetic information within hereditary breast cancer families. These data are supplemented with case studies of patients, highlighting the motivations for and against disclosure and il-

---

1. See Douglas F. Easton et al., *Breast and Ovarian Cancer Incidence in BRCA1-Mutation Carriers*, 56 AM. J. HUM. GENETICS 265 (1995); Deborah Ford et al., *Risks of Cancer in BRCA1-Mutation Carriers*, 345 LANCET 692 (1994); Richard Wooster et al., *Identification of the Breast Cancer Susceptibility Gene BRCA2*, 378 NATURE 789, 790 (1995). These studies, the first two of which are from the Breast Cancer Linkage Consortium, established that the lifetime risks of breast and ovarian cancer associated with BRCA1 mutations are about 85% and 63%, respectively, with onset often at a younger age than observed in the general population. See Easton et al., *supra*, at 270; Ford et al., at 270. Risks for breast cancer in women with BRCA2 mutations were found to be comparable to BRCA1, but the ovarian cancer risks were lower. See Wooster, *supra*, at 790. Prostate cancer risks appear to be elevated in male BRCA1 carriers. In addition, colon cancer risks may be elevated in men and women with a BRCA1 or BRCA2 mutation, and other more rare cancers have been associated with BRCA2 alterations. See *id.* Another study found lower risks of breast and ovarian cancer associated with three common mutations in Ashkenazi Jewish individuals who did not necessarily have a family history of cancer. Jeffery P. Struwing et al., *The Risk of Cancer Associated with Specific Mutations of BRCA1 and BRCA2 Among Ashkenazi Jews*, 336 NEW ENG. J. MED. 1401, 1401 (1997). The risks were still markedly elevated over the general population. See *id.* In addition, prostate cancer risks were elevated, though colon cancer risks were not. See *id.*; see also generally Wylie Burke et al., *Recommendations for Follow-up Care of Individuals with an Inherited Predisposition to Cancer: II. BRCA1 and BRCA2*, 277 JAMA 997 (1997) (discussing provisional recommendations for early detection and cancer prevention in individuals with a BRCA1 or BRCA2 mutation, including heightened surveillance often commencing at an early age, and reviewing the data regarding the options for prophylactic surgery).

2. See Caryn Lerman et al., *BRCA1 Testing in Families with Hereditary Breast-Ovarian Cancer: A Prospective Study of Patient Decision Making and Outcomes*, 275 JAMA 1885, 1889 (1996) (discussing patients' perception of the benefits, limitations, and risks of testing, which included social concerns such as fears about insurance discrimination, and concerns about emotional adaptation and response of relatives to test results).

S:\DKA400\DATA\M.L.H.1-2\MLH001.TXT:1

HUGHESD

Seq: 3

15-JUL-98

8:49

1998]

DISCLOSURE IN GENETIC TESTING

203

illustrating key counseling issues. Finally, we summarize these data and discuss the health-related and legal implications.

## II. FAMILY DISCLOSURE OF GENETIC INFORMATION IN THE BRCA1 AND BRCA2 GENETIC COUNSELING SETTING

Disclosure of genetic information about cancer susceptibility has numerous implications for patients, family members, health care providers, and researchers. In the clinical and research settings, disclosure of one's mutation status provides a gateway for other family members to have access to genetic testing research protocols. Typically, BRCA1/2 testing within a family begins with a woman who has been diagnosed with breast or ovarian cancer, often at a young age (referred to as the proband). If a known disease-conferring mutation is identified, other first-degree relatives such as siblings and children have a 50% likelihood of also carrying the mutation and having an increased cancer risk.<sup>3</sup> In some families, it is also possible to identify more distant relatives who are at increased risk such as nieces, nephews, and cousins. With knowledge of the particular mutation carried by the proband, it becomes possible to offer testing to other family members for that same mutation.<sup>4</sup> However, in the interest of protecting the confidentiality of the participant, researchers or clinicians should not approach other family members about their risk status or about testing. A common process, employed in most clinical research settings, is to discuss with the proband the implications of her test result for other family members as well as the attendant personal and social risks.<sup>5</sup> Probands are then given the option to contact their relatives directly, to have the health care provider contact their relatives,

---

3. See generally Barbara B. Biesecker et al., *Genetic Counseling for Families with Inherited Susceptibility to Breast and Ovarian Cancer*, 269 JAMA 1970 (1993). BRCA1 and BRCA2 alterations are inherited in an autosomal dominant fashion, which means that each child of a parent with an alteration has a 50% chance of having the same alteration. See generally *id.* Male and female offspring are at equal risk of inheriting BRCA1 and BRCA2 mutations. See generally *id.*

4. Within high-risk families, the advantage to first testing a woman with breast or ovarian cancer diagnosed at an early age is that she is most likely to carry an alteration if one is present within the family. See Maggie Ponder & Josephine M. Green, *BRCA1 Testing: Some Issues in Moving from Research to Service*, 5 PSYCHO-ONCOLOGY 223, 223 (1996). It is possible to test individuals without knowledge of whether there is a BRCA1 or BRCA2 mutation present in their family (e.g., if all relatives with breast or ovarian cancer are deceased). *Id.* at 228. In such scenarios, a positive result will still yield useful information. However, a negative test result is not considered to be informative because it is not possible to distinguish whether the patient did not inherit a mutation present in her family or whether there is no detectable BRCA1 or BRCA2 mutation in the family. *Id.* at 227.

5. See Biesecker et al., *supra* note 3, at 1972-75. The authors concluded that a protocol to test for presymptomatic BRCA1 gene mutations should include:



or not to have any further contact with relatives.<sup>6</sup> Probands are also provided with written materials to share with their relatives to facilitate the discussion.

The genetic counselor is perhaps best situated to facilitate informed decisions about family disclosure by reviewing the potential benefits and risks with the patient. In deciding whether to disclose a positive test result, one may consider the potential medical benefits for other relatives. For example, disclosure of one's own test result may be required to provide a relative with the opportunity to be tested for the specific mutation in the family, should she or he decide to do so.<sup>7</sup> As mentioned above, such information may have medical value, particularly to female family members who may have a significantly elevated breast and ovarian cancer risk.<sup>8</sup> A potential benefit to the proband is that disclosure of a positive test result may also elicit both emotional support and instrumental assistance in seeking and obtaining information and medical care.<sup>9</sup> However, disclosure of genetic test results has potential risks, including loss of privacy, employment and insurance discrimination, and stigmatization.<sup>10</sup> Individual distress and family conflict may also be generated by disclosure of genetic information.<sup>11</sup> Despite the importance of family disclosure, there are limited empirical data available on this topic.

---

(1) precounseling education and assessment; (2) a multidisciplinary team with expertise in the screening and management of breast and ovarian cancer, inheritance, DNA testing, and psychosocial counseling issues of late-onset disorders; and (3) follow-up services for the management of the increased risk for cancer as well as the residual emotional reactions on behalf of family members.

*Id.* at 1974; see also Lerman et al., *supra* note 2, at 1886-87 (BRCA1 counseling protocol).

6. See Biesecker et al., *supra* note 3, at 1972.

7. See Ponder & Green, *supra* note 4, at 227.

8. See Easton et al., *supra* note 1, at 265; Ford et al., *supra* note 1, at 692; Wooster et al., *supra* note 1, at 789; Struwing et al., *supra* note 1, at 1401.

9. See Biesecker et al., *supra* note 3, at 1972 (noting that a majority of family members opted to share the results of BRCA1 testing with family members in an effort to receive their support).

10. See Mark A. Rothstein, *Genetic Testing: Employability, Insurability, and Health Reform*, 17 J. NAT'L. CANCER INST. MONOGRAPHS 87 (1995); Paul R. Billings et al., *Discrimination as a Consequence of Genetic Testing*, 50 AM. J. HUM. GENETICS 476 (1992).

11. See Robert T. Croyle et al., *Psychological Responses to BRCA1 Mutation Testing: Preliminary Findings*, 16 HEALTH PSYCHOL. 63, 67-69 (1997) (demonstrating that female carriers with no history of cancer or prophylactic surgery had high levels of test-related distress as measured by standard psychological assessments, but that overall, levels of general distress were not increased in this group); Henry T. Lynch et al., *A Descriptive Study of BRCA1 Testing and Reactions to Disclosure of Test Results*, 79 CANCER 2219, 2223, 2225-26 (1997) (containing anecdotal, qualitative descriptions of patient responses to testing, including sadness and survivor guilt). *But see* Lerman et al., *supra* note 2, at 1890 (finding that a subset of the BRCA1 carriers described in the Lynch et al. paper did not exhibit increases in depression and functional impairment when evaluated using standardized quantitative measures).

1998]

## DISCLOSURE IN GENETIC TESTING

205

The following section provides an overview of published data about the processes and outcomes of family disclosure in the genetic testing context.

### III. LITERATURE REVIEW ON FAMILY COMMUNICATION REGARDING GENETIC TESTING

Initial research on family communication about genetic testing suggests that most individuals will contact family members to obtain information about their family's medical history before counseling. Researcher Josephine Green and colleagues found that 78% of women who were scheduled for a genetic counseling session for inherited breast-ovarian cancer susceptibility communicated with a family member before their appointment to obtain family history information.<sup>12</sup> Specifically, probands were most likely to contact female relatives (i.e., mothers or sisters) for information about their family history.<sup>13</sup> Reasons for not contacting relatives who could have provided medical information about the family included not wanting to upset the relative with discussions about cancer.<sup>14</sup> Other reasons for not contacting relatives included lost communication with relatives and large age differences between siblings.<sup>15</sup> This study also found that 88% of respondents shared their post-counseling summary letter with at least one relative.<sup>16</sup>

A no cap

Studies of family communication about other genetic disorders (e.g., cystic fibrosis) suggest that feedback provided by relatives through verbal and/or nonverbal communication may motivate or discourage individuals from undergoing genetic testing.<sup>17</sup> A study of cystic fibrosis testing found that a person's perceptions of their siblings' reactions to abortion was a significant predictor of usage of prenatal testing for this disorder.<sup>18</sup> Specifically, respondents who perceived that their siblings would approve of aborting an affected

12. See Josephine Green et al., *Family Communication and Genetic Counseling: The Case of Hereditary Breast and Ovarian Cancer*, 6 J. GENETIC COUNSELING 45, 51 (1997).

13. See *id.* at 51-52.

14. See *id.* at 52.

15. See *id.*

16. See *id.* at 53.

17. See Dorothy C. Wertz et al., *Attitudes Toward the Prenatal Diagnosis of Cystic Fibrosis: Factors in Decision Making Among Affected Families*, 50 AM. J. HUM. GENETICS 1077, 1083 (1992). Cystic fibrosis is a potentially lethal genetic disease which results in the production of abnormally thick mucus which can clog the lungs and cause severe infections. See generally Francis S. Collins, *Cystic Fibrosis: Molecular Biology and Therapeutic Implications*, 256 SCIENCE 774 (1992). Carriers of the disease have no symptoms, but carrier parents have a 25% chance of having an affected child. See *id.*

18. See Wertz et al., *supra* note 17, at 1082-83.

S:\DKA400\DATA\M.M.H.1-1\MEASUR.TXT

HUGHESD

Seq: 6

15-JUL-98

8:49

fetus were three times more likely to use prenatal diagnosis.<sup>19</sup> In the BRCA1/2 testing context, probands who had strong positive beliefs about the benefits of genetic testing were likely to also encourage other family members to participate in genetic testing.<sup>20</sup> These studies underscore the influence of family disclosure and communication on decision making about genetic testing.

Although most individuals may disclose their genetic test results to family members, many are reluctant to provide clinicians and researchers with direct access to these family members. In a survey of attitudes about BRCA1/2 testing among high-risk women, a majority (>80%) felt that health care providers should not disclose their test results to immediate family members without their written consent.<sup>21</sup> In a cystic fibrosis screening program, only 54% of probands provided the research team with contact information for their at-risk relatives.<sup>22</sup> Thus, most genetic testing participants desire to maintain control over the diffusion of genetic information to relatives. Further, these decisions are typically made without consulting with family members.

Willingness to communicate with family members about genetic testing and genetic disorders may be influenced by factors such as gender<sup>23</sup> and cultural background.<sup>24</sup> For example, women appear to be more likely to discuss genetic testing with their female relatives (i.e., daughters) than with male relatives (i.e., brothers).<sup>25</sup> This may be attributable to perceptions that only mothers, sisters, and daughters are at-risk for cancer.<sup>26</sup> Our own data on BRCA1/2 testing, presented in the next section, provide further support for gender differences in family communication about BRCA1/2 testing.

19. See *id.* at 1081-82.

20. See Andrea Parkas Patenaude et al., *Acceptance of Invitations for p53 and BRCA1 Predisposition Testing: Factors Influencing Potential Utilization of Cancer Genetic Testing*, 5 *PSYCHO-ONCOLOGY* 241, 245 (1996).

21. See Judith L. Benkendorf et al., *Patients' Attitudes About Autonomy and Confidentiality in Genetic Testing for Breast-Ovarian Cancer Susceptibility*, 73 *AM. J. MED. GENETICS* 296, 298 (1997).

22. See J.R. Sorenson et al., *Probands and Parent Assistance in Identifying Relatives for Cystic Fibrosis Carrier Testing*, 69 *AM. J. MED. GENETICS* 419, 421 (1996).

23. See Martin Richards, *Families, Kinship, and Genetics*, in *THE TROUBLED HELIX: SOCIAL AND PSYCHOLOGICAL IMPLICATIONS OF THE NEW HUMAN GENETICS* 249, 251 (Theresa Marteau & Martin Richards eds., 1996).

24. See James C. McCroskey & Virginia P. Richmond, *Willingness to Communicate: A Cognitive View*, in *COMMUNICATION, COGNITION, AND ANXIETY* 19, 31-32 (Melanie Booth-Butterfield ed., 1990).

25. See Ponder & Green, *supra* note 4, at 229-30.

26. See *id.* at 230.

1998]

## DISCLOSURE IN GENETIC TESTING

207

Family communication may also differ among individuals with different ethnic or cultural backgrounds.<sup>27</sup> Culture has been described as a system that influences behavior and perceptions.<sup>28</sup> For example, the culture of many African Americans may generally be characterized as emphasizing the principle of spirituality and valuing interconnectedness, uniqueness, positivity, and sharing.<sup>29</sup> The culture of many European Americans is generally based on individualism and values the right to choose, honesty, sharing, and communication.<sup>30</sup> Research has shown that patterns of family communication about BRCA1 testing differ between African American and Caucasian women.<sup>31</sup> In a recent study, Caucasian women at increased risk for breast cancer were significantly more likely than African American women to communicate about genetic testing with a spouse and a parent.<sup>32</sup> Specifically, 66% of Caucasian women discussed genetic testing for hereditary breast cancer with their spouse, and 40% discussed it with a parent versus about 27% of African American women who discussed this issue with a spouse or parent.<sup>33</sup>

#### IV. PRELIMINARY DATA ON THE DETERMINANTS AND OUTCOMES OF FAMILY COMMUNICATION ABOUT BRCA1 AND BRCA2 TESTING

##### A. Research Questions

The published literature described previously provides some initial insights into the processes and determinants of communication of genetic information within families. However, it is important to assess communication processes and outcomes in a systematic manner and to address several key questions about family communication which are unanswered at present. Our research on BRCA1/2 testing in hereditary breast cancer seeks to fill some gaps in our knowledge about family communication by addressing the following research questions:

27. See McCroskey & Richmond, *supra* note 24, at 31.

28. See COLLINS O. AIRHIZENBUWA, *HEALTH AND CULTURE: BEYOND THE WESTERN PARADIGM* 9 (1995).

29. See Anita P. Jackson & Susan J. Sears, *Implications of an Africentric Worldview in Reducing Stress for African American Women*, 71 J. COUNSELING & DEV. 184, 186 (1992).

30. See Judith N. Martin et al., *Conversational Improvement Strategies for Interethnic Communication: African American and European American Perspectives*, 61 COMM. MONOGRAPHS 236, 237 (1994).

31. See Chanita Ann Hughes, *Genetic Testing for Inherited Breast-Ovarian Cancer Susceptibility: The Role of Communication and Personality Characteristics*, 62, 64-65 (1997) (unpublished Ph.D. dissertation, Howard University) (on file with the Department of Psychology, Howard University).

32. See *id.* at 65.

33. See *id.*

(1) Among carriers and noncarriers of BRCA1/2 mutations, what are the rates of self-reported disclosure of BRCA1/2 test results to different family members?; (2) Are women more likely to disclose their BRCA1/2 test results than are males?; and (3) What are the psychological consequences to the proband of disclosing BRCA1/2 test results to family members? The first two of these questions are addressed in a family-based study of BRCA1/2 testing, conducted in collaboration with Dr. Henry Lynch at Creighton University. The third question is addressed in a clinic-based study conducted at the Lombardi Cancer Center at Georgetown University Medical Center.

*B. Study #1: A Family-Based Study of BRCA1 and BRCA2 Testing*

In this prospective cohort study, eligible participants are male and female members of hereditary breast cancer families who participated in earlier genetic linkage studies contributing to the isolation of the BRCA1/2 genes. Consequently, the pedigrees had been completed as part of the earlier research and the contact information on all family members was available. Thus, in contrast to most clinic-based studies, the proband is not placed in the position of providing contact information for other relatives at the time of study entry.

The current study was conducted on a family by family basis. First, letters of introduction were mailed to family members to inform them that the breast cancer susceptibility gene in their family had been identified and that genetic counseling and testing are now available. Consenting family members were asked to participate in a baseline telephone interview to assess demographic characteristics, risk factors, and psychosocial well-being. Individuals interested in genetic counseling and testing had the opportunity to participate in a pre-test education session; most of these sessions were conducted with the extended family. Those who elected to receive their BRCA1/2 test results did so after completing additional written consent forms and participating in individual genetic counseling. In this study, we are following mutation carriers, noncarriers, and decliners of BRCA1/2 testing for a one-year period to evaluate the psychosocial and medical impact of testing. The data on family communication presented here are based on the one-month follow-up assessment.

The frequencies for self-reported disclosure of BRCA1/2 test results among 201 carriers and noncarriers of BRCA1/2 mutations are shown in Figure 1. Overall, rates of disclosure within the first month following testing were quite high. For example, 81% of carriers disclosed their results to a sister and 60% disclosed to a brother. The rates of disclosure to minor children were surprisingly high, consider-

1998]

DISCLOSURE IN GENETIC TESTING

209

ing the fact that there are no immediate medical implications for young children.<sup>34</sup> Seventy-seven percent of carriers disclosed to an adult child, 47% disclosed to a child age fourteen to eighteen and 37% disclosed to a child under age thirteen.

FIGURE 1. FAMILY DISCLOSURE OF BRCA1/2 TEST RESULTS BY CARRIER STATUS

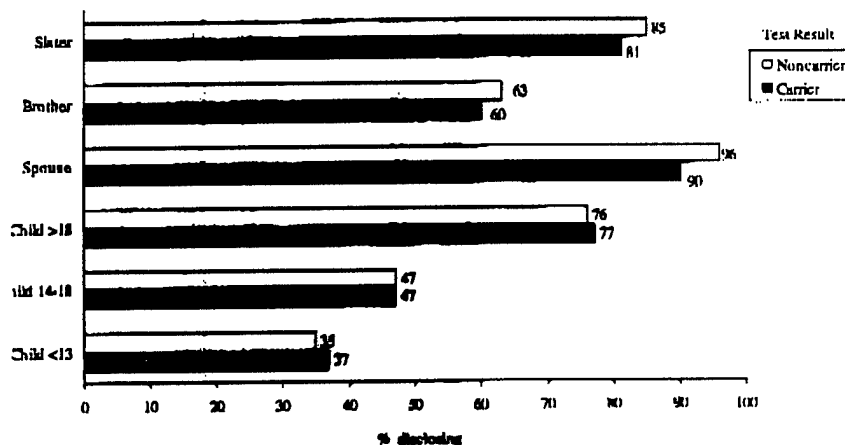

With respect to gender differences, self-reported rates of disclosure of test results among eighty-nine male and female mutation carriers are shown in Figure 2. Female carriers were more likely than males to disclose to a variety of family members. This was especially true for disclosure to sisters (89% of females versus 56% of males) and disclosure to children ages fourteen to eighteen (54% of females and

34. But see Ann-Marie Codori et al., *Genetic Testing for Cancer in Children: Short-term Psychological Effect*, 150 ARCHIVES PEDIATRIC ADOLESCENT MED. 1131 (1996); F.J.M. Grosfeld et al., *Psychological Risks of Genetically Testing Children for a Hereditary Cancer Syndrome*, 32 PATIENT EDUC. & COUNSELING 63, 64 (1997). These studies address genetic testing for conditions known as familial adenomatous polyposis, which may result in the development of colon cancer in adolescents, and multiple endocrine neoplasia type 2A, which is associated with a serious form of thyroid cancer that often affects children. See generally Codori et al., *supra*; Grosfeld et al., *supra*. In general, both studies concluded that there may be significant benefits to offering presymptomatic testing to children for predisposition to these disorders. See generally Codori et al., *supra*; Grosfeld et al., *supra*. There are other rare cancer predisposition syndromes for which it may be appropriate to test children, but the major reason for testing children should be under circumstances in which there is an immediate medical benefit. See The American Society of Human Genetics Board of Directors and The American College of Medical Genetics Board of Directors, *ASHG/ACMG Report: Points to Consider: Ethical, Legal, and Psychosocial Implications of Genetic Testing in Children and Adolescents*, 57 AM. J. HUM. GENETICS 1233, 1234-36 (1995). In addition, the potential psychological harm must be weighed against the possible benefits. See *id.*

such

△

△

→ can be associated with into for which prophylactic surgery in children is a consideration.

210

17% of males). One interpretation of these findings is that women are more comfortable communicating about health issues and dealing with the emotional sequelae of disclosure of a positive result. From a social perspective, it is not uncommon for women to take more of the responsibility for caretaking within the family.<sup>35</sup> It is also possible that the female spouses of the male mutation carriers in this study had disclosed the results to family members. However, these data are not available at the present time.

FIGURE 2. DISCLOSURE OF BRCA1/2 TEST RESULTS BY GENDER: CARRIERS ONLY

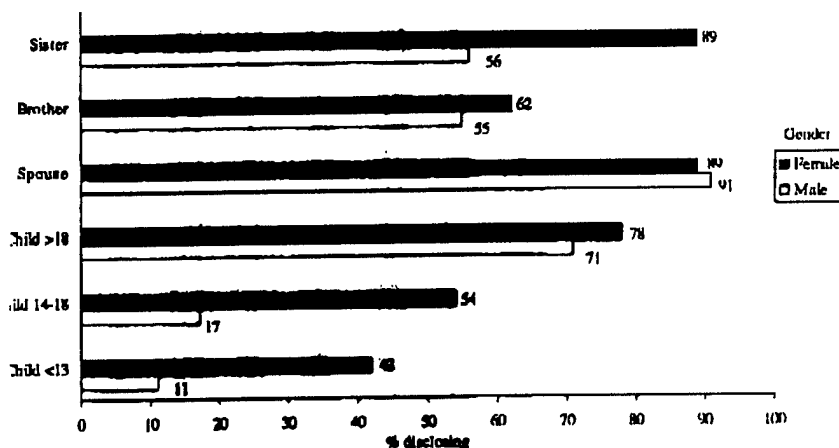

The results also indicated that the effects of carrier status (i.e., BRCA1/2 positive or negative) on disclosure varied by gender. For example, among males, noncarriers were more likely than carriers to disclose results to their sisters (78% versus 56%, respectively). By contrast, in females, the rate of disclosure to sisters was uniformly high (88%) and did not differ based on carrier status. The same pattern emerged for disclosure of BRCA1/2 test results to children. Among males, 55% of noncarriers and 17% of carriers disclosed their test results to a child age fourteen to eighteen. Among females, 53% disclosed to such a child, and there was no effect of carrier status on disclosure. Thus, it appears that men may be more comfortable sharing good news than bad news with other family members.

35. See Martin Richards, *Families, Kinship, and Genetics*, in *THE TROUBLED HELIX: SOCIAL AND PSYCHOLOGICAL IMPLICATIONS OF THE NEW HUMAN GENETICS* 249, 258 (Theresa Marteau & Martin Richards eds., 1996).

---

S13DKA400:(DATA.M.ML.H.1.3)ML.H302.TXT:1 HUGHESD Seq: 11 15-11-98 4:48

---

1998]

DISCLOSURE IN GENETIC TESTING

211

We also found that the likelihood of disclosing positive results with young children decreased as the education level of the participant increased. For example, 100% of carriers with less than high school education disclosed their results to a child age fourteen to eighteen, compared with 58% of high school and college graduates and 30% of participants with post-graduate education. To the extent that education level correlates with knowledge, we might interpret this to mean that increasing knowledge of the complexities and risks of disclosure (particularly to children) might dissuade some participants from disclosing to young children.

### C. Study #2: A Clinic-Based Study of BRCA1/2 Testing

As a result of their prior participation in genetic studies, the participants in the family-based study described above were more aware of the issues and complexities involved in genetic testing than most clinical populations. Further, counseling was performed on a family basis, thereby minimizing the disclosure burden to initial probands. Therefore, as a point of comparison, we are conducting a prospective cohort study of the outcomes of BRCA1/2 testing in the clinical setting. The study design is similar to that described above for Study #1, except that the testing process flows through the initial proband who is the gateway for providing access to other family members (after the proband's results are obtained, and if the result is positive). Further, all counseling and testing is conducted on an individual, rather than family, basis.

Despite differences in the method of ascertaining families, the rates of family disclosure in the clinic-based study were very similar to those for the family-based study. For example, about 81% of carriers and noncarriers disclosed to sisters and 45% disclosed to brothers. However, disclosure to children occurred less frequently in this setting and was more common among noncarriers than among carriers. For example, 40% of noncarriers disclosed their test results to a child age fourteen to eighteen as compared to 14% of carriers. Further, 21% of noncarriers disclosed to a child under age thirteen as compared to 9% of carriers. This suggests that some genetic testing participants may be motivated to disclose negative results for the purpose of reassuring their children.

With regard to the psychological impact of disclosure on the proband, the outcome appears to depend on the object of the disclosure. For example, BRCA1/2 carriers (mostly females in this study) who disclosed their result to their sister exhibited a small decrease in psychological distress, while those who elected not to tell exhibited a



small increase. This difference in trend was both statistically and clinically significant. Thus, this finding suggests that sharing a positive test result with a sister may initially have a positive effect on quality of life. This may be attributable to the fact that the proband fulfills a perceived responsibility to share information that could be medically significant to a close relative, and/or the fact that the proband may obtain emotional support from the relative.

By contrast, the reverse pattern was observed in the context of disclosure of positive test results to young children. In this case, probands who did not disclose their positive test results experienced reductions in distress, while those who did disclose experienced significant increases. Although preliminary, it is tempting to speculate that disclosure to young children may generate, rather than alleviate, psychological distress in carriers. Guilt about transmitting risk to one's offspring may be exacerbated by such discussions.

#### V. CASE STUDIES OF FAMILY DISCLOSURE IN THE CLINICAL RESEARCH SETTING

The concepts and results presented above are elucidated further by three case studies of the processes and outcomes of family disclosure of BRCA1/2 test results within the clinic-based study described above. These vignettes are based on actual cases but have been modified to protect privacy.

##### A. Case #1: *All in Good Time*

Ann is a fifty-five year old married Caucasian woman who tested positive for a BRCA1 alteration. Her medical history is significant for bilateral breast cancer diagnosed in her forties, for which she underwent mastectomies. She had her ovaries and uterus removed in her fifties as a preventive measure. Her mother died from ovarian cancer in her forties, and one of Ann's daughters had breast cancer at age thirty. Ann has two other adult daughters and an older brother and sister, none of whom has a history of cancer. Her siblings have adult sons and daughters. She also has several maternal cousins who are at risk for inheriting this alteration.

For Ann, there are few medical implications of this test result. However, there are several relatives who may now be tested. If found to carry this alteration, they would face increased risks for breast and ovarian cancer in women, and prostate cancer in male relatives.<sup>36</sup> During the initial pre-test genetic counseling session, Ann expressed

---

36. See Easton et al., *supra* note 1, at 265; Ford et al., *supra* note 1, at 692.

013DKA400:(DATA.M.M.H.1-2)HE.H03.TXT

HUGHESD

Page 13

15-JUL-98

8:49

1998]

## DISCLOSURE IN GENETIC TESTING

213

interest in testing to contribute to breast cancer research and also to gain information for her family, especially her daughters. Prior to obtaining her test results, Ann was concerned about the family's reaction to her results should she test positive, and acknowledged that, as a parent considering implications to her young adult daughters, she would harbor potential feelings of sadness, guilt, and even anger if she tested positive. She had only very limited discussions with her family about her decision to pursue testing. Of particular concern to her were the limitations in available screening and prevention options and how the information might affect her daughters' future childbearing decisions. Although she recognized the difficulty in communicating this information with her family, and the potential for significant emotional distress, she felt strongly about the importance of sharing this information.

When Ann received genetic counseling regarding her positive results, implications to family members were discussed in addition to exploring her own reactions and feelings. Of note, she was counseled that her daughter with breast cancer was very likely to carry this alteration, though Ann was not planning to share the information with her right away. The two individuals with whom Ann shared her results most immediately were her minister and her sister. Her sister was interested in testing and their discussions heightened Ann's concerns about the potential for insurance discrimination, as individuals without a prior history of cancer often have somewhat different worries about how their insurers will handle this type of "pre-existing" condition. She also began to explore with her sister issues related to the dissemination of this information to the rest of the family. Ann's sister had concerns about her own children learning about their aunt's test result.

Ann decided to defer discussion about her results with many relatives. For example, she decided not to disclose to her brother because he was having chronic medical problems. She also decided not to disclose to her daughter with breast cancer because she was undergoing chemotherapy, or to her two other daughters, one of whom was newly married and one of whom was pregnant. Ann clearly perceived the latter two events as happy occasions, and believed that news about her test result could wait until a more appropriate time. Within a year, she shared the information with all her daughters. Ann also contacted by phone some of her cousins with whom she had a relationship, but was not interested in contacting cousins with whom she had not seen or spoken to in many years. Eventually, her brother and sister were tested, but all of her daughters have declined testing at the

and her  
brother.

present time. Ann is undergoing counseling now to address her and her family's experiences with cancer and genetic testing, as well as other interpersonal issues.

*Analysis: Although some individuals are highly motivated to pursue testing for the sake of family members and to share test results with these relatives, established patterns of communication within the family and the occurrence of other life circumstances are likely to influence how, when, and with whom test results are discussed.*

### B. Case #2: Don't Ask, Don't Tell

Deborah is a fifty-four year old married Caucasian woman who tested positive for a BRCA2 alteration. Her medical history is significant for unilateral breast cancer diagnosed at age fifty-two for which she underwent breast conserving surgery (lumpectomy), followed by radiation and chemotherapy. Her sister had breast cancer in her mid-fifties, and there is a very strong family history of cancer on their father's side of the family, including breast cancer in two aunts, male breast cancer, pancreatic cancer, and ovarian cancer. With the exception of Deborah, all individuals in the family with a diagnosis of cancer have died. Deborah has three children in their twenties and several nieces in their thirties who she thought would probably be interested in genetic testing. She also has numerous cousins who are also at risk. Prior to learning her test results, Deborah had informed several relatives that she had obtained genetic testing and alerted them to the approximate time in which she would receive her results.

Upon learning her results, Deborah expressed "relief" at finally learning why she developed cancer. Unlike the previous case, these results could have significant medical implications for herself as well as her family. Deborah learned that she was at increased risk for developing another breast cancer (in her affected and opposite breast) and that she also faced an increased risk of ovarian cancer and possibly pancreatic cancer.<sup>37</sup> She was counseled about options for early detection (e.g., frequent screenings for breast cancer, blood tests, and

---

37. See Ford et al., *supra* note 1, at 693 (describing the risks of contralateral breast cancers in BRCA1 carriers estimated at 64% by age 70); Kenneth Offit, *BRCA1: A New Marker in the Management of Patients with Breast Cancer?*, 77 *CANCER* 599, 600 (1996) (discussing the possibility that women with BRCA1 and BRCA2 alterations may also be at risk for ipsilateral breast cancer and the potential impact on management decisions). It is likely that contralateral breast cancer risks are elevated in BRCA2 carriers as well. See Offit, *supra*, at 600; see also Wooster et al., *supra* note 1, at 790; Struewing et al., *supra* note 1, at 1401; Catherine M. Phelan et al., *Mutation Analysis of the BRCA2 Gene in 49 Site-Specific Breast Cancer Families*, 15 *NATURE GENETICS* 120, 121 (1996) (discussing other cancers associated with BRCA2 alterations including pancreatic cancer).

1998]

## DISCLOSURE IN GENETIC TESTING

215

ultrasounds for ovarian cancer) and risk reduction (e.g., use of Tamoxifen, a medication that may reduce the risk of another breast cancer; removal of her breasts and/or ovaries).<sup>38</sup> Although Deborah was concerned about these risks, she opted not to alter her medical management and believed that the other measures she employed to stay healthy, such as having a low fat diet and exercising, were sufficient and provided psychological benefits. She felt healthy and wanted to live with as few reminders of her cancer or her cancer risk as possible.

With respect to communication of her test results, within the first several weeks of learning her results, Deborah shared the information with her husband and a co-worker. She had also dropped hints about having her results to various family members including her children, and some of her nieces and cousins. She reported that none of these individuals inquired further as to what the results were or what the implications to them might be. Her feeling was that if they did not ask her directly for the information, she would not share it. She commented that as her children and nieces were young adults, there was no urgency to share this information, though she was counseled that women who have a BRCA2 alteration may face increased risks for breast and ovarian cancer even in their twenties and thirties. Because her result did not significantly change her medical management, she thought it was likely that it would not significantly impact others. She also feared that if relatives did get testing, they would associate testing positive with a "death sentence." Although she was aware that these relatives have a 50% chance of not having the alteration, and that learning such information could provide a substantial amount of reassurance about their cancer risks, she was more focused on the possibility of their testing positive. Through subsequent discussions with the counselor, Deborah revealed that at times, she felt somewhat guilty about "withholding information" from her family. One strategy for addressing this issue was to role play different language that could be used to disclose the information and to imagine the relatives' reaction along with her response.

It has been over a year since Deborah obtained her results, and no relatives have been notified of this information. Deborah believes that with time, her feelings about communicating her result may change, for example, as her children get older or as they consider having children. If there are changes in Deborah's own history or her

---

38. See Burke et al., *supra* note 1, at 997.

family history of cancer, these events may also affect her feelings about sharing the information.

*Analysis: Individuals' beliefs about the impact of test results for themselves may affect their perception of how or whether others will utilize the information, or when they should be notified of the information. The health care providers informed Deborah about who is at risk and offered to facilitate communication with these relatives about the availability of genetic counseling with the option of testing, but were respectful of her wishes not to share the information. In order for individuals to feel comfortable pursuing testing, they must know that researchers and clinicians will handle the information responsibly and respect their autonomy and decision process.*

### C. Case #3: A Family Affair

Margaret is a sixty-five year old married Caucasian woman who tested positive for a BRCA1 alteration. She had a history of breast cancer at age forty-five, for which she underwent a mastectomy of her affected breast and a preventive mastectomy of her opposite breast. Her family history is notable for two sisters with early onset breast cancer, one of whom also had ovarian cancer and was getting treatment for metastatic ovarian cancer at the time. Margaret also has two sisters and two brothers who have never had cancer. Their mother was diagnosed with breast cancer at age fifty. All of her siblings have adult children, and she has three daughters. Margaret sought genetic testing. She was initially interested in testing to learn about her risk for ovarian cancer and also to gain information for her family. Within six months of learning her results, Margaret opted to have her ovaries removed—a decision influenced by her sister's battle against ovarian cancer.

It was clear from the first meeting with Margaret that she assumed a matriarchal role in this family and that the family was very close. They were also united in family crises, such as the recent death of Margaret's husband and her sister's illness. Within a few months, all of her siblings participated in a group pre-test counseling session (per their request), along with Margaret, and openly shared their hopes and concerns regarding testing. They received their results individually, and all reported that they shared their results, regardless of the outcome, with their children. Some of those children later opted for testing. Margaret's daughters also opted for group counseling, and all received testing. Margaret and her siblings were interested in having the clinical research team assist them in contacting more distant relatives, such as great aunts and uncles and cousins, to invite

1998]

## DISCLOSURE IN GENETIC TESTING

217

them to participate in a free genetic counseling clinical research program. Some of these individuals did participate and were aware of Margaret's experiences, and looked to her for information and support, as did the rest of the family. During follow-up calls, family members often shared their feelings about how relatives were coping with the information. Although subjective, this information allowed the counselor to gain insight into the type of added support or information that could be offered. Margaret's involvement was instrumental in helping the family benefit from genetic counseling, regardless of whether or not they chose to get tested or what their result was if they did get testing.

*Analysis: In families that are close-knit, open, and have established lines of communication, the transmission of information about genetic test results may flow with relative ease. Individuals in these families often rely on each other for information, support, and advice about medical decision-making. Furthermore, the individual who initiates testing in such highly motivated families may be central in these activities. These important roles are often beyond the scope of what the counselor is able to provide. However, because there is concern that family members may feel somewhat pressured into getting genetic testing and making certain subsequent decisions, it is incumbent upon the counselor to ensure that individuals are aware of the full spectrum of benefits, limitations, and risks of testing before they decide whether to get tested. The counselor should also be available to help them assimilate and cope with the information.*

## VI. SUMMARY AND IMPLICATIONS

The quantitative and qualitative (case studies) data presented in this paper have implications, not only in the health care context, but also in the legal arena. The results of both a family-based and clinic-based approach to genetic counseling indicate that the vast majority of genetic counseling participants opted to disclose their test results to immediate adult family members. Consistent with previous research,<sup>39</sup> most of these individuals elected to share the information themselves, rather than have the information disclosed by counselors or other health care providers. Complex psychological and medical issues influenced the decision to disclose, as well as the timing and mode of disclosure. Clinicians and researchers should be sensitive also to cultural influences involved in decisions about family disclosure.

---

39. See Sorensen et al., *supra* note 22, at 421.

Thus, the ability to control the process of disclosure is of great importance to genetic counseling participants. This raises a variety of concerns about the disclosure of genetic information by other sources, such as healthcare providers, insurance companies, or government institutions. From a legal standpoint, the obligations and authority of other sources in disclosure of genetic information is far from clear. For example, two recent legal cases have rendered differing opinions about a physician's responsibility to inform relatives about their risk of developing a genetic disease. The first of these, *Pate v. Threlkel*,<sup>40</sup> concluded that the physician had a duty to warn the patient about the genetic nature of the disease and that the patient could then be expected to warn their family members.<sup>41</sup> It was also stated that disclosure laws would prohibit the physician from warning other family members.<sup>42</sup> The second case, *Safer v. Pack*,<sup>43</sup> reached a differing conclusion. In this case, it was decided that the physician did have a duty to inform the family of their risk of developing a genetic disease.<sup>44</sup> The second case is obviously at odds with both the physician's duty to protect patient confidentiality and with the explicit desires of patients to control the diffusion of their personal genetic information. While this apparent conflict is far from settled, a recent analysis suggests that health care providers have a responsibility to at least inform patients about the implications of their test results to relatives and to encourage (but not advise) patients to share this information.<sup>45</sup> In addition, the American Society of Human Genetics recently published a statement maintaining that "genetic information should be considered as medical information" and further outlining the "exceptional" circumstances under which a health care provider should have a discretionary right to disclose genetic information to at-risk family members.<sup>46</sup> It is not clear from this statement whether disclo-

40. 661 So.2d 278 (Fla. 1995).

41. *See id.* at 282.

42. *See id.*

43. 677 A.2d 1188 (N.J. Super. Ct. App. Div. 1996), *cert. denied*, 683 A.2d 1163 (N.J. 1996).

44. *See id.* at 1192.

45. *See* Benjamin S. Wilfond et al., *Cancer Genetic Susceptibility Testing: Ethical and Policy Implications for Future Research and Clinical Practice*, 10 J.L. MED. & ETHICS (forthcoming 1998).

46. *See* The American Society of Human Genetics Social Issues Subcommittee on Familial Disclosure, *ASHG Statement: Professional Disclosure of Familial Genetic Information* 62 AM. J. HUM. GENETICS 474, 474 (1998) (discussing that a provider may be permitted to disclose genetic information "where attempts to encourage disclosure on the part of the patient have failed; where the harm is highly likely to occur and is serious and foreseeable; where the at-risk relative(s) is identifiable; and where either the disease is preventable/treatable or medically accepted standards indicate that early monitoring will reduce the genetic risk"

1998]

## DISCLOSURE IN GENETIC TESTING

219

sure of BRCA1/2 test results would fall under this purview.<sup>47</sup> However, even with these considerations, the possibility that government institutions or insurance companies could order and disclose such information poses even greater threats to patient confidentiality and well-being.

The data presented herein also show that females are significantly more likely to disclose genetic information to their relatives, especially when test results are positive and when the relatives are minor children. A particular concern is that such patterns of disclosure may place females at greater risk in the context of family law disputes.<sup>48</sup> For example, it is conceivable that information about a positive mutation status and elevated cancer risk could be used against female mutation carriers in custody disputes or adoption proceedings.<sup>49</sup> This possibility underscores the importance of informing counseling participants about a myriad of potential risks associated with family disclosure beyond the medical and psychosocial risks that are typically addressed.

Although preliminary, other findings from our research suggest that both disclosure and nondisclosure of positive test results to relatives may result in increased psychological distress for the discloser, and possibly for the relatives with whom this information is shared, although data on the latter are not available. Thus, in addition to informing and counseling patients about the medical and legal risks noted above, providers may have an obligation to review the potentially adverse psychological effects of family disclosure. It is arguable that such information should be considered an essential component of the informed consent process which takes place prior to the provision of a blood sample for genetic testing and which is reinforced when results are disclosed.

In the coming years, as genes for several common multiple adult-onset conditions are identified, many more individuals will have the opportunity to learn what their future may hold, and will then have to address the inevitable familial implications of this knowledge. Given the complexities of the medical decision making and psychological adjustment associated with genetic testing, it is hoped that an under-

---

or where "[t]he harm that may result from failure to disclose should outweigh the harm that may result from disclosure").

47. See *id.* at 474-83.

48. Telephone Interview with Karen H. Rothenberg, Marjorie Cook Professor of Law and Director, Law and Health Care Program, University of Maryland School of Law (January 7, 1998).

49. *Id.*



118DKA400:(DATA.M.M.H.I-8)MLR02.7301 NEIGHZSD Seq: 20 15-JUL-98 R:47

220 JOURNAL OF HEALTH CARE LAW & POLICY [VOL. 1:201

standing of the unique determinants and consequences of disclosure to family members can help clinicians provide better counseling to these individuals and will encourage legislators to enact and enforce protections for patient autonomy and confidentiality. This strategy will help ensure that individuals who decide to pursue genetic testing, even in the context of its uncertainties, can obtain maximum benefit while the potential for harm is minimized.

# BRCA1 Sequence Analysis in Women at High Risk for Susceptibility Mutations

## Risk Factor Analysis and Implications for Genetic Testing

Donna Shattuck-Eidens, PhD; Arnold Oliphant, PhD; Melody McClure; Celeste McBride; Jamila Gupte, MPhil; Todd Rubano, ME; Dmitry Pruss, PhD; Sean V. Tavtigian, PhD; David H.-F. Teng, PhD; Nils Adey, PhD; Mark Staebell, MS; Kathryn Gumpfer; Ron Lundstrom, PhD; Mark Hulick; Mark Kelly; John Holmen, PhD; Beth Lingenfelter, MS; Susan Manley, MS; Frank Fujimura, PhD; Michael Luce, PhD; Brian Ward, PhD; Lisa Cannon-Albright, PhD; Linda Steele; Kenneth Offit, MD; Teresa Gilewski, MD; Larry Norton, MD; Karen Brown, MS; Charlene Schulz, MS; Heather Hampel, MS; Alice Schluger, MS; Elena Giulotto, PhD; Wainer Zoli, PhD; Alberto Ravaioli, MD; Heli Nevanlinna, PhD; Seppo Pyrhonen, MD, PhD; Peter Rowley, MD; Starlene Loader; Michael P. Osborne, MD; Mary Daly, MD; Isidore Tepler, MD; Paul L. Weinstein, MD; Jennifer L. Scalia, MS; Richard Michaelson, MD; Rodney J. Scott, PhD; Paolo Radice, PhD; Marco A. Pierotti, PhD; Judy E. Garber, MD; Claudine Isaacs, MD; Beth Peshkin, MS; Marc E. Lippman, MD; Michael H. Dosik, MD; Maria A. Caligo, MD; Robert M. Greenstein, MD; Robert Pilarski; Barbara Weber, MD; Renate Burgemeister, MD; Thomas S. Frank, MD; Mark H. Skolnick, PhD; Alun Thomas, PhD

**Context.**—A mutation in the *BRCA1* gene may confer substantial risk for breast and/or ovarian cancer. However, knowledge regarding all possible mutations and the relationship between risk factors and mutations is incomplete.

**Objectives.**—To identify *BRCA1* mutations and to determine factors that best predict presence of a deleterious *BRCA1* mutation in patients with breast and/or ovarian cancer.

**Design.**—A complete sequence analysis of the *BRCA1* coding sequence and flanking intronic regions was performed in 798 women in a collaborative effort involving institutions from the United States, Italy, Germany, Finland, and Switzerland.

**Participants.**—Institutions selected 798 persons representing families (1 person for each family) thought to be at elevated a priori risk of *BRCA1* mutation due to potential risk factors, such as multiple cases of breast cancer, early age of breast cancer diagnosis, and cases of ovarian cancer. No participant was from a family in which genetic markers showed linkage to the *BRCA1* locus.

**Major Outcome Measures.**—Sequence variants detected in this sample are presented along with analyses designed to determine predictive characteristics of those testing positive for *BRCA1* mutations.

**Results.**—In 102 women (12.8%), clearly deleterious mutations were detected. Fifty new genetic alterations were found including 24 deleterious mutations, 24 variants of unknown significance, and 2 rare polymorphisms. In a subset of 71 Ashkenazi Jewish women, only 2 distinct deleterious mutations were found: 185delAG in 17 cases and 5382insC in 7 cases. A bias in prior reports for mutations in exon 11 was revealed. Characteristics of a patient's specific diagnosis (unilateral or bilateral breast cancer, with or without ovarian cancer), early age at diagnosis, Ashkenazi Jewish ethnicity, and family history of cancer were positively associated with the probability of her carrying a deleterious *BRCA1* mutation.

**Conclusions.**—Using logistic regression analysis, we provide a method for evaluating the probability of a woman's carrying a deleterious *BRCA1* mutation for a wide range of cases, which can be an important tool for clinicians as they incorporate genetic susceptibility testing into their medical practice.

IN THE United States, a woman's lifetime risk of breast cancer is 10% by the age of 70 years<sup>1</sup> with more than 180 000 new cases of invasive breast cancer being diagnosed and more than 43 000 women dying from this disease annually.<sup>1</sup> Breast cancer etiology is multifactorial, involving environmental factors, hormones, genetic susceptibility, and genetic changes during progression. The role of genetic susceptibility in breast cancer has been intensely investigated; 5% to 10% of female breast cancer is due to inheritance of an altered, or mutated, copy of 1 of 2 genes known as *BRCA1* and *BRCA2*.<sup>2</sup>

---

For editorial comment see p 1284.

---

Women who inherit a mutated copy of either gene have an elevated lifetime risk of breast cancer, up to 87% by the age of 70 years<sup>3</sup> vs a population risk of 10%. These inherited mutations put women at greater risk for premenopausal breast cancer, with a 59% chance of breast cancer before the age of 50 years, often before the age of 40 years.<sup>3</sup> *BRCA1* is associated with a 44% risk of ovarian cancer by the age of 70 years.<sup>3</sup> Some

---

A complete list of authors' affiliations and financial disclosures appears at the end of this article.  
Reprints: Alun Thomas, PhD, Myriad Genetics, Inc, 390 Wakara Way, Salt Lake City, UT 84108.

JAMA. 1997;278:1242-1250

*BRCA1* and *BRCA2* mutations may confer lower risks for both cancers.<sup>4</sup> Inherited alterations in *BRCA2* are associated with increased risk of ovarian carcinoma, although less than that with alterations in *BRCA1*. About 10% of ovarian cancers are attributable to inherited mutations in cancer susceptibility genes,<sup>2</sup> mainly *BRCA1* and *BRCA2*.

A mutated copy of either gene may be inherited from the father or mother. Men may not only be carriers, but may be at risk for cancer. In families segregating mutant alleles of *BRCA2*, male breast cancer occurs at about 11% of the frequency of female breast cancer.<sup>5,6</sup> If age-specific incidence for males is similar to that for females, this translates to a risk of about 9% by the age of 70 years. *BRCA1* carriers may be at increased colon cancer risk and male carriers have increased prostate cancer risk,<sup>4</sup> although total lifetime cancer risk for men is far less than that for women with these mutations. Some ethnic groups are at high risk<sup>7</sup>; it is estimated that more than 2% of the 3 million US Jewish women of Ashkenazi descent carry specific deleterious *BRCA1* or *BRCA2* mutations.<sup>8,9</sup>

In collaboration with institutions in the United States, Italy, Germany, Finland, and Switzerland, Myriad Genetic Laboratories, Inc, has analyzed *BRCA1* coding sequence and flanking intronic regions in 798 women. Data on age at cancer diagnosis, ethnicity, and cancer history of first- and second-degree relatives were provided by each institution. Results of genetic testing are presented along with analyses designed to determine predictive characteristics of those testing positive for deleterious *BRCA1* mutations.

## METHODS

### Sample Ascertainment

A sample of 798 unrelated individuals from 20 institutions was selected from families thought to be at elevated a priori risk of *BRCA1* mutations. Most families were identified by the institution because of multiple cases of breast cancer, early age of breast cancer diagnosis, and cases of ovarian cancer, conditions known to be associated with germline *BRCA1* mutations. Some families extended to second-degree relatives. Blood samples from US institutions were collected from subjects in research studies on breast cancer genetics. Each person read and signed informed consent documents approved by the local institutional review board. All samples from other institutions were collected according to guidelines concerning research imposed by equivalent authorities. The study sample was limited to 1 person representing the family, and

no families known to be linked by genetic markers to *BRCA1* were included. As 2 common deleterious *BRCA1* mutations, 185delAG and 5382insC, are reported as more common in Ashkenazi populations,<sup>8</sup> Ashkenazi descent status was established when possible.

This heterogeneous sample represents the diversity in patients who present at high-risk clinics vs a controlled sampling done for family or population studies. Thus, we selected methods of analysis that do not require subgroup sample frequencies to reflect population frequencies. We can assess, for example, the probability that a woman with breast and ovarian cancer diagnosed at the age of 55 years has a deleterious *BRCA1* mutation but cannot estimate the frequency of such women in the general population.

### *BRCA1* Sequence Analysis

Thirty-five amplicons have been developed for *BRCA1* sequencing. *BRCA1* exon 11 is covered by 13 overlapping amplicons; remaining amplicons are 1 exon each. One additional polymerase chain reaction (PCR) is completed as a control for PCR product contamination. PCR amplification and dye-primer sequencing of both strands were done as previously described.<sup>10</sup> PCR primers for amplicons were designed to be amplified under the same conditions and were positioned so bases around splice sites for an exon could be sequenced to detect splice site mutations. All primers in introns were chosen to avoid common ALU or other repeats and always result in specific products. Primers were carefully placed so as not to cover common polymorphisms that might interfere with equal amplification of the 2 chromosomes.

To understand common polymorphisms in primer regions, we sequenced regions under our primers in 32 individuals. Samples from 8 persons each of self-reported northern European, Hispanic, Asian, and African-American descent were sequenced in intronic regions adjacent to each exon and in regions where primers were placed in the large exon (11) of the gene. The importance of this was evidenced by a *BRCA1* polymorphism, TTTGTAT(C/T)ATTCTAA, common in the Ashkenazi Jewish group in the intron preceding exon 2. It is in linkage disequilibrium with 185delAG and interfered with a primer used in PCR amplification in early stages of test development. Subsequently, no primers were used that covered an observed polymorphism.

Other factors must be considered regarding primer positioning. Genomic duplication of the promoter region and exon 2<sup>11,12</sup> requires primers that will selectively amplify *BRCA1* and not the duplicated region. Both forward and re-

verse exon 2 primers cover sequences that have 2 differences between the duplicated region and *BRCA1* introns and selectively amplify the *BRCA1* exon. In the intron preceding the 44 bases of *BRCA1* exon 9, there is a size polymorphism caused by deletion or insertion of a base in a mononucleotide T-repeat located 57 bases upstream of the exon. Sequencing from this direction in those heterozygous for this polymorphism yields an indecipherable combination of sequences of both chromosomes. Moving the primer beyond this polymorphism would place it too close to the exon to accurately determine the sequence of splice sites and the entire exon. Fortunately, the sequence is always readable from the reverse strand. The sequence of *BRCA1* exon 4 is only readable from the reverse strand because a region of poly(A) in the intron immediately preceding the exon on the forward strand causes stuttering during PCR.

Sensitivity of the sequence analysis was at least 98% in validation studies using blinded analysis of known positive controls, but sequence analysis of the *BRCA1* coding regions cannot detect deletion of complete exons or genes, or errors in RNA transcript processing unrelated to DNA exon sequence. The proportion of clinically important *BRCA1* and *BRCA2* defects attributable to such abnormalities is unknown but estimated to be between 5% and 15%.<sup>13</sup>

### Modeling of Risk Factors

We examined the relationship between information available on probands and their families and the presence of a deleterious *BRCA1* mutation by means of logistic regression. This method models the logarithm of the odds of carrying a deleterious *BRCA1* mutation as a linear function of covariates. If  $p$  is the probability of carrying a deleterious *BRCA1* mutation, then we fit  $\log(p/1-p) = \alpha + \beta_1 F_1 + \beta_2 F_2 + \dots + \beta_k F_k$ , where  $F_1, \dots, F_k$  are the factors being considered.

We considered the following factors as those most likely to be available to a physician assessing patient risk of carrying a mutation:

- Patient disease status, using 5 classifications: unilateral breast cancer, no ovarian cancer; bilateral breast cancer, no ovarian cancer; unilateral breast cancer with ovarian cancer; bilateral breast cancer with ovarian cancer; and ovarian cancer, no breast cancer. We restricted analysis to probands in one of these categories; we did not include the 11 unaffected probands (see "Results") in the data used for model fitting due to the small number and because they are not a random unaffected population subset.

Table 1.—Deleterious *BRCA1* Mutations\*

Mutation Name	Exon	Position In cDNA†	Base Change If Substitution	in BIC as of 12/31/96‡	No. Detected	No. With Haplotypes§		
						1-1	1-2	2-2
187delAG	2	187	...	Yes	27	2	17	6
IVS4-1G→T	...	...	G→T	No	1	1	0	0
Q60X	5	297	C→T	No	1	0	0	0
C61G	5	300	T→G	Yes	2	2	0	0
C64Y	5	310	G→A	Yes	1	0	1	0
IVS5+1G→T	...	...	G→T	No	1	0	1	0
IVS5-11T→G	...	...	T→G	Yes	1	0	1	0
IVS6-2delA	...	...	...	No	1	1	0	0
E143X	7	546	G→T	No	1	0	1	0
IVS8+2T→A	...	...	T→A	No	1	0	1	0
795delT	11	795	...	No	1	1	0	0
917delTT	11	917	...	Yes	3	2	1	0
W321X	11	1081	G→A	No	1	0	1	0
1240delC	11	1240	...	Yes	1	1	0	0
W372X	11	1235	G→A	No	1	1	0	0
1294del40	11	1294	...	Yes	1	1	0	0
K467X	11	1518	A→T	No	2	0	1	1
1675delA	11	1675	...	Yes	1	0	1	0
Q563X	11	1806	C→T	Yes	2	0	1	1
1942del4	11	1942	...	Yes	1	0	1	0
2080delA	11	2080	...	Yes	1	0	0	1
K679X	11	2154	A→T	No	2	1	1	0
2594delC	11	2594	...	Yes	1	1	0	0
2804delAA	11	2804	...	Yes	1	1	0	0
2925del4	11	2925	...	Yes	1	0	1	0
2954insT	11	2954	...	No	1	0	1	0
E1060X	11	3297	G→T	No	1	0	1	0
3600del11	11	3600	...	Yes	1	0	0	1
3604delA	11	3604	...	Yes	1	0	1	0
3731delA	11	3731	...	Yes	1	1	0	0
E1250X	11	3867	G→T	Yes	1	0	0	0
3875del4	11	3875	...	Yes	1	1	0	0
4154delA	11	4154	...	Yes	1	1	0	0
4184del4	11	4184	...	Yes	4	3	1	0
IVS11-2A→G	...	...	A→G	No	1	0	0	1
Q1395X	12	4302	C→T	No	1	1	0	0
Q1408X	13	4341	C→T	No	1	0	0	1
R1443X	13	4446	C→T	Yes	3	2	1	0
IVS14-2A→G	...	...	A→G	No	1	0	1	0
Y1563X	16	4808	C→G	Yes	1	1	0	0
5085del19	16	5085	...	No	2	2	0	0
E1694X	18	5199	G→T	No	1	0	1	0
W1718X	19	5273	G→A	No	1	0	0	0
5296del4	19	5296	...	No	1	0	1	0
R1751X	20	5370	C→T	No	1	0	1	0
5385insC	20	5385	...	Yes	17	14	3	0
IVS20-1G→A	...	...	G→A	No	1	1	0	0
R1835X	24	5622	C→T	Yes	1	1	0	0

\*In this and following tables, all mutations and genetic variants are named according to convention.<sup>14</sup> Missense: wild-type amino acid-codon number-mutated amino acid. Nonsense: wild-type amino acid-codon number-X indicating a stop codon. Insertions in coding region: nucleotide number of last base before insertion-ins-nucleotides inserted; if more than 2, only number of nucleotides is noted. Deletions in coding region: nucleotide number of first deleted nucleotide-del-nucleotides deleted; if more than 2, only number of nucleotides is noted. Mutations in noncoding regions or introns: IVS-intron number, same as preceding exon, then location of mutation relative to nearest exon (+ if downstream of exon, - if upstream of exon), then the description, ins or del as above, or nucleotide substitution. Ellipses indicate data not applicable.

†Nucleotide numbering starts at the first transcribed base according to GenBank entry U14680.

‡The Breast Cancer Information Core Database (BIC) can be reached on the internet at [www.nhgri.nih.gov/intramural\\_research/Lab\\_transfer/Bic](http://www.nhgri.nih.gov/intramural_research/Lab_transfer/Bic).

§Haplotype assignment as described in Table 4.

||Two mutations, 187delAG and 5385insC, are commonly referred to as 185delAG and 5382insC in other publications. They are referred to in the text by their commonly used names but are named according to the convention in this table.

However, some had novel *BRCA1* mutations that were reported.

- Patient age at first diagnosis of breast or ovarian cancer.

- Patient ethnicity with respect to Ashkenazi descent.

- Number of relatives affected with breast cancer, but not ovarian cancer.

- Number of relatives affected with ovarian cancer, but not breast cancer.

- Number of relatives affected with both breast and ovarian cancer. No distinction was made between first-degree relatives and other degrees of relatedness.

We had complete information on the above factors for 621 persons, ranging in age from 18 to 78 years. Of these, 81 had deleterious *BRCA1* mutations, 512 did not, and 28 had mutations of uncertain significance. The 593 clearly classified individuals were used for logistic regression analysis.

We fitted factors sequentially, adding the factor that most reduced the scaled deviance at each step. Overall mean and main effects were fitted first, then all pairwise interactions other than those between mutually exclusive disease status categories. Factors were fitted until reduction in scaled deviance was insignificant at the 5% level. We then removed factors that were not discernible from zero with a 5% test of hypothesis, leaving a model containing all main effects and an interaction term for a proband diagnosis of unilateral breast cancer with ovarian cancer, with a family history of ovarian cancer. This term was a negative factor, reducing risk when both main effects were present; however, because there were few probands with more than 1 relative with ovarian cancer in our data set, this was an overcorrection and was removed from the model. This analysis was performed using the GLIM function of the S-plus statistical package (Math Soft, Data Analysis Products Division, Seattle, Wash).

## RESULTS

Of the 798 study subjects, 554 had unilateral breast cancer, 84 had bilateral breast cancer, 30 had unilateral breast cancer and had ovarian cancer, 11 had bilateral breast cancer and had ovarian cancer, 40 had ovarian cancer and no breast cancer, and 11 did not have cancer but represented families with breast-ovarian cancer history (no affected person from these families was available for testing). There was incomplete information on cancer diagnosis for the remaining 68.

### Sequence Variants Detected

Deleterious mutations were detected in 102 women (12.8%); 50 new genetic alterations were found comprising 24 deleterious mutations, 24 variants of uncertain significance, and 2 rare polymorphisms. In the 71 Ashkenazi Jewish women in this sample, only 2 distinct deleterious mutations were identified: 185delAG in 17 cases and 5382insC in 7 cases. Tables 1 through 3 list the mutations and neutral polymorphisms and pro-

vide number of occurrences, mutation location, and whether the mutation had been reported prior to this study.

### Haplotypes

Association of alleles at neighboring loci, known as a haplotype, can allow understanding of the evolutionary development of variants. We have defined common haplotypes seen in the probands using 12 polymorphic sites; exon 4 C→T at 49, IVS8-57insT, Q653N, D693N, S694S, L771L, P871L, E1038G, S1040N, K1183R, S1436S, and S1613G. Haplotypes of the 12 loci seen in this sample are shown in Table 4. These were not used as a prognostic variable because they are not readily available for patient evaluation purposes. The first and most common haplotype, seen in 58% of the samples, is the consensus sequence at these 12 sites; the second most common, 25%, is a combination of variants at 8 of the sites. Haplotype 3 is related to haplotypes 1 and 2 by a recombination event between exons 11 and 13. Haplotypes 4 through 10 occur at low frequency and would require more than 1 recombination event to be related to the 2 common haplotypes.

These data suggest that haplotypes 1 and 2 represent common chromosomes on which mutations and other variations occur. Considering only homozygous individuals, all but one of the deleterious variants occur either in those homozygous for haplotype 1 or haplotype 2, but not in both. The exception was 185delAG, which was present in individuals homozygous for both of the most frequent haplotypes. In Ashkenazi subjects, 185delAG was confined to haplotype 2. However, 2 of the 5 non-Ashkenazi subjects with 185delAG were haplotype 1 homozygotes; none were haplotype 2 homozygotes. This mutation has either emerged independently in the non-Ashkenazi population<sup>15</sup> or recombination has occurred between the mutation site in exon 2 and the polymorphic markers used for haplotype analysis that occur in exons 8 to 16. To distinguish between these 2 possible scenarios, we analyzed an additional polymorphic marker, a T-to-C substitution 117 bases upstream of the exon 2 boundary. This substitution was found in all haplotype 2 chromosomes and no haplotype 1 chromosomes, and was absent from both haplotype 1 carriers of 185delAG, ruling out a simple recombination event as a possible explanation. We conclude that the 185delAG deletion has either occurred at least twice in human evolutionary history, on haplotype 2 in an Ashkenazi ancestral group and on haplotype 1 in a Caucasian ancestral group, or it has been transferred from one haplotype to the other by gene conversion.

Table 2.—Rare *BRCA1* Polymorphisms\*

Mutation Name	Exon	Position in cDNA†	Base Change if Substitution	In BIC as of 12/31/96‡	No. Detected	No. With Haplotypes§		
						1-1	1-2	2-2
K38K	3	233	G→A	Yes	1	1	0	0
T327T	11	1100	A→G	Yes	2	0	0	0
A622A	11	1985	G→A	Yes	1	1	0	0
R841W	11	2640	C→T	Yes	1	1	0	0
G911G	11	2852	A→G	Yes	2	0	0	0
P938P	11	2933	A→G	Yes	1	0	0	0
P1238L	11	3832	C→T	No	1	0	0	1
R1443G	13	4446	C→G	Yes	1	1	0	0
S1512I	15	4654	G→T	Yes	6	2	3	0
Q1604Q	16	4931	A→G	Yes	1	1	0	0
M1652I	16	5075	G→A	Yes	20	0	13	6
IVS8-17G→T	...	...	G→T	No	1	0	1	0
IVS12+31delGT	...	...	delGT	Yes	1	0	1	0

\*Rare is defined as frequency of prevalence <1.5%. Mutations and variants are named according to convention<sup>14</sup> (see first footnote to Table 1). Ellipses indicate data not applicable.

†Nucleotide numbering starts at the first transcribed base according to GenBank entry U14680.

‡The Breast Cancer Information Core Database (BIC) can be reached on the internet at [www.nhgri.nih.gov/Intramural\\_research/Lab\\_transfer/Bic](http://www.nhgri.nih.gov/Intramural_research/Lab_transfer/Bic).

§Haplotype assignment as described in Table 4.

Table 3.—*BRCA1* Variants of Uncertain Significance\*

Mutation Name	Exon	Position in cDNA†	Base Change if Substitution	In BIC as of 12/31/96‡	No. Detected	No. With Haplotypes§		
						1-1	1-2	2-2
L87V	6	378	T→G	No	1	0	0	0
Y179C	8	655	A→G	No	2	0	1	0
V191I	9	690	G→A	No	1	0	0	1
L204F	10	731	G→C	No	1	0	1	0
V271L	11	930	G→C	No	1	1	0	0
F486L	11	1575	T→C	No	2	0	1	0
R504H	11	1630	G→A	No	1	0	1	0
N550H	11	1767	A→C	No	2	0	1	0
L668F	11	2121	C→T	No	1	1	0	0
P727L	11	2299	C→T	No	1	0	1	0
K820E	11	2577	A→G	Yes	2	0	0	0
R866C	11	2715	C→T	No	1	0	1	0
M1008I	11	3143	G→A	No	1	0	0	0
R1028H	11	3202	G→A	No	1	1	0	0
A1142P	11	3543	G→C	No	1	1	0	0
T1196K	11	3706	C→A	No	1	1	0	0
R1347G	11	4158	A→G	Yes	7	4	3	0
H1421Y	13	4380	C→T	No	1	0	1	0
R1495M	14	4603	G→T	No	2	0	2	0
V1534M	15	4719	G→A	No	1	1	0	0
M1628T	16	5002	T→C	Yes	1	1	0	0
V1653M	16	5076	G→A	No	1	0	1	0
IVS18+6T→G	...	...	T→G	No	1	1	0	0
G1738E	20	5332	G→A	No	1	0	0	0
D1739G	20	5335	A→G	No	1	0	0	0
V1804D	23	5530	T→A	No	1	0	1	0
P1806A	23	5535	C→A	No	1	0	1	0

\*Mutations and variants are named according to convention<sup>14</sup> (see first footnote to Table 1). Ellipses indicate data not applicable.

†Nucleotide numbering starts at the first transcribed base according to GenBank entry U14680.

‡The Breast Cancer Information Core Database (BIC) can be reached on the internet at [www.nhgri.nih.gov/Intramural\\_research/Lab\\_transfer/Bic](http://www.nhgri.nih.gov/Intramural_research/Lab_transfer/Bic).

§Haplotype assignment as described in Table 4.

Although frequencies of the 2 major haplotypes do not vary markedly between the 2 ethnic groups most represented in our study, frequencies of the minor haplotypes suggest that this is probably not the case for other ethnic groups. The less frequent haplotypes, along with mutations found on their

backgrounds, are expected to originate from a variety of ancestral populations.

### Classification by Family Cancer History

Table 5 provides the incidence of deleterious *BRCA1* mutations by cancer

Table 4.—Common *BRCA1* Polymorphisms Defining Haplotypes\*

Polymorphism	Exon	Position In cDNA†	Haplotype									
			1	2	3	4	5	6	7	8	9	10
Exon 4 C→T	4	49‡	C	C	C	C	C	C	T	C	C	C
IVS8-57insT	IVS8	-57§	...	T	...	...	...	T	T	...	...	...
Q653N	11	1186	A	A	A	G	A	A	A	A	A	A
D693N	11	2196	G	G	G	G	G	A	A	G	G	G
S694S	11	2201	C	T	C	C	C	T	T	C	T	C
L771L	11	2430	T	C	T	T	T	C	C	T	T	T
P871L	11	2731	C	T	C	C	C	T	T	T	T	C
E1038G	11	3233	A	G	A	A	A	G	G	A	A	G
S1040N	11	3238	G	G	G	G	A	G	G	G	G	G
K1183R	11	3667	A	G	A	A	A	G	G	A	G	A
S1436S	13	4427	T	C	C	T	T	C	C	T	T	C
S1613G	16	4956	A	G	G	A	A	G	G	A	G	G
Occurrences in 1590 chromosomes			929	400	1	95	28	74	35	20	4	4

\*The 12 polymorphisms define 10 haplotypes. Mutations and variants are named according to convention\*\* (see first footnote to Table 1). Ellipses indicate data not applicable.

†Nucleotide numbering starts at the first transcribed base according to GenBank entry U14680.

‡Nucleotide position in exon 4, not part of cDNA in U14680.

§Relative to exon 9 junction.

Table 5.—Percentages of Deleterious *BRCA1* Mutations in Families of Breast-Ovarian Cancer Probands by Ethnicity, Mean Age of Cancer Diagnosis in Family, and Number of Subjects With Breast-Ovarian Cancer\*

No. of Cancer Cases in Family Including Proband		Mean Age (y) of Cancer Diagnosis in Family			
Breast	Ovarian	≤40, % (No.)	41-50, % (No.)	≥51, % (No.)	Total, % (No.)
<b>Ashkenazi</b>					
0	1	0 (0/1)	100 (1/1)	0 (0/0)	25 (1/4)
0	≥2	0 (0/0)	0 (0/0)	0 (0/0)	0 (0/0)
1	0	33 (1/3)	25 (1/4)	0 (0/0)	29 (2/7)
1	1	0 (0/1)	75 (3/4)	100 (1/1)	67 (4/6)
1	≥2	0 (0/0)	0 (0/1)	50 (1/2)	33 (1/3)
≥2	0	0 (0/3)	8 (1/12)	13 (2/15)	10 (3/30)
≥2	1	100 (3/3)	75 (6/8)	60 (3/5)	75 (12/16)
≥2	≥2	0 (0/0)	0 (0/0)	100 (1/1)	100 (1/1)
Total		36 (4/11)	40 (12/30)	33 (8/24)	36 (24/67)
<b>Non-Ashkenazi</b>					
0	1	0 (0/1)	0 (0/0)	0 (0/0)	0 (0/5)
0	≥2	0 (0/0)	40 (2/5)	0 (0/4)	30 (3/10)
1	0	6 (6/109)	9 (3/33)	5 (1/22)	6 (10/168)
1	1	0 (0/7)	18 (2/11)	7 (1/14)	9 (3/32)
1	≥2	100 (1/1)	40 (2/5)	25 (1/4)	40 (4/10)
≥2	0	18 (6/34)	8 (9/107)	2 (2/121)	7 (18/263)
≥2	1	63 (5/8)	35 (8/23)	18 (3/17)	33 (16/48)
≥2	≥2	100 (1/1)	75 (6/8)	29 (2/7)	56 (9/16)
Total		12 (19/161)	17 (32/192)	5 (10/189)	11 (63/552)

\*A person with both breast and ovarian cancer contributes 1 to the count of each type of cancer in the family. Number of *BRCA1*-positive families divided by the number of families in the category is given in parentheses. The "Total" column includes families for whom age information is missing.

history of the family associated with a proband. These are classified by number of breast and ovarian cancer cases, mean age of diagnosis of these cancers in the family, and Ashkenazi descent status. For this table, a person with both breast and ovarian cancer contributes 1 to the count of each type of cancer in the family. We do not have complete information for all values for all probands (information on age was unavailable for 12 of 619 cases regarding mean age of diagnosis in the family). Records with incomplete data have been omitted from analysis when appropriate.

### Assessment of Risk Factors

Table 6 summarizes results of the analysis described in "Methods." We estimate log odds, *L*, according to this equation:  $L = -0.080a + 1.41b + 0.0c + 1.29d + 2.08e + 3.39f + 1.68g + 0.31h + 1.06i + 1.68j$ , where *a* is age at diagnosis of breast and/or ovarian cancer; *b* is 1 if patient is of Ashkenazi descent, 0 otherwise; *c* is 1 if patient is diagnosed with unilateral breast cancer but not ovarian cancer, 0 otherwise (coefficient of *c* in the equation is 0 since this case is used as a baseline, and it is included for completeness); *d* is 1 if patient is diagnosed with

bilateral breast cancer but not ovarian cancer, 0 otherwise; *e* is 1 if patient is diagnosed with unilateral breast cancer and with ovarian cancer, 0 otherwise; *f* is 1 if patient is diagnosed with bilateral breast cancer and with ovarian cancer, 0 otherwise; *g* is 1 if patient is diagnosed with ovarian cancer, but not breast cancer, 0 otherwise; *h* is number of relatives with breast cancer, but not ovarian cancer; *i* is number of relatives with ovarian cancer, but not breast cancer; and *j* is number of relatives with breast and ovarian cancer. Note that all but one of *c* through *g* must be 0. The intercept term was not included because it was estimated to be 0.

Hence, we evaluate the probability of carrying a deleterious *BRCA1* mutation as  $p = \exp(L) / [1 + \exp(L)]$ . The probability of carrying a deleterious *BRCA1* mutation was calculated using the above logistic regression model. For example, a 30-year-old, non-Ashkenazi woman diagnosed with unilateral breast cancer but no ovarian cancer has an 8.3% probability of carrying a deleterious *BRCA1* mutation. By comparison, an Ashkenazi woman of the same age with the same diagnosis has a probability of 27%. For a 50-year-old woman diagnosed with unilateral breast cancer and with ovarian cancer, the probability is 37.6% or 12.8% depending on whether she is or is not of Ashkenazi descent.

The Figure gives the probability of carrying a deleterious *BRCA1* mutation for a range of factor values. We do not give risks for patients diagnosed before the age of 30 years because the otherwise log-linear trend between frequency and age of diagnosis ceases to be log-linear before the age of 30 years. Although in this study the 14 patients diagnosed with either breast or ovarian cancer younger than 27 years were not found to have deleterious *BRCA1* mutations, we have detected deleterious *BRCA1* mutations in breast cancer patients as young as 24 years (data not shown).

The data do not allow us to estimate the probability that a randomly selected woman from the general population with no diagnosis of breast or ovarian cancer carries a *BRCA1* mutation. However, risk can be estimated by risk assessment of a relative with breast and/or ovarian cancer and then adjusting for degree of relatedness between the two and the age and sex of the person being assessed.

### COMMENT

#### Using an Analysis of Genetic Susceptibility to Breast and Ovarian Cancer

Genetic susceptibility to breast and ovarian cancer has usually been deter-

mined solely on the basis of family history, which cannot distinguish clustering of breast tumors due to chance from inherited mutations in cancer susceptibility genes. Also, even offspring of someone with a *BRCA1* or *BRCA2* mutation has only a 1-in-2 chance of having the gene, so family history cannot identify with certainty which members are at risk. Reports have also described genetic susceptibility mutations in women without a strong family history.<sup>8,16</sup>

Identification of family members not at risk of hereditary breast and ovarian cancer is also of value. Relatives of cancer patients with *BRCA1* or *BRCA2* mutations are at risk for early-onset breast-ovarian cancer. Once a mutation is identified in a case using full sequence analysis, family members can be tested for only that mutation. People who test negative for this mutation-specific test do not carry the mutation and are at no increased risk by being related to carriers and have no risk of passing the mutation to their offspring. If there is no evidence for a breast-ovarian cancer gene inherited from the other side of the family, they can be considered to have breast-ovarian cancer risk equal to that of the general population.

Before identification of *BRCA1* and *BRCA2*, some professional organizations proposed restricting genetic susceptibility analysis to investigational use only,<sup>17</sup> concerned that full sequence analysis might be too technically challenging for clinical application. The American Society of Clinical Oncology (ASCO) recommended that genetic susceptibility testing be available for clinical use if appropriate guidelines are followed.<sup>18</sup> Such guidelines are designed to ensure that genetic susceptibility testing is offered only to appropriate patients and for purposes of guiding medical decisions.

#### Appropriate Use and Best Predictors of a Positive Test

The statement adopted by ASCO in 1996 recommended that cancer predisposition testing be offered only in the setting of a "strong family history of cancer or very early age of onset of disease"<sup>18</sup> and included examples of cases with high estimated probabilities (defined as >10%) of having a *BRCA1* mutation for whom testing was likely to be of clinical value. Our data indicate this threshold would be met by a woman with breast cancer before the age of 45 years and a relative with ovarian cancer, a woman with bilateral breast cancer before the age of 50 years and a relative with breast or ovarian cancer, a woman with ovarian cancer before the age of 50 years regardless of family history, and a

Table 6.—Results of Logistic Regression Model From Which Probabilities of Carrying a Deleterious *BRCA1* Mutation Are Derived\*

Factor	Coefficient	SE	P Value†	Reduction in Sum of Squares	P Value‡
Proband's age at diagnosis of breast and/or ovarian cancer	-0.080	0.007	<.001	360.6	<.001
No. of relatives with ovarian cancer but not breast cancer	1.058	0.262	<.001	26.0	<.001
Ashkenazi descent	1.410	0.351	<.001	23.1	<.001
No. of relatives with breast and ovarian cancer	1.676	0.460	<.001	16.1	<.001
Unilateral breast cancer with ovarian cancer	2.085	0.474	<.001	10.0	.002
Bilateral breast cancer with ovarian cancer	2.386	0.698	<.001	8.9	.003
Bilateral breast cancer but not ovarian cancer	1.297	0.377	<.001	10.5	.001
Ovarian cancer but not breast cancer	1.686	0.513	.001	7.9	.005
No. of relatives with breast cancer but not ovarian cancer	0.306	0.133	.02	5.1	.02

\*See Figure. Probabilities are derived according to equations provided in "Assessment of Risk Factors."

†For a test of the hypothesis that the coefficient is not zero.

‡For a test of the hypothesis that the reduction in sum of squares is statistically significant.

woman of Ashkenazi heritage with breast cancer before the age of 50 years. Thus, our data show that regarding the ASCO statement, a "strong family history" may include just 2 relatives in addition to the proband, and criteria of an "early age of onset" may be met by breast or ovarian cancer before the age of 50 years. Paradoxically, the earliest age of breast cancer onset (before age 27 years) appears to be relatively less likely to be associated with *BRCA1* mutations than between the ages of 30 and 50 years. Of course, the probability of a positive test is only one of the factors that determine whether testing is of clinical utility. Others cited by ASCO include physician ability to correctly interpret test results and influence of results on medical management.

Proband age, ethnicity, diagnosis, and family history are all significant factors in determining her risk of a deleterious *BRCA1* mutation. Odds of carrying a deleterious mutation decrease by 8% with each year added to the year of diagnosis. However, as reported,<sup>7</sup> this relationship breaks down when the age of diagnosis is younger than 30 years. Taking women diagnosed with unilateral breast cancer as baseline, odds increase by 3.7, 5.4, 8.0, and 10.9, respectively, for women diagnosed with bilateral breast, ovarian, unilateral breast with ovarian, and bilateral breast with ovarian cancers. An Ashkenazi woman's odds of a deleterious *BRCA1* mutation are more than 4.1-fold those for a non-Ashkenazi woman.

Odds increase by 5.3 for each relative with both breast and ovarian cancer, and by 2.9 for each relative with ovarian cancer only. The weakest odds factor is that of 1.4 for each relative with breast cancer, but not ovarian cancer. This factor is likely to be more important in a study that also tests for *BRCA2*; this analysis has selected those factors that not only

discriminate between familial and non-familial breast cancer, but are associated with *BRCA1* as opposed to *BRCA2* and other familial breast cancer genes. Diagnosis of bilateral breast cancer may be a stronger factor when *BRCA1* and *BRCA2* are deconfounded.

#### Predisposing Mutations

Frameshift and nonsense mutations present in *BRCA1*, including a frameshift that results in truncation of the last 11 amino acid residues, predispose to breast cancer. Thus, analysis of premature termination mutations in *BRCA1* is straightforward in all but the last 11 codons of the open reading frame. In the 798 women analyzed, 102 (12.8%) presented with clearly predisposing mutations. These 102 women had 1 of 48 different deleterious mutations presumed to cause predisposition to breast and/or ovarian cancer. Of these, 39 were truncating mutations, 2 were known predisposing missense mutations, and 7 changed conserved positions in consensus splice sites and are assumed to affect transcript splicing. Of the 48 mutations, 24 have not been previously reported, including 6 of 7 mutations assumed to affect transcript splicing. Of previously undetected mutations, 8 (33%) occur in exon 11 and 16 (67%) occur in other exons. Exon 11 is the largest exon in *BRCA1*, representing 61% of protein coding potential. Many groups have focused efforts on this exon because most of it is easily amplified from genomic DNA and is therefore accessible for mutation screening.<sup>19,20</sup> The remaining 39% of the *BRCA1* coding region is divided into 21 smaller exons which require considerably more effort to amplify and screen. It is likely that the reason 67% of new mutations were found in 39% of the gene is because there was more extensive coverage of exon 11 previously. In our study 50% of deleterious mutations identified are lo-



When a rare missense change does not segregate with affected family members, this is evidence the missense change is not deleterious. This method can be used to exclude a missense change from the deleterious mutation class, but many families do not have appropriate pedigree structure or sufficient samples for such an analysis. Segregation of a missense mutation to affected family members is not sufficient proof of causality. Such a change in a family has a 50% chance of occurring on the commonly inherited disease-associated chromosome.

When a genetic variant is seen at as high a frequency in the general population as in cancer patients, it can be regarded as nondeleterious. Many common nondeleterious *BRCA1* polymorphisms have been so classified, but with rare mutations sample sizes required to establish this argument can be prohibitively large. In our study, 21 variants of uncertain significance were seen only once in 798 subjects.

Analysis of the effect of a variant on *BRCA1* protein function is more problematic. The secondary structure of *BRCA1* is likely a series of independently folding globular domains.<sup>24,25</sup> While truncating mutations eliminate all domains occurring downstream in the normal protein structure, predisposing missense mutations are likely to affect the structure of a single domain. To date, 2 genes encoding proteins interacting with *BRCA1* are identified,<sup>26,27</sup> but the number will likely rise. Eventually, all protein-protein interacting domains will be mapped; it will then be possible to build individual missense polymorphisms into *BRCA1* expression constructs to test their effect on protein-protein interactions mapping to their vicinity. The subset of missense polymorphisms that alters protein-protein interactions is likely to be enriched for predisposing missense mutations.

Functional approaches will likely miss some predisposing missense mutations, and it is likely that some *BRCA1* protein-protein interactions or some protein activities that can be assayed are irrelevant to its role as a tumor suppressor. All *BRCA1* functional assays will likely have analogous drawbacks; thus, it seems unlikely that a globally informative analysis of rare missense polymorphisms of uncertain significance will be possible without a combined genetic and biochemical approach.

#### Limitations of This *BRCA1* Analysis

Techniques used to obtain these data have 3 limitations.

1. Only coding regions and intronic sequences adjacent to exons are se-

quenced. Mutations not in these regions may affect RNA transcription, splicing, or stability and thus affect protein levels or structure.<sup>28</sup> Data imply the presence of predisposing regulatory mutations in *BRCA1*,<sup>24</sup> inferred when the genotype is heterozygous at a position in a *BRCA1* exon, but apparently homozygous in the cDNA sequence at the same position. From our common polymorphism data, we estimate about 60% of people have at least 1 informative polymorphism in the expressed *BRCA1* sequence. Other tests could be developed to assay for this type of predisposing regulatory mutation if a deleterious mutation is not detected in the coding sequence or adjacent intronic sequences.

2. The technique is dependent on PCR amplification of both alleles. Deletions of primer sites or sequence variants in primer regions could cause differential amplification or failure to amplify an allele causing biased interpretation of sequencing data.<sup>28</sup> We have made a substantial effort to avoid common polymorphisms in our primer sequences (see "Methods").

3. Only 1 breast cancer susceptibility gene was analyzed herein. It is estimated *BRCA1* accounts for about 45% of familial breast cancer. Results of full *BRCA1* and *BRCA2* analyses on several hundred subjects will soon be available.

#### Clinical Impact of Analysis of Genetic Susceptibility to Breast and Ovarian Cancer

Several of the factors we identified that predict presence of a *BRCA1* deleterious mutation (early onset of breast cancer, Ashkenazi ancestry, family history of cancer) are similar to those cited by Couch et al.<sup>29</sup> We also found most tests had negative results despite family history of breast cancer, although we disagree with their statement that a negative test result in that context is "uninformative." A negative test result does reduce risk of hereditary breast and ovarian cancer in proportion to percentage of such cancer attributable to *BRCA1* mutations. It is important to determine which women without detectable *BRCA1* mutations have identifiable *BRCA2* mutations and to identify missense mutations that increase the risk of breast and ovarian cancer.

Use of this information to reduce the risk of breast and ovarian cancer remains an area of study. Myriad Genetics, Inc, in cooperation with Dana-Farber Cancer Institute, has established a confidential, voluntary, and independent patient registry of those with *BRCA1* and *BRCA2* test results. Such a registry, independently administered by the Dana-Farber Cancer Institute, is designed to

assess clinical significance of specific mutations and the outcome of medical or surgical interventions in subjects with results from complete *BRCA1* and *BRCA2* sequence analysis. These sequence results will be entered into a coded database without personal identifiers and correlated with follow-up information provided by participating physicians.

It is clear that the clinical availability of *BRCA1* and *BRCA2* sequence analysis has potential for beneficial impact on the care and counseling of women from high-risk families. It has generally not been possible for physicians to determine which individuals in a high-risk family are carriers of predisposing mutations; and individuals who may not have these mutations have undergone unnecessary interventions, including prophylactic surgery. Clinical availability of *BRCA1* and *BRCA2* sequence analysis for identification of mutation carriers makes it possible to identify predisposing mutations in affected persons and determine risks for family members. Strategies to reduce breast and ovarian cancer risk in carriers will also benefit from availability of sequencing of these genes.

From Myriad Genetics, Inc, Salt Lake City, Utah (Drs Shattuck-Eidens, Oliphant, Pruss, Tavtigian, Teng, Adey, Skolnick, and Thomas, and Mss McBride and Gupta and Mr Rubano); Myriad Genetic Laboratories, Inc, Salt Lake City, Utah (Mss McClure, Gumper, Lingenfelter, and Manley, Messrs Staebell, Hulick, and Kelly, and Drs Lundstrom, Holmen, Fujimura, Luce, Ward, and Frank); Department of Medical Informatics, University of Utah, Salt Lake City (Dr Cannon-Albright and Ms Steele); Memorial Sloan-Kettering Cancer Institute, New York, NY (Drs Offit, Gilewski, and Norton, and Mss Brown, Schulz, Hampel, and Schluger); Department of Genetics and Microbiology, University of Pavia, Pavia, Italy (Dr Giulotto); Department of Medical Oncology, Ospedale G. B. Morgagni-L. Pierantoni and Istituto Oncologico Romagnolo, Forlì, Italy (Dr Zoli); Department of Oncology, Ospedale Infermi di Rimini, Rimini, Italy (Dr Ravaioli); Departments of Obstetrics and Gynecology and Oncology, Helsinki University Central Hospital, Helsinki, Finland (Drs Nevanlinna and Pylhonen); University of Rochester, Rochester, NY (Dr Rowley and Ms Loader); Strang Cancer Prevention Center, New York, NY (Dr Osborne); Fox Chase Cancer Center, Philadelphia, Pa (Dr Daly); Bennett Cancer Center, Stamford, Conn (Drs Tepler and Weinstein and Ms Scalia); Cancer Center of Saint Barnabas, Livingston, NJ (Dr Michaelson); Department Forshung, Kantonsspital Basel, Basel, Switzerland (Dr Scott); Istituto Nazionale per lo Studio e la Cura dei Tumori, Milan, Italy (Drs Radice and Pierotti); Dana Farber Cancer Institute, Boston, Mass (Dr Garber); Lombardi Cancer Center, Georgetown University Medical Center, Washington, DC (Drs Isaacs and Lippman and Ms Peshkin); North Shore Hematology/Oncology Associates, PC, Setauket, NY (Dr Dosik); Istituto Anatomia Patologica, Pisa, Italy (Dr Caligo); Division of Human Genetics, University of Connecticut Health Sciences Center, Farmington (Dr Greenstein and Mr Pilarski); Department of Medicine, University of Pennsylvania, Philadelphia (Dr Weber); and Fraunhofer und medizinische Genetik, Munich, Germany (Dr Burgemeister). Dr Fujimura is now with the City of Hope Medical Center, Duarte, Calif.



Drs Shattuck-Eidens, Tavtigian, Lundstrom, Holmen, Skolnick, and Thomas, Mss McClure, Gupte, and Gumper, and Messrs Staebell, Hulick, and Kelly are employees of Myriad Genetics, Inc, or Myriad Genetic Laboratories, Inc, and own stock and have stock options in Myriad Genetics, Inc. Drs Oliphant, Pruss, Teng, Adey, Ward, and Frank, Mss McBride, Lingenfelter, and Manley, and Mr Rubano are employees of Myriad Genetics, Inc, or Myriad Genetic Laboratories, Inc, and have stock options in Myriad Genetics, Inc. Dr Skolnick is executive vice president of research and development and chief scientific officer and is on the board of directors of Myriad Genetics, Inc. Dr Oliphant is vice president of functional genomics at Myriad Genetics, Inc. Dr Holmen is vice president of informatics at Myriad Genetic Laboratories, Inc. Dr Ward is vice president of operations at Myriad Genetic

Laboratories, Inc, and has stock in Genzyme Corp and Genzyme Tissue Repair. Dr Frank is medical director and vice president of education at Myriad Genetic Laboratories, Inc. Dr Fujimura has stock in Quest Diagnostics. Dr Cannon-Albright has stock options for Myriad Genetics, Inc, has 4 research grants from the company, and is on its scientific advisory board. Dr Rowley has stock in Bristol-Myers, Chiron, Dupont, and Genentech and has a research grant from OncorMed. Dr Osborne has stock in IVAX Corp and consults for Schering-Plough and Hoffmann-La Roche. Dr Daly has an unrestricted educational grant from Genentech. Drs Tepler and Weinstein and Ms Scalia receive honoraria as members of the Myriad Speakers Bureau Faculty Program. Dr Weinstein has stock in Myriad Genetics, Inc, and Affymetrix. Dr Greenstein and Mr Pilarski receive honoraria as members of the

Myriad Speakers Bureau Faculty Program and receive funding from Genzyme Corp. Dr Weber is on the Myriad Genetic Laboratories, Inc, clinical advisory board and has stock options for the company.

This work was supported in part by the US Army grant DAMD17-96-1-6266 and National Institutes of Health grant CA-55914 (Dr Cannon-Albright), financial support from the Italian Ministry of Health and the Italian Association and Foundation for Cancer Research (Drs Radice and Pierotti), and Swiss Cancer League grants AKT 78, AKT 332, and AKT 463 (Dr Scott).

We thank Francine Bartholomew, Glenda Lowe, and Teresa Sadler for their contributions to the preparation of the manuscript.

Most importantly, we wish to thank all of the families that participated in this study.

## References

1. *Cancer Facts and Figures 1997*. Atlanta, Ga: American Cancer Society; 1997.
2. Claus EB, Schildkraut JM, Thompson WD, Risch NJ. The genetic attributable risk of breast and ovarian cancer. *Lancet*. 1996;77:2318-2324.
3. Ford DF, Easton DF, Bishop DT, Narod SA, Goldgar DE. Risks of cancer in *BRCA1*-mutation carriers. *Lancet*. 1994;343:692-695.
4. Struwing JP, Hartge P, Wacholder S, et al. The risk of cancer associated with specific mutations of *BRCA1* and *BRCA2* among Ashkenazi Jews. *N Engl J Med*. 1997;336:1401-1407.
5. Thorlacius S, Olafsdottir G, Tryggvadottir L, et al. A single *BRCA2* mutation in male and female breast cancer families from Iceland with varied cancer phenotypes. *Nat Genet*. 1996;13:117-119.
6. Phelan CM, Lancaster LM, Tonin P, et al. Mutation analysis of the *BRCA2* gene in 49 site-specific breast cancer families. *Nat Genet*. 1996;13:120-122.
7. Tonin P, Weber B, Offit K, et al. Frequency of recurrent *BRCA1* and *BRCA2* mutations in Ashkenazi Jewish breast cancer families. *Nat Med*. 1996;2:1179-1183.
8. Roa BB, Boyd AA, Volick K, Richards CS. Ashkenazi Jewish population frequencies for common mutations in *BRCA1* and *BRCA2*. *Nat Genet*. 1996;14:185-187.
9. Oddoux C, Struwing JP, Clayton CM, et al. The carrier frequency of the *BRCA2* 6174delT mutation among Ashkenazi Jewish individuals is approximately 1%. *Nat Genet*. 1996;14:188-190.
10. Tavtigian SV, Oliphant A, Shattuck-Eidens D, et al. Genomic organization, functional analysis, and mutation screening of *BRCA1* and *BRCA2*. In: Fortner JG, Sharp PA, eds. *General Motors Cancer Research Foundation Accomplishments in Cancer Research 1996*. New York, NY: Lippincott-Raven; 1997.
11. Barker DF, Liu X, Almeida ER. The *BRCA1* and 1A1.3B promoters are parallel elements of a genomic duplication at 17q21. *Genomics*. 1996;38:215-222.
12. Brown MA, Xu C-F, Nicolai H, et al. The 5' end of the *BRCA1* gene lies within a duplicated region of human chromosome 17q21. *Oncogene*. 1996;12:2507-2513.
13. Serova O, Montagna M, Torchard D, et al. A high incidence of *BRCA1* mutations in 20 breast-ovarian cancer families. *Am J Hum Genet*. 1996;58:42-51.
14. Beaudet AL, Tsui LC. A suggested nomenclature for designating mutations. *Hum Mut*. 1993;2:245-248.
15. Berman DB, Wagner-Costalas J, Schultz DC, Lynch HT, Daly M, Godwin AK. Two distinct origins of a common *BRCA1* mutation in breast-ovarian cancer families: a genetic study of 15 185delAG-mutation kindreds. *Am J Hum Genet*. 1996;58:1166-1176.
16. Langston AA, Malone KE, Thompson JD, Darling JR, Ostrander EA. *BRCA1* mutations in a population-based sample of young women with breast cancer. *N Engl J Med*. 1996;334:137-142.
17. Statement of the American Society of Human Genetics on genetic testing for breast and ovarian cancer predisposition. *Am J Hum Genet*. 1994;55:iv.
18. Statement of the American Society of Clinical Oncology: genetic testing for cancer susceptibility. *J Clin Oncol*. 1996;14:1730-1736.
19. Plummer SJ, Anton-Culver H, Webster L, et al. Detection of *BRCA1* mutations by the protein truncation test. *Hum Mol Genet*. 1995;4:1989-1991.
20. Hogervorst FB, Cornelis RS, Bout M, et al. Rapid detection of *BRCA1* mutations by the protein truncation test. *Nat Genet*. 1995;10:208-212.
21. Couch FJ, Weber BL, and the Breast Cancer Information Core. Mutations and polymorphisms in the familial early-onset breast cancer (*BRCA1*) gene. *Hum Mut*. 1996;8:8-18.
22. Durocher F, Shattuck-Eidens D, McClure M, et al. Comparison of *BRCA1* polymorphisms, rare sequence variants and/or missense mutations in unaffected and breast/ovarian cancer populations. *Hum Mol Genet*. 1996;5:835-842.
23. Barker DF, Almeida ER, Casey G, et al. *BRCA1* R841W: a strong candidate for a common mutation with moderate phenotype. *Genet Epidemiol*. 1996;13:595-604.
24. Miki Y, Swenson J, Shattuck-Eidens D, et al. A strong candidate for the breast and ovarian cancer susceptibility gene, *BRCA1*. *Science*. 1994;266:66-71.
25. Koonin EV, Altschul SF, Bork P. *BRCA1* protein products... functional motifs... *Nat Genet*. 1996;13:266-268.
26. Wu LC, Wang ZW, Tsan JT, et al. Identification of a RING protein that can interact in vivo with the *BRCA1* gene product. *Nat Genet*. 1996;14:430-440.
27. Chen C-F, Li S, Chen Y, et al. The nuclear localization sequences of the *BRCA1* protein interact with the importin- $\alpha$  subunit of the nuclear transport signal receptor. *J Biol Chem*. 1996;271:32863-32868.
28. Puget N, Torchard D, Serova-Sinilnikova OM, et al. A 1-kb Alu-mediated germ-line deletion removing *BRCA1* exon 17. *Cancer Res*. 1997;57:828-831.
29. Couch FJ, DeShano ML, Blackwood MA, et al. *BRCA1* mutations in women attending clinics that evaluate the risk of breast cancer. *N Engl J Med*. 1997;336:1409-1415.

# Sequence Analysis of *BRCA1* and *BRCA2*: Correlation of Mutations With Family History and Ovarian Cancer Risk

By Thomas S. Frank, Susan A. Manley, Olufunmilayo I. Olopade, Shelly Cummings, Judy E. Garber, Barbara Bernhardt, Karen Antman, Donna Russo, Marie E. Wood, Lisa Mullineau, Claudine Isaacs, Beth Peshkin, Sandra Buys, Vicki Venne, Peter T. Rowley, Starlene Loader, Kenneth Offit, Mark Robson, Heather Hampel, Dara Brener, Eric P. Winer, Shelly Clark, Barbara Weber, Louise C. Strong, Paula Rieger, Melody McClure, Brian E. Ward, Donna Shattuck-Eidens, Arnold Oliphant, Mark H. Skolnick, and Alun Thomas

**Purpose:** Previous studies of mutations in *BRCA1* or *BRCA2* have used detection methods that may underestimate the actual frequency of mutations and have analyzed women using heterogeneous criteria for risk of hereditary cancer.

**Patients and Methods:** A total of 238 women with breast cancer before age 50 or ovarian cancer at any age and at least one first- or second-degree relative with either diagnosis underwent sequence analysis of *BRCA1* followed by analysis of *BRCA2* (except for 27 women who declined analysis of *BRCA2* after a deleterious mutation was discovered in *BRCA1*). Results were correlated with personal and family history of malignancy.

**Results:** Deleterious mutations were identified in 94 (39%) women, including 59 of 117 (50%) from families

with ovarian cancer and 35 of 121 (29%) from families without ovarian cancer. Mutations were identified in 14 of 70 (20%) women with just one other relative who developed breast cancer before age 50. In women with breast cancer, mutations in *BRCA1* and *BRCA2* were associated with a 10-fold increased risk of subsequent ovarian carcinoma ( $P = .005$ ).

**Conclusion:** Because mutations in *BRCA1* and *BRCA2* in women with breast cancer are associated with an increased risk of ovarian cancer, analysis of these genes should be considered for women diagnosed with breast cancer who have a high probability of carrying a mutation according to the statistical model developed with these data.

*J Clin Oncol* 16:2417-2425. © 1998 by American Society of Clinical Oncology.

**I**NHERITANCE OF MUTATIONS in highly penetrant genes is believed to account for 7% of breast cancers and 10% of ovarian cancers.<sup>1</sup> Initial studies that used genetic linkage analysis indicated that mutations in *BRCA1* were responsible for 45% of hereditary breast cancers,<sup>2,3</sup> while mutations in *BRCA2* accounted for 35%.<sup>4</sup> Although some studies have addressed the frequency of mutations in *BRCA1* and *BRCA2* in women with a family history of breast cancer,<sup>5,6</sup> several factors lead to uncertainty about their findings. For instance, mutations in *BRCA2* are believed to account for a significant fraction of hereditary breast cancer,<sup>7</sup> but most of the reported studies have analyzed only *BRCA1*. In addition, many analyses have used techniques that are not as sensitive as complete sequencing.<sup>5,8,9</sup> Finally, the criteria used to include women likely to have hereditary breast cancer have been heterogeneous.

We have previously demonstrated that gene sequencing can be used to identify women who carry susceptibility mutations in *BRCA1*.<sup>10</sup> In this study, we use gene sequencing to analyze fully the coding regions and adjacent noncoding regions of both *BRCA1* and *BRCA2* in women who met uniform criteria for being at high risk of having inherited susceptibility to breast and ovarian cancer. These data have been correlated with information about the ancestry and the age at cancer diagnosis in the tested individual, as well as other relatives with cancer, to determine predictive characteristics and the proportion of women with early-onset breast

cancer or ovarian cancer, and a family history of either, who carry germline mutations in *BRCA1* and *BRCA2*.

## PATIENTS AND METHODS

### Patient Selection

Uniform criteria were used by 12 collaborating institutions with familial risk clinics. The majority of women were referred either before or after a diagnosis of cancer because of a family history that suggested a familial risk factor for breast or ovarian cancer, and one group—University of Rochester Medical Center—used a tumor registry to identify a small number of women who were subsequently invited to participate.

---

From Myriad Genetic Laboratories; University of Utah, Salt Lake City, UT; University of Chicago Medical Center, Chicago, IL; The Dana-Farber Cancer Institute, Boston, MA; Johns Hopkins University, Baltimore, MD; University of Colorado Cancer Center, Denver, CO; Georgetown University Medical Center, Washington, DC; University of Rochester Medical Center, Rochester; Memorial Sloan-Kettering Cancer Center; Columbia-Presbyterian Cancer Center, New York, NY; Duke University Medical Center, Durham, NC; University of Pennsylvania School of Medicine, Philadelphia, PA; and The University of Texas M.D. Anderson Cancer Center, Houston, TX.

Submitted November 12, 1997; accepted April 1, 1998.

Supported by Myriad Genetic Laboratories, Salt Lake City, UT.

Address reprint requests to Thomas S. Frank, MD, Medical Director, Myriad Genetic Laboratories, 320 Wakara Way, Salt Lake City, UT 84108; Email tfrank@myriad.com.

© 1998 by American Society of Clinical Oncology.

0732-183X/98/1607-0029\$3.00/0

After receiving counseling, some women declined to undergo genetic testing. Each individual who participated in this study read and signed informed consent documents approved by the local institutional review board. Women were excluded from analysis if a relative had a documented mutation in *BRCA1* or *BRCA2* or if their family had been determined by linkage analysis to carry a mutation in one of these genes. If two or more related individuals were tested for mutations in *BRCA1* or *BRCA2*, only the family member with the youngest age of diagnosis was included in the data analysis.

Women were eligible for this study if they had been diagnosed with invasive breast cancer before age 50 or ovarian cancer at any age and had at least one first- or second-degree female relative with either diagnosis. Diagnoses were obtained primarily through medical records and pathology reports, although for a minority of participants, some of the family history was not independently verified. The histologic type of breast or ovarian cancer was not specified. For each of the women in the study, the following information was required: geographic origin of the proband's ancestors; birth year and history of cancer, including site and age at diagnosis; relationship and years of birth and death for all female first-degree relatives regardless of whether they had cancer, as well as any history of cancer, including site and age at diagnosis; and relationship and years of birth and death for all other relatives who had ever been diagnosed with cancer, including site and age at diagnosis. The number of women who met these criteria was 238, of whom 219 had at least one first-degree relative diagnosed with breast cancer before age 50 or ovarian cancer and 19 had at least one second- (but not first-) degree relative with either diagnosis. Of the total, 105 met the minimal entry criteria of breast cancer under 50 and/or ovarian cancer at any age and only one first- or second-degree relative with either diagnosis. Almost all of the relatives for whom a history of cancer was provided were first-, second-, and third-degree relatives.

Two hundred women without ovarian cancer had a diagnosis of breast cancer before age 50, with a mean age of onset 39.9 years (range, 21 to 49; median, 40). Twenty-two women without breast cancer had a diagnosis of ovarian cancer, with a mean age of onset 46.0 years (range, 35 to 67; median, 45). Sixteen women had both breast cancer and ovarian cancer, with mean ages of onset 48.1 years for breast cancer (range, 32 to 66; median, 48) and 51.7 years for ovarian cancer (range, 29 to 75; median, 48). Of 238 women analyzed, 117 (49%) reported a history of ovarian cancer in themselves or at least one relative of any degree of relatedness. While male breast cancer was not included as a criterion for ascertainment, four women eligible for analysis indicated breast cancer in at least one male relative.

Sequence analysis of *BRCA1* was performed first. Each participant was subsequently given the opportunity for sequence analysis of *BRCA2*. Twenty-seven women in whom analysis of *BRCA1* disclosed the presence of a mutation known to adversely affect *BRCA1* protein function declined subsequent analysis of *BRCA2*, but were considered eligible for this study. In including these women in our analysis, we made the assumption that none of these 27 women had a deleterious mutation in *BRCA2*, which was based on the infrequency ( $\approx 0.1\%$ ) with which mutations in both genes have been observed in our clinical analysis. If, in fact, any of these women had deleterious mutations in both genes, the effect of this assumption would be to underestimate the prevalence of *BRCA2* mutations.

### BRCA1 and BRCA2 Sequence Analysis

Sequence analysis was performed at Myriad Genetic Laboratories, Salt Lake City, UT. Briefly, exons 2 to 24 of *BRCA1* and exons 2 to 27 of *BRCA2* were amplified using 82 pairs of polymerase chain reaction (PCR) primers designed to avoid common polymorphisms that might

inhibit equal amplification of both alleles. Dye primer sequencing was performed using fluorescent energy transfer primers (Amersham Life Science Inc, Cleveland, OH), the mutant Taq polymerase F667Y, and a thermal stable pyrophosphatase, both from Perkin Elmer, Norwalk, CT. Sequencing reaction products were electrophoresed and detected using a Perkin Elmer Applied Biosystems 377 sequencing apparatus. Analysis of sequence data was performed using software developed by Myriad Genetic Laboratories. All analyses that demonstrated mutations were repeated for verification.

All mutations and genetic variants were named using the convention of Beaudet and Tsui<sup>11</sup> with nucleotide numbering starting at the first transcribed base of *BRCA1* and *BRCA2* according to GenBank entries U14680 and U43746, respectively. By these conventions, the two *BRCA1* mutations referred to in other publications as 185delAG and 5382insC are called 187delAG and 5385insC, respectively, but their commonly used names are used in the text.

A mutation was considered to be deleterious if it led to premature truncation of the *BRCA1* protein product at least 10 amino acids from the C terminus or premature truncation of the *BRCA2* protein product at least 270 amino acids from the C terminus. These criteria were based on documentation of deleterious mutations that occurred at the C termini of *BRCA1*<sup>12</sup> and *BRCA2*.<sup>13</sup> In addition, the following specific *BRCA1* mutations were considered as deleterious on the basis of published data: IVS5-11 T > G (the mutation IVS5-11 T > G is listed in the Breast Cancer Information Core (BIC) as T to G ins59bp),<sup>12</sup> C61G,<sup>12</sup> C64G,<sup>14</sup> C64Y,<sup>14</sup> and M1775R.<sup>15</sup> The proteins produced from genes that contained deleterious mutations cannot function normally and are therefore assumed to increase the risk of developing breast and ovarian cancer.

All of the mutations in *BRCA1* and *BRCA2* discovered in the course of this study have been entered into the Breast Cancer Information Core (BIC).<sup>16</sup>

### Modeling of Risk Factors

*Logistic regression analysis.* We fit the polychotomous logistic regression model

$$\log(p1/p0) = a1 + b1 B + c1 C + \dots$$

$$\log(p2/p0) = a2 + b2 B + c2 C + \dots$$

where  $p1$  and  $p2$  are the probabilities that deleterious *BRCA1* or *BRCA2* mutations, respectively, are detected, and  $p0$  is the probability of a negative test. B, C, etc are the factors regressed on. We use the method implemented with the *glm* function of the Splus statistical package.<sup>17</sup>

We first fitted the main effects of the factors specified later, until the reduction in scaled deviance was not significant at a 5% level. Second-order interactions were then added by the same criterion. Factors not significantly different from zero were then removed, with the least significant removed first.

*Survival time analysis.* The expected time from diagnosis of breast cancer to onset of ovarian cancer and the time since onset of ovarian cancer for women with the different possible *BRCA* test results were again estimated using the *glm* function of Splus.<sup>17</sup>

## RESULTS

### Mutations Identified in BRCA1 and BRCA2

Overall, 94 (39%) of 238 women analyzed had clearly deleterious mutations. Sixty-three women had 32 different deleterious mutations in *BRCA1*, 15 of which were not in the

BIC at the time of detection. Thirty-one women had 27 different deleterious mutations in *BRCA2*, 12 of which were not in the BIC when detected. These mutations in *BRCA1* and *BRCA2* are listed in Table 1, along with the proband's personal and family history of cancer.

Genetic variants of uncertain significance not known to affect protein function adversely, excluding established polymorphisms, were identified in 33 (14%) of the remaining women. Four women had more than one such variant identified. These variants included 35 single-base substitutions in the coding region, or missense mutations, of which 14 were in *BRCA1* and 21 were in *BRCA2*, as well as nine intronic variants, of which six were in *BRCA1* and three were in *BRCA2*.

#### *Risk Factors for Mutations in BRCA1 and BRCA2*

The observed results are listed in Table 2. Deleterious mutations were identified in 70 of 200 women (35%) who had breast cancer diagnosed before 50 years of age, but no personal history of ovarian cancer: 47 mutations in *BRCA1* and 23 in *BRCA2*. The mean age of diagnosis of breast cancer was 37.6 years in mutation-positive women (range, 23 to 49; median, 38), compared with 41.2 years in mutation-negative women (range, 21 to 49, median, 42). Mutations were identified in 14 (20%) of 70 women with breast cancer who had only a single relative with breast cancer before the age of 50 and no relatives with ovarian cancer.

Two (6%) of 31 women who carried deleterious mutations in *BRCA2* indicated a family history of male breast cancer. Two other women in this study also indicated a family history of male breast cancer, but neither had an abnormality detected in either *BRCA2* or *BRCA1*.

Deleterious mutations were found in 20 of 47 (43%) women who identified themselves as Ashkenazi, including 13 observations of 185delAG and three observations of 5382insC in *BRCA1*, two observations of 6174delT in *BRCA2*, and two novel mutations 6696delTC and 6426delTT in *BRCA2*.

#### *Mutations in BRCA1 and BRCA2 Associated With Ovarian Cancer*

A history of ovarian cancer in the proband or relative was significantly associated with the presence of a deleterious mutation. Deleterious mutations were present in 59 of 117 (50%) women from families with at least one woman with ovarian cancer and in 35 of 121 (29%) women from families without any history of ovarian cancer. A logistic regression analysis that adjusts for the number of relatives with cancer in families with and without ovarian cancer is presented later. More than half of the deleterious mutations in *BRCA2*

(18 of 31, 58%) and *BRCA1* (41 of 63, 65%) were seen in association with ovarian cancer in the proband or a relative. Thus, nearly one third of the deleterious mutations in probands from ovarian cancer families were in *BRCA2* (18 of 59, 31%). No correlation was found between the presence or proportion of women in a family with ovarian cancer and the location of mutations within the *BRCA1* or *BRCA2* genes.

Mutations were identified in 24 of 38 (63%) women who themselves had ovarian cancer, 16 in *BRCA1* and eight in *BRCA2*. Twenty-two women with ovarian cancer did not have a diagnosis of breast cancer, of whom 10 (45%) carried mutations, eight in *BRCA1* and two in *BRCA2*. Interestingly, the mean age of diagnosis of ovarian cancer was 50.6 years (range, 35 to 75; median, 48) in mutation-positive women compared with 44.9 years (range, 29 to 74; median, 43) in mutation-negative women. This difference may indicate the presence in this study of women with tumors of the ovary, such as germ cell tumors, which have an earlier age of onset than ovarian carcinomas but which have not been associated with inherited mutations in *BRCA1* or *BRCA2*. The mean age of onset of ovarian cancer was 49.7 years for women with *BRCA1* mutations compared with 52.4 years for women with mutations in *BRCA2*.

#### *Mutations in BRCA1 and BRCA2 and the Rate of Developing Ovarian Cancer Following Breast Cancer*

Deleterious mutations were identified in 14 of 16 (88%) women with both breast and ovarian cancer, including nine (90%) of 10 women who developed breast cancer before age 50 and five (83%) of six women who developed breast cancer after age 50. Of 189 women in the study initially diagnosed with breast cancer, 11 subsequently developed ovarian cancer. Because women were eligible for this study on the basis of a diagnosis of ovarian cancer, the proportion of study participants with ovarian cancer would be expected to be higher in this group than in women ascertained only for a history of breast cancer, and thus the absolute risk of ovarian cancer following breast cancer could not be calculated. However, because ascertainment was blind to genotype, a comparison could be made between women with breast cancer with and without mutations in *BRCA1* and *BRCA2*. Among 11 women with breast cancer who subsequently developed ovarian cancer, six had deleterious mutations in *BRCA1*, four had deleterious mutations in *BRCA2*, and only one had no mutation in either. Thus, ovarian cancer followed breast cancer in six of 48 women with mutations in *BRCA1* and four of 25 women with mutations in *BRCA2*, compared with only one of 116 women without mutations in either gene. The rate of development of ovarian cancer per year was calculated to account for the relationship between

Table 1. Deleterious Mutations in BRCA1 and BRCA2: Associations With Breast and Ovarian Cancer

Mutation	Proband	Total No. of Relatives* With Breast Cancer Before the Age of 50 Years	Total No. of Relatives* With Ovarian Cancer (any age)
<i>BRCA1</i>			
185delAG	Breast cancer age 23	2	0
185delAG	Breast cancer age 43	0	3
185delAG	Breast cancer age 40	0	2
185delAG	Breast cancer age 44	0	1
185delAG	Breast cancer age 43	1	2
185delAG	Breast cancer age 43	3	1
185delAG	Breast cancer, bilateral, ages 34 and 37	1	1
185delAG	Breast cancer, bilateral, age 48 and ovarian cancer age 58	1	0
185delAG	Breast cancer, bilateral, ages 43 and 68	2	0
185delAG	Breast cancer age 32	0	1
185delAG	Breast cancer, bilateral, ages 37 and 47	1	0
185delAG	Ovarian cancer age 54	1	1
185delAG	Breast cancer age 37	1	1
185delAG	Breast cancer, bilateral, ages 38 and 47	1	0
185delAG	Breast cancer age 43	1	1
C61G	Breast cancer, bilateral, ages 29 and 54	6	1
C61G	Breast cancer, bilateral, ages 40 and 45	1	0
C61G	Ovarian cancer, age 55	1	2
448delAG	Breast cancer age 33	2	0
E143X	Breast cancer age 34	5	1
E143X	Breast cancer age 33	2	0
816delGT	Breast cancer age 36	6	3
1135insA	Breast cancer, bilateral, age 43	1	1
1205delGA	Breast cancer age 46	0	2
1294del40	Breast cancer age 38	3	0
1294del40	Breast cancer, bilateral, ages 32 and 36	1	1
1374delG	Breast cancer age 41	3	2
1832del5	Breast cancer age 34	4	1
2072del4	Breast cancer, bilateral, age 35	1	2
2190delA	Ovarian cancer age 35	1	2
2329delCA	Breast cancer, bilateral, ages 66 and 70 and ovarian cancer age 75	1	0
2576delC	Breast cancer, bilateral, ages 35 and 38	3	2
3600del11	Breast cancer, bilateral, ages 38 and 39	1	2
3604delA	Ovarian cancer age 36	1	1
3875del4	Ovarian cancer age 49	1	4
3875del4	Breast cancer age 40	2	0
3884insA	Breast cancer, bilateral, ages 28 and 34	1	1
3889delAG	Ovarian cancer age 35	2	0
3977del4	Ovarian cancer age 50	1	1
E908X	Breast cancer age 33	4	0
E1060X	Breast cancer age 31	1	0
Q563X	Breast cancer age 39, ovarian cancer age 42	2	0
Q780X	Breast cancer age 54, ovarian cancer age 55	1	0
Q780X	Breast cancer age 42, ovarian cancer age 40	0	1
4280delTC	Breast cancer, bilateral, age 38	3	0
R1443X	Breast cancer age 25	1	0
R1835X	Breast cancer age 36	2	1
R1835X	Breast cancer, bilateral, ages 33 and 39	1	0
4601delAA	Breast cancer age 33	1	0
Y1563X	Breast cancer age 32	2	0
5296del4	Breast cancer age 40	0	1
5296del4	Breast cancer, bilateral, age 24	4	0
5382insC†	Breast cancer age 65, ovarian cancer age 69	0	1
5382insC	Breast cancer age 41	1	0
5382insC	Breast cancer age 43	1	0
5382insC	Breast cancer age 44	1	0

Table 1. Deleterious Mutations in *BRCA1* and *BRCA2*: Associations With Breast and Ovarian Cancer (cont'd)

Mutation	Proband	Total No. of Relatives* With Breast Cancer Before the Age of 50 Years	Total No. of Relatives* With Ovarian Cancer (any age)
5382insC	Ovarian cancer age 52	0	2
5382insC	Breast cancer age 47, ovarian cancer age 48	1	1
5382insC	Breast cancer age 41, ovarian cancer age 42	2	2
5382insC	Breast cancer, bilateral, ages 33 and 39	3	0
5382insC	Breast cancer, bilateral, ages 39 and 58	1	1
5382insC	Breast cancer age 34	1	0
W1837X	Breast cancer age 40	5	1
<i>BRCA2</i>			
314delTT	Breast cancer, bilateral, ages 41 and 42	1	0
886delGT	Breast cancer, bilateral, ages 39 and 44	2	0
983delA	Breast cancer age 36	4	0
1982delA	Breast cancer, bilateral, age 40	2†	0
2041insA	Breast cancer age 33, ovarian cancer age 35	2	1
2041insA	Breast cancer age 47, ovarian cancer age 46	3†	0
Q321X	Breast cancer age 40	2	0
2157delG	Breast cancer age 30	1	1
2816insA	Ovarian cancer age 53	1	0
3036delA	Breast cancer age 47	3	2
3972delA	Breast and ovarian cancer age 48	2	0
4706delA	Breast cancer age 27	4	0
5466insT	Breast cancer age 40	0	1
5950delCT	Breast cancer age 47	3	1
6174delT	Breast cancer age 44	1	0
6174delT	Breast cancer age 52, ovarian cancer age 61	1	1
6174delT	Breast cancer age 49	2	0
6426delTT	Breast cancer, bilateral, ages 42 and 43	4	0
6503delTT	Breast cancer age 37	2	0
6696delTC	Breast cancer age 32, ovarian cancer age 40	1	1
6872insA	Breast cancer age 32	0	1
E1953X	Breast cancer age 45	3	1
E1953X	Breast cancer age 34	2	1
7172delA	Breast cancer age 40	0	1
7297delCT	Ovarian cancer age 67	0	1
7990delA	Breast cancer age 45	2	0
8141del5	Breast cancer age 43	1	1
9132delC	Breast cancer age 38	2	0
9558ins3del5	Breast cancer, bilateral, ages 61 and 68, and ovarian cancer age 69	0	1
R3128X	Breast cancer age 44	1	0
Y3098X	Breast cancer, bilateral, ages 46 and 52	1	1

\*Predominantly first-, second-, and third-degree relatives.

†Does not include 1 male relative with breast cancer.

the risk of developing ovarian cancer being related to the length of the observed interval following a diagnosis of breast cancer. In the absence of a deleterious mutation in either *BRCA1* or *BRCA2*, women diagnosed with breast cancer went on to develop ovarian cancer at a rate of 0.12% (SE, 0.12%), or about one woman per thousand per year. However, in the presence of a mutation in one of these genes, this rate was increased 10-fold to 1.4% per year (SE, 0.5%), or about 14 women per thousand per year. This rate was 1.3% per year (SE, 0.5%) with a mutation in *BRCA1* and 2.2% (SE, 1.0%) with a mutation in *BRCA2*, a difference that was not statistically significant. The probability of developing ovarian cancer following a diagnosis of breast cancer

was 10-fold greater in the presence of a mutation in *BRCA1* or *BRCA2* ( $P = .005$ ).

Excluding two unusual instances of women with ovarian cancer who survived 25 years, neither of whom carried mutations, the mean time of observation from the diagnosis of ovarian cancer with or without a diagnosis of breast cancer is 4.3 years both for women with mutations in *BRCA1* and without detectable mutations in either gene. This is significantly longer than the mean time of observation of 1.6 years for women with mutations in *BRCA2* ( $P = .023$ ), which suggests that decreased survival of ovarian cancer may be associated with mutations in *BRCA2*, but not *BRCA1*.

Table 2. Observed Results for 238 Women With Breast Cancer Before the Age of 50 Years or Ovarian Cancer, With at Least One First- or Second-Degree Relative With Either Diagnosis

Variable	Total No.	BRCA1 (+)		BRCA2 (+)		Total BRCA (+)	
		No.	%	No.	%	No.	%
(a) By diagnosis							
BrCa < 50 only	200	47	24	23	12	70	35
Unilateral	157	30	19	18	12	48	31
Bilateral	43	17	40	5	12	22	51
OvCa only	22	8	36	2	9	10	45
OvCa and BrCa	16	8	50	6	38	14	88
(b) By age at diagnosis of breast cancer*							
20-29	10	5	50	1	10	6	60
30-39	80	25	31	7	9	32	40
40-49	110	17	15	15	14	32	29
(c) By no. of relatives† with either breast cancer < age 50 or ovarian cancer*							
1	89	14	16	6	7	20	22
2	54	15	28	10	19	25	46
≥ 3	57	18	32	7	12	25	44
(d) By no. of relatives† with breast cancer < age 50, no family history of ovarian cancer*							
1	70	11	16	3	4	14	20
2	30	6	20	7	23	13	43
≥ 3	21	5	24	3	14	8	38
(e) By no. of relatives† with breast cancer < age 50, with family history of ovarian cancer*							
0	28	6	21	3	11	9	32
1	22	10	45	3	14	13	59
≥ 2	29	9	31	4	14	13	45
(f) By ancestry							
Non-Ashkenazi	191	47	24.6	27	14.1	74	38.7
Ashkenazi	47	16	32.6	4	8.7	20	42.6

Abbreviations: BrCa, breast cancer; OvCa, ovarian cancer.

\*Women ascertained by breast cancer before the age of 50 years without ovarian cancer.

†Predominantly first-, second-, and third-degree relatives.

#### Mutations in BRCA1 and BRCA2 and the Rate of Developing Contralateral Breast Cancer

In the absence of a deleterious mutation in either *BRCA1* or *BRCA2*, the estimated rate of developing contralateral breast cancer following an initial diagnosis of breast cancer was 2.8% per year (SE, 0.62%). However, in the presence of a mutation in one of these genes, this probability was increased almost twofold to 5.2% per year (SE, 1.1%). This rate was 5.6% per year (SE, 0.13%) with a mutation in *BRCA1* and 4.2% (SE, 1.7%) with a mutation in *BRCA2*, a difference that was not statistically significant. Although bilateral breast cancer was not a criterion for inclusion in this study, it is nonetheless possible that selection bias favored the enrollment of women with that history, and so the absolute risk of bilateral breast cancer associated with mutations that we observed is probably not representative of other women with mutations in these genes. However, a comparison between women with and without mutations in *BRCA1* and *BRCA2* is valid and a difference in rate of developing contralateral breast cancer between the mutation-

positive and mutation-negative patients was significant ( $P = .014$ ).

#### Modeling the Probability of Detecting a Mutation in BRCA1 or BRCA2

Results of the analysis of *BRCA1* and *BRCA2* in comparison to the identified risk factors were used as the basis of polychotomous logistic regression analysis.

Following the model-fitting procedure described in the Methods, we obtained a mathematical fit for the probability of detecting a deleterious mutation in *BRCA1* or *BRCA2* in women diagnosed with breast cancer before age 50. These results are listed in Table 3. The presence of ovarian cancer in the family history is noted in particular to increase the probability of a mutation, particularly in *BRCA1*.

No significant factors emerged from the smaller sample of women ascertained on the basis of ovarian cancer alone. Although male breast cancer was a significant predictor of a *BRCA2* mutation, the number of families with a history of male breast cancer (four) was small and so we have not included it as a predictive factor in Table 3.

Table 3. Modeled Probabilities of Women With Breast Cancer Under 50 Years of Age Carrying a Mutation in BRCA1 or BRCA2

Any Relative With BrCA < 50 Years?	Any Relative With OvCa?	Proband: Bilateral BrCa or OvCa?	Proband: BrCa < 40?	Modeled Probability of Mutation in BRCA1 (%)	Modeled Probability of Mutation in BRCA2 (%)	Modeled Probability of Mutation in BRCA1 or BRCA2 (%)
•				10.1	14.5	25
•			•	28.2	11.6	40
•		•		41.5	9.5	51
•		•	•	71.1	4.7	76
	•			22.9	12.5	35
	•		•	22.9	12.5	35
	•	•		65.0	5.7	71
	•	•	•	65.0	5.7	71
•	•			22.9	12.5	35
•	•		•	50.9	7.9	59
•	•	•		65.0	5.7	71
•	•	•	•	86.7	2.2	89

Results of Logistic Analysis for Women Ascertained by Diagnosis of Breast Cancer Before the Age of 50 Years

	Coefficient	SE	Z Score	P	Scaled Deviance
BRCA1 intercept	-2.01	0.34	5.9	.0000	
BRCA2 intercept	-1.65	0.22	7.5	.0000	78.31
BRCA1 ovarian relative	0.97	0.37	2.7	.0079	72.90
BRCA1 2 sites	1.83	0.66	2.8	.0052	68.98
BRCA2 male breast	2.14	1.03	2.1	.0380	64.14
BRCA1 diagnosis < 40 and breast relative < 50 interaction	1.25	0.36	3.5	.0006	52.53

NOTE. Based on analysis of women with at least 1 first- or second-degree relative with ovarian cancer or breast cancer before 50 years of age.

## DISCUSSION

While it has been estimated that 7% and 10% of breast and ovarian cancer are hereditary,<sup>1</sup> the proportion of hereditary breast and ovarian cancers attributable to mutations in *BRCA1* and *BRCA2* remains unclear. It was originally estimated that mutations in *BRCA1* accounted for 45% of families with hereditary site-specific breast cancer,<sup>3</sup> ie, exclusive of ovarian cancer. In contrast, Couch et al<sup>5</sup> found mutations in *BRCA1* in 7% of the women with a family history of site-specific breast cancer who were seen at a familial cancer clinic, but many women tend to overestimate the likelihood that they are at risk of hereditary breast cancer<sup>18</sup> and therefore may refer themselves to such clinics despite an absence of risk factors such as early age of onset of breast cancer. We identified mutations of *BRCA1* or *BRCA2* in 21 of 51 (41%) women with breast cancer before age 50 who had two or more relatives with early-onset breast cancer but none with ovarian cancer, which suggests that mutations in *BRCA1* and *BRCA2* may indeed account for a substantial proportion of women with hereditary site-specific early-onset breast cancer.

The probability of a mutation in either of these genes is

greater if ovarian cancer is present in the family history. As estimated from genetic linkage analysis, mutations in *BRCA1* were initially believed to be present in the majority (88%) of families with a history of ovarian as well as breast cancer.<sup>19</sup> and it has been demonstrated that germline mutations in *BRCA1* are more prevalent among families with both early-onset breast cancer and ovarian cancer than families with site-specific breast cancer.<sup>3,5</sup> Among the participants of this study, we observed deleterious mutations in either *BRCA1* or *BRCA2* in 55 of 110 (50%) women from families with both early-onset breast cancer and ovarian cancer, including 39 mutations in *BRCA1* and 16 in *BRCA2*.

It is not known whether most hereditary breast cancer is in fact site-specific or associated with ovarian cancer. A family history of ovarian cancer was present in nearly half of the families of women enrolled onto this study. This is notable because the incidence of ovarian cancer (15 per 100,000)<sup>20</sup> is even lower than the incidence of breast cancer below age 50 (32 per 100,000).<sup>21</sup> If this is a true indication of the frequent association of ovarian cancer with hereditary breast cancer, then studies of site-specific breast cancer families<sup>6,22</sup> may significantly underestimate the role of mutations in *BRCA1* and *BRCA2* in hereditary breast cancer. However, we cannot rule out that the prevalence of families with a history of ovarian cancer in our study was an artifact of ascertainment.

Although deleterious mutations were identified in 39% of the women analyzed, another 23% carried mutations not yet established to adversely affect protein function. Many of these are in fact likely to increase the risk of breast and ovarian cancer. For example, intronic mutations that occur one and two nucleotides from the ends of the exons are likely to interfere with mRNA splicing and stability, and we are currently analyzing such variants for this possibility. Also excluded from the deleterious category were most missense mutations, some of which, such as A1708E<sup>23</sup> (A1708E is also referred to as Ala1708Glu) in *BRCA1* and Y42C in *BRCA2*,<sup>24</sup> may well be deleterious. As the clinical significance of such mutations becomes more certain, the prevalence of mutations in *BRCA1* and *BRCA2* that confer susceptibility to breast and ovarian cancer will likely increase.

Overall, 33% of the deleterious mutations were found in *BRCA2*. This is substantially higher than a recent estimate of the contribution of *BRCA2* to very-early-onset breast cancer in a study of women with breast cancer diagnosed before age 32.<sup>8</sup> In our study, the proportion of breast cancers associated with mutations in *BRCA1* declined with increasing age of onset to age 50, while the proportion associated with mutations in *BRCA2* remained roughly unchanged (Table 2, row b). Thus, among women in this study, germline muta-



tions in *BRCA2* were less frequent than those in *BRCA1* in women diagnosed with breast cancer before age 40, but among women diagnosed between 40 and 49, mutations were found nearly equally in *BRCA1* and *BRCA2*. An analysis that included only women diagnosed before age 32 would therefore presumably lead to an underestimation of the prevalence of mutations in *BRCA2*.<sup>8</sup>

Because of the strong association between germline mutations in *BRCA1* and ovarian cancer,<sup>3</sup> a family history of ovarian cancer has been cited as an indication to look for mutations in that gene.<sup>25</sup> However, in our study, 30 of the germline mutations identified in women from breast-ovarian families occurred in *BRCA2*, which illustrates the limitation of restricting analysis to *BRCA1* in a woman with a personal or family history of ovarian cancer. Conversely, there have been attempts to use the location of mutations to predict the likelihood of developing ovarian cancer. Specifically, it has been suggested that ovarian cancer is most likely to be associated with mutations in the proximal third of *BRCA1*.<sup>26</sup> Our data, as well as those of others,<sup>5</sup> do not provide any evidence to support such an association.

One of the most important findings in this analysis was the observation that among women in this study with breast cancer, those with mutations in *BRCA1* and *BRCA2* were at a 10-fold increased risk of developing ovarian cancer. Significantly, mutations in *BRCA2* were as likely as those in *BRCA1* to be associated with the development of ovarian cancer following breast cancer in these women. Thus, recommendations for *BRCA1* mutation carriers with regard to surveillance<sup>27</sup> or consideration of prophylactic oophorectomy<sup>28</sup> may apply to women with breast cancer who carry germline mutations in *BRCA2*.

Although we were able to estimate from this analysis the relative likelihood of a mutation-carrier and non-mutation-carrier developing ovarian cancer as a second malignancy, it was not possible from this study to estimate the penetrance of mutations in *BRCA1* and *BRCA2* with regard to de novo ovarian cancer. Previous analyses of women from families with numerous instances of breast and ovarian cancer have

estimated that a mutation in *BRCA1* confers a 44 risk of ovarian cancer,<sup>29</sup> which is higher than the risk recently estimated for women analyzed without regard to family history.<sup>30</sup> The actual risk for women with the types of family histories as represented in this study (Table 1) may be between these two figures, although it should be noted that there are families in which mutations in *BRCA1* and *BRCA2* seem to confer a particularly high risk of ovarian carcinoma.<sup>29,31</sup>

Surprisingly, we did not find that Ashkenazi ancestry was associated with a significantly increased likelihood of identifying a deleterious mutation in *BRCA1* and *BRCA2*. Rather than contradicting previous studies<sup>5,10,32</sup> that clearly indicate an increased prevalence of certain mutations among Ashkenazim, this may instead indicate that in the setting of a strong family history, Ashkenazi ancestry does not discriminate between carriers and noncarriers of mutations in *BRCA1* and *BRCA2*. Another related finding was that two of the 20 (10%) mutations found in Ashkenazi women were novel mutations not previously described in this population. In conjunction with other, independent observations of such mutations,<sup>33</sup> this indicates that Ashkenazi women who lack the three most common mutations in this group may benefit from complete analysis of *BRCA1* and *BRCA2*.

Because mutations in *BRCA1* and *BRCA2* are relatively uncommon in the general population, the appropriate use of genetic identification of hereditary cancer requires identification of individuals with a high likelihood of carrying a mutation.<sup>34</sup> For some hereditary cancer syndromes, such as hereditary nonpolyposis colorectal cancer, criteria have been established<sup>35</sup> that provide specific guidelines for the identification of such individuals.<sup>36</sup> We hope that the modeled probabilities based on our data will be similarly useful in identifying women who are likely to carry a predisposing mutation in *BRCA1* or *BRCA2*.

#### ACKNOWLEDGMENT

We acknowledge Dr Walter Gilbert for his review of the manuscript.

#### REFERENCES

1. Claus EB, Schildkraut JM, Thompson WD, et al: The genetic attributable risk of breast and ovarian cancer. *Cancer* 77:2318-2324, 1996
2. Easton DF, Ford D, Bishop DT, et al: Breast and ovarian cancer incidence in *BRCA1*-mutation carriers. *Am J Hum Genet* 56:265-271, 1995
3. Easton DF, Bishop DT, Ford D, et al: Genetic linkage analysis in familial breast and ovarian cancer: Results from 214 families. *Am J Hum Genet* 52:678-701, 1993
4. Wooster R, Bignell G, Lancaster J, et al: Identification of the breast cancer susceptibility gene *BRCA2*. *Nature* 378:789-792, 1995
5. Couch FJ, DeShano ML, Blackwood MA, et al: *BRCA1* mutations in women attending clinics that evaluate the risk of breast cancer. *N Engl J Med* 336:1409-1415, 1997
6. Serova OM, Mazoyer S, Puget N, et al: Mutations in *BRCA1* and *BRCA2* in breast cancer families: Are there more breast cancer-susceptibility genes? *Am J Hum Genet* 60:486-495, 1997
7. Tavtigian SV, Simard J, Rommens J, et al: The complete *BRCA2* gene and mutations in chromosome 13q-linked kindreds. *Nat Genet* 12:333-337, 1996
8. Krainer M, Silva-Arrieta S, Fitzgerald MG, et al: Differential contributions of *BRCA1* and *BRCA2* to early-onset breast cancer. *N Engl J Med* 336:1416-1421, 1997
9. Stoppa-Lyonnet D, Laurent-Puig P, Essioux L, et al: *BRCA1*

sequence variations in 160 individuals referred to a breast/ovarian family cancer clinic. Institut Curie Breast Cancer Group. *Am J Hum Genet* 60:1021-1030, 1997

10. Shattuck-Eidens D, Oliphant A, McClure M, et al: *BRCA1* sequence analysis in women at high risk for susceptibility mutations: Risk factor analysis and implications for genetic testing. *JAMA* 278:1242-1250, 1997
11. Beaudet AL, Tsui LC: A suggested nomenclature for designating mutations. *Hum Mut* 2:245-248, 1993
12. Friedman LS, Ostermeyer EA, Szabo CI, et al: Confirmation of *BRCA1* by analysis of germline mutations linked to breast and ovarian cancer in ten families. *Nat Genet* 8:399-404, 1994
13. Mazoyer S, Dunning AM, Serova O, et al: A polymorphic stop codon in *BRCA2*. *Nat Genet* 14:253-254, 1996
14. Wu LC, Wang ZW, Tsan JT, et al: Identification of a RING protein that can interact in vivo with the *BRCA1* gene product. *Nat Genet* 14:430-440, 1996
15. Miki Y, Swensen J, Shattuck-Eidens D, et al: A strong candidate for the breast and ovarian cancer susceptibility gene *BRCA1*. *Science* 266:66-71, 1994
16. Breast Cancer Information Core: [http://www.nhgri.nih.gov/Intramural\\_research/Lab\\_transfer/BIC](http://www.nhgri.nih.gov/Intramural_research/Lab_transfer/BIC), 1997
17. Aitkin M, Anderson D, Francis B, et al: *Statistical Modelling in glim*. Oxford, United Kingdom, Oxford University Press, 1989
18. Tessaro I, Borstelmann N, Regan K, et al: Genetic testing for susceptibility to breast cancer: Findings from women's focus groups. *J Womens Health* 6:317-327, 1997
19. Narod SA, Ford D, Devilee P, et al: An evaluation of genetic heterogeneity in 145 breast-ovarian cancer families. Breast Cancer Linkage Consortium. *Am J Hum Genet* 56:254-264, 1995
20. Yancik R: Ovarian cancer. Age contrasts in incidence, histology, disease stage at diagnosis, and mortality. *Cancer* 71:517-523, 1993
21. Breast Cancer Facts and Figures 1996. Atlanta, GA, American Cancer Society, 1995, p 3
22. Phelan CM, Lancaster JM, Tonin P, et al: Mutation analysis of the *BRCA2* gene in 49 site-specific breast cancer families. *Nat Genet* 13:120-122, 1996
23. Chapman MS, Verma IM: Transcriptional activation by *BRCA1*. *Nature* 382:678-679, 1996
24. Milner J, Ponder B, Hughes-Davies L, et al: Transcriptional activation functions in *BRCA2*. *Nature* 386:772-773, 1997
25. Berchuck A, Cirisano F, Lancaster JM, et al: Role of *BRCA1* mutation screening in the management of familial ovarian cancer. *Am J Obstet Gynecol* 175:738-746, 1996
26. Gayther SA, Warren W, Mazoyer S, et al: Germline mutations of the *BRCA1* gene in breast and ovarian cancer families provide evidence for a genotype-phenotype correlation. *Nat Genet* 11:428-433, 1995
27. Burke W, Daly M, Garber J, et al: Recommendations for follow-up care of individuals with an inherited predisposition to cancer. II. *BRCA1* and *BRCA2*. Cancer Genetics Studies Consortium. *JAMA* 277:997-1003, 1997
28. NIH Consensus Development Panel on Ovarian Cancer: Ovarian cancer. Screening, treatment and follow-up. *JAMA* 273:491-497, 1995
29. Ford D, Easton DF, Bishop DT, et al: Risks of cancer in *BRCA1*-mutation carriers. *Lancet* 343:692-695, 1994
30. Struwing JP, Hartge P, Wacholder S, et al: The risk of cancer associated with specific mutations of *BRCA1* and *BRCA2* among Ashkenazi Jews. *N Engl J Med* 336:1401-1408, 1997
31. Easton DF, Steele L, Fields P, et al: Cancer risks in two large breast cancer families linked to *BRCA2* on chromosome 13q12-13. *Am J Hum Genet* 61:120-128, 1997
32. Tonin P, Weber B, Offit K, et al: Frequency of recurrent *BRCA1* and *BRCA2* mutations in Ashkenazi Jewish breast cancer families. *Nat Med* 2:1179-1183, 1996
33. Robson ME, Offit K: New *BRCA2* mutation in an Ashkenazi Jewish family with breast and ovarian cancer. *Lancet* 350:117-118, 1997
34. Statement of the American Society of Clinical Oncology: Genetic testing for cancer susceptibility. *J Clin Oncol* 14:1730-1736, 1996
35. Vasen HFA, Mecklin J-P, Meera Khan P, et al: The International Collaborative Group on Hereditary Non-Polyposis Colorectal Cancer (ICG-HNPCC). *Dis Colon Rectum* 34:424-425, 1991
36. Wijnen J, Meera Khan P, Vasen H, et al: Hereditary non-polyposis colorectal cancer families not complying with the Amsterdam criteria show extremely low frequency of mismatch-repair-gene mutations. *Am J Hum Genet* 61:329-335, 1997

**Project 2: A Coordinated Approach to Breast Cancer  
Diagnosis**

None

**Project 3: Development of Novel Antiangiogenic Therapies in Metastatic Breast Cancer**

None

## **Core 1: Patient Accession Core**

Appendix 1: Breast Cancer Educational Materials

Appendix 2: Poster Presentation, Cancer Literacy  
Conference

# lombardi

## **Thalidomide Study**

### **What is the purpose of this study?**

The purpose of this research study is to find out if the drug, Thalidomide, slows or controls the growth of your breast cancer. We will look at possible side effects and how they impact your lifestyle.

### **What does the study involve? What kinds of tests and treatments?**

Prior to entering the study, it is important that we be able to accurately describe and measure your disease. This can be done using x-rays, CT scans or MRIs, whichever your doctor feels is most appropriate. You will also be asked to have blood tests, urinalysis, EKG and a health history and physical before starting the study drug. The actual study involves your taking between 1 and 12 tablets a day (depending on your body weight) for 8 weeks. At 8 weeks, we will re-evaluate the status of your disease.

During the initial 8 weeks of treatment, we will be collecting blood samples to measure the drug level in the blood and to monitor any side effects of the drug. On Day 1 (the first day you receive drug) you will need to stay at the doctor's office for 8 hours because you will be having blood samples drawn at certain time points during that time. A total of 11 blood samples will be drawn on the first day and you will be asked to return the following day for 2 more samples at 9:00am and 1:00pm.

You will be asked to return to your doctor's office every two weeks for a history and physical and to monitor your progress while receiving this medication. During these visits, additional blood samples will be drawn and you will be monitored for side effects of the study drug. At the end of 8 weeks you will repeat the same tests you had prior to taking the drug Thalidomide.

### **What is likely to happen in my case with, or without, this new research treatment?**

With this new treatment, you could see your breast cancer decrease or stabilize. However, it is also possible that you would not see any benefit.

### **What are other choices and their advantages and disadvantages?**

You will be offered other standard treatments such as chemotherapy and/or radiation, surgery or other research drugs. You may also choose no treatment and we will follow you closely, treat any symptoms related to your disease, and support you in any way possible.

**(more)**

**How could the study effect my daily life?**

Medications effect people very differently. Thus it is not certain how Thalidomide will affect you. In cases where people have experienced side effects from Thalidomide, the most common side effects have been constipation, drowsiness, nausea, dry mouth and skin, redness of skin, headache, lower extremity swelling, increased appetite and weight gain, numbing and tingling of hands and feet. You will also need to see your doctor twice a week to have blood tests performed.

**What side effects could I expect from the study?**

The known side effects have been constipation, drowsiness, nausea, dry mouth and skin, redness of skin, headache, lower extremity swelling, increased appetite and weight gain, numbing and tingling of hands and feet. You may or may not experience one or more of these side effects.

**How long will the study last?**

You may continue on the study drug as long as your physician deems it appropriate. He or she will make this decision based on your ability to tolerate the medication and your disease's ability to remain stable or decrease.

**Will I have to be hospitalized? If so, how often and for how long?**

The study does not require you to stay in the hospital. However, you may experience side effects that may require hospitalization to ensure your safety and to treat side effects that may occur.

**Will I have any costs? Will any of the treatments be free?**

The study medication, Thalidomide, is free. All other medication, laboratory fees, physicians' fees and hospital costs will be charged to you or your insurance company just like any other medical service. Some insurance companies may not cover research trials. You should speak with your doctor about this before agreeing to participate in the study.

**If I am harmed as a result of the research, what treatment would I be entitled to?**

You are entitled to receive any necessary medical care for injury or disease that results from participation in this research study.

**What types of long-term follow up care is part of the study?**

The study does not require any long-term follow up care.

**Study Contact Information:**

Primary Physician:  
Research Nurse:  
Lombardi Cancer Center Principal Investigator: Dr. Said M. Baidas



## **Who is eligible for CARE?**

Since eligibility for the CARE program is subject to change as research progresses, please see the insert for the current eligibility criteria.

Participants must be at least age 18 and have at least one living family member who has had breast or ovarian cancer. While the CARE program focuses on women, male relatives may also be eligible.

**To learn more about the  
CARE Program and to find  
out if you are eligible to  
participate, please call  
(202) 687-1750**

*Produced by the Department  
of External Affairs, 4196*



**do you  
have a  
family  
history of  
breast or  
ovarian  
cancer**

GEORGETOWN  
UNIVERSITY  
MEDICAL CENTER





## **You may have heard**

or read in the news about breast and ovarian cancer susceptibility genes, such as BRCA1 and BRCA2. Here is your chance to find out more.

The **CARE** (Cancer Assessment and Risk Evaluation) Program is a genetic counseling and testing program offered by the Lombardi Cancer Center at Georgetown University Medical Center. Through the CARE Program, women receive information and counseling about their risks for breast and ovarian cancer—two cancers shown to be related to genes that are inherited, or passed down, in families.

## **This is a free program**

that is supported by research grants from the National Institutes of Health, the Department of Defense, and the Susan G. Komen Foundation.

## **Why should I participate in the CARE Program?**

By participating in the CARE Program, you may learn valuable information about your risk of developing breast and ovarian cancer that will help you in making decisions about your health care.

You also will be helping research efforts to learn more about the best ways to educate and counsel women who are at increased risk for breast and/or ovarian cancers. Ultimately, the goal is to reduce illness and death from these cancers.

## **What does the CARE Program involve?**

Each participant in the CARE Program will meet with a genetic counselor for approximately 1 to 2 hours and will receive:

- a detailed family history and risk factor assessment
- genetic education and counseling
- guidelines for cancer prevention and screening
- option of genetic testing for cancer susceptibility, if eligible
- information regarding cancer screening services and prevention trials

Since the CARE Program is a clinical research program, all participants are asked to complete four telephone interviews over a one-year period to evaluate the benefits of the program and develop future genetic counseling and testing programs. All information is confidential.

**If you had breast cancer,**

**you may be eligible for CARE if:**

- **You were diagnosed at age 45 or younger, and are of Jewish descent**
- **You were diagnosed before age 50 and you also have a first-degree relative (mother, sister, daughter) who had ovarian (any age) or breast cancer (before age 50)**
- **You were diagnosed before age 50 and you also have a first-degree relative (mother, sister, daughter) who had breast cancer at any age and are of Jewish descent.**

**If you had ovarian cancer,**

**you may be eligible for CARE if:**

- **You were diagnosed at age 50 or younger, and are of Jewish descent**
- **You also have a first-degree relative who had ovarian cancer (any age) or breast cancer (before age 50)**

**If you have not had breast or ovarian cancer,**

**your family may be eligible for CARE if:**

- **You have a first-degree relative (mother, sister, daughter) who had breast cancer at age 30 or younger, OR**
- **You have two first-degree relatives who had early-onset breast cancer (age 50 or younger) and/or ovarian cancer (any age), OR**
- **You have three relatives on the same side of the family with early-onset breast cancer and/or ovarian cancer**

# Clinical Trials

A Brief  
overview

lombardi

The  
Lombardi  
Cancer  
Center

*Research*  
*Education*  
*Treatment*

GEORGETOWN  
UNIVERSITY  
MEDICAL CENTER



**A** clinical trial is a systematic investigation of the effect of materials or methods, according to a formal study plan and generally in a human population with a particular disease or class of diseases.

## How Clinical Trials for Cancer Work

In cancer research, a clinical trial generally refers to the evaluation of treatment methods, such as surgery, drugs, or radiation techniques. Methods of cancer prevention, detection, or diagnosis may also be the subject of such studies. Cancer clinical trials are conducted not only to decrease illness and death but also to improve the methods and procedures for cancer detection, to improve the quality of life of cancer patients during and after treatment, and to ultimately prevent cancer altogether.

## Examples of Clinical Trials Protocols

Clinical trials are conducted to explore new drug developments for cancer. Protocols;

- examine the integration of multiple treatment modalities
- test new combinations of existing drugs or new dosing schedules and routes of administration
- assess new screening tests
- evaluate methods of supportive care
- teach and counsel individuals about lifestyle and behavior changes

## Clinical Trial Categories

Clinical trials are generally categorized into four groups, Phase I, Phase II, Phase III and Phase IV trials.

**Phase I** studies generally establish whether a treatment is safe and which dosages may be most effective.

**Phase II** studies assess the efficacy of treatment, after their safety and feasibility has been established in Phase I studies.

**Phase III** studies compare effective treatments, from Phase II studies, with currently accepted treatments.

**Phase IV** studies collect and compare data on established treatments.

## Additional Categories for Clinical Trials

Additional study categories that serve to evaluate treatments to prevent the recurrence of cancer after a patient has become clinically free of disease, and to evaluate treatments designed to reduce tumors to the point that they can be treated with standard therapies are considered adjuvant and neoadjuvant respectively.

Some clinical studies are designated Group C and Treatment Referral Center (TRC) protocols. Group C studies make accessible drugs that are not yet commercially available but have been submitted for or are close to approval by the Food and Drug Administration. Toxicities associated with Group C drugs are generally manageable at local hospitals, and the drug is provided by the National Cancer Institute to any qualified oncologist with an eligible patient. TRC protocols are a limited mechanism by which treatment on a clinical trial is provided at the NCI Clinical Center or at NCI-funded Cancer Centers to patients for whom no standard treatments are available and who do not qualify for existing clinical trials.

## Clinical Trial Benefits to Patients

For each type of clinical trial there may be anticipated benefits. In Phase I trials, there is always the potential, albeit limited, for therapeutic benefit. In Phase II trials the therapeutic outcomes are unknown at the outset. However, the benefit for some patients is anticipated based on preclinical data. Ethical considerations require that investigators of Phase II trials terminate studies when severe toxicity without compelling efficacy is observed. For patients participating in Phase III trials, whether for primary treatment or supportive care, they are receiving the most up-to-date treatment for a given indication. Supportive care studies serve to improve the quality of life for patients and their families through decreased discomfort and anxiety.

## Cancer Prevention & Early Detection Trials

Prevention and early detection studies assess prevention and screening techniques in people at increased risk for

developing cancer or for the population at large. These studies are designed to show that cancer incidence or mortality is reduced because of the intervention.

Prevention studies typically require long follow-up to assess the endpoints. Cancer prevention studies may involve drug intervention, prophylactic therapy, education and counseling for dietary or other life-style modification all aimed at reducing cancer incidence or delaying the onset of cancer. Cancer screening studies are designed to encourage participants to begin and continue screening on a regular basis. Overall the anticipated benefits are a decrease in cancer-related mortality and an increase in overall survival. For screening studies, the immediate outcome is a reduction in the incidence of advanced cancers.

### **Referring Patients for Participation in a Clinical Trial**

In many cases clinical trials offer state-of-the-art therapeutics for persons diagnosed with cancer. Generally, the trial compares state-of-the-art with standard treatment. Also, this is a way that patients can contribute in a very important way to cancer research. The decision to participate is one that you and your patient should arrive at together. Some issues you may want to address in making this decision include:

- the purpose of the study
- type of tests or treatments involved
- advantages and disadvantages
- study's impact on the patient's life and daily routine
- costs, side effects (if any), and likely outcomes.

### **Payment for Clinical Trials**

For the most part, clinical trials are paid for by the federal government and private industry (pharmaceutical companies). Physicians may sometimes be paid on a per-patient basis. Patients in a limited number of cancer prevention and early detection studies may also be paid a small fee to participate.



**GEORGETOWN**   
*The Art of Medicine*

Produced by the Department of External Affairs 9/97

WISQI

FREE  
*Genetic*  
Counseling &  
Testing  
*Program for*  
Breast Cancer

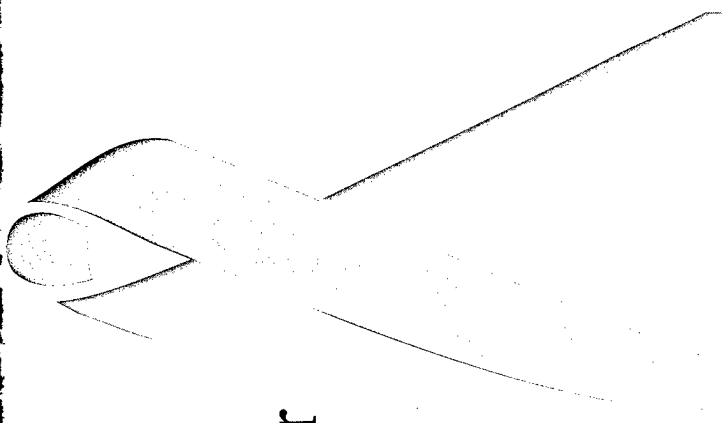

**I**

**IF** you have just been diagnosed with breast cancer and have not had all of your surgery please call **(202) 687-1750** to find out if you are eligible to participate.

*This program is supported by grants from the National Institutes of Health, the Department of Defense, and the Susan G. Komen Foundation.*

**SOI**

**Lombardi  
Cancer Center**  
Research • Education • Treatment



A Comprehensive Cancer Center Designated by the National Cancer Institute



**GEORGETOWN  
UNIVERSITY  
MEDICAL CENTER**

## **Core 2: Cancer Clinical and Economic Outcomes Evaluations Core**

Appendix 1: Data Abstraction Tools for BRCA1/2  
Natural History Model

Appendix 2: Protocol for Administration of CABCAD  
Participant Satisfaction Survey

Appendix 3: Survivorship Grant

Appendix 4: Core Meeting Minutes

Appendix 5: Core Consultations

Appendix 6: Funded Grants Including Core Members

Appendix 7: Publications Submitted by Core Members



**Appendix 1**

**Data Abstraction Tools  
for  
BRCA 1/2 Natural History Model**

**BRCA 1/2 NATURAL HISTORY MODEL**  
**DATA COLLECTION SHEET**

**I. BRCA 1/2 Testing and Subsequent Screening / Treatment**

Reference #: \_\_\_\_\_

Reviewer initial: \_\_\_\_\_

Date: \_\_\_/\_\_\_/\_\_\_

Entered in database(Initial): \_\_\_\_\_ Date: \_\_\_/\_\_\_/\_\_\_

Origin of Data

1 = published paper

2 = letter to editor

3= Other, please specify \_\_\_\_\_

**If total number of subjects  $\geq$  5, proceed; if fewer, stop.**

**Inclusion Questions**

S1. Data on (circle all that apply) present:

1= Prevalence of BRCA1/2

2= Sensitivity and specificity of BRCA testing

3= Prophylactic bilateral mastectomy (PBM) among BRCA-susceptible women

4= Prophylactic bilateral oophorectomy (PBO) among BRCA-susceptible women

5= Breast cancer screening among BRCA-susceptible women

6= Ovarian cancer screening among BRCA-susceptible women

7= Genetic counseling

8=None of the above (**STOP**)

9= Unknown (**CONFERENCE**)

S2. Meet criteria for potential eligibility?

1=Yes (**CONTINUE**)

2=No (**STOP**)

**Data Elements**

D1. Raw data presented in sufficient detail for re-analysis:

1=yes (**CONTINUE**)

2=no (**STOP**)

3=unsure (**CONFERENCE**)

D2. Study sample?

1=patients at risk for BRCA mutation (due to family history /ethnic background)

2=patients with BRCA mutation

3=general population

4=patients with breast / ovarian cancer

5=other, specify: \_\_\_\_\_

- D3. Study Design:  
 1=cohort  
 2=case-control  
 3=cross-sectional  
 4=case series (N>5)  
 5=Other (specify \_\_\_\_\_)  
 9=Unknown
- D4. Year of Publication: 19\_\_
- D5. Year of data collection:  
 Start: 19\_\_  
 Finish: 19\_\_
- D6. Country  
 1=US (Specify city: \_\_\_\_\_)  
 2=Africa (Specify: \_\_\_\_\_)  
 3=Europe (Specify: \_\_\_\_\_)  
 4=Asia (Specify: \_\_\_\_\_)  
 5=Central and South America (Specify: \_\_\_\_\_)  
 6=Other (Specify: \_\_\_\_\_)  
 9=Unknown
- D7. Total Sample Size: \_\_\_\_\_
- D8. Mean Age of total sample: \_\_\_\_\_ years
- D9. +/- SD \_\_\_\_\_ in mean age total sample
- D10. Age range, lowest \_\_\_\_\_ years, total sample
- D11. Age range, highest \_\_\_\_\_ years, total sample
- D12. Median age \_\_\_\_\_ years, total sample
- D13. Study entry criteria:  
 Ethnic background: \_\_\_\_\_  
 Family history of cancer: \_\_\_\_\_  
 Others: \_\_\_\_\_
- D14. Study setting:  
 1=Population based  
 2=Hospital gynecology/colposcopy clinic  
 3=HBOC (Hereditary Breast and Ovarian Cancer) families  
 4=Other hospital clinic (Specify: \_\_\_\_\_)  
 5=Other (Specify: \_\_\_\_\_)  
 9=Unknown

D15. Description of selection of study subjects present:

1=yes

2=no

D16. Statement of response rate (follow-up rate):

1=yes, list \_\_\_\_\_

2=no

D17. Method for BRCA 1/2 testing:

1=Gene sequencing

2=Common mutation panel

3=Both

4=Other, please specify \_\_\_\_\_

8=Not applicable

9=unknown

D18. Prevalence Rates

Diagnosis	N	Prevalence rate
BRCA1 positive		
BRCA2 positive		
BRCA 1/2 positive		

D19. Probability of subsequent surveillance and therapy after BRCA 1/2 testing.

Diagnosis	p(PBM)	p(PBO)	p(Intense breast ca screening) *	p(Usual breast ca screening) <sup>1</sup>	p(Usual ovarian ca screening) <sup>2</sup>	p(Counseling)
BRCA1+						
BRCA2+						
BRCA 1/2+						
BRCA 1/2-						
No test						

\*: Mammography / CBE at every \_\_\_\_\_.

1: Annual mammography / CBE at 50 years old and above.

2: Bimanual examination only.

D20. Sensitivity and Specificity of BRCA testing-- Common mutation

Type of common mutation examined: \_\_\_\_\_

Gold standard for diagnosis: Full gene sequencing. Other: \_\_\_\_\_

	BRCA +	BRCA -	Total
Test positive			
Test negative			
Total			

D21. Age stratification of prevalence rates possible?

1=yes (GO TO D22)

2=no (STOP)

D22. Please include tables here with listing of age strata and prevalence rates.

**BRCA 1/2 NATURAL HISTORY MODEL**  
**DATA COLLECTION SHEET**

**II. Disease initiation model (prevalence & incidence)**

Reference #: \_\_\_\_\_

Reviewer initial: \_\_\_\_\_

Date: \_\_\_/\_\_\_/\_\_\_

Entered in database(Initial): \_\_\_\_\_ Date: \_\_\_/\_\_\_/\_\_\_

Origin of Data

1 = published paper

2 = letter to editor

3= Other, please specify \_\_\_\_\_

**If total number of subjects  $\geq$  5, proceed; if fewer, stop.**

**Inclusion questions**

S1. Study sample BRCA positive?

1=Yes

2=No (**STOP**)

S2. Data on (circle all that apply) present:

1= Prevalence of breast cancer

2= Prevalence of ovarian cancer

3= Incidence of breast cancer

4= Incidence of ovarian cancer

5=None of the above (**STOP**)

S3. Meet criteria for potential eligibility?

1=Yes (**CONTINUE**)

2=No (**STOP**)

**Data Elements**

D1. Raw data presented in sufficient detail for re-analysis:

1=yes (**CONTINUE**)

2=no (**STOP**)

3=unsure (**CONFERENCE**)

D2. Study Design:

1=cohort

2=case-control

3=cross-sectional

4=case series (N>5)

5=Other (specify \_\_\_\_\_)

9=Unknown

- D3. Year of Publication: 19\_\_
- D4. Year of data collection:  
 Start: 19\_\_  
 Finish: 19\_\_
- D5. Country  
 1=US (Specify city: \_\_\_\_\_)  
 2=Africa (Specify: \_\_\_\_\_)  
 3=Europe (Specify: \_\_\_\_\_)  
 4=Asia (Specify: \_\_\_\_\_)  
 5=Central and South America (Specify: \_\_\_\_\_)  
 6=Other (Specify: \_\_\_\_\_)  
 9=Unknown
- D6. Total Sample Size: \_\_\_\_\_
- D7. Mean Age of total sample: \_\_\_\_\_ years
- D8. +/- SD \_\_\_\_\_ in mean age total sample
- D9. Age range, lowest \_\_\_\_ years, total sample
- D10. Age range, highest \_\_\_\_ years, total sample
- D11. Median age \_\_\_\_ years, total sample
- D12. Study entry criteria:  
 Ethnic background: \_\_\_\_\_  
 Family history of cancer: \_\_\_\_\_  
 Others: \_\_\_\_\_
- D13. Study setting:  
 1=Population based  
 2=Hospital gynecology/colposcopy clinic  
 3=HBOC (Hereditary Breast and Ovarian Cancer) families  
 4=Other hospital clinic (Specify: \_\_\_\_\_)  
 5=Other (Specify: \_\_\_\_\_)  
 9=Unknown
- D14. Description of selection of study subjects present:  
 1=yes  
 2=no

D15. Statement of response rate:  
 1=yes, list \_\_\_\_\_  
 2=no

D16. Method for BRCA 1/2 testing:  
 1=Gene sequencing  
 2=Common mutation panel  
 3=Both  
 4=Other, please specify \_\_\_\_\_  
 8=Not applicable  
 9=unknown

D27. Breast cancer prevalence and incidence rates for BRCA+ subjects:

Diagnosis	Breast Cancer Prevalence		Breast Cancer Incidence		
	N	Rate	N	Rate	Time interval
BRCA1 +					
BRCA2 +					
BRCA 1/2 +					

D18. Ovarian cancer prevalence and incidence rates for BRCA+ subjects:

Diagnosis	Ovarian Cancer Prevalence		Ovarian Cancer Incidence		
	N	Rate	N	Rate	Time interval
BRCA1 +					
BRCA2 +					
BRCA 1/2 +					

D19. Age stratification of results possible?  
 1=yes  
 2=no

D20. If age stratification possible, please include tables here with listing of strata.



**BRCA 1/2 NATURAL HISTORY MODEL**  
**DATA COLLECTION SHEET**

**III. Breast/Ovarian Cancer Surveillance (Sensitivity & Specificity)**

Reference #: \_\_\_\_\_

Reviewer initial: \_\_\_\_\_

Date: \_\_\_/\_\_\_/\_\_\_

Entered in database(Initial): \_\_\_\_\_ Date: \_\_\_/\_\_\_/\_\_\_

Origin of Data

1 = published paper

2 = letter to editor

3= Other, please specify \_\_\_\_\_

**If total number of subjects  $\geq 5$ , proceed; if fewer, stop.**

**Inclusion Questions**

S1. Data on cancer surveillance (circle all that apply) present:

1=Mammography/CBE for breast cancer

2=Bimanual examination for ovarian cancer

3=Trans-vaginal ultrasound (TVU) for ovarian cancer

4=CA-125 for ovarian cancer

8=None of the above (STOP)

9=Other (CONFERENCE)

S2. Data on **sensitivity and specificity** of the above surveillance tests present?

1=yes (CONTINUE)

2=no (STOP)

S3. Results of the surveillance test blinded to screening diagnosis?

1=Yes

2=No (STOP)

3=Unknown (CONFERENCE)

S4. Meet criteria for potential eligibility?

1=yes (CONTINUE)

2=no (STOP)

**Data Elements**

D1. Raw data presented in sufficient detail for re-analysis:

1=yes (CONTINUE)

2=no (STOP)

3=unsure (CONFERENCE)

- D2. Study sample?  
 1=women at risk for breast cancer (defined as having suspicious lesions found in mammography or CBE)  
 2=women at risk for ovarian cancer (with suspicious lesions)  
 3= women with breast cancer (STOP)  
 4=women with ovarian cancer (STOP)  
 5=healthy and at-risk women (Keep if separate analysis for the at-risk women is possible)  
 5=healthy women (no suspicions of cancer)  
 6=other (Specify: \_\_\_\_\_)  
 9=unknown
- D3. Study Design:  
 1=cohort  
 2=case-control  
 3=cross-sectional  
 4=case series (N>5)  
 5=Other (specify \_\_\_\_\_)  
 9=Unknown
- D4. Year of Publication: 19\_\_
- D5. Year of data collection:  
 Start: 19\_\_  
 Finish: 19\_\_
- D6. Country  
 1=US (Specify city: \_\_\_\_\_)  
 2=Africa (Specify: \_\_\_\_\_)  
 3=Europe (Specify: \_\_\_\_\_)  
 4=Asia (Specify: \_\_\_\_\_)  
 5=Central and South America (Specify: \_\_\_\_\_)  
 6=Other (Specify: \_\_\_\_\_)  
 9=Unknown
- D7. Total Sample Size: \_\_\_\_\_
- D8. Mean Age of total sample: \_\_\_\_\_ years
- D9. +/- SD \_\_\_\_\_ in mean age total sample
- D10. Age range, lowest \_\_\_\_\_ years, total sample
- D11. Age range, highest \_\_\_\_\_ years, total sample
- D12. Median age \_\_\_\_\_ years, total sample

D13. Study setting:  
 1=Population based  
 2=Hospital gynecology/colposcopy clinic  
 3=Other hospital clinic (Specify: \_\_\_\_\_)  
 4=Other (Specify: \_\_\_\_\_)  
 9=Unknown

D14. Description of selection of study subjects present:  
 1=yes  
 2=no

D15. Statement of response rate:  
 1=yes, list \_\_\_\_\_  
 2=no

D16. Gold standard diagnosis for breast cancer :  
 1=Mastectomy, lumpectomy, or excisional biopsy  
 2=Core biopsy, FNA, or sterotactic needle  
 3=Clinical follow-up  
 (Min. duration \_\_\_\_\_ mos. Average duration \_\_\_\_\_ mos.)  
 4=Other (specify: \_\_\_\_\_)  
 8=Not applicable  
 9=Unkonwn

D17. Gold standard diagnosis for ovarian cancer:  
 1= Oophorectomy  
 1= Ovarian biopsy  
 3=Clinical follow-up  
 (Min. duration \_\_\_\_\_ mos. Average duration \_\_\_\_\_ mos.)  
 4=Other (specify: \_\_\_\_\_)  
 8=Not applicable  
 9=Unkonwn

D18. Sensitivity and Specificity of mammography for patients with breast cancer.

#Pts with breast cancer	Breast cancer (+)	Breast cancer (-)	Total
Mammography (+)			
Mammography (-)			
Total			

D19. Sensitivity and Specificity of CBE patients with breast cancer.

#Pts with breast cancer	Breast cancer (+)	Breast cancer (-)	Total
CBE (+)			
CBE (-)			
Total			

D20. Sensitivity and Specificity of mammography/CBE for patients with breast cancer.

#Pts with breast cancer	Breast cancer (+)	Breast cancer (-)	Total
Mammography/CBE (+)			
Mammography/CBE (-)			
Total			

D21. Age stratification of sensitivity and specificity of mammography possible?

1=yes (GO TO D22)

2=no (GO TO D 23)

D22. If age stratification possible, please include tables here with listing of strata.

D23. Sensitivity and Specificity of bimanual examination for patients with ovarian cancer.

#Pts with ovarian cancer	Ovarian cancer (+)	Ovarian cancer (-)	Total
Bimanual exam (+)			
Bimanual exam (-)			
Total			

D24. Sensitivity and Specificity of trans-vaginal ultrasound (TVU) for patients with ovarian cancer.

#Pts with ovarian cancer	Ovarian cancer (+)	Ovarian cancer (-)	Total
TVU (+)			
TVU (-)			
Total			

D25. Sensitivity and Specificity of CA-125 for patients with ovarian cancer.

#Pts with ovarian cancer	Ovarian cancer (+)	Ovarian cancer (-)	Total
CA-125 (+)			
CA-125 (-)			
Total			

**BRCA 1/2 NATURAL HISTORY MODEL**  
**DATA COLLECTION SHEET**

**IV. Cancer initiation (Cancer staging by surveillance methods)**

Reference #: \_\_\_\_\_

Reviewer initial: \_\_\_\_\_

Date: \_\_\_/\_\_\_/\_\_\_

Entered in database(Initial): \_\_\_\_\_ Date: \_\_\_/\_\_\_/\_\_\_

Origin of Data

1 = published paper

2 = letter to editor

3= Other, please specify \_\_\_\_\_

**If total number of subjects  $\geq$  5, proceed; if fewer, stop.**

**Inclusion Questions**

S1. Data on cancer surveillance (circle all that apply) present:

1=Intense breast cancer screening

2=Prophylactic bilateral mastectomy

3=Ovarian cancer screening

4=Prophylactic bilateral oophorectomy

8=None of the above (**STOP**)

9=Unknown (**CONFERENCE**)

S2. Data on **stages of cancer diagnosis** found through the above surveillance or procedures present?

1=yes (**CONTINUE**)

2=no (**STOP**)

S3. Meet criteria for potential eligibility?

1=yes (**CONTINUE**)

2=no (**STOP**)

**Data Elements**

D1. Raw data presented in sufficient detail for re-analysis:

1=yes (**CONTINUE**)

2=no (**STOP**)

3=unsure (**CONFERENCE**)

D2. Study sample?  
1=patients at risk for breast cancer,  
Define: \_\_\_\_\_  
2=patients at risk for ovarian cancer,  
Define: \_\_\_\_\_  
3=patients with breast cancer (STOP)  
4=patients with ovarian cancer (STOP)  
5=healthy (no suspicion of cancer)  
6=other (Specify: \_\_\_\_\_)  
9=unknown

D3. Study samples were BRCA positive?  
1=Yes  
2=No  
3= Mixed  
4=Unknown

D4. Study Design:  
1=cohort  
2=case-control  
3=cross-sectional  
4=case series (N>5)  
5=Other (specify \_\_\_\_\_)  
9=Unknown

D5. Year of Publication: 19\_\_

D6. Year of data collection:  
Start: 19\_\_  
Finish: 19\_\_

D7. Country  
1=US (Specify city: \_\_\_\_\_)  
2=Africa (Specify: \_\_\_\_\_)  
3=Europe (Specify: \_\_\_\_\_)  
4=Asia (Specify: \_\_\_\_\_)  
5=Central and South America (Specify: \_\_\_\_\_)  
6=Other (Specify: \_\_\_\_\_)  
9=Unknown

D8. Total Sample Size: \_\_\_\_\_

D9. Mean Age of total sample: \_\_\_\_\_ years

D10. +/- SD \_\_\_\_\_ in mean age total sample

D11. Age range, lowest \_\_\_\_ years, total sample

D12. Age range, highest \_\_\_\_ years, total sample

D13. Median age \_\_\_\_ years, total sample

D14. Study setting:

- 1=Population based
- 2=Hospital gynecology/colposcopy clinic
- 3=Other hospital clinic (Specify: \_\_\_\_\_)
- 4=Other (Specify: \_\_\_\_\_)
- 9=Unknown

D15. Description of selection of study subjects present:

- 1=yes
- 2=no

D16. Statement of response rate:

- 1=yes, list \_\_\_\_\_
- 2=no

D17. Types of breast cancer classification used:

- 1=SEER (local, regional, distant)
- 2=TNM
- 3=AJCC
- 4=Other, specify: \_\_\_\_\_
- 5=Not applicable

D18. Types of ovarian cancer classification used:

- 1=SEER (local, regional, distant)
- 2=FIGO
- 3=AJCC
- 4=Other, specify: \_\_\_\_\_
- 5=Not applicable

D19. Frequency of stages of breast cancer found by intense screening or PBM:

Definition of intense breast cancer screening: \_\_\_\_\_

	In situ (%)	Local (%)	Regional (%)	Distant (%)	Time interval
Intense screening					
PBM					



D20. Frequency of stages of ovarian cancer found by screening or PBO:

Definition of intense breast cancer screening: \_\_\_\_\_

	In situ (%)	Local (%)	Regional (%)	Distant (%)	Time interval
Bimanual exam.					
Intense screening					
PBO					

D21. Age stratification of results possible?

1=yes

2=no

D22. If age stratification possible, please include tables here with listing of strata.

**BRCA 1/2 NATURAL HISTORY MODEL**  
**DATA COLLECTION SHEET**

**V.1. Breast cancer treatment by stages**

Reference #: \_\_\_\_\_

Reviewer initial: \_\_\_\_\_

Date: \_\_\_/\_\_\_/\_\_\_

Entered in database(Initial): \_\_\_\_\_ Date: \_\_\_/\_\_\_/\_\_\_

Origin of Data

1 = published paper

2 = letter to editor

3= Other, please specify \_\_\_\_\_

**If total number of subjects  $\geq$  5, proceed; if fewer, stop.**

**Inclusion Questions**

S1. Data on **stages of breast cancer** present?

1=yes

2=no (**STOP**)

S2. Data on breast cancer treatment available?

1=Yes

2=No (**STOP**)

S3. Data on types of treatment received at certain breast cancer stages available?

1=Yes

2=No (**STOP**)

**Data Elements**

D1. Raw data presented in sufficient detail for re-analysis:

1=yes

2=no (**STOP**)

3=unsure (**CONFERENCE**)

D2. Study samples were BRCA positive?

1=Yes

2=No

3=Mixed

4=Unknown

- D3. Study Design:  
 1=cohort  
 2=case-control  
 3=cross-sectional  
 4=case series (N>5)  
 5=Other (specify \_\_\_\_\_)  
 9=Unknown
- D4. Year of Publication: 19\_\_
- D5. Year of data collection:  
 Start: 19\_\_  
 Finish: 19\_\_
- D6. Country  
 1=US (Specify city: \_\_\_\_\_)  
 2=Africa (Specify: \_\_\_\_\_)  
 3=Europe (Specify: \_\_\_\_\_)  
 4=Asia (Specify: \_\_\_\_\_)  
 5=Central and South America (Specify: \_\_\_\_\_)  
 6=Other (Specify: \_\_\_\_\_)  
 9=Unknown
- D7. Total Sample Size: \_\_\_\_\_
- D8. Mean Age of total sample: \_\_\_\_\_ years
- D9. +/- SD \_\_\_\_\_ in mean age total sample
- D10. Age range, lowest \_\_\_\_ years, total sample
- D11. Age range, highest \_\_\_\_ years, total sample
- D12. Median age \_\_\_\_ years, total sample
- D13. Study setting:  
 1=Population based  
 2=Hospital gynecology/colposcopy clinic  
 3=Other hospital clinic (Specify: \_\_\_\_\_)  
 4=Other (Specify: \_\_\_\_\_)  
 9=Unknown
- D14. Description of selection of study subjects present:  
 1=yes  
 2=no

D15. Statement of response rate:  
 1=yes, list \_\_\_\_\_  
 2=no

D16. Types of breast cancer classification used:  
 1=SEER (local, regional, distant)  
 2=TNM  
 3=AJCC  
 4=Other, specify: \_\_\_\_\_  
 5=Not applicable

D17. Type of breast cancer surgery:  
 1=Mastectomy  
 2=Breast conserving surgery (BCS)  
 3=Prophylactic bilateral mastectomy (PBM)  
 4=Other, specify: \_\_\_\_\_  
 5=None

D18. Radiation therapy?  
 1=Yes  
 2=No  
 3=Unknown

D19. Axillary node dissection (AND)?  
 1=Yes  
 2=No  
 3=Unknown

D20. Chemotherapy?  
 1=Adjuvant  
 2= Neo-adjuvant  
 3=None

D21. Hormonal therapy (Tamoxifen)?  
 1=Yes  
 2=No  
 3=Unknown

D22. Frequency of types of breast cancer treatment by stages:

Check tx types from D17-D21					Local (%)	Regional (%)	Distant (%)
D17	D18	D19	D20	D21			
Total (by stage)					100%	100%	100%

D23. Age stratification of results possible?

1=yes

2=no

D24. If age stratification possible, please include tables here with listing of strata.

**BRCA 1/2 NATURAL HISTORY MODEL**  
DATA COLLECTION SHEET

**V.2. Ovarian cancer treatment by stages**

Reference #: \_\_\_\_\_

Reviewer initial: \_\_\_\_\_

Date: \_\_\_/\_\_\_/\_\_\_

Entered in database(Initial): \_\_\_\_\_ Date: \_\_\_/\_\_\_/\_\_\_

Origin of Data

1 = published paper

2 = letter to editor

3= Other, please specify \_\_\_\_\_

**If total number of subjects  $\geq$  5, proceed; if fewer, stop.**

**Inclusion Questions**

S1. Data on **stages of ovarian cancer** present?

1=yes

2=no (**STOP**)

S2. Data on ovarian cancer treatment available?

1=Yes

2=No (**STOP**)

S3. Data on types of treatment received at certain ovarian cancer stages available?

1=Yes

2=No (**STOP**)

**Data Elements**

D1. Raw data presented in sufficient detail for re-analysis:

1=yes

2=no (**STOP**)

3=unsure (**CONFERENCE**)

D2. Study samples were BRCA positive?

1=Yes

2=No

3=Mixed

4=Unknown

D3. Study Design:

1=cohort

2=case-control

3=cross-sectional

4=case series (N>5)

5=Other (specify \_\_\_\_\_)

9=Unknown

- D4. Year of Publication: 19\_\_
- D5. Year of data collection:  
 Start: 19\_\_  
 Finish: 19\_\_
- D6. Country  
 1=US (Specify city: \_\_\_\_\_)  
 2=Africa (Specify: \_\_\_\_\_)  
 3=Europe (Specify: \_\_\_\_\_)  
 4=Asia (Specify: \_\_\_\_\_)  
 5=Central and South America (Specify: \_\_\_\_\_)  
 6=Other (Specify: \_\_\_\_\_)  
 9=Unknown
- D7. Total Sample Size: \_\_\_\_\_
- D8. Mean Age of total sample: \_\_\_\_\_ years
- D9. +/- SD \_\_\_\_\_ in mean age total sample
- D10. Age range, lowest \_\_\_\_ years, total sample
- D11. Age range, highest \_\_\_\_ years, total sample
- D12. Median age \_\_\_\_ years, total sample
- D13. Study setting:  
 1=Population based  
 2=Hospital gynecology/colposcopy clinic  
 3=Other hospital clinic (Specify: \_\_\_\_\_)  
 4=Other (Specify: \_\_\_\_\_)  
 9=Unknown
- D14. Description of selection of study subjects present:  
 1=yes  
 2=no

D15. Statement of response rate:  
 1=yes, list \_\_\_\_\_  
 2=no

D16. Types of ovarian cancer classification used:  
 1=SEER (local, regional, distant)  
 2=FIGO  
 3=AJCC  
 4=Other, specify: \_\_\_\_\_  
 5=Not applicable

D17. Types of ovarian cancer treatment (Circle all that apply):  
 1=Total hysterectomy  
 2= Bilateral salpingo-oophorectomy  
 3= Unilateral salpingo-oophorectomy  
 4= Cytoreduction  
 5= Chemotherapy  
 6= Follow-up  
 7=Surgical end-staging (Second-look laparotomy)

D18. Frequency of types of ovarian cancer treatment by stages:

Type of tx from D17	Local (%)	Regional (%)	Distant (%)
Total (by stage)	100%	100%	100%

D19. Age stratification of results possible?  
 1=yes  
 2=no

D20. If age stratification possible, please include tables here with listing of strata.



**BRCA 1/2 NATURAL HISTORY MODEL**  
**DATA COLLECTION SHEET**

**VI.1. Breast cancer progression/recurrence rates**

Reference #: \_\_\_\_\_

Reviewer initial: \_\_\_\_\_

Date: \_\_\_/\_\_\_/\_\_\_

Entered in database(Initial): \_\_\_\_\_ Date: \_\_\_/\_\_\_/\_\_\_

Origin of Data

1 = published paper

2 = letter to editor

3= Other, please specify \_\_\_\_\_

**If total number of subjects  $\geq$  5, proceed; if fewer, stop.**

**Inclusion Questions**

S1. Data on **stages of breast cancer** present?

1=yes

2=no (**STOP**)

S2. Data on breast cancer treatment present?

1=Yes

2=No (**STOP**)

**Data Elements**

D1. Raw data presented in sufficient detail for re-analysis:

1=yes

2=no (**STOP**)

3=unsure (**CONFERENCE**)

D2. Data on progression/recurrence of breast cancer present?

1=Yes

2=No (**STOP**)

D3. Study samples were BRCA positive?

1=Yes

2=No

3=Mixed

4=Unknown

D4. Study Design:

1=cohort

2=case-control

- 3=cross-sectional
- 4=case series (N>5)
- 5=Other (specify \_\_\_\_\_)
- 9=Unknown

D5. Year of Publication: 19\_\_

D6. Year of data collection:

Start: 19\_\_

Finish: 19\_\_

D7. Country

1=US (Specify city: \_\_\_\_\_)

2=Africa (Specify: \_\_\_\_\_)

3=Europe (Specify: \_\_\_\_\_)

4=Asia (Specify: \_\_\_\_\_)

5=Central and South America (Specify: \_\_\_\_\_)

6=Other (Specify: \_\_\_\_\_)

9=Unknown

D8. Total Sample Size: \_\_\_\_\_

D9. Mean Age of total sample: \_\_\_\_\_ years

D10. +/- SD \_\_\_\_\_ in mean age total sample

D11. Age range, lowest \_\_\_\_\_ years, total sample

D12. Age range, highest \_\_\_\_\_ years, total sample

D13. Median age \_\_\_\_\_ years, total sample

D14. Study setting:

1=Population based

2=Hospital gynecology/colposcopy clinic

3=Other hospital clinic (Specify: \_\_\_\_\_)

4=Other (Specify: \_\_\_\_\_)

9=Unknown

- D15. Description of selection of study subjects present:  
1=yes  
2=no
- D16. Statement of response rate:  
1=yes, list \_\_\_\_\_  
2=no
- D17. Types of breast cancer classification used:  
1=SEER (local, regional, distant)  
2=TNM  
3=AJCC  
4=Other, specify: \_\_\_\_\_  
5=Not applicable
- D18. Type of breast cancer surgery:  
1=Mastectomy  
2=Breast conserving surgery (BCS)  
3=Prophylactic bilateral mastectomy (PBM)  
4=Other, specify: \_\_\_\_\_  
5=None
- D19. Radiation therapy?  
1=Yes  
2=No  
3=Unknown
- D20. Axillary node dissection (AND)?  
1=Yes  
2=No  
3=Unknown
- D21. Chemotherapy?  
1=Adjuvant  
2= Neo-adjuvant  
3=None
- D22. Hormonal therapy (Tamoxifen)?  
1=Yes  
2=No  
3=Unknown

D23. Cancer progression / recurrence:

Progression: New cancer found at a higher stage than the starting stage.

Recurrence: New cancer found at the same stage as the starting stage.

Starting stage	Number	F/U outcomes	Number	Rate of change	F/U time period
Local		No change			
		Complication			
		Recurrence (local)			
		Regional			
		Distant			
Regional		No Change			
		Complication			
		Recurrence (local/regional)			
		Distant			
Distant		Median survival			
		5-year survival			
		Annual mortality			

D24. Age stratification of results possible?

1=yes

2=no

D25. If age stratification possible, please include tables here with listing of strata.

**BRCA 1/2 NATURAL HISTORY MODEL**  
**DATA COLLECTION SHEET**

**VI.2. Ovarian cancer progression/recurrence**

Reference #: \_\_\_\_\_

Reviewer initial: \_\_\_\_\_

Date: \_\_\_/\_\_\_/\_\_\_

Entered in database(Initial): \_\_\_\_\_ Date: \_\_\_/\_\_\_/\_\_\_

Origin of Data

1 = published paper

2 = letter to editor

3= Other, please specify \_\_\_\_\_

**If total number of subjects  $\geq$  5, proceed; if fewer, stop.**

**Inclusion Questions**

S1. Data on **stages of ovarian cancer** present?

1=yes

2=no (**STOP**)

S2. Data on ovarian cancer treatment present?

1=Yes

2=No (**STOP**)

**Data Elements**

D1. Raw data presented in sufficient detail for re-analysis:

1=yes

2=no (**STOP**)

3=unsure (**CONFERENCE**)

D2. Data on progression/recurrence of ovarian cancer present?

1=Yes

2=No (**STOP**)

D3. Study samples were BRCA positive?

1=Yes

2=No

3=Mixed

4=Unknown

D4. Study Design:

1=cohort

2=case-control

3=cross-sectional

4=case series (N>5)

5=Other (specify \_\_\_\_\_)

9=Unknown

D5. Year of Publication: 19\_\_

D6. Year of data collection:

Start: 19\_\_

Finish: 19\_\_

D7. Country

1=US (Specify city: \_\_\_\_\_)

2=Africa (Specify: \_\_\_\_\_)

3=Europe (Specify: \_\_\_\_\_)

4=Asia (Specify: \_\_\_\_\_)

5=Central and South America (Specify: \_\_\_\_\_)

6=Other (Specify: \_\_\_\_\_)

9=Unknown

D8. Total Sample Size: \_\_\_\_\_

D9. Mean Age of total sample: \_\_\_\_\_ years

D10. +/- SD \_\_\_\_\_ in mean age total sample

D11. Age range, lowest \_\_\_\_ years, total sample

D12. Age range, highest \_\_\_\_ years, total sample

D13. Median age \_\_\_\_ years, total sample

D14. Study setting:

1=Population based

2=Hospital gynecology/colposcopy clinic

3=Other hospital clinic (Specify: \_\_\_\_\_)

4=Other (Specify: \_\_\_\_\_)

9=Unknown

D15. Description of selection of study subjects present:

1=yes

2=no

D16. Statement of response rate:

1=yes, list \_\_\_\_\_

2=no

D17. Types of ovarian cancer classification used:

1=SEER (local, regional, distant)

2=FIGO

3=AJCC

4=Other, specify: \_\_\_\_\_

5=Not applicable

D18. Types of ovarian cancer treatment (Circle all that apply):

1=Total hysterectomy

2= Bilateral salpingo-oophorectomy

3= Unilateral salpingo-oophorectomy

4= Cytoreduction

5= Chemotherapy

6= Follow-up

7=Surgical end-staging (Second-look laparotomy)

D19. Cancer progression / recurrence:

Progression: New cancer found at a higher stage than the starting stage.

Recurrence: New cancer found at the same stage as the starting stage.

Starting stage	Number	F/U outcomes	Number	Rate of change	F/U time period
Local		No change			
		Complication			
		Recurrence (local)			
		Regional			
		Distant			
Regional		No Change			
		Complication			
		Recurrence (local/regional)			
		Distant			
Distant		Median survival			
		5-year survival			
		Annual mortality			

D20. Age stratification of results possible?  
1=yes  
2=no

D21. If age stratification possible, please include tables here with listing of strata.



**BRCA 1/2 NATURAL HISTORY MODEL**  
DATA COLLECTION SHEET

**VII. Cancer incidence after surgical or chemo- prophylaxis**

Reference #: \_\_\_\_\_

Reviewer initial: \_\_\_\_\_

Date: \_\_\_/\_\_\_/\_\_\_

Entered in database(Initial): \_\_\_\_\_ Date: \_\_\_/\_\_\_/\_\_\_

Origin of Data

1 = published paper

2 = letter to editor

3= Other, please specify \_\_\_\_\_

**If total number of subjects  $\geq$  5, proceed; if fewer, stop.**

**Inclusion Questions**

S1. Data on prophylaxis (circle all that apply) present:

1=Prophylactic bilateral mastectomy

2=Prophylactic bilateral oophorectomy

3=Tomaxifen prophylaxis

4=Raloxifene prophylaxis

8=None of the above (STOP)

S2. Data on **incidence of cancer developed after prophylaxis** present?

1=yes (CONTINUE)

2=no (STOP)

S3. Meet criteria for potential eligibility?

1=yes (CONTINUE)

2=no (STOP)

**Data Elements**

D1. Raw data presented in sufficient detail for re-analysis:

1=yes (CONTINUE)

2=no (STOP)

3=unsure (CONFERENCE)

D2. Study sample?

1=patients at risk for breast cancer,

Define: \_\_\_\_\_  
2=patients at risk for ovarian cancer,  
Define: \_\_\_\_\_  
6=other (Specify: \_\_\_\_\_)  
9=unknown

D3. Study samples were BRCA1 or BRCA2 positive?

1=Yes, BRCA1 positive.  
2=Yes, BRCA2 positive.  
3=Yes, either BRCA1 or BRCA2 positive.  
4=Yes, BRCA1 and BRCA2 positive.  
5=No.  
6=Unknown

D4. Study Design:

1=cohort  
2=case-control  
3=cross-sectional  
4=case series (N>5)  
5=Other (specify \_\_\_\_\_)  
9=Unknown

D5. Year of Publication: 19\_\_

D6. Year of data collection:

Start: 19\_\_  
Finish: 19\_\_

D7. Country

1=US (Specify city: \_\_\_\_\_)  
2=Africa (Specify: \_\_\_\_\_)  
3=Europe (Specify: \_\_\_\_\_)  
4=Asia (Specify: \_\_\_\_\_)  
5=Central and South America (Specify: \_\_\_\_\_)  
6=Other (Specify: \_\_\_\_\_)  
9=Unknown

D8. Total Sample Size: \_\_\_\_\_

D9. Mean Age of total sample: \_\_\_\_\_ years

D10. +/- SD \_\_\_\_\_ in mean age total sample

D11. Age range, lowest \_\_\_\_\_ years, total sample

D12. Age range, highest \_\_\_\_\_ years, total sample

D13. Median age \_\_\_\_ years, total sample

D14. Study setting:

- 1=Population based
- 2=Hospital gynecology/colposcopy clinic
- 3=Other hospital clinic (Specify: \_\_\_\_\_)
- 4=Other (Specify: \_\_\_\_\_)
- 9=Unknown

D15. Description of selection of study subjects present:

- 1=yes
- 2=no

D16. Statement of response rate:

- 1=yes, list \_\_\_\_\_
- 2=no

D17. Breast cancer incidence after "PBM" or "No PBM":

	Breast CA	No breast CA	Incidence	Time interval
PBM				
No PBM				

Relative risk (No PBM vs PBM): \_\_\_\_\_

D18. Ovarian cancer incidence after PBO or "No PBO":

	Ovarian CA	No ovarian CA	Incidence	Time interval
PBO				
No PBO				

Relative risk (No PBO vs PBO): \_\_\_\_\_

D19. Breast cancer incidence after chemo-prophylaxis:

Chemo-prophylaxis	Breast CA	No breast CA	Incidence	Time interval
Tamoxifen				
No Tamoxifen				
Raloxifene				
No Raloxifene				

Relative risk (No vs Yes): \_\_\_\_\_

D20. Ovarian cancer incidence after chemo-prophylaxis:

Chemo-prophylaxis	Breast CA	No breast CA	Incidence	Time interval
Tamoxifen				
No Tamoxifen				
Raloxifene				
No Raloxifene				

Relative risk (No vs Yes): \_\_\_\_\_

D21. Age stratification of results possible?

1=yes

2=no

D22. If age stratification possible, please include tables here with listing of strata.

## **Appendix 2**

### **Protocol for Administration of CABCAD Participant Satisfaction Survey**

# TRAINING MANUAL FOR IMPLEMENTING CABCAD PARTICIPANT SATISFACTION SURVEY

## INTRODUCTION

The Participant Satisfaction Survey for the "A Coordinated Approach to the Diagnosis of Breast Cancer" study (CABCAD) is designed to measure the economic and satisfaction outcomes for study participants. It includes measures of participant time and travel costs, convenience, satisfaction, test acceptability, and preferences for the diagnostic tests.

The survey has been approved by IRB (#22-96) and the following instructions coincide with the descriptions in both the study protocol and the participant consent form. Informed consent is obtained as part of the CBD/CAB informed consent. Participants are asked to complete the survey which should take about 10 minutes to complete. Participants need not answer all the questions if they do not want to, but they can still participate in this study.

## MODE OF SURVEY ADMINISTRATION

The survey is designed for self-administration: Participants answer the questions on their own, and mark down their responses on the survey form. An introductory paragraph to participants on the first page helps them to understand the content of the survey.

If a participant is not capable of filling out the surveys by herself due to weakness resulting from the disease, the study coordinator should read the questions and categories of answers to the participant, and write down (circle down) the responses the participant gives.

## RESPONSIBILITIES OF THE STUDY COORDINATOR

At the end of each clinical visit, the study coordinator should:

- (1) Write down the participant identification number on the provided space on the upper right corner of the first page of the survey;
- (2) Hand the survey to the participant and ask the participant to complete the survey;
- (3) Inform participants of the purpose and the time needed for completing the survey, encourage participants to ask questions if they can not understand the meaning of any survey questions, and remind them to turn in the completed survey before they leave;

(Sample: Introductory conversation)

*Thank you again for participating in our program. Before you leave, I'd like to ask you to fill out the Participant Satisfaction Survey. This survey is designed to help us understand how you felt about the tests. Your answers will help us to improve things for future women like yourself. It will take approximately 10 minutes to complete the survey. If you have any questions about the survey or difficulties in filling out the survey, please let me know. I'll be happy to help you. Please return the completed survey to me when you finish.*

- (4) Explain the meaning of the questions to participants asking for help (See instructions below);
- (5) Collect completed surveys;
- (6) Check for completeness of the survey. If participants leave some of the questions blank (except the last question which is optional), ask if they want to answer those questions before they leave. If they do not wish to complete an answer, then leave it blank. Only one answer should be chosen or filled out for each question except for the open-ended question (Question 24).

After the visit, the study coordinator should:

- (1) Make a copy of the completed surveys;
- (2) Send the copy to Wenchi Liang at Cancer Clinical and Economic Outcomes Core;
- (3) File the original surveys in a safe and organized place for data entry.

## THE SURVEY QUESTIONS

The Patient Satisfaction Survey includes five sets of questions:

### (1) Time/travel arrangement (Questions 1-8)

1. *How did you get to Georgetown for the tests?*
2. *Are you employed outside of the home?*
3. *Did you take off from work to participate in this study?*
4. *Will you receive compensation for your time off work, such as personal leave, sick time, or vacation time?*
5. *Did you need to arrange for child care, spouse, or parent care while here taking the tests?*
6. *How much total time did you spend traveling from your home to Georgetown for the tests?*
7. *Once you got here, how much time did you spend getting all of the tests today, including waiting time?*
8. *We would like a general estimate of the total family income during the last month for you and all family members living with you. About how much money do you have coming into your household in each month (from jobs, interest, retirement plans, social security, investments, and social services)?*

These measures include types of transportation, time arrangement, compensation for taking off from work for the study, travel time, and waiting time. These items are particularly important when analyzing the total cost of the tests a participant receives through the study.

It should be noted that types of transportation (Question 1) and time spent on travel (Question 6) refer to the way participants come for the visit, not how they will use or spend when going back home. We will estimate the total travel cost by doubling the one-way cost.

### (2) Patient satisfaction (Questions 9-14)

9. *In terms of your **satisfaction**, how would you rate the tests you received at Georgetown today **overall**?*
10. *In terms of your **satisfaction**, how would you rate the **technical skills** (thoroughness, carefulness, competence) of the radiology staff?*
11. *In terms of your **satisfaction**, how would you rate the **personal manner** (courtesy, respect, sensitivity, friendliness) of the radiology staff?*

12. *In terms of your satisfaction, how would you rate convenience of getting the tests at Georgetown?*
13. *In terms of your satisfaction, how would you rate length of time spent waiting for the tests / in between tests?*
14. *In terms of your satisfaction, how would you rate explanation of what was done for you?*

We ask participants' degree of satisfaction with the tests as a whole, the technical skills and the personal manner of the radiology staff, the convenience of the study site, the time spent in waiting, and the explanation of the study and tests they received. These measures are an adaptation of the Medical Outcomes Study Visit Rating Questionnaire, a standardized questionnaire of satisfaction with health care. The participant should rate their experience from the study overall, not just one particular test. The next questions ask about individual tests.

(3) Test acceptability (Questions 15-20)

15. a) *How would you rate the level of discomfort that you experienced from a routine mammogram?*  
b) *How embarrassing was it for you to have a routine mammogram?*
16. a) *Compared to a routine mammogram how would you rate the level of discomfort that you experienced from the ultrasound test (sonogram, breast covered with jelly and checked in the mammography machine)?*  
b) *How embarrassing was it for you to have the ultrasound test?*
17. a) *Compared to a routine mammogram how would you rate the level of discomfort that you experienced from the MRI test (breast pictures taken while you lay on a table for 15 to 20 minutes)?*  
b) *How embarrassing was it for you to have the MRI test?*
18. a) *Compared to a routine mammogram how would you rate the level of discomfort that you experienced from the digital mammography test (the procedure similar to a routine mammogram)?*  
b) *How embarrassing was it for you to have the digital mammography test?*
19. a) *Compared to a routine mammogram how would you rate the level of discomfort that you experienced from the Sestamibi test (Nuclear image, breast pictures obtained on two different machines following a single injection of a trace amount of radioactive medicine into your vein)?*  
b) *How embarrassing was it for you to have the Sestamibi test?*
20. a) *Compared to a routine mammogram how would you rate the level of discomfort that you experienced from the nipple aspirate test (using a breast pump to extract a small amount of the fluid from the nipple) ?*  
b) *How embarrassing was it for you to have the nipple aspirate test?*

Participants are asked about their acceptance of the diagnostic tests they received at Georgetown. The acceptability of each test is measured by the degree of discomfort from the tests, and embarrassment associated with the test procedures, compared to a routine mammogram. Note that for each of the CABCAD tests, the level of discomfort is relative to having a routine mammogram. The participants should mark "did not receive the test" for any test they did not undergo, rather than leave the answers blank.

(4) Preferences: Willingness to pay (Questions 21-22)

*These next questions are hypothetical questions about having to pay for tests. These questions will NOT affect your bills for health care services. All tests in the project are provided at NO COST TO YOU. Your answers to these questions will help us understand how women like you might feel about the tests you had today.*



*Imagine for a moment that a woman who has had a problem on her mammogram could have a test, like one of the tests that you had today, **instead of a surgical biopsy**. If the test was **equally (100%) as good** at telling whether or not she had breast cancer, how much do you think a woman like her would be willing to pay out of her own pocket to have the test **instead of a biopsy**?*

\$ \_\_\_\_\_ .00

*(If you do not think she would be willing to pay anything, please put zero (0) in the space above.)*

*Now, again imagine for a moment that a woman who has had a problem on her mammogram could have a test, like one of the tests that you had today, **instead of a surgical biopsy**. If the test was **nearly (95%) as good** at telling whether or not she had breast cancer, how much do you think a woman like her would be willing to pay out of her own pocket to have the test **instead of a biopsy**?*

\$ \_\_\_\_\_ .00

*(If you do not think she would be willing to pay anything, please put zero (0) in the space above.)*

Purpose: These 2 questions are a measure of preference for the tests the participant had in the study today. The questions ask how much a woman would be willing to pay out of her own pocket to have one of the study tests instead of a biopsy. The first question asks the participant to imagine the test was as accurate at diagnosing cancer as the biopsy, the second asks the woman to imagine the test was almost (95%) as accurate. The more a woman is willing to pay, the more strongly the woman would prefer a test to a biopsy. These two questions are asked to better understand how much of a role diagnostic accuracy plays in preference for the tests compared to a biopsy. Note that we do not ask about a specific test, we ask the woman to think about the test that she would most prefer to have, if she had to have one of them.

#### Possible questions:

1) *Why are you asking this?* This question helps us understand how desirable or undesirable it would be for a woman to have one of the tests you had today instead of a biopsy to evaluate a breast abnormality.

2) *I had several tests today. Which test should I consider?* Whichever test you would most prefer to have, if you had to have one of the tests.

3) *What is the difference between Q21 and Q22?* In the first question, we would like to know how much you think a woman would be willing to pay if the test was just as good as a biopsy at diagnosing cancer. In the second question, we would like to know how much you think a woman would be willing to pay if the test were nearly, but not quite, as good as a biopsy at determining whether she had cancer. So, for the second question, 95 times out of 100, the test would give you the same answer as a biopsy would, but 5 times out of 100 it might tell that there was no cancer when a biopsy would have shown cancer, or that the test would show a cancer that wasn't found to be there by biopsy.

4) *How much should I pay?* There is no wrong answer to this; we just want to know how you feel about this. What do you think would be the most a woman in this situation would pay?

5) *Does insurance pay anything for the test? Does the woman have insurance?* While insurance might or might not pay part of the bill, we are not concerned with that part. How much do you think a women would be willing to *pay out of her own pocket*, regardless of whether or not she has insurance, or whether insurance covered costs additional to what she had to py on her own.

(5) Concluding questions (Question 23-24)

Participants are asked about their perceived vulnerability of getting breast cancer, compared to other women of the same age. Lastly, they are encouraged to give comments and suggestions on any aspects of the study from their experiences as participants. If the participant has any question about Question 24, please encourage them to note anything they think that we should know about their experience on the study.

If any questions are raised by the patients or in special occasions that the study coordinator does not know how to answer or deal with, the study coordinator should report to the Wenchi Liang immediately in order to maintain a consistent and straightforward mode of survey administration.

The original CABCAD Participant Satisfaction Survey is attached for reference.

## Participant Satisfaction Survey

### Georgetown University Medical Center Lombardi Cancer Center/ Radiology Department

We would like to thank you again for participating in our program. Now that you have had the tests, we would like to ask some questions to help us understand how you felt about the tests. Your opinion is important to us. Your answers will help us to improve things for future women like yourself. Remember, answering these questions does not affect the care that you will receive here at Georgetown, or from your regular health care provider. You do not have to answer any question you do not want to. All of your answers will be confidential, and we will not use your name. If you have any questions about how to fill out this survey, Miriam Mullins would be happy to help you.

Please **circle the one** most appropriate answer  
for each of the following questions.

First, we'd like to ask you some questions about how coming for these tests affects you.

1. How did you get to Georgetown for the tests? (Circle one)

Personal car, either drove self or brought by friend or relative	1
Taxi cab	2
Public transportation (bus, train, Metro subway; etc.)	3
Hospital/clinic supplied transportation	4
Walked	5
Community-based organization supplied transportation (including church, shelter, senior citizens center; etc.)	6
Other (Please write in what this was):	77
Do not want to answer	99

2. Are you employed outside of the home? (Circle one)

Yes (PLEASE GO TO QUESTION 3.)	1
No (PLEASE GO TO QUESTION 5.)	2
Do not want to answer	99

3. Did you take off from work to participate in this study? (Circle one)

Yes (PLEASE GO TO QUESTION 4.)	1
No (PLEASE GO TO QUESTION 5.)	2
Do not want to answer	99

4. Will you receive compensation for your time off work, such as personal leave, sick time, or vacation time? (Circle one)

Yes	1
No	2
Do not want to answer	99

5. Did you need to arrange for child care, spouse, or parent care while here taking the tests? (Circle one)

Yes	1
No	2
Do not want to answer	99

6. How much total time did you spend traveling from your home to Georgetown for the tests? (Circle one)

<10 minutes	1
10-29 minutes	2
30-59 minutes	3
One hour or more	4
Don't know / unsure	88
Do not want to answer	99

7. Once you got here, how much time did you spend getting all of the tests today, including waiting time? (Circle one)

0 to just under 2 hrs	1
2 to just under 4 hrs	2
4 to just under 6 hrs	3
6 to just under 8 hrs	4
> 8 hrs	5
Don't know / unsure	88
Do not want to answer	99

8. We would like a general estimate of the total family income during the last month for you and all family members living with you. About how much money do you have coming into your household in each month (from jobs, interest, retirement plans, social security, investments, and social services)? (Circle one)

Less than \$ 1,000	1
\$1,000 to \$1,999	2
\$2,000 to \$2,999	3
\$3,000 to \$3,999	4
\$4,000 to \$4,999	5
\$5,000 or more	6
Don't know / unsure	88
Do not want to answer	99

From question 9 to question 14 are questions about your satisfaction with your visit to Georgetown and the tests that you had today.

9. In terms of your **satisfaction**, how would you rate the tests you received at Georgetown today **overall**? (Circle one)

Excellent	1
Very Good	2
Good	3
Fair	4
Poor	5
Don't know / unsure	88
Do not want to answer	99

10. In terms of your **satisfaction**, how would you rate the **technical skills** (thoroughness, carefulness, competence) of the radiology staff? (Circle one)

Excellent	1
Very Good	2
Good	3
Fair	4
Poor	5
Don't know / unsure	88
Do not want to answer	99

11. In terms of your **satisfaction**, how would you rate the **personal manner** (courtesy, respect, sensitivity, friendliness) of the radiology staff? (Circle one)

Excellent	1
Very Good	2
Good	3
Fair	4
Poor	5
Don't know / unsure	88
Do not want to answer	99

12. In terms of your **satisfaction**, how would you rate **convenience** of getting the tests at Georgetown? (Circle one)

Excellent	1
Very Good	2
Good	3
Fair	4
Poor	5
Don't know / unsure	88
Do not want to answer	99

13. In terms of your **satisfaction**, how would you rate length of **time spent waiting** for the tests / in between tests? (Circle one)

Excellent	1
Very Good	2
Good	3
Fair	4
Poor	5
Don't know / unsure	88
Do not want to answer	99

14. In terms of your **satisfaction**, how would you rate **explanation** of what was done for you? (Circle one)

Excellent	1
Very Good	2
Good	3
Fair	4
Poor	5
Don't know / unsure	88
Do not want to answer	99

Now, we'd like to ask you about the degree of **discomfort** and **embarrassment** that you experienced in having the routine mammogram you had before today's visit.

15. a) How would you rate the level of **discomfort** that you experienced from a **routine mammogram**? (Circle one)

Extremely uncomfortable	1
Very uncomfortable	2
Somewhat uncomfortable	3
Mildly uncomfortable	4
Not uncomfortable at all	5
Don't know / unsure	88
Do not want to answer	99

- b) How **embarrassing** was it for you to have a **routine mammogram**? (Circle one)

Extremely embarrassing	1
Somewhat embarrassing	2
Mildly embarrassing	3
Not embarrassing at all	4
Don't know / unsure	88
Do not want to answer	99



These next questions are about the **tests** you had today. We'd like to know the degree of **discomfort** and **embarrassment** you experienced in each of the tests you received today.

16. a) Compared to a **routine mammogram** how would you rate the level of **discomfort** that you experienced from the **ultrasound test (sonogram, breast covered with jelly and checked in the mammography machine)?** (Circle one)

A lot less	1
A little less	2
No different	3
A little more	4
A lot more	5
Did not receive the ultrasound test	77
Don't know / unsure	88
Do not want to answer	99

- b) How **embarrassing** was it for you to have the **ultrasound test**? (Circle one)

Extremely embarrassing	1
Somewhat embarrassing	2
Mildly embarrassing	3
Not embarrassing at all	4
Did not receive the ultrasound test	77
Don't know / unsure	88
Do not want to answer	99

17. a) Compared to a **routine mammogram** how would you rate the level of **discomfort** that you experienced from the **MRI test** (breast pictures taken while you lay on a table for 15 to 20 minutes)? (Circle one)

A lot less	1
A little less	2
No different	3
A little more	4
A lot more	5
Did not receive the MRI test	77
Don't know / unsure	88
Do not want to answer	99

- b) How **embarrassing** was it for you to have the **MRI test**? (Circle one)

Extremely embarrassing	1
Somewhat embarrassing	2
Mildly embarrassing	3
Not embarrassing at all	4
Did not receive the MRI test	77
Don't know / unsure	88
Do not want to answer	99

18. a) Compared to a **routine mammogram** how would you rate the level of **discomfort** that you experienced from the **digital mammography test** (the procedure similar to a routine mammogram)? (Circle one)

A lot less	1
A little less	2
No different	3
A little more	4
A lot more	5
Did not receive the digital mammography test	77
Don't know / unsure	88
Do not want to answer	99

- b) How **embarrassing** was it for you to have the **digital mammography test**? (Circle one)

Extremely embarrassing	1
Somewhat embarrassing	2
Mildly embarrassing	3
Not embarrassing at all	4
Did not receive the digital mammography test	77
Don't know / unsure	88
Do not want to answer	99

19. a) Compared to a **routine mammogram** how would you rate the level of **discomfort** that you experienced from the **Sestamibi test (Nuclear image, breast pictures obtained on two different machines following a single injection of a trace amount of radioactive medicine into your vein)?** (Circle one)

A lot less	1
A little less	2
No different	3
A little more	4
A lot more	5
Did not receive the Sestamibi test	77
Don't know / unsure	88
Do not want to answer	99

- b) How **embarrassing** was it for you to have the **Sestamibi test?** (Circle one)

Extremely embarrassing	1
Somewhat embarrassing	2
Mildly embarrassing	3
Not embarrassing at all	4
Did not receive the Sestamibi test	77
Don't know / unsure	88
Do not want to answer	99

20. a) Compared to a **routine mammogram** how would you rate the level of **discomfort** that you experienced from the **nipple aspirate test** (using a breast pump to extract a small amount of the fluid from the nipple) ? (Circle one)

A lot less	1
A little less	2
No different	3
A little more	4
A lot more	5
Did not receive the nipple aspirate test	77
Don't know / unsure	88
Do not want to answer	99

- b) How **embarrassing** was it for you to have the **nipple aspirate test**? (Circle one)

Extremely embarrassing	1
Somewhat embarrassing	2
Mildly embarrassing	3
Not embarrassing at all	4
Did not receive the nipple aspirate test	77
Don't know / unsure	88
Do not want to answer	99

ID #: \_\_\_\_\_

These next questions are hypothetical questions about having to pay for tests. These questions will NOT affect your bills for health care services. All tests in the project are provided at NO COST TO YOU. Your answers to these questions will help us understand how women like you might feel about the tests you had today.

Imagine for a moment that a woman who has had a problem on her mammogram could have a test, like one of the tests that you had today, **instead** of a surgical biopsy. If the test was **equally (100%) as good** at telling whether or not she had breast cancer, how much do you think a woman like her would be willing to pay out of her own pocket to have the test **instead of a biopsy?**

\$ \_\_\_\_\_ .00 (21)

(If you do not think she would be willing to pay anything, please put zero (0) in the space above.)

Now, again imagine for a moment that a woman who has had a problem on her mammogram could have a test, like one of the tests that you had today, **instead** of a surgical biopsy. If the test was **nearly (95%) as good** at telling whether or not she had breast cancer, how much do you think a woman like her would be willing to pay out of her own pocket to have the test **instead of a biopsy?**

\$ \_\_\_\_\_ .00 (22)

(If you do not think she would be willing to pay anything, please put zero (0) in the space above.)

Now, please turn to the next page for the last questions.

23. In your opinion, compared to other women your age, what are your chances of getting breast cancer some day? Would you say they are ... (Circle one)

Much higher	1
A little higher	2
The same	3
A little less	4
Much Less	5
Don't know / not sure	88
Do not want to answer	99

24. Is there anything that we have not asked about that you would like to tell us about? We appreciate any comments you may have about your experience today.

---



---



---



---



---

**Thank you for taking your time to complete the study today. Please give your completed survey to Miriam Mullins. If you have any further questions about the project, please feel free to contact Miriam Mullins at (202)784-3359.**

## **Appendix 3**

### **Survivorship Grant**



DESCRIPTION. State the application's broad, long-term objectives and specific aims, making reference to the health relatedness of the project. Describe concisely the research design and methods for achieving these goals. Avoid summaries of past accomplishments and the use of the first person. This description is meant to serve as a succinct and accurate description of the proposed work when separated from the application. If the application is funded, this description, as is, will become public information. Therefore, do not include proprietary/confidential information. **DO NOT EXCEED THE SPACE PROVIDED.**

Although considerable research attention has addressed the psychosocial concerns of breast cancer patients, little is known about the transition from active treatment to survivorship. Clinical experience and limited data suggest that this period can be particularly stressful. In this competing continuation, we propose to develop and evaluate a relatively low-cost psychoeducational preparatory intervention to facilitate this transition. The proposed study builds on our prior research program in quality of life and breast cancer.

In this multi-center study, we will register 1260 newly-diagnosed breast cancer patients from Los Angeles, Washington, D.C., and Kansas City, KS, one month after definitive surgery, and prospectively recruit them for participation in a randomized controlled trial (RCT) designed to test and evaluate three different intervention approaches for improving post-treatment patient outcomes. The interventions will occur after the completion of primary/adjuvant therapy. We expect to consent and randomize at least 630 women to one of 3 groups: (A) CONTROL CONDITION: standard written information (NCI publication "Facing Forward"); (B) MINIMAL INTERVENTION: control + videotape that models coping and addresses the transition from patient to survivor; and (C) HIGH INTENSITY INTERVENTION: minimal intervention + brief counseling (one in-person session with follow-up telephone call) + additional written materials. We hypothesize that a brief, preparatory intervention that includes counseling will be the most effective strategy for improving the quality of life during the transition for patient to survivor.

The specific aims of this application are: (1) to measure the impact of the 3 preparatory interventions on subsequent cognitive adaptation, and emotional, physical and interpersonal functioning, 2 and 6 months after the intervention; (2) to evaluate a model derived from self-regulation and stress and coping theories which postulates that promotion of realistic expectancies regarding the treatment transition and of specific approach-oriented coping strategies will serve as mediators of the intervention's effectiveness on adaptive outcomes; (3) to conduct an economic evaluation of the RCT strategies, and to calculate the incremental costs per unit change in specific dimensions of quality of life.

PERFORMANCE SITE(S) (organization, city, state)

University of California, Los Angeles  
 University of Southern California, Los Angeles  
 Georgetown University, Washington, D.C.  
 University of Kansas, Lawrence

KEY PERSONNEL. See instructions on Page 11. Use continuation pages as needed to provide the required information in the format shown below.

Name	Organization	Role on Project
Patricia Ganz, MD	UCLA Schools of Medicine & Public Health	Principal Investigator
Thomas Belin, PhD	UCLA Departments of Psychiatry & Biostatistics	Co-Investigator
Gail Wyatt, PhD	UCLA Department of Psychiatry & Biobehavioral Science	Co-Investigator
Beth Leedham, PhD	UCLA School of Public Health	Project Director
Antronette Yancey, MD MPH	UCLA School of Public Health	Investigator
Beth Meyerowitz, PhD	University of Southern California	Co-P.I.
Julia Rowland, PhD	Georgetown University	Co-P.I.
Jeanne Mandelblatt, MD MPH	Georgetown University	Co-Investigator
John Lynch, MD	Medlantic Research Institute	Co-Investigator
Annette Stanton, PhD	University of Kansas	Co-P.I.
Carol Fabian, MD	University of Kansas	Co-Investigator
Robert Belt, MD	Oncology & Hematology Associates of Kansas City	Consultant

## **Appendix 4**

### **Core Meeting Minutes**

## Cancer Clinical and Economic Outcomes Core

### Monthly Meeting

2:15 ~ 3:15 p.m. 10/30/97  
CPC 4<sup>th</sup> floor Conference Room

#### Members:

*Jeanne Mandelblatt, MD, MPH	Claudine Isaacs, MD
*William Lawrence, MD, MSIE	Lenora Johnson, MPH, CHES
*Caroline Burnett, RN, ScD	*Wenchi Liang, DDS, PhD
*Karen Gold, PhD	Julia Rowland, PhD
Jack Hadley, PhD	Anna Ryan Robertson, MPH, CHES
Donna Hubbard-McCree, MPH, PhD	*Kate Taylor, PhD

\* Attendees

Next Meeting: 12/11 (Thur.) 2:15 ~ 3:15 p.m. (CPC 4 <sup>th</sup> floor Conference Room)		
Person	Assignments/Tasks	Due Date
Lenora / Anna	Complete PAC cost tracking sheets (up to 11/97)	12/10/97
Bill	Develop consultation sheet	12/08/97
All	Items for CORD/STP/QOL database	12/05/97

#### DoD Breast Cancer Studies

1. Copies of the year-2 non-competitive renewal were circulated (if you have not received a copy, please contact Wenchi). Bill summarized the role of the Core in the three major DoD studies: BRCA1/2 genetic testing for breast cancer susceptibility (CARE), new coordinated breast cancer diagnostic technologies (CAB/CAD), and novel anti-angiogenic palliative treatment of metastatic breast cancer (TNP-470 with Taxol, and Thalidomide).
  - a. BRCA1/2 (CARE):

We will assess health utilities, costs, and cost-effectiveness associated with genetic testing and counseling strategies. The survey instrument to measure patient utilities and costs has been approved by IRB. Beginning in the first week of November 1997, the survey will be administered to new patients and to existing patients during their follow-up visits.
  - b. CAB/CAD:

We will assess patient satisfaction, test acceptability, costs of, and preferences for, the diagnostic tests. The survey instrument has been submitted to the IRB, once approved data collection will begin immediately. We will attempt to complete surveys retrospectively on women already in the study.
  - c. Palliative Treatments (TNP-470 with Taxol / Thalidomide):

After several revisions, investigators of the TNP-470 project have decided to pair TNP-470 with Taxol and conduct a phase-one clinical trial, in the hope that the phase-two and three trials will follow. Although the phase-three trial is the ideal setting for the outcomes analyses, we presently will assess quality-of-life, costs, and patient satisfaction in the phase-one trial to evaluate patients' responses and describe the implementation process.

We also will evaluate the on-going Thalidomide study with respect to patient satisfaction, costs, and quality-of-life, by using the same design and instruments as for the TNP-470 and Taxol study. The protocol for the TNP-470 and Taxol study has been submitted to the IRB last Thursday (10/23), and we expect the IRB addendum for the Thalidomide study to be approved next month.

2. Cost data from PAC:

The Core will be assessing the costs and impact of the PAC patient recruitment activities. Lenora is in charge of collecting these data for the three DoD projects. She will report the total costs by categories spent during the first year of the grant, and then monthly to the Outcomes Core. Wenchi will follow up with Lenora to get the cost profiles for the past year, and obtain the monthly cost summary from her each month.

3. Core Library:

We have begun to collect and sort journals, books, and articles for the Core library, which is one of the objectives under the DoD grant. If anyone has any resource information, please contribute to the library. We expect to establish a comprehensive resource center and data base for future cost-effectiveness analysis and outcomes research.

### **Core Consultations**

1. Study on tumor markers:

Daniel Hayes and Char Akewanlop are planning a study of the preferences for early detection of metastatic breast cancer through tumor marker tests among asymptomatic breast cancer patients. Because early treatment of asymptomatic metastases does not increase cure rate or survival, the study will use an educational intervention to focus on the possible emotional and quality-of-life impact of early detection tests in an environment of uncertainty. They intend to compare the difference in women's preferences for the tumor marker tests before and after patient education about the lack of effectiveness data and clinical uncertainty.

Kate and Caroline suggested they conduct focus group discussions first, then pilot the educational materials to assess the changes in decision-making between pre- and post-intervention periods, and finally implement the educational materials in a randomized trial.

Karen mentioned the importance of physician education in addition to patient education, and the possible ethical dilemma as a result of assessing preferences for procedures without clinical evidence of increased cure rate or survival (i.e. effectiveness).

2. Mechanisms for consultation:

As the consultation activities increase over time, we need a systemic mechanism to track every step from the beginning to then end. Some suggestions are listed below:

a. A cover sheet for consultation:

Including basic information about the investigators, the project, and the specific requests for outcomes consultations. Bill will review a similar sheet from biostatistical

consultations, and will welcome any inputs from members.

b. A response sheet for consultation activities:

Including the suggestions made and materials provided by the Core, and the grant support needed for the consultations and/or collaborations.

c. CORD/STP/QOL Database:

We are working with Dan Hayes and Bruce Trock on developing a clinical database on all LCC patients. The Core will take the lead on developing a minimal set of quality-of-life questions for everyone coming to the clinic. Eventually, we want to develop a quality-of-life survey administrative system that is easy to administer and comprehensive enough to capture disease-specific issues. Through CORD, we wish to obtain these data from all patients in clinic. FACT, EORTC, and CARES were discussed. Anyone who has suggestions for measures that should be collected on all clinic patients with breast cancer (to start), should e-mail them to Bill or Wenchi. Items should be brief and able to be self-administered.

## **New Grants**

1. The HPV screening study:

We will conduct cost-effectiveness analyses of HPV tests as an adjunct to Pap smear screening for cervical cancer among women aged 45 and older. The population-based utilities will be estimated from multi-attribute utility health states through focus group discussions among women with cervical cancer. We will use the primarily collected utility measures, together with the probability estimates from the literature, to develop a mathematical model of disease history, from which we can compare the CE of three screening alternatives (HPV and Pap screening, HPV alone, and Pap smear alone). Donna is the project coordinator, and we will hire another research associate for epidemiology, biostatistics, and modeling support.

2. The CE of breast cancer control for older African American women:

This is a study of the cost-effectiveness of outreach to increase compliance with screening and follow up in older African American women.

3. Patti Ganz and Julia Rowland are planning a grant (for 11/1/97) to assist women with breast cancer in coping with the cancer transition from treatment to post-treatment survivorship. We will be performing a cost analysis of their psycho-educational interventions.

## Cancer Clinical and Economic Outcomes Core

### Monthly Meeting

2:00 ~ 3:00 pm 3/17/98

CPC 4<sup>th</sup> floor Conference Room

#### Members

Jeanne Mandelblatt,\* William Lawrence,\* Caroline Burnett,\* Karen Gold, Jack Hadley, Claudine Isaacs, Lenora Johnson,\* Wenchi Liang,\* Julia Rowland,\* Kate Taylor.\*

\* attendee

Next Meeting: 2:00 ~ 3:00 pm, May 5 (Tue.). CPC 4 <sup>th</sup> floor Conference Room	
Person	Assignments/Tasks
Jeanne	Circulate the revised version of LCC QoL data
All	Send consultation activities to Bill
All	Comments on the consultation sheet

#### DoD Breast Cancer Studies

- a. BRCA1/2 (CARE): As of 3/13, data have been collected from 34 women at baseline, 86 at 6-month f/u, and 61 at 12-month f/u. The new ovarian cancer scenario has been included in the current randomization process since 2/16, and 8 women have received this scenario. Due to relatively high TTO scores on breast metastasis, Bill and Wenchi will listen to several interviews to make sure interview process is appropriate and women understand TTO probing questions.
- b. CAB/CAD: Thirty-two patients completed the satisfaction survey, of which 28 have been entered into the database by Pam (the part-time work-study student). We found the variability of satisfaction with care, discomfort, and embarrassment scores from the 28 cases. We have contacted Bruce and will discuss issues on survey administration and possible survey revision in the future.
- c. Palliative Treatments (Thalidomide study): After a period of low recruitment, 3 women will come to this study in March. Duke University will also have one new patient. Univ. Of Chicago still waits for the IRB approval, probably will be approved in late March. TNP-470 will start recruiting patients in the near future.

#### 1. Cost data from PAC

Lenora reported that the PAC still tried to find out the best way to track time spent in the DoD projects. The staff meet regularly on the 3<sup>rd</sup> Thursday of each month, so Lenora will collect the information and report to Wenchi after the meeting. Jeanne

## Core Consultations

1. A cover sheet for consultation  
Bill distributed the consultation sheet for review and comments.
2. Serendipitous breast lesions found through MR imaging  
In response to the request made by Marc Lippman and MR radiologists, we conducted a decision analysis to estimate the positive predictive value of finding an incidental breast lesion on MR imaging not found in Mammography or CBE. Bill distributed the draft and asked interested people to read and comment on it.

## LCC QOL Data Collection & Oncology Managed Care Guideline

Jeanne presented a draft QOL questionnaire in the CORD meeting on 1/13. The development of an "Electronic Medical Record" system and a closer relationship between Georgetown Medical Center and managed care organizations make the design of QOL data more complicated. The managed care organizations (to be coordinated by Linda Meili) hope to assess QOL outcomes of inpatients first, and then outpatients. The next meeting to discuss this is Feb. 3, 1998, 9am, NRB 5<sup>th</sup> floor conference room.

Julia pointed out some unaddressed questions and concerns in the draft:

- a. EORTC is a treatment-specific instrument, which may not be appropriate for patients in cancer transition. SF-36 may be a better choice for more common situations. Adding more questions may make the measures more comprehensive, but we have to consider the length of time patients will agree to spend on filling out the survey.
- b. Would like anxiety measures and others related to mental health such as CESD, social support, and past psychological history. Julia will collect potential measures and report to the Core.
- c. The discussion sheet is a good idea to assess patients' need. Doctors need to be educated to use the information, but it may be hard to implement ( they don't have time and interest to do it). Julia suggested diet/nutrition, social functioning, and referral tracking being added into the sheet.
- d. The rating scale measuring satisfaction of care (page 12) may be hard for patients, because the "worst satisfaction" and "best satisfaction" are difficult to quantify. Suggesting of deleting the item.
- e. For follow-up patients, we need questions about the return of cancer and their current health status besides cancer (e.g. co-morbidity).
- f. As the cancer clinical trials in LCC increasingly incorporate QOL measures, we need to make sure patients won't fill out the same question twice--both in the clinical study and the general patient intake form. We need a clear mechanism to track who get what questions/studies and when.

## Cancer Clinical and Economic Outcomes Core

### Monthly Meeting

2:00 ~ 3:00 pm 3/17/98

CPC 4<sup>th</sup> floor Conference Room

#### Members

Jeanne Mandelblatt,\* William Lawrence,\* Caroline Burnett,\* Karen Gold, Jack Hadley, Claudine Isaacs, Lenora Johnson,\* Wenchi Liang,\* Julia Rowland,\* Kate Taylor.\*

\* attendee

**Next Meeting: 2:00 ~ 3:00 pm, May 5 (Tue.). CPC 4<sup>th</sup> floor Conference Room**

Person	Assignments/Tasks
Jeanne	Circulate the revised version of LCC QoL data
All	Send consultation activities to Bill
All	Comments on the consultation sheet

#### DoD Breast Cancer Studies

- a. BRCA1/2 (CARE): As of 3/13, data have been collected from 34 women at baseline, 86 at 6-month f/u, and 61 at 12-month f/u. The new ovarian cancer scenario has been included in the current randomization process since 2/16, and 8 women have received this scenario. Due to poor differentiation of TTO scores between BCS and metastasis, Bill and Wenchi will listen to several interviews to make sure interview process is appropriate and women understand TTO probing questions.
  - b. CAD/CAB: Thirty-two patients completed the satisfaction survey, of which 28 have been entered into the database by Pam (the part-time work-study student).
  - c. Thalidomide study: After a period of low recruitment, 3 women will come to this study in March. Duke University will also have one new patient. Univ. Of Chicago still waits for the IRB approval, probably will be approved in late March.
  - d. TNP-470: It is expected to start recruiting patients in the near future.
1. Cost data from PAC

Lenora reported that the PAC still tried to find out the best way to track time the staff spent on the DoD projects. The staff meet regularly on the 3<sup>rd</sup> Thursday of each month, so Lenora will collect the information and report to Wenchi after the meeting. In response to Jeanne's question--Can the recruitment be attributed to PAC costs--Lenora reported that they began to ask patients what information they received, where they visited their doctors, and how they heard about the program. The previous records couldn't relate recruitment to PAC costs very well, but these additional questions should work better.



## **Core Consultations**

The revised cover sheet for consultation was distributed in the meeting; any comments should be directed to Bill.

## **LCC CORD QOL Data Collection & Oncology Managed Care Guideline**

Jeanne will circulate the revised LCC QOL questionnaire. The questionnaire will also include basic socio-demographic and epidemiological data, and will be distributed at time of clinic visits. Dan Hayes, Bruce, Caryn, Jeanne, Bill, Julia, and Linda Meili are currently involved in the process. LCC hopes to use this instrument in conjunction with outcomes measures from managed care organizations (e.g. with the National Cancer Center Network). The next CORD meeting is scheduled on April 7, 1998, 8 am, NRB 5<sup>th</sup> floor conference room.

## **New Grants**

1. Costs of prevention: TENS study (Tobacco, exercise, nutrition, and screening)

The grant proposal was postponed because Kaiser Permanente decided not to take the lead in their HMO setting. Jon, Janet, Kate, Lenora, Bill, and Wenchi will continue to meet on a regular basis to discuss potential research direction in this area.

2. Caryn's two proposals were recently funded: Genetics network and telephone counseling. We will evaluate CEA in the counseling RCT. We may have the opportunity to submit a proposal to the Network.
3. Kate has a new grant on a one-year follow-up study on QOL and trial adherence of PLCO participants.
4. Julia reported her study that evaluates the QOL of breast cancer patients one year after their breast cancer treatment. The intervention aims at increasing patients' abilities to cope with cancer; the strategies include written materials, video, and one-on-one education by social workers. The grant score was ~ 27.5%.

## **Agenda for Next Meeting**

Revenue generation

## Cancer Clinical and Economic Outcomes Core

### Monthly Meeting

1:30 p.m. ~ 2:30 p.m. 5/5/98

CPC 4<sup>th</sup> floor Conference Room

#### Members

Jeanne Mandelblatt, William Lawrence,\* Caroline Burnett,\* Karen Gold,\* Jack Hadley, Claudine Isaacs, Lenora Johnson, Wenchi Liang,\* Julia Rowland, Kate Taylor.\*

\* attendee

Next Meeting: To be scheduled	
Person	Assignments/Tasks
Bill	Circulate the revised version of LCC CORD Questionnaire
Bill	Circulate the revised version of the Core consultation flyer
All	Comments on the Core consultation flyer

#### DoD Breast Cancer Studies

- a. BRCA1/2 (CARE): As of 5/19, data have been collected from 58 women at baseline, 120 at 6-month f/u, and 78 at 12-month f/u. Bill and Wenchi have listened to 4 interviews, 3 baselines and 1 12-month follow-up. Patients had no problems in terms of comprehension. Interviewers were competent and responsive to patients' questions. BCS and MRM received similar TTO and LRS. It is not clear whether TTO and LRS can reflect the expected low utility of metastasis. Bill and Wenchi will continue to listen to a few more interviews. Charles Le will also analyze the frequencies of, and relationships between, the TTO and LRS scores.

Wenchi continues to work on the literature review for parameters to be used in the BRCA model. The prophylactic treatment of Tamoxifen will be added to the model, under both BRCA+ and BRCA- arms.

- b. CAD/CAB: Forty-three patients completed the satisfaction survey, of which 28 have been entered into the database.
- c. Thalidomide study: Four patients completed both the baseline and four follow-up surveys (ending at the 8<sup>th</sup> week). Three patients completed only follow-up surveys. One on-treatment patient continues from the baseline to follow-ups. One more patient is needed to complete the trial.

Because patients did not show improvement, their treatment stopped at the 8<sup>th</sup> week. Decision has been made to end this trial early when the number of patients reaches 28 (now is 27).

- d. TNP-470: Need the contract signed by the pharmaceutical company and a research nurse before it starts to recruit patients.

## **LCC CORD QOL Data Collection**

In the last CORD meeting on April 7, the revised questionnaire was passed out, which included FACT-B, medical history, demographics, quality of life, risk factors, etc. Questions about satisfaction were dropped because LCC separately mails out a satisfaction survey to patients. Bill will circulate the newest version to everyone. The primary target population is women with breast cancer who come to outpatient care at Georgetown. This survey is ready for piloting, and will take 40 to 50 minutes to complete. Debbie will help pilot the survey in the clinic.

Caroline suggested to ask why women make the decision to come to LCC. Bill responded: If the purpose of the questions are only for marketing, the cross-sectional mail survey is good enough. If our Core wants to analyze these questions, we need a longitudinal design to measure change of satisfaction and decision-making over time.

## **Revenue Generation**

Bill presented a draft flyer that introduces the Core and its services to the researchers. In the future the Core will begin to consult studies for quality-of-life, CEA, and other areas relevant to the Core. The idea is to begin with the LCC studies first, and expand to studies outside of LCC. We may want to use actual pricing structure for consultations, instead of asking for percent of time of persons. A list of types of consultations and corresponding fees will be developed, which gives us more flexibility to use the resources.

Caroline, Bill, and Linda Meili were involved in the financial think tank. They discussed ways to get Managed Care Organization interested in the Core consultations. The purpose is to make LCC more attractive to patients through the assurance of a high-quality care.

Karen showed concerns about how hourly charged back will be distributed. It may not necessarily go to salary support; it can be distributed to the institution, the Core, etc. It is preferable not making the mechanism an indifference factor.

Caroline suggested that we mention what we have done in the flyer, and ask people to call individuals specialized in areas they need consultation from.

Bill will revise the flyer according to the suggestions in the meeting, and distribute to the Core members.

## **Patient Telephone Counseling (PTC) study (Caryn and Chanita)**

The cost analysis for the PTC study has started.

## **Appendix 5**

### **Core Consultations**

## CCEOC CONSULT REPORT

**Consultant(s):** K Gold

**Investigators(s):** Mandelblatt J

**Date:** 8/98

**Funding mechanism:**

**Reason for consultation:** Statistical support for meta-analysis on the relationship between HIV, HPV, and cervical cancer

**Service provided:** Performed meta-analysis

**Time required:** 25 hours

**Other resources:**

**Potential for funding for investigator:**

**Potential for future grant support for core:**

**Comments:** Manuscript is currently in preparation for submission

## CCEOC CONSULT REPORT

**Consultant(s):** K Gold

**Investigators(s):** WF Lawrence

**Date:** 8/98

**Funding mechanism:**

**Reason for consultation:** Assistance with Quality of life - utility regression

**Service provided:** Reviewed analysis and provided confidence interval calculation for regression equation to predict Quality of Well-Being scores from the MOS SF-12 survey

**Time required:** 2 hours

**Other resources:**

**Potential for funding for investigator:**

**Potential for future grant support for core:**

**Comments:** Manuscript is in preparation

## CCEOC CONSULT REPORT

**Consultant(s):** Gold K

**Investigators(s):** Dalton H, Pediatric Critical Care, GUMC

**Date:** 7/98

**Funding mechanism:**

**Reason for consultation:** Statistical support for outcomes analysis of extracorporeal life support use for children

**Service provided:** Statistical advice, performed analyses

**Time required:** 6 hours

**Other resources:**

**Potential for funding for investigator:**

**Potential for future grant support for core:**

**Comments:** Manuscript submitted.

## CCEOC CONSULT REPORT

**Consultant(s):** W. Lawrence, W. Liang, J Mandelblatt, K Gold

**Investigators(s):** M Freedman, B Trock

**Date:** 9/98

**Funding mechanism:**

**Reason for consultation:** DoD request to evaluate the benefit of pursuing incidental lesions found on breast MRI performed for CABCAD study

**Service provided:** Meta-analysis of MRI accuracy, Decision analysis of positive predictive value of MRI incidental lesion

**Time required:** WFL, WL - 3 months, approximately 40% time. JM- 3 months, approx. 5% time. KG - approx. 10 hours

**Other resources:** none

**Potential for funding for investigator:**

**Future grant support for core:**

**Comments:** Manuscript based on analysis currently in press at JNCI.



## CCEOC CONSULT REPORT

**Consultant(s):** W. Lawrence, W. Liang

**Investigators(s):** J Kerner

**Date:** 3/98

**Funding mechanism:** Possible NCI R01

**Reason for consultation:** Assess potential for cost or cost-effectiveness analysis of study to increase preventive health behaviors in community

**Service provided:** Review current literature on subject, assist with protocol design

**Time required:** 3 hours each meeting time, approx. 1 hour prep time

**Other resources:** none

**Potential for funding for investigator:** Possible NCI R01 funding of proposal

**Future grant support for core:**

**Comments:**

## CCEOC CONSULT REPORT

**Consultant(s):** W. Lawrence, W. Liang, C. Burnett, K. Taylor

**Investigators(s):** C. Akewonlop, MD, D. Hayes, M.D.

**Date:** 1/98

**Funding mechanism:** Gratis, For LCC or industry funding

**Reason for consultation:** Assistance with knowledge assessment of breast cancer tumor markers in LCC patients

**Service provided:** Assist with study design, assist with development and review knowledge assessment survey. Will assist with educational intervention

**Time required:** WFL, WL - 2 hours meeting time plus 1 hour prep. CB, KT - 1 hour review of materials

**Other resources:** none

**Potential for funding for investigator:** Currently for LCC or industry funding, potential for future NCI grant?

**Future grant support for core:** consultancy possible depending on future applications.

**Comments:**

## CCEOC CONSULT REPORT

**Consultant(s):** WF Lawrence

**Investigators(s):** Marc Schwartz, PhD

**Date:**8/98

**Funding mechanism:**NCI R-01

**Reason for consultation:** Proposal plans development of decision aid to assist with prophylaxis and surveillance decisions in women at high risk for breast cancer.

**Service provided:** Planning a cost-analysis, assisting with use of subjective expected utility theory as relates to decision making.

**Time required:** 4 hours as of 9/10/98

**Other resources:**

**Potential for funding for investigator:** Planned submission of R-01 in Oct. 1998

**Potential for future grant support for core:** WF Lawrence will be included as co-investigator

**Comments:**

## CCEOC CONSULT REPORT

**Consultant(s):** WF Lawrence

**Investigators(s):** J Klapow, Univ. of Alabama

**Date:** 10/97

**Funding mechanism:**

**Reason for consultation:** Need transformation between health status survey (SF-12) and utility index (Quality of Well-Being Index) for use in cost-effectiveness analysis of treatments for esophagitis.

**Service provided:** Same

**Time required:** 10 hours

**Other resources:**

**Potential for funding for investigator:**

**Potential for future grant support for core:**

**Comments:** Results to be presented at annual meeting of Society for Medical Decision Making. Manuscript in preparation.

## CCEOC CONSULT REPORT

**Consultant(s):** J Rowland

**Investigators(s):** K Schulman

**Date:** 7/98

**Funding mechanism:** Novartis

**Reason for consultation:** Develop and analyze pain and quality of life outcomes for use in evaluating the efficacy of new oncology drug, Zoledronate.

**Service provided:** Same

**Time required:** 10%

**Other resources:**

**Potential for funding for investigator:** Funded through Novartis

**Potential for future grant support for core:**

**Comments:**

## CCEOC CONSULT REPORT

**Consultant(s):** J Rowland, WF Lawrence

**Investigators(s):** Vered Stearns, MD, Oncology Fellow

**Date:** 6/97-7/98

**Funding mechanism:** Internal GUMC

**Reason for consultation:** Assistance in measuring QOL and hot-flash symptoms in a trial of Paxil for hot flashes in women with breast cancer.

**Service provided:** Assistance with study design, participant inclusion criteria. Refined hot flash questionnaire. Provided QOL measures including rating scale, CESD, post-menopausal sx index, MOS sleep and sexual function scales. Some advice on statistical analysis.

**Time required:** WFL - 10 hours  
Julia Rowland - 15 hours

**Other resources:**

**Potential for funding for investigator:** Pilot study. Could be future R01 if pilot successful.

**Potential for future grant support for core:** Same

**Comments:**

## **Appendix 6**

### **Funded Grants Including Core Members**

DESCRIPTION. State the application's broad, long-term objectives and specific aims, making reference to the health relatedness of the project. Describe concisely the research design and methods for achieving these goals. Avoid summaries of past accomplishments and the use of the first person. This description is meant to serve as a succinct and accurate description of the proposed work when separated from the application. If the application is funded, this description, as is, will become public information. Therefore, do not include proprietary/confidential information. **DO NOT EXCEED THE SPACE PROVIDED.**

In the last two decades, the death rate from breast cancer has fallen by about seven percent in younger white women. However, in this period African-American women, particularly older African-American women, have experienced a 26% increase in mortality, despite having a lower incidence of disease than their white counterparts. For all races of women, mammography screening can potentially reduce mortality by up to 30%. Prior cost-effectiveness analyses of breast cancer screening among general populations have demonstrated that reductions in mortality can be achieved at a reasonable cost per life year saved. However, there are no data on whether additional expenditures to enhance the cancer control process for African-American women, particularly older African-American women, might affect the overall cost-effectiveness of screening. To address this important gap in our knowledge, we have assembled an experienced multi-disciplinary team of health economists, geriatricians, mathematical modelers, oncologists, health service researchers, decision analysts, and epidemiologists. We will extend prior cost-effectiveness analyses by 1) using existing race-specific data to develop a simulation model of the natural history of disease specific to African-American women ages 50 to 74 years; 2) obtaining primary data on the utilities for breast cancer outcomes among African-Americans to generate quality-adjusted life-years (QALYs) as the outcome of analysis; 3) including non-medical direct (e.g., patient transportation costs, patient time costs); and 4) developing and estimating sub-models which evaluate the incremental costs and effects of programs specifically designed to improve the value of screening in this high-risk population (e.g., programs designed to enhance breast cancer screening use, prompt diagnosis after abnormal screening, and adherence to recommended treatment). We hypothesize that the added costs of targeted cancer control programs for vulnerable African-American women will be offset by the gains in quality-adjusted life years saved as a result of down-staging disease and improving treatment. The results of such analysis will be useful to inform the optimal design of health services delivery programs, and to highlight priority research and service areas to ensure that we reach targeted levels of breast cancer mortality reduction among all women in the US.

PERFORMANCE SITE(S) (organization, city, state)

New School for Social Research	New York	NY
Mount Sinai-NYU Medical Center	New York	NY
Georgetown University Medical Center	Washington	DC

KEY PERSONNEL. See instructions on Page 11. Use continuation pages as needed to provide the required information in the format shown below.

Name	Organization	Role on Project
Marianne C. Fahs, PhD, MPH	New School for Social Research	Principal Investigator
Nina J. Kontos, PhD	New School for Social Research	Project Coordinator
Clyde B. Schechter, MD	Mount Sinai-NYU Medical Center	Principal Investigator-Subcontract
Albert L. Siu, MD	Mount Sinai-NYU Medical Center	Investigator
Nina A. Bickell, MD	Mount Sinai-NYU Medical Center	Investigator
Donna R. Shelley, MD	Mount Sinai-NYU Medical Center	Investigator
Henry S. Sacks, MD, PhD	Mount Sinai-NYU Medical Center	Investigator
Jeanne S. Mandelblatt, MD	Georgetown University Medical Center	Principal Investigator-Subcontract
William Lawrence, MD	Georgetown University Medical Center	Investigator
Jon Kerner, PhD	Georgetown University Medical Center	Investigator
Caroline Burnett, RN, ScD	Georgetown University Medical Center	Investigator
Lenora Johnson, CHES	Georgetown University Medical Center	Sr. Health Educator



**DESCRIPTION.** State the application's broad, long-term objectives and specific aims, making reference to the health relatedness of the project. Describe concisely the research design and methods for achieving these goals. Avoid summaries of past accomplishments and the use of the first person. This description is meant to serve as a succinct and accurate description of the proposed work when separated from the application. If the application is funded, this description, as is, will become public information. Therefore, do not include proprietary/confidential information. **DO NOT EXCEED THE SPACE PROVIDED.**

As a result of the isolation of the BRCA1 and BRCA2 genes, genetic testing for breast-ovarian cancer susceptibility is now commercially available. Our ongoing research has documented the need for adjunctive psychosocial counseling approaches to improve the outcomes of genetic counseling and testing among identified carriers of BRCA1/2 mutations. The evaluation of such interventions has been highlighted as a research priority in two recent cancer research workshops. Thus, in this competitive renewal application, we propose a multi-institutional randomized trial to evaluate whether the outcomes of BRCA1/2 testing among female mutation carriers are improved by providing a psychosocial telephone counseling (PTC) intervention in addition to standard genetic counseling (SGC). The specific aims are: (1) to evaluate the efficacy of PTC delivered in conjunction with SGC, compared to SGC only; (2) to explore the mechanisms by which the PTC impacts on psychosocial and behavioral outcomes; (3) to identify carriers who are most and least likely to benefit from PTC; and (4) to conduct an economic evaluation of the two counseling strategies. The participants in this randomized trial are 290 female carriers of BRCA1/2 mutations and 290 female noncarriers. A baseline assessment will be conducted prior to the offer of testing to collect data on background variables (sociodemographics, medical and family history), moderator variables (personality style, social support), and baseline levels of outcome variables. Following *in-person* pre-test genetic counseling and informed consent, participants will have an opportunity to have BRCA1/2 testing. After providing additional written consent, they will receive their result during an individual *in-person* session with a genetic counselor. Following disclosure of mutation status, carriers of BRCA1/2 mutations will be assigned randomly to receive either SGC follow-up only or SGC plus PTC. The PTC protocol, adapted from the previous research of the study investigators, will be delivered in 6 sessions over a 3-month period after disclosure. Sessions will include supportive counseling and provide training in coping skills to enhance the outcomes of genetic testing. Follow-up interviews will be conducted at 1-, 4-, 6-, and 12-months post-disclosure to collect data on the following outcomes: comprehension, distress, family communication and functioning, adoption of recommended cancer screening practices, and satisfaction with decisions about prophylactic surgery. If beneficial and cost-effective, the proposed PTC intervention can be disseminated to varied research and clinical settings in which BRCA1/2 testing is offered.

**PERFORMANCE SITE(S)** (organization, city, state)

Lombardi Cancer Center (LCC), Georgetown University Medical Center (GUMC), Washington, D.C.  
 AMC Cancer Center/University of Colorado Health Sciences Center, Denver, Colorado  
 Rush Cancer Institute (RCI), Chicago, Illinois  
 Duke Comprehensive Cancer Center (DCCC), Durham, North Carolina

**KEY PERSONNEL.** See instructions on Page 11. Use continuation pages as needed to provide the required information in the format shown below.

Name	Organization	Role on Project
Caryn Lerman, Ph.D.	GUMC	Principal Investigator (PI)
Alfred Marcus, Ph.D.	AMC	Co-PI, Site PI
David Cella, Ph.D.	RCI	Co-PI, Site PI
Eric Winer, M.D.	DCCC	Co-PI, Site PI
Marc Schwartz, Ph.D.	GUMC	Co-PI
Lari Wenzel, Ph.D.	AMC	Co-investigator
Judith Benkendorf, M.S.	GUMC	Co-investigator
Jeanne Mandelblatt, M.D.	GUMC	Co-investigator
William Lawrence, M.D.	GUMC	Co-investigator
John Hanfelt, Ph.D.	GUMC	Co-investigator/Biostatistics
Mohammad Abbaszadegan, Ph.D.	GUMC	Co-investigator
Barbara Rimer, Dr., P.H.	DCCC	Co-investigator
Amy Peterman, Ph.D.	RCI	Co-investigator
Beth Peshkin, M.S.	GUMC	Co-investigator
Madison Powers, J.D., D.Phil.	GUMC	Consultant/Bioethics

DESCRIPTION. State the application's broad, long-term objectives and specific aims, making reference to the health relatedness of the project. Describe concisely the research design and methods for achieving these goals. Avoid summaries of past accomplishments and the use of the first person. This description is meant to serve as a succinct and accurate description of the proposed work when separated from the application. If the application is funded, this description, as is, will become public information. Therefore, do not include proprietary/confidential information. **DO NOT EXCEED THE SPACE PROVIDED.**

The utility of screening asymptomatic men for prostate cancer is controversial, as it has not yet been demonstrated that early diagnosis and treatment of prostate cancer in fact reduces mortality. Consequently, the NCI has recommended that prostate cancer screening should be preceded by patient education and by a process of informed consent. The goal of this research program is to develop and test methods of unbiased patient education, and to assist patients in realizing their own preferences until the definitive data from the PLCO Cancer Screening Trial are available. Importantly, The goal of the project is neither to promote nor to reduce prostate cancer screening. In the proposed research, I will conduct a prevalence study to assess the level of knowledge and understanding of the limitations and benefits of prostate cancer screening in a random community sample of 200 men. Next, in an intervention study, I will evaluate the effectiveness of two forms of video-based patient education, with effectiveness defined in terms of knowledge acquisition and patient satisfaction, among men who have registered for prostate cancer screening (N = 450). Subjects will be randomly assigned to one of three conditions: 1) no educational intervention (Standard Informed Consent), 2) video-based patient education designed to increase knowledge (Education Only); or 3) video-based patient education designed to increase knowledge and to challenge cognitive biases that may hinder knowledge acquisition (Education+). I will assess whether cognitive biases hinder comprehension of information that is central to making an informed decision, and whether intervening to reduce these biases results in increased knowledge and satisfaction. The purpose of this research is to facilitate informed decision making about prostate cancer screening while remaining neutral with regard to the controversy surrounding prostate cancer screening. The training program that I have proposed will complement my research program, by strengthening my background in epidemiology and biostatistics, bioethics, histopathology, and preventive oncology. With the rapid advances in these fields, it is increasingly important to have training in these disciplines in order meet my career goal of becoming an independent cancer prevention and control researcher. This award will allow me to obtain the training and experiences necessary to complement my background as a clinical psychologist, and to develop a stronger research program through collaborations with researchers from a wide array of disciplines.

PERFORMANCE SITE(S) (organization, city, state)

Georgetown University Medical Center  
Lombardi Cancer Center  
2233 Wisconsin Avenue, NW - Suite 400  
Washington, DC 20007

KEY PERSONNEL. See instructions on Page 11. Use continuation pages as needed to provide the required information in the format shown below.

Name	Organization	Role on Project
Kathryn L. Taylor, Ph.D.	Lombardi Cancer Center	Principal
	Georgetown University Medical Center	Investigator
Jon Kerner, Ph.D.	Lombardi Cancer Center	Primary
	Georgetown University Medical Center	Sponsor
Caryn Lerman, Ph.D.	Lombardi Cancer Center	Sponsor
	Georgetown University Medical Center	
Daniel Sulmasy, M.D., Ph.D.	Center for Clinical Bioethics	Consultant
	Georgetown University Medical Center	
Bruce Trock, Ph.D.	Lombardi Cancer Center	Consultant
	Georgetown University Medical Center	

Health-Related Quality of Life in the PLCO Cancer Screening Trial:  
The Impact of Random Assignment and Baseline Screening Results

Kathryn L. Taylor, Ph.D. & Edward Gelmann, M.D.  
Lombardi Cancer Center  
Georgetown University Medical Center

Background and Significance

There is considerable debate regarding the utility of diagnostic screening for prostate, lung, colorectal, and ovarian cancer in asymptomatic persons. Some of the issues under debate include cost effectiveness of screening programs, and a reduction in quality of life for patients who are diagnosed and treated, for whom there is sometimes a questionable survival benefit. In addition, the specificity and sensitivity of the available diagnostic techniques are somewhat limited, resulting in a relatively high rate of false positive results (e.g., a 36% false positive rate of prostate cancer screening was found by Cooner et al., 1990). The goal of the PLCO trial is to resolve this controversy and reduce the confusion regarding screening for these cancers.

The possibility of increased psychological distress and screening non-adherence may be exacerbated by the receipt of a false positive screening result. The psychological impact of a false positive screening result has been widely discussed (e.g., Eddy et al., 1988; Lerman et al., 1991; Wardle & Pope, 1992). Lerman et al. (1991) found that women who received a false positive mammogram experienced lasting elevations in psychological distress. However, subsequent mammography adherence was not affected in these subjects. Wardle et al. (1993) reported that women at risk for ovarian cancer who received a false positive screening result were more distressed relative to controls, but returned to baseline after the true negative result was received. To our knowledge, the psychological impact of a false positive screening result of prostate, lung, or colorectal cancer has not been studied, either in terms of psychological distress or subsequent adherence to screening recommendations. Additionally, the combination of a false positive screening result and being at risk for cancer has not previously been investigated in persons undergoing screening for prostate, lung, or colorectal cancer. Importantly, persons who are at high risk for one of these cancers may be especially vulnerable to increased psychological distress (and possibly reduced adherence), in the event they receive a false positive screening result.

Studying persons at risk for cancer adds an additional psychological aspect to cancer screening studies. Women at high risk for breast and ovarian cancer often report elevated levels of psychological distress (e.g., Kash et al., 1992; Schwartz et al., 1995). Further, elevated distress has been shown to predict poorer screening adherence (e.g., Kash et al., 1992; Lerman et al., 1993). However, the relationship between anxiety and adherence has not been studied among those at risk for prostate, ovarian, or lung cancers. Determining whether anxiety functions as a barrier to engaging in the recommended work-up following a positive screening, or to continued participation in the screening trial will provide important information for mass screening trials in prostate cancer.

We are proposing a prospective study to determine the impact of a) one's group assignment to either the screening or control arm and b) the baseline screening result, on health-related quality of life (HRQL; which includes psychological distress) among individuals participating in the PLCO trial. The findings regarding the impact of group assignment will help to determine the equivalence of the screening

and control arms at the baseline and one-year follow-up assessments. These data will address the question of the feasibility of conducting future HRQL studies with PLCO participants who have already completed the baseline assessment (i.e., are accrued at later points during the PLCO protocol). Further, the results of this study will provide needed information about the psychological and behavioral consequences of large screening trials. One of the concerns regarding diagnostic screenings is that psychological distress related to participating in the screening may not remit following notification of negative results. Furthermore, the psychological distress that remains may subsequently influence health behaviors or compliance with future diagnostic screenings. In turn, distress may lead to decreased adherence among the subsample who may benefit the most from screening (i.e., those who are at high risk). If evidence of increased distress and decreased adherence is found, intervention studies to reverse these unintended and detrimental effects of screening will be needed. Alternatively, if no long-term ill effects result from screening, this will challenge one aspect of the controversy regarding mass screening programs. This information is especially needed in prostate screening trials, given the wide participation in mass screening, and the fact that the false positive rate of screening can be substantial.

### Specific Aims

1. To compare HRQL levels in the screening and control arms at the baseline and the one year follow-up assessments. Further,

a) among participants in the screening arm, we will assess the impact of undergoing the baseline screening procedures on HRQL and satisfaction with one's decision to participate in the trial. Intent to remain in the trial and to comply with the trial procedures will also be assessed; and,

b) among participants in the control arm, we will assess the impact of assignment to the control arm on HRQL and satisfaction with one's decision to participate in the trial. Intent to remain in the trial and to comply with the trial procedures will also be assessed.

Specific Aim 2 involves only the screening arm participants.

2. To determine the impact of the screening result on HRQL (positive vs. negative), we will assess the screening participants within a week following notification of the results. Further,

a) among those with a positive screening result, we will assess the impact of undergoing the diagnostic tests on HRQL.

b) among those with a false positive screening result (determined after conclusion of the diagnostic work-up), we will assess the impact on HRQL and adherence to the trial procedures.

3. In each of the above aims, we will assess the association between HRQL and 1) the presence of risk factors (e.g., family history of cancer, race, smoking status, etc., depending on the screening site), 2) screening site (prostate, lung, colorectal, or ovarian), stratified by sex, and 3) sex differences (lung and colorectal sites).

## **Appendix 7**

### **Publications Submitted by Core Members**

**SERENDIPITY IN DIAGNOSTIC IMAGING:**

**Magnetic Resonance Imaging of the Breast**

William F. Lawrence, MD, MSIE<sup>1</sup>, Wenchi Liang, PhD<sup>1</sup>, Jeanne S. Mandelblatt, MD, MPH<sup>1</sup>,  
Karen F. Gold, PhD<sup>1</sup>, Matthew Freedman, MD<sup>2</sup>, Susan M. Ascher, MD<sup>2</sup>, Bruce J. Trock, PhD<sup>3</sup>,  
Polun Chang, PhD<sup>4</sup>

<sup>1</sup>Cancer Clinical and Economic Outcomes Core, Lombardi Cancer Center, <sup>2</sup>Department of  
Radiology, <sup>3</sup>Molecular Epidemiology, Lombardi Cancer Center, Georgetown University Medical  
Center, Washington, D.C., and <sup>4</sup>Institute of Public Health, National Yang-Ming University,  
Taipei, Taiwan

Correspondence and Request for Reprints:

William F. Lawrence, MD, MSIE

Cancer Clinical and Economic Outcomes Core

Lombardi Cancer Center

Georgetown University Medical Center

2233 Wisconsin Avenue, Suite 430

Washington, D.C. 20007

Phone: (202) 687-0817, Fax: (202) 687-0305, E-mail: lawrencw@gunet.georgetown.edu

Funded by Contract DAMD 17-96-C-6069, "Breast Cancer Support Contract," from the

Department of the Army

## **ABSTRACT**

**Background:** Magnetic resonance imaging (MRI) of the breast has been proposed as a non-invasive diagnostic test for evaluation of suspicious (index) lesions noted on mammography and/or clinical breast examination (CBE). However, women may have incidental (“serendipitous”) lesions detected by MRI that are not found on mammography or CBE. To understand better whether or not biopsy procedures should be performed to evaluate serendipitous lesions, we estimated the cancer risk for women with this type of lesion.

**Methods:** We used a decision analysis model to estimate the positive predictive value (i.e. the chance that a woman with a serendipitous lesion has cancer) of MRI for serendipitous lesions in women who had an abnormal mammogram and/or CBE suspicious for cancer (where biopsy procedure is recommended). We restricted the analysis to women whose index lesions were noncancerous, and used meta-analysis to determine the likelihood ratios (measures of how test results change the probability of having cancer) for MRI and the combination of CBE and mammography. The positive predictive value of MRI was calculated using the U.S. population prevalence of cancer and the likelihood ratios of the diagnostic tests.

**Results:** Under a wide variety of assumptions, the PPV of MRI was extremely low for serendipitous lesions. For instance, assuming a sensitivity and specificity of MRI of 95.6% and 68.6%, respectively, approximately four of 1000 55-to-59-year-old women with a serendipitous lesion would be expected to have cancer (positive predictive value = 0.44%, 95% confidence interval 0.24% - 0.67%).

**Conclusion:** In women with a suspicious lesion discovered by mammography and/or CBE that is

found to be benign, serendipitous breast lesions detected by MRI are extremely unlikely to represent invasive cancer. Immediate biopsy of such serendipitous lesions is, therefore, not recommended.

**KEY WORDS:** MRI, Breast Neoplasms, Diagnosis, Decision Analysis

Text = 5025 words (Including Methods = 2204 words), Abstract = 276 words, 3 Tables, 5 Figures, 1 Appendix



## INTRODUCTION

Mammography and clinical breast examination (CBE) are the current standard measures for breast cancer screening and initial evaluation of breast signs and symptoms. The combination of mammography and CBE has a moderate sensitivity and high specificity for breast cancer. However, the positive predictive value of these tests for cancer, especially when done for screening and in young women, may be quite low, due to a low prior probability of cancer. For example, in a large Canadian Screening Study, only 12% of women aged 40 to 49 years old who were recommended to have a biopsy procedure as a result of an abnormal screening mammogram or CBE actually had breast cancer (1). An estimated 600,000 breast biopsies are performed annually in the US (2); as many as 85% of these yield benign results (3-6). Thus, the potential economic and quality of life (7-12) impact of alternative diagnostic pathways could be substantial.

To reduce the number of biopsies performed on women who will ultimately be diagnosed with benign lesions, several intermediate diagnostic tests have been proposed (13,14). Such tests would need to have high sensitivity, so that there are few missed cancers, and ideally also have high specificity, so that women without breast cancer would not be required to undergo an unnecessary invasive procedure.

One test currently under investigation as an intermediate diagnostic test is magnetic resonance imaging (MRI) of the affected breast. Studies suggest that MRI will be quite sensitive, but may not be very specific, with specificity as low as 30% (15). Also, MRI of the breast has been reported to show breast lesions not found on either the initial mammogram or CBE. We

refer to these lesions as “serendipitous lesions” - lesions found incidentally in the work up of another breast lesion (16). These lesions raise a diagnostic dilemma: if the MRI has a higher sensitivity than conventional procedures, then cancer, if present, would be more likely to be detected by the MRI than the mammogram; on the other hand, if the specificity is truly much lower, then these serendipitous lesions are much more likely to be false positive lesions than if they were originally found on mammography or CBE. In addition, localizing these lesions for biopsy procedure would be quite difficult if other diagnostic modalities cannot detect them; in this case, an MRI-guided biopsy procedure may be necessary to ensure localization of the lesion.

If the suspicious lesion that prompted MRI evaluation is found to be benign, what should be done diagnostically to evaluate these “serendipitous” breast lesions found on MRI? Using decision analysis and the best estimates from a comprehensive literature review, we estimate the positive predictive value of these serendipitous lesions found on MRI, or the probability that women with serendipitous lesions truly have invasive breast cancer. These data, while preliminary, provide clinicians and patients with a framework for deciding on the appropriate work-up of unexpected breast lesions found by MRI.

## **METHODS**

There are no published data which specifically address the question of risk of cancer in a serendipitous MRI lesion detected in the course of diagnostic evaluation of another abnormality on mammogram and/or CBE (the “index lesion”). We restrict our analysis to the situation where the index lesion is not malignant, and calculate the probability that a women with a serendipitous

lesion has cancer based upon biopsy results for the index lesions, age, race, and degree of cancer risk. Women with malignant index lesions are excluded from this analysis.

### **The Decision Model**

We used standard decision-analytic techniques (17) to model the sequence of events leading to the finding of a serendipitous lesion on MRI of the breast, and to estimate the probability of cancer in the serendipitous lesion. We used a computer spreadsheet (Microsoft Excel v. 5.0 for Windows, Microsoft, Inc., Redmond, WA) for model construction.

As noted above, we define the "index lesion" as the lesion found on mammogram and/or CBE which prompted a recommendation for biopsy procedure and further evaluation. A "serendipitous lesion" represents a lesion seen on MRI that was not suspected by either the index mammogram or CBE.

The conceptual approach to the construction of the model is shown in Figure 1. A woman going to biopsy procedure for the index lesion will either have a benign or a malignant lesion. We assume that if the index lesion is malignant, the clinician may wish to pursue the serendipitous lesions for the possibility of a multicentric cancer, and these women are excluded from this analysis. If the woman has an index lesion that is benign, we assume the her initial probability of cancer is the U.S. population average for her age and race. We also assume that the woman does not have a personal history of breast cancer; this history could raise her initial probability of disease. By definition, the mammogram and the CBE for this woman was negative in the area of the serendipitous lesion, which lowers the probability of cancer. Her probability of

cancer given these prior negative tests is calculated using a Bayesian revision of probability (17), and is influenced by her probability of cancer before the test, and the sensitivity and specificity of the index mammography and CBE. The positive MRI raises her probability of cancer; this probability is affected by the sensitivity and specificity of MRI. Thus, overall our model calculates the probability of cancer given the positive MRI, a negative mammogram and CBE, and the initial probability of disease for women of different ages and races.

### **Model Parameters**

We estimated 3 parameters for this model: the likelihood ratio positive of MRI, the likelihood ratio negative of the combination of mammography and CBE, and the initial prevalence of breast cancer. The likelihood ratio positive is the ratio of sensitivity to one minus the specificity, and represents the degree to which a positive test raises the odds of diagnosis. The likelihood ratio negative is the ratio of one minus the sensitivity to specificity, and represents the degree to which a negative test lowers the probability of disease. Meta-analyses were conducted to estimate the likelihood ratios of MRI and mammography/CBE. Meta-analysis is a technique which can be used to summarize the results of good quality studies performed in diverse settings and populations (18-23). Such analyses are useful for new diagnostic tests, such as MRI, when no one study has sufficient power to address a particular question, and to summarize data across multiple studies on potentially different populations with different diagnostic thresholds for a positive test.

## Sensitivity and Specificity of MRI

Data for the sensitivity and specificity of breast MRI, used to calculate the likelihood ratio positive, came from the published medical literature. We performed a MEDLINE® (National Library of Medicine) search, from 1990-1997, using the terms “magnetic resonance imaging” and “breast neoplasms”. We also searched bibliographies of relevant articles. Inclusion criteria for the abstraction of data from an article included: (a) sample size of 10 or greater; (b) data were available on MRI and breast cancer results; (c) the study sample consisted of women at risk for cancer, defined as having a suspicious finding on CBE and/or mammogram, but without known cancer at study entry; (d) the MRI readers were blinded to the final diagnosis; and (e) the article was written in English. We did not exclude articles in which the MRI readers had access to mammography or clinical examination data, as we assumed that in clinical practice the MRI reader would review these data when reading the MRI.

For studies eligible for inclusion, the following data were abstracted: the study design, patient selection, number and age of subjects, method for MRI, method for diagnosing breast cancer, and the numbers of true positive, false positive, true negative, and false negative MRI results. While this study is concerned with the diagnosis of invasive breast cancer, we include diagnosis of ductal carcinoma in situ (DCIS) as a true positive diagnosis for the purposes of calculating the sensitivity and specificity of MRI. This assumption results in a higher positive predictive value of MRI than would not including DCIS as a true-positive result; assuming otherwise would result lower the specificity of MRI, lowering the positive predictive value.

Data could not be found on the diagnostic accuracy of MRI in specific areas of the breast

where the mammogram and CBE were negative. Thus, we assume that the sensitivity and specificity of MRI for the detection of breast cancer are the same for serendipitous lesions as they are for index lesions. Given the paucity of age-specific data, we also assume that the diagnostic accuracy of MRI is independent of age.

### Sensitivity and Specificity of Mammography and CBE

Data for the diagnostic characteristics of CBE and mammogram were derived from the four major randomized trials of breast cancer screening that employed both CBE and two-view mammography (1, 24-26). While only one of these studies was conducted in the U.S., we assume that the sensitivity and specificity of mammography and CBE are independent of the country in which the study was performed. Similar to MRI, data from these studies were abstracted to define true positive, false positive, true negative, and false negative results. We used the detection method (27) to calculate sensitivity of mammography and CBE. True positives were defined as screening detected cancers, whether found by mammogram, CBE, or both. False negatives were defined as those who were diagnosed as having breast cancer in the interval between screening tests. False positives were defined as those participants undergoing biopsies for benign lesions. True negatives were those who did not clinically develop cancer during the study follow-up period.

While probably not strictly true (28), we make the simplifying assumption that CBE and mammography test accuracy are independent of age. We examine this assumption in sensitivity analysis by calculating the effects of lower sensitivity for mammography/CBE for women under

age 50. While mammography may be less sensitive in this age group, these women also have a low prior probability of cancer.

We also assume that the diagnostic accuracy of CBE/mammography is conditionally independent of that of MRI, conditioned on the presence or absence of cancer (29). Thus, for example, if a woman has cancer and a positive MRI, her probability that the CBE and/or mammogram are positive is the same as it would be if she had cancer but a negative MRI.

### Breast Cancer Prevalence

Yearly incidence rates of breast cancer will underestimate breast cancer prevalence since not all breast cancer will be detected in the year following the onset of the malignancy. Data for the baseline prevalence of undiagnosed breast cancer in the US population were derived from a simulation model of the natural history of breast cancer (30,31). This model uses breast cancer incidence data from the Surveillance, Epidemiology, and End-Results (SEER) registry (32), as well as US population data (33) to estimate the prevalence of cancer by age, race (as reported in Ries, et al. (32): Black, White, and total population), and incidence rate. We estimate prevalence of invasive breast cancer only; our data does not include the prevalence of DCIS in the population. Data from this model have been validated against Wisconsin and Iowa tumor registry data (30). That model was used to calculate a ratio of detected disease to undetected disease. Using this ratio, we then estimated the age- and race-specific prevalence of disease. We also calculated prevalences for “high-risk” women, using twice the average U.S. population incidence rates to represent those at high risk. We use this high risk estimate to approximate the

increased risk of having a first degree relative with breast cancer (34-41) or of having previously had a biopsy showing benign breast disease (42-45).

## Analysis

### Meta-analysis

Using data from the literature of the sensitivity and specificity of the tests, we converted these data into likelihood ratios and pooled the data across studies using an analogue of a Mantel-Haenszel estimator. We use the ratio of the average sensitivities and complements of specificities to preserve the roles of the sensitivity and specificity in the calculation of the likelihood ratio in the estimator, and because this estimator is the closest analogue of the Mantel-Haenszel estimator of odds ratios (46). The estimator for the likelihood ratio positive for MRI was calculated using the formula:

$$LR_{MRI}^{+} = \frac{\sum_{i=1}^{12} \frac{TP_i}{TP_i + FN_i}}{\sum_{i=1}^{12} \left[ 1 - \frac{TN_i}{TN_i + FP_i} \right]}$$

where  $LR_{MRI}^{+}$  is the likelihood ratio positive of MRI,  $TP_i$  is the number of true positive diagnoses for study  $i$ ,  $FN_i$  is the number of false negatives,  $TN_i$  is the number of true negatives, and  $FP_i$  is then number of false positives. The likelihood ratio negative for the combination of mammography and CBE was calculated in a similar fashion.



The 95% confidence intervals were obtained using jack-knife estimation, recalculating likelihood ratios leaving one study out for each study in the analysis (47). The standard deviations (S.D.) of the means of the likelihood ratios were calculated using the following formula:

$$S.D. = \sqrt{\frac{n}{n-1} \times \sum_{i=1}^n [LR_i - \overline{LR}]^2}$$

where  $n$  is the number of studies in the analysis, and  $LR_i$  is the recalculated likelihood ratio leaving out study  $i$ . The 95% confidence intervals (C.I.) were then calculated by:

$$95\% C.I. = \overline{LR} \pm 1.96 \times S.D.$$

Independent estimation of sensitivity and specificity of a diagnostic test using Mantel-Haenszel meta-analytic methodology may underestimate true sensitivity and specificity (48). Thus, we performed the meta-analysis on the likelihood ratios, to recognize the interdependence of these two measures of accuracy. Since underestimation of the sensitivity and specificity of MRI would result in an underestimation of the probability of disease given a positive MRI, we also examined the sensitivity and specificity of this test using the technique of the summary receiver-operating characteristic curve (48). This technique creates an ROC curve based upon sensitivity and specificity data from multiple studies. This technique has the advantage, similar to our method of estimating likelihood ratios, of recognizing the interdependency of sensitivity and specificity. We also use this technique to test for homogeneity of the different MRI studies,

looking for outliers on the summary ROC curve.

### Positive Predictive Value of MRI

The probability of having cancer given a negative mammogram and CBE, but positive MRI (the post-test probability) was calculated using the following equations:

$$Post\text{-test Odds} = Pre\text{-test Odds} \times LR_{MAM,CBE-} \times LR_{MRI+},$$

where:

$$Pre\text{-test Odds} = \frac{Pre\text{-test Probability}}{1 - Pre\text{-test Probability}},$$

and post-test odds are converted to probability using the formula:

$$Post\text{-test Probability} = \frac{Post\text{-test Odds}}{1 + Post\text{-test Odds}},$$

$LR_{MAM,CBE-}$  is the likelihood ratio negative of mammography and CBE combined. The post-test probability represents the positive predictive value of MRI given that the mammogram and CBE were negative in the area of the suspicious lesion found on MRI. We use a person-level analysis to calculate the positive predictive value of MRI as opposed to a lesion-level analysis; thus the positive predictive value represents the probability that the woman has cancer given an MRI finding of a serendipitous lesion or lesions.

## Monte Carlo Simulations

We use Monte Carlo (49) stochastic simulations to calculate two-sided confidence intervals for the positive predictive value of MRI, given starting age, race, given that the mammogram, CBE, and index lesion biopsy are negative. In this simulation technique, each uncertain parameter (e.g. the likelihood ratio positive of MRI) is represented by a random variable that is chosen from a probability distribution reflecting the degree of uncertainty for that parameter. We used normal probability distributions to represent the three parameters in the model, each distribution was constrained to avoid illegal values. The probability of breast cancer and likelihood ratio negative of CBE/mammography were bounded between zero and one; the likelihood ratio positive for MRI was bounded as greater than or equal to one. The model was recalculated 5000 times for each set of parameters, using a Monte Carlo simulation software package (@Risk version 3.0 for Windows, Palisade Corp., Newfield, NY). The 95% confidence intervals for the likelihood ratios are shown in Table 1.

## Sensitivity Analyses

In order to test the effects of uncertainty in model parameters on model results, we performed several sensitivity analyses. These analyses involve varying the model parameters over a range of values. We performed sensitivity analyses on the initial prevalence of disease, the sensitivity and specificity of mammography/CBE, and the sensitivity and specificity of MRI. We also examined the effect of assuming that the combined sensitivity of mammography and

CBE was lower for younger women than for older women, using an approximate ratio of sensitivity of mammography in younger women to that of older women based upon the medical literature (28, 50-53).

## **RESULTS**

### **Meta-analyses**

The results of the literature search for the MRI parameters revealed 360 MEDLINE entries identified, of which 14 met eligibility criteria for use in the meta-analysis. After removal of duplicated data, we used 12 studies in the meta-analysis; these studies are summarized in the Appendix. Sensitivity of the studies ranged from 91% - 100%. The studies showed a wide range of specificity, ranging from 37% - 89%.

Parameter estimates for the likelihood ratios used in the analysis are shown in Table 1. The sensitivity and specificity for mammography/CBE and for MRI are included for reader information; the likelihood ratios were used for the model analyses. As can be seen in the table, the summary measure of sensitivity of MRI is quite high, but that of specificity is modest. The summary likelihood ratio positive for MRI, 3.05, is reasonably small. In comparison, the likelihood ratio positive of mammography/CBE would be 68.5, due to the very high specificity of the combination of these two tests.

Figure 2 shows the summary ROC curve for the MRI studies, along with the operating points of these studies. The curve shown is a partial ROC curve to avoid extrapolation past the

range of available data. While we combined studies using different MRI techniques, no study was an outlier on the regression used to create the curve, suggesting that no study was operating at a sensitivity and specificity significantly different from those combinations on the summary ROC curve.

### **Simulation Model Results**

Table 2 shows the calculated initial prevalence of disease for the overall population, whites, blacks, and women at "high risk". These figures represent roughly three times the SEER yearly incidence of disease. Among women having an abnormal mammogram and/or CBE who are recommended to have a biopsy procedure (American College of Radiology Categories 4 and 5), where that biopsy is negative for cancer, the estimated positive predictive values of serendipitous lesions found on MRI are listed in Table 3. For our baseline analysis, the product of the likelihood ratio negative of mammography and CBE and the likelihood ratio positive of MRI is less than one. As a result, the age- and race-specific positive predictive values of MRI for serendipitous lesions are actually smaller than the initial prevalences of cancer shown in Table 2. Positive predictive values range from less than 1% chance of disease, up to a high estimate of a 1.9% chance of malignancy in an MRI lesion found in an 80 year old, high risk woman. In general, the positive predictive value of MRI increases with age (Table 3). Older blacks tend to have a lower positive predictive value than older whites (although the confidence intervals overlap), but the positive predictive values for blacks and whites under age 60 are reasonably similar.

## Sensitivity analyses

### Cancer Prevalence

The relationship between the initial prevalence of cancer and the positive predictive value of MRI given a negative mammogram/CBE is shown in Figure 3. Under our baseline conditions of diagnostic accuracy, the positive predictive value of MRI for a serendipitous lesion is less than the starting prevalence of cancer. This finding is explained by the fact that, under our baseline estimates of diagnostic accuracy, the finding of a negative mammogram and CBE lowers the probability of disease more than the finding of a positive MRI raises the probability.

### Sensitivity and Specificity of MRI

Figure 4 displays a graph of the specificity of MRI (for a constant sensitivity) versus the positive predictive value of the MRI, given a negative mammogram and CBE, for selected age groups. For women of all ages, if the specificity of MRI were lower than our baseline estimate, then the positive predictive value of the test would be lower; If the specificity of MRI were to improve, then the positive predictive value of the test would improve. For example, for an average 60 year old woman to have a 5% chance of cancer with a positive MRI in this setting, the specificity of MRI would have to be over 95%. For all ages for women at average population risk, the specificity of MRI would need to be at least 94% to raise the positive predictive value to 5%. Improving the sensitivity of MRI will also slightly improve the positive predictive value,

but the analysis is not as dependent upon this parameter.

We also varied the likelihood ratio positive of MRI across the range of values represented in the summary ROC curve in Figure 2, bounded by the range of specificities seen in the analyzed studies. If the most specific point on the summary ROC curve is used, the likelihood ratio positive for MRI is 8.3, and the product of the likelihood ratios would be 1.5. Thus, if future use of MRI for a particular finding demonstrated a sensitivity and specificity at this point on the curve (92% and 89%, respectively), the positive MRI could raise the probability of cancer, for example from a pre-test probability of 1.5% to 2.3% for a 75 year old average woman in the population.

#### Sensitivity and Specificity of Mammography/CBE

Figure 5 shows a graph of the relation between the sensitivity of mammography and the positive predictive value of MRI. If mammography were more sensitive than our baseline estimate of 82%, the positive predictive value of MRI would be lower than estimated. As sensitivity of mammography/CBE decreases, the positive predictive value of the MRI increases, although even with a sensitivity of 40% for mammography/CBE, the positive predictive value of MRI does not reach 5% for average risk women. If the specificity of mammography/CBE decreases, then the positive predictive value will improve, although the analysis is much less dependent on changes in this value.

We also examined the effect of our assumption that the sensitivity of mammography and CBE are independent of age. In this sensitivity analysis, we assumed that the combined

sensitivity of mammography and CBE for woman younger than 50 years old was 0.8 times our baseline sensitivity. This assumption did not cause large changes; the PPV of MRI ranged from 0.3% for an average 35-39 year old woman to 1.5% for a 45-49 year old high-risk woman. The product of the likelihood ratios for this sensitivity analysis was 1.1; so the combination of negative mammography/CBE did not largely raise the probability of disease for these women whose initial prevalence of disease is small.

## **DISCUSSION**

We know of no other work that focuses on the issue of serendipitous breast lesions in women without known cancer. This work was initiated to help guide clinicians who were faced with decisions of whether or not to pursue serendipitous breast lesions found on MRI.

Our analysis has shown that the positive predictive value for cancer of serendipitous lesions found on MRI is quite low. There are several reasons that MRI has such low positive predictive values. First, the positive predictive value is affected by the probability of disease in the women who undergo the test. Overall, the general population prevalence of cancer is low.

Second, the mammogram and CBE add information to the MRI. The mammogram and CBE are, by definition, negative in the area that the serendipitous lesion was found. The fact that these two tests are negative lower the probability that a woman has cancer from her baseline. Our baseline estimates of the sensitivity and specificity of mammography and CBE suggest that the probability of cancer after these tests are negative are roughly one-fifth the initial chance of cancer.



Finally, the lack of specificity of MRI contributes to the low positive predictive value of this test. For our baseline estimates of diagnostic accuracy, the specificity of MRI would have to be 83% to have a positive predictive value of MRI for a serendipitous lesion equal to the initial prevalence of cancer. While the studies we examined uniformly reported sensitivity over 90% for MRI, the specificity of MRI ranged from 37% (54,55) - 89% (56). We have found on meta-analysis that the specificity is quite low; however, should future MRI techniques preserve current sensitivity while greatly improving specificity, then the positive predictive value may become high enough to warrant an immediate biopsy procedure for further evaluation. If the sensitivity of future techniques is similar, then the positive predictive values for serendipitous lesions found using these MRI techniques can be approximated by finding the appropriate value for a woman's age and the technique's specificity on the graph in Figure 4.

Sensitivity analyses show that the probability of cancer in these serendipitous lesions remain extremely low over a wide range of assumptions. As noted above, the analysis was perhaps most dependent on the specificity of MRI, with higher positive predictive values for higher specificity. However, to have the positive predictive value for a 50 year old woman raised to 5%, for example, the specificity of MRI would have to be 98% given our baseline estimate of sensitivity. Also, the lower the sensitivity of mammography and CBE combined, the better the positive predictive value of MRI; however, the sensitivity of mammography/CBE would have to be 55% for MRI to have a positive predictive value of 1% for 50-54 year old average-risk women.

There are several caveats that should be considered when evaluating our results. First, while our results are based upon the best estimates of MRI performance from currently available

medical literature, none of the studies specifically address MRI characteristics for incidental lesions. Ideally, future research would include a multi-center, consecutive case series in which all patients with serendipitous lesions and benign index lesions either had an excisional biopsy, an MRI guided biopsy procedure, or close clinical follow up to determine the probability of malignancy in these serendipitous lesions.

Second, we are currently unable to test the validity of the assumptions underlying this model. However, over a broad range of assumptions, our conclusions that MRI has a very low positive predictive value for serendipitous lesions does not change.

Third, we use a person level analysis, instead of a lesion level analysis. We use this level of analysis to calculate the probability that a woman with a serendipitous finding has cancer, instead of the probability that an individual lesion has cancer. While we are more interested in the former probability, it is difficult to estimate whether a systematic bias is introduced for women with multiple serendipitous lesions due to lack of data on the risk of cancer with multiple serendipitous lesions compared to a single lesion. If each lesion were statistically independent, then our results, which present data for an “average” woman with serendipitous lesions, would overestimate the probability of cancer in women with a single serendipitous lesion and underestimate the probability for women with multiple lesions. If the risk of cancer in each of multiple lesions is highly correlated, then the probability of cancer will be similar regardless of the number of lesions.

Fourth, we are interested in the probability of finding invasive breast cancer in this study; we do not include DCIS in the calculation for positive predictive value. Many women who are diagnosed with DCIS by biopsy do not develop invasive breast cancer (57), although if DCIS is

diagnosed then treatment is recommended (58). While currently the incidence of diagnosed DCIS is less than that of invasive cancer (32), autopsy studies suggest that the prevalence of undetected DCIS may be larger than that of undetected invasive cancer (59). Thus, if DCIS were included, the positive predictive value of MRI would increase over our estimates due to an increase in the pre-test probability of having disease, albeit by including lesions of more questionable significance than invasive cancers.

These results apply to women who are “typical members of the population”. We include “high-risk women”, e.g. someone with a strong family history of cancer or with a previous history of a biopsy for benign breast disease. This analysis does not apply to someone for whom there is a very high prior probability of cancer. Excluded from this analysis would be women who have a BRCA1 or BRCA2 breast cancer genetic susceptibility mutation, which put women at much higher lifetime risk of cancer than those with a family history but without a susceptibility mutation (60,61). Also excluded in this analysis are those women who have a high clinical suspicion of having a malignancy; for instance, if the serendipitous lesion were found in a woman who is being worked up for findings suspicious for metastases in other organs, or a woman who has known breast cancer or prior breast cancer, the results of this analysis would not be applicable. Also, this analysis is specific to one point in time. There are currently no data on the positive predictive value of MRI for lesions that change over time. Lesions increasing in size on follow-up MRI, for example, may have a higher probability of being cancer than the one-time finding of a serendipitous lesion modeled here.

Finally, the optimal threshold positive predictive value for cancer for which a biopsy procedure of a suspicious lesion should be performed is not well established. This threshold

probability would be dependent on a full evaluation of the risks and benefits of a biopsy procedure, for example balancing the risks of an invasive procedure versus the consequences of potentially delaying diagnosis of a malignancy. We provide the probabilities shown in Table 3 as data to assist clinicians and patients in making decisions about further evaluation of serendipitous MRI lesions. The results of this analysis indicate that the probability that a woman with serendipitous lesions found on MRI has breast cancer is lower than the approximately 15-35% probability of finding cancer in women currently undergoing a biopsy procedure (3-6). Thus, it is unlikely that an immediate biopsy procedure would be the most beneficial strategy.

In summary, we have found that, in women with a suspicious lesion on mammogram and/or CBE found to be benign, serendipitous breast lesions found on MRI are extremely unlikely to be malignant. While the risk is certainly not zero, for a typical woman the probability of cancer in these lesions is low enough that an immediate biopsy procedure could be avoided.

## REFERENCES

1. Miller AB, Baines CJ, To T, Wall C. Canadian National Breast Screening Study: 1. Breast cancer detection and death rates among women aged 40 to 49 years. *Can Med Assoc J*. 1992a; 147:1459-76.
2. Osteen RT, Cady B, Chmiel JS, et al. 1991 national survey of carcinoma of the breast by the Commission on Cancer. *J Am Coll Surg* 1994; 178: 213-9.
3. Winchester DP, Senen S, Immerman S, Blum MA. A systematic approach to the evaluation and management of breast masses. *Cancer* 1983; 51: 2535-40.
4. Yankaskas BC, Knelson MH, Abernathy ML, Cuttino JT, Clark RL. Needle localization biopsy of occult lesions of the breast: experience in 199 cases. *Invest Radiol* 1988;23:729-33.
5. Cardenosa G, Eklund GW. Rate of compliance with recommendations for additional mammographic views and biopsies. *Radiology* 1991;181:359-61.
6. Goedde TA, Frykberg ER, Crump JM, Lay SF, Turetsky DB, Linden SS. The impact of mammography on breast biopsy. *Am Surg* 1992;58:661-6.
7. Layfield LJ, Chrischilles EA, Cohen MB, Bottles K. The palpable breast nodule: A cost-

effectiveness analysis of alternate diagnostic approaches. *Cancer* 1993; 72: 1642-51.

8. Lindfors KK, Rosenquist CJ. Needle core biopsy guided with mammography: A study of cost-effectiveness. *Radiology* 1994; 190: 217-22.

9. Lieberman L, Fahs MC, Dershaw DD, et al. Impact of stereotaxic core breast biopsy on cost of diagnosis. *Radiology* 1995; 195: 633-7.

10. Hillner BE, Bear HD, Fajardo LL. Estimating the cost-effectiveness of Stereotaxic Biopsy for non-palpable breast abnormalities: A decision analysis model. *Acad Radiol.* 1996; 3:351-60.

11. Gram IT, Lund E, Slenker SE. Quality of life following a positive mammogram. *Br J Cancer.* 1990; 62:1108-22.

12. Parker RG. The "cost-effectiveness" of radiology and radiologists. *Radiology* 1993; 189: 363-9.

13. Frankel SD, Sickles EA. Morphologic criteria for interpreting abnormalities seen at breast MR imaging. *Radiology.* 1997; 202:633-4.

14. Khalkhali I, Mena I, Diggles L. Review of imaging techniques for the diagnosis of breast

cancer: a new role of prone scintomammography using technetium-99m sestamibi. *Eur J Nuc Med.* 1994; 21:357-62.

15. Heywang-Koebrunner SH. Diagnosis of breast cancer with MR--review after 1250 patient examinations. *Electromedica.* 1993;61:43-52.

16. McNaughton Collins M, Ransohoff DF, Barry MJ. Early detection of prostate cancer:serendipity strikes again. *JAMA.* 1997; 278:1516-9.

17. Sox HC, Blatt MA, Higgins MC, Marton, KI. *Medical Decision Making.* Massachusetts: Butterworth-Heinemann;1988.

18. Chalmers TC, Levin H, Sacks HS, et al. Meta-analysis of clinical trials as a scientific discipline: I. Control of bias and comparison with large cooperative trials. *Stat Med.* 1987a;6:315-25.

19. Chalmers TC, Berrier J, Sacks HS, et al. Meta-analysis of clinical trials as a scientific discipline: II. Replicate variability and comparison of studies that agree and disagree. *Stat Med.* 1987b;6:733-44.

20. Sacks HS, Berrier J, Reitman D, Ancona-Berk VA, Chalmers TC: Meta-analyses of randomized controlled trials. *N Engl J Med* 1987;316:450-5.

21. L'Abbe KA, Detsky AS, O'Rourke K: Meta-analysis in clinical research. *Ann Intern Med* 1987;10:224-33.
22. Lau J, Ioannidis JP, Schmid CH. Quantitative synthesis in systematic reviews. *Ann Intern Med* 1997;127:820-6.
23. Olkin I. Statistical and theoretical considerations in meta-analysis. *J Clin Epidemiol* 1995;48:133-46.
24. Shapiro S, Venet W, Strax P, Venet L. *Periodic Screening for Breast Cancer: The Health Insurance Plan Project and Its Sequelae, 1963-1986*. Baltimore: The Johns Hopkins University Press; 1988.
25. Chamberlain J, Coleman D, Moss S, et al. Sensitivity and specificity of screening in the UK Trial of Early Detection of Breast Cancer. In: Miller AB, Chamberlain J, Daye NE, et. al. eds. *Cancer Screening*. Cambridge: Cambridge University Press; 1991, pp 3-17.
26. Miller AB, Baines CJ, To T, Wall C. Canadian National Breast Screening Study: 2. Breast cancer detection and death rates among women aged 50 to 59 years. *Can Med Assoc J*. 1992; 147:1477-88.
27. Fletcher SW, Black W, Harris R, Rimer BK, Shapiro S. Report of the International



Workshop on Screening for Breast Cancer. J Natl Cancer Inst. 1993; 85:1644-56.

28. Kerlikowske K, Grady D, Barclay J, Sickles EA, Ernster V. Likelihood ratios for modern screening mammography: Risk of breast cancer based on age and mammographic interpretation. JAMA. 1996; 276:39-43.

29. Fryback DG. Bayes' theorem and conditional nonindependence of data in medical diagnosis. Comp Biomed Res 1978;11:423-34.

30. Chang P, Fryback DG. A simulation model of breast cancer natural history. Med Decis Making. 1992;12:345.

31. Chang P, Fryback DG. Rethinking the benefits of breast cancer screening. Med Decis Making. 1993; 13:382.

32. Ries LAG, Kosary CL, Hankey BF, Miller BA, Hurray A, Edwards BK (eds). *SEER Cancer Statistics Review. 1973-1994*, National Cancer Institute. NIH Publ No. 97-2789. Bethesda, MD, 1997.

33. U.S. Bureau of the Census, *Statistical Abstract of the United States: 1996* (116th edition.) Washington, DC 1996.

34. Colditz GA, Rosner BA, Speizer FE. Risk factors for breast cancer according to family history of breast cancer. *J Natl Cancer Inst.* Mar 1996;88(6): 365-71.
35. Colditz GA, Willett WC, Hunter DJ, et al. Family history, age and risk of breast cancer. Prospective data from the nurses' health study. *JAMA.* July 1993;270(3): 338-43.
36. Schwartz AG, King MC, Belle SH, Satariano WA, Swanson GM. Risk of breast cancer to relatives of young breast cancer patients. *JNCL.* Oct 1985;75(4): 665-8.
37. Slattery ML, Kerber RA. A comprehensive evaluation of family history and breast cancer risk. The Utah population database. *JAMA.* Oct 1993;270(13): 1563-68.
38. Sattin RW, Rubin GL, Webster LA, Huezco CM, Wingo PA, Ory HW, Layde PM. Family history and the risk of breast cancer. *JAMA.* April 1985;253(13): 1908-13.
39. Parazzini F, La Vecchia C, Negri E, Franceschi S, Tozzi L. Family history of breast, ovarian and endometrial cancer and risk of breast cancer. *Int J Epidemiol.* 1993; 22(4): 614-8.
40. Calle EE, Martin LM, Thun MJ, Miracle HL, Heath Jr. CW. Family history, age, and risk of fatal breast cancer. *Am J Epidemiol.* Nov 1993;138(9):675-81.
41. Bain C, Speizer FE, Rosner B, Belanger C, Hennekens CH. Family history of breast

cancer as a risk indicator for the disease. *Am J Epidemiol.* 1980;111(3): 301-8.

42. Dupont WD, Page DL. Breast cancer risk associated with proliferative disease, age at first birth, and a family history of breast cancer. *Am J Epidemiol.* 1987;125(5): 769-79.

43. Dupont WD, Page DL. Risk factors for breast cancer in women with proliferative breast disease. *N Engl J Med.* Jan 1985;312(3):146-51.

44. Carter CL, Corle DK, Micozzi MS, Schatzkin A, Taylor PR. A prospective study of the development of breast cancer in 16,692 women with benign breast disease. *Am J Epidemiol.* 1988;128(3): 467-77.

45. McDivitt RW, Stevens JA, Lee NC, et al. Histologic types of benign breast disease and the risk for breast cancer. *Cancer.* Mar 1992;69(6):1408-14.

46. Fleiss JL. *Statistical Methods for Rates and Proportions.* New York: John Wiley & Sons; 1981.

47. Rice JA. *Mathematical Statistics and Data Analysis.* Pacific Grove, CA: Wadsworth & Brooks; 1988.

48. Littenberg B, Moses LE. Estimating diagnostic accuracy from multiple conflicting

reports: A new meta-analytic method. *Med Decis Making*. Oct-Dec 1993;13(4):313-21.

49. Doubilet P; Begg CB; Weinstein MC; Braun P; McNeil BJ. Probabilistic sensitivity analysis using Monte Carlo simulation. A practical approach. *Med Decis Making*. Summer 1985;5(2):157-77.

50. Peer PGM, Verbeek ALM, Straatman H, Hendriks JHCL, Holland R. Age-specific sensitivities of mamographic screening for breast cancer. *Breast Cancer Res Treat*. 1996;38: 153-

51. Robertson CL. A private breast imaging practice: medical audit of 25,788 screening and 1,077 diagnostic examinations. *Radiology*. April 1993;187(1): 75-9.

52. Burhenne HJ, Burhenne LW, Goldberg F, et al. Interval breast cancers in the screening mammography program of British Columbia: analysis and classification. *AJR*. May 1994;162: 1067-71.

53. Tabar L, Fagerberg G, Chen HH, et al. Efficacy of breast cancer screening by age. New results from the Swedish two-country trial. *Cancer*. May 1995;75(10): 2507-17.

54. Cross MJ, Harms SE, Cheek JH, Peters GN, Jones RC. New horizons in the diagnosis and treatment of breast cancer using magnetic resonance imaging. *Am J Surg*. Dec 1993;166(6):749-53; discussion 753-5.

55. Harms SE, Flamig DP, Hesley KL, et al. MR imaging of the breast with rotating delivery of excitation off resonance: clinical experience with pathologic correlation. *Radiology*. May 1993;187(2):493-501.
56. Perman WH, Heiberg EV, Herrmann VM. Half-Fourier, three-dimensional technique for dynamic contrast-enhanced MR imaging of both breasts and axillae: initial characterization of breast lesions. *Radiology*. July 1996;200 (1):263-69.
57. Page PL, Dupont WD, Roger LW, Landenberger M. Intraductal carcinoma of the breast: follow-up after biopsy only. *Cancer*. 1982; 49:751-8.
58. The Steering Committee on Clinical Practice Guidelines for the Care and Treatment of Breast Cancer. The management of ductal carcinoma in situ (DCIS). *Can Med Assoc J*. 1998; 158 (3 suppl):S27-34.
59. Welch G, Black WC. Using autopsy series to estimate the disease "reservoir" for ductal carcinoma in situ of the breast: how much more breast cancer can we find? *Ann Intern Med*. 1997; 127:1023-8.
60. Easton DF, Ford D, Bishop DT, et al. Breast and ovarian cancer incidence in BRCA-1 mutation carriers. *Am J Human Genetics*. 1995; 56:265-71.

61. Wooster R, Bignell G, Lancaster J, et al. Identification of the breast cancer susceptibility gene BRCA2. *Nature*. 1995; 378: 789-92.
62. Boetes C, Barentsz JO, Mus RD, et al. MR characterization of suspicious breast lesions with a gadolinium-enhanced TurboFLASH subtraction technique. *Radiology*. Dec 1994;193:777-81.
63. Gilles R, Guinebretiere JM, Lucidarme O, et al. Nonpalpable breast tumors: diagnosis with contrast-enhanced subtraction dynamic MR imaging. *Radiology*. Jun 1994;191(3):625-31.
64. Turkat TJ, Klein BD, Polan RL, Richman RH. Dynamic MR mammography: a technique for potentially reducing the biopsy rate for benign breast disease. *J Magn Reson Imaging*. July-Aug 1994;4(4):563-68.
65. Stomper PC, Herman S, Klippenstein DL, et al. Suspect breast lesions: findings at dynamic gadolinium-enhanced MR imaging correlated with mammographic and pathologic features. *Radiology*. Nov 1995; 197(2):387-95.
66. Heiberg EV, Perman WH, Herrmann VM, Janney CG. Dynamic sequential 3D gadolinium-enhanced MRI of the whole breast. *Magn Reson Imaging*. 1996;14(4):337-48.
67. Obdeijn IM, Kuijpers TJ, van Dijk P, Wiggers T, Oudkerk M. MR lesion detection in a

breast cancer population. *J Magn Reson Imaging*. Nov-Dec 1996;6(6):849-54.

68. Bone B, Aspelin P, Bronge L, Isberg B, Perbeck L, Veress B. Diagnostic accuracy of mammography and contrast-enhanced MR imaging in 238 histologically verified breast lesions. *Acta Radiol*. Jul 1997;38(4 Pt 1):489-96.

69. Helbich TH, Becherer A, Trattnig S, et al. Differentiation of benign and malignant breast lesions: MR imaging versus Tc-99m sestamibi scintimammography. *Radiology*. Feb 1997;202(2):421-29.

70. Nunes LW, Schnall MD, Orel SG, et al. Breast MR imaging: interpretation model. *Radiology*. Mar 1997;202(3):833-41.

**APPENDIX - Summary of Magnetic Resonance Imaging (MRI) Studies Used in Analysis**

Year	Study (Reference #)	Level of analysis <sup>§</sup>	Sensitivity	Specificity	# Patients	Contrast MRI techniques*			Pre- & Post-contrast comparison
						Pre-contrast	Dynamic imaging	Post-contrast	
1993	Cross (54)	Lesion	95%	37%	41	RODEO	No	RODEO	No
1993	Harms (55)	Lesion	94%	37%	30	RODEO	No	RODEO	No
1994	Boetes (62)	Lesion	95%	86%	83	3D MP-RAGE	Turbo T1 SGE [60]	No	Subtraction
1994	Gilles (63)	Person	95%	53%	144	T1 spin-echo	T1 spin-echo [6]	T1 spin-echo	Subtraction
1994	Turkat (64)	Lesion	100%	83%	35	T2 spin-echo; T1 spoiled GRASS	T1 spoiled GRASS [8]	3D T1 spoiled GRASS	No
1995	Stomper (65)	Lesion	92%	65%	49	T1; T2 spin-echo; T1 SPGR	T1 SPGR [10]	No	Subtraction
1996	Heiberg (66)	Lesion	100%	73%	56	25 patients: T1; T2 31 patients: 3D SPGR	3D SPGR [8]	No	Subtraction
1996	Obdeijn (67)	Person	91%	67%	54	STIR	2D T1 SGE [3]	STIR	Subtraction
1996	Perman (56)	Lesion	100%	89%	28	T1 Full Fourier	T1 Full Fourier 3D Dynamic Half Fourier [6]	No	No
1997	Bone (68)	Breast	92%	72%	220	3D T1 SGE	No	3D T1 SGE	No
1997	Helbich (69)	Lesion	96%	82%	66	65 patients: T2; 3D T1 SGE 3 patients: T2; Dynamic T1 SGE	65 patients: 3D T1 SGE [6] 3 patients: Dynamic T1 SGE [6]	No	Subtraction
1997	Nunes (70)	Person	96%	79%	192	T1 spin-echo; T2 spin-echo	67 patients: 2D SPGR 125 patients: 3D SPGR	No	No

<sup>§</sup>Level of analysis refers to the unit used for calculating sensitivity and specificity.

\*RODEO= Rotating delivery of excitation off-resonance; MP-RAGE= Magnetization-prepared rapid gradient echo; SGE= Spoiled gradient echo;

GRASS= Gradient-recalled acquisition in the steady state; SPGR= spoiled gradient-recalled echo; STIR= Short tau inversion recovery; 2D, 3D= 2 or 3 dimension. Numbers in brackets represent the numbers of times images were acquired.

All studies used machines with 1.5 Tesla MRI units except for Helbich's study where a 0.5 Tesla machine was used on three patients.

All studies gave doses of gadolinium of 0.1 mg/kg body weight except for Boetes (0.2 mg/kg) and Obdeijn (20 ml for all patients).



**Table 1. Model Parameters**

<b>Parameter</b>	<b>Value</b>	<b>95% Confidence Intervals*</b>
Sensitivity of Mammography/CBE	82.2%	
Specificity of Mammography/CBE	98.8%	
Likelihood Ratio Negative of Mammography/CBE <sup>†</sup>	0.18	0.12 - 0.24
Sensitivity of MRI	95.6%	
Specificity of MRI	68.6%	
Likelihood Ratio Positive of MRI <sup>**</sup>	3.05	2.00 - 4.11

\* Confidence intervals are shown only for the likelihood ratios, the parameters used in the study.

<sup>†</sup> The likelihood ratio negative is defined as the ratio of one minus sensitivity to specificity.

<sup>\*\*</sup> The likelihood ratio positive is defined as the ratio of sensitivity to one minus specificity.

**Table 2. Estimated age- and race-specific prevalence of breast cancer\***

<b>Age</b>	<b>Total</b>	<b>White</b>	<b>Black</b>	<b>High Risk**</b>
35-39	0.24%	0.24%	0.25%	0.53%
40-44	0.40%	0.40%	0.44%	0.84%
45-49	0.63%	0.64%	0.65%	1.40%
50-54	0.68%	0.70%	0.60%	1.37%
55-59	0.79%	0.81%	0.74%	1.58%
60-64	0.98%	1.03%	0.82%	1.95%
65-69	1.17%	1.23%	0.98%	2.34%
70-74	1.42%	1.48%	1.17%	2.85%
75-79	1.53%	1.58%	1.27%	3.06%
80+	1.67%	1.73%	1.30%	3.34%

\* Values expressed as a percentage. 1% would be equivalent to 1000 cancer cases per 100,000 women.

\*\* A “high-risk” population is defined for this analysis as a population that has twice the age-specific incidence of breast cancer compared to the U.S. total population incidence.

**Table 3. Age- and Race-specific positive predictive value for cancer (with 95% confidence intervals) for women with a serendipitous breast lesion found on MRI, and a benign index lesion**

<b>Age</b>	<b>Total</b>	<b>White</b>	<b>Black</b>	<b>High Risk*</b>
35-39	0.13% (0.07-0.21)	0.13% (0.07-0.20)	0.14% (0.07-0.22)	0.29% (0.16-0.46)
40-44	0.22% (0.12-0.35)	0.22% (0.12-0.35)	0.24% (0.13-0.38)	0.46% (0.25-0.73)
45-49	0.35% (0.19-0.55)	0.35% (0.19-0.55)	0.36% (0.20-0.55)	0.78% (0.43-1.2)
50-54	0.38% (0.21-0.58)	0.39% (0.21-0.60)	0.33% (0.18-0.51)	0.76% (0.42-1.2)
55-59	0.44% (0.24-0.67)	0.45% (0.25-0.68)	0.41% (0.22-0.63)	0.88% (0.48-1.3)
60-64	0.54% (0.30-0.83)	0.57% (0.31-0.88)	0.45% (0.25-0.70)	1.1% (0.59-1.7)
65-69	0.65% (0.34-0.99)	0.68% (0.37-1.1)	0.54% (0.29-0.84)	1.3% (0.71-2.0)
70-74	0.78% (0.44-1.2)	0.82% (0.45-1.3)	0.65% (0.35-0.99)	1.6% (0.88-2.4)
75-79	0.84% (0.46-1.3)	0.87% (0.49-1.3)	0.70% (0.39-1.1)	1.7% (0.94-2.6)
80+	0.93% (0.51-1.4)	0.96% (0.52-1.5)	0.72% (0.39-1.1)	1.9% (1.0-2.9)

\* A “high-risk” population is defined for this analysis as a population that has twice the age-specific incidence of breast cancer compared to the U.S. total population incidence.

Figure 1. Algorithm for calculating the positive predictive value of serendipitous breast magnetic resonance imaging (MRI) lesions. CBE = Clinical breast examination.

Figure 2. Summary receiver-operating characteristic (ROC) curve for magnetic resonance imaging (MRI) of the breast. This curve represents a weighted summary of the studies on the diagnostic accuracy of MRI for the detection of breast cancer.

Figure 3. Sensitivity analysis of the effect of initial prevalence of cancer on the positive predictive value of magnetic resonance imaging (MRI), given a negative mammogram and clinical breast examination. The arrow marks the upper bound of the range of initial prevalences of cancer presented in Table 2. PPV = positive predictive value.

Figure 4. Sensitivity analysis on the effect of specificity of magnetic resonance imaging (MRI) on the positive predictive value of MRI, given a negative mammogram and clinical breast examination. Data are presented for four age groups of women at average population age-specific risk of breast cancer. PPV = positive predictive value.

Figure 5. Sensitivity analysis on the effect of sensitivity of mammography and CBE on the positive predictive value of MRI. Data are presented for 4 age groups of women at average population age-specific risk of breast cancer. PPV = positive predictive value.



TOP

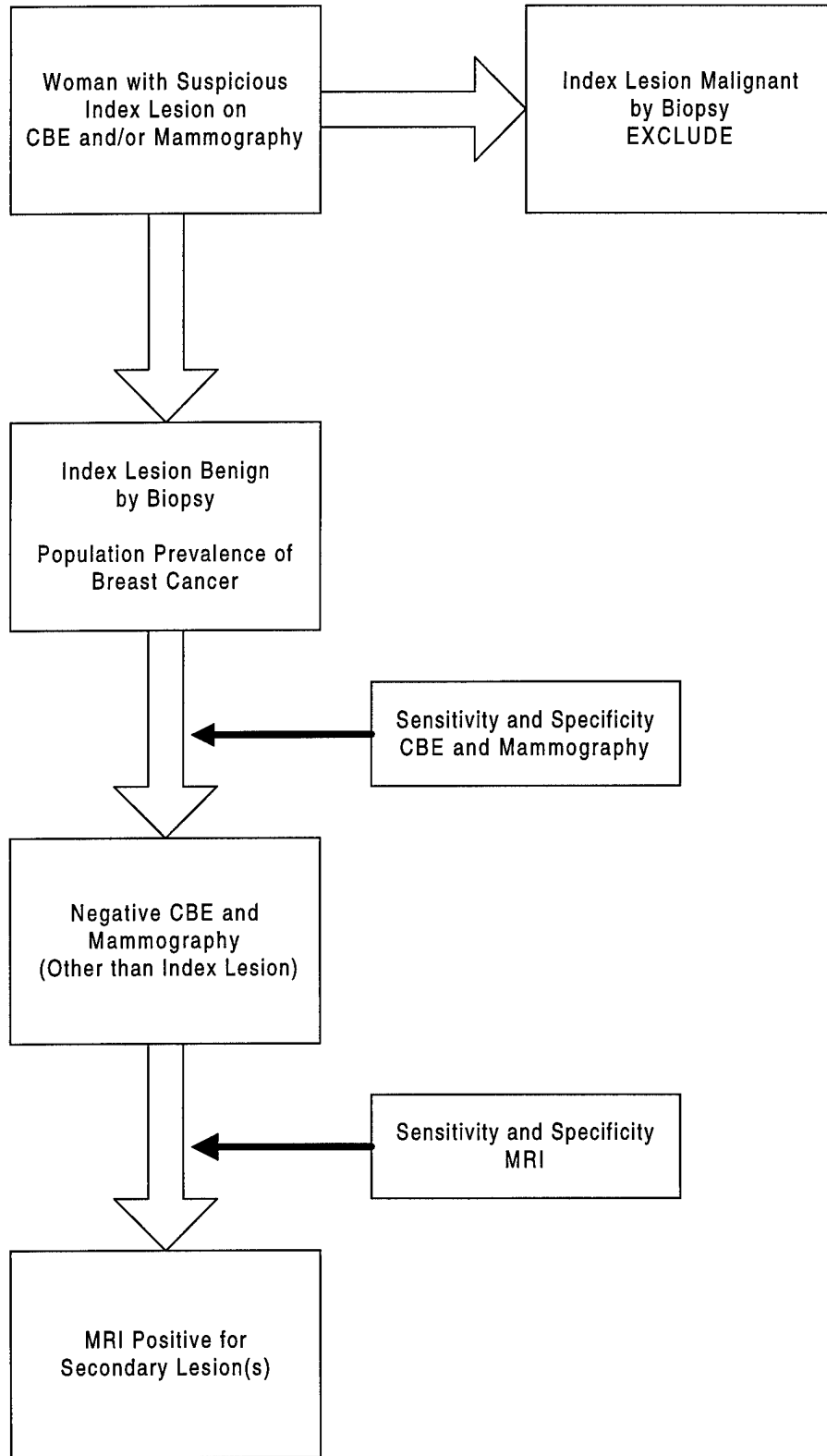

FIGURE 1

TOP

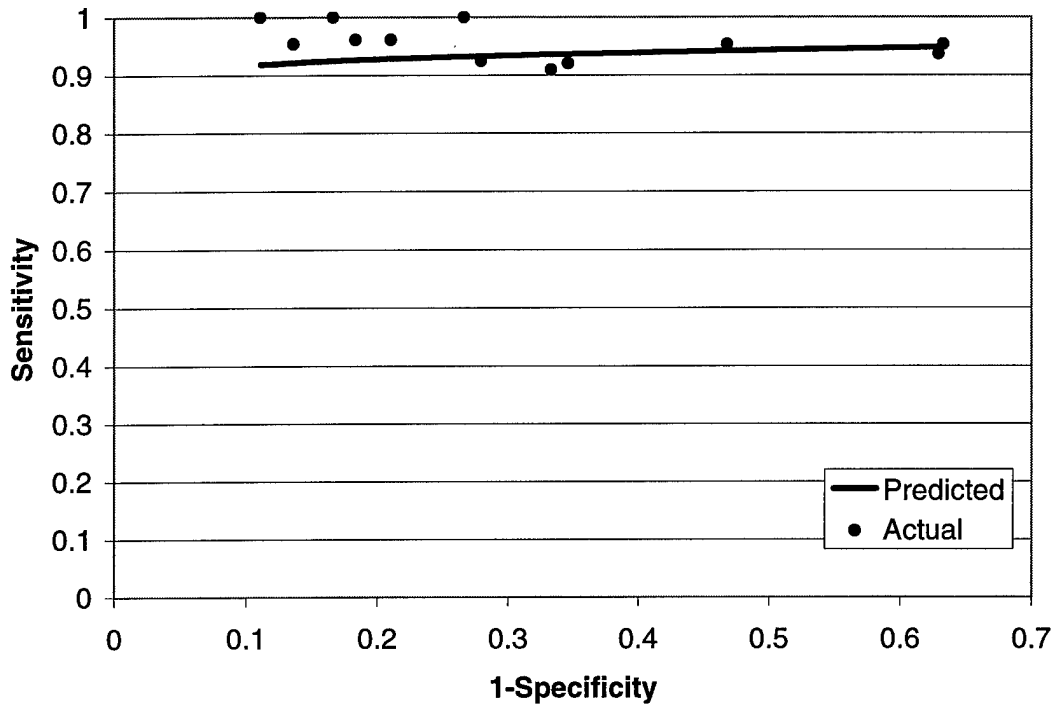

FIGURE 2

TOP

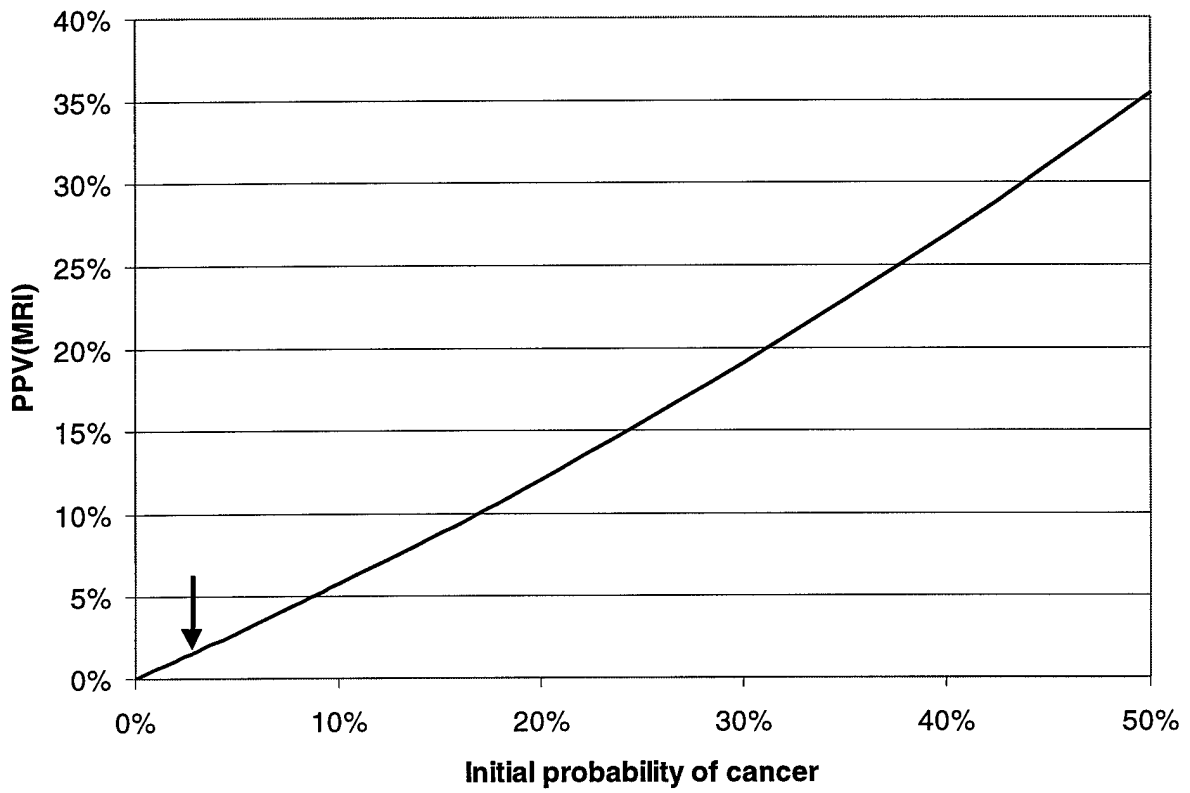

FIGURE 3

TOP

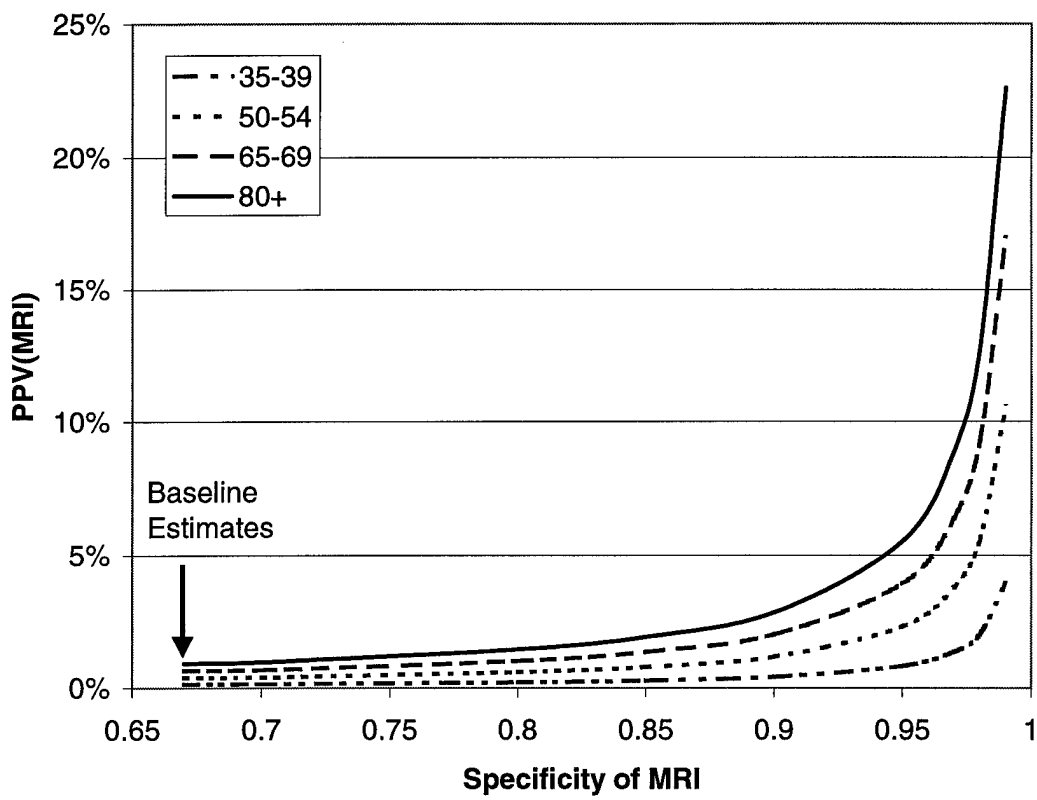

FIGURE 4

TOP

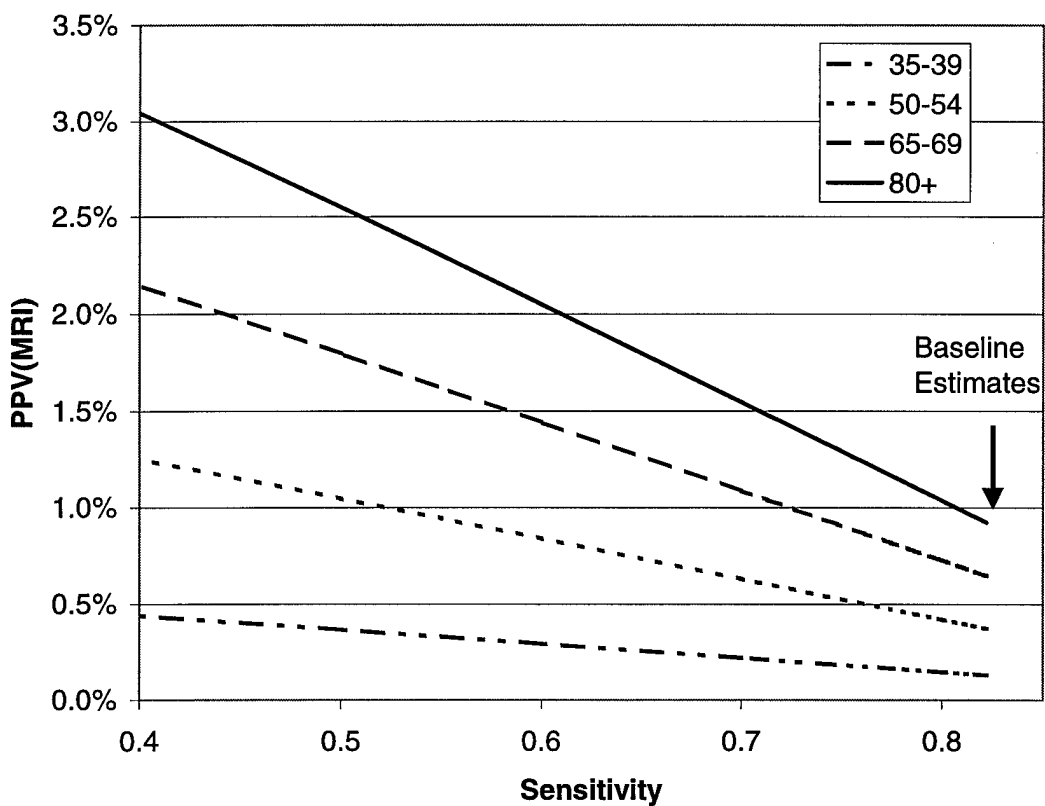

FIGURE 5

OTC Nicotine Replacement Therapy

**Does Over-the-Counter Nicotine Replacement Therapy  
Improve Smokers' Life Expectancy?**

William F. Lawrence<sup>1,2</sup>, Stevens S. Smith<sup>2,3</sup>, Timothy B. Baker<sup>2,3</sup>, and  
Michael C. Fiore<sup>2,4</sup>

<sup>1</sup>Cancer Clinical and Economic Outcomes Core, Lombardi Cancer Center,  
Georgetown University Medical Center

<sup>2</sup>Center for Tobacco Research and Intervention, University of Wisconsin Medical  
School

<sup>3</sup>Department of Psychology, University of Wisconsin-Madison

<sup>4</sup>Division of General Internal Medicine, Department of Medicine, University of  
Wisconsin Medical School

Address Correspondence  
and Reprint Requests to:

William F. Lawrence, MD, MS  
Cancer Clinical and Economic Outcomes Core  
Lombardi Cancer Center  
2233 Wisconsin Avenue, Suite 430  
Washington, D.C. 20007  
Phone: (202) 687-0817, FAX: (202) 687-0305  
E-mail: lawrencw@gunet.georgetown.edu

**Funding:** This study was funded by a grant from SmithKline Beecham. Dr. Lawrence is supported in part by Contract DAMD 17-96-C-6069, "Breast Cancer Support Contract," from the Department of the Army.

**Keywords:** Smoking cessation, public health, nicotine replacement therapy, decision analysis

Text=2300 words; 4 Tables; 2 Figures

**Abstract**

**Objective:** To determine the public health benefits in terms of number of quitters and life expectancy of making nicotine replacement available without prescription.

**Design:** A decision-analytic model was developed to compare the policy of over-the-counter (OTC) availability of nicotine replacement therapy to that of prescription (Rx) availability for the U.S. adult smoking population.

**Main Outcome Measures:** Long-term (6 month) quit rates, life expectancy, and smoking attributable mortality (SAM) rates.

**Results:** OTC availability of nicotine replacement therapy would result in 91,151 additional successful quitters over a 6 month period, and a cumulative total of approximately 1.7 million additional quitters over 25 years. All cause SAM would decrease by 348 deaths/year and 2,940 deaths/year at 6 months and 5 years, respectively. Relative to Rx nicotine replacement therapy availability, OTC availability would result in an average gain in life expectancy across the entire adult smoking population of 0.196 years per smoker. In sensitivity analyses, the benefits of OTC availability were evident across a wide range of changes in baseline parameters.



**Conclusions:** Compared to Rx availability of nicotine replacement, OTC availability would result in more successful quitters, fewer smoking-attributable deaths, and increased life expectancy for current smokers.

## FROM RESEARCH TO PRACTICE

## Assessing the Effectiveness of Health Interventions for Cost-Effectiveness Analysis

Jeanne S. Mandelblatt, MD, MPH, Dennis G. Fryback, PhD,  
Milton C. Weinstein, PhD, Louise B. Russell, PhD, Marthe R. Gold, MD, MPH,  
and members of the Panel on Cost-Effectiveness in Health and Medicine

Cost-effectiveness analysis (CEA) is an analytic tool in which the costs and effects of an intervention designed to prevent, diagnose, or treat disease are calculated and compared with an alternative strategy to achieve the same goals. The results of a CEA are presented as a ratio of costs to effects, where the effects are health outcomes such as cases of disease prevented, years of life gained, or quality-adjusted life years gained, rather than monetary measures, as in cost-benefit analysis. Conducting a CEA requires a framework for portraying the cascade of events that occur as a consequence of the decision to intervene, for describing the probability that each event will occur, for accounting how long each event will last, and describing how much each event costs and is valued by the population or individuals targeted by the intervention. Mathematical models are well suited to these purposes.

The purpose of this article is to provide an overview of modeling to estimate *net* effectiveness in a CEA (the difference in effectiveness between an intervention and the alternative to which it is being compared). Many of the principles described for estimating effectiveness apply equally to determining costs in a CEA. The main difference is that health events are weighted by costs in the numerator of the cost-effectiveness ratio, while they are often weighted by preference values in the denominator. Preference values, or utilities, reflect the fact that individuals or populations with similar ability (or disability) to function may regard that level of functioning differently. When preferences are incorporated into CEAs, the results are generally expressed as costs per quality-adjusted life years.<sup>1,2</sup> A discussion of measurement of costs and valuing outcomes is beyond the scope of this article; for further information on these, and other components of a CEA, the reader is referred else-

where.<sup>3-5</sup> Following some definitions of terms, this article is organized into two sections describing the process of estimating effectiveness in a CEA: the first presents a review of the sources of event probabilities, and the second describes the use of modeling to estimate effectiveness.

### DEFINITIONS

Effectiveness, which reflects the impact of an intervention of health in real practice settings, should be distin-

---

*Received from the Department of Medicine, Lombardi Cancer Center (Cancer Clinical and Economic Outcomes Core) and the Institute for Health Care Policy and Research, Georgetown University School of Medicine, Washington, DC (JSM); Departments of Preventive Medicine and Industrial Engineering, University of Wisconsin-Madison (DGF); Department of Health Policy and Management, Harvard School of Public Health, and Department of Medicine, Harvard Medical School, Boston, Mass. (MCW); Institute for Health, Health Care Policy, and Aging Research, and Department of Economics, Rutgers University, New Brunswick, NJ (LBR); and Community Health and Social Medicine, City University of New York Medical School, NY (MRG).*

*The Panel on Cost-Effectiveness in Health and Medicine was convened by the Office of Disease Prevention and Health Promotion. The work presented in this paper is the responsibility of the authors, and does not reflect the views of the U.S. Public Health Service.*

*Dr. Mandelblatt's work was supported, in part, by grant RO1 HS08395, "Care, Costs, and Outcomes of Breast Cancer in the Elderly," from the Agency for Health Care Policy and Research, and Contract DAMD17-96-C-6069, "Breast Cancer Center Support Contract," from the Department of the Army (the "Cancer Clinical and Economic Outcomes Core" is one of the projects funded by this contract).*

*Dr. Gold's work was conducted while she served as a Senior Policy Advisor in the Office of Disease Prevention and Health Promotion in the U.S. Public Health Service, Department of Health and Human Services, Washington, DC.*

*Address correspondence and reprint requests to Dr. Mandelblatt: Georgetown University School of Medicine, Lombardi Cancer Center, Cancer Clinical and Economic Outcomes Core, 2233 Wisconsin Ave., Suite 430, Washington, DC 20007.*

---

From Research to Practice, a Journal series, presents articles to heighten the clinician's awareness of research and methodology issues that have direct relevance to practice. If you wish to submit a manuscript for consideration for this series, please contact Cynthia D. Mulrow, MD, MSc, Associate Editor, at mulrow@uthscsa.edu, or contact the Journal of General Internal Medicine at (215) 823-4471 to receive the appropriate guidelines.

# IN PRESS

*Annals of Behavioral Medicine*

Spouse Support, Coping and Mood Among Individuals with Cancer

Sharon L. Manne

Fox Chase Cancer Center

Stephen J. Pape

City University of New York-Graduate Center

Kathryn L. Taylor and James Dougherty

Memorial Sloan-Kettering Cancer Center

This research was supported by National Cancer Institute First Award #57379 and Research Career Development Award #65727 to Sharon Manne. We are grateful to Jennifer Keates, Amy Eisenberg and Rachel Kless for collection of study data, and to Marc Glassman, Ph.D. for statistical assistance. Correspondence should be addressed to Sharon Manne at Fox Chase Cancer Center, 510 Township Line Road, Cheltenham, PA 19012.

Running Head: Spouse Support and Coping

**ABSTRACT**

A model of the relations between spouse support, coping and positive and negative mood was examined with 221 individuals with cancer using LISREL analyses. A moderating effect for patient life expectancy was predicted for disease prognosis. Results indicated that spouse criticism was associated with negative mood indirectly through avoidant coping strategies, and spouse support was associated with positive mood indirectly through positively-focused coping. Results did not support a moderating influence for life expectancy upon the association between spouse behaviors and patient coping. The results of this study are discussed in terms of their implications for psychosocial interventions to reduce psychological distress among individuals with cancer.

# Choosing Reconstruction After Mastectomy: A Qualitative Analysis

Kathleen M. Neill, Nell Armstrong, and Caroline B. Burnett

**Purpose/Objectives:** To describe women's perspectives on factors that influenced their decision to have reconstructive surgery after a breast cancer diagnosis.

**Design:** Exploratory, descriptive, qualitative study.

**Setting:** A comprehensive cancer center in an urban setting.

**Sample:** Eleven women who underwent mastectomy and reconstruction. Six participants had autologous transverse rectus abdominis musculocutaneous-flap reconstruction, four had saline implants, and one had a silicone implant. All but one reconstruction was performed at the time of mastectomy.

**Methods:** Open-ended, face-to-face interviews using an interview guide were conducted within one month of reconstruction. One to two follow-up interviews were conducted approximately six months later.

**Main Research Variables:** Decision making about reconstruction, perceptions of information needs and sources, sources of support, and factors important to decision making.

**Findings:** The main theme identified was Getting My Life Back. The participants described this in terms of the themes of Information Seeking, Talking It Over, and Seeking Normality. The interactive skills of the healthcare provider played an important role in the women's decision making.

**Conclusions:** Reconstruction minimized the negative consequences of breast cancer and its treatment for the women in the study. The decision-making process was aimed at getting the person's life back as close to what it was before the diagnosis as possible or improving it. The three themes of decision making are interactive in nature, with participants returning to Information Seeking and Talking It Over as necessary to increasing their understanding and clarifying their "normality goals."

**Implications for Nursing Practice:** Healthcare professionals should determine how a woman wants to participate in decision making as well as the kind, amount, and sources of information the individual with breast cancer wants to have to make her decisions. Healthcare providers are key sources of information about treatment options, and they are critical to patient satisfaction with the decision-making process and with the final results of the surgical procedure. Family members, friends, and other women with breast cancer play a crucial role in talking it over.

The increased variety of treatment options that are now available for women with breast cancer and the expectation that they will participate in treatment decision making have altered significantly the way in which healthcare professionals approach these women.

At least three factors have contributed to this change. First, as a result of a large number of clinical trials, modified radical mastectomy and breast-conserving surgery plus radiation therapy have been shown to provide equivalent outcomes relative to overall survival and quality of life (Fisher et al., 1995). Second, immediate reconstruction, in all but a few women who have had a mastectomy, has been found to be a reasonable and viable option (American Society of Plastic and Reconstructive Surgeons [ASPRS], 1994). Finally, as a result of the report from the President's Commission for the Study of Ethical Problems in Medicine and Biomedical and Behavioral Research (1982), the concept of shared decision making has become a standard expectation in patient-provider encounters. The impact that this participation in treatment decisions has had on women diagnosed with breast cancer is not well understood.

Women newly diagnosed with breast cancer are faced with a series of complex decisions that have the potential to alter their lives (Pierce, 1993). These decisions require that a woman consider (a) alternative approaches to the local treatment of her breast cancer, such as modified radical mastectomy or breast-conserving surgery and radiation therapy; (b) systemic therapy, such as adjuvant chemotherapy or hormonal therapy; (c) immediate versus delayed reconstruction if mastectomy is selected; (d) type of reconstruction, tissue transfer procedures, or implantation; and (e) saline versus silicone implant if implantation is her choice (Berrino, Campora, Leone, & Santi, 1992).

Women frequently are expected to make choices about each of these different treatment decisions at the same time. Sorting out the advantages and disadvantages of any one of these treatment choices, in the context of a recent diagnosis of breast cancer, may cause a woman significant anxiety, stress, and fear of choosing the wrong treatment option. Although an increasing body of literature exists on

---

*Kathleen M. Neill, DNSc, RN, is an assistant professor, Nell Armstrong, PhD, RN, is a clinical associate professor, and Caroline B. Burnett, ScD, RN, is an associate professor and investigator at the Lombardi Cancer Center, all at the Georgetown University Medical Center School of Nursing in Washington, DC. At the time that this study was conducted, Armstrong was director of Research and Development for Patient Care Services at Howard University Hospital in Washington, DC. The American Cancer Society (Institutional Research Grant-193) and Dow Corning Corporation supported this study. The primary investigator also acknowledges the support of the 3M Corporation Corporate Scholar Program at Georgetown University School of Nursing, where this investigation first developed. (Submitted June 1997. Accepted for publication October 29, 1997.)*

In press, Health Psychology

Distress, Personality, and Mammography

1

Distress, Personality, and Mammography Utilization Among Women

With a Family History of Breast Cancer

Marc D. Schwartz, Kathryn L. Taylor, and Kristen Willard

Georgetown University Medical Center

Jamie E. Siegel

Ruth M. Lamdan and Karen Moran

Robert Wood Johnson School

Allegheny University of the Health Sciences

of Medicine

Running head: DISTRESS, PERSONALITY, and MAMMOGRAPHY

Abstract

We examined the impact of cancer-specific distress and conscientiousness on mammography utilization among women who were at increased risk for breast cancer. Participants were 200 women who had at least one first degree relative with breast cancer. Overall, 80% of the participants had obtained a mammogram in the previous year. After controlling for potential confounders (perceived risk, decisional balance, and physician recommendation for mammography), the distress by conscientiousness interaction was significantly associated with mammography utilization. Simple effects analysis revealed that distress was negatively associated with mammography utilization among women who were low in conscientiousness and not related to mammography utilization among highly conscientiousness women. The results are discussed in terms of their implications regarding interventions designed to increase mammography utilization in this population.

Key Words: Mammography, Conscientiousness, Family history of breast cancer

## The Role of Coping in the Psychological Adjustment of African American Women with Early-Stage Breast Cancer

KATHRYN L. TAYLOR<sup>a\*</sup>, RUTH M. LAMDAN<sup>b</sup>, JAMIE E. SIEGEL<sup>c</sup>, BONNIE O'CONNOR<sup>d</sup>, KAREN MORAN<sup>b</sup>, JOHN LYNCH<sup>e</sup> and MARY HRYWNA<sup>a</sup>

<sup>a</sup>Division of Cancer Prevention and Control, Lombardi Cancer Center, and the Department of Psychiatry, Georgetown University Medical Center. <sup>b</sup>Department of Psychiatry, Allegheny University of the Health Sciences. <sup>c</sup>Division of Hematology/Oncology, Department of Medicine, Allegheny University of the Health Sciences. <sup>d</sup>Department of Community and Preventive Medicine, Allegheny University of the Health Sciences and <sup>e</sup>Washington Cancer Institute, Washington Hospital Center

(Received 16 December, 1997)

**Problem:** Although a significant amount of research has evaluated the psychological adjustment of women diagnosed with breast cancer, virtually all studies have focused on white, middle class patients. The present study investigated psychological distress and coping among a sample of African American women recently diagnosed with early-stage breast cancer, as part of an ongoing, longitudinal, randomized support group intervention.

**Methods:** Participants were 93 African American women with Stage 0 to Stage IIIA breast cancer who were within 10 months of definitive surgery. Subjects participated in a semi-structured interview and completed a series of standardized self-report questionnaires regarding coping strategies and general and cancer-specific psychological distress.

**Results:** Overall, participants were relatively well-adjusted to the illness, were more likely to endorse active compared to avoidant coping strategies, and multivariate analyses revealed that avoidant (but not active) coping strategies were positively associated with psychological distress, especially among younger women.

**Conclusions:** The present study provided evidence that several standardized measures of coping and psychological distress were appropriate for use with African American breast cancer patients. Further, the data suggested that among younger breast cancer patients, avoidant coping may be a potential indicant of psychological distress, whereas it appears to play much less of a role in distress among older patients.

**Keywords:** Breast Cancer, African American, Coping

\* Corresponding Author: Kathryn L. Taylor, Ph.D., Division of Cancer Prevention and Control, Lombardi Cancer Center, Georgetown University Medical Center, 2233 Wisconsin Ave., Suite 400, Washington, DC 20007. 202-687-0649 (phone); 202-687-0651 (fax); 202-687-0435 (Project Coordinator).