



DTIC QUALITY INSPECTED 2

19981009 071

DISTRIBUTION STATEMENT A
Approved for public release;
Distribution Unlimited

DEPARTMENT OF THE AIR FORCE
AIR UNIVERSITY
AIR FORCE INSTITUTE OF TECHNOLOGY

Wright-Patterson Air Force Base, Ohio

AFIT/GIM/LAL/98S-3

**A THREE-DIMENSIONAL
463L PALLET PACKING MODEL AND ALGORITHM**

THESIS

WESLEY E. MANSHIP, JR.
First Lieutenant, USAF

JENNIFER L. TILLEY
First Lieutenant, USAF

AFIT/GIM/LAL/98S-3

Approved for public release; distribution unlimited

The views expressed in this thesis are those of the authors and do not reflect the official policy or position of the Department of Defense or the U.S. Government.

AFIT/GIM/LAL/98S-3

**A THREE-DIMENSIONAL
463L PALLET PACKING MODEL AND ALGORITHM**

THESIS

**Presented to the Faculty of the Graduate School of Logistics and
Acquisition Management of the Air Force Institute of Technology**

Air University

Air Education and Training Command

**In Partial Fulfillment of the Requirements for the
Degree of Master of Science in Inventory Management**

**Wesley E. Manship, Jr, B.S.
First Lieutenant, USAF**

**Jennifer L. Tilley, B.S.
First Lieutenant, USAF**

September 1998

Approved for public release; Distribution unlimited

Acknowledgments

A special thanks goes out to Capt Marvin Arostegui, our thesis advisor for keeping us on the straight and narrow; to Maj Raymond Hill, our reader and mentor for his insistence on making a leap in a difficult area of mathematics; to Capt Joe Martin, our point of contact at Armstrong Labs and our greatest motivator; to Vicki Anderson, whose hard work and tireless effort saved us countless hours of research; and to Tim Bowman, our counterpart at TASC, Inc. who was always willing to listen and assist us in any way.

Also, to my two darling children Corinthia and Jeremiah, for their love and understanding through countless hours of class projects and “homework.” Their patience and numerous hugs have helped Wes and me through this program.

And finally a sincere heartfelt thanks goes out to both of our parents. We love you and appreciate your reassurance, humor, and support.

Wesley E. Manship Jr.
Jennifer L. Tilley

Table of Contents

	Page
Acknowledgments.....	ii
List of Figures.....	v
Abstract.....	vi
I. Introduction.....	1
1.0 Background.....	1
1.1 Statement of the Problem.....	4
1.2 Results.....	5
1.3 Research Questions.....	7
1.4 Summary.....	8
II. Literature Review.....	10
2.1 Introduction.....	10
2.2 Pallet Loading Problem.....	11
2.3 Current Pallet Building Process.....	12
2.4 Assumptions and Constraints.....	14
2.5 Existing Models.....	20
2.5.1 Interactive Pallet Loading System (IPLS).....	21
2.5.2 Deployable Mobility Execution System (DMES).....	24
2.5.3 Automated Air Load Planning System (AALPS).....	27
2.5.4 Airlift Loading Model (ALM).....	28
2.5.5 Dynamic Analysis and Replanning Tool (DART).....	29
2.5.6 Marine Air Ground Task Force II (MAGTF II).....	30
2.5.7 Load Estimator.....	31
2.6 Other Commercial Off The Shelf Software (COTS).....	32
2.6.1 CARgo Loading (CARLO) System.....	32
2.6.2 The Virtual Loader.....	33
2.6.3 PACKMAN.....	34
2.6.4 Stowage Tactics for User Flights (STUF).....	35
2.6.5 MaxLoad.....	36
2.7 Algorithms.....	38
III. Methodology.....	46
3.1 Introduction.....	46
3.2 Feasibility.....	46
3.3 Method.....	48
IV. Model and Algorithm.....	52
4.1 Introduction.....	52
4.2 Variables and Definitions.....	53

	Page
4.3 Models	53
4.3.1 Hazardous Materials Compatibility	53
4.3.2 Knapsack Model	56
4.3.3 Pallet Loading Model.....	57
4.4 Algorithm.....	61
4.4.1 Initialization and Hazard Class Compatibility.....	61
4.4.2 Knapsack Heuristic	62
4.4.3 Initial Solution to the Pallet Packing Model.....	63
4.4.4 Tabu Search	64
V. Conclusions and Recommendations	67
5.1 Introduction.....	67
5.2 Summary	71
5.3 Conclusions.....	74
5.4 Recommendations.....	76
Appendix A. 463L Pallet-packing Algorithm.....	79
Bibliography	84
Vita.....	90

List of Figures

Figure	Page
1. Integrated Deployment System.....	6
2. Aircraft Configurations.....	16
3. Hazardous Cargo Classes.....	18
4. Compatibility of Hazardous Materials.....	19
5. MaxLoad Display.....	37
6. UTC Baseline Evaluation	38
7. Options Comparison	48
8. Pallet Packing Algorithm.....	63
9. Read Data.....	79
10. Hazardous Constraints	80
11a. Apply New Candidate Item List To Pallet Packing Model.....	81
11b. Apply New Candidate Item List To Pallet Packing Model	82
12. Tabu Search	83

Abstract

As part of the Air Force Logistics Contingency Assessment Tool, Armstrong Laboratory determined the need for a software package to optimize the packing of 463L cargo pallets for deployments. In January 1998, TASC, Inc., to determine if optimizing the packing of 463L pallets was indeed possible, implemented a feasibility study. TASC, Inc. concluded that a linear program was infeasible due to time and size constraints.

Therefore, this research focuses on the development of a nonlinear model. An extensive literature review is conducted to detail the pallet loading problem, define the current pallet process, establish necessary assumptions and constraints, and examine possible algorithms to be used for the solution of the model. Also, other packing models are examined for possible use in the development of the nonlinear 463L pallet-packing model. The 463L pallet-packing model consists of three sub-models. These are a hazardous constraints linear program, a knapsack model, and a pallet-loading model. The complete model is solved using a knapsack heuristic and a tabu search.

A THREE-DIMENSIONAL 463L PALLET PACKING

MODEL AND ALGORITHM

I. INTRODUCTION

1.0 BACKGROUND:

Throughout post World War II history and especially in recent years, it is apparent that because of the elevating dependency and cost of strategic airlift that a better and perhaps optimal way of shipping cargo needs to be developed. In order to optimize the use of aircraft, it is not only pertinent to load an aircraft in the most optimum manner possible, but it is also necessary to focus on how to build up each individual pallet. If the optimization of aircraft loading is to be successful, it must begin at the lowest level possible. The standard aircraft pallet is the 463L pallet; therefore, this study will focus on creating a model that will load a 463L pallet in the most optimal method, given the constraints involved.

When the large-scale deployment of the military to South Viet Nam began in 1965, the Air Forces' Military Airlift Command (MAC) found itself faced with the unparalleled task of providing one of history's greatest troop and supply movement. Of course, this movement needed to take place rather urgently, despite MAC's limited resources. At the time, the command had only 34 squadrons, 21 squadrons of C-124 Globemasters, 3 squadrons of C-133 Cargomasters, 7 squadrons of C-130 Hercules, and 3

squadrons of C-135 Stratolifters. Of these, only the C-124 and the C-133 were designed to be cargo aircraft and they were approaching obsolescence (Berger, C. 1984). The fleet at this time was not suited for the massive airlift required to adequately support the Vietnam deployment even with the notable help of the then poorly equipped Air Force Reserve and National Guard.

To deal with this tremendous need for cargo lift, the development and production of such planes as the C-141 and the C-5 hastened. The C-141 Starlifter became active in August of 1965. A Starlifter could carry 67,620 pounds of cargo for 4000 miles so was a significant improvement over the C-124, which could only carry 50,000 pounds for about 1000 miles. The only problem was that a significant number of the C-141s were not produced in time to aid in the initial airlift efforts. By 1967 there were 100 C-141s, but that was not until after the initial two years of airlift had been completed. In 1969, the C-5 rolled off the production line and was promised to be the "answer-all." The C-5 could carry 164,383 pounds over 3000 miles (Berger, 1984). The biggest problem with this aircraft was its 70 percent mission capable rate. It was not dependable. However, these two aircraft systems did pick up some slack and, with its reduced workload, the C-141 continued as the Air Force's dependable workhorse. Despite new systems rolling off the assembly line to replace the aging MAC fleet as well as the support from the Guard and Reserve, the demand for airlift far outstripped airlift capacity.

The demand on the airlift capability of MAC was unparalleled up to this time. During 1965, the monthly average was 33,779 passengers and 9,123 tons of cargo. This jumped to a monthly average of 65,350 passengers and 42,296 tons of cargo in the fiscal

year of 1967. The totals are 53,198 tons of cargo and 175,539 passengers in 1965; 117,465 tons and 254,000 passengers in 1966, and 141,113 tons and 347,027 passengers in 1967 (Berger, 1984). Considering the large amount of airlift needed for this amount of troops and cargo, a system that would give the best possible loading solution for each plane that took off would have been a very valuable tool.

The biggest problems with the strategic airlift during this time period dealt with capacity issues as well as response problems. Both of these types of problems could have been eased with the use of an automated mobility system to optimize space on a specific pallet. Better pallet space utilization means fewer pallets thus decreasing space used on the plane and ultimately reducing the number of aircraft used. Such unused aircraft could be used at other departure points to move more units to the theater quicker.

Another more current example of a major airlift is the contingency known as Desert Shield/ Desert Storm. More tonnage was moved during the first six weeks of Desert Shield than in 65 weeks of the Berlin Airlift. During Phase 1, the Air Force flew 9,114 airlift sorties shipping 303,919 tons of cargo, 304,859 troops, and 400 tanks at a cost of nearly \$8 billion. During Phase 2, which was a time period of only three months, the major concern was increasing offensive ground capabilities as well as resupply. This cost another \$5.5 billion and brought the total airlift to 15,317 sorties, 519,458 tons, and 482,997 passengers. By 1 April 1991, 17,331 strategic airlift missions were flown (Head, 1992). Although airlift was critical to the success of Desert Shield/Desert Storm, efficiencies could have been gained with automated load planning systems.

Regardless of mission type, and whether peacetime or wartime airlift is being executed, it is extremely important that aircraft be used as efficiently as possible.... Aircraft are [currently] used inefficiently because... automated aircraft load planning systems currently used are not adequate and do not use detailed data in planning aircraft loads. (ORNL, 1986)

Also, in recent years, the increased emphasis on global reach as well as growing military commitments in diverse geographic locations separated by large distances has put a tremendous strain on declining military manpower and machinery. Each must be employed efficiently. Further, there has been a major decrease in the experience level of the Air Force because of major manpower reductions accomplished in large part with early retirement incentives. The Air Force will experience a severe shortage in experienced load planners in the future. The experience level and innovation of the Air Force airlift personnel that participated in Desert Storm were essential in the momentous accomplishment of this overall strategic airlift (Head, W.,1992). For these reasons, the U.S. military has come to re-realize the critical importance of efficiently using the existing scarce airlift resources.

1.1 STATEMENT OF THE PROBLEM:

The intent of this research is to establish the variables, constraints, and rules for the definition and subsequent development of a three-dimensional 463L pallet packing optimization model. This model will transition into a software tool becoming an essential part of an integrated deployment system (LOGCAT) for use as a “virtual” load or

logistics planner. The goal of the UTC-O subprogram of the LOGCAT system is to optimize the packing of 463L cargo pallets, decreasing the number of pallets used per UTC thus decreasing the number of aircraft required and money spent on airlift.

1.2 RESULTS:

The attempt to develop this total deployment package has resulted in the ongoing development of a totally integrated deployment system to be augmented by the Logistics Contingency Assessment Tool (LOGCAT) by Armstrong Laboratory at Wright-Patterson AFB in Ohio. Formally called the Enhanced Contingency Logistics Planning and Support Environment (ECLiPSE), LOGCAT is a tool for the entire deployment planning process cycle. "LOGCAT is a vision for improved wing-level deployment planning and re-planning."(Armstrong Laboratory, 1996) Currently, LOGCAT is composed of four different integrated themes: Survey Tool for Employment Planning (STEP), formerly Deployment Information and Support Environment (DISE); Unit Type Code Development, Tailoring, and Optimization (UTC-DTO); Beddown Capability Assessment Tool (BCAT); and Logistics Analysis to Improve Deployability (LOG-AID) (Computer Science Corporation, 1997).

The focus of this research and subprogram of LOGCAT, UTC-DTO is made up of two different components, an automated UTC development and tailoring subprogram (DT) and an automated pallet optimization package (O). The DT portion will automatically generate and optimize, or tailor, UTCs for specific missions. The goal for

the O portion is to generate optimal 463L pallet arrangements based on these UTCs (Computer Science Corporation, 1997).

LOGCAT will eventually be integrated into the current Air Force planning tools through the Integrated Deployment System (IDS). IDS will update the UTC-DTO with deployment requirements. STEP and BCAT will feed beddown capabilities into the UTC-DTO, which will then use “rule” based software to optimize or tailor forces for certain missions. Lastly, the IDS will be an information link or feed about the deployment process to MAJCOM planners. This is described in Figure 1 (Armstrong Laboratory, 1996).

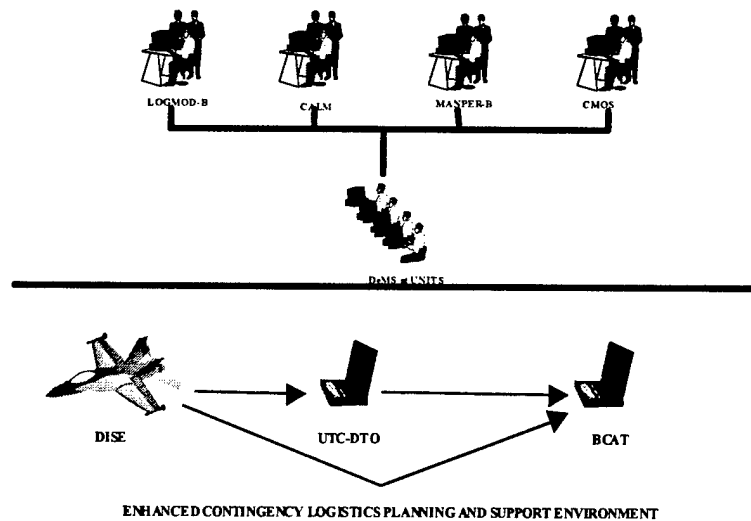

Figure 1. Integrated Deployment System (Armstrong Laboratory, 1996)

The ultimate result or goal is, of course, to develop a 3-D 463L pallet optimization software package (UTC-O) that will be used to minimize the number of pallets required for a deployment. This package or subprogram will be used in

conjunction and will interface with other integrated systems as described in figure 1. Armstrong Labs is hoping that through this study, the optimization package (UTC-O) can be developed. This study will also endeavor to show the pallet positions saved which will lead to fewer pallets used. Using less pallets will directly effect the amount of airlift needed for deployments. With airlift minimized, dollar savings will be realized. The money saved will have to be determined, using a rough cost analysis method due to the major portion of time spent in the development of the model. Because the UTC-O will provide a feasible solution to the palletization problem, timesavings will be realized. There will be no need to unload and repack. This will also decrease the amount of cargo getting frustrated by loadmasters finding errors in the pallet. Also, the complete interactive and graphical nature of the LOGCAT package, more specifically the UTC-O subprogram, will allow for contingency and exercise scenarios to be run real time on a desktop computer. This will facilitate training as well as decrease the cost of training for load planning scenarios. The most important result of the LOGCAT system, of which the UTC-O subprogram will be an essential component, is to increase combat readiness by making it easier for deployment planners to more efficiently deploy their unit's equipment and personnel anywhere on short notice.

1.3 RESEARCH QUESTIONS

1. What constraints must be incorporated into the model and what constraints are not incorporated into the model?

2. What algorithms could be used to optimize usage of pallet space?
3. What algorithms will work for the pallet optimization model and which ones will not be compatible?
4. What types of optimization software packages currently exist?
 - a. Is it possible that one of these be modified to fit the current need?
 - b. Ensure that this model will be compatible with other systems currently in use.
5. What should the final product be able to do?
 - a. Create a valid pallet load that is packed as efficiently as possible, considering all applicable constraints.
 - b. Download the data necessary to load the pallet from the TPFDDs, separate the necessary from the unnecessary data, and find the best list of items to load on a pallet.

1.4 SUMMARY

To ascertain the state of development of this problem and to establish the necessary assumptions as well as definitions for the understanding as well as the subsequent development of a model and algorithm, an extensive literature review is undertaken in Chapter II. First, the current pallet building process is examined. This provides the framework in which the optimization technique or the developed model must be placed to effect a change. The deployment process will not likely change so a determination must be made as to where this model can be inserted into the process without disrupting or changing the deployment scheduling. Next specifically, constraints

existent in the 463L pallet packing problem are identified and explained. After the identification of assumptions and constraints, a number of existing models are examined to determine the possibility of adapting embedded techniques to the particular problem of pallet packing. Also, a set of algorithms are reviewed with the underlying purpose of identifying the best or perhaps the combination of the best to aid in the development of a solution technique for the pallet packing process.

In Chapter III, the methodology for the development of the model is presented. Also, other options to the development of the model are examined such as the use of a Commercial Off The Shelf application with certain adjustments for military use. In Chapter IV, the model is described as well as the algorithm developed. Lastly, Chapter V will contain both conclusions and recommendations for the extension of this model as well as study into related areas.

II. LITERATURE REVIEW

2.1 INTRODUCTION

The goal of this thesis is to define a model of the three-dimensional 463L pallet-packing problem and propose an algorithm for the solution of this model. To accomplish this, many factors must be defined and examined. First, the pallet problem as well as some difficulties associated with it are discussed. The prime difficulty of the pallet-packing problem is the fact that it is NP hard, which means that finding an optimal solution can not be guaranteed to occur in a reasonable amount of processing time. A possible way around this is the layering method discussed. Next, the current pallet building process is defined in detail, as well as the connecting framework of other processes that may affect it. Also, the listing of this overall process allows the identification of optimal times to employ the algorithm developed in Chapter IV. After the entire deployment process including pallet packing is described, some cursory assumptions are defined as well as the identification of necessary constraints. Next, existing packing and cargo loading models with associated algorithms are examined for possible adaptation. Both aircraft loading as well as pallet or container packing systems are examined. Lastly, potential algorithms are examined for potential use.

2.2 PALLET LOADING PROBLEM

The pallet-loading problem is also known as the cutting stock problem. This problem has been described as an “orthogonal, rectangular packing problem that has been shown to be non-deterministic polynomial complete or NP complete” (Hodgson, 1981). A problem type is a member of the class NP if a solution algorithm's processing time can not be expressed as a polynomial function of the size, (i.e. number of variables) of the problem. The subclass of NP, NP complete, represents the hardest of all NP problems.

Hodgson (1981) defines two forms of the pallet-packing problem. These are the manufacturer's problem and the distributor's problem. The manufacturer's problem focuses on packing identical boxes on a pallet (Hodgson, 1981). The distributor's problem focuses on packing of different sized boxes on a pallet. Taylor (1994) identifies two sub-problems within each form, the two-dimensional and the three-dimensional pallet packing problem. Consider that when heights of boxes are nearly equal, the pallet is packed using a layer method. This layer method is solved using a two-dimensional process. However, this method falters when the heights of the boxes are extremely dissimilar. However, this problem can possibly be solved using Taylor's stacking methods. In stacking, columns are created and then the bottom space is optimized using a two-dimensional method.

2.3 CURRENT PALLET BUILDING PROCESS

The pallet building process suggests the variables and constraints for a pallet optimization model. As outlined in (Computer Science Corporation, 1997), the current process for building pallets is as follows. The rationale for the inclusion of the entire process involved with the initial stage of deployment is that the environment or the context in which the algorithm developed from the model defined in this thesis must be identified. This is necessary because the process itself will determine constraints and variables necessary for the development of the model and the later detailed development of an algorithm to be implemented within this process to give some solution to the packing problem, optimal or otherwise.

- I. UTC or unit tasking (defined as a LOGPLAN in the Contingency Operation/Mobility Planning and Execution System (COMPES)). This contains the Logistics Detail (LOGDET) for various UTCs.
- II. At this point, each increment of cargo must carry specific documentation which align with cargo preparation directives (AF Form 2279, pallet identifier, Unit Line Number (ULN), UTC, deployment echelon, increment number, and Transportation Control Number (TCN)).
- III. LOGDET is reduced to packing listings for increment numbers for each deployment echelon. The deployment echelon is an UTC capability that commanders must deploy as a single entity. Also, these deployment echelons identify the unit's

capabilities, material, and personnel requirements.

IV. Packing listings are made by logistics planners and then are distributed to various shops that hold the responsibility for building pallets.

V. Pallets are then built by unit augmentees with arranged formal education or on the job training. Pallet buildup is outlined in the Transportation Proficiency Center's paper entitled Palletization.

a. Selecting Cargo (based on destination, priority, and system entry time)

1. The highest priority must go first
2. System Entry Time (SET) refers to the time that the cargo arrives at the first shipping point responsible for starting a shipment through the transportation system. Basically, cargo held longest goes ahead of cargo held for shorter periods.
3. Destination of the aircraft and cargo will determine what to marry with what.

b. Positioning Cargo on the Pallet

1. Check pallet for damage.
2. Load heavy crated and boxed cargo first, preferably to the center of the pallet.
3. Lighter items on top and to the sides of the heavier items, considering that with the heavier in the center and the lighter items on the outside proper balance is ensured on the pallet.
4. Build the load in a square or pyramid shape to ensure easy handling.
5. Heed the writings on the item such as "THIS SIDE UP."
6. Cargo with special handling labels needs to be placed facing outward. General

labeled boxes do not need to be placed outward, however when possible place them facing out as well.

VI. When the pallets are finished, the required notifications are made to the deployment management functions.

VII. The pallets are now inspected and marshaled. Note: This is the first time that functional experts in the area of pallet building become involved with the process. Up to the point of being accepted and marshaled the units are responsible for rebuilding the pallet upon an aircraft change. Once the pallet has been accepted and marshaled the responsibility shifts to the base functional experts. In reality, since functional experts are sparse at most bases, unit assistance is often requested.

There are two possible points at which this notion of optimization planning can be applied. The first is just prior to the actual building of the pallet and the second is when a pallet must be rebuilt. This insertion of an automated optimal planner at these points in the process could save a considerable amount of time.

2.4 ASSUMPTIONS AND CONSTRAINTS

A well-defined set of constraints must be established to develop a viable mathematical model. Constraints define a feasible region of solutions over which an algorithm searches. Many possible constraints exist, length, width, and height of each box and the pallet, as well as, weight, pallet position, aircraft type, hazardous cargo, etc. Adding constraints reduces the feasible region and thus limits the number of possible

solutions. The trade-off is to add those constraints pertinent to the problem while retaining a parsimonious a model as possible.

The pallet itself suggests constraints. The 463L pallet has usable dimensions of 84" by 104" and all items must be contained inside this surface area in order to be strapped down by the required netting. The weight limit on each pallet is 10,000 pounds in total and 250 pounds per square inch (psi) to avoid damage to the pallet skin. The maximum weight for the pallet positions (positions on an aircraft where pallets are located) for different types of aircraft are listed in Figure 2; note that this takes into account the weight of the pallet and netting, which is a total of 355 pounds (Schroeder, 1997).

This effort assumes all items are rectangular. This is reasonable assumption since the information used by the UTC-O program is obtained from the Time-Phased Force Deployment Data (TPFDD). The TPFDD only contains length, width, and height information, but not whether the item is rectangular, circular, or pliable.

There are many ways to position and orient each box on a pallet. For instance, for any orientation, each box can be positioned six different ways on a pallet, one for each side. This implies that the degrees of freedom for these three variables, length, width, height alone, permit $n!6^n$ possible solutions for placing n boxes on the pallet (Nelson 1979); too many for mathematical formulation purposes. Therefore, it is assumed that all boxes are right side up, which is reasonable since many items, such as toolboxes, do remain "this end up." We assume orientation limits as well. We limit item rotation to 90 degrees horizontally.

C-130H

Pallet Positions	Weight	Height	Length	Width
1 & 2	10,354	96	104	84
3 & 4	10,354	96	98	84
5	8,500	96	104	84
6	4,664	76	104	84

(Note: Pallet Positions 3 & 4 require a 6 inch aisleway)

C-141

Pallet Positions	Weight	Height	Length	Width
1	10,354	76	104	84
2 Thru 12	10,354	96	104	84
13(ramp)	7,500	76	104	84

C-5 (A&B)

Pallet Positions	Weight	Height	Length	Width
1	7,500	96	104	84
2	7,500	96	104	84
3 Thru 34	10,354	96	104	84
35	7,500	76	104	84
36	7,500	76	104	84

C-17

Pallet Positions	Weight	Height	Length	Width
1	9,500	78	104	84
2 Thru 6	8,000	100	104	84
7	8,000	138	104	84
8	10,000	96	104	84
9 Thru 11	10,000	96	104	84

Figure 2. Aircraft Configurations (including pallet and netting)

Each pallet has a weight constraint, based on aircraft and aircraft pallet position (see Figure 2). This weight limit may vary almost 3,000 pounds from a forward position to a ramp position (PACAFP 76-1, 1989). Each type of aircraft and pallet position restricts the available height and width. Each standard pallet is 88" wide by 108" long, and aircraft type determines pallet height. Standard height is 96" but can be as short as 76" for a ramp position on an aircraft, or may vary where half the pallet can be 96" tall, but the other half can only be 88" tall due to the curvature of the aircraft, as in KC-135s.

Pallet density must also be considered. For example, a box weighing 50 psi cannot be placed on top of sensitive communications equipment thereby destroying the equipment.

Many restrictions are placed on loading hazardous cargo. There are nine main classes and a total of twenty subclasses of hazardous cargo (AFJMAN 24-204,1994). These different subclasses are defined as shown in Figure 3. According to Captain Wayne Young, a logistics and deployment planner, this is the most common source of "frustrated" cargo during a deployment. Cargo is considered "frustrated" when a flaw is discovered that requires re-packing the pallet. Loadmasters help to ensure aircraft will arrive at the destination safely. Many incidents can occur with hazardous materials, even with proper precautions. Therefore, hazardous cargo compatibility is a minimum requirement for any packing algorithm. Since TPFDDs contain each item's hazard class and division number, a heuristic can be added to select the most common hazardous class, ensure all items of that class are loaded onto a pallet and ensure that all other compatible hazard classes are included on the pallet. Including all other compatible classes on the same pallet minimizes complications during aircraft loading.

Hazard Class/Division Number	Hazard Class/Division Name
1.1	Explosives(w/mass explosive hazard)
1.2	Explosives(w/a projection hazard)
1.3	Explosives(w/predominately a fire hazard)
1.4	Explosives(w/no significant blast hazard)
1.5	Very insensitive explosives; blasting agents
1.6	Extremely insensitive detonating substances
2.1	Flammable gas
2.2	Nonflammable gas
2.3	Poisonous gas
3	Flammable liquid
4.1	Flammable solid
4.2	Spontaneously combustable material
4.3	Dangerous when wet material
5.1	Oxidizer
5.2	Organic peroxide
6.1	Poisonous material
6.2	Infectious substances (etiologic agents)
7	Radioactive material
8	Corrosive material
9	Miscellaneous hazardous material

Figure 3. Hazardous Cargo Classes (AFJMAN 24-204, 1994)

Figure 4 explains all possible combinations of constraints required by hazardous cargo, loading on a pallet. An X at the intersection of two classes implies that the two items cannot be on the same pallet. An O at the intersection of two classes implies that the two items cannot be placed on the same or an adjacent pallet. The O also indicates items that cannot be placed on the same aircraft. A blank implies compatibility. This study only considers compatibility or incompatibility for the same pallet. Only candidate items are placed on the candidate list for a pallet.

Class or Division	Model Num.	1.1/1.2	1.3	1.4	1.5	1.6	2.1	2.2	2.3 Gas A	2.3 Other	3	4.1	4.2	4.3	5.1	5.2	6.1 Liquid A	7	8 Liquid	
1.1/1.2	1		X	X	X	X	X		X	X	X	X	X	X	X	X	X	X	X	X
1.3	2	X					X		X	X	X	X	X	X	X	X	X	X	X	X
1.4	3	X					O		O	O	O		O				O		O	
1.5	4	X					O		O	O	O		O				O		O	
1.6	5	X					O		O	O	O		O				O		O	
2.1	6	X	X	O	O				X	O			O	O	O	O	O	O	O	O
2.2	7																			
2.3(zone A)	8	X	X	O	O		X				X	X	X	X	X	X				X
2.3(other)	9	X	X	O	O		O				O	O	O	O	O	O				O
3	10	X	X	O	O				X	O		O	O	O	O	O	X			
4.1	11	X	X						X	O	O						X		O	
4.2	12	X	X	O	O		O		X	O	O						X		X	
4.3	13	X	X				O		X	O	O						X		X	
5.1	14	X	X				O		X	O	O						X		O	
5.2	15	X	X				O		X	O	O						X		O	
6.1(Liquid A)	16	X	X	O	O	O	O				X	X	X	X	X	X				X
7	17	X	X				O													
8	18	X	X	O	O	O	O		X	O		O	X	X	O	O	X			

Figure 4. Compatibility of Hazardous Materials (AFJMAN 24-204, 1994)

Other constraints must be considered. There may be separation requirements between boxes on a pallet. The boxes cannot extend beyond the bounds of the pallet. Also, the maximum weight per pallet may depend on the aircraft load (ACL).

UTC integrity is another factor. Loading either keeps items together by UTC or combines them into a deployment unit. Each alternative has advantages and disadvantages. To build pallets based on the whole deployment gives the best possible packing scheme. Unfortunately, mathematically this approach increases the number of variables, which consequently leads to a dramatic increase the number of possible solutions. This increases algorithm solution time.

Focusing on individual UTCs when loading pallets drastically reduces the mathematical complexity, and simplifies actual building of the pallets. If a loadmaster

and his crew must search through all the boxes included in the deployment to find the specific box needed for the current pallet, they would never be able to build the pallets in the 24 hours required by (AFI 10-402, 1997). This also helps, since TPFDDs are developed for UTCs and many UTCs have the cargo palletized beforehand and waiting for deployment.

When looking at the entire deployment, priority is another constraint. Each item has a priority to ensure its arrival "on time." If the pallets are loaded according to UTCs, the priority constraint is simplified. The UTCs are designed so that individual UTCs are either all the same priority or, for very large UTCs, the priority for each section is designated. Therefore, for large UTCs, all that is required is dividing the different priorities, or sub-UTCs, into separate candidate lists, similar to having separate UTCs.

The pallet-loading problem is large and complex, but important. Solution algorithms must find solutions within minutes not the days or weeks of computing time required by some algorithms. We must next examine the issue of fast but efficient algorithms.

2.5 EXISTING MODELS

In this section, we examine some existing packing and cargo loading models. Many of these tools offer excellent capabilities for the improvement of the speed and accuracy of deployment planning. However, none of the tools specifically address the problem of 463L pallet packing optimization. A discussion of various existing cargo

aircraft related automated planning systems, including a general description, strengths and weaknesses, as well as the algorithm driving the model will be presented. The models discussed are the Interactive Pallet Loading System (IPLS), the Deployable Mobility Execution System (DMES), the Automated Air Load Planning System (AALPS), the Airlift Loading Model (ALM), the Dynamic Analysis and Replanning Tool (DART), and the Marine Air Ground Task Force II (MAGTF II). Also examined are two civilian packages used in the field of transportation. The first that will be discussed is an interactive system for the loading of cargo aircraft, specifically for the Scandinavian Airlines and it is called the CARgo Loading system (CARLO). Besides CARLO, other commercial off the shelf (COTS) packages are examined.

2.5.1 INTERACTIVE PALLET LOADING SYSTEM (IPLS). In 1981 Hodgson developed the IPLS as an interactive computerized system for the loading of pallets. Originally IPLS was designed to interface with the USAF Base Automated Mobility System (BAMS) data base, but it has recently been modified to accept LSAR data so the original code can be modified for different input data bases (Taylor, 1994). As described by Hodgson, IPLS uses a combination of dynamic programming and heuristics, as well as user interaction to efficiently load pallets. In the development of IPLS, Hodgson structured the system into two parts. Those parts are the data manipulator and the pallet loading procedure. The data manipulator inputs the data from BAMS and come out with a list of candidate items or boxes for the packing of the pallet. The pallet

loading procedure is the solution part of IPLS that heuristically achieves a feasible solution after generating a list of candidate boxes (Hodgson, 1981).

The options that IPLS presents are as follows:

1. Identify the list of items.
2. Sort the file of boxes.
3. Select subset of the boxes from the file.
4. View the BAMS file (It has been noted that other types of files can be used, i.e. LSAR).
5. Manipulate specific box or boxes.
6. Stack boxes prior to loading.

After this, the user can load the pallet, get a solution, temporarily remove the packed boxes from the pallet, or “crunch” loose boxes to tighten the solution toward the origin.

These menu driven options give the user numerous choices in loading the pallet. For instance, the user can possibly try to select boxes with the most common height, perhaps a set of the largest candidates, or lastly if height is variable among the boxes, use the stack boxes before loading option. The menu allows the user power to manipulate, as deemed necessary because of experience, the candidate boxes to generate a list of possible feasible solutions to pack the pallet (Hodgson, 1981).

As previously stated, the algorithm used in IPLS is a combination of dynamic programming and heuristics. Also of considerable consequence is the statement made by Hodgson as to the structure of this combination leading to the handling of hazardous material and the center of gravity problem without “loss.” Captain Taylor echoes

Hodgson's assertion (Taylor, 1994). This conflicts with a more recent finding presented in the *Unit Type Code Development, Tailoring, and Optimization (UTC-DTO) Phase 2 Final Report* prepared by Computer Sciences Corporation. This report found that mathematical techniques might not be useful for the traditional pallet-packing problem because of variables such as center of gravity and hazardous material placement and handling (Computer Science Corporation, 1997). This would mean that both the center of gravity and the hazardous handling problem are most likely not addressed in the IPLS algorithm structure. The overall IPLS procedure involves four dynamic equations. The first equation is simply used to find solutions to the two-dimensional pallet-loading problem. This equation is subject to a number of constraints of which the most interesting is the partition. The partition as defined by Hodgson is the "profile of box i removed from the right-hand edge of the left-hand subpallet." This means there could be quite a few partitions, which translates into considerable amount of computer storage and time for the solutions of the first equation. Because of this, a second equation is used to limit or partition the pallet into rectangles. Next, the L-shaped area is broken into to rectangular areas by the third equation. The fourth equation tackles the linear loading problem by considering both length and width and maximizing the linear coverage (Hodgson, 1981).

In conclusion, this could be an adaptable system because of the particular focus on pallet packing and feasible solution generation. Also, the data base manipulator can be readjusted to accept different data than it was initially designed for. Captain Taylor showed this with his conversion from BAMS to LSAR. This means that the manipulator

could possibly be rewritten to accept TPFDD information and in turn generate a list of suitable candidates to pack on the initial pallet and so forth. Hodgson does list a few shortcomings. First, the equipment in the early eighties was certainly not fast. Since solution times are dependent on both pallet size and the number of boxes, Hodgson made a plea for faster CPU times. Because of the greatly improved performance of computer systems today the speed as well as the core procedures of IPLS were increased (Taylor, 1994). Hodgson also stated that without “smart” three-dimensional graphics, the user would lack the necessary insight to understand and subsequently facilitate the loading process. This capability exists today. Lastly, the process by which Hodgson solves the pallet-packing problem is not truly a three-dimensional treatment. However, it may be a close approximation to an optimal solution and perhaps that could be considered an improvement.

2.5.2 DEPLOYABLE MOBILITY EXECUTION SYSTEM (DMES).

(Cochard and Yost, 1985) In the late seventies, the Air Force initiated the development of an automated load-planning program. The load planning system needed to have certain characteristics, as defined by the then Air Force Logistics Management Center (AFLMC). These characteristics were speed, flexibility, accuracy, ease of use, deployability, and efficiency. Speed was a reference to the relative length of time that it usually took for manual load planning. Cochard and Yost (1985) stated that it took around 100 hours to load plan all personnel and equipment to support a tactical fighter wing. They also noted that it is highly desirable to complete this task in six to twelve

hours, since this is the usual time allowed for such a unit to pack and go. Flexibility allows the user to interact with the system to tailor it to the units specific needs. With manual methods there was a problem with the plan looking fine on paper, but not working in reality. Thus an accurate system catches load planning errors before the actual build up begins. Considering the training curve that goes along with some computer intensive occupations, the typical military user may not have the necessary analytical skills to use a complex software program. Therefore, a straightforward and user friendly format needed to be employed. This package also needed to be rugged and deployable for use in a field environment. For Cochard and Yost, this also implied that the system needed to operate without the reliance on a large telecommunications network. Efficiency meant improving the overall aircraft utilization. The authors intended this model to be "computer aided" and not a "black box" which was fed numbers and produced an answer-all. This was because of the sheer number of rapid changes in priorities, aircraft availability, and other variations possible during a deployment. Essentially, the end model that was envisioned was a system that would quickly present the load planner with a number of alternative possible load plans given the necessary input.

DMES was developed as an airlift estimator and is divided into three distinct sections. These sections are the file manager, load-plan manager, and the load-planning facility.

The file manager section automates the previously manual task of dividing the larger set of equipment, supplies, and so forth into smaller subsets. Essentially, DMES

defines a set of subprograms called "Increment Options." This set of programs allows the user to both modify and track what is loaded on a particular aircraft. All the information generated from this set of programs can be stored on disk for later use.

The load-plan manager is the section of DMES that has a set of procedures called "Chalk Options." This essentially allows the user to list the cargo that is loaded on a specific aircraft, download statistics on the loads, delete load plans, and save load data.

The third section is the load-planning facility which contains the "Load Options" that allows the user to check such constraints as cargo height restrictions, allowable cabin load (ACL), axle weight restrictions, pounds per linear foot (PLF) limits, and incompatible hazardous cargo. Basically, the user chooses the type of plane upon which the cargo is loaded and once the capacity inputs are set, the system generates a load plan. Of course, the user may still modify the load plan by setting the priorities and so forth.

DMES makes use of a modified cutting stock heuristic to build the load. This modified cutting stock heuristic is a simple one-dimensional cutting stock algorithm that is subject to the constraints existent in the cargo bay of the aircraft. The plan that DMES generates is feasible 90 percent of the time on the initial generation. An iterative process can then be employed to get perhaps a better feasible solution.

In conclusion, it was shown that using DMES saved over 90 percent of the load planning man-hours. Along with this improvement, the aircraft utilization rate increased 10 to 20 percent. It was noted that a 10 percent increase in aircraft utilization gives a savings of \$20 million dollars annually in peacetime airlift. While an examination of the file manager program and the load-plan manager might be beneficial because of the

benefit of breaking down a list into a smaller listing as well as the potential benefits of the generation summary statistics, the one dimensional cutting stock heuristic used in obtain feasible solutions to the load-plan problem cannot be used for three-dimensional optimization or sheer generation of solutions for a three-dimensional pallet problem.

2.5.3 AUTOMATED AIR LOAD PLANNING SYSTEM (AALPS). The Automated Air Load Planning System (AALPS) provides the Army with a standardized, deployable automated load planning tool for all USAF and Civil Reserve Air Fleet (CRAF) aircraft. It was developed concurrently with the Air Forces' systems and has been successfully used, especially for helicopter transport, for a number of years. AALPS has the unique ability to do real time planning and execution of air loads using artificial intelligence, which reproduces heuristic methods used by expert load planners. Overall AALPS has the capability to support the planning and execution of unit air movements, facilitate the rapid determination of aircraft requirements to support the deploying force, and produce valid load plans and documentation based on actual source data (Computer Science Corporation, 1997). AALPS applies checks for the feasibility of loads. Included in these checks are checks for both two dimensional and three dimensional spatial clearance checks, axle weight and complete weight checks, adjusting for different equipment and aircraft configurations as well as mission specific constraints such as cross-loading and center of balance.

AALPS automates load planning while ensuring the feasibility for Air Force and CRAF aircraft. This system, however, is not an optimization package and it does not

specifically deal with the idea of packing boxes onto a 463L pallet (Computer Science Corporation, 1997).

2.5.4 AIRLIFT LOADING MODEL (ALM). Another model of interest is the Airlift Loading Model (ALM) which was recently renamed the Computer Aided Load Manifesting (CALM). Essentially, CALM is a more user-friendly version of DMES. The basic function of CALM is to provide standard automated capability to store and edit information on cargo increments. It also allows for the preplanning of aircraft cargo loads for peacetime or war. CALM interfaces with Cargo Movement Operations System (CMOS), Logistics Module Base Level (LOGMOD-B), and USMC MAGTF Deployment Support System. To correct problems and add several new enhancements, Version 5.1 of CALM was released in July 1995 and was entitled ALM. ALM was enhanced to simulate the loading of military and civilian aircraft to provide information as to the number of sorties needed to accomplish the deployment. The model simulates the loading of the aircraft with military equipment, troops, and palletized cargo. While this model does account for the deployment down to the pallet level, it still does not guarantee the best possible solution to either the amount of cargo on the pallet or the aircraft (Computer Science Corporation, 1997).

However, a recent study was completed at the Air Force Institute of Technology entitled "Solving Geometric Knapsack Problems using Tabu Search Heuristics" which compares the results obtained by ALM and could later be used as the "guts" of ALM. This work explores the geometric knapsack problem of airlift loading where cargo must

be chosen to pack in a given number of planes. The paper shows that this problem can be solved using a combination of a knapsack heuristic and a geometric heuristic. Then, it shows that JAVA is a very effective language for the implementation of the combination of heuristics (Chocalaad, 1998). Encouragingly, these techniques should be extendable into the realm of the problem identified in this paper.

Currently, the algorithm used in ALM is made up of several different user-selectable procedures. ALM is actually a simulation model used to determine the sequence to load vehicles and cargo onto aircraft thereby providing some type of aircraft load estimate. The algorithms behind ALM are the fill-gap, the top-down, and the floor utilization algorithms. The fill-gap is concerned with vehicle selection. The top-down algorithm loads cargo based on user specifications as to the sorting sequence for each item. Lastly, for the floor utilization loading algorithm, the user specifies a floor space to allowable cabin load (ACL) ratio (Computer Science Corporation, 1997).

2.5.5 DYNAMIC ANALYSIS AND REPLANNING TOOL (DART). Next, the Dynamic Analysis and Replanning Tool (DART) was developed concurrently with DMES. DART is an information management system enabling planners to edit, analyze, and retrieve transactions from Time-Phased Force Deployment Data (TPFDD) files via a Graphical User Interface (GUI). DART helps determine the feasibility of whether or not there are enough ships and planes allocated to deliver all personnel and material necessary to support the particular contingency or exercise. The benefit of DART is that this modification of the TPFDD and feasibility assessment of transportation models can

be accomplished in a matter of minutes and not hours or days required by other methods. DART helps planners deploy a large number of troops and equipment because it was primarily designed to estimate the feasibility of different movements of troops and equipment. DART does not feature the ability to deal with the build up of pallets, much less the optimization of the content of those pallets. Also, the hardware needed for this system can be rather costly and not very portable, limiting the deployability of the system (Computer Science Corporation, 1997).

2.5.6 MARINE AIR GROUND TASK FORCE II (MAGTF II). Another type of automated planning tool is the Marine Air Ground Task Force Warplanning System II (MAGTF II). Essentially, MAGTF II allows planners to develop force structures, tailor force list, compute sustainment, estimate plan lift requirements, and generate TPFDDs. This system's strong point is that it is highly portable. It can at any time upload to the Worldwide Military Command and Control System (WWMCCS) and convert MAGTF II TPFDDs into standard JOPES TPFDDs. Even though this system has capabilities for estimating lift requirements, it has no provisions for load planning (Computer Science Corporation, 1997). Therefore, this system will only give us a rough estimate of the airlift needed and like many of the other models will not optimize or load pallets. Again, if the space on the essential building block of a deployment, the pallet cannot be optimized or at least a best case scenario offered inefficient use of airlift would take place. Of course, this will lead to greater expenditure of resources. With this in mind,

one may say that money will not be an issue during wartime, but the wasteful use of resources in Desert Storm is still being debated.

2.5.7 LOAD ESTIMATOR. This was Captain Kirk Yost's revisit of the execution systems developed earlier to solve the problem of doing execution load plans and manifests for aircraft. Yost states that the execution systems, Deployable Mobility Execution System (DMES) and the Computer-Aided Load Manifesting system (CALM), are too slow, inaccurate, and "cumbersome" to do airlift estimation for any large scale operation. In saying this, Yost notes that with the development of the Airlift Deployment Analysis System (ADANS), a speedy and accurate airlift estimator was required (Yost, 1988).

The airlift estimator was designed to employ an "upper-bound, lower bound" approach. This estimator is based on a modified version of DMES and an algorithm that is based on "bin-packing" methods. The estimator gives bounds on the number of aircraft required for the airlift as well as producing "usable" first-cut load plans. An important note is the rate at which the system can generate the load plans. The system generates a typical load plan every two seconds. Also, the system allows a user to set priorities, aircraft, and compensates for changing ACL's (Yost, 1988).

A factor analysis accomplished in this study presented some constraint limiting results. The airlift estimate essentially depends on total cargo weight, total cargo length, amount of outsized and oversized cargo, and the amount of bulk. This is what the loadmasters have focused on for years (Yost, 1988).

There are several limitations identified by Yost in this study. With helicopter loads, the odd shape of the particular load severely limits the accuracy of the load plan. The estimator should not be used with helicopter loads. The author does give a linear program approach to use if a large number ($n \geq 50$) of helicopters are being moved. This does seem to be a noteworthy approach, however it does not display the ability to be extended to a three dimensional approach. Another limitation of the estimator is the fact that it does not allow the user to load by priority. The program can fake it by the user partitioning items into groups and then load the groups. For most airlift operations and pallet build ups, priority is of an essential nature so the end package needs to have some type of procedure to set priorities. Also, perhaps a severe limitation in respect to the 463L pallet building problem is the fact that this load estimator does not create baggage pallets which is essentially a continuous pallet loading problem (Yost, 1988). Also, it should be noted that this estimator was designed in 1983, but there has been no mention of its subsequent use in any of the airlift packages used since.

2.6 COMMERCIAL OFF THE SHELF SOFTWARE (COTS).

The CARLO system is at least ten years old so a search for current loading packages was performed. The current systems that are reviewed are the Virtual Loader by SDI, PACKMAN a computer program designed by Boeing Computer Services Co., Stowage Tactics for User Flights (STUF) which is used by NASA, and Maxload developed by TOPS Engineering Corporation.

2.6.1 CARgo Loading (CARLO) System. When developing useful technology, it is better not to reinvent the wheel. In keeping with the spirit of this premise, the military has examined certain off-the-shelf commercial systems. A good example of one of these systems is the CARgo LOading (CARLO) procedure developed by a Danish operations research student for a thesis competition. The system is currently being used by Scandinavian Airlines. CARLO is a useful tool when composing load plans for cargo carrying aircraft. It only takes five to ten minutes to set up a load plan using the system. This system is interactive, meaning that the load planner uses this system on a computer as a tool to augment his work. However, this system has a severe limit. The underlying algorithms will only handle, considering computer processing time, about seven or less different types of items loaded onto the plane. Also, because of processing speed, the number of legs on a flight is limited to two. This is too limiting for military deployment purposes. Even though it is a proven commercial load planning system, further research into the two algorithms driving the model has shown that it is not an optimal system (Larsen, 1980).

2.6.2 THE VIRTUAL LOADER. The Virtual Loader is a commercial off the shelf software package that is based in object oriented C++ that is specifically designed to satisfy a number of loading applications. The strength of this system is supposed to be its flexibility. It is touted to be extendable to satisfy nearly any loading requirements, which may be unique to any type of organization. Solution Dynamics Inc (SDI) states that their system can be built to generate solutions for filling boxes, loading single or mixed

product pallets, loading aircraft cargo bays, ships, railcars or trucks. There are several constraints that can be turned off and on with the ease of pushing a button. Also, consideration should be given to the fact that SDI will consult with an organization and customize the base Virtual Loader system to the requirements of the organization (Solution Dynamics Inc, 1998).

The Virtual Loader is made up of three sub components. These components are the Core Loading Algorithm (CLA) which is the part of the system that generates solutions, the Interface Layer which is the connection between the data and the CLA, and the Data Visualization Layer (DVL) which is the part of the system that creates graphical representations of the solutions. Each of these components supposedly can be customized to the end user's needs. Of particular interest is the CLA, which is composed of a set of algorithms that include weighing, queuing, stacking, and packing algorithms. All of these algorithms are controlled by what SDI calls the supervisory algorithm. This algorithm contains general rules and constraints that are used in controlling product orientation, the height of the stack, the priority of the load, etc. This is the extent of the detail offered from SDI. Further examination of this software package will be necessary to determine the degree to which it may be used in the 463L pallet-packing problem. Seemingly this package may be the answer, but the accuracy of the solutions is unknown. SDI will be contacted and the software will be tested (Solution Dynamics Inc, 1998).

2.6.3 PACKMAN. (Boeing Computer Services Co.) PACKMAN is a computer program that will find near optimal solutions to a packing problem with a number of

items in three-dimensional storage containers. This program takes into consideration several constraint factors such as container volume utilization, container weight limit utilization, and other considerations. As stated in the material from Boeing, PACKMAN allows users to specify a single rectangular container of designated length, width, and height. Also, the user sets the dimensions of the items to be stored as well as the criteria for packing and the priority or importance placed on each criterion.

The packing algorithm used by PACKMAN tries to find the best positioning of the cargo in the three-dimensional container as to best use the volume and weight capacity of the container. The literature states that the simulated annealing method employed by PACKMAN generates solutions within 23 percent of optimal. PACKMAN was released in 1991 and was written in Common LISP for the Macintosh platform.

2.6.4 STOWAGE TACTICS FOR USER FLIGHTS (STUF) (NASA Marshall Space Flight Center, 1996) NASA Marshall Space Flight Center uses Stowage Tactics for User Flights (STUF) to help Space Station users to develop efficient packing for their cargo. The Space Station has a stowage rack for a number of trays that contain the allotted cargo items. The user determines which trays to use and where those trays will go on the stowage rack. The actual placement of the cargo items can be determined either by the computer or the user. Weight and center of gravity are monitored and any out of bound constraints are highlighted for corrective action. STUF can combine all user cargo into one cargo manifest, which allows NASA to integrate all user stowage for a mission.

The interface used for STUF is menu driven. On the menu, there are two types of

tray packing modes: automatic and interactive. When a user is interested in packing hundreds of items both quickly and efficiently the interactive mode should be used. The automated mode allows the computer to place the items. As stated in the literature from Marshall Space Flight Center in Huntsville, Alabama, STUF can handle 9,999,999 cargo items, 999 trays, and 99 racks per packing operation.

STUF was released to a commercial software company, COSMIC in 1996 and was written to run with DesignCAD 3-D and is compatible for most standard IBM PC machines. STUF itself can fit on one 3.5 inch 1.44MB MS-DOS formatted disk.

2.6.5 MAXLOAD. MaxLoad is a software program developed by TOPS Engineering Corporation. This software is very similar to the Virtual Loader package addressed earlier. MaxLoad can adjust for pallet dimensions and consider any number of constraints. When providing a solution, a three-dimensional image of the packed pallet with each listed item is displayed.

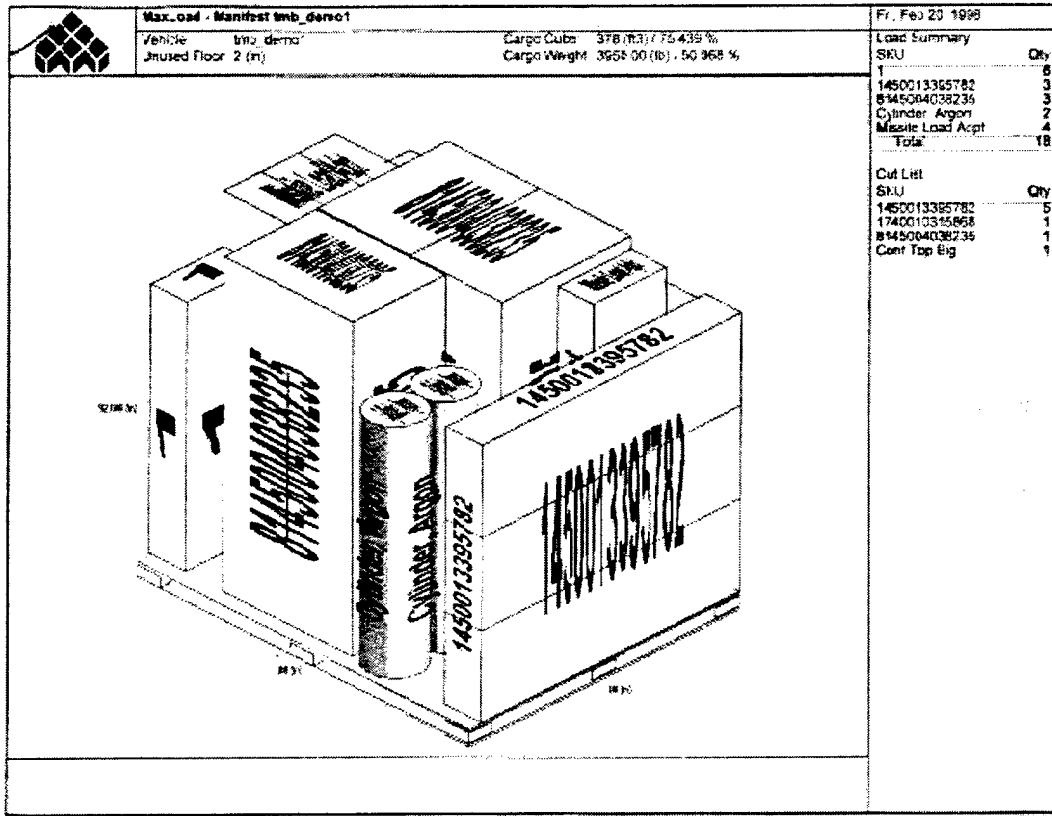

Figure 5. MaxLoad Display

The following is a comparison of MaxLoad and the actual load. Also, a comparison of Cape Pack is provided even though much of the information is not available. The comparison was provided by TASC and an update to this chart including other COTS packages will be forthcoming.

UTC	Ech	Software Application	Solution	# Pallets	Algorithm(s)	Avg%Vol	Avg%Wt	# Item	Tot%Vol	Avg%Vol-Last
3fqc9	E1	None	AF Pack	1	manual	74.90%	28.04%	7	74.90%	74.90%
		Tops Maxload Pro	1.1	2	L/R Front to back	37.55%	14.02%	7	75.10%	52.10%
		CapeSys LoadBase	1	2	L/R Space Evenly SDI Load Wizard	37.44%	14.06%	7	74.88%	45.06%
3fqc9	S1	None	AF Pack	5	Manual	66.94%	52.79%	134	334.71%	75.38%
		Tops Maxload Pro	1.2.2.2.4	5	Varied for best solution	66.96%	52.77%	134	334.78%	73.78%
		Tops Maxload Pro	1.2.2.3.3	5	Front to back	66.96%	52.77%	134	334.78%	72.63%
		Tops Maxload Pro	3.3.3.4.2.3	6	Space Evenly Mixed Pallet Floor to Ceiling	55.79%	43.98%	134	334.73%	58.67%
		CapeSys LoadBase	1	5	SDI Load Wizard	66.96%	52.76%	134	334.80%	73.75%
3fqc9	S2	None	AF Pack	1	Manual	42.54%	39.41%	9	42.54%	42.54%
		Tops Maxload Pro	2	1	Space evenly	42.54%	39.41%	9	42.54%	42.54%
		CapeSys LoadBase	1	1	SDI Load Wizard	42.54%	39.41%	9	42.54%	42.54%
3fqc9	S3	None	AF Pack	4	Manual	59.50%	35.76%	31	237.98%	73.42%
		Tops Maxload Pro	1.1.1.1	4	Varied for best solution	59.50%	35.77%	31	238.01%	71.73%
		Tops Maxload Pro	2.1.3.1.1	5	Front to back	47.60%	28.60%	31	238.00%	56.65%
		CapeSys LoadBase	1	5	Space evenly SDI Load Wizard	47.60%	28.61%	31	238.01%	56.84%
3fqk9	S1	None	AF Pack	4	Manual	57.88%	42.56%	54	231.52%	64.67%
		Tops Maxload Pro	1.1.1.1	4	Varied for best solution	57.89%	42.56%	54	231.54%	68.52%
		CapeSys LoadBase	1	4	SDI Load Wizard	57.89%	42.56%	54	231.54%	68.52%
3fqk9	S3	None	AF Pack	1	Manual	49.50%	12.73%	4	49.50%	49.50%
		Tops Maxload Pro	1	1	All	49.51%	12.73%	4	49.51%	49.51%
		CapeSys LoadBase	1	2	SDI Load Wizard	24.75%	6.36%	4	49.50%	42.47%

Notes: 463L pallet has usable dimensions of L84" x W104" x H93.75" (actual dimensions are L88 x W108 x h2.25, 190lbs, packed up to 96" high)

- Avg. % Volume is based on a 463L pallet having 474 ft³ of cargo space (actual volume is 485.3 ft³ including pallet)
- Avg. % Weight is based on a 463L pallet, which can support 7435lbs (actual max wt is 7500lbs, but cargo nets weigh 65lbs)
- Total % Volume (sum of all packed item's values) gives an indication of the theoretical minimum number of pallets required to pack all items.
- Avg% Vol-Last refers to the Avg.% Volume not including the last, or worst packed, pallet (because the last pallet is seldomly full for multiple-pallet UTCs)

Figure 6. UTC Baseline Evaluation

All of the above models were strong in certain areas, but none of them is capable of providing pallet level detail and an optimal solution.

2.7 ALGORITHMS

The goal of the packing problem is to find an optimal packing. Over the last thirty years many mathematicians have attempted to solve the three-dimensional packing problem. However, neither a combinatorial formulation nor an efficient optimization algorithm have been forthcoming. Therefore, sub-optimal or heuristic solution, is employed. There are a myriad of papers, reports, and theses that cover an overwhelming variety of methods for placing boxes on a pallet. The solutions range from linear

programming to heuristic solutions. More importantly, every report states that this is a very difficult mathematical problem.

Israel Brosh developed a method for cargo allocation that combines linear programming and heuristics. Brosh states that while his model formulation is nonlinear, a linear approximation can be driven to the optimal solution of his nonlinear model. The goal of his model is to use a linear approximation of his actual model and find the optimal solution to the approximation, then set an acceptable tolerance level for deviation in the solution and iterate. According to Brosh, this method converges to an optimal solution of the nonlinear model in an efficient manner, although no processing time data was provided. His conclusion is based on a corollary that states a “sequence of optimal solutions to the LP programs converge to the optimal solution of the non-LP program” (Brosh, 1981).

An area of research related to pallet packing is facility layout, as applied to circuit board layouts, factories, or any other type of floorplanning. The areas differ by focus. Floorplanning incorporates all items in the smallest amount of area possible. Pallet packing seeks to place as much into a given area as possible. Despite differing focus, several interesting and pertinent ideas floorplanning pertain to pallet packing.

Wang and Wong’s model starts with the largest items, which are all rectangular, using them to create a larger rectangle. The items are then treated as a single, larger entity used for placement in the final layout. Using this grouping method simplifies the number of rectangles that must be dealt with at any given time. Wang and Wong tested seven sets of data ranging from 24 to 120 rectangles (Wang and Wong, 1990).

Sutanthavibul, Shragowitz, and Rosen (1990) employed a mixed-integer linear programming (MILP) method to place 25 boxes in a minimized area in 4.25 minutes. While this seems impressive, it is important to realize that this is in two dimensions and once height is added, the problem will be increased by a factor of the number of layers that would be built using this method. It is also important to note that the only constraints considered were the dimensions of the items. According to the authors, a problem with 25 items leads to a MILP with 50 continuous variables, 600 integer variables, and 1250 constraints.

Dowland has explored techniques such as tree search algorithms, simulated annealing, and tabu search to solve the pallet-packing problem. Her earlier attempts were focused on cutting stock and a situation-specific exact algorithm using identical boxes in two dimensions (Dowland, 1987, 1990). In her 1987 article based on tree-search, Dowland's conclusions were aimed at the "manufacturers' problem" of identical boxes. Using identical boxes greatly simplifies the packing problem, making the use of a leveling technique relatively simple because of dimension uniformity. A leveling technique places all the boxes within a two-dimensional area. Subsequent layers are optimized and placed on preceding layers. Of course, if the boxes are uniform then there will be a uniformly level surface to place the second set of boxes and so forth. She also simplifies the tree-search by placing bounds on the search method. Even with identical boxes and well-defined boundaries, Dowland states that the problem takes "one to two minutes of mainframe CPU-time" (Dowland, 1987, 1990). In her 1990 article, Dowland focuses on a vertex coloring technique. The coloring technique consists of

allocation of different colors to any two adjacent vertices. She uses this method to approach a feasible solution through minimization of the number of colors. Therefore, she focuses on finding upper and lower bounds for the number of colors in the solution set. Dowsland states that “the graph coloring problem is itself difficult to solve and the additional constraints will only make this situation worse” (Dowsland, 1990).

Dowsland and Dowsland (1992) focused on the modeling and solution of the packing problems in two and three dimensions using a number of exact and heuristic approaches. They review bin-packing, pallet-packing, and strip-packing techniques that have been investigated. They state that “the increased combinatorial complexity of this [the three dimensional] problem over the two dimensional case means that exact solutions are unlikely to be effective” (Dowsland & Dowsland, 1992). Their conclusion is that each individual case needs its own set of constraints and circumstances to provide the best possible solution to the user’s scenario (Dowsland & Dowsland, 1992).

In her article on applying simulated annealing, Dowsland came to the conclusion that it was not a useful method, due in part because the standard monotonic cooling schedule was not successful in guiding the search toward optimal solutions. This leads to the required use of non-monotonic versions of simulated annealing (NMSA), which “was only moderately successful” (Dowsland, 1996). Since her NMSA solution was close, but could not quite reach the optimal solution, simple tabu thresholding (STT) was investigated.

In her 1996 article “Simple Tabu Thresholding and the Pallet Loading Problem,” Dowsland discusses her decision to use the memoryless method of tabu search; in order

to reduce the complexity involved in finding the solution. Dowsland uses a clever technique, to not only reduce the amount of overlap in boxes but also to limit the number of overlapping boxes. This additional technique assists the STT converge to a solution quicker. In order to determine the best method for subset selection, Dowsland evaluates six different methods for partitioning subsets, which included random, horizontal, vertical, position-indexed, or all positions. Unfortunately, Dowsland concludes that her STT approach “does not appear to be very much better than the undulating temperature version of SA [simulated annealing]” from her 1993 article.

Blazewicz, *et al* (1993) focused on comparing three pallet packing solution methods, of which tabu search (TS) proved to be the best solution in terms of minimizing wasted area, although it was not always the fastest method. Blazewicz and Walkowiak (1995), based on work by Glover (1977, 1986, 1989, 1991, 1992, which has been compiled into a text entitled *Tabu Search* (1997) by Glover and Laguna) focused on using TS to solve the pallet-packing problem. Although these papers only focus on two-dimensional space, they do handle irregular shapes. The authors provide a significant amount of data to back up their claims, including the time, number of iterations, and percentage of wasted space.

Blazewicz and Walkowiak (1995) continue their comparison using different parameters of the tabu search. They provide improved solutions by increasing the number of boxes that can be moved in one iteration, decreasing the number of iterations without improvements in the objective function that can occur before stopping, and varying the number of items on their search list. Their paper does an excellent job of

explaining the difficulty of the cutting stock problem, while demonstrating the processing time to find a solution. For example, to pack 20 items on a two-dimensional pallet takes between 7.45 minutes and 37 minutes, only considering the dimensions of the items, not weight or any other constraints. Unfortunately, it is difficult to ascertain any improvements in their current algorithm, since they failed to explain the significant increases in time for an identical number of items that occur in their 1995 paper.

The studies conducted by Blazewicz, *et al* provide valuable information on “intermediate” memory for tabu search. Intermediate memory only allows a specific number of tabu elements or moves. Once this limit is exceeded, the element is released to be reused. Although this increases the time required to find a solution, it does provide solutions with less wasted area (Blazewicz and Walkowiak, 1995).

Battiti and Tecchiolli have published extensively on the subject of tabu search approaches. In their 1994 article, Battiti and Tecchiolli focus on defining Reactive Tabu Search (RTS); how it works and how it can be used (Battiti and Tecchiolli, 1994). A subsequent article compared RTS to many of the commonly used meta-heuristics such as genetic algorithms (GA), neural networks (NN), and simulated annealing (SA). In their article, they showed that RTS “maintains an acceptable performance and is competitive in both cases (SA and NN) if the CPU time is considered” (Battiti and Tecchiolli, 1996).

Contrary to Dowsland, Blazewicz, Walkowiak and others who find tabu search to provide the better results, Szykman and Cagan suggest SA as the method of choice for component packing in three dimensions. Szykman and Cagan (1995; 1997) explain how SA should be used in a component packing situation that is similar to that of the pallet

packing scenario. First, they focus on a “perturbation algorithm for optimal component packing, a subset of general layout problems, which successfully extends these VLSI techniques to three dimensions for mechanical engineering applications” (Szykman and Cagan, 1995). They expanded their research to include three main objectives: “achieving high packing density, fitting components into a given container, and satisfying spatial constraints on components” (Szykman and Cagan, 1997). Although this article defines several spatial constraints, the time it takes to solve the models is quite excessive. For example, the authors use an example of a power drill that is composed of 18 cylinders. In their examples, they apply 90 constraints to cover all possible component situations. To build the required power drill using SA took an average of 130,000 iterations at 1000 iterations per second on a DEC Alpha 3000 workstation. This implies that approximately 2 minutes of workstation time is required.

Finally, Kevin Y. K. Ng uses a technique that is a multicriteria optimization approach. His approach is geared toward C-130s and uses the expertise of loadmasters. Ng uses goal programming to select pre-generated feasible loads based on subsets of required items. In this problem, time is not as much of a factor, since the feasible loads are derived in advance of the selection phase. Ng’s technique is simply to place the loads in the best positions on the aircraft, but his ideas lend themselves to going further and simply creating a complete set of alternative loads for each type of contingency for each UTC. Then, when a contingency arises, the proper pallet load plans can be followed.

This allows for a much greater flexibility in time from the LOG-AID allowance of 90 minutes for complete pallet buildup (Ng 92: 1200-1205).

III. METHODOLOGY

3.1 INTRODUCTION

In this section , the feasibility of developing a for the three-dimensional pallet packing problem is examined. Next, options for the treatment of this three-dimensional pallet packing problem will be put forth followed by a discussion of the methodology used in the development of the model.

3.2 FEASIBILITY

The Load Planning Automation Study (Section 1) shows the feasibility of optimizing the space utilization on the 463L pallet (Computer Science Corporation, 1997). Is there an automatic optimal way of packing a 463L aircraft cargo pallet at the UTC level?

Perhaps there may not be an optimal way of packing the 463L pallet, but building a more efficient automated solution to the packing problem is very feasible as defined in the Load Planning Automation Study (Computer Science Corporation, 1997). The CSC study states that it appears feasible both practically and technically that there are points within the packing process as defined above where technological insertion will be extremely beneficial (Computer Science Corporation, 1997).

When considering technical feasibility, the authors state that some issues must be considered. Those issues are the goodness of fit of the solution, the degree of automation and interaction between the planner and the system, the interaction of the subsystem within a larger system, and the extent to which the loading process is visually displayed. We will be dealing primarily with the goodness of fit aspect of the overall technical feasibility of this automated system. The authors of the CSC study define goodness of fit as being the aspect of the developed model fitting sufficiently well to produce results with substantial benefits. A realistic mathematical model requires constraints that represent the packing process as realistically as possible. However, for this research some aspects of the packing problem are excluded from the formulation for reasons previously discussed.

The feasibility of generating a true optimal solution to the loading of a 463L pallet may not exist, but heuristic methods should be considered in place of an optimal solution. As stated in the Computer Science Corporation study, the almost optimally solutions generated heuristically will most likely lead to reduced mobility footprint and greater speed with a reduced need for repack. This is the focus of our research effort.

Thus, for this thesis, the primary focus will be the development of a mathematical model of the three-dimensional packing problem with a complete compliment of Air Force specific and hazardous constraints. For future reference an examination should be made into each of these areas to ascertain the relative worth of pursuing either option.

	Advantages	Disadvantages
Port IPLS software	Can build on existing code. Program is free and available. Thesis indicates good performance. USAF will own software	Written in FORTRAN for Mac interactive approach. Performance not validated. “this end up” constraint enforced – no vertical rotation. Other constraints may be difficult to incorporate. No guarantee of improved pallet packing
Develop our own algorithm	Choice of language and OS. Can tailor from the beginning to incorporate constraints. USAF will own the software.	Starting code from scratch. No guarantee of improved pallet packing.
Team up with COTS vendor	Can build on existing API. Nice GUI and 3D imaging. Reasonable performance as is. Written in C++ for Win95/NT. Some basic constraints are supported.	Probably will require more time. Probably will require a bigger monetary investment. USAF will not own software. No guarantee of improved pallet packing.

Figure 7. Options Comparison (TASC)

3.3 METHOD

This study will follow the scope defined by the Computer Science Corporation in the December 1997 feasibility study entitled “Unit Type Code Development, Tailoring, and Optimization (UTC-DTO) Phase 2 Final Report.” As such, the scope of this research will focus, at least initially, on a single wing base level perspective, on a single fighter mission. This focus on the fighter mission takes into consideration the short-notice tasking for which a pallet optimization program would provide the most relief. Also, more data is available at a fighter base about deployments because that is what they do.

Specifically, we hope to make use of data from the F-16 C/D UTC 3FKM3 and two other support UTCs (HFBZP and HFAGC) as defined in the feasibility study above. Lastly, the aircraft considered in this study will be the C-130, C-141, C-5, and C-17.

Specifically in model development, we focus on two stages. First, we optimize the volume using a knapsack heuristic to choose the best boxes for the pallet. Then, a tabu search determines the placement of the boxes on the pallet. The tabu search approach is actually a series of tabu search instances where each iteration seeks to “build” layers of the boxes via a series of two-dimensional optimizations with the largest height setting the ceiling for one layer and the floor the next.

This model incorporates a number of assumptions and constraints. Initially, we assume that the boxes are uniform in size. Only rudimentary volumes are considered. For the uniform case, fixed cubes and for the non-uniform case, all rectilinear volumes and flat-faced cylinders. Another assumption is that the first box is placed with a corner at the origin of the pallet so all first boxes will start at $B(0,0,0)$. Of utmost importance is how priorities of cargo are handled. We assume that the UTC sets the priority. Since we will not break up a specific UTC, the priorities of the specific boxes will not be a constraint in our model. Since all the pallets for an UTC go out at the same chalk, this choice seems logical, meaning that it is not necessary to worry about the priority of items on the pallet, but just the pallet. Of course one of the main set of constraints deals with the height, width, length, and weight constraints physically set by the aircraft involved in this study. All of the necessary information is obtained in PACAFP 76-1. Besides dimensionality constraints, attention needs to be given to hazardous cargo. Some

hazardous cargo cannot be put on the same pallet next to each other. For that matter, some hazardous cargo cannot be put on a plane together. The total listing of hazardous cargo compatibilities is given in AFMAN 24-402 according to classes. Both the dimensionality and hazardous constraints are listed on the TPFDD meaning that the information is electronically available. When considering weight, center of gravity is very important and there will be a way to calculate this, but we will not determine it beforehand.

The essential push of this research is to develop a mathematical model and an optimization algorithm for the 463L pallet. This, however, is our ideal case. Because of the rigorous nature of this problem, an acceptable end product is actually a list of heuristic techniques. If this is the case and a heuristic is employed, then the factors that limit the model to a less than optimal solution should be defined. A functional model may need to be run in order to understand the breakdown of the model away from the optimal solution. A functional run can be further explored once the model has been developed. As per the above definition of LOGCAT and requirements set by Armstrong Lab, the solutions will need to be system friendly to three different systems. This means that the subprogram must be able to interact with LOGMOD, CMOSS, and UTC-DT. The programming language that will be used to code the algorithm for the solution of this model will be C++ or FORTRAN, which means that it is highly likely that this code will be compatible with the three systems previously listed. The end resulting model coupled with its solution algorithm will be used to pack a number of boxes from the previously listed UTC data. The algorithm will choose items based initially on density and then by

volume. This is accomplished after the hazardous cargo has been identified and placed according to class. After a best list of items has been generated, then the pallet is packed.

IV. MODEL AND ALGORITHM

4.1 INTRODUCTION

The goal of this model is to load a pallet to the maximum amount possible, while meeting the required constraints. This is a goal model, where each section of the objective equation is weighted according to the relative importance of the section.

Initially to better define and facilitate the understanding of the model, definitions of the variables used for the model will be discussed. The 463L pallet-packing model is a combination of three different models developed specifically to handle the pallet-packing problem. The first component model of the larger 463L pallet-packing model is the hazardous materials compatibility model. This sub-component ensures that hazardous cargo loaded onto the pallet is compatible with the other cargo. Also, it is assumed that the intention of the loadmaster is to put as much hazardous cargo on a single pallet as possible. The next sub-model is the knapsack model that is used to limit the candidate list. Next, the pallet-loading model defines the pallet load placement. This sub-model consists of an objective function that minimizes unused space and constraints enforcing logical box placement on a pallet. The chapter also introduces an algorithm combining a knapsack heuristic and a tabu search.

4.2 VARIABLES AND DEFINITIONS

y_m = candidate boxes include hazard class m material ($y_m = 1$) or not included ($y_m = 0$)

x_m = candidate boxes of hazard class m are on the pallet ($x_m = 1$)
or not on the pallet ($x_m = 0$)

X = total number of boxes

I = total length of pallet, 104 inches for 463L pallets

J = total width of pallet, 84 inches for 463L pallets

TH = Total Height allowable for pallet, determined by aircraft type

TW = Total Weight allowable for pallet, determined by aircraft type

TVA = Total Volume Available

l_x = length of box x

w_x = width of box x

h_x = height of box x

wt_x = weight of box x

W_m = the sum of the weights of items of hazard class m

V_m = the sum of the volumes of items of hazard class m

BL_{ijkx} = Bottom Left corner of box x

P_{ijk} = Pallet space ijk is occupied ($P_{ijk} > 0$) or empty ($P_{ijk} = 0$)

B_{ijkx} = Box space occupied by box x

D_x = Density of box x

EP = Empty space remaining on pallet Penalty

OL = Overlap Penalty

OH = Overhang Penalty

DP = Density Penalty

NGP = No go Penalty, the item is not included on the pallet

R_x = the rotation of box x , $\in \{0,1\}$

4.3 MODELS

4.3.1 HAZARDOUS MATERIALS COMPATIBILITY. In order to address the many issues that are raised when loading hazardous cargo, a separate model must be created to separate compatible and incompatible hazard classes and ensure the hazard classes that are on the current load list are considered. Several assumptions are included to simplify and clarify the model. These assumptions ease the evaluation and provide the

best possible environment for loadmasters. First, since the focus of this study is pallet loading, not aircraft loading, nonadjacent constraints have the same effect on this model as not on the same pallet constraints. Therefore, all constraints will be assumed to be the same and taken as such from Figure 4. Second, to ease the burden on the loadmasters and add less complication to the aircraft loading portion of deployment, the goal of this model is to load as many compatible hazardous items together as possible. Hence, the hazardous class model is as follows:

$$\max : \sum_{m=1}^{18} x_m \quad (1)$$

Subject to:

$$\begin{aligned} x_1 y_1 + x_i y_i &\leq 1 & i \in \{2,3,4,5,6,8,\dots,18\} & (2) \\ x_2 y_2 + x_i y_i &\leq 1 & i \in \{6,8,\dots,18\} & (3) \\ x_3 y_3 + x_i y_i &\leq 1 & i \in \{6,8,9,10,12,16,18\} & (4) \\ x_4 y_4 + x_i y_i &\leq 1 & i \in \{6,8,9,10,12,16,18\} & (5) \\ x_5 y_5 + x_i y_i &\leq 1 & i \in \{16,18\} & (6) \\ x_6 y_6 + x_i y_i &\leq 1 & i \in \{8,9,12,\dots,18\} & (7) \\ x_8 y_8 + x_i y_i &\leq 1 & i \in \{10,\dots,15,18\} & (8) \\ x_9 y_9 + x_i y_i &\leq 1 & i \in \{10,\dots,15,18\} & (9) \\ x_{10} y_{10} + x_i y_i &\leq 1 & i \in \{11,\dots,16\} & (10) \\ x_{11} y_{11} + x_i y_i &\leq 1 & i \in \{16,18\} & (11) \\ x_{12} y_{12} + x_i y_i &\leq 1 & i \in \{16,18\} & (12) \\ x_{13} y_{13} + x_i y_i &\leq 1 & i \in \{16,18\} & (13) \\ x_{14} y_{14} + x_i y_i &\leq 1 & i \in \{16,18\} & (14) \\ x_{15} y_{15} + x_i y_i &\leq 1 & i \in \{16,18\} & (15) \\ x_{16} y_{16} + x_i y_i &\leq 1 & i \in \{18\} & (16) \\ x_i, y_i &\in \{0,1\} & & (17) \end{aligned}$$

The goal of the objective equation (1) is to place the maximum number of compatible hazard classes from the existing classes on the pallet at a time. The other

equations (2-16) are simply a translation of the chart in Figure 4. It is important to note that the values for y_i will be determined prior to using the model. This is so all the incompatible cargo classes are defined and prevented from being chosen together.

Equation (17) is the domain for the variables x and y .

The above is one way of approaching the process of maximizing the hazardous material included on a pallet. Alternate methods that could possibly be considered are maximizing hazardous volume or weight. This could also be used as a menu giving the user the chance to choose the method most suitable for his purpose. The hazardous volume alternative model is as follows:

$$\max : \sum_{m=1}^{18} x_m \cdot V_m \quad (1b)$$

This consists of the total volume for all items of each class of hazardous. The volumes must be computed prior to use of the model for purposes of comparison. The next model, the hazardous weight alternative model, is similar in nature with the exception of having to discern the total weight for all items in the hazard class. The weight model is as follows:

$$\max : \sum_{m=1}^{18} x_m \cdot W_m \quad (1c)$$

For both the above alternatives, the constraints previously defined in the hazardous class model will remain unchanged.

4.3.2 KNAPSACK MODEL. Since the size of the candidate list plays an integral part in the manageability of this combinatorial problem, limiting the list will enhance the ability to solve the problem. Therefore, a simple knapsack heuristic will be used to limit the candidate list to only those that may fit in the available volume. A knapsack treats volume as a continuous quantity without regard to the actual dimensions of each box. We assume a candidate list of boxes, X total boxes, is available. These boxes are hazardous cargo compatible and carry geometrical and weight attributes.

$$\min : Q \tag{18}$$

Subject to:

$$\left(TVA - \sum_{x=1}^X (l_x \times h_x \times w_x) \times BL_{ijkx} \right) + Q = 0 \quad \forall i, j, k \tag{19}$$

$$\sum_{x=1}^X wt_x \times BL_{ijkx} \leq TW \quad \forall i, j, k, x \tag{20}$$

$$BL_{ijkx} \in \{0,1\} \quad \forall i, j, k, x \tag{21}$$

$$Q \geq 0 \tag{22}$$

This model is actually dependent on the previous hazardous constraints model. First, the total volume of hazardous material (TVH) that were deemed compatible is computed. If the TVH is greater than the total volume (TV), 104x84xTH, per pallet, then the hazardous items become the candidate list and the total volume available (TVA) is

equal to TV. Finally, equation (18) is minimized and has a minimum value of zero, controlled through equation (22). Hence, equation (19) can determine the maximum amount of hazardous that can be placed on the pallet becomes the new candidate item list (NCIL). Equation (20) is to ensure the weight of the items does not exceed the maximum total weight allowable.

If TVH is less than TV, then TVH must be subtracted from TV to arrive at TVA. Then all hazardous will be removed from the candidate list for this model, resulting in only non-hazardous items being selected to fill the remaining volume. Therefore, the goal of equations (19) and (20) is to find the remaining items on the pallet, besides the compatible hazardous material which will automatically be included on the pallet if it is less than TV. These items plus the hazardous cargo items are passed onto the pallet-loading model for placement on the pallet.

4.3.3 PALLET LOADING MODEL. The pallet-loading model attempts to place the list of items emanating from the knapsack model onto the specified pallet. A measurement increment is needed. We consider all boxes in terms of one-inch squares. All box sizes are rounded to the next higher inch. The type of aircraft on which the pallet is being loaded determines the maximum height of the pallet. The surface dimensions of the 463L pallet are (104, 84, TH) in inches. BL is the lower corner and used to define each box. From this point, the boxes can be placed on the pallet according to the lower corner and built to the length, width, and height of the specific box.

$$\begin{aligned}
& \min: \left(I \times J \times TH - \sum_{i=1}^I \sum_{j=1}^J \sum_{k=1}^{TH} P_{ijk} \right) \times EP + \sum_{i=1}^I \sum_{j=1}^J \sum_{k=1}^{TH} P_{ijk} (P_{ijk} - 1) \times OL \\
& + \sum_{i=1}^I \sum_{j=1}^J \sum_{k=1}^{TH-1} (P_{ijk+1} - P_{ijk}) \times P_{ijk+1} \times OH \\
& + \sum_{i=1}^I \sum_{j=1}^J \sum_{k=1}^{TH-1} \left(\sum_{x=1}^X D_x B_{ij(k+1)x} - \sum_{x=1}^X D_x B_{ij(k)x} \right)^+ \times DP + \sum_{x=1}^X \left(1 - \sum_{i=1}^I \sum_{j=1}^J \sum_{k=1}^{TH} BL_{ijkx} \right) \times NGR_x
\end{aligned} \tag{23}$$

Subject to:

$$\sum_{i=1}^I \sum_{j=1}^J \sum_{k=1}^K BL_{ijkx} \leq 1 \quad \forall x \tag{24}$$

$$\begin{aligned}
B_{ijkx} &= \sum_{i'=0}^{\min[(i-1), (l_x-1)]} \sum_{j'=0}^{\min[(j-1), (w_x-1)]} \sum_{k'=0}^{\min[(k-1), (h_x-1)]} BL_{i-i', j-j', k-k'} \times R_x \\
&+ \sum_{i'=0}^{\min[(j-1), (w_x-1)]} \sum_{j'=0}^{\min[(i-1), (l_x-1)]} \sum_{k'=0}^{\min[(k-1), (h_x-1)]} BL_{i-i', j-j', k-k'} \times (1 - R_x) \\
&\forall i, j, k, x
\end{aligned} \tag{25}$$

$$P_{ijk} = \sum_{x=1}^X B_{jikx} \quad \forall i, j, k \tag{26}$$

$$\sum_{x=1}^X \sum_{i=1}^I \sum_{j=1}^J \sum_{k=1}^{TH} BL_{ijkx} \times wt_x \leq TW \tag{27}$$

$$\begin{aligned}
BL_{ijkx} &\in \{0,1\} & \forall i, j, k, x \\
B_{ijkx} &\in \{0,1\} & \forall i, j, k, x \\
R_x &\in \{0,1\} & \forall x
\end{aligned}
\tag{28}$$

The nonlinear objective equation (23) describes the best method for placement of each box. Each section of the equation has a constant that contributes a specific weight to each section, depending on how important the user feels that section is to the objective equation. The objective equation is composed in sections that cover the soft constraints that are created when building a pallet. The first section tries to minimize the empty space remaining on the pallet. The second section penalizes overlap that may be created if two boxes are inadvertently placed across the same pallet space. The third section focuses on eliminating overhang within the usable area of the pallet, this is done by penalizing the area of a box that is placed with nothing underneath it. The fourth section is a density penalty, which is designed to place heavier boxes on the bottom and place a heavy penalty whenever a heavy box is placed onto a less dense box. The goal of the density penalty is to ensure that no items are crushed.

The final section of the objective equation is a “No Go” penalty. The object of this equation is to place as many boxes as possible onto each pallet. The NGP_x is dependent on the priority of the box. If the box is hazardous cargo and is in one of the classes chosen to be on this pallet, the weight will be large. Also, since this model is based on individual UTCs, a few UTCs have as many as seventeen pallets of cargo; with

this in mind, some UTCs have priorities within the UTC and therefore, that priority will also be a factor in the value of a particular box's "No Go" penalty.

The second set of equations contains the building blocks and constraints for the objective equation. They show how to create the values that will be used to solve the objective equation. The first equation (24) represents that there is only one corner point for each box. Equation (24) assigns a value of 1 to only one location in the BL matrix. Then, based on the location of the corner point, equation (25) builds the box matrix, B_{ijkx} either lengthwise or widthwise around that corner point. The orientation of the box is based on the value of R_x . If R_x is zero, the box is placed lengthwise along the 104 inch axis, if the value is one, the box is placed widthwise along the 104 inch axis of the pallet. R_x is defined in equation (28) This is based on the length, width, and height of each individual box. The limits are designed to ensure the search is only conducted within the area of the pallet.

The next equation (26) assigns values to the pallet space matrix by simply adding all the boxes selected to go onto the pallet into the positions they are currently holding in their box matrices B_{ijkx} , which then comprises the fully packed pallet. The fourth constraint (27) ensures the pallet does not exceed its maximum weight allowance. Finally, (28) defines the allowable values of the variables. The first term explains whether or not box x will be on a pallet or not. If all values of BL_{ijkx} are zero, then box x is not on the pallet, if the value is one the box is on the pallet. If the value of B_{ijkx} is one, then the box x is occupying the space (i, j, k) . Likewise, if the value of P_{ijk} is one or greater, then the space (i, j, k) on the pallet is occupied by one or more boxes

respectively. The possibility exists for more than one box to occupy the same space. Although this is penalized in the objective equation (23).

4.4 ALGORITHM

The goal of this algorithm is to create a loaded pallet, meeting all constraints, and loaded as tightly as possible. This is achieved using each of the three models defined above. The overall goal is to minimize the objective function of the pallet packing model above in an iterative fashion. All of the figures referenced in the following description are displayed in Appendix A.

This algorithm determines compatible classes and employs the knapsack to develop a candidate list. Next, a simple heuristic is employed to place items on the pallet in density order, placing boxes with greatest density first. Once an initial feasible solution is created, then tabu search moves the items using the nonlinear objective equation (23) to evaluate each tabu search point.

4.4.1 INITIALIZATION AND HAZARD CLASS COMPATIBILITY. First, all variables must be initialized to zero to ensure the pallet begins empty. Then, the type of aircraft and planned pallet position must be determined in order to determine the maximum pallet height and weight. If these values are unknown, a set maximum of 7,500 pounds and 96 inches will be assigned, since these values still meet the requirements of the pallet and most positions from Figure 2. Next, the list of items to be

loaded onto the pallet must be retrieved from the TPFDD (Figure 9). Once the list of items has been determined, it must be run through the hazardous materials integer-programming model according to the hazardous items contained on the list. This will eliminate all incompatible items from the candidate item list (CIL). This is shown in Figure 10. All items in each compatible hazard class must then be loaded to ensure compatibility issues are addressed.

4.4.2 KNAPSACK HEURISTIC. In order to narrow the CIL, a simple knapsack heuristic is used. The objective function (17) is based on the amount of hazardous cargo deemed compatible for this pallet. Once the amount has been determined, the correct value of TVA may be determined and the model may be run. Therefore, a new CIL (NCIL) will be created that consists of the compatible hazardous cargo from the hazardous cargo model, and if space permits, other non-hazardous cargo that may potentially fit on the pallet. This list will reduce the initial UTC, which may consist of several pallets of cargo, to a maximum number of items that may fit on one pallet, the NCIL (Figure 10).

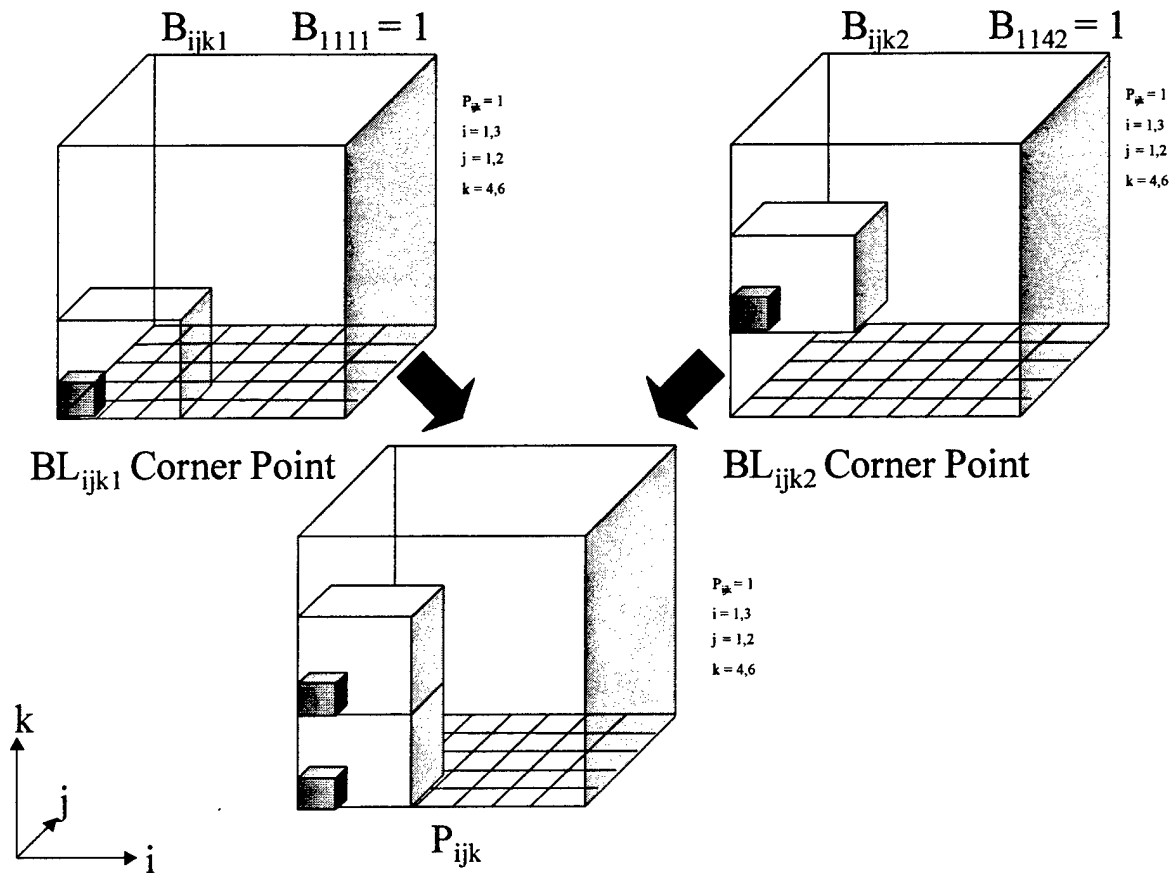

Figure 8. Pallet Packing Algorithm

4.4.3 INITIAL SOLUTION TO THE PALLET PACKING MODEL. Once the above has been completed, remaining items must be arranged according to density, with the densest at the top of the NCIL. Then, the pallet-loading model can be solved through the use of general heuristics and tabu search. The first step of the algorithm is to create an initial feasible solution. This is pictured in Figure 8 and flowcharted in Figure 11. This is done by placing the items on the pallet based on the lower corner of the box, building the box around its lower corner until the total length, width, and height have been filled. The position of the next box is chosen by a comparison between the length and width of the box about to be placed with the length and width of the boxes already

placed on the pallet. If the difference in the lengths is less than the difference in the widths, then the box will be placed widthwise to ensure the length remains relatively constant. This is done until a layer is completely full, then the height is incremented to ensure the maximum height of the boxes is covered. The next step is to start over with the densest box and build a second layer, and a third, until the pallet is filled. Each box is removed from the NCIL as it is placed on the pallet.

The boxes will be chosen by density until the volume reaches the total volume less the volume of the chosen hazardous cargo. Upon reaching the specified volume, only hazardous cargo can be loaded until either all hazardous cargo has been loaded or the maximum volume has been exceeded, whichever occurs first. If there is remaining volume and all hazardous cargo has been placed, the remaining items can then be placed. The number of iterations allowed for placing the boxes will be limited to the number of boxes in the CIL.

4.4.4 TABU SEARCH. Once as many items can be placed on the pallet as possible, tabu search will be used to move the boxes by their lower corners, attempting to further minimize the pallet loading objective equation (19). The tabu search method for this algorithm has been taken from several sources researched over the course of this study, to include Reeves (1993), Chocolaad (1998), and Blazewicz and Walkowiak (1995). Two different iterations will be used, one, a major iteration, to chose the focus box, and a second, minor, iteration will be used to move the selected box. The flowchart for the tabu search algorithm is shown in Figure 12.

A random order scan will be used to choose which box undergoes the minor iteration process at each major iteration. The boxes to be considered are those that were placed on the pallet in the initial solution and those remaining on the NCIL. Therefore, the random order scan is done on all the boxes originally chosen by the knapsack and hazardous models. The total number of minor iterations completed during each major iteration is designated n .

The Move Set, based on Chocolaad (1998), contains three types of possible moves. First, the standard translation move, where a box may be moved in one direction for a distance D . The evaluation criteria is limited by $D_{\min} = 1$, and $D_{\max} = \max([\frac{84}{n}]$, widthwise, or $[\frac{104}{n}]$, lengthwise, or $[\frac{TH}{n}]$, or 1), to limit the number of possible solutions the search must evaluate and to decrease the size of the move set as the number of iterations increase. The second type of move is the rotation, which in this model only includes changing the value of R_x from 0 to 1 or 1 to 0. This places the box lengthwise or widthwise, since the model was limited to these options. The final option is to swap boxes. The swap is evaluated for all boxes currently on the pallet and those remaining on the NCIL. Since bringing a box off the list and onto the pallet may provide a better solution than the box currently on the pallet, this option must be examined.

The cost function for this tabu search is equation (23), the objective function for our packing model. The above Move Set is evaluated for those moves which provide the best reduction to the objective function (23), since it is a minimization function. The "best move" is one with a negative value, which is the change in the objective function value.

Once a move is chosen and completed, it is considered tabu for t iterations of the minor iteration loop. The minor iteration loop is complete in either a set number of times, n , or once a specific number of non-improving moves has been taken, NI . At this time, the major iteration loop is activated and a new box is selected for evaluation. If this is done for a specific number of major iterations, NMI , with no improvements to the objective function, equation (23), then the program will stop all iterations. Values for iterations and tabu length may be set to fit the requirements of the users. This should lead to a best fit for the given boxes, with a penalty imposed for excluding any of the boxes on the list.

V. CONCLUSIONS AND RECOMMENDATIONS

5.1 INTRODUCTION

This study was undertaken to determine the decision variables and the constraints present in the three-dimensional 463L packing problem. These variables and constraints were used to facilitate the development of a three-dimensional 463L pallet packing model with the subsequent definition of an algorithm.

The three-dimensional packing problem is an NP-hard problem. This obtaining and verifying an optimal solution is impossible in a reasonable time period. For this reason the problem is defined in relatively simple terms. Even though the problem is defined in these somewhat basic terms, it is still very complex. Determining the variables and constraints for the three-dimensional packing of the 463L pallet, especially the prudent sometimes limiting selection of these variables and constraints is key to solving the model and then implementing the solution procedure in any Air Force system.

Considering the complexity of the problem, there are three ways to approach the process of creating an employable result for the Air Force. The three possible methods are to develop our own software, port IPLS software, or purchase a COTS product with the inherent expertise. These options are listed and discussed in chapter three. The primary focus of this chapter will be on our development of the model and related algorithm as well as well as the conclusions reached from that process. Although the best

choice may be to use COTS, TASC, Inc, an independent contractor employed by Armstrong Laboratory suggests that the initial development of a 463L pallet-packing model would be very beneficial. This is because once key Air Force elements are modeled, the extension of those elements into a working software program will most likely be less consuming in both time and cost. Lastly, recommendations for future research to extend this model will be presented.

Prior to the development of the model was the definition of research questions to drive the subsequent creation of the model and the algorithm.

Research Question #1

What constraints must be incorporated and are not incorporated into the model?

An important subset of this research as a whole, was the identification of the constraints involved in the 463L pallet building process and which constraints could be dropped from the model. This smaller set contains the essential constraints necessary for the adequate development of the model. These constraints are hazardous materials compatibility, non-uniform rectangular boxes, pallet height and weight, “this end up,” UTC integrity, density, and priority. More specifically for the 463L pallet-packing model the constraints were overhang, overlap, density, no go penalty, and the empty space penalty. Two constraints not considered were full box rotation and the use of non-rectangular objects. For our model, a box may be rotated 90 degrees, which is sufficient for rectangular boxes. The assumption of rectangular boxes is due to the format of the

TPFDD. It only contains length, width, and height information and no indication of the inherent shape of the object.

Research Question #2

What algorithms could be used to optimize usage of pallet space?

Currently, no algorithms for pallet packing problem guarantee an optimal solution in a reasonable amount of time. Hence, the goal is to find the “best” solution from the set of sub-optimal solutions. According to the research, the “best” solution appears to be a combination of a knapsack heuristic and a tabu search. Therefore, this is the model employed in this paper.

Research Question #3

What algorithms will work for the pallet optimization model and which ones will not be compatible?

Upon completion of the research, it is the conclusion that the knapsack and tabu search combination will work best in the situation, despite the lack of an “optimal” solution. The knapsack heuristic limits the number of boxes, available to those that may fit within the volume, discounting the actual shape of the box itself. Once the knapsack heuristic has been performed, the tabu search allows for certain moves to be considered illegal for a specified number of moves. Having this option eliminates redundancy that

may occur from the model reversing a move previously made. The two methods combined will significantly reduce the time to solution, which is imperative in any deployment scenario.

Research Question #4

What types of optimization software packages currently exist?

There are many packages listed in the literary review that encapsulate some of the features both nice and necessary for use either in an adaptive fashion or as a substitute for our model. However, even though many of the models were strong in certain areas, none of them is capable of providing the necessary pallet level detail or an optimal solution. Also, many of the models discussed do not realistically define the pallet packing process. Subsequently, the solution may be suspect. The best possible solution from these “optimization” packages is one that is almost as good as the one derived from the manual packing of a pallet.

Research Question #5

What should the final product be able to do?

The true thrust of this research is to eventually develop a system offering capabilities necessary to build up pallets in the most efficient way possible. There are six principle functional areas that the final product of the UTC-O subcomponent of UTC-DTO. The first is the process of getting the data into the system which will entail importing logistics details from LOGMOD-B. Next, reference information will need to

be provided such as aircraft specifications. Also, the user will need to have the ability to review and modify to ensure data integrity and indication of special requirements to be implemented. After, the user has specified some actions, then a program needs to be embedded into this package to find the optimal solution. Next, the results will need to be displayed in a useful manner to guide build-up activities. Lastly, this package will need to provide some type of what-if capability for the possible prediction of the effects of changes. All of this needs to be conveyed in a GUI type of interface to the level of personnel that build the pallet for the facilitation of training in this area. The above is what the end product is expected to accomplish, however this paper's focus is the development of a 463L pallet-packing model, which is the O part of UTC-O. The model as well as the algorithm can be used to satisfy the fourth principle listed. Of course, the possibility of obtaining an optimal solution through ours or any other model is very slim. However, a good solution may be arrived at by the 463L pallet-packing model and algorithm. For our model, the knapsack and tabu algorithms are used in conjunction to obtain the necessary data, separate the data, and find the best list to load on the pallet. The model also takes hazardous constraints into account.

5.2 SUMMARY

As the Department of Defense's budget grows smaller with each year, the need to employ diminishing resources to the fullest extent possible is key to very survival of the warfighting capability of the services. This is especially true in the area of military airlift,

which is primarily handled by the Air Force. In recent history, not only has the budget decreased bringing subsequent manning problems and equipment shortages, but also with the end of the Cold War the operational tempo of the Air Force has increased significantly. This is due partly to other than war operations such as humanitarian missions, but regardless the operational tempo is growing and resources to carry out this maelstrom of activity are shrinking.

Due to this dilemma, the new trend in the Air Force is to make the most efficient use of available airlift as possible. In the research, it was stated that aircraft are used inefficiently because of aircraft loading systems are not adequate and do not use detailed information in planning loads. To counter this problem, the Air Force through Armstrong Laboratory has been developing the Logistics Contingency Assessment Tool (LOGCAT), which is an integrated deployment system. This system consists of several components, each performing some aspect of the deployment process. The focus of this research consists of a smaller sub-component (UTC-O) of another component (UTC-DTO) of LOGCAT. UTC-O is the 463L pallet packing "optimization" portion. This is specifically where the efficient use of the aircraft is to be realized. The concept is that this portion of the overall process will generate optimal 463L pallet arrangements thereby saving space per pallet and subsequently space in the plane so that more materiel can be placed on that plane. This will save airlift.

Of course, due to reasons stated previously and specifically the NP-hard nature of the pallet-packing problem optimality may not be realized. However, good feasible solutions could possibly be obtained by employing the 463L pallet-packing model with

the associated algorithm. The 463L model employs a number of constraints to make the solutions meaningful. Hazardous materials constraints are included in the model as well as overhang, overlap, and density. The focus on rectangular boxes is primarily because the TPFDD, from which the data about the cargo to be loaded onto the pallet is obtained, only lists the length, height, width, and weight with no mention of the shape of the object to be loaded.

In conclusion, a set of three models has been developed and an algorithm has been defined to provide feasible solutions to the pallet packing problem in three-dimensions. The three models consist of a hazardous materials constraints model, a simple knapsack model, and a pallet packing model. While the pallet-packing model will only provide sub-optimal solutions to the pallet packing problem, it does provide feasible solutions that include most of the required constraints. The algorithm defined uses the three models to create a feasible solution for packing of the pallet. The algorithm consists of four sub-algorithms: a section where data is retrieved and initialization takes place, a section where hazard class compatibility is evaluated, a knapsack section to tailor the candidate list to a manageable size, an initial solution heuristic to place the boxes for preparation of the final phase, and finally, the tabu search phase where the goal is to refine the solution to a better feasible solution.

5.3 CONCLUSIONS

As previously stated, there are essentially three choices to be made as to the development of the UTC-O sub-component of LOGCAT. The choices are to either, use the model and algorithm as the basis for establishing working code, purchase COTS, or port ILPS.

The 463L pallet-packing model as well as the algorithm developed within these pages can be extended using a suitable programming language such as C++ or FORTRAN and then encapsulated into the entire LOGCAT package. One drawback is that this development could possibly take longer than the other two options. In a better light the software would be owned solely by the Air Force, which will allow freedom to modify the software as necessary. Also, the program can be tailored specifically for the 463L pallet-packing problem with all the necessary constraints from the beginning of development. However, commercial vendors have many products on the market that are advertised to pack pallets and display three-dimensional visuals of the packing procedure.

Another option the Air Force may follow is the employment of COTS. This would be a viable option to follow since there are packing packages that already exist that could possibly be modified to the needs of the Air Force. These packages are advertised to make use of graphical interfaces and pack spaces in a three-dimensional manner. However, the heuristics behind these products are not readily available so the validity of the solution could be in question. Even if this option is exploited, the 463L pallet-packing model should be used as a possible springboard for the project. This is due to the

nature of the pallet-packing problem as well as a commercial's possible lack of understanding about the military 463L pallet packing process. An inherent problem of not being familiar with the overall deployment process or any process specifically defined, as a military function will possibly lead the vendor down the road of constricting or perhaps faulty assumptions. In turn, this will possibly lead to an inferior product or a product that shows well in the lab under well-established and monitored conditions, but is doomed to failure in the field.

Another option discussed in the literature review was to port IPLS. This particular system could be adapted for use as the "optimization" program for UTC-O because of the focus on pallet packing and feasible solution generation. Also, IPLS could be written to accept TPFDD information and generate a list of suitable candidates. In 1981 when the concept of IPLS was realized, the hardware available to run this program was limited. Perhaps the hardware today would compensate for the slow processing times to obtain feasible solutions. However, even with the improved performance of the hardware, there is no guarantee of optimal pallet packing. Also, one of the essential constraints to the military 463L pallet-packing problem is the inclusion hazardous materials may not be easily attached to IPLS. However, IPLS will not cost anything to use as is and the software will be owned by the Air Force. The results of IPLS are not conclusive.

Working in conjunction with TASC, Inc, it has been determined that the most beneficial way to proceed is to make use of COTS software. Commercial companies are already developing like software. It should just be a matter of pairing the software within

the framework of LOGCAT. As a way to facilitate the ease of development of the UTC-O subprogram as well as understanding of the military process of pallet packing, our model and algorithm can be used as a starting point for the commercial vendor.

Specifically, the models and algorithm created for this thesis provide feasible but sub-optimal solutions. It is known that tabu search is quicker than most heuristics in approaching a solution, but this is the first algorithm based on three-dimensions published to date. Since no research in three-dimensions for any of the aforementioned algorithms has been done, comparison with the algorithm designed in this model cannot be made. Therefore, the value of this algorithm cannot be comparatively conclusive. Again to facilitate the ease of development of the COTS software, the models and algorithm developed in this thesis need to be used as a springboard.

5.4 RECOMMENDATIONS

Through this research, some opportunities for further research have been uncovered. The following recommendations for further study pertain mostly to the extension of the model developed within this paper.

1. Include other constraints to develop the model even further. However, it must be noted that adding constraints will explode the complexity of the problem.
2. Determine the possibility of limiting the constraints to a smaller subset with which a similar almost optimal answer can be obtained in a limited amount of time.
3. There are many algorithms, as discussed in the literature review section of this paper.

Determine the best or perhaps the best combination to handle this model. Handling could be defined as the most optimal, quickest, most flexible, portable, or any number of definitions of what the user considers the best. A determination of algorithms must be made based on the prioritization of user requirements.

4. Also, considering that the model has the best algorithms, there may be a “best” programming language to minimize time to solution, maximize portability or any other desired affect. Again, “best” would have to be determined by the user and it also may be a combination of factors. A possible important software factor would be the development of a Graphical User Interface (GUI) for the model since in concept the UTC-DTO will be used as a training aide and visual interface will be extremely important for the facilitation of the learning process.
5. When software is mentioned, the next natural topic usually is the hardware on which the software will be run. What is available to the Air Force? Which of these machines will the model run “best” on? Also, consider that the UTC-DTO is realized from the conceptual basis to a working system, then the need for mobility of the system will dictate the use of certain hardware. Is this hardware capable? Of course, the terms “best” and “capable” will need to be defined with respect to the use of the system.
6. Research in depth the possible benefits of using this model, IPLS, or the possibility of COTS. A side by side comparison of this three-dimensional model and algorithm and

IPLS as well as any COTS available would be useful in obtaining a concrete answer as to the relative worth of each. This was not accomplished in the initial research due to the nature of the problem as well as the time factor to complete such a task.

Appendix A: 463L Pallet-packing Algorithm

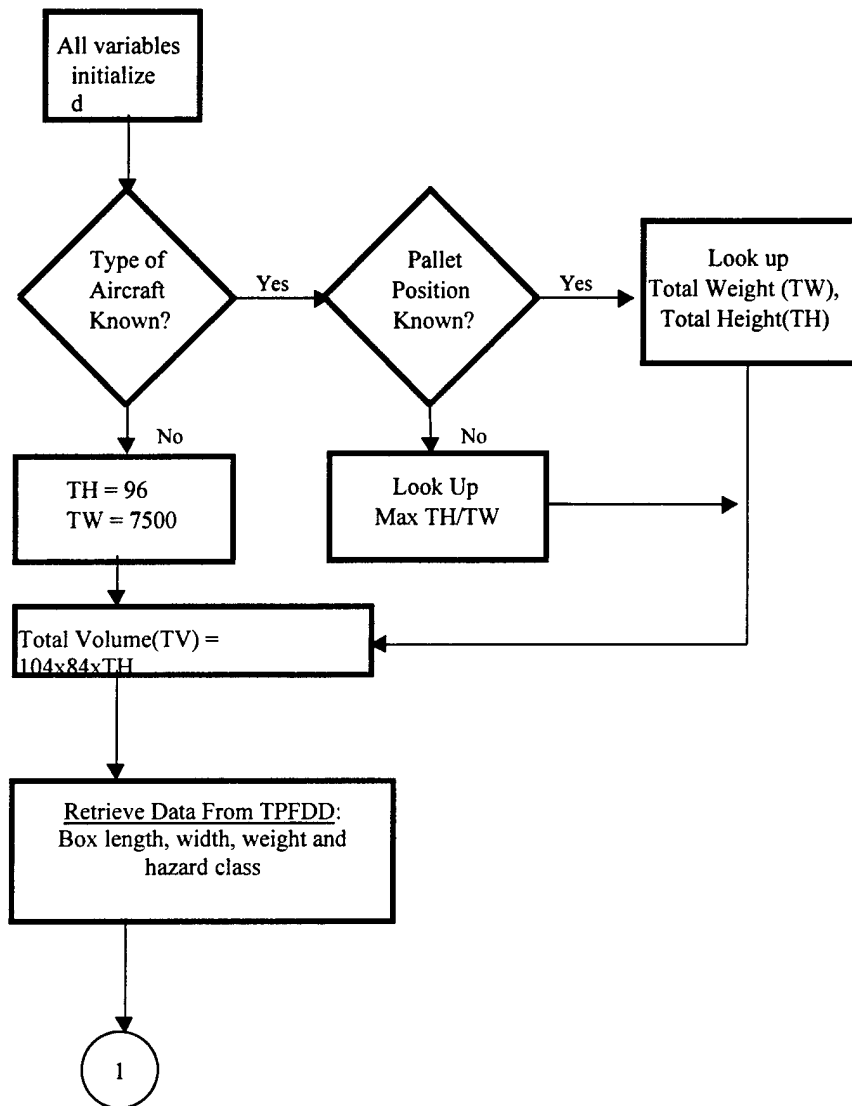

Figure 9. Read Data

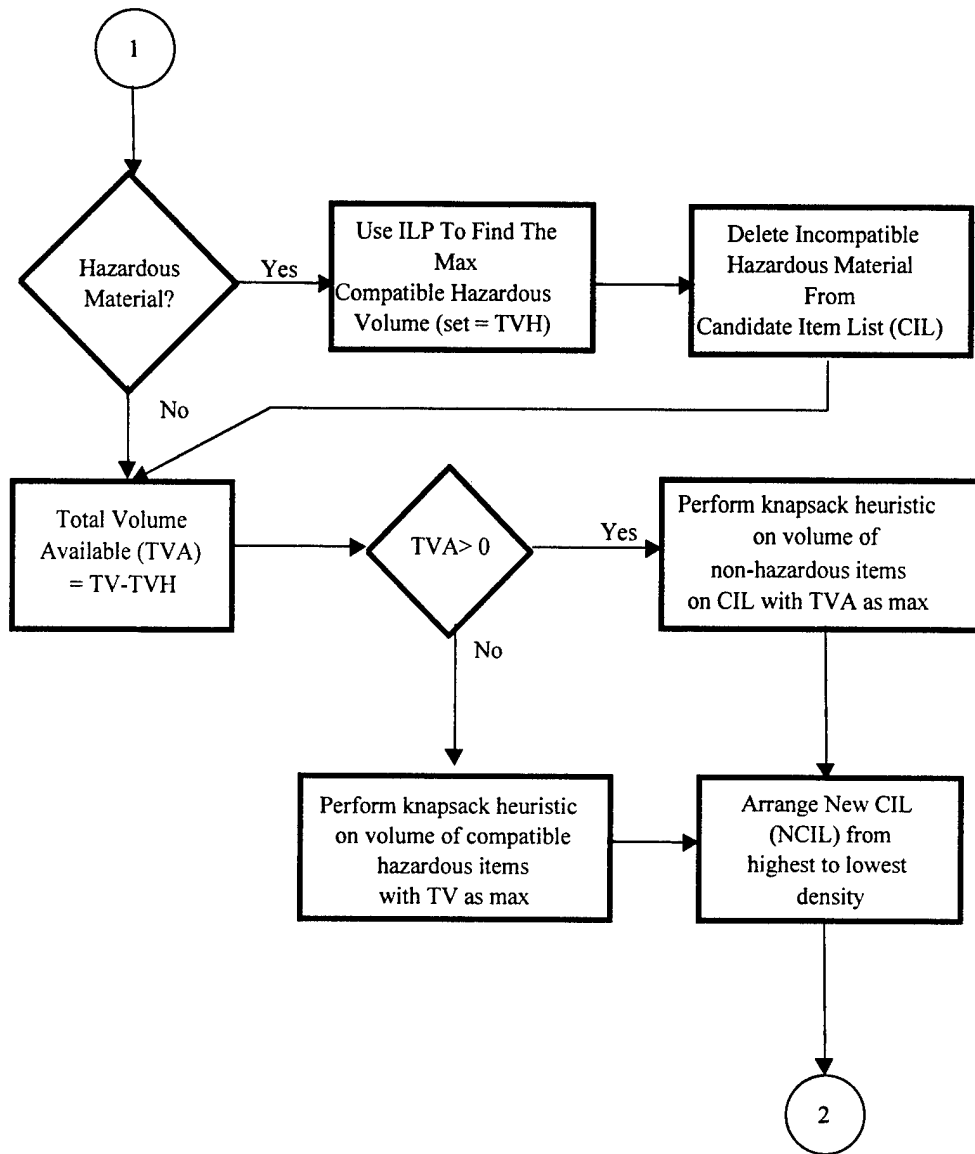

Figure 10. Hazardous Constraints

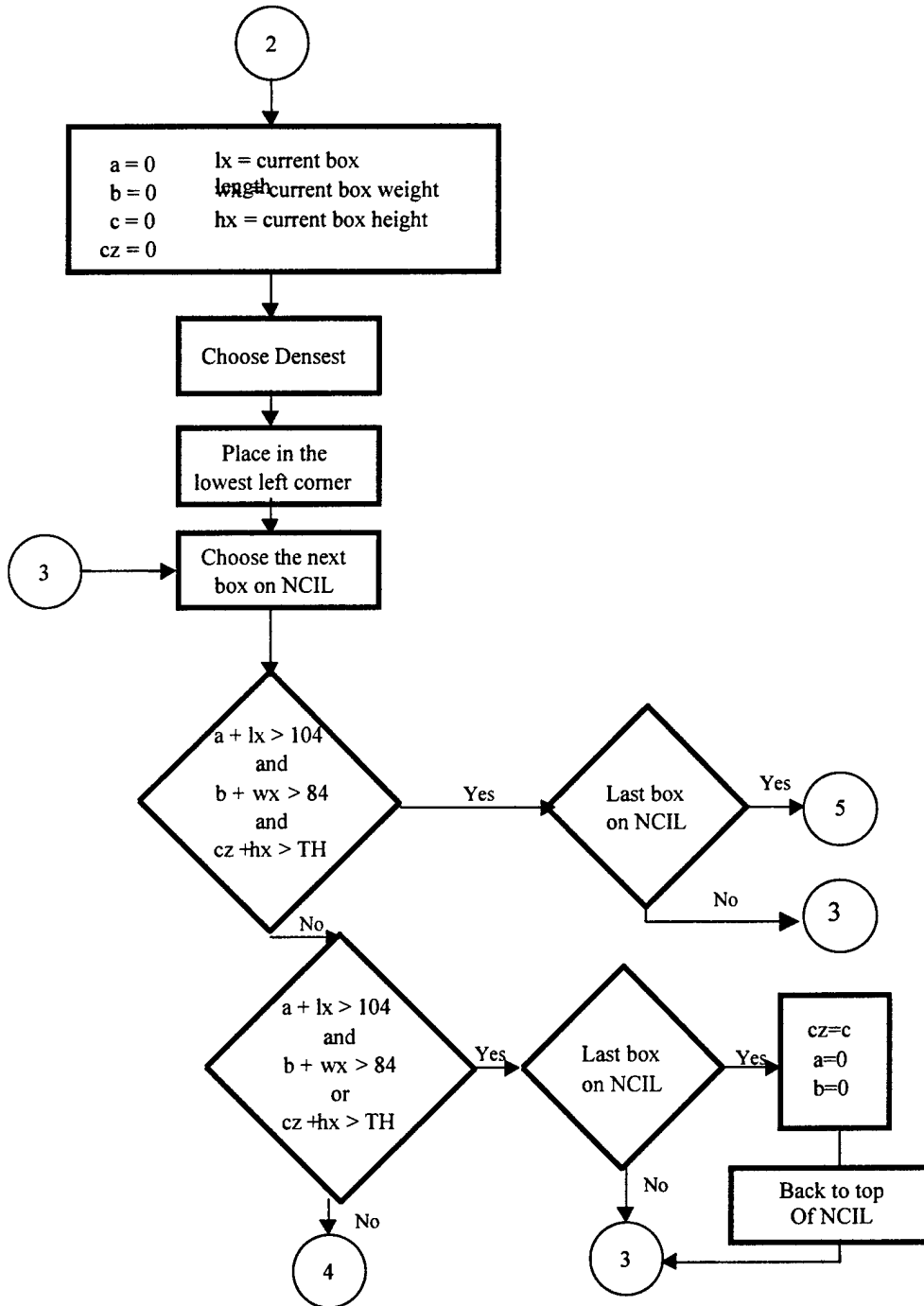

Figure 11a. Apply New Candidate Item List To Pallet Packing Model

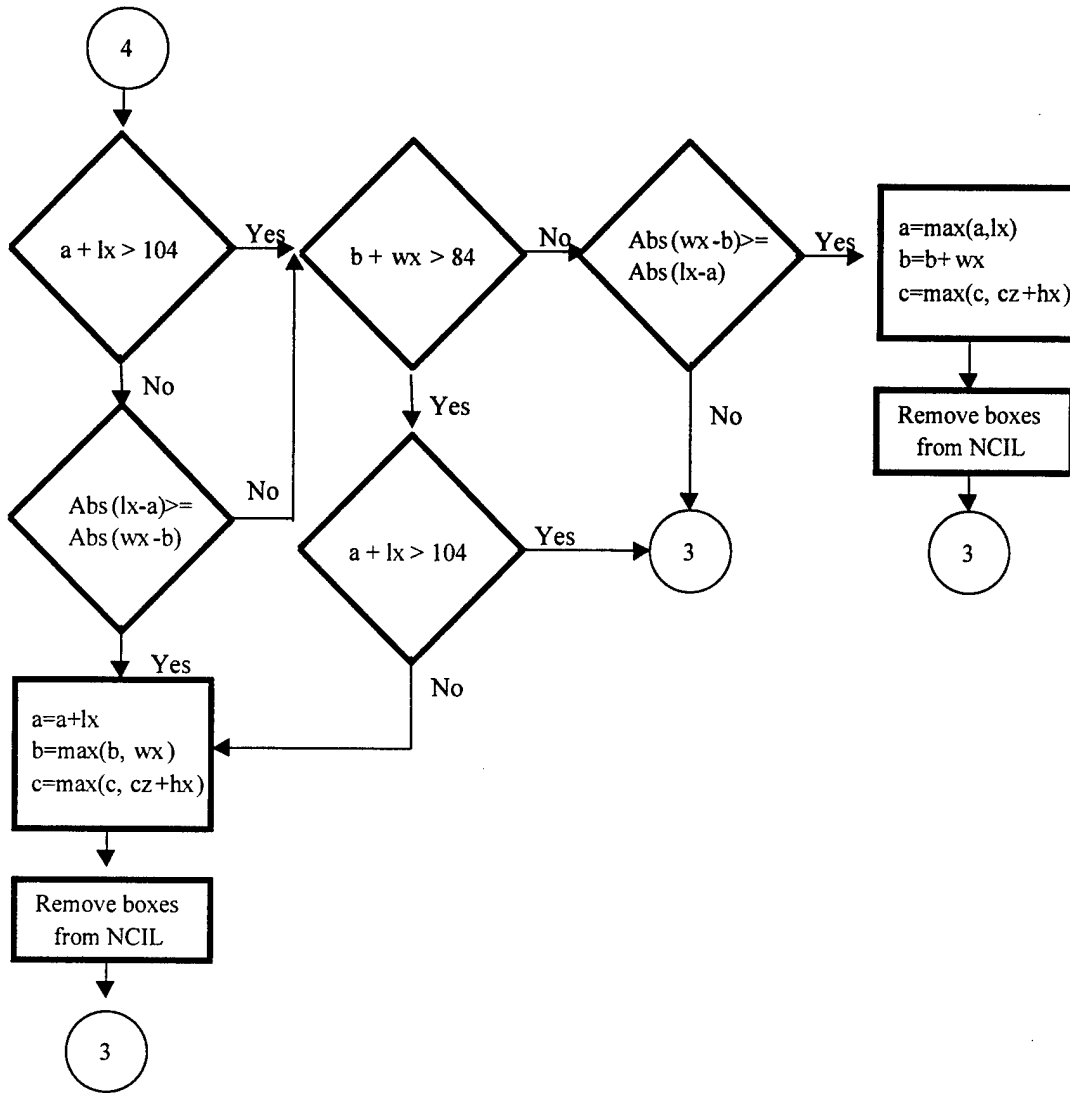

Figure 11b. Apply New Candidate Item List To Pallet Packing Model

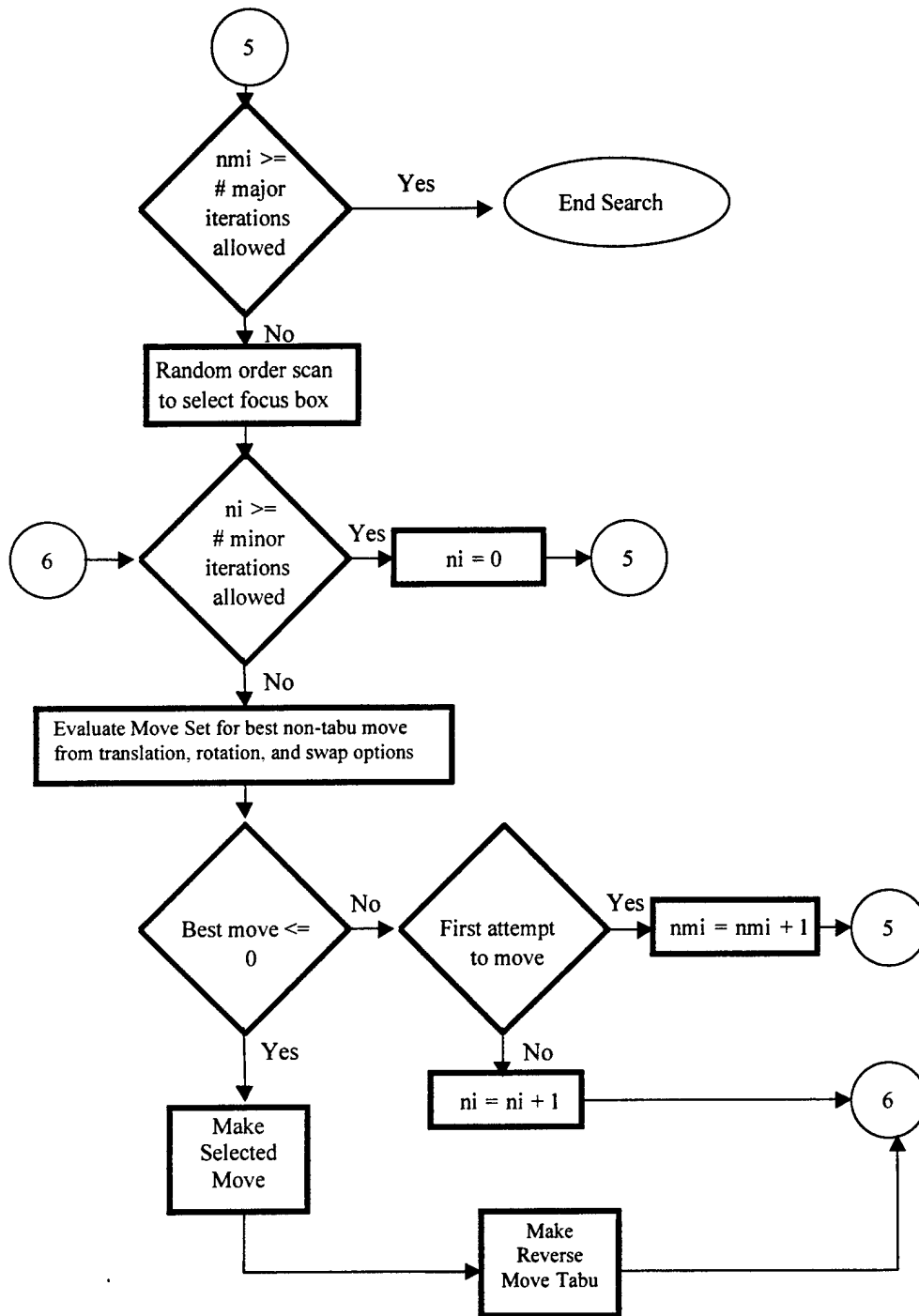

Figure 12. Tabu Search

BIBLIOGRAPHY

- Abdou, G. and J. Arghavani. (1997) "Interactive ILP Procedures for Stacking Optimization for the 3D Palletization Problem," *International Journal of Production Research* 35: 1287-1304.
- Armstrong Laboratory. *1996 Information Guide*. Logistics Research Division, Human Resources Directorate, Armstrong Laboratory, AFMC, Wright-Patterson AFB OH.
- Battiti, Roberto and Giampietro Tecchiolli. (1994) "The Reactive Tabu Search," *ORSA Journal on Computing* 6: 126-140.
- Battiti, Roberto and Giampietro Tecchiolli. (1996) "Local Search with Memory: Benchmarking RTS," *Operations Research/Management Science* 36:155-157.
- Battiti, Roberto, Giampietro Tecchiolli, and Paolo Tonella. (1996) "Vector Quantization With the Reactive Tabu Search," *Meta-heuristics Theory and Applications*, edited by Ibrahim H. Osman and James P. Kelly, 331-342, Kluwer Academic Publishers, 1996.
- Berger, Carl. *The United States Air Force in Southeast Asia, 1961-1973: An Illustrated Account*. Office of Air Force History, Washington DC 1984
- Bischoff, Eberhard E. and Michael D. Marriott. (1990) "A Comparative Evaluation of Heuristics for Container Loading," *European Journal of Operational Research* 44: 267-276.
- Blazewicz, J., P. Hawryluk, and R. Walkowiak. (1993) "Using a tabu search approach for solving the two-dimensional irregular cutting problem," *Annals of Operations Research* 41: 313-325.
- Blazewicz, J. and R. Walkowiak. (1995) "A local search approach for two-dimensional irregular cutting," *OR Spectrum* 17: 93-98.
- Boeing Computer Services Company. "Packman – Software for Cargo Packing Under Multiple Objectives." <http://cognac.cosmic.uga.edu/abstracts/mfs-28700.html>
- Brosh, Israel. (1981) "Optimal Cargo Allocation on Board a Plane: a Sequential Linear Programming Approach," *European Journal of Operational Research* 8: 40-46.
- Brown, A.R. (1969) *Optimum Packing and Depletion: The Computer in Space- and Resource-Usage*: 36 – 99. Jeffreys and Hill Limited.

- Byrd, Robert W. "463L Pallet Cycle Study Final Report," USAF Airlift Center, Scott AFB IL. 1983.
- Cagan, Jonathan. (1994) "Shape Annealing Solution to the Constrained Geometric Knapsack Problem," *Computer-Aided Design* 26: 763-770.
- Chen, C., S. Sarin, and B. Ram. (1991) "The Pallet Packing Problem for Non-uniform Box Sizes," *International Journal of Production Research* 29: 1963-1968.
- Chocolaad, Christopher A. Solving Geometric Knapsack Problems Using Tabu Search Heuristics. MS thesis, AFIT/GOR/ENS/98M-05. School of Engineering, Air Force Institute of Technology (AU), Wright-Patterson AFB OH, March 1998.
- Cochard, Douglas D. and Kirk A. Yost. (1985) "Improving Utilization of Air Force Cargo Aircraft," *Interfaces* 15: 53-68.
- Computer Sciences Corporation. *Unit Type Code Development, tailoring, and Optimization (UTC-DTO) Phase 2 Final Report*. Contract DCA100-94-D-00144. Falls Church VA: Defense Enterprise Integration Services, December 1997.
- Department of the Air Force. *Cargo Movement*. AFI 24-201. Washington: HQ USAF, 1 August 1996.
- Department of the Air Force. *Deployment Planning*. AFI 10-403. Washington: HQ USAF, 10 June 1994.
- Department of the Air Force. *Mobility for Air Force Materiel Command Support Forces*. AFI 10-408. Washington: HQ USAF, 25 April 1994.
- Department of the Air Force. *Mobilization Planning*. AFI 10-402. Washington: HQ USAF, 1 January 1997.
- Department of the Air Force. *Modernization Planning Documentation*. AFI 10-1401. Washington: HQ USAF, 22 May 1995.
- Department of the Air Force. *Preparation and Movement of Air Force Materiel*. AFD 24-2. Washington: HQ USAF, 21 April 1993.
- Department of the Air Force. *Preparing Hazardous Materials for Military Air Shipments*. AFJMAN 24-204. Washington: HQ USAF, 25 November 1994.
- Dowland, Kathryn A. (1987) "An Exact Algorithm for the Pallet Loading Problem," *European Journal of Operational Research* 31: 78-84.

- Dowsland, Kathryn A. (1990) "Efficient Automated Pallet Loading," *European Journal of Operational Research* 44: 232-238.
- Dowsland, Kathryn A. and William B. Dowsland. (1992) "Packing Problems," *European Journal of Operational Research* 56: 2-14.
- Dowsland, Kathryn A. (1993) "Some Experiments With Simulated Annealing Techniques for Packing Problems," *European Journal of Operational Research* 68: 398-399.
- Dowsland, Kathryn A. (1996) "Simple Tabu Thresholding and the Pallet Loading Problem," *Meta-Heuristics Theory and Applications*, edited by Ibrahim H. Osman and James P. Kelly, 381-405, Kluwer Academic Publishers, Netherlands.
- Dyckhoff, Harald. (1989) "A typology of cutting and packing problems," *European Journal of Operations Research* 44: 145-159.
- Freville A. and G. Plateau. (1993) "An Exact Search for the Solution of the Surrogate Dual of the 0-1 Bidimensional Knapsack Problem," *European Journal of Operational Research* 68: 413-421.
- Freville, A. and G. Plateau. (1994) "An Efficient Preprocessing Procedure for the Multidimensional 0-1 Knapsack Problem," *Discrete Applied Mathematics* 49: 189-212.
- Frieze, A. M. and M. R. G. Clarke. (1984) "Approximation Algorithms for the m -dimensional 0-1 Knapsack Problem," *European Journal of Operational Research* 15:100-109.
- Gehring, H., K. Menschner, and M. Meyer. (1990) "A Computer-Based Heuristic for Packing Pooled Shipment Containers," *European Journal of Operational Research* 44: 277-288.
- George, J. A. and D. F. Robinson. "A Heuristic for Packing Boxes into a Container," *Computational and Operations Research* 7: 147-156.
- Gerstel, Gerald. (1982) *Cargo Loading – A Proposed Approach for Maximizing Space Utilization of Containers Loaded With Palletized Loads*. David W. Taylor Naval Ship Research and Development Center, Bethesda MD. September 1982 (AD-A120 343).
- Glover, Fred and Manuel Laguna. (1997) *Tabu Search*. Kluwer Academic Publishers Netherlands, 231-308.

- Han, C., K. Knott, and P. Egbelu. (1989) "A Heuristic Approach to the Three-dimensional Cargo-loading Problem," *International Journal of Production Research* 27: 757-774.
- Head, William. (1992) "Air Power in the Persian Gulf: An Initial Search for the Right Lessons," *Air Force Journal of Logistics* 16:10-16.
- Hodgson, Thom J. Interactive Pallet Loading System (IPLS). Research Report 81-9. Contract F73AFL-00360001. Department of Industrial and Systems Engineering, University of Florida, Gainesville FL, June 1981.
- Irving, Janice. Unit Type Code (UTC) Life Cycle Study. AFLMA Final Report LX922148. Air Force Logistics Management Agency, Maxwell AFB, Gunter Annex, AL, October 1992.
- Ivancic, N., K. Mathur, and B. Mohanty. (1989) "An Integer Programming Based Heuristic Approach to the Three-dimensional Packing Problem," *Journal of Manufacturing and Operations Management* 2: 268-298.
- Jonak, Thomas E. (1970) Air Cargo Pallet Cube Utilization. Technical Report Series ASD-TR-70-7. Aeronautical Systems Division, Air Force Systems Command, Wright-Patterson Air Force Base OH, March 1970.
- Larsen, Ole and Gert Mikkelsen. (1980) "An Interactive System for the Loading of Cargo Aircraft," *European Journal of Operational Research* 4: 367-373.
- Lokketangen, Arne and Fred Glover. "Probabilistic Move Selection in Tabu Search for Zero-One Integer Programming Problems," *Meta-Heuristics Theory and Applications*, edited by Ibrahim H. Osman and James P. Kelly, 331-342, Kluwer Academic Publishers, Netherlands, 1996.
- Mazzola, J. B. and A. W. Neebe. (1993) "An Algorithm for the Bottleneck Generalized Assignment Problem," *Computers and Operations Research* 20: 355-362.
- McCarthy, Robert M. *Airlift Planning Handbook. Report 86-1660*. Air Command and Staff College (AU), Maxwell AFB AL, March 1986.
- NASA Marshall Space Flight Center. "STUF – Stowage Tactics for User Flights." <http://cognac.cosmic.uga.edu/abstracts/mfs-31101.html>
- Nelson, Napoleon Bonaparte, III. (1979) A Container Stuffing Algorithm For Rectangular Solids When Voids May Be Required. MS Thesis, Naval Postgraduate School, Monterey CA, September 1979 (AD A078274).

- Ng, Kevin Y. K. (1992) "A Multicriteria Optimization Approach to Aircraft Loading," *Operations Research* 40: 1200-1205.
- Oak Ridge National Labs, "Concept Description for the Airlift Deployment Analysis System (ADANS)," Military Airlift Command, Scott AFB IL, 1986.
- Pirkul, H. (1987) "A Heuristic Solution Procedure for the Multiconstraint Zero-One Knapsack Problem," *Naval Research Logistics* 34: 161-172.
- Reed, Thomas Gerald. *Binary Programming Models of Spatial Pattern Recognition: Applications in Remote Sensing Image Analysis*. MS thesis, AFIT/GSO/ENS/91D-15. School of Engineering, Air Force Institute of Technology (AU), Wright-Patterson AFB OH, December 1991 (AD - A243797).
- Reeves, Colin R. (1993) *Modern Heuristic Techniques for Combinatorial Problems*. John Wiley & Sons, 1-17, 70-150.
- Sanborn, Roderick S. *Knowledge-Based System for Load Planning Hazardous Cargo*. MS thesis, AFIT/GCS/ENG/86D-14. School of Engineering, Air Force Institute of Technology (AU), Wright-Patterson AFB OH, December 1986 (AD-A178 184).
- Schroeder, John, Christine Martinez, and Glen Galloway. *463L Pallet and Dunnage System Evaluation*. Armstrong Laboratory Report AL/HR-TP-1997-0043: 2-11. Armstrong Laboratory, Logistics Research Division, Wright-Patterson AFB OH.
- Sutanthavibul, Suphachai, Eugene Shragowitz, and J. Ben Rosen. (1990) "An Analytical Approach to Floorplan Design and Optimization," *27th ACM/IEEE Design Automation Conference*, 187-192.
- Szykman, Simon, and Jonathan Cagan. (1993) "Automated Generation of Optimally Directed Three Dimensional Component Layouts," *Advances in Design Automation 1*: 527-537. National Science Foundation grant DDM-9108832.
- Szykman, Simon, and Jonathan Cagan. (1995) "A Simulated Annealing-Based Approach to Three-Dimensional Component Packing," *Transactions of the ASME* 117:308-314.
- Szykman, Simon, and Jonathan Cagan. (1997) "Constrained Three-Dimensional Component Layout Using Simulated Annealing," *Transactions of the ASME* 119:28-35.

TASC, Inc. (8 May 1998) *Interim Project Report on the Feasibility of Finding Optimal Solutions to Three-Dimensional Packing Problems*. Contract number F41624-97-D-5002, Air Force Research Labs/HESR, Wright-Patterson AFB OH.

Wang, Ting-Chi, and D. F. Wong. (1990) "An Optimal Algorithm for Floorplan Area Optimization," *27th ACM/IEEE Design Automation Conference*. National Science Foundation grant MIP-8909586: 180-186.

Yost, Kirk A. Airlift Estimation for MAC Cargo Aircraft. AFLMC Final Report LY870104. Air Force Logistics Management Center, Gunter AFS AL (August 1988).

Vita

Lieutenant Wesley E. Manship Jr. was born on 20 June 1968 in Wurzburg, Germany. He graduated from S.R. Butler High School in Huntsville, Alabama in June 1986. After obtaining a certification to work in the field of electronics, he was employed as a line technician for Essex Cable. He entered undergraduate studies at the University of Alabama in Huntsville in 1988. In 1989, he was employed as a student engineer at Teledyne Brown Engineering through the cooperative learning program established at the university. During this employment, he worked on a number of programs including transceiver research for the TWIGGS project, providing relational database programming and creating a requirements tracer for Systems Engineering and Integration Projects Office, and providing database programming for the development of disaster relief models as well as marketing research for the Analysis and Simulation Office. He graduated from the University of Alabama in Huntsville in 1993 with a Bachelor of Science degree in Mathematics with a minor in Optics.

He was commissioned through OTS in 1995. His first duty station was Eielson AFB, Alaska where he was commander of the Materiel Storage and Distribution Flight and subsequently placed in command Materiel Management Flight. He entered the Graduate School of Logistics and Acquisition Management, Air Force Institute of Technology, Wright-Patterson AFB, Ohio in May 1997 in pursuit of a Master's degree in Inventory Management. His next assignment is to Macdill AFB, Florida.

Permanent Address: 3903 Grunden Drive
Huntsville, AL 35805

Vita

Lieutenant Jennifer L. Tilley, was born on 28 February 1970 in Urbana, Illinois. Because her father was in the Air Force she grew up all across the United States. She ultimately graduated from Cabrillo High School in Lompoc, California. She received her Bachelor of Science degree in Applied Mathematics from the University of California at Irvine. During her studies she worked as an intern for TRW's Space and Technology Group, in the Superconducting Electronics Research Area.

She was commissioned through OTS in 1995. Her first duty station was Malmstrom AFB, Montana, where she was both the Combat Operations Support Flight Commander and the Fuels Management Flight Commander. She entered the Graduate School of Logistics and Acquisition Management, Air Force Institute of Technology, Wright-Patterson AFB, Ohio in May 1997 in pursuit of a Master's degree in Inventory Management. Her next assignment is to the Air Force Logistics Management Agency, Gunter Annex, Montgomery, Alabama.

Permanent Address: 340 East Rockrimmon Blvd.
Colorado Springs, CO 80919

REPORT DOCUMENTATION PAGE

Form Approved
OMB No. 074-0188

Public reporting burden for this collection of information is estimated to average 1 hour per response, including the time for reviewing instructions, searching existing data sources, gathering and maintaining the data needed, and completing and reviewing the collection of information. Send comments regarding this burden estimate or any other aspect of the collection of information, including suggestions for reducing this burden to Washington Headquarters Services, Directorate for Information Operations and Reports, 1215 Jefferson Davis Highway, Suite 1204, Arlington, VA 22202-4302, and to the Office of Management and Budget, Paperwork Reduction Project (0704-0188), Washington, DC 20503

1. AGENCY USE ONLY (Leave blank)		2. REPORT DATE September 1998	3. REPORT TYPE AND DATES COVERED Master's Thesis	
4. TITLE AND SUBTITLE A THREE-DIMENSIONAL 463L PALLET PACKING MODEL AND ALGORITHM			5. FUNDING NUMBERS	
6. AUTHOR(S) Wesley E. Manship, Jr, First Lieutenant, USAF Jennifer L. Tilley, First Lieutenant, USAF				
7. PERFORMING ORGANIZATION NAME(S) AND ADDRESS(S) Air Force Institute of Technology 2950 P Street WPAFB OH 45433-7765			8. PERFORMING ORGANIZATION REPORT NUMBER AFIT/GIM/LAL/98S-3	
9. SPONSORING / MONITORING AGENCY NAME(S) AND ADDRESS(ES) Armstrong Laboratory AFRL/HERL WPAFB OH 45433-7765			10. SPONSORING / MONITORING AGENCY REPORT NUMBER	
11. SUPPLEMENTARY NOTES				
12a. DISTRIBUTION / AVAILABILITY STATEMENT Approved for public release; distribution unlimited			12b. DISTRIBUTION CODE	
13. ABSTRACT (<i>Maximum 200 Words</i>) <p>As part of the Air Force Logistics Contingency Assessment Tool, Armstrong Laboratory determined the need for a software package to optimize the packing of 463L cargo pallets for deployments. In January 1998, TASC, Inc., to determine if optimizing the packing of 463L pallets was indeed possible, implemented a feasibility study. TASC, Inc. concluded that a linear program was infeasible due to time and size constraints.</p> <p>Therefore, this research focuses on the development of a nonlinear model. An extensive literature review is conducted to detail the pallet loading problem, define the current pallet process, establish necessary assumptions and constraints, and examine possible algorithms to be used for the solution of the model. Also, other packing models are examined for possible use in the development of the nonlinear 463L pallet-packing model. The 463L pallet-packing model consists of three sub-models. These are a hazardous constraints linear program, a knapsack model, and a pallet-loading model. The complete model is solved using a knapsack heuristic and a tabu search.</p>				
14. Subject Terms Mathematical modeling, pallet packing, knapsack, tabu search, algorithms			15. NUMBER OF PAGES 104	
			16. PRICE CODE	
17. SECURITY CLASSIFICATION OF REPORT UNCLASSIFIED	18. SECURITY CLASSIFICATION OF THIS PAGE UNCLASSIFIED	19. SECURITY CLASSIFICATION OF ABSTRACT UNCLASSIFIED	20. LIMITATION OF ABSTRACT UL	

NSN 7540-01-280-5500

Standard Form 298 (Rev. 2-89)
Prescribed by ANSI Std. Z39-18
298-102

AFIT RESEARCH ASSESSMENT

The purpose of this questionnaire is to determine the potential for current and future applications of AFIT thesis research. **Please return completed questionnaire to:** AIR FORCE INSTITUTE OF TECHNOLOGY/LAC, 2950 P STREET, WRIGHT-PATTERSON AFB OH 45433-7765. Your response is **important**. Thank you.

1. Did this research contribute to a current research project? a. Yes b. No

2. Do you believe this research topic is significant enough that it would have been researched (or contracted) by your organization or another agency if AFIT had not researched it?

a. Yes b. No

3. **Please estimate** what this research would have cost in terms of manpower and dollars if it had been accomplished under contract or if it had been done in-house.

Man Years _____ \$ _____

4. Whether or not you were able to establish an equivalent value for this research (in Question 3), what is your estimate of its significance?

a. Highly Significant b. Significant c. Slightly Significant d. Of No Significance

5. Comments (Please feel free to use a separate sheet for more detailed answers and include it with this form):

Name and Grade

Organization

Position or Title

Address