

265263

JPRS 81384

28 July 1982

19980922 107

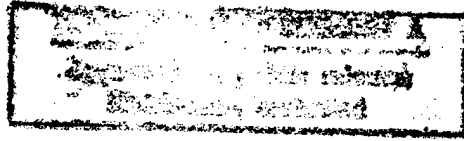

Worldwide Report

NUCLEAR DEVELOPMENT AND PROLIFERATION

No. 154

FBIS

FOREIGN BROADCAST INFORMATION SERVICE

12
62
A04

NOTE

JPRS publications contain information primarily from foreign newspapers, periodicals and books, but also from news agency transmissions and broadcasts. Materials from foreign-language sources are translated; those from English-language sources are transcribed or reprinted, with the original phrasing and other characteristics retained.

Headlines, editorial reports, and material enclosed in brackets [] are supplied by JPRS. Processing indicators such as [Text] or [Excerpt] in the first line of each item, or following the last line of a brief, indicate how the original information was processed. Where no processing indicator is given, the information was summarized or extracted.

Unfamiliar names rendered phonetically or transliterated are enclosed in parentheses. Words or names preceded by a question mark and enclosed in parentheses were not clear in the original but have been supplied as appropriate in context. Other unattributed parenthetical notes within the body of an item originate with the source. Times within items are as given by source.

The contents of this publication in no way represent the policies, views or attitudes of the U.S. Government.

PROCUREMENT OF PUBLICATIONS

JPRS publications may be ordered from the National Technical Information Service, Springfield, Virginia 22161. In ordering, it is recommended that the JPRS number, title, date and author, if applicable, of publication be cited.

Current JPRS publications are announced in Government Reports Announcements issued semi-monthly by the National Technical Information Service, and are listed in the Monthly Catalog of U.S. Government Publications issued by the Superintendent of Documents, U.S. Government Printing Office, Washington, D.C. 20402.

Correspondence pertaining to matters other than procurement may be addressed to Joint Publications Research Service, 1000 North Glebe Road, Arlington, Virginia 22201.

WORLDWIDE REPORT
NUCLEAR DEVELOPMENT AND PROLIFERATION

No. 154

CONTENTS

WORLDWIDE AFFAIRS

ROK-Canada Summit To Explore More Reactor Sales
(YONHAP, 6 Jul 82) 1

ASIA

INDIA

Gandhi: Heavy Water Production To Double
(Delhi Domestic Service, 2 Jul 82) 2

Briefs
Uranium Production To Double 3

JAPAN

AEC Outlines 10-Year Nuclear Development Program
(KYODO, 30 Jun 82) 4

MALAYSIA

Briefs
Nuclear Reactor in Operation 5

PEOPLE'S REPUBLIC OF CHINA

'MORNING POST' Reviews PRC Nuclear Development
(David Chen; SOUTH CHINA MORNING POST, 7 Jul 82) ... 6

TAIWAN

New Nuclear Energy Agreement With U.S. Sought
(CNA, 5 Jul 82) 8

Progress in Searching for Oil, Uranium Reported
(CNA, 25 May 82) 9

Taiwan Power Company Buys French Uranium
(Taipei International Service, 30 Jun 82) 10

Taipower Negotiating Nuclear Fuel Reprocessing
(CNA, 22 Jun 82) 11

EAST EUROPE

CZECHOSLOVAKIA

CPCZ Weekly Assesses Nuclear Powerplants
(Rudolf Unger; TRIBUNA, 30 Jun 82) 12

Briefs
CSSR-Cuba Nuclear Power Cooperation 13

LATIN AMERICA

BRAZIL

Vice President Speaks on Nuclear Weapons, Military Updating
(FOLHA DE SAO PAULO, 18 Jun 82) 14

Government Official Tells War College of Nuclear Plans
(O ESTADO DE SAO PAULO, 2 Jul 82) 16

IPEN Produces Uranium Hexafluoride on Laboratory Scale
(JORNAL DO BRASIL, 25 Jun 82) 18

Nuclear Corporations Accused of Featherbedding
(FOLHA DE SAO PAULO, various dates) 20

Director Denies Charges
NUCLEBRAS Issues Note
Major Stockholder Speaks

MEXICO

Prospects in Nuclear Energy Development Outlined (Mexico City International Service, 9 Jul 82)	23
Briefs	
Fear Threat to Environment	24

NEAR EAST AND NORTH AFRICA

IRAN

Atomic Energy Official on Bushehr Powerplant (Tehran Domestic Service, 29 Jun 82)	25
--	----

IRAQ

Nuclear Program Viewed on Anniversary of Israeli Raid (AL-DUSTUR, 14 Jun 82)	26
---	----

ISRAEL

Briefs	
Nuclear Reactor Not Economical	28

SUB-SAHARAN AFRICA

SOUTH AFRICA

Comprehensive Nuclear Control Bill Introduced (DIE TRANSVALER, 27 May 82)	29
Official Describes Nuclear Security Council (Johannesburg Domestic Service, 29 Jun 82)	30
Fines Imposed for Failure To Observe Nuclear Safety Measures (DIE BURGER, 17 Jun 82)	31

USSR

Export of Nuclear Materials, Technology Enacted (FOREIGN TRADE, Apr 82)	34
--	----

WEST EUROPE

FEDERAL REPUBLIC OF GERMANY

Atomic Waste Storage To Be Ready in 1988
(FRANKFURTER ALLGEMEINE, 19 Jun 82) 39

FRANCE

Tore Supra Tokamak To Use New Superconductor Magnet Technique
(CEA NOTES D'INFORMATION, Jan-Feb 82) 40

Briefs
Paris Reports No Confirmation 55

ROK-CANADA SUMMIT TO EXPLORE MORE REACTOR SALES

SK060149 Seoul YONHAP in English 0133 GMT 6 Jul 82

[Text] Ottawa, July 5 (YONHAP) -- A senior external affairs source said Monday that additional Canadian sales of Candu nuclear reactors to South Korea would be a major topic of discussion at the forthcoming Korea-Canada summit talks scheduled for Aug. 28 to 31.

According to the source, the further promotion of bilateral commercial ties will be a major item on the summit agenda, and additional Candu sales will be brought up in that context. Two-way trade between Seoul and Ottawa reached 1 billion [no monetary unit supplied] in 1981, nearly 40 per cent more than in 1980.

The source said it was his understanding that Prime Minister Pierre Trudeau had specifically mentioned Ottawa's interest in further Candu exports to Korea in a personal letter to former Premier Yu Chang-sun sent early this year.

Canada has already sold a 678-megawatt nuclear power plant to Korea, which is now under construction at Wolsong in southeast Korea. Canada wants to sell Korea three additional Candu units costing about 1.5 billion [no monetary unit supplied] the source said Ottawa urgently needs to sell more Candu units as its multi-billion-dollar nuclear industry is on the verge of collapse for lack of export sales. It has not sold a nuclear reactor at home or abroad since 1978.

CSO: 5100/2212

INDIA

GANDHI: HEAVY WATER PRODUCTION TO DOUBLE

BK021717 Delhi Domestic Service in English 1530 GMT 2 Jul 82

[Excerpt] The prime minister has said that technical problems responsible for delays in heavy water plants have been identified. These are being rectified to raise production of this crucial nuclear material. Mrs Gandhi was speaking at the consultative committee of members of Parliament attached to the Departments of Space, Atomic Energy, Electronics, Science and Technology, Environment and Ocean Development. The meeting of the committee was held in New Delhi today.

Mrs Gandhi said the Kota heavy water plant will start producing reactor-grade heavy water before the end of the year. A target of 80 tons has been set for the production of heavy water by March 1983. The current production is 45 tons.

CSO: 5100/2212

INDIA

BRIEFS

URANIUM PRODUCTION TO DOUBLE--The nuclear fuel complex [NFC], Hyderabad, is to double its production of natural uranium from 100 tons to 200 tons annually. This is to meet the growing requirements of this vital input in nuclear powerplants. A spokesman of the complex said in Hyderabad that the expansion program will be taken up in October next. The spokesman said that the NFC is supplying fuel to three power units at Kalpakkam, Kota and Narora. It will soon start supply to Kakrapara plant in Gujarat. [Text]
[BK061410 Delhi Domestic Service in English 1230 GMT 6 Jul 82]

CSO: 5100/2212

AEC OUTLINES 10-YEAR NUCLEAR DEVELOPMENT PROGRAM

OW301217 Tokyo KYODO in English 1208 GMT 30 Jun 82

[Text] Tokyo, June 30, KYODO -- Japan's Atomic Energy Commission (AEC) Wednesday decided on a 10-year nuclear power development program aimed at developing fast breeder reactors for practical use around 2010.

The AEC, headed by Ichiro Nakagawa, cabinet minister and chief of the Science and Technology Agency, compiled the sixth long-term project after reviewing the present plan worked out in 1978. Officials said the new program was mapped out in view of inflated expectations for stabilized supply of nuclear power.

The new long-term plan, budgeted at yen 5,400 billion (at 1982 prices), estimates nuclear power in fiscal 1990 at 46 million kilowatt-hours (KWH), rising to 90 million KWH in fiscal 2000.

It recommends that the next-generation fast breeder reactor be brought into commercial operation by around 2010, and that 3,000 SWU (separative work unit) tons of enriched uranium be produced domestically annually by around the year 2000.

The AEC also proposed full utilization of plutonium through the advanced thermal converter reactor and the light-water reactor by 1990.

It looked forward to private industry's positive collaboration in building and running these plants, and suggested that the time has come for Japan to consider exporting nuclear power technology and related equipment.

With these prospects in mind, the AEC emphasized the need for the nation to promote a nuclear nonproliferation policy.

CSO: 5100/2212

BRIEFS

NUCLEAR REACTOR IN OPERATION--Malaysia entered the nuclear era today when scientists at the Tun Ismail Atomic Center [PUSPATI] in Bangi regulated for the first time the operations of its reactor. Minister of Science, Technology and Environment Datuk Amar Stephen Yong was present at the event this evening. Works to start off the chain reaction fission of the reactor was carried out under the supervision of the contracting firm, General Atomic Company, and an official from the International Atomic Energy Authority, IAEA. Datuk Amar Stephen said the event is significant to the country as the PUSPATI reactor is officially in operation for the first time. It also marked the development of science, especially in nuclear technology. Further works to test the reactor would take at least another 2 weeks.
[Text] [BK281600 Kuala Lumpur Domestic Service in English 1130 GMT 28 Jun 82]

CSO: 5100/2212

'MORNING POST' REVIEWS PRC NUCLEAR DEVELOPMENT

HK070226 Hong Kong SOUTH CHINA MORNING POST in English 7 Jul 82 p 8

[By Foreign Affairs Editor David Chen]

[Text] The People's Liberation Army, which is undergoing extensive overall modernization, may now have tactical nuclear weapons in its arsenal, according to the Japanese news agency, JIJI.

In a dispatch from Beijing, the agency quoted the opinion of military analysts who examined a photograph published in a provincial newspaper, depicting a military exercise somewhere in the deserts of the Ningxia Hui Autonomous Region, in northwest China. The picture shows a mushroom cloud billowing from the desert hills and the caption to that picture says: "An 'atomic bomb' exploding deep in the ranks of the 'enemy.'"

The agency quoted Western military analysts in Beijing as saying that although the incident was "simulated," the exercise and the picture did indicate that China had already successfully developed small-scale tactical nuclear weapons and probably already had a certain number of such weapons in its arsenal.

Military analysts in Hong Kong said yesterday several exercises had taken place, particularly in the north and northwestern regions of China in the past year, but the Ningxia exercise, which was held in the second half of last month, appeared to be the biggest since the full-scale combined exercise in the hilly region of Zhangjiakou, 200 km northwest of Beijing, last September, when 200,000 troops took part.

A short report accompanying the picture said, in addition to the use of "atomic bomb," tactical fighters and bombers as well as rapid-firing rockets were also employed in the exercise. The exercise, the report went on, fully demonstrated the special qualities of modern warfare and the ability of the PLA to engage in such military conflicts.

Ningxia is a strategic autonomous region bordering on the People's Republic of Mongolia, where the Soviet Union stations several divisions. It is a part of the important border military region of Lanzhou, named after the provincial capital of Gansu Province. Only a month ago, Chinese television showed a full-dress parade in Lanzhou, with the participation of infantry, tank, artillery and missile units. The Lanzhou region is also the area where many of the army's missiles are tested.

In the middle of last year, China tested its first full-range ICBM with the successful launching of at least two such missiles into the southwestern Pacific. It was from the Lanzhou region, of which Ningxia is a part, that these missiles were launched.

The regional commander is General Du Yede, who took over from General Han Xianchu less than three years ago. Its political commissar is General Xiao Ke, another seasoned officer.

Development of the nuclear arsenal, including tactical weapons, is vested in the former Second Ministry of Machine Building Industry, now renamed the Ministry of Nuclear Industry. Although the personnel of the ministry changed drastically during and after the Cultural Revolution, scientists engaged in the development of nuclear devices have largely been left alone. They included the "father of China's atomic bomb," Dr Qian Sanqiang.

Until recently, the ministry was headed by an army officer, General Liu Wei. Since the reshuffle early this month, it has been headed by a woman scientist, 59-year-old Miss Zhang Zhen.

China first exploded a nuclear device at Lop Nor, southern Xinjiang, in October 1964. Since then, it has built up a sizeable arsenal of nuclear weapons, making it possibly the third largest nuclear power in the world.

The development of tactical nuclear weapons, if military analysts' assessments are correct, will represent a major step in this branch of weaponry.

Although not a signatory of the nuclear-ban treaty, China advocates disarmament of nuclear weapons.

CSO: 5100/2212

NEW NUCLEAR ENERGY AGREEMENT WITH U.S. SOUGHT

OW050405 Taipei CNA in English 0302 GMT 5 Jul 82

[Text] Taipei, 5 Jul (CNA) -- The government is actively cooperating with both the United States and Europe to push for the peaceful use of nuclear energy, according to the Atomic Energy Council of the Executive Yuan. In a report to Premier Sun Yun-hsuan Sunday the council revealed that the government is now drafting a new nuclear energy cooperation agreement with the United States in an attempt to speed up the use of nuclear energy in Taiwan. The Republic of China and the U.S. signed a cooperation agreement in 1955. The agreement is good for 40 years. It was amended once, in 1974. Cooperation with the U.S. has a great bearing on the research and development in the peaceful use of nuclear energy in Taiwan, the council reported.

The government sent experts to the United States and Belgium to study the use of nuclear energy and the technology behind safe stockpiling of nuclear waste. In addition, the government has invited experts from the U.S., Switzerland, Belgium and West Germany to give advice on nuclear energy use and to map out nuclear energy policies for reference. The government has sent and is continuing to let local experts make advanced studies on the possible course and take part in various training programs on how to achieve the safe use of nuclear power generation.

CSO: 5100/2212

TAIWAN

PROGRESS IN SEARCHING FOR OIL, URANIUM REPORTED

OW251011 Taipei CNA in English 0942 GMT 25 May 82

[Text] Taipei, 25 May 9CNA) -- The Republic of China, in an effort to ensure a stable supply of energy, has made significant progress in the search of oil and uranium in collaboration with foreign concerns.

Government sources said this nation has signed or is going to sign contracts on exploration of oil with the Philippines, Indonesia, the United Arab Emirates and the Marshall Islands. The state-run Chinese Petroleum Corp. (CPC) is also studying the feasibility of prospecting oil off the Ivory Coast.

In the development of uranium, CPC, Taiwan Power Company, and another government enterprise have started exploration work in Paraguay together with two companies from the United States and South Korea.

The sources said the joint venture in a Philippine oil zone started its drilling operations last month, while the survey work on Luzon, the chief island of the Philippines, is under way. Preliminary survey at an oil zone in Indonesia has been completed by CPC and seven other foreign companies, and international bidding will be made in July.

CPC's subsidiary firm, Overseas Petroleum and Investment Corp. (OPIC), has recently obtained a share in prospecting oil in the United Arab Emirates. OPIC has also signed a contract with authorities of the Marshall Islands on oil survey, and a contract on oil exploration is expected to be concluded in the near future.

This nation depends heavily on imports for its oil supply, and the government has been making strenuous efforts to explore oil at home and abroad. In addition, the government is also encouraging the development of alternate energy and conservation of energy. Official statistics show that this nation's consumption of oil and oil products last year dropped 7 percent from the preceding year, while the use of coal and other alternate energy was on the rise.

CSO: 5100/2212

TAIWAN

TAIWAN POWER COMPANY BUYS FRENCH URANIUM

OW041100 Taipei International Service in English 0100 GMT 30 Jun 82

[Text] The Taiwan Power Company has recently signed an agreement with COGEMA (Compagnie Generales des Materiaux Nucleaires) of France for the purchase of \$300 million worth of concentrated uranium for its nuclear power generation project. As soon as the agreement is approved by the French and the Chinese Governments, the purchase will be considered confirmed. According to specialists, the concentrated uranium supplied by France will be able to fuel a nuclear power plant with twin 1-million-kilowatt generators for 20 years.

CSO: 5100/2212

TAIWAN

TAIPOWER NEGOTIATING NUCLEAR FUEL REPROCESSING

OW220317 Taipei CNA in English 0252 GMT 22 Jun 82

[Text] Taipei, June 22 (CNA)--The Taiwan Power Company is negotiating with the French Company COGEMA (Compagnie Generales des Materiaux Nucleaires) to reprocess the spent fuel from the nation's nuclear power plants, which will exceed the storage capacity of each plant within 10 to 15 years, according to the utility's chairman, L.K. Chen. In a report to the Legislative Yuan, Chen said some of the reprocessed waste will be reused and the rest dumped. He declined to say where the reprocessed products would be used or to give any details on the talks. He stressed the products will not be used to make nuclear weapons.

COGEMA is a fully owned subsidiary of the French Atomic Energy Commission (CEA). It offers supplies and services for every stage in the nuclear fuel cycle, from concentrates uranium enrichment, fuel manufacture, in-core management, to transportation and reprocessing. In the last field, it is believed to be the most successful firm in the world. It also offers consultancy services for industrial projects at every stage of the nuclear cycle.

CSO: 5100/2212

CPCZ WEEKLY ASSESSES NUCLEAR POWERPLANTS

AU071513 Prague TRIBUNA in Czech No 26, 30 Jun 82 p 13

[Rudolf Unger article: "Program for the Future; Energy at the Crossroad"]

[Excerpt] Our reserves of steaming [energeticke] coal will be exhausted approximately in the year 2020, but already as early as the year 2000 they will actually begin to decrease. This reality is not only of great importance for the sphere of fuel, but also for the sphere of energy, since 11,800 MW of the current production of our energy system comes from thermal powerplants, 2,622 MW from hydroelectric powerplants and 880 MW from a nuclear powerplant. The logical consequence of the gradual reduction of the extraction of steaming coal also is the end of the historical era of the construction of thermal powerplants burning fossil fuels. The last "monuments" of this epoch are the Melnik "fivehundereder" and the individual blocks of the Prunerov II powerplant, which will go into operation this year.

In recent years our dependence on imported crude oil has been reflected in the sums allocated in the budget for the purchase of this priceless and vitally important liquid. However, the increased worldwide publicity surrounding prices of crude oil should not create the illusion that the generation of electricity from domestic resources -- be it coal or uranium ore -- costs next to nothing. If, for example, the construction of the Tusimice II powerplant with the installed capacity of 800 MW costs the state treasury more than Kcs4 billion, today's calculated price of the Temelin nuclear powerplant with the installed capacity of 4,000 MW already exceeds tenfold the cost of the Tusimice powerplant. The exceptional importance of this project is attested to not only by the Kcs50 billion allocated by the budget, but also by the concentration of this sum on an area of 240 hectares, where more than 10,000 construction and assembly workers will be deployed in the peak construction period.

The influence of energy generated by coal burning on the immediate as well as more distant environment is monumental, but at the same time also short-lived. Emissions from a powerplants' chimneys can -- by their omnipresence -- make the life of the population far and wide unpleasant and also considerably affect flora. But it is enough to halt the powerplant's operation and the skies above are azure blue again.

The ecological problems of nuclear engineering are different. Even during the full operation of the V-1 nuclear powerplant only a slight, white odorless little cloud leaves its chimney, and there is no fallout of solid particles. However, the storage of radioactive wastes, which result from the powerplant's operation and whose [radioactive] life is between 100 and 500 years, requires more attention and care. These wastes are temporarily stored in concrete blocks in the area of the powerplant, but for the future two regional storage places of radioactive wastes are being prepared -- in the Dukovany area for the Czech Socialist Republic, and in the Mochovce area for the Slovak Socialist Republic. The construction of the storage place, locating it in slightly permeable to impermeable soil, and the transformation of the wastes into solid matter create adequate safeguards against the escape of radioactive products into the vicinity of the storage place for the required safety [ochranna] period.

CZECHOSLOVAKIA

BRIEFS

CSSR-CUBA NUCLEAR POWER COOPERATION--First Deputy of the Ministry of Fuels and Power M. Rusnak met on 5 July with the director of the Cienfuegos, Cuba, nuclear power station J. C. Castro Palomino. Palomino has been in Prague on a study trip. Discussed was intensification in mutual cooperation between the CSSR and Cuba in the area of nuclear power. [Prague SVOBODNE SLOVO in Czech 6 Jul 82 p 4]

CSO: 5100/3025

BRAZIL

VICE PRESIDENT SPEAKS ON NUCLEAR WEAPONS, MILITARY UPDATING

Sao Paulo FOLHA DE SAO PAULO in Portuguese 18 Jun 82 p 5

[Text] Rio--The Brazilian Government's position on not developing atomic weapons is "implicit" in the nuclear agreement signed with Germany "but we have never said anything explicitly on that up to now," declared Vice President Aureliano Chaves yesterday. He refused to say whether or not Brazil intends to produce an atomic bomb in the long term, saying that "forecasts of the future cannot be made."

Aureliano Chaves recalled that Brazil is not a signatory of the Nuclear Arms Nonproliferation Treaty (NPT-1968) and that the treaty for banning nuclear weapons in Latin America (Tlatlelolco, 1967), which was signed by the country, has not yet been ratified. However, in the nuclear agreement with Germany, Brazil pledges to "use nuclear development for peaceful means" only.

The vice president, who with Minister of Navy Maximiano da Fonseca witnessed military exercises from on board the aircraft carrier "Minas Gerais," added that "More important than a declaration is a peaceful behavior and we have a behavior and a formal position in favor of peace and the peaceful solution of differences between countries."

Aureliano defended the "updating of the Armed Forces to the dimension and responsibilities Brazil has in the world today," qualifying this, however, by saying: "That does not mean the proposal of any arms race." To him "the basic problem for an armed force is the creation of technology for obtaining a certain degree of independence with respect to foreign equipment."

Position of Integrity

As far as Minister Maximiano de Fonseca is concerned, the fabrication of an atomic bomb "is simple, providing you have the raw material, which is enriched uranium." Pursuant to the agreement with Germany, however, Brazil cannot use German technology or the enriched uranium, fuel for the nuclear powerplants, for the production of bombs. It also agreed to submit to the supervision of the International Atomic Energy Agency.

Naval Aviation

"The great dream of the Navy is to have its own naval aviation," declared Minister Maximiano da Fonseca, who pointed out the importance of providing the aircraft carrier "Minas Gerais" with attack and intercept aircraft. At this time the aircraft carrier, the flagship of the fleet, has only six antiquated aircraft (American twin-engined P-16's) for antisubmarine missions, flown by officers of the Air Force.

According to the minister, the War of the Malvinas brought no lessons in terms of military usage but demonstrated that "a naval force without protection is sentenced to death." Maximiano said that the Navy "always claimed the right to operate the aircraft on board the 'Minas Gerais'," but has no interest in raising the question at this time because of a lack of resources and because he "maintains an excellent relationship with the minister of air."

8908

CSO: 5100/2206

BRAZIL

GOVERNMENT OFFICIAL TELLS WAR COLLEGE OF NUCLEAR PLANS

Sao Paulo O ESTADO DE SAO PAULO in Portuguese 2 Jul 82 p 29

[Text] The president of NUCLEBRAS [Brazilian Nuclear Corporations], Ambassador Paulo Nogueira Batista, declared yesterday that Brazil will be producing 60 tons of enriched uranium in 1986 and that in 1988 that capability will be raised to 300 tons per year. He also announced that NUCLEBRAS will begin to build its separative elements plant in Resende to produce its own "nozzles" and other equipment for the uranium enrichment plant.

Nogueira Batista also reported that next year NUCLEBRAS will begin the construction of the reprocessing plant, but refused to name the place where it will be installed. In a lecture at the War College [ESG], he declared that the nuclear agreement with Germany is a "package" in which the advantages to both sides were balanced harmoniously and for that reason there cannot be only a partial compliance by either of the parties.

That would mean, said the president of NUCLEBRAS, that the preservation of the agreement only in that which has to do with the transfer of fuel cycle technology, with the complete or even partial cancellation of the powerplant program, "a proposal made by some in good faith and by many with malice, would jeopardize the balance which is the great characteristic of the agreement, making its implementation unworkable."

Enrichment

For the first time, the president of NUCLEBRAS answered questions on the uranium enrichment process, saying that he does not have the slightest doubt that the "jet nozzle" system will work well and in a competitive manner compared to other processes such as gaseous diffusion and the ultracentrifuge.

Nogueira Batista said the "nozzle" process is not yet producing enriched uranium in Germany and that "it makes no sense to produce it on a laboratory scale because it would be uneconomical." He pointed out, however, that as of 1986 it will be producing on an industrial scale and that the last word on the economy of the process will be given in 1988 with the conclusion of the third phase.

He added that an initial cascade of 24 stages will be built first, using hydrogen as the conducting gas. Parallel with that unit, another will be built with a reduction of the "nozzles" to 100 micros, which represents "an improvement." That second unit will not use hydrogen but helium. Coupled to that industrial unit will come the third phase, which should be finished in 1988, using another system called "double deflation," also using helium gas.

8908

CSO: 5100/2206

IPEN PRODUCES URANIUM HEXAFLUORIDE ON LABORATORY SCALE

Rio de Janeiro JORNAL DO BRASIL in Portuguese 25 Jun 82 p 22

[Text] Sao Paulo--For the first time Brazil managed to produce a reasonable amount of uranium hexafluoride (UF6), the final raw material for the manufacture of the fuel for atomic powerplants. The material was processed by the IPEN--Nuclear and Energy Research Institute--in Sao Paulo, which already has a stock of nearly 50 kilos of the product.

This atomic material was produced on a laboratory scale, using an equally unusual prototype in the country, built by technicians of this institute for the production of fluorine, the basic ingredient for obtaining UF6. The program underway at the IPEN foresees the construction by 1984 of a pilot plant capable of producing up to 25 kilos of uranium hexafluoride per hour.

New Products

The IPEN, an agency linked to the Secretariat of Industry, Commerce, Science and Technology of the State, and to NUCLEBRAS, began this project from zero, since there was nothing of the type in the country or for sale abroad. The help of foreign technicians was required in the construction phase of the plant and even those services could not be provided at the desired rate because of a delay in the release of state funds in the first three months of this year.

In the technical area, according to the explanation by the superintendent of the institute, Hernani Lopes Amorim, the great problem was arriving at the production of fluorine.

"Up to then it was not done in Brazil and that which is used by industry came from abroad. It happens that there is no technology for sale abroad either and no one is willing to teach it," explained Amorim.

Thus, initially, the technicians built a device of electrolytic cells of 50 amperes each. Little by little more powerful prototypes were developed, it being possible to arrive at a 400-ampere unit which produced fluorine, which allowed the processing of uranium hexafluoride.

More than about the UF₆ itself, Hernani Amorim is euphoric about learning the technology of fluorine because of its propagating effect. The reason for this is that it will allow research, on a separate line, on sulphur hexafluoride (also inexistent in the country), which is the most advanced material for use in high voltage switches and transformers, replacing dielectric oil.

Uranium hexafluoride is the indispensable element for the fabrication of nuclear weapons, but this detail is a forbidden subject in conversations at the IPEN. In the first weeks of August, a 1,000-ampere fluorine device will be tested. In order for the plant to operate, six units of this same power will be necessary, or three 2,000-ampere units or a single 6,000-ampere unit.

The plant, which will be located on the University of Sao Paulo (USP) campus, will go into operation in March 1983, operating at below its technical capacity, however. In the following 12 months, the process will be improved until it will be possible to produce 25 kilos of UF₆ per hour, which will be the nominal capacity of the plant. The product will allow NUCLEBRAS to proceed to produce pure nuclear fuel in another plant which is now being built in Resende (Rio de Janeiro).

Pilot Plant Initiated 2 Years Ago

Sao Paulo--The work of creating and installing the IPEN uranium hexafluoride pilot plant was begun nearly 2 years ago. The team was put together by Professor Alcidio Abraao, former researcher of the institute's staff, who after the beginning of those services appointed the industrial director, Jose Adreatta, who should finish the program in March 1984, chief of the group. This is one of the most important and largest IPEN teams. It has more than 100 technicians and scientists, including some from abroad, "because we had nothing, we had to use information contained in existing bibliography," explained the superintendent of the institute, Hernani Amorim.

At this time, those foreign specialists are no longer members of the team installing the plant in the IPEN area--on the USP campus--in a building of its own which is being built near the site where uranium dioxide is being produced for the CNEN [National Nuclear Energy Commission].

8908

CSO: 5100/2206

NUCLEAR CORPORATIONS ACCUSED OF FEATHERBEDDING

Director Denies Charges

Sao Paulo FOLHA DE SAO PAULO in Portuguese 22 Jun 82 p 1

[Text] "Like all state companies, we have an excessive number of employees. At this time our staff consists of 3,000 people, of whom 1,800 perform essential activities," the director of NUCLEBRAS [Brazilian Nuclear Corporations], Nei Freire de Oliveira Junior, admitted in Sao Paulo yesterday.

He denied, however, that the maintenance of a surplus of 1,200 employees means "featherbedding in NUCLEBRAS." What exists, he argued "is that all state companies are infected by the virus of bloat; that is the Brazilian reality."

NUCLEBRAS Issues Note

Sao Paulo FOLHA DE SAO PAULO in Portuguese 23 Jun 82 p 21

[Text] With respect to statements made by its director Nei Freire de Oliveira Junior published in yesterday's edition of FOLHA, NUCLEBRAS released the following official note:

"NUCLEBRAS declares that the report published today (yesterday), the 22nd, in a Sao Paulo newspaper on the surplus of personnel in the company has no basis in fact.

"Despite the fact that it is a young company with a recently increased area of responsibility, NUCLEBRAS has been exercising a policy of austerity in matters of personnel, both in that which refers to quantity and that which refers to levels of remuneration for its employees, who are paid only 13 wages [meaning unclear].

"Examples of that concern may be found in the decision by the company to make periodic adjustments in its staff of workers, as happened in 1981 when 20 percent of the employees were dismissed, and recently by the introduction of efficiency evaluations, pursuant to which for every 10 employees there were two dismissals for every four promotions. The use by the company of audits to determine attendance is another instrument which reveals the orientation toward austerity mentioned above.

"NUCLEBRAS, as is of public knowledge, is, on the other hand, seeking to impose a model of overall work in contracting construction or installation at firm prices and deadlines which would automatically reduce the need for a structure heavy with management and supervisory personnel, contrary to what happens in contracts through administration.

"Without the pretension of having reached the desired level in the use of its human resources, an objective which the phase of establishing itself makes more difficult for the company, NUCLEBRAS believes it is proceeding with a consistent and continued activity in that direction."

Editor's Note: FOLHA restricted itself in its edition yesterday to publishing the words of NUCLEBRAS Director Nei Freire de Oliveira Junior. During a talk he gave at the "Symposium on Management," sponsored by the Enterprise Management Study Group, at the Hilton Hotel, he said verbatim: "At this time our staff consists of 3,000 people, of whom 1,800 perform essential activities." The director added that "all state companies are infected by the virus of bloat; that is the Brazilian reality."

Major Stockholder Speaks

Sao Paulo FOLHA DE SAO PAULO in Portuguese 25 Jun 82 p 34

[Text] "For what little it does, NUCLEBRAS should have 400 to 500 employees and not a staff of 3,000 persons," declared Physicist Romulo Ribeiro Pieroni, who is the major private stockholder (person of NUCLEBRAS, Pieroni was director of the IEA (Atomic Energy Institute, the unit which preceded the present IPEN--Nuclear and Energy Research Institute) in the period from 1961 to 1979.

According to Ribeiro Pieroni, "There is no effective research in NUCLEBRAS, whether it be of a scientific or technological nature. We received the completed project from Germany, we simply executed it." In addition to that, he declared, "Ninety percent of the 3,000 employees only learned of the term 'nuclear energy' when they became part of the staff of that state company."

According to him, who has followed the phase of the implantation of nuclear programs in various parts of the world, the Japanese fuel element plant itself, which is owned by Mitsubishi, has only 71 people working in it. In 1973, when Japan had nine thermonuclear powerplants in operation, the number of people involved in nuclear activities was fewer than 2,000, he said. Pieroni made it a point to point out, however, that these numbers refer to 1973. The situation remains unchanged because Japan has not significantly increased the number of thermonuclear powerplants in commercial operation.

Romulo Ribeiro Pierono explained that even as a stockholder in NUCLEBRAS--he underwrote 20,000 of the 1 million shares that NUCLEBRAS inherited from its predecessor, the Brazilian Nuclear Technology Company--he is not notified of the dates on which company meetings are held. That is why, even without having a deep knowledge of what is going on in the state company, he is of the opinion that almost all its employees perform bureaucratic or pseudotechnical functions.

"The most that a few employees do is to study the German project of the KWU Siemens without proposing any changes because that would mean the promotion of structural changes in the equipment provided by the KWU, which obviously is not of interest to the Germans," he concluded.

8908

CSO: 5100/2206

PROSPECTS IN NUCLEAR ENERGY DEVELOPMENT OUTLINED

PA111250 Mexico City International Service in Spanish 0200 GMT 9 Jul 82

[Text] Jose Andres de Oteyza Fernandez, secretary of patrimony and industrial development, once said that the nation's proven uranium reserves, calculated to be 8,993 tons, would suffice only to fuel the Laguna Verde nuclear plant for its productive life of 30 years.

Uranium exploration in Mexico began in 1957. To date, the areas being mined are located in the states of Chihuahua, Nuevo Leon, Tamaulipas, Coahuila, Zacatecas, Queretaro and Puebla. However, regions where conditions favor the formation of uranium and that should be investigated include more than half of the nation's territory, according to experts in the field.

The national uranium exploration program began under difficult conditions, in financial and economic terms. Between 1957 and 1970 the government invested only about 8 million pesos a year in the investigation, exploration and mining of uranium. Some 24 million pesos was invested in 1972 and 35 million was invested annually for the next 2 years; 76 million was invested in 1975, 50 million in 1977, 40 million in 1978, 250 million in 1979 and 390 million in 1980. The national energy program drafted by the Patrimony and Industrial Development Secretariat foresees the production of 4,780 tons of uranium from 1982 to 1991. The stored uranium will serve to initiate the operation of the country's first nuclear reactor in 1985 at Laguna Verde, Veracruz. This plant will supply electricity to meet the nation's requirements, thereby avoiding a total dependence on oil. Construction of Laguna Verde began in 1973 with the expectation that it would begin operating in 1978. Due to financial difficulties, however, the program was pushed back; according to latest reports, the plant will be in operation soon.

The national energy program envisages that Laguna Verde will produce 5.18 percent of the total electricity generated in Mexico by 1985. Currently, Laguna Verde works is 40 percent behind schedule. The delay has caused the cost of the project -- originally 4 billion pesos -- to have risen to approximately 75 billion. The government's growing interest in nuclear energy will permit this to become the second most important source of electricity in the country.

CSO: 5100/2212

BRIEFS

FEAR THREAT TO ENVIRONMENT--Mexico City, 30 Jun (NOTIMEX)--Mexico maintains the view that nuclear military arsenals are a threat to the environment and to the security of the species, the Foreign Relations Secretariat announced today. The Mexican Foreign Secretariat indicated that Mexico has always participated actively in efforts to guarantee ecological and environmental preservation, both of which are vital to the development of mankind. The secretariat noted that it has urged governments and the international community to strive to curb the arms race "in order to prevent further deterioration of the environment." It added that the greatest danger to ecology is the possibility of a worldwide conflagration. [By Mario Luis Altuzar] [Excerpts] [FL011245 Mexico City NOTIMEX in Spanish 0158 GMT 1 Jul 82]

CSO: 5100/2212

IRAN

ATOMIC ENERGY OFFICIAL ON BUSHEHR POWERPLANT

LD291203 Tehran Domestic Service in Persian 1030 GMT 29 Jun 82

[Text] The head of the atomic energy organization of Iran, who had visited France and Switzerland, took part in an interview with IRNA after returning to Tehran.

Concerning the results of his trip, he said: During this trip, as we expected, the local court passed a verdict in Iran's favor with regard to the problems of the Bushehr powerplant and according to this verdict 35,000 tons of equipment intended for the Bushehr atomic powerplant and half of the fuel needed by the plant as well as many parts and machinery will be put at Iran's disposal.

The head of the atomic energy organization added: If the Majlis decides that the atomic powerplant should be completed, the equipment and the machinery will be used in that plant. Anything not needed may be used in other projects.

Concerning the Eurodif company, he said: During the years before the Islamic revolution, Iran put \$1 billion as a loan at the disposal of the French atomic energy commission and the Eurodif company is a part of the commission. In addition, he said, as our contribution, Iran has paid more than half a billion francs to the Eurodif company.

The head of the atomic energy organization then said: In my recent trip to Paris, I again asked about Iran's money and what they have done with it but they did not give us a clear answer. In spite of the verdict of the court of appeals in Paris, the aforementioned company has refused to comply with the verdict.

CSO: 5100/2212

NUCLEAR PROGRAM VIEWED ON ANNIVERSARY OF ISRAELI RAID

London AL-DUSTUR in Arabic No 238, 14 Jun 82 p 125

[Article: "They're the Ones Watching Now"]

[Text] Iraq asserted that no power can sabotage its efforts at scientific and technical progress within the framework of its announced peaceful objectives. So said a newspaper bulletin issued by Iraqi cultural centers in Europe on the 1-year anniversary of the Zionist attack on Iraqi nuclear reactors.

In London, Sa'd al-Bazzaz, the Iraqi press advisor and press spokesman at the Iraqi Embassy in London, issued a statement in which he alluded that Iraq was on its guard on various occasions against far-reaching Zionist plots to place Iraq strategically within the scope of these plans. He said that Iraq called for Arab solidarity toward these efforts.

The press spokesman said the Zionist entity's success in striking blow after blow should not be attributed to any special capability on its part, or to the back of imperialist powers, as much as it is to the disarray of Arab ranks. Israeli official spokesman have stated publicly that they have provided military aid to Iran on the basis of their understanding that Iran is their natural ally, and that they are concerned that the Iranian regime should not be defeated in the ongoing war. Similarly, they are anxious to see the Iraqi army removed from direct confrontation with Israel. Despite the realization of this truth by all parties and their indication of its in their efforts to stop the war between Iraq and Iran, the Khomeyni regime still insists on continuing the war and cooperating with Tel Aviv against Iraq and the Arab parties concerned with confronting the Zionist enemy to standup in solidarity with Iraq and free its forces from their commitments in the Iranian front. But certain of these parties have done just the opposite by inciting Khomeyni to carry on the war with Iraq. Tel Aviv is backing them with war material, money and troops.

When Zionism undertook its new aggression, those so-called Arabs, who stood by and watched the day the Iraqi nuclear reactor was hit and helped the Khomeyni regime with the Zionists, now stand by and watch the annihilation of the Lebanese and Palestinian peoples while their forces stand only a few meters from the battlefield. They watch Lebanon get torn apart as they enter into an unholy alliance with the Zionist entity. New shame covers the Syrian regime. Every day exposes documented evidence of its treachery and its role of sabotage.

The press spokesman's statement said that, on the first anniversary of the shelling of the nuclear reactor, Iraq asserts that no power on earth can sabotage its efforts at scientific and technical development within the framework of its publicly-stated, peaceful objectives. The world is wary of the Israeli nuclear policy bent on aggressive goals and exposing the world's safety to danger. All powers call on the greedy heads of the Zionist entity to adhere to the nuclear non-proliferation treaty and other international obligations that impose inspection and supervision of operations in the anterooms of the Zionist nuclear reactors. Despite the desertion of lowly Arabs and the cooperation of Tel Aviv with Tehran, Iraq remains a symbol of the Arabs's determination to achieve rebirth, independence and progress.

In Athens, Na'il 'Abd-al-Jabbar, Iraqi press attache in Greece, issued a statement on the same occasion which reaffirmed that the treacherous attack on the Iraqi nuclear reactor is considered to be an affront to the most elementary rules of international behavior. It called on the Free World to make a resolution to suppress Zionist attacks on the Arab nation.

The statement added that the cooperation of certain enfeebled Arab regimes with the Persian regime, and their material and morale support of it at a time when all the evidence points to pre-planned and documented cooperation between the Zionist entity and the Persian regime in striking at Iraq, indicate the magnitude of this conspiracy which aims at suppressing the truth.

The statement said that those Arabs who stood by and watched when the Iraqi nuclear reactor was hit, today also watch as the Zionist enemy occupies new Arab territory in Lebanon. The statement asserted that Iraq will remain steadfast and strong, and that the treacherous Persian and Zionist forces will be unable to kill Iraq's spirit of victory and alter its triumphant course towards scientific and technical progress.

9945
CSO: 5100/4725

ISRAEL

BRIEFS

NUCLEAR REACTOR NOT ECONOMICAL--A special committee appointed by the energy minister thinks it will not be economical to build a nuclear power reactor made in Israel because it will cost two or three times as much as such a reactor purchased overseas. This was discovered by our correspondent Gadi Sukenik. The committee was appointed in order to examine all the aspects pertaining to building nuclear power reactors in Israel and is headed by Technion President 'Amos Horev. The committee convened this week for its final session and in a month will present its conclusions. [Text]
[TA010757 Jerusalem Domestic Service in Hebrew 0700 GMT 1 Jul 82]

CSO: 5100/4726

COMPREHENSIVE NUCLEAR CONTROL BILL INTRODUCED

Johannesburg DIE TRANSVALER in Afrikaans 27 May 82 p 4

Text Capetown--A comprehensive draft legislation for controlling all atomic or nuclear matters was published here yesterday.

The draft legislation on nuclear energy, which consists of 84 clauses, has provisions for the establishment of a Nuclear Energy Corp of South Africa and a Council for Nuclear Safety.

The Nuclear Energy Corp of South Africa will be doing research in the area of nuclear or atomic energy and undertake the production of nuclear or atomic energy for the purpose of enriching, processing and reprocessing source material and special nuclear material, according to the legislation. It will also exercise control over certain nuclear activities in the republic.

The Council on Nuclear Safety will have the responsibility of advising the corporation on nuclear licensing and it will also have responsibility in matters pertaining to safety and health connected with the building and using of nuclear installations and the storage and transportation of dangerous nuclear material.

Submarine

In compliance with the legislation, no ship or submarine propelled by nuclear power, or having dangerous nuclear material on board, shall proceed to South African territorial waters or to a South African port without obtaining a nuclear license from the corporation.

An important stipulation in the draft legislation provides for the accountability regarding nuclear damages. The procedures which must be followed in the event of such nuclear accidents are therein described, while it is also established that the corporation will keep records of the names of all persons who have found themselves in an ascertained area of risk during or after a nuclear accident.

7964

CSO: 5100/5674

OFFICIAL DESCRIBES NUCLEAR SECURITY COUNCIL

MB290808 Johannesburg Domestic Service in English 0500 GMT 29 Jun 82

[Text] The new executive of the Atomic Energy Corporation, Dr Wynand de Villiers, says an independent council which will control all security arrangements for all nuclear installations in the country is soon to be created. Addressing the Pretoria Press Club, he said it would be known as the Council for Nuclear Security.

It would function separately from the Atomic Energy Corporation, and the staff of the corporation, of its affiliates, or of the electricity supply commission would not be allowed to serve on it. He said the council would have the power to veto the license application of any nuclear installation, and would advise the government on all aspects of nuclear security.

Dr de Villiers said it was essential that a nuclear development program be established for South Africa as soon as possible. This would be one of the tasks of the corporation, which would come into existence this week, as part of the rationalization of the country's nuclear industry. He said he believed it would be profitable to establish plants like Koeberg in the eastern Cape and on the Natal coast in the foreseeable future. Dr de Villiers said that work on the Koeberg plant was progressing according to plan, and it would begin producing nuclear energy in the second half of the next year, 6 and 1/2 years after the project was launched. This was quite an achievement if it was considered that on average it took 12 years to establish a nuclear powerplant in the United States.

CSO: 5100/2212

FINES IMPOSED FOR FAILURE TO OBSERVE NUCLEAR SAFETY MEASURES

Capetown DIE BURGER in Afrikaans 17 Jun 82 p 13

[Text] A Kempton Park company which is using accelerated radioactive sources for inspection purposes, as well as a director and an employee of this company, were fined the day before yesterday by the Capetown District Court for the respective sums of 2,400, 200 and 500 rand.

The accused have violated the Atomic Energy Act as a result of not having complied with certain conditions attached to the authorization for using radioactive material for inspection purposes.

This case ensues from an incident of last year when an isotope at the Salt River power station was being used by an unauthorized person who lost the isotope in a steam kettle. He was inspecting a welded seam.

Melvin John Freeman (35) of Evandale, the director of Industrial Inspection (Pty) Ltd, appeared in court in the name of the company and in his own capacity. Freeman was fined 200 rand; a worker of the company, Paul Michael Stone (34) of 9 Washington St, Claremont was fined 500 rand and the company was given fines totaling 2,400 rand.

The accused appeared in court on the following charges:

On 22 April of last year they permitted an unauthorized person, a radiographer apprentice, a certain Mohammed Gaffor, to practice industrial radiography at the Salt River power station without the necessary supervision.

Gaffor was not given a medical inspection and declared medically fit for the work which he had performed.

Nothing was done to provide Gaffor with a pocket dosage meter. A pocket dosage meter is a safety instrument forming a part of the equipment of a radiation worker.

Stone failed to notify the responsible person and the owner of the premises that radioactive material was missing, or alternatively, that those found guilty failed to notify the Atomic Energy Board that the isotope was missing and neglected to take immediate measures to recover the isotope.

Those guilty had failed to maintain a logbook.

Sentence

Two of the charges (5 and 6) against all three of the accused were withdrawn.

The company admitted guilt to charges 1, 2, 3, 7 and the alternative to charge 4 and was therefore found guilty.

Stone was found guilty of having failed to notify the responsible person and the owner of the premises that the radioactive material was missing. The other charges against him were withdrawn.

Isotope

A. P. Hanekom, radiation inspector of the Atomic Energy Board (AEB) yesterday testified that one of the main functions of the AEB is to exercise control over radioactive material and to prevent the consequences which radiation can have on a person. "This is the reason why the AEB must be notified at all times when something of this nature is lost."

In this incident nobody was exposed to radiation. The isotope in the steam kettle was encased in a steel enclosure and he testified that it was recovered later.

Hanekom also testified that in 1978 a construction worker at Sasolburg picked up a similar isotope and put it in his shirt pocket. He incurred such severe radiation burns that later some of his fingers had to be amputated.

Stone testified that he failed to section off the area when in the course of the evening he looked for the missing isotope.

The state prosecutor, T. J. Prins, maintained that the AEB had approached the company for a report and that there is the possibility that the matter could have been covered up if the company had not been approached.

Attorney Prins said that it was clear that Stone was not qualified to work as a radiographer, because originally he failed to pass an examination which he had to take after his certification was withdrawn after the incident, but it was attested that he passed the examination later.

Verdict

In his verdict District Magistrate J. S. C. van Graan stated that the court heard that the gamma rays emitted by the isotope could cause cancer growths and could have extremely harmful effects on the body. "This is the reason that regulations are necessary for protecting the public."

Freeman was acquitted of the four charges 1, 2, 4, and 7, but he was found guilty of the alternative charge of having failed to inform the AEB immediately that the isotope was missing. Magistrate Van Graan said that Freeman was

not there when the incident took place. He came to Capetown as soon as possible and recovered the isotope. The necessary measures were also taken for preventing a similar incident in the company in the future.

S. C. Mortinson (of Bell, Dewar and Hall of Johannesburg) appeared on behalf of the accused.

7964

CSO: 5100/5677

EXPORT OF NUCLEAR MATERIALS, TECHNOLOGY ENACTED

Moscow FOREIGN TRADE in English No 4, Apr 82 pp 48-49

[Text] The USSR Council of Ministers on January 13, 1982 approved an Enactment on the export of nuclear materials, technologies, equipment, installations, special non-nuclear materials, and services. Below is given a summary of the Enactment.

The Enactment is for the regulation of the export of nuclear materials, technologies, equipment, installations, special non-nuclear materials, and services (Soviet nuclear exports) for peaceful purposes from the USSR to countries not possessing nuclear weapons.

The definition of the terms: nuclear materials, technologies, equipment, installations, special non-nuclear materials, and services referred to in the Enactment are given in the Annex.

Soviet nuclear exports are effected in accordance with the Soviet Union's policy on nuclear arms non-proliferation and its obligations arising out of the Treaty on the Non-Proliferation of Nuclear Weapons and other international treaties, agreements and understandings signed by the USSR.

Soviet nuclear exports to countries not in possession of nuclear weapons may take place, provided such countries undertake that the exported articles they acquire, as well as the nuclear and special non-nuclear materials, installations and equipment made on the basis of the exported articles or as a result of their application;

a) shall not be used for the manufacture of nuclear weapons or other nuclear explosive devices, or be used to attain any military aim;

b) shall be under the control (safeguards) of the International Atomic Energy Agency (IAEA) during the entire period of their actual utilization;

c) shall be given physical protection at a level not lower than that recommended by the IAEA;

d) will be re-exported (exported) or transferred from the jurisdiction of the recipient country only on the terms provided for in the Enactment; re-export or transfer of export articles proper will take place with the written consent of the relevant Soviet foreign trade organization (in the event of multi-stage re-export, such a consent may be obtained both directly from the Soviet foreign trade organization and through the intermediate re-exporters).

The obligations referred to above must be formalized by the competent government bodies of the recipient countries by assuming such obligations in connection with concrete nuclear deliveries from the USSR or by referring to their obligations under the existing multilateral or bilateral treaties, agreements, contracts and other contract law acts in which the Soviet Union or the relevant Soviet bodies and organizations participate.

Soviet nuclear export operations shall be performed by foreign trade organizations of the Ministry of Foreign Trade of the USSR and of the USSR State Committee for Foreign Economic Relations. Draft agreements and/or contracts with foreign partners as concerns the terms of nuclear exports shall be agreed with the State Committee for the Utilization of Atomic Energy of the USSR and the Ministry of Foreign Affairs of the USSR.

Nuclear export articles shipment may be initiated from the USSR only on receipt by the relevant Soviet foreign trade organization of the recipient country's obligations referred to above, and provided there is an agreement on safeguards between the recipient country and the IAEA, with all the additional documents thereto, which are necessary for effecting the said safeguards.

In the event obligations provided for in the Enactment are violated in the recipient country, nuclear exports from the USSR to that country shall be suspended until the said violation is eliminated.

Simultaneously with the suspension of exports the Ministry of Foreign Trade of the USSR and the USSR State Committee for Foreign Economic Relations, with the participation, if necessary, of the Ministry of Foreign Affairs of the USSR and the State Committee for the Utilization of Atomic Energy of the USSR shall take measures in accordance with the appropriate rules of international law and the USSR's international treaties to ensure the fulfillment by the recipient country of the obligations it has assumed.

ANNEX

to the Enactment on the export of nuclear materials, technologies, equipment, installations, special non-nuclear materials, and services.

Definition of the terms contained in the Enactment on the export of nuclear materials, technologies, equipment, installations, special non-nuclear materials, and services

The terms: nuclear materials, technologies, equipment, installations, special non-nuclear materials, and services referred to in the Enactment are defined as follows:

1. **Nuclear materials**—uranium (depleted, natural or enriched, including uranium-233), plutonium and thorium, any of these substances in the form of metal, alloy, chemical compound or concentrate in quantities exceeding the limits specified in subclause (a) for a definite recipient country during a period of 12 months with the exception of materials referred to in subclause (b).

a) enriched uranium, including uranium-233

plutonium 50 effective grams

natural uranium 500 kilograms

depleted uranium 1,000 kilograms

thorium 1,000 kilograms

b) plutonium with an isotopic concentration of plutonium-238 exceeding 80 per cent.

Uranium or plutonium used in gram quantities or less as sensing elements in instruments.

Depleted and natural uranium or thorium in relation of which there are assurances by the competent government bodies of the recipient country to the effect that they are intended for use in non-nuclear activities alone (such as the production of alloys and ceramics) as a result of which they practically cannot be regenerated.

2. **Technologies**—information of any kind (including samples of materials and models of equipment, and data communicated for the training of specialists), which can be used when designing, producing, exploiting or testing nuclear materials, equipment, installations and special non-nuclear materials.

3. Equipment and installations—any equipment and installations intended or prepared specifically for producing, processing or using nuclear or special non-nuclear materials, including:

3.1. Nuclear reactors capable of operation in controlled self-sustaining fission chain reaction conditions, excluding zero-energy reactors, the latter being defined as reactors with a designed maximum rate of plutonium production not exceeding 100 grams a year.

3.2. Reactor pressure vessels:

Metal vessels as complete units or as major shop-fabricated parts therefor which are especially designed or prepared to contain the core of a nuclear reactor as defined in paragraph 3.1 above and are capable of withstanding the operating pressure of the primary coolant.

3.3. Reactor fuel charging and discharging machines: Manipulative equipment especially designed or prepared for inserting or removing fuel in a nuclear reactor as defined in paragraph 3.1 above capable of on-load operation or employing technically sophisticated positioning or alignment features to allow complex off-load fuelling operations such as those in which direct viewing of or access to the fuel is not normally available.

3.4. Reactor control rods:

Rods especially designed or prepared for the control of the reaction rate in a nuclear reactor as defined in paragraph 3.1 above.

3.5. Reactor pressure tubes:

Tubes which are especially designed or prepared to contain fuel elements and the primary coolant in a reactor as defined in paragraph 3.1 above at an operating pressure in excess of 50 atmospheres.

3.6. Zirconium tubes:

Zirconium metal and alloys in the form of tubes or assemblies of tubes, and in quantities exceeding 500 kg per year, especially designed or prepared for use in a reactor as defined in paragraph 3.1 above, and in which the relationship of hafnium to zirconium is less than 1:500 parts by weight.

3.7. Primary coolant pumps:

Pumps especially designed or prepared for circulating liquid metal as primary coolant for nuclear reactors as defined in paragraph 3.1 above.

3.8. Plants and installations for the re-processing of irradiated fuel elements, and equipment especially designed or prepared therefor.

3.9. Plants and installations for the fabrication of fuel elements.

3.10. Equipment, other than analytical instruments, especially designed or prepared for the separation of the isotopes of uranium.

3.11. Plants and installations for production of heavy water, deuterium and deuterium compounds and equipment especially designed or prepared therefor.

4. Special non-nuclear materials:

4.1. Deuterium and heavy water:

Deuterium and any deuterium compound in which the ratio of deuterium to hydrogen exceeds 1:5,000 for use in a nuclear reactor as defined in paragraph 3.1 above in quantities exceeding 200 kg of deuterium atoms for any one recipient country in any period of 12 months.

4.2. Nuclear grade graphite:

Graphite having purity level better than five parts per million boron equivalent and with a density greater than 1.50 g/cu.cm, in quantities exceeding 30 metric tons for any one recipient country in any period of 12 months.

5. Services —Operations performed by the Soviet Union relating to any change in the form or properties of a foreign customer's nuclear and special non-nuclear materials, including operations relating to nuclear material isotopic enrichment, preparation of fresh and processing of irradiated nuclear fuel.

COPYRIGHT: "Vneshnayaya trgovlya", 1982 English translation.
"Foreign Trade", 1982

CSO: 5100/1005

ATOMIC WASTE STORAGE TO BE READY IN 1988

Frankfurt/Main FRANKFURTER ALLGEMEINE in German 19 June 82 page 5

[Text] The Federal Government is expecting the first final storage for weakly radioactive wastes and demolished parts of shutdown nuclear power plants in the Federal Republic of Germany to start operating by 1988. The final storage will be set up in the former "Konrad" Iron Ore Mining Works at Salzgitter-Bleckenstedt, whose suitability was investigated by the "Gesellschaft für Strahlen- und Umweltforschung mbH" (GSF), [Association for Radiation and Environmental Research] Munich. The GSF has now given in Salzgitter results of its more than 5 years of suitability studies completed in spring for the "Konrad" Mining Works, under a contract from the Federal Research Ministry. It is apparent from the 850 pages long final report of the GSF (F.A.Z. of 7 April) that "no aspects have been found counterindicating the suitability of the Mining Works as final storage for weakly radioactive wastes". This applies both to the geological and mining technology conditions and the nuclear technology safety requirements.

Naturally the hopes for satisfying the disposal expectations within 6 years is related to two decisive prerequisites. On one hand the prescribed planning procedure, whose beginning will presumably be decided in August by the competent "Physikalisch-Technische Bundesanstalt Braunschweig" [Physical and Technical Federal Agency of Braunschweig] (PTB) according to the announcements in Salzgitter must end duly with a positive decision of the Lower Saxony Ministry of Social Affairs. On the other hand it should be legally possible to take up the equipment of the Mining Works for final storage purposes already during the planning procedure, a point which has not yet been clarified by the competent legal authorities.

The Federal Government has already spent nearly 60 million marks for the previous research program for the "Konrad" final storage project. The operating costs for the Mining Works--ninety employees are still employed there currently--will be for this year alone 11.5 million marks; with the same personnel numbers they will probably increase slightly in the next few years. The investment costs for the conversion must be estimated at at least 100 million marks. According to the plans cavities of more than a million cubic meters can be excavated in the galleries of the Ore Mining Works which lie at depths between 800 and 1200 meters. The future final storage should take up altogether 500,000 cubic meters of weakly radioactive wastes, weighing altogether 1 million tons, about 20,000 cubic meters every year. About 200 employees would be needed to operate the final storage.

FRANCE

TORE SUPRA TOKAMAK TO USE NEW SUPERCONDUCTOR MAGNET TECHNIQUE

Paris CEA NOTES D'INFORMATION in French Jan-Feb 82 pp 14-20

[Article: "Controlled Thermonuclear Fusion: Tore Supra Will be the Backbone of Euratom-CEA's Program for the Next Ten Years"]

[Text] On 15 July 1981, the Advisory Committee for the European Fusion Program, meeting in Brussels, decided to grant priority status to the French Tokamak project*, Tore Supra. This decision now makes it possible to begin the construction of this large machine and to bring together all of the CEA's [French Atomic Energy Commission] resources for research on fusion by magnetic containment. These resources are now at Fontenay-aux-Roses and at Grenoble, and will be transferred to the Cadarache Nuclear Research Center. This decision effectively means that the Community will pay 45 percent of the cost of developing this machine.

Tore Supra will use for the first time superconductor magnets in a large-size Tokamak. It will form the backbone of the French program for the next 10 years. It is part of the research leading to a medium-field Tokamak reactor, which now seems to be the most promising line of fusion research.

* Tokamak: a device designed to contain a plasma within a toric chamber by using the combination of two magnetic fields: one main axial magnetic field, created by coils surrounding the toric chamber, and a secondary transversal magnetic field, created by an intense electric current passing through the plasma ring. This electric current also heats the plasma; it is induced by a transformer whose secondary winding is the plasma itself. The resulting magnetic field creates a moderate shearing action which favors the containment of the plasma.

The Tore Supra program does seem to complement the rest of the European program quite well, particularly the JET [Joint European Torus]. It is a necessary phase before undertaking the development of an experimental reactor, as proposed in the NET [Next European Torus] studies.

For the 1979-1983 5-year plan, the Community budget calls for spending 634 million ECU [European Currency Units] for the general program, in addition to 243 million ECU for the JET. In all, this amounts to over 5 billion francs.

This decision is the logical outcome of the efforts the CEA has been making since 1958. Its work has enabled it to achieve world-class results.

The entire Tore Supra operation has been a significant factor in decentralization. It has had a considerable impact on regional activity in France. During the first phase, work began at the construction site, and about 100 million francs were spent on civil engineering over a 5-year period. In the second phase, a new research laboratory was opened in the Provence-Cote d'Azur region. Based on the expected upgrading of resources, by 1986 this research facility will have over 350 physicists, engineers, and technicians, with an annual operating budget of about 200 million francs. This laboratory will establish very close relations with university research facilities and with the CNRS [National Center for Scientific Research] in the Provence-Cote d'Azur region.

Fusion Programs in the European Community and Throughout the World

Research on controlled fusion in the European Community nations is covered by association contracts with EURATOM, which provide financial contributions by the European Communities Commission. The European program covers the efforts of seven of the Community countries (Greece, Ireland, and Luxembourg do not contribute directly), and Sweden and Switzerland are associated by contract. The total Community effort for the 1979-1983 plan comes to over 5 billion francs.

The program presented by the Commission for the 1982-1986 period calls for a sizeable increase in activities of a technological nature in order to prepare for the post-JET phase (NET); it also includes taking over the operating expenses of the JET, and the investments needed so it can reach its goal of obtaining a thermonuclear plasma. The amount of spending budgeted comes to 1.5

billion ECU, which includes 442 million for the JET. Tables A and B give the proposed budgets for the two 5-year periods, broken down into major spending categories, along with a comparison of the non-JET budgets of the European countries for the first 3 years of the current plan. The reader will observe the relative importance of the German program (40.8 percent). France's share is a little less than 20 percent, to which should be added 2 percent of the JET spending paid as a direct contribution.

Research on Fusion by Magnetic Containment in the Community

Table A:	1979-1983 5-Year Plan (millions of ECU)	Program applications for 1982-1986 (millions of ECU)
General spending of Associations	496	613
Priority actions	130	212
JET support		34
Technology		190
Management and overhead costs	8	13
Total excluding JET	634	1,062
JET	243.1	442.3
Total	877.1	1,504.3

Table B: Comparison of Non-JET National Budgets for the 3-Year Period Covering 1979, 1980, and 1981

Country	Millions of ECU	Proportion (in %)
Federal Republic of Germany	168.4	40.8
France	81	19.6
Great Britain	75	18.2
Italy	36.5	8.8
Netherlands	21.2	5.1
Belgium	9.4	2.3
Denmark	2.6	0.6
Subtotal of Community countries	394.1	

Sweden	5.6	1.4
Switzerland	13.3	3.2
Total	413	100

As a comparison, the funding for this type of research in the United States was \$383 million in 1981 and will be \$460 million in 1982. Financing provided by the Soviets, which is not so well known, seems to have reached a plateau now, after being comparable to the U.S. funding for a long time. The Japanese budget, by itself, is of the same magnitude as the Community budget.

The French Program

The French program is conducted entirely by the CEA's department of fusion research, which uses the two sites of Fontenay-aux-Roses and Grenoble.

The CEA's fusion activities, which began in 1958 on a very modest scale, have gradually expanded. During the first 10 years of the program, their work was still highly diversified. A significant change was made in 1970, and the program then began to concentrate on the Tokamak and the development of plasma heating methods. These choices were found to be wise, and have enabled the CEA to reach a world-class level because of the quality of its results. Starting in 1973, the operation of the TFR [Fontenay-aux-Roses Tokamak] gave France a tool which was the best equipment of this type in the world, until the start of the large American Tokamak in Princeton in 1976. The use of powerful supplemental heating methods on this equipment enabled it to hold the world record for ion temperature in 1975, with a temperature of 20 million degrees in a plasma heated by neutron injection. Again in 1981 it held a world record with a plasma heated by high frequency, also to 20 million degrees, but with a plasma density comparable to that required for a thermonuclear fusion reactor plasma. These achievements have made the CEA the European leader in supplemental plasma heating, a technique that is essential for the future of fusion. A policy decision made in the Community program brought about a considerable development in active cooperation efforts for the use of these methods in other European devices. In 1981, 20 percent of the personnel and budget resources were devoted to these activities, 75 percent of which was for support of the JET program.

France's role in the Community program, which is now both important and recognized, led to the 15 July decision made in Brussels by the Advisory Committee for the European Fusion

Program, granting priority status to the French superconductor magnet Tokamak project. This decision means that 45 percent of the cost of developing this machine will be paid by the European Communities Commission.

The French project proposes a new technical solution, by the use of superconductor magnets in the presence of a rapidly varying magnetic field. This is a technological phase that is an essential technological stage leading to the development of the reactor. It will also provide a means of studying physical problems in conditions very close to those of the reactor but in a non-active machine, which is therefore more accessible than the JET will be. The JET is designed to reach plasma ignition as quickly as possible, by using a deuterium-tritium blend. Using the Tore Supra, different techniques of heating to the temperatures required for ignition and for studying the containment of plasmas at a high temperature can be studied. Tore Supra will also make long duration discharges, so that the continued interaction of the hot plasma with its material environment in the reactor can be studied.

The Tore Supra complements the European program quite well, particularly the JET.

France does plan to play a major part in the technological program which will be expanded during the years from 1982 to 1986. The CEA's contribution will be of particular importance, as the Community will benefit from the results of studies done on fission reactors. These technological studies will be conducted in the following areas: superconductor technology, use of tritium, regeneration of tritium in a lithium cover and extraction of the heat produced, behavior of the materials, and safety.

The advances in knowledge of magnetic containment in recent years have been quite significant both in France and elsewhere in the world. These advances have been helped by free and rapid communications throughout the entire world, including the USSR.

Current extrapolations suggest that the JET and its American counterpart, the TFTR, will before too many years provide a scientific demonstration of the feasibility of fusion. That is why preparations are starting now for the following generation, the NET. This is an important phase, but it will still not be a demonstration reactor producing electricity. The NET, which could be approved at the end of this decade, would produce thermonuclear power of several hundred megawatts. It would use

superconductor circuits and would have a cover for tritium regeneration. It should play an important part in the final development of a demonstration reactor (the thermonuclear equivalent of the Phenix reactor).

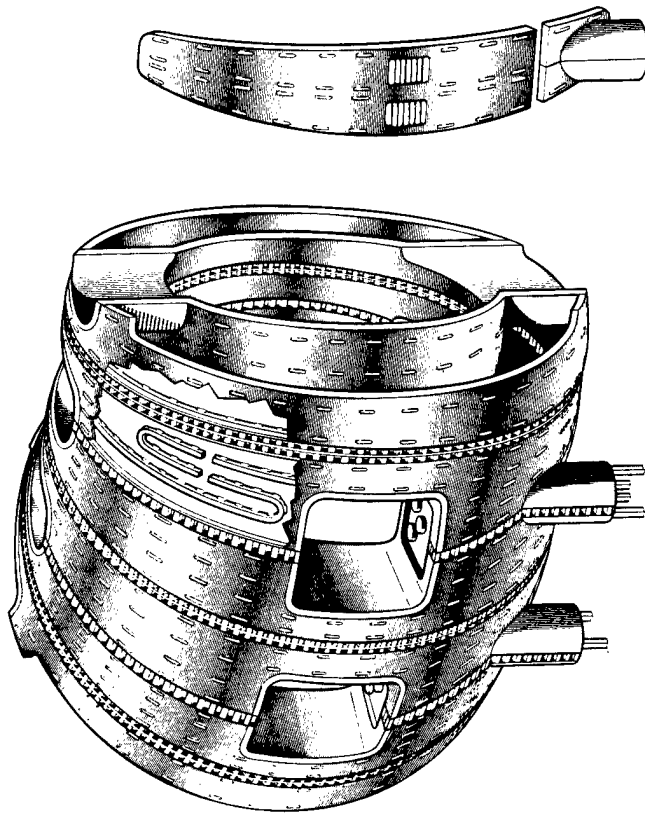

Figure 1: Portion of a thermal screen cooled with gaseous helium.

International cooperation for this expensive development is certainly desirable, but it is clear that Europe will have to acquire, like the United States and the USSR, mastery of all the necessary techniques required for the development of a fusion reactor.

The Tore-Supra Project in the Fusion Program

This project is part of the fusion by magnetic containment program. In this field research is typified by a difficult sort of overlapping of the problems related to the container--the containment device--and problems related to the content--the ionized gas or plasma. The containment device determines the performances of the plasma, and in return the behavior of the contained plasma determines the machine's specifications. So successive extrapolations are made, with each generation of the machine adding a useful contribution to our knowledge of the plasma, in preparation for the next phase.

The ultimate goal is obviously to obtain a sufficiently dense and well contained plasma, a plasma which is also sufficiently reactive (this means temperatures of 50 to 100 million degrees) so that the thermonuclear power produced in the plasma will reach and then exceed the power lost because of the magnetic configuration of the containment. At that point it is said that the plasma reaches ignition.

Several types of configurations are now under study throughout the world, but there are many laboratories which, like the EURATOM-CEA Association, at the end of the 1960s, began to concentrate their efforts on the method that seemed to be moving fastest toward ignition: the Tokamak process.

At present the Tokamak results can be analyzed as follows:

The containment of the plasma is less than had been expected initially, and it is highly probable that it is dominated by turbulence of a magnetohydrodynamic nature that is hard to apprehend theoretically. However, the diffusion associated with this turbulence has been studied experimentally, and it can be minimized by increasing the volume of the plasma, and thus the size of the containment device, and also by increasing the intensity of the magnetic field used for containment.

The temperature of the plasma can be increased considerably by using supplemental heating methods, as has been demonstrated at Fontenay-aux-Roses and at Grenoble.

On the basis of these results, projects have been designed to demonstrate the ignition of a deuterium-tritium plasma, which is the most easily fusible blend. The large-scale developments needed for this demonstration are the JET (EURATOM), the TFTR (United States), and the JT-60 (Japan) Tokamaks, which are to begin operating in the next few years.

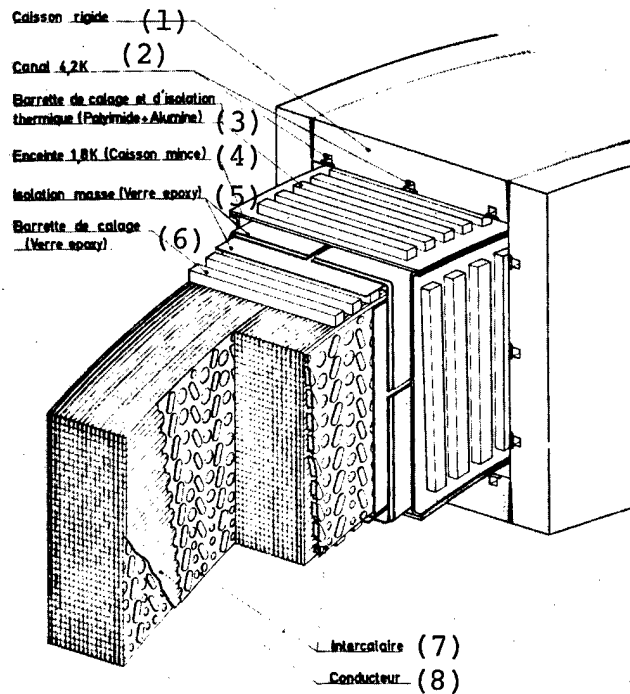

(9) PERSPECTIVE DE LA BOBINE TOROÏDALE

Figure 2: Cross section of a superconductor coil of Tore Supra.

Key:

1. Rigid enclosure
2. 4.2 K channel
3. Adjustment and thermal insulation rod (polyamid and aluminum)
4. 1.8 K enclosure (thin casing)
5. Mass insulation (epoxy glass)
6. Adjustment rod (epoxy glass)
7. Spacer
8. Conductor
9. View of toroidal coil

If favorable results are obtained with these Tokamaks, this would open the way toward a prototype thermonuclear reactor. With this in mind, it is necessary to minimize the reactor's energy consumption. This can be done by using superconductor magnets to create the magnetic configuration.

Given this context, the purpose of the Tore Supra, whose size is not sufficient for us to expect to achieve ignition (and in which the use of tritium is not necessary), is twofold. First, it is to build a superconductor magnet, use it in the real environment of a Tokamak and test it in conditions as similar as possible to the conditions of use of a thermonuclear reactor. Secondly, to contribute to the studies of supplemental heating of plasma in Tokamaks under the two fundamental aspects: transfer of power to the plasma and containment of the energy transferred to the plasma.

Tore Supra Description

Although Tore Supra is smaller than the Tokamaks designed for ignition, it does represent an advance over the equipment now being used for experiments. Its characteristics are:

- a. large torus radius: 2.25 meters;
- b. small plasma radius: 0.70 meter;
- c. current in the plasma: 1.7 million amps;
- d. magnetic guidance field: 4.5 tes/as.

With these features, it will be possible to produce plasmas with performances rather similar to those of the TFTR or even of the JET. The supplemental heating power will be about 10 megawatts for the plasma, with the possibility of doubling this in a later phase if the results so warrant.

The superconductor magnet creating the magnetic field has 18 coils, whose superconductor material is a niobium-titanium based composite. In order to increase the magnetic field which can be created with this type of material (and thus to augment the performances of the plasma) it was necessary to cool the coils to 1.7 kelvin by using superfluid helium. This combination of superconductivity for the current and superfluidity for cooling is an original solution which, once it has been tested in the Tore Supra, can be directly transposed to the reactor.

The superconductor magnet is placed in a toric cryostat in a vacuum in order to limit the thermal conduction. The internal free space, also of toric shape, forms the chamber housing the plasma, in which a strong vacuum is created. On each side of the toric superconductor magnet, that is, on the side of the cryostat and on the side of the plasma chamber, shields are placed to block the thermal radiation; the shields are cooled to 80 kelvins (see figure 1). Each coil (whose elements are shown

in figure 2) is placed in housing cooled to 4.5 kelvins, which provides the conductor it encloses with protection against the rapidly varying fields related to the current of 1.7 million amps induced in the plasma at each discharge.

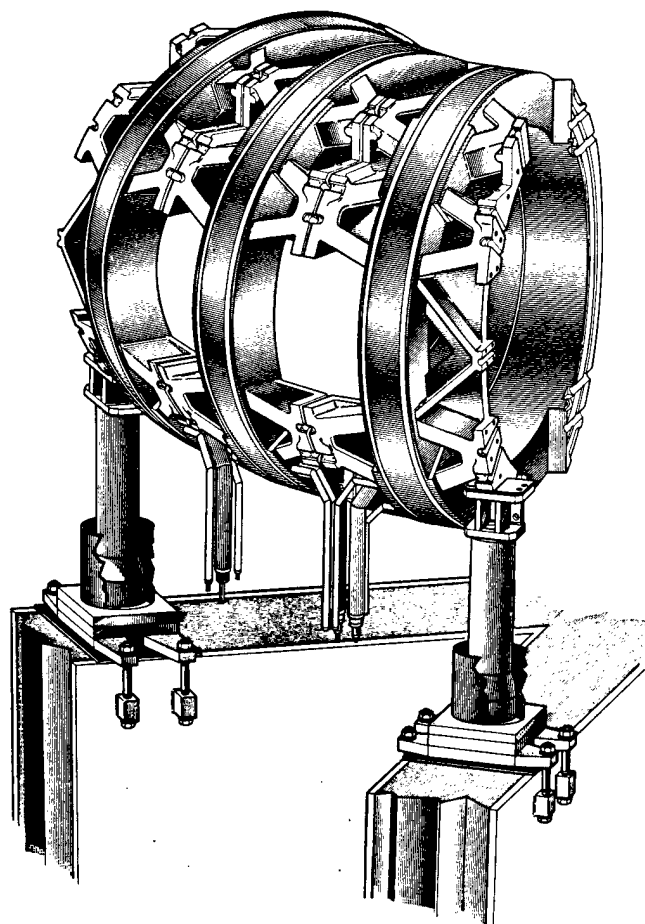

Figure 3: Section of a toroidal magnet.

The 18 coil housings, resting on their side surfaces, form a rigid arch (figure 3 shows a section of this arch) which resists the strong centripetal forces generated.

The cryogenic system associated with the superconductor magnet furnishes fluids at the different temperatures required: superfluid helium at 1.75 kelvin (1 atm) for cooling of the niobium-titanium superconductor; normal helium at 4.2 kelvins for cooling of the rigid housing structures; gaseous helium at 80 kelvins

(15 atm) for cooling of the thermal shields. These cooling powers are respectively: 300 watts, 1 kilowatt, and 40 kilowatts. The equipment was designed in order to minimize consumption at the lowest temperature. The use of large volume tanks serving as thermal ballast makes it possible to enclose the discontinuous operation of Tore Supra: one discharge every 4 minutes.

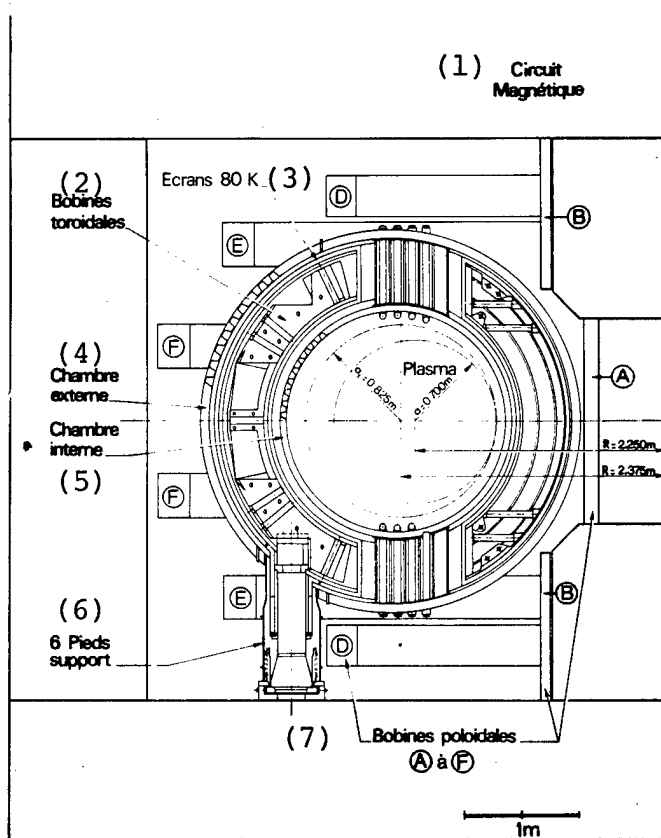

Figure 4: Poloidal circuit of Tore Supra showing the position of the poloidal coils in relation to the chamber and the plasma.

Key:

1. magnetic circuit
2. toroidal coils
3. 80 K shields
4. external chamber
5. internal chamber
6. six support structures
7. poloidal coils

The transformer inducing the current in the plasma uses an iron magnetic circuit weighing about 800 tons and divided into six arms which meet at the center of the machine. A cross section of one of these arms is given in figure 4. The variation of magnetic flow in this circuit can maintain in the plasma the discharge current of 1.7 million amps for 30 seconds.

The equipment will be formed in six practically identical sections, each with all the elements of the torus, assembled separately before being interconnected to form the torus. Such a module is given in figure 5, showing the various access points planned so that the plasma can be observed, and in order to introduce the heating power in the form of rapid neutron particles and electromagnetic waves.

Site of the Tore Supra Tokamak

The entire staff of the DRFC [Department of Controlled Fusion Research] now working at Fontenay-aux-Roses and at Grenoble will be transferred to the Tore Supra site at Cadarache in the summer of 1986. The facilities there are designed to house, in addition to the equipment needed for the operation of the machine itself, the laboratories which will be used by physicists responsible for designing and developing methods of heating and measurement suitable for the study of thermonuclear plasmas. The development of metrology is an important activity in all thermonuclear fusion laboratories.

The present architectural design of the project is shown in figure 6 [not included]. It has great possibilities for expansion, and the floor space already exceeds the areas used at Fontenay and at Grenoble for fusion activities.

The complex containing the machine and its related equipment occupies the central part of the site. Tore Supra will be placed in an area with 1,000 m² of usable space, whose 1.5-meter thick walls, made of boron-impregnated concrete, will provide biological protection against gamma radiation and against the neutron flows produced during discharges in a deuterium plasma.

In addition to this area, there will be areas provided for the assembly of modules and other units, for the power supply (supply of the transformer and plasma heating), for cryogenic facilities, and also for the operation of the machine (measurements and controls). Work should start toward mid-1982 and last until the summer of 1985.

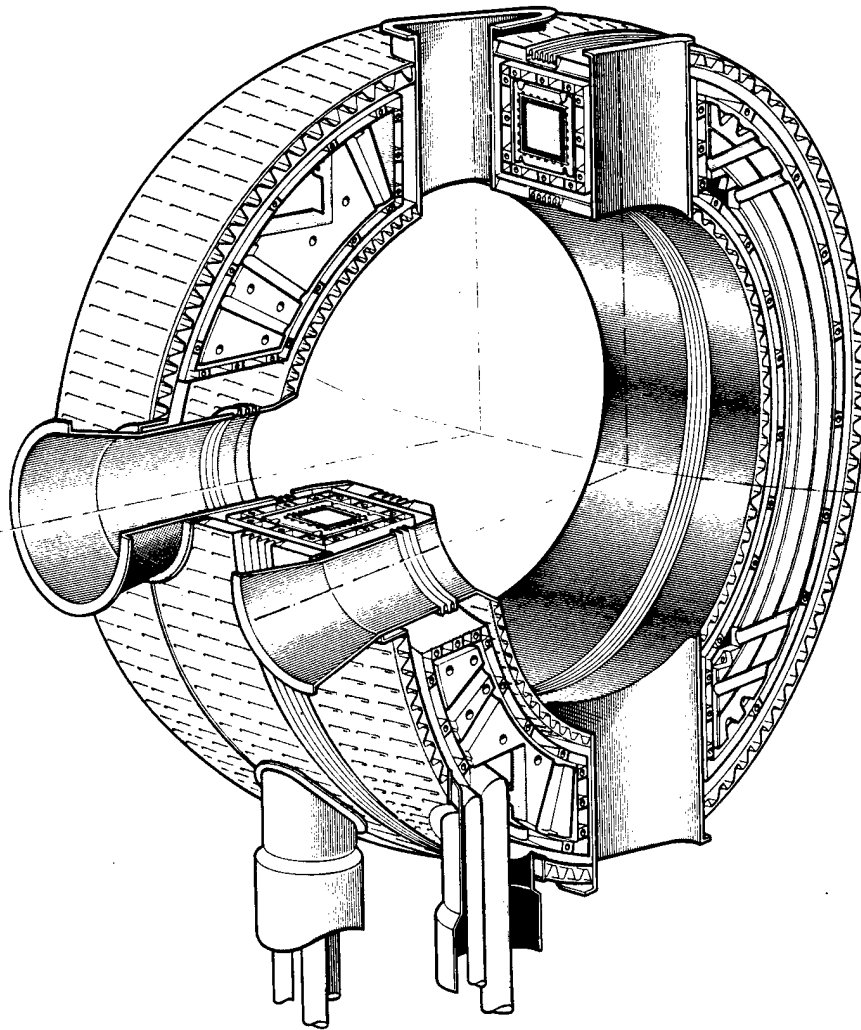

Figure 5: Cross section of a portion of a vacuum chamber equipped with thermal shields and toroidal field coils.

The Thermonuclear Reactor and the Energy Problem

In the future the world's energy needs will be so great that serious studies will have to be made of the various potential sources of energy. At the present time, nuclear energy seems to be the only source that could meet Europe's needs in the mid-term period. However, given the magnitude of the energy problem,

fission and fusion* should be considered as two complementary systems, not competitive methods. Fission research has shown that breeder reactors could form the base for tomorrow's electric power plants. At present fusion is in a very preliminary phase of development, but in the long term, it does offer a certain number of potential advantages. One advantage is that the products of fusion reaction are not radioactive, unlike fission products. Also, the quantity of fuel in reaction at each instant is low, which eliminates the risk of accidental racing. However, there is cause for some concern about the irradiation of the materials of the reactor structure, and about problems related to tritium, which will be present in a very large quantity. As for the deuterium and lithium supplies--these are the main fuels of the D-T reactor--the known reserves of high quality lithium have an energy content comparable to that of the world's reserves of uranium and thorium. Lithium could also be extracted from sea water or from low quality ores which are present in many parts of the world. Deuterium reserves are virtually inexhaustible.

* Fusion. The fusion process is based on the bonding energy released by the fusion (or combining) of light nuclei; this reaction produces a heavier nucleus. There are several types of fusion reactions involving light elements. The one that furnishes the greatest amount of energy and has the least stringent conditions, and thus the one that is of greatest interest, takes place between two types of hydrogen (isotopes): deuterium (D) and tritium (T). These two elements combine to produce a helium nucleus (${}^4\text{He}$) which is heavier and a neutron (n), ($\text{D} + \text{T} \rightarrow {}^4\text{He} + \text{n} + \text{energy}$). Moreover, during this phenomenon a great amount of energy is released which can be converted, first into heat in a peripheral moderating mantle, and then into electricity by means of conventional generators. Deuterium, which is found in water, is quite plentiful. Tritium, however, does not exist in nature and must be produced. Tritium can be produced in a lithium mantle surrounding the region of fusion. The neutrons created by the deuterium/tritium reaction are then captured by the lithium which disappears, and is replaced by tritium and helium.

Although it is very difficult, not to say dangerous, to risk a prediction about when there will be thermonuclear reactors producing electricity, we can imagine that a first demonstration reactor might be built during the period from 2000 to 2010. Then the first semi-industrial reactor might be ready during the period from 2020 to 2030.

Based on these assumptions, it will be about half a century before the first electricity-generating fusion reactors could technically be of any significance in terms of producing electricity.

The way seems promising and could provide our energy needs for several centuries. The research programs, the work being done, and the large funding being provided in all the major industrialized countries all show the importance of fusion.

7679

CSO: 5100/2172

FRANCE

BRIEFS

PARIS REPORTS NO CONFIRMATION--A new French nuclear test in Muroroa atoll in the Pacific was announced by the Government of New Zealand, but to date the information has not been confirmed in Paris. For several years now the French authorities have ceased to comment on this kind of experiment. The New Zealanders, very hostile to these nuclear tests, point out that the strength of the explosion was 20 kilotons more powerful than the first test this year on 21 March. Coincidence or not, this explosion took place at the very moment when French vulcanologist Haroun Tazieff was expected to arrive in Wellington, the New Zealand capital. Tazieff has been entrusted with a mission by the French Government on the consequences of the nuclear experiments in the Pacific on the environment. [Excerpt] [LD031240 Paris Domestic Service in French 1100 GMT 3 Jul 82]

CSO: 5100/2212

END