

**DAHLGREN DIVISION  
NAVAL SURFACE WARFARE CENTER**

Dahlgren, Virginia 22448-5100



---

**NSWCDD/TR-97/174**

**GRAPHITE HEATING ELEMENT OPERATING  
TEMPERATURE MEASUREMENTS IN THE NSWC  
HYPERVELOCITY WIND TUNNEL 9**

**BY MICHAEL A. METZGER  
STRATEGIC AND STRIKE SYSTEMS DEPARTMENT**

**SEPTEMBER 1997**

Approved for public release; distribution is unlimited.

**DTIC QUALITY INSPECTED 3**

19971006054

**REPORT DOCUMENTATION PAGE**Form Approved  
OMB No. 0704-0188

Public reporting burden for this collection of information is estimated to average 1 hour per response, including the time for reviewing instructions, search existing data sources, gathering and maintaining the data needed, and completing and reviewing the collection of information. Send comments regarding this burden or any other aspect of this collection of information, including suggestions for reducing this burden, to Washington Headquarters Services, Directorate for Information Operations and Reports, 1215 Jefferson Davis Highway, Suite 1204, Arlington, VA 22202-4302, and to the Office of Management and Budget, Paperwork Reduction Project (0704-0188), Washington, DC 20503.

<b>1. AGENCY USE ONLY (Leave blank)</b>		<b>2. REPORT DATE</b> September 1997	<b>3. REPORT TYPE AND DATES COVERED</b> Final	
<b>4. TITLE AND SUBTITLE</b> Graphite Heating Element Operating Temperature Measurements in the NSWC Hypervelocity Wind Tunnel 9			<b>5. FUNDING NUMBERS</b>	
<b>6. AUTHOR(s)</b> Michael Metzger				
<b>7. PERFORMING ORGANIZATION NAME(S) AND ADDRESS(ES)</b> Commander Naval Surface Warfare Center Dahlgren Division (Code K20) 17320 Dahlgren Road Dahlgren, VA 22448-5100			<b>8. PERFORMING ORGANIZATION REPORT NUMBER</b> NSWCDD/TR-97/174	
<b>9. SPONSORING/MONITORING AGENCY NAME(S) AND ADDRESS(ES)</b>			<b>10. SPONSORING/MONITORING AGENCY REPORT NUMBER</b>	
<b>11. SUPPLEMENTARY NOTES</b>				
<b>12a. DISTRIBUTION/AVAILABILITY STATEMENT</b> Approved for public release; distribution is unlimited.			<b>12b. DISTRIBUTION CODE</b>	
<b>13. ABSTRACT (Maximum 200 words)</b>  This report documents real-time temperature measurements of a graphite heating element operating in the Naval Surface Warfare Center, Dahlgren Division (NSWCDD) Hypervelocity Wind Tunnel No. 9 facility. Tunnel 9 uses a large graphite element to heat nitrogen gas to 3100°F prior to releasing this gas to the test section, where it achieves hypersonic speeds to Mach 16.5. The present effort focused on obtaining the operating temperature of an uncoated heating element with a view to determine if an oxidation-resistant, silicon-carbide coated, graphite element, of the same size now used in the facility, might be used to batch-heat air in the heating vessel. The reported results appear promising in that the measured peak surface temperature of the element could be held to below 4000°F during a standard heating cycle. The measured temperatures, which were well below the predicted service limits given in this report for the silicon-carbide coating system, suggest that a silicon-carbide coated element concept warrants further study.				
<b>14. SUBJECT TERMS</b> temperature, temperature measurement, thermocouple, tungsten-rhenium, heating element, graphite, silicon carbide, oxidation resistant coatings, hypersonic propulsion, wind tunnel, hypersonic			<b>15. NUMBER OF PAGES</b> 54	
			<b>16. PRICE CODE</b>	
<b>17. SECURITY CLASSIFICATION OF REPORTS</b> UNCLASSIFIED	<b>18. SECURITY CLASSIFICATION OF THIS PAGE</b> UNCLASSIFIED	<b>19. SECURITY CLASSIFICATION OF ABSTRACT</b> UNCLASSIFIED	<b>20. LIMITATION OF ABSTRACT</b> UL	

## FOREWORD

This report documents real-time temperature measurements of a graphite heating element operating in the Naval Surface Warfare Center, Dahlgren Division (NSWCDD) Hypervelocity Wind Tunnel No. 9 facility. Tunnel 9 uses a large graphite element to heat nitrogen gas up to 3100°F prior to releasing this gas to the test section where it achieves hypersonic speeds. The Tunnel 9 heating element operates in a harsh environment not normally conducive to thermocouple measurements. The hostile conditions include, for example, extremely high temperatures near 4000°F, ultra-high pressures, aerodynamic buffeting, electrified parts, and stray magnetic and electric fields generated by a 6500-A, AC electric current required to power the element.

This effort was part of a larger study to determine the feasibility of introducing air as a working fluid in Tunnel 9, which presently uses only nitrogen. The use of air as a working fluid would provide a valuable hypersonic test capability that could be used to study advanced propulsion concepts such as those envisioned for future hypersonic air breathing missiles and space planes. The present effort focused on obtaining the operating temperature of an uncoated heating element with a view to determine if an oxidation-resistant, silicon-carbide-coated, graphite heating element, of the same size as now used in the facility, might be used to batch-heat air in the heating vessel.

The author wishes to thank Dr. Mark Opeka for invaluable work on the selection of materials for the measuring instrument and for providing predictions of service-limit temperatures for the silicon-carbide coating system operating in the Tunnel 9 heater vessel. Also, thanks are extended to Mr. Douglas Newell, Mr. Stephen Rinaldi, and Mr. Raymond Schlegel for setting up and operating the real-time data acquisition system especially for these tests. Finally, thanks are extended to Mr. Patrick Moylan for overseeing the scheduling and testing in the Tunnel 9 facility.

Approved by:



C. A. KALIVRETENOS, Head  
Strategic and Strike Systems Department

## CONTENTS

<u>Chapter</u>		<u>Page</u>
1	INTRODUCTION .....	1
	BACKGROUND .....	1
2	NITROGEN PRESSURE AND TEMPERATURE TEST	
	DESCRIPTION .....	5
	BACKGROUND .....	5
	THERMOCOUPLE INSTALLATION .....	6
	CORRELATION BETWEEN THERMOCOUPLE "A" AND PEAK	
	TEMPERATURE .....	18
	NOTE ON CALIBRATION ERRORS AND CORRECTIONS .....	21
3	"NPAT" TEST RESULTS .....	23
	DATA CORRECTIONS .....	23
	DATA PRESENTATION .....	24
4	DISCUSSION OF "NPAT" TEST RESULTS .....	30
5	DATA CORRECTION ANALYSIS .....	32
	VAX COEFFICIENT FORMATTING OF TRAILING DIGITS .....	32
	MILLIVOLT-SOURCE INSERTION POINT ERROR .....	32
	USE OF INCORRECT CALIBRATION VOLTAGE FOR "A"	
	HIGH POINT .....	33
	REFERENCE OVEN .....	33
	ZERO .....	34
	CARBON DIFFUSION LAYER .....	34
	DATA CONSISTENCY .....	34
	DATA CORRECTIONS .....	34
6	SUMMARY AND CONCLUSIONS .....	36
	REFERENCES .....	37
	APPENDIX A—CALCULATION OF DATA CORRECTION TERMS .....	A-1
	DISTRIBUTION .....	(1)

## ILLUSTRATIONS

<u>Figure</u>		<u>Page</u>
1	VERTICAL HEATER AND DIAPHRAGM SECTION .....	2
2	OPERATING LIMITS OF SILICON CARBIDE IN TUNNEL 9 HEATER .....	3
3	LOCATIONS A, B, AND C THERMOCOUPLES .....	6
4	"A" THERMOCOUPLE WIRING PATH .....	7
5	TEMPERATURE MEASURING APPARATUS INSTALLED IN HEATER VESSEL .....	9
6	TUNGSTEN-RHENIUM THERMOCOUPLE POTTED INTO HEATER ELEMENT AT "A" LOCATION .....	10
7	BORON NITRIDE INSULATOR TUBES AND "A" THERMOCOUPLE .....	10
8	MACOR TERMINAL STRIP .....	11
9	COPPER PLUG ASSEMBLY AT "B" LOCATION .....	11
10	PER-CHANNEL THERMOCOUPLE SIGNAL PATH .....	12
11	mV1 AND mV2 CALIBRATION VOLTAGE INSERTION POINTS ....	15
12a	"A" AND "D" LOCATIONS ON HEATER ELEMENT .....	18
12b	"E" LOCATION ON HEATER ELEMENT .....	19
13	POINT "A" TEMPERATURE PROFILES IN J & K HEATER WALL ...	20
14	POINT "D" TEMPERATURE PROFILES IN J & K HEATER WALL ...	20
15	POINT "E" TEMPERATURE PROFILES IN K HEATER WALL .....	21
16	GRAPHITE HEATING ELEMENT TEMPERATURE VS. TIME FOR TEST NO. 1 (RUN 2378) .....	24
17	GRAPHITE HEATING ELEMENT TEMPERATURE VS. TIME FOR TEST NO. 2 (RUN 2379) .....	25
18	GRAPHITE HEATING ELEMENT TEMPERATURE VS. TIME FOR TEST O. 3 (RUN 2380) .....	25
19	GRAPHITE HEATING ELEMENT TEMPERATURE VS. TIME FOR TEST NO. 4 (RUN 2381) .....	26
20	GRAPHITE HEATING ELEMENT TEMPERATURE VS. TIME FOR TEST NO. 5 (RUN 2382) .....	26
21	PRESSURE VS. TEMPERATURE FOR TEST NO. 1 (RUN 2378) .....	27
22	PRESSURE VS. TEMPERATURE FOR TEST NO. 2 (RUN 2379) .....	27
23	PRESSURE VS. TEMPERATURE FOR TEST NO. 3 (RUN 2380) .....	28
24	PRESSURE VS. TEMPERATURE FOR TEST NO. 4 (RUN 2381) .....	28
25	PRESSURE VS. TEMPERATURE FOR TEST NO. 5 (RUN 2382) .....	29

## TABLES

<u>Table</u>		<u>Page</u>
1	POLYNOMIAL COEFFICIENTS FOR TYPE-C THERMOCOUPLES ...	13
2	POLYNOMIAL COEFFICIENTS FOR TYPE-K THERMOCOUPLES ...	14
3	CALIBRATION INPUT VOLTAGE VS. EQUIVALENT TRUE TEMPERATURE .....	15
4	NPAT CALIBRATION DATA .....	16
5	PEAK TEMPERATURES AT THERMOCOUPLE LOCATIONS "A" AND "C" AND PEAK GAS TEMPERATURE / PRESSURE .....	29

## CHAPTER 1

### INTRODUCTION

The Hypervelocity Wind Tunnel 9 uses a large electric graphite heating element, shown in Figure 1, to preheat high-pressure nitrogen working fluid in a vertical heater vessel prior to releasing this nitrogen into the tunnel nozzle, where it is expanded to hypersonic speeds in the tunnel test section. The element must heat high-pressure nitrogen at about room temperature to 3100°F over a 20-minute time period. The operating temperature of the element was not accurately known for many years because of the difficulties and cost in making an accurate measurement in the hyperpressure furnace within which the element operates. This furnace consists of a 43-ton, vertically mounted, steel pressure vessel used to contain the nitrogen under pressure. Thermocouples used to measure the element's temperature operated in a harsh environment consisting of: extremely high temperatures, nearing 4000°F; very large stray electric and magnetic fields generated by the electric element; an electrified and electrically conductive graphite heating element carrying a 5500-A, 60-Hz, AC current; ultra-high nitrogen pressures to 22,000 psi; and carbon-vapor laden atmosphere.

### BACKGROUND

In 1992 a task team was formed to investigate the possibility of using existing Tunnel 9 heating vessels to supply air as a working fluid to Tunnel 9 for hypersonic propulsion testing. Such a "Tunnel 9 Air" capability could be used to support ground testing of advanced hypersonic air-breathing propulsion systems such as envisioned for future hypersonic missiles and space plane concepts. Existing materials used in the heating vessel, such as graphite, carbon-carbon, and TZM (an alloy of molybdenum), are not compatible with hot air because the oxygen in the air will rapidly oxidize these materials even at moderately elevated temperatures. A graphite heating element coated with a 4-mil oxidation-resistant layer of silicon-carbide (SiC) was proposed as a way to heat the air within the vessel using otherwise standard electric heating methods. When exposed to the air atmosphere, the SiC coating forms an external protective silicon-dioxide (SiO<sub>2</sub>) film that protects the underlying SiC film and graphite substrate from rapid oxidation.

Commercially available SiC-coated graphite heating elements have a useful operating temperature in ambient air of approximately 3000°F. Up to this critical temperature, the SiC coating forms a protective SiO<sub>2</sub> surface film. Above this temperature, the SiO<sub>2</sub> film is disrupted by severe outgassing of gaseous reaction products formed at the interface between the SiC and SiO<sub>2</sub>. Frothing of the SiO<sub>2</sub> film occurs, causing rapid, active oxidation of the SiC coating and eventually exposing the graphite substrate to rapid oxidation. The 3000°F limit on temperature cited above clearly was not adequate for an "air" capability in Tunnel 9. This is because the air

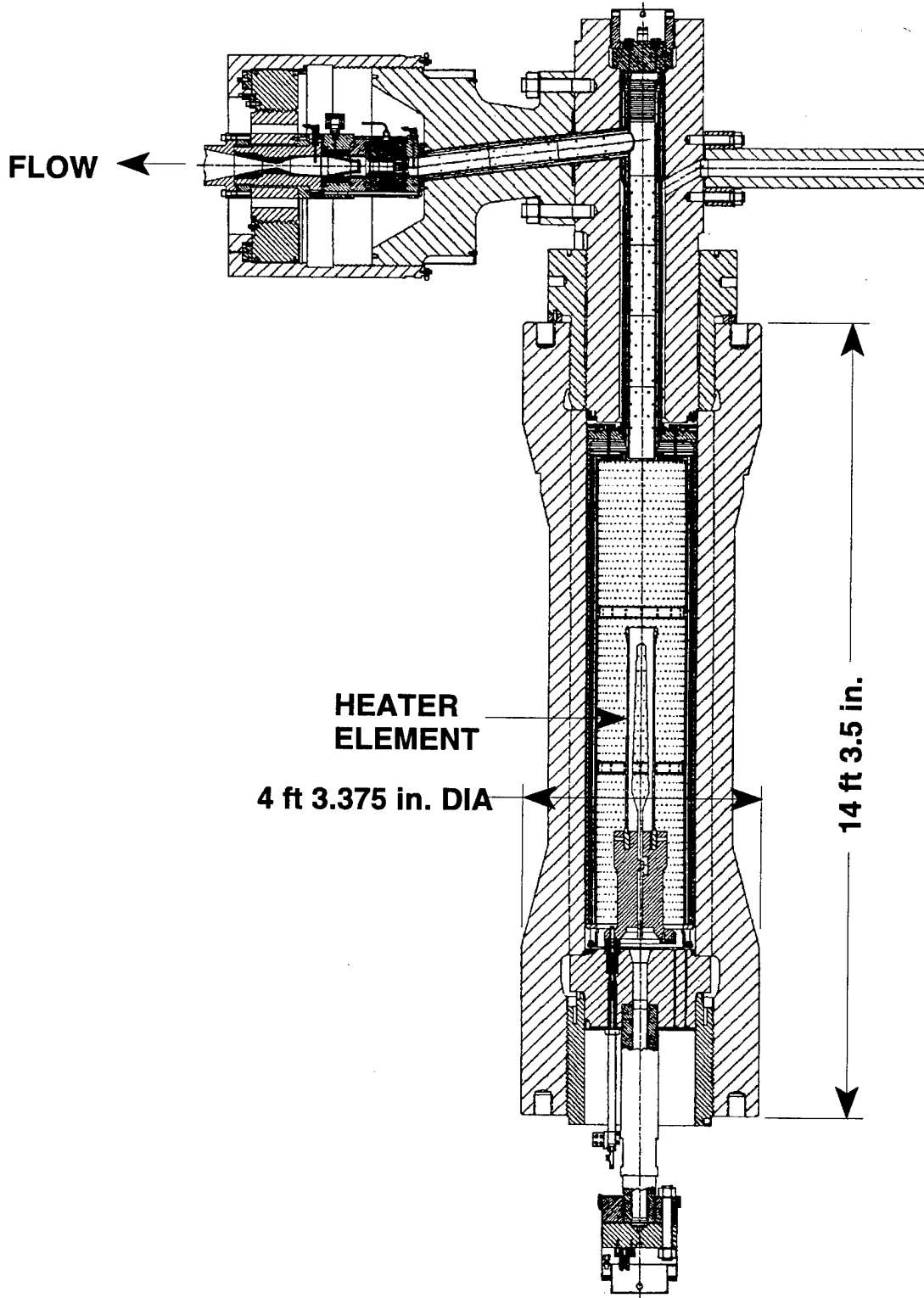

FIGURE 1. VERTICAL HEATER AND DIAPHRAGM SECTION



must be heated to at least 3000°F in a practical Tunnel 9 air facility; therefore, the heating element itself might have to operate at a surface temperature of perhaps 4000°F.

Mark Opeka, one of the task team members, suggested that the elevated air pressure existing during the heating process could considerably raise the critical temperature for the onset of active oxidation of the SiC coating. This increased critical temperature might effectively permit the higher element surface temperature required to heat air to the desired 3100°F. Opeka's predictions of absolute temperature limits of an SiC-coated system operating in air in Tunnel 9 are shown in Figure 2.

There were two unknowns in the process of assessing the practicality of operating an oxidation-resistant element as described. First, the maximum operating temperature of the Tunnel 9 heating elements had to be determined. Second, it was necessary to determine if there was a "best" or "optimum" electrical power-vs-time profile that would minimize the highest temperature the element would reach during heating of the air.

The first step toward determining the practicality of operating an SiC-coated graphite element was to measure the surface temperature of an uncoated graphite heating element to determine if it would remain within the predicted operating limits of the SiC coating, shown in Figure 2. To this end, the temperature of an actual heating element was measured while the element—operated in the Tunnel 9 facility—heated nitrogen gas to the same temperature and

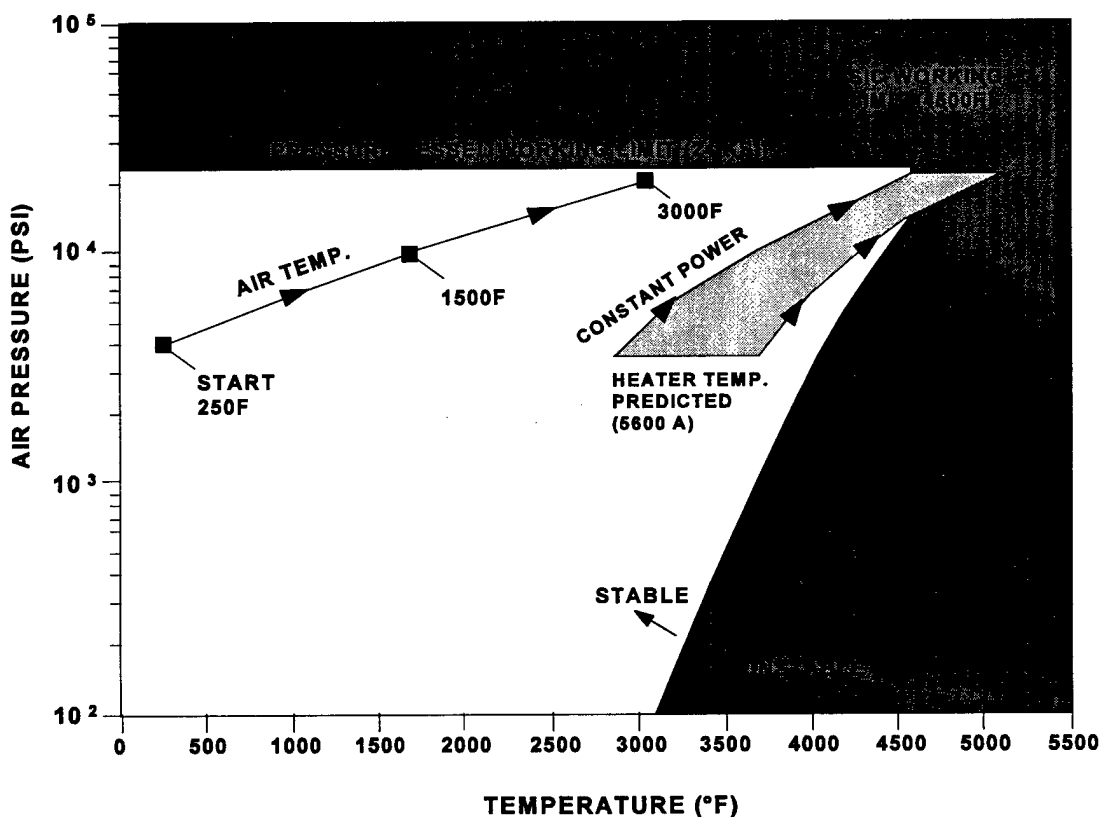

FIGURE 2. OPERATING LIMITS OF SILICON CARBIDE IN TUNNEL 9 HEATER

pressure end-condition envisioned for the Tunnel 9 air-heating process. The maximum element temperatures that would occur during the heating process were compared to the predicted SiC operating limits in order to determine whether or not the uncoated element's temperature remained within the predicted operating limits of the SiC coating. If results of this test showed promise, follow-on tests, not discussed here and not yet attempted, would measure the operating temperature of an SiC-coated element, again, heating nitrogen. These follow-on tests, if successful, would lead eventually to a trial test wherein an SiC-coated element would be used to heat a charge of air within a modified Tunnel 9 heater.

This report summarizes the results of five tests conducted in Tunnel 9. The operating temperature of both a graphite heating element and a graphite base used to support the element were measured with thermocouples during actual nitrogen batch heating.

## CHAPTER 2

### NITROGEN PRESSURE AND TEMPERATURE TEST DESCRIPTION

#### BACKGROUND

This five-test series, designated the "Nitrogen Pressure And Temperature" ("NPAT") Test, was performed in the existing Wind Tunnel 9 "Mach 14" north-leg facility, where the nitrogen pressure and temperature heating profiles are essentially identical to those envisioned for a Tunnel 9 air-heating concept. The principal objectives in taking the measurements were as follows:

- Determine what the maximum surface temperature of the element is as a function of heating process parameters, in particular as a function of the electric current driving the element.
- Determine if the element's temperature remains within the predicted operating limits of the SiC coating.
- Find an optimum electrical power profile that minimizes the highest temperature reached on the surface of the element during the heating process.

To this end, thermocouples were attached to the heating element and heating base at three key locations. The locations were designated "A", "B", and "C", as follows:

- Location A: Type-C tungsten-rhenium thermocouple, 0.020-in. diameter wire. Attached to one of the heater legs at the I.D. near the bottom fillets at the narrowest part of the heating leg, centered between the side fillets and 12.25 in. from the bottom end of the element. (Figure 3)
- Location B: Type-K chromel-alumel thermocouple, 0.020-in. diameter wire. Attached to the sidewall of one of the graphite heater base halves at the 10-in. diameter neckdown, 1 in. above the top surface of the base flange, on the plane of symmetry of the base half (Figure 3)
- Location C: Type-K chromel-alumel thermocouple, 0.020-in. diameter wire. Attached to the very bottom surface of the graphite support base, near the plane of symmetry (Figure 3)

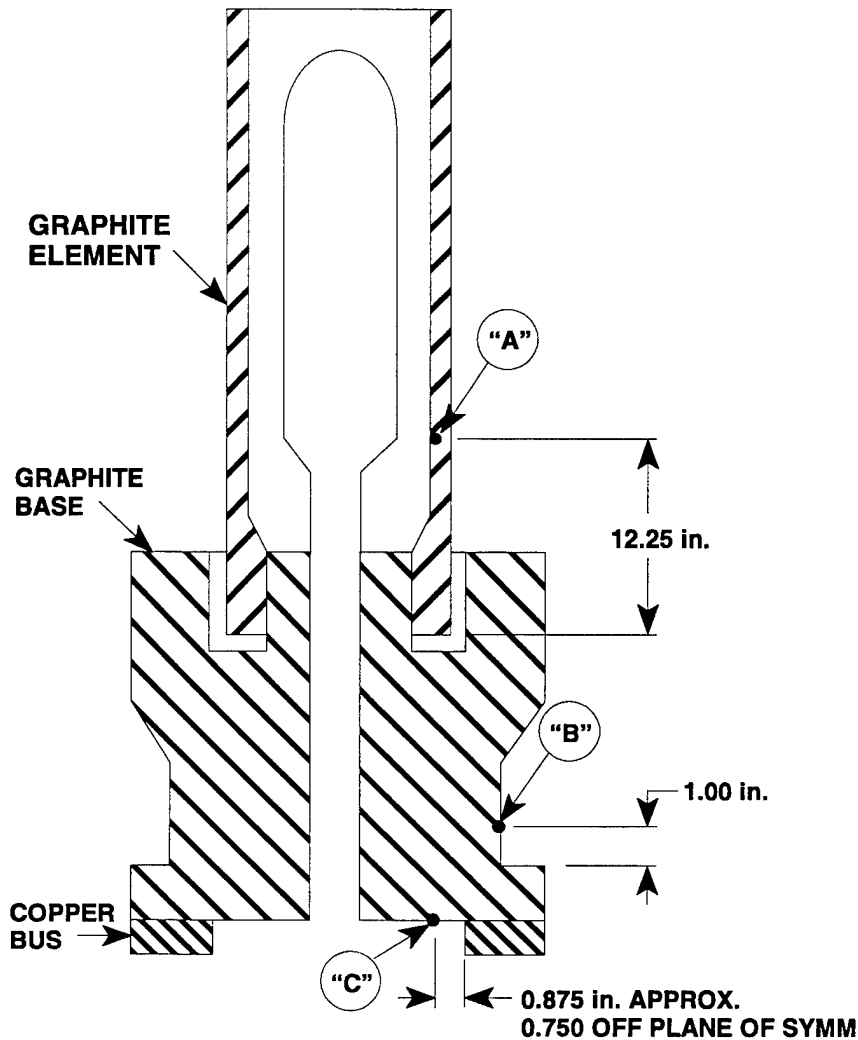

FIGURE 3. LOCATIONS A, B, AND C THERMOCOUPLES

### THERMOCOUPLE INSTALLATION

Since the element and base are made of graphite, it was not possible to tack-weld the thermocouples in place. Instead, two methods of attachment were used as follows: At location "A", a Type-C thermocouple prewelded bead was potted into a 0.113-in. diameter hole drilled 0.200-in. deep in the graphite leg at the ID location. Dylon grade GC-HS graphite cement was used to pot the bead in the hole. The graphite potting was cured by blowing air from heat guns onto the element at the location of the potted bead, while the temperature was measured using the bead itself as the thermocouple sensor. Curing of the potting required holding the temperature at 266°F for 4 hours; however, in our case the temperature was held for only 1 or 2 hours.

This potting method was not used at locations "B" and "C" owing to the large mass of the graphite base, which was impracticable to heat to the required 266°F cure temperature. Instead, a copper plug was specially designed to hold the thermocouple leads against a thermally conductive copper face, which was itself screwed into the base. A conical interface on the copper plug and the graphite base assured intimate thermal contact between thermocouple wire, copper,

and graphite. A belleville spring/washer arrangement ensured that the wires would maintain contact with the copper plug and precluded any loosening and subsequent loss of thermal contact between wire and plug. The special plug was usable only on the heater base at locations "B" and "C", where much lower temperatures were expected.

### Thermocouple "A" Installation

From the potted "A" thermocouple bead, the two bare thermocouple wires were routed down, first through individual Boron Nitride (BN) insulating tubes (maximum use temperature, approximately 5500°F) spaced 2.000 in. apart, as shown in Figure 4. BN insulator tubes were selected over alumina (melting point, 3800°F) since near the heating leg where the thermocouple was mounted, analytical Finite Element predictions had indicated that temperatures might exceed the melting point of alumina. The BN tubes were angled thru slots milled into the wall at the base of the heating element, in a low-temperature portion of the heater element leg. The BN tubes were held by threading them into the graphite heater base. The bottom end of the BN tubes emerged at a pocket milled into the side of the graphite support base. The overall arrangement not only allowed placement of the "A" thermocouple at the element ID, where it was believed the

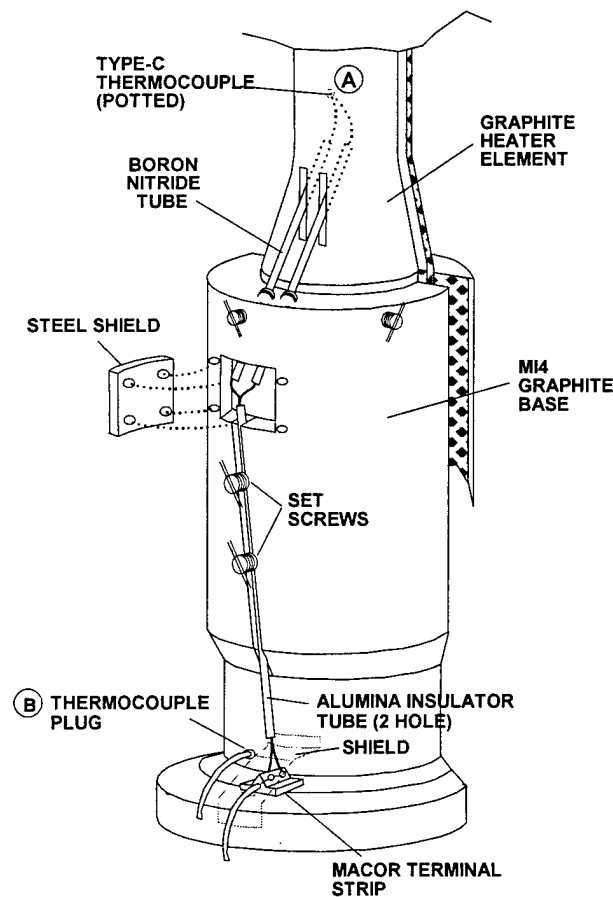

FIGURE 4. "A" THERMOCOUPLE WIRING PATH

highest element temperatures would occur (on account of self-radiation from the opposite leg), but also afforded some degree of protection of the wires and BN tubes from the high-velocity flow of nitrogen that occurs upward along the outside of the base during the tunnel blow that occurs after the nitrogen's heating period. A stainless steel access cover protected the wires emerging from the BN tubes at the side pocket. Within the side pocket, the bare wires exiting the two BN tubes were routed into a single, two-hole alumina insulator rod of 1/4-in. diameter. This rod was clamped in a groove milled into the side of the graphite base. This alumina insulator carried the two thermocouple wires down to a "Macor" terminal block mounted on top of the base flange of the element base. ("Macor" is a registered trademark of Corning Glass Works.) The Macor is a machinable glass ceramic having an advertised maximum use temperature of 1832°F. The two bare Type-C wires exiting at the bottom of the alumina two-hole insulator were each connected to one side of the Macor terminal block—the 5% rhenium leg connected to a "405" compensating alloy connector link and the 26% rhenium leg connected to a "426" compensating alloy link.

It was known from previous measurements that at the base flange of the heater support base, the temperature would not exceed 500°F; therefore, a transition was made at the Macor terminal strip from the bare Type-C thermocouple wire to a Type-C fiberglass-insulated duplex extension wire (maximum continuous use temperature 900°F). Each leg of the extension wire pair was attached to the corresponding connector links on the Macor block. From the Macor terminal block, the extension wire pair was routed through a stainless steel protector tube that carried them into a junction box bolted down to the steel bottom-closure plug of the heater. The wire cable was routed through this box and out to a 10-pin "military" connector that mated to the existing "East" 10-pin connector borrowed from one of four existing connectors used to carry thermocouple signals out of the heater vessel.

All wire connections at the Macor terminal block were spring-loaded by "sandwiching" the wires between two connector links, then placing either a Belleville or spring lockwasher over the top link and tightening the terminal screws over this.

The Macor terminal block itself was provided with a polished, angled, stainless steel radiation shield to reflect any radiation coming from the hot heater core above. This shield was important because the special "405/426" compensating alloy links maintain standard thermocouple accuracy limits up to a 500°F operating temperature. The radiation shield and closely spaced legs on the terminal block ensured that both legs would remain at essentially the same temperature, as is necessary to maintain accuracy even below 500°F. Fusible temperature-indicator paints (Reference 1) were used to verify that the temperature of the terminal strip never exceeded the 500°F, allowable operating temperature limit.

#### Thermocouple "B" and "C" Installation

Both "B" and "C" thermocouples used Type-K, 24-AWG (0.020-in.) duplex fiberglass-insulated pairs. As mentioned, the wires were clamped to a special copper attachment plug to form a thermocouple junction, and the plug was screwed into the graphite base. The fiberglass-insulated, duplex wire leads exiting from the end of each plug were routed through stainless

protector tubes to the junction box bolted down to the heater's bottom closure plug. Unlike the "A" thermocouple, in which the Macor terminal block was located outside the junction box, the "B" and "C" channels had their individual Macor terminal blocks located within this junction box. Chromel-alumel links were used to transition from the thermocouple wires to Type-K extension wires, which in turn went to the same 10-pin military connector to which the "A" extensions wires were connected. The wires were spring-loaded at the terminal block using the "sandwiching" method mentioned previously.

After installation, the location "B" thermocouple did not operate because of a wiring harness malfunction. Because the faulty portion of the harness was not accessible during these tests, the "B" location thermocouple was not repairable in time for these tests.

#### Photos of Test Apparatus

Figures 5 through 9 are photographs of the test apparatus showing the installation in the heater. Figure 5 shows an overall view of the temperature-measuring apparatus. Figures 6 and 7 are closeups of the location "A" tungsten-rhenium thermocouple potted into a heater element. Figures 8 and 9 are details of the Macor terminal strip and the copper plug used to measure the "B" and "C" location temperatures.

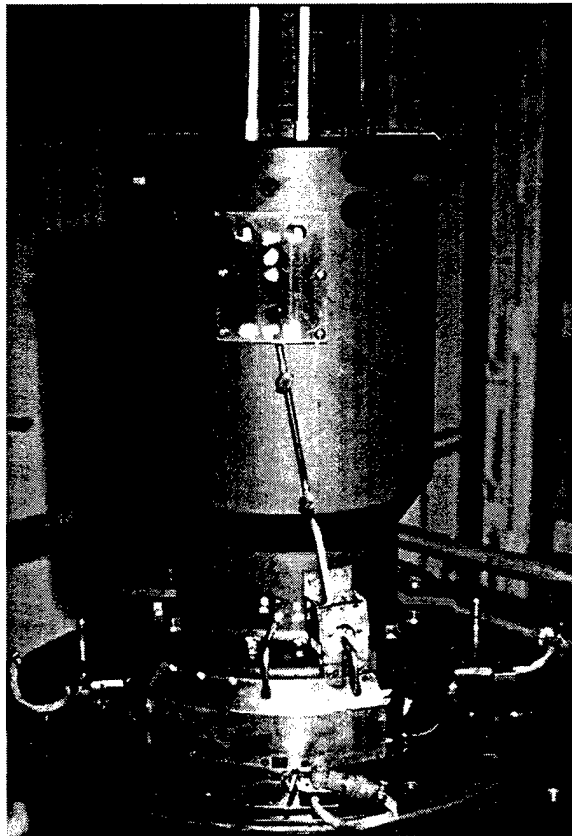

FIGURE 5. TEMPERATURE MEASURING APPARATUS INSTALLED IN HEATER VESSEL

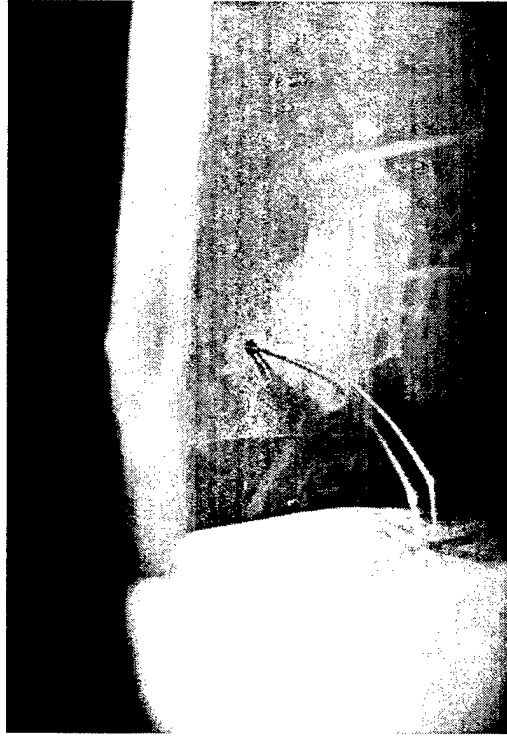

FIGURE 6. TUNGSTEN-RHENIUM THERMOCOUPLE POTTED INTO HEATER ELEMENT AT "A" LOCATION

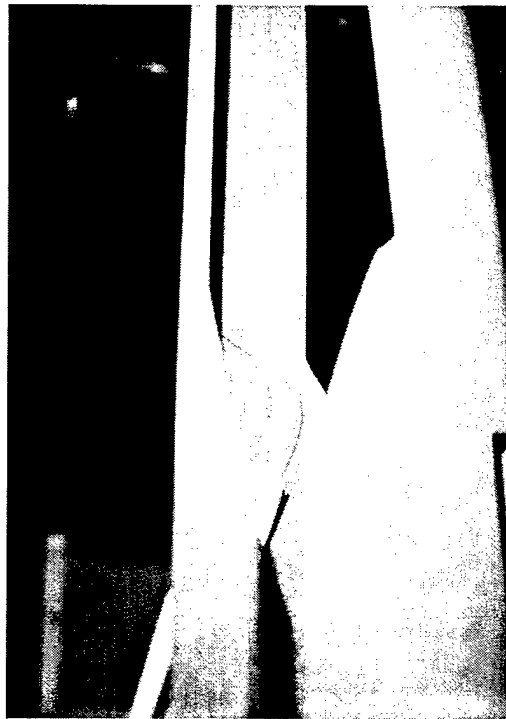

FIGURE 7. BORON NITRIDE INSULATOR TUBES AND "A" THERMOCOUPLE



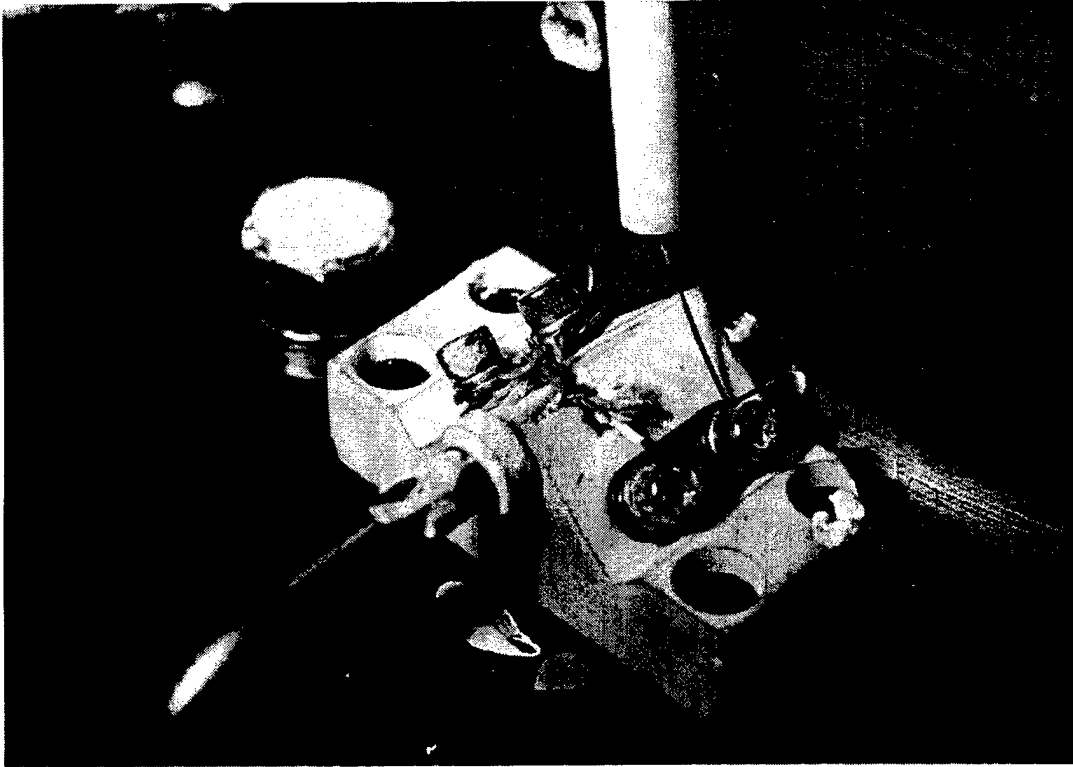

FIGURE 8. MACOR TERMINAL STRIP

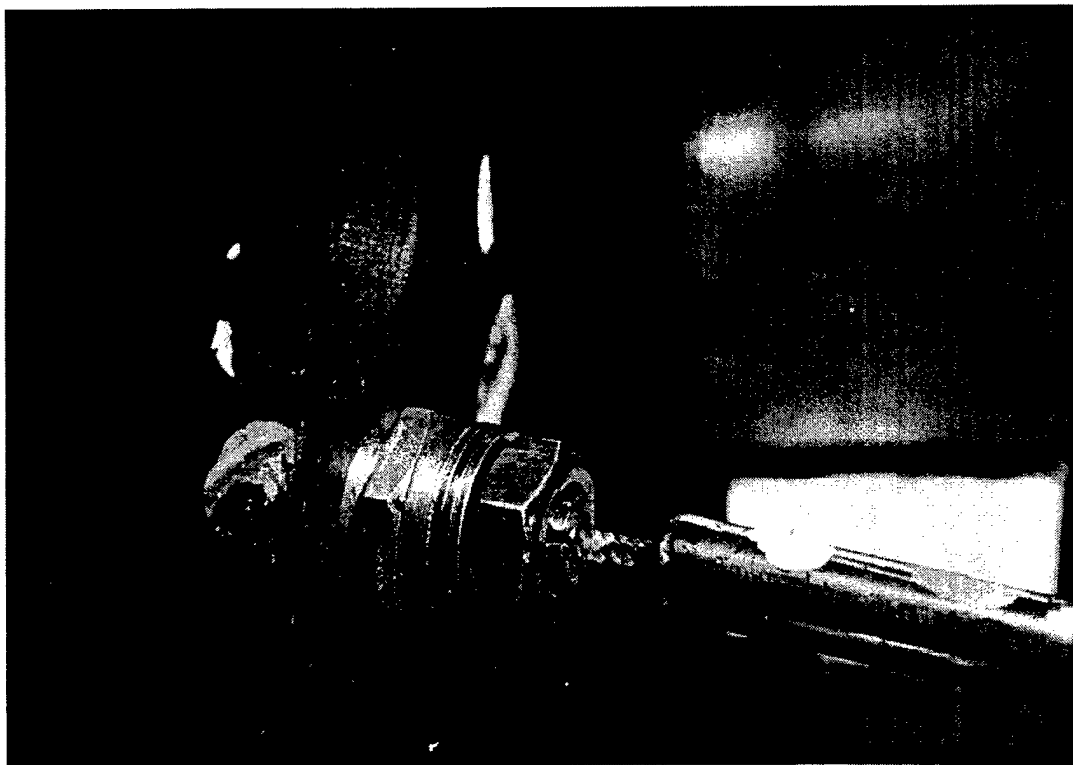

FIGURE 9. COPPER PLUG ASSEMBLY AT "B" LOCATION

Signal Routing

A block diagram in Figure 10 shows the per-channel, data-acquisition signal path for each of the thermocouple channels. Because each thermocouple was directly attached to the graphite heating element or graphite support base, the raw signal had a 60-Hz AC voltage, on the order of 100 V, superimposed on the signal during the entire heating period. A 150°F thermocouple reference oven was used (STA Systems Technology Associates, Inc, SN56021). The 150°F referenced thermocouple signal was passed through a Preston differential/buffer amplifier (Preston 8300 XWB Amp, model C) set to a gain of 1.0. The Preston Amp was used to buffer the raw signal by rejecting the common mode voltages (due mostly to the AC power source). The Preston Amp also attenuated signals above 10 Hz frequency with an internal low-pass filter set at 10 Hz. The output of the Preston Amp was, ideally, a 150°F referenced thermocouple signal voltage with all common mode voltages and noise above 10 Hz stripped off. This signal was passed to an "Analog" amplifier that amplified the signal by a voltage gain factor of 200.0. An Analog-to-Digital (A/D) converter then converted the amplified signal to a digital word having a value from 0 to 4096, corresponding to -10 to +10 V.

A VAX computer program used an internal curve-fit scheme to convert the amplified voltage back to a temperature value, as the figure shows. For the "A" thermocouple, a linear fit

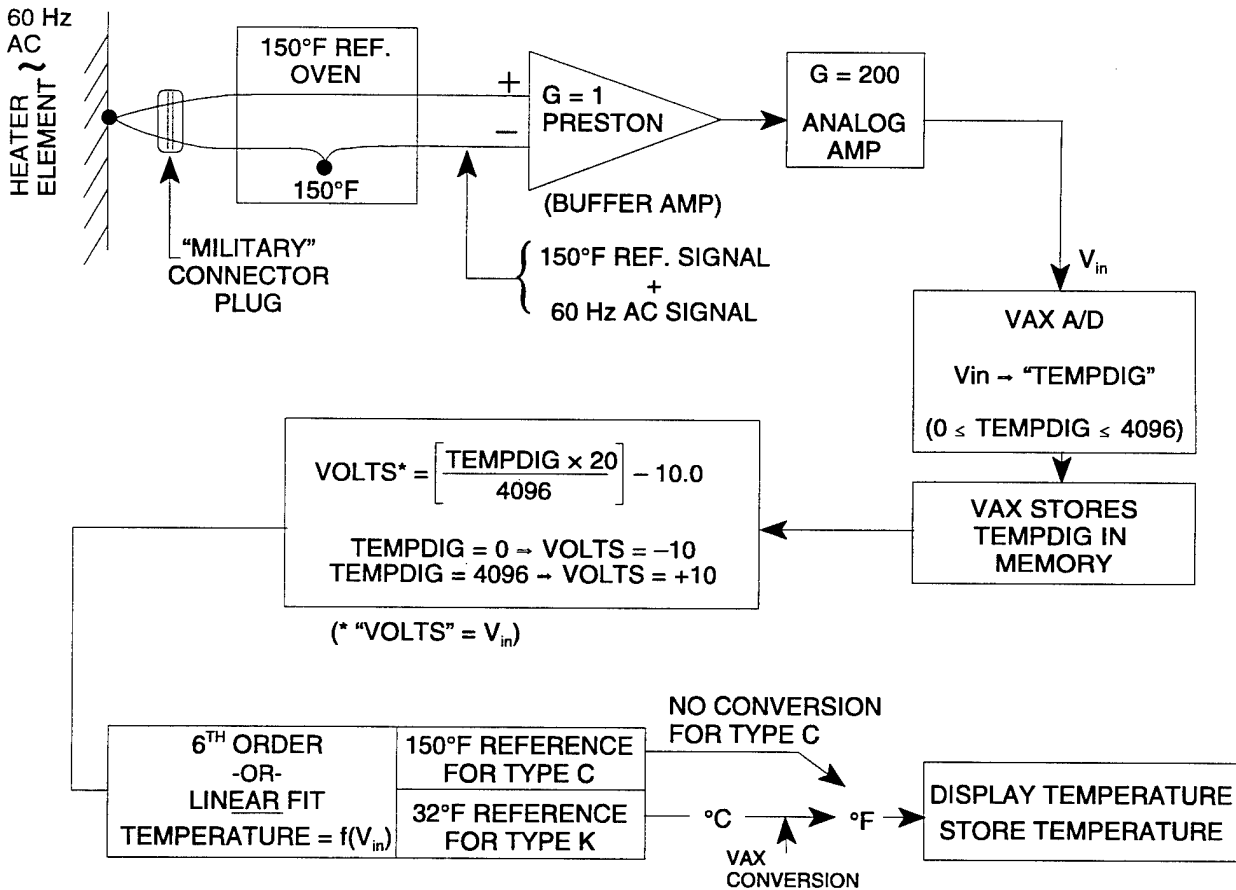

FIGURE 10. PER-CHANNEL THERMOCOUPLE SIGNAL PATH

was used up to a temperature of 637.7°F (corresponding to an amplified voltage level of 4.5 mV). Above 637.7°F, a 6th-order polynomial fit was used. The linear/6th-order fit combination used for the "A" location was essentially equivalent to the NIST calibration for a Type-C tungsten-rhenium thermocouple, but modified for a 150°F reference junction rather than a 32°F reference. For the "C" location chromel-alumel thermocouple, a 6th-order polynomial fit equivalent to a NIST calibration was used. However, instead of using the correct curve fit for a 150°F referenced signal (i.e., the output signal of the thermocouple circuit is zero volts when the temperature of the active junction equals the reference junction temperature of 150°F), a curve corresponding to a 32°F referenced signal (i.e., 32°F = zero output volts) was inadvertently used. The error produced by the VAX when using a nonlinear 32°F polynomial is generally not corrected with a simple, single-value temperature shift but rather with a single-value voltage shift. However, in this case the "C" location thermocouple operated always in a sufficiently linear region, so a simple temperature shift was acceptable.

The theoretical and actual coefficients for the 6th-order polynomial fit for the Type-C thermocouple (location "A") are shown in Table 1. Those for the Type-K thermocouple (location "C") are shown in Table 2. Note that some of the trailing digits for the coefficients used by the VAX are different from the trailing digits of the theoretical coefficients. The reason for this difference is that although the coefficients were entered correctly, the computer's formatting procedure apparently replaced the trailing digits with "random" digits. The reason for the substitution is not known, but is believed to be a software "bug" in the formatting program. In addition, the coefficient for the 3rd-order term for the "C" location thermocouple contained a reversed-digit typographical error. Careful analytic study showed that the total error due to both the VAX reformatting and the reversed digits was negligible for the temperature ranges of interest.

TABLE 1. POLYNOMIAL COEFFICIENTS FOR TYPE-C THERMOCOUPLES

Order	150°F Reference, 6th Order		150°F Reference, linear	
	Theoretical	Actual Used	Theoretical	Actual Used
0	-17.10626352	-17.1062622	151.3005	151.3005
1	919.8054128	919.8054199	540.5398	540.5398
2	-322.1283378	-322.1283264		
3	110.5056895	110.5056915		
4	-20.14156274	-20.1415634		
5	1.930167761	1.9301680		
6	-0.073333183	-0.0733330		

TABLE 2. POLYNOMIAL COEFFICIENTS FOR TYPE-K THERMOCOUPLES

Order	32°F Reference	
	Theoretical	Actual Used
0	-0.014823388	-0.014823
1	119.5493399	119.5493393
2	4.88568203	4.8856821
3	-2.217558885	-2.1275589
4	0.372132375	0.372132
5	-0.027125276	-0.0271250
6	0.000756882	0.0007570

Fusible temperature paints, rated at 400°F, were placed at key locations on the screw heads that secured the wires and links to the terminal blocks. Also, paints rated 400°, 475°, and 750°F were placed on all radiation shields, on the foot of the heater base, on the copper bus (which is bolted to the bottom of the graphite heater base), and on the graphite adjacent to the nonfunctioning “B” thermocouple. None of these paints melted during the course of this test series, indicating that the temperature at these locations never exceeded 400°F—well within the accuracy range of the extension wires.

### System Calibration

The calibration procedure involved removing the active thermocouple junction from the circuit at the military connector plug, shown in Figure 10. A millivolt source (Digitec 3110 Precision Voltage/Current source, HT series) was inserted in place of the thermocouple at “mV1”, shown in Figure 11. Calibration voltages were fed in, and the thermocouple output readings, appearing on a display screen in the control room, were recorded. All calibrations were two-point. For the first calibration, while the specified voltage input shown in Table 3 was applied, the Analog amplifiers were adjusted to achieve the exact high-point and low-point temperature readings given in Table 3 in the column labeled “Incorrect True Temperature Used”. It was not realized until after all five tests that the theoretical temperatures used for the specified calibration voltages were incorrect. The temperatures in the “Incorrect True Temperature Used” column of Table 3 are true only for the case where the millivolt source is inserted at the input to the Preston Amps, thus bypassing the 150°F reference junction. As indicated, the millivolt source was inserted as shown in Figure 11 so that it did NOT bypass the reference junction. The correct true temperatures for the given input voltages in Table 3—and for the millivolt source replacing only the active (non-reference) thermocouple junction, as was done in the actual calibrations—are also given in Table 3, in the column labeled “Equivalent True Temperature”.

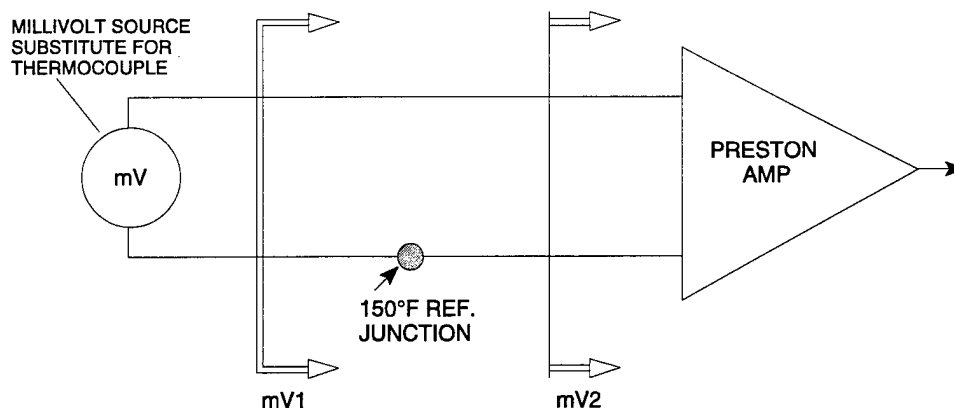

FIGURE 11. mV1 AND mV2 CALIBRATION VOLTAGE INSERTION POINTS

TABLE 3. CALIBRATION INPUT VOLTAGE VS. EQUIVALENT TRUE TEMPERATURE\*

	Calibration Volts Input (mV)	Equivalent True Temperature (°F)	Incorrect True Temperature Used (°F)
TYPE C	0.0	70	150
	36.1	4072	4200
TYPE K	0.0	70	150
	19.6	923	1000

\*Millivolt source replacing thermocouple with reference oven remaining in circuit. Figures based on an assumed room temperature of 70°F.

A two-point calibration, made for each thermocouple prior to the first test (Tunnel run 2378) was designated calibration 1. Calibration 1 was checked again after the fourth and fifth test runs and these checks are designated calibration checks 2 and 3 (check 2 made after tunnel run 2381, check 3 made after run 2382). Table 4 shows the calibration data. As shown, there are significant differences between calibration 1 and calibration checks 2 and 3, for both the "A" and "C" location thermocouples. It was discovered, while setting up to do calibration check 2, that the 150°F reference oven was switched on, but that the oven heaters were, in fact, off. Thus, the reference junction was at room temperature instead of 150°F. This caused the "A" thermocouple, when at room temperature, to read approximately 150°F on the VAX. The oven was repaired and the calibrations checked after the oven reached the 150°F reference temperature. However, it is believed that the oven was also at room temperature during calibration 1. The 150°F room temperature reading when the oven was off could therefore be explained as follows: For the "A" thermocouple, inserting zero millivolts at "mV1" in Figure 11, with the oven and reference junction at the same room temperature, would result in zero millivolts into the Preston Amp, making the VAX "think" that we had reference and active junctions both at 150°F, when in fact they were both at room temperature. When the oven later began to operate at a proper reference junction temperature of 150°F, the "A" temperature reading at the low-point calibration for

TABLE 4. NPAT CALIBRATION DATA

#	DATE	mV IN	VAX READING (°F)	COMMENTS
1	~24 MAR	0.0	150	TYPE C, "A" LOCATION, PRE-RUN 2378
1	"	36.09	4200	TYPE C, "A" LOCATION, PRE-RUN 2378
2	?	0.0	85	TYPE C, "A" LOCATION, POST-RUN 2381
2	"	36.1	4162	TYPE C, "A" LOCATION, POST-RUN 2381
3	4-5-93	0.0	77	TYPE C, "A" LOCATION, POST-RUN 2382
3	"	36.1	4150	TYPE C, "A" LOCATION (-0.13 V TO VAX)
1	~24 MAR	0.0	150	TYPE K, "C" LOCATION, PRE-RUN 2378
1	"	19.6	1000	TYPE K, "C" LOCATION, PRE-RUN 2378
2	?	0.0	36	TYPE K, "C" LOCATION, POST-RUN 2381
2	"	7.91	385	TYPE K, "C" LOCATION, POST-RUN 2381
2	"	19.6	901	TYPE K, "C" LOCATION, POST-RUN 2381
3	4-5-93	0.0	32	TYPE K, "C" LOCATION, POST-RUN 2382
3	"	7.91	380	TYPE K, "C" LOCATION, POST-RUN 2382
3	"	19.6	897	TYPE K, "C" LOCATION, POST-RUN 2382

checks 2 and 3 would read the existing room temperature, whatever it happened to be at the time of the calibration checks: in this case, 85° and 77°F, respectively.

Calibration checks 2 and 3 for the "C" location (Type-K) thermocouple show large downward zero-shifts on the order of 103° to 118°F, as Table 4 shows. However, these zero-shifts are only partially explained by the possibility that the calibration oven was off. The reason is that the large downward zero-shifts in VAX temperature calibration readings for calibration checks 2 and 3 are 49°F and 45°F more than what would occur had the oven been off when the original calibration points had been set. Moreover, and perhaps coincidentally, the temperature readings and input voltages used for calibration checks 2 and 3 essentially match the temperatures and corresponding output voltages for a standard Type-K thermocouple circuit having a 32°F reference junction, as listed in the standard NIST calibration table.

A test of the common mode-rejecting ratio of the Preston Amps was performed prior to the test by connecting a variable-voltage AC source to three substitute thermocouples (one Type-C and two Type-K) connected into the data system at the military connector. The AC voltage was varied from 0 to 120 V AC, and NO CHANGES were observed in the thermocouple readout voltages throughout the AC-input variation. The 10-Hz filter on each Preston Amp was tested for cutoff point and attenuation rate by connecting an AC voltage source across each amplifier input and recording the output. The results indicated that the attenuation at 60 Hz was 18.6 dB. This means that non-common-mode noise induced on the signal lines by the 60-Hz heater power source was attenuated by this amount.

The "A" location thermocouple was tested *in situ* several times for response to heat prior to closing the heater vessel. A "Minimite" heat gun was handheld 1 in. from the OD surface of the heating leg directly opposite the "A" thermocouple on the ID surface. The VAX temperature reading was monitored, and when the reading reached 140°F, the gun was removed and the cooling response recorded by the VAX. The cooling response data indicated that the responses were consistent with each other.

Finally, Reference 2 reported on independent calibrations made on Type-C thermocouples potted into 2020 Stackpole graphite and carbon-carbon samples with Dylon graphite cement, in the same manner that the "A" thermocouple was installed for these tests. These calibrations were conducted at Southern Research Institute (SRI) in anticipation of this test. These calibrations indicate that the potted thermocouples tracked the true temperature of the graphite sample very well (as measured by an optical pyrometer). Although the actual numerical calibrations performed by SRI were not used in this test, the SRI tests demonstrated that measuring temperature using a thermocouple bead potted directly into the graphite substrate was a viable method.

During the SRI calibration, the thermocouple wire reacted with the hot graphite. After times ranging from 25 to 62 minutes (depending on the temperature), a thermocouple would deteriorate to the point that it was no longer serviceable. In spite of progressive deterioration, thermocouple accuracy did not suffer greatly except near the end of the last of four SRI calibrations. In the Tunnel 9 test, because of the very high temperatures, the "A" thermocouple was also expected to have a finite service life. A typical Tunnel 9 heating period lasts only 15 to 20 minutes, which is a much shorter time than the SRI tests. However, because the exact

operating temperature of the heating element was not yet known, there remained the question of whether or not the thermocouple assembly would last through a single Tunnel 9 gas heating cycle.

### CORRELATION BETWEEN THERMOCOUPLE "A" AND PEAK TEMPERATURE

A correlation is required between the measured temperature at location "A" on the uncoated element and the maximum surface temperature on the SiC-coated element. An exact correlation does not exist; however, finite element studies provided an approximate analytical correlation between the expected temperature at the measurement point "A" and the peak surface temperatures occurring on the uncoated element. Reference 3 analyzed a standard "K" style heating element, which is, essentially, the heater design used for these tests. The analytic studies in Reference 3 suggested that two hot spots occur in the heating element leg, one near the top fillet and one near the bottom fillet. The hottest surface temperatures were found to occur at locations designated "D" and "E", shown in Figures 12a and 12b (it was assumed for these studies that the highest surface temperatures occur on the same radial line as the hottest interior point). Point "A", where thermocouple "A" was located, was not at either surface hot spot.

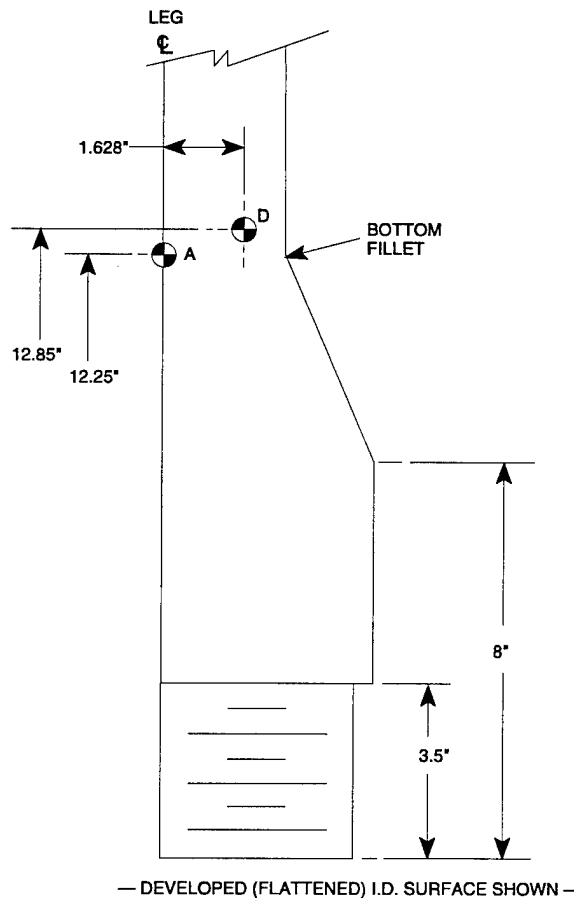

FIGURE 12a. "A" AND "D" LOCATIONS ON HEATER ELEMENT



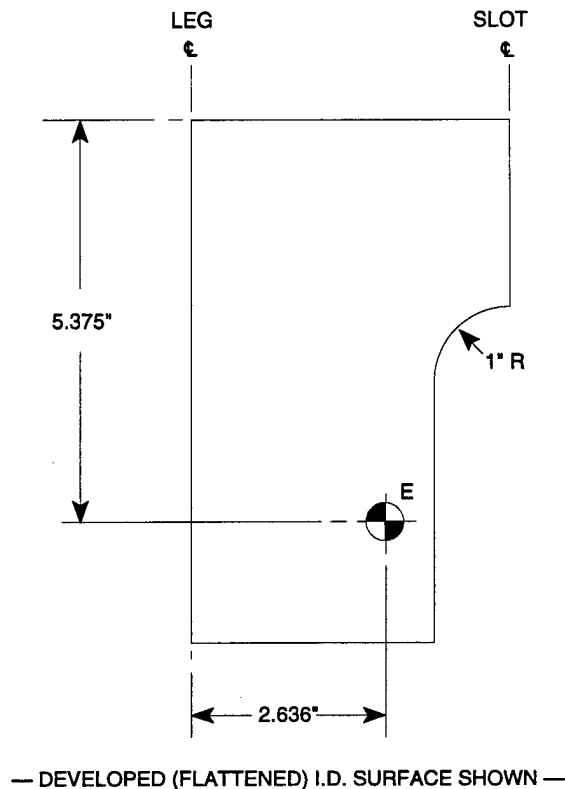

FIGURE 12b. "E" LOCATION ON HEATER ELEMENT

The Finite Element model for the "K" style heater, used in the Reference 3 studies, was used here, again, to provide the needed correlation. First, thru-the-wall temperature profiles were extracted for the "A", "D", and "E" locations in the model. The profiles were obtained at three points in time in the standard Mach 14 type heating cycle, as follows:

TIME	HEATER GAS TEMPERATURE (°F)	HEATER GAS PRESSURE (ksi)
"START OF HEATING"	300	3.6
"MIDDLE OF HEATING"	1600	9.4
"END OF HEATING"	3200	22.0

The estimated temperature profiles are shown in Figures 13 through 15. In all cases, a nominal 5650-A current is used. By assuming that thermocouple "A" will indicate the average temperature of the inner half-thickness of the wall (the bead was potted about halfway into the wall at the ID) a correlation between the "A" reading and the maximum surface temperatures at "D" and "E" can be obtained.

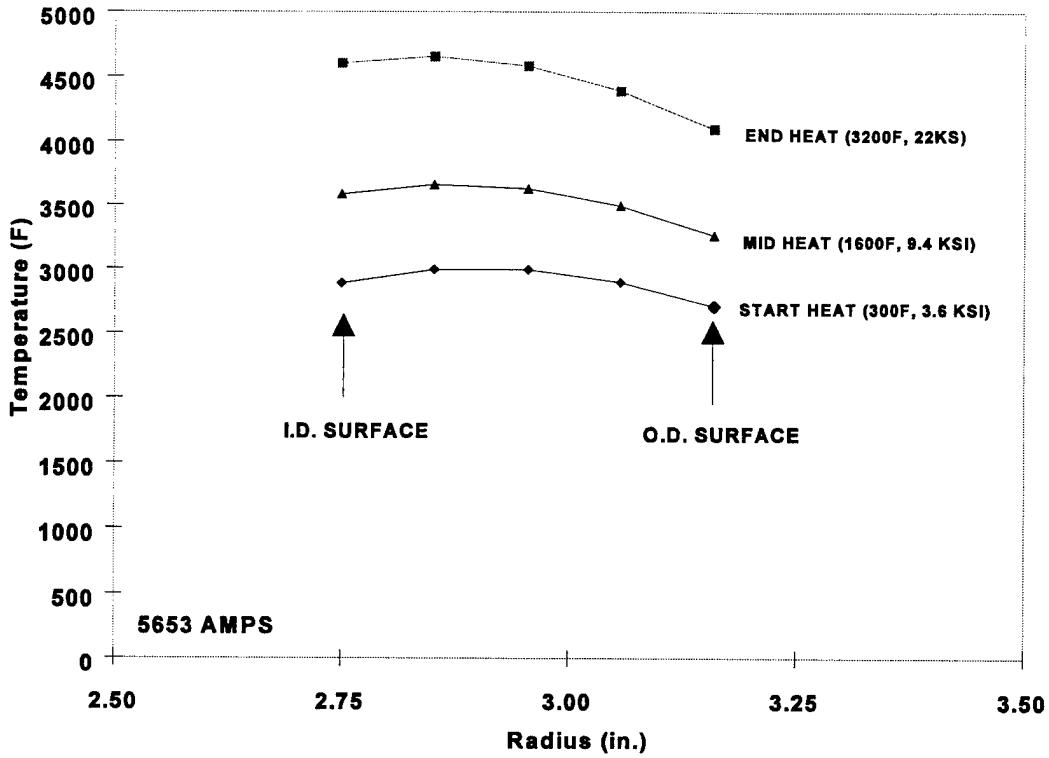

FIGURE 13. POINT "A" TEMPERATURE PROFILES IN J & K HEATER WALL

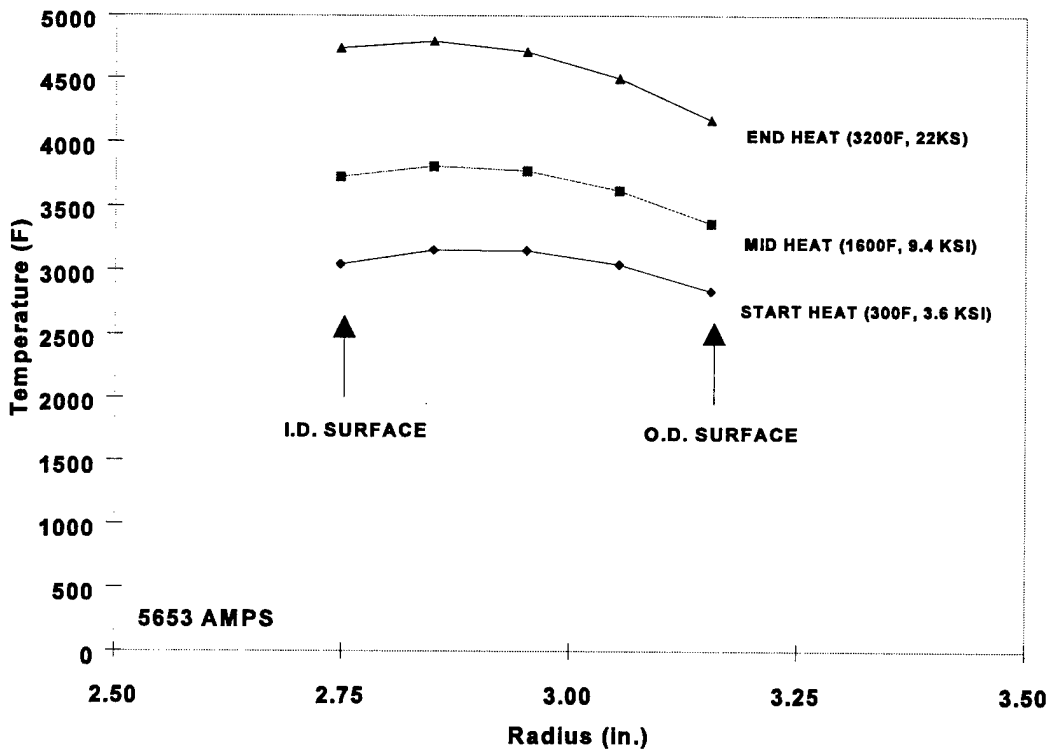

FIGURE 14. POINT "D" TEMPERATURE PROFILES IN J & K HEATER WALL

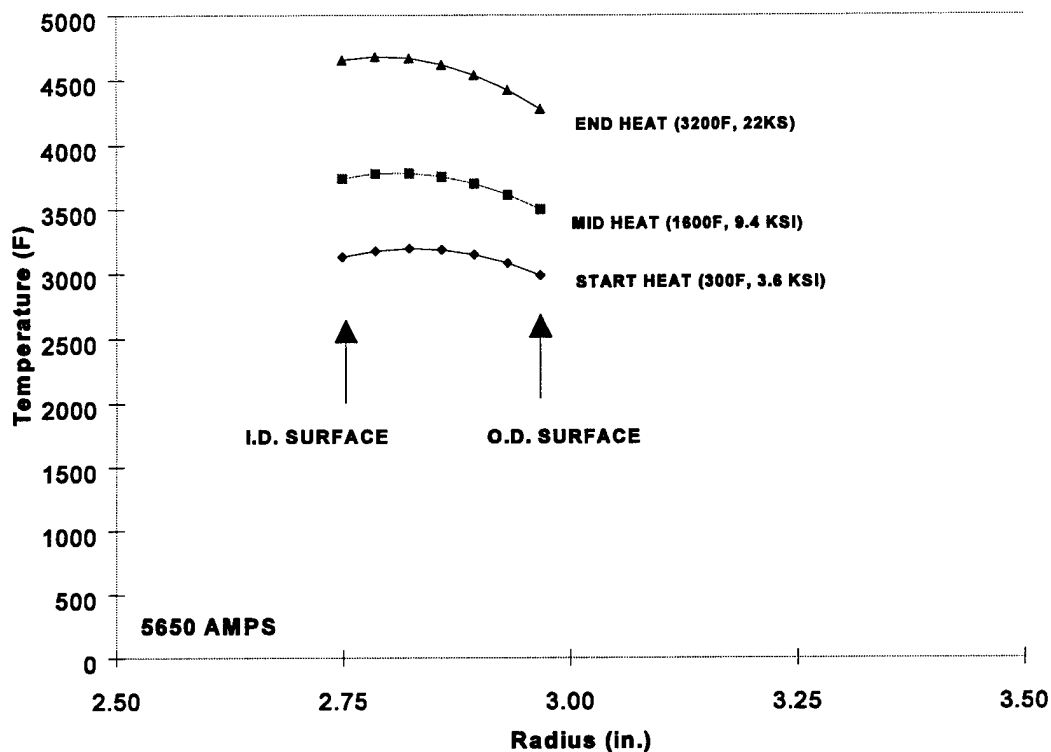

FIGURE 15. POINT "E" TEMPERATURE PROFILES IN K HEATER WALL

The correlation indicated that the average half-wall temperature at the "A" location was only slightly less than the maximum bottom ("D") and top ("E") surface temperatures (50° and 150°F less for bottom and top, respectively, at start of heating; 0° and 100°F less for top and bottom, respectively, at end of heating). Also, the top ("D") and bottom ("E") surface temperatures were found to be essentially equal to each other throughout the heating period. This meant that, for all practical purposes, the analytic correlation between the measured temperature at point "A", and the peak surface temperatures at the top and bottom hot spots is essentially 1 to 1, at the 5650-A current, for the entire heating cycle. Subsequent studies showed that this 1-to-1 correlation also held for the 4500-A and 6500-A electrical currents for locations "A" and "D" (location "E" was not investigated for these currents).

#### NOTE ON CALIBRATION ERRORS AND CORRECTIONS

Due to the calibration errors described above, and the malfunctioning of the 150°F reference oven, the raw data required corrections that are explained in Appendix A. Further, a detailed discussion of error sources, and their effect on data accuracy, appears in Chapter 5. Overall, the corrections to the "A" thermocouple data are relatively small (when considering the maximum temperatures measured). In spite of the problems encountered during calibration, only zero-shift calibrations for the "C" thermocouple were greatly affected. A reliable room temperature reference was available from an independent thermocouple located in the region where the "C" measurements were made. This reference was used to correct both the "A" and,

more importantly, the "C" thermocouple room temperature reference point. See Chapter 5 for further discussion of error sources.

## CHAPTER 3

### "NPAT" TEST RESULTS

The heating element and heating base temperatures were measured for five complete Mach 14 type heating cycles. The tunnel heating and run processes were standard in most regards, with the heater being precharged with nitrogen to 3000 psi nominally, then heated over an approximately 13- to 17-minute period to a nominal 21 ksi and 3100°F end condition.

In the actual test, the location "B" thermocouple did not operate because of a wiring harness malfunction. The "C" location thermocouple was operable for all five tests, without incident. Two "A" location thermocouples were tested. The first "A" location thermocouple, designated "No.1" lasted for two complete tunnel heating/run cycles (runs 2378 and 2379). The No. 1 thermocouple assembly was destroyed on handling after the second run (2379). The wire's extreme fragility and brittleness, resulting from the heat-induced recrystallization and attack by the hot graphite, caused it to break, at the point where it exited the graphite cement potting. A replacement "A" thermocouple, designated "No. 2" was installed, and it survived the next three Tunnel 9 heating/run cycles before it broke (runs 2380 through 2382).

The BN leadout tubes were bleached white where they jutted upwards from the heater base. The BN tubes were coated with a fine layer of graphite or carbon film where they protruded into the pocket milled into the side of the graphite base. This film apparently diffused into the surface of the BN because the film could not be easily rubbed off. This kind of coating is mentioned in Reference 1 and is thought to be deposited by gas-borne carbon atoms that "evaporated" off the hot graphite element, then recondensed on lower temperature surfaces and diffused into the surface as a result of the heat. This would also explain the observation of the bleached white upper portions of the BN tubes, where, owing to the direct heating of these tubes by the adjacent heating element, their surface was probably too hot to allow condensation of any carbon vapor during the heat cycle.

### DATA CORRECTIONS

The raw VAX data were corrected using schemes presented in Chapter 5 of this report.

DATA PRESENTATION

The data are presented several different ways. First, the data are plotted versus time in Figures 16 to 20. This method of presenting the data shows several heating process parameters of interest, such as temperature at locations "A" and "C", heater current, heater supply voltage, heater gas pressure and gas temperature, for the five tests.

Second, the data are plotted in a Pressure-versus-Temperature format. Here, Figures 21 through 25 show the data in a semi-log format with heater gas pressure versus temperature. This format is identical to Figure 2, which shows the predicted temperature limits of the SiC coating in an air atmosphere and the north heater vessel working pressure limits. Also shown is a Finite Element prediction of the heater temperature for a 5500-A constant current input to the heating element.

Finally, Table 5 shows the peak temperatures reached at location "A" and "C" for each of the five tests, the time of occurrence of each peak, the peak heater gas temperature and time of occurrence, and the corresponding gas pressure.

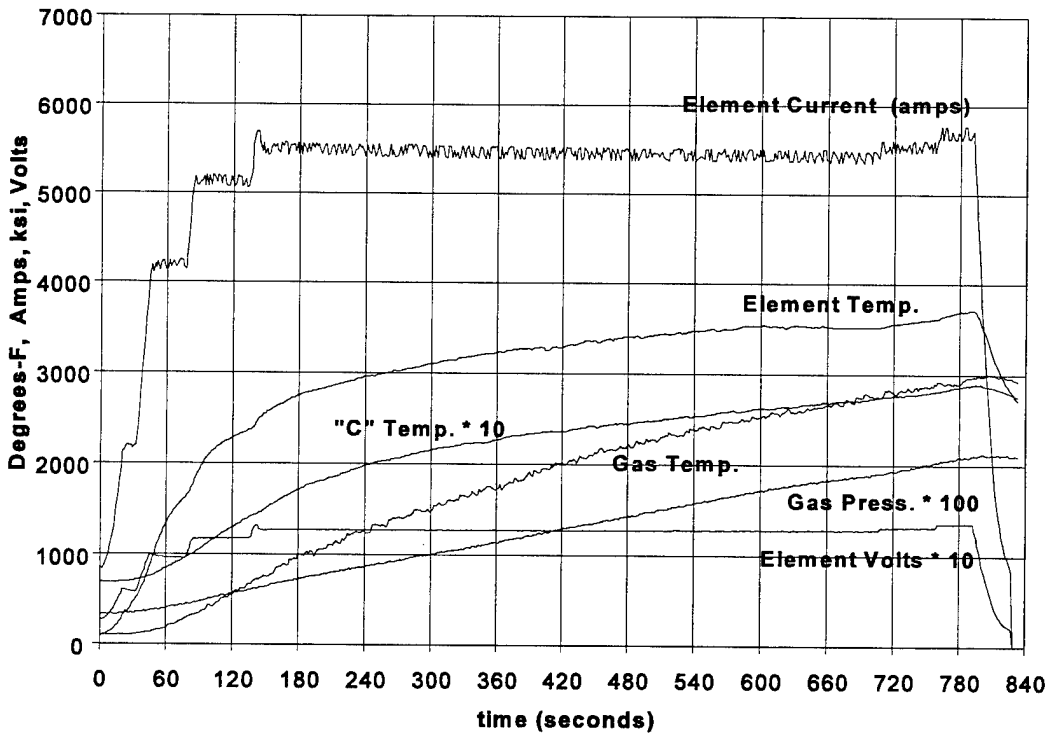

FIGURE 16. GRAPHITE HEATING ELEMENT TEMPERATURE VS. TIME FOR TEST NO. 1 (RUN 2378)

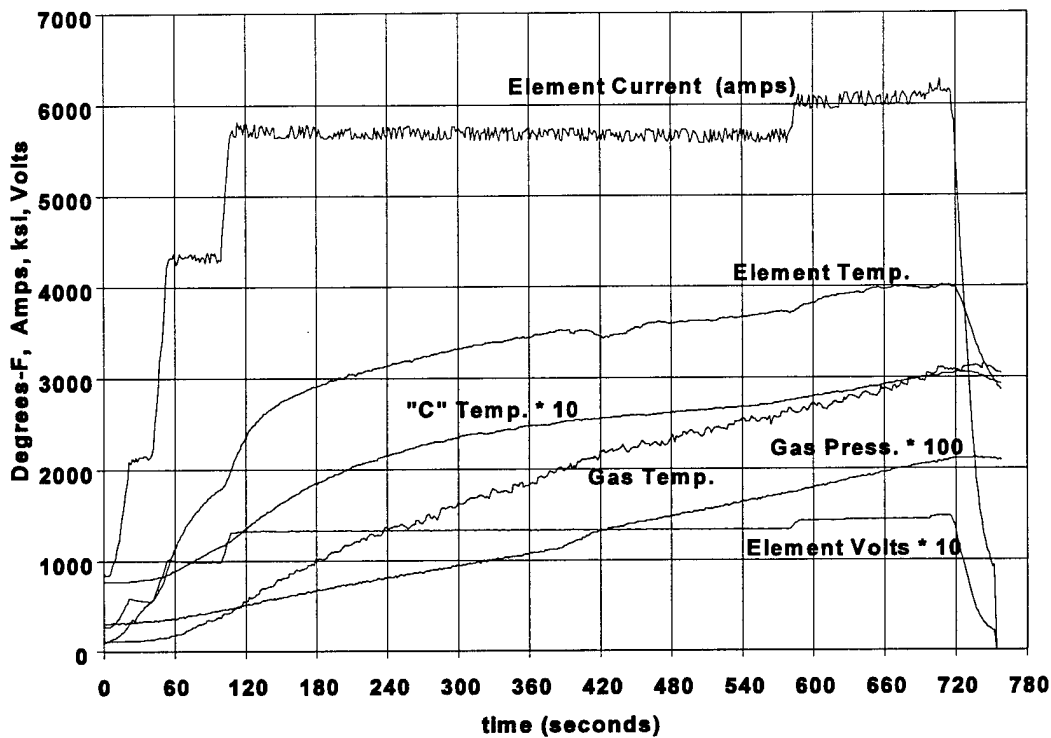

FIGURE 17. GRAPHITE HEATING ELEMENT TEMPERATURE VS. TIME FOR TEST NO. 2 (RUN 2379)

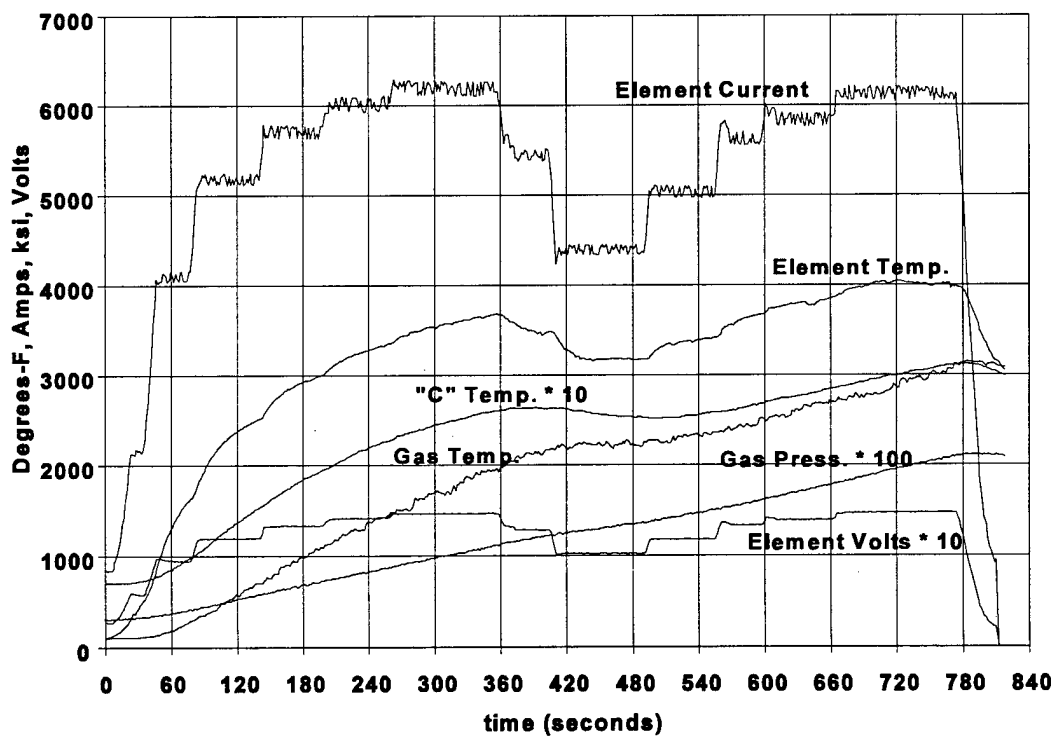

FIGURE 18. GRAPHITE HEATING ELEMENT TEMPERATURE VS. TIME FOR TEST NO. 3 (RUN 2380)

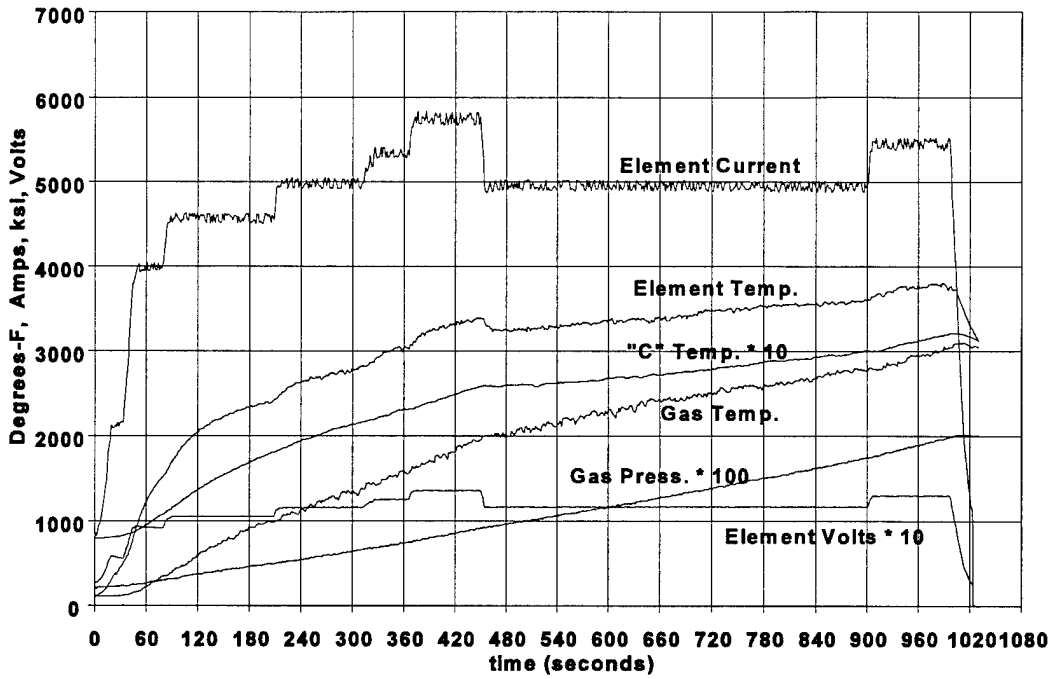

FIGURE 19. GRAPHITE HEATING ELEMENT TEMPERATURE VS. TIME FOR TEST NO. 4 (RUN 2381)

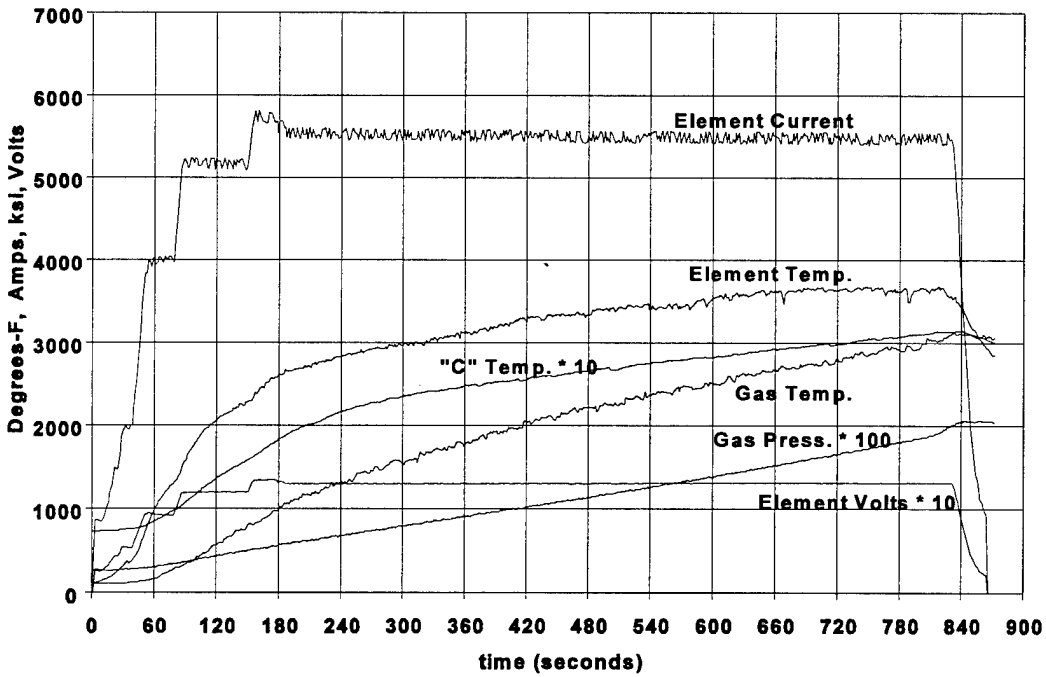

FIGURE 20. GRAPHITE HEATING ELEMENT TEMPERATURE VS. TIME FOR TEST NO. 5 (RUN 2382)



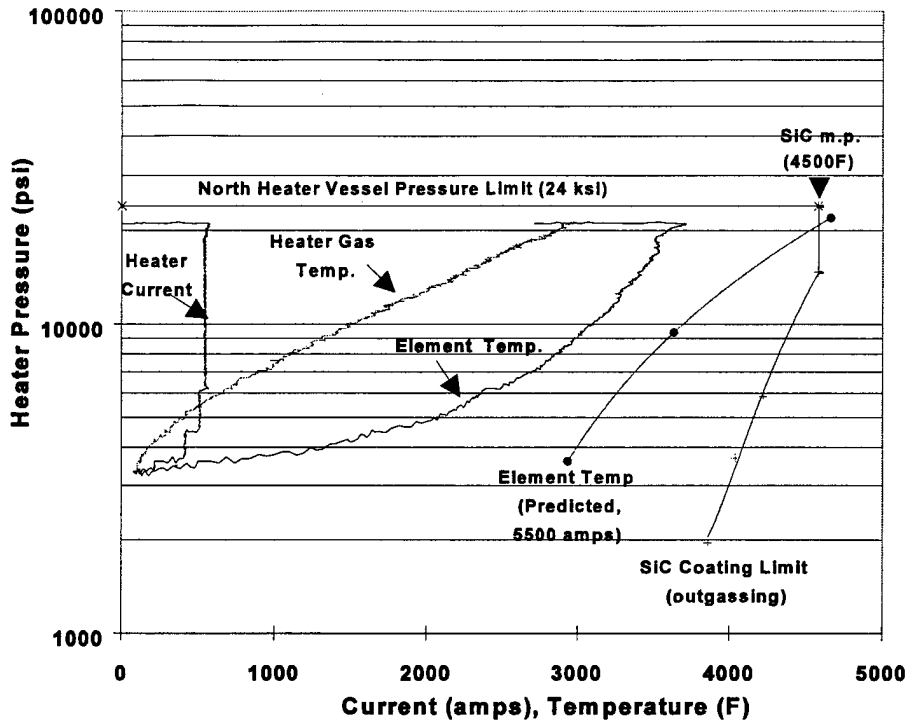

FIGURE 21. PRESSURE VS. TEMPERATURE FOR TEST NO. 1 (RUN 2378)

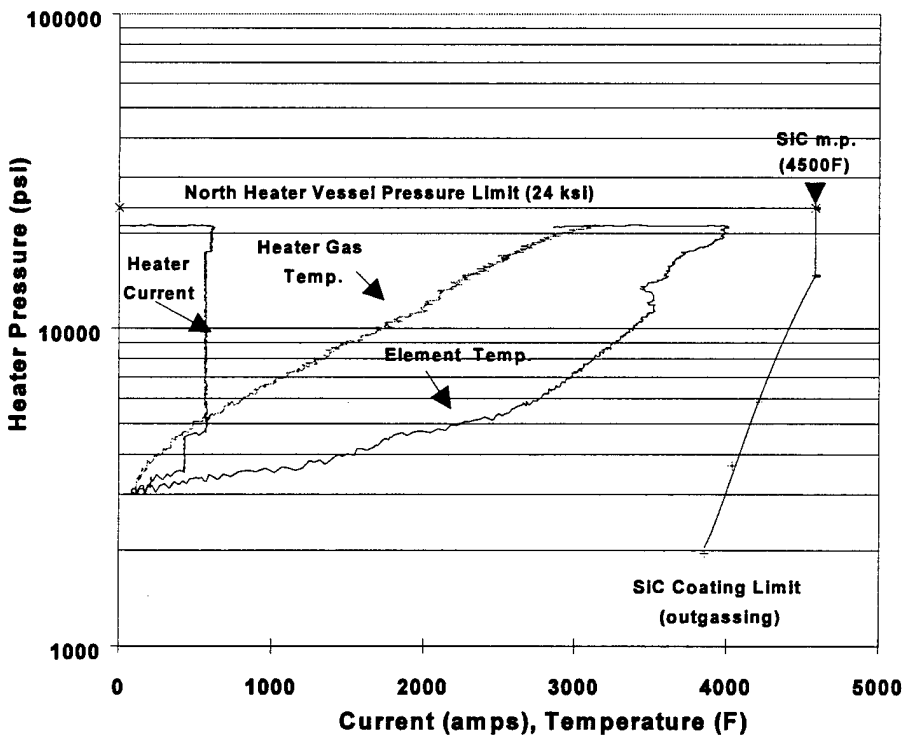

FIGURE 22. PRESSURE VS. TEMPERATURE FOR TEST NO. 2 (RUN 2379)

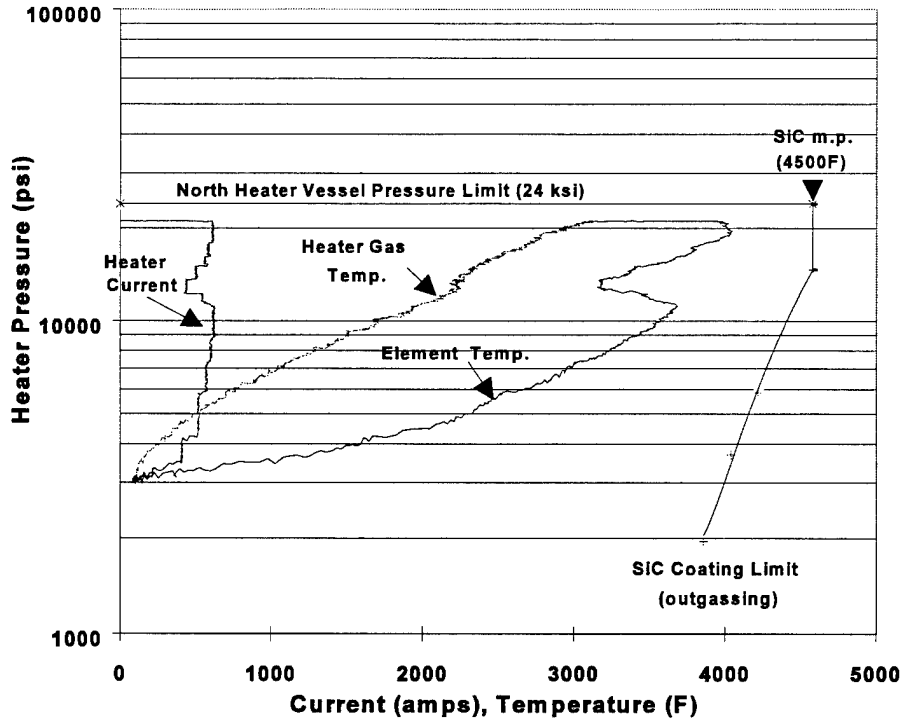

FIGURE 23. PRESSURE VS. TEMPERATURE FOR TEST NO. 3 (RUN 2380)

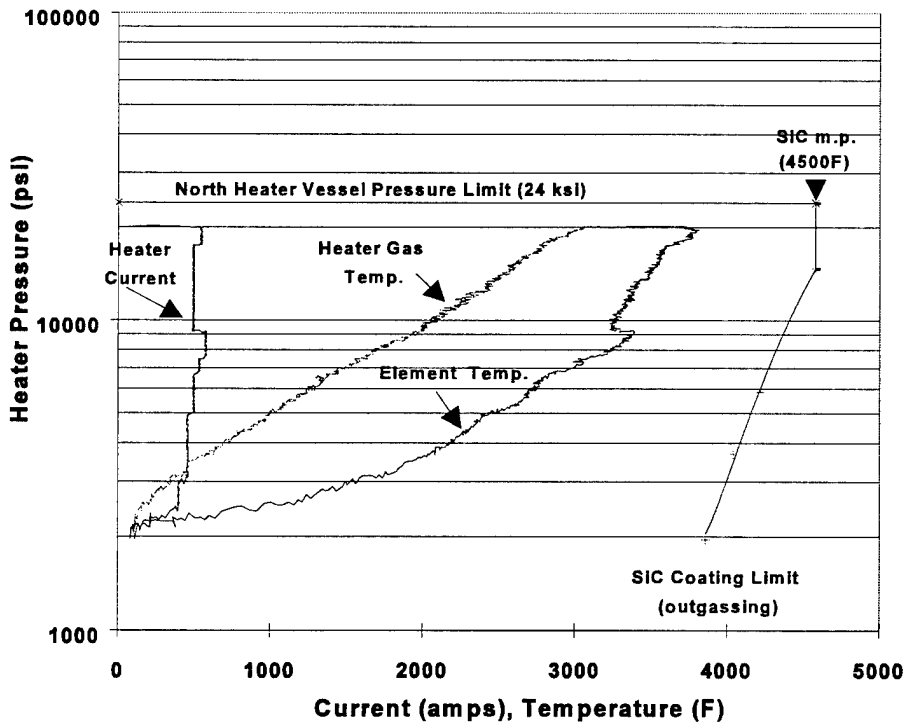

FIGURE 24. PRESSURE VS. TEMPERATURE FOR TEST NO. 4 (RUN 2381)

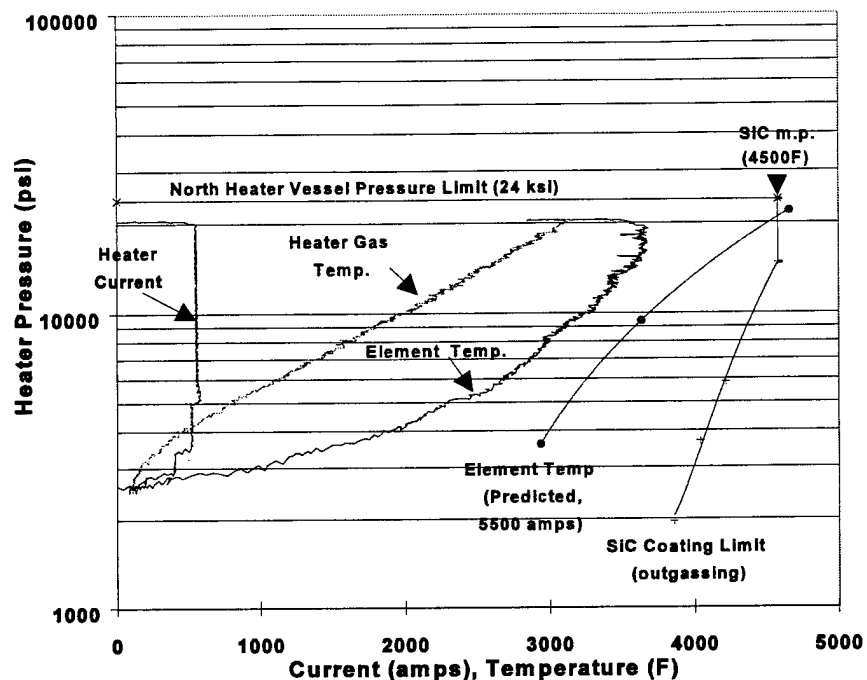

FIGURE 25. PRESSURE VS. TEMPERATURE FOR TEST NO. 5 (RUN 2382)

TABLE 5. PEAK TEMPERATURES AT THERMOCOUPLE LOCATIONS "A" AND "C" AND PEAK GAS TEMPERATURE/PRESSURE (Corrected Data)

Run No.	Temp A / Time	Temp C / Time	Temp Gas/Press Gas/Time
	(°F)/(sec)	(°F)/(sec)	(°F)/(ksi)/(sec)
2378	3711 / 790	289 / 795	3007 / 21.1 / 804
2379	4014 / 714	305 / 720	3132 / 21.2 / 737
2380	4048 / 722	311 / 777	3145 / 21.1 / 783
2381	3810 / 988	321 / 996	3102 / 20.1 / 1013
2382	3687 / 818	315 / 840	3124 / 20.1 / 832

During the heating process, several different electrical powering schemes were tried in an attempt to discover an "optimum" profile that would minimize the highest temperature that the heater element would attain during the heating process. The maximum temperature would usually be attained at or near the end of the heating process, when the gas is at its hottest. The element temperature is a function both of the gas temperature and the magnitude of the electrical current being passed through the element.

## CHAPTER 4

### DISCUSSION OF "NPAT" TEST RESULTS

The data for peak temperatures reached during each test indicate that the "A" location thermocouple had peak element temperatures ranging from 3687°F to 4048°F. The "C" location thermocouple peaks ranged from 289°F to 321°F.

Tests 1 and 5 used a 5500-A nominal heater current for the heating cycle (except for a short "power-up" phase at the beginning, where lower currents are used). Therefore the 5500-A Finite Element predicted temperature is also shown in Figures 21 and 25. The data for the first and fifth runs suggest that the Finite Element results overpredicted the maximum heater temperature. The reasons for this are not known at this time. Most probably, the convection and radiation heat transfer coefficients require adjustment.

As mentioned, different powering schemes were tried by varying the magnitude of the electric current passing through the heating element during the heating period. These schemes can be clearly seen in Figures 16 through 20. In all cases, a "power-up" from zero power is required, this being done in two steps. For tests 1 and 5, the current was maintained at a constant 5500 A for the remainder of the heating cycle. For test 2, the current was held at about 5700 A, then increased to 6000 A at the end. For test 3, a front-loading powering scheme was tried wherein a large power was introduced during the first half of the heating cycle by powering the element up to about 6200 A. Midway into the heating period, the amperage was sharply dropped to about 4300 A in hopes that residual heat in the element and walls of the insulation liner would continue to heat the gas, allowing a lower element temperature to be used at the end of the heat cycle. This scheme proved unsuccessful, as the data show. As soon as the element power was dropped, the gas temperature began to level off, requiring that the power be increased, in this case back up to 6200 A, in order to achieve the proper final heating end conditions. For test 4, a slightly milder front-loading power scheme was tried, which also failed.

Interestingly, the lowest peak element temperatures for the "A" location occurred during tests 1 and 5, where a constant 5500-A power was used. For example, the lowest peak of 3687°F occurred during the last test. Conversely, the highest peak element temperature at the "A" location was 4048°F and occurred during test 3, where the front-loading power scheme was tried.

Finally, concerning the ability of the heating element to maintain a temperature below predicted operating limits of the coating, the data suggest that this is very much a possibility. For example, at worst, the measured element temperature for test 3 remained well below the predicted

coating limits, never coming closer than about 500°F. At best, for test 5, the peak element temperature was never closer than 900°F from the predicted coating limit.

The "C" location peak thermocouple temperatures ranged from 289° to 321°F. This suggests that the bottom surface of an oxidation-resistant element base can possibly remain uncoated, as the temperatures may not reach levels high enough to cause undue oxidation. This is an important conclusion because the bottom surface of the element's base is attached to heavy, copper bus bars that function to transmit the electric current to the element's graphite substrate. If a coating is not required, then there is no question as to the feasibility of transferring the electric current to the element. Were an SiC coating required on this surface, the electrical characteristics of the coating would raise questions as to the feasibility of driving large currents through the coating.

Finally, for both "A" thermocouples, the signal can be seen to become increasingly noisy with heating time. This is most striking for the No. 2 thermocouple assembly for location "A", where, for its first heating cycle (test 3, run 2380), the temperature data are relatively smooth, as in Figure 18; whereas by the end of the second and for all of the third heating cycles, the signal shows gradually increasing amounts of noise. In all cases, however, the "A" location signal-to-noise ratio is very good.

## CHAPTER 5

### DATA CORRECTION ANALYSIS

The following are descriptions of potential error sources for the "A" and "C" location thermocouples. Each of these is discussed separately below:

#### "A" Location:

(a) VAX coefficient formatting error.

(b) Calibration Errors:

- i. The offset due to the millivolt-source insertion at the thermocouple (mV1) instead of at the input to the Preston Amp (mV2).
- ii. 150°F REFERENCE-OVEN-OFF malfunction during calibration 1.
- iii. Use of an incorrect calibration voltage for the high point.
- iv. Zero-shift.
- v. Carbon diffusion layer on BN tubes.

#### "C" Location:

(a) VAX formatting and typographical error.

(b) Calibration errors—same as for thermocouple "A", plus the following:

- i. The error due to use of the 32°F reference polynomial instead of the 150°F reference polynomial.

### VAX COEFFICIENT FORMATTING OF TRAILING DIGITS

Both items (a) above for the "A" and "C" thermocouples were determined to be negligible by plotting the temperatures that would be read for both correct and incorrect VAX coefficients.

### MILLIVOLT-SOURCE INSERTION POINT ERROR

Two possible millivolt source insertion points are shown in Figure 11, mV1 and mV2. Insertion point mV1 was used for these tests. A more straightforward calibration normally would involve simulating the thermocouple circuit voltage seen by the Preston Amp by inserting the millivolt source at mV2, then adjusting the VAX temperature reading—to make it equal to that temperature corresponding to the voltage tabulated in any calibration table established for the given reference temperature. Since calibration tables are typically based on 32°F reference-junction temperature, the fact that a 150°F reference was used is easily adjusted for using standard thermocouple laws.

In our case, the calibration voltage was inadvertently applied at mV1 instead of mV2, and the corresponding calibration table temperature, normally used for an mV2 calibration, was used as the calibration set point for the first calibration. However, inserting the source at mV1, in effect, simulates a different temperature than would be indicated by a standard calibration table: because both the reference junction and the active thermocouple junction are still effectively in the circuit and still generate a thermocouple output voltage of their own, which is added to the applied calibration voltage mV1. This error is easily corrected by adding the thermocouple circuit voltage to the applied calibration voltage to obtain the actual voltage that the Preston Amp really "sees" during the calibration. The temperature at which the thermocouple circuit will generate the same voltage in service as that seen by the Preston Amps during calibration can easily be obtained from standard calibration tables. This "true" temperature, and the incorrect calibration (VAX) temperature can then be used to correct the VAX temperature to the "true" temperature. Since the calibration voltage was applied at mV1, rather than mV2, this correction procedure requires knowing or estimating the active thermocouple junction temperature at the time of the calibration (see below), which was room temperature. In all cases, this estimated room temperature reference was 70°F.

#### USE OF INCORRECT CALIBRATION VOLTAGE FOR "A" HIGH POINT

The high-point calibration voltage used was 36.1 mV, to simulate a 4200°F thermocouple output. However, this is the voltage generated by a Type-C circuit operating with the active junction at 4200°F and the reference junction at 32°F. In our case, the reference junction was at 150°F, meaning the calibration voltage of 35.17 mV (36.1 - 0.927 mV) should have been applied, had the voltage been applied at mV2. This error is automatically accounted for using the same procedures listed above for "millivolt-source insertion point error".

#### REFERENCE OVEN

The reference oven was believed to be off for calibration 1 because this fits with the fact that the VAX reading was 150°F prior to calibration 2, when it was known that the oven heaters were off. The 150°F reading is the low-point temperature set for calibration 1 when: the effective active junction was at room temperature, the reference junction was believed to be at room temperature rather than 150°F, and 0 mV was fed in at mV1 (essentially a short circuit at mV1). If the oven reference temperature had been 150°F for calibration 1, and the reference junction temperature had subsequently shifted to room temperature for calibration 2, then the VAX reading prior to calibration 2 would have been about 230°F, rather than 150°F. As it was, when the reference and active junctions were both at room temperature, as in the case of calibration 1, the output should have read about 150°F, since this was the set point for these conditions. When the reference junction was returned to 150°F for calibration 2, with the active junction still at room temperature, it drove the "A" VAX reading from about 150°F down to 85°F.

## ZERO

For each of the five data sets, a zero-shift correction was obtained by referencing the VAX temperature reading during the preheat period and prior to precharging the heater vessel with nitrogen to the "TH09K" temperature reading occurring at the same time. "TH09K" designates the Type-K thermocouple "No.9" located on the heater insulation can at the OD of the can's lower support spool—this thermocouple is one of several liner temperatures routinely monitored by the Tunnel 9 temperature monitoring system. It was picked because of its proximity to the heater base.

## CARBON DIFFUSION LAYER

The carbon diffusion layer on the BN insulators is known to be somewhat conductive electrically (Reference 1), and the thermocouple signal was carried by wires contacting against this layer. Therefore, tests were conducted to determine the electrical shunting effect of the BN insulators' conductive carbon layer on the thermocouple reading carried by the wires. The following thermocouple wires were tested:

- Type-C, W5W26 Thermocouple (0.015-in. diameter)
- Type-XC, Thermocouple Extension (0.020-in. diameter)
- Type-K, Thermocouple (0.020-in. diameter)

The test consisted of continuous heating of the active thermocouple bead with a heat gun until it read from approximately 1080° to 1120°F in air. The temperature could be held to within  $\pm 5\%$  variation over small time periods of about a minute. The insulation was exposed on the two wire leads between the thermocouple bead and digital thermocouple meter (Omega Engineering model 2160A). The exposed leads between the thermocouple bead and meter were shunted against a sample of BN having a diffused carbon coating. Even with hard finger pressure applied to the exposed leads against the shunt, there was no observable effect on the thermocouple readings for Type C and XC wire, and only a small effect on the Type-K (less than 10°F drop in the reading).

## DATA CONSISTENCY

The raw data for the "A" thermocouple is relatively consistent from run to run for the heat-up phase of the heat cycle, and the raw data for the "C" thermocouple is also relatively consistent for this phase, suggesting that the large zero shift occurred primarily between the first calibration and the first test run.

## DATA CORRECTIONS

Each VAX temperature reading was adjusted to a corrected temperature reading as follows:



$$T_{\text{true}} = T_{\text{vax}} + \Delta T1 + \Delta T2$$

Where:

- $T_{\text{true}}$  = "True" corrected temperature.
- $T_{\text{vax}}$  = VAX temperature reading (i.e., raw temperature readings from VAX output).
- $\Delta T1$  = Room temperature zero-shift correction based on TH09K preheat/precharge reference reading.
- $\Delta T2$  = Gain correction based on NIST-table true temperature and 70°F room temperature estimate for both high-point and low-point true temperatures, versus averaged calibration 2 and 3 VAX readings for these points.

Calculations for the corrections appear in Appendix A. For all five data sets, the "A" data corrections varied smoothly from few degrees correction at room temperature, to no more than approximately -75°F correction at the maximum measured temperatures. For the "C" thermocouple, a relatively large zero-shift correction of about +40°F was necessary for all five data sets.

#### Overall Error

The test apparatus was designed to minimize errors due to thermal shunting (in the BN tubes), carbon diffusion layer shunting, and temperature gradients in the terminal blocks. This was accomplished by maintaining symmetry in the wire routing paths in the high temperature regions of the apparatus. The terminal blocks and extension wires were operated well within their standard use temperatures. The independent calibrations in Reference 2 indicate that the potting technique used here for thermocouple "A" is not expected to cause significant errors for these tests. Errors and uncertainties in the corrected data, due to common effects such as calibrations, proper use of thermocouples, rejection of AC power, etc., are believed to be small and not significant for the purpose for which this data is intended.

## CHAPTER 6

### SUMMARY AND CONCLUSIONS

Measurements were made of the operating temperature of a Tunnel 9 graphite heating element and a graphite support base as they heated nitrogen in the tunnel's process heater. One of the measurement locations was judiciously chosen to reflect what the maximum surface temperature of the element might be. The other measurement location was on the bottom surface of a large graphite base used to support the element inside of the large process vessel. The principal objectives of the tests were all achieved.

The temperature data appear in several formats in this report. The data suggest that the element's maximum surface temperature reached during each of five heating cycles ranged from 3687°F to 4048°F. The lowest maximum temperatures were attained during two heating cycles that both used a standard 5500-A constant power supplied to the element. This 5500-A constant-power scheme appears to represent an optimum with respect to maintaining the lowest possible maximum element temperature during the heating process. The element temperature never came nearer to the predicted SiC coating limits than 500°F, and in one test the element temperature stayed 900°F below the SiC limits.

On the bottom surface of the large graphite base used to support the heating element, the maximum measured temperatures ranged from 289°F to 321°F. This temperature range suggests that the bottom surface of the graphite support base may not require an SiC coating for oxidation protection when heating air. This is an important conclusion because the bottom surface of the support base mates with heavy, copper bus bars that function to transmit the electric current to the graphite base. If a coating is not required at this interface, then there is no question as to the feasibility of transferring the electric current to the support base.

Finally, the measured temperatures, which were well below the predicted service limits given in this report for the SiC coating system, suggest that an SiC-coated heating element concept for heating air in Tunnel 9 warrants further study.

**REFERENCES**

1. Metzger, M. A., "Notes on the Use of Fusible Temperature Indicators to Bound the Temperature of Hot Graphite in the NAVSWC Hypervelocity Wind Tunnel Facility" International Congress on Instrumentation in Aerospace Simulation Facilities, October 27-31, 1991.
2. Rogers, O. Van and Causey, S. J., *Mechanical and Thermal Properties of Candidate Carbon-Carbon Wind-Tunnel Heater Elements*, SRI Report SRI-MME-91-658-5912-6-F, Jul 1991.
3. Metzger, M. A., *Graphite Heating Element Thermal and Structural Performance in the NSWC Hypervelocity Wind Tunnel 9 -- A Finite Element Analysis*, NSWC TR-88-146, Jun 1988.

**APPENDIX A**  
**CALCULATION OF DATA CORRECTION TERMS**

## LOCATION "A" THERMOCOUPLE

The following calculations determine a linear correction to be made to the location "A" tungsten-rhenium thermocouple. Of the three calibration checks, the first calibration will not be considered because of questions about the operation of the reference oven. We assume that the millivolt meter is at 70°F during the calibration 2 and 3 measurements. (R.T. = room temperature)

**Low-point** (zero mV into mV1)

32° - 70°F → (0.288 mV) (") = output with 32°F reference  
 32° - 150°F → - (0.927 mV)  
 -----  
 - 0.639 mV To Preston Amp = output @ 70°F with 150°F reference junction  
 × 200  
 -----  
 - 127.8 mV from Analog Amp, goes to VAX or LINEAR FIT EQUATION  
 ↓  
 PLUG INTO VAX'S LINEAR FIT EQN = 82.2°F VAX SHOULD HAVE READ  
 ↓ WITH ZERO mV FED IN AT  
 ↓ R.T. OF 70°F.  
 TRUE TEMPERATURE = 70°F (estimated)

**High-point** (36.1 mV into mV1)

32° - 70°F → (0.288 mV)  
 32° - 150°F → - (0.927 mV)  
 mV source → 36.1 mV  
 -----  
 35.46 mV to Preston Amp → 35.46 | + 0.927 = 36.388 mV | → 4072°F |  
 ↓ 150 ref. 32 ref. NIST TABLE  
 ↓  
 35.46 = actual output @ 4072°F with 150°F reference junction  
 × 200  
 -----  
 7,092 mV from Analog Amp, goes to VAX 6th order polynomial fit eqn.  
 ↓  
 ↓  
 PLUG INTO VAX'S 6th ORDER EQN. = 4067°F, VAX SHOULD HAVE  
 ↓ READ WITH 36.1 mV FED IN  
 ↓  
 EQUIV. TRUE TEMP. = 4072°F (FROM NIST TABLES FOR 35.46 mV OUTPUT &  
 FOR 36.1 mV FED IN AT mV1)

TABLE A-1. ZERO SHIFT AND GAIN ERROR, LOCATION "A" THERMOCOUPLE

CAL NO.	EQUIV. TRUE TEMP. @ LOW POINT (°F)	VAX TEMP. READING (°F)	ZERO SHIFT (°F)	EQUIV. TRUE TEMP. @HIGH POINT (°F)	EQUIV. TRUE $\Delta T$ FROM TRUE ROOM TEMP. (°F)	VAX TEMP. READING (°F)	VAX $\Delta T$ FROM VAX ROOM TEMP. (°F)
2	70 (est.)	85	+ 15	4072	4002	4162	4077
3	70 (est.)	77	+ 7	4072	4002	4150	4073
							4075 avg.

See Figure A-1 for graphic representation of shift and gain corrections.

CORRECTION FORMULA

$$T_{true} = T_{vax} + \Delta T1 - \Delta T2 \quad (\text{data correction formula})$$

Where:

$T_{vax}$  = the VAX raw data

$$\Delta T2 = \text{GAIN CORRECTION} = \Delta T2^* \times (T_{vax} - T_{vax, R.T.})/4075$$

$$\Delta T2^* = 73F \text{ (see Figure A-1)}$$

$$\Delta T2 = (73 / 4075) (T_{vax} - T_{vax R.T.}) = (T_{vax} - T_{vax R.T.}) / 55.82$$

$$\begin{aligned} \Delta T1 &= \text{ROOM TEMP. ZERO SHIFT CORRECTION} \\ &= T_{true R.T.} - T_{vax R.T.} \end{aligned}$$

so:

$$T_{true} = T_{vax} + (T_{true R.T.} - T_{vax R.T.}) - (T_{vax} - T_{vax R.T.}) / 55.82$$

$$\begin{aligned} & \text{*****} & \text{*****} \\ & \Delta T1 & \Delta T2 \end{aligned}$$

TABLE A-2. TEST TEMPERATURES, LOCATION "A" THERMOCOUPLE

TEST NO. (TUNNEL 9 RUN)	True R.T. (THO9K) (°F)	T <sub>vax</sub> R.T.* (°F)	ZERO SHIFT $\Delta T_1$ (°F)	T/C ASSY NO.
1 (2378)	68.04	80.02	-11.98	1
2 (2379)	75.96	87.94	-11.98	1
3 (2380)	69.36	74.74	-5.38	2
4 (2381)	79.03	85.30	-6.27	2
5 (2382)	75.52	82.66	-7.14	2

\* T<sub>vax</sub> R.T. = Room temperature preheat VAX reading for location "A"

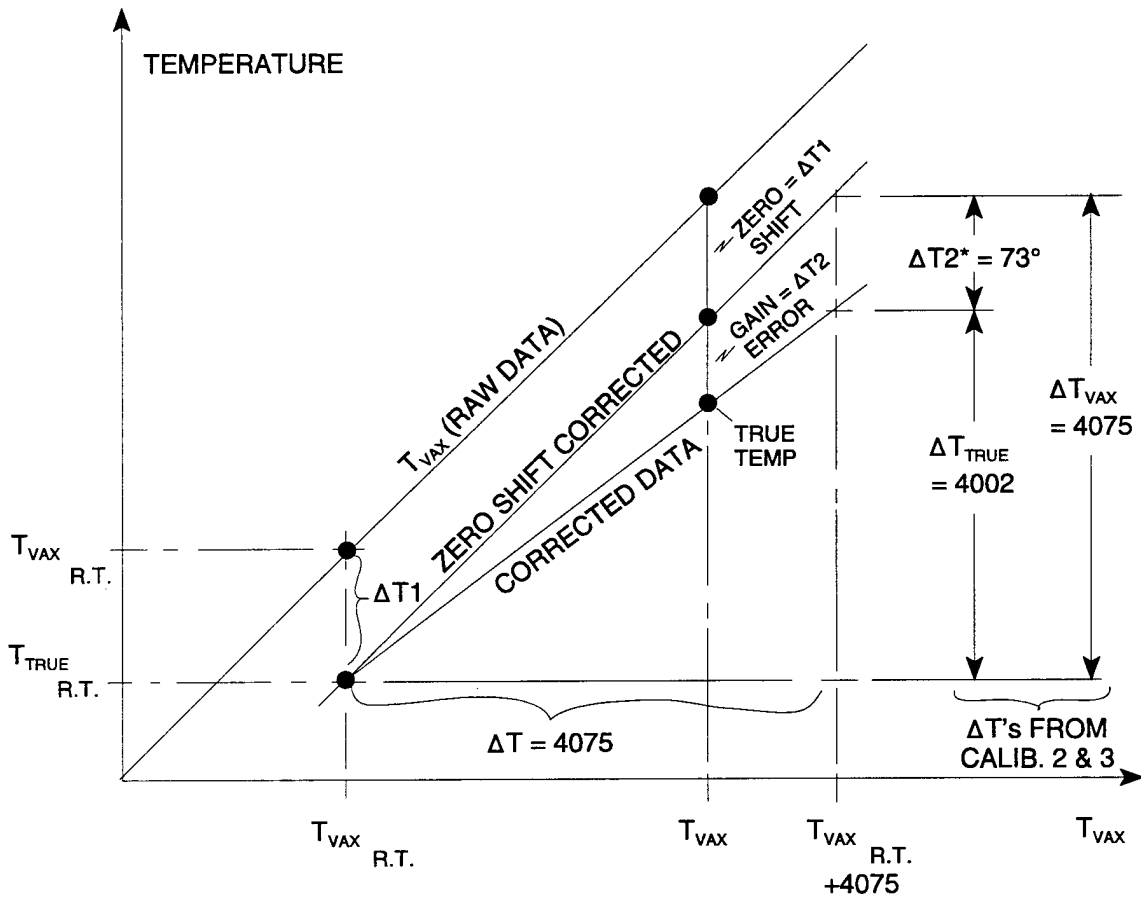

FIGURE A-1. LOCATION "A" DATA CORRECTIONS





EQN. EQUIV. TRUE TEMP. = 923°F FROM NIST TABLES FOR 17.777 PRODUCED BY 150°F REFERENCED THERMOCOUPLE SYSTEM & FOR 19.6 Mv FED IN AT mV1

TABLE A-3. ZERO SHIFT AND GAIN ERROR, LOCATION "C" THERMOCOUPLE

CAL NO.	EQUIV. TRUE TEMP. @ LOW POINT (°F)	VAX TEMP. READING (°F)	ZERO SHIFT (°F)	EQUIV. TRUE TEMP. @HIGH POINT (°F)	EQUIV. TRUE ΔT FROM TRUE ROOM TEMP. (°F)	VAX TEMP. READING (°F)	VAX ΔT FROM VAX ROOM TEMP. (°F)
2	70 (est.)	36	- 34	923	853	901	865
3	70 (est.)	32	- 38	923	853	897	865
							865 avg.

See Figure A-2 for graphic representation of shift and gain corrections.

CORRECTION FORMULA

$$T_{true} = T_{vax} + \Delta T1 - \Delta T2 \quad (\text{data correction formula})$$

Where:

$T_{vax}$  = the VAX raw data

$\Delta T2$  = GAIN CORRECTION =  $\Delta T2^* \times (T_{vax} - T_{vax, R.T.})/865$

$\Delta T2^*$  = 12F (see Figure A-2)

$\Delta T2$  =  $(12 / 865) (T_{vax} - T_{vax R.T.}) = (T_{vax} - T_{vax R.T.}) / 72.08$

$\Delta T1$  = ROOM TEMP. ZERO SHIFT CORRECTION  
 =  $T_{true R.T.} - T_{vax R.T.}$

so:

$$T_{true} = T_{vax} + (T_{true R.T.} - T_{vax R.T.}) - (T_{vax} - T_{vax R.T.}) / 72.08$$

$$\begin{matrix} \text{*****} & \text{*****} \\ \Delta T1 & \Delta T2 \end{matrix}$$

TABLE A-4. TEST TEMPERATURES, LOCATION "C" THERMOCOUPLE

TEST NO. (TUNNEL 9 RUN)	True R.T. (THO9K) (°F)	T <sub>vax</sub> R.T.* (°F)	ZERO SHIFT $\Delta T_1$ (°F)	T/C ASSY NO.
1 (2378)	67.60**	23.58	44.02	1
2 (2379)	75.96	31.97	43.99	1
3 (2380)	69.36	23.58	45.78	1
4 (2381)	79.48**	35.13	44.35	1
5 (2382)	75.52	31.97	43.55	1

\* T<sub>vax</sub> R.T. = Room temperature preheat VAX reading for location "C"

\*\* These values differ slightly from the corresponding thermocouple "A" table values because the reference temperatures were taken at different times.

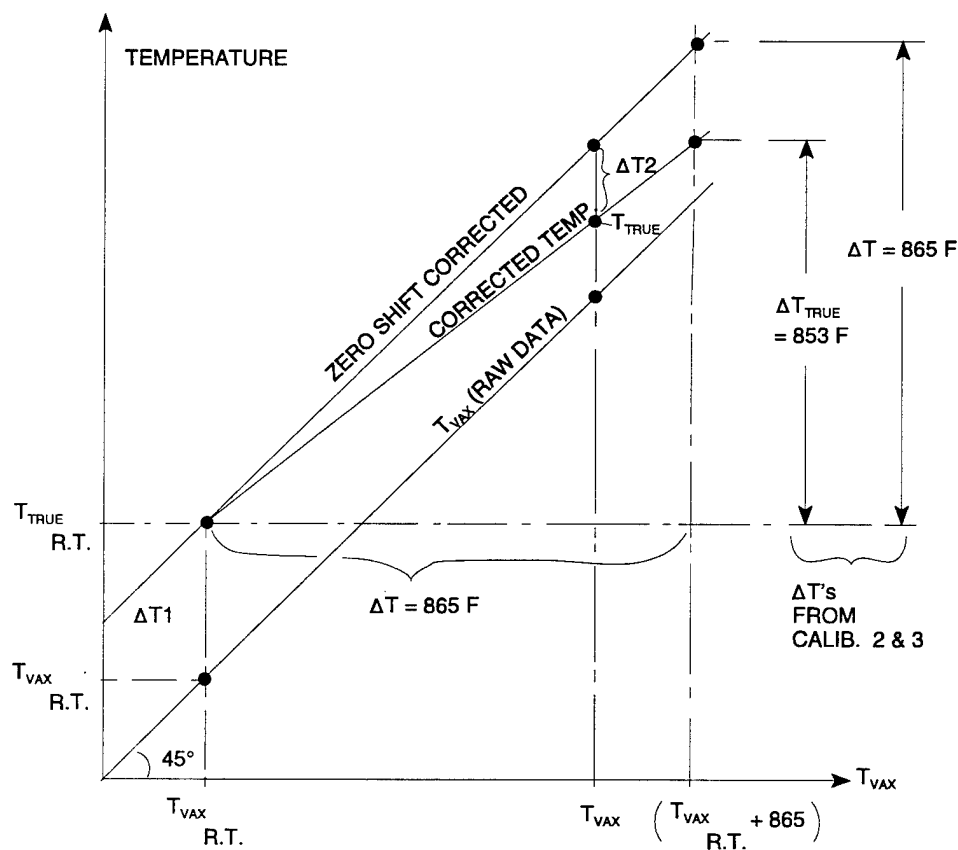

FIGURE A-2. LOCATION "C" DATA CORRECTIONS

**DISTRIBUTION**Copies**DOD ACTIVITIES (CONUS)**

ATTN M METZGER 11  
 AEDC WHITE OAK  
 10905 NEW HAMPSHIRE AVENUE  
 SILVER SPRING MD 20903-1050

ATTN DR M OPEKA 1  
 CARDEROCK DIVISION  
 NAVAL SURFACE WARFARE CENTER  
 9500 MACARTHUR BLVD  
 WEST BETHESDA MD 20817

ATTN CODE A76  
 (TECHNICAL LIBRARY) 1  
 COMMANDING OFFICER  
 CSSDD NSWC  
 6703 W HIGHWAY 98  
 PANAMA CITY FL 32407-7001

DEFENSE TECH INFORMATION CTR  
 8725 JOHN J KINGMAN RD  
 SUITE 0944  
 FORT BELVOIR VA 22060-6218 2

**NON-DOD ACTIVITIES (CONUS)**

THE CNA CORPORATION  
 P O BOX 16268  
 ALEXANDRIA VA 22302-0268 1

**INTERNAL**

B60 (TECHNICAL LIBRARY) 3  
 K 1