



**STRATEGY
RESEARCH
PROJECT**

The views expressed in this paper are those of the author and do not necessarily reflect the views of the Department of Defense or any of its agencies. This document may not be released for open publication until it has been cleared by the appropriate military service or government agency.

**TANK-LIGHT INFANTRY COMPANY OPERATIONS
(DRAFT FIELD MANUAL)**

BY

**LIEUTENANT COLONEL GREGORY A. STONE
United States Army**

**LIEUTENANT COLONEL DANIEL H. FRENCH
United States Army**

**LIEUTENANT COLONEL DAVIS D. TINDOLL
United States Army**

DISTRIBUTION STATEMENT A:

**Approved for public release.
Distribution is unlimited.**

DTIC QUALITY INSPECTED 3

USAWC CLASS OF 1997

U.S. ARMY WAR COLLEGE, CARLISLE BARRACKS, PA 17013-5050



19970624 101

Table of Contents

Chapter 1: Introduction

Chapter 2: Employment Considerations

- Section I: Organizations
- II: Employment Considerations
- III: Capabilities and Limitations

Chapter 3: Offensive Operations

- Section I: Fundamentals of the Offense
 - Purpose
 - Characteristics
 - Forms of Offense
 - Role of the Tank Platoon
- II: Planning
- III: Preparation
- IV: Execution - Tactical Movement
- V: Execution - Actions on Contact
 - Expected Contact
 - Unexpected Contact
- VI: Execution - Tactical Tasks
 - Tactical Task #1: Destroy an Inferior Force
 - Tactical Task #2: Attack by Fire
 - Tactical Task #3: Overwatch/Support by Fire
 - Tactical Task #4: Assault
 - Tactical Task #5: Bypass
 - Tactical Task #6: Reconnaissance by Fire
 - Tactical Task #7: Hasty Occupation of a Platoon BP (Defense)
 - Tactical Task #8: Hasty/In-Stride Breach
 - Tactical Task #9: Clear a Danger Area
- VII: Execution - Consolidation and Reorganization

Chapter 4: Defensive Operations

- Section I: Fundamentals of the Defense
- II: Planning
- III: Preparation
- IV: Execution

Chapter 5: Other Tactical Operations

- Section I: Movement to Contact (Search and Attack)
- II: Assembly Areas
- III: Linkup
- IV: Convoy Escort
- V: Passage of Lines
- VI: Breaching Operations
- VII: Follow and Support
- VIII: Perimeter Defense
- IX: Relief in Place
- X: Transporting Infantry

DTIC QUALITY INSPECTED 8

- XI: Limited Visibility Operations
- XII: Air Defense Operations
- XIII: Military Operations in Urban Terrain (MOUT)

Chapter 6: Combat Service Support

- Section I: Organization
- II: Supply Operations
 - Classes of supply
 - Methods of resupply
- III: Maintenance Operations
 - Initial Maintenance
 - Repair (forward)
 - Recovery
 - Evacuation

Appendix A: Equipment

- Section I: M1A1 Main Battle Tank
- II: M88 Medium Armored Recovery Vehicle
- III: Heavy Expanded Mobility Tactical Trucks (HEMTTs)

Appendix B: Training - Infantry Company/Tank Platoon Collective Task Crosswalk

- Section I: Movement to Contact
- II: Attack
- III: Ambush (*TBP*)
- IV: Reconnaissance and Security (*TBP*)
- V: Defend
- VI: Retrograde (*TBP*)

Appendix C: Tank Platoon Battle Drills Supporting Infantry Company Collective Tasks

- Battle Drill #1: Change of formation drill
- Battle Drill #2: Contact drill
- Battle Drill #3: Action drill
- Battle Drill #4: React to indirect fire drill
- Battle Drill #5: React to air attack drill

Appendix D: Critical Operations Checklists (*TBP*)

Appendix E: Example Situational Training Exercises (*TBP*)

Appendix F: Publications (*TBP*)

- Army Publications:
 - Army Training and Evaluation Programs (ARTEP)
 - Field Manuals (FM)
 - Soldier Training Publications (STP)
 - TRADOC Pamphlets

Command Publications:

Recommended Readings:

Joint and Multiservice Publications:

Glossary (TBP)

Page intentionally blank

Chapter 1: Introduction

“THE LACK OF INTEGRATION AND COOPERATION BETWEEN OUR INFANTRY AND ARMOR LED TO OUR EVENTUAL DOWNFALL.”

General Von Thoma
German Army, 1945

For years our Army has been wrestling with how to best integrate Light Infantry and Armor on the battlefield. The National Training Center, Joint Readiness Training Center, and the Combat Maneuver Training Center continue to show that although we realize this to be a problem, we can't quite come up with how to make this an effective fighting task organization. We must rid ourselves of any false impressions of this task organization, throw away our parochial views based on branch, and realize that tanks can be superb infantry support weapons.

The purpose of this manual is to provide a user-friendly handbook for use by infantry company commanders who will have a tank platoon task-organized to their company. The focus is on the infantry company and the tank platoon, with special attention provided to operations in restricted terrain.

Task organizing with armor and light infantry has some real advantages:

- This task organization is most effective when the strengths of one part of the force are used to compliment the limitations of the other.
- Armor forces push enemy forces into the light forces engagement areas.
- Armor forces are most effective when they can use their mobility, agility, and firepower (they provide accurate, long range, all weather firepower).
- Armor/light forces together can shape the battlefield to expose enemies vulnerabilities.
- The unique capabilities of each provide the commander great flexibility.

Clearly, combining armor and light forces further enhances combat capability. Tanks can provide accurate, long range supporting fires (day and night), provide a capability to suppress or destroy enemy vehicles, weapons and personnel, can fix or suppress enemy forces to allow infantry to breach obstacles or assault, and can breach obstacles. Light forces operations are aggressive and violent, with less constraints from terrain and weather. Improperly integrated, light infantry and armor forces become an ineffective fighting organization.

No one can accurately predict what the future battlefields will look like, nor can they readily point to what type of weapons and enemy we will face. If we are to be successful, we must be able to combine the strengths of our forces, in every possible environment, to insure accomplishment of the mission.

Page intentionally blank

Chapter 2: Employment Considerations

Regardless of terrain, infantry and armor units fight as part of a combined arms team. This maximizes their respective capabilities and minimizes their limitations. This chapter examines the infantry company and tank platoon organizations which can be expected to operate together on the battlefield today. It then discusses considerations for the employment of infantry task organized with tanks. It addresses capabilities and limitations of both infantry and armor forces, and concludes with a discussion of "Things Light Infantry Forget About Armor."

The task organization of a tank platoon to a light infantry company is usually for the accomplishment of a specific task and for a limited duration. This task organization command and control relationship is normally Operational Control (OPCON) due to the inability of the infantry company to provide requisite logistical support that an attached relationship would require. Armored and light forces are not normally integrated below the tactical command level of a company commander. This manual is focused on that task organization.

Section I:	Organizations
II:	Capabilities and Limitations
III:	Employment Considerations

Section I: Organizations

Tank Company (Figure 2-____).

- The tank company is organized, equipped, and trained to fight pure.
- It can also be task organized by higher headquarters to fight with infantry as a company team.
- The tank company consists of a headquarters and three tank platoons.
- The company headquarters is equipped with two tanks, one M113A2 armored personnel carrier (APC), two M1025 or M998 high-mobility multipurpose wheeled vehicles (HMMWV), and one cargo truck with a 400-gallon water trailer.
- A maintenance section from the battalion maintenance platoon is normally attached to the tank company. The maintenance section consists of one APC, one heavy recovery vehicle, and one utility truck with trailer carrying spare parts based on the prescribed load list (PLL). A medic, normally attached from the battalion medical platoon, travels in another APC.

Tank Platoon (Figure 2-____).

- The tank platoon is the smallest maneuver element within a tank company. The fundamental mission of the tank platoon is to close with and destroy the enemy.
- The platoon consists of four main battle tanks organized into two sections, with two tanks in each section.
- The Platoon Leader (Tank 1) and PSG (Tank 4) are the section leaders.
- Tank 2 is the wingman in the platoon leader's section. Tank 3 is the wingman in the PSG's section.

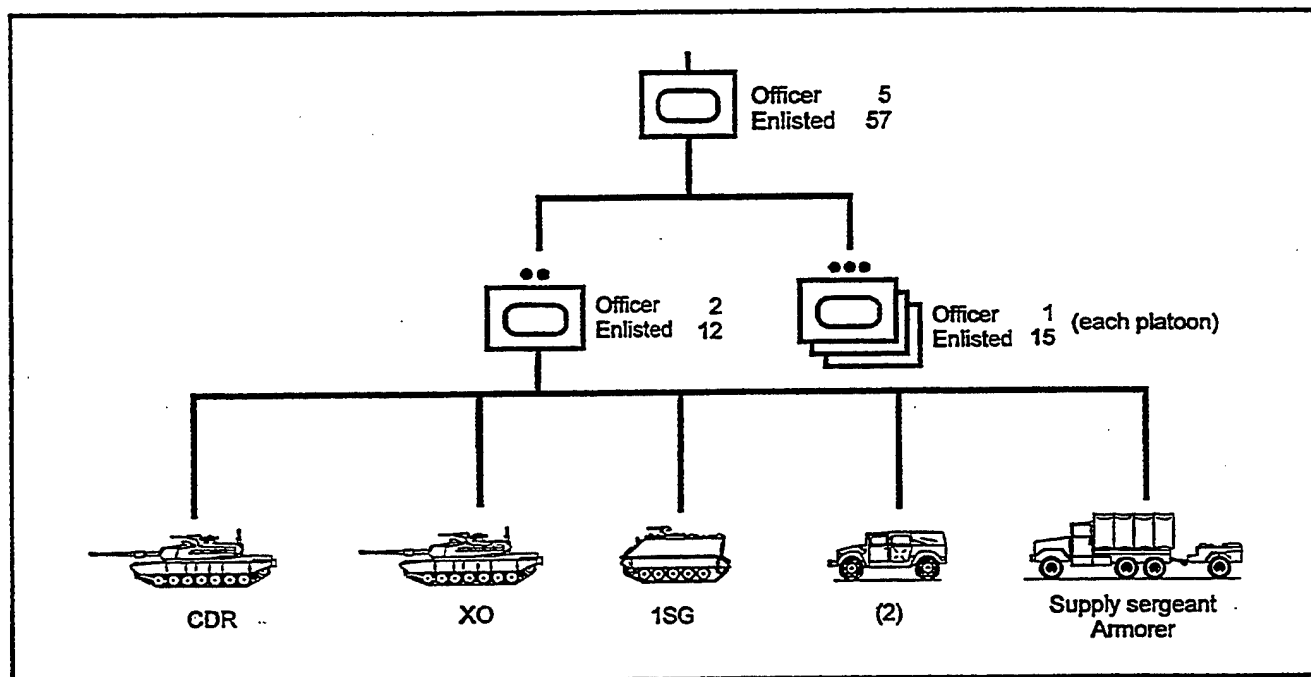
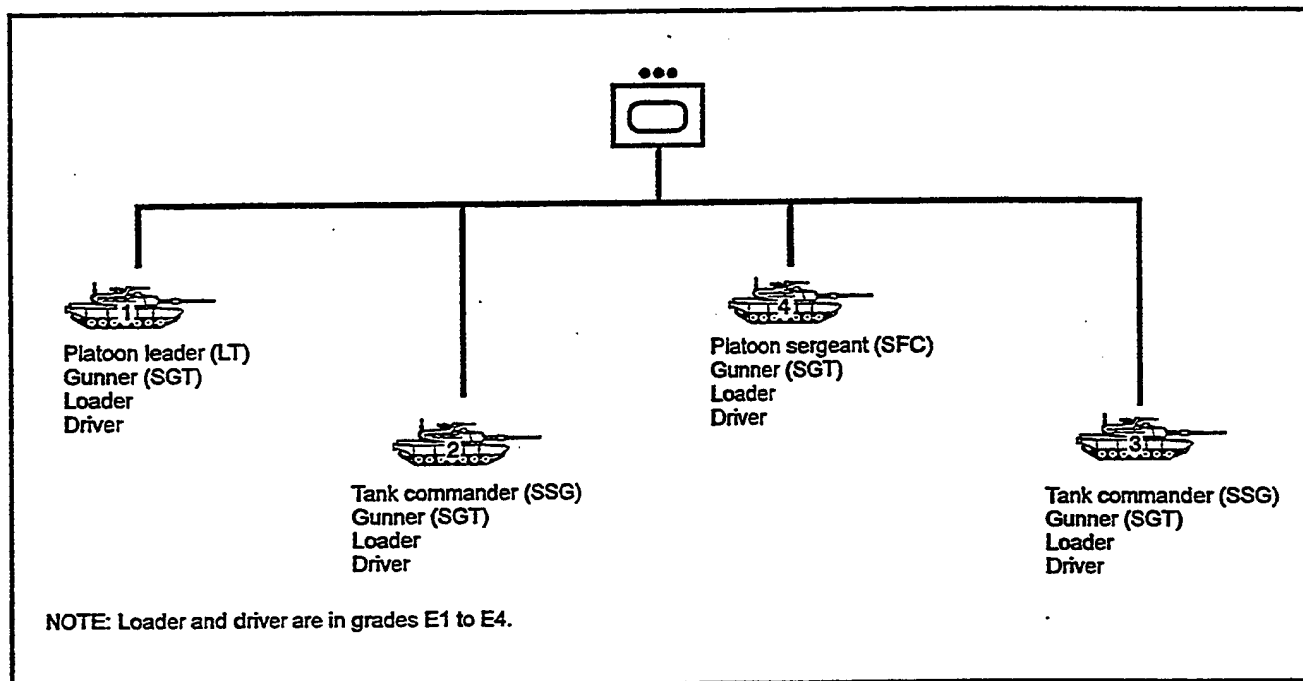

Figure 2-____. Tank Company



Reminder: There is only 1xM16A2 rifle per tank in the tank platoon. The remaining crewmen are armed with the M9 9mm pistol.

Figure 2-____. Tank Platoon

Section II: Capabilities and Limitations

Armored Force Capabilities and Limitations

Armored Forces Capabilities

- **Excellent cross-country mobility.**
- **Sophisticated communications systems.**
- **Enhanced target acquisition systems.**
- **Lethal firepower.**
- **Effective anti-armor protection.**
- **Ability to move rapidly under a variety of terrain conditions.**
- **Global Positioning Systems (GPS) and Inertial Position Navigation (POSNAV) systems allow tanks to move to virtually any designated location with great speed.**
- **Organic air defense against low-flying enemy aircraft.**
- **Conducts continuous operations in all weather and visibility conditions.**

Armored Forces Limitations

- **Tanks require extensive maintenance, proficient operators, and skilled mechanics.**
- **Daily resupply of large quantities of bulky petroleum products is required.**
- **Tanks are vulnerable to the weapons effects of other tanks, attack helicopters, mines, ATGMs, antitank guns, and close attack aircraft.**
- **When operating in restrictive terrain, reduced visibility leaves tanks vulnerable to dismounted infantry attacks.**
- **Existing or reinforcing obstacles can restrict or stop tank movement.**
- **Tanks are primarily dependent on radio communication. This makes them vulnerable to EW.**
- **Tanks have difficulty defending positions against enemy infantry due to few local security/dismount forces. All members of a tank platoon are crewmembers.**

Section III: Employment Considerations

Below are listed employment considerations for tank/light infantry task organizations. These are only meant to be considerations for the commander. All of these are dependent on training level, unit familiarity, and METT-T.

Command and Control

- Light force commander must consider the most serious threat to his force and try to use tanks to eliminate the threat.
- Tanks are the light forces' best weapon against enemy armor.
- Open terrain favors tanks.
- If no immediate mission, consider using tanks as a reserve.
- Tanks requires significant time for rearm, refuel, refit.
- The tank platoon leader should dismount when reconning positions with the infantry commander.
- Tanks need to know where light forces are located (use thermal markings, VS-17 panel, radio, telephone).
- Plan on signals for lifting and shifting fires. Also plan on back-up signals. Note: Noise and other audible signals are not appropriate signals to utilize in communicating with a tank platoon.
- Targets can be marked by tracer fire from tanks.
- Integrate tanks into infantry platoon defenses, but retain control under the tank platoon leader.
- In most operations, the infantry will have to establish direct contact with individual tanks.
- Communication between the infantry on the ground and the crewmen on the tank is difficult.
- The M1 series tanks have no external phone. Shouting above a roaring tank engine can be difficult at best.
- Preplanned signals work best. SOPs should be established during training.
- Most armor units will connect a TA-1 radio to the back right side of the turret to allow communication with dismounted infantry. Consider making this SOP for any operation involving tanks and light infantry.
- When approaching friendly troops, tanks should have their turrets traversed towards the enemy.
- All members of the tank platoon should be familiar with and use hand and arm signals employed by the infantry unit (see FM 21-60, Visual Signals).
- Tank platoons are prepared to execute operations (i.e. response time) based on the Readiness Condition (REDCON) level they are at. REDCON levels allow quick responses to changing situations and ensure completion of necessary work and rest plans. Company commanders should be specific in directing desired response times to the tank platoon leader. Figure 2-____ provides a doctrinal (LAW FM 17-15) laydown of standard tank platoon REDCON levels.
- The visual capability of the armored force is sometimes overlooked.
- The M1 series has thermal sights and limited image intensifiers that can range out to 1500 meters.
- The ability to clearly see can be altered by rain, snow fog, and smoke.
- Tanks can be an immense combat multiplier during limited visibility operations.
- The tank main gun can be a hazard. Light forces must know this.
- When firing sabot rounds, a downrange hazard is caused by the discarding of the stabilizing petals. These go out to 70 meters left or right of the gun line, and extend to a range of 1km.
- The main gun of the M1 series creates noise in excess of 140 decibels, out to approximately 635 meters.
- Single layer hearing protection such as ear plugs should allow infantry to work within 25 meters of the tank.
- M1 series tanks have extremely hot exhaust from the rear. Infantrymen should not stand or position equipment directly behind the tank.
- Tank smoke grenade launchers fire white phosphorous. Be aware!
- Laser rangefinders ARE NOT eyesafe!
- Tanks have dead space. See Figure 2-_____.

Intelligence

- **Tanks and infantry have different intelligence requirements.** Tanks must know the location of friendly and enemy AT weapons, obstacles, and trafficability.

Maneuver

- **Rate of movement is dependent on terrain suitability.** Tanks are better in open terrain, light forces are better in restrictive terrain.
- **In the defense, think about using tanks as the reserve or counterattack force.**
- **Use infantry as LP/OP for tanks.**
- **Maintain the tanks' ability to fire and maneuver.**
- **Position tanks to best control direct fires.**
- **Establish direct fire control measures.** Tank laser range finders are superb in helping to do this.
- **Tank weapons effects (both main gun and machine gun) can have devastating effects on dismounted infantry.**
- **Use tank thermal sights as recon/security.**
- **Use tanks for counterrecon.**
- **Tank exhausts are hot and can start foliage fires.** Pay attention.
- **Tanks can provide excellent direct fire support (bunker busters).**

Fire Support

- **Tank platoons have no FO.** Consider locating an FO with the tank platoon.
- **Use glint tape on tanks (for vehicle ID) if AC130 sorties are being flown.**

Mobility/Survivability

- **Restrictive terrain is a command interest**
- **Don't unnecessarily restrict tanks to roads.** They can move through extremely tough terrain.
- **A tank platoon may come to the infantry company with mine plows or rollers. Reminder: Mine plows are breaching devices. Mine rollers are proofing devices.**
- **Thermal sights can detect metallic mines.**
- **If the mine situation is not clear, stay on roads and trails.** Bypass or breach likely minefield locations, or clear the entire route.
- **Tanks may be able to self-generate a smoke screen (depending on the type of fuel used).** Regardless, the on-board smoke grenade launcher can always be used.
- **Tanks can provide mobility.**
- **Dig Tanks in.**
- **Tank crews should be trained in procedures to mount mine plows on their vehicles.**
- **Tanks should carry grappling hooks to clear obstacles.**
- **Infantry should secure engineers working on obstacles (or obstacle reduction); tanks should overwatch.**
- **SOSR: Suppress, obscure, secure and reduce obstacles.**

Air Defense

- **Give tanks high priority for ADA.**
- **Tanks can provide excellent close-in air defense against attack helicopters.**
- **Use VS17 panels for marking tanks and vehicles.** Note: If no friendly air planned - take them off!

Combat Service Support

- A tank platoon requires large amounts of fuel during operations. It can only operate for 9 to 10 hours without refueling. **DON'T FORGET THIS!**
- Refuel/Rearm time for a tank platoon is approximately 30 minutes.
- Know what HEMTTs and M88 do. Know what they look like.
- The combat capability of tanks is directly related to logistics.
- Tanks can help resupply and provide logistics assistance to light forces.
- Tanks should carry additional water when task organized to the infantry.
- Dedicate time to maintenance -- tanks have got to have it. They will not run long without it.
- Routine tank maintenance is noisy. It also requires light during periods of limited visibility.
- Check the status of the tank platoon's fuel transfer pumps. Inoperative pumps can seriously degrade maximum operating time.

<p>REDCON-1. Full alert; unit ready to move and fight.</p> <ul style="list-style-type: none">• NBC alarms and hot loop equipment stowed; OPs pulled in.• All personnel alert and mounted on vehicles; weapons manned.• Engines started.• Platoon is ready to move immediately. <p>NOTE: A variant of REDCON-1 is REDCON-1(-); the same conditions apply except that the vehicles are not started in REDCON-1(-).</p> <p>REDCON-2. Full alert; unit ready to fight.</p> <ul style="list-style-type: none">• Equipment stowed (except hot loop and NBC alarms).• Precombat checks complete.• All personnel alert and mounted in vehicles; weapons manned. (NOTE: Depending on the tactical situation and orders from the commander, dismounted OPs may remain in place.)• All (100 percent) digital and FM communications links operational.• Status reports submitted in accordance with company SOP.• Platoon is ready to move within 15 minutes of notification. <p>REDCON-3. Reduced alert.</p> <ul style="list-style-type: none">• Fifty percent of the platoon executes work and rest plans.• Remainder of the platoon executes security plan. Based on the commander's guidance and the enemy situation, some personnel executing the security plan may execute portions of the work plan.• Platoon is ready to move within 30 minutes of notification. <p>REDCON-4. Minimum alert.</p> <ul style="list-style-type: none">• OPs manned; one man per platoon designated to monitor radio and man turret weapons.• Digital and FM links with company and other platoons maintained.• Platoon is ready to move within one hour of notification.
--

Figure 2-____. REDCON Levels.

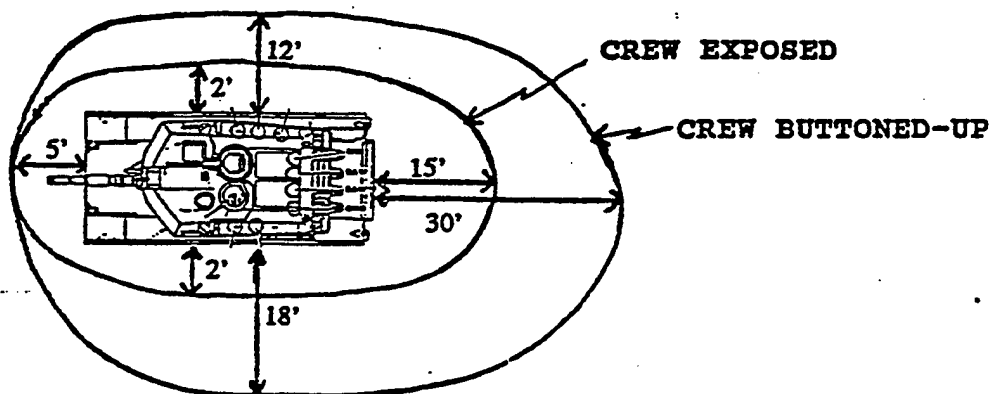

The M1A1C's visual deadspace is shown above. Infantry should not approach within this area without first gaining the attention of the tank crew.

Figure 2-____. Tank deadspace.

Page intentionally blank

Chapter 3: Offensive Operations

Offense is the decisive form of war. While tactical considerations may call for the infantry company to execute defensive operations for a period of time, defeat of the enemy requires a shift to offensive operations. To ensure the success of the attack, the company commander must understand the fundamentals of offense, the immense capabilities (and specific limitations) that the tank platoon brings to his company, and apply troop-leading procedures during the planning and preparation phases of the operation.

Section I:	Fundamentals of the Offense
II:	Planning
III:	Preparation
IV:	Execution - Tactical Movement
V:	Execution - Actions on Contact
VI:	Execution - Tactical Tasks
VII:	Execution - Consolidation and Reorganization

Section I: Fundamentals of the Offense

Purposes of the Offense

The main purpose of the offense is to **defeat, destroy or neutralize an enemy force**. Additionally, offensive operations are undertaken to secure key terrain, gain information, deprive the enemy of resources, deceive and divert the enemy, hold the enemy in position, disrupt the enemy attack, and to set the conditions for successful future operations.

Characteristics of the Offense

FM 100-5 describes the common characteristics of all offensive operations: surprise, concentration, speed, and audacity. To maximize the value of these characteristics, and the value of the tank platoon working with an infantry company, commanders must apply the following considerations concerning their tank platoons:

-Surprise

- Surprise maximizes the rifle company's ability to attack during limited visibility.
- Tank platoons achieve surprise by following solid operations security (OPSEC) procedures. Commanders must recognize the visual and sound signatures that their tank platoons will make on the battlefield.
- Tank platoons must make the best possible use of vehicle speed and covered and concealed routes during tactical movement.

- Concentration

- Concentrate combat power at the decisive point and time to achieve decisive results
- Tank platoons achieve concentration by massing the effects of their weapons systems without necessarily massing platoon vehicles at a single location.
- Modern navigation and position location/reporting systems, plus inherent tank mobility and speed, allow the platoon leader to disperse while retaining the ability to quickly mass.
- Tank platoons must remember that it is more important to move using covered and concealed routes to positions than it is to maintain precise formations and predetermined speeds.

- Speed

- Speed promotes surprise, keeps the enemy off balance, contributes to security of the attacking company, and prevents the defender from taking effective countermeasures.
- Tempo is the rate of speed of military action. It can range from fast to slow.
- The Company commander must recognize that synchronization of all his assets sets the stage successful action. He must ensure that all his platoons' movements are synchronized to support his intent and concept of the operation.
- Key thought: Use simple plans with decentralized control.
- Tank platoon and infantry platoons have vastly different speeds based on the factors of METT-T.

- Flexibility

- Expect uncertainties and be ready to exploit opportunities.
- Conduct a thorough rehearsal process; it is key.
- Use of a reserve increases a commander's flexibility. It is not an imperative - but always consider it.

- Audacity

- Audacity is marked by violent execution of the mission and a willingness to seize the initiative.
- The combination of tanks and infantry creates a powerful team, capable of executing operations with audacity in all types of terrain and conditions.
- Knowledge of the commander's intent two levels up allows the company commander to take advantage of battlefield opportunities whenever they present themselves.

Forms of Offense

The four general phases of Offensive Operations are Preparation, Attack, Exploitation, and Pursuit. The attack phase may include either a hasty or deliberate attack.

Role of the Tank Platoon

The tank platoon is an integral part of the company's offensive maneuver plan. The platoon is prepared to conduct tactical movement, actions on contact, consolidation, and reorganization in support of company operations. It can destroy, fix, or bypass an enemy as required by the commander's intent, the tactical situation, and the Rules of Engagement (ROE).

Section II: Planning

- The planning phase begins when the company receives the battalion WO or OPORD and ends when the company commander issues his own OPORD or FRAGO.

- During this phase, the company commander and subordinate leaders initiate troop-leading procedures. The commander should initiate rehearsals of tactical movement, battle drills, or breaching actions. These generic rehearsals allow his platoons to begin preparing for the mission.

- Once the platoon leaders have received the company order and prepared their plans, the generic rehearsals will be matched to the actual terrain and anticipated actions on enemy contact. Reminder: It is critical to involve the Tank Platoon Leader in all phases of the rehearsal process.

- In developing his OPORD or FRAGO, the commander must pay close attention to the capabilities and limitations inherent to the tank platoon in his task organization. Close attention to the Battlefield Operating Systems (BOS) will facilitate this process. Listed following this paragraph, and arranged in order, BOSs roughly follow the five-paragraph OPORD process, allowing the company commander to logically organize his thoughts to cover the mission. BOS elements are the following:

- Command and Control
- Intelligence
- Maneuver
- Fire Support
- Mobility and Survivability
- ADA
- CSS

Command and Control

1. Troop Leading Procedures: Tank Platoon leader's key function during the planning process. He must be fully involved in the company's planning process.

2. Coordination with the company commander is critical. Commander must address:

- Routes
- Intervals
- Movement speeds
- Orientations
- Fire Control Measures
- Signals to be utilized between platoons
- Communication
- IFF procedures

Command and Control Considerations:

- Use your tank platoon to eliminate the most serious direct fire threat to the company.
- Use tanks against armor.
- Guard against "piecemealing" of the tank platoon.
- Plan for maintenance time - tanks **HAVE TO HAVE IT!**
- Plan for the tank platoon as a company reserve if there is no immediate mission for it.

Intelligence

1. Enemy:

- **How will enemy disposition and possible courses of action affect the company's battle space? What does that imply for location and utilization of the tank platoon?**
- **Commander must ensure that the platoon leaders identify and plot:**
 - ⇒ **Known and suspected enemy positions** (that may affect their platoons).
 - ⇒ **Direct and indirect fire range fans** of enemy weapons systems.
 - ⇒ **Enemy overlay for IVIS** or appliqué digital systems should be updated (M1A2 only).
- **Commander must ensure platoon leaders identify terrain features or determine standoff distance of friendly weapons systems to negate the effects of enemy weapons.**
- **Platoon leaders must determine enemy's most probable of course of action in their area.**
- **Platoon leaders must identify anticipated contact situations:**
 - ⇒ **Will the enemy defend, delay or counterattack?**
 - ⇒ **Where and when is contact most likely?**
 - ⇒ **What type and size of force will the platoon face?**

2. Terrain

- **Commander analyzes terrain in terms of OAK-OC.**
- **Close attention to key terrain which could support unobstructed observation and fields of fire - danger areas.**
- **Commander and leaders conduct ground reconnaissance as far forward as possible. Must cover:**
 - ⇒ **Company and subordinate platoon movement to the LD**
 - ⇒ **Routes to the objective**
 - ⇒ **Actions on the objective**
 - **Consolidation**
 - **Reorganization**
- **Platoon leaders must brief the commander on the time-distance factors to any SPs or the LD.**
- **Use the tank platoon leader to help decide the best route for the tank platoon to utilize.**
- **Tank platoon leader should dismount and walk his proposed positions with the company commander.**

Intelligence Considerations:

- **Always plan for the use of the tank platoon's thermal sights. They are a terrific asset.**
- **Plan for use of the tank platoon in the reconnaissance and security role. Their mobility and firepower are valuable.**
- **Plan for the enemy's AT threat.**
- **Plan for the enemy's mine threat.**

Maneuver

1. Movement

- **Commander must synchronize the platoon maneuver plans with his commander's intent and specific instructions**
- **Commander must determine:**
 - ⇒ **Routes**
 - ⇒ **Movement techniques for the company (briefed on subordinate platoon techniques)**
 - ⇒ **Company formations based on:**
 - company battle-space
 - battalion scheme of maneuver
 - the likelihood of contact
 - the disparity between the tank platoon and infantry platoon movement rates

2. Direct Fires

- **Commander must identify attack by fire and support by fire positions for the platoons; platoon leaders must do the same in their planning process**
- **Commander must designate TRPs; assign sectors of fire, observation, and weapons orientation. Tank platoons bring an immense firepower capability to the commander, every effort must be made to maximize their potential**
- **Commander must address restrictions on fire (either imposed by the ROE, or based on the types of ammunition carried in the tank platoon)**

Maneuver Considerations:

- **Always consider the suitability of the terrain (bridge classifications; road restrictions) for movement of the company and its tanks.**
- **Make a conscious decision to either concentrate or disperse the tank platoon. Do not do it by "default."**
- **Protect your tanks! Attach infantry to the tank platoon for local security, ambushes, and LP/OPs.**
- **Tanks can provide excellent direct fire against field fortifications - "Bunker Busters."**
- **The tank platoon can be used to transport infantry in special circumstances. See Chapter 5 for more specific information.**

Fire Support

- **Most fire support planning is conducted at the company level (and higher).**
- **Commanders have platoon leaders review the plan. Their focus is on the responsibilities for initiating, lifting, and shifting indirect fires.**
- **Commanders should have the platoon leaders evaluate/recommend the use of smoke to:**
 - ⇒ **Help conceal or obscure movement.**

- ⇒ **Suppress likely enemy positions** while platoons are moving through danger areas.
- ⇒ **Mark and/or assist in navigation.**

Fire Support Considerations:

- **Tank platoons have no Forward Observer (FO).** Fires will be requested over the company command net.
- **Plan on the tank platoon receiving enemy indirect fire as it approaches an obstacle.**
- **If AC-130 sorties are expected during the operation, ensure the tank platoon is marked (on top) with glint tape.**

Mobility and Survivability

1. Obstacle Types

- **The company will encounter two types of obstacles: Existing and Reinforcing.**
 - ⇒ **Existing Obstacles:** Those present on the battlefield but **not emplaced through military effort.** They may be natural (such as streams, lakes, thick forests and mountains) or cultural (towns or railroad embankments)
 - ⇒ **Reinforcing Obstacles:** Those placed on the battlefield through military effort to **block, turn, disrupt, or fix the enemy.** Examples include minefields, wire, road craters, log cribs and tank ditches.

2. Breach Planning

- **The commander must designate the tank platoon to be part of the support, breach or assault force.**
- **The support force:**
 - 1) **Usually leads the company during movement**
 - 2) **Identifies the obstacle**
 - 3) **Suppresses enemy elements overwatching the obstacle to give the breach force the opportunity to penetrate the obstacle**
- **The breach force:**
 - 1) **Commander should designate the tank platoon as the breach force only if it is equipped with assets required to breach the type of obstacle present. Assets the tank platoon may have include demolitions, grappling hooks, mine plows, and mine rollers.**
 - 2) **The breach force is responsible for creating, proofing and marking a lane through the obstacle.**
 - 3) **The breach force secures the far side of the obstacle, then suppresses remaining enemy forces.**
- **The assault force moves through the breach to continue the attack.**

Mobility and Survivability Considerations:

- **Always plan for the mobility of the tank platoon.**
- **Know the capabilities/limitations of mine plows and rollers (see Chapter 5).**
- **Remember: Thermal sights can help to visually acquire mines. Do not, however, substitute this for proofing or assume all mines will be found.**
- **Remember: The tank's coax and commander's M2 machineguns can detonate mines. USE AS A LAST RESORT!**

- Company commander's should consider a request for additional engineer assets to support tanks (if the platoon comes without them).

Air Defense Artillery

Air Defense Considerations:

- Give the tank platoon high priority for ADA protection. The tanks are a lucrative and highly sought-out enemy target.
- Pay attention to IFF. One technique is to place VS 17 panels on top the turrets of the tanks. Reminder: If no friendly air operations are planned - remove the panels.

Combat Service Support

The commander ensures that leaders are familiar with maintenance and medical evacuation (MEDEVAC) procedures as outlined in paragraph 4 of the company OPORD or in the company's SOP. See Chapter 6 for details concerning CSS, and the necessity of involving the tank platoon leader in every phase of the company's CSS planning.

Combat Service Support considerations:

- The tank platoon can only operate for 9-10 hours without refueling.
- It will take approximately 30 minutes to refuel/rearm the tank platoon. This time will increase during periods of limited visibility and when in unfamiliar terrain.
- The sustained combat capability of the tank platoon is directly related to its logistics support. **PLAN FOR SELF-RECOVERY AND MAINTENANCE TIME!!!!**
- Use the tank platoon to carry extra water, ammunition and Class I for the company. The tanks can also be very helpful in conducting emergency resupply for the company.
- Tanks have organic tow cables and a varying number of tow bars per platoon. Find out how many.

Section III: Preparation

The commander takes into account the following BOS considerations during the Preparation phase.

Command and Control

- The company commander continues with his troop-leading procedures. He conducts rehearsals and inspections to ensure his platoons are ready for the upcoming operation.
- As this phase nears its end, leaders will conduct **Precombat Checks (PCCs) and Precombat Inspections (PCIs)** of their soldiers and equipment. Leaders should focus on the readiness of mission-essential equipment and ammunition, and on the mission understanding of subordinate elements, leaders, and individual soldiers. These inspections should be as thorough as time permits. The tank platoon should have a thorough PCI checklist; FKSM 17-15-3 has a detailed checklist.
- Procedures for a comprehensive program of checks and inspections includes:
 - ⇒ Perform before-operation maintenance checks; report or repair deficiencies. Company commander should request status.
 - ⇒ Perform prepare-to-fire checks for all weapons; report or repair deficiencies. Weapons must be boresighted and all sights referred. Machine guns and individual weapons are test-fired if possible. Commander should verify that all weapons have been boresighted.
 - ⇒ Perform communications checks of voice and digital systems (M1A2). Ensure tank crewmen are familiar with standard infantry hand and arm signals. Ensure tanks have TA-1 hooked up to right side of turret.
 - ⇒ Ensure soldiers in each subordinate element understand the plan, have posted current graphics, and are in the correct uniform and MOPP level.
 - ⇒ Upload vehicles in accordance with the unit's SOP. Standardization of load plans enables company leadership to quickly check the accountability of equipment. It also ensures standard locations for critical equipment; this can be very important when a leader is forced to switch vehicles during an operation.
 - ⇒ Review the supply status of rations, water, fuel, oil, all types of ammunition, pyrotechnics, first-aid kits, and batteries.
 - ⇒ Ensure vehicles are correctly camouflaged.
 - ⇒ Conduct a safety brief concerning operating with tanks. Include riding on and moving around tanks. Ensure tank crewmen understand the movement plan of the infantry platoons.
- In the company's tank platoon, TCs must understand the company scheme of maneuver. Other crewmen must understand the platoon scheme of maneuver. The equipment inspection for the tank platoon consists of checking each tank crew's ability to move, shoot and communicate.

Intelligence

- The company commander will continue to receive updated SPOTREPs listing known and suspected enemy locations as well as the latest friendly actions. The tank platoon leader also needs to know enemy anti-armor capabilities, the location of obstacles, and terrain trafficability.
- The company commander should ensure platoons plot the updated enemy and friendly locations on their overlays (and on the enemy overlay for digital systems).
- Based on his terrain reconnaissance, the commander adjusts the maneuver plan accordingly.

Maneuver

- The company should accomplish rehearsals as practice sessions to prepare for the upcoming operation. They are essential in ensuring thorough preparation, coordination, and understanding of the commander's plan and intent.
- Effective rehearsals require leaders and, when time permits, other company team crewmen to perform required tasks, ideally under conditions that are as close a possible to those expected for the actual operation. **AT THEIR BEST, REHEARSALS ARE INTERACTIVE, WITH THE FOCUS ON HOW THE ELEMENT WILL PERFORM THE ACTION CALLED FOR IN THE SCHEME OF MANEUVER.**
- Tank platoons bring a complex, different system to the infantry company. To maximize their synchronization with the remainder of the unit, rehearsals should include coverage of the following events:
 - ⇒ Movement from current positions.
 - ⇒ Routes to be utilized.
 - ⇒ Transporting infantry (see Chapter 5 for specific techniques and information).
 - ⇒ Platoon and company formations and movement techniques.
 - ⇒ Weapons orientation and fire control.
 - ⇒ Decision points.
 - ⇒ Actions on contact.
 - ⇒ Actions on the objective (Consolidation and Reorganization).
 - ⇒ Reporting procedures.
 - ⇒ Signals

Maneuver Considerations:

- Avoid maneuvering the tank platoon in single file. There may be terrain which requires this to happen - minimize wherever possible.
- Do not utilize the plow tanks (if in the tank platoon) to "break brush." They are not designed to do this. A broken plow tank is of no use in mine clearing operations.

Fire Support

- As part of the top-down fire planning system, the company commander must refine the fire plan from higher headquarters to meet his mission requirements.
- He must incorporate the results of his IPB and mission analysis and make key locations and targets from the fire plan an integral part of the company rehearsal.
- The company commander must work with the FSO to develop an observation plan as well as triggers for initiating or shifting fires. Plan for both indirect fires and CAS along routes.
- The company commander employs supporting fires in the offense to achieve a variety of operational goals. Based on the maneuverability and speed at which the tank platoon in the company can move, the following are critical to effective implementation of the fire support plan:
 - ⇒ **Suppression** of likely enemy antitank systems that could inhibit movement.
 - ⇒ **Fixing or neutralizing** of bypassed enemy elements.
 - ⇒ **Preparation** of enemy positions for an assault. Preparatory fires are normally used during a deliberate attack, with fires placed on key targets before the assault begins. The commander must weigh the benefits of preparatory fires against the potential loss of surprise.

- ⇒ **Obscuration** of enemy observation or screening of friendly maneuver. The company can take advantage of smoke in various maneuver situations. Tanks can also generate smoke through firing of their grenade launchers or onboard smoke generators.
- ⇒ **Support** of breaching operations. Fires can be used to obscure or suppress enemy elements that are overwatching reinforcing obstacles.
- ⇒ **Illumination** of enemy positions. Illumination fires are always included in contingency plans for night attacks.

Mobility and Survivability

- The **battalion task force may task organize the company with engineer assets** in addition to the tank platoon. This could include MICLICs, ACEs, or AVLBs.
- **Actions at obstacles should be rehearsed during the preparation phase. SUPPRESS** known or likely enemy positions, **OBSCURE** enemy forces from observing the breach point, **SECURE** the breach point, and **REDUCE** the obstacle. These actions are known by the acronym **SOSR**. See Chapter 5 for a more detailed discussion of actions at obstacles in accordance with **SOSR**.
- Breaching equipment should be checked during the **PCI**.

Mobility and Survivability Considerations:

- **Tanks carry grappling hooks** in the platoon's manual breach kit. These are very useful in obstacle reduction.
- **Use the tank platoon to scan for mines** with direct vision and thermal sights.
- **Camouflage your tanks!**

Air Defense Artillery

- The commander must plan for and rehearse **internal air security and active air defense measures**.
- **ADA requirements and procedures are normally dictated by SOP**.
- The commander must **anticipate possible contact with enemy air assets** by templating enemy helicopter and fixed-wing air corridors. The tank platoon's positioning and ability to engage enemy aircraft must be reflected in his plan.

Combat Service Support

- **CSS functions continue to be performed as far forward as the tactical situation will allow**.
- **Tank platoons must have a coordinated, timely and effective resupply operation. Resupply and preventive maintenance checks and services (PMCS) should be conducted during this phase.** Such operations can be time-consuming; they must be incorporated into the overall preparation phase.
- **Rehearsals should cover all aspects of the logistical plan to support the upcoming operation.** These rehearsals should include **emergency resupply plus personnel and vehicle evacuation procedures**. Chapter 7 includes additional information on **CSS planning, preparation and execution**.
- The company commander should receive a **backbrief from the tank platoon leader on the logistics plan for the platoon**.

Section IV: Execution - Tactical Movement

- The company OPORD will normally specify company and platoon formations and techniques of movement.
- The commander should position his elements where they will optimize the company's battle space and facilitate execution of his scheme of maneuver. Platoon leaders have the responsibility to recommend a different formation or technique of movement if a change will allow the platoon to more effectively contribute to the accomplishment of the company mission and protection of the force.
- If no formation or technique of movement is given in the company OPORD, platoon leaders will select the one that will make the most efficient use of their battle space and will best support the company scheme of maneuver.

While moving, platoons use terrain to provide cover and concealment.

Techniques of Movement

- The commander selects a technique of movement based on several battlefield factors:
 1. The likelihood of enemy contact.
 2. The availability of another element to provide overwatch for the moving element.
 3. The terrain over which the moving element will pass.
- In close terrain, such as rolling hills or countryside, platoons will normally overwatch other platoons.
- In restrictive terrain, such as mountains, forests, or urban areas, a tank section will rely on another tank section or dismounted infantry to overwatch its movement.

Movement Formations

- The company commander uses formations to:
 - ⇒ Establish the relationship of one platoon to another on the ground.
 - ⇒ Allow the company to place firepower where it is needed in support of the direct fire plan.
 - ⇒ Establish responsibilities for sector security among platoons.
 - ⇒ Facilitate execution of company battle drills and directed COAs.
 - ⇒ Alleviate confusion, and increase protection and speed.
- Formations are not intended to be rigid.
- Weapons orientation for all tanks should be adjusted to ensure optimum security.

Overwatch

- Overwatch is the tactical task in which an element observes and provides direct fire support for a friendly moving element.
- Typically, this task is best provided by the tank platoon. However, in very restricted terrain infantry may be required to overwatch as the tank platoon moves through close terrain.

- **Situational awareness is a crucial factor in all overwatch missions.** The objective is to prevent the enemy from surprising and engaging the moving unit.
- **The overwatch element must maintain communication with the moving force and provide early warning of enemy elements that could affect the moving force.** It also scans gaps and dead space within the moving element's formations.
- **If the overwatch element is unable to scan dead space and engage the enemy, it must alert the moving element of the lapse in coverage.**
- **The overwatch element must be able to support the moving force with immediate direct and indirect fires.** Although METT-T will ultimately dictate the length of the moving element's bounds, the maximum length should, in general, be limited to one-third of the maximum effective range of the overwatch element's weapons systems. This will both minimize the bounding element's exposure to enemy fires and leave the overwatch element with greater flexibility to engage enemy forces. In severely restricted terrain, bounds may be much shorter than one-third of the weapons range.
- **The overwatch element can be either stationary or on the move.** Figure 3-_____ illustrates what to look for and where to look during an overwatch mission.
- **Overwatch elements must also maintain 360-degree observation and security for themselves.**

Tactical Movement Considerations:

- **Avoid moving directly forward from an overwatch position or BP.**
- **Stay on low ground as much as possible.**
- **Scan the ground for disturbed earth, out of place features, and surface-laid mines.**
- **Remember: Overwatch elements cannot cover all of a moving element's gaps and dead space.**
- **All platoons must plan actions at danger areas.**

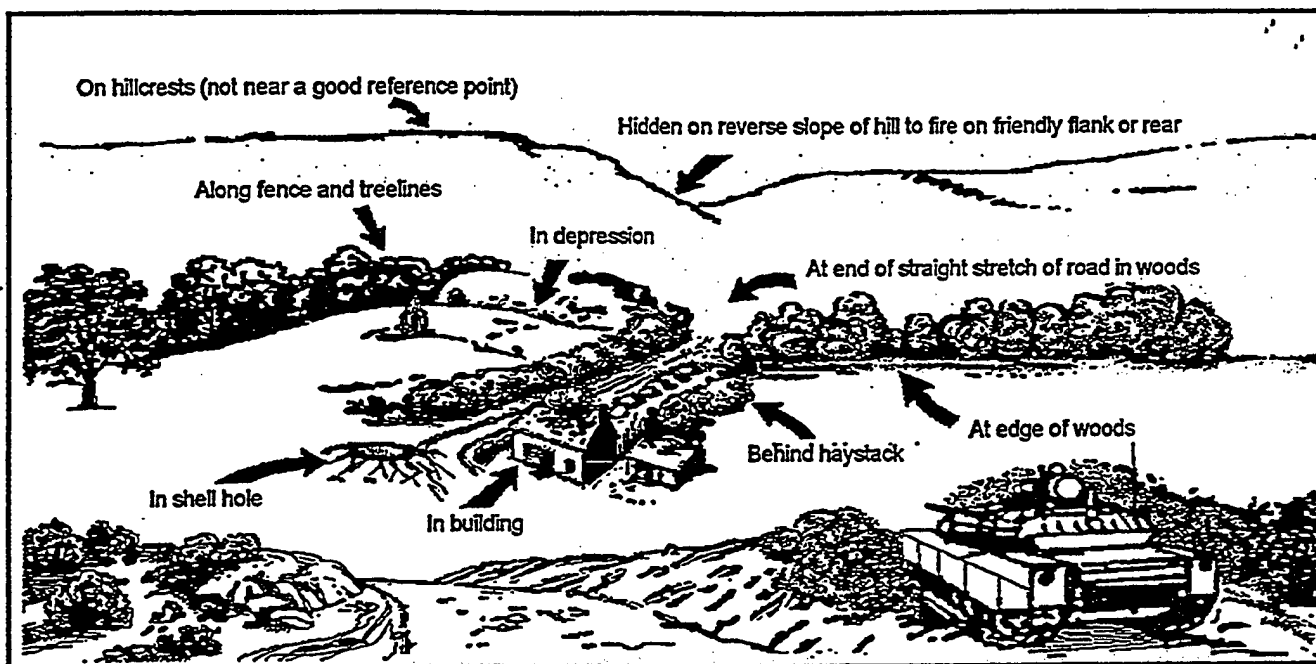

WHAT TO LOOK AND LISTEN FOR:	WHERE TO LOOK (see figure above):
<p>TANKS</p> <ul style="list-style-type: none"> • Engine noise, track clatter. • Exhaust smoke. • Antenna masts. • Engine, suspension heat sources. • Dust and reflections. • Firing signature (flash, blast). 	<ul style="list-style-type: none"> • Within 2,000 meters of moving element. • Near crests, next to buildings, in tree lines.
<p>ATGM</p> <ul style="list-style-type: none"> • Smoke signature of missile in flight. • Missile controller may be up to 100 meters from the launch site. • Human heat sources. 	<ul style="list-style-type: none"> • 400 to 4,000 meters from moving element. • May be launched from behind hilltops and ridge lines. • Roofs.
<p>OTHER ANTITANK WEAPONS</p> <ul style="list-style-type: none"> • Usually well-camouflaged. • Firing signature. • Hand-held and crew-served weapon systems. • Human heat sources. 	<ul style="list-style-type: none"> • Within 1,000 meters of moving element. • 360-degree observation needed to protect against tank ambush teams using hand-held weapons.. • Two or more may be employed on reverse slopes, protected by mines. • Usually on a flank.

Figure 3-____. Overwatch Techniques

Section V: Execution - Actions On Contact

In both offensive and defensive operations, **contact occurs when any member of the company observes enemy personnel or vehicles, observes or receives direct or indirect fire, or encounters any situation that requires an active or passive response to the enemy.** This includes reports of enemy contact through the chain of command or from an adjacent friendly element. The company initiates actions on contact when it recognizes one of the defined contact situations or on order from higher headquarters.

The commander should **use the planning process to anticipate the actions on contact** the company may be required to execute based on the enemy situation. The company can then rehearse these potential actions during the preparation phase of the operation.

The commander's **OPORD will assist the subordinate platoon leaders** in two ways:

1. The commander's scheme of maneuver will **direct the platoon leaders in planning how to kill** the templated or anticipated enemy force. The scheme of maneuver will define the roles of the platoons, to include the tank platoon, in maneuver and direct fire as part of the company plan.

2. The commander's coordinating instructions should **specify for the subordinate platoons the actions on contact that**, based on the size and activity of the anticipated enemy force, are related to the maneuver plan. These specific instructions may include:

- Engagement criteria
- Bypass criteria
- Displacement criteria
- Expected COAs

The Four Steps of Actions On Contact

The following four steps allow the company commander to execute actions on contact using a logical, well-organized decision-making process:

1. Deploy and report
2. Evaluate/develop the situation
3. Choose a course of action
4. Recommend/execute a course of action

The four-step process is **not a rigid, lockstep response to enemy contact.** The goal is to **provide an orderly framework** that enables the company and its platoons to survive the initial contact, then apply sound decision-making and timely actions to complete the operation.

Ideally, the company will acquire the enemy (visual contact) before being sighted by the enemy. It can then initiate physical contact on its own terms by executing the designated COA.

Subordinate platoons must react instinctively and instantly to the contact. Platoon leaders must decide whether to execute a preplanned battle drill or COA or to recommend and execute an alternate drill or action.

Step #1: Deploy and Report

Events that occur during the first step of actions on contact depend in great measure on whether the contact is expected or unexpected. Contact situations include (but are not limited to) the following:

- Visual contact (friendly elements may or may not be observed by the enemy).
- Physical contact with a superior, inferior, or unknown enemy.
- Indirect fire contact
- Contact with obstacles of enemy or unknown origin
- Contact with enemy or unknown aircraft
- Situations involving NBC conditions
- Situations involving electronic warfare tactics (such as jamming, interference, and imitative deception).

Expected Contact

- If the commander expects contact, he will already have deployed the company.
- If the company is alert to the likely presence of the enemy, it has a better chance of establishing first visual contact and then physical contact on its own terms.
- In a worst-case scenario, a platoon may be engaged by a previously undetected (but expected) enemy element. The platoon in contact would conduct a battle drill for its own survival and then initiate actions on contact. Most critically (for the tank platoon), if the contact entails enemy antitank fire, the tanks return fire immediately. In all cases, those fired upon alert the rest of the platoon, and the platoon leader the company commander, with a contact report. **Reminder: Identification of ANY/ALL AT weapons is critical information for the tank platoon leader.**

Unexpected Contact

- In most cases, the company will make unexpected contact with the enemy while using traveling or traveling overwatch.
- The element in contact or, if necessary, the entire company may have to deploy using battle drills to survive the initial contact.
- **Battle drills are not a substitute for planned COAs; rather, they buy time for the unit in contact, providing a framework for the company or a subordinate platoon to later develop the situation.**
- **Tank platoons can be expected to perform one of seven battle drills: (Note: Refer to the discussion and illustrations of the platoon battle drills in Appendix C).**
 1. Change of formation
 2. Contact
 3. Action
 4. React to indirect fire
 5. React to air attack
 6. React to nuclear attack
 7. React to chemical/biological attack

Whether contact is expected or unexpected, this step concludes with the unit deployed, the enemy suppressed or destroyed, and a contact report sent to battalion headquarters.

Step #2: Evaluate and develop the situation

While the company is deploying and/or executing a battle drill, the commander must **evaluate the situation**, and, as necessary, continue to maneuver to develop it.

The commander quickly **gathers as much information as possible**, either visually or through reports of the platoon(s) in contact.

He **analyzes the information** to determine critical operational considerations, including the following:

- **The size of the enemy element and whether it is an inferior or superior force.**
- **The location, composition, activity, and orientation of the enemy force.**
- **The impact of obstacles and terrain.**
- **Enemy capabilities (especially antiarmor capability).**
- **Probable enemy intentions.**
- **Friendly situation (location, strength, and capabilities).**
- **Possible friendly COAs to achieve the specified end state.**

An **inferior force** is defined as an enemy element that the company can destroy while remaining postured to conduct further operations.

A **superior force** is one that can be destroyed only through the combined effort of the company and battalion or brigade-level combat and CS assets.

Critical to the commander's assessment is the number of lethal weapon systems the enemy force is known to have, coupled with their current activity. This includes:

- **Antitank weaponry**
- **Wire-guided systems**
- **Automatic weapons**

Enemy activity can range from an entrenched force using prepared fighting positions to a unit conducting operations with little security.

After evaluating the situation, the commander may discover that he does not have enough information to determine the superiority or inferiority of the enemy force.

To make this determination, he must further develop the situation in accordance with the battalion commander's intent, using a combination of the following techniques:

- **Mounted and/or dismounted maneuver**
- **Indirect fire**
- **Reconnaissance by fire**
- **Dismounted surveillance**

Step #3: Choose and Recommend a Course of Action

Once the commander develops the situation and determines that he has enough information to make a decision, he selects a COA that both meets the requirements of the battalion commander's intent and is within the company's capabilities.

Nature of contact

The nature of contact (expected or unexpected) may have a significant impact on how long it takes a commander to develop, select, and recommend a COA.

Unexpected contact may complicate the commander's decision process if the company has to execute actions on contact at both the company and platoon levels to provide him with enough information to make the decision.

COA Procedures

The commander has several options in how he goes about the process of selecting and recommending a course of action:

- Direct the company to execute the original plan.
- Based on the situation, issue FRAGOs to refine the plan, ensuring it supports the original intent and that of the battalion commander.
- Based on known information in response to an unforeseen enemy or battlefield situation, report the situation and recommend an alternative course of action.
- If the battlefield picture is still vague, direct the company or a platoon to execute tactical maneuver and reconnaissance by fire to further develop the situation.

Use of tactical tasks

During the execution of actions on contact, the company commander can expect to perform company-level tactical tasks.

As a part of the company, the tank platoon can be expected to execute platoon-level tactical tasks. These tasks include (and are addressed with company-level considerations in Section VI of this chapter):

1. Destroy an Inferior Force
2. Attack by Fire
3. Overwatch/Support by Fire
4. Assault
5. Bypass
6. Reconnaissance by Fire
7. Hasty Occupation of a Platoon BP (Hasty Defense)
8. Hasty/In-Stride Breach
9. Clear a Danger Area

Step #4: Execute a COA

In this step, the company executes the appropriate COA. This will either be a continuation of the original plan (if no change is necessary) or an alternative COA.

As execution continues, more information will become available to the commander. Based on the emerging details, the commander may have to alter his COA during execution.

The company continues to execute the selected or refined COA until it accomplishes the original mission, receives a FRAGO from the battalion commander changing the mission or COA, or is ordered to execute consolidation and reorganization on the objective.

Examples of Actions on Contact

- The following examples illustrate Actions on Contact for two potential situations involving the company and its tank platoon.
- The illustrations are organized to show the four-step process for executing Actions on Contact.

Actions on Contact with an Anticipated Inferior Force

- Figures 3-____ through 3-____, show Actions on Contact when the company has encountered an inferior enemy element, and the tank platoon is the company's bounding element.
- In this case, the commander and tank platoon leader have anticipated contact with such a force and have planned for Actions on Contact by including possible COAs in their OPORDs and/or rehearsals.

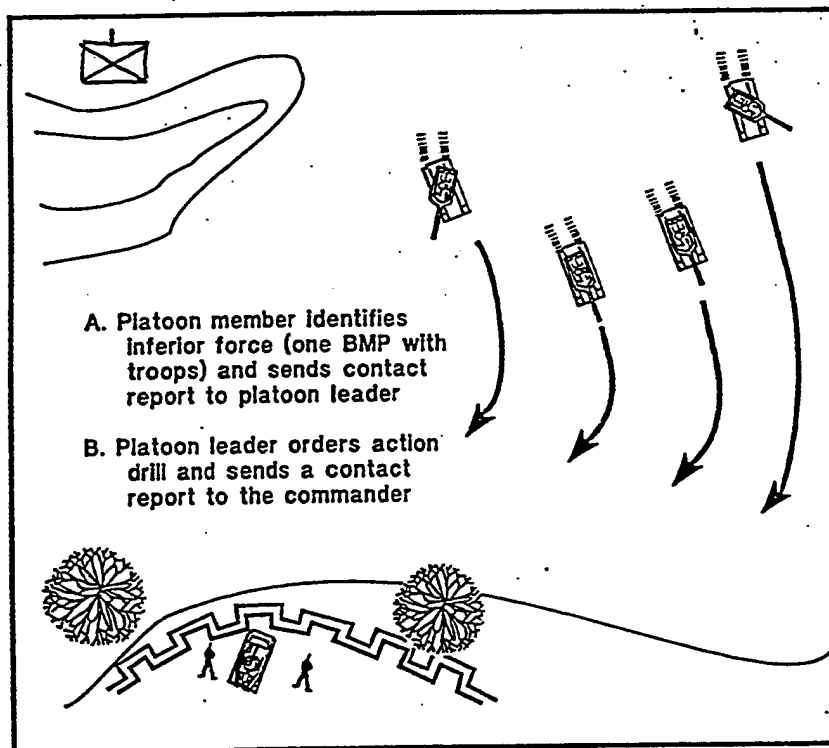

Company Actions/Options

- Continue mission.
- Elect to bypass.
- Overwatch the maneuvering tank platoon; support by fire.
- Leave dismounted security element with tank platoon (if bypass elected).

Tank Platoon Actions/Options

- Perform Action Drill.
- Develop the situation.
- Choose a platoon course of action.
- If appropriate, execute the assault.
- Be prepared to maneuver only section; 2d section continue mission with company.

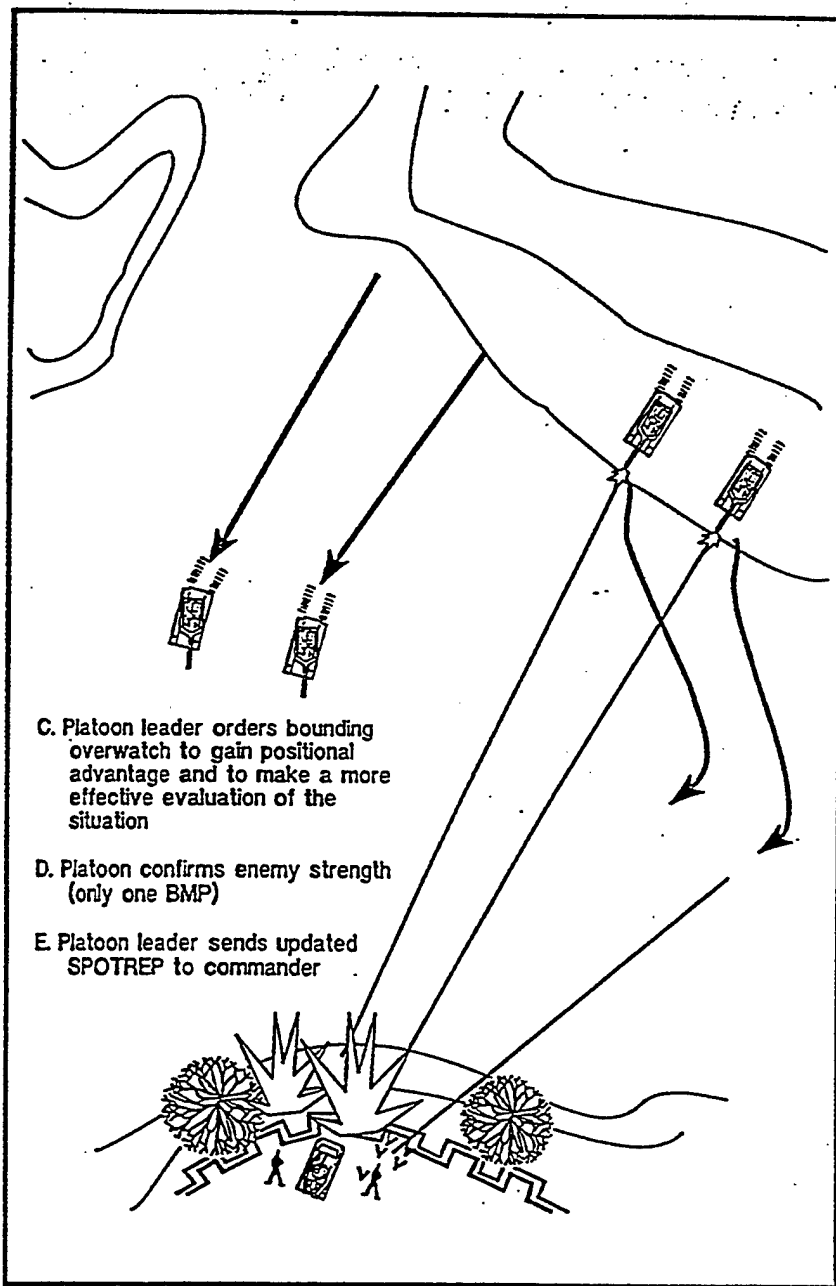

Figure 3- ____ . Actions on Contact (continued).

F. Platoon leader chooses to assault (in accordance with commander's OPORD)

G. Platoon leader informs the commander and orders the platoon to execute the assault

H. Platoon assaults and destroys BMP

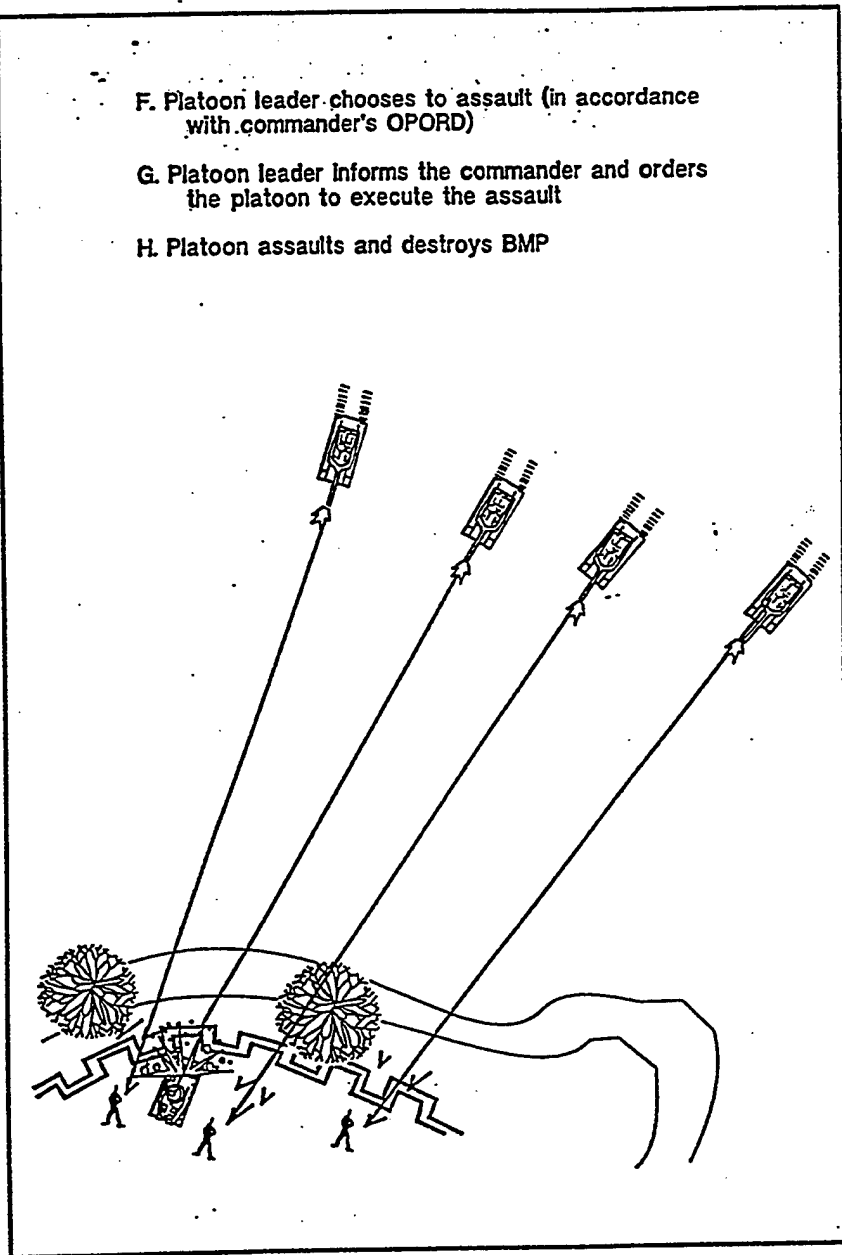
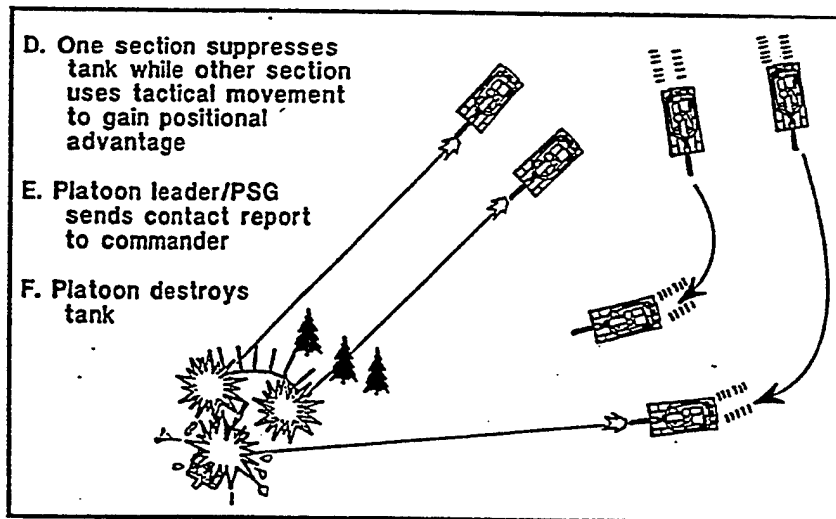
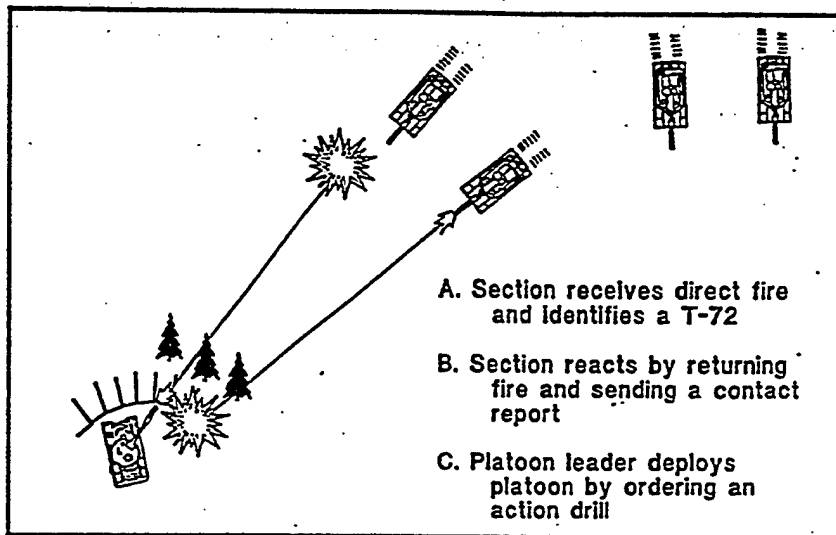

Figure 3-____. Actions on Contact (continued).

Actions on Contact with an Unanticipated Superior Force

Figures 3-____ through 3-____, show Actions on Contact when the company unexpectedly encounters a superior enemy force.



Company Actions/Options

- Elect to bypass.
- Assault
- Overwatch/support the tank platoon by fire.
- Leave dismounted security element with tank platoon (if bypass elected).

Tank Platoon Actions/Options

- Make initial enemy contact, deploy and report.
- Execute battle drill; platoon evaluates the drill as executed.
- Develop the situation and identify the superior enemy force.
- Choose and recommend alternate course of action to the commander; execute new course of action

Section VI: Tactical Tasks

This section addresses **nine doctrinal tactical tasks that the tank platoon may be required to execute while supporting the infantry company**. These complement warfighting actions that the company may be called upon to perform in battle which include Hasty Attack, Deliberate Attack, Raids, Ambushes, Spoiling Attacks, and Counterattacks. The commander may direct his platoons to execute these collective tactical tasks as part of the company's planned scheme of maneuver. He should cover execution of the tasks in the company OPORD. In addition, the tank platoon can use the tactical tasks as courses of action when it executes Actions on Contact (refer to the discussion in Section V).

The situations used in this section to describe tactical tasks executed by the tank platoon are **examples only**. They will not be applicable in every tactical operation, nor are they intended to prescribe any specific method or technique that the company must use in achieving the purpose of the operation. Ultimately, it is up to the commander on the ground to apply the principles discussed here, along with his knowledge of the situation, in developing the 'correct' tactical solution.

Following are the Tactical Tasks addressed in this section:

Tactical Task #1: Destroy an Inferior Force

Tactical Task #2: Attack by Fire

Tactical Task #3: Overwatch/Support by Fire

Tactical Task #4: Assault

Tactical Task #5: Bypass

Tactical Task #6: Reconnaissance by Fire

Tactical Task #7: Hasty Occupation of a Platoon BP (Hasty Defense)

Tactical Task #8: Hasty/In-Stride Breach

Tactical Task #9: Clear a Danger Area

Tactical Task #1: Destroy an Inferior Force.

- To maintain the tempo of an attack, the commander may order his tank platoon to destroy an inferior force, based either on his original plan or on recommendation of the tank platoon leader.
- The tank platoon leader will employ maneuver techniques (fire and tactical movement) in executing this task or course of action.
- When the tank platoon comes in contact with the enemy, the platoon leader will designate one section to overwatch or support by fire to suppress and/or destroy the enemy while the other section moves.
- The moving element will use appropriate movement techniques as well as covered and concealed routes to move to a position of advantage over the enemy. This position may offer dominating terrain that allows the platoon to attack enemy positions by direct fire, or it may provide covered routes that enable the section to close with and assault the enemy.
- Cross-talk among platoons in the company and the sections in the maneuvering tank platoon is important in ensuring mutual support.
- After destroying the inferior force, the tank platoon positions itself where it can most effectively prepare for subsequent actions. Figure 3-___ illustrates three potential situations in which the company's tank platoon is ordered to destroy an inferior force.

Tank platoon identifies one BMP forward of a motorized rifle platoon. The commander orders the platoon to destroy the BMP and to then occupy an SBF position to suppress the platoon.

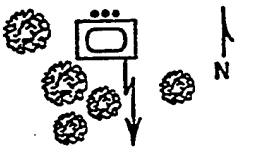

Tank platoon identifies an enemy OP (one BMP with dismounts). The commander orders destruction of the OP and plans to continue movement south.

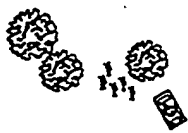
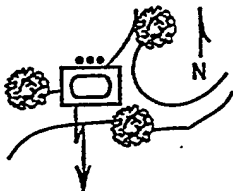

Platoon identifies enemy tanks conducting refueling operations with no security. The commander orders the platoon to execute an attack by fire.

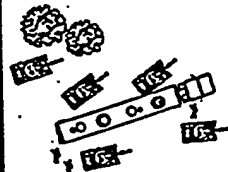
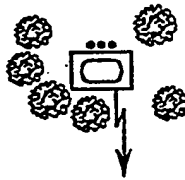

- Remember: The tank platoon must be prepared to continue the mission as two sections.
- Remember: The remainder of the infantry company may bypass, continue to overwatch the maneuvering tanks, or assault.
- Consider: Leaving a dismounted security element with the tanks maneuvering on the enemy.

Tactical Task #2: Attack by Fire

- An attack by fire entails the **employment of fires to destroy the enemy from a distance**. It is most commonly conducted when the mission or tactical situation does not dictate or support occupation of the objective.
- It is usually executed by the **supporting element in the offense; during defensive operations, it could often be utilized as the counterattack option for the tank platoon as the company's reserve force**.
- The **commander may order the tank platoon to execute this task, either as specified in his original plan or on recommendation of the tank platoon leader**.
- The **purpose is to destroy the enemy using long-range fires from dominating terrain or using standoff of the main gun**.
- **Planning and Preparation**. In planning and preparing for this task, the commander should consider the following actions:
 - ⇒ **Conduct line of sight analysis to identify the most favorable locations for attack by fire positions.**
 - ⇒ **Conduct direct and indirect fire planning and integration**. The commander or platoon leaders should designate TRPs and assign sectors of fire.
 - ⇒ **Determine triggers for lifting and shifting direct and indirect fires.**
 - ⇒ **Plan and rehearse actions on contact and maneuver to attack by fire positions.**
- **Execution**. This task begins with the establishment of blocking positions to fix the enemy force while the attack by fire force (tank platoon) maneuvers to its attack by fire position.
 - ⇒ **Both elements (blocking and attack by fire) have a part in security for the operation**. The attack force platoon can provide its own security by using the principles of maneuver and/or employing screening or obscuring smoke. The blocking force helps to protect the attack force by establishing a base of fire.
 - ⇒ **The attack by fire may be conducted well beyond the direct fire range of the blocking force platoon(s)**. It may not be possible to destroy the enemy from initial positions. The company may at first only be able to fix or attrit the enemy at extended ranges. Additional maneuver would then be required to close with the enemy and complete its destruction.
- Throughout the attack by fire operation, the company should adhere to the following guidelines:
 - ⇒ **Use infantry to secure ABF positions and to maintain local security.**
 - ⇒ **Maintain communications between the blocking and maneuver platoons.**
 - ⇒ **Maintain 360-degree security.**
 - ⇒ **Use maneuver to move to and occupy attack by fire positions.**
 - ⇒ **Execute timely, decisive actions on contact**
 - ⇒ **Destroy enemy security elements protecting the targeted force.**
 - ⇒ **Employ fires to attrit, fix, or destroy the enemy force.**
- Figures 3-____A and 3-____B illustrate attack by fire situations.

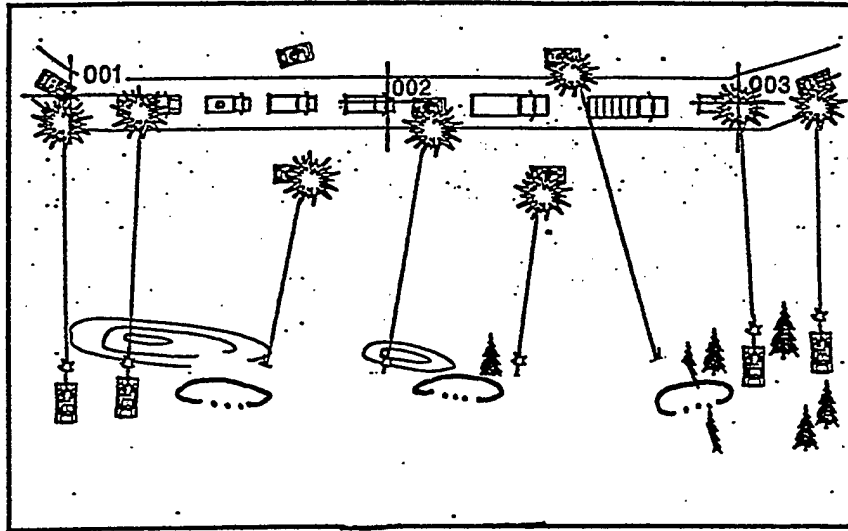

- Company assaults convoy.
- Tank platoon provides lead and trail security

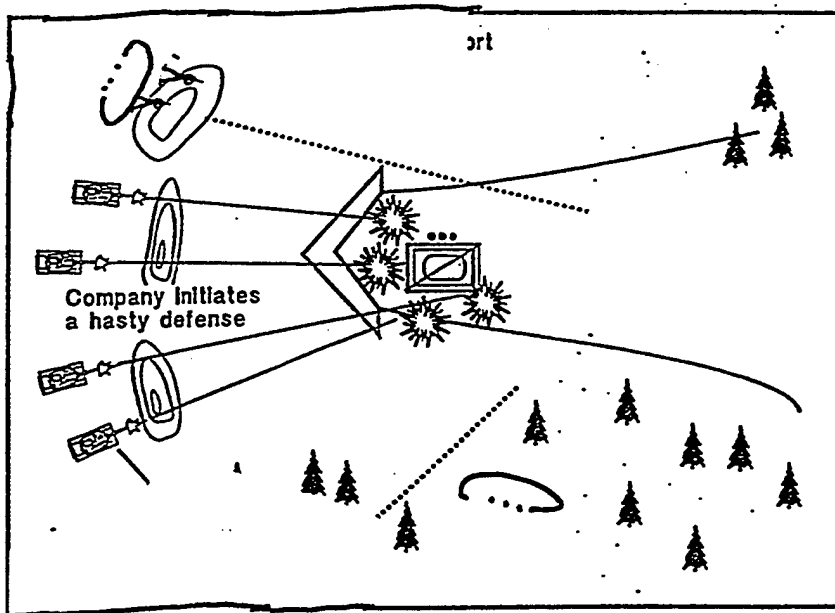

- Company initiates hasty defense.
- Tank platoon executes attack by fire.

Figures 3-____ A and 3-____ B. Attack by fire situations.

Tactical Task #3: Overwatch/Support by Fire

- Support by fire is the tactical task in which a maneuver element (platoon) moves to a position on the battlefield from which it can observe the enemy and engage him with direct fire. This support sets the conditions that allow the moving (supported) platoons to engage and destroy the enemy.
- The maneuver element does not, by itself, attempt to capture enemy forces or terrain.
- The purpose of the support by fire task is to observe the area of operations and provide direct long-range and indirect fire support for another platoon in the company. The primary objective is to prevent an enemy force from engaging the protected platoon.
- Support by fire normally entails maneuvering to a position and suppressing a specific enemy force, such as while protecting a breach or assault force. The techniques involved in occupying an overwatch or support by fire position and in controlling fires are similar to those for an attack by fire.
- **Planning and Preparation.** In planning and preparing for this task, the commander should consider the following actions (Note the similarity with the considerations for the attack by fire task):
 - ⇒ Conduct line of sight analysis to identify the most favorable locations for conducting support by fire.
 - ⇒ Conduct direct and indirect fire planning and integration. The commander or platoon leaders should designate TRPs and assign sectors of fire.
 - ⇒ Determine triggers for lifting and shifting direct and indirect fires.
 - ⇒ Plan and rehearse actions on contact and maneuver to support by fire positions.
 - ⇒ Plan for large Class V expenditures, especially machinegun ammunition.
- **Execution.** Situation awareness is crucial in all support by fire operations. Throughout the support by fire operations, the company should adhere to the following guidelines:
 - ⇒ Maintain communications with the moving platoon. This is an especially critical force protection/anti-fratricide measure.
 - ⇒ Be prepared to support the moving platoon with direct and indirect fires.
 - ⇒ Scan the area of operation. Prepare to acquire, lock on to, and destroy any element that threatens the moving platoon.
 - ⇒ Be patient. Enemy elements may be under cover or in prepared positions. Wait for them to expose themselves.
 - ⇒ Maintain 360-security.
 - ⇒ Be ready to lift or shift fires when masked by the moving force.
 - ⇒ Use tank cannons to kill exposed enemy vehicles.
 - ⇒ Employ machinegun fire to lay a base of sustained fire to keep the enemy fixed and/or suppressed in his 'holes.'
 - ⇒ Prevent the enemy from employing accurate direct fires against the moving platoon.
- Figure 3- ____ illustrates a support by fire in support of an assault.

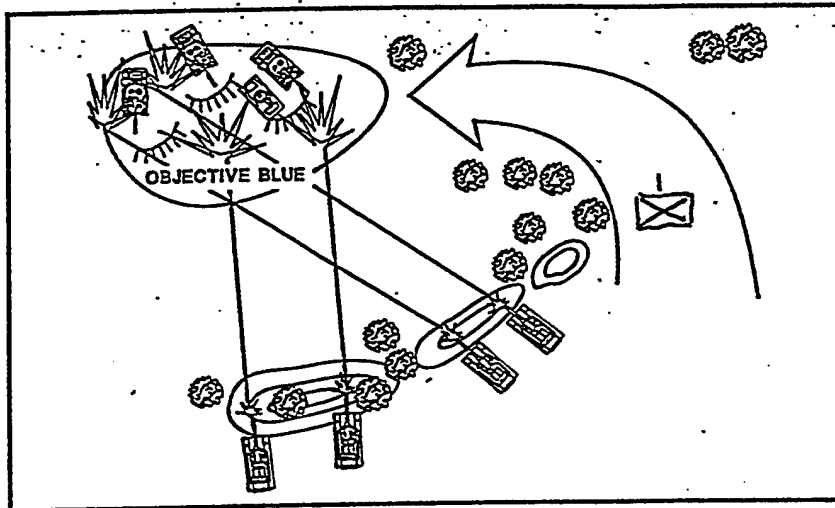

- Tank platoon supports by fire to suppress an enemy element during a company assault.

Figure 3-____. Support by fire in support of an assault.

Tactical Task #4: Assault

- The assault is a complex tactical task that entails closure with the enemy, under fire of his weapons, to the point that the assaulting force gains positional advantage over or destroys the enemy.
- The company may be required to assault prepared or unprepared enemy positions from either an offensive or defensive posture.
- Examples of situations that would require the company or its platoons to assault include the following:
 - ⇒ A platoon assault to secure the far side of an obstacle as part of a company breach.
 - ⇒ A company assault to penetrate an enemy MBA defense as part of a battalion deliberate attack.
 - ⇒ A company assault to complete the destruction of a defending enemy as part of a battalion attack.
 - ⇒ A company or platoon assault to destroy enemy security elements (such as ambush positions, CSOPs, or OPs) as part of a battalion attack.
 - ⇒ A company or platoon assault to destroy an ambush element (for example, this could occur in response to a near ambush during a tactical road march).
 - ⇒ A company or platoon ambush to destroy an attacking element as part of a counterattack or movement to contact.

Planning and Preparation. There are many dangers in an assault. Enemy fires, a rapidly changing environment, and the requirement to execute the assault on short notice may all be involved. The commander and his subordinate leaders should include the following considerations in their planning and preparation for the assault operation.

Enemy situation.

- The process of developing a clear and current picture of the enemy situation is the same in an assault as for other tactical operations.
- The commander may have to rely heavily on reports from other units in contact plus his own development of the situation.
- Clear, concise FRAGOs are critical to explain the enemy situation to subordinates.
- The commander and subordinate leaders must be prepared to make necessary adjustments to the scheme of maneuver based on the available information. Plans must be adapted to defeat the enemy to be faced on the ground and not the enemy depicted on a SITTEMP that no longer applies.

Maneuver.

- Assault entails closure with the enemy to gain positional advantage over him and, ultimately, to destroy him.
- Closure may require the company to conduct dismounted, mounted or a combination of maneuvers to assume the advantage. Inherent in this consideration are the inherent movement capabilities of the infantry and tank platoons.
- A mounted assault, by the tank platoon, maximizes the protection of the company's dismounted infantry platoons.
- Factors influencing the commander's decision include:
 - ⇒ The company's task and purpose. If directed to clear or seize an objective area, and the enemy has dismounted positions, it is likely that the company's assault will entail both mounted and dismounted maneuver.
 - ⇒ Trafficability of the objective area. If all or part of the objective area is not trafficable by the company's tank platoon, the commander must consider a dismounted assault. He must assess both existing obstacles (severely restrictive terrain) and reinforcing obstacles (such as minefields or entrenchments).

- ⇒ **Enemy antitank capabilities.** The presence of antitank assets on or around the objective puts the company's tank platoon at risk. The preferred COA is to neutralize these elements with suppressive and/or killing fires. If not possible, a dismounted assault may be required to eliminate these threats (or made in conjunction with a mounted assault).
- ⇒ **Effectiveness of mounted direct and indirect fires.** Should the tank platoon not be able to effectively suppress or destroy the enemy, the company may have to assault dismounted and conduct a belowground fight.

Fire Support.

- **Smoke can isolate the enemy force and prevent him from effectively repositioning or reinforcing his positions.**
- **Suppressive fires can fix adjacent or reserve elements, hindering their ability to reposition or reinforce.**

Mobility and Survivability

- **Conduct of an assault breach is a high-frequency task for the company when it takes part in an assault of prepared enemy positions.**
- **The commander must determine if a mounted or dismounted breach is possible, based on METT-T.**

Execution. During the planning and preparation phases, the commander should focus on the tactical considerations and actions that will affect execution of the assault. The following comments outline these factors, organized roughly in chronological order as they will occur on the battlefield.

- 1. Set the conditions for the assault.** The purpose is to achieve a 3-1 force ratio for the assaulting force. This is normally achieved by either attrition of the enemy on the objective area, or isolation of portions of the objective area.
 - ⇒ **Attrit the enemy force.** Employ CAS, killing artillery or mortar fires, or killing direct fires from support by fire positions.
 - ⇒ **Isolate the enemy or objective area.**
 - **Use screening or obscuring smoke.**
 - **Fix adjacent or reserve enemy elements with direct fires.**
- 2. Suppress the enemy on the objective.** The suppressing force normally requires at least a 1-1 force ratio to be successful.
- 3. Conduct actions at the assault position or PLD** (Note: an assault position may be used in conjunction with a PLD, or a PLD may be used in lieu of an assault position).
 - ⇒ **Verify current friendly and enemy situations.**
 - ⇒ **Issue FRAGOs/disseminate information to the lowest level.**
 - ⇒ **Confirm TRPs and direct fire responsibilities.**
 - ⇒ **Position artillery observers.**
 - ⇒ **Conduct final prepare-to-fire checks.**
 - ⇒ **Reorganize to compensate for combat losses.**
- 4. Conduct the assault breach.** Conducted with considerations made earlier concerning mobility and survivability.
- 5. Conduct the aboveground fight.**
 - ⇒ **Suppress and kill the enemy on the objective using accurate direct fires.**
 - ⇒ **Secure the objective from counterattack, direct fires, and indirect fire observers.**
 - ⇒ **Employ indirect fires (normally mortars) to isolate a small part of the objective.**
 - ⇒ **Maneuver on the enemy; force him to fight in two directions**
 - ⇒ **Rob the enemy of his initiative and limit his tactical options.**

6. Conduct the belowground fight.

- ⇒ **Establish a solid base of fire with the tank platoon.**
- ⇒ **Consider the use of restrictive fire measures.** Remember danger areas associated with the firing of the tank weapons systems.
- ⇒ **Maintain close coordination between the tank platoon/base of fire element, and the dismounted elements.**
- ⇒ **Focus base of fire on the destruction of key aboveground structures (especially CPs and bunkers, which normally contain crew-served weapons) and suppression and destruction of enemy vehicles.**
- ⇒ **Maintain close control of direct fires.** Techniques include:
 - **Flags on antennas of the dismounted elements' radios to mark forward progress.**
 - **Panels to mark cleared bunkers.**
 - **Visual signals to indicate when to lift/shift fires.**

7. Combined effects.

- **Once the dismounted infantry enters the trenchline or fortifications, the enemy is faced with a dilemma.**
- **Every action the enemy takes to avoid direct fire from the tanks places him back in position to face the infantry moving down the trench or through the fortification. The converse is true in the event the enemy attempts to avoid the infantry - they are directly exposed to tank fires.**

8. Consolidation and Reorganization. Please see Section VII of this chapter for a discussion of consolidation and reorganization.

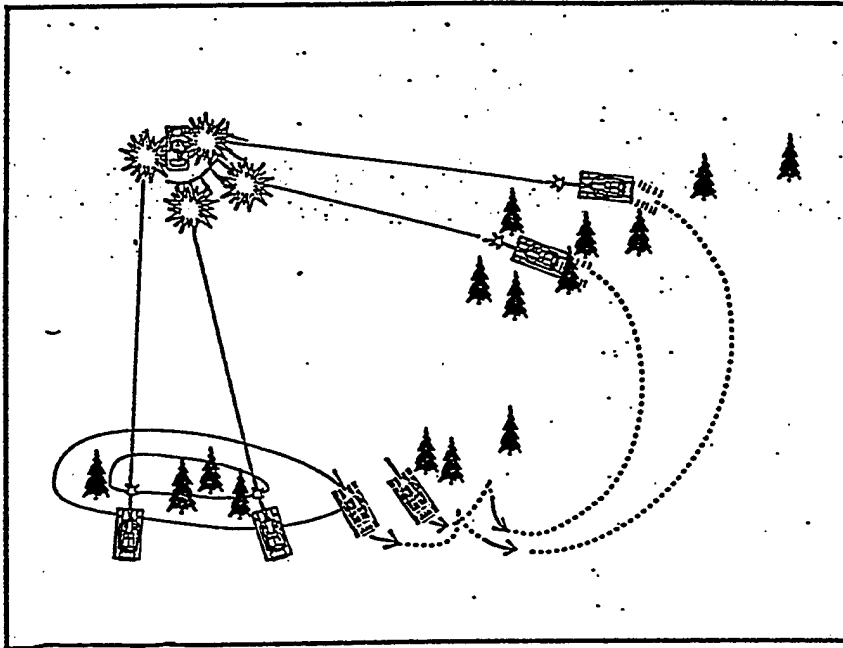

- Tank section assaults an inferior force as another section supports by fire.

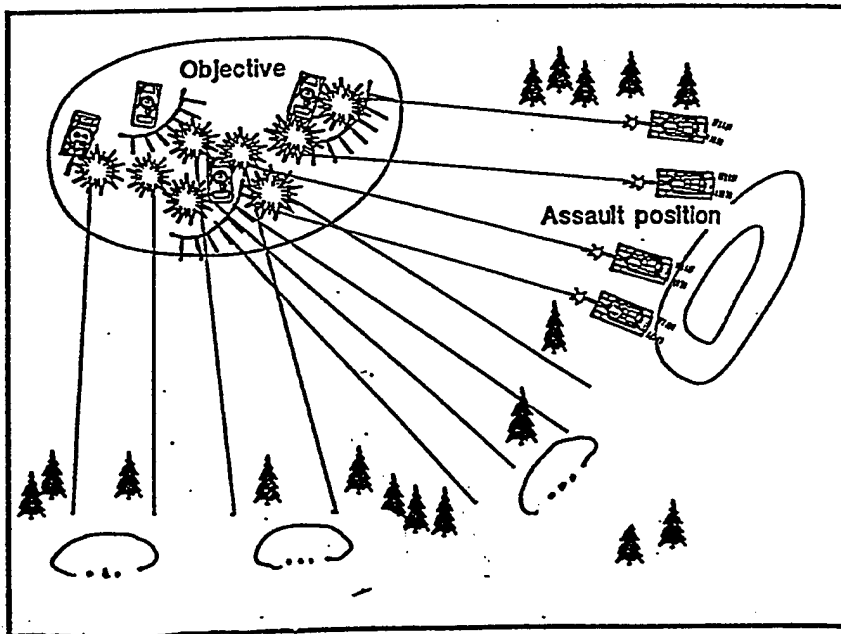

- Tank platoon executes assault.
- Company supports by fire.

Figure 3-____. Assault options with the tank platoon.

Tactical Task #5: Bypass

- The company may bypass an enemy force or obstacle to maintain the momentum of the attack. This course of action can be taken against either an inferior or superior force.
- The commander must designate a fixing force to maintain contact with the enemy and assist the remainder of the company during the bypass.
- The bypassing platoons use covered and/or concealed routes and, if possible, moves along bypass routes that are outside the enemy's direct fire range. These platoons may have to execute contact drills while executing the bypass.
- The company can employ smoke to obscure the enemy or to screen the bypassing force's movement.
- Once clear of the enemy, the supporting platoon or section hands the enemy over to another force, breaks contact, and rejoins the company. Platoons can employ tactical movement to break contact and continue the mission; they may also request supporting direct and indirect fires and smoke to suppress and obscure the enemy.
- See Figures 3-____ A and 3-____ B for an example bypass.

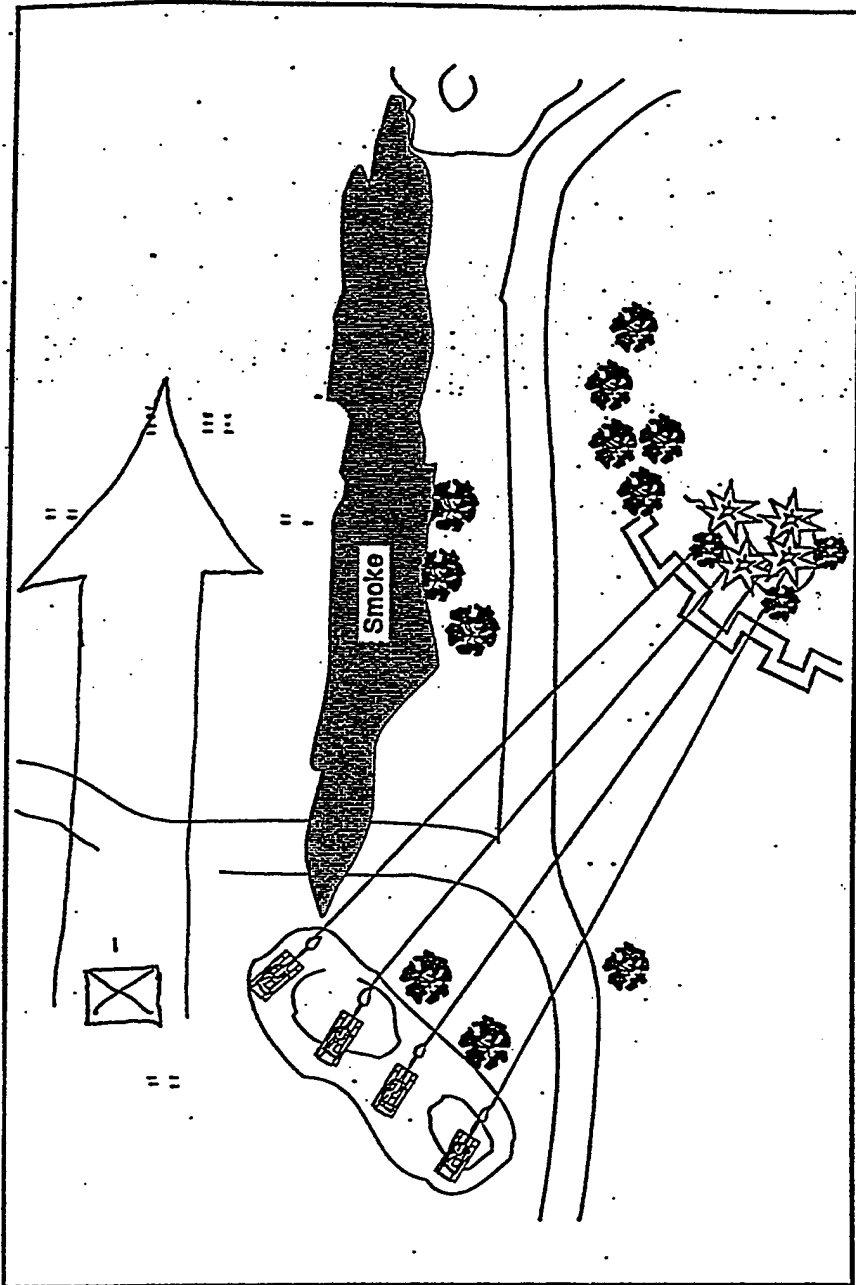

• Bypass

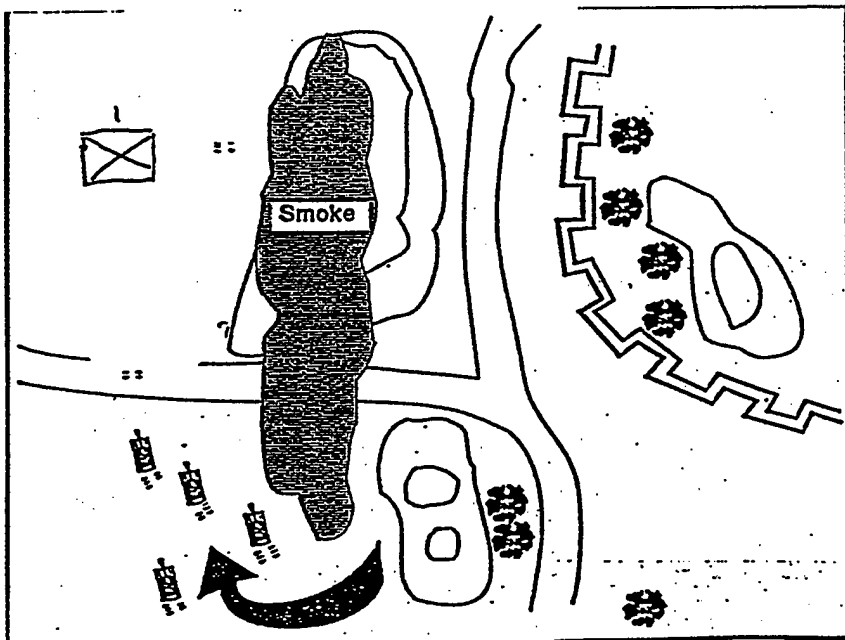

• Bypass (continued)

Figures 3-____ A and
3-____ B. Example
bypass.

Tactical Task #6: Reconnaissance by Fire

- The **objective** of reconnaissance by fire is to **gain tactical information** by placing fires on suspected enemy positions, causing the enemy to disclose his presence by movement or return of fire.
- The commander will direct platoon(s) to execute reconnaissance by fire when enemy contact is expected or when contact has occurred but the enemy situation is vague.
- This task is **normally conducted at platoon level** during actions on contact as the commander is trying to develop the situation.
- When the tank platoon is conducting reconnaissance by fire, it conducts tactical movement, occupying successive overwatch positions until it makes contact with the enemy or reaches the objective.
- The platoon conducting reconnaissance by fire should pay **particular attention to key terrain** that dominates danger areas, on built-up areas that dominate the surrounding terrain, and on uncleared wooded areas.
- **Key:** A disciplined enemy force may not return fire or move if it determines that the pattern or type of friendly fires are nonlethal.

Tactical Task #7: Hasty Occupation of a Platoon BP (Defense)

- Subordinate platoons may use this task if fixed or suppressed by enemy fire to the point where they no longer have the ability to move forward or bypass.
- Platoons may also conduct a hasty occupation of a platoon BP (defense) when the enemy executes a hasty attack.
- One of the company's platoons maintains contact or fixes the enemy in place until additional combat elements arrive or until ordered to move.
- Should the commander order an infantry platoon to execute the hasty occupation of a platoon BP, he can then utilize the tank platoon to maneuver and continue to develop the situation.
- Refer to Figure 3-___ for an illustration of an infantry platoon's hasty occupation of a platoon BP, with maneuver by the tank platoon to develop the situation.

Figure 3-_____. Infantry platoon hasty occupation of a platoon BP; maneuver by the tank platoon to develop the situation.

Tactical Task #8: Hasty/In-Stride Breach

- When contact with enemy obstacles is expected, the commander and subordinate platoon leaders must **plan and rehearse actions at obstacles.**
- **All platoons must know how to accomplish early detection of both anticipated and unexpected obstacles and how to react instinctively when contact is made.**
- The company's tank platoon has **only limited ability to deal independently with an obstacle or restriction.**
- **If equipped with a mine plow, the tank platoon can create track-width lanes through most wire, mines, and other reinforcing obstacles.**
- **The tank platoon cannot internally accomplish all of the SOSR elements of the breach (Suppress the enemy; Obscure the breach; create the lane and Secure the far side; Reduce the obstacle). Refer to the discussion of breaching operations, including SOSR procedures, in Chapter 5.**
- When platoons encounter an unexpected obstacle, they must assume **that the enemy is covering the obstacle with observation and fire. They must:**
 1. **Immediately seek cover and establish an overwatch. Scan for enemy in and around the obstacle and on dominant terrain adjacent to the obstacle.**
 2. **Attempt to locate a bypass.**
 3. **Determine the dimensions of the obstacle and report.**
- **Key point: It is critical that the tank platoon remain under cover if they are the platoon evaluating the situation. The platoon must NEVER attempt to approach the obstacle or breach area without first killing or obscuring enemy elements overwatching the obstacle.**
- The commander should employ **infantry to reconnoiter the obstacle; the tank platoon is ideally suited to provide overwatch.**
- If reconnaissance determines a bypass route, the commander may order the company to execute a bypass as the preferred course of action.
- **If a bypass is not possible, the commander may order a breaching operation, with the tank platoon executing a hasty breach (within their capabilities) or supporting a deliberate breach. Infantry can also help the tank platoon by finding and breaching or marking anti-tank obstacles.**

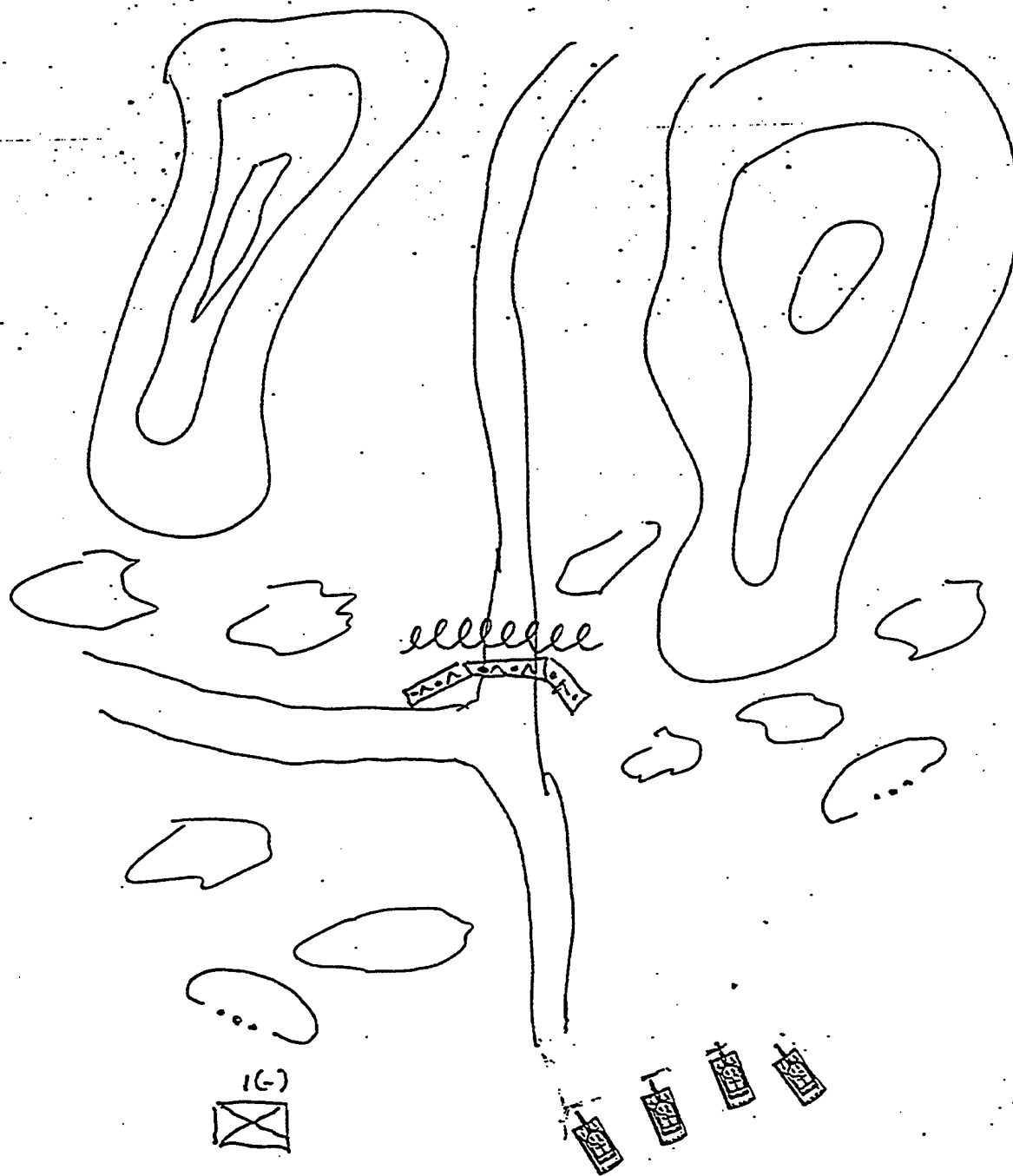

S - Infantry **SUPPRESS** enemy force. (Reminder: Do not forget indirect fire suppression capabilities).

O - Use smoke to **OBSCURE** enemy observation of the breach site. (Reminder: remember wind direction).

S - Infantry **SECURE** far side of the obstacle

R - Tank platoon **REDUCE** the obstacle (grappling hooks, plows, proof with roller)

Tactical Task #9: Clear a Danger Area

The company may be tasked with clearing danger areas during an attack, with the purpose of facilitating the movement of the remainder of the battalion, or as part of clearance of a specific objective area. In many cases, this will involve working in restrictive terrain. Situations in which the company may conduct this task include the following:

- **Clearance of a defile.** This includes high ground surrounding the defile and/or choke points within the defile. (Figure 3-_____).
- **Clearance of a heavily wooded area.** (Figure 3-_____).
- **Clearance of a built-up or strip area.** (Figure 3-_____).
- **Clearance of a road, trail, or other narrow corridor.** This may include obstacles or other obstructions on the actual roadway, as well as surrounding wooded and built-up areas.

Terrain Factors

The commander must take several important terrain considerations into account in planning and executing the clearance operation. These factors include:

- **Observation and fields of fire favor the enemy.** The company must neutralize this advantage to be successful. Identify dead space. Identify multiple support by fire positions; these support a complex scheme of maneuver that covers the company's approach, the actual clearance operation, and the movement beyond the danger area.
- **Cover and concealment are normally abundant for infantry but scarce for trail-bound tanks.** Lack of cover leaves tanks vulnerable to ATGM fires. Obstacles will influence the maneuver of any tank entering the danger area. The narrow corridors, trails, or roads associated with restrictive terrain can be easily obstructed with wire, mines, and log cribs.
- **Key terrain may include areas that dominate the approaches or exits for the danger area** as well as any terrain that dominates the fight inside the defile, wooded area, or built-up area.
- **Avenues of approach will be limited.** Consider the impact of canalization, and estimate how much time will be required to clear the danger area.

Enemy Situation

Careful analysis of the enemy situation is mandatory in any clearance operation. The evaluation should include the following actions:

- **Determine the location of the enemy's vehicles, key weapons, and infantry elements in the area of the operation.**
- **Identify the type and location of enemy reserve forces.**
- **Identify the type and location of enemy OPs and or CSOPs.**
- **Assess the impact of the enemy's NBC and/or artillery capabilities.**

Clearance procedures

Clearing a danger area is both time-consuming and resource intensive. During the planning process, the commander evaluates the tactical requirements, resources, and other considerations for each of the three phases of the operation:

1. Approach
2. Clear

3. Secure

Phase 1: Approach

The approach phase focuses on moving combat power into the danger area and posturing it to begin the clearance operation. The commander should take the following actions:

- **Establish support by fire positions with the tank platoon.** Destroy or suppress any known enemy positions to allow other platoons to approach the danger area.
- **Provide additional security by incorporating indirect suppressive fires and obscuring or screening smoke.**
- **Provide support by fire for the dismounted platoons.** Be prepared to cover the platoons as they enter the danger area, such as at the following:
 - ⇒ High ground on either side of a defile.
 - ⇒ Wooded areas on either side of a trail or road.
 - ⇒ Buildings on either side of an attack route in a built-up area.
- **Move infantry platoons along routes that provide cover and concealment.**

The approach phase ends when the infantry platoons are prepared to conduct an attack or movement to contact.

Phase #2: Clear

The clearance phase begins as the dismounted platoons begin their attack or movement to contact in and around the danger area. Examples of this movement include:

- On both sides of a defile, either along the ridge lines or high along the walls of the defile.
- Along the woodlines parallel to a road or trail.
- Around and between buildings on either side of the roadway in a built-up area.

The following actions and considerations are applicable for the clearance phase in a heavily wooded area:

- The dismounted platoons conduct clearance operations with support from the tank platoon. The tanks provide a base of fire as the infantry clears an area. The dismounts stop at designated point or terrain feature where observation is affected. They then provide a base of fire to allow the tanks to bound to new support by fire position. The cycle continues until the entire area has been cleared.
- The tank platoon is very effective in destroying bunkers and other fortified positions. They can also neutralize and/or penetrate ground-level floors in buildings, providing the infantry with access and support in these danger areas. NOTE: Caution must be made in having tanks penetrate ground-level floors in buildings which have basements.
- Within restrictive areas, the tank platoon should be brought forward only to accomplish specific missions that are within their capabilities. Factors which may limit the usefulness of tanks in clearance operations include:
 - ⇒ Short engagement ranges.
 - ⇒ Limitations in elevating the main gun. The tank's main gun can only elevate to +20 degrees.
 - ⇒ The significant blind spots associated with targets above the tank.
- Direct fire plans should cover responsibility for both horizontal and vertical observation of fire.
- Dismounted platoons should clear a defile from the top down and should be oriented on objectives on the far side of the defile.

- If task organized with the company, dismounted engineers with manual breaching capability should move with the infantry.

Phase #3: Secure

The company must secure the far side of the defile, built-up area, or wooded area until the battalion moves forward to pick up the fight beyond the restrictive terrain. If the restrictive terrain is large, the company may be directed to assist the passage of another company forward to continue the clearance operation. In completing the clearance operation, the company must be prepared to:

- Move tanks to establish support by fire positions on the far side of the danger area.
- Conduct support by fire to protect the deployment of the follow-on force that is assuming the fight or to destroy or suppress any enemy elements that threaten the battalion as it exits the restrictive terrain.
- Defeat any counterattacks.
- Protect the obstacle reduction effort.
- Maintain observation beyond the danger area.
- Integrate indirect fires as necessary.

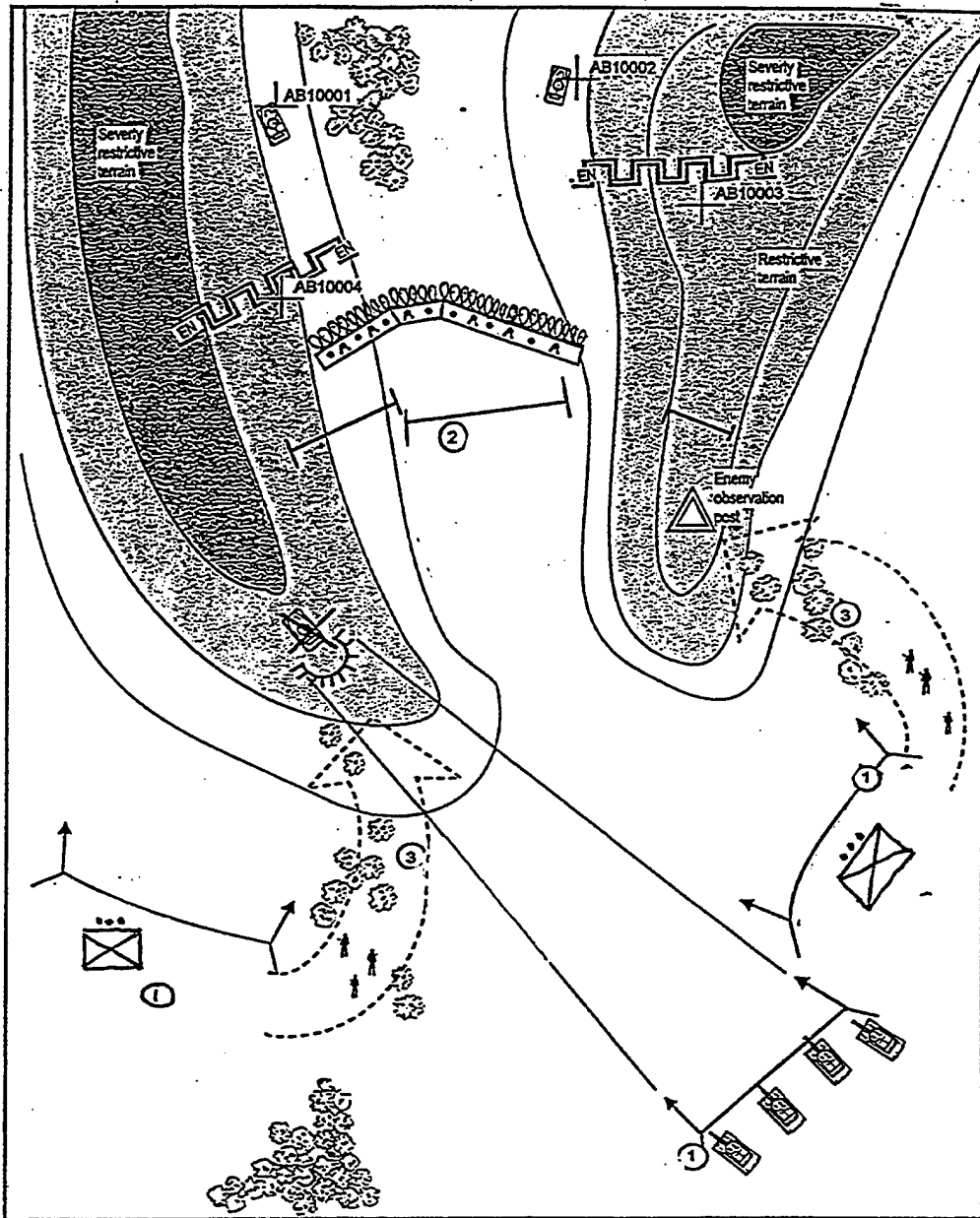

1. Company establishes SBF positions.
2. Smoke lines are used to isolate positions, and suppressive fires are initiated.
3. Infantry enters high ground adjacent to defile through covered and concealed terrain.

Figure 3-____. Company conducts the approach to a defile.

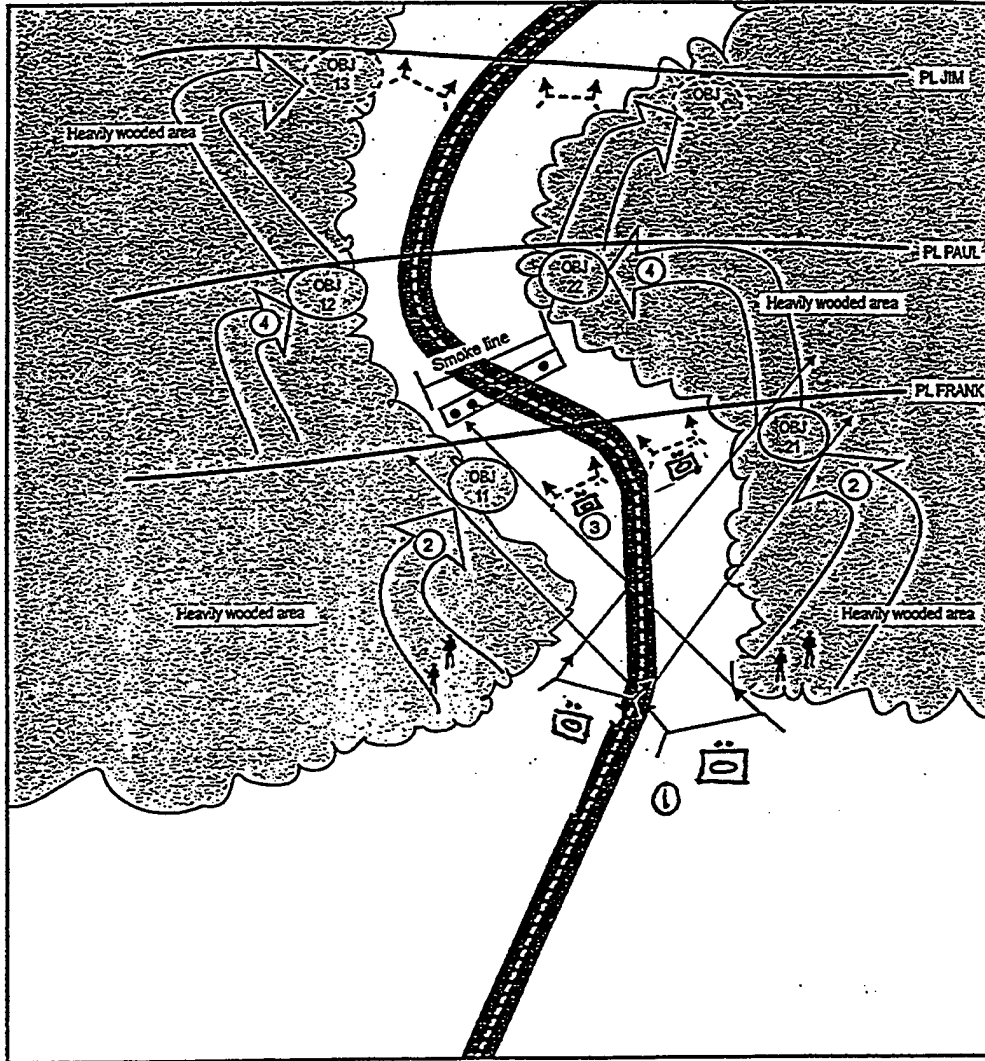

1. Tank platoon provides SBF for advance of infantry to PL FRANK.
2. Infantry maneuvers toward PL FRANK and secures OBJs 11 and 21.
3. Tank platoon bounds forward to new SBF position, with base of fire provided by infantry on OBJs 11 and 21.
4. Infantry maneuvers toward PL PAUL and secures OBJs 12 and 22, overwatched by tank platoon.

Figure 3- _____. Company conducts clearance operation in a heavily wooded area.

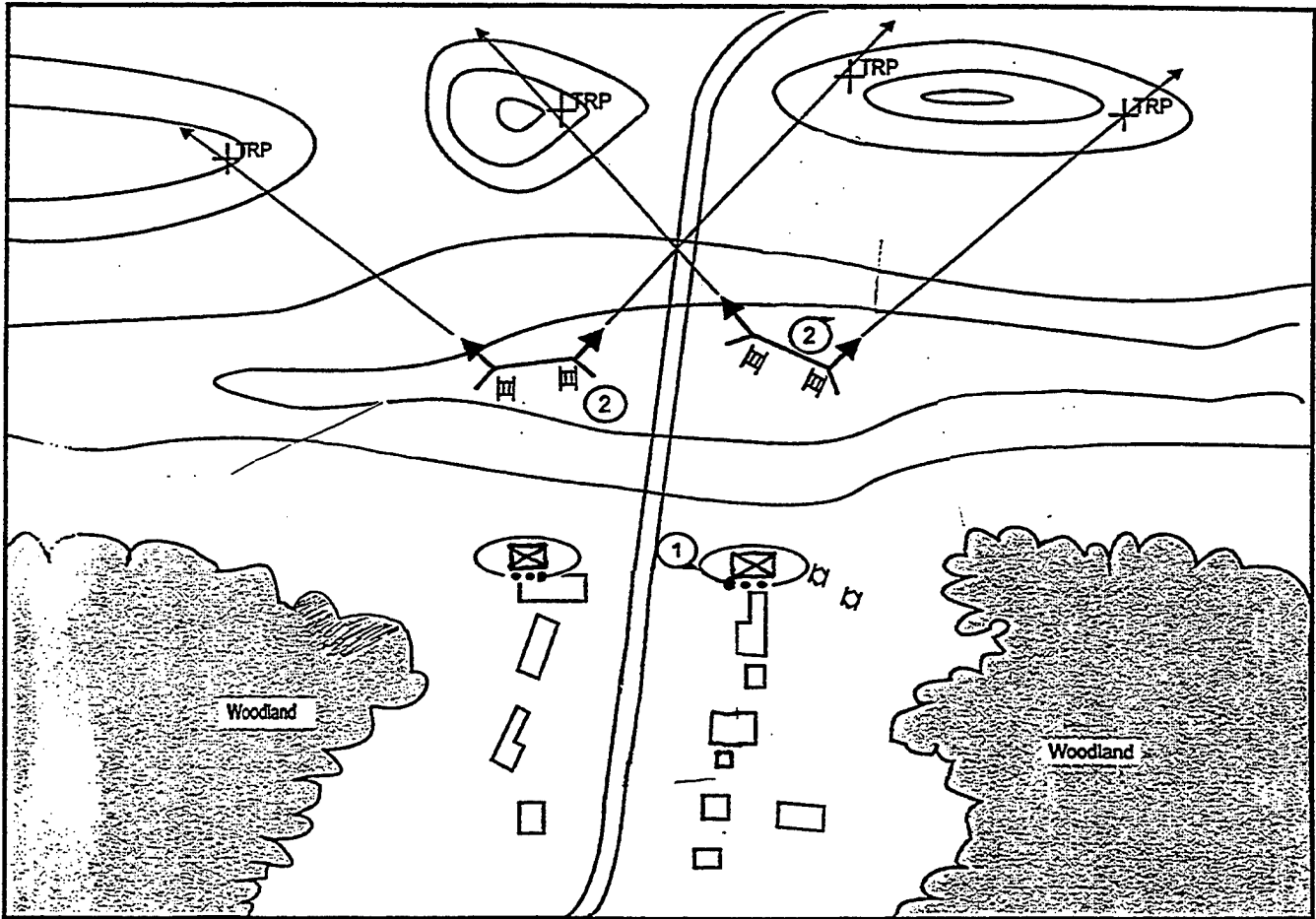

1. Infantry has completed clearance of strip area.

2. Tank platoon moves to far side of strip area.

Figure 3-____. Company secures the far side of a strip area.

Section VII: Execution - Consolidation and Reorganization

The company executes consolidation and reorganization on the objective to ensure that it is prepared to destroy an enemy counterattack or is prepared to resume the attack as soon as possible.

Consolidation

Consolidation consists of actions taken to secure the objective and defend against an enemy counterattack. The commander must use the troop-leading process to plan and prepare for this phase of the operation. He will designate platoon positions and weapons orientations. The goal for the tank platoon must be to occupy hull-down positions. He will ensure the company is prepared to conduct the following actions:

- Execution of main effort and reserve.
- Prepare for and assist the passage of follow-on forces.
- Eliminate enemy resistance on the objective.
- Establish security beyond the objective by securing areas that may be the source of enemy direct fires or artillery observation.
- Establish additional security measures such as OPs and patrols.
- Continue to improve security.
- Protect the obstacle reduction effort.
- Employment of the tank platoon in a blocking or counterattack role.
- Positioning the tank platoon to overwatch the infantry platoons.

Reorganization

Reorganization is the process of preparing for continued fighting. It is normally conducted concurrently with consolidation. The commander must ensure the company is prepared to take the following actions:

- Report the situation.
- Provide essential medical treatment and evacuate casualties.
- Secure EPWs.
- Cross-level personnel and adjust task organization as required.
- Conduct resupply operations, including rearming and refueling.
- Redistribute ammunition.
- Conduct required maintenance.

Page intentionally blank

Chapter 4: Defensive Operations

Defensive techniques are integrated in virtually all operations. They are used to accomplish a variety of tasks. Military forces defend until they gain sufficient strength to attack. Additionally, defensive operations are undertaken to gain time, to hold key terrain, to preoccupy the enemy in one area so friendly forces can attack elsewhere, and to erode enemy resources at a rapid rate while reinforcing friendly operations. Though the outcome of decisive combat derives from offensive action, commanders often find that it is necessary, even advisable, to defend. Once the choice has been made to defend, commanders must set the conditions for the defense in a way that allows friendly forces to withstand and hold the enemy while preparing to seize the initiative and return to the offense.

Section I:	Fundamentals of the Defense
II:	Planning
III:	Preparation
IV:	Execution

Section I: Fundamentals of the Defense

Purposes of the Defense

The immediate purposes of all defensive operations are to defeat an enemy attack and gain the initiative for offensive operations. The company may also conduct the defense to achieve one or more of the following purposes:

- Defeat an enemy attack.
- Gain time.
- Concentrate forces elsewhere.
- Control key or decisive terrain.
- Suppress and/or destroy enemy forces before launching offensive operations.
- Retain key terrain or facilities.

Characteristics of the Defense

FM 100-5 describes several characteristics of an effective defense:

- Preparation
- Security
- Disruption
- Mass and concentration
- Flexibility

To optimize these characteristics in the defense, the company commander should consider the following aspects of these factors:

- Preparation

- **Time management is the critical element** affecting preparation. This begins with the receipt of the WO, OPORD, or FRAGO. The defender arrives in the battle area before the attacker does. Use the time, and appropriate troop-leading procedures, wisely.
- **Reconnaissance of engagement areas, BPs, displacement routes, and the axis for possible counterattacks are especially critical.**

- Security

- **The company defense is designed to provide security;** security plans for the entire company (throughout all phases of the operation) must be integrated.
- **Early warning capabilities, potential mounted and dismounted avenues of approach, and the positioning of early warning devices and LPs/OPs to cover these avenues is essential.**

- Disruption, Mass and Concentration

- **The commander must concentrate combat power at the decisive place and time.**
- **The commander must plan to augment his direct fire plan with reinforcing obstacles, indirect fires, counterattacks, and retention of key terrain. This is a key step in disrupting enemy operations.**
- **The commander disrupts enemy synchronization and limits enemy flexibility by destroying enemy command and control vehicles and reconnaissance assets.**
- **Deception measures will further disrupt the enemy attack.**
- **Local counterattacks may be needed to maintain the integrity of the defense.**
- **Mass and concentration are achieved by maximizing the number of weapons that can fire into an engagement area, while optimizing the other combat systems and multipliers that are part of the commander's plan. The key is to concentrate combat power at the decisive time and place. Special focus should be placed on tanks in the tank platoon that can move from primary positions to alternate and supplementary positions to concentrate fires on the enemy.**

- Flexibility

- **Tactical flexibility stems from detailed planning, sound preparation and effective battle command.**
- **The commander has a variety of tools to enhance his company's flexibility:**
 - ⇒ **A detailed estimate.**
 - ⇒ **Thorough understanding of the battalion commander's intent and his company's purpose.**
 - ⇒ **Aggressive R&S efforts.**
 - ⇒ **Organization in depth and retention or reconstitution of a reserve (when applicable)**
- **The commander adds further flexibility to his defensive plan by addressing all possible contingencies:**
 - ⇒ **Planning for alternate, supplementary, and successive positions.**
 - ⇒ **Designing counterattack plans linked to potential enemy actions.**
- **Key to flexibility: SEE THE BATTLEFIELD, through your own eyes, and through timely, accurate reporting.**

Role of the Tank Platoon

Tank platoons participate in the company defense by performing one or more of the following operations:

- Participation in the counterreconnaissance/security effort
- Defend a BP
- Displace
- Counterattack
- Reserve

When defending a BP, the platoon may be tasked to:

- Destroy, block, or canalize enemy forces
- Retain terrain
- Displace to occupy subsequent BPs

In the counterattack or reserve mission, the tank platoon:

- Conducts tactical movement to occupy BPs or attack by fire positions.
- Executes hasty attacks, assaults or other actions based on the commander's intent.

Remember: Tank platoons should be retained under the tank platoon leader's control and made an integral portion of the company's defense.

Section II: Planning

- The planning phase of a defensive operation is a continuous process that begins when the company commander receives the battalion order (WO, FRAGO, or OPORD). It ends when the commander issues his own OPORD or FRAGO.
- Planning will continue into the preparation phase as the commander gains more information through the higher headquarters plan plus further reconnaissance and rehearsals.
- Reconnaissance and efficient time management during the planning phase are keys to a successful, coordinated company defense.
- Whether time permits a thorough ground reconnaissance or only a quick map reconnaissance, **IT IS CRITICAL THAT THE COMPANY COMMANDER IDENTIFY WHERE HE WANTS TO KILL THE ENEMY.** He must ensure that platoon leaders are absolutely clear in this regard. Platoon leaders must identify company TRPs that define the company engagement area(s); they in turn must identify platoon sectors of fire and tentative platoon BPs. **Planning for employment of the tank platoon should include potential displacement routes, additional positions, and counterattack contingencies.**
- The commander should include all platoon leaders, the XO, the FIST and the 1SG in his commander's reconnaissance. Platoon leaders should then (situation permitting) conduct their own reconnaissance. For the tank platoon, this reconnaissance would include the PSG and TCs. **Goal: Issue the OPORD, or as a minimum, a detailed WO, during the respective ground reconnaissance.**
- During the commander's reconnaissance, the tank platoon leader must identify, record and mark the tentative TRPs, decision points, fighting positions, and routes he thinks the platoon will use in executing the defense. It is critical that the tank platoon leader bring sufficient day and night marking materials (engineer stakes and tape, chem lights, or thermal paper).
- The tank platoon leader should record the exact (eight-digit coordinate) of each position in the platoon. This allows him to provide precise locations to the commander and platoon during occupation/preparation. Additionally, the commander must ensure the tank platoon leader knows the location of all other positions within the company.
- As in the offense, it is important that the commander make a careful evaluation of the following considerations based on the BOSSs.

Intelligence

- Security decisions are based on enemy capabilities. Subordinate platoons use OPs to provide early warning of enemy action. Their REDCON status and other OPSEC preparations enable them to respond in a timely fashion.
- OPSEC is especially critical during ground reconnaissance. Security must be provided for the reconnaissance.
- The commander must analyze terrain in conjunction with his knowledge of potential enemy courses of action to identify key terrain that may become potential enemy objectives.
- Identification of mounted and dismounted avenues of approach and probable enemy formations/support by fire positions enables the commander to best position the company's platoons. This will include analysis of available fields of fire and observation. Platoon leaders can then determine positions (to include individual tank positions in the tank platoon) which best allow their platoons to mass fires into the company engagement area.

- Subordinate platoons should complete reconnaissance by conducting initial coordination between adjacent platoons. This will establish mutual support/coherence and coverage of dead space in execution of the defense. Infantry platoons should understand the positioning of the tank platoon's tanks, in addition to its subsequent movement plans during the operation.

Intelligence Considerations:

- Protect the company - OPSEC is a lifesaver!
- Analyze terrain. Maximize the capabilities of the infantry and tanks to best defend.

Command and Control & Maneuver

- The commander will normally determine operational considerations such as OPSEC, occupation of firing positions, initiation of direct fires, primary and supplementary platoon sectors of fire, and disengagement criteria.

- The primary concern in selecting fighting positions for the tank platoon is the platoon's ability to concentrate and mass lethal fires into its sectors of fire/engagement areas. The tank is the commander's fastest tactical asset and the best killer of enemy armor.

- Depth and dispersion. Dispersing positions laterally and in depth helps to protect the company from enemy observation and fires. Company and platoon positions are established in depth; sufficient maneuver space must be provided in the tank platoon's positions to establish in-depth placement of tanks. Tank positions should be 100-250 meters apart based on METT-T. Dispersion of tank positions reduces vulnerability of the tanks to enemy fires, however it also increases the demands for local security in the area between the tanks. The commander should consider co-locating infantry with the tank platoon to assist in providing this local security.

- Flank positions. Whenever possible, primary and alternate fighting positions should allow engagement of the enemy in the flank and from two directions. An effective flank position provides the defender with a larger and more vulnerable target while leaving the attacker unsure of the location of the defense.

- Ideally, the company's tank platoon will occupy hull-down firing positions as the enemy crosses the direct fire trigger line. The trigger line should optimize weapon standoff, while the firing positions and the platoon leader's designated firing pattern should be selected to create the opportunity for flank engagements.

- Primary and alternate fighting positions for the tank platoon are oriented on the same sectors of fire. Supplementary fighting positions orient on different sectors of fire. Subsequent BPs are those that orient on sectors of fire along the same avenue of approach as the primary/alternate positions. Supplementary BPs are oriented on sectors of fire along different avenues of approach.

- The commander should plan disengagement criteria and develop a resulting disengagement plan. This should identify a break point and provide for overwatch between platoons. The tank platoon must be prepared to provide internal overwatch if it is not provided by another platoon. This plan should designate:

- Disengagement criteria.
- Routes to alternate, supplementary, and subsequent fighting positions and BPs.
- Direct fire suppression.
- Cover, concealment and rehearsals.

- Indirect fires and smoke.
- Obstacle integration.

- Tanks also provide the infantry commander a **great system for counterreconnaissance**. The combination of mobility, speed and ability to see the enemy during periods of limited visibility can be a tremendous asset during defensive operations. Following are some considerations:

- Plan for a rearward passage of lines by the tanks.
- Plan a battle position for the tanks to occupy when they return.
- Be aware tanks will have to run their engines during this mission (noise).
- Give each tank section an infantry squad for local security. Plan on them returning with tanks.
- Rehearse this drill. At a minimum make each tank commander walk his return route to the battle position.
- Clearly mark passage lanes through obstacles, and have a designated time and signal for closing obstacles.
- Plan alternate routes for tanks.
- Have a redundant, rehearsed commo plan.
- Have tank main guns turned towards enemy as they withdraw from counterrecon positions.

Command and Control & Maneuver Consideration:

A common mistake made by commanders is to give the tank platoon leader responsibility for the selection and preparation of defensive positions - and then never "checking back" on the suitability of the final positions selected. Give the tank platoon leader the responsibility - then ensure his plan is supportive of the overall company mission.

Fire Support

- Although most fire support planning is done by the company FIST, platoon leaders can, if necessary, provide the FIST with nominations for additional targets for inclusion in the battalion fire support plan.

- Platoon leaders should plan and request artillery targets on/at:

- Potential avenues of approach.
- Choke points along the avenues of approach.
- Possible enemy support by fire positions.
- Obstacles.
- Dead space within the platoon battle space.

- Each artillery target (in the tank platoon's area) should have a decision point overwatched by at least a tank crew or section. The decision point triggers the call for fire on a target to ensure that the impact of the rounds coincides with the enemy's arrival. The tank platoon's laser range finders or target-designation capabilities (on digitally equipped tanks) enhance its effectiveness in triggering artillery fires using decision points.

Mobility and Survivability

- The company's survivability effort is conducted in BPs or strongpoints to protect vehicles, weapons systems, and dismounted elements.

- The defensive effectiveness (and survivability) of tanks is greatly improved by the preparation of dug-in firing positions.
- Tank fighting positions are constructed with both hull-down firing positions and turret-down observation positions. The best is a "two-step" fighting position. In addition, the company may use engineer blade assets to dig in ammunition prestocks at platoon BPs or in individual tank fighting positions.
- The company commander must develop a plan for digging in the company; he should be prepared for the arrival of engineer assets and optimize the time they are available to the company. **THIS MUST INCLUDE PRIORITIZATION OF THE SURVIVABILITY EFFORT.** Effectively digging in a tank platoon takes time and thorough planning. Cover and/or concealment and soil composition must be considered. Sites to be avoided include those where the soil is overly soft, hard, wet, or rocky.
- The tank platoon leader will further plan his platoon's survivability efforts. His plan should specify the sequence in which his tanks will receive the digging assets. When designating priorities, he considers the survivability of unimproved positions and the relative importance of each firing position.

The engineer leader or dozer operator can estimate how much time it will take to improve/create firing positions. It can take a trained blade operator three hours to prepare an individual tank "two-step" fighting position. Figure 4-_____ illustrates the "two-step" position and lists considerations for its construction and use.

- The commander must ensure a thorough understanding of his intent for effective countermobility planning. Platoon leaders must know the commander's intent for each planned obstacle in addition to the personnel allocated to supervise or assist in the emplacement of the obstacle.

- The commander's intent should guide the emplacement of obstacles based on the following principles and characteristics:

- Obstacles must be integrated with and reinforce the scheme of maneuver and the direct fire plan.
- Obstacles should be integrated with existing obstacles.
- Obstacles should be employed in depth and positioned where they will surprise enemy forces.
- Obstacles should be covered by direct and indirect fires at all times. **AN OBSTACLE UNCOVERED AND UNWATCHED IS NOT AN OBSTACLE AT ALL.**

- Obstacles are generally used to disrupt, turn, fix, and block the enemy. Figure 4-_____ illustrates considerations for obstacle employment in relation to tank platoon BPs. If the commander does not specify an intent for obstacles, the platoon leader should analyze the situation and plan hasty or engineer-emplaced obstacles to meet these purposes:

- Block the final assault of an enemy force to the front of the platoon (the circled '1' in the figure).

- **Block the seams between tanks (or between adjacent platoons) (the circled '2').**
- **Disrupt enemy forces that are assaulting on the flanks of the platoon (the circled '3').**
- **Shape the engagement area by forcing the enemy elements to turn, slow down, stop, or flank themselves at known ranges in the engagement area (the circled '4').**

Mobility and Survivability Considerations:

- **Commander: ID where you want to KILL THE ENEMY!**
- **Include leaders in the planning effort. Do it "on the ground you will defend."**
- **OPSEC is critical.**
- **Prioritize survivability efforts.**
- **Ensure subordinates know the countermobility intent.**
- **"An obstacle uncovered is not an obstacle at all!"**

Air Defense Artillery

- See Chapter 6 for a discussion of ADA planning and employment.

Combat Service Support

- Platoon leaders will conduct resupply operations to replenish basic loads in accordance with the company plan.

- **Ammunition may be pre-positioned** on the battlefield to facilitate resupply once the battle has begun. Prestock requirements will be based on the commander's intent and scheme of maneuver (should mission analysis reveal that the company's ammunition needs during the operation will exceed its basic load).

- The commander must ensure that all elements know the locations of the forward and main aid stations. He must also plan and rehearse casualty evacuation procedures.

Combat Service Support Considerations:

- **The infantry company must plan for incorporation of the logistical slice of the tank platoon. This may include fuel (HEMIT) and recovery (M88) vehicles. They will need "husbanding" in the defense.**
- **Consider 24 hours as "station time" for a tank platoon which is not provided a parent unit CSS package.**
- **The combat capability of the tank platoon is directly related to logistics. Plan for tank recovery and maintenance.**

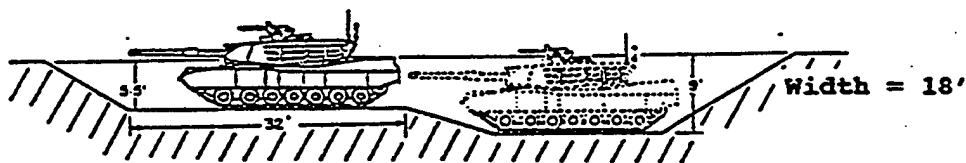

- Berms attract attention. Dig down, not up.
- Do not put spoil to the front, sides, or rear of the firing position. Reduce spoil so that it blends into existing terrain.
- Tie down all antennas and keep reflective surfaces covered.
- Make sure the firing position has a covered exit route and a covered route to the next firing position.
- Construct overhead cover and add camouflage to create a hide position if time and materials are available.

Figure 4-____. Dug-in firing positions.

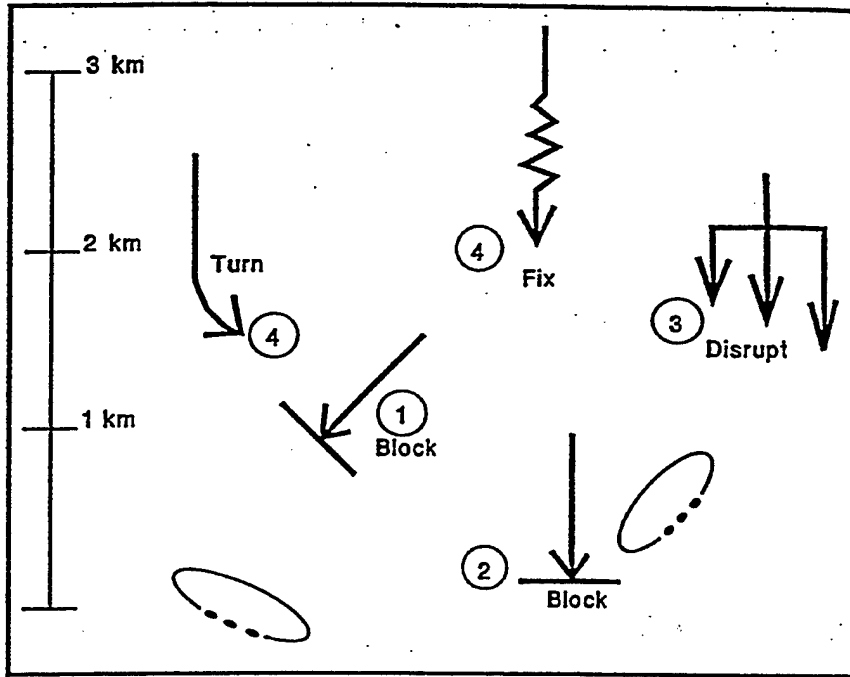

Figure 4-____. Considerations for obstacle employment.

Section III: Preparation

- Preparation of the defense begins after the company commander has issued his order and ends at the "Defend not later than ____" time specified in the OPORD.

- The commander designates the preparations to be made as priorities of work and identifies them in the initial company WO or OPORD. The following priorities, though listed sequentially, may have multiple priorities being accomplished simultaneously:

- Establish the company R&S plan.
- Post local security.
- Position tanks, TOWs, Dragons, machineguns, and soldiers. Assign sectors of fire.
- Position other company assets (CP, mortars, logistical support vehicles for the tanks, other vehicles).
- Designate FPLs/FPFs.
- Clear fields of fire. Prepare range cards/sector sketches.
- Adjust indirect fire FPFs.
- Prepare fighting positions (both individual and vehicle).
- Install wire communications.
- Emplace obstacles and mines.
- Mark/improve markings for TRPs and direct fire control measures.
- Improve primary fighting positions.
- Prepare alternate/supplementary positions.
- Establish/implement rest/sleep plan.
- Reconnoiter movements and routes.
- Rehearse the defense. Synchronize engagements and disengagements.
- Adjust positions and/or control measures as required.
- Stockpile ammunition, food and water.
- Dig trenches between positions.
- Continue to improve positions.

- The commander must weigh competing demands of security, firing position and obstacle preparation, rehearsals, and coordination against the amount of time available for preparation. This requirement places a premium on effective troop-leading procedures and time management during the preparation phase.

- The commander should designate the level of preparation for each BP in the company plan. There are three levels, listed here in descending order of thoroughness and time required:

- **Occupy.** This is complete preparation of the position from which the elements will defend. The position is fully reconnoitered, prepared, and occupied prior to the "Defend NLT" time in the OPORD.
- **Prepare.** This level includes the steps conducted during the planning and preparation phases for the deliberate occupation of a BP.
- **Reconnoiter.** This level of preparation consists of the steps conducted during the ground reconnaissance of the planning phase.

- The commander takes into account the following BOS considerations during the Preparation phase.

Intelligence

- **OPSEC is critical during defensive operations.** The company should adhere to effective OPSEC procedures to limit the effectiveness of enemy reconnaissance efforts.

- **Intelligence** which is updated by battalion or higher headquarters may cause the commander to reevaluate and adjust his timeline to ensure preparations are as complete as possible. For example, the tank platoon leader may determine that engineer assets only have time to dig hull-down firing positions rather than turret-down and hide positions. In another instance, the tank platoon leader may direct the engineers to prepare fighting positions for only one section because the other section has access to terrain that provides natural hull-down firing positions.

- **Simultaneous planning of subsequent positions** during the preparation of initial positions is a critical component of effective time management for the tank platoon leader. It is essential that he keep the commander informed of his work status.

Intelligence Considerations:

- **OPSEC, OPSEC, OPSEC**
- **Be prepared to reevaluate the plan as information becomes available.**

Command and Control & Maneuver

- The engagement area is where the commander intends to destroy an enemy force using the massed fires of all available weapons.

- The success of any engagement depends on the commander's successful integration (and the company's execution) of the obstacle plan, the indirect fire plan, and the direct fire plan in the engagement area.

- At the company level, engagement area development is a complex function demanding parallel planning and preparation. Despite its complexities, however, engagement area development resembles a drill in that the commander and his subordinate leaders use an orderly, fairly standard set of procedures. Beginning with an evaluation of METT-T, the process involves these steps:

- Identify all likely enemy avenues of approach.
- Determine the enemy scheme of maneuver.
- Determine where to kill the enemy.
- Emplace weapon systems.
- Plan and integrate obstacles.
- Plan and integrate indirect fires.
- Rehearse the execution of operations in the engagement area.

- Based on the amount of time available and the results of the commander's reconnaissance with the platoon leaders, the tank platoon in the company occupies a BP by executing either a hasty occupation or a deliberate occupation.

Hasty Occupation

- Often, only a minimum of planning time and information is available prior to execution. As a minimum, the tank platoon leader must have the following information when ordered to execute a hasty occupation of a BP:

- Where the commander wants to kill the enemy. The commander should identify company TRPs that define the company engagement area and platoon sectors of fire.
- The tentative location of the BP.

- Tank platoons conduct a hasty occupation under a variety of circumstances. During defensive operations, hasty occupation may take place during counterattack missions, after disengagement and movement to subsequent or supplementary BPs, or in response to FRAGOs reflecting a change of mission.

Deliberate Occupation

- The company's tank platoon can conduct deliberate occupation of a BP when the following exist:

- The enemy is not expected or has not been located within direct fire range.
- A friendly element is forward of the BP with the mission of providing security for the occupying platoon.

- To be most effective, BP occupation should begin from the enemy's perspective in the engagement area, with a reconnaissance party looking back toward the BP. The commander must provide permission for the party to move in front of the BP; adjacent infantry platoons must be informed. Using the enemy's perspective will assist the commander and platoon leaders in assessing the survivability of positions.

- Driving the engagement area is very useful in confirming that selected positions are tactically advantageous.

- The reconnaissance party then confirms and marks the company engagement area with platoon and section sectors of fire. Artillery TRPs, decision points, and tentative obstacle locations may also be marked. As necessary, fire control measures may be designated and/or marked using easily identifiable terrain features.

- The commander must ensure that BPs selected by the tank platoon do not conflict with those of adjacent platoons or companies and that they are effectively tied in with those elements.

- The commander should ensure that primary, alternate, and supplementary fighting positions achieve the desired effect for each TRP and the fighting of the overall engagement area. In simple terms, the commander must get the right number of weapon systems engaging where he wants them to.

- Reconnaissance of the engagement area is complete **WHEN ALL LEADERS ARE EXACTLY SURE OF WHERE THE COMMANDER WANTS TO KILL THE ENEMY**. Issues that should be backbriefed by Platoon Leaders to the commander include:

- Trigger lines.

- Engagement criteria.
- Fire patterns.
- Disengagement criteria and plan.
- Routes to supplementary or subsequent BPs.
- Marking of primary and alternate fighting positions.
- Individual tank positions.
- Platoon sector or engagement areas.
- TRPs.
- OPs (if used).
- Obstacles (if used).
- Indirect fire targets, including final protective fires (FPF) (if allocated).
- Dead space.

- Once the platoon leaders complete their fire plans, they report “ESTABLISHED” to the company commander.

Coordination

- **Coordination is initiated from left to right and from higher to lower. The commander must, however, focus specific attention on the addition of tanks to his task organization. CSS coordination must be extremely detailed, and will be vastly different from standard procedures for supporting the company. These considerations will be addressed in Chapter 6.**

- **Throughout the preparation phase, the tank platoon leader coordinates with adjacent platoons and other company elements. He must ensure that platoon sectors of fire overlap and that CS and CSS requirements are met.**

Rehearsals

- **Rehearsals are especially effective in helping the company to practice and coordinate necessary tactical skills.**

- **The purpose of an engagement area rehearsal is to ensure that every leader and soldier understands the plan and that elements can cover their assigned areas with direct and indirect fires.**

- **Specific areas to be covered include:**

- Passage of the counterreconnaissance force or other security force.
- Closure of lanes (as required).

- Movement from hide positions to the BP.
- Use of fire commands, triggers, and/or MELs to initiate fires.
- Preparation and transmission of critical reports using FM and digital systems.
- Execution of the fire support plan.
- Assessment of the effects of enemy weapon systems.
- Displacement to alternate, supplementary, or successive BPs.
- Evacuation of casualties.

- Rehearsals should begin as soon as the company issues its WO. Although the commander has several methods of rehearsing available to him, the most effective type (to fully synchronize the tank platoon into the company plan) is with the tank platoon fully mounted, and with rifle platoons occupying their fighting positions. The company XO can then move a series of vehicles through the engagement area to depict the enemy force while the commander and subordinate platoon leaders rehearse the battle from the company BP/platoon BPs.

Command and Control & Maneuver Considerations:

- The engagement area is where the killing takes place - make it right!
- Time can be an ally or a foe - use it wisely.
- Develop the engagement area from the enemy perspective - it works.
- Coordinate and rehearse - it's hard to do too much.

Fire Support

- All platoon leaders should confirm locations of artillery and mortar targets, adjust them as necessary, and mark them for daylight and limited visibility recognition.

- Decision points that will be used to request artillery on moving targets must be marked. These locations are based on the enemy's doctrinal rates of movement, the terrain, the time of flight of artillery rounds, and the priority of the target.

Fire Support Consideration: Target markings **MUST** be visible during daylight and limited visibility conditions.

Mobility and Survivability

- Because engineer assets are at a premium during defensive preparations, **THEY SHOULD NEVER BE ALLOWED TO REMAIN IDLE** for any reason other than maintenance checks and services.

- A member of the company or tank platoon leadership must **PHYSICALLY LINK UP WITH THE ENGINEERS AS DIRECTED IN THE COMPANY OPORD**. They should escort them to each firing position. The escort, and the tank platoon on arrival, provides local security and instructions to the engineers.

- The escort should remain with the engineer assets throughout their time with the company, ensuring adherence to the company plan, informing the commander of progress, and coordinating for movement between platoons and when the engineers are completed in the company area and to be released to another unit's control. The company XO should be considered for this role. **THE KEY FACTOR IS THAT THE ENGINEERS MUST NEVER BE 'BY THEMSELVES.'** THEY ARE FAR TOO VALUABLE OF AN ASSET. EVERY BIT OF THEIR TIME IN THE COMPANY AREA SHOULD BE MONITORED AND PRODUCTIVE.

Mobility and Survivability Considerations: Several factors can help the tank platoon significantly increase the number of kills it achieves while executing the defense.

- Firing positions should maximize weapon standoff and/or the platoon's ability to mass fires from survivable positions.
- Firing positions and obstacles should be complementary. The platoon should know the exact location of the start point, end point, and turns of any obstacles.
- TRPs can be located on obstacles to ensure more accurate calls for fire.

- In the defense, engineer mobility operations normally are of lower priority than survivability and countermobility. These efforts are labor-intensive and should be evaluated carefully prior to being directed.

Combat Service Support (See Chapter 6).

Section IV: Execution

- This section contains a "best case" chronological discussion of the procedures and considerations that apply during a tank platoon's execution of a defensive mission as a member of an infantry company.

Hide Position

- The tank platoon's hide positions are located behind its primary battle and/or fighting positions.

- While in the hide position, the platoon employs all applicable OPSEC measures to limit aerial, thermal, electronic, and visual detection. It deploys OPs to provide surveillance of its sectors of fire and early warning. It also maintains the REDCON status prescribed in the OPORD. **THE HIDE POSITION SHOULD NOT BE LOCATED ON OR NEAR OBVIOUS ARTILLERY TARGETS - THE ENEMY WILL MAKE CONCERTED EFFORTS TO FIND YOUR TANK PLATOON.**

Occupation of Firing Positions

- The tank platoon leader monitors intelligence reports provided on the company net. The platoon's REDCON status is upgraded as the enemy approaches or as directed.

- OP reports should not be the sole criterion triggering the platoon's occupation of fighting positions. Their observation is usually limited to the engagement area. If the enemy situation becomes unclear, the commander should consider directing the tank platoon to occupy turret-down positions for the purpose of scanning the engagement area and being prepared for immediate engagements.

Direct Fire

- During the direct fire fight, Squad Leaders and TCs describe the situation for their platoon leaders, who in turn describe what is happening for the commander. Contact reports, SPOTREPs, and SITREPs are used as appropriate. SPOTREPs and SITREPs are sent to list the number, types and locations of enemy vehicles observed, engaged, and/or destroyed and to provide the strength and status of friendly forces.

- All leaders involved in the reporting process must avoid sending redundant or inflated descriptions of the situation. **REPORT WHAT YOU SEE - DON'T ANALYZE, DON'T EXTRAPOLATE, DON'T INTERPOLATE.**

- The tank platoon can expend main gun ammunition quickly in a direct fire fight. The company (and platoon) must develop and execute resupply procedures to maintain a constant supply of main gun rounds. The platoon leader must balance the necessity of maintaining direct fires on the enemy against the demands imposed on the platoon's crews by the ammunition transfer process and the retrieval of prestock supplies.

Direct Fire Considerations:

- **Reminder: 2,500 meter planning range for the 120mm main gun.**
- **Decision to move is based on enemy movement rates, number of advancing enemy, accuracy and lethality of enemy fires.**

Displacement

- The company commander has established disengagement criteria in the OPORD. These criteria are primarily based on a specific number and type of enemy vehicles reaching a specified location (sometimes called the break point) to trigger displacement.

- In some instances, platoons may have to use bounding overwatch to the rear during tactical movement to subsequent positions. Distance to the subsequent position, the enemy's rate of advance, and terrain considerations (fields of fire) may not allow the original overwatch element to displace without the benefit of an overwatch of its own.

- Displacement is complete when platoons have occupied subsequent BPs and are prepared to continue the defense. If reconnaissance and rehearsals of this occupation were not possible, the platoons must conduct the steps of a hasty occupation.

Displacement Considerations:

- What should the disengagement criteria be?
- Has the criteria been met?
- Is the displacement covered or uncovered?
- Was displacement rehearsed?

Counterattacks

- The tank platoon is capable of conducting limited counterattacks, either alone or as a part of the company in the battalion's overall plan. The tank platoon is a potent asset for potential counterattacks in support of company operations.

- Tank platoons can accomplish the following purposes in executing counterattacks:

- Complete the destruction of the enemy forces in the company's assigned area.
- Regain key terrain.
- Relieve pressure on an engaged rifle platoon.
- Initiate offensive operations.

- Two methods are available to the commander in directing the tank platoon to counterattack: Counterattack by fire and counterattack by fire and movement. In both types, coordination and control are critical to success. Locations of routes and positions must be planned and disseminated to all company elements. If ANY adjustments to a route or position become necessary, the counterattacking tank platoon MUST TAKE IMMEDIATE ACTION TO ENSURE THAT OTHER PLATOONS LIFT AND SHIFT FIRES. Without this, fratricide becomes a real danger (See Figures 4-____ A and B).

Counterattack Considerations:

- Counterattack by fire: Maximize weapon standoff and/or cover.
- Counterattack by fire and movement: Close with and destroy the enemy.

Consolidation and Reorganization

- Once an enemy assault is defeated, leaders at all levels must ensure their soldiers are ready to continue with defensive operations, shift to the offense, or to displace. Critical actions include:

- Man key weapons.
- Secure EPWs.
- Reestablish security.
- Reestablish communications.
- Reestablish OPSEC.
- Treat or evacuate casualties.
- Redistribute ammunition and supplies.
- Reposition as necessary. Ensure positions are mutually supporting. Eliminate gaps/dead space created by defensive casualties or losses.
- Repair/replace obstacles.
- Continue to improve positions.

- Reorganization, the process of preparing for continued fighting, should be conducted per instructions in the OPOD. Reorganization in the defense is accomplished in the same manner as in the offense. See Chapter 3.

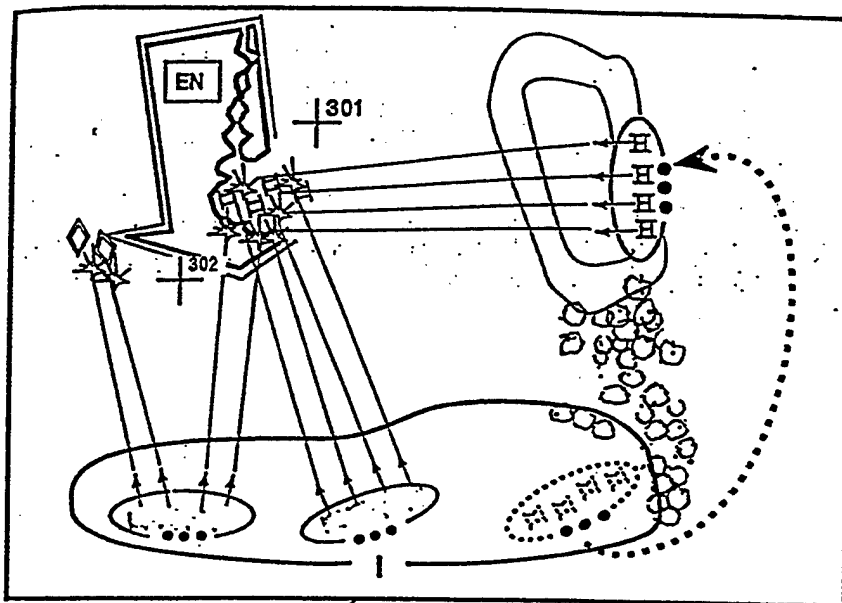

Figure 4-____. Counterattack by fire.

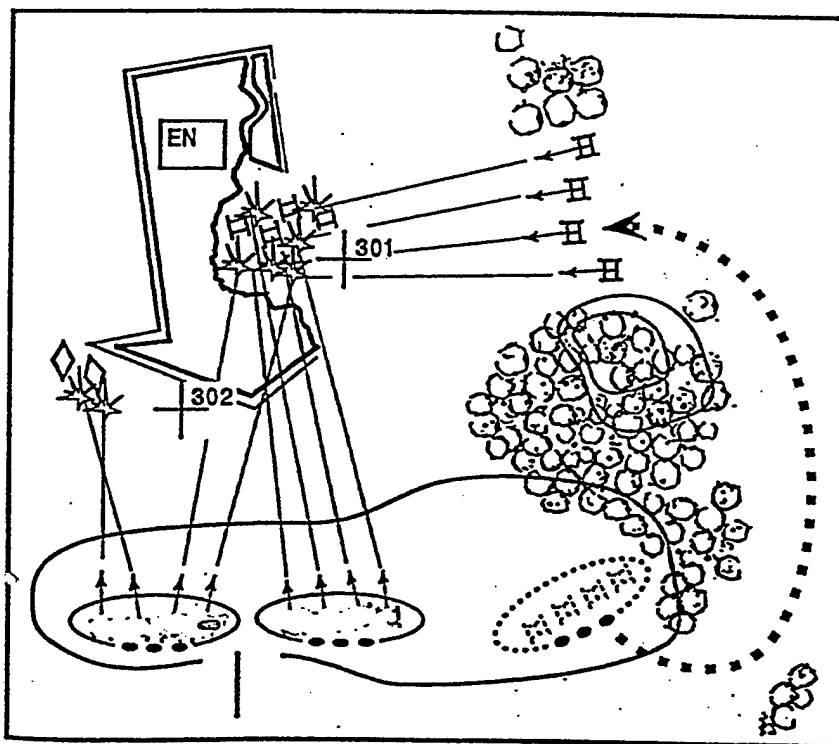

Figure 4-____. Counterattack by fire and movement.

Chapter 5: Other Tactical Operations

This chapter describes additional tasks the tank platoon may have to conduct as a member of the infantry company.

Section I:	Movement to Contact (Search and Attack)
II:	Assembly Areas
III:	Linkup
IV:	Convoy Escort
V:	Passage of Lines
VI:	Breaching Operations
VII:	Follow and Support
VIII:	Perimeter Defense
IX:	Relief in Place
X:	Transporting Infantry
XI:	Limited Visibility Operations
XII:	Air Defense Operations
XIII:	Military Operations in Urban Terrain (MOUT)

Section I: Movement to Contact (Search and Attack)

Movement to contact is an offensive operation used to gain and maintain contact with the enemy. It is normally used when the enemy situation is vague.

Fundamentals of the movement to contact:

- Make contact with the smallest friendly element.
- Rapidly develop friendly combat power.
- Provide all-around security.
- Report all information rapidly and accurately.

Search and attack technique:

- The commander should use small units (teams, squads, platoons) to **FIND** the enemy.
- The commander must then decide which force he will use to **FIX** the enemy and **FINISH** the enemy.
- The focus of friendly elements which are to **FIND** the enemy should be on likely enemy locations.

The search and attack technique is conducted in three phases:

Phase I: FIND the enemy.

- The commander will focus operations on reconnaissance to locate the enemy. Infantry squads and platoons are ideal for this task.
- When the **FIND** element makes contact with the enemy, it should immediately assess the situation and conduct appropriate battle drills.

Note: Establishing OPs/LPs near likely enemy movement routes or water/food sources can lead to an effective ambush.

Phase II: FIX the enemy.

- The goal for this phase is to avoid detection and achieve surprise.
- If detected, violence of action is critical.
- FIX force must limit the enemy's freedom of action. Routes of escape must be blocked.
- Maintain security.
- Concentrate combat power with your FIX force.

Phase III: FINISH the enemy.

- The tank platoon is an excellent choice for this task. This is especially true if the enemy is in a base camp, logistics site, or command site.
- Mortars should be located to support all platoons.
- Anti-armor assets can be used against enemy armor or for casualty evacuation.

Movement to Contact (Search and Attack) Considerations:

- Commander - make a conscious decision as to which element will FIND, FIX, or FINISH.
- Consider providing the tank platoon an infantry element for security if they are the FIX force.
- Consider maintaining a reserve to react quickly to changing enemy situations. The tank platoon is a superb choice for this task.

Section II: Assembly Areas

An assembly area is a site at which the company prepares for future operations. A well-planned assembly area will have the following characteristics:

- Cover/concealment from direct/indirect fire
- A location on defensible terrain.
- Concealment from enemy ground and air observation.
- Good drainage and a surface that will support the tank platoon.
- Suitable exits, entrances, and internal roads or trails.
- Sufficient space for dispersion of vehicles and equipment.
- Suitable landing sites (nearby) for helicopters

The commander plans for an assembly like planning for a perimeter defense. He assigns each platoon in the company a sector. This is a good time to allow the tank platoon to perform logistics and maintenance actions.

Normally, a quartering party is sent out to reconnoiter and organize the assembly area. The quartering party is established in accordance with the infantry company's SOP. This party may consist of one or two soldiers from the platoon, or even one tank from the platoon.

Once the assembly area has been prepared, the quartering party awaits the arrival of the company, maintaining surveillance and providing security of the area within its capabilities. **Quartering party members guide their platoons from the RP to their locations in the assembly area.** SOPs and prearranged signals and markers (for day and night occupations) should assist the TCs in finding their positions. **THE KEY CONSIDERATION IS TO MOVE QUICKLY INTO POSITION TO CLEAR THE ROUTE FOR THE FOLLOWING PLATOONS.**

Once in position, the platoons conduct a hasty occupation of their assigned BP as described in Chapter 4. They establish and maintain security. They coordinate with adjacent platoons and/or companies. These actions enable the platoons to defend from the assembly area if required. The platoons can then prepare for future operations by conducting troop-leading procedures and priorities of work in accordance with the company OPORD. These would include the following:

- Establish and maintain security. Establish OPs and execute patrols.
- Perform maintenance on vehicles, weapons, and communications equipment.
- Establish wire as the primary means of intra-assembly area communications.
- Prepare range cards/sector sketches.
- Verify weapon system status: Conduct boresighting, MRS updates, and test-firing.
- Conduct resupply, refueling and rearming operations.
- Conduct rehearsals and training for upcoming operations.
- Conduct PCIs.
- Construct fighting positions as time permits.
- Eat, rest, and conduct personal hygiene activities.

Normally, the tank platoon occupies an assembly area as an integral part of the infantry company. The company may be adjacent to or independent of the battalion. The company commander assigns a sector of responsibility and weapons orientations for each platoon in the company.

Section III: Linkup

A linkup is the meeting of friendly ground forces. Normally this will occur in enemy controlled areas. When the tank platoon moves from its parent company to join the infantry company, its initial contact with the infantry will be conducted as a linkup operation.

The linkup consists of two phases. Actions during these phases are critical to the execution of a speedy, safe operation.

Phase I: Planning. Plans must be detailed and include the following:

- **Site selection:**
 - ⇒ Identification of a primary and alternate linkup site that is easily located during periods of limited visibility.
 - ⇒ Identify a site that is defensible for a short period (as needed).
 - ⇒ Identify a site that has ready access and escape routes for both tanks and infantry. Pay particular attention to mobility for the tank platoon.
- **Recognition signals:**
 - ⇒ Establish far and near recognition signals. Exchange callsigns and frequencies, but avoid use of the radio if at all possible.
 - ⇒ Establish visual and voice recognition signals. VS 17 panels, chemical lights, and infrared lights are excellent choices.
- **Fires:**
 - ⇒ Plan fires to disguise movement (particularly for the tank platoon).
 - ⇒ Establish Restrictive Fire Lines (RFLs) or Critical Friendly Zones (CFZs) in/around linkup point locations.
- **Contingency Plans:** Establish contingency plans for the linkup operation. Examples would be:
 - ⇒ Enemy contact before linkup.
 - ⇒ Enemy contact during linkup.
 - ⇒ Enemy contact after linkup.
 - ⇒ Length of time for an element to wait at the linkup point (for arrival of the other element).
 - ⇒ Actions if an element fails to linkup.
 - ⇒ Actions at the alternate linkup point.

Phase II: Conduct of the linkup itself.

Linkup Considerations: Tank platoons are trained on a three-phase linkup operation. The specifics are very similar to those of the infantry.

- **Phase 1: Far recognition signal.** During this phase, the tank platoon and infantry company should establish communications before they reach direct fire range. The tank platoon leader should monitor the radio frequency of the infantry company.
- **Phase 2: Coordination and movement to the linkup point.** Before initiating movement to the linkup point, the platoon leader coordinates necessary tactical information with the company commander.
- **Phase 3: Linkup.** The tank platoon and infantry company enforce strict fire control measures to help prevent fratricide.

Section IV: Convoy Escort

This mission requires the tank platoon to **provide a convoy** (such as the infantry company mounted in trucks displacing to another sector or location) **with security and close-in protection** from direct fire while on the move. The platoon is well suited for this role because of its tanks' mobility, firepower, and armor protection against mines and direct and indirect fires. **The tank platoon provides the infantry commander optimum security** for the unit's move.

Battle Command

Battle command is especially critical because of the task organization of the convoy escort mission. **The relationship between the platoon leader and the convoy commander** (company commander, XO or other designated platoon leader) **must provide for unity of command and effort** if combat operations are required during the course of the mission.

The convoy commander should issue an OPORD to all vehicle commanders in the convoy prior to execution of the mission. Special emphasis should be placed on the following:

- Route of march (to include a strip map for each vehicle commander).
- Order of march.
- Actions at halts.
- Actions in case of breakdown.
- Actions on contact.
- Chain of command.
- Communications and signal information.

Tactical Disposition

During escort missions, **the convoy commander and tank platoon leader must establish and maintain security in all directions** and throughout the length of the convoy. They can adjust the disposition of the tank platoon, either as a unit or dispersed, to fit the security requirements of each particular situation. In large-scale escort missions, the platoon will operate as part of a larger escort force under control of the security force commander who is usually OPCON or attached to the convoy commander. **For the purposes of this discussion, the tank platoon will be conducting independent escort operations while attached to the infantry company.**

When the tank platoon executes a convoy escort mission independently, **the convoy commander and platoon leader will disperse the tanks throughout the convoy formation** to provide forward, flank, and rear security. Whenever possible, wingman tanks should maintain visual contact with their leaders. **Tanks equipped with mine plows or mine rollers should be located near the front** to respond to obstacles. At times, these assets may be required to move ahead of the convoy, acting as the reconnaissance element. If engineer assets are available, they may move with the lead tanks to assist in proofing of the convoy route. Figure 5-_____ illustrates this type of escort operation.

In some independent escort missions, **variations in terrain along the route may require (or allow) the platoon to operate using a modified traveling overwatch technique.** Figure 5-_____ illustrates such a situation. It shows one section leading the convoy while the other trails the convoy. Dispersion between vehicles in each section is sufficient to provide flank security. Depending on the terrain, the trail section may not be able to overwatch the movement of the lead section. This technique is especially useful when the enemy situation is more vague and the convoy route traverses terrain which provides flank overwatch opportunities for the tank platoon.

Actions on Contact

As the convoy moves to its new location, the enemy may attempt to harass or destroy it. This contact will usually occur in the form of an ambush, often with the use of a hastily prepared obstacle. The safety of the convoy then rests on the speed and effectiveness with which the escorting tank platoon can execute appropriate actions on contact.

Based on METT-T, either the entire platoon or a tank section may be designated as a reaction force. The reaction force performs its escort duties, conducts tactical movement, or occupies an assembly area as required until enemy contact occurs; it then is given a reaction mission by the convoy commander.

Actions at an Ambush

An ambush is one of the most effective ways to interdict a convoy. Conversely, reaction to an ambush must be **IMMEDIATE, OVERWHELMING, and DECISIVE**. Actions on contact must be planned for and rehearsed so they can be executed as a drill by all escort and convoy elements, with care taken to avoid fratricide.

In almost all situations, the platoon will take several specific, instantaneous actions when it must react to an ambush. These steps, illustrated in Figures 5-____A and 5-____B, include the following:

- As soon as they acquire an enemy force, the tank platoon actions toward the enemy (Figure 5-____A). The tanks seek covered positions between the convoy and the enemy and suppress the enemy with the highest possible volume of fire permitted by the ROE. Contact reports are submitted to higher headquarters as quickly as possible.
- The convoy commander retains control of the convoy vehicles and continues to move them along the route at the highest possible speed.
- Convoy vehicles, if armed, only return fire if the tank platoon has not positioned itself between the convoy and the enemy force.
- The tank platoon leader or convoy commander may request that any damaged or disabled vehicles be abandoned and pushed off the route (Figure 5-____B).
- The tank platoon leader uses SPOTREPs to keep the convoy commander informed. He can also call for and adjust indirect fires.

Once the convoy is clear of the kill zone, the tank platoon executes one of the following courses of action based on the commander's intent and the strength of the enemy force:

- Continue to suppress the enemy (with one section) as the other section (reaction force) (or infantry reaction force) moves to support (Figure 5-____A).
- Assault the enemy (Figure 5-____B).
- Break contact and move out of the kill zone (Figure 5-____C).

In most situations, tanks will continue to suppress the enemy or execute an assault. Contact should be broken only with the approval of the company commander.

Actions at an Obstacle

Obstacles are a major threat to convoys. The purpose of the route reconnaissance ahead of a convoy is to identify obstacles and either breach them or find bypasses. In some cases, however, the enemy or its obstacles may avoid detection by the reconnaissance element. If this happens, the convoy must take actions to reduce or bypass the obstacle.

Obstacles can be used to harass the convoy by delaying it. If the terrain is favorable, the obstacle may be able to stop the convoy altogether. In addition, obstacles may canalize or stop the convoy to set up an enemy ambush. When an obstacle is identified, the tank platoon faces two problems: reducing or bypassing the obstacle and maintaining protection for the convoy. Security becomes critical. Actions at the obstacle must be accomplished very quickly. The convoy commander and tank platoon leader must assume that the obstacle is overwatched and covered by the enemy.

To reduce the time the convoy is halted and thus to reduce its vulnerability, the following actions should occur when the tank platoon encounters a point-type obstacle:

- **The lead section/tank identifies the obstacle and directs the convoy to make a short halt and establish security. The tank platoon overwatches the obstacle and requests that the breach force move forward (Figure 5-_____).**
- **The tank platoon maintains 360-degree security of the convoy and provides overwatch as the breach force reconnoiters the obstacle in search of a bypass.**
- **Once all reconnaissance is complete, the convoy commander determines which of the following courses of action he will take:**
 1. **Bypass the obstacle.**
 2. **Breach the obstacle with the assets on hand.**
 3. **Breach the obstacle with reinforcing assets.**
- **The convoy commander sends a SPOTREP higher and requests support by combat reaction forces, engineer assets (if not a part of the company task organization), and aerial reconnaissance elements.**
- **Commander alerts artillery units to be prepared to provide fire support.**

Tanks equipped with mine plows are ideal for breaching most obstacles encountered during convoy escort missions. If the tank platoon is required to breach limited obstacles using plow tanks, the platoon leader must maintain the security of the convoy, ensuring that adequate support forces are in place to overwatch the breach operation.

Actions During Halts

If the halt is for any reason other than an obstacle, the following actions should be taken (Note: all the following off-the-route actions are taken assuming that the shoulders/sides of the route have been positively cleared of mines. Should that not have happened, all actions during the halt MUST take place along the route. Vehicles and personnel should NEVER LEAVE THE ROUTE when there is potential threat of mines).

- **The convoy commander signals the short halt and transmits the order via radio. All vehicles in the convoy assume a herringbone formation (Reminder: Herringbone formation is ONLY assumed if the shoulders of the roadway/convoy route have been positively cleared of mines).**
- **If possible, the tank platoon is positioned up to 100 meters beyond the convoy vehicles, which are just clear of the route (Figure 5-_____A).**

- When the order is given to move out, **convoy vehicles reestablish the movement formation, leaving space for the tanks** (Figure 5-____B). Once the convoy is in column, local security elements (if used) return to their vehicles, and the tanks rejoin the column (Figure 5-____C).
- When all elements are in the column, the convoy resumes movement.

Convoy Escort Consideration:

The commander should consider having an infantry element ride on the leading tanks if the convoy must traverse densely wooded or otherwise restrictive terrain (See Section X of this chapter for a discussion of transporting infantry on tanks).

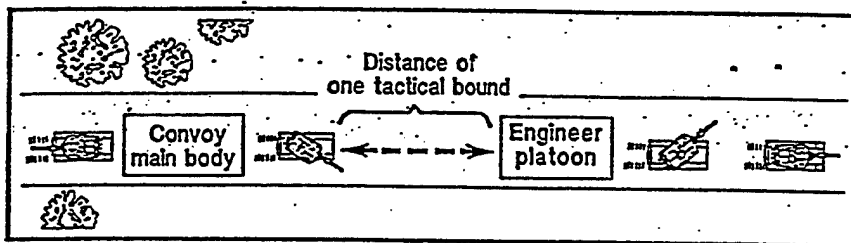

Figure 5-____. Tank platoon performing convoy escort independently.

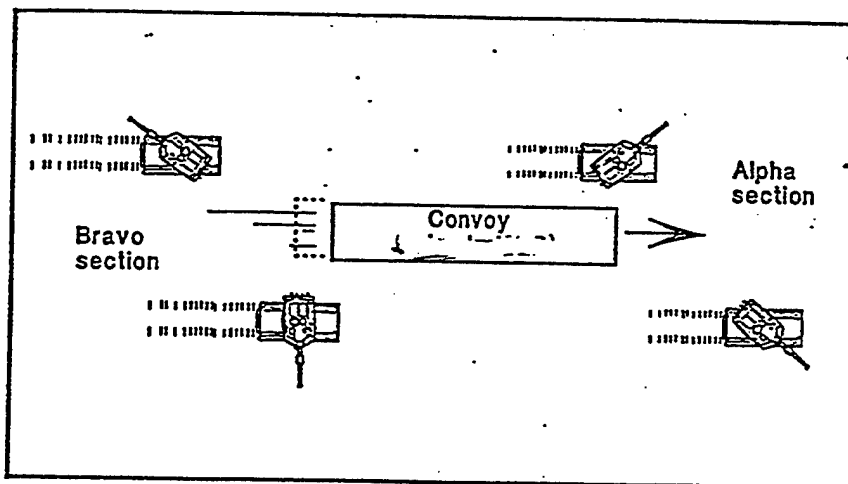
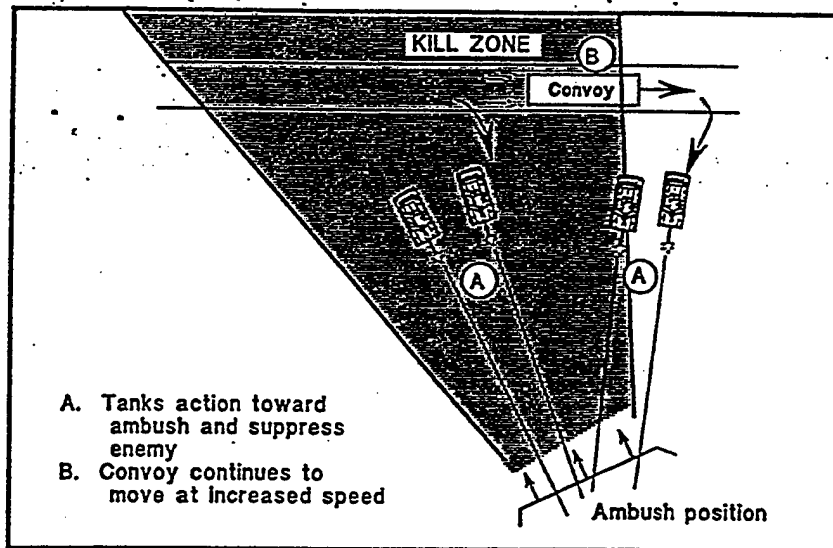
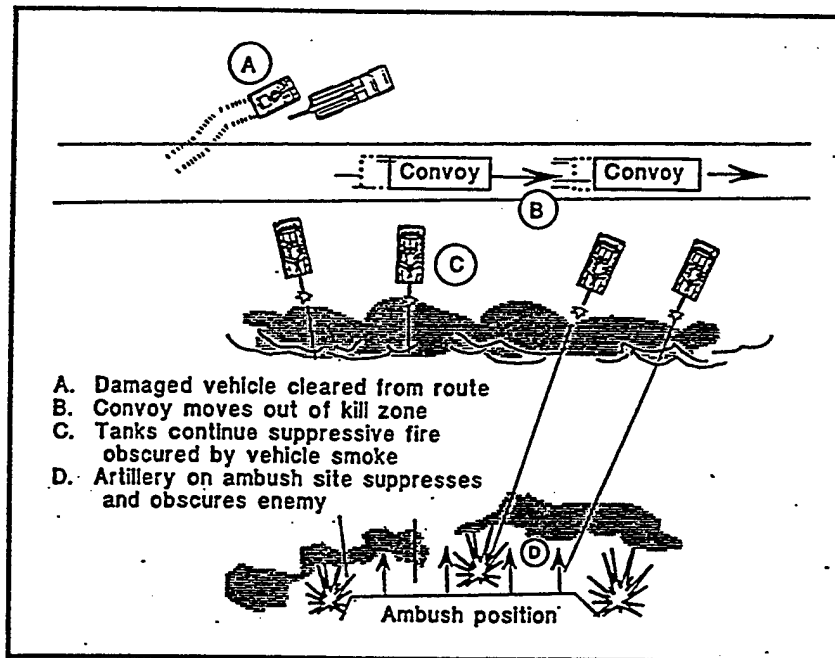

Figure 5-____. Tank platoon escort using modified traveling overwatch.



- A. Tanks action toward ambush and suppress enemy
- B. Convoy continues to move at increased speed

Figure 5-____. Convoy escort actions toward ambush.



- A. Damaged vehicle cleared from route
- B. Convoy moves out of kill zone
- C. Tanks continue suppressive fire obscured by vehicle smoke
- D. Artillery on ambush site suppresses and obscures enemy

Figure 5-____. Convoy continues to move.

Note: The commander may elect to dismount infantry to clear the ambush area and provide security for the tank platoon.

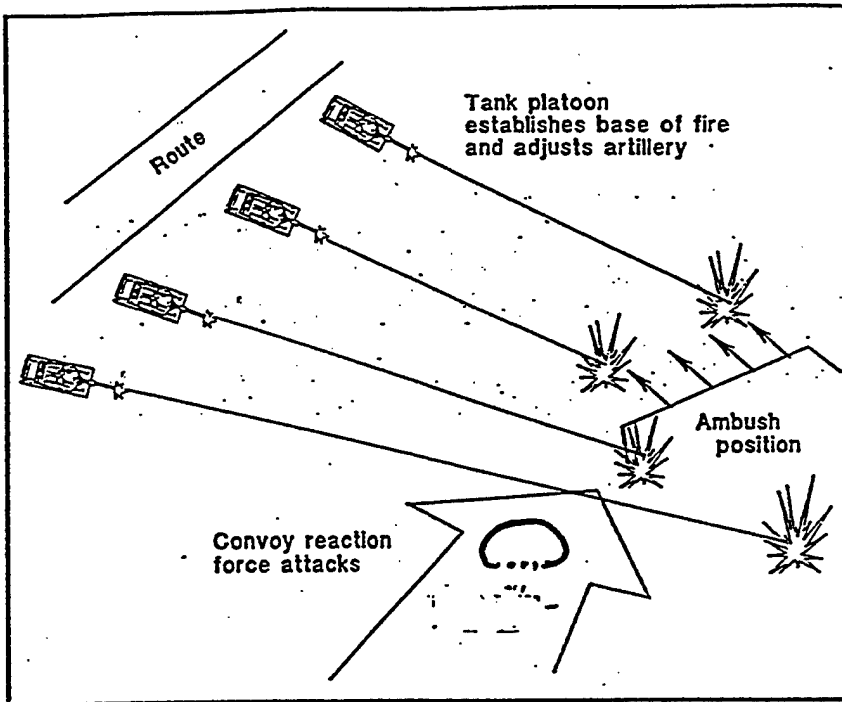

Figure 5-_____.
Escort suppresses
ambush for
reaction force
attack.

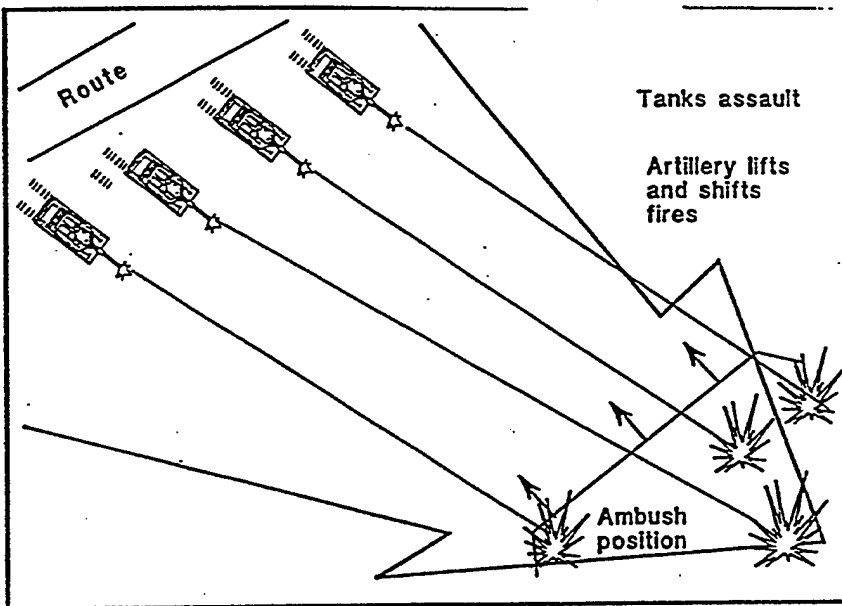

Figure 5-_____.
Escort assaults
ambush.

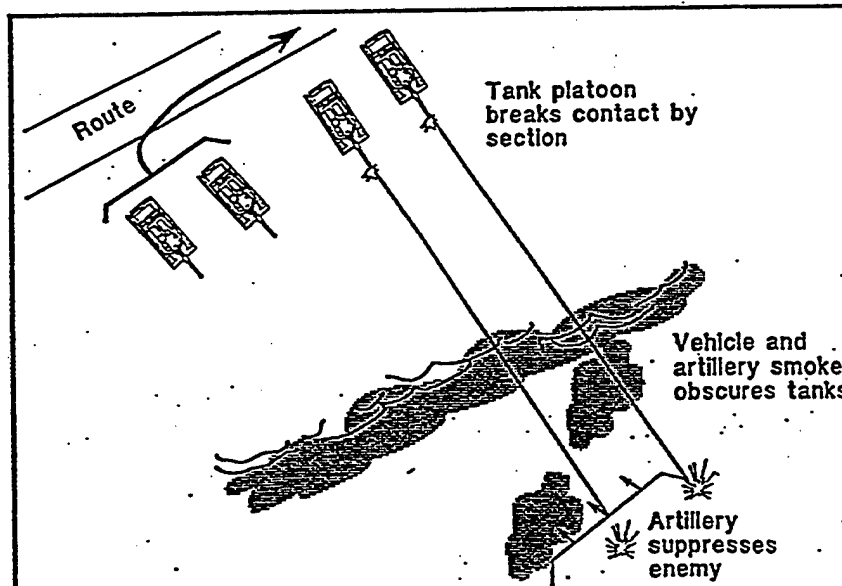

Figure 5-_____.
Escort breaks
contact.

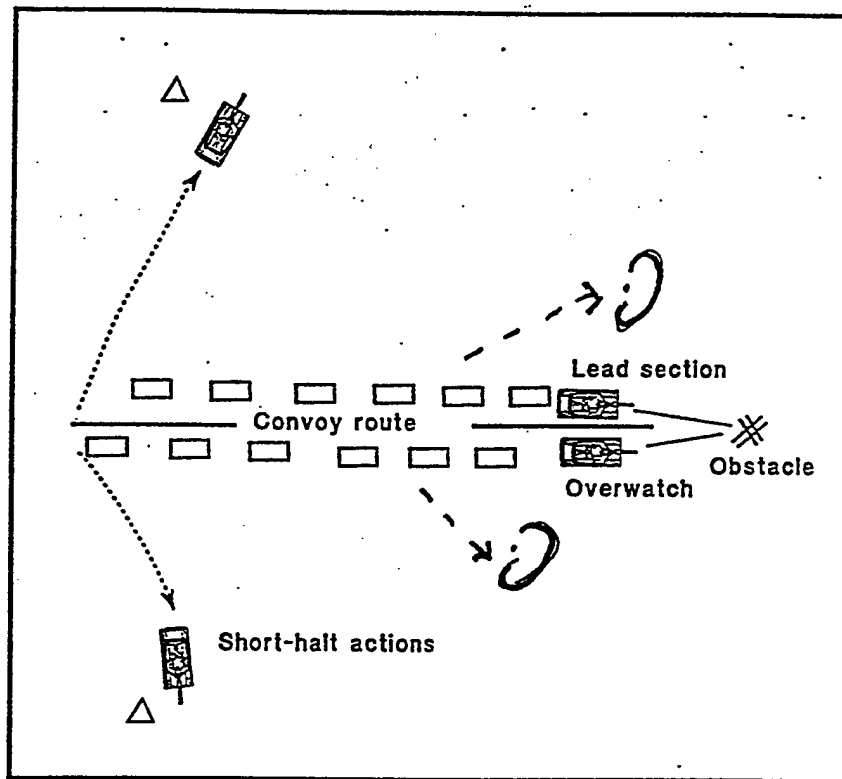

Figure 5-____. Convoy escort overwatches an obstacle.

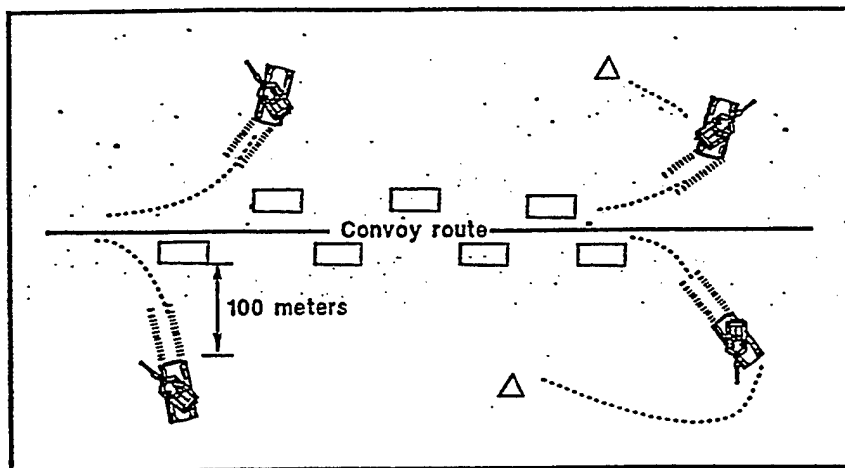

Figure 5-_____.
Convoy assumes
herringbone
formation

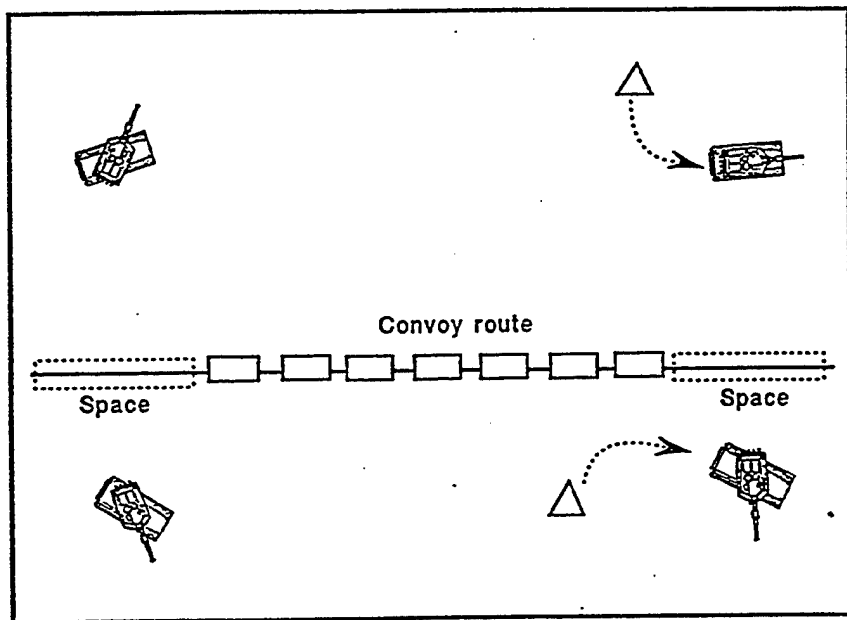

Figure 5-_____.
Convoy moves
back into column
formation.

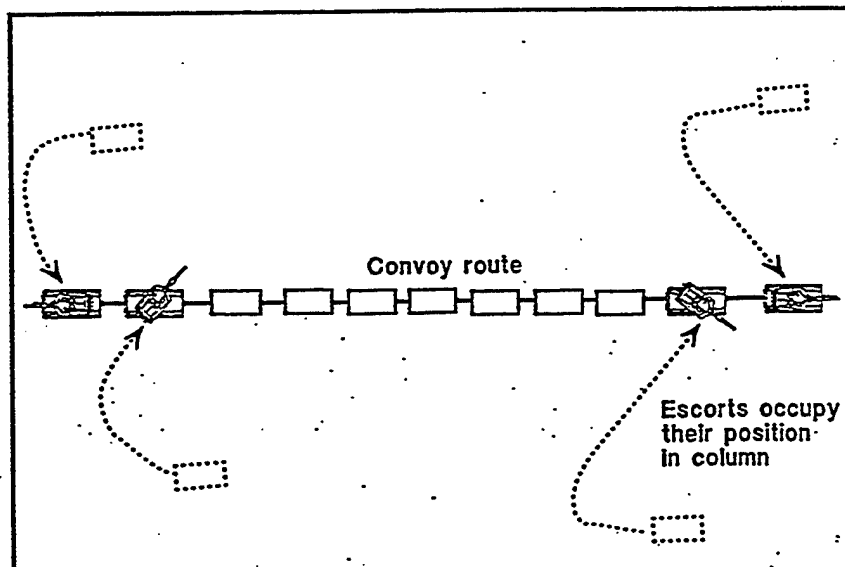

Figure 5-_____.
Convoy escort
vehicles rejoin
column.

Section V: Passage of Lines

The tank platoon participates in a passage of lines as a part of the infantry company to which it is attached. If the company is stationary, the platoon occupies defensive positions and assists the passing unit. If the company is passing through another unit, it executes tactical movement through the stationary unit. A passage may be forward or rearward.

Units are highly vulnerable during a passage of lines. Vehicles and personnel may be concentrated, and fires may be masked. The passing unit may not be able to maneuver and react to enemy contact.

Detailed reconnaissance and coordination are critical in overcoming these potential problems and ensuring the passage of lines is conducted quickly and smoothly. The company commander normally conducts all necessary reconnaissance and coordination for the passage. At times, he may designate the XO, 1SG, or a platoon leader to conduct liaison duties for reconnaissance and coordination. The following items of information are coordinated (an asterisk [*] indicates items that should be confirmed by reconnaissance):

- Unit designation and composition; type and number of passing vehicles.
- Passing unit arrival time(s).
- Location of attack positions or assembly areas.*
- Current enemy situation and other intelligence information.
- Location of key unit leaders.
- Stationary unit's mission and plan (to include OP, patrol, and obstacle locations).*
- Location of Contact Points, Passage Points, and Passage Lanes. * (Note: The use of GPS/POSNAV will simplify this process and help to speed the actual passage)
- Location of minefields or other obstacles (either friendly or enemy).
- Guide requirements.
- Order of march.
- Anticipated and possible actions on enemy contact.
- Supporting direct and indirect fires, including the location of the Restrictive Fire Line (RFL).*
- NBC conditions.
- Available CS and CSS assets and their locations.*
- Communications information (to include frequencies, digital data, and near and far recognition signals).
- Chain of command, including location of the Battle Handover Line (BHL).
- Additional procedures for the passage.

Forward Passage of Lines

During the forward passage, the passing unit first moves to an assembly area or an attack position behind the stationary unit. Designated liaison personnel move forward to link up with guides and confirm coordination information with the stationary unit. Guides then lead the passing elements through the passage lane. The Commander and FO should position themselves where they can observe critical areas of the passage.

The tank platoon conducts tactical movement to maximize its battle space within the limitations of the passage lane. Radio traffic is kept to a minimum. Disabled vehicles are bypassed. The platoon holds its fire until it passes the RFL. Once clear of passage lane restrictions, the platoon conducts tactical movement in accordance with the company OPORD.

Rearward Passage of Lines

Because of the increased chance of fratricide during a rearward passage, coordination of recognition signals and direct fire restrictions is critical. The passing unit contacts the stationary unit while it is still beyond direct fire range and conducts coordination as discussed previously. RFLs and near recognition signals are emphasized.

The passing unit then continues tactical movement toward the passage lane. Gun tubes are oriented on the enemy, and the passing unit is responsible for its own security until it passes the RFL. If guides are provided by the stationary unit, the passing unit may conduct a short halt to link up and coordinate with them. The passing unit moves quickly through the passage lane to a designated location behind the stationary unit.

Assisting a Passage of Lines

As noted, the tank platoon leader provides this assistance while it is in stationary defensive positions. This can occur after the platoon has consolidated on an objective or has occupied a BP. Coordinating instructions may be in the form of a company OPORD or a FRAGO issued over the radio. The platoon may or may not have coordinated directly with the passing unit.

The platoon leader ensures the platoon understands the points of coordination listed previously in this section. If the platoon is to provide guides to assist the passing unit, he selects the personnel and briefs them on the points of coordination. The guides are responsible for linking up with and guiding the passing unit through the passage lane and for closing obstacles as necessary.

Control of direct fires is a critical role for the element that is assisting the passage of line. In a forward passage, the stationary unit engages known enemy targets until the passing unit moves past the RFL (sometimes designated as the BHL). During a rearward passage, the passing unit contacts the stationary unit by radio at a point beyond the direct fire range of weapon systems. The stationary unit then holds all fires until the passing unit reaches the RFL.

Section VI: Breaching Operations

Obstacles are any obstructions that stop, delay, divert, or restrict movement. They are usually covered by observation and enhanced by direct or indirect fires. There are two categories of obstacles.

Existing Obstacles

These are already present on the battlefield and are not emplaced through military effort. They may be natural or man-made. Examples of natural obstacles (to movement of the tank platoon specifically) include:

- Ravines.
- Gullies.
- Gaps or ditches over 3 meters wide.
- Streams, rivers, or canals over 1 meter deep.
- Mountains or hills with a slope in excess of 60% (30 degrees).
- Lakes, swamps and marshes over 1 meter deep.
- Tree stumps and large rocks over 18 inches high.
- Forests or jungles with trees 8 inches or more in diameter and with less than 4 meters of space between trees on a slope.

Man-made obstacles include built-up areas such as towns, cities, or railroad embankments.

Reinforcing Obstacles

Placed on the battlefield through military effort, these are designed to slow, stop, or canalize the enemy. Whenever possible, both friendly and enemy forces will enhance the effectiveness of the reinforcing obstacles by tying them in with existing obstacles. Examples of reinforcing obstacles include:

- **Minefields.** The most common reinforcing obstacle on the battlefield (Figure 5-____).
- **Antitank ditches** (Figure 5-____). The antitank ditch may be reinforced with wire and/or mines to make it more complex and difficult for the attacker to overcome. (Note: Although soil from the ditch can be built up into a protective berm on the emplacing unit side, the decision to do this must be balanced against camouflage/OPSEC requirements).
- **Road Craters** (Figure 5-____). Road craters can be rapidly emplaced and are especially effective where restrictive terrain on the sides of a road or trail prevents a bypass. Craters should be at least 1.5 meters in depth and 6 meters in diameter. They should also be supplemented with mines and/or wire.
- **Abatis** (Figure 5-____). An abatis provides an effective barrier against vehicle movement. Trees are felled either by sawing or by use of explosives. The cut is made at least 1.5 meters above the ground, with the main trunks crisscrossed and pointed toward the enemy at approximately a 45-degree angle. The abatis is usually about 75 meters in depth and ideally is located on trails where there is no bypass. The trunk of each tree should remain attached to the stump to form an obstacle on the flanks of the abatis. Abatises are usually mined or booby-trapped.
- **Log Cribs** (Figure 5-____). A log crib is a framework of tree trunks or beams filled with dirt and rock. They are used to block roads or paths in restrictive terrain.
- **Wire Obstacles** (Figure 5-____). Wire obstacles are an effective and flexible antipersonnel barrier. They are frequently employed on dismounted avenues of approach in the form of tanglefoot, double- or triple-standard concertina, and four-strand fences. Employed in depth or in conjunction with mines, wire obstacles are also very effective against tanks and other vehicles. **Note: A single wire obstacle will have little effect on tracked armored vehicles. Their sprockets should effectively cut through such an obstacle.**

- **Tank Walls or Berms (Figure 5-_____)**. A tank wall or berm is constructed of dirt and rock to slow or canalize enemy tanks and other tracked vehicles. It will also give the defender "belly" shots while the attacker is unable to depress his weapon systems and engage.

Breaching Procedures

Breaching operations entail the coordinated efforts of three task organized elements: the support force, the breach force, and the assault force. The discussion in this section covers the actions and responsibilities of these elements as well as the tank platoon's role in the operation.

Breaching procedures must be accomplished in a systematic, organized fashion. Four basic actions are executed during breaching: Suppress, Obscure, Secure and Reduce. They are commonly known by the acronym SOSR.

1. **Suppress.** Sufficient support elements are employed to suppress enemy elements that are overwatching the obstacle. The support force used direct and indirect fires to accomplish this mission.
2. **Obscure.** The support force requests immediate or preplanned smoke to obscure breach force operations.
3. **Secure.** The breach force creates and proofs a lane through the obstacle, allowing the assault force to secure the far side of the obstacle.
4. **Reduce.** Actions are taken to further mark and reduce the obstacle and allow follow-on forces to continue the attack.

Support Force

The support force usually leads movement of the breach elements. After identifying the obstacle, it moves to covered and concealed areas and establishes support by fire positions. The support force leader sends a SPOTREP to the company commander. This report must describe:

- The location and complexity of the obstacle.
- The composition of enemy forces that are overwatching the obstacle.
- The location of possible bypasses.

The commander decides whether to maneuver to a bypass or to breach the obstacle. (Note: The commander must keep in mind that a bypass may lead to an enemy kill zone.)

Breach Force

The breach force receives the location of the obstacle or bypass by means of the support force SPOTREP. It then must organize internally to perform the following:

- Provide local security for the breach site as necessary.
- Conduct the actual breach by creating, proofing, and marking a lane through the obstacle or bypass.
- Move through the lane to provide security for the assault force on the far side of the obstacle. In some instances, the breach force may move to positions that allow it to suppress enemy elements overwatching the obstacle. At other times, it may assault the enemy, with suppressive fires provided by the support force.

The tank platoon can create a lane by itself if it is equipped with the assets required to breach the type of obstacle encountered. If the platoon does not have this capability, it may be required to provide close-in protection for attached engineers with breaching assets. Three breaching methods are available to the platoon:

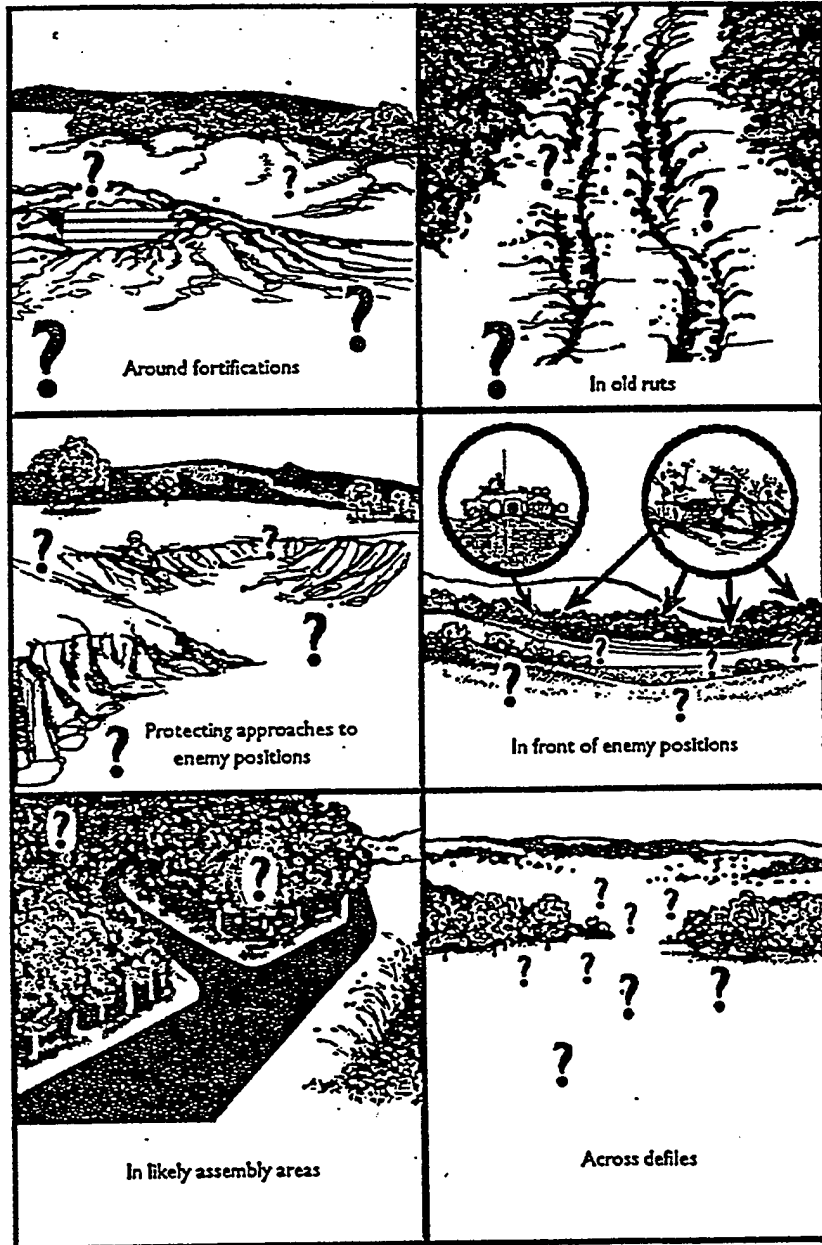

Figure 5-____. Potential minefield locations.

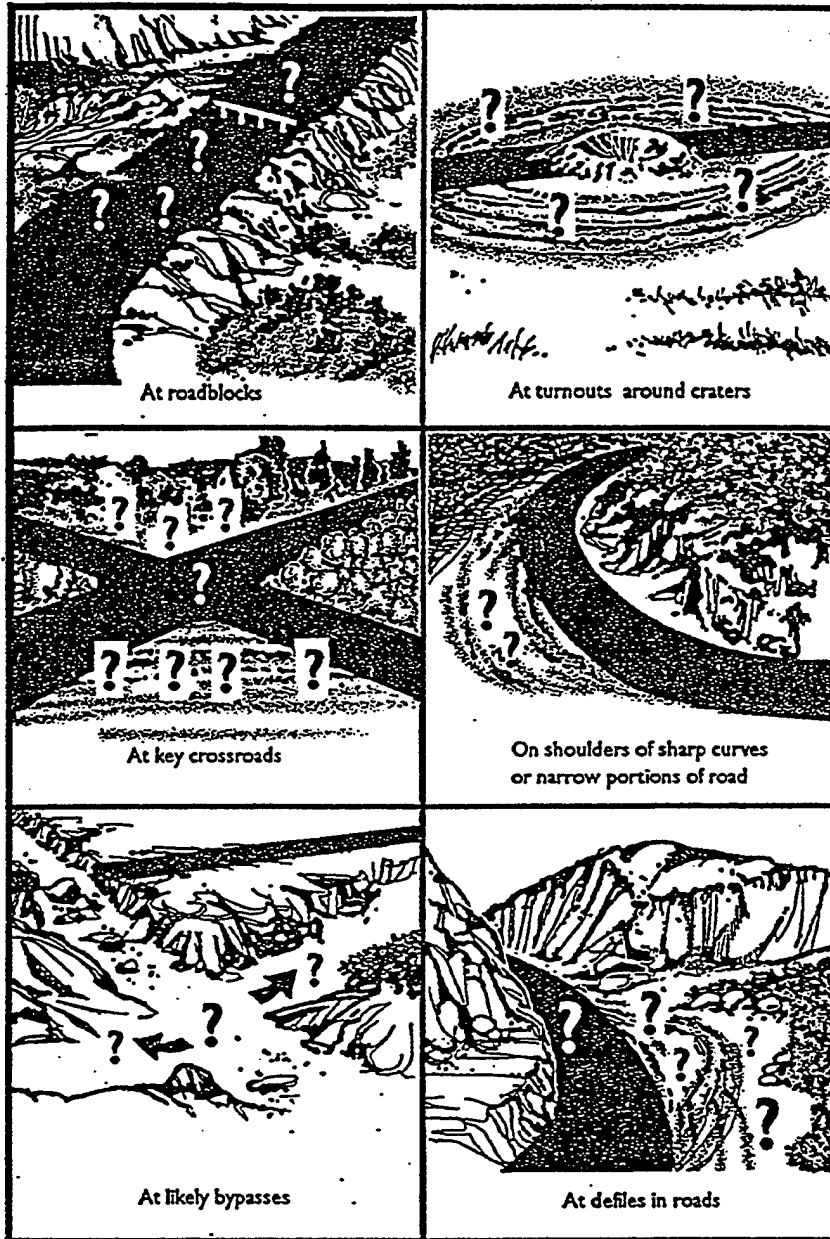

Figure 5-____. Potential minefield locations (continued).

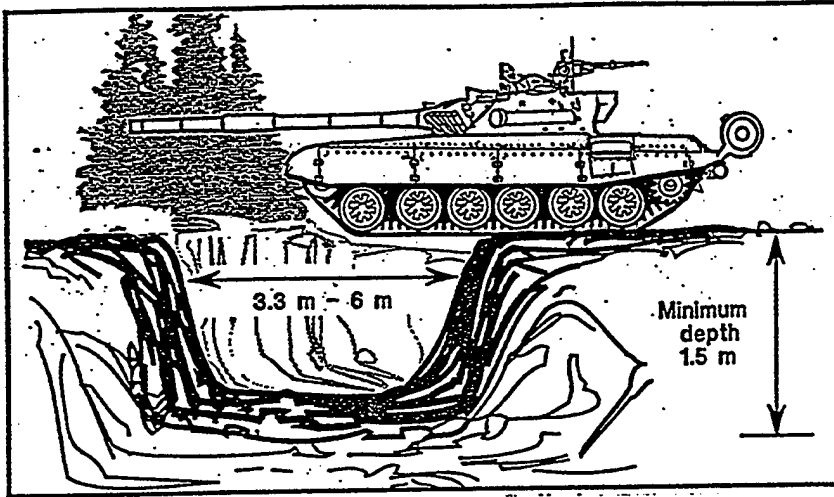

Figure 5-_____
Antitank ditch.



Figure 5-_____
Road craters.



Figure 5-_____
Abatis.

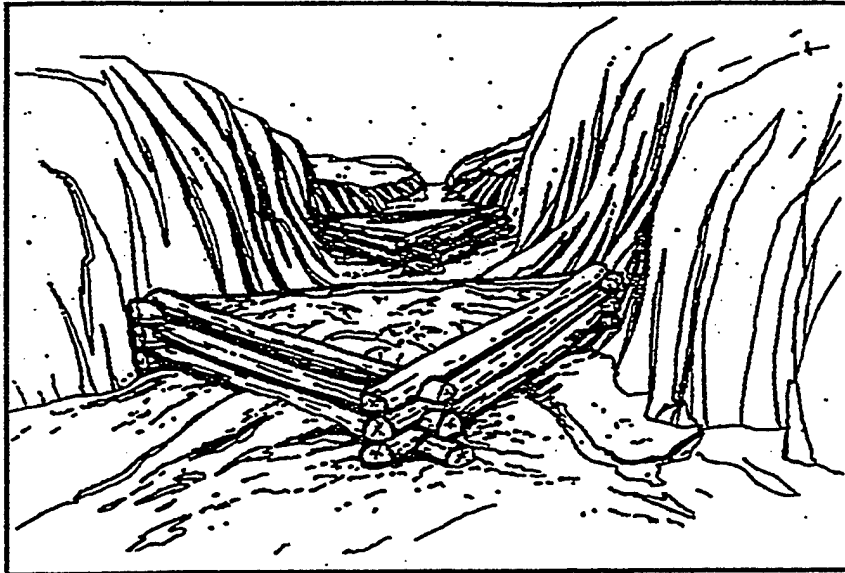

Figure 5-_____
Log cribs.

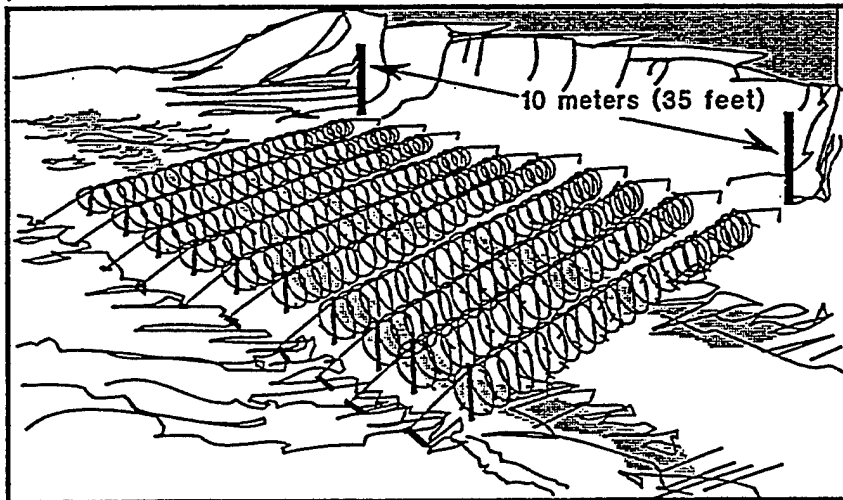

Figure 5-_____
Wire obstacle in
depth.



Figure 5-_____
Belly shot
created by tank
beam.

1. **Mechanical breaching**, usually with mine plows or mine rakes.
2. **Explosive breaching**, employing means such as the mine-clearing line charge (MICLIC), M173 Line Charge, or 1/4-pound blocks of TNT.
3. **Manual breaching**, with soldiers probing by hand or using such items as grappling hooks, shovels, picks, axes, and chain saws. **MANUAL BREACHING IS THE LEAST PREFERRED METHOD FOR THE TANK PLATOON.**

NOTE: In extreme cases, the company commander may order the platoon to force through an obstacle. This technique requires the breach force to move in column formation through the obstacle. If available, a disabled vehicle can be pushed ahead of the lead breach tank in an attempt to detonate mines.

The mine plow is the breaching device most commonly employed by the tank platoon. The parent tank company may allocate one to three plows per platoon. When properly equipped and supported, the platoon can create up to two lanes through an obstacle.

Plow tanks lead the breach force. Immediately following them are tanks that proof the lane. These are usually tanks equipped with mine rollers. This process ensures that the lane is clear. If the location and/or dimensions of the obstacle are unknown, the tank platoon leader may choose to lead with tanks equipped with mine rollers to identify the beginning of the obstacle. **ROLLERS, however, ARE NOT CLEARING VEHICLES – THEY ARE PROOFING VEHICLES.**

If the tank platoon is allocated one plow, the PSG's wingman normally serves as the breach tank. The PSG follows immediately behind to proof the lane and provide overwatch. The platoon leader's section follows the PSG.

If the platoon has two or more plows, it can create multiple lanes, usually 75 to 100 meters apart. The wingman tanks are normally equipped with the plows, with the section leaders' tanks following to proof the lanes and provide overwatch (Figure 5- ____ A).

To create a wider lane, two plow tanks can stagger their movement along a single lane (Figure 5- ____ B). An alternative method is for a plow tank to complete its initial pass through the obstacle, then to turn around and move back toward the friendly side to widen the lane or create a new lane.

After the lane is created and proofed, it can then be marked to ensure safe movement by vehicles and personnel. The commander should consider using infantry to assist in this task. This is critical for follow-on forces that may not know the exact location of the cleared lane. **Distinctive markers must show where the lane begins and ends.** A visible line down the center is effective. Another technique is to mark both sides of the breached lane (Figure 5- ____). **Regardless of the method of marking, ensure that the lane entrance is marked at least 100 meters out from the entrance.** Also, ensure guides are in place to assist in entering the lane. To minimize the necessary breaching time, the proofing tank may simultaneously mark the lane. **Unit SOPs will dictate marking methods and materials.** Commonly these include:

- Cleared lane mechanical marking systems (CLAMMS).
- Pathfinder system.
- Engineer stakes with tape.
- Guides.
- Chem lights and/or infrared lights.
- Expended shell casings.

Throughout the operation, the tank platoon leader provides continuous updates of the breach force's progress to the company commander. He also coordinates with the support force for suppressive fires.

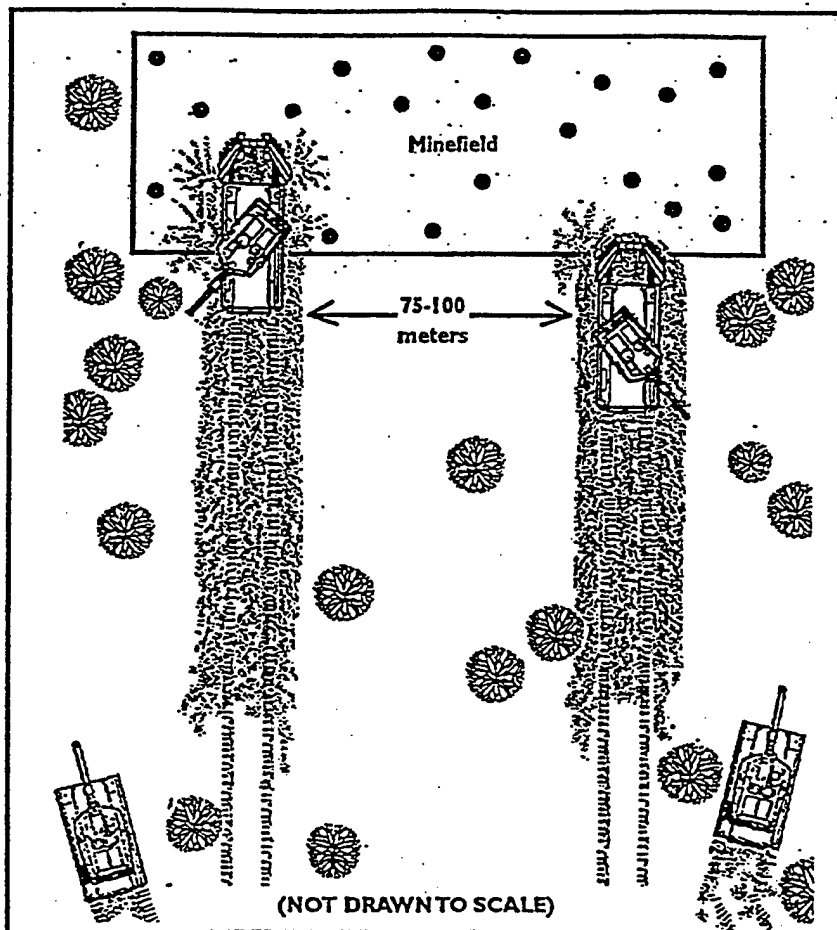

Figure 5-____. Plow tanks create multiple lanes while the section leader's tanks provide overwatch.

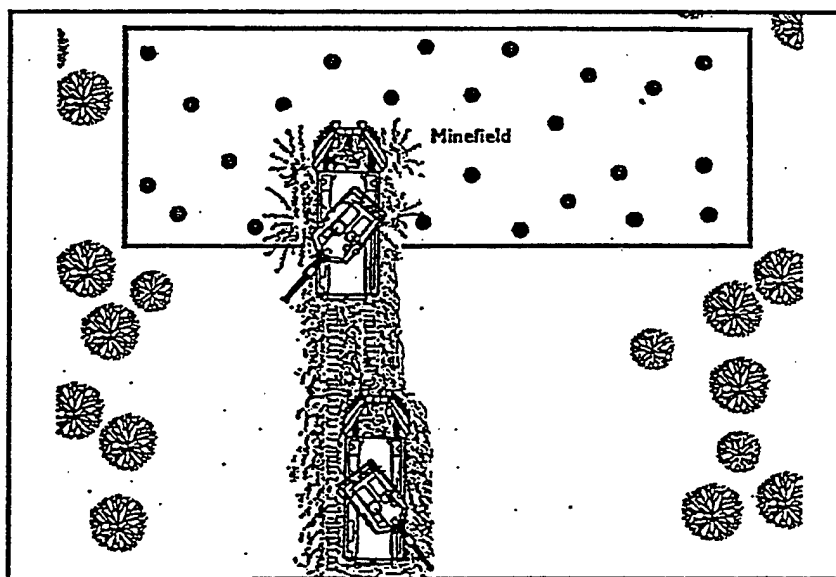

Figure 5-____. Plow tanks use staggered movement to create a wider lane.

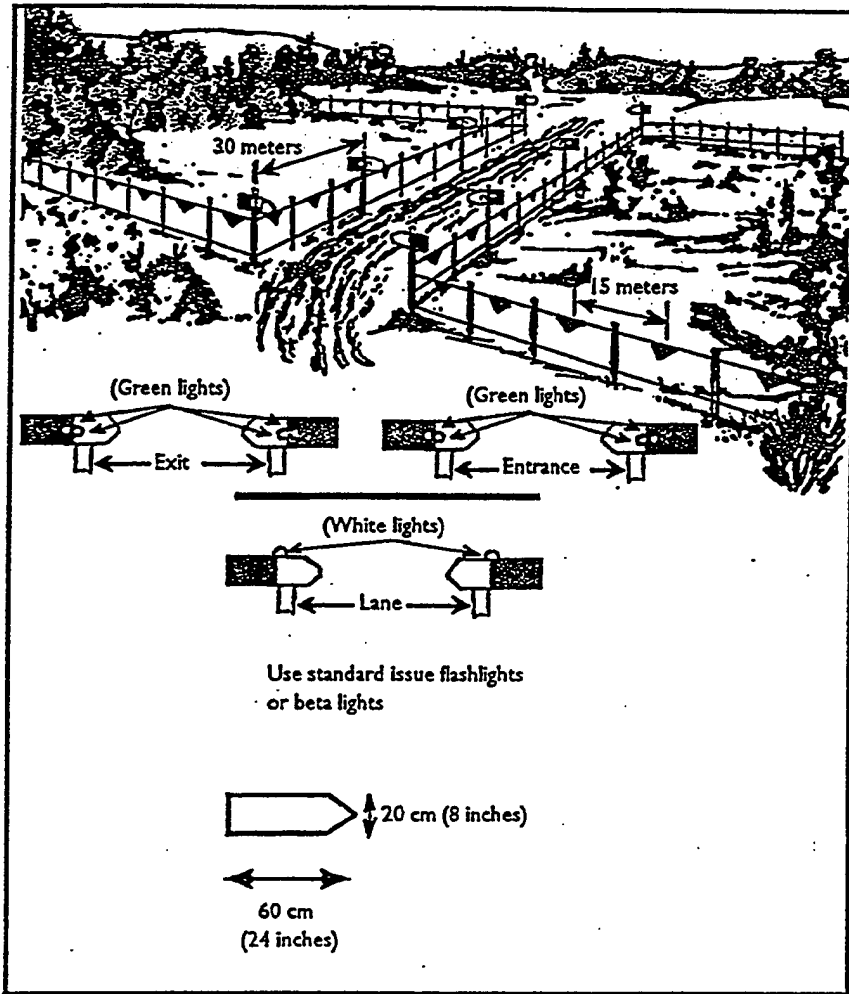

Figure 5-____. Sample technique for obstacle lane marking.

After marking is complete, the tank platoon leader reports the location of the lane and the method of marking to expedite the movement of the assault force. The assault force will often move behind the breach force and closely follow the breach vehicles through the new lane.

Assault Force

While the breach is in progress, the assault force assists the support force or follows the breach force. Once a lane is cleared through the obstacle, the assault force moves through the breach. It secures the far side of the obstacle by physical occupation and/or continues the attack in accordance with the commander's intent.

Section VII: Follow and Support

The tank platoon conducts follow and support missions when the enemy situation is extremely fluid or unknown. This is a normal mission in support of dismounted infantry.

During the follow phase of the mission, the platoon conducts tactical movement or occupies hasty BPs while the lead (supported) element (infantry company) moves. There is no requirement to overwatch the movement of the lead element. In fact, this could be counterproductive; the noise of the tank platoon that is following too closely could alert the enemy to the presence of the dismounted infantry. The tank platoon does, however, maintain a high degree of situational awareness. The platoon leader maintains constant communications with the company commander.

When the company's dismounted elements make contact with an enemy force they cannot destroy or bypass, they deploy into position, and suppress enemy AT weapons with direct and indirect fires. The commander then directs the tank platoon to destroy or suppress the enemy (Figure 5-____A). The tank platoon moves forward and links up with the infantry (Figure 5-____B). At the linkup point, the tank platoon leader coordinates the following with the commander (or other designated leader):

- Enemy disposition.
- Friendly disposition.
- Tentative maneuver plan.
- Any additional tactical information not already covered in the OPORD, including the use of guides, control of direct and indirect fires, close-in protections for the tank, and communications and signal information.

The tank platoon leader conducts a ground reconnaissance of the route to the final firing position and finalizes the plan with the commander.

The platoon then moves forward to the firing position, using guides provided by the dismounted platoons.

Depending on the amount of suppressive fires being received, the tanks may move to firing positions buttoned up. This, however, degrades the tank's target acquisition capability and makes it easier for dismounted enemy forces to attack the tank with small arms or machine guns.

If tank crews cannot immediately identify targets when they reach the firing position, the infantry designates each target using tracers, smoke grenades, or grenades fired from the M203 grenade launcher. Tanks then suppress or destroy targets using main gun or machine gun fire. When targets are destroyed, the infantry signals the tank platoon to cease fire.

Note: Restrictive terrain severely limits the mobility of the tank platoon. It further increases the platoon's vulnerability by limiting visibility for tank crews. Without the aid of infantrymen serving as guides and providing security, tanks have a much greater chance of becoming stuck in close terrain or of being the target of enemy fires. In these situations, the infantry must provide close-in protection and early warning against dismounted and mounted threats.

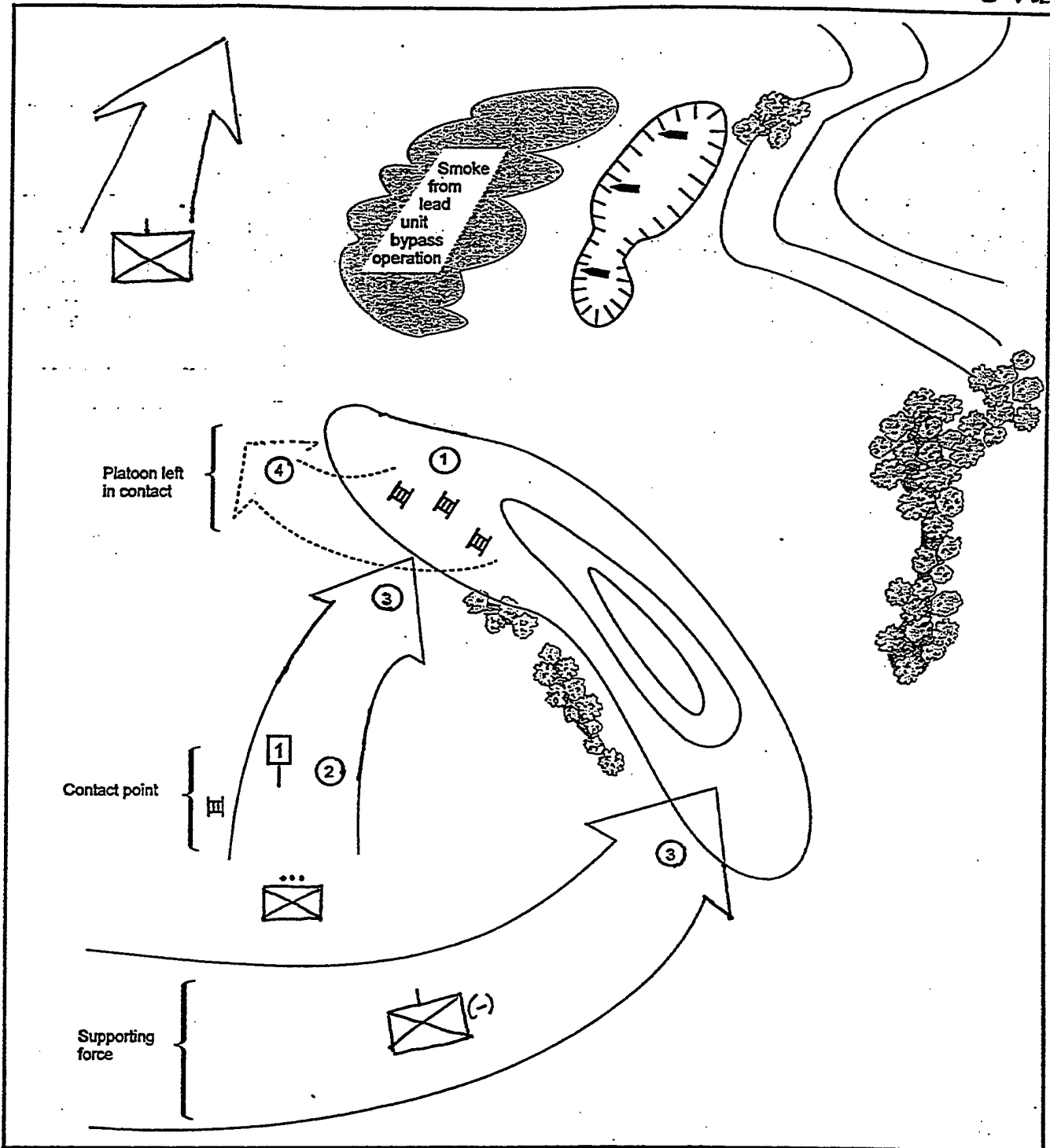

1. Tank platoon left in contact maintains contact with bypassed MRP.
2. Tank from platoon left in contact links up with platoon from supporting company at CONTACT POINT 1.
3. Supporting company assumes responsibility.
4. Tank platoon is released to join infantry company to which it is OPCON.

Figure 5-____. Example follow and support operation.

Section VIII: Perimeter Defense

The perimeter defense is conducted when there are no friendly units adjacent to the company.

Considerations for the execution of a perimeter defense include the following:

- Disperse the company with all-around security.
- One section of tanks, the entire platoon, or company AT assets orient on the most likely mounted avenues of approach.
- One section or the entire platoon may occupy an assembly area within the perimeter as a reserve or reaction force. Missions of this force include moving to BPs that block potential areas of enemy penetration, conducting counterattacks to destroy an enemy penetration, and moving to BPs that add firepower to a portion of the company's overall defense.
- Keep mortars near the center of the perimeter.
- To safely move and avoid disrupting other elements of the company's defense, the tank platoon must carefully coordinate, reconnoiter, and rehearse mounted movement to positions within the company's perimeter.
- Tanks must NEVER FIRE OVER THE HEADS OF UNPROTECTED PERSONNEL. The concussion of the main gun as well as discarded sabot petals can injure or kill friendly troops.
- Close coordination between the company commander, rifle platoon leaders, and tank platoon leader is critical. Tank crews must know the location and routes of dismounted OPs and patrols to help prevent fratricide. Additionally, the tank platoon must rely on dismounted infantry to provide security against enemy infiltration of the perimeter as well as close-in protection from dismounted attacks.

Section IX: Relief in Place

A relief in place occurs when one unit assumes the mission of another. It may be accomplished during either offensive or defensive operations. It is preferably conducted during periods of limited visibility.

A relief requires detailed planning. OPSEC is critical. When time is available the situation permits, the commander conducts a reconnaissance to confirm details of the relief. The two leaders should coordinate and exchange the following information:

- The enemy situation and other pertinent intelligence.
- Security measures in place by the unit being relieved.
- The tactical plan and fire support plans.
- The location of weapons and fighting positions.
- Sketch cards and fire plans (this includes grid locations for input into digital systems).
- Details of the relief, to include the sequence, the use of recognition signals and guides, and the time of change of responsibility for the area.
- The transfer of excess ammunition, POL, wire lines, and other materiel to the incoming platoon.
- Command and signal information.

After reconnaissance and coordination are complete, the commanders continue with troop-leading procedures and prepare to execute the relief. There are two methods by which to conduct a relief in place:

1. **Simultaneous.** All elements are relieved simultaneously.
2. **Sequential.** The relief takes place one unit at a time.

Initially, the relieving company moves to an assembly area behind the company to be relieved. Final coordination is conducted, and information is exchanged. The relieving company links up with guides or finalizes linkup procedures.

OPSEC is critical in preventing enemy reconnaissance and intelligence assets from identifying the weaknesses and vulnerabilities that occur during relief. Radio net discipline is the key to an effective, and secure, relief operation. Before beginning the relief, the relieving company changes to the outgoing company's frequency, and the two units operate on the same net throughout the relief. The relieving company observes radio listening silence while the outgoing company maintains normal radio traffic.

By monitoring the same frequency and maintaining the same digital links, leaders have the ability to contact others involved in the relief. Because of the proximity of the relieved and relieving companies, however, leaders must remember that the net will be crowded, with many stations and digital links competing for limited availability of "air time."

Once the relief is complete, there are two methods for returning to separate company frequencies. One technique is to have the incoming company switch back to its original frequency. The other is to have the outgoing company switch to an alternate frequency. There are several advantages for the latter technique:

- The relieving company establishes voice and digital communications and is prepared to defend immediately upon the exit of the relieved platoon.
- The relieving company never loses the digital link (if applicable) as it assumes the new mission. Once the relief is complete, the relieved company simply switches to an alternate FM frequency.
- Maintaining radio traffic on the same frequency before, during, and after the relief operation will help deceive the enemy as to whether a relief has occurred.

Section X: Transporting Infantry

At times, the tank platoon leader may be required to transport infantrymen on his tanks (Figure 5-____). This is done only when contact is not expected and moving through a secure area. If the platoon is moving as part of the infantry company and is tasked to provide security for the move, the lead section or element should not carry infantry.

Caution must be used when carrying infantry on top of tanks. In addition to safety concerns when mixing tired personnel with large, moving machinery, the ability of tanks to maneuver and fire if contact is made will be severely hindered.

Infantry and armor leaders must observe the following procedures, precautions, and considerations when infantrymen ride on tanks:

- When transporting infantry on a tank, at least five ropes should be stretched across the top of the turret to serve as handholds for infantry. These may be fastened with snaplinks to the top railing of the bustle rack on either side of the turret. Alternatively, a single long rope may be woven back and forth between the top railings.
- Infantry platoons should thoroughly practice mounting and dismounting procedures and actions on contact.
- Passengers must always alert the TC before mounting or dismounting.
- Passengers must follow the commands of the TC.
- Infantry platoons should be broken down into squad-size groups, similar to air assault chinks, with the infantry platoon leader on the tank platoon leader's tank and the infantry PSG on the tank PSG's tank.
- Infantry platoon leaders, PSGs, and team leaders should position themselves near the TC's hatch to talk to the TC and relay signals to the platoon.
- Each tank in the platoon should have a TA-1 in its case mounted on the right rear of the turret. This will be connected to intercom system and is for infantry to talk to the tank crew.
- All members of the tank platoon should become familiar with and use the hand and arm signals employed by the infantry per FM 21-60, Visual Signals.
- Tank crewmen must remember that the tank cannot return fire effectively with infantry on board.
- Whenever possible, passengers mount and dismount over the left front slope of the tank. This ensures that the driver can see the infantrymen and that the infantrymen do not pass in front of the coax machine gun.
- Passengers must always have three points of contact with the tank. They must also watch for low-hanging objects like tree branches.
- Passengers must ensure that they remain behind the tank's smoke grenade launchers. This will automatically keep them clear of all weapon systems.
- All passengers should wear hearing protection.
- Passengers should not ride with anything more than their battle gear. Rucksacks and B-bags should be transported by other means.
- Passengers **MUST** be prepared to take the following actions on contact:
 - ⇒ Wait for the tank to stop.
 - ⇒ At the TCs command, dismount **IMMEDIATELY** (one fire team on each side). **DO NOT** move forward of the turret.
 - ⇒ Move at least 5 meters to the side of the tank. **DO NOT** move behind or forward of the tank.
- If possible, the lead tank should not carry infantrymen. Riders restrict turret movement and are more likely to be injured or killed on initial contact.
- Infantrymen should scan in all directions. They may be able to spot a target the tank crew does not see.
- **DO NOT** move in front of the tank unless ordered to do so.
- **DO NOT** dismount a tank unless ordered or given permission to do so.

- **DO NOT dangle arms or legs, equipment, or anything else off the side of a tank.** They could get caught in the tracks, causing death, injury, or damage to the equipment or tank.
- **DO NOT carry too many riders on the tank.** Falls, burns, and clogged air intakes can result.
- **DO NOT fall asleep when riding.** The warm tank engine may induce drowsiness. A fall could be fatal.
- **DO NOT smoke when mounted on a tank.**
- **DO NOT stand near tanks during refueling and rearming.**
- **DO NOT stand near the rear of a tank with the engine running.** The tank's exhaust is extremely hot and can seriously burn.
- **DO NOT stand near a moving or turning tank at any time.** Tanks have a deceptively short turning radius.

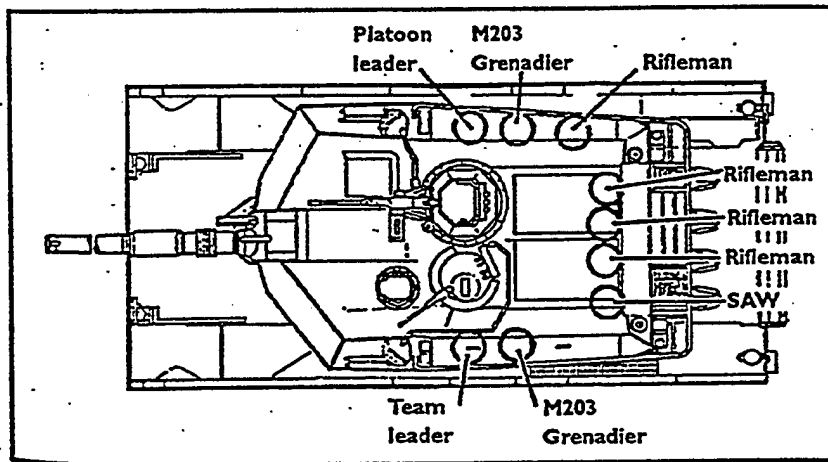

Figure 5-____. Sample positions for infantry riding on a tank.

Section XI: Limited Visibility Operations

Darkness obviously limits visibility on the battlefield, but there are other conditions that restrict visibility: dust, smoke, and other obscuration factors caused by weapon firing and movement of soldiers and equipment, as well as rain, snow, fog, sandstorms, and other weather conditions. The tank platoon must train to fight effectively in all types of visibility conditions.

Equipment

The tank platoon is equipped with the following types of equipment for use under limited visibility conditions:

- **Driver's night vision viewer.** This sight is either passive (the VVS-2) or thermal (the DTV). It enhances the driver's ability to move the tank and enables him to assist in target acquisition and to observe rounds in darkness or other limited visibility conditions.
- **PVS-7.** This passive vision device enables the TC to observe from his opened hatch to control movement and provide close-in security. There are normally two PVS-7s per tank.
- **Gunner's Primary Sight (GPS) and commander's extension.** This integrated thermal sight gives the gunner and TC the capability to see and engage targets under almost any visibility conditions.
- **CITV.** This is a fully-integrated, full-target engagement sight on the M1A2. It provides the TC with a redundant target acquisition and surveillance capability equivalent to that of the Gunner's Primary Sight and the Thermal Imaging System (TIS). The CITV extends the TC's field of view, giving him 360-degree observation capability independent of the Gunner's Primary Sight.

Figure 5-____ lists the comparative characteristics, capabilities, and limitations of passive and thermal sights.

Navigation

The tank platoon can employ a variety of techniques and equipment to assist the company commander in navigation. These include:

- **Compass and odometer (Figure 5-____).**
- **Fires.** Using artillery or mortars to fire smoke or ground-burst illumination can provide a useful check on estimated locations or preplanned targets.
- **Global Positioning Systems (GPS).** These systems receive signals from satellites or land-based transmitters. They calculate and display the position of the user in military grid coordinates as well as in degrees of latitude and longitude. Most GPS navigation readings are based on waypoints, the known positions entered into the system's memory. Once waypoints are entered in the GPS, the device can display information such as distance and direction from point to point.
- **Inertial navigation systems (M1A2).** Based on an initial calculation of the tank's location from a known point, inertial navigation systems use the rotation of the track to determine the location of the tank. The M1A2's POSNAV system is an example. POSNAV allows the TC to determine his exact location and gives him the ability to plot up to 99 waypoints. Tank drivers can then use the steer-to function on their driver's integrated display as they move toward the designated waypoints. To compensate for track slippage that could affect the accuracy of the inertial system, TCs should reinitialize their systems often using a GPS or a known point.
- **Shift from a known point.** Shifting from a known point is a convenient tool for the platoon leader to use as he maneuvers the platoon and disseminates control measures. The known point is usually a previously distributed graphic control measure. Shifts from known points are used routinely to control

combat operations. They make reporting of current platoon and enemy positions easier. Enemy locations, however, are identified only by using shifts from TRPs.

Note: many units routinely use the Terrain Index Reference System (TIRS) or the Grid Index Reference System (GIRS) to make shifts from a known point. TIRS identifies locations based on terrain points previously designated on an overlay. GIRS used intersections of four grid squares as the known points.

Vehicle Identification

The problem of vehicle identification is compounded in limited visibility conditions. All elements must be able to distinguish attached tanks and other friendly elements from those of the enemy. Most unit SOPs cover vehicle marking and identification procedures. In addition, the tank platoon can use the following techniques to enhance command and control and to help prevent fratricide:

- Attach color-coded lights or chemical lights to the rear of the turret or hull.
- Replace the brake light cover with color-coded plastic. Cover the headlights.
- Use luminous or thermal tape to "outline" tanks or to make battle boards.
- Use radio and digital systems (if available) to provide the platoon with frequent updates of friendly unit locations.

Tactical Movement and Attacks

The fundamentals for executing tactical movement and attacks are applicable during periods of limited visibility. The following paragraphs cover additional considerations/actions the company commander and tank platoon leader may make/take in the planning, preparation, and execution of these operations when visibility is restricted.

Planning Phase

- Pay particular attention to routes, formations, and navigational aids.
- Conduct a thorough route reconnaissance to identify locations where the tank platoon could become misoriented.
- The route reconnaissance must also focus on finding rough or restrictive terrain that will be even more difficult to negotiate during limited visibility periods. Such terrain may require a change in formation or movement technique or employment of dismounted ground guides.

Preparation Phase

- Conduct rehearsals in as many types of adverse conditions as possible.
- Stress light discipline.
- During the PCI, view each tank using a passive sight to ensure the sources of light have been dimmed or covered.
- Ensure that all personnel understand the platoon's projected actions during each phase of the operation. One technique: designate waypoints or phase lines as trigger points for platoon actions.

Execution Phase

- Use available night vision devices to assist with navigation and to enhance situational awareness.
- Assume the enemy possesses the same limited visibility observation capabilities as friendly units.
- Use terrain to mask movement; do not let limited visibility create a false sense of protection from observation.
- Reduce distance between tanks while moving. This allows tanks to observe one another and decreases the time necessary to react to enemy contact.

Limited Visibility Defense

The defensive fundamentals are applicable in limited visibility conditions. Additional considerations/actions for the commander and tank platoon leader to make/take in the planning, preparation and execution of the defense in limited visibility conditions follow:

Planning Phase

- Conduct a thorough reconnaissance, preferably during daylight, to mark positions and routes.
- Keep in mind that obscurants that limit visibility may also degrade the effectiveness of thermal sights and laser range finders. This may cause leaders to designate engagement areas that are closer than anticipated to the company's BPs.
- In marking positions, use materials that will facilitate occupation in either daylight or under limited visibility conditions.

Preparation Phase

- Ensure that decision points, TRPs and artillery targets are "thermalized" to allow for positive identification. Thermalized TRPs help TCs to more accurately estimate range to their targets when smoke or other factors inhibit the use of the laser range finder.
- Rehearse occupation and displacement during limited visibility conditions.
- Emplace mounted OPs to take advantage of the capabilities of the tanks' thermal sights.
- Dismounted OPs provide local security and augment mounted OPs with shorter-range observation and the ability to listen for approaching enemy elements.

Execution Phase

- Ensure that all soldiers understand the occupation and displacement criteria.
- Strictly enforce fire control measures.
- Use sketch cards and the tank platoon's CITVs (if available) to estimate target range when visibility factors prevent the use of their laser range finders.

PASSIVE SIGHTS	THERMAL SIGHTS
1. Limited by the amount of available light.	1. Not affected by light conditions.
2. Can be "washed out" by bright flashes of light.	2. Not affected by flashes of light.
3. Narrow field of view.	3. Choice of narrow or wide field of view.
4. Poor depth perception.	4. Poor depth perception.
5. Excellent capability for identifying sources of light (including IR).	5. Unable to detect sources of light.
6. Adverse weather conditions (heavy rain, dense fog, sandstorms, snow) limit the range of the sight and may render it useless.	6. Adverse weather conditions limit the range of the sight. On the other hand, the target acquisition capability of the sight may exceed the capability of the LRF to receive a return and compute an automatic ballistic solution.

Figure 5-____. Comparison of passive and thermal sights.

Section XII: Air Defense Operations

Passive Air Defense:

Passive Air Defense is the infantry company's and tank platoon's first line of defense against enemy air attack.

Passive air defense includes all measures other than active defense, taken to minimize the effects of hostile air attack.

There are two types of passive air defense: Attack avoidance and damage-limiting measures.

1. Attack Avoidance:

- The enemy pilot cannot attack what he cannot find.
- Utilize concealment, camouflage, deception, communications security, and any other necessary action to prevent enemy detection.
- Static tank positions must provide overhead concealment where possible. If not, they must camouflage.
 - Track marks leading into or out of vehicle positions must be obliterated.
 - Shiny objects that could reflect light and attract attention must be covered.

2. Damage-Limiting Measures:

- Dispersion is very effective to reduce the effects of enemy air attack.
- Early warning systems that include both visual and audible signals can help limit damage by enabling particularly the tank platoon to begin dispersion at the earliest possible moment.
- Use natural or man made cover to reduce the effects of enemy munitions. Folds in the earth, depressions, buildings and sandbagged positions can provide this protection.

Active Air Defense:

Active Air Defense occurs when the company must engage enemy aircraft.

All elements must understand that they can defend against an air attack, but cannot engage the aircraft that are attacking unless the weapon control status allows.

The weapons control status describes the relative degree of control in effect for air defense fires. It applies to all weapons systems. All elements will receive the status from the company commander. The three control statuses are:

1. WEAPONS FREE
2. WEAPONS TIGHT
3. WEAPONS HOLD

The tank platoon can effectively utilize both main gun and machine gun fire against enemy aircraft.

Engaging aircraft with volume fire is the way to effective use of machine gun fires. Fires are delivered on the platoon leader's command, and are directed at an aim point. Gunners do not attempt to track target with machine guns.

Several types of machine gun ammunition are used effectively by the tank platoon against helicopters. These are: multipurpose antitank (MPAT), high explosive antitank (HEAT), and armor-piercing discarding sabot (APDS). The aim point is always center mass.

Section XIII: Military Operations in Urban Terrain (MOUT)

Conducting MOUT operations in urban terrain is considered an infantryman's job, but an infantry force can suffer high casualties in prolonged house-to-house fighting. The proper employment of the tank platoon can be a decisive combat multiplier and result in fewer casualties. Tanks provide excellent direct fire capability, can isolate the objective, and cover armor counterattack avenues.

This appendix will examine various planning considerations for MOUT, the basic characteristics of offensive and defensive MOUT, and tactical techniques for MOUT operations. For more detailed information, refer to FM 90-10.

MOUT Planning Considerations.

Terrain Considerations:

- **Severe limitations on mobility.** The urban environment can be severely restrictive terrain for tanks. It is relatively easy for the enemy to emplace obstacles on city streets, creating almost limitless opportunities for ambush sites. Practiced obstacle reduction techniques are a must.
- **Extremely limited fields of fire.** These result in short engagement ranges, which are especially troublesome to tank weapons systems. Every street corner and every successive block becomes an intervisibility line, requiring careful overwatch and extreme caution.
- **A three-dimensional battlefield.** Multistory buildings and sewer systems create a variety of tactical problems. The commander must develop observation and direct fire plans that address the ground-level fight, the aboveground fight, and the belowground fight.

Tank weapons and equipment Considerations:

- **HEAT rounds are normally the primary main gun ammunition in the MOUT environment.**
- **SABOT ammunition has limited utility against most nonvehicular targets.** Reminder: Its discarding petals endanger friendly infantry.
- **Machine guns provide a steady, accurate platform for fire against troops, light structures, and light armor vehicles.**
- **The tank's main gun elevation and depression capability creates considerable dead space, especially at close ranges (see Chapter 2, Section III for a description and diagram of tank dead space):**

30m from building	above 10m (about 2-3 floors)
60m away	above 20m (6-7 floors)
90m away	above 30m (9-10 floors)
- **The tank commander must be unbuttoned to fire the M2 HB machinegun (M1A2).**
- **The M2 HB machinegun is extremely useful for recon by fire operations.**
- **When buttoned up, the tank crew has limited visibility to the sides and rear. They have no visibility to the top.**

- In MOUT operations, the tank should be outfitted with an external phone hookup for communications with the infantry.
- Tank generated smoke is extremely useful in the MOUT environment.
- Thermal sights are effective in the city.
- When tanks fire, their large fireball combines with loose dirt and masonry dust to create a smoke cloud that can degrade vision for 2-3 minutes. (you can move - but so can the enemy).
- The tank main gun's best effects are attained when firing perpendicular to the target. Firing angles greater than 45 degrees greatly reduce penetration.

Maneuver Considerations:

- Formation of combined arms teams at the lowest levels. MOUT may require task organization of infantry squads and tank sections.
- Vulnerability of friendly forces. Tanks are especially vulnerable to attack (and/or counterattack) from dismounted enemy infantry. Infantry needs to provide on the ground security for tanks.
- Tank size can provide infantry with cover from direct fire weapons.
- Requirement for cooperation. MOUT can only be successful when there is close cooperation between the infantry and tanks at the lowest level.

Combat Service Support Considerations:

- MOUT is resource intensive.
- Tanks will expend large amounts of Class V in MOUT operations.
- Protection requirements. Resupply elements are especially vulnerable to ambush during MOUT operations. Be prepared to protect them.

Command and Control Considerations:

- Communications problems. The low-level task organization during MOUT may require additional communications links, which can be disrupted by buildings and other urban terrain features.
- Fire control. Extensive direct fire planning and restrictive fire control measures are an absolute requirement in the MOUT environment.
- Proximity and visibility. Friendly elements often must operate in confined and restrictive areas during MOUT. They may not be able to see other nearby friendly forces. These dangers significantly increase the danger of fratricide.
- Clearance of ATGMs. Infantry must perform this task to protect the tanks.

- **ROE.** These rules may restrict the use of particular weapon systems or ammunition types.
- **The slow pace of MOUT.** This may prevent the company from taking full advantage of the speed and mobility of the tank platoon.
- **The tank section and infantry platoon is an effective combination with the infantry platoon leader in charge.**
- **Plan on rehearsing techniques for infantry to direct tank fires (small arm tracers, smoke, hand and arm signals).**
- **Rear security is critical.**
- **Tanks should always keep tow cables fastened to their front slopes so they can quickly recover other damaged tanks.**

Offensive MOUT.

Phases of Offensive MOUT. In the offense, MOUT is generally conducted as a deliberate attack. Phases of the operation are similar, as discussed below.

- **Conduct reconnaissance.** The reconnaissance phase for MOUT must provide the company commander with adequate intelligence to stage a deliberate attack. This intelligence must be extremely detailed. Detailed maps of the area must be distributed to the lowest level.
- **Isolate.** During this phase, the attacking company must prevent movement of enemy forces into or out of the area of operations.
- **Secure a foothold.** During this phase, the attacking company gains entrance to the urban area. It is critical that the tank platoon effectively employ its firepower to assist the infantry in securing the foothold.
- **Clear.** Infantry will clear the objective area.

Task Organization. The company will normally task organize into support, assault, and reserve forces. (Note: Refer to the discussion in Chapter 3 for additional information on organization for the offense.)

- **Support force.** The support force normally consists of the tank platoon. This allows the company commander to employ the tanks without compromising their survivability. The support force isolates the area of operations and the actual entry point into the urban area, allowing assault forces to secure a foothold.
- **Assault force.** The assault force is the element that gains the foothold in the urban area and conducts the clearance of actual objectives in the area. This is normally the infantry (task organized with engineers if available).
- **Reserve force.** The reserve force may include both infantry and tanks.
- **Figure 5-_____ illustrates a company operation in a strip area.**

Defensive MOUT.

- **Enemy forces outside the urban area.** While positioned in an urban area, the company may be tasked to defend against an enemy approaching from outside the area. In general, procedures and considerations are the same as those for defensive operations in open terrain. This type of MOUT may transition into an in-depth defense of the urban terrain.
- **Enemy forces within the urban area.** The company may be called upon to conduct any of several types of defensive operations. These include: defend in sector, defend a strongpoint, and defend a BP. Procedures and considerations for these defensive operations are generally similar to those used in more conventional open terrain. The commander should designate engagement areas that take advantage of integrated obstacles and urban terrain features that can be covered by direct and indirect fires.

Tactical Techniques for MOUT operations.

Crossing Danger Areas:

- The infantry squad/platoon occupies rooms adjacent to the crossing point.
- A tank is called up to the rear of the building. The remaining tank in the section provides overwatch for the moving tank (as possible).
- The infantry throws smoke grenades to draw the enemy's fire, but they do not cross the danger area.
- The tank uses its thermal sights to engage the enemy through the smoke with its coaxial machinegun or main gun.
- The infantry then throw smoke grenades and cross the danger area while the tank overwatches the crossing.

Establishing a Foothold:

- A lead tank section moves to overwatching positions that cover the objective without being in line with the intended infantry route of advance. The tanks use smoke and reconnaissance by fire with their machine-guns to draw enemy attention and small-arms fire.
- One or two tanks from the second section can lead the infantry along the axis of advance up to the first obstacles or the first building. If the enemy engages the infantry, a tank can instantly use white phosphorous grenades to its front and cover the infantry with its smoke generator to the rear while the infantry takes cover.
- The infantry can then approach the breach point along the flank of the tank using individual movement techniques. **CAUTION:** Once the smoke is generated, the tank must never back up until the infantry leader notifies the tank commander that he is clear to do so.

Breaching An Obstacle:

- When an obstacle is detected, a tank section is brought forward as close as possible into overwatch positions.

- **An initial burst of smoke is used to draw enemy fire. The tanks then attempt to suppress or destroy the enemy soldiers covering the obstacle.**
- **The rear element of the infantry (or engineers) quickly unpack pre-set charges and bring them forward. The infantry leader then selects a breach point that is wide enough for the tanks to maneuver through.**
- **At his command, the tanks secure the breach point and obscure it while the infantry or engineers set the charges. Once the charges are blown, more smoke may be required while a tow line is connected from the obstacle wire to the nearest tank.**
- **As the tank rapidly withdraws, it easily pulls the wire apart. Infantry elements can then move through and secure the far side.**
- **Reminder: Much smoke may be required to cover these operations.**

Street Movement:

- **The infantry identifies the general direction of the enemy and takes cover.**
- **The infantry leader then calls a tank section up into position between his element and the enemy.**
- **The infantry leader clears the tank to engage any enemy at will as it slowly moves down the street, parallel to the infantry's axis of advance. The infantry can then move from building to building in a crouch or high-crawl without smoke (provided they directly parallel to the route of the tank).**
- **The tank's movement is best coordinated by radio from the infantry leader. Plan on a tank being able to cover one infantry squad at a time.**

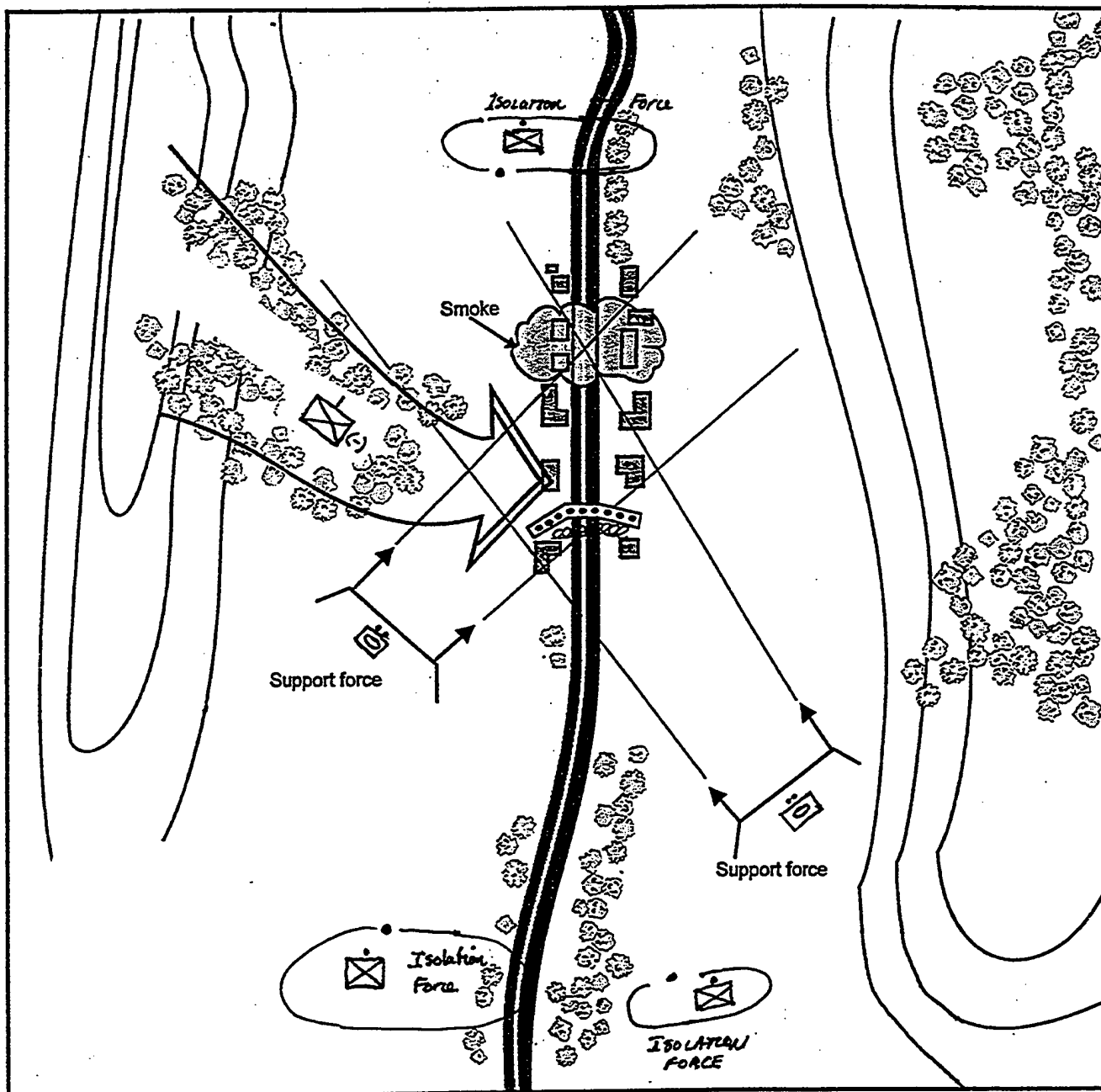

Figure 5-____. Example company offensive operation in a strip area.

Page intentionally blank

Chapter 6: Combat Service Support

The company commander must understand that the tank platoon has no organic combat service support assets. Normally the platoon sergeant will coordinate directly with both his organic company and the infantry company.

Routine CSS functions should be accomplished by SOP. These should include:

- Accountability, maintenance and safeguarding of assigned equipment.
- Reporting the status of personnel, equipment, and classes of supply.
- Requests for supplies
- Turn-in of equipment for repair
- Evacuation of personnel
- Evacuation of equipment and vehicles for replacement or repair.

Supply Operations

The tank platoon has large amounts of equipment and requires frequent resupply to accomplish the mission.

The company commander can expect a tank platoon to operate for a maximum of 24 hours without resupply.

The most forward CSS element of the tank platoon's parent company/team will be the company team combat trains. These trains should provide necessary vehicle recovery and maintenance services for the platoon. Immediate medical aid should be provided by the infantry company.

It will be necessary for the company commander and tank platoon leader to determine the best route for the platoon to utilize in moving to the trains location (and to conduct resupply).

Classes of Supply: The following are specific considerations that must be made for planning employment of the tank platoon.

Class I:

- **Potable water:** Should be replenished daily, either by refilling from a water trailer or by rotating 5-gallon cans. Each tank should maintain a minimum of 10 gallons of potable water. The platoon should also maintain a minimum amount of nonpotable water for vehicle and equipment maintenance. **TECHNIQUE:** Recycle previously used personal hygiene water.
- **Meals:** Should be eaten in shifts, never at a centralized location.

Class III and V:

- **Class III** comprises all types of POL products.
- **Class V** is ammunition, to include small arms, tank rounds, mines, demolition and fuzes. The M1A1 has a basic load capacity of: 40 main gun rounds; 900 Cal. 50; 11,400 7.62mm; 24 smoke grenades. (Note: The M1A2 has a basic load of 42 main gun rounds, with the remaining amounts identical to the M1A1).

- **Rearming and refueling** usually occur daily or at the conclusion of an operation. For optimum security, this should be accomplished under cover of darkness.
- It is important to insure the tank platoon leader controls the redistribution of supplies when fuel and ammunition cannot be delivered or when limited supplies are available.
- Commanders can expect tank platoons to utilize significant amounts of CI III even during routine operations. M1A1s and M1A2s both have a 504.4 gallon fuel capacity and achieve approximately .6 miles per gallon of fuel. Either tank will consume 30+ gallons per hour while operating at Tac Idle, plus approximately 10 gallons per hour at Basic Idle. **Commanders must METICULOUSLY PLAN FOR REQUIRED FUEL RESUPPLY OPERATIONS.**

Class IV:

- This class includes **construction and barrier materials** used for operations and obstacles and to improve fighting positions.
- **Tanks can be utilized to carry additional CI IV.** Insure this is worked out with the tank platoon leader to insure he plans for this in his load plan.

Class IX:

- This class comprises **repair parts** carried by the tank platoon's parent company maintenance team (or sent with the maintenance team accompanying the tank platoon).
- These basic load supplies are part of the company's **Prescribed Load List (PLL)**.
- **PLL items** carried by the tank platoon will usually include **spare track, road wheels, assorted bolts, machine gun parts, and light bulbs.** Commanders should verify the PLL items the tank platoon is carrying.
- Repair parts are issued in response to a specific request or are obtained by direct exchange of repairable parts, to include batteries for night vision devices and man-portable radios.

METHODS OF RESUPPLY

The tank platoon uses **three methods** in conducting resupply operations: **Prepositioning, routine resupply and emergency resupply.** Method to be used is dependent on METT-T.

Pre-Positioning

- **Classes IV and V** are usually the only supplies prepositioned. Class III resupply for the tank platoon should be done behind the battle position or enroute to link-up.
- **Carefully plan the amount of prestock.** The following are considerations for locations of prestock:
 - Availability of overhead cover.
 - Cover and concealment.
 - Security procedures required to safeguard the resupply operation.
 - Procedures for protecting friendly forces and supplies in the event that a prestock is

ignited.

- All leaders must know the exact location of the prestock site(s). They should verify these during reconnaissance or rehearsals. The commander must have a plan to remove or destroy prestocks to prevent the enemy from capturing them.
- Two methods of pre-positioning supplies are shown in figures 6-____ and 6-____:

Routine Resupply:

- Covers items in Classes I, III, V, and IX, as well as mail and any special request items.
- Should be conducted daily, preferably under periods of limited visibility.
- The tank platoon's organic company supply sergeant will assemble the LOGPAC in the infantry brigade's field trains area (assuming the parent company is attached to an infantry brigade). Once the LOGPAC is prepared for movement, the supply sergeant moves the vehicles forward from the field trains to the brigade's designated Logistic Release Point (LRP). The tank company 1SG (or his representative) meets the LOGPAC and then guides it to the company's designated resupply point. The tank platoon meets the LOGPAC at this location and executes the appropriate type of resupply operation (as discussed below). Figure 6-____ depicts a standard tank company LOGPAC which the infantry commander can expect to see resupplying the tank platoon.
- The tactical situation will dictate which type of resupply the tank platoon will use:
 - Tailgate (Figure 6-____).
 - Service station (or a variant) (Figure 6-____).

REMINDER: EITHER OF THESE OPERATIONS ARE NOISY, REQUIRE SPACE FOR THE TANKS AND OTHER VEHICLES TO MOVE IN/OUT, AND CAN BE DANGEROUS IF THERE ARE DISMOUNTED TROOPS IN THE AREA. CAREFULLY CHOOSE THE LOCATION FOR THE RESUPPLY OPERATION. IT REQUIRES ABOUT 30 MINUTES FOR A TANK PLATOON TO EXECUTE LOGPAC OPERATIONS.

- Normally, the tailgate method will only be used in assembly areas. The service station method involves the tanks moving to a centrally located point and rearming and refueling.

Maintenance Operations

The commander must recognize that proper maintenance is the key to keeping the tank platoon fully operational. Maintenance is a continuous process that starts with preventive measures taken by the tank crews.

As a general guideline, tank platoons will conduct repair and recovery as far forward as the situation allows.

Tank platoon maintenance begins with PMCS, a daily crew responsibility.







Tank crews are responsible for conducting initial maintenance, repair and recovery actions on site.

The M1A2 is equipped with embedded nonintrusive and intrusive diagnostic test capabilities. These tests enable crews to identify and isolate many systems and component failures prior to the arrival of organizational mechanics. When the crew isolates a problem using these tests, the organizational mechanic can verify the fault as soon as he arrives, and replace the component without further diagnostic testing.

Evacuation is necessary when a damaged tank cannot be repaired or when evacuation is the only means (besides friendly destruction) available to prevent capture or destruction by the enemy.

- The crew should remain with the tank to assist in evacuation and repair, to provide security, and to return the repaired tank to the platoon as quickly as possible.
- It is vital that the crew move the damaged vehicle to a covered position that allows the recovery vehicle to reach it without exposing the recovery vehicle to enemy fire.

As a last resort, other platoon tanks can evacuate the damaged tank for short distances. **USE THIS AS A LAST RESORT!**

PERSONNEL	VEHICLE
Supply sergeant	Supply truck (supplies, rations) and water trailer 
*PLL clerk**	PLL truck and trailer 
Systems mechanic** Mechanic	Tool truck and trailer 
Driver	Ammo truck 
Driver	Ammo truck 
Driver	Fuel truck 
Driver	Fuel truck 

* Optional, based on the situation.
** These personnel and assets usually meet the 1SG at the LRP.

Figure 6-____. Tank company LOGPAC

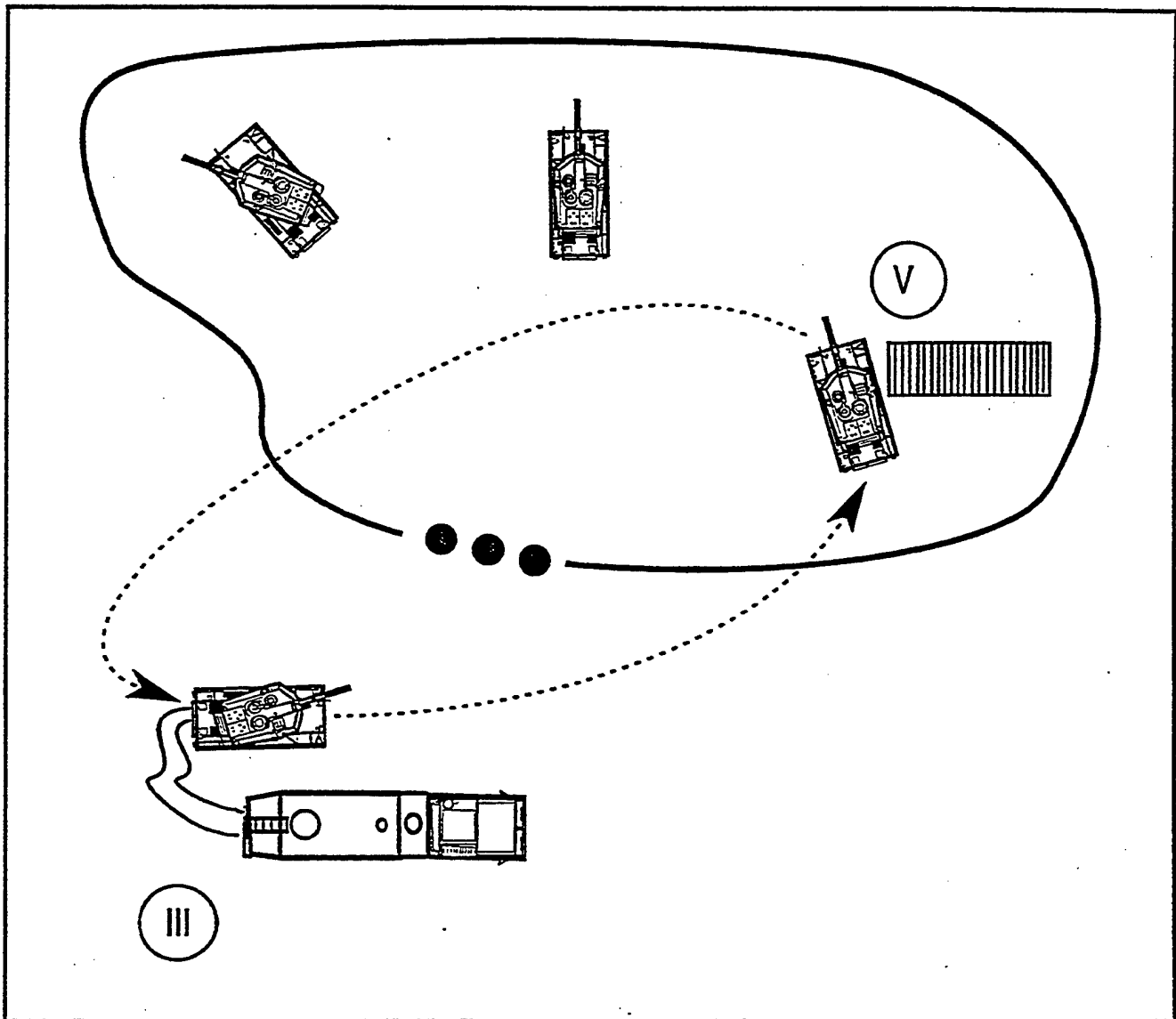

Figure 6-1: Prestock resupply operations - method 1.

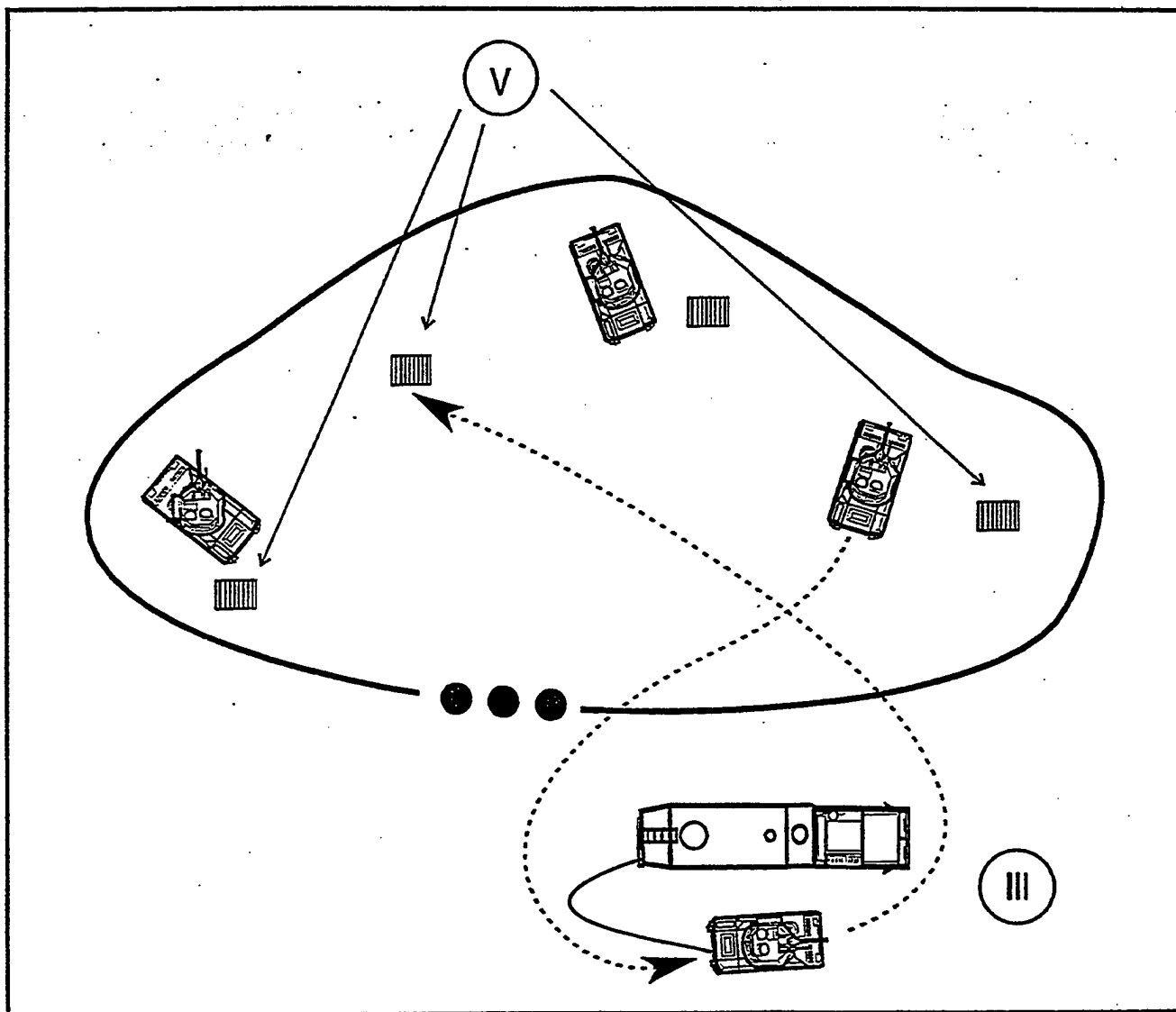

Figure 6-2: Prestock resupply operations - method 2.

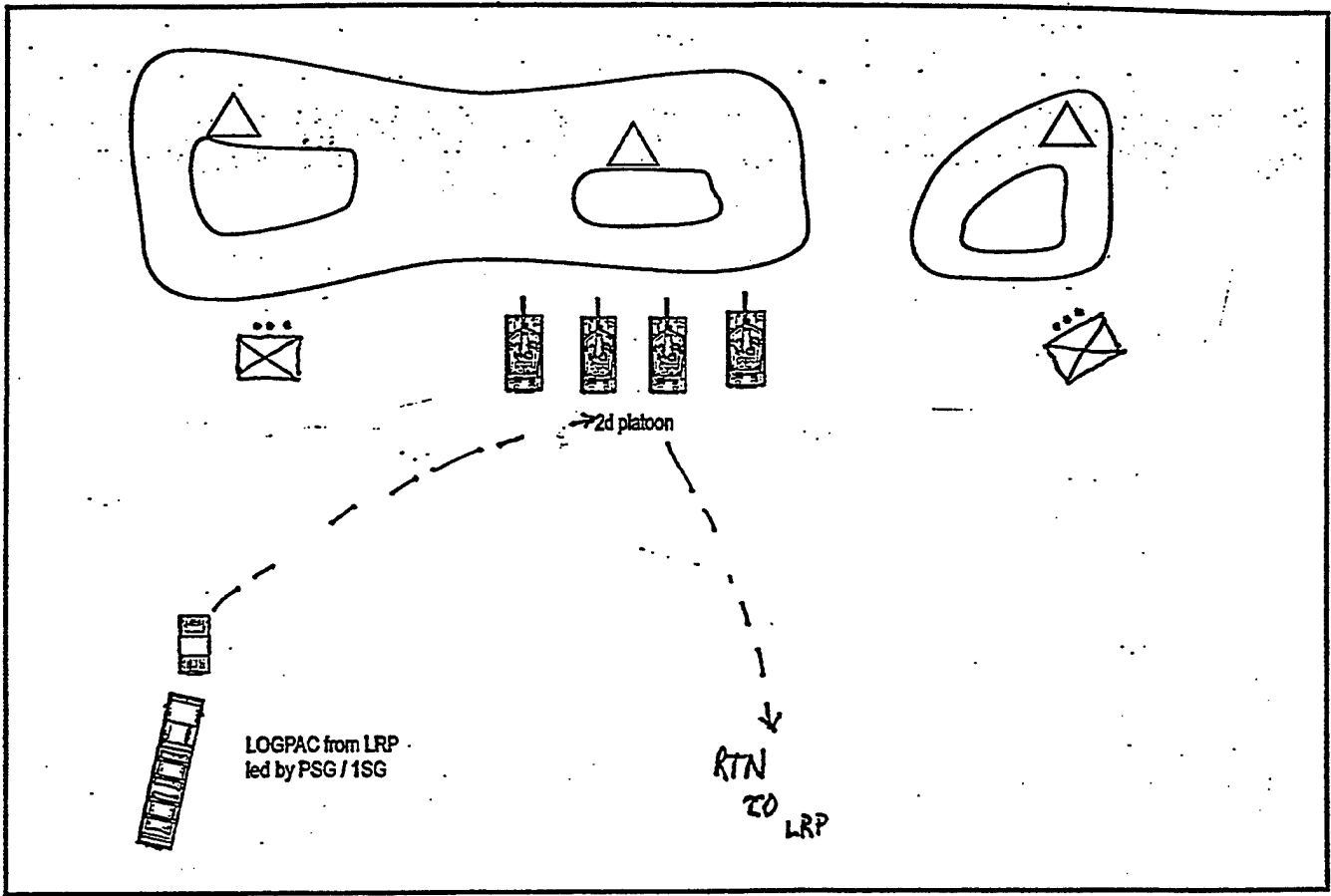

Figure 6-3. Tailgate resupply method.

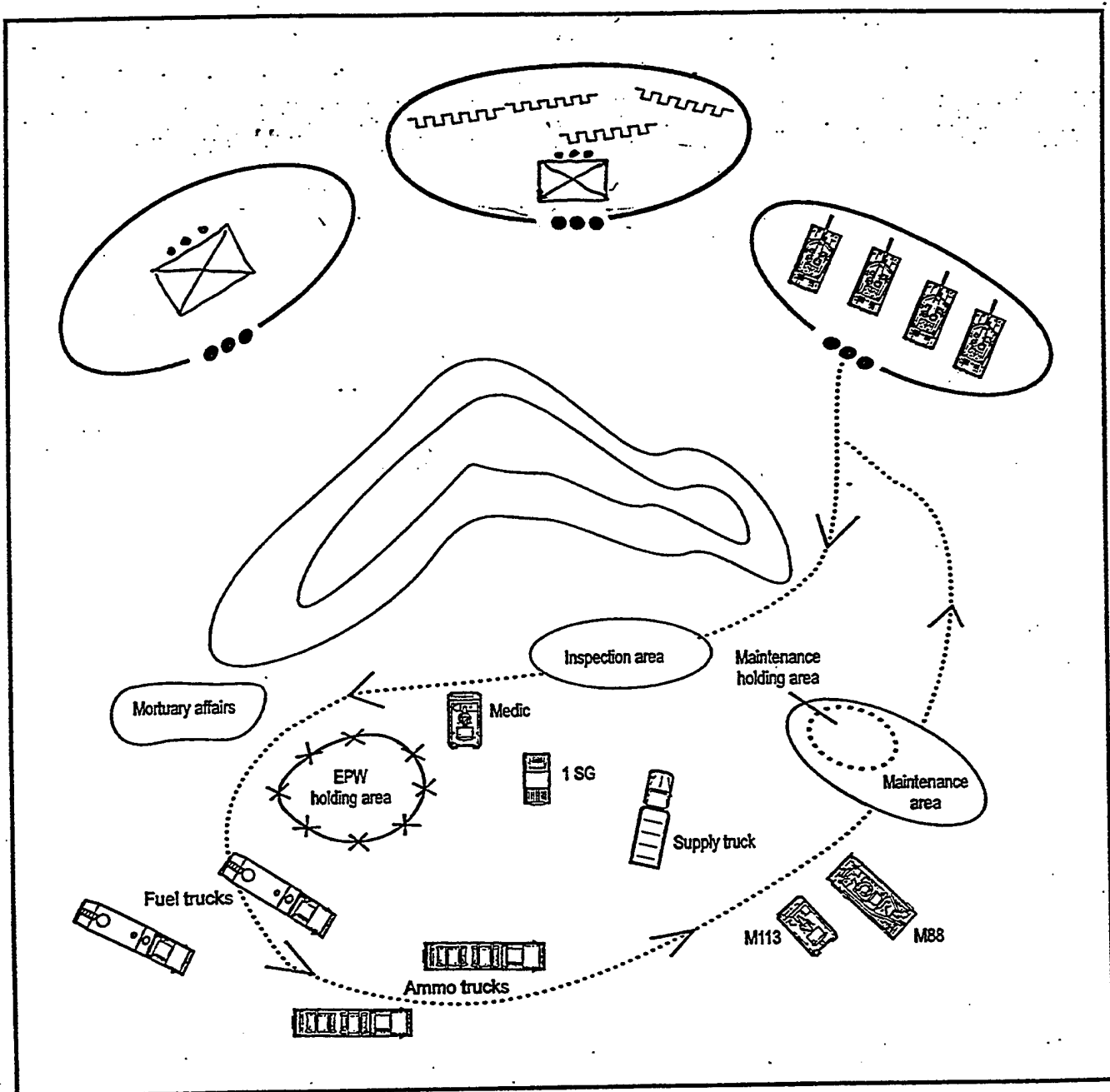

Figure 6-4. Service station resupply method.

Page intentionally blank

Appendix A: Equipment

To win in battle, leaders must have a clear understanding of the vehicles and equipment they will be operating or working with. This appendix will assist the infantry commander in evaluating transportability, sustainment, and mobility considerations for armored vehicles and equipment which may operate as a part of the tank/light infantry task organization.

Section I:	M1A1C Main Battle Tank
II:	M88 Medium Armored Recovery Vehicle
III:	Heavy Expanded Mobility Tactical Trucks (HEMTTs)

Section I: M-1A1C Main Battle Tank

- **Weight (combat loaded):** 65 tons
- **Length:** 32'3"
- **Width:** 12'0"
- **Armament:**
 - 120mm main gun (Planning range 3000m, max range 4000m)- 40 rounds on board
 - Commander's .50 Cal M2 HB Machine Gun (Planning range 1200-1600m)- 1000 rounds on board
 - M240 7.62 Machine Gun (Coax) (Range 900m)- 10,800 rounds on board
 - Loader's M240 7.62 Machine Gun (Data same as Coax)

- **Fuel capacity:** 520 gallons

- **Fire Control:**

1. The gunner and tank commander have **thermal night sights** which normally provide resolution out to 5-8 kilometers during the day and night. These planning ranges may be degraded by fog or dust, or when the temperature of the target is similar to that of the ambient air or the background. Thermal sight are often preferable to the normal day sights, because they can frequently detect targets that are concealed in vegetation.

2. The M1A1 has a **laser range finder** and a **ballistic computer** that accounts for such factors as range, wind, temperature, barometric pressure, ammunition type, cant of the tank, lead for moving targets, and tube wear. Its stabilization system gives the tank a shoot-on-the-move capability. The M1A1 can achieve first-round hits at ranges in excess of 3,000 meters. When equipped with a filter (as it normally is during training exercises), the laser range-finder is eye-safe. Without the filter it should be treated as a direct-fire weapon system out to 8,000 meters.

3. The **APFSDS-T ("Sabot")** is the more accurate and better anti-armor round, but discards metal "petals" that can strike anywhere in a zone seventy meters on either side of the tank and 1000 meters down range. Friendly troops should not be in this area when sabot rounds are fired. The sound of the main gun round can stun troops closer than 15 meters to the tank.

4. The **TCs .50 caliber machinegun** is not stabilized, but can deliver suppressive fire when employed on the move. The .50 cal may be fired while the tank is buttoned up, however a crewmember must reload externally after 100 rounds are fired. Elevation and traverse may only be accomplished from inside the turret. The .50 cal may be elevated to +65 degrees above the horizontal and depressed to -10 degrees.

5. The 7.62mm coax is stabilized and is extremely accurate. In addition, the plentiful supply of available ammunition makes it the most effective anti-infantry weapon on the tank. Tracer rounds are also very useful for designating targets and sectors of fire. The coax may be elevated to +20 degrees and depressed to -10 degrees.

6. The loader's 7.62 machinegun may not be fired while buttoned up, nor is this weapon stabilized. The weapon may be operated by anyone who climbs on top of the tank. It may be elevated to +65 degrees and depressed to -10 degrees.

7. The main gun rounds are distributed in the ready rack (18 rounds), the semi-ready rack (16 rounds), and hull (6 rounds). It normally takes approximately 30 minutes to replenish the ready rack.

- **Mobility Characteristics:**

1. Maximum speed (road): 42 mph

2. Cross-country speed: 30 mph

3. Operating Range (road): 280 miles

4. Operating time: 8-48 hours

5. Max step: 42 inches

6. Max span: 9 feet

7. Driver's IR scope: Provides excellent visibility; speeds at night or while in smoke approximate those in daylight.

- **Survivability Characteristics:**

1. The M1A1 is protected by special composite armor that, against many main battle tank rounds, can withstand a direct hit on its frontal arc. It can defeat all known AT missiles that hit the frontal arc.

2. The tank has blowout panels on top of the turret to direct any explosion outside of the tank should the basic load detonate.

3. The tank can generate a quick, self-protecting smoke screen by firing its grenade launchers (12 rounds total) that are mounted on the forward portion of the turret. These phosphorous rounds ignite in the air and create a thirty-second smoke screen 30 meters downrange of the turret's orientation. The smoke grenades can be extremely hazardous to infantry beneath them, and can ignite dry vegetation. The M-250 grenade launcher system can fire two salvos of six rounds each, or the entire load of 12 rounds during heavy rain or high winds. The smoke grenade launcher system requires external reloading once expended.

4. Smoke can also be generated to the rear of the tank by an on-board smoke generator that burns the tank's own fuel. The Vehicle Engine Exhaust Smoke System (VEESS) can be used repeatedly and for extended periods of time. The tank will often back up rapidly into the concealment of this smokescreen. In other situations, the tank will move forward rapidly to provide an extended smokescreen for other elements. The smoke generator can be employed only when the tank is burning diesel (DF-2) fuel; the smokescreen cannot be generated if JP-8 is used. Exposure to the smoke cloud for more than 5 minutes can cause temporary illness and irritate eyes and skin.

5. Much of the tank's survivability is obtained by its excellent acceleration. When it takes direct fire, the tank can be expected to make a rapid dash for the nearest available cover. The M1A1 crosses open areas quickly, with an ability to accelerate to 20 mph in less than 7 seconds.

6. The M1A1 has an overpressure system for operation in NBC environments.

• **Other capabilities, limitations, and requirements:**

1. The tank's exhaust is directed downwards and to the rear of the tank. This reduces the tank's heat signature and avoids the "rooster plume" that pinpoints the location of other armored vehicles when they accelerate. However, the intense heat (approximately 900 degrees) severely limits the ability of the tank to provide a moving shield for accompanying infantry. Soldiers can follow the tank closely by remaining directly behind the tracks. While the tank is idling, soldiers can approach to about 5 meters behind the exhaust grills. When the tank revs its engine, this distance increases to about 10 meters. Because of the hot exhaust, an M1A1 should not be used to tow another tank from the rear, as some of the components in the towed tank's engine could melt. Another drawback of the exhaust is that the tank may ignite dry brush directly to the rear of the vehicle. Finally, the exhaust provides limited decontamination capability on some types of equipment.

2. The M1A1 can transport infantry in special circumstances. See Chapter 5.

3. A tank crewman must dismount from the vehicle in order to determine an azimuth with his compass.

4. The tank's weight limits maneuver in mud and marshy terrain. Its size and weight limits maneuver in some urban/built-up areas.

5. Tanks have deadspace. See Chapter 2.

6. When the thermal sights are operating, the tank generates a whirring noise that can be heard 100 meters away, depending on conditions. The drain on the batteries requires the tank's engine to be run approximately every hour for about 15 minutes. Some tanks will need to be started even more frequently.

7. The tank crew has two sets of AN/PVS-7 night vision goggles.

8. The M1A1 is capable of carrying a mine plow or mine roller on the front. Tank companies are authorized four plows and two rollers.

- Rollers reduce the tank's speed to approximately 5 mph. Rollers are transported by the parent company and are only mounted for deliberate breaching operations on predesignated tanks equipped with installation brackets. Mounting the roller takes approximately 15 minutes.

- The mine plow has marginal impact upon the tank's maneuverability when it is carried. When the plow is lowered for clearing the tank must travel in a straight line. The added weight of the plow (7,500 pounds) increases the vehicle's fuel consumption by about 25%. The plow can be switched to another tank; this requires the plow's BII or an M88 and level ground. Depending on the experience of the crew, this takes between one and two hours with the BII, and about 4 hours with an M88.

- An M1A1 with a mounted plow exceeds the loading ramp capacity of the C-5. Consequently, M1A1s that deploy aurally will not have the plow, or the plow will have to be loaded on the aircraft separately. This would lengthen aircraft loading and offloading times, and will require additional time at the destination for remounting of the plow.

9. Indirect fire mode. Because the M1A1 carries only anti-tank main gun rounds and has no azimuth indicator, this is no longer a feasible use for the tank.

10. Communications. The M1A1 has an intercom system that can be integrated into telephone hot loops. The tank can also have a TA-1 telephone mounted on the right side of the turret so that infantry can communicate with the crew (see Chapter 5).

11. Logistics.

- **Fuel consumption** rates vary from 10 gallons per hour when idling to nearly 60 gallons per hour while traveling cross country. During continuous operations, a tank will need approximately 300 gallons of fuel every 8 hours; if the tanks have been used sparingly, they may only require about 50 gallons per day. Reminder: These amounts will vary depending upon the terrain, weather, and type of maneuver.

- The M1A1's **fuel capacity** of 504 gallons is distributed in two front tanks (106 gallons on the left and 149 gallons on the right) and a rear fuel tank (248 gallons). The vehicle burns fuel from the rear tank; when it is low the driver will press a switch to begin feeding fuel from a front tank to the rear. When possible, the vehicle should be topped off before the driver switches to a front tank, as this hastens the refueling process. It normally takes between five and 10 minutes to refuel an M1A1.

12. Maintenance.

- **Electrical Turret Network Box (TNB).** When inoperable, the tank crew can still operate the main gun manually, though with a significant loss of firepower effectiveness. New boxes are obtained from the company (tank battalion) PLL, and once on site require about 10 minutes to be installed.

- **Breaking track.** This is done to replace unserviceable track pads or to reposition a thrown track. The process of breaking and reassembling track takes at least 45 minutes, and longer under adverse conditions.

- **Pulling Pack.** The Full-Up Power Pack (FUPP) consists of two major assemblies: the engine ("pack") and the transmission ("rear mod"). It is usually preferable to replace the FUPP and turn it over to DS maintenance rather than to attempt to split the FUPP at the organizational level. Although the actual replacement process only takes about 45 minutes, associated procedures usually result in 2 to 4 hours of down time if a pack needs to be pulled. This could be extended to 10 - 12 hours if the pack must be picked up from the BSA. Packs must often be pulled in order to replace other inaccessible components; depending on the complications and the availability of repair parts, down time can be significantly longer.

- **Fuel filters.** Although found in the tank company PLL, availability of parts can become a problem if the unit has been issued bad fuel. Tanks have main fuel filters as well as in-line filters.

- **Hot engines.** Many repairs cannot be completed on a hot engine. It normally takes 2-3 hours for the M1A1's engine to cool down.

Figure A-____. The M1A1 Main Battle Tank.

Section II: M-88 Medium Armored Recovery Vehicle

- **Weight:** 56 tons
- **Length:** 27'1"
- **Width:** 11'3"
- **Height:** 9'7"
- **Road speed:** 30 mph
- **Range:** 222 miles
- **Max step:** 42 inches
- **Max span:** 103 inches
- **Equipment:**
 - Acetylene torch
 - Winch (45 ton capacity, 200ft cable)
 - A Frame hoist (6 ton lift)
 - Blade (for stability during winching- should not be used for dozing)
 - Tools
- **Consideration:** Depending on the circumstances of the recovery and whether or not the tank can provide power, an M88 can normally recover a mired tank on its own. Under extreme circumstances, two or even three M88s or tanks may be required to recover a tank. Although the M88 was not designed to pull the weight of the M1-series tanks, this can be done with care. It will, however, likely result in increased wear and maintenance requirements for the M88.

Figure A-____. The M88 Medium Armored Recovery Vehicle.

Section III: Heavy Expanded Mobility Tactical Trucks (HEMTTs)

- There are two types of HEMTTs:
 - M977 10-ton Cargo HEMTT
 - M978 HEMTT Fueler
- Three M977s are earmarked for each tank company in a tank battalion.
- The M977 a crane for loading/unloading ammunition. The crane can also be modified with a winch for recovery operations.
- Capacity for selected ammunition:

7.62mm	192,000 rounds
.50 Cal	48,000 rounds
120mm tank	240 rounds
TOW	84 missiles
- The HEMTT fueler has a capacity of 2500 gallons. The fueler has excellent off-road capability, and can normally follow armored vehicles in almost all types of terrain.
- The fueler has two nozzles, and normally takes less than 10 minutes to refuel a tank.

Figure A-____. The Heavy Expanded Mobility Tactical Truck (HEMTT).

Page intentionally blank

Appendix B: Training - Infantry Company/Tank Platoon Collective Task Crosswalk

The infantry rifle company has seven critical operations. This appendix will address the six operations which will be performed with a tank platoon attached.

Section I:	Movement to Contact
II:	Attack
III:	Ambush
IV:	Reconnaissance and Security
V:	Defend
VI:	Retrograde

Task Diagram. A task diagram is a diagram of the relationship between each operation and subordinate collective tasks involved in accomplishing the mission. Each task diagram provides the infantry company commander a diagram of the company operation and a listing of the infantry company and tank platoon collective tasks that comprise it. The collective tasks are taken from the appropriate MTPs of ARTEP 7-10-MTP and ARTEP 17-237-10-MTP. These task diagrams have been designed to become an integral part of a company's overall training plan. Connected by arrows are those tasks for both the company and tank platoon which are similar and support overall mission accomplishment. Figures B- 1, 3, 5, 7, 9, and 11 are task diagrams for the six infantry company operations addressed in this appendix.

Operation Outline. Corresponding to each task diagram is an operation outline that can be used for training, planning, and selecting collective tasks for training unit proficiency. The operation outline is used to select appropriate tasks when planning STXs, FTXs, or complete training programs.

- The first row under the operation is a listing of collective tasks that are normally performed each time the operation is executed. The additional collective tasks supporting that operation, below the first row and marked with one asterisk, are selected based on METT-T and the unit training status. Tasks which may be executed once, several times, or continuously in support of the operation are indicated with a double asterisk.
- Tank platoon collective tasks associated with the infantry company's collective tasks appear on the lines underneath the infantry tasks.
- Crosswalk. Appearing in bold print for both the infantry and tank platoon tasks are those tasks similar to both organizations which support overall mission accomplishment.

Figures B- 2, 4, 6, 8, 10, and 12 contain example operation outlines for the six critical operations for an infantry company with an attached tank platoon.

Section I: Movement to Contact

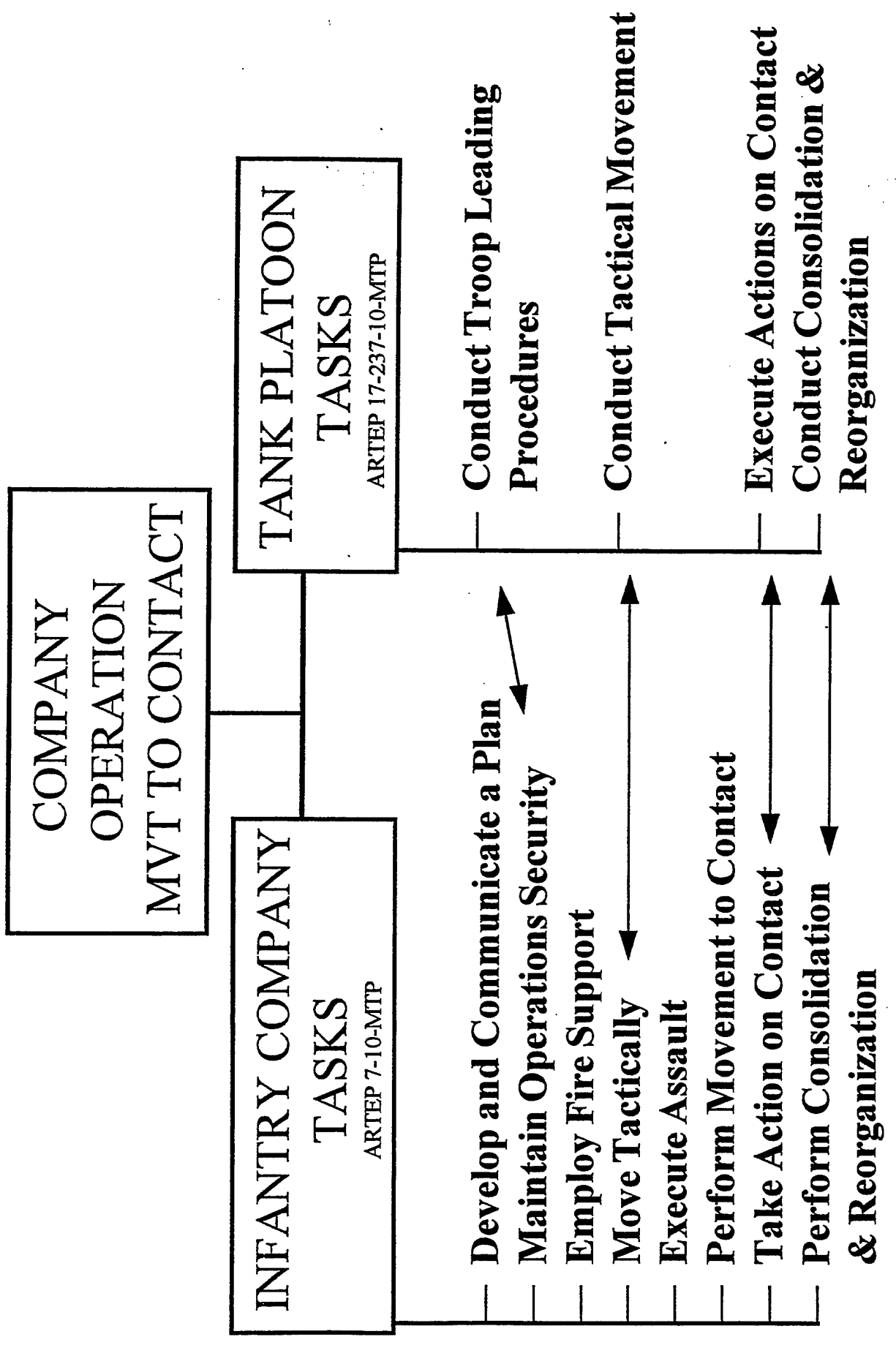

vimtc2.ppt

Section I: MOVEMENT TO CONTACT

(PLAN) ⇒ vimtc2.ppt
prep ⇒ vimtc3.ppt
execute ⇒ vimtc4.ppt

COMPANY

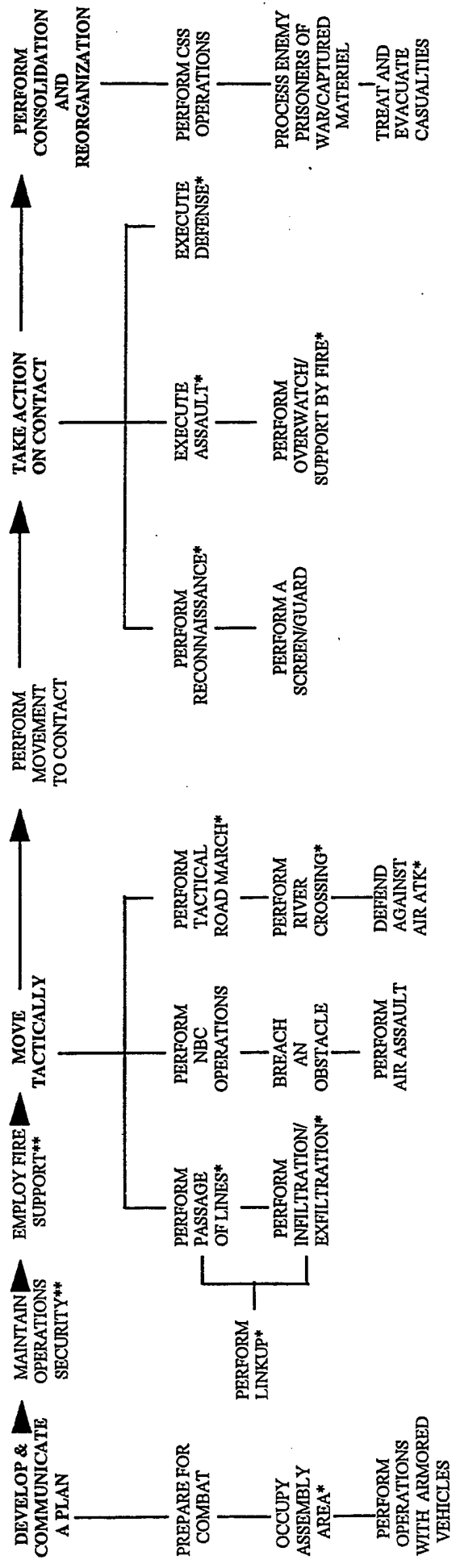

TANK PLATOON

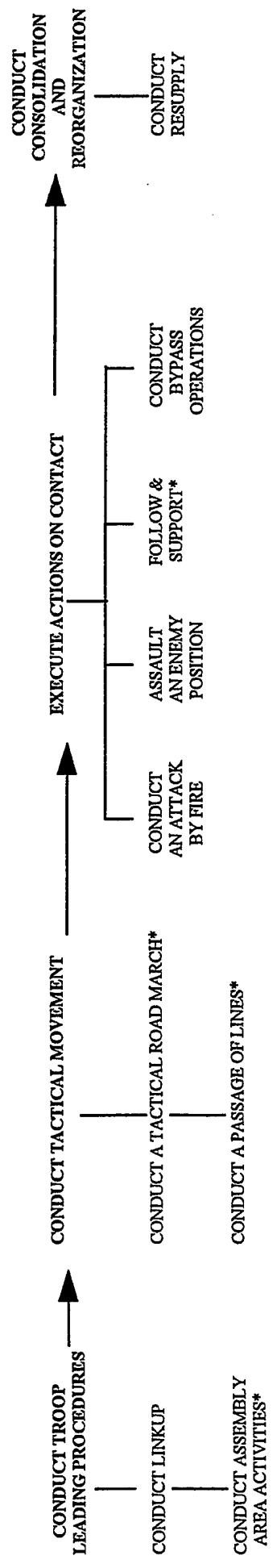

**CONDUCT PASSIVE AIR DEFENSE MEASURES
* CROSS AN NBC CONTAMINATED AREA

Figure B- Movement to Contact

*BASED ON METT-T AND TRAINING STATUS
** CONTINUOUSLY PERFORMED TASK

b. 11k.ppt

Section II: Attack

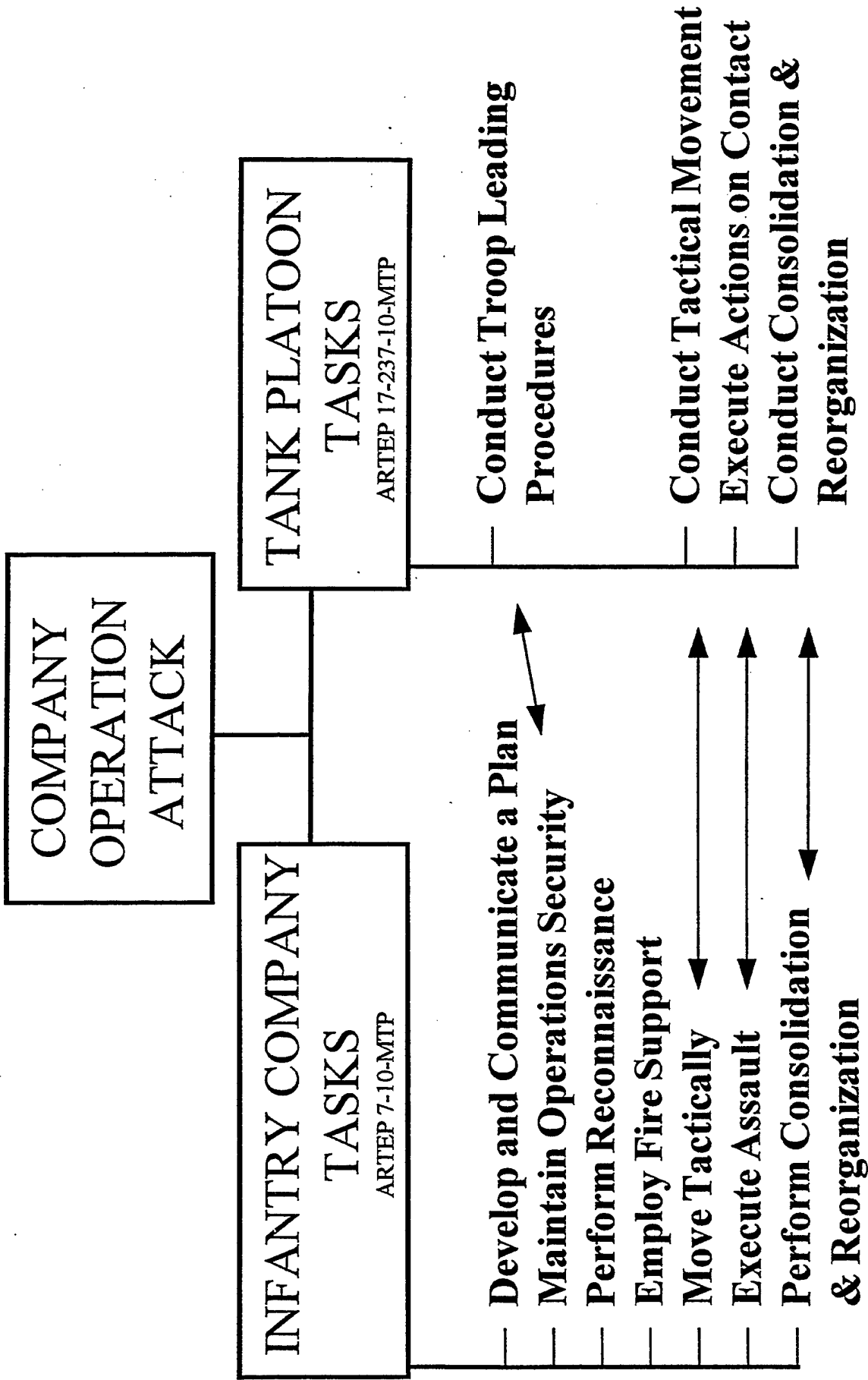

Section II: ATTACK

COMPANY

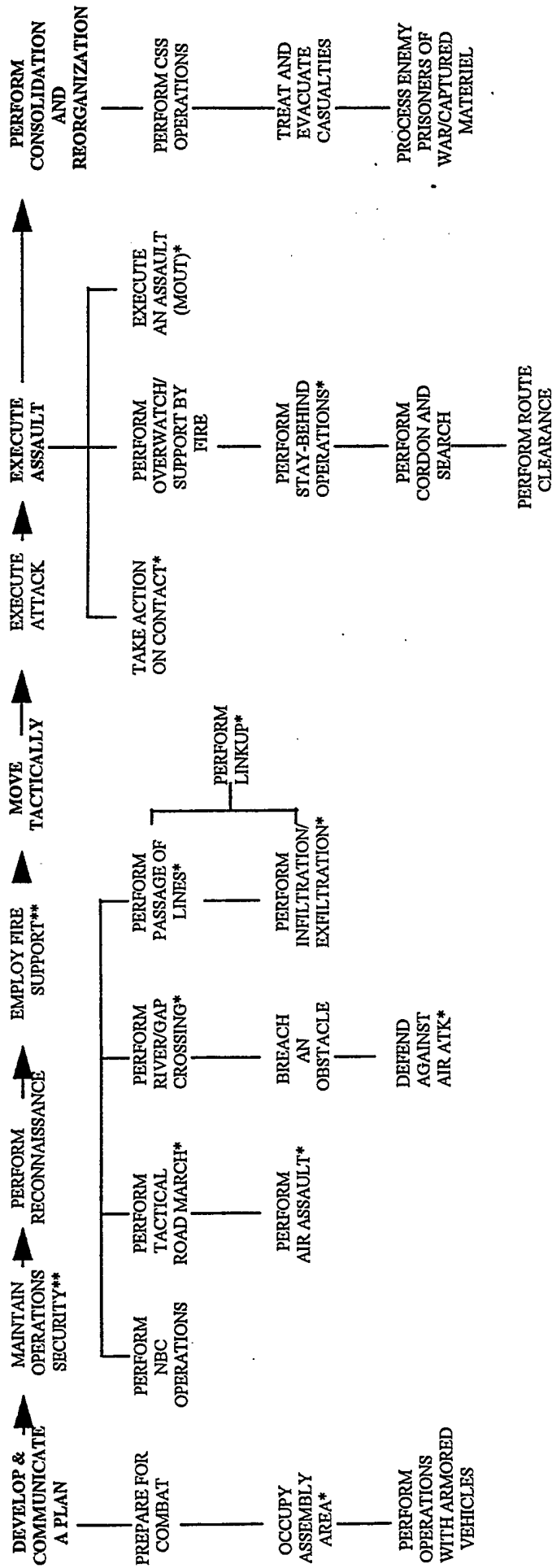

TANK PLATOON

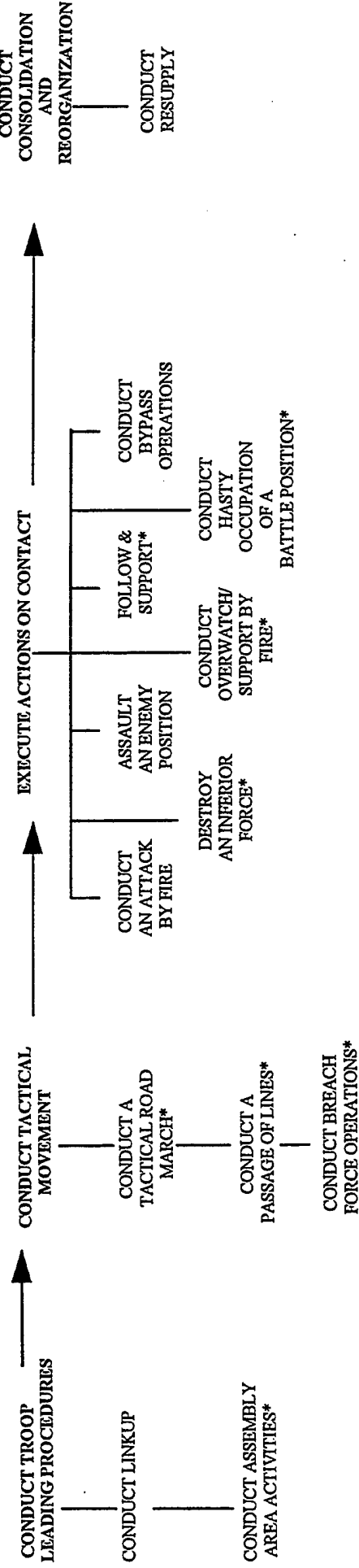

**BASED ON METT-T AND TRAINING STATUS
 ** CONTINUOUSLY PERFORMED TASK

Figure B-____. Attack

**CONDUCT PASSIVE AIR DEFENSE MEASURES
 *CROSS AN NBC CONTAMINATED AREA

det 1.ppt

Section V: Defend

COMPANY
OPERATION
DEFEND

INFANTRY COMPANY
TASKS
ARTEP 7-10-MTP

TANK PLATOON
TASKS
ARTEP 17-237-10-MTP

- Develop and Communicate a Plan
- Maintain Operations Security
- Move Tactically
- Perform Reconnaissance
- Perform Relief-in-Place
- Employ Fire Support
- Execute Defense
- Perform Consolidation & Reorganization

- Conduct Troop Leading Procedures
- Conduct Tactical Movement
- Conduct a Deliberate Occupation of a Plt Battle Position
- Conduct a Plt Defense
- Conduct Consolidation & Reorganization

0V0 2.ppt

Section V: DEFEND

COMPANY

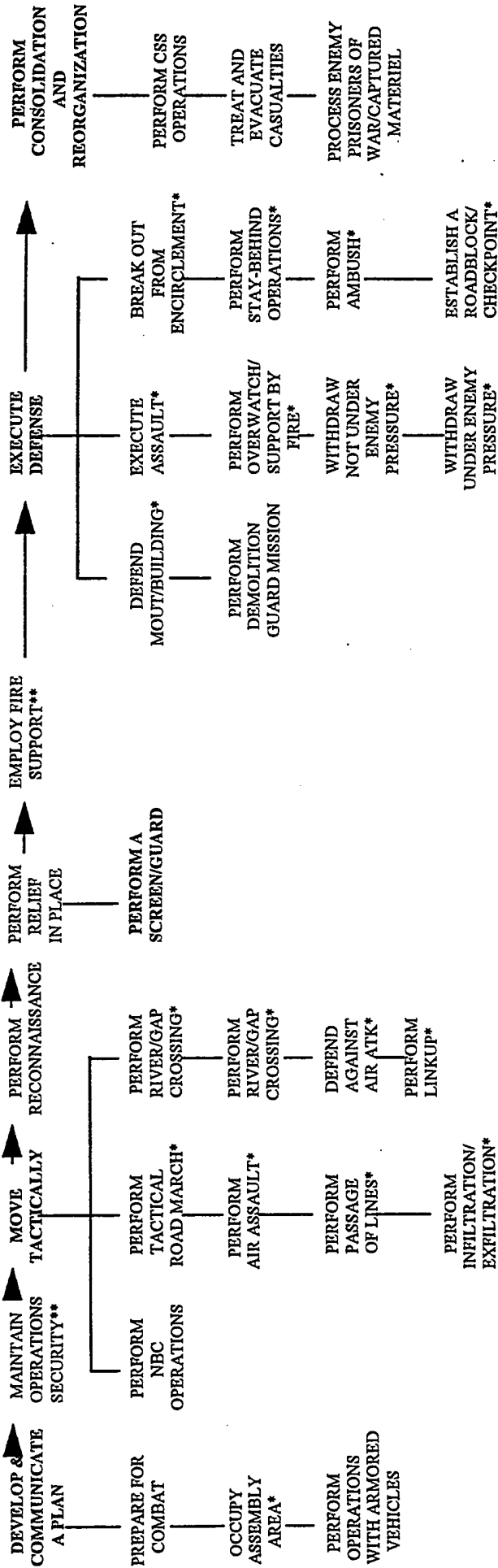

TANK PLATOON

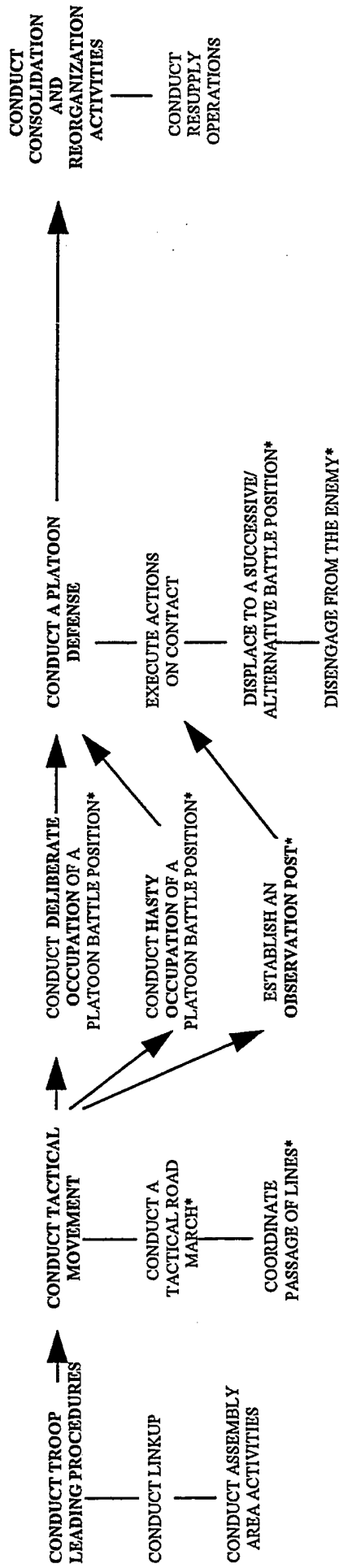

**CONDUCT PASSIVE AIR DEFENSE MEASURES
 *CONDUCT OPERATIONAL DECONTAMINATION
 **COORDINATE/ASSIST IN A PASSAGE OF LINES

*BASED ON METT-T AND TRAINING STATUS
 ** CONTINUOUSLY PERFORMED TASK

Figure B-____. Defend

Page intentionally blank

Appendix C: Tank Platoon Battle Drills Supporting Infantry Company Collective Tasks

Battle drills provide **virtually automatic responses** to situations in which the immediate and, in many cases, violent execution of an action is critical to the company's safety or success in combat.

Battle drills allow the company or a subordinate platoon to survive unexpected combat. They are also used by the company or a platoon to deploy as the first step of Actions on Contact.

Battle drills are **standardized collective actions**, executed with minimal instruction. They can be carried out under almost any type of battlefield conditions and from any formation or technique of movement.

Battle drills, however, are **never a substitute for well-developed, well-executed COAs**. They are seldom the ideal tactical solution in a given situation. The company can minimize the need for execution of battle drills by planning for all foreseen contact situations and then aggressively scanning during the operation to make initial (and first) contact with the enemy.

This appendix will address five standard battle drills tank platoons can be expected to execute.

- | |
|--|
| <p>Battle Drill #1: Change of formation drill
Battle Drill #2: Contact drill
Battle Drill #3: Action drill
Battle Drill #4: React to indirect fire drill
Battle Drill #5: React to air attack drill</p> |
|--|

The company commander and tank platoon leader must be ready to augment or adjust these basic drills based on the unique task organization of the tanks and light infantry, the threat, terrain, and ROE. In addition, they must ensure their platoons rehearse battle drills until they are able to execute the drills perfectly regardless of the command and control situation.

Battle Drill #1: Change of Formation Drill

This drill is executed to accomplish a rapid change of formation in response to a change in terrain or enemy situation.

The tank platoon leader must ensure that each TC knows the new formation, and the relative position of each tank in the new formation.

The platoon leader uses visual signals and/or the radio to initiate the drill.

Figure C-____ illustrates the movement of individual tanks during a change of formation drill from column to wedge to line.

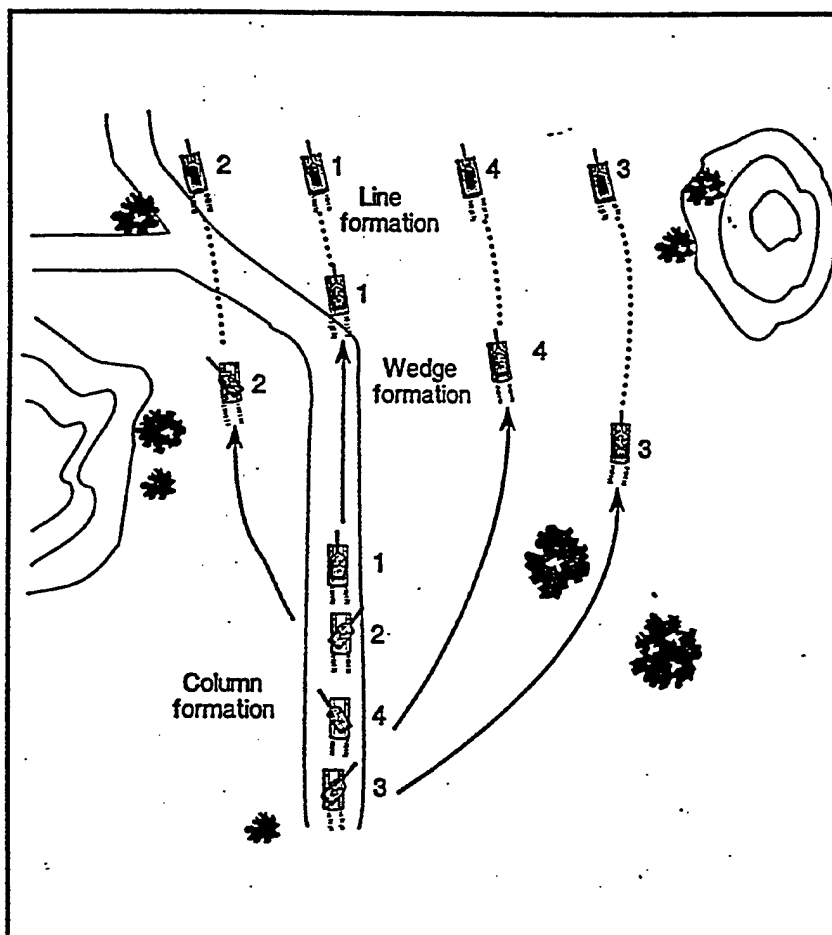

Figure C-____. Change of formation drill.

Battle Drill #2: Contact Drill

The contact drill enables the tank platoon to orient its weapon systems and engage an enemy without changing its direction or speed of movement along the axis of advance.

This drill is used when contact is made with small arms fire or when the platoon sights the enemy without being engaged and does not want to stop or slow its movement.

The platoon leader initiates the contact drill using visual signals and/or the radio. Over the radio, he uses the contact report format and adds the execution element "FIRE" as a platoon fire command.

Figure C-____ illustrates a contact drill from a wedge formation. Note the main gun orientation for wingman Tank 2. If a tank's weapon systems are masked by another tank, the masked tank maintains weapons orientation and flank security as prescribed in the OPOD. This is key in fratricide prevention.

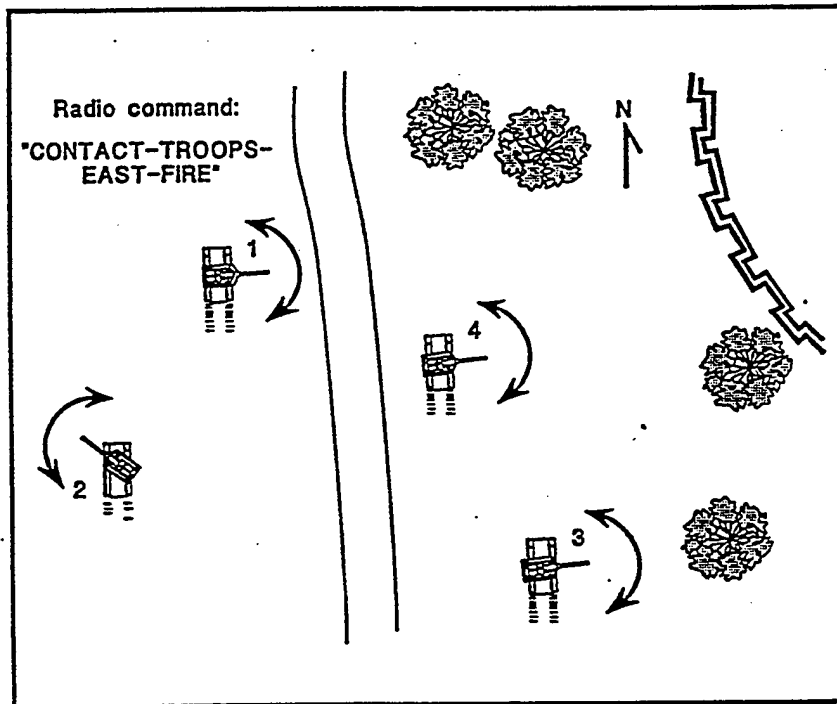

Figure C-____. Contact drill.

Battle Drill #3: Action Drill

The action drill permits the entire tank platoon to change direction rapidly in response to terrain conditions, obstacles, FRAGOs, or enemy contact.

The platoon leader uses visual signals or the radio to order the action drill, which can be initiated with or without enemy contact.

Action drill without enemy contact

- The platoon leader can execute an action drill to avoid a danger area or obstacle or to respond to FRAGOs.
- When the platoon leader initiates the action drill, tanks come on line and continue to move in the prescribed direction unless the platoon leader directs a change of formation.
- Figures C-____ A and C-____ B illustrate the tanks' relative positions during various action drills without contact.

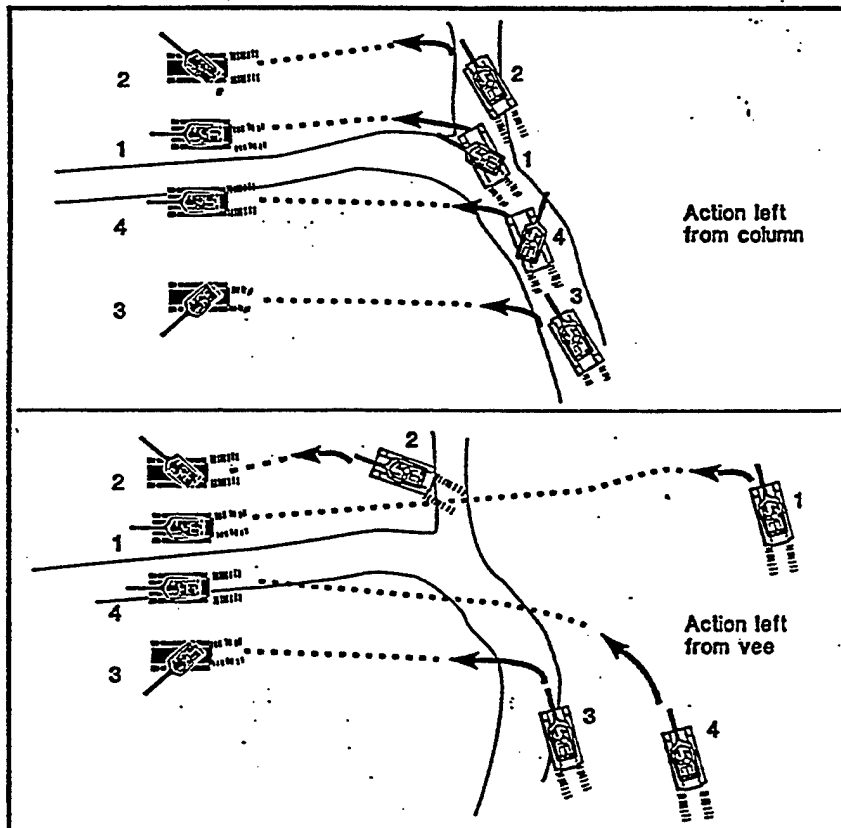

Figure C-____ A. Action drill without enemy contact.

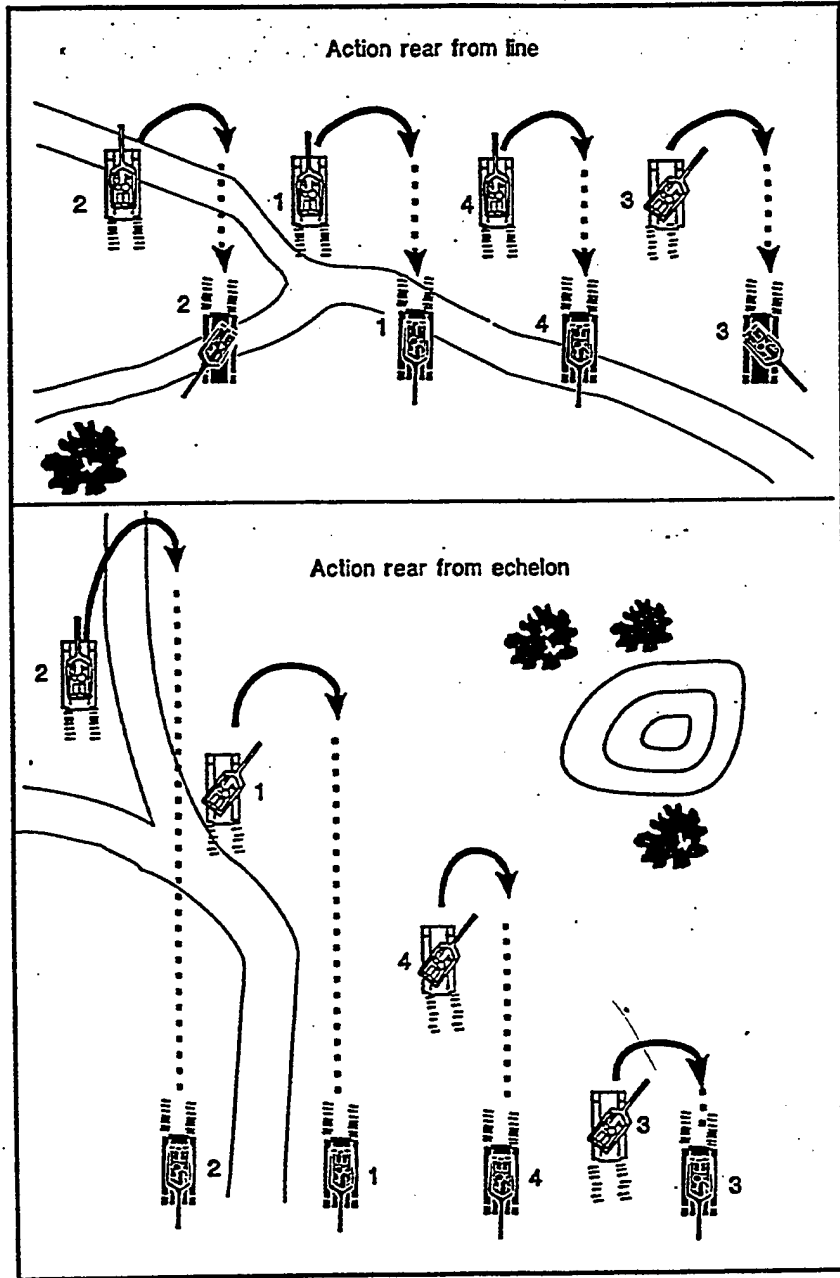

Figure C-___ B. Action drill without enemy contact (continued).

Action Drill with Enemy Contact

- Following a contact report alerting the company and tank platoon that enemy contact involves antitank weapon systems, the tank platoon leader can direct an action drill to orient his platoon's frontal armor toward the antitank fire while moving to cover and concealment.
- If the platoon cannot reach a covered and concealed position or achieve weapon standoff, the platoon leader directs the platoon to assault the enemy.
- Figures C-____ A through C-____ D illustrate examples of action drills in reaction to enemy contact.

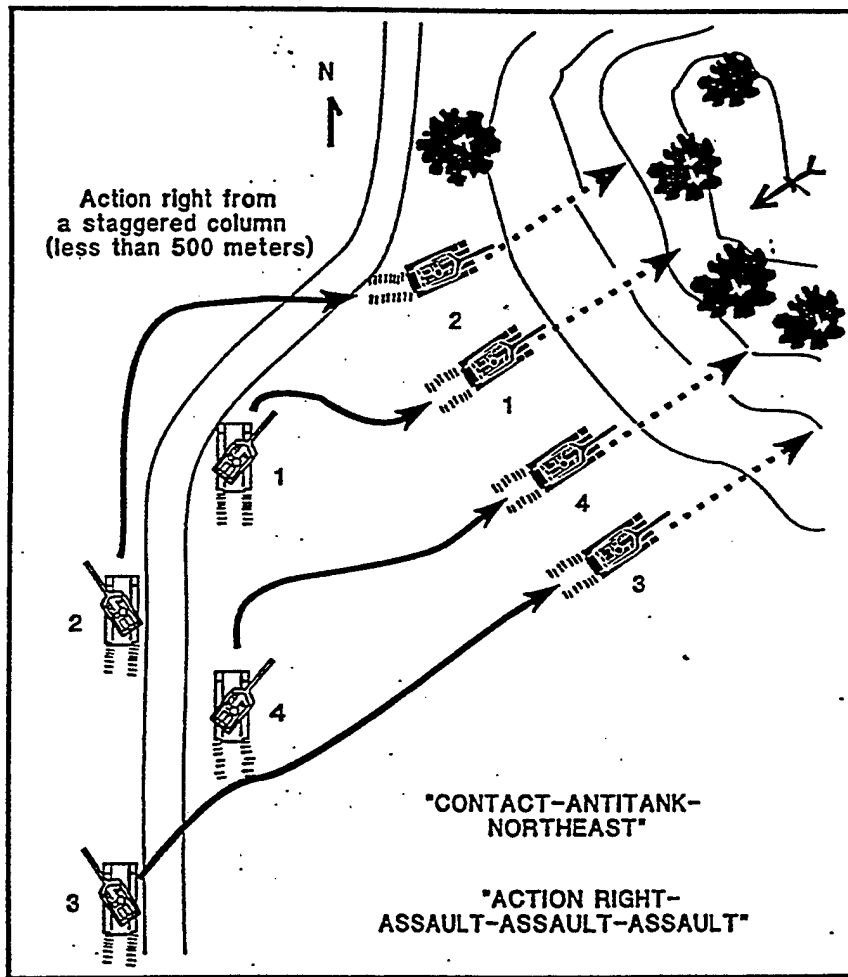

Figure C-____ A. Action drill with enemy contact.

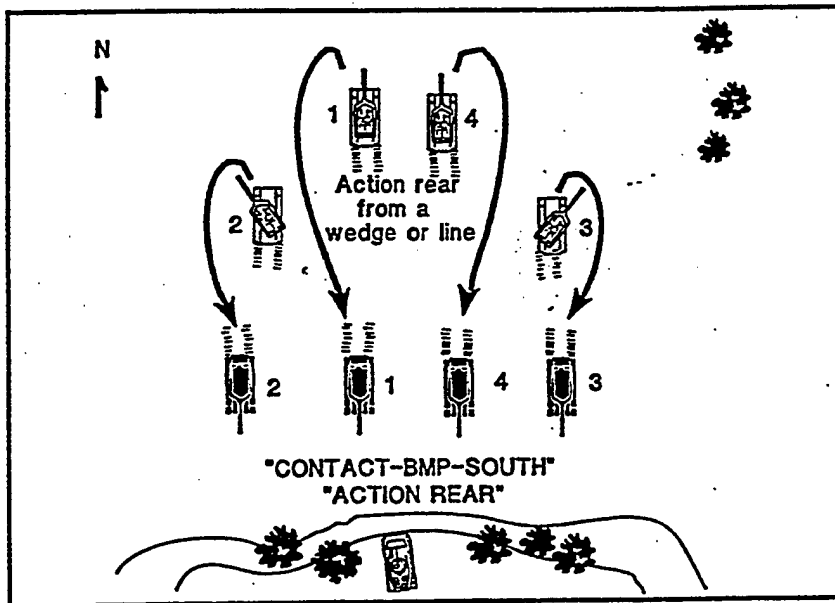

Figure C-____ B.
Action drill with enemy
contact (continued).

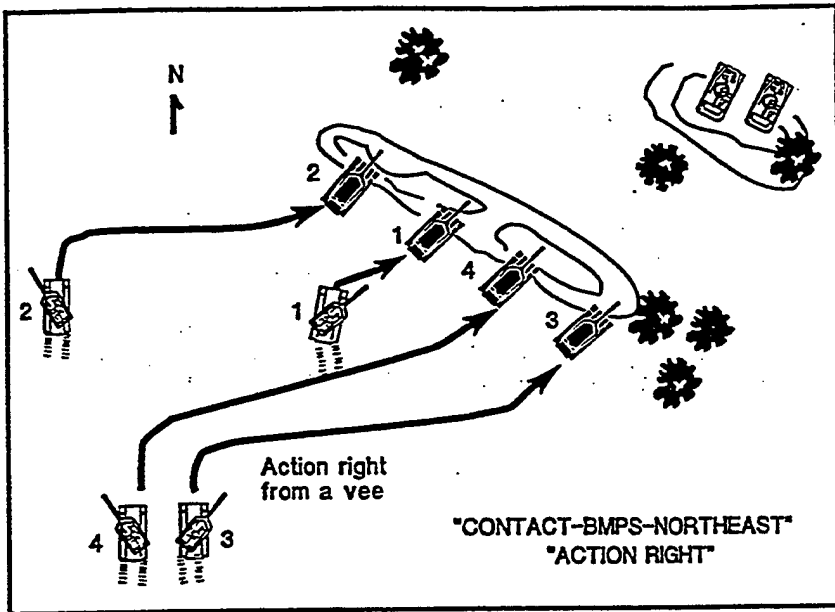

Figure C-____ C.
Action drill with enemy
contact (continued).

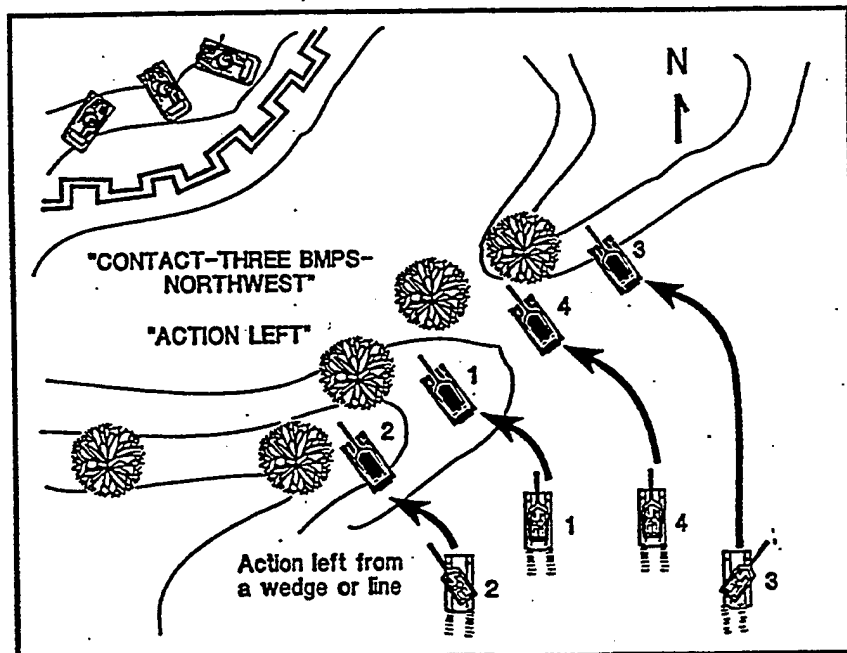

Figure C-____ D.
Action drill with enemy
contact (continued).

Battle Drill #4: React to Indirect Fire Drill

When the tank platoon receives unexpected indirect fire, it moves out of the impact area unless it is also engaged in direct fire contact or is directed to remain stationary.

TCs place their hatches in the open protected position; other crewmen close their hatches.

Crews close ballistic doors (M1A2 crews stow the CITV).

Crews mask based on the automatic masking criteria established in the OPORD or if they suspect the use of chemical weapons.

If the tank platoon is moving when it receives suppressive artillery fire, it executes an action drill to avoid the impact area or continues to move to clear the impact area and continue the mission. Once the platoon clears the artillery impact area, individual crews place their hatches in the appropriate position, open ballistic doors (M1A2 crews turn on the CITV), check antennas, and return to positions or continue the mission.

The commander should address the tank platoon's reaction to anticipated indirect fires in the actions on contact subparagraph of the company OPORD.

Critical: If infantry are mounted on tanks as indirect fire is received, they **MUST** dismount prior to execution of this drill.

Battle Drill #5: React to Air Attack Drill

- When the company or platoon observe high-performance aircraft, helicopters, or unmanned aerial vehicles (UAV) that could influence their mission, they initially take passive air defense measures unless the situation requires immediate active measures.
- In a passive air defense, the tank platoon takes actions to avoid detection altogether and/or to minimize the aircraft's target acquisition capability. The platoon also prepares for active air defense measures. Passive air defense involves three steps:
 1. **Alert the platoon/company with a contact report.**
 2. **Deploy or take appropriate action.** If the platoon is not in the direct path of an attacking aircraft, the platoon leader orders tanks to seek cover and concealment and halt with at least 100-meter interval between tanks.
 3. **Prepare to engage.** TCs and loaders get ready to engage the aircraft with machine gun or main gun fire on order of the platoon leader
- If the commander or platoon leader determine that the platoon is in the direct path of an attacking aircraft, the platoon leader will initiate the active react to air attack drill:
 1. **The platoon initiates fire.**
 - ⇒ The primary intent is to force the aircraft to take self-defense measures that alter their attack profile and reduce their effectiveness.
 - ⇒ The platoon leader may use a burst of tracers to designate an aim point for platoon machine gun antiaircraft fires (Figure C-_____).
 - ⇒ Volume is the key to effectiveness of these fires; tanks throw up a "wall of steel" through which aircraft must fly.
 - ⇒ The main gun is effective against hovering helicopters.
 - ⇒ The platoon leader may direct some tanks to engage high-performance aircraft with MPAT main gun rounds.
 2. **Tanks create a nonlinear target by moving as fast as possible at a 45-degree angle away from the path of flight and toward the attacking aircraft.** (Figure C-_____). The platoon maintains an interval of at least 100 meters between tanks (where possible), forcing aircraft to make several passes to engage the entire platoon.
 3. **When reacting to high performance aircraft, tanks move quickly to covered and concealed positions and freeze their movement for at least 60 seconds after the last flight of aircraft has passed. For enemy helicopters, the KEY is: GET TO COVER/CONCEALMENT OR KEEP MOVING!**
 4. **The platoon leader sends a SPOTREP to update the commander.**

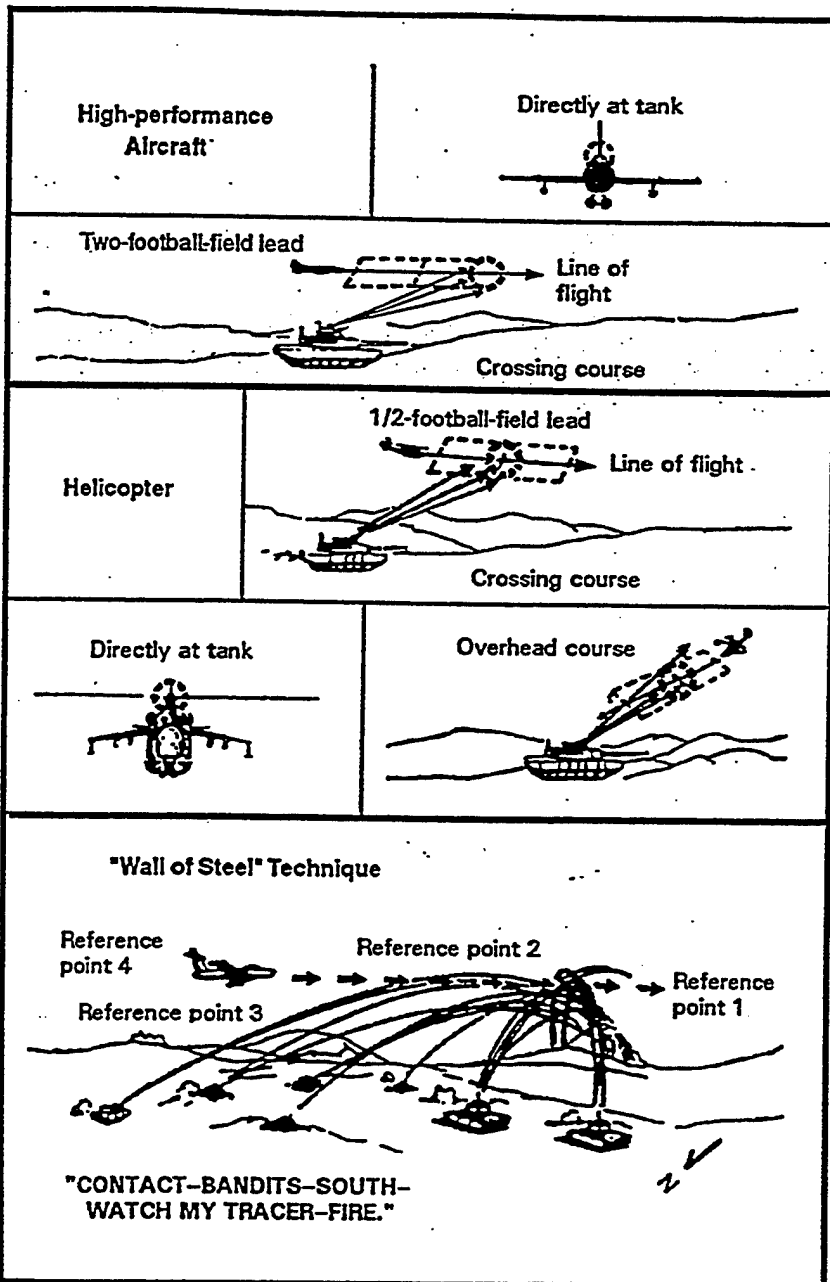

Figure C-____. Machine gun aim points.

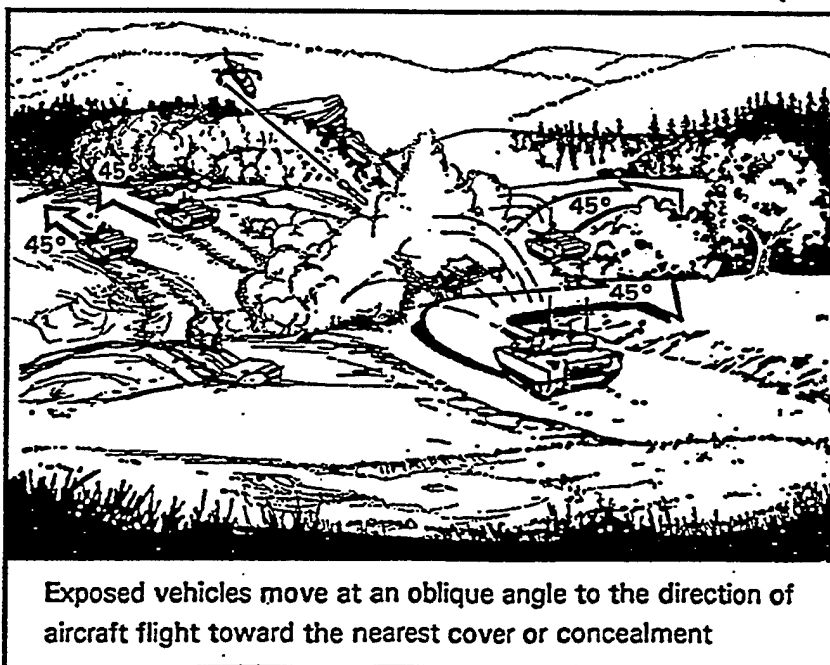

Figure C-____. Evading enemy aircraft.