

NAVAL POSTGRADUATE SCHOOL
Monterey, California



THESIS

DTIC QUALITY INSPECTED 2

**ROLES OF THE M1A1 TANK IN THE
UNITED STATES MARINE CORPS**

by

James W. Foster

December 1996

Thesis Advisor:
Associate Advisor:

Greg Walls
James E. Suchan

Approved for public release; distribution is unlimited.

19970507 144

REPORT DOCUMENTATION PAGE			Form Approved OMB No. 0704	
<p>Public reporting burden for this collection of information is estimated to average 1 hour per response, including the time for reviewing instruction, searching existing data sources, gathering and maintaining the data needed, and completing and reviewing the collection of information. Send comments regarding this burden estimate or any other aspect of this collection of information, including suggestions for reducing this burden, to Washington headquarters Services, Directorate for Information Operations and Reports, 1215 Jefferson Davis Highway, Suite 1204, Arlington, VA 22202-4302, and to the Office of Management and Budget, Paperwork Reduction Project (0704-0188) Washington DC 20503.</p>				
1. AGENCY USE ONLY (Leave blank)		2. REPORT DATE December, 1996	3. REPORT TYPE AND DATES COVERED Master's Thesis	
4. TITLE AND SUBTITLE ROLES OF THE M1A1 TANK IN THE UNITED STATES MARINE CORPS			5. FUNDING NUMBERS	
6. AUTHOR(S) Foster, James Wade				
7. PERFORMING ORGANIZATION NAME(S) AND ADDRESS(ES) Naval Postgraduate School Monterey CA 93943-5000			8. PERFORMING ORGANIZATION REPORT NUMBER	
9. SPONSORING/MONITORING AGENCY NAME(S) AND ADDRESS(ES)			10. SPONSORING/MONITORING AGENCY REPORT NUMBER	
11. SUPPLEMENTARY NOTES The views expressed in this thesis are those of the author and do not reflect the official policy or position of the Department of Defense or the U.S. Government.				
12a. DISTRIBUTION/AVAILABILITY STATEMENT Approved for public release; distribution unlimited			12b. DISTRIBUTION CODE	
13. ABSTRACT This thesis analyzes the operations the Marine Corps' M1A1 tanks could perform in support of the Marine Air-Ground Task Force (MAGTF). The research addresses the current and future capabilities of the M1A1 tank employed by today's Marine Corps. Based on these capabilities, lessons learned from training and combat, and conclusions from the 1996 Armor Conference, analysis of the M1A1's role in the Marine Corps are presented. This research and analysis satisfies the need, established during the Armor Conference, to articulate the capabilities of the M1A1 and the operations it could perform or support. Numerous operations, such as Operations Other Than War and Military Operations on Urban Terrain, which the M1A1 is not currently conducting or supporting are discussed, with the recommendation that the M1A1 be employed in these operations to improve the combat power of the MAGTF. Emphasis is placed on the M1A1's ability to conduct or support operations covering the full spectrum of warfare from high-intensity conflicts to peacekeeping operations.				
14. SUBJECT TERMS United States Marine Corps, Tank, Armor, Mechanized Warfare, Marine Air-Ground Task Force			15. NUMBER OF PAGES 84	
			16. PRICE CODE	
17. SECURITY CLASSIFICATION OF REPORT Unclassified	18. SECURITY CLASSIFICATION OF THIS PAGE Unclassified	19. SECURITY CLASSIFICATION OF ABSTRACT Unclassified	20. LIMITATION OF ABSTRACT UL	

Approved for public release; distribution is unlimited.

ROLES OF THE M1A1 TANK IN THE UNITED STATES MARINE CORPS

James W. Foster
Captain, United States Marine Corps
B.A., Vanderbilt University, 1991

Submitted in partial fulfillment
of the requirements for the degree of

MASTER OF SCIENCE IN MANAGEMENT

from the

**NAVAL POSTGRADUATE SCHOOL
December 1996**

Author:

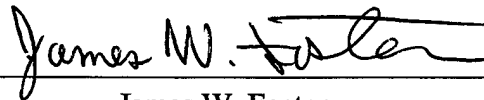

James W. Foster

Approved by:



Greg Walls, Thesis Advisor

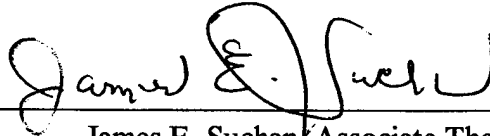

James E. Suchan, Associate Thesis Advisor

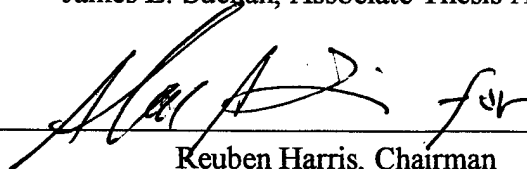

Reuben Harris, Chairman
Department of Systems Management

ABSTRACT

This thesis analyzes the operations the Marine Corps' M1A1 tanks could perform in support of the Marine Air-Ground Task Force (MAGTF). The research addresses the current and future capabilities of the M1A1 tank employed by today's Marine Corps. Based on these capabilities, lessons learned from training and combat, and conclusions from working groups during the 1996 Armor Conference, analysis on the M1A1's role in the Marine Corps are presented. This research and analysis satisfies the need, established during the Armor Conference, to articulate the capabilities of the M1A1 and the operations it could perform or support.

Numerous operations, such as Operations Other Than War and Military Operations on Urban Terrain, which the M1A1 is not currently conducting or supporting are discussed, with the recommendation that the M1A1 be employed in these operations to improve the combat power of the MAGTF. Emphasis is placed on the M1A1's ability to conduct or support operations covering the full spectrum of warfare from high-intensity conflicts to peace keeping operations.

TABLE OF CONTENTS

I. INTRODUCTION	1
A. OVERVIEW	1
B. OBJECTIVES OF RESEARCH	2
C. RESEARCH QUESTIONS	2
1. Primary Research Question	2
2. Subsidiary Research Questions	2
D. RESEARCH METHODOLOGY	3
1. Overview	3
2. Inclusion of Army Data	3
E. SCOPE OF THESIS	4
F. ORGANIZATION	4
II. LITERATURE REVIEW	5
A. INTRODUCTION	5
B. HISTORICAL THEORY OF ARMOR EMPLOYMENT	5
C. MARINE CORPS TANK EMPLOYMENT	6
1. Fleet Marine Force Manual 9-1	6
2. Operational Handbook 6-1	9

3. Fleet Marine Force Manual 6	10
D. ARMY TANK EMPLOYMENT	11
E. CONCLUSION	13
III. CURRENT TANK CAPABILITIES	15
A. INTRODUCTION	15
B. ARMOR PROTECTION	15
1. Vehicle Survivability	15
2. Crew Survivability	16
C. MOBILITY	17
1. General Description	17
2. Mobility Specifications	17
3. Power Train Specifications	18
4. Communication System Specifications	19
D. FIREPOWER	19
1. Introduction	19
2. Main Gun Specifications	19
3. Machine Gun Specifications	20
4. Fire Control Specifications	20

5. Other Firepower Assets	21
E. SHOCK EFFECT	22
F. SUMMARY OF CURRENT CAPABILITIES	23
IV. FUTURE TANK CAPABILITIES	25
A. INTRODUCTION	25
B. IMPROVED MOBILITY AND RELIABILITY	26
C. IMPROVED NIGHT VISION CAPABILITY	27
D. IMPROVED LETHALITY	28
1. Overview	28
2. Ammunition Improvements	28
3. Fire Control System Improvements	30
E. POTENTIAL IMPROVEMENTS	31
F. CONCLUSION	31
V. ANALYSIS	33
A. INTRODUCTION	33
B. OFFENSIVE OPERATIONS	33
1. Overview	33
2. Movement To Contact	34

3. Attack	35
4. Reconnaissance	36
5. Exploitation	37
6. Pursuit	37
7. Raid	38
8. Summary of Offensive Operations	39
C. DEFENSIVE OPERATIONS	39
1. Overview	39
2. Position Defense	39
a. <i>Security Force</i>	40
b. <i>Main Battle Force</i>	40
c. <i>Reserve</i>	41
3. Mobile Defense	41
4. Summary of Defensive Operations	42
D. OTHER TACTICAL OPERATIONS	42
1. Overview	42
2. Amphibious Operations	42
3. Breaching Operations	43

a. <i>Support Force</i>	43
b. <i>Breach Force</i>	44
c. <i>Assault Force</i>	44
4. Military Operations on Urban Terrain (MOUT)	44
5. Transition Operations	46
6. Summary of Other Tactical Operations	46
E. OPERATIONS OTHER THAN WAR (OOTW)	46
1. Overview	46
2. MIA1s in Somalia	47
3. MIA1s in Bosnia	48
4. Summary of Tanks in OOTW	49
F. EMERGING OPERATIONS	49
1. Overview	49
2. Commandant's Warfighting Lab Initiatives	49
a. <i>Engagement Coordination</i>	49
b. <i>Non-Lethal Weapons</i>	50
c. <i>CWL Summary</i>	51
3. Operational Maneuver From the Sea (OMFTS)	51

4. Summary of Emerging Operations	52
G. CONCLUSION	52
VI. CONCLUSIONS AND RECOMMENDATIONS	55
A. CONCLUSIONS	55
B. RECOMMENDATIONS FOR FURTHER RESEARCH	56
LIST OF REFERENCES	59
APPENDIX A. M1A1 DRAWINGS AND PICTURES	61
APPENDIX B. LIST OF ACRONYMS	67
INITIAL DISTRIBUTION LIST	69

I. INTRODUCTION

A. OVERVIEW

The United States Marine Corps has been employing tanks since 1925. The tanks utilized range from light expeditionary tanks such as the M2A4 during World War II to the medium M48A3 during Vietnam. Throughout, Marine tanks have performed operations designed to support the infantryman utilizing the tank's firepower, mobility and armor protection. In 1991 the Marine Corps replaced the M60A1 main battle tank with the M1A1 Abrams main battle tank. In doing so, they acquired a weapons system with significantly superior capabilities to those of the M60A1.

The M1A1 is currently employed within the Ground Combat Element (GCE) of a Marine Air-Ground Task Force (MAGTF). The MAGTF is the force structure the Marine Corps uses in deploying and employing Marine forces throughout the world. The MAGTF is composed of four elements: a Command Element (CE), a Ground Combat Element (GCE), an Aviation Combat Element (ACE) and a Combat Service Support Element (CSSE). The GCE conducts ground combat operations structured around an infantry unit which varies in size from an infantry battalion to a division. Combat support, including tanks, artillery and combat engineers, is also included in the GCE. The size of the tank unit supporting the GCE can vary from a platoon of four M1A1s to a battalion of 58 M1A1s.

During the 1996 Armor Conference, an annual meeting of Marine representatives of the armor community, the issue of what operations the M1A1 could perform in support of the MAGTF was discussed. The conference concluded that in addition to the operations the M1A1 is currently performing, other operations exist within the overall mission of the MAGTF which the M1A1 is capable of performing or supporting. The conference believed that the employment of the M1A1 in these additional operations would enhance the overall combat power of the MAGTF.

Since the introduction of the M1A1, the tank has been used almost exclusively as a separate element from the infantry, maneuvering against mechanized forces without regard for support the infantryman may require. While the conference believed this method of

employment was effective, they felt the M1A1 was being underutilized as an infantry support weapon. Thus, the need was established to articulate both the capabilities of the M1A1 and the operations this vehicle could perform in support of the MAGTF. This thesis will articulate the capabilities of the M1A1 and the operations it could perform. The analysis will assist MAGTF commanders by informing them of the capabilities of the M1A1 and the operations it is capable of conducting or supporting when Marine forces are employed around the world.

B. OBJECTIVES OF RESEARCH

The objectives of this study are to: 1) present the current capabilities and specifications of the M1A1 employed by the Marines, 2) present the planned and potential future capabilities and specifications of the M1A1 and 3) identify those operations the M1A1 could perform in support of the MAGTF based on its current and future capabilities.

C. RESEARCH QUESTIONS

1. Primary Research Question

What operations could the M1A1 tank perform in support of the Marine Air-Ground Task Force ?

2. Subsidiary Research Questions

- a. What operations beyond typical tank operations is the M1A1 capable of conducting in support of the MAGTF?
- b. What are the current capabilities of the Marine Corps' M1A1 tank?
- c. What future modifications to the M1A1 tank will improve the MAGTF Commander's ability to dominate the battlefield?
- d. What role will the M1A1 play in the Marine Corps' evolving doctrine of Operational Maneuver From the Sea (OMFTS)?

D. RESEARCH METHODOLOGY

1. Overview

The research and collection of data for the thesis is qualitative in nature. The analysis and presentation of literature on the employment of tanks will address the operations previously performed as well as those they currently perform. Literature review and data collection were used to determine the current and future capabilities of the M1A1. Analysis of lessons learned from previous Army and Marine Corps experiences with the M1A1, interviews with selected armor leaders, and notes from discussions at the Armor Conference are used to address those operations tanks could perform in support of the MAGTF.

2. Inclusion of Army Data

The discussion on the Army's methods of tank employment, as well as lessons learned from their operations with the M1A1 and information on the similar capabilities of the Army's and Marines' M1A1 in following chapters, will assist in analyzing the operations of Marine tanks addressed in Chapter V. While this thesis is not designed to be a comparison between Army and Marine tank operations, many of the lessons learned by the Army are valuable in understanding the current and potential future use of the M1A1 by the Marines. Furthermore, because the M1A1s employed by the two services are very similar, Army historical information regarding vehicle performance will be invaluable. Finally, since most tactics, techniques and procedures (TTPs) initially taught to Marine tank leaders at the Army's Armor School are virtually identical to those taught to Army tank leaders, the Marines leave with a foundation of skills built on both Army and Marine TTPs. Once these Marines gain experience in Fleet Marine Force (FMF) tank units, the basic TTPs employed and operations conducted will be tailored in order to best support the MAGTF, creating a tank force which is operationally similar, but not identical, to the Army. These similar TTPs, operations, and vehicle capabilities make it valuable to incorporate the Army's tank employment literature and experiences into this thesis.

E. SCOPE OF THESIS

This thesis will focus on the operations of tanks in support of the MAGTF. It will address operations currently assigned, operations previously executed, and potential future operations. It will also present an overview of the capabilities of the M1A1 tank, including planned improvements.

F. ORGANIZATION

Chapter II presents an overview on the historical employment of armor, Marine tank operations and Army tank operations. Chapter III discusses the current capabilities and specifications of the Marines' M1A1. Chapter IV discusses planned and potential future capabilities of the Marines' M1A1. Chapter V will then analyze the operations the Marines' M1A1s could perform in support of the MAGTF, based on their current and future capabilities. Chapter VI will provide conclusions with recommendations regarding tank employment in support of the MAGTF. Appendix A includes pictures and drawings of the principle components of the M1A1 discussed in Chapter III. Appendix B is a list of acronyms used throughout this thesis.

II. LITERATURE REVIEW

A. INTRODUCTION

While no study exists in Marine Corps' publications on the proper employment of the M1A1 tank within MAGTF operations, a variety of studies have been conducted which discuss various aspects of tank employment pertinent to the current capabilities of the M1A1. The purpose of the literature review is to familiarize the reader with publications on the historical theory of armor employment, Marine Corps tank employment, and U.S. Army tank employment. The historical theory will familiarize the reader with the early concept of armor warfare. Discussion on Marine Corps tank employment will focus on those studies which address specific tank employment methods as well as doctrine publications which incorporate the use of tanks by the Marines. Some studies examined consider the capabilities of the M1A1 while others do not. Those studies which do not consider the M1A1 are included because they are the most current versions of Marine tank employment publications. Army tank employment is introduced to provide the reader with a description of the Army's employment of the M1A1.

B. HISTORICAL THEORY OF ARMOR EMPLOYMENT

The most widely recognized historical theory of armor employment, Armored Warfare, was written in 1927 by J. F. C. Fuller. This study argued that weapons systems should be used to accomplish one or more of five objectives: find, fix, hit, protect, and destroy. While Fuller noted that the most effective means of accomplishing all five objectives was through the use of combined arms, a method of employing all weapons on the battlefield in a synchronized effort, he argued that tanks could accomplish all five on a high-intensity battlefield. Fuller characterized the high-intensity battlefield as one where highly organized forces would fight under a combined arms organization equipped with the latest artillery, tanks, and rifles. He argued that the tank's mobility and firepower would enable the tank to find and fix the enemy. The tank's firepower and shock action would be used to hit and destroy the enemy. The tank's armor would protect the crew as well as the friendly infantry following the tank, while the tank's firepower and shock action would destroy the enemy. [Ref. 1:p. 22-25]

Fuller further believed that tanks could fight in what is now referred to as low-intensity conflict (LIC). In his study on warfare in undeveloped and semi-civilized countries, Fuller categorized military operations into two groups: the maintenance of law and order and the crushing of revolt. In these operations, Fuller believed tank forces could successfully maintain the law using their mobility. This maintenance of the law could best be conducted by tanks because of their ability to maneuver from one zone of action to the next over extensive areas and all types of terrain. Fuller believed tanks could crush revolts using their mobility to quickly react to the revolt, combined with their application of firepower and shock effect against those creating the revolt. [Ref. 1:p. 164-168]

C. MARINE CORPS TANK EMPLOYMENT

1. Fleet Marine Force Manual 9-1

The use of firepower, shock action, armor protection, and mobility to describe the capabilities of tanks did not conclude with Armored Warfare. In 1981 the Marine Corps' Combat Development Command wrote the most current edition of Fleet Marine Force Manual (FMFM) 9-1, Tank Employment / Anti-mechanized Operations. This publication also addresses the capabilities of tanks in terms of their firepower, shock action, armor protection, and mobility. Tank Employment / Anti-mechanized Operations defines these terms as:

•**Armor-Protected Firepower:** The armored vehicle is an integrated weapons system capable of defeating most targets on the battlefield. The armored vehicle gun is a high velocity, direct fire weapon used primarily against enemy tanks and hard targets. The amount of ammunition carried aboard the vehicle and the types available permit armored vehicles to engage a wide variety of targets for sustained periods of combat. Its armor affords protection to the components of the armored vehicle, including its crew, from the effects of small arms fire, shell fragments, and some direct hits, depending on the type and range of the assaulting weapon. Its armor also allows the armored vehicle to close with the enemy and maneuver while under enemy fire or friendly supporting fires with a degree of immunity that other weapons systems do not possess. This armor protection also provides a significant degree of protection against the effects of nuclear and chemical weapons.

•**Mobility:** Armored vehicle units are capable of conducting mobile ground combat over a broad area of operations. Armored vehicle units may remain dispersed to mass at a focal point of action at a decisive time. When properly utilized, the armored vehicles' mobility can increase the strength of a supported unit by applying their firepower against the enemy at several points within a short period of time. Armored vehicles, by virtue of their full track, possess a high degree of cross-country mobility.

•**Shock Power:** The shock power of armored vehicles and mounted supporting troops causes a combined physical and psychological effect on the enemy. The shock power of armored vehicles is increased in proportion to the number of armored vehicles employed. Shock power, in a properly executed assault, has a devastating effect on enemy morale and a favorable effect on friendly morale. To exploit armored vehicle shock power, aggressive employment of the combat capability of combined arms teams is essential. [Ref. 2:p. 1-2]

These characteristics are addressed throughout FMFM 9-1, including the mission statement of Marine Corps tank units, "The basic task of Marine Corps tank units is to attack, disrupt, and destroy enemy forces through firepower, shock power, and maneuver in coordination with other arms" [Ref. 2:p. 1-2].

Although FMFM 9-1 uses the term shock power instead of Fuller's shock action, and later publications use the term shock effect, the author believes the terms shock power, shock action, and shock effect all refer to the tank's physical capabilities which create psychological shock on the battlefield. This shock is generated by using the tanks ability to quickly close on the enemy, its ability to overrun defensive infantry positions, and its considerable size and noise as it approaches an enemy. These effects of shock usually contribute to a rapid destruction of the enemy's will to fight.

Unlike Fuller's principles of finding, fixing, hitting, protecting, and destroying, functions which could be conducted in all types of operations, FMFM 9-1 applies the capabilities of the tank to offensive, defensive, and special operations. The doctrine in FMFM 9-1 breaks tank offensive operations into six missions:

- Movement to Contact
- Reconnaissance in Force
- Coordinated Attack
- Exploitation
- Pursuit
- Raid

Each of these missions is conducted capitalizing on the tank's firepower, armor-protection, shock power, and mobility to disrupt, disorganize and destroy the enemy. [Ref. 2:p. 1-38]

Defensive operations utilize the tank's firepower and mobility in a combined arms position defense, mobile defense or as the counterattack force. While FMFM 9-1 considers the tank capable of performing any of these defensive operations, it continually emphasizes that the tank is primarily an offensive weapon and is best utilized when held in reserve and employed as the counterattack force where its mobility and armor protection can be best utilized. [Ref. 2:p. 1-56]

The employment of tanks in special operations is briefly discussed in FMFM 9-1, emphasizing the tank's ability to support the infantry in operations against irregular forces by isolating, surrounding, and destroying the enemy. Similar to operations against irregular forces, tanks should be employed in urban areas as a supporting arm to the infantry by providing direct fires and protection from counterattacks. [Ref. 2:p. 1-74]

2. Operational Handbook 6-1

A more recent Marine Corps publication, Operational Handbook (OH) 6-1, Ground Combat Operations, briefly describes the use of tanks in support of the MAGTF. This publication emphasizes the Marine Corps' current doctrine of maneuver warfare, which has ten principles:

- Focus on the enemy; not on terrain objectives.
- Act more quickly than the enemy can react.
- Support maneuver by fire.
- Issue mission type orders.
- Avoid enemy strength and attack enemy weakness.
- Exploit tactical opportunities developed or located by subordinate units.
- Always designate a point of main effort.
- Avoid set rules and patterns.
- Act boldly and decisively.
- Command from the front. [Ref. 3:p. 1-5]

Based on these principles of maneuver warfare, OH 6-1 describes the mission of Marine Corps tanks, "Tanks locate, close with, and destroy the enemy utilizing armor protected firepower, shock action, and maneuver" [Ref. 3:p. 2-15].

Ground Combat Operations, similar to Tank Employment / Anti-mechanized Operations, breaks the roles of tanks into offensive and defensive operations. Offensive operations for tanks, according to OH 6-1, are:

- General
- Hasty Attack
- Deliberate Attack
- Movement to Contact
- Reconnaissance in Force
- Exploitation
- Pursuit

Ground Combat Operations assigns these missions based on the tank's significant offensive firepower, mobility, and shock action. [Ref. 3:p. 7-1]

Defensive operations outlined in OH 6-1 are similar to those in FMFM 9-1 and also emphasize the offensive nature of tanks, stating that the defensive commander should employ tanks as the counterattack force to take advantage of their mobility and firepower. Other defensive operations OH 6-1 assigns to tanks are:

- Defense against airborne and helicopter attack.
- Defense against amphibious assault.
- Defense against infiltration.
- Reducing penetrations.
- Defense of an urban area and defense at night. [Ref. 3:p. 8-1]

In addition to these offensive and defensive operations, OH 6-1 also discusses the use of tanks in support of security operations, counterinsurgency operations, and military operations short of war. Potential uses of tanks in security operations include performing as a screening, guarding, and covering force. Functions in counterinsurgency operations include strike operations, consolidation operations, fire support, patrolling, border control, and population allegiance. In military operations short of war, tanks may be used to conduct show of force operations, noncombatant evacuation operations, strike operations, military assistance to allies, and peacekeeping operations. [Ref. 3:p. 14-1]

3. Fleet Marine Force Manual 6

The most recent Marine Corps publication which discusses Marine tank employment is FMFM 6, Ground Combat Operations, written in 1995. In FMFM 6 the principle of maneuver warfare is restated, "Maneuver warfare is a warfighting philosophy that seeks to shatter the enemy's cohesion through a series of rapid, violent, and unexpected actions which create a turbulent and rapidly deteriorating situation with which the enemy cannot cope" [Ref. 4:p. 1-2]. This version of Ground Combat Operations is significant because it was written after the Marine Corps procured the M1A1, and therefore, considers the capabilities of the M1A1 tank, which were not considered in FMFM 9-1 or OH 6-1.

FMFM 6, similar to previously discussed publications, addresses the capabilities of the tank in terms of firepower, armor protection, shock effect, and mobility:

Tanks are the key element in creating shock effect for the Ground Combat Element (GCE). The firepower, armor protection, and mobility of tanks are well suited for exploiting breakthroughs and conducting counterattacks. They provide precision direct fires against enemy armor, fighting vehicles, and hardened positions. Combined with aviation forces and surface fire support, tanks and mechanized infantry provide the commander with a potent maneuver force capable of rapidly uncovering terrain and forcing the enemy to fight or displace. The mobility and range of tanks and vehicle mounted anti-armor guided missile systems allow their employment throughout the battlefield to include security operations. [Ref. 4:p. 2-9]

The principle missions of offensive and defensive operations, as well as Operations Other Than War (OOTW), prevail throughout FMFM 6. While FMFM 6 does not specifically address the employment of the M1A1, it does provide the reader with a description, although broad, of the capabilities of the M1A1. The description of the M1A1 in FMFM 6 is broad because this publication is designed as a reference on the overall concept of ground combat operations, not tank specific operations. A current Marine Corps publication which specifically addresses the employment of the M1A1 has not been written, making it necessary to rely on the Army's current tank employment publications to best understand the operations the M1A1 is capable of conducting or supporting.

D. ARMY TANK EMPLOYMENT

The final publication dealing with the employment of tanks is the U.S. Army's Field Manual (FM) 71-1, Tank and Mechanized Infantry Company Team, written in 1988. Although this is an Army doctrine publication, the reader must realize, as previously mentioned, that the M1A1 employed by the Army and Marine Corps are virtually identical in capabilities, and the tactics used by the Army are similar to those of Marine tank units. Additionally, even though this publication deals with the missions and employment of tanks as a Company Team rather than discussing these topics without regards to the size and structure of the unit, as previously discussed publications have, the document is worth reviewing because it considers the capabilities of the M1A1 in

developing appropriate tank operations. To understand the content of FM 71-1, the reader must realize two things: first, the Company Team in the Army is the building block for commanders in structuring a force to best counter the enemy. Second, a Company Team may consist of fourteen M1A1 tanks or a combination of tanks and Bradley Fighting Vehicles. This publication identifies the capabilities of a tank Company Team as:

- Capable of conducting operations requiring a high degree of firepower, mobility, armor protection, and shock effect.
- Capable of destroying enemy armor at long and close ranges.
- Capable of destroying mounted and dismounted infantry.
- Capable of conducting continuous operations under most terrain and weather conditions. [Ref. 5:p. 1-7]

Field Manual 71-1 considers the M1A1's advanced fire control system, armor package and weapons systems in developing the above capabilities. Field Manual 71-1 follows suit with previously discussed publications in characterizing tanks in terms of firepower, mobility, armor protection, and shock effect. These capabilities are also applied in terms of offensive and defensive operations, as well as other tactical operations. Offensive operations assigned to tanks in FM 71-1 include movement to contact, hasty attack, deliberate attack, exploitation, and pursuit [Ref. 5:p.3-1]. Defensive operations include destruction of enemy forces, defeating an enemy attack, gaining time, concentrating forces elsewhere, controlling key or decisive terrain, wearing down enemy forces prior to offensive operations, and retaining strategic, operational or tactical objectives [Ref. 5:p. 4-1]. Other tactical operations assigned to tanks include relief in place, passage of lines, delay, withdrawal, hasty water or gap crossing, and Military Operations on Urban Terrain (MOUT) [Ref. 5:p. 5-1].

The difference between FM 71-1 and previously mentioned Marine Corps publications is the doctrine the Army employs. Unlike the Marine Corps application of maneuver warfare, the Army fights using the concept of the AirLand battle. This doctrine emphasizes the Army's ability to conduct prompt and sustained combat operations on land

with forces capable of defeating the enemy, and seizing, occupying and defending land areas. Whereas the Marine Corps may employ the M1A1 utilizing maneuver warfare to destroy the enemy without the objective of occupying and defending land areas for prolonged periods of time. [Ref. 5:p. 1-1]

E. CONCLUSION

Each of the publications discussed emphasize the tank's capabilities based on armor protection, shock effect, firepower, and mobility. Armored Warfare is an excellent reference for the basic principles of armor employment. Tank Employment / Anti-mechanized Operations is the most detailed document on the employment of tanks in the Marine Corps. However, since it was written when the Marines were using the M60A1 tank and not the current M1A1, it fails to accurately address the employment of tanks based on the capabilities of the M1A1. Both versions of Ground Combat Operations, OH 6-1 and FMFM 6, discuss tank employment only in broad terms and are not designed for use as a reference document for the employment of tanks. Rather, these publications should be used to understand the overall scheme of Marine Corps ground combat operations.

While Tank and Mechanized Infantry Company Team was written to best describe the employment of the M1A1 tank, because it is an Army doctrine publication, the concept of employment under the Army's AirLand battle is somewhat different than the employment techniques of the Marines utilizing maneuver warfare. Since the Marine Corps has not revised FMFM 9-1 and other current publications are not specific to M1A1 tank employment in the Marine Corps, a need exists to articulate the capabilities of the Marines' M1A1 tank and tie these capabilities to the operations these tanks could perform in support of the MAGTF. Chapter III will address the current capabilities of the Marines' M1A1 tank.

III. CURRENT TANK CAPABILITIES

A. INTRODUCTION

This chapter discusses the current capabilities of the M1A1 tank used by the Marine Corps today. This information may be apparent to those readers familiar with the M1A1, it is provided for those not familiar with this tank and as a quick reference in understanding the M1A1's capabilities. The M1A1 is an improved version of the M1 Abrams main battle tank. It was developed under a joint venture between the U.S. Army and Marine Corps as a replacement for the M60 series tank. In designing the M1, the Army and Marine Corps stressed the importance of crew survivability, lethality and mobility. The final product and its improved versions, including the M1A1, provide the necessary survivability, lethality and mobility to address threat weapons systems of the current period and into the twenty-first century. The primary threat vehicles the M1 was designed to defeat include the latest versions of the Soviet made T-series tanks, including the T-72, T-80 and T-90. The M1A1's capabilities will now be discussed in terms of the four characteristics introduced in the literature review: armor protection, mobility, firepower, and shock effect.

B. ARMOR PROTECTION

1. Vehicle Survivability

The M1A1 employed by the Marines provides protection to its crew through the most substantial armor package ever applied to a U.S. tank. While most specifics on the armor is classified and will not be discussed here, the general characteristics of this armor are unclassified. The armor is made of steel encased depleted uranium, a substance two and a half times the density of homogeneous steel. The armor is concentrated around the tank's frontal sixty degrees, affording the tank crew the most protection in this area. This armor proved to be effective against Soviet built T-72 tanks during Operation Desert Storm in Southwest Asia. During the ground war seven different U.S. Army M1A1s with depleted uranium armor were engaged and hit by Iraqi T-72 tank rounds. These M1A1s sustained no substantial vehicle damage or injury to the tank crew. [Ref. 6:p. 138]

In addition to the direct fire protection afforded to the crew by this armor, the crew is also protected against Anti-tank Guided Missiles (ATGMs) over the frontal sixty degrees as well. Protection from small arms fire and fragmentation is provided around the entire vehicle. While primary protection against ATGMs is provided by the vehicle's armor, a missile countermeasure device is also used as a deterrent against ATGMs.

A smoke generation system, which sprays fuel over the exhaust manifold, provides an onboard smoke screening capability for use as an obscurant in both offensive and defensive operations. [Ref. 6:p. 142]

The immunity to small arms fire and fragmentation enables the tank to close against the enemy under both direct and indirect fire. This immunity to small arms fire was demonstrated in 1993 when Marine M1A1s employed during Operation Restore Hope in Somalia were routinely engaged by small arms fire without damage to the vehicle or injury to the crew. [Ref. 9:p. 1] This armor protection also allows the M1A1 to close on an objective under fire by friendly artillery and air, a practice routinely employed by the Marines using the concept of combined arms warfare.

2. Crew Survivability

The M1A1 was designed to afford the crew protection against not only threat weapon systems of the current and future period, but also against hazards inherent in the operation of an armored vehicle. This protection comes in the form of compartmentalization of explosive materials including ammunition and fuel. Ammunition is stored in an armor compartment accessed by the crew through hydraulic armor doors. If the ammunition compartment is hit by fire, blow-off panels on the turret roof direct the explosion away from the tank crew. An automatic fire sensing and suppression system further protects the crew against onboard fires. An over-pressure system, using bleed off air from the turbine engine routed through a system of filters, allows the tank to operate in all Nuclear, Biological and Chemical (NBC) environments. This NBC protection is further enhanced by an automatic detection device and onboard decontamination kits. [Ref. 7:p. 3-128]

This complement of armor and crew protection devices provides the tank crew with a significant degree of protection against current and future threat weapons systems.

C. MOBILITY

1. General Description

Tracked vehicles such as the tank have always had a considerable advantage in battlefield mobility over their wheeled counterparts because of their full track. In designing the M1A1, the Army and Marine Corps wanted a vehicle capable of maneuvering on all types of battlefields, including desert, jungle, mountain and urban terrain. The M1A1's suspension uses a series of torsion bars, rotary shock absorbers and road wheels to accommodate the significant weight of the vehicle while maintaining a stable platform for the crew. To improve the M1A1's mobility over the aging M60 tank, the M1A1 was built with a gas turbine engine. While several factors were taken into account before selecting a turbine engine instead of a diesel, including reliability and maintainability, the overriding factor was the better acceleration and top-end speed of the turbine over a diesel engine. The turbine engine allows the M1A1 to quickly maneuver from one battle position to the next, a concept considered critical in a position defense against an enemy with a significantly larger number of tanks.

2. Mobility Specifications

The M1A1 has a cruising range of 289 miles without refueling. The tank's maximum speed while governed is 42 miles per hour on a flat level surface and 30 miles per hour on cross country terrain. The tank is governed by a Digital Electronic Control Unit (DECU) which controls fuel flow to maximize fuel efficiency. By governing the speed of the vehicle, allowing the crew to operate the M1A1 no faster than 42 mph, the DECU also minimizes wear and tear on the suspension. Ungoverned speeds are significantly faster, but only used during war. The ungoverned speed and cruising range of the M1A1 were demonstrated during Operation Desert Storm when the Army's Seventh Corps traveled over 120 miles in twenty-four hours, fighting along the way, in an effort to stop the Iraqi Republican Guard equipped with T-72s. The decision to use the Army's M1A1s during this confrontation instead of the Marine M60A1s was based partially on the M1A1's superior cross-country mobility and firepower. [Ref. 6:p. 138]

In addition to the M1A1s impressive cross country mobility, it is capable of overcoming a variety of obstacles. The tank is capable of crossing a trench as wide as nine feet, providing it with the capability of crossing most hastily constructed tank trenches. Vertical obstacles as high as forty-two inches can be climbed, a height today's wheeled vehicles will not overcome. The M1A1 will climb a slope of up to sixty degrees. With the addition of a mine clearing blade, the tank is capable of clearing surface and buried mines up to six feet in front of it. This breaching can be conducted without the aid of supporting forces or in conjunction with engineer forces where obstacles such as large tank ditches or wire exist. [Ref. 10:p. 1]

The M1A1 is also capable of overcoming natural obstacles such as water. Without fording equipment, the M1A1 is capable of operating in water up to forty-eight inches in depth. With the use of the Deep Water Fording Kit (DWFK), an equipment upgrade designed for use by the Marines, the tank will ford water as deep as seventy-eight inches. The DWFK was designed for the Marine Corps for use when off-loading the tank from U.S. Navy ship-to-shore craft during amphibious operations. [Ref. 6:p. 141]

3. Power Train Specifications

The gas turbine is a multi-fuel engine capable of burning diesel, jet fuel and petrol. The engine generates 1500 horsepower at 3000 Revolutions Per Minute (RPM), creating a power-to-weight ratio of 27 Horsepower per Ton (HP/T), allowing it to accelerate from zero to twenty miles per hour in 6.8 seconds. The turbine is coupled to an automatic transmission with four forward and two reverse gears as well as an internal hydromechanical braking system. A twenty-four volt generator running off the turbine provides electrical power throughout the vehicle.

In order to conserve fuel and minimize noise and thermal signature, an External Auxiliary Power Unit (EAPU) can be used when operating in defensive positions. The EAPU is a small diesel generator located in the bustle rack which generates enough power to operate the communications and fire control systems as well as charge the vehicle's batteries.

4. Communication System Specifications

The M1A1 is equipped with a suite of communication equipment. Two Single Channel Ground and Airborne Radios (SINCGARS), standard Very High Frequency (VHF) radios in use throughout the Army and Marine Corps, are in each tank. The two radios allow the crew to monitor up to fourteen encrypted radio nets in single channel mode or two in frequency hopping mode. High-power amplifiers enable the crew to communicate to supported and supporting agencies over great distances. This communication capability is used extensively in dispersing and massing tank forces at the appropriate time so that the utility of the M1A1 is maximized. A Position Location and Reference System (PLRS) is also carried on each tank. This system allows the tank crew to accurately determine the position of their vehicle as well as that of other PLRS equipped vehicles. It is also capable of transmitting brief text messages to other PLRS equipped units.

D. FIREPOWER

1. Introduction

The M1A1's fire control system was designed to provide the tank crew with the most lethal tank on the battlefield. The result is a system capable of engaging long range targets from stationary positions or while on-the-move under most battlefield conditions. The weapon systems are compatible with North Atlantic Treaty Organization (NATO) standard ammunition and are capable of addressing the majority of conventional threat weapons systems, such as tanks, personnel carriers, helicopters, artillery, and reconnaissance vehicles on the current and future battlefield.

2. Main Gun Specifications

The tank main gun is a 120mm smoothbore cannon currently capable of firing two types of ammunition. The main gun can be traversed and fired around the full 360 degrees of the vehicle and elevated from -10 to +20 degrees. An armor piercing, fin stabilized, discarding sabot round is fired against heavy armor such as tanks and armored personnel carriers. This kinetic energy round has a maximum effective range of 2500 meters. While engagements beyond the maximum effective range of the round do not have as high a

probability of killing the target and are less accurate, engagements during Operation Desert Storm proved successful out to 4000 meters. The second main gun round, the High Explosive Anti-tank (HEAT) round, is a chemical energy round for use against hardened targets, such as bunkers, as well as lightly armored vehicles, including trucks and personnel carriers. The HEAT round has a maximum effective range of 2100 meters. A combination of forty SABOT and HEAT rounds are carried on each tank, thirty-four in a readily accessible compartment behind the crew in the turret and six in a hull storage area. [Ref. 8:p. 2]

3. Machine Gun Specifications

The M1A1 mounts three machine guns, two 7.62mm M240s and one 12.7mm (.50 caliber) M2. One M240 is mounted coaxially to the tank's main gun, is elevated and traversed on the same axis, and is controlled by the fire control system. The second M240 is mounted in the loader's position for use against troops, lightly armored vehicles, and aircraft. The loader's M240 can be elevated from -30 to +65 degrees. A total of 11,400 rounds of 7.62mm ammunition is carried in each tank. Both M240s are interchangeable, allowing the crew to replace the coaxially mounted machine gun with the loader's M240 if a malfunction occurs. The M240 has a maximum effective range of 900 meters.

The 12.7mm M2 is mounted at the commander's weapon station. This machine gun can be fired while the vehicle hatches are closed utilizing controls at the commander's station, which include a three power sight, or from outside the vehicle using the weapons trigger and iron sights. The M2 can be elevated from -10 to +65 degrees. The commander's weapon station is capable of traversing the full 360 degrees of the vehicle for use against lightly armored vehicles, troops, and aircraft. The M2 mount is designed to accommodate the M240 if a malfunction occurs with the M2. A total of 1000 rounds of 12.7mm ammunition is carried in each tank. [Ref. 6:p. 139]

4. Fire Control Specifications

The fire control system is designed to provide target sighting, ranging, aiming and firing of both the main gun and the 7.62mm coaxial machine gun. The system uses a combination of both automatic and manual inputs to create a digital ballistic firing solution

for both main and machine gun rounds. Automatic inputs include vehicle cant, cross wind, lead, and range. Manual inputs include air temperature, barometric pressure, and ammunition temperature. Air temperature and barometric pressure are obtained from intelligence reports. Ammunition temperature is considered to be the same as that in the ammunition compartment which is measured by an onboard thermostat located at the gunner's position.

Two sights are tied into the fire control system. One is an optical sight for use during periods of good visibility. The second sight is a thermal Forward Looking Infrared (FLIR) sight for visibility during night or periods of low visibility, including smoke and battlefield obscuration. Both sights have three and ten power magnification capabilities for wide and narrow fields of view. The laser range finder allows the crew to quickly determine the range to a target. Other elements of the fire control system include elevation and azimuth stabilization systems enabling the tank crew to engage targets from stationary positions or while on-the-move at all angles of attack.

An extension of the gunner's sight and override system allow the tank commander to fire the main gun and coaxial machine gun from the commander's position. This capability allows the tank to be operated using a three man crew, if required.

A secondary fire control system is also present, using an eight power sight and mechanical and electrical firing devices in the event the primary fire control system malfunctions or is damaged.

5. Other Firepower Assets

In addition to the tank's main gun and machine guns, each crew member carries a 9mm pistol. One 5.56mm rifle is also carried for crew protection when dismounted. A total of 120 9mm rounds and 180 5.56mm rounds is typically carried on each tank. A combination of anti-tank and anti-personnel mines, grenades, and concertina wire is also carried based upon the tactical situation. Two smoke grenade launchers mounted on the turret's sides fire red phosphorous grenades for obscuration against ATGMs.

E. SHOCK EFFECT

The shock effect of the M1A1 is not attributed to any one capability of the vehicle, rather it is developed through the tank crew's use of its weapons systems, maneuverability, and armor when closing against an enemy. The M1A1's ability to quickly accelerate and travel across all types of terrain allows it to maneuver against and into the enemy. Its ability to engage all types of targets while on the move under the full spectrum of weather conditions and visibility further enhance its shock effect. Finally, the vehicle's armor protection allows the crew to literally run over the enemy without fear of damaging the vehicle or injuring the crew. These cumulative capabilities all contribute to the tank's ability to demoralize an enemy incapable of stopping this vehicle as it closes on their position, creating overwhelming shock effect.

F. SUMMARY OF CURRENT CAPABILITIES

The M1A1 currently employed by the Marines is a lethal, maneuverable, and survivable weapon system which can provide a significant amount of combat power to the MAGTF. These capabilities are summarized in the following table for quick reference. Chapter IV will address planned improvements to the Marines' M1A1 which will further improve the combat power available to the MAGTF.

Weight	67.7 tons (Combat loaded)
Length	385 inches
Width	144 inches
Height	114 inches (without DWFK)
Ground clearance	19 inches
Fuel Capacity	495 gals (useable)
Cruising range	289 miles
Horsepower	1500 at 3000 rpm
Power-to-weight ratio	27 hp/ton
Maximum Speed	42 mph (30 mph cross country)
Acceleration	0-20 mph in 6.8 seconds
Fording depth	48 inches (78 inches with DWFK)
Vertical crossing	42 inches
Trench crossing	9 feet
Slope climb	60 degrees
Main gun	M256 smoothbore cannon
Commander's weapon	M2 12.7mm (.50 caliber) machine gun
Loader's weapon	M240 7.62mm machine gun
Coaxial weapon	M240 7.62mm machine gun
Fire control	Digital ballistic computer with automatic and manual inputs
Sights	Day and night (thermal) in 3 or 10 power
Armor	Steel encased depleted uranium

Table 1. Current tank capabilities and specifications.

IV. FUTURE TANK CAPABILITIES

A. INTRODUCTION

This chapter describes the planned and potential future capabilities of the M1A1 tank employed by the Marine Corps. Planned improvements include those modifications which have been funded and are scheduled to be implemented. Potential improvements include modifications which are currently under consideration for funding and implementation.

Similar to most weapons systems, the Abrams tank continues to be improved as technology advances and the threat changes. The M1A2 is the follow-on to the M1A1. The primary difference between the M1A1 and the M1A2 is the addition of an intra and inter-vehicle information system. The inter-vehicle information system allows the tank crew to communicate digitally across the battlefield. The intra-vehicular information system allows the crew to more accurately monitor and diagnose their tank through an onboard computer which monitors the automotive and fire control components of the tank.

The second difference between the M1A1 and M1A2 is the addition of a second sight for the main gun, enabling the tank commander to search one sector while the gunner searches another.

While the Army is currently upgrading their M1 tanks into the M1A2 configuration, modifications which will improve the vehicle's firepower, mobility, and reliability, the Marine Corps, because of limited fiscal resources, has chosen to improve their M1A1 through selected modifications. While these modifications do not include all upgrades used in converting an M1A1 to an M1A2, those which the Marine Corps considers most effective and affordable are either planned or have the potential to be implemented on the Marines' M1A1.

Some modifications result from lessons learned during training and combat, while others focus on improving the tank with advanced technology. The goal with all modifications is to continually improve the tank U.S. forces employ around the world. Planned modifications will be introduced first, followed by potential modifications.

B. IMPROVED MOBILITY AND RELIABILITY

One of the M1A1's vulnerabilities, discovered during training as well as Operation Desert Storm, is the turbine engine's requirement for clean air. During training at both Army and Marine Corps desert training centers, the turbine engine's air filtration system quickly became clogged by dust, sand, and rocks. To clean the filtration system filters, the vehicle must be stopped, the filters removed, and thoroughly cleaned by crewmen. This cleaning must occur after every twenty-four hours of operation and takes one to two hours to complete. When the filters are not frequently cleaned, foreign object damage (FOD) may occur to the turbine engine, resulting in degraded performance and shorter engine life.

During Operation Desert Storm the Army replaced these filters rather than stopping, removing, cleaning and reinstalling the filters. Obviously, if a tank crew must stop and clean these filters or operate their vehicle in a degraded mode, the mission is subject to failure. To solve this problem, an initiative was begun shortly after Desert Storm to procure the Pulse Jet Air System (PJAS), which can clean these filters without having to remove them or stop the vehicle. This system monitors the filters for air flow-through. Once the flow level decreases to a point which could degrade the engine's performance, an automatic system using jet air from the engine blows the sand, dust, or dirt out of the filters. Because the system is automatic, the vehicle does not have to stop in the middle of operations.

The M1A1's capabilities are improved with this system in several ways. First, PJAS will improve the reliability of the engine. Since the filters are constantly monitored and cleaned, the engine will be less likely to shut down due to FOD. This is a critical capability if the tank is closing on an objective and the engine suddenly shuts down due to clogged filters. With PJAS this vulnerability is significantly minimized. Second, PJAS improves the mobility of the M1A1 because it ensures the engine will operate at peak performance.

Third, PJAS will reduce the cost of repairing or replacing the turbine engine. In March, 1996, the Army Tank Automotive and Armaments Command conducted a cost-benefit analysis of PJAS for the Marine Corps. The results showed that PJAS will

save \$30,430 per vehicle per year in repair and replacement costs [Ref. 10:p. 19]. The Marine Corps is currently modifying its M1A1s with PJAS with scheduled completion in Fiscal Year (FY) 1998.

C. IMPROVED NIGHT VISION CAPABILITY

During operations at night or periods of limited visibility, the driver on the M1A1 uses a passive night sight. This sight magnifies the ambient light in a manner similar to current night vision goggles. While this sight is successful in aiding the driver during limited visibility, it is dependent on the amount of ambient light. The presence of obscuration such as smoke or fog severely degrades this passive device. To improve the driver's ability to see during limited visibility, the Marine Corps plans to modify all combat vehicles, including the M1A1, with a thermal viewer for the driver.

This Driver's Thermal Viewer (DTV), the AN/VAS-5 DVE, is a second generation Forward Looking Infrared (FLIR) system with significant advantages over the current AN/VVS-2 passive device. First of all, it will allow the driver to see through obscurants such as dust, fog, rain, snow, and smoke during both day and night operations. Secondly, it will allow the driver to see when no ambient light is present due to cloud or tree cover. Finally, it will allow the driver to see on a battlefield where gun fire, flares, or fire are present. This capability to see through obscurants common on a battlefield will allow the crew to better utilize the tank in a combat situation. Better vision at night will ensure the driver maneuvers the tank along the desired route, keeping the tank on course in support of its mission.

Tests conducted by the Army's Night Vision Lab (NVL) after Desert Storm showed that the AN/VAS-5 DVE significantly improved the driver's ability to see through dust, smoke, and fog. Additionally, driving during both day and night, and in areas where flashes and fires were present, was easier using the new system rather than the current passive device. Finally, tests showed that a stationary target can be detected using the DVE out to 1200 meters, a moving target out to 2000 meters. This is a capability the current passive device does not offer. [Ref. 12:p. 14]

Since the Marine Corps is planning to modify all armored vehicles with the Driver's Thermal Viewer, this is an improved capability for not only the Marines' tanks, but all combat vehicles. Modification is scheduled to begin in FY 98.

D. IMPROVED LETHALITY

1. Overview

To keep pace with developing technologies and improvements to threat weapon systems, the Marine Corps is considering several modifications to the M1A1 to improve its lethality. There are two methods for improving the lethality of the M1A1: 1) field improved munitions with more lethality than ammunition currently in use, and 2) modify the fire control system to improve the accuracy of the ammunition employed. The Marine Corps is in the process of fielding advanced munitions and is considering technological improvements to the M1A1's fire control system.

2. Ammunition Improvements

Three main gun rounds are currently being fielded or in development for use with the M1A1's 120mm main gun. The Marine Corps recently modified the fire control system on their M1A1s in anticipation of fielding two of these rounds. The first, which is already fielded, is the M830A1 HEAT-MP-T or MPAT round. The MPAT round is a high explosive multipurpose round with an anti-helicopter defeat capability. A manually operated proximity switch allows the tank crewman to choose either ground or air mode for the round. In the ground mode the MPAT is similar in characteristics and capabilities to the current HEAT round. In this mode it is designed to defeat light armored vehicles, buildings, bunkers, and Anti-tank Guided Missile (ATGM) platforms. When the round is fired in air mode, a proximity fuse senses when the round is within seven meters of a large metal object such as a helicopter. When the proximity fuse senses the helicopter, the round explodes, scattering shrapnel in the vicinity of the targeted helicopter. [Ref. 13:p. 1]

With the fielding of the MPAT round, the tank is now capable of defeating attack helicopters, a threat the M1A1 was previously incapable of addressing. This capability significantly improves both the lethality and survivability of the tank. Range of the MPAT in both modes is classified.

The second round the M1A1's fire control system has been modified to fire is the Smart Target Activated Fire and Forget (STAFF) round. This is the first smart munition designed for use by Army and Marine M1A1s. The STAFF round uses a dual millimeter wave radar, microprocessor control and an Explosively Formed Penetrator (EFP). The radar scans the line of flight for targets and utilizes onboard software to discriminate potential targets from battlefield clutter and countermeasures. Once a target is found, the electronic brain rolls the warhead down to the target. The EFP, once aligned with the target, is fired upon impact on top of the target. The capability to attack the top of a target is significant since most armored vehicles are more vulnerable on their top and bottom than their front and sides. This round also provides the capability to destroy targets not in the line of sight. Once the general vicinity of a target is identified, via intelligence or airborne reconnaissance, the round is fired in the targets general vicinity with the onboard guidance system directing the round towards the target.

The range, terminal effects, and current fielding status of the STAFF round are classified. The capabilities, as described, will significantly improve the lethality of the M1A1. Since the STAFF round is a fire and forget round, it not only improves the tanks ability to engage targets on the battlefield, it enables the tank to fire the round and immediately maneuver to another position, reducing the likelihood of becoming detected.

The third round under development is the X-ROD. This round uses a depleted uranium long-rod penetrator, similar to the current SABOT round. The X-ROD, unlike the SABOT round, is a smart munition. The round uses a millimeter wave sensor which compares the electronic signature of the intended target with those in its memory to confirm the target as viable. The sensor guides the round to the target, making minor corrections to allow for slight deviations that can occur when fired at moving targets or targets several kilometers away. When the sensor determines the round is a kilometer away from the target, it ignites a rocket motor to increase the round's velocity as it closes on the target. The tremendous velocity provided by the rocket motor and accuracy provided by the onboard sensor will enable the tank to engage targets at greater ranges with a higher probability than current rounds. The X-ROD is currently in proof-of-principle testing. Actual range and terminal effects are classified. [Ref. 14:p. 23]

3. Fire Control System Improvements

To improve the target detection and accuracy of the M1A1, the Marine Corps is considering two improvements to the current fire control system. The first is the replacement of the current thermal sight with a second generation thermal sight. The current thermal sight is a first generation analog FLIR with three and ten power magnification capability. Advantages of the second generation FLIR over the current system include digital output, built-in stabilization, improved poor weather capability, twenty power magnification, better resolution, and better reliability and maintainability. [Ref. 15:p. 2]

In conjunction with replacing the thermal sight with the second generation sight is the anticipated replacement of the current laser range finder with a Multi-Function Laser System (MFLS). The current laser range finder is a non-eye safe laser capable of determining ranges of targets out to 7990 meters. The MFLS will provide the gunner with the capability to determine the target range out to 10,000 meters. This range finder operates at a higher repetition rate with narrower beam divergence for higher accuracy during operations in smoke, dust, and fog.

The second function of the MFLS is designating targets for smart munitions. In this role the laser is capable of transmitting a continuous beam which is coded to interface with laser guided munitions launched from aircraft. The MFLS is capable of designating targets out to 6000 meters.

The third function of the MFLS is for use in identifying targets as friend or foe. In the target profiler mode, the MFLS transmits pulses of light to the target, interprets the shape of the target based upon the returned light, and determines what the target is using an Aid Target Recognition (ATR) processor. The ATR determines the vehicle type by comparing the returned light against a database containing values of returned light associated with particular vehicles. The processor then displays the name of the vehicle in the gunner's and commander's sights. The commander or gunner makes the final determination on whether the vehicle is friend or foe, based on their knowledge of friendly and enemy vehicles operating in the area. In this mode the MFLS will profile targets out to 5000 meters. [Ref. 15:p. 10-12]

Through the replacement of the current thermal sight and laser range finder, the lethality and utility of the M1A1 will improve significantly. The new thermal sight will allow the tank crew to see further under all battlefield conditions, allowing them to engage targets at greater distances with better accuracy. The MFLS will provide accurate ranges to targets in all battlefield conditions, enable the tank to designate for smart munitions, and assist the crew in identifying targets before becoming engaged.

E. POTENTIAL IMPROVEMENTS

The improvements discussed are those which the Marine Corps considers to be the most feasible modifications to their M1A1s. Since technology and threat weapon systems will continue to improve, the Marine Corps must continue to modify their M1A1s to counter future threat systems. Several modifications have been proposed by the tank community which have the potential to be implemented as technology develops and fiscal resources become available. These improvements include a main gun smoke round, an automatic boresighting system for the fire control system, and the conversion of the analog computer system to a digital system similar to that found on the M1A2.

F. CONCLUSION

The planned and potential improvements to the Marines' M1A1s will enhance their capabilities through improved lethality, mobility, and reliability. These additional capabilities must be considered when Marine tanks are employed in support of MAGTF operations.

V. ANALYSIS

A. INTRODUCTION

This chapter analyzes the operations the Marine Corps' M1A1 tanks could perform in support of MAGTF operations. The following operations are analyzed in this chapter: offensive operations, defensive operations, other tactical operations, Operations Other Than War (OOTW), and emerging operations. In these operations, tanks can perform one or more of the following missions: as an infantry support force, as an anti-armor force, or as a maneuver force.

The analysis is based on the capabilities now and in the future of the M1A1, as described in Chapters III and IV. Lessons learned from both training and combat operations involving the M1A1, as well as conclusions from the 1996 Armor Conference, are included to support this analysis. While not every operation the MAGTF may conduct is included in this analysis, those which are most likely to benefit from the employment of the M1A1 are presented.

B. OFFENSIVE OPERATIONS

1. Overview

Offensive operations are designed to destroy the enemy, rather than seize terrain or strong points. During offensive operations, the force must possess sufficient firepower, maneuverability, lethality, flexibility, and protection to engage and destroy the enemy on a fluid battlefield. The offensive force must utilize their maneuverability and speed to surprise the enemy, attack the enemy's support structure, and disrupt his organization. The offensive force must also be capable of massing and dispersing its elements at the decisive time and place.

2. Movement To Contact

Movement to contact is conducted to establish or regain contact with the enemy. Once contact is made with the enemy, the force must be capable of rapidly maneuvering against the enemy to hit the weakest areas. The M1A1 tank is well suited to participate in a movement to contact. Its ability to maneuver over all types of terrain in most weather conditions allows the tank crew to rapidly hit the enemy's vulnerable areas. During the initial contact, the M1A1's firepower, specifically the long range of its main gun and high powered sights, will allow the tank crew to engage and destroy the lead elements of the enemy before the enemy is capable of reacting to the tank's fire. This early destruction of the enemy's leading forces will limit the enemy's intelligence gathering capability and force him to fight without the aid of an accurate picture of the battlefield.

The communication package in the M1A1 will further facilitate conduct of the operation through coordination of artillery and air against the encountered enemy. This coordination of arms is essential in a mechanized battle where the enemy may possess a larger number and variety of tanks, armored personnel carriers, and artillery. To counter this threat, the MAGTF coordinates artillery and aircraft through its lead element, typically tank forces. The tank force is capable of rapidly coordinating MAGTF air and artillery assets against the enemy. The M1A1's powerful suite of communication equipment enables the tank crew to communicate to all MAGTF assets up to 50 kilometers away. Additional communication equipment, such as High Frequency (HF) and Ultra High Frequency (UHF) radios, are frequently added to the M1A1's standard communication equipment to further enhance the tank force's ability to coordinate MAGTF fires on the enemy.

This communication suite will also facilitate rapid dissemination of intelligence gathered by the tank forces and deployment of the force in the most appropriate manner. The MAGTF commander's ability to know the battlefield and position forces is improved when the M1A1's long range communication capability is employed to relay battlefield intelligence to subordinate and supporting forces of the MAGTF.

The armor protection and survivability features of the M1A1 further enhance its ability to conduct a movement to contact. The armor will provide a degree of protection

for the crew against fire from the lead elements of the enemy, allowing it to operate against most conventional forces. The tank's thermal sights will allow the crew to engage the enemy through battlefield obscurity, such as smoke, which the enemy may employ in an effort to break contact. If tanks are employed as the lead element in the movement to contact, their smoke generating capability can be used to cover the movement of follow-on forces as they maneuver to hit the enemy in the flank or rear.

The capability of today's tank force to conduct a movement to contact with the M1A1 is superior to prior Marine tank forces employing the M60A1. The M60A1 was less maneuverable over cross country terrain, had a maximum cross country speed of only 17 mph, had significantly less armor protection, and was unable to operate on an obscured battlefield because it did not have a thermal sight.

3. Attack

An attack may occur if the enemy location is known or after contact has been made. Attacks require a great deal of firepower, mobility, protection, and flexibility. The most successful attack is performed by a combined arms team, utilizing infantry, artillery, armor, and air assets. The M1A1 is well suited to conduct attacks as part of a combined arms team. The range, cross country mobility, and speed of the M1A1 allows the MAGTF to rapidly cover terrain as they engage the enemy.

Once in the attack, the M1A1 can be employed in several manners. One method of employing tanks in the attack is attack by fire. In this method, the tank closes, firing as it moves, to destroy the enemy. As the enemy is destroyed, the tank force continues to move, allowing follow-on forces to clear the enemy from the objective. This capability to fire while on-the-move did not exist with the M60A1. Since the M1A1 can fire on-the-move, attack speed is increased, improving the MAGTF's element of surprise, while minimizing the amount of time the enemy has to react. The M1A1's accurate fire control system, lethal main gun, and ability to operate under most weather and battlefield conditions further enhance the M1A1's ability to conduct a more rapid and destructive attack than tank forces employing the M60A1.

The second form of attack is the assault. The assault is conducted when the enemy is capable of surviving an attack by fire. This may occur if the enemy possesses tanks or

fortified positions which are not destroyed by the tank's long range main gun fire or artillery and aircraft fires coordinated at the beginning of the attack. This form of attack requires the mobility and firepower of an attack by fire operation as well as armor protection for crew and vehicle survivability. The assault requires the force to fire on the enemy as it closes on and into the objective. The M1A1 is excellent for use in the assault. Its firepower and mobility allow the crew to quickly close on the enemy while engaging him. The armor package affords the crew protection from enemy fire as the tank closes on the enemy. As the tank moves onto the objective, the enemy will be subject to the shock effect created by the size and speed of the tank as it literally runs over their position. This shock effect will force the enemy to either fight in place or surrender.

The third type of attack the M1A1 can perform is support by fire. This type of attack utilizes the tank's main gun to destroy enemy vehicles at long range and the tank's machine guns for suppressive fire as a second force assaults the objective. In situations where the enemy does not possess significant anti-armor assets, this is the most efficient method of employing tanks in the attack. Since the tank carries three machine guns and a large amount of ammunition, the crew is capable of suppressing the enemy while an infantry force assaults the objective. While tank forces employing the M60A1 routinely conducted support by fire operations, they were limited because the M60A1 only carried two machine guns and half as much machine gun ammunition as the M1A1. The increased range and lethality of the M1A1's main gun over the M60A1's main gun further improves the tank forces ability to conduct a support by fire.

4. Reconnaissance

The M1A1 is capable of supporting two forms of reconnaissance: reconnaissance by fire and reconnaissance in force. Reconnaissance by fire is designed to force the enemy to return fire, exposing his position and type of weapons employed. Since the enemy may perceive the tank as the main attack force, the enemy will hopefully respond with his most lethal weapons. This reaction will allow the tank crew to identify the enemy's position and weapons. Since the M1A1's main gun is capable of long range engagements, the crew can conduct reconnaissance by fire without coming within range of enemy conventional weapons, such as tanks or reconnaissance vehicles. In close terrain, the tank's machine

guns can be employed to draw enemy fire while the armor will protect the crew from enemy machine gun and ATGM fires.

Reconnaissance in force is a deliberate attack designed to gain information on the enemy without becoming decisively engaged. The M1A1 tank's mobility, speed, and firepower allow the crew to quickly engage the enemy and then disengage, allowing them to gather knowledge on the enemy's strength, disposition, and weapons systems.

Marine forces employing the M60A1 rarely conducted reconnaissance operations because of this vehicle's inability to rapidly move over cross country terrain, its inability to engage targets at long ranges, its minimal amount of armor protection, and its lack of a thermal sight for use on an obscured battlefield.

5. Exploitation

Exploitation operations are conducted following an attack to completely destroy a disorganized and weakened enemy. Tanks can play a crucial role in combined arms exploitation operations. The M1A1's cross country speed of 30 mph and 300 mile cruising range enable it to quickly maneuver behind the enemy's front line. The tank's ability to identify targets through battlefield obscuration, such as smoke and fire from the assault, will enable the crew to engage enemy vehicles and emplacements other weapons systems in the combined arms team are unable to identify. This is another operation the M60A1 was less capable of conducting because of its limited speed, range, and lack of a thermal sight. Other assets in the MAGTF still do not possess the capability to identify and engage the enemy through battlefield obscuration, which makes the M1A1 the ideal weapon system for leading an exploitation.

6. Pursuit

Pursuit operations employ two forces, a direct pressure force and an encircling force to destroy the remaining enemy elements after an attack. The direct pressure force engages the enemy while the encircling force maneuvers to hit the enemy's flank and rear while blocking possible avenues of escape. The M1A1 is best utilized as an element in the direct pressure force, utilizing its mobility, firepower, and thermal sights to push the enemy into the encircling force.

Attack helicopters are the preferred weapon system for the encircling force. Although, under conditions which would not allow these systems to fly, such as heavy smoke or fog, tanks could successfully conduct this operation. The speed and maneuverability of the M1A1 allows the tank force to quickly move around the enemy. Also, the capability of the M1A1's fire control system to identify and engage targets through smoke or fog provides an alternative to the MAGTF commander when attack helicopters are unavailable or cannot fly due to adverse conditions.

7. Raid

Raids are attacks deep into enemy territory, designed to achieve a specific objective, such as destruction of a command site or supply depot. The M1A1 tank is an excellent weapon system for use in raids against high priority targets which must be destroyed immediately.

Typically, raids are conducted by small, light forces which can attack a target and withdraw without being detected. This type of raid usually involves helicopters delivering the force or airplanes delivering smart munitions. Under poor weather conditions or different tactical situations, these aircraft may not be able to fly or may be committed elsewhere.

The M1A1 provides the MAGTF commander with an alternative weapon system for use under this scenario. The M1A1's speed and long range firepower will enable the crew to quickly reach the objective, destroy it, and return to friendly lines. The armor protection and high power communication capabilities of the M1A1 will protect the crew from enemy fire during the raid and allow for coordination of supporting fire, if required. While the M1A1 is not quiet and is not usually considered for use in covert operations, if a high speed avenue of approach, such as a road, is available to the target, the M1A1 is capable of rapidly moving within range of and destroying the target.

If the M1A1 is employed in a raid, a tradeoff does exist. Because of the vehicles size and noise, the enemy may detect the tank and attempt to destroy it. This may force the tank crew to leave the vehicle behind while they egress back to friendly lines on foot. The priority of the target must be weighed against the probability of losing one or more M1A1's behind enemy lines when employing the M1A1 in raid operations.

Once the Marine Corps fields the smart munitions and Multi-Function Laser System (MFLS) discussed in Chapter IV, the role of tanks in raid operations can expand. The smart munitions will allow the tank crew to engage targets beyond the line of sight, and the MFLS will allow the crew to laser designate the target for aircraft guided smart munitions. These improved capabilities may allow the MAGTF commander to conduct a raid at greater distances with fewer forces. It may even be possible to conduct the raid employing the smart munitions without ever crossing into enemy territory. The full extent of the M1A1's capability to conduct raids utilizing these improvements will only be known after they are fielded.

8. Summary of Offensive Operations

M1A1 equipped tank forces are capable of conducting or supporting MAGTF forces employed in the operations discussed above. The application of their firepower, mobility, armor protection, and shock effect can contribute significantly to a combined arms force conducting these operations. The M1A1 is far superior to any other weapon system in the GCE. Its ability to rapidly maneuver over most terrain and to identify and engage targets under most conditions make it necessary to consider employing the M1A1 in any offensive operation conducted by the MAGTF.

C. DEFENSIVE OPERATIONS

1. Overview

Defensive operations are designed to force the enemy to fight on terrain the defending force has prepared. This terrain may be key tactical areas or an area where the defending force can canalize and stop the enemy. There are two primary types of defenses: a position defense and a mobile defense. Within each type of defense there are operations which tanks can perform in support of the MAGTF's defensive scheme.

2. Position Defense

Position defenses are designed to deny the enemy access to critical terrain. The position defense employs all elements of the combined arms team with weapons systems arranged to mutually support each other in order to mass fire on the enemy once in range. There are three elements of the position defense: the security force, the main battle force,

and the reserve. The M1A1 tank can contribute to the position defense as part of each of these forces.

a. Security Force

Three types of security forces are employed in the position defense: covering forces, guard forces, and screening forces. The covering force operates in front of the defended position to engage, delay or disrupt the enemy. Tanks can contribute to covering force operations through the application of their mobility and long range firepower. The tank crew can maneuver in front of the position defense, rapidly identify and engage the enemy, and egress back to the defended position.

The guard force protects the main force from observation, direct fire, and surprise attack. Typically the guard force is positioned along the flanks of the main force while a cover force operates in front of the main force. In the guard role, tanks can utilize their mobility and long range communication and observation capability to provide the position defense commander with intelligence on enemy movement and strength. The firepower of the M1A1's main gun allows the crew to engage an enemy conducting a surprise attack from the flank. The tank's mobility will allow the crew to continue to repel the enemy attack if it must withdraw back to the main battle force.

Screening forces are employed to gain and maintain contact with the enemy, provide intelligence on the enemy's actions, and attack the enemy with supporting arms. The screening force will not engage the enemy unless required for self-defense. In the screening role, the M1A1's mobility, long range firepower, and communication capabilities allow the tank crew to operate forward of the main battle force to identify the enemy's movements while providing the force with enough firepower to protect itself from enemy attack.

b. Main Battle Force

The main battle force is arranged within the position defense to engage the enemy once he comes within range. While tanks possess significant firepower for use in this role, they are less effective in this role because of the limited maneuver space characteristic of a position defense. Tanks should not be employed as the main battle force unless the situation requires the use of their firepower.

c. Reserve

The reserve force in the position defense is held behind the main battle force in an area protected from enemy direct fire. The reserve is employed to exploit enemy weaknesses once engaged by the main battle force, to reinforce the main battle force, or to serve as the counterattack force. Tanks are well suited to operate as the reserve force. Their speed and maneuverability allow the tank crew to quickly maneuver to the area where the enemy has become disorganized or where friendly forces require reinforcement. As the counterattack force, tanks can utilize their mobility and firepower to rapidly hit the enemy once he is within the main battle area. Since the position defense may disrupt the enemy's organization, his forces may not be prepared for a counterattack by tanks. The MAGTF commander can regain the initiative by employing the M1A1 in the counterattack force. Since the tanks have not been previously engaged, they can quickly move to engage the disorganized enemy.

3. Mobile Defense

Unlike the position defense, which is designed to deny the enemy terrain, the mobile defense is designed to push the enemy into an area where he can be destroyed through offensive action by the defending force. The mobile defense employs forces which will disrupt, fix, and then destroy the enemy. Disruption of the enemy is conducted by a force similar to the security forces employed in the position defense.

Fixing the enemy is conducted by forces employed along strong points to canalize and then stop the enemy's movement. The destruction of the enemy is then conducted by a counterattack or strike force. The M1A1 is best employed as the counterattack or strike force in a mobile defense. The tank's mobility, firepower, and armor protection enable the crew to rapidly close on the fixed enemy and destroy him with main gun and machine gun fire. The armor protection will ensure the tank is capable of closing on the enemy while minimizing injury to the crew. The communication capabilities of the tank will further enhance the crew's ability to destroy the fixed enemy in the counterattack or strike role, through the coordination of supporting air and artillery fires.

4. Summary of Defensive Operations

The M1A1 can be employed in both a position or mobile defense as part of one or more of the elements discussed above. The significant offensive capabilities of the M1A1 must be taken into consideration when employing the M1A1 in these defenses. If tanks are employed as part of the main battle force, the mobility of the M1A1 is not being fully utilized. If other assets with a high degree of mobility, such as attack helicopters, are available for conducting the counterattack, then it is feasible to employ the M1A1 as part of the main battle force. If these assets are not available, M1A1 equipped forces should be employed as the counterattack or strike force where their capabilities to rapidly maneuver and engage the enemy are maximized.

The capability of the M1A1 to rapidly maneuver against an enemy fixed within a defensive position, shoot on-the-move, and see through battlefield obscuration are all capabilities commanders employing the M60A1 did not have. Therefore, the commander must consider the added capabilities of the M1A1 over the M60A1 in employing tanks in his defense.

D. OTHER TACTICAL OPERATIONS

1. Overview

Other tactical operations are those operations which may be conducted during the offense, defense, or at times when the MAGTF is preparing for a new operation during the conduct of a campaign. The versatility of the M1A1 will allow the tank crew to conduct a variety of operations which will support the MAGTF's ability to build combat power ashore, transition from the defense to the offense, and overcome enemy emplaced obstacles.

2. Amphibious Operations

Amphibious operations are conducted to place forces ashore for follow-on operations against the enemy. The amphibious operation may be conducted against an opposing force or without opposition. Under either scenario, amphibious operations require a great deal of planning and coordination to place sufficient combat power ashore.

Because of limited ship-to-shore craft availability and the significant weight of the M1A1, tanks are not typically part of the initial wave of forces ashore.

While these constraints do exist, the use of the M1A1's Deep Water Fording Kit provides some flexibility in landing tanks. The Deep Water Fording Kit provides the M1A1 with the capability to disembark from a ship-to-shore craft which cannot land on the shore because of the beach gradient. As long as the craft can maneuver to an area where the water depth is 78 inches or less, the tank can move off the craft, into the water, and onto the beach. These operations were successfully conducted when a platoon of M1A1s were deployed with a Marine Expeditionary Unit (MEU) in 1995. [Ref. 21:p.1]

The MAGTF commander must also consider the enormous amount of combat power each tank brings to the battle in structuring the amphibious force. By putting a platoon of tanks ashore in the first waves of the assault, the MAGTF rapidly builds its combat power ashore. The M1A1, once ashore, can quickly move inland to provide a zone of protection for follow-on forces. Their armor protection and firepower can be employed to defeat the defending enemy forces.

3. Breaching Operations

Breaching operations are conducted to overcome enemy emplaced obstacles such as tank ditches, wire, and mines. The enemy may place the obstacles in an area where he can fire on the force that encounters the obstacle, or the enemy may place obstacles just to slow the opposing force. Once an obstacle is encountered, the MAGTF will conduct a breach of the obstacle using three forces: a support force, a breaching force, and an assault force. The M1A1 can contribute to the success of each of these forces.

a. Support Force

The role of the support force is to provide fire support while the breach is being conducted. This fire support should suppress or destroy the enemy so that the breaching force can clear the obstacle without coming under fire from the enemy. The M1A1 is a superb weapon system for use in this support role. The tank's main gun and machine guns can effectively suppress and destroy the enemy. The M1A1's armor protection, mobility, and communication capabilities allow the tank crew to position the

tank where it can adequately support the breach force and coordinate supporting fires from air and artillery assets.

b. Breach Force

The breach force is task organized to overcome obstacles emplaced by the enemy. Tanks, along with infantry and combat engineer forces, are capable of quickly breaching most obstacles on the battlefield. The primary role of tanks as an element in the breach force is to clear mines with the M1 mine clearing blade. In addition to the tanks capability to clear mines within the obstacle, the tanks armor protection and communications allow the crew to maneuver to the edge of the obstacle and provide intelligence to the MAGTF commander on the structure of the obstacle. The armor protection, in conjunction with suppressive fires provided by the support force, allows the tank crew to collect this intelligence while minimizing injury to crew members or damage to the vehicle.

Once the breach force tanks are positioned at the edge of the obstacle, they can provide close in fire support to the combat engineers and infantry clearing other portions of the obstacle. The M1A1's smoke generating capability allows the crew to create a smoke screen between the breach force and the enemy, further minimizing the breach forces' probability of being successfully engaged by the enemy. The success of this smoke screen is dependent on favorable weather conditions which carry the smoke in the enemy's direction.

c. Assault Force

The role of the assault force is to rapidly move through the obstacle once it has been cleared and assault the enemy. The M1A1 is an excellent weapon system for conducting the assault portion of a breaching operation. The tank's capability to rapidly accelerate and fire on-the-move through battlefield obscuration allows the tank crew to engage and destroy the enemy as the assault force moves through and clears the obstacle.

4. Military Operations on Urban Terrain (MOUT)

Military operations on urban terrain are conducted to attack an enemy defending a built-up area such as a town or city. This type of operation is conducted predominately by the infantry, requiring building by building movement to clear the enemy as the force

moves through the area. Typically, tanks are employed in MOUT as a direct fire support asset, providing fires from outside of the built-up area in support of the infantry. Tanks can also be used to protect high speed avenues of approach the enemy may use to conduct a counterattack.

While these roles are the most traditional employment techniques for tanks in MOUT, the M1A1 is capable of operating within the built-up area as a close-in fire support asset to the infantry. A tank section (two M1A1s) may provide a significant advantage to an infantry platoon conducting MOUT. The tank's thermal sight assists the crew in identifying enemy positions. The crew can fire HEAT rounds to create holes in buildings and destroy barricades. The tanks three machine guns can provide suppressive fires for the infantry. The tanks smoke generating capability can create a smoke screen to cover the movement of the infantry. The M1A1's mine clearing blade can clear mines and smash through barricades.

The shock effect of the M1A1 can create a psychological advantage to the supported infantry and a psychological burden for the enemy. The supported infantry gain this advantage because of the knowledge that they have a highly lethal weapon system in direct support of their effort. The enemy experiences shock effect because of their inability to destroy the tank due to its armor protection. The enemy's machine gun fire and shoulder fired anti-tank weapons aimed at the frontal armor will have little effect on the M1A1.

In 1992 the Army conducted an operation in a MOUT environment to test the feasibility of employing the M1A1 in this type of operation. The results were significant. An infantry platoon of twenty-five men attacking a five to ten man enemy force without tank support suffered ten to twenty-five casualties and ultimately failed. The same size force attacking with tank support succeeded in destroying the enemy while suffering no more than three casualties. [Ref. 17:p. 24]

These tests further concluded that the best task organization for MOUT was a tank section in support of each infantry platoon. In addition to the added firepower the M1A1 provided during these tests, the M1A1 was utilized as an emergency evacuation platform,

a logistics carrier, and as an escort platform. These innovative employment techniques demonstrate the inherent versatility of the M1A1.

While these tests were significant, limitations do exist in the employment of the M1A1 in MOUT. The enemy may employ anti-tank missiles against the tanks. While the M1A1's frontal armor will protect it from ATGMs, an ATGM fired at the rear or side of the M1A1 could disable the tank, limiting its ability to support the infantry. To minimize the effects of ATGMs, tanks should move with the infantry, ensuring no enemy is able to engage the tanks from the rear or sides.

Training for this creative type of M1A1 employment is rarely conducted in the Marine Corps, but must be considered to ensure the MAGTF is utilizing all available assets during MOUT.

5. Transition Operations

Transition operations are those operations conducted throughout the battle to reposition forces, overcome natural obstacles, or reorganize. These types of operations include passage of lines, relief in place, withdrawal, linkup, hasty river crossing, and assembly area operations. These operations require the flexibility and versatility of a weapon system capable of overcoming natural obstacles, conducting operations at night and during periods of limited visibility, and providing support to other forces. The M1A1 is capable, in concert with other forces of the combined arms team, of successfully participating in these operations.

6. Summary of Other Tactical Operations

The M1A1 is capable of conducting or supporting operations such as amphibious operations, breaching operations, Military Operations on Urban Terrain, and transition operations. With the inclusion of the M1A1 in each of these operations, the firepower, mobility, and survivability of the force will be enhanced.

E. OPERATIONS OTHER THAN WAR (OOTW)

1. Overview

Operations Other Than War is a broad term used to describe those operations not involving direct conflict with an enemy, such as promoting regional stability, supporting

democratic initiatives and objectives, retaining U.S. influence, providing humanitarian assistance, and assisting civilian authorities. Recent Operations Other Than War where the M1A1 has been employed include Operation Restore Hope in Somalia to provide humanitarian assistance and Operations in Bosnia to support NATO's implementation of the Dayton peace agreement. These operations utilized the M1A1's versatility to conduct show of force, quick reaction, patrol, and convoy escort operations.

2. M1A1s in Somalia

The Marine Corps employed a platoon of M1A1s in Somalia during Operation Restore Hope in 1993. The most effective task organization was usually a tank section supporting an infantry company. The shock effect from the M1A1 helped to deter aggression by belligerent forces and provide a psychological advantage to the supported infantry. The tanks mobility and breaching capabilities allowed the tanks to maneuver unimpeded throughout the city, overcoming road blocks and debris emplaced by forces opposed to the Marines' presence. The tank's thermal sight enabled the crew to identify potential threats to the Marine infantry patrols, allowing the crew to alert the infantry of a possible ambush site or sniper position. The tank's armor protection and size drew the fire from belligerent forces away from the infantry towards the vehicle. Since the armor protects the crew against small arms fire and fragmentation, this method of employment proved very successful in relieving pressure on the infantry without forcing the tanks to return fire. The heavily armored M1A1 discouraged the use of anti-tank weapons and mines the belligerent forces may have considered employing. [Ref. 9:p. 7]

On occasion, tank forces were used to conduct firepower demonstrations. The M1A1's mobility and firepower enabled the crew to quickly maneuver to an area to conduct demonstrations utilizing the tank's machine guns. While the main gun was not employed during Operation Restore Hope, its presence served as a further indication of the Marines' resolve to protect its forces.

The employment of the M1A1 as part of a Quick Reaction Force (QRF) provides immediate support to a friendly force which has become engaged. On October 3rd, when Army Ranger helicopters were shot down and the soldiers killed by belligerents, the Army had to organize an extraction force using Malaysian and Pakistani units equipped with

tanks. Lack of an armor supported QRF is considered to be one of the contributing factors to the casualties which occurred. [Ref. 18:p. 58]

The M1A1 was also employed as a convoy escort. In this role the tank's cruising range, mobility, and thermal sight were utilized to assist with convoy security. The tank could quickly destroy roadblocks, identify potential ambush sights, and engage belligerent forces, if necessary.

The tank was also employed in some rather unconventional methods. Tanks were used to clear trails by beating down overgrown brush. The M1A1 was also used to remove abandoned vehicles which were blocking intersections and main roads. These actions demonstrated the Marines' willingness to assist the locals. [Ref. 9:p. 5]

The M1A1s employed in Somalia demonstrated the versatility of tanks in OOTW. Those involved in this operation consider the tank to be a critical element in the conduct of a successful operation in an environment such as Somalia. While many consider the tank to be an offensive weapon only for use in war against mechanized forces, the Marines who employed the M1A1 in Operation Restore Hope proved the tank can contribute to the success of the MAGTF in OOTW.

3. M1A1s in Bosnia

The Army began employing two battalions of M1A1 tanks along with other vehicles of the 1st Armored Division in Bosnia in December, 1995. Their mission is to enforce the peace agreement reached at the Dayton peace accord as part of a multinational force under the direction of NATO. The M1A1 has been used very effectively during this peace enforcement operation. The tanks have been employed as mobile check points and road blocks; and with the use of the Army's mine roller system for the M1A1, tanks have succeeded in clearing roads blocked by mine fields.

The majority of the M1A1s in Bosnia are being employed as part of a QRF, allowing the commander to rapidly reinforce areas or protect soldiers who come under hostile fire. Their most significant contribution is their presence. This presence is a psychological advantage to U.S. forces who are familiar with the M1A1's capabilities and know it can quickly come to their aid if required. [Ref. 19:p. 10] While most types of operations conducted in Somalia with the M1A1 have not been required in Bosnia, the

ability of this tank to conduct operations to protect U.S. forces if required make the employment of the M1A1 crucial in peace enforcement operations.

4. Summary of Tanks in OOTW

The use of the M1A1 in Somalia and Bosnia are two excellent examples of the tank's flexibility in supporting operations which do not involve typical combat operations. The M1A1 is an extremely versatile weapon system which could play a decisive role in any Operation Other Than War. Similar to tank employment against a known enemy in a combat environment, tank employment in OOTW must be conducted in support of and with the support of the infantry. One-dimensional forces should never be employed, particularly in OOTW, where the situation can quickly change from peace to conflict.

F. EMERGING OPERATIONS

1. Overview

Emerging operations are those operations which are being developed for future use. The Marine Corps recently established the Commandant's Warfighting Lab (CWL) to experiment with new operational concepts in an effort to better employ emerging technology and address future threats. The Marine Corps is also in the process of developing a new form of amphibious operation, Operational Maneuver From The Sea (OMFTS). The M1A1 has potential to be employed in these emerging operations.

2. Commandant's Warfighting Lab Initiatives

The CWL envisions the future battlefield as lethal, chaotic, opportunistic, asymmetric, and public in both low and high intensity situations. The mission of the CWL is to evaluate new operational concepts and technologies and assess their applicability and value to tactics, techniques, procedures, and organization of the operating forces. [Ref. 20:p. 2]

a. Engagement Coordination

One of the objectives of the CWL is to experiment with new methods of coordinating fires from artillery, naval gun fire, and aircraft. This experiment is designed to utilize emerging digital communication technologies to rapidly engage the enemy with

smart guided and conventional munitions. While this experiment is focused on employing small infantry forces in teams which are easily emplaced and extracted, the role of tanks should be considered in future operations requiring laser designation for smart munitions and digital communication.

The M1A1 has the communication capability to transmit information digitally for coordinating these types of engagements, which meets the CWL's desire to digitally coordinate fires. With the addition of the MFLS and smart tank rounds, the tank crew will have the capability to laser designate for aircraft delivered smart munitions and engage targets beyond the line of sight with the STAFF round. The advantage of utilizing the M1A1 in engagement coordination over a light infantry force is the inherent protection and mobility the M1A1 provides the crew.

b. Non-Lethal Weapons

The CWL is also considering the employment of non-lethal weapons designed to impose the Marines' will on others without injuring the opposing force. This experiment is designed to explore the benefits of new non-lethal weapons, such as foam guns or non-toxic sprays, for use in operations such as riot control.

The M1A1 may not seem like a logical choice when deploying forces to control, without harming, people. The M1A1 does, however, possess some unique capabilities which could be employed to control a crowd. The M1A1's ability to intimidate is a significant non-lethal method of crowd control. Army forces in Bosnia create this shock effect by simply driving the M1A1s through areas where belligerents may exist. The theory is, if these people see the size and hear the noise of the M1A1, they will think twice before opposing the peace force. The tank's smoke generating capability and high temperature exhaust, when directed towards the opposition, are other capabilities which could be employed to disrupt a crowd. Marines who employed the M1A1 in Somalia considered this to be an excellent way of dispersing a crowd. They sighted the tank's size, noise, and hot exhaust as the characteristics which enabled them to control the crowd without inflicting serious or permanent injuries. [Ref. 21:p. 5]

c. CWL Summary

The operations discussed are only two of the many experiments the CWL is considering in developing new operational concepts. The employment of the M1A1 is not feasible in all operations. It is, however, one of the most technologically advanced weapon systems in the MAGTF, and should be considered as new operational concepts develop.

3. Operational Maneuver From the Sea (OMFSTS)

Operational maneuver from the sea is the application of maneuver warfare to operations in a maritime environment. The objective is to conduct a seamless operation from the sea to an objective inland without the requirement to land a force, buildup combat power ashore, and then move inland towards the objective. [Ref. 4:p. 4-1] Operational requirements include the concentration of firepower at the decisive point, application of shock effect to overcome enemy resistance at the beach, and flexibility to exploit enemy weaknesses as they are discovered inland. The M1A1 is an excellent weapon system for meeting these requirements. [Ref. 4:p. 4-6]

The M1A1 creates an enormous amount of shock effect when employed. The speed and cross country mobility of the M1A1 will allow the crew to rapidly move inland and mass its fires at the decisive time and place. Furthermore, the M1A1 is a flexible weapon system, capable of engaging most threat weapons systems on the battlefield. As these threat systems improve, the M1A1 will improve as well, providing the MAGTF commander with the ability to mass fires, conduct long range engagements, and coordinate indirect fires from greater distances.

The difficulty in employing the M1A1 in OMFSTS is the limited number of ship-to-shore craft capable of rapidly transporting the M1A1 ashore. While some craft are capable of carrying the M1A1, the capacity of these craft is rapidly utilized by the large and heavy M1A1. As such, the type of combat power needed ashore must be weighed against the capacity of each craft available to the commander.

4. Summary of Emerging Operations

The experimentation with new operational concepts by the Marine Corps is a critical step in the process of ensuring Marines employed in all environments are well equipped and trained to win and survive in future conflicts. Continuous experimentation and evaluation to maximize the M1A1's utility in future conflicts will serve the Marine Corps well.

G. CONCLUSION

This chapter discussed a variety of operations tanks could perform in support of the MAGTF. The M1A1 is a highly versatile weapon system which has the potential to be employed in conflicts ranging from high-intensity war against a sophisticated enemy to low-intensity peace enforcement operations in third world countries. In each operation discussed, the employment of tanks must be done in conjunction with other forces, including infantry, artillery, and aircraft.

Tanks are capable of conducting these operations in missions which utilize the tank as a maneuver element, an infantry support element, or as an anti-armor element. While not every possible operation the MAGTF could be tasked with conducting has been discussed, those which could most benefit from the firepower, mobility, armor protection, and shock effect of the M1A1 have been presented. Table 2 summarizes the operations which the M1A1 could perform and the capabilities of the M1A1 which contribute to the success of each operation.

Operation	Firepower	Mobility	Armor	Shock Effect	Communications
Movement to Contact	X	X	X		X
Attack	X	X	X	X	X
Reconnaissance	X	X	X		X
Exploitation	X	X		X	X
Pursuit	X	X		X	X
Raid	X	X	X		X
Security	X	X	X		X
Position Defense	X	X	X		X
Mobile Defense	X	X	X		X
Amphibious	X	X	X	X	X
Breaching	X	X	X		X
MOUT	X	X	X	X	X
Transition		X			X
OOTW	X	X	X	X	X
Engagement Coordination	X	X	X		X
Non-lethal Weapons		X		X	X
OMFTS	X	X	X	X	X

Table 2. Summary of M1A1 capabilities utilized to conduct each operation.

VI. CONCLUSIONS AND RECOMMENDATIONS

A. CONCLUSIONS

The primary purpose of this thesis was to analyze those operations the M1A1 tank could perform in support of the Marine Air-Ground Task Force. The research and analysis demonstrate the M1A1's ability to conduct or support operations along the entire spectrum of warfare. While the M1A1 is most capable of conducting high-intensity operations in war, it is a versatile weapon system capable of supporting forces and operating in environments not normally considered, such as peacekeeping and Military Operations on Urban Terrain.

The M1A1 is capable of conducting or supporting offensive, defensive, and other tactical operations. Some of the operations discussed include a movement to contact, reconnaissance, position and mobile defenses, amphibious operations, and breaching operations, among others. In each operation, the MAGTF benefits from the M1A1's firepower, mobility, armor protection, shock effect, and communication capabilities to rapidly shape the battle in the MAGTF's favor.

While one or more characteristics of the M1A1 may contribute most to the MAGTF's success for each particular operation discussed, such as the vehicle's firepower and mobility in conducting a movement to contact, the versatility of the M1A1 enables it to conduct or support virtually any operation the MAGTF may be tasked with conducting. It is this versatility which must be considered when MAGTF commanders structure their force to accomplish the mission at hand.

In addition to the thesis' primary purpose, four subsidiary research questions were addressed. The first dealt with exploring what operations the M1A1 is capable of conducting or supporting outside of typical tank operations. The analysis provided insight into the employment of the M1A1 in Operations Other Than War, Military Operations on Urban Terrain, and several emerging operations currently under consideration by the Commandant's Warfighting Lab.

The second and third subsidiary research questions prompted a critical look at what are the current and future capabilities of the Marines' M1A1 tank. The current M1A1 tanks employed by the Marines possess the armor protection, mobility, and firepower required to counter current threat weapon systems. The vehicle's survivability features enable the tank crew to employ it in operations previously not possible. The M1A1's lethality enables the crew to engage enemy forces at greater ranges with more accuracy. The mobility of the M1A1 enables the tank crew to operate in virtually any environment at speeds which facilitate rapid destruction of the enemy. Future modifications will enable the tank crew to see further, engage targets at greater distances, operate under the most adverse weather and battlefield conditions, and improve the reliability of the vehicle.

The fourth subsidiary research question developed analysis on the M1A1's role in the Marine Corps' evolving doctrine of Operational Maneuver From the Sea (OMFTS). Since each M1A1 possesses a significant amount of firepower and mobility, the employment of the M1A1 in OMFTS will enable the MAGTF commander to rapidly mass fires deep into enemy territory. The analysis also addressed the challenges associated with placing the M1A1 ashore via ship-to-shore craft. Since OMFTS is still in the developmental stage, further analysis is required to understand the appropriate use of the M1A1 in OMFTS.

B. RECOMMENDATIONS FOR FURTHER RESEARCH

The capabilities of the M1A1 will continue to improve as technology develops and fiscal resources become available. As OMFTS doctrine develops, the employment of the M1A1 must be studied. To address these areas, a follow-on study should ask the following questions:

1. What technological improvements should be made to the M1A1 to support emerging operations?
2. How can the M1A1 be transported from ship-to-shore during OMFTS without constraining the MAGTF's ability to place other assets ashore?

Additionally, further research should be conducted to determine the most effective method of employing the M1A1 in military operations on urban terrain and in operations other than war. These are areas where the M1A1 is well suited for use, but where limited experience exists on the best methods of employment.

LIST OF REFERENCES

1. Fuller, J. F. C. Armored Warfare. Westport, CT: Greenwood Press, 1983.
2. Fleet Marine Force Manual 9-1, Tank Employment / Anti-mechanized Operations, Marine Corps Combat Development Command, 1981.
3. Operational Handbook 6-1, Ground Combat Operations, Marine Corps Combat Development Command, 1988.
4. Fleet Marine Force Manual 6, Ground Combat Operations, Marine Corps Combat Development Command, 1995.
5. Field Manual 71-1, Tank and Mechanized Infantry Company Team, Headquarters, Department of the Army, 1988.
6. Jane's Armour and Artillery, Jane's Information Group, Inc., 1995.
7. Characteristics and Description Book, M1A1 Tank, U.S. Army New Equipment Training Team, Fort Knox, KY, 1988.
8. M1A1 Abrams Tank Characteristics, U.S. Military Academy World Wide Web weapons file, (<http://www.dmi.usma.edu/weapons/m1a1spec.htm>), 1996.
9. Presentation notes from Major M.F. Campbell, USMC Mounted Operations Somalia, June, 1996.
10. United States Marine Corps Fact File, M1 Mine Clearing Blade System, U.S. Marine Corps World Wide Web weapons file, (<http://www.usmc.mil/factfile/221e.htm>), 1996.
11. Pulse Jet Air System Cost Benefit Analysis, U.S. Army Tank Automotive and Armaments Command, Warren, MI, March, 1996.
12. Presentation notes from J.C. Sutton, Chief, Thermal Branch, PM-NVEO, Horizontal Technology Integration Program for Thermal Driving Viewers, May, 1994.
13. Final Memorandum of Notification for the Cartridge, 120mm: HEAT-MP-T, M830A1, Department of the Army, Picatinny Arsenal, NJ, February, 1993.
14. Held, B.J., "Tomorrow's Smart Tank Munitions", Armor, March-April, 1995.

15. Kennedy, Howard, "Second Generation FLIR sensors at Texas Instruments: an overview", Texas Instruments Technical Journal, January-February, 1996.
16. Presentation notes from T. Jo, Multi-Function Laser System, May, 1995.
17. Beston, W.R., "Tanks and Urban Combat", Armor, July-August, 1992.
18. Allard, K., "Somalia Operations: Lessons Learned", National Defense University Press, January, 1995.
19. Lehner, C., "Bosnia Report: Task Force Eagle's Armor and Cavalry Operations in Bosnia", Armor, May-June, 1996.
20. Presentation notes, The Draft CWL Five Year Experimentation Plan, Marine Corps Combat Development Command, April, 1996.
21. Notes taken by the author during the 1996 Armor Conference, Fort Knox, KY, June, 1996.

APPENDIX A. M1A1 DRAWINGS AND PICTURES

This appendix is provided to assist those readers not familiar with the components of the M1A1 tank discussed throughout this thesis.

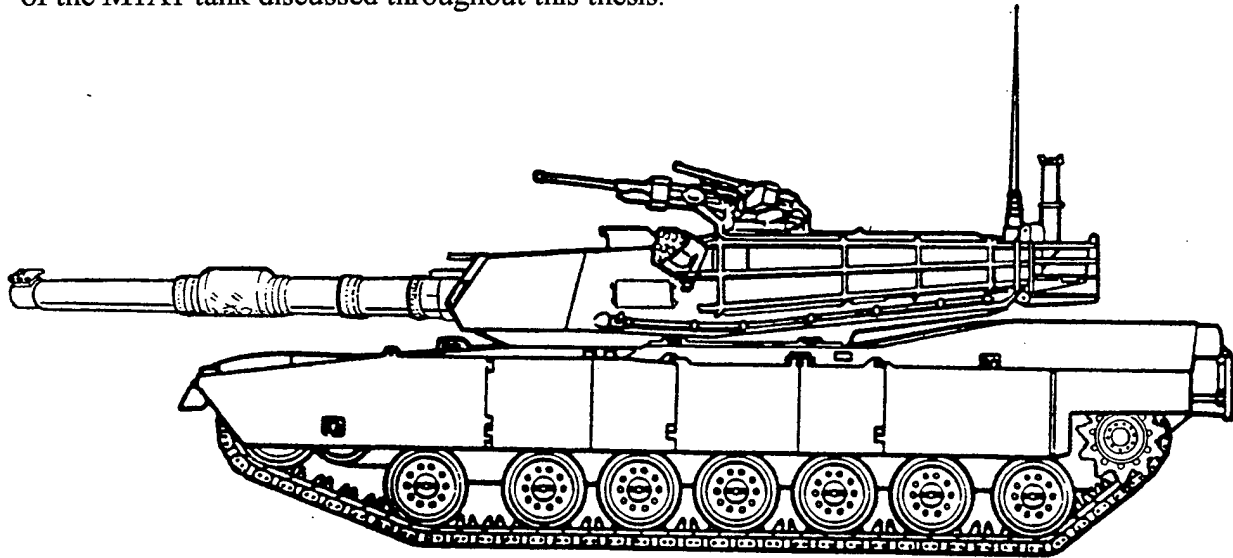

Figure 1. Left side view of M1A1 Tank. [Ref. 7:p. 2-2]

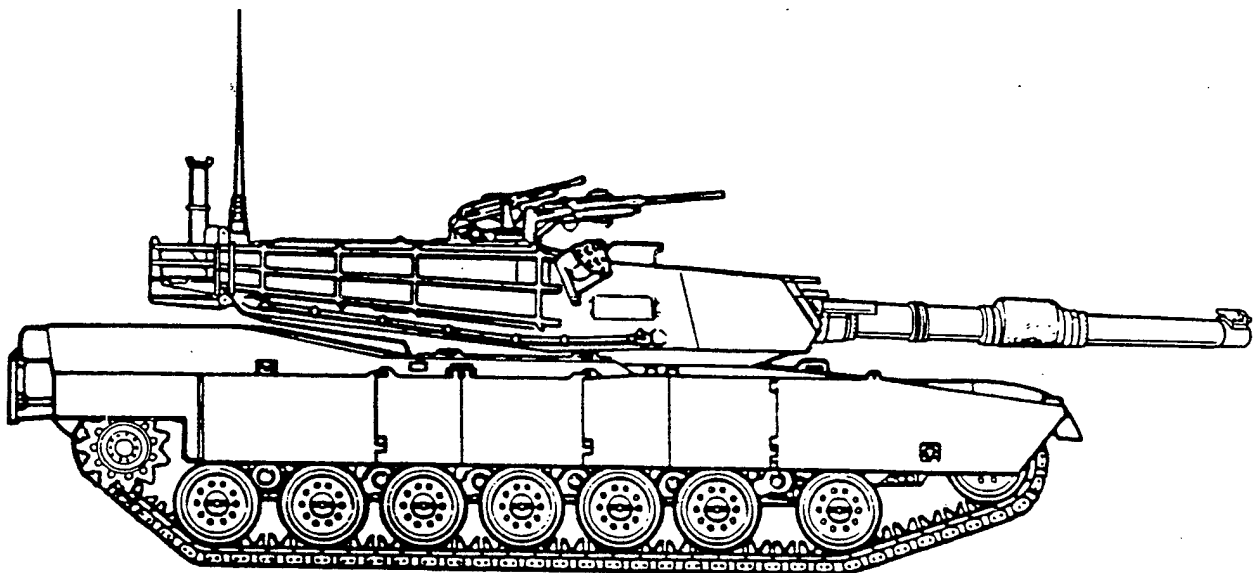

Figure 2. Right side view of M1A1 Tank. [Ref. 7:p. 2-2]

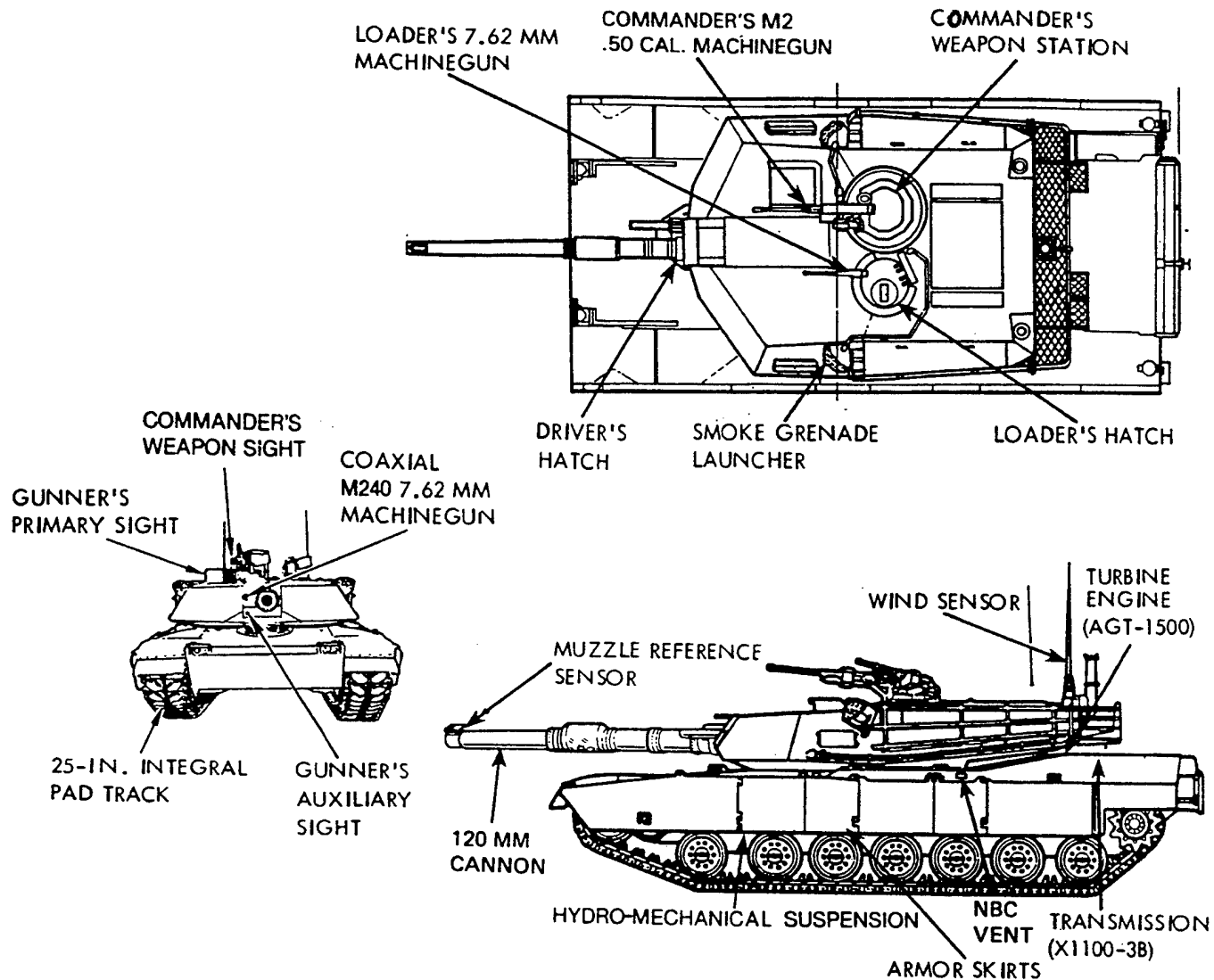

Figure 3. M1A1 Tank External Features. [Ref. 7:p. 2-5]

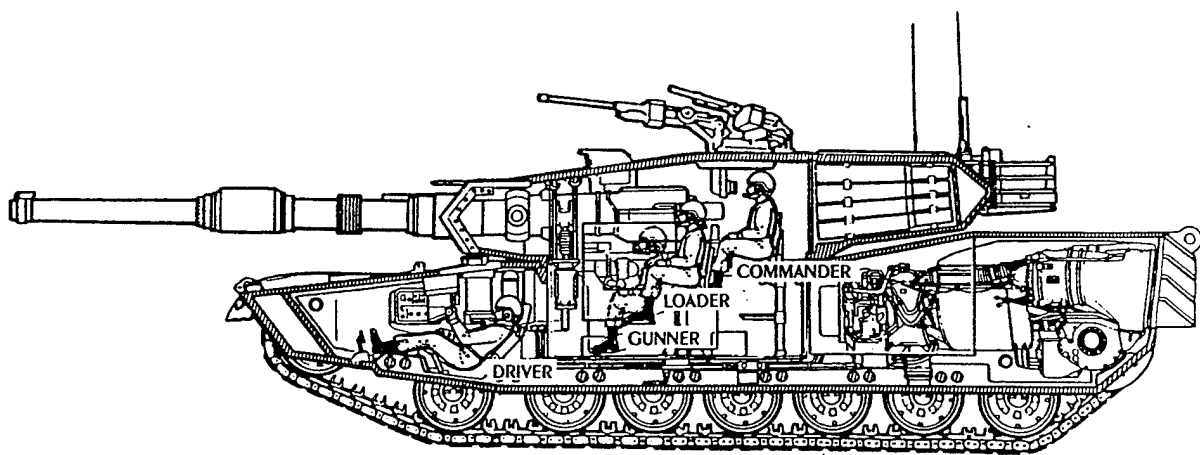

Figure 4. Cutaway view of M1A1 Tank showing crew positions. [Ref. 6:p. 137]

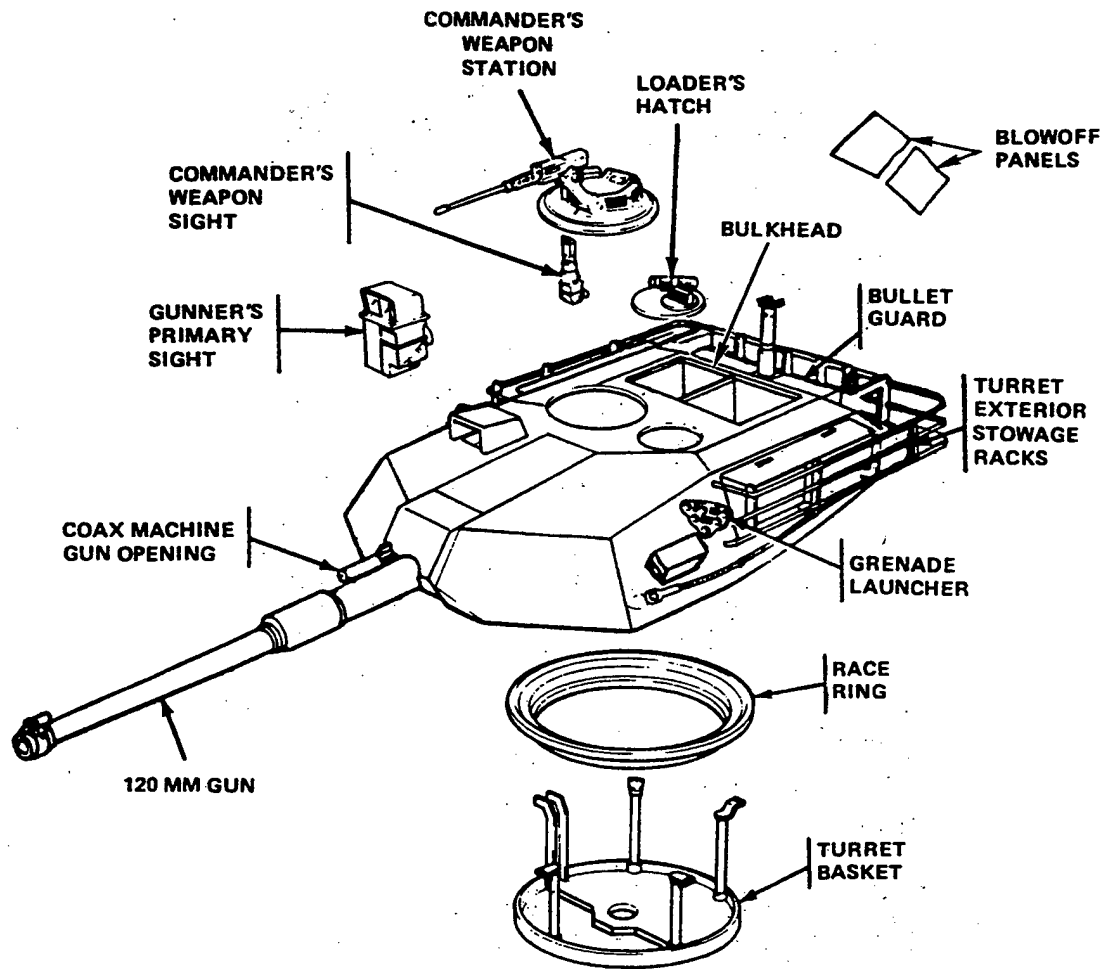

Figure 5. M1A1 Tank Turret Structural Features. [Ref. 7:p. 3-32]

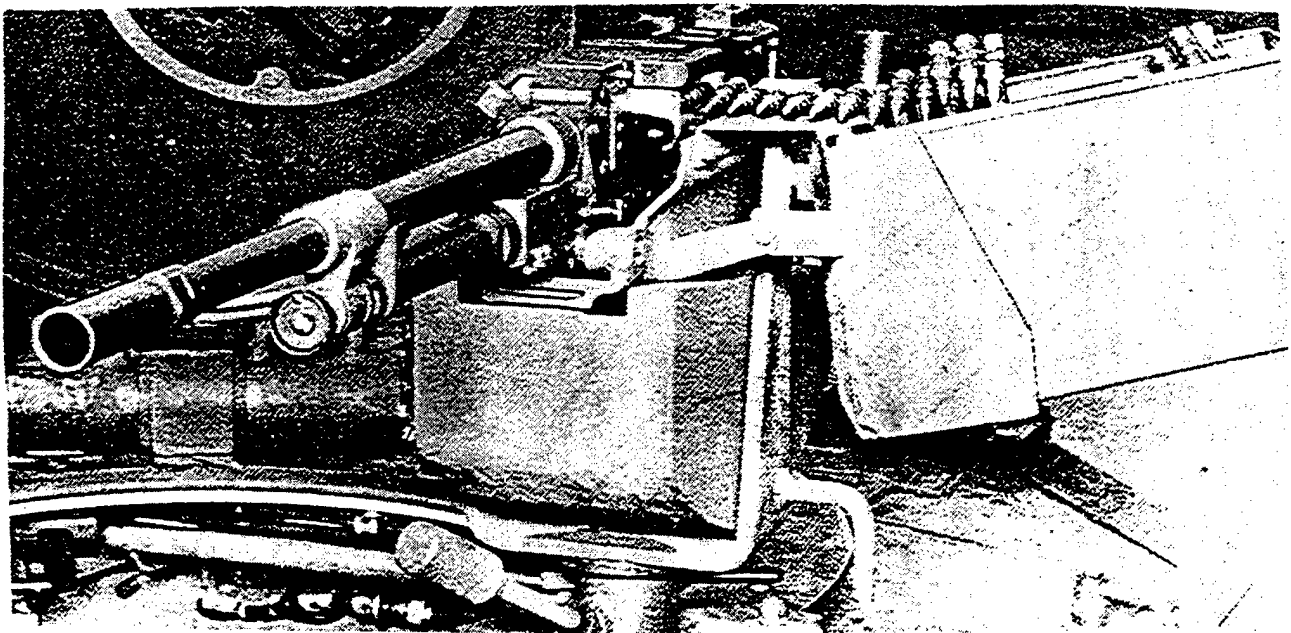

Figure 6. M240 Loader's Machine Gun. [Ref. 6:p. 3-104]

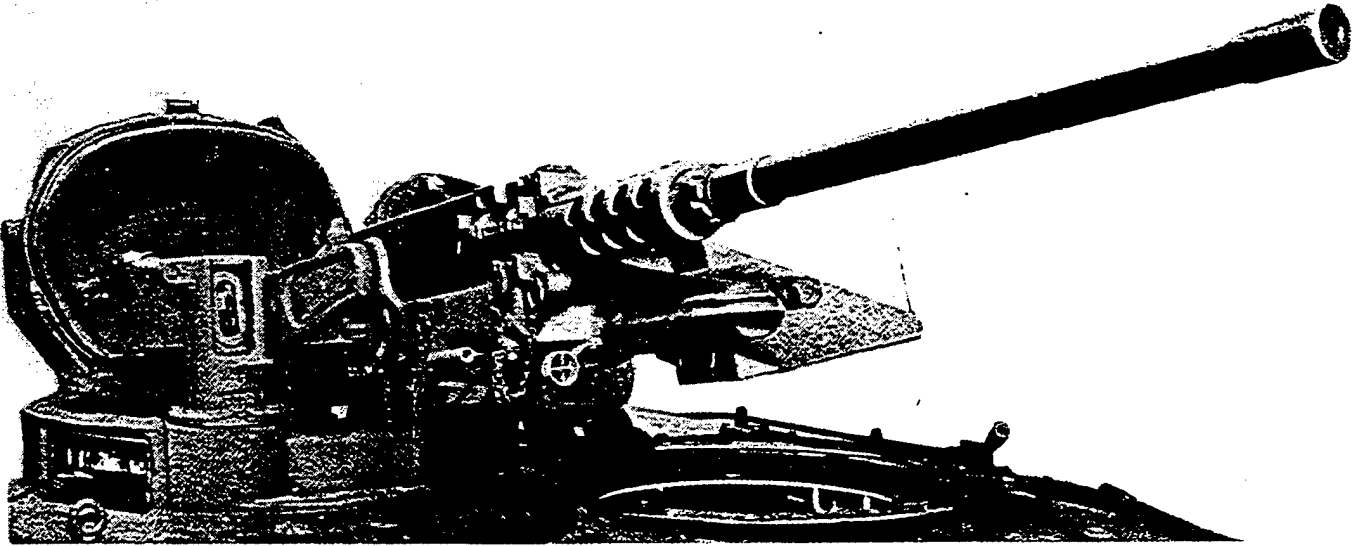

Figure 7. M2 Commander's Machine Gun. [Ref. 6:p. 3-105]

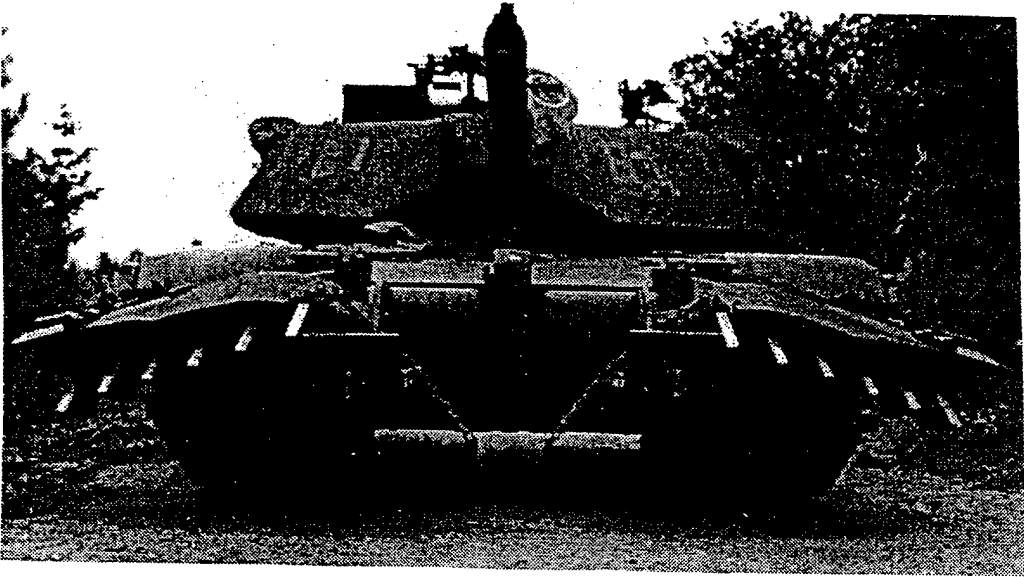

Figure 8. M1A1 Tank with Mine Clearing Blade installed. [Ref. 6:p. 139]

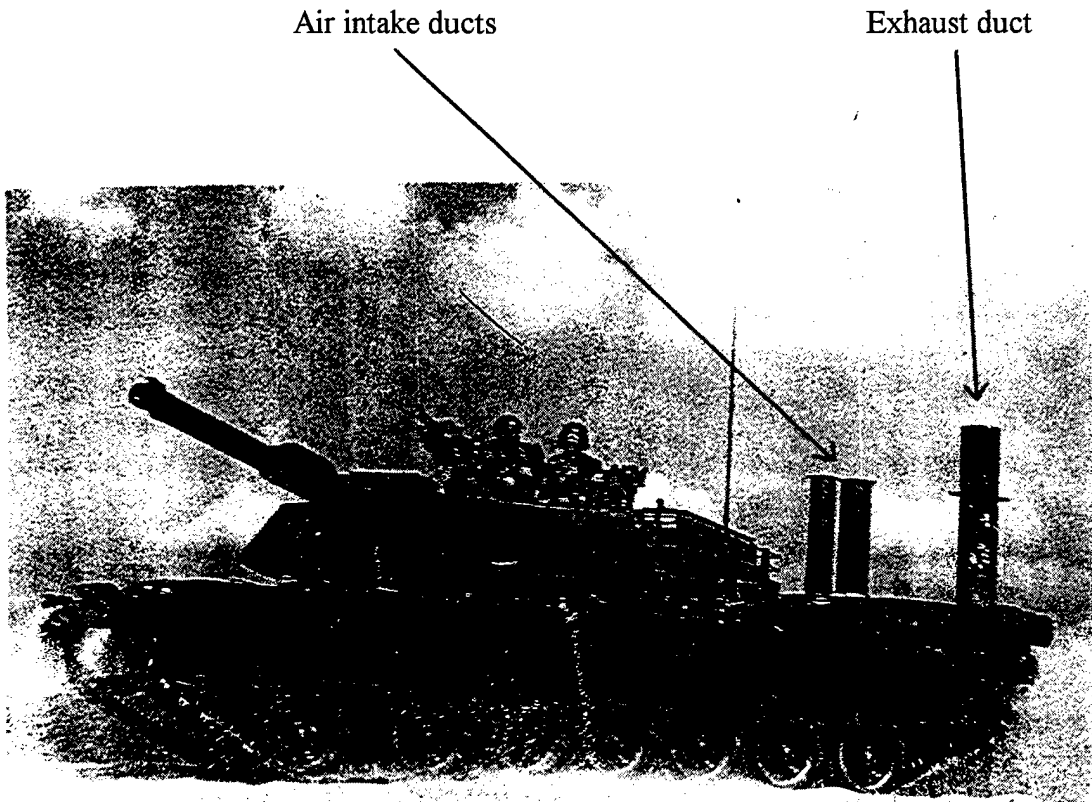

Figure 9. M1A1 Tank with Deep Water Fording Kit installed. [Ref. 6:p. 139]

APPENDIX B. LIST OF ACRONYMS

ATR	Aid Target Recognition
ATGM	Anti-tank Guided Missile
ACE	Aviation Combat Element
CSSE	Combat Service Support Element
CE	Command Element
CWL	Commandant's Warfighting Lab
DWFK	Deep Water Forging Kit
DECU	Digital Electronic Control Unit
DTV	Driver's Thermal Viewer
EFP	Explosively Formed Penetrator
EAPU	External Auxiliary Power Unit
FM	Field Manual
FY	Fiscal Year
FMF	Fleet Marine Force
FMFM	Fleet Marine Force Manual
FOD	Foreign Object Damage
FLIR	Forward Looking Infrared
GCE	Ground Combat Element
HEAT	High Explosive Anti-tank
HF	High Frequency
LIC	Low Intensity Conflict
MAGTF	Marine Air-Ground Task Force
MEU	Marine Expeditionary Unit
MOUT	Military Operations on Urban Terrain
MFLS	Multi-Function Laser System
NATO	North Atlantic Treaty Organization
NVEO	Night Vision and Electronics Office
NVL	Night Vision Lab
NBC	Nuclear, Biological, and Chemical
OH	Operational Handbook
OMFTS	Operational Maneuver From the Sea
OOTW	Operations Other Than War
PLRS	Position Location and Reference System
PJAS	Pulse Jet Air System
QRF	Quick Reaction Force
SINGARS	Single Channel Ground and Airborne Radio System
STAFF	Smart Target Activated Fire and Forget
TTPs	Tactics, Techniques, and Procedures
UHF	Ultra High Frequency

INITIAL DISTRIBUTION LIST

	Number of Copies
1. Defense Technical Information Center..... 8725 John J. Kingman Rd., Ste 0944 Ft. Belvoir, VA 22060-6218	2
2. Dudley Knox Library..... Naval Postgraduate School 411 Dyer Rd. Monterey, CA 93943-5101	2
3. Director, Training and Education..... MCCDC, Code C46 1019 Elliot Rd. Quantico, VA 22134-5027	1
4. Director, Marine Corps Research Center..... MCCDC, Code C40RC 2040 Broadway Street Quantico, VA 22134-5107	2
5. Director, Studies and Analysis Division..... MCCDC, Code C45 300 Russell Road Quantico, VA 22134-5130	1
6. Curricular Officer, Code 36..... Naval Postgraduate School Monterey, CA 93943-5002	1
7. LTC Greg Walls, Code SM/WI..... Naval Postgraduate School Monterey, CA 93943-5101	1
8. Professor James E. Suchan, Code SM/Sa..... Naval Postgraduate School Monterey, CA 93943-5101	1
9. Captain Wade Foster..... 800 Ridgeside Road Milford, MI 48353	2

- 10. Commanding Officer (Attn: ATZK-MC)..... 1
 Building 2350 Bailey Hall
 US Army Armor Center
 Fort Knox, KY 40121-5200

- 11. Inspector-Instructor..... 1
 4th Tank Battalion
 45482 Hercules Rd., Suite #2
 San Diego, CA 92145-5680

- 12. Colonel Diggs..... 1
 1524 Visotano
 Oceanside, CA 92055

- 13. Major F. Milburn..... 1
 Headquarters, U.S. Marine Corps (POE-27)
 2 Navy Annex
 Washington, DC 20380-1775

- 14. LtCol D.W. Beal..... 1
 PM, Tank systems (CBGT)
 MARCORSYSCOM
 2033 Barnett Road
 Quantico, VA 22134

- 15. Major P.M. Patch..... 1
 Requirements Division (C 443)
 3300 Russell Road
 MCCDC
 Quantico, VA 22134

- 16. Major R.S. West..... 1
 Standards Branch (C 461G)
 Training & Education Division, MCCDC
 2008 Elliot Road (Suite 119)
 Quantico, VA 22134-5029

- 17. Major S.M. Sessis..... 1
 Amphibious Warfare School
 2077 Geiger Road, MCCDC
 Quantico, VA 22134

18. Major R. Angel..... 1
 USMC LNO to the USAARMC
 Directorate of Force Development
 Bldg. 1109-C, Room C-14
 Attn: ATZK-FDL
 Fort Knox, KY 40121-5200
19. LtCol T.F. Thaler..... 1
 2nd Tank Bn, 2nd Mar Div
 PSC Box 20091
 Camp Legeune, NC 28542-0091
20. LtCol R. Carlton..... 1
 1st Tank Bn, 1st Mar Div Fwd
 MCAGCC Box 788260
 Twentynine Palms, CA 92278-8260
21. LtCol J. McNeal..... 1
 Inspector / Instructor
 8th Tank Bn 4th Mar Div
 439 Paul Road
 Rochester, NY 14624-4790
22. Capt D.S. Sylvester..... 1
 24 Bedford Drive
 Palm Coast, FL 32137
23. Capt M.C. Goodpasture..... 1
 XO MCSFCo
 PSC 819 Box 13
 FPO AE 09645-2700